

AUGUST 1983
\$2.00

THE RECORDING INDUSTRY MAGAZINE

Mix

Interview: Phil Collins

Studio Design Special Issue

**Bill Putnam
Bee Gees'
Studio**

**Music Video
Production**

**Steve Allen
T-Bone Burnett**

**Listings:
Designers
and Suppliers**

MR-4 28/24 \$39,900
MR-4 36/24 \$49,900

It's a small price to pay for GREATNESS.

Harrison Systems has always built GREAT CONSOLES.
Harrison Systems has also had GREAT PRICES.

We know that what you have always wanted was a GREAT
CONSOLE, but what you need is a small price.

Now, you get the price, *and*
you get a Harrison



 Harrison

HARRISON SYSTEMS, INC. • P.O. Box 22964, Nashville, Tennessee 37202 • (615) 834-1184 • Telex 555133

SERIES 4 FEATURES: All transformerless design • Thick-film resistor networks • 5532/5534/LF353/5532/5534 amplifiers • Minimum audio-path design • State-variable equalizer • +4 dB (or +8 dB) balanced outputs • Automated fader • Extensive patching • DIN (Tuchel) interconnects • DIN Eurocard internal connectors • Center-detent panpots • Center-detent = EQ controls • All sends switchable main/monitor • All EQ sections switchable main/monitor • 4 mono sends, plus 1 stereo send • Automatic PFL • Optional non-interrupting stereo solo • New high RF-immunity transformerless mic preamplifiers • Dual switchable mic inputs to each module • 24 tracks, plus direct outs (MR) • 8 stereo groups, plus 4 stereo programs, plus 4 mono programs (TV) • Extensive internal and external communications • Multitrack interface from stereo groups (TV) • All-aluminum (lightweight) housing • Internal or external patching • Various meter options • P&G faders.

*Prices shown are for direct factory sales in USA, FOB Factory, installation not included. Commissioning into a prepared facility is included. Prices outside of the USA are higher due to freight, duty, dealer service support, etc. Normal payment terms are 30% with order, 70% prior to shipment. Price, specifications, terms, and availability are subject to change and are determined only at the time of sale.

Circle #001 on Reader Service Card

World Radio History



Cover:
 (Top): New York's Editel audio suite specializes in sound for visual media. It was designed by NYC-based audio consultant and studio designer, Vin Gizzi.

Photo: © Mark Ross, 1983
 (Bottom): Crescendo Audio Productions, Inc., in San Juan, Puerto Rico, is the multi-media brainchild of New York-based engineer Alan Manger. The LEDE™ acoustical design of the former movie theatre was by Chips Davis.
Photo: Jochi Melero

Corner photo: Linda Matlow



What constitutes state-of-the-art recording *studio design* in 1983? George Petersen has been in touch with several top designers, suppliers and operators of recently-built major studios and passes along their observations on the World Class of '83. Page 26

DEPARTMENTS

- 6 CURRENT
- 8 SESSIONS/
STUDIO NEWS
- 62 PREVIEW
- 64 LUNCHING WITH
BONZAI:
STEVE ALLEN
by Mr. Bonzai
- 83 BOOKSHELF
- 108 INTERNATIONAL
UPDATE: IRISH
RECORDING
by Alexandra
Connolly
- 116 CLASSIFIEDS
- 118 ADVERTISERS'
INDEX

LISTINGS

- 37 STUDIO DESIGNERS,
ACOUSTICAL
CONSULTING,
EQUIPMENT SUPPLY,
INSTALLATION/
MAINTENANCE

MUSIC

- 84 PHIL COLLINS
by Bruce Pilato
- 89 MUSIC NOTES
 - T BONE BURNETT
 - CHICAGO MUSIC ATTORNEY
 - MIXWORDS
 - FAR SIDE
 - BACKWARD MASKING
- 97 PLAYBACK

AUDIO

- 13 INTERVIEW:
BILL PUTNAM
by Larry Blakely
- 21 THE NEW
SOUND LABS
by Josef Woodard
- 26 STUDIO DESIGNER'S
FORUM
by George Petersen
- 32 LEDE VS. EDEL
by Michael Rettinger
- 52 BEARSVILLE
by Bruce Pilato
- 57 DIGITAL
DISCUSSIONS
by Ken Pohlmann
- 68 ARTIST STUDIO:
BEE GEES'
MIDDLE EAR
by Tom Paine
- 76 SOUND ON STAGE:
CHICAGO'S PARK
WEST
by Gregory A.
DeTogne

VIDEO

- 100 MUSIC VIDEO
PRODUCTION:
CHUCK MANGIONE
TAPING
by Lou CasaBianca
- 106 VIDEO NEWS
by Mia Amato

For a group as successful as the *Bee Gees* to invest in their own studio is not too surprising. The manner in which they went about it, however, is not your typical artist studio piece. Trusty Tom Paine gives us the inside story on this very hot facility called *Middle Ear*. Page 68

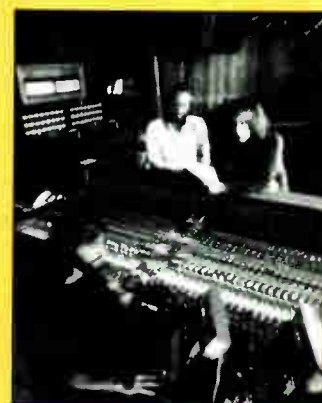

Studio owner & builder, equipment inventor & manufacturer, artist, engineer & producer *Milton T. "Bill" Putnam* is one of the true pioneers in the modern recording industry. Larry Blakely relays Part I of Putnam's adventures in recording. Page 13

This month we begin *Music Video Production*, dealing with the nuts and bolts of studio and field production. Lou CasaBianca passes along the producer's & director's perspectives on some of the more innovative music projects making their way to the video screen. Page 100



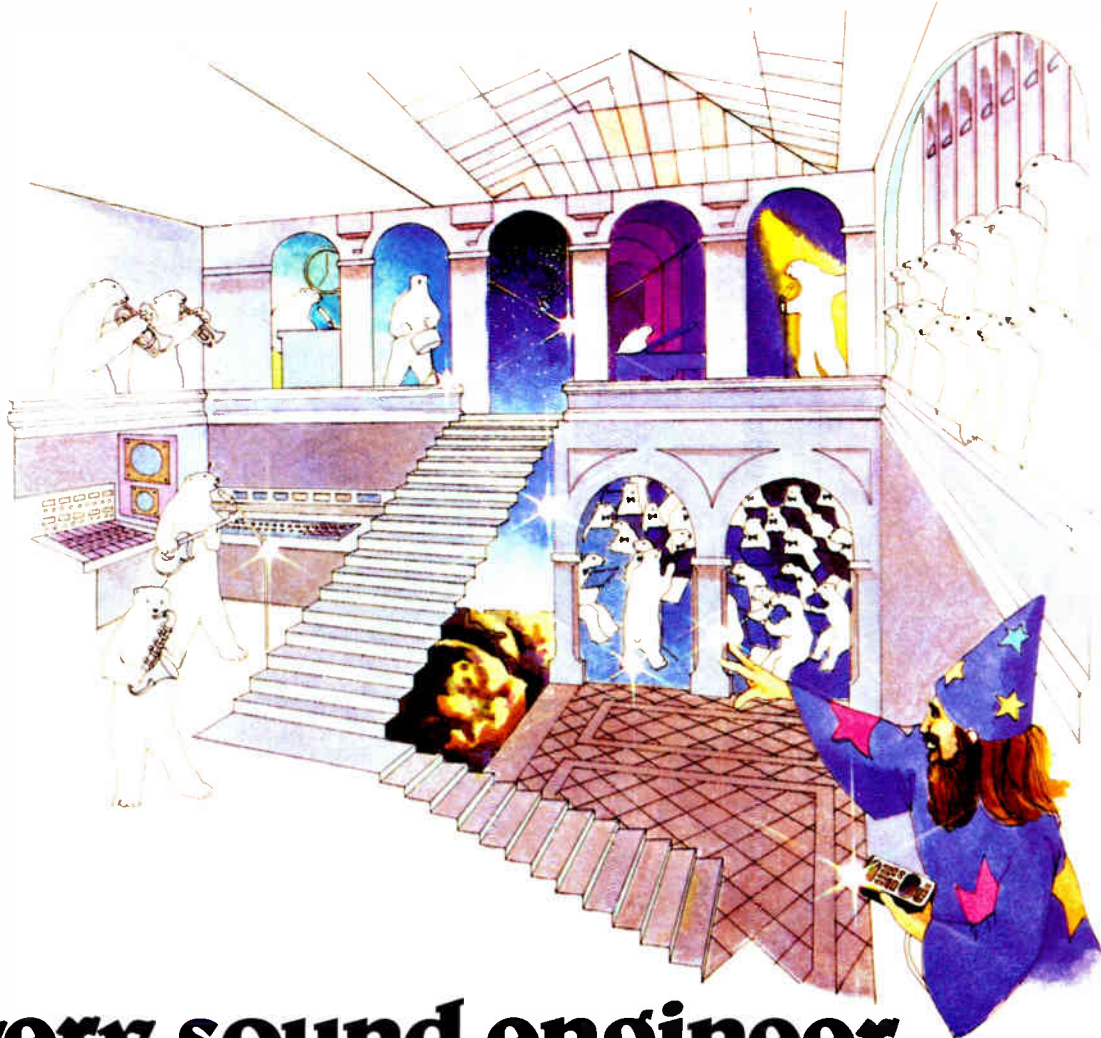

Every sound engineer needs a little magic

The Ursa Major 8X32 digital reverberator puts pure magic at your fingertips. Touch a button and you're transported to a concert hall stage. Touch another and hear sound roll through vast, empty canyons. And another, to conjure up a bright, tight plate that adds body to brass and drums. And then another: a larger plate, warm and beautifully balanced for voices.

In fact, the 8X32 lets you create and explore an almost infinite universe of acoustic environments. Four pre-set programs establish basic spatial qualities; then, the microprocessor-based controls allow you to separately fine tune all seven key reverberation parameters. For more control, there's a full remote console, LEDs that constantly display all the panel set tings, and 64 registers of

non-volatile memory to preserve and recall useful set-ups. And the 8X32's acoustic spaces *sound real*. Rich, uncolored and clean—even with difficult material and decay times as long as 20 seconds.

If you'd like to add a little magic to your sound, spend some time with an 8X32. We invite you to write us for detailed system specifications, prices (surprisingly low), and the name of a local Ursa Major dealer. See for yourself what it's like to acquire powers you once thought existed only in your imagination.

The 8X32 DIGITAL REVERBERATOR



URSA MAJOR, Inc.

Box 18, Belmont, MA 02178 USA • Telephone (617) 489-0303
Telex: 921405 URSAMAJOR BELM

Circle #002 on Reader Service Card

PUBLISHER/
EDITOR David M. Schwartz

PUBLISHER/
GENERAL MANAGER Penny Riker Jacob

ASSOCIATE PUBLISHER/
ADVERTISING DIRECTOR
Hillel Resner

ASSISTANT EDITOR
George Petersen

MUSIC EDITOR
David Gans

EDITOR AT LARGE
Mr. Bonzai

CONTRIBUTING EDITORS
Mia Amato
Lou CasaBianca
Chris Haseleu
Bruce Pilato
Ken Pohlmann
James Riordan
Neal Weinstock

ADVERTISING DEPARTMENT
ACCOUNT EXECUTIVES
Jeffrey Turner
Kathy Arnold
Harry Mensack

CLASSIFIED DEPT./STUDIO SERVICES
Kathy Arnold

ART DIRECTOR
Tim Gleason

ASST. ART DIRECTOR
Debbi Russell

DESIGN & PRODUCTION
Victoria Boss
Bonnie Blair Ofshe

TYPESETTING
C.J. Walter

CIRCULATION MANAGER
Mary Holland

CIRCULATION ASSISTANT
Renee Barron

CONTROLLER
Mike Stevens

ACCOUNTING ASSISTANT
Allison Hershey

TRAFFIC MANAGER
Ron Ward

PROJECTS DIRECTOR
Craig Wingate

ADMINISTRATIVE ASSISTANT
Patsy Messerer

Mix Magazine is published at 2608 9th St., Berkeley, CA 94710 and is © 1983, by Mix Publications, Inc. This is Volume Seven, Number Eight, August, 1983. Mix (ISSN 0164-9957) is published monthly. Subscriptions are available for \$24.00 per year. Single or back issue price is \$3.00. Subscriptions outside U.S.A. are \$36.00.

Please address all correspondence and changes of address to Mix Magazine, 2608 Ninth St., Berkeley, CA 94710 (415) 843-7901. Controlled circulation postage paid at Berkeley, CA and additional mailing offices.

Mix Magazine is distributed in recording studios, pro-audio stores, music stores and other related businesses. If you have a recording or music related business and would like to distribute Mix, please give us a call.

Display advertising rates, specs and closing dates are available upon request.

This publication may not be reproduced or quoted in whole or in part by mimeograph or any other printed means, without written permission of the publishers.

Don't miss our great Fall lineup...

September:

Studios of Southern California
Sound for Film and Video
Cassette Recorders for the Studio
Equalization Update
Bill Putnam - Part II
Jimmy Webb
Hall and Oates

October:

AES New Products
Studio Maintenance and Modifications
Music Video Update
Digital Recording Forum
Fibre Optic Studio Applications
Getting the Most from Eight Track
Test Equipment

November:

North Central Studios
Canadian Recording
Digital Tools of the Future
Limiters and Compressors

December:

Tape-to-Disk Special
CD Replication
Direct Metal Mastering

Advertising Closing Dates:

October issue: August 8

November issue: September 7

December Issue: October 7

Mix

 The Recording Industry Magazine

CURRENT

Records Lose, Tapes Gain in RIAA Survey

Using newly developed data, the Recording Industry Association of America (RIAA) and its Market Research Committee has recently released information which provides a comprehensive analysis of shipments of records and pre-recorded tapes by U.S. manufacturers between 1979 and 1982.

Based on those data, RIAA's figures show that there was a 9.4% decline in dollar volume at suggested retail list prices during that same period. In 1982, about 576 million units were shipped, down from 635 million units shipped in 1981. Volume at suggested retail list prices in 1982 was \$3.59 billion, down from \$3.97 billion in 1981.

When viewed in relation to the 1978 peak sales volume year for the industry when revenue topped \$4.1 billion, 1982's activity

reflects a dropoff of 13%. Over that 5-year period album sales decreased 29% as far as units sold and 14% in dollar volume. Single records were down 28% in units, but were up 9% in revenue. The big winner was pre-recorded tapes, with an increase of nearly 200% for units sold and 206% rise in dollar volume for the period.

RIAA President Stanley Gortikov expressed concern about the continued decline of shipments and revenues revealed by these figures. "These figures dramatically portray the troubled economic circumstances of our industry," Gortikov said.

The information is based on shipments data of companies reporting to RIAA and on data compiled by NPD Special Industry Services through an ongoing survey of 13,000 households that began in 1979.

NSCA Holds Conference

The National Sound and Communications Association's first stand-alone expo and conference in Las Vegas in early May, employing table top displays and technical sessions, attracted nearly five hundred contractors from around the U.S. and Canada.

The exhibit floor was laid out for traffic flow and maximum visibility, with the table top format and only one booth per exhibitor allowed. Beginning early each morning with general sessions, contractors were kept busy until eight in the evening with sessions and exhibits. "The con-

tractor had to bring four people to cover each workshop and the exhibit floor effectively," commented Chuck Rancilio, Chairman of the Rep liaison committee.

"Next year's convention will be at the Sahara Hotel the week of April 22nd," reports NSCA President, Bud McKinney of Lloyd F. McKinney Associates, Hayward, California. "We'll house our people in the same tower as the manufacturer suites. The sessions and exhibits will all be in the hotel, too."

For more information about the Association for electronic systems contractors, contact NSCA at 5105 Tollview Drive, Suite 201, Rolling Meadows, Illinois 60008, (312) 577-8350.

notes

Dolby Laboratories of San Francisco has announced the appointment of **Bill Jasper** President and Chief Operating Officer. Company founder **Ray Dolby** now assumes the title of Chairman and Chief Executive Officer. . . . **Peter Horsman** has been appointed director of marketing and sales of **Gauss Loudspeakers**, of Sun Valley, CA. . . . **Datatronics, Inc.** of Reston, VA, will now be marketing its audio and broadcast product lines directly from its manufacturing facilities in the greater Washington, D.C. area, rather than through the distributors the company has used in the past. . . . **Thomas E. Mintner** has been promoted to Director, **Studer** Products and will assume responsibility for administration of the Studer Division throughout the U.S., including

sales, marketing and technical areas. . . . **Barry Roche** has been appointed President of **Neve**, headquartered in Bethel, CT. . . . **Ampex Corp.** of Redwood City, CA, has promoted **Edwin Engberg** to business manager of audio tape products and **Philip Ritti** to business manager of video tape products. . . . **Restoration**, recently relocated to 15904 Strathern St. in Van Nuys, CA, has appointed **Rick Olsen** chief of maintenance and **Chris Olsen** as Marketing Manager. . . . **Crown International**, of Elkhart, IN, has reorganized its engineering department in the microphone products area to include **John Bachman** as group manager for the development of the PZM. . . . **Joel Brooks** has moved to Pasadena, CA, to become chief engineer for the newly-established cassette division of **Wakefield**

Summer CES Sets Record

The 1983 International Summer Consumer Electronics Show, held at Chicago's McCormick Place in early June, attracted 83,311 attendees, an all-time CES record.

Featured at the show was a special display of the year's most innovative consumer electronics products, as judged by a panel of industry writers and editors. Included in this exhibit were such items as NEC's second generation CD-803 E Compact Disc Player; Polk Audio's SDA-2 Speaker System with 3-D imaging; Sony's SL-2700 Betamax with Beta HiFi boasting an 80 dB stereo audio dynamic range on videocassette; Studer Revox B251 Integrated Amplifier with dual microprocessor control of all operating modes; Yamaha's Portasound MP-1 Keyboard with a built-in microprinter that prints out melody lines, staff, time signatures, rhythm and chord names; and Crown's Sound Grabber microphone for high fidelity recording on audio and video cassettes.

Also featured for the first time was a showcase of the best in software, which was dominated by video games, but included Commodore's 'Music Machine' for playing a home computer like a musical instrument, Michael Nesmith's Video 45 'Rio/Cruisin', Elton John's 'Visions' laserdisc and, of course, Jane Fonda's 'Workout' video.

Other highlights of the event centered around the digital audio disc, lightweight video cassette recorders and video cameras, high tech telephones, attractively-priced home computer systems and a diversity of software.

Manufacturing, Inc., the Phoenix-based record pressing firm. . . . **Wayne Freeman** of **Soundcraft Electronics**, in Santa Monica, CA, has announced the appointments of **Larry Schara** as Field Sales Manager, **Mary Gutierrez** as Sales Administrator for the complete product line, **Gary Lynn** as Service Manager for consoles and tape machines and **Erika Lopez** to handle all advertising and public relations for the company. . . . **Sound Technology** of Campbell, CA, has appointed **Hartmann Sales** of Maplewood, NJ, as its representative for the New York and New England regions. . . . **AEG Telefunken** Nachrichtentechnik GmbH has changed its name to A N T Nachrichtentechnik GmbH, headquartered in Backnang, West Germany, and represented in the U.S. by **Solway, Inc.** of Hollywood, FL.

DOLBY® NOISE REDUCTION FOR THE 1980'S

SP multi-track unit

360 single-track units

CN 221B for
Sony BVH
1000/1100

CN 226 for
Ampex
VPR-2

CN 234 for
Sony BVH 2000

Dolby noise reduction is keeping pace with today's demand for high-quality sound — everywhere. With the introduction of such products as plug-in modules for VTRs and the SP multi-track unit, it is easier than ever before to protect *all* your irreplaceable audio tracks from hiss, hum, and print-through. From broadcasting to music recording, from video sweetening to motion picture dubbing, Dolby A-type NR reliably continues to fulfill its original promise: effective noise reduction combined with complete signal integrity.

Dolby Laboratories Inc., 731 Sansome St., San Francisco, CA 94111.
Telephone 415-393-0300. Telex 34409, 346 Clapham Road, London SW6,
Telephone 01-720-1111, Telex 919109. "Dolby" and the double D symbol
are trademarks of Dolby Laboratories Licensing Corp. S83/5050

 **Dolby®**

Circle #003 on Reader Service Card

NORTHWEST

Recent audio post production for video projects at *Phil Edwards Recording*, San Francisco, CA, include three shows mixed from live PER recordings at the Paul Masson Chateau featuring *Airto & Flora Purim*, *McCoy Tyner*, *Bobby Hutcherson* and others. The shows, produced by *Blaise Cook*, will air on PBS with subsequent international distribution. . . . At *Hyde Street Studios*, San Francisco, *Brian Risner* has been editing and sweetening *Weather Report's* next single in studio D. *Les Stuck* assisted on the session. . . . 1983 Bammie winners *Ian Shelter* were at *Russian Hill Recording*, San Francisco, with *Bruce Steinberg* producing, *Jeff Kliment* engineering, and now in progress is audio post production for "The Right Stuff," (directed by Phil Kaufman), *Richard Hymns* supervising dialog, *Richard Greene* engineering, *Gary Clayton* assisting. . . . Also in San Francisco, *Dave Barrett* has just completed recording a four song demo tape of his own originals at *Independent Sound*, who inaugurated their newly installed 24 track recording system on the project. . . . At *T&B Audio Labs*, in San Francisco, three songs for *Wayne Wang's* ("Chan Is Missing") newest film are being recorded: a Chinese version of "My Boyfriend's Back," "Kung Fu Aerobics," and "Chinese Wax Museum." Produced by *Philip Gotanda* and *Michael Sasaki* and engineered by *Mark Ellinger*. . . . At *Montage Recording Studios*, Newark, CA, albums for *Doug Baker* and *Aryon* completed and due for release this summer. Now tracking an album for *Max Lynx* with *Will Mullins* producing for Gypsy Productions and *Dave Hartzheim* engineering. . . . Austin based rockers, *The Explosives*, stopped off at *Starlight Sound Studios* in Richmond, CA, while on their recent west coast tour to record the single "Rockabilly Woman" b/w "Law of the Jungle," produced by ex-Creedence bassist *Stu Cook* for his Ready Go label and engineered by *Karl Derfler*. . . . Activity with the *Bodacious Audio* Inc. mobile unit (Harbor Sound Complex, Sausalito, CA) includes a "live" album for the *David Crosby Band* which featured David Crosby, Austin DeLone, Tony Saunders, Jay David, and Slick. *Jerry Biesler* producing, *Tom Anderson* engineering, with *Dana Chappell*, *John Clavin*, *Bill Ashlee*, *Brian Hauck*, *Nancy Evans*, and *Herb Pallant* assisting. . . . *The Rayons* are at *Patchwork Productions*, San Rafael, CA, cutting tracks for a future release. *Ann Fry* is producing, with *Jeffrey Norman* engineering. . . . Recent sessions at *Custom Recording/Studio C*, in Stockton, CA, include *Bob Forman* with *Don Evans* producing and *Drew Palmer* engineering. . . . *Alpha Dea Productions*, of Provo, UT, recently completed a thirty minute television pilot at *Osmond Studio* in Orem, UT, entitled "Once Upon a Time" and is included in a ten part series

made for cable television. Producers are *Alan Foote*, *John L. Lee*, and *David Eyre*, with *Michael L. Schaertle* directing. . . . At *Mushroom Studios*, Vancouver, Canada, local band *44* is recording tracks for an EP or possible album project to be released by Aquarius Records, *Ed Stasium* producing, *Lindsay Kidd* engineering with *Dave "The Rave" Ogilvie* assisting.

SOUTHWEST

In Houston, TX, *Ric Tangle and the Squares* have completed production on their fully-mastered 7-song demo at *ACA Studios*. Produced by *Rick Poss*, engineered in 24 tracks by *Andy Bradley*. . . . At *Rivendell Recorders*, Pasadena, TX, vocalist *Lotus LoCaste* is demoing some tunes aiming at releasing two in 45 form. Studio bassist, *Dan Smith*, is producing. . . . Sessions at *Rosewood Studios*, Tyler, TX, include producer *John Rosasco* completing demos for *The Cruse Family's* upcoming LP for CBS Priority Records. *Greg Hunt* engineering. Also, *Tim Gillespie* co-producing tracks with *Hobbit* for Bruce Stover & Associates. . . . *Sound Arts Recording*, Houston, TX, has entered into mobile recording with its first multi-track/video shoot of the *Barbara Pennington Band*, recorded live. Final audio production was mixed at Sound Arts. Audio engineers were *Jeff Wells*, *Mark Nooney* and *Charlie Cosme*. Video was handled by *Television Video Productions' Alton Christensen* and *Steve Long*. . . . *Big Picture Productions*, Houston, TX, has completed a three-song demo featuring music written by *Tim Munson*. Recorded and mixed at *Rampart Studios*, the project features *Buck McKinney* on vocals, produced and engineered by *Dan Yeaney*. . . . At *Musician's Recording Studios*, Houston, TX, *Sandy Stewart* has been laying overdubs on her project for Modern Records. The executive producer of the project is *Gordon Perry*.

NORTHEAST

At *Le Studio*, Morin Heights, Quebec, *Asia* is recording their second album for Geffen Records. *Mike Stone* is producing and co-engineering with *Paul Northfield*. The record will be mixed on Le Studio's JVC digital system and released on CD. . . . *Comfort Sound*, Toronto, Ontario, has recently expanded to 24 tracks, with a new Ampex MM1200, and Capitol recording artists *Surrender* were the first clients to use it on a live session. . . . The new live *Pat Benatar* album, recorded during her last tour, is currently being mixed by producer *Neil Geraldo* and engineer *Guy Charbonneau* with New York City-based *Le Mobile* in Los Angeles. Assisting is

Cliff Bonnell. . . . At *Secret Sound Studio* in New York City, *Schrapnel* is recording their EP for Elektra/Asylum Records. *Vince Ely* is producing with *Scott Noll* engineering and *Warren Bruleigh* assisting. . . . Happenings at *Celestial Sounds*, New York City, include: *Melba Moore* for Capitol Records. *Paul Lawrence Jones III* and *Kashif* producing. . . . At *39th Street Music Productions, Inc.*, New York City, *Howard King* and *Kevin Robinson* are finishing up tracks for the new *Network* album for Salsoul Records. *Dave Olivier* handling the engineering duties. . . . At *Blank Tapes Recording Studios*, New York City, *John Morales* and *Sergio Munzibai* mixing *Thelma Houston* and *Wilton Felder* for MCA Records. *Butch Jones* engineering. . . . Talk show host *Merv Griffin* brought his show to New York City for taping recently, and all the show's remote portions were edited at New York City's *International Production Center (IPC)*. . . . Sessions at *Sigma Sound Studios* in New York City include tracking and mixing dates with Warner recording artist *Madonna*. *John "Jellybean" Benitez* has been producing, *Jay Mark* engineering, and *Melanie West*, *Linda Randazzo* and *Elisa Gura* assisting. . . . At *Bearsville Sound Studio*, Bearsville, NY, sessions include: *Mick Ronson* producing *Tom Pacheco* and *Tom Edmonds* engineering a project with *Skywire*. . . . At *Calf Audio*, Ithaca, NY, *Mark Rust* completed a 24 track LP for Catskill Mountain Records, produced by *Bill Usher*. The LP features a song dedicated to the late Harry Chapin. His brother, *Tom Chapin*, performed both guitar and vocal tracks on the cut "I'll Remember Harry" along with *Mark Rust*. . . . Recent guests at the *Boogie Hotel*, Port Jefferson, NY, include: *Blue Oyster Cult* recording a new album for CBS Records. *Bruce Fairbairn* producing, *Dave Wittman* engineering. *Chris Isca* assisting. . . . At *Midnight Modulation*, Saugerties, NY, *Jules Shear* producing demo for *Pal Shazar* with *Stephen Hague* at the board, and *John Sebastian* and *Artie Traum* overdubbing on *Priscilla Herdman's* album, *Michael Bitterman* engineering. . . . At *Eastern Artists Recording Studios*, East Orange, NY, *John Robie* has recently completed tracks for *Elenore Mill's* "Get Wet" (Plateau Records), and *Quadrant Six's* "The Lone Wolf" (RFC/Atlantic), and is currently working on tracks for *Jenny Burton's* Atlantic Records LP. . . . Activities at *Sigma Sound Studios* in Philadelphia, PA, include *Grover Washington, Jr.* producing his new album for Elektra/Asylum. *Peter Humphreys* engineered and *Barry Craig* assisted. . . . At *Plum Studio*, Haverhill, MA, *The Inkspots* have completed two tunes for radio airplay and *Shaharazod* (RCA Records) have completed one tune for upcoming release. . . . At *Syncro Sound Studios* in Boston, MA, *Stephen Hague* has completed an EP by *Hilary* for Backstreet Records with *Walter Turbitt* engineering, and *Ministry* were in to remix two of the songs from their current Arista

At last a rival for the SCM 762



The new Soundcraft SCM 760

For three years now, the SCM 762 multitrack from Soundcraft has been in a field on its own.

No one else has been able to produce a 24 track machine with as many professional features, with the same Soundcraft quality, and for anything like our price.

So it was up to us to improve on our own standards. Like fitting the interchangeable 16/24 track headblock as standard, and incorporating an improved servo control. The new welded steel frame gives extra strength and durability too, while the machine is still transportable enough to move around wherever you need it.

Yet you can still buy the SCM 760 for less than you'd pay for a second hand model of any other multitrack. And that makes Soundcraft the all round winners for 24 track recording – every time.

Soundcraft

Soundcraft Magnetics Limited, 5-8 Great Sutton Street,
London, EC1V 0BX, England. Tel: 01-251 3631. Telex: 21198.

Soundcraft Electronics USA, 1517 20th. Street,
Santa Monica, California 90404. Tel: (213) 453 4591. Telex: 664923.

LP. *Ian Taylor* engineering, assisted by *G.S.* . . . At *Fishtraks Recording Studios*, Portsmouth, NH, singer/songwriter *Brownie McIntosh* and WHEB morning drive DJ *Ted Garland* recorded "The Walkman Song" for use on Ted's show and for performance at WHEB's Comedy Night. . . . At *Trod Nossel Recording Studios*, Wallingford, CT, advertising and audio/video projects included *Mintz* and *Hoke* completing Northeast Utilities' and Edward's Food Warehouse radio spots and Massachusetts Mutual Life producing a sound track for their TV ID, engineered by *Richard P. Robinson* and *Douglas Korman Snyder*. . . . Album projects at *RBY Studios*, Southbury, CT, include: *Mother Goose Nursery* and the seventeen piece *AI Root Band*.

SOUTHEAST

Mark Knopfler (of Dire Straits) recently completed producing the new *Bob Dylan* album at *Compass Point Studios*, Nassau, The Bahamas. The sessions included *Sly Dunbar* on drums and *Robbie Shakespeare* on bass. . . . The *Charlie Daniels Band* has been cutting tracks at *Woodland Sound Studios*, Nashville, for their Epic Records LP. *John Boylan* is producer, with *Paul Grupp* engineering. *Ken Cribblez* is assisting. . . . Mastering projects completed at Nashville's *Disc Mastering Inc.*, by owner/engineer *Randy Kling* include: *Charley Pride's* "Night Games" single; a new album for Polygram Records by the *Kendalls*; and *Waylon's* new single, "Living Legends." . . . Studio activity at *The Shock House Recording Studio* in Nashville include: *Bill Carmack* with *Mike Shockley* producing and engineering along with *Jon Hines*, and *Sam McBe* producing the *Diamond Brothers* with Hines engineering. . . . At *Music City Music Hall* in Nashville, *Charley Pride* is working on his next album for RCA with producer *Norro Wilson* and engineer *Bill Harris*. . . . At Nashville's *Soundshop Recording Studios*, *Dolly Parton* was in remixing a concert recorded live in London to be released on HBO. Producing was *Gregg Perry* and engineering was *Ernie Winfrey*. . . . *Mac Davis* was at *Sound Emporium* in Nashville, cutting tracks with producer *Garth Fundis*. *Fundis* and *Gary Laney* engineering. . . . Recording at Atlanta's *Web IV* is Arista recording artist *Paul Davis*. Engineering the new album project are Davis' co-producer *Ed Seay* and *Tommy Cooper*. . . . *Julio Iglesias* has just returned from a concert tour of Japan to *Criteria Recording Studios* in Miami, to continue work on his forthcoming American album. Producer *Ramon Arcusa* is at the helm with engineering assistance from *Bob Castle*. . . . Activity at *New River Studios*, Fort Lauderdale, FL, includes a promo film score for Festive Cruise Lines by producer/writer *Tom Hartman* with *Vince Oliveri* engineering, assisted by *Ted Stein*. . . . The *Full Sail Dream Machine Mobile*, out of Altamonte Springs, FL, was recently in Cincinnati, OH, recording *Prodigal* for Heartland Records. *Jon Phelps* producing. *Greg McNeily*, *Rytt Hirshberg* and *Gary Platt* engineering. . . . At *Emerald Sound*, Nashville, *Eddie Rabbitt* working on project with producer *David Malloy*. *Joe Bogan* engineering, *Russ Martin*, *Keith Odle* assisting.

NORTH CENTRAL

At *the Disc Ltd.*, East Detroit, MI, *Carl J. Vest* and *Samikel DeLeon* are finishing tracks on funk group *You*. *Earl Size* engineering. . . . *Solid Sound, Inc.* of Ann Arbor, MI, reports *Dave Barrett* has completed his first album titled "Surprise." Also *Sasi Productions* is recording a musical film score for an industrial film starring *Joe Namath*. . . . *Dillon Bustin* has completed his new album at *Audio Village*, Bloomington, IN; *Bob Lucas* producing. . . . At *5th Floor Recording Studio*, in Cincinnati, OH, *Adrian Belew* just finished mixing his second album for Island Records. *Gary Platt* did the mix. . . . At *QCA Recording Studios* in Cincinnati, OH, *The Deele* is recording an album on Solar Records produced by *Reggie Calloway* and *Jeffrey Cooper*, engineered by *Ric Probst*, *Jim Greene* and *Robin Jenney*.

SOUTHERN CALIFORNIA

Producer *Chase Williams* was at *Sunset Sound*, in Hollywood, doing a video mix for a *Joni Mitchell* project, *Larry Hirsch* engineering, *Bill Jackson* assisting. . . . The *Westwood One* mobile unit from Los Angeles was seen in action at the *US Festival*, mixing and recording the show. . . . *Juice Newton* is tracking for a new Capitol LP at *Conway Recording Studio* in Hollywood, *Richard Landis* is producing the project with *Joe Chiccarelli* engineering. . . . Singer/songwriter/producer *Mark Stein* is in at *Pasha Studios* in Hollywood producing tracks for local band *Modern Design*. *Duane Baron* is engineering. . . . *John Bahler Associates* in Los Angeles used its new Synclavier II synthesizer on a 60 second radio spot for Twin Dragon Almond Cookies. *John La Brucherie* produced. *Gerry Klein* was the account executive. Music was composed by *John Bahler* with lyrics by *Jerry Whitman*. . . . At *Larrabee Sound Recording Studio*, Los Angeles, *Stanley Clarke* (CBS) is laying down tracks for a solo LP with *Erik Zobler* engineering and *Toni Greene* assisting. . . . Recent remote projects by *Tim Pinch Recording*, in Glendale, include *Sparks* (live at Magic Mountain), and *Henry Mancini* at the Coconut Grove, engineered by *Tim Pinch*, *Rex Olson* and *John Falzarano*. . . . *Reggae group Third World* was at *Kendun Recorders* in Burbank mixing their new CBS album, engineered by *Les Cooper*. . . . At *Sound Image Studio*, North Hollywood, *The Secrets* were in with co-producer *Randy Burns* completing their new single "Ride Sally Ride" which will be included on their debut album on Sound Image Records. . . . At *Circle Sound Studios* in San Diego, *Spencer Nilson* is completing his album "Spenc," produced and engineered by *Terry A. Setter*.

studio news

EMI's *Studios 301* in Sydney, Australia, has announced their Sony digital recording and master-

ing facility is now available for both in-house and remote projects, making it the first commercially accessible system of its kind in Australia. The Sony digital equipment is a 2-channel stereo system comprised of a digital processor (PCM 1610), two recorders (BVU 200B), and an editing unit (DAE 1100). The system also contains a special digital preview unit for disk mastering (DDU 1510), which is used when cutting a conventional record in *Studios 301's* mastering rooms. . . . *Recording Arts Center* in Eugene, OR, has recently opened for business. Formerly *Producers Studio*, the 24 track recording facility has undergone extensive acoustical treatment/remodeling and has upgraded its equipment to include a new 224X Lexicon reverb, Telefunken 2 track, Valley People Gain Brain IIs, Kepex IIs, and Max1 Qs, as well as two Neumann U-89s, Sennheiser 421s and three new Crown power amps. . . . *Quadrasonic Recording Studio* in New York City has announced the acquisition of an automated Harrison 3232C console, in addition to *Quadrasonic's* Studer 1/2 track mastering machine, Donny Osmond's dolbies and the availability of *Ron Johnson*, engineer (formerly of Electric Lady). . . . *TSI*, in Newton Falls, OH, has announced the completion of a new 24 track facility. The equipment list includes MCI JH-24, Otari 5050B, UREI 813B, Ursa Major 8x32. . . . *Beggar's Banquet* recording studio is now open for business at its new location, 540 B East Todd Rd., Santa Rosa, CA 95401. The electronics include a Tascam 16 track recorder/reproducer, Sound Workshop 24x16x16 console, Echoplex reverb unit, Eventide H949 harmonizer-digital delay, DeltaLab delay, dbx, UREI, Valley People, limiter/compressor, expander/gates, Ashly parametric equalization, Otari and Technics 2 track machines. . . . *Air Craft Communications Inc.*, from Pittsburgh, PA, has recently upgraded their 8 track facility to 16 tracks. The new equipment includes an Ampex MM-1200 and an Allen Heath /Syncon Series B 26x24 console, while still maintaining a new Otari Mk III 8 track. . . . *A.M.I. Records*, in Hendersonville, TN, has nearly completed construction of their new 24 track facility which features an MCI 636 40x24 console and UREI 813 monitors. While the studio was designed primarily for A.M.I. artists, it will also be available to outside clients. The 1400 square foot studio was designed by *Robert Austin Bealmear*. . . . *Paul Zaza* has opened *Zaza Sound Productions Limited*, a new 24 track studio in Toronto, Canada. The MCI-equipped facility has a 40'x30' main room, three isolation booths, and video synchronization (to 3/4" U-matic) for film scoring, video sweetening, and jingle work. . . . *Sagittarius Productions* has opened a full-service 8 track studio in Bingham, ME. The studio has a Carvin MX 1608 console, Tascam 80-8 recorder with dbx and a 24'x30' main room with iso booth. *Sagittarius* will also offer cassette duplication and custom label printing. . . . *Greene Street Recording Inc.*, NYC, has added to its selection of outboard gear, an AMS Model RMX 16 digital reverberation system. It features a full 18 kHz bandwidth and 90 dB dynamic range which can also store 90 user programmed settings. Also new is the Aphex II studio aural exciter.

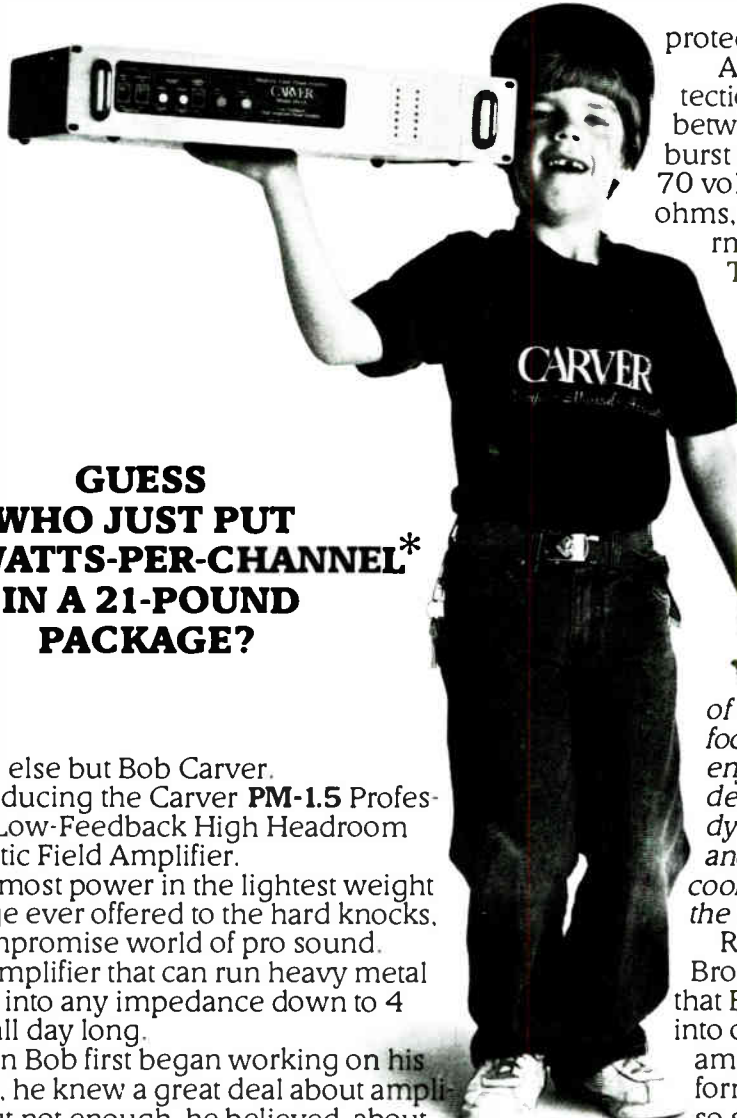

**GUESS
WHO JUST PUT
450 WATTS-PER-CHANNEL*
IN A 21-POUND
PACKAGE?**

Who else but Bob Carver. Introducing the Carver **PM-1.5** Professional Low-Feedback High Headroom Magnetic Field Amplifier.

The most power in the lightest weight package ever offered to the hard knocks, no-compromise world of pro sound.

An amplifier that can run heavy metal flat-out into any impedance down to 4 ohms all day long.

When Bob first began working on his PM-1.5, he knew a great deal about amplifiers but not enough, he believed, about the night-in night-out requirements (and wish dreams) of the pro sound world. And so he spent much time consulting with a large number of sound reinforcement professionals, including the "pros' pro," Clair Brothers.

Clair Brothers asked for lower input ac line current, greater transformer thermal capacity, dual modes of precision balanced inputs with 1% resistors, back-to-front cooling with a fully proportional fan system that can just tick over at idle or blast 1000 ft/min. to keep output transistor temperatures constant. They wanted greater noise immunity and unbelievable long-term, high-power operation, as well as a 3/16" front panel with deep-recessed controls.

Others wanted rear rack-mounts, adjustable protection circuit thresholds, front panel selectable clipping eliminator, and even a sequential soft-start power-up mode.

Now that the PM-1.5 has undergone thousands of lab test hours and seven months of hard road testing, Clair Brothers, Bob, and you get all that and more.

The PM-1.5 is designed to run balls-to-the-wall, even into 4 ohms day and night without compromising itself or your drivers. Because the PM-1.5 has three special adjustable speaker

protection circuits.

An adjustable Short-Term Speaker Protection circuit adjusts dynamic headroom between 60 and 77 volts with a short term burst capability of 70 volts rms at 8 ohms, or 60 volts rms at 4 ohms.



Front-panel-adjustable protection circuits.

The circuit locks-in to the control setting after 0.5 seconds.

An adjustable Long-Term Speaker Protection circuit matches the time constant of the output shutdown circuit to your PA or monitor system.

Finally, the Clipping Eliminator detects clipping lasting longer than 30 milliseconds and attenuates the input signal just enough to pull the PM-1.5 out of clipping.

As for sound quality, consider this quote from **The Audio Critic Magazine**, "...the equal of any power amplifier in transparency, focus and smoothness. We especially enjoy hearing spatial detail, instrumental definition and completely natural dynamics. At this level of sonic performance, the astoundingly small size and cool operation become icing on the cake..."

Roy Clair and Ron Borthwick of Clair Brothers said it this way, "We are amazed that Bob was able to put the same wattage into one-fourth the volume of conventional amplifiers without sacrificing audio performance. It's hard to believe that an amp so small and lightweight can put out so much clean power. But it does!"

Whether you run a megawatt sound company, a struggling bar band, or a recording studio gearing up for digital, the PM-1.5 will pay you. In increased portability and reduced freight costs. In freedom from expensive blown drivers. In sheer sonic excellence.

Write for a detailed brochure today or give your local pro store no peace until they order you 21 pounds of pure power.

*Power: 8 ohms, 450 watts/chan 20 Hz-20 kHz both channels driven with less than 0.1% THD. 4 ohms, 600 watts/chan rms 20 Hz-20 kHz both channels driven with less than 0.1% THD. 16 ohms, 300 watts/chan 20 Hz-20 kHz both channels driven with less than 0.1% THD. 2 ohms, 525 watts/chan at clipping, 1kHz, with less than 0.2% THD. Note: 2-ohm specification for information purposes only. Operation at 2 ohms is permissible but not recommended. **IM Distortion:** Less than 0.1% SMPTE. **Frequency Response:** -3 dB at 3 Hz, -3 dB at 80 kHz. **Damping:** 200 at 1 kHz. **Gain:** 26 dB. **Noise:** Better than 115 dB below 450W A-weighted. **Input:** Balanced to ground, XLR or phone. **Impedance:** 15k-ohm each leg, balanced to ground. **Bridging:** 1200W into 8 ohms, 1000W into 16 ohms, accessed through rear-panel recessed switch. **Dimensions:** 19 in wide, 3 1/2 in high, 10 3/4 in deep. Weight: 21 lbs



CARVER

(206) 483-1202 P.O. Box 664 Woodinville, WA 98072

Circle #004 on Reader Service Card

AL JARREAU'S MUSIC HELPS MAKE COLORFUL READING.

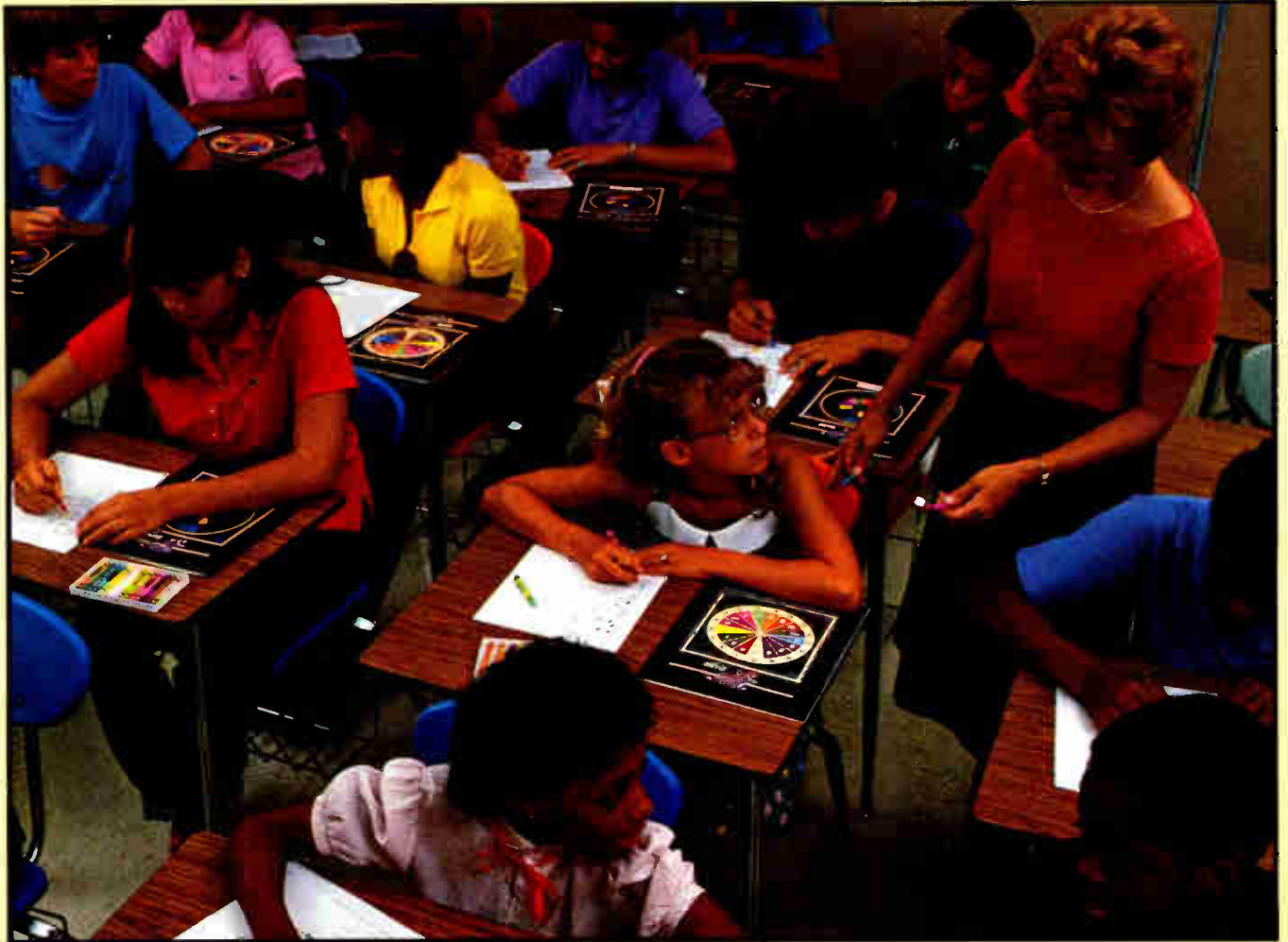

ColorSounds is a unique combination of music and color that advances the reading capabilities of children.

Instead of getting turned off to school because they can't read, kids master reading in an exciting new way...while listening to popular music.

Al Jarreau contributed one thousand dollars to support this special educational technique. And the Ampex Golden Reel Award made it possible. It's more than just another award. It's a thousand dollars to a charity named by

artists receiving the honor.

For Al Jarreau, *Breakin' Away* was the album, Dawn-breaker and Garden Rake were the recording studios and the kids of ColorSounds were the winners.

So far, over a quarter of a million dollars in Golden Reel contributions have gone to designated charities. For children's diseases. The arts. Environmental associations. The needy.

Our warmest congratulations to Al Jarreau, Dawn-breaker, Garden Rake, and to

all of the other fine recording professionals who've earned the Golden Reel Award.

AMPEX

Ampex Corporation • One of The Signal Companies



by Larry Blakely

M.T. "Bill" Putnam is a true Renaissance man in the recording industry. He is the founder of United/Western Recorders in Hollywood and UREI (United Recording and Electronics Industries). He is a respected pioneer in recording studio acoustics, was the first to use reverberation and echo for commercial recordings, developed the first multi-band equalizers, conceived ambient microphone techniques and did much early developmental work on stereophonic recording. Recently Bill took the time to tell us about his formative years in audio and acoustics.

Putnam was born on February 20, 1920 in Danville, Illinois, a town of 25,000 located south of Chicago. His father was in the coal mining business, owned some strip mines, some retail coal yards in Danville, started a manufacturing company for large truck scales, and encouraged Bill to be involved in business enterprises.

Bill's interest in music was primarily influenced by his father and mother. "My dad had a radio program on WDW in Tuscola, IL, one of the older radio stations in the country, and the home of Gene Autry before he moved to WLS and the number one country radio show, National Barn Dance.

"I think my interest in radio and electronics really started while I was in the Boy Scouts. I had decided to get a merit badge in something that was called 'wireless,' and built a crystal set and a one-tube radio (with my dad's help), which got KDKA in Pittsburg! I built my own private telegraph system which ran down the block to a couple of my friends' houses, but since none of us knew the Morse code very well, we weren't able to handle much traffic.

"It was through my interest in radio and a lot of encouragement from my dad that I became interested in 'ham' radio. In 1933, at 13, I made my first attempt at taking the ham radio operators exam in Chicago. I took my first taxi cab ride to the Federal Communications building on Wacker Drive, the first skyscraper I had ever seen. To make a long story short, I flunked the code exam. Two years later I returned and got my Class B ham ticket, the equivalent to today's General Class ham radio license. So I became a ham radio

an interview with BILL PUTNAM

part one



Above: After Bill's early attempts at aeronautics failed to get off the ground, he refocused his energies on electronics and acoustics

Right: Bill Putnam



operator at the age of 15. Hallcrafters, Skybuddy, Hammerlund and National, the popular brands of ham radio equipment, were too expensive for my very low budget, so I had to build my own.

"In my early years of high school I had a part time job working for a friend in a radio shop where I learned repair. My friend also had a PA system, which I rented out to the local city parks for their amateur

shows. From this I learned PA systems, and, most of all, about feedback, which made them howl.

"I have a great enthusiasm for show business and I liked singing with dance bands. At the age of 15, I sang on weekends with a number of regional bands that played primarily on college campuses. This was when I first started to develop my interest in jazz and the music business, and realizing that musicians were my

favorite people."

Putnam went to high school with Dick Van Dyke and the well-known society entertainer, Bobby Short. "Dick was very active in all the high school plays and Bobby was frequently an entertainer at high school assemblies. I was also an entertainer at high school assemblies, and kept a balance between my interest in entertaining and electronics. My interest and activity in ham radio continued to grow through all these years. I became a ham in every sense.

"By the time I was a junior in high school, my activities were primarily singing with dance bands. I was making five bucks a night, a lot of money in those days. (This included the PA system rental, which might be a comment on how well I sang.) My activity in ham radio and my business enterprise had progressed to the point that I then owned my own radio shop. I must have had more nerve than sense, because I really was not well qualified. My dad, who believed strongly in doing everything on a business basis, rented me some space in the back of his office for \$7.00 a month. I was able to hire another friend part time, who had graduated from high school, and I succeeded in

making a deal with the Goodrich Silvertown Tire Service Company to install Motorola and Arvin car radios on weekends, charging something like \$2.00 to install a car radio. I did this on Friday nights and all day Saturday. I remember one disaster that I had working on a Cadillac. I had laid out the template for the car antenna and drilled the holes. Suddenly I discovered that the way I had mounted the standoff insulators prevented the door from opening. Fortunately, the owner of the car turned out to be a pretty reasonable guy and I had the panel refinished by the Cadillac dealer, who leaded in the holes. That was a bitter and, needless to say, very valuable learning experience.

"The radio shop was quite a success and I was very fortunate in that when I got in over my head repairing radios, which I frequently did, I could get on the phone with the distributor for RCA and National Union Radio Tubes and he would help me wade through it. I had limited working capital but I was able to get National Union Radio tubes on consignment. After a certain quantity of tubes, I could buy test equipment from them at a discount. So I acquired most of my test equipment in

this manner.

"After I sold the radio shop for \$700 and had graduated from high school, I knew exactly what I wanted to do vocationally. I wanted to get into radio broadcasting in the technical area. I chose a small college in Valparaiso, Indiana, which had started out as Dodge Radio Institute and later became Valparaiso Technical Institute (VTI). At the time I started there, the school had just elected a new president by the name of Dr. J.B. Hershman, who had previously chaired the Physics Department at the University of Indiana, at Bloomington. This gentleman, and an individual by the name of Clويد Patton, probably had more influence on my academic career than anyone else. Hershman's field of specialization was sound acoustics and, oddly enough, antennas. These were exactly the fields of specialization I had chosen and I was absolutely enamored with him. It was not until the second semester that I actually met him as a professor. I stood in awe of him, both as a teacher and author.

"During the time I attended VTI, I continued my singing activities and worked with some bands, on a somewhat regular basis, around Gary,



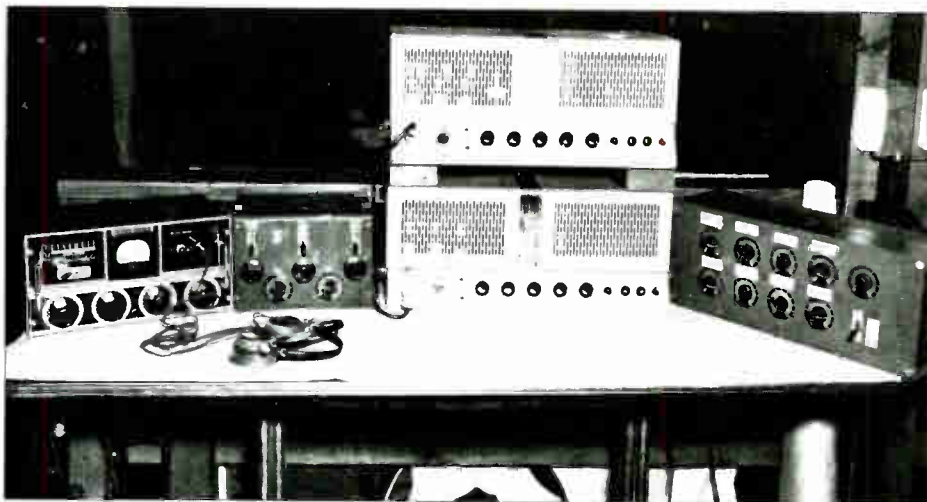

The Signal Corps, vintage 1942 remote recording equipment. On the left is the Gates Dynamote mixer; to the right of the mixer is a home brew submixer; two RCA 50-watt power amplifiers, one which was modified to drive the cutter head and to the right is another home-built submixer.

Indiana, Michigan City and Chicago. These were the days of the dance band remotes and I was able to get on some of the larger radio stations around Chicago, working with Bill Fryer who had a popular regional band.

"After my graduation from VTI, I applied for a position at a number of radio stations and was hired as a transmitter engineer at WDWS in Champaign, IL, a station owned by

the Champaign News Gazette newspaper. This radio station was also the home of the University of Illinois, and it was my intention to continue my education there. Working the transmitter shifts gave me the opportunity to build a lot of equipment, in addition to experimenting. During this time I developed a greater interest in audio and high quality sound reproduction.

"In 1941 I confronted another example of 'not knowing what I didn't

know' when I decided to start writing magazine articles. I submitted an article entitled 'High Fidelity Phonograph Amplifier' (with inverse feedback, yet!) to Gernsback Publications, which was published in *Radio and Television* magazine in 1941. Subsequently, I continued to write articles for the magazine, which was a Ziff Davis publication. The editor of this magazine was Oliver Reed, who later wrote a famous book called *Tinfoil to*

TOA TRANSDUCER TECHNOLOGY: PRECISION-ENGINEERED TO DELIVER FORMIDABLE PERFORMANCE.

Technical data available on request.



Professional Sound & Communications

TOA Electronics, Inc., 480 Carlton Court
South San Francisco, CA 94080 (415) 588-2538

In Canada: TCA Electronics, Inc., 10712-181 Street
Edmonton, Alberta T5S 1K8 (403) 489-5511

© 1983 TOA Electronics, Inc.

Stereo."

Putnam got his First Class radio telephone license in 1939, at the age of 19. After working for about a year at WDWS in Champaign, a new radio station, WDAN, went on the air in his home town of Danville. "The salary was \$5.00 a week better, so I applied, got the job and went to work there. They had a brand new RCA transmitter and their studios were in Danville's finest hotel. WDAN was also the station on which Dick Van Dyke started his career as a disc jockey.

"One January evening I noticed that one of the tower lights was out. The company policy was to hire a guy from the power company to climb this 312 foot tower and replace

the lights. Three hundred twelve feet was pretty high in January, especially with the snow and wind, but knowing they paid \$25.00 to change the lights, I decided I would do this and be a wealthy hero. It was a very scary experience. I climbed the tower carrying a gunny sack with two 1500 watt lights and, when I got to the top and braced myself, the tower was swaying back and forth like an upside down pendulum. But I did get the bulbs changed, and it took me almost 2 hours to climb back down the tower. I had forgotten to tell anyone at the studio that I was leaving the transmitter and the phone had been ringing off the wall. The chief engineer was waiting for me and said, 'Guess what?

You're fired!' After our tempers had quieted down, I found out that they took a dim view of station personnel changing the tower lights. By the next morning I had succeeded in getting my job back.

"Approximately 6 months later I was contacted by the station owner and program director of WDWS in Champaign to see if I would be interested in coming back as chief engineer. It was an overwhelming challenge, and I accepted the job at a substantial increase in pay. Here, I had a lot of opportunities to originate network feeds. We were feeding NBC, ABC and CBS the Big 10 football games for national broadcast.

"The first play by play announcer I worked with was Tom Harman, an All-American football player who lacked experience as a radio announcer. Part of the job that I performed, as a remote engineer, was doing the spotting. I had rigged up a spotting device with a series of lights for both offense and defense. The lights had replaceable name cards above them, and I would turn on the appropriate light with a toggle switch, depending on who carried the ball and who made the tackle... a little gadget that proved to be very helpful in doing play by play football games."

Soon Putnam got involved in upgrading at the station. "I talked the boss into letting me build a transmitter rather than buying a new RCA or Western Electric, which were the most popular in those days. So I took it as a great challenge and built a transmitter and was even able to get the thing approved and signed off by the FCC inspector. The transmitter worked well and it stayed in service, to my knowledge, for about 10 years after that."

By 1941, at the age of 21, Putnam had received a draft notice. "I became aware, through the trade publications, that there were civil service jobs available in the radio engineering section of the 6th Army in Chicago. So I took a civil service exam, passed it and became a civil service employee as assistant Army Corps radio engineer for what was then known as the 6th Army Service Command. I was stationed at the Civic Opera Bldg. and I had a great chief signal officer who was a 'West Pointer.' I was involved in a variety of activities, being on temporary assignment to the air force, installing 'radio ranges.' At the time I didn't know much about this, other than that 'radio ranges' had something to do with giving bearings to aircraft.

"Meanwhile, I continued my writing. I was writing articles primarily having to do with audio and high

SYSTEM 8

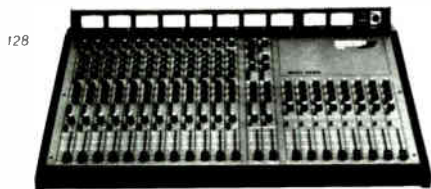
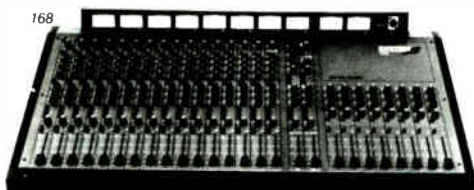

FEATURES INCLUDE

- * External Power Supply with Phantom Power option.
- * 3 Band EQ with Mid sweep and selectable shelving.
- * Long travel fader. * Peak LED on all inputs.
- * Insert points on inputs and outputs

The amazing 1616 with full 16 track monitoring. Shown here with the E x 8 Expander module



AHB

Allen & Heath Brenell Ltd.
69 Ship St.
Brighton, Sussex
England

Circle #006 on Reader Service Card

AHB

Allen & Heath Brenell (USA) Ltd.
5 Connair Road
Orange
Connecticut 06477
USA
(203) 795-3594



EXPLORE THE LEADING EDGE OF ENTERTAINMENT TECHNOLOGY

A few highlights from MIX VIDEO, Volume One, the first in a series of one hour programs presenting the best and the latest that entertainment technology has to offer:

■ **LES PAUL:** an exclusive interview at home with the legendary recording artist credited with the invention of the electric guitar and multi-track recording, as well as this year's Grammy winner for lifetime achievement.

■ **COMPUTER ANIMATION:** a visit with Denver-based Computer Image Corporation to see the latest generation of image manipulation from the originators of the medium.

■ **STUDIO TOUR:** Criteria, the Miami recording giant with credits for over 100 gold and platinum records, gears up for digital audio and first rate music video production.

■ **ENGINEERING:** Veteran studio engineer Jim Gaines discusses how he and producers Jerry Wexler and Barry Beckett shaped the sounds on Carlos Santana's latest album, *Havana Moon*.

■ **PRODUCER'S DESK:** David Rubinson shares his special insight into the space age music technology of Herbie Hancock.

■ **STUDIO MUSICIAN:** Allstar session bassist Carol Kaye (Beach Boys, Supremes, Four Tops, . . .) tells the story of an incredible career.

■ **PLUS:** The History of Recording, Computer Tools for Musicians, Convention Updates, New Product spotlights and, for the lighter side of recording, Mr. Bonzai takes us to the "Other Side of the Tracks."

Mix Video, the hour long electronic magazine, takes you behind the scenes for the sights and sounds of the new entertainment technology. It's the material that you want to learn and the information that you need to know . . . an action reference for studio, classroom or home study. And it's available now in stereo (mono compatible) on VHS and Beta cassettes.

Mail the attached coupon today. If not absolutely satisfied, you may return Mix Video within 15 days for a complete refund.

© 1983 Illustrated Mix Productions

YES I would like to see the MIX VIDEO, VOLUME ONE
 (no special introductory price) \$39.95

Name _____

Address _____

City _____ State _____ Zip _____

Send me 1 () 2 () 3 () copies of MIX VIDEO, VOLUME ONE for \$39.95 each.

NAME _____

ADDRESS _____

CITY _____ STATE _____ ZIP _____

SEND ME 1 () 2 () 3 () COPIES OF MIX VIDEO, VOLUME ONE FOR \$39.95 EACH.

Some early recording lathes Putnam built in 1945-46. They were belt driven with overhead Rek-O-Kut feed screws and Olson cutter heads. These were the designs used for the recording and rebroadcast of the ABC network shows for over 2 years at the inception of Universal Recording in 1946.

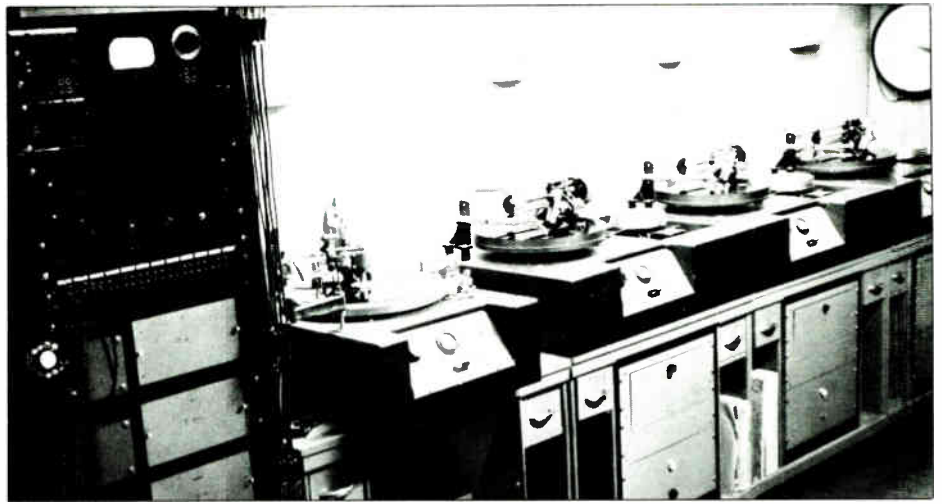

quality phonograph reproduction. I wrote an article on the various phase inverters, cathode followers and other types. It was a fairly comprehensive article. I wrote a couple of articles on carrier current devices and also on a 3-band tone control circuit with separate stages for low, mid, and high frequencies. It provided independent gain for each stage and each had its own independent control. This was published in *Radio and Electronics* and, to my knowledge, was the first amplifier that had three frequency bands with boost and attenuation.

In addition to installing 'radio ranges,' Putnam became interested in mine detectors used by the Signal Corps. "They had a search coil on a large broomstick, and a very heavy battery pack with large vacuum tubes. I conceived that it might be possible to use hearing aid tubes and more advanced bridge circuits as a way to miniaturize the mine detector. I started working on this project in my spare time. I had talked at length with the chief signal officer of the 6th Service Command about the prospects of miniaturizing the mine detector and shortly thereafter had a visit from a couple of men in civilian clothes, whom I later found out were members of the Secret Service. They asked a lot of questions, like how small the device could be made. They told me that they were interested in making a personal gun detector that could be worn in the sleeve of a dress suit and could detect a small caliber handgun.

"I was then assigned full time to develop this project, working in a lab of a small hearing aid company in Chicago on South Michigan Ave. We developed a small, concealable gun detector, which was used at the Tri-Power Conference for the protection of President Roosevelt and Secret Service personnel.

"Another project I got involved

in was setting up a backup link to Europe via Hudson Bay, using Rhombic and Grounded V antennas. RCA Communications and Federal Telegraph facilities were located at Crown Point, Indiana, a St. John Indiana and Merryville. With the permission of the Chief Signal Officer of the 6th Command, I was able to call in Dr. Hershman from VTI as a consultant. With his guidance and a lot of 'boring up' and homework on my part, we were able to complete the projects.

"My work with Armed Forces Radio also involved recording dance bands, one of which was headed by Wayne King. This was a low priority assignment but something I enjoyed very much. I had to scrounge around and put together all the recording equipment. In that band were two famous singers, Bob Eberly, who recently passed away, and the late Buddy Clark. Bob Eberly was with the Dorsey Brothers and Buddy was an artist on Columbia Records. At this particular time both men were at the top of the *Billboard* charts as singers. Each had been drafted into Special Services or some other branch of the Army. We recorded a number of shows which were played by Armed Forces Radio overseas and throughout the country as part of a recruiting program. I became close friends with Wayne King and that friendship lasted many years. I continued to record him after the war on Decca records on many, many occasions. A number of musicians I met in that band are now studio musicians in Hollywood.

"Recording, at that time, was a low priority project, but for me it was a labor of love. I had built a belt drive turntable, my first attempt at trying to put together some professional recording equipment. The mixers I used were purchased from Gates Radio, portable broadcaster mixers called the

Gates Dynamote. The mikes were RCA 44Bs (that was before the 44BX), the RCA 74B (which looked like the 44BX but was only 2/3 the size), the Western Electric 633 'Salt Shaker,' Western Electric 630 'Eight Ball,' and the Western Electric 639 'Bird Cage.' It was surprising how well we did, considering the equipment we had to work with."

After a stint at Fort Sheraton, Putnam was inducted into the army and was attached to do specific projects for G2 (military intelligence) in covert operations. "I recall one occasion in which we hid in the attic of a house for some time while I was on loan from the Signal Corps to G2. This involved a phone tap operation. I had some other contact with G2 installing communication equipment in vehicles disguised as laundry vans and delivery trucks. I got to know a number of the members of G2 through the gun detector project and I had tremendous respect for the members of the Secret Service and G2 with whom I worked.

"As the war was winding down I was sent to Los Angeles and relocated out on Santa Monica Blvd. as an instructor for broadcast operations. We were setting up a number of low-powered broadcast stations to be operated by Armed Forces Radio Service in the European theatre and we were teaching the fundamental operations of broadcast stations. It was during this time that my interest and activity as an author, writing about audio and sound equipment, stimulated a growing interest in recording, something in which I would get much more involved after the war." ■

Next month Bill will talk about the history of Universal Recording and some of his pioneering efforts and experiences in the early years of the recording industry.

At United/Western Studios It's One Pro After Another

The Blasters
Barry Manilow
Australian Crawl
Hughes/Thrall
Tom Wopat
Stevie Nicks
Dave Mason
Frizzell & West
Janet Jackson
Albert Lee
Sheena Easton
Diana Ross
Martin Mull
Chuck Mangione
Rick Nelson
Joe Cocker
Kris Kristofferson
Jerry Knight
B.J. Thomas
Ronnie Milsap
J.J. Cale
Eddie Money
Altered Images
Bow Wow Wow
Gladys Knight
& the Pips

The BusBoys
Sissy Spacek
Blondie
David Lindley
The Go Go's
Naughty Sweeties
Brian Wilson
Barbara Mandrell
Wet Betty
Rodney Crowell
Lionel Ritchie
Paul Horn
Conway Twitty
Micky Gilley
The KingBees
Shawn Cassidy
Mike Post
Oak Ridge Boys
Statler Bros.
Bill Conti
Peter Matz
Manhattan Transfer
Bobby Vinton
Dudley Moore
Liza Minelli

From One Pro To Another
United/Western Studios
6000 Sunset Blvd.
Hollywood, California 90028
(213) 469-3983



The UREI power amplifiers are designed to extend UREI quality from our low level signal processing all the way through to our exclusive Time Align™ studio monitors.

The New UREI Power Amplifiers

Careful evaluation of competitive power amplifiers indicates that while in some cases adequate reliability has been

achieved, audible performance is often marginal.

The UREI 6000 Series amplifiers offer the knowledgeable professional the reliability he demands and the sound quality he deserves.

Exceptionally large power supplies and exceedingly high speed, high current circuitry combine to produce low-end punch and high-end sparkle which is unexcelled in professional power amps. Moderate use of negative feedback results in fast recovery from transient overloads and avoids excessive high order harmonic distortion when the amplifier is driven into clipping.

The Model 6500 Listening Amplifier

Two totally independent plug-in channels, removable from the front panel,

each with its own power supply and continuously variable cooling fan. Exclusive Conductor Compensation™ corrects for wire loss and transducer related load anomalies, resulting in absolutely accurate waveforms at the speaker terminals. 275 Watts per channel into 8 ohms, 600 Watts per channel into 2 ohms. Standard rack mount, 7" high.

The Model 6300 Dual Channel Power Amplifier

225 Watts per channel into 8 ohms, 380 Watts per channel into 4 ohms. 5 1/4" rack space!

The Model 6250 Dual Channel Power Amplifier

150 Watts per channel into 8 ohms, 200 Watts per channel into 4 ohms. 3 1/2" rack space!

The Model 6150 Dual Channel Power Amplifier

80 Watts per channel into 8 ohms, 80 Watts per channel into 4 ohms. 1 3/4" rack space!!

Audition the UREI Power Amplifiers at your professional sound dealer and discover how good a reliable amplifier can sound.

From One Pro to Another—trust all your toughest signal processing needs to UREI.

®Time-Align is a Trademark of E.M. Long Assoc., Oakland, CA. All referenced Trademarks are property of, or licensed by, United Recording Electronics Industries, a URC Company.

UREI From One Pro To Another

United Recording Electronics Industries
8460 San Fernando Road, Sun Valley, California 91352 (213) 757-1000 Telex: 65-1389 UREI SNVY
Worldwide: Gotham Export Corporation, New York; Canada: Gould Marketing, Montreal H47 1E5

See your professional audio products dealer for full technical information. © UREI 1981



Lee De Carlo in Sound Labs Studio 3 control room

the 'new' sound labs

by Josef Woodard

Lee De Carlo has logged an imposing career as an engineer for such disparate projects as The Rolling Stones, Funkadelic, Black Sabbath, John Lennon, and, recently, salvaging the soundtrack to the movie "Flashdance." In the case of "Flashdance," De Carlo rectified a syncing problem by encoding a clap track onto different Apple computers, each handling a separate function. When interfaced, the computers trued the sound to image: a simple and swift solution to a potentially tedious task.

When Sound Labs, a studio run by Bob Gaudio (producer of The Four Seasons, among others) and Frankie Valle, was itself getting financially out of sync, they, too, called on their old friend De Carlo - not as engineer, but as an audio problem-solver. His reputation preceded him; as chief engineer at the buzzing Record Plant for 5 years, De Carlo effected design changes in two of the four studios which may have had an impact on the general sound of the music industry

"What I did in the designing was a real radical departure from what was going on at that time," De Carlo remembers as we talked in Studio 1 of Sound Labs. "They were using a lot of traps, drum booths and little sectioned-off rooms. I was never a big fan of that anyway, particularly coming out of New York, where everything was geared towards a more live sound, whereas California then leaned towards a dead sound. When I had the opportunity to rebuild the room, I decided to go for what was like a soundstage - real live but under control; everything was relieved from side to side. Now that's become pretty much the accepted thing."

As Studio C gained in popularity, Record Plant owner Chris Stone recognized De Carlo's design savvy and gave him lease to redo Studio A. The resulting room has earned the distinction as the premier mixing location. De Carlo claims, "Everything sounds good in it. When I finished it, as with Studio C, everybody hated it and loved it - because I built it for

ACCEPT NO SUBSTITUTES!

CHIPS DAVIS
LEDE™ and Beyond

Phone: (702) 731-1917
Lede™ SYNAUDCON

TresVirgos Studios
San Rafael, CA
Crescendo Audio Productions
San Juan, P.R.
STARMUSIKPRODUKTION GHmb
Hamburg, W. Germany
Radio-TV Caracas
Caracas, Ven.
Las Vegas Recording
Las Vegas, NV

Sounds Interchange
Toronto, Can.
Audio Archives
Syracuse Univ., NY
NBC-TV Post-11
Burbank, CA
Music Place
Birmingham, AL
McClellan Place Mastering
Toronto, Can. (Cons.)

Circle #008 on Reader Service Card

PUERTO RICO

ADVANTAGES	DISADVANTAGES
<ol style="list-style-type: none"> 1. CRESCENDO AUDIO PRODUCTIONS <ul style="list-style-type: none"> • world class recording studio • 24 track in-house & on location recording • LEDE™ control rooms • high speed film mixing/16 & 35mm • complete scoring facilities 2. TROPICAL PARADISE <ul style="list-style-type: none"> • beautiful beaches • rain forest • tennis and golf 3. WATER SPORTS <ul style="list-style-type: none"> • clear warm water • great fishing • fantastic boating • coral reefs for diving 	<ol style="list-style-type: none"> 1. NO SUSHI BARS

BASK IN OUR SUN...BATHE IN OUR SOUND

Crescendo
Audio Productions

Tel: (809) 792-1970
707 Calle Constitucion
Puerto Nuevo, Puerto Rico 00920

Circle #009 on Reader Service Card

myself. I stayed in that room for close to two years, until I went to New York to do Lennon's *Double Fantasy* album. Nobody else had gotten into the room - they said, 'Oh, that room's garbage; only De Carlo knows how to work the room.' I went away to do Lennon's album—that was a good five months—I came back and everyone was working in the studio. I couldn't get back in my own room again."

The principle difference between Record Plant's renovation and Sound Labs' plans boiled down to budgets. Sound Labs, comprised of three studios on the second floor of a building in Hollywood, didn't have nearly the blank-check ambition of Record Plant. De Carlo notes, "Chris [Stone] has really been the prophet of diversification within the whole complex of studios: recording department, mobile, movie scoring, the whole ball of wax. So he could spread out when the record economy started to go down the tubes. Which is good when you've got a lot of money to work with. But this is a small studio, they don't have all the bucks, or the space to diversify."

"Frankie and Bob bought the studio basically to do their own recording, but now they're in a bit of trouble and they have to pump their own money into it. So I'm searching for an idea, but there's just not that much money to work with. All of a sudden it occurs to me that there must be a lot of studios in the same situation, that are small and are funky but that are good, but they just don't have the bucks to spread out and carry themselves. When I was figuring out what I was going to do here, I thought, 'I know where I'm going to track; I know where I'm going to mix on every project I do. Well, that leaves overdubs.' I start thinking, 'Wait a minute, this is a pretty cool facility for overdubbing.' Number one, there's not a lot of traffic in the halls; people aren't getting laid in the Jacuzzi. With overdubs, you have to sit and think. I thought, 'Hey, I'll make the best place in town to do your vocals.'"

Concentrating his energies on developing a sort of overdubbing headquarters, De Carlo sought out a diverse set of construction standards and recording equipment to make for a flexible and definitive studio. He constructed an eclectic list of goods and ideas. In planning for a new control room, De Carlo is using a lot of the Record Plant dimensions, the same geometric ratios, wall angles and speaker height. His monitoring system, however, is different in approach - Tannoys and a JBL 18" mid-range driver, propelled by a tube amplifier. De Carlo believes in the virtue of tubes.

RESPONSE OF A KLIPSCHORN,[®] SIZE OF A SHOE BOX.

The new kg²[®] just introduced at SCES offers working professionals a quality, full-range minimonitor.

A rear mounted, 10" passive radiator provides substantial, clean bass. A new crossover and voice coil provides an uncommon richness to vocals. Exceptional 100° horizontal and vertical dispersion allows a multitude of placement options. Real wood cabinetry assures you of a loudspeaker that looks as good as it sounds.

Specifications are: 35 Hz to 20 kHz \pm 3 dB, sensitivity of 90 dB/SPL, one watt one meter.

The new kg² is simply one of the best minimonitor options on the market today. See and hear it at your KLIPSCH[®] dealer. He's in the Yellow Pages.

 **klipsch**[®]

A Legend In Sound.[™]

P.O. BOX 688, HOPE, ARKANSAS USA 71801

Circle #010 on Reader Service Card

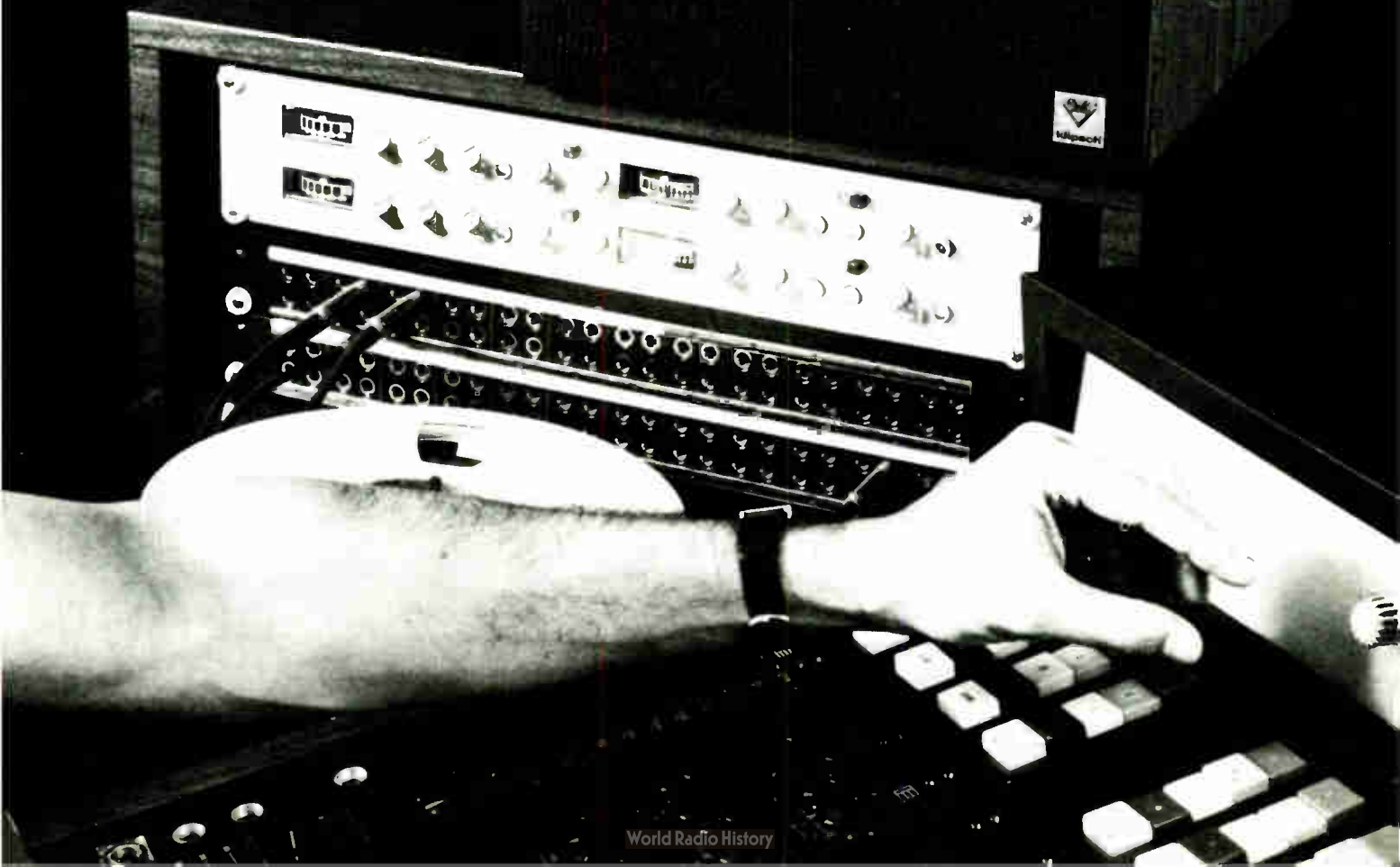



De Carlo points out some of Sound Lab's vintage electronics

"The reason for the different monitors is to get rid of a lot of the fatigue you have when you work in a room over a long period of time, especially when you're doing overdubs, because it's usually guitars, synthesizers and stuff like that. And if you use big old JBLs, honking at you from like 1k to 5k for 12 hours, you can't hear the phone ringing when you walk out of the room. So I'm putting in a soft monitoring system that's pleasant to the ear. You can sit in there, turn it up loud, get yourself hyped, do everything you have to. But you're not saturating your Eustachian tube with, you know, 2500 cycles banging away."

In plotting the new face of Sound Labs, De Carlo turned to materials normally considered rare and antiquated in technological terms. "I went out and got a whole bunch of tube preamps from Europe, beating the bushes, and found old Altec 1576 mike preamps, bought a bunch of [Neumann] 49 and 47 microphones, all tube, power supplies - 67s and that whole number. I like the sound of the vocals in England, which is high impedance, so now we're running high impedance and low impedance. You have a choice. *Nobody* gives you a choice.

"I'm buying input modules from all sorts of different consoles. I've got the first Trident A range series input modules, which are the best equalizers in the whole world. I've got old API 550s and a couple of Helios input modules. So when you walk into a room and you go in to do your overdubs, you've got your choice of 4 or 5 different consoles, sitting right there. You can use any combination—preamps, equalizers, line amps—of all these different pieces of consoles and put it right into the circuit you're using at the time.

"If you don't want to use those input modules, then you can go with straight tube stuff: tube mike to tube mike pre and band, into the machine without even touching the console. Just full-tilt even-harmonic distortion. I've got old tube outboard as well as brand new, esoteric kinds of outboard

- we're going crazy with outboard, the whole gamut. We're buying stuff that's 15 or 20 years old - even a 40 year old RCA OP6 mike. The tubes are like something Winfield would take batting practice with; they're just enormous. But nothing sounds like a tube. Anybody that works in audio knows that tubes sound better than solid state - it's a fact."

Not all of the Sound Labs' format will be tube, De Carlo stresses. The underlying maxim behind the revamped studio will be to accommodate the needs of clients within the specialist framework of overdubbing. Tubes, of course, were overwhelmed by the infinitely more practical, serviceable circuitry of solid state. And De Carlo's affection for them is not nostalgic, but aesthetic. In fact, along with a desire to bring together the best of technologies gone by, Sound Labs will remain state-of-the-art; Studio 1 is computerized and is being rewired, stripped of its entangled copper wiring in favor of new fiber optics.

"I'm having a lot of cooperation from Bell Labs. They're being real supportive, because fiber optics are the only way of the future as a conductor. If the United States government wanted to attach all their computers together so they could talk to each other, there's not enough copper in the world to do it, unmined. There's physically not enough copper in the ground to make the wire to attach the computers. Fiber optics is unlimited. And with copper you've got the problem of active capacitance; every 35 feet you lose .75 dB."

It all came down to retaining the existing values within the studio and rethinking its less desirable aspects. Encountering the environs of Studio 2, for instance, De Carlo discovered a natural acoustic wonder.

Sound Labs was originally built some 20 years ago by Armin Steiner, whose approach to studio construction was more intuitive, from the hip, than guided by advanced sonic theory. "It's not the high tech, sophisticated acoustician kind of approach," De Carlo claims. "Some old guy came in and said, 'Hey, put wood over here and over here pour the cement.' That's really what it is; some old buzzard who really knew what the fuck he was doing. It's built sheetrock/soundboard/sheetrock/ply. Mass is your friend. When you're building, the more mass you have the denser you are and the denser you are the safer and truer you are. Once the wall starts moving, you're in trouble. Also, the whole room is lead-lined. That's why we can afford to go high impedance; everything's lead-lined so there's no problem with RF, CBs and taxicabs and that kind of stuff. On the Lennon album working at Hit Factory we had

to turn the amplifiers towards the Empire State Building after 6 o'clock at night to cancel the RF.

"The first thing I did with the room was start soaking it in 8 gallons of linseed oil. Now you walk into the room and you can hear the air change. It's just a real nice old room where the wood's really settled and it would be a sin to touch it. It's real neutral, pleasing to the ear. There's no boxiness, no slap to it. We can do tracks in there. Bob's in there right now with Roberta Flack and Peabo Bryson. But it really is a wonderful vocal room. It's the kind of place where you can talk and actually hear yourself, not just through your jawbone, but through your own ears."

While the studio in 2 will be left to its own devices, De Carlo has been applying remodeling ideas elsewhere in the complex. Studio 3 was the first finished product of De Carlo's handiwork. Armed with a series of Trident A80 consoles as well as sundry input modules, 3 is ideal for mixing, with walls running as infinitely unparallel surfaces—a narrow-arc'd V formation—to reduced standing waves. Extending the space behind the console considerably back, De Carlo hopes to address the logistics of recording synthesizer parts, as synthesizers increasingly invaded the ranks of music.

"The biggest pain is having the guy out in the studio and trying to talk to him on the talkback while he's programming. So everybody does their synthesizer stuff in the control room. Which is great, but everybody's control rooms are really small, so you've got synthesizers laying on their sides, you've got 'em underneath the console, you've got one side on a chair and the other on the console so you gotta crawl under it and everything and it's a drag. So, Studio 3 is set up for mixing and also to do synthesizer work in. You look and there's space. Boddicker can walk in there and set everything up, and Boddicker's nuts; he's got everything going everywhere."

De Carlo's renovation of Sound Labs is both a symptom of the economic low ebb in the music industry and a model of resourceful thinking. Extending tentacles in new directions, the theory of diversification, is one tack. Barring the available materials to do so, De Carlo decided to narrow the focus, to specialize. And, judging from his past track record, the studio may soon become overdub central. "That's basically what we're catering to - grabbing the overdubs," De Carlo concurs. "Do your basic tracks wherever you want to do them, but when it comes to overdubs, we're set up better than most places to do it." ■



A MIXER TO SWEAR BY. NOT AT.

When you know exactly what you want but your console keeps saying, "You can't get there from here", there's something you can do besides screaming and pounding your fists. Haul yourself down to your TASCAM dealer and take a hard look at our M-16.

For production requiring 16 to 24 inputs, you're not going to find a faster board anywhere. With the M-16 you don't need fingers the size of pencils, arms as long as your legs and a photographic memory . . . you just need to know what you want to hear.

Our M-16 has the most sensible layout, most versatile EQ and monitor sections and the most flexible signal routing of any board at the price.

Whether you're cutting radio spots, doing production/post-production for film or video, making demos or building multi-image audio, the M-16 has both the features and price to keep your bottom line black and your toughest clients happy.

Relax. Get a grip on yourself and give our M16 a good hard look. See your TASCAM dealer or write TASCAM Production Products, 7733 Telegraph Road, Montebello, California 90640, (213) 726-0303.

Copyright 1983—TEAC Corporation of America.

TASCAM
TEAC Production Products

Circle #013 on Reader Service Card

the World class of '83

by **George Petersen**

Over the past year studio designers throughout the U.S. have found major growth in audio for video and media/film facilities, with the market for audio-only studios particularly strong outside of the U.S., especially in Latin America, Asia and Africa.

The economic realities of the 1980s have brought new directions into studio design, as facilities look toward diversification into new media and cost effective construction/installation techniques. Yet, at the same time, world class facilities are seeking to improve their position in the market,

and the demand for digital has put considerable pressure on these studios in terms of improved acoustics, lower main and control room noise floors, and accurate monitoring systems. The acceptance of this technology poses perhaps the greatest challenge to today's studio designer.

Jeff Cooper, architect/acoustician from Woodland Hills, CA, has been involved in more and more film/video projects over the past few years. His current involvement with George Lucas began in 1977, when he designed a screening room for George in Los Angeles. Since Lucasfilm moved to



PHOTO: BILL LOWE

Two views of the I.L.M. Lucasfilm dubbing theatre in San Rafael, CA. Design © Jeff Cooper.



PHOTO: BILL LOWE

the San Francisco Bay Area, Jeff has designed facilities at Industrial Light and Magic (the Lucas-owned technical center in San Rafael, CA), and consulted on the early stages of the Lucas Ranch.

The most recent Lucas/Cooper project is a digital film mixing and recording studio at I.L.M., which was completed in time for the soundtrack mix of *Return of the Jedi*. The room serves three purposes: as a film dubbing/mixing theatre, a 100-seat state-of-the-art presentation theatre/screening room, and as a live recording studio with Foley pits for sound effects recording. Jeff Cooper commented about the room's unique design: "Imagine how quiet a studio must be in order to effectively record the sounds of Wookie fur being gently patted in distant galaxies." In actuality, the room noise measures in at an unearthly NC 15.

The acoustical design of the room is as practical as it is beautiful. The walls are constructed of continuous hand crafted duffusers, with insets of stretched velvet over acoustical panels. The duffusers provide recessed lighting and air conditioning dispersal in addition to their acoustical functions.

The room utilizes the THX speaker system developed by Tom Holman at Lucasfilm. Surround speakers are hidden into the duffusers. A custom modified Neve music recording console was installed and suits all three of the studio's functions. Stearns/Letizi of Petaluma, CA, handled the facility's construction.

Some of Jeff's other media projects include a new film mixing theatre for Goldwyn/Warner Studios in Hollywood, a film mixing theatre for Fantasy Films in Berkeley, CA, and a master plan design concept for Hanna Barbera in Hollywood. The HB project incorporates a video dubbing studio, an audio recording studio, computerized editing facilities, and current plans for remodeling other production spaces to include computer animation technology.

"We're trying to consolidate a direction for the industry so technical facilities aren't built in or remodeled from office spaces," Jeff explained. "I.L.M. is a good example of this - a technical building that was built from the ground up to handle a variety of computer operations, sound recording, and film mixing. It was built in a building designed specifically for that, as compared to Fantasy Films which was built into their office building. At Fantasy Films the building was designed with 25' column centers and 11' floor to

ceiling heights. So the only way to get those spaces was to bridge column

"There's a Renaissance of building studios where you just record. There were a lot of hits cut in the '50s and '60s in garages or whatever, and we see a resurgence in that type of thing in artist-owned studios."

spacing and knock out floor slabs - an expensive reconstruction. We're trying to make the industry aware that you can build buildings a lot more efficiently with master planning. The key word is ergonomics."

Sound Interchange, a new 24 track studio in Toronto, went on-line in June 1983. The LEDE-designed facility (by Chips Davis of Las Vegas) uses an experimental custom monitoring system developed by Klaus Fortier, PhD., who teaches at the University of Ottawa. The all-cone speaker system is a phase coherent four-way design with active crossovers and two 15" JBL bass drivers, a 10" JBL for low-midrange, and two Danish drivers for the top end.

"The studio decided to take a chance and see if this [monitor] design really worked," Chips explained, "so I designed the room around the speakers. They went up to the Canadian Testing Labs, who said they were the best speakers they ever measured. When we took the [Tecron TEF System 10] computer in, that verified it. The room was phenomenally flat. I've never seen

Studio Soundcraft

Make Music, Not Noise!

Audio Engineering Associates' modular approach to studio wiring gets your system up quickly and keeps the noise out. Take delivery on a Soundcraft console one day ... make music the next. Give yourself the professional advantage.

Call:



audio engineering associates

1029 north allen avenue pasadena, ca. 91104

(213) 798-9127

References supplied
upon request

Interface With
The Best

Circle #080 on Reader Service Card

The inside story.

Spectra Sound introduces the Model 1500 twenty-seven band Graphic Equalizer.

For nearly two decades, engineers at Spectra Sound have consistently led the industry in developing and producing the quietest and the lowest distortion professional audio products. This unequaled performance record continues with the introduction of the Model 1500 twenty-seven band graphic equalizer. The Model 1500 represents a significant improvement over current equalizer technology.



THE LOWEST DISTORTION

The THD and the IM distortion of the Model 1500 are below .0018%, test equipment residual, 20Hz to 20kHz, +18dBv.

THE LOWEST NOISE

The Model 1500 is the quietest equalizer available. The signal to noise ratio is 104dB below +4dBv, unweighted, 20Hz to 20kHz.

HAND CALIBRATED BAND-CENTERS

Each of the twenty-seven bands of the Model 1500 is hand-calibrated to be within two percent of band-center tolerance.

Additionally, the innovative design of the Model 1500 offers the user versatile and simplified operation.

SWITCHABLE EQUALIZATION RANGES

The Model 1500 has switchable equalization ranges of either ± 6 dB, or ± 12 dB.

COMPLETE SYSTEM BYPASS

A bypass switch completely removes the equalizer from the signal path.

For further information contact:

Spectra Sound 

3750 Airport Road
Ogden, Utah 84403
(801) 392-7531

Spectra Sound is a wholly owned subsidiary of Spectra Sonics

Circle #081 on Reader Service Card
World Radio History

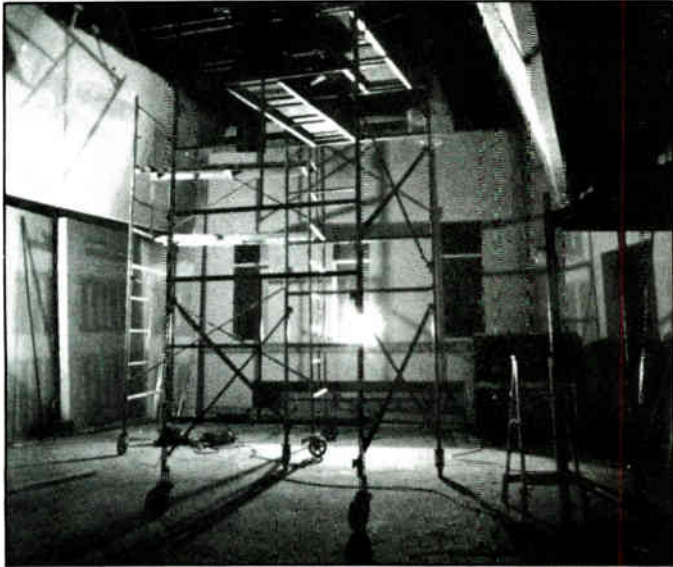

Dallas Sound Lab under construction

Ridge Boys, and the work should be completed by September. Bob Todrank, of Valley Audio talked about the job: "We're taking the old control room and making it part of the studio, and we're adding a new building which will be the new control room. It's going to be a very large control

room, sort of a multi-level project along the lines of the LEDE concept."

Valley Audio is also building a major 45' tractor/trailer remote truck for a new company in Georgia. "We hope to have it on-line in early October. It'll be a full twin 24 track unit with Otari MTR-90 recorders. The owners also want a lounge with separate monitoring facilities and wired for overdub use." Asked about the price of such a vehicle, Bob said it would be in the \$300,000 range.

—page 32

or measured anybody's room that came out like this. From 23 Hz to 22 kHz, it's $\pm 1\frac{3}{4}$ dB. They are probably the best sounding speakers I've ever heard."

Chips plans to use a similar version of the monitors (with single bass drivers) for his new design project at Starmusik in Hamburg, Germany.

Nashville's Emerald Sound, owned by producer/songwriters Even Stevens and David Malloy, went on-line last October. The studio's unique band-shell shaped design (28' x 24' with a 25' ceiling at its highest point) was by Jack Edwards. The studio also incorporates three isolation rooms and a piano alcove. The control room features a Neve 8058 console, Studer tape machines, and custom monitors by David LaBarre.

Valley Audio, in Nashville, is currently working on an extensive remodeling project for Superior Recording Studio, in Hendersonville, TN. The studio is owned by the Oak



Emerald Sound, Nashville, Tennessee

Acoustilog

Reverberation Timer 232A

Measure room acoustics:

- Studios
- Control Rooms
- Concert Halls

- Easy one-person operation
- 2% accuracy
- Built-in pink noise
- Measures at 19 center frequencies, 63 Hz to 12 kHz
- 2 noise averaging filters
- Many options and outputs available
- Weighs only 3 lbs.
- Foam case available

Only \$795

Acoustilog

IMPulser

- Battery powered
- Measures speaker polarity, flutter echo, time delay, ringing and more
- Uses any triggered scope for display
- No false triggering as with "red light/green light" polarity testers
- Variable pulse width and repetition rate
- Excellent pulse source for realistic TL tests

Only \$295

Also available as an option to the 232A Reverb Timer

Write or call for further information.

Acoustilog, Inc.

19 Mercer Street
New York, NY 10013
Telephone: (212)925-1365



Circle #082 on Reader Service Card

MODULAR PERFECTION

THE NEXT STEP TOWARD QUALITY AUDIO PRODUCTIONS

PREFABRICATED ACOUSTICAL ROOM SECTIONS

- Building block concept
- Modules available in varying degrees of absorption
- Variety of interior treatments available
- Optional RF shielding

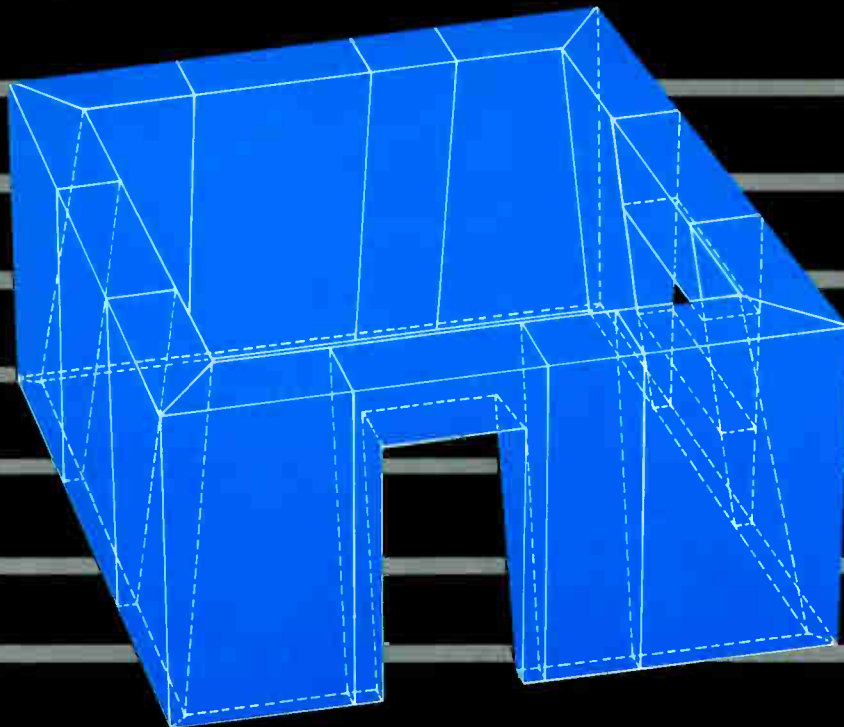

Sure, there's a lot of good hardware out there. And software is getting better and better, like the Compact Disc. Today's competitive marketplace demands the very best, and the missing link in audio production remains: the studio or control room itself. Acoustical design, long regarded as "black magic" best left to high priced consultants and architects, is the next step forward toward quality productions.

Wouldn't it be great to have:

- A comprehensive acoustical design for your new facility with no hidden costs
- An expandable, re-usable system of acoustical room sections which can be used to assemble rooms in a variety of shapes and sizes

- A modular building system which can be erected in record time and then disassembled and moved to a new location if necessary - avoiding large capital investments in fixed leasehold improvements

Modular Perfection specializes in modular acoustical environments, built in our own factory and delivered to you ready for installation. Our track record includes some of the world's most successful studios, rooms which have produced gold and platinum records for artists like the Bee Gees, Dionne Warwick, and Barbra Streisand.

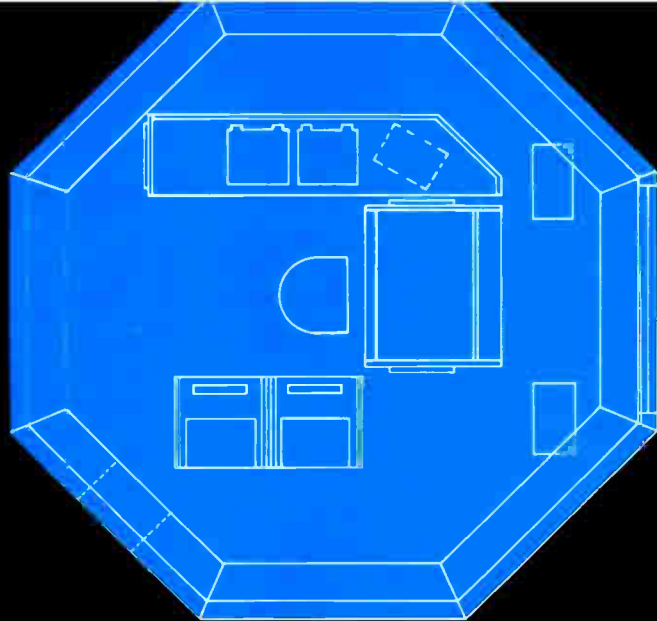

CONTROL ROOMS FOR PRODUCTION, RECORDING, VIDEO EDITING

- Octagonal shape eliminates standing waves
- Maximum isolation
- Available in a wide variety of sizes
- Acoustically correct
- Variety of interior treatments available
- Optional RF shielding

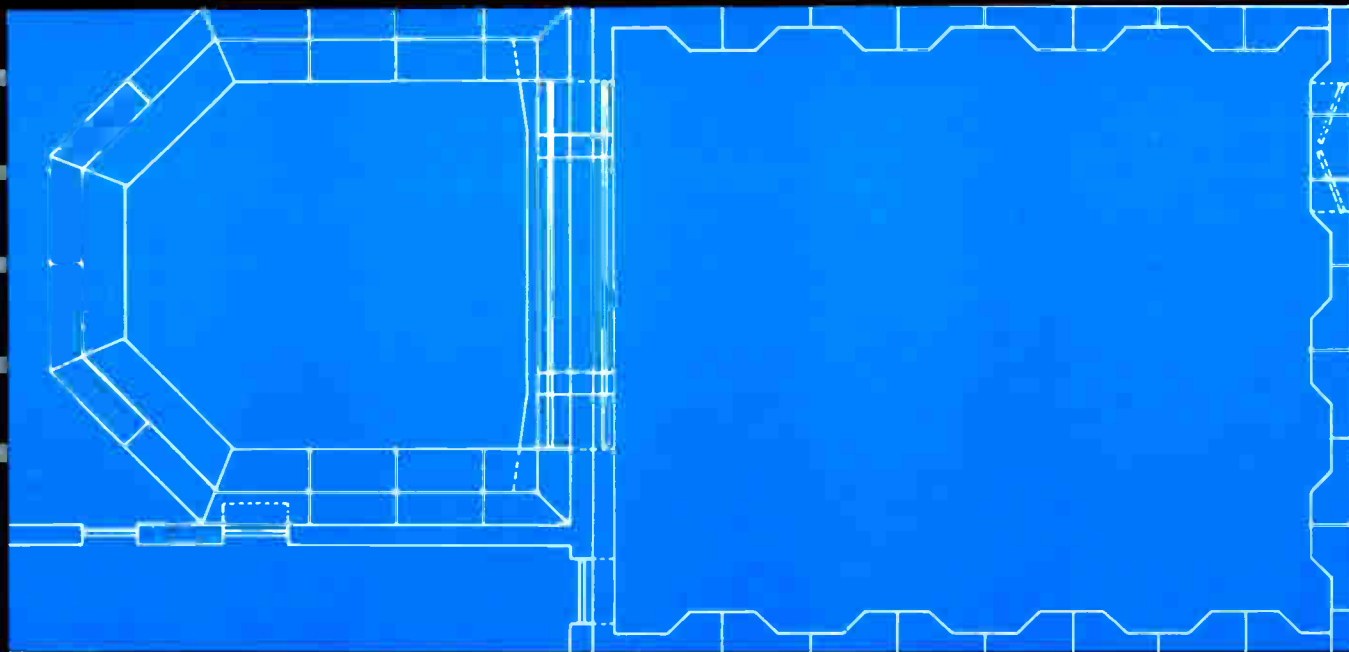

OR A COMPLETE STUDIO COMPLEX

Whether you need a small production room or a complete studio and control room complex, the experts from Modular Perfection are ready to work with you on pragmatic approaches to good sound. Shown are but a few of our most successful designs. When you're thinking of a new facility, or upgrading an older one, call Modular Perfection for acoustics - a whole new approach to sound design.

World Radio History

Circle #011 on Reader Service Card

MODULAR PERFECTION

14205 N.E. 18th Ave.,
Miami, FL 33181, (305) 944-6731

FILAMENT PRO AUDIO

15 Years of Experience
in Sound Reinforcement
& Recording
**We sell over
200 lines of the
best Pro Equipment**

August Specials
Mixers by
ALLEN & HEATH
BIAMP
NEI
PULSAR-WALKER
RAMSA
SOUNDTRAX
TRIDENT
STUDIO MIXER

Prices Quoted by Phone

Write for free line card
& sale sheet.

FILAMENT PRO AUDIO

143 E. Arrow Highway
San Dimas, CA 91773
(213) 339-0081
(714) 592-2848

*Serving the industry
since 1968*

Circle #012 on Reader Service Card

—from page 29

In Chicago, Doug Ordon of AVC Systems has recently equipped a home studio for Kerry Livgren, songwriter/guitarist for the group Kansas. The studio, in Atlanta, GA, features an Otari MTR-90 24 track, and a Soundcraft 2400 console. Doug commented on the difference between the mid-

west and the coast markets: "There's a Renaissance of building studios where you just record. There were a lot of hits cut in the '50s and '60s in garages or whatever, and we see a resurgence in that type of thing in artist-owned studios. That isn't to say there aren't turnkey studios being built, but frankly, in the midwest, there isn't the kind of —page 34

LEDE vs. EDEL

by Michael Rettinger,
Consultant on Acoustics

Three theories may be cited with respect to the optimal disposition of the soft and hard materials in a control room:

One may be called the LEDE theory.¹ The word stands for Live-End/Dead-End, and originally, from the 1930s to the 1970s, meant a live end about the sound source—real instruments in a studio or a loudspeaker in a reproduce chamber—and a dead end opposite the live end. Don Davis had the term trademarked, but understood it as a dead or absorptive environment about the reproducers and a live or reflective end opposite the sound radiators.

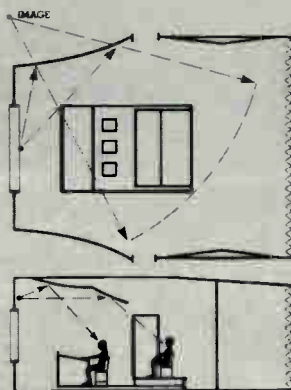

Plan and elevation of a control room built according to the EDEL principle

His idea is to prevent first reflections from the loudspeakers from being directed to the mixer, thus avoiding "comb-filter" effects, that is, interferences between the direct and reflected sound waves. This can be demonstrated with an oscilloscope and TDS or time-delay spectroscopy. It is assumed that the mixer, listening in this time-gap period free from interference, will hear the music exactly the way the microphone "hears" it on the stage. To gain

acoustic perspective at the mixing console, the rear wall of the control room is kept live, but must be highly corrugated to prevent low-frequency echoes from the hard surfaces there.

So far, the opinions on LEDE have been divided, some considering the results superior, others absolutely unacceptable. One objection offered by this writer is the unavoidable low-frequency reflections from the hard monitoring window below the loudspeakers result in a tonal unbalance at the mixing console. While the first reflections from the more directional mid-range and high-frequency components from a complex signal can be attenuated by a highly absorptive environment near the monitoring loudspeakers, those from the bass notes cannot.

Another reservation is the fact that a single microphone at the mixer's console and TDS oscilloscope cannot represent what a person hears. The use of two microphones in a dummy head, properly phased and adjusted for pressure doubling, with the microphone outputs rectified before combining them, still does not represent what the ear hears. The reason is that the brain has a subconscious capacity to reject unwanted sounds, like reverberation, echoes, etc. Hence Lord Rayleigh's dictum that the subject of sound is so subjective that for the decisions made by the ear there can be no appeal.²

But even besides these subjective matters there are also objective ones. To provide thoroughly diffused low-frequency reflections from the staggered, baffled, or corrugated rear wall in the control room, the size of these obstacles should be commensurate with the wavelength of the bass notes. At 50 Hz, with the wavelength equal to 22.5 feet, these projections become much larger than the length of many conventional control rooms; even at 100 Hz the depth of the space behind the console becomes highly expensive.

In opposition to the LEDE philosophy there is the EDEL one, LEDE spelled backward. This is the old scheme whereby the wall behind the —page 35

ENGINEERS... PRODUCERS... AUDIO/VIDEO PROS...

IF YOU'RE IN THE STUDIO YOU'RE IN THE MIX



Mix makes it easy for you, the audio/video production professional, to stay abreast of the latest developments in a rapidly changing industry. Every month, Mix brings you the most up-to-date news and information on all aspects of audio, video and music production and technology. **Don't miss an issue! To receive your personal copy of Mix, tear out and return the subscription card below.**

MORE THAN 1/3 OFF!

SUBSCRIBE TO *Mix*

THE RECORDING INDUSTRY MAGAZINE

- One year \$18
 - Two years \$32
- Outside U.S. add \$12 per year

* Check/Money Order
 Bill me
 Visa/MC _____
 Expires _____
 Signature _____

***CASH BONUS! Send payment (check/M.O.) with order and receive 2 free copies of Mix.**

Please check the appropriate boxes in order to help us process your order.

Co. Name _____
 Name _____
 Address _____
 City _____ State _____
 Zip _____ Phone _____

OCCUPATION

- | | |
|---|---------------------------------------|
| 170 <input type="checkbox"/> Technician | 720 <input type="checkbox"/> Musician |
| 171 <input type="checkbox"/> Producer | <input type="checkbox"/> Student |
| 172 <input type="checkbox"/> Engineer | <input type="checkbox"/> Sales |
| <input type="checkbox"/> Owner/Manager | <input type="checkbox"/> Other _____ |

TYPE OF BUSINESS

- | | |
|--|---|
| 110 <input type="checkbox"/> Recording Studio | 185 <input type="checkbox"/> Video prdn/broadcast |
| 120 <input type="checkbox"/> 4-track | 210 <input type="checkbox"/> Manufacturer |
| 130 <input type="checkbox"/> 8-track | 260 <input type="checkbox"/> Mastering/pressing/duplication |
| 140 <input type="checkbox"/> 16-track | 310 <input type="checkbox"/> Retailer |
| 140 <input type="checkbox"/> 24-track | 410 <input type="checkbox"/> Mfr's. representative |
| 100 <input type="checkbox"/> Other | 610 <input type="checkbox"/> School |
| 175 <input type="checkbox"/> Sound Reinforcement | <input type="checkbox"/> Other _____ |

AUGUST 1983

Where did you get this copy of Mix?

MORE THAN 1/3 OFF!

SUBSCRIBE TO *Mix*

THE RECORDING INDUSTRY MAGAZINE

- One year \$18
 - Two years \$32
- Outside U.S. add \$12 per year

* Check/Money Order
 Bill me
 Visa/MC _____
 Expires _____
 Signature _____

***CASH BONUS! Send payment (check/M.O.) with order and receive 2 free copies of Mix.**

Please check the appropriate boxes in order to help us process your order.

Co. Name _____
 Name _____
 Address _____
 City _____ State _____
 Zip _____ Phone _____

OCCUPATION

- | | |
|---|---------------------------------------|
| 170 <input type="checkbox"/> Technician | 720 <input type="checkbox"/> Musician |
| 171 <input type="checkbox"/> Producer | <input type="checkbox"/> Student |
| 172 <input type="checkbox"/> Engineer | <input type="checkbox"/> Sales |
| <input type="checkbox"/> Owner/Manager | <input type="checkbox"/> Other _____ |

TYPE OF BUSINESS

- | | |
|--|---|
| 110 <input type="checkbox"/> Recording Studio: | 185 <input type="checkbox"/> Video prdn/broadcast |
| 120 <input type="checkbox"/> 4-track | 210 <input type="checkbox"/> Manufacturer |
| 130 <input type="checkbox"/> 8-track | 260 <input type="checkbox"/> Mastering/pressing/duplication |
| 140 <input type="checkbox"/> 16-track | 310 <input type="checkbox"/> Retailer |
| 140 <input type="checkbox"/> 24-track | 410 <input type="checkbox"/> Mfr's. representative |
| 100 <input type="checkbox"/> Other | 610 <input type="checkbox"/> School |
| 175 <input type="checkbox"/> Sound Reinforcement | <input type="checkbox"/> Other _____ |

AUGUST 1983

ENGINEERS... PRODUCERS... AUDIO/VIDEO PROS...

IF YOU'RE IN THE STUDIO YOU'RE IN THE MIX



Mix makes it easy for you, the audio/video production professional, to stay abreast of the latest developments in a rapidly changing industry. Every month, Mix brings you the most up-to-date news and information on all aspects of audio, video and music production and technology. *Don't miss an issue! To receive your personal copy of Mix, tear out and return the subscription card below.*



NO POSTAGE
NECESSARY
IF MAILED
IN THE
UNITED STATES

BUSINESS REPLY CARD
FIRST CLASS PERMIT NO. 2994 BERKELEY, CA

POSTAGE WILL BE PAID BY ADDRESSEE

Mix Magazine
P.O. Box 6395
Albany, CA 94706



NO POSTAGE
NECESSARY
IF MAILED
IN THE
UNITED STATES

BUSINESS REPLY CARD
FIRST CLASS PERMIT NO. 2994 BERKELEY, CA

POSTAGE WILL BE PAID BY ADDRESSEE

Mix Magazine
P.O. Box 6395
Albany, CA 94706



IF YOU'RE IN THE STUDIO
YOU'RE IN THE MIX!



From coast to coast and in 43 foreign countries, audio, video, and music professionals read **Mix Magazine!** For the latest industry news, illuminating articles on hardware and production techniques, exclusive interviews with today's movers and innovators, as well as

the last word on the marriage of audio and video, **Mix** is your best source for the information you need to help you do your job in these competitive times.

Don't miss an issue — Subscribe today!

BRYSTON



The most respected audiophile-quality power amplifier line in the world was available first to professionals! Bryston amplifiers bring with them years of hands-on experience in sound-studios, where they have proven their unique accuracy; on the road, where they have proven absolutely unmatched reliability; in hundreds of professional installations all over the world, where they continue to prove every day that for uses requiring flawless sonic quality, tremendous load-driving ability and zero down-time, Bryston has no equal.

Discover the advantages of the Bryston philosophy for sonic perfection and on-the-road reliability.

For further, more detailed information, and a list of dealers in your area, contact one of our Distributors:

BRYSTON VERMONT
RFD#4, Berlin, Montpelier, Vermont 05602
(802) 223-6159

BRYSTON MARKETING LTD
57 Westmore Dr., Rexdale Ont., Canada M9V 3Y6
(416) 746-0300

Circle #014 on Reader Service Card



SIERRA AUDIO CORPORATION

announces the completion of

ATLANTIC RECORDS STUDIO A, MANHATTAN

Designed by Tom Hidley Built by Kent Duncan

Many thanks to:

AHMET ERTEGUN SHELDON VOGEL MEL LEWINTER
PAUL SLOMAN RON SARNER MIKE YAMMA
JIM FALCONER J.B. RIVERA

and the entire ATLANTIC STUDIOS staff...



SIERRA HIDLEY DESIGN
721 South Glenwood Place
Burbank, California 91506 USA
Telephone (213) 843-8200
Telex 662745 (K DUNCAN BUBK)

Worldwide exclusive agents of Tom Hidley and Kent Duncan Design

Circle #015 on Reader Service Card

STUDIO DESIGN FORUM

—from page 32

base that exists in New York and the west coast.

Master-Mix, the dedicated remix and mastering facility in Nashville, is now completely operational. The studio, which was reported in the March issue of Mix, was designed by Steve Durr. The facility is equipped with John Meyer 833 monitors, which "clients are knocked out by," according to manager Tom Semmes. "Hardly a day goes by when someone doesn't come in strictly by word of mouth to hear those

"A lot of design techniques in the past were marketed as the ultimate answer, and were not based in physics. More and more studios today are interested in what kind of test equipment you have, your testing methods, and your philosophies of acoustics."

monitors."

Harvey Pro Audio/Video, in New York City, completed the construction of EMCA Studios (owned by the Young & Rubicam agency) in Santo Domingo, Dominican Republic. Gene Perry designed the 24 track music and jingle studio earlier this year: "I had done a small room for them about five years ago - very low end, with Tascam eight track equipment. And with that equipment, they had been doing about 85% of the commercials in Latin Ameri-

—page 114

—from page 32, LEDE vs. EDEL

mixer is kept absorbent so that what one hears at his console is very much what the listener at home hears in his hi-fi den or living room, complete with the "comb-filter" effects which Davis claims are so destructive to the quality of music. This writer sometimes wonders what orchestral music would sound like when no interference effects could be made to exist between the instruments of an ensemble. Possibly the quality would be the same as raising the output of one instrument by a number of decibels, as by turning up the volume control of a loudspeaker amplifier, which undoubtedly would result in absolutely unacceptable symphonic music.

The illustration shows the plan and elevation of a control room according to the EDEL principle. Note the reflective and convex environment about the two stereophonic reproducers, as if it were the extension of an exponential horn. Not shown is the acoustic treatment of the sidewalls to prevent echoes between these surfaces, nor the type of acoustic treatment of the

floor which often contains raised or stepped portions for this working area for the variety of personnel there, particularly during re-recording of a film or TV production. It is important to have a large working area for such a facility, so uniform hearing conditions about the console are important, rather than one "ideal" hearing position.

The third theory of control room acoustics might be called a compromise of the LEDE and the EDEL type of room.³ It consists of a more or less uniform disposition of the soft and hard materials. Conceivably many existing control rooms are of this type, the rear wall containing 1" acoustic tile instead of the deeper acoustic treatment recommended for an EDEL enclosure, with the front end of the enclosure being only moderately reflective, and with the sidewalls and ceiling also treated in moderation with sound-absorbent products. One might designate such a scheme MOD, for moderate.

There still remains the factor of how to change the reverberation peri-

od of a control room for the reproduction of classical music. A control room with a 500 Hz reverberation time of .3 seconds generally has an absorptivity of .35 as calculated by the Eyring-Norris formula. As may readily be determined, however, to increase the time from .3 to .4 seconds, or 33%, requires a reduction in the average absorptivity from .35 to .276, or 21%, when the ratio of room volume V to total interior surface S equals 2.6. This may be obtained with reversible panels, absorbent on one side and reflective on the other side.

¹Davis, Don, "Concept for the Control of Acoustic and Psychoacoustic Parameters in Recording Control Rooms," *AES Journal*, Sept. 1980, Vol. 25, No. 9, p. 585.

²Rayleigh, Lord, *Theory of Sound*, V.1., P.1., Macmillan and Co., London, 1937.

³Augsburger, G.L., "Contemporary Mixdown Room Design," *dB Magazine*, Nov. 1981, Vol. 15, No. 11, p. 54

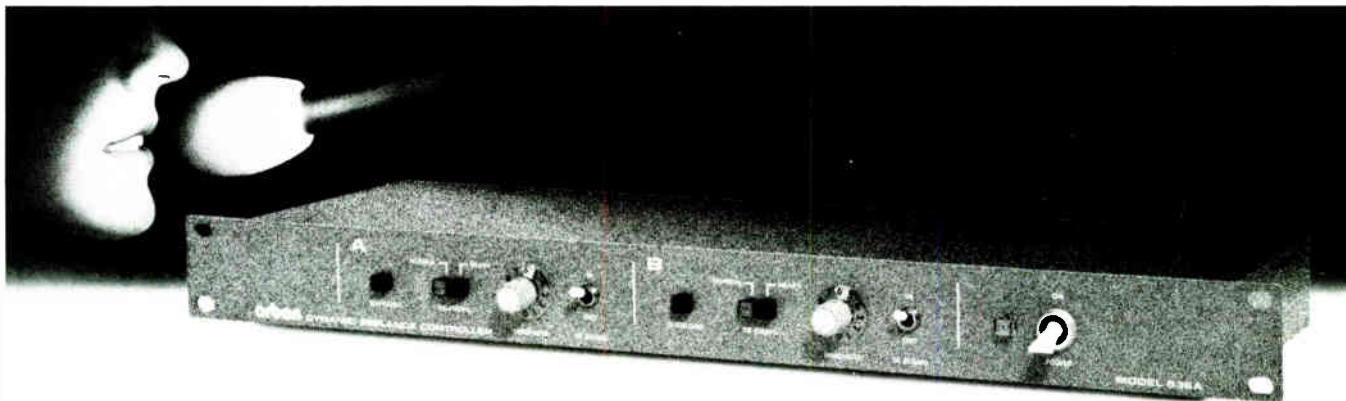

A new way to stamp out a nasssty habit.

It's no secret: Some of the greatest singers and announcers in the world habitually have problems with their "esses". And small sibilance problems can turn into big ones when extra compression, equalization, and other signal processing is used.

Now Orban, the de-essing expert, introduces the *new* Model 536A—a two-channel line-level de-esser with fast, simple setup, and the same unsurpassed performance as our popular single-channel 526A. All at less cost-per-channel.

Orban's control techniques offer accurate de-essing of voice tracks regardless of input levels. Accordingly, the 536A lets you EQ without compromise and record tight-to-the-mike without fear—you're protected from excessive sibilance energy which might otherwise overload tape, disk, cassette, or optical film. Call or write today for details on the new Orban 536A De-Esser. And help control a nasssty habit.

orban

Orban Associates Inc., 645 Bryant Street
San Francisco, CA 94107 (415) 957-1067
TLX: 17-1480

Circle #016 on Reader Service Card

DO SOMETHING GOOD FOR YOURSELF

The creation of the Audioarts Engineering 8X Series console marks a new turning point in the technology accessible to the 8, 16 and 24 track recording profession. This console series affords the features and technical excellence previously available only in larger track formats — features like three-band sweepable frequency semi-parametric equalization, full 24 track monitoring capability, mixdown subgrouping, stereo monitor sends, electronically balanced inputs and outputs, truly flexible effect send and return functions, and fully modular plug-in construction.

The features don't stop here; 8X Series consoles also include super solo sections (giving instant access to pre-fader, post-fader and tape solo), comprehensive state and talkback systems, a built-in calibration oscillator, and a high speed LED metering array in an easy-to-read meter bridge assembly. Standard module features include XLR balanced inputs (both mic and line), XLR balanced outputs (buss and stereo master outs), continuously variable mic and line input gain controls, switchable phantom power, phase reverse, pad, 12dB/octave high pass filter, EQ bypass switch, channel

on button (w/LED indicator), channel peak clip LED, and the exclusive Audioarts Engineering M-104 precision conductive plastic linear fader.

The 8X is an excellent choice for the small studio in need of upgrading performance or expanding format. For the large studio the 8X is an idea system for your Studio B or 24 track mixdown room. Because it is compact the 8X is also ideally suited to video and remote recording applications.

Whatever your application, the Audioarts Engineering 8X recording console comes loaded with features previously not found on medium format systems. The mixing engineer is afforded maximum control and creative freedom. The technical excellence of this console approaches the theoretical limits of today's technology. If you demand sonic excellence, meticulous craftsmanship and flexible control take a good look at the 8X.



AUDIOARTS® ENGINEERING

A DIVISION OF WHEATSTONE CORPORATION
5 COLLINS ROAD, BETHANY, CT. 06525 (203) 393-0887

In stock at Professional Audio Services & Supply Company, Burbank, CA. (213-843-6320)

Circle #017 on Reader Service Card

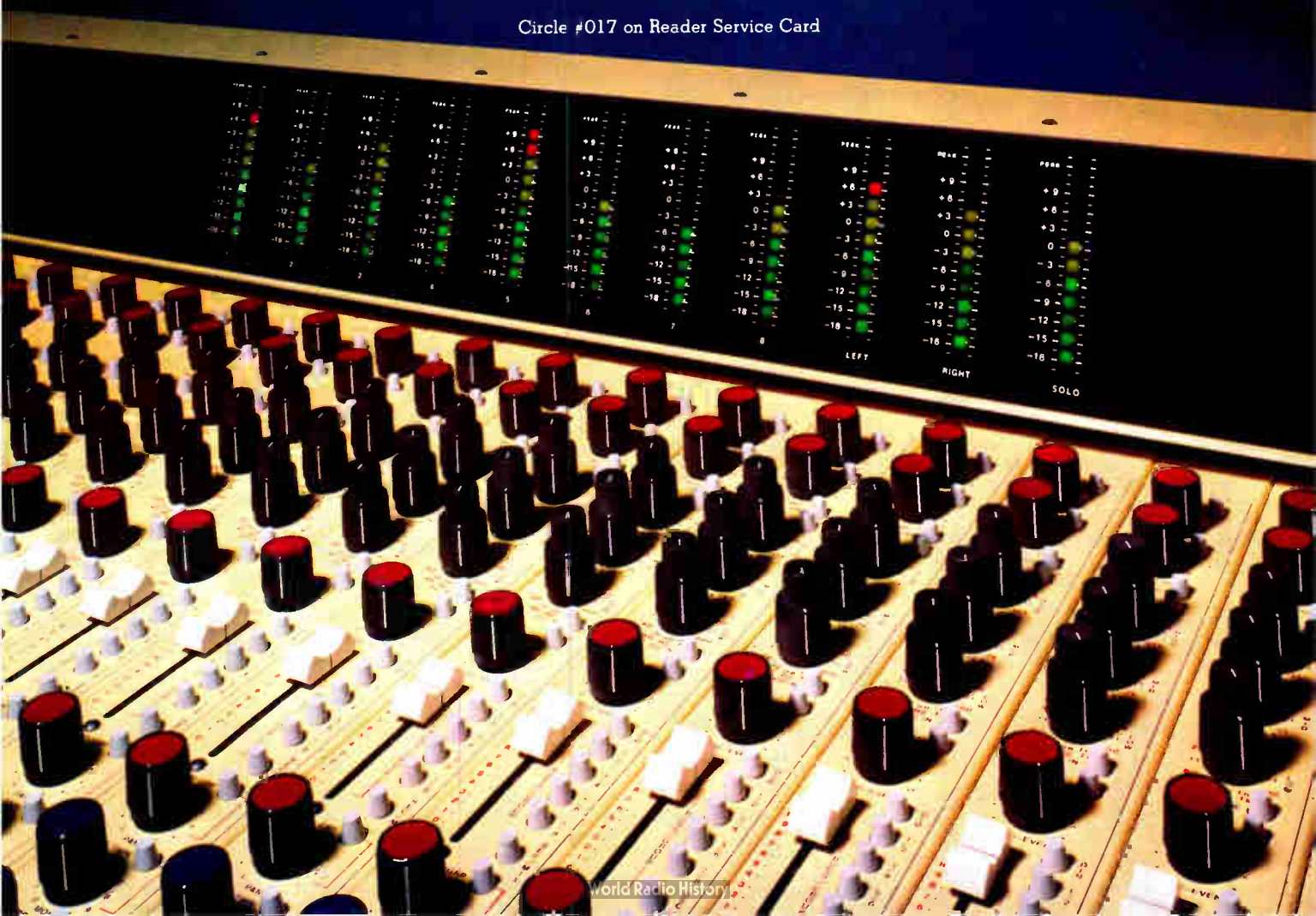

STUDIO DESIGNERS & SUPPLIERS

LEGEND: **SD**: STUDIO DESIGNER; **AC**: ACOUSTICAL CONSULTING; **SES**: STUDIO EQUIPMENT SUPPLY; **EI**: EQUIPMENT INSTALLATION/MAINTENANCE/SERVICING

NORTHEAST

ACOUSTIC DESIGN/CONSTRUCTION - JOSEPH J. JULIEN
SD, AC, EI
5 Donaldson Pl., Roslyn, NY 11577
(516) 621-8872
Contact: John Julien

ACOUSTICCOOL DESIGNS CO.
SES, EI
P.O. Box 436 Jackson Heights, NY 11372
Contact: Anthony Tracy
Services offered, credits, specialization: Acousticcool Designs specialize in controlled room environments. We reduce possible background noises to the lowest possible contemporary levels, while maintaining appropriate air flow, conditioning and space availability. Proven track record. Write for details.

ACOUSTILOG, INC.
SD, AC, SES, EI
19 Mercer St., New York, NY 10013
(212) 925-1365
Contact: Alan Fierstein

ALTEI SOUND OF CT INC.
SD, SES, EI
2392 Main St., Bridgeport, CT 06606
(203) 374-0162
Contact: D. Cantalini, M. D'Amore



ANALOGIQUE PROFESSIONAL SYSTEMS
New York, NY

ANALOGIQUE PROFESSIONAL SYSTEMS
SD, AC
17 W. 17th St., New York, NY 10011
(212) 989-4240
Contact: George Reis
Services offered, credits, specialization: With a background of 15 years in acoustic design and engineering involving some of the largest projects in Europe (Vogue and Philips recording complexes) and Africa (Satel in Benin and King Sunny Ade in Nigeria), Mr. Francis Milano, senior designer and engineer for Analogique Professional Systems, is now based in New York City. As an accomplished musician and physicist, Mr. Milano's philosophy is that acoustics must respect music and psychoacoustics. Appalled at what passes for acoustic design and engineering in America, Mr. Milano is determined to bring his philosophy to the United States. This philosophy ensures that the project is done right the first time, avoiding costly adjustments and painful mistakes. Past projects include Gang Studio, Translab Mastering, Delphine Studio, Radio Monte Carlo, Nova Broadcast and Production Studios, and a state of the art motion picture projection and sound studio for Philippe Sarde (Quest for Fire).

ANDREWS AUDIO CONSULTANTS
SD, AC, SES, EI
347 West 39th St., New York, NY 10018
(212) 674-6934
Contact: David M. Andrews

AST SOUND
SES, EI
250 West Broadway, New York, NY 10013
(212) 226-7785
Contact: Lenny Berlingieri

THE AUDIOLAB
SD, AC, SES, EI
146 French St., New Brunswick, NJ 08901
(201) 249-9191
Contact: Phil Greenspun or Peter Borchard
Services offered, credits, specialization: Because of our in-depth studio experience in both analog and digital recording techniques and almost two decades of experience in designing and outfitting recording rooms, we are in a unique position to have seen the various pitfalls stumbled into by large and small alike. In the quest for better product, many recording personnel and, frankly, many equipment suppliers, tend to specify that which is old and familiar. As a result, improvements that are possible are overlooked. We accept every new problem as a challenge rather than as a license for rehash. Whereas we work for large and small clients alike, the particular opportunity for the smaller studio is impressive. We can act as your tech support. All equipment is checked and calibrated before delivery and when you have a problem, our extensive service capability is at your call. May it be that you are looking for this refreshing difference?

AUDIOTECHNIQUES
SD, AC, SES, EI
652 Glenbrook Rd., Stamford, CT 06906
(203) 359-2312
Contact: Ham Brosious

AUDIOTECHNIQUES, INC.
Studio Sales Department
SD, AC, SES, EI
1619 Broadway, 4th Fl., New York, NY 10019
(800) 223-2486, (212) 586-5989
Contact: Malt Brosious

Services offered, credits, specialization: Audiotechniques, Inc. offers a complete turnkey studio capability from mono to twin 24 track. After 12 years of experience serving record companies, independent recording studios, radio and TV stations, home recording facilities, and a variety of other users of professional recording equipment, Audiotechniques is recognized as one of the most capable recording studio suppliers in the world. Audiotechniques maintains offices and technical facilities in both New York City and Stamford, CT, with satellite sales/service centers in Boston and Washington, DC. Audiotechniques studio design and equipment specialists will be pleased to give you a quote.

BOYNTON STUDIO, INC.
SES
Melody Pines Farm, Morris, NY 13808
(607) 263-5695
Contact: Fred Hohman, Bob Boynton

CALF AUDIO INC.
AC, SES, EI
157 Gray Rd., Ithaca, NY 14850
(607) 272-8964
Contact: Barny Cole

CAPE COD AUDIO
AC, SES, EI
80 Enterprise Rd., Hyannis, MA 02601
(617) 775-1710
Contact: C. Davis



CALF AUDIO

CALF AUDIO INC.
Ithaca, NY

CARUSO MUSIC STORE, INC.
SES
20 Bank St., New London, CT 06320
(203) 442-9600
Contact: Larry Caruso

CONNECTRONICS CORPORATION
(formerly Canford Audio)
SES
652 Glenbrook Rd., Stamford, CT 06906
(203) 324-2889
Contact: Richard Chilvers

CRAMER AUDIO & VIDEO SYSTEMS
SD, SES, EI
120 Hampton Ave., Needham, MA 02194
(617) 449-2100 or (800) 343-5800
Contact: Mark Parsons, Les Arnold

DADDY'S JUNKY MUSIC STORES, INC.
SES, EI
361 South Broadway, Salem, NH 03079
(603) 893-4420
Contact: Mark Rogers

DANBURY ELECTRONIC MUSIC CENTER
SES
98 Federal Rd., Danbury, CT 06810
(203) 792-5543
Contact: Gary Schwartz

DSL PRO AUDIO
SD, AC, SES, EI
1165 Mass Ave., Arlington, MA 02174
(617) 646-3950
Contact: James D. Bazin, vice president

Services offered, credits, specialization: DSL is experienced in recording studio design, installation and equipment supply, as well as design and installation of sound systems and lighting for fixed installation facilities.

EAR CRAFT
AC, SES, EI
14 4th St., Dover, NH 03820
(603) 749-3138
Contact: Brian Fischer

EAST COAST SOUND
SD, AC, SES, EI
40 Main St., Danbury, CT 06810
(203) 748-2261
Contact: Ed Roman

STUDIO DESIGNERS & SUPPLIERS

LEGEND SD: STUDIO DESIGNER, AC: ACOUSTICAL CONSULTING, SES: STUDIO EQUIPMENT SUPPLY, EI: EQUIPMENT INSTALLATION/MAINTENANCE/SERVICING

ROSNER CUSTOM SOUND, INC.
SES, EI
 11-38 31st Ave., Long Island City, NY 11106
 (212) 726-5600
 Contact: Alex Rosner

S + C ENGINEERING, R + D
SD, AC, SES, EI
 8 Summit Ave., Sharon, MA 02067
 (617) 784-6996
 Contact: Skip Sweeney



DSL PRO AUDIO
 Arlington, MA

G&T HARRIS, INC.
SD, AC, SES, EI
 215 Lexington Ave., New York, NY 10016
 (212) 481-6500
 Contact: John W. Kryda, V.P. Engineering



HARVEY PROFESSIONAL AUDIO/VIDEO
 New York, NY

HARVEY PROFESSIONAL AUDIO/VIDEO
SD, AC, SES, EI
 25 W. 45th St., New York, NY 10036
 (212) 921-5920
 Contact: Gene Perry

LAKE SYSTEMS CORP.
SES, EI
 55 Chapel St., Newton, MA 02160
 (617) 244-6881
 Contact: Bill F. Hower, Millbank

Services offered, credits, specialization: Lake stocks over 100 lines of professional and video equipment. Top studio designers consult into and architect consistently specify Lake systems for system design, equipment requirements, and their knowledge of time-efficient installation. An on-site team of service has been in business for over 30 years and can handle any size job, from a small production studio to night club, fully blown, multi-track recording studios, TV and radio stations, casinos and stadiums. We are in the forefront of the digital audio movement and leaders in inter-computer-to-studio link. We are committed to our client.

LANDY ASSOCIATES, INC.
SES, EI
 1890 E. Marlton Pike, Cherry Hill, NJ 08003
 (609) 424-4660
 Contact: James F. Landy, President

MARTIN AUDIO/VIDEO CORPORATION
SES, EI
 423 W. 55th St., New York, NY 10019
 (212) 541-5900
 Contact: Courtney Spencer

MICROPHONICS
SES
 P.O. Box 37, Brooklyn, NY 11204
 (212) 438-6400
 Contact: Leon Sternheim

THE MIXINGBOARD
SES, EI
 124 Intervale Ave., Burlington, VT 05401
 (802) 658-4793
 Contact: Steven Hirsch

NEW YORK TECHNICAL SUPPORT, LTD.
SD, EI
 1440 Midland Ave., Suite 1-D, Bronxville, NY 10708
 (914) 446-2112

Contact: Greg Hanks, Rosemarie Lopresti
Services offered, credits, specialization: New York Technical Support, Ltd. is a full service maintenance firm that caters to the technical needs of the recording, film, and broadcast industries. We provide design, consultation, installation and repair services. Our specialties include: field service, power and ground distribution analysis and fault finding, tape machine optimization, EMT tuning, modification and refurbishment, custom design and manufacturing, installation and wiring services, contract maintenance service. We are factory trained to service Ampex, MCI, Neve, Scully and Trident equipment. Our work is guaranteed.

PROFESSIONAL MUSIC AUDIO ENGINEERING
SES, EI
 2600 Commercial Drive, N. Providence, RI 02904
 (401) 353-6221
 Contact: Peter M. Archambault

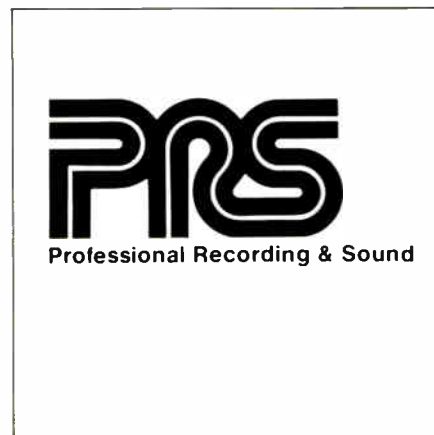

PROFESSIONAL RECORDING AND SOUND, PRS
 Boston, MA

PROFESSIONAL RECORDING AND SOUND, PRS
SD, AC, SES, EI
 1616 Soldiers Field Rd., Boston, MA 02135
 (800) 343-3001
 Contact: Peter Enzel

Services offered, credits, specialization: The unique autonomy of the PRS recording, broadcast and sound reinforcement divisions provides an unusual ability to satisfy the varying spectrum of audio needs required by these markets. These diverse abilities allow us to pioneer the industry by introducing new products and product applications which maximize the productivity of our clients in all of our disciplines. PRS supplies innovation, system concepts and system designs, providing the best use of technology in the most cost-effective manner. Because of our experience with acoustical and operational problems, our installed facilities achieve a symbiotic relationship between acoustics, layout and equipment. In addition, maintaining a national customer base puts us in touch with new ideas and industry trends which we incorporate in design and product application for our clients' benefit.

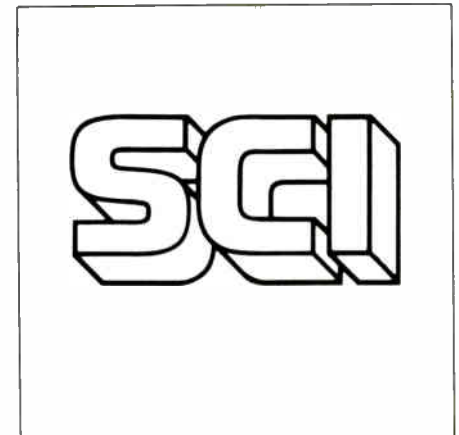

SCHARFF COMMUNICATIONS
 New York, NY

SCHARFF COMMUNICATIONS
SES, EI
 1600 Broadway, New York, NY 10019
 (914) 747-0333
 Contact: Peter Scharff, Josh Weisberg

SILVER & HORLAND, INC.
SES
 170 West 48th St., New York, NY 10036
 (212) 869-3870
 Contact: Pat Chupko

SOUND SYSTEMS SERVICE
AC, SES, EI
 72 W. Sylvania Ave., Neptune City, NJ 07753
 (201) 775-7007
 Contact: Joe Belmonte



JOHN M. STORYK ASSOCIATES
 New York, NY

JOHN M. STORYK ASSOCIATES
SD, AC
 31 Union Square West, New York, NY 10003
 (212) 675-1166

Contact: John Storyk, Alex Major
Services offered, credits, specialization: John M. Storyk Associates is one of the nation's leading architectural and acoustical design firms offering design and consulting services in the video and audio fields. The firm specializes in the design of studios, control rooms, theaters, and interformat media facilities. Formerly known as Sugarloaf View, the firm has been responsible for the design of over 300 audio and video studios throughout the U.S., Europe, Africa, and South America. John Storyk is a principal and co-founder of Metropolis Studios in New York City. Metropolis will be an electronic cinematography studio complex for video, audio, television, and film production and post-production. It will contain two VARMS (Video/Audio Recording and Mixing Stages) designed by Storyk. The VARMS will be one of the first studios designed specifically for the simultaneous recording of broadcast video and digital audio essential for the recording of high quality video disks and video cassettes, among other things.

STUDIO ELECTRONICS & ACOUSTICS
SD, AC, EI
87 W. Palisade Ave., Englewood, NJ 07631
(201) 894-1014

Contact: Manos Nomikos

Services offered, credits, specialization: Studio Design—for musicians and song writers who need their own private studio, we provide the best package, specially designed to meet each individual's needs and budget. Each package includes: equipment, system design, installation, acoustics and training of operation. Service—repair of consumer or professional audio video equipment. Field service, maintenance. Specialization—tape recorders, modifications.

TDM AUDIO, INC.

AC, SES, EI
240 W. 49th St., New York, NY 10019
(212) 245-4640

Contact: Vinnie Macri



TEKCOM CORPORATION
Philadelphia, PA

TEKCOM CORPORATION

AC, SES, EI
408 Vine St., Philadelphia, PA 19106
(215) 627-6700

Contact: Lou Maresca

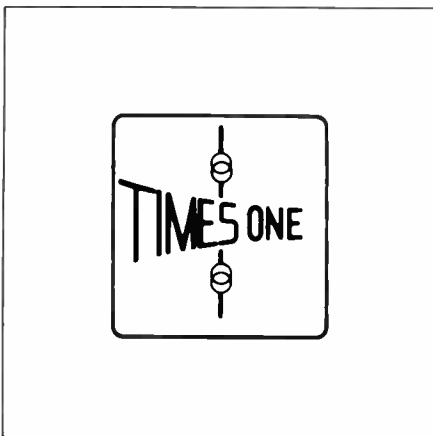

TIMES ONE
New York, NY

TIMES ONE c/o DESIGN WORKSHOP

AC, EI
305 East 46th St., New York, NY 10017
(800) 428-4022 - data; (212) 935-7222 - technical information

Services offered, credits, specialization: Times One offers 13 years' experience in application engineering for indoor and outdoor sound reinforcement system designs. Manufacturers of dual monaural and single power supply amplifiers ranging at this time from 50 - 400 watts per side at 8 ohms, and up to 700 watts and 4 ohms and 2 ohms. Times One technology has been used in major recording studios to master records in the final mixdown, and also by critical musicians who want the best that is available. Design Workshop Division of Northam Marketing.

UNISTAGE, INC.

SES
330 Genesee St., Buffalo, NY 14204
(716) 853-6500

Contact: Sound Department

WASHINGTON MUSIC CENTER

SD, AC, SES, EI
11151 Viers Mill Rd., Wheaton, MD 20902

(301) 946-8808
Contact: Robert Levin or Carl Culos

HUBERT WILKE, INC.

SD, AC
260 Madison Ave., 19th Floor, New York, NY 10016
(212) 578-4646

WOLFF ASSOCIATES

EI
6063 Arlington Blvd., Falls Church, VA 22044
(703) 241-2880

Contact: Paul Wolff

(919) 274-4682
Contact: Jim Elliott

BACKSTAGE INC.

SES, EI
310 W. Broad St., Richmond, VA 23220
(804) 644-1433

Contact: Cameron Grainger, Jim Spencer

BLEVINS AUDIO EXCHANGE

SES
1905-A Dabbs Ct., Nashville, TN 37217
(615) 361-0470

Contact: Randy Blevins

SOUTHEAST

ACE MUSIC CENTER, INC.

SD, AC, SES, EI
13630 W. Dixie Highway, N. Miami, FL 33161
(305) 891-6201

Contact: Neil Hurharde

ALL PRO SOUND

SD, AC, SES, EI
5355 N. Palafox St., Pensacola, FL 32503
(904) 432-5780

Contact: Richard Couture

AUDIO ARCHITECTS, INC.

SD, AC, SES, EI
823 19th Ave. South, Nashville, TN 37203
(615) 320-0463

Contact: Allen Humblough, George Juodenas

AUDIO IMAGE

SD, AC, SES, EI
3685 N. Federal Hwy., Pompano Beach, FL 33064
(305) 943-5590 Rob Henion

AUDIO, LIGHT & MUSICAL

SES, EI
3301 N. Military Hwy., Norfolk, VA 23518
(804) 853-2424

Contact: Lou Fritzing

AUDIO UNLIMITED OF NORTH AMERICA, INC.

SES, EI
11 Battleground Court, Greensboro, NC 27408

CONN AUDIO/VIDEO SYSTEMS dba SOUNDBOX

SES
1127 S. Patrick Dr., Suite 17, Satellite Beach, FL 32937
(305) 773-2433

Contact: Jay Conn

BOB DIX, INC. - BDI

SES
P.O. Box 31, Marion, VA 24354
(703) 783-2001

Contact: Bob Dix

STEVEN DURR & ASSOCIATES

SD, AC
3144 Glen Cliff Rd., Nashville, TN 37211
(615) 833-6281

Contact: Steven Durr

Services offered, credits, specialization: Durr and Associates are primarily involved in recording studio, sound reinforcement design and consultation. We specialize in control room, studio acoustics and loudspeakers. We have been giving personalized service throughout the country for more than 12 years. References upon request.

EXECUTIVE COMMUNICATIONS CORPORATION

SES, EI
2872 Hartland Rd., Falls Church, VA 22043
(703) 573-6910

Contact: David Eltzroth

GRAY COMMUNICATIONS CONSULTANTS, INC.

SES
1605 S. Bumby, Orlando, FL 37806
(305) 896-7414

Contact: Jean Siervinow

World Class Audio

- SOUND REINFORCEMENT
- STUDIO DESIGN
- EQUIPMENT SALES
- CUSTOM MANUFACTURING
- TOTAL SERVICE SUPPORT

At LD Systems, We Don't Just Sell Sound Equipment,
WE SELL KNOWLEDGE



LD SYSTEMS, INC.

467 W. 38TH HOUSTON, TEXAS 77018 (713) 695-9400

Circle #018 on Reader Service Card

IDEAL ACOUSTICS
SD, AC, SES, EI
110 Willow Rd., Starkville, MS 39759
(601) 324-1020
Contact: Dr. W.S. Shepard

Services offered, credits, specialization: Acoustic Consulting registered professional engineer with many years of experience in acoustic design, noise control and sound reproduction. Fully instrumented laboratory for performance verification and evaluation. Real Time Analyzer, etc. Let us solve all your studio reproduction problems. No problems are too complex for our analysis. Studio equipment supply: Tascam, Crown, PZM, Nakamichi, Klipsch, JBL, Otari, Hevox, etc. Visit our outstanding showrooms with equipment set up for evaluation. Complete equipment installation, maintenance and servicing available. Open any time by appointment. Ask for Steve Shepard. References supplied on request.

CHRIS JONES - DESIGNS
SD, AC
115 Waverly Hall Close, Roswell, GA 30075
(404) 993-2366
Contact: Chris Jones



MODULAR PERFECTION
Miami, FL

MODULAR PERFECTION
SD, AC
14205 N.E. 18th Ave., Miami, FL 33182
(305) 944-6731
Contact: Seth Snyder

Services offered, credits, specialization: Modular Perfection manufactures pre-fabricated room wall sections for recording studios and control rooms. Each modular section is available in varying degrees of acoustical brightness or absorption. Credits: Middle Ear Studios (Bee Gees' private studio), Right Track Recording, New York, NY, Coconuts Recording Studio, Miami, International Sound Studio, Miami, Discos Sonotec, Djs Recording Studio, Miami, Starke Lake Studio, Orlando, FL, Sony Corp. of America, NAR Convention, Las Vegas, NV.

J.H. NYGAARD & ASSOCIATES
SD, AC
11155 N.E. 12th Ave., Miami, FL 33161
(305) 893-8187
Contact: Jim Nygaard

ONYX SYSTEMS, INC.
AC, SES, EI
2615 N. Orange Ave., Orlando, FL 32804
(305) 894-7034
Contact: Phillip Hab

PARAGON MUSIC CENTER INC.
EI
2139 W. Hillsborough Ave., Tampa, FL 33603
(813) 876-3459
Contact: Dick Humore

QUALITY SOUND ENTERPRISE, INC.
AC, SES, EI
833 Bragg Blvd., Fayetteville, NC 28301
(919) 483-1212
Contact: Mark N. Lynch

RECORDING STUDIO EQUIPMENT CO.
SES, EI
14205 N.E. 18th Ave., N. Miami, FL 33182
(305) 945-9774
Contact: Seth Snyder
Services offered, credits, specialization: Sales, service and installation of professional recording equipment. We distribute products for the following companies: MCI division of Sony Corp., Ramsa, UREI, Crown Studio Technologies, Eventide, Clockworks, dbx, Dolby Labs, Neumann, AKG, Sennheiser, Sony, Beyer. Credits: Middle Ear (Bee Gees' private studio), Sunshine

Sound (KC and the Sunshine Band), Flyshore Recording, Compas, Point Re-ordains, Quadradial Cinema, Djs Recording Studio, Tuff Recording, Tuff Gong (Bob Marley's studio), International Sound, Studio Center Sound Recording, Starke Lake Studio, Coconuts Recording Studio, Studio HN, Boyeta, Columbia



RECORDING STUDIO EQUIPMENT
Miami, FL

RELIABLE MUSIC - PRO AUDIO DIVISION
SD, AC, SES, EI
1001 S. Independence Blvd., Charlotte, NC 28202
(704) 375-8662
Contact: John Saviano, David F. Hite

S.C.M.S. - PRO AUDIO WHEREHOUSE
SES
800 N. Polk St., Pineville (Charlotte), NC 28134
East: (800) 438-6040,
West and North Central: (704) 889-4509
Contact: Noel Walker

SPECTRUM SOUND, INC.
SD, AC, SES
429 Space Park North, Goodlettsville, TN 37072
(615) 859-4381
Contact: Ken Fetter

STEREO SALES & AUDIO REPAIR SERVICE
SD, AC, SES, EI
637 W. Tennessee St., Tallahassee, FL 32301
(904) 224-2635
Contact: W.T. Metasco, AFS

STUDIO SUPPLY
SD, SES
11155 N.E. 12th Ave., Miami, FL 33161
(305) 893-8187
Contact: Jim Nygaard

STUDIO SUPPLY CO., INC.
SD, AC, SES, EI
P.O. Box 280, Nashville, TN 37202
(615) 327-3075
Contact: Tom Lilly, John Alderson

STUDIOWORKS
SES, EI
1018 Central Ave., Charlotte, NC 28204
(704) 375-1053
Contact: Jimmy Locke

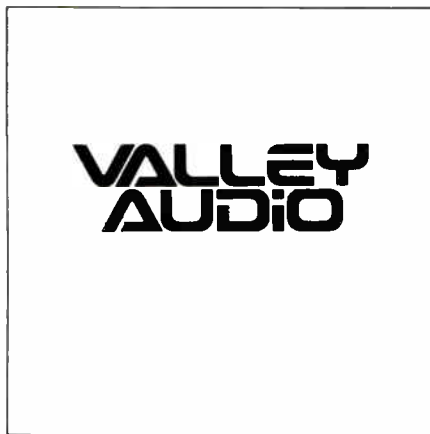

VALLEY AUDIO
Nashville, TN

VALLEY AUDIO
SD, AC, SES, EI
2821 Erica Place, P.O. Box 40743,
Nashville, TN 37204-3111
(615) 383-4732
Contact: Bob Todorak

WILLCUTT SOUND SYSTEMS
c/o Willcutt Guitar Shoppe, Inc.
AC, SES
419 Rosemonte Garden, Lexington, KY 40503
(606) 276-2713
Contact: T. Robert Willcutt

WILSON AUDIO SALES
SES
210 Old Hickory Blvd. #53, Nashville, TN 37221
(615) 356-0372
Contact: Wally Wilson

NORTH CENTRAL

ALLIED BROADCAST EQUIPMENT
SES
5097 N. Elston Ave., Chicago, IL 60630
(312) 794-0224
Contact: Tom Harle

ALLIED BROADCAST EQUIPMENT
SES
635 South E Street, Richmond, IN 47374
(317) 962-8596
Contact: David Burns

ANTECH LABS
SD, AC, SES, EI
11118 Olive St. Rd., St. Louis, MO 63141
(314) 997-5666
Contact: Bob Higginbotham

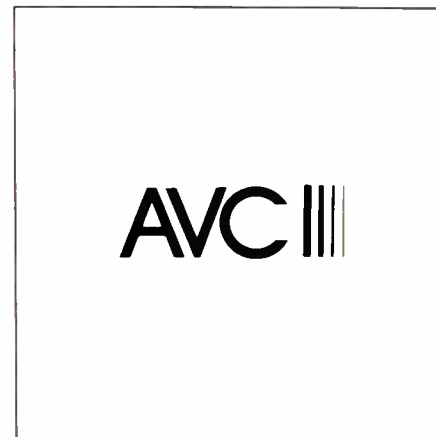

AVC SYSTEMS, INC.
Minneapolis, MN and Elmhurst, IL

AVC SYSTEMS INC.
SD, AC, SES, EI
1517 East Lake St., Minneapolis, MN 55407
(612) 729-8305 and
747 Church Rd., Suite A6, Elmhurst, IL 60126
(312) 279-6580

Services offered, credits, specialization: Complete design, equipment selection, installation and maintenance services available. Showrooms in both Minneapolis and Chicago, displaying over 150 lines of professional audio equipment for recording studio, audio for video, film or AV products, remote vans, permanent sound systems. Sales and service on Otari, MTR series 2-24 tracks, Harrison Systems, Soundcraft, Lexicon, JBL, Ampex, Tascam 2-16 track, Eventide, BTX, Ramsa, Echo Plate, MICMIX, AKG, DeltaLab, Dolby, Neumann, Sennheiser, Fostex pro, Crown, BGW, MXR, Orban, Klark-Teknik, Omnicraft, Clear-Com, Bose, Altec, Biamp, ADR, MRL, IVIE, Shure, Technics, HME, Vega, Telex, Calrec, Atlas, Symetrix, UREI, Studer-Revox, CSI, Switchcraft, Neutrik, Scotch, Agta and Sonex/loam

BRIDGEWATER CUSTOM SOUND
SD, AC, SES, EI
15957 South Halsted, Harvey, IL 60426
(312) 596-0309
Contact: Jay Bridgewater

The only way to go.

AUDIO EDITING

Up to 12 audio or video machines may be controlled or synchronized.

As many as 999 frame accurate, automated punch in/punch outs may be recorded at a time.

The time code locations of your sound effects and theme music library can be stored in a computerized directory and easily recalled when needed.

Options include control of some of the most widely used outboard processors for time compression or scene-by-scene correction of reverb, equalization, etc.

VIDEO EDITING

Two machine record capability permits A/B roll video editing while recording basic tracks on a synchronized multi-track audio master.

Many switcher effects and audio sweetening decisions can be made on the off-line edit decision list.

Elaborate audio and video decision lists can be separately created and combined prior to final on-line assembly.

Edit lists may be alternately formatted to conform to proposed SMPTE standards.

Production switcher interfaces available to order.



Edward Joseph

Together.

Yesterday's editing systems just can't meet today's demand for high quality audio. Automated Studio Technologies solves this problem by introducing electronic audio editing techniques as sophisticated as those taken for granted in video production. Bridging the gap between these two industries allows us to provide the one editing system that is truly at home in either an audio or video post-production environment.

Audio sweetening has never been easier or more accurate. Recording an entire sequence of tightly timed sound effects, for example, becomes a simple matter of finding the cue points. Making changes is no problem either. We've even provided a way to put your entire music and effects library right at your fingertips! Combining this capability with frame accurate video editing means just three things: saving time, money and your nerves.

Distributed through Harvey Professional Audio/Video, 25 West 45th St., New York, N.Y. 10036 (212) 398-0995

Circle #019 on Reader Service Card

STUDIO DESIGNERS & SUPPLIERS

LEGEND **SD** STUDIO DESIGNER, **AC** ACOUSTICAL CONSULTING, **SES**: STUDIO EQUIPMENT SUPPLY, **EI**: EQUIPMENT INSTALLATION/MAINTENANCE/SERVICING

KHS/OTM SOUND COMPANY & ELECTRO-ACOUSTIC RESEARCH
SD, AC
 108 Birch, Park Forest, IL 60466
 Written appointment only
 Contact: Klaus H Seliger, President

MILAM AUDIO
SD, AC, SES, EI
 1470 Valle Vista Blvd., Pekin, IL 61554
 (309) 346-3161, service: (309) 346-6431
 Contact: Jerry Milam

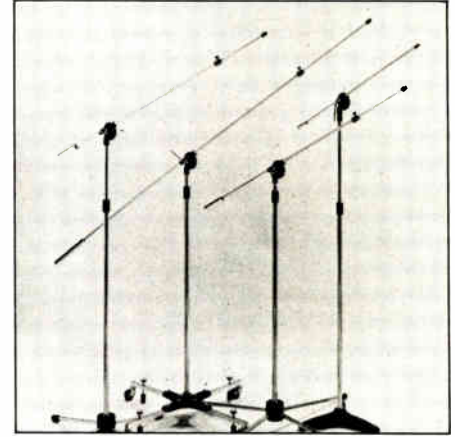

*KEITH MONKS AUDIO (U.S.A.)
 Palatine, IL*

KEITH MONKS AUDIO (U.S.A.)
SES
 P.O. Box 1069, Palatine, IL 60078
 (800) 562-5872
 Contact: Glenn Mullis

NEWCOME SOUND, INC.
SES, EI
 4684 Indianola Ave., Columbus, OH 43214
 (614) 268-5605
 Contact: Charlie Teets

PRECISION AUDIO, INC.
AC
 18582 U.S. 20, Bristol, IN 46507
 (219) 295-7493
 Contact: Sanford Swartzendruber

PYRAMID AUDIO INC.
SD, AC, SES, EI
 450 W. Taft Dr., South Holland, IL 60473
 (312) 339-8014
 Contact: Rob Vukelich

GEORGE RONDINELLI MUSIC
SES
 1101 Main, Dubuque, IA 52001
 (319) 583-3838
 Contact: George Rondinelli

SOUND SOLUTIONS, INC.
SD, SES, EI
 5701 Canton Center Rd., Canton, MI 48187
 (313) 453-6586
 Contact: Dave Hill

SOUND WORLD
SES, EI
 1808 SE 3rd Ave., Rochester, MN 55901
 (507) 288-8326
 Contact: Nick Alexakis, Ray Hylland

SOUNDZ MUSIC RENTALS & SALES
SES
 516 N. Milwaukee Ave., Wheeling, IL 60090
 (312) 537-8211
 Contact: C. Ehan

SWALLEN'S
SES
 3700 Red Bank Rd., Cincinnati, OH 45227
 (513) 898-2003
 Contact: Paul Niehaus

CLINE COMMUNICATIONS
EI
 1242 1/2 Remington Rd., Schaumburg, IL 60195
 (312) 882-2433
 Contact: Brian Cline

ECLIPSE CONCERT SYSTEMS, INC.
SES
 1062 Wagon Wheel Trail, Mendota Heights, MN 55120
 (612) 451-8878
 Contact: Mike Justen

FLANNER'S PRO AUDIO, INC.

*FLANNER'S PRO AUDIO, INC.
 Waukesha, WI*

FLANNER'S PRO AUDIO, INC.
SD, AC, SES, EI
 2323C Bluemound Rd., Waukesha, WI 53186
 (414) 785-9166 or out of WS, (800) 558-0880
 Contact: John Loeper

FULL COMPASS SYSTEMS

*FULL COMPASS SYSTEMS
 Madison, WI*

FULL COMPASS SYSTEMS
SD, AC, SES
 6729 Seybold Rd., Madison, WI 53719
 (608) 271-1100
 Contact: Jonathan Lipp

Services offered, credits, specialization: Consultation, specification, budget, design, custom work, installation. Consultation, specification, budget: Full Compass Systems, Ltd offers expert help in the specification of equipment for any production facility to fit any budget. Design control room layout for best human engineering. Design studio layout for best efficiency and co-existence with video production. Custom work. Full Compass Systems, Ltd will modify existing equipment or create equipment that may not exist. Installation: expert wiring of patch fields and system interface. Full Compass systems, Ltd offers rebatable against purchase consultation. Attention to budget and appropriateness are first criteria.

GILL CUSTOM HOUSE, INC.
SD, SES, EI
 8813 W. 95th St., Palos Hills, IL 60465
 (312) 598-2400
 Contact: John Gill, Greg Messer

HOOD INDUSTRIES
EI
 5700 Superior Ave., Cleveland, OH 44103
 (216) 431-4663
 Contact: Jack Boessneck

HSA/HEATHER SOUND AMPLIFICATION
AC, SES
 121 Lincolnway West, Mishawaka, IN 46544
 (219) 255-6100
 Contact: Richard R Johnson

HY JAMES
The Audio Professionals

*HY JAMES - THE AUDIO PROFESSIONALS
 Farmington Hill, MI*

HY JAMES - THE AUDIO PROFESSIONALS
SD, AC, SES, EI
 24166 Haggerty Rd., Farmington Hills, MI 48018
 (313) 471-0027

Contact: Henry J Root
Services offered, credits, specialization: A new location with greatly expanded demo facilities inventory and equipment service and custom fabrication are just a few of the new things at Hy James. The Otari MTR-90 and MTR-10 are our featured tape recorders along with our own 30 ips version of the Revox PR-99 and the new Nagra T. The complete Tascam line also has its Michigan home at Hy James. Neotek and Soundcraft consoles are featured and included in our demo rooms. Large monitors are auditioned in our own I E C listening room. For the audio professional, it's Hy James - The Audio Professionals.

ICB AUDIO CO.
AC, SES, EI
 1349 E. Macmillan, Cincinnati, OH 45206
 (513) 281-5535
 Contact: Ian Budd

Services offered, credits, specialization: ICB Audio is a specialized consultation company offering technical support, installation, equipment sales, training and education services to the recording studio industry. The company is owned by Ian Budd, who also provides the technical leadership and direction for the company. His track record includes technical management for Allen & Heath in England, acoustical training services for the U.S. government, and wide range consultation and installation for multi-track recording studios. ICB Audio specializes in low cost, high quality equipment and installations. Its current product line includes Allen & Heath, Otari, Eastern Acoustics, Ursa Major, EchoPlate, Symetrix, MRL, Loft, Audio Technica and more. ICB Audio co-presents courses in recording studio maintenance, acoustics and technical/business aspects of operations. The company has developed a strong reputation in the industry through customer service and post sale support.

KAVCO, INC.
SD, SES, EI
 3931 Image Drive, Dayton, OH 45414
 (513) 898-2003
 Contact: John Ellis, John Wright

STUDIO DESIGNERS & SUPPLIERS

LEGEND SD: STUDIO DESIGNER, AC: ACOUSTICAL CONSULTING, SES: STUDIO EQUIPMENT SUPPLY, EI: EQUIPMENT INSTALLATION/MAINTENANCE/SERVICING

SYNDER SYSTEMS
SES
16638 E. Warren, Detroit, MI 48224
(313) 881-5167
Contact: Ken Snyder

THOMPSON ELECTRONICS CO.
AC, SES, EI
3522 W. Harmon Hwy., Peoria, IL 61604
(309) 637-2277
Contact: Craig A. Thompson President

NORTHWEST

A & G ASSOCIATES
SES
433 Fairview Ave. North, Seattle, WA 98109
(800) 426-9233 (orders only)
(206) 621-9222 (information only)
Office also in Portland, OR, San Francisco, CA, midwest
and southeast
Contact: Renard Bertrand

APPLIED TECHNOLOGY, INC.
SD, AC, SES, EI
11 North Highway 89, North Salt Lake City, Utah 84054
(801) 292-0075/292-0184
Contact: Bill Cheney

ASSOCIATED SOUND
SES, EI
2120 P. Street, Sacramento, CA 95816

(916) 443-4773, Reno (702) 329-2401
Contact: Wally Clark, Tom Lewis

AUDIO & VIDEO ARTS
AC, SES
P.O. Box 398, Simi Valley, CA 93062
(805) 583-0540

AUDIOHOUSE
SES
10288 E. Jewel Ave #45, Denver, CO 90231
(303) 751-2268
Contact: George Chapex

AUDIOWORKS
SD, SES, EI
654 Irwin, San Rafael, CA 94901
(415) 457-1722
Contact: Phil Crescenzo

AURACOUSTIC RESEARCH & ENGINEERING
SD, AC, SES, EI
448 DuBois, San Rafael, CA 94901
(415) 459-5152
Contact: Dr. Richie Moore

KENNETH A. BACON ASSOCIATES
SES
24 Commercial Blvd., Suite E, Novato, CA 94947
(415) 883-5041
Contact: Kenneth A. Bacon

BANANAS AT LARGE
SES, EI
802 4th St., San Rafael, CA 94901
(415) 457-7600
Contact: J.D. Sharp

BARATH ACOUSTICS, INC.
SD, AC, SES, EI
7800 East Iliff, Denver, CO 80231
(303) 750-6474
Contact: Jim Barath, Joe Erick, Harry Warman

BLACKWOOD SOUND & ELECTRIC
EI
329 North 175th St., Seattle, WA 98133
(206) 546-1316
Contact: Ed Blackwood

BROWNELL SOUND & HI FI, INC.
SES, EI
3601 S.E. Concord, Milwaukie, OR 97222
(503) 659-0394
Contact: Curtis Brownell

CALIBRATION STANDARD INSTRUMENTS
AC
P.O. Box 2727, Oakland, CA 94602
(415) 531-8725
Contact: Debbie

RICK DAVIS, AUDIO ENGINEER
SD, AC, SES, EI
456 W. Charleston Rd., Palo Alto, CA 94306
(415) 493-3696
Contact: Rick Davis
Services offered, credits, specialization: I'll design/build/modify/buy/install anything you need in audio systems, digital or analog, logic systems, AC power systems for a studio or facility on wheels or not. Also will help you with acoustics, video (CCTV) and film sound. Specializations are custom consoles, console or system modifications, installations, problem solving and general tech support. I've been in prof audio since '69. Have built systems or projects for many studios and musicians including: Neil Young, Keith Knudsen and John McFee (Doobie Bros.), Industrial

HY JAMES - NEOTEK User's List:

Pearl Sound
Canton, MI
Ben Grosse
40x24 Series II w/VCA
Grouping

A² Studios
Ann Arbor, MI
Al and Dee Hirshman
56x24 Series III
(The Biggest Neotek Ever Built)

**The University of Michigan
Electronic Music Studio**
Ann Arbor, MI
Dr. George B. Wilson
16x8 Series I

Ron Rose Productions
Southfield, MI
Bill Bryan
28x24 Series II
w/Valley People Automation

K & R Recording
Southfield, MI
Ken Glazza
28x24 Series II

Reel Sound
Southfield, MI
Jamie Ascenso
28x24 Series II

Audiograph Productions
Haslett, MI
Glen Brown
32x24 Series II

Central Michigan University
Mt. Pleasant, MI
Dave Vest
16 Input Production Console

Sound Space
Yellow Springs, OH
Chris Hertzler
32x24 Series II

Peter Bankert Music
Ann Arbor, MI
Pete Bankert
24x8 Series I

Detroit Board of Education
Detroit, MI
Cliff Wiehr
20x8 Series II

T. J. Sound
Warren, MI
Jeff Brigs
16x8 Series I

Tyrone Parker
Pontiac, MI
16x8 Series I

HY JAMES — The Audio Professionals

24166 Haggerty Rd. • Farmington Hills, MI 48018 • (313) 471-0027

Circle #020 on Reader Service Card

in a maze about
audio equipment



get to the point

for:
used pro audio equipment
consignment sales
service and maintenance

we
are the people to call

**B.A.E.
INC.**

Blevins Audio Exchange
Nashville, Tn.
615-361-8429

see our ad in the classifieds

Circle #021 on Reader Service Card

THE CONNECTION
FOR USED AUDIO EQUIPMENT



CONSOLES • TAPE MACHINES
OUTBOARD EQUIPMENT
MICROPHONES
BUY • SELL • TRADE

NEW CATALOG



Summit Audio

P.O. Box 1678 Los Gatos, Ca. 95031
408/395-2448

Circle #022 on Reader Service Card

STUDIO DESIGNER & SUPPLIER

LEGEND: SD: STUDIO DESIGNER; AC: ACOUSTICAL CONSULTING; SES: STUDIO EQUIPMENT SUPPLY; EI: EQUIPMENT INSTALLATION/MAINTENANCE/SERVICING

Light and Magic, San Francisco Ballet, Wally Heider - SF, Russian Hill Recording, Villa Recorders and wait, there's more

**RICK
DAVIS**
AUDIO ENGINEER

RICK DAVIS, AUDIO ENGINEER
Palo Alto, CA

DB AUDIO
AC, EI
2578 Shattuck, Berkeley, CA 94704
(415) 548-8733
Contact: Doug Blackwell

Services offered, credits, specialization: Specializing in professional playback (home reference room) systems. Supplier and consultants to the San Francisco Opera, KOED, U.C. Berkeley Music Library, Oakland Museum, numerous contractors and thousands of satisfied home music listeners. Doug Blackwell, owner, is a graduate in electronics, lectures at U.C. Berkeley in acoustical and mechanical engineering, member Board of Advisors of Orton Audio reference guide publications, member San Francisco Symphony Foundation, musician, and a highly interested consultant available to recommend and install quality stereo systems (and service) for your home or reference playback room. Come listen!

HORSESHOE MUSIC COMPANY
SES
2419 S.E. 39th Ave., Portland, OR 97214
(503) 235-7095
Contact: Mark Miller

HUN SOUND INC.
AC, SES, EI
647 Irwin St., San Rafael, CA 94901
(415) 454-2911
Contact: Mike Kerby

HUPPIN'S
SES
421 W. Main, Spokane, WA 99201
(509) 747-6055
Contact: Alan Perry - Manager

LASCO AUDIO, INC.
SD, AC, SES, EI
3402 "C" St. NE, Suite #209, Auburn, WA 98002
(206) 852-7556
Contact: Alan or Tern

LEO'S PROFESSIONAL AUDIO
SD, SES, EI
5447 Telegraph Ave., Oakland, CA 94609
(415) 652-1553
Contact: Bob Ulius, General Manager

LISTENUP AUDIOSYSTEMS
SES, EI
515 E. Exposition St., Denver, CO 80209
(303) 778-0949
Contact: Bill Rollin

**LEO'S
PROFESSIONAL
AUDIO**

LEO'S PROFESSIONAL AUDIO
Oakland, CA

MARCOM
SES
P.O. Box 66507, Scotts Valley, CA 95066
(408) 438-4273
Contact: Ted Trapp

THE MUSIC ROOM
SES
137 W. Center, Kalispell, MT 59901
(406) 755-3677
Contact: F. Weber, A. Bovera

NORTHWESTERN, INC.
SES
1224 S.W. Broadway, Portland, OR 97205
(503) 226-0170
Contact: Bob Lindahl

OLYMPIA AUDIO/VIDEO PROFESSIONALS
SES, EI
5711 Lacey Blvd., #307, Lacey, WA 98503
(206) 459-3841
Contact: Joe Contes

PAOLETTI/LEWITZ/ASSOCIATES INC.
AC
40 Gold St., San Francisco, CA 94133
(415) 391-7610
Contact: Dennis or Joel

PATCHWORK PRODUCTIONS, INC./PATCHBAY STUDIOS
SD, AC
2111 Franciscan Blvd., San Rafael, CA 94901
(415) 459-2331
Contact: P.G. Elliott

PERFORMANCE AUDIO
SES, EI
2358 So. Main, Salt Lake City, UT 84115
(801) 355-8890
Contact: Klay Anderson

PRO AUDIO SYSTEMS
SES
11057 8th Ave. N.E., Seattle, WA 98125
(206) 367-6800
Contact: Studio Sales Tom Martin, Broadcast Sales David Dewey

PRO MEDIA
SD, SES, EI
185 Berry St., Suite 358, San Francisco, CA 94107
(415) 957-1383
Contact: Debra Kay

Services offered, credits, specialization: Pro Media's support to the professional users of sound equipment is aimed at maintaining the most up-to-date products from the leading manufacturers in the industry. The latest technical advances from Meyer Sound Labs, Lexicon, AB Systems, Altec, dbx, Sennheiser, Crown, Vega, Revox, HME, Studiomaster, E-V, TEAC/Tascam, Yamaha,

Shure, JBL, Ampex, UREI, Trident, AKG, etc., are immediately available from Pro Media's extensive inventory of rental equipment. All equipment is serviced and tested by experienced Pro Media technical personnel. Our technical staff is available to assist in the support of your sound reinforcement equipment needs from design, to delivery, to installation, to complete on-site system engineering. Custom designed speaker systems feature Meyer Sound Labs, custom designed patching systems have been developed from Pro Media's extensive field experience; custom Pro Media rack systems incorporate power and processing equipment. All Pro Media systems include the latest state-of-the-art equipment and design and are available to meet your specific sound reinforcement needs.



PRO MEDIA
San Francisco, CA

DENNIS RICE STUDIO SERVICES
SD, AC, ES, EI
1907 Ardith Dr., Pleasant Hill, CA 94523
(415) 689-6718
Contact: Dennis Rice

RMS SOUND
SES, EI
17517 15th N.E., Seattle, WA 98155
(206) 362-0491
Contact: Greg Paisley

SKIP'S MUSIC, INC.
SES
2740 Auburn Blvd., Sacramento, CA 95821
(916) 484-7575
Contact: Matt Flynn or Larry Gosch

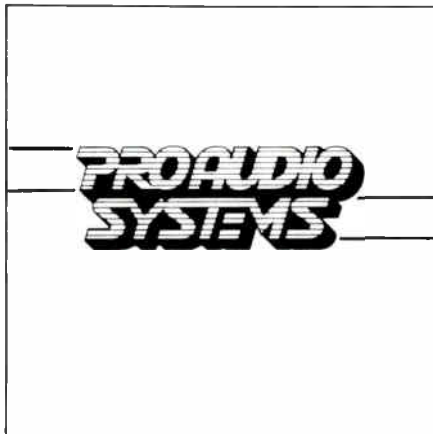

PRO AUDIO SYSTEMS
Seattle, WA

SONIC LANDSCAPES
SD, AC
24 Belvedere St., Suite H, San Rafael, CA 94901
(415) 459-1675
Contact: Randy Sparks

Services offered, credits, specialization: At Sonic Landscapes our goal is to help build your studio. We work directly with our clients to assist in the realization of their project. Reinforcing your ideas with solid acoustic principles, and innovative design concepts, we can build a strong foundation for your successful venture. Services offered: LEDE* type or traditional acoustic designs, full construction blueprints, interior design, sound system design and installation supervision, acoustical analysis and basic consulting. Studio construction is easily integrated through our "on retainer" project contractor. Clients include: The Automatt, San Francisco, CA, Russian Hill Recording, S.F., CA, El Dorado

Saloon/Nightclub, Sacramento, CA; Pacific Telephone, KZST Radio, Santa Rosa, CA, Robert Berke Recording, S.F., CA, and most recently, AVID, Inc. Audio/Video Recording, Redwood City, CA (*LEDE is a trademark of Synergetic Audio Concepts, San Juan Capistrano, CA)



SONIC LANDSCAPES
San Rafael, CA

SOUND GENESIS
SD, AC, SES, EI
2001 Bryant St., San Francisco, CA 94110
(415) 285-8900
Contact: David Angress

SOUND WEST
AC, EI
E. 9907 Sprague, Spokane, WA 99206
(509) 924-9210
Contact: Thom Owen or James Rhines

SUMMIT AUDIO
SES
P.O. 1678, Los Gatos, CA 95030
(408) 395-2448
Contact: Mike Papp
Services offered, credits, specialization: • Brokering better audio and video equipment • On-line computer buy/sell listings • Transport, insurance, and packing for export arranged • Purchase of complete studio packages • Appraisals

TRAX AUDIO
SES, EI
2470 North Fairfield Rd., Layton, UT 84041
(801) 776-4271
Contact: Jeff Ostler

WILSON, IHRIG & ASSOC., INC.
AC
5776 Broadway, Oakland, CA 94618
(415) 658-6719
Contact: David P. Walsh
Services offered, credits, specialization: Based on nearly twenty years experience in the acoustical design of all types of recording and performance facilities and in the measurement, evaluation, prediction and control of noise and vibration, Wilson, Ihrig & Associates, Inc. (WIA) has earned a reputation as one of the nation's leading acoustical consulting firms. By virtue of the technical expertise developed by our professional staff, we are eminently qualified to provide consulting services on a wide range of acoustical projects. In addition, our precision noise and vibration measuring equipment and extensive laboratory facilities provide us with the capability of performing detailed acoustical analyses when required to solve complex problems. Whether your project requires innovation, state-of-the-art engineering and architectural solutions or simple answers to more routine noise and vibration problems, WIA can provide you with the appropriate level of assistance and design you need.

SOUTHWEST

ABADON/SUN, INC.
SD, AC, SES, EI
P.O. Box 6520, San Antonio, TX 78209
(512) 824-8781
Contact: Woody Smith
Services offered, credits, specialization: Specializing in cost-effective multi-track systems, including pre-wired packages from Soundcraft, Tascam and Fostex. Acoustic consultation available at reduced rates, to full turn-key design and installation.

SENNHEISER

MD421U	\$208.-	HD414	\$ 44.-
MD431U	\$224.-	HD420	\$ 50.-
MD441U	\$289.-	HD222	\$ 67.-
MD427U	\$155.-	Other Models . . Call	

(800) 431-3232 **MICROPHONICS** (212) 438-6400
P.O. Box 37, Brooklyn, NY 11204



ANALOGIQUE IS PROUD TO ANNOUNCE THE ARRIVAL OF FRANCIS MILANO INTERNATIONALLY RENOWNED ACOUSTIC DESIGN ENGINEER TO ITS N.Y. HEADQUARTERS

Analogique's Professional Division combines the best in Creativity, Professionalism, and Experience in the design and construction of Recording Studios. With a solid track record of more than 40 Recording Facility Projects constructed world-wide over the past ten years, Analogique is completely qualified to handle your studio construction needs. Please feel free to call us, if we might be of service to you.



Circle #023 on Reader Service Card

STUDIO DESIGNERS & SUPPLIERS

LEGEND SD: STUDIO DESIGNER; AC: ACOUSTICAL CONSULTING; SES: STUDIO EQUIPMENT SUPPLY; EI: EQUIPMENT INSTALLATION/MAINTENANCE/SERVICING

ASSOCIATED PRODUCTIONS OF TEXAS
SD, AC, EI
222 College at Presa, San Antonio, TX 78205
(512) 227-3400
Contact: Henry W. Lam, Jr.

AUDIO SYSTEMS CORP.
SES
P.O. Box 17562, San Antonio, TX 78217
(512) 824-6402
Contact: John York

BILLY'S BAND AID
SES, EI
2106 Ave. Q, Lubbock, TX 79405
(806) 762-2258
Contact: Robert Kosloske

BROOK MAYS AUDIO SERVICES
SD, SES, EI
644 W. Mockingbird, Dallas, TX 75247
(214) 631-0921
Contact: Steve Porter

CHIPS DAVIS LEDE™ DESIGN
SD, AC
3364 Clandara Ave., Las Vegas, NV 89121
(702) 731-1917
Contact: Chips Davis

Services offered, credits, specialization: Chips Davis designed the first LEDE™ (Live End-Dead End) control room at his own facility, Las Vegas Recording, Las Vegas, Nevada. With the completion of Tres Virgos Studios in San Rafael, California, Davis has redefined both the art and science of control room design. Tres Virgos has been acclaimed internationally as one of the world's finest recording studios. Among Chips Davis' facilities you might like to visit are: Radio-TV Caracas, Caracas, Venezuela, Crescendo Productions in San Juan, Puerto Rico, a 3-studio multi-media complex, Audio Archives at Syracuse University in New York, Sounds Interchange in Toronto, Ontario, Starmusikproduktion in Hamburg, Germany, and NBC Post Production Room 2 in Burbank, CA. Services include complete design, construction, electronic, marketing and management supervision as well as on-site and turnkey services. The business advantages of a predictable technologically superior Chips Davis LEDE™ Design will even make your accountant smile!

EAR PRO AUDIO
SD, AC, SES, EI
947 S. 48th St., Tempe, AZ 85281
(602) 968-8675
Contact: John Gibson, Ed Vogt

Services offered, credits, specialization: EAR Professional Audio specializes in sales and service of professional audio equipment for broadcast, recording, public address, and audio for video. They distribute a variety of products including: 2" 24 channel tape machines by Otari, production consoles by Soundcraft and audio for video hardware by BTX. EAR's clientel are primarily broadcasters and production houses located in the greater southwest United States. In their short 6 year history, EAR has seen a dramatic maturing in their area which includes Arizona, Colorado, Utah, and New Mexico. The principal work being done by these production houses is supported by industrial and independent production companies (film, video and audio).

FENTRISS SOUND CO.
SES, EI
508 N. Walnut, Oklahoma City, OK 73104
(405) 232-1566
Contact: Steve Simmons

FORD AUDIO-VIDEO INC.
SD, AC, SES, EI
4800 W. 1-40, Oklahoma City, OK 73128
4715 E. 41st St., Tulsa, OK 74135
(405) 946-9966; (918) 663-4730
Contact: Randy Riebe, Jim Ford

Services offered, credits, specialization: Ford Audio-Video Inc. of Oklahoma City and Tulsa has continued their response to the ever increasing need of the Southwest's recording studios. The firm's Oklahoma City based operation offers complete studio packages tailored according to the application and budget of the end user. The company offers a wide selection of recording products as well as the manufacturing of their own "OCTAVE AUDIO" product line, which includes their unique head cue system for recording studios. Other services Ford Audio-Video offers are on board technicians, fully equipped installation crews, complete wood shop and carpentry facilities, and expedient shipping/receiving.

JOINER PELTON ROSE INC.

Consultants in Acoustics

JOINER, PELTON, ROSE, INC.
Dallas, TX

JOINER, PELTON, ROSE, INC.
Consultants in Acoustics
SD, AC
10110 Monroe Drive, Dallas, TX 75229
(214) 350-2384

Contact: David Joiner, Huss Berger
Services offered, credits, specialization: Founded in 1954 JPR is one of the largest acoustical consulting firms in the country. We are a company of engineers, architects, and scientists who deal exclusively in acoustics.

Our recording studio design team is comprised of people who relate to the recording industry and have experience collectively as recording engineers, session musicians, and studio owners and managers. The design is tailored to meet our client's needs and market goals.

We have a wide range of instruments used in the design and testing of acoustic, vibration and electroacoustic systems including HTA, wave analyzers, chart and level recorders, FFT computers and a full TEF measurement system. Recording studio and control room design, architectural noise control, room acoustics, acoustic performance, ventilation and testing, computerized design electroacoustics, environmental acoustics, industrial noise control.

L.D. SYSTEMS
SES, EI
467 W. 38th St., Houston, TX 77018
(713) 695-9400
Contact: Bruce Colman

METEX INTERNATIONAL INC.
AC, SES, EI
1217 Lincoln St., Laredo, TX 78040
(512) 722-3941
Contact: Frank Puente, General Manager
Services offered, credits, specialization: Product lines: Crown International, JBL Pro, Cabaret, DeltaLab, Ashley Audio, Altec Lansing, MXR Pro Shure-Products, TGA, Panasonic, Humana, JBL Pro, TEAC, Tascam. Consultations: PA sound reinforcement installations, retail establishment.

MIDCOM, INC.
SES, EI
2231 E. Division, Arlington, TX 76011
(817) 461-2211 metro
Contact: Mike Simpson, Mark Allison, Jim Fitzeraera

MUSIC STAND, INC.
SES, EI
245 S. Plumer #20, Tucson, AZ 85719
(602) 884-7627
Contact: Paul Rosendo

PELTON/BLUM
Consultants in Acoustics
AC
4144 North Central Expwy., Suite 300, Dallas, TX 75204
(214) 821-8010
Contact: Howard K. Pelton

RECORDER CENTER
SES
2003 N. Henderson, Dallas, TX 75206
(214) 826-8700
Contact: John, Carm

SOUTHWEST PRO AUDIO

SOUTHWEST PRO AUDIO, INC.
Austin, TX

SOUTHWEST PRO AUDIO, INC.
SES, EI
1500 Summit St., Austin, TX 78741
(512) 443-4567; Dallas office: (214) 271-2300
Contact: Austin: Greg Kincaid, Smith Dallas: Dennis Low
Services offered, credits, specialization: MCI Sony sales, service and parts support. Over 50 lines of other professional audio equipment. Complete audio systems design, installation and service.

VESELY MUSIC CO.
EI
1729 E. Charleston Blvd., Las Vegas, NV 89104
(702) 382-8777
Contact: Jaymie Nemes

WESTBROOK AUDIO
SD, AC, SES, EI
11836 Judd Ct., Suite 336, Dallas, TX 75243
(214) 699-1203
Contact: Paul Westbrook

Services offered, credits, specialization: Westbrook Audio is a multi-faceted corporation. Its services include studio design and consultation, audio and video facility construction, equipment sales, service and installation.

As a contractor and leader of studio design in the Southwest, WAI applies new concepts along with 20 years of experience in the recording business, resulting in highly creative and extremely functional facilities.

Westbrook Audio is the choice in studio construction and equipment supply. By having its own building crew, WAI eliminates the risk of losing any attention to detail and is being a representative of over 60 professional equipment lines, selection and quality is of the highest integrity.

SOUTHERN CALIFORNIA

ADVANCED SOUND SYSTEMS
SD, AC, SES, EI
2641 Fontezuela Dr., Hacienda Heights, CA 91745
(213) 333-6629
Contact: Rick Rucio

ALL STAR SOUND & RECORDING
SD, AC, SES, EI
1070 E. Front St., #1, Ventura, CA 93001
(805) 653-6661
Contact: Bob Spittle

AUDIO AFFECTS
SES
P.O. Box 6327, Beverly Hills, CA 90212
(213) 986-9902
Contact: Derra Shelley and Craig Hundley

AUDIO CONSULTANT COORDINATION
SD, AC
c/o A. Englund, 2040 Ave. of the Stars, Suite #400
Los Angeles, CA 90067
(Offices also in Rio de Janeiro and Paris)
(213) 207-1274
Contact: Claude Venet, Martin Paull & Associates

Services offered, credits, specialization: We are architects/engineers/designers/planners specializing in recording studios, theatres and auditoriums. We provide engineering in acoustics, electro and architectural acoustics, sound reinforcement systems, noise and vibration controls.



**audio engineering
associates**

AUDIO ENGINEERING ASSOCIATES
Pasadena, CA

AUDIO ENGINEERING ASSOCIATES
SD, SES, EI
1029 N. Allen Ave., Pasadena, CA 91104
(213) 798-9127
Contact: Wes Dooley, Chief Engineer

AUDIO INDUSTRIES CORP.
SD, SES, EI
1419 N. LaBrea Ave., Hollywood, CA 90028
(213) 851-4111
Contact: Hal Michaels

AUDIO SERVICE CORP.
SES
4210 Lankershim Blvd., North Hollywood, CA 91602
(213) 980-9891
Contact: Mark Chatnisky

AUDIO STUFF
SES
12115 A Woodruff Ave., Downey, CA 90241
(213) 803-1037
Contact: Vince Motel

Services offered, credits, specialization: Audio Stuff warehouses Sonex Sound absorbing foam. We also deal in mixing boards, power amps, signal processing and microphones. We also have pressure zone microphones and PZM experimental models for rent or sale.

RUDI BREUER
SD, AC
635 West Ave., S-14, Palmdale, CA 93550
(805) 273-3792
Contact: Rudi Breuer

CASTLE MUSIC
SES
5796 Calle Real, Goleta, CA 93117
(805) 964-9827
Contact: Ron Resnick

COAST RECORDING EQUIPMENT SUPPLY, INC.
SES
6114 Santa Monica Blvd., Hollywood, CA 90038
(213) 462-6058
Contact: Jerry Cabbage

JEFF COOPER, CONSULTANTS
Architecture/Acoustics/Engineering
SE, AC
22627 Cavalier St., Woodland Hills, CA 91364
(213) 887-9100
Contact: Jeff Cooper

DYNO MY PIANO
SES, EI
P.O. Box 1007, Burbank, CA 91507
(213) 845-7864
Contact: Chuck Monte

Services offered, credits, specialization: Dyno My Piano, famous for Rhodes modifications. Chuck Monte, founder of Dyno, is offering direct to studios his "Signature Series" custom line of Rhodes 73 stage keyboards designed for recording. The Signa-

كوكبة
Creative Studio Design FOR THE Eighties

ARCHITECTURAL ACOUSTICS
DESIGN/CONSULTATION/ANALYSIS

415/459-1675

24 BELVEDERE STREET/SUITE H/SAN RAFAEL/CALIFORNIA/94901

Circle #024 on Reader Service Card

TASCAM 16 TR & 50 SERIES

Pro audio is not measured in dBm, track widths or dollars, but dependability, accountability, and above all, performance.

See how RELIABLE and TASCAM can help improve your sound and your bottom line.

RECORDING STUDIO, BROADCAST AUDIO & SOUND REINFORCEMENT EQUIPMENT.

704/375-8662

Reliable Music

PRO AUDIO DIVISION 1001 S. INDEPENDENCE BLVD. CHARLOTTE, NC 28202

Circle #025 on Reader Service Card

STUDIO DESIGNERS & SUPPLIERS

LEGEND: SD: STUDIO DESIGNER, AC: ACOUSTICAL CONSULTING, SES: STUDIO EQUIPMENT SUPPLY, EI: EQUIPMENT INSTALLATION/MAINTENANCE/SERVICING



FILAMENT PRO AUDIO
San Dimas, CA

FILAMENT PRO AUDIO
SD, SES
143 E. Arrow Highway, San Dimas, CA 91773
(714) 592-2848, (213) 339-0081
Contact: Ken Hopkins, Frank Offensten

JANCO PROFESSIONAL SOUND
SES, EI
3441 30th St., San Diego, CA 92104
(619) 280-7080
Contact: Mr. Emery



JBR SOUND PRODUCTS
Long Beach, CA, Las Vegas, NV; Honolulu, HI

JBR SOUND PRODUCTS
SD, AC, SES
20950 Brant Ave., Long Beach, CA 90810
(213) 638-0349, (213) 636-3403, (714) 975-0248
2627 South Lamb #54, Las Vegas, NV 89121
(702) 457-7277
615 Piikoi St., Ste. 104, Honolulu, HI 96814
(808) 526-1358
Contact: John Rudy

Services offered, credits, specialization: John B Rudy Company is one of the West Coast's largest distributors of wire and cable products. Family-owned and operated, John B Rudy Company has been serving major business and industry since 1947. JBR Sound Products, a division of John B Rudy Company, draws on the expertise and resources of John B Rudy Company to provide you with a full line of audio and video products and services. John Rudy heads an experienced staff of audio and video specialists offering professional services, creative advice, and competitive pricing. JBR Sound Products offers acoustic consulting and studio design along with an extensive line of audio, video, wire, and cable for your studio needs. Our custom cable construction includes snakes, microphone cords, patching cords, stripping, respooling, and computer cable assemblies.

LA SOUND CO.
SES
12547 Sherman Way Unit F, N. Hollywood, CA 91605
(213) 765-6900
Contact: Richard Rakke

LAKESIDE ASSOCIATES INC.
SD, AC, SES, EI
27939 Chiclana, Mission Viejo, CA 92692
(714) 855-3171
Contact: Sieve Fouce, Carl Yanchar



DYNOMY PIANO
Burbank, CA

ture Series modifications include in-board EQ, dual chorus Tri Stereo-Tremelo™, balanced outputs, EMI/RFI shielding, ultimate support leg system your choice of red white blue black and beige Tolex covering, flight case vinyl cover and personalized



DYNOMY PIANO
Burbank, CA

brass engraved name-plate. New product release Tri Stereo Chorus, rack mount studio quality chorus/flanger. Offers two speed controls, three waveform intensity, stereo balance outputs.

EVERYTHING AUDIO
SD, AC, SES, EI
16055 Ventura Blvd., #1001, Encino, CA 91436
(213) 995-4175
Contact: Brian Cornfield

F ALTON EVEREST
Registered Consulting Engineer
SD, AC
6275 South Roundhill Drive, Whittier, CA 90601
(213) 698-8831

Realize Your Dream

If you want to build your own recording studio, we can help. 4,8,16 or 24 tracks. Over 70 lines of professional audio equipment to choose from. We stock the best and ignore the rest!

You can count on quality... you can count on us. OTARI, JBL, CROWN, DBX, AKG, RAMSA, SOUNDCRAFT, LOGEX 8, SHURE, DELTALAB, MICMIX, MXR, QUANTUM, TASCAM, BEYER, AUDIO-TECHNICA, VALLEY PEOPLE, LEXICON, QSC, SESCON, EXR, FOSTEX, SENNHEISER, COUNTRYMAN, and 50 more to choose from.

You can also realize your dream in our in-house recording studio. 8,16,24 track recording. Sound as good as you know you should!

NEW WORLD

4877 Mercury Street, San Diego, California 92111
Professional Audio Sales 1 800-854-2005 (except CA) 1-714-569-1944
Recording Studio (bookings) 1 800-854-2006 (except CA) 1-714-569-7367

Circle #026 on Reader Service Card

STUDIO DESIGNERS & SUPPLIERS

LEGEND: **SD**: STUDIO DESIGNER; **AC**: ACOUSTICAL CONSULTING; **SES**: STUDIO EQUIPMENT SUPPLY; **EI**: EQUIPMENT INSTALLATION/MAINTENANCE/SERVICING

LANE AUDIO & RECORDS
SD, AC, SES, EI for *Sonic Restoration only*
P.O. Box 29171, Los Angeles, CA 90029
(213) 469-8007
Contact: M R Lane

MARCOM
SES
21243 Ventura Blvd., Suite 145, Woodland Hills, CA 91364
(213) 703-0381
Contact: Doug Howland

NEOTEK WEST
SES, EI
4007 W. 6th St., Los Angeles, CA 90020
(213) 387-7999
Contact: Lincoln Zimmanck or Lon LeMaster

NEW ERA WOOD WORKS
SD, AC, EI
14851 Aetna St., Van Nuys, CA 91411
(213) 785-3358
Contact: Dick Pyles

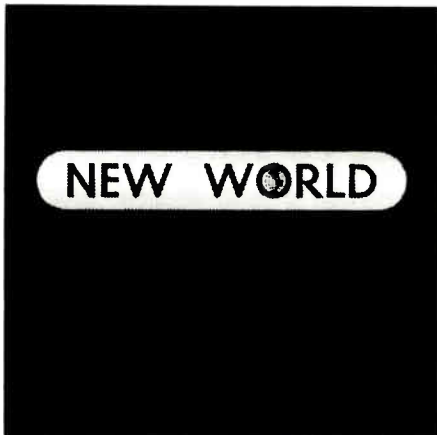

NEW WORLD AUDIO, INC.
San Diego, CA

NEW WORLD AUDIO, INC.
SD, AC, SES, EI
4877 Mercury St., San Diego, CA 92111
(619) 569-1944
Contact: Jim Scott

PERCEPTION INC.
SD, AC
P.O. Box 39536, Los Angeles, CA 90039
(213) 938-5271

Contact: G L Augspurger
Services offered, credits, specialization: This consulting group is headed by well-known acoustician and studio design expert George L. Augspurger. His wide experience with commercially successful TV, film and recording studios covers every major record label as well as the most prestigious independent studios. Projects currently underway include four major recording complexes, a number of studio remodeling designs, acoustical consultation for auditoriums and film sound stages, two TV sweetening room designs, and acoustical corrections in three existing studios. Perception Inc. provides professional consulting and design services to architects, builders and studio owners; it has no association with any contractor or equipment supplier. In addition to studio design services and acoustical consultation, the company provides extensive acoustics testing capabilities. Mr. Augspurger is a member of the Audio Engineering Society, Acoustical Society of America, U.S. Institute for Theatre Technology, American Theatre Association and National Council of Acoustical Consultants.

PRO SOUND & LIGHTING
Div. of The Wm. Dettman Co.
SES
17875 Beach Blvd., Huntington Beach, CA 92648
(714) 891-7330
Contact: Bill Dettman, Mike Dimatto
Services offered, credits, specialization: Rentals and sales of

Tascam Portastudio, 4 & 8 track and studio cassette decks, Studio-master mixers, Shure and E.V. mikes and accessories, Technics turntables, MXR and Furman signal processors, monitors, power amps, wireless systems, complete rehearsal systems, lighting systems, lamps and gels, Anvil cases. Daily, 3 day, weekly, monthly rentals. 100% of all rentals apply towards purchase. Phone for free brochure (714) 891-7330, Mon - Fri 10 - 7, Sat 10 - 2.

Professional Audio Services & Supply Company

PROFESSIONAL AUDIO SERVICES & SUPPLY COMPANY
Burbank, CA

PROFESSIONAL AUDIO SERVICES & SUPPLY COMPANY
SES, EI
99 E. Magnolia Blvd., Suite 215, Burbank, CA 91502
(213) 843-6320
Contact: Bob Hacken

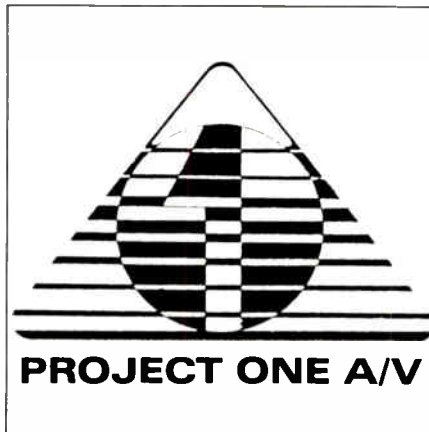

PROJECT ONE A/V
Hollywood, CA

PROJECT ONE A/V
SES
6669 Blvd. Crossroads of the World, Hollywood, CA 90028
(213) 464-2285

Services offered, credits, specialization: Professional audio/video tape supply—authorized dealer for Aclat, Ampex, Scotch, Maxell, TDK. Distribute short-length, normal, and high-bias cassettes, 2" mastering tapes, 1/2", 3/4", 1" video tape, 3M editing supplies, 12 colors of pressure sensitive cassette labels, and a lot more.

Also offer fine audio and video duplication. For catalog and samples send \$1. We ship everywhere from stock at super competitive prices. For studios we offer special accommodation pricing on all tape products.

SCOTT PUTNAM
Studio Design and General Contractor
SD, AC
7345 Cantaloupe Ave., Van Nuys, CA 91405
(213) 786-8288

SALES & SERVICE

JH-24 SERIES

PROFESSIONAL 24-TRACK AUDIO RECORDER

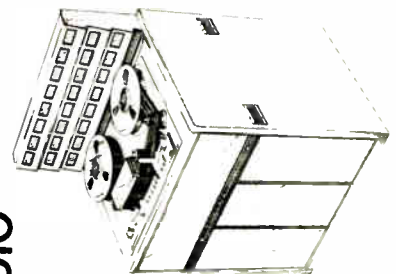

MCI



Model shown: JH-24 w/standard system remote control and optional Auto-Locator III mounted to JH-20 Accessory Stand

**SOUTHWEST
PRO AUDIO**
BRANCH OFFICE
DALLAS, TEXAS
214 271-2300
1500 SUMMIT ST.
AUSTIN, TEXAS 78741
512 443-4567

TOLL FREE • TOLL FREE
TEXAS
800-252-7014
800-531-5113

Circle #027 on Reader Service Card

STUDIO DESIGNERS & SUPPLIERS

LEGEND **SD** STUDIO DESIGNER **AC** ACOUSTICAL CONSULTING **SES**: STUDIO EQUIPMENT SUPPLY, **EI**: EQUIPMENT INSTALLATION/MAINTENANCE/SERVICING

MICHAEL RETTINGER
SD, AC
5007 Haskell Ave., Encino, CA 91436
(213) 784-3985
Contact: M. Rettinger

ROLLS ELECTRONIC CORP
SES
4260 Lankershim Blvd., W. Hollywood, CA 91602
(213) 877-8877
Contact: John Tait

SHORELINE LTD. TELEPRODUCTIONS SYSTEMS
SES, EI
3459 Cahuengo Blvd. West, Los Angeles, CA 90068
(213) 851-1236
Contact: Tom Giann

SIERRA HIDLEY DESIGN
SD, AC, EI
721 So. Glenwood Place, Burbank, CA 91506
(213) 843-8200; Tlx: 662745 (K Duncan)
Contact: Kent Duncan
Services offered, credits, specialization: Sierra Hidley Design has completed over 325 studios on six continents. Projects underway include Atlantic Records New York City, a 4th project for Danish radio, Copenhagen, a 16th studio for CBS-Sony in Hong Kong, Center TV in Hong Kong, Studio South in Austin, mobiles for Danish radio and Reelsound in Texas. From Caribou Ranch to Kendun Re-orders, can you afford not to take advantage of the experience?

SIGNAL ELECTRONICS
Div. of S E Electronics
SES, EI
22307 Ocean Ave., Torrance, CA 90505
(213) 378-5277
Contact: J A Gagnon

SMITH, FAUSE & ASSOCIATES, INC.
AC
2049 Century Park East, Suite 550, Los Angeles, CA 90067
(213) 552-9875
Contact: Howard Smith, Kenneth Fause

SOUND ADVICE
SD, AC, SES, EI
7611 Slater Ave., Suite N, Huntington Beach, CA 92647
(714) 842-2213
Contact: David Kennedy

SOUND ADVICE, INC.
SD
P.O. Box 278, Cazadero, CA 95421
(707) 632-5911
Contact: Tom Kraus

THE SOUND SOLUTION
SES, EI
1211 4th St., Santa Monica, CA 90401
(213) 393-5332
Contact: David Epstein

SOUND UNLIMITED SYSTEMS
SD, AC, SES, EI
6315 Laurel Canyon Blvd., N. Hollywood, CA 91606
(213) 506-8216
Contact: Ed King

SPEAKER REPAIR OF CALIFORNIA
EI
4334 Sunset Blvd., #2, Hollywood, CA 90029
(213) 666-4161
Contact: Stephan Christoffersen
Services offered, credits, specialization: McIntosh, Hewlett Packard, L D J Electronics, B + K custom paging and intercom designs. Services speaker re-coning, rebuilding, tailoring magnetization. Costs approx \$3.50 - \$9 per cone-inch. Senda by UPS freight. Free return after 3 day cleaning, glueing, re-centering and latquino process. Clients include: Rod Stewart, Frank Zappa, The Who, Stanley Clarke, Heider Studios, Glen Glen Sound, The Record Plant.

STUDIO MAINTENANCE SERVICE INC.
SD, AC, SES, EI
12458-60 Magnolia, N Hollywood, CA 91607
(213) 877-3311
Contact: Dave Michaels

SUNTRONICS
SES
7760 Balboa Blvd., Van Nuys, CA 91406
(213) 781-2537, 781-2604
1620 W. Foothill Blvd, Upland, CA 91786
(714) 985-0701, 985-5307
7560 Garden Grove Blvd., Westminster, CA 92683
(714) 898-6368, 898-9036
11151 Pierce St., Riverside, CA 92515
(714) 359-6058, 359-5102

SYE MITCHELL SOUND CO., INC.
SD, AC, SES, EI
22301 Cass Ave., Woodland Hills, CA 91364
(213) 348-4977
Contact: Sye Mitchell

VIDEO SYSTEMS NETWORK
SD, AC, SES, EI
12530 Beatrice St., Los Angeles, CA 90066
(213) 306-4675
Contact: Bob Daly

VJ ELECTRONICS, INC.
SES, EI
913 W. 223rd St., Torrance, CA 90502
(213) 533-5980
Contact: I. Mark Wilkinson

WESTLAKE AUDIO
SD, AC, SES, EI
7265 Santa Monica Blvd., Los Angeles, CA 90046
(213) 655-0303
Contact: Glenn Phoenix

OUTSIDE THE U.S.

AUDIOTECH ACOUSTICS
AD, AC
4 Budgell Terrace, Toronto, Ontario M6S 1B4 Canada
(416) 769-9641
Contact: Terry Medwedky
Services offered, credits, specialization: Audiotech specializes in the acoustic design of control rooms, studio and related facilities. We also consult on facility planning, layout, construction and interior finishes. We provide acoustic tuning services and analysis of control rooms and monitoring systems. Recent projects have ranged from private home studios to multi-studio facilities. Other consultations have included community colleges and churches. References are available upon request.

COMMERCIAL ELECTRONICS LTD.
SES
1335 Burrard St., Vancouver, B.C. V6Z 1Z7 Canada
(604) 669-5525
Contact: David Brown

ERIKSON MUSIC RECORDING
Division of Jam Industries Ltd.
SES
378 Isabay, St. Laurent, Quebec H4T 1W1 Canada
(514) 738-3000
Contact: Eddy Shenker
Services offered, credits, specialization: Exclusive Canadian distributor for Fostex personal multitrack.

GERR ELECTRO ACOUSTICS LTD
SES
363 Adelaide St. E., Toronto, Ontario M5A 1N3 Canada
(416) 868-0528; Telex: 065-24385
Contact: Gerry Eschweiler, General Sales Manager
Services offered, credits, specialization: Supplying and servicing the audio production and broadcast industries. Special services include production and multitrack studio design and installa-

Fostex

PERSONAL MULTITRACK

ERIKSON MUSIC RECORDING
Quebec, Canada

tion, live media theatre sound and communications systems, wireless microphone and wireless intercom rentals, and custom products. Manufacturers represented: Audio Kinetics Audio + Design, Diskmix, HME, Lexicon, Meyer Sound Labs, Midas, Otari, MTR, RTS, Satt Electronics, Sound Workshop, Tannoy, UREI, and many more.

JACKSON MUSIC LTD
SD, AC, SES, EI
The Studios, Rickmansworth, Herts, England
0923-772351
Contact: Malcolm Jackson

KEEN KRAFT MUSIC LTD.
SES
1505 - 17th Ave. S.W., Calgary, Alberta T2T 0E2 Canada
(403) 244-5555
Contact: Dwayne Wells/Kevin Gilbert
10204 - 107th Ave., Edmonton, Alberta, Canada
(403) 423-4448
Contact: Peter Janus/Earl Cameron

MUSIC EQUIPMENT SALES
SD, AC, SES, EI
34 Parkdale Ave. N., Hamilton, Ontario L8H 5W8 Canada
(416) 545-0404
Contact: Bill Longley

Services offered, credits, specialization: Music Equipment Sales offers studio design and acoustic consulting services for the musician or organization just now entering the world of controlled sound. Our cost effective and practical methods yield professional results anyone can afford. M.E.S. supports studio design with products from TEAC/Tascam, Fostex, Soundcraft, Ramco, Biamp Systems, AKG Audio Technica, Aphex, dbx, DeltaLab, Klipsch, Electro Voice, Symetrix, K & M, Neutrik, Switchcraft, BGW, Loft, Alter Lansing, HH Electronics, Studiomaster, OSC, Crown, Shure, Koru, Roland, Belden, Gotham Cable, Cetec-Gauss, Lexicon, Rekus-Heinz, Tapco, MXR, Ampex and 3M tape, Klark Teknik, Goldline. Let Music Equipment Sales help you choose the best equipment to fit your application and budget. The right solution doesn't have to be expensive. Our commitment extends to include complete installation and maintenance of all our clients' equipment.

Please note:

On page 59 of last month's issue (Vol. 7, No. 7) the toll free number for **Southwest Pro Audio** was incorrectly listed. It should have been **800/531-5113** (outside Texas)

Correction:

In the June issue in Preview, the Crown PZM 2.5 was incorrectly listed at \$259. That should have been \$369.

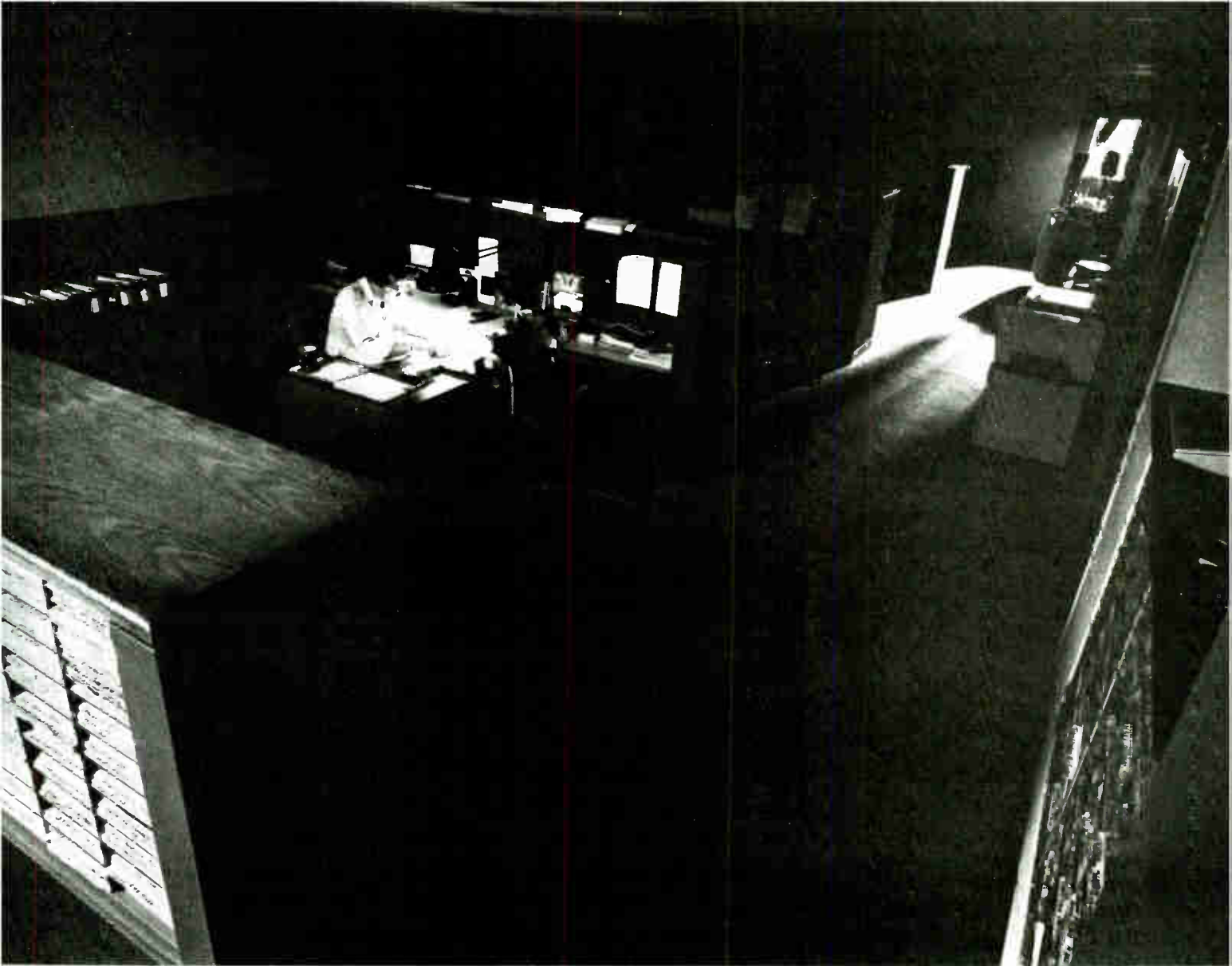

Like all of our people, Mike is a self-starter. Getting him to stop is another story.

You may not know us firsthand, but you've probably heard of our reputation for the kind of people who just won't stop until the job is done *right*.

And we back up our hardworking people with an unusually wide range of products at competitive prices, unprecedented parts support and our unique demo facilities.

Today, Martin is regarded by most professionals as the number one studio equipment dealer in the country. And while being the biggest may be great, being known as the best is even better.

 **martin audio** ... Put us to work for you.

Martin's comprehensive product range includes: Harrison Systems, Otari MTR Series, Sound Workshop, AD&R/SCAMP, AKG, Ampex, Aphex, ATI, Audioarts, Auratone, Beyer, BGW, BTX, Calrec, Clear-Com, Crown/PZM, CS, dbx, dbx/digital, Deltalab, Denon, DISKMIX, Dolby, Ecoplate, E.V. Eventide, Fostex, H/H, HME, Klark, Teknik, JBL, Lexicon, LinnDrum, Marshall, McIntosh, Micmix/Master Room, MXR, Neumann, Orban, Otari, Ramsa, RTS, Sennheiser, Shure, Simon Systems, Sony Pro Audio, Sony Video, Studer/Revox, Tannoy, TASCAM, Technics, 360 Systems, UREI, Ursa Major, Valley People, Visonik, White, Yamaha, and many more. **Martin Audio-Video Corp.**, 423 W 55th Street, New York, NY 10019 (212) 541-5900 Telex 971846

Circle #110 on Reader Service Card

World Radio History



PHOTOS: DAGS GRINBERGS



by Bruce Pilato

BEARSVILLE STUDIOS



Whenever the word "Woodstock" is mentioned, certain distinct images often come to mind. The word has become synonymous with the youth movement of the late 1960s and the huge rock festival which brought

600,000 men, women and children together for three days of "love, fun and music." It is also the name of a small town, established in 1902, which has always been a haven for artists.

Tucked in a valley between the Hudson River and the Catskill Mountains, the scenic resort-like area became a home for myriad great musicians of the '60s and '70s, including Bob Dylan, The Band, Todd Rundgren, Paul Butterfield and Jimi Hendrix. It is estimated that 10% of the 6,800 people who live in the Woodstock area are professional musicians.

Close to Woodstock is the even smaller town of Bearsville, whose most famous resident is Albert Grossman. Next to Brian Epstein, Grossman was the most important rock manager of the '60s, best known for his direction of Dylan, The Band and Janis Joplin, among others. After Joplin's death in 1970, he eased out of managing and set up Bearsville Records. In that same year, he opened Bearsville Recording Studios.



Last year, Grossman decided it was time to upgrade the studio in order to compete with the big rooms in New York City and Los Angeles. After six months of planning and another six months of reconstruction,

Grossman has put together one of the best state-of-the-art recording studios in the U.S.

"The cycle came around and we were starting to get outdated in a couple of areas," according to Griff McGree, the studio's manager for the last six years. "So we decided to change the entire control room, to increase the size for the comfort of our clients and make it symmetrical."

Prior to working for Bearsville, McGree

managed The Record Plant in New York and worked for D.I.R. Broadcasting, as well as many other studios. Years of working in studios had taught him that a major change was needed, not only in the structural design of the control room but also in the interior of the main studios. In addition, the entire complex (both studios A and B) would need to be outfitted with new equipment.



On the recommendation of chief engineer Ken McKim, noted audio consultant and architect George Augspurger was brought in to design the new plan. Together, the three of them, under the watchful eye of

Grossman, put it all together.

Studios A and B are housed in the original building built by Grossman in 1970. At that time a nearby barn had been converted to a rehearsal studio and the large farmhouse next door was remodeled in order to house visiting musicians and their families.

The new plan included adding a wing to the farmhouse for offices, saunas, hot tubs, showers, an exercise room and a lounge to increase the comfort level. Tie lines between the rehearsal barn and the new studio were laid and a video communications chain was added.

Despite a series of ultra-successful albums which came out of the original studio, such as Meatloaf's *Bat Out of Hell*, platinum albums by the Isley Brothers and hit LPs by The Tubes, Patti Smith and The Band, the room is now better suited for the sound demands of contemporary artists.

Both McGree and McKim credit Augspurger with much of the new complex's success. According to McGree, the new control room needs no "equalizers at all. It lets the speaker work to its maximum efficiency. It came out dead nuts on the money - I think that's rare these days."

page 54

Pictured above: Studio A and (inset) outside of studio building

STEREO IMAGING

DISPERSION

PHASE ALIGNED

PORTABLE

EXPENSIVE

ACCURACY—NOT FLATTERY

Knowing exactly "what's on the tape" is of paramount importance to the professional recording engineer and producer. Unfortunately, many recording, mixing, mastering and listening rooms are less than ideal, making truly accurate monitoring difficult.

For over a decade, permanently installed Westlake Audio studio monitors have been the worldwide choice of professionals who demand accurate reference monitors. Now, that same precision is available in the Westlake Audio BBSM series of Portable Reference Monitors.

The BBSM's pinpoint stereo imaging, wide bandwidth, totally symmetrical polar pattern and coherent wave front, even when monitoring as close as 18 inches, are a result of a unique combination of drivers, crossover and mounting configuration. Best of all, this has been achieved in a size that makes these Reference Monitors easy to carry with you from studio to studio.



BBSM-6F



BBSM6

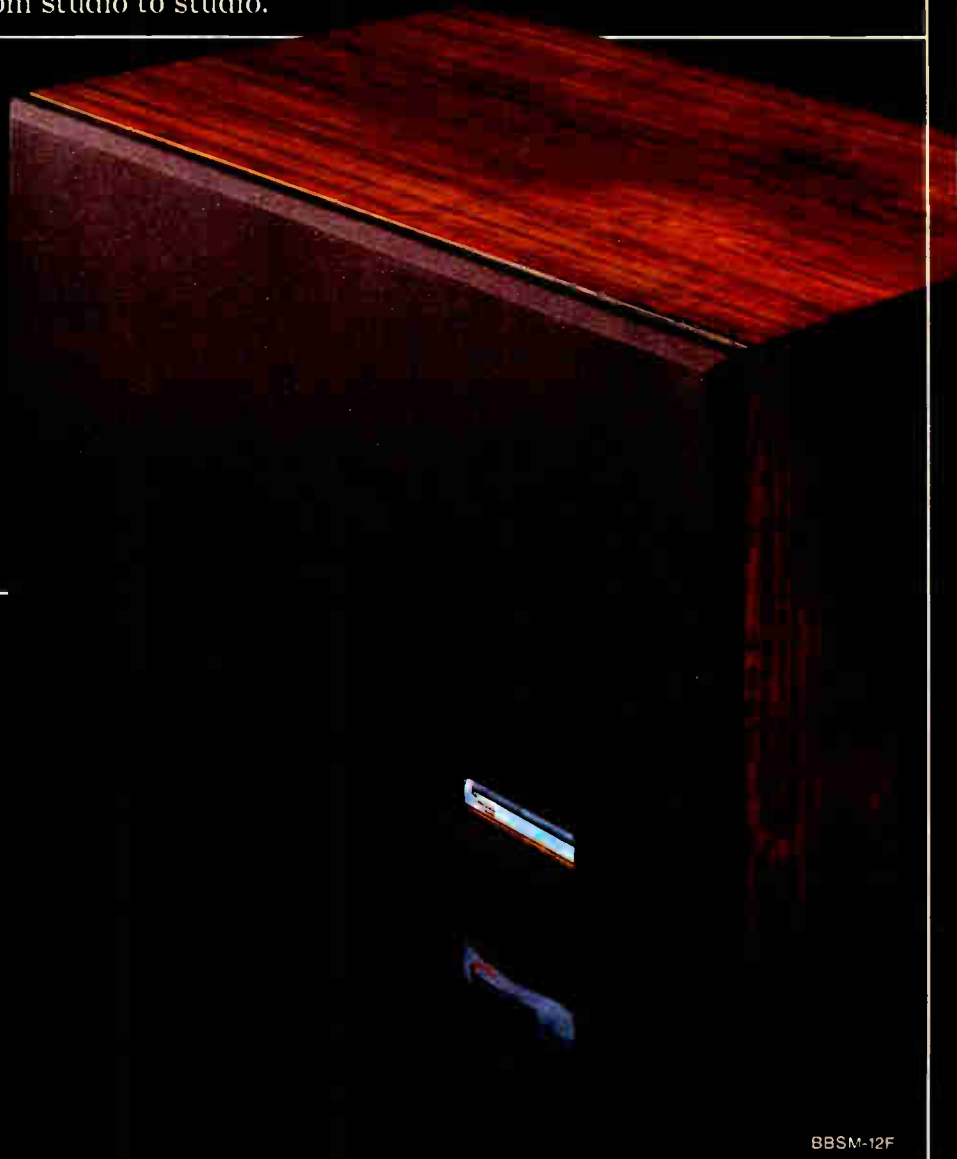

BBSM-12F

from acoustic design
to down beat...

**Westlake
Audio**

Manufacturing Research
and Development
2696 Lavery Court, Unit 18
Newbury Park, California 91320
(805) 499-3686

Circle #029 on Reader Service Card

World Radio History

Augsburger had definite goals in mind when he took on the project last year. He wanted to achieve optimum geometry between the monitor speakers and the board; convenient access to tape machines and outboard gear; comfortable seating in the rear of the control room; and acoustic treatment which allowed final tuning without rebuilding the room.

"I believe very strongly there is no one design approach that is right," said Augspurger from his office in Los Angeles, "until you've tried some others." He then told McGree and McKim to "slow down" while he developed four completely different designs they could consider before selecting a final plan.

After ten years in product development and marketing with JBL, Augspurger went into business for himself in 1971 as a private audio consultant. He has since become one of the country's leading audio architects and has at one time or another worked on most of the major studios both in the U.S. and abroad.

When a plan was finally chosen, Grossman's in-house construction crew followed the design to within 1/16 of an inch. Augspurger never supervised the job; yet, when he returned four months later to tune the room, he was amazed to find everything checked out perfectly.

One of the studio's highlights is its ability to alter the room acoustics to yield either a bright or flat environment. This was achieved by constructing movable vertical panels which slide out and can be placed on top of one another.

"As trends changed," explained McGree, "we realized there was a need to brighten up the sound. In years past, people were after a flat or non-reverberant sound. We made the walls so you could have either a reflective or absorptive surface, or any combination therein."

The trio also decided not to equip the studio with digital recorders at this time, and instead opted for the height of analog equipment.

"As of right now," said Augspurger, "permanently installed digital equipment is only fine if you're someone like Stevie Wonder who gets involved in projects that you know are going to be *all* digital. For a commercial studio which has to cater to a variety of people right now, the state-of-the-art analog stuff sounds as good as digital, if not better. It's been demonstrated in a number of tests. The big advantage in digital right now is in tape deterioration and things like that. There's no question that digital is going to be the recording medium of the future, but because there is very little standardization and such a wide variety of approaches right now, I think a studio is

smarter to have outboard digital gear available or have a source where they can input digital gear, but to stick with analog for another 3 or 4 years."

Among the new equipment selected for the room was a Neve 8068 32 input console, UREI 813A monitors, and the EMT 251 microprocessor-controlled digital reverberation system. Studer 24 and 2 track recorders were chosen to complete the package.

Bearsville Studios' picturesque location sets it apart from other studios. The beautiful countryside with green pastures and bubbling brooks adds a certain irresistible edge. Another advantage lies in the fact that the studios are located within driving distance (2 hours) from New York City. "We see less transient traffic than you see in New York City," said McGree. "Clients usually come up here and devote themselves for a month or six weeks." Lodging in the farmhouse is a mere \$20 per day.

"The big advantage," Augspurger agrees, "is the location. From my standpoint, that control room is a state-of-the-art control room. Some people are going to like it better than others, but I don't think there is anybody who could walk into that room and say, 'This is not a good room.' It is a good room. So when you get that kind of a room in a relaxed location... this gives them a very nice package to offer."

Meyer Sound

Introducing the Meyer Sound 833 Studio Reference Monitor*

* Patents applied for

Acoustical Specifications:
(with power amplifier rated at 250 watts per channel continuous into 8 ohms)

Frequency Response	35-18,000 ± 3dbHz
System Time Delay (including electronics)	± 350us. 100-20,000Hz ± 25 us. 2,000-20,000Hz
High Frequency Dispersion	
Vertical	40 degrees
Horizontal	80 degrees
Maximum SPL	
Continuous	120 dB
Peak	130 dB
List Price (two loudspeakers and control electronics. Amplifier not included)	\$4,950.

Meyer Sound Laboratories Inc.
2194 Edison Ave.
San Leandro, CA 94577
415/569-2866

Meyer Sound

IT'S OUR DIME...

ACCESSIT
EVENTIDE
PROTON
AMPEX
OTARI
FUJI
JBL
AKG
SHURE
CROWN
NEOTEK
SENNHEISER



CANFORD CABLE
McINTOSH
ORBAN
RAMSA
UREI
E-V
ADS
DBX
BEYER
TASCAM
MICMIX
TANDBERG

USE IT!

Sales • Service • Design • Consultation

1(800)558-0880

For all of your audio/video needs we
stock the most sought-after products
at nationally competitive prices

FLANNER'S PRO AUDIO, INC.

Serving The Recording & Broadcast Industries

Circle #031 on Reader Service Card

The best sound. The most features. The original.



LinnDrum – the programmable digital drum machine with studio quality sounds. Listen to the long, deep noiseless toms – the crisp, sizzling, long-sustaining cymbals and hi hat – the punchy bass and snare – and clear, well-recorded percussion.

Add to this LinnDrum's ease of operation, flexibility, and attention to detail and it's no wonder that for recordings and live performance LinnDrum is the overwhelming choice of professionals worldwide.

Consider these features: (Features in red are available only on LinnDrum.)

- **Studio quality noiseless digital recordings of real drums stored in computer memories** – ride and crash cymbals, bass, snare, sidestick snare, open and closed hi hat, 3 toms, 2 congas, cabasa, tambourine, cowbell, and hand claps.
- **Exclusive circuitry permits long sustain time and extended high frequency response** – especially noticeable on crash and ride cymbals, hi hat, toms, and snare.
- **NEW! 98 rhythm patterns** – all programmable in real time with adjustable error correction.
- **2600 note (event) internal programming capacity.**
- **16 volume and pan controls** – one for every drum.
- **16 individual output jacks** – one for every drum.
- **"Shuffle" or "swing" feel may be adjusted on existing rhythm patterns (including presets).**
- Any time signature may be used.
- Dynamics are programmable.
- **Drums are tunable by front panel controls and by control voltage inputs.**
- **NEW! Large library of user-changeable plug-in drum sound chips.** Includes all popular drum sounds, a wide variety of percussion instruments, and special effects. Most chips cost only \$40 (USA).
- **NEW! Custom sound chip service.** Linn Electronics will convert customer-supplied tapes into custom plug-in sound chips. Most sounds cost only \$40 (USA).
- Hi hat decay adjustable on front panel.
- In "song" mode, complex arrangements may be easily constructed – internal capacity is 49 songs.
- **5 trigger inputs enable all drums to be directly triggered by drum synthesizer pads, tape tracks, or any audio source.**
- **Programmable trigger output enables external synthesizer sounds to be programmed into rhythm patterns.**
- **NEW! Digital tempo readout in beats-per-minute, and frames-per-beat.**
- Will sync to tape/synthesizers/sequencers.
- Programmed data is retained with power off. May also be stored on cassette tape.
- Simple, musician-oriented operation.
- Size: 11 3/8" x 22" x 4 3/8".

Shop around and compare, then buy the real one – LinnDrum from the inventors of the digital drum machine:

Linn

LINN ELECTRONICS, INC.
18720 Oxnard Street
Tarzana, California 91356
(213) 708-8131

Call or write us for a free demo record and color brochure.

Circle #032 on Reader Service Card
World Radio History

PART II

DIGITAL DISCUSSIONS

A DIGITAL AUDIO SYSTEM

We are almost there. Our monthly discourses on diverse digital topics such as number systems, flip flops, microprocessors, memory, programming, sampling and quantizing, and conversion have brought us to within striking distance of a completed design. I think that you'll be pleasantly surprised to see how easily these topics can be consolidated into a system which can digitally store or process any analog audio signal, and transform the data back into analog material suitable for human hearing. Our design will be more conceptual than practical, but that last transition isn't anything that a lot of money can't accomplish. The important thing is that we have rather quickly reconciled the elements which comprise a digital audio system, and de-toothed a lot of the fears which some people persist in attributing to digital audio. But let's not celebrate prematurely - there are still two more pieces to consider.

We have examined the concept of sampling, and seen how circuit designers have devised methods to convert an analog signal into a digital word. However, the idea of a sampled input must be properly interfaced with the hardware A/D, with a simple yet crucial piece of additional hardware known as a sample-and-hold (S/H) circuit. Specifically, the S/H circuit must pick an analog voltage and retain it while the A/D performs its conversion. Without the S/H, the input to the A/D would continuously (analogly) change and the converter could never output its data. Fortunately, a S/H is a piece of cake. The world's simplest S/H is shown in Fig. 1. Essentially, its only function is to acquire an input signal and track it until it is instructed to hold the signal, and retain this value of the input signal until it is again instructed to change mode.

The problem with our simple circuit is that it causes too much source and output loading. The capacitor also tends to lose its charge rather quickly, causing a voltage droop in the held value. Thus, a more practical S/H circuit requires some modification. A JFET input op amp follower is usually used on the output and the device's extremely high input impedance helps to preserve the capacitor's charge. The switch usually finds incarnation as a JFET chosen to operate as cleanly and accurately as possible to minimize an unevenness in the sampling called aperture jitter. In addition, source loading problems leading to slow response time must be solved by placing a buffer amplifier before the

sampling switch; the input is isolated from the holding capacitor, and the buffer amplifier provides the capacitor charging current. Finally, to hold the line on droop, capacitors made of polycarbonate, polyethylene, or Teflon dielectric are used. Thus, we have devised a S/H with input and output buffering, accurate storing capabilities, and external switching control. But for our purposes, let's throw in one more trick.

In terms of our digital system, the S/H accepts the audio analog input and relays its held value to the A/D. It is the A/D, or more probably, the host

computer, which tells the S/H when to hold, and for how long. For A/D conversion we would like to further modify the S/H because the input voltage variations during the conversion time can exceed the resolution of the A/D. Thus we add one more switch as shown in Fig. 2. We sample by closing switch A for a duration smaller than the conversion time to charge the capacitor C to the input voltage. At the end of the conversion time, switch B is closed to discharge C and thus prepare for another sample. Remember that this opening and closing of switches all takes place so we can hold an analog voltage for a

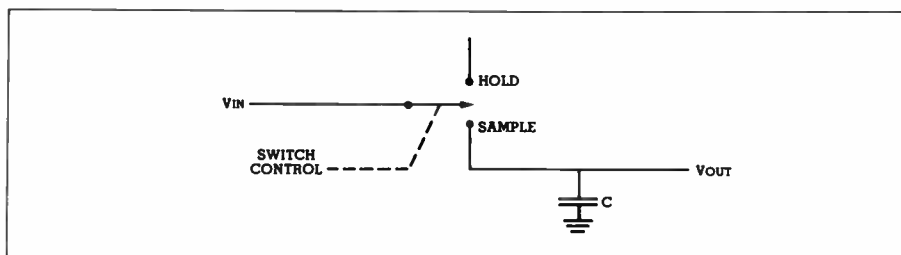

Fig. 1: Simple sample-and-hold circuit

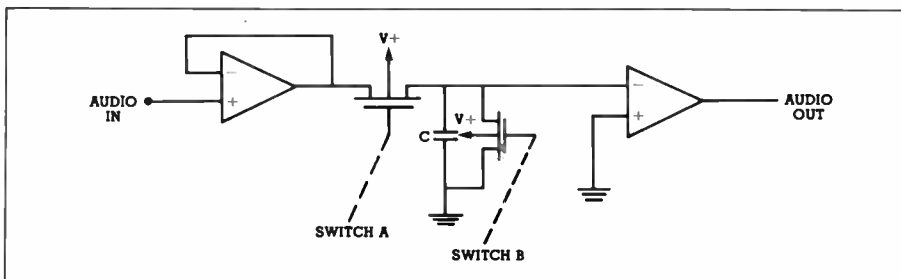

Fig. 2: A practical sample-and-hold circuit

very short time, while the A/D does its work. The output of the S/H is thus an intermediate signal, a discrete staircase of the original analog signal, but still not a digital word. In general, sample-and-hold circuits perform their function quite innocuously. The designer must only be careful to choose a device with appropriate bandwidth and aperture times.

The final pieces in our digital design form a preface and postscript to our system. In our discussion of sampling, we noted the importance of the Nyquist rate and the fact that any digital system must be bandlimited to at least half of its sampling frequency. Thus, a system sampling at 44 kHz must limit its audio input to 22 kHz, at most. Obviously, we need some sort of lowpass filter here, and hopefully one with a sharp characteristic so that we may extend the usable audio bandwidth as far as possible, and one which introduces as little phase funny business as possible.

There are a number of contenders for this job. Some of the favorites are the types corresponding to the Bessel, Butterworth, or Chebyshev polynomials. An ideal filter would offer a flat passband and a brick wall leading to an infinite loss stopband, with linear phase throughout. For a given filter order the Chebyshev lowpass gives a closer approximation to the ideal filter characteristic than the Bessel or Butterworth, at the price of some ripple in the passband. A sixth-order Chebyshev lowpass filter is shown in Fig. 3, and general amplitude and phase plots of a Chebyshev design are shown in Fig. 4.

As you can see, the results improve dramatically with the filter's order. Commercial digital systems might employ a ninth-order Chebyshev filter. Whichever design is chosen, and whatever order, the intent remains the same – to bandlimit the input audio frequency before it enters the digital system.

Perhaps surprisingly, a second filter is placed at the output of a digital system. Although the reason can be intuitively observed, the underlying basis involves some highly interesting mathematics; we might look at it both ways.

Mathematically, a very curious situation arose as we sampled the audio signal. Specifically, we multiplied the time domain audio signal with the time domain sampling (pulse) signal. In terms of the spectrum of these two signals, this convolution has produced a new sampled spectrum identical to the original unsampled spectrum. However, the spectrum is infinitely repeated across the frequency domain at multiples of the sampling rate. To convert this sampled information back into analog information, we must destroy all of the look-alike spectrums, leaving only the

frequency-correct one. This is accomplished by lowpass filtering the output of the D/A converter.

On a more intuitive level, think of the staircase function leaving the D/A – just as the output of the S/H was an intermediate staircase function, the output of the D/A must be converted one more time. Those stairsteps comprising the analog signal occur as high frequencies compared to the desired audio signal. The answer is, once again, to strip away the high frequency stair steps, using a lowpass filter at the end of the digitizing signal chain. And with this filter firmly in place, we have arrived at a complete digital audio system design.

A block diagram of our digital system is shown in Fig. 5. I think the simplicity of the diagram both illustrates the straightforward elegance of digital processing, and obscures the high-powered technology required to prac-

tically realize such designs. But technology is cheap, and getting cheaper. The important point is the incredible utility of our design. Such a system can translate any acoustic (or electrical) audio signal into the digital domain, and store the signal as binary data. Whether the storage medium is tape, disk, or cartridge, and the mechanism is magnetic or laser optical, we have put the signal in a long-lasting and virtually error-free environment. Signal processing becomes greatly facilitated—any mixing or manipulation involves only software interaction with the stored data—any processing mathematically conceivable could be programmed, and the data correspondingly transformed.

Editing likewise takes on new dimensions—upon command any piece of data may be linked with any other piece—edits may be previewed, and the data subsequently put back in any con-

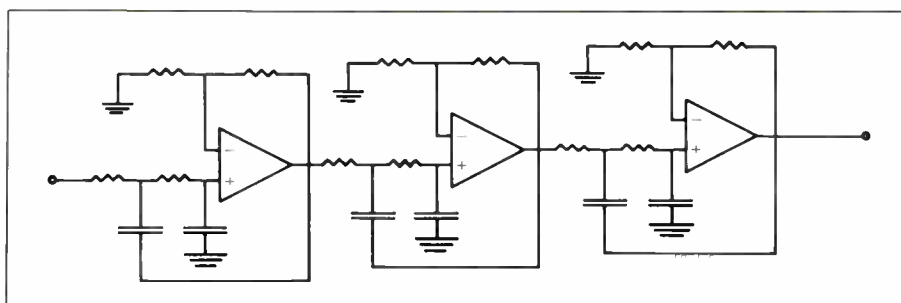

Fig. 3: Sixth-order Chebyshev filter

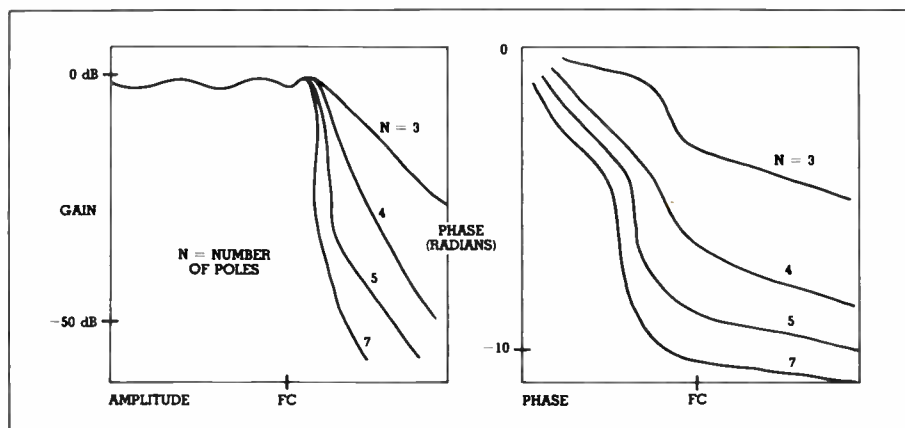

Fig. 4: Chebyshev filter characteristics

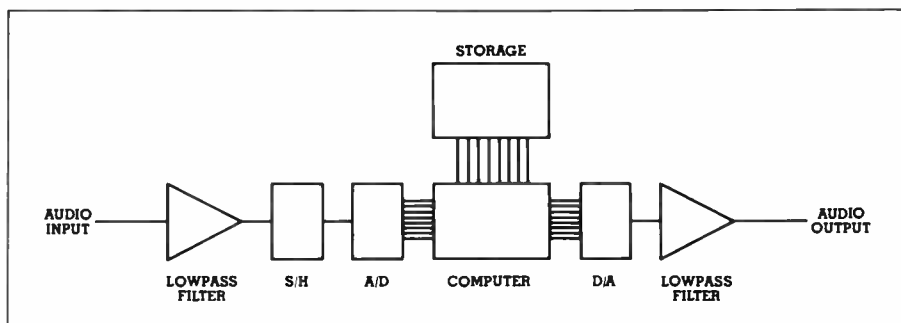

Fig. 5: A digital audio system

figuration – the possibilities are endless. And this data may be reproduced without generation loss and manufactured into commercial medium so that the identical information recorded in the studio is heard in the home or car.

Finally, the overall quality of the digital sound is potentially far beyond even the theoretical limits of analog recording. The audio data is as immutable as the numbers of which it is comprised and is far more than an *analog* of the original music. Take a good look at our block diagram of a digital audio system. Because of it, recorded sound has just taken a quantum leap and begun an entirely new technical evolution.

And yet our audio processor design is already a bona fide classic; it embodies the oldest, most brute force, (and perhaps highest quality) of digital design philosophies. Specifically, it represents a linear pulse code modulation (PCM) type of design in which, theoretically, the only sources of traditional error are the two analog filters and the quantization process. At this point in digital evolution, the PCM is the most widely used type of system. VLSI chips have been developed by manufacturers to handle all of the PCM processing and provide for error detection and

correction. In addition, A/D and D/A's have been combined on one chip. The result is a newborn and increasingly cost-effective technology which already reveals the best analog recorders and processors.

Now the name of the game is diversification – and the fun is just beginning. Although the professionals use fixed head reel to reel tape recorders, a particularly ingenious type of digital recorder utilizes a video cartridge recorder for its storage medium. A 14 bit PCM signal with a sampling frequency of 44 kHz requires a recording capability greater than 2 MHz. A fixed head must labor to accomplish that bandwidth, whereas a rotating video head handles it easily. Current incarnations of this type of recorder are the Technics SV-P100 and Sony PCM-F1. If you still have doubts about digital audio recording, or believe that the cost is prohibitive, I invite you to audition these recorders.

And as I say, this is just the beginning. PCM is the current favorite. Virtually all professional recorders, as well as the VCR consumer recorders, use PCM, but meanwhile the competition hasn't been sitting around listening to their wax cylinders. Next month we'll take a look at some very promising al-

ternatives which may prove to be the next generation of digital recorders.

Oh, I have to repeat something I said above. I want you to go out and listen to a digital recording this month. If you've read this many Digital Discussions, you must have some interest in digital recording – but I still run across too many readers who admit they've never heard a digital recording. I want each of you to get off your overstuffed chairs and go to a good hi-fi store and listen to a digital tape recording this month—and I don't mean some analog record that says digital on it—I mean a digitally recorded digital tape or laser disk. Well, what are you waiting for? ■

REFERENCES

Blesser, Barry. *Digitization of Audio*. AES Journal, October, 1978.

Garrett, Patrick H. *Analog I/O Design*. Acquisitions, Conversion, Recovery. Reston Publishing, 1981.

Hoeschele, David F., Jr. *Analog-to-Digital/Digital-to-Analog Conversion Techniques*. John Wiley and Sons, 1968.

Lancaster, Don. *Active-Filter Cookbook*. Howard Sams and Co., 1975.

Since 1973

MASTERS OF AURAL GRATIFICATION

. . . our sound design is an art form!

Design

•
Equipment

•
Consultation

VALLEY AUDIO

2821 Erica Place
P.O. Box 40743
Nashville, TN 37204-3111
615-383-4732

DIV. OF TODRANK TECHNICAL SYSTEMS, INC.

Circle #033 on Reader Service Card

20 reasons why the QSC Model 1400 should cost more.

And why it doesn't.

Until now, designing a premium professional amplifier was seemingly a set procedure. All that was needed to introduce a new product was a new feature, a hot new component, more power, or perhaps some complicated circuit gimmickry designed to impress others with "technical superiority."

The results were almost always the same: very little improvement in real-world

performance or reliability accompanied by a hefty increase in price.

But we at QSC decided that you deserved more than that.

So we went back to square one, taking a hard look at professional amplifier design and construction basics.

We found a lot of room for improvement. Time and technology had changed things.

Approaches that had been taken for granted for years were

out of date. They needed re-evaluation...and a breath of fresh air.

With that in mind, we designed Series One. A line of amps that include a host of features (including many advancements gained from our revolutionary Series Three amplifiers) and the finest in high quality/high performance components. We examined existing construction and assembly methods and re-engineered them to be much more efficient.

The result is almost unbelievable. Take the Model 1400 for example. It's equal to or better than any premium power amp on the market in terms of features, performance, reliability, or quality of components. In terms of price,

it could command a comparable price tag. But the same rethinking that made the Model 1400 technologically superior also made it less expensive. How much less? Like we said, it's almost unbelievable: only \$698.00.*

In all modesty, we feel that we've created a whole new price-class of premium power amplifiers. A look at the features we've outlined here will give you some indication of the technology that makes the QSC Model 1400 uniquely superior. Ironically, many are the same features that make it so affordable.

To find out more about the 1400, see your QSC Audio Products dealer. After all, can you afford not to?

*Manufacturer's suggested retail price.

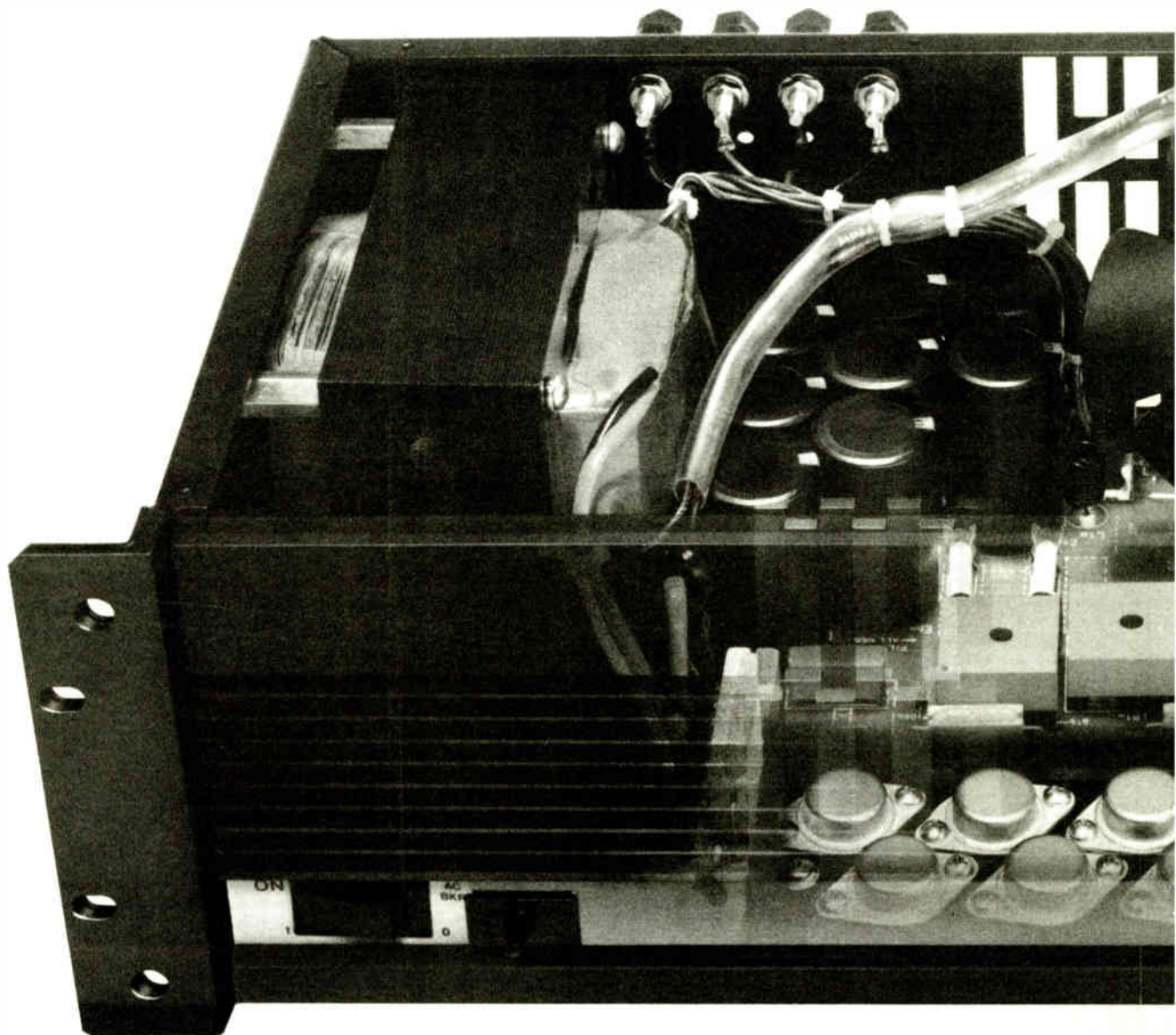

- 1. Power**
A hefty 200 watts per channel @ 8 ohms, 300 watts per channel @ 4 ohms, 20-20kHz, both channels driven.
- 2. Lightweight, Compact Size**
Advanced design reduces weight to a mere 27 lbs.
- 3. Flow-Through Cooling**
High-turbulence heatsink thermally coupled to faceplate dramatically reduces weight. Two-speed fan with back-to-front airflow also helps keep rack cool.
- 4. Case-Grounded Output Transistors**
Provide a 25% improvement in thermal transfer increasing reliability through reduction of thermal cycling fatigue and insulation breakdown.

PREMIUM COMPONENTS

- 5. Large SOA, High Speed, Mesa Output Transistors**
Renowned for their ruggedness and audiophile sound.

- 6. 5532 Op-Amp Front End**
High speed, low-noise, and low-distortion op-amp designed explicitly for high-performance audio.
- 7. High-Density, Low ESR Filter Capacitors**
The very latest in advanced foil technology, reduces size and weight while improving performance.
- 8. FR-4 Fiberglass PCB's**
High quality circuit boards.
- 9. Single Piece 14-Gauge Steel Chassis with Integral Rock Mounts**
Thicker than normal for extra strength, no welds to crack or screws to loosen.
- 10. Full Complementary Output Circuit**
For optimum performance and power.
- 11. Independent DC and Sub-Audio Speaker Protection**
Circuit design inherently protects speaker from DC or sub-audio

surges due to output failure. Acts independently on each channel.

- 12. Dual Power Supplies**
Split power transformer with separate rectifiers and filters. Provides better channel separation and improved reliability.
- 13. Patented Output Averaging™ Short-Circuit Protection**
Provides superior short circuit protection without the audio degradation found in VI limiting.
- 14. Thumpless Turn-On, Turn-Off**
Input muting relay provides turn-on delay and instant turn-off to protect sensitive drivers and speakers.
- 15. Active Balanced Inputs**
For superior audio performance while reducing cable-induced hum.
- 16. Octal Input Socket**
Accepts active and passive input modules such as comp/limiters, crossovers, and transformers.
- 17. ¼" RTS, XLR, and Barrier Inputs**
No need for adapters.

- 18. Mono-Bridging and Input Programming Switches**
Maximum flexibility without jumpers or patch cords.
- 19. Optional 70-Volt Output Transformers**
Mount right on the back for use in distributed systems.
- 20. 2 Years Parts and Labor Warranty**
A quality product backed by an extended warranty.

QSC Audio Products
1926 Placentia Avenue
Costa Mesa, CA 92627



CANADA: SF MARKETING, INC., 312 Benjamin Hudson, Montreal, Quebec, Canada H4N1L4
INTERNATIONAL: E AND E INSTRUMENTS INTERNATIONAL, INC., 23011 Moulton Parkway, Building F7, Laguna Hills, CA 92653
Write for details and specifications on these and other products

Circle #034 on Reader Service Card

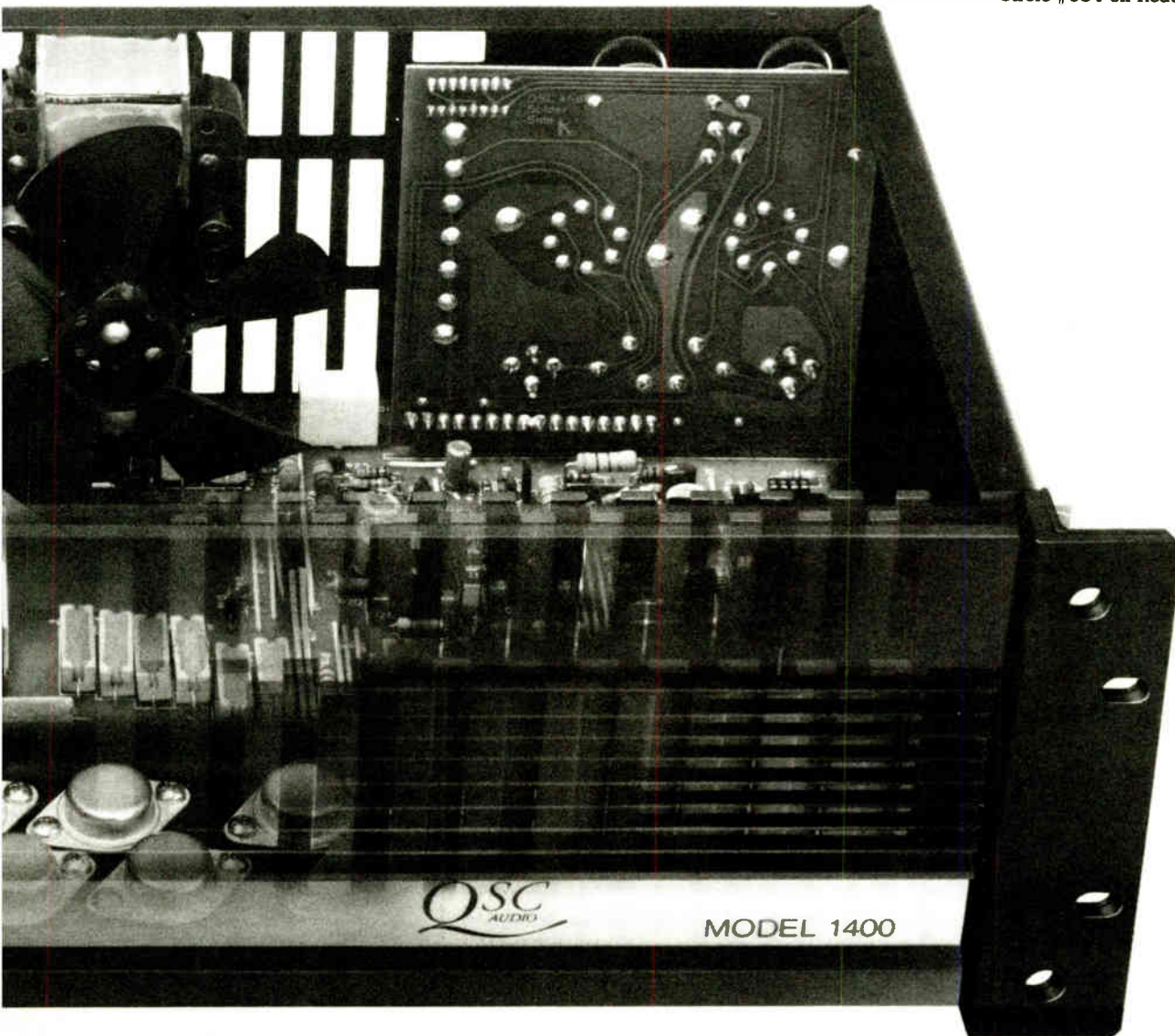

PREVIEW



TEF® SYSTEM 10 SPECTRUM ANALYZER BY TECRON

The TEF System 10, which comes complete in a 22" x 18" x 7.5" metal case and weighs forty pounds, performs complete spectral analysis (DC to 31 kHz) of spaces, structures, components and materials. A complete analysis of a concert hall, according to the manufacturer, can be accomplished with the TEF System 10 in much less than half a day.

The major physical components of the TEF machine include a 92 character keyboard on a hinged cover, a 7" green-phosphor CRT, 5¼" mini-floppy disk drive (dual disk optional), a rear panel with all input/output connections, three Z80 microprocessors and sealed lead/acid batteries which float on the DC buss, providing emergency power to complete tests in progress.

The TEF System 10 is a 96k RAM computer, capable of performing all standard types of digital computation. It is a hybrid, utilizing both digital and analog signal processing. It is software based and menu driven, with a complete machine description and operating instructions built into software. Data-recording programs even include a "scratch-pad" option to enter job descriptions.

The TEF System 10 is offered with standard equipment and software at \$14,500, F.O.B. Elkhart, Indiana.

Circle #035 on Reader Service Card



CARVER ENTERS PRO SOUND WITH 21-LB, 450 WATT/CHANNEL POWER AMP

Carver Corporation, acclaimed for its high fidelity electronic components, has announced the introduction of the Carver Magnetic Field Power Amplifier PM-1.5, a professional low-feedback high headroom amplifier.

Weighing 21 pounds and measuring only 19" wide, 3½" high, and 10⅓" deep, the Carver 450 watt/channel (into 8 ohms) PM-1.5 carries a manufacturer's suggested retail price of \$995.

Special features of the Carver PM-1.5 include: fully proportional fan cooling; no "thermaling out"; recessed front panel controls; adjustable speaker protection circuit thresholds; remote turn-on sequencer with soft-start "power-up" mode; dynamic headroom controller; dual modes of precision balanced inputs with 1% resistors; clipping eliminator; easy-to-see LED power monitoring; reinforced front and rear rack mounts.

Circle #036 on Reader Service Card

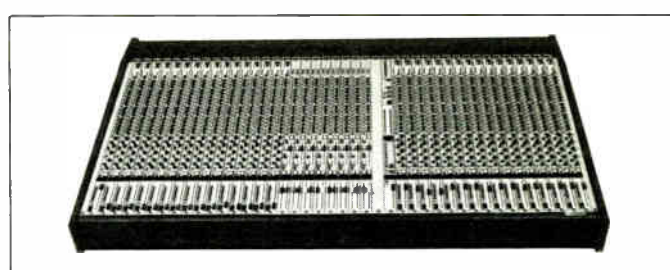

HARRISON SM-5 MONITOR CONSOLES

Harrison Systems, in late April, delivered the first of its new SM-5 stage monitor mixing consoles to Showco, Inc., for use with their upcoming summer tour with David Bowie. The new console is the result of a joint design effort between Harrison, Showco, and Clair Brothers. Showco has ordered 10 and Clair Brothers has ordered 6 of the new consoles, which are capable of generating 32 separate mixes.

Harrison is currently in full production of the SM-5, which includes such features as sixteen main mixing busses, sixteen group re-assign busses, four-band fully parametric EQ, a group muting matrix, and VCA grouping. The main frame is fabricated from welded box steel and can hold up to 32 inputs.

Circle #037 on Reader Service Card



BRUEL & KJAER ENTERS STUDIO MICROPHONE MARKET

After 25 years experience building calibration and measurement microphones, Bruel & Kjaer has entered the music recording field with a family of four unconventional, omni-directional, pre-polarized condenser microphones designed specifically for professional studio and location use.

Type 4003 is a low-noise (15 dBA typical) microphone designed for general purpose near-field recording of soloists and ensembles. Harmonic distortion of these microphones does not exceed 0.01% at 94 dB peak SPL, and is less than 1% at 134 peak SPL. Amplitude response is extremely smooth and varies less than ±2 dB on-axis from 20 Hz to 20 kHz. Phase response is highly linear to beyond 25 kHz on-axis and 20 kHz at 90°, and any two microphones are phase matched to within ±10° over the range 50 Hz to 20 kHz. Type 4006 is acoustically identical but standard P48 powered, and has 11 dB less headroom than its line powered equivalent.

Type 4004 is a smaller diaphragm microphone that is optimized for close microphoning of high intensity sound sources. Its flat amplitude response extends one octave higher to 40 kHz and it will accept levels to 148 dB peak SPL without exceeding 1% THD at any frequency and 168 dB peak SPL at mid-band before clipping. Its phantom-powered equivalent is Type 4007 with 153 dB peak SPL limit.

All B&K professional recording microphones are supplied with a calibration chart with individually plotted frequency response curve and other important data, wind-screen, stand bracket, 5 meter cable and mahogany carrying case.

Circle #038 on Reader Service Card



R.J. BRAND REEL CASSETTE

The Reel Cassette features metal reels within the cassette that, says the manufacturer, eliminate friction on the tape edges and insure better alignment between the tape and the heads. The result is extended life and improved frequency response. The high bias tape features a pure chromium dioxide magnetic layer utilizing chrome micro-crystal coating technology developed by BASF. High bias and standard bias tapes are offered, in 46, 60 and 90 minute lengths; other lengths and tape formulas are also available.

Circle #039 on Reader Service Card



VALLEY PEOPLE, INC. 430 SERIES SIGNAL PROCESSORS

Valley People, Inc. has announced the successor to their popular 410/420 series Dyna-Mite™ and Dyna-Mic multi-function signal processors. The 430 Series consists of two channels of the Dyna-Mite signal processor. Each channel is individually capable of performing limiting, expanding, noise-gating, keying, FM limiting, de-essing and voice-over. The two channels may be coupled for stereo operation.

Included in each Dyna-Mite channel is Valley People's Linear Integration Detector, which yields flatter VU meter readings in the limiting mode than that achieved by devices using peak or RMS detection schemes.

The mode 431 is a combination of one Dyna-Mite and one Dyna-Mic channel. The model 432 is two channels of Dyna-Mic. The Dyna-Mic employs modified Trans-Amp™ transformerless preamplifier technology. Each of the Dyna-Mic's two independent preamplifier sections will accept a variety of input sources including mics, musical instruments, semi-pro outputs, and line levels.

All models may be ordered with an optional, front panel jack which allows the user ready access to inputs, external inputs, outputs, patch points, and control/meter functions by use of a patch cord at the rear panel.

Circle #041 on Reader Service Card

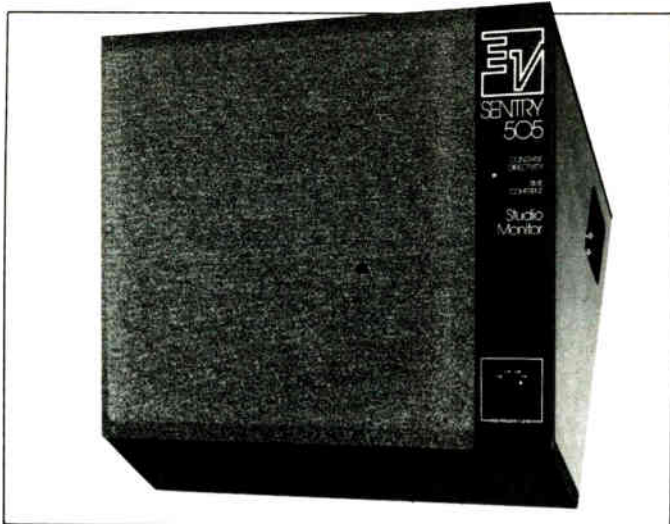

ELECTRO-VOICE ADDS SENTRY 505 MONITOR

Electro-Voice has announced the release of the Sentry 505 Studio Monitor Speaker, featuring an angled enclosure for ceiling/wall mounting locations. The Sentry 505 has been carefully calculated to roll off the system's low frequency at a rate that compensates for the bass boost which occurs when a speaker system is mounted in a "quarter space" environment (where the speaker is mounted at the intersection of two large surfaces such as a ceiling and wall).

The Sentry 505 is a 2-way speaker system with a 12", high excursion woofer and a tweeter capable of handling a full 25 watts. The crossover frequency is 1500 Hz. Frequency response is claimed to be essentially flat from 40 to 18,000 Hz. The unit can produce 96 dB (1 watt, 1 meter, anechoic). Frequency response of the system can be extended down to 28 Hz with the addition of the SEQ low frequency step-down kit. The Sentry 505 weighs 60 lbs., is supplied in a matte black vinyl-covered enclosure, and includes mounting brackets.

Circle #040 on Reader Service Card

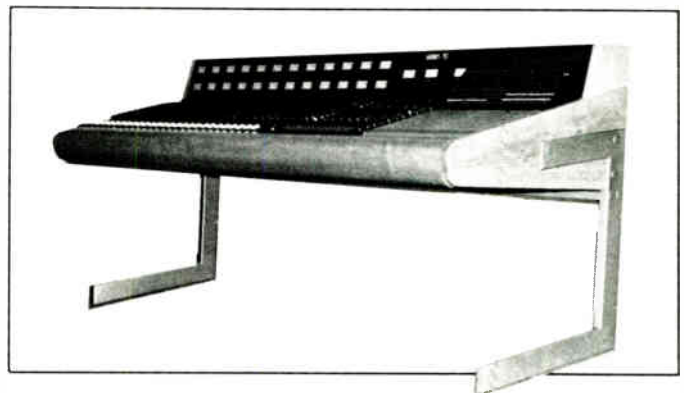

TRIDENT SERIES 70 16/24 TRACK MIXER

Styled after the Series 80, the Trident Series 70 mixer offers 28/16 frame with 4-way echo return module, and there is also provision for adding an 8-way monitor module for 24 track requirements. Its features include: comprehensive patchfield (308 jacks); four-band EQ; separate mike and line gain controls; LED level indicators on each input module; 16 group outputs and separate stereo master outputs; and long throw conductive plastic faders. Monitoring facilities include monitor pan, monitor level and mute for each group output/machine return. Price for the 24x16 configuration is \$19,500 and \$21,700 for the 28x16x24.

Circle #042 on Reader Service Card

will the real Steve Allen please stand up



PHOTOS MR BONZAI

LUNCHING WITH BONZAI

by Mr. Bonzai

Steve Allen is a modern Renaissance Man. His many roles include author (27 books on such topics as humor, history, and music), musician (over 30 albums) and composer (4,000 published songs, among them such hits as "This Could Be the Start of Something Big" and "Picnic"). He is best known as the television and radio celebrity who has been on the air since the Forties.

We began this lunching just after he and his wife Jayne had finished taping a television show at their home in Los Angeles. I asked what he was currently involved in and a grenade of projects exploded.

He is writing the book, music, and lyrics for a musical version of Dickens' "A Christmas Carol" to be produced by Irwin Allen. "He usually produces disaster films," Steve informed me with a laugh.

He is also providing music and lyrics for a musical based on a book called "Chinese Jews" by Ted Allen (no relation). The story documents the engaging saga of an isolated sect that survived in China for a thousand years.

He is singing for two weeks at Michael's Pub in New York City and conducting a big band performing his compositions.

He is also working on an album of new Christmas songs, with Rod McKuen writing the lyrics. Proceeds from the project will go to the Salvation Army.

"I'm usually working on a dozen or so projects at once," Steve explained.

Bonzai: What's the most recent book you've written?

Allen: I just finished *How to Think*.

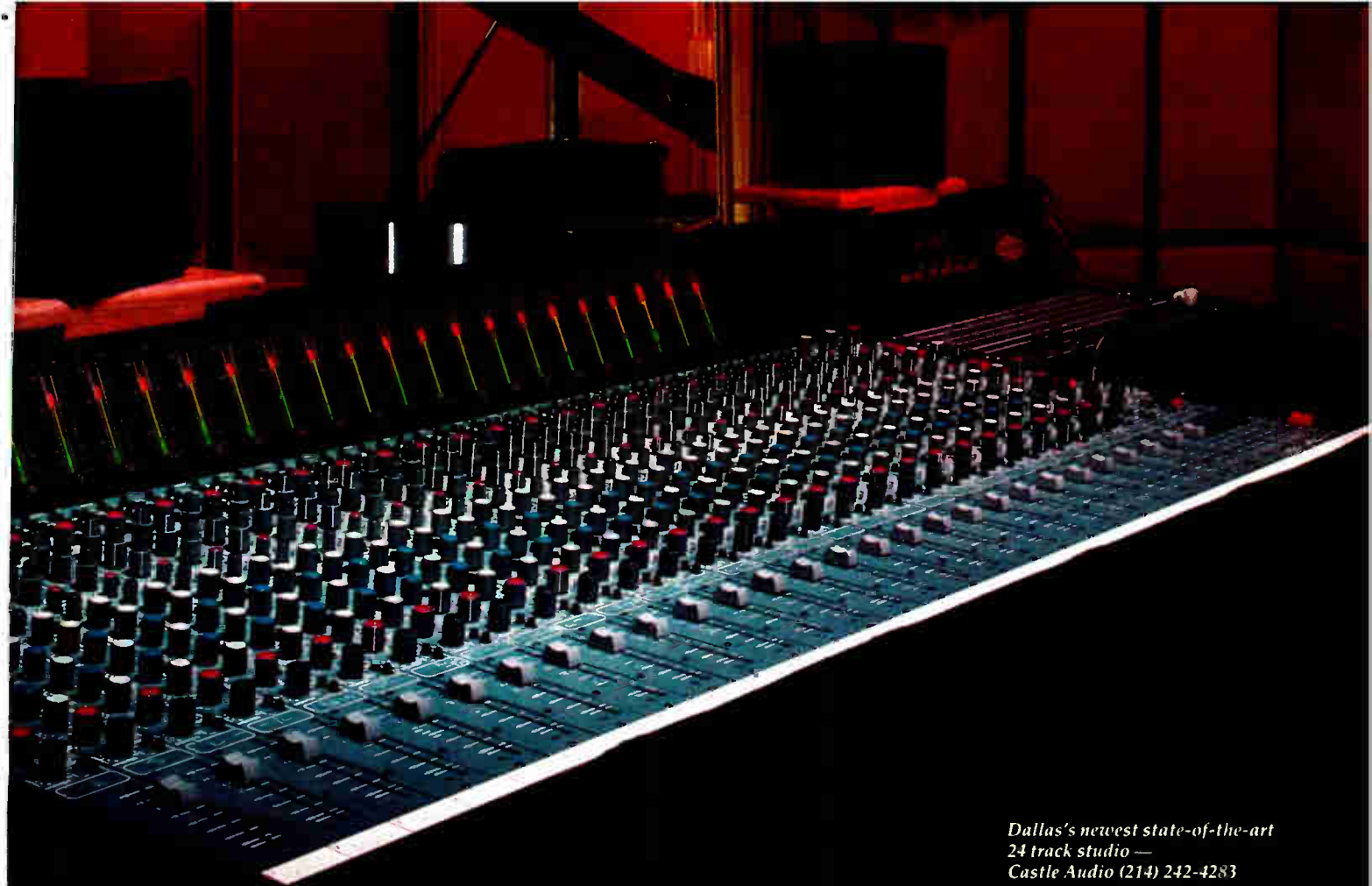

Dallas's newest state-of-the-art
24 track studio —
Castle Audio (214) 242-4283

ANGELA

NOT JUST ANOTHER PRETTY FACE

When we created ANGELA we knew she had to have more than just good looks. We insisted she be the finest low-cost 24 track console in the world. For her to achieve this, we had to maintain total integrity in all aspects of her design and construction. We refused to give her inferior components like PC board patch bays, ribbon connectors or an inexpensive chassis that flexes. Instead, we built her with the same superior design and manufacturing techniques found in our M2500 and M3000 Super Consoles... and is ANGELA built! She has Mil-Spec Patch Bays, a Hard-Buss Mother

Board, Gold Pin Edge Connectors, and her amplifiers are 5532-4s and TLO 74s and she has a Perfectly Rigid Carbon Steel Chassis. Sound appealing? To find out more about ANGELA or to arrange a personal demonstration, contact us at (213) 508-9788 for the name of your nearest AMEK dealer.

AMEK CONSOLES, Inc. U.S.A.
11540 Ventura Boulevard
Studio City, California 91604
(213) 508-9788

AMEK SYSTEMS & CONTROLS
Islington Mill James Street
Salford M3, 5HW, England
061-834-6747

Circle #043 on Reader Service Card

STANDARD FEATURES:

- 28 Inputs, 24 Buss, 24 Monitoring
- 6 Sends, 6 Returns
- Advanced transformerless mic preamp very low noise, typically -130 dB
- Phantom power
- 4 Stereo Sub-groups
- Switchable PPM VU light meters
- 4 band EQ with 2 position 'Q' in 2 mids
- Separate control room and studio monitoring facilities
- Extra heavy duty toroidal power supply
- In place solo
- Fader reverse
- Monitor section can be used for 28 additional returns to stereo mix buss giving total of 62 returns in mixdown mode
- A one year parts and 6 month labor warranty

OPTIONAL FEATURES:

- Full VCA Automation
- Frame sizes up to 56 inputs
- Additional VU and Phase Meters
- Available in one piece "in line" or two piece "L" shaped chassis
- Separate 24 Track Monitor Mixer mounted in producer's desk

I've been concerned for a good many years about the fact that the American people are getting dumber, so I'd like to stop that, or at least delay it somewhat. The book deals with the technicalities of reason, debating, and there are some practical suggestions which will make you smarter, such as: stop listening to so much garbage music, listen to more classical music; stop listening to screaming rock disc jockeys and listen to public radio; watch less commercial television and watch more public television – that sort of thing.

The book is an extension of a record album I did about 15 years ago, which was designed to introduce children to some of the basic elements of reason. For quite a few years I have been recommending instruction in reasoning at the kindergarten and first grade level. I thought I would demonstrate how simple it was and maybe some teachers would take it from there and do a much better job of it.

I'm also working on a book called *How to Be Funny.*"

Bonzai: You certainly don't mind taking a rather godlike stance.

Allen: Well, I'm an absolute klutz and a dunce about most of the things in the world, but there are several things concerning which I am somewhat of an expert. So, in my capacity as an expert I must enlighten those who know less, and in turn I go to those who know a great deal more and learn from them. It's exactly how a society should work.

It may have something to do with the fact that I formed an attachment and a respect for professional comedy, and the humor of life, almost in infancy. I guess the average person who ends up being a comedian doesn't even think of it until he's 12, or 26, depending on the case. My mother and father were a vaudeville comedy team. By hanging around backstage I was exposed to a lot of professional comedy. And on the real life level my mother's whole family were very funny people (with the exception of one square aunt). A slightly sarcastic wit was part of the normal mode of communication in the home and that may have something to do with it. But another factor related to my respect for other comedians, major and minor, is that I have an enormous respect for talent itself.

Bonzai: Robert Benchley is my humorist godfather. Do you have a godfather of your own?

Allen: Benchley is probably as close as you can come. My tastes are so broad that it's hard to say there was only one influence, but Benchley was

my original idol, and pretty much still is. He always delights me, but I don't see any trace of his influence in my own work.

Bonzai: What are the musical influences in your life?

Allen: I am a melody freak. Consequently, I'm almost always annoyed these days when I see a modern musical. I was overjoyed several months ago when I saw "Showboat," because that score has, as I recall, eight great melodies. Today, the average musical has no great melodies. It may have other musical virtues, maybe great music for dancing, but where the hell are the melodies? You might think that all songwriters can write melodies, but the answer is 'no.' A computer, or a four year old child can drop glass on metal and it will ring some tones.

I love the great composers, like



Jerome Kern, Sigmond Romberg, Victor Herbert, Cole Porter, Irving Berlin. These people are gods to me. They had the gift of melody.

Bonzai: Is that what is missing in modern popular music?

Allen: We're talking about a matter of degree, and every so often a lovely song does come along. Henry Mancini gave us eight or ten lovely tunes. Bert Bacharach gave us eight or ten lovely songs. Jim Webb – six or seven terrific songs. . . . Anthony Newley . . . The Beatles – six or seven terrific songs. Michel Legrand is my favorite contemporary composer. Anyone who wants to know how to do a musical should go see "The Umbrellas of Cherbourg." Or if its on cassette, they should watch it nineteen times – that's how to compose music. It's pure opera from beginning to end and yet any nine year old kid can enjoy it. It's

not arty or over the heads of people, and there is one glorious melody after another.

Bonzai: We've had a slump in the recording industry over the past few years and now the new hope is music videos. Do you think that the visual element will move us even farther away from a concern for melody?

Allen: That's a very important question. I have seen maybe 20 of these little mini-shows and I liked them all visually. The camera directors are very creative – much more creative than most of what you see on television. I haven't seen a bad one in terms of television production, but most of the music is utter garbage. It almost doesn't matter what the music is, but if you get some great looking chick or a weird looking English guy with purple hair it's interesting to see the guy jumping around in his green underwear. But most of it isn't singing. Ever since—I don't know if it was Joe Cocker that first showed up and had no voice at all—Bob Dylan—there are a lot of people you can blame, but the point is, basically, music went off the edge of a quality cliff. I know it sounds almost too pat to be true, but it's pretty much the year 1950. The '20s, '30s, and '40s were a glorious golden age of American melody. If you start looking at the hit parade in the 1950s it's either little commercial novelties like "How Much Is That Doggie in the Window" or what I call black leather jacket music – surfing kind of music, which is mostly garbage as music. It may be fun to be surfing and drinking beer and riding in an open convertible with a pretty blonde—hurray for that—that's Americana. I'm not putting down sunshine, or California, but as music it's pretty much garbage.

Through the '50s, '60s, '70s and the first few years of the '80s there has been a thread of quality, though. There was a healthy breath of fresh air introduced by the South American composers – Jobim and the others. Stan Getz came back from South America and recorded a tune called "Desifinado," which opened the door to 57 other great songs. There have always been exceptions, but most of what has been happening in the record business was garbage from start to finish.

[At this point I pulled out an album recorded by Steve Allen many years ago under a pseudonym and quoted the liner notes to the album: *The Discovery of Buck Hammer*, Hanover M8001:]

Bonzai: "Golly Gee Boogie," is something of a surprise in that instead of one of the standard 8-beat left-hand

patterns, Hammer bangs out a thick, five-fingered guitar-chunking sort of rhythm with a more four-four feeling, yet managing to retain the mood of boogie-woogie and the blues.

This then is Buck Hammer. Backwoods barrel-house king. Boogie-woogie pioneer. Lonely, lost soul. That rare thing, a creative artist. It is a pity that he did not, as a young man, go to New York or Chicago or Kansas City and mingle with other young jazz greats. For Hammer's greatness lies in his promise perhaps more than in his achievement . . .

The editor of *Mix* asked that I bring this album along to the interview - who is Buck Hammer?

Allen: [Laughs] Well, I put this out as a put-on to the jazz critics and the music world generally. It worked just the way I thought it would. It got great reviews - jazz critics loved it, because they thought I was dead and black and you can't knock a dead black jazz musician - it's un-American. The one kind of jazz piano that I play pretty passably is boogie woogie. I purposely wrote scholarly, stuffy, analytical liner notes, but all the references are frauds.

A few months later I did another album called *The Wild Piano of Marianne Jackson*. We took a picture of a lovely lady who worked for us at the time, Mary Sears, who was our housekeeper. We sat her at the piano, she wore a pair of Jayne's earrings, and she didn't know one note from the other. She posed with her hands on the keys and smiled like this [wild and crazy smile]. Again, the jazz critics were fooled, and they liked her. I really carried that one to a terrible length. One of the jazz magazines gave her about an 82 on a scale of 100, but they said something critical, so I dictated a couple of letters. I put them on blue, feminine stationery, and had my secretary sign them as the artist. One particular letter said, 'I thank you for your compliments, but I want you to know . . . ' and she argued with whatever the critic had said and they ran the letter in the magazine.

Bonzai: Have you ever written a song and found yourself surprised by the record someone has recorded?

Allen: Two instances come to mind. I wrote a lyric to a famous jazz standard, "South Rampart Street Parade," and sent it to the publisher. I got a call from the recording director at Decca and he said he has a surprise for me - 'I'd like you to hear a new record.' It was Bing Crosby and The Andrews Sisters - so that was one of the big thrills I had as a songwriter. I didn't even know it was being discussed.

But there was another instance with Louis Armstrong, who was a

giant. I loved him as a musician - a cute guy, too, but I absolutely hated the recording he made. It wasn't his fault. There are certain chord progressions that I call backwards chords.

"Tea for Two" - it starts with what might be called the middle of a standard chord progression and goes backwards instead of the usual 'one, two, three, four.' Another famous song written with those backwards chords is "Honeysuckle Rose" - it starts with the same harmonies as "Tea for Two." So I wrote a song called "Cool Yule." I was thrilled to hear that Louis was going to record it, but the arranger, without ever calling me to ask, had taken it upon himself to change the harmonies

of the song and make it simple basic tonic chords which took the whole strength out of it. It just destroyed the song.

Bonzai: Since so much of your life has been a performance in one form or another - if you were suddenly stranded on a desert island with no audience, but you had a piano . . .

Allen: If I had a piano, I'd be perfectly happy-I'd eat the piano-no, but I'd be perfectly happy because 90% of my piano playing has never been heard by anyone but me. It happens here in the house or wherever I may live. I'm addicted to piano. I have to have a piano the way you have to

-page 111

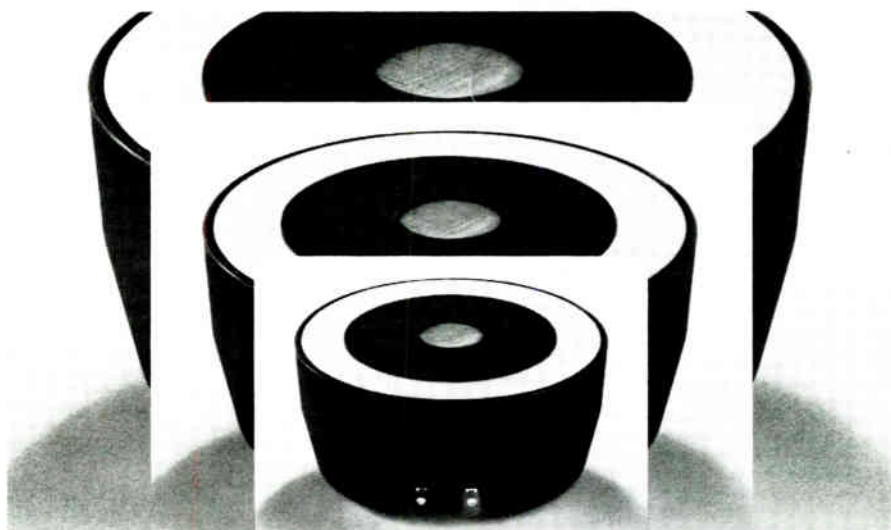

MORE FOR LESS

The RCF N-480 High Technology Compression Driver gives you more power handling, more extended response, less distortion, and it will cost you at least 50% less than any comparable driver on the market today.

More Power Handling for 50% less . . . 150 watts continuous program, 75w rms long term sine wave @ 1,200 Hz and up, 100w program and 50w rms long term @ 800 Hz and up.

More Extended Response for 50% less . . . equal to the finest aluminum and titanium compression drivers in high frequency response.

More Fidelity for 50% less . . . with low inherent distortion thanks to a high dampening composite material diaphragm.

For more information, contact us today.

EASTERN ACOUSTIC WORKS

P.O. Box 111
Framingham, Mass. 01701
(617) 620-1478



Circle #044 on Reader Service Card



PHOTO: ED SLATER

SOMEWHERE IN MIAMI BEACH



The Bee Gees' Middle Ear

by Tom Paine

There's a nondescript warehouse-type building somewhere in Miami Beach. It looks like so many of those "taxpayers" that one might easily pass it by, except for the odd teenager hanging around outside with a camera. The kids hang around to catch a glimpse of one of their favorite personalities, for this is the site of Middle Ear, the personal studio of the Bee Gees, one of the past two decades' most enduring musical success stories.

Middle Ear was built about three years ago and has since become the source of some of today's most popular music, including "Guilty," "Living Eyes," "Heartbreaker," and now music for the new movie *Stayin' Alive*. The funny thing was how it all evolved - when the Bee Gees and their management moved to Miami Beach in the late seventies, they didn't think they would be building a studio and continuing the long tradition of major musical production in South Florida.

Leasing a building which had been designed as a warehouse and then "evolving it" into a major new recording venue is an interesting story, bringing to light a number of technical and aesthetic problems that demanded some unusual solutions. In fact, the existence and success of Middle Ear proves one can put a successful studio almost

anywhere today if the right combination of dedication, design talent, and money exists.



A few years after the band moved to Miami Beach they decided they could use a home base and a place to store their equipment. They scouted around and found a seven year old warehouse structure which had been used to store cut-out records, of all things. It was located conveniently to the band members' houses and seemed to fit the bill nicely. In January of 1979 the building was leased, and soon most of the group's equipment was moved in from outside storage. In the spring of 1979 the band was riding high on the phenomenal success of *Saturday Night Fever*, and they began preparations for a summer tour. They needed a place to rehearse and the building seemed to be the logical answer. As a warehouse the acoustics were pretty awful—uneven and full of reflections—and the group sought advice on how to acoustically treat the room, quickly. They contacted Lutz H. Meyer of MCI and he suggested that they get in touch with Seth Snyder, a local MCI dealer who also provided studio design and construction services. Seth and his associates at a company called Modular Perfection had developed studio designs consisting of prefabricated acoustical "building blocks" which could be assembled in a variety of ways to create spaces that are acoustically correct and aesthetically pleasing. The modules could be installed and then removed for setup in another location, if needed, and

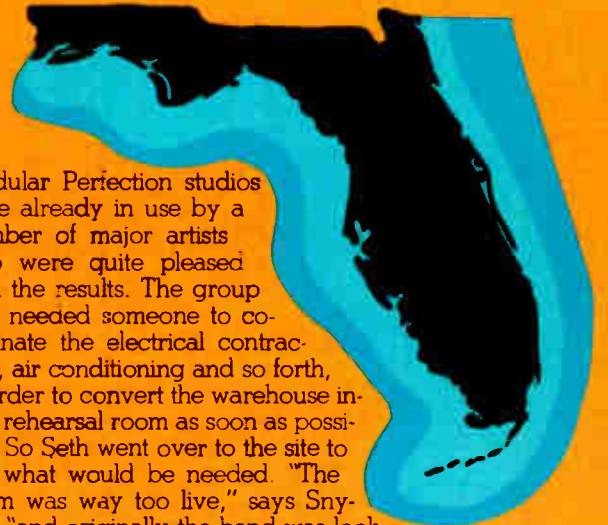

Modular Perfection studios were already in use by a number of major artists who were quite pleased with the results. The group also needed someone to coordinate the electrical contracting, air conditioning and so forth, in order to convert the warehouse into a rehearsal room as soon as possible. So Seth went over to the site to see what would be needed. "The room was way too live," says Snyder, "and originally the band was looking for something temporary, inexpensive, and expedient, just enough to make it okay for rehearsals."

But Seth just happened to have most of the modules necessary to do a great treatment job at Modular Perfection's Orlando factory, having built them for inventory just prior to the spring A.E.S. in L.A. "So I offered them a chance to check out the Modular system, and worked out a ceiling treatment as well. The deal was that they could 'borrow' the studio modules to see what they were like and if they liked them, they could buy them. We were contracted to do the ceiling treatment, which the room would have needed anyway, and shortly after we returned from the A.E.S., we started work on the room."

—page 70

EVOLUTION

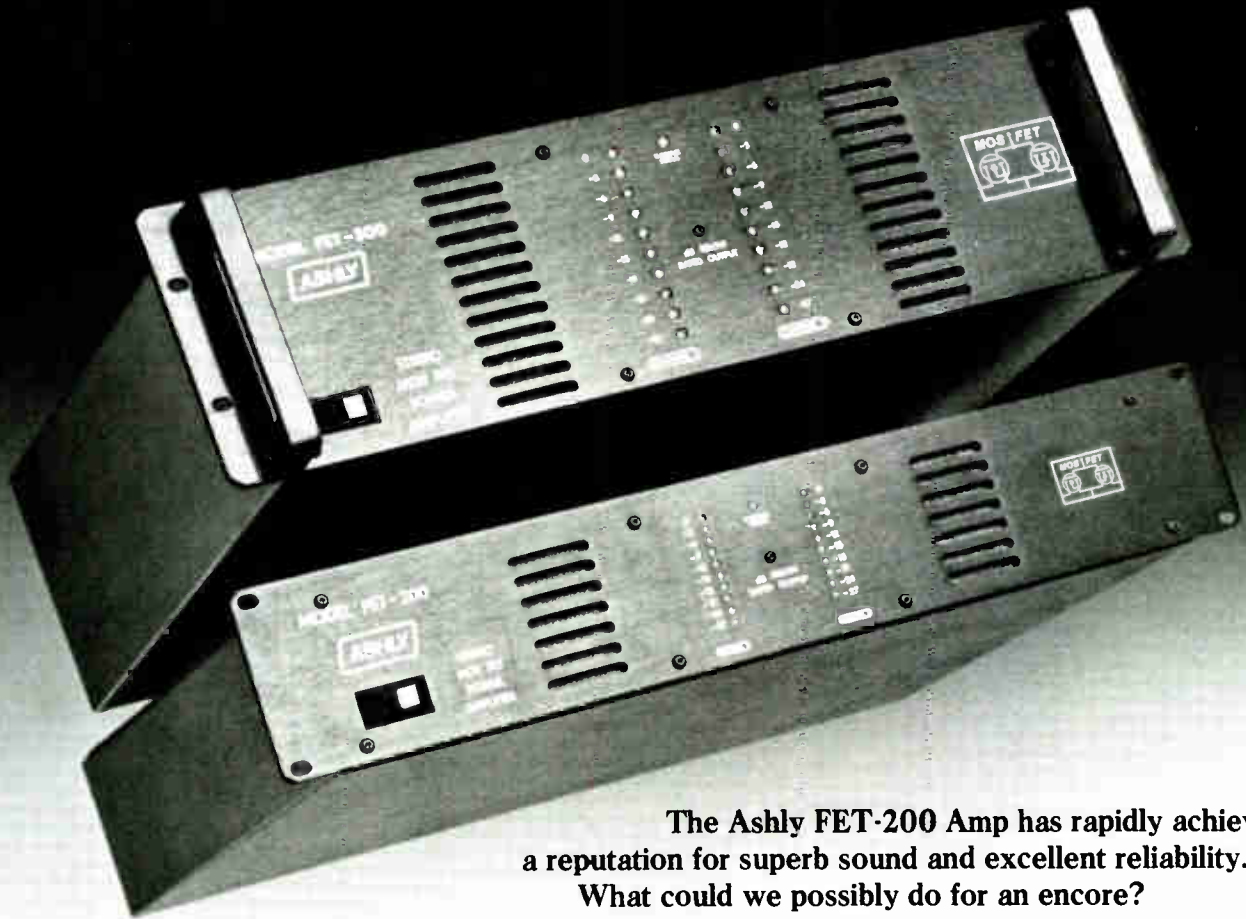

The Ashly FET-200 Amp has rapidly achieved a reputation for superb sound and excellent reliability. What could we possibly do for an encore?

Introducing the FET-500. Now when you need power, you've got it. 500 watts into 8 ohms and 800 watts into 4. Plus everything you expect from an Ashly Amp: MOS-FET's, lowest noise and distortion, quiet fan cooling, balanced inputs... simply more of a good thing.

Ashly. It's a natural selection.



EVERYTHING YOU HEAR IS TRUE

Circle #045 on Reader Service Card

World Radio History

For more information on Ashly Pro Audio Equipment, send in this coupon or call us toll-free at (800) 828-6308. In New York State, call collect (716) 544-5191.

NAME _____ CITY _____ STATE _____ ZIP _____

TELEPHONE _____

I'm also interested in: Crossovers
 Equalizers Limiters Preamps

Ashly Audio, Inc., 100 Fernwood Avenue
 Rochester, New York 14621 (716) 544-5191

In Canada: GERRAUDIO, Inc.
 363 Adelaide Street East,
 Toronto Ontario M5A 1N3,
 (416) 361-1667

Thirty-eight of Modular's standard "semi-live" modules were installed around the perimeter of the main 28' x 65' room and over three thousand acoustical "cones" or wedges were glued to the ceiling. Since the band was eager to begin rehearsals, the installation team was under considerable time pressure and they completed the job in just three days – largely because of the use of prefabricated modular parts.

After four or five days of rehearsals Barry Gibb remarked that the room sounded "really good," and he wondered if the band shouldn't build a recording studio in the building. "Just put the control room over there," he said, pointing to the other end of the large room. So what once was a cut-out record warehouse, then a rehearsal room, was now to be a state-of-the-art recording studio. Again Seth and Modular Perfection were called in to talk to the management. Seth was asked to make up a list of the equipment that would be needed, and to develop a proposal for a Modular control room, the studio modules, and also to finish off the upstairs into offices, a tape dubbing room, and an artist's lounge. The band was just about to leave on tour and everybody thought that it would be

great if the studio could be ready by the time they returned.

Seth got together with Karl Richardson, for years the band's principal engineer, to develop an equipment list and some preliminary designs. Karl approved of the Modular concept in general and made some additions to the equipment list. He also wanted a very large, dramatic control room/studio window of a specific shape, suggested designs for monitor speaker cabinets, and asked about a convection cooling system – noiseless in operation and also distributed by Modular Perfection. Early in the summer of 1979 the next stage in the building's evolution began in earnest. And naturally problems associated with the building's original design and location started to surface... things which were of little consequence as a warehouse or rehearsal room, but could be absolutely deadly for a recording studio.



For starters, it was determined that double 8" thick concrete walls were needed to properly isolate the control room from the studio. The ground floor had always sounded hollow and seemed a little flexible, even though it was

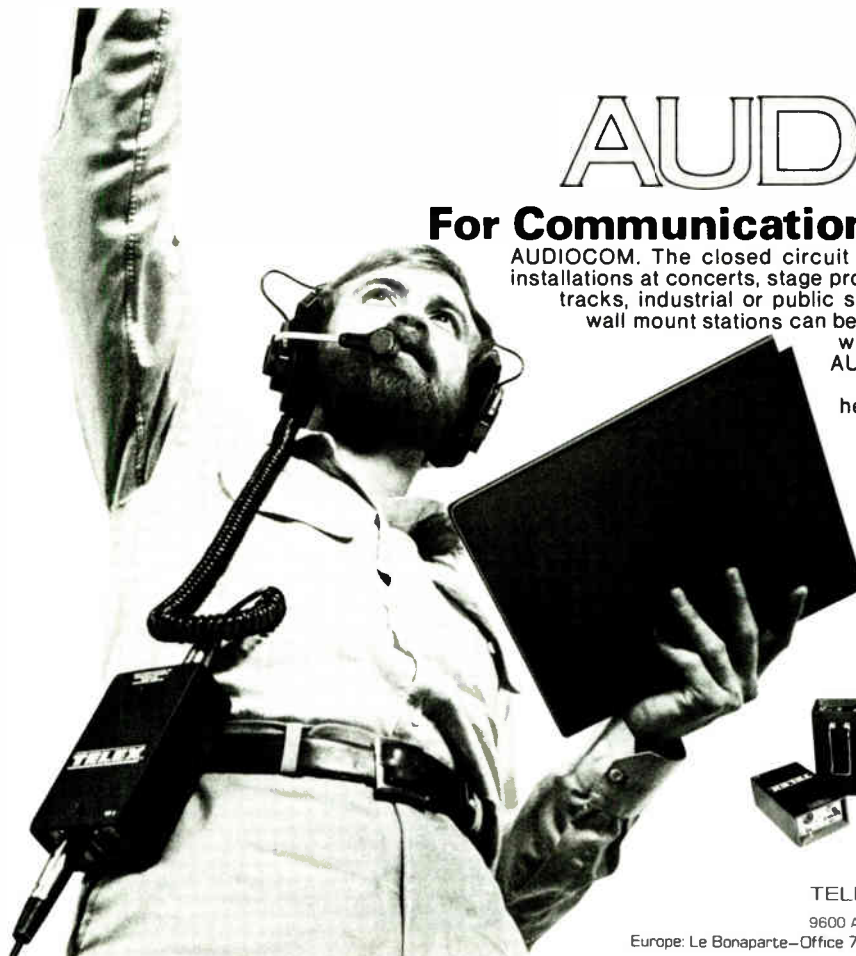

PHOTO: DAVID MOORE

Irregularly shaped wall cavities of slot absorber/diffusers and bass traps

supposed to be poured concrete. A void of nearly three feet was found when the floor's load bearing capacity was checked. Settling since the building had been completed created this space and caused cracks in the slab above, making the floor incapable of supporting the weight of a large double wall. In order to solve this problem, over 100 tons of concrete had to be pumped into the space under the floor, forming a solid piling under the building.

The studio is equipped with an MCI JH-556D console, and its immunity to RF noise was about to be tested to the limit, because this warehouse was



TELEX

AUDIOCOM

For Communications Behind The Scene

AUDIOCOM. The closed circuit intercom for small, large, portable or fixed installations at concerts, stage productions, film or TV studios, stadiums or race tracks, industrial or public safety applications. AUDIOCOM belt packs or wall mount stations can be "daisy-chained" by the dozens over five miles

without degradation in signal quality or strength. AUDIOCOM interfaces with other sound systems and telephone circuits. AUDIOCOM includes headsets, mics, cables, switchboards, signalling kits, even battery packs for remote locations; the complete intercom system for communications behind the scene.

Quality products for the audio professional.



TELEX

TELEX COMMUNICATIONS, INC.

9600 Aldrich Ave. So., Minneapolis, MN 55420 U.S.A.

Europe: Le Bonaparte—Office 711, Centre Affaires Paris-Nord, 93153 Le Blanc-Mesnil, France.

across the street from the transmitting tower of a 5000 watt AM radio station. A number of things were done in the construction phase to eliminate potential problems with noise, among them building the control room out of modules with the RF shielding option—grounded metal screen in each module—making the room an RF shielded enclosure.

When the system was completely installed and grounded there was still a problem of induced RF noise on some but not all of the mike inputs. By isolating lines the problem was even-

tually traced to induced RF in shielded mike lines running into the studio. Disconnecting the lines from the console eliminated the noise from all channels, further proving the point. Plug-in low pass networks were designed and installed on the noisy lines and completely eliminated the problem.



Since the lines were already buried in the walls and kind of hard to get to for detailed analysis, many

theories have been advanced as to why only certain lines picked up noise. Perhaps the most interesting of these is that the inner lines in the bundle were the quiet ones, being shielded by the effect of all the outer lines.

The radio station transmitter and tower have been moved to another site now, but the studio operated successfully when the tower was less than 200 feet from the console inputs – and the control room was almost right on top of the buried copper forming the ground plane.

—page 72

AN INTERVIEW WITH KARL RICHARDSON

CHIEF ENGINEER AT MIDDLE EAR

by Tom Paine

When preparing this article I had the opportunity to talk with Karl about some of the production techniques that are used at Middle Ear, recent projects and audio in general.

Mix: I'd like to ask you about dual synchronized multi-track work, because it's something that Middle Ear uses extensively as a production technique. In talking with people at shows and all it's remarkable how many you run across who still think that the major advantage is that you wind up with 48 tracks, or 44, or whatever.

Richardson: Yes, that's right.

Mix: Could we talk about a recent project, like Heartbreaker, or something else in which various special aspects of the dual twenty four track setup were used?

Richardson: Well, I think that the new Bee Gees record, *Stayin' Alive*, is one of the more complex records that we have done recently. The sound track for "Stayin' Alive" [the movie]



PHOTO: BOB SHERMAN

required five songs, and the album will be out by the time this is published. It was done with dual multi-tracks and a lot of the material was assembled from various tracks all on the same "slave" reel. We worked with a live band and we would, let's say, pick the performance of a guitar player based on... well, you know, he might have played a great bridge on one of the takes, and he never quite had that amount of emotion or feeling in the bridge on any of the other takes. So, since everything was SMPTE synchronized, we would go back and get that bridge from that guitar performance and lay it on a "second generation" master, or whatever you might call it.

The way we kept everything synchronized musically was that on every slave reel we had Barry's rhythm guitar and a shaker-sort of a click track, so that the music coming through the player's headphones was always the same arrangement of the song, and the tempo stayed the same.

But as far as what the drum fills became, or the bass line, or any of the other stuff, we could choose which

takes or parts of takes we wanted. We would have guitar slave reels, percussion slaves, string slaves, synthesizer slaves and so on, so instead of trying to splice twenty four track tape together, we had the ability to rearrange musicians' performances more easily, letting them fly a little more freely.

Mix: In the production of *Stayin' Alive*, how many tracks or slave reels do you remember using? I remember once that someone at Middle Ear told me you did a production where there were 140 reels of tape for one number...

Richardson: Must have been the Streisand record.

Mix: Well, what's the count on tracks for *Stayin' Alive*?

Richardson: I really don't know. I would suppose it was into the hundreds of tracks.

For instance, if we do a bank of choir with the guys, and they're all singing "ahhh" or whatever in harmony, we might do twelve tracks of that on a harmony slave reel just to

—page 74

The large trapezoidal windows used between the studio and control room are two pieces of glass cut to shape. One pane is 3/4" thick, and the other 5/8". The thicker window was originally specified at 1/2", but it was cracked during the cutting process and the glass supply house offered the three quarter pane as a replacement. The windows are 16' long and 9' high at the center. They are set in a custom-milled solid oak frame which is isolated from the wall by 8" thick rubber plugs pounded in after the frame was set. Altogether the frame and window assembly weighs over 5000 pounds.



The ceiling needed aesthetic treatment, so a suspended ceiling frame was hung under the rows of glued-on cones. Honeycomb grilles were installed around the perimeter for air conditioning, and frames covered with grille cloth were set into the large middle area of the grid. No duct work or air isolation baffles were required in the studio because the room is cooled entirely by a noiseless convection cooling system. As the room was tuned up a number of reflective "clouds" were hung under the cones and over the grille cloth in various areas of the studio, forming a wide variety of reflective and absorptive surfaces.

The time needed to solve structural problems with the building and the need for very careful system installation delayed putting the room on-line until mid-winter, but finally in early 1980, all was ready.

As a personal studio, Middle



PHOTO: DAVID MOORE

Middle Ear setup for Kenny Rogers session

Ear is not open for outside bookings and even its location is kept shrouded in mystery. The studio is the tool of the production team (Barry Gibb, Albhy Galuten and Karl Richardson) which has been involved with most of the Bee Gees' later releases. In addition to Bee Gees productions, the team has worked on albums here for Barbra Streisand, Dionne Warwick, and most recently the music for *Stayin' Alive* and a Kenny Rogers album. The room has been as busy or busier than many public re-

ording venues - quite an achievement given the economic climate of the past two years.



When I talked to Barry and Maurice Gibb about their studio, they made some good points about why artists have their own rooms, and why Middle Ear was built and equipped the way it is. Barry: "One of the nicest

Designed by **MCI**® A Division of Sony Corporation of America
 Sold and Serviced by **PROAUDIO SYSTEMS**
 FEATURING MCI AND OTHER FINE PROFESSIONAL STUDIO EQUIPMENT

11057 8th Avenue N.E. • Seattle, Washington 98125 • (206) 367-6800

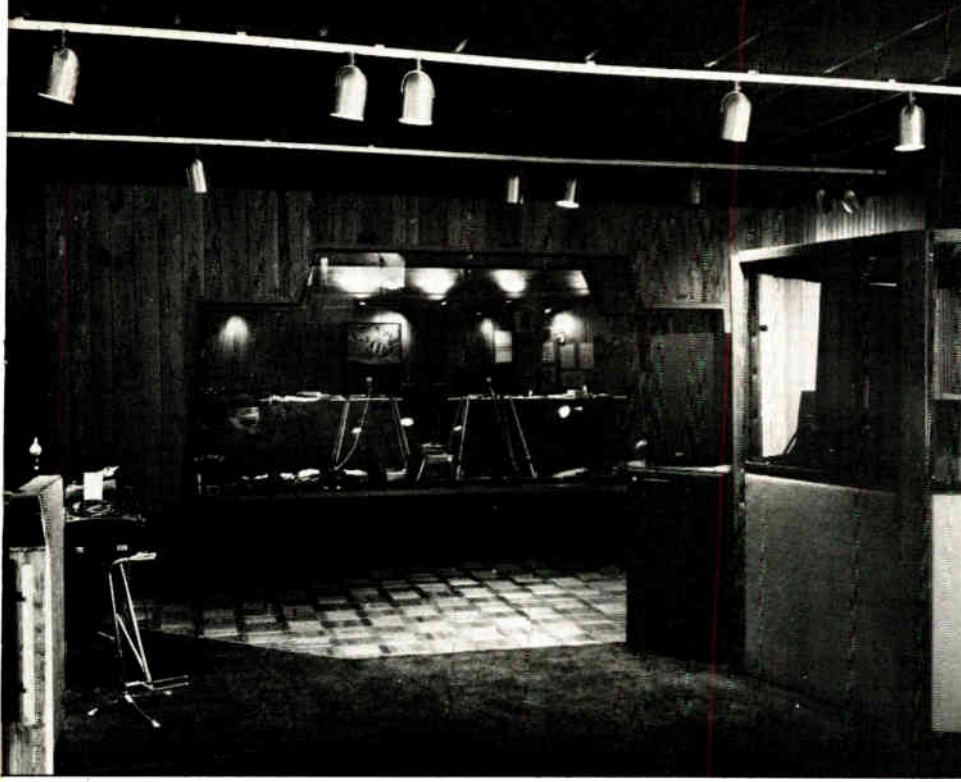

Middle Ear control room from studio side

PHOTO DAVID MOORE

things about having your own studio is the ability to leave complicated setups on the console or in the studio and know that no other act is going to be booked in the morning so you will have to change it all back again in the afternoon. We can make our own hours, and fine tune setups for days if necessary, which enables us to complete projects in a way that gives us much more creative freedom. Middle Ear is a laboratory for developing new techniques which may lead to tomorrow's hit sounds, and we can experiment with presenting artists in new ways through our production companies."

When asked about the room and the equipment choice (MCI console and multi-tracks), Barry commented, "When we decided to make our rehearsal room into a studio, we knew that we had to have the very best of everything. We had been working over at Criteria, and we wanted dual multi-track capability - priceless when you do a lot of overdubs. Our MCI JH-556D is the best that MCI has and we're pleased with it. I'm going to be building a home studio soon and I hope that I can equip it with an MCI system."

About the studio itself, Barry says, "The Modular Perfection system gave us a great sounding room without spending a fortune and we were able to get the studio up and rolling without all kinds of headaches from architects and contractors. When you have a good sounding studio, good equipment, and have great people like Karl and Alby to work with, you have everything go-

ing for you. As a producer I'm ready to use every trick in the book in order to make a great sounding record, and one that is a commercial success. *Guilty* is a good example - the back tracks were laid down at Criteria, the vocals in Los Angeles, and the overdubs and mixing here at Middle Ear. Although both "Guilty" and "What Kind of Fool" were originally written as solos, we turned them into duets for the record."

Maurice Gibb: "The use of multiple slave tapes for vocals really helped us on this material, because it gave us the flexibility to pick lyrics that had been sung with everything right . . . in time, or key, and with the correct emotional interpretation that really makes a song come alive. I think everyone was very pleased with the vocal styling on Barbra's album, and although every performance she gave was a good one, the production team could assemble all of it into something really terrific."



What's next for Middle Ear? A lot depends on the success of the new film, "Stayin' Alive", which may lead to a solo album effort by Barry Gibb. The Kenny Rogers album will be completed soon, and there is a Diana Ross project in the wind. One thing is for certain, though. With the resources in talent and equipment available at Middle Ear, we are sure to be hearing a lot from them. ■

EVERYTHING FOR THE CASSETTE PRODUCER AND USER

KENNETH A. BACON ASSOCIATES 24-E Commercial Blvd., Novato, CA 94947 415-883-5041

CALL TOLL-FREE ANS. SERVICE 800-824-7888 Ask for operator 751

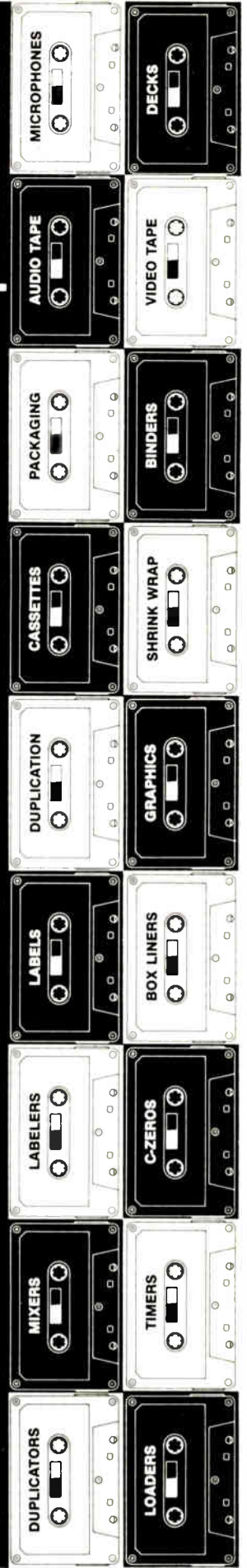

Circle #048 on Reader Service Card

—from page 71, Richardson

get the depth. Every performance is slightly different, and it sounds like a, well, like a church choir with 150 voices and everybody says, "That sounds wonderful."

Mix: Don't some of these "assembly" techniques take something away from the musician's interpretation of his part?

Richardson: I guess that it takes a little bit of the creativity away from the musician and puts it in the hands of the producer and engineer. In a sense we spend less time chasing off-the-wall ideas. . .

Mix: Since the songs from *Stayin' Alive* were to be used in a motion picture as well as an album release, were there any special aspects of the production because of this requirement? Did you have to do a movie mix as well as the record?

Richardson: Yes. We had to do a simultaneous eight track mix . . . separate vocals, separate band, and so forth. Modern stereo film uses Dolby Matrix sound, which is a four-channel to two-channel to four-channel matrix. Release prints are two-channel, and it gets reconstructed into four channels in the theater, surround sound or whatever. That was, well . . . that was

an interesting headache. We even had to use one of those new little MCI JH-800s as a submixer just to mix down the eight tracks so we could hear it. Film has left, center, right, and "back" information. So we had four JBL speakers in the control room, as well as two Westlakes, the big speakers, and a pair of Auratones. So we had a pretty crazy monitoring situation. It worked out, though. . . I mean, the film people in California were very happy with the takes, and they've been in the business a long time so I assume everything was okay.

Mix: So they transferred those takes to sprocketed mag film recorders, or locked it up directly?

Richardson: Yes; they take the tracks and dub them to mag film stock for the final mixing, and that worked out pretty well. Doing that job got to be mass confusion at times, 'cause we really aren't set up to be a scoring stage. . . for one thing the speakers are a little too close.

Mix: And you don't have those 3' wide VU meters under the screen.

Richardson: Really.

Mix: Are there any production or engineering things that somebody wanting to work with dual synchronized multi-tracks should remember as an engineer, or have you any advice for the studio that's just about to run out and buy a second 24 track and some sort of synchronizer?

Richardson: Well, the way we work is to make what we call a master tape. Let's say it has a rhythm section on it, some kind of vocals, code, and we're in an overdub situation. What I will do sometimes is mix that whole master tape down to a pair of tracks on another reel of tape—a SMPTE coded slave—and now we have twenty open tracks or whatever we have, and have the freedom of overdubbing on all of these tracks. But you have to remember that the mix transferred from the master will be the mix that everyone has to overdub to, and a lot of times this isn't an ideal situation because you might want to pull up the drums, or bass, or whatever.

Mix: So you might make a bunch of slaves with different stereo mixes on them?

Richardson: No. What I do a lot of times is use up to 12 tracks on the slave tapes, like separate bass, drums, guitar, vocals, background vocals, and strings, for example. In a sense then, I can get a different groove going for an overdub session without making another transfer or going back

There are many ways to split a mic, but only one way is best

Jensen MB-series Mic Splitter Transformers

When you need to split a mic, you should use a transformer because it provides a balanced, isolated signal to the input of each mixer; none of the mixers' grounds need be connected to each other (via the mic cable) so ground-loop induced noise is easily avoided. There must be a Faraday shield on each winding so that the transformer will not provide a path for capacitive coupling of common mode noise.

JENSEN TRANSFORMERS are best because, in addition to meeting these requirements, they minimize degradation of the mic signal's frequency response, phase response, and distortion characteristics. To prevent common mode noise from being converted to a differential signal, each end of every winding in a JENSEN TRANSFORMER has its capacitance precision-matched to that winding's Faraday shield. These are just a few of the reasons why most engineers end up using JENSEN splitter transformers.

The JENSEN JE-MB-C, JE-MB-D and JE-MB-E microphone bridging transformers will split a mic signal to 2, 3 or 4 mixers.

Insist on the best... insist on a JENSEN.

jensen transformers
By REICHENBACH ENGINEERING

10735 BURBANK BLVD. / N. HOLLYWOOD, CA 91601
(213) 876-0059

Visitors by appointment only.
Closed Fridays.

Circle #049 on Reader Service Card

to the "master." So I think it's a good idea to carry around extra tracks, and of course these are completely expendable . . . if I'm carrying around a background vocal track and it doesn't have anything to do with the overdub, if I need it I'll just go over it. That's one trick we've learned over the years - if you can, always carry around enough stuff so you can almost remix the record. "Shorthand mix," or whatever you want to call it.

Mix: Do you really need twenty open tracks on any given slave tape?

Richardson: Well, sometimes you do. On the Streisand project we used two different 24 track slave tapes just for her vocals on one song. There were a few lines that she just wasn't nailing, so we would have her come in on different days and sing the song. We would always take the whole vocal, because she might beat something that she did the previous day. So consequently we wound up saving something like 25 tracks of just her vocals, or bits and pieces on separate tracks. Like you might take the last line of the bridge eight times or something, because she has her own interpretation, and you want the best

performance possible. So we just have plenty to choose from, which can be very time consuming.

Another thing is that we work primarily second generation with all these slave tapes. A lot of things you don't want to take second generation, like bass for example.

Mix: So that would stay on the original master tape, for example. And in mixing it would be locked up to the slave.

Richardson: Yes, and other things that you didn't want to take second generation would stay on that reel as well.

Mix: I've heard that a lot of times you lay back slave material to the master in stereo pairs, so that in mixing you are balancing stereo pairs against one another. I guess this saves time.

Richardson: Yes, it does. And another advantage of doing this while keeping all the slave material is . . . let's say you do the background vocals, and then you do the strings, and all of a sudden one of the background vocal chords doesn't sound right. You can always go back to the vocal slave tape and rebalance the chord and

then punch it in on your stereo compilation tracks. Musically, you're in a better situation. A lot of times we've discovered in a mixing situation that we no longer like the balance that we had originally because at that time we didn't have enough information on the record. We can always go back to our slaves and change things.

Mix: Another technique for expanding the number of tracks available for overdubs is "dumping" or "track bouncing," that is, combining and moving around groups of tracks within the same 24 track tape. How do you contrast that with dual synchronized multi-tracks?

Richardson: When you do track dumping or bouncing, you have to pick up information with the record head, and you create balances that you can't change when the whole mix comes together. Let's say you do a dump or bounce of background vocals on 5 tracks down to 2 . . . you're stuck with that balance forever. Hindsight is important sometimes . . . to be able to go back and change it. That's why we hang onto all of our stuff for a long time.

—page 113

Announcing . . . the New Cost-Effective

ECOPLATE™ III,

size 56"x 38"x 9", scaled for the Cost-Effective Studio

IF YOU'VE BEEN "GETTING BY" WITH SOMETHING LESS THAN A TRULY PROFESSIONAL REVERB SYSTEM, THEN THE NEW ECOPLATE III IS FOR YOU. PLATE REVERBS ARE THE STANDARD OF THE INDUSTRY WITH THE SMOOTH, BRIGHT SOUND OTHER SYSTEMS TRY TO IMITATE. NOW, FOR ONLY \$1695, YOU CAN STEP UP TO THE BEST. OR, IF YOU ALREADY OWN AN ECOPLATE OR OTHER FINE REVERB, THE III CAN GIVE YOU A SECOND SYSTEM FOR A MODEST PRICE.

Reverb Time: Variable .5 to 5 sec.

Signal to Noise: 65 db

Frequency Response: 80-20 KHz

Input: - 10 or + 4 dbm 10K ohms, unbalanced, 10K ohms

Stereo Outputs: + 4dbm (. 24dbm max.)
50 ohm unbalanced

Size & Weight: 56"x 38"x 9", 109 lb.

Equalization: Both Hi and Lo Variable

New Shock-Mounted Plate Tension System
is Pre-tuned at the Factory
Eliminating Tuning Problems.

**STUDIO
TECHNOLOGIES, INC.**

6666 N. Lincoln Ave., Lincolnwood, IL 60645 • (312) 676-9400
An affiliate of Programming Technologies, Inc.

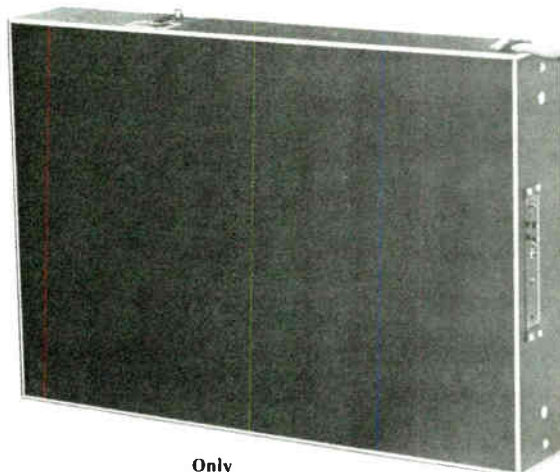

Only
\$1695

Circle #050 on Reader Service Card



by Gregory A. De Togne

PHOTO: PAUL NAIKIN

CHICAGO'S PARK WEST

FROM BAWDY HOUSE TO VERSATILE ENTERTAINMENT MECCA

The day I walked in on Todd Rundgren's sound check at Chicago's Park West, one of the city's premier nightclubs located five minutes from the Loop, there were already people lining up for the show that was 2½ hours away. They all stared at me as I strode past them with my briefcase, and was let in through the

main doors to see Gregg Kincaid, the club's stage manager.

Inside, as preparations for the act were being completed, I tried to find Gregg in the hectic activity that was swirling around me. Busboys scurried about setting up tables and chairs while the roadies and other sound people hurried to get everything into place. Jim Nudd, the chief sound

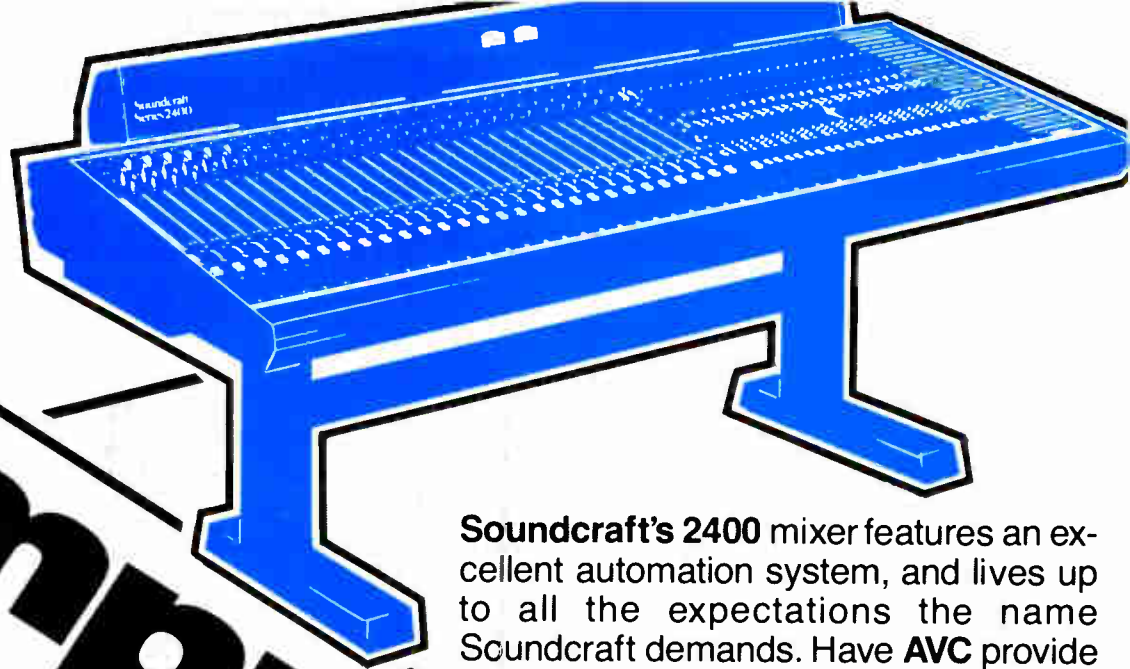

COMPUTER AID MIX

Have AVC lead you into the world of computer aided mixdown:

Soundcraft's 2400 mixer features an excellent automation system, and lives up to all the expectations the name Soundcraft demands. Have AVC provide your studio with this affordable tape based system that locks up smoothly with the Otari MTR 90-II workhorse 24 track tape machine.

AVC Systems Inc. can put together the right automation combination to provide total flexibility for Audio-Video, Audio-Film, and Multimedia Interface. AVC works with studio designers and consultants from concept to completion. AVC Systems Inc. of Minneapolis and Chicago.

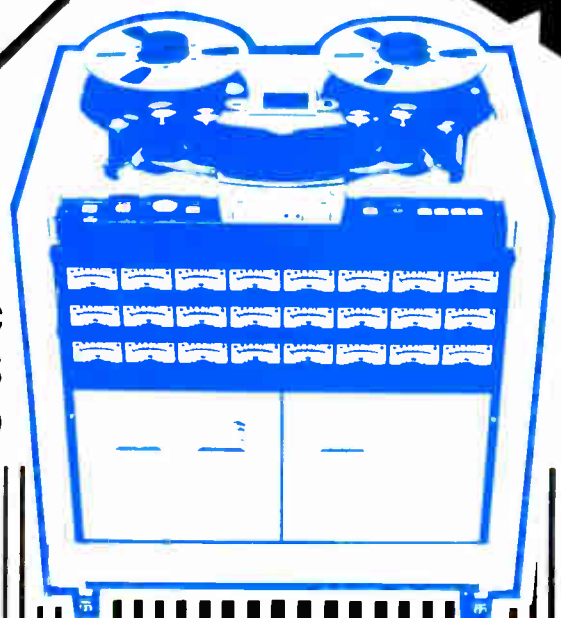

AVC SYSTEMS INCORPORATED

AVC

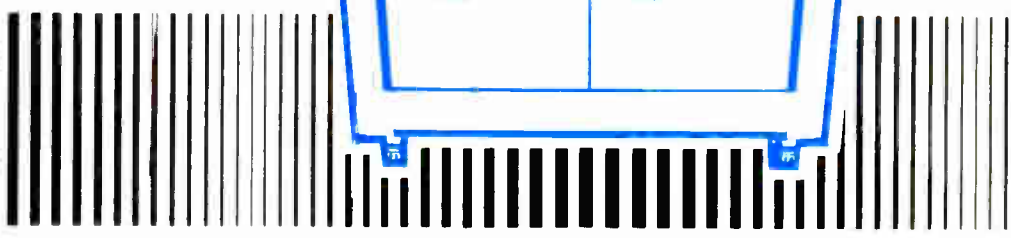

1517 E. LAKE ST. MPLS., MN 55407 • (612) 729-8305
747 CHURCH RD. SUITE A6, ELMHURST, IL 60126 • (312) 279-6580

Circle #051 on Reader Service Card
World Radio History

SOUND SYSTEM

BUZZ

ITS TOO BAD YOU
CANT ALWAYS KEEP IT CLEAN

BUT NOW
ITS ONLY TEMPORARY
INTERFERENCE WITH
A
MODEL PS-1



In addition to reducing RFI the PS-1 can also protect your sound reinforcement equipment from:

- HIGH VOLTAGE TRANSIENTS
- UNEXPECTED POWER UP TRANSIENTS
- IMPROPER LINE POLARITY

linear & digital systems, inc.
46 marco lane
centerville, oh.45459

Circle #052 on Reader Service Card

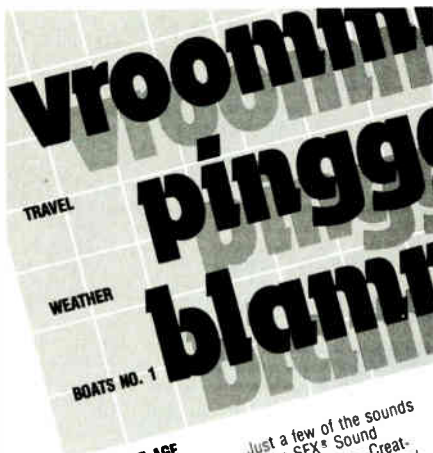

Just a few of the sounds in the SFX® Sound Effects Library—Created with the professional in mind. Choose from our 16 albums listed to the left. For ordering information write or call: SFX®, Box 401, Skokie, IL 60077, 312.775.5505

SFX®

- THE JET AGE
- CONSTRUCTION
- LIGHT AIRCRAFT
- SURF AND WATER
- TRANSPORTATION
- INDUSTRIAL NO. 1
- ATMOSPHERE NO. 1
- ATMOSPHERE NO. 2
- ATMOSPHERE NO. 3
- FIRE AND DISASTER
- LITTLE SOUNDS NO. 1
- PEOPLE AND CROWDS
- HOUSEHOLD/WORKSHOP

Circle #053 on Reader Service Card

—from page 76

technician, was taking time out from his usual chores to polish the grand piano onstage that Rundgren would use that night. Nudd, an always affable person, seemed impervious to all the craziness. He meticulously went about his business while the stage monitors were undergoing some extremely amplified testing in the direct vicinity of his ears, and people ran about stringing wires around the stage. A thunderstorm could have erupted inside, and it wouldn't have bothered him in the least.

The Park West, which first opened its doors on May 12, 1977 as a venue for acts that have ranged from The Rolling Stones to Henny Youngman, is owned by Dale Niedermaier, who is largely responsible for saving the building from certain destruction after it had almost decayed to the point of no return in the mid '70s. Constructed six decades ago, the place has done time as a burlesque house, legitimate theatre, and from 1961 until 1973, as the Town Theatre, an X-rated porn palace that was closed for good by Mayor Richard J. Daley during a showing of "Deep Throat."

Today, the structure has undergone complete renovation, and was named "Best Club in America" in a Performance Magazine poll. The club is an opulent testimony to the skill in design that Niedermaier acquired during the years he ran his own highly successful display business. With a seating capacity of 800, the interior is graced with rich carpeting and plushly upholstered booths that rise up from behind the tables at the front of the stage. Additional seating is available between the rows of booths, and a balcony spans the rear and portions of the side walls. The front of the balcony is covered with large sheets of Alucobond, an anodized aluminum material with a plastic center that resembles stainless steel. The German-made Alucobond adds an aura of high-tech richness to the room's mysteriously black ambience. Overhead, a large domed area extends up from the center of the ceiling, and houses a mirror ball.

Some of the club's unique features include a state-of-the-art sound system, theatrical and special effects lighting, and an electronic workshop that is used for "dance-stand" shows that are accompanied by video and recorded music, among other things.

In addition to scheduled performances and private parties, the Park West is also the scene of live broadcasts, two of which have been the world's largest via satellite; one,



(Above) The sound control position at Chicago's Park West

(Below) One side of the Park West's main speaker array

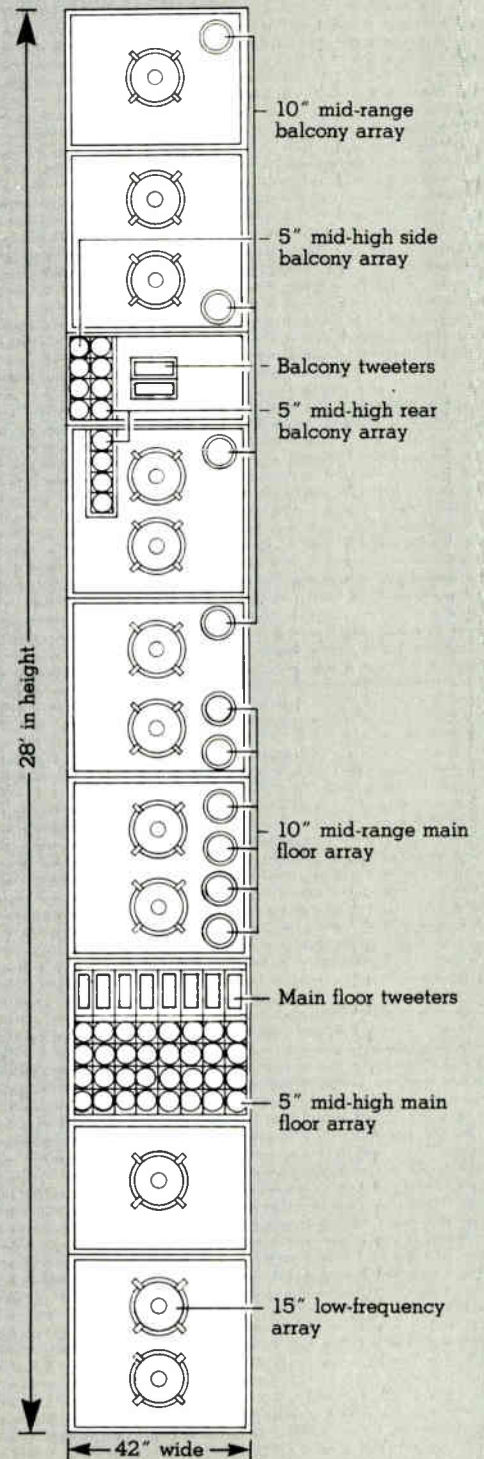

starring Hall and Oates, was heard on 80 radio stations around the country and in Canada. The other was a televised appearance by Tammy Wynette and Don Williams that was seen by 21,000,000 people as part of a nationwide broadcast by the Nashville Network.

Rundgren sauntered onstage in corduroys and well-worn running shoes at about 5:15 for the sound check. With a few minor adjustments, he liked how his guitars and piano sounded, but it took a vociferous verbal exchange between the stage and the mixing board to get the mike at front center to work right. After fifteen minutes, it was over, and Rundgren vanished to the dressing room upstairs. Gregg finally appeared, crawling out from behind one of the two giant video screens that had been placed to the side of the piano for Rundgren's show. As stage manager, his duties naturally include everything from knowing the intricate workings of the sound and lighting systems to making sure the night's performer is satisfied with his accommodations and the food. Coincidentally, Gregg has spent a year on the road with Rundgren, as stage manager, and has worked on tours by just about everybody, including Bob Hope.

My interview with him rambled into all kinds of areas, but mainly covered the various aspects of the sound system, lights, and audio console. We stood by the entrance to the main floor, and amidst everyone else's chatter, Gregg started telling me about what makes the place tick.

"The Park West is a great club for live performers and private affairs because it is a fully self-contained facility," he told me. "We've got everything right here you could possibly want to put on a good show."

On that note, we began to go over the technical support systems, starting with the lights. A Rainbow two-scene 48 channel board is at the heart of the setup, which is installed in the balcony and contains 80 instruments in all. Sony 3/4" U-Matic tape decks are on hand for recording and visual display, and 575-watt HMI Satellite I follow spots were chosen to highlight the main action.

From the vantage point in the balcony, you can barely make out the two huge columns of speakers that flank the stage and almost blend into the walls. They stand like giant monoliths from floor to ceiling, towering over everything in sight. Gregg was glad to launch into an explanation of what was in them and how they got there, but before describing the system a few words are in order for a clearer understanding . . .

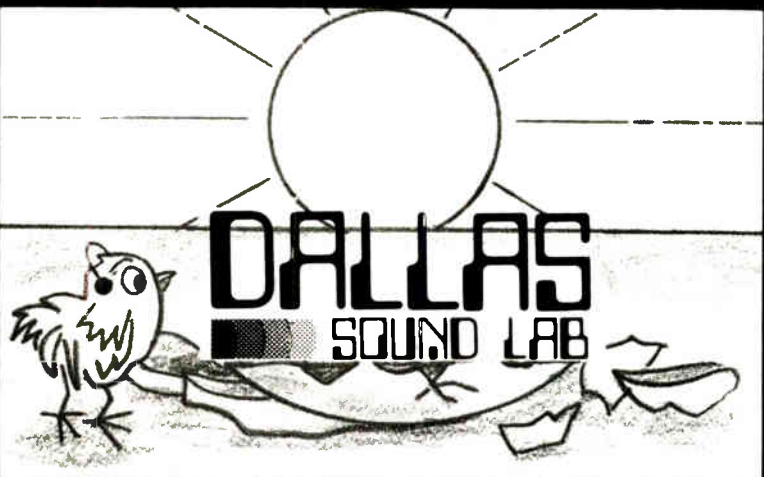
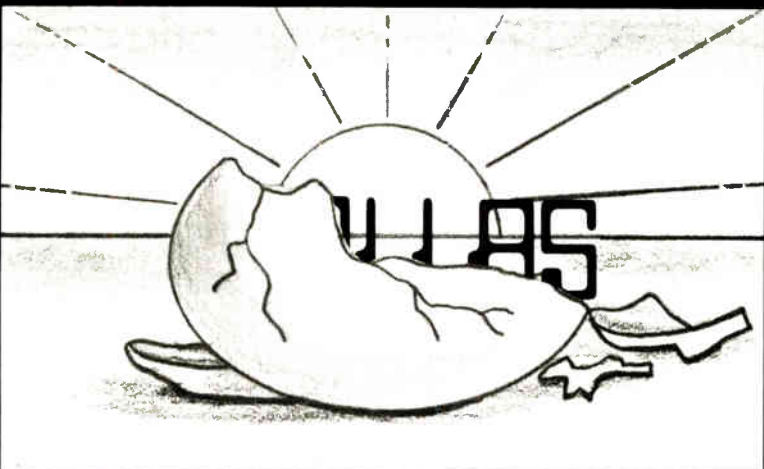
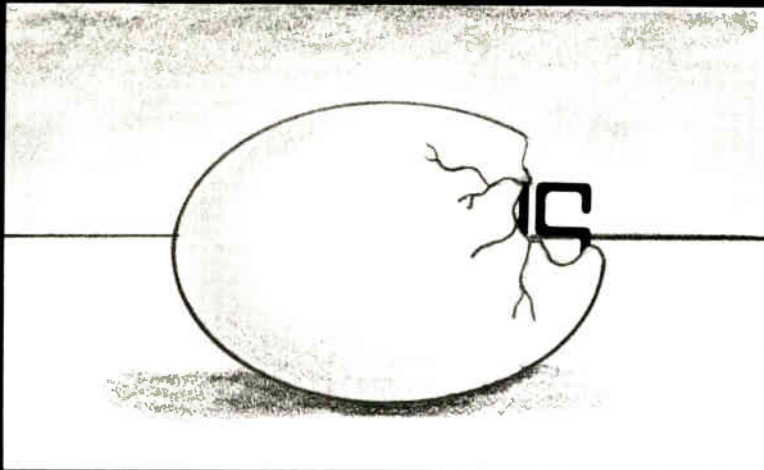

We made it...

Studio Design by:

**JOINER
PELTON
ROSE**

INC. Consultants in Acoustics
(214)350-2384

Studio Construction by:

MARCON
Construction Inc.

(214)980-0210

Now open in the Dallas Communications Complex (214)869-1122

Circle #054 on Reader Service Card



Circle #055 on Reader Service Card

Shortly after it opened in the spring of '77, one critic called the Park West "the million dollar joint with the ten cent sound system." Club owner Niedermaier remembers that in the beginning, "People kept telling me that everything I did in the way of sound was wrong." The echo and reverberation were so bad that patrons complained of leaving the room with a ringing in their ears that rivaled the sounds of a bookie joint equipped with ninety-seven phones on a busy day."

To remedy the problem, Ron Maluchnik, who was stage manager at the time, brought in a local group of sound technicians in 1978 from Modular Sound Systems Inc., makers of Bag End loudspeakers. After conducting six months of tests with portable speaker arrays, Bag End's Jim Wischmeyer and Henry Heine conceived the idea for the current sound system, which utilizes long, columnar arrays to overcome the echo and provide a clearly defined sound throughout the room.

When the project was completed, at its centerpiece were the two monstrous 27' pillars of sound that contain 152 drivers collectively. With a total of well over 10,000 watts pulsating through the #8 speaker wire used throughout, the twin towers form a proscenium around the stage and are each outfitted with their own amplifiers.

The columns are made of nine individual enclosures, and are so immense that they have become part of the structural integrity of the building. Weighing 3500 lbs. apiece, they are attached via steel cables to the main support beams of the roof. Although the modules are perfectly balanced for stacking, (even at this extreme height), six 20-foot steel straps are bolted to each cabinet and run along the side of the columns as a safety precaution. The enclosures were put into place with a block and tackle suspended from the ceiling. After they were positioned, they were loaded with custom-made drivers and wired. Each side contains an array of twelve 15s at the low end, ten 10s for low-mid frequencies, forty-four 5s for hi-mid reproduction, and ten tweeters. A Yamaha PM-2000 console handles the mixing chores of the 4-way system, which is separated at 250, 1,000, and 4,000 Hz by a Brooke Siren crossover.

The design theory that this leviathan is based upon is rooted in the work of acoustical engineer Harry F. Olson, PhD, Director of RCA's Research Laboratory in the '40s and '50s, and later work by Ron Wickersham of Alembic, Inc. By drawing

NOW OPEN!

"The Little Room"

TresVirgos Studios

(415) 456-7666
San Rafael, California

Circle #056 on Reader Service Card

upon their theories of directivity in speaker arrays, Bag End constructed columns that are long for low frequencies, and progressively shorter as frequencies get higher, in direct relationship to column length and the frequencies reproduced by each array. Through experimentation, it was found that this arrangement was effective because it insured that directivity stayed virtually the same throughout the frequency bands.

In the Park West installation, the size of each column was designed to extend the direct sound experience of the near field farther into the listening environment. The main floor array (there are two arrays – one for the main floor, and one for the balcony), has a bass column of 27', a low-mid column of six feet, a hi-mid column of 1½', and about 6" of radiating surface for the tweeters. A long-throw array (twice as long as the main floor), was chosen for the balcony, to compensate for its greater distance from the stage area. Given the scientifically researched physical configurations of the new system, people in the audience don't even realize that there ever was an echo problem. Wherever you go in the room—front or back, or left or right, the sound is uniform, and the balance is the same.

At the conclusion of our discussion of the sound system, Gregg was summoned to some far corner of the club to take care of another last-minute crisis. I walked back to the mixing board, where Jim Nudd was playing with some of the switches. Everything was just about ready, and the doors were scheduled to open shortly. When I glanced outside, I made out some of the same faces I had seen in line on the way in, standing in front of a herd of people that was waiting to thunder through the doors. In a few minutes, the fruits of all the labor that had gone into making the club what it is would become apparent. Jim and I went upstairs to an area above the ceiling where there is a series of trap doors to facilitate the changing of lightbulbs, and old props from the past, including a diving board used by Laurie Anderson in one of her recent visits. From our elevated position, we looked down on the audience as it streamed in. The floor became alive with people that all bee-lined toward the tables in front.

When we descended from our eagle's perch, Jim stayed in the balcony and I grabbed a seat on the main floor. The house lights went out, Rundgren appeared onstage, and with what seemed like a flick of a switch, the entire Park West burst into life...

The staff of Leo's Professional Audio proudly announces their appointment as the northern California distributor for **MCI** and **SONY** professional audio products.



Visit our newest showroom and see why **MCI** is the world's most widely accepted professional recording equipment and why Leo's is now, more than ever...

**Everything You Need
For Stage or Studio!**



LEO'S

PROFESSIONAL AUDIO

5447 TELEGRAPH AVE., OAKLAND, CA 94609 (415) 652-1553

Circle #057 on Reader Service Card

HAVE A RECORDING STUDIO PROBLEM?

Call DataLine*

A service provided by

SPARS

A Non-profit Organization
Dedicated To Excellence Through
Innovation · Education · Communication

* The Society of Professional Audio Recording Studios offers SPARS members, and non-members referred by a SPARS member, a national telephone 'hot-line.'

Questions regarding any area of recording studio operations including business, audio engineering, and technical maintenance will be answered by SPARS-approved sources at no charge.

Want a problem solved?
Call SPARS -
(305) 443-0686



SPARS Board of Directors and Consultants

Murray R. Allen Universal Recording Corporation, Chicago	Guy Costa Motown/Hittville USA Los Angeles	Malcolm Pierce Rosenberg Wolav & Rosenberg Philadelphia
Jerry Baines United Western Studios Los Angeles	Mack Ememan Criteria Recording Miami	Christopher Stone Record Plant, Inc. Los Angeles
Charles Benanty Soundworks Digital Audio/Video Studios New York	Leroy Friedman Columbia Recording Studios, New York	Joseph D. Tarsia Sigma Sound Studios Philadelphia
Nick Cullinan Alpha Audio Richmond	Lenard Pearlman Fulfil-Chicago	David Teig New York
	John Rosen Fania Professional Services, Nashville	John Woram Woram Audio Associates New York

Circle #058 on Reader Service Card

SCMS

SPECIALIZING IN TURN-KEY
PRODUCTION FACILITIES

REPRESENTING:

AKG	ORBAN
APHEX	OTARI
ATLAS	QUANTUM
AUDIOTECHNICA	SENNHEISER
AURATONE	SESCOM
BEYER	SHURE
CROWN	SPENDOR
DAVID HAFNER	MONITORS
DBX	SWITCHCRAFT
ECHOPLATE	TECHNICS
EDCOR	TELEX
E-V	TENTEL
EVENTIDE	TRIDENT
ITAM	UREI
JBL	VIKING CASES
LOFT	XEDIT/EDITALL
MICMIX	AND MANY MORE
NORTRONICS	

MCI

A Division of Sony Corporation of America

Check our \$. Call us!

(704) 889-4508
(800) 438-6040
(toll free, East Coast)

Circle #059 on Reader Service Card

Protect Your Copies of Mix Magazine



MIX MAGAZINE is a year-round reference tool. That's why we're offering these hand-crafted binders and library files to keep your issues safe, ordered, and readily-accessible. Both styles are bound in textured crimson leatherette, embossed with the gold-leafed MIX logo. Gold transfer slips are included for indexing volume and year.

LIBRARY FILES: 12 issues are organized for storage and slide out individually for use.

BINDERS: 12 issues are bound for protection and open flat for easy reference.

Both are handsome additions to your bookshelf.

Mail coupon to Mix Binders, 2608 Ninth Street, Berkeley, CA 94710.

Please send me:

___ Library Files @ \$6.00, 3 for \$17.00 \$ ___

___ Binders @ \$8.00, 3 for \$22.00 \$ ___

California residents add 6.5% sales tax \$ ___

Add \$1.50 per file or binder for postage
and handling (\$3.00 outside U.S.) \$ ___

Total \$ ___

Name _____

Company _____

Address _____

City _____ State _____ Zip _____

Please charge to my ___ Visa ___ Mastercard
(Minimum credit card order: \$20.00)

Credit card # _____ Expires _____

Signature _____

Satisfaction guaranteed or money refunded. Please allow 4-6 weeks for delivery. Make checks payable to Mix Magazine.

Best On Our Bookshelf

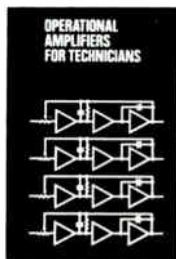

OPERATIONAL AMPLIFIERS FOR TECHNICIANS
Jefferson Boyce
 Uses a functional approach supported by graphical and algebraic methods, an understandable and highly applicable text.
 (1) \$25.95



THE PLATINUM RAINBOW
Bob Monaco, James Riordan
 How to approach the music business rationally. It covers almost every angle of the industry, creative and business. The best of its kind.
 (2) \$9.95

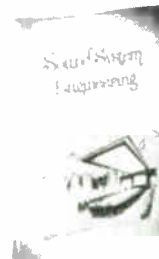

SOUND SYSTEM ENGINEERING
Don & Carolyn Davis
 The best book on electronic sound reinforcement systems. Integrates all available, useful information in a concise, logical form.
 (3) \$21.95



HOW TO BUILD A Small Budget Recording Studio from Scratch
Scratch F. Alton Everest
 All background information and specifics to design, construct, operate a budget studio. Includes 12 tested designs.
 (4) \$9.95



PRACTICAL TECHNIQUES for the Recording Engineer
Sherman Keene
 The most comprehensive treatise on the "real world" of recording. Thorough, in-depth, understandable.
 (5) 29.75

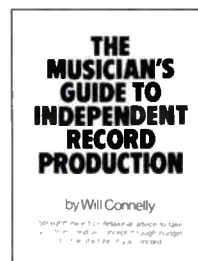

MUSICIAN'S GUIDE TO INDEPENDENT RECORD PRODUCTION
Will Connolly
 Straightforward advice on the entire process of record-making for the aspiring producer. Hardcover
 (6) \$12.95

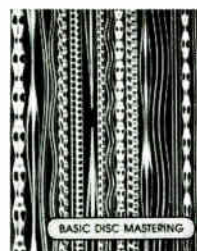

BASIC DISK MASTERING
Larry Bodin
 A primary reference source for engineers and producers. The only book to deal comprehensively with disk mastering.
 (7) \$10.95

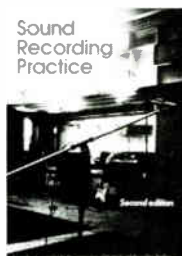

SOUND RECORDING PRACTICE edited by *John Borwick*
 Updated handbook compiled by the Association of Professional Recording Studios, designed for the user.
 (8) \$55.00

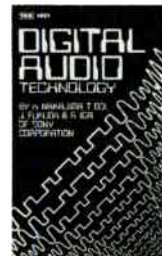

DIGITAL AUDIO TECHNOLOGY
H. Nakajima, T. Doi, J. Fukuda, A. Iga, of Sony Corp.
 Authoritative handbook covering fundamentals of digital PCM recording, audio and video disk systems. Hardcover
 (9) \$18.95



CRITICAL LISTENING
 An audio training course, 10 self-study lessons, text, and 5 pre-recorded cassettes. Fine tune your hearing to recognize audio subtleties.
 (10) \$129.95

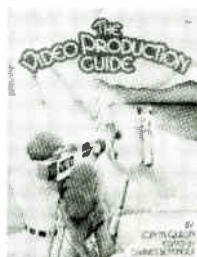

VIDEO PRODUCTION GUIDE
Lon McQuillin
 Lively, comprehensive coverage of both studio and location production from the viewpoint of the producer and director.
 (11) \$28.95

Best On Our Bookshelf

Please indicate how many copies of each title

			PRICE
_____ 1	_____ 6	_____ 11	_____
_____ 2	_____ 7	_____ 12	_____
_____ 3	_____ 8	_____ 13	_____
_____ 4	_____ 9	_____ 14	_____
_____ 5	_____ 10	_____ 15	_____

Subtotal _____

California residents add 6.5% sales tax
 Include \$2.00 postage & handling per title
 (\$3.00 outside U.S.)

Enclosed check or money order for total \$ _____

Name _____

Address _____

City _____ State _____ Zip _____

Mail to: MIX BOOKSHELF, 2608 Ninth St., Berkeley, CA 94710

Please allow 4 - 6 weeks for delivery.

Aug83

Please write for our complete catalog of audio, video and music books.

PHIL COLLINS



PHOTO LINDA MATLOW



PHOTO STEVE HALLOWAY

ROCK & ROLL WORKAHOLIC

by Bruce C. Pilato

Phil Collins is on the phone in his hotel room in Buffalo with a problem: Stig Anderson, manager of ABBA, is trying to get him to produce the second Frida solo album but Phil can't because he's booked through 1984. "I just can't do it this year," he says diplomatically. "If she wants to do one this year, she'll have to do it with someone else."

Flipping through his mental calendar, Collins sees no end in sight to the blizzard of projects to which he has committed himself - and that suits Collins just fine. Throughout all of last year all you had to do was take a quick glance at the pop charts and there you'd find him in his various roles as performer, producer, session musician, and songwriter, associated with no less than a half dozen hits, among them records by himself, Genesis, Robert Plant, and Frida. That's not to mention additional production work with Brand X, John Martyn and Peter Gabriel, plus six solid months of touring both as a solo act and with Genesis.

"I like to keep busy" is an understatement, to say the least. With a full schedule of writing, recording, producing and touring mapped out

DOD Electronics announces a new line of high quality signal processing equipment. . . .

The DOD Pro Products Group



The all new DOD Professional Products Group contains the most advanced pieces of equipment needed by the professional signal processing - from digital to analog delay units, filters to thirty one band graphic equalizers and much, much more.

Each product in the DOD Pro Products Group has been designed with the professional in mind. All DOD products have built-in safety features and circuit protectors for quick and easy operation. Each product contains the latest circuit technology for performance and reliability. And all DOD products are manufactured and tested in America.

Check out the new DOD Pro Products Group - your local DOD dealer and see why DOD products to be the most cost-effective quality equipment.

DOD

For more information
call or write:
DOD Electronics Corp.
262 South 300 West
Salt Lake City, Utah
801-485-8534

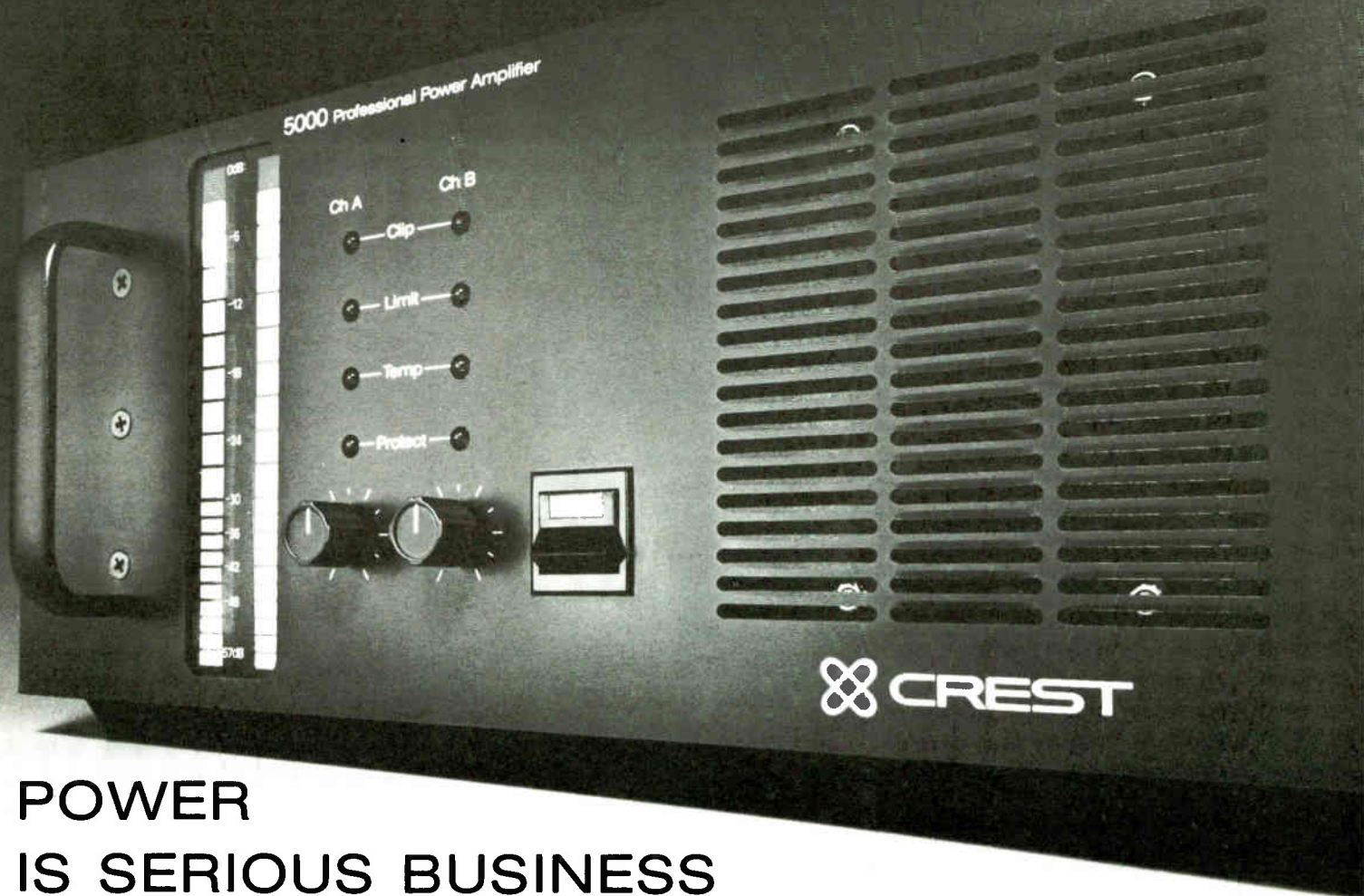

POWER IS SERIOUS BUSINESS

It's easy for manufacturers to talk about impressive power ratings. But if power is achieved by sacrificing reliability and distortion levels, what use is it?

Crest provides power without compromise. Our measurements meet FTC regulations which subject power amplifiers to enormous stress test conditions. The Crest Model 5000 amplifier FTC rates into 2 ohms at 800 watts a side, both channels driven, but has a total of 5600 watts of output transistor capability. Conservative use of power transistors and massive heatsinking delivers . . . power without compromise.

Independent dual power supplies with oversized semi-toroidal transformers and high rated capacitors provide that extra current to minimize channel

crosstalk, and handle large transients and quick level changes.

With balanced inputs, external circuit breakers, speaker protection, and "turn-on thump" delay standard, Crest provides all of the necessary features for the real world.

The result . . . sonic superiority, reliability, rugged construction, and power output levels well within the safe, cool operating area of the amplifier.

With a range of seven models, from the 35 watt Model 1001 to the 350 watt Model 5001 (FTC 8 ohm specs), Crest will fill your amplification requirements.

For complete technical specifications, see your Crest Audio professional dealer or write to us.

Power is serious business.

 **CREST AUDIO**

for 1983 and 1984, Collins surely stands as one of rock and roll's true workaholics. Despite his preplanned future, however, Collins is only concerned with *today*.

"We're having a *fabulous* time!" says Collins later that evening to a packed auditorium of 11,000 fans. "Are you having a *fabulous* time, too?" As if he wasn't sure, Collins cocks an ear to the audience and waits. Milliseconds later, he is nearly knocked down by their thunderous applause. "Good, then let's carry on."

Tonight, Phil is onstage with his own group, The Fabulous Jacuzzi's And One Neat Guy. It's a different style of show from the one he is known for with Genesis. There is much more humor, and—the enjoyment of all—much more variety in the music. And variety is the key to Collins' success. He goes out of his way to make sure there is plenty of it in his life.

Although The Fabulous Jacuzzi's are essentially the same touring lineup as Genesis (with Tony Banks and Mike Rutherford replaced by Peter Robinson and Mo Foster, respectively) the musical distance between the two groups is gigantic.

"It's very different," says Collins after the show. "The nature of the songs in my show is very, very different. I'm up there singing something I wrote from a very personal experience, songs that I feel very close to. And audiences are enjoying them. I'm *amazed* at how many people are enjoying the show. With Genesis we've got a reputation that precedes us and there's 10 to 12 years of albums to choose from, but with my show it's a totally unproven quantity. There are 20 three- or four-minute tunes, as opposed to four or five twenty-minute tunes with Genesis. It's so very different, and I get an amazing amount of satisfaction from that."

Born in Chiswick, England, in 1951, Collins' first gig in show biz was as a child actor. Although his love for music—and drums in particular—goes back to age 5, Collins spent most of his childhood developing his theatrical skills (which would help him years later when he became frontman for one of the world's most popular rock groups). At 14, he was playing the Artful Dodger in a West End London version of "Oliver" when he made a brief appearance in The Beatles' film *A Hard Day's Night* as a cheering fan during the concert scene. Soon after that experience, Phil Collins knew it was on the concert stage that he, too, belonged.

—page 105

eastcoast sound specialties



Audioarts • Ashly

**Itam • Fostex • Otari • Tascam • Urei •
Orban • AB • Crown • BGW • TMS
Studiomixer • Deltalab • Eventide • Lex-
icon • Symetrix • Master Room • Ramsa •
DBX • Aphex • Audio Technica • Valley
People • EXR • Senheiser • AKG • Com-
munity • NEI • Sound Tracs • Speck •
Oberheim • Synergy • Sequential Circuits**

FAMOUS PRICE GUARANTEE

Eastcoast Sound guarantees the absolute lowest prices anywhere. If you can beat our price on any system within 30 days after you purchase, we will refund to you the difference.

40 Main St. • Danbury, Ct. 06810 • (203) 748-2799
884 Boston Post Rd. • West Haven, Ct. 06516

Circle #062 on Reader Service Card

Exquisite
Sound

Modest Cost

GRD

AMERICA'S MOST
EXPERIENCED
REAL TIME DUPLICATOR

HIGH QUALITY PRINTING
AND ASSEMBLY

CUSTOM LOADED BLANK
AGFA CASSETTES, CHROME

(602) 252-0077
P.O. BOX 13054
PHX., AZ 85002
Canada Division
(403) 283-8068

THE RECORDERS Quartz-lock Auto Bias
30-20,000 Hz. 0.25% w/r m/s Dolby B -
more than 67 dB S/N ratio

Circle #063 on Reader Service Card

BILL BRUFORD AND SIMMONS DRUMS: PROOF THAT THE FUTURE WORKS.



Bill Bruford doesn't play the new Simmons electronic kit because it's the most amazing looking set ever made. Or because it comes in a range of 7 dazzling colours. Or because it can fit comfortably in the trunk of even the smallest auto.

Bill's not bothered about things like that.

But, as a truly creative musician, what he is bothered about is finding the kit that can help him extend the frontiers of his craft.

Bill uses Simmons live and in the studio because (unlike most electronic drums) our kits are for playing. Not for playing with.

"I believe that, just as the electric guitar revolutionized guitar-playing, the

Circle #064 on Reader Service Card

introduction of Simmons drums is just the beginning of a new era that will make the drummer's art more challenging, more exciting than ever before."

But you don't have to take Bill's word for it. Send \$2 to us at Simmons Group Centre Inc., PO Box 1444, Reseda, CA 91335 and we'll send you a special recording of Simmons drums in action.

Then, like Bill Bruford, you'll be convinced that the sound of Simmons really is the sound of things to come.

And if you'd like to see Bill play Simmons on video, write, enclosing \$53.95, for 'Bruford and the Beat' to Axis Video Inc., PO Box 21322, Baltimore, Maryland 21208.

SIMMONS

THE DRUMS OF THE FUTURE

SIMMONS GROUP CENTRE INCORPORATED, PO BOX 1444, RESEDA, CALIFORNIA 91335. TELEPHONE: 213 884 2653.

World Radio History

T-Bone Burnett: A Rocker and a Thinker

"This is music for people who like to think," wrote my friend and colleague, Blair Jackson, of T-Bone Burnett's 1982 mini-LP, *Trap Door*. Burnett's music also happens to be, for the most part, driving, hooky rock music that won't disappoint those who prefer dancing to Durkheim. His new LP, tentatively titled *Weapons* and scheduled for late August release, features guitarists Ry Cooder, Mick Ronson, Richard Thompson, and none other than Pete Townshend, who insisted that Burnett open for The Who on several American dates of their (not-so) final tour. All of those players know how to deliver the power, and so does T-Bone.

Burnett, a Texan in his mid-30's, started out as a record producer in his native state at the age of 16. "I did a lot of R&B records," he recalls. "I produced *Paralyzed*, by the Legendary Stardust Cowboy; Robert Ely and his Five Careless Lovers; and a lot of local stuff. . . ." He also produced an album by Delbert and Glen, the former being Delbert McClinton, who went on to solo fame.

He went to New York in the mid-'70s to work with his friend Bobby Neuwirth, and thereby became involved in Bob Dylan's Rolling Thunder Review - which was his first-ever experience as a performer. Out of that came the Alpha Band, which consisted of Burnett on guitar, vocals and piano; Steven Soles, vocals and guitar; and

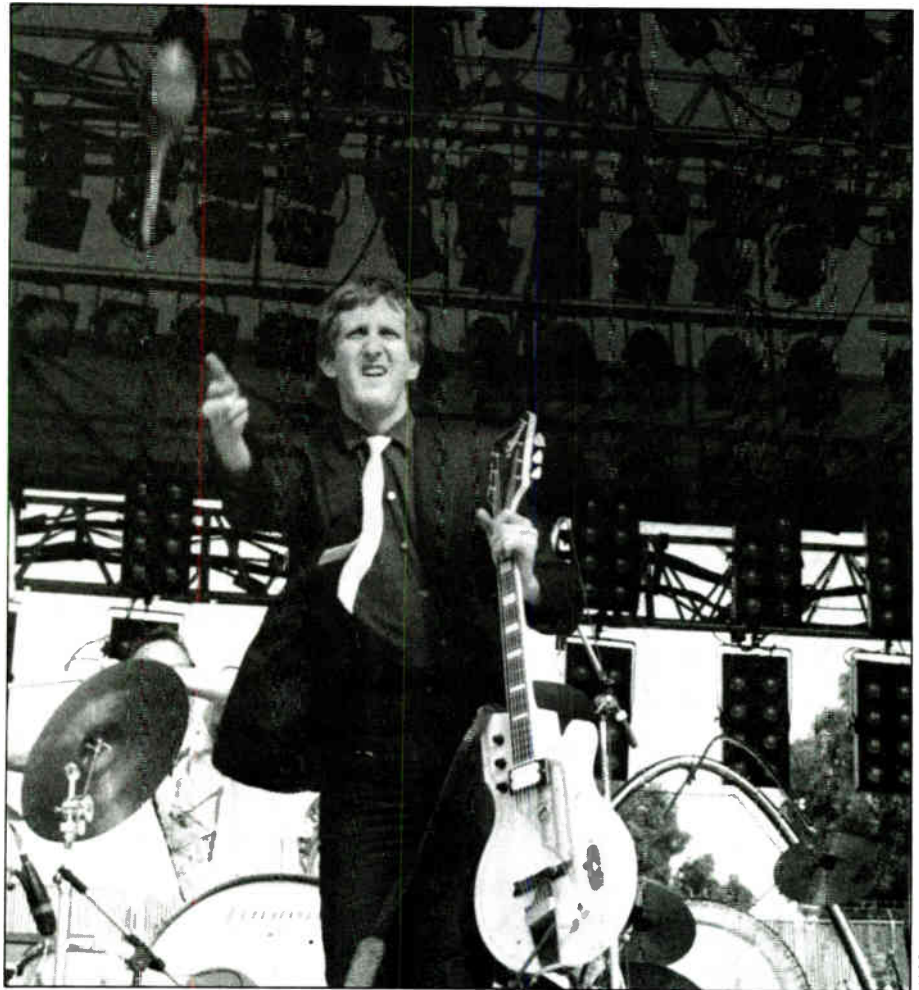

PHOTO: DAVID GANS

David Mansfield (who also appears on *Weapons*) playing pedal steel, mandolin, guitar and violin. "The Alpha Band was funny," Burnett recalls. "Steven was going in one direction and I was going in another. He would do a song and then I would do a song, kind of like a

ping-pong game or something. I wanted to be The Rolling Stones and he wanted to be Jackson Browne, or something like that, and the audience ended up going, "What kind of music do these guys play?"

—page 92

THE FAR SIDE

By GARY LARSON



"Well, there it goes again . . . Every night when we bed down, that confounded harmonica starts in."

Linda Mensch: Full-Time Music Lawyer

"I come into every negotiation with a win/win attitude," says Chicago music attorney Linda Mensch. "Both sides should come away from the table feeling they've won *something*."

"That doesn't sound very hard-line, I'm afraid," she concedes, "but I really am interested in knowing what both sides want from a deal."

Whatever her tack, 1983 has been a prolific year for the attorney, employed by the entertainment-oriented firm of Katten, Muchin, Zavis, Pearl and Galler. In addition to finalizing contracts for artists in the two areas in

which she believes she excels—new music (Ministry, 8½, the Elvis Brothers and Combo Audio) and R&B (the Chili-Lites, the Dells, Juni of the Ohio Players and Con Funk Shun)—Mensch helped an older client, Cheap Trick, move full-steam into the movie soundtrack field.

The 32-year-old New York native is the first to concede that she shouldn't reap all the credit for these deals. Her role, she explains, varies from making the overtures and following them through to merely fine-tooth-combing the papers once a deal is already agreed to in principle.

It's the ones in which she *did* actively participate that Mensch considers to be her most rewarding. "In the case of Ministry, we put a package together," she says. "Not only did the material have to be right, but we had to have production lined up. We had to



convince a studio owner or engineer to let the group in on spec or a low-fee basis in order to get their demo down. The record company then took a look

at the team we'd assembled and said among themselves, 'We've got all these people betting on the artist - a manager, an agent, an attorney, a producer and a studio, all of whom have better things to do with their time. Let's listen to this artist seriously.'"

Mensch's role consists of weighing the offers and pushing for the highest possible royalty and equitable foreign licensing arrangements. She's the one who draws up the client's proposed contract and examines the draft submitted by the record company's counsel. Her work, however, is in no way synonymous with that of a personal manager, something she recommends her clients enlist by the time they're ready to talk to the labels.

"I'm not interested where it gets down to the point of risk," she explains in distinguishing her function from that of a manager. "As an attorney, I don't take a percentage. As a general rule, I charge by the hour no matter what I do for a client. *My* bosses want to know how I've spent my day, as they're well entitled. I'm not going to benefit from a successful negotiation except in reputation - it's the same fee whether I call a record company or just inspect

some papers.

"This way, I give fair counsel," she adds. "The little rock group comes to me and asks, 'Why would you care about *us*?' I do, because the pay's the same."

Her feelings on the music industry are nowhere near as cut and dried. "I truly love this business, even if it does sometimes resemble a cross between a battleground and a '60s toga party. And I'm in the middle, armed for battle. On the one hand I have to be this person my clients can relate to, always pleasant and understanding. On the other hand, I have to tell the client his manager is an idiot - *if* he is.

"At the moment, I'm really into new music, though I wish Chicago had a new music station I could jog to in the morning. And I like R&B, which dates back to my days of repping the Ohio Players."

Eventually, Mensch would like to expand her repertoire to include production. She's already offered her two cents to professional producers whose closeness to a project may have shrouded their ear for detail at a given moment. Mensch has picked out wrong chords and out-of-tune vocals, but admits her role in this area may always be a limited one. "I'm neither a musician nor an engineer," she says. "I just know when I *don't* like something, and usually producers and artists agree when I've pointed something out in the studio."

Mensch remains optimistic about the record business, even in the face of flagging sales. She's come to appreciate a blight she'd previously ignored - that of home taping. "I had the new Ministry album on my desk the first day it was out, and a few people in my office asked if they could tape it. 'No! Go out and buy it!' And these were entertainment lawyers who should know!"

When Mensch isn't at her desk or out of town negotiating contracts, she can be seen carousing the Chicago clubs, scouting new talent. "It's smart to get me out to see a band live, because I love live music," she says, "even if the tape I hear on Monday morning may dock my enthusiasm."

She doesn't mind the seven-days-and-nights-a-week commitment to her work, she claims, but does try to escape it occasionally. "I take a lot of this stuff home with me. And to an extent, I take everything very personally," she says. "But at some point, I have to cut it off. I have to say to myself, 'It's not *my* life. It's someone else's. All I can do is tell them what I *think* is going to work. And they can do whatever they want.'"

—Cary Baker

Take A Stand!

Four models of light weight, adjustable "fish-pole" booms

Durable, colorful and quickly adjusted, Keith Monks stands are crafted in Britain and used around the world. On stage or in the studio, they maintain their attractive appearance and smooth operation. Matching booms adjust with the flip of a single lever. Stable, reliable and cleanly designed, Keith Monks stands are the attractive alternative. Call or write today for catalogues & prices.

A wide range of large studio stands and sturdy tripods to heights of 15'6" is also available.

KEITH MONKS AUDIO (USA) INC
1169 Tower Road Schaumburg, IL 60195 (312) 885-0066

Circle #065 on Reader Service Card

Carvin

The Professional's Choice

Professional Groups like: Pat Benatar, Roy Clark, Heart, Jefferson Starship, Marshall Tucker, Pink Floyd, The Scorpions and Frank Zappa choose Carvin because they feel it's the best!

At Carvin you're not only buying the best, but our "Pro Net" prices are attractive because you're buying Direct from us. Send \$1 for your 1983 80 page Color Catalog. Send \$2 to RUSH by 1st Class mail, \$5 for foreign countries. For product information, Call Toll-Free 800-854-2235 (Calif. 800-542-6070) Master Charge & Visa accepted.

Direct Pro Net Prices on all Carvin Products as shown

- A R540-M Concert 90° Radial Horn — Pro Net \$269 List \$495
 - B 1330-M Horn-loaded Bass System — \$239 List \$495
 - C 980-M Pro Radial Horn / Bass System — \$349 List \$695
 - D 750-M Pro Stage Monitor — \$169 List \$295
 - E MX1202 12 Ch Stereo Recording Board — \$1195 List \$2595
 - F DCA800 800W (bridged) Stereo Power Amp — \$599 List \$1095
 - G DCM301 300W Monitor Amp w 9 band EQ — \$349 List \$695
 - H EQ2029 29 Band 1/3 Octave Equalizer — \$259 List \$495
 - I XC1000 Stereo Electronic Crossover — \$269 List \$495
 - J DC200 Koa Guitar with Gold Plating — \$570 List \$1140
 - K XB112 All-Tube 1-12" "X" amp w Celestion — start at \$449
 - L B215-M Dual 15" MagnaLab Bass Enclosure — \$249 List \$495
 - M PB150 Bass Head w Compressor & Parametric — \$399 List \$795
 - N V412-M Lead Stack w 4 12" Celestion spks — \$399 List 795
 - O X100-B British 100W "X" Amp head — \$579 List \$1195
- JBL speakers optional on most models.

Write: CARVIN, Dept. MX-43, 1155 Industrial Ave., Escondido, CA 92025

Circle #066 on Reader Service Card



1983 CATALOG
 \$1 for Bulk Mail \$2 for First Class Mail

Name _____
Street _____
City _____ State _____ Zip _____
MX-43

Backward Masking Backlash

The issue of backward masking has raised its infernal head in recent months, with religious leaders accusing rock musicians of burying Satanic messages in their tracks. And it appears that there's some truth to the charges.

A press release crossed my desk last month from the people who represent Styx, a rock band. Noting the Arkansas State Legislature passed a bill requiring any record which contains backward-masked messages be labeled as such, the Styx publicist informs the world that *Kilroy Was Here* is stamped thusly: "By Order of the Majority for Musical Morality, this record contains secret, backward messages."

How convenient. The theme of *Kilroy Was Here* is the takeover of the country by extremists; the plot concerns a "rock and roll hero" who is imprisoned by an outfit calling itself (you guessed it) the Majority for Musical Morality. The masked message is as fol-

lows: "Annuit coeptis novus ordo seclorum." The press release spelled it wrong, and I don't care to find out how they pronounced the phrase on the album, but despite its sinister Latin appearance, it's got to be a fairly harmless message—it's the one inscribed on the Great Seal of the United States, and as such it appears on every American dollar bill, right next to that groovy psychedelic pyramid with the eyeball on top.

T-Bone Burnett, himself a seriously religious man (and who is profiled elsewhere in these pages this month), has also embedded a secret message in one of the tracks of his forthcoming album. The Texan intoned his in the vernacular, however, and this is what it says: "You're listening to the record backwards, stupid."

—D.G.

—from page 89, *T-Bone Burnett*

On his first solo album, *Truth Decay* (on the now-defunct Takoma label), "I just went back to the first music I ever liked—Jimmy Reed, Hank Williams, Lefty Frizzell, Junior Parker, John-

ny Cash—on the theory that if you're doing a mathematical problem and you come up with the wrong answer, you have to go back and find where you made your mistake and proceed from there."

His Warner Bros. debut, *Trap Door*, included a strange reading of "Diamonds Are a Girl's Best Friend," originally sung by Marilyn Monroe in the 1953 film, *Gentlemen Prefer Blondes*. "There are big collections of Broadway show tunes you can buy; I got stacks and stacks of them and started listening, and I was amazed at how great they are," says Burnett. "The older songs are very literate and funny, and so many of them are relevant today, even though the melodies belong back then. People write words these days that don't mean anything—they're just trying to say whatever's fashionable—but those old lyrics are timeless."

Burnett was content to remain behind the scenes as a producer and songwriter for many years, "but it's come to the point where I have to get out and do what I do, which is write and play music," he says. "I think that by getting on stage in the first place, you're admitting that you're wildly insecure,

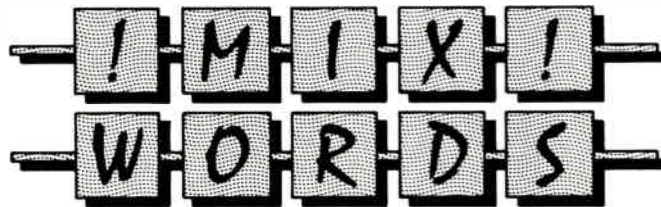

ACROSS

1. Celebrants of Castille Day?
6. J.E.B. Stuart was one (2 wds)
10. Preferred horse
14. Assign portions
15. Repetitive mnemonic acquisition
16. Bring aboard
17. Aerie, to Chaucer
18. If 26 down were a sheriff, this would be his 44?
20. Silly or spruce _____
21. Series of movements (Mus.)
22. Werner started it
23. Wing-like
25. Writing liquid
27. Rock pitcher
30. Replacement
34. Elks' meeting?
35. _____ mater
38. Arctic direction to Juan
39. Draught (2 wds)
40. Certain linen
42. To carry or sustain
43. Ice cream with root beer
45. Fired
46. Nomad's dwelling (Var.)
47. Some leather types
49. Used a divining rod
51. Precedes 'fu'
52. Valuable violin
54. Mouths
57. Swelling caused by fluid
59. Tristan's beloved
63. _____ a medicine for noise?
65. Aquatic mammal
66. Bakery worker
67. Uncertainty factor
58. Desert inn (Var.)
69. Falls out
70. Back talk
71. They were, to Ovid

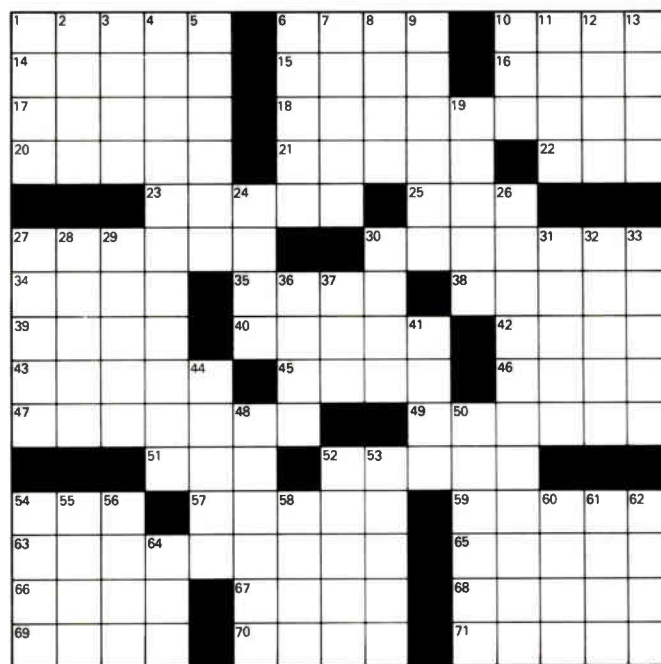

DOWN

1. Past tense of sing
 2. _____ margarine
 3. Likewise
 4. 26 Down really cooks with these
 5. Detective of fiction
 6. Have _____ (Take it easy)
 7. Croquet
 8. Small case
 9. Michael Jackson hit
 10. The Champ
 11. Demolish
 12. Summer coolers
 13. Mr. Reynolds
 19. Noted Bolshevik
 24. ".....smell" "
 26. Audio engineer
 27. Isaac Hayes' soundtrack
 28. Multi-phase current inventor
 29. Constellation including Betelgeuse
 30. Common sign in stores
 31. Free-standing stage light supports
 32. Length of a day's march (Mil.)
 33. Incarnadine again
 36. Hoodoo spirits
 37. Venerable publication
 41. Sicilian commune
 44. Credo
 48. Intuitions or phase-rays
 50. Futile
 52. Awry
 53. Conceals
 54. Norse god
 55. One of the Reeds
 56. Like fine wine
 58. Kazan
 60. Something else, to Juanita
 61. Wiry
 62. Allowance for waste
 64. Fed. agency
- (Solution Next Month)

© 1983 Armand E. St. Martin

that you need love and acceptance – and a lot of it, not just a friend saying, ‘Hey, you’re okay.’ You need to feel like you’re worth something. But that is the condition of *every* person, in the audience and on Earth. I think love is the fuel we run on – and I don’t mean the 1960s, hippie sort of vague love, some faceless force in the universe. I mean divine love.

“I’m a Christian, so I believe in the love of God for His creation, and the love of man for himself and for each other – and also for the creation. That’s the glue that holds the creation together, I think.”

Mix: I have read variously that you have been a Christian all your life and that you and several others converted right after the Rolling Thunder tour. Which is it?

Burnett: My grandfather was Secretary of the Southern Baptist Convention for 25 years; my father and I were very active in the Episcopal church when I was growing up. My parents got divorced, and that began my rebellion – I lost my child’s faith. I didn’t go to church, didn’t live a Christian life, but believing in God was a part of me that I

couldn’t shake. I would say that God made me a Christian, and only He can unmake me a Christian. Nobody’s going to take it away from me, including myself.

Mix: Have you tried? Have you tested your faith hard?

Burnett: When I was a kid I tested it *real* hard, as hard as anybody else.

Mix: And your faith sustained you and itself?

Burnett: Well, I got to a point where I’d actually reached the end of my tether. During the Alpha Band, when I made the first tentative steps out on my own [as a performer], it was too awful. I couldn’t deal with the reality of what was going on.

A friend gave me a book called *The Dust of Death*, by Os Guinness – of the Guinness family. It just struck home to me; it was accurate and literate and smart, and it turned out that the guy was a Christian. I was shocked that a Christian had actually done something intelligent, you know, because my view of Christianity at the time was sort of like Pat Boone – white belts and white shoes . . .

As I view it, Christianity has nothing to do, ultimately, with morality. There are really only two religions on Earth: the religion of law and the religion of grace. The religion of law is Judaism, Buddhism, Mohammedanism, Taoism—capitalism and communism, which are secularizations, in a sense, of the religion of law—and any other ism you want to name.

Then there’s Christianity, the religion of grace, which says pretty much that no one can fulfill the law at all. It’s impossible for man to fulfill the law, so God—the author of this play—wrote himself into the play and fulfilled the law for us as an act of atonement.

Mix: Where does that leave us?

Burnett: It leaves us in a position where we can accept the grace of God or not. I have no idea of how anyone can believe this piece of foolishness – that a man was born on Earth of a virgin and was actually God incarnate; that he died on a cross and was buried, descended into Hell, and three days later was back on Earth walking around and then ascended into Heaven. It’s so against everything we as enlightened men are trained to think—but I do

A NECESSARY ADVANTAGE FOR TODAY'S MUSICIAN.

Professional, Amateur, Teacher or Student. Whether you entertain friends at home, or you play for sell-out crowds, there's one musical instrument that actually makes you a better musician. **SOUNDCHASER**. Soundchaser is intelligent. It teaches, records, synthesizes, and even prints music.

What sets Soundchaser apart from other musical instruments is the software. Not just any software, but the kind of programming that has made Soundchaser the #1 choice of musicians, educators and computer users worldwide. Software that's easy to use. Software that delivers all the excitement and creative freedom you want, without the confusion and high price you'd expect.

Become one of today's musicians, find out what Soundchaser can do for you. Soundchaser. A necessary advantage for everyone.

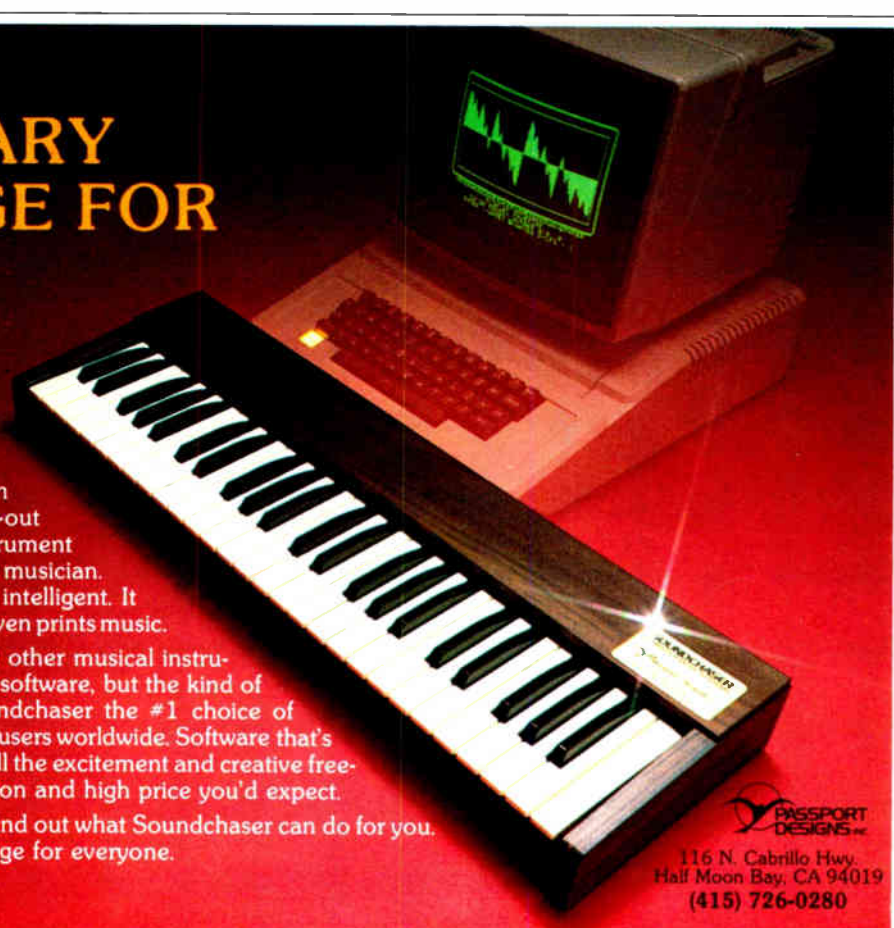

PASSPORT DESIGNS
 116 N. Cabrillo Hwy.
 Half Moon Bay, CA 94019
 (415) 726-0280

Circle #067 on Reader Service Card



The UNUSON Corporation would like to express it's gratitude to the following companies for their participation in adding to the success of the 1983 US Festival, for sponsoring a professional sound system and/or providing a professional engineering team at each of our four specialty talent performance stages, VIP, and press conference sites.

From all at US... to all of you.



Kevin Korecky
Raymond Gallant
Michael Haugh
Shirley Fletcher
Keith Finch



Larry Cumings
Chris Ostrander
Kip Rooker
Bob MacGregor
Bruce Boles
Doug Cuningham



John Hauschild
Greg Vincy
Tom Smead

SOUND SYSTEMS
SERVICES

*of
California*

William Hosch
Dave Griffiths
Jose Guardiola
Tori Nobles
Bill Zimmer



CONCEPT GROUP LIGHTING
Kevin Boone
Ron Conway
Alan Woodle

—from page 93

believe it.

The resurrection of Christ . . . is still the most potent scandal in our history. It's a very volatile subject; it's an authenticated historical fact, and it can be debunked just as anything can be debunked.

Mix: I'm skeptical, too, of people who see the light at a time of deep personal crisis, when there's such a gigantic hole in one's spiritual or physical side that he needs to have Christ rush in and fill it. It seems like a pretty opportune time to adopt the ritual.

Burnett: Carl Jung used the metaphor of Jonah and the whale - religious conversion out of mental breakdown, going into the depths of darkness and coming out with a whole new frame of mind. But yeah, I know . . . you see people go into so many areas of spiritual crisis, and some of them become loonies -

Mix: The burden of deciding your own fate becomes so heavy that you find somebody else to turn it over to - est, the Democratic Party, Jesus - anything.

Burnett: "Somebody run my life for me." But in the scriptures, He says, "You have to use your will." Anyway, you can't judge Christianity by the people who call themselves Christians.

Mix: That's the problem: what has been done in the name of Christ through the centuries.

Burnett: But Christianity has survived Christians for 2000 years now, which from my point of view is more evidence that maybe there is something going on here. I'm very skeptical, too, but I've found skepticism to be a really good basis for faith: if it continues to answer for itself through all your doubts, then your faith is made stronger.

I'm probably as skeptical as you are, but because of some act that's been performed on me—this is all conjecture—there may be places where I'm more accepting of certain things than you are. When I was younger I was a complete cynic. I never accepted anything: I was never a hippie, never looked at astrology, never went for rock 'n'roll stars . . .

Mix: And here you are playing rock'n' roll music. What are you looking for out of this?

Burnett: I'm not real conscious of what I'm looking for out of it. I'd like to earn a living playing music, but that's certainly not what motivates me.

I want to make really honest, generous, resonant music. I think we live in an age when a lot of people don't want

to feel anything, because life is so painful. So they cut themselves off from pain - but they also cut themselves off from love and joy and hope and a lot of other feelings.

On the other side of that, there are a lot of people desperately crying out for a point of view, for somebody to stand up and say just what he thinks - to give a point of view.

I think you can give your point of view as clearly and powerfully as you can, but I think that's about the end of what an artist can do. The part about selling yourself makes it hard - you have to be careful of what you're selling; if you're going to allow yourself to be held up as an image, then you have to be responsible with that image. Like it or not, there are human lives out there that you're affecting. It's easy to say, "That's their problem," but you have to be responsible.

—David Gans

Product News

The Great British Spring has 12 springs of varying length, mass and coil diameter, designed to complement each other for smooth, flutter-free reverberation. The manufacturers say they've avoided electronic circuitry wherever possible and left it to the springs to do their thing, yielding "virtually flutter-free" sound with extended response in the higher frequencies. During final checkout a frequency response printout is made, so the user can see exactly how that particular unit measures up. It's available in three configurations: unbalanced, with 1/4" stereo jack inputs and outputs; unbalanced, with XLR connectors; and balanced, with XLR connectors.

Circle #099 on Reader Service Card

It was bound to happen, and it looks like a pretty good idea: Sye Mitchell's **Hot Stix** is a series of cassettes containing pre-programmed software for Linn, Oberheim, E-mu or MXR drum machines. Each tape has 36 thematically related programs in varying measure lengths designed to be linked together as the user sees fit. Styles available include rock, country, R&B, pop, and new wave, with more than one set of presets planned for each. Call Sye or Ina Mitchell at (213) 348-4977.

Circle #100 on Reader Service Card

The **49-HT**, Nady Systems' new wireless hand-held microphone, boasts an Audio Technica PR60 mike

head, Nady's exclusive 3-channel capabilities and patented "lo-noise" design, and an antenna built into the mike instead of dangling outside. The **49-HT** joins the Nady **49-GT** musical instrument system and the Nady **49-LT** lavalier mike in the less expensive 49 product line.

Circle #101 on Reader Service Card

MXR's new **Series 2000** effects pedals—Distortion +, Dyna Comp, Phaser, Stereo Flanger, Stereo Chorus and Time Delay—include all the standard features plus a multiple-function in-

terface connector that provides such capabilities as remote switching, remote status indication and selection of the highest voltage power source available (when AC adapter is used).

Circle #102 on Reader Service Card

Korg's **PME-40X** system is a lightweight pedalboard with space for four effects. Available pedals include stereo chorus, stereo flanger, compressor, graphic equalizer, tube-sound overdrive, distortion, and an external selector for looping other effects.

Circle #103 on Reader Service Card



TAKE A STAND!

Of course the KS-22 Multiple Keyboard Stand wasn't designed to double as a high bar, but no other keyboard stand has versatility, strength, and stability like this!

Versatility

The KS-22 allows you to choose both the number of tiers you require and the tier widths. Tier sizes are available in six inch increments, from 36 to 54 inches wide.

Strength

The KS-22 accommodates any number of instruments up to a total load of 450 pounds! Ultimate Support Systems are constructed of lightweight aluminum alloy tubing and glass-reinforced polycarbonate parts, together, yielding an end product that's as handsome as it is strong.

Stability

We know how you like to pound out your sound, so our unique leg design and cross-bracing has created a stand that doesn't get the shakes under pressure.

When your gig is finished, the entire stand disassembles in minutes and slips into a slender waterproof tote bag which is included.



Discover Ultimate Support Systems' new KS-12 Single Keyboard Stand, the little brother to the KS-22, along with Ultimate's other musical and lighting stand products at your local dealer OR send \$100 for a complete US\$ brochure

Distributed in Canada by Roland Canada

1331X Red Cedar Circle, Fort Collins, Colorado 80524 (303) 493-4488

Circle #069 on Reader Service Card

HEAR HERE!

Hear us here:

FRANCIS FORD COPPOLA
VAN MORRISON
YAMAHA-COMBO
TAMARIN PRODUCTIONS
JOHN ADAMS
PATRICK COWLEY
BOYS TOWN GANG
SPENCER BREWER
MERL SAUNDERS
IRA STEIN/RUSSELL WALDER
CORNELIUS BUMPUS
JOANNIE GREGGAINS
BLUE SMOKE
JULIE STAFFORD
BILL SUMMERS
ELLY RIBEIRO
MASON TAYLOR
T and N EXPRESS
FRONT ROW
LEO SWIFT
POPPY
IAN SHELTER

"Rumblefish"
"Inarticulate Speech"
"DX-FM Synthesizer Demo Tape"
"WestAmerica" Winner 1983 PZM Challenge
"Light Over Water"
"Mindwarp"
"Disc Charge"
"Where Angels Walk"
"San Francisco After Dark"
"Elements"
"BEACON"
"Joannie III"
"Russian Hands, Roman Fingers"
"I'm No Angel"
"Summer in London"
"So Por Amor"
"Children As Teachers Of Peace"
"T and N Express"
"My Love, My Song"
"Inaccessible"
"Somebody New"
"Show You!"

Univ
W.B.
Cass.
"WestAmerica" Winner 1983 PZM Challenge
ECM
Megatone
Moby Dick
Ind.
Summertone
Windham Hill
Broadbeach
Peter Pan Records
Sizzler
Rankin Records
MCA
Elly
MTM Records
Macmoon Records
TBC
Leo Swift
Katsar Records
Clausic Records

**Tres Virgos
Studios** 

(415) 456-7666
San Rafael, California

Lede™ SYNAUDCON

Circle #074 on Reader Service Card



DAVID BOWIE
Let's Dance
 EMI SO-17093

Produced by David Bowie/Nile Rodgers; engineered by Bob Clearmountain for Fast Forward Productions, assisted by Dave Greenberg; mixed by Clearmountain, assisted by Bowie and Rodgers; mastered by Bob Ludwig at Masterdisk, New York City.

The prodigal chameleon returns. Appearances have never been everything with David Bowie, but his various visages down the fast parade of years—Ziggy Stardust, Aladdin Sane, the Thin White Duke, the demimonde dandy—have given flesh to his shifting musical stances. Witness the eerily lucid cover of *Let's Dance*: a lean, clean, tow-headed Bowie with antique boxing gear and overlaid dancing diagrams. Yes, Bowie the musical contender is back in the ring, after a 2½ year sabbatical trading music for Thespian adventures, and is stronger than ever. But more than a reflection of Bowie's career status, the cover mirrors the music; *Let's Dance* is a gripping album, artful, elusive and athletic.

Bowie-mania is at a high-water mark presently; he's been a busy magazine coverboy, played an awe-inspiring set at the much-touted US festival (his first American show in five years, to the ominous tune of \$1.5 mil) and is enjoying a stupendous commercial reception to the new album. Part of his unparalleled popularity is a reward for his new-found honesty: in interviews, Bowie fesses up and punctures his role-playing mythic balloon. He's decided to strip away the costumes and manners that have always played heavily in his work and just be his wry, white-soul self. Consequently, *Let's Dance* is tearing up the charts and reaching heretofore unindoctrinated Bowie followers.

And the kudos is justly delivered. Bowie has come up with what is essentially the follow-up to 1975's *Young Americans*, the R&B album that rescued Bowie from his pretentious glam-rock instincts. *Let's Dance* is a surprisingly crisp and accessible set of tunes, the bright energy of which is aided by the production guidance of Chic's Nile Rodgers — he makes the parts and the charts

speak plainly and pithily, as opposed to the more eccentric and sometimes chaotic fabric of Bowie's previous *Scary Monsters*. On *Monsters*, Bowie etched the personal and general psychic demons we face as modern humans. Now he reconsiders; c'est la vie, he says. Let's dance.

Well, it's not as simple as that. The album is full of subliminal currents that demand double takes. The title cut, pert dance floor provocation that it is, sets up its pummeling neo-disco groove with an incongruous vocal arpeggio on the 5 chord, recalling "Back in the USSR." Bowie growls the first line "Put on your red shoes and dance the blues" and implicitly questions the motive in dancing at all. For joy? For despair? He puts the subject into ironic relief, laughing as he preaches, like he did in "Fame" ("Puts you there, where things are hollow") and "Fashion" ("We are the Goon squad and we're coming to town.") But Bowie is not really a preacher, he's a dramatist. The arrangement shines coolly on "Let's Dance" — the taut, airy chord punches and the big, semi-canned snare splats ground horn charts that are now in the pocket, now in the ozone. Bowie jockeys up his range to the key word, "flower," in good, grooving company.

One barometer of Bowie's temperament over the years has been his varying tastes in guitar players. Here, Nile Rodgers provides controlled, reliable rhythm parts, but the spotlight goes to blues-rock plectrist Stevie Ray Vaughan, brother of the Fabulous Thunderbirds' Jimmy Vaughan. Vaughan plays with a non-heady fervor on the title cut and on the rockier rendition of "Cat People (Putting Out the Fire)" which is the antithesis of Andrian Belew's guitaristic animalism of the past few Bowie albums. Vaughan's stinging riffs refract Bowie's quivering, bittersweet vocal on "China Girl" — a Bowie-Iggy Pop tune that, of all the cuts, sticks hardest in the memory. Disarmingly, "China Girl" changes from a bright-eyed melody and cheerful, pseudo-Oriental intervals on guitar to a dour minor mode; the major-minor conflict is uncanny. Likewise, the burning "Modern Love" states its groove much more plainly than its lyrical case. An almost Stax-like energy, with bari sax solo, underscores a refrain chant that moves from "modern love" to "church on time" to "God and man." His romantic ambivalence is erased on "Without You," a dotted-quarter rhythm out of "Ashes to Ashes" and a vulnerable, high register vocal.

Side two opens with the distinctly Peter Gabriel-like "Ricochet," which trips on its own self-serious weight. "Criminal World" fares better in a similar mold, but the prize winner is "Shake It," closing the project on a thick-flanked bit of Bowie soul — celebrating his renewed belief in love and in the therapy of shaking it. And here's where Bowie dwarfs the recent spate of kooky synth soul bands and earns his crown as perhaps the most important pop figure since The Beatles. It's a balance of propulsion and engima: baring your soul to an insatiable backbeat and at the same time rekindling the timeless question, what the hell is this all about?

Let's Dance signals a fruitful artist-producer synergy between Bowie and Rodgers. While not as daring as some of Bowie's works, it chortles and electrifies with an authority you'd be hard-pressed to match with any record this year. Though appealing to a more common listener denominator, Bowie is still a bona fide hero beneath the din of hype

—Josef Woodard

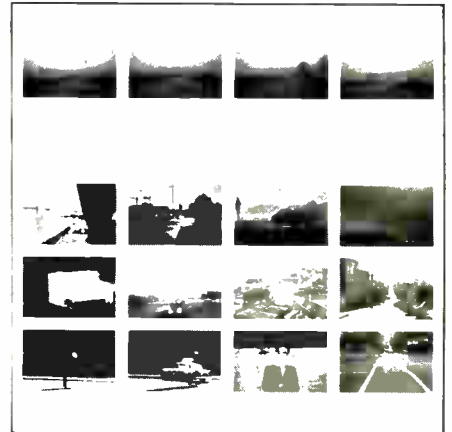

TRAVELS
Pat Metheny Group
 ECM 1-23791

Produced by Pat Metheny and Manfred Eicher; engineered by Randy Ezratty with Gary Geller (of Effanel Sound, New York); mixed by Jan Erik Konigshaug at Talent Studio, Oslo

The thing that sets Pat Metheny apart from his jazz contemporaries more than anything else is the way he and his band interact with their audience. The Pat Metheny Group is anything but a quartet of stereotypical jazz introverts, and their audience hardly resembles a roomful of coolly detached jazz buffs.

In concert, the Metheny Group runs onto the stage like a football team charging onto the field. They smile, they laugh, they occasionally leap into the air — and above all they play to the **audience**, not to themselves. The crowd—which bears an uncanny resemblance to a rock audience—responds by applauding familiar songs or themes (even modulations) and screaming out song titles and encouraging words.

All of Metheny's previous solo, group, and extracurricular releases have displayed the excitement of his guitar playing and the superior lyricism of his compositions, but *Travels*, his first live LP, is the best example so far of his group's finely-tuned dynamic sense. Recorded last summer and fall with percussion master Nana Vasconcelos joining the group—drummer Dan Gottlieb, bassist Steve Rodby, pianist/composer Lyle Mays, and Metheny—the four-sided album offers a double dose (more than ninety minutes) of Metheny magic.

"Extradition" further illustrates Pat's recent explorations with guitar synthesizers, and "Straight on Red" leans toward his fascination

You shouldn't have to deal with a used car salesman to buy a console.



Your studio is only as good as the equipment in it. The last thing you need is a "Deal" on a piece of equipment that you don't want.

Call us. We'll listen to what you want and we'll find it for you. Period.

We don't sell gear, we equip studios.



TOM SEMMES ASSOCIATES

1035 Draughton Avenue • Box 40108
Nashville, Tennessee 37204
(615) 292-8130
Telex 786569 TOM SEMMES NAS

Circle #070 on Reader Service Card

Computer Software For The Music Industry

Packages For:

- Recording Studios
- Publishers
- Songwriters
- Musicians / Singers
- Bands / Touring Artists

... And More On The Way

MetroGnome

P.O. Box 120974
Nashville, TN 37212
(615) 298-4948

Distributed By: Passport Designs
Half Moon Bay, CA

Circle #071 on Reader Service Card

with Brazilian and Afro-Cuban rhythms, while "Song for Bilbao" combines both strains. The title tune (yet another collaboration from Metheny and Mays) and "Farmer's Trust" (written by Pat alone) showcase the guitarist's unique way of stating an economical but memorable melody line.

Group warhorses "Phase Dance" and "San Lorenzo," the beginning and end pieces of innumerable Metheny concerts, sound as fresh as they did on the *Pat Metheny Group* album from 1978. The ambitious "As Falls Wichita, So Falls Wichita Falls" (from the Metheny/Mays album of the same name) is recreated in all its splendor, and the beautiful "Are You Going with Me" sounds even better than it did on *Offramp*. The PMG is one of the few ensembles that can put on a two-hour show of instrumental jazz for an audience raised on Genesis and Pink Floyd and hold their interest. The vinyl version of their live set accomplishes the same thing.

On the group's current tour, Paul Wertico has replaced Gottlieb on drums, and Argentinian percussionist Pedro Aznar has taken Vasconcelos' place, so perhaps *Travels* marks the end of a chapter in the Metheny book. No doubt there are volumes still to come.

—Dan Forte



THE KINKS *State of Confusion* Arista AL8-8108

Produced by Ray Davies; engineered by John Rollo and Damian Korner; recorded and mixed at Konk Studios, North London, with additional mixing at The Hit Factory, New York, and Grand Slam Studios, West Orange, NJ

Who's confused? What's confused? Is it the state of Great Britain or the state of married bliss or the state of our fragile emotions? I like an album that opens with screams of agony. Gets your attention. Brother Dave, the edge on your guitar could cut through carbon steel. Uh-oh. Mick, drummers teetering on the brink of age 40 should not attempt power punk. (Cardiac arrest, y'know, mate.) Ray says the cold, tough lady has a heart of gold. Ms. Chrissie? But who's the guy poised in the window of the high-rise? I think he'll jump. Or crawl back into bed and escape into dreams of unimaginable pleasures. Or join the Young Conservatives. I'm not sure. Let's retreat into nostalgia! Let's all go dancing! What, they tore it down and put in a parking lot? Didn't we go through this with Joni a few years back?

Check the computer. Hmm. Yes uh, no. Wait, it's a definite maybe! (I think.) HELP, I'M CONFUSED!

This, in summary, is the essence of the Kinks' latest offering, *State of Confusion*. As a treatise on the fragmentation of modern life it is devastatingly successful; but, as the form imitates the content, I find it difficult to approach this album analytically.

We'll skirt the problem temporarily by first noting the Kinks' new sound for the '80s. At their toughest, these guys can still pump out as much energy as young new-wavers who were rocking in their prams when "You Really Got Me" lurched up the charts nearly two decades ago. Mick Avory's drums have expanded to cavern size, Jim Rodford's bass pulses with frantic urgency, and Dave Davies' guitar seethes with taut aggression. (On the intro of "Labor of Love," for example, he does to "Here Comes the Bride" what Hendrix did to "The Star Spangled Banner.") When the group pulls back in tempo, Ray Davies' wistful vocals are wrapped in swirling synthesizers and framed with finely etched percussion. As producer and arranger, Ray knows precisely how to manipulate texture and structure—in endless variety—to support his miniature dramas, his poignant vignettes, and his biting social commentaries. Which leads us back into bedlam.

Perhaps we can impose some artificial order by splitting the cuts into two groups: those focusing on the confusion of our personal lives, and those dealing with the chaos in society as a whole.

As is fitting for our times, Ray Davies' social and political commentaries are now built on a foundation of trip-hammer tempos, slashing guitars, and tense (but brilliantly modulated) vocals. In the title cut Ray examines, with anger and despair, the disintegration of post-industrial Western society: gunshots in the night, water in the basement, and a lover who runs off as soon as the telly goes on the blink. "Definite Maybe" lashes out against a computerized bureaucracy wherein people shuffle down endless corridors into long queues where they wait for hours, only to discover all decisions are on hold in the data banks. "Young Conservatives" mocks the complacent young Thatcherites ("Well Respected Man," second generation), while "Clichés of the World (B Movie)" watches with detached horror as one man poises on the edge of a desperate leap from a bleak high-rise existence to the motorway winding below. The institution of marriage falls under a double-edged sword of savage caricature and aching regrets: "Labor of Love" equates wedded bliss with a two-headed transplant ("You get the feeling that you're never alone"), while "Property" takes a bittersweet look at the settlement that follows the inevitable collapse.

It's all standard Kinks fare, to be sure, but updated with a rather unsettling tone. The innocence of "Dedicated Follower of Fashion" will not serve as a prelude to 1984. Nevertheless, Ray refuses to succumb to Orwellian inevitability. There is a way out, the way of the heart, and we discover this (pardon) ray of hope in three subtle, sensitive, and emotionally evocative songs.

"Come Dancing" and "Heart of Gold" are both gems. The first, written about his sister, is Kinks nostalgia at its best. The second, almost cer-

tainly written about Chrissie Hynde, reveals the hidden, tender side of this important friend and mother. The woman revealed in "Don't Forget to Dance" is not as obvious, but that doesn't keep this from becoming the most heart-wrenching Kinks song in years. It's better than "Misfits" or "Little Bit of Emotion," and perhaps the equal—in impact if not in scope—of "Celluloid Heroes."

State of Confusion is the Kinks' 24th all-new LP, a count which includes the two live albums but excludes all repackagings, foreign and domestic. Ray Davies and cohorts may oscillate between hope and despair, but you get the feeling they'll keep it together for at least one more year. After all, the conjunction of the group's 20th anniversary, their 25th LP, Ray's 40th birthday, and the year 1984 foretells an essential addition to the Kink kronicles.

—Sam Borgerson

New and Noteworthy

The Plimsouls, **Everywhere at Once** (Geffen) — To the casual ear this album sounds like "LA Wave meets Heartbreaker Rock," but principal songwriter Peter Case has a lot more to say on the Plimsouls' second album than Petty's been able to come up with lately. The energy of the band's performances, and Case's flat-out vocals (reminiscent of Mick Jagger in the days when he meant it) just burn rings around the competition, especially on "Magic Touch," "I'll Get Lucky," and a pair of covers, "Lie, Beg, Borrow and Steal" and "My Life Ain't Easy." Jeff Eyrich's debut as a producer is an auspicious one; it's an '80s sensibility delivered with the flat-out raging power of the British Invasion years.

—David Gans

Gregory James Quartet, **Madagascar** (Rogue) — Electric jazz-rock fusion presented with the same painstaking care toward sound and graphics as Windham Hill's acoustic albums. Guitarist Gregory James even recorded this album at WH's home base, the Music Annex, and employed their graphic designer, Anne Ackerman. Stylistically, though, it's in a different category altogether. James calls it "new wave instrumentals," but while there's a certain urban tension in his originals and Sy Oliver's "For Harry Carney," it's more like the soundtrack to a Martin Scorsese film than a Graham Parker rhythm track. Still and all, James proves that despite what you've heard, fusion can still sound interesting. (Rogue Records, 952-A Vallejo Street, San Francisco, CA 94133.)

—Dan Forte

"Weird Al" **Yankovic** (Rock'n'Roll Records) — You've probably heard his squid-brained squeezebox parodies of several deserving hits—"I Love Rocky Road," "Stop Draggin' My Car Around," "Another One Rides the Bus," "My Bologna," and the current video fave, "Ricky." Having heard each once, you needn't—nay, shouldn't—buy this record; if you do, hide it from your kids, because they'll play it again and again. In between the more-or-less clever re-writes, Yankovic has included some more-or-less dreadful originals.

—D.G.

24 trk head assy's \$300?

YES! AND OTHER HEAD ASSEMBLIES EVEN LESS.

The secret behind the low price, is Restoration's ability to restore ALL types of audio or video head(s), whatever the track configuration, back to OEM specification.

If you feel your heads aren't delivering the high quality they used to, let Restoration evaluate them at **NO CHARGE**. Restoration promises to deliver your restored tape head(s) in 24 hours, ready to perform at peak efficiency, at about 1/10th the cost of its new replacement.

Also available is a complete line of replacement Studio, Duplicator, and Broadcasting Heads from:

NORTRONICS • TASCAM • TELEX

"Lick the High Cost of Audio Heads"

RESTORATION

refurb repair new

VISA master charge

15904 Strathern Street • Van Nuys, CA 91406 • (213) 994-6602 • Telex: 66-2922

Circle #072 on Reader Service Card

audiotrack

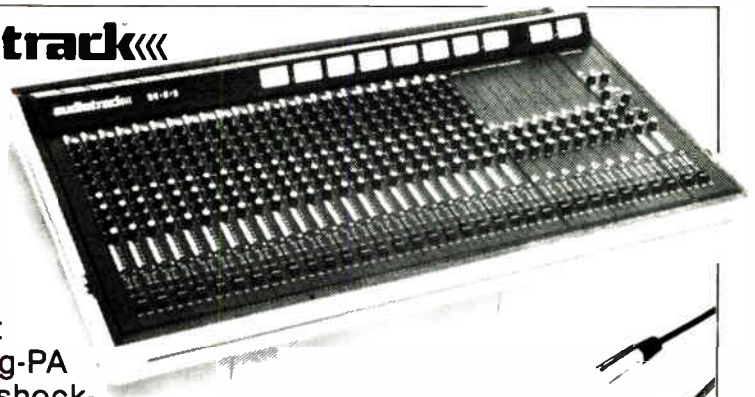

16 input,
10 output
Recording-PA
Mixer in shock-
mount roadcase. Now only **\$1990⁰⁰**

**Electro-Voice® RE 20 and 635A
PRICES SO LOW WE PROMISED
NOT TO PRINT THEM!**



120 PRODUCT LINES FOR THE PROFESSIONAL
Tape Recorders • Mixers • Amplifiers • Turntables
Signal Processing • Mics • Tape • Cassettes
Test Equipment • Speakers • Headphones • Intercoms



6729 SEYBOLD RD., MADISON, WI 53719

TOLL FREE IN ALL
50 STATES
1 (800) 356-5844
IN WISCONSIN
1 (800) 362-5445
LOCAL (608) 271-1100

Circle #073 on Reader Service Card

THE SIGHT AND SOUND OF

Chuck Mangione

by Lou CasaBianca

The music film and video producer/director is probably the person least likely to be stereotyped in today's world of network and cable TV music video production. He or she could be a BBC producer with 20 years' experience, or the artist's or group's manager, someone who was in PR at the label, or possibly a film student who knows the lead singer. Increasingly it's someone who has been in television or filmmaking. However, many record producers and artists themselves are moving into the producer's or director's chair. What is more definable, more predictable, is the nature of the challenge in mounting and completing a visual music production. The purpose of this column is to address the technical and strategic requirements of this extremely creative and demanding process.

Composer, musician, producer, Chuck Mangione has released his newest album, *Journey to a Rainbow*, on CBS Records, consisting of six new Mangione compositions. Chuck is a winner of two Grammys: Best Instrumental Composition for *Bellavia*, and Best Pop Instrumental Performance for *Children of Sanchez*. His album *Feels So Good* is now a double-platinum-plus classic. The Chuck Mangione Quartet tours internationally nine months out of the year, performing a two-hour in-concert set that is a tour-de-force of musicianship.

Chuck Mangione is no stranger to film and video. On a recent trip to Florida, he visited Miami's Criteria Recording Studios. At the same time, I was directing a series of music videos for Emmanuel, the largest-selling Spanish-speaking artist on RCA

International Records. Following completion of his most recent album, *Journey to a Rainbow* (Columbia FC38686), Chuck's manager Joe DiMaria called to discuss production of three music videos for their production company, Gates Music, Inc. What



CLOSE-UP: *The insert close-ups were shot from several angles. Director of Photography/Cameraman, Joe Van Witsen, zooms in for another close-up.*

PHOTO: JOHN LATTI

followed might be considered a textbook case in the anatomy of a music video production.

CREATIVE DIRECTION

The first three points agreed upon were:

1) The number and titles of songs to be shot: the album title track "Journey to a Rainbow," "Butter Corn Lady" and "Love Bug Boogie;"

2) The shooting script concepts and production format: live and sync in studio soundstage to original 24-track

with 2-channel mixdown;

3) The budget: approximately \$30,000.

The production creative direction was based on a commitment to integrate Chuck's visions as composer/performer in the pre-and post-production phases of the project. We developed a collaborative overview in the music selection and the visual approach we would take toward each song. In a number of Chuck's previous video projects, he has been literally "locked out" of the editing process.

I suggested that we co-produce the video, and, with a common ground of experience in music audio production to draw from, it was easy to bring him up to speed on the video production process. In this way, Chuck had greater input to the crea-

THE SET: Studio "A" at Criteria Film + Video, Miami, Florida, is a 90' hard cyc film/video soundstage and 24-track recording studio. Photograph is from rear of cyc facing the set and control room.



PHOTO JOHN LATTIA

The Complete Amplifier

There is no power amplification system like the SPECTRA SONICS Model 701. As the most complete power amplification system available, the 701 Power Amplifier may be employed with measureable improvements in performance, expandability, reliability, and serviceability.

A POWER AMPLIFIER PERFORMANCE BREAK-THROUGH

The performance of the 701 Power Amplifier is second to none. Extremely low noise and distortion are only a part of the 701's exceptional performance characteristics. Amplifier overload due to audio program peaks are virtually eliminated by the 701. Recovery time for up to 1000% peak overload is less than one microsecond, resulting in higher sound pressure levels when operating on audio program material. Even with two ohm loading, stability is not a problem with the 701. The amplifier is unconditionally stable, thus preventing thermal "avalanche" of the amplifier.

For further information contact:

SPECTRA SONICS 

Circle #075 on Reader Service Card
World Radio History

3750 Airport Road Ogden, Utah 84403 (801) 392-7531

R.O. Studios

A STATE OF THE ART FACILITY

24 TRACK RECORDING

(415) 676-7237

Circle #076 on Reader Service Card

Q: The Department of Defense picked what sound effects library as the one to use in all their radio stations around the world?

The Production EFX Library. 5 stereo albums arranged by categories. Shouldn't you give a listen?

A:

Stereo Sound Effects



PRODUCTION EFX LIBRARY
2325 Girard Ave. S.
Minneapolis, MN 55405

Circle #077 on Reader Service Card

tive process throughout the project and hands-on experience and exposure to the video production and editing process.

THE PRODUCTION CONCEPT

Once the music was selected, we videotaped a live performance of the band at The Auditorium in West Palm Beach, Florida. The production concept was to create a live soundstage version of the Quartet's in-concert presentation. This concept was carried through in the video production by using the actual lighting crew and gear from the in-concert performance. Video production was scheduled to take advantage of the band's Easter break from concert performance so that the band members, crew and equipment would be available.

two Sony BVU-800s in sync and in isolation. Each song was shot from two synchronous positions in five or six takes, providing six to eight different camera positions to choose from on any given shot or at any specific point in the music track. This enabled us to create the illusion of a multi-camera shoot without the reality of the associated expenses. The key to completing the shooting of all three songs in one 12-hour session was comprehensive pre-production planning.

AUDIO

The original stereo mixdown master versions of the songs were bounced to 4-track with time code on channel 4. This was played back on a Sony/MCI JH110 and layed in sync on the BVU 800's audio and time code tracks. Each song began with a



PHOTO: JOHN LATTA

THE PLAYBACK: The unique advantage of video is the ability to review immediate visual playback. Here Chuck Mangione monitors playback from Sony BVU 800s.

LOCATION

Criteria Film + Video's Studio A was selected as the location for the production. Studio A was one of the original recording studios/film and video soundstages and was used by Criteria in the music scoring production of almost one hundred feature films. Criteria's president, Mack Emerman, served as executive producer.

VIDEO

In order to capture the feeling of live performance, two Sharp #XC700 cameras were selected. One camera was on a Moviola crane providing establishing and wide shots with truck and dolly movements provided by a crab dolly. The other camera was at or below eye level, on a tripod or hand-held. Each song was storyboarded with camera angles, lighting, set design and wardrobe locked-in before or by the shoot date.

Time-coded audio was sent to

discrete time code number, and every take of that song was synced with reset time code so that the same point in each song would always have the same time code number. As the band would be playing back live to the half-track masters, the Criteria Studio A playback system was supplemented by adding Chuck's stage monitor speakers.

LIGHTING

By enhancing the existing stage lighting with the appropriate key and fill lights, we were able to create a rainbow light pattern backdrop that duplicated the in-concert lighting setup for "Journey to a Rainbow." This helped to conserve an already tight budget. A new lighting design was created for "Butter Corn Lady;" the look was tropical, and the colors were lime, yellow and sky blue. The "Love Bug Boogie" lighting was magenta and gold against a black and white

hard cyc backdrop, simulating a hard edge graphic look.

EDITING

An off-line edit decision list was created on a Convergence ECS104 Editor using 3/4" time coded window dubs. (User bits can be used on the video window dub, when available, to even further define or characterize takes or shots. Theoretically, as long as the decision lists are created on computers that can talk to each other, for example CMX to CMX, you should be able to make your creative decisions and edit tests off-line, at 3/4" post-production rates.) Final assembly was edited with a Datatron editing system, on three Sony BVE 1100 1" machines at Universal Video in North Miami Beach with editor Dean Prenarsi. New time coded audio was layed back on the 1" to provide master mixdown audio quality on the final edits. Switching, special effects and digital video effects were executed on a Grass Valley Switcher with one channel of Qantel DVE.

PRODUCTION RECAP

The goal for the use of the three music videos is additional promotion for Chuck's new album. In what is becoming a more common strategy, the music videos were completed before the album was released. The potential venues for exposure include cable and syndicated music video clip programs, international television and in-store promotion. Several 30- and 60-second commercial spot announcements will be cut from the footage as well. The opportunity for increased exposure has expanded recently with the addition of music video clip programs broadcast by CNN and NBC. Simultaneous release of the LP and video promotional materials is an important step in a coordinated marketing program.

...

It is amazing how important a good sense of humor can become under stress and 25,000 watts of lighting. It was a pleasure to work with Chuck, the Quartet, Joe DiMaria, the Gates Music road crew, Mack Emerman and the Criteria Film + Video staff and engineers. The crew and particularly Chuck and the band helped keep it light, delivering professional performances take after take. Good music lends itself to good visual illustration.

We invite you to tell us who your favorite video artists are; what your favorite clips are; and we will at-

—page 113

VIDEO & AUDIO COME TOGETHER AT SHORELINE, LTD.



With the introduction of JVC's new **CR6650 TAPE HANDLER SERIES**, with the SMPTE address channel, balanced audio tracks and direct plug-in interface capabilities...

...now you're ready for **AUDIO SWEETENING** with your existing multi-track recorder...and the **BTX SHADOW** that will control both transports with 1/100 frame accuracy. If that sounds good wait til you hear the final mix on the CR6650...

Truly Great
Innovations
From
JVC

SHORELINE
TELEPRODUCTION SYSTEMS

Shoreline, Ltd.
3459 Cahuenga Boulevard West
Hollywood, CA 90068
(213) 851-1236 • Northern CA (415) 632-6400

Circle #078 on Reader Service Card

Audio & Video Systems One Source—Peirce-Phelps

Yes—it's rare to find **one source** for professional **Audio/Video** Systems, with major lines such as Ikegami, Sony Broadcast, CMX, **MCI, Crown, JBL**...And hundreds more.

For the past two decades, our qualified personnel have been helping clients with:

- Mobile Production Facilities
- Video Edit Suites
- TV Production/Post Production Studios
- **Recording Studios**
- **Entertainment Venues**
- **Broadcast Studios**

The One-Source Supplier

Peirce-Phelps, Inc.
2000 N. 59th Street
Philadelphia, PA 19131

PA 1-215-879-7236 (Audio)
PA 1-215-879-7171 (Video)
U.S. 1-800-523-4682

CLIP AND SEND
FOR FAST SERVICE

I'm interested in Audio Video

OUR PROJECT IS: _____

NAME _____ TITLE _____

COMPANY _____

ADDRESS _____

CITY _____ STATE _____ ZIP _____

TELEPHONE () _____

Circle #096 on Reader Service Card

TRIAD STUDIOS
• 24 track recording •

4572 - 150th Ave. NE, Redmond, WA 98052 (206) 881-9322

Technical equipment listed in the circular graphic:
MCI 2-track JH-24 trans-formerless
MCI 2-track JH-110B's (transformerless)
Technics RSM85, Teac C
Neotek Series III
Neotek Series III
Hofler DH500 - MONITOR AM
Yamaha NS10 M - 6TL
Alesis - MIXIN
Alesis - MONITOR SPEAKERS
Alesis - MONITOR AM
Alesis - MONITOR AM

Circle #079 on Reader Service Card

—from page 87

By 17, he had given up acting to become a full time drummer with a little-known group called Flaming Youth. In 1970 he was asked to join Genesis, replacing original drummer John Mayhew. From 1971 through 1975 he drummed for the group as they slowly became a major rock attraction behind the provocative theatrics of Peter Gabriel.

In 1975, just as the group was on the brink of superstardom, Gabriel left to pursue a solo career and fans and critics alike figured it was curtains for the group. However, they were determined to continue, and after months of fruitless auditions for a lead singer Collins found himself the new frontman.

"The other members had previously discounted the idea because I was the drummer and they didn't dare ask me because they assumed that I would never give up the drums. But in fact, it was just a question of me doing it rather than letting someone else muck it up," says Collins.

"Peter [Gabriel] and I thought he would be very good for the group," Tony Banks said recently. "Quite honestly, he became far better than I ever thought he would. He has ended up by far the best in the band."

With Collins at the helm, at

least visually and vocally, Genesis

became one of the most popular groups in rock's history with a string of ultra-successful albums including *A Trick of the Tail*, *Duke*, and *Abacab*. But being an overachiever, Collins was not ready to settle for what Genesis had accomplished. He joined a jazz group (Brand X) part time, began producing other artists and doing session work, and in 1981, embarked on a solo career.

With platinum records, sellout tours and critical acclaim for his own career, and by the fact that Collins himself has called his solo work "the most important thing to me," one might feel he views Genesis as a sideline these days. "Saying Genesis is a sideline isn't quite accurate. Genesis is a close second - I mean, I know that the band has a lot more to do. We're all very, very into it. We're putting more into it now than we have in a long, long time. We enjoy recording and touring and we're looking forward to the next album, and then after that the next tour," Collins asserts.

"A solo album implies a certain kind of temporary leave. I don't want it to appear like that, because it isn't. So therefore, I'm trying to clarify my point. I say it's the most important thing to me because it's something I'm

—page 112



JBR Sound Products Professional Studio and Video Products

Servicing the television,
broadcast, recording, and
remote industries.

We Specialize In Service

JBR Sound Products has been the leader in the professional sound industry since 1947. We offer unique personal service, an extensive product line, and competitive pricing. Our service has helped make us the choice of professionals around the world.

AKG PRODUCTS
ALPHA WIRE & CABLE
AMPHENOL CONNECTORS
ANVIL CASES
ATLAS
AUDIO ENVELOPE
AURATONE
BELDEN WIRE & CABLE
BEYER
B.T.X.
CANARE CABLE
CLEAR-COMM INTERCOM SYSTEMS
COUNTRYMAN ASSOC.
CROWN
CROWN/PEM
CUSTOM MIC CORD, SNAKES
DAVID HAFLER COMPANY
ELECTRO-VOICE

EXCALIBUR CASES
H. & H. AMPS
H.M.E. ELECTRONICS
KANGAROO VIDEO PRODUCTS
KEITH MONK AUDIO
KLARK-TEKNIK
KLIPSCH SPEAKERS
LEXICON
NEUMANN
NEUTRIK
R.T.S.
SENNHEISSER
SHURE
SONY
STARBIRD MIC STANDS
SWITCHCRAFT
WHITE INSTRUMENT

(213) 636-6934
(213) 636-3403 / (714) 975-0248
LONG BEACH, CA.

(702) 457-7277
LAS VEGAS, NEV.

(808) 526-1358
HAWAII

Circle #097 on Reader Service Card



IF IT ISN'T ON THE TAPE IT WON'T BE ON THE DISK

"Our Disks are sounding even better since we began mastering with
Strategic Sound's transformerless I/O Cards in our ATR 100s."
"Set-up's easier tool!" "Nice job guys."

(415) 456-7666

TresVirgos
Studios

Circle #098 on Reader Service Card

VIDEO NEWS

by Mia Amato

A VISUAL JUKEBOX

The video jukebox, talked about for years, attempted by several different manufacturers, is now a reality. *Video Music International*, which introduced its "StarTime Video Muzzik-boxx" last January now has over a dozen units on line in pizzerias and arcades in the U.S.

The coin operated jukeboxes play promo videos supplied by record labels in exchange for a small monthly royalty. Model 3000, priced at around \$10,000, resembles an old-fashioned Wurlitzer with a TV screen. According to VMI spokeswoman *Cheryl Neely*, over a hundred machines have been ordered. The standardized contract for record companies, she says, calls for a royalty of about fifty cents per month for each video selection, regardless of the number of plays or machines in the field.

Record companies which participated in the experimental phase of the jukebox included *Motown, Arista, EMI, Columbia, Chrystalis, Polygram* and *Warners*. First labels to sign, though, were three small independent record companies: *Destiny Records, Solid Oak Productions* and *Deltavision*. Then *EMI Liberty, Capitol* and *Arista* signed contracts to provide a first run of videos of such bands as *Air Supply, Thompson Twins, Flock of Seagulls, The Busboys, and Haircut 100*.

"Taped programs will change from month to month and will eventually cater to special interests like country and western," Neely says. While the monetary return to labels is small, the jukebox device will provide another outlet for video clips, offering more promotional mileage for the price of clip production costs.

Video Music International, based in Los Angeles, is owned by *Jack Millman*, a former jazz trumpet player whose past includes stints as a nightclub owner and one time manager of the *Beach Boys*. VMI required that the

bars, arcades, laundromats and student unions who purchase the machines agree to take a new music tape periodically. Machines in use now have an hour-long tape of selections at 50¢ a play. The beginning of each song is pulse-encoded on the tape and responds to a patented controller. But it's just not as easy as punching A-7.

"A problem in the sequencing of material has to do with the fact that it takes a bit of time to shuttle from one song to another on the tape," Neely said. "To offset this, a second videotape is played during the period when the jukebox is in the search mode." The second tape would play a commercial—VMI is exploring clients for this—or the second tape might play video art or abstract imagery between tunes or when no one is feeding the machine quarters.

VMI's jukeboxes are running in *Higbee's Restaurant* in Danvers, MA; at the *Fresh Air Tavern* in Spokane; in the offices of *Lexington Broadcasting* in New York City; at *Funsville U.S.A.* arcade in Ohio;

Godfather Pizza in Thornton, Ohio, at the *Campbell Record* store in Huntington Beach, CA. The nightclub, *Underground*, formerly *Studio 54*, has ordered three.

STUDIO REPORT: High Tech Growth

Madison, Wisconsin has a new million-dollar video facility, *Russtad/Wickhem Productions*, to serve the midwest region. The studio, formerly offices of WISC-TV, boasts two video editing suites, 16-track audio production, and 40' x 60' stage. The studio's owned by local radio personality John Rustad and video producer Bob Wickhem.

National Video in NYC couped two impressive acquisitions, the first being a production deal to supply all taping and postwork for *ATI Video Enterprises*. ATI produces *Night Flight* and *Radio 99*, musical programs for *USA Cable Network*, as well as *FM-TV*, a half hour series syndicated in 70 broadcast TV markets. ATI producer *Stuart Shapiro* has already taped interview segments with *Devo, Journey, Grace Slick, Neil Young* and *Lou Reed* at National's studios, incorporating the extensive battery of special effects available there.

National has also beefed up its audio effects department by bringing on staff SFX specialist *Norman Kasow* and Kasow's collection of 45,000 sound effects.

Also in New York, *Matrix Video* has an *Ampex ADO* special effects generator now sharing rackspace

THE INTERNATIONAL PROGRAM MARKETPLACE

Knowledge Industry Publications, Inc. held its second International Program Marketplace at the New York Hilton on May 23, 24, 25. The event was hosted by Knowledge Industries President, Eliot A. Minsker and Conference Director Peter Caranicas. About three hundred people (twice as many as last year) attended this year's Marketplace. Technically, the venue offers an opportunity for producers of broadcast, cable, home video and theatrical programming to meet with buyers, distributors, packagers and investors.

Predictably, there were many more sellers than buyers. However, the annual event has good intentions, and, with continued growth, could become a viable program marketplace.

The format of the three-day event featured conference presentations in the morning with screenings

and roundtable discussions in the afternoon. The conference subjects and roundtable discussions were well planned and provided excellent in-depth data. Some of the speakers represented companies like: Warner-Amex Satellite, Hearst ABC Video, Thorn EMI Video, RCA/Columbia Pictures Video, Playboy Channel and Cable Health Network. MTV was conspicuous by its absence.

Marketplace organizers anticipate expanding the music video element in next year's program, which will be held March 14, 15, and 16 at the New York Hilton. As a veteran attendee of video software conventions (NAB, NAPTE, VIDCOM, NCTA, etc.), I would give the IPM an "A" for effort, while anticipating a more balanced (buyers vs. sellers) event next year.

—Lou CasaBianca

with the firm's *Grass Valley DVE*, *Thompson* graphics and animation generator, slow motion disc and the *Ampex ESS-2* digital still store. *Onomatopoeia, Inc.* marked its tenth anniversary in the audio business by opening a fourth mixing room built specially for video. The new Studio A is already heavily booked for commercial work and features a 16 by 8 *Allen & Heath Brenell* console and the automated *BTX 4600* synchronizer to slave up to four audio decks.

In Hollywood, *Action Video* posted a series of TV spots for *MCA Records*. A spot promoting *The Who's* "Greatest Hits" LP was edited from footage of last year's tour; four spots for "Country Fever" show album covers of MCA C&W artists zipping through time-lapse clouds.

They don't even have their new stationery yet but *Harlequin Studios* has opened its doors to music video in the LA suburb of Northridge. The two-story audio recording facility now has a 35' x 40' stage available for videotaping in U-matic or 1" formats. *Synopsis Video* has been busy with four video promos for MCA artists *The Trees* and their album, *Sleep Convention*. Other projects include clip work for *Festival Records* of Australia.

PROMO: See You in the Movies

CBS/Epic Records is showing the promo for the *Merle Haggard-Wilkie Nelson* duet single, "Pancho and Lefty," in movie theaters as a short. 35 mm versions of the five-minute clip are coupled with features such as *Blue Thunder*, *Breathless*, and *Return of the Jedi* at selected cinemas. Epic is also supplying the theaters with lobby posters and coupons good for a dollar off the price of the "Pancho and Lefty" album.

Never throw anything out. That's the word from *Graeme Whifler*, who directed the filmed promo of "Cool Places" for *Sparks'* latest album. Background for the clip is a set of miniatures he created. "A lot of the stuff came from my old train set," Whifler admits.

Known locally as the Rod Serling of rock video for his weird clips of weird bands (*Snakefinger*, *The Residents*, *Tuxedomoon*, *Renaldo & the Loaf*), Whifler lensed "Cool Places" at Cine Rent West in San Francisco. *Russell* and *Ron Mael* of *Sparks* and *Jane Weidlin* of the *Go-Go's* perform; Mael does some sinister magic tricks and demonstrated a previously unknown skill as a contortionist. His bizarre physical stunts prompted the Musicians Union to require that a licensed chiropractor be present on the set during filming. ■

We've Put SIZZLE Into Echo and Reverb
-At an Affordable Price-



The main problem with most echo and reverb units is that they don't have the high frequency response it takes to "cut" through the mix and add the type of clarity and depth that vocals in particular need. Our Echo Control Center provides over twice the frequency response of units costing almost twice as much as ours. The reverb section is the quietest, crispest, and least boomy portable unit we have seen.

Capabilities include: •Straight Delay •Echo and Reverb •Doubling •Slapback •Chorus and Vibrato •Over 95 dB Delay Dynamic Range.

Write for a 24 page brochure on our full product line and a demo record.

Compress/Limit/De-Ess and Noise Gate/Key/Duck
-Two Channels/Push Button Stereo/Independent Tracking-



The CLX-2 is the most versatile two channel compressor/limiter/expander you have ever seen. We use the BEST Voltage Controlled Amplifier available; the EGC-101 and the latest Feed Forward design technology to produce the most natural and musical sounding compression and noise gating obtainable at any price. Knee type compression switchable in or out.

Write for a 24 page brochure on our full product line and a demo record.

LT Sound, Dept. P PO Box 338,
Stone Mountain, GA 30086 Phone: (404) 493-1258

Circle #083 on Reader Service Card

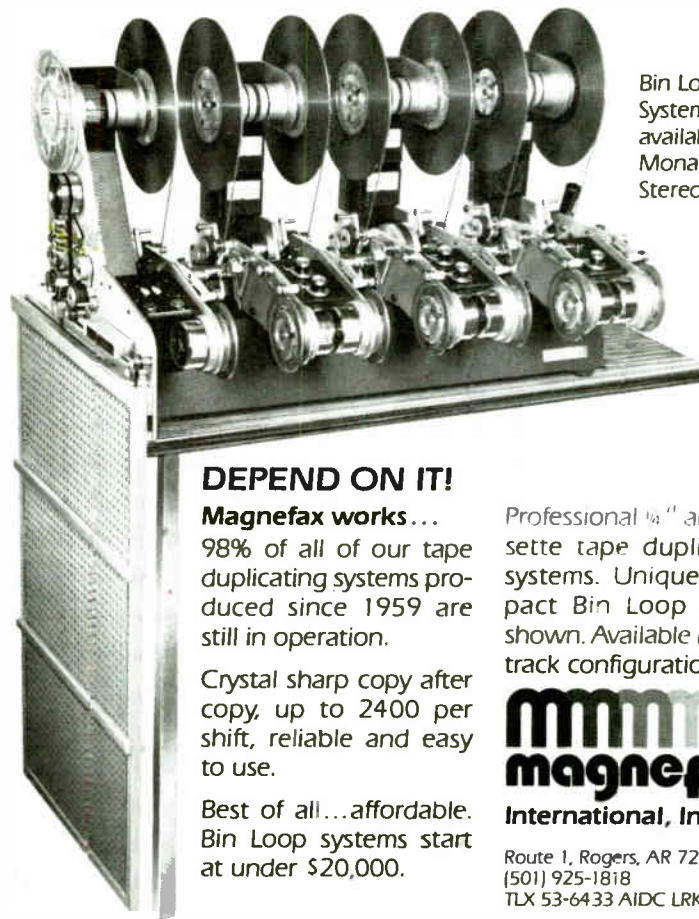

Bin Loop System available in Monaural or Stereo

DEPEND ON IT!

Magnifax works...

98% of all of our tape duplicating systems produced since 1959 are still in operation.

Crystal sharp copy after copy, up to 2400 per shift, reliable and easy to use.

Best of all...affordable. Bin Loop systems start at under \$20,000.

Professional 1/4" and cassette tape duplication systems. Unique, compact Bin Loop model shown. Available in most track configurations.



International, Inc.

Route 1, Rogers, AR 72756
(501) 925-1818
TLX 53-6433 AIDC LRK

Circle #068 on Reader Service Card

Recording in Ireland

by **Alexandra Connolly**

Ireland is a small island about one quarter the size of California and, as most readers probably know, comprises two countries: Northern Ireland (N.I.) and the South of Ireland (Eire). N.I. is part of the UK and Eire is separated from the North by a border and has its own currency, the Punt.

Ireland is dotted with approximately thirty recording studios, most of which are small and limited in ability; but there are, on the other hand, several well-equipped studios turning out quality products.

The whole island profuses all kinds of music, C&W probably having the largest share of the market, followed by pop/rock, folk and gospel. For established rock bands, local recording studios tend to be a stepping stone in the struggle towards getting signed by a British record company. To come anywhere near signing, the Irish band plus manager must be an efficient unit turning out original material and greasing the way for the British A&R man across the Irish Seas and, for those N.I. bands, into bomb-blasted Belfast. Needless to say, this is an expensive business and most do not make it.

The C&W circuit is large, with many fine bands recording and cutting albums here and selling to the Irish market with little need to go far afield. The same applies to gospel.

Traditional folk bands tend to record in Ireland even after making it to the top of the UK folk charts. Perhaps this illuminates the ethnic differences between the several kinds of folk music coexisting within Ireland and the UK, Irish traditional music being best produced by Irishmen from that tradition.

For such a small country, Ireland is prolific in its output of fine music and accomplished musicians of international repute, some of whom include Van Morrison, Thin Lizzy, U2, Horslips, Rory Gallagher, The Chieftans, Clannad, Blackthorn, Dana, The Undertone, and Stiff Little Fingers.

Bands recently signed by EMI include The Bank Robbers, Silent Running and Cruella de Ville from the North and Tokyo Olympics from the South. All four give excellent live performances and may in time join the ranks of the above-mentioned.

Following is a representative listing of some of the more popular recording facilities on the island:

Echo, reverb, delay: Program Technologies Eco-plate, Rebis delay line, Korg DDL

Outboard equipment: Audio & Design Scamp rack, Rebis noise gates
Instruments available: Bechstein grand piano, guitars

History: opened Jan. 1983

Major recent work: C&W and gospel LPs. Bank Robbers single.

Hyde Park Studio

120 Coach Road, Templepatrick, N.I.

Manager: George Doherty

Tape recorders: 16 track MCI, 4 track Scully, 4 track Ampex, 2 track MCI

Mixing consoles: MCI JH400

Monitor system: Crown/JBL Tannoy

Echo, reverb, delay: Roland digital delay, EMT 140 reverb

Outboard equipment: Audio & Design Scamp rack, Aphex Aural Exciter, Vibe De-esser, Eventide Harmonizer H910, UREI 1176 peak limiter, A & D Vocal Stressor

Instruments available: baby grand piano, Hammond B3, drum kit

History: Opened 8 years ago

Major recent work: various C&W LPs: Roly Daniels, Ann Williamson, Brendan Quinn

Northsound Recording Studios Killeshill, Donaghmore, N.I.

Manager: Ray Stewart

Tape recorders: 24 track Studer

Mixing consoles: Soundcraft 1624 series

Monitor system: HH/JBL

Echo, reverb, delay: EMT plate

Major recent work: Northsound handles mostly C&W work

Trend

10 Hagan Court, Lad Lane, Dublin 2, Eire

Manager: Paul Waldron

Tape recorders: 8 track Soundcraft, 2 track Otari

Mixing consoles: Soundcraft 800

Monitor system: Quad/Tannoy

Echo, reverb, delay: GBS, Rebis

Outboard equipment: comp/limiter, Dolby A, noise gates

Instruments available: 3 days notice on anything

History: opened in 1968; rebuilt 1982

Major recent work: Barry Moore LP, Kieran Harper LP, various singles

Windmill Lane Studios

4 Windmill Lane, Dublin 2, Eire

Manager: Irene Keogh

Tape recorders: 24 track Otari

Mixing consoles: MCI

Monitor system: Crown/JBL

Echo, reverb, delay: EMT plate, Lexicon

CueComber

2 Fairview Avenue, Whitehead, N.I.

Manager: Colin Martin

Tape recorders: 16 track Soundcraft

Mixing consoles: Neve, BCM

Monitor system: Crown/Mission

Echo, reverb, delay: Quad 8 CPR 16

Outboard equipment: Audio &

Design Scamp rack

Instruments available: drum kit

History: 3 years old. Mobile.

Major recent work: video with Van Morrison, "The Schooner;" Jimmy Kennedy live album

Eerie Music Mobile

14 Walnut Court, Dublin 9, Eire

Manager: Tony Barry

Tape recorders: 24 track Otari

Mixing consoles: Soundcraft 3B series

Monitor system: Quad/JBL, Tannoy

Echo, reverb, delay: EMT plate, AKG spring reverb

Outboard equipment: MXR pitch transposer/harmonizer, Audio &

Design Scamp rack

Instruments available: drum kit, keyboards, guitars

History: opened Jan 1983. Mobile.

Major recent work: recorded Thin Lizzy for live album



Homestead Studios

7 Ballylummin Park, Agohill, Ballymena, N.I.

Manager: Sean Wallace

Tape recorders: 24 track Soundcraft

Mixing consoles: Allen & Heath Syncon

Monitor system: Turner/Tannoy

DOCTOR CLICK

The Doctor Click Rhythm Controller makes it possible for the first time to synchronize the world of sequencer, drum machine, synthesizer composition with any one of the systems on the market or combinations of the systems on the market. Furthermore, the Doctor Click will cause sequencers, drum machines and synthesizers to play in time with a human drummer. It will also read click tracks and sync codes. The internal metronome provides both beats per minute and frames per beat calibrations.

THE DOCTOR CLICK RHYTHM CONTROLLER BREAKS THE BRAND BARRIER

SEQUENCERS		DRUM MACHINES		SYNTHESIZERS*	
DSX	Bass Line TB303	Linn LM-1	CR5000	Prophet 5	Modular Moog Juno 6
Prophet 10	CSQ600	LinnDrum	CR8000	Prophet 10	OBX Juno 60
Polysequencer	SH101	DMX	CR68	Prophet 600	OBXa Polysix
Pro One	Emulator	Drumulator	CR78	Prophet T8	OB8 Poly 61
Model 800	Fairlight	TR808	KPR-77	Minimoog	JP4 Voyetra-8
Microcomposer MC4	Synclavier	Drumatics TR606		Memorymoog	JP8
Chroma					

* (VCA, VCF, VCO, Gate, Trigger or Arpeggiator as provided on each unit.)

Measures
17½" x 11" x 4½" x 2½".
Weight is 8 pounds.

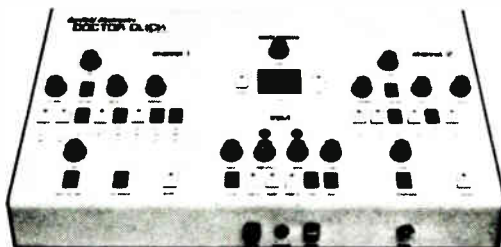

Warranty is one year.
Call or write for location
of your nearest dealer

ONE DOCTOR CLICK CONTAINS ALL OF THESE PROBLEM SOLVING DEVICES

- | | | |
|---|--------------------|------------------------------|
| 4 Fixed Clock Outputs | 2 Rhythm Envelopes | Headphone/Speaker Output |
| 2 Variable Clock Outputs | Pulse Counter | Roland 5 Pin DIN Sync Output |
| 2 Metronomes | Pulse Shaper | External Clock Input |
| 2 FSK Sync Code Decoders
(Covers Linn, Oberheim, Roland) | Gate Output | Footswitch Controls |

The brand to brand problems of timebase, voltage level and polarity are solved by the Doctor Click's diverse output capability.

The ability of the Doctor Click to connect to many units at once coupled with its footswitch control capability makes it ideal for multiple sequencer, drum machine, synthesizer live applications.

Since the Doctor Click metronome produces beats per minute and frames per beat calibrations it is always convenient to get just the tempo you need. It is even possible to get fractional tempos such as 118½ beats per minute.

The Doctor Click's two independent rhythm actuated envelopes allow VCF, VCA and VCO parameters of synthesizers to be modulated in 32 rhythm values ranging from four measure cycle to 64th note triplet with variable attack, decay, sustain and amount. This eliminates the problem of rhythmic drift when using a conventional LFO.

The ability of the Doctor Click to transform metronome click tracks into timebase clocks allows frames per beat music film work to be

done with virtually any sequencer, drum machine or synthesizer. The ability of the Doctor Click to read live tracks allows sequencers, drum machines and synthesizers to play in sync with the varying tempos of a human drummer or a built click track. The ability of the Doctor Click to accept external clocking or either of the types of FSK sync to tape codes allows sequencers, drum machines and synthesizers to be synced to any existing track. The pulse shaper circuit turns a pulse from an instrument into a trigger waveform allowing synthesizers to sync to a drum fill. The headphone output allows click tracks in multiples of the tempo to be generated and is capable of driving a speaker. The pulse counter can be used to program sequencers in higher timebases, quickly combining greater rhythmic resolution with step programming accuracy. The step programming switch can be used to step program sequencers that normally do not have this capability.

Used on tracks by Brian Banks, Tony Basil, John Berkman, Michael Boddicker, Kim Carnes, Suzanne Ciani, Joe Conlan, Chris Cross, Bill Cuomo, Jim Cypherd, Paul Delph, Barry DeVorzon, Don Felder, Paul Fox, Dominic Frontier, Terry Fryer, Albhy Galuten, Lou Garisto, Herbie Hancock, Johnny Harris, Hawk, James Horner, Thelma Houston, Michael Jackson, Quincy Jones, Jeffrey Kawalek, Gordon Lightfoot, Jerry Lilledahl, Johnny Mandel, Manhattan Transfer, Paul Marcus, Jason Miles, NBC Movie of the Week, Randy Newman, Keith Olsen, Paramount, Joel Peskin, Oscar Peterson, Greg Phillingaines, Jean-Luc Ponte, Steve Porcaro, Phil Ramone, Lee Ritenour, Steve Schaeffer, Mike Sembello, Mark Shifman, John Steinhoff, Sound Arts, Ian Underwood, Universal, Donna Washington, Stevie Winwood, Pia Zadora.

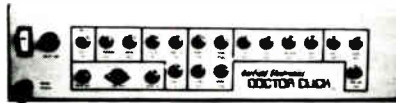

GARFIELD ELECTRONICS P.O.B. 1941, BURBANK, CA 91507 (213) 840-8939

tone GENERATORS

for critical slide synchronizers and other applications.

Zero cross detection.
Automatic repulse and many other features.

Two models to choose from.

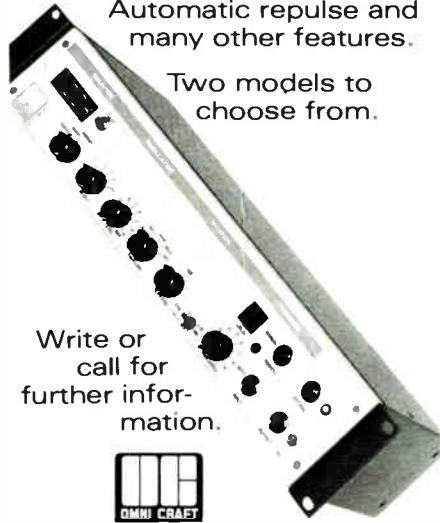

Write or call for further information.



Rt 4 Box 40
Lockport, IL 60441
(815) 838-1285

Circle #092 on Reader Service Card

PROFESSIONAL AUDIO EQUIPMENT

Authorized Distributor for:

 crown

 JBL

SHURE

 Urei

TASCAM

dbx

...other quality brands available

Outside Peoria, in Illinois,
call toll-free

1-800-323-3300
or call 309-637-2277

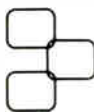

THOMPSON
ELECTRONICS
COMPANY

3522 W. Harmon Highway
Peoria, Illinois 61604

Circle #093 on Reader Service Card

—from page 105

wholly responsible for, right down to the advertising and the T-shirts. I take as much control over how I am represented as I can."

Genesis, on the other hand, is a true democracy. All decisions are made through the three permanent members, as is most of the writing and the arranging. "We write music as a corporate unit," says Collins of the group's composing setup. "We did it that way much more so with *Abacab*—and some with *Duke*—than we did on previous albums."

Critics, however, feel that Collins has forced too much of his own musical direction on Genesis and especially now that both Collins and Genesis use the Phenix Horns (borrowed from Earth, Wind & Fire) on record and in concert, the two are beginning to sound dangerously similar.

"The fact that you put horns on them suddenly drags them closer together than if you didn't have horns on them," says Collins in his defense. "The thing is, people have very definite preconceptions as to what a band should sound like if they've lived with them for 10 or 12 years, as they have with Genesis. Some of them try to put us in a certain box and they don't like us to get out. If you get out of that

box, it surprises them.

"The horns may never play with Genesis again. It was just a thing that we did at the time because we felt the material called for it. Rather than trying to simulate a horn section with synthesizers and stuff, we thought, 'Let's go for the whole thing. And I know the best horn section in the world! So let's go and try to get them on it.' So, as you see, it's not the kind of thing where they'll make a cameo appearance on every Genesis album."

Collins' interest in recording deepened as Genesis became more and more involved in the production of their records, around the time Gabriel left. Collins started making more elaborate demos in his home studio and began studying Genesis producer David Hentschel's techniques.

In 1981, he made a series of demos of songs that dealt with a painful divorce he had just gone through. Those songs, deemed "too personal" for Genesis, became his first solo LP, *Face Value*. Much of that record and his second, *Hello I Must Be Going*, were originally recorded on an 8 track in his home. After Collins laid down the original keyboards and drum machine tracks there, he brought the tapes to a 24 track studio and continued overdubbing there.

"I just do it at home. 'In the Air'

and all that stuff was done at home and then I went into a studio and put the drums on top of it. I usually go into the studio and play along with the drum machine and then we either use the drum machine or take it away. The vocals and horns I do at a proper studio because the sound is better.

"Pleasing me is as easy as being clammed up in a little room doing that. I've got twice as much equipment in my bedroom as The Beatles had when they did *Sgt. Pepper*. I think to myself, 'I'm not going to pay through the nose and have people running around waiting for me to get my part right.' I just do it at home. I never set out to make *Face Value*; it made itself. I just made these demos at home and I like them so much I decided to use them."

In his home Collins has a Brenell 1" eight track machine that cost him \$10,000— which, he says, "is not expensive if you think of what you're getting."

Collins plays drums on nearly every studio project he's involved with (including the monster traps on Frida's "I Know There's Something Going On"), and tries to vary his drum sound with each recording. "I'm the kind of player that will sound different whoever I'm playing with. Bill Bruford will always sound like Bill no matter

what he does, and that's very distinctive. Tony Williams sounds like Tony Williams, no matter what he does. Steve Gadd can sound very different—I mean, his technique is very distinctive—but he sounds very different and that's where I'm coming from. If I'm playing with John Martyn there's no sense in me steaming in there with an 'In the Air' style; I've got to be aware and sensitive to the music.

"Even on Frida's album, there's two different drum kits; I always carry a double-headed kit and a single-headed kit and different weights of cymbals. Sometimes we open up the ambient mikes and sometimes we keep it really closed. It depends on what the song needs; there's no hard and fast rule. That's what being a good producer has really been to me.

"The word 'producer' is a very glamorous word for someone really that is more of a director," says Collins. "You just need a good pair of ears and a bit of good sense about what's good and what's bad and what's right and what's wrong."

For Phil Collins, not everything is that simple. For one thing, there's the matter of finding time to complete the myriad projects he's committed himself to. And when everything scheduled has been accomplished, maybe he'll have some time to relax ... around 1985.

—from page 75, *Richardson*

Mix: Are there any technical advantages to using the dual multi-tracks?

Richardson: Every time you dump down, you always use the play head, never using sync to move tracks around within the same tape. There are distinct sonic advantages to doing it this way, and you can also easily move things around in time. Let's say a guy plays a note a little late. Hey, you can just slide him up a frame, and he's back in meter.

Mix: In order to do this do you need a system that can initiate record automatically on a SMPTE frame number?

Richardson: Oh no. You just do it by hand. You know where the downbeat is, and if the guy's late, he's late. To us, late can be 5 to 10 milliseconds and a frame is a lot longer than that [33 ms]. A lot of times we will run the SMPTE track through a DDL [digital delay line] and then we can slide time all over the place.

Mix: You run the code itself through a DDL?

Richardson: Yes. It's the only way we can get less than one frame offset, say 5 to 10 milliseconds on the whole track or just a piece of it. Of course you can't use just any old DDL for this purpose. It has to have the bandwidth necessary to pass the timecode without messing it up.

Mix: Are there any particular advantages to the MCI JH-556D for doing dual multi-track work?

Richardson: Well, you've got to have that many faders [the MCI JH-556D is a split console with 26 I/Os on a side]. If you've got that many tracks, you've got to have that many faders, otherwise you're going to spend most of your time making patches and dumping mixes. You're just going to spend an awful lot of time in the patch bay. Also, it's nice that track eleven of the left hand machine shows up on track eleven on the left hand side of the console, and that track eleven of the right hand machine shows up on the right hand side, track eleven.

Mix: Can you use dual multi-tracks with a smaller console?

Richardson: You can do it; we've done it. We've done it with an MCI 36-input board using the little faders as a submix to a stereo buss, but that precludes the use of certain echo sends or track assignments, EQ, or whatever. You're a little shortchanged. If you want EQ on eleven you have to pop it in on which eleven you want,

so there's a little brain scramble going on if you want to do it without all those faders and I/Os.

Mix: What do you think about the sound of the Modular studio design?

Richardson: It sounded good to begin with, and it's getting better all the time. We've found over the years that you can't expect to get the best sounds out of a room on the first couple of records. I think that after you get the first five or six albums in, or perhaps 100 or 200 sessions, you start to get a real good feel for where the drums might want to be in the room, or where it sounds really good to do vocals... and you keep screwing around with the monitors until you're satisfied. I don't know of any professional studio where they have "nailed down" the monitors and then left them alone. As soon as you blow a driver, you have to start screwing around with them, and maybe make them better.

Also, it takes time to get used to the quirks that are present in any room. If you mix three or four records and then hear them on the radio you realize much better what you've done, because in the control room you can't always see the forest for the trees... you get a record out there, and then a little later hear it on somebody's stereo in their living room and you say, "Ah, now I know what I was hearing in the bottom end in the control room." But that kind of hindsight is the only way to know that. That's why when a good installation is finished and smart people get in there and have the opportunity to fine tune it, that's when a studio becomes a real functioning entity and a great sounding room.

We were limited for size when the studio was built, so it's a good thing that we do a lot of overdubbing and mixing. It's very seldom that we have to have a whole lot of players out in the studio, and it can get crowded when we do.

Mix: What about the control room?

Richardson: The Modular design control room is huge, and that's very convenient. We've got enough room for all our synthesizers, all of our little guitar setups, bass setups, whatever. Everybody plays in the control room all the time. It really cuts down on the communication difficulties in going through the glass and headphones and all that stuff. Most people making modern records today spend an awful lot of time in the control room, so you've got to have a large, comfortable space in which to work. ■

Introducing
**THE
SOUND EFFECTS
LIBRARY
FOR
PROFESSIONALS**

- 3000 STEREO EFFECTS
- 30 HOURS OF SOUNDS
- 125 TAPES at 7½ or 15ips
- PRICED FROM \$1500.00
- NO ROYALTY PAYMENTS EVER

"Some of our Clients."

- * ABC
- * NBC
- * CBS
- * Walt Disney



86 McGill Street,
Toronto, Ontario,
Canada. M5B 1H2
(416) 977-0512

Circle #094 on Reader Service Card

—from page 103, *MVP*

tempt to answer questions about the people behind the scenes, the production techniques and the equipment used in this expanding area of entertainment technology.

Lou Casabianca, managing director of Speed of Light Communications in San Francisco and director/co-producer of "Mix Video," has produced and directed film and video music pieces for Journey (CBS), Narada Michael Walden (Atlantic), Emmanuel (RCA International) and Chuck Mangione (CBS). Mr. Casabianca is also an audio producer with a background including record production on Island Records with "AutomaticMan" (Michael Shrieve, drums; Todd Cochran, keyboards; Pat Thrall, guitar; and Doni Harvey, bass) "Go" with Yamashta, Windwood and Shrieve (Al DiMeola, guitar, Klaus Schulze, synthesizer) and "Go II: Live in Paris." Free lance film and video credits include production with HBO, Showtime, MTV, Ampex, GTE, Bill Graham, Syntauri Corporation and Criteria Film + Video. He has extensive background in computer animation and the use of computers in music, film and video production. ■

**Full Line
Professional
Audio Dealer**

Specializing in
State of the Art
P.A. and
Professional
Recording Equipment

Featuring:

- JBL
- NEOTEK
- AMPEX
- OTARI

Dealer Authorized Speaker
Reconing and Maintenance for
All Electronics and Tape
Transports



Circle #089 on Reader Service Card

"From One Serious Music Maker To Another"

TAPE IT EASY

- PROFESSIONAL BLANK AUDIO AND VIDEO TAPE SUPPLIES AT VERY LAID BACK PRICES
- FINE CASSETTE AND TAPE TRANSFERS
- SHORT LENGTHS OF HI BIAS OR NORMAL BIAS CASSETTES NOW IN STOCK



**from one of L.A.'s
major wholesale
distributors**



AMPEX

Scotch 3M

(213) 464-2285
For Samples and Catalog

Project One A/V
6669 Sunset Blvd., Crossroads of the World
Hollywood, California, 90028

Circle #090 on Reader Service Card

—from page 34

ca, a substantial amount of business from that little room. Their first thought on upgrading was to go to 24 track, but that was impractical as the space was too small."

The new studio now has a large control room, equipped with Ampex recorders and an APSI 3000A console, and the main room features variable acoustical panels which mechanically revolve.

Joiner, Pelton, Rose, Inc., of Dallas, TX, was founded by John Joiner. One of their recent projects was the design of Dallas Sound Lab, in Irving, TX, which opened last month. The Dallas Sound Lab facility consists of three rooms for audio / video / film recording, mixing, and scoring. The first class installation included a great amount of attention to details such as full Faraday shielding of all conduits. "None of the conduit touches itself or any metal in the building," explained designer Russ Berger. "It's all completely isolated except at one central point. This will give them the lowest possible noise floor in their equipment."

Other Joiner, Pelton, Rose projects on the horizon include a soundstage, two 24 track studios, and five video editing suites for Tele-Image, in Texas, and another soundstage for The Soundstage, at the Dallas Communications Complex in Las Colinas.

Berger has noticed a design trend of "... a grassroots movement back towards physical acoustics. Plain hard acoustics. A lot of design techniques in the past were marketed as the ultimate answer, and were not based in physics. More and more studios today are interested in what kind of test equipment you have, your testing methods, and your philosophies of acoustics."

Francis Milano, the senior designer for Analogique, New York City, reports they are currently designing a large studio complex for King Sunny Adé in Nigeria. "This is a very big project. We are working step by step, because there are a lot of problems

when working in Africa, even in Nigeria, which is an economically open country. Sunny Adé is a star there, and feels he is obligated to have something at his star level. So he is including a motel, a studio, swimming pools, a record pressing plant, publishing companies, everything."

Analogique moved from Paris to New York to concentrate on the American design market, and is now planning Right Track Studios in Manhattan. Construction of the 24 track facility with video production and post capability will begin this fall.

Music Annex Recording Studios, in Menlo Park, CA, has completed two major renovation projects, designed by George Augspurger. The new control room in Studio C features an MCI 24 track recorder, an Amek 28 x 24 console, and UREI monitors. The control room is wired to both the Studio C main room and a separate soundstage for video and film shoots. Studio B has been set up as a dedicated eight track mixing/overdub room. Studio B will allow budget minded producers to complete their projects in a state-of-the-art audio environment with access to a

"If we know the equipment going in and the physical dimensions, it's possible to install an entire studio and troubleshoot it in a day, and expect it to work."

wide selection of outboard and signal processing gear.

Sonic Landscapes, of Sausalito, CA, has completed the design for Avid Studios, an audio/video complex in Redwood City, CA. The one million dollar facility will incorporate a modified live end/dead end control room with a variable acoustic studio and video post production rooms.

"For this project, we're taking the concept of a quiet control room to its ultimate end," explained designer Randy Sparks. "We're using a Convection-Air system. It's noiseless air conditioning, with an NC rating of below 15, which is phenomenal. There's no moving air. We also have a digital [lighting] dimmer pack we're using, and by removing the dimmer control pack at the main service, you can eliminate the buzz. We also have a keypad dimmer

accessory mounted in the console area which the engineer can operate without going to a large 1200 watt wall-mounted dimmer. Coupled with the air conditioning, and by isolating amplifier fan noise and enclosing the tape decks in some sound isolated soffits, we've lowered the noise floor of the room quite substantially."

Audio Engineering Associates, Pasadena, CA, has developed a modular system for studio wiring installations. This system was put into use at Stevie Wonder's new studio in Los Angeles. The studio was built at the site of the original C.P. MacGregor facility on Western Avenue. Stevie bought the facility some time ago to use as a rehearsal space, and parked a Record Plant remote truck nearby, on a monthly basis, which housed his digital multi-track recorder. He finally decided it made more sense to build on the facility instead of renting, and wanted the place completed as soon as possible.

The design team included: Jack Edwards, architect; George Augs-

purger, acoustic consultant; Ken Fause, for electrical and grounding; and Audio Engineering for the electronics interface and audio wiring. "We had the place ready to install about three days before the month was up," explained Wes Dooley, AEA Chief Engineer. "We did the whole place on a pre-planned basis, so as soon as they could give us conduit, we could give them audio. This is something we had been concerned about for some time - the ability to do a modular audio interconnect. If we know the equipment going in and the physical dimensions, it's possible to install an entire studio and troubleshoot it in a day, and expect it to work."

Besides installation speed, the modular wiring system offers other advantages as well. "Sometimes people say they want to get a studio in a space right now," Wes explained, "but when the lease ends, they're going to move. Using the modular approach, you can move out one day, move in another day and be running. So the money you put into the wiring is in fact an investment rather than a write-off." ■

EVERYTHING IN AUDIO CASSETTE DUPLICATION

Spectrum Fidelity Magnetics is a one-stop source for duplication and packaging of audio cassettes. From seminars to sermons, sales talks to lectures, educational programs to highest quality music, our bin-loop equipment gives you back what's on your master tape. We also specialize in duplication of computer programs. Our prices are competitive, our turn around time fast, and our minimum is only 200 copies of one title. Call us toll-free. **1-800-441-8854.**



SPECTRUM FIDELITY MAGNETICS
1770 Lincoln Highway East
Lancaster, PA 17602
717-295-9275

Circle #091 on Reader Service Card

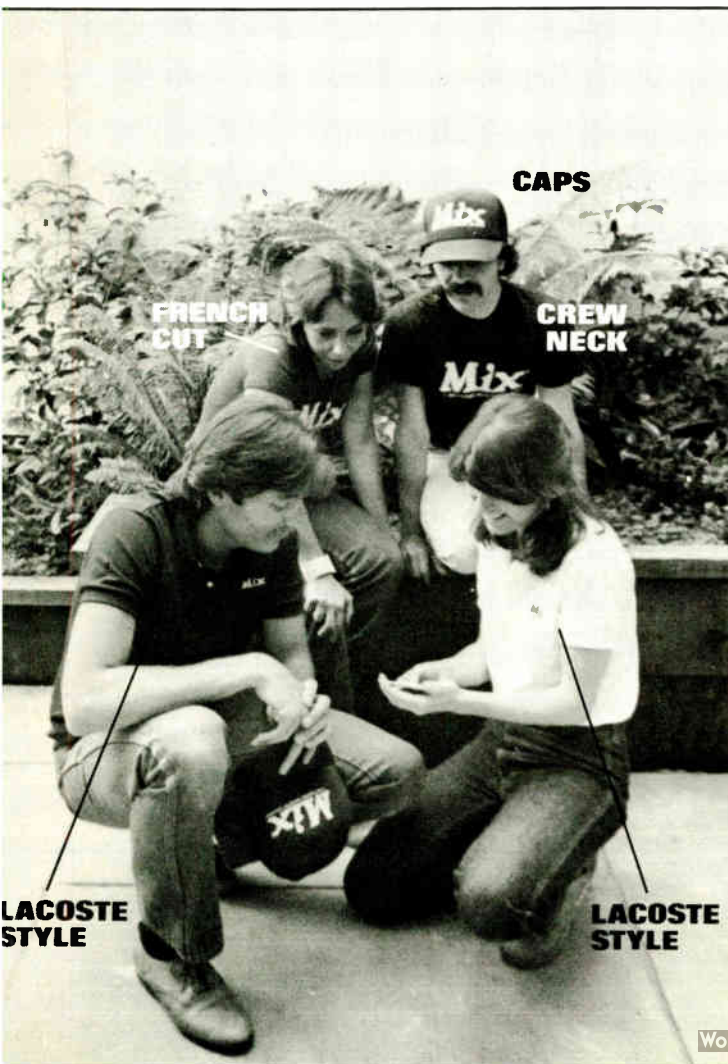

TOPS

IN THE BUSINESS

If you're in the recording industry, you want to keep up with the latest trends. So keep your wardrobe up-to-date with the new MIX shirts. ■ NOW AVAILABLE: Lacoste style (w/fashion collar) navy, white - \$22.50 ea. French cut (women's sizes) navy, black - \$8.00 ea. Crew neck (men's sizes) navy, black - \$8.00 ea. Caps (adjustable) navy, red - \$5.00 ea. ■ All T-Shirts available in S, M, L and XL. ■ 10% off on orders of 5 or more shirts. Buy for your staff and customers! Order now!

Mail to: Mix T-Shirts, P.O. Box 6395, Albany, CA 94706. Enclose check or money order payable to Mix Magazine.

ITEM	NO.	COLOR	SIZE	PRICE

Add \$1.50 for postage and handling per item.

CA residents add 6.5% sales tax to T-Shirt total:

TOTAL _____

Name _____

Address _____

City _____ State _____ Zip _____

Equipment For Sale

SNAKES & CABLES, multi-pair, mic cables & coax. Any length & combination of connectors. Ground lifts, splitters, & multi-pin connectors avail. 19-channel snakes - 100' from \$330. 20' mic cables from \$10.

Auburn Sound Corp.
(301) 459-1959

LOWEST PRICES ANYWHERE!

Don't buy anything until you have checked our prices. Guaranteed to be the lowest anywhere! Send for our free listing.

Audio Systems Corporation
P.O. Box 17562
San Antonio, TX 78217
Dept. MIX
(512) 824-6402

USED RECORDING EQUIPMENT Bought & Sold. We have Neumann & AKG tube mics of all kinds. API 550's & other misc. outboard equipment.

(415) 441-8934 or 527-6167

PROFESSIONAL AUDIO EQUIPMENT

Shop for pro audio from N.Y.'s leader no matter where you live! Use the Harvey Pro Hot Line (800) 223-2642 (except N.Y. Ak & Hr.) Expert advice in-depth parts dept. 3/4 video systems available. Broadest selection such as Otari EXR Ampex Tascam and more. Write or call for price or product info.

Harvey Professional Products Division
25 W. 45th Street
New York, NY 10036
(212) 921-5920

Q. LOCK 3.10 SMPTE SYNCHRONIZER/EDITOR

Now Factory Direct Only

For audio sweetening, ADR (looping), and music recording. Interlocks audio, video and film recorders. Supplied complete with all cables, connectors, readers, keyboard, generator, and one year warranty. Prices start at \$13,950.



4721 Laurel Canyon Boulevard Suite 209
North Hollywood California 91607
213/980-5717 Telex 194781
Toll Free Outside California 1-800-423-3666

FOR SALE

M-16 Dolby Pack w/cables and roll-away rack - \$9,500.
Contact Val Valentin
(213) 766-9573

Like new - Tascam 8516 - Priced to sell. Sound Workshop mod. 1280B w/expander 24x8. Ampex AD-15 duplicator. Tangent 3216 28x24. Scully 8-track. Neumann U48. Crown EQ-2. Steve (405) 721-9191 or (405) 232-1566

WE HAVE THEM BOTH
Buyers & Sellers for new & used Professional Audio Equipment.
Call today for our new list.
Contact B.A.E., Inc.
(formerly Blevins Audio)
(615) 361-0470

NEOTEK WEST Sales & Service of New & Used Neotek audio consoles. Demo sale on Fostex monitors, amps; mics, & headphones. **Neotek West** 4007 W. 6th St. L.A., CA 90020 (213) 387-7999

Call for a hands-on demonstration.

AUDIOHOUSE SELLS Valley People, MICMIX, Echoplate, Symetrix and EXR Exciter at the best prices. (303) 751-2268.



HI-TECH GEAR

LINNORUM 360 DIGITAL KEYBOARD, PROPHET 5 600 PRO 1 MOOG, ROLAND, YAMAHA KORG SIMMONS ORUM MOODLES CHROMA SYNERGY DR CLICK EMULATOR DRUMULATOR CASIO SALES CONSULTATION, COMPUTER INTERFACE
GAND MUSIC (312) 446-4263
780 FRONTAGE ROAD, NORTHFIELD, IL

UREI 1176LN Peak Limiter - Best Offer. (415) 457-8736 (eve) Dick.

BUILD YOUR OWN STEREO PLATE REVERB SYSTEM For less than \$350. No Exotic Parts, Minimum of Mech. Ability. COMPLETE DETAILED PLANS \$41.00 \$43.46 in TN

HOW-TO ENTERPRISES
RT. 2, BOX 96
GALLATIN, TN 37066

NEUMANN MASTERING SYSTEM Including tape machine, SX68 head, VG66 Amplifier Rack, level sets, HF limiters, Elliptical Equalizer and variable pitch and depth. \$38,500. Dolby M16 16 track noise reduction. \$8,500. Call Jim at (513) 681-8402.

AVOID TECHNO SHOCK SYNDROME!

Complete musical electronic equipment consulting & buying service. Best prices and service in the country - guaranteed.
Contact the R₂ Network
(213) 768-7448

OTARI 1010 HIGH SPEED DUPLICATING SYSTEM - current model - MINT condition. Ampex AG440 - 8 - \$3,800. Ampex AG440 - 4 - \$1,950. Nagra III - \$1,800. Ampex 350 (deck only) - \$300. Contact Stewart at (213) 466-6141

CLASSIC AUDIO COLLECTOR'S ITEMS - Neve console - 8048 - 32/16/24, 1081 EQs. Many, many extras - 65K. 4 AKG C-24 mics - mint condition - \$2,000 ea. Studer A80 16 trk - 18K. Studer A80 - 8 trk 10K. EECO MQS 103 synchronizer - 9K. Q-Lock 310 synchronizer - 13K. Auditorics 501 26/16/24 - 15K. API 40/16/24 automated - 60K. Many, many additional pieces available. CALL OCEAN AUDIO EXCHANGE - (213) 454-6043

TUBE MICS: U-47, M49 & C12, also Nagra 4S available. Call Bill at (312) 751-1216. Please leave a message if you get my machine.

2-trk Ampex ATR-800 Dealer demo. Complete w/factory console & pedestal, monitor panel, edit marker & real-time counter. This machine is **NEW** and has been used for display only. New price: \$6085.00. Will sell for \$4,500 - complete. (704) 889-4508 or (800) 438-6040. Ask for CAL.

Trident TSM recording console, 40 input, 24 buss, 32 monitor, 4 years old, no modifications. Fact sheet and photos available. \$68,000. (914) 725-3519

USED STUDIO EQUIPMENT

MCI JH-10 16 track w/Autolocator & 8 track heads; Otari 5050 2 track machine; Otari 5050BF full track machine; Neotek Series I 20x8 console; 2 White 4001 EQ; Eventide 949 Harmonizer; AKG, Shure, EV, Beyer, Sennheiser mics; 4 Switchcraft Patch Bays w/25 patch cords; 2 JBL 4313 Studio Monitors; Kimball 6'8" grand piano. For more info call John: (317) 299-9601 or (317) 291-7186.

Looking for Eventide SP2016 or H949? Space Station, Banner, RTA, ADR, Scamp? Need AKG, BGW, dbx, E/V, Neumann, Orban, Sennheiser, Shure, Technics, UREI or White products? Best price & service. Contact John:
UAR (512) 690-8888
8535 Fairhaven
San Antonio, TX 78229

AMPEX RECORDERS: ATR800, ATR100, MM1200 Demonstrators. AG440, 350, and 351 trade-ins offered at prices to sell today. We are an AMPEX dealer. WE WANT RCA 44BX & NEUMANN U47 MICS in trade. NORTHWESTERN, INC. 1-800-547-2252

PLATE REVERBS - NEW \$1,395

Announcing the X-3500 PLATE REVERB. Hearing is believing! For free demo tape call or write: Cornerstone Systems 703 S. Second Street Milwaukee, WI 53204 (414) 643-0879

FOR SALE:

dbx 216 16-channel noise reduction unit, Quantum QM12A. 12 channel mixer, Eventide H910 Harmonizer w/keyboard and various outboard gear. (314) 445-5728

Automated mix-down systems for VIRTUALLY ANY 16 or 8-track studio by Rolland Studio Systems of Japan. New - was \$8,500 - dropped to \$6,000. Closing out at \$2,250. An absolute must! Includes mixer w/SMPTE, VCA pack, only 2-4 hours to interface. All poly synth flight cases still on sale. Starsound (800) 354-7252.

24 Ch. dbx 208 PROF. NOISE RED. +4 dBm, balanced, modular, w/ spare cards and gold plated harness, over 1 year left on warranty. \$8,000 firm.
PAIR McIntOSH M1-75 MONO TUBE POWER AMPS. 100 watts each, in good cond. \$600 pair.
PAIR ALTEC 9844A MONITORS in good cond. \$700 pair.
(212) 840-1350

MCI JH114 16-trk. Comes w/Autolocator II, 800 total hours. Owned since new, MINT!! Will take 1" 8-trk. on trade. Cash - \$16,500. Trade - \$18,000. (612) 475-3152

MUST SELL: OTARI MX5050B half track, Orban 672A equalizer, Orban 424A compressor. All items are new. For more information contact: Randy (800) 654-6744

KEPEX AND GAINBRAINS For Sale

8 Kepex and 4 Gainbrains Rack Mounted With Power Supply Prophet 10 w/flight case & updated Polysequencer \$5,500
1 PSA-2 Crown Power Amplifier \$1200
(212) 242-2100

FOR SALE

Tangent 3216 16 x 16 console
 Otari MTR-90 16 trk recorder
 w/Autolocator
 Low hours/Mint condition.
 (312) 525-6565

NEUMANN VMS-70 SAL/SX-74/
 Technics SP-02 motor cutting system.
 New condition, 5 yrs old.
 KAWAI 9' concert grand. Ivory
 keys, 5 yrs old. Excellent condition,
 \$10,500 obo (213) 204-2854

Dolbies 361's \$850
 2 Kepex rack 8KPX 4GB 2500
 Cooper Time Cube 750
 Harmonizer H910 900
 B&B 24ch VCA Grouper 7500
 4 Nakamichi 600II cass 250 ea
 2 Nakamichi 700II cass 500 ea
 Hollywood Sound (213) 467-1411

Studios For Sale

Excellent opportunity in Dallas.
 MCI 16-trk w/Autolocator plus 8-trk
 heads, 16-channel Speck console
 w/parametric, dbx, digital delay,
 plate reverb, good mics - 3 Neu-
 manns, grand piano, Rhodes, Fend-
 er bass, 2 booths, headphones, etc.
 Completely wired & running - ex-
 cellent sound - low rent - FOR DE-
 TAILS - (214) 239-8128

King Realty, Inc. presents for sale
 Devonshire Sound Studios, an in-
 ternationally recognized state-of-
 the-art, four studio, sound record-
 ing complex with video capability.
 For information and detailed bro-
 chure contact Kathy Small or Dave
 Cowdrey, 13369 Ventura Blvd.,
 Sherman Oaks, CA 91423
 (213) 788-7900

Record & Tape Services and Supplies

BOOST STUDIO PROFITS!
 Substitute Strand 620 1/4" pro mas-
 tering tape for your brand.

SAVE 1/2 or MORE!

No quality loss - fully guaranteed.
 Bias compatible with Ampex 406/
 456. Formerly available only in LA.
 For information call FULLER
 SOUND (213) 660-4914

CASSETTE DUPLICATION in Real
 Time using Nakamichi cassette
 decks for impressive quality. Fast
 turn-around. Best rates. Labels, in-
 serts & shrink wrap available, from
 10 to 10,000. AUDIOHOUSE (303)
 751-2268

AGFA CHROME & normal bias
 BLANK CASSETTES. CUSTOM
 LOADING to the length you need.
 Your music deserves the best -
 your budget deserves a bargain.

GRD

P.O. Box 13054
 Phoenix, AZ 85002
 (602) 252-0077

WHO TALKS ABOUT SOUND?
 Nobody but A + R, because WE
 MAKE THE BEST SOUNDING
 CUSTOM RECORDS. Hear for
 yourself; call for free sample.

(214) 741-2027

A + R Records & Tapes
 902 N. Industrial Blvd.

Dallas, TX

WHEN QUALITY MATTERS

RECORD PRESSING

Top-quality LP packages at
 super low prices. Album design
 available. Check us first!

H.R. Productions

(415) 930-7573

PROFESSIONAL RECORDING SUPPLIES

We are a major distributor of
 Ampex, Agfa & 3M bulk & reel
 master tape from 1/4" to 2". We
 also stock empty reels, boxes,
 video cassettes, Norelco boxes &
 other recording supplies. We man-
 ufacture custom length bulk
 cassettes using top quality tapes.
 Cassette duplication service avail-
 able. Please call or write for our
 FREE catalog.

Advance Recording Products

7190 Clairmont Mesa Blvd.,
 San Diego, CA 92111
 In Calif.: (800) 858-1061
 CA Phone No: (619) 277-2540

AGFA MASTERTAPE & CASSET-
 TES. Super prices. Example: 1/4" x
 2400' bulk = \$10.53 and C-60 for
 86¢ (case quantities). Send for
 wholesale price list. WORLD
 CLASS TAPE, Box 7611 Ann Arbor,
 MI. 48105 (313) 662-0667

CUSTOM LENGTH CHROME CASSETTES

Rolls Royce of Custom Cassette
 BASF Chrome tape only
 UNITED TAPE COMPANY
 10746 Magnolia
 N. Hollywood, CA
 (213) 980-6700. Ask for Steve

DISC MASTERING - Cut
 from your tapes at low cost -
 Plating, Pressing, Labels &
 Jackets - LPs, EPs & 45s. Write
 for free information:
 THE CUTTING EDGE, Box 217,
 Ferndale, NY 12734,
 (914) 292-5965.

FACTORY DIRECT PRICES ON 3M TAPE.

We can save you money.

We ship from stock.
 Small quantity orders O.K.

STUDIOWORKS

(800) 438-5921

Maintenance Services & Repair

SPEAKER RECONING: 48-hour
 turnaround on most speakers.
 Gauss, JBL, Altec, Renkus-
 Heinz, Emilar warranty station.
 Call or write for info:

ALL STAR SOUND

(805) 653-6661

1070 E. Front #1,

Ventura, CA 93001

SPEAKER REPAIRS

Factory authorized service center
 Altec • EV • Gauss • JBL • UREI
 Replacement diaphragm assem-
 blies in stock.

AST Sound, 250 W. Broadway,
 NY, NY 10013; (212) 226-7785

SPEAKER REPAIR OF CALIFORNIA
 4334 Sunset Blvd. #2, L.A., CA
 90029. Experts since 1939 - speak-
 er rebuilding, tailoring, \$3.50 - \$9
 per cone-inch. Microphone repair.
 Freight free return after 3-day
 cleaning, glueing, centering &
 fatiguing; as for Rod Stewart, Zap-
 pa, Who, Heider, Glen-Glenn.

(213) 666-4161

API CONSOLE SERVICE

Wolff Associates will refurbish,
 repair, update or modify your API
 consoles. Factory experience, refer-
 ences available. Factory replace-
 ment parts. Grounding, hum &
 noise elimination. Will travel any-
 where. Call Paul (703) 241-2880

Recording Services

featuring
 JVC
 DIGITAL
 (305) 446-2477

Instruments For Sale

Fender Twin Amp (15" JBL K130) -
 \$225. Baldwin 5'2" Walnut Grand
 Piano - \$5,950. Cassio Cassiotone
 401 - \$295.

(415) 457-8736 (eve) Dick

Alvarez 12-string guitar w/case.
 Excellent condition. Estimated
 value - \$250. Must sacrifice at
 \$180. Call Kathy (415) 843-7901
 (days), (415) 924-5543 (eve.)

Business Opportunities

Dealers Wanted

THE REEL CASSETTE TRANS-
 PORTS YOUR SOUND INTO THE
 FUTURE. Record today's music on
 tomorrow's tape! And get the pro
 advantage of reel to reel recording
 in a cassette. We deliver the quality
 and reliability you want for your re-
 cordings in the Brand cassette that
 is a pleasure to behold. REEL CAS-
 SETTES have a lifetime guarantee,
 and they cost no more than other
 premium cassettes. Contact ARCH
 IMAGE, Box 2325, San Anselmo,
 CA 94960. (415) 485-4276 to order
 now.

Employment Wanted

PROFESSIONAL SERVICES

System design, installation,
 maintenance. Studio, film,
 video, sweetening. Custom
 work specialists.

TECHNICAL SERVICES CO.

Box 35053,
 Dallas, TX 75235
 (214) 827-3286

Employment Offered

Experienced Salesman needed.

Professional Audio, the West
 Coast's fastest growing pro audio
 dealer, is seeking a few knowledge-
 able, experienced sales people.
 Excellent growth & earnings poten-
 tials. Positions are available immed-
 iately. CALL

(213) 843-6320. Ask for Bob.

Signal Processing Engineers
 Also, several other audio positions
 including designers and mixers,
 with audio companies in USA. Call
 Bill, N.C. Personnel (704) 334-0033.
 Resume: 2227 Hassell Pl., Char-
 lotte, NC 28209. Confidential treat-
 ment assured. Fee paid. Serving
 the audio industry.

Major Manhattan 24-track recording facility looking for Studio Manager. Please send resume. Replies held confidential. Send to: Mix Magazine
P.O. Box 6395 Dept. ADL
Berkeley, CA

PRO AUDIO SALES - Excellent opportunity for exp. salesperson for outside sales in North. Cal. Will consider a background in wholesale, engineering, or related fields. Reply in confidence to Bob Ulius, Leo's Professional Audio, 5447 Telegraph, Oakland, CA 94609; (415) 652-1553

Miscellaneous

Are you a recording artist or producer interested in obtaining National and/or Regional airplay? If so, contact Professional Advertising Consultants, 11325 Pegasus, Ste. W-249, Dallas, TX 75238 or phone Bill Reardon at (214) 349-9415. We are an advertising agency with a totally unique approach to record promotion.

Instruction

"PRACTICAL TECHNIQUES FOR THE RECORDING ENGINEER"
Not a conventional recording book. See "The Best on Our Bookshelf" section in this magazine.

THE CORRESPONDENCE COURSE: Private instruction in recording theory from a world-class author/lecturer. Certificate course. Two textbooks, homework, final exams, unlimited dialog with the author via cassette. Installment plan.

FOR SCHOOLS - complete course materials. Teacher's Manual (lesson plans for two textbooks, reading, homework, suggested session content), Student's Workbook, Final Exams.

FOR INFORMATION OR TO ORDER contact:

S.K.P.

1626 N. Wilcox No. B-677
Hollywood, CA 90028

Order by phone using Visa or MasterCard by calling (213) 708-2933.

How to place a Mix Classified
Please print or type in CAPITAL LETTERS and lower case where you want the same to appear in your classified ad. There are 8 lines to the inch and approx. 32 characters to the line. \$50/inch - 1" minimum. Additional lines \$10 per line. **Bold Type** \$10 per line. Black border \$10 extra. Logos or display advertising up to 4" will be charged at \$75/inch.

DEADLINE IS 6 WEEKS PRECEDING ISSUE DATE. Multiple insertion categories available (check one).

- | | | |
|---|---|---|
| <input type="checkbox"/> Employment Wanted | <input type="checkbox"/> Equipment Rentals | <input type="checkbox"/> Equipment Wanted |
| <input type="checkbox"/> Instruction | <input type="checkbox"/> Recording Services | <input type="checkbox"/> Rehearsal Space |
| <input type="checkbox"/> Employment Offered | <input type="checkbox"/> Miscellaneous | <input type="checkbox"/> Equipment For Sale |
| | <input type="checkbox"/> Maintenance Services | |

Name _____

Address _____

Phone _____

If paying by: VISA MASTERCARD Card #: _____

Exp. Date _____ Name on card: _____

Signature _____

Payment by check or money order must accompany ad.

Mail to: **Mix Classified 2608 9th St. Berkeley, CA 94710**
(415) 843-7901

ADVERTISERS' INDEX

PAGE ADVERTISER

29 Acoustilog
16 Allen & Heath Brenell
65 Amek Consoles Inc.
12 Ampex AVSD
45 Analogique
69 Ashly Audio
110 ASI/Abadon Sun
27 Audio Engineering Associates
36 Audioarts Engineering
77 AVC Systems
44 Blevins Audio Exchange (B.A.E.)
34 Bryston Vermont
11 Carver Corporation
91 Carvin Corporation
22 Chips Davis
22 Crescendo Audio Productions
86 Crest Audio
79 Dallas Sound Lab
119 DeltaLab Research
85 DOD Electronics
7 Dolby Laboratories
87 East Coast Sound
67 Eastern Acoustic Works
32 Filament Pro Audio
55 Flanner's Pro Audio
99 Full Compass Systems
109 Garfield Electronics
87 GRD
94 Ground Floor Productions
2 Harrison Systems
41 Harvey Pro Audio
43 Hy James Audio

PAGE ADVERTISER

74 Jensen Transformers
105 JBR Company
80 Kable King
90 Keith Monks
73 Kenneth A. Bacon Associates
23 Klipsch & Associates
39 LD Systems
81 Leo's Professional Audio
78 Linear & Digital
56 Linn Electronics
107 LT Sound
107 Magnefax International
51 Martin Audio
98 MetroGnome
54 Meyer Sound Labs
45 Microphonics
30-31 Modular Perfection
48 New World Audio
112 Omnicraft
35 Orban Associates
120 Otari Corporation
93 Passport Design
104 Peirce/Phelps
110 Polyline Corporation
72 Pro Audio Systems
102 Production EFX Library
114 Project One A/V
111 QCA
60-61 QSC Audio Products
47 Reliable Music
99 Restoration
102 RO Studios

PAGE ADVERTISER

82 SCMS
78 SFX Effects
103 Shoreline, Ltd.
34 Sierra Audio
88 Simmons Group Centre
47 Sonic Landscapes
113 Sound Ideas Sound Effects Library
9 Soundcraft Electronics
49 Southwest Pro Audio
82 SPARS
28, 101 Spectra Sonics
115 Spectrum Fidelity Magnetics
75 Studio Technologies
44 Summit Audio
25 Tascam
114 TekCom Corporation
70 Telex Communications
112 Thompson Electronics Co.
111 Times One
14-15 TOA Electronics
98 Tom Semmes Associates
80, 96 Tres Virgos Studios
105 Tres Virgos/Strategic Sound
104 Triad Studios
95 Ultimate Support Systems
19 United/Western Studios
20 UREI
4 Ursa Major
59 Valley Audio
53 Westlake Audio

INTRODUCING EFFECTRON II FROM DELTALAB

**LOW COST,
FULL BANDWIDTH,
HIGH PERFORMANCE,
DIGITAL DELAY.**

The EFFECTRON™ II is an enhanced EFFECTRON. We have added many features per our customers suggestions. These features depend on Model and include Increased flanging range, external infinite repeat, increased input range, stereo output and even lower prices!

The EFFECTRON II series is still the only low cost, full bandwidth (16KHZ), high performance line of digital delay processors. Visit your local dealer and check it out !!!
Listen and Compare

ADM-1024
Full
Second Delay
\$599*

ADM-64
Flanger/Doubler
\$299*

ADM-256
1/4 Second Delay
\$449*



Music & Electronics . . . Naturally!

*Manufacturer's Suggested Retail

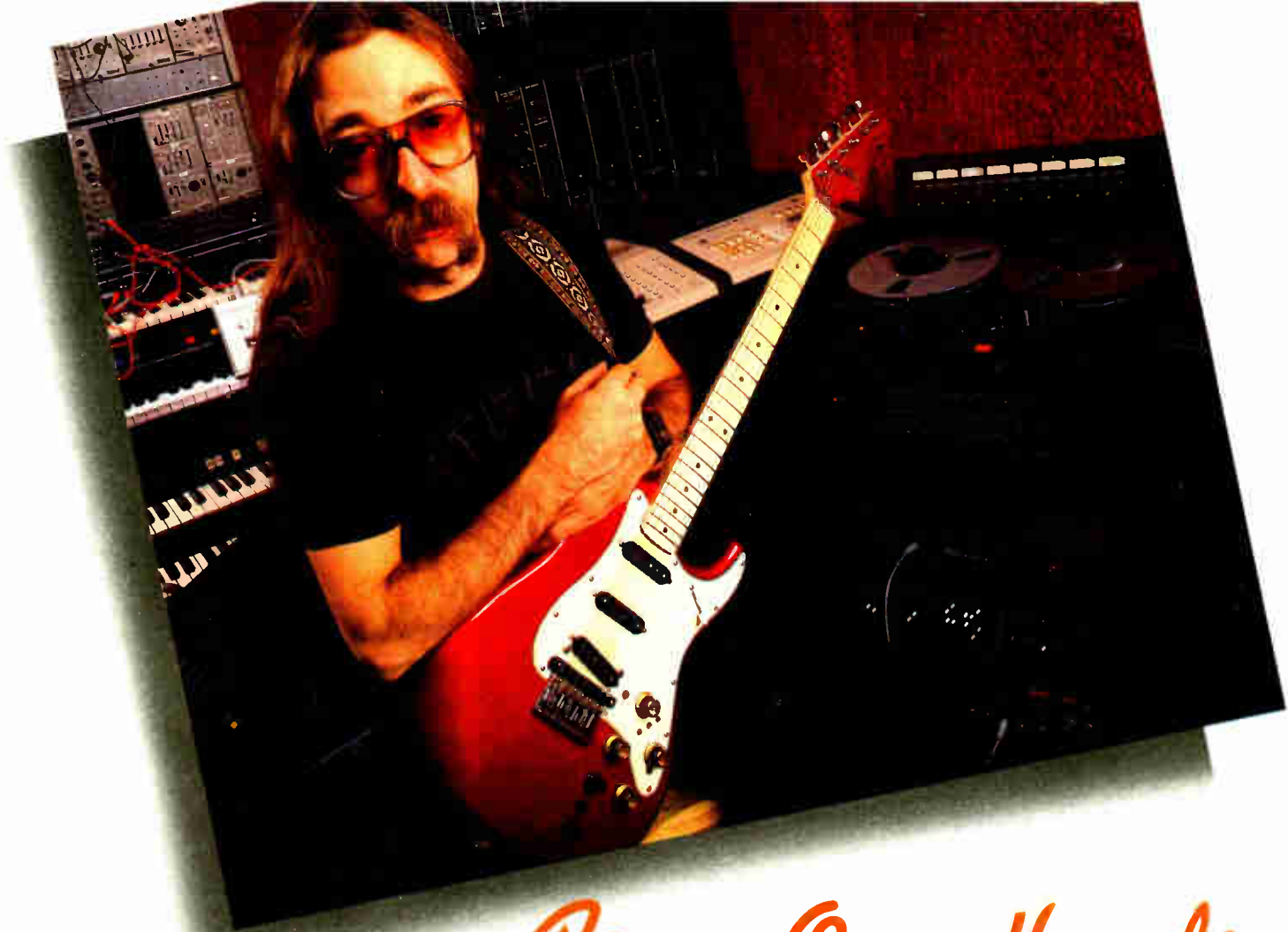

From Our Hands To Jeff Baxter's



The Otari
1/2" eight channel
MK III-8

Before Producer/Artist Jeff Baxter rolls into expensive studio time, he rolls tape on an Otari machine. At Home. In his studio, Casual Sound.

"The Otari saves me a great deal of time and money. A recording studio was never intended to be a \$150.00 per hour rehearsal hall, so I work out ideas and refine the tunes before I go into the studio.

All my pre-production recording for the last several years has been on my Otari. That machine has never left my studio, -it's been incredibly reliable.

There's a lot of musical moments that have been captured on that machine ... some of which have been

directly transferred to the final multitrack masters... Elliot Randall, Doobie Brothers, on and on. The Steely Dan Pretzel Logic album was mastered on an Otari 2-Track. And, that's obviously a statement in itself... how I feel about the quality of the sound."

Jeff Baxter's always been into instruments that musicians can afford. It's obvious that he's also been heavily involved at the leading-edge of recording technology.

Besides telling you his feelings about Otari tape machines, there's just one other tip Jeff would like to leave you with:

"Try anything and everything and always roll tape."

Circle #095 on Reader Service Card

OTARI. Technology You Can Touch.

Otari Corporation, 2 Davis Drive, Belmont, CA 94002
Tel: (415) 592-8311 Telex: 910-376-4890

© 1982 Otari Corporation