

9836818

# EDISON Phonograph Monthly.

EXACT REPRODUCTION

By  
Wendell Moore

First Edition  
January 1976



*Reprinted By  
Pennant Litho, Inc.  
Louisville, Kentucky*

1903 - 04 - VOLUME I, NUMBER I

BOOK NUMBER 403

*Wendell Moore*

N 1 L 55  
. 29  
. E 3  
F - -

*This book is dedicated to M. R. McMillion and the thousands of phonograph collectors who are active in preserving the true Edison phonograph story – historically and mechanically.*

*My thanks also to William R. Rawson and Edward Orbann, of Thomas A. Edison Industries, for their favorable comment in their letter of October 15th, 1965.*

*Wendell Moore*

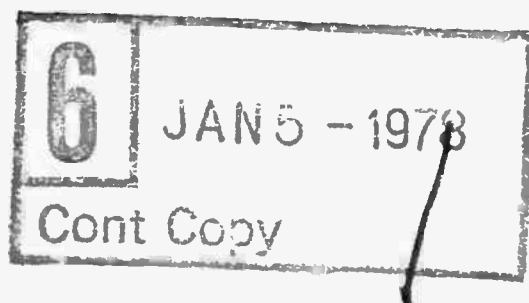

86 JPM 07 W/M  
M/M 20 MAR 78

## PREFACE

In 1964, while traveling in search of all kinds of mechanical music, I was fortunate to find and purchase a set of Edison Phonograph monthly bulletins. The set was from the first issue - March, 1903 through December, 1916 - 166 different bulletins, all consecutive numbers.

As all collectors will attest, circumstances surrounding all fortunate finds are generally worth talking about, so here is an accounting of this one.

In October, 1964, while in DeLand, Florida, I stopped and asked a druggist if he knew anyone who would part with an article of music. At least 24 out of 25 times you get a negative answer, but this time I got a favorable one.

I went to the address given me and a very kind lady told me that Mr. McMillion was very ill and he shouldn't talk. As I explained my business and what I came to their house for, I heard a weak voice from inside asking her to bring me on in. At that time I met a most unforgettable man - Mr. M. R. McMillion.

Mac had been an Edison dealer from around the turn of the century - all the way through the 1920's until radio sounded the death knell for the Phonograph. All this time he religiously cared for every E.P.M. as they came to him every month. They were invaluable to him in selecting new records every month full knowledge of every new machine; etc. In short, he had a pipeline to the front office and the knowledge that kept Edison great.

The years passed and Mac passed away; but now, 73 years after he saved the first E.P.M., we were able to enjoy them as he did. This fact is so - Because of one man - M. R. McMillion.

# TECHNICAL INDEX

Publication began March, 1903, so the index runs from March, 1903, through February, 1904, coinciding with the contents of book.

	MONTH	PAGE		MONTH	PAGE
— A —					
Ajax Phono . . . . .	Apr . . . . .	9	Megahorn . . . . .	Jun . . . . .	15
				Jul . . . . .	16
— B —			— N —		
Bijou Phono . . . . .	Apr . . . . .	9			
B & G Horn . . . . .	Jun . . . . .	11			
— C —			— O —		
Concert Records . . . . .	Apr . . . . .	7			
	Jan . . . . .	6			
	Feb . . . . .	7			
Concert Phono . . . . .	Apr . . . . .	9			
	Aug . . . . .	9			
	Sep . . . . .	4			
	Feb . . . . .	9			
Climax Phono . . . . .	Apr . . . . .	9			
Commercial Phono . . . . .	Apr . . . . .	6			
	May . . . . .	7			
— D —			— P —		
— E —			Phonogram. . . . .	Mar . . . . .	4,7
Edison Photo . . . . .	Mar . . . . .	3		Jul . . . . .	11
Excelsior . . . . .	Apr . . . . .	9	Phonautograph . . . . .	Sep . . . . .	7
— F —			— Q —		
— G —			Questions & Answers . . . . .	Apr . . . . .	7
Gem Phono . . . . .	Mar . . . . .	4,5		May . . . . .	10
	Apr . . . . .	4,5,9			
	Jul . . . . .	4,8			
	Sep . . . . .	4			
	Nov . . . . .	9			
	Feb . . . . .	7			
— H —			— R —		
Home Phone. . . . .	Mar . . . . .	4	Reproducers: Model B . . . . .	Mar . . . . .	5
	Apr . . . . .	5,9		Feb . . . . .	6
	Jul . . . . .	4,8,10,14	Reproducers: Model C . . . . .	Mar . . . . .	5
	Aug . . . . .	9		Apr . . . . .	5,7
	Sep . . . . .	4,5,6,7		Jul . . . . .	11
	Oct . . . . .	6		Sep . . . . .	4
	Jan . . . . .	10,12		Feb . . . . .	12
	Feb . . . . .	9,10,11,12	Reproducers: Model D . . . . .	Mar . . . . .	5
Horns. . . . .	Jun . . . . .	15	Record Cabinets. . . . .	Mar . . . . .	7
	Jul . . . . .	10,16		Apr . . . . .	4
	Aug . . . . .	16		Jun . . . . .	11
	Sep . . . . .	15,16		Jul . . . . .	10,16
	Oct . . . . .	5,14,15,16		Aug . . . . .	14
	Nov . . . . .	16		Oct . . . . .	15
	Jan . . . . .	9,11		Nov . . . . .	18,23
	Feb . . . . .	9,12,13	Recorders . . . . .	Mar . . . . .	5
Horn Cranes . . . . .	Nov . . . . .	9,18,20,22, 23,24	Repeating Attachment . . . . .	Sep . . . . .	4
	Feb . . . . .	12			
— I —			— S —		
— J —			Standard Phono. . . . .	Mar . . . . .	4
— K —				Apr . . . . .	4,9
Kinetoscope . . . . .	Mar . . . . .	5		May . . . . .	4
	Aug . . . . .	15		Jun . . . . .	11
	Sep . . . . .	13,14,15		Jul . . . . .	4,8,10
— L —				Aug . . . . .	7,9
Lambert Lawsuit . . . . .	Mar . . . . .	5		Sep . . . . .	4
Lift Mechanism . . . . .	May . . . . .	4		Oct . . . . .	5
— M —				Nov . . . . .	7
Moulded Records . . . . .	Apr . . . . .	7		Jan . . . . .	5,6
	Aug . . . . .	11		Feb . . . . .	7,9,11,12,13
			Speed Gauge. . . . .	Nov . . . . .	15
			Supplies . . . . .	Nov . . . . .	17
			— T —		
			Triumph Phono . . . . .	Mar . . . . .	4
				Apr . . . . .	4,9
				May . . . . .	7,8
				Jun . . . . .	11
				Jul . . . . .	4,8,10
				Sep . . . . .	5,6,10
				Oct . . . . .	5
				Jan . . . . .	5,9
				Feb . . . . .	5,7,10,12
			Triton Phono . . . . .	Apr . . . . .	9
				May . . . . .	7,8
				Aug . . . . .	9
			— U —		
			Uncle Josh . . . . .	Oct . . . . .	4
				Nov . . . . .	20,22
			— V —		
			— W —		
			— X Y Z —		



# EDISON Phonograph Monthly

PUBLISHED FOR TRADE USE ONLY BY  
THE NATIONAL PHONOGRAPH CO.

VOL. 1.

NEW YORK, MARCH, 1903.

No. 1.

*The National Phonograph Co.,*  
ORANGE, N. J.

NEW YORK: 83 CHAMBERS STREET.  
CHICAGO: 144 WABASH AVENUE.  
SAN FRANCISCO: 933 MARKET STREET.  
ANTWERP: 32 REMPART SAINT GEORGES.

## EDISON PHONOGRAPHS AND RECORDS.

All communications to THE PHONOGRAPH MONTHLY should be addressed to the Advertising Department, 83 Chambers Street, New York.

### C O N T E N T S

	Page
Announcement.....	1
Advance List of April Records.....	2
Mr. Edison of To-Day.....	3
Wittman Company Enjoined.....	3
List Prices Must Be Maintained.....	3
New Machine Catalogue.....	4
Mr. Herbert A. Shattuck.....	4
C. W. N. Handbook.....	4
Numerical Record Catalogue.....	4
Decision against the Lambert Record.....	5
Discount Sheet Errata.....	5
Supplement for Catalogue No. 380.....	5
Chinese Moulded Records.....	6
New Record Lists.....	6
Billy Golden's Records.....	6
Our Policy.....	7
The Phonogram.....	7
The March Records.....	8
How We "Follow Up".....	8
March Advertising.....	8

### TO THE TRADE.

THE EDISON PHONOGRAPH MONTHLY owes its birth to the belief by this Company that some means of keeping in closer touch with the Jobbers and Dealers has become a necessity. The Company also believes that the trade will at once recognize the advantage of a medium that shall at least monthly keep it informed concerning Phonographs and Records. To keep the trade advised on these subjects will be the sole aim of the MONTHLY. It will take the place of the Monthly Advance List of New Records, which will no longer be issued in its former shape. The list of new Records for April is given on the next page of this issue and will hereafter be found on that page. The MONTHLY will keep the trade posted on

changes made in the Phonograph from time to time, will give new goods listed or dropped from the list, will note the progress of new catalogues being gotten up, and refer to new advertising matter of any kind about to be issued. In a word, it will endeavor to further the sale of Phonographs and Records by doing all in its power to advance the interests of the Jobbers and Dealers. To this end we ask the co-operation of the latter. Our interests are alike. The more we do to add to the popularity of the Phonograph or to increase the demand for Records, the more you profit. Consequently, anything that you may do to assist in this movement of publicity must eventually return to your advantage.

We want your criticism, if you have one, of the plan of getting out the MONTHLY, and would regard you as advancing our joint cause if you will give us your candid opinion of it, accompanied by a suggestion or two as to ways of improving it. We know what we want to say and do concerning its object, but we cannot see the subject from your side. So, let us have your opinion, whether favorable or adverse. You can scarcely write a line that will not assist in making the MONTHLY a valuable adjunct to your business.

We especially want to know what subjects you would like touched upon each month. Are you in the dark about any part of the business? Let us know, then, and we will throw some light upon it. If occasion demands, we will publish a department of questions and answers, for a reply to the query of one Jobber or Dealer will serve to settle that very point in the mind of others. The MONTHLY will occasionally treat upon plans for increasing business, and will ask the trade for contributions on the subject. It will have comments from the Mechanical Department, the Sales Department, the Credit Department and others. Let us have your good will and co-operation.

THIS ISSUE CONTAINS THE ADVANCE LIST OF APRIL RECORDS. ORDER FROM IT.

## ADVANCE LIST OF NEW EDISON MOULDED RECORDS FOR APRIL, 1903

*FIFTEEN DOMESTIC TITLES      ONE FOREIGN TITLE*

RECORDS listed herein will be ready for shipment as near April 1st, 1903, as possible, at which time Jobbers' stock orders, if placed prior to March 15th, will be shipped.

April Supplements will bear the date of April 1st, and will be forwarded to Jobbers with their stock order for Records.

Retail Dealers should place stock orders with their Jobbers at once, to insure prompt shipment as soon as Jobbers' stock is received.

Stock orders for Records contained in this list must be written on separate order blanks, and letters relating to April Records should refer to no other matter.

Kindly comply with above requests and thus aid your Jobber and ourselves in handling advance orders.

- |       |  |  |                                  |
|-------|--|--|----------------------------------|
| 8377  | Selection from <i>The Sultan of Sulu</i> | <i>Introducing Since</i>                           |                                  |
|       |  | <i>I First Met You</i>                             | Peerless Orchestra               |
| 8378  | The Song Bird of Melody Lane             | <i>Waltz song from</i>                             |                                  |
|       |  | <i>Mr. Blue Beard</i>                              | Thompson                         |
| 8379  | Pretty Peggy                             | <i>Song and dance</i>                              | <i>Bells with orchestra</i>      |
|       |  |  | <i>accompaniment</i> Rubsam      |
| 8380  | Somebody's Waiting for Me                |  | <i>Descriptive song</i> Harlan   |
| 8381  | The Beer that Made Milwaukee Famous      | <i>Comic song</i>                                  |                                  |
|       |  | <i>from Mr. Blue Beard</i>                         | Favor                            |
| 8382  | Alice Where Art Thou                     | <i>Cornet and trombone duet</i>                    |                                  |
|       |  |  | Bohumir Kyril & Leroy Haines     |
| 8383  | Hebrew Vaudeville Specialty              | <i>Introducing parody on Rip Van</i>               |                                  |
|       |  | <i>Winkle was a Lucky Man, talking and singing</i> | Julian Rose                      |
| 8384  | It's the Man in the Soldier Suit         | <i>Descriptive male duet</i>                       |                                  |
|       |  |  | W. H. Thompson & Albert Campbell |
| 8385  | Heidelberg (Stein song)                  | <i>from The Prince of Pilsen</i>                   | MacDonough                       |
| 8386  | When the Winter Time Comes 'Round        | <i>Comic waltz song</i>                            |                                  |
|       |  | <i>Male duet</i>                                   | Collins & Harlan                 |
| 8387  | Alagazam March                           | <i>Xylophone with orchestra accompaniment</i>      | Hopkins                          |
| 8388  | What's the Matter with the Moon To-Night | <i>Descriptive</i>                                 |                                  |
|       |  | <i>song from The Mocking Bird</i>                  | Arthur Clifford                  |
| 8389  | I Wonder Why Bill Bailey Don't Come Home | <i>Coon song</i>                                   |                                  |
|       |  | <i>with orchestra accompaniment</i>                | Collins                          |
| 8390  | When Our Lips in Kisses Met              | <i>Contralto and basso duet</i>                    |                                  |
|       |  | <i>from When Johnny Comes Marching Home</i>        |                                  |
|       |  |  | Miss Morgan & Mr. Stanley        |
| 8391  | Selection from Maritana                  |  | Edison Concert Band              |
| 12812 | Hamavdel Von ein groben jung             |  | <i>Comic Hebrew song</i> Seiden  |

Edison Moulded Records are made only in Standard size. Both Standard and Concert Records may be ordered from this list. Order by Number, not title. If Concert Records are wanted, give the number and letter C.





Copyright 1902 by Scientific American.

### MR. EDISON OF TO-DAY.

THE *Scientific American* of December 27, 1902, contained a half-tone portrait and sketch of Thomas A. Edison. The portrait is so characteristic of Mr. Edison as his associates see him in their daily work that it is here reproduced by permission of Munn & Co., publishers of *Scientific American*. The photograph was taken in Mr. Edison's Laboratory at Orange, N. J., a privilege accorded to few persons, and is marked by a naturalness that it would be difficult to attain had the subject posed before a professional photographer. It is the latest picture made of Mr. Edison, and for faithfulness one of the best. The article that accompanied the picture in *Scientific American* was very interesting, being written in an anecdotal and sketchy style rather than biographical.

### WITTMANN COMPANY ENJOINED.

LAST Fall the Wittmann Company, of Kansas City, Mo., and Lincoln, Neb., began cutting prices on Edison Phonographs, Records and Blanks, in violation of its agreement with the National Phonograph Company. We at once instituted proceedings against the Wittmann Company, and on January 30th, 1903, Judge Munger, in the U. S. Circuit Court for the District of Nebraska, issued two restraining orders, one enjoining

the Wittmann Company from "directly or indirectly selling or causing to be sold at prices less than the prices set out in the terms and conditions of the contract set up and described and referred to in complainant's bill, all Phonographs, Records and Blanks furnished and sold by the complainant to the defendant and its predecessors." The other restrained the Wittmann Company from selling or using Phonographs from which the numbers have been erased.

### LIST PRICES MUST BE MAINTAINED.

FOLLOWING is a copy of the final decree of the U. S. Circuit Court, Western District of Pennsylvania, in the case of the National Phonograph Company against Kaufmann Bros., of Pittsburg, restraining them from violating the Edison patents by cutting prices, and assessing the damages and costs to be paid the National Company at \$1,500 :

U. S. CIRCUIT COURT,  
 WESTERN DISTRICT OF PENNSYLVANIA.

EDISON PHONOGRAPH CO. AND NATIONAL PHONOGRAPH CO., vs. JACOB KAUFMANN, MORRIS KAUF- MANN, HENRY KAUFMANN AND ISAAC KAUFMANN.	In Equity No. 8 May Term, 1901.
---	---------------------------------------

And now, January 30th, 1903, this cause coming on to be heard on final hearing on bill, answer, replication and proofs, it is adjudged and decreed that the plaintiffs are entitled to the relief prayed for in their bill of complaint and that a perpetual injunction do issue against the defendants as prayed for in said bill of complaint.

And a reference to a Master being waived, it is ordered that the profits, damages and costs to be recovered by the plaintiffs from the defendants be assessed at the sum of fifteen hundred dollars, and that execution do issue therefor according to the rules and practice of this court.

BY THE COURT.

This decision is the final result of the policy of this company in promptly and vigorously prosecuting all violations of its contracts. Kaufmann Bros. operate one of the largest Department Stores in Pittsburg. They were on our list of suspended dealers; and, knowing of our established plan of business, they purchased Phonographs and Edison Records from one of our jobbers, who had signed the regular agreement. They then started in to cut prices. The Court granted us two preliminary injunctions, declaring Kaufmann Bros. to be infringers of the Edison patents and enjoining them from using or selling Edison Machines and Edison Records; which preliminary injunctions were followed by final decrees in due course. The decree printed above is a complete vindication of the legality of our position and furnishes a precedent for any similar cases that may occur.

**FORTHCOMING MACHINE CATALOGUE.**

**A** NEW Catalogue of the Phonograph— it will be Form 375—will be ready for the trade about March 15th. It will be the most expensive and most attractive catalogue yet gotten out by this Company. It will contain twenty-four pages, with a handsome cover having a plush effect. The plush surrounds a half-tone picture of Mr. Edison. Both cover and inside will be printed on Dill & Collins' papers. The illustrations of the various types of the Phonograph are the best that could be made. In order to get the best results the several styles of machines were consigned to the Photo-Chromotype Company, of Philadelphia, who made a set of beautiful wash drawings of them. These drawings were in turn made into vignetted half-tones of a superior character. This catalogue will not contain any matter referring to outfits or accessories, but will be strictly a machine catalogue. The Advertising Department will receive orders for this catalogue, but reserves the right to hold them until a sufficient supply has been received from the printer to supply all Jobbers with a quantity. It also reserves the right to reduce the size of the orders where the quantity asked for seems excessive. Jobbers will do better if they order a small supply and re-order later.

This catalogue will be too expensive to use for circulating by mail and to save the necessity for doing so we expect to get out for shipment with the catalogue an exceedingly attractive four-page folder, advertising the Gem, Standard, Home and Triumph Phonographs. The Advertising Department will enter orders for this folder also.

**MR. HERBERT A. SHATTUCK.**

**I**N October last Mr. Shattuck was compelled by ill health to relinquish his position as Manager of the Advertising Department of this Company. We desire even at this late day to say a word with respect to his connection with the Company. Mr. Shattuck entered our employ five years ago, when the business of the Company was comparatively small. He created the Advertising Department, introducing into it the various systems now in use. He worked faithfully, unremittently, untiringly in our behalf and to him is due no small share of credit for the present widespread popularity of the Edison Phonograph. He severed his connection with the National Phonograph Company solely because of ill health and that such action became necessary was deeply regretted by his associates.

**C. W. N. HANDBOOK.**

**O**NE of the features of the *Phonogram* a year or more ago was a series of articles, running through about fourteen numbers, by C. W. Noyes, of Cincinnati, on the use of the Phonograph and the art of making Phonograph Records. These were written from the viewpoint of a man of practical experience and made those issues of the *Phonogram* much sought after. Mr. Noyes has now re-written the articles, added new material to them and the whole has been published in book form by Ilsen & Co., of Cincinnati. The book contains 78 pages, 5x8, is profusely illustrated and is sold at 50 cents for cloth and 25 cents for paper covers. It is the most up-to-date treatise on the subjects treated. Ilsen & Co. will fill orders for it.

**NUMERICAL RECORD CATALOGUE.**

**A** NEW Numerical Catalogue of Records, Form 395, which included all domestic and foreign selections listed to March 1, 1903, was sent out to the entire trade in February. As this catalogue is for store use only, it was decided that five copies to each Jobber and one to each Dealer should be sufficient for their needs, and that number was mailed. We have since been compelled to refuse a number of requests for a quantity of them. A very small edition was printed of this catalogue, and it is now practically impossible to fill orders for more than a few copies at a time. Dealers should not depend upon their Jobbers for extra copies when needed, but write direct to the Advertising Department of this company.

Through an oversight, four foreign selections were omitted from this Numerical Catalogue. They were 12124, 12125, 12127 and 12141, all German selections by Hugo Gottschall. The trade is hereby advised that these titles are still made and may be ordered as before. Make a note of this in your catalogue.

**T**HE supply of the brown advertising card, Form 288; the "Figure It Out Puzzle," Form 277, and the Key Puzzle, Form 278, is exhausted, and no more orders for them can be filled.

If you get tired of talking about the same thing, remember that other people, while they may know about you and what you have to sell, need gentle, constant reminders of the fact.—*Business Problems.*



### DECISION AGAINST THE LAMBERT RECORD.

IN the suit of the National Phonograph Company against the Lambert Company, for infringement of our patent rights, the United States Circuit Court at Chicago has just decided that the Edison patent covering the tapering-bore Phonograph record is a valid patent, and that it is infringed by the Lambert record. A decree has been entered, awarding the National Phonograph Company profits and damages, and also an injunction against the Lambert Company. As is usual in such cases, the Lambert Company has taken an appeal and has secured a suspension of the injunction until the appeal is decided, but we have every reason to believe that the favorable decision of the Circuit Court will not be disturbed. The following statements are taken from the opinion of the Court:

"The complainants have made considerable improvements, both novel and useful, which are entitled to a generous construction. The first question presented is whether defendants' record or phonogram is an infringement of claims 1 and 2 of complainants' patent No. 382,418 for a phonogram having a bore tapered throughout its length. Or, in other words, is defendants' phonogram or record, with its end flanges varying in depth to engage a tapered mandrel at each end of the record, an equivalent of complainants' tapered bore?"

"Defendants' device is of material rigid and strong enough to effect this result with no other than end frictional engagements with the mandrel. Defendants claim that their record may be used upon a stepped mandrel just as well. In my judgment, this would not alter the character of the device. Complainant was the first to establish frictional engagement of the record with the mandrel *at both ends, as well as throughout its length*. I am further of the opinion from the record that the defendants' device, with its end flanges varying in depth to engage a tapering mandrel, is an infringement of claims 1 and 2 of complainants' said patent No. 382,418, and that as to such infringement complainant is entitled to the injunction prayed."

We hereby notify all dealers that the selling of the Lambert records provided with end flanges varying in depth to engage a tapering mandrel is an act of infringement, for which we will hold them liable, and that we propose to enforce our rights, which have now been acknowledged by the Courts, by bringing suits against dealers handling such Lambert records.

### A PLEASED ENTHUSIAST.

A Chicago correspondent in writing to this Company for a catalogue said:

"I use the most pleasing and smoothest running machine in the world—the Edison Home Phonograph. Wouldn't have a disc machine for a gift."

### DISCOUNT SHEET ERRATA.

THAT portion of the Jobbers' and Dealers' Discount Sheet, Form 386 J, referring to Edison Reproducers and Recorders, should be changed to read as follows:

	Jobbers.	Dealers.
Edison Reproducers, Model B,	40%	30%
“ “ Models C & D	50%	40%
“ Recorders,	50%	40%

The discounts on Model B Reproducers have always been 40 and 30 per cent., but they were omitted when Form 386 J was printed.

### BON VOYAGE.

JAMES H. WHITE, who for a number of years has had charge of the Kinetoscope Department of the Edison Manufacturing Company, of Orange, N. J., sailed on February 5th, to take charge of the Antwerp office of the National Phonograph Company.

### DELAY IN SHIPMENT OF MARCH RECORDS.

THE National Phonograph Company, under date of February 24th issued the following notice to the Jobbers:

"Owing to the large increase in orders for March Records, together with the large and increased orders received for Records previously listed, it will be impossible for us to make shipment of March Records before the middle or latter part of March."

### SUPPLEMENT FOR CATALOGUE No. 380.

RECORD Catalogues No. 380 sent out in February included a four-page supplement, giving the November, December, January and February Records. Jobbers and Dealers who have a supply on hand of the former edition may have a sufficient number of these supplements to make their catalogues complete by advising the Advertising Department of the number required. State how you want them shipped.

### A PHONOGRAPH FOR THE EMPEROR OF JAPAN.

IN commemoration of the opening of the Industrial Exposition at Osaka, Japan, on March 1st, the Emperor of Japan was presented with a Phonograph by Thomas A. Edison. It was finished in an unusually handsome manner. The presentation was made through Waichi Araki, of the firm of Y. Araki & Co., Osaka, Japan, who was in this country in the interest of the Japanese government.

## CHINESE MOULDED RECORDS.

**I**N the February Advance List we announced the making of forty-six Moulded Records in Chinese. These were made at San Francisco especially for The National Phonograph Company. In order that they might be made in the most careful manner, we had Walter H. Miller, Manager of the Record Department at our factory at Orange, N. J., make a special trip to California. He took with him the most approved devices for Record-making and as the result of his efforts we are able to place before the thousands of Phonograph enthusiasts a lot of the best Chinese Records yet made for any talking machine. They are the most unique Records ever made in a foreign language. These forty-six Records comprise nineteen different subjects. It was found necessary in nine instances, in order to give the song or selections in a satisfactory manner for the Chinese trade, to use more than one Record for the entire selection. For instance, the first title on the list is a song, with orchestra accompaniment, entitled "To Destroy the Four Gates." This required twelve Records to give the complete song. They are twelve of the most curious Records ever reproduced by the Phonograph. They are numbered from 12741 to 12752 inclusive. The remainder of the list of these Records are as follows:

12753 to 12755. Song, with orchestra accompaniment, entitled "A Widow's Lament." Requires three Records to give song complete.

12756-12761. Song, with orchestra accompaniment, entitled "Assembly on a Sand Bank." Requires six Records to give song complete.

12762-12764. Comic recitation, by Sher Doy Wong. Requires three Records to give recitation complete.

12765. Song, with orchestra accompaniment, entitled "The Nest in a Shoe."

12766. Song, with orchestra accompaniment, entitled "To Visit a Friend."

12767. Song, with orchestra accompaniment, entitled "Traveling by the West Lake."

12768. Song, with orchestra accompaniment, entitled "Chu Leong Collects Rent."

12769. Song, with orchestra accompaniment, entitled "An Old Valet Carries a Letter."

12770-12771. Song, with orchestra accompaniment, entitled "A Wise Man in the Snow." Requires two Records to give song complete.

12772-12773. Song, with orchestra accompaniment, entitled "The Death of Coong Ming." Requires two Records to give song complete.

12774. Comic recitation, by Sher Doy Wong.

12775. Comic recitation, by Foong Wong Song.

12776. Comic recitation, "The Wizard Captures a Demon."

12777-12780. Chinese band selection, entitled "To Celebrate Long Life and Present a Son." Requires four Records to give song complete.

12781. Chinese Band selection.

12782-12783. Chinese Band selection. Requires two Records to give selection complete.

12784-12785. Chinese Band selection, entitled "To Prepare Dinner." Requires two Records to give selections complete.

12786. Chinese Band selection, entitled "To Persuade a King."

A circular concerning these Records, printed part in English and part in Chinese, has been prepared by this Company and was mailed to the entire trade early in February. A small quantity of these circulars will be furnished to such Jobbers and Dealers as may be able to use them to advantage among the Chinese of their cities. Address requests to the Advertising Department.

## NEW RECORD LISTS.

**T**HE plan followed at the Edison Laboratory at Orange, N. J., in deciding upon lists of new Records each month, has reached such a degree of perfection that in most instances Jobbers and Dealers when placing advance orders include the entire list, simply ordering a larger number of such titles as in their opinion are likely to sell more rapidly. Dealers report that not infrequently their customers order the entire list in advance, experience having shown them that few undesirable selections ever get on the list. In making up the advance list our Record Department endeavors to make it sufficiently varied to suit all tastes and the verdict of the public, as demonstrated by its patronage, is that it succeeds perfectly.

## BILLY GOLDEN'S RECORDS.

**T**HE January Records welcomed Billy Golden back into the fold of talent for the National Phonograph Company, and the listing of his songs was followed by an almost unprecedented demand for them. The three songs made by him for the January list, "Turkey in the Straw, (No. 8293); "Roll on the Ground," (No. 8298), and "Mixed Ale Party," (No. 8311), have been ordered in quantities beyond the capacity of the factory to make them. The February list of Records showed two more selections by Golden, "Rabbit Hash," (No. 8328), and "Uncle Jefferson," (No. 8343) and these were also ordered heavily. "The Wedding Over the Hill" (No. 8358), listed in March, promises to be a large seller.



### OUR POLICY.

**T**HE policy upon which the National Phonograph Company is conducting its business is embodied in the following notice, which now appears upon all of its catalogues:

Every Edison Phonograph and every Edison Record and Blank is sold by the NATIONAL PHONOGRAPH COMPANY under restrictions as to the persons to whom and the prices at which such Phonographs, Records and Blanks are to be sold, and as to the removal or change in whole or in part of the serial numbers on such Phonographs. Any violation of such restrictions terminates the license to use and vend such Phonographs, Records and Blanks implied from the sale thereof, and any subsequent use or sale of such Phonographs, Records or Blanks is an infringement of the Edison Patents.

The object of this policy, as every one in the trade knows, is to maintain uniform prices and prevent the sale of our goods at cut rates. It is a policy that should commend itself to every wise business man; it should require no threats or persuasion to enforce. Indiscriminate cutting of prices brings no advantage to any one. Wherever permitted without check the cut of one dealer is met the following day by a competitor, who goes him a point better, and in a short time, both are selling at prices that do not yield a proper business profit. Before long the dealers are anxious to combine and find a way to induce people to pay list prices again.

This Company purposes enforcing its policy to the fullest extent. It is investigating cases of price cutting—cases where men have pledged themselves, over their signature, to comply with the terms of the Company—and as fast as conclusive evidence is obtained the offenders are placed on a suspended list and every obstacle put in the way of their buying Phonographs and Records. This has a salutary effect in most cases. Where it does not we begin suit for injunction and damages just as soon as we can collect the necessary evidence.

The demand for Edison Phonographs and Records is so widespread that it is simply impossible for a dealer in talking machines to do without them. The public know too well that Thomas A. Edison invented the Phonograph with its many improvements and they know, also, that other devices are but inferior imitations of his. A dealer may cajole a customer into taking some other machine, but in nine cases out of ten his customer becomes disgusted and wants an Edison Phonograph. Such has been the experience of thousands and must from the very nature of things continue to be the case. People want Edison goods and they will not be fooled.

### THE PHONOGRAM.

**S**INCE we decided in December to discontinue the publication of the *Phonogram* we have received almost daily letters asking "Why are you discontinuing the *Phonogram*?" "Are you going to get out anything else of the same character to take its place?"

Then the mails have brought expressions like these: "I am sorry that you are giving up the *Phonogram*." "I have always thought the *Phonogram* a bright little publication and I shall miss it very much." "I shall miss the monthly visits of the *Phonogram*."

We are not surprised that correspondents should express themselves in this regretful manner. We should have been disappointed in ourselves had we taken out of monthly circulation 60,000 copies of the *Phonogram* without quite a considerable number of persons missing it. We should have felt that we had gone to considerable expense without getting any return.

When it was decided to discontinue the *Phonogram* it was not deemed of sufficient importance to get out a special letter informing the trade as to our reasons for doing so. The PHONOGRAPH MONTHLY is just the medium for saying a word on the subject. Briefly stated our decision was reached because of the conviction that the benefit to the business was not commensurate with the cost of the publication.

It was found that a large majority of those who wanted the *Phonogram* sought it chiefly for the list of new Records given in it each month, a demand that was being met by the attractive Record Supplement that we are getting out in large quantities each month. Other reasons of a business nature entered into the decision that closed the *Phonogram's* existence. The fact that we have not had a greater number of protests against the discontinuance of the *Phonogram* confirms our opinion that we have made no mistake in stopping it.

Concerning a substitute for the *Phonogram*, we might say that nothing of the same character is now contemplated.

### NO MORE 180 PEG CABINETS.

**I**T has been decided to discontinue furnishing the 180 Peg Record Cabinets listed in the Catalogue of Accessories. No more orders for them will be filled.

The EDISON PHONOGRAPH MONTHLY will be issued in four, six or eight page form as may be found necessary from month to month.

### THE MARCH RECORDS.

**A** FEATURE of the March Records was No. 8349, "Dream of the Tyrolienne" (Traum der Sennerin), a violin and flute duet by Eugene Jaudas and Louis Atz. The latter's names appeared among the Edison talent for the first time. This Record is the first good violin and flute duet ever made and our Record Department is delighted over its success. The air of the selection is exceedingly pleasing and it is played artistically, the instruments blending finely, yet each retains its individuality throughout. The Record is one that is certain to sell largely. This March list gives one selection by Alfred Campbell, who will be remembered as one of the former favorites among the Edison talent. Another feature of the list is No. 8347, "Hiawatha," played by the Edison Concert Band. This has become widely known in the music trade as the \$10,000 composition. It is a charming air and must become very popular.

Additional single copies of the PHONOGRAPH MONTHLY will be mailed to the trade upon request. We cannot send copies to others.

### HOW WE "FOLLOW UP."

*National Phonograph Company, New York City.*

GENTLEMEN—Your postal of recent date at hand. Yes, I have heard from your Dealer. Have had letters and personal visits from no less than four of them since I wrote you for Catalogue of Records. Any one who follows up their customers in this manner certainly deserves success if they do not get it. Yes, I own a Phonograph and have owned one for several years—one of the large spring motors that run sixteen records. Have several hundred Records and may have several hundred more before I get done with it as I never seem to tire of the Phonograph. Have recently purchased one of the new reproducers and have quite a number of the new records. \* \* \*

With best wishes, I remain  
Very truly yours,

Does this not show, Mr. Dealer, that we are sending business your way?

### NEW ELECTROTYPE PRICE LIST.

**A** NEW catalogue of electrotypes will be ready for the use of the trade in about a month.

### MARCH ADVERTISING.

**T**HE advertisement herewith of the National Phonograph Company will appear in the March number of the following publications:

Leslie's Popular Monthly.  
McClure's Magazine.  
Munsey's Magazine.  
Scribner's Magazine.  
Argosy.  
Harper's Magazine.  
Everybody's.  
Pearson's.  
Ainslie's.  
Smart Set.  
Good Housekeeping.  
Success.  
Lippincott's.  
National Magazine.  
Overland.  
Metropolitan.  
Booklovers' Magazine,  
Saturday Evening Post.  
Collier's Weekly.  
Life.  
Town Topics.  
Outlook.  
New Era Magazine Supplement.

(The latter is the Magazine Supplement to the Sunday issues of one of the largest daily papers in each of fifty different cities.)

The aggregate circulation of these mediums is about 4,500,000 copies. Since the benefit of this expensive advertising can only come to us through the Jobbers and Dealers, we ask that you do your share toward pushing Edison Phonographs and Edison Records by advertising in the local papers, street cars, etc.

**PURE DELIGHT found in The EDISON  
PHONOGRAPH**

**Use Edison  
Moulded Records  
Make Records of  
your own.**

NONE GENUINE  
WITHOUT  
THIS  
*Thomas A Edison*  
TRADE  
MARK





The **PHONOGRAPH** led all talking machines into prominence.

The **PHONOGRAPH** leads all in volume, sweetness and clearness of the sound produced.

The **PHONOGRAPH** is the machine with which successful records can be made at home.

The **PHONOGRAPH** catalogues and Record lists are free to all dealers.

**NATIONAL PHONOGRAPH CO., Orange, N. J.**  
New York, 83 Chambers Street. Chicago, 144 Wabash Avenue. San Francisco, 933 Market Street. Europe, 32 Rempart Saint Georges, Antwerp, Belgium.



# EDISON Phonograph Monthly

PUBLISHED FOR TRADE USE ONLY BY  
THE NATIONAL PHONOGRAPH CO.

VOL. 1.

NEW YORK, APRIL, 1903.

No. 2.

*The National Phonograph Co.,*  
ORANGE, N. J.

NEW YORK: 83 CHAMBERS STREET.  
CHICAGO: 304 WABASH AVENUE.  
SAN FRANCISCO: 933 MARKET STREET.  
ANTWERP: 32 REMPART SAINT GEORGES.

## EDISON PHONOGRAPHS AND RECORDS.

All communications to THE PHONOGRAPH MONTHLY should be addressed to the Advertising Department, 83 Chambers Street, New York.

### C O N T E N T S

	Page
Advance List May Records.....	2
The Wittmann Case .....	3 & 8
About Delayed Orders.....	3
Anticipate Orders.....	3
About Printed Matter.....	4
Progressive Advertising. ....	4
An Enthusiastic Dealer.....	5
Trade Notes.....	5
The May Record List .....	5
Unique "Ads".....	6
Foreign Records .....	6
Commercial Phonograph.....	6
Trade Questions and Answers.....	7
Gleaned from the Press .....	7
No Concert Records by the Moulded Process .....	7
Among the Jobbers.....	8
A New National Air .....	9
Correct Gross Weight .....	9
List of Suspended Dealers .....	9
Trade Opinions on the Monthly.....	10
Jobbers of Phonographs and Records .....	11
April Advertising.....	12

### ON PUSHING GOODS.

**W**E shall be glad to publish in these columns contributions from Jobbers and Dealers concerning plans for selling Edison Phonographs and Records. A Jobber having a successful method of getting his goods before the public can lose nothing by telling the trade about it and may be doing some one a good turn. His competitors at home already know how he does it and those at a distance cannot affect his trade.

### VOLUME I, NUMBER 1.

**T**HE first issue of the EDISON PHONOGRAPH MONTHLY has been cordially received by the trade. In another column we print the comments of a number of Jobbers and Dealers. Many others wrote in a similar manner, our limited space making it impossible to print more of them this month. Without exception all commend the publication as furnishing an excellent method of "talking shop." Not a few correspondents offer suggestions for adding to the value of the MONTHLY which we shall take pleasure in acting upon. One writer asks two questions of interest, and these, with replies, are published elsewhere. Matters of this kind will be similarly treated each month and we believe that the department will be one of the most valuable features of the MONTHLY. A number of points concerning the Phonograph and Reproducers are constantly being asked about by Dealers. It will be the mission of this paper to answer such questions here as well as replying direct by mail.

We have had requests from Jobbers to send them a quantity of the MONTHLY. It will be impossible to do this. The edition each month will only be sufficient to send five copies to each Jobber and one to each Dealer. Every Dealer who has signed an agreement should be on our mailing list. If he is not it is because his name has not been sent in by the Jobbers. If Dealers complain that they do not receive our advertising matter by mail, Jobbers should advise the Advertising Department. The matter will receive prompt attention.

The Chicago office of the National Phonograph Company has been moved from 144 Wabash avenue to larger quarters at 304 Wabash avenue. The growth of the business in that territory made the change necessary.

**THE ADVANCE LIST OF MAY RECORDS APPEARS ON PAGE 2. ORDER FROM IT. NO OTHER ADVANCE LIST WILL BE ISSUED.**

## ADVANCE LIST OF NEW EDISON MOULDED RECORDS FOR MAY, 1903

### T W E L V E   D O M E S T I C   T I T L E S

RECORDS listed herein will be ready for shipment as near May 1st, 1903, as possible, at which time Jobbers' stock orders, if placed prior to April 20th, will be shipped.

May Supplements will bear the date of May 1st, and will be forwarded to Jobbers with their stock order for Records.

Retail Dealers should place stock orders with their Jobbers at once, to insure prompt shipment as soon as Jobbers' stock is received.

Stock orders for Records contained in this list must be written on separate order blanks, and letters relating to May Records should refer to no other matter.

Kindly comply with above requests and thus aid your Jobber and ourselves in handling advance orders.

8392 In Old Alabama Peerless Orchestra  
*Characteristic Barn Dance*

8393 My Little Pansy Collins  
*Serio-comic song with orchestra accompaniment from The Billionaire*

8394 Violets (Transcription) Piano solo Frank P. Banta

8395 Life's Dream Is O'er Miss Chapell & Mr. Stricklett  
*Soprano and Tenor Duet*

X✓ 8396 Under the Bamboo Tree Medley J. Frank Hopkins  
*Introducing The Little Gypsy Maid—Xylophone solo with  
orchestra accompaniment*

8397 The Banquet in Misery Hall Descriptive song Harlan

8398 Blaze Away March (with bells) Edison Concert Band

8399 I Wonder If Your Love Will Last Thompson & Campbell  
*Sentimental male duet*

8400 Hamlet Was a Melancholy Dane Favor  
*Comic song from Mr. Blue Beard*

8401 Glory Arthur Clifford  
*March song from The Billionaire*

8402 Waltz Me Down the Alley Sallie (Waltz song) Collins & Harlan  
*Male duet*

8403 Hebrew Vaudeville Specialty Julian Rose  
*Introducing parody on In the Good Old Summer Time*

Edison Moulded Records are made only in Standard size. Both Standard and Concert Records may be ordered from this list. Order by Number, not title. If Concert Records are wanted, give the number and letter C.

## FURTHER DECISIONS IN OUR FAVOR IN THE WITTMANN CASE.

ONE after another the courts of the country are upholding the validity of the agreement system of the National Phonograph Company. Last month we noted in these columns the granting of two restraining orders by Judge Munger, of the U. S. Circuit Court for the District of Nebraska, restraining the Wittmann Company, of Lincoln, Neb., and Kansas City, Mo., from cutting prices and also from changing the serial numbers on Phonographs. Just as we go to press with this issue, we are advised that the same judge and court have issued two preliminary injunctions against the Wittmann Company for the same violations of contract. Abstracts of the opinions appear on another page.

## ABOUT DELAYED ORDERS.

IF we did not feel that some explanation was due the trade because of the delay in filling orders, we would rather not refer in these columns to the growth of our business in the last six months. A year ago we believed that our factory facilities at Orange, N. J., were sufficient to meet all demands for a long time. Early in the fall orders began to increase beyond their usual number, making it necessary to work overtime in some departments. Soon other departments were working the same way. Then the working force was increased in every department and still the orders exceeded the output. The holidays found several departments working with one force during the day and another all night, the factory being closed at no time except Sundays. We thought that the unusual demand was due to the holiday season and that January would see a let-up, giving us a chance to catch up with orders. It pleases us to have such a volume of business but at the same time we regret that anyone has to wait a day for our goods.

We have perfected plans for several additions to our factory and until they can be built we must ask the trade to bear with us patiently. Rely upon it that nothing is being left undone to get goods on the market. If we were disposed to be boastful and give out figures showing the number of Phonographs and Moulded Records that we are shipping each week the public would be amazed. It is evident that the talking machine idea has grown tremendously throughout the entire world and that the

Edison Phonograph, as the leading type, is reaping the harvest.

The situation was such on March 1st that it was deemed advisable to cut down the number of new Records to be listed in April and instead of thirty or more, as has been the custom, a list of only sixteen was made up. This will, we believe, aid materially in filling orders for Records previously listed. For the same reason a small advance list has been made up for May, and we expect that before that time we shall be filling orders as fast as received.

## ANTICIPATE ORDERS.

A JOBBER suggests that we advise the trade in these columns not to promise too prompt delivery of Phonographs, Records and Reproducers, in view of the inability of the Company to make them fast enough to fill orders. While it is just as well that the trade should understand the situation, we think that both Jobbers and Dealers should anticipate the probable demand in their territory and place orders in advance, instead of waiting until their stocks run low. There is no risk in keeping a large stock of Edison goods. They are as stable as flour and just as certain to sell.

## RECORDS BY MAIL 17 CENTS NOT 10 CENTS.

IN the new machine catalogue, Form 375, through a misunderstanding, the price for mailing Records is given as ten cents. This was formerly the cost when they were mailed unregistered. In many cases, however, claims were made that they were not received and it was decided to mail no more unless registered. This increased the mailing cost to seventeen cents. We make every effort to induce users of Records to buy from the trade, but when they insist upon having them mailed we are compelled to add the cost of mailing and registering.

Jobbers and Dealers who are in doubt as to whether to address the Company at Orange or New York are advised to write to the New York office, unless they are replying to a communication sent direct from the factory. All orders must be sent to the New York office.

Jobbers and Dealers should keep a file of the PHONOGRAPH MONTHLY. They will find it useful to refer to from time to time.



### ABOUT PRINTED MATTER.

We have placed an order for a handsome show card for window displays. It will be a celluloid card,  $9\frac{1}{2} \times 19\frac{1}{2}$  inches in size, and lithographed in six colors. It will probably be the middle of May before it can be sent out to the trade. It is the handsomest card of its kind ever gotten out by this Company.

A new edition of the Foreign Record Catalogue, Form 381, will be issued about June 1st. If orders for the present edition are cut down it will be because we want to make the supply last till the new catalogue appears.

Orders for Record Catalogue No. 380 will shortly be filled with a new edition, which will include the March and April titles. The trade is asked to use up those now on hand before ordering a new lot. The present issue may be made complete by adding the March Supplement.

Catalogue of Parts, No. 371, is exhausted. Another edition is in preparation, but as it will be arranged on different lines it will not be ready for about two months.

The new machine catalogue, Form No. 375, is now being sent out to the trade. This catalogue is too expensive to be used in quantities for circularizing by mail, and those who contemplate such advertising will be given a supply of a very attractive four page folder, Form 414. This folder is nicely printed on fine coated paper and shows the Gem, Standard, Home and Triumph types in good style.

Advance copies of a pretty card, Form No. 409, illustrating the lad who with a hatchet is trying to find the band that he can hear so plainly but cannot see, have just been sent to the trade. It has been gotten out for mailing and for use at openings, fairs or any similar occasion where it is desired to freely give away an attractive card. Get a supply through your Jobber.

The new electrotype catalogue, Form No. 415, has been received from the printer. Since only a portion of the trade use electrotypes, it will be sent only to such Jobbers and Dealers as order it.

Dealers buying through Jobbers are requested to get printed matter in the same manner. This makes it possible for us to send out catalogues, etc., more expeditiously and at less expense. Catalogues are too heavy to send by mail and small quantities cannot be sent by freight. If Dealers cannot be supplied by their Jobbers and insist upon our sending a small quantity in an emergency, they must pay express charges and advise how we shall ship. The same rule applies to direct Dealers.

A new edition of the Accessories Catalogue, No. 376, will soon go to press, and in it the 72-peg, 120-peg and 180-peg cabinets will no longer be listed. Orders will only be filled till the present stock is exhausted. The Edison "V" Battery will also be omitted from this catalogue.

For the information of Dealers who thought we had overlooked them in sending out the March Supplements and Bulletins, and who wrote concerning them, we would state that neither are sent out to any one in the trade until the Records for the month have been shipped. The delay in shipping the March Records caused a similar delay with Supplements and Bulletins.

### PROGRESSIVE ADVERTISING.

THE past month has seen some most progressive Phonograph advertising on the part of several enterprising Jobbers. Plenty of advertising in a local manner has been done for a long time, but few have taken up the matter in a general way. In February the Vim Company, of Chicago, came out with a very attractive advertisement in *Collier's Weekly*, of New York City. Since then S. B. Davega, of New York, has offered the Phonograph on the dollar a week plan in the columns of *Success* and other magazines. The Eastern Talking Machine Company, of Boston, has a full page advertisement in the April issue of the *National Magazine*, devoted entirely to offering Edison Phonographs and Records on the mail order plan.

The Siegel-Cooper Co., of New York, has been running an advertisement ten and a half inches deep and three columns wide in every daily paper of large circulation in New York City and adjoining cities, devoted exclusively to the sale of Edison Phonographs and Records on the instalment plan. Their returns have been of the most gratifying character.

All of the above advertising has been done entirely by the firms named and without any arrangement or understanding of any kind with this Company. In no case was it even suggested and except in one instance we did not know of the advertising until it appeared in print. Credit for the enterprise is alone due these firms. They know the merit of the Edison Phonograph and have been willing to expend large sums to further its sale.

Dolly.—Have you learned to manage your "auto" yet?

Daisy.—Very nearly. I can do everything but stop it and steer it!



**AN ENTHUSIASTIC DEALER.**

F. J. Collingwood, manager for the C. F. Jackson Co., Dealers at Norwalk, Ohio, under date of January 23, wrote the following letter to this Company, and later he gladly consented to its use in the MONTHLY:

*National Phonograph Company.*

GENTLEMEN—I have just finished playing over your selections gotten out for January, and I feel as though I must congratulate you upon your wonderful success in Record making; also your new Model C Reproducer. I have no doubt that you are bothered with similar letters, but I must give vent to my feelings. I have thought every time I have received the Records for each month that I would write you but have not until I received the January list, and they are all so very fine I had to do it. Would say that I have handled the — make for several years, but since your new Reproducer came out and your Moulded Records I have no use for the —. The \$25.00 — machine I sold at \$15.00, and their records at fifteen cents to get rid of them, and now handle only the Edison Records and machines.

Several evenings in the week I have a machine and Records at my house and ask people to come and hear them. I find it very amusing to see how perfectly carried away they are with the outfit, it being so much better than they could imagine. This has been the means of selling several Edison outfits. I have induced three customers this week to get rid of the — machine which I had sold them and buy the Edison.

People who have been down on talking machines are lovers of the new Edison. I would rather have an Edison Gem than the — \$20.00 or \$25.00 machine. I have put them to a test side by side. It seems now as though you must stop trying to get anything better, for some of the Records now seem as if they were better than the real thing.

---

**The sale of an Edison Phonograph is but the beginning of business. The sale of Records goes on indefinitely.**

---

**TRADE NOTES.**

**A**FTER commenting favorably upon the PHONOGRAPH MONTHLY, F. N. Green, of Willimantic, Conn., writes: "In making an exhibit of Edison Phonograph and Edison Moulded Records at the Stafford Springs Agricultural Society of Connecticut I was presented with a large diploma of merit for excellence of Edison Phonograph and Records over all other machines."

A Dealer to whom we referred an inquiry concerning Edison goods writes: "As I believe it is of interest to you to know the results of my work among the people referred to on your inquiry card, I beg to advise you that I

am now shipping a Phonograph with a complete outfit to the party at Woodburn, Va., and am expecting an order from one of the others at an early date. I will greatly appreciate further suggestions of the same character."

A fact not generally known in the trade is that electric light companies throughout the country will bear the entire cost of installing electric signs where storekeepers will contract to burn a certain amount of light each year. A Phonograph dealer in Brooklyn has such a sign, and its advertising value is worth many times what it costs him.

Bernard Bearwald, of 373 West 11th street, New York City, sends a communication to the PHONOGRAPH MONTHLY in which he makes several excellent suggestions, and talks interestingly of his success in selling Phonographs. We regret that the length of the letter makes it impossible to publish it in full. One of his suggestions is that dealers should furnish us with a list of their customers, to whom we should send lists of the new Records each month, such lists to bear the name of the dealer. Such a plan would result in a large amount of business, but the lists would be so large and the cost so great as to be almost prohibitory.

**HOW A WESTERN JOBBER SOLD HIS 14-INCH HORNS.**

**O**NE of the problems that all Jobbers and large Dealers have to contend with is to find a way of disposing of their stock of 14-inch horns, left on their hands when customers exchange them for larger horns. A Western Jobber cleaned out his stock recently in a very clever manner. A political campaign in his city made such a demand for tin horns that the supply gave out. Seizing the opportunity, this Jobber had a lot of tin mouth-pieces made to fit the 14-inch horns and soon sold his entire stock at a nominal but satisfactory figure. Quite clever, wasn't it?

**THE MAY RECORD LIST.**

**T**HE list of new titles for May, given on page 2 of this issue, number only twelve, but they are especially good. A feature of the list is a piano solo, "Violets," by Frank P. Banta, one of the best piano players for Record making in the country. This is probably the first really successful piano Record ever made. The list as a whole is well assorted and every owner of a Phonograph should have the entire dozen.

## WRITE DEPARTMENTS—NOT INDIVIDUALS.

THE National Phonograph Company desires that the trade, in writing to the company, shall address letters to the department and not to its head by name. If you want your letter to go direct to the Sales Department address it to that department. Write in the same way to the Credit Department, the Advertising Department, etc. If your letters are personally addressed to the head of a department and he should be out of town, those in charge do not know whether you are writing about company matters or not. If you write to the department there can be no such doubt and your correspondence will get immediate attention.

## UNIQUE "ADS" OF LIVE DEALERS.



Every night a concert in your own home  
 Every evening at home a pleasant one  
**Edison's Band will play for you**  
 Edison's Singers will sing for you  
**Entertain yourself, family, and friends**  
 Enjoy yourself with a genuine

## EDISON PHONOGRAPH

I sell them from \$10. up. New Moulded Records.  
 F. P. Monfort, 416 Douglas St., Sioux City, Iowa.

*Mailing Card—one-fourth of original size.*

**Edison's**   
  **Latest**

**P** Stands for Phonograph of Edisons Make  
**H** Stands for Him who will no other take.  
**O** Stands for Orders which exceeds the supply  
**N** Stands for Natural Tone of records you buy.  
**O** Stands for Others of inferior kind  
**G** Stands for Gem not left behind.  
**R** Stands for Records the best in the land  
**A** Stands for Artists in Edison's Band.  
**P** Stands for People who own a machine  
**H** Stands for Happiness there to be seen.

**Bowen The Jeweler**

*Newspaper Advertisement reduced from two columns wide. Mr. Bowen is a dealer at Kewanee, Ill.*

## FOREIGN RECORDS.

MANY dealers do not realize that in the foreign Edison Moulded Records they have some of the most desirable selections ever made for the Phonograph. Because they are made in foreign languages they do not regard them as having any value for general sale. This was aptly illustrated by an incident that came to the notice of one of our salesmen in a large Eastern city. A gentleman asked a large dealer if he had an Edison Record with the title "Ave Maria." The dealer looked through a catalogue of domestic selections and regretted that the title was not listed. A day or so later the gentleman made the same inquiry of another dealer in the same city. The dealer replied:

"Yes, I have Gounod's "Ave Maria," and put the Record on a Phonograph for his caller's benefit. It was not the one wanted. Tosti's "Ave Maria" was accordingly played and this proved to be just what was sought. A sale followed and the gentleman went away much pleased. The incident showed that the second dealer had given the foreign records the attention they deserved. In the foreign list are many excellent selections, and dealers would do well to extol their merits to English-speaking customers as well as those of foreign birth.

## COMMERCIAL PHONOGRAPH.

WE are constantly asked, "When are you going to get out a Commercial Phonograph?" To such inquirers we reply that the Edison Commercial Phonograph will not be put on the market until it is a much more perfect machine than any device now in use. A number of experts, under Mr. Edison's supervision, are constantly at work on a Phonograph for commercial dictation and transcribing. They are daily getting nearer the point of excellence that Mr. Edison insists must be reached before the machine can be sold, but we cannot say just when it will be put on the market. When its sale is definitely announced the public may rely upon the Edison Commercial Phonograph being a thoroughly practicable machine for office use.

ONCE or twice every month we send out new printed matter by mail to the entire trade. Those who fail to receive this matter regularly should write direct to the Advertising Department, in order that the cause of the trouble may be looked up.

Be honest, straightforward and explicit—the future customer will prove more satisfied, more lasting.—Direct Advertising.



**TRADE QUESTIONS AND ANSWERS.**

*From Sante Fe, Watch Co., Topeka, Kans.*  
—We have this day received the first copy of the PHONOGRAPH MONTHLY and are glad to know that you will have something of the kind to keep us posted. Please answer these questions through the columns of your MONTHLY. 1st. We often find that Reproducers, when they come from Jobbers, have a blast or jar to them; this is not always the case, so there must be a remedy. We have not been able to improve them. 2nd. In regard to cutting prices; where we find through our customers that certain Dealers are cutting prices, what evidence do the Edison people require before they will take any action; before whom do we place it?

ANSWERS—1st. If a Reproducer blasts, it may be due to the diaphragm not being clamped tight enough, or the rubber cushion underneath the diaphragm may have slipped from the seat in the cup, leaving the diaphragm loose at that point. The remedy is to take the Reproducer apart and see whether the rubber cushion fills the seat in the cup. After the diaphragm is placed in position, care should be taken that the top gasket also fills the cup, and should be stretched if too small. Care also should be taken not to stretch it too much, in which case it would buckle and prevent the diaphragm from lying flat. It may be necessary to try several times before the exact tightness of diaphragm is determined to stop the blasting.

2d. The evidence we require in order to take action, is to have goods purchased at cut price, properly marked for identification by the person who made the purchase, together with receipted bill and affidavit, with witness. This evidence should be sent to our Sales Department.

**ALWAYS AS ADVERTISED.**

IT is to be seriously questioned if an advertiser ever advanced his interests one jot by lying about his goods, especially where the buyer must order on faith.

If the article doesn't come up to what is promised for it, the trade that results won't stick, and often it is only in the future patronage that the profit lies.—*Fame.*

The secret of the success of the Edison Phonograph is due to the fact that it is found to be "as advertised." No claims are ever made for it that are not fully carried out. Mr. Edison never allows anything to be said about the Phonograph or Records that misrepresents them in any way.

**GLEANED FROM THE PRESS.**

A HARTFORD, Conn., woman has brought suit for divorce against her husband, and part of her evidence is said to be a number of Phonograph Records, giving conversations that took place between her husband and the other woman in the case. World Radio History

Thomas A. Edison says genius is two per cent. inspiration and ninety-eight per cent. perspiration. Thomas is certainly right. He is the genius to whom we owe more than to any living man our ability to transact business with ease and comfort. Quadruplex telegraphy, the incandescent electric light and the microphone, which makes the telephone of to-day practicable, are his, and we know his genius to be of the inspiration and perspiration kind.—*Batten's Wedge.*

A Swiss mechanic claims to have invented an automatic baby's nurse. The apparatus is attached to a cradle. If the baby cries air waves cause specially arranged wires to operate a Phonograph, which sings a lullaby, while, simultaneously, clockwork is released and rocks the cradle. When the crying stops the wires cease to vibrate and the cradle stops rocking.

**CONCERT RECORDS NOT MADE BY THE MOULDED PROCESS.**

OCCASIONALLY a Dealer asks when we are going to make Concert Records by the moulded process. The Concert Record was originally placed on the market in consequence of a demand for a Record loud enough for exhibition purposes. It met the demand fully, and thousands of them were sold. Then the small Record was made by the moulded process, and it proved to be as loud as the Concert Record, causing the demand for the latter to fall off greatly. The new moulded Record in the small size so completely fills every need for the Phonograph that no serious attention has been given the matter of making Concert Records by the same process. For the present, at least, it will not be done.

**A JOBBER'S INVITATION.**

THOMAS WARDELL, a Jobber at Lowell, Mass., has adopted the plan of sending out the following card each month to those whom he thinks will be interested:

DEAR SIR:—For the next three days we shall play this month's Records continuously. You are invited to step in and hear them.

Very respectfully yours,

THOMAS WARDELL.

111 Central street, Lowell.

THE Advertising Department of this Company will consider it a favor if Jobbers and Dealers will send it clippings of their advertisements in daily or weekly papers, magazines, or other publications. Address them to the Department.

IN THE CIRCUIT COURT OF THE UNITED STATES FOR THE DISTRICT OF NEBRASKA.

EDISON PHONOGRAPH COMPANY, Complainant,

v.

THE WITTMANN COMPANY, Respondent.

No. 101, V.

MEMORANDUM OPINION.

MUNGER, *D. J.*

This is an action brought by complainant to restrain the respondent from disposing of certain phonographs having the serial number placed thereon erased or obliterated.

The petition is framed upon the theory that the obliterating of the serial number is an infringement of complainant's patent. There does not appear to have been any contract between complainant and respondent. The articles in question were purchased by respondent from other dealers or jobbers, but it appears from the evidence that respondent was aware of the provisions of the contracts under which the machines were placed upon the market for use and sale. The objection of respondent to the introduction in evidence of the alleged contract between the Omaha Bicycle Company and respondent, on the ground that no foundation for the same existed, is sustained, and such contract has not received consideration.

There was placed upon each machine a plate, having plainly and distinctly engraved thereon, among other words, the following:

"This machine is sold upon the condition that it is licensed to be used or vended only so long as this serial number S— is not removed or changed in whole or in part."

It is alleged that the serial numbers have been obliterated, and it is charged that such obliteration was done by respondent. That these serial numbers were obliterated and that it was done by respondent is not denied, but it is claimed that such act does not constitute an infringement, and as there was no contract between complainant and respondent, the action cannot be maintained.

The Court of Appeals of this Circuit in *Dickerson v. Tinling*, 84 Fed. 192-195, with reference to the sale of a patented article upon conditions, uses this language:

"If the corporation sold the patented article subject to such a restriction, the purchasers, with notice of this limitation, whether immediate or remote, could acquire no better right than strangers to infringe upon the monopoly secured by the patent."

This, in effect, is a holding that the owner of a patented article may, in disposing of the same, impose such conditions as he sees fit, and a violation of those conditions upon the part of any subsequent owner, with notice thereof, would be an infringement of the patent. Such seems to be the law as announced in *Edison Phonograph Company v. Pike*, 116 Fed. 893.

For these reasons the injunction, as prayed, will be granted, upon complainant executing to respondent a bond to be approved by the Clerk of the Court, conditioned as provided by law, in the sum of \$5,000; such bond to be given within ten days.

IN THE CIRCUIT COURT OF THE UNITED STATES FOR THE DISTRICT OF NEBRASKA.

NATIONAL PHONOGRAPH COMPANY, Complainant,

v.

THE WITTMANN COMPANY, Respondent.

No. 97, V.

MEMORANDUM OPINION.

MUNGER, *D. J.*

This is an application to enjoin the respondent from disposing of certain phonographs and records in violation of a contract between complainant and respondent. The provisions of the contract material to the consideration in this inquiry are in substance that the Company will not sell said articles at less than the price stated in said contract; and it is charged in the bill and established by the evidence that the respondent has violated the contract in this respect by making sales in violation of the agreement. This is sought to be justified on the part of respondent on the ground that complainant first violated the terms of the contract, which violation on the part of complainant absolved the respondent from being further bound by the contract; or, to be stated in another way, that complainant, in asking equity must do equity, and that, having first violated the contract it is not in a situation to ask for the aid of a court of equity.

It is clear from the authorities, I think, that complainant is entitled to the relief asked under the terms of the contract, unless it shall appear that the contract was first violated upon the part of complainant, and that by reason thereof complainant cannot invoke the aid of a court of equity for its enforcement in the respect sought in this action.

I have carefully read the various affidavits and correspondence offered in evidence, and am not satisfied that respondent has shown a breach of the contract upon the part of complainant. Respondent's claim is that their contract gave them the exclusive right as jobbers within certain territory for a certain period of time, and that complainant violated this provision of the contract by furnishing the articles to other jobbers within such territory.

As stated, I am unable to find from the evidence offered that complainant did give to respondent the exclusive right to job the machines within the territory designated.

Such being the case, a temporary order of injunction will be granted as prayed, upon complainant executing to respondent a bond to be approved by the Clerk of the Court, with the usual conditions, in the sum of \$5,000; such bond to be given within ten days.

Such being the case, a temporary order of injunction will be granted as prayed, upon complainant executing to respondent a bond to be approved by the Clerk of the Court, with the usual conditions, in the sum of \$5,000; such bond to be given within ten days.

AMONG THE JOBBERS.

THE MacGowan Cycle Company, of New Haven, Conn., has been succeeded by the Pardee-Ellenberger Company.

The Ray Company now has stores in fourteen cities.

The Bauland Company, at Fulton and Duffield streets, Brooklyn, has been succeeded by Chapman & Co.

The Pittsburg Phonograph Co. has removed to 937 Liberty avenue, Pittsburg.

The Theo. F. Bentel Co., of Pittsburg, is now located at 433 Wood street.

The Ray Company branch at Cincinnati has removed from 308 Walnut street to 143 W. 5th street, and the Ray Company branch at Nashville has moved from 606 Church street to 30 The Arcade.

OUR PHONOGRAPH HAND-BOOK.

SINCE the reduction in the price of the Handbook of the Phonograph from seventy-five cents to fifty we have had an increased demand for it. We still have a supply on hand and can fill trade orders for it. The book contains 180 pages of information and ninety illustrations about the Phonograph, Record making and kindred topics. It is bound in buckram, with board covers.

WILLIE WISELY'S WAY.

Mrs. Wisely—John, I was just reading about a man who traded his wife for a phonograph. Now isn't that horrible?

Mr. Wisely—Not at all, Mary; a phonograph will not talk without winding. He knew his

World Radio Business.—N. Y. Evening Sun.



## SUSPENDED LIST, APRIL 1, 1903,—SUPERSEDING ALL PREVIOUS LISTS.

## KANSAS.

LAWRENCE—BELL BROS.

## MASSACHUSETTS.

LAWRENCE—LORD &amp; CO., 314 Essex street.

MALDEN—A. T. FULLER.

NEW BEDFORD—H. B. DEWOLFF.

## MICHIGAN.

DETROIT—F. J. SCHWANKOVSKY.

SAGINAW—GEO. W. EMENDORFER.

## MISSOURI.

KANSAS CITY—THE WITTMANN CO.

## NEBRASKA.

LINCOLN—THE WITTMANN CO.

OMAHA—THE WITTMANN CO.

## NEW JERSEY.

ATLANTIC CITY—SAMUEL D. WOLF, 32-34  
Arkansas avenue.

BAYONNE—I. WIGDOR, 450 Avenue D.

JERSEY CITY—W. L. HOFFMAN, 151 Mont-  
gomery street.

NEWARK—R. L. CORWIN.

PATERSON—CHAS. H. KELLY, 25 N. Main st.

WEST HOBOKEN—EMIL HOLLANDER, or  
THE WEST HOBOKEN BICYCLE &  
PHONOGRAPH CO., 619 Spring street.

## NEW YORK.

BEDFORD PARK—GEO. H. TYRRELL.

NEW YORK CITY—A. T. ARMSTRONG, or  
AMERICAN PHONOGRAPH CO., 106  
Wall street.

R. L. CORWIN, also Newark, N. J.

EAGLE PHONOGRAPH CO., or C.  
LOWENTHAL, 83 Nassau Street.EMPIRE PHONOGRAPH CO., 2 West  
14th street.HAWTHORNE & SHEBLE, 297 Broad-  
way, also Philadelphia, Pa.R. H. INGERSOLL & BRO., 67 Cort-  
landt street.

W. L. ISAACS, 114 Fulton street.

S. LEMBURG &amp; CO., 194 Broadway.

J. McELLYNNE, 202 Broadway.

F. M. PRESCOTT, 44 Broad street.

STAR CREDIT CO., or Paul Sacks, 180  
East Houston st. and 57 Third ave.

SARATOGA—W. J. TOTTON.

## OHIO.

CINCINNATI—J. L. ANDEM.

SPRINGFIELD—D. &amp; M. VANDERPOOL.

UHRICHSVILLE—F. A. MAZURIE.

## PENNSYLVANIA.

PHILADELPHIA—HAWTHORNE & SHEBLE,  
604 Chestnut street.

## RHODE ISLAND.

PROVIDENCE—F. P. MOORE.

Jobbers and Dealers are asked to co-operate with us, FOR OUR MUTUAL GOOD, by being careful that they do not supply any of the above named firms with our apparatus.

## A NEW NATIONAL AIR.

“MY Own United States,” the patriotic song from “When Johnny Comes Marching Home,” promises to become a national air of this country. It is now being sung in hundreds of the public schools in all sections and its popularity is growing with wonderful rapidity. Both music and words are very stirring, especially when sung by a chorus. This song was listed by this Company in February and the demand for it has been large.

## CORRECT GROSS WEIGHTS.

Changes in the equipment and manner of packing have from time to time changed the gross weights of the several styles of the Phonograph. The correct weights are given in the following table.

Gem...	22 lbs.	1 case
Standard .....	50 “	“
Home .....	70 “	“
Triumph .....	90 “	“
Concert.....	135 “	2 cases
Excelsior .....	100 “	“
Bijou .....	68 “	“
Ajax .....	420 “	4 “
Climax .....	335 “	3 “
Triton.....	85 “	1 case

### TRADE OPINIONS ON THE MONTHLY.

*The Pittsburg Phonograph Co.:—*

We have gone over the EDISON PHONOGRAPH MONTHLY and are much pleased with its contents, as it gives a great deal of condensed information and in connection the advanced list of new moulded records, which makes it a very useful and attractive sheet.

*J. W. Maple, Ridgeway, Mo.:—*

I received first copy of PHONOGRAPH MONTHLY. Have read every word and find it full of valuable information. Will be pleased to receive it regularly.

*L. R. Porter, Brockton, Mass.:—*

Vol. I, No. 1, EDISON PHONOGRAPH MONTHLY, at hand. It's just what I wanted to see. Long may it live.

*C. W. Noyes, Ilsen & Co., Cincinnati, O.:—*

I beg to acknowledge receipt of the EDISON PHONOGRAPH MONTHLY. I really think this paper will be greatly appreciated by Phonograph dealers in general. The only suggestion I might make that would improve the MONTHLY would be to give us more of it. I was very sorry to reach the last page. I hope it may grow each month and develop finally into a magazine of twenty-five or thirty pages. I feel sure that there is enough news in the Phonographic world to fill this much space in small type.

*James A. Spead, Newfields, N. H.:—*

No. 1 of the EDISON PHONOGRAPH MONTHLY at hand. Thanks. I think this is just what the trade has wanted for a long time. It will put the retail trade in touch with the home office, and keep all hands posted as to what is doing and will be done.

*Douglas & Co., New York City:—*

We commend your enterprise in issuing the EDISON PHONOGRAPH MONTHLY, which should be of great assistance to both Jobbers and Dealers.

*Morley Bros., Saginaw, Mich.:—*

We are in receipt of the No. 1 EDISON PHONOGRAPH MONTHLY, which meets our hearty commendation.

*J. H. Snyder, Uhrichville, O.:—*

The EDISON PHONOGRAPH MONTHLY is immense and is something we have been looking for. Every Jobber and Dealer should be proud of it. I for one will not leave a stone unturned to make it a success. \* \* \* We are all one family, and children should assist the father. Let us all put our heads and ideas together and note the results.

*E. S. Perkins, Sunapee, N. H.:—*

Am very much pleased with the PHONOGRAPH MONTHLY and hope that it will be continued. Would say that it keeps the Dealers in touch with ideas and improvements and gives notice of all advertising matter about to be published.

*Albert Palmer, Garrett, Ind.:—*

It is with pleasure I can say that I am very much taken up with the EDISON PHONOGRAPH MONTHLY, and it will be an ever looked for and welcome visitor at my place of business. I am putting all my time in selling Edison goods, for I think there is no other like them.

I am doing all I can to advertise them. I will tell you about how many Edison Records I have sold in a city of about 4,500 people. I have sold in the past year over 3,000 Records. How is that for doing business?

*H. A. Richards, Parry Harbor, Ont.:—*

I think that the PHONOGRAPH MONTHLY is a good move in the right direction. Think that the exchange column will be all right.

*J. B. Rich, Hobart, N. Y.:—*

The first copy of the PHONOGRAPH MONTHLY received. It is just what Dealers in Phonographs and Phonograph goods want. You ask for suggestions and criticisms. If the new MONTHLY is worth anything it is worth preserving. I would suggest that you have a cheap binder made that will hold twenty-four numbers with cord in the back so that each number can be put in the binder when received. Send it only to Dealers interested who will ask for it, or, if you wish, who will pay for it. Should you decide to get out a binder put me down for the first copy. I will pay the price. [We will look into this matter. —Advg. Dept.]

*Henry Rau, Jersey City, N. J.:—*

I received the PHONOGRAPH MONTHLY and carefully noted contents. I think that it fills a long felt want, as it will keep the Dealers in close touch with the "National."

*J. W. Dilbeck, Morrilton, Ark.:—*

Your first copy of the PHONOGRAPH MONTHLY received. Please accept thanks for the same. I like it much better than the Phonogram.

*N. C. Hall, Fort Worth, Texas:—*

I have just received a copy of the EDISON PHONOGRAPH MONTHLY. Thanks. It is just what the Dealer needs. I am very much pleased with your method of assisting the Dealers. The Edison Phonograph is the only talking machine of real merit on the market. There is a constantly growing demand for it.

*J. A. Anderson, Stromsburg, Neb.:—*

The new EDISON PHONOGRAPH MONTHLY received, which I think is all right. Am glad to see that the prices on Edison goods are to be maintained.

*Wesley T. Harrison, Williamstown, Ky.:—*

I have the pleasure of acknowledging the receipt of your paper, Vol. 1, No. 1, and have carefully read every word of same. I believe that it will be of great benefit to Dealers.

*Robert F. Storey, Mt. Holly, N. J.:—*

I am in receipt of a copy of the first issue of the EDISON PHONOGRAPH MONTHLY, and I was very much pleased with it.

*The Musical Supply Co., South Bend, Ind.:—*

The first copy of the PHONOGRAPH MONTHLY is certainly a welcome visitor. We have felt the necessity of something of its nature for some time. The advance list of records is certainly desirable, and I don't see how a Dealer could get along without it. It is needless to say that although we handle all makes, the Edison Machine and Record sales lead five to one. We keep all the machines and over five hundred Edison Records in stock, and are fast securing the entire trade of northern Indiana.



## JOBBERERS OF PHONOGRAPHS AND RECORDS.

The following is a list of firms in the various cities of the United States and Canada who are handling Edison Phonographs and Records as Jobbers:

## ALABAMA.

**Birmingham**—The Ray Co., 2027 Second avenue.  
**Mobile**—The Ray Co., 54 Dauphin street.

## CALIFORNIA.

**San Francisco**—Peter Bacigalupi, 933 Market street.

## COLORADO.

**Denver**—Denver Dry Goods Co., California and 16th streets.  
 Western Phonograph Co., 619 16th street.

## CONNECTICUT.

**Middletown**—Caulkins & Post Co., 406-408 Main street.  
**New Haven**—Pardee-Ellenberger Co., 155 Orange st.

## GEORGIA.

**Atlanta**—The Ray Co., 6 S. Broad street.  
**Savannah**—The Ray Co., 116-118 Barnard street.

## ILLINOIS.

**Chicago**—Oscar J. Junge, 245 E. Chicago avenue.  
 Kelley Cigar Co., 80-82 Wabash avenue.  
 James I. Lyons, 73 Fifth avenue.  
 The Ray Co., 90 Washington street.  
 Siegel-Cooper Co., State and Congress sts.  
 Talking Machine Co., 107 Madison street.  
 The Vim Co., 68 E. Lake street.  
 Montgomery Ward & Co., 111 Michigan ave.  
**Peoria**—Peoria Phonograph Co., 314 S. Adams street.

## INDIANA.

**Indianapolis**—Kipp Bros. Co., 37 S. Meridian street.  
 The Ray Co., 234 Massachusetts avenue.  
 Wahl & Gaasch, 119 S. Illinois street.  
**Lafayette**—Wahl & Gaasch, 304 Main street.

## KENTUCKY.

**Louisville**—The Ray Co., 640 Fourth avenue.

## LOUISIANA.

**New Orleans**—National Automatic Fire Alarm Co., 618 Gravier street.  
 The Ray Co., 111 Camp street.

## MAINE.

**Bangor**—Bangor Phonograph Co.  
**Portland**—W. H. Ross & Son, 207 Commercial street.

## MASSACHUSETTS.

**Boston**—Boston Cycle & Sundry Co., 7 Hanover street.  
 Eastern Talking Machine Co., 176 Tremont street.  
 J. C. Haynes & Co., 453 Washington street.  
 Iver Johnson Sporting Goods Co., 163 Washington street.  
 Read & Read, 558 Washington street.  
**Fitchburg**—Iver Johnson Sporting Goods Co.  
**Lowell**—Ring Music Co., 133 Merrimac street.  
 Thomas Wardell, 111 Central street.  
**Worcester**—Iver Johnson Sporting Goods Co.

## MICHIGAN.

**Detroit**—American Phonograph Co., 106 Woodward avenue.  
 Grinnell Bros. Music House, 219 Woodward avenue.  
 Russell Phonograph Co., 168 Griswold street.  
**Saginaw**—Morley Bros.

## MINNESOTA.

**Minneapolis**—Thomas C. Hough, 234 Nicollet avenue.  
**St. Paul**—Minnesota Phonograph Co., 37 E. 7th street.

## MISSOURI.

**Kansas City**—J. W. Jenkins' Sons Music Co., 1013-1015 Walnut street.  
**St. Louis**—Conroy Co., 1115 Olive street.  
 The Ray Co., 923 Olive street.

## NEBRASKA.

**Lincoln**—H. E. Sidles Cycle Co., 1317 O street.  
**Omaha**—H. E. Fredrickson, 1502-1510 Capitol avenue.  
 Nebraska Cycle Co., 15th and Harney streets.

## NEW JERSEY.

**Hoboken**—Eclipse Phonograph Co., 306 Washington street.  
**Newark**—H. J. Koehler Sporting Goods Co., 845 Broad street.  
 A. O. Petit, 42 New street.  
**Paterson**—James K. O'Dea, 117 Ellison street.  
**Plainfield**—Frank L. C. Martin Auto. Co., 310 Park avenue.  
**Trenton**—Stoll Blank Book and Stationery Co.

## NEW YORK.

**Brooklyn**—Chapman & Co., Fulton and Duffield streets.  
 A. D. Matthews' Sons, 394 Fulton street.  
 Price Phonograph Co., 1224 Broadway.  
**Buffalo**—P. A. Powers, 643 Main street.  
**Elmira**—Elmira Arms Co., 117 Main street.  
**Gloversville**—American Phonograph Co.  
**Kingston**—Forsyth & Davis.  
**New York City**—Barkelaw & Kent Co., 36 Vesey street.  
 Bettini Phonograph Co., 110 Fifth ave.  
 Blackman Talking Machine Co., 19 Beekman street.  
 J. F. Blackman & Son, 142d street and 3d avenue.  
 I. Davega, Jr., 802 Third avenue.  
 S. B. Davega, 32 E. 14th street.  
 Douglas & Co., 89 Chambers street.  
 H. S. Gordon, 139 Fifth avenue.  
 Hacker & Horn, 148 E. 58th street.  
 Harry Jackson, 1960 Third avenue and 790 Ninth avenue.  
 Jacot Music Box Co., 39 Union Square.  
 Victor H. Rapke, 1661 Second avenue.  
 Siegel-Cooper Co., Sixth avenue and 18th street.  
**Rochester**—Mackie Piano O. & M. Co., 100 State street.  
 Talking Machine Co., 99 E. Main street.  
**Schenectady**—Jay A. Rickard & Co., 253 State street.  
**Syracuse**—W. D. Andrews, 216 E. Railroad street.  
**Troy**—James Lucey, 359-361 Fulton street.  
**Utica**—Clark, Horrocks & Co., 54 Genesee street.

## OHIO.

**Canton**—Klein & Heffelman Co., 216 N. Market street.  
**Cincinnati**—Ilsen & Co., 25 W. 6th street.  
 The Ray Co., 143 West 5th street.  
**Cleveland**—The Ray Co., 264 Erie street.  
 W. J. Roberts, Jr., 254-256 Arcade.  
**Columbus**—Perry B. Whitsit Co., 213 S. High street.  
**Dayton**—Niehaus & Doshe, 35 E. 5th street.  
**East Liverpool**—Smith & Phillips Music Co.

## PENNSYLVANIA.

**Allegheny**—Henry Braun, 500 Federal street.  
**Allentown**—G. C. Aschbach, 539 Hamilton street.  
**Easton**—William Werner, 401 Northampton street.  
**Philadelphia**—C. J. Heppe & Son, 1117 Chestnut street.  
 Penn Phonograph Co., 19 S. 9th street.  
 Wells Phonograph Co., 41 N. 9th street.  
 Western Electric Co., 931-933 Market street.  
 H. A. Weymann & Son, 1022 Market street.  
**Pittsburg**—Theo. F. Bentel Co., Inc., 433 Wood street.  
 Kaufmann Bros., Fifth avenue and Smithfield street.  
 H. Kleber & Bro., 221 Fifth avenue.  
 C. C. Mellor Co., 319 Fifth avenue.  
 Pittsburg Phonograph Co., 937 Liberty street.  
**Reading**—Lichty Phonograph Co., 641 Penn street.  
 Reading Phonograph Co., 757 Penn street.  
**Scranton**—Charles B. Scott, 119 Franklin avenue.

## RHODE ISLAND.

**Providence**—J. A. Foster Co., Weybosset and Dorrance streets.  
 Murray, Blanchard, Young & Co., 26-30 Pine street.

## TENNESSEE.

**Knoxville**—Reynolds Phonograph Co., 319 Clinch st.  
**Memphis**—The Ray Co., Lyceum Building.  
**Nashville**—The Ray Co., 30 The Arcade.

## TEXAS.

**Dallas**—C. B. Harris, Agt., 347 Main street.  
**Waco**—Waco Electric Supply Co., 518 Austin avenue.

## VIRGINIA.

**Richmond**—The Ray Co., 729 Main street.

## WISCONSIN.

**Milwaukee**—McGreal Bros., 173 3d street.

## CANADA.

**Toronto**—R. S. Williams & Sons, 143 Yonge street.

# LOVERS of MUSIC LOVE The EDISON PHONOGRAPH



NONE GENUINE WITHOUT  
THIS

TRADE  
*Thomas A Edison*  
MARK

The PHONOGRAPH is the only machine that **satisfies** the musical ear. Those who judge the PHONOGRAPH by the old styles, or by other "talking machines," should visit the nearest dealer and hear Mr. Edison's marvelous improvements, that produce this perfect result.

PHONOGRAPH Catalogues and Record Lists are Free at all dealers. Five thousand stores sell PHONOGRAPHS. Nine Styles, \$10.00 to \$100.00. Records 50c; \$5.00 per dozen.

NATIONAL  
PHONOGRAPH  
COMPANY

Orange, New Jersey  
New York, 83 Chambers  
St., Chicago, 304 Wabash  
Ave. San Francisco, 933  
Market St. Europe, 32  
Rempert Saint Georges,  
Antwerp, Belgium.

## APRIL ADVERTISING.

**T**HE advertisement of the NATIONAL PHONOGRAPH COMPANY will appear in the following publications in April:

Ainslie's.  
Argosy.  
Bookman.  
Brown Book.  
Century.  
Collier's Weekly.  
Commercialist.  
Craftsman.  
Current Literature.  
Four-Track News.  
Harper's Magazine.  
Life.  
Lippincott's.  
McClure's.  
Metropolitan.  
Musical Record and Review.  
Munsey's.  
National Magazine.  
New Era Magazine Supplements.  
Outdoor Life.  
Outlook.  
Overland.  
Pearson's.  
Review of Reviews.  
Saturday Evening Post.

Science and Industry.  
Scientific American.  
Scribner's.  
Smart Set.  
Strand.  
Success.  
Sunset Magazine.  
Town Topics.  
World's Work.

This means that nearly 6,000,000 homes in the United States and Canada will have an opportunity of knowing about the Edison Phonograph and Edison Records. It means an immense amount of publicity for our goods, all of which goes to the benefit of the Jobbers and Dealers, since we sell only through the trade and have no retail stores anywhere. Having done this much to popularize the products of Mr. Edison's genius, it only remains for the trade to do such advertising in local, daily or weekly papers, street cars, etc., as will tell the public in their localities where Edison Phonographs and Records may be had. We have found that the dealer who does the most advertising in this way is the one who is doing the most business and who is way ahead of his less enterprising competitor.



# EDISON Phonograph Monthly

PUBLISHED FOR TRADE USE ONLY BY  
THE NATIONAL PHONOGRAPH CO.

VOL. 1.

NEW YORK, MAY, 1903.

No. 3.

*The National Phonograph Co.,*

ORANGE, N. J.

NEW YORK: 83 CHAMBERS STREET.  
CHICAGO: 304 WABASH AVENUE.  
SAN FRANCISCO: 933 MARKET STREET.  
ANTWERP: 32 REMPART SAINT GEORGES.

EDISON PHONOGRAPHS AND RECORDS.

All communications to THE PHONOGRAPH MONTHLY should be addressed to the Advertising Department, 83 Chambers Street, New York.

C O N T E N T S

A New Agreement .....	I, 3
Advance List June Records .....	2
Our Export Trade .....	3
New Lift Mechanism on the Standard....	4
A Dealer's Frank Comparison .....	4
Edison's Favorite Invention .....	5, 6, 7
About Local Advertising .....	7
The Commercial Phonograph .....	7
An Every Day Experience .....	8
To Make Records in the Arctic Regions..	8
Important Notice.....	8
About Printed Matter .....	9
More Comments on the Monthly.....	9
What Madame Albani Said of the Phono- graph .....	10
Pointers on the June List .....	11
Trading Stamps a Violation of the Agree- ment .....	12
Mr. Logue to Come East .....	12
No More Trade Mark Electros .....	12
Form Numbers of Printed Matter .....	12
Dealers Who Will Co-operate .....	13
Suspended List .....	13
Edison Laboratory and Works of the Na- tional Phonograph Co., Orange, N. J.,	14
Jobbers in Edison Goods .....	15
Talking Machine as an Aid.....	16
May Advertising .....	16

One mail on May 7 brought us forty-eight different orders from one Jobber. This shows that in spite of the statements of competing companies there is still "something doing" in Edison goods. This lot of orders establishes a record as to number received at one time from one Jobber.

## A NEW AGREEMENT.

### HOW IT AFFECTS JOBBERS.

A new Agreement between the National Phonograph Company and the various Jobbers in Edison Phonographs and Records is now being signed by the latter. It is dated May 1, and will go into effect July 1. One of its most important new provisions is the naming of a fixed amount of business that must be done each year to enable a firm to continue to get Jobbers' discounts. At the same time the amount of the initial order to be placed by a Jobber has been increased. These changes have been made with a view of protecting Jobbers so that it will not be possible for a firm to buy a Jobber's quantity when taking up the line and then do practically only a retail business afterwards. In a word the Company is endeavoring to compel firms to do a jobbing business in order to get and continue to receive Jobbers' discounts. Other changes are shown in the following notice, which is being laid before every Jobber when asked to sign the new Agreement:

### NOTICE.

Before signing AGREEMENT handed you herewith, we would call your particular attention to the following changes in PRICE LIST and CONDITIONS OF SALE, as compared with PRICE LIST and CONDITIONS OF SALE heretofore in effect:

1st.—That the special price of Five Dollars (\$5.00) per dozen on Edison Records (Standard size) applies only when a full dozen or more is purchased at one time.

2nd.—In paragraph No. 1. That in addition to persons purchasing the required amount of apparatus, signing AGREEMENT, etc., they must have an established STORE in which to display and handle our goods, before they are entitled to Dealers' discounts.

3rd.—In paragraph No. 5. Jobbers must keep a record of the serial number of ALL Phonographs sold by them to Dealers, and furnish a copy thereof to the National Phonograph Company upon request.

4th.—In paragraph No. 6. That the allowance for old Records, taken in exchange for new Edison Records sold at full retail list price of 50 cents each, must not exceed fifteen (15) cents each.

5th.—In paragraph No. 8. For all Dealers established by you, an AGREEMENT, properly signed, MUST be forwarded at ONCE. Such AGREEMENT must also bear the signature of a witness.

(Continued on page 3.)

THE ADVANCE LIST OF JUNE RECORDS APPEARS ON PAGE 2. ORDER FROM IT. NO OTHER ADVANCE LIST WILL BE ISSUED.

## ADVANCE LIST OF NEW EDISON MOULDED RECORDS FOR JUNE, 1903

*T W E N T Y     D O M E S T I C     T I T L E S*  
*O N E     F O R E I G N     T I T L E*

RECORDS listed below will be ready for shipment as near June 1st, 1903, as possible, at which time Jobbers' stock orders, if placed prior to May 20th, will be shipped.

June Supplements will bear the date of June 1st, and will be forwarded to Jobbers with their stock order for Records.

Retail Dealers should place stock orders with their Jobbers at once, to insure prompt shipment as soon as Jobbers' stock is received.

Stock orders for Records contained in this list must be written on separate order blanks, and letters relating to June Records should refer to no other matter.

Kindly comply with above requests and thus aid your Jobber and ourselves in handling advance orders.

### DOMESTIC

- |        |  |  |                                  |
|--------|--|--|----------------------------------|
| X 8404 | Spring of Love                         | <i>Violin and flute duet</i>   | Eugene Jaudas & Louis Atz        |
| X 8405 | Won't You Roll Dem Eyes                |  | Arthur Collins                   |
|        |  | <i>Coon song with orchestra accompaniment</i>                              |                                  |
| 8406   | Up the Street March                    |  | Edison Concert Band              |
| 8407   | If I But Knew                          |  | William H. Thompson              |
|        |  | <i>Sentimental song from the Sultan of Sulu</i>                            |                                  |
| 8408   | The Mississippi Bubble                 |  | Banjo Vess L. Ossman             |
| 8409   | In the Valley where the Bluebirds Sing |  | Byron G. Harlan                  |
|        |  | <i>Descriptive song with orchestra accompaniment</i>                       |                                  |
| X 8410 | My Country 'Tis of Thee                | <i>Quartette</i>   | Edison Male Quartette            |
| X 8411 | Julie                                  | <i>Serio-comic song from Mr. Blue Beard</i>                                | Edward M. Favor                  |
| 8412   | Down Where the Wurzburger Flows Medley |  | J. F. Hopkins                    |
|        |  | <i>Introducing Susie Anna, Xylophone solo with orchestra accompaniment</i> |                                  |
| 8413   | Long Ago                               | <i>Sentimental song</i>  | Arthur Clifford                  |
| 8414   | Cupidietta                             | <i>Intermezzo</i>  | Peerless Orchestra               |
| 8415   | Down at Lover's Roost                  | <i>Waltz song</i>  | Harry MacDonough                 |
| 8416   | Butterfly Gavotte                      |  | Edward F. Rubsam                 |
|        |  | <i>Bell solo with orchestra accompaniment</i>                              |                                  |
| 8417   | Hebrew Vaudeville Specialty            |  | Julian Rose                      |
|        |  | <i>Introducing parody on When the Boys Go Marching By</i>                  |                                  |
| 8418   | Sing, Smile, Slumber (Gounod)          |  | Cornet Bohumir Kryl              |
| 8419   | In the Starlight                       | <i>Contralto and basso duet</i>  | Miss Morgan & Mr. Stanley        |
| 8420   | Little Dinah Jones                     |  | J. F. Hopkins                    |
|        |  | <i>Xylophone solo with orchestra accompaniment</i>                         |                                  |
| 8421   | Ma Starlight Sue                       | <i>Male duet</i>   | W. H. Thompson & Albert Campbell |
| 8422   | Refuge                                 |  | Mendelssohn Mixed Quartette      |
| 8423   | Hebrew Vaudeville Specialty            |  | Julian Rose                      |
|        |  | <i>Introducing parody on Go 'Way Back and Sit Down</i>                     |                                  |

### FOREIGN

12813 to 12826. These are 14 Japanese titles, about which a special circular will be issued in June. (The numbers are inserted here to keep the list complete.)

12827 Kol Nidre. *Hebrew religious song* Frank Seiden

Edison Moulded Records are made only in Standard size. Both Standard and Concert Records may be ordered from this list. Order by Number, not title. If Concert Records are wanted, give the number and letter C.



(Continued from page 1.)

We bring these changes to your attention, owing to the numerous complaints recently received in connection therewith, and to give you notice that for any further violation of these particular clauses, immediate action will be taken and the Jobber so violating will be liable to immediate suspension, as well as such legal action as the case may warrant.

NATIONAL PHONOGRAPH COMPANY.

New York, May 1, 1903.

#### HOW DEALERS ARE AFFECTED.

The changes affecting Dealers are shown by the following notice, a copy of which is attached to every Agreement that Jobbers will lay before Dealers prior to July 1:

#### NOTICE.

Before signing AGREEMENT handed you herewith, we would call your particular attention to the following changes in PRICE LIST and CONDITIONS OF SALE, as compared with PRICE LIST and CONDITIONS OF SALE heretofore in effect:

1st.—That the special price of Five Dollars (\$5.00) per dozen on Edison Records (Standard size) applies only when a full dozen or more is purchased at one time.

2nd.—That in taking up our line you must have an established STORE suitable to display and handle same.

3rd.—In paragraph No. 4. That the allowance for old Records, taken in exchange for new Edison Records sold at full retail list price of 50 cents each, must not exceed fifteen (15) cents each.

We bring these changes to your attention, owing to the numerous complaints recently received in connection therewith, and to give you notice that for any further violation of these particular clauses, immediate action will be taken and the Dealer so violating will be liable to immediate suspension, as well as such legal action as the case may warrant.

NATIONAL PHONOGRAPH COMPANY.

New York, May 1, 1903.

The changes in both Jobbers' and Dealers' agreements are only such as the experience of the past few years have shown are essential to the proper continuance of the system under which Edison Phonographs and Records are sold—a system that time has demonstrated is one of the best in use in connection with any line of business. We believe that the entire trade will concur in the wisdom of these changes.

**The price of \$5.00 per dozen on Edison records can be allowed only when a full dozen, or more, are purchased at one time, or actually paid for in advance.**

The Edison Phonograph was given much unsolicited advertising throughout Japan in March and April through the presentation of a Phonograph to the Emperor of Japan by Mr. Edison, mention of which was made in the March MONTHLY. The presentation was referred to in all the Japanese papers. Some of the articles were copied in Japanese papers published in San Francisco, and these in turn found their way into American papers.

#### OUR EXPORT TRADE.

The demand for Edison Phonographs and Records in Europe, South America and Australia is rapidly becoming one of the important features of our business. During the past year the business of our Foreign Department was more than double what it was the year before and a still greater impetus has been given the export trade since James H. White went to Antwerp, Belgium, as manager of sales for Europe. The Continent for some time has been flooded with talking machines of crude construction and doing imperfect work—the kind of devices that have caused many persons to feel prejudiced against talking machines in general. These cheap machines have not reached South America to the same extent, and the Edison Phonograph has long been the most popular instrument of its kind in that country. The people in various countries of Europe are rapidly awakening to the fact that the Phonograph is in a class by itself. Its fame as a sweet and satisfactory musical instrument has become so general in the past year that it has not been possible for months to make Phonographs fast enough to meet the demand. The sale of Records has been no less satisfactory than the demand for machines. Edison Phonographs and Records seem destined to have a splendid future in foreign countries.

#### WHY A LARGE DEPARTMENT STORE BECAME JOBBERS IN EDISON GOODS.

The hold that the Edison Phonograph has upon the public was again demonstrated during April, when one of the largest department stores in the country, located in a large Eastern city, came to us voluntarily, and without solicitation became Jobbers in our goods, placing one of the largest initial orders ever received by this Company. The firm referred to had been handling goods of a competing company and the fact was recently given wide publicity. And yet so many calls were made upon them for Edison Phonographs and Edison Records that their business judgment caused them to become Jobbers in our goods.

Dealers whose names are not now on our mailing list correctly are requested to send their proper addresses to the Advertising Department. Every month we learn of errors of this kind in our mail list and realize that there must be others of which we have no knowledge.

### NEW LIFT MECHANISM ON THE STANDARD PHONOGRAPH.

All Standard Phonographs now being shipped from our factory at Orange are equipped with a new lift mechanism, which is extremely simple in operation. It takes the place of the old style lift lever. Instead of the latter there is a button attached to a moveable pin which passes through holes in the lower end of the speaker arm. To raise the speaker arm it is only necessary to lift the button a trifle and at the same time press it toward the mandrel. The end of the pin then slips through the holes in the speaker arm and rests on the straight edge. To lower the speaker arm the button is pulled out and the arm descends by its own weight. The operation is shown in the following cut:

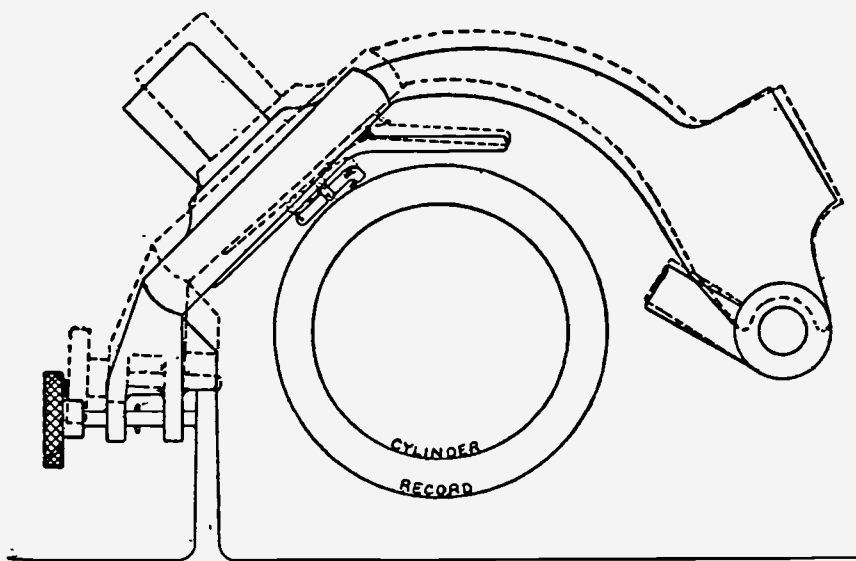

The solid lines show the speaker arm lowered for reproducing, and the dotted lines the arm raised and the pin resting on the straight edge. It will be noticed that the sliding pin has a lug on each side which prevents it from pulling out or passing in too far.

### RECORD SHIPMENTS.

Although our factory worked day and night we were not able to complete the shipments of March Records till May 1st. The manufacture of April Records is already under way and we hope to get them all shipped before May 20. The May list will then follow immediately. An effort will be made to get June Records out soon after June 1, and to get back to normal conditions by July. We believe that with the increased factory facilities now under way there will be no repetition in the future of the delay of the past two months.

**Jobbers or Dealers violate their Agreement when they give trading stamps with Edison Phonographs or Records.**

### A DEALER'S FRANK COMPARISON.

We are in receipt of an attractively printed circular from a New York city Dealer. which, after referring to the good qualities of the Edison Phonograph makes the following comparison between cylinder and disk machines:

On these machines [the Edison Phonograph] records can be made as easily as they can be reproduced and they can be erased, and the surface made ready for the reception of a new record many times. The Phonograph is quite different from the so-called Disk Machine in this respect. In order to make a record on a Disk Machine, it must be made by an expensive and complicated recording device, supplemented by a cumbersome and intricate process, nor can the disk be again used if the record becomes worn or the subject matter unserviceable.

In the use of this last machine it is necessary to renew the little steel needles, which trace the sound waves, with each change of record, while on the *Phonograph*, the reproducing point is a sapphire ball which is permanent. The hard flat disk can be handled roughly and will stand misuse that would ruin a wax cylinder; but so will a street piano stand usage that would ruin a fine piano, while at the same time it is louder. The buyer of a fine Phonograph does not buy records to throw on the floor, or at the cat. The Phonograph records are for the purpose of reproducing the most delicate phenomena in nature—Sound Waves.

The undersigned having secured the agency for the sale of the *only desirable* Talking Machine—*The Edison Phonograph*, are prepared to furnish you with one or more of these instruments for cash or on the *easy payment plan of One Dollar Weekly*. Send for catalogue and prices, or if you find it inconvenient to call, our representative will call on you with an instrument and demonstrate their superiority over all other talking machines.

DEMAREST SEWING MACHINE Co.,

M. L. Gregson, Proprietor,

153 West 23d Street, New York City.

**The selling of Edison Records by card system, whereby the price of \$5.00 per dozen is eventually allowed, but where a full dozen records are not purchased, or paid for, at one time, is a violation of contract.**

In the March MONTHLY comment was made upon No. 8349, "Dream of the Tyrolienne," a violin and flute duet by Eugene Jaudas and Louis Atz, which was included in the March Records. The statements then made have been fully confirmed by the public. All who have heard the Record pronounce it one of the sweetest ever made for the Phonograph or any other style of talking machine. Every Phonograph owner will want it in his collection.



## EDISON'S FAVORITE INVENTION.

By Joe Mitchell Chapple.

The following interesting article on the Phonograph appeared in the May issue of the *National Magazine*, accompanied by a full page picture of Mr. Edison:

Of all the names to conjure with, in a horoscope of the present century, none surpasses that of Thomas Alva Edison. When I entered his laboratory at Orange, New Jersey, I felt that it was truly a shrine of the great inventive genius of the age.

There I saw the Wizard, just one day past his fifty-sixth birthday, mixing a substance in a mortar, pestle in hand, more with the air of an absorbed and concentrated workman than of the great inventor of an age. Attired in a light gray suit covered with stains of real labor, with spectacles focused well down on his nose, he was involved in the intricacies of a new process of making Portland cement so as to bring the price within the range of a commercial necessity.

There is a gentle and sweet winsomeness in the smile of Thomas A. Edison that is attractive. His blue eyes light up, and there is an expression of kindness in his countenance that one seldom sees in the face of a man. He left his work and took me through an arsenal of chemicals, compounds and contrivances to a quiet corner, where, on plain stools, we could talk. Mr. William E. Gilmore, the president and manager of the National Phonograph Company, was with me, and it was plain to see where the successful alliance has been formed that has made the Edison phonograph so great and so complete a commercial success.

As he leaned back on the bench from his stool, Mr. Edison began to talk in his own quaint quizzical way, with an expressive twitch of the mouth and shoulders by way of emphasis. He is slightly deaf, which he minds but little, as do those with him, and his voice has a gentle softness that is charming. His keen eye catches the words and expressions so quickly that one soon forgets that the ears of the man who invented the phonograph, as well as a thousand other things, do not absorb every sound of articulation. Perhaps he hears just enough to concentrate his attention only on things that count.

My first interrogation as to his favorite invention child, among the long array of his brain creations, elicited a prompt reply.

"The phonograph—the phonograph, by all means!" he exclaimed, with the enthusiasm of a lad with his first kite. "It has been a long time since the first phonograph, as we count time nowadays, and improvements come every day; but I think I have accomplished more the past year on it than in any of the years before. My ambition is to have it so perfect that it will reproduce your Boston symphonies to perfection, giving the distinct intonation of every instrument.

"Yes sir, the Edison Phonograph has more than a commercial mission to perform, although that is the first practical point we seek. It will make American homes brighter and more cheerful and attractive. If we can produce them so cheaply that they can go into every home and bring the little circle in touch

with the greatest music and oratory of all time, I shall esteem a life's work well repaid. These long winter evenings, in the solitude of isolated homes—I knew what they were as a boy—there is where the real character of the individual is determined."

It was plain to see that in this laboratory, containing almost all, if not all, the known substances on earth; from lima beans, cotton skins, chemicals, including every known mineral ranging from kalium, that ignites water and is preserved in benzine, to radium, ten times as valuable as gold; there was a Wizard who worked with real things, as well as with ideas. This has been the great characteristic of Mr. Edison's work. He has practicalized products as well as projects, and produced them at a cost that has brought them within the range of every day use, as he did the incandescent light. I shall never look upon an electric light again without recalling a picture of the modest man who made it all possible.

When asked as to how he came to invent the phonograph, he replied in his grimly humorous way:

"All things within reason are possible, if you keep at them long enough, but the phonograph when first discovered, was as great a surprise to me as it is to the world. I was working on some telephone receivers and observed the point moved and made a whirring sound, as it does recording a telegraph message. I put a piece of tin foil on a cylinder and it recorded sound, a whirring noise, that seemed to me, then, almost articulate. From that moment, I was convinced that sound could be practically recorded and reproduced.

"In those days, I used to make a rough draft of my ideas on paper, and mark the price on the paper for the boys to produce the machine according to specifications. Sometimes it was nine dollars—sometimes it was ninety dollars. The question of profits never entered their heads. They made it. Sometimes it was a profit for a day's work, other times a loss of a month. But dear old John Kruesi, who recently died at Schenectady, made my first phonograph for me, and his quaint, German-accented comments in broken English were always cheery and optimistic. We took it in a box to the office of the *Scientific American* in New York. I had recorded the verse—

*Mary had a little lamb,  
Its fleece was white as snow,  
And everywhere that Mary went,  
The lamb was sure to go,—*

and the reproduction of my own voice sounded almost supernatural at first. Of course the articulation was not especially distinct,—unless you knew what the words were,—but it revealed the wonderful possibilities in the perfection of the work performed on that piece of tin foil."

Those who recall the days when Edison introduced the first phonograph, remember the tremendous sensation it occasioned. Here he was twenty years after, as enthusiastic as ever, and at work on the same machine, the Edison phonograph, which has echoed the human voice in every country on earth. The original plant of the Phonograph Company was a modest beginning, which has been added to,



building by building, until now it covers acres and requires the work of thousands of skilled artisans, night and day, to supply the demand for machines and records. At first it was thought the phonograph would be only a fad, a curiosity; but to-day it has developed into a household article, as essential to the home as organ or piano.

The front part of Mr. Edison's famous laboratory, which is connected direct with the works of the Phonograph Company, is a large library and museum with several lofts. In the center are the bits of statuary and a business-like array of desks; for the great inventor can come right from his chemical tests, or electric elaborations, or forge and smithy, and dip into a patent law question or a bit of legal transaction with the poise and equanimity that he passes from one experiment to another.

Behind a net-work of iron bars, in the adjoining room, is a collection of almost every known material and substance—a sort of scientific Noah's Ark. To inventory this collection, or rather to collect it direct from the markets of the world, would represent a sum far into the millions, and the various articles there would run up into many thousands; and yet Edison could tell you where every bolt or bottle was located, and almost go to it in the dark. He lives, breathes and has his being in his laboratory, and a few couches scattered about would indicate his desire to sleep there for the few hours of rest he requires.

Always at it—eternally at it—never quitting—and with the genius to see clear through propositions pronounced impossible, this seems to state concisely the genius of Mr. Edison.

"It is the simple things that stagger," he resumed. "They are so simple that they are overlooked, oftentimes, by the inventor and scientist. The most wonderful achievements are small things that men have been stumbling over for centuries past, and generations to come will likely have similar things to say of us."

Here a forge, there a cauldron, and here an oven; here a room with delicate electrical appliances; opposite, a complete X-ray outfit; in an adjoining room a regiment of draftsmen, poring over blue prints. On one floor a gigantic machine shop, with chemical appliances interspersed. Here on a bench are several pieces of plate glass on brown paper, on which the inventor has been scraping with his knife. All this great establishment in connection with the Phonograph plant, from gigantic castings to the most delicate films; for experimenting and testing the plans and ideas of the great Edison. In this one initial workshop were evolved and perfected the ideas which have created great industrial plants all over the world and given enjoyment to millions. All from the genius of the one modest, gray-haired man, who goes apparently at random from one thing to another in that gigantic chemical, mechanical, electrical museum, as impulse leads him. Every stage of the work is carefully noted, recorded, discussed and argued, for there is no time lost by Thomas A. Edison in taking up the threads of his work.

A pen picture of Thomas A. Edison cannot be made without telling of his phonograph, for that is the one thing upon which his greatest personal enthusiasm concentrates. Those who

have Edison's phonograph have what has done more than any other one thing to contribute to his greatness. The early records, containing the voice of Gladstone and Bismarck, were a priceless heritage, only recently destroyed by accident; the voice of William McKinley is preserved by the Edison phonograph for future ages. The phonograph now supplies the part of instructor in all the modern languages. And all this is the result of the keen but kindly blue-eyed man, whose vim and inventive genius first comprehended all of the great and almost bewildering commercial possibilities of what was at first regarded chiefly as a toy of scientific investigation, or a laboratory exhibit.

Since 1881 Mr. Gilmore, the present president and general manager of the Edison Phonograph Company, has been associated with the Edison interests, but it was not until 1894 that he became the head of the Phonograph Company. He has seen the magic development of the phonograph under the master's genius. Perhaps no man is closer to Thomas A. Edison than the president of the National Phonograph Company, and it is he who has made a commercial triumph of the invention. The industry now gives employment to 1,500 in this one company alone, and the process of manufacture is an interesting and fascinating study of the full voltage of an Edison idea, once it enters the arena of industrial development.

The array of automatic machines, singing their busy songs in "making the parts" as if by some great invisible directing force; the assembling of the various parts; the nickeling vats; the japanning room; even to the boxing and crating of the various types of machines, labeled for all parts of the world, is a scene beyond the wildest prophecy of a century ago.

The Edison phonograph is more than a mere article of commerce. It has a moral influence in the charm it lends to the glow of the home circle, and has become more than the *National Edison phonograph*—it is truly international. The triumph of American commercial designs is inseparably linked with the inventions of Edison. Thousands, with the aid of the phonograph, are mastering the languages, to enlist in the conquest of trade, who would feel that they could not afford the time or expense of a tutor.

To me the most fascinating portion of the great Edison phonograph plant was the record-making building, where the magnificent records are being made. Here was Kryl, the great cornetist, with hat and coat off—his collar unloosed, his long hair flowing, pouring the masterly strains into a funnel, beside which stood two operators, watching minutely every detail.

A slight error is made, which to an audience would pass unnoticed, but Kryl shakes his locks—the record is destroyed, and he begins all over playing a strain that in a short time is to echo all over the world. The accompanist at the piano, placed on a high platform to bring the sound within the range of the large trumpet, patiently repeats the interludes.

There are rooms fitted up for brass bands, vocal choruses and orchestras with elevations adjusted according to the science of sound, to get the best possible results for the records. There are chimes of bells, in fact, all of the



properties of a theatre, for here the indelible record is made that time cannot wither. It is marvelous how this great department is kept busy to supply the world with something new for every hour of the day. Years ago the new piece of sheet music was purchased after its popularity was assured; now it is the new record that takes up the main burden of the distribution of popular airs.

The new records are of much darker color than formerly, and are much more loud and distinct. A contrast of records recently made and those made a year ago, showed a marked improvement, and with Mr. Edison's watchful eye on the lookout for further advancement, one feels that the Edison will remain the standard phonograph of the times. The records are now electrotyped in gold, so that they are all virtually and actually "originals," instead of reproductions, as formerly. The whole process is so simple when once understood as to be startling, and, as Mr. Edison remarked, "It's strange that it was not made a practical success before."

Scattered through the various departments, from X-ray to machine lathe room, are those rough pencil drafts, made by Mr. Edison. His drawings have nothing of the polished finish and exactness of the blue print in the drafting room, but they have the vitality of the great and yet simple idea. These drafts are made oft-times to show the impossibility as well as possibility of a project. And in all the range of ideas from the first tin-foil record to the perfected wax record of 1903, Thomas A. Edison has surpassed even his own expectations in the phonograph. It is the one predominating hobby of his life, and with a phonograph in the home, every American home has a souvenir remembrance and reminder of what Thomas A. Edison considers the greatest achievement of his life.

#### ABOUT LOCAL ADVERTISING.

Occasionally a Dealer asks to have this Company do some advertising in his field for his special advantage. We are compelled by our policy to refuse such requests. If but a few Dealers were selling our goods we should take pleasure in making an advertising appropriation for the benefit of each, and we could afford to do the same for all. With over 5,000 Dealers in Edison Phonographs and Records the situation is very different. Our system does not permit one Dealer to have the slightest advantage over any other in selling our goods, and to be consistent we cannot show a few Dealers favors and deny them to the remainder. The utmost care is taken to see that no one is discriminated against in shipping goods or sending out printed matter. An appropriation of \$50 for advertising each Dealer locally would be as small as could be used to advantage, but even that amount to each Dealer would mean an additional expenditure yearly of over \$250,000—an expenditure quite out of the question.

We think that Dealers will see the question in the same light as we do, and will realize that when we refuse to do local advertising it is because of a desire to maintain a consistent policy, and not because of the small amount that individual cases would involve.

#### MORE ABOUT THE COMMERCIAL PHONOGRAPH.

A private exhibition of the perfected Edison Commercial Phonograph was made in April before Mr. Edison, President William E. Gilmore, and the heads of our various departments. It was given a thorough trial and pronounced by all to be perfect. It must not be inferred from this, however, that the Commercial Phonograph is ready for the market. Such will not be the case for some months. Before even another machine can be made it will be necessary to build special machinery to manufacture a number of special parts. A sufficient number of the machines will then be made to equip all the departments of the National Phonograph Company. This will furnish a demonstration of the complete success of the Edison Commercial Phonograph. Just as soon as it can properly be done the machine and its methods of operation will be fully described in these columns.

#### APPROVES THE MARCH SELECTIONS.

Under date of May 4 the Pardee-Ellenberger Co., Jobbers in Edison Phonographs and Records at New Haven, wrote:

The March selections came duly to hand and they seem to have met with very general approval with the trade, if our orders are any indication. We have heard only good words for the list and want to compliment you on the quality of the goods and the character of the selections. Several of them, such as "Sweet and Low," "Monkey Shines on the Mobile Levee" and the "Symphia Waltzes" are particularly fine. If this high standard is maintained there is no chance of Edison goods losing the prestige they already hold.

#### THE TRIUMPH A TRIUMPH INDEED.

T. W. Betker, a Dealer at Rushville, Ind., in a letter to his Jobber, Kipp Bros. Co., Indianapolis, Ind., said:

The Triumph Phonograph is certainly well deserving of its name, for it is certainly a triumph in the reproduction of music. The maker should certainly triumph over his achievements, and the possessor cannot help the triumphal feeling, which the Triumph Phonograph is bound to inspire in him when it plays. Long may the Edison lead.

### AN EVERY DAY EXPERIENCE.

A New York Jobber tells an interesting story of an experience he had in selling an Edison Phonograph. He keeps in stock every make of talking machines. One day a gentleman asked to be shown a talking machine, naming the style he wanted. Its merits were fully explained, various airs were played upon it and a sale was soon made. The manager of the store, finding the customer could spare the time, played various other musical devices and concluded by playing a Moulded Record on an Edison Phonograph. The gentleman asked to have played on the Phonograph the same air he had heard on the other machine. Then he had the air replayed on the machine he had just bought. The outcome of the comparison was the repudiation of the order just placed and the purchase of an Edison Triumph Phonograph.

The name of the Jobber having this experience and the name of the repudiated machine may be had from our Advertising Department by any one who doubts the story. There is little occasion, however, to doubt it, for it is an experience that many Dealers are having who carry Edison Phonographs and any other style of talking machines.

### TO MAKE RECORDS IN THE ARCTIC REGIONS.

Captain J. E. Bernier, of Ottawa, Canada, will in a few months head an expedition to the Arctic regions that is being fitted out under the direction of the Canadian government. His outfit will include an Edison Phonograph, a lot of Records and a quantity of blanks. The entire outfit will be loaned Captain Bernier by the Jacot Music Box Co., of New York city. The Records will serve to amuse the explorers during the long Arctic nights and it is hoped with the blanks to make many interesting and valuable Records. One of Captain Bernier's officers will be given special instruction in Record making before the ship sails.

In acknowledging the receipt of the Suspended List sent out in April, Edwin C. Putnam, a Dealer at Millbury, Mass., wrote:

Can assure you we will co-operate with you in keeping the goods out of these people's hands. The stand that you take and people like you (The Eastman Kodak Co. for instance), is one of the best things in the world to induce retailers to push your goods. I used to sell \* \* \* goods entirely, but for the last two years have not sold more than three of their records. We know that they can't buy an Edison Record anywhere for less than we can sell them, and it makes it more satisfactory for us and them too.

### SAT UP ALL NIGHT TO LISTEN TO THE PHONOGRAPH.

A Michigan dealer sends the following interesting experience with reference to the sale of an Edison Phonograph :

GENTLEMEN :—I asked for and obtained the agency for selling the Edison Phonographs and Records from the Chicago House in March. My first order from the House was for three machines and 152 Records.

When the Phonographs arrived I started up the Triumph for one of my customers at 7.30 P. M. and it was run all night until 5.30 the next morning. One of the listeners was a lady who had given music lessons on the piano and organ for twenty-five years, and another was a gentleman who had led Orchestras and Brass Bands for over twenty years. Other listeners belonged to orchestras and bands and others were great lovers of fine music. So you see how the Edison Phonograph is appreciated here.

Very truly yours,

ORION J. FAY, M. D.

Carleton, Mich., April 21, 1903.

### IMPORTANT NOTICE.

The price of \$5.00 per dozen, as quoted on Edison Records, applies and can be allowed only when a full dozen or more are purchased at one time. The use of a card system or any other method, whereby the dozen price (\$5.00) is allowed on Records purchased in less quantity than one dozen, at one time, is a cut in price; therefore a violation of agreement. Any Dealer or Jobber violating Agreement in this manner, will be subject to immediate suspension and such further action as the case may warrant.

### AMONG THE JOBBERS.

H. A. Weymann & Son, of Philadelphia, moved in April from 1022 Market street to 923 Market street.

The Bettini Phonograph Laboratory, of New York city, moved on May 1 from 110 Fifth avenue to 80 Chambers street, opposite the office of the National Phonograph Company.

The Ray Company, of Louisville, during April opened branch stores at Kansas City, Mo., and Toledo, O.

Thomas C. Hough, of Minneapolis, Minn., has moved from 234 Nicollet avenue to 714 Hennepin avenue.

Dealers are urged to sign the new Agreement promptly and keep their names on our mailing list.



**ABOUT PRINTED MATTER.**

Among the new things in the way of printed matter is a pamphlet entitled "The Art of Making Phonograph Records." It is Form No. 427. The matter of successfully making Phonograph Records is so much a question of experiment and experience that no treatise can cover the subject thoroughly. The best that can be done is to offer general suggestions, and that is what our little booklet does. The subject is treated under the following heads: Introduction, Selecting a Recorder, Adjusting the Phonograph, Blank Cylinders, Concerning Horns, Making Talking Records, Vocal Records, Band Records, Violin, String Orchestra, Banjo and Mandolin Records; Vocal Duets and Quartettes. We want all Jobbers and Dealers to have a sufficient supply of these booklets to give one to every owner of an Edison Phonograph who is interested in making Records, but the edition at our disposal is not large enough to permit them being used for general circulation. A sample copy is being sent out with the April Supplements.

A new edition of Catalogue of Accessories and Coin-Slot Phonographs, Form 376, is now ready. It is simply a reprint of the catalogue now being used and contains no new matter. Jobbers will please use up those they have on hand before placing a new order.

Form 409, the card showing in colors the curious boy and his hatchet, and Form 414, the four-page machine folder, are in much demand by the trade.

The mails daily bring requests from Dealers for a supply of catalogues and other printed matter, but no instructions are given concerning shipping. We want every Dealer to have a reasonable quantity of catalogues, etc., and if he cannot get it from his Jobber we want him to write us. We feel, however, that when we make no charge for printed matter we have done all that can be expected of us and that Dealers should pay expressage. Catalogues are too heavy to send by mail and we cannot send them that way.

In a few days we shall send to every Dealer on our list an order entitling the holder to one of the celluloid show cards now being made by this Company, and upon presentation of this order any Jobber through whom the Dealer has signed will supply the card. If a Dealer buys direct, the card will be sent with the next goods shipped from the factory after the order is sent back to us. Jobbers will be instructed to send them to none but bona fide Dealers who have signed through them. This plan will get one of the cards in the hands of every Dealer and will avoid duplication.

After many delays the printer has delivered the eight-page booklet "Looking for the Band," about which the Jobbers were advised in February. Orders then placed, both for imprints and without, will be shipped before May 20. Further orders for this booklet, if not too large, will be filled to those in the trade who will agree to use in some specially nice way. The booklet shows the series of pictures of the two little girls "Looking for the Band" which were used on hanger No. 366. A sample copy will be mailed this month.

**KIND WORDS ABOUT THE MONTHLY.**

*Theo. F. Bentel Co., Pittsburg, Pa.:*

The EDISON PHONOGRAPH MONTHLY, published exclusively for the benefit of the trade, came to us in due time, and we are very glad to receive it, as it contains some very valuable information, and the idea strikes us as an exceptionally good one, and removes any possibility of over-sight on the part of regular Jobbers in supplying Suspended Dealers. There are a number of other points that strike us as good ones, but this fact alone is worth the cost of the issue. Again congratulating you on the issue and hoping it will continue, we remain.

*L. S. Atkinson, Tilton, N. H.:*

Your new MONTHLY is all right and fills a long felt want.

*Monroe S. North, Batavia, N. Y.:*

I have found the first two copies of the PHONOGRAPH MONTHLY full of valuable information, and that is just what I want as I am young in the business, sixteen years of age.

*Daniel R. Weed, Jr., Matteawan, N. Y.:*

Have received the second issue of the EDISON PHONOGRAPH MONTHLY and to show you my appreciation would say I would be willing to contribute to the support of it if I thought it was to be discontinued, and I think I voice the sentiment of many more admiring Dealers. The EDISON PHONOGRAPH MONTHLY in the printing line is like the new Moulded Records in the Record line—the best on the market.

*George E. Buss, New Philadelphia, O.:*

I thank you very much for the EDISON PHONOGRAPH MONTHLY. It will, in my mind, keep the Phonograph world together.

*E. N. Whitford, Great Cacapon, W. Va.:*

Have just received the April number of PHONOGRAPH MONTHLY, but you failed to send me the March number. Please send me one. I think you have done a splendid thing in issuing this journal as it will be a help to Dealers.

*Turner & Kennerdell, Kittanning, Pa.:*

Our April PHONOGRAPH MONTHLY does not contain page 2, giving the May list of Records. Kindly send us a complete number. The MONTHLY is of great value to the Dealer, and we do not want to miss any number or part of a number.

*C. C. Bubbenzer, Bunkie, La.:*

I am in receipt of your PHONOGRAPH MONTHLY, which I heartily welcome. I think this publication fills a long felt want.

*Elmer O. Bechtolt, Germantown, O.:*

I to-day received No. 2 of the EDISON PHONOGRAPH MONTHLY; and have derived much good from a careful perusal. I haven't received No. 1 and ask you to kindly send me same, so that I can keep a complete file of them.

*Robert E. Snipes, Selma, N. C.:*

I have received two issues of your PHONOGRAPH MONTHLY and must say that much credit is due the promoters of this neat and helpful little volume. It can prove nothing less than greatly beneficial to Phonograph Jobbers and Dealers at large.

*W. A. Bowen, Kewanee, Ill.*

We thank you for the compliment paid us in bringing our efforts out so nicely in placing our "ad" in your April EDISON PHONOGRAPH MONTHLY. It's a fine publication. We wish you all kinds of success and predict that flattering results will follow in the furthering of your immense business. We carry other machines in stock because we cannot get rid of them or close them out at any price.

*H. W. Kelly, Pittsburg, Pa.:*

Your PHONOGRAPH MONTHLY is just what was wanted to bring all the friends of the Phonograph together. I hope that it will increase in size and contents.

*John Pfleuger, 899 N. Talmon Avenue, Chicago.*

I did not receive the first issue of the Edison Phonograph Monthly. Please send me one. Have been expecting something of this kind for a long time, and it has come at last. It is a great benefit to us Dealers. It keeps us out of trouble with customers on many points which they argue with us.

## TRADE QUESTIONS AND ANSWERS.

*F. N. Green, Willimantic, Conn.:* Q.—

Have recently received machines with a loud humming noise caused by the governors; would like to know how to overcome it. A.—The application of a little graphite or vaseline will usually cause the noise to disappear.

The Jacot Music Box Co., of Union Square, New York, in one day last month sold an Edison Phonograph to Mrs. Andrew Carnegie, another to Reginald Vanderbilt and a third that was sent as a wedding present to Miss Katherine Neilson, who was married to Mr. Vanderbilt in April. Each machine was a Triumph.

**Jobbers or Dealers giving trading stamps with Edison goods are liable to suspension for violation of contract.**

## GLAD TO PUSH EDISON GOODS.

C. A. Dodds, Dealer, at Patoka, Ill., writes under date of May 2d :

Yours of the 29th ult. advising me of the request of \_\_\_\_\_, of Vandalia, Ill., is at hand. I thank you for the same, and have written him to-day. Rest assured he will hear from me until he either buys or concludes not to buy. This feature is one of the several that makes a Dealer glad to push Edison goods, and especially so when they are his favorite, as is the case here.

## WHAT MADAME ALBANI SAID OF THE PHONOGRAPH.

One of the most interesting letters received by the Advertising Department in the past month was the following from a Dealer at Montreal, Canada :

On receipt of this month's MONTHLY I notice you request clippings of advertisements, and I herewith enclose a clipping of my advertisement which appeared in four of the best papers in this city. I consider the statement as in the advertisement of considerable honor as

well as a great advertisement for the Edison machine, for in Canada as well as all over the world, Madame Albani's name is known to everybody, and her statements are highly valuable.

Yours truly,

J. H. SUPERIOR.

The clipping referred to was from the Montreal *Daily Star* of April 3, 1903, and it is herewith reproduced :

# Madame Albani's Visit.

During her recent stay in this City, on March 27th last, the Canadian prima donna paid a special visit to our store, No. 2458 St. Catherine St., and hearing several selections on the

## EDISON PHONOGRAPH

She was delighted with the wonderful reproduction, also the ability of RECORDING your voice, to perfection, to be heard at any time and as often as desired, and expressed her delight, saying "IT'S SURPRISINGLY MARVELLOUS."

You will all agree with her opinion, if you only hear the Genuine Phonograph. PRICES TO SUIT ALL PURSES.

CANADIAN HEADQUARTERS:—

**The J. H. SUPERIOR PHONOGRAPH & MUSIC CO.**

2458 St. Catherine Street, MONTREAL.

79x1

Reduced from a three column advertisement.



### POINTERS ON THE JUNE LIST.

The list of Records for June comprises twenty domestic selections and one foreign selection. It is a list fully up to the standard of this company. The numbers and titles are given in order on page 2 of this issue. For the information of the trade we give below a brief comment on each title.

No. 8404, "Spring of Love," is another violin and flute duet by Eugene Jaudas and Louis Atz, whose Record in the March list has won unstinted praise throughout the trade. This new selection is played with more volume of sound and the air is equally pretty. It will be fully as popular as No. 8349 in the March list. No. 8405, "Won't You Roll Dem Eyes," is a coon song with orchestra accompaniment, sung by Arthur Collins in his usual clever manner. The song itself is one that has become very popular.

No. 8406, "Up the Street March," by the Edison Concert Band, is a selection that has been made popular throughout New England by the fact that the students of Harvard College have taken it up and made it one of their college airs. It is added to the list in response to a large demand from our New England trade.

No. 8407, "If I But Knew," is a sentimental song from the tuneful comic opera "The Sultan of Sulu." It is sung by William H. Thompson, whose singing of sentimental airs has caused his Records to be much in demand. No. 8408, "The Mississippi Bubble," is another clever banjo solo by Vess L. Ossman. Every lover of banjo Records will want this one. No. 8409, "In the Valley Where the Bluebirds Sing," is a descriptive song by Byron G. Harlan and is accompanied by the Edison Symphony Orchestra. It is a pretty air, introducing in the chorus the singing of birds, ringing of chimes and an echo effect sung by a soprano voice. This will sell wherever played.

No. 8410, "My Country 'Tis of Thee," gives the Edison Male Quartette an excellent opportunity to display its abilities in making a quartette Record. No. 8411, "Julie," is a song from Mr. "Bluebeard" which has become a great favorite on account of its swing and rhythmic air. It is sung by Edward M. Favor. No. 8412, "Down Where the Wurzburger Flows Medley," introduces the air "Susie Anna." It is a xylophone solo by J. F. Hopkins with orchestra accompaniment, and cannot fail to be as good a seller as all the xylophone solos made by Mr. Hopkins have been.

No. 8413, "Long Ago," is another sentimental song. It is sung by Arthur Clifford.

The words of this song tell a cute little story. No. 8414, "Cupidietta," is an intermezzo composed by Tobani, whose work "Hearts and Flowers" has made him known throughout the entire world. It is claimed by some that this new selection, "Cupidietta," will be as great a favorite with music loving people.

No. 8415, "Down at Lover's Roost," is a waltz song. It is sung in an excellent manner by Harry MacDonough. No. 8416, "Butterfly Gavotte," is a bell solo played by Edward F. Rubsam, accompanied by the orchestra. Mr. Rubsam's bell solos have always found a ready sale, and this one will be equally in demand.

Nos. 8417 and 8423 are two more of the series of Hebrew specialties by Julian Rose. They open with the usual talk in Hebrew dialect, followed by singing. The song in 8417 is a parody on "When the Boys go Marching By," and that in 8423 is a parody on "Go 'Way Back and Sit Down." One or more of Mr. Rose's Hebrew specialties will be found in every complete selection of Edison Records. No. 8418, "Sing, Smile, Slumber," is the same air as Gounod's "Serenade." It is given as a cornet solo by Bohumir Kryl, and is played as only Mr. Kryl can play for Record making.

No. 8419, "In the Starlight," is another of those delightful contralto and bass duets by Miss Morgan and Mr. Stanley, which have been so much admired since the first one was listed in February. In No. 8420 Mr. Hopkins gives that well known air "Little Dinah Jones," an excellent rendition on the xylophone, accompanied by the Edison Orchestra. No. 8421, "Ma Starlight Sue," is a nicely sung duet by Thompson and Campbell. No. 8422 "Refuge," by the Mendelssohn Mixed Quartette, will find much favor among those who prefer the more serious Records.

No. 12827, "Kol Nidre," the only foreign selection listed for June, is the great Hebrew religious song. It is sung by Frank Seiden. Mention is made in the list on page 2 of Nos. 12813 to 12826, Japanese Records, simply to retain the numerical order of the list. These Records will not be ready for trade use till late in June, before which time a special circular will be issued.

---

The London office of the National Phonograph Company, Ltd., has been changed from 56 Chancery Lane to 52 Gray's Inn Road, Holborn.

### TRADING STAMPS A VIOLATION OF AGREEMENT.

We have received letters from several Dealers asking if it is allowable to give trading stamps with Edison Phonographs, Records and Blanks. We take this means of informing the trade that giving trading stamps is equivalent to giving a discount on goods and is a violation of our Agreement, rendering the violators liable to the same penalties as for price cutting. The principle involved is the same as if a Dealer openly offered a discount on all sales, and we cannot countenance it in any instance. A New York Department store handling our goods created a sensation in the city early this month by offering to give trading stamps with purchases in every department. When we called their attention to the matter, the offer was modified to except Edison Phonographs and Records, and these are now sold as restricted goods.

### MR. LOGUE TO COME EAST.

W. S. Logue, who for nearly a year has had charge of the Chicago office of the National Phonograph Company, will come East on June 5 to become Manager of Sales for the battery department of the Edison Manufacturing Company and also Manager of Sales for the Bates Manufacturing Company. The latter positions have been held by J. W. Gladstone since the organization of the two companies several years ago. Mr. Gladstone will embark in business for himself. Under Mr. Logue's management the business handled by the Chicago office has largely increased. Mr. Logue's successor has not yet been chosen.

### NO MORE TRADE MARK ELECTROS.

By the advice of counsel, we have decided to send out no more electros of Mr. Edison or his signature, Nos. 332, 376, 434 and 435, all being trade-marks of this Company. A few copies of the new electrotype catalogue, No. 415, have been sent out showing these electrotypes on the second page, but in the remainder of the edition they will be eliminated. The trade is asked to send in no more orders for these electros.

A play put on at the Third Avenue Theatre, New York city, on April 7, has an Edison Phonograph for its central figure. Two villains plot to rob a safe and throw the blame on the hero. A phonograph record is made of their conversation, however, and at the proper moment the record is reproduced and the villains are given a knockout blow.

### FORM NUMBERS OF PRINTED MATTER.

The following is a list of the form numbers of catalogues and other printed matter in use at the present time by the National Phonograph Co.

#### FORM.

- 291. Jingle Book No. 3.
- 366. "Looking for the Band" Hanger.
- 371. Catalogue of Parts—superseding Form 270.
- 375. Catalogue of Phonographs—superseding Form 345.
- 376. Catalogue of Accessories and Coin Slot Phonographs—superseding Form 342.
- 380. Catalogue of Domestic Records—superseding Form 360.
- 381. Catalogue of Foreign Records.
- 386J. Jobbers Discount Sheet—superseding Form 355 J.
- 387D. Dealers Discount Sheet—superseding Form 355 D.
- 390. "Soldier" Hanger.
- 391. "Sailor" Hanger.
- 392. "Uncle Sam" Hanger.
- 393. "Coon" Hanger.
- 394. "Birds" Hanger (will be sent out this month).
- 395. Numerical Catalogue of all Records—superseding Form 251.
- 398. March Bulletin of Records.
- 399. April Bulletin of Records.
- 400. Chinese Record Folder.
- 402. May Record Supplement.
- 407. March Record Supplement.
- 408. May Record Bulletin.
- 409, 410. "Looking for Band" Card, (given a different number on each side through error.)
- 412. Supplement to Record Catalogue—shows titles listed from Nov. to Feb.
- 414. Four-page Folder, showing Gem, Standard, Home and Triumph.
- 415. Electrotype Catalogue—superseding Form 256.
- 416. April Record Supplement.
- 418. "Looking for the Band" Booklet.
- 419. April Suspended List.
- 425. Record Order Pads in 5 sheets (sheets A, B & C for Domestic titles; sheets E & F for Foreign).
- 427. Art of Making Records—superseding Form 64.
- 430. Jobbers Agreement (new form)—superseding forms 130 and 131.
- 440. Dealers Agreement (new form)—superseding Forms 140 and 141.

In ordering printed matter the trade is asked to use these form numbers. It will facilitate handling same.

Any Dealer or Jobber selling Edison records by card system, or otherwise, whereby the dozen price (\$5.00) is allowed on sales of less than one dozen actually taken or paid for at one time, will be considered a violator of Agreement, and liable to immediate suspension. See explanatory paragraph, page 8.



**SUSPENDED LIST, APRIL 1, 1903.—SUPERSEDING ALL PREVIOUS LISTS.****KANSAS.**

LAWRENCE—BELL BROS.

**MASSACHUSETTS.**

LAWRENCE—LORD &amp; CO., 314 Essex street.

MALDEN—A. T. FULLER.

NEW BEDFORD—H. B. DEWOLFF.

**MICHIGAN.**

DETROIT—F. J. SCHWANKOVSKY.

SAGINAW—GEO. W. EMENDORFER.

**MISSOURI.**

KANSAS CITY—THE WITTMANN CO.

**NEBRASKA.**

LINCOLN—THE WITTMANN CO.

OMAHA—THE WITTMANN CO.

**NEW JERSEY.**ATLANTIC CITY—SAMUEL D. WOLF, 32-34  
Arkansas avenue.

BAYONNE—I. WIGDOR, 450 Avenue D.

JERSEY CITY—W. L. HOFFMAN, 151 Mont-  
gomery street.

NEWARK—R. L. CORWIN.

PATERSON—CHAS. H. KELLY, 25 N. Main st.

WEST HOBOKEN—EMIL HOLLANDER, or  
THE WEST HOBOKEN BICYCLE &  
PHONOGRAPH CO., 619 Spring street.**NEW YORK.**

BEDFORD PARK—GEO. H. TYRRELL.

NEW YORK CITY—A. T. ARMSTRONG, or  
AMERICAN PHONOGRAPH CO., 106  
Wall street.

R. L. CORWIN, also Newark, N. J.

EAGLE PHONOGRAPH CO., or C.  
LOWENTHAL, 83 Nassau Street.EMPIRE PHONOGRAPH CO., 2 West  
14th street.HAWTHORNE & SHEBLE, 297 Broad-  
way, also Philadelphia, Pa.R. H. INGERSOLL & BRO., 67 Cort-  
landt street.

W. L. ISAACS, 114 Fulton street.

S. LEMBURG &amp; CO., 194 Broadway.

J. McELLYNNE, 202 Broadway.

F. M. PRESCOTT, 44 Broad street.

STAR CREDIT CO., or Paul Sacks, 180  
East Houston st. and 57 Third ave.

SARATOGA—W. J. TOTTEN.

**OHIO.**

CINCINNATI—J. L. ANDEM.

SPRINGFIELD—D. &amp; M. VANDERPOOL.

UHRICHSVILLE—F. A. MAZURIE.

**PENNSYLVANIA.**PHILADELPHIA—HAWTHORNE & SHEBLE,  
604 Chestnut street.**RHODE ISLAND.**

PROVIDENCE—F. P. MOORE.

**Jobbers and Dealers are asked to co-operate with us, FOR OUR MUTUAL GOOD, by being careful that they do not supply any of the above named firms with our apparatus.**

**DEALERS WHO WILL CO-OPERATE.**

GENTLEMEN :—We are in receipt of your notice for the trade containing the suspended list of agents and agencies. We are not only glad to acknowledge the receipt of these lists from you from time to time, but we take pleasure in saying that not a cent's worth of goods could possibly be obtained from us by any of the firms mentioned in said list or any of the agencies if we knew it. It could do them no good, as they could only get them at retail price if they would buy them.

I hope that you will continue to pursue "to a finish" all violators of their contract with the National Phonograph Co.; they should all be stung out of the hives as they are a continuous nuisance and an all around menace to every legitimate Dealer.

Yours respectfully,  
W. T. GELTZ.

Mansfield, O., May 4, 1903.

GENTLEMEN :—I acknowledge the receipt of Suspended List of April 1, and fully expect to

co-operate with you. I want to thank you for the "addresses" of parties concerning Phonographs, etc. I am more than pleased with your Phonograph Monthly, and understand now the cause of the delay in not receiving my March order. I am pleased to note the great increase in your business. It shows the people know a good thing.

H. C. LENTZ.

Cairo, Ill., May 3, 1903.

GENTLEMEN :—In acknowledging the receipt of the list of suspended Dealers, I wish to congratulate you on the firmness of the Company in weeding out the price cutters. I realize that it must be very trying and difficult at times to procure the necessary evidence against a certain class of agreement breakers. I can see from the list that you have been persistently after them.

C. H. FREEMAN.

Bloomington, Ill., May 2, 1903.

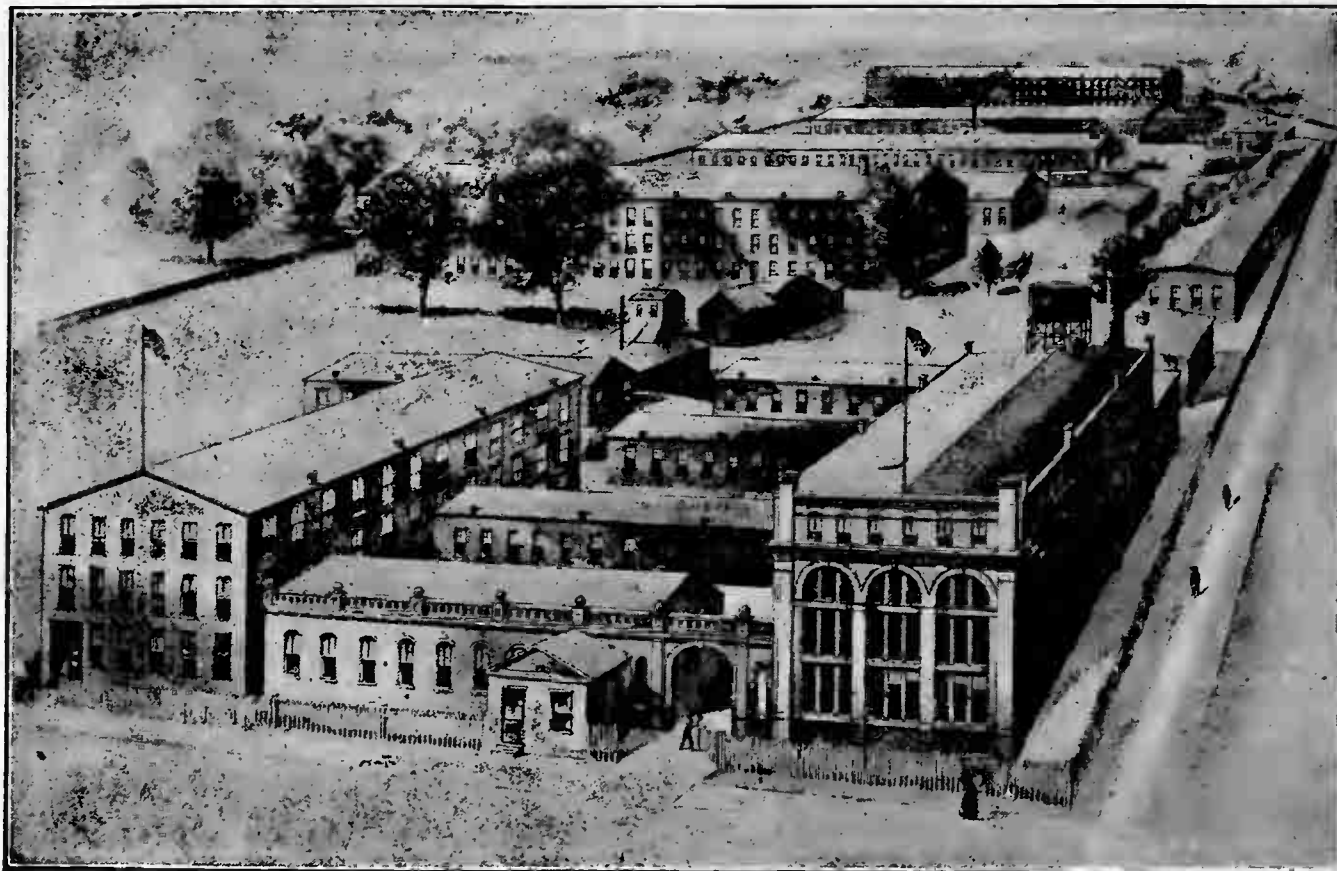

**Edison Laboratory and Works of the National Phonograph Co., Orange, N J.**

The brick building at the right in the foreground is Mr. Edison's laboratory and workshop; built by him when he moved from Menlo Park to Orange. The four smaller buildings to the left of the laboratory are also used by Mr. Edison for experimental work.

The three-story building at the left in front is where the moulded records are made. In the other buildings are made the various parts of the Phonograph.

---

**It is worth while to work hard to sell an Edison Phonograph, for such a sale means a pleased customer, who will become a regular purchaser of Records. A few such customers make up a nice business.**

---

**When you receive the new Records each month, Mr. Dealer, invite the public to hear you play them, and invite the fullest comparison between the Edison Phonograph and other styles of talking machines. It will pay.**



## JOBBER OF PHONOGRAPHS AND RECORDS.

The following is a list of firms in the various cities of the United States and Canada who are handling Edison Phonographs and Records as Jobbers:

## ALABAMA.

**Birmingham**—The Ray Co., 2027 Second avenue.  
**Mobile**—The Ray Co., 54 Dauphin street.

## CALIFORNIA.

**San Francisco**—Peter Bacigalupi, 933 Market street.

## COLORADO.

**Denver**—Denver Dry Goods Co., California and 16th streets.  
 Western Phonograph Co., 619 16th street.

## CONNECTICUT.

**Middletown**—Caulkins & Post Co., 406-408 Main street.  
**New Haven**—Pardee-Ellenberger Co., 155 Orange st.

## GEORGIA.

**Atlanta**—The Ray Co., 6 S. Broad street.  
**Savannah**—The Ray Co., 116-118 Barnard street.

## ILLINOIS.

**Chicago**—Oscar J. Junge, 245 E. Chicago avenue.  
 Kelley Cigar Co., 80-82 Wabash avenue.  
 James I. Lyons, 73 Fifth avenue.  
 The Ray Co., 90 Washington street.  
 Siegel-Cooper Co., State and Congress sts.  
 Talking Machine Co., 107 Madison street.  
 The Vim Co., 68 E. Lake street.  
 Montgomery Ward & Co., 111 Michigan ave.  
**Peoria**—Peoria Phonograph Co., 314 S. Adams street.

## INDIANA.

**Indianapolis**—Kipp Bros. Co., 37 S. Meridian street.  
 The Ray Co., 234 Massachusetts avenue.  
 Wahl & Gaasch, 119 S. Illinois street.  
**Lafayette**—Wahl & Gaasch, 304 Main street.

## KENTUCKY.

**Louisville**—The Ray Co., 640 Fourth avenue.

## LOUISIANA.

**New Orleans**—National Automatic Fire Alarm Co., 618 Gravier street.  
 The Ray Co., 111 Camp street.

## MAINE.

**Bangor**—Bangor Phonograph Co.  
**Portland**—W. H. Ross & Son, 207 Commercial street.

## MASSACHUSETTS.

**Boston**—Boston Cycle & Sundry Co., 7 Hanover street.  
 Eastern Talking Machine Co., 176 Tremont street.  
 J. C. Haynes & Co., 453 Washington street.  
 Iver Johnson Sporting Goods Co., 163 Washington street.  
 Read & Read, 558 Washington street.  
**Fitchburg**—Iver Johnson Sporting Goods Co.  
**Lowell**—Ring Music Co., 133 Merrimac street.  
 Thomas Wardell, 111 Central street.  
**Worcester**—Iver Johnson Sporting Goods Co.

## MICHIGAN.

**Detroit**—American Phonograph Co., 106 Woodward avenue.  
 Grinnell Bros. Music House, 219 Woodward avenue.  
**Saginaw**—Morley Bros.

## MINNESOTA.

**Minneapolis**—Thomas C. Hough, 714 Hennepin ave.  
**St. Paul**—Minnesota Phonograph Co., 37 E. 7th street.

## MISSOURI.

**Kansas City**—J. W. Jenkins' Sons Music Co., 1013-1015 Walnut street.

The Ray Co.

**St. Louis**—Conroy Co., 1115 Olive street.  
 The Ray Co., 923 Olive street.

## NEBRASKA.

**Lincoln**—H. E. Sidles Cycle Co., 1317 O street.  
**Omaha**—H. E. Fredrickson, 1502-1510 Capitol avenue.  
 Nebraska Cycle Co., 15th and Harney streets.

## NEW JERSEY.

**Hoboken**—Eclipse Phonograph Co., 306 Washington street.  
**Newark**—H. J. Koehler Sporting Goods Co., 845 Broad street.  
 A. O. Petit, 42 New street.  
**Paterson**—James K. O'Dea, 117 Ellison street.  
**Plainfield**—Frank L. C. Martin Auto. Co., 310 Park avenue.  
**Trenton**—Stoll Blank Book and Stationery Co.

## NEW YORK.

**Brooklyn**—Chapman & Co., Fulton and Duffield streets.  
 A. D. Matthews' Sons, 394 Fulton street.  
 Price Phonograph Co., 1224 Broadway.  
**Buffalo**—P. A. Powers, 643 Main street.  
**Elmira**—Elmira Arms Co., 117 Main street.  
**Gloversville**—American Phonograph Co.  
**Kingston**—Forsyth & Davis.  
**New York City**—Barkelaw & Kent Co., 36 Vesey street.  
 Bettini Phonograph Co., 80 Chambers street.  
 Blackman Talking Machine Co., 19 Beekman street.  
 J. F. Blackman & Son, 142d street and 3d avenue.  
 I. Davega, Jr., 802 Third avenue.  
 S. B. Davega, 32 E. 14th street.  
 Douglas & Co., 89 Chambers street.  
 H. S. Gordon, 139 Fifth avenue.  
 Hacker & Horn, 148 E. 58th street.  
 Harry Jackson, 1960 Third avenue and 790 Ninth avenue.  
 Jacot Music Box Co., 39 Union Square.  
 Victor H. Rapke, 1661 Second avenue.  
 Rosenfield Mfg Co. 568 Hudson st.  
 Siegel-Cooper Co., Sixth avenue and 18th street.  
**Rochester**—Mackie Piano O. & M. Co., 100 State street.  
 Talking Machine Co., 99 E. Main street.  
**Schenectady**—Jay A. Rickard & Co., 253 State street.  
**Syracuse**—W. D. Andrews, 216 E. Railroad street.  
**Troy**—James Lucey, 359-361 Fulton street.  
**Utica**—Clark, Horrocks & Co., 54 Genesee street.

## OHIO.

**Canton**—Klein & Heffelman Co., 216 N. Market street.  
**Cincinnati**—Ilsen & Co., 25 W. 6th street.  
 The Ray Co., 143 West 5th street.  
**Cleveland**—The Ray Co., 264 Erie street.  
 W. J. Roberts, Jr., 254-256 Arcade.  
**Columbus**—Perry B. Whitsit Co., 213 S. High street.  
**Dayton**—Niehaus & Doshe, 35 E. 5th street.  
**East Liverpool**—Smith & Phillips Music Co.

## PENNSYLVANIA.

**Allegheny**—Henry Braun, 500 Federal street.  
**Allentown**—G. C. Aschbach, 539 Hamilton street.  
**Easton**—William Werner, 401 Northampton street.  
**Philadelphia**—C. J. Heppe & Son, 1117 Chestnut street.  
 Lit Bros., Market and 6th streets.  
 Penn Phonograph Co., 19 S. 9th street.  
 Wells Phonograph Co., 41 N. 9th street.  
 Western Electric Co., 931-933 Market street.  
 H. A. Weymann & Son, 923 Market street.  
**Pittsburg**—Theo. F. Bentel Co., Inc., 433 Wood street.  
 Kaufmann Bros., Fifth avenue and Smithfield street.  
 H. Kleber & Bro., 221 Fifth avenue.  
 C. C. Mellor Co., 319 Fifth avenue.  
 Pittsburg Phonograph Co., 937 Liberty street.  
**Reading**—Lichty Phonograph Co., 641 Penn street.  
 Reading Phonograph Co., 757 Penn street.  
**Scranton**—Charles B. Scott, 119 Franklin avenue.

## RHODE ISLAND.

**Providence**—J. A. Foster Co., Weybosset and Dorrance streets.  
 Murray, Blanchard, Young & Co., 26-30 Pine street.

## TENNESSEE.

**Memphis**—The Ray Co., Lyceum Building.  
**Nashville**—The Ray Co., 30 The Arcade.

## TEXAS.]

**Dallas**—C. B. Harris, Agt., 347 Main street.  
**Waco**—Waco Electric Supply Co., 518 Austin avenue.

## VIRGINIA.

**Richmond**—The Ray Co., 729 Main street.

## WISCONSIN.

**Milwaukee**—McGreal Bros., 173 3d street.

## CANADA.

**Toronto**—R. S. Williams & Sons, 143 Yonge street.

### THE TALKING MACHINE AS AN AID.

The Phonograph in its various forms has thus far been more a thing of amusement than of practical advantage. The talking machine is a most wonderful affair and its uses must become of great benefit in scientific and other practical matters. In fact it is gradually working up to fill a place in the arts and utilities of life. The anthropologist and philologist are finding it a great aid to their investigations. The Academy of Sciences in New York city is making a collection of the various dialects of Austria, Germany, France, India and the North American Indians, which is to be preserved for future use. A method of preservation of the Records has been devised, and in the future the historian, novelist and philologist will find them of great value in their studies. There are indeed a thousand ways in which the talking machine may be of practical use, both in immediate service and in the preservation of spoken language.—*Musical Trade Review*.

### HOW A STOLEN PHONOGRAPH INFORMED THE POLICE.

A New York city thief made the mistake of his life on April 21 when he stole a Phonograph from a resident of the Bronx district. He forgot that the Phonograph was a talking machine. The owner of the Phonograph gave the police its number and names of several Records stolen at the same time. Two detectives sent out to find the stolen property were passing a shop on Third avenue when they heard a Phonograph playing one of the missing tunes. Entering they found the thief trying to sell the stolen machine and Records.

**Giving trading stamps with Edison Phonographs and Records is a violation of our Agreement and will not be allowed.**

### MAY ADVERTISING.

The May advertising of the National Phonograph Co. introduces to the trade and the public a new Phonograph girl. Her charming and smiling face appeared in half and quarter pages in the following May publications:

American Boy, Argosy, Booklovers, Bookman, Brown Book, Collier's Weekly, Craftsman, Current Literature, Everybody's, Four Track News, Field & Stream, Good Housekeeping, Harper's Magazine, Life, Lippincott's, Metropolitan, Munsey's, National Magazine, Outing, Outlook, Overland, Pearson's, Photo Era, Popular Monthly, Recreation, Review of Reviews, St. Nicholas, Saturday Evening Post, Smart Set, Success, Town and Country, Town Topics.

Advertisements of the Company in other forms also appeared in the Commercialist, Musical Record and Review, Overland Magazine, Science and Industry, and many smaller publications.

There are few lines that yield such quick results from a little pushing as Edison Phonographs and Records. The experience of Jobbers and Dealers everywhere is that local advertising, sending out circulars by mail, etc., are at once followed by a gratifying increase in business. The public is fully aware of the superior character of Mr. Edison's inventions, and the Dealers who are pushing the business are getting excellent results. Let the people know, Mr. Dealer, that you carry a complete stock of machines and can get Records at short notice, if you cannot carry a full stock

## EVERYONE LOVES The EDISON PHONOGRAPH

NONE GENUINE WITHOUT  
THIS  
TRADE  
*Thomas A Edison*  
MARK



The Phonograph is distinguished from other talking machines by its absolute freedom from scratching and pure, natural tones of music or voice.

The Phonograph is infinitely superior.

The Phonograph is sold in 5,000 stores. Call at the nearest dealer's and hear the modern Phonograph with the new Edison Moulded Records and the New Reproducer. Phonographs from \$10.00 to \$100.00. Records, 50c.; \$5.00 per dozen.

**NATIONAL PHONOGRAPH CO., Orange, N. J.**

NEW YORK, 83 Chambers St. CHICAGO, 304 Wabash Ave. SAN FRANCISCO, 933 Market St. EUROPE, 32 Rempart Saint Georges, ANTWERP, BELGIUM.

and thus get your share of business. Get a quantity of circulars printed by the company and see that they go to the people interested in music. If your Jobber cannot supply you, write us direct. All we ask is that you pay expressage. If you are nearer to Chicago write our branch office at 304 Wabash avenue.



# EDISON Phonograph Monthly

PUBLISHED FOR TRADE USE ONLY BY  
THE NATIONAL PHONOGRAPH CO.

VOL. 1

NEW YORK, JUNE, 1903.

No. 4.

*The National Phonograph Co.,*  
ORANGE, N. J.

NEW YORK: 83 CHAMBERS STREET.  
CHICAGO: 304 WABASH AVENUE.  
SAN FRANCISCO: 933 MARKET STREET.  
ANTWERP: 32 REMPART SAINT GEORGES.  
LONDON: 52 GRAY'S INN ROAD, HOLBORN.

## EDISON PHONOGRAPHS AND RECORDS.

All communications to THE PHONOGRAPH MONTHLY should be addressed to the Advertising Department, 83 Chambers Street, New York.

### C O N T E N T S

New Agreement Generally Approved . . .	1, 3
Advance List July Records . . . . .	2
More Factory Room . . . . .	3
Mr. Ireton Promoted . . . . .	3
Suits Dismissed . . . . .	4
Selling Suggestions . . . . .	4
No Changes Contemplated . . . . .	4
The July Records . . . . .	5, 6
The Phonograph Advertisement in the Public Eye . . . . .	6
Appreciative Comment . . . . .	7
Japanese Records . . . . .	7
Co-operating Dealers . . . . .	8
How Some Dealers Push the Business . . . .	8
Concerning Printed Matter . . . . .	9
A Jobber's Prize Selection . . . . .	9
See that all Phonograph Owners Get a Supplement . . . . .	10
Posters and Street Car Cards . . . . .	10
A Phonograph Incident in the Philip- pines . . . . .	10
Record Shipments . . . . .	10
What the World Has Lost . . . . .	11
Listed Records by Other Talent . . . . .	11
A Chicago Phonograph Enthusiast . . . . .	11
Criticisms and Suggestions Wanted . . . . .	12
Anent the Phonograph "Crank," . . . . .	12
The Phonograph Way Ahead . . . . .	12
A Jobber's Original Advertisement . . . . .	13
"Happy" Gets a New Hat . . . . .	13
An Author's View on the Phonograph for Dictation Purposes . . . . .	13, 14
Suspended List, June 1, 1903 . . . . .	15
June Advertising . . . . .	16

## NEW AGREEMENT GENERALLY APPROVED.

The new Agreement, which was laid before all our Jobbers early in May, has been signed almost without exception. The exceptions have been not because of any criticism of the Agreement itself, but because of distance or some immaterial reason. The unanimity and willingness with which the Jobbers signed this Agreement have been most gratifying. Before the blanks were sent out and the changes explained, we rather expected more or less objection to some of the clauses; although we believed at the same time that when the Jobbers were fully acquainted with the intent of the changes they would gladly co-operate with us in putting the Agreement into force. Such proved to be the case. The Jobbers not only signed willingly, but in many instances wrote us, commending the result sought in having the new Agreement signed.

The Agreement is now being laid before the Retail Dealers by the Jobbers, and already large numbers of the Agreements have been returned to us, properly signed and witnessed, showing quite clearly that the Dealers mean to co-operate fully in the matter.

We believe that the system under which this Company is now conducting business is one of the fairest and most just in use in the business world to-day, and we further believe that the changes made in the system by this new Agreement will add further to the benefit of all concerned. The changes were determined upon only after the most careful consideration and discussion, and we have no doubt that those who may at first object, being disposed to question their value, in the end will be the warmest in commending them. We therefore urge all Retail Dealers to carefully read the new Agreement upon receiving it, and if the same meets with their approval sign it

(Continued on page 3.)

THE ADVANCE LIST OF JULY RECORDS APPEARS ON PAGE 2. ORDER FROM  
IT NO OTHER ADVANCE LIST WILL BE ISSUED.

# ADVANCE LIST OF NEW EDISON MOULDED RECORDS FOR JULY, 1903

## T W E N T Y - F I V E D O M E S T I C T I T L E S

RECORDS listed below will be ready for shipment as near July 1st, 1903, as possible, at which time Jobbers' stock orders, if placed prior to June 20th, will be shipped.

July Supplements will bear the date of July 1st, and will be forwarded to Jobbers with their stock order for Records.

Retail Dealers should place stock orders with their Jobbers at once, to insure prompt shipment as soon as Jobbers' stock is received.

Stock orders for Records contained in this list must be written on separate order blanks, and letters relating to July Records should refer to no other matter.

Kindly comply with above requests and thus aid your Jobber and ourselves in handling advance orders.

- |        |   |   |
|--------|---|---|
| 8424   | American Patrol (Patrol effect)   | Edison Concert Band   |
| X 8425 | Hiawatha (His song to Minnehaha)<br><i>With orchestra accompaniment</i>             | MacDonough  |
| 8426   | My Old Kentucky Home (Organ effect)   | <i>Mandolin</i> Siegel  |
| X 8427 | The Lord's Prayer and Gloria Patri  | Mendelssohn Mixed Quartette                                       |
| 8428   | Heart's Desire  | <i>Violin and flute duet</i> Jaudas & Atz                         |
| 8429   | Marriage is Sublime   | <i>Comic male duet</i> Collins & Harlan                           |
| 8430   | Mighty 'lak a Rose (Nevin)  | <i>Song</i> Clifford  |
| 8431   | De Beriot's 6th Air with Variations   | <i>Violin</i> D'Almaine   |
| 8432   | Polacca from Mignon   | Edison Concert Band   |
| 8433   | Stradella Overture  | Edison Concert Band   |
| 8434   | Every Morn I Bring her Chicken (Coon idea of the<br>song "Violets")                 | <i>With orchestra accompaniment</i> Collins                       |
| X 8435 | 'Deed I Do  | <i>Contralto and basso coon duet</i><br>Miss Morgan & Mr. Stanley |
| X 8436 | Massa's in the Cold, Cold Ground  | Edison Male Quartette   |
| 8437   | Engaging an Opera Company (Vaudeville)  | Dudley  |
| 8438   | Sweet Rose  | <i>Song and dance with yodel</i> Watson                           |
| 8439   | Intermezzo from Cavalleria Rusticana  | Edison Symphony Orchestra   |
| 8440   | I'm a Jonah Man   | <i>Coon song</i> Collins  |
| 8441   | Reuben Haskins of Skowhegan, Maine (A rural ditty)                                  | Len Spencer   |
| 8442   | Selection from Peggy from Paris   | Edison Symphony Orchestra   |
| 8443   | Pretty Little Dinah Jones<br><i>Coon love song with orchestra accompaniment</i>     | MacDonough  |
| 8444   | Annie Laurie (Dudley Buck)  | Edison Brass Quartette  |
| 8445   | I Could Love You in a Steam Heat Flat   | <i>Coon song</i> Harry West                                       |
| 8446   | Farewell Beloved  | Miss Chapell & Mr. Stricklett<br><i>Soprano and tenor duet</i>    |
| 8447   | Hurrah for Baffin's Bay   | <i>Comic male duet</i> Collins & Harlan                           |
| 8448   | Hebrew Vaudeville Specialty<br><i>Introducing parody on "On a Sunday Afternoon"</i> | Rose  |

Edison Moulded Records are made only in Standard size. Both Standard and Concert Records may be ordered from this list. Order by Number, not title. If Concert Records are wanted, give the number and letter C.



(Continued from page 1.)

in the presence of a witness without delay. If there be any who prefer to ask questions before signing, we would urge them to follow the matter up at once until fully satisfied as to the wisdom of signing; in other words, do not lay the matter to one side at the risk of having it lost sight of or forgotten. Give it immediate attention, and keep in good standing with Jobbers and this Company. We want to see every Dealer's Agreement in our files before July 1, the time when the new Agreement will be in force. Those who have not signed by July 1 may find themselves put to considerable trouble in getting goods promptly and in receiving printed matter.

We realize that we are putting our Jobbers to considerable trouble in asking them to get all their Dealers to sign this Agreement, but we would like still further to trespass on their good nature and ask them to follow up such Dealers as may be slow in returning the Agreements properly signed and witnessed. If, after reasonable time, any Dealers have not responded, write them again, and point out the desirability of having the matter taken care of without delay.

Following are some of the comments of Jobbers on the new Agreement:

NEW YORK, May 18, 1903.

We are glad to be able to compliment you on the successful outcome of the latest evidence of your liberal policy. We refer to the 35-cent rate for exchanging records. On April 27th we received notice from you that this change in price would go into effect on July 1, 1903. Notwithstanding the length of time which you allowed us to prepare our customers for the new price, we immediately substituted the new exchange price, and, up to the time of writing, we have yet to hear of any valid complaint from a single one of our thousands of customers.

We have always had an enormous exchange business, and we are confident (as results have already demonstrated) that the raising of the exchange price will be in no way detrimental to the general welfare and the continued prosperity of the Edison Phonograph, but, on the contrary, will benefit all concerned to no little extent.

Hoping that you will keep up the good work, and, with the assurance of our heartiest support, we are.

S. B. D. AVEGA.

MILWAUKEE, Wis., May 13, 1903.

Your letter of the 9th, enclosing Price List, Terms of Sale, and Agreement Form 430, Dated May 1, 1903, received. We have signed same and return herewith.

The changes you have made in Conditions of Sale, both to Jobber and Dealers, are, in our opinion, an excellent move, inasmuch as it draws a line on certain points that Jobbers and Dealers have heretofore been able to crawl out of, in case they are found violating that part requiring Dealers to have an estab-

lished place of business, in which to display machines and records. This we trust will be rigidly enforced. We know of a number of cases where Jobbers in the West have given Dealers' discounts to peddlers and fakirs traveling around the country selling patent medicine or doing work of that sort.

We will conform strictly to terms and conditions. Very truly yours,

McGREAL BROS.

READING, Pa., May 11, 1903.

We enclose you the Jobbers and Dealers Agreement received by us this morning, properly signed and witnessed. Having both carefully read same, would say that we fully endorse your methods and know that we can easily sell the required amount of goods. If you will send us new Retail Dealers' Agreements we shall be glad to have our listed Dealers sign same and return to you at our earliest convenience. We predict increased business for the summer.

READING PHONOGRAPH Co.,  
E. A. Gicker, Mgr.

NEWARK, N. J., April 25, 1903.

We take pleasure in returning to you the new form of contract, properly signed. We do this with pleasure, and feel quite confident that with your usual attention a great deal of good will be derived by all Jobbers and Dealers of your apparatus. Yours very truly,

A. O. Petit.

### MORE FACTORY ROOM.

The matter of increasing our factory facilities at Orange is well under way. The first department receiving this attention is, that in which the Reproducers are made, and it is hoped shortly to make Reproducers as fast as they are demanded by the trade. This building also includes the Shipping Department, and the enlargement of the building will give ample room for that important end of the business. The contemplated changes in other buildings will be begun shortly, and it is expected that they will be ready for an increased business in the fall.

### MR. IRETON PROMOTED.

Albert C. Ireton, one of the salesmen of the National Phonograph Company, was on May 18 promoted to the position of Assistant Manager of Sales and will hereafter be found at the New York office. Mr. Ireton has had considerable experience in the Phonograph business, having been with the old United States Phonograph Company at Newark, N. J., for two years and with the National Phonograph Company for four years. For some time past he has sold our goods in New York, New Jersey and Connecticut.

### SUITS DISMISSED.

We take pleasure in calling the attention of our Jobbers and Dealers to the following copies of Decrees, dismissing suits brought by the New York Phonograph Company against two of our prominent Jobbers in New York city. The suits were attempts to assert the old exclusive license claimed by one of the so-called "sub-companies" of the defunct North American Phonograph Company. The suits were abandoned when called for trial.

At a Special Term of the New York Supreme Court for the County of Westchester, held at the County Court House at White Plains, New York, on the 18th day of May, 1903.

Present:

HON. SAMUEL T. MADDOX, *Justice*.

NEW YORK PHONOGRAPH COMPANY,	<i>Plaintiff,</i>
<i>against</i>	
SOL. B. DAVEGA,	<i>Defendant.</i>

This action having been regularly called for trial at a Special Term of this Court on the 18th day of May, 1903, and the defendant herein having appeared by his attorneys, Robinson, Biddle & Ward, and no one appearing on behalf of the plaintiff, and the defendant having moved that the complaint herein be dismissed,

NOW, on motion of Robinson, Biddle & Ward, attorneys for the defendant, it is

ORDERED that the complaint be and it hereby is dismissed.

S. T. M.

At a Special Term of the New York Supreme Court for the County of Westchester, held at the County Court House at White Plains, New York, on the 18th day of May, 1903.

Present:

HON. SAMUEL T. MADDOX, *Justice*.

NEW YORK PHONOGRAPH COMPANY,	<i>Plaintiff,</i>
<i>against</i>	
AZEL D. MATTHEWS, <i>et al.</i> trading as A. D. Matthews & Sons,	<i>Defendants.</i>

This action having been regularly called for trial at a Special Term of this Court on the 18th day of May, 1903, and the defendants herein having appeared by their attorneys, Robinson, Biddle & Ward, and no one appearing on behalf of the plaintiff, and the defendants having moved that the complaint herein be dismissed,

NOW, on motion of Robinson, Biddle & Ward, attorneys for the defendants, it is

ORDERED that the complaint be and it hereby is dismissed.

S. T. M.

### SELLING SUGGESTIONS.

Fairs will be the principal attraction in all parts of the country during the next three months. These should furnish Dealers an excellent opportunity to push Edison Phonographs and Records. We would suggest that Dealers secure space at such fairs, make an exhibit of the several styles of machines, select a lot of the most pleasing Records with which to give free concerts and give away printed matter to those who will not fail to gather around to hear the music. We have several kinds of circulars that we are willing to furnish in quantities for such use. They are forms 291, 409, 414, 418, and 428. Dealers who intend making exhibits at fairs should

write us for samples of these forms and then ask the Jobbers through whom they deal to get them a supply. It takes time to get printed matter in this way, and it is not too early to give the matter immediate attention.

Dealers whose places of business are near summer resorts, either in the mountains or by the sea, should find the hotels at those places good customers for Phonographs. The Edison Phonograph is an ideal device for entertaining guests at a hotel. Its cost is small, it is easy to operate and the Records at the command of the public make it possible to have all the newest and most popular music. Scores of hotel proprietors would make a Phonograph a part of their outfit if they could be told of its merits and made to realize how attractive it is for amusement purposes.

Young Men's Christian Associations should also prove profitable customers for Edison goods. There are none so poor that could not afford a Phonograph and a supply of Records, and no one will deny that they would prove a great attraction to the young members of the Associations.

### NO CHANGES CONTEMPLATED.

One of our Jobbers recently said to us that if he could be sure that there would be no changes in the various types of Phonographs this year, he would place an order for five hundred machines. We replied that he could be certain that no radical changes would be made in any of the several types this year. Such is the case, and we desire the entire trade to know it. The Edison Phonograph today is the best machine ever put out by this Company, and is the superior of any talking machine device on the market. It does not require radical changes to improve it, and none such will be made. We do not say that time may not bring about further improvements in the Phonograph, but none are under contemplation at the present time. We make this statement now in order that the trade may feel safe in placing orders for the fall season. To place orders will make it possible for us to manufacture machines during the summer, and will enable the trade to avoid the annoying delays of last year when hundreds of orders came in at one time and the demand far exceeded our ability to supply.

**We desire Dealers to invite the fullest comparison by the public between the Edison Phonograph and other styles of talking machines. Such comparison cannot fail to sell Phonographs.**



### THE JULY RECORDS.

With the May Records not yet shipped from the factory, it is a far cry to talk about July Records. But we have been told time and again by Jobbers and Dealers that the getting out of new lists of Records each month is the life of the business; so we shall continue to get out a new lot each month, and to write about them, no matter whether those of previous months have been shipped on time or not. There is no other one thing in the Phonograph business in which so much interest is felt by the trade as in the lists of new Records sent out each month. He will be a hard man to suit who will not find in the July Records a number of selections entirely to his liking. The list comprises twenty-five Domestic selections and covers a wide variety of subjects. In the list are three selections by the Edison Concert Band, two by the Edison Symphony Orchestra, two quartettes, four duets, seven vocal solos, two instrumental solos, one instrumental duet, three talking and singing records, and one selection by the Brass Quartette. The list, as a whole, furnishes additional evidence that our Record Making Department never stands still—that it is constantly improving.

The selections by the Edison Concert Band are Nos. 8424, American Patrol, with patrol effect; 8432, Polacca, from "Mignon," and 8433, the Stradella Overture. In the first named three patriotic songs are played with patrol effect, the whole forming a novel Record. The last two were made after the Edison Band had been rearranged by taking out some of the former players and substituting for them others of superior talent. These two Records show a marked difference in execution even over the work of the former band, which was one of the best in the country for making Records.

In No. 8425 Harry MacDonough sings the famous \$10,000 song, "Hiawatha," with orchestra accompaniment. This song as an instrumental Record found a large sale, and, given now as a vocal solo, it cannot fail to be equally popular. It is probably one of the best advertised songs in the country. No. 8426, My Old Kentucky Home, is a mandolin solo by Samuel Siegel, an exceedingly clever player. This selection is given with an organ effect, and mandolin players will appreciate the difficult work necessary to get such a result on this instrument.

No. 8427, The Lord's Prayer and Gloria Patri, by the Mendelssohn Mixed Quartette, is another Record that will appeal strongly to those who prefer the more serious titles. This

quartette is composed of Miss Chapell, Miss Morgan, Mr. Stanley and Mr. Stricklett, and they have succeeded in making Records that have never been equaled for mixed voices. It has always been a difficult matter to make successful Records of female voices, and after months of careful experimentation our Record Department has succeeded in getting perfect results in quartettes and duets. It is now at work on solos, and expects before long to list some very good songs by female voices. No. 8428, "Heart's Desire," is another of the series of violin and flute duets by Eugene Jaudas and Louis Atz, the Record showing the splendid blending of these two instruments.

No. 8429, "Marriage is Sublime," is a comic male duet by Collins and Harlan. This popular comic opera hit is exceedingly funny and is sung most cleverly. No. 8430, "Mighty Oak a Rose," by Nevin, is a coon lullaby, sung in Arthur Clifford's best style.

Lovers of classical music will be pleased with No. 8431, De Beriot's Sixth Air with Variations, played as a violin solo by Charles D'Almaine. Mr. D'Almaine's ability as a maker of violin Records is too well known to need comment. In No. 8434 and No. 8440 we have two of Arthur Collins' inimitable coon songs. The first named, "Every Morn I Bring Her Chicken," gives a coon's idea of the song, "Violets." It is sung with orchestra accompaniment. No. 8440, "I'm a Jonah Man," will rank as a seller with the other coon songs made by Mr. Collins in the past few months. In No. 8435, "'Deed I Do," Miss Morgan and Mr. Stanley have somewhat departed from the sentimental songs they have been singing as contralto and bass duets, this title being a coon song, although of a sentimental character. It is one of the best Records in the list, and will further enhance the popularity of these two singers.

No. 8436, "Massa's in the Cold, Cold Ground," is the other quartette on the list, and is sung by the Edison Male Quartette. The first and second verses are sung by the bass, accompanied by a sort of vocal rag time. It is a good quartette Record. In No. 8437, "Engaging an Opera Company," S. H. Dudley tells of the troubles of the impresario in trying the voices of would-be opera singers. No. 8438, "Sweet Rose," is a song and dance with Yodel, all given in Geo. P. Watson's best style.

The two selections by the Edison Symphony Orchestra, 8439, Intermezzo from "Cavalleria Rusticana," and 8442, Selection from "Peggy from Paris," are both played as only this organization can make orchestra Records. In No. 8443 Harry MacDonough gives a vocal

rendition of the coon love song, "Pretty Little Dinah Jones," and is accompanied by the orchestra. This air is given in the June list as a xylophone solo.

Many admirers of Edison Records regard those made by the Edison Brass Quartette as the most desirable of all instrumental Records. Such will find No. 8444, "Annie Laurie," with music by Dudley Buck, fully equal to any of those made by these players. No. 8445, "I Could Love You in a Steam-Heat Flat," introduces in Harry West a new singer of coon songs for the Edison Phonograph. The good impression that this Record will make will be heightened with later songs by Mr. West.

No. 8446, "Farewell, Beloved," soprano and tenor duet, by Miss Chapell and Mr. Stricklett, is another Record in which the soprano voice is given clearly and pleasantly. Collins and Harlan in No. 8447, "Hurrah for Baffin's Bay," have an exceedingly funny duet. The manner in which this song mixes up nautical terms would make a sailor seasick. No. 8448 is another Hebrew vaudeville specialty by Julian Rose. In this Mr. Rose gives his usual ludicrous talk in Hebrew dialect, and follows it with a parody on "On a Sunday Afternoon."

### THE PHONOGRAPH ADVERTISEMENT IN THE PUBLIC EYE.

One of the features of the *Booklover's Magazine*, of Philadelphia, published in the interest of the Booklover's Library, is a monthly competition in which prizes are offered for the best full-page, half-page and quarter-page advertisements in its columns. The advertisements receiving the most votes each month are considered the prize advertisements, and then the prize winners are chosen by the best reasons given by the competitors for their choice. The object of the competition is to get readers to carefully look over the advertising pages and in this it succeeds admirably. In the May issue the National Phonograph Company had a half-page advertisement. It was the same Phonograph girl as shown on the last page of this issue, except that the advertisement was enlarged to a half page. This advertisement was chosen by many as the most attractive in the May issue, but it did not receive enough votes to be classed as a prize advertisement. Some of the reasons for choosing our advertisement were so interesting that we reprint them here, believing that our readers will find them equally readable. They are:

Both good "Talking Machines."

The machine which pleases such a girl must please everybody.

The girl's expression shows what a pleasure a Phonograph is.

Edison's Phonograph will banish the thoughts of the day.

Something a woman will listen to and not talk back.

You hear as well as see what is being advertised.

Her evident enjoyment arouses our desire to hear also.

A machine that inspires such love sells itself.

Only a perfect instrument could cause that look of joy.

Suggests the wonderful entertainment in the Phonograph.

It suggests the amusement and pleasure afforded, with convincing evidence of merit and popularity.

Suggests the enjoyment and pleasure of the Edison Phonograph.

Everybody stops to look at a pretty face.

The face shows the pleasure derived.

No need of a second glance to determine the meaning.

We are at once interested in that which everyone loves.

Certainly appears lovable and mutely eloquent.

This ad. is clear, concise—fully illustrates the Phonograph.

Speaks for itself.

Very attractive, and highly expressive of keen pleasure and interest.

It talks for itself.

Her smiling face tells she hears a natural, loving voice.

A silent expression of pleasure appealing to the multitude.

Attractive girl, attractive machine, combined into a most attractive total.

Her look in your eye makes one want to buy.

The girl takes the eye, and then, Edison the ear.

We feel the girl's pleasure and feeling makes us interested.

If it could win her, it must win us all.

Because a pretty girl is *always* good.

The news it conveys is good news.

It appeals to the one in search of home amusement.

Phonographic love, to thrill the heart, must be natural indeed.

Portrays the genuine pleasure of listening to the Edison Phonograph.

Shows the importance of getting Edison machines for pleasing results.

Expressive of the "Edison's" human and lovable characteristics.

Only clear, natural tones could result in the listener's delight.

Announces an amusing and instructive entertainment for all without effort.

It is evident that its keynote is enjoyment.

It both appeals and persuades.

It speaks for itself.

Solace for our ills, a handsome woman and a Phonograph.

The Phonograph pleases the girl, and it will please all.

**The sale of a Phonograph must be made  
before you can sell Records.**



**APPRECIATIVE COMMENT.**

*C. J. Heppe & Son, Philadelphia.*

The current issue of the Edison PHONOGRAPH MONTHLY is indeed a success, and is in direct line with other efforts of the National Phonograph Company in that it is progressive.

The *Phonogram* in its day served as a pioneer to blaze the way for the MONTHLY, as did the tin foil machine for the Triumph. The present number is particularly interesting as it brings to the notice of Jobber and Dealer the conditions under which Phonographs and Records are sold.

The moral effect of a monthly monitor, like the PHONOGRAPH MONTHLY, is incalculable. The "Family Talk" which covers so many points and rules must assist all Jobbers and Dealers. Salesmen will also work to better advantage by a perusal of these articles. The analysis of the new issues of Records is a commendable feature.

Would suggest that the authors' names be included in the discussion of these new numbers, as some good selling points are to be gained in knowing the story of a song or other selection. We are often asked the history of a popular number.

Wishing you the success your efforts deserve.

May 14, 1903.

*H. W. Mosier, Stockton, Cal.:*

It is with intense gratification that I acknowledge receipt of the EDISON PHONOGRAPH MONTHLY. A better step toward keeping Jobber and Dealer in touch with all that is progressive with this industry that is making marvellous strides and gaining foothold the world over, was never made. Whenever introduced in the home, the Phonograph becomes one of the family. By letting the people know about the Edison Phonograph and Edison Records, my sales have increased tremendously.

May 7, 1903.

*W. R. Mosley, Lothair, Ga.:*

I have received two issues of your Edison Phonograph Monthly, and must say that it proves a great help to Jobbers and Dealers. The promoters of this little volume deserve much credit and I hope to receive a copy every month promptly. It is a great help to me.

May 30, 1903.

*H. S. Hayes, Southfield, W. Va.:*

The PHONOGRAPH MONTHLY for May just reached me and I think it a great aid to Dealers as it contains many valuable hints and suggestions, all of which if followed are bound to result in increased business for the Dealer in Edison goods.

May 25, 1903.

*Demorest Sewing Machine Co., M. L. Gregson, Proprietor, No. 153 West 23d Street, New York.*

A copy of your PHONOGRAPH MONTHLY of May issue reached me a day or two ago. I digested everything in it, and was so pleased with its contents that I cannot refrain from saying that you are to be congratulated upon the novel idea of keeping in touch with your agents. It certainly has a tendency to cause the Dealer to feel that you are interested in

his success, thereby bringing about that close business relation that should always exist between an enterprising and energetic manufacturer and the one who comes in direct contact with the purchaser. I venture to say that the majority of your agents feel as I do in this regard and that beneficial results in the shape of increased sales will follow as a natural result of your latest enterprise.

May 25, 1903.

*McKenzie Novelty Company, Butte, Montana.*

I have just received the May number of the PHONOGRAPH MONTHLY, and think it fills a long felt want. Have got more information from this number of the MONTHLY that I desired than from all the advertising matter I received from the company for months. Kindly send me back numbers for 1903.

May 25, 1903.

*Frank H. Malone, Dothan, Ala.:*

I received the second and third issues of the EDISON PHONOGRAPH MONTHLY, but have not received the first issue, please send me a copy. I am glad for myself and all other Dealers that you have gotten out such a magazine devoted to the Phonograph trade. I think your Monthly is the nicest magazine of its kind that I ever saw. It is just what I have been expecting and wishing for. I know it will be a big help to all Dealers and Jobbers. I wish your Monthly much success and hope it will grow in volume.

May 25, 1903.

*The Reading Phonograph Co., Reading, Pa.,  
Edw. A. Gicker, Manager.*

The EDISON PHONOGRAPH MONTHLY is to the Jobber and Dealer what the new model "C" Reproducer is to the old Phonograph, new life. At once interesting and instructive, it shows the protection afforded all Jobbers and Dealers of Edison goods. We feel that the trade will be greatly benefited by the many good points shown in this MONTHLY and think that every man in the business to-day should read each MONTHLY carefully, from beginning to end.

May 16, 1903.

*C. F. Littlepage, Anthony, Kan.:*

I beg to acknowledge the receipt of the March and April numbers of your most interesting and valuable magazine, the EDISON PHONOGRAPH MONTHLY. It ought to be in the hands of every owner of an Edison Phonograph. I have shown it to some music lovers and owners of Edison Records. They all thought it would be a welcome visitor. I hope you will continue to enlarge and give us more of it. I for one will pay for such a magazine if you will name your price. With best wishes for your success.

**JAPANESE RECORDS.**

Some time in July we shall get out a folder with reference to the Japanese Records, and will then be in shape to fill orders for them.

**In ordering supplies or repair parts give the name and number of the Phonograph for which they are wanted.**

**CO-OPERATING DEALERS.**

ASBURY PARK, N. J., May 9, 1903.

Your circular letter of April 1, 1903 (Form 419), received and contents noted. Your policy of protection is too thoroughly appreciated by me to permit any act of mine to tear down the structure you are trying to build up for the benefit of us all. C. R. ZACHARIAS.

AMANA, Iowa, May 6, 1903.

I herewith state the receipt of Suspended List, April 1st. I intend fully to co-operate with you. ANDREW SCHIFF.

SYRACUSE, N. Y., May 14, 1903.

Beg to acknowledge receipt of your list of Suspended Dealers up to April 1, 1903. We wish to assure you that you have our hearty co-operation in your dealings with these people. Right here, we wish to say just a word as regarding the March list of Records. It is certainly a winner and far ahead of anything yet received from your house. From the advance list of April, May and June, we see still greater advancement in the quality of the Records. Every month shows a gain in the tone and clearness of the Records and it is appreciated by our customers, as is shown by our increase of sales.

Assuring you our hearty support at all times.

HOFFMAN & WEAVER.

GERMANTOWN, Ky., May 5, 1903.

In reply to the Suspended List April 1, will say I will co-operate with you, and no suspended Dealer can get Phonographs or any goods of any kind from me.

E. E. HENDRIXSON.

**HOW SOME DEALERS PUSH THE BUSINESS.**

BOSTON, Mass., May 15, 1903.

Your monthly magazine is one of the best things you have ever issued towards interesting the trade in a general way. The many points of great value tend to keep the Dealers "talking" machines. The many novel ways the smaller dealers have of keeping the Edison goods before the public interests me very much. But here is one which differs some from those in your magazine. During a short trip in one of our suburban towns the other evening I was attracted by a large crowd in the square who were watching a moving picture machine. At intervals the operators would show the picture of T. A. Edison and announce that they were headquarters for Edison Phonographs and Records. They did a good business. I feel that it is worthy of mention in your magazine and I trust you will find space for it.

This enterprising house was the Prospect Phonograph Co., Cambridge, Mass.

S. J. FREEMAN.

[Mr. Freeman is connected with the Eastern Talking Machine Co., Boston, Mass.]

GARRETT, Ind., May 25, 1903.

The third edition of the EDISON PHONOGRAPH MONTHLY at hand. Am so well pleased that I can hardly wait till the next number arrives. I would like to tell you and all other Dealers how I advertise my

business. When I receive my stock of new Records I hang a large sign in the window announcing "Fresh supply of Edison Records just received. Free concert to-night. Come one and all. Bring your wife or some one else's wife, or your sweetheart. Your baby will sleep while you hear the free concert." I advise others to try a similar plan and see what good results they will have.

ALBERT PALMER.

MATTEAWAN, N. Y., May, 1903.

One of the best methods I find of advertising the Phonograph is to play it and I can tell you the ones we use in our stores are going about all the time. I have notices put in the local papers every time we receive a new shipment of Records and when we find a Record that takes extraordinarily well we put in a special notice inviting people to come in and hear that *one*, and then they stay to hear more, and I have found that it often causes the sale of a machine. Another good plan is to always accept an invitation to play at private parties or entertainments and do it gratis, for as the old saw says, "You can catch more flies with molasses than you can with vinegar."

In shipping out Records in barrels I take this liberty to suggest you put on this sign,

"A BARREL OF FUN,"

EDISON NEW MOULDED RECORDS.

Yours very truly,

DANIEL R. WEED, JR.

Harry E. Stover, a Dealer at Hagerstown, Md., under date of May 27, comments as follows on his success in selling Edison Phonographs and Records:

The Standard has been taking everything in sight. I have a \* \* \* and several types of \* \* \* machines, and when a customer comes in and wants a talking machine I give him his choice. I have sold nothing but Edison machines since you have made your new Records and Reproducers in the spring of 1902.

HARRY E. STOVER.

W. G. Fawcett, a dealer at Salem, Ohio, sends us a circular printed with a half tone picture of Arthur Collins, the singer of coon songs for the Edison Phonograph. The circular also gives the names of a number of Records made by Mr. Collins, and calls attention to the fact that Mr. Fawcett carries a full line of these and all other Phonograph Records. The circular is well printed, and presents the matter in good style. We understand that it is Mr. Fawcett's intention to get out similar circulars for other makers of Edison Records and distribute them to his customers.

"Our Record Boy does nothing but play Records, but don't hesitate to call and hear them at any time," is a suggestive phrase in a Phonograph advertisement of Wright's Music House, 349 Washington street, Portland, Oregon, which occupied two-thirds of a page in the Portland papers on May 23 and following days.



**CONCERNING PRINTED MATTER.**

Form No. 428 is another four page folder, samples of which will be sent out to the trade this month. This folder shows the first Phonograph made by Mr. Edison and also the Triumph type, and includes a general argument on the merits of the Phonograph and Edison Records. This has been gotten out in large quantities, and we should be glad to have Jobbers and Dealers use them where they can do so to advantage.

The fact does not appear to be known to all Dealers that we get out a set of Record Order Sheets, giving the numbers of all Records listed by us. These are printed so that it is only necessary to insert the figures showing the quantity of such Records as it is desired to order. We are anxious to have these Record Order Sheets used by all Dealers who order any considerable number of Records at one time. They not only make it easier for a customer to send an order, but they prevent mistakes and make it possible to handle orders with greater facility at our factory.

We have been much disappointed in not receiving the supply of the new celluloid placard from the manufacturer. They should have been in before this, but various causes have combined in delaying their completion. As soon as we receive them, we shall take immediate steps to get them in the hands of the trade. Until then, we must ask the Jobbers and Dealers to have patience.

The four page folder, "Music in Every Home," was so largely demanded by the trade that we have used up the first edition of 250,000 copies. A new edition is now being printed, and will be ready for use in about a month.

We have on hand a large supply of the colored lithographed card, No. 409, showing the boy "Looking for the Band." This should be a very useful card for sending out with mail matter, and we shall be glad to furnish it to all Dealers who will make careful use of it. We might say concerning this, as well as all other printed matter issued by this Company, that we have plenty of it for such Dealers as will use it advantageously, but have not a single card to be wasted.

The carrying limitations of a one cent postage stamp caused us to omit the sending out of a colored poster in May. It will go out with the June matter, possibly with this copy of the MONTHLY.

Catalogue of Parts, No. 371, is daily expected from the printer. Jobbers and Dealers who have orders on file for this form, will get them as soon as they are received.

**A JOBBER'S PRIZE SELECTION.**

The following is a reprint of a circular issued by a Jobber at Easton, Pa., and it is published here to show what one Jobber regards as "a Prize Selection" of Edison Records:

15,000 EDISON RECORDS.

WERNER MUSIC HOUSE,  
Cor. 4th and Northampton Streets, Easton, Pa.

We now have all the Edison Records in catalogue in stock to select from.

SPECIAL LIST OF 37 EDISON RECORDS.

These are what we call *A Prize Selection*—the cream out of the bunch. We have them. Call and hear them. Each one is worth having. We try our best to keep you informed and do all we know how to please you. Will you in return kindly give us your business?

- 7626 Fantasia Somnambula (Clarinet)
- 8339 Dixie Medley (Banjo)
- 7881 Sunflower Dance (Banjo)
- 8363 Good-Night Quartette from "Martha"  
(Brass Quartette)
- 8349 Dream of the Tyrolienne  
(Violin and Flute)
- 2810 Nightingale and Frog (Piccolo)
- 8347 Hiawatha (Band)
- 8376 Symphia Waltzes (Band)
- 8333 Boston Commandery March (Band)
- 8305 The Coliseum March (Band)
- 8297 Tipperary March (Band)
- 8366 Mr. Dooley Medley, introducing "Just  
Kiss Yourself Good-Bye" (Xylophone)
- 8303 Heimweh, Longing for Home (Zither)
- 8085 Parody on "Good-Bye Dolly Grey"
- 8304 Suawnee River (Parody)
- 8373 Larboard Watch (Duet)
- 8255 They Were All Doing the Same (Duet)
- 8256 O That We Two Were Maying (Duet)
- 8198 Fare Thee Well, Molly Darling (Duet)
- 8096 Rehearsal for the Husking Bee (Duet)
- 8140 Down on the Old Plantation (Orchestra)
- 7785 Selection from the Burgomaster  
(Orchestra)
- 7936 March from the Strollers (Orchestra)
- 589 Narcissus March (Orchestra)
- 7742 Hearts and Flowers (Orchestra)
- 644 Titl's Serenade (Orchestra)
- 8295 Marriage Bells (Bells)
- 8375 The Cuckoo Song  
(Talking, Whistling and Singing Duet)
- 8114 The Robin Song  
(Singing and Whistling)
- 8275 Just Kiss Yourself Good-Bye (Song)
- 8240 Come Down My Evening Star (Song)
- 8219 Jerry Murphy Was a Friend of Mine  
(Song)
- 8112 Bill Bailey, Won't You Please Come  
Home (Song)
- 8125 Mister Dooley (Song)
- 8118 In the Good Old Summer Time (Song)
- 8152 Molly Come Drive the Cows Home  
(Song)
- 8193 Please Let Me Sleep (Song)

**You cannot sell Records, Mr. Dealer, till  
you sell Phonographs. This done and a  
good Record trade is assured.**

### SEE THAT ALL PHONOGRAPH OWNERS GET A SUPPLEMENT.

The monthly supplement of Records issued by us should go to all owners of Phonographs in United States and Canada. The theory of the Company in getting out this supplement is that Jobbers shall have a sufficient supply to furnish all of their sub-dealers with them, and that the latter shall see that they are sent to all customers who have bought Phonographs. Dealers who do not get a supply for this purpose should take the matter up with their Jobber, and if the latter is not getting a large enough supply to meet such demands, we desire that he shall increase his order with us. Sending these supplements to owners of Phonographs means more business for the Dealer, the Jobber and ourselves, and all should do everything possible to get it.

### POSTERS AND STREET CAR CARDS.

Once in a great while we get a request from a Dealer for a supply of cards for street car advertising, but up to the present time the demand has not been sufficient to warrant the expense of getting out a line of these cards. We are willing, however, to bear the expense of lithographing not only street car placards but also a lot of four and eight sheet posters, if the Jobbers and Dealers can use them to advantage. To that end, we shall be glad to know from the trade whether they will bear the cost of street car advertising or putting up posters, if we will go to the expense of having the same printed or lithographed. The policy of treating all Dealers alike makes it impossible for us to do any advertising of this kind in certain territories and neglecting others, and the cost of doing it for all is too great to be considered. If it is done at all, it must be done by each Dealer in his own locality, and not by us. We shall be glad to hear from the trade on this subject.

### AS GOOD AS GOLD BONDS.

1224 BROADWAY, BROOKLYN, May 16, 1903.

Enclosed find advertisement and clipping from our local weekly paper, which speaks very highly of the Edison Phonograph and Records. I hope in the next five years to further increase my business, as I believe I will do more and more each year. When I started four years ago I only had three machines and 150 Records, and now I carry for my retail department about fifty machines and 5,000 to 10,000 Records, which goes to show what can be done with the Edison Phonographs. Any live dealer can do business if he will carry the goods, or, as the best Chief New York ever had said, "be caught with the goods" in stock. This will go to show any dealer that Edison goods are as good as gold bonds.

H. S. PRICE, Ed Radio History

### A PHONOGRAPH INCIDENT IN THE PHILIPPINES.

In a letter to Mr. Edison, from Manila, in the Philippine Islands, a correspondent writes as follows:

Craving indulgence for occupying your valuable time, I wish to relate an amusing incident which occurred in his far-away country apropos of the Phonograph. The story compares favorably with the yarn on the countryman in the States, which has been so widely advertised.

While giving an advertising exhibition in an interior town, an old native walked up to the horn and gazed steadily into it for a long time, then veered around and examined the box, then looked intently at the operator—at the ceiling, on the floor, returned to the horn, took out a kerchief, mopped his brow, went outside, brought in an old woman, went through the same antics as before, and exclaimed to his companion, "Mother of God, we hear the voice of the Devil, but he is invisible." At that moment the operator put on a stirring band selection, and when it became exhausted the old man caught the woman by the arm and dragged her to the door, murmuring as he went: "Holy Saint Mary, the Devil has visited Heaven and is serenading God."

I have been selling Edison Phonographs for one year on these Islands in the interests of The American Book and News Company, and have had some very interesting experiences.

Have on hand a number of excellent native dialect impressions which may be of use to you.

Sincerely trusting that I have not bored you, and awaiting your good disposition regarding the dialect records, I am, sir, yours to command,

LEW DAVIS.

Legaspi, Province Albay, P. I., April 11, '03.

### RECORD SHIPMENTS.

No effort was spared in hurrying forward the making of the April Records, but it was not until June 2 that the last of them were shipped. We have already begun to make the May Records, and confidently expect to get them out by the 25th of this month. If we succeed in doing this, the June Records will be shipped early in July, probably not more than two weeks later than would have been the case had we not been so far behind with orders.

### ONE OF THE BEST LINES HE HAS EVER HANDLED.

HAGERSVILLE, Ont., May 27, 1903.

Received No. 3 of the Phonograph Monthly. Please send me Nos. 1 and 2. Want to make a file for future reference. It is just what we need in the business and would willingly remit you a subscriber's price, but fail to find any mention of that item. The Phonograph is proving to be one of the best lines that I have ever handled and am pushing it for all it is worth.

J. H. HEAD.



**WHAT THE WORLD HAS LOST.***(From the Salt Lake Tribune.)*

In an interview with Thomas A. Edison in the *National Magazine*, Joe Mitchell Chapple reports the great inventor as saying, in reply to an inquiry as to which of his inventions was his favorite:

"The phonograph—the phonograph, by all means! It has been a long time since the first phonograph, as we count time nowadays, and improvements come every day; but I think I have accomplished more the past year on it than in any of the years before. My ambition is to have it so perfect that it will reproduce your Boston symphonies to perfection, giving the distinct intonation of every instrument."

And the speaker is represented as speaking "with all the enthusiasm of a boy with his first kite." Well he may be enthusiastic, for the phonograph is one of the sort of inventions that is not only marvelous in itself, but it is marvelous that one should have thought of such a thing as within the range of practical possibilities. To catch the human voice and fix its speech and tones in durable form and for all time, is a thing so incredible to the ordinary mind as to partake much of the nature of the miraculous. And when it was demonstrated as a brilliant fact, then the thought at once arose, What a misfortune to the human race that this invention was not known of old, so that the voice and speech of the great ones of the ages could have come down to us with exactness. How many questions would it not solve, if we had the living voice of Cæsar, Cicero, Demosthenes, Pericles, the Rameses, Alexander the Great, and above all, the Master! The thought is well calculated to bring newly to the mind the losses we have sustained because this and some other inventions were born too late. If we could hear the voice of Menes in directions to his overseers in the building of the great pyramid, we would no longer be in doubt why he built it. If we could hear Cicero's orations, there would be no uncertainty about the pronunciation of Latin. If we could hear the voice of Assurbanipal, we would know the origin and methods of Assyrian and Babylonian civilization. If we could have the conversations of Hammurabi, we would know where he got his great civil code, and what his ideas were of the ancient days, that had been lost sight of in the mists of the ages, even in his time. The world has lost so much in the way of perished knowledge that might have been preserved, that it is hungry to learn as much as it can of its loss, and a little resentful that there was no Edison, in the

ancient world, to provide for its preservation while yet it was in position for transmission to posterity.

**LISTED RECORDS BY OTHER TALENT.**

Hereafter, all Records of the following titles shipped from our factory will be sung by Arthur Clifford instead of J. J. Fisher.

7011. Love's Sorrow.

7735. I'll be Your Sweetheart.

7654. Believe.

The many admirers of Mr. Clifford's Records will approve the substitution.

All Records hereafter made of No. 7850, "I Must a Been a Dreamin'" will be sung by Collins and Harlan and not by Collins and Natus as now listed

In a letter to our Foreign Department received late in May an important Dealer in England wrote:

"After trying many kinds of Talking Machine Records, we have decided to push your gold moulded Records only, and shall stock no other. They are the loudest, clearest and purest in tone and are entirely free from 'scrapeiness.'"

**LIKES OUR "FOLLOW UP" METHOD.**

FAIRYGROVE, Mich., May 27, 1903.

Some time ago I received a card from you stating that ———, of Unionville, Mich., had written you asking about the Edison Phonograph and Records, and asking me to follow the matter up, which I did, and sold him an Edison Standard Phonograph and one dozen Records. Since that time I have taken his order for a larger horn. I appreciate your way of doing business and assure you that I shall do all in my power to sell your goods.

A. H. MOSES.

**A CHICAGO PHONOGRAPH ENTHUSIAST.**

CHICAGO, Ill., May 2, 1903.

I have one retail customer of whom I want to tell you about. March 1 of this year we sold him a Triumph outfit with a 56-inch by 28-inch bell, B. & G. horn, a cabinet for 144 Records and two dozen Records. He now has 404 Standard Records, and has had built in his house a cabinet that holds 650 Records (in addition to the cabinet sold him.) This cabinet is a handsome thing with silk curtains in front, costing him all told, \$43.50 for the cabinet complete, and his 144 cabinet cost him \$20. We are having a horn factory make him now a special horn 56 inches long with a 16-inch throat where brass and steel are joined, and this horn will cost him \$40. Enthusiastic! You never saw just such a gentleman. He is a Hungarian and a fine baritone singer.

I do not believe there is a finer or better constructed collection in Chicago—if in the United States—than his. THE RAY Co.,

Per E. B. Walthall, Manager.

Have any of our Jobbers or Dealers an equally enthusiastic customer?

### CRITICISMS AND SUGGESTIONS WANTED.

It is evident from the many letters we have received that the getting out of the EDISON PHONOGRAPH MONTHLY is fully approved by the trade. We should, however, like something more than mere approval. We cannot believe that the MONTHLY has no shortcomings, and would like to have its readers point out what they are. It must fail to cover some points concerning the Phonograph business, and we would consider it a favor if such failures were brought to our attention. We also would be glad to have suggestions for making the MONTHLY more interesting to the trade. Criticisms and suggestions cannot fail to make the MONTHLY a more readable publication.

### ANENT THE PHONOGRAPH "CRANK."

Referring to your invitation on the first page of the first number of the EDISON PHONOGRAPH MONTHLY, I feel like saying a few words in favor of the continuance of such a journal.

When one buys a Phonograph, he immediately becomes more or less of a "crank" in relation thereto. He thinks he can improve it in various ways; he thinks his own machine is better than that of his neighbors; he experiments and breaks things; he makes records of his dog and his cat and his grandmother.

The braying of a jackass in the barn affords him infinite delight, because there is an opportunity to reproduce; the sound of the chanticleer that wakes all the people in the neighborhood at 4 A. M., causing them to let go their hold on sleep and profanity, is, to the owner of the Phonograph, a veritable charm—another opportunity to reproduce. A funeral passes, headed by a band; his wife wants to find out all about the departed, but *he* cares not who rides in the front vehicle; his only ambition is to poke his horn out of the window and "take" the dirge. If you call upon him, he talks nothing but Phonograph, and brings out his machine and holds you far into the night, practicing upon you with his collection of records. In other words, he is a crank of the first order, and until he gets over the disease he buys everything that comes along; only mention that it has to do with the Phonograph, and out comes his pocketbook.

Now, it seems to me that this sort of people should be catered to. It is peculiar, but it is human nature, nevertheless, that people like to see things in print concerning the fad that has possession of them for the moment. They

like to know what other people are doing, and to exploit their own ingenuity.

These people, I say, ought to be looked after. They are going to spend all the money they have—that is a foregone conclusion when they start in. The disease has got to run its course, and it is only charity for the dealer to help the victim. The trade should have something to send to its retail customers every month, something broad, something bright, something breezy, something worth reading, and filled with hints to keep the "crank's" brain and hand busy. That is just what the trade wants, and it need not be very expensive. Books, circulars, catalogues—these can never take the place of a once-a-month, up-to-date little magazine. Moreover, if properly carried on, there would be a balance on the right side of the ledger at the close of the year, be the expense never so great.

J. N. KIMBALL.

1358 Broadway, New York City.

May 8, 1903.

### THE PHONOGRAPH WAY AHEAD.

ANTHONY, KAN., May 9, 1903.

I want to tell you that the Edison Phonograph, with the new moulded Records, are far ahead of the flat disk records. There are several of the disk machines here in stores. I took an Edison Phonograph and new Records and put them side by side with the disk machine. People who were in the habit of passing by on account of the buzzing and scratching of the disk, came in and they complimented the clearness and naturalness of tone of the Edison machines and Records. Once in a while you can get a pretty fair record on the disk machines, but you find that an owner of a disk machine has very few good records. When you hear them you hear a terrible scratching noise that spoils the record. That grating sound is not very musical to the ears. A merchant here owns a late-improved \$50 disk machine. It is a loud affair and a few records that were considered good five weeks ago are now almost worthless. I have used new moulded Edison Records for a year, and they are as good and clear as when first bought. You can throw this in the waste basket, but I wanted to tell you my experience with the different machines. I think more of your new moulded Records each time I get a new lot. Wishing you success,

C. F. LITTLEPAGE.

**Any Dealer or Jobber selling Edison Records by card system, or otherwise, whereby the dozen price (\$5.00) is allowed on sales of less than one dozen actually taken or paid for at one time, will be considered a violator of Agreement, and liable to immediate suspension.**



**A JOBBER'S ORIGINAL ADVERTISE-  
MENT.**

NEW YORK, May 13, 1903.

I forward herewith electrotype for use in the PHONOGRAPH MONTHLY, in accordance with your request for original advertisements. The poetry quite clearly explains the wonderful field which an Edison Phonograph covers and also impresses one with the unlimited

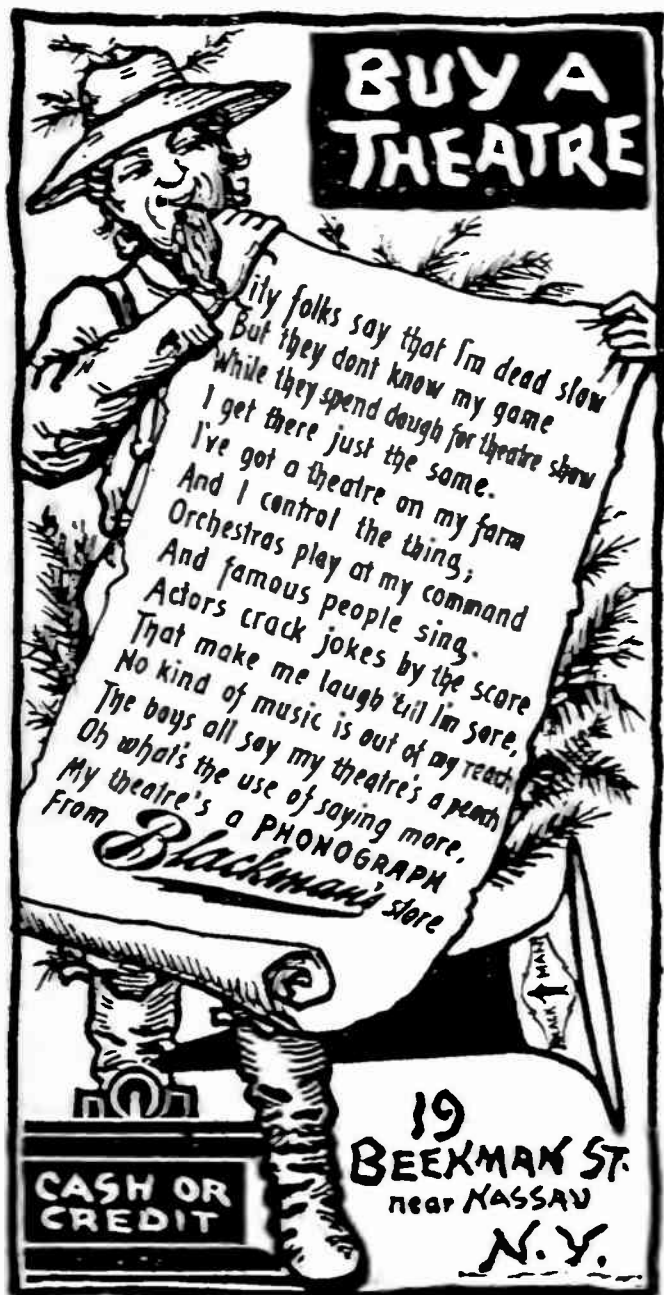

variety of music it furnishes.

This advertisement was run for about one month and a half in the leading New York theatre programmes. Trusting you may find this worthy of attention in your MONTHLY, I beg to remain, sincerely yours,

BLACKMAN TALKING MACHINE Co.,  
J. Newcomb Blackman, Prop.

**GREAT FUTURE IN THE PHONOGRAPH.**

"There is certainly a great future in the Phonograph, and no one is now recognizing this condition more thoroughly than the general music dealer. When one stops to think what steps forward have been made since Edison's tinfoil cylinder, considered an absolute failure from a practical standpoint from the start, to the present day talking machine, the advance toward perfection is scarcely realizable. Yet I believe still more remarkable improvements are to come, and in the near future; and perhaps what we may now think a wonderful achievement will then be a back number."—Interview in *Music Trade Review*



**"HAPPY" GETS A NEW HAT.**

"Happy Hooligan" has substituted an Edison Moulded Record for the time honored tin can; at least, that is the conception of W. C. Patrick, one of our Western salesmen, as presented in the above drawing.

**AN AUTHOR'S VIEWS ON THE PHONOGRAPH FOR DICTATION PURPOSES.**

The March issue of the *Author*, the official publication of the British Society of Authors, contained an article on the use of the Phonograph for dictation. It is entitled, "The Shorthand Substitute," and is written by C. H. Cook, whose writings under the *nom de plume* of "John Bickerdyke," are widely known. The article is of such interest that liberal extracts are here made from it:

**THE SHORTHAND SUBSTITUTE.**

I have no pen in my hand; there is no shorthand writer in the room worrying me to repeat what I said, and asking the way to spell this or that word; there is no typewriter in front of me with its odious click, click; and yet this article is being evolved rapidly and without effort. Now and again I press a key, but that is all. When I have dictated to the extent of 800 words, I push aside a little lever, place a wax cylinder in a box, label it No. 1, and have no more care or trouble about the matter until the afternoon, when my amanuensis brings me a neatly-typed article for revision. Thanks to an excellent voice recording and reproducing machine, I have done most of my literary work and correspondence after this fashion for some years. The only serious fault I have to find with the system is that in course of time the Phonograph comes to be regarded as almost indispensable, and that when away from home without my mechanical assistant, literary work of any kind becomes a grievous toil. Undoubtedly there are writers who could not use the Phonograph with advantage. Some cannot dictate. In other cases the voice possesses a somewhat muffled



quality, which makes the record of it too indistinct for the amanuensis to understand when phonographically reproduced, and I may say here that women make by far the clearest record. There are, again, authors who are incapable of understanding and managing the most simple piece of machinery, though they somehow seem to learn to use a pen, which is an infinitely more difficult instrument to manage than a Phonograph, and takes much longer in the learning. But there are large numbers of authors and journalists by whom the Phonograph would be found as useful as I have found it, and for whose advantage I venture to offer some account of my experiences. I have only heard of two authors who use the Phonograph—Mr. Guy Boothby and Mr. Houghton Townley—and the output of these is considerable. A few business men use them in their offices instead of shorthand clerks. One whom I know—Mr. Upcott Gill, publisher—has used a Phonograph for many years for his correspondence.

The first question which an author will naturally ask himself is, "Can I do as good work if I dictate as if I write?" This is very largely a personal matter, depending on the idiosyncrasy of the individual. The author who thinks and writes slowly, and whose literary output rarely exceeds 500 words in a day, should, I think, confine himself to the pen, but those who compose about 2,000 words a day or more are likely to keep up a better average quality of work if they dictate than if they write. The reason I express this opinion is that after about 1,000 words have been written with the pen there is a certain amount of bodily fatigue which affects the mind to a certain extent, and toward the end of the day's work, the quality of the literary matter is inclined to suffer in consequence of the writer's bodily weariness. As a general rule the literary man should, during and just before his hours of work, avoid anything which tends either to distract or weary him. The Phonograph itself is undoubtedly when first possessed something in the nature of a distraction; but this feeling passes off, and very soon one's hand does the slight manipulation which is required without conscious reference to the mind, just as the hands of the piano player work mechanically while the eyes and mind of the player are fixed on the page of music.

This question was one which I considered very anxiously in connection with my own work, and the conclusion I came to was that dictated work was, on the whole, as good as work with pen and ink. I was able in this connection, to compare two novels. The first, "Lady Val's Elopement," was written by me in pencil, and as the revised draft was almost illegible, I dictated it to a shorthand writer, making further alterations as I went. After the shorthand notes had been transcribed, I revised the story for the third time and sent it to press. With this I can compare "Her Wild Oats," a novel which was dictated in a very few weeks, though the arrangement and scheme of it required many months of work. I can get no indication of which was the better book from the reviews; but it appears to me (if an author is able to judge his own work)

that the wholly-dictated book was the better, and from the publisher's point of view it was by far the most successful. It is shorter and generally less verbose than the written novel, and the dialogue is more crisp. The books are long out of print, so I do not hesitate to mention them by name, in order that others may decide whether my judgment is correct or not on this point, which is one of considerable importance.

It is a good many years now since the first Phonographs were introduced. A serious mistake was then made by the owners of the patent. It was supposed that pretty well everyone would require a Phonograph, and that the invention would come into general use for correspondence, business purposes, etc. Instead of manufacturing the machines at a moderate price and selling them, the company merely hired them out on rather high terms, making an arrangement for the lessees to be visited by an inspector from time to time, who would look over their instruments and keep them in order. This system was an absolute failure. The Phonographs were little used, but within the last few years have come into popular favor in the shape of what I may term musical toys. Talking and music reproducing machines of various kinds are now sold at a low price by quite a number of makers, and at the present day the practical and useful side of the Phonograph seems in danger of being lost sight of. The entertainment Phonograph is not suitable for literary work, and an unguided author is likely to get a machine which for his particular purpose is of little use.

\* \* \* \* \*

I find that Phonographs have several advantages beyond those which are obvious. In the first place the author and his amanuensis can both be working at the same time, which doubles the time the amanuensis can give to transcription. Secondly, the author can work at any time it pleases him. Shorthand writers who have to come up to the study at eleven o'clock at night will not often be found in a very amiable frame of mind. The author who has a Phonograph into which he can dictate at night, can please himself as to his hours. Thirdly, the machine is, I need hardly say, an endless source of amusement to one's friends, for even those made specially for literary and business purposes will reproduce music, songs, etc., with more or less accuracy, and the friend who is not interested in literary matters is sometimes very much interested in the Phonograph. And, lastly, where members of an author's family are anxious to assist him in his labors, they can always do so by shaving the cylinders and by writing out for him anything he may dictate into the Phonograph, for obviously no knowledge of shorthand is necessary. One of my delights in my leisure moments is to place my Phonograph at the back of the piano, ramble about over the keys, and imagine I am composing. The Phonograph makes a record of the resulting sounds and enables me to study them and hear what poor stuff I have evolved. The instrument may be therefore recommended as a moderator of vanity.

The most pleasant way to hear music, or indeed any sounds, reproduced by the Phono-



## SUSPENDED LIST, JUNE 1, 1903.—SUPERSEDING ALL PREVIOUS LISTS.

## KANSAS.

LAWRENCE—BELL BROS.

## MASSACHUSETTS.

LAWRENCE—LORD &amp; CO., 314 Essex street.

MALDEN—A. T. FULLER.

NEW BEDFORD—H. B. DEWOLFF.

## MICHIGAN.

DETROIT—F. J. SCHWANKOVSKY.

SAGINAW—GEO. W. EMENDORFER.

## MISSOURI.

KANSAS CITY—THE WITTMANN CO.

## NEBRASKA.

LINCOLN—THE WITTMANN CO.

OMAHA—THE WITTMANN CO.

## NEW JERSEY.

ATLANTIC CITY—SAMUEL D. WOLF, 32-34  
Arkansas avenue.

BAYONNE—I. WIGDOR, 450 Avenue D.

JERSEY CITY—W. L. HOFFMAN, 151 Mont-  
gomery street.

NEWARK—R. L. CORWIN.

PATERSON—CHAS. H. KELLY, 25 N. Main st.

WEST HOBOKEN—EMIL HOLLANDER, or  
THE WEST HOBOKEN BICYCLE &  
PHONOGRAPH CO., 619 Spring street.

\* Added since last Suspended List was issued, April 1, 1903.

**Jobbers and Dealers are asked to co-operate with us, FOR OUR MUTUAL GOOD, by being careful that they do not supply any of the above named firms with our apparatus.**

## NEW YORK.

BEDFORD PARK—GEO. H. TYRRELL.

NEW YORK CITY—A. T. ARMSTRONG, or  
AMERICAN PHONOGRAPH CO., 106  
Wall street.

R. L. CORWIN, also Newark, N. J.

EAGLE PHONOGRAPH CO., or C.  
LOWENTHAL, 83 Nassau Street.EMPIRE PHONOGRAPH CO., 2 West  
14th street.HAWTHORNE & SHEBLE, 297 Broad-  
way, also Philadelphia, Pa.R. H. INGERSOLL & BRO., 67 Cort-  
landt street.

W. L. ISAACS, 114 Fulton street.

S. LEMBURG &amp; CO., 194 Broadway.

J. McELLYNNE, 202 Broadway.

F. M. PRESCOTT, 44 Broad street.

STAR CREDIT CO., or Paul Sacks, 180  
East Houston st. and 57 Third ave.

SARATOGA—W. J. TOTTEN.

## OHIO.

CINCINNATI—J. L. ANDEM.

SPRINGFIELD—D. &amp; M. VANDERPOOL.

UHRICHSVILLE—F. A. MAZURIE.

## PENNSYLVANIA.

PHILADELPHIA—HAWTHORNE & SHEBLE,  
604 Chestnut street.

PITTSBURG—\*A. LIPPARD, 615 Wylie avenue.

## RHODE ISLAND.

PROVIDENCE—F. P. MOORE.

graph is through thin, hard rubber tubes, the ends of which are connected with the ears like the modern stethoscope. These fine tubes have the curious property of softening away the grating or hissing noise, which is really the reproduction of the noise of the sapphire cutting into the wax, while at the same time increasing and rendering more faithfully than the trumpet the sounds one desires to hear. When a trumpet is used objectionable sounds are emphasized, and there is a good deal of metallic vibration as well. I should explain I am referring to the literary Phonograph and not those specially constructed for concert use. When dictating it is best to speak into the metal trumpet provided with the machine.

It is perhaps interesting to mention that the foregoing remarks are recorded on exactly three cylinders and a half, and therefore in all probability consist of about 3,600 words.

**Dealers are urged to sign the new Agreement promptly.**

## THE MEGAHORN.

Most of the devices gotten out for improving the Phonograph amount to little when tested by experience. The Douglas megahorn, however, is one of the devices which seems to have real merit. The horn is made of hard-finished pressed board (not *papier mache*). It is constructed of several pieces built around a model or mould on a plan of an ever-increasing circle, there not being a straight line in the entire construction.

Authorities on acoustics pronounce this horn the best of its kind in use for reproducing of records. It is made in two sizes, as follows: Mega Jr., 22 inches long with 13-inch bell; mega large, 32 inches long with 24-inch bell. A few points claimed by the manufacturer of this horn is that a greater individuality is given to instrumental records, distributing the volume of tone and imparting a resonant quality not to be had in any other horn.

# The E. W. N. Handbook of the Phonograph

— AND —

## Instructions for Making Records.

BY C. W. NOYES.

### Every Owner

Of a talking machine should have a copy of this valuable book. It is replete with **Instructions for the Care and Use of the Phonograph**, and the chapters devoted to **RECORD MAKING** are compiled from the author's many years of experience in some of the principal laboratories of this country.

Any one possessed of ordinary intelligence can make a perfect record if the directions are followed.

**Fully Illustrated — Handsomely Bound.**

**PAPER, 25 CENTS.**

**CLOTH, 50 CENTS.**

Mailed Postpaid on Receipt of Price.

For Sale by All Jobbers, or **ILSEN & COMPANY, Cincinnati, Ohio.**  
DEALERS WRITE FOR DISCOUNTS.

### JUNE ADVERTISING.

"The Phonograph is sold in 5,000 stores. Call at the nearest Dealers and hear the modern Phonograph with the new *Edison Moulded Records* and the *New Reproducer*." This is again the theme of the advertising of the National Phonograph Co. for June. It directs the attention of the public to the Dealers in Edison Phonographs and Records, and if there is any value in advertising it is constantly creating business for the Dealers. If a Dealer is making the effort he should keep the public informed of the fact that he sells Edison goods, then this advertising is of almost as much value to him as if his name and address appeared in it. Should the advertisement make an impression upon an individual sufficient to induce him to look into the merits of the Phonograph, then he instantly calls to mind the Dealer who has been keeping his name in the papers as selling Edison Phonographs and Records. In this way Dealers may at a small expenditure get much benefit from the general advertising of this Company—advertising that costs many thousands of dollars more than he could spend himself.

The mediums used by this Company in June were the following: Ainslee's, American Boy, Brown Book, Century, Collier's, Craftsmen, Everybody's, Field and Stream, Independent, Life, McClure's, Metropolitan, Musical Record and Review, Outing, Outwest, Overland, Photo Era, Saturday Evening Post, Scribner's, Smart Set, Strand, Success, Town Topics, Town and Country.

## EVERYONE LOVES THE EDISON PHONOGRAPH

NONE GENUINE WITHOUT  
THIS  
TRADE  
*Thomas A. Edison*  
MARK

The Phonograph is distinguished from other talking machines by its absolute freedom from scratching and pure, natural tones of music or voice.

The Phonograph is infinitely superior.

The Phonograph is sold in 5,000 stores. Call at the nearest dealer's and hear the modern Phonograph with the new *Edison Moulded Records* and the *New Reproducer*.

Phonographs from \$10.00 to \$100.00.  
Records, 50c.; \$5.00 per dozen.

NATIONAL PHONOGRAPH CO., Orange, N. J.

NEW YORK, 83 Chambers St. CHICAGO, 304 Wabash Ave. SAN FRANCISCO, 933  
Market St. EUROPE, 32 Rempart Saint Georges, ANTWERP, BELGIUM.



# EDISON Phonograph Monthly

PUBLISHED FOR TRADE USE ONLY BY  
THE NATIONAL PHONOGRAPH CO.

VOL. 1.

NEW YORK, JULY, 1903.

No. 5.

*The National Phonograph Co.,*  
ORANGE, N. J.

NEW YORK: 83 CHAMBERS STREET.  
CHICAGO: 304 WABASH AVENUE.  
SAN FRANCISCO: 933 MARKET STREET.  
ANTWERP: 32 REMPART SAINT GEORGES.  
LONDON: 52 GRAY'S INN ROAD, HOLBORN.

## EDISON PHONOGRAPHS AND RECORDS.

All communications to THE PHONOGRAPH MONTHLY should be addressed to the Advertising Department, 83 Chambers Street, New York.

### C O N T E N T S

Order Early for Fall Trade.....	1
Advance List August Records.....	2
Price-Cutters Will Suffer Sooner or Later.	3
Agreements To Be Signed with Every Jobber .....	3
Record Shipments.....	3
Order and Injunction in "The Fair" Case..	4
Instalment Plans for Selling Phonographs.	4
Factory Additions.....	5
French, German and Spanish I. C. S. Lan- guage Outfits.....	5
The August List.....	6
A Pioneer in the Phonograph Business...	7
On "Following Up".....	7
Posters and Street Car Cards.....	7
Dealers Must Sign Agreement at Once....	7
About Printed Matter.....	8
Price-Cutting Abroad.....	9
Odd Uses for the Phonograph.....	9
Why Bill Bailey Returned Home.....	9
Detroit "Raises" Chicago.....	10
Owens Over 1,900 Records.....	10
A Large Advertising Horn.....	11
Among the Jobbers.....	11
Thomas A. Edison's Patents.....	12
Phonograph for Dictation Purposes.....	12
Suspended List.....	14
A Jobber's Large Order.....	15
July Advertising.....	15
A Reporter Hears Our Chimes Records...	12
A Phonograph Incident in the Philippines	13
A Dealer's Commendation .....	13
A Peculiar Phonograph Belt.. ..	14

## ORDER EARLY FOR THE FALL TRADE.

Although it is July, it is none too early to begin to think of the fall. Jobbers and Dealers who were handling our goods a year ago will recollect how difficult it was towards winter to get Phonographs, Reproducers and Records promptly. This was largely due to the great influx of orders as the holiday season approached. A similar difficulty may be avoided by placing orders for goods in advance; in other words, anticipate your fall needs. Look over your last year's business to see what goods you sold, then take account of stock so as to determine what styles of machine or what Record titles you are short of, and then place orders for sufficient goods to make your stock complete. Bear in mind, if you are a Dealer, that it takes time to get an order to your Jobber; it takes more time for him to place his order with us, and, as shipments are made by freight, it takes considerable time to get goods to him, to say nothing of the possible delays at the factory in consequence of the number of orders already on file. Your order, however, will get attention in its turn, if others are ahead of it, and in this way you will get your goods at about the time you are needing them most. Even if you should get them ahead of your demand, there is no chance for loss in having them. There will be no changes in the styles of Phonographs this fall; there are scarcely any Record titles not saleable at all times and there is no likelihood of loss because you have a complete stock. We know from past experience that business is very frequently lost because a customer cannot get a Phonograph quickly or get a supply of Records of his choice when he wants them. Having a stock on hand, therefore, makes it possible to sell more goods than would otherwise be possible without it. Anticipate your wants; place orders early.

**The Phonograph will sell itself. Play it.**

THE ADVANCE LIST OF JULY RECORDS APPEARS ON PAGE 2. ORDER FROM IT. NO OTHER ADVANCE LIST WILL BE ISSUED.

## ADVANCE LIST OF NEW EDISON MOULDED RECORDS FOR AUGUST, 1903

RECORDS listed below will be ready for shipment as near August 1st, 1903, as possible, at which time Jobbers' stock orders, if placed prior to July 20th, will be shipped.

August Supplements will bear the date of August 1st, and will be forwarded to Jobbers with their stock order for Records.

Retail Dealers should place stock orders with their Jobbers at once, to insure prompt shipment as soon as Jobbers' stock is received.

Stock orders for Records contained in this list must be written on separate order blanks, and letters relating to July Records should refer to no other matter.

Kindly comply with above requests and thus aid your Jobber and ourselves in handling advance orders.

- |        |   |   |
|--------|---|---|
| 8449   | Badinage (Victor Herbert)   | Edison Concert Band   |
| —8450  | Ballet Music from Faust, Part I                                       | Edison Concert Band   |
|        | <i>Waltz corps de ballet</i>  |   |
| 8451   | Love's Dream After the Ball (Czibulka)                                | Edison Concert Band   |
| 8452   | I'm 'Thinkin' of You All of de While                                  | <i>Coon song</i> Billy Murray   |
| 8453   | Alec Busby, Don't Go Away   | <i>Coon song</i> Billy Murray   |
| 8454   | Up-to-date Minstrelsy No. 1   | Edison Modern Minstrels   |
|        | <i>Introducing song "My Love I Dare Not Tell," by Arthur Clifford</i> |   |
| 8455   | Heart Bowed Down, Aria from "The Bohemian Girl"                       | Tuson   |
|        | <i>Clarinet solo with orchestra accompaniment</i>                     |   |
| 8456   | Congo Love Song   | MacDonough  |
|        | <i>By composer of "Under the Bamboo Tree"</i>                         |   |
| 8457   | A Scene in a Country Store  | Harlan & Stanley  |
|        | <i>Comic Rube talking and singing duet</i>                            |   |
| 8458   | The Moss Rose (Rose-Mousse, Valse lente) a Parisian Success           | Edison Symphony Orchestra   |
| 8459   | A Lucky Duck, a web-foot promenade with "quack" effect                | Edison Symphony Orchestra   |
|        | <i>By composer of "The Mosquito Parade"</i>                           |   |
| X 8460 | You Can't Fool All the People All the Time                            | <i>Coon song</i> Collins  |
|        | <i>(Marie Cahill's big hit)</i>                                       |   |
| 8461   | Onward Christian Soldiers   | Mendelssohn Mixed Quartette   |
| 8462   | Alita (Wild Flower) Bells   | Albert Benzler  |
|        | <i>With orchestra accompaniment</i>                                   |   |
| 8463   | While the Moon Shines Bright  | Harlan  |
|        | <i>Waltz song with orchestra accompaniment</i>                        |   |
| 8464   | On the High Alps (Lander Idylle)                                      | <i>Violin and flute duet</i> Jaudas & Atz   |
| 8465   | Only a Dream of the Golden Past                                       | <i>Descriptive song</i> Franklyn Wallace  |
| 8466   | My Emmaleen   | <i>Coon song from "Peggy from Paris"</i> Collins  |
| X 8467 | When We Get Married   | <i>Comic song</i> Denny   |
| X 8468 | There's a Mother Always Waiting for You at Home,<br>Sweet Home        | <i>Male duet</i> Harlan & Stanley   |
| 8469   | It's a Lovely Day for a Walk  | Miss Morgan & Mr. Stanley   |
|        | <i>Serio-comic contralto and basso duet</i>                           |   |
| 8470   | Coming Thro' the Rye, Theme and Variations,                           | Mazziotta   |
|        | <i>Piccolo solo with orchestra accompaniment</i>                      |   |
| 8471   | Ephasafa Dill   | <i>Comic coon male duet</i> Collins & Harlan  |
| 8472   | The Girl Who Comes in From the West                                   | <i>Serio-comic song from "Peggy from Paris" with orchestra accompaniment</i> MacDonough |
| 8473   | Santiago Waltz  | <i>Xylophone solo with orchestra accompaniment</i> Hopkins                              |

Edison Moulded Records are made only in Standard size. Both Standard and Concert Records may be ordered from this list. Order by Number, not title. If Concert Records are wanted, give the number and letter C.



### A SMALL SUSPENDED LIST.

The fact that out of nearly 5,500 Dealers in Edison goods we find it necessary to place only thirty-four on the Suspended List is a record of which we are proud. Even thirty-four is a high number, for we know that several of the firms on this List are no longer in the Phonograph business. The smallness of the number shows that there is little price cutting in Edison goods. It is most gratifying to us to find the trade living up to our Agreement System with such unanimity. This is doubtless because Jobbers and Dealers have found from experience that it is much more profitable and more satisfactory to sell Phonographs and Records at a uniform price than to endeavor to increase their business by selling at less than the established prices.

### PRICE CUTTERS WILL SUFFER SOONER OR LATER.

Occasionally we get a letter from an impatient Dealer, informing us that his competitor is cutting prices, and demanding that some immediate action be taken to stop it. He cites instances of customers leaving his place after learning that he will not sell at less than the established prices and later returning with the statement that they had bought goods at his rival's store at a discount. Too frequently the only evidence that a Dealer has is the statement of the customer made under such circumstances, and it would, of course, be impossible to take action upon such testimony. Even, however, where a Dealer goes to further trouble and has someone buy goods at his competitor's store at a cut price, it is difficult to stop it at once. It takes time to lay the information before the Jobber who is selling to the price cutter, in order that he may refuse to sell him any further goods. This frequently must be done in the case of several Jobbers through whom a Dealer may buy. Those who keep faith with the company, however, may depend upon it that sooner or later price cutters will be summarily dealt with. Their supply of goods will be cut off, and if they are individuals whom it would pay to bring suit against, we shall bring action against them. We, therefore, ask the complaining Dealer to continue to send us his evidence and be patient.

### ADVERTISEMENTS WILL BE ACCEPTED FOR THE MONTHLY.

Since the first issue of the PHONOGRAPH MONTHLY, we have had inquiries as to whether we would run in its columns the advertisements of other goods. At first it was thought better to do no advertising except for this company,

but last month the matter was re-considered so far as to agree to publish advertisements of goods or articles allied to the Phonograph trade, such as horns, cabinets, handbooks, etc. In consequence of this re-consideration, we accepted an order from Ilsen & Company, of Cincinnati, to advertise their Handbook of the Phonograph. This will explain why the advertisement appeared in the June issue. The rate of \$10 per page or \$5 a half page has been fixed upon for this advertising, no advertisement for less than a half page being accepted. We are not soliciting advertising, but if firms selling goods to the Phonograph trade desire to use the columns of the MONTHLY to reach Jobbers and Dealers they may do so at these rates.

### AGREEMENTS TO BE SIGNED WITH EVERY JOBBER.

Jobbers frequently complain that Dealers think they can buy Edison goods through any Jobber on our list so long as they signed an Agreement through any one Jobber. This understanding is wrong. In order to deal with any Jobber, a Dealer must sign an Agreement through him, and if he is buying through half a dozen Jobbers, he must sign as many different Agreements. A Jobber who does not have an Agreement of this kind has no knowledge that a Dealer has signed at all. It is not enough that the Dealer claims that he has signed or that he even shows a duplicate of the Agreement he has signed. He *must* sign with *every* Jobber through whom he desires to buy.

Kellar, the magician, recently bought an Edison Phonograph from one of our New York City Jobbers. This is the way that the Jobber put the question: "If Kellar is the king of amusement makers and the Phonograph amuses Kellar, is not the Phonograph greater than the king?"

### RECORD SHIPMENTS.

We are glad to be able to report that we are gradually catching up on the shipments of the monthly Records. Those for May were completed on June 20th and the June list will be in the hands of the trade before July 10th. If we continue to make the same gain we shall be caught up by September. We had hoped to do better than this, anticipating a decrease in orders with the approach of summer, but the volume of business shows so little change from that of midwinter that it has not been possible to do so.

ANOTHER DECISION SUSTAINING AND PROTECTING THE NATIONAL PHONOGRAPH COMPANY, ITS JOBBERS AND DEALERS IN THE SALE OF EDISON PHONOGRAPHS AND RECORDS.

Below will be found copies of an order and an injunction recently entered in a suit brought by the National Phonograph Company, to prevent "The Fair," a department store in Chicago, from selling Edison Records procured by them without their signing the required Agreement.

We might add in this connection, that "The Fair" has now signed Agreement with us, and will, we believe, hereafter live up to our Terms and Conditions in every respect.

THE ORDER.

Circuit Court of the United States. Northern District of Illinois, Northern Division.

Monday, May 25, 1903.

Present, Hon. CHRISTIAN C. KOHLSAAT, District Judge.

EDISON PHONOGRAPH COMPANY, AND NATIONAL PHONOGRAPH COMPANY, vs. THE FAIR (a corporation). No. 26613.

This cause coming on to be heard upon the pleadings, the demurrer of defendant herein having been overruled, Mr. Charles K. Offield, appearing in behalf of complainants, and Mr. Walter Chamberlin, in behalf of defendant; and it appearing to the Court that the defendant does not further desire to contest this action, and admits the truth of the allegations of the Bill of Complaint, and has settled and paid to complainants the profits and damages asserted and contended for in said Bill of Complaint, now, therefore, it is Ordered, Adjudged and Decreed, that a perpetual injunction issue in accordance with the prayer of said Bill of Complaint filed herein, and that the defendant pay the taxable Court costs in this action, and that this Decree thereupon and thereby is final.

Northern District of Illinois, Northern Division, ss.:

I, Marshall E. Sampsell, Clerk of the Circuit Court of the United States, for said Northern District of Illinois, do hereby certify the above and foregoing to be a true and complete copy of the Order entered of record in said Court on the twenty-fifth day of May, A. D. 1903, in the cause wherein Edison Phonograph Company and National Phonograph Company are the complainants and The Fair (a corporation) is the defendant, as the same appears from the original records of said Court now remaining in my custody and control.

In Testimony Whereof, I have hereunto set my hand and affixed the seal of said Court at my office in Chicago, in said District, this twenty-fifth day of May, A. D. 1903. MARSHALL E. SAMPSELL, Clerk.

THE INJUNCTION.

United States Circuit Court. Northern District of Illinois, Northern Division.

EDISON PHONOGRAPH COMPANY, et al., Complainants, vs. THE FAIR (a corporation), Defendant. In Equity.

The President of the United States of America to The Fair, its officers, agents, attorneys, servants and workmen, and each and every of them.

GREETINGS:

Whereas in a certain final decree made in our Circuit Court of the United States for the Northern District of Illinois, Northern Division, on the twenty-fifth day of May, 1903, in a certain case therein depending wherein Edison Phonograph Company and National Phonograph Company are complainants and the said The Fair is defendant, it was ordered, adjudged and

decreed that a perpetual injunction should issue against you, the said The Fair, in accordance with the prayer of the complainants' bill of complaint filed therein; we therefore, in consideration of the premises, do hereby strictly enjoin and command you, the said The Fair, your officers, agents, attorneys, servants and workmen, under the penalty that may fall thereon, that you and every of you do from henceforth and forever absolutely desist and refrain from directly or indirectly using or causing to be used, selling or causing to be sold, any apparatus, articles or devices, embodying or constructed or operating in accordance with the inventions and improvement set forth in Letters Patent of the United States numbered 386,974 and 382,418 respectively, without the license of the said complainants

Witness, Melville W. Fuller, Chief Justice of our Supreme Court, this twelfth day of June, 1903.

[Seal]. MARSHALL E. SAMPSELL, Clerk.

OFFIELD, TOWLE & LINTHICUM.

HOWARD W. HAYES, Solicitors.

Service accepted of the above injunctive order:

WALTER H. CHAMBERLIN,

June 13, 1903.

For Defendant.

INSTALMENT PLANS FOR SELLING PHONOGRAPHS.

Some weeks ago a Western Jobber wrote to our Sales Department with reference to the plan followed by Dealers who make a feature of selling Phonographs and Records on the instalment or easy payment plan. The reply of the Sales Department covered the ground so fully that it is printed below:

Replying to that portion of yours of the 6th inst., relative to plan adopted by Dealers in selling Phonographs on the instalment, easy-payment, weekly or monthly payment basis, we have made inquiry of six different Dealers in this city, who do a very large business in this manner, and find their system to be as follows:

They add to list price of machines, with regular outfit, as follows: Gem, \$2 to \$3; Standard, \$2 to \$3; Home, \$3 to \$5; Triumph, \$5 to \$10.

Terms of payment as follows: In one case \$1 down on any outfit, and \$1 per week until paid for. In all other cases, first payment runs \$3 down on Gem, \$5 on Standard, \$10 on Home, and from \$15 to \$20 on Triumph, with weekly payments of \$1 per week until full amount is paid.

In no case are Records or accessories, such as large size horns, Record cases, etc., included on the instalment basis. Such goods are cash down.

In all cases a lease is taken, which makes the outfit the property of the Dealer until it is paid for in full. Any Dealer taking up the instalment business can, of course, use such agreement or lease as he thinks best.

In talking this method of doing business over with our different Dealers here, we find it is a very successful one, and they all report the percentage of loss on instalment business is less than on their regular credit business. Writer knows, from personal investigation, that all of the six dealers referred to have made a lot of money by selling our apparatus in this manner, and as this system of selling goods is being taken up more extensively every day, and in almost every city in the country, fully believes if you will take it up and be the pioneers in that direction in your city, you would meet with unqualified success.



**FACTORY ADDITIONS.**

The improvements now being made to the factory of the National Phonograph Company, at Orange, N. J., comprise two things: First, an entirely new brick building; second, adding a second story to a building that has been in use several years. The new brick building will be a two-story structure, 66 feet wide and 276 feet long, with an L 58 by 105 at one end. It will be built with 16-inch walls and little effort will be made at exterior ornamentation. This building will be devoted entirely to the manufacture of Moulded Records. Under its roof every process will be carried out, from the mixing of the special composition, up through the moulding, testing and other processes, till they are wrapped in cotton and paper and then packed in cases for shipment to all parts of the world. It is expected that with this building we shall have facilities for turning out twice as many Records as at present. The building now used for Record making will be devoted to making Masters and Moulds, both of which branches are badly cramped for room at present.

The building that is having a story added to it is a frame structure 50 by 279. Its one story was used for assembling, making reproducers, testing machines, for packing, and as a store room, and every department was working at a disadvantage for want of proper working space. In adding another story to the building considerable ingenuity was shown by the architect in charge. With every foot of space in constant demand during working hours and frequently far into the night, it became necessary to make the improvement without interfering with work. The building was therefore literally sawed in half from the roof to the ground. The north half was then raised by jacks to the required height, supported by heavy wooden columns, with steel beams, inclosed on the sides and floors laid. Between 200 and 300 men remained at work while the work was going on, and soon found themselves working twenty feet above their old quarters on the ground floor. The force at work on the ground floor of the southern half of the building moved into the new floor of the northern end, and the southern portion is now being raised to the same height as the other half. This addition will add 13,900 feet of floor space to the building. Each department will get a large slice of this increase and all will be in splendid shape to take care of an increased business.

**Keep ahead of the demand for goods by ordering early.**

**FRENCH, GERMAN, SPANISH I. C. S. LANGUAGE OUTFITS.**

The International Correspondence School of Scranton, Pa., has been most successful in the past few years with its use of the Edison Phonograph in teaching its French, German and Spanish language courses. Students using the Phonograph and the Records prepared by the school have been unanimous in their praises of them. The system is a pronounced success. Up to the present time it has not been possible to secure these language study outfits except from the International Correspondence School. This institution has now decided to place the outfits in the hands of the Phonograph trade generally, and Nelson C. Durand, manager of the language department of the school, is taking the matter up with Jobbers and Dealers as rapidly as possible. He expects to call personally upon many of them and to correspond with the others. Any who may desire immediate information should address Mr. Durand at Scranton.

The advent of the I. C. S. Language Study Outfits opens a new field for the Edison Dealer by helping him to place the Phonograph in more homes and keeping alive the interest of customers. Only regular Edison Jobbers and Dealers may purchase the class of goods and regular Edison contracts, mentioning the language material, must be signed before sales will be made. The standard prices are given below:

Set of 25 I. C. S. Records and Textbooks sold in combination.....	25.00
Complete I. C. S. Language Outfit, Records and Textbooks, without correspondence instruction.....	50.00
I. C. S. Phonograph Outfits sold separately .....	\$30.00
Set of 25 I. C. S. Records, sold separately	18.00

Attractive posters and advertising matter are furnished by the International Correspondence Schools of Scranton, Pa., in connection with their sales. We hope that the trade will post themselves on this new feature of the business at the first opportunity.

NEWTOWN, Iowa, June 4, 1913.

I acknowledge receipt of list of suspended Dealers and desire to congratulate you on the splendid system used in connection with your business. I shall certainly co-operate with you in keeping out the price-cutters. I know from experience that the Phonograph is the only really dependable talking machine sold to-day at any price. I admire their perfect mechanical construction, which speaks well for the skill of the workmen who make them.

W. E. DINGMAN.

One of our Pennsylvania Dealers is a furniture dealer and undertaker, and sells Phonographs as a side line. Can any other Dealer show a greater contrast in business?

### THE AUGUST LIST.

In the twenty-five new Record titles listed for August our Record Department has prepared what we regard as a real treat for lovers of the Edison Phonograph. The list contains more new and novel things than any similar list in some time past. The first title, No. 8449, "Badinage," is a composition by Victor Herbert. It illustrates in a musical way the carrying on of a vivacious conversation, some clever effects being given. The composition may be found on the best concert programmes. It is very popular among music lovers. Our new band does it full justice. The second selection by the band, No. 8450, gives Part I. of the Ballet Music from "Faust" (waltz for the corps de ballet), written by Gounod. This is one of the prettiest parts of this famous ballet music. Parts II., III. and IV. will be listed later. A third band title is No. 8451, "Love's Dream After the Ball," by Czibulka. This beautiful concert number is played by the best bands and orchestras.

Nos. 8452 and 8453, "I'm Thinkin' of You All de While" and "Alec Busby, Don't Go Away," are coon songs by Billy Murray, a new man on our staff of entertainers. He sings these songs in a highly amusing manner and gives evidence of being a success. The demand for our minstrel Records already listed has induced us to make another. It is No. 8454, "Up-to-Date Minstrels No. 1." It is made by the Edison Modern Minstrels, and in it Arthur Clifford sings "My Love I Dare Not Tell."

No. 8455, "Heart Bowed Down," aria from "The Bohemian Girl," is one of the novel things on the list. It is a clarinet solo by William Tuson, but it is accompanied by an orchestra instead of the piano, as all clarinet solos of the past have been. A more perfect Record would be hard to make. In No. 8456 Harry MacDonough sings "Congo Love Song," written by the composer of "Under the Bamboo Tree," and it will probably be as popular. No. 8457, "A Scene in a Country Store," a Rube talking and singing duet by Harlan and Stanley, will cause many a merry laugh.

The Edison Symphony Orchestra has two selections in this list. No. 8458 is a Paris success called "Rose Mousse." We have given it the English name, "Moss Rose." It is a delightful waltz air. No. 8459, "A Lucky Duck," is styled on our list as a "web-foot" promenade, with "quack" effect. It is written by Howard Whitney, composer of "The Mosquito Parade," and it has been played with great success in the far West. In San Francisco for weeks everybody did nothing but "quack."

No. 8460 gives "You Can't Fool All the People All the Time," the coon song in which Marie Cahill has just made such a hit in New York city. Arthur Collins sings it in an excellent manner. Those who heard "Refuge," by the Mendelssohn Mixed Quartette, in the June list, cannot fail to be pleased with No. 8461, "Onward, Christian Soldiers," by the same quartette.

No. 8462, "Alita" (Wild Flower), is a bells solo, with orchestra accompaniment, played by Albert Bengler, another new entertainer. In No. 8463 Byron G. Harlan sings another of his sentimental songs, called "When the Moon Shines Bright." So popular have the violin and flute duets by Jaudas and Atz become that a monthly list is not now complete without one. That in the August list is "On the High Alps." It is a pretty air and played charmingly. No. 8465, "Only a Dream of the Golden Past," brings Franklyn Wallace back to the public ear. This song will deepen the good impression made by his previous selections.

In the July list we gave a selection from "Peggy from Paris," by the Edison Symphony Orchestra. This bright musical comedy by George Ade and William Loraine, is now enjoying a popular run at Boston, and it is shortly to be produced in New York. This month we give two songs from this operetta, No. 8466, "My Emmaleen," a coon song by Arthur Collins, and No. 8472, "The Girl Who Comes in from the West," a serio-comic song by Harry MacDonough. Both are catchy airs and will be whistled the country over ere long.

No. 8467, "When We Get Married," brings before Phonograph users another selection by Will F. Denny, and all who know about his clever singing of songs of this character will recognize in the title a song suited to his talent. No. 8468, "There's a Mother Always Waiting for You at Home, Sweet Home," is a well-rendered duet by Harlan and Stanley. Miss Morgan and Mr. Stanley again sing pleasingly in No. 8469, "It's a Lovely Day for a Walk." In playing No. 8470, "Coming Thro' the Rye," theme and variations, by Frank S. Mazziotta, the piccolo was accompanied by the orchestra for the first time, and an excellent Record was secured.

No. 8471, "Ephasafa Dill," is a comic coon duet by Collins and Harlan, and it is sung with good blend and swing. No. 8473, "Santiago Waltz," is another one of J. Frank Hopkins' excellent xylophone solos.

**If you have not signed the new Agreement do it at once and keep in good stand-**



## A PIONEER IN THE PHONOGRAPH BUSINESS.

COLTON, California, June 20, 1903.

Beg to acknowledge receipt of your late list of suspended Dealers. THE PHONOGRAPH MONTHLY comes to hand regular, and I am greatly pleased with it. I am one of the oldest Phonograph Agents in the West; I bought Phonographs from the North American Co. before you had a Jobber in San Francisco. I believe I am the only person in California that has been handling Phonograph goods exclusively for ten or more years, all other Dealers I have seen handle something else along with Phonographs, but I have had plenty to do with Phonographs alone. I make it a point to repair every Edison Phonograph I see out of order. I do not wait for my customers to come to me, I go to them; I am well known all over this State and parts of Mexico.

I want to tell you about one party in San Diego, Cal. He is a German; he bought a Concert Machine when they sold for \$125, and Records for \$4 each. He has now upwards of 500 Records and has paid out about \$800 for Phonograph goods. The first time I went to his place of business with a Phonograph he told me he would not have one of them in his stable. (I think some one had just been in ahead of me trying to sell him a Scratchophone).

In the way of advertising I have had several suits of clothing made up in a sort of a uniform, yet different than any I have seen any one else wear, with the letters "Edison Phonographs" on the cap.

At present I have a large nickel-plated badge with the words Edison Phonograph Agent. The Phonograph is "O. K." and I want the people to know that I am in the business.

THOMAS H. LEONARD.

Who has sold Phonographs continuously longer than Mr. Leonard?

### ON "FOLLOWING UP."

Most of our Dealers know all about our system of following up the inquiries that we receive from our advertisements. For the benefit, however, of new Dealers, we desire to again refer to the matter. When a reply to an advertisement is received by us, the catalogues or information requested are at once mailed and the inquirer advised that his request has been referred to the Dealers nearest him. The location of the inquirer is then looked up, and all Dealers in his vicinity are advised that he is seeking information about Phonographs or Records. The result is that the prospective buyer gets almost immediate attention from one or more Dealers, and we know of thousands of cases where sales have followed. It must be evident to Dealers that a company which goes to this trouble for their benefit must be a good one to tie up to. It is but one of many things being done to turn business over to the trade instead of seeking to get it direct.

## POSTERS AND STREET CAR CARDS.

The reference in the June MONTHLY to our getting out a supply of posters for use on billboards and placards for use in street cars was responded to by only a few Jobbers and Dealers, and they, in some instances, had interpreted the paragraph to mean that the posters and placards were already to be had for the asking. To get up posters and placards in an attractive manner and in a large quantity means the expenditure of considerable money. It would be unwise to go to this expense and then find that the trade did not care to use them, unless we bore the expense of posting or putting the placards in street cars. The paragraph referred to was intended to get from the trade some idea as to the possible use of these advertising forms. The responses thus far are not enough to warrant us in going ahead with the work; but before deciding the matter, we will wait another month and see how many other Jobbers or Dealers write us on the subject.

## DEALERS MUST SIGN AGREEMENT AT ONCE.

July 1 was the time fixed when the new Retail Dealers' Agreement would go into effect. That date now being past, Dealers who have not signed the new Agreement are liable to be put to considerable trouble in getting goods. If the matter has escaped the attention of any Dealers and they have not yet signed, it will be advisable for them to sign at once and forward Agreement to their Jobber, or to either of our offices if they are dealing direct. We do not want to be harsh with any one in the trade or to take their names off our books; but if Dealers do not sign, we have no other option in the matter under our system.

Under date of June 23, the American Phonograph Co., Gloversville, N. Y., writes:—"The continued holding on of the season's business has passed all calculations as compared with past years."

3821 Sydenham St.,

PHILADELPHIA, June 18, 1903.

I wish to assure you that you have my hearty co-operation in your dealings with all named on the suspended list.

The PHONOGRAPH MONTHLY is welcome and greatly appreciated, and trust it will grow each month and develop finally into a magazine of twenty-five or thirty pages. I shall do all I can to help the good work along.

Assuring you my hearty support at all times, I am, yours truly,

J. M. EISENHUTH.

### ABOUT PRINTED MATTER.

Requests to mail the PHONOGRAPH MONTHLY to individuals outside of the trade cannot be granted. It is published only for the information of the trade.

A new edition has been printed of Form No. 414, the four-page folder showing the Gem, Standard, Home and Triumph types of the Phonograph on its inside pages. New half-tones of the machines have been made and the matter on the last page has been rewritten.

Recognizing the justness of the complaints from Dealers that hangers come out of the mail badly creased after being folded, we have decided to adopt some other means of mailing them. The next lot will probably go out in mailing tubes and we shall be glad to know if they reach Dealers in better shape. In the absence of complaints we shall assume that the service is better. The same method will probably be adopted for mailing the Record bulletin.

We would again ask Dealers to get catalogues and other printed matter from their Jobbers instead of writing direct to us for it. We have no means of knowing how much business a Dealer is doing and without that knowledge cannot form any estimate as to what a Dealer should have in the way of advertising literature. The Jobber should have a good stock of this matter on hand and be in a position to save the Dealer transportation charges on it.

With the May Record supplements a variation was made in the style of work on these slips. As all the trade now know, the May supplement showed a youthful imitator of Sousa, with eyeglasses and medals, leading the band, the music of which is issuing from the horn of a Standard Phonograph. The June supplement will show the Phonograph amusing a group of foreigners, each one of whom represents a different nation. Still another idea will be illustrated with the July list.

Some of our Dealers do not seem to be aware of the fact that we furnish, without charge, an order book for their use. They are probably Dealers who have taken up the line since these books were sent to all Dealers, a year or more ago. We are desirous that all Dealers shall have one of these books on hand at all times and use them in placing orders. They are printed in duplicate, enabling Dealers to keep a carbon copy of their order. Ask your Jobber for an order book, or, if you are

buying direct, have one mailed from the New York office.

Some time in July we will send out the first of a new series of posters lithographed in a manner quite different from anything heretofore issued by this company. There are three posters in the series, each 11x25 inches in size. Each shows the Phonograph in connection with some attractive scene. The first to be issued is Form No. 431, showing the Phonograph amusing three lonesome Summer girls. Its caption is "More Fun Than a Man. The Man is in the Edison Phonograph." In August we will send out the second of the series, Form No. 432, showing a pair of lovers on a yacht at sea and spending their idle time listening to the Phonograph. Its title is "Two's Company. Three's More Fun with the Edison Phonograph." The third of the series will be issued in September. It shows the Phonograph entertaining a dinner party. It is called "The Up-to-date After-Dinner Speaker, the Edison Phonograph." Only one of these posters will be sent out each month, and we believe they will be considered among the best things yet gotten out for the use of the trade.

The paragraph in the June MONTHLY called "Selling Suggestions" has brought us a good many requests for sample copies of the five forms which we suggested could be used to advantage in advertising the Phonograph at fairs, etc. If those who have received these forms desire to get a supply for the uses named, we wish that they would write their Jobbers in order that the latter may send us an order for a sufficient quantity to fill their demands. Some Dealers have asked us if we could print their names upon the circulars. We have been compelled to reply that it was not feasible. To stand ready to do imprinting for 5,500 Dealers is more of a proposition than we can undertake, and we can see no way of doing it for a few unless we are ready to do it for all. Dealers can have this work done as cheaply as we can, for in all cases the circulars are printed and cut so that they can only be printed one at a time, no matter where the work is done.

### "WELL PLEASED."

GRAND SALINE, Texas, June 21, 1903.

I received your Phonograph all right and in good shape. Am well pleased with it. It is the only Edison Phonograph in the little town of Grand Saline, which has a population of 2,500. We have two ———phones in the town but you can scarcely make out what they play. There is a very good chance here to sell four or five of your Phonographs as people are wild over mine.

C. C. STEPHENS.



**PRICE CUTTING ABROAD.**

Until very recently we had never felt the necessity of adopting measures to regulate the sale of our goods abroad, as our prices have always been maintained. Of late, however, on account of the unprecedented sale of our apparatus, there has arisen a tendency in certain territories to cut prices, particularly on Phonographs and Records. Immediately this matter was brought to our attention we prepared to meet the exigency by arranging a form of Agreement similar to that in use so long and successfully in this country. We have received numerous communications of late from our most important clients abroad urging us to make this Agreement operative at once. This Agreement is now in the printer's hands, and as soon as received they will be distributed among the Dealers and Jobbers for their signatures, as we propose to take immediate steps to stop this ruinous practice of price cutting. In the event of any Jobber or Dealer violating this Agreement after same has been properly signed, we will take steps to cut off his supply, as we are determined to keep the sale of our apparatus on a sound basis.

That we will have the hearty co-operation of the trade in correcting this abuse, we do not for a moment doubt. We can assure our clients that we propose to protect their interests in this matter, and we ask our friends abroad to support us in this endeavor.

**ODD USES FOR THE PHONOGRAPH.**

A Chicago paper recently contained an article telling how a leading Paris dentist uses the Phonograph to lessen pain while extracting teeth.

Several photographers in the East have introduced the Phonograph in their studios as a means of getting their patrons to "look pleasant."

A Philadelphia dealer in pet stock is quoted by the *Philadelphia Record* as having trained a parrot to repeat advertising phrases by means of a Phonograph. He thinks that his idea has a great advertising future.

KITTANNING, Pa., June 16, 1903.

We take pleasure in signing the enclosed contract, and once more must congratulate you on the betterment of your policy, which we assure you will be to our mutual advantage.

We are particularly pleased with the second paragraph, in which parties taking up your line, must have an established store suitable to display same. This will correct an evil which we have suffered from somewhat. Wishing you continued prosperity, we remain, yours truly,

FURNEE & KENNERDELL

**WHY BILL BAILEY RETURNED HOME.**

MALDEN, Mass., June 9, 1903.

Inclosed find one of my May booklets, which I thought would interest you. The verses are original, and are intended to show the influence that the Phonograph, the bicycle and good cigars had on Bill Bailey, by inducing him to return to his lady-love, where the influence of gold failed, as shown in the April No. 8389 "I Wonder Why Bill Bailey Don't Come Home."

JAMES CONWAY,  
Manager Malden Sporting Goods Co.

The folder referred to by Mr. Conway had a pretty design on the first page, a list of the May Records on the second page and the following verses on the third page:

**THE REASON BILL BAILEY CAME HOME.**

On a dark and stormy night  
The rain was falling fast,  
Bill Bailey's former lady love  
Was thinking of the past.  
As Bill was passing by,  
He heard his sweetheart cry:  
Come back again, Bill Bailey,  
Come to your sweetheart true;  
I've got a lovely Phonograph,  
And the latest Records, too;  
I've got a bike for you to ride,  
And cigars for you to smoke;  
Come home again, Bill Bailey,  
My heart is nearly broke.  
They live happy now together,  
And it makes Bill Bailey laugh,  
The comic songs and speeches  
On his lady's Phonograph.

**TRADE ADVERTISEMENTS.**

O. W. Teffts, of 541 Albany street, Little Falls, N. Y., sends us a clipping of an advertisement that occupied three full columns in a local paper. It is full of good arguments about Edison Phonographs and Records, is well arranged and displayed in good style. We regret that space will not permit us to reproduce the advertisement or quote at length from it.

Other enterprising Jobbers and Dealers who have sent clippings or papers containing their advertisements during June were the following: McGreal Bros., 173 Third street, Milwaukee; Samuel T. Shroff, 920 Fourth street, Sioux City, Ia.; Monroe S. North, 46 Main street, Batavia, N. Y.

Wright's Music House, at Portland, Oregon, gets out a large mailing card every month when it gets a new lot of Edison Records and extends the following invitation to the public:

We beg to inform you that we have just received another shipment of new Edison Moulded Records. Our "Record Boy" does nothing but play Records, so do not hesitate to call and hear them at any time. We sell genuine Edison Phonographs from \$10 to \$100, cash or instalments. Wright's Music House,

Cordrays, 349 Wash. street, Portland, Or.

### DETROIT "RAISES" CHICAGO.

Apropos of the Chicago Phonograph enthusiast referred to in the June issue of the EDISON PHONOGRAPH MONTHLY, E. Percy Ashton, manager of the American Phonograph Co., Detroit, Mich., sends the following:

DETROIT, Mich., June 12, 1903.

About six years ago we sold O. R. Looker, President of the Michigan Mutual Life Insurance Company, a Triumph machine, and a few months later a Bettini attachment, since which time we have exchanged his original Triumph machine for a new model Triumph and sold him another Triumph and a Standard. Both of these Triumph machines are in his music room together with an imported music box (which cost \$1,100) and an expensive piano. One Triumph is equipped with the Edison diaphragm, the other is equipped with a Bettini. The Standard Phonograph is in the children's room.

Further we sold Mr. Looker a solid mahogany 100-pin cabinet for \$35.00, two mahogany veneer 180-pin cabinets at \$30 each. Besides these he has had built a quarter sawed oak cabinet in imitation of a book-case, with bevel glass doors and silk curtains, to hold carrying cases. The capacity of this cabinet is something over 1,000 Records. Mr. Looker has at present almost every Record made by the National Phonograph Company, most of the Bettini Records, some Perfection Records, has visited every original Record plant in New York and purchased samples of their work. He has bought at least 3,000 Records from me to date.

In asking Mr. Looker for this data he wished me to impress upon you the fact that he has not bought this stock because he is crazy on the subject but as an educator and diversion from business. He has a most complete machine shop and carpenter's bench in his house and considers his investment an economical one.

Just a word on diaphragms. Mr. Looker took his Bettini diaphragm to pieces and copying after the laminated micro diaphragm used in the model "C" reproducer has gone one notch farther on the Bettini as he uses ten laminations in a very novel and unique way. The slightest whisper, even the echo of the Record making room being quite plain. The effect is startling, the fact uncanny, even to an old experienced hand in the business. We have a standing order to deliver to Mr. Looker one each of the new monthly Records as soon as received. I think that the Chicago enthusiast is not in it with the Detroit enthusiast.

Can any one "call" or "raise" Detroit?

### OWNS OVER 1,900 RECORDS.

Concerning enthusiastic users of the Phonograph, one of our Western salesmen writes:

I know a very prominent lawyer in this city who has a Triumph and 650 Edison (selected) Records. He is a music lover, and has studied at Milan, Italy. He thinks our Records by Rossi, Sala, and Mielino the finest ever produced. He says further that Rossi is more than the equal of 'De Reszke. I have met another gentleman who, I think,

lives at Kewanee, Ill., who told me he had over 1,200 of our old wax records; many over five years old, which are as good as when first purchased. In addition he now has over 700 moulded—bringing his total to over 1,900. I believe there are about thirty parties in Chicago and suburbs who own Triumphs and who have collections running from 100 to 300 Records each.

### GEORGIA ENTERS THE LIST.

89 CHAMBERS ST., NEW YORK, June 23, 1903.

One of our customers in Georgia calls our attention to a statement in a recent issue of the PHONOGRAPH MONTHLY, that a Chicago house claims to have a customer with 404 Standard Records in his collection. He states, "You have a customer in me who has nearly double that number of Records, and a hall 36 feet long by 14 wide, built specially in which to use an Edison Triumph Phonograph, where more than 100 visitors hear it every week, while often the street outside is filled with hearers." This customer is a well known resident of Fort Gaines, Georgia.

DOUGLAS & Co.

MANSFIELD, Ohio, June 25, 1903.

Several days ago the writer gave a public entertainment with a Home Phonograph, and the letter herewith enclosed will speak for itself as to how well the same was appreciated by the listeners.

"Give the Phonograph the floor" occasionally and it will advertise itself in a nice modest manner.

Would it not be a nice idea to have a Record made especially for the opening of such an entertainment?

Respectfully,

J. H. BURKHOLDER.

The letter referred to by Mr. Burkholder was one from Branch No. 5, Catholic Knights of Ohio, thanking him for a Phonograph entertainment given by him.

### AN ADVERTISING HORN 8 FEET 8 INCHES LONG WITH A 3 FOOT 3 INCH BELL.

"Perhaps the largest advertising horn in use is the one that hangs in front of our supply house," writes E. A. Batchelor, manager of the Utica Electric and Phonograph Supply House, at Utica, N. Y. "We use this horn and a Home Phonograph to give concerts on certain evenings during the week. Every night that we use it the street becomes so crowded that it is hard for anyone to pass through. This horn is made of galvanized iron and bronzed with aluminum. It is very distinct and full of volume. It may be easily heard above the rumbling of the street railroads and the rattling of wagons. Any Dealer wishing to build a horn of this size may ascertain the cost of the horn and a swinging arm to hold same from the building by writing to Frank Ecker, iron pattern maker, 12 Pearl street, Utica, N. Y. We believe this will be of great value to Phonograph Dealers who will take hold of it. No Dealer need think this is an experiment, for it is not; it is in actual use at our store."



**AMONG THE JOBBERS.**

The firm of Hacker & Horn, of New York city, has been succeeded by Oscar Hacker, and he has moved to 2 Murray street.

The Ring Music Co., of Lowell, Mass., has moved from 133 Merrimac street to No. 112 on the same street.

The Eclipse Phonograph Co., of Hoboken, N. J., has moved from 306 Washington street to more commodious quarters at 205 Washington street.

Wahl & Gaasch, of Lafayette and Indianapolis, Ind., have opened a branch store at 47 West 5th street, Cincinnati, O.

The Russell Phonograph Co., of 168 Griswold street, Detroit, Mich., is now owned and operated under the name of the Ray Company. It is a branch store of the latter company.

James I. Lyons, of Chicago, has opened a branch store at Theatre Arcade, New Orleans.

Hereafter Records made of No. 5710, "Because," will be sung by Albert C. Campbell and not by Joe Natus.

**PERSONAL.**

Frank K. Dolbeer, manager of the Credit Department of the National Phonograph Co., attended the annual convention of the National Association of Credit Men at St. Louis, June 8 to 11, as a delegate of the New York Credit Men's Association. While in the West he called upon our Jobbers in Chicago, Milwaukee, Lafayette and Cincinnati.

The Blankenbaker Phonograph Concert Co., of Louisville, Ky., sends out a mailing card having on its back a photograph of the head of the company standing alongside of an Edison Home Phonograph. It makes the following announcement:

LOUISVILLE, Ky., June 17, 1903.

We give Phonograph concerts for all occasions. Over 500 Records to select from. We also make Records. Have a few made. They talk for themselves. Address, The Blankenbaker Phonograph Concert Co., P. O. Box 1447, Station D.

David Downer, a Dealer at La Junta, Colo., sends a clipping from a local paper, giving the programme of a Phonograph concert given at Shadow Town, Devils Lake, on June 17. The entire programme was played by a Phonograph.

**Jobbers or Dealers violate their Agreement when they give trading stamps with Edison Phonographs or Records.**

**NOT INJURED BY THE FLOOD.**

In a news and cigar store on Central avenue near Ewing street an Edison Phonograph that was six feet under the flood and all through it was grinding out its tunes as cheerfully to-day as if nothing had ever happened to upset its tranquility. The flood did not injure it.—*Kansas City Star*, June 11, 1903.

In sending us the above clipping the J. W. Jenkins' Sons Music Co., of Kansas City, Mo., wrote:

"The machine referred to is one we sold, and it was under water eight days. The cabinet of the machine was so filled with mud when it was taken out that it did not seem possible that anything could ever be done with the machine again, but the facts are as stated in the article, which is that the machine is playing as perfectly as ever. The Records, which were also under water for the same length of time, seem to be as perfect as ever."

**IT COULDN'T BE BETTER.**

DOWLING, Mich., June 22, 1903.

My last dozen Records came in fine shape and in quick time. Of all fine Records No. 8349 is simply out of sight. My speaker talks as plain again as when it came. Couldn't be better; send any reference to me. I'll give you the glad hand. My machine has the name of the finest ever heard. People who have traveled a good bit pronounce it the finest. I wonder if you know how fine my machine talks and sings after three months' use.

G. E. FERGUSON.

LAVELLE, Pa., June 22, 1903.

The Phonograph business is steadily increasing. I have received the EDISON PHONOGRAPH MONTHLY since its first issue and want to say that it is the best publication of its kind that I have yet seen. The *Phonogram* was good but was too small. The MONTHLY beats it as the new model Reproducer C beats the old style or automatic speaker as it was called. I am willing to pay for it if you named the price, as I do not want to be without it.

Every Friday night I give a free Phonograph concert from a high porch in front of my place, which attracts great crowds of people who line the sidewalks in front of my place. An idea struck me that if I had a Moulded Record (Standard size), telling about the different styles Phonographs and Records all through, the Record would be something new and would attract the attention of hearers so that they would buy. I am willing to pay a fair price for such a Record. Let me hear from you on this subject. I am going to work just as hard as I can to sell more Phonographs and more Records.

J. A. SNYDER.

**The selling of Edison Records by card system, whereby the price of \$5.00 per dozen is eventually allowed, but where a full dozen Records are not purchased, or paid for, at one time, is a violation of contract.**

### THOMAS A. EDISON'S PATENTS.

The clerks of the Patent Office began several years ago to keep a systematic account of the patents issued to Thomas A. Edison. They have his various inventions tabulated and indexed, so that they can put their hands on each different idea he has protected by patent from the beginning of his marvelous career of invention. When a pending claim is allowed, as it no doubt will be this month, Mr. Edison will have received 791 patents in all.

He is not adding to the list as many ideas nowadays as he did some years ago. Up to 1895 he had taken out 711 patents. Since then he has added to the list from three to twenty-three patents each year. Last year he took out nineteen. In ordinary fees for patents Mr. Edison has spent over \$51,000.—*New York Times.*

### PHONOGRAPH FOR DICTATION PURPOSES.

J. N. Kimball, of 1358 Broadway, New York City, is a Dealer who makes a feature of specially fitting up Edison Phonographs for dictation purposes. That he has met with success in his special field may be seen from the following few of the many endorsements he has received:

*From J. E. Fuller, Principal Shorthand Department, Goldey College, Wilmington, Del. ("Home" Outfit.):*

"I am glad to say that we are well pleased with the machine. It has made a decided hit with the school, and I find it even more useful than I had expected."

*From J. T. Thomson, Principal Steubenville Business College, Steubenville, Ohio. ("Triumph" Outfit.):*

"We are obtaining splendid results from the machine. Our students are taking more interest in their work than they have manifested for some time and the improvement in speed is quite marked."

*From Mrs. K. Coar, Putnam (Conn.) High School. ("Home" Outfit.):*

"I had four boys in my graduating class whom I simply despaired of finishing in good form, until the Phonograph was given us. Great benefit is, that the instructor has more time to overlook the work of each individual in the class. I have put your suggestion into practice and feel sure that I shall see lasting results."

*From S. P. Benthysen, Principal Shorthand Department, Grand Prairie Seminary, Onarga, Ill. ("Home" Outfit.):*

"I am pleased with the Phonograph. It is doing excellent work; beyond my expectations. I find I can set it to work, in the hands of a responsible student, and go about the room and do other things that are necessary. Please send us material to add more pupils to the system."

*From J. D. Paxton, Principal Shorthand Department, Wesleyan University, University Place, Nebraska:*

"Your dictation records are 'just the stuff.' The subject matter pleases my young folks very much, the speed being just about right for beginners. Within a few weeks I hope to send for more, dictated at a higher rate of speed."

*From M. J. H. Badell, of Los Angeles, Cal.:*

"Persistently used, it will increase speed and at the same time tends to give an accurate set to one's hand. I passed the examination for reporter in Orange County (Cal.) Superior Court with no other aid to speed than the Phonograph."

### A REPORTER HEARS OUR CHINESE RECORDS.

WORCESTER, MASS., June 8, 1903.

I inclose a clipping from a local paper in regard to an outfit that I sold to a Chinaman. I received from my Jobber some of the yellow slips containing the names of the various Chinese Records, and left some in the different Chinese laundries that I passed going to and from the office. It resulted in a sale of about \$40 worth of Edison goods, a Standard machine, about thirty Records, with a large horn and some small stuff. E. H. WILSON.

The article is from the *Worcester Telegram*, and is so funny that we know it cannot fail to interest the trade:

### MUSIC ALA CHOP SUEY.

CHARLIE GOEY ORDERS TWO DOZEN EDISON PHONOGRAPH CHINESE RECORDS.

"Pinge-pongee dong, Sher Doy Wong, lal-lie wow-ee-lallee-wee-ee."

That is an accurate phonetic report of the first line of a comic recitation entitled "Sher Doy Wong," as reproduced on an Edison Phonograph Record in Chinese.

Charlie Goey is the up-to-date Chinaman who owns this Record, along with twenty-five others, all in Chinese. They are the first of this sort ever brought into Worcester country, and it is understood there are no others in New England outside of Boston and Providence.

Charlie Goey is quite a goer in things that are modern; he wears 'Melican clothes and does a thriving laundry business at 616 South-bridge street. He learned that the wonderful talkee machines could talk Chinese like a Pekin mandarin and through Everett H. Wilson, of 7 Blossom street, bought twenty-six Edison Records and a Phonograph. The Records were made in San Francisco.

A *Telegram* reporter was privileged to hear selections from these records, yesterday, and he has eaten nothing but chop suey since. One of the most remarkable things about these new century talking marvels that reproduce the oldest language known, is that it is necessary to use from two to a dozen of them in giving just one Chinese selection.

The first selection was from a Chinese band, entitled "To Prepare Dinner." The best way to describe a Chinese band is to say that it is different from anything else. Like Chinese



voices, there is little bass in the tones, while all manner of shrill notes abound.

The music started off with a crash of dinner gongs that seemed to be the end of the selection in the beginning by announcing dinner was already prepared. Following that the music was something tremendous; something fearful. Whole handfuls of high C's and E flats were torn out by the roots and scattered broadcast through the Phonograph horn into the room.

Crashes like falling of brass kettles, snorts like an automobile on a strike, sonorous sounds like an exhausted locomotive, blowing of horns, squaling of pigs, roaring of lions, and many sounds that were invented by Confucius 500 years B. C. were assembled in that selection. No Salvation army band could have stood a minute in open air competition with that aggregation of Chinese musicians who made the Record in San Francisco. That part of the music was terrible, and only the choicest adjectives from pink laundry checks could adequately describe it. Quite remarkable, however, was the high, thin, sweet single note of pure melody that ran through the entire selection like a silver thread through sackcloth.

There was one selection, song and orchestra, that was good music, accurate time and sweet melody from beginning to end. It was called "A Widow's Lament," and seemed lively enough to have been called a rejoicing instead. A wonderful song entitled "To Destroy the Four Gates" needed twelve Records to complete. A sample of one Record was sufficient for the *Telegram* reporter, who was satisfied that at least five gates had already been destroyed.

Some of the titles of these selections were "Assembly on a Sand Bank," which was full of grit; "The Nest in a Shoe," with orchestra accompaniment to boot; "To Visit a Friend," who would probably instantly cease to be a friend after that; "A Wise Man in the Snow," who probably figured on beating the new ice trust in Worcester and "To Persuade a King," which only aces could beat.

Mr. Wilson said the first three of these Records came several days ago and Charles Goey heard them. He had ordered a few to see if they were really good Chinese selections adulterated with other languages at the factory. Solemnly Charlie sat down before the big brass horn and listened.

Mr. Wilson tried him with the comic recitation, "Sher Doy Wong." Sher Doy must have been a funny boy as he spouted a whole bunch of Chinese through that brass horn that made Charlie's mouth widen from ear to ear in a grin of pure delight. When the band Record was tried the terrible music settled it and Charlie instantly ordered a couple dozen Records and a Phonograph, which arrived yesterday and from now on he will entertain Worcester Chinamen with Phonograph selections from the first Chinese Records ever introduced in Worcester.

#### KEEPS PHONOGRAPH PEOPLE BUSY.

When a musical comedy is rated a success, its song "hits" are not only in demand through its publishers, but the manufacturers of Phonograph Records are called upon almost as quickly to furnish a supply.—*Music Trade Review*.

#### A PHONOGRAPH INCIDENT IN THE PHILIPPINES.

The following, addressed to Mr. Edison, was received on May 26, too late for the June issue of the EDISON PHONOGRAPH MONTHLY:

LEGASPI, PROVINCE ALBAY, P. I.,  
April 11, 1903.

Thomas A. Edison, New York, N. Y.—  
Most Esteemed Sir: Craving indulgence for occupying your valuable time, I wish to relate an amusing incident which occurred in this far-away country *apropos* of the Phonograph. The story compares favorably with the yarn on the countryman in the States, which has been so widely advertised.

While giving an advertising exhibition in an interior town, an old native walked up to the horn and gazed steadily into it for a long time; then veered around and examined the box; then looked intently at the operator, at the ceiling, on the floor, returned to the horn, took out a kerchief, mopped his brow, went outside, brought in an old woman, went through the same antics as before and exclaimed to his companion: "Mother of God, we hear the voice of the devil, but he is invisible." At that moment the operator put on a stirring band selection, and when it became exhausted the old man caught the woman by the arm and dragged her to the door, murmuring as he went: "Holy Saint Mary, the devil has visited heaven, and is serenading God."

I have been selling Edison Phonographs for one year on these islands in the interests of the American Book and News Co., and have had some very interesting experiences. Yours to command,  
LEW DAVIS.

#### A DEALER'S COMMENDATION.

BLOOMINGTON, ILL., June 25, 1903.

Having read the new contract and conditions, and having signed it with pleasure, I wish to compliment you on its completeness and the comprehensive way in which you have treated its several provisions. It has no loopholes, no double meaning; every signer must know just exactly what he has to do. There is no way for him to plead, "I didn't understand its provisions." In looking at the contract from a business point of view, it must be of great value to the National Phonograph Company, for the prices being fixed and maintained gives to the Edison Phonographs and Records a standing and value. To the Dealer it gives an assurance that his goods are worth to-morrow what they are worth to-day, and warrants him in carrying a full and complete line of Edison Machines and Records in stock. To the purchaser it gives the satisfaction of knowing that he has bought his Edison Machine and Records at the lowest standard price. The contract being printed in a neat and attractive form can be easily framed and hung in a conspicuous place and it will often help the Dealer in handling some close-fisted buyer. I believe it would be a good suggestion to have Dealers frame their contracts and place them where they can be plainly seen. I am, yours,  
C. H. FREEMAN.

[In connection with the latter suggestion we would say that we are now getting out a copy

of the principal parts of the Agreement, to be used for framing or hanging up in the stores of our Dealers.]

### A PECULIAR PHONOGRAPH BELT.

CINCINNATI, O., June 29, 1903.

Peculiar things sometimes happen in connection with repairs on Phonographs. We sold a Home Phonograph to a family in Kentucky some six or eight months ago, and they have been good customers since. The three daughters, who seem to have the instrument in their care, have purchased a number of records. The last time they had occasion to call on us they mentioned to the writer that their machine was not working particularly well; that it would at times dis-cord. In endeavoring to locate the trouble, I inquired if the belt seemed to slip. One of the young ladies informed me that shortly after they had

purchased the machine the belt was broken. Evidently they had put on a new belt of their own manufacture, and as they said this they looked from one to the other, and seemed to be tickled. I didn't quite understand why until the machine came in for repair, when my attention was called to the belt used thereon. I am inclosing it herewith. The only question in my mind is which one of the young ladies it belonged to. Yours very truly,

ILSEN & Co., Per C. W. Noyes.

[The inclosure was a black elastic garter.]

CARMEL, IND., June 27, 1903.

In acknowledging the receipt of the list of suspended Dealers, would like to say that I congratulate you on the way you have of doing business, for it is so much easier selling anything when they are strictly one price.

GEORGE W. HINSHAW.

### SUSPENDED LIST, JULY 1, 1903.—SUPERSEDING ALL PREVIOUS LISTS.

#### KANSAS.

LAWRENCE—BELL BROS.

#### MASSACHUSETTS.

LAWRENCE—LORD & CO., 314 Essex street.

MALDEN—A. T. FULLER.

NEW BEDFORD—H. B. DEWOLFF.

#### MICHIGAN.

DETROIT—F. J. SCHWANKOVSKY.

SAGINAW—GEO. W. EMENDORFER.

#### MISSOURI.

KANSAS CITY—THE WITTMANN CO.

#### NEBRASKA.

LINCOLN—THE WITTMANN CO.

OMAHA—THE WITTMANN CO.

#### NEW JERSEY.

ATLANTIC CITY—SAMUEL D. WOLF, 32-34 Arkansas avenue.

BAYONNE—I. WIGDOR, 450 Avenue D.

JERSEY CITY—W. L. HOFFMAN, 151 Montgomery street.

NEWARK—R. L. CORWIN.

PATERSON—CHAS. H. KELLY, 25 N. Main st.

WEST HOBOKEN—EMIL HOLLANDER, or THE WEST HOBOKEN BICYCLE & PHONOGRAPH CO., 619 Spring street.

#### NEW YORK.

BEDFORD PARK—GEO. H. TYRRELL.

NEW YORK CITY—A. T. ARMSTRONG, or AMERICAN PHONOGRAPH CO., 106 Wall street.

R. L. CORWIN, also Newark, N. J.

EAGLE PHONOGRAPH CO., or C. LOWENTHAL, 83 Nassau Street.

EMPIRE PHONOGRAPH CO., 2 West 14th street.

HAWTHORNE & SHEBLE, 297 Broadway, also Philadelphia, Pa.

R. H. INGERSOLL & BRO., 67 Cortlandt street.

W. L. ISAACS, 114 Fulton street.

S. LEMBURG & CO., 194 Broadway.

J. McELLYNNE, 202 Broadway.

F. M. PRESCOTT, 44 Broad street.

STAR CREDIT CO., or Paul Sacks, 180 East Houston st. and 57 Third ave.

SARATOGA—W. J. TOTTEN.

#### OHIO.

CINCINNATI—J. L. ANDEM.

SPRINGFIELD—D. & M. VANDERPOOL.

UHRICHSVILLE—F. A. MAZURIE.

#### PENNSYLVANIA.

PHILADELPHIA—\*A. R. CASSADY, 2783 Emerald street.

HAWTHORNE & SHEBLE, 604 Chestnut street.

PITTSBURG—A. LIPPARD, 615 Wylie avenue.

#### RHODE ISLAND.

PROVIDENCE—F. P. MOORE.

\* Added since last Suspended List was issued, June 1, 1903.

**Jobbers and Dealers are asked to co-operate with us, FOR OUR MUTUAL GOOD, by being careful that they do not supply any of the above named firms with our apparatus.**





C. A. RAY, PRESIDENT.

Louisville, St. Louis, Detroit, Cincinnati, Chicago, Atlanta, Memphis, Nashville, Cleveland, Birmingham, New Orleans, Savannah, Indianapolis, Knoxville, Baltimore, Richmond, Va., Mobile, Kansas City, Toledo.

CAPITAL \$75,000.

**THE RAY CO.**

EDISON LABORATORY PRODUCTS.



RECEIVED  
JUN 17 1903  
Ans'd.....

June 15th, 1903.

National Phonograph Co.,  
83 Chambers St., N. Y.,  
C. H. Wilson, Esq.,  
Mgr. of Sales:-

Dear Sir:-

Enclosed we hand you our order for fifteen hundred and fifty (1550) Phonographs, assorted types, two hundred (200) Model "C" Reproducers, fifty (50) Model "B" Reproducers and fifty (50) Recorders.

You will please ship these goods immediately as per shipping directions hereto attached.

Yours truly,

The Ray Co.,

By... *C. A. Ray* Prest.

The above letter explains itself. In sending the order Mr. Ray wrote that he was proud of his ability to use so many Phonographs. We are quite as proud as Mr. Ray over the order. It is gratifying to be able to put on the market a machine that will enable a Jobber to sell so large a number.

**JULY ADVERTISING.**

The July advertisement of the Edison Phonograph, shown in the adjoining column, is, we believe, one of the most attractive yet issued by this company. The fair operator is the same young lady who appeared in the June advertising. The type matter accompanying the picture again appeals to the public to call at the Dealer's and hear the Phonograph—another effort to put business in the way of the Dealer. The mediums used in July were:

Atlantic Monthly, Booklovers, Bookman, Brown Book, Collier's, Current Literature, Field and Stream, Harper's, Leslie's Popular Monthly, Life, Lippincott's, Munsey's Magazine, National Magazine, Outing, Pearson's, Review of Reviews, Saturday Evening Post, Smart Set, Sunset Magazine, Town Topics, Town and Country, World's Work, Mines and Minerals, Scientific American, Musical Record and Review, Outdoor Life, Craftsman, Photo Era, Independent.

**ENTRANCING. The EDISON PHONOGRAPH**

Don't judge the **Phonograph** by what you have heard—the imitations or the old styles—but call at the nearest dealer's and hear the **Phonograph** with Mr. Edison's recent improvements.

5000 DEALERS SELL PHONOGRAPHS  
**NATIONAL PHONOGRAPH CO., Orange, N. J.**  
 NEW YORK: 83 Chambers St. CHICAGO: 804 Wabash Ave. SAN FRANCISCO: 933 Market St. EUROPE: ANTWERP, BELGIUM: 32 Rempart Saint Georges

# The E. W. N. Handbook of the Phonograph

— AND —

## Instructions for Making Records.

BY C. W. NOYES.

### Every Owner

Of a talking machine should have a copy of this valuable book. It is replete with **Instructions for the Care and Use of the Phonograph**, and the chapters devoted to **RECORD**

**MAKING** are compiled from the author's many years of experience in some of the principal laboratories of this country.

Any one possessed of ordinary intelligence can make a perfect record if the directions are followed.

Fully Illustrated—Handsomely Bound.

PAPER, 25 CENTS.

CLOTH, 50 CENTS.

Mailed Postpaid on Receipt of Price.

For Sale by All Jobbers, or

**ILSEN & COMPANY, Cincinnati, Ohio.**

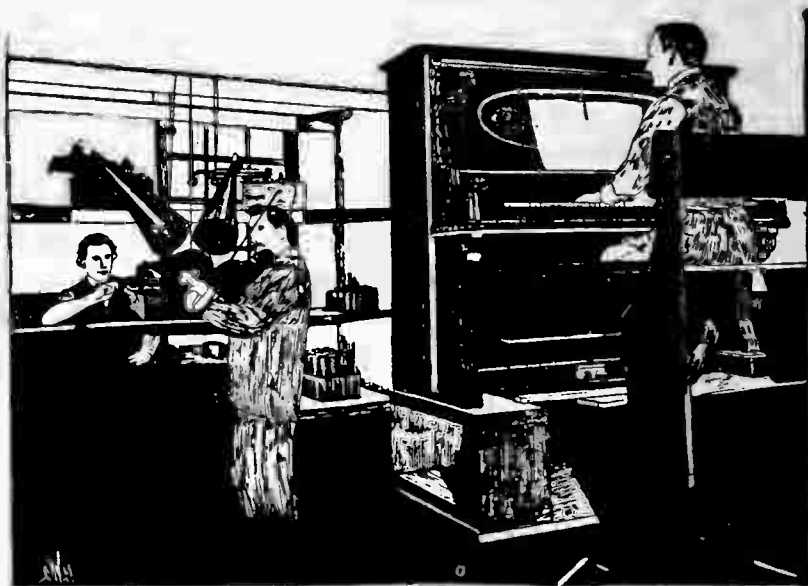

DEALERS WRITE FOR DISCOUNTS.

# A CARD TO THE TRADE JOBBER AND DEALERS

Interested in giving their customers best results are invited to write us for quotations on

## DOUGLAS

### *Mega (Paper) Horns and Record Cabinets*

The Horn that Made us Famous.

Superior to any metal horn made in purity, volume and absence of metallic tones. **GREAT AIDS TO THE SALE OF PHONOGRAPHS AND RECORDS.**

- “MEGA” . . . . . List \$7.50  
Length 32 inches; Width 24 inches.
- “MEGA JR.” . . . . . List \$2.25  
Length 22 inches; Width 13 inches.
- MEGA RECORDING HORN, List \$1.50  
Length 24 inches; Width 6 3/4 inches.

Look for the Trade Mark

“PHONO-MEGA.”

Attractive and Substantial.

Superior to any Line in the Market,  
**STRONGLY MADE.**

**BEAUTIFULLY FINISHED.**

- 100 Peg Polished Oak, List \$12.00
- 125 “ “ “ “ 14.00
- 125 “ Quartered Oak, “ 15.50
- 150 “ “ “ “ 18.00

**Prices Restricted.**

WRITE FOR SPECIAL LEAFLETS AND NET PRICES.

## DOUGLAS & CO.,

89 Chambers Street,

NEW YORK.

71 Reade Street,



# EDISON Phonograph Monthly

PUBLISHED FOR TRADE USE ONLY BY  
THE NATIONAL PHONOGRAPH CO.

VOL. 1.

NEW YORK, AUGUST, 1903.

No.

*The National Phonograph Co.,*

ORANGE, N. J.

NEW YORK: 83 CHAMBERS STREET.  
CHICAGO: 304 WABASH AVENUE.  
SAN FRANCISCO: 933 MARKET STREET.  
ANTWERP: 32 REMPART SAINT GEORGES.  
LONDON: 52 GRAY'S INN ROAD, HOLBORN.

## EDISON PHONOGRAPHS AND RECORDS.

All communications to THE PHONOGRAPH MONTHLY should be addressed to the Advertising Department, 83 Chambers Street, New York.

### C O N T E N T S

Headquarters of National Phonograph Co., London.....	I
Making Records Abroad.....	I
September Advance List of Records.....	2
No More Goods or Printed Matter to Dealers Who Have Not Signed New Agreement.....	3
Personal.....	3
Agreements Not Sent In.....	3
Japanese Records.....	4
As Busy As In Winter.....	4
Phonograph Incidents.....	4
A Jobber's "Anticipation" of Fall Business.....	4
Comments on September Records.....	5
Window Displays.....	6
Sir Thomas Lipton and the Phonograph... ..	6
A Jobbing Firm's New Quarters.....	6
A Novel Suggestion.....	6
Made Happy with a Standard Phonograph.....	7
Comments from Abroad.....	7
Persistence Commended.....	7
August Advertising.....	7
A Talking Machine Publication.....	8
Trade Advertisements.....	8
Record Shipments.....	8
Current Catalogues and Printed Matter....	8
Sought the Best.....	8
More About That Georgia Collection.....	9
Made a Rival Machine Look Cheap.....	9
Home Phonograph Outsells All Other Machines.....	9
I. C. S. Language Outfits.....	10
No General Edition at Present.....	10
Moulded Records for Phonographs.....	11
Advertising Department Matters.....	14



Headquarters of the National Phonograph Co., 52 Gray's Inn Road, Holborn, London, England.

### MAKING RECORDS ABROAD.

The National Phonograph Co. is making extensive arrangements for the increase of its business abroad. A permanent master Record-making plant has been established at 52 Gray's Inn Road, Holborn, W. C., London, where master Records of prominent British military and civil bands, high class instrumentalists and vocalists, as well as various comedians and comic singers are being constantly made. Master Record plants are also to be established in the chief cities and musical centers of six other European countries.

(Continued on Page Three.)

THE ADVANCE LIST OF SEPTEMBER RECORDS APPEARS ON PAGE 2. ORDER FROM IT. NO OTHER ADVANCE LIST WILL BE ISSUED.

## ADVANCE LIST OF NEW EDISON MOULDED RECORDS FOR SEPT., 1903

RECORDS listed below will be ready for shipment as near September 1st, 1903, as possible, at which time Jobbers' stock orders, if placed prior to August 15th, will be shipped.

September Supplements will bear the date of September 1st, and will be forwarded to Jobbers with their stock order for Records.

Retail Dealers should place stock orders with their Jobbers at once, to insure prompt shipment as soon as Jobbers' stock is received.

Stock orders for Records contained in this list must be written on separate order blanks, and letters relating to September Records should refer to no other matter.

Kindly comply with above requests and thus aid your Jobber and ourselves in handling advance orders.

- |                 |  |  |
|-----------------|--|--|
| 8474            | Anona (Intermezzo)                                   | Edison Concert Band                                |
| 8475            | Parody on Hiawatha                                   | <i>Comic male duet</i> Collins & Harlin            |
| 8476            | Hot Scotch March                                     | Hopkins  |
|                 | <i>Xylophone solo with orchestra accompaniment</i>   |  |
| 8477            | I Could Never Love Like That                         | <i>Coon song</i> Billy Murray                      |
| 8478            | You'd Better Ask Me                                  | <i>Traditional Irish ballad</i> Clifford           |
| 8479            | The Chapel   | <i>Male Quartette</i> Edison Quartette             |
| 8480            | When We Were Boys                                    | <i>Sentimental male duet</i> Harlan & Stanley      |
| 8481            | Come Where My Love Lies Dreaming                     | Edison Brass Quartette                             |
| 8482            | National Fantasia (Kryl)                             | <i>Cornet solo</i> Kryl                            |
| 8483            | My Little Coney Isle                                 | <i>Waltz song</i> Harry L. Tally                   |
| 8484            | Two Rubes in an Eating House                         | Harlan & Stanley                                   |
|                 | <i>Comic Rube talking and singing duet</i>           |  |
| 8485            | Scarecrow Dance                                      | <i>Characteristic</i> Edison Symphony Orchestra    |
| 8486            | When Jane and I Were Wed                             | Harlan   |
|                 | <i>Descriptive song with orchestra accompaniment</i> |  |
| 8487            | The Minstrel Boy                                     | <i>Bagpipe</i> McAuliffe                           |
| <del>8488</del> | I Ain' Got No Use for Sleep                          | <i>Coon song</i> Collins                           |
| <del>8489</del> | Bungalow   | <i>A Hindoo love song</i> Edison Concert Band      |
| <del>8490</del> | Ballet Music from Mathias Sandorph                   | Tuson  |
|                 | <i>Clarinet solo with orchestra accompaniment</i>    |  |
| <del>8491</del> | Medley of Coon Songs                                 | Golden   |
| 8492            | The Star Dreamer                                     | <i>Oriental serenade</i> Edison Symphony Orchestra |
| 8493            | Dreamy Eyes  | <i>Banjo</i> Ossman                                |
| 8494            | Though It Was Within this Hour We Met                | <i>Duet from "Robin Hood"</i>                      |
|                 |  | Miss Morgan and Mr. Stanley                        |
| 8495            | Mountain Echoes                                      | <i>Violin and flute duet</i> Jaudas & Atz          |
| 8496            | Home, Sweet Home (John Howard Payne)                 | Mendelssohn Mixed Quartette                        |
| 8497            | Drink to Me Only with Thine Eyes                     | Walter Wheatley                                    |
|                 | <i>Old English song</i>                              |  |
| 8498            | Hebrew Vaudeville Specialty                          | Rose   |
|                 | <i>Introducing parody on "Ain't that a Shame"</i>    |  |

Edison Moulded Records are made only in Standard size. Both Standard and Concert Records may be ordered from this list. Order by Number, not title. If Concert Records are wanted, give the number and letter C.



(Continued from Page One.)

These master Records will be shipped to the laboratory at Orange, N. J., where moulds will be made and duplicate Records turned out and shipped to Europe for sale. This will be done until plants can be established for making duplicates. The company proposes doing this as quickly as possible, and in this way cover the entire field with Edison Records. It is the intention of the National Phonograph Co. to secure Records of the voices of all the great artists of the world.

### NO MORE GOODS OR PRINTED MATTER TO DEALERS WHO HAVE NOT SIGNED THE NEW AGREEMENT.

This issue of the EDISON PHONOGRAPH MONTHLY will be the last printed matter of any kind that will be sent out from the Advertising Department to any Dealers except those who have signed the new Agreement. Dealers, therefore, who find that their names have been dropped from our mailing list or who find that their orders for goods are held up will understand that it is because their signed Agreement is not on file at our office. We hope that every Dealer who has not yet signed will do so at once, either through his Jobber or through us direct and keep himself in good standing. We believe that every Dealer now handling Edison goods desires to continue to do so, but he cannot expect to get goods, printed matter, etc., if he does not sign the new Agreement. Not to sign one is to cause trouble for you and ourselves in getting reinstated and getting your name back on our books.

### PERSONAL.

Among the visitors at our New York office during July were E. F. Taft, manager of the Eastern Talking Machine Co., Boston; L. E. McGreal, of McGreal Bros., Milwaukee, Wis.; W. D. Andrews, of Syracuse, N. Y., and J. M. Linscott, of the Boston Cycle and Sundry Co., Boston.

William E. Gilmore, President and General Manager of the National Phonograph Co., sailed on the Oceanic, on July 29, for a business and pleasure trip to England and the continent. He was accompanied by Mrs. Gilmore. They will be absent till September. James H. White, European Manager of Sales for the National Phonograph Co., sailed on the same steamer.

**Jobbers are urged to send in all Dealers Agreements.**

### AGREEMENTS NOT SENT IN.

Putting into effect the new Agreement brought to light the fact that some Jobbers were selling goods to Dealers who had signed an Agreement, but a copy of which had not been sent to us. Just why such Jobbers did this is difficult to understand. There are so many advantages on the side of a strict adherence to the Agreement system that it would seem impossible to believe that it has been done intentionally. The only disadvantage that could possibly arise to a Jobber is in giving to this company the names of the Dealers to whom he sells Edison goods. Experience of the past has shown that this is no disadvantage. This company does not make any effort to solicit orders direct. On the other hand, it has a number of men traveling constantly, who are securing orders from Dealers and turning them over to Jobbers. If we desired direct orders, it would not be necessary to do this. The policy of the company is to sell everything through the trade, and, as far as possible, to have Dealers buy through Jobbers. On the other hand, there are many advantages in having Dealers sign Agreements and in sending copies of them to us. In the first place, a Jobber who sells to unsigned Dealers is liable to have his supply of goods cut off for failing to comply with the Agreement that he has signed himself. It is also, in a measure, hindering the furtherance of a protective policy that has proven of great advantage to this Company, to Jobbers and to Dealers. Then, too, when a Dealer signs an Agreement and it is sent to this Company, the name of the Dealer is put on our mailing list, and once or twice every month he receives copies of printed matter issued by the Company, together with the PHONOGRAPH MONTHLY, and is thereby kept much better informed concerning the Edison Phonographs and Records than he could possibly be, if his name were not on our mailing list.

This matter of selling goods to unsigned Dealers is one about which a great deal could be said, did space permit. We hope that all Jobbers will realize that the matter of getting Dealers to sign Agreements is a thing that is even more advantageous to them than it is to us, and that we shall have their entire cooperation in making the system a complete success.

### SUSPENDED LIST OMITTED THIS MONTH.

Lack of space has made it necessary to omit the Suspended List this month. It has not been changed since July 1st. Copies in circular form are being mailed with this issue of the MONTHLY.

### JAPANESE RECORDS.

In the Advance List of new Records for June reference was made to fourteen Japanese titles. We shall issue a folder in August concerning these Japanese selections, and will then be ready to fill orders for them. The selections are as follows:

- 12813—Kimigayo. National Anthem of Japan.  
Sung by Sokichi Kudzuoka.
- 12814—Suruganaru. Song of Mount Fuji.  
Sung by Sokichi Kudzuoka.
- 12815—Imayo. Song of Four Seasons. Sung  
by Sokichi Kudzuoka.
- 12816—Hotaru no hikari. "The Firefly's Light."  
Air of "Auld Lang Syne." Sung by  
Sokichi Kudzuoka.
- 12817—Ukikumo. "Fleecy Clouds." Sung by  
Sokichi Kudzuoka.
- 12818—Omoi izureba. A Student's Thoughts  
of Home. Air of "Bonny Doon." Sung  
by Sokichi Kudzuoka.
- 12819—Ware no Kami ni. "Nearer My God  
to Thee." Sung by Sokichi Kudzuoka.
- 12820—Kappore. Dancing song. Sung by  
Otake Tanaka.
- 12821—Suiryo bushi. Two love songs. "Think  
It Over," with Shamisen accompaniment.  
Sung by Otake Tanaka.
- 12822—Komori uta. Japanese lullaby. Sung  
by Sokichi Kudzuoka.
- 12823—Hitotsutoya. Japanese New Year's  
Song. Sung by Sokichi Kudzuoka.
- 12824—Kii no Kuni. Song to the God of Rice.  
Sung by Sokichi Kudzuoka.
- 12825—Dodoitsu. Three Love Songs. Sung by  
Sokichi Kudzuoka.
- 12826—Kappore. Dancing Song. Sung by  
Sokichi Kudzuoka.

Selections 12822, 12823, 12824, 12825, 12826 are accompanied with an instrument similar to the mandolin; the others are accompanied with piano.

### AS BUSY AS IN WINTER.

The demand for the Edison product this summer has broken all records in the history of the National Phonograph Co. The falling off in business that we naturally expected in July and August has not materialized. We are as busy at our factory in Orange as we were in the height of the winter season and orders continue to come in in a surprising manner. Instead of cutting down our factory force as usual at this season we have made large additions to it, and this number will be still further increased as soon as we get our new buildings completed. The popularity of the Edison Phonograph, with its improvements, and the Moulded Records, is increasing in leaps and bounds.

"Goodness, Maria, was that Phonograph open during a dog fight?"

"No, I turned it on last night when you were sleeping. Perhaps you will believe now that you snore?"—*Talking Machine News.*

### PHONOGRAPH INCIDENTS.

"Some odd things happen in connection with the sale of Phonographs," said L. Kaiser, Assistant Manager for Douglas & Company, Jobbers in Phonographs, New York city. "Some days ago a native of Finland came into our store and asked to be shown a Phonograph. He could only speak enough English to make his wants understood, gestures forming a large part of his conversation. We showed him a Phonograph and played two or three selections upon it. He did not, however, seem to care for the music. We then put on a Recorder, and got him to sing a song to the machine in his own language. When we put back the Reproducer and re-played the song for him, his face brightened and he clapped his hands in joy. A moment later his pleasure gave way to tears. He finally bought the Phonograph and a supply of Records and Blanks."

"Another odd incident occurred in connection with a resident of a suburban town. We sold a Phonograph to a resident of the place and heard nothing from it for several weeks. One day the wife of the purchaser of the instrument came into our place and said that the Phonograph had completely changed the nature of her husband. Before he bought it he was of a morose, moody disposition. Now, she said, he has learned to hum and whistle the airs played on the Phonograph and has become a veritable "Sunny Jim" in character. He goes to his work with a smile on his face and returns in a cheerful manner, and his home life is the reverse of what it was before he bought the Phonograph."

### A JOBBER'S "ANTICIPATION" OF FALL BUSINESS.

The following letter tells its own story in a most suggestive manner:

DOUGLAS & COMPANY,  
EDISON PHONOGRAPHS,  
Wholesale, Export, Retail.  
89 Chambers Street and 71 Reade Street,  
NEW YORK, July 24, 1903.

NATIONAL PHONOGRAPH Co., Orange, N. J.

GENTLEMEN:—Herewith find our order for five thousand Phonographs, as per specifications marked thereon, all to be shipped pro rata, as promptly as possible.

The entire order to be delivered before December 20, 1903. The above is in addition to orders for immediate delivery now on file, which we trust you will forward with the utmost possible dispatch.

Very truly yours,  
DOUGLAS & Co.,  
A. C. D. Loucks, Mgr.

**Have you signed the new agreement, Mr. Dealer? If not, do so at once.**



**COMMENTS ON SEPTEMBER RECORDS.**

Twenty-five selections are again listed for September. This number will probably be issued each month. It is as many as the Jobbers and Dealers care to have put out monthly; it is as many as we can fill orders for with our present factory facilities, and it is a list large enough to furnish variety for all tastes. The September list is unusually varied in character, and includes some new and novel things. It also introduces two new Record makers to our patrons.

The newly arranged Edison Concert Band has two titles in the list and both show marked improvement over the work of the old band. This is not only because the band itself is better, but because those in charge of the Record-making department are constantly improving in their methods. The band selections are No. 8474, "Anona" (intermezzo), and No. 8489, "Bungaloo." "Anona" was written by Vivian Grey, the *nom de plume* of Miss Mabel McKinley, a niece of the late President. In commenting upon this composition, the *Telegraph* of May 10, 1903, said: "To 'Anona,' the intermezzo, nothing can be given but the highest praise. It is by that mysterious 'Vivian Grey.' The characterization of it is certainly novel and the motive is delightful. Without in any way comparing it with 'Hiawatha,' it may be said that it fully equals it in sweetness, tenderness and romance." As played by the Edison Concert Band it is an unsurpassed Record.

"Bungaloo," the other band selection, is a Hindoo love song, and its music is of a novel character, at once suggestive of a foreign clime. The use of the cymbals is greater in this Record than ever before attempted but their tones are not so prominent as to be unpleasant. It is a well made Record.

The Edison Symphony Orchestra has two more of its well-executed Records in the list, Nos. 8485 and 8492. The first is "The Scarecrow Dance," and its music is characteristic of its title. It is written by Justus Ringelben. No. 8492 is "The Star Dreamer," an Oriental serenade, composed by Theodore Bendix.

The Records made by the Edison Brass Quartette have become so popular that a monthly list would be incomplete without one. That for September is No. 8481, "Come Where My Love Lies Dreaming," and it is finely rendered. This is one of those old airs whose charm never grows less.

Eugene Jaudas and Louis Atz in No. 8495, "Mountain Echoes," contribute another of their delightful violin and flute duets. The music is Alpine in character and very sweet.

The instrumental solos are fully up to the reputation of their several makers. J. Frank Hopkins, in No. 8476, "Hot Scotch March," has a xylophone solo, with orchestra accompaniment, that has a good swing. It is made with the clever execution usual to Mr. Hopkins' work.

Bohumir Kryl, our cornet soloist, plays in No. 8482, "National Fantasia," one of his own

compositions. It is as cleverly written as it is played. The triple tone variations of "Yankee Doodle" are especially good.

James C. McAuliffe, in No. 8487, "The Minstrel Boy," makes the first bagpipe solo for some time. This one will suit those fond of bagpipe music.

William Tuson's rendition of the ballet music from "Mathias Sandorph" as a clarinet solo, in No. 8490, is musicianly, and makes a fine Record. Its runs are excellent and the entire Record is free from blasting or unpleasant noises.

Vess L. Ossman's banjo contribution is No. 8493, "Dreamy Eyes," written by the composer of "Creole Belles." Mr. Ossman's banjo work is always of the highest class and this new selection is up to his standard.

The vocal selections on the September list could hardly be better. Each is as good a piece of Record making as the experience of years can make it. There are two quartettes on the list. The Edison Male Quartette sings "The Chapel," No. 8479, a composition written in a low key, the bass parts predominating. It is somewhat religious in character. The Mendelssohn Mixed Quartette, in No. 8496, gives a very artistic rendition of John Howard Payne's famous song, "Home, Sweet Home." The Record cannot fail to please those who admire the work of a quartette of male and female voices. It will be appropriate for a concluding number in a home entertainment.

The duets are four in number, two humorous and two sentimental in character. Collins and Harlan, in No. 8475, sing a comic parody on "Hiawatha," which cannot fail to be a good seller. The duet work of these singers can hardly be improved.

Harlan and Stanley, in No. 8484, "Two Rubes in an Eating House," add another to this entertaining Rube series. The situation is extremely ludicrous and the dialogue witty and characteristic. The scene closes uproariously with the two rubes singing the old coon song, "Shine On." "You two Rubes are all right," is the congratulatory comment of the other guests.

Harlan and Stanley's sentimental song, No. 8480, "When We Were Boys," is a lingering and tuneful melody set to a very pretty story describing events (quoting the beginning of the refrain) "When we were boys together, down on the dear old farm." Entertainingly rendered and perfectly recorded—a fine Record.

Miss Morgan and Mr. Stanley, whose contralto and bass duets have become such a feature of the Edison Records, sing "Though It Was Within This Hour We Met," from "Robin Hood." It is No. 8494. Lovers of operatic airs will surely want this Record.

Solo Records are made by eight different artists, two of them being listed for the first time. The new men are Harry L. Tally and Walter Wheatley, both well known singers in vaudeville. Mr. Tally sings "My Little Coney Isle," No. 8483. It is a waltz song after the style of "The Good Old Summer Time." Mr. Tally has a good voice and makes an excellent Record.

Mr. Wheatley's selection is No. 8497, "Drink to Me Only with Thine Eyes," an old but ever delightful English song. Mr. Wheatley's

splendid voice does full justice to the melody.

Billy Murray, whose name appeared in the August list for the first time, has for September another well rendered coon song. It is No. 8477, "I Could Never Love Like That." Mr. Murray is a natural singer of coon songs, and, having an excellent voice, will ere long rank among the leaders in this class of work.

Arthur Clifford's song, "You'd Better Ask Me," No. 8478, is a quaint bit of music. It is a traditional Irish ballad and must be heard to be appreciated. The music is by Herman Lohrer.

Byron G. Harlan, in No. 8486, "When Jane and I Were Wed," has made an unusually attractive Record. It has an orchestral accompaniment, and is descriptive of a church wedding. It introduces the ringing of church bells, the organ playing the "Lohengrin" wedding march as the wedding party enter the church, the blessing of the clergyman after the ceremony, and the playing of the Mendelssohn wedding march as the party leave the church. This is all woven together so cleverly as to make a Record of more than ordinary merit.

Arthur Collins' coon song for the month is No. 8488, "I Ain't Got No Use for Sleep." This is a companion song to "Please Let Me Sleep," No. 8193, and Mr. Collins' rich voice has transferred it to wax in a perfect manner.

Billy Golden's contribution, No. 8491, "Medley of Coon Songs," will please the many admirers of his characteristic Records. No one else makes Records just like Golden's. Few Records are in greater demand.

Julian Rose, in No. 8498, adds another amusing Record to the Hebrew vaudeville series. The parody is on "Ain't That a Shame?"

#### WINDOW DISPLAYS.

C. A. Laureigh, a Dealer in Phonographs and Records at Orange, N. J., has quite a novel window display at his store. In one corner of the window he has hung a large brass horn and has arranged a large number of Record boxes so that the boxes seem to be pouring out of the bell of the horn and filling the window. He calls the display "The Horn of Plenty." It has attracted much attention from passersby. The idea is one that others may follow at practically no expense.

The Advertising Department will be glad to receive from Dealers descriptions or photographs of their window displays. This is a subject of much interest to the entire trade, and Dealers having novel displays will confer a favor upon others by sending facts about them for publication.

#### SIR THOMAS LIPTON AND THE PHONOGRAPH.

Sir Thomas Lipton, who is again a very prominent figure in the public eye, has two Phonographs on his steam yacht "Erin." He also has 400 master Records on board. His guests select their own pieces and make up the programmes.

#### A JOBBING FIRM'S NEW QUARTERS.

On July 1 the Price Phonograph Company opened its new retail store at 1258 Broadway, Brooklyn, which it considers one of the finest establishments of the kind in the country. It has every facility for the satisfactory display of the Phonograph business in all its details. It has several private Record rooms for its patrons, having learned from past experience that this is essential for a proper and satisfactory selection of Records, avoiding the delay and confusion resulting from having but one room for this purpose. Machines and outfits are neatly and tastefully arranged, enabling the company to readily give its patrons all information necessary as to prices, etc. The company now has everything in readiness for the opening of the busy season in the early fall, and is prepared to meet the large business which it expects to have, as all signs point to a very successful season in the Phonographic line. The store that the company has at 1224 Broadway, Brooklyn, will be used exclusively for the wholesale end of the company's business.

#### A NOVEL SUGGESTION.

NEW ALBANY, Ind., July 17, 1903.

I have been attracting the public's attention by the Phonograph (which perhaps some readers of the MONTHLY would like to try, as it is an idea of my own and does not take much work to arrange for) at my headquarters as follows:

Arrange seven Phonographs on the counters or tables in the display room so as to be distinctly heard from the street by passers by, select the following Records and place one on each machine: Nos. 7885, 607, 8355, 8293, 2226, 3877, 8335. Place a 24 or 30-inch horn on each machine, personally announce that there will be a street fair or Midway in the store within a few minutes, start all of the machines as near one time as possible and listen to the result, which will be an exact reproduction of one of those famous Midways that almost every one is so familiar with.

You may also arrange the seven machines in a half circle and use another machine with a blank Record and preserve your experiment, which I have done. This will satisfy some inquisitive customer who has not heard the original and will save you time in arranging the machines for his special benefit. Try it and see if it does not attract attention.

O. C. THOMPSON,  
Manager for the Ray Co., New Albany, Ind.

#### INVENTION MULTIFARIUM.

"I see," said Mrs. Rolande Parke, "that a machine has been invented to shave a man and take the place of the barber."

"Well, I be durned!" exclaimed her spouse; "it's funny the number of uses they can put the Phonograph to, ain't it?"—*Baltimore News.*



## MADE HAPPY WITH A STANDARD PHONOGRAPH.

JAMESTOWN, N. Y., July 15, 1903.

In the EDISON PHONOGRAPH MONTHLY for May I was reading "An Every Day Experience," and it called to mind one that I had which is not an every day one but ought to be. I called on two brothers who owned another style of Talking Machine, to sell them some Moulded Records. They said that the ones they had were worn out as they had never seen or heard any Edison Moulded ones. I took my case containing thirty-six, and undertook to play them on their machine. Before starting the machine they had to fasten the crosshead to glass with a piece of chewing gum. The outcome was that I did not make a sale of a single Record as the machine was intent on chewing gum. So I left my case there and the next night I took a Standard Phonograph there and played, and sold nearly half of the Records. In less than a week I sold them the Phonograph after refusing to trade for their machine. They still have it on their hands. They have \$38 invested in it and are trying to get \$10 for it. But, if they never sell it, they were made happy with a Standard Edison Phonograph.

C. J. DODGE.

## COMMENTS FROM ABROAD.

The following are extracts from letters written by Dealers in Europe and England to our Foreign Department:

*From a Dealer in Sarthe, France.*

I am pleased to acknowledge receipt of your new PHONOGRAPH MONTHLY. This is just the publication your Dealers in France should receive, for my part *I want it*, and beg you not to omit mailing it to me regularly. As a matter of record I have for the past eight years retained all of your catalogues and have them nicely bound, as I thoroughly appreciate their value. I wish you would continue mailing me all your literature and especially your EDISON PHONOGRAPH MONTHLY.

*Dealer in Walthamstow, Essex, England.*

I have purchased one of your Standard Phonographs with latest model reproducer, and the result with your Gold Moulded Records is marvellous and delightful to listen to. Some of your marches by the Grand Concert Band which I have just obtained here, viz: "Imperial Edward," "Semper Fidelis," "Pan-American Exposition," "Rip Van Winkle," and various others, are very fine, as also are the Edison Male Quartette and Cornet Solo Records.

*From a Dealer in London, England.*

I am a great admirer and user of Edison Phonographs and Records. I have used many kinds of talking machines, but have never found anything to touch the Edison Phonograph, and in my opinion it is the acme of perfection.

The Alien — Don't you like to stand in a great city street and feel the great pulse of humanity?

Citizen — Yes; but I'm a physician, anyway. — *Detroit Free Press.*

## AN UNSOLICITED TESTIMONIAL.

We are indebted to the *New York Times* of July 20, 1903, for the following unsolicited paragraph on the Phonograph and its Records:

Phonographs have to some extent taken the place of the music box, particularly for people who do not care for the delicacy of tone of the latter. A Phonograph is sold without Records. They cost with a 14-inch horn from \$10 up—\$20, \$30, \$50, and \$75. Those with larger horns are more expensive. There have been people who have said that the Phonograph was a fad which would lose its hold after a time, but while people like variety and prefer a vocal selection, as the majority of people do, to instrumental music, the Phonograph is likely to be popular. One may have the music of any known instrument, bass, tenor, or soprano voice, at will, or an entire concert if it seems worth while.

Records cost 50 cents apiece, or \$5 a dozen. There are two kinds of Phonographs, one working with a spring motor or clock work, and the other by electricity. The battery is separate from these, and any kind desired may be used: The less expensive Phonographs will run two Records with one winding, and the more costly fourteen with one winding.

## PERSISTENCE COMMENDED.

ERIE, Pa., July 11, 1903.

We beg to acknowledge receipt of your late list of Suspended Dealers, dated July 1, and wish to commend you for the persistence taken in this part of your enormous business.

Your firm are certainly doing their part nobly in compelling Dealers to live up to their Agreement with you, and every Dealer in the country should assist you in seeing that your just rules and requirements are properly enforced.

We receive the PHONOGRAPH MONTHLY regularly, and feel that it is almost equal to a face to face talk with your firm. It certainly is greatly appreciated by the trade, and should be confined to the trade, and not given out for general distribution. We feel that the Edison Phonographs and Records are becoming more popular every succeeding month.

G. W. COCHRAN Co.

## AUGUST ADVERTISING.

The publications used by the National Phonograph Co. in August for advertising its goods were the following: Ainslee's, Argosy, Atlantic, Association Men, Collier's, Craftsman, Everybody's, Independent, Life, Metropolitan, Musical Record and Review, Mines and Minerals, Outwest, Recreation, Strand, Sunset, Scribner's, Success, Town Topics, Town and Country.

The orders thus far sent us for "Hiawatha," sung by Harry McDonough in the July list of new Records, shows that this famous song has lost none of its popularity. When listed as a band selection in March it proved the best selling Record thus far this year. Mr. McDonough's solo will excel it in popularity.

### A TALKING MACHINE PUBLICATION.

We have received the first three issues of the *Talking Machine News*, published by E. T. Heron & Co., 9 Tottenham street, London, England. It is published in the interest of the entire talking machine trade in England and announces that it will treat all styles with equal fairness. The numbers thus far issued are full of interesting matter.

### TRADE ADVERTISEMENTS.

A novel advertisement of Edison goods was that of the Minnesota Phonograph Company, 37 East 7th street, St. Paul, Minn., which appeared in the *St. Paul Daily News* of July 9. The advertisement was printed in red ink, while the remainder of the paper was printed in black, as usual. It was an advertisement that would attract more attention than an entire page printed in the usual manner. It stood out so strongly that no reader of the paper could fail to see it. It was a most creditable bit of advertising.

### RECORD SHIPMENTS.

We are steadily catching up on orders for the monthly Records. The June Records were entirely shipped early in July, and the July Records were out of the factory on July 29. This leaves only the August list to be sent out. It is probable that these will go out early in August, and that the September list will get back to the normal time of shipping, viz: on or before September 1. We hope from that time to make regular shipments each month and have them out before the first of the month.

### CURRENT CATALOGUES AND PRINTED FORMS.

The following is a list of the form numbers of catalogues and other printed matter furnished to the trade at the present time:

- 291 Jingle Book No. 3.
- 371 Catalogue of Parts.
- 375 Catalogue of Phonographs.
- 376 Catalogue of Accessories and Coin Slot Phonographs.
- 381 Catalogue of Foreign Records.
- 390 Soldier Hanger.
- 391 Sailor Hanger.
- 395 Numerical Catalogue of all Records.
- 400 Chinese Record Folder.
- 404 July Supplement.
- 409 "Looking for Band" Card.
- 414 Four-page Folder showing Gem, Standard, Home and Triumph.
- 415 Electrotpe Catalogue.
- 418 Looking for Band Booklet.
- 425 Record Order Pads in 5 sheets (sheets A, B, and C for Domestic titles; sheets E and F for Foreign.)  
E and F for Foreign.)
- 427 Art of Making Records.
- 428 Four-page Advertising Folder.
- 431 "Summer Girls" Hanger.
- 446 July Bulletin.

### SOUGHT THE BEST.

PRAIRIE CITY, Ill., July 14, 1903

We signed the new contract July 1, 1903, and it is a source of great pleasure to us to realize how well you protect the Dealer, and assist him in the selling of your goods.

We have been receiving your list of Suspended Dealers, and we will co-operate with you in every manner possible to put down this ruinous practice of price cutting, etc., and we only wish that other manufacturers would follow up these same methods, thereby protecting the retail dealer to the fullest extent.

The EDISON PHONOGRAPH MONTHLY has reached us regular since its first publication. We thank you for same, and trust we may not miss a single number, as it is of great interest to us, also a great help in many ways.

We have been selling Edison Phonographs and Records, in connection with our jewelry business for the past three years, and we have built up a nice business here in that line. We obtain our goods through your general agent, Eugene Zimmermann, of the Peoria Phonograph Co., Peoria, Ill.

About four years ago we were selling —phones, but being a great admirer of Mr. Edison, his achievements and inventions, we naturally sought for the best sound reproducing machine on the market.

During the past year we have had very numerous inquiries for Piano Records, but have always been compelled to tell our customers that no exclusive piano solos had as yet been manufactured. Since the piano Record "Violets," by Frank P. Banta, has been made, it has been pronounced here as very fine, by all who have heard it, and we trust the demand will be so great for these particular Records that you will find it to your interest to add a piano solo to your list every month.

During the fall and winter we give Phonograph concerts every two weeks, inviting all our jewelry customers and Phonograph patrons to spend a few hours in our store and hear the Moulded Record selections.

In this manner we do a great amount of free advertising, to say nothing of the local newspaper advertising and distribution of your printed matter. As a result of these concerts we find it is a good way to sell your goods, and we invariably sell from one to two machines as a direct result of these entertain-  
ACKERMAN & Co.

### MEANS TO GET MORE BUSINESS.

MOUNT CARMEL, Pa., July 14, 1903.

I will give you my idea on the EDISON PHONOGRAPH MONTHLY and about advertising matter. I think the MONTHLY is the best thing that ever could have been printed, because it lets one Dealer know what the other is doing, and how they do business, and you can learn and see where you make mistakes, and you can increase your business by doing the same. Through the PHONOGRAPH MONTHLY I intend to increase my business fifty per cent. I intend to advertise more than I did; I intend to do as the Western Dealer did, sell on the easy payment plan, and I have no one to thank but the MONTHLY for the idea.

D. E. HERB.



### MORE ABOUT THAT GEORGIA COLLECTION.

At our request last month, Douglas & Co., of 89 Chambers street, New York, wrote to their customer at Fort Gaines, Ga., whose collection of Edison Records was referred to in the July issue of the EDISON PHONOGRAPH MONTHLY, for permission to use his name and for more information about his collection. With true Southern courtesy the gentleman in question replied as follows:

FORT GAINES, Ga., July 2, 1903.  
Messrs. Douglas & Co., New York, N. Y.

GENTLEMEN.—You have my permission to use my name in any way that can be of benefit. I hardly know what to say about my collection.

At my residence on Hancock street I keep for my own amusement three Phonographs, two that play the Standard, and one that plays the Concert Records. While I find the Edison Concert Records all that is claimed for them, the Edison Triumph Machine with the Edison Standard Records have proved the favorite. For my Concert machine I have a hall fifty feet long. In an adjoining room, 16x18 feet, I have the two other machines, and over seven hundred of the late Moulded Records. These Records are kept in two large cases, and in two cabinets, each holding one hundred and twenty Records, and have twenty-four one dozen boxes filled with Records.

I found that this floor space was often crowded with visitors, and am building (to be completed next week) another room, 14x18 feet, and thirteen and a half feet from floor to ceiling. The hall and room mentioned have a ceiling a little higher. This new room, built especially for the Triumph Edison, connects with the other hall and room, and is reached from the street by two entrances, one a piazza eighty-five feet in length.

My business (dealer in fancy poultry,) requires my attention only from 7 to 9 A. M., and I have plenty of time to entertain my friends with this wonderful invention, which seems more wonderful the more we see of it. I have used the machines for four years, and feel that I have just learned to appreciate it. As an entertainer, nothing can approach the Edison machine. Very respectfully,

F. E. GRIST.

Colonel Grist has been a resident of Fort Gaines for more than fifty years; has been Mayor of the city and held other positions of trust.

### GETS POINTS FROM OTHERS' LETTERS.

APPLETON, Wis., July 20, 1903.

I am in receipt of July MONTHLY, and must say I find many points of interest in each and every issue. I like your policy and you can rely on me carrying out my end of it every time. Daniel R. Weed, Jr.'s suggestion as to a "Barrel of Fun" is very good. I like the correspondence column as I am a very extensive advertiser and pick up a good many ideas from others' suggestions.

H. E. PEARSON.

### MADE A RIVAL MACHINE LOOK CHEAP

GERMANTOWN, Ky., June 29, 1903.

I beg to acknowledge receipt of your June Suspended List. I wish to assure you that no suspended Dealer on this list can get Phonographs, Records or any of Edison's goods from me. And I trust all Dealers will cooperate with you. The new Agreement I signed June 10 and sent you, and I believe that the system under which this company is now conducting business is one of the fairest and most just systems laid down, and that it will benefit all concerned.

Now a word for the PHONOGRAPH MONTHLY. I have received three issues and must say that much credit is due to the promoters of this neat and helpful little volume. I do not want to miss any number or part of a number.

I recently made a competing machine look cheap. On June 25 I took a trip over in Robertson county, about twelve miles from Germantown. I stopped at Mr. Hester's store, known as the Hitt P. O. The manager of the store played two airs on the —phone and then called on me to play the Phonograph. I took an Edison Standard Phonograph from my buggy, set it up and started it. After playing eight airs one of the listeners said, "that is the best talking machine I ever heard. Say, it makes the —phone look as cheap as a coffee mill." He said that right. I would just about as soon hear a coffee mill as a —phone.

E. E. HENDRIXSON.

### HOME PHONOGRAPH OUTSELLS ALL OTHER MACHINES.

BROCKTON, Mass., July 1, 1903.

I beg to acknowledge receipt of Suspended List to June 1. And I want to say a word for the PHONOGRAPH MONTHLY. I have received all four numbers and read every word from beginning to end. I look for each issue long before it arrives. \* \* \* While I am a rent for every talking machine made, I sell more Home Phonographs than all the other kinds put together. The Home is good enough for me. And it is good enough for me to sell, so I push it along. Sometimes I have a customer come into my store to buy a machine that don't seem to know just which machine to buy. I get right to work and play the same piece by the same artist on each machine, and that settles it right away. They always take the Home Phonograph. My business is not yet very large but growing every day. I started about a year ago with three machines and 150 Records. To-day I carry a stock of about a dozen machines and 1,000 Records.

L. R. PORTER.

### RECORD CABINETS.

The Catalogue of Accessories, Form 376, now being furnished to the trade does not show any Record Cabinets, it having been decided to discontinue listing them after the present supply is exhausted. We still have a few of these cabinets at the factory, and Jobbers and Dealers who have a demand for them should write to our Sales Department and ascertain just what we can furnish.



### I. C. S. LANGUAGE OUTFITS.

Nelson C. Durand, Manager of the Language Course of the International Correspondence Schools, Scranton, Pa., reports that he is making very satisfactory progress in the matter of having I. C. S. language outfits handled by the trade. He did not begin to lay the matter before the Jobbers personally until June 15, but by July 21 he had secured signed Agreements from the following Jobbers:

Blackman Talking Machine Co., New York.  
I. Davega, Jr., New York.  
Douglas & Company, New York.  
Jacot Music Box Co., New York.  
Boston Cycle Co., Boston.  
Eastern Talking Machine Co., Boston.  
J. C. Haynes & Co., Boston.  
Wells Phonograph Co., Philadelphia.  
Pardee-Ellenberger Co., New Haven.  
W. H. Ross & Co., Portland.  
Murray, Blanchard, Young & Co., Providence.  
Thomas Wardell, Lowell, Mass.  
Forsyth & Davis, Kingston, N. Y.  
W. D. Andrews, Syracuse, N. Y.  
Edisonia Co., Newark, N. J.

Mr. Durand will shortly make a trip West for the purpose of getting Jobbers in that section to handle the line. The advertisement of the International Correspondence Schools in another part of this issue points out that an owner of the Phonograph may now have a double use for his machine. He may get as much amusement out of it as he now does and at the same time may use it for the study of French, German and Spanish. The International Correspondence Schools have met with wonderful success in teaching languages by the use of the Phonograph, and when the public find that it will be possible to purchase these language outfits from local Dealers, the use of the Phonograph for that purpose will be even greater.

### CANNOT GET GOODS FAST ENOUGH.

COLORADO SPRINGS, Col., July 16, 1903.

We acknowledge receipt of the late Suspended List and also the PHONOGRAPH MONTHLY for July. We are glad to get the little paper as it contains lots of good suggestions for the Dealers. We are doing a very nice business in this city in Edison goods. The only trouble we have is to get the popular Records to keep up our stock. We carry from 1,000 to 1,500 Records on hand all the time and sell lots of them.

THE WEBER CYCLE & SUPPLY Co.

### RECOMMEND THEM TO ALL.

DANVILLE, Ill., July 14, 1903.

Suspended List received and will act accordingly. You are on the right track. We have handled your Moulded Records ever since their introduction and have yet to find a poor one. We therefore recommend them to all.

BENJAMIN'S TEMPLE OF MUSIC

### NO GENERAL EDITION AT PRESENT.

Some correspondents have suggested that in their opinion it would be a popular move to get out an edition of the EDISON PHONOGRAPH MONTHLY that could be sent to the general public. Several Dealers have offered to pay for a certain number of copies each month. It is improbable that anything in this direction will be done at present. Such an edition would involve too many changes and cost more than it would be possible to get back in money or results. We feel quite satisfied with the good feeling accorded the MONTHLY as now published and will not change it just now.

### PHONOGRAPH EXHIBIT WON A PRIZE.

The town of Watsonville, Cal., had a celebration on July 3 and 4, and the committee in charge of the affair offered a prize for the best decorated store front and show windows. The prize was won by Steinhauser & Eaton, Dealers in Edison Phonographs and Records. Steinhauser & Eaton are druggists and have two show windows. One of these was used exclusively for a display of Edison goods. Photographs of the front windows show that the committee made no mistake in awarding the prize to this enterprising firm.

### SUPERIOR TO ALL OTHERS.

CRESTON, O., July 18, 1903.

I acknowledge list of Suspended Dealers, and congratulate you on your system of doing business. It is the best protection to the straight Dealer that I know of and I certainly co-operate with you in keeping out the price cutting of others.

I am a music man from my boyhood and I know that the Edison Phonograph is the best constructed and plainest talking machine that is built, reproducing the natural tone and voice superior to all others.

D. S. REICHARD.

### WOULD CREATE CONFIDENCE.

NEW YORK, July 7, 1903.

I acknowledge receipt of your favor of June 20, enclosing copy of decree and injunction in suit by your company against "The Fair," of Chicago. If the other talking machine companies would protect the Jobbers and Dealers half as well as the National Phonograph Co., in my opinion it would give the talking machine business a solid foundation, and create confidence, which now is woefully lacking.

G. L. GOODDAY.

### WILL NOT SELL SUSPENDED DEALERS

TUSCARAWAS, O., July 14, 1903.

We have to-day received Suspended List of July 1, 1903. We will be very careful and not supply any of those people with your machines or Records. You can depend on it, for we are very careful. We are greatly pleased with the EDISON PHONOGRAPH MONTHLY. It keeps us in touch with everything that is going on.

REISER & HOUK.



## MOULDED RECORDS FOR PHONO- GRAPHS.

The *American Machinist* of New York, for July 9 contained an exceedingly well written and interesting article on the process of making Edison Moulded Records. It is given in full below, the drawings being reproduced on a somewhat smaller scale than they appeared in the article:

"Just play that 'Hapsburg March' once more, boys," the leader of the band calls out: the man behind the megaphone announces " 'Hapsburg March' played by the Edison Concert Band," and the band bursts into music and the making of a Phonograph record is under way. It is a record of wax, and one which, if sufficiently well produced to pass inspection, becomes a master record from which a mold will be formed for the making of a great number of wax cylinders destined to reproduce the "Hapsburg March" in all parts of the world.

At least once each week this band of trained musicians—each one an artist—plays at the Edison Laboratory, Orange, N. J., making new master records; on other days throughout the week vocalists and others are engaged in similar undertakings. It might be truthfully said therefore that there is always an entertainment of some kind at this unique establishment. The band comprises about twenty-five pieces; and in the arranging of the various instruments in front of the Phonograph horn there are many interesting departures from the conventional band groupings. It was formerly the practice to use in the band room a number of Phonographs, each making a master as the sound waves entered the horns. These masters were then placed in duplicating machines and other records reproduced from them, the master record and blank rotating together and the instrument for cutting the blank being controlled by a guide following the indentation in the surface of the master. Now but one Phonograph is employed for making master records; this has a horn 4 feet long, 18 inches in diameter at the mouth, and placed horizontally at a height of 4 feet from the floor. Seats at various heights are provided for the musicians, and the latter are so placed that each of the instruments will be at the proper elevation and angle, and at the right distance from the horn, so that the different parts will be correctly balanced in the record. In locating the instruments to gain the desired effect several of the men are faced in a direction rendering it impossible for them to see the leader, and in order that they may follow his direction intelligently the walls of the room have been provided with a series of large mirrors. In making a band record bass drums are never used, as these blur or "fog" the record; cymbals are seldom used and snare drums in solo parts only.

The master, and also the actual or working records, are shaped as shown in Fig. 1. They are—for the majority of the Edison Phonographs—about  $4\frac{1}{2}$  inches long and 2  $\frac{3}{16}$  inches diameter. The bore is taper,  $\frac{1}{8}$  inch to the foot, to suit the Phonograph mandrel, and a number of recesses are formed, as shown, leaving bearing rings or surfaces 3-16

wide. The master blanks are moulded from a white wax preparation; the inside is finished and the outside then turned a few thousandths

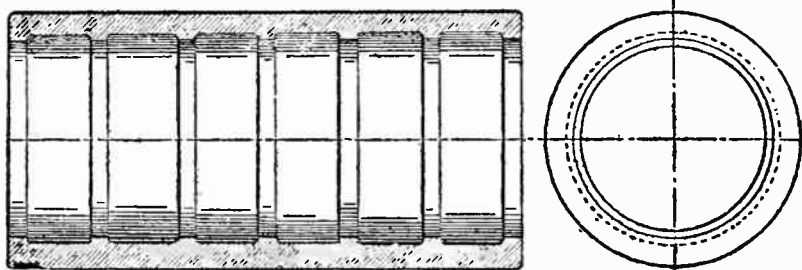

FIG 1.—End View and Section of Phonograph Record.

of an inch taper, the finished cylinders being as smooth as glass and having the appearance of polished ivory. They are turned, or shaved, in small Phonographs mounted on a workbench and belted from shafts at the back of the bench. The horns are, of course, removed from the machines, and provision is made for blowing the chips from the work. The cutting tool operating at the back of each machine is adjusted by means of a screw with a micrometer dial. The work naturally is rotated at a high speed.

Not every blank cylinder that is placed in the Phonograph behind the big horn comes out a perfect master; far from it. More or less experimenting is required to find for the case in hand the best suited recorder, that is the sensitive diaphragm with its holder and sapphire cutting point. And then great attention has to be paid to the proper bringing out of the different voices. The master records as they are made are thoroughly tested both by musical and mechanical inspectors, to detect any errors or imperfections in the quality of the music reproduced or the workmanship of the record. With the master running in the Phonograph the trained ears of the specialists enable them to detect the most minute imperfections; as a result many masters which to most people would appear to be all that could be desired, are rejected. Such masters as satisfy all requirements under this inspection are tested again later on to make doubly sure that they are satisfactory from a musical point of view. An examination under a powerful microscope is then made, to determine if the wax surface of the cylinder is satisfactory in all particulars. Then comes the making of the mold from the master record.

The first operation in the construction of the mold is the plating of the surface of the wax master. This to the average man would seem a difficult proposition. Fig. 2 gives an idea of the apparatus invented by Mr. Edison and employed in accomplishing this seemingly impossible task. The wax cylinder is shown at *a* in this engraving; and at *b* is a head over which the cylinder is slipped and which acts as a support for the latter, it being placed as shown on the conical-ended post *c*. At the top of *b* is secured an armature *d*; and over armature, cylinder and support is placed the glass *e*, this resting on a ground glass base *f*. By means of the pipe *g*, connected to a vacuum pump, the air is exhausted from the glass jar—the plating being perforated in a vacuum. At *h h* are two glass uprights, insulated from the base by hard rubber bushings *i i* and carrying conductors *j j*, around which the ends of the glass supports are sealed.



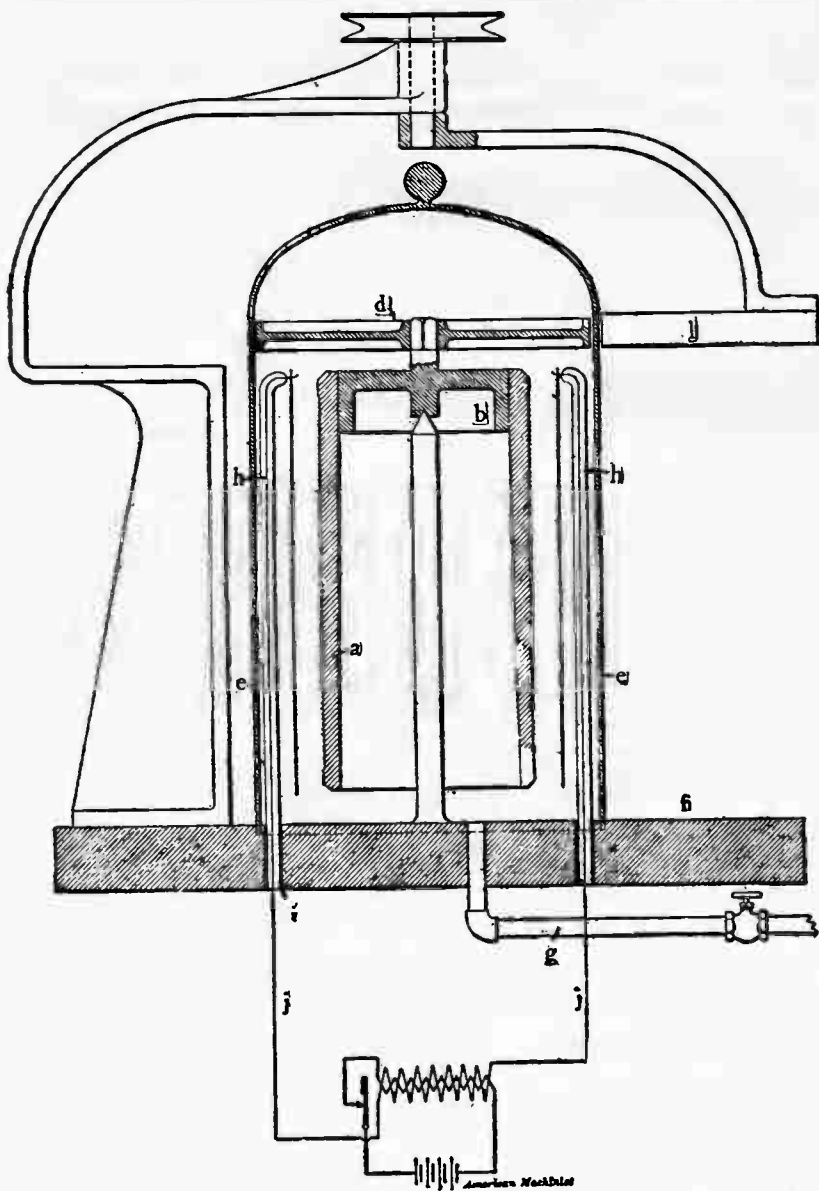

FIG. 2. Apparatus for Plating Records.

The conductors are hooked at the top, and on these hooks are suspended two strips of gold leaf *k k*. The magnet *l* is arranged to be revolved by means of the pulleys shown, and armature *d* and the wax cylinder turn with it. An arc being established between the electrodes suspended on the conductors, the gold is vaporized and—as the wax record rotates in the vacuum—is deposited in an infinitesimally thin coating upon the surface of the cylinder.

The master record now having received its plating of gold is electro copper plated, about four days being required to secure the desired thickness of copper—nearly 1-16 inch. This copper shell, with the master still within it, is then turned off smooth and straight and fitted into a brass shell, which forms really the body of the mold. A section through the mold would now appear something like Fig. 3, *m* being the master, *n* the copper shell (between which the wax surface is the minutely thin coating of gold), and *o* the brass shell in

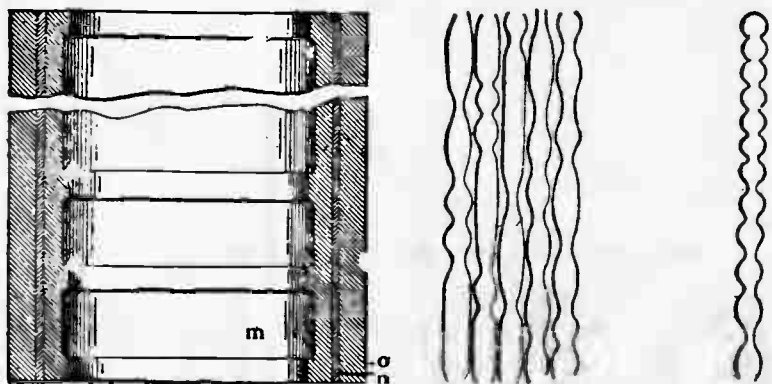

FIG. 3.—Section of Mould. FIG. 6.—Appearance of Record under Microscope.

which is fitted the copper sleeve. The wax is removed from the mold by placing the latter

for a few moments in a temperature slightly lower than that of the work-room, the contraction of the wax releasing it from the metal. The inside of the mold, which is now gold lined, is thoroughly cleaned by washing with benzine, and the mold is ready for business.

For holding the wax preparation from which the records are formed, a number of long tanks, subdivided into nearly square compartments and heated by gas, are provided. The melted wax in these tanks is dark brown in color—in fact, nearly black. In molding the record the mold is lowered into the hot wax by means of an arrangement shown roughly in Fig. 4. In this sketch *p* is the mold, *q* a cap

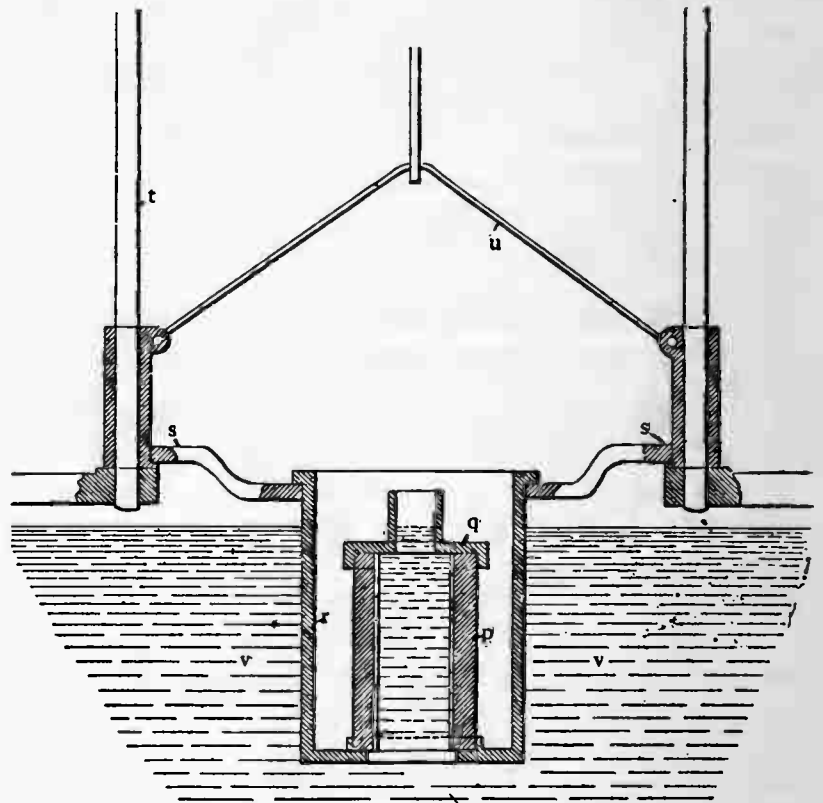

FIG. 4. Molding a Record.

placed over the top of the latter, and *r* a can in which the mold is placed and held, as indicated, in a vertical position. The can is carried in a frame *s*, which may be moved up and down on uprights *t* by means of the wire bail *u*. The can is lowered into the tank until the top of the mold is below the surface of the wax *v*, the latter entering the mold through the large opening in the bottom of the can. The wax as it passes up into the mold solidifies on coming into contact with the metal and a hollow cylinder of wax is thus formed, the thickness of the cylinder wall depending of course upon the length of time the mold is immersed and also upon the temperature of the liquid. After remaining in the wax for a minute or so the can is lifted, the cap taken off and the mold removed. The wax adhering to the bottom of the latter is removed by a knife and the mold is then slipped into a special chuck in a machine of the monitor type. Inside shaving tools held in the turret of this machine are then run into the wax cylinder to finish the bore. These tools are made of steel tubing cut away to the center for a length sufficient to reach through the cylinder and ground to a sharp edge. The tools are somewhat smaller than the rough hole left in the work, and after being run in to the right distance they are brought over against the wax wall by a lever which serves to move the turret laterally on its carriage. Three tools are required to finish the bore; the first roughs out a plain taper hole; the second (which is



notched at the edge) cuts the half-dozen grooves around the inside of the cylinder; the third, or finishing tool, brings the narrow bearing surfaces left to the correct taper. These shaving tools operate very readily as the work is rotated at a very high speed, the material of course being a little softer than anything the average screw machine operator has ever had anything to do with.

When the work is removed from the machine the wax contracts sufficiently in a moment to admit of the record being removed from the mold. And as fast as the records are finished inside they are placed on cast-iron shells, or hollow plugs, to prevent their being injured or becoming distorted in further cooling. They are next slipped, one at a time, on a taper arbor held in a machine spindle which is constantly in rotation, and the ends are here finished. After this operation each record is carefully inspected to see if it runs true and if it is free from flaws of all kinds. Passing this inspection, the record is packed in cotton, slipped into a cylindrical pasteboard box and packed ready for shipment.

The molding of these records is without doubt one of the most delicate, accurate and interesting operations ever performed in a shop. Just consider for a moment the shallowness of the indentations in the surface of the master record; the gold plating of the wax surface—indentations and all; the preservation in the mold of each and every tiny swell corresponding to its hollow in the master; the accurate reproduction on an endless number of records of every indentation in the surface of the original wax cylinder. The deepest of the impressions in the master are something less than one one-thousandth of an inch; the shallowest are much less than this. The surface of the cylinder presents a wavy appearance not unlike that of a chattering lathe job, besprinkled as it is with these tiny impressions. And yet all the circumferential grooves traced in the wax by the recording sapphire, and every shallow indentation—no matter how insignificant it may appear—are faithfully reproduced in the surface of the molded record.

With this process a much harder preparation can be used and a more durable record made than was possible under the old method of cutting each cylinder, and besides there is practically no wear upon the mold and the thousandth record molded in it is as clear and sharp and will reproduce the vibrations originally received by the master record as well as the first one cast.

A sectional view of the recording device used is given in Fig. 5, *a* being the diaphragm of glass or mica about .005 inch thick and 1 3-16 inches in diameter; *b* the metal rim in which the diaphragm is held by means of a ring of wax, a thin rubber ring being placed, as shown, under the disk; *c* a tube with spherical end matching a seat formed in the hub of *b*; *d* the body of the device bored to receive *c* and provided at the back with a neck to receive the tube at the end of the Phonograph horn. The part *b* is hinged at *e*, and at *f* is a stop pin limiting the downward movement of the diaphragm rim or weight. The recording point is shown at *g*; the holder *h* for the latter is cemented at the inner end to the diaphragm and at the outer end is attached to the rim *b*. The enlarged view at the top shows the sapphire point *g* more clearly. It has a body about .040 inch diameter cupped at the end, as indicated, to form a keen cutting edge and is reduced at the back to form a shank to fit a hole drilled in holder *h*. A good idea of the appearance—under a powerful microscope—of the surface of a record operated upon by this recorder is given in Fig. 6. The center lines of these rows of indentations are actually 0.01 inch apart as the lead screw rotating with the record arbor and feeding the recorder along the wax cylinder is cut 100 threads to the inch. The line traced on the record is therefore a thread of 0.01 inch pitch.

Some very curious results are produced in the wax by the vibrating diaphragm and recorder; the string of nearly round impressions shown to the right in this engraving illustrating the effect produced by a single xylophone note.

A sectional view of the reproducer is shown in Fig. 7. Here *i* is the diaphragm built up of three disks of mica, and held by a clamping ring between rubber rings in a shell or body *j*, the latter having the same general outline as the body of the recorder. At *k* is a hinged weight limited in its outward and downward movement by a stop-pin, and provided with a lug in which arm *l* carrying reproducer point *m* is pivoted. This arm is connected by a link with the diaphragm and causes the latter to vibrate as the reproducer follows the path formed by the recorder, the sound waves originally recorded being now reproduced. The sapphire *m* is shown enlarged above the section and it will be noticed that the head is button shaped, this form following readily the deepest and shortest indentation in the record. These reproducing points, like those used in recording, are all made at the Orange shops, a large number of bench tools being used on this work alone.

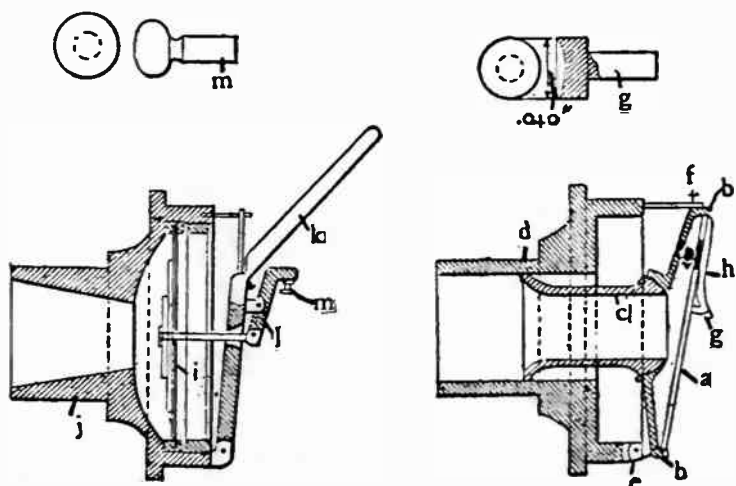

FIG. 5. The Recorder. FIG. 7. The Reproducer.

## PICTURES AND SKETCHES OF THE "TALENT."

An Illinois Dealer suggests that the PHONOGRAPH MONTHLY should contain each month a half tone cut and sketch of one or more of the artists who make Records for the Edison Phonograph. Similar suggestions have been made by others and we expect to do something in this line before long.

### ADVERTISING DEPARTMENT MATTERS

It is not likely that we shall get out a series of posters and street car cards. The cost of this kind of advertising is too great for most Dealers. The number who have been written about them is too small to warrant us in having the work done.

We have on hand a small quantity of the monthly Record supplements issued since January. They are of no use for the purpose of pushing new Records but most of them are quite attractive and some Dealer may find them useful for general advertising. We shall be glad to supply them as long as they last.

Sample copies of the new edition of the four-page machine folder, Form 414, showing the Gem, Standard, Home and Triumph Phonographs, has just been sent by mail to the entire trade. We regard this as a very useful folder. The edition just printed will permit us to fill orders for reasonable quantities.

A paragraph in the July issue of the EDISON PHONOGRAPH MONTHLY, concerning the furnishing of Order Books to Dealers, has caused some Jobbers considerable annoyance. The paragraph made it appear as if we furnished an Order Book which could be used by Dealers

to order goods through Jobbers. This was an unfortunate mistake. The Order Book is one that can only be used by Jobbers in ordering goods from us and by such Dealers as place orders direct, and not through Jobbers. It bears the name and address of the New York office of this company, and could not be used for ordering through Jobbers without causing confusion. The Advertising Department asks the trade to accept its apologies for this error.

We have received from the printer a supply of hangers showing the Price List, Terms and Conditions of Sale under which Edison Phonographs and Records are sold. It is form 454. It has been issued for the purpose of supplying Dealers with something that they may either frame or hang up in their stores, and thereby show doubtful customers the conditions imposed upon them in the sale of Edison goods. This hanger will be mailed to all Dealers some time in August. It is being held up, along with the Celluloid Card, in order that only those Dealers who sign the new Agreement will be supplied with it. The hanger will be mailed direct, but the show cards will be placed through the Jobbers. A card will be sent to every signed Dealer, entitling him to one of these cards, and Jobbers will not be allowed to give out any of them except to Dealers who produce this card.

## CYLINDER RECORD CABINETS

made with the practical knowledge of what a Cylinder Record Cabinet ought to be. We illustrate two popular leaders—and there are others.

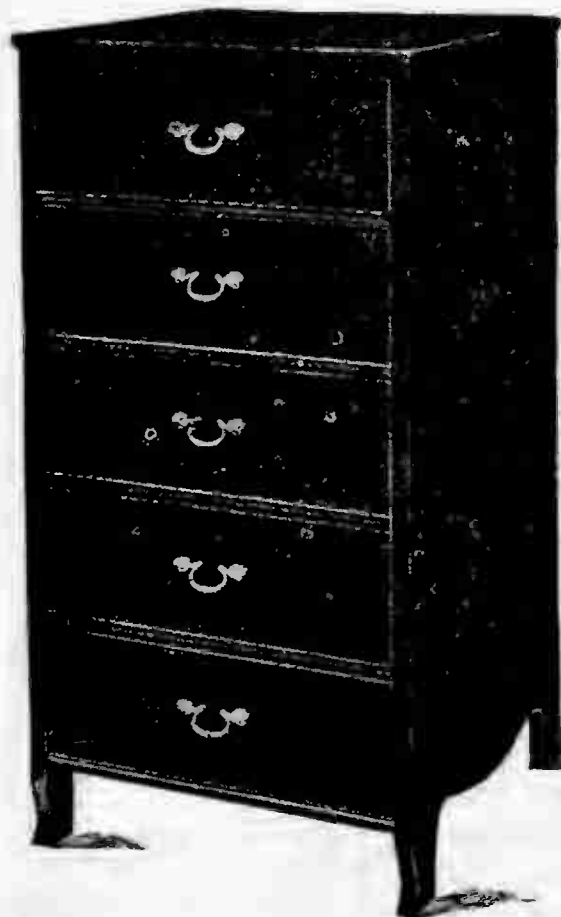

No. 2.

**No. 2.** Height 37 inches, width 19 inches, depth 18½ inches; five drawers with stops, 180 pins, Mahogany veneered front and top, birch imitation sides, false back, piano finish..... **22.50**

**No. 3.** Height 37 inches, width 19 inches, depth 20 inches; five drawers with stops, 180 pins, quartered oak front, back, both sides and top, piano finish..... **28.00**

Dealers will find it profitable to write for special discounts. These cabinets are made in the most reliable manner—in the best standard of furniture making.



No. 3.

# AMERICAN PHONOGRAPH COMPANY

106 Woodward Ave., Detroit, Mich., U. S. A.



# TO PHONOGRAPH DEALERS:

Live dealers who have used the EDISON KINETOSCOPE with MOVING PICTURE FILMS and ILLUSTRATED SONG SLIDES, accompanied by PHONOGRAPH RECORDS, to attract crowds and advertise their business, have made striking successes.

*Write for Detailed Plans,* giving answers to the following questions:

1. Is there at your disposal a low building or roof upon which to hang a stereopticon curtain from 12 to 20 feet square for use at night?
2. Or have you a large show window for an 8 to 12 foot curtain, and a deep store which you are willing to darken during the show, while the crowds gather?
3. Can you obtain the electric current for light, preferably 110 volts direct?
4. Do you want to add to your profits by advertising your neighbors' business?

## KLEINE OPTICAL CO.,

52 State Street, Chicago, Ill.

**Largest Distributors of Edison Kinetoscopes and  
Films in the United States.**

(FACTORY DISCOUNT ALLOWED TO DEALERS ENTITLED TO THEM.)

# Language Study on the Phonograph.

Every Phonograph now has a double use—amusement and language study. French, German and Spanish have been successfully taught for the past three years by the I. C. S. Language System with Repeating Phonograph. Each Language Outfit contains 25 Edison Moulded Language Records and 40 I. C. S. textbooks in pamphlet form.

**These Language Outfits are  
now offered to the trade  
complete for \$50.00, or  
the records and textbooks  
only at \$25.00. -- -- --**

FOR FURTHER PARTICULARS ADDRESS

**INTERNATIONAL CORRESPONDENCE SCHOOLS  
SCRANTON, PA.**

Language Department, Nelson C. Durand, Manager.

# The C. W. N. Handbook of the Phonograph

— AND —

## Instructions for Making Records.

BY C. W. NOYES.

**Every Owner** Of a talking machine should have a copy of this valuable book. It is replete with **Instructions for the Care and Use of the Phonograph**, and the chapters devoted to **RECORD MAKING** are compiled from the author's many years of experience in some of the principal laboratories of this country.

Any one possessed of ordinary intelligence can make a perfect record if the directions are followed.

Fully Illustrated—Handsomely Bound.

PAPER, 25 CENTS.

CLOTH, 50 CENTS.

Mailed Postpaid on Receipt of Price.

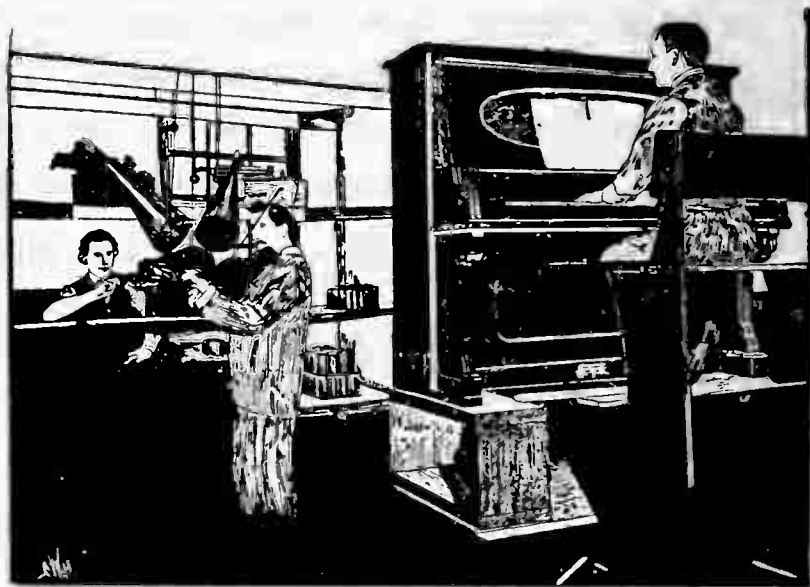

For Sale by All Jobbers, or

**ILSEN & COMPANY, Cincinnati, Ohio.**

DEALERS WRITE FOR DISCOUNTS.

## A CARD TO THE TRADE JOBBER AND DEALERS

Interested in giving their customers best results are invited to write us for quotations on

### DOUGLAS

#### *Mega (Paper) Horns and Record Cabinets*

The Horn that Made us Famous.

Superior to any metal horn made in purity, volume and absence of metallic tones.  
**GREAT AIDS TO THE SALE OF PHONOGRAPHS AND RECORDS.**

"MEGA"	List	\$7.50
Length 32 inches; Width 24 inches.		
"MEGA JR."	List	\$2.25
Length 22 inches; Width 13 inches.		
MEGA RECORDING HORN,	List	\$1.50
Length 24 inches; Width 6 3/4 inches.		

Look for the Trade Mark

"PHONO-MEGA."

Attractive and Substantial.

Superior to any Line in the Market,  
**STRONGLY MADE.**

**BEAUTIFULLY FINISHED.**

100 Peg Polished Oak,	List	\$12.00
125 " " "	"	14.00
125 " Quartered Oak,	"	15.50
150 " " "	"	18.00

**Prices Restricted.**

WRITE FOR SPECIAL LEAFLETS AND NET PRICES.

### DOUGLAS & CO.,

89 Chambers Street,

NEW YORK.

71 Reade Street,



# EDISON Phonograph Monthly

PUBLISHED FOR TRADE USE ONLY BY  
THE NATIONAL PHONOGRAPH CO.

VOL. 1.

NEW YORK, SEPTEMBER, 1903.

No. 7.

*The National Phonograph Co.,*

ORANGE, N. J.

NEW YORK: 83 CHAMBERS STREET.  
CHICAGO: 304 WABASH AVENUE.  
SAN FRANCISCO: 933 MARKET STREET.  
ANTWERP: 32 REMPART SAINT GEORGES.

## EDISON PHONOGRAPHS AND RECORDS.

All communications to THE PHONOGRAPH MONTHLY should be addressed to the Advertising Department, 83 Chambers Street, New York.

C O N T E N T S

Explain Its Improvements.....	1
Record Shipments.....	1
Advance List of October Records.....	2
Dealers Should Write Nearest Headquarters Building Progress.....	3
Art Calendar for 1904.....	3
Get the Writing Habit.....	3
Japanese Records.....	3
Plan for Fall and Winter.....	3
Binder for EDISON PHONOGRAPH MONTHLY.	4
A Catalogue Suggestion.....	4
New Style Repeating Attachment.....	5
A. O. U. W. Lodge Entertained with a Phonograph.....	6
To Edison Is Due the Honor.....	7
Non-Signers Removed from Mail List.....	7
Personal.....	7
Comments on October Records.....	8
September Advertising.....	9
Phonograph Should Be in More Homes Than Any Other Musical Instrument..	10
Favors a Publication for the Trade Only..	10
Gives an Open Air Concert.....	10
Best Selling Records.....	11
Publicity Methods of Enterprising Jobbers and Dealers.....	12
About Printed Matter.....	13
Sales of Moving Picture Outfits by Phonograph Dealers.....	13
September Suspended List.....	14

### EXPLAIN ITS IMPROVEMENTS.

It should be part of the duty of every Dealer in Edison goods to convince the people of his city that the Edison Phonograph has made marvellous advances in the past few years. Many persons heard the Phonograph in its early days and formed an unfavorable opinion of it which has remained to this day. They became prejudiced against it and still retain their dislike solely because they have not heard the present-day Phonograph and know nothing of its improvements. It is the daily experience of Dealers to have people, after hearing some of the new Moulded Records, exclaim, "Why I did not know that the Phonograph could make music like that." Hundreds of sales have followed incidents of this kind. It is not enough, Mr. Dealer, that we know how good the Phonograph is or that you consider it the best talking machine in existence. We are striving to get the public to call at your stores and hear it play some of the new Records. Follow this up by urging the people on all occasions to come in. Then put on Records calculated to suit the taste of each individual. Don't put on rag time coon songs when your judgment tells you that your customer prefers music of a different character. Endeavor to ascertain their preferences and then play Records to suit them. A little care in this respect will do much to increase sales and the popularity of the Phonograph.

### RECORD SHIPMENTS.

The demand for Records continues to be so heavy that it has been impossible to make much headway during the past month in gaining on the time for shipping August Records. The last of these were not shipped from our factory until after August 25. We had hoped to gain a week or more on this time, but had not anticipated such a steady demand for Records, both for August and for those previously listed.

THE ADVANCE LIST OF OCTOBER RECORDS APPEARS ON PAGE 2. ORDER FROM IT. NO OTHER ADVANCE LIST WILL BE ISSUED.

## ADVANCE LIST OF NEW EDISON MOULDED RECORDS FOR OCT., 1903

RECORDS listed below will be ready for shipment as near October 1st, 1903, as possible, at which time Jobbers' stock orders, if placed prior to September 15th, will be shipped.

October Supplements will bear the date of October 1st, and will be forwarded to Jobbers with their stock order for Records.

Retail Dealers should place stock orders with their Jobbers at once, to insure prompt shipment as soon as Jobbers' stock is received.

Stock orders for Records contained in this list must be written on separate order blanks, and letters relating to October Records should refer to no other matter.

Kindly comply with above requests and thus aid your Jobber and ourselves in handling advance orders.

- |                 |   |   |
|-----------------|---|---|
| 8499            | Happy Days  | Miss Corrinne Morgan  |
|                 | <i>Contralto song with violin obligato</i>                                    |   |
| <del>8500</del> | American Standard March   | Edison Military Band  |
| 8501            | Always in the Way   | Byron G. Harlan   |
|                 | <i>Chas. K. Harris' latest descriptive song, with orchestra accompaniment</i> |   |
| 8502            | Hungarian Dance No. 1 (Brahms)  | Edison Hungarian Orchestra                                  |
| <del>8503</del> | Praise Ye, from Attila  | Metropolitan Mixed Trio                                     |
| 8504            | The Laughing Medley   | <i>Male Quartette</i> Invincible Quartette                  |
| 8505            | In Starlight  | <i>Sentimental Song</i> W. H. Thompson                      |
| 8506            | Thy Sentinel Am I   | Frank C. Stanley  |
|                 | <i>Basso song with orchestra accompaniment</i>                                |   |
| 8507            | Leona Polka   | Leo Zimmerman   |
|                 | <i>Trombone solo, accompanied by the Edison Concert Band.</i>                 |   |
| 8508            | Budget of Short Stories (Humorous)  | Len Spencer   |
| <del>8509</del> | It Was the Dutch  | <i>Comic male duet</i> Collins & Harlan                     |
| 8510            | Sweet Remembrance   | <i>Intermezzo</i> Edison Symphony Orchestra                 |
| <del>8511</del> | Waiting for the Dinner Horn to Blow   | Harlan & Stanley  |
|                 | <i>Comic Rube talking and singing male duet</i>                               |   |
| 8512            | Must You  | <i>Comic song from "Wizard of Oz"</i> Edwin M. Favor        |
| 8513            | Le Tremolo  | <i>Flute solo with orchestra accompaniment</i> Charles Molé |
| 8514            | Poverty's Tears Ebb and Flow  | W. H. Thompson  |
|                 | <i>As sung in Edward Harrigan's "Old Lavender"</i>                            |   |
| <del>8515</del> | Good Bye Eliza Jane   | <i>New coon song</i> Arthur Collins                         |
| <del>8516</del> | Ballet Music from Faust, Part 2   | Edison Concert Band   |
|                 | <i>(Entry of Helen and Her Trojan Maidens)</i>                                |   |
| 8517            | Down on the Farm  | <i>New descriptive song</i> Franklyn Wallace                |
| 8518            | There's Music in the Air  | <i>March Song</i> Harry L. Talley                           |
| 8519            | The Crowd on McNally's Back Stoop   | Collins & Harlan  |
|                 | <i>Waltz song, male duet</i>  |   |
| 8520            | Love's Dilemma (She is so Queer)  | <i>Love song</i> Arthur Clifford                            |
| 8521            | Wou't You Kindly Hum Old Home Sweet Home to Me                                | <i>Coon song</i> Billy Murray                               |
| 8522            | My Cosy Corner Girl   | Harry MacDonough  |
|                 | <i>Descriptive song with orchestra accompaniment</i>                          |   |
| 8523            | Love and Passion (Pensée Pathétique)  | Edison Symphony Orchestra                                   |

Edison Moulded Records are made only in Standard size. Both Standard and Concert Records may be ordered from this list. Order by Number, not title. If Concert Records are wanted, give the number and letter C.



## DEALERS SHOULD WRITE NEAREST HEADQUARTERS.

Dealers in Edison Phonographs and Records will get better service if they will address this company at its office nearest to their city or towns. Those doing business in Wyoming, Colorado, New Mexico, North Dakota, South Dakota, Nebraska, Kansas, Missouri, Oklahoma, Minnesota, Iowa, Michigan, Illinois, and Indiana should refer all matters pertaining to the business to our Chicago office, 304 Wabash avenue. Dealers in Washington, Oregon, California, Nevada, Idaho, Utah, Arizona and Montana should be able to get better attention through Peter Bacigalupi, 933 Market street, San Francisco, headquarters for our goods on the Pacific coast. He gets large quantities of goods by water from our factory and is able to save Dealers part of the heavy transportation charges when goods are shipped overland by freight. Canadian Dealers will find it advantageous to deal with R. S. Williams & Sons Co., 143 Yonge street, Toronto, Canada. Dealers in all States not named above should address their correspondence to our New York office.

## BUILDING PROGRESS.

Excellent progress is being made in the new building operations at our factory in Orange, New Jersey. The new Record building is going up rapidly, the laying of bricks for the first story being about completed. Our architect has promised that we shall be making Records in this new building before December 1. The work of adding a story to the building used for assembling, packing and shipping, is completed.

## ART CALENDAR FOR 1904.

We expect within the next month to make definite announcement concerning an unusually fine Art Calendar for 1904 that we shall issue the latter part of this year. It will not, however, be distributed gratuitously, but will be sold to the trade at a price which will enable every Jobber and Dealer to purchase a limited number for distribution as Christmas souvenirs among his best customers. The calendar will comprise six sheets, each printed in twelve colors, with different sketches, the drawing of which will equal the work of the best artists in the country. It will be gotten out on lines similar to the Art Calendar of the Armour Beef Company, of Chicago, the Fencing Girl Calendar of the Chicago and Alton Railroad and the Art Calendar of the Chicago, Milwaukee and St. Paul Railroad, all of which were in tremendous demand all over the coun-

try. In addition to placing these calendars before the trade, we expect to advertise their sale at twenty-five cents each in the same manner as the above-named calendars were sold. Further details about this calendar will be given next month, about which time we hope to have a sufficient number of samples to send one to each Jobber.

## GET THE WRITING HABIT.

As the columns of the PHONOGRAPH MONTHLY show from time to time, we are receiving some very interesting letters concerning trade matters from Jobbers and Dealers. We shall be glad to receive more of these. By this, we do not mean letters in praise of the EDISON PHONOGRAPH MONTHLY, but those containing suggestions for its improvement, criticisms of its treatment of matters, descriptions of methods of selling goods, advertising, window displays, etc., Phonograph incidents and the many other every day happenings in connection with the sale of Phonographs and Records.

## JAPANESE RECORDS.

With the August Bulletins and Supplements was mailed a folder of the Japanese Records, Form 464. We are now in a position to supply orders for these Records. With the exception of two, these Japanese Records are by Sokichi Kudzuoko, who possesses an excellent voice for Record making. We think that these Japanese titles will become quite popular in the English trade for the reason that some of them are sung to well known English tunes. For instance, No. 12816, "Hotaru no hikari," is sung to the air of "Auld Lang Syne;" No. 12818, "Omoi izureba," is sung to the air of "Bonny Doon;" No. 12819, "Ware no Kami ni," is the Japanese version of "Nearer My God to Thee," and is sung to the same tune. These Japanese Records are very different in character from the Chinese Records listed by this company, and should find even a greater sale in this country.

## PLAN FOR FALL AND WINTER.

Now that the vacation days are about over, it is time to give serious attention to fall and winter business. Keep in mind the difficulty of a year ago in getting orders filled, look over your stock carefully, ascertain how much business you did in the fall and winter of last year, and place orders accordingly. Your Jobber will be very glad to have you order goods well in advance, and we shall be equally pleased for the longer time in which to get goods into the

hands of the Jobbers. The time was when there was considerable uncertainty as to the future of the Phonograph and Record business, but that time is past. Just as close calculations can be made in this business at the present time as are possible in the sale of groceries or dry goods, and Dealers are safe in placing orders accordingly.

#### BINDER FOR THE E. P. M.

We have placed an order for a supply of binders for the EDISON PHONOGRAPH MONTHLY. Each binder will hold twelve issues. Each issue may be put in the binder as fast as it appears and each may be removed without disturbing the others. The binders will be attractive in appearance and be suitably lettered with the name of the publication. They will be sent postpaid for fifty cents to Dealers who have signed the new Agreement. Send orders to the Advertising Department and they will be filled as soon as binders are received. One cent or two cent stamps accepted.

#### A CATALOGUE SUGGESTION.

"Let me give you a suggestion," said one of our Jobbers to the Advertising Department, when in the city recently. "In your Record Catalogue you classify titles beginning with 'A' or 'The' under the letters 'A' and 'T,' etc. As a result when a customer asks for the Record 'The Bedouin Love Song,' we are not quite certain until we look whether we shall find it classed under 'T' or 'B.' In my opinion, it would be better to drop the use of the articles 'The,' 'A' and 'An,' and classify accordingly. This would classify 'The Bedouin Love Song' under the 'B's,' and would make it possible to find it more readily." This suggestion seemed to be a good one, and we shall probably act upon it in issuing the next edition of our Record Catalogue. This instance is cited here to show the trade how helpful it is to have Jobbers and Dealers make suggestion concerning seemingly small matters which come to their attention. We shall be glad to hear from others in a similar way.

#### HOME OUTSELLING THE STANDARD.

WATERLOO, Ohio, Aug. 8, 1903.

We have received the August number of the EDISON PHONOGRAPH MONTHLY and Suspended List, and expect to fully co-operate with you. While the *Phonogram* was always a welcome little sheet we think the new EDISON PHONOGRAPH MONTHLY is as much better as the Moulded Record and model C Reproducer are better than the old style.

If a man will only read the MONTHLY he will get information that would take years to get otherwise and put him in shape to talk intelligently when a person asks a question about talking machines.

Last year the Standard was our best seller, but this year we have been selling Home machines when in other years we sold very little of any in the hot months. We look for a large talking machine trade this fall. We formerly handled the ——— goods, but are glad we changed. We may be compelled to put in a line of disc goods, not that we expect to sell many, but there is a certain demand for noise among some people that must be filled. Where a person has the two styles of machines, Edison and disc, side by side, it is strange to see why any one will ever invest in a disc.

JENNISH & WHITNEY.

#### A UNIQUE WINDOW DISPLAY.

MOUNT CARMEL, Pa., Aug. 11, 1903.

Your MONTHLY received this morning and I was well pleased with same. I think the August number was the best yet published. You talk about a window display, I think I have the best of them. All I have is a large sugar barrel with a Gem machine in it. On the barrel is a large sign reading, "Barrels of fun in an Edison Phonograph." More people look at that than any window display I ever had. The entire window is covered with whitening and only three peep holes. It is lots of fun to see people "rubber."

D. E. HERB.

#### FROM NEW ZEALAND.

WELLINGTON, N. Z., July 6, 1903.

Your EDISON PHONOGRAPH MONTHLY to hand, for which accept our best thanks. Kindly see we get this interesting pamphlet posted monthly. As to your article on pushing goods I forwarded the manager a Palmerston newspaper containing a paragraph to the effect that we gave a public demonstration from the band rotunda situated in our large city square. We used a Concert Phonograph, and the newspaper was very flattering in its remarks on the loudness and tone of machine, and trusted we would soon favor the public again at intervals.

ENOS S. PEGLER.

#### ARE PAYING REGULAR PRICES.

BARABOA, Wis., Aug. 7, 1903.

Yours of late date containing lists of Suspended Dealers received to-day. You can rest assured we will do all we can to maintain prices on Edison goods. Some of our customers have left us at different times to do better, but they have returned and are not kicking about paying regular prices.

C. C. THOMPSON & SON.

#### VOTES FOR PICTURES OF THE "TALENT."

HARPER, Kan., Aug. 8, 1903.

Your Suspended List, Form 466, for August, at hand, also the PHONOGRAPH MONTHLY. It is getting better all the time. I vote for pictures and description of the "talent."

M. S. LIDEN,  
Of Liden & Liden.



**NEW STYLE REPEATING ATTACHMENT.**

The accompanying cut shows our new style Repeating Attachment applied to the Triumph Phonograph, and illustrates equally well its application to the larger spring motor and electric machines. On the Home Phonograph a slight variation in construction is made, which will be spoken of further on.

The operation of the device is very simple and will be readily understood from the cut and what follows, since we know that to accomplish the result sought it is only necessary to lift the speaker arm at the end of Record and at the same time engage it with some returning means. This returning means is a deep grooved screw S, supported in bearings at the back of the machine body and driven

inner end of L, tending to pull it down, thus bringing the pin down on top of straight edge and lifting the speaker arm; at the outer end of the lever L a latch G is pivoted, so that when L is pushed down, allowing the speaker arm to drop, the feed nut to engage the feed screw and the arm to ride on straight edge as usual, this latch hooks under the edge of plate C, retaining it in that position, the spring tending to pull it in the opposite direction.

To automatically release this latch G at the end of the record, there is an adjustable stop H, mounted on the right hand end of the machine body and as the speaker arm advances to the right the latch L comes against this stop and the arm continues until it has unhooked the latch, at which instant the spring draws

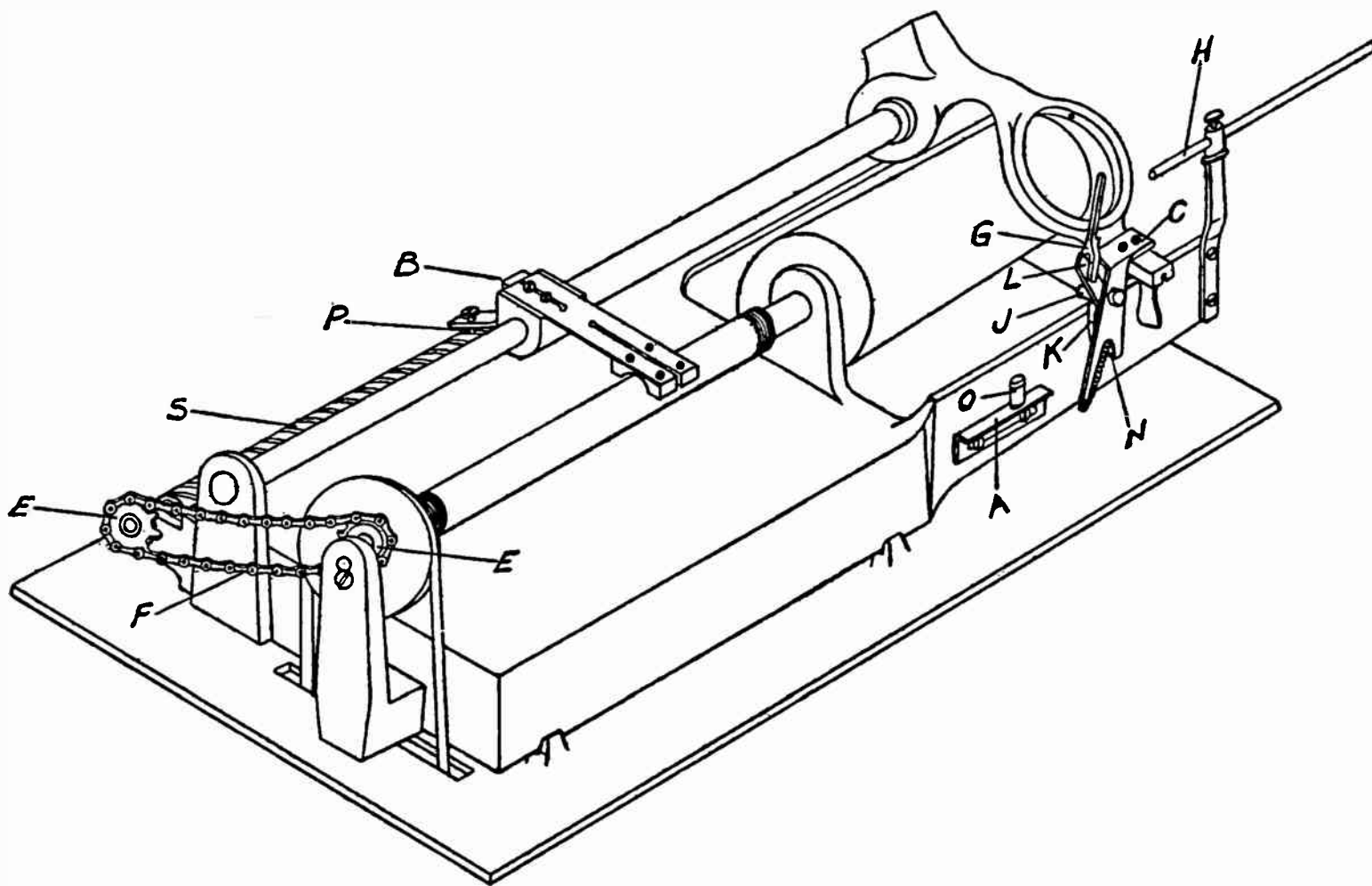

by means of sprockets E-E and chain F, running from the main shaft to it. To engage the speaker arm with this screw there is a plate B rigidly fastened to back of arm and projecting out over the return screw. The projecting end of this plate carries a pin P on its under side, of the right diameter and proper position to enter the groove in the return screw when the speaker arm has been lifted sufficiently to disengage the feed nut from the feed screw.

To lift the speaker arm at the close of the record, a plate C is firmly screwed to the forward projection of speaker arm and carries on its inner side a pivoted lever L, which in turn carries on its inner end, a pin J, which projects back over the top of straight edge and serves as lift lever. A spring is also attached to the

the lever down, thus lifting the speaker arm, which disengages feed nut and screw and brings the pin P into slot of the return screw S, which carries the speaker arm back to the left.

The cut shows it returning. On its way back, the post O engages a swinging pawl K on lever L and resets it, locking the latch L under plate C, leaving the speaker arm free to drop back on the straight edge as soon as foot N of plate C, now riding on top of plate A, drops off at the extreme left of its travel, thus completing one entire operation, which will be automatically duplicated as long as the machine runs.

One great advantage of this attachment is that when the machine is reproducing there is

no power used for anything else, as it is self contained and uses power only during the return.

In applying it to the Home machine, the return screw S is mounted directly on the motor on the inside of machine and is driven by gears instead of chain and sprocket; the plate B is longer and extends out over the back edge of top plate, passing through the cabinet; otherwise, all attachments are identical in design.

This attachment is sold at the same price as the one now listed in Catalogue No. 375.

### AN A. U. O. W. LODGE ENTERTAINED WITH A PHONOGRAPH.

The following letter was received on the day that the forms of the PHONOGRAPH MONTHLY for August were closed. It was addressed to Peter Bacigalupi, Jobber in Edison goods at San Francisco:

SAN FRANCISCO, July 18, 1903.

On Thursday evening, July 16, Burns' Lodge, No. 68, A. O. U. W., gave an entertainment immediately after the installation of officers, consisting in part of addresses by a number of the old members as well as the installing Grand Officers, and also vocal and instrumental selections rendered by means of the Edison Triumph Phonograph which you so kindly loaned me for the occasion. The concert was an overwhelming success and demonstrated most clearly the advantage of using the Phonograph for public as well as private entertainments. Every number on the programme (of which I enclose you a copy) was enthusiastically applauded and had to be repeated, some of them *three and four times*. I was most agreeably surprised at the result myself, as I had an idea that the hall would be too large to fill with the volume of sound from my horn, as I had never used it in a room larger than an ordinary parlor; as a matter of fact it was a decided advantage to have more space and every note was as clear to those in the hall who were seated at least forty feet from the stand on which the machine was placed, as it was to those who were within eight or ten feet. At the close of the entertainment I was given a rising vote of thanks by the members, and was invited to give a similar concert when we celebrate our "silver" anniversary. Permit me to extend to you my thanks for your kindness in loaning me the Triumph as it would have entailed considerable trouble on me to have taken my Victor and the large cabinet on which it is mounted from my residence to the hall. The Triumph answered every purpose, and with the assistance of a friend, I had no difficulty in taking it, together with my horn, tripod, and carrying case of Records. After more than a year's experience with the Phonograph I am still as enthusiastic as ever: in fact, I am known among my friends as a Phonograph "crank," a title that does not annoy me in the least as I have received more enjoyment listening to the "choir invisible" of my Phonograph than I could have secured from any other source that I am aware

of at the present time. I note from the EDISON PHONOGRAPH MONTHLY for June that there will be a splendid list to choose from for July and I shall await the arrival of same with delight. The instrumental duet for violin and flute, by Jaudas and Atz, violin solo—De Beriot's 6th air with variations, by D'Almaine, Annie Laurie, by the Edison Brass Quartette, together with many other gems, will be a musical treat to which I look forward with pleasure.

JOHN W. SEELEY,

(The Edison Phonograph Enthusiast.)

NOTE—In the near future I shall send you a classified list of my Records (of which you are aware I have over 200) and perhaps we can make some Eastern "cranks" open their eyes to the fact that there are some people out here in the "wild and woolly" West who can appreciate a *good thing* when they see and hear it.

[The Records played by Mr. Seeley during the evening were the following: Nos. 7600, 527, 8256, 8366, 8288, 8272, 3608, 8048, 8349, 8223, 8101, 8382, 8303, 644. They were well selected as those who will take the trouble to look up their titles may ascertain.]

### CANNOT KEEP STOCKED UP.

The following is an extract from a letter received in August from the Minnesota Phonograph Co., St. Paul, Minn.:

Enclosed please find an additional order for stock Records, which please add to our order now at your factory. We are extremely low on these numbers and it would be a great accommodation to us if you would kindly rush this order through the factory.

We have been trying to anticipate our wants in regards to our Record stock, but the people of St. Paul have taken so kindly to Edison Phonographs and Records, that we have found it an utter impossibility to keep our stock in near the shape that it should be.

MINNESOTA PHONOGRAPH CO.

### GIVE THE BEST SATISFACTION.

POTSDAM, N. Y., August 17, 1903.

Your August list of Suspended Dealers at hand. I am glad to note that you use all Dealers alike, both large and small. I cannot understand why Dealers wish to cut prices on your goods, as their own merit will sell them, and I can honestly say that the Edison goods give the best satisfaction of any on the market.

H. D. FRENCH.

### TESTIMONIAL.

The following is an unsolicited testimonial from a Phonograph admirer:

ALEXANDRIA, VA., August 13, 1903.

When I decided to purchase a Phonograph nearly a year ago, I wanted to be sure of getting the best on the market. With this object in view, I looked at a number of other styles of machines. I decided to purchase an Edison Phonograph. The Edison is a magnificent machine, both in quality of tone, which is superb, and in outward style and finish.

G. C. GOODRICH.



### TO EDISON IS DUE THE HONOR.

A correspondent to the *Talking Machine News*, London, England, furnishes the following information concerning the early attempts at reproducing sound:

Edison was not the first man that tried to solve the problem of recording and reproducing human speech—but in pre-Edison days the utmost accomplished was in the direction of tracings (generally on a smoked surface) illustrative of voice vibrations. Leon Scott's "talking machine" never existed, neither was it "a practical attempt to solve the problem of voice reproduction." The crux of the problem was infinitely more in the direction of reproducing than in recording, and this (the reproducing of speech) Scott never even mentions. What Scott accomplished, and great honour is due to him for it, was the invention of the Phonograph, in 1856. This uncouth looking instrument marked, in its operation, a distinct advance, yet the utmost it did was tracing sound vibrations on a smoked surface. The tracings had no permanence whatever. Much less was there any thought of reproducing from them. In reference to Charles Cros, the case is different, yet not to the extent some may think. There seems also no room for doubt that neither Edison or Cros knew of each other's work, or idea, in this direction. Cros never made a machine, and never got beyond theory, but all the same he theorized well. He was hardly an inventor, but a thinker. He could not, as Edison can, foresee practical realizations from small indications. Still Cros's ideas were brilliant, and worthy of high praise. Du Moncel doubted if the instrument described by Cros could ever be capable of reproducing speech. The Abbe Leblanc also made several attempts to carry out the instructions of Cros, but without success. Attempts to make a phonograph were also made by M. Napoli and M. Deprez, also without success. To Edison alone is due the honour of solving the great problem. He first worked out not only a practical principle, but evolved from that principle a practical result. Dr. Maier, in his interesting description of Larranaga's phonograph, well says, in reference to pre-Edison efforts:—"Previous records of sound suggested no practical way of reproducing it, nor was this effected until Edison produced his talking phonograph." As to Edison, in the world of invention I believe, he is the most imitated man.

### THANATOPSIS.

H. C. Bickle, Dealer at Chardon, Ohio, sends the following clipping from *Geauga County Record* of August 7:

The exhibition of the Edison Home Phonograph by H. C. Bickle attracts much attention. The seemingly inexhaustible repertoire of exquisite music which is daily produced by the obliging exhibitor of this marvelous invention is a source of pleasure to many. But the climax was reached when Mr. Bickle announced that ex-Sheriff Edward Clapp's matchless rendition of Bryant's "Thanatopsis" was ready for reproduction. The Record was taken by John

Chapman, and it requires very little stretch of imagination for the listener to see the venerable ex-Sheriff's every gesture as the marvelous poem is rendered, word for word, with perfect imitation of detail in expression.

### A TRANSPOSITION ERROR.

The interesting article on "Moulded Records for Phonographs" reprinted from the *American Machinist* in the August issue of the PHONOGRAPH MONTHLY, contained an annoying error in make-up. On page 13 the cuts of the Recorder and Reproducer were transposed, the cut of the Reproducer appearing over the title of the Recorder and vice versa. Fortunately the PHONOGRAPH MONTHLY circulates only among Phonograph Dealers and the error deceived no one. In spite of this fact, however, we regret that it occurred. We thank the various Dealers who pointed out the error.

### NON-SIGNERS REMOVED FROM MAIL LIST.

Jobbers who receive complaints from their Dealers that they have not received this issue of the PHONOGRAPH MONTHLY or other printed matter usually sent out by this company, will understand that it is because such Dealers have either not signed the new Agreement or because their Agreement has not been forwarded to us to make our records complete. All Dealers who had not signed the new Agreement on September 1 were removed from our mailing list and will not be restored to the list until they have conformed to our request in the matter of signing the new Agreement.

### PERSONAL.

Among the visitors at our New York office the past month were W. H. Beck, of the Eastern Talking Machine Co., Boston; P. E. Conroy, of the Conroy Co., St. Louis, Mo.; Fred and Henry Babson, of the Talking Machine Co., Chicago, Ill.; Henry Winkelman, of John C. Haynes Co., Boston, Mass.; C. A. Ray, of the Ray Co., Louisville, Ky.; P. A. Powers, Buffalo, N. Y.; William Werner, Easton, Pa.; J. E. Ellenberger, of Pardee-Ellenberger Co., New Haven, Conn.; H. Shields, of the Denver Dry Goods Co., Denver, Colo.

C. B. Haynes, who for two years represented this company in the middle West and who for the past two years has been with the Armour Company, of Chicago, has been re-engaged as salesman by the National Phonograph Co. His territory will be New York State, (except New York city and Brooklyn), and part of New Jersey and Connecticut.

## COMMENTS ON OCTOBER RECORDS.

The October list of new Moulded Records abounds in new features. In this respect it is one of the notable lists of the year. Perhaps the most attractive of these new features is the listing of a selection by the Edison Military Band, an entirely new organization and different in every respect, man for man, from the Edison Concert Band. This organization has been perfected for the purpose of making Records of music of a military character. The instruments entering into its makeup are different from those of the ordinary band, and the music rendered is of a distinctly military character. The selection listed for October is No. 8500, "American Standard March." It is difficult in an article of this length to attempt to describe the work of this new band, and we will leave it to the hearers of this selection to ascertain the difference for themselves. We think that for certain kinds of music the results achieved by this organization are superior to those of the old.

Another new feature of the October list is the introduction of the Edison Hungarian Orchestra to the lovers of the Edison Phonograph and its Records. Everyone knows that the music played by a Hungarian orchestra is much different from that of an ordinary orchestra. The reason for it is that Hungarian orchestras include several instruments seldom found in a modern orchestra. One of the instruments peculiar to a Hungarian orchestra is the cymbals—not the cymbals used in connection with a brass band and bass drum, but an instrument resembling the dulcimer. It is, however, much larger in size, and contains many more strings. In the selection listed—No. 8502, "Hungarian Dance No. 1," by Brahms—the peculiar music of the cymbals is brought out in a marked manner, and the Record is one quite different from that played by the Edison Symphony Orchestra.

The third feature is No. 8503, "Praise Ye," from Attila, sung by the Metropolitan Mixed Trio. This selection was formerly made in the old Wax Records under the name of "Attila," and was discontinued when the new Moulded Records were first made. It was a Record always in great demand, and has been put back on the list in response to a general demand for it. The singing of the selection by this trio makes the Record a much better one than when formerly listed.

A fourth feature for October is the listing of one of the best Records ever made by a woman's voice. It is No. 8499, "Happy Days," and is sung by Miss Corrinne Morgan, with violin obligato. The song itself is a charming

one. It is sung by Miss Morgan with entire absence of all objectionable features of Records made by women's voices, and the violin obligato adds much to the attractiveness of the Record. We believe that this Record will be one of the most popular of the entire list, if not for the year.

With No. 8513, "Le Tremolo," a flute solo with orchestra accompaniment, Charles Molé (pronounced Mo-lay) makes his bow to the great *clientele* of the Edison Phonograph. Mr. Molé was formerly with the Boston Symphony Orchestra, in which organization he played first flute. As a soloist on the flute he is the equal of any one now before the public. The selection that Mr. Molé plays for his initial number is a clear and sweet air, and is one that affords him an excellent opportunity of showing his ability as a flute player.

No. 8514, "Poverty's Tears Ebb and Flow," sung by W. H. Thompson, is a selection that will doubtless cause many to wonder why it is being listed at the present time. We do it because of the popular demand that has existed ever since the introduction of the new Moulded Record. Hundreds will remember the success with which Edward Harrigan sang this song in "Old Lavender," and few who heard it will fail to recall it with pleasure. It is doubtless this feeling which caused so many of our friends to ask us to make it available for use on the Phonograph. Mr. Thompson's excellent voice does full justice to the song and makes it a most desirable Record. Mr. Thompson has a second selection in the October list, No. 8505, "In Starlight," a love song of the better or more standard class and one of Mr. Thompson's best efforts.

In No. 8501, "Always in the Way," Byron G. Harlan sings Charles K. Harris' latest descriptive song, with orchestra accompaniment. The publisher of this song predicts for it great popularity. It is already well known in certain parts of the country.

The Invincible Male Quartette, in No. 8504, "The Laughing Medley," sing a selection in which the laughing effects are well brought out.

Frank C. Stanley, in No. 8506, "Thy Sentinel Am I," makes an excellent contribution to the monthly list. Mr. Stanley's voice requires no commendation on our part. It is as well known as the Phonograph itself. The selection is accompanied by the orchestra.

The trombone makes an exceedingly attractive Record, and in No. 8507, "Leona Polka," Leo Zimmerman has one of great excellence. It is accompanied by the Edison Concert Band, a new feature in work of this kind. Something out of the ordinary is No. 8508, "A Budget of Short Stories" (and, of course, they are funny stories), made by Len Spencer.

Collins and Harlan have two excellent male



duets in the list. They are both humorous, as usual. No. 8509, "It Was the Dutch," is sung in Dutch dialect, but the dialect is not exaggerated and is easily understood. The song is somewhat on the "Mr. Dooley" style. The words are by Vincent Bryan and the music by Neil Moret. The other selection by these clever artists is No. 8519, "The Crowd on McNally's Back Stoop." It is one of the waltz songs so popular for the past year or two.

The Edison Symphony Orchestra has two selections on the list, both charming selections and made perfectly. They are, No. 8510, "Sweet Remembrance," a new intermezzo composed by Alfred Müller-Norden, now being played by all the best orchestras and meeting with instant favor; and No. 8523, "Love and Passion" (Pensee Pathetique). This is described by its composer, J. F. Bellois, as being a pathetic thought. The melody is of the "Hearts and Flowers" character, orchestrated to feature the oboe, violoncello, flute and violin parts.

No. 8511, "Waiting for the Dinner Horn to Blow," is another characteristic Rube talking and singing duet by Harlan and Stanley. It fully equals in fun any of this popular series already listed.

In No. 8512 Edward M. Favor sings "Must You?" one of the hits in the musical success, "The Wizard of Oz." Mr. Favor cleverly brings out the good points of the song. Arthur Collins' solo Record is No. 8515, "Good-Bye Eliza Jane." This is not the old song with this name, but a new and popular "coon" com-

position, the words of which are by Andrew B. Sterling and the music by Harry von Tilzer. It goes without saying that Mr. Collins makes a good Record of the song.

The Edison Concert Band in No. 8516 plays "Ballet Music from Faust, No. 2," and make a Record fully as artistic as was "Ballet Music, No. 1," in the September list. No. 8517, "Down on the Farm," is another new song with an old name. It is quite unlike its namesake. Franklyn Wallace sings it in good style.

Harry Talley, who made his first Edison Record in the September list, has another in October. It is No. 8518, "There's Music in the Air," a march song, the words of which are by Andrew B. Sterling and the music by Silvio B. Hein. Arthur Clifford's contribution is No. 8520, "Love's Dilemma" ("She Is So Queer"). As its title indicates, it is a love song, and Mr. Clifford sings it nicely.

The name of No. 8521, "Won't You Kindly Hum Old Home, Sweet Home, to Me?" would seem to the ordinary individual as being too long to be good, but such is not the case. It is a coon song of the "Bill Bailey" family, and is meeting with success wherever sung on the vaudeville stage. This Record of it is made by Billy Murray, whose "coon" song Records have become very popular. The last solo Record on the list is No. 8522, "My Cosy Corner Girl," made by Harry McDonough. This air first became popular as an orchestra selection and then words were written for it by Charles Noel Douglas. The music was composed by John W. Bratton.

### SEPTEMBER ADVERTISING.

The accompanying cut of our September advertisement shows the new Phonograph Girl in still another attractive pose. Again, Mr. Dealer, does this advertisement direct the attention of the public to your stores. "Don't buy any talking machine until you have heard the Phonograph at the nearest Dealers. Five thousand stores sell Phonographs." It is all for your direct benefit, and, of course, indirectly, for our own; but it is an honest effort to see that you get your share instead of trying to have orders sent directly to us. In return, you should see that every reasonable effort is made to inform the public that you are "the nearest Dealer," and that you can supply all wants in the Phonograph line. Our September advertisement appeared in the following publications: The Bookman, Century, Collier's, Craftsman, Harper's, Independent, Leslie's Popular Monthly, Life, Metropolitan, Mines and Minerals, Munsey's, Music Record and Review, National, Out Door Life, Recreation, Review of Reviews, Saturday Evening Post, Scientific American, Smart Set, Sunset Magazine and World's Work.

The EDISON

# PHONOGRAPH



The **Phonograph** is the most delightful of all home entertainments. Don't buy any talking machine until you have heard the **Phonograph** at the nearest dealer's.

5000 STORES SELL PHONOGRAPHS WITH MR. EDISON'S RECENT WONDERFUL IMPROVEMENTS.

**National Phonograph Co., Orange, N. J.**

NEW YORK 83 Chambers St.	CHICAGO 304 Wabash Ave.	SAN FRANCISCO 933 Market St.
EUROPE: ANTWERP, BELGIUM, 32 Rempart Saint Georges		

## PHONOGRAPH SHOULD BE IN MORE HOMES THAN ANY OTHER MUSICAL INSTRUMENT.

We wonder if Dealers realize that of all the musical instruments now in existence none should find their way into as many homes as the Phonograph. Such is not the case at the present time, but it should be if proper effort was made. The Phonograph should be in more homes than the piano for the reason that its cost is not one-tenth that of the latter instrument. More of them should be in general use than the violin, banjo, or other solo instrument because the latter require months of training to be able to use them satisfactorily, while the Phonograph requires no skill whatever—anyone may play it. The Phonograph is the greatest of all music making devices because of its easy adaptability to homes of all classes.

## FAVORS A PUBLICATION FOR THE TRADE ONLY.

SUNAPEE, N. H., Aug. 10, 1903.

Acknowledge receipt for the August list of Suspended Dealers. Also note that some Dealers advocate that the EDISON PHONOGRAPH MONTHLY should be published in large quantities for distribution among Phonograph owners and intending purchasers. I would like to say that in my opinion the National Phonograph Co. issues a great plenty of advertising matter for distribution among the public at present—by this I do not mean any too much—but I think that the Dealers should have a paper issued to them only, wherein any business concerning discounts or other private matter can be discussed freely. Also think that the hanger No. 454 showing price list, terms and conditions of sale under which Edison Phonographs and Records are sold, to frame or hang in the store, will be a fine thing as some people always think that the goods that they want can be secured at a discount from some Dealer. Thanking you for the numbers of the PHONOGRAPH MONTHLY already received and hoping that it will be continued on the present lines indefinitely. In reviewing the policy of the National Phonograph Co. in protecting its Dealers, also their customers, I think that the business is carried on in as near a perfect manner as it is possible to handle such a large business.

E. S. PERKINS.

## TRADE INCREASES EACH MONTH.

QUITMAN, Mo., Aug. 5, 1903.

We are in receipt of the PHONOGRAPH MONTHLY and think it one of the best we have had the good fortune to read. The article, "Moulded Records for Phonographs," gives us an idea as to the care and time that is given to produce the Records as we get them.

Do not fail to send us the MONTHLY regularly for we do not want to miss any of the trade ideas given in it. Our Record trade increases each month.

J. R. BOYER.

## WOULD NOT PLAY WHEN FULL.

PIGEON, Mich., July 24, 1903.

We acknowledge with pleasure the receipt of the last issue of the EDISON PHONOGRAPH MONTHLY and found it very interesting. We had a peculiar circumstance occur the other day and we thought it might be of interest to the readers of the paper. We sold an Edison Standard machine to a gentleman who owns the hotel and has a bar in connection. The other day he brought us the machine and wanted it fixed up. Said something was the matter with it, and there certainly was. Upon removing the Reproducer and holding it upside down we found that it was full of beer, which goes to prove that the Standard is a strictly temperate machine and will not play when full.

LEIPPRANDT BROS.

## GIVES AN OPEN AIR CONCERT.

J. A. Foster, Dealer at Lisbon Falls, Me., sends one of the circulars he gets out each month when he receives each new lot of Edison Moulded Records. It was set in display type and was arranged as follows:

FREE OPEN AIR  
CONCERT

SATURDAY EVENING, AUGUST 8, '03.

consisting of the July list of

NEW EDISON MOULDED RECORDS

Made in Standard Size, \$5.00 per dozen.

[Here was given the July list of Records.]

Concert takes place in front of FOSTER'S Store at 7.00 Sharp.

Why not buy a Phonograph? \$10, 20, 30, 50, \$100. By Paying ONLY \$1.00 PER WEEK.

Catalogues and full information on request.

MUSIC FOR EVERY HOME.

Do not forget the day and date  
FOSTER'S

## MONTHLY "COMMENTS" A VALUABLE GUIDE.

FORT GAINES, Ga., Aug. 8, 1903.

I acknowledge receipt of Suspended List for August, and it is my pleasure to state I will not violate my contract, will under no circumstance deal with names published.

In this connection allow me to thank you for the EDISON PHONOGRAPH MONTHLY. It is precisely what has long been needed. Among the many matters of interest are the "comments" on the monthly issue of Records. I was much interested in "Comments on September Records," these will form a valuable guide.

F. E. GRIST.

Hereafter Record No. 7013, "The Toreador Song," by J. J. Fisher, will be sung by Arthur Clifford.



**BEST SELLING RECORDS.**

The Record Department at our factory in Orange makes up a list every month of the best selling Records of the monthly Supplements and also the best sellers for the month of all titles previously listed. This record of sales is so interesting that we have given up in this issue considerable space in referring to the subject and commenting upon these lists as far back as January. This comment is interesting as showing the tastes of the public in the matter of Phonograph Records. In January we listed thirty-three Domestic Records. Of these the fifteen best sellers were the following:

- 8293. Turkey in the Straw.....Golden
- 8313. Strike Out McCracken.Collins & Harlan
- 8314. Nationality Medley,  
Invincible Quartette
- 8287. On Broadway in Dahomey Bye and Bye  
Collins & Harlan
- 8298. Roll on the Ground.....Golden
- 8285. Eva—Xylophone .....Hopkins
- 8295. Marriage Bells.....Rubsam
- 8294. Tell Me Dusky Maiden,  
Harlan & Stanley
- 8311. Mixed Ale Party.....Golden
- 8300. In the Sweet Bye and Bye.....Libby
- 8290. Dance of the Skeletons.....Band
- 8306. There's No Place Like Home...Harlan
- 8301. Dat's de Way to Spell Chicken..Collins
- 8291. When It's All Goin' Out and Nothin'  
Comin' In.....Quinn
- 8309. I'm so Tired Livin' I Don't Care When  
I Die.....Collins

In February thirty-two Domestic titles were listed, and of these the following fifteen were the most in demand:

- 8325. Reminiscences of Minstrelsy..Minstrels
- 8326. Echoes of Minstrelsy.....Minstrels
- 8329. My Own United States.....Thompson
- 8315. Katie My Southern Rose....Thompson
- 8317. I've Got My Eyes on You.....Band
- 8331. Little Cotton Dolly...Edison Quartette
- 8335. Turkish Patrol.....Hopkins
- 8321. Good Night, Good Night, Beloved,  
Mixed Quartette
- 8319. Trouble.....Collins & Harlan
- 8332. I'll Kill the Man Who Swiped My Can,  
Collins & Harlan
- 8337. Second Reg. Conn. N. G.....Band
- 8338. When the Autumn Leaves are Falling,  
Harlan & Stanley
- 8333. Boston Commandery March.....Band
- 8342. Noreen Mavourneen.....Harlan
- 8341. I'll be Busy All Next Week....Collins

There were thirty titles listed in March, and the following fifteen lead all the rest, the difference in sales between the highest and the lowest of the fifteen being 2,400 Records:

- 8366. Mr. Dooley Medley—Xylophone.  
Hopkins
- 8347. Hiawatha.....Edison Concert Band
- 8368. Monkey Shines on the Mobile Levee,  
Edison Band
- 8372. O'Brien.....Collins & Harlan

- 8373. Larboard Watch.....Harlan & Stanley
- 8356. Sweet and Low,  
Mendelssohn Mixed Quartette
- 8352. The Lost Chord.....Edison Quartette
- 8376. Dream of the Tyrolienne..Jaudas & Atz
- 8349. Home Ain't Nothing Like This..Collins
- 8370. Health, Wealth and Happiness Waltzes,  
Orchestra
- 8351. Please Mamma Buy Me a Baby..Harlan
- 8369. Cuckoo Song.....Harlan & Belmont
- 8375. Symphia Waltzes.Edison Concert Band
- 8365. Then I'd Be Satisfied With Life..Favor
- 8354. The Pooh Bah of Blackville Town,  
Collins

Only fifteen titles were listed in April, and of these the following five had the greatest demand:

- 8389. I Wonder Why Bill Bailey Don't Come  
Home .....Collins
- 8379. Pretty Peggy—Bells.....Rubsam
- 8386. When the Winter Time Comes Round,  
Collins & Harlan
- 8387. Alagazam March—Xylophone..Hopkins
- 8390. When Our Lips in Kisses Met,  
Morgan & Stanley

Of the twelve titles listed in May the following five proved the most popular:

- 8396. Under the Bamboo Tree—Xylophone,  
Hopkins
- 8394. Violets—Piano .....Banta
- 8398. Blaze Away March,  
Edison Concert Band
- 8402. Waltz Me Down the Alley Sally,  
Collins & Harlan
- 8395. Life's Dream is O'er,  
Chapell & Stricklett

In the June list there were twenty titles, the ten leaders of which were the following:

- 8412. Down Where the Wurzburger Flows,  
Hopkins
- 8416. Butterfly Gavotte—Bells.....Rubsam
- 8409. In the Valley Where the Bluebirds  
Sing .....Harlan
- 8404. Spring of Love.....Jaudas & Atz
- 8419. In the Starlight.....Morgan & Stanley
- 8420. Little Dinah Jones—Xylophone,  
Hopkins
- 8421. Ma Starlight Sue,  
Thompson & Campbell
- 8406. Up the Street March,  
Edison Concert Band
- 8405. Won't You Roll Dem Eyes....Collins
- 8422. Refuge..Mendelssohn Mixed Quartette

Of the twenty-five Records listed in July the ten leaders were as follows:

- 8425. Hiawatha ..... MacDonough
- 8428. Heart's Desire.....Jaudas & Atz
- 8424. American Patrol.....Band
- 8434. Every Morn I Bring Her Chicken.  
Collins
- 8429. Marriage Is Sublime..Collins & Harlan
- 8435. 'Deed I Do.....Morgan & Stanley
- 8440. I'm a Jonah Man.....Collins
- 8417. Hurrah for Baffins Bay.  
Collins & Harlan
- 8436. Massa's in the Cold, Cold Ground.  
Male Quartette
- 8443. Pretty Little Dinah Jones.MacDonough

The ten best selling Records of the August list were the following:

8457. A Scene in a Country Store. Harlan & Stanley  
 8473. Santiago Waltz.....Hopkins  
 8462. Alita ..... Benzler  
 8454. Up-to-date Minstrels, No. 1....Clifford  
 8468. There's Always a Mother Waiting for You.....Harlan & Stanley  
 8456. Congo Love Song.....MacDonough  
 8471. Ephasafa Dill.....Collins & Harlan  
 8451. Love's Dream After the Ball.....Band  
 8460. You Can't Fool All the People All the Time ..... Collins  
 8459. A Lucky Duck.....Orchestra

### PUBLICITY METHODS OF ENTERPRISING JOBBERS AND DEALERS.

The Iver Johnson Sporting Goods Co., of Boston, issued a very clever and attractive mailing folder in July for the purpose of advising their Dealers with reference to the August advance list of new Edison Moulded Records. It had a lithographed design on the outside, showing a hand grasping a hammer and about to drive a nail into a board. Above the hand and hammer were the words "Square on the Head." On the center panel inside was the August list and above it this phrase, "You will hit the nail square on the head if you send us your order early for Phonographs and Records." On another panel was the article from the July PHONOGRAPH MONTHLY headed "Order Early for the Fall Trade." Altogether the folder could not fail to attract attention.

Copies of trade advertising cards, folders and novelties have been received from the Hartford Phonograph Co., 25 Asylum street, Hartford, Conn.; Musical Supply Co., 122 North Michigan street, South Bend, Ind.

That William H. Keller, of Easton, Pa., is a live Dealer in Edison goods was shown by his full column advertisement of Phonographs and Records in the *Easton Free Press* and *Easton Daily Express* of August 4. Mr. Keller is a persistent advertiser.

One of the most useful advertising novelties that we have seen in some time was a folder sent out in July by W. J. Roberts, Jr., Jobber in Edison goods at Cleveland, Ohio. Attached to the second page of the folder were about forty needles of various sizes and for all possible uses. The evident cost of the novelty at once compelled the recipient to seek the name of the enterprising firm sending it out.

One of our New York city Jobbers has had a frame made in which to place the Bulletin of new Records as it appears each month. The frame is kept in the show window as part of the display and as the Bulletin is printed in

two colors it is much more attractive than when hung up loosely. Many more people read the list when framed than they did before. We do not know how much of this is done throughout the trade but the idea is good and Dealers would do well to copy it. The cost of a neat oak frame is small and as the Bulletin is always the same size the frame may be used a long time.

In the April issue of the PHONOGRAPH MONTHLY comment was made upon some Phonograph advertising in the *National Magazine* by the Eastern Talking Machine Company, of Boston. In this advertisement the company named announced the sale of Edison Phonographs and Records on the mail order plan. Desiring to know what success the company had with this advertising, we questioned Mr. E. F. Taft, Manager of the company, when at our New York office, recently, concerning it. Mr. Taft said that it was so successful that they not only received orders for goods from the New England States, but shipped goods as far West as Illinois, and as far South as Texas on account of the advertisement. He also said that his company were so well satisfied with the results that they expected to continue it on the same lines this fall.

Many Jobbers are now making a feature of getting out each month a card or folder giving the numbers and titles of the Edison Moulded Records for the month and mailing them to their various customers. We have received copies of lists of this character issued by the Blackman Talking Machine Company, 19 Beekman street, New York, issued for the months of May, June, July and August. Each new list is gotten out in some unique way and in a different style from any that preceded it. This company reports that it finds this mode of keeping its customers posted quite profitable.

Thomas Wardell, Jobber at Lowell, Mass., has flattered the PHONOGRAPH MONTHLY by deeming its monthly comments upon the advance list of new Moulded Records as having sufficient advertising value to reproduce in circular form and mail copies to his customers. We have heard indirectly that a large jobbing firm in Boston contemplates doing the same thing. The idea seems good. While these monthly comments are far from complete, they furnish information about the new lists that could not be written by the Jobbers themselves. It will be our aim to have these articles contain as many points for the guidance of the trade and their customers as may be possible without making them too lengthy.



**ABOUT PRINTED MATTER.**

The edition of Catalogue of Foreign Records, Form 381, that has been in use since January 1, 1903, is exhausted. Orders now being received will be filled with a new edition in September. Jobbers whose orders for Foreign Record Catalogues are not filled promptly will understand the reason for the delay.

We have on hand a small quantity of the compartment boxes used by Dealers for holding catalogues and other printed matter, known to some as "Take one boxes." Each box contains four compartments. They are covered with black paper and present a neat appearance. We can supply these in quantities from ten to twenty-five to such Jobbers as did not receive a supply last year, or we will mail one to any Dealer sending six cents to pay postage on it.

The Numerical Catalogue, Form 395, is nearly out of print. We cannot supply it in quantities to Jobbers, and this will explain why several orders sent in by Jobbers recently for this catalogue have not been filled. The few copies we have left will be used for supplying new Dealers in Edison goods and for such demands as seem urgent.

In printing the edition of Catalogue of Parts, Form 371, dated June 1, two trifling errors crept in. On page 11 the price of the Motor Frame Holding Screw Posts for the Home Motor is printed in the repair column, when it should appear in the supply column. On page 16 the price of the Triumph Spring Retaining Washer is listed under the supply column, when it should appear in the repair column.

We have had numerous requests during the past month for copies of Form 454, the hanger showing the Price List and Terms and Conditions of Sale under which Edison Phonographs and Records are sold. We have not yet sent out any of this form for the reason that we do not want them to get into the hands of people who are no longer handling our goods. We have removed from our mailing list all Dealers who have not signed the new Agreement, and with this issue of the EDISON PHONOGRAPH MONTHLY we are mailing one of these hangers and an order for a celluloid card to all Dealers.

Requests to have their names and addresses printed on catalogues and other advertising matter are still occasionally received from Dealers. We are compelled to refuse them. It is quite impossible to do this work for nearly

5,500 Dealers, and, as we have before said, it would be impolitic to do it for a few and refuse it to others. Even if Dealers were willing to pay the cost we still should not want the task of consigning from one to ten different forms to a printer, looking after the work, repacking, shipping and billing the charges, especially when it would cost the Dealer just as much as if he had the work done in his own city. Most Dealers put their names and addresses on with a rubber stamp and with care it can be done neatly.

**LEARN SPANISH.**

Most readers will recall the article, "A Message to Garcia," written by Elbert Hubbard in the *Philistine* and published in editions of hundreds of thousands by the New York Central Railroad. Captain Rowan was the man who "carried the message," and he is now located at Manhattan, Kansas, where he heard an Edison Phonograph and a Spanish Record from the International Correspondence School Language System. That he was very much impressed is shown by the following endorsement:

MANHATTAN, KANSAS, February 24, 1903.

I have examined the method of teaching Spanish in the International Correspondence Schools, and have no hesitation in recommending the course to any one who is desirous of quickly learning to use that language practically. By that method it is possible to get the correct pronunciation so that one may understand and be understood by Spaniards.

Very sincerely,

A. S. ROWAN.

Captain Nineteenth Infantry.

**OUR SYSTEM A BENEFIT TO SMALL DEALERS.**

WALLINGFORD, Conn., July 27, 1903.

The writer is a very enthusiastic Phonograph Dealer. I realize that your system of doing business is a great thing for the small retail Dealer and I only wish other goods could be sold in the same manner.

HERBERT G. MIX

**SALES OF MOVING PICTURE OUTFITS BY PHONOGRAPH DEALERS.**

Dealers in Phonographs have an occasional inquiry for prices and general information concerning Edison Kinetoscopes and Films. These inquiries are frequently not productive of results, because the Dealer may not carry these goods in stock, and from lack of experience is unable to give the information required. This article intends to point out the manner in which such inquiries can be turned into profit, and good results obtained from the small investment necessary.

Edison Kinetoscopes are made in two styles,

the Exhibition model selling at \$115, and the Universal model, at \$75. The latter has recently been placed on the market. Both instruments are high grade moving picture machines and none of the competing instruments on the market can be compared with it.

Edison moving picture Films are divided into two classes, A and B. Class A retails at 15 cents per foot for subjects of any length; class B sells for 12 cents per foot. The price classification is determined by considerations other than quality, such as the original cost of obtaining the negative from which the films are made.

The price conditions relative to the selling of Edison Kinetoscopes and Films are the same as with the Phonograph and Records. List prices must be maintained. The effective carrying out of this policy has been of benefit to all Dealers in Kinetoscopes and Films, and price cutting is practically unknown as well as unnecessary.

The Phonograph Dealer who receives an inquiry for information need not have special

knowledge of the goods, as the printed matter issued by the Edison Manufacturing Co. covers the subject thoroughly, and this can be transmitted to the customer. If the Dealer is asked whether he can furnish out of stock any of the subjects listed in the Film catalogue he will answer in the negative and still not be at a disadvantage in competition with other Dealers. It is impracticable to carry a complete line of Films in stock. Many of the subjects are ordered but rarely, and the Edison list is very large, comprising many hundreds of Films. Orders for Films sent to the factory will be filled in from one to three days.

In accepting orders for Films, it should be understood between the Dealer and customer that they cannot be placed conditionally and the Films must be accepted when received. It would not pay the Dealer to order Films subject to examination, with chances of rejection.

The Dealer's first investment should embrace the following as a minimum: Two Edison Kinetoscopes of either style; first order for two machines being requisite to entitle the Dealer to a trade discount; 1,000 feet of moving picture Films, assorted subjects, including comics, mysterious and traveling scenes. A

### SUSPENDED LIST, SEPTEMBER 1, 1903.—SUPERSEDING ALL PREVIOUS LISTS.

#### KANSAS.

LAWRENCE—BELL BROS.

#### MASSACHUSETTS.

LAWRENCE—LORD & CO., 314 Essex street.

MALDEN—A. T. FULLER.

NEW BEDFORD—H. B. DEWOLFF.

#### MICHIGAN.

DETROIT—F. J. SCHWANKOVSKY.

SAGINAW—GEO. W. EMENDORFER.

#### MISSOURI.

KANSAS CITY—THE WITTMANN CO.

#### NEBRASKA.

LINCOLN—THE WITTMANN CO.

OMAHA—THE WITTMANN CO.

#### NEW JERSEY.

ATLANTIC CITY—SAMUEL D. WOLF, 32-34 Arkansas avenue.

BAYONNE—I. WIGDOR, 450 Avenue D.

JERSEY CITY—W. L. HOFFMAN, 151 Montgomery street.

NEWARK—R. L. CORWIN.

PATERSON—CHAS. H. KELLY, 25 N. Main st.

WEST HOBOKEN—EMIL HOLLANDER, or THE WEST HOBOKEN BICYCLE & PHONOGRAPH CO., 619 Spring street.

#### NEW YORK.

BEDFORD PARK—GEO. H. TYRRELL.

NEW YORK CITY—A. T. ARMSTRONG, or AMERICAN PHONOGRAPH CO., 106 Wall street.

R. L. CORWIN, also Newark, N. J.

EAGLE PHONOGRAPH CO., or C. LOWENTHAL, 83 Nassau Street.

EMPIRE PHONOGRAPH CO., 2 West 14th street.

HAWTHORNE & SHEBLE, 297 Broadway, also Philadelphia, Pa.

R. H. INGERSOLL & BRO., 67 Cortlandt street.

W. L. ISAACS, 114 Fulton street.

S. LEMBÜRG & CO., 194 Broadway.

J. McELLYNNE, 202 Broadway.

\*RICHMOND PEASE, 44 W. 132d st.

F. M. PRESCOTT, 44 Broad street.

STAR CREDIT CO., or Paul Sacks, 180 East Houston st. and 57 Third ave.

SARATOGA—W. J. TOTTEN.

#### OHIO.

CINCINNATI—J. L. ANDEM.

SPRINGFIELD—D. & M. VANDERPOOL.

UHRICHSVILLE—F. A. MAZURIE.

#### PENNSYLVANIA.

PHILADELPHIA—A. R. CASSIDY, 2783 Emerald street.

HAWTHORNE & SHEBLE, 604 Chestnut street.

PITTSBURG—A. LIPPARD, 615 Wylie avenue.

#### RHODE ISLAND.

PROVIDENCE—F. P. MOORE.

\*Added since last Suspended List was issued August 1, 1903.

**Jobbers and Dealers are asked to co-operate with us, FOR OUR MUTUAL GOOD, by being careful that they do not supply any of the above named firms with our apparatus.**



few additional objective lenses, condensers, lime light burners, curtains, and other accessories would complete the necessary stock. The total investment of the Dealer need not exceed \$300. Instruments and Films can easily be replaced as sold.

It is desirable that the Dealer have a dark room for demonstration. Any room that can be darkened is sufficient, and the dimensions may vary. The instrument is placed at one end and a screen or white sheet hung opposite. The distance between the sheet and the machine may vary from 60 down to 15 feet. For dark room purposes a 40 foot throw is desirable. Most of the Dealers in moving picture apparatus are restricted to smaller rooms, some of them using as short a range as 15 feet. For a 20 foot distance use a 10 foot sheet; for 40 foot a 12 or 15 foot. As the size of the picture increases in ratio with the distance, it will be twice as large at 40 feet as at 20 feet, and the results will be more effective.

The electric light is the most practicable for use with the Kinetoscope. The alternating current can be used, although the direct is preferable, at 110 volts if this is to be obtained. The alternating current usually runs at about 52 or 104 volts. The local electrician can make the connections; which having once been made, the light becomes the simplest of all to operate, as well as the most effective.

Customers will ask for information about light other than electric, to be used in projecting machines. Traveling exhibitors frequently exhibit in halls where the current is not to be had, and another form of illuminant must be provided. For this purpose the lime light

gases can be purchased in tanks from the calcium light companies, but as this involves repeated express or freight charges and possible delays, a gas making outfit with which the exhibitor can make his own gas is often purchased instead. These outfits range in price from \$40 to \$75 retail. Catalogues issued by Dealers who make a specialty of projection instruments describe the various types. Customers should be advised to purchase the best, which are usually the highest priced; cheap gas making outfits are dangerous, because liable to explode.

The arc electric and lime light are the only illuminants that are satisfactory for moving picture work. Acetylene and vapor lights are frequently powerful enough for lantern slides, but rarely answer the requirements for moving pictures. The sale of Kinetoscopes with inferior illuminants should be discouraged.

Buyers of moving picture goods may wish to purchase lantern slides, or other stereopticon goods. It is not necessary to carry these in stock unless the volume of business warrants. They can usually be obtained from stereopticon houses at short notice.

Dealers in all parts of the country can be promptly supplied with Kinetoscopes and Films. This is necessary to facilitate sales when the Dealer's stock is limited. Interested Dealers may get information concerning discounts, etc., by writing the Edison Manufacturing Co., at Orange, N. J., or to any of the following selling agents: The Kinetograph Co., 41 East 21st street, New York; Kleine Optical Co., 52 State street, Chicago, or Peter Bacigalupi, 933 Market street, San Francisco.

## ALLEN'S JAPANESE LACQUERED HORN

BLACK OUTSIDE

RED INSIDE

HIGHEST JAPANESE ART

IMPORTED

Weight 28 ozs.

30 inches long

15 inch Bell

PRICE - - TEN DOLLARS.

Peter Bacigalupi, Sole Agent U. S. A.

933 MARKET STREET,

SAN FRANCISCO.

THIS IS AN IDEAL HORN, MADE AFTER YEARS OF EXPERIMENTING BY A CONNOISSEUR. DOES AWAY WITH ALL THE METALLIC SOUNDS FOUND IN OTHER HORNS.

# The E. W. N. Handbook of the Phonograph

— AND —

## Instructions for Making Records.

BY C. W. NOYES.

### Every Owner

Of a talking machine should have a copy of this valuable book. It is replete with **Instructions for the Care and Use of the Phonograph**, and the chapters devoted to **RECORD**

**MAKING** are compiled from the author's many years of experience in some of the principal laboratories of this country.

Any one possessed of ordinary intelligence can make a perfect record if the directions are followed.

Fully Illustrated—Handsomely Bound.

PAPER, 25 CENTS.

CLOTH, 50 CENTS.

Mailed Postpaid on Receipt of Price.

For Sale by All Jobbers, or

**ILSEN & COMPANY, Cincinnati, Ohio.**

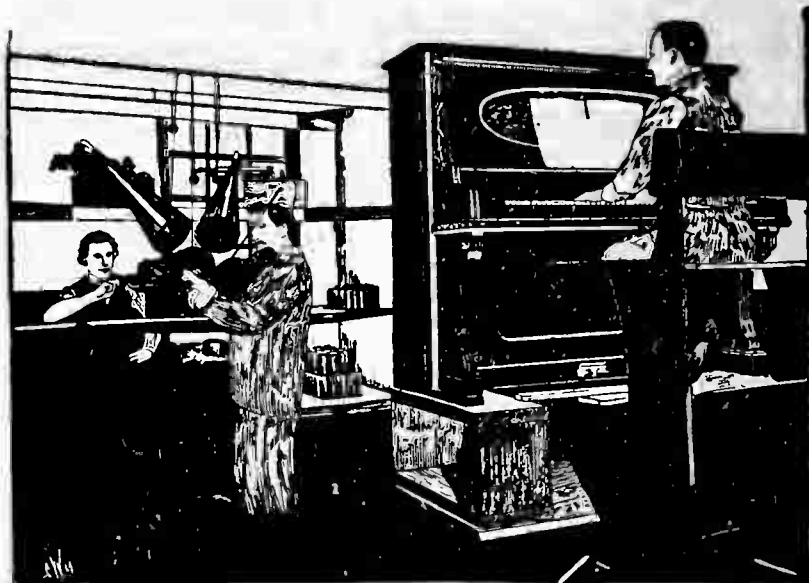

DEALERS WRITE FOR DISCOUNTS.

# A CARD TO THE TRADE JOBBER AND DEALERS

Interested in giving their customers best results are invited to write us for quotations on

## DOUGLAS

### *Mega (Paper) Horns and Record Cabinets*

The Horn that Made us Famous.

Attractive and Substantial.

Superior to any metal horn made in purity, volume and absence of metallic tones. **GREAT AIDS TO THE SALE OF PHONOGRAPHS AND RECORDS.**

Superior to any Line in the Market, **STRONGLY MADE.**

**BEAUTIFULLY FINISHED.**

- “MEGA” . . . . . List \$7.50  
Length 32 inches ; Width 24 inches.
- “MEGA JR.” . . . . . List \$2.25  
Length 22 inches ; Width 13 inches.
- MEGA RECORDING HORN, . . . . . List \$1.50  
Length 24 inches ; Width 6¾ inches.

- 100 Peg Polished Oak, . . . . . List \$12.00
- 125 “ “ “ “ . . . . . “ 14.00
- 125 “ Quartered Oak, . . . . . “ 15.50
- 150 “ “ “ “ . . . . . “ 18.00

Look for the Trade Mark  
“PHONO-MEGA.”

Prices Restricted.

WRITE FOR SPECIAL LEAFLETS AND NET PRICES.

## DOUGLAS & CO.,

89 Chambers Street,

71 Reade Street,

NEW YORK.



# EDISON Phonograph Monthly

PUBLISHED FOR TRADE USE ONLY BY  
THE NATIONAL PHONOGRAPH CO.

VOL. 1.

NEW YORK, OCTOBER, 1903.

No. 8.

*The National Phonograph Co.,*

ORANGE, N. J.

NEW YORK: 83 CHAMBERS STREET.  
CHICAGO: 304 WABASH AVENUE.  
SAN FRANCISCO: 933 MARKET STREET.  
ANTWERP: 32 REMPART SAINT GEORGES.

## EDISON PHONOGRAPHS AND RECORDS.

All communications to THE PHONOGRAPH MONTHLY should be addressed to the Advertising Department, 83 Chambers Street, New York.

### C O N T E N T S

To the Trade.....	1
Advance List of November Records.....	2
More Injunctions Against Violators of Agreement.....	3
The Phonograph for Nervousness.....	4
Don't Hold Back Agreements.....	4
Teach Your Customers to Make Records..	4
Punkin' Centre Stories.....	4
Will Even Stand Abuse.....	5
A Jobber Criticises.....	5
All's Lovely.....	5
Canadian Dealers Must Sign by Nov. 1....	5
County Fair Advertising.....	5
Record Titles in Rhyme.....	6
Printed Matter.....	6
October Advertising.....	6
Advertising Language Study Outfits.....	7
Comments on November Records.....	8
Fair Exhibits a Success.....	9
A West Australian Advertisement.....	10
Personal.....	10
Best Selling Records.....	11
The Agreement Hanger.....	11
Trade Advertising.....	11
Suspended List, October 1.....	12
Jobbers of Phonographs and Records.....	13

### TO THE TRADE.

Jobbers and Dealers in Edison Phonographs and Records are hereby, formally advised that no change will be made in prices or discounts on Phonographs or Records. Announcement has repeatedly been made to the trade that no changes of any kind, either in the style of the various types of Phonographs or in the prices of Phonographs or Records, were in contemplation, and nothing has taken place that will have any effect upon this decision. Relying upon our statements in these matters, orders have been placed with us for large quantities of machines and Records. The fact that there are cheaper goods on the market has never been considered in fixing prices for Edison goods.

The National Phonograph Company protects its Jobbers and Dealers to the utmost, and will continue to protect them in maintaining the prices of Phonographs and Records as they now exist.

Very truly yours,

NATIONAL PHONOGRAPH CO.

W. E. Gilmore,

President and General Manager.

September 29, 1903.

The foregoing is a copy of a letter mailed on September 29 to all our Jobbers and Dealers. It explains itself.

Edison Phonographs and Edison Records are worth all that is asked for them, and no reason exists for cutting the price. Every article bearing the trademark of Thomas A. Edison has always been sold at the highest market price. And they have been the cheapest

THE ADVANCE LIST OF NOVEMBER RECORDS APPEARS ON PAGE 2. ORDER FROM IT. NO OTHER ADVANCE LIST WILL BE ISSUED.

## ADVANCE LIST OF NEW EDISON MOULDED RECORDS FOR NOV., 1903

RECORDS listed below will be ready for shipment as near November 1st, 1903, as possible, at which time Jobbers' stock orders, if placed prior to October 15th, will be shipped.

November Supplements will bear the date of November 1st, and will be forwarded to Jobbers with their stock order for Records.

Retail Dealers should place stock orders with their Jobbers at once, to insure prompt shipment as soon as Jobbers' stock is received.

Stock orders for Records contained in this list must be written on separate order blanks, and letters relating to November Records should refer to no other matter.

Kindly comply with above requests and thus aid your Jobber and ourselves in handling advance orders.

- |      |   |                                  |
|------|---|----------------------------------|
| 8524 | Jack Tar March (Sousa's latest)   | Edison Concert Band              |
| 8525 | Any Rags <i>Coon song with orchestra accompaniment</i>  | Arthur Collins                   |
| 8526 | By the Sycamore Tree<br><i>Song from "The Rogers Brothers in London"</i>  | Harry MacDonough                 |
| 8527 | Selection from Three Little Maids, introducing "The Miller's Daughter"  | Edison Symphony Orchestra        |
| 8528 | He Was a Sailor <i>Comic male duet</i>  | Collins & Harlan                 |
| 8529 | The Girl I Left Behind Me Medley, introducing "Auld Lang Syne" and Bugles   | U. S. Marine Fife and Drum Corps |
| 8530 | When the Fields are White with Cotton<br><i>Descriptive love song</i>   | Francklyn Wallace                |
| 8531 | A Handful of Earth from Mother's Grave<br><i>As sung in Joe Murphy's Irish play, "Shaun Rue"</i>                    | W. H. Thompson                   |
| 8532 | Laughing Water (A novelette)<br><i>Conducted by the composer, Frederick W. Hager</i>                                | Edison Concert Band              |
| 8533 | In the Village by the Sea<br><i>Descriptive, love song with orchestra accompaniment</i>                             | Byron G. Harlan                  |
| 8534 | I Like You, Lil, for Fair<br><i>George Ade's comic character song from "Peggy from Paris"</i>                       | Dan W. Quinn                     |
| 8535 | The Vacant Chair (or We Shall Meet but We Shall Miss Him)<br><i>Song accompanied by the Edison Military Band</i>    | Byron G. Harlan                  |
| 8536 | Beaumarie (Caprice-Gavotte)<br><i>Bell solo with orchestra accompaniment</i>  | Albert Benzler                   |
| 8537 | Nigger Stew (Characteristic) <i>Male quartette</i>  | Invincible Quartette             |
| 8538 | Waldmere March  | Edison Military Band             |
| 8539 | Out Where the Breakers Roar <i>Descriptive basso song</i>   | Frank C. Stanley                 |
| 8540 | The Lobster's Promenade   | <i>Banjo solo</i> Fred Van Epps  |
| 8541 | Under a Panama  | <i>Coon song</i> Billy Murray    |
| 8542 | Four Leaf Clover  | <i>Song</i> Arthur Clifford      |
| 8543 | Once in Awhile<br><i>Contralto song with Violin obligato</i>  | Miss Corinne Morgan              |
| 8544 | Goldfinch Polka<br><i>Piccolo solo with orchestra accompaniment.</i>  | Frank S. Mazziotta               |
| 8545 | My Alamo Love<br><i>Song hit from the musical play, "The Tenderfoot"</i>  | Harry MacDonough                 |
| 8546 | Le Secret Polka (Polka Brilliante)<br><i>Cornet solo played by composer and accompanied by Edison Military Band</i> | John Hazel                       |
| 8547 | Mister Breezy Was an Easy Mark<br><i>Comic song from "The Rogers Bros. in London"</i>                               | Will F. Denny                    |
| 8548 | The Sun Dance (Characteristic Indian Dance)   | Edison Symphony Orchestra        |

Edison Moulded Records are made only in Standard size. Both Standard and Concert Records may be ordered from this list. Order by Number, not title. If Concert Records are wanted, give the number and letter C.



at that. Cheapest because they represent in quality the best that can be made. Mr. Edison is never satisfied with himself or his people unless that is so. Edison products never fail to satisfy, and they will ever command prices possible with no competing goods.

Our policy of protection has ever had the good feeling of the trade, and as we have no retail stores in various parts of the country to oppose them and get a large share of the retail trade, the Dealers have always cordially co-operated with us. We firmly believe that this will continue to be the case and that nothing further on our part is necessary to improve it.

Continue in the future, Mr. Dealer, as you have in the past, to demonstrate to the public the superior qualities of the Edison products, and the competition of cheap goods will never affect you.

**MORE INJUNCTIONS AGAINST VIOLATORS OF AGREEMENT.**

Following are copies of preliminary injunctions granted by the Circuit Court for the Western Division of the Western District of Missouri against Frank M. Woodbury, of Kansas City, restraining him from selling Phonographs or Records by any violation of agreement, and from selling Phonographs from which the serial numbers have been erased ;

IN THE CIRCUIT COURT FOR THE WESTERN DIVISION OF THE WESTERN DISTRICT OF MISSOURI.

IN EQUITY.

No. 2781 { Patents Nos. 388,974 }  
 { 382,418 }

**ORDER FOR PRELIMINARY INJUNCTION.**

Now on this day this cause came on to be heard on application by complainants for a preliminary injunction against the defendant in consonance with the allegations and prayer of the complainants' original bill of complaint heretofore filed in this cause.

And on reading the said original bill of complaint and the waiver by defendant of notice of application by complainants for a preliminary injunction, and on reading and considering the affidavits filed therein on behalf of the complainants in support of their application for a preliminary injunction, and the affidavits filed herein on behalf of defendants in opposition thereto, and the complainants' exhibits having been considered, and counsel for defendant, as well as for complainants, having waived notice of this application, and the court being fully advised in the premises, and it appearing to the court from the bill of complaint and affidavits that defendant has infringed the complainants' patents Nos. 386,974 and 382,418 by selling without the license of complainants certain devices covered by the claims of said patents, to wit, a certain Edison Standard Phonograph, and certain sound records, being the complainants' exhibits herein ;

NOW, THEREFORE, IT IS ORDERED, adjudged and decreed, that upon the complainants' executing to defendant within ten days a bond in the sum of \$2,500.00 conditioned as provided by law and to be approved by the Clerk of this Court, a preliminary injunction do issue pursuant to the prayer herein, strictly commanding and enjoining the defendant, his clerks, agents, servants, workmen, attorneys, employees, and associ-

ates, under the pains and penalties which in case of disobedience may fall upon them and each of them, that they forthwith and until the further order of this court, desist from making, using, or vending without first hereafter procuring the consent or permission of complainants, the phonographs, phonograms or records covered by the several claims of complainants' letters patent Nos. 386,974 and 382,418,

This order will not restrain the defendant from selling phonographs, phonograms or phonograph records which were manufactured and sold by complainant to defendant or to jobbers, or retail dealers without restrictions as to sale prior to May 1st, 1901, and which were thereafter sold to defendant by such dealers or jobbers.

JOHN F. PHILLIPS,  
*Judge.*

Dated, this 11th day of September, A.D., 1903.

IN THE CIRCUIT COURT FOR THE WESTERN DIVISION OF THE WESTERN DISTRICT OF MISSOURI.

IN EQUITY.

No. 2780 (Patent No 386,974).

Edison Phonograph Company and National Phonograph Company.....Complainants

vs.

Frank H. Woodbury.....Defendant.

**ORDER FOR PRELIMINARY INJUNCTION.**

Now on this day this cause came on to be heard on application by complainants for a preliminary injunction against the defendant in consonance with the allegations and prayer of the complainants' original bill of complaint heretofore filed in this cause.

And on reading the said original bill of complaint, and the waiver by defendant of notice of application by complainants for a preliminary injunction, and on reading and considering the affidavits filed herein in behalf of the complainants in support of their application for a preliminary injunction, and the affidavits filed herein on behalf of defendant in opposition thereto, and the complainants' exhibits having been considered, and counsel for defendant, as well as for complainants having waived notice of this application, and the court being fully advised in the premises, and it appearing to the court from the bill of complaint and affidavits that defendant has infringed the complainants' patent No. 386,974 by selling, without the license of complainants, devices covered by the claims of said patent, to wit, a certain Edison Standard Phonograph, being complainants' exhibit herein ;

NOW, THEREFORE, IT IS ORDERED, adjudged and decreed that upon the complainants executing to defendant, within ten days, a bond in the sum of \$2,500.00, conditioned as provided by law, and to be approved by the Clerk of this Court, a preliminary injunction do issue, pursuant to the prayer herein, strictly commanding and enjoining the defendant, his clerks, agents, servants, workmen, attorneys, employees, and associates, under the pains and penalties which in case of disobedience may fall upon them and each of them, that they forthwith and until the further order of this court, desist from directly or indirectly, using or causing to be used, or selling or causing to be sold, any phonographs embodying or constructed or operating in accordance with the inventions or improvements set forth in complainants' letters patent No. 386,974, and from which phonographs the serial numbers have been erased, obliterated, or removed.

JOHN F. PHILLIPS,  
*Judge.*

Dated, this 11th day of September, A.D., 1903.

**VIOLATIONS OF CONTRACT.**

For the benefit of those who have become Dealers in Phonographs within the past three months we desire to repeat the statements made in the May issue of the PHONOGRAPH MONTHLY, to the effect that Records may be sold on the card system *only* when a full dozen at \$5.00 is purchased or paid for at one time. Giving trading stamps with Phonographs or Records is also a violation of contract.

### THE PHONOGRAPH FOR NERVOUSNESS.

A New York Jobber recently told a curious instance in connection with the sale of a Phonograph. His customer, a prominent business man, had a wife who was so extremely nervous that she would not even see her friends. She practically shut herself indoors, would not leave the house, and was rapidly developing into a morbid state that almost threatened to affect her reason. Her husband tried many different things in the hope of interesting her and get her mind away from her conditions and surroundings. Hearing a Phonograph one day, it occurred to him that possibly here was something that might interest his wife. He induced her to consent to having one sent to his house, at the same time making a careful selection of such Records as seemed to him to be of the proper character. In purchasing the machine he told the Jobber in question about the condition of his wife and why he was buying it. Some weeks later he returned to the store and said that the Phonograph had been a success beyond his utmost expectations. His wife had become interested in it from the start. She readily learned to operate it and frequently ran it for long periods of time. Her condition improved at once, and he said that she had reached a point where she would go out for a walk or a drive, and actually asked to see company. He attributed the entire change solely to the use of the Phonograph. This may read like a testimonial in a patent medicine advertisement, but its truth is fully vouched for.

### DON'T HOLD BACK AGREEMENTS.

We do not know that such is the case, but if there are any Jobbers who hold back the Agreements of their sub-dealers with the idea that they are protecting their own interests, we would like to disabuse their minds. When the name of a Dealer is sent to us, it is entered upon our books, and when we receive inquiries concerning our goods from people living in that locality, we write the Dealer informing him of such inquiry, and we also advise the inquirer that goods can be had at this Dealer's store. In thousands of cases of this kind sales have followed. These sales mean business for the Jobber and business for the Dealer. They mean business that would not have been possible had the Jobber withheld the Dealer's Agreement. Then, too, every Dealer whose name is on our books is sent samples of the printed matter every month, frequently twice a month. This printed matter includes the PHONOGRAPH MONTHLY, Bulletin or Supplements of new Records as they appear,

catalogues, cards, folders and various other advertising literature, all of which keep the Dealer fully informed concerning the Phonograph business, and enable him to not only do more business, but to do it more intelligently. A Jobber can make no greater mistake than to believe that we desire the names of his Dealers for our direct benefit. Everything done by this company is for the benefit of the trade, and our system in this respect has the same end in view.

### TEACH YOUR CUSTOMERS TO MAKE RECORDS.

To demonstrate the value a little time spent by Dealers in teaching their customers to make Records is evidenced in the following from Douglas & Co., Jobbers of this city, as related by G. H. Baker, a well known Dealer of Ossining, N. Y.

Mr. Baker has three Records he uses for this purpose, a tenor solo made by himself, a song by his daughter, and the third Record made by a three-year-old child of a well known judge. These Records always interest the listener and are a strong influence in effecting a sale. When the judge referred to heard the Record made by his little daughter, he ordered a \$50 outfit from Mr. Baker, and an uncle of the child purchased a \$40 outfit.

### PUNKIN CENTRE STORIES.

Cal Stewart's fun, so well known to users of Edison Records, has just been published in book form under the title of "Uncle Josh Weathersby's 'Punkin Centre' Stories." The matter has been written by Mr. Stewart himself, and the preface of his book gives the following reason for doing it:

The one particular object in writing this book is to furnish you with an occasional laugh, and the writer with an occasional dollar. If you get the laugh you have your equivalent, and the writer has his.

In Uncle Josh Weathersby you have a purely imaginary character, yet one true to life. A character chuck full of sunshine and rural simplicity. Take him as you find him, and in his experiences you will observe there is a bright side to everything.

The book is just as funny in print as Mr. Stewart is in the Phonograph. It contains all his humorous sketches, which are illustrated, and the book is handsomely bound with illuminated covers. Its contents afford one continuous laugh. The Penn Phonograph Company, 19 South 9th street, Philadelphia, are distributors to the talking machine trade for this work, and in their advertisement elsewhere in this issue they are offering liberal discounts to the trade.



**WILL EVEN STAND ABUSE.**

"A rather interesting matter came to our attention to-day," wrote C. J. Heppe & Son, of Philadelphia, under date of September 22. "A Standard Phonograph was brought to us for repairs with practically all of the top broken away from the bed plate. All the machine parts were badly rusted, and upon questioning the owner, we elicited the information that this Phonograph had been laying under a pile of rubbish in the cellar of his home for more than a year, that he had unearthed it and wanted to use it.

"We wound it up to test it and found that even with all the rust and accumulated filth in the motor parts, it started off promptly, and practically needed no attention with the exception of cleaning and oiling. We have always realized that the Edison product will stand use, but cannot realize how this one withstood so much abuse."

**A JOBBER CRITICISES.**

One of our Jobbers has written the Advertising Department, criticising it for omitting from the August issue of the EDISON PHONOGRAPH MONTHLY the list of Suspended Dealers. We confess that the omission was a mistake, and promise not to offend in the same manner again. The same Jobber suggests that the list of distributors be published more frequently. We will endeavor to publish it more often in the future.

**ALL'S LOVELY.**

With the exception of Canada, which has been delayed for legal reasons, our new Agreement is in full force throughout the country and is working satisfactorily. Dealers who have gone out of business have been removed from our mail list and hosts of new ones have been added, and everything has again resumed its normal condition. We shall be glad if Jobbers will advise us of any cases where their Dealers do not receive matter by mail. We have endeavored, of course, to get on our mail list every signer of the new Agreement, but with so large a number it is quite possible that here and there a name has been overlooked. If Dealers find errors in the address that comes to them, we shall also be glad to have them send corrections direct to the Advertising Department.

**CANADIAN DEALERS MUST SIGN BY NOVEMBER 1.**

Owing to a legal delay Canadian Phonograph Dealers were not asked to sign the new Agreement until September. Their names were continued on our mail list in the meantime,

and this will be done until November 1. All who desire to continue in the Phonograph business must sign by that time. Those whose Agreements are not in the hands of their Jobbers by that date will find it difficult to get orders filled. Their names will also be removed from our mailing list.

**COUNTY FAIR ADVERTISING.**

It is now too late for county fair advertising, but the following letter is re-printed as showing an interesting manner of awakening the interest of Dealers in the matter. It was sent by The Theo. F. Bentel Co., Inc., of Pittsburgh, to all of its Dealers:

The question of whether it is profitable to exhibit at County "Fairs" is one that you have no doubt considered. Our own experience, together with others, has proven to us that it is one of the best mediums of advertising that a Dealer can adopt. You come in contact with a class of people whom you could not meet otherwise. You meet them face to face, thus furnishing you an opportunity to explain the merits of the goods, and furthermore, give the prospective buyer an opportunity to judge for himself. He hears the goods, and therefore does it not appeal to him in the same vein as were you to send him a beautiful lithograph cut, accompanied by a circular letter, explaining its virtue in glowing language. As we stated before, we have tried it and found it profitable as an investment and a good medium of advertising. You can sell enough and more goods than the small expense attached to it. We furnish you all the catalogues free of charge—think the matter over and see if it won't pay you to try it. The investment is small and the returns as great as you make it.

**E. P. M. AS AN ADVERTISING MEDIUM**

E. A. Batchelor, Manager of the Utica Electric and Phonograph Co., in ordering a half-page advertisement in the PHONOGRAPH MONTHLY for October, writes:

"The little article in your PHONOGRAPH MONTHLY for July, 'An Advertising Horn Eight Feet Eight Inches Long With a Three Foot Three Inch Bell,' has been read by most every Dealer in the Country, we guess, owing to the large amount of inquiries coming in every day. We have hired Mr. Ecker to make horns for us, and have filled several orders for same."

The advertisement of this horn may be found in another column.

**SOLD TWO TRIUMPHS.**

SPRINGFIELD, Mo., Sept. 11, 1903.

I have just sold two Triumph machines to one man. A wealthy miller of this city called at my place several days ago and said he wanted to hear a Phonograph. I played the Triumph machine, and he was so well pleased he bought two, paying cash for same. I learned later one was for his superintendent at the mill. The Edison is all right.

MORTON LINES.

**RECORD TITLES IN RHYME.**

J. A. Conway, Manager of the Walden Sporting Goods Co., Walden, Mass., issued another attractive folder last month, advertising the September list of new Records. In it he ingeniously weaves into poetry the titles of some recent Edison Records as follows:

**REQUEST.**

Sing me a song of the Sunny South  
Where the sweet magnolias bloom  
Sing again that sweet refrain,  
The Whistling Girl, or Laughing Coon.

Please go 'way and let me sleep,  
Under the bamboo tree,  
Down where the Wurzburger flows,  
Somebody's waiting for me.

In the valley where the bluebirds sing,  
I wonder if your love will last.  
I could love you in a steam heat flat  
If I could only blot out the past.

While the band is playing Dixie  
Or My Country 'tis of Thee,  
Any old place I can hang my hat  
Is Home, Sweet Home to me.

J. A. CONWAY.

**PRINTED MATTER.**

The new Catalogue of Domestic Records is now in the hands of the printer, and will be ready for the use of the trade sometime the latter part of October. This will contain all Records listed to and including October. Orders now being received for Record Catalogues 380 are being cut down in some instances for the twofold purpose of making our present supply last until the new edition is printed and to see that the Dealers do not have a large supply of the present edition when the new one appears. Every Jobber and Dealer wants to be up to date with the printed matter, and will thank us to see that he does not have on hand catalogues that do not include the latest titles. The new catalogue will be somewhat different from the one now in use, in that it will have a colored cover, made necessary by the additional Records listed in the last three months.

We expect to make announcement next month concerning the new Machine Catalogue. Preparations are being made for a new edition, but the details are not sufficiently definite to give to the trade. We shall, however, take the liberty of holding down orders for Machine Catalogues of the present edition so as to make our present stock last until the new ones are printed.

The new edition of Foreign Record Catalogue, Form 381, was received from the printer in September and samples copies were sent out with September Bulletins and Supplements

to the entire trade. This catalogue includes not only all foreign selections listed to and including September, but it also contains Chinese and Japanese selections.

**OCTOBER ADVERTISING.**

In the advertising of this company for October, the same cut and copy was used as in September. This cut shows the Phonograph as a means of entertainment, and the copy urges prospective purchasers not to buy any talking machine until they have visited the nearest Dealer and heard the Phonograph. The mediums used were the following: Argosy, Current Literature, McClure's, Munsey, Saturday Evening Post, Field and Stream, Craftsman, Ainslee's, The Bookman, Brown Book, Colliers, Everybody's, Good Housekeeping, Life, Lippincott's, National Magazine, Pearson's, Scribner's, St. Nicholas, Strand, Success, Smart Set, Town Topics and Sunset Magazine.

**AMONG THE JOBBERS.**

The Bangor Sporting Goods Co., of Bangor, Me., has combined its interests with S. L. Crosby. The new firm will be known as the S. L. Crosby Co.

**ANTEDATED THE E. P. M. COMMENTS.**

PHILADELPHIA, Sept. 7, 1903.

We note in your September MONTHLY that Thomas Wardell, at Lowell, Mass., has adopted your monthly comments, and put same into circular form. We think that we are the original ones to ever use this method of advertising, as the writer personally issued such a list even prior to the time that you printed it in your MONTHLY. Of the list of Records that were issued we selected from twelve to eighteen, and made such comment as we felt would be about correct. We adopted this style of advertising in February of this year.

WELLS PHONOGRAPH Co.,  
LOUIS BUEHN, Sec'y and Treas.

**PRAISE OUR RECORD MAKING.**

SPOKANE, Wash., Sept. 11, 1903.

Suspended List of September I received, and you can depend upon our co-operation as regards prices for all times. Advance list for October received and it certainly is a "dandy." We delight in receiving the PHONOGRAPH MONTHLY, and always place an order for the list of Records therein at once.

We keep three styles of machines, the genuine Edison, the scratching machine and the choking machine. The latter two are wall flowers. The Home Edison is out-selling the others at present.

There has been a great call among our customers at both stores for My Old New Hampshire Home, as sung by the Edison Quartette, and Dear Old Bess and I, by Natus,



also *The Picture No Artist Can Paint*, by Harlan and Stanley. You are certainly doing wonderfully in the advancement of Record making and hope you will be able to keep up the good work.

FOSTER & FOSTER.

### ONE RECORD PLAYED 1525 TIMES.

COATSVILLE, Pa., September 27, 1903.

I wish to give the following report in reference to one of your Records. I purchased one of your Moulded Records—don't know the number just now—it was *Hiawatha* (Band Record.) This record was subjected to the *very hardest* service in "Slot machine gallery" at the park and afterward in Philadelphia. It played 1525 times that we can account for before it was worn out. I consider this very remarkable, as there are wax Records of other makes that will not stand one-fourth of this service.

F. K. WILSON.

[This is not such an unusual case as it appears, for we believe that most Edison Moulded Records can be played equally long.]

### EASIER TO SELL.

CARMEL, Ind., Sept. 7, 1903.

I think the Edison Records are the easiest to sell of anything I ever sold, for they can talk for themselves better than we can talk for them.

GEORGE W. HINSHAW.

### ADVERTISING LANGUAGE STUDY OUTFITS.

Below is given one of a series of reading notice advertisements that R. S. Williams & Sons Co., Ltd., of 143 Yonge street, Toronto, Canada, are running in the Toronto daily papers:

"Me muchee pleased!"

That was all he could say, just "me muchee pleased!"

It was a strange sight when, the other day in Toronto, a number of Edison Phonographic Records filled in China were reeled off to the sons of the Orient. They looked at the machine as they would look to their God—in awe, in reverence, and with faces that spoke peculiar amazement. And when they had heard their own strange language spoken with perfect enunciation, when they heard the sounds of their streets and the tom-toms and stringed instruments of Pekin, they were too astonished to say much, too frightened; but one, more bold than the rest, said: "Me muchee pleased!"

This morning a Frenchman from Paris walked into the R. S. Williams Piano warehouses, 143 Yonge street. He was in Toronto to attend the Exhibition.

Going up to the offices of Mr. Stanton, the General Manager, and Mr. Richard Williams, the Vice-President of the company, he shook hands.

Then the members of the firm asked him to the Phonograph Department.

Placing a Record on the machine, the man from Paris heard the French of the Parisian Capital spoken fluently.

The old plan of learning a language from

flesh and blood is a dead one. To-day the most enlightened minds of the world learn difficult pronunciations over the Phonograph, and the students in languages who are the most up-to-date are doing the same.

This morning, after the Frenchman from Paris had gone out from the Williams store, I entered and then and there received my first lesson in French, for I never knew how to properly say "I do not speak French."

Mr. Stanton placed a student Record on the Phonograph and handed me a book. It was great. I wanted to argue with the teacher, but he wouldn't stop.

"You see," said Mr. Williams, "by this arrangement and by plans we are formulating, languages may be taught in every city and hamlet in Canada, and if any Dealer wants any information we can explain the matter very clearly by mail."

Supposing a student wants to study in his own room, he can have the Phonograph going, and, by a patent attachment, no one else but himself will hear it.

And then the machine started on phrases—*Je parle; Vous parlez aussi Anglais n'est-ce pas?* And I knew by the book that it said: *You speak English also, do you not?*

Here was perfect pronunciation. A man asked Demosthenes: "What is the first requisite to perfect oratory?" "Action," he replied. "And the second?" "Action!" "The third?" "Action!"

And so in learning a living language repetition is the great essential.

Well, you know how tireless a Phonograph is, don't you?

It never has a headache or the blues. It never gets thick-tongued.

The fast ships, the fast trains, and the wireless telegraphy are bringing the great live nations very near together. It is almost absolutely necessary now for the rising man or woman to know something of German, Spanish, and French.

G. W. Johnson, commercial master at Upper Canada College, has sized the thing up nicely, and says:

"I desire to express to you my appreciation of your method of teaching modern languages. It is perfection accentuated. When I began your lessons in French a few months ago I had a knowledge of the language—a book knowledge—but I desired to be able to speak it with the freedom, ease, and accent of a native Parisian. No living teacher could have helped so fully, so constantly, so untiringly, and so satisfactorily as your French Records have helped me. The living voice could not have been plainer; the living teacher could hardly have endured the unlimited and continuous repetitions which I demanded, and I could ill afford the expense of such constant ministrations. I have gone over the course many times and with increasing pleasure. Latterly, I just seated myself in front of the machine and let it talk to me over and over and over again, till my mind and ears have become completely saturated with French words and French sounds, so that now French seems almost as natural to me as English itself."

And the writer got two or three lessons this morning, and walked out saying "*Je parle Francais et allemand.*"

## COMMENTS ON NOVEMBER RECORDS.

Now comes the time for a new crop of popular airs. With musical plays running at several of the New York theatres, extensive additions have been made to the list of compositions likely to become popular throughout the country. The list of new Records for November includes several selections which have already made a decided hit among those who have heard the musical comedies now on view in New York. Each of these musical comedies contains other airs which may become popular, but that fact cannot definitely be determined at the present time. Since it is practically impossible to list all pleasing selections given in comic operas or musical plays, we have selected for November only such as thus far really have met popular favor.

We have listed two selections from Rogers Brothers' new musical comedy called "The Rogers Brothers in London," both of which are being repeatedly encored at each performance of the play, and are selling heavily in music stores. The first of these selections is No. 8526, "By the Sycamore Tree," and is sung by Harry MacDonough. The words of this song were written by George B. Hobart and the music by Max Hoffmann. Mr. MacDonough's articulation is always good, and buyers of this Record will have no trouble in catching the words as well as the air. The other Rogers Brothers' selection on the list is No. 8547, "Mister Breezy Was an Easy Mark." This tells of the adventures of a Texan in New York and his readiness to give up his money rather than take any chances of his wife's learning of his escapades. Will F. Denny makes the Record in good style, the words and air being clearly brought out. This song is written by Ed. Gardenier, and the music is by M. Melville Ellis.

No. 8527 is a selection from "The Three Little Maids," a play now running at Daly's theatre, New York. The selection introduces "The Miller's Daughter," a song which is even better known than the play itself. The air of this composition is exceedingly pretty, and every lover of popular music will want the Record. It is played by the Edison Symphony Orchestra, and is practically a perfect orchestra Record.

George Ade's operetta, "Peggy from Paris," is not exactly new, having run in Boston and Chicago before coming to New York. Some of its popular airs have already been listed, but the play still continues to yield taking songs. The November list includes No. 8534, "I Like You Lil, for Fair," from this play. Our Record of it is sung by Dan W. Quinn, and his rendition is quite as good as the song is given in the play itself.

The musical play, "The Tenderfoot," which has not yet reached New York, but which promises long runs wherever presented, yields for the list No. 8545, "My Alamo Love." The words are by Richard Carle and the music by

H. L. Heartz; the Record is made by Harry MacDonough. The air is a good one and will certainly be popular.

Not from any musical comedy or opera, but yet very popular, is John Philip Sousa's new "Jack Tar March." It is No. 8524, and is played by the Edison Concert Band. This selection is quite unique. In it is played a sailor's hornpipe, and the music also gives the "bosens'" whistle and the bells noting the time on board ship. This air has become popular, aside from Sousa's fame.

Another fine selection by the Edison Concert Band is No. 8532, "Laughing Water" (characteristic). When this Record was made the Edison Concert Band was led by Frederick W. Hager, the composer of this very clever selection. This composition is written to suggest various kinds of laughing voices, from the shrill laughter of a child to the deep one of the adult, and from the laugh of the individual to that of many voices. Our band does the selection full justice.

Another unique Record is No. 8548, "The Sun Dance." The music is written to suggest this characteristic Indian dance, and the Record ends with the whoops of the Indians. The Record is made by the Edison Symphony Orchestra, and although the music is difficult to play, the Record is well made. Phonograph users who like odd Records will appreciate this one.

The Edison Military Band, whose Records have already met with wide sale, has one selection in the November list, No. 8538, "Waldmere March," composed by F. H. Losey. This is written in the Sousa style and has a good march air.

No. 8546, "Le Secret Polka" (Polka Brillante), is a cornet solo formerly listed in the wax records. It is a very pretty air, but has not been listed in the Moulded Records until now because of the difficulty in finding a soloist who could play it to our satisfaction. We were finally able to induce Mr. John Hazel, the composer of the piece, to play it for us. The result is a cornet solo of unusual excellence, both from a musical and mechanical standpoint, the Record being free from blasting and other objectionable noises. The solo is accompanied by the Edison Concert Band and the accompaniment is a decidedly pleasing feature.

A monthly list without a coon song by Arthur Collins would be like a play with a prominent actor missing. Mr. Collins' November selection, No. 8525, is "Any Rags." This is styled a coon song, but is quite unlike ordinary songs of this kind. It has a good air, the words come out clearly and distinctly, and the Record is well made in every respect. It has an orchestra accompaniment. Thomas S. Allen wrote both the words and the music.

No. 8528, "He Was a Sailor," is a comic male duet by Collins and Harlan, and gives a very unique description of Bill Perkins, who was a sailor but who was never on the sea. A sailor's hornpipe is played at the end of each chorus. This Record is quite in line with the comic male duets already listed by these two people. The words and music of the song are by Jerome and Schwartz.

No. 8529, "The Girl I Left Behind Me Medley," is a field music Record introducing "Auld Lang Syne." It is played by the U. S.



Marine Fife and Drum Corps, with good work by the drums, fifes and bugles.

No. 8530, "When the Fields are White With Cotton," is a song written by Robert F. Roden, and the music was composed by Max S. Witt. This descriptive song, as its name implies, is a song of the South, and is sung for our Record by Francklyn Wallace. Mr. Wallace's Records are steadily increasing in popularity.

No. 8531, "A Handful of Earth from Mother's Grave," is another selection made by request. The words and music of this song are by Joe Murphy, the old time favorite Irish comedian, and was sung with great success in the play "Shaun Rue." The Record of it is made by William H. Thompson.

No. 8533, "In the Village by the Sea," is a descriptive ballad sung by Byron G. Harlan, accompanied by the orchestra. There is a family resemblance in all selections of this kind, but they are good sellers. The words of this ballad were written by Andrew B. Sterling, and the music is by Stanley Crawford.

In No. 8535, "The Vacant Chair, (or We Shall Meet but We Shall Miss Him)," we list an old and well known air. It is sung by Byron G. Harlan, accompanied by the Edison Military Band. The words of this song are by Herney Stevenson Washburn, and the music by G. F. Root. This Record was made because of the repeated requests for it.

In No. 8536, "Beaumarie" (Caprice-Gavotte), Albert Benzler has a bell solo with orchestra accompaniment. The air is pretty, and the Record well made. B. S. Carnes is the writer of the music.

No. 8537, "Nigger Stew," is an excellent quartette Record made by the Invincible Quartette.

No. 8539, "Out Where the Breakers Roar," is a selection which pays tribute in song to the life saving crews of the coast and their work. It is a descriptive bass solo, and is sung with splendid effects by Frank C. Stanley. The song is similar in character to "Asleep in the Deep," and other compositions requiring an unusually deep voice. Mr. Stanley meets all the requirements of the song without effort. The words of this composition are by Harlow Hyde, and the music was written by H. W. Petrie.

In No. 8540, "The Lobster's Promenade," Fred Van Epps adds another excellent banjo solo to those already catalogued. The composer is Porter Steele.

In No. 8541, "Under a Panama," we have a coon song by Billy Murray. It is a play upon the titles of various other songs of this kind, and is quite unique. Mr. Murray's Records are daily becoming more popular, and many Phonograph admirers regard him as one of the best makers of coon song Records now before the public. "Under the Panama" was written by Vincent Bryan, and the music was composed by J. B. Mullen.

No. 8542, "Four Leaf Clover," by Arthur Clifford, is a song written by Ella Higginson, with music by Leila M. Brownell. The four leaves of the clover are hope, faith, love and luck. The words of the song are as pleasing as Mr. Clifford's rendition.

In No. 8543, "Once in a While," Miss Corinne Morgan has another contralto song with

violin obligato. Records by female voices are becoming more and more popular, and this one by Miss Morgan is an excellent addition to the list. The violin obligato is especially pleasing. This song was written by H. L. D'Arcy Jaxone, and the music is by Caroline Lowthian.

No. 8544, "Goldfinch Polka," is a piccolo solo by Frank S. Mazziota, and has an orchestra accompaniment. The solo part of the Record is good and the accompaniment is also an attractive feature. This Record was written by J. Occa.

### FAIR EXHIBITS A SUCCESS.

LINCOLN, Neb., Sept. 11, 1903.

This is the last day of the State Fair at Lincoln, Neb. As you know, we have had quite an extensive exhibit of Edison Phonographs and Records in the Mercantile Hall, and will say that we think it was the greatest advertisement which we have ever had, not only for our own city business, but for the entire West, as we have met people from the Missouri River to the wild cattle ranges of the West, and also the Indians of the Indian Reservations, and will say that our booth was the center of attraction of all the booths in this hall, and we were kept busy answering questions "if that was one of those Phonographs we read about," and all of the other foolish questions which have been mentioned in the PHONOGRAPH MONTHLY in the last issues.

We think that it would be the greatest advertising scheme going if you would see that yourself or your Jobbers would exhibit machines and Records at every State Fair in the United States, and we believe that all of our agents in the West will appreciate this fact that it will do them all good in making sales, as we always, in conversation with the people inquiring, mentioned the Edison agent who was nearest to their homes.

One thing we noticed, the 30,000 forms, No. 409B, and the pamphlets of the four machines that we distributed, were not thrown away on the grounds, but were taken home by nearly every person we gave them to. This goes to show that the people in the West are interested in this line of goods.

H. E. SIDLES CYCLE Co.

### WILL ALWAYS PUSH EDISON GOODS.

HOBOKEN, N. J., September 8, 1903.

Have received September Suspended List, and with pleasure state, that if all and every business was conducted like yours, there would be no trouble for a small Dealer or business man like myself. Even if I handle other so-called talking machines, I always did and will in the future push your goods. I have found that where I sell an Edison Phonograph, the purchasers become steady customers. They always come back for Records, and each claims to have the Phonograph in town. To one customer I have sold over 500 Records, and he waits patiently for the new Records every month. I don't think I have sold 500 Records to all the customers together to whom I have sold other styles. I promise you that I will keep the Agreement I signed as long as I am in business.

H. JAFFEE.

**A WEST AUSTRALIAN ADVERTISEMENT**

The circular copied below comes from a customer of our Foreign Department at Esperance Bay, West Australia:

Y Y Y Y Y Y Y  
Be without a  
PHONOGRAPH  
There is nothing  
UNDER THE SUN  
To equal the  
P H O N O G R A P H  
AS A MODERN ENTERTAINER.

**IT WILL**

Make you laugh and sing, talk with you and teach you how to talk, teach you pronunciation and how to recite, teach you how little you know and how much you have to learn, will teach you when to mind your own business and talk only when asked to, teach you when you buy one how much enjoyment there is in having one, will drive away the blues and keep you from talking about your neighbor.

EDISON'S PHONOGRAPHS have no rivals, and they are the best talking machines made

**W H Y B E W I T H O U T O N E .**

What made me sick  
And hard to please,  
And pray upon my bended knees  
That its everlasting noise would cease,  
The ———phone.

What made me laugh  
And dance with glee,  
And sing with joy and happy be,  
And kept me from going out on the spree,  
The Phonograph.

G. VINCENT & CO.,  
Importer of Edison's Phonographs,  
Records, etc.

All goods of Edison manufacture can be indented.

**PERSONAL.**

M. Francois Albert, junior member of the firm of Albert & Son, Albert Building, 137-139 King St., Sydney, Australia, is in New York City on business for his firm. Mr. Albert is accompanied by his wife and son and recently favored us with a call. Albert & Son handle a full line of our goods and are very important clients. Francois Albert alternates with his father, Jaques Albert, in making annual visits to this country. It is needless to state that we anticipate these visits with genuine pleasure.

Among the Jobbers who called at our New York office during September were William Werner, of Easton, Pa.; George Ilsen, of Ilsen & Co., Cincinnati; H. L. Ellenberger, of the Pardee-Ellenberger Co.

C. W. Noyes, who is well known throughout the Phonograph trade as the writer of the C. W. N. Handbook of the Phonograph, has joined forces with the Ray Company, of Louisville, Ky., and will spend most of his time in

visiting the various branch stores of that company.

**GLAD HE IS A "PHONOGRAPH CRANK".**

NEW IBERIA, Sept. 9, 1903.

I am fortunate enough to be so situated to get your valuable PHONOGRAPH MONTHLY, and I must say it is the best of its kind for Dealers and owners of Phonographs I have ever seen. I look with longing to the day when I can get a hold of it, to see what more you have to say about this wonderful invention. I am but a poor engineer, and still I own one Edison Triumph Phonograph with twelve dozens of the best selected Records. I would not part with this outfit for double its value, because some of these Records cannot be obtained in this neighborhood. I am called a Phonograph crank, and I am glad of it. It shows that I am an up-to-date man.

I notice that you ask for remarks that will improve your paper. I would suggest as others have, you publish a cut of two or three of your talent each month. I know that it would very much improve it.

W. L. BROUSSARD.

**CAPTURES A FIRST PREMIUM.**

I advertised extensively for the Edison Phonograph during the Henry County Fair. My oldest son, two young ladies and myself included, put forth our best efforts to make this advertising a success. In doing so we succeeded in capturing the first premium for the best decorated booth, and distributed quite a large number of circulars, &c.

WILLIAM J. STILLEY.

**BEST SELLING RECORDS.**

The twenty best selling Edison Records from the entire catalogue for August, exclusive of the September Supplement, were the following:

- 8347 Hiawatha.....Edison Band
- 8425 Hiawatha—Song..... McDonough
- 2018 Holy City.....McDonough
- 8260 Tell me Pretty Maiden..Edison Sextette
- 8424 American Patrol.....Edison Band
- 8398 Blaze Away March.....Edison Band
- 8256 O That We Two Were Maying,  
Morgan and Stanley
- 8435 'Deed I Do.....Morgan and Stanley
- 8409 In the Valley Where the Bluebirds  
Sing..... Harlan
- 8295 Marriage Bells—Bells.....Rubsam
- 8473 Santiago Waltz—Xylophone....Hopkins
- 8083 Warblers' Serenade.....Edison Band
- 19 Under the Double Eagle March,  
Edison Band
- 8379 Pretty Peggy—Bells.....Rubsam
- 8366 Mr. Dooley—Xylophone.....Hopkins
- 8462 Alita (Wild Flower)—Bells....Benzler
- 8349 Dream of the Tyrolienne. Jaudas and Atz
- 8286 Under the Rose.....Clifford
- 8454 Up-to-date Minstrels.....
- 8468 There's a Mother Always Waiting for  
You at Home Sweet Home.  
Harlan and Stanley

Out of the twenty-five Records listed for September the twelve best sellers were the following:



- 8475 Parody on Hiawatha. Collins and Harlan
- 8483 My Little Coney Isle. . . . Harry L. Tally
- 8484 Two Rubes in an Eating House,  
Harlan and Stanley
- 8476 Hot Scotch March—Xylophone. Hopkins
- 8486 When Jane and I Were Wed. . . . Harlan
- 8474 Anona. . . . . Edison Band
- 8480 When We Were Boys,  
Harlan and Stanley
- 8496 Home Sweet Home,  
Mendelssohn Mixed Quartette
- 8485 Scarecrow Dance. . . . Edison Orchestra
- 8479 The Chapel. . . . . Edison Quartette
- 8489 Bungalow. . . . . Edison Band
- 8494 Though It Was Within This Hour We  
Met. . . . . Morgan and Stanley

**THE AGREEMENT HANGER.**

About September 1 we mailed to the trade, with the September PHONOGRAPH MONTHLY and other forms, copies of the Agreement hanger, Form 454, showing the terms and conditions under which Edison goods are sold. It was intended to be hung up in the stores of Dealers. Following are some of the comments we have received from Dealers:

I think it will save the retail Dealers a lot of talking to have it placed in a conspicuous place so the public can see it.

W. J. MONKHOUSE, Altoona, Ont.

We acknowledge the receipt of your Suspended List under date of September 1, and wish to assure you we will watch it closely. The Price List for framing is a good idea. We will frame and display same.

FURNEE & KENNERDELL,  
Kittanning, Pa.

The large Retailers' list and Conditions just received, and we have hung same in our store.

J. H. & S. M. ROBINSON,  
Hudson, Mass.

The Retail Dealers' Price List and Condition of Sales is just what we wanted. Some people think the small Dealer is so hard up for trade that he will give the machines away so that he can sell Records. Let the good work go on, I have my hold on a spoke.

HOWARD T. TRIPP,  
237 Linden St.,  
Brooklyn, N. Y.

I received the Retail Dealers' Price List and Condition of Sale, which I will put up in a prominent place. Also received Suspended List of September 1, 1903, and will abide by same. I am much pleased with Edison Records and Phonographs. I will sell no others as long as I can get Edison's.

OAKES M. PALMER,  
Gardiner, Maine.

We will put the Retailers' Price List and Conditions of Sale in a conspicuous place.

GRINNELL BROS.,  
Kalamazoo, Mich.

Your Dealer's Price List and Conditions are the proper thing. It is something necessary

for our protection. There is too much juggling with prices, which tends to make a show of the Dealer, and the article loses its merit to a certain extent with the people.

Yours respectfully,

F. M. NEAL,

Manager Bridgeport Decorating Co.  
Bridgeport, Conn., Sept. 21, 1903.

**TRADE ADVERTISING.**

The Eastern Talking Machine Company, of Boston, Mass., had a full page advertisement in the *National Magazine* for October, the entire page being devoted to booming the Phonograph as a teacher of languages in connection with the I. C. S. language courses.

J. W. Jenkins' Sons Music Co., Jobbers in Phonographs at Kansas City, Mo., ran a series of unusually attractive and well written advertisements in the *Kansas City Star* during July and August. They occupied a quarter page of space. We quote from one of them as follows:

The Edison Phonograph. The original and best talking machine; will bring new life into your home! It will make it easier to entertain company. With it you can amuse your family and friends whenever you wish with a programme of clear, sweet, enjoyable music ranging from ragtime to the best musical compositions. The Edison Phonograph plays everything, sings everything, whistles everything, recites everything, talks everything.

From another we quote:

**THE PHONOGRAPH UPON THE FARM.**

It brightens the monotony of farm life. It entertains your callers. It will furnish amusement for a whole party. Its sacred music will make bright the long Sunday afternoons. It will keep the boys at home. Too many farm homes lack the cheering influences of music. The Phonograph will remedy that.

McGreal Bros., Jobbers in Phonographs at Milwaukee, Wis., announced the beginning of their second year in business on September 1 with the following advertisement in the Milwaukee papers:

**WATCH OUR SMOKE**

SECOND CAMPAIGN OPENS WITH A BOOM.

GENERAL IMITATION VANQUISHED. . GENERAL MERIT WINS!

JUST ONE YEAR IN BUSINESS—JUST 2404 EDISON PHONOGRAPHS AND 58,000 EDISON RECORDS SOLD IN MILWAUKEE ALONE.

We are distributors of Edison Phonographs and Records for Wisconsin. We are to-day the largest exclusive Phonograph Dealers in the world.

M C G R E A L B R O S.  
THE TALKING MACHINE MEN.

173 Third St., just north of Grand Ave.  
Sold \$1.00 down, \$1.00 a week to residents of Milwaukee.

With its supplement of August Records the Eastern Talking Machine Co., of Boston, mailed a circular to their customers, giving the comments on August Records from the PHONOGRAPH MONTHLY for July. Concerning the success of the plan they write as follows:

That it was a benefit to us is proven by the fact that we have received thus far this month almost double the number of orders through the mail than we usually have heretofore for the new Records, and that it is appreciated by our customers is assured, for we have already received several letters commending the "Pointers," one of which we give copy of. J. M. B., of St. Johns, N. B., writes under date of September 3: "I am in receipt each month of the list of new Records, and appreciate very much your kindness. The 'Pointers' accompanying the list this month is something very timely and is a great help to parties at a distance who are unable to hear Records before buying. I hope you will issue these pointers every month."

We might add that *we* are so well pleased with the results obtained by the sending out of these "Pointers," that we shall continue to supply them to our customers, and therefore trust that the "Comments" on the new Records in the MONTHLY will not be discontinued.

The Boston Cycle & Sundry Company issued another unique novelty in September to furnish

their Dealers with the list of new Records for October and solicit their orders. It was a mailing card printed in colors on the reverse side. This showed a scene on a dock at the river with a colored stevedore pushing a truck upon which is loaded a wooden case. This case is attached to a card, and when opened discloses the October list with the usual blank space for the Dealer's order. It was even more attractive than the one gotten out by this house to exploit the September Records.

The article on "Moulded Records for Phonographs," published in the *American Machinist* on July 9, was re-printed in the *English Mechanic and World of Science* on August 14, the illustrations also being reproduced in the same size as they appeared in the *American Machinist*.

Copies of advertisements of Edison goods have been received from the following Dealers: Steinhauser & Eaton, Watsonville, Cal.; William H. Keller, Easton, Pa.; C. Mattingly, Owensboro, Ky.; George E. Buss, New Philadelphia, Ohio.

### SUSPENDED LIST, OCTOBER 1, 1903.—SUPERSEDING ALL PREVIOUS LISTS.

#### KANSAS.

LAWRENCE—BELL BROS.

#### MASSACHUSETTS.

LAWRENCE—LORD & CO., 314 Essex street.

MALDEN—A. T. FULLER.

NEW BEDFORD—H. B. DEWOLFF.

#### MICHIGAN.

DETROIT—F. J. SCHWANKOVSKY.

SAGINAW—GEO. W. EMENDORFER.

#### MISSOURI.

KANSAS CITY—THE WITTMANN CO.

#### NEBRASKA.

LINCOLN—THE WITTMANN CO.

OMAHA—THE WITTMANN CO.

#### NEW JERSEY.

ATLANTIC CITY—SAMUEL D. WOLF, 32-34 Arkansas avenue.

BAYONNE—I. WIGDOR, 450 Avenue D.

JERSEY CITY—W. L. HOFFMAN, 151 Montgomery street.

NEWARK—R. L. CORWIN.

PATERSON—CHAS. H. KELLY, 25 N. Main st.

WEST HOBOKEN—EMIL HOLLANDER, or THE WEST HOBOKEN BICYCLE & PHONOGRAPH CO., 619 Spring street.

#### NEW YORK.

BEDFORD PARK—GEO. H. TYRRELL.

\*HOBART—F. H. MARSHALL.

NEW YORK CITY—A. T. ARMSTRONG, or AMERICAN PHONOGRAPH CO., 106 Wall street.

R. L. CORWIN, also Newark, N. J.

EAGLE PHONOGRAPH CO., or C. LOWENTHAL, 83 Nassau Street.

EMPIRE PHONOGRAPH CO., 2 West 14th street.

HAWTHORNE & SHEBLE, 297 Broadway, also Philadelphia, Pa.

R. H. INGERSOLL & BRO., 67 Cortlandt street.

W. L. ISAACS, 114 Fulton street.

S. LEMBURG & CO., 194 Broadway.

J. McELLYNNE, 202 Broadway.

RICHARD PEASE, 44 W. 132d st.

F. M. PRESCOTT, 44 Broad street.

SARATOGA—W. J. TOTTEN.

#### OHIO.

CINCINNATI—J. L. ANDEM.

SPRINGFIELD—D. & M. VANDERPOOL.

UHRICHSVILLE—F. A. MAZURIE.

#### PENNSYLVANIA.

PHILADELPHIA—A. R. CASSIDY, 2783 Emerald street.

HAWTHORNE & SHEBLE, 604 Chestnut street.

PITTSBURG—A. LIPPARD, 615 Wylie avenue.

#### RHODE ISLAND.

PROVIDENCE—F. P. MOORE.

\*Added since last Suspended List was issued September 1, 1903.

**Jobbers and Dealers are asked to co-operate with us, FOR OUR MUTUAL GOOD, by being careful that they do not supply any of the above named firms with our apparatus.**



## JOBBERS OF EDISON PHONOGRAPHS AND RECORDS.

## ALABAMA.

**Birmingham**—The Ray Co., 2025 Second avenue.  
**Mobile**—The Ray Co., 54 Dauphin street.

## CALIFORNIA.

**San Francisco**—Peter Bacigalupi, 933 Market street.

## COLORADO.

**Denver**—Denver Dry Goods Co., 619 16th street.

## CONNECTICUT.

**Middletown**—Caulkins & Post Co., 406-408 Main street.  
**New Haven**—Pardee-Ellenberger Co., 155 Orange st.

## GEORGIA.

**Atlanta**—The Ray Co., 6 S. Broad street.  
**Savannah**—The Ray Co., 116-118 Barnard street.

## ILLINOIS.

**Chicago**—Oscar J. Junge, 245 E. Chicago avenue.  
 Kelley Cigar Co., 80-82 Wabash avenue.  
 James I. Lyons, 73 Fifth avenue.  
 The Ray Co., 90 Washington street.  
 Siegel-Cooper Co., State and Congress sts.  
 Talking Machine Co., 107 Madison street.  
 The Vim Co., 68 E. Lake street.  
 Montgomery Ward & Co., 111 Michigan ave.  
**Peoria**—Peoria Phonograph Co., 314 S. Adams street.

## INDIANA.

**Indianapolis**—Kipp Bros. Co., 37 S. Meridian street.  
 The Ray Co., 234 Massachusetts avenue.  
 Wahl-Gaasch Co., 119 S. Illinois street.  
**Lafayette**—Wahl-Gaasch Co., 304 Main street.

## KENTUCKY.

**Louisville**—The Ray Co., 640 Fourth avenue.

## LOUISIANA.

**New Orleans**—James I. Lyons, Theatre Arcade.  
 National Automatic Fire Alarm Co., 614 Gravier street.  
 The Ray Co., 111 Camp street.

## MAINE.

**Bangor**—S. L. Crosby Co., 186 Exchange street.  
**Portland**—W. H. Ross & Son, 207 Commercial street.

## MASSACHUSETTS.

**Boston**—Boston Cycle & Sundry Co., 48 Hanover street.  
 Eastern Talking Machine Co., 177 Tremont street.  
 J. C. Haynes & Co., 451 Washington street.  
 Iver Johnson Sporting Goods Co., 163 Washington street.  
 Read & Read, 558 Washington street.  
**Fitchburg**—Iver Johnson Sporting Goods Co., 247 Main street.  
**Lowell**—Ring Music Co., 112 Merrimac street.  
 Thomas Wardell, 111 Central street.  
**Worcester**—Iver Johnson Sporting Goods Co., 304 Main street.

## MICHIGAN.

**Detroit**—American Phonograph Co., 106 Woodward avenue.  
 Grinnell Bros. Music House, 219 Woodward avenue.  
 The Ray Co., 168 Griswold street.  
**Saginaw**—Morley Bros.

## MINNESOTA.

**Minneapolis**—Thomas C. Hough, 714 Hennepin ave.  
**St. Paul**—Minnesota Phonograph Co., 37 E. 7th street.

## MISSOURI.

**Kansas City**—J. W. Jenkins' Sons Music Co., 1013-1015 Walnut street.  
 The Ray Co., 1021 Grand avenue.  
**St. Louis**—Conroy Co., 1115 Olive street.  
 The Ray Co., 923 Olive street.

## NEBRASKA.

**Lincoln**—H. E. Sidles Cycle Co., 1317 O street.  
**Omaha**—H. E. Fredrickson, 1502-1510 Capitol avenue.  
 Nebraska Cycle Co., 15th and Harney streets.

## NEW JERSEY.

**Hoboken**—Eclipse Phonograph Co., 205 Washington street.  
**Newark**—H. J. Koehler Sporting Goods Co., 845 Broad street.  
 A. O. Petit, 42 New street.  
**Paterson**—James K. O'Dea, 117 Ellison street.  
**Plainfield**—Frank L. C. Martin Auto. Co., 810 Park avenue.  
**Trenton**—Stoll Blank Book and Stationery Co., 30 E. State street.

## NEW YORK.

**Brooklyn**—Chapman & Co., Fulton and Duffield streets.  
 A. D. Matthews' Sons, 394 Fulton street.  
 Price Phonograph Co., 1258 Broadway.  
**Buffalo**—P. A. Powers, 643 Main street.  
**Elmira**—Elmira Arms Co., 117 Main street.  
**Gloversville**—American Phonograph Co., 99 W. Fulton street.  
**Kingston**—Forsyth & Davis, 307 Wall street.  
**New York City**—Bettini Phonograph Co., 80 Chambers street.  
 Blackman Talking Machine Co., 19 Beekman street.  
 J. F. Blackman & Son, 2654 3d avenue.  
 I. Davega, Jr., 802 Third avenue.  
 S. B. Davega, 32 E. 14th street.  
 Douglas & Co., 89 Chambers street.  
 H. S. Gordon, 139 Fifth avenue.  
 O. Hacker, 2 Murray street.  
 Harry Jackson, 219 Bowery.  
 Jacot Music Box Co., 39 Union Square.  
 Victor H. Rapke, 1661 Second avenue.  
 Rosenfield Mfg Co., 587 Hudson st.  
 Siegel-Cooper Co., Sixth avenue and 18th street.  
**Rochester**—Mackie Piano O. & M. Co., 100 State street.  
**Schenectady**—Jay A. Rickard & Co., 253 State street.  
**Syracuse**—W. D. Andrews, 216 E. Railroad street.  
**Troy**—James Lucey, 359-361 Fulton street.  
**Utica**—Clark, Horrocks & Co., 54 Genesee street.

## OHIO.

**Canton**—Klein & Heffelman Co., 216 N. Market street.  
**Cincinnati**—Ilsen & Co., 25 W. 6th street.  
 The Ray Co., 143 West 5th street.  
 Wahl-Gaasch Co., 47 W. 5th street.  
**Cleveland**—The Ray Co., 266 Erie street.  
 W. J. Roberts, Jr., 254-256 Arcade.  
**Columbus**—Perry B. Whitsit Co., 213 S. High street.  
**Dayton**—Niehaus & Doshe, 35 E. 5th street.  
**East Liverpool**—Smith & Phillips Music Co.  
**Toledo**—Hayes Music Co., 608 Cherry street.  
 The Ray Co., 606 Madison street.

## PENNSYLVANIA.

**Allegheny**—Henry Braun, 500 Federal street.  
**Allentown**—G. C. Aschbach, 539 Hamilton street.  
**Easton**—William Werner, 401 Northampton street.  
**Philadelphia**—C. J. Heppe & Son, 1117 Chestnut street.  
 Lit Bros., Market and 8th streets.  
 Penn Phonograph Co., 19 S. 9th street.  
 Wells Phonograph Co., 41 N. 9th street.  
 Western Electric Co., 931-933 Market street.  
 H. A. Weymann & Son, 923 Market street.  
**Pittsburg**—Theo. F. Bentel Co., Inc., 433 Wood street.  
 Kaufmann Bros., Fifth avenue and Smithfield street.  
 H. Kleber & Bro., 221 Fifth avenue.  
 C. C. Mellor Co., 319 Fifth avenue.  
 Pittsburg Phonograph Co., 937 Liberty avenue.  
**Reading**—Reading Phonograph Co., 757 Penn street.  
**Scranton**—Charles B. Scott, 119 Franklin avenue.

## RHODE ISLAND.

**Providence**—J. M. Dean Co., 785-795 Westminster street.  
 J. A. Foster Co., Weybosset and Dorrance streets.  
 Household Furniture Co., 231-237 Weybosset street.  
 Murray, Blanchard, Young & Co., 26-30 Pine street.

## TENNESSEE.

**Knoxville**—The Ray Co., 319 Clinch street.  
**Memphis**—The Ray Co., Lyceum Building, 2nd and Jefferson streets.  
**Nashville**—The Ray Co., 30 The Arcade

## TEXAS.

**Dallas**—C. B. Harris, Agt., 347 Main street.  
**Waco**—Waco Electric Supply Co., 518 Austin avenue.

## VIRGINIA.

**Richmond**—The Ray Co., 729 E. Main street.

## WISCONSIN

**Milwaukee**—McGreal Bros., 173 3d street.

## CANADA.

**Toronto**—R. S. Williams & Sons Co., Ltd., 143 Yonge street.

# Uncle Josh Weatherby's Punkin Centre Stories

IN BOOK FORM.

Written by Mr. Cal Stewart.

**200 PAGES OF FUN AND LAUGHTER**

Contains all his humorous sketches as told by him in the various makes of talking machine records, together with several new stories and poems. The book is handsomely bound with illuminated cover. EACH STORY IS ILLUSTRATED, depicting the most laughable incidents in the sketch.

**PRICE \$1.00.**

Liberal Discounts to Jobbers and Dealers. Write for Quotations.

**PENN PHONOGRAPH CO.**

*Distributors to the Talking Machine Trade*

*19 South Ninth Street, Philadelphia, Pa.*

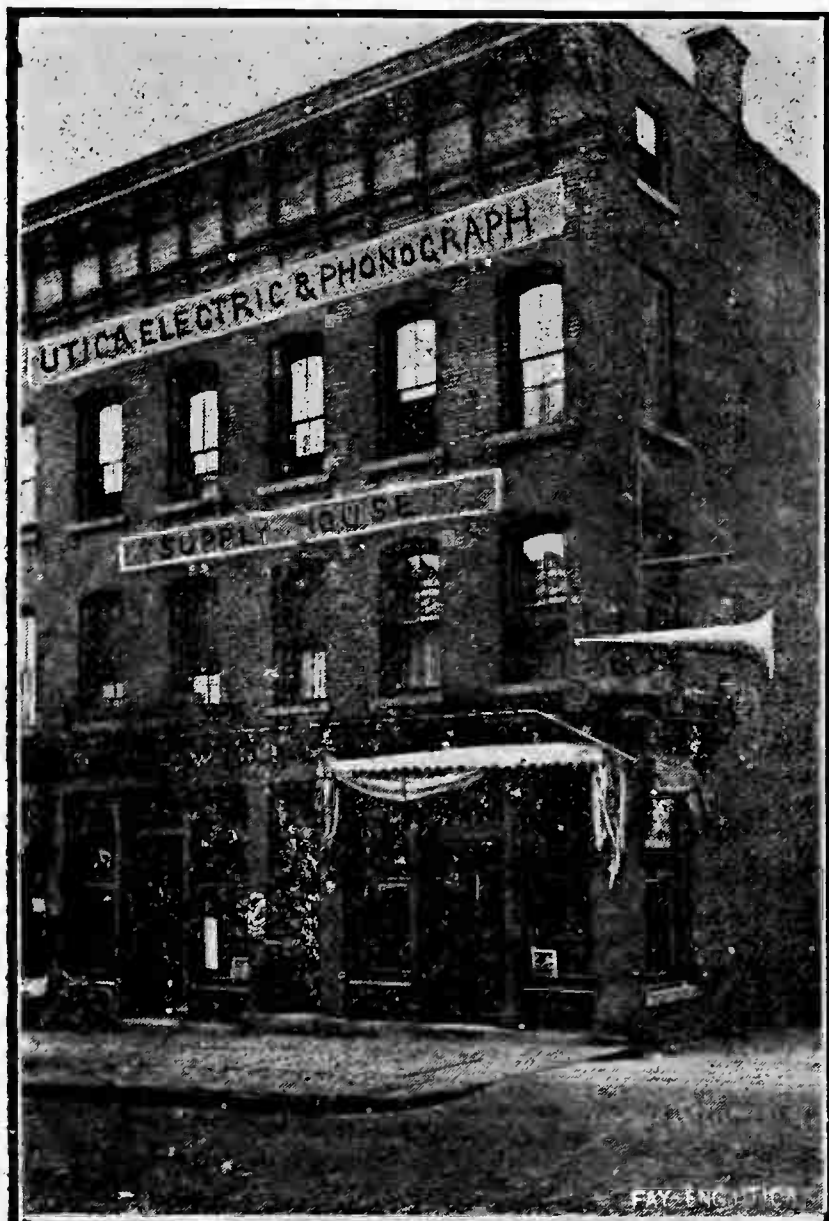

**THIS IS THE 8 FOOT  
HORN**

LOOK FOR IT IN THE

**JULY ISSUE**

OF THE EDISON PHONOGRAPH MONTHLY

**THE BEST WAY TO ADVERTISE**

WRITE FOR PRICES

**Utica Electric and  
Phonograph Supply House**

EDWIN A. BATCHELOR

**12 PEARL ST., UTICA, N. Y.**



# CYLINDER RECORD CABINETS

made with the practical knowledge of what a Cylinder Record Cabinet ought to be. We illustrate two popular leaders—and there are others.

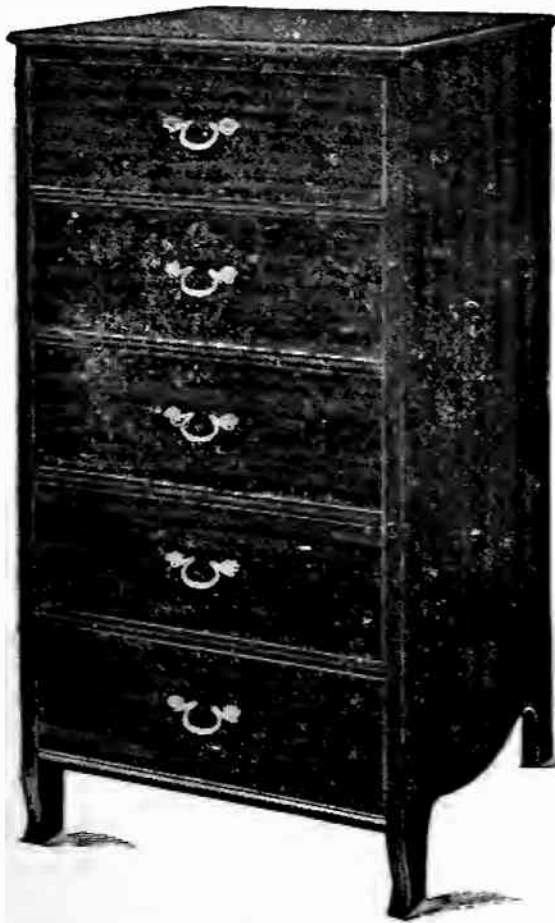

No. 2.

**No. 2.** Height 37 inches, width 19 inches, depth 18½ inches; five drawers with stops, 180 pins, Mahogany veneered front and top, birch imitation sides, false back, piano finish..... **22.50**

**No. 3.** Height 37 inches, width 19 inches, depth 20 inches; five drawers with stops, 180 pins, quartered oak front, back, both sides and top, piano finish . . . **28.00**

Dealers will find it profitable to write for special discounts. These cabinets are made in the most reliable manner—in the best standard of furniture making.



No. 3.

**AMERICAN PHONOGRAPH COMPANY**

106 Woodward Ave., Detroit, Mich., U. S. A.

## ALLEN'S JAPANESE LACQUERED HORN

BLACK OUTSIDE

RED INSIDE

HIGHEST JAPANESE ART

IMPORTED

Weight 28 ozs.

30 inches long

15 inch Bell

PRICE - - TEN DOLLARS.

Peter Bacigalupi, Sole Agent U. S. A.

933 MARKET STREET,

SAN FRANCISCO.

THIS IS AN IDEAL, HORN, MADE AFTER YEARS OF EXPERIMENTING BY A CONNOISSEUR. DOES AWAY WITH ALL THE METALLIC SOUNDS FOUND IN OTHER HORNS.

# The E. W. N. Handbook of the Phonograph

— AND —

## Instructions for Making Records.

BY C. W. NOYES.

### Every Owner

Of a talking machine should have a copy of this valuable book. It is replete with **Instructions for the Care and Use of the Phonograph**, and the chapters devoted to **RECORD**

**MAKING** are compiled from the author's many years of experience in some of the principal laboratories of this country.

Any one possessed of ordinary intelligence can make a perfect record if the directions are followed.

Fully Illustrated—Handsomely Bound.

PAPER, 25 CENTS.

CLOTH, 50 CENTS.

Mailed Postpaid on Receipt of Price.

For Sale by All Jobbers, or

**ILSEN & COMPANY, Cincinnati, Ohio.**

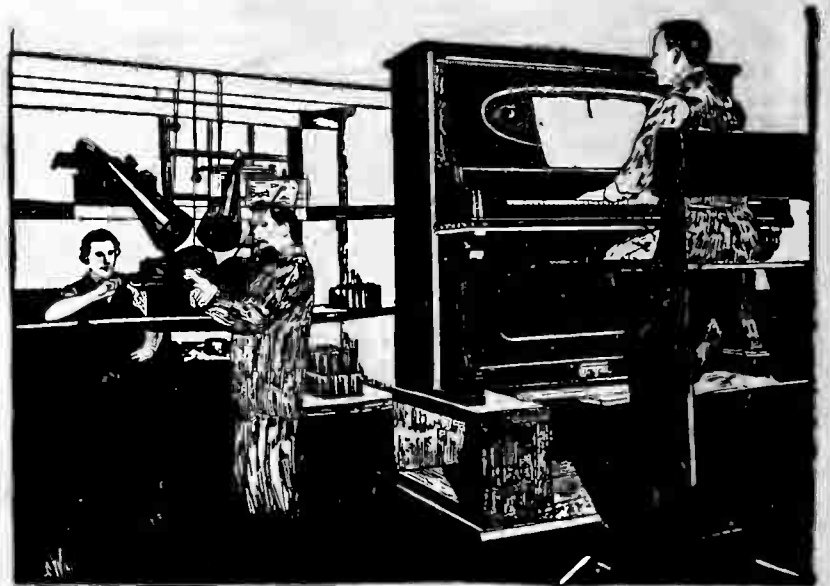

DEALERS WRITE FOR DISCOUNTS.

## A CARD TO THE TRADE JOBBER AND DEALERS

Interested in giving their customers best results are invited to write us for quotations on

### DOUGLAS

### *Mega (Paper) Horns and Record Cabinets*

The Horn that Made us Famous.

Attractive and Substantial.

Superior to any metal horn made in purity, volume and absence of metallic tones.  
**GREAT AIDS TO THE SALE OF PHONOGRAPHS AND RECORDS.**

Superior to any Line in the Market,  
**STRONGLY MADE.**

**BEAUTIFULLY FINISHED.**

- "MEGA" . . . . . List **\$7.50**  
Length 32 inches; Width 24 inches.
- "MEGA JR." . . . . . List **\$2.25**  
Length 22 inches; Width 13 inches.
- MEGA RECORDING HORN, List **\$1.50**  
Length 24 inches; Width 6 3/4 inches.

- 100 Peg Polished Oak, List **\$12.00**
- 125 " " " " " **14.00**
- 125 " Quartered Oak, " **15.50**
- 150 " " " " " **18.00**

Look for the Trade Mark  
**"PHONO-MEGA."**

**Prices Restricted.**

WRITE FOR SPECIAL LEAFLETS AND NET PRICES.

## DOUGLAS & CO.,

89 Chambers Street,

71 Reade Street,

**NEW YORK.**



# EDISON Phonograph Monthly

PUBLISHED FOR TRADE USE ONLY BY  
THE NATIONAL PHONOGRAPH CO.

VOL. 1.

NEW YORK, NOVEMBER, 1903.

No. 9.

*The National Phonograph Co.,*

ORANGE, N. J.

NEW YORK: 83 CHAMBERS STREET.

CHICAGO: 304 WABASH AVENUE.

SAN FRANCISCO: 933 MARKET STREET.

ANTWERP: 32 REMPART SAINT GEORGES.

## EDISON PHONOGRAPHS AND RECORDS.

All communications to THE PHONOGRAPH MONTHLY should be addressed to the Advertising Department, 83 Chambers Street, New York.

### C O N T E N T S

Good Records and Others.....	1
Advance List of December Records.....	2
Special Advance List of British and French-Canadian Records.....	3
British and French-Canadian Records.....	4
Keep Sending Agreements.....	5
Phonograph Art Calendar.....	5
Changes in Accessories Catalogue.....	6
"Comments" for Trade Use.....	6
Frames for Record Bulletins.....	6
Phonographs for Lodges.....	7
Increase in Advertising Rates.....	7
Pays to Carry a Full Line.....	8
Get After the Y. M. C. A.'s.....	8
Stock Up for Holidays.....	8
Retained Phonograph Literature.....	8
Trade Literature and Advertising.....	9
Edison's Latest.....	9
The Phonograph's Description of Itself ...	9
Among the Jobbers.....	9
Printed Matter.....	10
Business Keeps Coming.....	11
Comments on December Records.....	11
Little Talk About a Talking Machine. ...	13
November Advertising.....	14
Dealers' Comparison of Two Kinds of Literature.....	14
Best Selling Records.....	15
To Determine a Speed of 160 Revolutions. 15	
Suspended List.....	16

## GOOD RECORDS AND OTHERS.

As every one in the Phonograph trade knows the announcement made by this company a month ago to the effect that no change would be made in the price of Edison Phonographs and Records was due to the fact that another company had cut the price of its records to twenty-five cents each. So far as action on the part of this company is concerned, no further statement was necessary. It has always been our policy to attend strictly to our own business and pay no attention to that of others. The world is wide and there is room for us all, whether makers of good or inferior products. All kinds have their uses.

Continuing this policy, we should not dignify the company in question by referring to its official confirmation of the price at which its records have sold for a long time. But our trade is writing on the subject, and in order to avoid a lot of correspondence, we must ask the indulgence of our friends in departing from our policy and publishing this article.

There is no likelihood of our making a reduction in the price of Records, nor is there any need of such a step. The manufacturers of the cheap record referred to were compelled to announce a lower price for it because unable to successfully compete with the Edison Record. The acknowledged superiority of the Edison Gold Moulded Record had brought its business to a point where it was compelled to sell at a lower price or cease the manufacture of cylindrical records altogether. The manufacturers alone are the only ones in the entire talking machine trade of this or any other country who will deny this. The same superiority of our Records which brought about this condition will enable us to continue to get fifty cents each for them. The gold moulded process by which Edison Records are made is employed only by us and the results secured by its use are attained by no other

(Continued on page 4.)

THE ADVANCE LIST OF DECEMBER RECORDS APPEARS ON PAGE 2. SPECIAL ADVANCE LIST OF BRITISH AND FRENCH-CANADIAN SELECTIONS APPEARS ON PAGE 3. ORDER FROM THEM.

## ADVANCE LIST OF NEW EDISON GOLD MOULDED RECORDS FOR DECEMBER, 1903

RECORDS listed below will be ready for shipment as near December 1st, 1903, as possible, at which time Jobbers' stock orders, if placed prior to November 15th, will be shipped.

December Supplements will bear the date of December 1st, and will be forwarded to Jobbers with their stock order for Records.

Retail Dealers should place stock orders with their Jobbers at once, to insure prompt shipment as soon as Jobbers' stock is received.

Stock orders for Records contained in this list must be written on separate order blanks, and letters relating to December Records should refer to no other matter.

Kindly comply with above requests and thus aid your Jobber and ourselves in handling advance orders.

- |      |  |   |
|------|--|---|
| 8549 | Southern Smiles March, by the composer of "Peaceful Henry"   | Edison Military Band  |
| 8550 | Bedelia, an Irish Coon Serenade  | Billy Murray  |
| 8551 | The Flowers of Dixie Land<br><i>As sung by Lillian Russell in Weber &amp; Fields' "Whoop Dee-Do"</i>                       | Francklyn Wallace   |
| 8552 | Trixie   | <i>Serio-comic song</i> Will F. Denny   |
| 8553 | I'm Going to Leave<br><i>Coon male duet, with banjo accompaniment by Vess L. Ossman</i>                                    | Collins & Harlan  |
| 8554 | Soko, Moorish March-Intermezzo   | Edison Symphony Orchestra   |
| 8555 | Tell Me that Beautiful Story<br><i>tone duet</i>   | <i>Sentimental Tenor and Baritone duet</i> Andrew Schneider & Francklyn Wallace |
| 8556 | The Last Farewell<br><i>Expressly written and composed by Chas. K. Harris for Adelina Patti's Farewell Tour of America</i> | Francklyn Wallace   |
| 8557 | Scene in a Country Blacksmith Shop<br><i>Comic Rube singing and Talking male Duet</i>                                      | Harlan & Stanley  |
| 8558 | The Miller's Daughter<br><i>Descriptive song with orchestra accom from "Three Little Maids"</i>                            | Harry MacDonough  |
| 8559 | That's How I Love You Mame   | <i>Bowery Love song</i> Arthur Collins  |
| 8560 | North and South Medley<br><i>Introducing "Marching Through Georgia" and "Dixie" and Bugles</i>                             | U. S. Marine Fife and Drum Corps  |
| 8561 | Down Where the Swanee River Flows<br><i>Descriptive song with orchestra accompaniment</i>                                  | Byron G. Harlan   |
| 8562 | Peaceful Henry<br><i>Characteristic March and Two-step</i>   | Edison Concert Band   |
| 8563 | Won't You Write a Letter, Papa   | <i>Male duet</i> Harlan & Stanley   |
| 8564 | Up in the Cocoanut Tree<br><i>Love Song of the Cocoanut Grove</i>  | Billy Murray  |
| 8565 | Sammy  | <i>Serio-comic song from "Wizard of Oz"</i> Harry MacDonough                    |
| 8566 | Melody of Love   | Edison Symphony Orchestra   |
| 8567 | Moriarity  | <i>Comic Irish male duet</i> Collins & Harlan                                   |
| 8568 | The Girl You Love<br><i>Serio-comic song with orchestra accom. from "Three Little Maids"</i>                               | Harry MacDonough  |
| 8569 | The Two Comrades Polka<br><i>Cornet duet accompanied by the Edison Military Band</i>                                       | John Hazel & Frank S. Seltzer   |
| 8570 | I'm Longing for You Sweetheart Day by Day<br><i>Sentimental song</i>   | Francklyn Wallace   |
| 8571 | Keep on A-Shining Silv'ry Moon<br><i>Song and quartette chorus with orchestra accompaniment</i>                            | Edison Quartette  |
| 8572 | The Maid of Timbuctoo<br><i>As sung by Lillian Russell in Weber &amp; Fields' "Whoop Dee-Do"</i>                           | Harry MacDonough  |
| 8573 | Any Rags Medley, introducing the Coon song "Any Rags" and other popular songs  | Edison Military Band  |

Edison Gold Moulded Records are made only in Standard size. Both Standard and Concert Records may be ordered from this list. Order by Number, not title. If Concert Records are wanted, give the number and letter C.



## SPECIAL ADVANCE LIST

### of British and French-Canadian Selections Edison Gold Moulded Records.

These special British and French-Canadian Records will be ready for shipment, if possible, with the December Records, providing Jobbers' stock orders have been placed prior to November 15. We reserve the right, however, to defer shipment of these Records till a later date should the demand for regular Records make it impossible to manufacture these special selections in time for such shipment.

Special supplements will be issued for these selections and will be forwarded with the Records to such Jobbers as order a supply.

Jobbers are requested to order these Records on separate sheets and not on sheets with orders for regular Records or other goods.

Retail dealers should place stock orders with the Jobbers at once, to insure prompt shipment as soon as Jobbers' stock is received.

#### BRITISH SELECTIONS.

- 12828 March, "His Majesty,"  
British Military Band
- 12829 War March of the Priests,  
British Military Band
- 12830 "Tommy Atkins" and "Soldiers of the King,"  
British Military Band
- 12831 Selection from "The School Girl,"  
British Military Band
- 12832 Motherland (San Toy), Leonard Mackay
- 12833 Bonnie Banks o' Loch Lomond,  
Miss Octavia Barry
- 12834 "Coo" (From "A Country Girl"),  
Miss Octavia Barry
- 12835 I've Made Up My Mind to Sail Away,  
Leonard Mackay
- 12836 Queen of Love,  
Hamilton Hill
- 12837 Bird Imitations, I, Miss Maud Dewey  
Blackbird, Nightingale, Thrush.
- 12838 Salvage Man, (Dan Leno),  
Fred T. Daniels
- 12840 Forward March, British Military Band
- 12841 Tres Jolie Waltz, British Military Band
- 12842 Selection from a Country Girl, No. 1,  
British Military Band
- 12843 Selection from a Country Girl, No. 2,  
British Military Band
- 12844 Skylark,  
Hamilton Hill
- 12845 Best of All,  
Hamilton Hill
- 12846 Let Her Drown,  
Leonard Mackay
- 12847 O! The Business (Harry Randall),  
Leonard Mackay
- 12848 Blue Bells of Scotland,  
Thomas Reid
- 12849 Robin Adair,  
Thomas Reid
- 12850 Mary of Argyle,  
Thomas Reid
- 12851 Killarney,  
Miss Octavia Barry
- 12852 Selection of Popular Songs, II,  
British Military Band
- 12853 Selection of Popular Songs, III,  
British Military Band
- 12854 Intermezzo from "Cavalleria Rusticana,"  
British Military Band
- 12855 I'll be True,  
Hamilton Hill
- 12856 Once,  
Hamilton Hill
- 12857 The Auld Hoose, (Scotch Song),  
Thomas Reid
- 12858 Bonnie Dundee,  
Thomas Reid
- 12859 At the Seaside (Ernest Shand),  
Leonard Mackay
- 12860 Oh! Isn't it Singular, (Ernest Shand),  
Leonard Mackay
- 12861 Recruiting Sergeant, (Dan Leno),  
Fred T. Daniels

- 12862 Banks of Allan Water,  
Miss Octavia Barry
- 12863 Bird Imitations, II Miss Maud Dewey  
Canary, Skylark, Chaffinch.

#### FRENCH-CANADIAN SELECTIONS.

- 12876 Blue Bells of Scotland,  
("The Kilties") 48th Highlanders' Band
- 12877 Cock of the North,  
("The Kilties") 48th Highlanders' Band
- 12878 Rob Roy,  
("The Kilties") 48th Highlanders' Band
- 12879 Coming Through the Rye,  
("The Kilties") 48th Highlanders' Band
- 12880 Pretty Maid Milking Her Cow—Bagpipe,  
J. C. McAuliffe
- 12881 Paddy on the Turnpike—Bagpipe,  
J. C. McAuliffe
- 12882 Donnybrook Fair—Bagpipe,  
J. C. McAuliffe
- 12883 Jonas dans la Baleine,  
H. Cartel
- 12884 Manzelle Duplumeau,  
H. Cartel
- 12885 Le Flegme,  
H. Cartel
- 12886 L'Enfant du Regiment,  
H. Cartel
- 12887 O Miledy,  
H. Cartel
- 12888 Y connait tout c't' animal-la,  
H. Cartel
- 12889 V'la les poires,  
H. Cartel
- 12890 La Sonnerie d'Alame,  
H. Cartel
- 12891 La Gobinois,  
R. Harmant
- 12892 Je M'Suis Roulé,  
R. Harmant
- 12893 Ca Va Très Bien,  
R. Harmant
- 12894 Bibi Bobino,  
R. Harmant
- 12895 Elles En Veulent,  
R. Harmant
- 12896 Ayez pitié D'Elle,  
R. Harmant
- 12897 C'que Jen'comprends pas,  
R. Harmant
- 12898 Faut R'Miser Ca,  
Léo Méry
- 12899 Tout le long du Boulevard,  
Léo Méry
- 12900 Les Jours qu'il Fait Froid,  
Léo Méry
- 12901 Conscrit Soldat,  
Léo Méry
- 12902 La femme du Boulier,  
F. Kelm
- 12903 Nous avons fait Comme eux,  
F. Kelm
- 12904 La Marseillaise,  
F. Kelm
- 12905 Les Petits Joyeux,  
F. Kelm
- 12906 Vielle Fille,  
F. Kelm
- 12907 Larirette et Ionlonla,  
F. Kelm
- 12908 La Vigne au Vin,  
F. Kelm
- 12909 Romeo et Juliette (Duett),  
Rhea et Harmant
- 12910 Petite Flûte et Cordon Bleu,  
Rhea et Harmant
- 12911 Jen 'ai pas l'habitude de fumes,  
Edmund Lamoureux
- 12912 En Suivant le Regiment, Mme. Harmant

These Edison Gold Moulded Records are made only in Standard size. Both Standard and Concert Records may be ordered from this list. Order by Number, not title. If Concert Records are wanted, give number and letter C.

(Continued from page 1.)

manufacturer. Edison Records are in a class by themselves. The American people know this and as they are essentially a people who want the best to be had our Records will continue to find a ready sale.

As a result of the announced reduction in its price, the record that we are dignifying by so much attention has in a single month become the "bargain lot" record of the country. It has to-day no fixed price. It can be bought at retail for one dollar a dozen, if the advertisements of dealers can be believed. Department stores are selling it at fifteen cents as an advertisement of their talking machine department. Some Dealers who sell these records as well as the Edison Gold Moulded get fifty cents each for the latter and find it difficult to dispose of the others for sixteen cents. One Dealer advertised his "bargain lot" records at sixteen cents each," and said: "If you don't like them bring them back when they are worn out and we will allow you fifteen cents each for them in exchange for Edison Records. This will make them cost you but one cent each, and they are really worth it." This is but a sample of the feeling entertained by the trade in general toward these records. Its manufacturers may sell them in their own retail stores, but no dealer can handle them with the expectation of making money out of their sale. The record situation may be compared to the sale of typewriters. There are machines on the market that sell at from \$5.00 to \$50.00, but fifty business men buy \$100 machines to one purchasing the cheaper type, and yet both continue in business. In a world so big as this there is room for the Edison Gold Moulded Record at fifty cents each, and for the other with its 18-cents-to-day - and - 12 - cents - to-morrow price, with quality to correspond.

#### **DON'T BELIEVE IN PRICE CUTTING.**

CEDAR BLUFF, ALA., Oct. 12, 1903.

We acknowledge receipt of Suspended List of October 1. You can depend on us "sticking to the text." We don't believe in price cutting anyway. Jos. W. M. WITT & SON.

#### **AGREEMENT HANGER JUST THE THING.**

CRESCENT CITY, CAL., Oct. 9, 1903.

I acknowledge receipt of the late Suspended List and also the Hanger, form 454, and will certainly co-operate with you. Allow me to thank you for the Hanger. It is exactly what I have been wanting for a long time, as the people of my town think they can get Edison goods cheaper by sending out of town. It will be of a great benefit to me.

PETER DUFFY, known Scotch songs and selections from pop-

#### **BRITISH AND FRENCH-CANADIAN RECORDS.**

On Page 3 of this issue we print a special Advance List of British and French-Canadian Records, made by the Edison Gold Moulded process. The Masters for these Records were made some time ago, but for various reasons no announcement has been made concerning them. We have been making Gold Moulded Records of the British titles for some time, but our London and Antwerp offices have been and are still demanding more than we can make of them. They are listed now because our new Record plant is nearing completion and we expect in a short time to have facilities that will enable us to fill orders for these titles, besides giving better attention to orders of the trade in this country. The same enlarged facilities made it possible to list the French-Canadian selections. On Page 3 we state that advance orders for both British and French-Canadian Records, if received before November 10, will be ready for shipment, if possible, with the December Records. We reserve the right, however, to hold back the shipment of these special lists if orders for regular Records or delay in getting into our new Record plant make it impossible to fill orders for them.

The thirty-five titles in the British list will afford the American public a good opportunity of comparing the Records made in the two countries. The verdict would probably be decided by the personal feelings of the listener, for the British Records are well made and an Englishman would doubtless claim that they are superior to those made here. These British selections were made at our Recording Plant in London, by English bands and singers, and the only American feature in connection with them was the direction given by recording experts sent from our factory at Orange. They may therefore be called strictly British Records.

Eleven of the selections are made by the British Military Band, and it would be hard to find an equal number of better rendered band Records. They are made with unusual volume of tone and the band plays with great precision and fine attack. The selections are sufficiently varied to suit all tastes. Five Records are made by Leonard Mackay, who has a fine baritone voice. His songs are both sentimental and humorous. The four selections by Miss Octavia Barry are unusually good Records of a soprano voice, the most difficult of all voices to reproduce in a pleasing manner. Miss Barry's selections are well



ular operas. Hamilton Hill, the Australian baritone, has five selections in the list, part humorous and part sentimental. Miss Maud Dewey, perhaps the best woman whistler in the world, has given in two Records some remarkable imitations of English singing birds, the blackbird, nightingale, thrush, canary, skylark, and chaffinch. These Records will especially remind every Englishman of his native country. Fred T. Daniels makes two talking and singing Records, both being titles made famous in Great Britain by Dan Leno. Five old Scotch songs have been given to the list by Thomas Reid, whose excellent baritone voice has made splendid Records.

Of the thirty-seven French-Canadian selections four are made by the famous "Kilties" Band of the Forty-eighth Highlanders, and three are bagpipe solos by J. C. McAuliffe. The others are solos and duets in French, most of them being of a comic character. They are a well-made lot of Records and cannot fail to be popular in Canadian territory. Lack of space and time makes it impossible to give a detailed description of them.

#### FAIR OPENED BY PHONOGRAPH.

The value of the Phonograph was demonstrated in a remarkable manner at the Maidenhead [England] Baptist Church yesterday afternoon. The pastor of the church, the Rev. R. R. Williams, was stricken with illness a few days ago in the midst of arranging a bazaar in aid of the organ fund. Mr. Thomas Timberlake took a Phonograph to the bedroom of the pastor, who spoke an opening message into the instrument.

The experiment was a great success, the brief address by the pastor being received by a large audience with pleasure at the opening of the bazaar yesterday.—*From the London Daily Mail.*

#### KEEP SENDING AGREEMENTS.

We would again urge Jobbers to keep sending in Agreements of new Dealers. To have their names on our files aids the Dealer, aids the Jobbers and aids ourselves. It is of benefit all around. It will pay Jobbers to look over their lists occasionally to make sure that they have sent in the Agreements and Index Cards of every Dealer who has signed. We will also thank them if they will keep us advised from time to time concerning Dealers who have discontinued handling Phonographs and Records or who have recently gone out of business. We desire to take their names from our mailing list.

#### PHONOGRAPH ART CALENDAR.

The Phonograph Art Calendar for 1904 still drags. Copies are expected daily from the lithographers, and one will be mailed to each Jobber, accompanied by a letter on the subject. Retail Dealers who feel that they would like a few copies to sell or give to their customers are asked to write the Advertising Department for information. This Calendar was gotten up with the intention of advertising its sale by means of our magazine announcements. This will still be done, the advertisement first appearing in the December issues. Its price by mail will be twenty-five cents, postpaid. It costs fifteen cents a copy and such Jobbers and Dealers as may desire one or more copies will be supplied at cost.

This Calendar is equal in every respect to any similar art Calendar yet issued, and since no advertising appears on the face of the sheets it may be hung up anywhere in the home. It consists of six sheets, 10½ x 14½ inches in size, beautifully lithographed in twelve colors on fine embossed paper. The sheets are tied together with white satin ribbon.

The sketches are the work of John Cassel, the well known artist, and are of the most attractive character. Cupid is a prominent figure in all of the sketches, his match-making propensities being charmingly brought out in each. The sheet for January and February shows a young couple stopping while out sleighing to lift Cupid in out of the snow. March and April shows a young artist gazing enraptured upon the fair one whose portrait he is painting. Cupid holds the palette, a mischievous smile on his face the while. On the May and June sheet a youth and young damsel sit side by side in a birch canoe. Cupid, paddle in hand, is furnishing the motive power. July and August shows a pair of lovers in steamer chairs on board ship. They are "holding hands." Cupid appears, tray in hand, as the up-to-date steward. September and October are typified by a young Indian brave and a charming squaw who are making love while Cupid plays on his lute. November and December shows a hunting scene, but the young couple have laid aside their guns and are sitting side by side on a log, with Cupid between them. A hunting dog in the background looks reproachfully at this unsportsmanlike method of hunting.

An argument on Edison Phonographs and Records appears on the backs of the sheets, but it does not in any manner mar the attractiveness of the Calendar.

## CHANGES IN ACCESSORIES CATALOGUE.

The present edition of Catalogue Form 376, Phonograph Accessories and Coin-Slot Phonographs, is exhausted, and an order has been placed with the printer for a new supply. These are expected about November 1. Hereafter Phonograph Accessories and Coin-Slot Phonographs will not be printed in one Catalogue, but will be issued as separate folders. The Coin-Slot Folder will be Form 484 and the Accessories Folder, Form 485. In the new edition of the Coin-Slot Folder no changes have been made. In the Accessories Folder, Record Boxes and Record Carrying Cases have been omitted. These will no longer be carried as accessories. We will fill orders for such of these goods as we may have at the factory and when the stock is gone we shall discontinue their sale. The eighteen-inch Flexible Connection has also been omitted from this Folder. Several changes have been made in the prices of Way Rails with and without Tubes and Flexible Connections. The new prices of these will be as follows:

6-way Rails, with Tubes and Flexible Connection .....	\$5.80
10-way Rails, with Tubes and Flexible Connection .....	7.40
14-way Rails, with Tubes and Flexible Connection .....	9.20
17-way Rails, with Tubes and Flexible Connection .....	10.35
6-way Rails, only.....	3.00
10-way Rails, only.....	3.25
14-way Rails, only.....	3.50
17-way Rails, only.....	3.70

### "COMMENTS" FOR TRADE USE.

Early in October we received a letter from a Jobber approving the plan of the Eastern States Jobber who sends to his retail trade each month a reprint of the Comments on New Records from the EDISON PHONOGRAPH MONTHLY. This Jobber also suggested that these Comments be printed each month for use by the Jobbers in general, either at the expense of this company or at the expense of the Jobbers themselves, if the company did not feel that it could bear the additional expense. We did not feel that we could send out the sheets in large quantities in addition to the Supplements now being issued; but we sent out a letter to all Jobbers, advising them that if they desired to have us print these Comments each month, we would do so at the actual cost of printing. This cost was given in the circular at \$1.25 for 500, with imprint of the Dealer, or \$2.25 per thousand with

imprint. The letter brought responses from a number of Jobbers who ordered such a quantity of the Comments that it was possible to issue them at less cost than these figures. The Comments for November were printed on one side of a single sheet, but if the demand is sufficient we will have them printed in booklet form. This has been requested by some Jobbers and we think that it can be done at very little more expense than the prices given above for single sheets. Printed in book form they will make a very desirable method of advertising. If any Dealers would like to have us print for them a supply of these Comments, we shall take pleasure in filling their orders, but they must suggest a way of getting them in their hands without cost to us. This might be done by placing orders with Jobbers, or, if Dealers are ordering direct from us, we can ship them with other goods. We would suggest that if a Dealer is interested in this matter he write us for one of the letters sent to Jobbers and any other information he may desire on the subject.

### FRAMES FOR RECORD BULLETINS.

In a recent issue of the PHONOGRAPH MONTHLY reference was made to a New York Jobber who made a feature of framing copies of the Record Bulletin and displaying them in the window. This Jobber has found this feature so popular that he has had a stock of these frames made and has sold a number of them to his Dealers, as many as six at one time. When a Bulletin is placed in a frame it forms an attractive part of an exhibit, whether in the show window or on the walls of the store. The New York Jobber in question has also framed supplements and other display advertising matter issued by this Company and these frames add much to the attractiveness of his store. We do not know whether or not other Jobbers handle these frames, but they would find it quite an accommodation to their Dealers if they would do so. They are made for the New York Jobber in question at a price that enables him to sell them to his Dealers for fifty cents each.

### MERIT ALL PRAISE GIVEN THEM.

VACAVILLE, CAL., Oct. 7, 1903.

We hereby acknowledge receipt of Suspended List dated October 1. You may rest assured that we will uphold the Dealers' Agreement, as we are of the opinion that the way you handle this tremendous business is the *only way*. The goods merit all the praise that can be spoken of them and are *well worth* the prices stipulated by you.

HOPE MUSIC STORE.



### PHONOGRAPHS FOR LODGES.

The Phonograph should be a feature of Lodge work throughout the country. One of the difficulties in successfully conducting secret societies and similar organizations is the finding of some means of interesting the members. How many faithful officers have been discouraged because of the poor attendance at meetings! Their own talent in the way of providing amusement is soon exhausted, and they are almost at their wits' end to offer inducements for members to attend. We believe that in nine cases out of ten the attendance at meetings of this character would be greatly improved if the lodges would purchase Phonographs and then make a selection each month of the new Records as they appear.

These remarks are offered as suggestions to induce Dealers to take the matter up with societies and see if they cannot be made to see the situation in the same light. With an initial expenditure of about \$30 and an outlay of \$5 a month a lodge would have a means of keeping its members constantly amused. The initial purchase would result in bringing out members to hear the Records, and the purchase of a dozen new ones each month would keep the interest alive. This sort of a campaign would also result in considerable advertising for the Dealer. Every Phonograph and every lot of Records sold for a purpose of this kind would be a constant advertisement for the Dealer. The way to follow up this matter is to make a list of all the lodges in your town or city and then send a series of letters to one or more of the officers, including in some instances postage for a reply. The number of societies in the average town or city is not so large but that letters could be typewritten at practically no expense to the sender, and the postage would be a small matter. It would be strange, indeed, if from one to a dozen Phonographs could not be sold by this method in every place where it was taken up, the number depending upon the size of the city.

Another good way to introduce the matter is to offer to play a selected lot of Records on the Phonograph for lodges as an introduction to the purchase of a machine, allowing the lodge ample opportunity to notify its members of your intention to do so. In many cases an entertainment of this kind would be followed by the vote of the lodge to purchase an outfit.

A Repeating Attachment for the Home Phonograph will be listed in the new edition of our Machine Catalogue, Form 500. It will be catalogue No. A 11051, Code Word *Sirius*, price \$15.00.

### INCREASE IN ADVERTISING RATES.

Beginning with the January issue, the advertising rates of the EDISON PHONOGRAPH MONTHLY will be \$20 per page, instead of \$10 as at present. Copy for half or quarter pages will be accepted at a pro rata rate. This advance is not made because of a desire on our part to make money out of those who desire to advertise in the columns of the PHONOGRAPH MONTHLY. It is done simply with the expectation that it will cut down the number of pages of advertising over the number now appearing in its columns. When it was decided to accept advertising from Jobbers and Dealers for these columns, we did not think that we would be called upon at any time to publish more than two pages. This we could do and yet be able to have sufficient space for such reading matter and such other information as we desire to lay before the trade. With six or more pages, however, it has become necessary to add additional pages over the sixteen which we had fixed as the number we thought sufficient for this publication. The additional advertising will probably pay the cost of adding the extra pages. This is the only extra cost we have, unless it should be found necessary to send out other printed matter in the same inclosure with the PHONOGRAPH MONTHLY. Then the extra pages would add one cent for every copy sent out. This with an edition of 7,500 copies is more than we can afford in connection with this publication. We believe that this advanced advertising rate will result in cutting down the number of pages to three or less in each issue, and if it does not, then the additional revenue obtained from the greater number of pages will pay for whatever additional postage we may have to lay out. We have no desire to make the PHONOGRAPH MONTHLY a money-making publication. We simply want to keep its cost down to a certain point. We believe that even with the increased rate for advertising the PHONOGRAPH MONTHLY is one of the best mediums that the Phonograph trade could possibly use in exploiting its goods.

### AMUSES HIS CUSTOMERS WITH PHONOGRAPH MUSIC.

SHAKESPEARE, Ky., Oct. 14, 1903.

Your Suspended List for October 1, 1903, just received, and will do all to keep these dealers from handling your apparatus and hope all others will do the same. I keep one of your Standard Machines running in the store for the amusement of my customers.

J. F. BEDFORD.

[Mr. Bedford conducts a General Store.]

### PAYS TO CARRY A FULL LINE.

A Jobber recently related to us an experience he had with a Brooklyn Dealer which will show to many Dealers in Edison Phonographs why they do not make a great success in selling these goods. Like many other Dealers, the Brooklyn man bought a few machines and a small stock of Records. He ordered in a small way from time to time, and finally said to the salesman of the jobbing house: "I do not seem to make much of a success of this business and think that I shall give it up entirely." The salesman replied: "Unless you conduct your business in a different manner than you are doing, I agree with you that it will be better to give it up entirely. Unless you feel able to put in a larger stock and carry a complete line of Records, it is really hardly worth while trying to make much of a success of it." The Dealer asked a number of questions and then agreed to think the matter over. The outcome of the conversation was an order to put in every Record in the entire catalogue and a larger supply of machines. In telling of this Dealer's experience, the Jobber said that the Dealer is now doing one of the best businesses of anyone in the line in Brooklyn. He carries a complete stock at all times, and his customers are sure of finding what they want when they enter the place. This experience is the same as many Dealers throughout the country have had. They buy one, two or three machines and two or three hundred Records, and endeavor with this outfit to carry on a Phonograph business. It is an even chance that when they are asked for a certain Record they do not have it in stock and if they get it at all they are compelled to send to their Jobber some distance away, occasioning a loss of time, or, in many instances, failing to make a sale at all. The successful Dealers in this line to-day are those who carry the entire stock of Records as shown in the catalogue. All Dealers, like the Dealer in Brooklyn, would do well to think this matter over.

### GET AFTER THE Y. M. C. A.'S.

In every city of size in the country there is a Young Men's Christian Association. Every such association is constantly devising means of amusement for its members and those who frequent the rooms of its buildings. Every such association, therefore, should be ready to meet a Dealer half way in an effort to sell it a Phonograph and a supply of Records. Of all musical devices that might be placed in a building of this kind, the Phonograph is unquestionably one of the most popular. Its

simplicity of operation makes it possible for anyone to operate without injuring it. Our lists of Records includes numbers of airs which are popular among young men. Altogether the Phonograph is an ideal instrument for Young Men's Christian Associations, and every Dealer should make every reasonable effort to sell one to the association in his town.

### STOCK UP FOR HOLIDAYS.

Dealers would do well at this time to look over their stock of Phonographs and Records and make up an order so as to have a full supply of both in the holiday season. The experience of past years has been that the demand for Edison goods is greater at the holiday season than at any other time in the year, and Dealers who do not have a large stock on hand fail to get the business. There is no risk whatever in stocking up in this manner, for prices are not to be changed and our goods will be just as saleable in January and February as in December. It will only mean a little more outlay of money in anticipation of business, but it cannot fail to pay in the end.

### RETAINED PHONOGRAPH LITERATURE.

Ilsen & Company, Jobbers at Cincinnati, report a similar experience with advertising matter concerning Phonographs distributed at a fair as was written about last month by H. E. Sidles Cycle Company, of Lincoln, Neb. Ilsen & Company made an exhibit at a recent fair in Cincinnati and they state that after the close each night they purposely looked around to see whether or not circulars given out by them had been kept or thrown away. They were able to find very few of them, showing that in nearly every case the recipient of these folders and cards took them away, although the floor was strewn with printed matter of almost every other exhibit.

We have received a supply of Binders for the EDISON PHONOGRAPH MONTHLY and will take pleasure in sending one prepaid to any Jobber or Dealer upon receipt of fifty cents. These Binders are neat in appearance, and are lettered with the name of the publication. They will hold copies for one year.

### DOING BUSINESS A PLEASURE.

LACONA, IOWA, Oct. 10, 1903.

I have just received your October 1st list of Suspended Dealers. It is a pleasure to do business with a firm who makes it possible for the retailer to get full prices.

S. A. RALSTON.



### TRADE LITERATURE AND ADVERTISING.

The plan of getting out cards, folders, etc., showing the list of new Records each month is steadily on the increase. In past issues we have given the names of several Jobbers who have done this for some time. We have this month received copies of these lists from R. S. Williams & Sons Co., Ltd., Toronto, Canada; Penn Phonograph Co., Philadelphia, and Grinnell Bros., Detroit, Mich. The folder issued by R. S. Williams & Sons Co. is most attractively printed in red and black ink on coated paper. The front page shows a picture of the two little girls "Looking for the Band," and below the picture the following neat phrase is printed in imitation of handwriting:

"EDISON.

"THESE ARE THE RECORDS THAT ARE MAKING THE TALKING MACHINE THE MOST POPULAR ENTERTAINMENT OF THE TIMES."

The folder of the Penn Phonograph Co. is printed on bright red paper and is a "warm" bit of literature.

Grinnell Bros. sent out their list in the shape of a large mailing card.

Copies of newspapers containing advertisements of Edison goods have been received from the Penn Phonograph Co., Philadelphia; J. W. Jenkins' Sons Music Co., Kansas City, Mo.; the Ray Co., New Orleans; W. J. Devall, Pittsfield, Mass.; R. S. Williams & Sons Co., Toronto, Canada; P. A. Powers, Buffalo, N. Y.; Graves & Co.'s Music Store, Portland, Oregon.

Specimens of advertising literature exploiting Edison goods have been received from McGreal Bros., Milwaukee, Wis.; Eastern Talking Machine Co., Boston; George E. Buss, New Philadelphia, Ohio; Newark Phonograph Co., Newark, N. J.; Prospect Phonograph Co., Cambridge, Mass.

### EDISON'S LATEST.

P Stands for Phonograph of Edison's make.  
 H Stands for Him who will no other take.  
 O Stands for Orders which exceed the supply.  
 N Stands for Natural Tone of Records you buy.  
 O Stands for Others of inferior kind.  
 G Stands for "Gem," not left behind.  
 R Stands for Records, the best in the land.  
 A Stands for Artists in Edison Band.  
 P Stands for People who own a Machine.  
 H Stands for Happiness there to be seen.

An advertisement used by the Phonograph Exchange, Albert Hall, Commercial Road, Portsmouth, England.

### THE PHONOGRAPH'S DESCRIPTION OF ITSELF.

I am the Phonograph, without teeth or tongue,  
 I am not very old nor yet very young,  
 Still I sing any song that ever was sung,  
 And I speak every language under the sun.

You may whistle or sing, you may wail or cry,  
 And you get it all back in my reply;  
 Whatever the message you give to me,  
 Returned again each word will be.

The rush of the river, the ocean's roar,  
 The surges thundering on the shore,  
 The cry of man, or beast, or bird,  
 Or any sound that ever was heard.

If given to me, I give again  
 In all their force distinct and plain;  
 And yet I am dead, devoid of breath,  
 And my silence is like the silence of death.

The land that with wires has girdled the earth  
 Is the glorious land that gave ME birth,  
 And I love to warble the musical bars  
 Of that grand old song of the "Stripes and Stars."

### AMONG THE JOBBERS.

The Waco Electric Supply Co., of Waco, Texas, has been succeeded by the Duncan-Hobson Electric Co., who have removed to 225 Elm street, Dallas, Texas, with a branch house at Houston.

The Vim Co., of Chicago, has opened a branch house at 704 West Walnut street, Des Moines, Iowa.

The Ray Co. branch at Atlanta, Ga., has removed to 72 Whitehall street.

### NEW STYLE HORN CRANE.

Victor H. Rapke, of 1661 Second avenue, New York, in another column, advertises a new style of clamp horn crane for use with horns as large as thirty-six inches and having 20½ inch bells. Up to the present time it has been necessary to have a stand for horns of this size. The cut in the advertisement shows just how the crane clamps to any talking machine except the smallest styles.

### WILL AID HIS OTHER LINES.

524 WEST BROADWAY, NEW YORK.

October 12, 1903.

Since I became a dealer in the goods of the National Phonograph Company about a month ago I have been quite successful in their sale. I see a good future for my other lines through the sale of these goods, for I expect to carry a good stock and to co-operate with you in every respect.

PAUL CAZENAVE.

**PERSONAL.**

We were very pleasantly surprised to receive a call from E. A. Osborne, senior member of the firm of Osborne & Jerdan, 393 George street, Sydney, New South Wales, Australia. Mr. Osborne expects to spend some time in this country, dividing his time between New York and Philadelphia in the interest of his firm. Osborne & Jerdan are very large dealers in Edison apparatus, and have a fine display of our goods at their store and ware-rooms. It is a source of great pleasure to meet our foreign friends from time to time, as we are enabled thereby to keep in close touch with them and their interests.

W. E. Gilmore, President of the National Phonograph Company, and Mrs. Gilmore returned on October 6 from a two months' trip to Europe. Mr. Gilmore went abroad to look over the foreign field and make arrangements for the extension of the business in Great Britain and Europe. He and Mrs. Gilmore then made a tour of the Continent. They went over on the *Teutonic* and returned on the *Deutschland*.

C. H. Wilson, Manager of Sales of this company, returned October 3 from an extended trip through the West. He visited Jobbers at Syracuse, Buffalo, Toronto, Detroit, Cleveland, Chicago, Minneapolis, St. Paul, Omaha, Lincoln, Denver, Kansas City, St. Louis, Indianapolis, Columbus, Canton, Allegheny and Pittsburg.

Visitors from a distance who called at the New York office during the past month were C. A. Ray, President of the Ray Co., of Louisville, Ky.; E. F. Taft, of the Eastern Talking Machine Co., Boston; J. H. Superior, of Montreal; Peter Bacigalupi, of San Francisco, Cal.

**PRINTED MATTER.**

All orders for Record Catalogues are now being filled from the new edition, Form 490. This Catalogue contains all Records listed to and including October. Jobbers who have already filed with us orders for large quantities of this catalogue are asked to be patient if they do not get the entire quantity at one time. We cannot obtain the entire edition from the printer at once, and shall therefore be compelled to make partial shipments until all Jobbers needing Catalogues have had a supply. The remainder of the orders will be filled as soon as possible thereafter.

Now that the December Advance List has been issued, we shall at once take up the matter of preparing copy for a new Numerical Catalogue to be issued about January 1. This is an official

will include all Records, both domestic and foreign, listed to and including December, 1903. It is our present intention to issue this catalogue twice a year hereafter, January 1 and July 1.

The new Machine Catalogue, Form 500, will be ready for the use of the trade early in November. This will be printed upon an entirely new line and will, we think, be one of the most attractive editions issued by this Company. It will be printed in two colors throughout, and besides its novel features, it will show the various types of the Phonograph in a neat attractive way. As soon as a supply is received from the printer, sample copies will be mailed to all Jobbers and Dealers. The principal object in issuing this catalogue in this form is to have a booklet that will be more useful for holiday purposes than an ordinary catalogue would be.

The little blue ticket, Form 351, now being sent out with all Records from our factory shows a transposition of the matter so as to bring the circle at the top of the ticket. This was done in response to a demand that the slip be so changed as to make it easier to cut it off and paste it on top of Record Boxes, and also to bring the title nearer the top of the slip, so that when the Record sets inside of the pegs in a Record Box the title will be more easily read. If the upper part of the ticket is now cut off on the cutting line, it will go on top of the single Record Boxes without any further cutting.

We have received from Fred G. Temme, a printer at Orange, a very attractive mailing card printed in colors after the style of souvenir cards now so popular at sea-side and mountain resorts. The card shows pictures of the Edison Laboratory; of "Glenmont," the home of Thomas A. Edison, and the entrance to Llewellyn Park, in which Mr. Edison's home is situated. If this card should interest any of our trade, Mr. Temme will doubtless be willing to furnish quotations upon it. His address is Orange, N. J.

**DIDN'T HAVE "FAMILY TROUBLES."**

Daniel R. Weed, Jr., of Matteawan, N. Y., sends the following:

A married lady called at my store a short time ago and asked for some Records. After hearing the ones she called for, she asked me if I wouldn't play some comic ones for her, so that she might get them if they suited. I played different ones for her, and while one of the Records was playing I said to her, "Have you got 'Family Troubles?'" She said, with a surprised look on her face, "No." She thought I was asking about her family affairs instead of the Record of that name.



**BUSINESS KEEPS COMING.**

"The Phonograph business is one of the best that I have ever had connection with," said an enthusiastic Jobber at our New York office a few weeks ago. "It is one of the few businesses in which the customer nearly always comes back. If I sell a man a piano, he may buy a little sheet music, and that is the end of it. It is also true of other musical instruments. But when I sell him a Phonograph, my business with him is practically only begun. He not only continues to buy Records from the catalogue, but he becomes a monthly customer when each new lot of Records appears. Then again, every machine and every lot of Records that is sold is an advertisement of the business, and is constantly bringing in new customers. In fact, it is a business that is constantly advertising itself."

This is practically the situation in connection with the sale of Phonographs and Records. It is worth while making an unusual effort to sell a few to get started. A start of this kind once made, the business practically grows without effort. A Dealer that has only one Phonograph and a few Records in his store has at his command a means of advertising, not only the Phonograph line but also his own business that cannot be had in any other line of goods.

**PHONOGRAPH MUSIC FOR A WEDDING.**

S. B. Davega, a Jobber at 32 East 14th street, New York, recently furnished Phonograph music for a wedding in 121st street. He sent a man with a machine and a specially selected lot of Records to the home of the bride. The guests were entertained before and after the ceremony with various selections and the Mendelssohn wedding march was played as the bridal party entered the parlor. This use of the Phonograph was sought by those in charge of the wedding in preference to an orchestra. Mr. Davega frequently supplies Phonograph music for social gatherings and entertainments, but this was his first experience in supplanting the orchestra or pianist at a wedding.

**SEEN RISE AND FALL OF MANY IMITATIONS.**

STOCKTON, CAL., October 15, 1903.

The Suspended List, October 1, 1903, and October EDISON PHONOGRAPH MONTHLY received this day. I am now entering the tenth year of handling Edison Phonographs and Records exclusively, and during that period I have seen the rise and fall of many imitations making a path for their superior—Edison Phonograph and Records. You may always depend on me for hearty co-operation.

H. W. Mosier

**COMMENTS ON DECEMBER RECORDS.**

The twenty-five new Edison Gold Moulded Records, which the National Phonograph Company has prepared as an offering for the holiday season, are beyond question the best lot of Records ever issued in one month for use on the Edison Phonograph. No similar list before issued represents so much expenditure of time and money as does that for December. The titles throughout are of the most popular character and most of them include new and novel features, besides being rendered in a manner which shows clearly the progress being made at the Edison Laboratory each month in making Records. Anyone hearing the entire list will realize that no expense is being spared to maintain the reputation of Edison Records as the best of their kind. Now that others have abandoned the competition with us, we purpose demonstrating more positively than ever that Edison Gold Moulded Records are in a class by themselves. This December list of new Records shows marked improvement over those of previous months and each succeeding month will be equally better. This list shows a greater number of singing Records than usual and will probably be more popular on that account, especially since the titles are for the most part songs that have been approved by the public throughout the country and have been made into Records in the most perfect manner. Owners of the Edison Phonograph make no mistake if they buy this entire list.

Perhaps the most notable of these new Records is No. 8556, "The Last Farewell." Unless all plans miscarry, this Record will be one of great popularity. In February last Robert Grau, Manager of Adelina Patti's farewell tour in this country, wrote to Charles K. Harris, the celebrated song writer, stating that it was his desire, and also of his associates, that in her farewell tour Madame Patti should sing a distinctively American ballad as an encore, the ballad being written by a representative composer of American music. Mr. Grau asked Mr. Harris to write such a song, stipulating that Mr. Harris should continue his efforts until he had written one that Madame Patti should approve. Mr. Harris wrote this selection, "The Last Farewell." It is a ballad of the "Home Sweet Home" order, and is one of Mr. Harris' best efforts. It was sent to Madame Patti and her acceptance was received by cablegram. She has agreed to sing it at her opening concert to be given in New York City on November 2d. Scarcely a doubt exists that she will do it. If she does, the popularity of the song is assured, and it will in a short time become one of the most talked of songs of the day. Even if it did not have such an introduction to the public ear as will be given it by Madame Patti, it would still become a song of wide fame because of its real merit. The Edison Record



made of the song is by Francklyn Wallace and he has sung it in the most careful manner, making a Record of recognized superiority. It will be strange indeed if the demand for it does not exceed that of any Edison Record yet made.

Another novelty is No. 8553, "I'm Going to Leave," a coon male duet by Collins and Harlan with banjo accompaniment by Vess L. Ossman. The latter is a star performer and to get him to play a banjo accompaniment of this character is something unusual in Record making. "I'm Going to Leave" was written by Walter Wilson, and it is a coon song of a most attractive character, the air being especially pleasing. Collins and Harlan have sung it in excellent style.

Another title which represents unusual difficulties in the way of Record making is No. 8571, "Keep on Shining Silv'ry Moon," which included a solo, a chorus by the Edison Quartette and an orchestra accompaniment. The words of this song are by Arthur J. Lamb and the music by Ben M. Jerome. The music is pretty and the Record throughout is played in a striking manner.

Two songs that are being sung by Lillian Russell in Weber and Fields' "Whoop-Dee-Doo" are given in No. 8551 and No. 8572. The first of these two is "The Flowers of Dixie Land." This is quite the hit of this musical comedy. It goes without saying that the air is a pleasing one, for Miss Russell will sing nothing else. It is sung for this Record by Francklyn Wallace, whose voice is especially well adapted for it. Miss Russell's other selection, No. 8572, "A Maid of Timbuctoo," is sung by Harry MacDonough. This song is quite unlike any song Miss Russell has sung for some time, and many persons will like the air quite as well as that of the other selection just named.

No. 8569 is another Record which requires unusual care and attention in the making of the Master. It is the "Two Comrades Polka," a cornet duet by John Hazel and Frank T. Seltzer, accompanied by the Edison Military Band. This composition is by J. S. Scott. It has a delightful air, is played in a masterful manner by Messrs. Hazel and Seltzer, and the band accompaniment is an attractive feature.

"The Miller's Daughter," which is the most popular song in the "Three Little Maids," and which was listed last month as an orchestra selection, is given in No. 8558 as a song by Harry MacDonough, with orchestra accompaniment. We can say nothing more in praise of this charming ballad than was said last month. Mr. MacDonough's fine voice and clear articulation makes of the song an unusually attractive Record. The orchestra accompaniment is also a pleasing feature. No. 8568, "The Girl You Love," is another song from "Three Little Maids." This is also sung by Mr. MacDonough, and it has an orchestra accompaniment. Paul A. Rubens wrote the words and music of both of these songs.

No. 8555, "Tell Me That Beautiful Story," a sentimental tenor and baritone duet by Andrew Schneider and Francklyn Wallace, introduces to the Edison clientele a new Record maker in Mr. Schneider. He has a cultivated baritone voice and is a prominent concert singer. The Record of this duet is very fine and can-

not fail to please. The words of the song were written by Arthur J. Lamb and the music is by Albert Von Tilzer.

The Edison Military Band has two selections in the December List, Nos. 8549 and 8573. The first is "Southern Smiles March," written by E. Harry Kelley, the composer of "Peaceful Henry." It is published by the J. W. Jenkins' Sons Music Company, of Kansas City, Mo., and has been cordially received wherever played. Many musical organizations of the country have made it part of their daily programmes. The Record by the Edison Military Band does the selection full justice. The other Record by the Edison Military Band, No. 8573, is "Any Rags Medley." It introduces that clever composition "Any Rags" and also "My Little Coney Isle," "Down on the Farm" and "Pretty Little Dinah Jones," the Record closing with the chorus of "Any Rags."

In No. 8550, "Bedelia," an Irish coon serenade, Billy Murray has broken away from the singing of coon songs in which he has found many admirers among the users of Edison Records. This song has made a big hit throughout the country. Mr. Murray's rendition of it is even better than his coon Records. The words and music of the song are by Jerome and Schwartz. Mr. Murray also has a coon song in No. 8564, "Up in the Coconut Tree." The words are by Edward Madden and the music by Theodore Morse. The song tells of the love of a chimpanzee, the king of the coconut tree. The piano accompaniment of this Record is quite a feature. This song is a big seller in the music stores, and we anticipate that Records will sell equally well.

"Trixie," the title of No. 8552, is another song that is having wide popularity throughout the country. It is a serio-comic song of a coon character and is sung effectively by Will F. Denny. Andrew D. Sterling composed the words of this song and Harry Von Tilzer the music.

No. 8554, "Soko," a Moorish march-intermezzo, by the Edison Symphony Orchestra, is an air that reminds one of "Anona." It is equally well rendered and extremely pleasing in every respect.

No. 8557, "Scene in a Country Blacksmith's Shop," is perhaps one of the best of the "Rube" singing and talking male duets yet made by Harlan and Stanley. The dialogue is especially clear, the humor excellent, violin music is introduced and the Record closes with the singing of "Nellie Blv." Those who have been pleased with these "Rube" Records of the past cannot fail to like this one.

Arthur Collins has so long been making Records of coon songs that it seems quite difficult to imagine him as making any other kind. Yet in No. 8558, "That's How I Love You, Mame," he has made a superior Record of this well known Bowery love song. The song tells of the Bowery tough's adoration of his "Mame," and Mr. Collins has only put enough of the dialect into it to carry out the idea of the composer. In spite of the title, the song is quite sentimental. It was written by Vincent Bryan and the music is by J. B. Mullen.

No. 8560, "North and South Medley," is another Record by the U. S. Marine Fife and



Drum Corps. It introduces "Marching Through Georgia," "Dixie," and the bugle work is excellent.

Harry Von Tilzer, the well known song writer, has been most successful in his adaptation of the names of old songs for new compositions. No. 8561, "Down Where the Swanee River Flows," is an especially good example of this success. It is a descriptive song and is rendered with orchestra accompaniment by Byron G. Harlan. This song has become very popular in the music stores. It has a very pleasing air and Mr. Harlan sings it in good style.

"Peaceful Henry," the title of No. 8562, is a characteristic march and two-step played by the Edison Concert Band. It was composed by E. Harry Kelly and has already achieved great musical success. It will certainly, however, have a vogue for a long time and be one of the airs always played for dance music,—one of those airs that dancers always ask for. The Record as made by the Edison Concert Band could hardly be better.

It is seldom that we are able to offer a better male duet than is given in No. 8563, "Won't You Write a Letter, Papa." It is sung by Harlan and Stanley and is very pleasing. The song tells of a child's request to her papa to write a letter to the angels asking them to send her mamma back to her. The music is quite in accord with the song and the Record is bound to sell. The words and music of it are by Thomas J. Hughes and Charles Miller.

In No. 8565 Harry MacDonough gives an excellent Record of "Sammy," the serio-comic song from the "Wizard of Oz." Mr. MacDonough's distinct articulation is especially good in songs of this character.

No. 8566, "Melody of Love," by the Edison Symphony Orchestra, is a Record that will especially appeal to those who are fond of fine musical compositions. It has a soft, pleasing melody. It introduces the singing of birds, good violin music and the playing of bells. It is altogether a delightful Record.

In No. 8567, Collins and Harlan present in "Moriarity" a comic Irish male duet. This tells in verse of the glorious things done by Moriarity and reminds one of the fame of Dooley. The air is good and the Record is made in the usual excellent style of these two artists. The words of the song are by Charles Hqrwitz and the music by Fred T. Bowers.

No. 8570, "I'm Longing for You, Sweetheart, Day by Day," is a sentimental song rendered by Francklyn Wallace. The success of this song in sheet music form cannot fail to make a demand for it in Edison Records, and those who buy it will not be disappointed in Mr. Wallace's rendition, of the air. The words of the song are by H. Wakefield Smith and the music by James W. Casey.

### SUPERFLUOUS.

Duffer—You ought to buy a talking machine. There's nothing like one to keep a fellow home nights.

Suffer—Buy one? I married one. That's what keeps me out.

### "A LITTLE TALK ABOUT A TALKING MACHINE."

It is seldom that Dealers get out more attractive advertising literature than the booklet sent us by the Bergen Empire Athletic Goods Co., of 5603 Third avenue, Brooklyn. It is a booklet of eight pages and cover, the whole of a size small enough to go in an ordinary business envelope. The cover is of gray paper, printed in red and white inks, and it overhangs the inside pages on three sides. The first page bears the above title. The inside pages are of antique paper and are attached to the cover with red silk cord. The argument on the merits of Edison Phonographs and Records is so good that we take pleasure in quoting part of it:

The Edison Phonograph of to-day is acknowledged on all sides to be the leading talking machine and this recognition is the result of pure merit.

In all the points that make for leadership in talking machines, such as ease in handling, simplicity, durability, style, or the ability to faithfully record and reproduce sounds, the Edison is far and away ahead of its rivals.

There is no other form of amusement for the home that is at once so satisfactory, so easily controlled or that offers such a vast range of subjects as does the Edison Phonograph.

It brings to you all that is best in music, both vocal and instrumental, rendered by leading artists of the day.

The musical selections run from the best productions of the leading old masters of music to the big hit of the current comic opera or the popular song of the day.

It is no exaggeration to say, that the rendition of these pieces is often far above the best efforts of some of our leading orchestras and bands.

The leading hits in the way of the latest popular songs are all listed in the Phonograph catalogue and there are also many of the good old favorites that never wear out. The vocalists who sing these songs for the Phonograph generally confine themselves to one sort of song, as for instance, comic, coon, sacred, or sentimental, and the result is the songs are sung in such a way as to bring out the best in the selection.

The talking Records are pretty hard to beat in the way of real humor and are often as funny as a whole farce.

Persons often desire to make a Record themselves. With the Edison Phonograph this is easily done—a simple change in the mechanism makes the machine ready for use.

Considered in the way of an investment, the Edison Phonograph is as good as a bank account. It is something that is always ready to amuse you and it cannot become tired. You will never grow weary of it on account of the always growing number and variety of Records. It will give unending instruction and amusement. It will brighten many a dull hour and make time pass more pleasantly.

Then follows a reference to the plan of the company in selling Phonographs on instal-

# A JOY AT HOME. The EDISON PHONOGRAPH

NONE GENUINE WITHOUT  
THIS

TRADE  
Thomas A Edison  
MARK



PHOTO. COPYRIGHT.

Of all devices for producing music in the home no one questions the infinite superiority of the Phonograph, who knows it as it is to-day; clear, sweet-toned and free from all mechanical noises.

It is not one instrument, but all instruments in solo or orchestra; with the perfect instrument, the human voice, included.

Many people are prejudiced by hearing imitation machines or obsolete styles, and do not realize that Mr. Edison's recent improvements have made the Phonograph delightful even to the most critical trained musician.

It is a musical educator and general entertainer in one.

*The nearest dealer will gladly let you hear the Phonograph in its perfection. Five thousand stores sell Phonographs. . . .*

**NATIONAL PHONOGRAPH CO.,  
Orange, N. J.**

NEW YORK                      CHICAGO                      SAN FRANCISCO  
83 Chambers St.              304 Wabash Ave.              933 Market St.  
EUROPE: ANTWERP, BELGIUM, 32 Rempart Saint Georges.

## "A JOY AT HOME."

The use of half page copy makes it possible to present a longer argument than usual in the November advertising of this Company. It also introduces a somewhat new style of illustration. So charming a child as here shown could not be otherwise than "A Joy at Home"; a phrase that applies equally well to the Phonograph. The mediums used in November were:

Argosy, Atlantic, Bookman, Colliers', Century, Craftsman, Current Literature, Everybody's, Four Track, Harper's Monthly, Independent, Life, Lippincott's, McClure's, Munsey's, Metropolitan, Musical Record & Review, National Magazine, Outdoor Life, Outlook, Pearson's, Review of Reviews, Saturday Evening Post, St. Nicholas, Strand, Success, Scribner's, Smart Set, Town Topics, World's Work.

Are you letting the people of your city or town know that you carry Edison Phonographs and Records?

## A DEALER'S COMPARISON OF TWO KINDS OF RECORDS.

A Kansas Dealer, whose name will be furnished to any Dealer upon request, sends the following under date of October 17:

Well, here I come again. I have had some experience in buying some of the latest new Moulded Records, Cut Price twenty-five cents each. These records were advertised equal to any other records made. Well, some of the owners of talking machines here wanted to try them. I sent an order for three dozen of the latest and marked my first and second choice. I got about five first choice, the balance second and a few others that were rather back numbers.

I was eager to see the new moulded extra loud records that could be sold for twenty-five cents each. Some of my customers wanted a fifty-cent record for twenty-five cents and did not care whether it was an Edison or some other make. I opened the box, examined each record, and, to tell the truth, I could not tell the difference between them and the late new Moulded Edison Records by *their looks*. Their *color* was *black like Edison Records*; the *impressions* were *deeply cut like Edison Records*, and they were as nice looking as the genuine Edison Records. But when the test came—what a difference between them and the latest Edison Records! They were loud enough, and that was all. They were run the same rate of speed as Edison Records, but the songs by *quartettes* and *minstrels* were so mingled up and run together that the words were not plainly understood. If the song was accompanied by orchestra the music drowned the words. And talk about orchestra and band: they simply are not in it with Edison Records. Put on a new Moulded Edison Record; start the Phonograph and it don't make any difference whether it is a *Band, Orchestra, Banjo,*



*Cornet*, or other musical instrument; it is reproduced with that *clear, sweet, natural musical* tone that is *free from blast* and that *noisy, scratching* sound so often found in the inferior class of records. Put on a song Record, and whether it be a *solo, duet* or *quartette*, and you will hear the song faithfully reproduced without that awful scratch to mar the beauty of sound. It is only when the song is finished that you realize the fact that you have only been listening to an Edison Record reproduced on an Edison Phonograph.

Well, to make a long story short, when my customers heard the new twenty-five cent records they said that they would rather pay fifty cents and get Records that everybody liked. They did not consider that there was any comparison. Edison Records were the only ones that gave satisfaction. I might have sold them twenty-five cent records if they had heard them *first*, but after hearing the new Edison Records, they concluded that they would pay the Edison price and get the best. I can conscientiously and knowingly say to all intending purchasers of Records that when you send an order for twenty-five cent records, *don't* expect to get a Record as good as the genuine fifty-cent Edison. If you do, you will certainly be disappointed.

### BEST SELLING RECORDS.

Of the twenty-five new Records listed for October, the ten most demanded by the public were the following:

- 8509 It Was the Dutch....Collins and Harlan
- 8511 Waiting for the Dinner Horn to Blow.....Harlan and Stanley
- 8501 Always in the Way.....Harlan
- 8504 The Laughing Medley.....  
.....Invincible Quartette
- 8519 The Crowd on McNally's Back Stoop  
.....Collins and Harlan
- 8522 My Cosey Corner Girl.....MacDonough
- 8500 American Standard March.....  
.....Edison Military Band
- 8517 Down on the Farm.....Wallace
- 8503 Praise Ye, from "Attila".....  
.....Metropolitan Trio
- 8515 Good Bye, Eliza Jane.....Collins

The twenty best selling Records for the month of September from the entire Catalogue, exclusive of October, were the following:

- 8347 Hiawatha..... Band
- 8473 Santiago Waltz (Xylophone)....Hopkins
- 8474 Anona..... Band
- 8425 Hiawatha..... MacDonough
- 8468 There's a Mother Always Waiting  
.....Harlan and Stanley
- 2018 Holy City.....MacDonough
- 19 Under the Double Eagle March....Band
- 8398 Blaze Away March.....Band
- 8409 In the Valley Where the Bluebirds  
Sing..... Harlan
- 8256 O That We Two Were Maying.....  
.....Morgan and Stanley
- 8295 Marriage Bells.....Rubsam
- 8422 Refuge....Mendelssohn Mixed Quartette
- 8475 Parody on Hiawatha..Collins and Harlan
- 8435 'Deed I Do.....Morgan and Stanley

- 8480 When We Were Boys.....  
.....Harlan and Stanley
- 4 American Republic March.....Band
- 8260 Tell Me Pretty Maiden..Edison Sextette
- 527 Echoes of the Forest.....Orchestra
- 621 Stars and Stripes Forever March...  
..... Orchestra

### LANGUAGE TEACHING BY PHONOGRAPH

The following letter explains itself:  
INTERNATIONAL CORRESPONDENCE SCHOOLS,  
Scranton, Pa.

GENTLEMEN—Your system of teaching languages is certainly all that could be desired by any one wishing a practical knowledge of a foreign language. I have nearly completed the French Course, and from the first the study has been a source of pleasure and recreation; results have been better than I expected. I have no difficulty whatever in making myself understood when speaking with French people, which makes me satisfied with the pronunciation and colloquial style acquired. The old joke about the unintelligible French spoken by an American will not apply to a student of your school who gives the course a careful study. Respectfully,

A. N. EAST.

September 6, 1903.

Mr. East is General Freight and Passenger Agent, Illinois Southern Railway Co. He is only one of many thousands who have easily learned French, German, or Spanish, at their homes, in perfect ease, by the I. C. S. Language System with the Edison Phonograph.

### TO DETERMINE A SPEED OF 160 REVOLUTIONS.

J. S. Hooven, of the Hooven Novelty Mfg. Co., Hazelton, Pa., sends the following:

"Here is something that may be of interest to the PHONOGRAPH MONTHLY. How do you determine that a Phonograph is running 160 revolutions per minute? We found that it was a difficult job to count each revolution at that speed but by running very slow we could count them, so we ran it 160 turns, then we measured the distance the arm had traveled and found it to be 1 39-64 inches.

"Now here is our rule. Cut a small strip of cardboard exactly 1 39-64 inches in length, start your Phonograph with the arm against the frame, let it run one minute and see if the cardboard gauge fits exactly between the space it traveled. It is then easy to determine whether it should be speeded faster or slower and with a few trials you can get it exact."

### MUCH PLEASSED WITH THE GOODS.

FLOWERVILLE, MICH., Oct. 5, 1903.

Your September list of Suspended Dealers at hand. I am glad to note you give Dealers a list of those who you do not want to get your goods, as they have gone against your orders. I am very much pleased with the goods I have received and shall do my part to help increase the sales of the same.

Hoping to be kept in touch with the Phonograph world, I am  
A. M. WIGTON.

**THAT 8-FOOT ADVERTISING HORN.**

The Utica Electric and Phonograph Supply House, Utica, N. Y., is meeting with much success in selling its eight-foot advertising horn. The following letter is one of those this company is constantly receiving concerning this horn:

WELLSBORO, PA., Oct. 5, 1903.

Utica Electric and Phonograph Supply House,  
12 Pearl St., Utica, N. Y.

GENTLEMEN:—I received the horn and attachments October 3. Have not had it put up outside yet, but have tried it inside of building and am well satisfied with the results. It is more natural than any horn I have ever tried, and I have used them all, both metal and fibre and all sizes.

J. H. SMITH.

**"COMMENTS" SELL RECORDS.**

RENOVO, PA., Oct. 13, 1903.

I have received from you postal referring to an inquiry for Phonograph and Supplies and have forwarded letter, etc. Permit me to extend my thanks for your treatment. I consider that the system you are pursuing towards the retailer is better than that we receive from

competing companies in the Talking Machine business. I have been the recipient of your various circulars, relating to price cutters.

I consider your MONTHLY superior to the PHONOGRAM which it succeeds. The department explanatory of new Records for current month is, to my mind, worth the price of the paper, and would suggest that if possible a circular be forwarded for distribution to customers. It would be good profitable advertising. My experience has been that upon showing the copy of the MONTHLY to my customers the explanation relating to new Records has been the means of selling Records and enabling a customer to make an intelligent selection.

W. M. EDMONDSON.

**AN ADVERTISING IDEA.**

LOWELL, Mass., October 9, 1903.

I beg to submit the following as an advertising idea:

BUY THE BEST,  
EDISON RECORDS  
HAVE STOOD THE TEST.

I have had a large sign made of the above. I think the jingle is catchy, and what is more it is the truth.

THOMAS WARDELL.

**SUSPENDED LIST, NOVEMBER 1, 1903.—SUPERSEDING ALL PREVIOUS LISTS.****KANSAS.**

LAWRENCE—BELL BROS.

**MASSACHUSETTS.**

LAWRENCE—LORD & CO., 314 Essex street.

\*E. O. MOSHER, 420 Essex street.

MALDEN—A. T. FULLER.

NEW BEDFORD—H. B. DEWOLFF.

**MICHIGAN.**

DETROIT—F. J. SCHWANKOVSKY.

SAGINAW—GEO. W. EMENDORFER.

**MISSOURI.**

KANSAS CITY—THE WITTMANN CO.

**NEBRASKA.**

LINCOLN—THE WITTMANN CO.

OMAHA—THE WITTMANN CO.

**NEW JERSEY.**

ATLANTIC CITY—SAMUEL D. WOLF, 32-34  
Arkansas avenue.

BAYONNE—I. WIGDOR, 450 Avenue D.

JERSEY CITY—W. L. HOFFMAN, 151 Mont-  
gomery street.

NEWARK—R. L. CORWIN.

PATERSON—CHAS. H. KELLY, 25 N. Main st.

WEST HOBOKEN—EMIL HOLLANDER, or  
THE WEST HOBOKEN BICYCLE &  
PHONOGRAPH CO., 619 Spring street.

**NEW YORK.**

BEDFORD PARK—GEO. H. TYRRELL.

HOBART—F. H. MARSHALL.

NEW YORK CITY—A. T. ARMSTRONG, or  
AMERICAN PHONOGRAPH CO., 106  
Wall street.

R. L. CORWIN, also Newark, N. J.

EAGLE PHONOGRAPH CO., or C.  
LOWENTHAL, 83 Nassau Street.

EMPIRE PHONOGRAPH CO., 2 West  
14th street.

HAWTHORNE & SHEBLE, 297 Broad-  
way, also Philadelphia, Pa.

R. H. INGERSOLL & BRO., 67 Cort-  
landt street.

W. L. ISAACS, 114 Fulton street.

S. LEMBURG & CO., 194 Broadway.

J. McELLYNNE, 202 Broadway.

RICHARD PEASE, 44 W. 132d st.

F. M. PRESCOTT, 44 Broad street.

SARATOGA—W. J. TOTTEN.

**OHIO.**

CINCINNATI—J. L. ANDEM.

SPRINGFIELD—D. & M. VANDERPOOL.

UHRICHSVILLE—F. A. MAZURIE.

**PENNSYLVANIA.**

PHILADELPHIA—A. R. CASSIDY, 2783 Em-  
erald street.

HAWTHORNE & SHEBLE, 604 Chest-  
nut street.

PITTSBURG—A. LIPPARD, 615 Wylie avenue.

**RHODE ISLAND.**

PROVIDENCE—F. P. MOORE.

\*Added since last Suspended List was issued October 1, 1903.

**Jobbers and Dealers are asked to co-operate with us, FOR OUR MUTUAL GOOD, by being careful that they do not supply any of the above named firms with our apparatus.**



DEAL DIRECT AND SAVE AGENT'S COMMISSION. WE HAVE NO AGENTS.

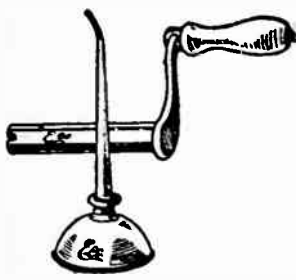

LARGEST AND MOST THOROUGHLY EQUIPPED HOUSE IN THIS COUNTRY,

DEALING EXCLUSIVELY IN

# Talking Machines and General Supplies.

All goods guaranteed to be as represented or money refunded.

## \$5.10 Worth Supplies for \$1.00

We will ship you **PREPAID** the following goods if you are a dealer in Talking Machines (one outfit only):

1 Hearing Tube, (unassembled,) 3 Cross Heads, 10 Gaskets, 3 Mica Discs, 3 New Shape Rubbers, 3 Oil Cans, 1 Needle Box, 10 Rubber Nails, 6 Belts, 3 Q Governor Springs. These are figured at list price.

If you do not care to accept the above offer, send us your address and we will mail you our new price list just out.

We wish to impress upon the trade that there is no Petit except A. O. Petit connected with this house and he does not travel.

**TERMS CASH WITH ORDER UNLESS REFERENCES GIVEN.**

### We Meet All Prices

Open Wednesday and Saturday Evenings.

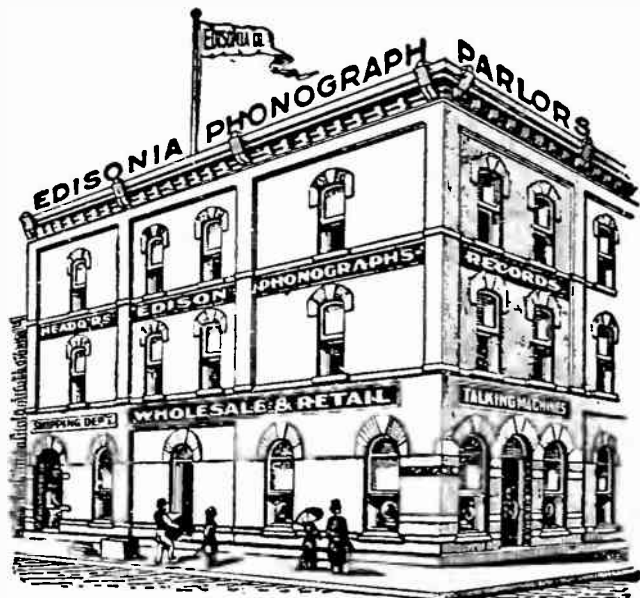

# THE EDISONIA CO.

CORNER NEW & HALSEY STS. BE SURE OF NAME

Newark, N. J., U. S. A.

A. O. PETIT, President and Treasurer

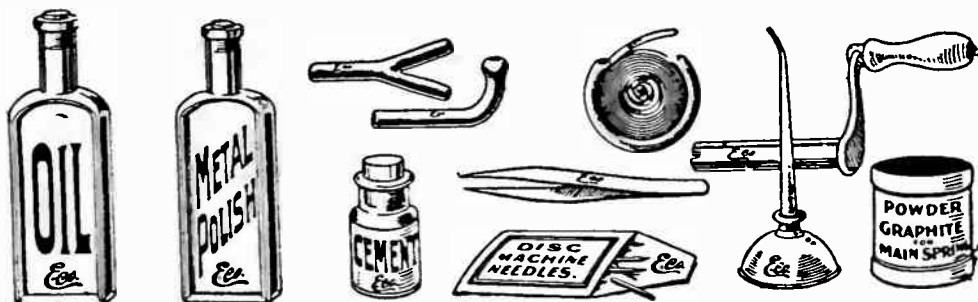

WE HAVE NO AGENTS. DEAL DIRECT AND SAVE AGENT'S COMMISSION.

# IF YOU ARE SURE



100 Peg Golden Oak Cabinet, \$7.75.  
100 Peg Figured Oak Cabinet, \$8.50.

of quick delivery of goods from your jobber you can greatly increase your business with less capital because you can turn your money quicker. A large and complete stock makes it possible for us to do this.

Let Us Demonstrate It to You.

## Supplies a Specialty

Write for special prices on Horns.

### 100 PEG RECORD CABINETS.

These can be supplied in Green to match Edison Machine Cabinets or in Brown.

Try Our Professional Recording and Reproducing Horns.

## BETTINI PHONOGRAPH CO.

80 CHAMBERS STREET,  
NEW YORK.

# The Newest and Best.



No. 18. New Clamp Horn Cranes (patent applied for) for Horns as large as 36 inches, with 20½-inch Bells.....Price, \$2.00

No. 18 New Clamp Horn Crane (patent applied for) can be used with Horns as large as 36 inches, with 20½ inch Bells, on all types of Talking Machines except the very small ones. It can be put on in a minute, and does not deface the cabinet in any way, as no screws are driven into the cabinet of the machine. Beautifully nickel plated and polished. Packed one in a box, with full directions. **Price, \$2.00.**

For Sale by VICTOR H. RAPKE, 1661 2d Ave., New York City.

Liberal Discounts to Jobbers and Dealers.





**A Full  
Edison Hand**

# Double Service

**FOR EVERY PHONOGRAPH**

**T**HOUSANDS of Phonographs are doing "double service" since the introduction of I. C. S. Language Outfits by the International Correspondence Schools, of Scranton, Pa. Mr. Dealer, are you familiar with these Language Outfits prepared and protected for the Edison trade? If not, you should send for sample records and full particulars to your jobber at once and be able to solicit for them.

## SAMPLE LANGUAGE LESSONS AT COST

Regular French, German, and Spanish Lessons are offered to the Trade as samples. They are put up in sets containing three (3) Molded Conversational Records and three (3) 40-page Textbooks, complete with full directions for demonstrating.

*The following Jobbers of I. C. S. Outfits will supply these sample sets at \$1.50 net, expressage prepaid to any part of the United States or Canada:*

PORTLAND, ME., W. H. Ross & Son.  
 LOWELL, MASS., Thomas Wardell.  
 BOSTON, MASS., J. C. Haynes & Co.  
 " " Boston Cycle & Sundry Co.  
 " " Eastern Talking Machine Co.  
 NEW HAVEN, CONN., Pardee-Ellenberger Co.  
 PROVIDENCE, R. I., Murray, Blanchard, Young  
 KINGSTON, N. Y., Forsyth & Davis. [ & Co.  
 SYRACUSE, N. Y., W. D. Andrews.  
 NEW YORK CITY, Blackman Talking Machine Co.  
 " " I. Davega, Jr.  
 " " Douglas & Co.  
 " " Jacot Music Box Co.  
 NEWARK, N. J., The Edisona Co.  
 PHILADELPHIA, PA., Wells Phonograph Co.

EASTON, PA., William Werner.  
 BUFFALO, N. Y., P. A. Powers.  
 ROCHESTER, N. Y., Talking Machine Co.  
 COLUMBUS, OHIO, Perry B. Whitsit Co.  
 DAYTON, OHIO, Niehaus & Dohse.  
 CHICAGO, ILL., O. J. Junge.  
 " " James I. Lyons.  
 MILWAUKEE, WIS., McGreal Bros.  
 MINNEAPOLIS, MINN., Thos. C. Hough.  
 OMAHA, NEB., Nebraska Cycle Co.  
 KANSAS CITY, MO., J. W. Jenkins' Sons Music  
 ST. LOUIS, MO., The Conroy Co. [Co.  
 TORONTO, CAN., R. S. Williams & Sons Co.  
 NINETEEN STORES, The Ray Co.

# SILK FINISH HORNS

They are as the name implies

**“FINE AS SILK.”**

**Bells of Brass. Bodies of Steel.**  
**Outside Covered with Black Silky Cloth.**  
**Inside Japanned.**  
**No Counter Vibration. No Rattle.**  
**All Absorbed by Cloth Covering.**

Don't be deceived, but get the best made.  
 Write for information and prices on the

## Most Popular Horn Produced

Dealers write for Discounts and Sample.  
 Direct all communications to Lafayette House.

Send to us also for the famous book,

**Uncle Josh Weathersby's Punkin Centre Stories,**

IN BOOK FORM, WRITTEN BY MR. CAL. STEWART.

**PRICE, \$1.00.**

**WAHL-GAASCH CO.,**  
 (INCORPORATED)

**Jobbers of Phonograph Supplies,**

**CINCINNATI,**  
 47 W. 5th Street.

**LAFAYETTE,**  
 304 Main Street.

**INDIANAPOLIS,**  
 199 S. Illinois Street,  
 (Grand Hotel Block)



# New England Dealers in Edison Goods

## CAN BUT APPRECIATE

That to have their orders filled promptly and fully is an advantage in almost any line of business, but in none more so than the Talking Machine business.

## COMPETITION IS KEEN,

and a customer kept waiting, is at best a dissatisfied one and often a customer lost.

## A PROGRESSIVE HOUSE

handling one line of goods exclusively can give better service in that line than a house that considers the line a side issue and gives it only a part of their time and attention.

## CONCENTRATION OF TIME

and thought and progressiveness brings success. Contact with success breeds success.

## THERE IS A MORAL TO IT ALL.

It's this. Send us your orders for

# Edison Phonographs, Records and Supplies,

and they will be filled promptly and fully the day we receive them, enabling you in turn to give your customers prompt and satisfactory service, which is the key to successful business building.

## We are exclusive New England Distributors

of several specialties for Talking Machines, about which we shall tell you in the December issue of the MONTHLY. **If you can't wait write us for particulars now.**

# THE EASTERN TALKING MACHINE CO.

**Distributors Exclusively of Everything for  
Talking Machines.**

**177 Tremont St.,**

**Boston, Mass.**

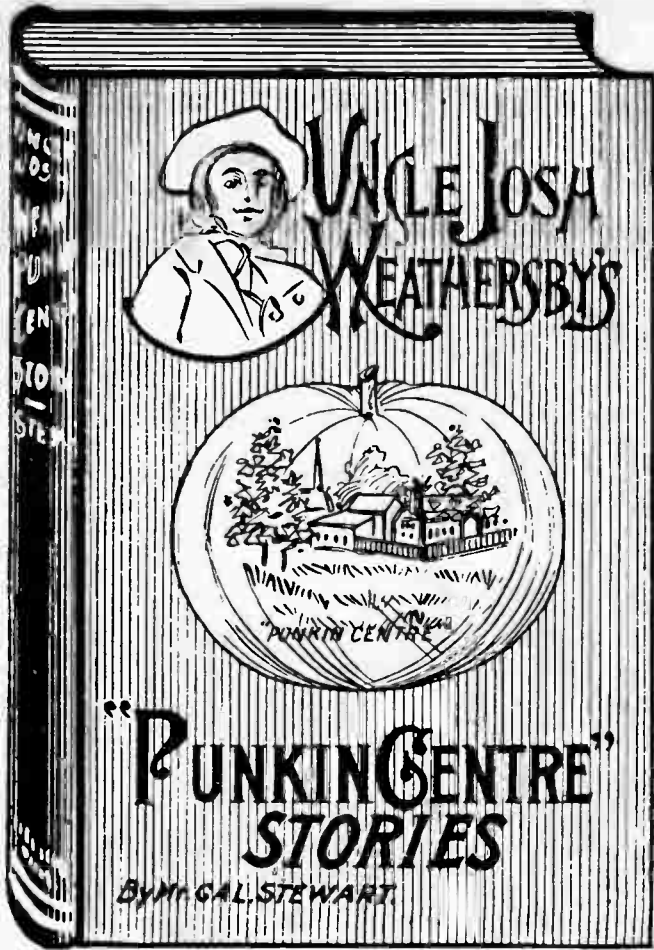

# Uncle Josh Weathersby's "Punkin Centre" Stories

IN BOOK FORM.

WRITTEN BY MR. CAL STEWART.

## 200 PAGES OF FUN AND LAUGHTER

Contains all his humorous sketches as told by him in the various makes of talking machine records, together with several new stories and poems. The book is handsomely bound with illuminated cover. EACH STORY IS ILLUSTRATED, depicting the most laughable incidents in the sketch.

**PRICE, \$1.00.**

Liberal Discounts to Jobbers and Dealers.  
Write for Quotations.

### **PENN PHONOGRAPH CO.**

*Distributors to the Talking Machine Trade*

**19 South Ninth Street, Philadelphia, Pa.**

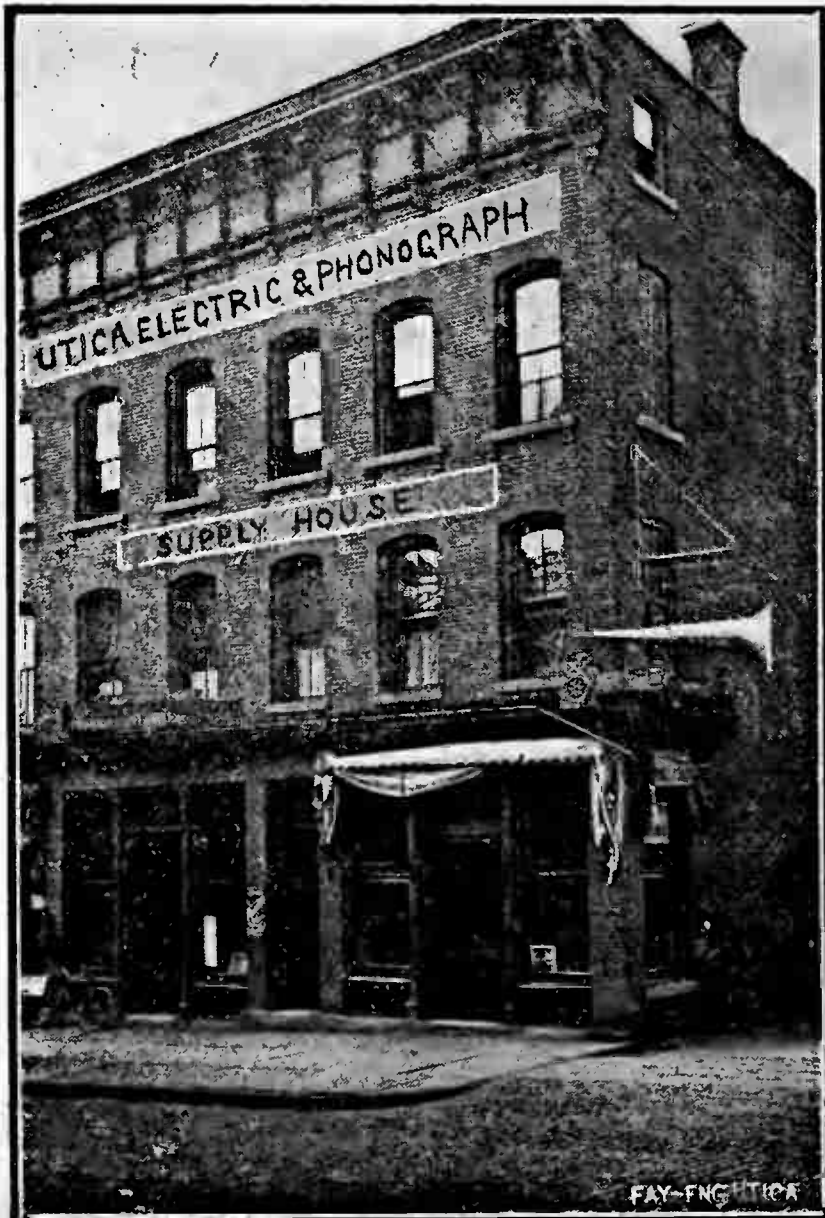

# THIS IS THE 8 FOOT HORN

LOOK FOR IT IN THE

**JULY ISSUE**

OF THE EDISON PHONOGRAPH MONTHLY

## THE BEST WAY TO ADVERTISE

WRITE FOR PRICES

**Utica Electric and  
Phonograph Supply House**

EDWIN A. BATCHELOR

**12 PEARL ST., UTICA, N. Y.**



# CYLINDER RECORD CABINETS

made with the practical knowledge of what a Cylinder Record Cabinet ought to be. We illustrate two popular leaders—and there are others.



No. 2.

**No. 2.** Height 37 inches, width 19 inches, depth 18½ inches; five drawers with stops, 180 pins, Mahogany veneered front and top, birch imitation sides, false back, piano finish..... **22.50**

**No. 3.** Height 37 inches, width 19 inches, depth 20 inches; five drawers with stops, 180 pins, quartered oak front, back, both sides and top, piano finish . . . **28.00**

Dealers will find it profitable to write for special discounts. These cabinets are made in the most reliable manner—in the best standard of furniture making.



No. 3.

**AMERICAN PHONOGRAPH COMPANY**

106 Woodward Ave., Detroit, Mich., U. S. A.

## ALLEN'S JAPANESE LACQUERED HORN

BLACK OUTSIDE

RED INSIDE

HIGHEST JAPANESE ART

IMPORTED

Weight 28 ozs.

30 inches long

15 inch Bell

PRICE - - TEN DOLLARS.

Peter Bacigalupi, Sole Agent U. S. A.

933 MARKET STREET,

SAN FRANCISCO.

THIS IS AN IDEAL HORN, MADE AFTER YEARS OF EXPERIMENTING BY A CONNOISSEUR. DOES AWAY WITH ALL THE METALLIC SOUNDS FOUND IN OTHER HORNS.

# The E. W. N. Handbook of the Phonograph

— AND —

## Instructions for Making Records.

BY C. W. NOYES.

### Every Owner

Of a talking machine should have a copy of this valuable book. It is replete with **Instructions for the Care and Use of the Phonograph**, and the chapters devoted to **RECORD**

**MAKING** are compiled from the author's many years of experience in some of the principal laboratories of this country.

Any one possessed of ordinary intelligence can make a perfect record if the directions are followed.

**Fully Illustrated—Handsomely Bound.**

**PAPER, 25 CENTS.**

**CLOTH, 50 CENTS.**

Mailed Postpaid on Receipt of Price.

For Sale by All Jobbers, or

**ILSEN & COMPANY, Cincinnati, Ohio.**

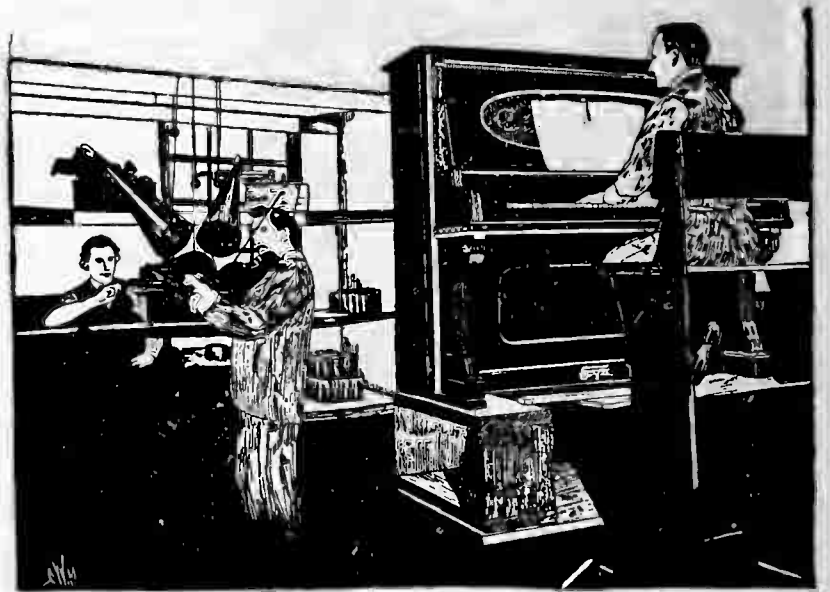

DEALERS WRITE FOR DISCOUNTS.

## A CARD TO THE TRADE JOBBER AND DEALERS

Interested in giving their customers best results are invited to write us for quotations on

### DOUGLAS

### *Mega (Paper) Horns and Record Cabinets*

The Horn that Made us Famous.

Superior to any metal horn made in purity, volume and absence of metallic tones.  
**GREAT AIDS TO THE SALE OF PHONOGRAPHS AND RECORDS.**

“MEGA” . . . . . List \$7.50  
Length 32 inches; Width 24 inches.  
“MEGA JR.” . . . . List \$2.25  
Length 22 inches; Width 13 inches.  
MEGA RECORDING HORN, List \$1.50  
Length 24 inches; Width 6¾ inches.

Look for the Trade Mark

“PHONO-MEGA.”

WRITE FOR SPECIAL LEAFLETS AND NET PRICES.

Attractive and Substantial.

Superior to any Line in the Market,  
**STRONGLY MADE.**

**BEAUTIFULLY FINISHED.**

100 Peg Polished Oak,	List \$12.00
125 “ “ “	“ 14.00
125 “ Quartered Oak,	“ 15.50
150 “ “ “	“ 18.00

**Prices Restricted.**

## DOUGLAS & CO.,

89 Chambers Street,

NEW YORK.

71 Reade Street,



# EDISON Phonograph Monthly

PUBLISHED FOR TRADE USE ONLY BY  
THE NATIONAL PHONOGRAPH CO.

VOL. 1.

NEW YORK, DECEMBER, 1903.

No. 10

*The National Phonograph Co.,*

ORANGE, N. J.

NEW YORK: 83 CHAMBERS STREET.

CHICAGO: 304 WABASH AVENUE.

SAN FRANCISCO: 933 MARKET STREET.

ANTWERP: 32 REMPART SAINT GEORGES.

## THE RECORD SITUATION.

Every day makes it clearer that there are now two classes of cylindrical records—the Edison Gold Moulded and the “steen cent” kind. We believe that there is a large market for both and that neither will interfere with the other. There are a large number of persons who will buy nothing unless it is cheap. Quality is of little consideration. So it will be with records for talking machines. As long as the record has on it the music they want it is all that is necessary.

On the other hand there is a larger number of lovers of music with discriminating powers who will buy nothing but the best to be had. To them quality comes first. If a record pleases them its price is not considered. A good record is a constant pleasure; a poor one, an abomination.

From the latter class the National Phonograph Co. is getting the largest business in its history—a business that now exceeds its factory capacity and that threatens to exceed even the extensive enlargements now under way and planned for the future.

Dollar watches are made in large numbers but their sale and use never affected the marketing of better goods. More high grade watches are sold to-day than at any time in the history of the world. Hundred dollar typewriters increase in number daily, and yet many cheaper machines are to be had.

So with the Edison Gold Moulded Record. Made by the best process ever invented for the purpose, a process used by no other manufacturer, and one that insures the best possible quality and most uniform results; made by the leading record making people of the world and under the direction of men who have devoted most of their lives to a study of the art; upheld in price by the fairest system of its kind ever devised in the business world, the Edison Gold Moulded Record will continue in its successful career, with the admiration of the buyer and the respect of the Dealer.

## EDISON PHONOGRAPHS AND RECORDS.

All communications to THE PHONOGRAPH MONTHLY should be addressed to the Advertising Department, 83 Chambers Street, New York.

C	O	N	T	E	N	T	S
The Record Situation.....							1
Advance List of Edison Gold Moulded Records for January.....							2
Always Protecting.....							3
A Story Without a Moral.....							3
No More Advertising in EDISON PHONO- GRAPH MONTHLY.....							4
Phonograph Holds the Secret of the Mojaves.....							4
The I. C. S. Language Courses.....							5
And Better Lists To Come.....							5
Printed Matter.....							6
Among Jobbers.....							6
Partial Shipments.....							6
Cheap Plan for Carrying a Stock of Records							7
Phonograph Art Calendar.....							7
Trade Advertisements and Novelties.....							8
Dealers' Comments in Brief.....							8
Made Here and Heard in Germany.....							9
Record Shipments.....							9
Personal.....							9
Dealers Suspended in November.....							9
Comments on January Records.....							10
I. C. S. Language Outfit Requires No Initial Quantity.....							11
December Advertising.....							12
Suspended List, December 1, 1903.....							13
Jobbers of Edison Phonographs and Records							16

THE ADVANCE LIST OF JANUARY RECORDS APPEARS ON PAGE 2. ORDER FROM IT. NO OTHER ADVANCE LIST WILL BE ISSUED.

# ADVANCE LIST OF NEW EDISON GOLD MOULDED RECORDS FOR JANUARY, 1904

RECORDS listed below will be ready for shipment as near January 1st, 1904, as possible, at which time Jobbers' stock orders, if placed prior to December 15th, will be shipped.

January Supplements will bear the date of January 1st, and will be forwarded to Jobbers with their stock order for Records.

Retail Dealers should place stock orders with their Jobbers at once, to insure prompt shipment as soon as Jobbers' stock is received.

- |       |  |   |
|-------|--|---|
| 8574  | Bedelia Medley   | Edison Military Band  |
|       | <i>Introducing "The Maid of Timbuctoo," "By the Sycamore Tree," and "Keep on A Shining Silv'ry Moon"</i> |   |
| 8575  | Under the Anheuser Bush  | Billy Murray  |
|       | <i>By the composer of "Down Where the Wurzburger Flows," waltz song with orchestra accompaniment</i>     |   |
| 8576  | Keep off the Grass   | Vess L. Ossman  |
|       | <i>Banjo with orchestra accompaniment</i>  |   |
| 8577  | Nobody's Looking but the Owl and the Moon  | Miss Morgan and Mr. Stanley                                       |
|       | <i>Contralto and basso duet</i>  |   |
| 8578  | The Rooster Dance  | Edison Symphony Orchestra   |
|       | <i>Characteristic selection from "The Runaways"</i>  |   |
| 8579  | Peggy Brady  | Harry MacDonough  |
|       | <i>Waltz song from "The Isle of Spice" with orchestra accompaniment</i>                                  |   |
| 8580  | Hickory Bill   | Talking and banjo Len Spencer and Parke Turner                    |
| 8581  | My Dixie Lou   | Arthur Collins  |
|       | <i>Coon love song with orchestra accompaniment</i>   |   |
| 8582  | The Last Rose of Summer  | Cornet Bohumir Kryl   |
| 8583  | Like a Star that Falls from Heaven   | Francklyn Wallace   |
|       | <i>Descriptive song</i>  |   |
| 8584  | Dixie Girl   | <i>Characteristic march and two-step</i> Edison Concert Band      |
| 8585  | An Evening Call in Jayville Center   | Harlan and Stanley  |
|       | <i>Comic Rube singing and talking male duet</i>  |   |
| 8586  | Uncle Sammy March  | J. Frank Hopkins  |
|       | <i>Xylophone with orchestra accompaniment</i>  |   |
| 8587  | The New Colonial March   | Edison Military Band  |
| 8588  | What Would the Neighbors Say   | <i>Comic male duet</i> Collins and Harlan                         |
| 8589  | Sukey Sue  | Harry MacDonough  |
|       | <i>Coon love song with orchestra accompaniment</i>   |   |
| 8590  | Little Dolly Driftwood   | Byron G. Harlan   |
|       | <i>Descriptive song by the composer of "Anona," with orchestra accompaniment</i>                         |   |
| 8591  | Come Ye Disconsolate   | <i>Organ effect, mandolin</i> Samuel Siegel                       |
| 8592  | Celia  | <i>Coon love song with orchestra accompaniment</i> Arthur Collins |
| 8593  | The Whistling Bowery Boy   | <i>Song with whistling</i> S. H. Dudley                           |
| 8594  | The Banjo Evangelist   | Len Spencer and Parke Hunter                                      |
|       | <i>Comic talking selection, introducing banjo</i>  |   |
| 8595  | Pretty as a Butterfly  | Albert Benzler  |
|       | <i>(Bobby Newcomb's song and dance) Bells with orchestra accompaniment</i>                               |   |
| 8596  | Felice   | <i>(Canzonetta)</i> Edison Symphony Orchestra                     |
| 8597  | Mary Ellen   | Billy Murray  |
|       | <i>Irish coon serenade with orchestra accompaniment</i>  |   |
| 8598  | Two of Us  | John Hazel and Frank S. Seltzer                                   |
|       | <i>Cornet duet accompanied by the Edison Military Band</i>   |   |
| 12913 | Malkes   | <i>Comic Hebrew song</i> Frank Seiden                             |
| 12914 | Dem Rebens chochmes  | <i>Comic Hebrew song</i> Frank Seiden                             |

Edison Gold Moulded Records are made only in Standard size. Both Standard and Concert Records may be ordered from this list. Order by Number, not title. If Concert Records are wanted, give the number and letter C.



**ALWAYS PROTECTING.**

An incident occurred in New York City on November 4th which furnished an excellent means of comparing the popularity of two companies manufacturing and selling cylindrical Records, one of which is the National Phonograph Company. A New York jobbing firm failed some time ago, and its stock of all kinds of talking machines and records was offered for sale on the date mentioned. In the stock was a large number of Edison Records. In order to make sure that these Records did not fall into the hands of unauthorized Dealers, C. H. Wilson, Manager of Sales of this company, was present. When our Records were offered, the highest bid was made by Mr. Wilson, and he took the entire lot. The sale was largely attended by authorized Edison Dealers and when Mr. Wilson stepped forward and his identity became known as the purchaser of the entire lot of Records, one impulsive Dealer shouted out "What is the matter with Edison? Three cheers for Edison!" Cheer after cheer followed and for several minutes it was impossible for the auctioneer to proceed with his business. It was the most remarkable expression of good feeling toward this company that we have heard of in some time. To have allowed these Records to be sold to an unauthorized Dealer and by him possibly disposed of at cut prices would have affected the business of practically every Dealer in and near New York City. To have the entire lot bought back by the company was gratifying to every Dealer who attended the auction, as well as to every one interested in the business.

**OPENED BY MEANS OF A FIRE.**

ROCHESTER, N. Y., Nov. 4, 1903.

A few evenings ago there was a fire in the tailor shop above our store and the firemen broke in our door believing the fire worse than it was, for the chemical put it out. After the excitement was over the officer in charge of the store sent me the following note which struck me as being about the funniest thing I have seen in some time and I thought it might strike the readers of the PHONOGRAPH MONTHLY as funny, also. I will not try to spell it the way he did.

Manager of the Talking Machine Co.,  
No. 43 Lawn Street.

SIR. The Talking Machine Co:—Your store has been opened *by means* of a fire upstairs. Please come and fix door or tell the boy where the manager lives.

Officer Pat Hennessey.

W. B. B. SMITH, Mgr.,  
The Talking Machine Co.,  
Rochester, N. Y.

**A STORY WITHOUT A MORAL.**

One of our Western Jobbers relates an incident that is amusing as showing the stature of some men. For the purpose of telling the story we will say that the Jobber's name is Mack. The list of our Jobbers will not show such a name, but real names are not necessary for the purpose. Mr. Mack was selling the "steen cent" records. One day his stenographer answered a telephone call and a male voice asked if Mr. Mack had any more of the "steen cent" records on hand. He had just bought some and found them so fine that he wanted more. He was told that there were still several hundred in stock. He gave a name and address and said that he would be right over to get a dozen or two. His name and address could not be found in the list of record buyers kept in the store.

The next day the young lady in the store had a similar telephone conversation and recognized the voice as that of the man who had called the day before. He praised the "steen cent" records as the best ever and would call that evening to get some. He gave another name and address. As none of the parties to whom Mr. Mack had sold "steen cent" records had paid them any compliments, but, on the contrary, had stated that they would have no more at any price, he began to suspect the sincerity of the telephoning individual, and directed his stenographer to call him to the 'phone if the man called up again.

The opportunity came a few days later. The telephone rang and upon answering it the young lady found the same voice asking questions. Mr. Mack was close at hand and at a sign from his stenographer took the receiver. A man's voice told him how he had bought some "steen cent" records and had found them superior to the Edison, etc., etc.

Mr. Mack recognized the voice as that of the manager of the branch house of the company manufacturing the "steen cent" record and called him by name, assuring him that so far he was the only one who had said anything good about the records in question. Mr. Manager denied his identity at first, giving a fictitious name and address, but after a little further pressure he admitted the fact. He asked Mr. Mack how he knew who called him up. Mr. Mack replied that as he was the only person who could speak well of the "steen cent" record he was satisfied that he knew where the messages came from.

The smallness of the incident does not permit the story to have a moral.

**NO MORE ADVERTISING IN E. P. M.**

The November issue of the PHONOGRAPH MONTHLY had scarcely been issued, containing the announcement to the effect that beginning with January the advertising rates in it would be increased to \$20 per page, before another decision was reached to cut out all advertising of every description except that of the International Correspondence Schools, advertising the Phonograph Language Course. It was found that Jobbers who were not availing themselves of the opportunity to advertise in its columns were dissatisfied because the advertisements of others were accepted. They claimed that the PHONOGRAPH MONTHLY was mailed to all signed Dealers, and it furnished one Jobber with a means of soliciting business from Dealers of another Jobber. Since we did not want anything to affect the cordial relations between all Jobbers and this company, it was decided to cut out all advertising with the exception above noted. To have continued the publication of advertisements would possibly have furnished some Jobbers with an excuse for withholding Agreements, which we are exceedingly anxious shall not be done. Then, too, there was in these advertisements an opportunity for friction, so that altogether it seemed wisest to cut out all the advertising at once. All enterprising Jobbers and Dealers had begun to realize that the PHONOGRAPH MONTHLY was an exceedingly good medium for their business, and had we continued accepting advertisements the publication would have been self supporting in another month. We feel that we can better afford to sacrifice whatever income may have been derived from this source, however, rather than do anything to affect our relations with the trade.

**ON MAKING RECORDS ABROAD.**

SYDNEY, Sept. 26, 1903.

By chance a copy of your valuable little journal, the PHONOGRAPH MONTHLY, has fallen into our hands. This little journal fills a long felt want to us people who are so far away from you. We read with pleasure one article in it, remaking Records abroad. We can assure you that this is something to look forward to, and when it comes about it will no doubt double the Australian trade with the National Phonograph Co. Our customers are always asking us for English songs, bands, comic songs, sung by well known English singers. A comic song Record sells five to one of any other Record, and vocal Records sell ten to one of bands and other musical instruments. The ideas one learns from this little journal is valuable to dealers in the talking machine line.

W. J. DEANE & SON.

**PHONOGRAPH HOLDS THE SECRET OF MOJAVES.**

For the past month the western building of the Affiliated Colleges of the University of California has been the scene of a unique bit of scientific research. Through the efforts of Dr. A. L. Kroeber, secretary of the department of anthropology, aided by Captain Joe Nelson and Captain Jack Jones, two Mojave Indians from the Needles, the Mojave customs, language, ceremonies, etc., are now on record in the form of over 100 Phonographic cylinders. The two Indians, who for nearly a month past have been talking and singing into the Phonograph for the benefit of science, left last night to rejoin their people at the Needles.

For some time the university, through its department of anthropology, has been engaged in an ethnological and archaeological survey of the State. With a view to the studying of the Mojave Indian, Captain Joe and Captain Jack were imported from their homes in the South. The Mojave language, although a very complete one, has no symbols by which the words can be recorded in writing; consequently the Phonograph was pressed into service to accomplish what the pen could not.

Captain Joe among his own people is a chief of high standing and comes rightly by the distinction of Captain, the title given by the Mexicans in early days to all bona fide Indian chiefs. As an evidence of his standing with the Federal authorities, Captain Joe carries a bundle of letters from various officials of the Interior and the Army.

Among the Phonographic Records, which are the result of the visit of these two Mojave chiefs, is a song rendered by Captain Joe which covers nearly sixty cylinders. It is a semi-religious ceremony and takes the entire night in its rendition. Beside the Phonographic cylinders, Dr. Kroeber has in his possession a large amount of data bearing upon the tribal history, customs and traditions of the Mojave Indians.—*San Francisco Examiner*, Nov. 12, 1903.

**A PUSHING DEALER.**

STOCKTON, CAL., Nov. 9, 1903.

The ever-welcomed EDISON PHONOGRAPH MONTHLY and Suspended List, under date of November, received to-day. I am letting the people of Sacramento and San Joaquin Valleys know that I carry Edison Phonographs and Records. Seven mediums are used, having a combined weekly circulation of 35,000 copies, besides advertising through the mails. Next week will see our advertisements doubled. Last year's experience has taught me to advertise more extensively this time of the year.

H. W. MOSIER.



**AND BETTER LISTS TO COME.**

A Philadelphia Jobber wrote: "If you keep on making Records as fine as October and November lists you will put the \_\_\_\_\_ record up Salt River." We have no desire to do such an unkind act, but have no hesitancy in saying that the December list is even better than the two months named, and that each month in the future will find a similar improvement. Every month will contain pleasing novelties, and the entire list will be so good that no one will err who places an order for the entire lot.

**THE I. C. S. LANGUAGE COURSES.**

UNIVERSITY OF WISCONSIN,  
MADISON, WIS., Oct. 30, 1903.

*International Correspondence Schools,  
French Department,  
Scranton, Pa.*

DEAR SIR:—It is a very great pleasure to me, I assure you, to add my name to the list of those, your students, who have found that the Phonograph Method does teach French. The conversation, grammar and composition courses have proved practical and interesting, also I must add, though the world has not been accustomed to expect anything interesting in the usual dry-as-dust grammar. That the said usually dry-as-dust grammatical matter has been so presented as to seem a necessary and not at all disagreeable comment on the lesson, the usual method being quite the reverse, reflects great credit on the I. C. S. system. As to the Phonograph Records: every person studying a foreign language with the intention of learning to speak it should have the help of these Records. For acquiring an accurate pronunciation the Phonograph offers one great advantage, an advantage that cannot be too strongly emphasized:—*tireless repetition* of a word or phrase, *endless repetition* if you please. Some persons with quick auditory perception may learn a new sound upon once hearing it, or upon hearing it a small number of times. The majority, however, are not so blessed. The new sound must be dinned into the ear before it is fixed. The Phonograph will do, here, what very few teachers attempt to do, or in fact can do.

As to the "kind of French" the machine speaks, several of my French-speaking friends who were at first a little inclined to scoff at the idea of "machine-made language," are quite ready to testify to the purity of the Parisian accent. The course as a whole offers a practical means for making rapid and thorough progress toward a very real and solid "speaking acquaintance" with the language. Perhaps I can offer no surer proof of my estimate than this: that I wish you to send me the Spanish Records and text-books.

If any other word from me can be of any use to you I will be glad to have you offer suggestions.

Yours very truly,  
R. B. MACNISH, Instructor.

**LETTERS SENT TO OLD DEALERS.**

When the new Agreement went into effect on September 1st, we took off from our mailing list the names of all Dealers who had not signed the new Agreement. We found that there were quite a large number of such names. Believing that it was not businesslike to drop them without some further attention, we sent out a letter to all such, asking why they had dropped the Phonograph business and had not signed our new Agreement. This letter fell into the hands of persons who had signed the new Agreement, but for one reason or another, the Agreement either had not been sent to us by their Jobber or we had failed to get their names on our mailing list. These are now being straightened out as quickly as possible, and we shall shortly have back on our mailing list all Dealers who are entitled to be there. We ask the indulgence, either for the Jobbers or ourselves, of those Dealers whose names have been dropped by us through no fault of their own. We would also ask all Dealers to keep us advised of any changes in their addresses and to write us if their printed matter is now coming to them with errors in the address.

**A CORRECTION.**

Through an error the paragraph in the November issue of the EDISON PHONOGRAPH MONTHLY, concerning the furnishing of Phonograph music at a New York City wedding, was credited to S. B. Davega, of East 14th street. As a matter of fact the music was furnished by I. Davega, Jr., of 802 Third avenue and 125 West 125th street, New York.

**AN EDISON RECORD PLAYED 3,000 TIMES.**

MEMPHIS, TENN., Oct. 28, 1903.

I noticed in your October number where one Edison Record was played 1,525 times. I can go you one better, as I have a customer here in Memphis who says he played one on a slot machine 3,000 times. How is that for the wear of Edison Records?

W. L. HUGHES,  
Manager for the Ray Co.,  
Memphis, Tenn.

**LIKES OUR PLAN OF ASSISTING DEALERS.**

TUPELO, Miss., Nov. 2, 1903.

I write to thank you for the names you sent me of parties who wrote you in regard to Edison Phonographs and Records. I wrote each and succeeded in selling Mr. \_\_\_\_\_, of Ripley. I like your plans of business, also the protection afforded by having each Dealer sign Agreement.

J. R. PHILIPS.

**PRINTED MATTER.**

Just as the new Record Catalogue, Form 490, was coming along from the printer in good shape, something fell on the locked up form and smashed a lot of the plates, causing a delay of about ten days before new plates could be made and the run begun over again. Consequently, shipments of catalogues have been delayed. They are now coming through nicely, and we hope to have no further trouble in supplying the needs of the trade.

The first copies of the new Machine Catalogue, Form 500, are only now being received, fully six weeks behind the most positive promises of the printer. We are now sending this catalogue out to Jobbers as fast as we receive it, and if the unexpected does not happen, we shall soon have part shipments in every one's hands. Those who are accustomed to having a large quantity of literature printed will probably appreciate some of the troubles we have had in the past six weeks in having printed work done, especially since all printers and lithographers are more than busy at this season of the year.

The reprint in sheet form of the Comments on new Records each month, which was done with the November Comments for the first time, proved much more popular than we had anticipated. A quantity was ordered by 33 different Jobbers who have renewed their orders for another month. As before explained, these sheets will be printed at their cost to us, viz: 20 cents per hundred if blank and 25 cents additional, with each order without regard to quantity, for such orders as may be imprinted with Jobbers' names and addresses. The sheet will be printed in different colors each month, that for November being white and that for December being yellow.

We have had printed a neat four page folder in red and dark green ink on a light green tinted paper for use in the holiday season. We have not had time to advise Jobbers with reference to it, but shall send out to each with December Records such quantity of these folders as we think can be used to advantage. The edition will be 250,000, and we shall send out almost the entire lot in this manner, reserving a smaller quantity for Dealers' orders or for such Jobbers as feel that they must have a few additional copies.

**AMONG JOBBERS.**

C. B. Scott, Jobber at Scranton, Pa., has been succeeded by Ackerman & Co. The latter are located in the Coal Exchange Building.

In the advertisement of the Wahl-Gaasch Co., of Lafayette and Indianapolis, Ind., and Cincinnati, in the November issue of the EDISON PHONOGRAPH MONTHLY, the address of the Indianapolis house was incorrectly given as No. 199 instead of 119 S. Illinois street.

The Wells Phonograph Co., of Philadelphia, who are among the most frequent and persistent advertisers of Edison goods, recently received a postal card from Mexico, written in Spanish, which upon being translated was found to be a request for Catalogues of Edison Phonographs and Records. They were puzzled to know how the inquirer could have obtained their name and address, but presumed that it was due to their newspaper advertising.

**PARTIAL SHIPMENTS.**

A New York City Jobber a few days ago said "Why don't you put a paragraph in the PHONOGRAPH MONTHLY telling Dealers that when they get short shipments on machines and Records it is not always the fault of their Jobber? As you know, we are not always able to get either machines, Records, Reproducers or supplies as fast as we want them or in such quantities as we order. You ought to make it clear that when the factory does not fill our orders in full, we, in turn, are compelled to make short shipments to our Dealers." We are compelled to admit the truth of this Jobber's statements. The demands for machines, Records and other goods are such as at times to make it impossible to fill all orders in full. We therefore are compelled to make part shipments in order that every Jobber may get his share of the goods being manufactured. We would ask the Dealers to be as patient in the matter as possible, relying upon our assurance that we are doing at all times all that we can to take care of the needs of the trade.

**WELL PAID FOR HIS COUNTY EXHIBIT.**

FAYETTE, ME., Oct. 20, 1903.

Acting on the suggestion given in the PHONOGRAPH MONTHLY I took three machines and an assortment of Records to the county fair where I showed up the machines and distributed advertising matter. I have been well paid for my trouble in direct results. Only just show the *Edison Machine* and let it be heard and it will sell itself.

A. A. CAMPBELL.



## CHEAP PLAN FOR CARRYING A STOCK OF RECORDS.

For the benefit of those Dealers who have not been able to find a satisfactory way of keeping a stock of Records, we would like to comment upon the plan adopted by Victor H. Rapke, of 1661 Second Avenue, New York, in taking care of his Retail stock. Mr. Rapke is also a Jobber. In order to have a way of carrying his retail stock so as to be readily accessible, and also enable him to carry all Records listed in the catalogues, he recently had made a lot of paper board boxes, each large enough to hold six small Record cartons lying on their sides, with their covers showing outward. Each box had compartments for six Records. The boxes are in size about  $2\frac{5}{8}$  inches high,  $4\frac{1}{2}$  inches deep and  $16\frac{3}{4}$  inches long. Each compartment is practically  $2\frac{5}{8} \times 2\frac{5}{8} \times 4\frac{1}{2}$  inches deep, just large enough to permit a Record carton to be slipped in and out easily. Then Mr. Rapke had made a series of good sized numbers and gave each carton a number corresponding to the numbers in the catalogue. The boxes are made small enough to permit of their being placed one upon the other without the use of shelving of any kind. A little thought will show the Dealer that this is a very inexpensive way of carrying his stock of Records. The boxes that Mr. Rapke had made cost him \$3.50 a hundred. An expenditure of \$14 gave sufficient boxes to carry every Record in our list. The box makers in any of the large cities should be able to make similar boxes at practically the same cost. Records arranged in a system like this are not only readily accessible to those in charge of the store, but the vacant compartments show at once what Records are needed to supply the stock. Doubtless, other Jobbers and Dealers throughout the trade have excellent methods of taking care of their stock of Records, and we shall be glad if some of them will send us a letter explaining how they do it. These suggestions cannot fail to be of interest to the entire trade.

## OUTDISTANCES ALL OTHERS.

ERIE, PA., Nov. 9, 1903.

Will co-operate with you in endeavoring to maintain your just requirements and commendable business methods. Price cutters are detestable creatures and should be sidetracked as speedily as possible. We are having a steady and increasing trade in Edison Phonographs. We handle other makes of talking machines, but consider the Phonograph the superior of them all. For perfect reproduction of very delicate sound waves the Phonograph has them all out-distanced.

G. W. COCHRAN COMPANY.

## PHONOGRAPH ART CALENDAR.

The Phonograph Art Calendar for 1904 is now ready. It was described in these columns last month, and is, we believe, quite as effective as any similar calendar yet issued. We think that it will be an excellent souvenir to be used as a holiday present by Jobbers and Dealers to their best patrons. It is something that cannot fail to be appreciated and to be kept throughout the year. Sample copies have been mailed to all Jobbers, and their orders when received will be filled and made ready for shipment with other goods. The price of the calendar will be its cost of production to us, viz: 15 cents each. Dealers who are interested in the subject are asked to send 15 cents in stamps for a sample copy. We do not feel that we can send copies to Dealers without making a charge for them.

## MOVED INTO LARGER QUARTERS.

The large increase in the talking machine business of the Boston Cycle and Sundry Co. has necessitated removal of this department into larger quarters. They have recently taken an entire floor in the large building at 48 Hanover street, and in the future all of the wholesale business will be done from this address rather than the previous address on Federal street. The new quarters are fitted up on a large scale in anticipation of a much larger business than ever before, having accommodations for over 60,000 Records. Some idea of the growth of this business may be obtained from the fact that two years ago this firm's standing order for new Records was for twenty-five of each, while now their orders run as high as 1,000 copies of a single selection.

Owing to the more central location and better facilities for handling the business there seems to be every prospect of a large increase of an already large talking machine business.

## NO TROUBLE TO CONVINCING HIS CUSTOMERS.

BONHAM, TEXAS, Oct. 21, 1903.

We received your advice as to the inquiry of — — — — —, of this place, and we have just filled his order for one dozen Records and this in face of the fact that the — — — — — records are handled here at \$3 per dozen. We had no trouble in convincing Mr. — — — — — that the Edison Records were far superior to any made and that they were well worth the price asked for them. Thanking you for your kindness in directing him to us and assuring you that we will at all times hold up the price and talk up Edison goods,

CHAS. DAVIS & Co.

## TRADE ADVERTISEMENTS AND NOVELTIES.

Among the interesting advertising literature received from the trade during the past month was a set of six of the Perry pictures from Emil Meinardus, of Chilton, Wis. The pictures bore on the back an excellent argument on the advantage of buying an Edison Phonograph. Part of the advertising was also printed in German.

L. R. Porter, a Dealer at Brockton, Mass., had a four-inch double-column advertisement in the papers of his city on November 10, largely devoted to calling attention to the Edison Record of "Any Rags," sung by Arthur Collins and listed in November.

Copies of newspaper advertisements, circulars or other advertising literature have been received from the Penn Phonograph Co., Philadelphia; Stratton's, Brownsville, Tenn.; C. Veeder, Rosendale, N. Y.; L. C. Hartzell, Holyoke, Mass.; Blackman Talking Machine Co., New York; Boston Cycle and Sundry Co., Boston; Eastern Talking Machine Co., Boston; George E. Buss, New Philadelphia, O.

Jobbers and Dealers are urged to send our Advertising Department copies of any advertising they may do or get out.

## DEALERS' COMMENTS IN BRIEF.

"Will co-operate with you, for I think your plan a benefit and a success."—*C. F. Littlepage, Anthony, Kas.*

"I will co-operate with pleasure and am highly pleased with your method of doing business."—*P. L. Gordon, Fairfield, Ia.*

"I am much pleased with Edison Phonographs and Records, and I will keep strictly to your conditions. They are the best on the market."—*E. S. Krauss, East Greenville, Pa.*

"Since I am a strong opposer to all price cutting, you can rely on my hearty support."—*A. F. Wohlenberg, Kooskia, Idaho.*

"You will have my co-operation to the best of my ability, for I have no use for price cutters."—*George W. Hinshaw, Carmel, Ind.*

"You need have no fear of my changing prices of Phonographs, Records or supplies manufactured by Edison."—*W. A. Waddams, Chico, Cal.*

"We would not care to handle Edison goods if regular prices could not be maintained."—*C. C. Thompson & Son, Baraboo, Wis.*

"We are doing all we can for Edison Phonographs, Records and supplies, knowing that they are the best."—*Prospect Phonograph Co., Cambridge, Mass.*

"Edison goods are good enough for me."—*J. W. Thrasher, Guinda, Cal.*

"We will uphold the Dealers' Agreement, as we know of no other company that helps and protects the Edison Phonograph Dealers,

as you do. We expect to do the largest 'Edison' business in the history of our five years in business."—*S. D. LaRoe & Son, Woonsocket, R. I.*

"Am acting in strict accordance with the agreements, 'giving the Edison Machine its dues as the best.' The knowledge that prices are uniform induced me to put my whole energy into selling them, and they take well in our part of the country. Last year I made an effort to sell the ——— and sold quite a few, but customers could send off and get disks as cheaply as I could and now, presto—the trade comes my way on Records."—*John P. Best, Hamilton, Ill.*

"Will file Suspended List for reference in order to co-operate with you in your efforts to maintain uniform prices over the United States."—*Cummings, Shepherd & Co., Fort Worth, Texas.*

"Your Suspended List of November received. You may rest assured we will never have our name on that List."—*J. B. Meiler & Sons, Dayton, O.*

"It is a pleasure to do business with a firm which makes it possible for retailers to get full prices."—*W. E. Hall, 2918 Third avenue, New York City.*

"Your latest List of Suspended Dealers received, and we assure you our hearty co-operation to prevent their obtaining machines or supplies. We also appreciate the MONTHLY."—*L. J. Schreiber, Plymouth, Mass.*

"Your November Suspended List at hand. Kindly acknowledge my approval of same. It is the only systematic way of protecting the trade and doing away with the price 'butcher.' I am handling your goods to good advantage and have compared them with other makes and am fully decided as to which is the inferior."—*Wm. F. Hunt, Wanatah, Ind.*

"We shall use our best endeavors to keep Edison's goods on top."—*W. C. Cutler, Baker City, Ore.*

"We gladly agree to co-operate with you, because from experience we know that there is none superior to that of Edison's. It is just what we have been looking for for a long time. Our motto is when we have a good thing, hold to it, and this is certainly it!"—*Srb Bros., Dodge, Neb.*

"You may count on me for one in supporting the text. I have a good trade, considering the territory, only small place of business, but the people do admire the Edison Phonograph."—*Peter Nordstrom, Jr., Walsburg, Kas.*

"Edison Phonographs and Records have taken the lead in my county, and will keep it as long as I am in the business here."—*Peter J. Duffy, Crescent City, Cal.*

A Connecticut Dealer, who handles all makes of talking machines, writes: "Have you heard 'Any Rags?' in the ——— [the bargain counter record]. *It is rotten.* I am not selling any ——— now. Only sold thirty last week."



**MADE HERE AND HEARD IN GERMANY.**

"I would like to tell you about a man from Germany, who came in our store a few days ago, and had us put a Record on the Home Phonograph for him," said A. R. Ingram, manager for the Ray Co., in Cleveland, O. "When the machine was started the reproduction was that of a dog barking and howling; the gentleman explained to us that it was a Record made by his dog in Germany—a dog in Germany, barking in the United States. This man purchased a Home Phonograph, one dozen blank Records, Recording Horn, thirty-six inch Amplifying Horn, just for the purpose of making Records. He has an Edison Phonograph at his home in Germany, and gave the one he purchased of us to his daughter here in this city. His wife's mother lives with the daughter, and this old lady makes Records here and sends them to her grandchildren in Germany, where they are reproduced on an Edison Phonograph, making the interesting combination of a grandmother in the United States talking to grandchildren in Germany."

**WANTS HIS RECORDS AT ONCE.**

A Dealer at Matteawan, N. Y., states that he has a customer who had a telephone put in his house in order that he may be at once informed when the new Edison Phonograph Records arrive each month. He is an enthusiast and wants his Records at the earliest moment possible.

**RECORD SHIPMENTS.**

After striving for a year to catch up, we were able to ship November Records close to the first of the month. It is expected that December Records will go out from the factory equally early and be in the hands of the trade in good season for the holiday trade.

**THEY GIVE THE BEST SATISFACTION.**

BETHEL, ME., Nov. 13, 1903.

I acknowledge receipt of Suspended List of November 1, also copy of EDISON PHONOGRAPH MONTHLY, for which accept thanks. I find that the Edison machines and Records are the best on the market and the only kind that people will buy here. They give the very best of satisfaction in every case. You may look for my hearty co-operation with you.

C. O. FOSTER.

**IT BACKS THE RETAILERS.**

BELMONT, N. H., Nov. 12, 1903.

We have just received your November 1st list of Suspended Dealers. It is a pleasure to do business with a firm that backs the retailers so they can get full prices for their machines.

F. C. HALL & Co.

**PERSONAL.**

The out-of-town Jobbers who called at our New York office during the past month were: G. L. Ackerman, of Ackerman & Co., Scranton, Pa.; N. D. Griffin, of the American Phonograph Co., Gloversville, N. Y.; William Werner, Easton, Pa.; W. O. Pardee, of Pardee-Ellenberger Co., New Haven, Conn.; Mr. Caulkins, of the Caulkins & Post Co., Middletown, Conn.; Mr. Williams, of the Western Electric Co., Philadelphia; Mr. Babson, of the Talking Machine Co., Chicago; James K. O'Dea, Paterson, N. J.

**DEALERS SUSPENDED IN NOVEMBER.**

The following Dealers have been placed upon our Suspended List during the past month, and the trade is warned against selling them Edison goods of any description:—

Hopkins-Sears Co., or Hopkins Bros. Company, Des Moines, Iowa.

E. M. Gowenlock, Clay Centre, Kansas.

Marvin A. Cote, Saratoga Springs, New York.

Bentley & Craig, Boulder, Colorado.

Osborn Gillette, or the Boston Jewelry Company, L. F. Maloney, Manager, Woburn, Mass.

Finch & Hahn, Schenectady and Albany, New York.

F. A. McMaster & Co., Nashua, N. H.

**UNIQUE WINDOW DISPLAY.**

A Trenton (N. J.) paper wrote as follows concerning a window display made by the Stoll Blank Book and Stationery Co. of that city:

Stoll's blank book and stationery store has an attractive window display of October Phonograph Records. The Records are enclosed in circular paste board boxes and arranged to represent a house. On either side of the door, right up close to the window, are two small Phonographs.

The house, which is two stories high, is only one of the many unique features which the firm has displayed in advertising the Phonograph.

**RATHER HAVE EDISON AT 50 Cents THAN ANY OTHER AT 10 Cents.**

CARMEL, IND., Nov. 6, 1903.

You can always depend on me to do my part in holding prices on Edison goods, for they are well worth the price. When the so-called Leader twenty-five-cent record came out I lost some trade, but when I got some of them that were also on the Edison List and by the same artists and then played both kinds to my customers, they all said they would rather have Edison Records at fifty cents than the others at ten cents, as they sounded just like disc records.

GEORGE W. HINSHAW.

### COMMENTS ON JANUARY RECORDS.

The list of Edison Gold Moulded Records issued for the opening month of the new year by the National Phonograph Company is fully up to the high standard set by the December list. It is another list full of popular airs, the newest music and attractive novelties. One of its features is the large number of Records made with orchestra and band accompaniment. The use of piano for accompanying songs has now become a thing of the past with the making of Edison Gold Moulded Records. Occasionally it may be found necessary on account of the peculiar composition of a song to have it sung with piano accompaniment, but such occasions will be rare. The use of an orchestra or band for accompaniments makes a Record of unusual richness and brilliancy, and adds greatly to its value. To have a full-sized orchestra or band play simply the accompaniment to a singer means much in the way of expense and trouble, but neither expense nor trouble will be allowed to stand in the way of more emphatically emphasizing the superiority of Edison Gold Moulded Records. The process by which they are made has always enabled the National Phonograph Company to make the most uniform, the most brilliant, the smoothest and the richest cylindrical Record on the market. Its reputation as the best will now be enhanced by the introduction of many novelties and new features. No reduction will be made in the price of these Records, but the utmost pains and care will be taken to make them more than ever worth their cost to the public. No product bearing the name of Edison is known as cheap goods, and the word cheap will never be used in connection with the Edison Gold Moulded Record, unless it be to say that it is cheap at the price asked for it. It will never be used as a record with which to advertise bargain sales and attract attention to goods of other make. The January list comprises twenty-five domestic and two foreign selections. Any Phonograph owner can buy the entire list without hearing them and not be disappointed in one.

The opening number on the list is No. 8574, "Bedelia Medley." In December was listed a medley of the popular song, "Any Rags," made by the Edison Military Band, and it was received with such favor that it was determined to make a similar medley in January of some other popular song. "Bedelia," which was one of the most popular songs on the December list, was chosen. The "Bedelia Medley" is also made by the Edison Military Band. It opens with the first verse of "Bedelia," followed by "The Maid of Timbuctoo," "By the Sycamore Tree," and "Keep On A-Shining, Silv'ry

Moon," and then closes with the chorus of "Bedelia." This combination of airs, coupled with the splendid work of the band, makes a great Record.

Harry Von Tilzer, who wrote "Down Where the Wurzbürger Flows," a song that achieved wide popularity, has just written another which he and his publishers believe will be equally popular. It is No. 8575, "Under the Anheuser Bush," and is not intended in any way to advertise wet goods. The National Phonograph Company secured by special permission the early use of the music of the song, and has made an excellent record of it. It has been sung by Billy Murray, with unusual care and with splendid enunciation. The song has a waltz air, and the singer is accompanied by the Edison Symphony Orchestra.

The banjo Record with orchestra accompaniment made by Vess L. Ossman in December was such a success that another has been made for January. It is No. 8576, "Keep Off the Grass," and it also is made by Mr. Ossman. It will be difficult for lovers of banjo music to determine which of the two Records is the most attractive. Most of them will decide the question by buying both Records. Those who do so will make no mistake.

The contralto and basso duets by Miss Morgan and Mr. Stanley are one of the features of each monthly list of new Records made at the Edison Laboratory, and that for January is fully as pleasing as any yet made by these artists. It is No. 8577, "Nobody's Looking but the Owl and the Moon." The pleasing air of the well known song is much enhanced by the charming blend of the singers' voices. The contralto voice is subdued and there are no blasts.

One of the hits in "The Runaways," which ran so long in New York, is a dance by a comedian made up as a huge rooster. No. 8578, "The Rooster Dance," is a Record made of the music to which the comedian dances. It is a very clever characteristic composition, the crowing of a rooster being given by first one and then another of the instruments in the orchestra, all blending well with the general work of the orchestra. The Record is made by the Edison Symphony Orchestra in faultless style.

No. 8579, "Peggy Brady," is a waltz song of the "Good Old Summer Time" style, still so very popular. It is now being sung in "The Isle of Spice," which is running in Chicago, and is drawing large crowds at every performance. "Peggy Brady" will eventually be as popular as "My Little Coney Isle" and other songs of the waltz order. The Record of the selection is made by Harry MacDonough, whose fine voice and clear articulation combine to make it most desirable.

In No. 8580, "Hickory Bill," Len Spencer and Parke Turner have made an interesting Record which tells by means of a dialogue and banjo music how "Hickory Bill's" brother found him after years of separation. No one could play the banjo like "Hickory Bill," and this led his brother to identify him. A Record out of the ordinary.

Arthur Collins, in No. 8581, "My Dixie Lou," has a Record that is quite up to his usual high standard of coon love songs. The song is by



Harry Von Tilzer and has a very pleasing air. Mr. Collins not only sings it nicely, but the song is accompanied by the orchestra, the two making a splendid selection.

Bohumir Kryl has made no better cornet Record at the Edison Laboratory than No. 8582, "The Last Rose of Summer." It is straight cornet playing without frills or fireworks and reminds one of the best days of the late Jules Levy.

Francklyn Wallace's solo Record for January is No. 8583, "Like a Star That Falls from Heaven," a descriptive song written by Arthur J. Lamb and set to music by Kerry Mills. Mr. Wallace sings it in a very satisfactory manner. It cannot fail to please those who admire this style of songs.

No. 8584, "Dixie Girl," is a characteristic march and two-step played by the Edison Concert Band. This composition is the work of J. Bodewalt Lampe, and it is published by the Whitney-Warner Co. It is well written and well played by the Edison Concert Band.

No. 8585, "An Evening Call in Jayville Center," is another of the very popular series of Rube talking and singing male duets by Harlan and Stanley. The comedy and singing are both good.

J. Frank Hopkins has in No. 8586, "Uncle Sammy March," a fine xylophone solo, accompanied by the orchestra. The latter makes an excellent background for Mr. Hopkins' clever playing. This is a good two-step. It was written by Abe Wolzman.

Perhaps the best instrumental Record of the month is No. 8587, "The New Colonial March," a new composition by R. B. Hall, and published by the John Church Company. The Record is made by the Edison Military Band. We believe that it will be as popular as the "American Standard March." It has a very pretty air and is played admirably.

Collins and Harlan's comic male duet for the month is No. 8588, "What Would the Neighbors Say?" Besides being a comic selection it has a decidedly pleasing tune and it is sung in the usual good style of these well-known Record duetists.

Harry MacDonough has a second solo Record in the list in No. 8589, "Sukey Sue," a coon love song with orchestra accompaniment. It has a pleasing air and is a well made Record.

In No. 8590 Byron G. Harlan sings "Little Dolly Driftwood," a descriptive song written by Vivian Grey (Miss Mabel McKinley, niece of the late President McKinley), the composer of "Anona." The tune is charming. Mr. Harlan sings it in good style, and the orchestra accompaniment gives the whole a fine setting.

No. 8591, "Come Ye Disconsolate," is a mandolin Record by Samuel Siegel. It is played with organ effect and will be especially attractive to mandolin players or those partial to the music of that instrument. Mr. Siegel's mandolin work is that of the real artist.

No. 8592, "Celia," is a coon love song with orchestra accompaniment. It is sung by Arthur Collins and bears all the evidences of the pains taken by Mr. Collins to make a good Record. The work of the flutes and clarinets is a pretty feature of the accompaniment. The words and music of this selection are by Smart and Willman.

It is some time since S. H. Dudley has made a whistling Record for the Edison Phonograph. No. 8593, "The Whistling Bowery Boy," shows that Mr. Dudley has lost none of his skill as a whistler of the first grade.

No. 8594 is another unique Record by Len Spencer and Parke Hunter. It is called "The Banjo Evangelist," and introduces a comic negro dialogue and banjo music.

Bobby Newcomb's well known song and dance, "Pretty as a Butterfly," has been made into a fine bells Record, with orchestra accompaniment, by Albert Benzler. It is No. 8595, and is one of the desirable numbers.

No. 8596, "Felice," is a canzonetta with a most charming and delicate air. It is played by the Edison Symphony Orchestra. This Record will be especially pleasing to lovers of music of a classical character.

In No. 8597 Billy Murray has another excellent solo Record. It is "Mary Ellen," an Irish serenade that reminds one of "Bedelia," with which song it is expected to divide honors. The music of "Mary Ellen" is by Tom Lemonier.

The cornet duet listed in December as played by John Hazel and Frank S. Selzer, has proved to be such a hit that another has been included in the January list. It is No. 8598, "Two of Us," and is in every respect as fine a Record as that given last month. The selection itself is just as pretty and the work of the cornets fully as artistic.

Nos. 12913 and 12914 are two comic selections in the Hebrew language by Frank Seiden.

### I. C. S. LANGUAGE OUTFITS REQUIRE NO INITIAL QUANTITY.

The International Correspondence Schools of Scranton, Pa., have made it extremely easy for Dealers to sell their language outfits with practically no expense or risk. As they are advertising on pages 14 and 15 of this issue, they will send to any Dealer, expressage prepaid, a sample outfit, including three Records and text books, for \$1.50. With this outfit the Dealer may explain the merits of the system and order only such goods as are required by his customers. The text books explain the system fully, the Records are made in foreign languages and the Dealer himself has the Phonograph. With these the Dealer has a language outfit that will make it easy for him to demonstrate to possible purchasers just what the International Correspondence Schools Language Courses consist of.

### A PACIFIC COAST CO-OPERATOR.

HEMET, CAL., Oct. 18, 1903.

I will state that I have received Suspended List. I will join you heartily in keeping up the reputation that the Edison goods have gained. I will also join in sustaining the present prices on said goods.

ALVA C. VAN WINKLE.



# BETTER THAN TOYS. The EDISON PHONOGRAPH

TRADE  
Thomas A Edison  
MARK



The PHONOGRAPH is the best present, because of its inexhaustible variety and its educational value. Thousands of selections are catalogued and at least 25 are added each month.

The wonderful superiority in musical performance and technical excellence of Edison Gold Moulded Records has forced other makers to officially admit that they cannot compete.

Go to the nearest dealer's and hear Mr. Edison's latest improvements.

DEALERS EVERYWHERE  
SELL PHONOGRAPHS

The Phonograph Art Calendar, 6 beautiful cards, lithographed in 12 colors, size 10½ by 14½ inches, no advertising in sight, sent on receipt of 25 cents at New York office

NATIONAL PHONOGRAPH CO.  
Orange, N. J.

NEW YORK 83 Chambers St.  
CHICAGO 304 Wabash Ave  
SAN FRANCISCO 933 Market St.  
EUROPE: ANTWERP, BELGIUM  
32 Rempart St. Georges.

## DECEMBER ADVERTISING.

The above Phonograph Advertisement appeared in full pages, half pages and quarter pages in the following December publications: Ainslee's, Argosy, Atlantic, Bookman, Brown Book, Century, Collier's, Country Life, Craftsman, Current Literature, Everybody's, Field and Stream, Four-Track News, Harper's Monthly, Independent, Leslie's Popular Monthly, Life, Lippincott's, Metropolitan, Munsey's, National Magazine, News Letter of San Francisco, Outing, Pearson's, Review of Reviews, Saturday Evening Post, Scribner's, Smart Set, Strand, Success, Sunset, Town Topics, World's Work.

This publicity should have been of much benefit to the trade.

## CHINESE RECORDS GIVE SATISFACTION

The following is an extract from a letter received from a Dealer in Rangoon, India, referring to our Chinese Records:

"I have great pleasure in advising you that the Phonographs and Chinese Records recently supplied have given great satisfaction, and were disposed of as fast as they came in. My Chinese customers (the purchasers) were delighted with them, and stated that the tunes were admirably clear and natural."

## DOING A RELIGIOUS WORK.

A Nebraska Dealer, who asks that his name and city be not published, sends the following incident:

Last winter I received an order for a Phonograph and one dozen Records from another county with the request that I include "one religious piece." I sent No. 1539, "Safe in the Arms of Jesus." About a month later the old gentleman's son-in-law was in the store and I asked him how the selection of Records sent had suited the folks. He said they were all right, and that "Father will sit and play 'Safe in the Arms of Jesus' over and over, and with the tears running down his cheeks he will say: 'I ain't there boys, I ain't there; I ought to be but I ain't.'" I thought at first of reporting the case to some neighboring minister, but on reflection concluded that they had had their chance and the Phonograph was doing the work better than they had done it, so I left it to this wonderfully versatile machine.

## NO WEAR ON EDISON REPRODUCERS.

FORT DODGE, Iowa, Oct. 10, 1903.

I notice a paragraph in the October PHONOGRAPH MONTHLY from Coatsville, Pa., where a Record ran 1525 times. I ran an Edison Reproducer at least 10,000 times and if there was any difference the last time was better than the first. Then I sold it to a gentleman who would not buy anything he did not know was all right.

S. W. COREY.



**SELLS ONLY EDISON RECORDS.**

RANDOLPH, VT., Nov. 13, 1903.

In talking about other records which are sold at twenty-five cents and sixteen cents and any old price they can get, will say in order to satisfy the curiosity of some of my customers I ordered a few of them. One customer had a dozen, others two and three each, but they all say they do not care for any more of them. They say that some are good and plain and lots of them are harsh. One customer asked me to exchange his for the Edison and was willing to pay me thirty cents difference and I told him I certainly could not exchange Records, and I certainly did not care to stock up with records that people would not buy. So he said he would keep the best of them and would shave down

the remainder. I am glad to say that I have not one Record in stock but the Edison. I sold \_\_\_\_\_ records long before I did Edison's, but have found out the difference and am satisfied with them, and so are my customers.

J. E. JERD.

**SOLD THREE PHONOGRAPHS IN ONE FAMILY.**

COLON, MICH., Nov. 16, 1903.

I have received November EDISON PHONOGRAPH MONTHLY with Suspended List. Am having a good trade in Edison Phonographs. Recently sold three in one family, as they are about the only kind of talking machine sold here. The three sold in one family were one Triumph and two Home Phonographs.

O. B. CULVER.

**SUSPENDED LIST, DECEMBER 1, 1903.—SUPERSEDING ALL PREVIOUS LISTS.****COLORADO.**

\*BOULDER—BENTLEY & CRAIG.

**IOWA.**

\*DES MOINES—HOPKINS-SEARS CO., or HOPKINS BROS. COMPANY.

**KANSAS.**

\*CLAY CENTRE—E. M. GOWENLOCK.  
LAWRENCE—BELL BROS.

**MASSACHUSETTS.**

LAWRENCE—LORD & CO., 314 Essex street.  
E. O. MOSHER, 420 Essex street.  
MALDEN—A. T. FULLER.  
NEW BEDFORD—H. B. DEWOLFF.  
\*WOBURN—OSBORN GILLETTE, or THE BOLTON JEWELRY COMPANY, L. F. MALONEY, Manager.

**MICHIGAN.**

DETROIT—F. J. SCHWANKOVSKY.  
SAGINAW—GEO. W. EMENDORFER.

**MISSOURI.**

KANSAS CITY—THE WITTMANN CO.

**NEBRASKA.**

LINCOLN—THE WITTMANN CO.  
OMAHA—THE WITTMANN CO.

**NEW HAMPSHIRE.**

\*NASHUA—F. A. McMASTER & CO.

**NEW JERSEY.**

ATLANTIC CITY—SAMUEL D. WOLF, 32-34 Arkansas avenue.  
BAYONNE—I. WIGDOR, 450 Avenue D.  
JERSEY CITY—W. L. HOFFMAN, 151 Montgomery street.  
NEWARK—R. L. CORWIN.  
PATERSON—CHAS. H. KELLY, 25 N. Main st.  
WEST HOBOKEN—EMIL HOLLANDER, or THE WEST HOBOKEN BICYCLE & PHONOGRAPH CO., 619 Spring street.

**NEW YORK.**

BEDFORD PARK—GEO. H. TYRRELL.  
HOBART—F. H. MARSHALL.  
NEW YORK CITY—A. T. ARMSTRONG, or AMERICAN PHONOGRAPH CO., 106 Wall street.  
R. L. CORWIN, also Newark, N. J.  
EAGLE PHONOGRAPH CO., or C. LOWENTHAL, 83 Nassau Street.  
EMPIRE PHONOGRAPH CO., 2 West 14th street.  
HAWTHORNE & SHEBLE, 297 Broadway, also Philadelphia, Pa.  
R. H. INGERSOLL & BRO., 67 Cortlandt street.  
W. L. ISAACS, 114 Fulton street.  
S. LEMBURG & CO., 194 Broadway.  
J. McELLYNNE, 202 Broadway.  
RICHARD PEASE, 44 W. 132d st.  
F. M. PRESCOTT, 44 Broad street.  
SARATOGA—W. J. TOTTEN.  
\*SARATOGA SPRINGS—MARVIN A. COTE.  
\*SCHNECTADY AND ALBANY—FINCH & HAHN.

**OHIO.**

CINCINNATI—J. L. ANDEM.  
SPRINGFIELD—D. & M. VANDERPOOL.  
UHRICHVILLE—F. A. MAZURIE.

**PENNSYLVANIA.**

PHILADELPHIA—A. R. CASSIDY, 2783 Emerald street.  
HAWTHORNE & SHEBLE, 604 Chestnut street, or Oxford street and Wascher street.  
PITTSBURG—A. LIPPARD, 615 Wylie avenue.

**RHODE ISLAND.**

PROVIDENCE—F. P. MOORE.

\*Added since last Suspended List was issued November 1, 1903.

Jobbers and Dealers are asked to co-operate with us, FOR OUR MUTUAL GOOD, by being careful that they do not supply any of the above named firms with our apparatus.

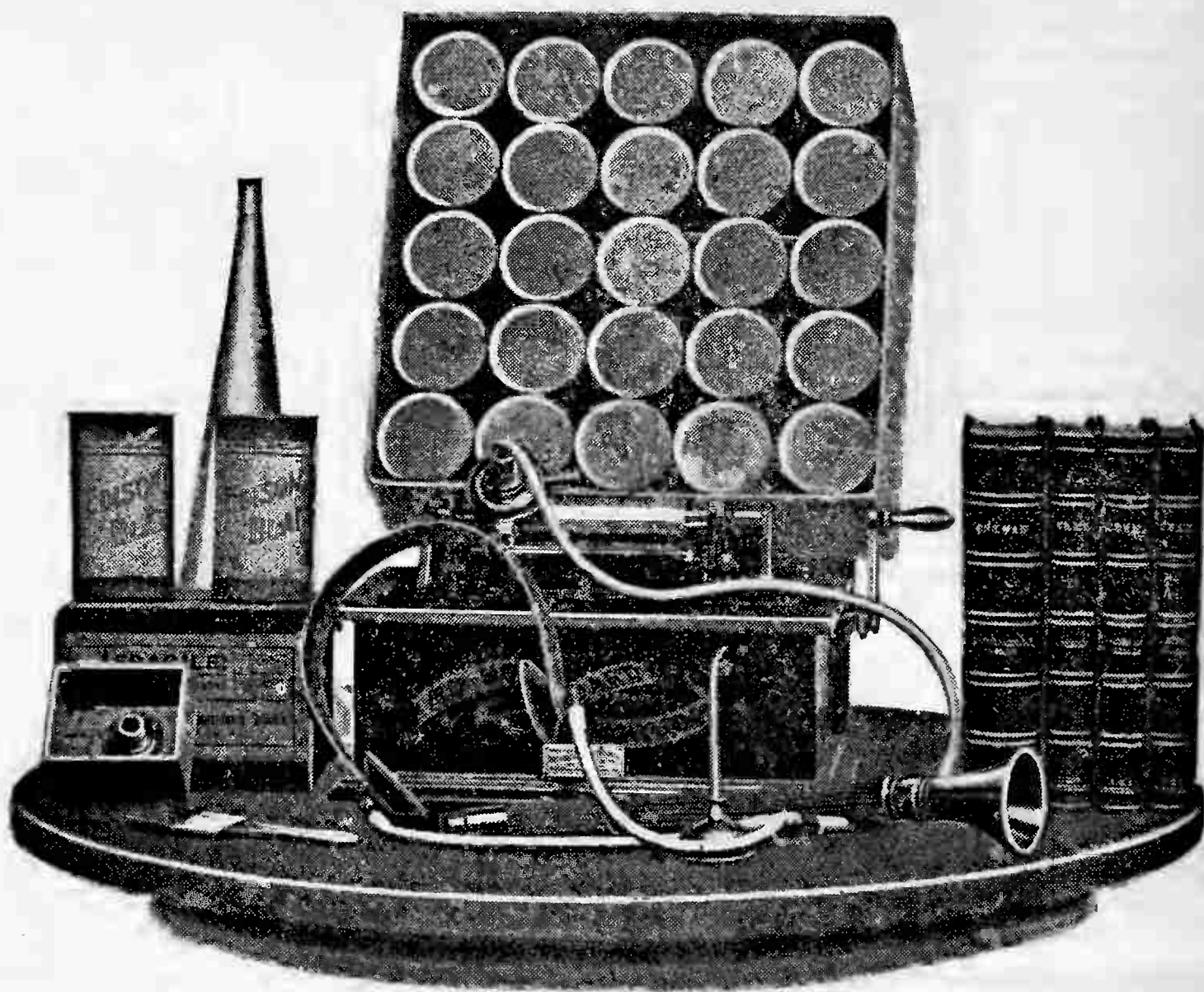

## **I. C. S. Phonograph Outfit, Records, and Textbooks**

*Prepared by the*

**International Correspondence Schools  
of Scranton, Pa.**

**and protected for the Trade by Edison Agreements**

---

If you are an Edison retail dealer, that is enough. You are elected to represent the I. C. S. Language Outfits with no risk and with sure profits.

There is no risk, because you *order what you want when you need it*. The Outfits are kept in stock by leading jobbers with no restriction on the quantity you are to order at any time.

True, you must demonstrate the language lessons in order to sell them, but all such work is effective, because you advertise your store and the general features of the phonograph in the most attractive manner.



The progressive Edison dealer is prepared to use arguments with his customers like these:



(1) *“Edison Phonographs are the only talking machines perfectly adapted for double service—amusement and language study. We want you to hear this I. C. S. Language Lesson, prepared specially for the Edison Phonograph, then you will understand why this machine offers the best investment.”*

(2) *“The proof of the perfection attained by the Edison Phonograph is listening to an I. C. S. Language Lesson. Use the hearing tubes and get close to the living voice of the professor. There is no scratching—only the marvelously natural conversation.”*

You could sell many I. C. S. Outfits if you had the lessons to demonstrate. Here is a sample-lesson offer made only to the Edison retail trade: *Three (3) regular I. C. S. Lessons (French, German, and Spanish), consisting of three (3) I. C. S. Molded Records and three (3) forty-page textbooks will be sent prepaid to any address in the United States or Canada, with full information for demonstrating. Price \$1.50 net.*

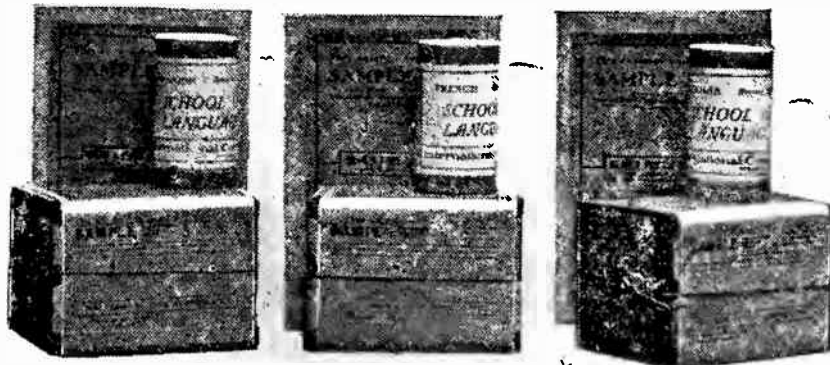

### Order Today From the Following Jobbers of I. C. S. Outfits:

PORTLAND, ME., W. H. Ross & Son  
 LOWELL, MASS., Thomas Wardell  
 BOSTON, MASS., Eastern Talking Machine Co.  
 BOSTON, MASS., J. C. Haynes & Co.  
 BOSTON, MASS., Boston Cycle & Sundry Co.  
 NEW HAVEN, CONN., Pardee-Ellenberger Co.  
 PROVIDENCE, R. I., Murray, Blanchard, Young & Co.  
 KINGSTON, N. Y., Forsyth & Davis  
 SYRACUSE, N. Y., W. D. Andrews  
 NEW YORK CITY, Blackman Talking Machine Co.  
 NEW YORK CITY, I. Davega, Jr.  
 NEW YORK CITY, Douglas & Co.  
 NEW YORK CITY, Jacot Music Box Co.  
 NEWARK, N. J., The Edsonia Co.  
 PHILADELPHIA, PA., Wells Phonograph Co.

EASTON, PA., William Werner  
 BUFFALO, N. Y., P. A. Powers  
 ROCHESTER, N. Y., Talking Machine Co.  
 COLUMBUS, OHIO, Perry B. Whitsit Co.  
 DAYTON, OHIO, Niehaus & Dohse  
 CHICAGO, ILL., O. J. Junge  
 CHICAGO, ILL., James I. Lyons  
 MILWAUKEE, WIS., McGreal Bros.  
 MINNEAPOLIS, MINN., Thos. C. Hough  
 OMAHA, NEB., Nebraska Cycle Co.  
 KANSAS CITY, MO., J. W. Jenkins' Sons Music Co.  
 ST. LOUIS, MO., The Conroy Co.  
 TORONTO, CAN., R. S. Williams & Sons Co.  
 SAN FRANCISCO, CAL., Peter Bacigalupi  
 NINETEEN STORES, The Ray Co.

## JOBBERs OF EDISON PHONOGRAPHS AND RECORDS.

### ALABAMA.

**Birmingham**—The Ray Co., 2025 Second avenue.  
**Mobile**—The Ray Co., 54 Dauphin street.

### CALIFORNIA.

**San Francisco**—Peter Bacigalupi, 933 Market street.

### COLORADO.

**Denver**—Denver Dry Goods Co., 619 16th street.

### CONNECTICUT.

**Middletown**—Caulkins & Post Co., 406-408 Main street.  
**New Haven**—Pardee-Ellenberger Co., 155 Orange st.

### GEORGIA.

**Atlanta**—The Ray Co., 72 Whitehall street.  
**Savannah**—The Ray Co., 116-118 Barnard street.

### ILLINOIS.

**Chicago**—Oscar J. Junge, 245 E. Chicago avenue.  
 Kelley Cigar Co., 80-82 Wabash avenue.  
 James I. Lyons, 73 Fifth avenue.  
 The Ray Co., 90 Washington street.  
 Siegel-Cooper Co., State and Congress sts.  
 Talking Machine Co., 107 Madison street.  
 The Vim Co., 68 E. Lake street.  
 Montgomery Ward & Co., 111 Michigan ave.  
**Peoria**—Peoria Phonograph Co., 314 S. Adams street.

### INDIANA.

**Indianapolis**—Kipp Bros. Co., 37 S. Meridian street.  
 The Ray Co., 234 Massachusetts avenue.  
 Wahl-Gaasch Co., 119 S. Illinois street.  
**Lafayette**—Wahl-Gaasch Co., 304 Main street.

### IOWA.

**Des Moines**—The Vim Co., 704 West Walnut street.

### KENTUCKY.

**Louisville**—The Ray Co., 640 Fourth avenue.

### LOUISIANA.

**New Orleans**—James I. Lyons, Theatre Arcade.  
 National Automatic Fire Alarm Co., 614 Gravier street.  
 The Ray Co., 111 Camp street.

### MAINE.

**Bangor**—S. L. Crosby Co., 186 Exchange street.  
**Portland**—W. H. Ross & Son, 207 Commercial street.

### MASSACHUSETTS.

**Boston**—Boston Cycle & Sundry Co., 48 Hanover street.  
 Eastern Talking Machine Co., 177 Tremont street.  
 J. C. Haynes & Co., 451 Washington street.  
 Iver Johnson Sporting Goods Co., 163 Washington street.  
 Read & Read, 558 Washington street.  
**Fitchburg**—Iver Johnson Sporting Goods Co., 247 Main street.  
**Lowell**—Ring Music Co., 112 Merrimac street.  
 Thomas Wardell, 111 Central street.  
**Worcester**—Iver Johnson Sporting Goods Co., 304 Main street.

### MICHIGAN.

**Detroit**—American Phonograph Co., 106 Woodward avenue.  
 Grinnell Bros. Music House, 219 Woodward avenue.  
 The Ray Co., 168 Griswold street.  
**Saginaw**—Morley Bros.

### MINNESOTA.

**Minneapolis**—Thomas C. Hough, 714 Hennepin ave.  
**St. Paul**—Minnesota Phonograph Co., 37 E. 7th street.

### MISSOURI.

**Kansas City**—J. W. Jenkins' Sons Music Co., 1013-1015 Walnut street.  
 The Ray Co., 1021 Grand avenue.  
**St. Louis**—Conroy Co., 1115 Olive street.  
 The Ray Co., 923 Olive street.

### NEBRASKA.

**Lincoln**—H. E. Sidles Cycle Co., 1317 O street.  
**Omaha**—H. E. Fredrickson, 1502-1510 Capitol avenue.  
 Nebraska Cycle Co., 15th and Harney streets.

### NEW JERSEY.

**Hoboken**—Eclipse Phonograph Co., 205 Washington street.  
**Newark**—H. J. Koehler Sporting Goods Co., 845 Broad street.  
 A. O. Petit, New and Halsey streets.  
**Paterson**—James K. O'Dea, 117 Ellison street.  
**Plainfield**—Frank L. C. Martin Auto. Co., 810 Park avenue.  
**Trenton**—Stoll Blank Book and Stationery Co., 30 E. State street.

### NEW YORK.

**Brooklyn**—Chapman & Co., Fulton and Duffield streets.  
 A. D. Matthews' Sons, 394 Fulton street.  
 Price Phonograph Co., 1258 Broadway.  
**Buffalo**—P. A. Powers, 643 Main street.  
**Elmira**—Elmira Arms Co., 117 Main street.  
**Gloversville**—American Phonograph Co., 99 W. Fulton street.  
**Kingston**—Forsyth & Davis, 307 Wall street.  
**New York City**—Bettini Phonograph Co., 80 Chambers street.  
 Blackman Talking Machine Co., 19 Beekman street.  
 J. F. Blackman & Son, 2654 3d avenue.  
 I. Davega, Jr., 802 Third avenue.  
 S. B. Davega, 32 E. 14th street.  
 Douglas & Co., 89 Chambers street.  
 H. S. Gordon, 139 Fifth avenue.  
 O. Hacker, 2 Murray street.  
 Harry Jackson, 219 Bowery.  
 Jacot Music Box Co., 39 Union Square.  
 Victor H. Rapke, 1661 Second avenue.  
 Rosenfield Mfg Co., 587 Hudson st.  
 Siegel-Cooper Co., Sixth avenue and 18th street.  
**Rochester**—A. J. Deninger, 347 North street.  
 Mackie Piano O. & M. Co., 100 State street.  
**Schenectady**—Jay A. Rickard & Co., 253 State street.  
**Syracuse**—W. D. Andrews, 216 E. Railroad street.  
**Troy**—James Lucey, 359-361 Fulton street.  
**Utica**—Clark, Horrocks & Co., 54 Genesee street.

### OHIO.

**Canton**—Klein & Heffelman Co., 216 N. Market street.  
**Cincinnati**—Ilsen & Co., 25 W. 6th street.  
 The Ray Co., 143 West 5th street.  
 Wahl-Gaasch Co., 47 W. 5th street.  
**Cleveland**—The Ray Co., 266 Erie street.  
 W. J. Roberts, Jr., 254-256 Arcade.  
**Columbus**—Perry B. Whitsit Co., 213 S. High street.  
**Dayton**—Niehaus & Doshe, 35 E. 5th street.  
**East Liverpool**—Smith & Phillips Music Co.  
**Toledo**—Hayes Music Co., 608 Cherry street.

### PENNSYLVANIA.

**Allegheny**—Henry Braun, 500 Federal street.  
**Allentown**—G. C. Aschbach, 539 Hamilton street.  
**Easton**—William Werner, 401 Northampton street.  
**Philadelphia**—C. J. Heppe & Son, 1117 Chestnut street.  
 Lit Bros., Market and 8th streets.  
 Penn Phonograph Co., 19 S. 9th street.  
 Wells Phonograph Co., 41 N. 9th street.  
 Western Electric Co., 931-933 Market street.  
 H. A. Weymann & Son, 923 Market street.  
**Pittsburg**—Theo. F. Bentel Co., Inc., 433 Wood street.  
 Kaufmann Bros., Fifth avenue and Smithfield street.  
 H. Kleber & Bro., 221 Fifth avenue.  
 C. C. Mellor Co., 319 Fifth avenue.  
 Pittsburg Phonograph Co., 937 Liberty avenue.  
**Reading**—Reading Phonograph Co., 757 Penn street.  
**Scranton**—Acker an & Co., Coal Exchange Building.  
 Technical Supply Co.

### RHODE ISLAND.

**Providence**—J. M. Dean Co., 785-795 Westminster street.  
 J. A. Foster Co., Weybosset and Dorrance streets.  
 Household Furniture Co., 231-237 Weybosset street.  
 Murray, Blanchard, Young & Co., 26-30 Pine street.

### TENNESSEE.

**Knoxville**—The Ray Co., 319 Clinch street.  
**Memphis**—The Ray Co., Lyceum Building, 2nd and Jefferson streets.  
**Nashville**—The Ray Co., 30 The Arcade.

### TEXAS.

**Dallas**—C. B. Harris, Agt., 347 Main street.  
 Duncan-Hobson Electric Co., 225 Elm street.  
**Houston**—Duncan-Hobson Electric Co.

### VIRGINIA.

**Richmond**—The Ray Co., 729 E. Main street.

### WISCONSIN.

**Milwaukee**—McGreal Bros., 173 3d street.

### CANADA.

**Toronto**—R. S. Williams & Sons Co., Ltd., 143 Yonge street.



# EDISON Phonograph Monthly

PUBLISHED FOR TRADE USE ONLY BY  
THE NATIONAL PHONOGRAPH CO.

VOL. 1.

NEW YORK, JANUARY, 1904.

No. 11

*The National Phonograph Co.,*

ORANGE, N. J.

NEW YORK: 83 CHAMBERS STREET.

CHICAGO: 304 WABASH AVENUE.

SAN FRANCISCO: 933 MARKET STREET.

ANTWERP: 32 REMPART SAINT GEORGES.

NATIONAL PHONOGRAPH CO., LTD., 25 CLERKENWELL  
ROAD, LONDON, ENG.

## EDISON PHONOGRAPHS AND RECORDS.

All communications to THE PHONOGRAPH MONTHLY should be addressed to the Advertising Department, 83 Chambers Street, New York.

C O N T E N T S

Still Crowded with Record Business.....	1
Advance List of Edison Gold Moulded Records for February.....	2
Death of Judge Hayes.....	3
New Headquarters of the National Phono- graph Co., Ltd., London, England.....	3
Frank P. Banta.....	4
Of General Interest.....	4
A Way To Learn a Popular Song.....	4
Child's Cries Sold a Phonograph.....	5
An Unusual Caller.....	5
Names of "Out of Business" Dealers Wanted.....	6
Printed Matter.....	6
Record Suggestions Gladly Received.....	6
A Tribute.....	6
Comments on February Records.....	7
Educators Approve Language Courses with Edison Phonographs.....	8
A Dealer To Be Proud of.....	9
Extracts from Trade Letters.....	9
Phonograph Sings and Talks the Parts....	11
Omitted British Selection.....	11
Trade Novelties.....	12
Neat Device for Use with Phonograph at Sea.....	12
Dealers' Advertising.....	13
January Advertising.....	13
Suspended List, January 1, 1904.....	14
Jobbers of Edison Phonographs and Records	15

## STILL CROWDED WITH RECORD BUSI- NESS.

Notwithstanding the reduction in price of another make of cylindrical record, which the trade might naturally expect would affect the sale of Edison Gold Moulded Records, the factory of the National Phonograph Company, at Orange, N. J., has never made so many Records as at the present time. Our Record plant is being run day and night, with two entirely different forces of hands, and in spite of the utmost efforts we are unable to turn out Records as fast as orders come in. We have but one plant in this country, and cannot get any more goods out of it no matter what the inducement might be. The demand for Edison goods is always greatest at this time of the year, but in no previous year has such a demand been made upon the factory. It is greater now because our manufacturing facilities are larger and we are as far behind with orders as in any other year. If the reduction in the price of records has had any effect upon the trade it has been to cause the public to buy just so many more than usual. It has proved our claim that a cheap record will not affect the sale of a better one; that there is room for two classes, just as there is room for good and cheap pianos; good typewriters and low-priced imitations. If the Edison Gold Moulded Record had not proved its superiority there would have been no reason for cutting the price of the competing record. No manufacturer doing a good business cuts the price of his goods in half; he would only do it under compulsion, and to hold business or get back a losing one. The reduction in price was an admission of Edison superiority. If the Edison Gold Moulded Record was then superior it is now much more so, for greater pains are being taken and no expense spared to improve the latter. No cylindrical Records

[Continued on page 3.]

THE ADVANCE LIST OF FEBRUARY RECORDS APPEARS ON PAGE 2. ORDER FROM IT. NO OTHER ADVANCE LIST WILL BE ISSUED.

# ADVANCE LIST OF NEW EDISON GOLD MOULDED RECORDS FOR FEBRUARY, 1904

RECORDS listed below will be ready for shipment as near Feb. 1st, 1904, as possible, at which time Jobbers' stock orders, if placed prior to Jan. 15th, will be shipped. January Supplements will be forwarded to Jobbers with their stock order for Records. Retail Dealers should place stock orders with their Jobbers at once, to insure prompt shipment as soon as Jobbers' stock is received.

- 8599 It Was the Dutch Medley Edison Military Band  
*Introducing "It Was the Dutch," "Under the Anheuser Bush," "Up in a Coconut Tree," "Always in the Way" and "Celia"*
- 8600 Your Mother Wants You Home, Boy Byron G. Harlan  
*(Paul Dresser's latest) Descriptive song with orchestra accompaniment*
- 8601 Far Away Soprano and tenor duet Miss Chappel and Mr. Stricklett
- 8602 Wouldn't It Make You Hungry Bob Roberts  
*Coon song with orchestra accompaniment*
- 8603 Lovey Mary (Characteristic dance) Edison Symphony Orchestra
- 8604 Clancy's Prize Waltz Contest Len Spencer  
*A Bowery dance hall scene, with various typical characters and orchestra*
- 8605 A Dream (Bartlett) George Seymour Lenox  
*Sentimental song with orchestra accompaniment*
- 8606 Marching 'Thro' Georgia Harlan and Stanley  
*Song and duet chorus with orchestra accompaniment and drum corps effect*
- 8607 At the Mountain Inn (Idyl) Violin and flute duet Jaudas and Atz
- 8608 Barney Irish male duet with orchestra accom. Collins and Harlan
- 8609 Cary Waltz Bohumir Kryl  
*Cornet solo with orchestra accompaniment, played by the composer*
- 8610 Coonville's Colored Band Arthur Collins  
*Descriptive coon march song with orchestra accompaniment*
- 8611 Your Dad Gave His Life for His Country Francklyn Wallace  
*Descriptive song with orchestra accompaniment*
- 8612 The American Flag March Whistling solo Joe Belmont
- 8613 Dear Old Girl Harry MacDonough  
*Sentimental song with orchestra accompaniment*
- 8614 The Cavalier March Edison Concert Band
- 8615 If You're Such a Great Star, Why Don't You Shine Arthur Collins  
*Coon song with orchestra accompaniment*
- 8616 Merry Birds Polka Frank S. Mazziotta  
*Piccolo solo with orchestra accompaniment*
- 8617 The Woodchuck Song Bob Roberts  
*With orchestra accom., as sung by Fay Templeton in "The Runaways"*
- 8618 Razzle Dazzle Vess L. Ossman  
*(Characteristic cake walk) Banjo solo with orchestra accompaniment*
- 8619 Reuben Haskins' Ride on a Cyclone Auto Len Spencer  
*A realistic comic descriptive talking selection*
- 8620 The Bridal Rose (Overture) Edison Symphony Orchestra
- 8621 I Ain't Got No Time Collins and Harlan  
*Comic coon male duet with orchestra accompaniment*
- 8622 Girlish Dreams Albert Benzler  
*(Gavotte) Bell solo with orchestra accompaniment*
- 8623 Daughter of Love Waltz Edison Military Band  
*(Recorded at slow tempo for dancing)*

Edison Gold Moulded Records are made only in Standard size. Both Standard and Concert Records may be ordered from this list. Order by Number, not title. If Concert Records are wanted, give the number and letter C.



ever made by this or any other company equal those now being made at the Edison Laboratory. Nor are we satisfied with this. Nothing is being left undone to make each month's output better than the month before. Dealers and owners of Edison Phonographs may depend upon it that Edison Gold Moulded Records will always be the highest type on the market.

We have received hundreds of letters from Jobbers and Dealers in all parts of the country commending our decision to make no reduction in the price of our Records, and asserting their ability to get fifty cents each for them as easily as they can get a less price for other kinds. That this is so is shown by the lack of price-cutting on our goods; the necessity for it does not exist.

#### DEATH OF JUDGE HAYES.

It is with deep regret that we announce the death, at Newark, N. J., on November 26th, of Howard W. Hayes, general counsel for the National Phonograph Company. Mr. Hayes had been the legal adviser of this company for several years and in such capacity had rendered almost invaluable services. During that time he conducted every important suit brought to maintain our rights in the courts and few there were in which he did not obtain a favorable decision. Besides possessing unusual legal ability, he was a man of resources, and he had a faculty of successfully applying his legal knowledge to commercial affairs. Only those who relied upon his advice and acted upon his suggestions can know how keenly his death was felt by Mr. Edison and the officials of this company.

Mr. Hayes was born in Newark, N. J., May 9, 1858. He prepared for college at the Newark Academy and the Phillips Academy, at Andover, Mass., and graduated from Yale in the class of '79. In 1881 he graduated from the Columbia Law School and soon afterward became a counsellor in New York and New Jersey. Mr. Hayes was successful in his legal practice. In the controversy over the boundary between Delaware and this State he was associated with the Attorney General of New Jersey. In 1888 Mr. Hayes was appointed assistant United States Attorney, and later he served as a police justice in Newark. He was a director in the Howard Savings Bank, the National Newark Banking Company, a member of the Essex County Park Commission, a member of the Essex Club, the Essex County Country Club, and belonged to the collegiate Zeta Psi Fraternity. In politics he was a Democrat. He is survived by a widow.



#### NEW HEADQUARTERS OF THE NATIONAL PHONOGRAPH CO., LTD., LONDON, ENGLAND.

By the time this issue of the EDISON PHONOGRAPH MONTHLY reaches England the European headquarters of the National Phonograph Co., Ltd., will be located at 25 Clerkenwell road, London, E. C. All the continental offices of the company will be operated from and controlled by the London office. The National Phonograph Co., Limited, will carry a stock of at least one million Records at the Clerkenwell road premises; will equip and operate a complete repair department for Edison Phonographs, and for Edison laboratory products. The building will be equipped for carrying the most complete stock of Phonographs and Records, sufficient to supply all the British Isles. The complete office staff of the company will also be quartered in the same building, occupying the entire ground floor. The Shipping Department will be maintained on the St. John street side of the building, where all goods will be received and shipped. The National Phonograph Co., Limited, hope hereafter to make all deliveries of goods in British territory from Clerkenwell road premises.

Alfred K. Hobbs, a Dealer at Manchester, N. H., sends a photograph of a Phonograph window display recently made by him. Nothing but Edison goods and Edison posters and cards are shown. Few Dealers in any of the large cities make a better display than is shown in this photograph.



**FRANK P. BANTA.**

Frank P. Banta died at his home in New York City on November 30. The average Dealer in Edison Phonographs and Records will recall the fact that the list of Edison Records includes a piano selection—the only one in the catalogue—No. 8394, "Violets," made by Mr. Banta, but beyond this the death of Mr. Banta will at first awaken little interest. Mr. Banta was, however, better known in the Phonograph world for his work than for his personal identity. His were the hands that played the piano accompaniments to more than half of the Records in the Edison catalogue and his was the musical ability that re-arranged or re-wrote the music which has made the piano accompaniments to Edison Records so attractive. Accompaniments as ordinarily written cannot be used in Record making. Each selection requires a practically new arrangement of the music. In this Mr. Banta was remarkably successful. He was one of the first pianists to play for the Phonograph. He began when quite young and was constantly identified with Record making at the Edison Laboratory to the day of his death. He was also a composer of numerous musical successes. His "Halimar," oriental rondo, our Record No. 8051, was played by all the famous musical organizations in the country. His piano solo, transcription of the song "Violets" which he composed has been much admired. His versatile talents made him one of the most valuable men in the Edison organization and his place will not soon be filled by any one man.

At his death Mr. Banta was but thirty-three years old. He had been in poor health for some time, but his death was wholly unlooked for by his family and friends. His death was doubtless hastened by overwork, for he was ambitious and a hard worker. He was unusually popular among his musical associates and with those for whom he worked. His death was deeply regretted. Men like Frank P. Banta are few and can ill be spared.

The list of Jobbers and Dealers who have advertised Edison Phonographs and Records extensively during the past month or more includes practically every name on our mailing list. To enumerate them would be impracticable in the limited space at our command. Even those who have sent in copies of their advertisements would make a list of unusual length.

**The Edison Gold Moulded Records—never found on bargain counters.**

**OF GENERAL INTEREST.**

The latest thing in talking machine enterprise is a catalogue of all records made by the various companies manufacturing cylindrical and disk records, the first number of which has just appeared and includes all records listed to and including December, 1903. This is being published by L. S. Gardner, Theatre Arcade, New Orleans, La. It gives in comprehensive form the number and title of every record gotten out by the various companies and is a publication that should be of much value to the talking machine trade, to which it is sold on a subscription basis.

We have received several complaints from Dealers that we had omitted from the December issue of the PHONOGRAPH MONTHLY the list of best selling Records. This omission was intentional, it having been deemed inadvisable to continue its publication.

W. L. Brousart, an owner of a Triumph Phonograph at New Iberia, La., writes concerning an interesting incident in the making of a Record. He has a collection of Records of all instruments used at the Edison Laboratory, and was anxious to add to this a Record of a steam calliope. The opportunity came one day when a floating palace came to his city and anchored about 150 yards from his house. The calliope was playing popular airs at intervals, and Mr. Brousart succeeded in spite of the distance in making a very good Record of "In the Good Old Summer Time," as played by this steam musical device, if "musical" the calliope can be called.

**A WAY TO LEARN A POPULAR SONG.**

An advertising friend tells an amusing and interesting story of how his Phonograph helped an acquaintance out in a social matter. This acquaintance was down on a programme to do something at a dinner. He wasn't much of a speaker, but could sing fairly well, so he elected to sing. The affair was arranged at a late hour and he had but a short time to prepare himself for the occasion. So he hunted up his advertising friend, selected the song "It Was the Dutch" as his offering for the after dinner festivity, and spent the evening in playing this selection on the Phonograph again and again until he learned the music and the words so far as the Record gave the latter, and later he supplemented it with the printed words. This plan of learning a popular song was effectual, although rather hard on the advertising man's family, who heard more of this one selection than they would have heard from choice.



**A CHILD'S CRIES SOLD A PHONOGRAPH**

A. Estrin, a Dealer at 381 Palisades avenue, Jersey City Heights, tells an interesting incident in connection with the sale of a Standard Phonograph. He had a friend who was very much prejudiced against talking machines of all kinds, and who had resisted all importunities on the part of the Dealer. One day the wife of this gentleman with her child called at the store of the Dealer. While there something went wrong with the youngster, and he began to cry loudly. Partly for amusement, the Dealer hastily put on a Recorder and made a Record of the child's crying, his cries continuing to the end of the Record. About the middle of the Record he stopped it long enough to make the announcement that the Record was made by the child of his friend, giving his name. The next time his friend came in, the dealer put the Record on, after coaxing him for some time to listen to it. His friend displayed little interest in it until he came to the point where the name of the maker of the Record was announced. He heard it to the end with much greater pleasure. He then wanted to buy the Record. The Dealer refused to sell it, and in order to become the possessor of it, his friend bought a Standard machine and other Records. All of this shows that there are more ways than one to sell a Phonograph.

**AN UNUSUAL CALLER.**

"A few weeks ago a New York weekly published an article telling how parrots could be made to talk by Phonograph, using for illustrations, disk machines," writes Alden March Collins, of C. J. Heppe & Son, Philadelphia. "A lady who was born many years before sound transmitting machines were perfected read the article, but could not understand. Using her own words: 'I do wish you would show me how parrots may be made to talk; how do you repeat the words so that the bird will hear them so many times that he must say them?'" The article was all wrong, since no recorder can be used with the disk machines. Our salesman played an Edison Triumph, and the old lady was more mystified than ever. 'I don't see the person I am hearing, but I have four parrots at home and have tried for a month to make one of them say "Aunt Lou" and he won't talk at all.' The machine was arranged for recording and the salesman repeated 'Polly, say "Aunt Lou"' for two minutes. The old lady's surprise and delight was a picture fit for the inventor to see when she heard the result. Now Polly has no peace, but the old lady has a Triumph."

**CATALOGUE OF I. C. S. GOODS.**

The International Correspondence Schools of Scranton, Pa., have just issued a complete catalogue pertaining to their Language Courses. It is a pamphlet of sixteen pages and includes all necessary information concerning the use of the Edison Phonograph in connection with their Language Courses. It also gives detailed information about the books, etc., required by the courses. The text suggests the use of the Edison Phonograph for "double service"—amusement and language study. The pamphlet has been written so that Dealers may put their names on the back cover and send it to prospective customers. Dealers interested should ask any of the Jobbers named in the advertisement of the International Correspondence Schools, on page 16, to send them a copy of the catalogue.

Steinhauser & Eaton, Edison Dealers at Watsonville, Cal., issue a complete almanac and handbook, in which only goods sold in their store are advertised. Edison Phonographs and Records get an excellent showing.

Among the advertisers in the *Chinese Free Press*, published in the Chinese language, at San Francisco, appears the name of Dr. Tom She Bin & Sons, 615 Kearney street, announcing the sale of Edison Phonographs and Gold Moulded Records.

**A PHONOGRAPH ENTERTAINMENT AT CARACAS.**

The managers of *El Pregonera*, a Spanish paper published at Caracas, Venezuela, opened its offices on the night of November 29th for a Phonograph exhibition, and on December 1st *El Pregonera* referred to it as follows:

Saturday night our offices were favored with a gathering of friends, accompanied by the ladies of their families, the occasion being a Phonograph entertainment tendered by Señor J. Santa de Leon.

Two apparatus were put in use, one of which was an Edison Concert; both of these apparatus were admirably perfected, as all others lately received by Mr. J. Santa de Leon. The purity of the sound is absolutely complete in this famous invention of the Wizard of Menlo Park, and therefore there is nothing to detract from the illusion of originality produced by these musical selections. We heard about twenty-four Records, the extensive repertoire possessed by this gentleman; songs, tenor airs, duets, popular songs, military selections by brass bands, etc., all of which were loudly applauded.

We thank Mr. J. Santa de Leon in our behalf as well as in that of the distinguished company composing the audience, for the most charming evening tendered.

### NAMES OF "OUT OF BUSINESS" DEALERS WANTED.

Jobbers will confer a favor upon our Advertising Department if they will at least once or twice in each year go over the list of their Sub-Dealers and advise us of any names that should be taken from our mailing list. Dealers will go out of business and we do not desire to continue mailing them literature when they have no further use for it. A little attention to a matter of this kind will be appreciated by our Advertising Department.

### PRINTED MATTER.

The trade is hereby advised that printed forms Nos. 414, 418 and 428 are out of print and cannot be supplied in any quantity.

The use by Jobbers of sheets giving the Comments on new Records each month seems to be on the increase. The number printed each month is larger, and more Jobbers are ordering them than before.

We expect late in January to mail a new Numerical Catalogue to every Jobber and Dealer on our mailing list. This copy is intended for the store use of a Dealer and should be kept until the next edition appears. The present edition will not permit of duplication. It will therefore be useless for Jobbers to order them in quantities with a view of sending another copy to their Dealers. A few extra copies will, of course, be sent to Jobbers, but no large quantity will be sent out. It will save correspondence if Jobbers will not ask for them in quantities.

The December Supplement was the first of a new series of eight to be sent out in as many consecutive months. These have been printed in a simpler style than those previously issued, it having been found that plainer Supplements will answer every purpose of the Dealer. Some Dealers were of the opinion that a perfectly plain one would be as good as a colored one, but we did not care to make so radical a departure at one time.

The quantity of interesting matter submitted to us for insertion in the PHONOGRAPH MONTHLY is frequently more than we can use in the issue of one month. We are, therefore, compelled to discriminate between some of the matter and to lay part of it over for another month. We desire, however, to have Dealers continue to send us readable matter for use in its columns. Facts in connection with the sale of Edison Phonographs and Records are especially desirable. We shall also be glad to receive suggestions from Dealers on methods of carrying a stock economically

### RECORD SUGGESTIONS GLADLY RECEIVED.

Occasionally we receive a letter from a Jobber or a Dealer offering suggestions concerning the making of a Record or the listing of a certain musical composition among our Records. These are always referred to our Record Department and receive due consideration. The fact may not be generally known to the trade, but we shall be glad to receive at any time suggestions that Dealers may care to send in. Such will be carefully considered by our Record Department. We may not be able to follow all of them, but such suggestions may result in very decided benefit to the entire trade. We are, therefore, glad at all times to hear from our Dealers on such matters.

### A TRIBUTE.

The following tribute to the Edison Phonograph comes from an admiring user at St. Paul, Minn:

ST. PAUL, MINN., Nov. 5, 1903.

I have had one of your Standard Phonographs in my home only a short time, in which it has given me much pleasure.

I believe that you have done more than most of our great men to-day in helping to make people happy, and affording wholesome pleasure and amusement in homes in every part of the universe.

By spending a few dollars one can bring the music of a grand opera to the bedside of an invalid. The blind may be entertained as never before.

People of all nations speaking different languages find that same pleasure in listening to its music. The old and the young alike find pleasure in listening to your Phonograph, for it will play all kinds of music to suit all kinds of people. The invalid seems to gain strength while listening to its cheerful notes. The babe is hushed to sleep by its sweet lullabies; while its martial music stirs the heart of every patriotic youth who hears it.

People tired with the labors of the day may rest and become refreshed while listening to the brazen voice of a brass band or the melodious strains of an orchestra, or, perhaps, a vocal solo rendered by some famous artist. The sad are made glad; the sorrowful happy; and the weary rested. As "music hath charms to soothe the savage breast," so also it has a subtle power to rest our tired nerves.

LEON C. MEAD.

### ARE SIMPLY PERFECT.

The following is an extract from a letter received from A. Eberbach, Santiago, Chile:

"I received the shipment of Phonographs and Records, *per* S. S. Cacique, in good condition. The improvements both in Records and Reproducers are striking, and I beg you to accept my compliments. The Edison Concert Records—Bands, Orchestras, etc.—are simply perfect."



**COMMENTS ON FEBRUARY RECORDS.**

Of sufficient variety to suit every taste is the advance list of new Edison Gold Moulded Records for February. He will be critical, indeed, who cannot find in the list a number of Records to suit his taste. The list comprises the usual twenty-five domestic selections and is nicely balanced in the number of band, orchestra and instrumental selections and in the number of singing and talking Records. The quality, too, is all that can be desired. The list represents the most advanced methods and skill in the art of making Phonograph Records. The men or women who play, sing or talk for the Master Records are the best to be had and the men who direct every detail of the various processes have spent years under the general supervision of Mr. Edison. The men in the Record department of the Edison Laboratory are always abreast of the times. They not only have the experience gained by Mr. Edison's and their own unceasing experiments, but they at once avail themselves of any new discoveries made in other record making plants. Each selection, therefore, is the best that present human knowledge can make.

In putting out a list of twenty-five new Edison Gold Moulded Records each month no claim is made that every title will suit every individual. On the contrary, it is made up with a view of suiting the tastes of the greatest number and as many different sections of the country as possible. Long experience has taught the people at the Edison Laboratory just what the public wants in Phonograph Records and the advance lists sent out by the National Phonograph Company meet this want to a nicety.

No. 8599, "It Was the Dutch Medley," is another of the series of medley Records being made by the Edison Military Band, one being listed each month. This one introduces "It Was the Dutch," "Under the Anheuser Bush," "Up in a Coconut Tree," "Always in the Way," and "Celia." It is quite unusual to get five popular airs on one Record.

No. 8600, "Your Mother Wants You Home, Boy," is a splendid Record of Paul Dresser's latest song hit. It is sung by Byron G. Harlan and has an excellent orchestra accompaniment.

No. 8601, "Far Away," is an unusually fine soprano and tenor duet by Miss Chapell and Mr. Stricklett. This song was written by Mrs. J. W. Bliss. It has a charming air and the Record is made with excellent blend of the voices.

No. 8602, "Wouldn't It Make You Hungry?" is an unusually characteristic coon song by Bob Roberts, with orchestra accompaniment.

A very hungry coon is told by his lady friend that she is going to dine on "Little Neck clams, thick cut of roast beef rare, hot chicken swimmin' in gravy, hash browned, pomme de terre, asparagus tips dipped in butter, corn, tomatoes, and pie." This forms the refrain of the song and Mr. Roberts sings it with much unction. This song is written and published by Harry Von Tilzer.

No. 8603, "Lovey Mary," is a characteristic dance air of uncommon charm. It is played by the Edison Symphony Orchestra in an artistic manner.

No. 8604, "Clancy's Prize Waltz Contest," is a tale of a Bowery dance hall by Len Spencer. It introduces typical Bowery characters and orchestra music. Clancy offers a De Barrios diamond ring for the best lady dancer and a meerschaum cigarette holder for the best "gent" dancer, and it is announced that Clancy's only interest in the dance is the sale of the "booze." The dance begins to the music of "My Little Coney Isle," when word comes up from below that the bar is doing "nottin'." The orchestra is instructed to play that "t'irsty" music, "de Wurzburger." The prizes are awarded to the lady with the red hat, the green veil, and the pink shirtwaist, and to the "gent" with the derby hat and the linen duster. One of Mr. Spencer's best Records.

No. 8605, "A Dream," is J. C. Bartlett's delightful sentimental song. It is sung by George Seymour Lenox, who has a fine tenor voice and sings in a finished manner. It is one of the best Records of a tenor voice ever made at the Edison Laboratory. Mr. Lenox was accompanied by an orchestra.

No. 8606, "Marching Thro' Georgia," is a duet Record by Collins and Harlan of that patriotic air which will ever live in the hearts of Americans. The chorus is sung as a duet. The singers are accompanied by the orchestra and drum corps effects are introduced. It is a Record that will remain in collections when Records of later music have been forgotten.

No. 8607, "At the Mountain Inn," is another of those delightful bits of Alpine music played as a violin and flute duet by Jaudas and Atz. The sweet and graceful character of this music suggests the country from which it emanates. These duets have met with great favor among lovers of Phonograph Records.

No. 8608, "Barney," is a companion Irish song to "Bedelia," although its air does not resemble the latter in any way. It has character of its own and is a rollicking Irish ditty. It is sung as a duet by Collins and Harlan, with orchestra accompaniment, and is made with unusual volume of tone. The music of this song is by Ed. Rogers, and it is published by Harry Von Tilzer.

No. 8609, "Cary Waltz," is an original composition by Bohumir Kryl, the famous cornetist, and he plays it as a cornet solo, with orchestra accompaniment. The music is as creditable to Mr. Kryl as his ability to play the cornet. It is a splendid Record in every respect.

No. 8610, "Coonville's Colored Band," is a descriptive coon march song by Arthur Collins and has an orchestra accompaniment. The music is full of life and vim, and Mr. Collins enters into the spirit of the song in making the Record. The music reminds one of the coon



marching songs so popular a few years ago. Davids and Meakin are the authors and M. Witmark is the publisher.

No. 8611, "Your Dad Gave His Life for His Country," is a patriotic song of Decoration Day; the kind of song that touches a popular chord in the average American. It is sung artistically by Francklyn Wallace, and has an orchestra accompaniment. The words are by Harry J. Breen and the music by T. Mayo Geary.

No. 8612, "American Flag March," is a clever whistling solo by Joe Belmont, the first Record by Mr. Belmont that we have been able to list in several months.

"No. 8613, "Dear Old Girl," is a pathetic and sentimental ballad, with orchestra accompaniment, nicely sung by Harry MacDonough. Records of this character are always in demand. The words are by Richard Henry Buck and the music by Theo. F. Morse.

No. 8614, "The Cavalier March," by the Edison Concert Band, is a splendid twostep air and a Record that will sell whenever played for admirers of band Records.

No. 8615, "If You're Such a Great Star, Why Don't You Shine?" is a coon song Record in Arthur Collins' best style. The song portrays the scorn and indignation of a coon girl, who was taken to the circus by a gentleman friend. He had told her that he was a great star, but at the circus she found him in one of the cages. Mr. Collins sings the part splendidly. With orchestra accompaniment it makes a Record that will be a good seller.

No. 8616, "Merry Birds Polka," is another well-made and delightful addition to the list of piccolo Records made by Frank S. Mazziota. Few instruments make such clear Records as the piccolo, and when played by an artist like Mr. Mazziota they are doubly desirable. "Merry Birds Polka" is accompanied by the orchestra. It was written by J. S. Cox.

No. 8617, "The Woodchuck's Song," is a Record of Fay Templeton's song in "The Runaways," made by Bob Roberts, a baritone who is thereby introduced to buyers of Edison Gold Moulded Records. This song has for its chorus the old query, "How much wood would a woodchuck chuck if a woodchuck would chuck wood?" The Record has an orchestra accompaniment. The music of the song is by Theodore F. Morse and the words by Robert Hobart Davis.

No. 8618, "Razzle Dazzle," is a characteristic cakewalk air played as a banjo solo by Vess L. Ossman, whose talent needs no comment. The orchestra accompaniment makes the Record exceedingly attractive. "Razzle Dazzle" is the work of Harry Von Tilzer and is cleverly written.

No. 8619, "Reuben Haskin's Ride on a Cyclone Auto," is an unusually good talking Record by Len Spencer. It gives in a realistic and extremely funny manner a description of a Maine farmer's ride in an automobile; how he is frightened out of his wits by the terrific speed of the machine, and how it ran over and killed chickens and dogs on the way. This Record will be a great laugh provoker.

No. 8620, "The Bridal Rose," is an overture by the Edison Symphony Orchestra. It is a pretty bit of music and played in the best possible manner.

No. 8621, "I Ain't Got No Time," is a comic coon duet by Collins and Harlan. This Record is also made with orchestra accompaniment, and with No. 8608 are the first Records ever made at the Edison Laboratory with such accompaniment. "I Ain't Got No Time" is an excellent Record and will attract more than ordinary attention. Mr. Collins sings the air and at each pause Mr. Harlan breaks in with a funny remark. The chorus is then sung as a duet. Felix F. Feist wrote the words and Ted S. Barron the music of this song.

No. 8622, "Girlish Dreams," is a bell solo by Albert Benzler, with orchestra accompaniment. The air is pretty. Mr. Benzler plays it perfectly, and the orchestra music adds to the attractiveness of the Record. This composition was written by E. Holst.

No. 8623, "Daughter of Love Waltz," is a fine Record by the Edison Military Band. Its music is very attractive and the band execution could not be better. It was recorded at slow tempo for dancing. The music is by C. W. Bennet.

### EDUCATORS APPROVE LANGUAGE COURSES WITH EDISON PHONOGRAPHS.

Modern educators are becoming deeply interested in the Phonograph method of teaching French, German and Spanish employed by the International Correspondence Schools of Scranton, Pa. We have received newspaper clippings telling of demonstrations made at teachers' conventions in Duluth, Minn., and Chardon, Ohio, of the value of the Phonograph as an aid in teaching languages. The following endorsement shows how educators are taking up the matter:—

Department of Romance Languages,  
Johns Hopkins University,  
Baltimore, Md.

*International Correspondence Schools of Scranton, Pa.*

*Mr. A. Menke, Jr., Asst. Supt., Baltimore, Md.*

DEAR SIR:—I wish to thank you again for your most interesting exposition of the method of teaching modern languages with the aid of the Phonograph, now in use by the International Correspondence Schools. The Phonograph Records are excellent and so carefully graded that the student can understand the grammatical construction as well as the meaning from the first. The accompanying textbook is put together on a rational basis and contains far more minute explanations of rules and idiomatic usages than an instructor usually gives in class. The system of correcting the student's pronunciation by means of the Phonograph should also be entirely satisfactory in view of the standard quality of the machine in use.

I wish to add that I consider the system superior to any other method of phonographic language teaching now on the market, and, I may say, the least expensive for the learner because of the equipment provided.

MURRAY P. BRUSH,  
Associate in Romance Languages.



### A DEALER TO BE PROUD OF.

One of the most enthusiastic Dealers in Edison Phonographs and Records is the Keely Phonograph Co., H. P. Keely, manager, 6109 Penn avenue, Pittsburgh, Pa. Mr. Keely never sells any other make of talking machines or records if by any means he can avoid it. Edison goods have not Dealers more loyal than he. One of his many unique ways of advertising is a rubber stamp with which he prints the following on all his mail matter:

EDISON RECORDS (The Only)

50c each, \$5.00 Doz.

——— Records (Indestructible)

25c each, \$3.00 Doz.

——— Records, X P

ANY OLD PRICE.

IF YOU CANNOT BUY GOOD ONES,

WE SELL THE IMITATION

Hard Brittle and Easily Broken Super  
Hardened.

We asked Mr. Keely if he objected to a mention of his rubber stamp in these columns and received the following characteristic letter from him:

In regard to my "ad" you are very welcome to use the same and also use my name. In reference to my experiences in handling disks will say that the disk machine, no matter who makes it, is a "dead one," and should be treated the same as any other public nuisance. Any one selling or using same should be fined or given ninety days in the workhouse. I have sold every make of disk records in the market for one cent an inch (this means diameter, not circumference), and consider myself well rid of such truck. I will never be found with the evidence on me again. I have sold over 3,000 Edison Phonographs which have made me famous as Keely's Talk and seven disk machines, for which I hope to be forgiven in the hereafter. I have seven enemies. They bought the disk machines. This does not include their families who were tortured by them.

The disk machine carrying cases are not in demand, as nearly every house has an attic which answers the purpose very shortly after the disks are purchased. The most novel use for a disk machine is that made by a farmer who feeds his poultry corn with a lavish hand and then starts his disk machine and they take to the woods hungry rather than eat in such torture. The trolley cars in Pittsburg are very musical in a disk sense when they are climbing the hill; if anything, they make sweeter music. The growl and grind is there without the trouble of changing the needle. I have several disk machines on hand, but shudder when compelled to play one, as all musical customers leave at once. The X. P. (X poor), hard, brittle and easily broken record is not much in demand, as they are cheap in price, cheap in sound and made by a cheap concern, who employ only men who use cheap and slippery methods to dispose of this junk. Radio Know they are. I will uphold the Dealers'

Mr. Keely's reference to selling disk records at one cent an inch is an actual fact of almost daily occurrence. When asked the price of disk records he replies: "One cent an inch," and actually sells them for seven or ten cents, according to diameter. Another of his unique methods of advertising is to announce a sale of the cheap cylindrical records at ten cents a dozen, and he carries out his promise. He had been holding a sale of this kind one day each week and disposing of cheap cylindrical records at twenty-five cents a dozen. The manager of the branch store of the manufacturers of these records was skeptical concerning the sales and sent a boy with twenty-five cents to the Keely store to buy a dozen. The boy returned with the dozen records and fifteen cents in change, saying: "They're selling them for ten cents a dozen to-day." With all this Mr. Keely is a staunch upholder of the Edison Agreement and prices.

### EXTRACTS FROM TRADE LETTERS.

"You may depend we will co-operate with your text to the letter."—*Pierce & Quinn, Northport, Wash.*

"I have never seen any occasion for price cutting on Edison goods, therefore you can rest assured of my hearty co-operation.—*E. S. Harper, Moons, Ohio.*

"We are very much pleased with new Records which have orchestra and band accompaniments. In our little town more interest is being taken in the Edison Phonograph. We have sold to pleased customers nine Home Phonographs.—*Thos. Coates, Prescott, Ariz.*

"In looking over the MONTHLY I see a great talk about the 'steen cent' records. They remind me of a corner band when most of the players are out collecting the pennies. The best story I have is this: We were playing November Records for a couple of customers when in came one of our cranks with two 'steen cent' records. He told me he had Laughing Water (No. 8532 on our list), and asked to hear ours. I played steen and ours and sold three of ours on the spot, one of them to the crank.—*Howard T. Tripp, Brooklyn, N. Y.*

"We wish to thank you for postal received a short time ago stating the name of a party that wrote you for catalogues. We called on them and got an order for some Edison Records and he has bought eight Records every week, and last Saturday we sold him a Triumph and a 42-inch horn. This is only one case of your great help to dealers of Edison goods."—*S. D. LaRoe & Son, Woonsocket, R. I.*

"December Suspended List received. I think you are doing a noble act with these cutters, and hope the good work will go on."—*W. M. Henderson, Port Chester, N. Y.*

Am handling nothing but Edison Machines and Records. My customers say they are the best and the cheapest in the long run, and I will uphold the Dealers'

agreement and see that there is no price-cutting on Edison goods down this way.—*Albert J. Vodon, Sandwich, Mass.*

"We have not adorned (?) our racks with the 'steen cent' records, nor do we want to. Our motto shall be: 'Stick to those who have stuck to us.' Wishing you a prosperous future, to which we will contribute our share."—*James T. Coughlin, New York City.*

"I have no trouble in selling Edison goods without cutting the prices, for I think the Edison Phonographs and Records are the best in the world."—*James Cowen, Ehrenfeld, Pa.*

"We hereby acknowledge receipt of December List of Suspended Dealers, and we note with surprise that Dealers in seven different cities have been added since the last List was published. We cannot understand how some Dealers can be so short sighted as to try to evade the conditions of the contract. We assure you of our hearty co-operation in assisting you to keep the Edison business on as sound a basis as it is now conducted, and to this end we will certainly refuse to supply Edison goods to any Suspended Dealers."—*The Klein & Heffelman Co., Canton, Ohio.*

"We acknowledge receipt of your Suspended List and assure you that none of the suspended firms can purchase from our agency any of your Phonographs or supplies. Why don't you add at the bottom of your Suspended List: Firms that violate a written contract are not safe people to do business with. The growing glory of the world is the Edison Phonograph."—*Boehm & Strickler, Ellenboro, W. Va.*

"I will join you in keeping up the reputation that the Edison goods have gained. I will also join you in sustaining the present prices on said goods."—*William F. Teed, Uniontown, Pa.*

"We acknowledge the receipt of your Suspended List, and we think it is a good plan of knowing who tries to spoil the trade. You may be assured that we intend to co-operate with you to hold the trade right."—*S. M. Feldt & Co., Holdrege, Neb.*

"I read with interest the article in the December PHONOGRAPH MONTHLY in regard to the best manner of handling a retail stock of Records. I have tried various ways, but think that the 'wire Record rack,' made by the Syracuse Wire Works, the only thing. It is not expensive, is neat, attractive and most convenient. You may be sure of my hearty co-operation to prevent price cutting."—*I. F. Eastman, Lewiston, Me.*

"The Phonograph business is pretty good with me. I have sold fifteen machines up to date, and will sell more before the year is out. A party put in a \_\_\_\_\_ agency here. He lasted about one month and hunted pastures new. He sold a few records, but not a single machine. The Edison was too much for him. He will have to hunt out a town where the Edison is not sold to do business."—*Z. J. Lefevre, Los Gatos, Cal.*

"I am an opposer to price cutting and have no sympathy for those that allow their names to appear on the Suspended List. They surely don't know when they have got a snap."—*George E. Bonner, Tama, Iowa.*

"I will not sell any of Edison's goods to any one that is on the Suspended List. Your goods give perfect satisfaction."—*Henry F. Townsend, Wilton Junction, Iowa.*

"I think your Records are the best ever made and the plainest I have ever heard. My customers think so, too. I will always stick by the Edison goods."—*Bert G. Smith, Trichewang, Mass.*

"The Edison Phonograph is taking the lead wherever it is introduced, and the Records cannot be excelled by any other make."—*J. H. Allhouse, Shelby, Ohio.*

"I will stick up for the Phonograph every jump in the road. If everybody is giving the 'steen cent' records the same recommend that I am they will soon be out of the talking machine business. I have handled the Edison Records for over four years now and I will never handle anything else so long as I can get the Edison goods. I handle all makes of machines and sell the Edison over them all. I had a customer to-day for a machine and he wanted a disk, so I played the disk for him and then I played the Edison Home. He said: 'Fix up the Home; that is good enough for me.' I sold him a little over \$100 worth of goods, all Edison, too. I am still selling the Edison Records at fifty cents each, and I have the business, too. Wishing you all a merry Christmas and a happy New Year."—*C. W. Jacobs, Hastings, Neb.*

"You can depend upon us doing all in our power to further the interest of the National Phonograph Co."—*O. B. Daspit's Sons, Houma, La.*

"Several of my customers asked me why I did not sell the \_\_\_\_\_ record, so I got one sample to show them. Well, that was enough. I still have the sample; no one wants it. I have one customer who has bought of me over 175 Records, all Edison Gold Moulded Records."—*Henry Taubman, St. Johnsville, N. Y.*

"Edison machines give the very best of satisfaction about here. You may expect my co-operation with you."—*H. C. Stevens, Philippi, W. Va.*

"You are on the right track. I have handled your Moulded Records ever since their introduction and have yet to find a poor one. I therefore recommend them to all."—*R. L. Hayward, Barre, Vt.*

"I am heartily in accord with you. I will do all in my power to keep the trade where it is—on sound business principles. I tell my customers that the Edison machine is the only talking machine in the world; also the Moulded Records are wonderful. I do not handle any other machine or records, and I would not if they gave them to me for nothing. This you can rely on."—*W. E. Hall, New York City.*

"Your Records are the only Records. In the EDISON PHONOGRAPH MONTHLY we see that one dealer says that Edison Gold Moulded Records are worth fifty to the others' ten cents. We say that the Edison Records are the cheapest Records made; and if price was \$1 each they would still be the cheapest Record made, as it is the best."—*The George W. Page Co., Winter Park, Fla.*



"Your Suspended List received, and we will see that none of these firms get Edison goods from us at less than contract price."—*Fulton Mercantile Co., Verndale, Minn.*

"You can depend on me keeping up the prices on all Edison goods and not selling any goods to any one you have dropped from your List. I am doing a nice business this winter, and hope to sell about one thousand Records during the holidays. I do think Edison Records are getting better all the time. It is impossible to sell \_\_\_\_\_ goods here."—*Albert Palmer, Garrett, Ind.*

"We have no time or place in our store for anything but the 'Edison' in the talking machine line. Price cutters have no right to live (commercially), and we will do all we can to kill them and the 'steen cent' records."—*Hooven Novelty Mfg. Co., Hazleton, Pa.*

"We have had some little experience lately with the 'steen cent' records, and wish to say now that we will never leave the Edison fold again. We have a fairly liberal dose of these records yet, and may decide soon to give them away, as they will not sell, and our room is valuable. We enjoy the Edison goods very much ourselves, and only wish we had sufficient trade to sell ten times as many as we do."—*W. A. Garver, Canal Dover, Ohio.*

"It is a pleasure to deal with a house that lives up to what it publishes, and that is what you folks do. We are not envious of our competitors, but we do like to see the Dealers suspended that don't live up to your contract. We are Edison people from the word go, and hope to do more in the future with your goods."—*Frank W. Thomas, Albany, N. Y.*

"Am glad to see that you keep up the price on Records. I can get fifty cents just as easy as sixteen cents. You can depend that I will not cut prices."—*Charles B. Keim, Louisville, Ohio.*

"We are much pleased with the last edition of Records, as they are perfect. We will handle no other, for we know and appreciate good music when we hear it and do our trade."—*Hammett & Cook, Philadelphia, Pa.*

"I for one will not sell any of your apparatus to any of the Suspended List or to customers for less than the list prices, as I think they are fully worth all you ask for them. I have as good a chance for as many sales as any of your authorized Dealers under your rules and regulations, and when I get so I can't comply with these I will resign from the business."—*Joshua Boss, Liberty, R. I.*

"I talk National goods forever; in fact, they talk for themselves."—*W. B. Hall, Sr., Riverside, N. J.*

"We opened up our Edison Phonograph Department quite recently, and both the sale of the apparatus and Records for same has been more than satisfactory to us. The only thing that we now have to regret is, that we did not open this department up at least a year earlier."—*O. K. Houck Piano Co., Memphis, Tenn.*

### A WONDERFUL REPRODUCTION.

C. J. Heppe & Son, of Philadelphia, write: "A. Bonanzo, 'one of the leading structural engineers of the country, who is at the same time an authority on good music, considers Edison Record No. 8490, Ballet Music, Mathias Sandorph, with Clarinet Solo, the most wonderful reproduction of a wood wind instrument he has ever heard. To use his own words, 'It is as natural as the thing itself.'"

### A PHONOGRAPH SINGS AND TALKS THE PARTS.

Samuel Briggs, Jr., a boy living on Stacy street, Burlington, N. J., has constructed a toy theatre that excites the envy of his young friends and the marvel of older acquaintances. The miniature stage is two feet deep, two feet high and three feet wide, and is so arranged that the scenes may be easily and quickly shifted behind an automatically rolling curtain. The ingenious young owner has made up scenery for the different acts which he presents. The backgrounds and landscapes are clipped from show posters, while paper or wax figures represent the actors. The plays range from the minstrel to the drama, the illustrations showing scenes from Dumont's Minstrels and "Way Down East." In the pit the wax figures of the orchestra appear in the attitude of furnishing the stage music, and a mechanical doll drums noisily on a toy piano. Another feature of this miniature playhouse is that it is connected with a Phonograph, which talks, sings or plays the parts of the actors. The clever boy, who is but eleven years of age, has delighted many an audience, adults as well as children, with this home-made toy.—*Philadelphia North American, December 14, 1903.*

### OMITTED BRITISH SELECTION.

No. 12839, "Auld Lang Syne," by Thomas Reid, was omitted from the list of British Records issued in December. We have moulds of this Record and can fill orders for it.

Douglas & Company, Jobbers at 89 Chambers street, New York City, recently had a customer from New Jersey call at their place and buy a Home Phonograph. He does not sell Edison goods, but those of another company, and said that he desired to purchase a good machine for his personal use. He therefore bought an Edison Phonograph.

### "EDISON RECORDS."

"There are numerous imitations, with many claims of superiority, but there is no other Record made that equals the genuine Edison, for perfect tonal qualities."—*From a Holiday Folder issued by R. S. Williams & Sons Co., Ltd., Toronto, Canada.*

### TRADE NOVELTIES.

The Kremmer Indicator Co., of 829 DeKalb avenue, Brooklyn, N. Y., is marketing an indicator to regulate time and speed on Phonographs.

The Syracuse Wire Works, of Syracuse, N. Y., is manufacturing a wire rack for the convenient handling of Phonograph Records.

In the November issue of the PHONOGRAPH MONTHLY we published an advertisement of a new horn crane made by Victor H. Rapke, of 1661 Second avenue, New York City. This is one of the advertisements that we regret being unable to continue in these columns. It advertises an article of much interest to every Dealer and Jobber and conflicts with the business of none of them. This horn crane has attracted considerable attention in the trade as being a most useful device. It is clamped to the under side of any style of talking machine in such a way as to serve all the purposes of any horn crane, and yet not be in the way at all. Readers interested in this horn crane are referred to Page 18 of the PHONOGRAPH MONTHLY for October.

Some time ago we published a paragraph from the Hooven Novelty Manufacturing Company, of 84 North Wyoming street, Hazleton, Pa., referring to a device for determining when an Edison Phonograph is being run at a speed of 160 revolutions per minute. This device was a little card cut to the exact length of a minute of travel of the Phonograph arm running at the rate of 160 revolutions per minute. This company has now had this device manufactured in polished steel, and is anxious to get in touch with Dealers, with a view of furnishing them with a quantity to give away for advertising purposes to owners of Phonographs. In their own city they got out a letter offering to give one of these devices to each of their customers who would call, and found that it resulted in increased business.

The forms of the PHONOGRAPH MONTHLY practically close on the 20th of each month. We do not get the Advance List until the 25th, but the forms are supposed to be ready by that time with the exception of inserting the Advance List and Comments on the same. Therefore matter sent in about the 20th of the month must be frequently held over, and if it does not appear in the current issue, the senders will understand that it was received too late for use.

### A NEAT DEVICE FOR USE WITH PHONOGRAPH AT SEA.

Phonograph Dealers who sell goods for use by ship captains and owners of yachts will read the following with interest:

T. S. S. "TAURIC."

PORTLAND, ME., Oct. 19, 1903.

I have an Edison Home Phonograph, and as my occupation is a marine engineer, I am almost continually at sea, where the Phonograph always accompanies me, and has done so for the past two and a half years. For a time I found some difficulty in playing the machine at sea, on account of the great vibration and rolling of the vessel. I tried several means to get something like results, and after several futile attempts I got a spring, similar to the one I am sending you, and fixed it to a strong hook in the roof of my cabin. On to the spring I hang a shelf two feet six inches long by one foot wide, with strong cords from each corner, and of equal and suitable length. The opposite ends are all brought together and secured to a hook and

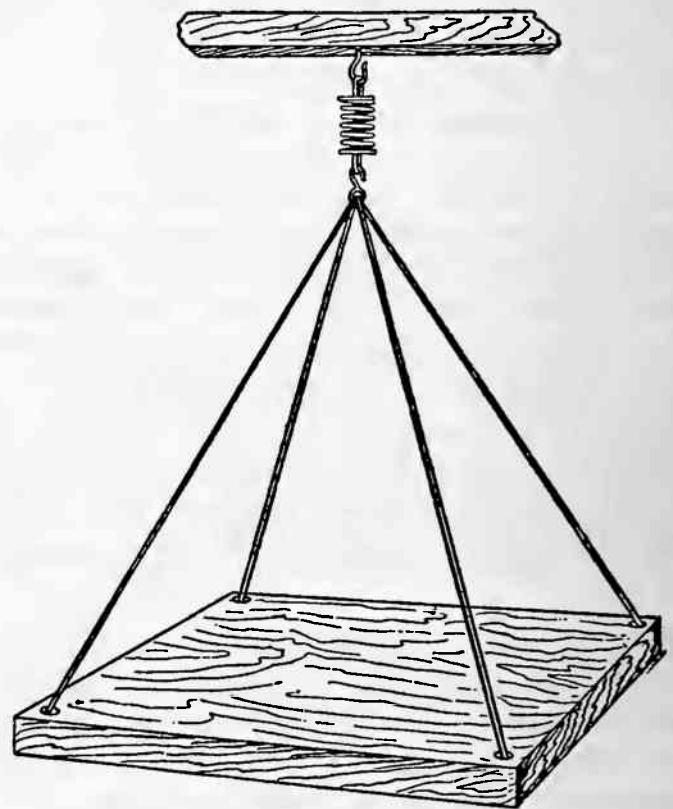

the whole contrivance supports the Phonograph. The result is absolutely the best. It makes no difference how the ship rolls or pitches, the machine plays in good shape, without any discordant sounds or jumping over sound waves, or anything that is disagreeable to a lover of music. The reason I have sent this to you is I thought it might be of service to those who would like to have their Phonographs on their yachts, a la Sir Thomas Lipton and others, who no doubt have to abandon all idea of a tune or a song when at sea. Since I hit upon this simple plan I spend many a happy hour, while otherwise things would be very slow. Several persons who have seen this affair think it is first-class and are surprised to hear the machine playing away in good shape, although the vessel may be rolling all over the ocean.

A. W. BYRNE,  
Chief Engineer.



## DEALERS' ADVERTISING.

Between the acts at the Murray Hill Theatre in New York City advertisements are shown on the curtain by means of a kinoscope. Among the advertisements thus displayed is that of I. Davega, Jr., a New York Jobber, showing a Phonograph, a camera and a bicycle with the words "A dollar a week will buy any of these articles" underneath the three.

The Eastern Talking Machine Company, of Boston, heads its January Advance List with the following phrase: "January Edison Gold Moulded Records. Moulded in gold; as good as gold; staple as flour, and not on the bargain counters of Department Stores." Every loyal Edison Dealer will agree that this phrase is good.

The Star Phonograph Company, of 1034 Broadway, Brooklyn, had quite a unique window display during December. It had two figures made up, one showing Uncle Sam taking off his hat to the Phonograph and the other showing the Boy with the Hatchet look-

ing for the Band. These were attached to motors and both figures worked constantly, in a very life-like manner. It follows that they attracted much attention from passers-by.

William D. Hall, Sr., a Dealer at Riverside, N. J., gives a Phonograph party at his store each week and distributes cards among the callers. He then plays a number of Records on the Phonograph, leaving out the announcement at the beginning of the Record. Afterwards he gives prizes to those who guess most correctly the names of the band, orchestra, or individual making the Record. He finds this quite a success in pushing business.

Unusually pretty is a Christmas folder sent to us by Charles E. Robertson, a Dealer at West Philadelphia, Pa. It is excellently printed with green ink on green paper and is a credit to the printer who turned it out. The folder shows a list of the Edison Gold Moulded Records for December and a number of articles suitable as gifts for users of talking machines.

## JANUARY ADVERTISING.

The advertisement below was published in full, half and quarter pages, in about twenty January magazines and periodicals.

# MECHANICALLY SUPERIOR. The EDISON PHONOGRAPH

EDISON  
GOLD  
MOULDED  
RECORDS  
THE MOST  
BRILLIANT OF ALL

THE EXCLUSIVE USE OF PERMANENT GOLD MOULDS ACHIEVES THE RICHEST PUREST MOST NATURAL REPRODUCTIONS OF SOUND EVER MADE.— RECORDS 50¢ \$5 PER DOZEN

LASTS YEARS LONGER AND  
GIVES MORE SATISFACTION  
THAN IMITATIONS

TRADE  
*Thomas A. Edison*  
MARK



**NATIONAL PHONOGRAPH COMPANY, Orange, N. J.** NEW YORK 83 Chambers St. CHICAGO 304 Wabash Ave. SAN FRANCISCO 933 Market St. EUROPE: ANTWERP, BELGIUM 32 Rempart St. Georges

Phonographs provide amusement and also instruction through I. C. S. Language study records.

### FOOLS THE RABBITS WITH A PHONOGRAPH.

There is a law in Lake County, Illinois, against chasing the rabbit out of his warm burrow or brush heap by means of the squeaking ferret. The *Chicago Tribune* of December 13, contained an article telling at length how a hunter gets around the law by means of a Phonograph. He made a Record of a squeaking ferret and with it succeeds in frightening the rabbits as much as with the real article. The squire who was asked to arrest the offender refused and reasoned thus: Suppose a gang of men should surround your

house, and hoot, and yell, and hammer on the doors until you ran out in a fright and then robbed your house. That would be riot and robbery. But suppose some one should load up a Phonograph with these yells, and hoots, and cries, and set the machine outside your house some night and turn it loose—you couldn't arrest any one for riot, could you? It would be a practical joke, wouldn't it? And no judge or jury could hold you for a practical joke played on a rabbit, could it? Well, I guess not."

In the meantime, says the *Tribune*, the mere dog who "knows his master's voice" is entirely passe in Lake County, Illinois.

### SUSPENDED LIST, JANUARY 1, 1904.—SUPERSEDING ALL PREVIOUS LISTS.

#### COLORADO.

BOULDER—BENTLEY & CRAIG.

#### IOWA.

DES MOINES—HOPKINS-SEARS CO., or HOPKINS BROS. COMPANY.

#### KANSAS.

CLAY CENTRE—E. M. GOWENLOCK.  
LAWRENCE—BELL BROS.

#### MASSACHUSETTS.

LAWRENCE—LORD & CO., 314 Essex street.  
E. O. MOSHER, 420 Essex street.

MALDEN—A. T. FULLER.

NEW BEDFORD—H. B. DEWOLFF.

WOBURN—OSBORN GILLETTE, or THE BOLTON JEWELRY COMPANY, L. F. MALONEY, Manager.

#### MICHIGAN.

DETROIT—F. J. SCHWANKOVSKY.  
SAGINAW—GEO. W. EMENDORFER.

#### MISSOURI.

KANSAS CITY—THE WITTMANN CO.

#### NEBRASKA.

LINCOLN—THE WITTMANN CO.  
OMAHA—THE WITTMANN CO.

#### NEW HAMPSHIRE.

NASHUA—F. A. McMASTER & CO.

#### NEW JERSEY.

ATLANTIC CITY—SAMUEL D. WOLF, 32-34 Arkansas avenue.

BAYONNE—I. WIGDOR, 450 Avenue D.

JERSEY CITY—W. L. HOFFMAN, 151 Montgomery street.

NEWARK—R. L. CORWIN; also New York City.

PATERSON—CHAS. H. KELLY, 25 N. Main st.

\*PLAINFIELD—S. W. FRUCHT, or R. FRUCHT; also New York City.

WEST HOBOKEN—EMIL HOLLANDER, or THE WEST HOBOKEN BICYCLE & PHONOGRAPH CO., 619 Spring street.

#### NEW YORK.

ALBANY—FINCH & HAHN; also Schenectady.

BEDFORD PARK—GEO. H. TYRRELL.

#### NEW YORK—Continued.

HOBART—F. H. MARSHALL.

NEW YORK CITY—A. T. ARMSTRONG, or AMERICAN PHONOGRAPH CO., 106 Wall street.

\*BRONX PHONOGRAPH CO., or DAVID SWITKY, 506 Willis Avenue.

R. L. CORWIN; also Newark, N. J.

EAGLE PHONOGRAPH CO., or C. LOWENTHAL, 83 Nassau Street.

EMPIRE PHONOGRAPH CO., 2 West 14th street.

\*S. W. FRUCHT, or R. FRUCHT, 7 Barclay st., or 68 Cortlandt st.; also Plainfield, N. J.

\*O. HACKER, 2 Murray street.

HAWTHORNE & SHEBLE, 297 Broadway; also Philadelphia, Pa.

\*N. HORN, 148 E. 58th street.

R. H. INGERSOLL & BRO., 67 Cortlandt street.

W. L. ISAACS, 114 Fulton street.

S. LEMBURG & CO., 194 Broadway.

J. McELLYNNE, 202 Broadway.

RICHARD PEASE, 44 W. 132d st.

F. M. PRESCOTT, 44 Broad street.

SARATOGA—W. J. TOTTEN.

SARATOGA SPRINGS—MARVIN A. COTE.

SCHENECTADY—FINCH & HAHN; also Albany.

#### OHIO.

CINCINNATI—J. L. ANDEM.

SPRINGFIELD—D. & M. VANDERPOOL.

UHRICHVILLE—F. A. MAZURIE.

#### PENNSYLVANIA.

PHILADELPHIA—A. R. CASSIDY, 2783 Emerald street.

HAWTHORNE & SHEBLE, 604 Chestnut street, or Oxford and Wascher streets; also New York City.

PITTSBURG—A. LIPPARD, 615 Wylie avenue.

#### RHODE ISLAND.

PROVIDENCE—F. P. MOORE.

#### WISCONSIN.

\*MILWAUKEE—J. C. BLATZEK.

\*Added since last Suspended List was issued December 1, 1903.

Jobbers and Dealers are asked to co-operate with us, FOR OUR MUTUAL GOOD, by being careful that they do not supply any of the above named firms with our apparatus, either at addresses given or any other address.



## JOBBERS OF EDISON PHONOGRAPHS AND RECORDS.

## ALABAMA.

**Birmingham**—The Ray Co., 2025 Second avenue.  
**Mobile**—The Ray Co., 54 Dauphin street.

## CALIFORNIA.

**San Francisco**—Peter Bacigalupi, 933 Market street.

## COLORADO.

**Denver**—Denver Dry Goods Co., 619 16th street.

## CONNECTICUT.

**Middletown**—Caulkins & Post Co., 406-408 Main street.  
**New Haven**—Pardee-Ellenberger Co., 155 Orange st.

## GEORGIA.

**Atlanta**—The Ray Co., 72 Whitehall street.  
**Savannah**—The Ray Co., 116-118 Barnard street.

## ILLINOIS.

**Chicago**—Oscar J. Junge, 245 E. Chicago avenue.  
 Kelley Cigar Co., 80-82 Wabash avenue.  
 James I. Lyons, 73 Fifth avenue.  
 The Ray Co., 90 Washington street.  
 Siegel-Cooper Co., State and Congress sts.  
 Talking Machine Co., 107 Madison street.  
 The Vim Co., 68 E. Lake street.  
 Montgomery Ward & Co., 111 Michigan ave.  
**Peoria**—Peoria Phonograph Co., 314 S. Adams street.

## INDIANA.

**Indianapolis**—Kipp Bros. Co., 37 S. Meridian street.  
 The Ray Co., 234 Massachusetts avenue.

## IOWA.

**Des Moines**—The Vim Co., 704 West Walnut street.

## KENTUCKY.

**Louisville**—The Ray Co., 640 Fourth avenue.

## LOUISIANA.

**New Orleans**—James I. Lyons, Theatre Arcade.  
 National Automatic Fire Alarm Co., 614 Gravier street.  
 The Ray Co., 111 Camp street.

## MAINE.

**Bangor**—S. L. Crosby Co., 186 Exchange street.  
**Portland**—W. H. Ross & Son, 207 Commercial street.

## MASSACHUSETTS.

**Boston**—Boston Cycle & Sundry Co., 48 Hanover street.  
 Eastern Talking Machine Co., 177 Tremont street.  
 J. C. Haynes & Co., 451 Washington street.  
 Iver Johnson Sporting Goods Co., 163 Washington street.  
 Read & Read, 558 Washington street.  
**Fitchburg**—Iver Johnson Sporting Goods Co., 247 Main street.  
**Lowell**—Ring Music Co., 112 Merrimac street.  
 Thomas Wardell, 111 Central street.  
**Worcester**—Iver Johnson Sporting Goods Co., 304 Main street.

## MICHIGAN.

**Detroit**—American Phonograph Co., 106 Woodward avenue.  
 Grinnell Bros. Music House, 219 Woodward avenue.  
 The Ray Co., 168 Griswold street.  
**Saginaw**—Morley Bros.

## MINNESOTA.

**Minneapolis**—Thomas C. Hough, 714 Hennepin ave.  
**St. Paul**—Minnesota Phonograph Co., 37 E. 7th street.

## MISSOURI.

**Kansas City**—J. W. Jenkins' Sons Music Co., 1013-1015 Walnut street.  
 The Ray Co., 1021 Grand avenue.  
**St. Louis**—Conroy Co., 1115 Olive street.  
 The Ray Co., 923 Olive street.

## NEBRASKA.

**Lincoln**—H. E. Sidles Cycle Co., 1317 O street.  
**Omaha**—H. E. Fredrickson, 1502-1510 Capitol avenue.  
 Nebraska Cycle Co., 15th and Harney streets.

## NEW JERSEY.

**Hoboken**—Eclipse Phonograph Co., 205 Washington street.  
**Newark**—Edisonia Co., New and Halsey streets.  
 H. J. Koehler Sporting Goods Co., 845 Broad street.  
**Paterson**—James K. O'Dea, 117 Ellison street.  
**Plainfield**—Frank L. C. Martin Auto. Co., 810 Park avenue.  
**Trenton**—Stoll Blank Book and Stationery Co., 30 E. State street.

## NEW YORK.

**Brooklyn**—Chapman & Co., Fulton and Duffield streets.  
 A. D. Matthews' Sons, 394 Fulton street.  
 Price Phonograph Co., 1258 Broadway.  
**Buffalo**—P. A. Powers, 643 Main street.  
**Elmira**—Elmira Arms Co., 117 Main street.  
**Gloversville**—American Phonograph Co., 99 W. Fulton street.  
**Kingston**—Forsyth & Davis, 307 Wall street.  
**New York City**—Barkelaw & Co., 36 Vesey street.  
 Bettini Phonograph Co., 80 Chambers street  
 Blackman Talking Machine Co., 19 Beekman street.  
 J. F. Blackman & Son, 2654 3d avenue.  
 I. Davega, Jr., 802 Third avenue.  
 S. B. Davega, 32 E. 14th street.  
 Douglas & Co., 89 Chambers street.  
 H. S. Gordon, 139 Fifth avenue.  
 Harry Jackson, 219 Bowery.  
 Jacot Music Box Co., 39 Union Square.  
 Victor H. Rapke, 1661 Second avenue.  
 Rosenfield Mfg Co., 587 Hudson st.  
 Siegel-Cooper Co., Sixth avenue and 18th street.  
 John Wanamaker, Broadway and 9th street.  
**Rochester**—A. J. Deninger, 347 North street.  
 Mackie Piano, O. & M. Co., 100 State street.  
**Schenectady**—Jay A. Rickard & Co., 253 State street.  
**Syracuse**—W. D. Andrews, 216 E. Railroad street.  
**Troy**—James Lucey, 359-361 Fulton street.  
**Utica**—Clark, Horrocks & Co., 54 Genesee street.

## OHIO.

**Canton**—Klein & Heffelman Co., 216 N. Market street.  
**Cincinnati**—Ilson & Co., 25 W. 6th street.  
 The Ray Co., 143 West 5th street.  
**Cleveland**—The Ray Co., 266 Erie street.  
 W. J. Roberts, Jr., 254-256 Arcade.  
**Columbus**—Perry B. Whitsit Co., 213 S. High street.  
**Dayton**—Niehaus & Doshe, 35 E. 5th street.  
**East Live pool**—Smith & Phillips Music Co.  
**Toledo**—Hayes Music Co., 608 Cherry street.

## PENNSYLVANIA.

**Allegheny**—Henry Braun, 500 Federal street.  
**Allentown**—G. C. Aschbach, 539 Hamilton street.  
**Easton**—William Werner, 401 Northampton street.  
**Philadelphia**—C. J. Heppe & Son, 1117 Chestnut street.  
 Lit Bros., Market and 8th streets.  
 Penn Phonograph Co., 19 S. 9th street.  
 John Wanamaker.  
 Wells Phonograph Co., 41 N. 9th street.  
 Western Electric Co., 931-933 Market street.  
 H. A. Weymann & Son, 923 Market street.  
**Pittsburg**—Theo. F. Bentel Co., Inc., 433 Wood street.  
 Kaufmann Bros., Fifth avenue and Smithfield street.  
 H. Kleber & Bro., 221 Fifth avenue.  
 C. C. Mellor Co., 319 Fifth avenue.  
 Pittsburg Phonograph Co., 937 Liberty avenue.  
**Reading**—Reading Phonograph Co., 757 Penn street.  
**Scranton**—Ackerina & Co., Coal Exchange Building.  
 Technical Supply Co.

## RHODE ISLAND.

**Providence**—J. M. Dean Co., 785-795 Westminster street.  
 J. A. Foster Co., Weybosset and Dorrance streets.  
 Household Furniture Co., 231-237 Weybosset street.  
 Murray, Blanchard, Young & Co., 26-30 Pine street.  
 A. T. Scattergood & Co., 106-110 N. Main street.

## TENNESSEE.

**Knoxville**—The Ray Co., 319 Clinch street.  
**Memphis**—The Ray Co., Lyceum Building, 2nd and Jefferson streets.  
**Nashville**—The Ray Co., 30 The Arcade.

## TEXAS.

**Dallas**—C. B. Harris, Agt., 347 Main street.

## VIRGINIA.

**Richmond**—The Ray Co., 729 E. Main street.

## WISCONSIN.

**Milwaukee**—McGreal Bros., 173 3d street.

## CANADA.

**Toronto**—R. S. Williams & Sons Co., Ltd., 143 Yonge street.



# LOOK FOR DOUBLE SERVICE

## For Every Edison Phonograph

**To the Edison Trade** Wise dealers have both eyes open for business, and are quick to grasp the opportunity of securing more business through "Double Service." It is certain that those who buy Language Outfits, afterwards buy amusement records; then there are language sales to be made to thousands of Phonograph owners who perhaps are not active buyers. As a selling point for the Edison Phonograph there is nothing more unique and forcible than an I. C. S. Language Lesson.

## Prepare Yourself at Once

Ask for the new free Catalogue of I. C. S. Language Outfits, and order the Demonstrating Outfit, consisting of three (3) Molded Records with Textbooks, delivered prepaid in the United States or Canada. **Price, \$1.50**

### Apply to the Following Jobbers of I. C. S. Outfits

PORTLAND, ME., W. H. Ross & Son  
 LOWELL, MASS., Thomas Wardell  
 BOSTON, MASS., Eastern Talking Machine Co.  
 BOSTON, MASS., J. C. Haynes & Co.  
 BOSTON, MASS., Boston Cycle & Sundry Co.  
 NEW HAVEN, CONN., Pardee-Ellenberger Co.  
 PROVIDENCE, R. I., Murray, Blanchard, Young & Co.  
 KINGSTON, N. Y., Forsyth & Davis  
 SYRACUSE, N. Y., W. D. Andrews  
 NEW YORK CITY, Blackman Talking Machine Co.  
 NEW YORK CITY, I. Davega, Jr.  
 NEW YORK CITY, Douglas & Co.  
 NEW YORK CITY, Jacot Music Box Co.  
 NEW YORK CITY, John Wanamaker  
 NEWARK, N. J., The Edisonia Co.  
 PHILADELPHIA, PA., Wells Phonograph Co.

EASTON, PA., William Werner  
 BUFFALO, N. Y., P. A. Powers  
 ROCHESTER, N. Y., Talking Machine Co.  
 COLUMBUS, OHIO, Perry B. Whitsit Co.  
 DAYTON, OHIO, Niehaus & Dohse  
 CHICAGO, ILL., O. J. Junge  
 CHICAGO, ILL., James I. Lyons  
 MILWAUKEE, WIS., McGreal Bros.  
 MINNEAPOLIS, MINN., Thos. C. Hough  
 OMAHA, NEB., Nebraska Cycle Co.  
 KANSAS CITY, MO., J. W. Jenkins' Sons Music Co.  
 ST. LOUIS, MO., The Conroy Co.  
 TORONTO, CAN., R. S. Williams & Sons Co.  
 SAN FRANCISCO, CAL., Peter Bacigalupi  
 NINETEEN STORES, The Ray Co.



# EDISON Phonograph Monthly

PUBLISHED FOR TRADE USE ONLY BY  
THE NATIONAL PHONOGRAPH CO.

VOL. 1.

NEW YORK, FEBRUARY, 1904.

No. 12

*The National Phonograph Co.,*

ORANGE, N. J.

NEW YORK: 83 CHAMBERS STREET.

CHICAGO: 304 WABASH AVENUE.

SAN FRANCISCO: 933 MARKET STREET.

NATIONAL PHONOGRAPH CO., LTD., 25 CLERKENWELL  
ROAD, LONDON, ENG.

## EDISON PHONOGRAPHS AND RECORDS.

All communications to THE PHONOGRAPH MONTHLY should be addressed to the Advertising Department, 83 Chambers Street, New York.

C	O	N	T	E	N	T	S
Anent Records.....							1
Advance List of Edison Gold Moulded Records for March.....							3
Mr. Gilmore on the Present and Future...							3
Western Freight Rates Reduced.....							3
Phonograph Records as Part of a School Exhibit.....							4
Loyal Dealers.....							4
Visiting Jobbers.....							4
Phonograph Takes the Place of an Orches- tra at a Theatre.....							5
Novel Way of Using a Phonograph at a Christmas Entertainment.....							5
Printed Matter.....							6
Cheap Records as an Aid in Selling Goods A Publicity Method That Other Dealers Might Follow.....							7
Queen Victoria's Phonograph Message.....							7
Comments on March Records.....							8
Window Displays.....							9
Playing Records by Telephone.....							10
A Dealer's Argument.....							11
No Use for Any But Edison Goods.....							11
New Record Box.....							7
Makes Selling Goods Easy.....							12
A Model "Follow Up" Letter.....							12
Mammoth Phonograph Horn.....							13
Window Display Made by the Stoll Blank Book and Stationery Co.....							13
Suspended List, February 1, 1904.....							14
Jobbers of Edison Phonographs and Records							15

## ANENT RECORDS.

The inability of our factory to fill orders for Records is not the only evidence we have that the Edison Gold Moulded Record is holding its own everywhere as the leading cylindrical Record on the market. An investigation into the output of every factory in the country making cylinder Records shows that we are to-day, and have been for months, making fifty per cent. more Records than any other company. This statement is made on the most reliable information, and the claim of others to the contrary is the merest buncombe. Besides this, letters from the trade in all parts of the country show that Dealers generally are selling as many Edison Records as ever before. This business is being done purely on the merit of the Edison product. Many of our Dealers have put in a line of cheap Records and are using them as a means of selling Edison Records. They play them side by side, and invariably make a sale when a customer is looking for quality. For the richest, clearest and smoothest effects, for its wearing qualities and for its all round desirability, the Edison Gold Moulded Record has no equal; and the buying public admit it.

We are again compelled to ask the indulgence of the trade for our tardiness in making shipments of January Records, the last of them not leaving the factory till January 27, nearly three weeks later than should have been the case. Orders for Records previously listed were so numerous and so urgent that we felt compelled to devote considerable time in manufacturing to fill them, with the result that the January list was held up. We had hoped to get into our new Record plant long before this, but delays in getting ironwork, the extreme cold weather and the difficulty of moving a plant that works nights as well as days have combined to put off the day of occupancy. Until we can get into this new building we must

[Continued on page 3.]

THE ADVANCE LIST OF MARCH RECORDS APPEARS ON PAGE 2. ORDER FROM IT. NO OTHER ADVANCE LIST WILL BE ISSUED.

# ADVANCE LIST OF NEW EDISON GOLD MOULDED RECORDS FOR MARCH, 1904

RECORDS listed below will be ready for shipment as near Mar. 1st, 1904, as possible, at which time Jobbers' stock orders, if placed prior to Feb. 15th, will be shipped. March Supplements will be forwarded to Jobbers with their stock order for Records. Retail Dealers should place stock orders with their Jobbers at once, to insure prompt shipment as soon as Jobbers' stock is received.

- 8624— The Gondolier (Intermezzo) Edison Military Band  
*The new \$5,000 instrumental hit purchased by the popularizers of "Hiawatha"*
- 8625 Maydee (Pretty South Sea Island Lady) Arthur Collins  
*Song with orchestra accompaniment*
- 8626 For Sale—A Baby Byron G. Harlan  
*Charles K. Harris' new descriptive song with orchestra accomp.*
- 8627 A Winter's Evening (Overture) Edison Symphony Orchestra
- 8628 Somebody's Waiting 'neath Southern Skies Harry MacDonough and John H. Bieling  
*Sentimental male duet with orchestra accompaniment*
- X 8629 Bye, Bye, My Honey Coon song Billy Golden
- 8630 Du Du, air and variations Bohumir Kryl  
*Cornet solo with orchestra accompaniment*
- 8631 Alabama Minstrels Minstrels  
*Introducing the ballad "Down in Mobile Long Ago," sung by Harry MacDonough*
- 8632 Uncle Sammy March (Holzmann's Latest) Edison Military Band
- 8633 I'm Longing for My Old Kentucky Home Harry Anthony  
*Descriptive song with orchestra accompaniment*
- 8634 In the Lives of Famous Men Bob Roberts  
*Comic song with orchestra accompaniment*
- 8635 Auction Sale of a Musical Instrument Store Len Spencer and Parke Hunter  
*Comic descriptive talking selection, introducing various musical instruments and effects*
- 8636 Träumerei Mandolin solo Samuel Siegel
- X 8637 Hannah Won't You Open that Door Arthur Collins  
*Coon song with orchestra accompaniment*
- 8638 Medley of National Airs U. S. Marine Fife & Drum Corps  
*Introducing "The Red, White and Blue" and "Yankee Doodle," and Bugles*
- 8639 Beautiful Birds Sing On Harlan & Belmont  
*Whistling and singing male duet with orchestra accompaniment*
- X 8640 Navajo (Indian Love Song) Harry MacDonough  
*As sung by Marie Cahill in "Nancy Brown," with orchestra accomp.*
- 8641 Swedish Garde March Edison Military Band
- 8642 Over the Pilsener Foam Collins & Harlan  
*By the writer of "Down Where the Wurzburger Flows." Male duet with orchestra accompaniment*
- 8643 Dance of the Song Birds Edison Symphony Orchestra
- 8644 I'm Just Barely Living That's All Bob Roberts  
*Coon song with orchestra accompaniment*
- 8645 Where the Sunset Turns the Ocean's Blue to Gold Byron G. Harlan  
*Descriptive song with orchestra accompaniment*
- 8646 Sweetest Girl in Dixie Harry MacDonough  
*Descriptive song with orchestra accompaniment*
- 8647 My Little Irish Canary Collins & Harlan  
*Waltz song, male duet with orchestra accompaniment*
- 8648 Barney Medley Edison Military Band  
*Introducing "Barney," "In the Village by the Sea," "Congo Love Song," and "Coonville's Cullud Band"*



(Continued from page 1.)

ask the trade to be patient. Unless the business increases beyond our expectations, we shall before long be in splendid shape to not only fill orders for catalogue numbers promptly but get out those for the monthly supplement on time.

Beginning this month, a new plan will go into effect with Jobbers, by which they will be enabled to hear all new Records before placing an order for them. For two years or more Jobbers have had nothing upon which to base their judgment of each new list except their general knowledge of the selection and the individual making it, and latterly by the information furnished in the monthly "Comments." A letter was sent to Jobbers in January, offering to send a complete set of each new lot of Records to each Jobber who placed an order for a set and agreed to pay express charges on them. Without exception, all Jobbers have availed themselves of the offer, and a shipment of samples of March Records was made to each on February 5, allowing each Jobber time to play the Records over and still get his order in by the 15th of the month. The plan has met with the most cordial approval of all the Jobbers, and it is expected to be of much assistance in placing orders.

### MR. GILMORE ON THE PRESENT AND FUTURE.

W. E. Gilmore, President and General Manager of the National Phonograph Co., gave an impromptu and informal dinner to a number of Jobbers and officials of the company at Martin's, New York City, on the night of January 21. Twenty-eight were present. The occasion was of a more than ordinary interest for the reason that Mr. Gilmore, on behalf of the company, made his first public announcement concerning the present and future policy of the company.

Mr. Gilmore first referred with much feeling to the loyalty to the Edison product on the part of Jobbers through the entire country; a loyalty in which he felt the greatest pride and a loyalty that meant much for the success of the National Phonograph Company.

Mr. Gilmore then spoke in detail of the introduction upon the market of a cheap cylindrical Record. He said that he was in Europe at the time the announcement was made and he cabled a reply to the effect that no change should be made in the Edison Record. He admitted that the cheap Record had disturbed the trade, and he referred also to the general unrest in all lines of business. He did not

doubt that the lower-priced record had affected the business of some of the Edison Jobbers, but he could say with all sincerity that it had not affected the output of the factory at Orange. The quantity of goods manufactured in the last five months had never been larger. This fact had made it practically impossible for him to put into effect plans which had been under consideration for some time and which would, he thought, not only retain the present prestige of the business but would add greatly to its volume.

He would not say definitely what the plans of the company were, but, whatever the improvements promulgated and carried out, the trade would be taken care of and fully protected. There would be no cutting prices and none would be permitted. The policy of the company in this respect would be carried out with even greater vigor than at any time in the past.

The National Phonograph Company never had said to any of its Jobbers that they should not carry a line of talking machine goods made by other people, but had preferred that they should carry them, if they felt by so doing they could add to their profits. Personally, he was satisfied to have this done. He felt sure that the Edison product would sell the quicker when brought into comparison with others. He closed by inviting the Jobbers present to express themselves frankly on any phase of the business which in their judgment required change or improvement. Every Jobber present availed himself of the opportunity to express his opinion. They suggested changes in equipment and prices of machines; spoke of improvements that they thought could be made in the making of Records; discussed restrictions in selling goods; spoke of credit plans, and dwelt at length upon the situation in general. The trend of this exchange of views may be summed up as follows: No change was necessary in the price of the Edison Record, but, on the contrary, a higher price should be asked for it, if it could be made better; the price of the various types of machines should be increased so as to furnish a better equipment than at present; the cheap Record was cutting much less figure than had been expected, several of the speakers stating that while they had put in the line of them they believed that they had increased the sale of Edison Records by so doing; that the Agreement of the National Phonograph Company should be even more rigidly enforced for the benefit of all concerned, and that Jobbers generally should cooperate with the National Company in eliminating the commercial "dead-beat" from the trade.

### WESTERN FREIGHT RATES REDUCED.

At the recent meeting of the Western Classification Committee, the freight rate on Phonographs in the territory west of Chicago and St. Louis was reduced from double first class to one and one-half times first class, effective February 1st.

## PHONOGRAPH RECORDS AS PART OF A SCHOOL EXHIBIT.

The public schools of Milwaukee, Wis., are to be represented at the St. Louis Exposition this year, and part of their exhibition will be Phonograph demonstrations of class work, recitations, etc. The school authorities took up the matter with McGreal Bros., of Milwaukee, as agents for Edison Phonographs and Records, and another talking machine company. In spite of special inducements on the part of the latter, the Board of School Directors awarded the contract to McGreal Bros. at full list prices. Following is a copy of the official order:

BOARD OF SCHOOL DIRECTORS, MILWAUKEE, WIS.  
Henry E. Legler, Secretary.

Milwaukee, Dec. 29, 1903.

MCGREAL BROS., 173 Third Street, City:

Gentlemen—The World's Fair Committee of the Milwaukee Board of School Directors have awarded to you the contract for supplying Edison (largest size) Phonograph Records and Cabinets at the following figures:

1 Phonograph with brass horn (30 in.).....	\$35.00
2 Home Phonographs at \$30.....	60.00
2 Sets of three-way ear tubes at 50 cts. a way.....	3.00
3 Cabinets No. 517 in weathered oak at \$17.50.....	52.50

Records at 25 cents each.

Time consumed in taking records, 50 cents per hour; work to begin January 18.

Henry E. Legler, Secretary.

McGreal Bros. have agreed to furnish a man, a Phonograph and the necessary apparatus for making Records, and about ten days will be consumed in visiting the different schools. This contract is a distinct endorsement of the Edison product, for the school authorities went over the matter with unusual care, finally selecting the McGreal Bros.' proposition at a higher figure than offered by the competing company. Dealers in Edison Phonographs and Records who visit the St. Louis Fair during the coming Summer should look up Milwaukee's school exhibit and inspect the result of this new feature. The Milwaukee *Free Press* on January 17 said of this matter:

"Singing of Milwaukee school children will be heard at the Louisiana World's Fair in St. Louis as the result of the departure of the School Board. It has engaged McGreal Bros., 173 Third street, dealers in Phonographs, to make Records of the voices of the children. These Records will be sent to the Edison Laboratory at Orange, N. J., where they will be duplicated and sent to the Fair.

"Nearly every school in the city will be represented. A class from each school, the number being left to the discretion of those in charge, will be taken to the offices of McGreal Bros., where a record of their singing ability will be made by Phonographs. About 100 Records will be taken. It is the intention of those in charge to have twelve classes a day taken to the offices, and each class will be allotted one-half hour.

"McGreal Bros. have brought Harvey Emmons to the city to conduct the taking of records. Mr. Emmons has been engaged in this

line for fifteen years with the National Phonograph Company, of Orange, N. J., a part of the Edison Company. He arrived in the city yesterday with special paraphernalia."

## LOYAL DEALERS.

One of the most gratifying things in connection with our business is the loyalty to the Edison product shown by Jobbers and Dealers everywhere. It has always been a feature in which the officials of the National Phonograph Company have felt the greatest pride, but it has never been so strongly manifested as in the past five months. Our salesmen meet it everywhere. Whenever an official of the company comes in contact with one of the trade he finds that Edison Phonographs and Records are being pushed to the exclusion of other goods. Letters from all parts of the country are full of kind words for Edison goods and the National Phonograph Company. All of this is gratifying to the company because it shows that the trade has realized beyond question that our chief aim is to sell our product through Jobbers and Dealers and not at retail. It is a complete recognition of our policy, and shows an absence of distrust on the part of the trade. It is a strong approval of the plan we are following in restricting prices, protecting the trade and prosecuting those who violate our Agreement; a plan that grants no favors to a few, but treats all with absolute uniformity. There will be no change in this plan, but on the contrary nothing will be left undone to make it more effective in increasing the business of Jobbers and Dealers.

## VISITING JOBBERS

The visiting Jobbers from out of town during January were the following: William Werner, of Easton, Pa.; S. J. Francis and D. R. Harvey, of the Iver-Johnson Sporting Goods Co., Boston; John N. Willys, of the Elmira Arms Co., Elmira, N. Y.; W. O. Pardee and H. L. Ellenberger, of Pardee-Ellenberger Co., New Haven, Conn.; H. E. Fredrickson, Omaha, Neb.; J. M. Linscott and G. A. Patten, of the Boston Cycle and Sundry Co., Boston; Louis Buehn, of the Wells Phono. Co., Philadelphia; W. D. Andrews, of Syracuse, N. Y.

## ART CALENDAR EDITION EXHAUSTED.

The edition of the Phonograph Art Calendar is now exhausted and no more orders from the trade can be filled. This calendar was everywhere conceded to be one of the most attractive issued by any firm for advertising purposes.



### PHONOGRAPH TAKES THE PLACE OF AN ORCHESTRA AT A THEATRE.

"Immediately on taking charge of this store fortune threw an excellent opportunity in my hands of giving the Triumph Phonograph a hearing by a select audience," writes John E. Finney, successor to The Ray Co., at Savannah, Ga., under date of January 5.

"The management of the local theatre have been having considerable trouble with their orchestra, and on Thursday evening last Virginia Harned was booked to present 'Iris.' One of the largest audiences of the season assembled at the theatre, and it was learned at the last moment that the orchestra was not to put in an appearance. The writer stepped in the breach and supplied the place of the orchestra with the Triumph, and a selection of operatic and popular music, playing before the performance and during the intermission. The innovation caused some amusement at the start, but before the evening the occasion made many new friends for the Edison wonder, judging from the frequent and long applause following our selections.

"We made good beyond doubt; for the management requested that we repeat our 'orchestra' for Roselle Knott, who, with 'When Knighthood Was in Flower,' attracted a large audience at a matinee on Friday and a brilliant audience at night. Our end was a pronounced success, and has been favorably commented on by the papers here. I write this to you because while I have been pretty well posted on the doings of playhouses generally, I have never heard of this being done before. Whole entertainments have been given without doubt; but never as an orchestra that I have heard.

"We have been asked to continue this week, which we are doing. The *Savannah Press*, in commenting on the performance of 'Iris,' says in part: 'Not the least enjoyable part of the evening was contributed by the Edison Phonograph. With this device Mr. Lauten has graph, which, in place of the orchestra, supplied the musical end of the evening.'"

### ADVERTISING PHRASES USED BY SOME PROGRESSIVE DEALERS.

Edison Phonographs double the pleasure of living.—*Douglass & Co., New York city.*

Unapproachable in its perfection—the Edison Phonograph.—*John E. Finney, Savannah, Ga.*

Don't be fooled, the Genuine Edison Gold Moulded Record will outlast six of any other style wax records. The Edison Record is, in fact, the only genuine Moulded Record made.—*Wells Phonograph Co., Philadelphia.*

The Great Edison Phonograph sings its own praises and leads the world.—*Keller's Music House, Easton, Pa.*

Edison Gold Moulded Records: Moulded in gold, as good as gold, staple as flour, and are not on the bargain counters of department stores.—*The Eastern Talking Machine Company, Boston, Mass.*

If you use the standard or cylinder Records and want the very best then you simply want the Edison.—*C. R. Zacharias, Asbury Park, N. J.*

### A NOVEL WAY OF USING THE PHONOGRAPH FOR A CHRISTMAS ENTERTAINMENT.

The Pardee-Ellenberger Co., of New Haven, Conn., send the following contribution from F. W. Willoughby, of East Haven, a Phonograph enthusiast:

There was a family gathering of twenty-four in New Haven, Conn., on Christmas Day and the Phonograph was used as a "Santa Claus." For instance, one of the party had a favorite Record—"The Parrot Said." At the finish of the Record he received a large green parrot. The Record entitled "The Miller's Daughter" was then played, all joining in the chorus. The Record "Anona" was played for a "two-step" with good success, the music being loud and clear. Another of the party had a favorite Record, "Turkey in the Straw," by Billy Golden, and at the finish of this Record a turkey stuffed with straw was given. The Military Lancers was then played for a good old-fashioned square dance, the music and prompting being very distinct. Then the party sang "Won't You Roll Them Eyes," by Arthur Collins. Another of the party is a great lover of Indians. "Hiawatha" was then played and an Indian was presented. A number of two-steps and waltzes were played for dancing and gave excellent satisfaction. Still another of the party who thought "Under the Bamboo Tree" was "about what the Doctor ordered" was given a Bamboo Queen. The owner of the machine played the Record "High Up in a Coconut Tree," and was the recipient of five monkeys. "Turkey in the Straw" was then played for a Virginia reel, and so on through the day the Phonograph was brought in as a funmaker, and was a grand success, there being no end to the uses to which a Phonograph can be put.

### A PHONOGRAPH PARTY.

"Enclosed find copy of rather unique invitation, which proved profitable to both Mr. Delahanty and ourselves, as each guest bought from one to three Records. O. J. JUNGE, 245 E. Chicago Ave., Chicago, Ill."

The invitation was as follows:

WHOA BILL! WHOA BILL!  
STOP! BACK UP!

Mr. O. J. Junge, you are respectfully invited to attend an Edison Phonograph Party, to be given by Mr. and Mrs. Edward F. Delahanty, at their Summer home, 311 Illinois street, Saturday evening, August 8, 1903. The leading man of the evening will be Mr. James Hall, and DON'T FORGET TO BRING YOUR RECORD. As ever, your old-time friends,

MR. and MRS. E. E. DELAHANTY.

J. H. Snyder, a Dealer at Urichsville, Ohio, on one Sunday recently gave a Phonograph entertainment to about 100 inmates of the county infirmary, in place of their usual Sunday afternoon preaching service. The inmates declared that the Phonograph entertainment was better than that led by the minister.

**PRINTED MATTER.**

We do not seem to be able to make Dealers understand our position with reference to sending out printed matter. Most Dealers have no direct connection with the company, and it is not possible to send them printed matter with their goods. In most instances the quantity of printed matter supplied to Dealers is not large enough to make a freight shipment. Therefore, only one other way remains, to get the matter into the hands of the Dealer, viz., to send it by express at his expense. Instead of having Dealers ask us to do even this, we prefer that they get printed matter from their Jobbers. We endeavor to keep the latter supplied, and they should be able most of the time to take care of the wants of the Dealers. If a Dealer cannot get this attention, we are willing to do whatever we can to assist him, but it must be understood that such orders for printed matter can only be sent by express at the expense of the Dealer.

The printing in sheet form for the use of the trade of the Comments on new Records from the PHONOGRAPH MONTHLY continues to be popular. A number of Dealers have written that they would like to use these sheets if they could get them. All such and others interested may have these Comments mailed to them by remitting to the Advertising Department postage stamps at the rate of 20 cents per hundred for the Comments and 8 cents for postage. The amount is so small that we must ask Dealers to send postage with their order.

We have had printed a quantity of gummed stickers 1x1½ inches in size, printed in gold on black paper, for the use of such Dealers as will agree to stick them on envelopes, packages or any other matter going out of their stores. The different forms of these are as follows:

**EDISON GOLD MOULDED RECORDS.**

Richest, Smoothest, Most Brilliant.

**EDISON GOLD MOULDED RECORDS.**

Sustained by their Reputation.

**EDISON GOLD MOULDED RECORDS.**

No Scratch. No Changing Needles.

**EDISON GOLD MOULDED RECORDS.**

They Praise Themselves. Hear Them.

These can be sent out by mail, and we shall be glad to furnish small quantities to all Dealers who will agree to use them to advantage.

A new Dealers' Discount Sheet was recently mailed to the entire trade. This contains but few changes. The only change of importance is that of straightening out the matter of discounts on Model B Reproducers, which was not clear in the former Discount Sheet. We have also cut out the discounts on some accessories that we are no longer carrying.

A new Record Catalogue will be issued about March 1st which will contain all Records listed to and including March. If the trade finds that the Advertising Department is cutting down orders for the present catalogue it will understand that this is being done in order to make

the present edition last until March 1st, and because we do not want the trade to have many of the present catalogue on hand when the new one comes out.

The last of the series of colored hangers, Form 433, was mailed to the trade in January. New designs are under consideration and will be sent out later in the year.

Catalogue of Parts, Form 371, has been superseded by Form 515, but the latter includes no new matter and no changes of any moment. Dealers who have catalogue Form 371 on hand will find it quite as reliable as the new edition.

We are reprinting Form 427, a booklet on the Art of Making Phonograph Records. This is a booklet that might be used to advantage by all Dealers. The Record-making feature is one in which the Edison Phonograph excels all others beyond a question of doubt, and it should be made more of a talking point in the sale of machines than is now done. Then, too, many individuals who now own a Phonograph, but whose interest in it has waned, may be induced to take a new interest if given this little booklet on making Phonograph Records.

### **CHEAP RECORDS AS AN AID IN SELLING EDISON RECORDS.**

Campello, Mass., Jan. 18, 1904.

I have put a man on the road, selling and advertising Edison Phonographs, and his principal work, together with mine, is taking in the shoe factories at the noon hour. The city of Brockton is one of the largest shoe cities in the world and employs about 12,000 operators in that capacity. Now, our method is to call at the factory, set up our machine, and give them a concert during the noon hour, at the same time giving out circulars and advertising matter to each and every one. We find that this is a fine idea, and we have made lots of sales this way, together with lots of advertising.

I put in a stock of ——— Records. I have been slow not to put them in before, for I am certain that they will be a help in selling Edison goods. Lots of people realize that the ——— looks very similar to the Edison, but when they hear the two it gives them a very different idea, and I find that I am right in this respect. I have sold a great many Edisons to people who have come in to buy ———.

One particular instance I would like to mention. A gentleman called at my store the other evening and asked if I kept ——— Records, and if he could hear some. I played about a half dozen of the ———, and he picked out two of them. Then I put an Edison in without his knowing it. When the piece was played he said, "That is the finest Record that I have ever heard; you can save that out for me."

I then informed him that that was an Edison, and he said: "What did you do that for?" I replied that I simply wanted to show him the difference. So I put the Edison back on the shelf, and put on more ———'s. After the next ——— was played, he said: "I want that Edison Record you just played if it costs me a dollar."

GEORGE J. DONAHUE.



### A PUBLICITY METHOD THAT OTHER DEALERS MIGHT FOLLOW.

John E. Finney, successor to The Ray Co., at Savannah, Ga., gave a complimentary concert with an Edison Triumph Phonograph to Mistletoe Camp, No. 4, W. O. W., at its annual banquet and installation of officers on January 8. Mr. Finney operated the machine personally and worked up considerable "ad" talk during the evening. The following programme was given:

1. Southern Smiles—March.....  
.....Edison Military Band  
(Note absence of "Scratch" and "Blast" effects.)
2. Up in a Coconut Tree—Song.....  
.....Billy Murray
3. Le Secret-Polka—Cornet Solo.. John Hazel
4. Sammy—Song ..... Harry McDonough
5. Laughing Water..... Edison Concert Band
6. Down in the Depths—Song.....  
.....Frank C. Stanley
7. Waldmere March... Edison Military Band
8. When Kate and I Were Coming  
Through the Rye..... Byron G. Harlan
9. Peaceful Henry..... Edison Concert Band
10. The Girl You Love—Song.....  
.....Harry MacDonough
11. Donkey Laugh..... Peerless Orchestra
12. In Silence—Song..... Arthur Clifford
13. Any Rags—Medley.. Edison Military Band
14. Jack Tar—March... Edison Concert Band
15. Violin Solo..... Chas. D'Almaine
16. Piano Solo..... Frank P. Banta
17. Thy Beaming Eyes—Song. Arthur Clifford
18. Amourese Vals ..... Peerless Orchestra

### A PRIMITIVE DIAPHRAGM.

John Rogers, of the Knoxville Typewriter Exchange, Knoxville, Tenn., recently wrote:

It is truly said that "Necessity is the mother of invention," but it is curious to see what necessity brings forth sometimes. For example, note the enclosed diaphragm which we have just taken out of a reproducer sent in from a remote mountain district.

The diaphragm was a piece of thin tin, plain solder had taken the place of stratena, and the rubber gasket was a piece of rubber cut with scissors. It would be interesting to know how this device reproduced sound.

### NEW RECORD BOX.

We are planning to adopt a new style box for packing single Records. It will be made so that it will not be necessary to wrap the Records in cotton. It will be slightly over  $2\frac{3}{4}$  inches in diameter and  $4\frac{5}{8}$  inches long. It will have a countersink top and bottom of nearly a half-inch so as to hold the Record firmly on the peg inside the box. We cannot yet say when we shall begin to use this box. Reference is made to it in order that Dealers may know of its size in putting in new racks or re-arranging their present racks.

### A WORD FOR THE GEM.

"One of our regular customers called last week," wrote C. J. Heppe & Son, of Philadelphia, recently "and made this remark: 'I want to buy a Phonograph as good as the one I have just sold. I have had a Gem for two years, and last Saturday evening one of my neighbors called and asked if I would sell it; I told him I paid \$10 for it and couldn't sell it for less, but that it had been running for two years. The neighbor went home and in half an hour came back with the \$10, saying he would rather have a machine that had been run two years than a new one he did not know anything about.' Our customer purchased a Standard and went away much pleased.

### QUEEN VICTORIA'S PHONOGRAPH MESSAGE.

Sir John Harrington—for he has been knighted by King Edward—is the only person who ever succeeded in inducing the late Queen Victoria to talk into a Phonograph. And she did this reluctantly, merely because he explained to her the immense weight that a message from her to the Emperor of Abyssinia conveyed in that fashion would have upon the monarch of Ethiopia.

Queen Victoria, however, stipulated that once her message had been delivered to the negus the record should be destroyed, and pledged Sir John Harrington to see to this in person. Menelik was so delighted at hearing the Queen's voice that he promptly demanded that the record should be handed over to him. But Sir John naturally was obliged to defer to the commands of his royal mistress, and, taking hold of the record, he stamped it to pieces in the presence of the negus.—*London letter to the Chicago Daily Tribune.*

### A LETTER FROM HALIFAX.

9 MATLOCK ST., LEE MOUNT, HALIFAX.

I now have great pleasure in thanking you for the EDISON PHONOGRAPH MONTHLY. Both myself and friends have read and looked it over many times. It puts us people right up to date. It tells us what to look out for and what is coming, and, best of all, what is popular. I have been using Concert Records up till now for exhibiting, but I have taken large cylinder off and put a small one on, with just one an Edison's. It is a pleasure to look at a selection of Records at the present time—every one an Edison's. It is a pleasure to look at a Edison Gold Moulded Record, and much more to hear one. I think I ought to know when I hear one, having been in the line twelve years. There is a lot of cheap rubbish on the market here at the present time—Record destroying machines and all kinds of "moulded" rubbish.

By the way, I am sorry to see that my countrymen should stoop so low as to *throw dirt* by advertising as they have done against the Gem Machine. In my estimation it is the neatest, compact and best little machine that has ever been produced at the price, and always gives satisfaction. I never knew any one his bargain yet.

ALFRED HOYLE.

### COMMENTS ON MARCH RECORDS.

Plenty of variety marks the list of new Edison Gold Moulded Records for March. The twenty-five new Records for the month include four by the Edison Military Band, two by the Edison Symphony Orchestra, a cornet solo, a mandolin solo, four vocal duets, ten vocal solos, one talking with music, one fife and drum corps and one minstrel. The purchaser of the entire list will find himself the possessor of a lot of Records that will furnish a delightful evening's entertainment and be sufficiently diversified to amuse any company, either large or small. All of the vocal selections but one are accompanied by a complete orchestra, and these accompaniments are a most delightful feature of each Record. Those who buy any of them will find the accompaniments quite as attractive as the songs themselves.

No. 8624, "The Gondolier," an intermezzo played by the Edison Military Band, is the new \$5,000 instrumental hit purchased by Shapiro, Remick & Co., proprietors of the Whitney-Warner Company, who popularized "Hiawatha." The publishers expect as great popularity for "The Gondolier" as was achieved by "Creole Belles" and "Hiawatha." This selection has an exceedingly attractive air, and is played by the Edison Military Band in a manner that does the selection full justice. It is certain to be a popular Record.

No. 8625, "Maydee" ("Pretty South Sea Island Lady"), is a song written by Arthur J. Lamb, the music of which was composed by Harry Von Tilzer. This song, with orchestra accompaniment, as sung by Arthur Collins, is a worthy addition to Mr. Collins' long list of good selling Records. The air of the song is of a character that cannot fail to make this Record popular.

No. 8626, "For Sale—A Baby," is a new descriptive song by Charles K. Harris, and is sung with orchestra accompaniment by Byron G. Harlan. Mr. Harlan's rendition of Mr. Harris' songs has made this class of Records in great demand. The story told by the song is very pathetic. Mr. Harlan sings the selection in excellent style.

No. 8627, "A Winter's Evening," an overture by the Edison Symphony Orchestra, is taken from "To-Night We Say Farewell," a potpourri by R. Schleppegrall. The music is charming and the Record is finely played.

No. 8628, "Somebody's Waiting 'Neath Southern Skies," is a sentimental male duet by Harry MacDonough and John H. Bieling, who sing together for the first time. The result of their effort is a Record of much merit, their voices blending together finely. An orchestra accompaniment adds to the beauty of the selection. The words of the song are by Arthur J. Lamb and the music by John W. Bratton.

No. 8629, "Bye, Bye, My Honey," is another of Billy Golden's inimitable coon songs, the demand for which shows little signs of diminution. "Bye, Bye, My Honey," is as full of coon talking and singing as "Rabbit Hash," and should equal it in popularity.

No. 8630, "Du Du," air and variations, is a cornet solo, with orchestra accompaniment, played by Bohumir Kryl. This composition shows what can be done with the cornet when played by an artist of the first rank.

No. 8631, "Alabama Minstrels," is the first of a new series of minstrel Records, and is made by the Edison Minstrels. The introductory overture is the "Tariff Galop," and after the usual jokes Harry MacDonough sings the ballad, "Down in Mobile Long Ago," the chorus being sung by a quartette. One of the best minstrel Records ever made and one that represents unusual care and expense in the making. All who hear this Record will realize that in making Master Records the National Phonograph Co. is leaving nothing undone to make its Records superior to anything on the market.

No. 8632, "Uncle Sammy March," is a two-step by Holzmann, and is played by the Edison Military Band. It has a bell solo and is an excellent Record in every respect. This selection was listed in January as a xylophone solo and became very popular. It has been made as a band Record at the general request of the trade. It will be one of the best sellers on the list.

No. 8633, "I'm Longing for My Old Kentucky Home," is a descriptive song, with orchestra accompaniment, which introduces to the Edison Phonograph public Harry Anthony, a new singer. Mr. Anthony is a well known vocalist, and has a fine tenor voice. His first Record is an excellent one and promises much for the future. The music of this song is very pretty. It was written by J. B. Muller. The words are by Vincent Bryan.

No. 8634, "In the Lives of Famous Men," is a comic song with orchestra accompaniment. It is sung by Rob Roberts. It is topical in character and shows how great men gain distinction. It has witty hits on Washington, Columbus, Macbeth, Wagner and other men of fame. Edward P. Moran is the writer of the words of this ditty and Seymour Furth wrote the music. Every word can be clearly understood, adding much to the desirability of the selection.

No. 8635, "Auction Sale of a Musical Instrument Store," is a good descriptive talking and musical Record by Len Spencer and Parke Hunter. It introduces various musical instruments and musical effects, with a funny talk by Mr. Spencer upon the merits of each instrument as it is put up for auction.

No. 8636, "Träumerei," is a mandolin solo of Schumann's delightful composition, and is played by Samuel Siegel. It is an excellent mandolin Record.

No. 8637, "Hannah, Won't You Open That Door?" is a coon song, with orchestra accompaniment, by Arthur Collins. It is a song of the "Bill Bailey" style. It tells how Bill Johnson stands outside the door, cold and hungry, and appeals to Hannah to open the door and let him in. The air is catchy, the words funny,



and Mr. Collins sings in a manner that shows what a good voice and earnest effort will do toward building up a reputation for a singer. If this Record does not prove popular the judgment of all who have heard it will be at fault.

No. 8638, "Medley of National Airs," is a Record by the United States Marine Fife and Drum Corps and introduces "The Red, White and Blue," "Yankee Doodle," and the playing of bugles. It will be popular with those who like Records of this character. The playing of the bugles is excellently brought out.

No. 8639, "Beautiful Birds, Sing On," by Harlan and Belmont, is a whistling and singing duet, with orchestra accompaniment, that will be in great demand. Mr. Belmont does the whistling in a most artistic manner and joins in singing the chorus, Mr. Harlan singing the air. The music is unusually pretty.

No. 8640, "Navajo," is a Record of the now well known Indian love song by Marie Cahill in "Nancy Brown." The Record is made by Harry MacDonough with orchestra accompaniment, and it gives a fine rendering of this popular song. It will certainly be a great seller. Harry W. Williams wrote the words of this song and Egbert Van Alatyne wrote the music. This song is listed at a most opportune time, for it is being sung and played everywhere. It is so well known that there cannot fail to be a great demand for it in Edison Records.

No. 8641, "Swedish Garde March," by the Edison Military Band, is a Record of an excellent march very popular in the Northwest, and listed in response to demand from Phonograph enthusiasts in that part of the country. It will be a much-admired Record, for it has a soldierly air and is played in the unequalled style of the Edison Military Band.

No. 8642, "Over the Pilsener Foam," is a song by the writer of "Down Where the Wurzburger Flows," and is sung as a male duet, with orchestra accompaniment, by Collins and Harlan. The air has a good swing and the chorus will be popular. The words and music of this song are by Vincent Bryan and J. B. Mullen. It goes without saying that Collins and Harlan make the Record artistically.

No. 8643, "Dance of the Song Birds," by the Edison Symphony Orchestra, is a novel composition by Benjamin Richmond and arranged by C. A. Egener. Interspersed with the music is the warbling of several species of birds, making a Record of unusual attractiveness. It would be difficult to find a more beautiful reproduction of sound.

No. 8644, "I'm Just Barely Living, That's All," is another coon song, with orchestra accompaniment, by Rob Roberts, whose Records are proving an excellent addition to the monthly list. This song tells of a coon's hard luck in speculation and in the Klondike gold fields. The words are by Harry Brown and the music by Tom Lemoinier.

No. 8645, "Where the Sunset Turns the Ocean's Blue to Gold," is a descriptive song, with orchestra accompaniment, by Byron G. Harlan. The words of this song are by Eva Fern Buckler and the music by H. W. Petrie. Besides its pretty air, prominent features are

the ringing of bells and the singing of birds. Mr. Harlan's singing will make it a good selling Record.

No. 8646, "Sweetest Girl in Dixie," is a pretty descriptive song, with orchestra accompaniment, sung by Harry MacDonough. The words of this song are by James O'Dea and the music by Robert Adams. Mr. MacDonough makes the Record with excellent voice and clear articulation. The latter, in fact, is a feature of all of Mr. MacDonough's Records.

No. 8647, "My Little Irish Canary," is a new member of the popular waltz family, and is sung as a male duet, with orchestra accompaniment, by Collins and Harlan. A feature of the song is the warbling of a canary. The Record is made in the usual careful manner characteristic of the work of these two singers, and will make the air popular all over the country. The words of this song were written by Andrew B. Sterling and the music is by Will M. Cook.

No. 8648, "Barney Medley," is another of the popular medleys, one of which is being issued each month. This one introduces "Barney," "In the Village by the Sea," "Congo Love Song," and "Coonville's Cullud Band." This Record will be popular not alone because it is finely played, but because it gives the airs of four different songs, all of which are well known and popular.

#### WINDOW DISPLAYS.

On another page we print a picture of a window display made by the Stoll Blank and Stationery Co., of Trenton, N. J. We shall be glad to have other enterprising Jobbers or Dealers send us photographs of any unusually good window display they may make. Such as possess sufficient merit will be reproduced in these columns.

"My Phonograph department had a very novel attraction in the window during the holidays," writes Andrew Redmond, a Dealer at Harrisburg, Pa. "It was as follows: We had nine small (14-inch) horns placed in a semi-circle, with a colored electric light in each of them. The window was trimmed in black. Under these small horns we set a Concert Phonograph, with a 24-inch horn attached, the horn having a red electric light inside it. The remainder of the space was taken up with a Home, a Standard, reproducers, tubes, single Record boxes, and one and two dozen Record boxes.

"It made quite an attraction and, best of all, an excellent advertisement in that line."

#### LETTERS FROM DEALERS.

We have received an unusual number of letters from Jobbers and Dealers—letters full of kind and encouraging words—but owing to a crowd of other matter we have been able to print only a few of them. Next month we will give them more space.

**PLAYING RECORDS BY TELEPHONE.**

Albert E. Lauten, of the Washington Cycle Company, New York City, has arranged a device by which he makes it possible to play Records by telephone; in other words, a device which enables him to put a Record on a Phonograph in his store and enables any user of the telephone to hear it almost as satisfactorily as he would if in the store. Mr. Lauten places the Phonograph within twenty inches of the telephone transmitter, which must be lowered to a point exactly at right angles from the wall. He then connects the Phonograph and the telephone with  $\frac{5}{8}$  inch bicycle tubing, polished on the inside as brightly as possible, using fluxine, a brazing compound found in bicycle stores. This tubing is connected to the Phonograph with the usual rubber tubing, the edge of the metal tubing at the point of connection being filed within, so as to permit of ready transmission of the sound waves. The mouthpiece is unscrewed and the tubing placed within one-thirty-second of an inch from the diaphragm of the telephone.

It is quite impossible in this article to explain in detail just how these connections are made, but any one with a mechanical turn of mind will doubtless be able to accomplish the same result, even though they do not arrange the device in the same way that Mr. Lauten has done. With the receiver of the telephone it is possible to talk to the customer at the other end of the wire, or the Phonograph horn may be placed inside the mouth piece and the Record heard in the same room in which the Phonograph is played; in other words, the sounds from the Records may pass through two telephones and come back to the operator at the machine. With this device Mr. Lauten has played a Record for a customer in Jersey City and heard it in his store at the same time. We have no doubt that if any Dealers are interested in the matter, Mr. Lauten will be willing to furnish information about it upon request.

**A SUCCESSFUL DEALER.**

Zanesville, Ohio, Jan. 14, 1904.

My experience in the Phonograph business has been somewhat different than what I expected when I first took it in as a side line in connection with the sewing machine business. I thought that if I could clear a profit of three or four dollars a week I would be doing very well. If I can do as I should the rest of the month, my first year, ending with January, will be a business of over \$5,000. I started with a stock of 150 Records and three Phonographs. Now I carry a stock of over 2,000 Edison Records with from 12 to 15 Phonographs on hand. I am doing a payment business with the machines, but Records are cash. I never have any calls for ——— goods, and as for ——— machines and discs, while I have the three machines on hand I bought seven or eight months ago, and I sell a few of their Records. I don't think that it has ever paid me. So with what little I know of the business I will stay with the Edison goods. As a new Dealer for the first year, I do not think that I have done so bad. To the Edison Company must be given the credit for holding up prices.

CHARLES A. WILLIAMS.

**A HANDSOME SALE.**

H. Jaffee, a Dealer at Hoboken, N. J., reports the sale of a Triumph Phonograph, a large horn and stand, cabinet and 150 Edison Gold Moulded Records to one customer and at one time. He claims that this sale is almost a record breaker.

**OUTDOOR PHONOGRAPH EXHIBITIONS AT 13 BELOW ZERO.**

M. Smith & Co., of Quebec, Canada, recently wrote that they were giving outdoor exhibitions at 13 degrees below zero with an Edison Home Phonograph. They made a seven-eighths inch hole in the door frame and passed through the end of an eighteen inch long rubber tube, attaching the horn outside of door, and the other end of the tube to the Home machine inside. They found that playing music in this manner was a good advertising medium.

**THE EDISON PHONOGRAPH STANDS FIRE.**

"Not long ago a dwelling caught fire here in our neighborhood in which was an Edison Phonograph and a piano," writes L. R. Porter, of Brockton, Mass. "Strange as it may seem the piano was pretty well burnt up but the Phonograph escaped with hardly a scratch. After the fire was out some one in the crowd standing around remarked that it was singular that the piano should get burned and the Phonograph not. A lad in short trousers then spoke up. "Oh, that's easy. You see the firemen can't play on the piano, but they can all play on the Phonograph." Cheers were given for the kid and the Edison Phonograph."

**I. C. S. MATTERS.**

AMHERST COLLEGE.

Amherst, Mass, January 15, 1904.

The system of teaching German employed by The International Correspondence Schools has been in use in my German Club for nearly a year. The Phonograph Records and the instruction books have proved an invaluable aid in acquiring the spoken language, and in supplementing the work of the class room. I believe every college could make good use of this system in connection with the regular methods of instruction.

H. B. RICHARDSON, Professor of German.

Asbury Park, N. J., Jan. 9, 1904.

INTERNATIONAL TEXT BOOK Co., Scranton, Pa. :  
Seeing your advertisement in December issue of the EDISON PHONOGRAPH MONTHLY, I sent to Douglas & Co., of New York, for a sample set of Language Records and text books, and have succeeded in selling one set of German along with the Phonograph, and feel sure that other sales will result. I thank you for your interest and pains taken in getting me started right.

C. R. ZACHARIAS.



**A DEALER'S ARGUMENT.**

One of the most interesting bits of printing matter received from Dealers during the past month was a four-page folder, containing the following unique argument in favor of the purchase of an Edison Phonograph:

**A SUGGESTION TO RURAL SCHOOL TEACHERS.**

Whether teaching is your life work or only a temporary expedient, you want to be successful at it and you cannot afford to neglect any means that will contribute to that success.

As an *invaluable assistant* to your work I wish to suggest to you the Edison Phonograph.

To those of you who are acquainted with the merits of this machine a multitude of ideas will immediately occur for its use in the school room.

To those of you who are not familiar with it I will enumerate a few only, and after you have a Phonograph in your school new uses will constantly occur to you.

**CAN YOU SING?**

If not, the Phonograph will lead the singing for you. All the national songs and the grandest hymns are on the list of the Phonograph Records and sung in such a way, too, as few, if any, persons drawing a district school salary can equal. The pupils will soon learn the songs from—and sing them with—the Phonograph. The machine has no low-spirited days; it never has a cold; it always puts the same life and spirit into its songs, so the school will learn to sing well.

**DO YOU PLAY?**

If you have ever attended the city schools you know what an important part instrumental march music plays in the training there. It gives all the spirit to the calisthenic exercises, and many well authenticated cases attest the inestimable value in saving life and preventing panic among the pupils of the drill used in dismissing school. The habit of this drill and the readiness of the response by the children to the familiar march music becomes second nature. The rural school seldom possesses an instrument of any kind, and the Phonograph is the most easily obtained, and its portability alone makes it the only possible one in many cases.

Perhaps you are teaching languages, or are yourself, in spare moments, studying language. Here you will find the records with absolutely correct pronunciations of great assistance. Your pupils could practice pronunciation while you are busy at something else—or you acquire it yourself, as you could not otherwise without an expensive teacher. The Phonograph is always ready to repeat patiently and distinctly. It has no nerves—does not get cross and scold, or call you dull and stupid. It never tires of a scholar, and will not get impatient with the dullest.

If you are a musician you will enjoy playing the music of the masters to the school, and in this way many will be able to hear music of a class that never in their life time would they hear were it not for the Phonograph. When you realize that the blare of the circus band once a year and the country town brass band are the only music that many people ever hear, and that with the Phonograph you can give them the performances of the very best

orchestras and the music of the grand operas, you will find a new interest in life in watching the development of the instinctive musical sense that exists in embryo in many tender natures in the remotest settlements.

Many other ideas suggest themselves, but I will stop with this for the present.

Buy a Phonograph. Buy one at once; even if it takes the big end of a month's salary, buy. You will be surprised and pleased at your own and the scholars' pleasure in it, and it may be the one thing that decides your board to call you back next year.

I enclose price list and hope to have your early order. Write to me anyway. Yours truly,

E. R. GUTHRIE,  
1540 O Street, Lincoln, Neb.

**NO USE FOR ANY BUT EDISON GOODS.**

Vincentown, N. J., Jan. 14, 1904.

Your Suspended List received, and will say that no one gets anything from me only at list prices. As for ——— Records, I would not have them given to me, as I have had a little experience in them. I had a \$60 ——— machine that I bought from a man that had got an Edison Home. He had got tired of the old one, so I got it cheap. One day a young man passing my place heard me playing my machine; he had a Standard and three dozen Records in a case. His business was to give entertainments at public schools. Well, I thought that I would like to try some of his Records, so he said, "With pleasure; use any you like." After I had played a few he asked me if he might put his machine behind my large horn. I said yes. Well I found a great difference, but did not pretend to know it. I said: "How will you trade?" But he shook his head. I offered him \$5, then \$10; but he said: "Look here, boss, I would not have that machine as a gift." Well, I felt so cheap I did not know what to do with mine. I believe if anybody had offered me ten cents for mine I would have taken it. So I chanced it off, and now that I am a Dealer I don't want any Machine or Records but Edison's. They don't scratch or wear the sapphire flat and run two crests at one time, but give clear and distinct music. I am not afraid to sell an Edison, for I know they will give satisfaction; but as for the ———, why, I have some now that have been brought back and I cannot sell them around here or even give them away.

WILLIAM HOBSON.

**AN ENGLISH DEALER'S COMMENTATION.**

Following is an extract from a letter written to our London office by James A. Bailey, a Dealer at Cross Green, Soham, England:

Cross Green, Soham, Eng., Dec. 29, 1903.

Just a line to say that since you fixed the prices for Edison Machines and Records we increased our stock and have pleasure in stating that this Christmas we have sold three times the quantity of machines and Records that we have previously disposed of. We shall always keep as good a stock as possible if prices are strictly fixed in future.

**MAKES SELLING GOODS EASY.**

O. C. Thompson, a Dealer at New Albany, Ind., has devised an attachment to the Phonograph which he is using at his store and in which many readers of the PHONOGRAPH MONTHLY will be considerably interested. Mr. Thompson describes the device as follows:

"To a Home machine (or any other type) bore a hole in the start lever and attach a chain, which should run over a shieve at the edge of the machine, which will prevent chain from scratching varnish. To this chain is attached a weight, which will, when dropped about three or four inches, throw the start lever and cause the machine to start. This weight is a part of an electrical contrivance known as a chain drop (commonly used in fire engine houses for opening doors, dropping harness, etc., when an alarm is sounded), which I constructed myself. This chain drop is connected to a set of dry batteries through a common door bell switch and a Victor door trip, which is on the front store door. I put on the machine a record which I made especially for the occasion and then set same ready for operation, taking care that the beginning of the record is far enough from the end that the machine will attain the proper speed before any results are heard.

"I then make it a point to seclude myself from view of any one who may enter the store. The result is as follows: A customer enters, and in doing so the opening of the door causes the door trip to close the circuit through the chain drop magnets. This in turn releases the hook that holds up the weight, the weight drops and starts the machine to running, but the closing of the store door, etc., drowns the sound of the falling weight and the customer does not know that he has started the machine. By this time the machine has gained its speed, and when the customer looks around and sees no one in view the machine begins as follows: 'Do you want to see the proprietor? Well, just have a chair and I will call him. Mr. ———, here is a party that would like to see you in regard to a Phonograph.'

"By this time you are aware of the surroundings, and all that is necessary is to go up to the prospective buyer and take his purse from his hand, count out enough to pay for a good machine and some Records, hand him back the balance in his purse and go to wrapping up your sale.

"This outfit could also be used to an advantage for turning away collar button and lead pencil merchants who bother you every day, or perhaps refusing some one-arm or peg-leg railroad man who is seeking enough money to pay his fare to Mexico or the Islands."

**A MODEL "FOLLOW UP" LETTER.**

O. K. Houck Piano Co., Dealers at 359 Main street, Memphis, Tenn., send out the letter given below to the names sent them by this Company. It covers the ground so thoroughly that we gained the consent of the writers to reproduce it:

DEAR SIR:—Your recent inquiry to the National Phonograph Co., New York City, has been referred to us for attention. We take pleasure in forwarding you to-day by mail, under separate cover, catalogues of Edison Phonographs, also records for same.

Detail information about these wonderful instruments will be found in the catalogue. We do, however, wish to call your special attention to the most desirable styles in the medium price instruments.

We unhesitatingly recommend the following outfits which we have supplied to many of our patrons, and they have given universal satisfaction:

No. 1.

- 1 Edison Standard Phonograph equipped with Model C Reproducer, plays six Records with one winding; price, net .....\$20 00
  - 1 Dozen Records..... 5 00
  - 1 Solid brass horn, 30 inches long, with 13¾ inch bell... 4 00
  - 1 Nickel plated stand for supporting horn..... 2 00
  - 1 Record carrying box, capacity 24 Records..... 75
- \$31 75

No. 2.

- 1 Edison Home Phonograph, equipped with Model C Reproducer, plays seven Records with one winding; price, net.....\$30 00
  - 1 Dozen Records..... 5 00
  - 1 Solid brass horn 30 inches long with 16½ inch bell.... 5 00
  - 1 Nickel plated stand for supporting horn..... 2 00
  - 1 Record carrying box, capacity 24 Records..... 75
- \$42 75

No. 3.

- 1 Edison Triumph Phonograph equipped with Model C Reproducer, plays fourteen Records with one winding; price, net.....\$50 00
  - 1 Dozen Records..... 5 00
  - 1 Solid brass horn, 42 inches long with 20½ inch bell.... 10 00
  - 1 Nickel plated stand for supporting horn..... 2 00
  - 1 Record carrying box, capacity 24 Records..... 75
- \$67 75

We can, of course, reduce the price of any of these outfits by cutting down some of the accessories, furnishing smaller horns, etc. We would not, however, advise this, for the outfits described above are almost perfect.

We want to thank you for giving us this opportunity of writing you about these beautiful instruments, and in the event you wish any further information about them do not hesitate to write us on the subject, as it will afford us pleasure to answer your questions in detail.

We trust that the purchase of a Phonograph will have your careful consideration, and we hope you will decide to favor us with your order.





### A MAMMOTH PHONOGRAPH HORN.

The above is a photograph of a mammoth Phonograph Horn used by D. R. Wilson, a Dealer at Shenandoah, Ia., in giving entertainments with a Standard Phonograph at the Page County Fair last fall. The horn weighs 420 pounds, is 21 feet long, and has a bell 10 feet across.

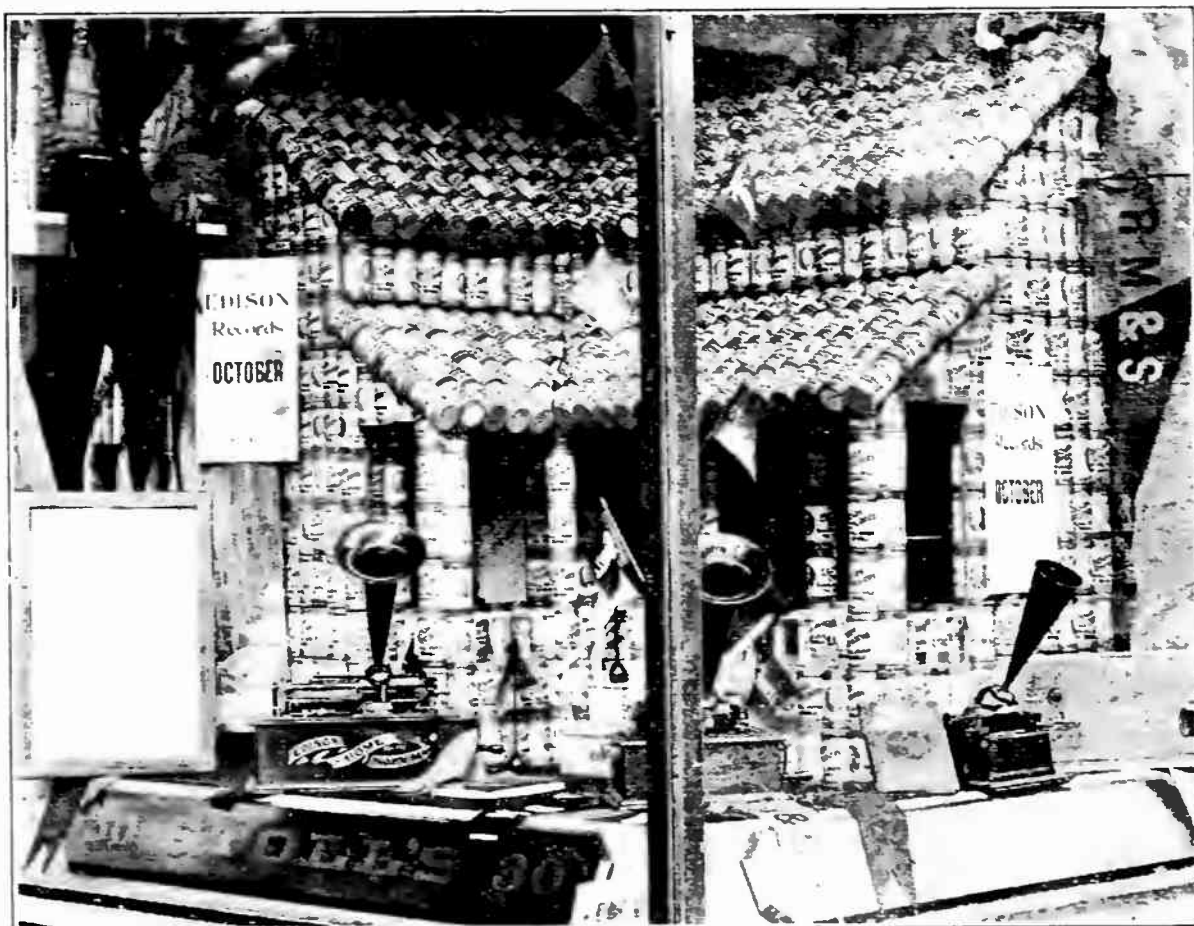

WINDOW DISPLAY MADE BY THE STOLL BLANK BOOK AND STATIONERY CO.,  
TRENTON, N. J.



**HE GOES AFTER BUSINESS.**

Picton, Ont., Jan. 18, 1904.

I have only had the privilege of selling Edison Phonographs in Picton since October 31, but handled them at West Lake for about four years. I keep two horses, and when I hear of a party who wants a Phonograph I just put one in the rig and call on him. I don't have to bring it back. I find it pays to go to them and not wait for them to come to you. I have sold three machines in a day—not so bad for a small town. In regards to Suspended List, I would say, if a man can't sell the Edison goods without cutting prices he had better give it up to some one who can. I have no trouble. I bought a disk machine for the purpose of comparing, and I am something like Keely, I have no use for them. If I want a noise I will buy a drum.

S. M. BROWN.

**"NOTHING BUT THE BEST."**

Hallowell, Me., Jan. 12, 1904.

We do not do a large business, but we endeavor to carry nothing but the *best*, therefore we have in stock nothing but Edison Machines and Records. We occasionally sell a disc machine, but have noticed that whenever this happens the sale is made to some one who is looking for *quantity* and not *quality*. Was much impressed with the expression used by a lady in our store. In speaking of a disc machine which is on sale, *at cut price*, in this city, she said: "It certainly sounds like nothing human or mechanical that I have ever heard." We are doing some advertising and are taking the stand that the Edison goods are sold on their merits and that we do not have to "cut price" in order to make sales.

HORACE G. TURNER.

**SUSPENDED LIST, FEBRUARY 1, 1904.—SUPERSEDING ALL PREVIOUS LISTS.****COLORADO.**

BOULDER—BENTLEY & CRAIG.

**KANSAS.**

CLAY CENTRE—E. M. GOWENLOCK.

LAWRENCE—BELL BROS.

**MASSACHUSETTS.**

LAWRENCE—LORD & CO., 314 Essex street.

E. O. MOSHER, 420 Essex street.

MALDEN—A. T. FULLER.

NEW BEDFORD—H. B. DEWOLFF.

WOBURN—OSBORN GILLETTE, or THE BOLTON JEWELRY COMPANY, L. F. MALONEY, Manager.

**MICHIGAN.**

DETROIT—F. J. SCHWANKOVSKY.

SAGINAW—GEO. W. EMENDORFER.

**MISSOURI.**

KANSAS CITY—THE WITTMANN CO.

**NEBRASKA.**

LINCOLN—THE WITTMANN CO.

OMAHA—THE WITTMANN CO.

**NEW HAMPSHIRE.**

NASHUA—F. A. McMASTER & CO.

**NEW JERSEY.**

ATLANTIC CITY—SAMUEL D. WOLF, 32-34 Arkansas avenue.

BAYONNE—I. WIGDOR, 450 Avenue D.

JERSEY CITY—W. L. HOFFMAN, 151 Montgomery street.

NEWARK—R. L. CORWIN; also New York City.

PATERSON—CHAS. H. KELLY, 25 N. Main st.

PLAINFIELD—S. W. FRUCHT, or R. FRUCHT; also New York City.

WEST HOBOKEN—EMIL HOLLANDER, or THE WEST HOBOKEN BICYCLE & PHONOGRAPH CO., 619 Spring street.

**NEW YORK.**

ALBANY—FINCH & HAHN; also Schenectady.

BEDFORD PARK—GEO. H. TYRRELL.

**NEW YORK—Continued.**

HOBART—F. H. MARSHALL.

NEW YORK CITY—A. T. ARMSTRONG, or AMERICAN PHONOGRAPH CO., 106 Wall street.

BRONX PHONOGRAPH CO., or DAVID SWITKY, 506 Willis Avenue.

R. L. CORWIN; also Newark, N. J.

EAGLE PHONOGRAPH CO., or C. LOWENTHAL, 83 Nassau Street.

EMPIRE PHONOGRAPH CO., 2 West 14th street.

S. W. FRUCHT, or R. FRUCHT, 7 Barclay st., or 68 Cortlandt st.; also Plainfield, N. J.

O. HACKER, 2 Murray street.

HAWTHORNE & SHEBLE, 297 Broadway; also Philadelphia, Pa.

N. HORN, 148 E. 58th street.

R. H. INGERSOLL & BRO., 67 Cortlandt street.

W. L. ISAACS, 114 Fulton street.

S. LEMBURG & CO., 194 Broadway.

J. McELLYNNE, 202 Broadway.

RICHARD PEASE, 44 W. 132d st.

F. M. PRESCOTT, 44 Broad street.

SARATOGA—W. J. TOTTEN.

SARATOGA SPRINGS—MARVIN A. COTE.

SCHENECTADY—FINCH & HAHN; also Albany.

**OHIO.**

CINCINNATI—J. L. ANDEM.

SPRINGFIELD—D. & M. VANDERPOOL.

UHRICHSVILLE—F. A. MAZURIE.

**PENNSYLVANIA.**

PHILADELPHIA—A. R. CASSIDY, 2783 Emerald street.

HAWTHORNE & SHEBLE, 604 Chestnut street, or Oxford and Wascher streets; also New York City.

PITTSBURG—A. LIPPARD, 615 Wylie avenue.

**RHODE ISLAND.**

PROVIDENCE—F. P. MOORE.

**WISCONSIN.**

MILWAUKEE—J. C. BLATZEK.

**Jobbers and Dealers are asked to co-operate with us, FOR OUR MUTUAL GOOD, by being careful that they do not supply any of the above named firms with our apparatus, either at addresses given or any other address.**



## JOBBERS OF EDISON PHONOGRAPHS AND RECORDS.

## ALABAMA.

**Birmingham**—The Ray Co., 2025 Second avenue.  
**Mobile**—The Ray Co., 54 Dauphin street.

## CALIFORNIA.

**San Francisco**—Peter Bacigalupi, 933 Market street.

## COLORADO.

**Denver**—Denver Dry Goods Co., 619 16th street.

## CONNECTICUT.

**Middletown**—Caulkins & Post Co., 406-408 Main street.  
**New Haven**—Pardee-Ellenberger Co., 155 Orange st.

## GEORGIA.

**Atlanta**—The Ray Co., 72 Whitehall street.

## ILLINOIS.

**Chicago**—Oscar J. Junge, 245 E. Chicago avenue.  
 Kelley Cigar Co., 80-82 Wabash avenue.  
 James I. Lyons, 73 Fifth avenue.  
 The Ray Co., 90 Washington street.  
 Siegel-Cooper Co., State and Congress sts.  
 Talking Machine Co., 107 Madison street.  
 The Vim Co., 68 E. Lake street.  
 Montgomery Ward & Co., 111 Michigan ave.  
**Peoria**—Peoria Phonograph Co., 314 S. Adams street.

## INDIANA.

**Indianapolis**—Kipp Bros. Co., 37 S. Meridian street.  
 The Ray Co., 234 Massachusetts avenue.  
 Wahl-Gaasch Co., 119 S. Illinois street.  
**Lafayette**—Wahl-Gaasch Co., 304 Main street.

## IOWA.

**Des Moines**—The Vim Co., 704 West Walnut street.

## KENTUCKY.

**Louisville**—The Ray Co., 640 Fourth avenue.

## LOUISIANA.

**New Orleans**—James I. Lyons, Theatre Arcade.  
 National Automatic Fire Alarm Co., 614 Gravier street.  
 The Ray Co., 111 Camp street.

## MAINE.

**Bangor**—S. L. Crosby Co., 186 Exchange street.  
**Portland**—W. H. Ross & Son, 207 Commercial street.

## MASSACHUSETTS.

**Boston**—Boston Cycle & Sundry Co., 48 Hanover street.  
 Eastern Talking Machine Co., 177 Tremont street.  
 J. C. Haynes & Co., 451 Washington street.  
 Iver Johnson Sporting Goods Co., 163 Washington street.  
 Read & Read, 558 Washington street.  
**Fitchburg**—Iver Johnson Sporting Goods Co., 247 Main street.  
**Lowell**—Ring Music Co., 112 Merrimac street.  
 Thomas Wardell, 111 Central street.  
**Worcester**—Iver Johnson Sporting Goods Co., 304 Main street.

## MICHIGAN.

**Detroit**—American Phonograph Co., 106 Woodward avenue.  
 Grinnell Bros. Music House, 219 Woodward avenue.  
 The Ray Co., 168 Griswold street.  
**Saginaw**—Morley Bros.

## MINNESOTA.

**Minneapolis**—Thomas C. Hough, 714 Hennepin ave.  
**St. Paul**—Minnesota Phonograph Co., 37 E. 7th street.

## MISSOURI.

**Kansas City**—J. W. Jenkins' Sons Music Co., 1013-1015 Walnut street.  
 The Ray Co., 1021 Grand avenue.  
**St. Louis**—Conroy Co., 1115 Olive street.  
 The Ray Co., 923 Olive street.

## NEBRASKA.

**Lincoln**—H. E. Sidles Cycle Co., 1317 O street.  
**Omaha**—H. E. Fredrickson, 1502-1510 Capitol avenue.  
 Nebraska Cycle Co., 15th and Harney streets.

## NEW JERSEY.

**Hoboken**—Eclipse Phonograph Co., 205 Washington street.  
**Newark**—H. J. Koehler Sporting Goods Co., 845 Broad street.  
 A. O. Pettit, New and Halsey streets.  
**Paterson**—James K. O'Dea, 117 Ellison street.  
**Plainfield**—Frank L. C. Martin Auto. Co., 810 Park avenue.  
**Trenton**—Stoll Blank Book and Stationery Co., 30 E. State street.

## NEW YORK.

**Brooklyn**—Chapman & Co., Fulton and Duffield streets.  
 A. D. Matthews' Sons, 394 Fulton street.  
 Price Phonograph Co., 1258 Broadway.  
**Buffalo**—P. A. Powers, 643 Main street.  
**Elmira**—Elmira Arms Co., 117 Main street.  
**Gloversville**—American Phonograph Co., 99 W. Fulton street.  
**Kingston**—Forsyth & Davis, 307 Wall street.  
**New York City**—Barkelaw & Co., 36 Vesey street.  
 Bettini Phonograph Co., 80 Chambers street.  
 Blackman Talking Machine Co., 19 Beekman street.  
 J. F. Blackman & Son, 2654 3d avenue.  
 I. Davega, Jr., 802 Third avenue.  
 S. B. Davega, 32 E. 14th street.  
 Douglas & Co., 89 Chambers street  
 H. S. Gordon, 139 Fifth avenue.  
 Harry Jackson, 219 Bowery.  
 Jacot Music Box Co., 39 Union Square.  
 Victor H. Rapke, 1661 Second avenue.  
 Rosenfield Mfg Co., 587 Hudson st.  
 Siegel-Cooper Co., Sixth avenue and 18th street.  
 John Wanamaker, Broadway and 9th street.  
**Rochester**—A. J. Deninger, 347 North street.  
 Mackie Piano, O. & M. Co., 100 State street.  
**Schenectady**—Jay A. Rickard & Co., 253 State street.  
**Syracuse**—W. D. Andrews, 216 E. Railroad street.  
**Troy**—James Lucey, 359-361 Fulton street.  
**Utica**—Clark, Horrocks & Co., 54 Genesee street.

## OHIO.

**Canton**—Klein & Heffelman Co., 216 N. Market street.  
**Cincinnati**—Ilsen & Co., 25 W. 6th street.  
 The Ray Co., 143 West 5th street.  
 Wahl-Gaasch Co., 47 W. 5th street.  
**Cleveland**—The Ray Co., 266 Erie street.  
 W. J. Roberts, Jr., 254-256 Arcade.  
**Columbus**—Perry B. Whitsit Co., 213 S. High street.  
**Dayton**—Niehaus & Doshe, 35 E. 5th street.  
**East Liverpool**—Smith & Phillips Music Co.  
**Toledo**—Hayes Music Co., 608 Cherry street.

## PENNSYLVANIA.

**Allegheny**—Henry Braun, 500 Federal street.  
**Allentown**—G. C. Aschbach, 539 Hamilton street.  
**Easton**—William Werner, 401 Northampton street.  
**Philadelphia**—C. J. Heppe & Son, 1117 Chestnut street.  
 Lit Bros., Market and 8th streets.  
 Penn Phonograph Co., 19 S. 9th street.  
 John Wanamaker.  
 Wells Phonograph Co., 41 N. 9th street  
 Western Electric Co., 931-933 Market street.  
 H. A. Weymann & Son, 923 Market street.  
**Pittsburg**—Theo. F. Bentel Co., Inc., 433 Wood street.  
 Kaufmann Bros., Fifth avenue and Smithfield street.  
 H. Kleber & Bro., 221 Fifth avenue.  
 C. C. Mellor Co., 319 Fifth avenue.  
 Pittsburg Phonograph Co., 937 Liberty avenue.  
**Reading**—Reading Phonograph Co., 757 Penn street.  
**Scranton**—Ackerman & Co., Coal Exchange Building.  
 Technical Supply Co.

## RHODE ISLAND.

**Providence**—J. M. Dean Co., 785-795 Westminster street.  
 J. A. Foster Co., Weybosset and Dorrance streets.  
 Household Furniture Co., 231-237 Weybosset street.  
 Murray, Blanchard, Young & Co., 26-30 Pine street.  
 A. T. Scattergood & Co., 106-110 N. Main street.

## TENNESSEE.

**Memphis**—The Ray Co., Lyceum Building, and Jefferson streets.  
**Nashville**—The Ray Co., 30 The Arcade.

## TEXAS.

**Dallas**—C. B. Harris, Agt., 347 Main street.

## VIRGINIA.

**Richmond**—The Ray Co., 729 E. Main street.

## WISCONSIN.

**Milwaukee**—McGreal Bros., 173 3d street.

## CANADA.

**Toronto**—R. S. Williams & Sons Co., Limited, 143 Yonge street.





## Equip Yourself for Double Service

We will furnish any Edison dealer with I. C. S. literature and a demonstrating outfit consisting of 3 moulded Records with I. C. S. Textbooks in French, German, Spanish, delivered prepaid in the United States and Canada for

### \$1.50

### Apply to the Following Jobbers of I. C. S. Outfits

PORTLAND, ME., W. H. Ross & Son  
 LOWELL, MASS., Thomas Wardell  
 BOSTON, MASS., Eastern Talking Machine Co.  
 BOSTON, MASS., J. C. Haynes & Co.  
 BOSTON, MASS., Boston Cycle & Sundry Co.  
 NEW HAVEN, CONN., Pardec-Ellenberger Co.  
 PROVIDENCE, R. I., Murray, Blanchard, Young & Co.  
 KINGSTON, N. Y., Forsyth & Davis  
 SYRACUSE, N. Y., W. D. Andrews  
 NEW YORK CITY, Blackman Talking Machine Co.  
 NEW YORK CITY, I. Davega, Jr.  
 NEW YORK CITY, Douglas & Co.  
 NEW YORK CITY, Jacot Music Box Co.  
 NEW YORK CITY, John Wanamaker  
 NEWARK, N. J., The Edison Co.  
 PLAINFIELD, N. J., F. L. C. Martin Automobile Co.

PHILADELPHIA, PA., Wells Phonograph Co.  
 EASTON, PA., William Werner  
 BUFFALO, N. Y., P. A. Powers  
 ROCHESTER, N. Y., Talking Machine Co.  
 COLUMBUS, OHIO, Perry B. Whitsit Co.  
 DAYTON, OHIO, Niehaus & Dohse  
 CHICAGO, ILL., O. J. Junge  
 CHICAGO, ILL., James I. Lyons  
 MILWAUKEE, WIS., McGreal Bros.  
 MINNEAPOLIS, MINN., Thos. C. Hough  
 OMAHA, NEB., Nebraska Cycle Co.  
 KANSAS CITY, MO., J. W. Jenkins' Sons Music Co.  
 ST. LOUIS, MO., The Conroy Co.  
 TORONTO, CAN., R. S. Williams & Sons Co.  
 SAN FRANCISCO, CAL., Peter Bacigalupi  
 NINETEEN STORES, The Ray Co.