

studio sound

September 1979 60p

AND BROADCAST ENGINEERING

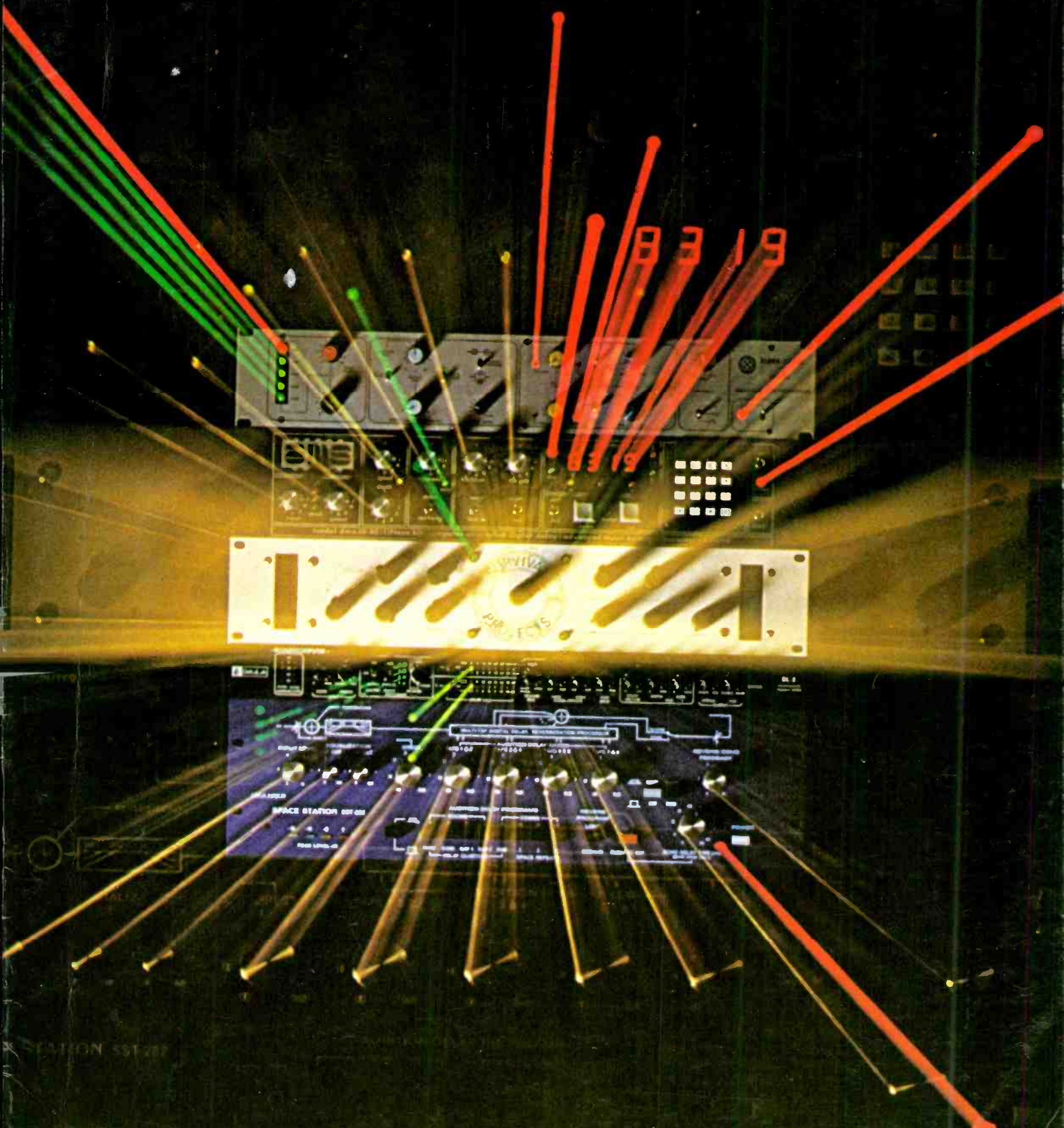

Effects

MIDAS 1979 extend the possibilities

Midas design philosophy has provided high quality signal processing in a compact and rugged frame of innovative modular design, making the P.R. system the choice of professionals. Backed by extensive research into advanced technology components plus thorough understanding and analysis of over 350 consoles sold in the last seven years, the P.R. system has come of age.

24 into 6/2 VCA controlled Theatre Sound Reinforcement

Console providing six separate pre-set mixes with integral cross-fade and remote automation interface facilities. another example of P.R. system versatility.

How can MIDAS experience benefit you?

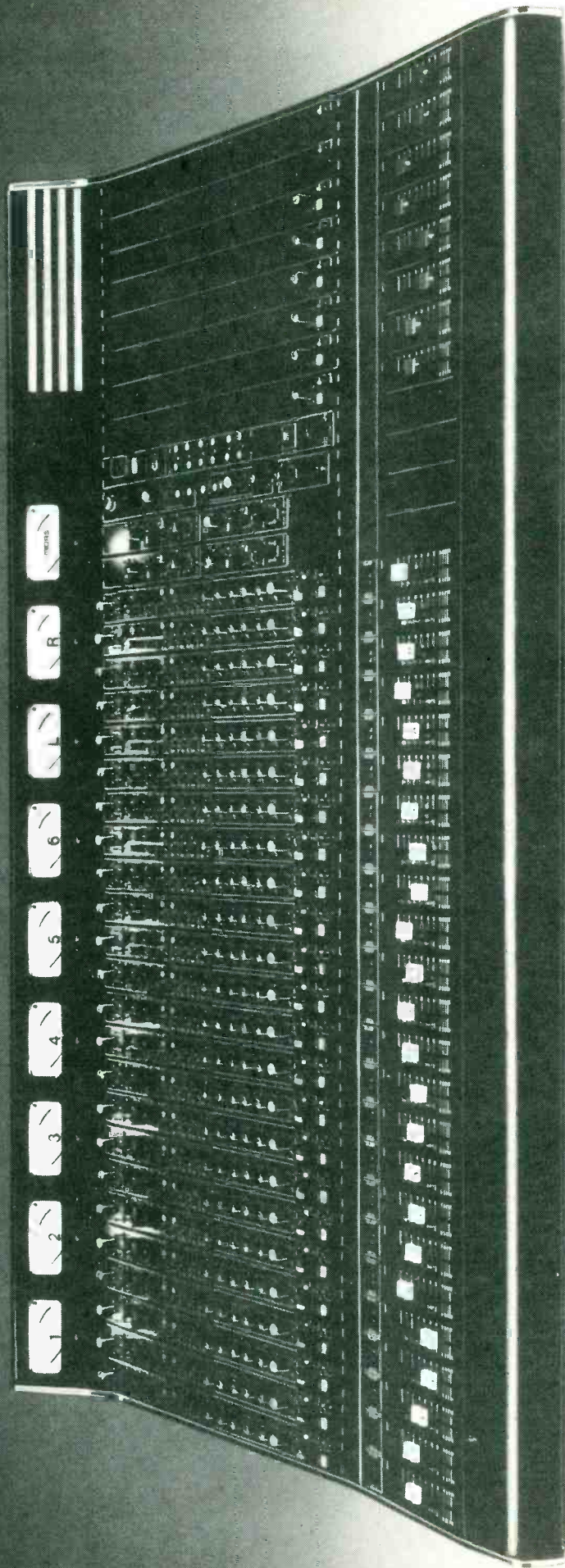

MIDAS AUDIO SYSTEMS LTD. DAVID SOLARI, 54-56 STATHOPE STREET, EUSTON, LONDON N1 3EX. TEL: 01-588-7060. OI: 587-7679.
MIDAS AUDIO CORPORATION, BOB SIEGROVE, 730 MAIN STREET, NIAGARA FALLS, NEW YORK 14301, U.S.A. TEL: 716-282-4100.
MIDAS CANADA, FRANK DIMISKERN, GERR. ELECTRO-ACOUSTICS, 365 ADELAIDE ST. EAST, TORONTO M5B 4R9, ONTARIO, CANADA. TEL: 416-868-0528.

EDITOR

ANGUS ROBERTSON

ASSISTANT EDITOR

NOEL BELL

PRODUCTION EDITOR

DRUSILLA DALRYMPLE

CONSULTANT

HUGH FORD

**EDITOR'S
PERSONAL ASSISTANT**

WENDY SMEETH

**ASSISTANT
ADVERTISEMENT MANAGER**

PHIL GUY

ADVERTISEMENT SECRETARY

AUDREY SLATFORD

PUBLISHER

DOUGLAS G. SHUARD

Editorial and Advertising Offices:**LINK HOUSE, DINGWALL AVENUE,
CROYDON CR9 2TA, GREAT BRITAIN****Phone: 01-686 2599****International: +44 1 686 2599****Telex: 947709****Telegrams: Aviculture Croydon****© Link House Publications Ltd 1979****All rights reserved***STUDIO SOUND is published on the second Friday
of the preceding month.***SUBSCRIPTIONS***STUDIO SOUND is available on a rigidly controlled
requested basis only to qualified personnel (see back
page for terms of control), or for an annual cost of
£9.50 to non-qualifying readers or where more than
two copies are required in a studio or small organisation.**EUROPE Subscription cost £9.50.**UNITED STATES Surface mail subscription \$25,
airmail subscription \$45.**OVERSEAS Surface mail subscription £12.50, airmail
subscription £22.50.**All subscription and circulation enquiries to:**Subscription Dept, Link House Publications Ltd, Robert
Rogers House, New Orchard, Poole, Dorset BH15 1LL,
Great Britain.**Phone: 02013 71171.**Telex: 417109.***BACK COPIES***A limited number of back copies are available, 60p each***BINDERS***Loose-leaf binders for annual volumes of STUDIO
SOUND are available from Modern Bookbinders,
Chadwick Street, Blackburn, Lancashire. Price is £2
(UK and overseas). Please quote the volume number
or date when ordering.*MEMBER OF THE AUDIT
BUREAU OF CIRCULATION*Total average net circulation of 13,366 per issue during
1978. UK: 6,257. Overseas: 7,109.***A LINK HOUSE GROUP
MAGAZINE**

studio sound

AND BROADCAST ENGINEERING

NEWS	28
STUDIO DIARY	including Portland 34
THE DELAY DILEMMA	Mike Woodward 38
APRS EXHIBITION '79, A REPORT	Noel Bell 42
MONTREUX, A REPORT	Angus Robertson 54
BUSINESS	56
EFFECTS: WHO USES WHAT?	58
SURVEY: EFFECTS	62
REVIEWS: Hugh Ford	
_____ EMT 244 DIGITAL REVERBERATION UNIT	76
_____ EVENTIDE H949 HARMONIZER	80

From reading press reports over the past few months, you could be forgiven for thinking that the music business is finished and no longer a profitable venture. Just a month before EMI sold half its record business to Paramount, it took no less than 172 pages of advertisements in a single issue of *Billboard* magazine, the majority in full colour and printed as a supplement—and a superb production job it must be said. However, this does not alter the fact that the British record market is now claimed to be a 'loss leader' in breaking talent, for export, where the 'real' money is made. Record companies claim that an advertising budget of over £100,000 is required to break an act—and then spend most of that money 'breaking' established acts such as Wings and Diana Ross with expensive TV spot advertising. There was a time when the product sold itself because it was worth buying, and when there was innovation in repertoire instead of the latest Greatest Hits of . . . re-issues—indeed the industry has been bemoaning EMI because there has simply not been a Seventies act to repeat the Beatles success of the Sixties. There have been some very promising newcomers, Kate Bush in particular, but that long running success has not been repeated yet.

Production and marketing costs are becoming a problem for much of industry, and while we accept paying 50p for a packet of cereal, unfortunately records (and magazines for that matter) are the first losers when it comes to 'discretionary' spending, and so there is a limit to the public's patience as prices soar yet again. Also, it's no good trying to persuade buyers that albums are cheaper now, relative to inflation, than they were. After all you can't live on plastic! Albums have always cost more in Britain than the United States, currently about \$10.50 against \$8, and this is simply becoming too high for the buyer, while leaving little profit margin for the record company. Even in the USA, record company profits are being hit. But what is causing the problem? Is it the recession, poor merchandise, lack of high calibre talent, the growth of radio and discos, poor marketing, pirating and bootlegging, home cassette copying, a saturated market, or simply the end of an era?

Now that the Audio Engineering Society has decided to hold its 1980 European convention in London (rather than Monte Carlo, where a certain number of us were looking forward to spending a hard working week), we are faced with the situation of having two large professional audio exhibitions (AES and APRS) and also the PA exhibition organised by the Association of Sound and Communications Engineers, all being held in Central London within four months of each other. Many companies are involved with all three exhibitions and quite rightly ask why they should be expected to support all three. Will visitors actually want to visit all the exhibitions, or just select the best, or perhaps the cheapest—APRS is free entry, while AES will cost about £15 for the convention and about £2 to £5 for the exhibition only. And even then it is being held in the far from large London Hilton—the APRS' Connaught Room location is adequately 'discussed' elsewhere in this issue. From everybody's viewpoint, it would make considerable sense for the two exhibitions to be combined (perhaps even all three), in a proper exhibition centre with attached hotels for demonstration suites. Unfortunately such a centre does not yet exist in London (until the Barbican opens presently many years behind schedule) but Brighton (less than an hour from London by train, about the same as Wembley if you are unlucky), houses such a complex where the exhibition and convention could be held in civilised surroundings. Unfortunately the profits made by each of the organisations concerned are such that the conflict is difficult to break. Perhaps the exhibitors, whose support is essential for any show, will make their feelings known to the relevant organisations.

Cover by Adrian Mott and Ray Hyden. Thanks to Feldon Audio
AMS and Scenic Sounds for loan of the equipment.

SEPTEMBER 1979 VOL. 21 NO. 9



Artistic licence?

We at QUAD go to a very great deal of trouble to ensure that with a QUAD 33 in the Cancel position, the voltage delivered to your loudspeakers is a virtually exact RIAA transfer of the voltage the pickup will produce into a stated passive load. Nothing added – nothing taken away.

A visiting journalist recently suggested that we should not do this. Final adjustment should be done by ear, he said.

What an opportunity!

After all we know that if we add a little warmth with a subtle boost in the lower middle and balance this with an ever so gentle hump in the quack region (2-3kHz), we can make most programmes sound superficially more impressive. Come to that, why not change the 3180uS to 5000uS adding a little more 'heft' that most people will fall for. We could even make a special model for the boom and tizz brigade.

Been to any live concerts recently ?

For further details on the full range of QUAD products write to :
 The Acoustical Manufacturing Co. Ltd.,
 Huntingdon, Cambs. PE18 7DB
 Telephone : (0480) 52561

QUAD 

for the closest approach to the original sound
 QUAD is a Registered Trade Mark

Hot off the drawing board

SERIES 80

Trident's new console that has designs on all 16 and 24-track studios.

At last — the mixing console specially developed for 16 and 24-track studios, bearing the Trident stamp of quality and expertise.

This latest addition to Trident's range of mixers spans the area between the superb TSM consoles and the adaptable Fleximix system — taking the TSM's facilities and tailoring them to a surprisingly compact 16 or 24-track format.

But the best surprise of all is its competitive price: £15-20,000 (depending on format), so now you'll be able to keep both your studio engineer and bank manager happy.

Ken Bray and Steve Gunn have all the information. Phone them, and let the Series 80 take you into the 80's in style.

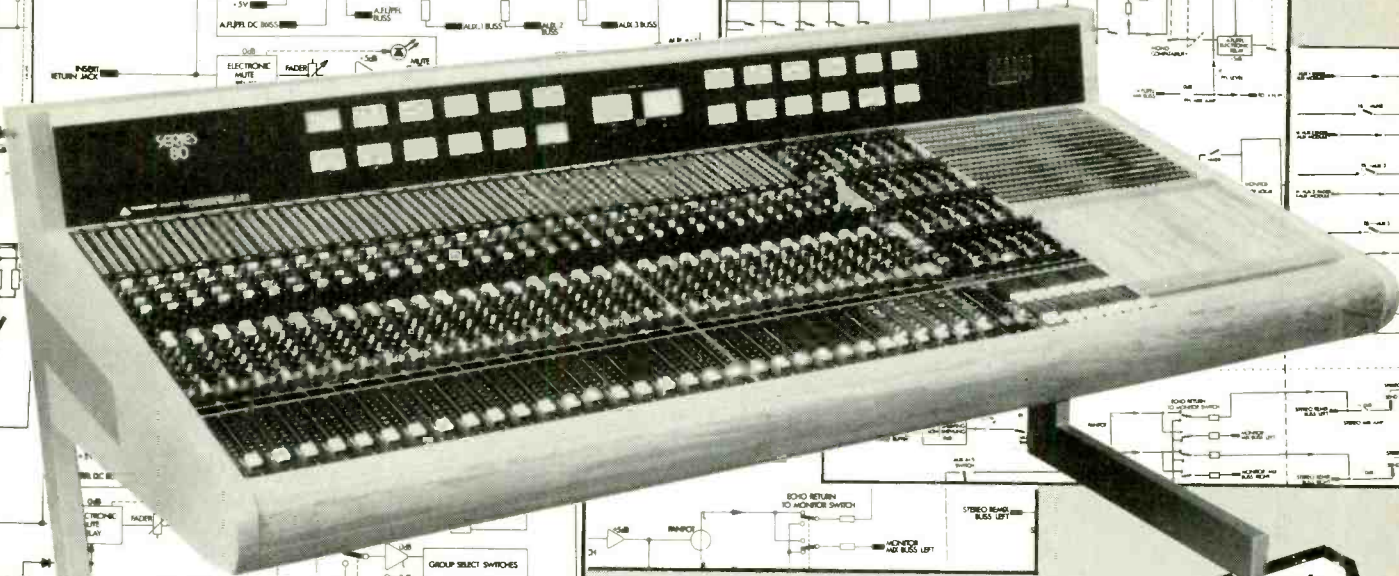
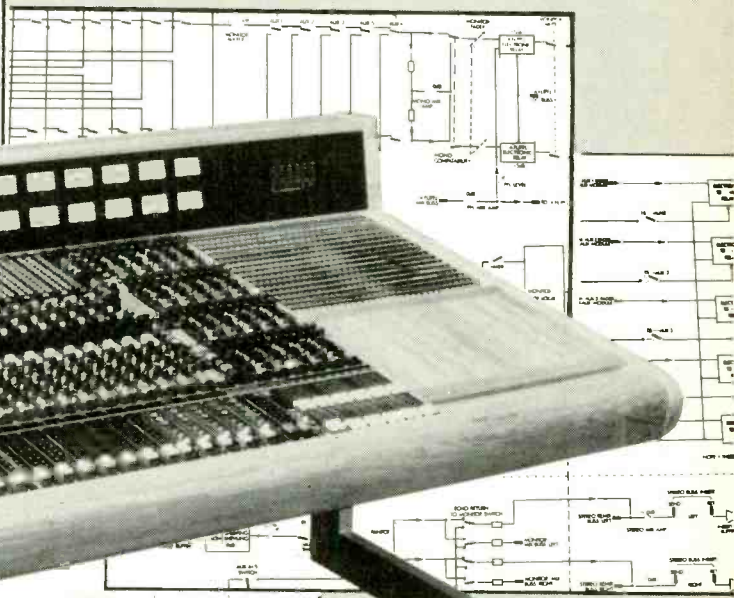
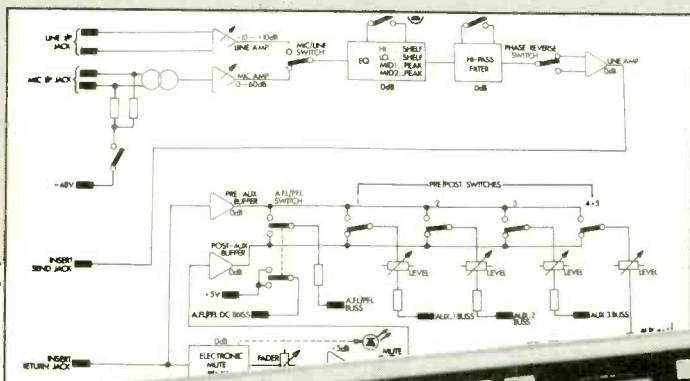

AUTOMATION-READY



Trident Audio Developments Limited
Shepperton Studio Centre, Squires Bridge Road, Shepperton, Middlesex, England.
Telephone: Chertsey (09328) 60241 Telex: 8813982

America Area 1 Studio Maintenance Services, California. Tel: 213-877-3311 **America Area 2** Sound 80 Inc., Minneapolis. Tel: 612-721-6341 **America Area 3** Winteradio Companies, Parma, Ohio. Tel: 216-886-5536 **America Area 4** Empirical Audio, New York. Tel: 914-762-3089 **Australia** John Barry Group, Sydney. Tel: 61-2-439-6985
Belgium Naybies, Brussels. Tel: 32-2-734-31-38 **Canada** La Salle Audio Products Ltd, Montreal. Tel: 513-342-2511 **France** Lazare Electronics, Paris. Tel: 33-1-878-62-10
Germany Peter Struven, Hamburg. Tel: 49-40-801028 **Holland** Cadac Holland BV, Hilversum. Tel: 31-35-17722 **Italy** Audio Products International, Milan. Tel: 392-273-896
Japan Continental Far East, Tokyo. Tel: 81-3-583-8451 **South Africa** Leephy (Pty) Ltd., Johannesburg 2092. Tel: 010-48-3821 **Spain** Neotecnica S.A.E., Madrid. Tel: 34-1-242-09-00



REW Professional Audio

Now Bigger And Better Than Ever!

Entire 2000 Sq
AT 114-116

EQUALIZERS

SOUNDCRAFTSMEN

Graphic EQ's.

- SAE Parametric EQ's.
- JVC SEA 10 (2 x 5 Band), SEA20 (2 x 7 Band)
- TECHNICS SH9010 (2 x 5 Band), SH9090 (1 x 10 Band)
- MXR (1 x 5 Band), (1 x 10 Band), (2 x 10 Band)
- MM-Pace (2 x Band), SR271 (1 x 27 Band)

WOLLENSAK
WOLLENSAK/West
End Distributors

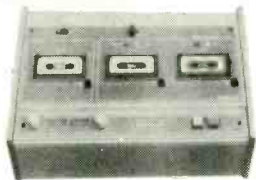

High Speed Duplicators.
£1498.90 + VAT. New 2772A/V gives 2 stereo musicassettes in under 4 minutes. Call in for a demonstration.

UHER PORTABLE RECORDERS

As used by most Broadcasting Companies. All models in stock plus every accessory available.



Very low prices, e.g. 4000IC £225 + VAT.
+ SONY + NAKAMICHI + JVC + TECHNICS + TEAC.
Portables all Off the Shelf.

REVOX

Incredible stocks at ridiculous prices!



A77, B77, A700 Off the Shelf. High speed, low speed, vari-pitch + all accessories! Ring us now for the lowest price.

TAPE AT TRADE PRICES

Any quantity—same price— $\frac{1}{4}$ " tape, $10\frac{1}{2}$ " reels.



- AGFA PEM368 Metal £10.06
 - AGFA PEM368 Plastic £7.79
 - SCOTCH 207 Metal £9.81
 - SCOTCH 207 Plastic £8.03
 - MAXELL UD180 Metal £8.89
 - TDK AUDUA LB3600 Met £11.40
 - TDK AUDUA L3600M Met £9.50
 - SONY SLH-11-1100BL Met £10.00
 - SONY SLH-740B Metal £6.89
 - REVOX 601 Metal £11.80
 - REVOX 601 Plastic £10.00
- All above prices exclusive of VAT. Also large stocks of 7" & 5" reels.

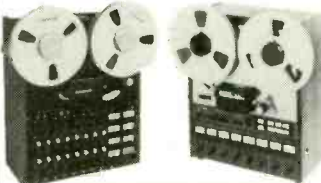

8 TRACKS $\frac{1}{2}$ " or 1"

Both Tascam and Brenell Recorders in stock for immediate delivery. Plus complete range of 8 Track ancillaries.

MICS-OVER 500 ALWAYS IN STOCK!

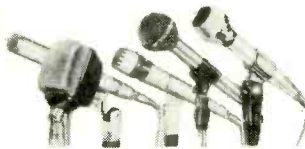

AKG We carry every model inc. capacitors
BEYER Most dynamic + ribbons.
CALREC 600 Range.
SENNHEISER Large stocks.
SONY All models.
NAKAMICHI All models.
E.V. Selected range.
SHURE Very large range.
NEUMANN All popular models.
+ Cables, Transformers, Stands, Connectors & Clips, Windshields, etc.

CANNON XLR'S ANY QUANTITY—SAME PRICE

- XLR-3-110 £1.39 + VAT
- XLR-3-120 £1.06 + VAT
- XLR-3-310 £1.85 + VAT
- XLR-3-320 £1.06 + VAT

AMPLIFIERS

HH S500D, TPA, All stage amplifiers.
SAE From 2 x 50 watts to 2 x 400 watts RMS.
QUAD 405, 303, 50E usually in stock.
JPS A fantastic range of budget studio amps.
AMCRON DC 300A, D150A, D60. Trade prices.

SPECIAL OFFER

AMCRON D150A
£311 + VAT FEW ONLY

TEAC A3340S

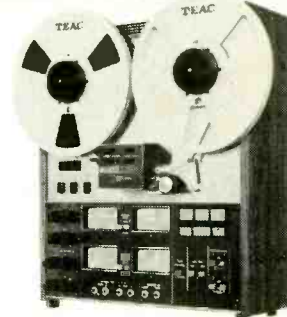

4-channel recorder. Symul-sinc. $10\frac{1}{2}$ " reels, $7\frac{1}{2}$ " + 15 ips. NOW BACK IN STOCK Price on application.

MIXERS

The widest range under one roof!

From £35-£2500. Mixers in stock:
SOUNDCRAFT 16/2, 12/2, 12/4 Series II.
HH 16/2, 12/2.
MM All models.
TEAC-TASCAM Models 1, 2, 3, 5 + Accessories.
CANARY 10/2, 10/4.
HILL 16/2, 10/2.
SONY MX8, MX510, MX650. Plus ALLEN & HEATH, JVC, UHER, EAGLE, etc.

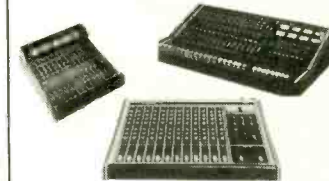

Plus Echo's, Phasers, Flangers, Limiters, Noise Reducers, Expanders, Mix-Downs, Mic Stands, Cable Drums, Disco Gear, Chassis Speakers, Studio Monitors, Headphones, Demags, Splicers, etc.



PRO-AUDIO & DISCO: 114-116 Charing Cross Road, WC2 01-836 2372 7851
Also separate floor of Hi-Fi and Video Phone 01-240 3386/7
TAX-FREE EXPORT & EXPRESS MAIL ORDER: REW House, 10-12 High Street, Colliers Wood, SW19. 01-540 9684 ● Also at 230 Tottenham Court Road, W.1.

The Professional Everything Store

1st Basement Area
 CHARING CROSS ROAD

Lowest Prices Largest Stocks. All Studio & Stage Equipment

EXCLUSIVE FROM REW

SAE A superb range of studio electronics from the U.S.A.



POWER AMPLIFIERS < PARAMETRIC EQUALIZERS

Prices exclude VAT

2800 Parametric equalizer 2 x 4 Bands	£408.00
1800 Parametric equalizer 2 x 2 Bands	£239.00
4000 Electronic crossover, stereo, variable frequency	£155.00
4100 Digital time delay, stereo	£354.00
2200 Power amplifier 2 x 100 watts	£346.00
2400L Power amplifier 2 x 200 watts	£578.00
2500 Power amplifier 2 x 300 watts	£755.00
2600 Power amplifier 2 x 400 watts	£887.00
5000 Impulse noise reduction unit	£176.00

SOUNDCRAFTSMEN

America's Largest Manufacturer of Graphic Equalizers

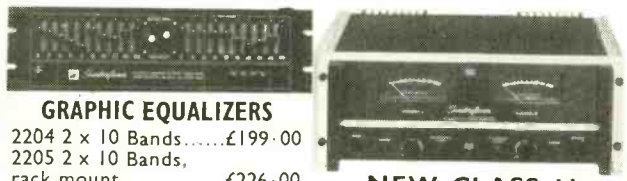

GRAPHIC EQUALIZERS

2204 2 x 10 Bands	£199.00
2205 2 x 10 Bands, rack mount	£226.00
2209 2 x 10 Bands, rack mount, 600 ohm balanced in/out XLR	£319.00

NEW CLASS H POWER AMPLIFIER

MA5002 2 x 250
 watts, meters

Prices exclude VAT

HH DIGITAL MULTI ECHO

Studio quality at an economic price. Facilities include A.D.T., echo and reverb. Fully electronic (no tapes or discs) giving exceptionally low noise.



Open 9.30 am — 6 pm — 6 days a week
 Just walk in — 95% of advertised
 gear available off the shelf

Payment by: Cash,
 Barclaycard, Access,
 American Express, Diners,
 HP (Instant credit possible)

**THE LOW PRICE HOT
 LINE 01-836 2372**

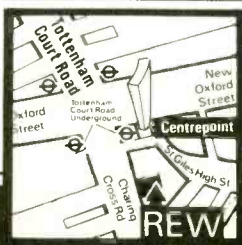

**NEAREST TUBE STATION
 TOTTENHAM COURT ROAD UNDERGROUND**

POWER AMPLIFICATION BY MUSTANG



Our SS.100 and SS.50 are economical amplifiers with outputs of up to 175 and 100 Watts RMS into 4-16 ohms, typical THD figures being 0.1%, slewing rate > 10v/us, noise > 90dB down, zero level input, and full electronic protection. Considering these points with their proven reliability and robust construction, plug in output transistors and driver board, optional balanced input and 100V line output, and virtually ex stock despatches we reckon we take some beating! Contact us now for the full technical specifications.

Manufacturers of mixers, integrated mixer amplifiers and slave amplifiers, studio power amplifiers, transformers, lighting control equipment and cabinets for the home and export markets. Contact us for full illustrated technical brochures.

MUSTANG COMMUNICATIONS

Nelson Street, Scarborough,
 North Yorkshire YO12 7SZ
 England
 Telephone 0723-63298



THE ACOUSTIC SCREENS from AK



- Space saving corner interlock system
- Welded metal frames
- Attractive 'cigarette proof' covering material
- Wide differential non crushing castors
 - Custom size option
 - Roof sections to match

SONAPANEL ACOUSTIC SYSTEM

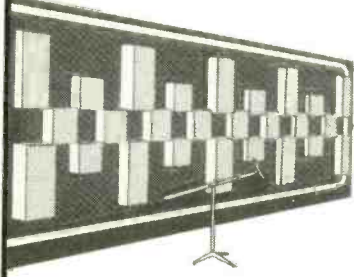

- Economic and flexible
- Individual layout scope
- Fast delivery
- Detachable fixture allows relocation or resale



AUDIO KINETICS (UK) LIMITED
 Verulam Road, St Albans, Herts, AL3 4DH. Tel: 32191. Telex: 299951

fact: viscous-damping straightens out all your records



your favourite record may be a tangle of warps

Your pickup cartridge "sees" such records as twisted, heaving surfaces, jolting up and down 0.5 to 8 times a second. Even records that look flat have warps, and a warped record can change the cartridge-to-record distance, the tracking force, and the vertical tracking angle. Warps produce frequency "wow" and distortion, and can dangerously overload speakers and amplifiers.

What's more, somewhere between 5 and 15 Hz, every pickup arm-cartridge system has a resonance frequency—a frequency at which a warp will produce an exaggerated response that may result in mistracking and in extreme cases, cause serious damage to both the record and stylus.

The Shure V15 Type IV is the first cartridge in the world to incorporate effectively the principles of viscous damping. The Dynamic Stabilizer acts something like a "shock absorber," carrying the cartridge over surface irregularities without distortion, without bottoming out, and without risk of damage to records or stylus. It even protects the stylus should it be dropped accidentally onto the record.

the role of the Dynamic Stabilizer:

The V15 Type IV's Dynamic Stabilizer makes certain you hear the recorded information, not the warps. The viscous-damping system of the Dynamic Stabilizer resists rapid changes in the cartridge-to-record distance. This remarkable Shure innovation eases the stylus over warps without affecting the tracking force on warped or unwarped portions of the record. And the pickup arm-cartridge resonance is attenuated to a subaudible level. As further bonuses, the Dynamic Stabilizer cushions the stylus from accidental impacts, and the carbon fibres in the "brush" conduct static electricity from the record surface to earth!

For more information write for the V15 Type IV Product Brochure.

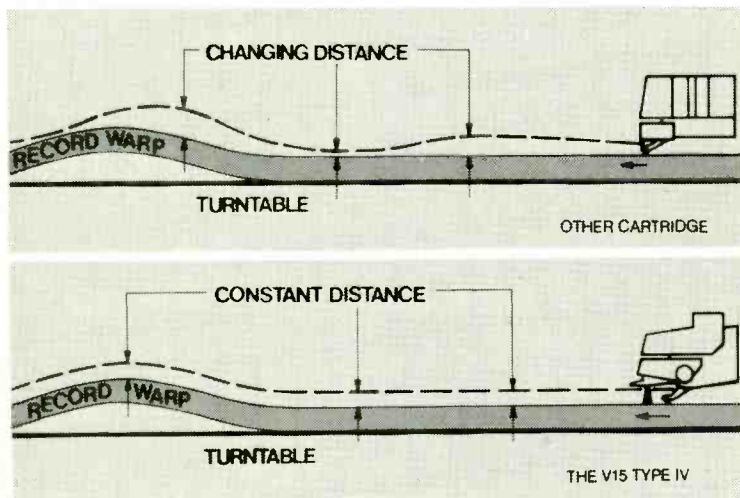

**V15 Type IV
the viscous-damped cartridge by...**



Shure Electronics Limited, Eccleston Road, Maidstone ME15 6AU Telephone: Maidstone (0622) 59881

SAVE MONEY SAVE TIME

WHAT IS OPTIONAL FOR THE OTHERS IS FOR US A MATTER OF COURSE

- * From 16 to 52 in/out channels
- * 24 channel busses including panning
- * 4 band parametric equalizer
- * Continuously variable Hipass filter
- * Up to 28 sends as standard
- * 3 different channel mute grouping
- * Momentary short travel mute switches
- * All solo facilities including «Solo in place» either in monitor or in remix mode
- * 3 master status logically reversible on each channel
- * 28 light meters either vu or PPM and phasemeter as standard
- * 28 Iso frequency third octave analyzer
- * PLUS 30, RS64 automation with separate mute and level encoding using one 6502 microprocessor per channel
- * High quality and high performance components
- * Tough, reliable and attractively designed

PLUS 30

42, rue Pierre Nicole
75005 PARIS - Tél. 634.01.36
FRANCE



C 424

C 422

C 34



Mics for every recording situation

- The C 422 is a new stereo condenser microphone, designed as a quadrophonic condenser microphone for 4-channel-recordings. The C 422 has two twin diaphragm systems, which allows each channel's polar response to be electronically adjusted with the remote control unit S 42 E. Suitable for MS and XY stereo technique. The upper capsule can be rotated through 180° for selection of the base angle in any recording situation.

- In the top of the housing of the C 424 are two elastically suspended twin diaphragm capsules, of which the upper one is also rotatable for selection of the base angle be-

tween front left/rear right and front right/rear left. Colour coded channels.

- The C 34 comb. is a small stereo condenser mic for studio and mobile use. The polar pattern for each channel may be selected in 9 steps via remote control unit S 42. Upper system rotatable through an angle of 180°.



AKG Acoustics Ltd.
191 The Vale, London W3 7QS
TF: 01-749 2042 (5 lines)
TX: 289 38 (akgmic g)

www.americanradiohistory.com

Send this coupon for information about AKG products

- STEREO HEADPHONES
 MICROPHONES
 MAGNETIC CARTRIDGES

Name _____

Street _____

Town _____



“We’ve £150,000 worth of recording gear working 24 hours a day — all fed from the OTARI MX5050B. On a cost effectiveness basis alone the MX5050B is unbeatable, but when taking into account sheer professionalism and performance, it is unequalled by recorders three times the price.”

Mike McLoughlin, Chief Engineer, Independent Tape Duplicators, Aylesbury.



The Otari MX5050B costs little more than modified domestic recorders. That little extra buys so much more.

1. Proper editing facilities with calibrated splicing block.
2. Four heads provide 2 or 4 track replay.
3. Bias and EQ adjustable from front panel.
4. Switchable NAB and IEC EQ.
5. XLR Connectors.
6. +28 dBm 600 ohm balanced output.
7. Direct drive capstan servo with varispeed.
8. Variable or preset output level.
9. 70 dB (weighted) signal/noise ratio.
10. Sel sync on each channel.

OTARI from ITA

1-7 Harewood Avenue, Marylebone Road, London NW1. Tel: 01-724 2497. Telex: 21879.

VOCODER TALK:

The vocoder has become one of the most intriguing and powerful sound processors in a short period of time during which Synton acquired a leading position on a very fast expanding market.

Synton specially designed Syntovox Triple Two to be an easy-to-use unit for live sessions on stage or in the studio.

One of the most impressive features of Syntovox 222 is that it can add an extra dimension to a musical performance by means of the direct vocal control over each played note.

Syntovox 222 is the new way to avoid fiddling with knobs, kicking foot switches and pumping foot pedals or stringing noisy effect boxes in quest of the creation of the personal touch.



The price will make you nervous. **£525.00**

SYNTOVOX 222 TRIPLE TWO'S THE ONE

synton[®]

P.O.B. 83 • 3620 AB BREUKELEN • HOLLAND • ☎ 03462 3499
U.K. Distributor: **TRAD ELECTRONIC SALES LTD.** 149B St. Albans Road, Watford Herts.
Tel: Watford 47988 Telex: 262741

Following the world's most successful
four channel recorder isn't easy.
Unless it's the new A3440 by TEAC.



TEAC from ITA

1-7 Harewood Avenue, Marylebone Road, London NW1. Tel: 01-724 2497. Telex: 21879.

Our business is helping you with yours

Considering or upgrading a multitrack system?
We offer a select range of studio equipment, backed with advice, demonstration and service. Turnkey sell, install, lease or hire.

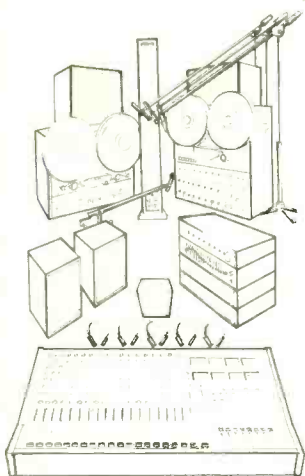

SYSTEMS

As our name implies, at **TURNKEY** we specialise in systems.

From the simplest four channel setup to large eight or sixteen track installations, we can tailor a package to fit your exact needs.

This can include acoustics advice, wiring, consoles, training and so on.

Ask for our 'Quotation Sheet' or call Andrew Stirling now, on 01-440 9221 and discuss your requirements first hand.

MONITORING

QUAD is a remarkable company that has stayed in the forefront of monitor amplifiers for over a decade. Their current series, the 303 and 405 are available for medium and high power use.

JBL and **TANNOY** share the market for studio monitors worldwide. We demonstrate and supply matched systems for budget and big-time monitoring. The renowned **AURATONE** mini-mighty speaker cubes, are also in stock.

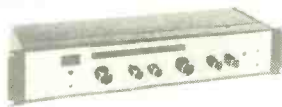

SIGNAL PROCESSORS

The choice is immense. We cannot sell them all so we pick and choose the best.

Take **MXR** for example. This American based company has grown from making effects for guitars to studio equipment for professionals. Their digital

MICROPHONES

As with speaker systems, the choice of microphones is very much one of personal preference and we stock a range to satisfy most requirements. Our current favourites are the new **CSE** range by **AKG**. This is a system (in similar lines to the revolutionary **C451** range some years ago) of interchangeable bodies and capsules. As electret technology is used, the prices are correspondingly low.



delay and graphics are second to none.

Roland of synthesiser fame, have introduced their 'Studio Series' of rack-mount units, including a phaser/flanger with extensive control facilities.

We also have the budget **ACCESSIT** range.

ACCESSORIES

As well as supplying standard plugs, tapes etc., We have developed an exclusive range of 'hard to find' studio accessories.



Take for example our 'Great British Spring' - a high quality stereo reverb developed for the budget concious studio.

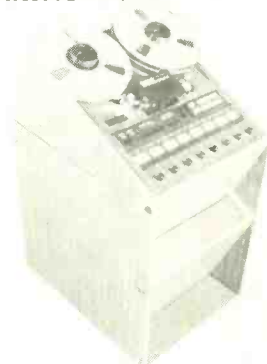

We also have . . . mike boxes . . . track sheets . . . preamplifiers . . . direct boxes . . . rolling consoles . . . and much more.

Full details in our 'TURNKEY by mail' catalogue.

MIXERS

Our exclusive 1478 is a freebie with all four track recorders. Treble, bass, pan and level on four channels.

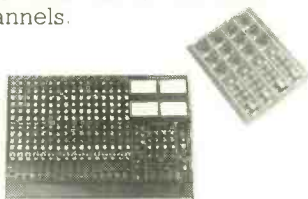

The **RSD**, 16 by 4, offers great value for money in budget multitrack mixers. Packed with features and our own mods for 8 track.

SOUNDCRAFT is well known for its' state of the art performance. We have extensive experience of the Series Two, 16 by 8.

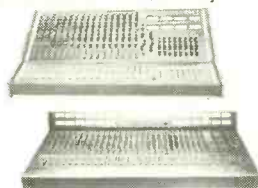

SYNCON by **A&H** is a major breakthrough in the design of big consoles for 16 and 24 track. We offer fast delivery and installation.

TAPE RECORDERS

REVOX lead in the field of 2 track mastering. The new **B77** includes all the features that were hot-rodded to the **A77**.

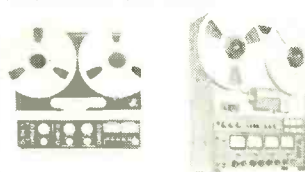

TEAC's new **3440** is the updated version of the **3440S**. Now with varispeed, logic switching, monitoring and motion sensing.

The **TASCAM 80-8** is the most reliable half inch, 8 track recorder available. We also supply **dBx** and a studio console optionally.

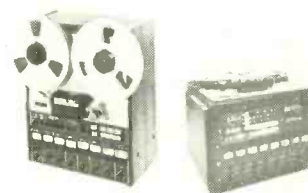

The 8 track, one inch from **SOUNDCRAFT MAGNETICS** is a sophisticated workhorse with unique remote control facilities.



Write or call for a free copy of the 'Turnkey Book', the 'Turnkey by mail' catalogue and **TEAC's** 'Are you ready for Multitrack' book.

You are welcome to come and visit our extensive demonstration showroom at any time during normal office hours.

**8 East Barnet Road,
New Barnet,
Herts EN4 8RW**

**Supply & Installation
of Recording Equipment
Telephone 01-440 9221
Telex: 25769**

turnkey

We satisfied their requirements. We can satisfy yours.

C.E.G.B.
University of Cambridge
Dept. of the Environment
Rolls Royce
BBC
ITN
Decca
EMI
Royal Courts of Justice
London Weekend TV
Capital Radio

ATV
Rediffusion Reditune
Pye TVT
Ministry of Defence
TEK Cairo
Israel: Ministry of Defence
Radio Swansea
Piccadilly Radio
The Who
Queen
British Rail

Kodak
Wiggins Teape
Molinare Sound
Precision Tapes
Guyana Broadcasting
Dick James Music
Sound Developments
Roundhouse
Olympic Studios
Imperial College
Institute of
Oceanographic Science

British Gas
Central Office of Information
U.K. Universities
Island Records
Marconi
Metro Radio
National Coal Board
NBC News
Audio International
RCA
Royal College of Music
etc etc



REVOX from ITA

1-7 Harewood Avenue, Marylebone Road, London NW1. Tel: 01-724 2497. Telex: 21879.



**This new
Lexicon reverb
brings
great sound
down to size.**

**Model 224 reverberation system
has the sound, the controls,
the compactness you've always wanted.**

The remarkable — and remarkably compact — Lexicon 224 digital reverberation system gives you superb sound unmatched by any other system available today — electronic, digital or mechanical. You get smooth, natural decay without coloration, "twang" or "boing".

And you get unprecedented control over all significant reverberation parameters. It's industry's first reverb with a built-in control memory that provides instant push-button recall of previously set effects.

Model 224 saves studio space and is fully portable. Its 5½" x 8" remote control console puts reverb control right at the producer's fingertips. The system's high speed digital processor holds up to eight different programs and requires only 7 inches of rack space.

Currently available programs include: concert hall programs with stereo input and four outputs that create the space and depth of a live performance with decay times of 0.6 seconds to 70 seconds; acoustic chamber programs that provide sound equal to the best reverberation chambers; plate programs that outperform the highest quality reverberation plates or other mechanical devices with full control of all parameters including pre-delay of up to 256 milliseconds.

Model 224. A major advance from Lexicon. Once you've heard it, you'll never want to do another session without it.

Lexicon

Lexicon, Inc., 60 Turner Street, Waltham, MA 02154 (617) 891-6790

ITAM 806.

A new standard in compact multitrack recorders.

NEW compact cabinet, with optional console base.

NEW tape heads, giving outstanding cross-talk characteristics.

THREE VERSIONS

8 channel, half inch tape

4 channel, half inch tape

4 channel, quarter inch tape

Built-in wide ranging varispeed ($\pm 100\%$).

Modular electronics.

Logging versions available (down to 15/16 ips)



ITAM from ITA

1-7 Harewood Avenue, Marylebone Road, London NW1. Tel: 01-724 2497. Telex: 21879.

FRANCE: Son Professionnel, 2 Rue des Tennerolles, 92210 Saint Cloud (Paris) Tel: 602 6815

More than the best connections...

Cables, cords, jackfields, connectors, switches, adaptors, components, tools, faders, DI boxes, intercoms, headsets, service aids, microphone-stands, goosenecks, cable drums, racks & cabinets, level indicators, a portable Dolby 'A'-type noise-reduction unit, and more.

112-PAGE 1979 CATALOGUE, FREE
ON REQUEST

FUTURE FILM DEVELOPMENTS
36/38 Lexington St, London, W1R 3HR
Tel: 01-437 1892/3 Telex: 21624 ALOFFD G
Cables: Allotrope - London W1

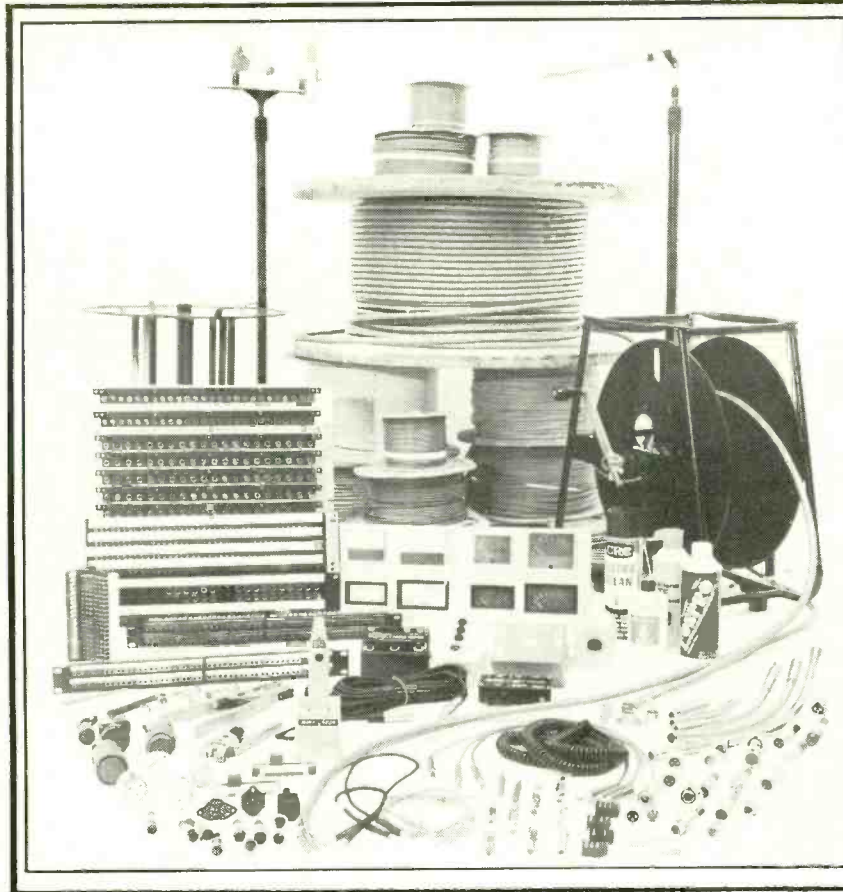

CONCORD S2000

A **new** approach to mixing pleasure

True in line multitrack console with sophisticated electronic switching. More useful operational modes, easily selected, thanks to P.R.O.M. programmed status switching. High quality electronics. Small size, clear ergonomical layout.

Economical price, best value for money console available



World Sales
Pieter Bollen Geluidstechniek,
Eindhoven,
Netherlands.
Phone 40-512777

UK Sales **Raindirk Limited** Downham Market Norfolk Tel. 03663-2165 Telex No. 817737

AEG-TELEFUNKEN

Studio-Compander telcom c4
for live and production

When every sound matters!



THE NEW CHANCE FOR TOP SOUND-QUALITY — 30 dB OF DYNAMIC GAIN!

Improving the dynamic range of sound-recording — Records can be produced with dynamic of direct cuts. Improving the dynamic range for optical sound recording and with analog or digital time delay or echo units. Noise suppression on audio-transmission lines.

STUDIO-COMPANDER-SYSTEM telcom c4

- Gain in dynamic range up to 30 dB
- No "breathing" tape noise
- No level adjustments
- No sound overshooting in ensuing systems
- Total harmonic distortion $\leq 0.2\%$ at low frequencies
- Integrated system-identification



Studio-technique by
AEG-TELEFUNKEN

Coupon

we ask for:

- descriptive literature
- consulting without obligation

Address

AEG-TELEFUNKEN
Nachrichten- und Verkehrstechnik
Fachbereich Elektro-Akustik
Lindener Straße 15
D-3340 Wolfenbüttel
Telephone 05221/82-287
Telefax 05221/82-287

THE NEW MOST IMPORTANT LINK



IN THE P.A. CHAIN ...
M 260 NS
**DYNAMIC RIBBON
MICROPHONE**

Specifications:

Frequency Response: 50 - 18 000 Hz
Polar Pattern: Hypercardioid
Output Level: 0,9 mV/Pa \pm -60 dbm
EIA Sensitivity Rating: -153 dbm
Electrical Impedance: 200 ohms
Load Impedance: > 1000 ohms
Excellent anti-feedback characteristic over the whole frequency range.

Send now for Brochure to:
BEYER DYNAMIC (GB) LTD.,
1, Clair Rd., Haywards Heath, Sussex.

NAME

ADDRESS

*music
laboratory*

72-74 Eversholt Street, London NW1.
Telephone 01-388 5392

HIRE DEPARTMENT PRICE LIST

SUMMER 1979

	1 DAY	3 DAYS	WEEK
TAPE RECORDERS			
2 Track Revox A77	12.00	25.00	35.00
2 Track Revox B77	15.00	27.00	40.00
4 Track Teac 3440	18.00	30.00	45.00
8 Track Teac 80 8 with DBX	45.00	85.00	130.00
8 Track Brenell Mini 8	45.00	85.00	130.00
POWER AMPS			
Quad 405	12.00	20.00	25.00
Bose 1800	15.00	25.00	35.00
Quatre GC 500	15.00	25.00	35.00
MIXERS			
Teac Model 2A 6-4	12.00	17.00	22.00
Teac Model 5 8-4	25.00	45.00	65.00
Yamaha PM430 8-2	15.00	25.00	35.00
Yamaha PM700 12-2	20.00	35.00	50.00
Yamaha PM1000 16-4	35.00	50.00	75.00
Allen Heath Mod 3 16-8	40.00	60.00	85.00
SPEAKERS (per pair)			
Tannoy Devons	15.00	25.00	30.00
Bose 802	20.00	30.00	40.00
Auratones	5.00	10.00	15.00
MICS			
Neumann U47 inc. power supply	10.00	20.00	25.00
Neumann U87 inc. power supply	10.00	20.00	25.00
Neumann KM86 inc. power supply	10.00	20.00	25.00
Sennheiser SM58	5.00	8.00	10.00
AKG D12	5.00	8.00	10.00
AKG D202	5.00	8.00	10.00
AKG C451 inc. power supply	5.00	8.00	10.00
NOISE REDUCTION UNITS			
DBX 155	10.00	15.00	25.00
Dolby 361	10.00		35.00
ECHO/DELAY UNITS			
Roland Space Echo	10.00	20.00	25.00
Orban Stereo Reverb	15.00	25.00	30.00
Yamaha Analog Delay	10.00	20.00	25.00
MXR Digital Delay	15.00	25.00	40.00
MICROPHONE STANDS			
Floor	3.00	4.00	6.00
Table	3.00	4.00	6.00
Boom	3.00	4.00	6.00
Bass	3.00	4.00	6.00
COMPRESSORS			
DBX 160	10.00	15.00	25.00
GRAPHIC EQUALISERS			
MXR 2 - 15	10.00	15.00	25.00
MXR 1 - 31	10.00	15.00	25.00
HEADPHONE EQUIPMENT			
Beyer DT 100 Headphones	3.00	4.00	6.00
Music Lab 6 Way Splitter Box	3.00	4.00	6.00
TAPE RECORDER ACCESSORIES			
Remote Control Revox A77	3.00	4.00	6.00
Remote Control Revox B77	3.00	4.00	6.00
Remote Control Teac 3440	3.00	4.00	6.00
Remote Control Teac 80-8	3.00	4.00	6.00
Varispeed Revox B77	3.00	4.00	6.00
EDITING BLOCKS			
1/4" 1/2" 1" 2"	3.00	4.00	6.00
DIRECT INJECTION BOXES			
Music Lab D.I. Box	3.00	4.00	6.00
HI-FI			
Cassette	10.00	15.00	20.00
Record Deck	10.00	15.00	20.00
Amps	10.00	15.00	20.00
Tuner	10.00	15.00	20.00
EFFECTS			
Roland Stereo Phaser	10.00	20.00	25.00
MXR Flanger Doubler	10.00	20.00	25.00
MXR Harmonizer	15.00	25.00	40.00
Roland Rhythm Unit	15.00	25.00	40.00

(Please add 15% V.A.T.)

*music
laboratory*

Music Laboratory
72-74 Eversholt Street
London NW1
Tel: 01-388 5392

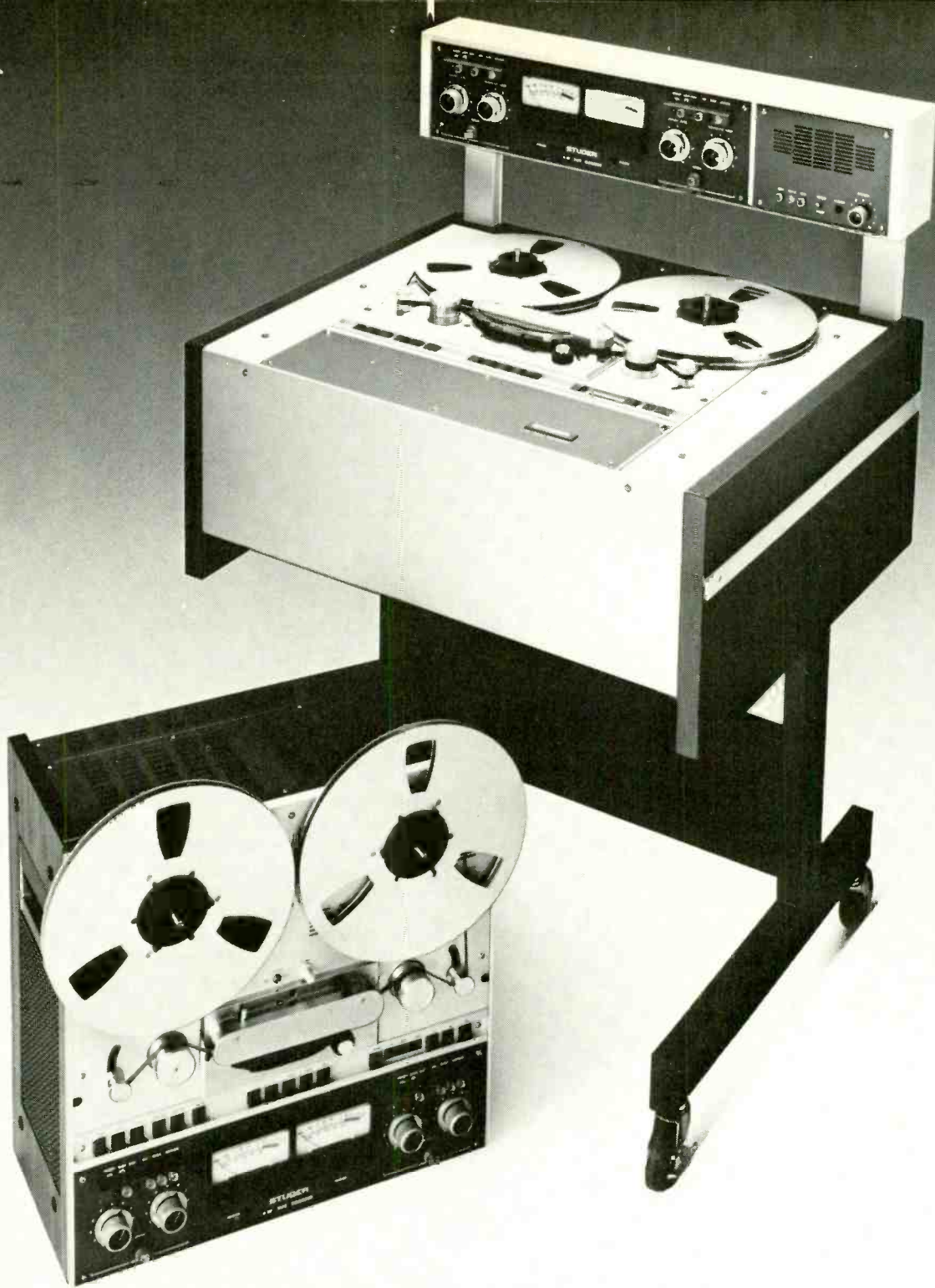

The Robust Movers.

When a Studer machine is needed as a rugged, reliable work-horse in the studio or mobile unit, the B67 is the natural choice.

The value-for-money B67 offers proven reliability and performance to justify its acceptance as the direct replacement to the renowned B62.

For more information contact F.W.O. Bauch Limited.

STUDER
INTERNATIONAL AG
CH-8105 Regensdorf Telephone (01) 840 29 60

F.W.O. Bauch Limited

49 Theobald Street, Boreham Wood, Hertfordshire WD6 4RZ
Telephone 01-953 0091, Telex 27502

STUDER REVOX AMERICA INC Nashville
Telephone (615) 329-9576

STUDER FRANCE S A R L Paris
Telephone 533 5858
www.americanradiohistory.com

STUDER REVOX CANADA LTD Toronto
Telephone (416) 423-2831

BTS ACOUSTIC DESIGN SERVICES

BTS is a company of specialists with extensive experience and knowledge of the acoustic design and layout of studios and buildings.

- We can:
- analyse, using the most up to date computer-based equipment, the acoustic qualities of specialist rooms and buildings used by programme producers, training establishments and media centres in any part of the world.
 - advise on all aspects of layout and construction.
 - establish personnel needs and propose staffing levels.

The BTS system of acoustic treatment uses a proven range of modular acoustic panels, guaranteeing results. Installation is easy and the system is highly flexible — 90 per cent of the materials are reusable for a change of layout or expansion.

To get further details of the full range of services which BTS offer, please telephone or write to Alan Foster, and also ask him for the BTS catalogue.



Broadcast Training and Services Ltd.

2 Hills Road Cambridge CB2 1JP England
Tel: Cambridge (STD 0223) 62392

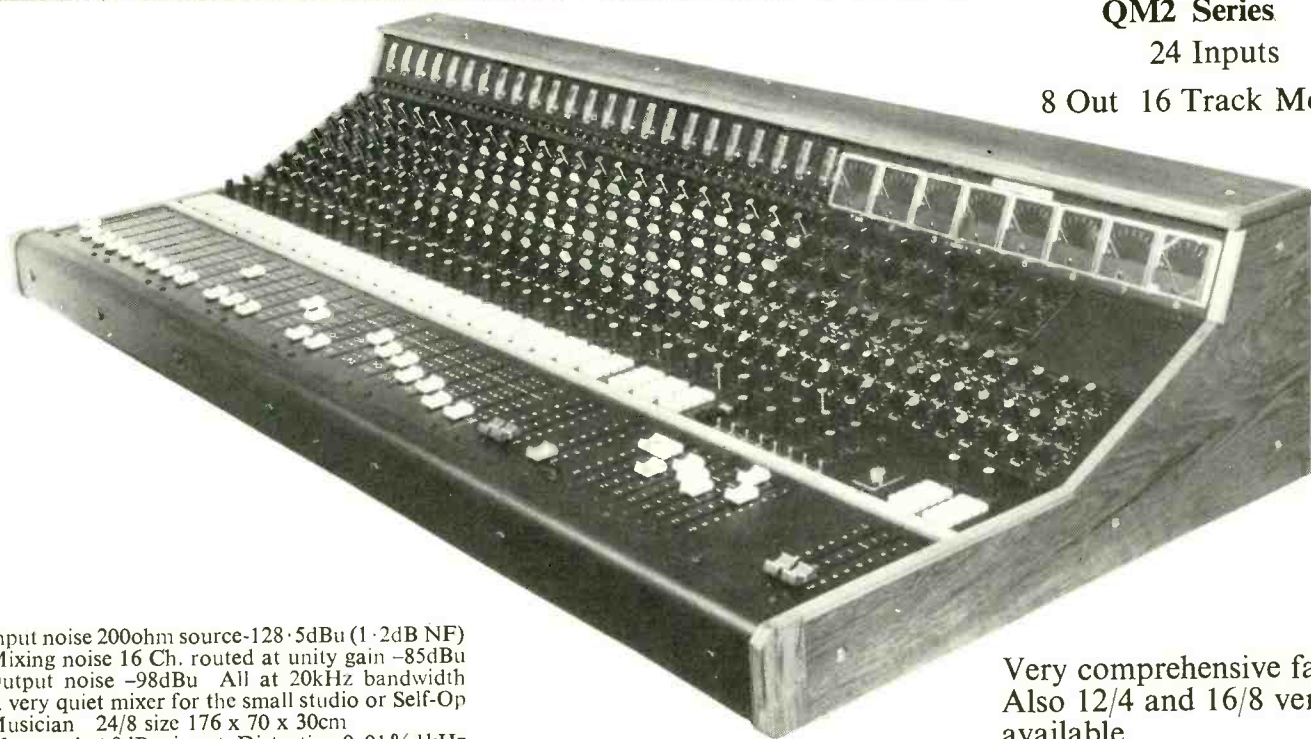

QM2 Series

24 Inputs

8 Out 16 Track Monitor

Input noise 200ohm source -128·5dBu (1·2dB NF)
*Mixing noise 16 Ch. routed at unity gain -85dBu
Output noise -98dBu All at 20kHz bandwidth
A very quiet mixer for the small studio or Self-Op
Musician 24/8 size 176 x 70 x 30cm
*Measured at 0dBm input: Distortion 0·01% 1kHz

Very comprehensive facilities
Also 12/4 and 16/8 versions
available

CHILTON MAGNETIC TAPES LTD.

Chilton Works, Garden Road,
Richmond, Surrey, U.K.
Tel: 01-876-7957

CBS STUDIOS INTRODUCE THE MASTER OF WHITFIELD STREET

A NEW cutting suite that's a cut above the rest, utilising the new Neumann *VMS-80* computer-controlled cutting lathe (the first in the UK) and the MCI *JH-110M* programmable 'pre-listen' tape machine.



CBS STUDIOS now offer possibly the most advanced cutting facility in the world. Microprocessor-controlled tape and disc-cutting equipment now make it possible to 'nest' adjacent grooves even closer than before, thus making exceptionally economical use of the lacquer surface. On 'average' material, this can mean up to a 30% increase in time or level on the master lacquer. With programme material of normal time and cutting levels, this also means a more 'secure' cut: there's almost no chance of error. The sophistication of this new system means that at last the cutting engineer can concentrate on the **art** of cutting, without worrying about the machinery. Direct studio lines also facilitate trouble-free direct-to-disk work. The console of course offers full equalisation and level control, with two separate equaliser systems which can be set up during a cut and switched across manually or under automatic control. Check us out for the best in mastering techniques and equipment—for a cut above the rest.



CONTACT
CBS STUDIOS
31/37 WHITFIELD STREET
LONDON W1
Tel. 01-636 3434

when it comes to harmonisers AMS hold all the cards

AMS, producers of the finest digital delay line in the world—the dmx 15-80, have now produced another trump card, the AMS pitch-changer.



CUE COMMUNICATIONS LTD.

MCI House, 54-56 Stanhope Street,

London NW1 3EX Tel: 01 398 7867/8

Fax: 261116

WE HOLD THINGS UP ALL AROUND THE WORLD!

Today, everyone gets used to things being held up. In a studio, the only 'hold up' that is welcomed is a microphone on a good stand! When you use KEITH MONKS stands, you can set them and forget them! The versatile design, together with a very wide range, means that KEITH MONKS stands deal with those difficult jobs as easily as the simple ones.

KEITH MONKS (AUDIO) LIMITED produce what is probably the most complete range of microphone stands that is generally available, the world over. Designed and made to a very high technical standard, they are readily accepted in so many fields; international radio and television, major sound studios, public address systems, local radio and many more.

Find out for yourself why so many people have relied on KEITH MONKS STANDS for so long.

KEITH MONKS (AUDIO) LTD

26-28 READING ROAD SOUTH, FLEET,
ALDERSHOT, HAMPSHIRE, ENGLAND

Tel. (02514) 205678/9

Telex: 858606

U.S.A. DISTRIBUTOR
KEITH MONKS (U.S.A.) INC.
652 GLENBROOK ROAD, STAMFORD CONN.
Tel. 06906

U.K. Distributors

AMDIO,
26-28 Reading Road South,
Fleet,
Aldershot, Hants.
tel. (02514) 20567/8/9

R.E.W. Professional,
114 Charing Cross Road,
London, W.C.2.
tel. 01-836 2372

STUDIO EQUIPMENT SERVICES,

The Studio Shop,
Oxgate Farm,
Coles Green Road,
London, N.W.2.
tel. 01-452 1979

TURNKEY,

8 East Barnet Road,
New Barnet,
Herts.
tel. 01-440 9221

FUTURE FILM DEVELOPMENTS

36-38 Lexington Street,
London, W.1.

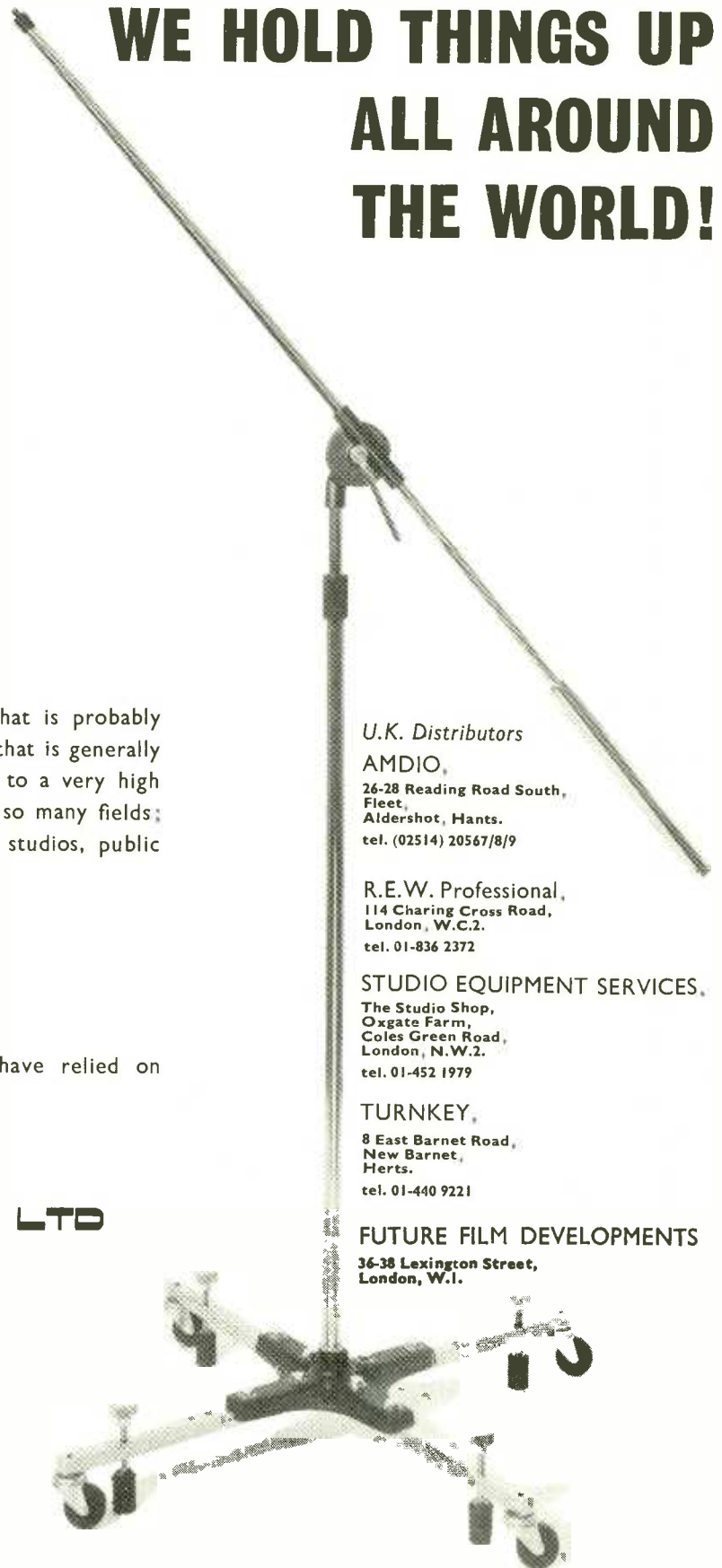

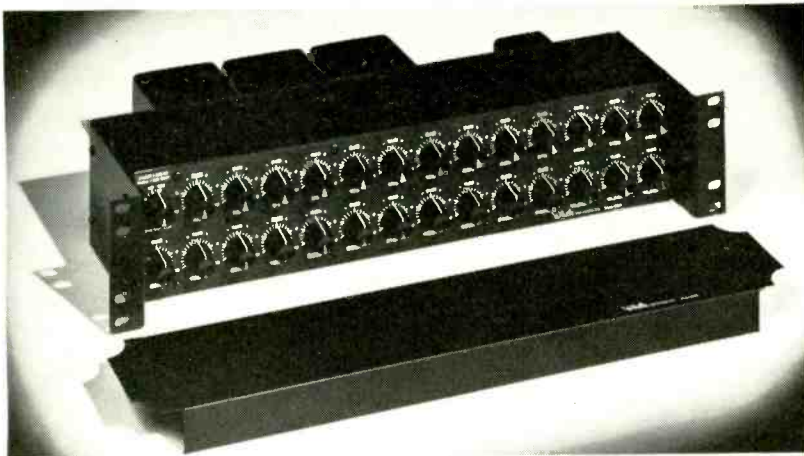

SERIES 4000 ACTIVE EQUALISER

FEATURES:

- 27 1/3 octave bands on ISO centers from 40 Hz through 16 kHz.
- 10 dB boost or cut on continuous control. Equal Q in both boost and cut conditions.
- Variable high-pass filter from 20 Hz to 160 Hz with 12 dB/octave roll-off.
- Filter Q optimized for best summation with adjacent bands.

- Noise guaranteed to be -90 dBm or better.
 - Sealed Mil-Spec pots.
 - EQ IN/ OUT switch on front panel
- PLUS OPTIONAL CROSSOVERS FOR BI-AMPING!**
- Dual buffered outputs for bi-amp operation.
 - Accessory socket to permit insertion of 12 dB/oct. or 18 dB/oct. low level crossover for bi-amp outputs.

MONITOR EQUALISER!

ALSO:

ANALYSERS

- MODEL 140 1/3 OCTAVE ANALYSER FOR ROOM EQ
- MODEL 142A SIGNAL MONITOR
- MODEL 150 OCTAVE BAND ANALYSER

White

**instruments,
incorporated**

P. O. Box 698 AUSTIN TEXAS 78767
PHONE AREA 512/892-0752

Scenic Sounds Equipment,
97-99 Dean Street, London W1. Tel: 734 2812

Belgium
S. E. D. Rue Sara Straat 145
1040 Bruxelles Tel: 522 7064
A. R. C. SPRL Rue Th. Decuyper 134
1200 Bruxelles Tel: 771 3063

France
3M France SA Mincome Div
Boulevard de l'Orise
95000 Cergy
Tel: 749 0275

Denmark
Lake Audio APS
Amalervej 40
DK-2300 Copenhagen S
Tel: 570 600

Holland
Prestar Bollen Geluidstechniek
Haselweg 6 Eindhoven
Tel: 512 777

Norway
Swing Benum AS Skovvn 22
Oslo 2 Tel: 565 753

Sweden
Tel: 5 Ton Musik & Elektronik AB
Kungsgatan 5
411 19 Gullenborg
Tel: 130 216
Spain
M. Llewellyn Jones
AP Postal 8178
Madrid 8 Spain
Tel: 637 0752

MODULAR STAGE-LINK SYSTEMS

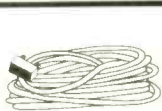

CABLES
FOIL SCREENED MULTI PAIR
AUDIO AND INSTRUMENTATION
CABLES 6-12-15-19-27-31 PAIR

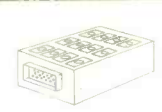

STAGE BOXES
OPTIONS: XLR, 3 POLE, 2 POLE JACKS
Each fitted with Multi-pin Connector.
Up to 31 balanced inputs/outputs.

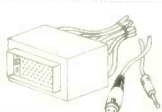

ADAPTORS
OPTIONS: XLR, 3 POLE, 2 POLE JACKS
Each fitted with Multi-pin Connector.
Up to 31 balanced outputs/inputs.

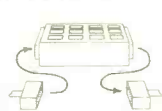

SUB UNIT EXTENSION
inputs/outputs.



CABLE REELS

SCAL
STEVE GRANHAM AUDIO LIMITED

20, VICTORIA ROAD, NEW BARNET,
HERTFORDSHIRE, EN4 9PF
PHONE 01 449 3663
TELEX 87515 WISCO G

CANFORD AUDIO

STARGATE WORKS, RYTON
TYNE and WEAR, NE40 3EX
Tel: RYTON (089422) 4515



AUTOMATIC CABLE TESTER

- * Advanced three way cable tester
- * Operated by single push button—and switches off automatically at end of test
- * Tests for all possible faults—if none present gives OK indication
- * Accepts XLR, PO Jack or Bantam Jack
- *** Unnecessary to bring both ends of cable to tester—making it ideal for fault finding in situ
- * MAKES CABLE TESTING FUN

STUDIO ACOUSTIC TABLES



- * Purpose built for radio, production and TV
 - * Other shapes available, choice of colours
- RING FOR LEAFLETS AND PRICES

elektroimpex

BUDAPEST

THE FIRST OFFICIAL SUPPLIER TO THE MOSCOW
OLYMPIC GAMES OFFERS

ELEKTROIMPEX-HUNGARY
H-1392 Budapest, P. O. Box 296.

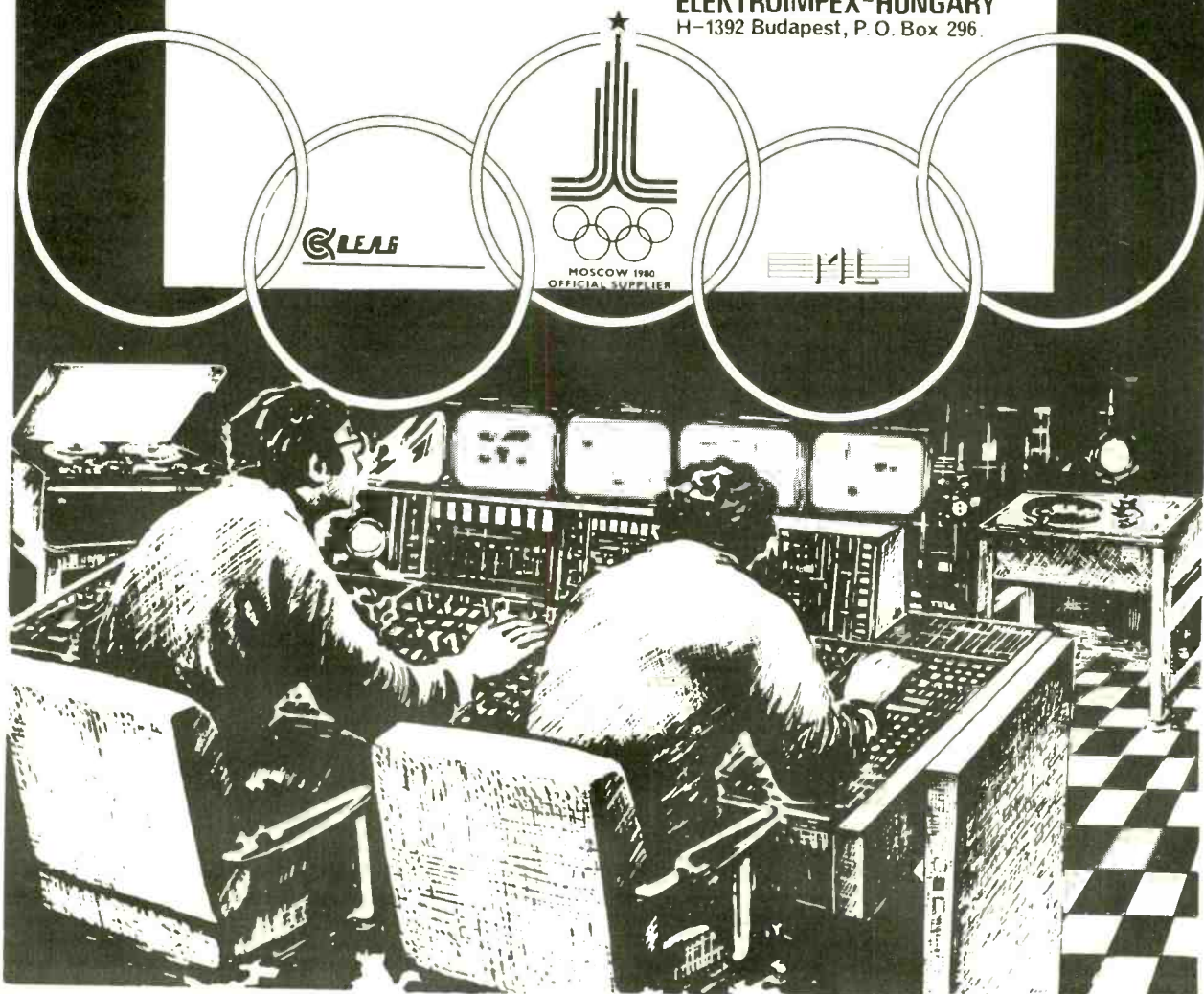

Tandberg restructured

Further to our report on the difficulties facing Tandbergs Radiofabrikk A/S in our March issue, we have now received details of the restructuring of the Norwegian company. A new international Tandberg company has been formed and of the four specialist divisions of the old company, three have already been successfully reformed. The Data Products Division has been established as a separate corporation, whilst the former Educational Division and Tape Products Division have been formed into a new company named Tandberg Industrier A/S. The future of the Colour Television Division—the poor performance of which in Scandinavia was primarily the cause of the Group's difficulties—has yet to be resolved. With regard to the British marketing operation this will gradually be transferred to a new UK Tandberg company, a British subsidiary of Tandberg Industrier A/S.

New Neumann mic

Neumann has introduced a new condenser microphone, *Model U89*. This is the latest of the *FET-80* 48V phantom powered series and although the same shape as the *U87*, is smaller. The new mic uses a totally new condenser capsule containing exposed capsule elements, including two gold sputtered polyester membranes, all of which are at 0V potential. Neumann claim that this results in greater security against capsule failure resulting from humidity, human breath and accumulating dirt. The *U89* has five directional characteristics: cardioid, figure-8, omnidirectional, hyper-cardioid, and wide cardioid; and Neumann claim that all the patterns have a directional integrity previously only available in the miniature *KM Series*. The *U89* has 10 transistors and will tolerate an undistorted sound pressure tolerance 12dB better than the *U87*. The mic has two selectable low frequency roll-off curves at 80Hz and 160Hz and is fitted with a 6dB overload protection switch. Accessories such as wind screen, elastic suspension and battery supplies are available. Georg Neumann GmbH, Charlottenstrasse 3, D-1000 Berlin 61, West Germany. Phone: (030) 251-4091. Agents: FWO Bauch (UK), Gotham Audio (USA). ▶

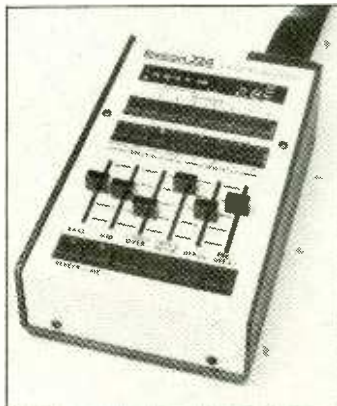

New Lexicon Digital Reverb System

Lexicon has introduced the new *Model 224* reverberation system which comprises a rack mount unit plus a remote control unit allowing control over all significant parameters. The system features a built-in control memory that provides instant push-button recall of previously set effects and the unit's high speed digital processor will accept up to eight different programs. Lexicon has developed a library of programs including concert hall programs with stereo input and four outputs with decay times of 0.6s to 70s, while pre-delay of up to 256ms is also available. Once a basic program is selected it is then tuned by adjusting six slide pots two of which allow the bass and mid-range reverberation to be set independently.

Lexicon Inc, 60 Turner Street, Waltham, Mass 02154, USA. Phone: (617) 891-6790. UK: (*Model 244* only), Scenic Sounds Equipment, 97-99 Dean Street, London W1V 5RA. Phone: 01-734 2812. Telex: 27939.



Allen and Heath

Allen and Heath has recently commissioned a complete AHB 8-track package system for the song-writing duo Gallagher and Lyle. Based in Kent, the studio will be used for album projects and demo work. A portable flight-cased 8-track system has also been supplied to John Entwistle of The Who. On

a larger scale a complete 24-track package has been commissioned by Turnkey Limited for a purpose-built studio for Hank Marvin. Heart of the system is a 24-track *Syncon* console which is fitted with 28-input/output modules. We also understand that four *Syncon* consoles have been delivered to German studios.

New Neve 5315 desk installed at Anglia TV



Contracts

● Lyrec has supplied 24-track multitrack recorders to a number of New York studios including Phil Ramone, Illenipa, and Wizard Sound Studio.

● Essex Music has recently converted its Trident *TSM* console to the fully automated *Fadex* system and joined Sarm Studios amongst those opting for automated *TSM*'s. In addition recent studios who have placed orders or taken delivery are Rockfield Studio, John Kongos Studio, Majestic Studio, and Chipping Norton Studio. In the USA *TSM* consoles have been delivered to Cherokee and Wizard Studios in Los Angeles, Radio Band of America and Location Recorders of Hollywood, and to Sound 80 of Minneapolis. Sound 80's console is being used in conjunction with the 3M digital recording system. Sound 80 has also ordered a new Trident *Series 80* console in a 48-input version for its mobile.

● The Christian Broadcasting Network has purchased two custom consoles from Neve for its new studio complex being constructed in Norfolk, Virginia. In addition American group *Foghat* has purchased a Neve 24-track console for their private Long Island studio.

● EMI Tape has signed a contract with BBC Radio to supply its *850 Series* professional tapes in various

lengths and configurations.

● Solid State Logic has installed an *SL 4000* computerised mixing console in Studio 3 at AB Europa Film's Stockholm studios.

● Neve has supplied a customised 52-input channel mixdown console with *Necam* automation to Utopia Studios, London.

● Neve has supplied Anglia Television with a custom-built 36 input console based on the Neve *5315* console. In addition Neve has also supplied Anglia with an *8301* 10-channel "Kelso" transportable console which has been fitted in a new three camera OB unit manufactured by Marconi.

● Storno Ltd has won a contract valued at approximately £1 million to supply a complete radio communication system to facilitate the administrative and organisational functions of the Moscow Olympic Games.

● Siemens AG has received a £1 million contract from the Norwegian telecommunications administration for a nationwide digital sound programme network. The network allows all radio stations and broadcast transmitters to be interconnected through existing radio links and is designed to transmit stereo programmes with a 15kHz bandwidth. Siemens are also installing digital sound systems in Holland and Denmark. 30 ▶

six of the best!

from Orban

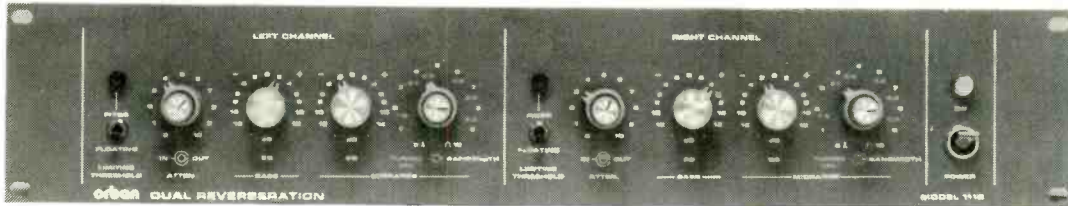

111B Reverb Unit
Two channel high quality spring reverberation unit

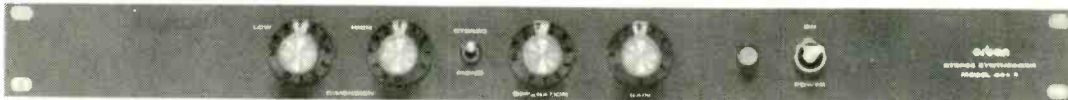

245E Stereo Synthesiser
Uses a unique and patented process to create a realistic and mono compatible synthesised stereo from a mono source



516EC Dynamic Sibilance Controller
Three Independent channels of easily adjusted and effective de-essing
Tracking over a wide range of input signals



526 Dynamic Sibilance Controller
Balanced in- balanced out single channel de-esser
with two levels of de-essing and peak level indicator

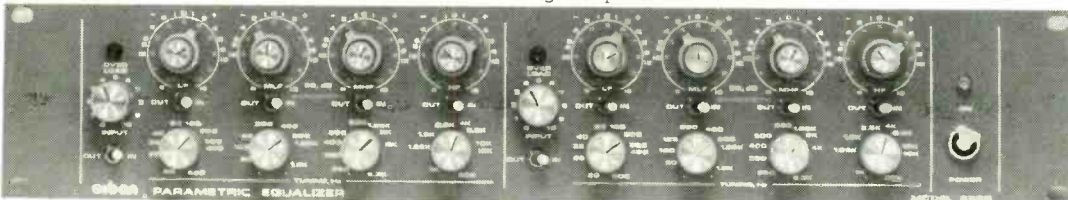

622B Parametric Equaliser
Two channels of overlapping four band parametric equalisation
with continuously variable tuning, equalisation level and bandwidth

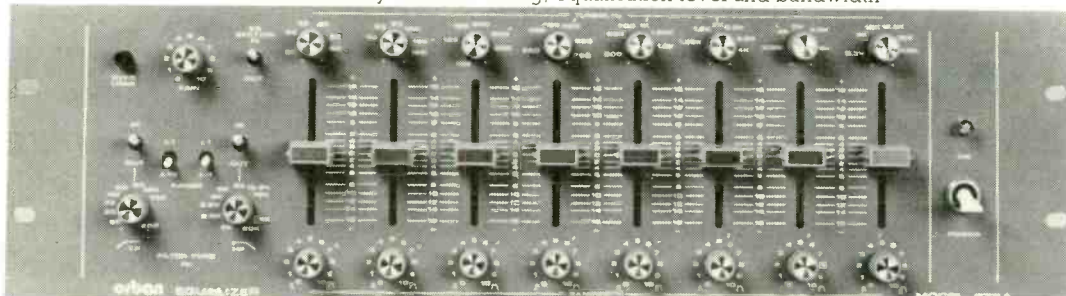

672 8-Band Parametric Type Equaliser
Continuously variable band width and Q selectable high pan - low pan filtering
dual outputs for use as electronic crossover

European Master Distributor



Scenic Sounds Equipment

97-99 Dean Street, London W1V 5RA Telephone : 01-734 2812/3/4/5

England Industrial Tape Applications Belgium Sait (Bruxelles) Finland MS-Audiotron France Schaeffer, Riesser & Cie Germany Estemac Greece Audiolab Hellas
Holland Cadac Holland (Hilversum) Italy Audio Products International (Milano) Spain M. Llewellyn-Jones Sweden Tal & Ton

www.americanradiohistory.com

Infinity Systems new products

Infinity Systems has introduced three new products—the *Reference Standard 4.5* loudspeaker system which replaces the old *QLS* system; the *InfiniTesmal* loudspeaker; and the *Hybrid Class A* power amplifier. The *RS 4.5* is a 3-way loudspeaker utilising two 12in dual voice coil woofers, four electro-magnetic induction midrange drivers in a dipole configuration, and four electro-magnetic induction tweeters, one of these being rear facing. The system features a control unit which allows the loudspeakers to be bi-amplified and the low and low-mid frequency crossover points to be adjusted in 11 1/3-octave steps from 75 to 300Hz. Frequency response is 24Hz-32kHz \pm 3dB; impedance 4 Ω ; crossover frequencies 150Hz (adjustable) and 5kHz; and power handling is 100W per channel minimum (bi-amp—100W per channel minimum bass section, 75W per channel minimum mid/high section). The *InfiniTesmal* is a

2-way loudspeaker with a 5in dual voice coil woofer and an electro-magnetic induction tweeter. Frequency response is 65Hz-32kHz \pm 2dB; impedance 4 Ω ; crossover frequency 3kHz; and power handling 65W rms per channel maximum. The *Hybrid Class A* power amplifier has a valve input stage and Class A transistor output stage, is of low feedback design and utilises high transconductance pentode valves operated as triodes. A feature of the amplifier is complex logic circuitry which controls and protects the unit, and a small information screen which indicates the operational mode or advises of any cause of malfunction. Output power is 150W rms per channel into 8 Ω (20Hz-20kHz). Infinity Systems Inc, 7930 Deering Avenue, Canoga Park, Cal 91304, USA. Phone: (213) 883-4800. UK: Infinity Systems (UK) Limited, PO Box 14, 17 St Martin's Street, Wallingford, Oxon OX10 0EB. Phone: 0491 37773.

Metal tapes

Suddenly everyone is talking about 'pure metal tape'. To set the record straight, this doesn't herald a return to the long gone days of Valdemar Poulson who in the 19th century devised a steel wire recorder, or of Ludwig Blattner who actually sold steel tape Blattnerphones to the BBC in the early 1930s. Instead it heralds a new generation of magnetic tape coatings which, at least for the time being, is of considerable technical interest to the studio engineer.

Since its commercial introduction soon after the Second World War, plastic-base magnetic tape has been coated with a wide variety of mixes based on the magnetic oxides of iron. Following research work by Dupont, coatings based on magnetic oxides of chromium were developed and are of course now widely available for audio and video cassette use. Chrome oxide can offer a higher remanence and coercivity than conventional iron oxide and this is of particular value in the cassette fields where for economy and long playing times it is desirable to cram as much information and energy onto as little tape as possible. The move towards pure metal media, formed by coating the plastic base with a dispersion of finely divided pure iron or alloy particles, is a natural progression in the search for even higher coercivities. Whereas oxide tapes offer coercivities of up to around 500 oersted, coercivities of 1,000 oersted and over are available from pure metal powder tape.

The availability of pure metal tape has been delayed for two reasons. The extremely high coercivity calls for commensurately high bias with all the attendant problems of record and erase head saturation. Moreover finely divided iron powder is extremely difficult to handle. At best it rusts, at worst it explodes. Moreover the coating binder has to be carefully chosen to prevent rusting of the finished tape if it is subsequently stored, before or after use, in a moist atmosphere. 3M, Fuji, TDK, Philips and BASF have all been working on pure metal tape for many years now and most will admit privately that although it proved relatively easy to make a few samples, it has proved extremely difficult to provide reliable quality production runs. Both Philips and 3M have announced the availability of audio cassettes loaded with pure metal tape (the Scotch brand-name is Metafine) although Philips subsequently withdrew their product, and it remains to be seen how soon Fuji, TDK

and BASF come onto the market.

It also remains to be seen how plentiful stocks will be. Ordinary audio cassette recorders intended for use with ferric or chrome oxide tapes will hopelessly underbias metal tape (and risk distorting and boosting HF response to an unpleasantly unnatural level), but this is unlikely to deter the average punter from 'having a go'. The very fact that metal tape costs around four times as much as ferric (£5 for a C90 metal cassette) will probably encourage rather than discourage some purchases. Ignorant or devious shop salesmen will inevitably sell metal tape as 'the best available' simply because it's the most expensive.

So far there is no firm talk of making pure metal tape available in wider gauge and on open reels for domestic, semi-professional or studio use. Indeed it seems highly unlikely that any such move will be made in the foreseeable future. The reason is the same as for chromium tape—no studio demand. Whereas audio cassette (and video cassette) technology with its dedication to low tape speed and narrow track width can benefit from super high density recording, the studio world is not bound by similar restraints. There is no special incentive for studio tape recorders to run at slower speed and use narrower tracks than at present. There is thus no incentive for the studio world to make the redesign moves necessary to take advantage of the potential offered by metal tape. There is in fact very little incentive now that digital tape recording has been presented to the studio world as a quantum step forward. It may well be that metal tape will find its niche in the studio as a carrier medium for digital sound.

In this area there is a call for higher packing density than is readily available from existing analogue equipment running at standard tape speed and metal tape might well bridge the gap. Even so, the acceptance of metal tape by the studio world will be slow. We now know that plastic tape coated with iron oxide has a reliable lifespan (if carefully stored) of well over a quarter of a century. But no one yet can possibly guarantee the lifetime of a pure metal recording, under a range of practical storage conditions. And studios will not lightly run the risk of finding that their valuable master recordings are auto destructing by gradual transition of the pure metal coating into non-magnetic oxide residue.

Adrian Hope

32 ▶

Future Film Developments catalogue

Future Film Developments has just produced a superb 112-page catalogue detailing its range of cables, cords, connectors, jack-fields, tools and accessories. The catalogue is fully comprehensive with each item fully described, illustrated and (most importantly) priced, making it an excellent reference item. The catalogue is available on request and is entirely free of charge.

Future Film Developments, 36/38 Lexington Street, London W1R 3HR, UK. Phone: 01-437 1892.

An amazing array of Future Film equipment



Windsor Electronic

A new company, Windsor Electronic Systems Ltd, has been formed under the direction of Alice (Stancoil) Ltd's managing director, Ted Fletcher, to design and manufacture specialist equipment for the broadcasting and recording industries. WES not surprisingly is closely associated with Alice who are to market the new company's products. The present product range includes an outside broadcast mixer/transmission system for sports commentary and news reporting, a low noise dual 4-band equaliser, and a compact phase correlation meter. WES has also been appointed a distributor for Scully recording and logging machines for broadcast use. Windsor Electronic Systems Ltd, 58/60 Grove Road, Windsor, Berks, UK. Phone: 07535 53779.

CISCO'79

CISCO'79, the third international biennial fair of cinema, theatre, convention hall equipment, disco equipment, cinema and video production equipment and related materials is to take place from October 22-26 at the Parc des Expositions, Porte de Versailles, Paris. Full information is available from International Equipment & Services Exhibition Organisation Ltd, 9 Stafford Street, London W1, UK. Phone: 01-499 2317.

THE JENSEN DIRECT INJECT BOX BY SCENIC SOUNDS EQUIPMENT



- HIGH QUALITY JENSEN TRANSFORMER
- PO GRADE JACK SOCKETS
- RECESSED SWITCHES PROTECT AGAINST DAMAGE AND DUST
- GROUND LIFT SWITCH
- SWITCHABLE PAD
- SWITCHABLE HF ROLL OFF
- LESS THAN 0.02% THD AT 1KHz



For full details on the Direct Inject Box please contact:

Scenic Sounds Equipment
97-99 Dean Street,
London W1V 5RA.
Tel: 01-734 2812/3/4/5

THE MARSHALL TIME MODULATOR™

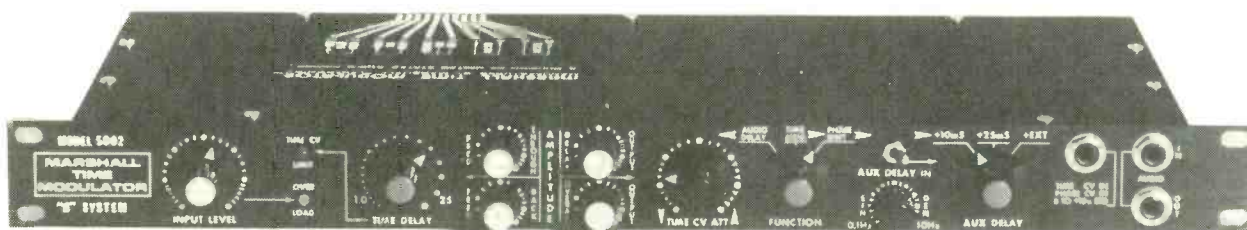

“DOES EVERYTHING A MARSHALL TIME MODULATOR™ DOES.”

Others claim it; we do it.

The Marshall Time Modulator™ started it all, and is now the reference standard to which others compare. Even the effects introduced by the Time Modulator™ have become industry standards; such as Positive Flanging™, Negative Flanging™, ADT™, Card-board Tube Echo™, Resonant Flanging™ and others.

We have not been sitting back and resting these past three years since the Time Modula-

tor™ was introduced. Every advancement in the technologies that apply to delay processing has been incorporated in the new Time Modulator™, assuring performance and specifications that exceed the very best of the newcomers.

New advances now make the unit even more versatile; with an internal power supply and up to 400 milliseconds of delay at 95 dB.

Ask your local Marshall representative for our demonstration kit and record, or ask

us directly, and see why the first is still the best.

MARSHALL ELECTRONIC,
1205 YORK RD. SUITE 14,
LUTHERVILLE, MD. 21093,
USA (301) 484-2220



UK Distributors
Scenic Sounds Equipment,
97-99 Dean Street,
London W1V 5RA
Tel: 01-734 2812

Audix ILR package

A studio technical information package is now available from Audix which enables potential broadcasting companies to prepare capital equipment budgets and plan facilities with a minimum of time, trouble and expenditure. The package is part of a complete service Audix are now offering to commercial radio stations and potential ILR stations which entails Audix taking over the technical side of setting up a station, from supplying full specifications and cost details for approval by the IBA, to turnkey installation and even staff training. The complete package includes everything a station needs to be able to go 'on air' within a small budget. A wrap-round shaped console has been designed for operator/announce studios, one or two of which are normally installed. The consoles are comprehensively equipped for mono and stereo monitoring in accordance with IBA requirements, and they also incorporate clean-feed outputs and outside source switching facilities. In addition to these the package includes a production studio for recording interviews and jingles, a central technical area for monitoring the output of the station, and equipment for news and outside broadcasts. Any number of additional facilities can be added to this low-cost basic package and Audix provide details of other manufacturers' equipment recommended for use with the studio package.

Audix Ltd, Station Road, Wenden, Saffron Walden, Essex CB11 4L9, UK.

Phone: 0799 40888.

Speck 800D console

The Speck 800D is a 16 input, 8/16 output modular studio console with a master module and communications module housed in a sturdy mainframe having 10 VU meters. Each input has eight pannable assigns, 3-band parametric eq, three sends, pan, stereo solo, and a long throw fader. Additionally each input also has a second line input with independent fader, 2-band eq and pan. As the console has two discrete line inputs for each input module and 16 assignable direct outputs in addition to eight sub-masters, this makes it very flexible in operation. An additional feature is that the stereo programme buss is independent of the eight-track assign section allowing the console to feed a number of recorders simultaneously during mixdown. Price of the console is \$9,800.

Speck Electronics, 7400 Greenbush Avenue, North Hollywood, Ca 91605, USA. Phone: (213) 764-1200.

Broadcast Equipment Show

The fourth Sound Broadcasting Equipment Show, sponsored by Audio & Design (Recording) Ltd, is to be held (as in previous years) at the IBA's Crawley Court Centre near Winchester on Tuesday, November 6 from 6.30pm until 10.30pm. Over 20 companies will be exhibiting and visitors to the show are reminded that entrance is by invitation only. Full details are available from Dave McVittie, Exhibition Manager, Audio & Design (Recording) Ltd, 84 Oxford Road, Reading RG1 7LJ, UK. Phone: 0734 53411.

New AR Loudspeakers ▶

Following the recent introduction in the United States of the AR9 loudspeaker, this model has been joined by a smaller model, the AR90, developed and designed for the European market. Both models are floor standing systems and have two side-firing bass drivers mounted at floor level and wired in parallel operating up to 200Hz. These bass drivers are positioned such that speaker image reflection at low frequencies is removed—the only difference between the models being the size of enclosure and the size of bass drivers (12in in the AR9 and 10in in the AR90). Both loudspeakers utilise 8in lower midrange drivers, 1½in upper midrange drivers, and ¾in high range drivers in a vertical array with the same crossover frequencies at 200Hz, 1200Hz and 7kHz. The loudspeakers are internally damped and have an 'acoustic blanket' (a layer of absorbent material on the front panel surrounding the midrange and high frequency drivers), which it is claimed effectively suppresses sound wave reflection from the enclosure edges and grille frame. Both models also have three 3-position switches for lower midrange, upper midrange and high range level control. The AR9 has a frequency response of 18Hz-30kHz (DIN), an impedance of 4Ω (3.2Ω minimum), and will produce 87dB SPL for 1W at 1m. The AR90 has a frequency response of 23Hz-30kHz (DIN), an impedance of 4Ω (3.2Ω minimum), and will also produce 87dB SPL for 1W at 1m. Nominal power handling is 175W for the AR9 and 150W for the AR90. Retail prices are £854 for the AR9 and £650 for the AR90



and both models are subject to a full 5-year warranty covering construction and performance. Other news from AR is that the AR10 is to be discontinued.

Teledyne Acoustic Research, High Street, Houghton Regis, Dunstable, Beds LU5 5QJ, UK. Phone: 0582 603151.

ARP Instruments distributorship

Stateside Electronics informs us that it has terminated its distributorship of ARP Instruments products. We understand that the London Synthesiser Centre are to be the new exclusive dealers and that they will be taking over full responsibility for all future servicing and warranty repairs. Stateside Electronics will continue to market FRAP transducers, Mugsy flight cases, P & N stands, Switchcraft plugs and connectors, Belden cables, and Stateside stage leads and professional accessories alongside the Peavey range.

50th Anniversary of Emile Berliner's Death

August 3 marked the 50th anniversary of the death of the man who created today's recording industry and made voice and music broadcasting possible. Emile Berliner invented the microphone in 1877 and a decade later invented and developed the first commercial disc record. As such it would be impossible to let the great man's anniversary pass without notice and it is interesting to note that in the USA, as a mark of respect, NBC observed moments of silence on its entire network to mark the passing of broadcasting's benefactor a half-century ago.

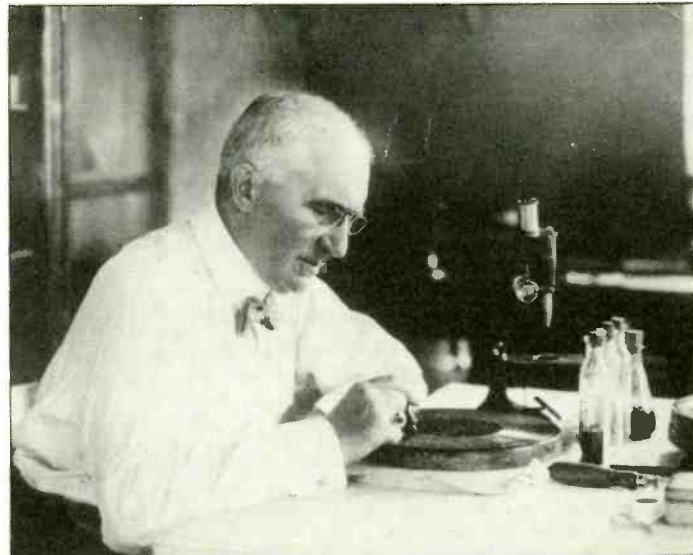

Right: Emile Berliner in his Washington Laboratory

APRS digital course

Readers will be interested to learn that the APRS course on Digital Electronics for Studio Staff which John Borwick reported on in our August issue, is to be repeated in November. The course will take the same format and will again be limited to 24 persons. Venue will be Great Fosters, Egham, Surrey and the dates are November 2-4. Full details and application forms are available from E L Masck, APRS Secretary, 23 Chestnut Avenue, Chorleywood, Herts WD3 4HA, UK. Phone: 09327 72907.

The amazing 32-track Telefunken 'magnetophon' 15A. A new dimension in studio recording technology.



AEG-TELEFUNKEN

Tape Recorder Division,
Postfach 2154,
D-7750 Konstanz, West Germany.
Telephone: (7531) 86-2460.
Telex: 733233.

Hayden Laboratories Limited,
Hayden House, Churchfield Road,
Chalfont St. Peter, Bucks SL9 9EW.
Telephone: Gerrards Cross 88447.
Telex: 849469.

HAYDEN

Exclusive UK Agent

Available in 8, 16, 24 and 32-track format.

studio diary

When Dick van de Velden went to London to order a new mixing console, he came back with an engineer. The console in question was a Midas 24-track, and the company arranged a studio visit so he could see one at work. When he heard and saw what the engineer was doing with the console, he signed both up. The console took seven months to arrive, but that gave Dick, and Robin Freeman the engineer, plenty of time to convert the old film studio into the new large Relight Studio and get the acoustics right. It was the first 24-track studio in the Netherlands, and still continues to attract top domestic and foreign artists.

The original studio was formed in 1971 with 4-track Philips equipment and Dick began the slow process of building a business and a reputation in the Dutch recording scene. Working a 16-hour day recording regional and national acts, his launching pad to success was a string of hits by one artist Which takes us up to 1976 when he went to London.

The studios are set in wooded countryside, outside the village of Hilvarenbeek, just a few kilometres north of the Dutch/Belgian border. At present there are two studios: the original small 4-track Studio Two, shortly to be converted to a small 24-track, and the large 24-track, designated Studio One. The control room is large, effective floor area 133 sq ft, which is just as well as the desk in question (Midas 24-track 36/in 28/out) is laid out in what Robin calls 'The old English style', ie inputs left, outputs right. This makes for a big desk, but you can see at a glance what is happening. Some of the special features of the custom-built desk are: equalisation on foldbacks and echo sends, eight auxiliary sends, switchable pre and post fade, 4-band parametric equalisers, and high and lowpass filters. The monitor section can sum together with input channels to create a 60-input console if needed. For instance, bass and drums, or guitar and voice can be sub-grouped, so the mix-down can be done with four or five pairs of stereo faders.

Monitoring is via enormous JBL 4350s with Amcron DC300A bi-amps delivering 1,200W, as loud as live, and that's the way some people like it. Two Tannoy Lockwoods give a flatter response and are also used for checking mixdowns; in addition there are the ubiquitous Auratones.

Recording is with an MCI

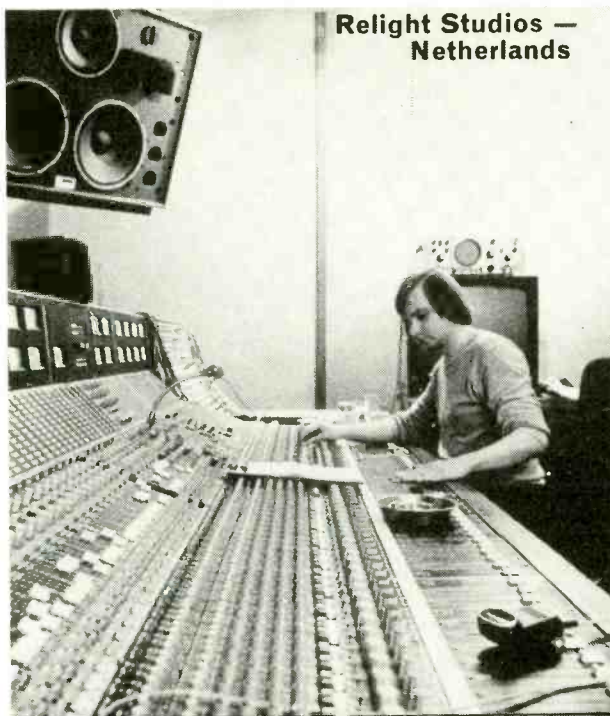

multitrack, with Dolby on all 24 tracks and two 2-track Studers. Auxiliary equipment includes Eventide *Harmonizers*, delay lines and flangers, Kepex expanders and noise gates, three different makes of compressor from a total of eight including A&D, Urei and an old Pye. "If a producer wants anything else, a Vocoder for instance, we hire it, and those who are regular clients know that," says Robin.

The main studio is large, covering an area of 2453 sq ft. Conversion of the old film studio was planned and carried out using the ears and accumulated experience of Dick and Robin. The ceiling and walls are stepped and angled in order to achieve dead at the control room end and live at the opposite end. There are in fact three distinct areas and the dead and medium areas can be adjusted by lifting the carpet tiles which cover the floor in those areas. There is a large isolated 'live' area adjoining the main studio for the bathroom sound. With an effective floor area of 968 sq ft, it's big enough to accommodate a complete string section. (The biggest session they have had totalled 65 people). By the time you reach this room you are a long way from the control room so there is a TV camera link to the control room.

The small isolation booth leading off the dead part of the studio has interesting insulation material—half coconut shells filled with concrete. It seems to work fine for vocal, percussion and other dubs. There is a small absolutely dead area for the 'dry' sound and a small room containing the three EMT stereo plates. Studio instruments include tympany, melotron, vibes, a Yamaha CS80 synthesiser and a few other bits of percussion, a 'tack' or 'jangle' piano and a Bechstein baby grand. A concert Steinway is hired in for groups, like Genesis and Gentle Giant, who requested it.

There are 50 mics available: Neumann, AKG, Sennheiser, Electro-Voice, Shure etc. Once again, anything else can be hired in. The size of the studio means that there are no problems with leakage etc; drums generally go on the 'live' floor, suitably screened off.

The equipment in Studio Two consists of a Philips OC 71 broadcast desk which started it all in 1972, two Philips 2-tracks, four Pye limiters, various odd equalisers, and an echo wheel. At the moment it is used for demos for

local bands and commercials or as a rehearsal room for Studio One. It will shortly be rebuilt to a 24-track remix room. The control room will grow to accommodate the larger desk and the studio will lose some of its 646 sq ft. Still large enough for two large drum kits though, so it will probably be mainly a remix and overdub room. "We will probably get an MCI or Necam desk, but in any case it will be automated," says Robin.

Other personnel at the studio are Martien Weijtmans, who keeps everything up to scratch, Marijke, who cooks and serves up drinks at the bar in the studio, and Corrie, who does the bookings. At the moment they are looking for a replacement engineer for Frenchman Pierre Geoffroy Chateau, who freelances at the studio.

Relight is one of the 'heavy' studios in the Netherlands. "Between ourselves and one or two others, we hold most of the Dutch market in terms of work produced, at least as far as Rock goes. It's down to personnel and approach really," says Robin. Asked to elucidate he says: "One that fits in with the way most rock bands work". Reason for the success according to Dick is: "A combination of factors. Our Midas desk was the first of its kind and the first 24-track in Holland. It features equalisation at every step; the overbridge facility means that every range can be equalised. It's also quadraphonic; not that that means much these days. But I think the combination of the good desk and a good engineer, who can really make it work for him, plus the area we are in, is the answer. We are in the country, yet easy to get to. And we can arrange everything that a group might need at a reasonable price. We try and put ourselves in their shoes and get involved in what they are trying to achieve. It's also a small holiday for the foreign bands," says Dick.

The first foreign rock band to 'discover' Relight was Genesis. David Hentschel, their producer, heard about the new studio, checked it out, and liked what he saw. Genesis subsequently recorded *Wind and Wuthering* and *Then There Were Three* there. This acted as a green light for other bands from the UK including Strawbs, Black Sabbath, Peter Gabriel and Cat Stevens. The cream of the new Dutch rock scene, Herman Brood, Grupo Sportivo and Sweet d'Buster also record there. Most of the bookings are in fact by

established bands and mostly for 14/21-day sessions, although day bookings are not unusual. The studio is healthily fully booked for the next five months. Rates are Hfl 260 per hour for Studio One, and Hfl 60 for Studio Two. Hfl 2250 per day for Studio One; rates for longer bookings are negotiable.

Projects on the cards include the sync mixing of the soundtrack for a film on the Dutch rock scene, and the soundtrack of a musical currently being written by Cat Stevens. The intriguingly named *Phoney and the Hardcore*, from the Ariola stable, are also due to cut their first album shortly with American producer Neil Merriweather. Future plans for Relight, apart from the conversion of Studio Two to 24-track, is the addition of a cutting room. "So many artists want to cut their tracks with the engineer, that it's almost a must. At the moment Robin has to nip over to Abbey Road or somewhere else. We are looking forward to the day when we can cut it here," concluded Dick.

Bill Third

EMI studios upgraded

EMI has completed a rebuilding and re-equipment programme for its Sydney, Australia recording studios at a cost of £1 million. Rebuilt, it comprises two studios and a mixdown suite all equipped with Neve 8078 40-channel 32-track consoles. The mixdown suite is also fitted with Neve's *Necam* computer assisted mixdown system. The EMI complex contains an 87 ton floating room on a glass fibre bed insulated from the rest of the building by rubber buffers. The studios are equipped with the latest innovations in acoustic design and ancillary equipment, and include monitoring from a choice of JBL or Tannoy loudspeakers mounted on rotating platforms. The facility also has three mastering rooms offering direct-to-disc or *Necam*-to-disc cutting facilities.

EMI has also recently completed rebuilding its Hong Kong studio with a 16-track Neve console capable of being upgraded to 24-track, and Studer multitrack equipment.

Marquee live recording

Marquee Studios has announced the re-introduction of audio and video links to the adjoining Marquee Club thereby allowing live recordings to be made once

again. This facility disappeared temporarily when Marquee underwent refurbishment and improvement last year, but now bands appearing at the Marquee can be recorded in the 24-track studio at a cost less than most mobile units. Marquee can accommodate the usual services required for colour film and video tape production. Further information can be obtained from Larry Bartlett or Kathy Smith on 01-437 6731. Marquee Studios, 10 Richmond Mews, Dean Street, London W1.

Soundmixers Studio C, New York

Further to the news item in our July issue on Sierra/Hidley—Soundmixers, New York we have been informed that its new Sierra/Hidley designed Studio C is complete. Studio C is the first in New York for 12 years to use the Sierra/Hidley team and incorporates a low distortion and wide dispersion Sierra monitor system and a Hidley active trap system. Main design criterion for Soundmixers' Studio C was to achieve an essentially flat, unvoiced frequency response with negligible acoustic phase shift.

Portland Recording Studios, London

Readers who are tuned into the London studio grapevine will know that Portland Recording Studios is in fact the former IBC Sound Recording Studios. Situated at 35 Portland Place, just up the road from the BBC at Langham Place, the studio has been redesigned and re-equipped, and is now being relaunched following purchase by

Portland's in-house designed 32/24 console



Chas Chandler's Barn Records group of companies. The renamed studio has been added to the Barn group's record, publishing and production companies, and incorporates Radiotracks, the group's radio commercial production company.

Housed amidst a block of Georgian terraced town houses, Portland Recording Studios has a long history going back over 45 years. The building first housed a recording studio in the early Thirties when among others it was frequented by band leader Eric Robinson, and in later years was used to record many American TV programme music scores. In the Sixties IBC took over the studio and the later years of that decade and the early Seventies saw IBC recording (and setting the pace in the charts) with many top name groups. Users in this period included the Bee Gees, Cream, Status Quo, Jimi Hendrix, Slade, and The Who for their *Tommy* album.

Unfortunately, when IBC was taken over by a city-based group of companies, following a series of takeovers, IBC became rather left behind in the studio stakes largely through a lack of up-dating and a reliance upon former glories. Because of this the holding company which owned IBC decided to sell the studio in 1978. In June of last year Chas Chandler made the first move to purchase IBC and by mid-July purchase was completed and Barn had moved in having bought the offices, studio, disc cutting and tape copying facilities. The situation now is that the Barn Records group occupies all of the building and a long term rebuilding

36 ▶

and expansion programme is now underway. The first stage of this to be undertaken was the rebuilding of the main studio, this being closed down at the end of October and reopened end of March 1979.

The changes made to the recording studio and control room involved substantial re-equipment and revamping. The control room has been enlarged, but retains the 24-track console which was designed and built by the former IBC technicians. This console is a 32/24 desk with parametric eq and offers a capability of six subgroups, additionally having a separate 24-channel monitoring sub-console to the right of the main console, thereby forming an L-shaped console configuration. Even though the console is rather large compared with the latest off-the-shelf designs the enlarging of the control room has meant that despite this, the room is extremely spacious and comfortable to work in.

Chas Chandler's experience of production has obviously been put to good effect as the control room is a 'no-fuss' design perfectly tailored to the needs of doing the job in hand with the minimum of distractions. As with another studio I visited recently (Morgan) the ancillary equipment is mounted in a rack mount casing on castors which can be pushed out of the way when not needed. Whenever any of the ancillary units are required these can be quickly connected to the console via its patchbay in less time than it takes to read this. While on the subject of ancillary equipment this comprises: three MXR digital delays; Audio & Design F769X-R Vocal-stresser and F760S limiter, plus Scamp filters, autopanner and noise gates; Klark-Teknik DN34 analogue time processor; Eventide Harmonizer and flanger; and a Trio cassette deck. Chas Chandler told me that when re-equipping he had only ordered the ancillary units he had found to be the most useful in his experience, hence the perhaps slightly less wide-ranging than usual selection. However, this is not to say that the available units do not offer a more than adequate range of processing units. The remainder of the equipment in the control room is two Ampex ATR-700 2-track machines and an Ampex MM-1200 24-track with an Audio Kinetics XT24 Intelocator. The loudspeakers are Tannoy HPDs driven by Crown DC300A.

As with the vast majority of studios, this one is also equipped with Dolby noise reduction. In addition the studio has three stereo

EMT echo plates at present temporarily housed on a lower floor of the building pending further rebuilding, when the plates will be transferred to the basement. Incidentally both the control room and studio are fully airconditioned.

The studio itself is one of the more unusual I have seen. Some 1,600 sq ft, it will accommodate about 55 musicians and boasts an Adam fireplace on the righthand wall. The studio takes up two floors of the building and is over 20ft high. It is laid out so the control room is at the upper floor level at one end, ie it is an overhead control room with steps down to the studio along the righthand wall. Underneath the control room is an isolation booth and to the left where an access passageway is present at the upper level there is another section of the studio with reduced height. These different ceiling heights together with the studio's wide selection of acoustic isolation panels allow a wide variety

anticipate that more than 40-50% of studio time will be taken up by the record company's own activities. Accordingly, the studio is available for hire in the usual manner with Barn Records having to book studio time just like anyone else. Hire rate of the studio is £50 per hour plus materials, with any overtime charged at an additional £10 per hour. Incidentally current users of the studio include Splinter, Slade and Nick van Edde.

Portland Recording Studios also has a disc cutting facility and voice-over/radio commercial production facility. The disc cutting studio is the preserve of George Peckham who previously ran the cutting rooms at Apple and latterly the Master Room. George will be joined by a second disc cutting engineer in November, Chas informed me, but meanwhile will soldier on by himself. The cutting room has been fitted with a new in-house designed console and has a Studer A80 2-track pre-listen machine

lathe is a Neumann VMS70 with Neumann VG74 amplification and the loudspeakers are IMF Reference Monitor MkIVs.

The voice-over studios are presently temporarily housed on one of the lower floors of the building but will eventually be moved to the basement as and when rebuilding is completed. In charge of this section is Geoff Oliver. The control room for the voice-over studios houses another in-house designed console, designed by Dennis King (head of the technical department) and his two assistants. This console has 16-input channels and has both stereo and 8-channel outputs feeding Leavers-Rich 2-track machines and an Ampex 8-track. The control room is also fitted with a number of Technics turntables whilst monitoring is carried out over a pair of JBL monitors.

Portland Recording Studios and Chas Chandler have in the short time since the Barn group took over made substantial progress. Although a great proportion of the work remains to be done in the form of rebuilding—especially the basement area—the main studio is now in the form in which it will remain for the immediate future. As far as recording engineers are concerned, Portland has a young, friendly and knowledgeable team in Dave Garland, Andy Miller, and Mark O'Donoghue. Allied to this Portland also has the experience of George Peckham and Dennis King. This coupled to the production and management acumen of Chas Chandler and Mike Hales should augur well for its future success.

View of Portland's Studio from the overhead control room



of ambient conditions to be catered for. In case readers are wondering, the control room has an excellent view of the studio (apart from the isolation booth) despite being at a high level, and no operational problems have been encountered from this arrangement. The walls of the studio have been treated with bass absorption panels and it has a wide selection of mics including AKG, Beyer, Neumann, Sennheiser, and a number of vintage BBC designs. The studio also has available a Bechstein grand piano, Challen honky-tonk piano, and a Hammond C3 organ.

Although the studio, naturally enough, will be used by Barn Records, Chas Chandler and Barn Records' MD Mike Hales do not

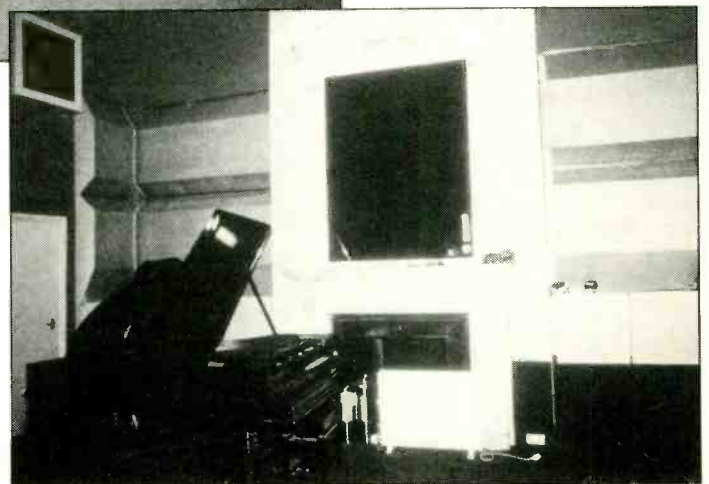

Adam fireplace dwarfs Bechstein's grand piano

together with a 3M 2-track. Equalisation includes Ortofon, Urei 1176LN, and Orban Parasound 622B parametric eq. The cutting

Portland Recording Studios, 35 Portland Place, London W1N 3AG. Phone: 01-637 2111.

Noel Bell

Imagination fuses two powerful illusions.

**Experimentation leads to the
discovery of new realities.**



Introducing the MXR Flanger/Doubler.
For more information see your MXR dealer or write us.

Atlantex Music Ltd., 34, Bancroft, Hitchin, Herts.
SG5 1LA. Tel. Hitchin (0462) 31511. Telex : 826967.



**Professional
Products Group**

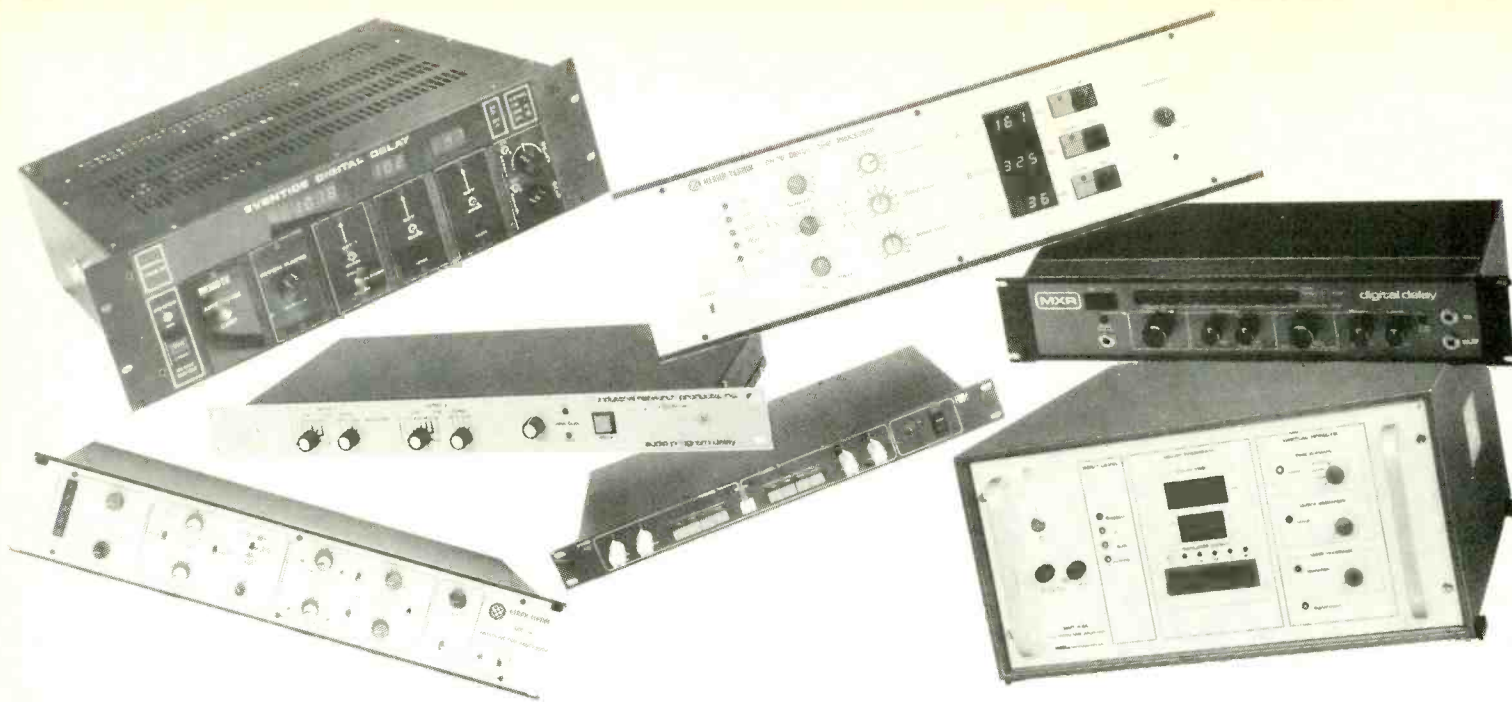

The delay dilemma

Mike Woodward (Klark-Teknik)

DELAYED audio signals are used in numerous applications, but until recently this delay was achievable only by electro-mechanical means such as stressed plates, springs, tape recorders—all of which have limited areas of operation as well as being cumbersome. Due to the advancement of semi-conductor technology, we are now able to delay audio signals both effectively and inexpensively by purely electronic means, thus allowing extremely versatile units to be housed in just a few inches of rack space.

Although the use of semiconductors in delay applications is relatively new, two distinct systems already exist, the analogue system and the digital system.

The analogue system uses one of a family of devices, collectively called charge transfer devices, which store the audio signal in terms of charge on a capacitor. The digital system, as the name implies, actually converts the audio signal into a digital code, in the form of digital 'words'. These words can then be stored in a memory and can be controlled and reconverted to audio at will. Both systems will now be considered in more detail.

The analogue system—using charge transfer devices (CTD's). The CTD consists of a serial chain of electronic switches and storage capacitors—fig 1 shows a typical arrangement. The charge stores can be moved along the chain by the application of external clock pulses. These charge stores represent

There are currently both analogue and digital delay systems on the market, and this article looks at each type giving the advantages and disadvantages that may be found. Mike Woodward is design and application engineer at Klark-Teknik.

samples of the audio signal, which are moved from an input to an output terminal by the clock pulses. In fig 1, the clock pulses $\phi 1$ and $\phi 2$ are out-of-phase squarewaves. On each pulse of $\phi 1$ the input voltage is sampled onto CS, the pulse of $\phi 2$ shifts this initial sample onto C1 and also shifts the charge from C2 onto C3. The next pulse of $\phi 1$ takes a new sample onto CS and also shifts the charge from C1 onto C2 and from C3 onto C4. It can be seen that on every pulse of $\phi 1$, all the odd numbered charge stores are moved onto the next store along the chain, and on every pulse of $\phi 2$ all the even numbered charge stores are moved on. At the end of the chain, the last two charge stores are buffered, and appear as outputs.

Summing these outputs together produces a continuous output signal which is similar to the original, but delayed by a fixed

amount of time. The length of this delay will depend on the number of charge stores and on the clock frequency. The number of stores will be fixed according to the number in each device, and the number of devices used (a typical device may have 256 stores). Thereafter the delay time becomes a function of the clock frequency, and is inversely proportional to it—the higher the frequency, the shorter the delay.

The maximum and minimum delay per device is obviously determined by the minimum and maximum clock frequencies. Since the clock frequency is also the sampling rate of the input signal, it must satisfy the sampling theorem, ie it must always be more than twice the maximum input signal frequency, otherwise a true representation of the input signal cannot be realised at the output. Assuming a maximum

input signal frequency of 15kHz, the minimum clock frequency must be greater than 30kHz and would be kept to at least 40kHz in most designs. This would give a maximum delay of 6.4ms for a 256 stage device. The maximum clock frequency will usually be restricted by the device, the limiting factor being the charge transfer capability. When the clock is running at high frequency, the efficiency of the charge transfer is reduced, ie not all the charge is transferred from one store to the next. This results in a drop in output level, and an increase in second harmonic distortion.

There are various types of CTD devices available using different semiconductor fabrication which give a similar performance. Rather than describe the different types (as new ones appear regularly on the market) suffice it to say that each one has slight advantages and disadvantages over the others, and that their particular merits should be studied in depth by the designer, before choosing one for a specific application. The dynamic range of all CTD's currently available is insufficient for professional use. To overcome this, a noise reduction system of some type is usually used. This is a very important part of an analogue delay system, and will be discussed later.

To create longer delays at full bandwidth, a number of devices can be cascaded. Although this causes an increase in noise, in practice this can be tolerated, again provided that an efficient noise reduction system is used. The

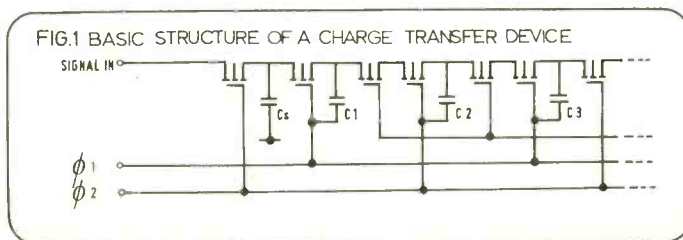

maximum delay available at full bandwidth, whilst still maintaining an acceptable performance for professional use, is about 50ms (8 x 256 stage, cascaded devices).

There are alternative ways of coupling CTD's rather than simply cascading them which will improve the performance considerably. Viz:

- a Parallel—multiplexed operation.
- b Balanced (differential) operation.
- c Balanced—multiplexed operation, a combination of 1 and 2 (see fig 2).

In the parallel or multiplexed mode, two devices are run in parallel with the clock phases inverted on the second device. The input signal is now alternatively sampled by each device, effectively doubling the sampling rate for a given clock frequency. One output from each device is summed together, and so twice the delay is available without adding to the noise. In the balanced mode, two delay sections are used, the signal to each section being out-of-phase. The delayed outputs are then summed in a differential amplifier. This effectively cancels even-order harmonic distortion and removes clock glitches. Combining these two methods gives a marked increase in system performance, but is rather expensive as it uses twice the number of CTD's for a given delay.

As the input is being sampled and is not a continuous operation, another important and often overlooked component in an analogue system are the input and output filters. It is important to restrict the input frequency to satisfy the sampling theorem, and a steep lowpass input filter is required. If this is not included, severe high frequency distortion and modulation occur. A similar filter is required at the output to remove the sample steps and reconstitute a continuous signal, it also helps to remove any glitches (clock feed through) present.

The digital system

As concluded from the previous section, the main problem with analogue delay systems is an increase in noise when the CTD's are used in multiples to achieve longer delays. In the digital system, however, once the signal has been converted into a digital code, it is virtually immune from additional noise and distortion. Therefore it is possible to store the signal indefinitely, without degradation. The basic digital system can be split into three parts, for ease of explanation:

- a The input section and A/D converter.
- b The memory and memory control.
- c The output section and D/A converter.

a) The input section and A/D converter.

The A/D converter changes the analogue signal into a series of binary coded words. The length of the words determines the resolution of the converter and hence the noise floor. Each digit or 'bit' of the binary word is roughly equivalent to a 6dB dynamic range, thus a 12-bit word = 72dB dynamic range and a 16-bit word = 96dB. The designer can therefore specify the word length by the required dynamic range of the system. The A/D converter samples the analogue input signal and again the sampling rate must satisfy the sampling theorem. Therefore the converter must have a minimum operating speed of between 25µs (40kHz) and 20µs (50kHz) in order to give a good audio performance with a 15kHz to 18kHz frequency response. The ideal converter should therefore have a resolution of at least 16 bits, and a conversion time of less than 25µs.

There are several possible A/D converter types, but the best system for attaining the required performance is currently the successive approximation converter. A 16-bit A/D converter of this type having the necessary operating speed is unfortunately extremely expensive. By comparison, a 16-bit converter could cost 10 times as much as a 12-bit version, and about 40 times as much as a 10-bit version. Because of the high cost of our 'ideal' converter, one or

more of the following alternatives are usually chosen:

- a Reducing the signal bandwidth of the system, hence the sampling rate. A slower converter, which is much less costly, can then be used.
- b Reducing the dynamic range of the system, using a converter with a shorter word length.
- c Using a shorter word length plus noise reduction, pre-scaling or non-linearising techniques to increase the dynamic range.

Most high quality systems on the market today use the third alternative and keep to a full 15kHz bandwidth. The different methods used to extend the dynamic range of the system will be discussed later.

As in the analogue system, the A/D converter sampling the audio signal needs to be preceded by a steep lowpass filter, to restrict the input signal bandwidth to the limits set by the sampling theorem. This is even more important in the digital system than in the analogue one, as we are working with a much higher dynamic range.

b) The Memory and Memory Control

Digital information can be stored in many media, eg magnetic tape, magnetic cores, optional devices, semiconductors, but as we are only concerned with a maximum storage time of a second or so, we shall confine ourselves to two semiconductor systems that are generally used. The first is the shift register (fig 3), also called the 'first in first

out' (FIFO). In this device the digital information is moved through the cells of the memory by the clock pulses. The delay time is determined (as with the CTD device used in the analogue system), by the number of cells in the device and the frequency of the clock. This form of memory is limited in its uses as continuously variable control of the delay time is not possible and complex processing techniques cannot be realised. Shift registers were used in most early delay lines, and are currently used in lower cost units, or in applications where only a few delay settings are required.

The second type of semiconductor memory is called the random access memory (RAM). In this device each individual stored cell can be accessed at any time, and in any sequence. Information can then be written into, or read from, the cell. With present technology, very dense RAMs are available in small packages. A delay line having a delay time adjustable from 0 to several seconds, in 20µs increments, is feasible with the latest of these devices. Although the method of controlling RAMs is more complex and more expensive than shift registers, their versatility justifies the expense.

c) The D/A converter and output section.

Since the D/A converter changes the digital code back into an analogue signal, it must therefore

40 ▶

FIG 2 BALANCED/MULTIPLYED CONFIGURATION

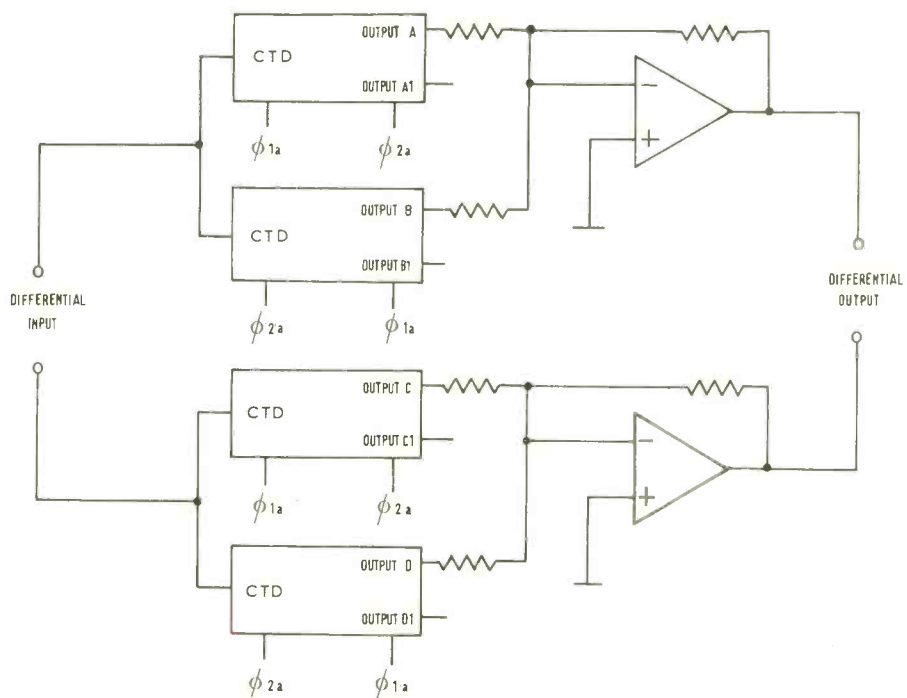

The delay dilemma

perform to the same resolution and speed as the A/D converter. The D/A process is, however, much simpler than the A/D, and the performance is easier to achieve. The signal at the output of the D/A converter is comprised of a series of steps which have to be removed by a very sharp lowpass filter. Fig 4 shows a typical digital delay system in block diagram form.

Specifications—what they don't tell you.

Why is it that electronic delays, which look impressive on a specification sheet and sound impressive in theory, are often a disappointment in practice? The problem is that written specifications can be very misleading when applied to both analogue and digital systems. This is partly due to specification figures not being mentioned by the manufacturers, and partly because many of the figures require different interpretation than when applied to conventional analogue equipment.

Frequency Response

As described previously, both analogue and digital systems require sharp input and output filters, and these must be taken into account when reading bandwidth specifications. If a particular unit claims to have a frequency bandwidth of 12kHz, the response at 16kHz may be -70dB! In contrast, a mechanical delay having 8kHz bandwidth will have a fairly gradual attenuation slope at higher frequencies, and a small amount of high frequency energy will always be present. For studio applications, therefore, a bandwidth of at least 15kHz is desirable. For PA applications this is sometimes not so important.

Many products on the market have switchable delay ranges, which also switch the bandwidth, ie a x2 delay switch will halve the bandwidth. This is sometimes not mentioned.

Analogue delay units having a variable delay control, often have specifications quoted at one specific delay setting. Usually frequency response and distortion varies slightly with delay length, but of course on poorly designed products this variation can be quite high.

Dynamic Range

This specification causes more bewilderment than any other, and it is quoted in a variety of ways. The dynamic range of a system is the difference in dBs between the maximum signal level and the noise floor measured with no signal present. The problem is that it is usually quoted at one particular

frequency, say 1kHz. If high frequency pre-emphasis and de-emphasis has been used, in order to reduce high frequency noise, the dynamic range at 10kHz will be considerably less than the 1kHz figure—very often this is not stated. Also if any sort of noise reduction system has been used, the actual signal-to-noise ratio when a full signal is present is only as good as the signal-to-noise ratio of the straight system, ie most noise reduction systems are only effective on low level signals, and they rely on the fact that high level signals will mask the noise. It must be realised, however, that a high level, low frequency signal will not adequately mask high frequency noise.

Many delay products, analogue and digital, use simple noise reduction systems designed for domestic tape recorders. These often give poor results because although a tape recorder can accept quite substantial overloads for short periods due to the nature of their distortion curve, delay systems, especially digital ones, distort very severely once the maximum level has been reached, being very similar in nature to a transistor amplifier at clipping point.

The noise in an analogue system is usually generated by the CTD itself. Although this is usually 70dB below the maximum signal, it is a much more objectionable noise than the familiar tape hiss. It usually has quite a high peak level, and is not evenly spread over the audio spectrum, but centred on

certain frequencies in the 2kHz-10kHz range (very often sub harmonics of the clock frequency). To make matters worse the noise varies considerably with clock frequency, which means that when the delay is 'swept', the noise will pump up and down. To successfully reduce the subjective effect of this, a specialised compander should be used, preferably a band split design also having fast attack times to prevent overload occurring. Units designed to have the lowest possible 'straight' noise will also perform better than those that are not.

In a digital system the main source of noise is the so-called 'quantising error', caused by the least significant bit (LSB) of the converters 'hopping' between '1' and '0'. This noise also has a very high annoyance factor, therefore a dynamic range of at least 90dB is desirable. Although analogue compressors are used in some designs, more complex systems tend to use prescaling techniques to extend their dynamic range. These give a much higher performance because attack and release times are instantaneous. The noise is more effectively masked by the signal as it only appears on the individual peaks of the waveform. As with the analogue compander, the straight system noise should be kept as low as possible, ie a converter using a 12-bit linear code which has been extended to 15 bits, would give a better subjective performance than one using a 10-bit linear code extended to 15 bits. However, both would still be classed as quasi 15-bit converters, and both systems would be capable of a 90dB dynamic range. The number of

linear bits used is the important factor (see footnote).

As the specification of the noise reduction system employed cannot be meaningfully quoted, the only way to ensure that a particular piece of equipment will give an acceptable subjective performance, is to try the unit out in the relevant application for which it is required.

Analogue or digital

Having briefly outlined the basic techniques of the two systems, it can be seen that each has distinct advantages in some areas of operation, and equally, has disadvantages in others. Since the analogue system is usually less expensive than the digital one, this is a major point of consideration. It is particularly good for swept applications such as sound effects. Long sweeps of up to 70:1 are attainable in a good design without adverse side effects. The power used is generally low, so there are no heat dissipation problems, and reliability is high. Units are also usually very compact. The major disadvantage is that for full bandwidth delays of longer than 80ms or so, noise becomes a significant factor, and the performance cannot be considered as 'professional' with present technology.

Digital systems, however, are quite the reverse. They are generally expensive, particularly so for short delays, since a major part of the unit cost is in the converters. Their main advantage is that the length of delay does not affect the performance at all, and for straight delays, a top quality delay line will be considerably better than the very best analogue system. In studio applications such as prereverb delay, they are unsurpassed. To continuously vary the delay length, however, is quite complicated, and usually side band noise is generated. Digital sound effects units, which sweep their delay length by varying the master clock, are usually restricted to short sweep lengths (4:1 maximum). Therefore for many effects such as flanging they will not compete with an analogue system.

In short, if high audio performance is the main criterion, and only straight delays are required, then a digital delay system is far superior to an analogue one. However, for short delays, and sound effects in particular, an analogue system provides the better alternative, at a lower cost. ■

Footnote

This is only a very brief explanation of the subjective performance of digital codes, and should therefore only be regarded as a guide. For more detailed information on digital conversion many papers have been published, eg *Digitization of Audio* — Barry A Blesser — AES Journal — October 1978.

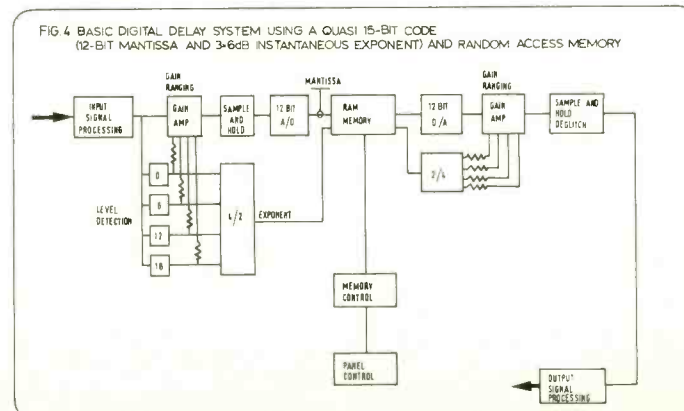
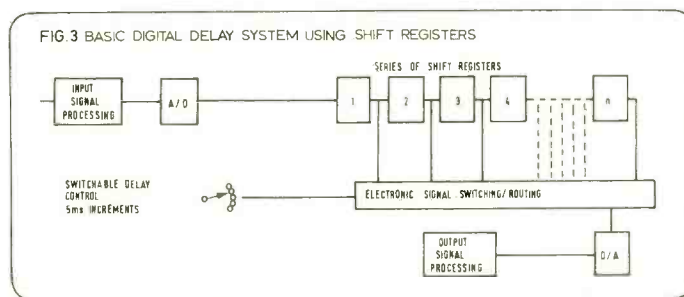

The 1980's are brought one step nearer by the introduction of the MTR-90. This new sophisticated design is based on accumulated technology and innovation which have been the hallmark of Otari for over 15 years.

The new-generation tape transport incorporates a pinch-roller-free direct drive capstan with phase-locked-loop dc-servo circuitry. Tape speeds are 15/30 ips with $\pm 20\%$ stepless varispeed and a digital percentage readout. Features include full dc-servo on supply and take-up

motors for constant tape tension, automatic switching between input/sync/reproduce electronics with gapless punch-in/punch-out. And a sliding tape-speed controller, built-in digital timer, auto/manual motor-driven head shields plus 40-ohm balanced output, to name but a few. It comes with the latest electronics featuring a single plug-in card per channel.

The MTR-90 is also available in a 16-track frame, and a 16-track prewired for 24 which can be upgraded to a 24-track machine simply

and economically. For the full story, get in contact with your nearest Otari distributor.

OTARI

Japan: Otari Electric Co., Ltd.
4-29-18 Minami Ogikubo, Suginami-ku, Tokyo 167,
Phone: (03) 333-9631

U.S.A: Otari Corporation,
981 Industrial Road, San Carlos, California 94070,
Phone: (415) 593-1648

Announcing the new 24-track designed for 1980's. Otari MTR-90.



APRS Exhibition 79, A Report

Noel Bell



THIS YEAR'S APRS Exhibition, the 12th annual exhibition of the Association of Professional Recording Studios, was as well attended as previous exhibitions and with all available exhibition space taken had a total of 94 exhibitors displaying their products. This was my first APRS exhibition, and, I like many found the Connaught Rooms to be somewhat of a rabbit warren when trying to track down certain exhibitors. Even with the aid of the excellent APRS exhibition guide it was difficult to work out how you got to the furthest reaches of the exhibition's upper floor level. With a bit of investigation I managed to track every exhibitor down (also pointing a number of puzzled visitors in the right direction); however, I wonder how many visitors failed to find the elusive section.

As many of our readers will know, it is not APRS policy to allow active/sound demonstrations. This for an exhibition devoted to the sound recording industry may seem slightly strange but while the exhibition remains at its present venue, accompanied by a lack of acoustic isolation between exhibition stands, there is really no alternative. Any exhibitor wishing to demonstrate its products using an active sound source must do so over headphones—a trifle unfortunate for loudspeaker manufacturers though! These remarks with regard to the exhibition evidently are not solely my own views as a letter was circulating amongst exhibitors, basically along the same lines as my comments, but mooted the possibility of a change of exhibition venue. Perhaps the lack of air-conditioning in the Connaught Rooms, plus the fact that during the exhibition London was suffering a mini-heatwave, was acting as an irritant to previously placid exhibitors, but I think not. There appears to be a widespread feeling that a change of venue is needed. Where that venue would be is another matter but one possibility is the Cunard International Hotel. This has a large ballroom which is ideal for static and

The APRS Exhibition 79 took place from June 20 to 22 at its traditional overcrowded venue, the Connaught Rooms, London. Due to the exhibition's size, Noel Bell's report is split into two; part one this month, part two in October.



MCI/EMI JH-220 2-channel digital stereo tape recorder non-sound reproducing display. In addition there are available a number of conference rooms and an almost unlimited number of hotel rooms which could be used for sound demonstrations or for exhibitors requiring only limited space. As the venue for one of Europe's largest hi-fi exhibitions and the ASCE exhibition, the hotel has proved it is capable of handling such an exhibition with the minimum of hassles. However, it remains to be seen whether next year we will be forsaking the Connaught Rooms for another venue. The fact that the European AES exhibition is now being held in London next spring (at the Hilton) might also create problems for the

APRS show.

But back to the exhibition itself. By far the most interesting development was the joint announcement by EMI and MCI that MCI have entered into a licensing agreement with EMI, under which MCI will manufacture digital tape recording equipment in Florida based on technology developed by EMI. A prototype of the first machine to be completed under the agreement—the MCI *JH-220* two-channel digital stereo tape recorder—was introduced and demonstrated at a 'press launch' held in one corner of a wine bar adjacent to the exhibition on the first day (but not shown at the exhibition). This proved to be a most unsatisfactory venue and the demonstration of a recording of Mercury from Holst's Planets suite was not helped by the fact that the loudspeakers being used were on resonant wooden floor boards. Despite this, a brief hearing confirmed that the EMI system has a wide frequency response and dynamic range. Distortion was impossible to assess, however, due to the nature of the venue. We will be able to report more fully on the system's subjective performance in a future issue as further demonstrations are to be organised.

The EMI digital system and the MCI digital recorder are the result of some seven years work by EMI's Central Research Laboratories at Hayes in Middlesex. The prototype MCI *JH-220* uses EMI electronics married to an MCI transport together with jointly developed EMI/MCI read/write electronics. The recorder has a 50kHz sampling rate and uses two tracks for each channel. Although permitting the use of 16-bit coding, the recorder currently uses a 12+2 code as outlined in the paper EMI presented at the AES 63rd Convention in Los Angeles. Accordingly, the recorder uses a digital block format with interblock gaps and a comprehensive cyclic error correction system. The packing density of the recorder is 25,000 bits per inch and it operates at a speed of

44 ▶

The Technology Must Serve The Music

This one thought is reflected in every facet of Solid State Logic's Master Recording Consoles. From the beginning, we wanted to offer the artists in our industry a truly exceptional instrument which would not limit their expression in any way. After years of quiet and deliberate work, we have created an unprecedented marriage of hardware, firmware and software with advantages and potentials years ahead of any other studio system.

SSL's ULTRALOCATOR, for example, brings automation to recording as well as mixing. The multi-track transport is directed to unlimited cue points which may be requested by songtitle, verse or other words, as well as sequential numbers and timecodes. All session data, such as track assignments and comments on takes, can be stored on floppy disc for video display or hardcopy printout. The proprietary SUPERCUE system enables unerringly accurate programmable drop-ins with tandem multi-track, monitor, and foldback switching.

SSL's SOFTWARE ASSISTED MIXING (SAM) is easily the most useful and easy to use mixing automation ever. SAM automatically selects the appropriate fader status, displays VCA levels on a built-in video screen, stores unlimited mixes, and enables extensive off-line manipulation of those mixes. Best of all, SAM is software based, which means he easily learns lots of new tricks to keep you ahead of the pack.

SSL's SIGNAL PROCESSING includes a full-feature compressor/limiter/expander/gate in each module. Front panel "Link" buttons enable an unlimited number of strapped stereo or quad units to be freely configured across the board. The module's four band parametric equaliser has continuously variable Q in each of the overlapping mid-bands, selectable peaking or shelving in the high and low bands, and separate variable HP and LP filters. Pushbutton switching enables the equaliser to be placed at the channel input, the channel output, in the dynamics unit sidechain, or in the monitor mixer. The dynamics unit can also be switched to the monitor mixer.

SSL has developed these and many other innovations to free the production team from the tedious, purely mechanical aspects of multi-track work, so that they may apply their full skills and judgment towards perfecting the artist's performance. If that sounds like music to your ears, contact us for additional notes. Or visit us at the Brussels or Los Angeles AES shows.

Solid State Logic
—at the leading edge of
recording technology

Solid State Logic

Stonesfield • Oxford, England
099 389 324 • TLX 837400

Milan, Michigan • USA
313 663-6444 • TLX 230504

Sales and Distribution

North America

Washington Musicworks Inc.
3421 M Street N.W.
Washington, DC 20007
Doug Dickey
East Coast (202) 333-1500
West Coast (213) 464-8034
TLX 440519

UK

Solid State Logic
Stonesfield
Oxford, England
Colin Sanders
099 389 324
TLX 837400

Italy

AEG Telefunken
Viale Brianza 20
20092 Cinisello Balsamo
A. Savasi
Milan 61798
TLX 31473

Germany

B.F.E.
65 Mainz 23
Postfach 81
West Germany
Jeff Nieckau
Mainz 42430
TLX 4187300

APRS REPORT

30in/s. The objective performance of the recorder is frequency response dc-20kHz with 0.03% distortion and a dynamic range of approximately 90dB.

Production models of the *JH-220* will be available towards the end of this year and first priority will be to equip EMI recording studios throughout the world. MCI's Lutz Meyer stated that the likely cost of the recorder will be around \$20,000, and that the company hope to be able to manufacture some 600 *JH-220* machines during 1980 should the industry's requirements call for rapid volume production. With regard to future joint EMI/MCI projects under the licensing agreement, these will include the manufacture of an editing system as well as multi-channel digital tape recorders. Development work on both these projects is nearing completion, with a prototype EMI editing system at present undergoing operational evaluation, and it is hoped that prototypes of both will be completed by MCI by the end of this year and that they



Above:
Soundcraft
Series 1600

Right:
Solid State Logic's
new SL4000E



Above:
New Neve
8108 console

Right:
Trident
series 80



will go into production early in 1980.

Although MCI were not exhibiting the digital tape recorder on their stand they did show their *JH-500C Series* automated console which includes improved circuitry and 'swinging' op amps as standard and is available in four frame sizes. In addition MCI also had on display their *Autolocator III* and *Autolock* synchroniser, plus a selection of their tape recorders including the *JH-110-8* which is finding increasing use in broadcast applications, and which we understand the BBC are interested in purchasing.

Consoles

Perhaps the most interesting console on display at this year's APRS was the new Neve *Model 8108* which made its debut at AES Los Angeles. This console is one of the most advanced software controlled consoles around and it dispenses with conventional frame wiring favouring sophisticated mother board construction instead. The console is available with up to 56 input channels each incorporating fully parametric eq, filter, and up to 48 outputs. In addition to this the console also has an extremely neat and comprehensive micro-

processor controlled touch sensitive central assignment panel for signal routing which includes enter and recall facilities to any of four integral memory stores. As if this weren't enough the console can also transfer complex console assignment patterns from memory to console at the touch of a button, and additionally the console's integration system can give instant readout of the channel and track configurations. You don't get all this for nothing, though, as a typical price for the console is in the region of £90,000. It was interesting to see that Neve also had a *Model 8078* console fitted with *Necam* automation on display too, perhaps to remind visitors that the company will continue to manufacture its standard consoles and also perhaps to illustrate just how radical the new console is.

Returning to the more mundane but no less

interesting consoles *Audio Kinetics* were showing a *Quad-Eight Coronado* console featuring *Compumix III* automation. The *Coronado* is a 40-input console with 24 mixing busses, quad mixdown and monitoring facilities, and is a VCA design with six subgroup masters. A very flexible console, the *Coronado* can be supplied with a complete range of optional accessory modules including phantom power supply, stepped parametric eq system, and transformerless mic preamps.

Solid State Logic showed their new *SL4000 E Series* console and studio computer automation system at APRS. Although this has been exhibited at AES it was its first UK exhibition appearance and it drew suitably appreciative visitors. Featuring integrated console control of all multi-track functions in tandem with monitor and foldback switching,

extensive signal processing capability, and channel, group and monitor level automation, the console is available in versions up to 48 inputs with all versions having 32 output busses, quad master output busses with integral comp/limiter, and extensive aux send and return flexibility. The computer system will maintain reel information, tracklists, song titles and cue points; then uses this data to accurately programme drop-ins, automatically cycle overdub passages, and autolocate. All computer commands are executed in plain English and are verified on a built-in TV monitor which also displays fader and VCA levels.

Shepperton-based *Trident Audio Developments* introduced the new *Series 80* modular console, a lower cost format based on the

46 ▶

If you can't wait for our 32-track digital recorder...



buy our M79 now.

This year 3M will introduce their Digital Recorder into Europe. It will be the first. And it will be the best sound recording equipment in the world.

Today, 3M can still sell you the best sound recording equipment in the world. The M79 range.

It's the one that's used in the best studios, large and small. It's the one favoured by the best groups, like The Who, Rolling Stones, 10 CC, and Queen.

It'll give you 8-track to 24-track from a single console:

And you can link your existing machines up with our SMPTE Synchroniser and M79 to take you all the way to 46-track, on audio plus audio or audio plus video.

If you haven't seen the M79 at work, call John Prigmore at Bracknell (0344) 58445 or write to him at 3M United Kingdom Limited, FREEPOST, Bracknell, Berks RG12 1BR.

And find out for yourself why M79 is the choice of superstars and super studios.

3M is a trademark

The 3M logo, consisting of the letters '3M' in a bold, red, sans-serif font.

APRS REPORT

successful *TSM Series*. Featuring a 32 into 24 group format with separate monitoring, the console has 4-band eq including two swept mid-ranges, five aux sends, separate mic and line inputs, separate stereo remix buss, electronically balanced line inputs, and electronic relay-less switching. Other features include compact size (only just over 7ft for the 32-24 frame), +24dBm output capability, fully modular patchbay with 512 patch points, bargraph LED metering, and the capability of automation using the Fadex/Trident system. The *Series 80* is available in any input/output configuration and for a fully equipped 32/24 console without automation (which can be retrofitted at any time) costs approximately £19,000. In addition to the *Series 80*, Trident also showed their *Fleximix* system which is being successfully used in a number of West-End theatres as well as its many other applications.

Soundcraft Electronics were showing a number of interesting products including a new console series. The new consoles designated the *Series 400* are modular 4-group, 8-track monitoring consoles available in 12/18/26 input configurations with four output and stereo remix busses. The input channels feature separate mic and line gain controls, phantom power, phase and line input switches, 4-band eq with sweepable frequency low and high-mid bands, three aux sends and long travel faders. Metering is by LED bargraph meters and the aux master module is fitted with a line up oscillator. High quality German-manufactured detent potentiometers are used throughout. Prices of the *Series 400* start from about £2,500, and the 18/4 configuration costs approximately £3,250. Soundcraft also had on display their modular *Series 1600* console system which features submaster and monitor channels separately located from the input channels. These consoles also allow the group/monitor channels to be divided into two sections thus allowing creation of a submaster with or without aux sends and pan, plus an effect return with 3-band eq, again with or without aux sends and pan. The *Series 1600* is available in a 16/16 configuration from £6,700 and in a 24/16 configuration from £8,500, either version offering excellent value for money. In addition to these consoles, Soundcraft also showed their *Series 3B* console which is a revised version of the *Series 3*.

On the subject of value for money, Malcolm Hill Associates were showing the new *K Series* of consoles. Represented by a 24/16 console the *K Series* are extremely neat modular consoles and feature free group selection 4-band eq, plus four independent aux sends and LED level indication on each channel. In addition the console has P & G faders, conventional metering and a separate monitor mix. A wide choice of options are available within the standard format and the company is willing to provide custom modifications at a low cost. The company additionally guarantees the consoles for five years for all parts except those parts which are subject to normal wear and tear. Prices of the *K Series* start from £4,000 for a 16/4 model with a 24/16 model costing approximately £6,000, while a 32+8/24 console costs approximately £11,000.

Clive Green & Co have been appointed UK distributors for the Enertec range of consoles and tape recorders. Most readers will recall



Above: Malcolm Hill stand the new *K Series* rather prominent in the foreground

Right: Wrap-round console based on the *MXT-1000* from Audix



that Clive was previously MD of Cadac (London) Limited, and in addition to his involvement with Enertec he offers a studio consultancy service.

Magnetic Tapes were showing their new *Chilton QM2* range of consoles available with 12 to 24 inputs, 4 outputs and 8-track monitoring, or with 16 to 24 inputs, 8 outputs and 16-track monitoring. The consoles are fitted

with standard or parametric eq, full sweep high and low pass filters, peak reading VU meters with LED overload, push button channel assignment, and 48V phantom powering.

APRS saw the introduction by Audix of their ILR on-air console package. This comprises a specially designed "wrap-round" console based on the popular *MXT-1000* range. The console is comprehensively equipped for mono and stereo monitoring and incorporates clean-feed outputs and outside source switching facilities. Being marketed as a standard package the console makes it much simpler for ILR stations to be equipped at a reasonable cost and without the necessity of extensive custom building. Typical price for a package based on the *MXT-1000* is approximately £5,000.

Amek showed their *M 3000* VCA-assisted in-line console intended for 24/32/48-track recording. The standard console is a 36 input desk offering simultaneous quad, stereo and mono mixes from 32 tracks, with dc sub-grouping of VCA-assisted channel and echo return faders. Each input has a mic and two differential line inputs, variable 4-band para-

48 ▶

STEREO DISC AMPLIFIER 3

A reference amplifier for disc monitoring and transfer when replay signals of the highest quality are required.

Based on the Surrey Electronics Disc Amplifier 2 and manufactured under licence, two unbalanced outputs are provided enabling Line and DIN level inputs to be driven simultaneously. To facilitate cartridge matching, a wide range of switchable load capacitance and resistance values are provided, together with left and right 20 turn gain presets.

DYNAMIC INTERMODULATION DISTORTION

It is widely recognised that two pieces of equipment may have the same Total Harmonic and Static Intermodulation distortion performance yet sound quite different. Remaining distortion is attributed to transient distortion effects and these can be quantified with a combined square wave and sine wave test signal. The signal used consists of a 3.18kHz square wave through single pole —3dB at 100kHz plus 15kHz sine wave, 4:1 amplitude ratio. The signal after pre-emphasis is shown above. Distortion in the equipment under test will produce sum and difference products and the RMS sum of those below 15kHz quoted relative to the amplitude of the 15kHz sine wave is the Dynamic Intermodulation Distortion.

High (Line) output: Loaded with 10kΩ, 1kHz at —44dBV.7 (5mV) set for 0dBV.7 output.
Pre-emphasised input 500mV pk-pk —70dB, 0.03% measurement limit.

Price: cash with order, UK postage and 15% VAT inclusive £169

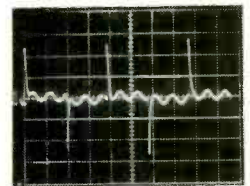

Dominus P.O. BOX 1, CRANLEIGH, SURREY. Tel. 04866 6477



"The original A77 had set a standard by which I have judged other domestic and semi-professional recorders for many years. It is now clear that the new B77 sets a new standard not easily surpassed at its price"

Angus McKenzie (March 1978)

REVOX

For the full story contact F.W.O. Bauch Ltd, 49 Theobald St, Boreham Wood, Herts, WD6 4RZ

Imperial War Museum

London

Audio Technician

The Museum illustrates and records all aspects of the two world wars and all other military operations involving Britain and the Commonwealth since 1914. This post is in the Department of Sound Records, where the technical operations are based on a Sound Suite incorporating Leevers-Rich E200 and Revox tape machines, disc reproducers, a Neve BCM 10/2 mixing desk and ancillary facilities.

The technician appointed will be responsible for the control of studio recording, transfer operations, routine servicing and maintenance of all the audio equipment, some location recording, control of public listening facilities in the Museum and the provision and maintenance of certain archival lists and procedural records. In addition the successful candidate will work from old recordings and those produced on domestic equipment, and assist in the production of programme material for use in the Museum's public and educational services.

This post has been exempted from the Government's ban on recruitment. Candidates must have an ONC in engineering TEC/SCOTEC Cert or C & G Pt II in a relevant subject or an equivalent or higher qualification, and an aggregate of at least 8 years' training (eg apprenticeships and/or full time study) and experience. Practical experience of operating and maintaining audio equipment and a theoretical knowledge of sound recording essential.

Salary, starting at £4850 rises to £5390. **Salaries under review.** Non-contributory pension scheme.

For further details and an application form (to be returned by 5 September 1979) write to Civil Service Commission, Alencon Link, Basingstoke, Hants RG21 1JB, or telephone Basingstoke (0256) 68551 (answering service operates outside office hours). **Please quote ref: T/5127.**

APRS REPORT

quad solo, programmable and groupable muting, and eight automated dc submasters with audio subgrouping available in remix. Comprehensive studio and control monitoring is provided with two independently addressed stereo cue outlets and the console also features a talkback system, oscillator, and eight automated echo returns four of which are assignable to multitrack.

Several new products were shown by Alice including the 12-48 semi-modular 12 input, 4-group mixer with 8-track monitoring designed for low budget studios. The 12-48 is the first in a new range of medium cost mixers and all models have in-built oscillator and full talkback facilities, multi-track monitoring with echo and sync foldback, stereo mixdown with monitoring, direct channel outputs, channel and group inserts, and a choice of faders. Alice also showed a prototype of their new STM 8 portable production/transmission mixer designed to replace the now discontinued STM 6. We understand the STM 8 will go into production from October and it is a three mono/five stereo portable mixer with the same facilities as the STM 6 plus a number of new

features including noiseless digital on/off channel switching, comprehensive monitoring, and a choice of meter and fader types.

Midas Audio showed a new version of their PR System console with several new facilities including in-place solo, bargraph metering to DIN and Nordic specifications and additional facilities for 16/24-track applications. The range of 20 standard modules together with the modular mainframe concept provides many console format variations to cater for various applications.

Twced Audio introduced a new semi-standard broadcast system offering six frame sizes from 12 to 32 inputs with either three stereo outputs or 4-group output remixed to stereo or mono. Comprehensive metering and monitoring is provided and all the equipment meets IBA, ITCA or FCC specifications. There is a choice of 11 input modules providing mic input, mono line input, and stereo line input, and most modules are interchangeable providing a choice of layout to individual requirements. There is enough room available in the frames to plug in ancillary modules such as limiters, compressors, noise gates, equalisers, etc. and two of the frames are suitable for on-air applications.

Alice portable mixers: 828 (left) and new STM 8 (right)

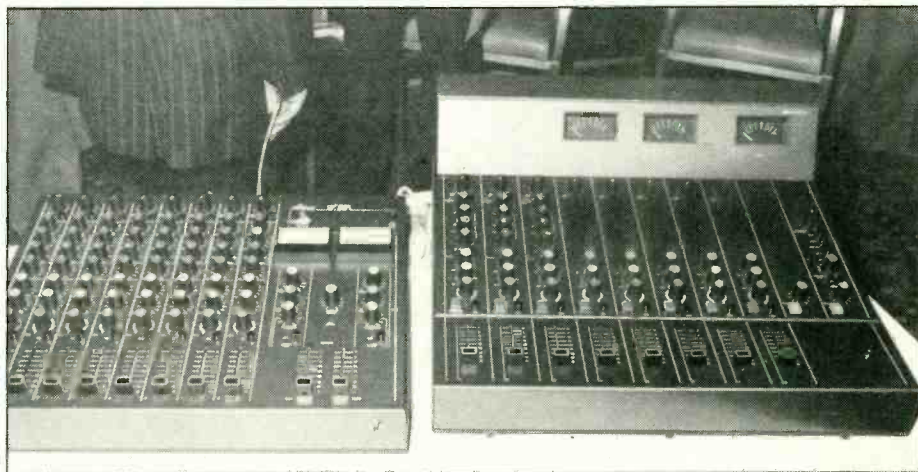

Tape and tape machines

Soundcraft Electronics' sister company Soundcraft Magnetics introduced in prototype form a 16-track version of their SCM 381-8 1in 8-track tape recorder. Designated the SCM 381-16, the new model uses the same transport and electronics as the 8-track, but with a 16-track 2in head block, 16-track electronics, and with a permanent remote control facility. Although the company has not yet decided whether to market the new recorder yet, they were extremely pleased by the response from visitors at APRS, so it is likely that they will decide to produce the recorder. Should they decide to go ahead with production it is anticipated that the price of the SCM 381-16 will be approximately £7,500.

Of more than passing interest was the introduction of a new tape recorder from NEAL Ferrograph. The new recorder which is in the Ferrograph range is the SP7 and is available as a 'custom-built' reel-to-reel recorder designed specifically for the studio and semiprofessional markets in hospital broadcasting and industrial outlets. The recorder is custom-built in as much as the fact that while it is a 3-head, 3-

speed, 3-motor recorder using the same transport and logic controls as the Logic 7, it is modular and many optional facilities can be specified from a standard range. Options available include mono, stereo including mono selection, line in/line out, mic input(s), a choice of different mono and stereo tape heads, a choice of tape speeds, either IEC/CCIR or NAB equalisation, balanced line in/out, Dolby B on the stereo models, and optional 10W power amps and loudspeakers. Price of a basic mono recorder is £395, a basic stereo recorder costs £495, while a stereo recorder incorporating all applicable options will cost approximately £800.

Two new versions of the Proline 2000TC and Proline 1000 recorders were introduced by Leevers-Rich. The first new product is a pilot tone version of the Proline 2000TC 4in recorder which is equipped with a resolver unit for record and replay of FM and AM pilot tone systems and with a plug-in headblock available to cover all track formats. The second new product is the Proline 1000 logger recorder. Based on the standard Proline 1000 4in

50 ▶

H/H MOS-FET the dawn of a new age in power amplifiers



H/H Electronic demonstrates clear technological leadership in introducing the world's first MOS-FET Professional Power amplifiers. Suffice it to say that MOS-FET technology offers overwhelming performance and reliability advantages over existing bipolar transistor designs. These outstanding new amplifiers leave the competition well and truly *behind*.

For your professional sound systems, specify *perfection* – specify H/H MOS-FET power amplifiers.



H/H Electronic, Viking Way, Bar Hill, Cambridge CB3 8EL. Telephone Crafts Hill (0954) 81140. Telex 817515 HH Elec G.

STILL THE BEST CARTRIDGE MACHINE

Cuemaster

(WE STOCK ALL THE SPARES!)



Granet

Communications Ltd.

39 BEECHCROFT MANOR, OATLANDS
DRIVE, WEYBRIDGE, SURREY KT13 9NZ

Weybridge (0932) 47785

APRS REPORT

recorder, the logger has a tape speed of $\frac{1}{8}$ in/s, uses four channels and is suitable for dual operation with auto change over, and complies with the latest IBA specifications for logging recorders.

On display from Lyrec was their *Model TR532* multi-track recorder with the recently introduced *TPC* microprocessor controlled tape position controller which can be built into the standard remote control unit. The *TPC* is built up around four displays comprising tape position, A, B and keyboard, with the latter three positions being used to programme the unit for searching different tape positions. The unit can recycle between two positions and its memory can store 16 tape positions which can be recalled and searched. In addition to the *TPC* Lyrec also showed their *ATC* microcomputer controlled and programmed audio and tape controller for the

until selected tape speed is reached. The tape control section of the *ATC* is no less comprehensive and versatile and has a full set of the usual tape controls plus a real time tape counter, continuously variable speed in the range $7\frac{1}{2}$ in/s to 60 in/s, continuous display of selected varispeed, a direct search function to three tape positions with individual display of each position, a shuttle mode, playtime computing for shuttle distance, 16 tape position memory with memory display, mutual loading of tape position between displays, and provision of an output for an additional remote mounted tape position display.

Colin Broad of **CB Electronics** once again was showing his excellent tape electronics featuring equalisation to both American and European standards with phase correction, full monitoring, solo switching with automatic muting of other channels, a noise gate on each channel, a fast line-up system, silent drop in, slate input, and optional *CAT 22* noise reduc-



Left:
Neal-Ferroglyph
SP7



Right:
Soundcraft's
prototype
SCM 381-16
with remote control
facility on the left

first time in the UK. The audio control section of the *ATC* has individual selectors controlling the output from each track, ready/safe buttons for each track for easy drop in/out, individually selectable pre or post tape and sync audio signal, automatic sync switching at drop in/out, solo 'in place' on each track selectable in groups or single tracks, a master control to switch all tracks simultaneously between safe/line/sync/repro, automatic audio switching in stop and wind modes, and tape signal muting

tion. Colin informed us that a multitrack tape recorder, the *400 Series*, would be available from the company in the autumn and that this would be a 2in machine using their own transport and available in 16-track, 16/24-track and 24-track versions. Prices of the new recorders are likely to start from around £12,000.

Whilst on the subject of ancillary tape electronics it should be noted that **Audio**

52 ►

Publison Audio Professional Manufacturing

CATCH THE 'NEW' SOUND WITH THE 'NEW' AUDIO COMPUTER!...



DHM 83 B

By means of complex digital manipulation of memorized sounds (memory capacity : 210 kilobit), this device allows many original effects :

Dual delay, with various combinations bandwidth – maximum delay (bandwidth up to 20 kHz. Delay up to 1200 mS. On request, up to 5000 mS).

Echo

Pitch shifting, from -2 to $+1$ octave. Sophisticated micro computer operates phase-coincidence of joining points, and eliminates "glitches". Minimum and maximum delays of pitch-shifting are adjustable.

Automatic arpeggio

Reversed sound : electronic equivalent of a magnetic tape running reversed. Reversed sound can be itself pitch-shifted.

Memory latch : memorized sound can repeat indefinitely. Start, length, reading sense and pitch-shifting of repeating sequency are adjustable. Numerous applications : rhythm with any natural sound, memory synthesizer, by means of associated keyboard, ETC !



DHM 89 B2

Similar to DHM 83 B, but with true stereo possibility : 2 independent inputs, 2 independent pitch ratio.

FOR FURTHER INFORMATION CONTACT PETER DEAN

Publison Audio Professional

5-7-9 RUE CRESPIN DU GAST 75011 PARIS

TEL : (0-10-33-1-) 357 64 08

APRS REPORT

Kinetics have appointed 3M as the European marketing agents for their *QLOCK 210* synchroniser. The *QLOCK 210* was being shown in its production form and is an SMPTE generator/synchroniser designed for simple operation of audio/audio or audio/video machine combinations and able to facilitate 46-track recording by the splitting of the master and slave record functions.

In addition to the *QLOCK 210*, 3M also market Wollensak cassette duplicators. This year's APRS saw two recently introduced models being shown. The first, the *Model 2772AV*, is a compact desk top high speed cassette to cassette duplicator capable of producing two mono or stereo duplicates from the cassette master. Operating at 25in/s, the duplicator features automatic erasure of old programme, automatic end of tape rewind, a five-position bias selector switch, and a warning light which lights when a cassette either jams or is of insufficient length for the master programme. The second model being shown was the *2790AV* portable high speed half-track cassette duplicator with a master and one copy position again operating at 25in/s.

Lee Engineering showed the Capitol/EMI stereo compatible *Andiopak AA-3* cartridges for which they are the UK agents. The *AA-3* cartridges were introduced earlier this year and feature a new high output/low noise tape formulation which gives the tapes improved signal-to-noise and distortion characteristics. Lee Engineering also introduced to the UK the Ampro range of cartridge machines including the *Model 3000* record/reproducer with high speed cue, automatic splice finder, optional erase head, digital message timer, plus the conventional mono/stereo, single or three cue tone choices. Also from Ampro was the *Monomax* matrixing system for use with any cartridge or open reel equipment. Finally the company was showing the new *QRK Galaxy* studio turntable, with digital switching, dc Hall-effect motor, slip-cueing, back-cue, and direct LED speed readout.

Two new items were shown by Amity Schroeder, a triple stack cartridge machine, and a range of console mounted multitrack tape recorders, both these items being a logical progression from the company's established range of broadcast cartridge machines and

wide tape transports. The triple stack cartridge machine is built to the same standards as the *Cartmaster* single deck recorders and players, and utilises three 12.7mm machined aluminium deck plates in a vertical line, all driven from a common 12mm shaft extended from a Papst servo capstan motor. Heads are Nortronics, and all assemblies are on plug-in pcb's. The multitrack recorders are based on the company's 1in and 2in tape transports and are available in 8/16/24-track configurations. The machines include full metal console mounting, VU meter penthouse, modular electronics, transformer balanced outputs, XLR input/output connectors, and very comprehensive remote control facilities all fitted as standard.

In the magnetic tape field BASF showed their latest formulation professional tape, *SPR50 LHL*, and their new *Ferro LH* range of $\frac{1}{4}$ in tapes designed to replace the *LH Hi-Fi* and *Ferro Super LH* tapes. Pyral also introduced their new generation of studio mastering tapes, *Type CJ90*, which is available in $\frac{1}{4}$ in, $\frac{1}{2}$ in, 1in and 2in widths and lengths up to 2400ft. The tapes are claimed to have a higher output level throughout the audio range and an improved signal-to-noise level.

Leeholme Audio Services exhibited their range of high quality blank and prerecorded cassettes including their specialised length professional blank cassettes. Also in conjunction with Crowmay the company exhibited its high speed cassette duplicating equipment.

Harman (Audio) were exhibiting a wide range of equipment from the Teac/Tascam range including three new units. First of these was the *A3440* four-channel simul-sync machine which is the successor to the *A3340S*. The *A3440* offers improved performance and additionally features $\pm 5\%$ pitch control and flexible headphone monitoring including the facility to select any combination of tracks for monitoring whilst overdubbing. A 4-channel noise reduction unit, the *RX9*, is available using the professional dbx system. Also on display was the Tascam *35-2* 2-track mastering machine with built-in dbx noise reduction. The other two new units were the *A108SYNC*, the first cassette deck to offer synchronised overdubbing, and the Teac *C1* professional cassette deck offering many features including three motor PLL-servo dual-capstan logic controlled transport, punch-in recording, plug-in interchangeable bias/eq cards, three heads, optional dbx interface, and optional 4/2 mixer.

New Audio Systems Components

AS 6002 3-motor, 3-head, 3-speed stereo tape machine with electronic braking and tape tensioning, 4-input mixer, individual line/mic attenuators, digital readout peak reading meters, switchable NAB/CCIR replay eq, and sound-on-sound and echo facilities.

Price £599.



APHEX SYSTEMS LTD.

7801 Melrose Avenue,
Los Angeles,
California 90046
Tel: (213) 655-1411
TWX: 910-321-5762

APHEX AUDIO SYSTEMS AUSTRALIA, PTY. LTD.

(Sydney) Tel: 261381
TLX: (790) AA24035

APHEX BENELUX

(Brussels) Tel: (02) 345.44.44
TLX: (846) 26409 (TEMBEL B)

APHEX BRAZIL

(Rio de Janeiro) Tel: 205.35.66
TLX: (391) 1121008 (XPSPC BR)

APHEX AUDIO SYSTEMS CANADA, LTD.

(Toronto) Tel: (416) 363-8138
TLX: 06225500 (OCTO TOR)

APHEX CHICAGO LTD.

Tel: (312) 642-8910

APHEX DENMARK

Tel: (01) 59 1200

APHEX COLORADO, LTD.

(Golden) Tel: (303) 278-2561

APHEX FRANCE S.A.R.L.

(Paris) Tel: (1) 500.57.87
TLX: (842) 290846 (IPARIS)

APHEX GERMANY, GmbH

(Frankfurt) Tel: (0 64 42) 53.03
TLX: (841) 184174 (INTRO D)

APHEX HAWAII, LTD.

(Honolulu) Tel: (808) 521-6793
TLX: 7430148 (SOUND)

APHEX ISRAEL

(Tel Aviv) Tel: 232-143

APHEX JAPAN, LTD.

(Tokyo) Tel: 478 7641
TLX: (781) 2224244 (NNR)

APHEX MIDLANTIC

(Washington D.C.)
Tel: (202) 363-1223

APHEX NEW ENGLAND

(Boston) Tel: (617) 232-0404

APHEX NEW YORK, LTD.

(West Orange, New Jersey)
Tel: (201) 736-3422/(212) 964-7444
TWX: 710.994.5806 (APHEX LTD. WOGF)

APHEX SCANDIA

(Stockholm) Tel: 08-67.80.69

APHEX SOUTH, INC.

(Nashville) Tel: (615) 327-3075

APHEX SYSTEMS (SUISSE) SA

(Le Mont-Sur Lausanne)
Tel: 021/33.33.55
TLX: (845) 24107 (VOGUE CH)

APHEX TEXAS, LTD.

(Dallas) Tel: (214) 351-6772
TLX: 732715 (APHEX DAL)

APHEX AUDIO SYSTEMS UK, LTD.

(London) Tel: 01-359 5275
TLX: 268279 BRITRO G

APHEX WEST

(Los Angeles) Tel: (213) 655-1411
TWX: 910.321.5762 (APHEX WEST LSA)



Parametric Equaliser

A very versatile instrument for getting sounds just right. It's modular and directly retrofits APSI 550. EQ is peak or shelf. Filter is high or low pass, tunable. Bandwidth is 20Hz to 20kHz. Reciprocal cut or boost on EQ.

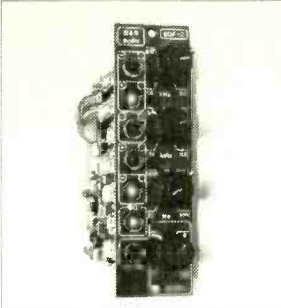

Input	High level	+ 30dBm (max) at 34KΩ
	Low level	+ 20dBm (max) at 11KΩ
Output	High level	+ 30dBm with - 93dBm noise
	Low level	+ 20dBm with - 103dBm noise
Frequency response	EQ & filters out	10Hz to 20kHz, ± 0.1dB
	EQ & filters in	20 Hz to 20kHz, - 1dB
Distortion	Harmonic & IM	< 0.1%
Transient response	Slew rate	> 10V/μ sec.
Power		± 12V to ± 18V at 75mA

Voltage Controlled Attenuator

The first high quality VCA in the professional audio market. It's available in chip form for OEM, with full input and output facilities for direct fitting to any automated console with existing VCAs. However, we can design a VCA package to fit any other manufacture.



Band width		DC to 50MHz
THD	+ 10dBm input	0.004% (20Hz to 20kHz)
IMD	+ 14dBm input	0.03%
Noise	Unity gain	- 90dBV; ± 1dB
Modulation noise		6.5dB
Overshoot & ringing		None
Slew rate		> 10V/μ sec.
Input impedance		20KΩ
Input level		+ 20dBV
Gain		0dB
Attenuation		> 100dB; 20Hz to 20kHz
Control voltage		Can be scaled as needed
DC shift	Vs Attenuation	≤ 5mV
Power		Regulated ± 15V at + 25, -33mA

Grouping and Automation System

With this system, you can now add semi-automation to your console at a fraction of the cost of a new one. Adaptable logic and extensive matrix grouping make up to ten 24-channel presets available. And since the unit is portable, it can be moved from one studio to another in minutes, for the most efficient use of studio time. It's expandable from 8 channels and it's just as useful for PA grouping as studio mixdown. For MCI equipment, a compatible automation package is available.

Our own Voltage Controlled Attenuators (VCA) are used throughout, whose high quality assure minimal sound degradation. Maximum output is + 24dBm. The system comes in two parts—control console and VCA case. The control console has group control modules, each containing grouping switches, mute switch and fader, and a master control module with master fader. The VCA case is self powered and houses the appropriate number of VCA cards and all the input/output XLR connectors.

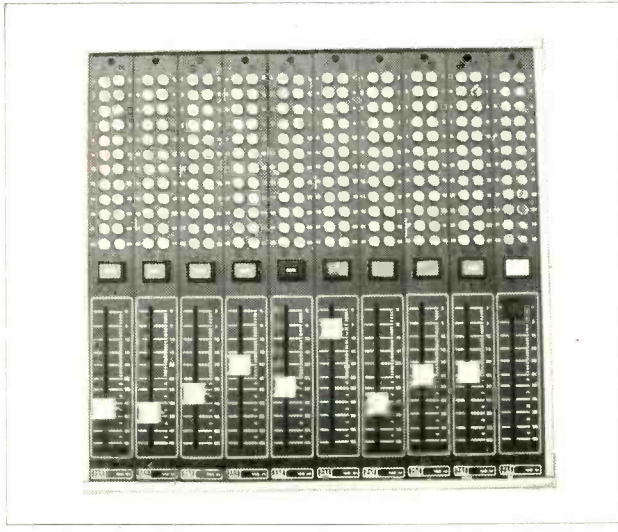

Aphex

The Aphex Aural Exciter

One of the most exciting signal processors to have been invented. It brings sound to life and makes it louder, without any actual change in level. It does it by introducing phase information in the form of a series of minute delays whose magnitude depends on frequency.

The formula by which the Aphex device selectively processes the audio signal has been arrived at after considerable research into the mechanisms of the ear. In particular as to how it receives complex phase information relating to the actual location of a sound source. Aphex sounds amazing on most instruments, including the human voice.

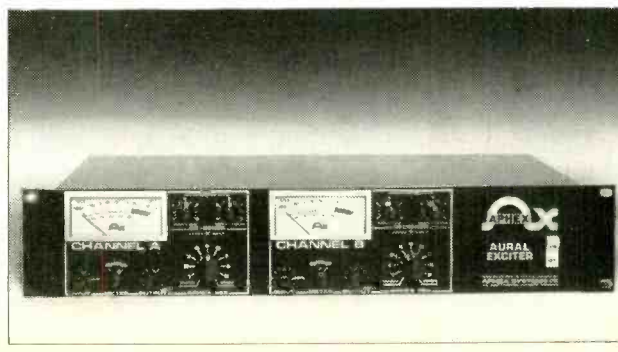

Aphex Audio Systems (UK) Ltd
35 Britannia Row
London N18QH
Telephone: 01-359 5275
Telex: 268279 Britro G.



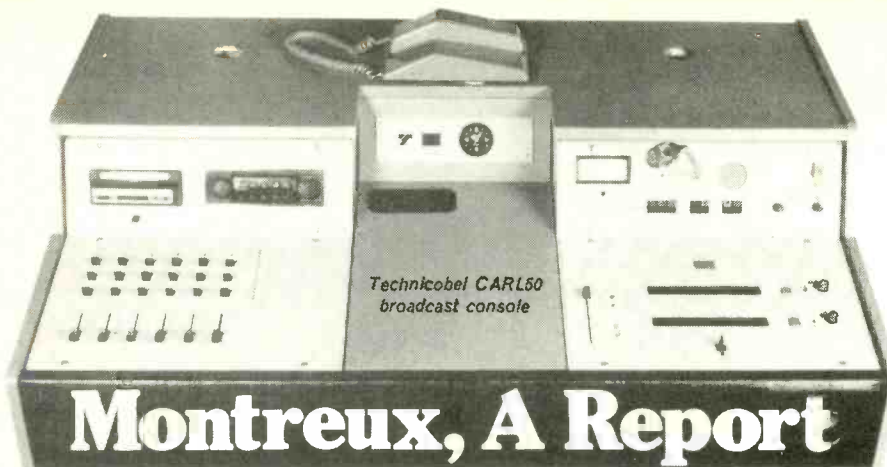

Montreux, A Report

OVER 10,000 broadcasters from 53 countries visited the 11th Montreux International Symposium and Technical Exhibition held at the end of May in the Swiss resort of, yes, Montreux. Perhaps the most unusual aspect of the Montreux symposium is that it is organised not by some prestigious society (or many such societies in the case of IBC in London), but by people appointed by the town of Montreux itself. Certainly it is virtually impossible to book a hotel room in Montreux during the six-day show, and most visitors leave the resort with an empty wallet or a large pile of credit card vouchers. So it is really about business, both for the organisers and the 155 exhibitors from 16 countries who have now outgrown two large exhibition buildings, resulting in a large temporary hall being built this year—most exhibitors unfortunate enough to be placed there considered it an oven. But the organisation of the symposium and exhibition is impeccable, and a new exhibition hall is being built for the next show in 1981.

Like NAB on which I reported in July *Studio Sound*, Montreux is primarily an exhibition for television equipment, cable broadcasting gear, and television and radio transmitters; but there is a significant sound presence. Much of that seen has however been shown at least once before this year either at NAB or the two AES exhibitions [(indeed there have been two other exhibitions since (APRS and CES) and I have found several companies (including Amber, Dolby and Revox/Studer) at each of these six exhibitions, and many other companies have managed five out of six (including Audio & Design Recording and Ampex)]. So there were not a large number of new products shown at Montreux, but nevertheless some significant ones.

Crow of Reading Ltd introduced an electronic 'jingle generator', otherwise known as the *Model MMB32 Ident and Music Generator*. Basically, a musical sequence of 5 to 10 seconds is electronically generated, a single master oscillator being used to produce the 13 semitones of a complete octave. A further circuit provides the timing or rhythm information, the total sequence being divided into 32 basic periods, either 32 short notes or 16 longer notes etc. Alternatively, by using a single note, morse code can be generated for precise identification purposes. Programme boards may be changed through an aperture in the rack-mounting unit's front panel.

Enertec (now distributed in the UK by Clive

Green & Co) unveiled a new generation of magnetic film recorders, the *DPS16/35*. Film transport is by a single capstan without pressure roller, and automatic tape tension is maintained in both tape directions. Run-up speed is only 200ms while the transport will run at up to 30x normal speed when locked to a telecine or VTR. Synchronising is by mains frequency, pilot tone, or timecode, while a zero locator and programmable electronic loop is provided to simplify film handling. The *DPS16/35* will operate on both 16mm and 35mm perforated magnetic film by changing sprockets, heads and spool holders. An optional picture analyser (TV camera) may be added so that the unit may be used for directly dubbing magnetic striped film, while viewing pictures. Enertec also showed the *F462* professional mono, stereo and two-track tape recorder range which was launched at Brussels, and the *UPS5000* range of console.

Technicobel introduced a rather unusual broadcast console developed for the French channel *FR3*, the *CARL50*. Unlike normal broadcasting consoles which are based on the knob-a-channel system (to use vision mixer terminology), the new console instead uses two banks of push switches with LED indicators, and a single fader that allows mixing between banks (what is called an AB bank vision mixer). So the majority of source selection is by simple push button control, and if a fade is required, the second source is selected on the other bank (both banks having common inputs), allowing a crossfade. The presenter's microphone is separately switched after the crossfader, together with a telephone hybrid for phone-in conversations. The unit uses a 12x2 switching matrix, and the second bank may be used for recording while the first is used for transmission. The console may

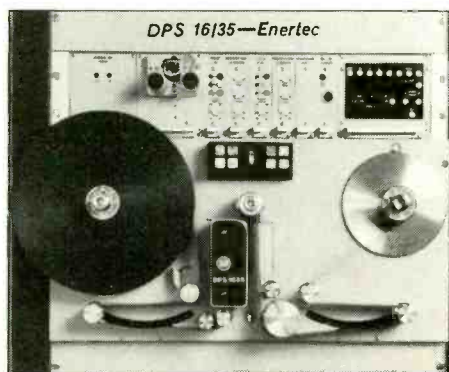

also be fitted with a *PMA50* premixer which provides six microphone inputs (for the associated interview/talk studio, and each channel has a limiter so that levels don't have to be watched too closely. The console as supplied can be seen in the photo with the premixer left, and 2-bank mixer right—whether the car radio would meet IBA off-air receiving specifications is another matter!

Other new products introduced by Technicobel included the *RB60* broadcast mixing console which uses 6-channel master cards, allowing consoles of up to 42 inputs to be constructed, with six aux sends, and either four or eight groups and full facilities for echo routing and returns, talkback, oscillator and output modules.

The *CRA60* echo chamber mounts in a standard 19in rack and uses helical springs to obtain a great temporal density of original echoes, and resonant frequencies with optimum decay. It has stereo outputs delivering two distinct reverberated outputs with independent adjustment over 1.5s to 5s. Initial delay is adjustable from 0 to 33ms and the system is remote controlled.

The *COMA50* audio communications equipment is designed for routing signals in small broadcasting stations; the *CFD60* is a dual channel parametric equaliser each with four bands in the ranges 30Hz to 370Hz, 100Hz to 3.6kHz, 430Hz to 9.6kHz and 5.4kHz to 16kHz, with slope from 3 to 12dB/octave, and gain from ± 15 dB. While the *CFD60* is horizontally presented for rack mounting, the *CF50* is similar but module mounting with two fully parametric bands. Finally, the *NG50* is a dynamic noise gate for module mounting with threshold from +10dB to -40dB, and decay variable from 50ms to 3s.

The Norwegian company *Tore Seem A/S* was showing the *SEESAM* broadcast console system which is available in versions up to 40 inputs (being supplied to the Norwegian Broadcasting Company for a music studio and a TV studio) and has microprocessor controlled routing from a central panel, and each channel has a multitrack output taken before the fader (switchable before or after eq and comp/gate) which may be used while the console is being used for live transmissions. The faders are automated and each channel includes a compressor/expander/gate with an LED column to indicate gains.

Finally, the Swedish Telecommunications Administration was showing a Public Information system that may be added to conventional FM stereo transmitters providing a data channel with about a 1,200 band transmission rate which is transmitted on a phase modulated 57MHz subcarrier which is locked to pilot tone, the two side tones being added to the stereo multiplex signal, providing a deviation of ± 3 kHz. Each 26-bit block of information includes 10 error control bits to alleviate reception problems. The data channel can be used for many purposes including identification of the received station either by a simple channel number display for portable receivers, or a line of information for alphanumeric display, such as the programme name, traffic information, or even a national personal paging network provided over existing transmitters which usually already provide full national coverage in most countries.

And that is the end of the exhibition season. Now we can all recover for four months until the November shows. **Angus Robertson**

Roland RE Series

The choice of professionals.



CHORUS ECHO
RE-301



SPACE ECHO
RE-201



SPACE ECHO
RE-101

Tall Stories

JOEL TALL was recently in London briefly. Who? The chances are that younger engineers will never have heard of Joel Tall. But every day they'll be using a tape editing block that owes its existence to Tall, even if it's not an actual *Editall*. In fact Tall is the father of modern tape editing. Now in his seventies, Joel Tall has some fascinating stories to tell. Way back in the Twenties he started to turn his fascination for radio into a profit making business. He was blessed with the trouble shooters sixth sense that engineers either have or have not got. "If I can hear something wrong I know where to look—and if I can't hear anything, then I also know where to look", says Tall. In the Depression years he made a living by going from door to door offering to "fix anything for one dollar". Subsequently radio firms started to employ him to trouble shoot. One had replaced rubber wound components with cotton wound replicas because they were cheaper. Once sold, the sets switched themselves on and off as the humidity changed. Tall pinpointed the fault just ahead of the firm going bust. In 1942 he volunteered for the Navy but was turned down because of something wrong with his mouth. "I'm, not going to eat the Japs", he argued but Uncle Sam was adamant. NBC offered him a job starting next week and CBS offered him one starting tomorrow. He joined CBS and stayed 21 years. One of his first trouble shooting jobs was a transmitter that went unstable as soon as a maintenance engineer had checked it over, pronounced it perfect and gone home. Tall realised that closing the transmitter cabinet's door produced a resonant cavity and sent it off into oscillation. He invented what subsequently became the *Editall* splicing block in 1949, out of sheer necessity. When Tall joined CBS in 1942 recordings were made either on disc or wire. Magnetic tape was only being used in Germany. At the end of the war Jack Mullin, who was subsequently to become Bing Crosby's tape engineer, brought back to the USA a Magnetophon tape recorder which ran at 30in/s. Although Tall reckons the Germans were experimenting with tape editing during the war years (some of those early recordings of Hitler yelling at the crowd contain some very abrupt transitions from voice to applause), it seems pretty clear that he was the first engineer in the USA to edit sound recordings. In 1946 Tall developed a technique of making aesthetically acceptable wire recording edits. After cutting and tying the wire he would anneal the joint with the hot end of a cigarette. This erased all magnetism at the knot and produced the equivalent of a blooped optical film edit. Then in September 1947 he put together a CBS radio documentary called *The British Crisis* (has nothing changed?) using very fragile paper tape. From then on the rest is more or less history. But the history books don't tell it all. Originally all editing was with a pair of scissors, a firm

hand and a steady eye. All attempts at holding the tape flat on a cutting surface failed. Then one night Tall dreamed of the answer—a curved and grooved channel precision-machined to a few ten thousandths of an inch. It worked and the *Editall* was born. In his own words Tall made "scads of money" from his other invention—the *Editab*, a sort of pre-packaged, pre-cut strip of joining tape now sold to amateurs. He made his fortune out of *Editabs* because for four years virtually every 8-track cartridge in the world used an *Editab* with built-in metal foil to control cross-track switching on replay. It was the only efficient and rapid way of attaching the foil and joining the tape at one and the same time. Another idea which almost certainly originated with Tall is reverse rerecording to cancel phase shift distortion.

An autobiography is promised so it would be a pity to blow too many anecdotal stories—like for instance how Tall managed to cure Woody Herman's autochanger of flinging only Woody Herman recordings across the room, how Guy Lombardo's brother was persuaded to sing into a dead mic and how an attempt at using the Carnegie Hall lavatories as an extra echo chamber worked fine until someone felt the call of nature and pulled a chain to flush the toilet.

My only quarrel with Joel Tall is that I reckon we have him to blame for canned laughter on TV and radio shows. Way back in the Forties Tall was recording a show when the comedian totally screwed up a gag, telling the punch line in the middle of the joke and drawing only an embarrassed murmur of laughter from the audience. Tall just restructured the joke by cutting it down to individual sentences and rebuilding them in the correct order to put the punch line at the end where it belonged. He then lifted some bellowing laughter from an earlier and more successful joke and broadcast the result. "I'll never work live again", said the comedian.

British plating problems

Enigma, the now-not-so-small British record company that specialises in classical recordings made with simple microphone techniques, has reluctantly washed its hands of British plating and pressing facilities. Until recently Enigma records have been plated and pressed in the UK, either by WEA at West Drayton (once the Island plant) or by Sound Manufacturing of High Wycombe. But it's been no secret in the trade that Enigma has been dissatisfied both with the quality of metal work and quality control in the pressing plants. The plating issue came to a head recently when one of two masters from the same session was plated in England and the other in Germany. Enigma, along with reviewers, thought the results comparable to British chalk and German cheese. After behind the scenes trials Enigma has now done a deal with Teldec in Germany to both plate and press all discs in the future. Astonishingly it's even cheaper for Enigma to send their work to Germany.

So as of now, all new platings and pressings will originate from Teldec and will be identified as such by a new 'super-cut' logo. A relaunch this autumn will publicise the change of policy. The first Enigma super-cut issue is the Schubert *Great C Major* Symphony (No 9) which is somewhat special in its own right. For what is believed to be the first time ever the full unabridged version of the symphony, all 64 minutes of it, will be crammed onto a single LP. "We wanted to give Teldec something to get its teeth into," says Enigma. The next issue is also interesting: Beethoven Chamber Music performed by the Music Group of London and recorded with a crossed figure-of-eight pair of Schoeps mics in pure Blumlein fashion. Thanks to Teldec's lower prices (and excluding VAT changes) the Enigma super cuts will for the time being sell at the same price as the original catalogue. What an indictment of the British record pressing industry!

FEEDBACK UNDER CONTROL STABILIZER

The stabilizer is a high quality frequency shifter for howl reduction on speech and music. It offers variable shifts either up or down between 1 and 10 Hertz so allowing choice of the optimum shift for the particular acoustics and sound sources involved in each installation.

5 Hz FIXED SHIFT CIRCUIT BOARDS as WW July 1973 article but improved noise level, lower distortion, adjustment-free oscillator and IC sockets: Mark 3. Small enough to be built inside the cabinets of many amplifiers. Complete kit and board £30. Board built and aligned £38. Including psu and mains transformer. DESIGNER APPROVED. C. W. O. less 5% + VAT 15%.

SURREY ELECTRONICS

The Forge, Luicks Green, Cranleigh, Surrey
GU6 7BG
Telephone 04866 5997

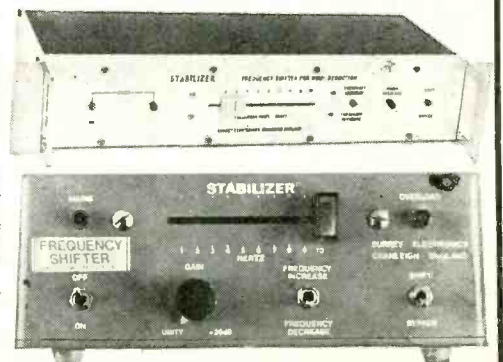

Just add a studio...

The Sescom range of mike splitters and combiners, incorporating a new generation of transformers, is capable of taking higher input levels and passing phantom power to the mikes.

Microphone splitters and combiners



In-line transformers and accessories

The Sescom series of audio transformers, filters and related devices are designed to be simply fitted in the line between two units.



Cable tester



This strong, die-cast unit is designed for use in the field, when reliability is essential. Simply plug in your XLR 3-pin male to female cable, or 3-core jack to jack, and the three red lights will enable you to quickly pin-point breaks or shorts in any part of the plugs.

Direct injection boxes



The Sescom range of DI boxes is probably the most used by recording studios and PA companies throughout America and the UK.

Featuring professional quality with rugged construction, they are designed to be used with any modern electronic instrument, and all models have low-impedance balanced output.

Sescom leads...others follow



Sescom twin core microphone extension cords, available in 5, 25, 25 (thin), and 100 foot lengths, are made from high quality rubber type cable with XLR 3-pin audio connectors. Shown is the 25T thin belden lead.

Audio modules



Sescom audio modules are designed for easy fitting and servicing, operating from a single power supply and shielded to prevent hum pick up. All these units plug into standard 8 or 11-pin plugs.

Make ends meet with

SESCOM

Quality Engineered Sound Products

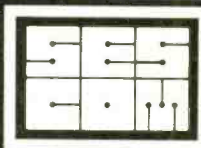

Distributed by



Atlantex

34 Bancroft Mitchin Hertfordshire
Tel. 0462-31511 Telex: 826967



Ask for the latest Sescom catalogue now, or ring our hotline 0462 31511 quoting your Access or Barclaycard number for immediate despatch.

OTARI

Reel to Cassette Duplicator

Unquestionably the finest in-cassette copier available. Two-speed reel master ($3\frac{3}{4}$ and $7\frac{1}{2}$ ips) and six servo-controlled slave units with ferrite heads. Eight times speed; four channels copied simultaneously. Highest attainable performance.

£4190 + VAT

ITA

1-7 Harewood Avenue,
Marylebone Road, London NW1.
Tel: 01-724 2497. Telex: 21879

DP4050 -OCF



Effects: Who Uses What?

Although not a comprehensive studio survey the results are taken from a questionnaire sent to some 350 studios throughout the world. This dipstick survey was designed to discover which studios were using which delay, reverb and effects units and was also designed to ascertain the value of usefulness studios placed on such units.

THE RESULTS of our dipstick survey into who uses which delay, reverb and effects units holds no real surprises. In total 167, or roughly half the studios approached, replied to our questionnaire and we have tabulated the replies in alphabetical order and country by country. We asked studios to indicate not only which effects equipment they used but also whether they used any given unit or manufacturer's products often or occasionally and whether the units were owned, leased or hired but while all the studios indicated which equipment they used, not all specified how often it was used. The main tables indicate who uses what, while **Table 1** gives the total number of sampled studios who use a particular manufacturer's units, the percentage of sampled studios using these units, what percentage used these units often, what percentage used the units occasionally, and what percentage did not specify usefulness. It should be noted that the percentages are accurate only to the nearest 0.1%.

With regard to **Table 1** it will be seen that for Aphex effects units and the EMS *Vocoder*, the percentage of occasional use is much higher than average. The reason for this is quite straightforward, both are generally used on an ad hoc basis depending upon a particular studio's clients' needs. In the case of Aphex effects units it should also be borne in mind that these are leased on an album rental basis by the manufacturer.

On the question of leasing or hiring we asked studios to indicate whether units were owned, leased or hired. Apart from the aforementioned leased Aphex units very few units were hired. The number of hired units seemed to depend upon studio's clients' needs. The results of this section of our questionnaire showed that in the vast majority of cases hiring accounted for less than 1.8% of the total number of studios (many units were totally studio owned); however, apart from Aphex there was one other exception. This concerned the EMS *Vocoder*, again. Of the 15.6% of EMS users no less

than 12.0% were hired and only 3.6% were owned by studios.

Turning to **Table 2**, it will be seen that this tabulates the miscellaneous units which studios stated they used, in the same format as **Table 1**. However, it should be noted that these units are probably under-represented in this survey as the onus was on the replying studio to specify additional units. Higher unit totals and percentages are likely to have resulted had the units been included as specifics in the questionnaire. Another point to be borne in mind with regard to miscellaneous units is that **Table 2** does not include effects units from EMI and Polygram whose studios often use their own-designed and manufactured units. It is also worth noting that although the EMS *Vocoder* was the most popular vocoder unit two studios indicated that they used Korg and Sennheiser vocoders, respectively.

In a more generalised vein it is illuminating to note that studios throughout the world appear to use much the same equipment, whatever their geographic location. The only over-riding question which affects the distribution of units being the availability of importers for foreign manufactured units, plus the necessary service back-up.

As stated at the opening of these comments on our dipstick survey, the results hold no surprises. Established units such as AKG reverb or EMT plate reverb naturally are used in large numbers worldwide, while units which are still relatively new to the market, or units which are more esoteric and less necessary to the day to day work of studios, are to be found in smaller numbers. Perhaps if we were to repeat the survey in a couple of years time some of the most recently introduced units would be used in greater numbers, but we doubt whether the overall view will change much in the short term. As digital recording and mixing/editing becomes prevalent no doubt there will be changes in the types of units being used, but only time will tell.

60 ▶

TABLE 1

UNITS	Number of Studios	Percentage of Studios	Percentage use often	Percentage use occasionally	Percentage use unspecified
AKG Reverb	95	56.9%	34.1%	16.2%	6.6%
Altec Delay	2	1.2%	0.6%	0.6%	—
AMS Delay/Effects	17	10.2%	5.4%	2.4%	2.4%
Aphex Effects	79	47.3%	10.8%	34.7%	1.8%
Audio & Design Effects	70	41.9%	25.1%	9.6%	7.2%
Deltalab Delay/Effects	20	12.0%	5.4%	5.4%	1.2%
EMS Vocoder	26	15.6%	1.2%	14.4%	—
EMT Plate Reverb	143	85.6%	69.4%	3.6%	12.6%
EMT Digital Reverb	35	20.9%	10.8%	6.0%	4.1%
Eventide Delay/Effects	140	83.8%	58.7%	10.8%	14.4%
Klark-Teknik Effects	29	17.4%	7.2%	7.8%	2.4%
Lexicon Delay	44	26.3%	16.2%	6.0%	4.2%
Loft Delay	6	3.6%	2.4%	0.6%	0.6%
Marshall Effects	58	34.7%	13.8%	12.6%	8.4%
MicMix Effects	10	6.0%	2.4%	3.6%	—
MicMix Reverb	33	19.8%	7.8%	7.8%	4.2%
MXR Delay/Effects	46	27.5%	13.2%	11.4%	3.0%
Orban Effects	79	47.3%	22.8%	14.4%	10.2%
Quad/Eight Delay	3	1.8%	0.6%	0.6%	0.6%
Urei Effects	86	51.5%	28.7%	12.6%	10.2%
Ursa Major Effects	7	4.2%	1.8%	1.2%	1.2%

TABLE 2

UNITS	Number of Studios	Percentage of Studios	Percentage use often	Percentage use occasionally	Percentage use unspecified
Allison Kepex	11	6.6%	3.6%	1.2%	1.8%
Allison Gain Brain	6	3.6%	2.4%	0.6%	0.6%
APSI Effects	1	0.6%	—	—	0.6%
BEL Effects	6	3.6%	0.6%	1.2%	1.8%
Cooper Time Cube	7	4.2%	1.2%	—	3.0%
Countryman Effects	1	0.6%	0.6%	—	—
dbx Effects	3	1.8%	—	1.2%	0.6%
Dynacord Effects	1	0.6%	—	—	0.6%
EXR Exciter	5	3.0%	1.2%	0.6%	1.2%
Fairchild Effects	5	3.0%	1.2%	1.2%	0.6%
Filltek Effects	1	0.6%	0.6%	—	—
Meyer Effects	7	4.2%	0.6%	2.4%	1.2%
Mutron Effects	3	1.8%	—	0.6%	1.2%
Pandora Effects	5	3.0%	1.8%	0.6%	0.6%
Pultec Effects	3	1.8%	0.6%	0.6%	0.6%
Rebis Effects	2	1.2%	—	0.6%	0.6%
Roland Effects	3	1.8%	1.2%	0.6%	—
Sound Workshop	3	1.8%	1.2%	0.6%	—
Survival Projects	3	1.8%	0.6%	1.2%	—
Synton Effects	2	1.2%	1.2%	—	—
Triad Effects	1	0.6%	—	—	0.6%

EFFECTS: WHO USES WHAT	AKG Reverb	Altec Delay	AMS Delay/Effects	Aphex Effects	Audio & Design Effects	Deltalab Delay/Effects	EMS Vocoder	EMT Plate Reverb	EMT Digital Reverb	Eventide Delay/Effects	Klark-Teknik Effects	Lexicon Delay	Loft Delay	Marshall Effects	MicMix Effects	MicMix Reverb	MXR Delay/Effects	Orban Effects	Quad/Eight Delay	Urei Effects	Ursa Major Effects	Miscellaneous
AUSTRIA Tonstudio Heinz Wien-Film	●				●			●●	●	●	●											
BELGIUM Just Born Studios	●		●								●										●	Sound Workshop
CANADA Damon Sound Eastern Sound Experience Studios Le Mobile Filtroson Little Mountain Manta Sound Phase One RCA Studios Sounds Interchange Springfield Sound Studio Six	●●●●●			●●●●●	●●●●●	●		●●●●●	●●	●●●●●	●	●●●●●	●	●●●●●	●	●●●●●	●●●●●	●●●●●	●●●●●	●●●●●	●●●●●	Survival Projects Pandora
CZECHOSLOVAKIA Opus	●							●														
DENMARK Roc Studios Soundtrack Studio 39	●●				●●			●	●	●●	●			●	●	●●					●●	
FINLAND MTV Music Studios	●			●	●			●	●	●								●			●	
FRANCE Le Chateau Studio Disques	●				●●			●	●	●		●									●	Kepex
GREECE Polysound					●	●		●									●	●				Sound Workshop
ITALY Regson Studio Trevisani Zeus	●●	●		●	●			●●	●●	●●		●●				●	●	●●	●●	●		
JAPAN JVC (Victor) Studio King Records Nippon Columbia Onkio Haus	●●			●●●●	●●	●		●●●●	●	●●●●							●	●●	●	●		Mutron
NETHERLANDS Artisound BMI Telstar EMI Studio The Music Farm Studio Arnold Mühren Wisseloord/Phonogram	●●●●●			●●●●	●●●●		●	●●●●	●	●●●●	●●			●		●	●●	●●		●		Synton Kepex, Gain Brain, Synton Fairchild Polygram
SPAIN EMI-Odeon Estudios Gema Eurosonic Hispavox	●●●●		●	●●●●	●			●●●●	●●	●	●	●		●		●	●			●		

EFFECTS : WHO USES WHAT	AKG Reverb	Altec Delay	AMS Delay/Effects	Aphex Effects	Audio & Design Effects	Deltalab Delay/Effects	EMS Vocoder	EMT Plate Reverb	EMT Digital Reverb	Eventide Delay/Effects	Kiark-Teknik Effects	Lexicon Delay	Loft Delay	Marshall Effects	MicMix Effects	MicMix Reverb	MXR Delay/Effects	Orban Effects	Quad/Eight Delay	Urei Effects	Ursa Major Effects	Miscellaneous
SWEDEN Glen Studio KMH Studio Studio Decibel	●			●	●			●	●	●		●		●	●	●	●	●	●	●	●	Pandora
SWITZERLAND Mountain Recording Sinus Studio	●			●	●		●	●	●	●	●					●	●	●	●	●	●	Filtek
UNITED KINGDOM Acorn Air Studios Amazon Anvil Audio International Berwick Street Studios Central Recorders Chappell Studio Chipping Norton Studios Coach House Eden Studios EMI-Abbey Road Essex Studio The Factory Highland Studios Hydepark Studios Jackson Recording R. G. Jones Konk Magritte Music Maison Rouge Marcus Music UK Marquee Studios Mayfair Sound Nova Sound Recording The Old Smithy Pebble Beach Sound Pluto Studios Polydor Portland Recording Ramport Roundhouse Recording SARM Stacey Road Strawberry Recording Strawberry South Tape One Studios Threshold/Decca Townhouse Trident T.W. Music The Workhouse	●	●	●	●	●	●	●	●	●	●	●	●	●	●	●	●	●	●	●	●	●	Gain Brain, Meyer, BEL Wifos Survival Projects Abbey Road, BEL Roland Cooper Time Cube, Roland Fairchild BEL APSI, Meyer, Kepex Triad Meyer, Mutron Meyer, BEL Roland Survival Projects, Kepex, BEL Countryman Meyer, Kepex, dbx Time Line, Cooper Time Cube Kepex, Rebis
USA Allen Zentz Recording Alpha Audio Arrest Recording Atlantic Studios Audio-Video Recorders The Automatt Bearsville Sound Benson Sound Bias Recording Bonneville Productions Bradley's Barn CI Recording	●	●	●	●	●	●	●	●	●	●	●	●	●	●	●	●	●	●	●	●	●	Cooper Time Cube EXR

Survey: Effects

ACCESSIT (UK)

Accessit, 8 East Barnet Road, New Barnet, Herts.
Phone: 01-440 9221. Telex: 25769.

Reverberation Unit

Type: low cost mechanical spring reverberation unit using custom dual element spring.

Reverb decay time: 3.5s.

S/N: 58dB.

Input: from -30dBm 33kΩ.

Output: from 0dBm 600Ω.

Distortion: less than 0.2% direct.

Features: bass and treble eq, mix control, output level, echo send level, operates from 24V power supply.

Price: £27.

AKG (Austria)

AKG GmbH, Brunhildengasse 1, A-1150 Vienna, Austria.

Phone: (222) 921746. Telex: 131839

UK: AKG Acoustics Ltd, 191 The Vale, London W3 7QS.

Phone: 01-749 2042. Telex: 28938.

USA: Philips Audio Video Systems Corp, 91 McKee Drive, Mahwah, NJ 7430.

Phone: (201) 529-3800. Telex: 710-988 5348.

BX10

Type: two-channel 'portable' mechanical reverb unit.

Reverb decay time: 1.5, 2.5 or 3.5s measured with 1/3-octave pink noise at 500Hz.

Frequency response: within ±6dB, 50-8kHz.

Crosstalk: better than 35dB.

Noise: better than 65dB rms weighted to DIN 45505.

Features: bass (±8dB at 150Hz) and treble (±4dB at 5kHz) controls; independent reverb/mix control.

Price: £1,376.

BX15

Type: two-channel 'portable' mechanical reverb unit.

Reverb decay time: 1.5-3.5s in 0.5s steps.

Crosstalk: better than 35dB.

Noise: better than 66dB unweighted.

Features: as BX10.

Price: £1,876.

BX20

Type: two-channel mechanical reverb unit with remote control.

Reverb decay time: 2-4.5s, continuously variable.

Although we last surveyed Effects only 15 months ago, the market is changing so rapidly, that here we are again. The generic term Effects includes echo and reverberation, digital delays, harmonising units, flangers, phase shifters, and so on.

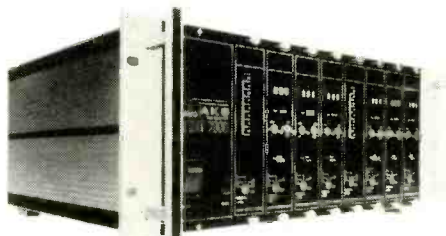

AKG TDU 7000

Frequency response: within ±5dB, 20-8kHz.

Crosstalk: better than 60dB.

Noise: better than 63dB unweighted at +8dBm output.

Price: £2,744.

BX5

Type: stereo reverberation unit intended for use in smaller studios and broadcasting stations.

Reverb decay time: 1, 2 or 3 seconds.

Reverb intensity: control provided for each channel to mix in "dry" and purely reverb signals.

Features: artificial reverberation produced by Torsional Transmission Line. Silent decay time adjustment in 3 steps. Adjustable input sensitivity to match unit with any other equipment. Built-in highly effective parametric equalizer, separately adjustable for each channel. Overload indication by two red light-emitting diodes. Reverb drive level readout on VU-meter. Ideally suited for mobile use owing to small size and low weight.

Technical specification: full specification not available at time of going to press.

Price: to be announced.

BXM

Type: mono reverberation unit intended mainly to be used by professional musicians on stage.

Description: the unit has one input and two output connectors (the outputs being connected in parallel). There is one additional connector for controlling the effects by an external foot-switch. The basic

concept of 'reverberation only' has been expanded by electronically produced effects. The following controls are provided: Input level: high-low (sensitivity = -46/-26dBm); Input volume: continuous control after a range of 40dB; Output volume: continuous control over a range of 12dB (the output level will vary between -6 and +6dBm); Reverb drive level: VU reading by an illuminated instrument; Input overload: red LED with fast response, indicating peak value of drive signal.

Reverb Section:

Reverb time: short-long (approx. 1.5 and 30s).

Bass: cut and boost by about 8dB at 150Hz.

Treble: cut and boost by about 12dB at 5kHz.

Delay Section:

Delay on/off: delays of about 50, 100, 150 and 200ms may be switched individually or in any combination.

Multi-echo: continuous feedback control to vary from simple delays to repeated echoes for special effects.

Clock rate: clock frequency and consequently the set delay times may be manually varied continuously over a wide range for special effects.

Effects Section:

Effects intensity: continuous control of selected effects in relation to the original dry signal.

Effects mix: either delayed reverberation or delay and reverb superimposed may be selected.

Effects select: to choose between 'delays only' or 'reverberation only'.

Technical specification: full specification not available at time of going to press.

Price: to be announced.

TDU 7000

Type: time delay unit.

Description: digital time delay unit with 16k random access memories. It provides a frequency range of 30 to 15,000Hz, dynamic range of 90dB and a 12+2-bit system. The housing is designed for a common 19in slide-in rack.

Basic Unit N700:

Housing with power supply unit and clock generator, one or more input modules M710, output modules M720, delay expansion M730, remote control module M740 and effects module M750. The basic unit N700 comprises eight module receptacles, the configuration may be chosen as desired. Automatic by-pass in case of sudden voltage loss, or fuse change during operation.

Input Module M710:

Balanced input stage, low-pass filter, limiter, 14-bit A/D converter, RAM with addressing logic.

Other features: adjustable nominal input, the deviation from nominal input is indicated by LED-band, 3-pin XLR-type connector.

NEAL FERROGRAPH



Yours logically

FERROGRAPH LOGIC 7. Semi-professional Reel to Reel Recorder; 3 speed, logic/remote control, Stereo, $\frac{1}{2}$ or $\frac{1}{4}$ track, Dolby, 10w per channel. North East Audio Ltd, Simonside Works, South Shields, Tyne and Wear NE34 9NX Telephone: South Shields (0632) 566321 Telex: 537227

SURVEY: EFFECTS

AKG cont'd

Output Module M720:

14-bit D/A converter, low-pass filter, balancing transformers, binary coding system of time pre-selection. Three separate switches on the front for adjusting the desired delay time in steps of units, tens and hundreds. Maximum value to be reached is 399ms.

Special features: by-pass switch for digital part, switch for setting the delay time to one-tenth of the indicated value, adjustable nominal output level, 3-pin XLR-type connector.

Modules M730, M740 and M750 are under preparation.

Recommended applications: broadcast and sound studios, large PA systems, stages.

Technical data: 12+2-bit system (with floating decimal point).

Frequency range: 30Hz to 15kHz \pm 1dB.

Weighted noise level (based on maximum output level): 93dB (A-filter), 87dB (C-filter).

Nominal input level (adjustable): -22, -6, 0, +6 and +12dBm.

Nominal output level (adjustable): -6, 0, +6 and +12dBm.

Limiter response level (limiter incorporated in any input module): 12dB above nominal input level setting.

Limiter range: 20dB.

Max output level: 12dB above nominal output level setting on output module.

Input impedance: 10k Ω .

Output impedance: 50 Ω (-6 to +6dBm), 50 Ω (+12dBm).

Load impedance: 600 Ω .

Harmonic distortion: 0.1% at 1kHz (including digitising noise) and for complete frequency range at nominal level \leq 0.2%.

Pre- and de-emphasis: 50 μ s.

Dimensions:

M700: 483 x 178 x 366mm.

M710: 40 x 173 x 380mm.

M720: 40 x 173 x 380mm.

Weights:

M700: 7.05kg.

M710: 1.11kg.

M720: 0.91kg.

Price: to be announced.

ALLEN & HEATH (UK)

Allen & Heath Ltd, Pembroke House, Campsbourne Road, Hornsey, London N8, UK.

Phone: 01-340 3291. Telex: 267727.

ADT Unit

This unit uses an analogue bucket brigade technique to provide two channels of delay of up to 24ms delay/channel in 6ms increments. It incorporates XLR connectors and is designed for 0dBm nominal line level operation. Quoted frequency response is \pm 3dB, 30-12.5kHz with a corresponding distortion factor of less than 0.5%. A front-panel switch enables serialisation of delay channels.

Price: £256.

ALTEC (USA)

Altec Sound Products Division, 1515 South Manchester Avenue, Anaheim, Ca 92803, USA.

Phone: (714) 774-2900. Telex: 655415.

Europe: Altec Sound Products Ltd, 17 Park Place, Stevenage, Herts SG1 1DU, UK.
Phone: 0438 3241.

Model 1640 Time Delay System

This unit is intended primarily for sound reinforcement applications where delays are needed for loudspeakers within a rig. Six outputs provide delays at fixed 20ms intervals up to a maximum of 120ms. Units can be cascaded to provide a maximum delay of 600ms. Frequency response is a quoted +1, -3dB, 20-12kHz, dynamic range 89dB 'typical' and total harmonic distortion less than 1% at +18dB input.

Model 1660/1661 Time Delay System

These units use digital ram-type circuits to provide up to six delayed outputs continuously variable in the range 0-510ms. Delay time setting is by means of front-panel thumbwheels. Frequency response is a quoted \pm 1dB, 20-15kHz, dynamic range 93dB and total harmonic distortion less than 0.1% at +18dB input. Model 1661 is a tamper-proof version of Model 1660 with a cover fitted over the thumbwheel controls

AMS (UK)

Advanced Music Systems, Wallstreams Lane, Worthorne Village, Burnley, Lancs, UK.

Phone: 0282 36943.

Distributor: Cue Communications Ltd, MCI House, 54/56 Stanhope Street, London NW1 3EX.

Phone: 01-388 7867. Telex: 261116.

USA: Quintech Inc, North Hollywood.

DM 2-20 Flanger/Vibrato/Delay Generator

This unit allows either manual or automatic flanging. Front panel controls allow a choice of phase/stereo/delay where stereo gives psycho-acoustic image shifting between speakers. A section of speed, depth and ramp generation controls are also included to realistically simulate the effects of a 'Leslie-type tone cabinet'. It is supplied in a 19in rack-mounting case with XLR connectors and operates at normal line level. The unit can be supplied balanced/unbalanced.

DMX 15-80 Programmable Digital Time Processor

This unit is a 15-bit digital delay system offering a bandwidth of 18kHz and a signal-to-noise ratio of better than 90dB at all delays. The system can offer over 4 seconds of delay, accept a pitch change card for harmonising effects and up to two reverb cards with 9 programs of reverb on each. The programmability of the system also allows two independent outputs, one selected pitch change and one selected reverb program, or two selected reverb programs to be stored and recalled from any one of nine stores. Controls include a Keypad and 'nudge buttons' for data entry, feedback and high pass filters for regeneration effects. A delay + original mix control. Speed and depth controls for a VCO section. Input and output gain controls and switches to change phase and lock-in the DDL contents.

APHEX (USA)

Aphex Systems Ltd, 7801 Melrose Avenue, Los Angeles, Cal 90046, USA.

UK: Aphex Audio Systems (UK) Ltd, 35 Britannia Row, London N1 8QH.

Phone: 01-359 5275. Telex: 268279.

Aural Exciter

Type: unit that 'adds brilliance and clarity to instruments and vocals'. The Aphex Aural Exciter

signal comprises a low level carrier that is added onto the main signal, the subcarrier containing slightly delayed signal that has passed a frequency dependent phase shift and delay. When this new signal is heard by the ear, the delay/phase combination causes an apparent dislocation of perceived sound orientation providing increased spatiality and presence.

Price: not available for sale, but leased per minute of final recorded product.

AUDIO & DESIGN (RECORDING) (UK)

Audio & Design (Recording) Ltd, 84 Oxford Road, Reading, Berks RG1 7LJ, UK.

Phone: 0734 53411. Telex: 847605.

US: Audio & Design Recording Inc, PO Box 902, Marina, Calif. 93933.

Phone: (408) 372-9036.

S24 Time Shape Module

This is an ADT/flanger and time domain processor from the SCAMP range. Features include input limiter to prevent overload of delay line; 1.2-45ms delay range; positive and negative flange; spin control for 100% feedback effect; programme-controlled delay/flange; oscillator control of delay time with variable modulation and frequency effect; and stereo reverb and delay capability with two or more modules. Frequency response is a quoted +0, -0.5dB, 20-15kHz at any delay setting.

Price: £495.

S23 Pan Effects Module

A new module from the SCAMP range offering different pan patterns with trigger, speed and envelope-following functions. Track reversal and normal modes are indicated by two LEDs that also show speed of panning action. Noise level is claimed to be below -96dB ref +8dBm and frequency response \pm 0.5dB, 20-20kHz.

Price: £250.

BEL (UK)

BEL Electronics, 48 Aylesbury Street, Bletchley, Milton Keynes MK2 8A.

Phone: 0908 641063

Marketing: Don Larking Audio Sales, 50 Cheap-side, Luton, Beds.

Phone: 0582 27195/26693.

BF20 Stereo Flanger

'True stereo flanger, pure and simple.' Voltage controlled stereo flanging with two independent delay circuits. Three operating modes: manual, envelope or oscillator. Stereo outputs which can be opposed to give two dimensional see-saw panning effects and image shift. Unit can be used as a mono flanger and keyed externally, feedback control for increased depth and additional pitch changing effects.

Price: balanced £500, unbal £450.

DATATON (Sweden)

Dataton AB, Box 257, S-58102 Linköping, Sweden.

Phone: 013 100711.

System 3000

Dataton manufactures a series of 13 modules which include a 1000-step, microprocessor-based 'program sequencer' providing analogue voltage control through internal d-to-a converters of up to eight VC units directly. There is also a serial addressed digital output capable of instructing 56 peripherals such as slide projectors, lighting, etc.

Other modules include:

3002 VC Sound Generators

Four voltage controlled sound generators, each adjustable from 10Hz to 10.24kHz. Control is either linear (1000Hz/V) or exponential (1 octave/V). Each channel has variable waveform and preset level.

Deltalab DL2 Acousticcomputer



Rebis RA200 Series

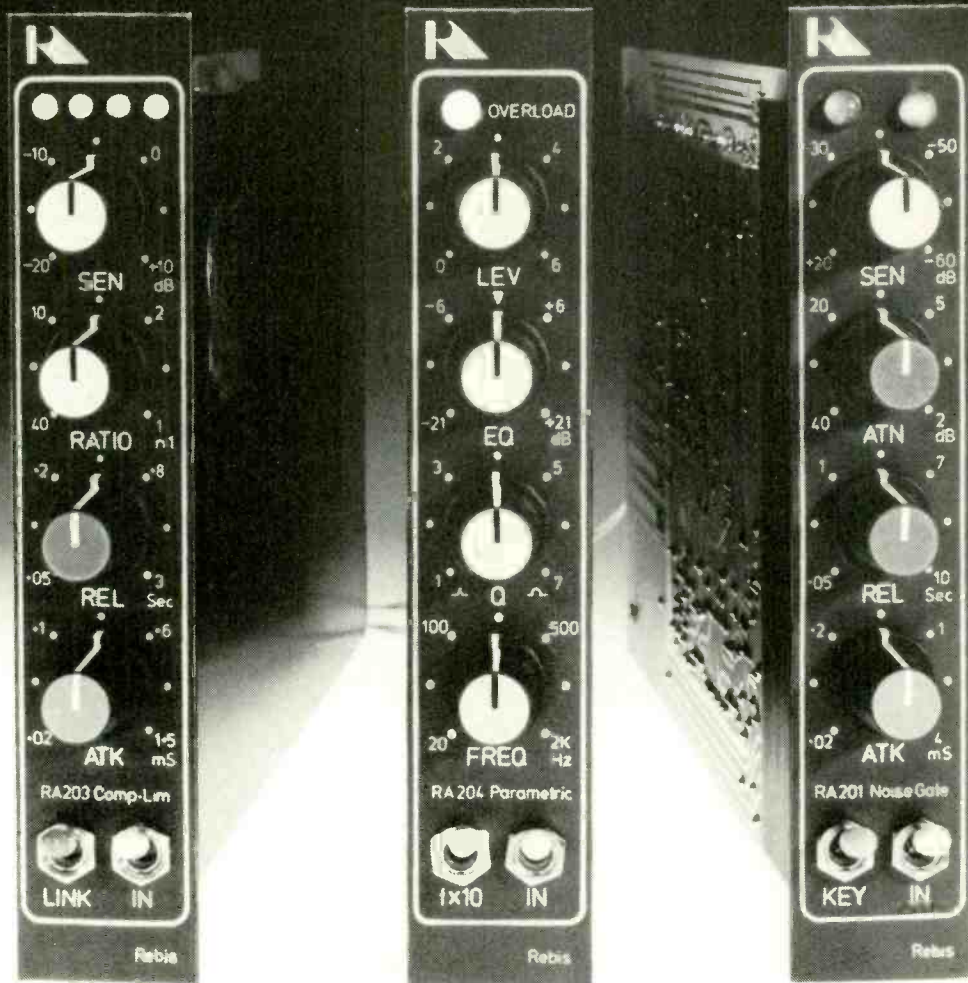

The most compact modular system of professional studio equipment.

RA203 Compressor-Limiter. A flexible and effective unit for dynamic control and musical shaping. Continuously variable control of all parameters and link switch for stereo operation or voice over.

RA204 Parametric Equaliser. A single fully parametric section covering the whole audio spectrum in two overlapping ranges. Ideal for augmentation of restricted desk EQ or in cascade for more complex equalisation.

RA201 Noise Gate. Indispensable in both studio recording and live PA work for eliminating unwanted low level signals, or creating a tight clean drum sound. Also available RA201X Noise Gate to retrofit Kepex rack.

RA200 Rack. Accommodates up to 16 RA200 Series modules in 5.25" (3U) of 19" rack space.

RA200 Power Supply Unit. Fully stabilised supply for up to 16 RA200 Series modules.

Prices: RA 203 Compressor-Limiter £115 · RA204 Parametric Equaliser £62 · RA201 Noise Gate £62 · RA200 Rack £80 · RA200 PSU £78

For further information contact:

Rebis Audio, Kinver Street, Stourbridge, West Midlands DY85AB, England. Tel. Brierley Hill (0384) 71865



EXPORT AND AGENCY ENQUIRIES TO:

Scenic Sounds Equipment,

97-99 Dean Street, London W1V 5RA

Telephone: 01-734 2812

SURVEY: EFFECTS

Dataton cont'd

3103 Filter

Four channels of VCF networks with selectable notch lowpass, bandpass and highpass. There are internal limiters that squash amplitude peaks created under high operating 'Q' conditions. Q variable between 0.7 and 50.

3104 Envelope Shaper

Four-channel envelope shaper with a 'versatile' triggering system. Main functions include attack, decay, release and off time variable from 0.01 to 10s.

Quad Equalizer/Preamp 3107

Four channels of pre-amplifications, electronically balanced inputs, each with phase reverse switch and five-band equalizer and pan pot for two-channel stereo output.

3203 Joystick Module

Two joysticks each expanding from two to four channels. Signal paths are voltage-controlled, enabling interface with other VC busses.

3205 Mixer Module

Four-input/four-output unit, cascadable to arbitrary number of inputs/outputs. Two pan controls included on each channel and one echo-send control. Outputs may easily be grouped to stereo or quad outputs.

Quad Signal Analyzer 3314

Microprocessor based pitch- and envelope follower. Four independent channels. Digital serial output for direct connection to *Program Sequencer 3301*. Four VCO outputs, 1 V/octave, four VCA outputs, 1 V/10 dB.

DELTALAB (USA)

Deltalab Research Inc, 25 Drum Hill Road, Chelmsford, Mass 01824, USA.

Phone: (617) 458-2545.

UK: Scenic Sounds Equipment, 97-99 Dean Street, London W1V 5RA.

Phone: 01-734 2812. Telex: 27939.

DL1

Type: broadband digital delay line.

Delay principle: digital electronic.

Delay capacity: switchable 0 to 100ms or 160ms.

Outputs: three separately variable delayed independent outputs, A and B set either internally or on the front panel, C set internally.

Frequency response: 20Hz to 15kHz +1 -3dB, at -14dB.

Dynamic range: 100ms range 90dB A weighted, 85dB broadband. 160ms range 85dB A weighted, 80dB broadband.

Pre-emphasis: 50ms.

Output levels: front balanced +20dB, unbal +14dB, rear balanced +24dB, unbal +18dB.

Price: \$1,200, £698.

DL2 Acousticcomputer

Basic technical specification as for *DL1*, but provides combination digital delay and special effects which has two independent pre-reverberation delays. Variable timebase with VCO.

Delay capacity: parallel mode Ch A 0.5 to 152ms, Ch B 0.25 to 88ms, serial mode Ch A 0.5 to 152ms, Ch A + B 0.75 to 240ms. Provides 16 reverb programs, two independent channels with stereo imaging, and equalisation.

Price: \$1,750, £995.

Lexicon Prime Time Digital Delay

DL3

Basically similar to *DL1* with similar technical specification but with single delay output, internal delay setting and limited front panel controls.

Price: \$850, £495.

DYNACORD (West Germany)

Dynacord Electronic GmbH, PO Box 68, D-8440 Straubing, West Germany.

Phone: 09 421 3541.

UK: Beyer Dynamic (GB) Ltd, 1 Clair Road, Haywards Heath, Sussex.

Phone: 0444 51003.

USA: Dynacord Electronics Inc, PO Box 26038, Philadelphia, Pa 19128.

Phone: (215) 482-4992.

DRS78

Type: digital echo/reverberation unit.

Delay principle: digital electronic.

Delay capacity: 0 to 320ms, three delays pre-programmable, three switched decays.

Frequency response: effects channel 20Hz to 8kHz, direct to 20kHz.

Dynamic range: not specified.

Output levels: universal 200mV, patch jack 1mV, original stereo, effects modified stereo and original stereo all 775mV.

Price: £1,110.

TAM19

Type: time axis manipulation device providing stereo flanging, stereo phasing, stereo pitch shifting, double tracking, mono-stereo conversion and stereo space-sound simulation. Uses two analogue lag or delay lines with three internal generators—triangle, sine and AVRGD (averaged) which can be mixed in any desired combination.

Price: £510.

SRS56

Type: stereo reverberation system.

Delay system: electronic, type not specified.

Delay capacity: 30ms to 560ms, reverberation time 30ms to 20s.

S/N: delay 80dB A weighted, 75dB CCIR.

Frequency response: 20Hz to 20kHz.

Distortion: delay 2%.

Price: £810.

EMT (West Germany)

EMT-Franz GmbH, Postfach 1520, D-7630 Lahr, West Germany.

Phone: 078-25512. Telex: 754319.

UK: FWO Bauch Ltd, 49 Theobald Street, Borehamwood, Herts WD6 4RZ.

Phone: 01-953 0091. Telex: 27502.

US: Gotham Audio Corp, 741 Washington Street, New York, NY 10014.

Phone: (212) 741-7411. Telex: 129269.

EMT 140TS/Q

Delay principle: plate.

Reverb period: 1-4s, adjustable.

Controls: reverberation time (remote control optional).

Other features: quadraphonic (140Q); stereo (140TS).

Noise: 50dB below full output, for 2s reverb time.

EMT 240

Delay principle: stereo plate.

Reverb period: 1-4s, adjustable.

Controls: reverberation time.

Noise: 60dB below full output, unweighted.

Resistance to external noise: 80 phn max ambient level.

EMT 250

Reverberation principle: digital electronic.

Decay time (at 1kHz): 0.4 to 4.5s controllable in 16 steps.

Decay time at bass frequencies: time factor of between 0.5 and 2 times nominal decay period.

Decay time at treble frequencies: time factor of

between 0.25 and 1 times nominal decay period.

Initial delay: from 0 to 315ms in five steps; there is an additional delay of up to 60ms in 20ms steps.

Outputs: four each programmable with individual delay characteristics.

Special effects: phasing, chorus (tonal duplications), super long delay (up to 10s) and echo (single shot from 5 to 315ms).

Noise: better than 70dB.

Frequency response: +1, -3dB, 30 to 10.8kHz.

Total harmonic distortion: less than 0.5%.

EMT 244

Reverberation principle: digital electronic.

Decay time: 0.4-4.5s in 16 steps (frequency dependent).

Frequency response: +1, -3dB, 30-8kHz.

Dynamic range: 65dB at 2s decay time.

EMT 444

Type: digital delay unit with multiple outputs.

Delay time: 1-255ms in 1ms steps.

Features: 'echo' and 'phasing' programs.

EMT 446

Type: digital signature tune repetitor available in versions (with equal memory capacities), to store 5s using 12-bit words and 14.5kHz bandwidth, 6s using 10-bits and 14.5kHz, and 12s using 10-bits with 7kHz bandwidth.

EVENTIDE (USA)

Eventide Clockworks Inc, 265 West 54th Street, New York, NY 10019, USA.

Phone: (212) 581 9290.

UK: Feldon Audio Ltd, 126 Great Portland Street, London W1N 5PH.

Phone: 01-580 4314. Telex: 28668.

Agents in most countries.

Model 1745M Digital Delay

Delay time: 0-320ms, continuously variable.

Controls: front-panel 'delay set' using digital read-out to indicate delay period; 'double' switch to double delay and halve bandwidth.

Features: options for pre-wiring delay periods; remote control unit with ANSI/IEEE interface buss.

Frequency response: ±1dB, 30-16kHz.

Noise: 78dB below output.

Price: standard £2,247, pitch version £2,408.

Model H910 Harmonizer

This unit modifies the time domain of the input signal. Through digital processing it effects a plus or minus 1-octave pitch change, the actual pitch change being shown on a 3-digit front-panel readout. The integral delay lines may be used independently of the pitch shift for straight delay effects such as slap-back, flanging and reverb.

Delay time: 0.3-60ms in pitch-shift mode; 0-112ms in 7.5ms steps for straight delay.

Frequency response: ±1dB, 20-12kHz in the delay mode.

Dynamic range: greater than 90dB.

Price: £1,005.

Model 2830 Omnipressor

This unit is described as a professional-quality dynamic modifier, combining the characteristics of a compressor, expander, noise gate and limiter in one unit. Its dynamic reversal feature makes high-level input signals lower than corresponding low-level inputs. Musically, this reverses the attack-decay envelope of plucked string and similar instruments, and gives the effect of 'talking backwards' when applied to a voice signal.

Price: £345.

Model FL201 Instant Flanger

This is a successor to the well-known *Instant Phaser*. It uses what is described as a true time delay circuit, producing many more nulls and thus much deeper effect than previously available.

Delay time: 200µs to 10ms, front-panel adjustable or via external control voltage. (Up to 50ms maximum by internal adjustment.)

68 ▶

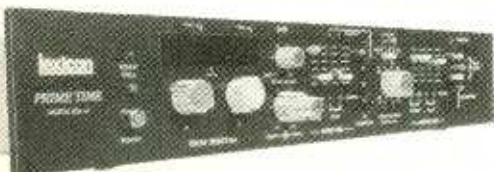

TT. RESERVE NAGRA® 4.

T/CELL
MPRESSION

LINE & PLAYB.



Introducing our new mascot.

At this year's Motion Picture Academy Awards Nagra Kudelski were presented with an Oscar in recognition of the unique contribution made by the 4.2 sound recorder.

We were delighted, of course.

But since this is the third time in as many years, we thought we should take the hint.

So, as you see, we are seriously

considering making Oscar our new mascot.

After all, why shouldn't we crow a little, we earned it.

NAGRA KUDELSKI

HAYDEN

Hayden Laboratories Limited,
Hayden House, Churchfield Road,
Chalfont St Peter, Bucks.

Exclusive UK Agent Tel: Gerrards Cross 88447. Telex: 849469.

SURVEY: EFFECTS

Eventide cont'd

Oscillator: 0.05-20Hz, continuously variable, to alter flanging effect.

Features: 'bounce' control to simulate effect of tape-machine flanging by varying delay in the same manner as a motor or servo 'hunting'.

Price: £365 with feedback control.

Model S1066

This is basically a 16-output digital delay line. Instead of each delay time being set by knobs or switches—making the unit rather cumbersome to use—a programmable read-only memory selects the time of each output and its amplitude and phase. For one input the 16 delays are spread to two outputs in a sequence determined by the ROMs, enabling stereo effects to be achieved. Up to 32 individual programs can be selected by means of a front-panel switch block or keyboard.

Price: on application.

BD955

Broadcast delay line for profanity purposes providing a maximum 6.4s delay with a response of 15kHz, other versions available with 1.6s and 3.2s and at 7.5kHz. Unique feature is a 'catch up' mode that gradually extends the delay time to the maximum virtually undetectably, after the 'dump' button has been pressed to lose the period in the memory. The *BD955* can also be used in production where it offers delays varying from 6.5ms for doubling, to create unusual echo effects, and provide echo delay.

Price: £1,232 to £3,321 depending upon frequency and delay time.

H949

Harmonizer providing one octave up, two octaves down pitch change.

Delay principle: electronic digital.

Delay capacity: in pitch change mode 0 to 300ms in 50ms steps, in delay mode 0 to 393.75ms in 6.25ms steps.

Outputs: two, main and delay only.

Frequency response: 20Hz to 15kHz ± 1 dB.

Dynamic range: 96dB.

Distortion: 0.15% at reference output level.

Features: remote computer control using IEEE standard interface buss, *HK940* keyboard can be used to control the pitch ratio in discrete musical steps. Two selectable algorithms to optimise pitch change performance.

Price: £1,287.

EXR (USA)

EXR Corporation, 11523 Dexter-Pinckney Road, Pinckney, Michigan 48169, USA.
Phone: (313) 878-9445.

EXR Exciter Model EX2

'The *EXR Exciter* restores natural presence, clarity, fullness and individual signal separation lost in the audio reproduction chain and adds to the apparent signal strength without noticeably triggering limiters or compressors.' Each of the four enhancement settings are a precise variation of the five integral functions performed within the *Exciter*: pre-selective phase notching, time manipulation, frequency manipulation, psychoacoustic manipulation, psychoacoustic replacement.

Price: on application.

*Loft Modular Devices Inc
Series 440 Delay Line/Flanger*

FURMAN SOUND (USA)

Furman Sound Inc, 616 Canal Street, San Rafael, Cal 94901, USA.

Phone: (415) 456-6766.

RV-1

Type: mechanical reverberation system using shock mounted dual *Accutronics* 16in spring assembly, and a fast attack peak limiter providing protection from spurious noises such as pops and boings, that arise from transducer overloading.

Decay time: 1.8s.

Frequency response: 45Hz to 1kHz with many closely spaced peaks and dips.

S/N: 74dB A weighted.

EQ: ± 20 dB treble and bass.

Price: \$250.

GELF (UK)

Gelf Electronics Ltd, 38 Home Close, Bletchley, Milton Keynes MK3 6JE.

Phone: 0908 77503.

Auto Phasing Unit GP14

Voltage controlled phasing unit having four control functions: manual, sweep oscillator, envelope, remote. The oscillator range is 0.05Hz to 4Hz with 11 switched positions, depth control controls the amount the oscillator affects the filter. Envelope controls are threshold (-30 dB to $+8$ dBm) and decay 30ms to 3s.

Price: £280.

H/H (UK)

H/H Electronics, Viking Way, Bar Hill, Cambridge CB3 8EL.

Phone: 0954 81140. **Telex:** 817515.

Digital Multi Echo Unit

Type: provides automatic double tracking, echo with variable delay times and repeat, and reverb using *Accutronics* spring. Eight pushbuttons can give up to 240 combinations of amazing sound.

Delay system: delay is analogue electronic CCD, reverb is mechanical.

Delay capacity: four settings, 21.5ms to 73ms, 58ms to 200ms, 77ms to 256ms, 92ms to 312ms.

Frequency response: to 230ms 30Hz to 5kHz, to 312ms max 3.5kHz.

Features: treble and bass eq, mic input, echo and repeat volumes.

Price: £257.

Digital Echo Unit

Type: uses simple mode select switch to obtain six switched echo/repeat effects: automatic double tracking, short echo plus two repeats, medium echo plus two repeats, long echo plus long repeats, special effects I (single echo multiple repeats), and special effects II (multiple echoes repeats).

Delay system: analogue electronic CCD.

Delay capacity: ADT echo 34ms, repeat 42ms, short echo 66ms, repeat 74ms, medium echo 185ms, repeat 193ms, long echo 208ms, repeat 216ms.

Frequency response: to 5kHz, long echo 3.5kHz.

Features: treble and bass eq, echo and repeat volume.

Price: £236.

INDUSTRIAL RESEARCH PRODUCTS (USA)

Industrial Research Products Inc, 321 North Bond Street, Elk Grove Village, ILL 60007, USA.
Phone: (312) 439-3600.

UK: Knowles Electronics Ltd, Victoria Road, Burgess Hill, Sussex.

Phone: 04446 5432. **Telex:** 87460.

DA-4006 and DA-4007 Audio Signal Delay

These are basic rack-mounting models.

Delay principle: electronic digital.

Delay capacity: no limit by tandem connection to additional chassis.

Frequency response: 2dB, 40-12kHz.

Dynamic range (at 400Hz): 80dB (*DA-4006*); 90dB (*DA-4007*).

Distortion (at 1dB below max output at 400Hz): less than 0.5% THD (*DA-4006/7*).

Noise (20-20kHz bandwidth): 80dB below max output (*DA-4006*); 90dB below max output (*DA-4007*).

Price: between \$1,000 and \$4,000.

DA-4008 Audio Program Delay

Delay principle: electronic digital.

Delay capacity: 240ms max in single chassis.

Outputs: 1-5 per chassis, switchable in 10ms steps (5ms option available).

Frequency response: 2dB, 40-12kHz.

Dynamic range (at 400Hz): 90dB.

Distortion (at 1dB below max output at 400Hz): less than 0.5% THD.

Noise (20-20kHz bandwidth): 90dB below max output.

Price: between \$1,800 and \$5,000.

DC-4011 Audio Program Delay

Delay principle: digital CCD.

Delay capacity: 96ms in 4ms increments.

Outputs: two.

Frequency response: 2dB, 20-15kHz.

Dynamic range: greater than 90dB.

Noise: 90dB below maximum output level.

Price: \$1,300.

DD-4012 Sound Delay Module

Similar in specification to the *DC-4011* unit.

Delay principle: digital CCD.

Delay capacity: 64ms (96ms optional) adjustable in 4ms increments.

Outputs: one (second optional).

Frequency response: 2dB, 20-15kHz.

Dynamic range: greater than 90dB.

Noise: 90dB below maximum output level.

Price: \$1,200.

KLARK-TEKNIK (UK)

Klark-Teknik Research Ltd, Kidderminster, Worcs, UK.

Phone: 0562 64027 and 741515. **Telex:** 339821.

US: Klark-Teknik, 155 Michael Drive, Syosset, NY 11791.

Phone: (516) 364-1900. **Telex:** 961396.

DN34 Analogue Time Processor

The *DN34* Analogue Time Processor is an exceptionally versatile signal processing and special effects unit, designed around two discrete, independently-controllable delay sections. An intensive development programme along with the introduction of greatly improved charge-transfer devices, has enabled the design of this unit to represent the ultimate in current state-of-the-art analogue delay technology. The *DN34* Analogue Time Processor achieves all the effects expected of this type of product, but with significantly improved performance.

Price: £790.

DN36 Analogue Time Processor

This unit is a dual-channel voltage-controlled delay system. The delay (0.5-50ms continuously variable) can be set manually or controlled automatically. A built-in modulator allows the delay length to be swept in various function patterns at variable rates and depths. Multipath feedback controls are included to enable synthesis of several time-related effects, including reverb, phasing, flanging, vibrato, chorus, single/double repeat echo, doppler shift, ADT, modulated delay etc.

Price: £850.





Professionals Swear by Them, Competitors, at Them.

They're the new BGW pro amps you'll go for - From top to bottom, The Model 10 Electronic Crossover, The Model 100B Power Amp, and the 250E Power Amp. Each one an extension of our basic philosophy at BGW; The Best.

Whether its a simple resistor or a complex semiconductor, BGW is dedicated to the principle that a pro knows the difference between "good enough" and "outstanding." Because we know that quality in a pro product is indeed something you can see, touch and hear, everything that goes into a BGW product, everything we do in its manufacture, is designed to back up the man who depends on our gear to make his living. And, like all BGW products, the new 250E with our exclusive arc-scale power indicators joins with the new 100B and Model 10 in answer to your demands. They're worthy additions to the solid-gold reputation that's been earned in recording studios, discos and concert stages throughout the world.

If you're not already a BGW Pro we invite you to compare any of our products with anybody else's. Anybody's. You'll then see why so many of your pro friends swear by us. And our competitors, at us.

Go For The Best



BGW Systems, Inc.
 13130 South Yukon Avenue,
 Hawthorne, California 90250
 In Canada: Omnimedia Corp.,
 9653 Cote de Liesse
 Dorval, Quebec H9P 1A3

SURVEY: EFFECTS

Klark-Teknik cont'd

DN70 Digital Time Processor

This unit combines three separate digital delay lines, the delay of which can be a maximum of 163, 326 or 652ms. Separate DDL outputs are provided, plus a mixed input/delayed output. Front-panel controls include DDL output mix and regeneration level. The high clocking speed of 50kHz is claimed to extend frequency response to 15kHz without the need for an excessively sharp filter. Dynamic range is a quoted 90dB.

Prices: depend on delay option, between £1,750 163ms and £1,950 for 652ms delay; expander kits to extend delay cost £400.

DN71 Controller

This unit is an add on device for the DN70. Plugging directly on to the DN70's control buss, it allows full control over any of the three outputs. Functions available included delay setting in 20ms steps, versatile pitch control, fully controllable time swept effects and a freeze control which locks the entire delay into a continuous loop. Further DN71's may be connected to allow simultaneous control over various outputs.

LEXICON (USA)

Lexicon Inc, 60 Turner Street, Waltham, Mass 02154, USA.

Phone: (617) 891-6790.

UK: FWO Bauch Ltd, 49 Theobald Street, Borehamwood, Herts WD6 4RZ.

Phone: 01-953 0092. Telex: 27502.

Model 102-S Digital Delay

Type: two-channel DDL with built-in voltage-controlled oscillator for special effects, including vibrato, 'doubling with varying time delay and pitch shift', 'time-delay panning', Doppler shift, flanging, chorus etc.

Delay time: 48-192ms per channel in 3ms steps (each channel may contain up to four delay modules of 48ms each), plus mono delays up to 384ms by cascading channels.

Output: one or two per channel.

Frequency response: 2dB, 20-15kHz.

Dynamic range: 95dB 'typical'.

Distortion and noise: less than 0.2% at limit reference and 1kHz.

Price: \$2,700, delay modules 48ms \$220.

Model 92 Digital Delay

Type: single-channel DDL with two independently adjustable outputs.

Delay time: 0-120ms in 7.5ms steps.

Frequency response: +1 -2dB, 20-12kHz.

Dynamic range: 95dB 'typical'.

Distortion and noise: less than 0.08% at limit reference and 1kHz.

Price: \$1,250.

Varispeech Model 27

This unit shifts pitch in real time from two times higher than normal to 0.4 times lower. It also incorporates a recirculation feature and a front-panel mixer for mixing direct with shifted signals. The manufacturer quotes a dynamic range of 58dB and a frequency range 100-5kHz. The signal interface is 0dBm nominal.

Price: \$750.

Model 93 Prime Time

Type: digital delay/processor/mixer combining digital audio delays, VCO timebase modulator, full mixing facilities and special effect controls.

Delay system: digital electronic.

Delay capacity: 0 to 128ms full bandwidth, optional half bandwidth with add-on Delay Module Memory, then 256ms.

Delay taps: two, individually selectable in 60 steps with digital display of each setting.

Delay multiply: x2, x4 or x8 (2.048s) with add-on



MXR digital delay, flanger/doubler and pitch transposer with optional display

memory option.

VCO modulation: depth adjustable to 100% of delay, from 0.1Hz to 20Hz.

Frequency response: 20Hz to 12kHz +1dB -3dB at -12dB below limit level. Bandwidth is reduced to 6kHz, 3kHz and 1.5kHz with delay multiply at x2, x4 and x8 respectively.

Dynamic range: 95dB typical, 90dB A weighted, 86dB unweighted.

Features: five fader input mixer, recirculated delay roll-off individually controlled from 15kHz to 800Hz, output mixer, delay bypass, phase inversion, remote control.

Price: \$1,485.

Model 91 Digital Delay System

Basically similar to Model 92 but only one output.

Price: \$985.

LEXICON (USA)

UK: Scenic Sounds Equipment, 97-99 Dean Street, London W1V 5RA.

Phone: 01-734 2812. Telex: 27939.

Model 224 Reverberation System

Type: electronic digital reverberation system comprising portable controller and rack-mounted electronics (7in high). The computer-based system has two inputs for four outputs, and interchangeable programs to simulate chambers, plates, concert halls etc. Includes pre-delay of up to 256ms, with decays from 600ms to 70s. S/N is 80dB with two-second decay.

Price: basic system \$6,500, additional programmes \$85 per pair.

LOFT (USA)

Loft Modular Devices Inc, 91 Elm Street, Manchester, Conn 06040, USA.

Phone: (203) 646-7806.

Series 440 Analogue Delay Line/Flanger

This unit will provide a wide variety of effects including slap-back, loudness enhancement, 'stereo synthesis', Doppler, flanging, Leslie-type sound, vibrato, altering reverb chamber characteristics, tunnel inversions, feed-back control, and double and triple tracking, with voltage-controlled pitch and timing errors 'for added realism'. The manufacturer claims bandwidth is 18kHz at 40ms delay and 9kHz at 80ms. A noise reduction system is incorporated. The sweep ratio is 10:1 and works in all four delay ranges to any degree desired. No quantising noise, step error, or offensive non-harmonic distortion are present as in digital delay systems. Three jacks are included for external control of line in/out, external voltage control of delay time, and for the voltage control of another secondary unit.

Frequency response (bandwidth set control to 18kHz): ± 2 dB, 30-18kHz in delay mode; ± 0.5 dB 20-20kHz 'dry-only'.

Delay time: 0.5-150ms in four ranges.

Noise: less than +75dBm.

Distortion: typically 0.4%.

Price: \$750.

MARSHALL (USA)

Marshall Electronic, 1205 York Road, Suite 14,

Lutherville, Maryland 21093, USA.

Phone: (301) 484-2220.

UK: Scenic Sounds Equipment, 97-99 Dean Street, London W1V 5RA.

Phone: 01-734 2812. Telex: 27939.

Model 5002 Time Modulator

This is a time domain modifier incorporating two analogue delay lines that can be used serially or in conjunction with each other. A voltage controlled clock and an internal (0.1-10Hz) sine wave generator enables delay control effects to be produced. In conjunction with both delay lines the time modulation effect produces a triple-track sound with or without harmonisation. Use of a common mixing buss creates the usual flanging effects between the delay lines and the cleanfeed signal. The maximum delay period is 105ms. Dynamic range is a claimed 80dB and frequency range 15kHz.

Price: £1,000.

Minimodulator

Type: pushbutton digitally programmed time modulator incorporating broadband 225ms analogue delay line with 450ms at 7kHz option. Easily repeatable time domain effects. Dynamic range 95dB, programmable LFO sweep instigation, remote digital effects programming, no tracking filters, headroom indicator bar.

Price: £700.

MICMIX (USA)

MicMix Audio Products Inc, 2995 Ladybird Lane, Dallas, Texas 75220, USA.

Phone: (214) 352-3811.

UK: Scenic Sounds Equipment, 97-99 Dean Street, London W1V 5RA.

Phone: 01-734 2812. Telex: 27939.

Dynaflanger

This unit is claimed to possess the unique feature of being able to dynamically control the flanging effect in response to the program material. This is achieved by measuring the spectral or amplitude energy content of the input signal and instantaneously developing and applying a corresponding control voltage to modify the resulting output signal. Three modes of operation are offered: highpass filter, lowpass filter and envelope follower. In the filter modes the internal time delay for the flanging effect is dynamically varied according to the spectral distribution of the input signal. A tracking switch allows the notch spacings to increase or decrease with increasing input frequency. In the envelope-follower mode the flanging effect is dynamically controlled in accordance with the instantaneous peak amplitude envelope of the input signal. An unweighted residual output noise (20kHz bandwidth) of less than -90dBm is quoted for the direct signal output, and less than -78dBm for the delayed.

Price: £490.

Master Room Series Reverb

Reverb principle: spring.

Decay times: 3, 5 and 7s.

Signal interface: nominally +4dBm.

Resistance to external noise: 110dB spl.

Controls: 'brilliance'.

Price: Master Room II £915; III £982; IV £1,112.

Studio B Series Reverb

Regarding signal interface and acoustic isolation, the Studio B series are similar to the Master Room Series. They also have the following operational features:

Decay time: B2 nominal 2s adjustable 1-2s; B3 nominal 3s adjustable 2-4s.

Echo delay: B2 20ms, B3 50ms.

Both models have a remote electronics box fitted with metering and decay, level and extensive middle frequency eq.

Super C Series Reverb

Mainly as Studio B Series but with comprehensive equalisation facilities.

NEW from *Alice* the 12.48

12 Balanced mic inputs, with separate line and re-mix inputs and direct post-fader outputs.

4 Output groups, with multiple connectors for 8-track and stereo tape machines.

8 Track monitoring with individual A/B, gain, pan, foldback and monitor echo.

plus channel and group inserts
stereo A/B
talkback,
oscillator and
many other features.

Alice 12.48

BROADCAST QUALITY — at a BUDGET PRICE

Alice (STANCOIL LTD)

ALEXANDRA ROAD . WINDSOR . ENGLAND . Telephone WINDSOR 51056/7

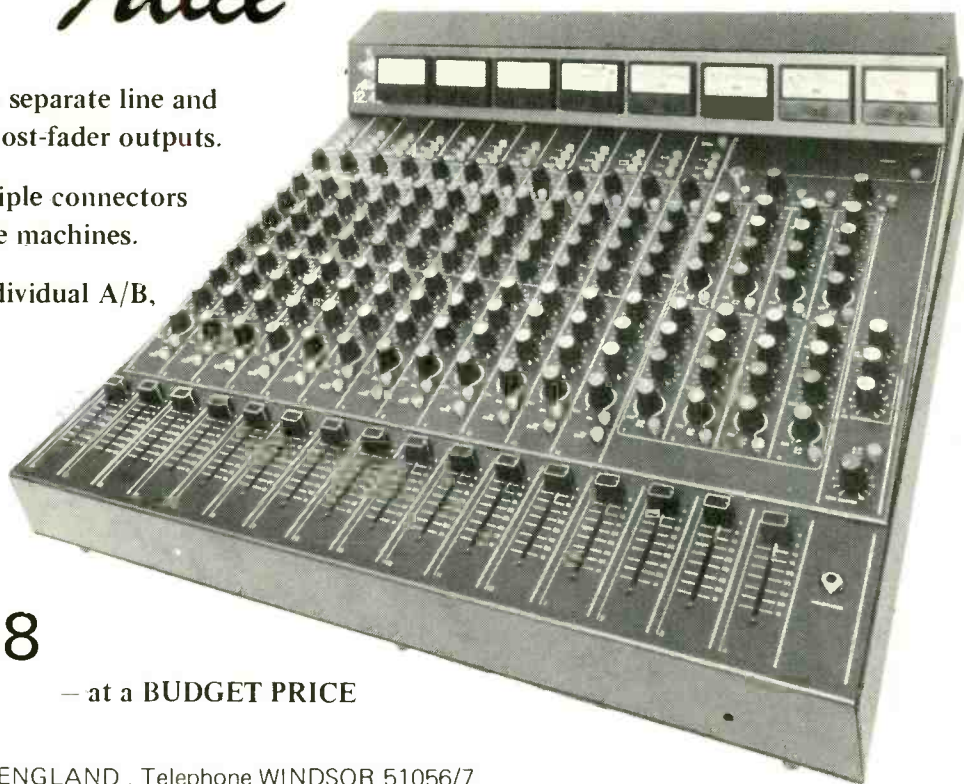

Penny Dropped?

Switchcraft QG Connectors are money savers

Because we have introduced an attractive new quantity discount structure. Switchcraft are still the same high quality, with unique features such as captive design screws and shell ground terminals.

Two new additions to the range are —

FAS-DISCONNECT

A new non-locking feature allowing immediate disconnection that requires only a 4 lb (1.8 kg) force. Great for that fast equipment take-down in hard to reach, darkened areas. Stage hands never had it so good!

REAR MOUNTED RECEPTACLES

The new Y series QG receptacles permit a complete sub assembly to be soldered, cleaned and tested prior to chassis mounting.

Available with PC or solder terminals with lock or Fas-disconnect latching, the Y series offers real savings in production costs. Extra colour trim escutcheons provide functional panel trimming and colour coding.

Switchcraft QG Connectors are just right for audio mixers consoles, PA systems and in computer applications.

The professionals choose Switchcraft QG and save the pennies!



SWITCHCRAFT QG
INC. QUICK RELEASE

F.W.O. Bauch Limited

49 Theobald Street, Boreham Wood, Hertfordshire WD6 4RZ
Telephone 01-953 0091, Telex 27502

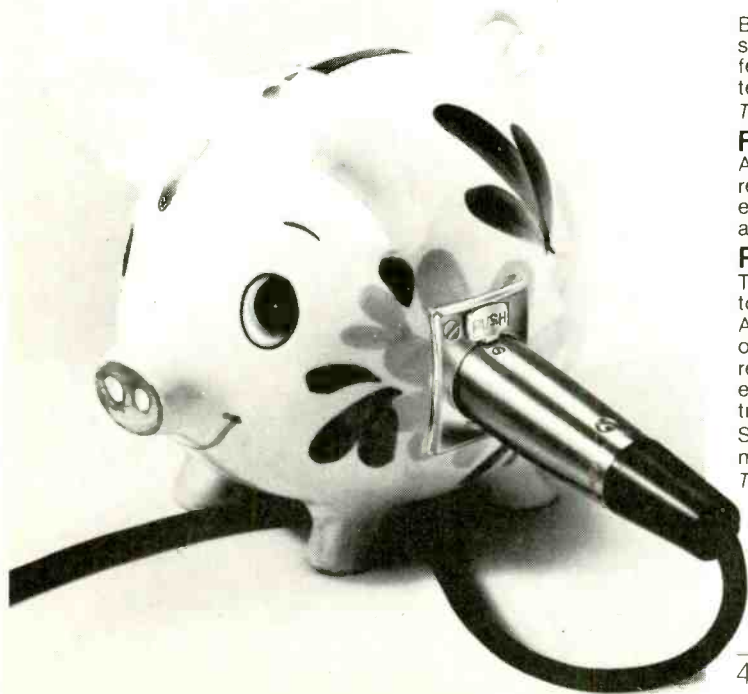

SURVEY: EFFECTS

MicMix cont'd

Decay time: as *Studio B Series* with same adjustment range.

Distortion: less than 0.1% on direct signal path/less than 5% reverb path.

Noise: better than -66dB unweighted.

Acoustic isolation: 110dB.

Delay on echo: 15 and 30ms (*Models 2 and 3* respectively).

XL305

'The first reverb to offer the natural sound performance of a plate or chamber in a compact and easily portable rack-mounting unit only 3½in high, yet offering full stereo facilities with a 3.25s delay.'

Price: unbal £750, bal £825.

MXR (USA)

MXR Innovations Inc, 277 N Goodman Street, Rochester, NY 14607, USA.

Phone: (716) 422-5320.

UK: Atlantex Music Ltd, 34 Bankcroft, Hitchin, Herts.

Phone: 0462 31511. Telex: 826967.

Digital Delay

Type: digital delay line with processing. Basic effects are discrete echoes, doubling and hard reverb, and also effects such as flanging, pitch alterations (vibrato, pitch bending), frequency modulation, and infinite (non-deteriorating) repeat-hold.

Delay principle: electronic digital.

Delay capacity: with 20kHz bandwidth, 40ms per board to maximum 160ms. Also bandwidths of 10kHz, 5kHz and 2.5kHz providing maximum delay of 1.28s. Variable delay range 4:1 continuous. Also regeneration control for multiple echoes.

Outputs: one.

Oscillator: sweep 0.1Hz to 1kHz in two ranges.

Frequency response: 20Hz to 20kHz ±1dB, reduced in other modes.

Residual noise: 80dB below limit threshold.

Features: provides dry/delay mix with invert phase.

Price: £783.16.

Flanger/Doubler

Type: signal processing unit providing a variety of time delay effects, offers flanging and doubling modes with a single pushbutton, vibrato and reverb.

Delay system: analogue CCD for longer delay for doubling effects, BBD for shorter delays for flanging.

Delay range: doubling 17.5ms to 70ms, flanging 0.25ms to 5ms.

Sweep speed: 0.03Hz to 20Hz.

Bandwidth: delay 15kHz, dry 25kHz.

Input noise: dry -92dB, flanging -90dB, doubling -85dB (A weighted).

Price: £450.

Pitch Transposer

Type: shifts pitch in real time, which, when mixed with the original pitch, creates a harmony. Shifting is from one octave down, to one octave up. The *Pitch Transposer* may also be used for doubling, pitch correction and choral effects.

Dynamic range: 80dB.

Frequency response: 36Hz to 11kHz -3dB.

Distortion: 0.25%.

Price: £699, digital display providing readout of pitch shift in number of musical half steps of ratio input to output pitch £200.

Auto Phaser

Type: phasing module that fits into *Professional Products Rack*, provides 1,080° phase shift, centre notch range variable from 100Hz to 10kHz manually, automatically, or via external input. Noise -85dB, frequency response 30Hz to 20kHz ±1dB, dry/wet mixing.

Price: £148.13.

Auto Flanger

Type: auto flanging module that fits into *Professional Products Rack*, time delay range 0.2ms to 2ms (variable), frequency response effect 30Hz to 15kHz ±2dB, dry to 20kHz ±1dB. Manual or auto sweeping, 0.05Hz to 10Hz, 0 to 100% depth.

Price: £243.16.

ORBAN (USA)

Orban Associates Inc, 645 Bryant Street, San Francisco, Ca 94107, USA.

Phone: (415) 957-1063.

UK: Scenic Sounds Equipment, 97-99 Dean Street, London W1V 5RA.

Phone: 01-734 2812. Telex: 27939.

111B Reverb

Type: two-channel spring reverb unit with four spring lines per channel.

Decay time: about 2s to -40dB.

Delay time: 30ms between direct path and onset of reverberation.

Features: built-in limiter can operate in fixed or floating threshold modes to eliminate unwanted noises (eg 'twangs' and 'bongs') due to step changes in programme levels; bass-shelf eq at 500Hz and parametric eq on middle giving control of frequency, boost and bandwidth.

Price: £450.

245E Stereo Synthesiser

This unit is for the generation of simulated stereo from mono sources. Front-panel controls comprise 'dimension' (high- and low-frequency processing), 'separation' and 'gain'.

Price: £220.

526 De-esser

Type: dynamic sibilance controller with threshold and level controls, and two levels of de-essing. Provides effective de-essing over a 15dB input range by examining the presence of energy in the spectrum above 6kHz which exceeds a level set by the threshold control. Such energy is ducked with 1ms attack and 10ms recovery.

Price: £240.

516EC De-esser

Three channel de-esser having only one level of de-essing.

Price: £420.

PUBLISON (France)

Publison Audio Professional, 5-11 rue Crespin du Gast, F-75011 Paris, France.

Phone: 357.64.08.

DHM89B2

Type: stereo digital audio computer providing digital manipulation of memorised sounds. Basic features are dual digital delay with various combinations of bandwidth/max delay, 5, 10, 20kHz, delay up to 1,200ms. Dual echo by association with basic delays, pitch shifting from -2 to +1 octave with two independent ratios, the max and min delays between which pitch shifting operates are presettable allowing the adjustment of additional delay. Automatic arpeggio, reversed sound, memorised mode. Level indicator, feedback, coarse and fine pitch ratio, feedback.

Price: on application.

DHM83B

Similar to *DHM89B2* but delay is max 600ms at 5kHz, delay is quasi stereo, with two outputs for one input, and there is one pitch ratio only.

Sound Workshop 262 stereo reverb



Statik SA100

Fullmost

Type: relief enhancer designed to increase the brightness of music or speech.

Price: on application.

QUAD/EIGHT (USA)

Quad/Eight International, 11929 Vose Street, North Hollywood, Ca 91605, USA.

Phone: (213) 764-1516. Telex: 662446.

UK: Audio Kinetics (UK) Ltd, Verulam Road, St Albans, Herts AL3 4DH.

Phone: 0727 32191. Telex: 299951.

CPR-16A Reverb

Type: programmable electronic reverb system.

Effects: acoustic chambers, mechanical plates, spring lines and tape loops.

Reverb decay time: 250ms to 20s, adjustable.

Controls: decay time ('room size'), high-frequency damping, low-frequency filtering and program select.

Noise: less than -80dBm.

Dynamic range: better than 80dB.

Price: £3,495.

TM499A

Type: digital delay line (same as Altec 1660/1).

Principle: digital electronic, RAM.

Delay capacity: 85ms/module, selectable in 1ms increments, 510ms maximum with six modules.

Outputs: max four output modules, independently selectable.

Frequency response: 20Hz to 15kHz ±1dB.

Dynamic range: 93dB.

Features: time delay controls protrude through the front cover enabling setting, overload LED.

Price: basic £1,518, memory cards 85ms £345, output modules £204.

QUANTUM (USA)

Quantum Audio Labs Inc, 1905 Riverside Drive, Glendale, Ca 91201, USA.

Phone: (213) 841-0970.

QA-201 Reverb

This stereo chamber utilises two *Accutronics* reverb units, with each chamber being provided with its own input level and high-frequency tone control. A built-in compressor-limiter is said to permit optimum drive to each reverb unit.

Price: \$450.

ROLAND STUDIO SYSTEMS (Japan)

USA: Roland Corp US, 2401 Saybrook Avenue, Los Angeles, Ca 90040, USA.

Phone: (213) 685-5141.

UK: Brodr Jorgensen (UK) Ltd, Great West Trading Estate, 983 Great West Road, Brentford, Middx TW8 9DN.

Phone: 01-568 4578. Telex: 888941.

PH830

Type: stereo phase shifter providing an internal sweep oscillator with three waveform options for different phase effects and an LED for visual indication of the sweep frequency. Centre notch range 30Hz (two channels in series) to 10kHz, variable manually, automatically or externally. Sweep speed 0.016Hz to 10Hz.

Price: \$795.

RV-800

Type: stereo reverberation unit incorporating an optional compressor to increase headroom and allow reverb signals to be added to low level signals.

And now... the new improved Eventide Harmonizer: Model H949

Eventide's new Model H949 starts where the H910 left off...with outstanding new features like time reversal, randomised delay, flanging and repeat. New digital circuitry and random access memories now actually transpose input signals by one full octave up and no less than two full octaves down.

- * Two outputs, each with up to 400 ms of delay.
- * Two selectable algorithms to optimize pitch change performance.
- * Micro pitch change ensures extremely precise, stable settings.
- * Long delay permits simulated reverb.
- * High and low feedback equalization, coupled with the use of delay and pitch change makes possible a range of special effects hitherto unobtainable.
- * 15 kHz band width.
- * 96 dB dynamic range.
- * Dual colour LEDs give markedly improved front panel readability.
- * Switchable 115/240 volts.



* Harmonizer is a trade mark of Eventide Corporation.



UK Distributors

Feldon Audio Ltd.,

126 Great Portland Street, London W.1. Tel: 01-580 4314. Telex: London 28668.

SURVEY: EFFECTS

Roland Systems cont'd

Reverb time approx 3s, direct/reverb mixing, level VU on each channel.
Price: \$850.

SOUND WORKSHOP (USA)

Sound Workshop Professional Audio Products Inc, 1324 Motor Parkway, Hauppauge, NY 11787, USA.

Phone: (516) 582-6210.

UK: TRAD Electronic Sales Ltd, 149B St Albans Road, Watford, Herts.

Phone: 0923 47988. **Telex:** 262741.

262 Stereo Reverberation System

Mechanical stereo reverberation system featuring extended low and high frequency response, two channels of equalisation with ± 15 dB sweepable from 50Hz to 1kHz, and 500Hz to 10kHz. It features dry/wet mixing, full drive into 600 ohms, LED level indicators, active balanced inputs and matched bi-FET preamps.

Price: \$700, with transformer balance and XLRs \$750.

STATIK (UK)

Statik Acoustics, Coppice Trading Estate, Kidderminster, Worcs DY11 7HS.

Phone: 0562 741515/64027. **Telex:** 339821.

SA100 Dynamic Delay/Flanger

Type: delay system offering analogue delay based effects such as flanging, doppler shifts and automatic double tracking, and also longer, single delays for echo and repeat effects together with a mix of a number of offset delays in the reverb mode.

Delay system:

Delay capacity: delay mode 16kHz 4ms to 40ms, 8kHz 8ms to 80ms, 4kHz 16ms to 160ms; flange mode 16kHz 0.66ms to 6.6ms, 8kHz bandwidth 1.3ms to 13.3ms, 4kHz 2.67ms to 26.7ms. Option extra cards.

Outputs: one.

Sweeping: 10:1 range, 0.1 to 30s.

Dynamic range: 85dB in all modes.

Features: internal limiter, front panel jacks, inverted comb output allows stereo flanging effects, regeneration control, two repetitive sweep waveforms plus dynamic for wide range and speed controls.

Price: £490.

SA20 Dual Reverberation System

Type: mechanical reverberation system using multiple springs featuring reduced 'splash' and a smooth decay response, input limiter plus contoured detection circuit allows max S/N, high and low frequency controls, initial delay 35ms, decay time 2s.

Price: £350.

STRAMP (West Germany)

Peter Struven GmbH, Bornheide 19, 2000-Hamburg 53, West Germany.

Phone: 040-801028.

Echo-700

This is a combined stereo echo (plus reverb), phaser and vibrato unit. Also because the delay and effects sections can be linked other special effects may be created. Delay time for the first echo is continuously variable to a maximum of 300ms. Frequency range of the delay chain is claimed to exceed 8kHz 'flat' (original signal: 20-20kHz).

SURVIVAL PROJECTS (UK)

UK: Scenic Sounds Equipment, 97-99 Dean Dean Street, London W1V 5RA.

Phone: 01-734 2812. **Telex:** 27939.

Autopanner

Type: quad/stereo automatic panning unit which



▲ Symetrix phase filter

will slave or be slaved by other effects units to produce simultaneous panning and flanging, phasing or pitch shifting. Will also duck and vibrato.

Price: £550.

SYMETRIX (USA)

Symetrix Inc, 109 Bell Street, Seattle, Washington 98121, USA.

Phone: (206) 682-3076.

Phase Filter

Uses frequency notching techniques to achieve phasing effects. Eight 90° phase delays in the signal path create four notches, so the notches are related by constant frequency bandwidths rather than octaves as in flangers. Includes input level control, two variable low frequency oscillators with LED rate indicators, manual/auto sweep for LFO2, blend control, and depth and resonance.

Price: \$299.

SYNTRON (Holland)

Syntron Electronics BV, Zandpad 46, POB 83, NL-3630 AB Breukelen, Netherlands.

Phone: 03462 3499. **Telex:** 40541.

UK: Trad Electronics Ltd, 149B St Albans Road, Watford, Herts.

Phone: 0923 47988. **Telex:** 262741.

USA: Parasound Inc, 680 Beach Street, San Francisco, Cal 94109.

Phone: (415) 673-4544.

Phaser 203

Unit providing up to 2,100° of pure analogue phase shift under the control of an LFO with a range from 0.05Hz to 10Hz and a pure envelope follower which automatically adjusts itself to any input signal larger than -20dB for max control voltage output.

Price: £350.

Syntovox 221

20-channel electronics effects vocoder which is basically a 20-channel audio analyser, synthesiser and a control system. The 20 specially designed filters are spaced at approx 1/4-octave spacing with 54dB/octave slopes. The 20 control voltage outputs are directed to a 20x20 matrix system and a multi-way output connector. The 20-channel synthesiser has one input and one output, and identical filters to the analyser, each channel having a modulator with a control voltage input whose sensitivity can be adjusted.

Price: £3,000.

Syntovox 222

This is a simplified vocoder based on the 221 using separate analysis and synthesis but simplified for stage use without the individual channel control and matrixing available on the 221.

Price: £495.

UREI (USA)

United Recording Electronics Industries, 8460 San Fernando Road, Sun Valley, Cal 91352, USA.

Phone: (213) 767-1000. **Telex:** 651389.

UK: FWO Bauch Ltd, 49 Theobald Street, Borehamwood, Herts WD6 4RZ.

Phone: 01-953 0091. **Telex:** 27502.

Model 927

Type: digital delay line with four outputs.

Delay system: digital electronic, 14-bit.



▲ Syntovox 221

Delay capacity: 0 to 127ms.

Outputs: four separate outputs with individually adjustable delays in 1ms steps.

Dynamic range: 90dB.

Frequency response: 20Hz to 12kHz ± 0.25 dB.

Features: LED array level indicators.

URSA MAJOR (USA)

Ursa Major, Box 18, Belmont, Mass 02178, USA.

Phone: (617) 489-2039.

UK: Feldon Audio Ltd, 126 Great Portland Street, London W1.

Phone: 01-580 4314. **Telex:** 28668.

SST-282 Space Station

A complete processing centre for reverberation, multitape delay line, feedback delay and echo. There are four basic families of audition delay programmes: rooms, combs, delay clusters and space repeats.

Delay system: digital electronic, RAMs.

Delay taps: 16 programs of eight delay tap times, the taps may be mixed separately with direct sound in a 10-channel mixer, and also reverb/echo added.

Delay capacity: 255ms.

Frequency response: 20Hz to 7kHz +1dB -4dB, to 6kHz -1dB.

Dynamic range: 80dB.

Decay time: 0 to 3.5s max.

Price: \$1,995, £1,183.

WMS (USA)

Wasatch Music Systems, Box 9175, Salt Lake City, Utah 84109, USA.

Phone: (801) 467-4722.

900-A

This is a digital delay capable of producing a variety of effects, including negative and positive flanging, Doppler, vibrato and chorus, pitch shifting, ADT, 'Leslie speaker simulation' and cardboard tube echo. Delay is variable up to a maximum of 20ms.

Price: approx \$350.

LATE ENTRY

EMS (UK)

Electronic Music Studios (Sales), 277 Putney Bridge Road, London SW15.

Phone: 01-788 3491

Service and technical: EMS Music Manufacturing Ltd, John's Road, Wareham, Dorset.

Phone: 09295 3621.

West Germany: EMS, Finkenstrasse 4, D-7257 Ditzingen/Heimerdingen, West Germany.

Phone: 07152 53273.

Vocoder 1000

This is a 'baby sister' to the EMS Vocoder designed for live use, and has 16 filter sections with 16 envelope followers and modulators. It includes an internal pulse oscillator and noise generator.

Price: about £750.

40 Channel Remix Console supplied recently to Olympic Sound Studios, London.

The Series III De Luxe range of mixing console represents a high quality versatile system. A fully detailed colour brochure, including price lists, is available direct from the factory or agents.

AGENTS:

Canada

C.O.R.A. Inc.
131-18eme Rue, 1046 Quebec P.O.,
Canada Tel. 418-522-1397

Denmark

Audiophil
Howitzej, 49-1 2000 Copenhagen,
Denmark Tel. 134 1622

Netherlands
& Belgium

Pieter Bollen, Geluidstechniek bv,
Hastelweg 6, Eindhoven,
Holland. Tel. 40 51 2777/520662

South Africa

Prosound,
Eikham, Upper Level Pretoria Street,
Hillbrow, Johannesburg 2001,
South Africa. Tel. 642-8721/1 209

Spain

Telco Sociedad Limitada, Gravina 27
Madrid, Spain. Tel. 1 231 7840

France

Reditec,
62-66 Rue Louis Ampere,
93330 Neuilly/Marne, France
Tel. 300 96 30

W. Germany

Elmus GmbH,
D1 Berlin 12,
Henderstrabe 16,
W. Germany. Tel. 030 312 2012

Acoustics Audio Import

Curtiusstrabe 85,
4300 Essen 1. Tel. 0201 70 17 34

U.S.A.

(Brochure Service Only)
Keith Monks Audio (USA),
652 Glenbrook Road,
Glenbrook CT 06906
Tel. (203) 348-4969

Raindirk Limited Downham Market Norfolk Tel. 03663-2165 Telex No. 817737

reviews

EMT 244 Digital Reverberation Unit

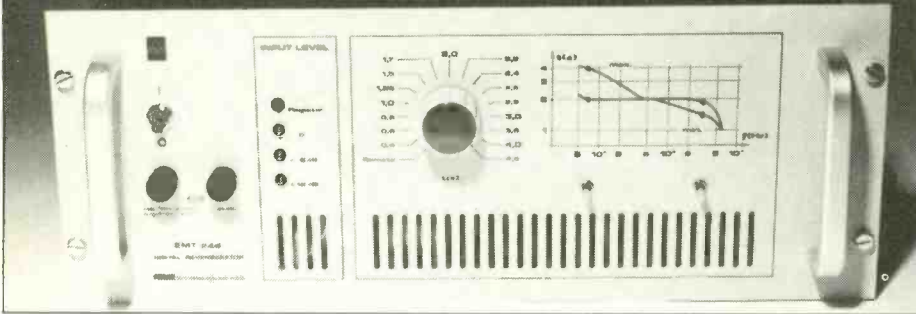

MANUFACTURER'S SPECIFICATION

Reverberation time at 500Hz: 0.4s to 4.5s selectable in 16 steps.

Reverberation time at 100Hz: selectable in two steps, linear or boost.

Reverberation time at 6kHz: selectable in two steps, linear or roll off.

Digital coding A/D and D/A converters: 13-bit.

Analogue input: balanced, input impedance greater than 5kΩ. Nominal input level +6dB adjustable between -10dB and +15dB.

Analogue output: two balanced outputs. Output impedance less than 60Ω. Output level nominally +6dB adjustable between -10dB and +15dB.

Overload margin: 6dB greater than the adjusted nominal level, maximum +21dB.

Signal-to-noise ratio at 2s reverberation time: 65dB.

Frequency response 30Hz to 8kHz: +1/-3dB.

Remote control: five conductor electrical cable for dc control.

Dimensions: 20.1 x 8.4 x 19.1in (505 x 210 x 480mm).

Weight: approximately 44lb (20kg).

Power consumption: 70VA.

Price: £3,713.

Manufacturer: EMT-FRANZ GmbH, Postfach 1520, D-7630 Lahr, West Germany.

UK: FWO Bauch Ltd, 49 Theobald Street, Boreham Wood, Hertfordshire.

IN the April 1977 edition of *Studio Sound* I had the pleasure of reviewing the EMT 250 digital reverberation unit. Whilst that unit included effects in addition to pure reverberation it was necessary then to include purpose-built digital computers to obtain the required processing speed in order to achieve a digital reverberation unit.

The new EMT 244 is also a pure digital reverberation unit but the extraordinary progress in micro-electronics enabled the use of multiplexed microprocessors in lieu of a purpose-built computer. This has not only simplified the design of the unit, but also reduced the cost. However the audio bandwidth has been dropped from 11kHz, for the 250, to 8kHz on the 244.

Normal room reverberation consists of a number of reflection modes each of which has a different decay time and a different density of reflections. These conditions are simulated

in the EMT reverberation unit by storing a 'reverberation programme' in a read-only memory, and storing the audio input in a random access memory. Reverberation is achieved by the reverberation programme operating upon the contents of the stored audio in digital form stored in a 13-bit format.

The unit has a 19in rack-mounting chassis which may be mounted into an optional case for table top use. The front panel features are: power on/off switch with an incandescent lamp power indicator adjacent and two fuses properly identified but strangely of imperial size.

Next the input level indicator comprising one red and three green LEDs. The top red LED is identified as 'register' and is illuminated as a result of digital overload at the input or output of the unit whilst the three green LEDs are identified as 0dB, -6dB and -12dB and indicate normal operating levels.

The larger than life centrally mounted 17-position rotary switch selects the reverberation time from 0.4s up to 4.5s in intervals of 0.5s above 3s and generally in 0.2s steps below 3s—16 different reverberation times are provided,

with position 17 permitting remote control of the reverberation time.

And finally, two miniature toggle switches above which is a frequency/time graph incorporating four LED indicators. Normally the reverberation time is constant against frequency from about 50Hz to 4kHz above which it falls. One toggle switch increases the reverberation time at low frequencies up to double the mid-frequency time at 50Hz, and the other reduces the reverberation time at high frequencies above 2kHz so it is halved at 8kHz compared with mid frequencies. The graph shows these characteristics with green LEDs at high and low frequency positions which illuminate during normal operation. When either toggle switch is operated a red LED is illuminated on the boost or cut graph positioned at high or low frequencies as appropriate.

The IEC power input plug at the rear of the unit has both American and European plugged mains leads provided and a rotary voltage selector covering the normal range of voltages from 100V to 240V ac. There is a removable link for isolating the signal earth from the chassis earth together with a chassis earth terminal; usual practice for EMT and one that I feel is sensible. The audio input and the two pseudo-stereo outputs are XLR connectors for use in the floating output mode with ¼in single pole jack sockets in the unbalanced input and/or output mode—input and output levels being set by means of screwdriver-operated potentiometers at the rear panel. And lastly, the remote control socket, which permits a number of remote functions.

The LED level indicators may be duplicated at the remote position requiring four LED indicators and four 200Ω resistors at the end of a 5-way cable. Also the reverberation time setting may be remotely controlled by a number of means. If the full set of time adjustments is required a 16-way, 4-pole switch is needed. However, if not all adjustments are required, an 8-way, 3-pole switch will provide eight

78 ►

FIG.1
EMT 244
FREQUENCY
RESPONSE AT 0dB

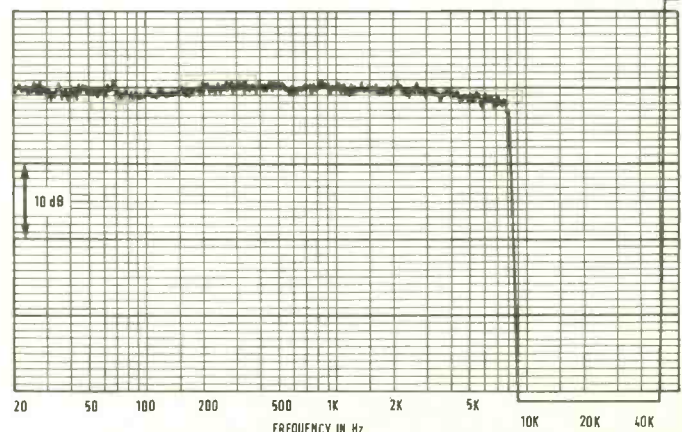

4 YEAR OLD TRIDENT CONSOLE 30 INPUTS 16 GROUPS presently installed at our Luton showroom has 16 monitors, 8 further monitor channels available if required **£10,000**

Other large consoles available
 HELIOS 26 x 24 x 24
 HELIOS 36 x 24 x 24
 HELIOS 32 x 24 x 24 AUTOMATED
 TRIDENT A RANGE 32 x 24 x 24 18 months old
 TRIDENT 28 x 12 x 24

USED EQUIPMENT

SCULLY Mono Lathe complete	£1,800
Neumann stereo cutting lathe mod VMM Special	...
STUDER A80 16 track 15/30 ips 5,000 hours	£12,000
STUDER A80 8 track 3000 hours	£6,500
AMPEX MM1100 16 track 15/30 ips remote	£11,000
SCULLY 280 8 track in console	£3,500
BRENNEL Mini 8 with Allen & Heath Mod 2 mixer 9 months old	£5,200
AUDIO DEVELOPMENTS Pico Mixer 6 x 2 in flt/case and with psu	£600
TRIDENT 10 into 4 Fleximix	£2,350
MM 16 input 8 group mixer as new	£1,000
AMPEX AG 440 stereo machine	£1,200
AMPEX AG 440 desk in trolley with Studer B62 electronics and varispeed	£1,400
REVOX A700 immaculate	£1,000
REVOX A77 Mk3	£350
22 input 8 group custom mixer	£1,500
Monitors: Various including Lockwood Majors/Universal Majors/Minors all with a choice of red/gold or HPD drivers, also Cadac monitors with amps	...
JBL L65	£400
Tannoy Ardens with HPDs	£300
Tannoy Devons	£200
HH TPA50 amp	£75
AUDIO & DESIGN stereo eq unit E 900RS	£350
5 feet tall equipment racks	£75
BBC 19 inch rack inc. psu 6 line drive amps 2ppm	...
Drivers and meters 2 mic amps	£300
Close circuit tv camera and 9in. monitor	£200
Various mics inc. Neumann KM 53 and KM 54 Crown D 60 amps	£130
PYE stereo comp/lims	£350
DBX 216 professional noise reduction 16 channels	£3,300
Guaranteed once used Scotch 250 2in. tape, per reel	£25
HAMMOND T100 organ	£750

NEW EQUIPMENT

B.E.L. Noise reduction units 8 tracks	£500
Stereo units	£130
Power supplies for valve mics	£60
B.E.L. BF20 stereo flangers	£450
WASP synth	£160
SENNHEISER MKH 110 condenser mics and psu's	£120
TRIDENT Fleximix	...
PA/CE 27 way graphic equalisers	£199
Revox A77 high speed	£450
REVOX B77 high speed	£500
REVOX B77 low speed	£450
All MXR and SESCOM products	...

STUDIOS FOR SALE

Large country house, 40 minutes west London. Large grounds, fully equipped 16 track studio. No external noise problems. Would suit producer or wealthy musician. Details upon request. Well-established West Midlands commercial studio, A.C.T.T. recognised. Very well equipped on large site comprising 800sq.ft. studios, large control room, offices, rest room, workshop, 3-bedroom house and car park. Details upon request.

ALL PRICES EXCLUSIVE OF V.A.T.

Don Larking
Audio Sales

50 CHEAPSIDE, LUTON, BEDS.

Telephone: Luton 27195, 26693, 422387

Telex No. 825488

THE PROFESSIONALS SHOP



Professionals speak very highly of our microphones and monitors

Ev In microphones and monitors Electro-Voice leads all the way

What Electro-Voice has to offer by way of microphones and monitors sounds really good. The numerous wireless, TV and recording studios using Electro-Voice microphones and monitors show it.

Where only the best is good enough, Electro-Voice is always there. Be it with studio- or soloist-, omnidirectional-, Single-D-cardioid-, variable-D-cardioid microphones or monitors speakers.

Why not send in the coupon and get detailed particulars? You will immediately realize that every Electro-Voice product is backed up by an outstanding technology, and why professionals always speak so highly of our microphones and monitors.

COUPON

Please forward detailed particulars on Electro-Voice microphones Electro-Voice loudspeaker systems

Name _____

Address _____

Send to: Electro-Voice Division
 Gulton Europe Ltd.
 Maple Works
 Old Shoreham Road
 Hove BN3 7EY

settings over the reverberation time range 0.6s up to 4.5s. Finally, by changing an internal interface board, the EMT 140B unit as used with the EMT 140 plate or the EMT 240 foil may be used with the meter still functional.

Input, outputs and overload

Input sensitivity with a warbled sinewave or with 1/3-octave white noise at 1kHz is normally factory set to +6dBm for the onset of illumination of the green 0dB LED level indicator. However, the input sensitivity was adjustable over a wide range with the measured range for the onset of the green 0dB indicator, using the floating input, measuring +16dBm to -13dBm—more than adequate for most matching purposes.

The alternative unbalanced input at the rear panel jack socket was found to be approximately 7dB more sensitive, the input impedance of this input being 9.8kΩ and that of the floating input 10.5kΩ, both being satisfactorily high. Common mode rejection at the floating input was excellent being 82dB at 1kHz falling to a most respectable 78dB at 50Hz.

The change for the floating to the unbalanced input is accomplished by changing a small plug-in board within the unit, the alternative board is provided with the accessory pack, supplied with the unit—this includes spare fuses and all necessary connectors.

The output is always transformer coupled and floating, but, naturally one end can be grounded to provide an unbalanced output. The output impedance was very low, in the order of 12Ω at 1kHz with the nominal output level adjustable over the range +14dBm to -14dBm which is again more than adequate.

Level indication was excellent, the indicators having an attack time of less than 100μs together with a peak hold which provided very good readability on transients. The red 'register' indicator became illuminated at levels 6dB above the 0dB green indicator which is the input clipping point. Thus the 0dB indicator provides a safe margin of operation with the two lower level indicators set at exactly 6dB intervals.

Frequency response and noise

The frequency response of the unit was independent of either the reverberation time setting or the input level. This showed that no pre-emphasis was used but unlike many delay units a constant clock frequency was.

As can be seen from fig 1, a spectrum analysis of pink noise passing through the reverberator, the frequency response is flat from 20Hz up to 8kHz at which point a sharp anti-aliasing filter cuts the response. As a result of this filter's characteristics there was never any sign of beating effects at high frequencies. However the frequency response extended to very low frequencies and if severe distortion is to be avoided inputs at 10Hz at levels above -12dBm, which the unit distinctly disliked, should not be used.

With the unit's gain setting as received, such that the nominal input and output levels were equal at +6dBm, the noise in the output depended upon the reverberation time setting and the bass and treble reverberation time options. In the flat reverberation time setting

FIG. 2
EMT 244 REVERBERATION
TIME SET TO 2s
EFFECT OF
BOOST AND CUT

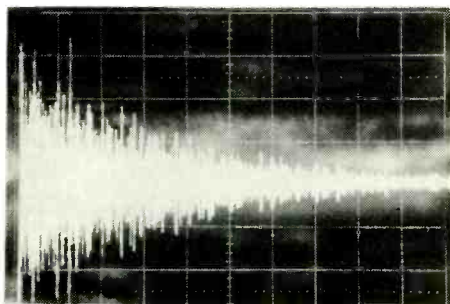
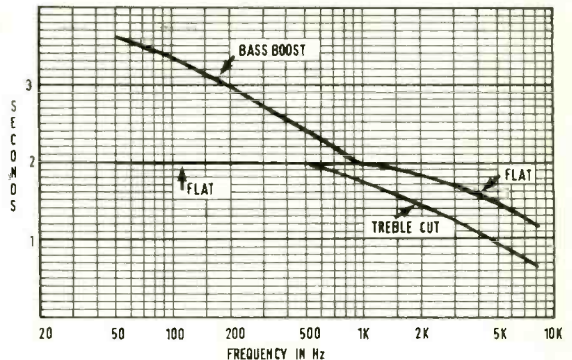

Fig. 3

versus frequency, the output noise referred to +6dBm was as Table 1.

TABLE 1	REVERBERATION TIME		
	0.4s	2s	4.5s
Band limited 22Hz to 22kHz rms	-64.0dB	-60.5dB	-57.5dB
A-weighted rms	-64.0dB	-60.5dB	-57.0dB
CCIR-weighted rms	-55.0dB	-51.0dB	-47.5dB
CCIR-weighted quasi-peak	-51.0dB	-47.0dB	-43.0dB

With the bass and treble switches flat the worst case for noise was at 4.5s reverberation time and the best case at 0.4s reverberation time again in the flat positions where the noise performance was as above. As reverberation is normally added to the original signals at low levels the above performance is perfectly adequate.

Spectrum analysis of the output noise showed that spurious tones were at extremely low levels with insignificant power frequency components and clock frequency components at 54kHz, 79dB below nominal output, 70dB down at 36kHz and 94dB down at 18kHz.

Reverberation characteristics

The reverberation time was measured using 1/3-octave bands of random noise and by measuring the decay time to -60dB by means of the common Bruel & Kjaer level recorder and the reverberation time protractor.

Using this method the reverberation time calibrations were within the accuracy of the measurement method at 1kHz. Fig 2 shows

the relation between reverberation time and frequency in the flat position of the treble and bass switches and in the active positions which increase bass reverberation and cut treble reverberation time. These two functions proportionally effected the reverberation time at settings other than the 2s setting shown.

Fig 3 shows the decay characteristic after the application of a burst of tone; it can be seen that the defined reflections exist as in a real room as opposed to the steady exponential decay of other reverberation units. This characteristic was also quite apparent in the decay plots which exhibited the typical peaks associated with early reflections.

Subjective listening tests and a variety of programme material when listening with the two outputs in the stereophonic configuration, gave pleasing results with a good spatial property. Without the cut in treble reverberation time the results were sometimes a little 'hard' but there was no comparison between the performance of this unit and mechanical reverberation units.

At the time of writing only a provisional instruction manual was available so it was not possible to comment upon the ease of servicing, and whilst the integrated circuits within the unit are identified with numbers, many of the maker's identifications had been removed for obvious reasons!

Inside the unit, along the left side, the power supplies are completely screened from the main electronics and the majority are contained on a large glass fibre printed circuit board which covers the remains of the cabinet area at a sloping angle. A second board plugs vertically into the main board and a small interface board in the base is connected by ribbon cables. Overall the standard of construction is excellent with good quality components and an uncluttered layout with very easy access to all components.

Summary

If you require really natural reverberation it appears that the use of a digital unit is mandatory and the EMT 244 gives excellent results; it is perhaps surprising though that no prereverberation delay has been incorporated.

The performance is very good, measured and subjectively, and on a par with the all singing and dancing EMT 250 which has more facilities but at a much higher cost.

Hugh Ford

The Versatile Quad-Eight CL22 Can Make It Better

Compress. Limit. & Expand.

At the heart of the most versatile signal conditioning device available lies an exclusive, advanced feed-forward VCA controlled circuit design. This helps to eliminate common control and distortion problems in ordinary, conventional compressors and limiters. Like all Quad-Eight precision modular products, the CL22 is available in 19" rack and standard 1-1/2" console configurations. Contact us now for more juicy details.

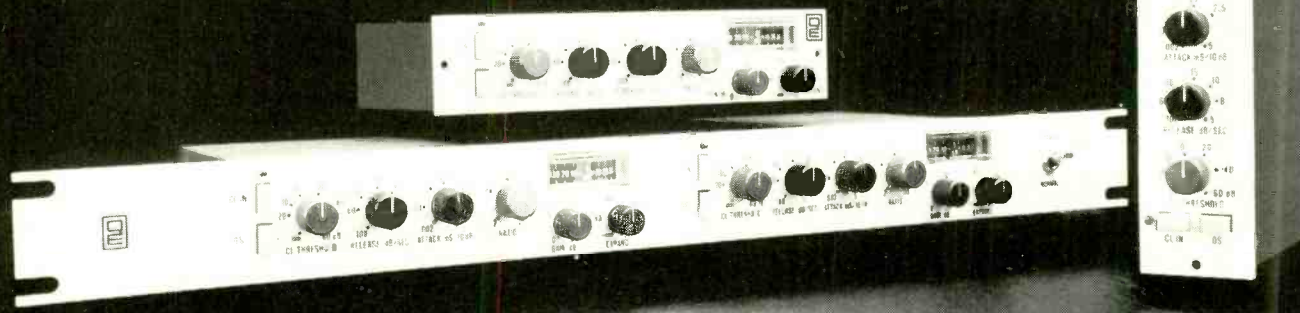

For the Artist in Every Engineer.

Quad-Eight Electronics/Quad-Eight International, 11229 Voss Street, North Hollywood, California 91605, (213) 764-1516 Telex: 662-446



MXR 2x15 Band Graphic Equaliser



MXR Digital Delay



Revox B77

We are one of the leading equipment sales and installation companies, offering you a friendly and helpful service.

Every item we supply is tested and aligned in our own workshops, and after-sales service is always readily available.

We supply anything from an XLR to a complete 8-track studio installation, at competitive prices to clients that include recording and AV studios, government departments, schools, radio stations, theatres and PA companies in all parts of the world.

Our stocks include AKG, Allen & Heath, Beyer, Brenell, Ferrograph, JBL, MXR, Neal, Quad, Revox, Sescam, Shure, Sonifex, Studiomaster, Tannoy, Teac, and Uher.

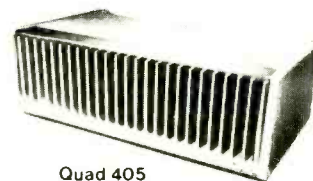

Quad 405



Allen & Heath Series 3

STUDIO EQUIPMENT SERVICES

Studio Equipment Services Ltd.
The Studio Shop, Oxgate Farm
Coles Green Road, London NW2 7EY
Telephone: 01-452 1979

reviews



MANUFACTURER'S SPECIFICATION (preliminary)

Input characteristics: impedance nominal 10k Ω , maximum level +24dBm. Level for full dynamic range is from -10dBm to +24dBm.

Output characteristics: impedance nominal 150 Ω . Suitable for driving 600 Ω or greater at +18dBm. Electronically balanced.

Distortion: less than 0.15% at 1kHz, reference output level.

Dynamic range: greater than 96dB from clipping to noise floor.

Pitch variation: one octave up, two octaves down, continuously variable. 4-digit readout indicates precise ratio.

Delay: main output in pitch change mode, 0 to 100ms in 50ms steps. In delay mode, 0 to 393.7ms in 6.25ms steps. Delay only output, 0 to 393.7ms in 6.25ms steps.

Frequency response: at any delay, unity pitch ratio, 20Hz to 15kHz \pm 1dB. No degradation with increasing delay.

Dimensions: requires 3 $\frac{1}{2}$ x 19in (889 x 482.6mm) panel space. Extends 11 $\frac{1}{2}$ in (298.5mm) behind panel.

Power requirements: switchable between 115V ac, 50/60Hz, and 230V ac, 50/60Hz. Nominal power dissipation 45W.

Remote control: provision has been made for control by microcomputer using the IEEE standard interface buss (IEEE 488/1975). The *HK940* keyboard can be used to control the pitch ratio in discrete musical steps. Option 01 mono keyboard controls one harmoniser; option 06 polyphonic keyboard controls up to three harmonisers. An input is provided to phase lock the harmoniser to any synthesiser. A 3V peak-to-peak signal is required. The pitch may be varied by a control voltage input in the 0-5V to 0-15V range (internally selected).

Price: £1,295.

Manufacturer: Eventide Clockworks Inc, 265 West 54th Street, New York, NY 10019, USA. **UK:** Feldon Audio Ltd, 126 Great Portland Street, London W1.

THE Eventide *H949 Harmonizer* is not only a pitch shifter but provides a number of other interesting facilities as well. The pitch changing facility itself covers as far as one octave up in pitch, or two octaves down with a choice of two algorithms—a feature which can save the situation where pitch shifting gives severe distortion on a particular programme material. In addition to wide range pitch shifting there is a facility called 'micro pitch shift' which allows the amount of shift about zero to be finely set.

A single input provides two outputs, one is always the input signal or a delayed version of the input signal with the delay selectable in 6.25ms increments, up to a nominal 393.75ms; while the other, called the main output, is also

capable of simply being a delayed output but with a separate delay setting over the same range, or alternatively the special effects output.

When in the special effects mode the main output may also be delayed but only in increments of 50ms with a maximum delay capability of 350ms. The effects available in addition to pitch shifting and delay are a random delay feature, flanging, reversing the input signal in time and repeating a section of the input signal.

To widen the scope of the unit two feedback paths are provided, one from the delay output to the input and the other from the main output to the input. Independent feedback level controls have high and low frequency boost/cut controls common to the feedback path.

The unit has a 19in rack-mounting chassis only two units (3 $\frac{1}{2}$ in) high and the controls are divided into: an input section, feedback section and pitch ratio section, which has logically arranged pushbutton switches in horizontal array below these sections.

The input section contains the input level potentiometer, a locking pushbutton to activate the repeat function and four LED input level indicators. The top one is red and identified as 'limit', the three lower green LEDs identified as 'normal' and a yellow LED as 'present' which is illuminated in the presence of an input signal.

Within the equaliser section are two feedback level controls for the main and delay outputs, plus two further potentiometers for controlling high and low frequency equalisation in the feedback path, either boost or cut is available in both cases.

Turning to the harmoniser section a large knob driving a 270° potentiometer sets the pitch shift which is displayed on a 4-digit, 7-segment display in terms of pitch ratio. To the right of the pitch control three interlocked pushbuttons select the control mode which may be either manual via the front panel control, from an external keyboard or, from the sum of the manual control and an external control voltage.

This leaves the horizontal row of pushbutton switches at the bottom of the panel. To the left is a 'line' pushbutton which simply connects the input to the output, bypassing all the electronics—I'm not always happy about this arrangement because of possible difficulties with changes in loading.

Next a set of six locking pushbuttons for

setting the delay time of the delay output. These insert 6.25ms, 12.5ms, 25ms, 50ms, 100ms and 200ms delay thus providing increments of 6.25ms up to a total of 393.75ms.

A 'function select' button follows which operates in conjunction with the next four buttons which are interlocked and each one has two functions depending upon the position of the function select button. When the function select button is depressed the unit is in the pitch change mode and the next four buttons select normal or external pitch change over the range one octave up to two octaves down, or micro pitch change, sharp or flat over about \pm 10% range. With the function select button out, the four further pushbuttons select the remaining functions: delay, random delay, flanging or reverse. The next button selects one of two algorithms in the pitch change mode with a further six buttons selecting the delay in the main output by the same means as the delay in the delay output. However, the 6.25ms, 12.5ms and 25ms buttons may only be used in the delay mode of the main channel.

The rear audio input and outputs are in the form of electronically balanced connections via XLR connectors. The mains power input is a standard IEC connector with a built-in voltage selector/power fuse, clearly identified. An 8-pin DIN connector provides for external keyboard control of pitch shift in discrete musical steps and the remaining connections are in barrier strip form.

A feature of the interface connections is that they allow a servo type tape recorder to have its speed controlled in a manner inverse to the pitch change. For instance: speech may be speeded up or slowed down while retaining the correct pitch. These servo outputs include the common servo frequencies of 19.2kHz, 9.6kHz and 60Hz (alternatively 50Hz). Additional connections include external control of pitch by a control voltage, bias output, reference frequency and a further single keyboard connection.

Space is provided for connection to a microprocessor via a standard IEEE buss. This interfaces all front panel controls except the input gain control and the feedback gain and equalisation controls.

All the electronics within are on good quality glass fibre printed circuit boards, interconnected by ribbon cables and connectors. Two large boards covering virtually the base area of the unit house a mass of integrated circuits with a further board supporting all the readily replaced front panel controls. As it's a prototype no servicing information is available and I hope the manufacturer will identify components in the production version. But even so for a prototype the component layout was very tidy and the standard of construction good.

Input and outputs

The electronically balanced input was found to have a common mode rejection ratio of

82 ►

SON SALES LTD present the new
SPR-1 UNIVERSAL SYNCHRONISER
 FOR ALL YOUR FILM SOUND TRANSFERS



- * Handles 50Hz AND 60Hz Neopilot sync. pulses
- * Resolves 10Hz, 25Hz and 30Hz Subaudio (SN) pulses
- * Drives and slaves ALL modern portable reel-to-reel recorders
- * Use with Nagra III/IV and our spool adaptors for ALL 6.25mm. AND 3.81mm (SN) sync. tapes.
- * Locks to line frequency, built-in crystal or ext. ref.
- * Unrivalled for versatility and economy

Send for fully descriptive colour brochure to:-

SON SALES LTD.

2 HIGH ST., PORT ST. MARY, ISLE OF MAN
 Telephone: 0624 - 83 4294

Telex: SON Sales, c/o 629313 COMCAB G
 New York Agent: John Messenger, Apt 2H, 300 W. 23rd St.,
 N.Y. 10011 Telephone: (212) 6919567

AVAILABLE SOON - SON - 3 Control Unit for
 Nagra SN recorders (3 mic inputs)

MODEL 126 CARTRIDGE MACHINE

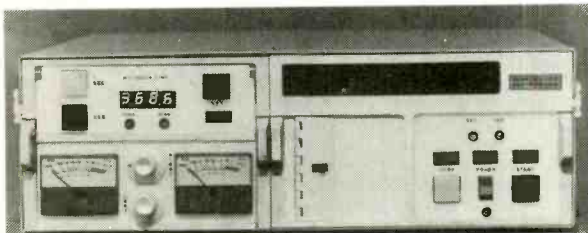

Stereo Record/Reproducer with Recorded Time Indication
 (other models available)

FEATURES

- ★ MEETS NAB, IEC CARTRIDGE SPECIFICATIONS
- ★ COMPATIBLE WITH COMMERCIAL RADIO USE
- ★ FLUTTER -15% WEIGHTED
- ★ NOISE AND HUM LESS THAN -47dB (STEREO)
 -50dB (MONO) RE 160 nWb/m
- ★ HIGH AND LOW EQUALISATION
- ★ HINGED FRONT PANEL AFFORDS ACCESS TO
 ALL MAINTENANCE CONTROLS
- ★ COMPATIBLE WITH NEW HIGH OUTPUT TAPE

LEE ENGINEERING LTD.

NAPIER HOUSE, BRIDGE STREET,
 WALTON-ON-THAMES,
 SURREY, ENGLAND KT12 1AP

TEL: WALTON-ON-THAMES 43124/5/6

TELEX: 928475

TRAD

**ELECTRONICS
 SALES LTD.**

FOR SALE

Neve 24-16-16 6 Echo Sends>Returns ...	£20,000
Neve 10-2 Portable in Flight Case ...	£4,000
Cadac 28-24 L Type A Great Desk ...	£28,000
Amek 2016 20-16 in Nice Condition ...	£6,500
Hill 32-24 As New ...	£8,000
Trident 'B' 24-16-16 ...	£11,500
Itam 10-4 Mk II ...	£550
Sound Techniques 28-24 Chelsea ...	£15,000
Studer A80 Mk II 16 Track ...	£12,500
3M M79 16 Track ...	£10,500
MCI 24 Track JH100 with Autolocate ...	£14,500
Ampex MMI000 16 Track ...	£6,500
Lyrec TR532 16 Track with Remote and Autolocate 6 Months old ...	£14,500
Amity Schroeder 16 Track with Remote ...	£4,900
6 Studer C37 Stereo with Transistors Elecs Each ...	£1,500
1 Studer C37 Stereo Valve Elecs ...	£750
2 Ampex AG440 Stereo ... Each	£1,200
Studer A62 Stereo ...	£1,100
Teac 3440S 4 Track ¼" Mint ...	£650
Otari 4 Track on Console ½" ...	£1,200
4 Scully 8 Track on 1" 280 Models ... From	£3,000
2 Scully 4 Track on 1" x ½" 280 Type ... From	£1,400
Bias 1000 ¼" Mono Full Track ...	£600
Eventide Harmonizers New ... From	£850
20 Dolby A361 ... Each	£295
20 Dolby A360 ... Each	£275
Dolby M24H 2 Months old ...	£7,000
Eventide Flanger ...	£300
Pandora Time Line ...	£450
Radford 25 Watt x 2 Valve Amps and Con- trol Unit ...	£200

All goods listed above in stock at time of going to press

Prices are exclusive of V.A.T.

**149B ST. ALBANS ROAD
 WATFORD, HERTS.**

Tel. WATFORD 47988

Telex 262741

54dB at frequencies below 1kHz with the input impedance high at 530kΩ across the balanced input, or 260kΩ with one leg of the input grounded. This input impedance was maintained at any input gain setting with +2dBm required to illuminate the top LED level indicator at maximum gain and the maximum input level that could be handled was +21dBm which is quite satisfactory.

The main output and the delay output were similar in performance and both electronically balanced, the maximum output was +20dBm loaded into 600Ω from a source impedance of 150Ω in each leg of the outputs.

When loaded into 600Ω the maximum gain of the unit was +13dB at 1kHz, there being a straight wired connection between the input and both outputs in the bypass mode.

The peak sensing level display has a satisfactory peak hold time and a fast attack time which is vital for digital devices. However at 1kHz the red overload LED illuminated at 1dB above input clipping with the top green LED illuminating at only 1dB below clipping, which leaves a rather small margin of error. The lower green LEDs illuminated at 5dB and 15dB below clipping respectively. However it was found that the level display was highly sensitive to frequency and in this respect it was not satisfactory; furthermore, it was quite possible to run into severe output overload with no overload indication.

Frequency response and noise

The overall frequency response (fig 1) shows the top trace at maximum level in the pitch shift mode with zero pitch shift in operation. The middle trace is the same as the top but with the level 10dB lower; it can be seen that the anti-aliasing filter becomes highly effective at 15kHz with a substantially flat response down to 20Hz.

The lower trace depicts the frequency response at the same level but with x2 pitch shift in operation. Remembering that as far as the output is concerned the frequency scale must be multiplied by two, the output frequency response is ±2dB from 40Hz to 10kHz which is not too bad for this type of effects unit.

Noise in the output was independent of the gain control setting but differed between the

main output and the delay output. Naturally the noise in the main output depended upon the function selected, so, the figures in Table 1 show the worst case condition when referred to the maximum output level of +20dBm.

TABLE 1 MEASUREMENT METHOD	DYNAMIC RANGE	
	DELAYED OUTPUT	MAIN OUTPUT
Band limited 22Hz to 22kHz rms	90.0dB	96.0dB
A-weighted rms	93.5dB	96.0dB
CCIR-weighted rms	86.0dB	83.0dB
CCIR-weighted quasi-peak	82.0dB	80.0dB

These figures represent a very good performance and no significant mains frequency components were present in the output with all spurious clock frequency components at least 100dB below full output.

Distortion

The second and third harmonic distortion was investigated in all modes and found to be worst in the delay mode; this condition at +20dBm output was shown to be satisfactory as depicted in fig 2. As may be expected the level of distortion, particularly at low frequencies, fell with falling output level.

When pitch shifting it was possible to have many non-harmonically related tones in the output and these depended upon the algorithm selected and the nature of the signal being handled in addition to the degree of pitch shift.

It is quite impossible to put a number to these spuri which are common to all pitch shifting systems, but it is fair to say that most programme material can be pitch shifted for effects without any unpleasant results if care is taken.

The degree of pitch shift available was found to be 0.218 downwards, as far as 2.072 upwards, with the latter producing unpleasant subjective effects when the 2.000 mark was exceeded. The accuracy of pitch shift indication was excellent with the indication within one digit of the display.

In the micro pitch shift mode the available

audio & design recording worldwide

- Australia**
Audio & Recording, Tel: 261 1383
- Austria**
Peter Mueller, Tel: 229 9 444 233
- Belgium**
ASC/SED, Brussels. Tel: 02 522 7064
- Brazil**
Serion Ltd, Sao Paulo. Tel: 34 8725
- Canada**
BCB Electronics Ltd., Ontario Tel: (065) 24478
- Caribbean**
Dynamic Sounds Recording, Jamaica Tel: 933 9138
- Denmark**
Audiophil, Copenhagen. Tel: (01) 341 622
- Eastern Europe**
Denis Tyler Ltd., UK. Tel: (089 54) 43681
- France**
3M France, Paris. Tel: (1) 031 6161
- West Germany**
Elmus GmbH, Berlin. Tel: (030) 312 2012
- Greece**
Audiolab Hellas, Tel: 822 5222
- Holland**
Pieter Bollen, Eindhoven. Tel: (040) 512 777
- Italy**
Roje Telcomunicazioni, Milan. Tel: 415 4141
- Japan**
Nissch-Iwai Co. Ltd., Tel: (03) 544 8311
- Korea**
Yushin Co. Ltd., Seoul. Tel: 69 3261
- New Zealand**
General Video Co. Ltd., Tel: 872 574
- Norway**
Siv. Ing. Benum & Co., Tel: (02) 56 57 53
- Spain**
Fading, Madrid. Tel: 446 8325
- South Africa**
Eltron (Pty) Ltd., Tel: 23 0018
- South East Asia**
O'Connor's (Pty) Ltd., Singapore 5
Tel: 637 944
- Sweden**
KMH IjudAb, Tel: (08) 690 120
- Switzerland**
Audiocom Tel: 031 955 742
- Tahiti**
Oceanic Garage, Papeete.
- United States of America**
Audio & Design Recording Inc.
Nigel Branwell
PO Box 902, Calif.93933 Tel: (408) 372 9036
- UK and All Other Territories

84 ►

FIG. 1
EVENTIDE H949
FREQUENCY RESPONSE

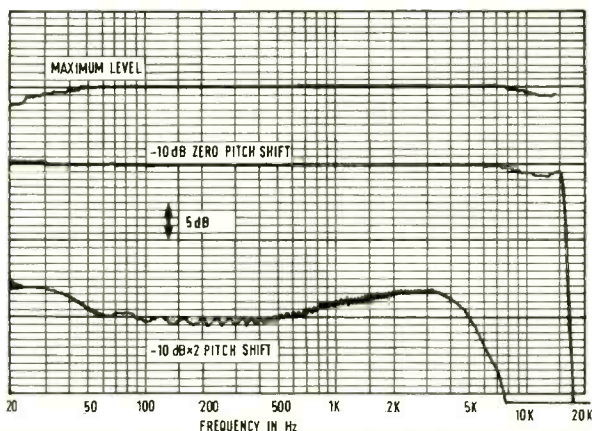

EFFECT A CHANGE

TWO NEW MODULES FROM ADR TO BRING A NEW CONCEPT OF EFFECT PROCESSING TO THE SCAMP RANGE

S23 PAN EFFECTS MODULE

- ★ Automatic Panning
- ★ Patterned Sweep Control
- ★ External or Manual Trigger
- ★ Trigger, Rate & Speed Controls
- ★ Stereo Unit
- ★ Stereo/ Vibrato effect from mono
- ★ Criss-Cross or Revolving action

S24 TIME SHAPE MODULE

- ★ Automatic Double Tracking
- ★ Flanging, pos or neg
- ★ Spin, pos or neg
- ★ Limited Spin
- ★ Hall effect
- ★ Hollowing
- ★ and many, many more.....



NOW OFFICIAL!



audio & design (recording) ltd.
84 OXFORD ROAD, READING RG1 7LJ, BERKS., ENGLAND
Telephone: Reading (0734) 53411 Telex: 847 605 a/b Tillex G



FIG. 2
EVENTIDE H949
2nd & 3rd
HARMONIC AT 20dBm
DELAY MODE

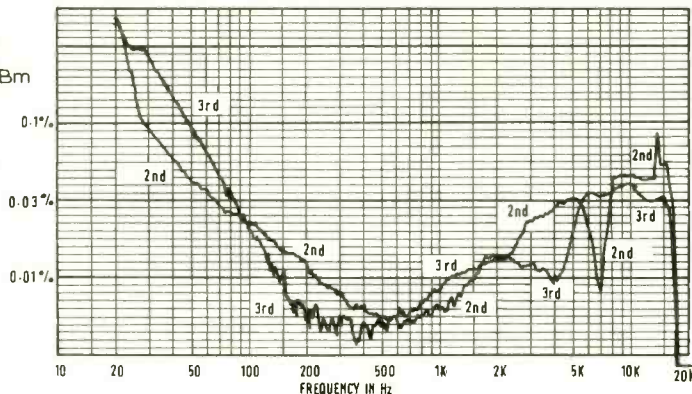
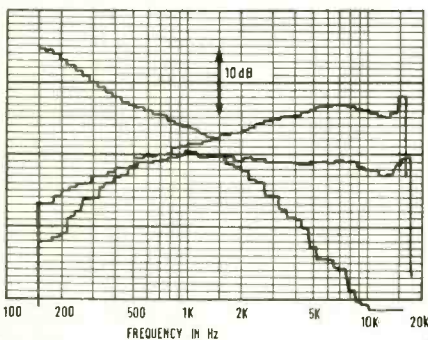

FIG. 3 EVENTIDE H949 FEEDBACK EQUALISER



range of shifting was 1.09 down to 0.910 with the indication accuracy again within the readability of the digital display.

Likewise checking the accuracy of the delay steps showed the calibration accuracy was within 0.5% allowing for the 70µs inherent delay.

Regarding the feedback equalisers their frequency response at the mid position of the controls and the extreme positions is shown in fig 3, showing that there is more than ample cut and boost, but, the mid point of the bass equaliser is not satisfactory.

Subjective impressions

In the pitch shifting mode this unit can produce some very unusual and interesting effects but some care is needed if large pitch shifts (particularly upwards) are to be achieved without unwanted side effects. The incorporation of two pitch shift algorithms is particularly useful for overcoming such difficulties which are inherent in pitch shift systems.

The reverse facility is probably most useful on percussive sounds and it appears that this function takes blocks of input signal and reverses them in time block by block.

Similarly the repeat function works on 400ms long blocks of sound, repeating them for as long as required. This can be very effective when repeating short sequences of rhythm. Flanging was most natural and effective, as it was possible to stop the flanging at any frequency offset by pressing the external

keyboard button; the flanging continues from this point when the button is released.

Summary

This prototype unit provides a new collection of effects at a most moderate cost and I feel it will be a very popular unit when it comes into production later this year.

Being a prototype there are of course a few shortcomings, but, I trust the manufacturer will put these to rights in the production version.

Hugh Ford

MANUFACTURER'S COMMENT

1) Your criticism of the in-out switch is valid in that it is possible to cause changes in the loading of succeeding circuitry, but we feel the diagnostic advantage of such a hard wired isolating switch to be more valuable.

2) The IEEE 488 interface is now finalised and it provides remote control of all front panel operating modes, and complete control of delay in one sample increments rather than 6.25ms increments. Remote control of pitch ratio, and the ability to read and transmit to the controller the settings of all the above modes and controls. It will not contain the ability to read or modify the feedback level or in/out control.

3) The level indicator actually responds to the bit pattern on the A/D converter rather than input signal, and the level between clipping and 'normal' is fairly small, but will be increased on the production version. We suspect the reason the converter clipped before the overload, was because of misalignment of the DC offset pot. Because the indicator responds to audio level after processing, and because frequency sensitive processing does take place, the frequency dependence referred to in the review is unavoidable. We will try to adjust the various gains to assure that output clipping cannot take place without a front panel indication.

4) The feedback boost and cut filters have been redesigned in the production units. We believe the errors in the mid position to be caused by pots with incorrect tapers having been used in the prototype.

Richard Factor, Eventide Clockworks

JBL PROFESSIONAL DEALERS
IN THE U.K.



FORMULA SOUND
LIMITED

FORMULA SOUND LIMITED
3 Waterloo Road
Stockport Cheshire
Telephone 061-480 3781



Kirkham Electronics

Mill Hall, Mill Lane,
Diss, Norfolk, IP21 4XL
Telephone (037 976) 639



PROFESSIONAL AUDIO SYSTEMS
35 Britannia Row
London N1 8QH
Telephone 01-359 0956



P. A. Hire & Sales
Unit F New Crescent Works
Nicol Road
London NW10 9AX
Telephone 01-961 3295



8, East Barnet Road
New Barnet
HERTS
Telephone 01-449 2344
Telex 25769



REW Audio Visual
126 Charing Cross Rd.
London WC2
Telephone 01-836 2372/7851

For further information contact
Harman (Audio) U.K. Ltd.

St. John's Road
Tylers Green
High Wycombe
Bucks HP10 8HR
Telephone
049481-5331



GET IT ALL

HEAR FROM US BEFORE YOU HEAR FROM THEM.

Today's broadcasting equipment and standards let you transmit things you never could before.

Like tape hiss, cue tone leakage and turntable rumble, to name a few.

And that's precisely why you need the JBL 4301 Broadcast Monitor.

It lets you hear everything you're transmitting. All the good stuff. And, all the bad. So you can detect the flaws before your listeners do.

The 4301 is super-compact, so it fits all EIA Standard racks. 19" h x 11½" d x 12¼" w.

And it's made by JBL. The recognized leader in professional sound equipment.

Just give us your name and address and we'll send you all the 4301's very impressive specs.

Along with the name of your nearest JBL Professional Products Dealer.

He'll tell you everything you need to hear.



JBL

GET IT ALL.

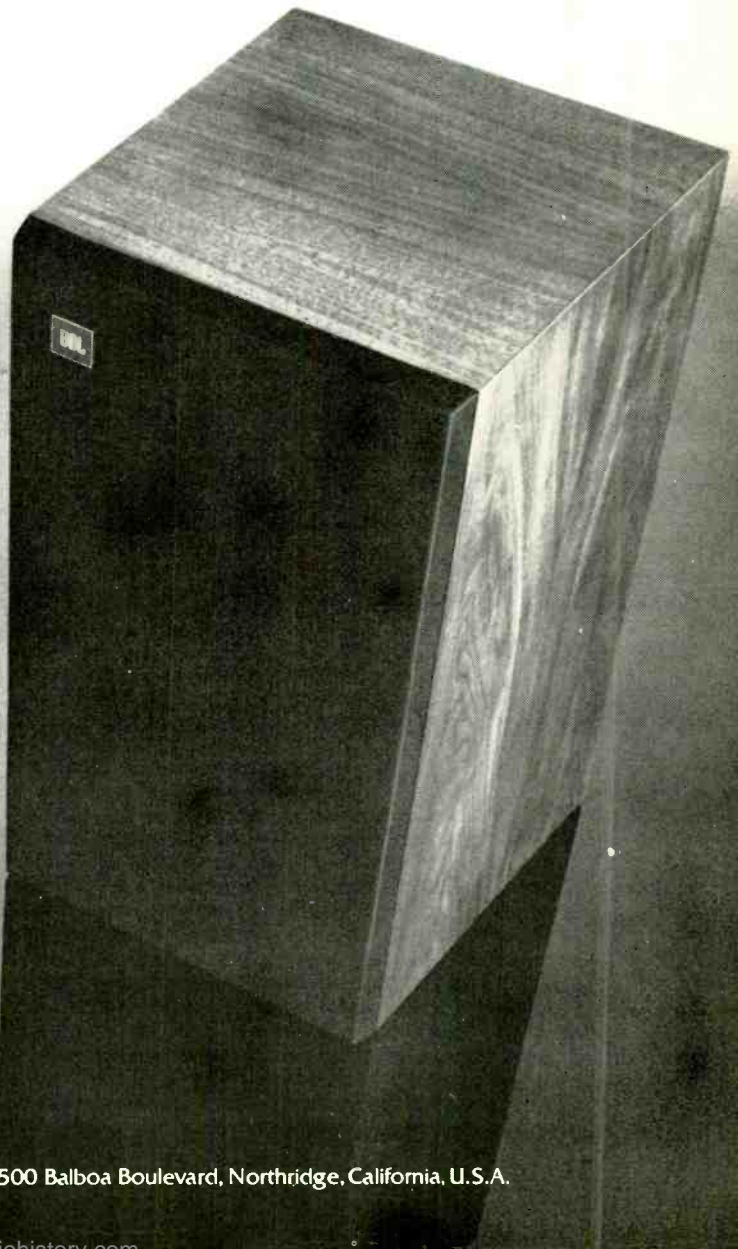

CASSETTE PROBLEMS?



IF you require high class work, produced by a company with a background of experience that very few can match, but at a price you can afford then we are the people for you. We offer you a complete pre-recorded and blank cassette service that includes:-

- C3-C96 specialised lengths.
- 32:1 Open reel loop bin duplication.
- Master dubbing service.
- Dolby A & B facilities.
- Demo cassette available on request.
- Sample cassette produced from your loop bin master at no extra charge.
- Agfa/BASF magnetic tape or technical equivalent.
- ICM/Hellerman cassettes or technical equivalent.
- Design, artwork and print service.
- Guaranteed fast turnaround.

For a quotation or technical advice contact us on 01 524 2131



LEE HOLME AUDIO SERVICES LTD

7 Mount View Road, Chingford, London E4 7EF

Tel: 01 524 2131
24 Hr. Ansaphone

AN ACCURATELY MATCHED 8-TRACK STUDIO PACKAGE AT A PRICE YOU CAN'T AFFORD TO MISS . . .

ALLEN & HEATH BRENELL MINI 8 STUDIO PACKAGE, COMPRISING:

- MOD III CONSOLE 16 X 8
- HEAVY DUTY POWER SUPPLY
- BRENELL MINI 8 1 INCH COMPATIBLE
STUDIO RECORDER
- DIGITAL TAPE COUNTER
- ELECTRONIC VARISPEED UNIT
- PRO-LIMITER
- OUR ADVICE & TECHNICAL BACKUP
ARE AT YOUR DISPOSAL
- FINANCE AVAILABLE

WRITE OR TELEPHONE FOR DETAILS TODAY



CATHEDRAL SOUND LTD.,
FOURWAYS, MORRIS LANE,
HALSALL, ORMSKIRK,
LANCS. L39 8SX
TEL. HALSALL (0704) 840328

The Balance is in your Favour

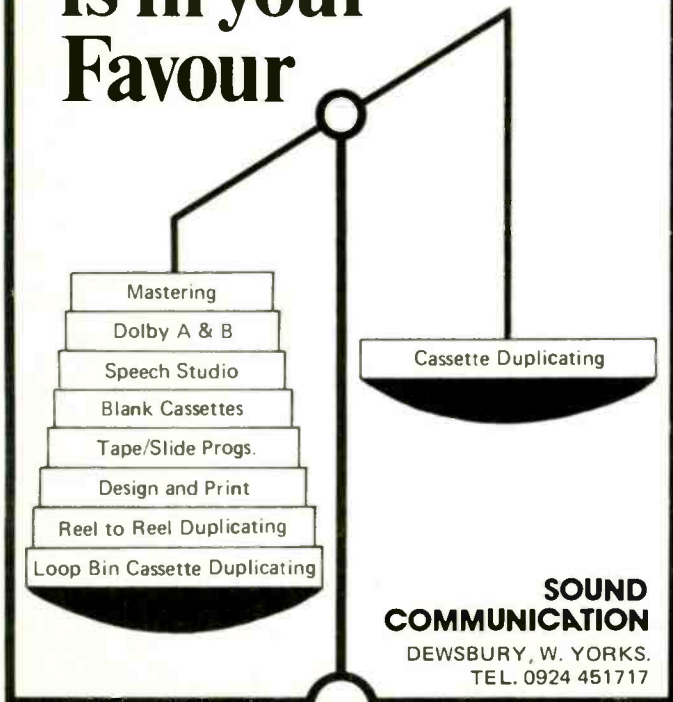

**SOUND
COMMUNICATION**
DEWSBURY, W. YORKS.
TEL. 0924 451717



Illustrated above are the two latest additions to the well-known range of WOELKE Wow and Flutter Meters, the ME 201 Flutter Classification Unit, and the ME 401 Automatic Distortion Meter. Fuller details on application.

LENNARD DEVELOPMENTS LIMITED

206 Chase Side, Enfield, EN2 0QX
Tel. (01) 363-8238/9

Classified Advertisements

Advertisements for this section must be pre-paid. The rate is **22p** per word, minimum **£4.40**. Box Nos. **60p** extra. Semi-display rates on application. Copy and remittance for advertisements in **OCTOBER 1979** issue must reach these offices by **11th AUGUST 1979** addressed to: The Advertisement Manager, **Studio Sound**, Link House, Dingwall Avenue, Croydon CR9 2TA.

Note: Advertisement copy must be clearly printed in block capitals or typewritten. Replies to Box Nos. should be addressed to the Advertisement Manager, Studio Sound, Link House, Dingwall Avenue, Croydon CR9 2TA, and the Box No. quoted on the outside of the envelope. The district after Box No. indicates its locality. **SEX DISCRIMINATION ACT 1975:** No job advertisement which indicates or can reasonably be understood as indicating an intention to discriminate on grounds of sex (e.g. by inviting applications only from males or only from females) may be accepted, unless (1) the job is for the purpose of a private household or (2) it is in a business employing less than six persons or (3) it is otherwise excepted from the requirements of the Sex Discrimination Act. A statement must be made at the time the advertisement is placed saying which of the exceptions in the Act is considered to apply.

The attention of advertisers is drawn to "The Business Advertisements (Disclosure) Order 1977", which requires that, from 1st January 1978, all advertisements by persons who seek to sell goods in the course of business must make that fact clear. From the above date, consumers therefore should know whether an advertisement relates to a sale by a trader or a private seller.

STUDIO FACILITIES

★**Disc Cutting Masters and Demos, Pressings, Cassettes, Mobile Recording Studio.** Free brochure. TAM Studio, 13a Hamilton Way, London N.3. Tel. 01-346 0033. K

★**Radio Production Studios for Commercials, Voice-Overs, A.V. Soundtracks, Audio Promotions. D.I.Y. or complete service.** Mark Stevens Productions Limited. 01-485 8087. L

★**Vinyl pressings from your tapes. Labels. S.A.E. for list.** Dero Records, P.O. Box 2, Morecambe, Lancs. X

IF YOU NEED . . .

Cassette Duplication	Empty Tape Spools
Blank Cassettes	White Tape Boxes
1/4" Tape	8T Cartridge Bodies
Leader Tape	Lubricated Tape
Splicing Tape	Head Cleaner Tape

Why not ring us on 01-399 2476/7 and let us quote you for your next requirements.

MEDIATAPE LIMITED, 29a Tolworth Park Road, Surbiton, Surrey.
01-399 2476/7

★**Fanfare Records.** Tape-disc pressings, demo's, masters, any quantity. Studio/mobile Neumann disc cutter. S.A.E. brochure. 1 Broomfield Close, Rydes Hill, Guildford. Tel. 0483 61684. X

SERVICES

★**Studio Design.** Complete acoustic design and measurement services for new studios and studio expansions. Monitor system equalisation service. Acoustic Technology Ltd., 58 The Avenue, Southampton SO1 2TA. Phone (0703) 37811. US Office: 320 Dresser Tower, 601 Jefferson, Houston, Texas 77002. Tel. 713/759-9768. X

SHORT-RUN CASSETTE DUPLICATING

Hi-Speed Mono One to One stereo 10-250 24hr service

Write or phone for rate card to:

SIMON STABLE PROMOTIONS

Inglebrook, West End, Launton, Oxon
Tel. 08692-2831 (Bicester)

CASSETTE COPYING IN THE MIDLANDS

Specialists in short run productions. Prices from 1p per minute, inc. cassette and library case. Label and Inlay card printing, plus services and supplies for film, disc and AV productions.

Write or phone for rate card to:

AUDICORD RECORDS

10 The Chapel, Shilton Road, Barwell, Leics
LE9 8HB. Tel. 0455-47298 (24 hr. answering service)

★**Pressings of classical quality (colour also) promptly manufactured from your Master tapes.** Sleeve printing, mailing service. Studio or mobile units for Master recording. Specify requirements to Mike Bull, Sound News Studios, 18 Blenheim Road, London W4 1ES. Tel. 01-995 1661. M

★**We are high speed cassette duplicators able to deliver quality product at short notice.** Our prices are very competitive and we can quote for any length and quantity. For further details contact Mike Newton at Fifth Avenue Recording Co on Harlow 39256. J

COUNTY RECORDING SERVICE

From your tapes we cut master discs, demo discs, using our Scully lathe fitted with the latest ME/76 UK stereo disc-cutting system.
Dolby 'A', Dolby 'B' and DBX Noise Reduction.
Telephone Bracknell (0344) 54935.
London Road, Binfield, Bracknell, Berks, England

TAPE COPYING SERVICES

We specialise in short run cassette duplication.
NO JOB TOO SMALL
Fast turnaround, reliable service
LOW COST
STEREO—MONO—PULSED
01-723 6301 (Baker Street)

CASSETTE COPYING

STEREO / MONO

From your master tape only first-class quality, any quantity supplied. Example 100 C90 cassettes 75p each, including library case.

R.F.W. RECORDINGS SUPPLIES
50 BEDFORD LANE, FELTHAM, MIDDLESEX
Tel. 01-890 6064

CASSETTE FAST-COPYING

Stereo or Mono. High Quality. Prompt Personal Service. Also bulk supplies of excellent virgin cassettes.

SOUND CASSETTE SERVICES Ltd.

P.O. BOX 2, GERRARDS CROSS, BUCKS.
Tel. 02813 84409

HIGH SPEED CASSETTE COPYING IN MONO OR STEREO AT COMPETITIVE PRICES

Long or short runs.
Blank cassettes supplied in bulk.
A growing reputation for reliability.

MORARD SOUND PRODUCTIONS

THORNTON HEATH, SURREY

Telephone 01-689 7424

RECORDING ENGINEERS/PRODUCERS

Challenging career opportunities teaching courses in record producing, engineering, and management sciences for college of recording arts and sciences. Professional studio and surroundings. Full and part time. Commencing September. Relevant industry experience essential. Preference given to candidates with academic credentials/training skills. Send résumé/portfolio to: Director, Trebas Institute of Recording Arts, Suite 3235, 1 Place Ville Marie, Montreal, Quebec, Canada H3B 3M7

SPR

SPEECH RECORDING
CASSETTE DUPLICATING
OPEN-REEL DUPLICATING
LANGUAGES/AUDIO-VISUAL

SPEECH-PLUS RECORDINGS LTD

32, PAGES WALK, SOUTHWARK, LONDON SE1 4SB.

01-231 0961/2



72-74 Eversholt Street, London NW1. Telephone 01-388 5392.

SERVICE DEPARTMENT

REVOX

G.36 A77 B77 A700	
General Service	£30.00 plus parts
Overhaul	£45.00 plus parts
Re-alignment	£15.00

A77 Modifications	
High Speed Conversion	£120.00
Varispeed (remote controlled)	£100.00
Self-Sync	£50.00
Flat Top Edit Conversion	£100.00
Flutter Damper Conversion A77 (mk 1)	£30.00
Automatic Double Tracking	£50.00
1/2 track conversion	£100.00
XLR Connector Panel	£50.00
Balance Transformers (per channel)	£20.00

TEAC

3300 3340 3340S 3440	
General Service	£30.00 plus parts
Overhaul	£45.00 plus parts
Re-alignment	£15.00

Teac/Tascam 80-B	
General Service	£50.00 plus parts
New Heads Fitted	£350.00 inc. labour
Cooling Fan	£25.00 inc. labour
Varispeed Kit VKS 80-B	£150.00 inc. labour

Teac-Tascam Mixers 2A 3 5	£30.00 plus parts
---------------------------	-------------------

TANNOY

Red Gold - HPD	
15" cone assembly	£27.00
12" cone assembly	£25.00
10" cone assembly	£25.00
Diaphragm (all models)	£23.00
Labour charge per unit	£15.00

*For safe delivery of Revox A77, B77, 700 and Teac 3340 3440 we can arrange the use of flight cases. Charged at cost.

*All prices excluding V.A.T.

*All work subject to our conditions of service.

Mail Order Protection Scheme (Limited Liability)

If you order from mail order advertisers in this magazine and pay by post in advance of delivery, this publication (*Studio Sound*) will consider you for compensation if the advertisers should become insolvent or bankrupt, provided:

- 1) You have not received the goods or had your money returned; and
- 2) You write to the publisher of this publication (*Studio Sound*) explaining the position not earlier than 28 days from the day you sent your order and not later than two months from that day.

Please do not wait until the last moment to inform us. When you write, we will tell you how to make your claim and what evidence of payment is required.

We guarantee to meet claims from readers made in accordance with the above procedure as soon as possible after the advertiser has been declared bankrupt or insolvent up to a limit of £1,500 per annum for any one advertiser so affected and up to £4,050 per annum in respect of all insolvent advertisers. Claims may be paid for higher amounts, or when the above procedure has not been complied with, at the discretion of this publication (*Studio Sound*) but we do not guarantee to do so in view of the need to set some limit to this commitment and to learn quickly of readers' difficulties.

This guarantee covers only advance payments sent in direct response to an advertisement in this magazine (not, for example, payments made in response to catalogues etc., received as a result of answering such advertisements). Classified advertisements are excluded.

NEW STUDIO

requires Calrec Series 2000 mics, Nagra 5 and Studer A62 machines, also Luton head fan. Contact:

R. Silver, Forth Bridge Recording Studio, Newton House, Newton, Scotland. Tel. 031-331 3298

FOR SALE—TRADE

★Add accurate level control to your mixer with the Cathedral LA3 comp/limiter module. Excellent performance at moderate cost. Build your own mixer with Cathedral low noise channel modules dispatched post free to any part of the world. Cathedral Sound Ltd., Fourways, Morris Lane, Halsall, Lancs L39. Tel. Halsall (0704) 840328. X

NEAL FERROGRAPH

NEAL		FERROGRAPH	
S 102	Rec. £268.50	7602H Deck	£516 S
S 103	Rec. £297.00	7604H Deck	£416 E
A 104	Rply £226.00	7622H Amps	£594 R
L 110	Rec. £316.00	7624H Amps	£594 V
E 102AV	Rec. £383.00	7602DH Dk/Dol	£612 I
S 103AV	Rec. £422.50	7604DH Dk/Dol	£612 C
140	Rec. £478.00	7622DH Am/DI	£690 E
302	Rec. £295.50	7624DH Am/DI	£690 E

VAT and Carriage extra, pro rata

PHOTO ACOUSTICS LIMITED

255a St. Albans Road, Watford. Tel. 32006
Newport Pagnell (0908) 610625

BROADCAST CARTRIDGES

Large selection available ex stock. Competitive prices. Standard lengths.



Custom winding. Lubricated tape. Also full range of tape cartridge storage systems.

JOHN A. STEVEN
Professional Recording Equipment
Brentwood (0277) 215485

★Soundcraft Studio console 24/16, 23 PPM's, P. & G. faders, sweep E.Q., 260 position patching (mint) \$19,500.00 U.S. Ampex MM-1100 16-track, 500 hours, like new, \$17,500.00 U.S. 3M M79 16-track, w/selectake, \$15,900.00 U.S. Ampex ATR-100 2-track, mint, \$6,800.00 U.S. Phone: 1-902-469-3243 (Canada). J

★Bose 802 speakers with equalisation £475 per pair or £432 without equalisation. Amcron DC 300 £498 and D150A at £310. All prices plus VAT. Contact Geoff Yates, C.A.V.S. Ltd., 01-363 6125. A

WOLLENSAK

CASSETTE FAST COPIERS

2770 mono & 2772 stereo, meticulously aligned.

REDUCED PRICES

SOUND CASSETTE SERVICES Ltd.

P.O. Box 2, Gerrards Cross, Bucks. SL9 7PH

Tel. 02813 84409

★Yorkshire. Erricks of Bradford. Tascam, JBL, Bose, AKG, Beyer, Calrec, Revox, Ferrograph Sales, Service, Exchanges, Leasing. 1st floor 8 Channel Studio Hire. Bradford (0274) 22972 (Roger). X

CODEC NO HASSLE NOISE REDUCTION SYSTEM

Gives 25dB of noise reduction with no side effects and no setting up procedure. Preproduction 4-track switchable code-decode unit from as little as £125 plus VAT. Will soon cost over £200. Buy direct now. Details of this professional quality system from:

DB ELECTRONICS

2 Ash Street, Buxton, Derbyshire
SK17 6LL
Phone 0298 3756

CADEY

16 track and 24 track tape
recorders for 2" tape.

16 track - £3,700. 24 track - £4,700

contact **Steve** at **Cadey Tape Recorders Ltd.**
59 Yantlet Drive, Strood, Kent.

Tel. 0634 - 76117

ITA EXPANSION

We need more high calibre engineers conversant with current recording equipment. Applicants must be able to assume responsibility in return for attractive salary and secure future.

Apply: **Chief Engineer**

**ITA 1-7 Harewood Avenue,
Marylebone Road, London NW1**

01-724 2497

SITUATIONS VACANT

CARDIFF BROADCASTING

CHIEF ENGINEER (Female or Male)

required to join the successful group now setting up the Welsh capital city's independent local radio station.

Applicants will have enthusiasm for local radio and relevant technical experience, as well as suitable qualifications. A commensurate salary will be paid initially in the range £7,000 to £8,000 p.a.

Please write in confidence giving full personal and career details to:

TONY GORARD, Chief Executive

Cardiff Broadcasting,
c/o Chapter Arts Centre, Market Road, Canton, Cardiff
(Mark the envelope 'personal')

LBC RADIO

MAINTENANCE SUPERVISOR

Due to expansion of the Company's activities, LBC Radio has a vacancy for an experienced maintenance supervisor, to work in our broadcasting studios just off Fleet Street.

Suitable applicants must be familiar with the maintenance and operation of broadcast and ancillary equipment, and have had experience in a broadcasting environment. They must also be able to work within, as well as supervise, the small maintenance team.

Shift working will be required from time to time although the hours will normally take the form of 9-5, Monday to Friday.

The position attracts an excellent salary with good conditions and five weeks annual holiday.

Applications to: **Roger Francis,
Head of Engineering,
LBC Radio,
Communications House,
Gough Square,
London E.C.4.**

Technical staff required for a major recording studios in central London. Experience desirable coupled with a good knowledge of Audio.

Please reply in writing to

Box No. 811

FILM DUBBING MIXER

16mm, NEW THEATRE

CENTRAL LONDON BOX 810

FOR SALE—PRIVATE

★**Studer J 37 1in 4-track** with large tape stock; 50m Belden 15x 2-core screened, with XLR stage box; dynamic and ribbon mics; four reels unused 1in NAB Racal 888; stands; jackfield; 150m armoured 2-core screened cable; no reasonable offers refused. Locks Heath 84146. H

SOUNDCRAFT II 16/8 MIXER

**BRAND NEW PENNY & GILES FADERS
PARAMETRIC EQ**

Immediate Delivery

£3960

Contact Mr. Finlay 229-3400

★**Studio for sale or rent, 8-track operational, £20,000 or £100 per week.** Long lease. Situated in tax haven. Apply P.O. Box 38, Douglas, Isle of Man. J

FOR SALE

**ONE AUDIO DEVELOPMENTS
MICRO MIXER**

JEAN VANDERMOULEN -

059 506708

Prinsenlaan 30 Oostendé, Belgium

★**Studer A80 16-track 30/15, line input modification, 5,333 hours, recently re-lapped heads, complete with spares and manual.** £11,500. Apply (060 885) (Brailles) 269, private and well cared for. J

★**1in 8-track 284 Scully, excellent condition, £3,500.** A & H 14 x 8 x 8 mixer, noise gate, stereo compressor, £1,250. Other equipment also available. Tel. 01-534 5472 (24 hours). K

★**Scully Vari-pitch disc-cutting lathe** with Neumann stereo amplifiers in console rack, accessories and spares. Any reasonable offer over £1,250 accepted. Tel. 041 639 2061. J

★**Otari DP-6700 3 machines, Otari DP-6755 2 machines, all for sale cheap as needless.** Condition good. Contact Stereokassetti OY, Box 40, 11101 Riihimaki 10, Finland. Tel. 14-30731. Telex 1505 RIIHI SF. J

★**Oberhein 2-Voice Synth £1000.** Yamaha SS30 string synth £490. Immaculate condition. Tel. 01-486 4488 ext. 325 (Sue Lenton). J

★**JBL L200's, excellent condition, £300 each.** Audio Design F769X-R Vocal Stressor, also excellent condition, £550 o.n.o. Quad 405 Power Amplifier, as new, £140 o.n.o. Box No. 812 c/o *Studio Sound*. J

★**Cadey 16 track, 18 months old, £3,500.** Tel. 0634-76117. J

Interested in a
SOUND CAREER?



Trebas Institute of Recording Arts
will put you

ON THE RIGHT TRACK.

Professional two-year training program in:

- RECORD PRODUCING
- SOUND ENGINEERING
- MANAGEMENT

FREE brochure. Fall courses. **APPLY NOW!**

TREBAS, Suite 3235, 1 Place Ville Marie,
Montreal, P.Q., Canada H3B 3M7 Tel. (514) 871-1067

WANTED

★Wanted. Revox and Teac Tape Recorders. Best prices paid. R.E.W. Professional Audio. 01-836 2372. X

SITUATIONS WANTED

★Young Sound Engineer, presently employed with Mobile, 8-track experienced, seeks post as Assistant/Trainee Engineer in a good studio. Willing to work hard. Mike Newbon, 01-363 9563 (after 6). J

★Film Dubbing Mixer, fully experienced, available on freelance basis. Will travel at home or abroad. Also available for recording equipment installation consultancy of film location recording service with equipment. Lionel Strutt. Tel. 01-953 9214. Telex 912881. K

ANNOUNCEMENTS

TRIDENT AUDIO

would like to point out that Kevin Godley and Lol Creme did not mix their latest album at Essex Studios as stated in last month's advertisement but were mixing a single for an independent record company. Kevin and Lol have been working at Surrey Sound and are in fact mixing their latest album at that studio.

Get binding!

Keep your copies of STUDIO SOUND in smart black binders (each holds 12 copies) with title in golden block letters on the spine. Price: £2.00 each which includes inland and overseas postage. Send your order with cheque or postal order to: Modern Book Binders Ltd. Chadwick Street, Blackburn, Lancs. (state clearly your name and address and the relevant magazine title).

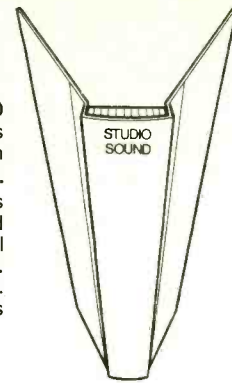

LINK HOUSE GROUP

ADVERTISERS PLEASE NOTE

13TH EDITION

In addition to its normal monthly publication, STUDIO SOUND is producing a **SPECIAL INTERNATIONAL EDITION**.

Published as a reference point to the Recording Industry, this prestigious edition will focus on the current state of the ART IN RECORDING, and will contain reports from all over the world.

Copy date for advertisements is the 14th August '79.

For further details, please contact Phil Guy on 01-686 2599.

INDEX TO DISPLAY ADVERTISERS

A	Acoustical Manufacturing	4	G	Graham, Steve, Audio Ltd.	26	O	Otari	41
	A.E.G.	19		Granet Communications	50	P	Plus 30	9
	AKG	10	H	Harrison	IBC		Publison	51
	Alice (Stancoil) Ltd.	71		Hayden Laboratories	33, 67	Q	Quad 8	79
	Aphex	52, 53		H.H. Electronics	49	R	Raindirk Ltd.	18, 75
	Atlantex Music	57	I				Rebis Audio	65
	Audio & Design (Recording) Ltd.	82, 83		ITA	11, 13, 15, 17, 57		Revox	47
	Audio Kinetics	7	J				R.E.W.	6, 7
B	Bauch, F. W. O.	21, 71		JBL	84, 85	S	Scenic Sounds	29, 31
	Beyer Dynamics	20	K				Shure Electronics	8
	B.G.W.	69		Klark-Teknik	IBC		Solid State Logic	43
	Brodr Jorgensen	55	L				Sound Communications	86
	B.T.S. Ltd.	22		Larking, Don	77		SQL Sales Ltd.	81
C	Canford Audio Ltd.	26		Lee Engineering	81		Studio Equipment Services	79
	Cathedral Sounds	86		Leeholme	86		Surrey Electronics	56
	CBS Studios	23		Lennard Developments	86		Synton	12
	Civil Service	48		Lexicon	16	T	3M	45
D			M				Trad Electronics	81
	Dominus	46		Magnetic Tapes	22		Trident	5
E				MCI	24		Turnkey	14
	Electro-Voice	77		Midamplification	IFC	W		
	Elektroimpex	27		Monks, Keith	25		White Instruments	26
F				Music Laboratories	20			
	Feldon Audio	73		Mustang Communications	7			
	Future Film Developments	18	N	MXR	37			
				Neal Ferrograph	63			

STUDIO SOUND is available without charge to qualified readers: these are directors, managers, executives and key personnel actively engaged in sound recording, broadcasting and cinematograph industries in any part of the world. The Publisher reserves the right to refuse applications considered inappropriate and restrict the number of free copies sent to any one company or organisation. Non-qualifying readers can buy STUDIO SOUND at an annual subscription of £9.50. All enquiries to: Subscription Department, Link House, Robert Rogers House, New Orchard, Poole, Dorset BH15 1LU. Tel. Poole (02013) 71171. Published by Link House Magazines (Croydon) Limited on behalf of the proprietors Link House Publications Limited, Robert Rogers House, New Orchard, Poole, Dorset BH15 1LU and printed by Arthurs Press Ltd., Woodchester, Stroud, Glos. GL5 5PB.

SOME COMPANIES GIVE YOU A PRICE THAT SOUNDS GOOD. HARRISON GIVES YOU A CONSOLE THAT SOUNDS GOOD!

And "good sound" is what our business is all about. That's why we build consoles with you, the engineer and studio owner, in mind. We use the highest quality components and circuit designs in our consoles. These give you maximum reliability and the cleanest and quietest possible sound. The almost unlimited flexibility of a Harrison console gives the recording and balance engineers the opportunity to be truly creative. Quality, reliability and flexibility. Others talk about these features... Harrison delivers them in every console. Harrison consoles, a sound investment.

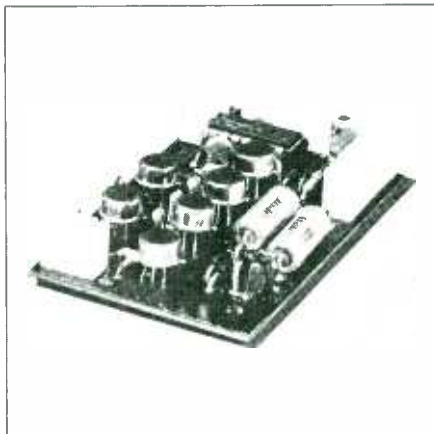
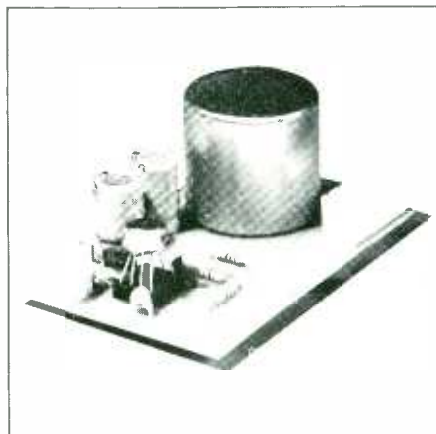
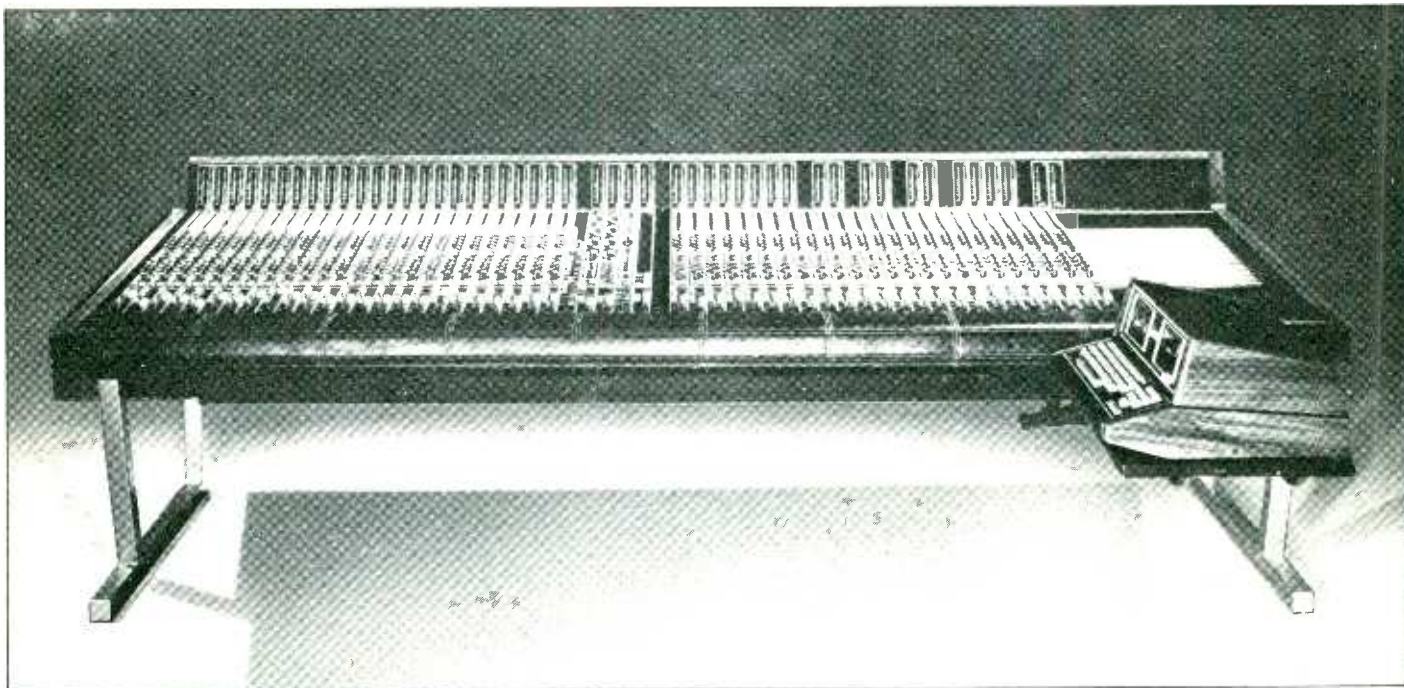

HARRISON Model 4832. 48 input channels. 32 output channels, with Harrison AUTOSET automation programmer.

Now, Harrison also gives you a choice. Console Models 4832, 4432, 4032 and 3232 are available with your choice of microphone preamplifiers: with or without input transformers.

For further information regarding the complete line of Harrison consoles and automation systems, please contact the Harrison professional audio dealer in your area:

AUSTRALIA: SONTRON INSTRUMENTS, MELBOURNE • **AUSTRIA:** STUDER-REVOX, WIEN • **BELGIUM:** SAIT ELECTRONICS, BRUXELLES • **BRAZIL:** LAREX ELECTRONICA, RIO DE JANEIRO • **CANADA:** J-MAR ELECTRONICS, TORONTO • **DENMARK:** QUALI-FI, KLAMPENBORG • **EASTERN EUROPE:** STUDER INTERNATIONAL, REGENSDORF, SWITZERLAND • **FAR EAST:** STUDER-REVOX, HONG KONG • **FINLAND:** INTO, HELSINKI • **FRANCE:** STUDER FRANCE, PARIS • **GERMANY:** EMT FRANZ, KIPPENHEIM • **GREECE:** ELECTRONICA, ATHENS • **ITALY:** AUDIO PRODUCTS INTERNATIONAL, MILANO • **JAPAN:** SHINDENSHI MANUFACTURING, TOKYO • **MEXICO:** ACCURATE SOUND, REDWOOD CITY, CALIFORNIA • **NETHERLANDS:** HEIJNEN, GENNEP • **NORWAY:** AUDIOTRON, OSLO • **SPAIN:** NEOTECNICA, MADRID • **SWEDEN:** ELFA RADIO & TELEVISION, SOLNA • **SWITZERLAND:** STUDER INTERNATIONAL, REGENSDORF • **UNITED KINGDOM:** SCENIC SOUNDS EQUIPMENT, LONDON

EXPORT AGENT:

Audio Systems International
128 North Highland Avenue
Los Angeles, California 90036
Tel: (213) 933-2210 • Telex: 686101

FACTORY:

Harrison International Corp.
Post Office Box 22964
Nashville, Tennessee 37202
Tel: (615) 834-1184 • Telex: 555133

You should know it's the best.

By now you should know that Klark-Teknik has the reputation for manufacturing the ultimate in signal processing products.

Each one represents the very best in its specific technology.

Our substantial research and development commitment ensures not only this but also maximum operational flexibility.

All our products undergo an exhaustive test procedure which involves visual checks, bench

alignment, burn-in period and, finally, performance verification using a music source.

Whoever you are, wherever you are, insist on the best.

Klark-Teknik.

As if you didn't know.



KLARK-TEKNIK

For more information and 'Independent Technical Reviews' of our complete range, contact: Klark-Teknik Research Limited, Kidderminster DY11 7RE, Worcs., England. Tel: (0562) 741515/64027 Telex: 339821



1. DN70 digital time processor

The latest technology in digital conversion puts this delay line in a class of its own.

2. DN71 A low cost, add-on sound effects generator to compliment the DN70.

3. DN34 analogue time processor

The most versatile delay-based sound effects unit on the market today.

4. DN27 and DN22 The most respected graphic equalizers throughout the world. Often copied, never equalled.

Worldwide Distributors: AUSTRALIA: Klarion Enterprises, S. Melbourne.
 BELGIUM: S.E.D. Spri, Bruxelles. CANADA: Hammond Industrial Imports, Malton, Ontario.
 DENMARK: Teamsound, Graested. FRANCE: R.E.D., Studio Centre, Paris.
 GERMANY: Hausmann Concert Electronic, Berlin. HOLLAND: Pieter Bollen, Eindhoven.
 ITALY: Laboacustica Srl., Roma. JAPAN: Hibino Electro Sound, Tokyo.
 NORWAY: Siv. Ing. Bensum, Oslo. NEW ZEALAND: General Video, Wellington.
 SINGAPORE: Ultraliniar International. SOUTH AFRICA: Colosseum Acoustics, Johannesburg.
 SPAIN: Mabel Sdad, Barcelona. SWITZERLAND: Dr. W.A. Gunter, Zurich.
 U.S.A.: Hammond Industries, Syosset, N.Y.