

# STUDIO SOUND

POSTPRODUCTION • RECORDING • BROADCAST

www.studio-sound.com



## PURPLE POWER

David Z on Prince and production



### REVIEWS

- Soundcraft RM1d
- Shure KSM44
- MBHO MBD 219
- HHb Circle 3P
- Marantz CDR631
- ACS-11 MicroMixer
- Prosoniq TimeFactory
- tc electronic Triple-C
- Tracer Diamond Cut Live
- Sonic Foundry Vegas Video



**Island Life: Recording strategies for the Maltese market**  
**Herbie Hancock: Classic tracks meet modern media**  
**Audio conversion: Hardware, theory and practise**  
**CD-R: The recordable CD explained**



# Libra Post world class performance for today's budgets

Whatever your business –  
drama, trailers, long-form,  
commercials or feature  
– Libra Post offers the  
performance you need at a  
budget that's right.

Stereo and surround mixes  
without running out of  
busses, control for multiple  
recorders and VTRs, facility-  
wide networking plus the  
option to add the world's  
fastest editor for less than  
you think – don't worry,  
we've thought of it all.

#### KEY BENEFITS INCLUDE:

- ◆ Neve sound quality
- ◆ Operator and Freelancer-  
friendly
- ◆ Menu-free mixing for better  
mixes faster
- ◆ Up to 192 channels in a  
compact footprint



Main image: AMC, UK



Les Auditoriums de Boulogne, France



Giesing Team, Germany



dB Post, UK

## Digital First – Digital Best



HEAD OFFICE – AMS Neve plc · Billington Road · Burnley · Lancs BB11 5UB · England · Tel: +44 (0) 1282 457011

Fax: +44 (0) 1282 417282 · LONDON – Tel: +44 (0)20 7916 2828 · Fax: +44 (0)20 7916 2827

GERMANY – Tel: +49 61 31 9 42 5220 · Fax: +49 61 31 9 42 5210 · NEW YORK – Tel: +1 (212) 965 1400 · Fax: +1 (212) 965 3739

HOLLYWOOD – Tel: +1 (818) 753 8789 · Fax: +1 (818) 623 4839 · TORONTO – Tel: +1 (416) 365 3363 · Fax: +1 (416) 365 1044

e-mail: [enquiry@ams-neve.com](mailto:enquiry@ams-neve.com) – <http://www.ams-neve.com>



## ANALYSIS

- 4 Editorial**  
On trade show associations and alternative surroundings
- 6 Soundings**  
Breaking news on professional audio, post and broadcast
- 58 2000 Roundup**  
The pro-audio year in context—from a variety of viewpoints
- 63 Drink & Drive**  
Audio industry rallies to charity quest for French wine
- 74 Letters**  
Your stance on mixing technologies and metaphors
- 74 World Events**  
Updating the professional's personal events calendar
- 78 The Wish List**  
Chris Kimsey kits out a professional tracking studio

## FEATURES

### RECORDING

- 14 The Farmhouse**  
Mixing island high life with high-tech farm life makes Malta magnificent
- 42 David Z**  
Talking of musical revolution with Prince's right-hand man
- 46 Herbie Hancock**  
Learning to work in surround is no longer optional, only getting it right is

### TECHNOLOGY

- 48 Audio Conversion**  
The background to chip manufacture and usage for pro-conversion
- 52 Audio Conversion**  
Interpolating between sampling theory and engineering practise
- 66 Dr John**  
The purpose and the mechanisms behind video scanning systems

- 68 Masterclass**  
All you ever needed to know about CD-R but were too busy to ask

## REVIEWS

- 18 Soundcraft RM1d**  
Soundcraft's first digital desk is a self-op radio console
- 22 Sonic Foundry Vegas Video**  
Blurring the line between audio and video editing software
- 24 Marantz CDR631**  
Exclusive look at the next-generation of CD recorders
- 26 HHb Circle 3P**  
The definitive loudspeaker review
- 28 ACS-11 MicroMixer**  
A 3-channel stereo location mixer steeped in audio individuality
- 32 Prosoniq TimeFactory**  
The neural network approach to audio time and pitch scaling
- 34 Shure KSM44**  
A large-diaphragm condenser mic is American masters' new flagship
- 36 tc electronic Triple-C**  
A new affordable 3-band compressor continues the Danish tradition
- 38 MBHO MBD 219**  
Three new studio-friendly high-quality dynamic mics from Germany
- 40 Tracer Diamond Cut Live**  
A new state-of-the-art audio restoration package for the PC

## COLUMNISTS

- 64 Technology**  
Barry Fox watches the watermark testing programme roll over its critics
- 64 Business**  
Dan Daley meets the rich kids with the biggest cars and a recording studio
- 64 Delivery**  
Kevin Hilton joins digital delivery systems' challenge to content providers

14



46



36



34

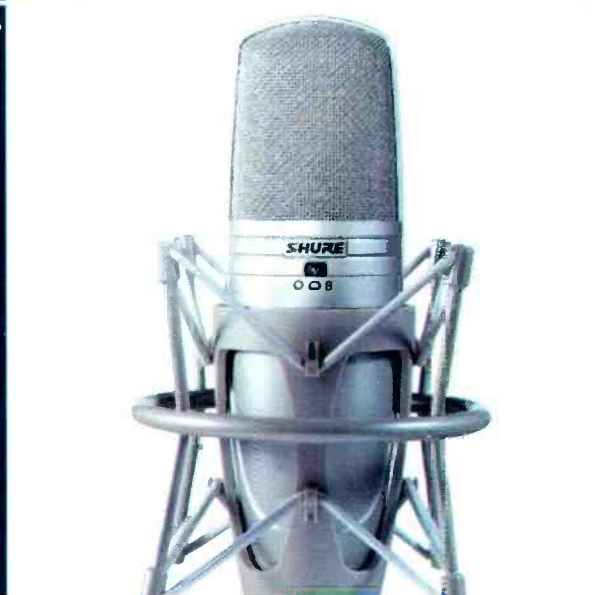

22

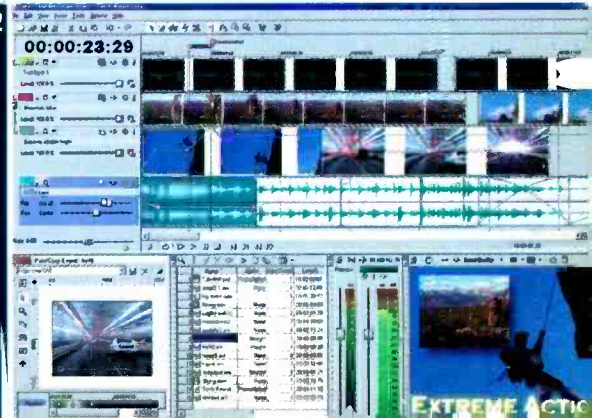

# Customer satisfaction

A concasternation of circumstances has guaranteed that next year's autumn exhibition schedule will be a hairy one. The proximity of PLASA in the UK, AES in New York, and the IBC in Amsterdam will cause a number of manufacturers some substantial and, it has to be said, costly problems.

While it is understandable that a live sound show in Europe, an international broadcast show in Europe and a US pro audio event could care less about each other's business, the realities say that in honesty they must. The truth is that the near overlap is uncomfortable for many with regard to the AES and IBC, there are an unfortunate few for which all three shows demand investment and attendance.

And all this against a backdrop of an industry that more than a decade ago spawned the Pro Audio Exhibitor's Group as a pressure group of manufacturers reacting to the number and density of exhibitions on the international circuit. Action centred around a strategic boycott and the threat of more to come. Results were never that apparent but exhibition organisers seemed to listen.

That decade has seen enormous changes in the nature of exhibitions, 10 years ago the UK had a largely healthy APRS and associated show. Recent developments and non developments of co-operation between the APRS and PLASA have served to underline the fact that a trade association with a strong exhibition is a strong association, a matter that must ring with irony in the APRS which declined advances for co-operation from the fledgling PLASA many years ago. APRS originated subjects like the MPC (Music Producers Guild) and APPS (Association of Post Production Services) are proactive and vibrant and reflect the more traditional interests of trade association activity but lack the big trade show hook to



hang their coats on—something that most successful exhibitions achieve through affiliation.

The incredible upshot is that the UK has no dedicated pro audio production orientated exhibition despite the importance of the market as an originator of the equipment that the world uses. Most worryingly this has been the case for a number of years now and there are no indications that this is likely to change. UK professional end users are obliged to travel abroad to keep abreast of technology. Those that cannot have missed out on generations of technology while their counterparts in France and Germany, for example, have had progress mapped out on their doorsteps.

There are lessons to be learnt. Exhibition organisers must talk to each other and consider the wider picture to avoid conflict, alienation and to spare the discomfort of supporting manufacturers. Never neglect the changing information needs of the humble attendee. He is the customer.

**Zenon Schoepe, executive editor**

## Never mind the quality...

THE LATEST CHAPTER in Philips' and Sony's collective drive to establish Super Audio CD as a legitimate and viable audio format saw a further gathering of journalists at London's Abbey Road studios recently. There, against the historic backdrop of Studio 2, we were treated to an update on professional developments from Philips' Paul Reynolds and introduced to 'Strinc' by Sony's David Walstra, the companies' Super Audio evangelists. We were also reminded of the roster of supporting recording companies and their SACD catalogues, and treated to playbacks of a variety of recordings from different genres from a range of available and forthcoming consumer players.

Along with the music, we were offered insights into the way that several of the artists viewed the surround aspects of the format. Simon Heyworth's re-presentation of Mike Oldfield's *Tubular Bells*, for example, was reckoned to be true to the original intent of the quad recording. Finally. And predictably. Less predictable were the inclusion of dance music in the demo library and comments attributed to one of its authors—DJ Jean, responsible for one of the moment's more ubiquitous hits. Claiming that most of his work is '80% in mono' may initially have seemed at odds with a multi-channel delivery format, but a little thought puts it all in perspective...

Accustomed to the classical and jazz fare that accompanies almost any hi-fidelity rollout, the Abbey Road audience seemed reluctant to take Reynolds up on his offer of some less polite rock and dance music. There seemed to be something vaguely disgraceful about putting 'that' kind of noise through

'this' kind of system. And indeed, there was a palpable unease as overdriven guitars and big beats issued from five B&W monitors. But it proved a couple of points.

Not for the first time, these apparently antagonistic musical forms found themselves with much in common; dance following where metal has lead. Where rock guitars once challenged microphones and recorders to capture their anger, rock production has become a fine art in the hands of Bruce Fairbairn and Trevor Horn. And where dance has revelled in the limited bandwidth and surface noise of worn vinyl, it is preparing to make the same transition. Where it differs greatly, however, is how those additional channels come into play.

If stereo is a bit of a miss on a dancefloor, five or more channels offer a solution. Discarding the concept of a soundstage that represents a musical performance, multi-channel working meets the dancefloor's lack of orientation and raises the stakes by offering a further level of management for the elements and effects that sit above those creating the groove. With '80%' of the mix in mono, the remaining 20 is free to roam the floor with the kind of freedom previously only available in proprietary club sound systems.

The idea of structuring a mix in this way is not new but where it has previously been limited by the lack of a standard (Ambisonics once put its hand up but had it slapped down), SACD offers to make it a workable option. And unlike many other aspects of dance, this one will work in your lounge.

**Tim Goodyer, editor**



**United Business Media,**  
**8 Montague Close, London Bridge,**  
**London SE1 9UR, UK.**  
**Fax: +44 (0)20 7407 7102**  
**Net: www.prostudio.studio-sound.com**

Emails: (initialsurname@unitedbusinessmedia.com)

Direct lines: +44 (0)20 7940 (extension).

### EDITORIAL

**Executive Editor: Zenon Schoepe. X: 8513**

**Editor: Tim Goodyer. X: 8578**

**Production Editor: Dawn Boulwood. X: 8523**

**Secretary: Eileen Sullivan. X: 8524**

### Consultant Editors:

**Broadcast: Florian Camerer, ORF, Vienna.**

**Chris Wolters, VTM, Brussels.**

**Postproduction: Paulo Biondi,**

**International Recording, Rome.**

**Lloyd Billing, The Tape Gallery, London.**

**Recording: Arthur Baker, producer-remixer.**

**Trevor Fletcher, Criteria Studios, Miami.**

**Consultants: Francis Rumsey; John Watkinson**

**Columnists: Dan Daley; Barry Fox; Kevin Hilton**

**Bench-testers: Keith Holland; Paul Miller**

**Regular Contributors: Jim Betteridge;**

**Richard Buskin; Simon Croft;**

**Ben Duncan; Dave Foister; Tim Frost;**

**Neil Hillman; Rob James; Caroline Moss; Philip**

**Newell; Terry Nelson; Martin Polon;**

**George Shilling; Simon Trask**

**News Editor: Phil Ward**

### ADVERTISEMENT SALES

**Group Ad Manager: Richard Lawn. X: 8531**

**Ad Manager: Sue Gould. X: 8517**

**Classified Sales: Peter Lawn. X: 8518**

**Ad Production: Mark Saunders. X: 8606**

**Circulation Manager: Louise Mulholland. X: 8653**

**PA to the Publisher: Lianne Davey. X: 8598**

**Associate Publisher: Joe Hosken. X: 8602**

**Publisher: Steve Haysom. X: 8521**

**Executive Director: Doug Shuard**



# The MT Digital Multitrack Console. Relax. It's an SSL.



"The MT transcends the analogue and digital worlds by providing a very warm sound - similar to the 9K - while having the superior attack and transient response, quietness and dynamic range of the digital world."

*Dana Jon Chappelle,  
Engineer / Mixer.*



"The MT's sonic warmth and purity, rock solid automation, and speed of operation sets a new standard in recording -- giving us the best of both the analogue and digital worlds."

*Martin Böhm,  
Owner / Chief Engineer,  
MG Sound, Vienna.*



"In live shows like TFI Friday and Party in the Park, featuring a number of bands in quick succession, the instant reset on the MT is a tremendous advantage. The familiarity of the SSL control surface makes for a much gentler learning curve, and, of course, the sonic quality is a given."

*Will Shapland,  
Senior Recording Engineer,  
Manor Mobiles.*

"...with the MT, at last there's a digital console for someone like me who truly loves music."

*Bruce Swedien,  
Engineer / Producer.*



"Nobody had to show me how it worked."

*Lou Gonzalez, Owner,  
Quad Recording Studio.*

"I can honestly say that I find the MT to be more transparent than an analogue console."

*Thierry Rogen, Owner,  
Mega Studios, Paris.*

"...the console's great. Not only does it provide outstanding automation but it sounds amazing - with a level of warmth not normally associated with digital."

*Patrick Mühren,  
Engineer / Mixer.*



"I loved the clarity of the overall sound and the separation of the stereo image. SSL know everything about ergonomics and for me, the MT is not the best digital console in the world, it's the BEST console in the world."

*Yves Jaget, Engineer,  
Le Voyageur Studios.*



**Axiom-MT.**

The digital console that works the way you work.



## Axiom-MT Studios include:

Quad Recording, NY · Romanian Radio · Aigle Music, Ireland · Mega Paris · Telemetropole (2 consoles), Canada · Manor Mobiles · Sully Sound · Le Voyageur Mobile · The Hot Line, France · MG Sound · Skip Saylor · Avatar · Imagica Shinagawa, Japan · Sound Stage, Nashville · Kampo, NY · Studio Tonmeister, Germany · Weryton Music, Germany · Arnold Mühren, Holland · 6 x Private Studios, USA · Hit Factory, NY · Sheffield Mobile · Ubi Soft, Canada · Space Music, France · Blue Sound, France · Euromedia, France · National Theatre, Japan · Media City, Cairo · SWR, Germany



# Solid State Logic

## International Headquarters

Begbroke, Oxford, OX5 1RU, England

Tel: +44 (0)1865 842300

Fax: +44 (0)1865 842118

E-mail: [sales@solid-state-logic.com](mailto:sales@solid-state-logic.com)

<http://www.solid-state-logic.com>



New York  
+1 (0)212 315 1111

Los Angeles  
+1 (0)323 463 4444

Tokyo  
+81 (0)3 5474 1144

Paris  
+33 (0)1 3460 4666

Milan  
+39 (0)9 2328 094

Toronto  
+1 (0)905 655 7792

Singapore  
+65 (0)438 2272



## CONTRACTS

**Chicago's** The Chicago Recording Company has ordered four Euphonix System 5 consoles. CRC operates 12 studios including eight audio post suites, three music recording studios and a DVD authoring suite and specialises in sound design and mixing for television commercials and music recording. The new consoles will replace four of the post suite consoles and range in size from 16-faders, 64-channel to 32-fader, 100-channel configurations. Projects currently underway include those for McDonalds, Nintendo, Coors, Reebok and Kelloggs. Chicago Recording Company, US. Tel: +1 312 822 9333. Euphonix, US. Tel: +1 650 855 0400.

**Mumbai-based** Sunny Super Sound has increased the storage capacity of the SSL OmniMix production system installed in its Dolby surround mixing room and added 16 channels of audio processing to its two SL4000 consoles. Empire Audio, also of Mumbai, has added eight channels to its SL4000 console in its surround film mixing theatre. A second SL4000 console has also been installed at Empire Audio for music recording. Sunny Super Sound, India. Tel: +354 22 620 1267. SSL, UK. Tel: +44 1865 842300.

**Austrian** recording studio, Thomas Rabitsch Music Production has replaced its five-year-old analogue



console with a new AMS Neve Capricorn digital desk. The studio, which was originally designed by owner and ex-Falco band leader Rabitsch, was modified by Austrian AMS Neve rep Peter Willensdorfer to accommodate the console and has already hosted a film score for Buena Vista Vienna and a remix of Austrian band Heinz. AMS Neve, UK. Tel: +44 1285 457011.

## Rising streams

**Europe:** The second Streaming Media Europe conference and exhibition took place recently in the cavernous and rather unattractive surroundings of London's Earls Court. The first European event was held last year in Amsterdam at the RAI Centre, and the scale and character of the two events could hardly have been more different. The exhibition had grown in size by more than 400%, from a little under 30 exhibitors last year to more than 130, and the number of visitors over the three days had also increased substantially.

The exhibition pulled together a wide variety of companies, encompassing categories such as content management, business-to-business, hosting-networks and live events (the top four in terms of number of companies listed), authoring tools, codecs, corporate communications, encoding services, production services, and servers. In fact, the provisioning infrastructure for streaming media has grown significantly since last year. And with Europe being awash with pan-European backbone IP networks, there's no shortage of companies offering to host streaming

media delivery services. Intel, meanwhile, is setting up its own global network and streaming media service, and during the show announced the opening of its European broadcast operations centre in the UK.

The conference once again ran as three parallel tracks, devoted to business, content and technology, with keynote addresses starting off each day. The success of *Big Brother* this past year has been a significant development for streaming media, and there was an emerging consensus during the conference that the future for entertainment lay in a synergy of traditional passive media and interactive new media incorporating streaming media. Meanwhile, an emerging theme was that of mobile delivery of streaming media. Europe's perceived lead in next-generation mobile delivery makes it attractive to companies operating in the streaming media industry. There was also a nascent debate over the relative merits of 'walled garden' versus Internet-based (what could be called 'open field') content delivery.

While much has changed since last year's event, bemoaning the state of 'last mile' delivery was once again a recurring theme, and content providers were still asking how they could make money out of streaming media. But overall there was a sense that streaming media is steadily moving towards realising its potential.

## New recordable disc format

**Japan-US:** As a result of a liaison, Nagano-based TDK and California-based Calimetrics have announced a new recordable-rewritable optical disc technology based on Calimetrics' MultiLevel Recording (ML). The new format will accommodate three times the capacity and operate at three times the speed of conventional CD-R/RW, carrying more than 2Gb of data at 36x on specially formatted ML blank discs as well as 700Mb on standard CD-R/RW discs as 12x operation.

With competitively-priced drives expected next year, new write-once discs will offer highest available transfer rates at lowest cost of any currently-available random access removable storage format. It is not, however, being viewed by its developers as a replacement for recordable DVD, but as a bridge 'to the era of inexpensive recordable DVD'.

'Our two companies have been working together for more than a year on the project,' commented Calimetrics president and CEO Kenneth Campbell. 'TDK's expertise in optical recording technology and their willingness to support the technology with a substantial equity investment

## Chinese whisper

CHINA'S FIRST EVER large-scale commercial recording facility has opened in Beijing. Oasis Studios features many of the world's leading pro audio brands and is associated with YYYY Productions Ltd, a music management, concert promotion and video production enterprise. The facility is a first in many ways. It has the first SL9080j console in a commercial facility within China; the first Sony 3348HR DASH machine; the first Lexicon 960L unit; the first to electronic System 6000; and the first pair of Genelec 1036As in China.

It was designed by Sam Toyoshima, and claims the largest control room in Asia. The 15,000ft<sup>2</sup> complex includes two control rooms: The Ocean Room, which is where the SSL is installed; and The Jungle Room, which is based around Pro Tools with ProControl interface. *Studio Sound* spoke with Dindae Sheena, vice-president and chief operating officer of both Oasis Studios and YYYY Productions.

**Q:** As a commercial facility, who has funded the project?

It was totally privately funded. I am not at liberty to say by whom, but in terms of audio production, this is the most exciting thing ever to happen here. It puts China on the map with a lot of the other world class facilities that were only available in the States or the UK up until now.

**Q:** What is the relationship between Oasis and YYYY Productions, and what kind of work does YYYY do?

YYYY Productions is the parent company of Oasis Studios. It does artist management, international and domestic concert planning and promotions, it has a video production division and of course the studios. We are currently managing three artists, one of which is already signed with Sony.

As for the concert promotions, we were commissioned by MGM Grand this year to do the Chinese New Year Millennium Concert in Vegas. Our video production team is

currently doing a 52-episode entertainment weekly magazine for Beijing Cable TV (BCTV). And Oasis is already booked out by producers from Taiwan, Singapore and Malaysia. There is also a lot of interest from government agencies to work with us on various projects.

**Q:** Which distribution company managed the delivery and installation of the equipment? Has there been any direct support from any of the manufacturers?

The systems integration was handled by Singapore-based Team 108 Technical Services. Because of the huge exposure for our facility, a lot of the manufacturers also got personally involved, especially Genelec and SSL. They have given us tremendous support.

We are proud to say that we have the first pair of Genelec 1036As in China. Sam Toyoshima personally saw through the whole construction. It is indeed an honour to have a studio designed and built by a man that is truly a legend.

**Q:** Is there one live area serving both control rooms? Or is one control room for recording while the other is for editing and postproduction?

The way this facility is designed, we can have both rooms working as one or as two separate studios altogether. What this means is that we could have clients tracking in the SSL (Ocean) room and we could have a mix session going on simultaneously in the Pro Tools (Jungle) room. This could also go vice-versa, tracking in Pro Tools and mixing in SSL.

Both rooms have full access to all booths. There are six booths in total, each with a totally different acoustic characteristic.

**Q:** What are the dimensions of the live areas?

The largest studio can house an 80-piece orchestra and has a great view of the lake outside through its full-height windows. It's approximately 3,500ft<sup>2</sup>. Ceiling height is 5m. The SSL control room, by the way, is the largest in Asia.

Oasis Studios, Email: dindae@yyyy.com.





**Russia:** The Cathedral of Christ the Savior, the largest Orthodox church in the world, has been re-built. Now housing an ATI Paragon II console the Moscow Cathedral was built to commemorate the Russian victory over Napoleon but was demolished by the Soviets in 1931 who built an outdoor swimming pool on the site. Reconstruction began in 1995 with Moscow-based sound installer Slawa Serdyukov of Pro Sound Lab handling the installation. In St Petersburg, the Mariinsky Theatre is the site of the latest Amek Media 51 installation. The 28-input desk has been part funded by the World Bank to facilitate multichannel recording and broadcast of the theatre's opera performances with an eye to surround release.

in Calimetrics have significantly accelerated the development of the ML format'.

It is further claimed that hardware manufacturers will be able to add 'ML capability' to existing lines of CD-R/RW drives without altering existing optics, mechanics or manufacturing infrastructure. ML also retains backward compatibility with conventional CD-R/RW recording, enabling users to retain the universal compatibility aspects of CD when required. It is expected that the near future will see a significant demand for the new technology before it migrates to the DVD platform where it should offer similar gains in recording capacity and write speed.

## SBES, oh yes

**UK:** It could be seen as fatuous and maybe unnecessary, to state that radio broadcasting has changed dramatically during the 25 years of the Sound Broadcasting Equipment Show (SBES). But that would only be if the industry had altered greatly every year this once quaint, almost marginalised exhibition took place. Widespread stereo and FM notwithstanding,

it has only been in the last 10 years that massive changes have been seen. With the implementation of DAB over the past five years, it was realised that the medium could undergo fundamental change that, in one scenario, could turn it into 'cheap television'. So while SBES reflected the on-going development and adoption of new digital technology, there are still links back to the traditions of steam wireless. What is emerging is a mixture of the modern and the vaguely familiar.

Internet connection is increasingly familiar but it is still new, a novelty even, in a radio context. Fairlight On Air has incorporated automatic Internet publishing into its core CoStar automation system and is promoting management of multimedia content (audio, text, video and images). The intention is to give audio-on-demand with format conversion and full XML interfacing. CoStar's Internet capability relies on drag and drop methodology and was designed to be used by non-technical 'authors', including journalists and DJs.

The company still mainly known as 'the Selector people', RCS, has similarly introduced web-based products. RadioShow is

## VCS acquires Studer from Harman

**Germany:** German broadcast systems company VCS is to acquire Studer from the Harman group of companies by the end of the year. The development will see VCS and Studer combine under the Studersystems brand headquartered in Bochum, Germany to offer a wide range of products and services for the infrastructure of radio and TV broadcasters. It is describing itself as the first international full-service provider for professional studio technology and computer-aided broadcasting.

Studersystems will employ 380 under chairman Klaus Meng from VCS with Studer's Bruno Hochstrasse as sales and marketing director. 'Studersystems AG is the result of a merger between two highly innovative, complementary companies,' said Meng.

VCS was founded 20 years ago and provides systems for digital broadcast technology in radio and TV, meteorological satellite reception and IT solutions.

a new suite of software aimed at both traditional broadcasters preparing Internet sites and dedicated webcasters.

## TownHouse Vision

**UK:** West London's TownHouse Studios is to open its first film and television audio post-production studio at the end of the year. The facility, to be called TownHouse Vision (THV), will be based on the Pro Tools 24 Mix+ platform and will feature 5.1 monitoring. Head of postproduction, Julian MacDonald, describes the venture as 'a hybrid of the existing sound postproduction studios. It has been designed to cater for every aspect of the sound process, covering tracklaying, ADR, Foley, voice-over, commentary and dubbing, all within the one environment.'

'This kind of flexibility means that whether the project is a low budget feature or a 5-minute corporate presentation, a drama series, animation, documentary or CD-ROM, we are able to offer access to any combination of disciplines instantly.'

Townhouse occupies a site formerly used by Goldhawk Film Studios, and is now part of the EMI-owned Virgin Studios Group. Since the late 1970s it has established a reputation for high-quality rock 'n' roll recording, and this expertise is hoped to distinguish the post operation.

'What will make THV so different from other work environments is the way our Pro Tools studio can operate' continues MacDonald. 'With seamless Avid integration and 5.1 surround sound we are set up to provide all of today's audio post applications

## CONTRACTS

**Nashville**-based Emerald Entertainment's Masterfonics division has recently purchased two additional Alesis MasterLink units for use throughout the facility. Emerald Recording, US. Tel: +1 615 321 0511. Alesis, US. Tel: +1 310 558 4530.

**Brazilian** record company Trama has provided South America with its first Amek Media 51 console as part of its new recording facility. The San Paolo facility chose the 44-channel desk and Genelec surround monitoring system specifically to handle tracklaying and surround mixing of Trama Records' roster of popular and electronic music signings. Amek, UK. Tel: +44 161 868 2400.

**Miami's** The Gallery Recording Studios recently opened with Genelec 1039A active monitors as the studio's main array. The one-room studio, designed by Ross Alexander and built by owner-producer Rick Howell, has already been host to Dreamworks Records' new band Vocal Point, and become a favourite of noted Latino producer Bebu Silvetti, who has worked with Luis Miguel among others. Genelec, US. Tel: +1 508 652 0900.

**Tokyo**-based Sony PCL has installed a 112-channel SSL Avant digital console at the heart of its new THX-approved mixing theatre, the largest Avant in Japan. Since opening in August, the studio has been fully employed by the Sony KK subsidiary, mixing and sweetening audio for high-profile surround sound projects. Also in Tokyo, postproduction facility Imagica has ordered a second 64-channel Avant digital console for its Akasaka Video Center and national broadcaster NHK has ordered a third Avant for video postproduction. SSL, Japan. Tel: +81 3 5474 1144.

**Munich's** latest post facility has been built in a converted cinema by London-based design concern Munro Associates and Binnberg-Pfeifer. Film & FernsehSynchron's latest facility is equipped with an AMS Neve DFC console and a THX-approved Martin monitoring system joining sister operations elsewhere in Munich and Berlin. Munro Associates, UK. Tel: +44 20 7403 3808.

**London** facilities group The Farm is to open three Digidesign Pro Tools AV-XL audio suites at a new Dean Street



## CONTRACTS

facility, Home. All suites will be equipped with Avid Meridien video cards for file interchange with the facility's Avid Media Composer off-line, on-line, and Symphony and expanded Pro Control consoles. Digidesign, UK. Tel: +44 1753 653322.

**Beijing's** new Oasis Studios has opened with an SSL SL9080j analogue console and Genelec 1036A monitors sharing centre stage. A subsidiary of YYYY Productions, the new facility is intended to become one of China's premier recording and mixing studios with an eye to establishing in international clientele based on artists from China, Hong Kong, Korea, Japan and Taiwan. Designed by Sam Toyoshima. Oasis offers two control rooms and will accommodate a 60-piece orchestra. It is the first Chinese studio to take a 9000j-series desk. SSL, UK. Tel: +44 1865 842300.

**America's** National Archives and Records Administration (NARA) has chosen the AudioCube for restoration and archival requirements at its Washington DC facility. Two NARA systems are configured identically with dual 700MHz Pentium processors and a full compliment of hardware including 100Mbit Ethernet and host a comprehensive selection of 24-bit, 96kHz restoration tools, including DeClicker, DeNoiser, DeCrackler, DeScratcher, DeClipper, DeBuzz, FreeFilter, Azimuth, Spectralizer and Multicomp. Sascom, US. Tel: +1 905 469 8080.

**Philadelphia's** Metropolitan Recording has opened Control Room A offering a 72-channel SSL 9000j analogue console and Quedsted 212 monitors. Designed by Toronto-based acoustic consultants Pilchner Schoustal, presently specifying Quedsted 5.1 systems for 3-studio complex, Angel Mountain Studios. Metropolitan is affiliated with RuffNation/Warner Brothers Records whose artists include The Fugees, Wyclef Jean and Cypress Hill. Quedsted, UK. Tel: +44 208 566 2488. SSL, UK. Tel: +44 1865 8842300.

The **New York** HQ of America's NBC broadcaster has replaced its analogue predecessor with a 96-input Sony Oxford digital console in Studio 6A's music room, the home of *Late Night With Conan O'Brien*. In various newsrooms and production stages around the Rockefeller complex, NBC has also installed

within the one space at the touch of a button. 'With one editor to cover all aspects, THV can offer personal collaboration, dedication and consistent creativity which can sometimes be lacking in more fragmented setups. In those traditional environments it is easy to see how the costs of running four or five different studios with editors and technicians to cover each discipline escalate. These costs are passed on to the client, and can force an unhappy compromise or even rule out all together certain areas of sound post.'

## Virgin Clyde

**UK:** Virgin Radio has agreed a contract with Clyde Broadcast to provide eight new digital studios at its Soho HQ. Comprising three dedicated on-air studios, six production studios, two transfer

suites and a 'comprehensive' central technical facility. Acoustic treatment for all rooms is in Clyde's hands and all studios will be equipped with Klotz digital routers and mixers, with the production studio using Sony DMX R-100 desks.

'Virgin have always been at the leading edge of ideas and technology, so it makes sense to go for the leading system solution,' commented Virgin's Alex Lakey following Clyde's turnkey work for Scottish station Beat 106. 'I saw the DC-II surface at NAB this year and decided that was the way to go—Klotz have a much more modern appearance and incorporate some great features that will make our facilities work more efficiently.'

With the completion of this project, Clyde will have installed Klotz systems in all three of the UK's national radio stations. Also having installed a Klotz Vadis

console, Kent-based Invicta Radio is continuing its migration to digital operation with CTA routing equipment from Clyde. Next to be installed is the UK's first DC-II console.

## Internet radio first

**France-UK:** Ride the Tiger, backed by Chrysalis Group and powered by the French Dalet Digital Media Systems software, has launched the UK's first 'personalised multichannel Internet radio station': [www.puremix.com](http://www.puremix.com).

Puremix.com delivers a non-stop music mix tailored to users' tastes offering a 'radio-like audio stream of uninterrupted music, Internet Jockey's

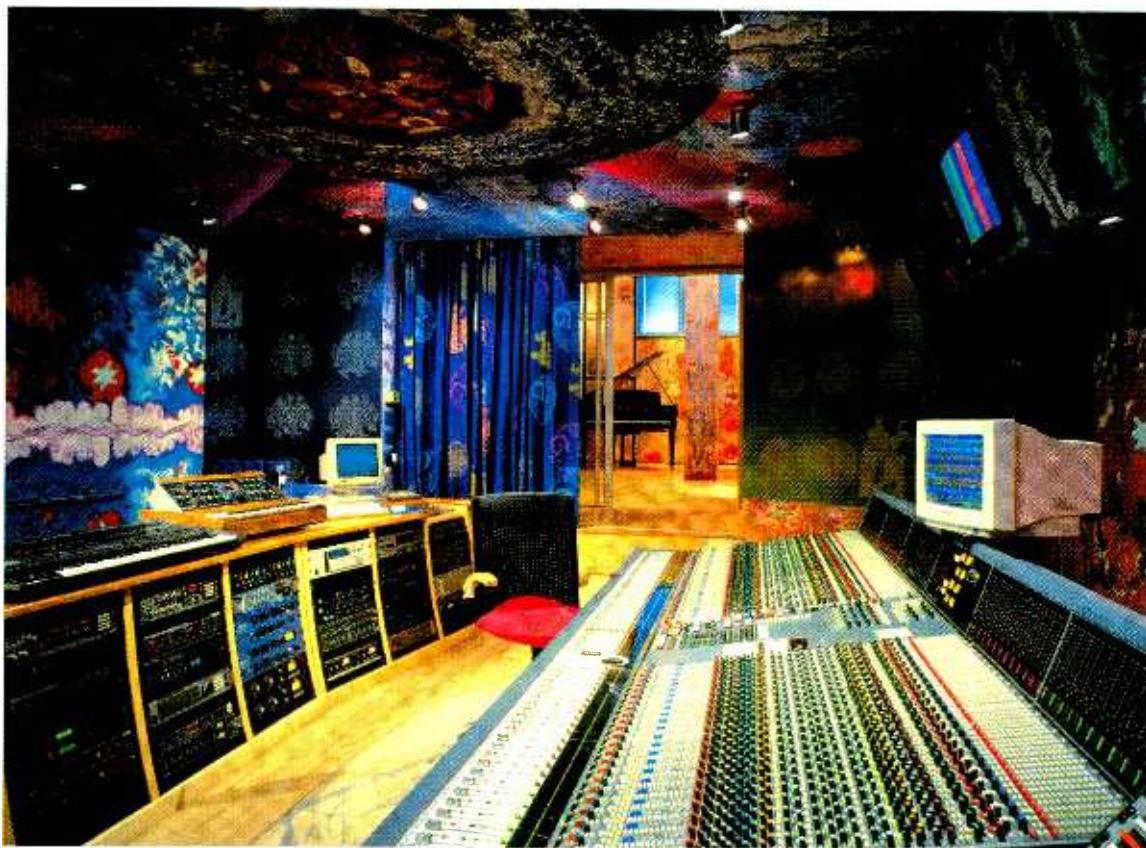

**US-UK:** Audio Internet pioneer, Rocket Network has announced a Charter Partnership with London's Strongroom studio complex forming the Strongroom Rocket Center. As such, Strongroom is the first brick-and-mortar studio in Europe to join the program which already includes American operations such as Hum Music+Sound Design, Serafine Studios, and Berklee College of Music. Rocket's Charter Partners are able to offer branded private Internet recording studios with access to Rocket's Internet infrastructure which includes a network of collaboration spaces for audio production, a talent search, 24-7 access to their work, online storage capabilities and other tools. The global production network is accessible via Rocket Power applications such as Emagic's Logic Audio Platinum 4.6 and Steinberg's Cubase and additional applications which will be available in coming months. Strongroom MD Rob Buckler said, 'What we want to do with Rocket is expand the concept of networking our on-site studios beyond the walls of our building. We will be able to offer engineers, producers and artists the ability to work with us—and with each other—wherever they are in the world.' Pam Miller, President and CEO of Rocket Network added, 'Rocket Network's technology is a perfect compliment to brick-and-mortar studios and traditional ways of producing audio for film, CDs, web sites and broadcast. We look forward to having Strongroom's professional clients experience the benefits of our global production network and services.'  
Net: [www.rocketnetwork.com](http://www.rocketnetwork.com)



# TRIPLE•C

COMPRESSION MEANS EXPRESSION



## THE ONLY INSERT COMPRESSOR YOU WILL EVER NEED !

TRIPLE•C can deal with virtually any given source material. The three Compression techniques combined with an analog style user interface, presets and full MIDI automation make TRIPLE•C the most versatile and ergonomic Compressor on the market. Insert TRIPLE•C on a single channel or on a Sub group and achieve comprehensive results.

### MULTI BAND COMPRESSION

Multi band Compression allows TRIPLE•C to spectrally Compress your source material in three bands independently. The finesse and expression applied using TC's multi-award winning Compressor algorithm ensures that Low, Mid and High bands processing avoid typical artifacts like "pumping" and "breathing" and reacts more intelligently avoiding overshoots and unwanted distortion. Consequently Compression becomes more transparent, yet more effective.

### ENVELOPE COMPRESSION

A brand new type of TC Electronic Compression allows you to alter the dynamic envelope of the incoming source by changing the Attack and Release gain. Applying this to percussive source material will allow you to change the original expression and thereby create an entire new sound. You have never heard anything like it!

### FULL BAND COMPRESSION

The most common form of Compression, TRIPLE•C simulates the best analog Compressors with the added luxury of user presets to achieve that "in your face" full band sound instantly.

### PRESETS

50 factory presets optimized for Vocals, Guitar, Bass, Breakbeats and more + 100 User presets.

### 24-BIT DIGITAL IN/OUT

24-bit Digital I/O's combined with balanced analog I/O's allow TRIPLE•C to be used in both digital and analog applications.

TRIPLE•C is available in both single and stereo channel versions.

**t.c. electronic**  
ULTIMATE SOUND MACHINES

TC ELECTRONIC A/S • DENMARK • ☎ + 45 8742 7000  
TC ELECTRONIC UK • FREE ☎ 0800 917 8926 • FREE [FAX] 0800 917 6510  
INFOUK@TCELECTRONIC.COM • WWW.TCELECTRONIC.COM

[www.americanradiohistory.com](http://www.americanradiohistory.com)



## CONTRACTS

Aphex Model 1788 remote-controlled mic preamps and remote controllers. Sony Corporation of America. Tel: +1 201 930 1000. Aphex Systems, US. Tel: +1 818 767 2929.

**London's** new Out Of Eden studio is a collaboration between composer, keyboard, player and producer Andy Richards and Eden Studios. Designed by Mike Gardner and Philip Love, the studio's centrepiece is a 48-channel Fairlight FAME2, the first to be installed in the world, integrated with a Pro Tools system giving 88 tracks of 24-bit audio. Monitoring is 5.1 via M&K (LCR) with M&K 2510 passive rears, and a sub-bass unit. Richards has worked with Frankie Goes To Hollywood, George Michael and Annie Lennox, and has production credits with artists including Pet Shop Boys, and Dusty Springfield. Out Of Eden, UK. Tel: +44 20 8995 5432.

**New York-based** Sound One, now part of Liberty Livewire, has purchased two AMS Neve Digital Film Consoles. The facility takes roughly 90% of the New York film market, plus multiple television series and projects. Recent film credits include *Shaft*, *Sleepy Hollow* and *Mission to Mars*. The new consoles will be installed this autumn. AMS Neve, New York. Tel: +1 212 965 1400.

**America's** Aphex Systems recently supplied three Model 1788 mic preamps configured with digital I-O option, plus a remote controller unit to the new Federation Concert Hall in Hobart, Tasmania. The 1,100-seat Concert Hall is being developed by the ABC, Australia's national broadcaster, and the Grand Chancellor Hotel chain, and will be the future home of the Tasmanian Symphony Orchestra. Acoustic design was by Ove Arup & Partners, based in Sydney, Australia. East Coast Audio, Australia. Tel: +61 3 8517 3811. Aphex Systems, US. Tel: +1 818 767 2929.

**Las Vegas-based** Pompei Records has installed a 56-fader Euphonix console to serve its growing base of dance productions. As well as offering a new recording studio, the facility serves as home to an independent recording label that specialises in promoting both local and national acts in a 'booming' local music scene. Pompei Records, US. Tel: +1 702 433 6900. Euphonix, US. Tel: +1 650.846-1190.



**Italy: Nautilus Studios has added a selection of EAR valve outboard to its mastering arsenal. Both of the facility's mastering rooms offer SADiE 24/96 systems and PMC monitoring with the Blue room (pictured) also having a 5.1 AMS Neve console. New to the cast are four EAR 660 compressors, two 823 mono EQs and once 825 stereo EQ supplied by Funky Junk in Milan. Other Italian action includes Larione's Neve 8108 (Florence), Fono Video Sync's Soundtracs Virtua (Milan), La Pineta's SSL 4000G (Livorno) and Laba Studios' DDA DCM232 (Caserta).**

(Js), plus audio elements such as sweepers and promotions', with no gaps between tracks. The domain uses Dalet5.1 to acquire, edit and broadcast music or recorded audio for the radio, Internet, digital satellite, and private

broadcast networks. For music playout, logs are constructed and mixed using the in-flight mix editor. When the streams are played out, Dalet automatically exports metadata fields such as IJ, Artist and Track Name in XML, which is then con-

verted by a third party system and published in the puremix.com player on the web site. Dalet's UK subsidiary provided installation, support and project management services throughout the project.

Ande Macpherson, joint MD at puremix.com, commented, 'In this dynamic area Dalet has moved from radio playout systems into Internet-ready audio streamers extremely well. The puremix listening experience is unparalleled on the Internet.'

## The alliance of science

**US:** California-based WaveFrame has acquired the assets and trade names of Berkley-based software company Diaquest Inc, effective 1st July 2000. Diaquest's video tools for image networking, animation and video device control for Media 100, Adobe Photoshop, After Effects, Premiere and Kinetix 3D Studio Max from Discreet Logic and disk recorders from Accom, Abekas, Sierra Design Labs and others. The lines have proven successful in broadcast television, desktop video production, special effects, scientific visualisation and animation quarters, and are expected to integrate well with WaveFrame.

## APRS PLASA talks fail

THE MERGING OF MEMBERSHIPS of the UK's Association of Professional Recording Services (APRS) and the Professional Lighting & Sound Association (PLASA) has stalled. Earlier this year a proposal was put forward to migrate APRS membership into PLASA, creating the prospect of a single UK trade show to serve both the live and recording markets and suggesting a greater homogeneity for professional audio than at any stage since the 1960s. However, the current board of the APRS has voted to reject such a move, and is proposing sweeping changes to its own constitution in order to best serve its members. *Studio Sound* spoke to Peter Filleul, currently acting as executive director for the APRS.

**Q: What has been the APRS Board's response to merging APRS membership with PLASA?**

As you know we have been in concerted discussions with PLASA for some months. These discussions culminated in a proposal from PLASA's committee the terms of which would have led to PLASA taking over the APRS membership and the dissolution of the APRS once and for all.

After much heart-searching we came to the view that the audio recording industry would best be served by retaining and reviving an independent trade association. In any event, we believe that such a momentous change should be decided by the members themselves.

**Q: What aspects of the different markets served by APRS and PLASA are incompatible?**

In many ways we are parallel but separate industries. PLASA's focus on public performance and entertainment makes them an ideal choice for businesses that have markets in that area. Studios, pressers and duplicators and studio personnel serve an entirely different market and have very different needs.

There is some cross-over in the manufacturing area, but

most companies have clearly delineated markets. Another cultural issue was that PLASA has no infrastructure that supports separate sectors, and we were concerned to retain a separate, authoritative voice for our membership.

**Q: Who are the key executives in the APRS at this stage?**

We are currently unable to support a chief executive. Mark Broad is now developing his own business providing text and copywriting services. Francesca Smith continues as our administrator, dealing with day-to-day enquiries and event organisation.

The current board is focussing on a package of services, benefits and events for next year but we will also be taking a long and hard look at the association itself, what members want from it and how to re-shape it so it can serve its members better.

**Q: What are the prospects for a London recording show in the future?**

Venue permitting, very good. Hosting a UK-based Recording Technology-type show is very important to many of our members, but running exhibitions and conferences is a deeply competitive business nowadays. We expect to work with partners to present a recording show in 2001—I can't say who our partners will be, or where or when yet, but plans are developing very positively. Watch this space.

**Q: How can the APRS strengthen the industry?**

The creative as well as the service sides of the recording industry are facing a time of extraordinary change. At such a time it is vital that the recording industry has its own trade association to provide tailored services, group benefits and focussed advice and representation at a government level.

As an association of small, technology-based businesses we have achieved a great deal, especially in areas looking to the future of the whole industry such as education and training, and influencing new legislation.

Developing a new structure will allow us, in addition, to focus more on the particular needs of individual industry sectors as well as to broaden our reach to include the new communities of recording professionals.



# The New 960L Multi-channel Digital Effects System



- | Redefines World-class Reverberation
- | 24-bit/96kHz Processing
- | Lexicon 3DPM™ Algorithms (3-Dimensional Perceptual Modeling)
- | True Multi-channel Surround Sound and Stereo Reverb Processing
- | LARC2™ Remote Control: 480L-based Intuitive User Interface
- | Flexible Input and Output Mixing Capabilities
- | Expandable Audio & Control I/O
- | Hardware & Software Expandable DSP
- | Extensive Sonic Palette of Factory Programs
- | Eight Touch-Sensitive Motorized Faders
- | Assignable Joystick for Surround Panning and Creative Parameter Control
- | Standard Configuration: Multiple 3DPM™ DSP Configurations: Stereo, 5.1 Surround, and Combined
- | Eight 24-bit/96kHz Balanced XLR Analog I/O
- | Four Stereo Pairs of 24-bit/96kHz AES/EBU Digital I/O
- | MIDI In/Out/Thru
- | BNC Word Clock Input/Output/Loopthru
- | 3.5" Floppy Drive
- | CD-ROM Drive for Software Upgrades



THIS IS THE FUTURE

**lexicon**



## APPOINTMENTS

**Waves** has appointed Bob Reardon, formerly vice president of European sales, to the position of vice president of marketing in Los Angeles. Reardon's background includes studio ownership, music and postproduction work as well as stints at Editel and Lexicon.

**Studer** has announced the appointment of Prodromos Constantinou as successor to John Carey as president of its North American operations, Carey having been named vice president of business development at Klotz Digital. Constantinou will work from Studer's Toronto offices maintaining sales offices in NY, LA and Nashville.



Carey's responsibilities range from OEM partnerships to implementation of the company's X4P Internet products.

**Sonifex** has appointed Andrew Winmill to the role of UK Sales Manager, following the departure of Tim Lowther who has taken a role as a freelance project manager. Winmill's background is in broadcasting, covering installation to presentation.

**Dobson Sound Productions**, the London-based rental company, has appointed Nick Hughes as technical manager. A graduate of the Tonmeister course at the University of Surrey, Hughes has experience in service and repair of professional audio equipment, most recently with Boffin Island, the service company for Funky Junk.

**AldeaVision**, formerly ABL Canada, has appointed Lionel Bentoilla as president and CEO. Previously president and CEO of AldeaVision Network Systems, Bentoilla has over 15 years of experience in telecommunications including time at Nortel Networks, Consortel and Nexfotel.

**SADiE** has announced the appointment of Jayson Tomlin as national sales manager for the US. Working from Nashville, his responsibilities will include expanding SADiE's dealer sales.

'President Ron Franklin described the move as: 'part of our strategy to expand into a broad-based media company. The talents of Diaquest's staff will be helpful as we begin to integrate video capabilities into our workstation products and develop new media tool sets for the Internet.'

Also in California, Universal Audio has completed acquisition of Kind of Loud Technologies. Both companies were co-founded by Bill Putnam, specialising in analogue recording and DSP audio production tools respectively, and have been brought together under the slogan, 'Analog Ears, Digital Minds'.

'As we looked to the future, it became clear that by combining our resources and technologies we had the necessary ingredients to create a formidable company with tremendous potential,' commented CEO Putnam. 'We are well underway developing our next product line.'

Sonic Solutions has announced a strategic alliance with InterVideo, developer of PC video and audio software to market DVD authoring application for home users. Called InterVideo MyDVD by Sonic, the low-cost authoring application is part of InterVideo's WinCinema software solutions built upon the same formatting engine as Sonic's DVD Creator, DVD Fusion and DVDIt! used to Hollywood movie, corporate, and consumer DVD titles. This release provides access to entry-level DVD publishing with an upgrade path to any of Sonic's professional DVD authoring products. Joe Monastiero, VP of sales and marketing for InterVideo commented, 'This alliance provides InterVideo with the opportunity to add Sonic's DVD authoring technology to our existing suite of



**World: The three winners of Studio Sound's competition for a celebratory 'Gold' liveried Sonifex Redbox RB-DA6 distribution amplifier have been judged as follows: freelance engineer Roger McMinn from Birmingham joins Italian musician, engineer and producer, Alberto Cima and Dr Joydev Lahiri from India, the chief technical manager of the Indian government's Audio DSP Project in their winning streak. Marking 1000 Redbox sales, the giveaway sees Sonifex' red range finding favour with radio stations, TV studios, video and recording suites. The range includes the RB-MA2 dual mic amp, RB-SM2 stereo-to-mono convertor, RB-SL2 2-channel limiter, RB-HD6 6-way headphone distribution amplifier, RB-SC1 sample-rate convertor, RB-ADDA audio convertor, RB-DDA6A AES-EBU distribution amp and the new RB-MM1 mix minus generator. The complete list can be found at [www.sonifex.co.uk](http://www.sonifex.co.uk)**

multimedia solutions, while simultaneously giving Sonic access to a much larger audience.'

Fairlight USA and Soundtracs have further cemented their relationship with

Fairlight handling sales and support of Soundtracs' digital consoles in the US. The announcement follows the successful pairing of Fairlight's workstations with Soundtracs' DPC-II console.

## Music producers cash in

THE UK'S MUSIC PRODUCERS GUILD has broken new ground by securing Arts Council funding, which will be used to support various education and promotion activities. According to Graeme Wall of the Arts Council's music department, 'Education and advice for our future generations of music producers is extremely important'. One early initiative is the granting of one year's free membership of the MPG to graduates of MPG-APRS-approved sound technology courses. Newly elected chairman of the MPG Phil Harding spoke to *Studio Sound*.

**Q: How did the idea of government funding occur to you?**

It's been a year or so of picking up the pieces from RePro, and we first made a presentation to the Arts Council to get funding for one of our Special Interest Groups. I run the one on education, and I was doing lecture tours and noticing that a lot of our members were being asked to participate in courses around the country. So we decided to push this successful aspect of the MPG and make it a working business in its own right, and applied for funding under the Arts Council grant scheme called Firestarter for new arts-related businesses.

**Q: So the funding only applies to educational activities?**

Our presentation highlighted those activities; we did some forums around universities in London, and we wanted to take that idea right round the country. That was a specific need for funding.

**Q: Is that tour now a reality?**

Yes, in February. We've had to wait a little while for the money actually to come through.

**Q: What was the secret of the successful bid?**

I think the Arts Council was impressed with the idea that big-name music people were willing to go out to places like Norwich, Manchester and Glasgow and actually meet youngsters and talk to them. We don't want to hide away in an ivory tower.

**Q: What are the remaining links with APRS?**

We are affiliated to the European Sound Directors Association (ESDA), which was a Peter Filleul/RePro initiative, and Peter is a patron of MPG. He is also, obviously, a very senior figure within APRS.

**Q: What would it take to strengthen that link?**

Well, the feeling was that it was wrong for individual, creative people such as producers to be directly affiliated to the manufacturers. Obviously there is a lot of common ground, but there would have to be no automatic obligation to support manufacturers' marketing efforts.

**Q: What hopes are there for further pan-European associations?**

Well, Tony Platt and I have been lecturing in Helsinki, so there may eventually be an MPG Finland...

The MPG Board now includes vice chairman Tony Platt and newly elected members Steve Parr, Blue Weaver, Chris Thorne and Andrew East.



# Are you monitoring the situation?

At AMEK we certainly are.

An escalating need for multichannel audio for Music Recording, Post-Production and Broadcast environments has prompted us to offer a unique solution. Designed from the ground up with your future in mind, Media 51 is an investment that specifically addresses surround formats up to 5.1, allowing you to effortlessly mix stems whilst also providing comprehensive monitoring up to 7.1 for external stems.

Media 51 has evolved from the proven ergonomics and design principles of the 'Big' console (1000 installed worldwide). It not only guarantees a short learning curve, but also provides an intuitive and flexible introduction to the world of surround.

Our mastery of analogue circuitry is second to none. An audio path of exceptionally high quality is provided via an EQ and Mic Pre, designed by the legendary Mr. Rupert Neve. Additionally we've included our highly acclaimed Supertrue™ automation system. This includes Virtual Dynamics™, Visual FX, Recall for knobs/switches and machine control, which means you don't have to compromise on functionality.

Audition the first-class surround capability and pure sonic performance of the Media 51 today and experience its true value.



# Media 51

*Artistry in Analogue™*



Manchester  
+44 (0) 161 868 2400



US Headquarters  
+1 (888) 286 9358

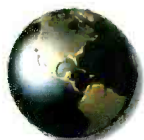

Los Angeles  
+1 (800) 585 6875



Tokyo  
+81 (3) 5707 0575

#### International Headquarters

Langley House, Third Avenue,  
Trafford Park, Manchester  
M17 1FG, United Kingdom

T: +44 (0) 161 868 2400 E: amek@amek.com  
F: +44 (0) 161 873 8010 W: www.amek.com

■ A Harman International Company







# LIFE ON THE FARM

Measuring investment against opportunity, technology and application are essential elements in the business plan for a successful studio. **Zenon Schoepe** visits Malta and finds himself on the farm

**E**XHIBITING AN UNUSUAL and thoughtful balance of modern technology in a pleasant and flexible work environment, Farmhouse Studios demonstrates a precise tailoring of investment to suit the spending potential of its client base. The choice of equipment also reflects the requirement to serve a music recording clientele and to be good for sound for picture work in broadcast and other release. And The Farm is in Malta, an island better known for its incredible history and holiday resort potential than its recording heritage but a beautiful and special place to do business in the middle of the Mediterranean. The Maltese Islands,

which also include Comino and Gozo, enjoy a fabulous climate with mild winters—cold winds, snow, frost and fog are unknown—and a hot summer season from mid-July through mid-September.

The studio is built within the home of owner Paul Zammit Cutajar who started adapting the 400-year-old farm house to the purpose in 1996. Zammit Cutajar is a musician who trod the route of touring and recording until settling down with his own recording facilities for his own work and his sound for picture commissions. He spotted the farm house, needed somewhere to work, set up his equipment in it and things grew from there in the traditional home

studio becomes commercial studio model. He owns the building and a lot of land around it which gives plenty of scope to build many more rooms should he ever have to. A short drive from the town of Malta, like most farm houses the building is positioned in a quiet and secluded location and offers a persuasive package.

Zammit Cutajar runs the studio as well as engineering and producing with additional support from assistant Gavin Attard. The old and original courtyard has been sealed into the building releasing more space for a live area while also providing solid foundations and sturdy walls. By maintaining





Despite the Maltese islands' population of 360,000, four TV stations, incorporating national and political operations, plus cable serve their viewing requirements with a high quota of targeted local production and interestingly all channels carry advertising.

While much TV production work is kept in house by the broadcasters, Zammit Cutajar gets involved with TV commercials, video documentaries, and corporate videos. Some 70% of the studio's work is accounted for by music recording although when analysed from the perspective of income then music and the broadcast related other work quickly achieve a 50-50 split. 'You could say that I use the commercials work to subsidise the music recording,' observes Zammit Cutajar, 'but I also produce and there are local bands that sing in English, have promise and now have the facilities with a place like this to make good recordings. I take them on and attempt to promote them abroad.

'We use the local market as a testbench to see how the band goes, to measure the reaction from the public and to see if they can build up a fan base,' he says.

The inclusion of on-site CD duplication facilities adds a lot of value for local releases and this service is sold as part of the studio package for upcoming acts.

Film buffs will know that much of Ridley Scott's *Gladiator* film was shot in Malta including the majority of the many stadium scenes. Notable clients have included none other than General Maximus Aurelius (Russell Crowe) who took time out from his blood letting exploits to record tracks at Farmhouse during the course of the filming.

Control room monitoring is Genelec 1037 with 1032s at the rear with a sub for 5.1. 'I suppose my choice of Genelec stems from my SAE course where I learnt to understand monitors. And I'm very happy with them,' says Zammit Cutajar who adds that his decision was steered more by academic insights than by fashion. 'I listened to an album I did recently in London in here and we heard things that we simply hadn't heard on it before. The other thing is that I spend a lot of time in the studio and I can go 10 hours on these speakers. I'm not saying that my ears don't get tired, but I am saying that they don't get as tired as quickly. Besides it's always your eyes that give up first when you're working on screen.' Which is a neat link to the fact that Farmhouse runs a Digidesign Pro Tools as its primary recording and editing medium.

'When we were building this place we were reading about DVD and rather than have to rip up the walls at some stage further down the line we installed a 5.1 system from the onset and that was four years

ago,' he continues. 'The thing is we're still working in stereo and we haven't had a 5.1 job in. The progress of DVD has been disappointing, I expected it to move much faster than it has. The industry has taken ages to standardise yet the potential is still strong. Hopefully the music industry will embrace it and start producing albums on DVD in numbers and then we're set up.'

Unusually Zammit Cutajar runs two cascaded Yamaha 02Rs as the main console with an assortment of supporting equipment and plays to the desks' strengths by employing the automation and digital control aspects while adopting the popular approach of going through outboard for the recording path. 'For mic pres I prefer the Aphex 107s, I have 10 of those plus Focusrite Greens and two Avalons. I go through these straight to Pro Tools and monitor through the 02Rs.'

Pro Tools is the system of choice for 'the serious stuff' and at the time of the visit Zammit Cutajar was waiting for a quiet weekend to install and familiarise himself with version 5.0. 'I'm a keen user of Emagic Logic Platinum for the simple reason that I do a lot of MIDI work here and the editing on the MIDI is excellent,' he explains. 'But I will be investigating the new MIDI capabilities on Pro Tools V5.0 when I have the time. At the moment I differentiate sessions into audio only work on Pro Tools and if its MIDI and audio then it's Logic. Pro Tools 5.0 could change all this but it depends on just how good the MIDI editing is for me.'

He's heavily into the plug-ins side of Pro Tools with honourable mentions made for Focusrite, Line6 Amp

the original surfaces wherever possible the live area enjoys a delicate and natural acoustic ambience which has found favour with a number of classical soloists.

Zammit Cutajar designed the whole place himself after he returned from an SAE course in London where he indulged his interests in acoustics. 'I have to say that a lot of this fell into place as I didn't have many of the usual problems to sort out that are common when designing a studio in a town, such as high isolation issues for example,' he says. 'The building was extremely sturdy to begin with, I floated all the floors and ceilings. It was relatively simple.'

However, the process did involve adding to the original building to make it up to the required space and this has been conducted in a sympathetic manner and in keeping with the rest of house—the joins cannot be spotted.

The primary clients are for music recording but Zammit Cutajar admits that he has always harboured a passion for sound for picture work and to this end he incorporates a fair amount of post related work for TV documentaries and local production.



Zammit Cutajar and assistant Ira Losco.



# FACILITY



Farm and AutoTune—it's amazing the effect that telling a singer you have AutoTune has.'

While Valetta remains the old commercial centre of Malta, the island's advertising agencies have their own bases complete with picture editing facilities outside of the city but Farmhouse steps in for the

sound contingent. Not surprisingly voice-over talent is in short supply and it's possible for the same characters to keep cropping up in adverts but as Zammit Cutajar points out 'that's where a system like Pro Tools comes in, I can change the character of the voice quickly and easily.'

Farmhouse may have gravitated towards music recording as its mainstay but its owner has the space and the plan to add a dedicated commercials room should demand require it as he underlines that a single control room facility serving a number of different task starts to limit its own natural development should it be successful, which it clearly is. 'I'll need to bring in more people, there'll be more building and it becomes a bigger business,' he says.

The 02Rs are integral to the workings of the studio and can produce stunning results but Zammit Cutajar understands that international clientele may well turn its nose up at them. 'There is an irony involved with equipping a studio,' he explains. 'I firmly believe that it is the final result that matters and how you get it is less important. However, you want to be taken seriously and you have to attract business and that is down entirely to the location and the sorts of things you have on your equipment list.'

'The question is what to get next. As far as I am concerned it's either the Sony R100 or the Euphonix System 5,' he laughs. 'The thing is if we really do want to attract international business then the System 5 would be a draw but would involve enormous investment and more building. The Sony desk would be a better solution for us if we intend to remain at the level we are at but want to improve the convenience.'

He says that it comes down to equations of investment, expansion and potential return although he is resigned to the fact that he will never recover the money he has already invested in the studio's infrastructure.

'On balance I think I will go for the Sony desk in the short term and see how the business develops,' says Zammit Cutajar. 'After all this studio has only been going for four years and to be honest I wouldn't have dreamt then that we would have got up to even our present position in that time.'

He has the space, the formula, the determination and the wherewithal. It's still very early days for a remarkable working concern on a beautiful island. □

## Contact:

### Farmhouse Studios,

The Cottage, Qrendi Road, Siggiewi QRM 16, Malta.

**Tel:** +356 463 551

**Fax:** +356 463 532

**Email:** info@farmhouse-studios.com

**Net:** farmhouse-studios.com



## The Package

THE STUDIO IS AVAILABLE for hire for £80 per hour or £550 per day but The Farmhouse has also put together an attractive all inclusive package based on two people block booking for seven days. This weighs in at £750 per day and includes accommodation (B&3) at the Westin Dragonara 5 star Hotel (located 20 minutes from the studio), return flight to any European destination, and transport to and from the airport and the studio. Additional people are charged at £150 per person per day. Malta's climate, sea, scenery and night life are thrown in for free.

On-site accommodation was being built at the time of the visit and when completed will



have enough room to house a band. The client will be free to choose between the hotel or the new quarters.



# MASSIVE PASSIVE STEREO TUBE EQ



**A PICTURE IS WORTH A THOUSAND WORDS...**

Perhaps, but would photographs of our Variable Mu or VOXBOX have created their successes alone?

You have to hear this gear. You have to use this gear. Put your hands on the knobs and crank 'em.

Engineers who have already gotten hold of the MASSIVE PASSIVE have told us: "Why does it make everything sound so much better?", "It's organic and orgasmic.", "It's a f%#king powerhouse.", "It's unlike any other EQ.", "This is IT. The sound I've always dreamt of but couldn't ever get until now."

**GOT THE PICTURE?**

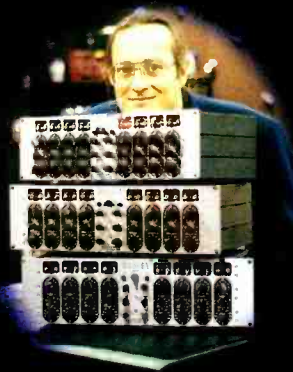

**Craig 'HUTCH' Hutchison designed these monsters...**

The MASSIVE PASSIVE is a two channel, four band equalizer, with additional high pass and low pass filters. "Passive" refers to the tone shaping part of this clever new EQ design not using any active circuitry. Only metal film resistors, film capacitors and hand-wound inductors sculpt the sound, kinda like a Pultec EQ on hyper-steroids. Super-beefy, hugely-high-headroom Manley all-tube make-up gain amplifiers deliver your tunes into the next realm. You'll need to experience this.

Contact us for your nearest authorized MANLEY dealer.

**MANLEY**



**MANLEY LABORATORIES, INC.**

13880 MAGNOLIA AVE.  
CHINO, CA. 91710 USA  
TEL: (909) 627-4256  
FAX: (909) 628-2482  
emanley@manleylabs.com  
<http://www.manleylabs.com>





# Soundcraft RM1d

Making a belated entry in to digital desks, Soundcraft has chosen radio as its first area of assault. **Zenon Schoepe** pushes up the faders and says it's a beautiful morning, there are 10-mile tailbacks on the M25, and we'll be back with the phone-in mystery voice competition after this from Judas Priest...



**D**ESIGNING A CONSOLE for radio purposes is an exercise fraught with complications. The problem resides in the popular understanding of the role of the self-op and just how much they should be allowed to access, control or alter. Where the issue complicates is that there are a variety of degrees of responsibility and control between the jock and his technical support services. On the one hand you have stations that are technically well supported and supervised where the jock is monitored and at the other extreme you have small establishments, or even stations in which the DJ pretty much has to do it all and switch the lights off when he's finished.

Finding this balance is precisely why a look at radio desk offerings reveals such a disparity in the level of control readily accessed and the simplicity of the top layer arrangement. It's why at one extreme you will find radio desks with a fader and large coloured buttons that are hit with a mallet and are accompanied by a collection of pram activity toys that squeak and rattle, and at the other end there are more sophisticated interfaces for DJs who can be trusted to behave. Neither solution is necessarily the best but the graduation between these extremes ensures that a solution does exist for most combinations of requirements.

Digital radio desks, and there is now quite a healthy selection of concepts as a visit to an NAB exhibition will verify, have merely served to reinforce the differences in working practices across the world, outside of national broadcast institutions and throughout the private sector from small-scale station to would-be national conglomerate. In many ways digital radio desks, by their design, dictate that while it is possible to satisfy the jock's simple top layer coupled with the hidden depths required by the technical support services, they also require the manufacturer to make ergonomic and presentation decisions and concessions. Consequently most

digital interpretations remain valid to a target audience but need to be investigated individually to decide whether they fit in with your requirements.

Soundcraft's RM1d is an important product as it is the first digital product with the company brand on it—the 328 and 324 desks are technically Spirit badged products. That Soundcraft should have chosen the radio market to debut in this way is interesting as it builds a connection with the radio market that harks back to MBI among other more recent offerings. The designer who did the initial

concept was Chris Humphrey who is ex-MBI and also designed most of the other analogue on-air consoles Soundcraft make, such as the RM105, Series 10, and Series 15. The original brief for the RM1d was as a digital version of his RM105, in fact the footprint is identical, making upgrading from a 105 a straight physical swap-out.

The connection with 328-324 technology needs to be clarified. There are a number of visual clues that kind of suggest a 328 connection although I find it difficult to be specific about precisely what—maybe there is a similarity in some of the switch gear and displays or maybe it has to do with the immediacy of the presentation and the ease of operation.

RM1d technology is said to be a step up from the 328, although it is based on similar building blocks. The new desk uses a more expandable and flexible internal architecture, using plug-in DSP modules and a backplane system into which I-O cards are connected.

Currently it is only available in the 6-channel version

## Connections

**WORD CLOCK SOURCING OPTIONS** are available along with sample rate converters on inputs and flexible routing of outputs to digital connectors. Converters are 24-bit.

There's a good selection of remote start and stop functions, red light control, mutes and logics via 25-ways. A 37-way handles a variety of external source monitors and inputs.

Studio and control room monitoring are taken care of by two largely identical and clearly laid out top panel sections with lots of buttons.

The desk comes with four assignable mic-line inputs, the first two of which have analogue inserts. Eight extra analogue inputs can be accessed through

seen here for around £5000 (UK) although a 12-fader version is in the works and groups 6-fader blocks either side of a central script tray with roughly twice the digital and analogue I-O for roughly twice the price. There will also be a 12-fader expander sidecar unit, physically the same size as the 6-fader console, that links to the 6-fader or 12-fader desks for a maximum of 24 simultaneous. The expander also has additional I-Os which are similar to that on the 12-fader console.

The desk operating software can be upgraded from a PC via RS232 and the version 1.00 software on the reviewed desk is the first production release. While solid and seemingly unflappable despite my best efforts Soundcraft did point out that a few features were not active but will be added in the near future as part of a process of improvement and user request.

These omissions include Lockout, which will enable password protection of any of the console's front panel controls, the channel's HPF and the compressor in the dynamics section has time constants that do not yet have the range to enable heavy-sounding compression effects.

The RM1d's automation is snapshot based and presses the MIDI ports in to action for memory dumps and restores. MIDI can also be employed for dynamic automation of console parameters although this is not essential for radio use.

Currently the options stand at P&G faders instead of the Alps models used and various metering types: vu, PPM 1-7, DIN PPM, EBU PPM.

So what do you get. The frame is a compact unit that crams a surprising amount of control by way of switches and pots into not much space at all. The 6-channel strips have 100mm faders working with a 4-character alphanumeric display, a panel that displays input, routing and processing activity plus switches for PFL, ON, PEAK-LIMIT LED, INPUT 2 selector, which switches between this and INPUT 1 per strip, and an EDIT switch (equates to a SELECT switch) for assigning channel parameter control over to the pots and switches of the Edit Strip.

The Edit Strip is familiar in presentation to the parameter control available in a horizontal strip on the 328 using continuous controllers working in conjunction

an interface box to the rear panel TDIF. Analogue outputs emerge on the 37-way connector and the main stereo buses are on XLRs plus four line-clean feed outs, a balanced mono output, two monitor line outputs and pairs of studio and presenter's headphones.

There are four AES-EBU inputs and an SPDIF with more available through TDIF and the use of an AES-EBU to TDIF interface box, for example. Two AES-EBU and an SPDIF are provided for digital outputs with the same flexibility as the inputs afforded through the TDIF with the aforementioned interface box.

Power comes up through a locking monster snake and an external rackmount power supply.



# digital confidence

In today's rapidly evolving media landscape, confidence in new technology has to be earned. With the abundance of equipment being introduced, can you depend on your supplier, the product reliability, the life-span? Can you know if you've allowed for all the possibilities of new mix formats, digital input/output configurations and new standards of automation which may appear without warning?

The solution is simple. A product supplied by a manufacturer with over a quarter of a Century of experience, having now installed more than 350 digital consoles and gained a reputation for a cast iron commitment to user support.

The solution is elegant. The new Soundtracs DS-3 digital production console.

Integrated within the dynamic control surface of the DS-3 lies a uniquely futuristic approach to console ergonomics. Breathtakingly easy to operate at the same time as exceeding the requirements of the World's most demanding facilities and operators.

Gain confidence in the digital future, investigate the new DS-3.



## FEATURES

- 64 or 96 digital channels
- 24 bit conversion
- 96kHz mix operation option
- Simultaneous stereo, LCRS and 5.1
- 25 fader worksurface
- Interactive touch screens
- Instant reset
- Comprehensive automation
- Advanced machine control
- EQ and dynamics presets
- Six band parametric equalisers
- 32 x 6 monitor matrix

# DS-3

digital production console

[www.soundtracs.com](http://www.soundtracs.com)

Soundtracs PLC, The Clock House, 4 Dorking Road, Epsom, Surrey, KT18 7LX, England Tel: +44 (0) 1372 845 600 Fax: +44 (0) 1372 845 656 Email: [sales@soundtracs.com](mailto:sales@soundtracs.com)  
In the USA, contact Fairlight USA, 844 N Seward Street, Hollywood CA 90038 Tel: +1 323 465 0070 Fax: +1 323 465 0080 Email: [soundtracs@fairlightusa.com](mailto:soundtracs@fairlightusa.com)

[www.americanradiohistory.com](http://www.americanradiohistory.com)



## REVIEW

with LED circles for positional information. On the RM1d these are clumped in vertical blocks and offer fewer parameters. You get shelving 10kHz and 100Hz and a 500Hz to 8kHz peaking mid EQ all with  $\pm 12$ dB plus a  $\pm 12$ dB make up gain trim. There's also a 80Hz high-pass and EQ bypass and access to the two aux buses switchable pre-post individually. An aux master control acts on the two buses and remains active regardless of the channel selected and allows grouping for stereo. Routing to the two stereo output buses is through a pan-balance pot.

For the majority of operation this is all the driver will need to concern themselves with. In fact if the desk has been set up and planned well enough in advance there will be little if no requirement to go anywhere near the Edit Strip. Consequently the desk configuration is an important process and thankfully this also benefits from simple operation although we now enter the realm of the menu.

Working in conjunction with a rather small, SPX90-era type LCD, cursor keys and a parameter dial, a small panel concerns itself with the desk set-up, dynamics, and pre-set management. As far as input assignment is concerned, it sets an operational approach that is retained throughout the rest of the desk's workings. Hit the SET-UP button in the menus section, select channel assign and hit SET-UP again. Strike the EDIT button on the channel you're interested in and with the menu dial select the input source from the available list which is reflected on the channel strip's alphanumeric display. There is no saving routine involved as such but entire desk setups of various input



and routing and processing configurations can be stored as a snapshot to 128 locations which cover the entire desk including the digitally controlled mic preamps.

Simple really with the only hindrance being the size of the LCD which necessitates the use of not immediately obvious abbreviations so it can display a chunk of meaningful information. This said you do eventually get a handle on the lingo but I can't understand why the display couldn't have just been a bigger.

From the same screen you can name inputs, adjust mic and line gain, switch phantom power, allocate one of the four mic-line inputs for talkback duties and alter guest headphones level.

Four line clean feed outputs can be organised as prefade direct outs for any channel, as a mix minus arrangement of the two main stereo outputs or as continuous talkback feeds. They are linkable for stereo. Faders can be programmed to perform muting of various signals when opened.

Dynamics take in combinations of gate, compressor and limiter while there's a 'Lexicon' stereo effects processor built in through 32 factory presets and 96 user locations. The Lexicon can be driven from either aux, can be bypassed and feeds directly in to the main stereo buses through a level value adjusted in the menu.

In honesty the adjustment of processors parameters is where the LCD really starts to feel small as a lot of scrolling is involved. Having the effects is a nice bonus but probably unlikely to be used by all installations. The constituent parts have the makings of a voice processor

but the manner of presentation is less immediate or convenient than a dedicated IU-high processor box can be.

Two timers are mounted in the meter bridge and can be fired from a fader or run manually. These are accompanied by a squawk speaker and associated talkback and cue controls plus large vu meters on the review model although other options are available.

Operationally this desk is child's play which is as it should be given the target market. There is always a danger of intellectualising the transition from analogue-to-digital in a new market and making evaluations and appraisals that should be left alone. The RM1d is incredibly friendly and approachable and even its hidden depth is not that deep or involved. Careful snapshot planning and organisation for all eventualities should make this a one button set and forget type of a board.

As I said, the precise requirements and operating practices of one radio station will load the appeal of the RM1d quite dramatically. For some the adjustment of mic-gain through the menu may be unacceptable, for example, while for others it will be a strong selling point. Some may decide that there is simply too much control available from the surface while others will be grateful of it. Either way it is difficult to dislike this desk because it does manage to tread the thin line of overlap acceptance between DJ and engineering support.

Most significantly the RM1d is an excellent digital first attempt by Soundcraft to break new ground in an existing market and to offer something distinctly different. Investigate. □

### Contact:

Soundcraft. UK. Tel: +44 1707 665000  
Soundcraft. US. Tel: +1 615 360 0471  
Net: www.soundcraft.com

## 'No exceptions have been made'

...This is the ORIGINAL 'A' series design, as copyrighted in 1973 by Malcolm Toft and his company, Trident Audio Developments Ltd.

From the original blueprints of the Trident A series, comes the dual A series channel. This is real inductive EQ, identical in design and sound to the world famous original. By blending the best modern analogue recording technology with the classic module from the world famous Trident Audio Developments Company, the memorable design and sound of the original

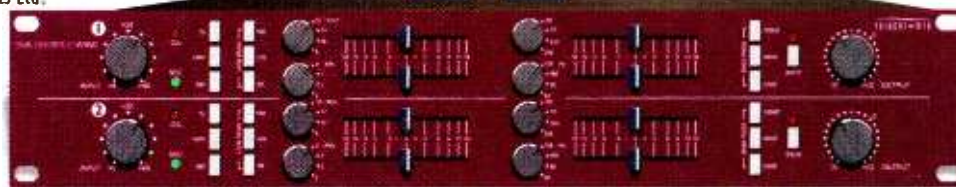

### Signature-one

Mic pre, high/low pass variable filters, classic 4 band parametric EQ. The Signature one offers Trident-MTA console channel quality and sound in a small rack package.

### Signature-two

Dual mic pre and classic 4 band sweep EQs. Compact, quality stereo/dual mono mic pre/EQ tracking solution.

### iX-one - 16channel mic/line interface



16 quality mic/line pre amplifier channels to handle all studio sound sources into digital systems. A fantastic solution.

[www.joemeek.net](http://www.joemeek.net) Fletcher Electroacoustics Ltd, St Mary's, Barton Road, Torquay, TQ1 4DP, England, tel ~ +44 1803 321921 fax ~ +44 1803 321922

## 'No expenses spared'

Trident A series console has been preserved and authentically recreated. The new

Trident MT-A series Dual Discrete Channel presents the most revered design of the Trident Audio Developments company in a package that will compliment any modern professional studio. *Luxury EQ in the making.*

"It's not like the original - it IS the original"

## Super Tube

Multi pattern-ultra presence TB-47 Meekrophone



The new JOEMEER TB-47 ultra presence tube Meekrophone

"The sheer presence and drive of recordings is astonishing, vocal tracks cut through the mix in the nicest possible way. There is no need to create a 'hole' for the voice; I find my EQ section getting dusty." T.Carey, producer

TRIDENT MTA  
[www.trident-mta.com](http://www.trident-mta.com)



# +++ NEW+++THE SCOPE STUDIO PRODUCT+++SCOPE /SP (Studio Package)+++

## SCOPE /SP Highlight #1

SP-Mix. The first virtual digital mixer which can compete functionally as well as aesthetically with the big professional consoles.

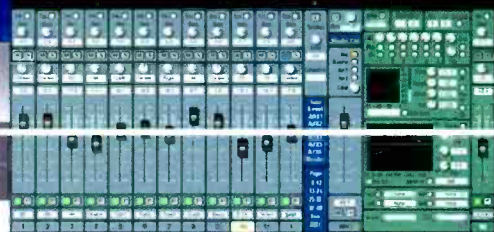

## SCOPE /SP Highlight #2

STS-5000. The most powerful software sampler ever. Realtime time stretching and pitch shifting with formant correction. 25 different filter types. Also handles 32-bit / 96 kHz samples. Up to 64 stereo voices. Compatible to the major sample libraries.



## SCOPE /SP Highlight #3

VDAT. Connects to existing Alesis ADATs (and BRC if available) via the 9 pin interface. Supplements or replaces your ADAT setup without annoying winding times, unnecessary tape wear or creative error messages. Up to 128 tracks. Combine virtual and "real" units. Remote-control VDAT via your "real" BRC. Work on tape only when you need a compatible tape copy. Pretty slick, huh?



## SCOPE /SP Highlight #4

The SCOPE board, with its fifteen DSPs, is your personal time machine. SCOPE /SP puts you years ahead of native systems. Both hardware and software can be expanded still further at any time - in modular fashion, with great flexibility. Only the power of a SCOPE system makes virtual software technology tangible.

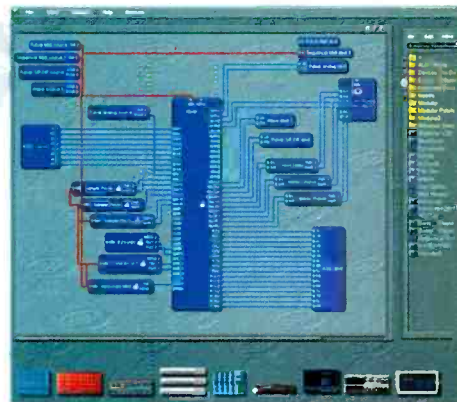

One year after unveiling the SCOPE development system, CreamWare now presents the eagerly anticipated studio product SCOPE /SP. Now you don't have to be a developer to take advantage of all the amenities which SCOPE technology offers.

SCOPE /SP truly is a milestone in studio technology. The system offers all of the advantages of the software world, bolstered by the indispensable power and performance of dedicated hardware. Finally, you can seamlessly merge the possibilities of the latest software technology with your existing studio environment. SCOPE /SP will change the way you think about software.

Thanks to advanced DSP technology, SCOPE /SP is entirely latency-free. Via virtual cables you can make any desired routing - even connect software instruments to any other audio signal within your studio. The SCOPE /SP tone generators not only offer superb sonic quality, you can also play and use them "live" like any other instrument in your studio.

SCOPE /SP can be integrated perfectly into any imaginable studio configuration. You won't need any special drivers or a budget for the training of system administrators. The term "compatibility problem" will soon be a foreign word to you. Simply connect the SCOPE /SP hardware I/Os (and thus the system's software devices) via normal audio cables - just like you do with all of your other gear.

All of this makes SCOPE /SP not merely a uniquely powerful upgrade to any ProTools™ configuration. Thanks to its powerful features, SCOPE /SP is the key to the digital future for any audio studio.

# +++ NEW+++THE SCOPE STUDIO PRODUCT+++SCOPE /SP (Studio Package)+++

For more information please contact [www.creamware.com](http://www.creamware.com) [info@creamware.com](mailto:info@creamware.com) or your CreamWare dealer.

Tel.: (604) 435-0540 Fax: (604) 435-9937

**creamw@re**  
SOFTWARE GETS REAL™



# Sonic Foundry Vegas Video

The shotgun marriage of audio and video continues in Vegas, appropriately enough. **Rob James** reckons it a good bet as arranged marriages go

**Y**OU MAY BE WONDERING what a review of a video software package is doing in the leading pro-audio magazine? The simple explanation is there is a revolution going on. *The Blair Witch Project* and *Time Code* are just the tip of a very large iceberg—one sound professionals cannot afford to ignore.

The same thing that is happening in video is already a *fait accompli* in sound, and I fully expect to hear the same old howls of protest from 'professional facilities' with major investments in hardware. It has become increasingly obvious that the real opportunities for growing business in pro-audio are coming from radio, film, television, games and the latest buzzword, 'streaming'. Leaving aside the practicality issues of broadband streaming, there is already a real hunger for material to go on the web. There is also a great deal of pressure in broadcast towards multi-skilling. In the future, a lot of people are going to find themselves unemployable unless they can deal with pictures as well as sound. There will always be room for specialisation at the high end but it is fast disappearing in many other areas.

This is enabling and democratising technology. It does for media production what DTP did for publishing and native processing audio workstations have done for music. And all the same caveats apply. Vegas will not turn you into Steven Spielberg any more than Cubase or Logic will turn you into Yello (substitute your favourite artist). What it does do is put the tools within reach of a greater number of people than ever before. It also enables those who already have the skills to experiment in ways which would previously have been prohibitively expensive.

Certainly there will be a lot of technically and artistically standard work produced but have you watched broadcast television lately? Vegas is, in the right hands, capable of delivering results which are more than adequate both technically and artistically.

Although not a widely publicised feature, Avid Audiovision has always been able to cut pictures. Digidesign's Pro Tools can do it, as can SADiE equipped with the Portia option. With the best will in the world the picture editing facilities in all of these are fairly rudimentary and really aimed at providing a guide picture for sound work. The picture editing is included simply to deal with last minute changes. Many professional and semi-professional video editing solutions have audio mixing capabilities but not anywhere near as comprehensive as a standalone DAW.

This makes good use of dockable windows and offers a variety of methods of controlling parameters of plug-ins without resorting to the usual graphical copy of a mixing console. All the same audio features are to be found in Vegas Video and the user interface is effectively identical. Amazingly, the intermingling of formats and frame rates also applies to video making it easy to compile projects from a rag bag of sources.

Obviously there are many more tools and windows relating to the video functions but, if you are familiar with the audio package, you are more than halfway through the learning curve for the combined version. A major part of the rest of the curve is familiarity with the concepts of video editing, and processing. As you might expect, there is also a whole new vocabulary to learn—key frames, compositing, motion tracking, alpha channel and so on.

Hardware requirements are modest by today's standards. I used a P3 800 with 256Mb of RAM and two 30Gb UDMA 100 drives, one for audio, one for video. To put this into perspective, a machine with this sort of spec is half the price of the P3 450 I bought 18 months ago. A video capture card is also required. There are any number of these, both analogue and



It has been a source of considerable annoyance that the entry cost of producing serious picture content with complex high-quality sound has either been prohibitively high or necessitated doing picture work in one application and sound in another. This is at best cumbersome and at worst has a tendency to involve major headaches with sync and file exchange. Vegas Video is the first of a new breed of product where the richness of the feature set for video matches the sound capabilities or vice versa.

In my previous review of Vegas Audio, then known as Vegas Pro (*Studio Sound*, July 2000), I was impressed by the quality of many of the audio algorithms, its agnosticism over formats, sample rates and bit depths and the novel user interface.

DV, at widely varying prices, mostly a lot less than a decent audio card. IEE1394 (FireWire) is used for DV and should be OHCI compliant. If purchasing specifically for use with any particular software package it is wise to make sure the card works with your system.

Since this is a native processing package there are real performance benefits to be had from a dual processor system and fast SCSI drives. Striped RAID arrays are even better although none of this is necessary to achieve good results. It will simply improve speed and throughput. (Sonic Foundry supplies an excellent tutorial and I strongly recommend working through this as it provides a painless introduction to many of the more complex features.)



There is an unlimited number of audio and video tracks available. Video tracks take precedence from the top down. For simple editing and crossfading the operations involved are almost exactly the same as for audio—clicking and dragging the line at the top of a segment will lower the gain on an audio track and increase the transparency on a video track. The more complex picture effects require some thought and practice, especially among video novices. A wide range of effects are possible, including still images, titles, picture in picture, transitions, filters and motion effects. As with the audio, crossfades can be produced by clicking and dragging a video clip so it overlaps another. The shape of the crossfade can be adjusted by right-clicking and picking from a list. For a more complex transition, you choose the type from a pull-down menu and drag it over the crossfade and drop it.

All effects are previewed in real-time but there is, as you might expect, a catch. A lot of number crunching is involved in transforming pictures which uses a lot of processing power and in complex sections the previews will become jerky, making lip sync difficult or impossible to judge. One solution is to reduce the quality of the preview, which effectively means the frame rate, or to render the section and drop it back into the project. In any case all projects have to be rendered before they can be output to a file or to external tape.

When I first began to edit, I was a little concerned about the lack of numeric displays of event length, in and out points and so on. Then I remembered the Edit Details window which displays and dynamically updates all this information for the highlighted event. I suspect people who have not previously used high-end editors will not even think about it.

I have been looking at a number of low-cost native processing video editing packages and from what I have seen so far they seem to be at roughly the same stage the audio equivalents were a couple of years ago. Which is to say they are close to the edge of what the hardware can do. There are other similarities, all the fun of hardware and software incompatibilities and of course, plug-ins. However, the amount which can already be achieved with a little patience is astonishing to those of us who grew up with 6-figure hardware solutions.

Capture of new material takes place in a separate application and the other missing item is batch capture from DV. This is not something I miss due to the way I work but I can understand why it is an issue for some people. In any case the majority

of cards come with a capture application and most support batch processing.

In contrast to several of the alternatives, Vegas Video feels responsive and intuitive. If I want a crossfade in video or audio I expect to be able to drag the incoming over the end of the outgoing and listen to or look at the result to see if I like it. Many other applications require the use of separate tracks for incoming and outgoing clips and a lot more steps to achieve the same result. In several it is necessary to render before you can preview the fade and if you change it you have to re-render. This is even more applicable to complex functions.

Sonic Foundry is refreshingly honest about possible limitations imposed by the hardware and offers several strategies to overcome them. In any case, for many applications, where very-high-quality, full-screen pictures are not an issue the limitations are not particularly onerous. For example in web streaming the realistic bandwidth currently available precludes the use of broadcast frame rates and resolution.

When it comes to overall crunching performance—rendering before output—there is no discernible difference between most native processing applications. This is to be expected since the dominant factor is the speed of the hardware. Small variations occur due to the relative efficiency of the algorithms employed but this really amounts to ‘roundabouts and swings’. The great advantage with the native processing approach is the continuing downward spiral in cost and increasing performance of PCs. Providing the source material is of high enough quality Vegas is capable of exporting in a form suitable for broadcast formats such as D1 all the way down to the popular streaming codecs such as RealMedia, Quicktime and Windows Media.

I found the whole experience exciting. From the fluidity of the interface and the degree of control to the polished results which it is possible to achieve.

Even a low resolution 15fps project looks (and sounds) remarkably good when rendered into 25fps full screen (PAL) and viewed on a TV.

Vegas can equally well be used as an off-line non-linear editor with the final product being an EDI in GVG9600 or Sony 9100 formats although, as with most other off-line editors, complex effects will be lost and represented as crossfades.

For someone from an audio background approaching video for the first time Vegas Video is a near ideal introduction. If you are not quite ready to jump in the deep end by attempting complete projects Vegas is good for ‘traditional’ sound for picture work. Dual monitors are supported (given a suitable video card) so you can dedicate one to preview

picture and do the clever stuff with the sound on the other.

There are a couple of real limitations for particular applications. There is no video MPEG output—yet—but this rules out using Vegas for DVD or CD Video origination unless you use third-party software to convert from one of the supported output formats. Sonic Foundry is working on it. But the user interface is remarkably consistent whether you are dealing with video or audio this really makes a difference to the learning curve. You can use it to produce conventional or seriously complex, effects laden, projects. Given the low price premium, anyone considering Vegas Audio would be mad not to give the video version a try. Equally, anyone from a video background looking for something with serious audio features should audition Vegas Video.

Sonic Foundry must be congratulated on producing the first of a new generation of tools. □

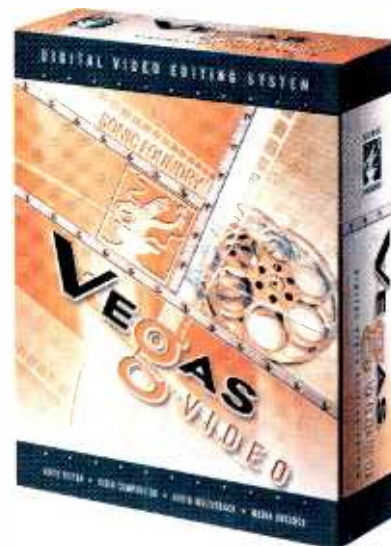

**Contact:**

**Sonic Foundry, US**  
**Tel:** +1 608 256 3133  
**Fax:** +1 608 256 2519  
**Net:** www.sonicfoundry.com



**You can Hear the Difference**

[www.athensmastering.com](http://www.athensmastering.com)

108 Zoodochou Pigis str, 114 73 Athens, Greece: Tel:+(30 1) 383 6252 Fax: +(30 1) 330 6 811 email@athensmastering.com

- Floating LEDE rooms
- ATC monitors with sub
- KRELL preamps, D/A converters
- SONIC SOLUTIONS 96/24 systems with full No Noise
- WEISS 96/24 system including A/D conversion
- EQ's - Compressors - Limiters
- AVALON 2077 Class A Analog Mastering Equalizer
- CRANE SONG Class A Analog Compressor - Limiter
- STUDER - TASCAM 1/4" and 1/2"





## REVIEW

# MARANTZ CDR631

Everybody knows that standalone audio CD-R machines are getting cheaper and slicker. **Zenon Schoepe** reports on a representative from the next games level and the first to market with CD text capability

Representing the next generation of CD-R from Marantz this new machine is presented in 2k livery which is much in keeping with the distinctive look of the company's new CD players (*Studio Sound*, August 2000). In fact from a distance you'd be hard pushed to identify it as a CD-R as it's got the players' clustering and arrangement of buttons complete with colour coded 'vital' keys and that large dial.

The interesting thing is the ingenuity involved in adapting the players' control layout for the different functions of CD-R operation and it has to be said that Marantz has done a good job. It's also done a good job with the connection options. Thus you get balanced XLR inputs, with rear panel input trimmers, and phonos with a rear panel switch selecting between them. Analogue output is on phono. Digital I-O takes in AES-EBU input and SPDIF coaxial I-O with a loop through connector and SPDIF optical input. A rear panel switch selects between AES-EBU and SPDIF connection. Ultimate input selection is down to a front panel switch which works in conjunction with these switch settings.

The machine comes with an infra-red remote, and a fairly nice one to boot, but RC5 ports are provided on the back for connecting and controlling the machine from other Marantz equipment.

Incorporating an automatic sample rate convertor the CDR631 handles CD-Rs and CD-RWs and is the first machine in this generation that I have used with CD Text capability. Text info for such things as band and track names are stored in the machine's memory until a disc is finalised at which point it is transferred to the disc. Marantz' interpretation allows for roughly 20 tracks worth of 60-character text and the machine will hold some 50 discs worth in its memory. Should memory limitations be encountered, and in the normal run of things this seems to be fairly unlikely, you can release extra memory by erasing text that you don't need. The process is performed after the recording is complete and allows you name the disc, the artist and the tracks. The routine is fairly straightforward and involves entering characters from the remote's numeric keypad or via the front panel dial (which can be pressed to enter a value) so it's not exactly speedy. Connection of a PC keyboard, as some of the MD machines do, would make the business more imme-

diately and inspiring, however, there can be no denying that a disc with text on it must win hands down every time in the information stakes over one that doesn't. Which brings me to the not inconsiderable issue of compatibility of CD text on run-of-the-mill professional players. Most will not display the text as they have nowhere to display it on and this must be a consideration for anyone who is taken by the idea of CD Text in much the same way that text on MD adds enormous value to the format in a busy production environment. The simplest solution is of course to employ the CDR631 for playback duties as well and it performs as a very able CD player in its own right. Marantz would, of course, also want you to consider its aforementioned range of new CD players which are all CD Text capable.

The dual nature of the CDR631 is reflected in the inclusion of dedicated CD and CD-R buttons on the machine's remote which flick the machine between these two related but quite different roles. As a player it delivers programmed playback with random and repeat functions as well as audible search and a useful scan play mode which delivers 10-second snatches of each track in succession. It is adequate but nowhere near the



Unsurpassed

Focusrite  
Quad Mic-pre

[www.focusrite.com](http://www.focusrite.com)

Red 1: Quad mic-pre £1925 +VAT  
Red 8: dual mic-pre £1225 +VAT

☆ Red Range - the industry reference for analogue signal processing

for a list of dedicated red centres visit our website at [www.focusrite.com/reds](http://www.focusrite.com/reds)





sophistication of the PMD330/PMD331/PMD340 players I keep referring to.

As a recorder it is obvious that Marantz is now distilling its CD-R machine operations in to really streamlined operation. Either that or I have become unnaturally comfortable with Marantz CD-R logic.

Supported recording modes are Record Disc, Record Track and Manual Record all of which are widely recognised and self explanatory. A Make CD mode creates a synchronised recording by starting the source and finalises the disc at the end automatically.

Auto track incrementing follows incoming IDs or is fired from a 'silence' of more than 2.7s. A 3s silence can be inserted at the head of a track.

For certain modes auto track increment can be defeated and replaced by manual entry from a dedicated front panel key or a prominent button on the remote. There's also an Auto Stop function and copy protection which can be on, defeated or single copy. When in record standby the dial can be used to set recording balance. All these functions are accessed from a dedicated front panel MENU button. The dial also serves to

adjust recording level in modes that require it.

The usual unfinalising and erase routines for CD-RW are present, the metering is adequate with a sensible fall back rate on the peak hold but it's not a patch on that found on the Marantz CDR640, for example. The display accommodates the expected different time displays but is not the excellent LCD-type of the PMD players. However, it does incorporate a display of the first 20 tracks as a row of numbers across the middle of the panel which extinguish as you progress through the disk. You are notified of the existence of track numbers above 20 only by the presence of a + sign though.

In the final analysis the CDR631 acquits itself well by virtue of 'streamlining' out what some might be regarded as nonessential functions and packaging together a nice sounding and rock solid CD Text capable CD-R/RW machine with an able and CD text capable player. Build quality is good and it feels fairly unburstable.

This machine will appeal to the more experienced CD-R user who is familiar with other machines and is comfortable with the medium. For them the lack of such frills as adjustable threshold levels and programmable delay will not be missed or seen as a disadvantage. For newcomers it represents an affordable way in to audio CD production that is simple and satisfying to use. Put this machine high on your list of those worthy of consideration. □

### Contact:

**Marantz UK.**

**Tel/Fax:** +44 1753 686080.

**Marantz Professional.** The Netherlands.

**Tel:** +31 40 27 36634. **Fax:** +31 40 27 35578

**Focusrite**  
Dual Compressor  
Limiter

**Dynamic!**

red 3: dual compressor/limiter £2295 +VAT  
red 7: mic-pre and dynamics £1595 +VAT

[www.focusrite.com](http://www.focusrite.com)

☆ red range - the industry reference for analogue dynamic processing

for a list of dedicated red centres visit our website at [www.focusrite.com/recs](http://www.focusrite.com/recs)

[www.americanradiohistory.com](http://www.americanradiohistory.com)



# HHb Circle 3P

Studio Sound's 'bench test' loudspeaker reviews continue with the HHb Circle 3P. **Keith Holland** reports

**T**HE HHb CIRCLE 3P is a small, two-way, passive loudspeaker comprising a 140mm diameter woofer with a NRSC cone, and a 25mm soft-dome tweeter, mounted vertically on a sculptured front baffle. In common with other loudspeakers from the HHb stable, the cone of the woofer is coloured purple, giving the loudspeaker a distinctive and recognisable appearance;



both drivers are magnetically shielded. The cabinet is a sealed-box design with external dimensions of 175mm wide by 270mm high by 205mm deep, and each loudspeaker weighs 3.7kg. HHb suggests use with power amplifiers in the 30W-100W range with power handling rated at 60W (programme). This figure, along with the quoted sensitivity of 83dB SPL for 1W at 1 metre gives the loudspeaker an approximate maximum output capability of 100dB SPL at 1 metre under free-field conditions.

Fig.1 shows the on-axis frequency response and harmonic distortion for the Circle 3P. The response is seen to lie within  $\pm 3$ dB limits from 100Hz to 20kHz, with a second-order low-frequency roll-off, characteristic of a closed-box system, giving -10dB at about 60Hz. Looking at the shape of the frequency response curve, particularly the 'edge diffraction' hump at around 1kHz and the restricted low-frequency extension, it is likely that this loudspeaker could benefit from flush-mounting in a wall. Sensitivity is, as specified, about 83dB SPL for 1W at 1 metre, which is low by modern standards. The low-frequency harmonic distortion is quite high,

peaking at -25dB (5%) for the 2nd harmonic and -20dB (10%) for the 3rd harmonic, both at 50Hz (ignoring the higher peaks at 30Hz which are well outside the bandwidth of the loudspeaker), but the performance improves at higher frequencies where the levels are maintained below -45dB (0.5%) from 100Hz upwards. The horizontal and vertical off-axis responses are shown in Figs.5 and 6 respectively. Directivity is controlled in both planes, with no evidence of mid-frequency narrowing or side-lobes, but the characteristic crossover notch at 3.5kHz, due to driver spacing, is evident in the vertical plane. The dip in response at 18kHz, which is only evident at 30° in the upward direction, is strange but of little concern at such a high frequency.

The step response for the Circle 3P (Fig.3) shows very accurate time alignment between the two drivers, with a steep, virtually uninterrupted leading edge, and the acoustic source position (Fig.2) is seen to move to a maximum of only 1.2 metres behind the loudspeaker at low frequencies. These results both indicate that the Circle 3P should be very accurate at reproducing transient signals. The waterfall plot (Fig.7) shows that the decay at low frequencies is nearly as fast as that at high frequencies (limited, in this plot, by the process window function), which is a further indication of accurate transient response. The low-level ringing at around 200Hz in the waterfall plot is evidence that the small dip in on-axis response at that frequency is probably due to resonant behaviour, possibly in the cabinet. Fig.4 shows the power cepstrum plot derived from the on-axis frequency response. There is some evidence of echoes at about 50 and 100 microseconds, but otherwise the plot is relatively clean.

To sum up, the HHb Circle 3P is a commendable performer. The time domain response is particularly noteworthy, suggesting accurate reproduction of transient signals with little resonant 'hangover'. The limited low-frequency extension and relatively high low-frequency harmonic distortion are perhaps not surprising in a loudspeaker of such diminutive proportions and, when considered alongside the low sensitivity and power handling, it is clear that this loudspeaker is not intended for high-level listening. □

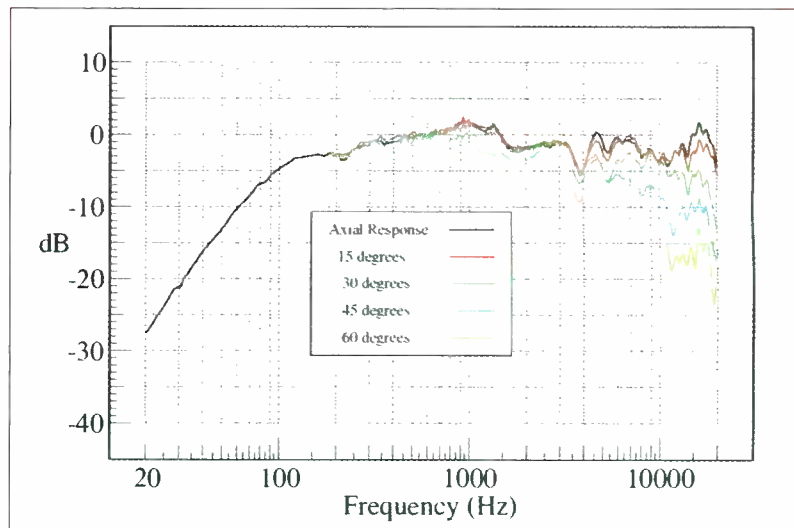

Fig.5: Horizontal Directivity

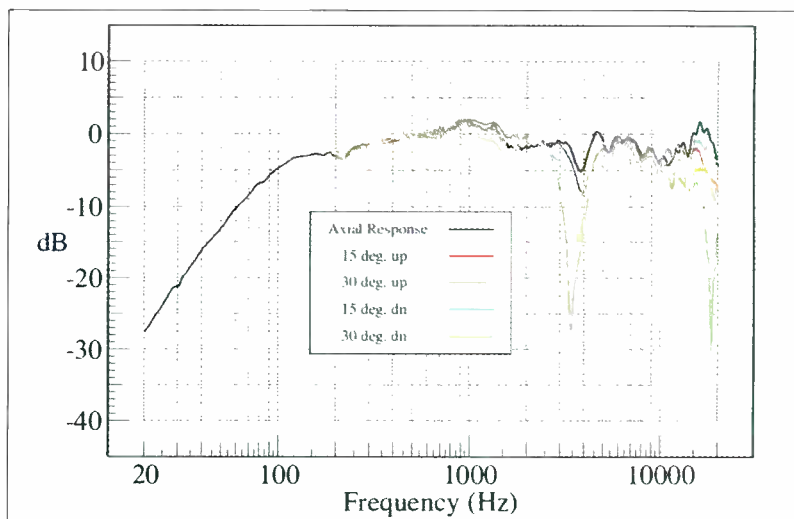

Fig.6: Vertical Directivity

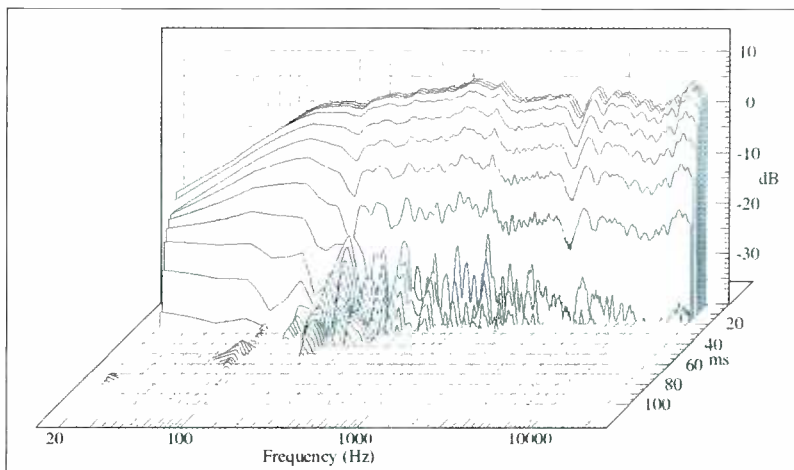

Fig.7: Waterfall

**Contact**

HHb, UK  
 Tel: +44 20 8962 5000  
 Fax: +44 20 8962 5050  
 Net: www.hhb.co.uk  
 HHb, US  
 Tel: +1 310 319 1111  
 Fax: +1 310 319 1311

**Methodology**

Studio Sound, April, page 14  
 Net: www.prostudio.com/studiosound/apr98/r\_tannoy.html



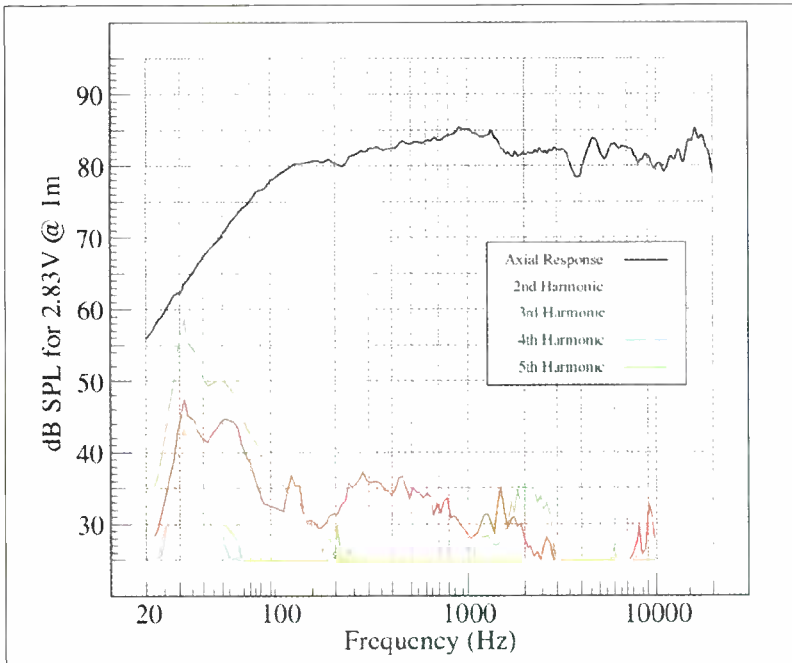

Fig. 1: On-axis Frequency Response and Distortion

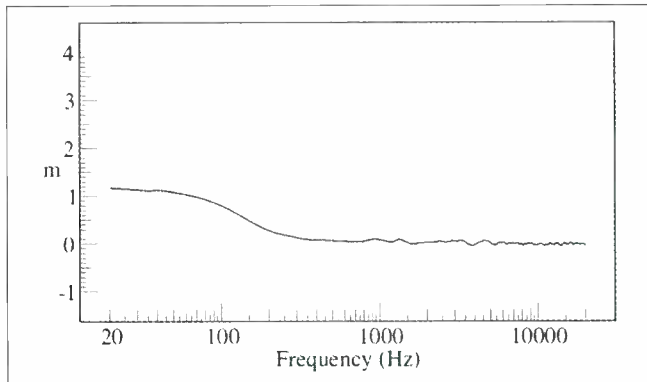

Fig. 2: Acoustic Source

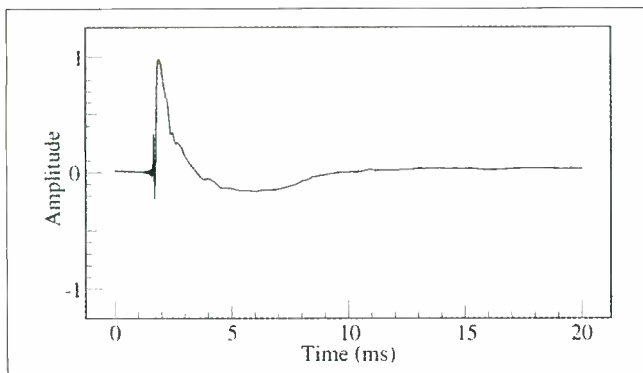

Fig. 3: Step Response

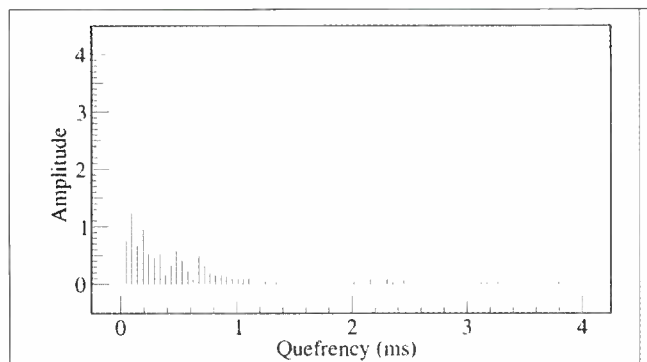

Fig. 4: Power Cepstrum

prolight-sound.de

# prolight+sound

Experience a new world:  
The stage of the future.

In Frankfurt the global market prepares for a big entrance. At Pro Light+Sound, the international trade fair for event and communications technology, production and entertainment. Global market leaders will display their latest innovations. Here you will see, hear and experience the trends of tomorrow.

**March 7 – 11, 2001**  
Halls 5.0 and 6.0 (Light- and Stage technology) are open up until 10th March 2001 inclusively

Collins & Erskine, Messe Frankfurt  
Representatives in the United Kingdom  
2nd Floor, Chancery House  
25-27 Chancery Street, London, EC4N 4EJ  
Phone: 020 74 80 40 80, Fax: 020 74 80 40 81  
info@collins-erskine.co.uk

 Messe Frankfurt



# Audio Consumer Service ACS-11

Shedding baggage and packing ACS' newest mixer, **Neil Hillman** discovers a shrewd marriage of sufficiency and efficiency. Take a trip with a new stereo location mixer

**A**SOUND RECORDIST IS, by nature, an individual. A cameraman wouldn't agree of course; cameramen lump all sound recordists into the same category: over-fed and overpaid technocrats who constrain them from exploring the wider parameters of visual enchantment. As individuals then, there is perhaps only one thing that we would ever agree on: cameramen, by nature, are moaners. What's the difference between an A320 Airbus and a 10-hour day with a cameraman? When you get off an airbus the whining stops.

Of course some of my best friends are cameramen but it helps to illustrate the point that mixer manu-

Housed in a reassuringly robust die-cast aluminum case with cream-coloured epoxy finish, first impressions of the ACS-11 are of its slim profile and of its home build, Maplin-kit feel. But this belies the clarity of its audio, and its ability to function in a big, grown-up world demanding M-S and AB stereo functionality.

The control surfaces are contained to the top and two of the sides, with the internal batteries loaded via a sprung cartridge into the bottom face. Four 1.5V AA batteries provide sufficient energy for the phantom power available on all three inputs and an operating time of around five hours; with sensi-

level pot, the monitoring matrix, a 4-pin male Neutrik connector for an external power supply and finally a 7-pin male Neutrik connector for connection of audio to and from the outside world. Pins 1 and 2 carry the left output, Pins 3 and 4 the right. Pins 5 and 6 are the unbalanced return left and right signals and Pin 7 is grounded. Many mixers have standardised on a 10-pin system—usually through a Hirose connector—providing balanced return feeds but in general, camcorder monitor feeds can be so dirty with either poor monitoring circuitry or time code data crosstalk that the ACS' unbalanced feeds are perfectly adequate. The 0dBm outputs at -12dB on the PPM correspond to a standard 0.775V.

The monitoring matrix allows for individual selection of: Left, Right, Mono, AB, MS and M outputs. External power between 8V–24V may be connected to the 4-pin socket, with Pin 4 carrying the positive voltage. The steady-state operating current is taken from the external adaptor providing the voltage exceeds 8.5V. The current drawn is stated as 350mA.

The day-to-day business is carried out on the top control surface, dominated by two elements: an LCD bar-graph metering system window to the left, and the three red-capped rotary faders to its right. The PPM ballistics of the meters are represented on a digital-type scale, with on-screen calibrations fixed at -

40dB, -30dB, -20dB, -12dB, -9dB, -6dB and 0dB. There is no master output fader—the output being set at a nominal -12dB—but presumably somewhere there is a trim pot to adjust such things as oscillator output level, as the test mixer offered its line-up tone somewhere between -9dB and -12dB. A nice feature however is the ability to simultaneously view the output and return levels on the twin-bar metering; the top bar graph looking at the output, the bottom pair the return. Without external power connected, the LCD screen is not as easy to read as perhaps it should be; as the back-light does not operate from the internal batteries. The power LED next to the screen gives an indication of full power through a steady yellow state, which changes to a flashing state when the battery power is low. Inputs 1 and 2 may be ganged

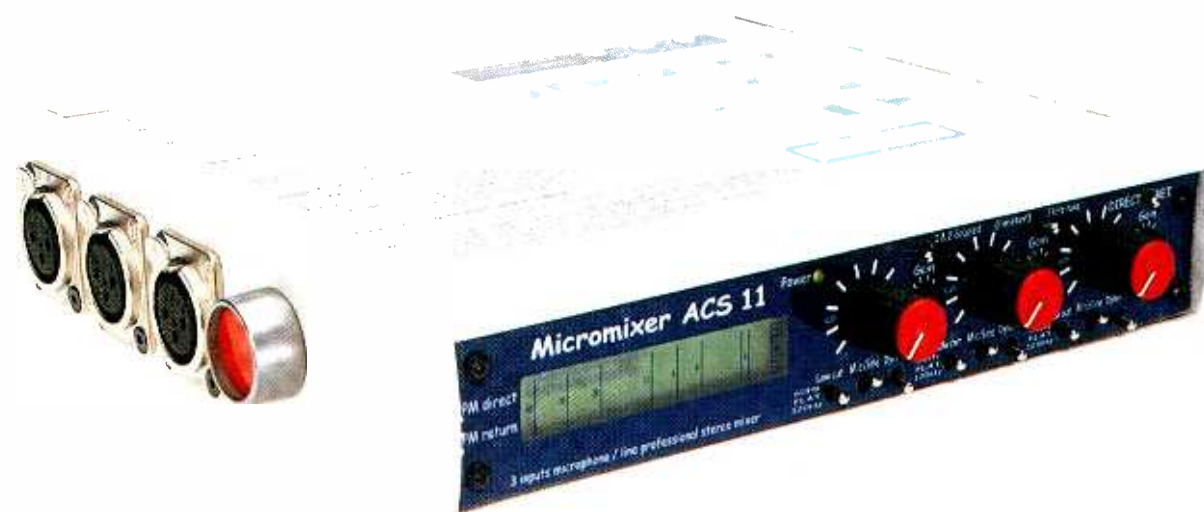

facturers have known for a long time—we all want quite different things from our mixers. Being undoubtedly the most personal item of any location recordist's tools, and certainly the most prized, great deliberation will have taken place before the final choice is made.

The ACS-11 MicroMixer is a 3-channel stereo location mixer, and as individual as they come. Ask ACS nicely and the company will even provide a bespoke design for your particular needs. The Belgian Audio Consumer Service company—ACS—has introduced the ACS-11 MicroMixer to cater for the very basic requirements of stereo acquisition in the field, and at a price to match. More used to producing location film drama desks—the ACS-10, with a host of features that include its own time code generator—this simpler design is somewhat of a departure.

ble power management this would probably equate to a days filming.

The left-hand side of the mixer houses a large, glove-friendly on-off push-button (that initiates a mixer model number and the software version loaded message on the front LCD metering screen), and the three female Neutrik XLR input sockets for the mic-line inputs. These were unmarked on the demonstration model, but Input 1 is closest to the operator. Inputs 1 and 2 are used as the stereo input for suitable microphones, ganged by a setting on the front control panel. The maximum input level is stated as being 1.2V rms, with an input impedance greater than 40kΩ. Phantom power is provided at 48V.

The right-hand side panel houses from the top: the 1/4-inch stereo headphone socket, the headphone



# Never say Never again...

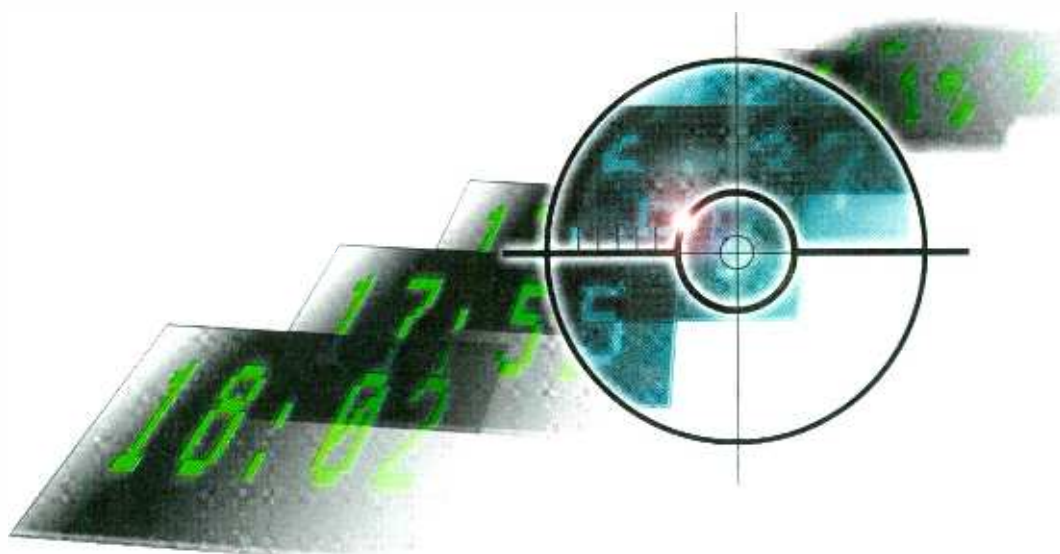

Your working hard, the new movie trailer's final mix is due tomorrow by 10 am, everything is going great and then you hear it, somebody made a mistake, you think it might be about twenty edits back, but you don't have a backup!

## The bad news...

In this ever changing fast paced world of studio project deadlines one mistake like this can quickly add up to hours, or even days of extra work costing you both time and money.

## The good news...

With Nuendo mistakes are a thing of the past.

Thanks to Nuendo's powerful unlimited Undo and Redo it's no problem if a mistake is twenty edits back or a hundred. The Edit History window displays all changes made the past hour, three hours or until you Close the project making it easy to target that potentially costly mistake. And rest easy as the original audio files remain untouched unless you choose otherwise.

But Nuendo goes even further. You can process any audio segment with a wide variety of powerful edit operations and plug in effects with the integrated Sample Editor, or even from directly within the Project or Browser windows. And as each segment has its own individual off-line history which is stored with the Project, the edits you make today can be selectively removed, or even re-applied with new parameters within seconds tomorrow giving you total freedom of choice.

With Nuendo you'll never say never again...



The top piece of the Edit History window indicates events you can Undo/Redo while the Offline History window below it shows the various processes that can be modified, replaced, or removed for each audio segment.



New Times  
New Thinking

**Steinberg**

www.nuendo.com

www.americanradiohistory.com



## REVIEW



together through a toggle switch above and in-between Channel 1 and 2 pots for stereo microphone work, leaving Channel 3 free for such things as either a presenter's personal microphone or a hand-held 'stick' mic. Each channel has its own rotary fader with 10 un-numbered reference marks, and alongside each fader is a gain trim-pot that provides for continuous gain adjustment between -60dB 'mic-level' and -10dB 'line-level'. Below the gain preset is a 3-way toggle switch for routing the channel to either L (left), L+R (left and right) or R (right) buses. Three similar toggle switches sit underneath each channel fader and allow selection of Low Cut—switchable between Flat, 60Hz and 120Hz and offering a 12dB/octave slope; Mic or Line input selection; and Dynamic or P48 phantom microphone powering. Two further, similar, toggle switches exist on the top of this right-hand side, these being a 3-position switch to switch the limiter in or out or the selection of the 1kHz tone generator. The review mixer did not in fact have a limiter fitted, this being the choice of the

recordist for whom this mixer had been built but a limiter option is available for those, who like me, feel that working without a limiter is like going out on a cold day without any underpants on: it's survivable and nobody can know or tell—but its an uncomfortable sensation that is best not to be commended to anyone other than the brave, the foolhardy or the kinky.

The last toggle switch is for switching between the direct output and return signals. While the meter continuously reads both the output and return, a confidence boosting flick across the 'out' and 'in' signals with the ears can achieve in a fraction of the time what the eyes need time to process.

The ACS-11 is clearly designed to be a simple, no-frills, over-the-shoulder mixer that caters for the basic requirements of stereo news-gathering operations in a simple, no-frills manner. That this little device achieves its goal admirably—with a signal-to-noise ratio of 104dB, crosstalk greater than 80dB and a 35dB headroom—shows that the experience gained

from the production of the larger, more sophisticated location drama desk, the ACS-10, has had definite benefits for this design.

The ACS-11 MicroMixer is quirky; it's different, it's interesting and of course, it's very individual. Priced at 1,850 Euros (roughly just under £1,500, UK) also makes the ACS-11 attractive. Dedicated to news gathering for instance, where very clearly defined requirements exist and are predicted, or as an outboard pre-mixer to a separate recording DAT or MiniDisc, or even as an aid to the dreadful and dreaded occurrence of untrained

production staff creating an ever deeper nadir in television history, with their badly operated DV-Cam lash-ups, the ACS-11 stands up well to scrutiny; but for the Journeyman recordist, covering any and every possibility of location sound, the lack of flexibility—consistent to its budget price and design purpose—would rule it out of a recordist's 'main' mixer equation.

As with guitars, mixers embrace variations on a basic design theme to meet specific requirements. But who would doubt the validity of unorthodox methods, when the result from turning a Fender Stratocaster upside down and playing it left-handed can produce such spectacular results?

### Contact:

**ACS Audio Consumer Service**, Belgium  
Tel: +32 3 6755337 Fax: +32 3 6755268  
E-mail: [acs@busmail.net](mailto:acs@busmail.net)  
Net: [www.listen.to/acs](http://www.listen.to/acs)

handle with care

"The thing I like most about the 3541 is the sound pressure handling," says Steve Power, producer of "Sing When You're Winning," Robbie Williams' latest hit album. "Robbie's got a hell of a loud voice. We had a track on the previous album where half the vocal was completely ruined because there was no mic that could handle his volume - he'd already distorted it before it got anywhere near the mic amp! The 3541 can actually handle it."

**DPA**  
MICROPHONES

[www.dpamicrophones.com](http://www.dpamicrophones.com)

What will you like most about the new Type 3541 large-diaphragm microphone kit - incorporating the world's most sonically advanced recording technology? Find out more and arrange your demonstration now at [www.dpamicrophones.com](http://www.dpamicrophones.com)

Gydevang 44, DK-3450 Allerød, Denmark  
Tel: +45 48 14 28 28, Fax: +45 48 14 27 00  
Email: [info@dpamicrophones.com](mailto:info@dpamicrophones.com)





WHEN L.W.  
 RAN INTO S.P.  
 AT JFK, THEIR  
 THX<sup>®</sup> APPROVED  
**LSR25Ps**  
 GAVE FLIGHT  
 TO NEW  
 CREATIVITY.

As you can see, the all-new THX<sup>®</sup> Approved LSR25P powered monitors are really taking off. That's because key industry professionals are discovering one very simple



A talented musician, successful composer and recognized producer, Lenny White is considered one of music's real innovators. He's played with such greats as Miles Davis, Chick Corea and Stanley Clark, and has also collaborated on some of the most recognized and influential music of the past three decades, including the new CD *On the One*, with Sammy Peralta.

and indisputable fact: the LSR25P consistently outperforms any other monitor in its class. As a result, it's gaining popularity in all critical monitoring applications, from digital workstations and near field stereo to 5.1 mixing. In fact, the LSR25P is as comfortable on the road as it is on the meter bridge.

Every LSR25P incorporates JBL's revolutionary Linear Spatial Reference (LSR) performance characteristics, assuring a mix that sounds consistent from room to room. What's more, the two-way 5.25", bi-amplified LSR25P



Sammy Peralta loves music. That pure and simple fact comes through strikingly clear as he sits at his keyboard tinkering with half-written tunes. Sammy's background includes work with talents including Tito Puente and Willie Bermudez. "I have to be careful because I can get so lost in the music, I sometimes forget I have a family that would like a little of my attention too".

also features 150 watts of linear power as well as purpose-built transducers with JBL's most current thinking and designs. This last point has earned the entire LSR family of monitors continual critical acclaim for more than three years.

One last point: Sammy Peralta's new CD *On the One* featuring Lenny White was mixed entirely with LSR monitors.

**LSR.**



H A Harman International Company

[www.jblpro.com](http://www.jblpro.com)

© 2000 JBL Professional



# Prosoniq TimeFactory

TimeFactory employs artificial neural network-based processing to apply time and pitch scaling to digital audio files. **Simon Trask** clocks in

**T**IMEFACTORY, a standalone program dedicated to applying time and pitch processing to digital audio files is available for Mac OS and Windows 95-98 platforms. The program uses a proprietary near-lossless algorithm called MPEX (Minimum Perceived Loss Time EXpansion/Compression) to provide high-quality time and pitch scaling. Based on research begun by the company in the early nineties into human perception, and using an artificial neural network technique, the algorithm eschews 'conventional' mathematical approaches in favour of a simplified computer simulation of human nerve cells. The software also implements a proprietary algorithm, timbreWizard, designed to avoid 'munchkinisation' effects which commonly occur with pitch shifting. According to the limited information provided in the manual and on the Prosoniq website ([www.prosoniq.com/html/mpex.html](http://www.prosoniq.com/html/mpex.html)), MPEX 'looks

at your recording in regular intervals and learns its musical aspects, and then tries to extend it in a natural sounding way.' Prosoniq describes this process as 'Still a long way from being as sophisticated as a human, but still far better than anything else based on pure maths.' In other words, TimeFactory is positioned by the company as the *creme de la creme* of time-pitch scaling software.

There's just one window, the Batch List, into which you load and then time and/or pitch scale audio files. You can load files either via the File menu, the folder icon button at the bottom of the window, or the much quicker method of dragging and dropping the files into the Batch List window. Because the window isn't that wide, there's plenty of desktop space for dragging files from the Finder into the window. You can also drag in multiple files if you want. Clicking on the folder icon button brings up an Open dialogue. The File menu method gives you three options: Open Audio File, Open Split Stereo File, and

Open Multiple Files. The Split option provides a special two-stage Open dialogue which lets you load both mono files of a split stereo file, while the Multiple option keeps throwing up the Open dialogue until you click on CANCEL, allowing you to load as many files as you want consecutively. Another useful function within TimeFactory is Reveal In Finder, which opens up the selected file's folder onto the desktop and highlights the file icon.

Once in the Batch List, you can select a file by clicking anywhere within its display area. You can playback your files within TimeFactory by clicking on the arrow icon button or pressing the spacebar. To stop playback at

File	
Open Audio File...	
Open Split Stereo File...	⌘I
Open Multiple Files...	⌘L
Save as...	⌘S
Process Selected Files	⌘M
Choose External Editor...	⌘E
Open Selection in Editor	⌘T
Reveal in Finder	⌘R
Quit	⌘Q

any time, you press the space bar again or click within the popup window that appears with the message 'Playing <filenames>' during playback. You can't do anything else at all on your Mac while a file is playing, which is perhaps fair enough if you're totally focussed on working within the program.

There is an alternative option which is to open the file into a designated external editor. TimeFactory's File menu has an option for choosing an external editor, and a function for opening the selected file in that editor. (Users of the Mac version of TimeFactory who don't have an existing editor can use the free version of Prosoniq's SonicWORX audio editor on Prosoniq's web site.) TimeFactory can't record audio itself, so an external recorder of some kind is a necessity.

The listing for each file in the Batch List window shows sample rate, bit depth, and (to the nearest second) duration of the file. TimeFactory can load and save files in AIFF, WAV, and (on the Mac only) SDII formats, and supports 8-bit, 16-bit and 24-bit resolutions along with 22.05kHz, 44.1kHz, 48kHz and 96kHz sample rates. For pitch scaling you can set semitone and cent values, either by typing them in or by clicking on the up and down arrow buttons. For duration-speed time scaling, you have to type in values. The adjacent drop-down menu lets you select from seconds, percentage and BPM display values; in the case of BPMs, TimeFactory won't calculate them for you, instead you have to enter a figure manually. In each case TimeFactory supports fractional values to several decimal places. When you load a file, the default semitone and cent values are of course zero, while the percentage is 100% and the seconds value is the exact duration of the file to multiple decimal places. To create a new, scaled file, you enter the values you want into the existing file's parameter fields, then click on the DSP icon button, press COMMAND+M, or select Process Selected Files from the File menu. A processing window containing a progress bar and a numerical timer countdown pops up. In this case it is possible to do other things on your Mac while TimeFactory processes the file. When the processing is finished, the new file is added to the end of file list in the window. TimeFactory automatically prefixes the file name with the semitone, cent and duration-speed values for the file. Pitch and time scaling can be applied to a file at the same time, though processing will take longer. You can take a pitch and time scaled file and further process it within TimeFactory.

The list presentation format in TimeFactory makes it easy to switch between different files, which is useful for comparison. The program also has a Preserve Formants and the Algorithm menu gives you a choice of four processing algorithms: monophonic-voice-instr, polyphonic (fast), polyphonic (best), and

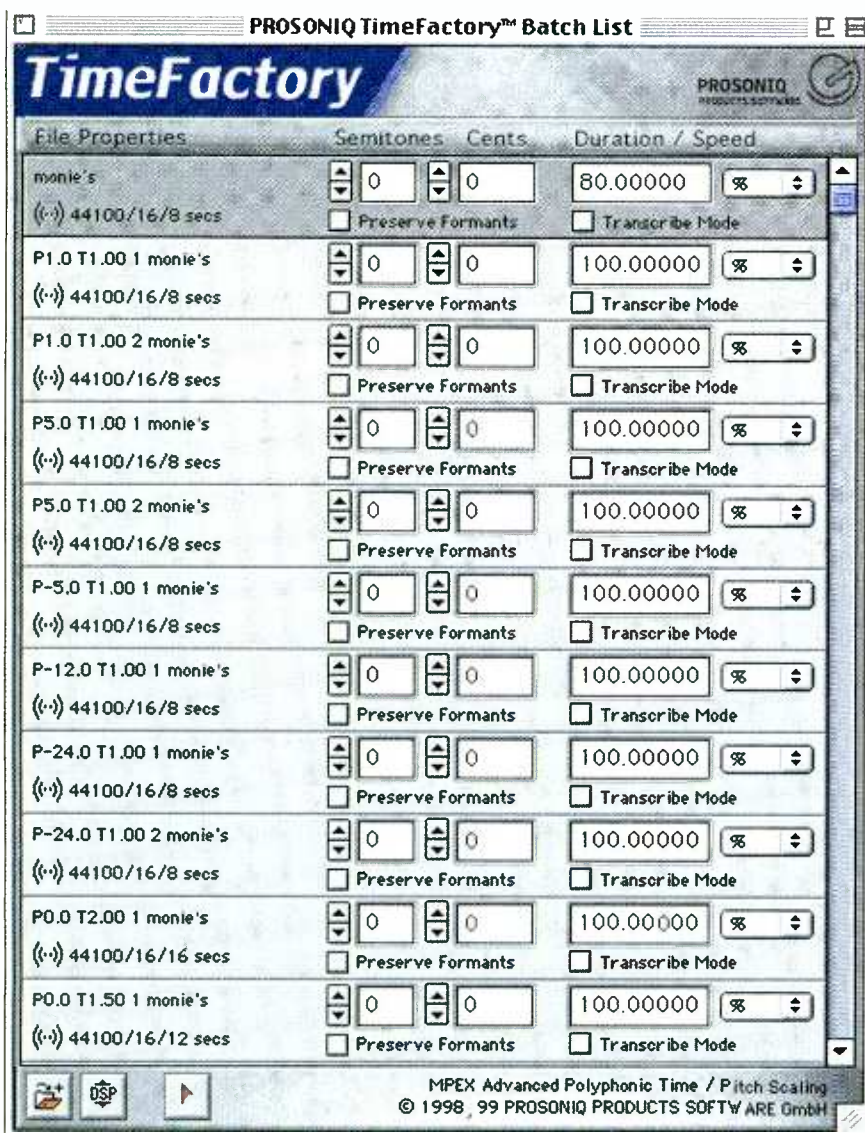



polyphonic for classical music. The first is by far the quickest, and as the name indicates is intended for single voice-instrument mono tracks. With the other three, you'll have to play it literally by ear to decide which is best for the material you're working on, and don't presume that you must use the Best (slower) option.

The simplest way to use TimeFactory is with the Transcribe function. If you tick the Transcribe Mode box, the other settings grey out, and when you start processing TimeFactory creates a 200% time-scaled (half-speed) version of the file. You could set the duration setting to 200% but the Transcribe option is optimised for speed at slight expense of quality.

As the function's name indicates, it has been included to facilitate music transcription. You can record or copy and paste a section of music into a new audio file in your editor, load it into TimeFactory, then use Transcribe mode to halve its speed without changing the pitch. Of course, you can then Transcribe the Transcribed file and halve the speed again. Quite apart from the advantages for transcription, this function is a quick and not so

#### Algorithm

- Monophonic/Voice/Instr.
- ✓ Polyphonic (fast)
- Polyphonic (best)
- Polyphonic for Classics

dirty way to get some interesting creative results by drastically slowing down the music.

File processing is definitely non-real-time, and the faster the computer you use the better, especially for polyphonic processing. For instance, Transcribe mode on a 22s vocal file took 1m 31s on the G3/233 and 41s on the G4/400. The same file took 1m 13s to time scale to 80% in mono-voice-instr mode on the G3, and 29s on the G4. Eighty per cent time scaling using the polyphonic (fast) algorithm took 3m 58s and 1m 40s respectively. Using the Preserve Formants feature made little difference to the processing times. These figures give some idea of how long file processing takes with TimeFactory. You can transpose up to  $\pm 24$  semitones from the original (and further if you scale a scaled file), while on accidentally typing in 1200% rather than 120% I ended up with a file that had metamorphosed into a 'slow motion' soundscape which yielded some great effects.

You don't have to process a complete file in order to hear the results of your settings. Press CANCEL at any time during processing and TimeFactory creates a new file processed with your settings up to that point. You can't select segments within a file to test, but then all you need to do is copy out the relevant segment into a separate file in your editor and work on that in TimeFactory. Incidentally, files can easily be removed from the Batch List window individually or in groups by selecting them and then pressing DELETE (hold down SHIFT to select multiple files).

TimeFactory provides a simple, focussed presentation of a complex, focussed task, and as such is a refreshingly easy program to use. At the same time it doesn't come cheap, and the absence of bells and whistles may make it seem expensive. However, what you're paying for is sheer excellence. The sonic quality, accuracy and transparency of the pitch and-or time scaled files which TimeFactory produces are impressive, even going beyond the sort of pitch and time ranges that you

would likely be using in everyday adjustment work. SonicWORX, a similarly easy to use, straightforward yet sophisticated program makes a good companion. Thanks to the Internet, you can easily get hold of a time-limited demo version of TimeFactory, and also a free version of SonicWORX.

TimeFactory gives excellent results and provides great flexibility with the minimum of fuss. If you need to adjust the pitch and-or duration of audio files, then you should give Prosoniq's program a try. □

#### Contact:

Prosoniq, Germany  
Email: info@prosoniq.com

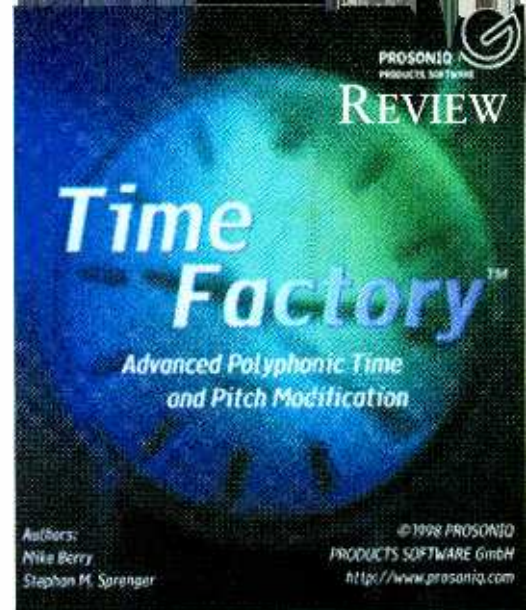

## TUBETECH SMC 2A ANALOG STEREO MULTIBAND COMPRESSOR



The TUBE-TECH SMC 2A is an all tube based stereo multiband opto compressor. It features variable x-over frequencies between the three bands. Each band features separate ratio, threshold, attack, release and gaincontrol. A master output gain controls the overall level.

#### World wide representation:

Australia: (02)9975 1211 Belgium: (011)23 23 55 Brazil: (011)604 8339 Czech republic: (0455)631 555  
Denmark: 43 99 88 77 Finland: (95)123 530 France: (03)8721 8210 Germany: (089)609 7670 Greece: (1)8238 200  
Holland: (010)414 7055 Hong Kong: 2408 2322 Italy: (051)766 648 Japan: (03)5489 3281 Korea: (02)565 3565  
Norway: 88 00 89 89 Poland: (622)44 66 99 Portugal: (1)7 1220 10 Russia: (095)784 7575 Slovak Republic: (07) 214 051  
Singapore: (225)5115 Spain: (3)319 5358 Sweden: (046)32 02 70 Switzerland: (01)840 0144 Taiwan: (2)2719 2388  
Thailand: (226)23015 Turkey: (0212)272 9750 UK: (1691)6585 50 USA: (805)373 1828

## LYDKRAFT

Lydkraft Aps • Ved Damhussøen 38  
DK 2720 Vanløse • DENMARK



# Shure KSM44

Bidding hard for a slice of the professional condenser market, Shure has unveiled the KSM44. **George Shilling** is buying

**S**HURE HAS MADE great microphones for years. Even today, very few rock and pop sessions don't at some point involve the use of Shure dynamics. Oddly, at the condenser end of the market, Shure has never quite cracked it.

The KSM44 aims to be the breakthrough. It is a flagship model for the company: a side-address condenser with multiple polar patterns. A 1-inch dual diaphragm, transformerless design with internal class-A electronics, it is obviously designed for studio use. Powered by a 48V phantom supply, it comes in a padded metal case with a quick-locking swivel mounting clip, and a conventional-style elastic shock mount. Both feature a knurled lock nut that screws onto a thread around the XLR socket at the base of the mic. All the hardware is precisely machined, and felt secure. The mic itself comes in a plush fabric bag, and a clear, informative manual is included.

The KSM44 is torpedo-shaped, quite weighty at 490g—about the same as a Neumann U87Ai, although about an inch shorter—and beautifully constructed. The grille is a very fine metal mesh and looks the part with stylish fifties curves and an even more retro space-age feel when placed in the suspension mount. There are neat switches arranged in similar positions to those on an 87: on the front is pattern selection, and on the rear are 15dB pad and bass roll-offs. These all operate positively, and are easy to use—no need to search for a biro here. Patterns available are cardioid, omni and figure-of-eight, so it seems that Shure is very obviously targeting the Neumann U87 market. With all patterns, the low frequency response is great, only just starting to dip around 20Hz. At the high frequency end of the graph, there is some on-axis treble



lift. In the cardioid pattern there are a couple of bumps at around 6kHz and 12kHz of a couple of dB or so, adding a pleasant clarity and detail. In omni mode there is a 4dB boost at about 12kHz on-axis, while in bi-polar mode the boost at 6kHz is accentuated. This mic has particularly low self-noise, at 7dB this matches the figure for Neumann's TLM103.

In a shoot-out on a vocal recording session with a powerful and dynamic male singer, the enhanced clarity and detail of the Shure won out over an older Neumann U87. The KSM44 seemed to reject sounds coming from the rear slightly better than the U87 in cardioid mode. On cello, the KSM44 sounded extremely natural and uncoloured. Two contrasting positions were experimented with, and in each case, little EQ was required at the recording and mixing stages, the sound seeming to 'settle in' amongst other sounds. When auditioned alongside Abbey Road's vintage valve mics such as Neumann U47 and U67 models, the KSM44 acquitted itself admirably, with arguably more detail, although, unsurprisingly, less low-mid warmth.

The choice of two bass-roll-offs is a useful feature. There is an 18dB per octave cut-off at 80Hz. The more gentle roll-off is a 6dB per octave filter at 115Hz which is more suited to proximity-effect compensation.

The omni mode exhibits almost perfect omni-directionality up to above 5kHz, with higher frequencies becoming gradually more directional, whilst the figure-of-eight's response is roughly comparable to that of the rival U87.

At approximately half the price of a Neumann U87, this mic represents superb value. A quality model such as the KSM44 can only enhance the good name of Shure. This is a good upgrade for those wishing to progress from budget models such as Oktava, and has the sound and feel of a top-flight professional mic. Expect to see it in a studio near you soon... □

#### Contact:

**Shure Brothers Inc** US  
 Tel: +1 847 866 2200. Fax: +1 847 866 2279.  
**Shure GmbH**, Germany  
 Tel: +49 7131 72140. Fax: +49 7131 721414.

## NEW TECHNOLOGIES

### Fostex enters 24-bit 24 track fray

Fostex has revealed details of the D2424, a 96kHz, 24-bit, 24-track hard disk recorder that will start shipping in XX for £2399 (+VAT UK) for a single caddie system with 15Gb drive. The machine boasts an additional 32 tracks to the 24 available at full resolution and comes with 24-channel ADAT I-Os and 8-in, 24-out analogue balanced inputs as standard. There's also a secondary storage bay, optional DVD-RAM drive for storage-backup, double mountable drives, a new rugged hard disk caddie, sync to external video signal allowing precise sync with a P2 editor and six time code frame rates. The box features 128 times



over-sampling AKM converters and multiple undo limited only by available disk space and editing status complete with a Chrono-select undo function which stamps edits with date and time information automatically. Fostex D2424 retails at £2,399 + vat including.  
 SCV. UK. Tel +44 20 7923 1892

### Midas broadcast console

Building on the considerable success that its consoles enjoy in broadcast environments and the inclusion of broadcast comms panels on its boards for some years, Midas has unveiled a dedicated broadcast console called the Broadcast 2000. Designed for TV studios and mobile video production but also film and music post, the desk is 7.1 capable with AES-EBU I/O converters available as an option together with AV router interfaces and snapshot automation. The desk is available in 24 to 72-channel frames and can be loaded with any combination of mono and stereo modules. Other features include Midas EQ, six auxes, eight mix minus buses plus eight stereo subgroups.

**Adaptive-controlled digital processing by Jünger Audio**

2ch ... 4ch ... multichannel

r

evolution

www.juenger-audio.com

phone +49(30)6777210

fax +49(30)67772146

info@juenger-audio.com

- for analog signals
- for digital signals
- for digital multichannel formats
- for SDI-signals with embedded audio

C8000

modular processing system



# STUDER



Music from composed by Pablo Picasso and Studer.

## Studer Creates TV Broadcasting Solutions

### For future transmission

Studer's digital solutions make sense to today's television broadcasters. Easy to learn, easy to use and easy to maintain, Studer systems can be quickly and reliably integrated at every operational level. And, at Studer, we also understand the importance of tomorrow. Our systems architecture is future-proof because we have built in the opportunities for expansion and upgrading to new formats. Because protecting your financial investment is all part of the Studer broadcasting solution.

Over the last 50 years, Studer's name has become synonymous with reliability. Thousands of TV broadcasters all over the world put their trust and their professional reputations in our hands. Because our technology will not let them down. Because it is by Studer.

**Studer  
Professional Audio AG**

CH-8105 Regensdorf-Zurich  
Switzerland  
Phone +41 1 870 75 11  
Fax +41 1 870 71 34  
eMail [info@studer.ch](mailto:info@studer.ch)

[www.studer.ch](http://www.studer.ch)



The new Studer D950 M2 Digital Mixing System



# tc electronic Triple·C

Extending the range and appeal of its budget range, tc's latest baby is a flexible dynamics processor. **Dave Foister** discovers the power of three

OVER THE PAST YEAR or so, tc electronic has shown that it can manage the difficult task of maintaining product ranges at both ends of the market with equal competence. At the top end, tc's System 6000 stands alongside other products as the standard for multichannel effects processing; at the entry-level end, the M-One and D-Two have shown what can be achieved at very low cost. It's this range that is now joined by the Triple·C compressor.

Part of what the Triple·C does owes much to the Finalizers, tc product family. These all-singing, all-dancing mastering processors are based around a 3-band dynamics processing chain, where the frequency spectrum is split into three user-definable bands, each of which is separately compressed, limited and expanded-gated in order to allow maximum transparency even with heavy processing. The facility to do this forms one of three operating modes of the Triple·C and gives it its name.

Alternatively, the name could refer to the operating modes themselves, which comprise the 3-band approach, a conventional full-band compressor, and

know about the current settings is there somewhere, however small, and the important stuff like gain reduction in the three bands is highly visible. The gain reduction display is the biggest part of the screen, and shows both how hard the box is working and how much extra gain has been applied in each band. Like the Finalizers, the Triple·C allows a kind of broad dynamic EQ by having gain trims for the high and low bands as well as overall gain makeup, and the meters manage to show all this clearly.

The band gain controls have an alternative function in adjusting the fixed envelope setting of the Triple·C. With one for attack and one for release, they allow a wide variety of dynamic envelopes to be superimposed on the incoming signal, and a small graphic in the display shows an approximation of what's been done. This is obviously particularly applicable to individual percussion sounds and allows serious changes to be made to the envelope.

The factory presets offer a useful and illustrative range of ideas, helpfully indicating the operating mode they are built on, so that you know whether you're in full-band or multi-band mode. The broad delineation



a novel feature where the unit can impose its own envelope on the incoming signal—not the first time I've seen this but flexibly implemented here.

This sophistication is married to the kind of analogue-style front panel approach of the other less expensive processors like the Finalizer Express, where primary functions have dedicated knobs and the digital access is only required for more in-depth setup. This means that parameters like Threshold, Ratio, Attack and Release have their own controls live on the panel all the time, so that once a basic configuration is in place everything needed to adjust it is available immediately without recourse to menus, nudge keys, data wheels or any of the other things that slow you down.

It's still important to remember, however, that the control system is all-digital; otherwise you can be caught out by the need to pass a control through its stored value before it becomes active. For all its analogue look and feel, this is a purely digital box, with 50 factory presets and 100 user memories, while the controls are conventional pots rather than continuous encoders and therefore only go manual when their positions match the value in memory. Using this is helped by the display, the bottom part of which is a line showing the current parameter and its current value. If you turn a knob, its setting immediately appears here and if it doesn't change as you move it, you haven't nulled it yet.

The display is similar to those on the M-One and D-Two, with several clearly-demarcated sections and clever use of colour and combinations of text and graphic icons. Virtually everything you could need to

is between minimising the obvious effects of the compression by using multi-band, and using full-band compression as a deliberate change to the signal, although of course it's not as clear-cut as that. Certainly the multi-band mode offers a powerful tool for compression of a full stereo mix, providing heaps of compression with minimal side-effects. At the same time both modes can be used on individual signals (vocals have several presets devoted to them) with as much or as little subtlety as required. I used a medium vocal compressor and a tube bass compressor, both of which did the job I needed with minimal tweaking. Note that although there are two channels for stereo, they can't be used independently for two separate mono signals.

The chassis follows the M-One D-Two hybrid style but even at this price manages to include SPDIF digital I-O and balanced pro-level analogue, albeit on TRS jacks. It also looks good and is analogue-easy to find your way around. tc has shown already that it can come down to budget price levels without too much compromise on the quality and features, and the Triple·C does a good job of reinforcing that impression. □

## Contact:

**tc electronic**, Denmark  
**Tel:** +45 8742 7000  
**Fax:** +45 8742 7010  
**tc electronic**, US  
**Tel:** +1 805 373 1828  
**Fax:** +1 805 379 2648  
**Net:** www.tcelectronic.com

## NEW TECHNOLOGIES

two stereo masters and four VCA sub-mute groups and five monitor modules. Inputs have a separate mix minus bus and limiter per input with automated gain adjustment, mic-line selection plus and eight-input preselector.  
 Midas, UK. Tel: +44 1562 7415154.

### Eventide remotes

Eventide's DSP7000 is described as its most powerful stereo effects processor to date. Described as a having



four times the processing power of a DSP4000, the new box has 500 factory presets with 24-bit/96kHz conversion. Operation is similar to the DSP4000 but Eventide's PC-based Vsigfile graphic editor can be used along with Internet downloaded software upgrades. The box can also be used with the Eve/Net network remote control which permits the control of multiple stereo DSP7000s and multichannel Orvilles from multiple remote locations. The news coincides with the announcement of the faceplate control-less Orville/R and the DSP750 which has hundreds of additional presets over the DSP7000 that are applicable to post and broadcast, and a stereo 87s sampler.  
 HHB, UK. Tel: +44 20 8962 5000  
 Net: www.eventide.com

### Cheaper on-air

Studer's On-Air 1000 digital desk is derived from the On-Air 2000 and is said to provide the proven technology to a lower section of the market. Ten channel faders and two master faders retain the most important operating elements and adjacent read outs with detailed information available on a central monochrome touchscreen with adjustment via four pots located beneath it. The desk is available in two versions—the first offering five stereo line inputs and two digital inputs, the second with five digital inputs and two stereo line inputs. Other features include two analogue inserts, a serial interface, GPIO, time sync, digital clock sync and remote interface top telephone hybrids.  
 Studer, Switzerland. Tel: + 41 1 870 7511

### Fairlight's QDC

Fairlight's new QDC core technology, which is now being applied across the company's range of product, features a dual processor control system with embedded fast wide SCSI and sync system which is tightly coupled to an array of independent DSP processor cards. Each card contains eight SHARCs arranged in pairs with 128Mb of buffer memory. The basic system supports four of these DSP cards and the system architecture supports expansion up to eight cards for 64 SHARCs. The technology permits simultaneous seamless and gapless 48-track punch in and out at 48kHz and 24-bit resolution from one disk. Benefiting from this is the MFX3.48 which offers vastly increased speed and performance over its predecessor and sports a backup system that may be configured



# marantz®

## Professional

### one touch (auto)mastering

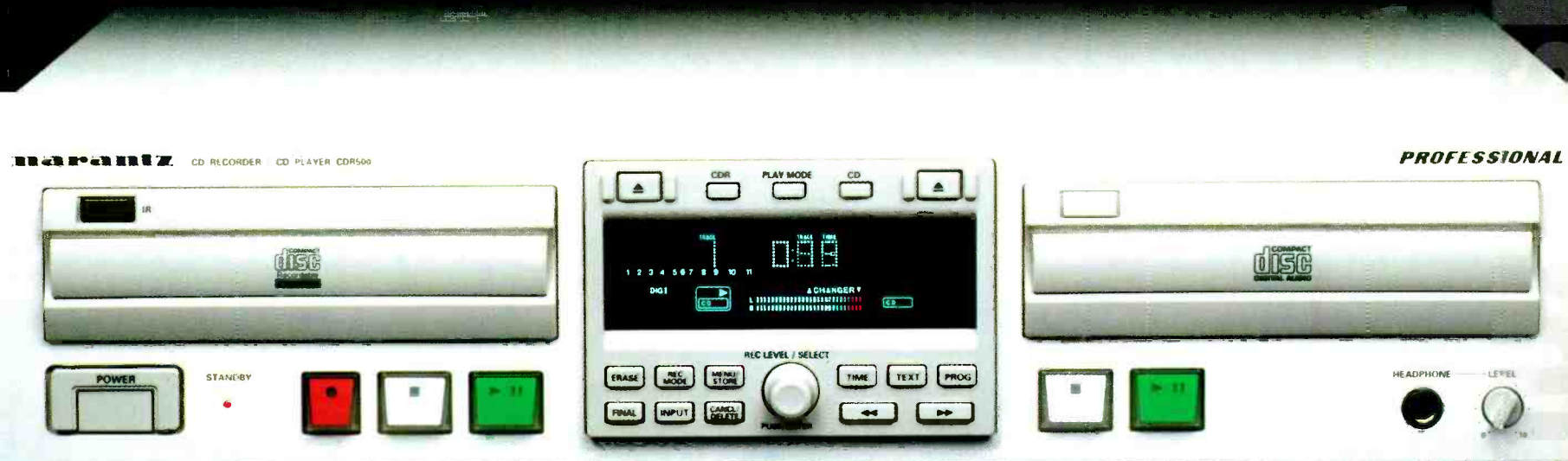

Introducing the Marantz CDR500 Combination CDR Recorder/CD Player with AUTOMASTER™.

Until now "proper" Red Book mastering was only possible in a CD mastering studio.

When burning a CDR, everytime the laser stops errors are created in the linking points. These are skipped over during replay in a conventional CD player, producing the familiar muting effect between tracks.

Prior to pressing a CD, a mastering plant will search for and correct these errors before making the final Glassmaster, enabling the production of the complete CD in a single Disc At Once process. This involves the high speed transfer of the programme material to Exabyte tape or hard disk in an intermediary process that incurs additional cost and may introduce increased levels of jitter to the detriment of the recording.

The Marantz CDR500 with on-board AUTOMASTER™ enables you to produce a properly finalised CD ready for pressing; simple, quick & inexpensive.

And that's not all. A wealth of other professional features including DSP Audio Buffer, CD Text Writing, Normal and High speed (2x) duplication, full SCMS manipulation, balanced (XLR) analogue inputs with level trim, SPDIF Digital inputs/outputs and full CD/CDRW playback, combine to make the Marantz CDR500 the essential studio tool.

**MARANTZ PROFESSIONAL - EXCEPTIONAL BY DESIGN**

## CDR500 COMBINATION CD RECORDER/CDPLAYER



# MBHO dynamics & headset

A dynamic vocal mic designed for the recording studio is a rare sighting but worth the wait. **Dave Foister** lends eyes and ears to MBHO's latest

**G**ERMAN MANUFACTURER MBHO is little known over here despite its impressive range of very competitive studio condenser microphones, and its links with Jecklin that show themselves in the Jecklin and Schneider Disc stereo mounting systems. In fact there's even more to MBHO, as shown by a strange package that appeared recently containing two hand-held dynamic microphones and a headset.

MBHO describes its condenser microphones as hand-made, and certainly they look to be lovingly designed and built. Many manufacturers put this kind of effort into their studio equipment but then go all mass-produced for the less expensive stage stuff and dynamics. Not so MBHO, whose dynamics here exude the same kind of quality as the condensers. They are substantial and heavy, with solid metal bodies



and rugged grilles, and are finished in the kind of matt powder grey effect normally associated with Schoeps. The shape too is unconventional, with echoes of the old AKG D202 in the capsule and a large girth around the body. A basic stand mount is supplied that allows fairly easy grabbing off the stand by a singer.

There are three models, although they share the same basic designation of MBD 219. The only difference between them is the polar pattern, indicated in the catalogue by a suffix of C, S or O, and on the microphone bodies themselves by a graphic of the pattern. The options are the obvious ones of cardioid, hyper-supercardioid, plus the much rarer (certainly in the field of dynamic microphones) omni. The only one I was not provided with was the omni, so I was able to try most of the things such microphones might be expected to be good at.

Obviously live vocals are the primary candidate, and here they made an immediately favourable impression. The handling noise and pop immunity were both very good, and the singer was comfortable; most importantly, the sound was particularly smooth and open. There's a hint of brightness and presence lift, but without the harshness that can often accompany this kind of character. This suggested that they would be more than happy in the kind of situations where dynamics thrive in the studio, and again they didn't disappoint. Snare

## NEW TECHNOLOGIES

with Exabyte Mammoth 2 tapes to operate in background at 40x mono playback speed. Fairlight's Fusion console for on air broadcasting applications, offers digital mixing, routing and control with DSP functions on all input and outputs. The console has a depth of just 72mm and can handle 96 digital or analogue inputs per unit and scaled to 264 x 264 input and outputs per DSP frame. The console is available with Windows configuration and routing software and integrated support is also provided for Fairlight On Air's CoSTAR Radio Automation Control System. Fairlight, Europe. Tel: +44 7267 3323.

### Sync generator

Lucid's SSG192 studio sync generator provides a master clock for synchronising digital audio and video



studio equipment, with connectors that support word clock, AES11, video blackburst, Digidesign's 256X Superclock, and the proprietary Lucid UltraClock. It features 15 internal clock rates and three external sources any of which can act as the master clock to control connected equipment. For film and video, the SSG192 can reference to, or serve as, the house video blackburst generator. It supports NTSC 59.94, NTSC 60, or PAL-SECAM 50 Hz formats. A front-panel LED set provides a simple calculation for all common pull-up and pull-down rates using 0.1% and 4% correction factors. Lucid announced today at the 109th Audio Engineering Society Convention in





**NEW TECHNOLOGIES**

Los Angeles that the company has entered into a partnership with WaveFrame. The Lucid line of I-O converters will now be available through WaveFrame's dealer channel for use with WaveFrame-7 and FrameWorks-DX Digital Audio Workstations. Lucid, US. Tel: +1 425 742 1518.

**Multichannel tool**

Gold Line's 5.1 Audio Toolkit DVD is designed to facilitate surround sound system setup. It contains over 80 test signals and music tracks laid out in logical progression for quick calibration and debugging of 5.1 systems. Contents include midrange, wideband and LF pink noise, 1/2-point check signals, imaging tests, LF headroom tests, 1/2-octave burst headroom test, noise leakage tests, sinewave signals, swept sinewave signals, 5.1 channel music and low frequency response measurements. Gold Line, US. Tel: +1 203 938 2588.

**Lawo diamond AV**

Lawo has launched the diamond AV console in a standardised format for TV production (equating to a high-performance console at a competitive price and with short delivery time, according to the company) and the mc2 Broadcast. The latter combines ATM audio technology with the ergonomic, modular new control panel and is designed for on-air and production use in radio and TV with snapshot and dynamic automation, talkback system, and mix-minus conference system. Lawo, Germany. Tel: +49 7222 10020.

was handled well, the hypercardioid pattern reducing spill, and miking up a guitar cabinet gave good clean results with plenty of edge where needed. I particularly enjoyed using one on saxophone, where the tonal quality was enhanced and pushed forward while still coming over as basically clean and true.

These are seriously good microphones of their type. If these are the kind of things MBHO has to offer, they deserve to be more widely known, as anybody using existing dynamic vocal microphones in the usual variety of ways ought to give them a listen. Overall, quite a find.

The company's headset is equally interesting in a different way. The headphones themselves are MB's own Quart model, and were a pleasant surprise indeed, offering a very complete frequency response and excellent comfort. They are a fairly lightweight circumaural enclosed design and have enough swivels and suspension components to sit on the ears for long periods without fatigue, although on this headset the comfort was compromised somewhat by the boom arm hanging off the left hand side. Otherwise they have all the attributes of good monitoring headphones.

The microphone boom is a short gooseneck, and allows the use of a couple of components of the standard MBHO modular condenser microphone range. Attached to the gooseneck with a small spider suspension is the cardioid capsule with bass roll-off, while at the other end is the MBP 648 preamplifier body with its integral output XLR. It's not often you get a microphone of this calibre hanging off a headset, and the benefits show immediately. The capsule sits naturally pointing at the mouth, slightly off to the side to avoid pops, and delivers real clarity and quality. A small circular windscreen is provided, clipping neatly over the end of the capsule, although it is such a lightweight skeleton structure that it almost looks as though some-



thing's missing. It's still effective though, which means that the obvious risks of using a capsule of this type in this situation are minimised.

It wasn't clear whether the headset I had was a prototype or a production model; there was no attempt to integrate the wiring for the microphone and the headphones, with the result that the straight thin microphone cable was taped on to the coily 4-core headphone cable at a few points, making a recipe for tangle misery. If this were corrected, the result would be a likely winner, as there can't be many headsets on the market with such quality in both components. □

**Contact:**

**Mikrofonbau Haun, Germany.**  
**Tel: +49 62 61 79 70. Fax: +49 62 61 71 10.**  
**Net: www.mbho.de**  
**Sixpac, Germany**  
**Tel: +49 66 76 82 66. Fax: +49 66 76 82 67.**  
**Net: sixpac-asvc.de**  
**MBHO Microphones, US**  
**Tel: +1 718 963 2777. Fax: +1 718 320 4890**  
**Net: www.mbho.com**

Following the tremendous success of our award winning 1029A, we are pleased to announce two new additions to the compact bi-amp range. The most versatile little professional monitor on the market is now available in three versions: 1029A Analog, 2029A S/P-DIF Digital + Analog, and the 2029B AES/EBU 24bit/96kHz Digital + Analog. Activate yourself and visit our website: [www.genelec.com](http://www.genelec.com) to learn more about your digital future.

BYTES



**GENELEC®**  
 ACTIVE MONITORING

The Whole Truth And Nothing But The Truth

International enquiries:  
 Genelec, Oivitie 5, FIN-74100, Iisalmi, Finland,  
 Phone +358-17-813311, Fax +358-17-812267  
 In the U.S. please contact Genelec, Inc., 7 Tech Circle, Natick, MA 01760  
 Phone 508/652-0900, Fax 508/652-0909, Web: [www.genelec.com](http://www.genelec.com)



# Tracer Diamond Cut Live

Taking pride of place in Tracer's audio restoration packages, DC Live shifts into real-time and top gear. **Dave Foister** rides along

IT'S NOT THAT LONG since I was testing Tracer Technologies' Diamond Cut Audio Restoration Tools (DC-Art) on my Pentium 233 and being impressed by the reasonable speed with which it carried out its functions, although none was designed to run as a real-time process and they had to be used one at a time. How things have moved on—today I'm running the latest addition to the DC-Art range on my 750MHz Pentium III laptop and running more processes, several simultaneously, and in real time. This is DC-Art Live, the upgrade that sits above the recently-introduced Millennium version in the pecking order and represents the current state of the art at Diamond Cut Productions.

Millennium represented a step forward in that it allows several processes to be chained together, previewed in real time and then run as a single pass. The obvious benefit of this, particularly when you're dealing with restoration functions, is that if there's any interaction between the processes you hear it right away. It's all too easy to discover too late that a little over-processing in an early pass has compromised a later process' ability to deal with what's left, and with DC-Art operating as it originally did there was no alternative to going all the way back and re-doing everything. Millennium changed that and streamlined the whole process; the Live version does all this, and does the final processing in real time. The big news is that it can also carry out its processing on a live through signal, as well as working on WAV files like the other versions.

The palette of available processes seems to have grown since the original version. Many of them are specifically intended for various elements of restoration, but there are some creative processes as well. Thus the impulse filter for removing clicks and crackles remains, along with the average filter, the median filter, the continuous and dynamic noise filters, low-pass, high-pass and band-pass filters, and there's a new brickwall filter configurable in all three modes as well as bandstop. The graphic and parabolic equalisers can be regarded as either restoration or creative tools, but the reverb, the valve stage emulation and the Punch and Crunch process are unquestionably there for enhancement and creative use.

Like many of the processes, the reverb module now has more parameters and the algorithm has been improved. The results are now on a par with the kind of reverb plug-in that comes bundled with a DAW, if not a little better. The valve emulation too has added functions, with models of no less than ten different valve types, including a new push-pull 2A3 circuit

suggested by Les Paul. Punch and Crunch is a dynamics module that can either be used to expand an over-compressed signal (Punch) or to deliver extreme compression for on-air loudness (Crunch), and does both across four frequency bands to allow heavy processing with reduced side-effects.

The big addition is the Multi-Filter facility, where all the processes appear in one big window and can be dragged on to a line representing the signal path. They can be placed in any order, and processes can be used more than once in the same chain—the presets include several with multiple valve simulation stages, for exam-

ple. Since the processing is run by the host computer, the number of processes that can be run simultaneously depends on the PC itself, and this limit is complicated by the fact that different processes make different demands on the DSP. As a guide, my Pentium III running at 600MHz could handle five or six of some processes but crashed with a similar number

of some others. Four seemed safe throughout, and this gives a powerful palette of treatments that can be run in real time and whose interaction can be allowed for without time-consuming re-runs.

The control windows for all the processes can be opened simultaneously for individual adjustment and bypass, although as they all open centre screen by default, a bit of judicious placement is required to avoid clutter. The assembled chain can then be used live, without prior hard disk recording, for live broadcasts and recordings, and for surveillance—remember that several of the tools have powerful forensic applications. If a record is required of what happened live, the audio output of the chain can be logged direct to the PC's hard drive as a WAV file. Complete chains with all their settings can be saved to disk just like the presets for the individual processes.

DC-Live gives you an awful lot for your money, and virtually all of it does a terrific job, subjectively comparable with far more expensive systems. I have to say I remain unconvinced by the continuous noise filter, which even on the demo preset, specially tailored for the supplied demo sound file, left considerable footprints all over it; but everything else is effective and easy to set up, and now very fast as well. For powerful precise restoration coupled with enhancement and production tools, there can't be much on the market at anything like this price to touch it. □

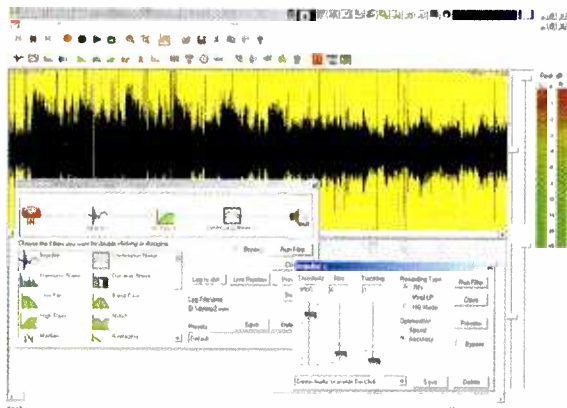

## NEW TECHNOLOGIES

### Format convertor

Euphonix' FC727 format convertor enables a variety of digital I-O formats, including Digidesign Pro Tools, to directly interface with System 5 consoles and R-1 multitracks using MADI connections. In addition to bidirectional conversion between TDIF, AES-EBU, SDIF-2, ADAT, ProDigi and MADI formats, the FC727 also links directly to Digidesign Pro Tools, including automatic upsampling from 24-bit/48kHz tracks to 24-bit/96kHz tracks. A total of 56 Pro Tools channels can be carried via a single FC727 connection. Euphonix has also demonstrated the eDeck application for replaying and format-converting high-quality digital audio mix files, and then moving them securely over computer networks and the Internet. The Rocket Powered software will be made available as a free download in Windows format (MacOS to follow), from the company's web site, [www.euphonix.com](http://www.euphonix.com), and from Rocket Network at [www.rocketnetwork.com](http://www.rocketnetwork.com). System 5 V2.0 software offers fail-safe and self-diagnostics, multiformat channels, expansion of the integrated PatchNet, plus a number of features developed specifically for the music recording, postproduction and broadcast industries. Euphonix, Europe. Tel: +44 208 901 7510.

### Waves reverb

Waves has debuted the Renaissance Reverberator as the third in the series, preceded by the Renaissance Compressor and the Renaissance EQ, for TDM formats and Native formats including RTAS, Audiosuite, VST, DirectX, and MAS. With just a few straightforward controls and simple interfaces, it features rich reverb tails, plus a second generation early reflection system, providing density and texture. The Renaissance Reverberator is available in the Waves' Gold TDM package, Waves' Gold Native package and Renaissance Collection for TDM and Native. Waves, Israel. Tel: +972 3 6081648.

### Micron's Phantom Booms

The Micron Phantom Boom battery-operated phantom power unit gives wireless freedom to sound recordists and television crews when operating boom-mounted microphones. It provides a transformer-balanced connection and supplies a 48V feed to any phantom-powered microphone mounted on the end of a boom, and is compatible with any belt-pack style transmitter. The Micron Phantom Boom incorporates a highly efficient DC-to-DC converter to ensure long battery life, with the integral 1:1 transformer providing complete bi-directional DC isolation for microphone and transmitter. Offering an ultra-quiet noise floor, the Phantom Boom utilises a 300kHz oscillator to ensure the frequency is way above the audible spectrum. Micron, UK. Tel: +44 208 341 3500.

### Dialog4 additions

Sountainer is the first portable MP3 recorder-player to be equipped with a microphone input, line I-O and USB interface. Designed for reporter field use, MP3 files can be transmitted over the Internet to the radio-TV station via the USB Interface. Price EURO 430.00 including 64Mb memory and microphone and line cables. MusicTaxi NET is Dialog4's latest codec development allowing the use of ISDN, X.21, TCP-IP and UDP-IP transmission over 10base tx and ATM network—TCP-IP for point to point, UDP-IP for broadcast and multicast transmission. Dialog4, Germany. Tel: +49 7141 22660.

### Contact:

**Tracer Technologies, US**  
Tel: +1 717 843 5833  
Fax: +1 717 843 2264  
Web: [www.tracertek.com](http://www.tracertek.com)



# test our resolution

TASCAM is advancing the cause of affordable 24 bit production with its latest generation DTRS recorders. The DA-78HR and DA-98HR digital multitrack recorders provide an HR recording capability based around an established industry standard format and familiar operational topography, ensuring that the transition to 24 bit production is not only cost effective but also painless.

For music recording and project studio applications, the DA-78HR provides discrete HR optimised analogue and digital circuitry Time-Code I/O, on-board SMPTE sync, MIDI IN/OUT/THRU, and Word Sync I/O as well as on-board 24 bit analogue and TDIF I/Os.

For advanced recording, AV post production and mastering applications, the DA-98HR

covers all bases. 96 kHz 4-track and 192 kHz 2-track recording modes, SMPTE, MIDI and video sync, serial and parallel control ports, 8-channel AES/EBU and TDIF digital I/O, optional IF-AN98 8-channel 24 bit analogue I/O card, an extensive menu-driven control environment with large, comprehensive LCD display, self-illuminated transport controls, individual input monitor switches and switchable reference levels, amount to the most advanced tape based multitrack recorder yet.

Of course, these new recorders are fully compatible with standard 16 bit DTRS operation and can be integrated within systems comprising any combination of up to 16 DA-88, DA-38, or DA-98 machines (up to 128 tracks).



DA 78HR / DA 98HR HIGH RESOLUTION MODULAR DIGITAL MULTITRACK RECORDER



All DTRS models supplied with free Fujii tape.\*

\*Offer applies to European territories only, for limited period.

## TASCAM

a whole world of recording



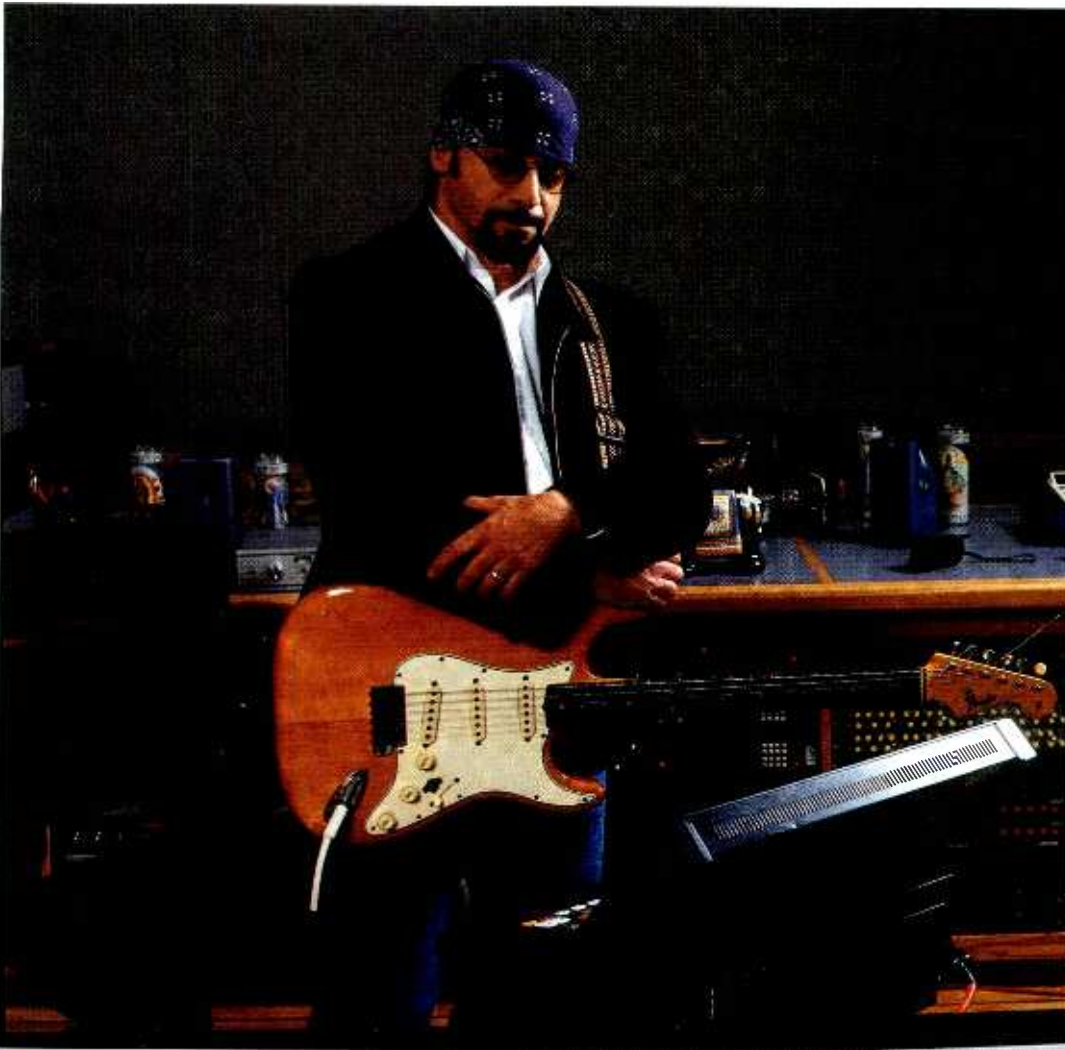

# PRINCE VALIANT

With production credits running longer than most and including Prince, David Z helped put Minneapolis on the map. **Dan Daley** finds him surveying Nashville

**I**N AN INDUSTRY whose trends change on a weekly basis and careers more frequently still, there is something to be said for staying one's course. It's like the old joke about how, if you stand on the corner of 42nd Street and Broadway in New York City long enough, you will see everyone you know pass by at some point.

Producer David Z's career has been like that. He's amassed a discography that's heavily laden with blue-hued roots and R&B filigrees, even though these organic characteristics have often taken the form of pop artists. And there have been long periods in his 30-odd-year career in which he wondered if fate had placed him in a sort of box.

'I had become known as the guy who does everyone's first record. For a long time, I didn't think I'd ever do anyone's second,' is how Z (*ne Rivkin*) once summed up his career. As producer, engineer, mixer and arranger, he has assisted an eclectic assortment of artists, from early productions with Prince (for whom he produced

early demos and singles like 'Kiss' and engineered and/or mixed records, including *Purple Rain*, in their shared hometown of Minneapolis), through other R&Bers such as Janet Jackson and Sheila E, rockers Billy Idol and Fine Young Cannibals (whose 'She Drives Me Crazy' garnered Z the Grammy nomination for Best Producer in 1990), alternative's Big Head Todd and Collective Soul, blues acts Buddy Guy, Kenny Wayne Shepherd and Johnny Lang, and that master of eclecticism himself, guitarist Leo Kotke.

The way Z views the world's mechanics has changed. He not only did Johnny Lang's second album—which went as platinum as the first—but is working on the string slinger's third, due out in March, the same month that Fine Young Cannibals' vocalist Roland Gift's solo record, which Z produced, will also appear. And as we speak, Z is working at London's Sarm West, producing a record that will accompany a documentary on legendary British blues *macher* John Mayall.

Z may get around a bit but he has never strayed

far from the rootsy music that he's had an undeniable affinity for all of his life. He may still be in a bit of a box, a rootsy, bluesy one. But the box is roomier than before...

David Z comes from Minneapolis. North Minneapolis, more precisely, that same rough-and-tumble part of that frigid northerly town that gave the world Prince Rogers Nelson, Morris Day and a small but noisome host of R&B-rock artists who put Minneapolis on the music culture map for raucous moments in the 1980s. A guitarist in his earlier years, Z learnt the engineering trade in local studios, where he met Prince, around 1976, when The Artist was still in his teens and looking for a deal with his band, Grand Central.

'I was working as a staff engineer at Sound 80 in Minneapolis when someone brought [Prince] in and paid for a demo,' Z recalls. 'I had met him a year or so before because everyone knew everybody in Minneapolis in the music business in those days. It's a small town, really. He was around 16 at that time. When he came into the studio, his friend asked me to record three or four songs for a demo. I thought the music was okay.'

So did Warner Records, who on the strength of that demo signed Prince and launched his career and helped fuel the brief but often brilliant ascendancy of Minneapolis' musical moment. (One which more than a few in the industry assert set the stage for Seattle's own coup against the hegemony of New York and Los Angeles in the following decade.) In fact, Z's brother, Bobby, wound up playing drums for Prince for a while, and it was his cousin, Cliff, who got the demo tape to a Warner's promo man. ('It's cold and we don't have a lot of people up there, so everybody doubles,' he wisecracks.) Z watched as Prince turned into the ultimate auteur in the studio, composing, playing and singing everything himself.

'The record company wanted to sign him but they didn't believe he could play and do all of this stuff by himself,' Z remembers. 'So they came down to the studio before they signed him. It was [Warner Music braintrust] Lenny Waronker, Russ Titelman and Gary Katz. They watched us lay down a song and realised that Prince really didn't need anyone else. Then they signed him.'

However, Z got his first taste of music-biz disappointment when another producer was brought in to do the first record. But he took heart from the fact that three of the demos, mostly in their original form, including the songs 'Soft and Wet' and 'Just As Long As We're Together', made it onto the album.

'I got aced out of it, but it was no great shakes,' Z says now. 'I was still new to the whole thing, too. Eventually, I came back into the Prince fold, slowly, and started doing more things for him.' What started as a series of edits for the records *Delirious* and *Erotic City* became Z engineering in Record Plant Remote's Black Truck, with Dave Hewitt and Kooster McAllister, on the classic *Purple Rain* sessions, which were actually a live concert—a benefit for a Minneapolis dance company—at which Prince introduced the New Revolution, with cohorts Wendy and Lisa, and a line-up of new songs, which Z recalls went over rather poorly with the home town crowd, who wanted to hear Prince's current hits instead. With very little additional sweetening, *Purple Rain*'s live version became the big hit, giving Prince the kind of power few artists ever or would ever have in terms of telling his label what kind of music he was going to make. (When he and Z cut 'Kiss', in 1986, Warners at first refused to release it as a single, saying the deletion of the bass guitar from the entire record was too radical for radio. Prince said, in effect, you're putting it out. They did. It became a huge hit.)



Z would go on to cut other tracks for Prince. But in the meantime, he was also pursuing his own career as a producer, a pursuit Prince helped with, if only because his own stable of artists was growing too fast for him to play every note. Z produced the track 'Funky Town' for the group Lipps, Inc part of the Prince fold and he did tracks with Prince cronies Sheila E and Joe Jones for Paisley Park Records, Prince's custom label with Warners. He also got a studio within the Paisley Park recording complex Prince built in his hometown.

'It was great, it was the first time anyone had ever referred to me as a producer,' says Z. 'But it was all practice for going out on your own as a producer.'

Outside of a long association with Prince, the artist that broke Z's sophomore jinx, the one who first came back for a second album and now a third was blues guitar wunderkind Johnny Lang. As with Prince and other artists he's worked with, Z produced the original demos that got the artist, originally known as 'Kid' Johnny Lang, signed. Z had already established serious blues bona fides with the first album production for Kenny Wayne Sheppard, another blues guitar genius. But in Lang, Z saw an entire package: an artist who was an exceptional instrumentalist, a good and soulful vocalist, and someone with a sense of emotional and historical context to the blues that could act as sympathetic ballast to Z's own feelings in that department as they set out to make a credible blues record that would also sell credible numbers in a pop marketplace.

'We had developed a team, a real team,' Z says of the collaboration. 'The demos had established a direction and we kept going from there.'

That direction was, in Z's words, 'to put a new face on the blues. Blues simply hadn't been rethinking itself and reinventing itself like other forms of music had. Country managed to reinvent itself by emulating rock bands like the Eagles and Mellencamp and taking a bunch of pop influences in. Blues wasn't doing that. It was in many ways an older art form, and it sounded like it. There's a demographic out there in the pop market for blues—people like Clapton and Bonnie Raitt proved that. But there weren't enough people trying to do it. We tried with Kenny Wayne Sheppard, who is a great guitarist and artist, but the whole package wasn't there, because Kenny didn't sing. With Johnny, we finally had the package.'

The production of Lang's first two records is an illustration of both Z's approach to production overall, and the issues that a producer faces in the studio when trying to adhere to an aesthetic yet do so in a commercially acceptable way. Artistically, Z says he recognised the other genre elements that Lang brought to the table, such as the R&B elements in his vocal approach, which Z says reminded him of Al Green, Stax Records and Sam & Dave. In fact, it was likely those sorts of elements that attracted Z to the project in the first place. 'I didn't want it to be just straight 12-bar blues,' he explains. 'That's why choosing the songs was so important.'

What Z brings mechanically to a production is not only a sense of rhythm but the rhythm itself. One of the first devotees of the Linn drum machine when it appeared in the 1970s, Z found it was the instrument through which he could best express his own artistic visions and share them with the artist and the production. A drum machine has been his interlocutor in the studio ever since. In fact, the first time I saw Z at work in the studio, he was hunched over a drum machine, an old E-mu SP1200 (his favourite), creating loops for a Steve Cropper session at Sound Kitchen Studios, in Nashville. It was the drum machine that gave his most widely known single production—Fine Young Cannibals' 'She Drives Me Crazy'—its signature and often-surreptitiously-sampled snare sound which became the basis for the track, which had no live drummer at all.

On the song he calls 'my triple-platinum parachute', the snare sound was a combination of an internal Linn sample, a ruler banging on a headless snare recorded through a Shure 57, and the whole thing pumped through a pair of Auratone speakers—the transducer counterpart to the 12-bit Linn—which had been set atop another snare drum to add some resonant rattle to the sound. Plus, the Linn sample had been heavily tweaked with EQ at 1kHz, partially to mitigate the inherent dullness of the low-bit Linn sound and in part to add weirdness and a sharper edge to the sound. It certainly went on to become one of the most famous—and sampled—snare drums in history.

It was this approach, bringing not only a new array of sampled sounds but also what Z calls polyrhythms, to blues, that formed the basis of the production with Lang.

'The way I look at it, to make a contemporary blues record for a pop audience, we needed to bring some more modern recording techniques and ideas into the studio along with the blues,' Z says. 'Loops and hip-hop ideas. The thing is, in the blues and in other music genres like country, melodies and chord progressions don't change, but beats define an era. They are totally different from the sixties to the eighties, for instance. It brings the music into the current era. I think doing that also makes it easier for the record company to understand, too.'

'I use the E-mu [SP-1200] exclusively. It's an old machine; it's 12-bit, kind of low-fi, but that's part of its charm. But I use it mostly as a sequencer. The sounds come from everywhere and anywhere. I make up a lot of my own. I try to make them out of real sounds—slapping a ruler against a desk, that sort of thing—and then layer them into what I call sandwiches. I do that with all the kick and snare sounds.'

The first Lang record, as well as the initial demos, was done at House of Blues Studios in Memphis, where Z lived at the time. Other tracks were cut in Minneapolis, at Oarfin Studios, where Z added a more vintage approach to blues to complement the drum machine loops. 'I went to the Salvation Army and got a bunch of old blankets and put them up all over the recording room to deaden the sound,' he recalls. 'When I had been a songwriter signed to A&M in the 1970s, they had sent me down to Muscle Shoals [Alabama] and I worked a couple of the studios there, like Quinvy Sound and Muscle Shoals Studios. Quinvy had a completely burlapped wall, and that's how they got that really dead Muscle Shoals sound. So I wanted to get the same effect at Oarfin. So I'm putting up blankets all over the walls and the assistant engineers thought I was nuts. It looked like the inside of a sultan's tent. But the first album had that great dry sound—no room ambience, no reverb. Where the sound came from was the fact that we had the whole band

playing together in one room at the same time. And we were able to keep a lot of Johnny's vocals from those same takes. We just repaired bits and pieces of them. But mostly that was a record made by a blues band in the same sort of environment that blues records had always been made in, just with a few contemporary touches like the loops and grooves.'

There were some subtle but important touches, though. Lang's guitar was played through a Fender VibraKing amplifier, heavily hot-rodged but miked only with two Shure 57 microphones, one in the front pointed roughly at the control strip along the top of the amp, completely off speaker axis, about a foot away from the amp; the other was placed behind the open-back speaker cabinet. 'Johnny doesn't like that real bright Fender amp sound,



so we experimented with the microphone positions, getting the thicker parts of the sound and adding top-end EQ on the console,' Z explains. 'And we kept the microphones away from the speaker cones.'

The drums were placed on a riser in a corner of the room, a technique Z uses to catch the low frequencies from underneath the riser as the kick drum resonates it. And the kick drum was not exactly off-the-shelf, either; Z took two of them, joined the main one to a second which had no head on either end, and made a long tube of the two of them, placing an AKG D-12 near the inside head and a Neumann U47 near the lip of the outer drum.

Z says he's not picky about too many things, including studios. He has no particular favourites when it comes to monitoring or consoles, simply preferring good low-frequency response on the former and the availability of API 550 EQ modules outboard with the latter. One monitoring talisman he won't give up, though, is taking a final mix back to his 1988 BMW 635, which describes as having the 'the absolute worst stereo system I've ever heard, a total piece of crap'. If it sounds good on that, says Z, then the mix is done.

The end result was a very organic-sounding record,



WWW.SYSTEM6000.COM

## INTERVIEW

one which took the record label aback initially. And therein lies the philosophical issue. When a major record label pays major dollars to make a (hopefully) major record, it ostensibly intends to send that record through the tradition channels of radio to build momentum. And A&M didn't hear a radio record, Z knew. 'But our goal wasn't to make it a pop record,' he says. 'We wanted to make a cool record. There was nothing like it out there on the radio; we were forging new territory, at least as far as pop records were concerned.'

As it turns out, Lang bypassed the conventional radio promotional route, instead building fan base by touring relentlessly, an option available to a 15-year-old prodigy. Ironically enough, after the record went platinum and both A&M and Lang wanted Z to return for the second record, it was Z's decision to take the second one in a more polished and slick (his word) pop direction, a move even he seems somewhat at a loss to completely explain now. 'The second record was not as blues-based,' he agrees. 'It was slicker in terms of production. Actually, in retrospect, I like the sound of the first one better. I think this one was slicker because we used a bigger band, there were more elements to manage, and the songs tended to be more pop-oriented, and they lent themselves to bigger productions. I take total fault for that. The simpler approach was better.'

There wasn't much to take fault for, though; Lang's second record went as platinum as the first, and like the first found its audience through exposure to an entire collection of songs and the attitude they convey, not through singles on the radio. And Z is back in the studio with Lang, working on the third record. Actually, as we spoke, they were still in the preproduction stage, searching for the songs that would define the album's approach. And you could hear the ambiguity bouncing around inside Z's head as he says, 'We're in a position now where Johnny is one hit away from becoming a pop star. He's built the underground audience and now he has to cross over.'

Z pauses, almost mournful of the idea, as though it were someone on the verge of passing to another dimension of spirit, not of record sales. Nor does he sound totally convinced when he adds, 'It has to be a natural transition, not forced'. Pause. 'We're still in research and development on that.'

Whatever happens with Lang, Z's sophomore jinx is broken, and artists are returning for second and third outings with him. (As well as new artist relationships—it was his work with Lang that brought Z to the attention of John Mayall.) Similarly, he's staying with his decision to remain based in Nashville, where he has yet to produce a country record (though he won't rule it out) but where he likes the access the city offers in terms of recording and talent resources.

Like other non-country producers with significant track records, Z had come to Nashville—more precisely, its affluent southern suburb Franklin—in search of the most common goal, enhanced quality of life; but also in search of a Nashville that has proved elusive but which still tantalises with potential: Nashville as a non-country market.

'I've pretty much mostly lived in non-music-centre cities; I thought it was time I moved to one,' says Z. Nashville is, in many ways, just what a once-itinerant producer like Z is looking for: it has the quality of life that he felt neither New York nor Los Angeles could

provide (Z has at least some of his four children with him part of the time); a reputation as a music centre, albeit a country one; and a burgeoning alternative music scene, as well as a studio and pro audio infrastructure—engineers, musicians, rental houses—that rivals those on the coasts.

'What I'm doing now is using Nashville as a base to do all sorts of records from'—Z's first record there was Leo Kotke's most recent, recorded at Woodland Digital—'but at the same time looking for ways to get into the country loop, which operates differently than in any other music city. The thing is, I don't want to copy the Eagles licks, which is what a lot of Nashville country records sound like these days.'

But where Nashville had often been opaque for many of the migrant pop producers who moved there and used little more than the studios and the Interstates, Z says he does not want to make Nashville transpar-



ent to his productions: Chet Atkins guested on the Kotke record, as did rising star vocalist Kim Parent. 'You have to really dig to find people like that in other cities; in Nashville, they're all over the place,' says Z. 'When I move to a city, I want to use everything that city has, from musicians to studios. But I don't want to let the city limit what I can do. I didn't just do blues in Memphis. I want to do country in Nashville, but I want to be able to do other things, as well.'

Nashville resonates for Z for another reason, though. While the corporate infrastructure in Nashville makes it harder to break in, it's a great place to consistently get the second record. 'It's harder to get the first record in Nashville but once you do, they're more willing to stick with the team that did it,' he says. 'After all those years never doing the second record, I think it's encouraging that I can be in an environment where the producers reap the benefits of developing the artists in the first place. And on the non-country side, I think Nashville can have a working music culture apart from country. People have been trying to do that for a long time, but what that means is that there's something there. In Minneapolis I did my damndest to help that scene get started. So I don't have a problem trying to do the same thing in Nashville.' □



# Pro Tools 5.1



## The New Standard

### Integrated Surround Mixing

*Edit, process and deliver multiple formats simultaneously*



### Expanded Control Surface Options

*More ProControl™ channels and new dedicated edit controller*

### More Processing Power and Flexibility

*Host processing on TDM systems plus improved DSP efficiency*



### Total Session Portability

*Take Pro Tools® sessions between studios and keep all data intact*

### New Creativity and Editing Tools

*Enhanced MIDI, automatic beat detection and single-click navigation*

**Join us !**  
For more information  
and to reserve your space,  
ring **01753 658 496**

**CAVA Studios, Glasgow**  
**Monday, December 11th**

**The Green Room, Manchester**  
**Tuesday, December 12th**

[www.digidesign.com/protools](http://www.digidesign.com/protools)

*The Power of True Integration*

**digidesign®**

©9/00. Digidesign and Pro Tools are registered trademarks of Avid Technology, Inc. or its subsidiaries or divisions. All trademarks are the property of their respective holders. All features and specifications subject to change without notice.

A division of **Avid**



# RETURN VOYAGE

Recreating his classic *Maiden Voyage* recording for 96kHz surround, Herbie Hancock recruited 5.1 Production and the Sound Moves mobile. **George Shilling** reports

AS PART OF A SERIES OF CONCERTS welcoming Kurt Masur to his new role as principal conductor of the London Philharmonic Orchestra, Herbie Hancock performed a version of his classic sixties Blue Note release *Maiden Voyage* with the orchestra at the Royal Festival Hall. Hancock, being a great fan of surround sound, saw the opportunity to record the concert for a presentation at the US AES Show due to follow a mere two weeks after the event. The unusual requirement of recording it at 24-bit, 96kHz made for a limited choice of recording equipment. Steve Williams' Sound Moves truck with the larger of his two Soundtracs DPC-II desks fitted the bill.

The choice of desk made particular sense given the involvement of Ken Caillat, best known for engineering and co-producing the classic Fleetwood Mac album *Rumours*. These days he is also known for his pioneering work in surround sound recording and particularly 5.1 format mixing in his role as President of 5.1 Production Services, part of the ascendant 5.1 Entertainment Group. Caillat's 5.1 Studios houses two DPC-II's.

Caillat and his fellow 5.1 engineer Claus Trelby were conducting a hectic sound check, and Sound Moves' trainee Robin Delwiche was assisting with the setting-up, when I cornered them to talk about the recording,

'It's been only eight days since we were asked to do this gig,' Caillat begins. 'Herbie originally wasn't sure he'd use this for a record. We thought it would be a really good experiment—I.P.O., Herbie Hancock, you can't lose on that one—so it just means with less time we are doing more work than we would have. Normally I would have two people onstage, and an engineer plus the tech in the truck. In this case the house got very little information also, so they're doing a lot on the fly, suddenly finding out there are two more instruments, throwing up a mic and sharing it with us. Many times they don't have a chance to tell us what's changed.'

Rigging in was no problem for the Sound Moves boys: 'It was one of our shorter runs,' explains Steve Williams. 'We have a Pro-Bel fibre-optic system, as the MADI is only designed for 50 metres. We can do up to several kilometres on fibre-optic, but on this occasion it was just under 100 metres. We have multiple fibres, which means we could do four racks of 56 inputs and outputs at 24-bit, 48kHz.'

The 5.1 surround format is gaining wider respect amongst the musical community. Caillat concurs: 'Herbie is an established artist. He has said "I have always thought in surround", and the moment Q-Sound came around he was jumping on it because it gave him more counterpoint and more parts. It was

always tough to take all those instruments and fit it down to stereo. You don't think of it as tough because it's what our job is, but the moment you start mixing in 5.1 and take 20 instruments and place them in five speakers, each instrument sits in a larger percentage of space and has more fullness to it. Everything here is also being shot on DV. Herbie said "I wish you could do it in 5.1", and I said "As a matter of fact, we certainly could". It started with just Herbie, but his manager also manages Yossou N' Dour who is playing two sets, so we will record him also and see what's there.'

This concert recording is particularly notable for its pioneering use of 96kHz, 24-bit when converting the output of the mic amplifiers to digital, with the retention of the data in this format all the way through to the finished product—a DVD release. Caillat has made extensive use of this format for releases by the three record labels that come under the umbrella of the 5.1 Entertainment Group. He is carving out a niche for himself as a specialist 5.1 remixer of catalogue material, most notably the aforementioned *Rumours*.

Caillat: 'Warner Records approached us to do some 96k/DVD-A business. We thought that if they were going to remix old records to 24-96 for re-release this could be a phenomenal business. We hired a studio and did a 5.1 mix of *Rumours* and it sounded incredible. The thing about 5.1 is we think this is what it should be like. Like being in the studio or at a live performance—we listen in real life in 360°. Everyone who hears *Rumours* says "I can hear things I didn't know were in that mix". It was in the mix, but it is right there now. The people from Warners loved it, so we decided to incorporate this into our business.'

'Then came the problem of how to record 96k. We heard about the Soundtracs console which had 96k capabilities, surround panning, and it turned out to be really great sounding, great EQ and total recall. Because there are so many variables with a 5.1 mix we decided that a total recall console would make this a lot easier and more commercially viable, and actually more affordable. Sometimes you want to feed some of the vocal effects to the centre, instead of just left and right. We get the mix up to 90% or 95%, then the label or artist—or us—might hear it and decide to make adjustments, and we can recall it literally in 30s. The Euphonix can do that, but we thought the Soundtracs was more user-friendly and intuitive. We







found the console, then we found the Euphonix R-1 recorder, then we had to find converters and get the whole procedure down. Claus pioneered a method of doing backups—we rapidly acquired a huge amount of hard drives—and we now have a 2-inch thick book detailing the procedure, the layout on the hard drives and so on. We don't cut any corners, we try to find the original masters, and send the R-1 wherever we need to. We mix to another R-1, all at 96k, then downsample for 48k and Dolby Digital and DTS. So what started out as a simple idea became a logistical problem which was a challenge.

'We've got 27 titles out now. Some are licensed from other labels—Huey Lewis, Kim Carnes, Fleetwood Mac and Sting for example. Recently people came along wanting to release new material in this format, so we did Aaron Neville, the new Sting concert, Hanson, Herbie Hancock, and Yossou N' Dour today. These come out on DVD with audio and video with 48k and 96k on the same disc. We are one of the only companies doing surround audio, and this years US AES Show is all about surround.'

5.1 Entertainment has close relationships with a number of manufacturers. Trelby explains: 'I do a lot of conceptual software development with Soundtracs, te electronic and Euphonix, and about 10 companies will use our material for demonstrations at the AES.'

'Originally when we heard about this job I called Todd Wells of Soundtracs to see if he had a console we could put in a back room of the concert hall.' He elaborates on the background to this particular event. 'Todd suggested the Sound Moves truck which has been used for lots of high-profile jobs but this is probably the first time anyone did a large scale 96k location recording. There are not many trucks capable of 24-96, so we generally rent a truck that we can fit to work. The day before yesterday this truck was parked up at Soundtracs to replace some cards, because the 96k cards are new. The desk has been capable of 96k previously, but never had 96k A-D cards until now. They've got some really nice A-D and D-A 24-96 cards—they have I-O cards with sample rate conversion on the cards now, so the hardware I-Os are very well specified. The stage boxes connect to the truck via a fibre-optic cable. This comes into a box that has insert cards which can be configured however you want—analogue, TDIF, whatever—and the cool thing about this console is that you can do different sample rates simultaneously. The stage boxes have line in, mic in and analogue insert on the card.

The mic inputs have analogue gain stages, which are digitally controlled remotely from the desk, to make the best use of bits. You can choose mic or line input, which share a digital back end. You can insert analogue equipment at the stage box, or do it in the truck, but then of course you have to convert again. At the studio we tend to only use digital processing once in the digital domain, such as the tc M6000 and Finalizer, all at 96k. On this project, all processing is done using the desk. The desk has onboard compression, limiting, gating and EQ, which will be used where appropriate. When we mix in Los Angeles we use the onboard processors, and they sound great. After calling Todd Wells, I then called Euphonix to get an R-1 recorder.'

Unfortunately, the only available machine was already booked out, so Caillat and Trelby brought their own over from 5.1. 'This project will be taken back to 5.1 Studios in LA on hard disk drives from the R-1 for mixing on our DPC-II. The R-1 stores a proprietary format on removable hard drives. You get 88 minutes on 12 tracks at 96k on each drive. For the AES Show demonstration the mixes will probably be played back from a Genex 8500. But when we deliver to authoring and MLP we lay back to the R-1.'

The concert was also being multitracked to Sound Moves' bank of six Tascam DA-78HR machines as a 48kHz 24-bit backup. Williams explains, 'They use one of the standard DPC racks which we have modified to give us 'double-headability' for backing up, so they were fed with the same signal as the R-1 simultaneously.'

The orchestra was section-miked, but particular thought had been given to the surround aspect. Trelby

continues: 'For ambience we are using a Soundfield mic with the surround decode on, up on the balconies, 20 or 25ft in the air, just behind the conductor. This hall is extremely dead, apparently the artificial reverberation system isn't in use today. In all there are about 36 mics coming into the console. We are limited by the fact we are at 96k as to what we can do with the desk,' explains Trelby, as inevitably doubling the sample rate halves the number of available channels. Twenty-four of the most vital signals were fed at 96kHz, with the remaining (less critical) inputs at 48kHz.

'There are additional audience mics at the sides on the rearmost balcony boxes which are omnis. Herbie Hancock is accompanied by the London Philharmonic Orchestra Ensemble, about 45 musicians. Also there is a drummer and a bass player. The piano is miked in stereo, high-low. The bass player has an upright bass, but is using an amp. So we have a DI and a mic on his amp. And there is a conventional mic setup on the kit.'

The Sound Moves truck comfortably housed the Miller & Kreisel monitoring system, which Caillat brought in to use instead of Sound Moves' Proac Studio 2 system, while the R-1's rackable components neatly slotted into the machine room, which became host to the huge quantity of cardboard boxes for these temporary residents. The fact that the DPC-II is a desk and not just a control surface is an immense help in limited space, as Williams explains...

'The nice thing is that there is no external equipment rack, the mix engine is inside the desk. The only thing that's remote—which is fantastic—is the external A-D and D-A conversion racks which you can place where you want them, namely onstage.' □

### Sound Moves' Steve Williams on the Soundtracs DPC II

'THIS IS THE successor to the Virtua which was Soundtracs first digital desk, which had a quarter of the I-O capability and was designed primarily for postproduction. We were the first UK purchaser of one of these, and the second worldwide. I am continually amazed at what we can do with it. We saw Todd Wells [Soundtracs MD] and he was worried it wasn't the right tool for our job. This was basically a postproduction tool, but with my wide broadcast experience, I saw the potential for applications that we could make use of. Since we bought it a number of broadcasters have expressed an interest. Initially it was bought for location sound recording, but we ended up doing so much postproduction at base that within a year we bought a second one for our new 5.1 postproduction facility for TV and DVD work.' Both of Sound Moves' DPC-IIs have 160 inputs, although the first has 96 faders, and the second 48, 'which is perfect for postproduction,' according to Williams. 'Before this, we had an analogue Neve 80-channel truck, which still goes out regularly and does rock and roll gigs and stuff like the Wimbledon Tennis Championships for NBC.'



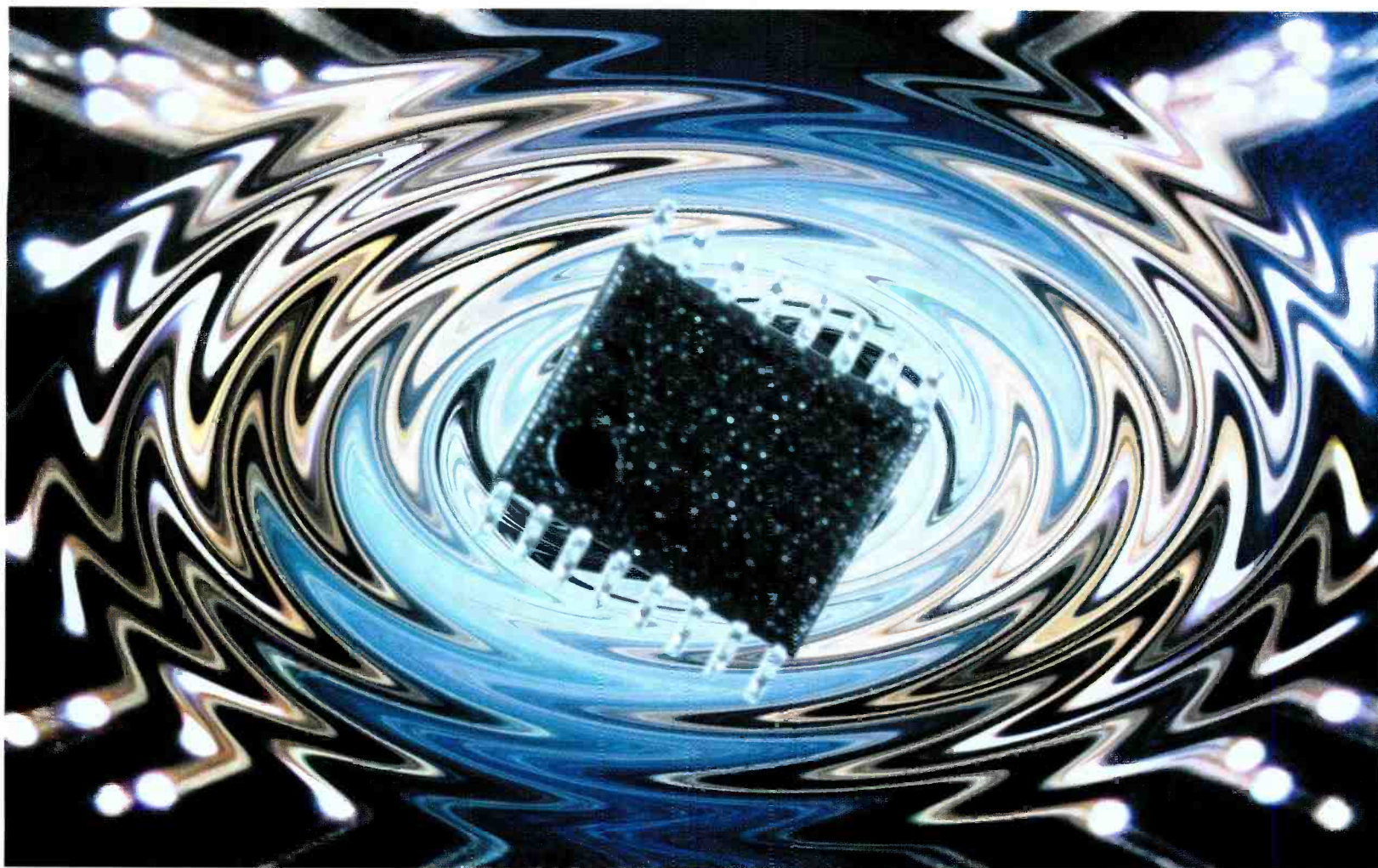

# CIRCUITS AND BUMPS

The importance of converters is in inverse proportion to most engineers' ability to understand them. **Martin Polon** turns the spotlight on digital audio's black box

**N**O COMPONENT IN THE DIGITAL recording chain is more misunderstood than the digital audio converter. This is true for the conversion aspects of mixing consoles, recorders, DSP boxes, input-output hardware for computers running recording software and extends to external audio converters at all price levels. Even in its nomenclature, converters leave some professionals and many project studio personnel in the dark about the devices that make digital audio recording and playback possible. Is 'DAC' the generic category for digital audio converters or is this, as in the hi-fi industry, the specific category for D-A converter chips—the obverse of the A-D converter chip?

As the former, DACs come in all sizes and electronic shapes and responses and have to be used in asymmetrical pairs with input chips that convert analogue audio to digital samples and return them to the analogue domain for possible further processing and final reproduction.

It is easy to appreciate why only those well versed

in the science and mathematics of digital audio conversion really understand it. These folks, perhaps assisted by the talisman of a scientific calculator (preferably Hewlett Packard) appreciate the nearly

40 pages of formulae necessary to explain the magic of digital audio conversion. To the uninitiated—which happens to be the majority of all audio practitioners—conversion remains a buzzword that is accepted in good faith. Perhaps it is easiest to think of audio converters as machines slicing an analogue salami into a series of thin, precise and uniform slices and then presenting these to the digital domain for further processing—the more slices there are and the more accurately they are sliced, the better they represent the original salami.

Ultimately, converter technology is based on the pulse code modulation (PCM) scheme which was invented before World War II (actually in 1938) and began to see use in telecommunications applications at that time. Today, it is important to remember that PCM conversion is both a complicated technology and a controversial one. There is the use of multiple components including the converter chips that either sample or restore analogue audio, resistive and capacitive analogue and-or digital filter circuits that prevent

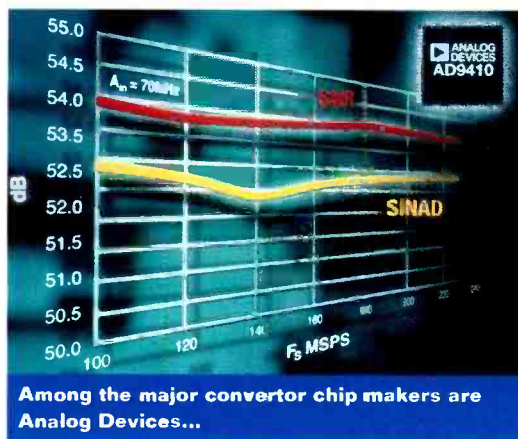



excessive emphasis of unwanted frequencies, wide bandwidth op-amps to compensate for filter loss and to present signals at a high enough level to drive other components, precision clock modules to accurately run the high number of sampling evolutions per second accurately and stable, well-filtered power supplies to assure reliable operation of all the other needed components. Converter circuits can either reside in their entirety on a single chip, or share their components between chips and discrete elements on the surrounding circuit board. They can consist of discrete wired analogue filters with large components to perform the filtering or use digital filters, either located on a separate chip or on the same chip as the converter components. The converter chips can be of the so-called '1-bit' sigma-delta type with lowered requirements for conventional filtering and that can trade resolution in amplitude for resolution in time or they can be of the 'R-2R' type with both analogue and digital sections on the same chip, including laser trimmed resistors. A Colinear device can be made by combining two R-2R devices in a monolithic chip structure, of which the sign magnitude option provides D-A chip performance amongst the highest magnitude of finite audio resolution. The devices can over sample 2x, 4x or 8x at 16 bits, and in similar relationships at 18 bits, 20 bits or 24 bits and at frequencies of 44.1kHz, 48kHz or 96kHz. Specific D-A converters have been designed to work in conjunction with USB ports, firewire, direct streaming digital, DSP chips, microprocessors and optical elements.

In oversampling, performed to move filtering requirements beyond at least twice the human top-

end audibility of 20kHz (44.1kHz including head room), A-D conversion uses a digital low-pass filter to perform decimation. D-A oversampled signals are created by a process of interpolation in which 'zeros' are inserted between every valid bit received. Overall audio response, noise and distortion in all D-As is dependent in either mode or direction upon four factors: quantisation error, dynamic range, sampling rate and noise floor. These factors are determined by the type of converter used, the number of bits sampled and their sampling rate, and the specific application. Other factors include the clock accuracy and its freedom from jitter and the addition dither. Oh, and do remember that all digital information converted to analogue status word for digital word, will by definition contain a minimal number of errors—but errors just the same.

Confusing, you bet. The problem is that as many audio experts as there are, there are approximately the same number of opinions as to the validity of this method or that method of processing analogue-audio to or from digital-audio and the various options one can take

technologically. Do you use sigma-delta or do you use R-2R and what rate do you sample or oversample?

Perhaps a better way to look at digital-audio converters, is to understand the manufacturing industry that has grown up around these semiconductor products. You must remember that the D-A business developed out of and has remained parallel to the DC or 'dawn to dusk' data conversion business in which similar devices with much greater bandwidth and tolerances are sold at a much higher price for a broad range of non-audio data acquisition. At first glance, it might seem with the recent acquisition of converter specialist Burr-Brown by Texas Instruments which has its own multi-varied chip converter lines, that there is now one giant presence dominating the converter manufacturing business. The reality is that the US Government did not block that acquisition and that other manufacturers of D-A semiconductor



... AKM...

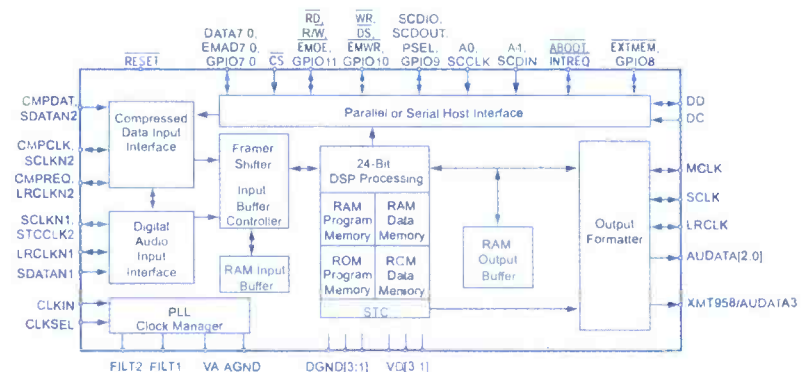

An audio decoder schematic from the Crystal family

classic analogue EQ's & compressors  
in the digital domain with 5.1 and 7.1  
surround sound capability - and pigs might fly.

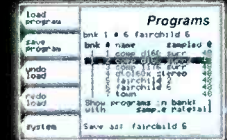
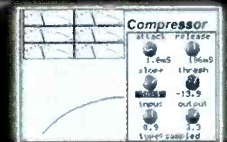
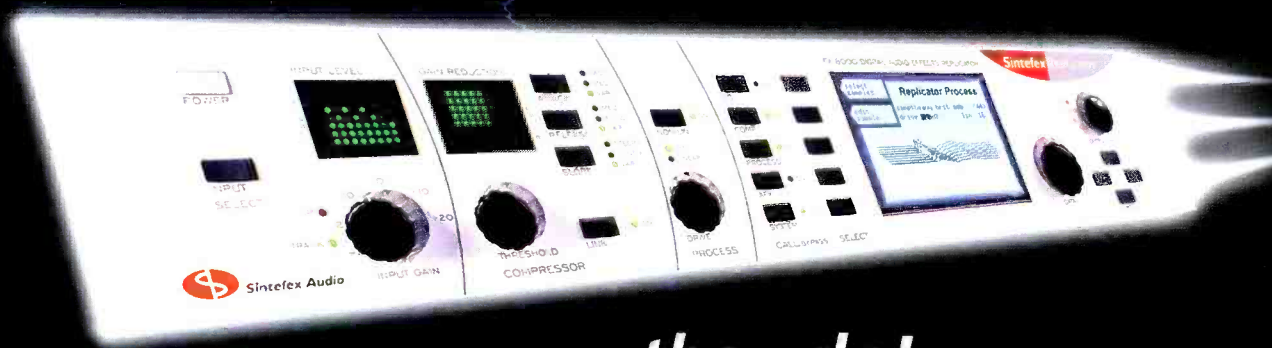

...they do!



**Sintefex Audio**  
www.sintefex.com

Sintefex Audio, Lda  
Vale Formosinho, S. Marcos da Serra, P-8375, Portugal  
Tel: +351 282 361748 Fax: +351 282 361749  
or contact our UK distributor, SADIE on 01353 648 888

The FX8000 Replicator. The next generation in digital technology.

- simulates analogue sound in your digital setup from 2 to 8 channels
- multi channel compression, EQ and other effects from 2 to 8 channels
- sample and modify analogue paths
- store real effects for later use



# CONVERSION

devices such as Cirrus-Crystal still have a viable position in the convertor trade.

Perhaps equally as important to the reality of the D-A chip manufacturing business financial bottom line are the broad-based conversion products priced at \$2 and up. We who live in the professional audio world would like to think that the D-A marketplace revolves around our digital mixing consoles and digital audio recorders of all kinds etc. It's an appealing vanity to think that professional audio calls the D-A shots, as it were. Yet the actual demand variables for the chip makers who have invested in the convertor business, clearly show that these \$20 to \$100 or more pro-audio devices represent a relatively small piece of the total convertor market place.

The reality is that the research and engineering efforts being placed by the chip makers into the improvement of the D-A devices that will convert digital-to-analogue and analogue-to-digital are for such uses as cellular telephones, set-top TV digital interface boxes, internet telephones, computer sound boards and sound chips on computer logic boards, and the biggest demand cycle of them all—D-A convertor chips in compact disc players and DVD players, whose sales numbers are recorded in the hundreds of millions world-wide.

The number one issue in manufacturing these lower-end D-A chips is as a cost-controlled product and as one chip maker opted 'silicon real estate suffers along with performance as price and size are lowered'. Despite the fact that these chips are not intended for use in

most professional audio applications, their presence is a temptation to some lower end manufacturers who recognise that substituting less expensive chips may offer economies of scale to both buyers and sellers of digital audio gear.

For exactly that reason, as well as a number of others including a desire to provide studio users with optimum facilities for digital audio conversion, there is a category of free-standing external convertors. Devices from the likes of Apogee, Prism Sound and Digital Audio Denmark have pushed the convertor envelope far beyond anything D-As from the major chip makers can attempt with circuit-board mounted devices. The chips found in these convertors are the best available, costing hundreds of dollars and-or may indeed be DC 'dawn to dusk' industrial convertor chips. All auxiliary elements of a convertor (such as anti-aliasing filters) are mounted on discrete circuit boards, and it is these elements that refine audio quality, decrease various kinds of spectral distortion and demark one manufacturer's convertor from another's in topology and performance. Such boxes also serve as sample-rate convertors to match various sampling rates and connection formats.

In the studio, external convertors can be substituted for the conventional D-A chips in the digital chain. It is obvious that state-of-the-art studios try to

stay in the digital domain once a signal such as a microphone is fed into a mixing console, with all connections after that between the console and the digital recorder for example, staying in the digital domain all the way to postproduction. Creating the final recorded version via playback from the digital recorder re-enters the console for mixdown also in the digital domain. The same for the recorded copy via CD-R that finally goes to the mastering house. With everything remaining digital, ultimately only a set of the external convertors sufficient to cover (for example) 16 microphone inputs might have to be acquired. With top-end studios spending \$1/4m for a digital mixing console, the technical vanity of using external convertors and having these convertors available—increases audio quality and the overall flexibility of the studio at a price not even 10% of the cost of the digital mixing console. This is not to say that six-figure mixing consoles use inadequate

convertors but rather that size and space limitations still exert their influence on design considerations. More important, by using external convertors for less expensive digital mixing desks, a major limiting factor in overall digital signal quality can be bypassed.

If there is a bottom line here, it is the purest case of 'you get what you pay for' to be found in the pro-audio arena. There is no doubt that digital audio convertors as a category are significantly more price sensitive than most if not all other components used in pro-audio products. Add that to the fact that professional level convertors designed to

be used inside of other products run a far lower numerical volume than their consumer cousins and thus provide a lowered profit margin to chip makers—who in turn have less incentive to improve the breed. Yet the products virtually establish the standard of fidelity and audio quality to be found in digital studio units that use them.

It is not that there are major discrepancies between the conversion chips made by the major and minor convertor vendors. Instead, each designer of equipment that uses convertors has to weigh the trade-offs between chips as well as the convertor cost issue for products being designed for the studio marketplace. A 16-channel digital-mixer designed to be sold for \$5,000 with \$25 convertors cannot use the \$100 per chip convertors used in a \$15,000 digital-mixer. A rule-of-thumb according to one studio equipment maker, is that digital audio convertors should cost less than 10% of the overall retail price of a studio product.

It is safe to say that we have demystified convertors—by only a little, since it would take an entire issue of this publication with a scientific calculator shrink wrapped to the issue to do so. For the end user, the best advice is to listen to a product you intend to purchase and question those who already have the same product in their facility. Talk to the converted. □

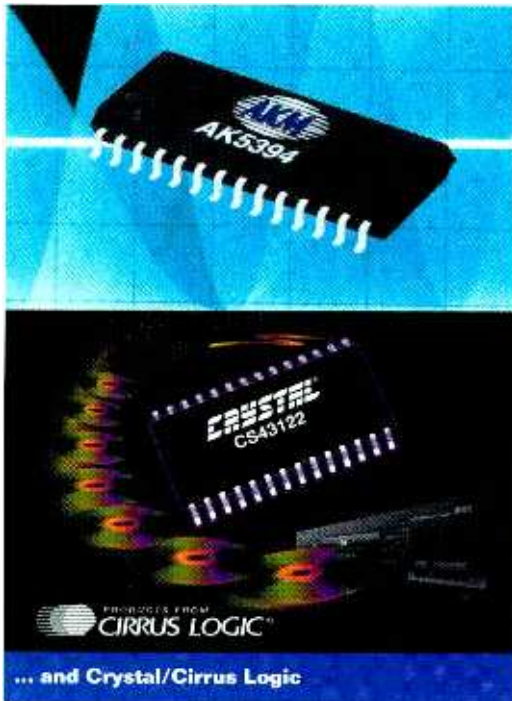

## PORTADISC

### INTERNATIONAL DISTRIBUTORS

**AUSTRALIA: AUDIO PRODUCTS AUSTRALIA PTY LTD**  
Tel: 617 5502 8229 Fax: 617 5502 9229  
Contact: Michael Guest

**AUSTRIA: STUDER AUSTRIA GMBH**  
Tel: 01 865 1676 Fax: 01 865 167999  
Contact: Reinhold Fliedl

**BRAZIL: VISOM BRASIL**  
Tel: 021 493 7312 Fax: 021 493 9590  
Contact: Carlos De Andrade

**CANADA: HHB COMMUNICATIONS CANADA LTD**  
Tel: 416 867 9000 Fax: 416 867 1080  
Contact: Dave Dysart

**CZECH REPUBLIC: AUDIOPOLIS**  
Tel: 02 3332 2132 Fax: 02 3332 4172  
Contact: Jan Adam

**DENMARK: INTERSTAGE**  
Tel: 39 46 0000 Fax: 39 46 0040  
Contact: Finn Juul

**FINLAND: HEDCOM**  
Tel: 358 9 6828 4600 Fax: 358 9 6828 4674  
Contact: Jarmo Rovas

**FRANCE: MILLE ET UN SONS**  
Tel: 01 46 67 0210 Fax: 01 47 89 8171  
Contact: Richard Broomfield

**GERMANY: TRIUS**  
Tel: 05451 940810 Fax: 05451 940819  
Contact: Hubert Dierselhuus

**GREECE: KEM ELECTRONICS**  
Tel: 01 674 8514 Fax: 01 674 6384  
Contact: Thimos Kolikotsis

**HOLLAND: TM AUDIO HOLLAND BV**  
Tel: 030 241 4070 Fax: 030 241 0002  
Contact: Peter de Fouw

**HONG KONG: DIGITAL MEDIA TECHNOLOGY**  
Tel: 2 721 0343 Fax: 2 366 6883  
Contact: Wilson Choi

**HUNGARY: HELS CO LTD**  
Tel: 01 335 0859 Fax: 01 346 0267  
Contact: Zoltan Szeles

**IRELAND: BIG BEAR SOUND LTD**  
Tel: 01 662 3411 Fax: 01 668 5253  
Contact: Julian Douglas

**ISRAEL: BAND PRO FILM VIDEO INC**  
Tel: 03 673 1891 Fax: 03 673 1894  
Contact: Oler Menashe

**ITALY: AUDIO EQUIPMENT SRL**  
Tel: 039 212 221 Fax: 039 214 0011  
Contact: Donatella Quadro

**MALDIVES: ISLAND ACOUSTIC PTE LTD**  
Tel: 960 31 0032 Fax: 960 31 8264  
Contact: Mohamed Habib

**MEXICO: PRO AUDIO DIGITAL**  
Tel: 525 531 58 58 Fax: 525 203 00 18  
Contact: Ingacio Rodriguez Bach

**NEW ZEALAND: SOUND TECHNIQUES**  
Tel: 09 846 3349 Fax: 09 846 3347  
Contact: Stephen Buckland

**NORWAY: LYDROMMET AS**  
Tel: 47 22 09 1610 Fax: 47 22 09 1611  
Contact: Christian Wille

**POLAND: DAVE S. C.**  
Tel: 22 826 4912 Fax: 22 826 4912  
Contact: Bogdan Wojciechowski

**PORTUGAL: ELECTRO SOUND PORTUGESA**  
Tel: 01 417 0004 Fax: 01 418 8093  
Contact: Carlos Cunha

**RUSSIA: A&T TRAOE INC**  
Tel: 295 796 9262 Fax: 095 796 9264  
Contact: Alexei Gorsky

**SINGAPORE/ASIA: SENNHEISER ELECTRONIC ASIA PTE LTD**  
Tel: 273 5202 Fax: 273 5038  
Contact: Donn Ho

**SOUTH AFRICA: E. M. S.**  
Tel: 011 482 4470 Fax: 011 726 2552  
Contact: Dennis Feldman

**SPAIN: LEXON**  
Tel: 93 602 1400 Fax: 93 602 1402  
Contact: Robert Serrat

**SWEDEN: POL TEKNIK AB**  
Tel: 08 449 4440 Fax: 08 88 4533  
Contact: Jarmo Masko

**SWITZERLAND: DR. W.A. GUNTHER AG**  
Tel: 01 910 4545 Fax: 01 910 3544  
Contact: Roland Bricchi

**SYRIA: HAMZEH & PARTNERS CO**  
Tel: 11 333 3753 Fax: 11 373 1573  
Contact: Khaled Hamzeh

**TAIWAN: DMT TAIWAN LTD**  
Tel: 02 516 4318 Fax: 02 515 9881  
Contact: Honton Sze

**TURKEY: SF DIS TICARET AS**  
Tel: 0212 227 9625 Fax: 0212 227 9654  
Contact: Samim Mutluer

**USA: HHB COMMUNICATIONS (USA) LLC**  
Tel: 310 319 1111 Fax: 310 319 1311  
Contact: David Beesley



**HHB Communications Limited**

73-75 Scrubs Lane · London NW10 6QU · UK  
Tel: 020 8962 5000 Fax: 020 8962 5050 E-Mail: sales@hhb.co.uk  
Visit HHB on line at <http://www.hhb.co.uk>



PORTADISC

# ANYWHERE, ANYTIME.



Introducing the new  
HHB PORTADISC™,  
a professional portable

MiniDisc recorder that's always ready to take the hard knocks of audio acquisition on the move. The PORTADISC uses a tough, precision MD drive for maximum durability - not a flimsy, consumer mechanism. And with a frequency response of 10Hz - 20kHz and a dynamic range greater than 96dB, you'll be making recordings of exceptional quality. Despite its surprisingly affordable price, the PORTADISC is packed with the features you need like ultra low noise



balanced mic inputs, coaxial and optical digital I/Os, flexible powering options and a comprehensive range of accessories supplied as standard. And the PORTADISC is the only MD portable to feature a USB interface so you can stream audio to and from your workstation. When you're working in the field, you need a recorder you can rely on, anywhere, anytime. Contact HHB today for full information on the PORTADISC system.



HHB Communications Ltd · 73-75 Scrubs Lane, London NW10 6QU  
Tel: 020 8962 5000 · Fax: 020 8962 5050 · E-Mail: sales@hnb.co.uk  
HHB Communications USA LLC · 1410 Centinela Avenue, Los Angeles, CA 90025-2501, USA  
Tel: 310 319 1111 · Fax: 310 319 1311 · E-Mail: sales@hhbusa.com  
HHB Communications Canada Ltd · 260 King Street East, Toronto, Ontario M5A 4L5, Canada  
Tel: 416 867 9000 · Fax: 416 867 1080 · E-Mail: sales@hnbcanada.com

[www.hhb.co.uk](http://www.hhb.co.uk)





# PRECISION CONVERSION

Conversion is critical to audio quality but too often convertor quality is inadequate. **John Watkinson** argues that it is not acceptable to question sampling theory as an alternative to good engineering

**D**IGITAL AUDIO IS NO MORE than an alternative way of describing an audio waveform. The difficulty of converting in and out of the digital domain is more than compensated by the ease with which data can be recorded, transmitted or manipulated in computer-related hardware. Techniques such as error correction and time-base correction mean that the data leaving the A-D convertor and their relationship to time are perfectly represented to the D-A convertor so that the sound quality is independent of the characteristics of any medium through which the data have passed. In fact, this potential transparency of the digital domain transfers the entire responsibility for sound quality to the A-D.

The A-D contains an information capacity limit because it has finite bandwidth and resolution. As a compatible D-A should have an identical information capacity, it follows that a well-engineered D-A should not cause any further impairment. Fig. 1a shows that the information capacity is the product of bandwidth and signal-to-noise ratio, in the same way that the area of a door is the product of its width and height. All signals have a finite information content and all audio equipment, analogue or digital, has finite information capacity. If the information capacity of an audio device is the size of the door, the information content of an audio signal is the size of the box we are trying to get through the door. As Fig. 1b shows, if the box is shorter and narrower than the door, there's no problem. However, if the box is too big, it won't fit. Passing an audio signal through a device of lower information capacity is like forcing a box through a door which is too small—it gets damaged.

In the case of an audio signal, the ultimate doorway is the human hearing system. If the information content of the reproduced sound exceeds the capacity of the human hearing system, human listeners will consider it perfect. In real audio applications, the analogue signals to be converted may already contain less information than the ear's capacity—signals from vinyl disc or cassette tape prove the point. Thus in general, a successful A-D only needs more information capacity than the information content of the signal to be converted. Even if this signal is non-ideal, the A-D won't make it any worse.

On the other hand, if a signal is going to be manipulated in the digital domain, by changing the level or

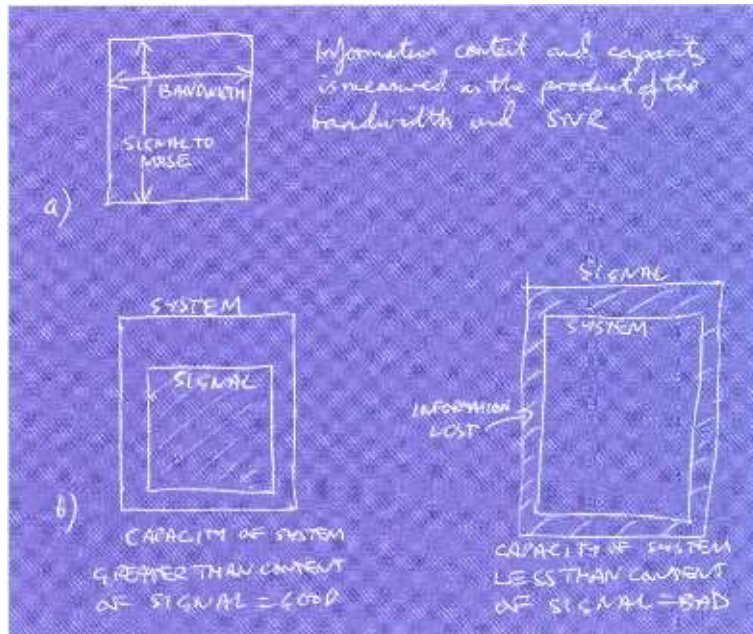

**Fig.1: Information capacity and information content are measured in the same units (a). If the capacity is not high enough (b) some information is lost**

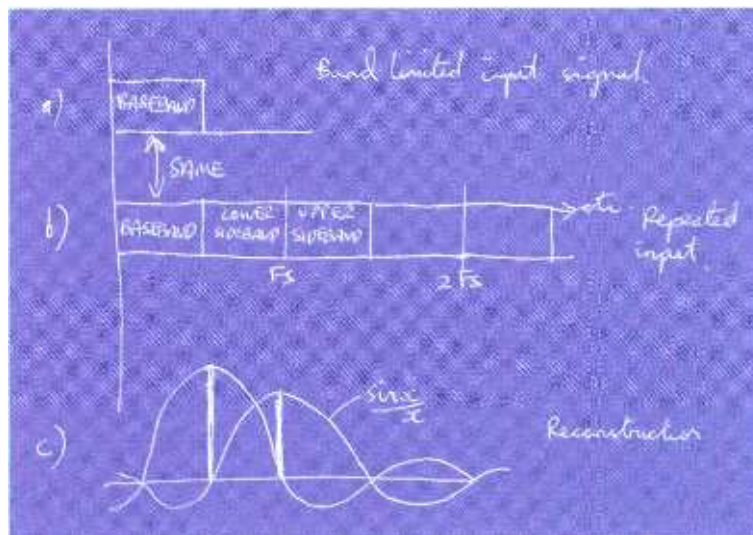

**Fig.2: At (a) the input is band limited by a filter. At (b) the sampling process simply repeats the baseband in the frequency domain. There is not loss of information, and removing the sidebands in a second filter restores the original baseband of (a). In the time domain (c) samples are filtered to become  $\frac{\sin x}{x}$  impulses**

the EQ, the A-D information capacity may have to be greater than the ear's capacity to allow for sub-optimal use of levels and finite precision in the processing.

The bandwidth of an A-D is a function of the sampling rate while the SNR is a function of the word length. These topics can be treated separately before considering techniques such as oversampling which

permit some horse trading between the two domains.

The initial guide for the choice of a sampling rate is sampling theory. This has a long history, dating from the work of Whittaker during the First World War, with major contributions from Nyquist, Shannon and Kotelnikov. Given the nature of scientific method, had any of these individuals got it wrong, this would have been pointed out long ago. Sampling theory only predicts what is possible under ideal conditions but if these conditions are met then perfect reconstruction is possible with Nyquist rate sampling. What this means is that it is theoretically possible for the output waveform to be identical to the input waveform when the sampling rate is twice the signal bandwidth.

The requirements for perfect reconstruction are strict and are set out below:

The input signal must pass through an ideal, linear phase, low-pass filter which cuts off totally at a frequency of one half of the sampling rate (the Nyquist frequency).

The samples must be taken at absolutely regular intervals and the voltage of the waveform must be measured at a point, not averaged over any time period.

The samples must not be increased in width in any way but must be passed through a second filter, identical to the first. Then within a bandwidth of half the sampling rate, the output waveform will be identical to the input waveform.

Fig.2 shows that in the frequency domain it is easy to see how this works. At Fig.2a the input is band limited by an ideal filter. The sampling process causes the baseband spectrum to repeat (Fig.2b), so there is no increase or loss of information. The second filter simply removes the repeat spectra, leaving the baseband as it was.

Fig.2c shows perfect reconstruction in the time domain. The impulse response of an ideal low-pass filter is a  $\frac{\sin x}{x}$  curve. When Nyquist sampling is used, each impulse passes through zero at the site of all of the other samples. Thus at the centre of each sample, only that sample determines the output voltage. In between the samples the sum of the contributions from a theoretically infinite number of impulses recreates the continuous waveform. Shannon proved this mathematically.



The theory of perfect reconstruction at the Nyquist rate is only a theory because in practice these requirements cannot be met. However, sampling theory is useful because it puts an absolute limit on what is possible, which real equipment may approach but not exceed.

It is important to appreciate that, when considering sampling systems which can actually be made, the expedient of raising the sampling rate by a moderate amount above the Nyquist rate allows perfect waveform delivery to be approached very closely indeed; far more closely than any analogue technology can offer.

One of the practical issues with sampling theory is that the ideal filters cannot be realised. A filter with a 'brick wall' frequency response causes an infinite delay to the signal, which would be useful for archiving purposes! In order to make the delay finite, the filter has to have a sloping transition region (Fig.3). In theory, an anti-

aliasing filter with a sloping response cannot completely prevent aliasing, it can only reduce the level. Figs.3b and Fig.3c show that raising the sampling rate simply drives the aliasing to a lower level. However, with a reasonably steep filter, the aliasing products are driven to a level which is so low that it is comparable to the noise floor of the system. In this case the aliasing can be neglected. With reasonable sampling rates such as 48kHz, the basebandwidth is so wide that there will in any case be very little energy to cause aliasing and so with real signals the filter will appear to work better than its specification would suggest.

Another practical issue is that producing point samples which are effectively of zero period is also impossible. A track-hold circuit in a conventional A-D and flash converters make a good approximation to point sampling but the problem comes in practical D-A converters. Fig.4a shows that to output a zero duration pulse, which has a flat spectrum, requires infinite bandwidth, besides which the pulse has no energy. In practice, finite width pulses have to be used a (Fig.4b). The spectrum of an infinitely short pulse is not flat, but droops, causing an HF roll off which is known as aperture effect. If the pulses are extended until they fill the sample period, this is called a zero-order-hold process and the roll off amounts to about 4dB at the Nyquist frequency. Unfortunately, many digital audio textbooks suggest that this is the only way to handle conversion, which is misleading. If the pulses occupy about 10% of the sample period, the roll off is negligible, otherwise it can be equalised.

The remaining practical issue with sampling is the adequate suppression of jitter. If the samples are not reproduced with the same time relationship as when

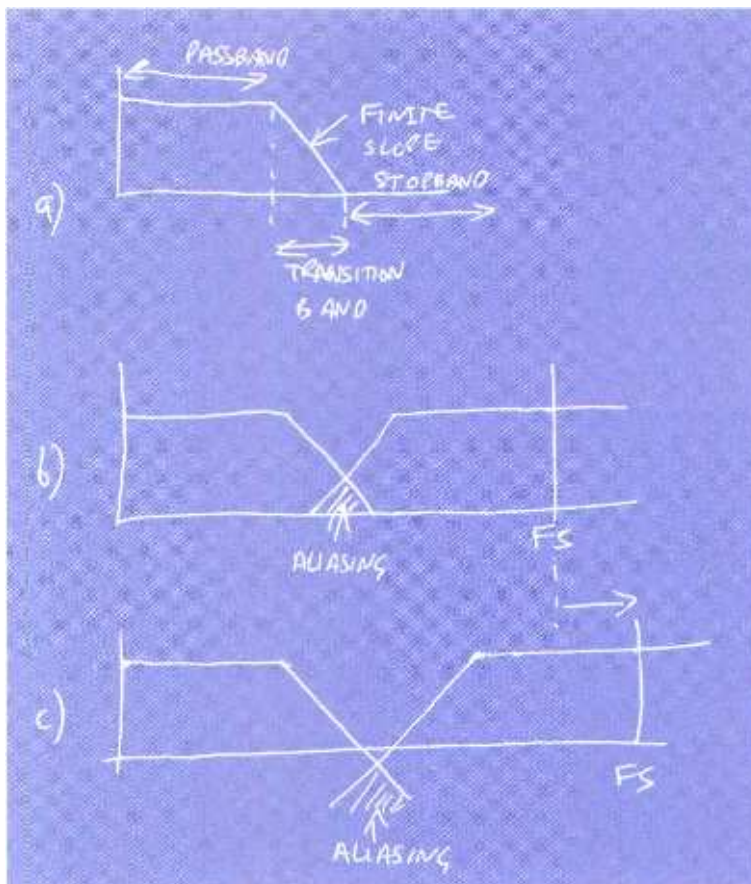

**Fig.3: All practical filters must have a finite slope (a). This means that there will always be aliasing (b). However, raising the sampling rate as in (c) will reduce the aliasing level**

they were taken, the waveform is distorted. Fig.5 shows the problem. If the accuracy of the samples is to be determined by the converter wordlength, the jitter must be small enough that any error in the waveform it causes is smaller than the size of a quantising interval. Typical audio converters need jitter to be less than about 100ps. This is a remarkably strict figure and few converters meet it as it requires the entire converter clock system to be treated as an analogue process with a high signal-to-noise ratio.

Turning to quantising, the concept is easy. The voltage of the sample is expressed as a whole number proportional to the voltage. In digital systems this number will be coded in the binary system. This means that practical systems always have a number of steps or quantising intervals close to a power of two. Forcing the sample level to that of the nearest step causes distortion, but this can be completely eliminated by the application of dither. Vanderkooy and Lipshitz have shown mathematically that a correctly dithered quantiser is perfectly linear and so need not cause any signal distortion at all. The only penalty is that a slight extension in wordlength is needed.

Fig.6 summarises the theory and the practice. In the time domain, practicality requires a slight increase in sampling rate and in the voltage domain, practicality requires a slight increase in the wordlength. The result is that real converters can be made in which the output waveform can resemble the input waveform to any accuracy we choose to engineer. In other words there is no fundamental problem, only the engineering-business problem of making the possible affordable.

This is where oversampling comes in. Returning to Fig.1, if we want to make the door bigger, sometimes

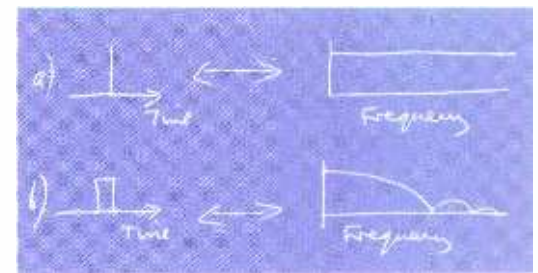

**Fig.4: Infinitely narrow pulse (a) has a flat spectrum, whereas broad pulse (b) has a drooping spectrum. This causes a non-flat frequency response in a sampled system**

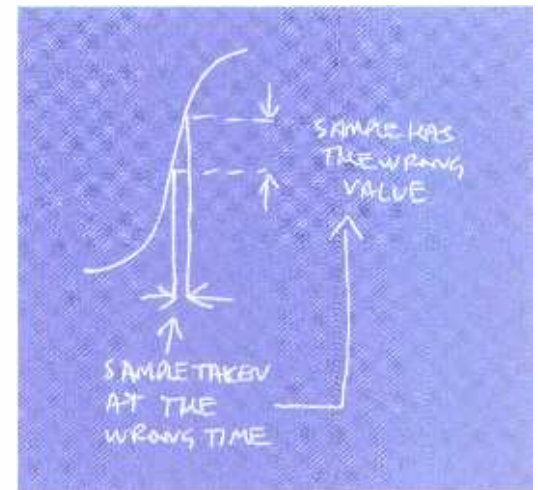

**Fig.5: In an ideal converter, jitter should be so low that the error shown here is smaller than the quantising step**

it's easier to make it wider than it is to make it taller. Oversampling is a system which allows us to use the available area without being too concerned over the shape. In A-Ds, adding resolution is difficult because it requires parts of great precision and stability, whereas making the whole thing go at a higher frequency is often easier.

For example, if we have a 16-bit converter and it is required to increase the resolution, this can actually be done by raising the sampling rate at the converter and then lowering it again in a filter. Fig.7 shows that if the sampling rate is doubled, twice as many samples are taken of the input than are needed for the required bandwidth and so the samples are passed through a half band filter. This has the effect of averaging pairs of samples. If a pair of samples have the same value, the filtered result is unchanged but if they differ by one step, the average of the two is a level of half a step in between the two. This doubling of the number of steps is the equivalent of having an extra bit in the converter, provided, of course that the averaging process is ideal.

Oversampling has some further advantages. Fig.7 also shows that the anti-aliasing filter can have twice the bandwidth but only needs a flat response over the first half. This relaxes the specification of the analogue filter. The remainder of the anti-aliasing process is carried out in the digital filter. Note that the combination of the analogue filter and the digital filter must still display linear phase and adequate suppression of the stop-band.

Working on the constant area principle, adding one bit to the word doubles the size of the coding range, so a doubling of sampling rate is worth one bit of resolution. If we try to obtain a large increase



# CONVERSION

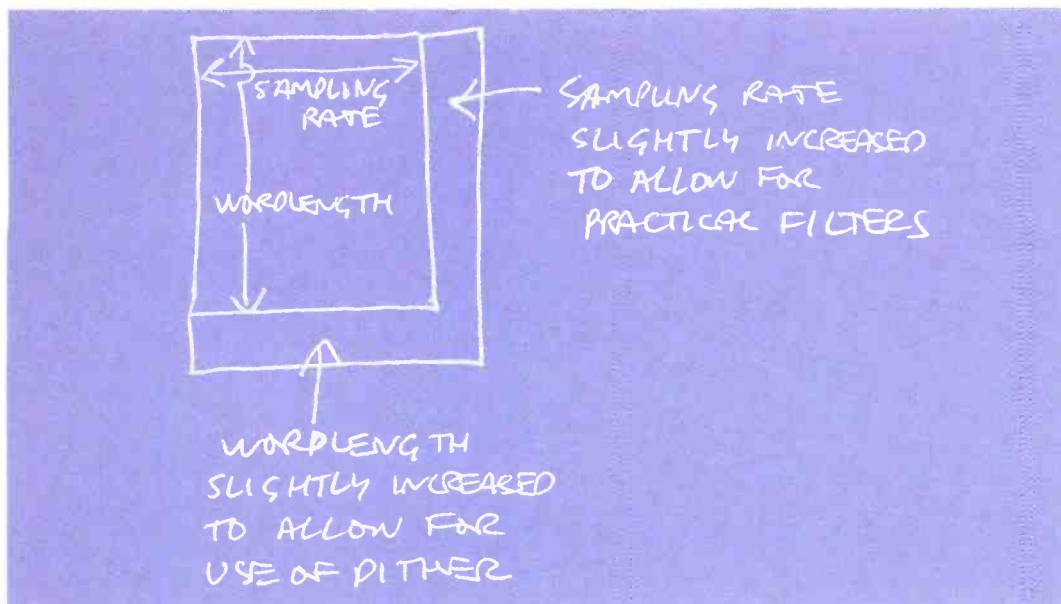

**Fig.6: Sampling rate and wordlength are raised slightly in practice**

in wordlength, the sampling rate will become very high indeed.

One solution that has become popular is to use a technique known as noise shaping. In an oversampling converter with a conventional quantiser, the noise floor is flat (Fig.8a) and the noise level goes down by 6dB for every halving of the bandwidth. However, if the noise floor is not flat, the noise will reduce disproportionately.

The degree of resolution extension which can be obtained with noise shaping is such that the converter element itself only need to have a resolution of a few bits and so it can be implemented using a flash converter which is an inherently high-speed low-resolution device. Noise shaping converter topologies typically work by feeding back the quantising error of earlier conversions so that it can modify later conversions in a way that minimises the error.

Fig.8b shows a Sigma-DPCM converter in which the previous conversion is compared with the input to produce an error which is quantised to produce the next conversion. The integrator is a low-pass filtering element but it is in a feedback loop so that the over-

all effect on the quantising error is that it is high-pass filtered. Using a higher order filter is common because the higher the filter order, the greater the reduction in

noise (Fig.8c). However, it should be clear from a casual inspection of Fig.8b that it cannot have a symmetrical impulse response because there is a delay in the loop. This stage cannot be phase linear. Thus in the absence of an additional phase correction stage to linearise the overall phase response, the noise shaping converter is not phase linear and violates the rules of reconstruction outlined above. The higher the order of the converter, the less phase linear it will be.

Noise shaping converters depend critically on the performance of the low-pass filter-decimator, which simultaneously filters out the noise, reduces the sampling rate and extends the resolution. If the performance of the filter is inadequate, it may extend the wordlength more than it extends the resolution. If this sounds contradictory, consider a 16-bit audio signal in which the bottom three bits had been replaced by random numbers. This would be a 16-bit signal with 13-bit resolution. Because of the inevitable wordlength extension when sample values are multiplied by coefficients in filters, it is trivially easy to get a long wordlength out of a noise shaping converter. However, this does not prove anything. The bits have to mean something.

Fig.9 shows the key parameters of the filter. These are the pass-band ripple, the stop-band attenuation,

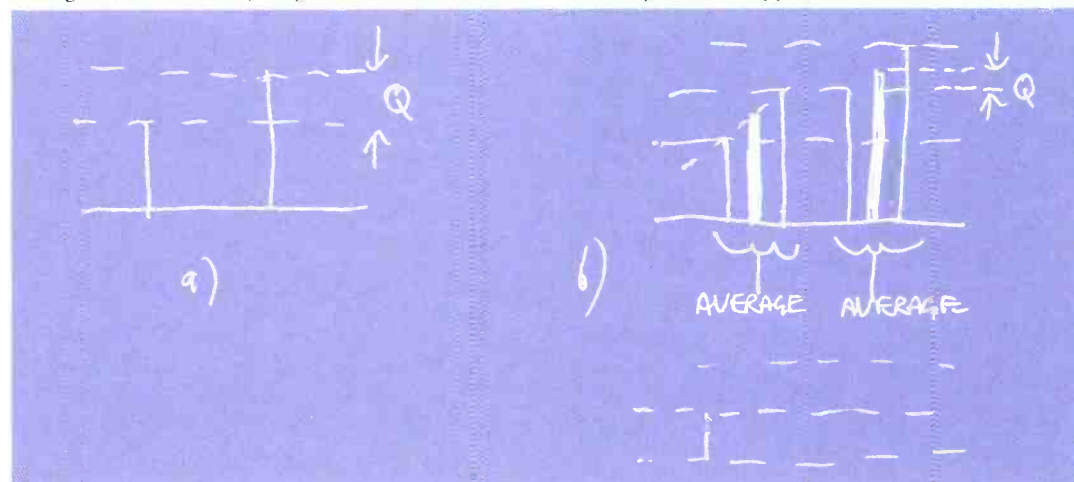

**Fig.7: At (a) resolution is set by quantising step size. However at (b) doubling the sampling rate allows pairs of samples to be averaged, halving the step size possible**

There's nothing in its price range to match it.  
Chris Tsangarides (Engineer Gary Moore)

"It sounds absolutely amazing!"  
Tom Gilling (Engineer Damon Albarn)

# vtecconsole

**valve technology**

There are hundreds of mixers on the market. But none that look, feel or sound like this one. If you're working with digital multitrack recorders, then the award winning VTC console offers something very special - the classic warmth of valves combined with the functional demands of modern music production. Believe us - the VTC simply has no competition!

**m.i.p.a.**

**TL Audio VTC**

1000-WINNER  
TL Audio VTC

"Call me predictable, but I want one, and I want it now." Studio Sound

"You can't replace the vibe of this desk, and the warmth it has is incredible." The Mix

**TL Audio**

[www.tlaudio.co.uk](http://www.tlaudio.co.uk)

TL Audio Limited, Sonic Touch, Iceni Court, Icknield Way, Letchworth, Herts SG6 1TN UK  
Tel: +44 (0)1462 680888 Fax: +44 (0)1462 680999 email: info@tlaudio.co.uk



and the slope. Pass-band ripple produces pre-echoes which are audible. The slope cannot begin until the top of the audio band, so an inadequate slope will raise the frequency at which full attenuation is achieved, thus admitting more noise and degrading resolution. These parameters are made acceptable by designing a filter with a large enough window. In other words if the filter doesn't have access to a sufficient time span of samples, it can't have enough frequency resolution.

In a noise shaping converter, the filter-decimator is at all times faced with a high level of noise at its input. By definition it must have a stop-band attenuation at least as good as the quoted resolution. If it does not, some of the low-order output bits will represent noise or aliased noise.

In the stop-band, assuming a basically reasonable filter design, the ultimate attenuation is determined by the arithmetic precision of the processing. This applies equally to the samples and to the coefficients. Assuming that a 20-bit converter is the goal, the arithmetic has to be accurate to one part in a million otherwise the 20 bits emerging won't carry 20 bits of information.

Fig. 10 shows the various stages of a noise shaping converter to point out where performance can be lost. If high resolution is a goal, the analogue parts, the error amplifier and the integrator, must have outstanding performance. This is difficult enough but that performance must be achieved in the close proximity of high-frequency digital circuitry. One of the difficulties in designing a precision converter is to stop it interfering with itself either by common impedances or via radiation.

The flash converter is a possible source of error. Unless all of the quantising intervals are of exactly the same voltage, the transfer function will be nonlinear. Ordinarily this would result in distortion but in a noise shaping converter the A-D transfer function is put in a different place relative to audio ground on each sample so that the distortion is turned to noise. This is preferable to distortion, but it will reduce the resolution of the converter. The same is

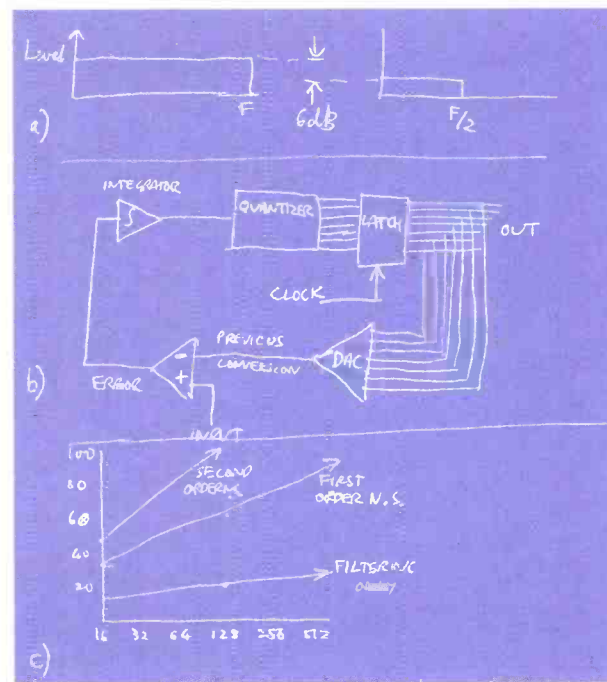

**Fig.8: At (a) simple reduction of bandwidth by a factor of two results in 6dB less noise, or one extra bit. At (b) a noise shaping converter with an integrator in the feedback loop has a rising noise floor. This gives better resolution increase as shown in (c)**

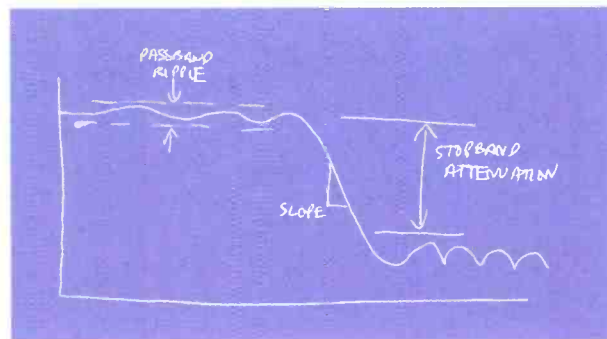

**Fig.9: A digital filter may have the above characteristic. It needs enough points or samples in the window for an adequate slope, and sufficient precision to lower the stopband level**

true of jitter. To some extent with a high oversampling factor the effect of truly random jitter will be filtered out, but in the close proximity of digital circuitry, assuming that the jitter is random is dangerous.

The filter decimator must accept highly noisy data at the high oversampling rate and subject it to a low-pass filtering process of adequate precision. The necessary multiplications will cause wordlength extension which is where the increased resolution comes from, but this will not happen if early stages of the filter have insufficient precision. Precision costs processing power. A steep cut filter with low pass-band ripple needs a large window with more multiplications per output sample. Longer wordlengths to achieve high-precision need more logic.

The converter must be phase linear and so the impulse response of the low-pass filter must be asymmetrical in the opposite sense to that of the converter element. Asymmetric filters are more expensive because they cannot use a trick called folding which halves the number of multiplications to be performed.

Let's imagine that the converter of Fig.10 almost meets its specification. The analogue input stages are picking up a noise and noise is also causing some clock jitter. The nonlinearity of the flash converter is causing further noise. The filter decimator coefficients and logic are not quite accurate enough and the filter is folded to same money, so the converter is not phase linear. The result of this tolerance build-up is that the audible performance of the converter isn't quite as good as it could be.

A quick solution is to double the sampling rate from 48kHz to 96kHz. The converter distortion is now averaged in the listener's ear over twice the bandwidth, as is the noise due to inadequate precision in the filter. The phase linearity is twice as good. To no-one's surprise it sounds better.

The next step is to think up some pseudoscience which explains that human hearing actually has twice its previously measured bandwidth and that what we need is a new high sampling rate. If only it were true. □

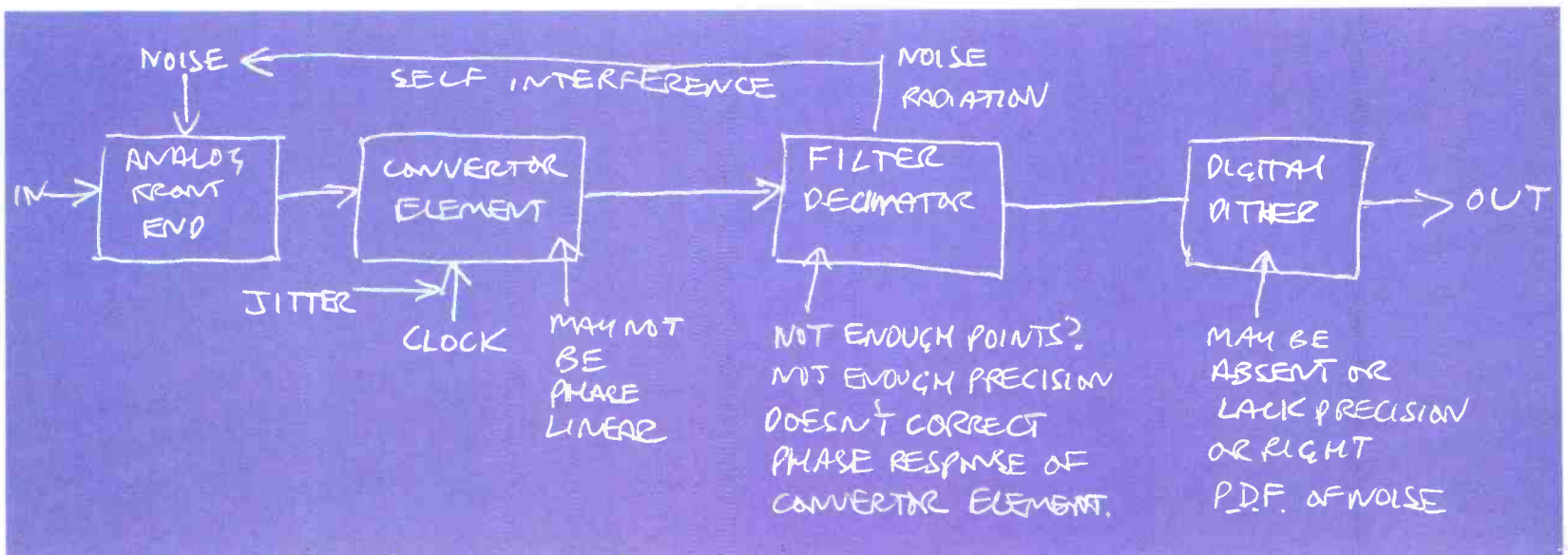

**Fig.10: Noise shaping ADC showing some of the places in which loss of resolution may take place**



# BE A PLAYER

REAL PLAYERS KNOW THE PLACE TO GO FOR ALL THEIR MUSIC NEEDS: THE DIRECT INFORMATION LINE TO PROFESSIONALS AND INDUSTRY EXPERTS, LESSONS THAT REFINE YOUR PLAYING AND HELP CREATE A SIGNATURE STYLE, INSTRUCTION TO GET EXCEPTIONAL SOUND ON STAGE AND IN THE STUDIO, TIPS AND TECHNIQUES ON PLAYING MUSIC FROM APPALACHIA TO AUSTRALIA AND EVERYWHERE IN BETWEEN, A FULLY CUSTOMIZED WEBSITE BASED ON YOUR INDIVIDUAL NEEDS. FROM NOW ON, YOUR DESTINATION OF CHOICE IS THE MUSIC PLAYER NETWORK @ [MUSICPLAYER.COM](http://MUSICPLAYER.COM)

**REGISTER NOW**





# MUSICPLAYER.COM

## THE MUSIC PLAYER NETWORK

GUITAR PLAYER • KEYBOARD • EQ • BASS PLAYER • GIG • MC<sup>2</sup> • EXTREME GROOVE • MUSIC GEAR ONLINE

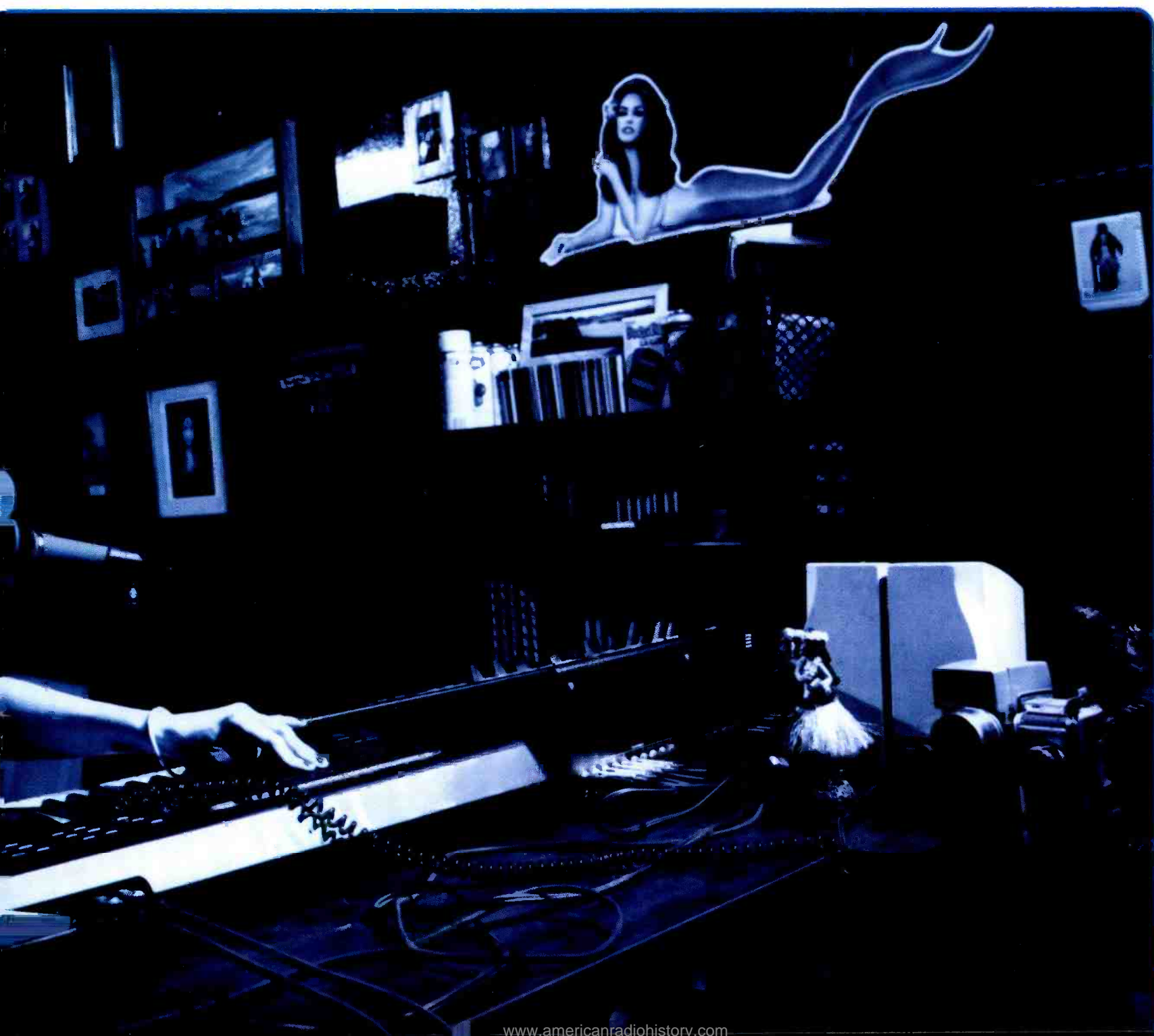



# Millennium moments

An elite selection of audio's activists and observers take time out to present their personal view of the past year. Much has changed and much endured in the soundtrack to the Millennium year

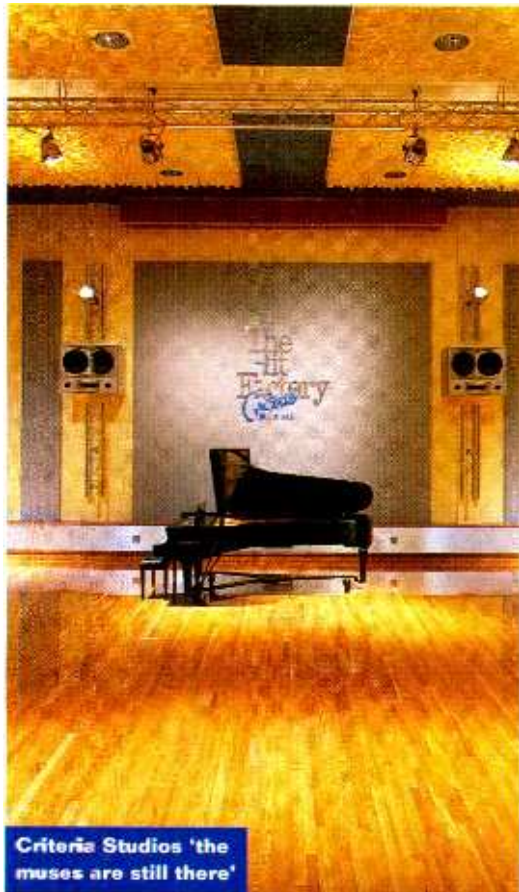

Criteria Studios 'the muses are still there'



AMS Neve 88R 'something of a surprise'

## Random access

THE NEW YEAR saw my little corner of the world in the midst of some chaos. The venerable Criteria Studios had been purchased by New York's Hit Factory and were undergoing massive renovations. New ownership, new equipment, and new ideas; hell—just about everything was new. It was interesting however, to observe and participate in the integration of an existing facility with the best designers, direction, and equipment money could buy. It's not an ad for the facility, but if you're curious: yes, the muses are still there.

What essentially started with inexpensive, high-quality, small-format digital machines has exponentially increased with the sophistication of hard-disk based editors and the proliferation of personal production environments.

In many instances, the producer is behind the creation and use of the personal production environment while in others, different people are involved in the process. In any event, the tools technology has afforded have resulted in changes for producers, engineers and facilities.

It has also been my experience that South Florida specifically, and the industry in general, has seen a higher percentage of budgets designated as 'All In', producer administered funds. Basically if you are given \$100k to make a record and you spend \$40k, you make \$60k. I believe that at least in part this is the gas in the vehicle that sends you down the road to the personal production environment.

For an engineer the roles have also changed. While many old school engineers mistakenly believed that life would continue as usual, the advent of digital audio workstations has necessitated a change to the skills in a successful engineer's arsenal. Those engineers that recognised this early on had a clear advantage and it's showing. Those that didn't realise it and haven't adapted—well; they are delivering mail. On an emotional level, many engineers have also had to face the fact that now you don't drive to the commercial studios every day. You may have to go to the producers' garage or spare bedroom. The engineer of 2000 and beyond must be able to adapt and embrace new technologies and realise that their education is an ongoing process.

There has always been a stratification of recording studios, however continued technology-based advancements have widened the gap between the players. In some markets, certain classifications of facilities are in danger of disappearing entirely. Certainly at the level of the facility I am most familiar with, the key lies in anticipating and adapting to those changes.

While the technical support, acoustic properties of the rooms and the level of service must remain high, there are evolving concerns. We are no longer just recording studios: equipment purchases must be made with a different future in mind. A portion of our business now and a larger portion in the future will revolve around the flow of data. Today it's format, bit depth, sample rate conversion and

compatibility with production environments and other facilities. Tomorrow it's all manner of information control systems from next door to the next continent.

Speaking of the next continent, some of us delude ourselves into thinking that English is the only language. The year 2000 saw an organisation give Hispanics a world-wide platform. NARAS (National Academy of Recording Arts and Sciences), the good people who bring you the Grammy Awards, founded it's first international equivalent: LARAS (Latin Academy of Recording Arts and Sciences). Formed in 1997, the Academy began with cultural, educational and advocacy programs. This year LARAS presented the first Latin Grammy Awards. Long overdue artistic recognition for cultures encompassing over 15 countries and a quarter of a billion persons if you ask me.

**Trevor Fletcher,**  
The Hit Factory Criteria Miami

## The dreamers of dreams...

THE MOST INTERESTING (and only) musical project I've worked on in the year 2000 was my solo-collaboration album. I've actually been in the midst of it for close to three years, but I'm beginning to see the light at the end of the tunnel now. Having the opportunity to work with, become friends or continue friendships with talented artists and good people like assorted members of Ash, Mogwai, Fridge, Rezzent, Alabama 3, Voy; and Mani, Hooky, Pharoah Sanders, Sean Dickinson, Astrid Williamson, Tim Wheeler, Rennie Pilgrim, Clint Boon, Sandi Shaw, Alan Vega and Peaches has been the most enjoyable thing about my Millennium year. Musically intense (in a punk-dance-melodic mode) with bits of everything you might (or mightn't) expect from that list of collaborators and a full dose of me, it's the best music I've made in over 10, maybe 15 years. I'm hoping for a deal before Christmas; ho, ho, ho.

The best piece of technology I discovered this year has been around for a while (I'm a bit slow). It's called a laptop PC with the Sonic Foundry Acid program. I've started most of my tracks this year in it; it's so useable (easy even for a pre-computer type like me) that tracks almost make themselves. Also Fruity Loops, another new discovery is pretty dope too.

The trend this year has been no focused trend as far as I can see. I guess There's a bit of a Mancunian revival with Badly Drawn Boy-Twisted Nerve-Doves-Alpine Stars happening but I look for the early eightiess punk-dance revival to start happening with such acts as Peaches, Play Group and maybe even my record leading the way into 2001.

**Arthur Baker, artist and record producer**



## The god of small things

IF DATA IS to become our new god, we need to write some new commandments. For while a scant handful of us are taking due care of business, the rest of us are still struggling with lost word processor files, oblivious to the significance of events around us. If you entrust your audio files to Rocket Network, for example, not only is your work secured by multiple redundancy technology (Thou Shalt Save) but also by retinal scans of the staff who have access to them (Thou Shalt Not Bootleg).

At home and at work, the standardisation forced upon you by Microsoft will continue to ease hackers into your universe. The more astute of you will be finding leaner packages that deliver improved security as a peripheral benefit to stability, flexibility and affordability (Thou Shalt Diversify). And the hard demarcation between work and leisure will continue to blur as remote working and hordesking become widespread (Thou Shalt Seek Mobility And Independence). Broadband communications will bring a smile to your face and the studio to your home, while increased use of your mobile phone for both business and pleasure will tarnish its novelty and cause you to question who pays the bill (Thou Shalt Seek Arbitration).

Away from the workplace, if running your future home is to involve a central server containing not only your entire music, video and picture libraries but also your accounts and your Christmas card list, you would do well to recognise its worth (Thou Shalt Seek Multiple Redundancy). But don't expect to guard against a Ford Transit being driven through your lounge (Thou Shalt Not Need To Redecorate) because the bandits will hijack data not hardware and its greatest value will be in selling it back to you (Thou Shalt Encrypt). The leisure time you are enticed to devote to the increasing pleasures of the Internet may be part of your undoing (Thou Shalt Not Surf Unprotected).

But most consistently of all, your children will show familiarity and irreverence for a technology that has so readily redefined your world (Thou Shalt Ultimately Seek Religion).

**Tim Goodyer, Studio Sound editor**

## Shapes of things

2000 WILL NOT be remembered for stacks of new product releases but different measures indicate a year of pivotal importance in other ways.

High points have to include the Tascam MX-2424 which, while it was shown for the first time last year, beat the opposition to market and has shipped in numbers. The old cost-performance, 'offering today what was unthinkable only three years ago' and 'you've never had it so good' clichés all ring particularly resonantly with this box and there are bits and pieces to come on it that should ensure longevity. This and the Mackie and Fostex machines create a formidable deterrent to tape.

AMS Neve's 88R was something of a surprise, not because it arrived when it did, but that it followed the pattern that it did. Very much a next generation all-new V, it would be a bold man who'd claim this is the last large analogue superconsole that will ever be built. But then it probably is.

In keeping with the increased accessibility to 24-96, there's been a rash of interesting and more affordable and multichannel convertor box solutions like the ones for Genex. Accessible quality front ends remain the last obstacle to opening these particular flood gates.

By far and away the most important release of the year is Sonic Foundry's Vegas Video. Essentially Vegas



**Audient ASP 8024 console the analogue console enjoys a revival**

Audio with picture editing capability added, this native package makes avoiding picture more trouble than embracing it. Others are likely to follow, we are at the beginnings of a new way of working if you can be persuaded. This and the possibilities opened up by DVD authoring bode well for the audio business.

Elsewhere television and domestic viewing patterns are under threat by new home technologies that will let you watch, record and avoid according to your habits and preferences. Reception of this new method is divided in to those who are excited by it and those who are plain scared.

**Zenon Schoepe, Studio Sound executive editor**

## Welcome to the pressure dome

I DIDN'T WANT IT, you didn't want it, but the finance minister in the government of progress has spent all our hard-earned mullah on a monument to welcome in the 21st Century of sound recording. The layout has been designed on the lines of the 2000 Paris AES show, to wit, the only way to find anything is to keep walking around in circles until you stumble on it by chance. Welcome to the pressure dome...

The dome is divided into a number of zones; first there's the recording studio scrap yard. Pro Tools has now become the *de facto* way to make records. The recording studio has increasingly become the place where you line up your faders in a straight line and then mix everything in Pro Tools because of the control it gives you over every aspect of your mix. It hasn't taken long for customers to do away with the middleman, and so, sadly, this year we have said goodbye to a number of highly respected establishments due to financial implausibility.

The impossibility of getting anywhere in our capital cities in less than two hours has resulted in Digidesign and Rocket Network devising increasingly clever ways of you not having to leave your home.

We're now over three years into the DVD age; initial sceptics about the medium have been gainsaid by the enthusiasm of the consumer for DVDs and wide-screen televisions, yet the only market for 5.1 mixes in the UK is for film soundtracks for delivery to dubs and the sporadic live concert remix. DTS has been trying to persuade record companies to release 5.1 versions of their new releases to the extent of paying for mixes off its own back, but the general experience of everyone involved in promoting 5.1 is of pushing a heavy boulder up a steep hill. We know that it's eventually going to roll down the other side, but we're starting to run out of Red Bull. In some ways consumers are ahead of industry professionals in their



**Tascam MW2424 'star of the year'**



**Steve Parr takes in the view from the trenches**



# SIRIUS



## Digital Broadcast Mixing Console.

- Sample rate converters on all inputs.
- 24 bit AD/DA converters
- 32 bit floating point DSP.
- 64-32-64 in/output Matrix.
- 4 band EQ / Dynamics / 32 busses.
- Motors on all pots and faders.
- Modular construction.
- Networking capability.
- Instant user configurability.
- GPIO's per input.
- Very short learning curve.

D&R Electronica b.v.

The Netherlands

Phone: +31 294 418014

Fax: +31 294 416987

Email: [info@d-r.nl](mailto:info@d-r.nl) Website: [www.d-r.nl](http://www.d-r.nl)



We love to create



appetite for such things—just look at the example of MP3 usage—but there seems to be a lack of awareness that home systems are capable of playing back music specifically mixed for the format. Thanks to Lexicon, tc, Magtrax, Kind of Loud and the others for inventing the tools, but we'd all like the chance to use them.

At one end of the DVD-A/SA-CD/MP3 jousting zone we have a proliferation of MP3 players that are readily available for sale in the high street. While we're all still waiting for ADSL, MP3 has been a useful way of quickly moving demos from place to place, but as we proved in an experiment at Hear No Evil earlier in the year, is no substitute for full-bandwidth audio.

At the other end of the scale we have expensive players with little software and less public appeal, the usual politics over watermarking, and hey, you can't even record on them. Nothing will happen here until common or garden DVD players have DVD Audio and SA-CD capability. And have I missed something, or is the CD player not all but dead?

**Steve Parr, Hear No Evil Studios**

### Best and better

IN MANY WAYS the most satisfying and interesting thing I've been across this year comes from some students at Bournemouth University Media School. Since nobody had ever told them they couldn't they managed to produce highly innovative and polished work using basic Soundscape systems. Sure, they took a long time doing it but they managed to prove conclusively, if time is not an issue, it is possible to do really good work on equipment costing a fraction of the big boys toys.

Lessons learnt: We must be perpetually vigilant against complacency and question assumptions. The ancient law that states, 'you pay more to get less but it works faster' is still true.

By far the most interesting thing I've had my hands on this year is Vegas Video. I, and many others, have

### New Year proclamation

THE MOST INTERESTING project I was involved in during 2000 was making The Proclaimers' new album: they are incredible songwriters and gave quite unique vocal performances. The most promising piece of technology to have appeared is the Sony DMXR100. It is unbelievably good—certainly the most fun I've ever had on a mixing console! As for trends, I have hopefully created a new trend—it can be heard on the new Proclaimers album.

**Chris Kimsey, producer**



In front of and behind the scenes of reality TV, 'hours of boredom punctuated by moments of sheer terror'

been predicting multi-skilling in TV for years (at least since 1993). The missing ingredient, the enabling technology to allow this to happen naturally rather than be forced by financial pressures, has been conspicuous by its absence. Suddenly, out of the blue and from an unexpected source with no track record in video, Vegas Video appeared. I would be the first to admit there are many areas which will require modification before this is accepted as a regular broadcast tool but it has shown the way. The first application to really address the issues of a consistent interface for sound and picture together with equal weight given to both in terms of features. Watch out for a raft of imitations as others catch up. In hardware terms, the star of the year has to be the Tascam MX-2424. This re-defines the price-performance ratio for hard-disk recorders.

The most depressing thing about this year has been the paucity of innovative hardware or software for sound. Even worse is the number of announcements which have either failed to arrive anywhere near their due dates or have limped, haltingly onto the stage offering relatively little which cannot already be had elsewhere. Let's hope for better things next year.

**Rob James, contributor**

### Living on air

THE MOST INTERESTING project of 2000 was without doubt building a complete house including control rooms for VTMs version of *Big Brother*. Very interesting indeed because we had only one month of preparation time (brainstorming, planning and drawing signal flows) and three weeks to build the technical infrastructure from scratch to finish.

The project included the use of some 26 cameras including hotheads, fixed cameras and some infra-red cameras, almost all of them remote controlled, together with 50 microphones (12 of them wireless). All these sound sources had to be distributed to two identical mixing consoles (in order to mix two





**e**mbrace the future  
of electronic media



**NAB2001 is the only tradeshow of its kind for e-media professionals.**  
Conference sessions and exhibits deliver insight, knowledge and technology  
crafted especially for a global audience — and targeted to fuel your success.

Connect at the most complete e-media experience in the world.  
For more information or to register, visit [www.nab.org/conventions](http://www.nab.org/conventions)

**Conferences: 21–26 April 2001 • Exhibits: 23–26 April • Las Vegas, Nevada USA**





## New Studio Sound

Launched in 1958 as *The Tape Recorder*, *Studio Sound* enjoyed its most radical redesign in September 2000. Changes in format, styling and presentation found favour with the critics of pro-audio while new editorial opportunities spurred its expert authors to new heights of journalistic achievement. Best of all, the (e)mail box filled with the praise of readers. Thank you all. Make the best of 2001...

**Tim Goodyer & Zenon Schoepe**

independent programme streams) and to many different other destinations including 12 live Internet streams. It actually came down to a fully featured miniature broadcast studio.

Interesting new trends of 2000 included the revival of analogue mixing consoles for live and broadcast work. Indeed, many manufacturers came up again with new analogue devices. There are good reasons for this—for live, and especially live TV broadcast work, every function or parameter of a desk must be directly accessible to the operator(s). Digital consoles that fulfil this requirement are usually found only in the upper price class. In live work, all forms of signal delay are not only a nuisance but sometimes cause on-air problems. Digital consoles (and processors) always introduce signal delay in the chain. Analogue consoles don't. And although reliability and serviceability of digital consoles have improved, they are still not comparable to the 'old' analogue ones. Finally (but not unimportantly) the price-quality level of analogue consoles within each class is still better compared to digital. You simply need to take a look at the new Audient console to see what I mean.

Among the products that caught my attention lately are the portable palm-size hand-held solid-state recorders like the Nagra ARES-P and the Maycom. The Roland VM 7000 series mixing console came to me as a surprise. Basically constructed as a PA console, it came in usefully in the *Big Brother* project.

Something I have been desperately looking for but haven't found yet is a premium voice processor that includes lots of presets (user definable), has a 4-band fully-parametric EQ and that can be programmed without first spending half a day reading the manual. Most voice processors have presets, a full compressor-

limiter and EQ section with only three bands. This is exactly one band short while those offering 4-band EQ require a rocket scientist to navigate the software.

**Chris Wolters, VTM**

## Goodbye 2000

WITH A FEW MOMENTS to reflect on the past year, I noted the following in the notes for my memoirs:

On experience, I worked a few shifts as Sound Supervisor on Channel 5's *Jailbreak* programme following a chance meeting with Sound Moves' Steve Williams. For a music engineer like myself, this was an eye-opener and a bit like being an airline pilot—hours of boredom punctuated by moments of sheer terror. But it was a nice change not to have to listen to a 4-minute song a hundred times a day.

On equipment, I was very impressed with the Soundtracs DPC-II console which actually seems to have been designed by people who know something of what occurs in studio situations, unlike the designers of certain other digital desks I have used. The knobs are where they should be and the displays are great. Having said that, I still prefer an analogue desk with one knob per function...

On trends, it seems that high-quality analogue recording equipment is being issued and reissued like never before. I find it astonishing that so many great microphone amplifiers, compressors, EQs and suchlike—stuff with big old-fashioned knobs—from Helios, Trident, API, Thermionic Culture, Mutronics, Manley, Mr Rupert Neve (Amek), Tim de Paravicini (EAR) and Universal Audio are all still available and thriving in the digital age of 2000. Who would have predicted this 10 years ago?

**George Shilling, contributor**

# Hear the Power!



**"StartREC is the first Digital Audio Editing System combined with Multidrive CD-R duplication capability designed specifically for the Audio Professional from Microboards. The StartREC offers audio Professionals advanced hard disk editing tools, and the ability to create simultaneously up to four custom audio CD's in a convenient rackmountable or desktop configuration.**





**StartREC™**  
**"StartREC is the final piece of the puzzle"**  
 Joe Mattis - King BusQu t Flower Hour  
**"StartREC's powerful editing features combined with its CD R duplication capability, and its convenient rack mount design, make my work fast and easy"**  
 Jordan Rudess - Dream Theater



**www.microboardsproaudio.com**  
 dealer enquiries welcome  
 sales@microboards.co.uk

**Europe**  
 Telephone: 44-1789 415 898  
 Facsimile: 44-1789 415 575

**USA**  
 Telephone: (952) 556 1600  
 Facsimile: (952) 556 1620





# DRIVEN TO DRINK

*Studio Sound* again fielded a car for the Great Ormond Street Hospital for Sick Children Beaujolais Nouveau charity challenge. **Zenon Schoepe** recounts tales of Erik Carlsson and a peacefully sleeping navigator

**T**HE THIRD THURSDAY in November saw the annual pilgrimage from the UK to the South East of France to collect the first of the Beaujolais Nouveau in aid of the Great Ormond Street for Sick Children's charity. For the second year *Studio Sound* fielded a car for the event sponsored by leading industry names and piloted by Zenon Schoepe. Navigator for the duration was industry stalwart Louis Austin of the Home Service chosen predominantly for his selection of incredible stories amassed from years as a recording engineer which would fill the hours on the long and tortuous overnight drive down to the Beaujolais region leaving Calais at midnight. As a young man, Austin had also trained as a mechanic on the early SAAB 2-stroke 96 cars, a fact that was secretly important to Schoepe who was anxious about the likelihood of his 1973 SAAB 96 V4

going the distance to collect the wine for his sponsors and returning with it and its occupants back to the British Isles. Some would say that choosing a navigator for their map reading skills may have been a better bet.

While not quite the oldest car on the Challenge the *Studio Sound* team were, as last year, considerably outgunned in the horsepower stakes by all but a Barbot Special 'Racing' Citroen 2CV which it also left for dead technologically in having a roof, windscreen wipers and a heater.

Entry numbers were down 50% over last year due to last minute cancellations by a host of participants who had had to withdraw due to reasons related to the flooding that plagued the UK. However, weather in France was nothing like the snow, sleet and rain that had accompanied last year's competitors.

Rather than being a speed trial, the event is a navigational exercise with the object being to reach the destination of Macon in the shortest possible distance taking in a check point at Reims along the way. Consequently 'Vasco da Gama' Austin's



*This year's sponsors include:*

- Marantz Professional
- Solid State Logic
- Digidesign
- Dolby
- Studer
- Euphonix
- Sennheiser
- Genelec
- Soundscape
- Dimes&Sillitoe
- Mr Steven Grice

abilities and experience were tested to the full but he seemed so confident that he even allowed himself to fall asleep for the best part of two hours.

The duo arrived in Macon some nine hours after departure covering 438 miles which was a respectable margin off the winning distance of 417 miles but an annoying three miles more than it would have taken to win its class.

Most importantly *Studio Sound* had raised £3,600 for the Charity with the organisers extending enormous gratitude to the generosity of the pro audio industry. The car returned to the UK without missing a beat after 1100 miles in 52 hours with the wine in intact and its occupants still talking. □





# The protection racket

Even as Verance-equipped DVD players roll off the production line, the much-criticised watermark testing programme rolls on, writes **Barry Fox**

**T**HE COLLATED RESULTS of the London watermark listening tests show a coin-toss 50-50 split between those who could hear something and those who couldn't. But time and events continue to expose the fiasco as a PR charade that pointlessly wasted everybody's time.

When the test procedures and choice of music were heavily criticised, the SDMI said the tests were nothing to do with them. Although the London event was intended to 'allay fears' about watermarking DVD-Audio, the decision to use the Verance system for DVD-A had already been cast in silicon, and players from Panasonic with integrated Verance sensor chips were already on a boat from the Japanese factory. So there was no way the London tests could have affected the DVD-A launch. Panasonic's European and UK HQs did not even know the tests were happening. 4C Entity, the shadowy body which chose the Verance mark for DVD-A, did not even bother to attend.

Also, we now know that the London tests were carried out with a 12-bit data payload in the watermark, although 4C's tests in the US a year ago, used both 12-bit and 72-bit payloads. Audibility is cross-linked to payload, so why quietly reduce it?

First reports of the IFPI-SDMI's new round of tests, to find a Phase 2 watermark for Internet delivery (with added functions) tell that the music and methodology was far better. This is tantamount to an admission that no-one, except the poor suckers who gave up their precious time to attend, took the London event seriously. The issues for the recording and audio industry have now shaken down into two clear questions; will the music industry actually use the Verance watermark for DVD-A, and how quickly will hackers defeat it?

Anti-trust laws around the world have forced the music industry and DVD Forum lawyers to make the watermarking and copy-protection or copy-

management appear 'optional'. In theory, electronics manufacturers need not pay to build the system into new disc players, and the record companies need not pay to mark discs. But in practice it looks as if there is a lot less choice than the lawyers would like to pretend.

Reckoning that DVD-Audio was not created primarily as a fee-earning plaything for lawyers, I have been trying to translate the music industry's legal jargon into plain English. Here is my best shot:

The recording industry requested copy-management for DVD-A and 4C Entity (Intel, IBM, Matsushita, Toshiba) is the body asked by the recording industry to engineer a system. The system which they engineered combines encryption (C2 from Matsushita) and watermarking (the SDMI-Verance system which 4C now licenses to third parties). The DVD Forum decreed that from 1st October, 2000, all players sold with the DVD-A logo must include the Verance watermark.

The 4C watermark works hand in hand with 4C encryption to control copying. A player without watermarking could not be sold under the official DVD-A name-logo.

Although—for anti-trust reasons—a player with watermarking but not 4C encryption (a so-called 'vanilla' player) could be labelled DVD-A, no-one would dare sell such a player because it would not play 4C encrypted discs. The recording industry asked for the 4C system so must be expected to use it on at least some DVD-A discs. So anyone selling a DVD-player that did not play all DVD-A discs would fall foul of the Consumer Protection laws.

So the only players which shops will dare sell, and that customers will dare buy, are DVD-A players with 4C encryption and watermarking. Thus, outside the Alice in Wonderland world of music industry law, manufacturers are left with no practical choice. If they want to make DVD-A players they must pay to use 4C encryption and watermarking.

So how secure is the system the music companies, hardware manufacturers and consumers are being forced to buy?

In September the SDMI posted samples of watermarked material on its web site, and offered six \$10,000 prizes to any hackers who could strip the watermark and send the music back unscathed. The Linux Journal and Electronic Frontier Foundation, dubbed the challenge a cheap way to buy consultancy, and boycotted the SDMI site. So some of the best brains preferred to bide their time. Some may even have backed off because they reckoned the FBI could see it as an easy opportunity to arrest them. If you have ever tangled with music industry, you may sympathise with their paranoia. Despite this and the short time scale, just a couple of weeks for entries, 447 people responded to the challenge. The most solid claims to success come from a team of computer scientists at Princeton University. The SDMI says it is now evaluating the results.

If you want a prediction, I'll bet we get an SDMI blah blah that no-one did a completely successful hack job, but their attempts have helped the industry come up with a Version 2 mark, which really is absolutely 100% hackproof, and a few people will be offered some dollars as a music industry thank-you for their time and trouble.

# Rich kids

Rich kids may attract the most scorn but they have the biggest cars and often own a recording studio too, writes **Dan Daley**

**A**MERICANS HAVE ALWAYS had ambivalent attitudes towards wealth. We tax and vilify the rich, yet still accord them license that rock stars would envy. The rich are, in many ways, the new rock stars, particularly since so many of them come from the high-tech domain, the entertainment industry of the 21st Century.

America still reveres the notion of Horatio Alger, the central character of 19th century penny novels who in each one starts with nothing and ends up with everything, but his aversion to self-aggrandisement would keep him off most 'A' party lists. Donald Trump, on the other hand, needs no introduction on this side of the Atlantic precisely because of his gift for self-promotion. No one really knows how wealthy he is, or—given all the leverage his deals have required over the years—if he even has any money at all. Who cares, we reason? He acts rich and that's good enough.

This comes to mind because of some recent, random conversations about the nature of the fiscal backgrounds of a few studio owners in the US. The term 'rich kid', with all its negative connotations, is not a new one to the studio business. As soon as rate problems manifest themselves in a particular area or city, some among the studio community there start making dagger-eyes at the affluence—parental and otherwise—of certain studio owners. It's somehow as if, when rates go down, there is something less than pure about keeping facilities running on money that is not directly derived from studio revenue. This is an old song in this business, but its tune has become more intense lately as competition gets sharper. If I had a dollar for every time someone takes me off to the side to complain about that such-and-such studio owner is gliding by while everyone else is suffering because 'he has family money, you know...', I'd be, well, rich.

There is a surfeit of independently wealthy studio owners in the business these days. There's a studio, outfitted with the nicest Italian marble you've ever seen, in a bank building in downtown Boca Raton, Florida—one of the epicentres of family money in America, from the Kennedys on down—that is owned by a fellow who owns a major-league baseball team. Paul Allen, co-founder of Microsoft and a well-documented music groupie, has from all reports a pretty nice studio, too—on his yacht. We won't even discuss the legendary Sultan of Bahrain.

The fact is, owning a recording studio has long been a way for the starry-eyed well-to-do to get their hooks into the entertainment business. You don't have to be musically capable or even inclined to own a recording studio. And whether the intentions of the wealthy in procuring their own studios is to enhance the status of their entourage or just because they genuinely like music, it rarely matters to other studio owners, for whom the rich have become a lightning rod for complaints about the business in general.

But what about the rich who were made rich by music in the first place? If there has been an impact by any category of studio in recent years, it is the producer-owned facility. Working from the base notion





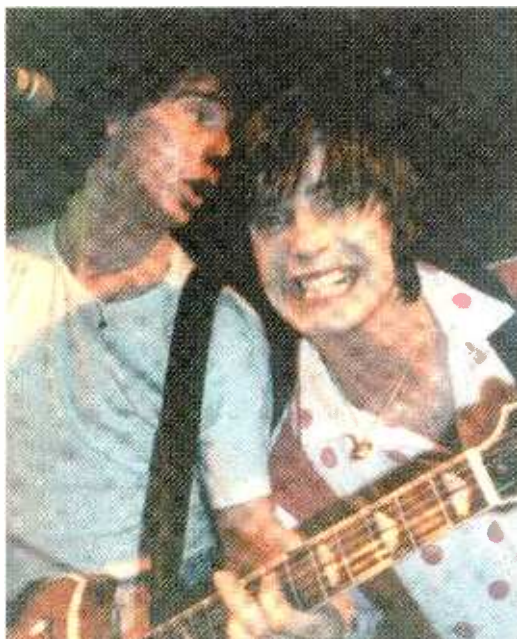

that anyone can do anything they want with their money, assuming it's reasonably legal and ethical, producers are not morally constrained from having their own facilities. From a purely green-eyeshade perspective, it usually makes economic sense to own the means of production, as even most Marxists would agree.

But when producers who have been mainstay clients of music studios in a particular community for years become competitors in it, that's when the rules really change. When an artist has his or her own studio, they can take a certain amount of studio-time revenue out of circulation; when producers do it, they multiply that lost revenue exponentially; and when a producer is also an executive at a record label, the damage is almost immeasurable, Nashville and New York City being textbook cases.

Yet producers are often immune from the same criticisms directed at those whose wealth derives from other means. Perhaps it's because the producer is still a potential client: they can still come back to the studios they abandoned when they created their own. That's a canard most of the time; once producers realise the benefits of having their own facilities, they rarely book time at commercial studios at anywhere near the levels they once did. And should a producer's career go a bit cold, and their studio gets let out for hire on the open market...

I'm not suggesting that producers should be banned from having their own recording facilities. The creative imperative would never stand for it, and neither would makers of large-format recording consoles and other gear. But studio owners would do well to adjust their perspectives on how the industry has changed and where the power and the threats really lie. A massive armada of project studios hasn't really had the same impact on their revenues as the loss of one successful producer to home-studio ownership, and neither has the occasional rich kid done them in as often as the loss of mixes by someone who gets on the charts regularly.

If the rich annoy you now, wait until the full effect of an increasingly corporate-owned studio industry kicks in, such as how the audio post business will reel as Liberty Livewire's US and European facility acquisitions take more and more market share. And all of a sudden, getting on *Who Wants to be a Millionaire* seems less like buying a lottery ticket and more like a valid business strategy.

## Broadcast broadside

The new-found bandwidth of digital delivery systems is challenging content providers and technology architects equally, writes **Kevin Hilton**

**L**IFE SHOULD NOT BE BASED on an obvious interrogative process but sometimes there is a need to ask questions to move matters on. All questions can lead to some kind of conclusion but it is preferable to ask the right ones. During IBC 2000 the IBC interviewed a clutch of chief executives of leading technology organisations why broadcasters should be concerned with broadband communications. Looking back, the question should have been what broadcasters could do with the technology, because it is a certainty that broadcasting will be concerned with broadband to varying degrees.

A refreshingly retro view—kicking against the continuing push of new technology and back to 'traditional' media—was taken by François Carayol, CEO of Canal+ Technologies. 'Broadcasting has always been broadband,' he states, perhaps controversially. 'Telcos are giving the impression that they have suddenly discovered broadband but the video and audio that cable and satellite delivers is already broadband. Terrestrial is a little more constrained in terms of bandwidth but with digital TV the increased signal means there is more capacity and, consequently, more channels.'

As a service provider more interested in the head-end and the consumer's home, Carayol says Canal+ Technologies is 'agnostic' about the means of delivery. This more than implies that content suppliers—a horrible phrase but this discussion does not just centre around broadcasters—will choose how to send their material to best suit their needs.

Someone more than aware of this is Michael Dolan, principal of consulting company TerraByte Technology, which represents DirecTV on data-related matters. Among his concerns are issues of deployment, looking at what infrastructures will be necessary to deliver IP material. 'The technology itself is starting to establish,' he says. 'The big thing now is the infrastructure and how people are going to get the large number of hits needed to make this work delivered in a way that is going to be useful.'

A network provider currently creating part of that infrastructure is Storm Telecommunications, originally set up in January 1998 in the wake of the deregulation of the European telecoms market. Initially trading on its voice network—StormVoice—with connection points in New York, London, Paris, Frankfurt, Amsterdam, Zurich and Vienna, the company is becoming an Optical-switched Service Provider (OSP), rolling out a fibre-optic network in both Europe and the US.

Storm's chief technical officer, Andy Wood, explains the reason for this: 'There is very little flexibility there [in established SDH and DWDM technology] to distribute and manage content. Switched optical technology enables users to connect to var-

ious points either through our management centre or through their own facilities. Our intention is to create a network across Europe that will enable broadcasters and postproduction studios to send content, work on it and then send it on again.'

Part of this network is a 'content warehouse' in Frankfurt, where material can be cached. 'It is intended as an alternative to satellite,' says Wood, 'which is good for situations where it is difficult to get a fixed network but where it is possible, using optical land connections is preferable. Fibre switching enables the pipe to be dialled up when it is needed, with guaranteed restoration. The connection is also transparent to protocols. It is an effective way to transmit material.'

Broadband—and ADSL in particular—has been promoted as an 'always on' technology. Some in broadcasting have expressed doubts over this, saying that what is needed is a higher capacity ISDN, which is a dial-up technology. Andy Wood agrees that what most customers want is bandwidth that they only pay for when they need it. There is also a desire to get away from booking connections several weeks in advance, which may burden users with a long-term link. An undoubted advance but it does mean that those wonderfully grumpy men at link centres are now an endangered species.

At one time engineers could comfortably concern themselves with technology and their own budgets; whether the overall company made money was somebody else's worry. Now the technology and business sides of the Internet and broadband communications cannot be completely separated. 'Everyone wants to know how they are going to make money out of it,' says Andy Wood. 'We are seeing a growth in the movement of data, with a proliferation of activity on the Internet. Customers are viewing content and information differently and are asking for flexibility and affordable prices.'

François Carayol at Canal+ Technologies concurred, 'Technology is not a constraint on this sector. It will help push it on and be used by people with good creative ideas. The real constraint is the financial capacity of network providers. It requires a tremendous amount of investment to establish a broadband network. That is the area we must be looking at.'

Something of a delicious turnaround. Now the creative and technical people can give the bean-counters a hard time. An unexpected but pleasurable side-effect of technology that means everyone will have to ask the right questions of each other.

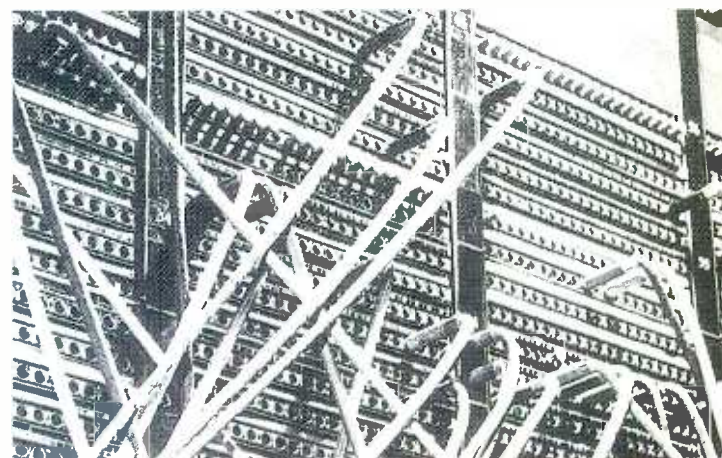



# SCANNING

Turning his attention to the nuts and bolts of video, **John Watkinson** looks at the purpose and mechanisms of scanning

**T**ELEVISION IS MEANT to carry moving images from one place to another, but this is remarkably difficult. Images themselves are two-dimensional while the motion with respect to time introduces a third dimension. On the other hand, electrical and radio signals can easily carry a single signal. In the analogue domain this is a varying voltage, whereas in the digital domain it is a varying binary number.

The problem, then, becomes one of converting a

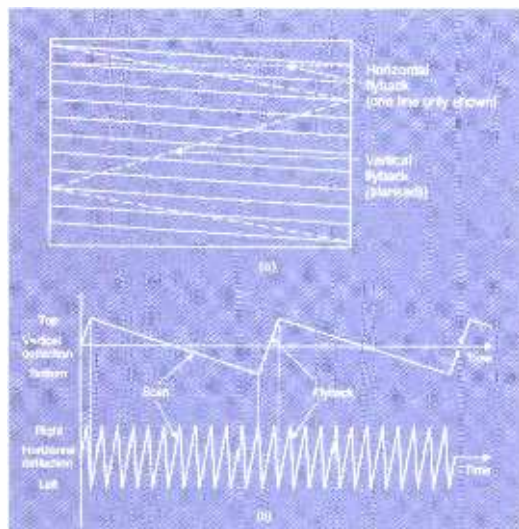

**Fig. 1:** Scanning converts two-dimensional images into a signal which can be sent electronically. In (a) the scanning of camera and display must be identical. The scanning is controlled by horizontal and vertical sawtooth waveforms (b)

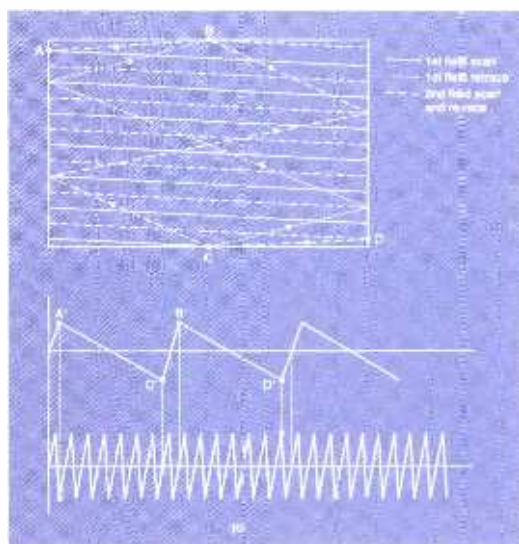
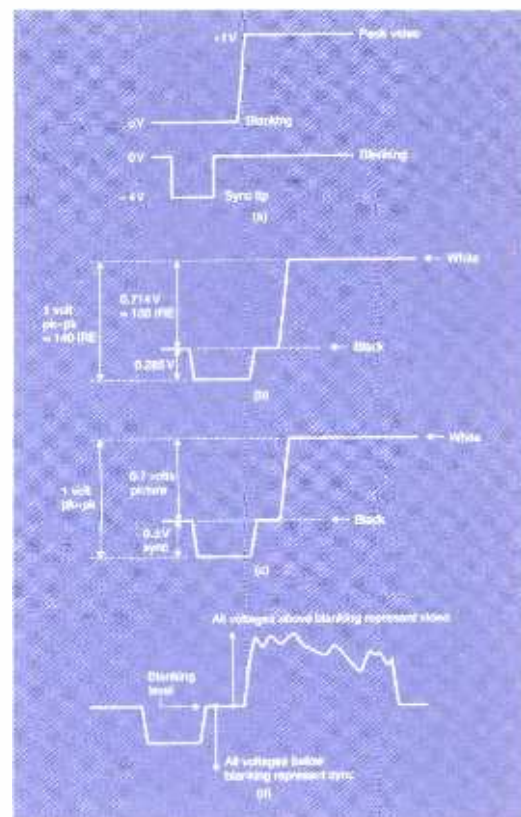

**Fig. 1c:** Where two vertical scans are needed to complete a whole number of lines, the scan is interlaced. The frame is now split into two fields

two-dimensional image into a single voltage changing with time. This varying voltage may or may not be put into an A—D convertor to make a digital signal. Fig. 1a shows the principle of scanning, without any complications due to colour—which will be addressed in the future. A monochrome TV camera produces a video signal whose voltage is a function of the image brightness at a single point on the sensor. This voltage is converted back to the brightness of the same point on the display. The points on the sensor and display must be scanned synchronously if the picture is to be recreated properly. If this is done rapidly enough, it is largely invisible to the eye. Fig. 1b shows that the scanning is controlled by a triangular or sawtooth waveform in each dimension which causes a constant speed forward scan followed by a rapid return, or 'fly-back'. As the horizontal scan is much more rapid than the vertical scan the image is broken up into lines which are very nearly horizontal. This structure of scanned lines is known as a raster—which has nothing whatsoever to do with worshipping the late Emperor Haile Selassie of Ethiopia.

In the example of Fig. 1b, the horizontal scanning frequency or line rate—called  $F_h$  or sometimes just  $H$ —is an integer multiple of the vertical scanning frequency or frame rate. A progressive scan system results in which every frame is identical. This is the correct way of doing things, which is generally avoided in television if at all possible. Fig. 1c shows an interlaced system in which there is a whole number of lines in two vertical scans now known as fields. The first field begins with a full line and ends on a half line and the second field begins with a half line and ends with a full line. The lines from the two fields interlace, or mesh, on the screen. An odd number of lines is needed in the frame, hence 525 lines in NTSC and 625 lines in PAL. The French did once have a triple interlaced standard but you really don't want to know about that. (The problems caused by using interlace will be discussed in a future article.) In modern systems using MPEG compression, interlace is no longer necessary.

It is fairly obvious that the horizontal and vertical scanning at the camera is simultaneously replicated at the display. This is the job of the synchronising, or sync, system which must send timing information to the display alongside the video signal. In very early television equipment this was achieved using two quite separate or noncomposite signals. Fig. 2a shows one of the first television signal standards developed in the US in which the video waveform had an amplitude of 1V pk-pk and the sync signal had an amplitude of 4V pk-pk. In practice, it was more convenient to combine both into a single electrical waveform. At the time this was called composite video and it carried the synchronising information as well as the scanned brightness signal. The single signal is effectively shared by using some of the flyback period for synchronising.



**Fig. 2:** Early video used separate vision and sync signals shown in (a). The US one volt video waveform in (b) has 10:4 video/sync ratio. (c) European systems use 7:3 ratio to avoid odd voltages. (d) Sync separation relies on two voltage ranges in the signal

To create the composite video signal, the 4V sync signal was attenuated by a factor of 10 and added to the video to produce a 1.4V pk-pk signal. This was the origin of the 10:4 video:sync relationship which remains to this day in US analogue television practice. Later the amplitude was reduced to 1V pk-pk so that the signal had the same range as the original non-composite video.

The 10:4 ratio was retained when this was done and the result was some rather odd voltages, as Fig. 2b shows. In an attempt to simplify matters, a new unit called the IRE unit (after the Institute of Radio Engineers) was devised. Originally this was defined as 1% of the video voltage swing, independent of the actual amplitude in use, but it came in practice to mean 1% of 0.714V. In European analogue systems shown in Fig. 2c the messy numbers were avoided by using a 7:3 ratio and the waveforms are always measured in mV. Whilst such a signal was originally called composite video, today it would be referred to as monochrome video or abbreviated to Y, meaning luma carrying syncs although in practice the 'S' is often omitted.

With syncs and video combined into one signal for transmission, the next problem is how to separate them. Fig. 2d shows that the voltage swing needed to go from black to peak white is less than the total swing available. In a standard analogue video signal the maximum amplitude is 1V pk-to-pk. The upper part of the voltage range represents the variations in brightness of the image from black to white. Signals below this range are 'blacker than black' and cannot be seen on the display. These signals are used for synchronisation.

Fig. 3a shows the line synchronising system part



way through a field or frame. The part of the waveform which corresponds to the forward scan is called the active line and during the active line the voltage represents the brightness of the image. In between the active line periods are horizontal blanking intervals in which the signal voltage will be at or below black. Fig.3b shows that in some US systems the active line voltage is superimposed on a pedestal or black level setup voltage of 7.5 IRE. The purpose of this setup is to ensure that the blanking interval signal is below black on simple displays so that it is guaranteed to be invisible on the screen. When setup is used, black level and blanking level differ by the pedestal height. When setup is not used, black level and blanking level are one and the same.

The blanking period immediately after the active line is known as the front porch, which is followed by the leading edge of sync. When the leading edge of sync passes through 50% of its own amplitude, the horizontal retrace pulse is considered to have occurred. The flat part at the bottom of the horizontal sync pulse is known as sync tip and this is followed by the trailing edge of sync which returns the waveform to blanking level. The signal remains at blanking level during the back porch during which the display completes the horizontal flyback. The sync pulses have sloping edges because if they were square they would require infinite bandwidth and this would play havoc with the allocation of discrete channels in the TV broadcast bands.

The vertical synchronisation system is more complex because the vertical flyback period is much longer than the horizontal line period and horizontal synchronisation must be maintained throughout it. The vertical synchronising pulses are much longer than horizontal pulses so that they are readily distinguish-

able. Fig.4a shows a simple approach to vertical synchronising. The signal remains predominantly at sync tip for several lines to indicate the vertical retrace, but returns to blanking level briefly immediately prior to the leading edges of the horizontal sync, which continues throughout.

Interlace complicates matters as usual, as in one vertical interval the vertical sync pulse coincides with a horizontal sync pulse whereas in the next the vertical sync pulse occurs half way down a line as can be seen in Fig.4b.

In practice, the long vertical sync pulses were found to disturb the average signal voltage too much and to reduce the effect extra equalising pulses were put in, half way between the horizontal sync pulses. Fig.4c shows the final result of an interlaced system with equalising pulses. The vertical blanking interval can be seen, with the vertical pulse itself towards the beginning.

In digital video signals it is possible to synchronise simply by digitising the analogue sync pulses. However, this is inefficient because many samples are needed to describe them. In practice, the analogue sync pulses are used to generate timing reference signals (TRS) which are special codes inserted in the video data which indicate the picture timing. In a manner comparable to the analogue approach of dividing the video voltage range into two, one for syncs, the solution in the digital domain is the same: certain bit combinations are reserved for TRS codes and these cannot occur in legal video. TRS codes will be considered in a future article. □

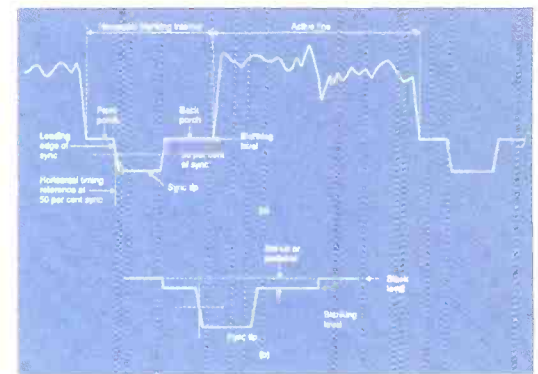

Fig.3: (a) Part of a video waveform with important features named. (b) Use of pedestal or set-up

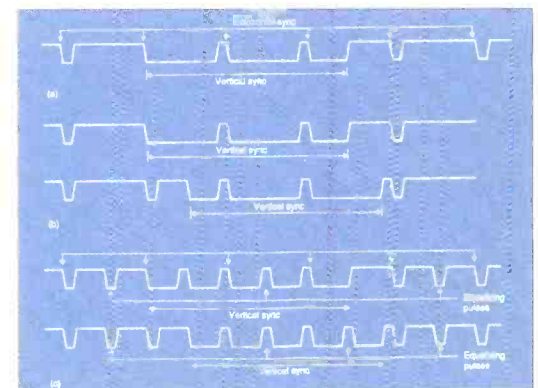

Fig.4: (a) A simple vertical pulse is longer than a horizontal pulse. (b) In an interlaced system there are two relationships between H and V. (c) The use of equalising pulses to balance the DC component of the signal



RICHMOND  
FILM  
SERVICES

+44 (0) 181 940 6077



FOR ALL  
**DENECKE INC.**  
TIMECODE EQUIPMENT  
SALES AND RENTAL

ALL IN ONE

Phasemeter

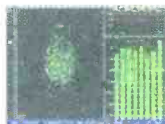

Audio Oscilloscope

Multichannel PPM

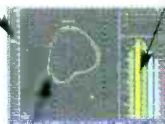

5.1 Surround

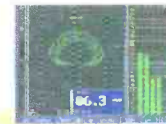

Loudness Lec(m)

14:08:45  
00:06:12  
00:01:57

Clock/Timer function



18 x 16 Audio Matrix



FFT-Spektrum analyser  
1/3 Octave Spectrum analyser

...and more!

[ ...see what you hear ]



DK-AUDIO • Marielundvej 37D • DK-2730 Herlev • Denmark  
Phone: +45 44 85 02 55 • Fax: +45 44 85 02 50  
e-mail: info@dk-audio.com • www.dk-audio.com



# CD-R

Appearing initially as audio playback only, CD has now become the standard for storage of digital data whether it is audio, computer software or graphics. HHb technical service manager **Paul Isaacs** explains the formats and machine maintenance

**T**HE DESIGNERS OF CD were surprised by the reliability of the CD system because of the complexities of the various optical and electronic sub-systems—it worked better than anticipated in practice. However, slight misalignments and dirty or worn parts can result in corrupt data especially in a CD-R system.

In order to write a CD-R it is necessary to melt an organic dye, which requires about 10x higher laser power than that required for playback. As a laser ages, it deteriorates and requires a higher drive current to maintain the same power levels. It is therefore recommended that laser power alignment is checked every 500 hours or so. If laser power is too low, the organic dye may not melt properly causing an inaccurate transition from pit to land. If the laser power is too high, the organic dye may be over heated causing poorly defined pit and land lengths. Laser power is therefore crucial in maintaining a low jitter signal.

As far as the user is concerned, cleaning the laser lens is the only maintenance that they can do, although only those with a delicate touch should tackle this. In many cases, accessibility to the laser lens is difficult, in which case cleaning should be left to qualified service personnel. There are commercial lens cleaners on the market, but HHb believes cleaning is safer and more effective when using a cotton bud with cleaning fluid. If the lens is glass, use an alcohol based cleaner, if plastic, use distilled water. Beware of leaving cotton bud hairs on the lens surface!

Most modern CD players do not require any adjustment as the system software performs alignment. If

a calibration problem exists, the cause is usually the laser. CD-R machines, however, do still require alignment. The following adjustments are necessary to ensure reliable operation.

Playback laser power—if out of alignment can cause playback skipping, digital noise on audio (glitching) and an inability to recognise discs, especially CD-R discs, as these have lower reflectivity compared to commercial CDs.

Record laser power—If too low, the dye layer will not reach melting point and therefore no recording is possible. If the laser power is slightly out of alignment, inaccurate burning of pits may result in a high-jitter RF signal. This CD playback RF signal is often referred to as an 'eye pattern' which is shown. A well-recorded signal is shown together with a badly recorded signal. Notice that the

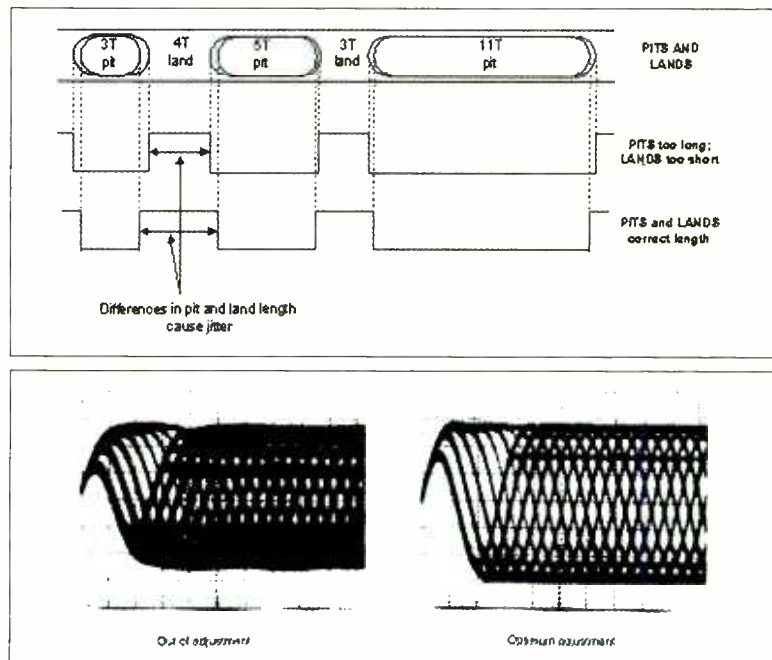

diamond shapes (eyes) in the well-recorded signal trace are clearly identifiable, whereas they are extremely blurred in the badly recorded signal trace. The latter is caused by inaccurate and widely varying pit and land lengths (high jitter) and would probably result in a high block error rate (BLER).

Why does the RF signal resemble an 'eye pattern' during playback of a CD? What you are actually seeing is the intensity of laser light reflected from the 3T to 11T pits and lands overlaying one another. This is shown more clearly in the other figure.

Focus servo offset voltage, gain—If out of alignment, may prevent the machine from detecting a disc or cause a noisy eye pattern, which may result in audible errors.

Tracking servo offset voltage gain—If out of alignment, will reduce the machine's ability to lock to the spiral data track on the disc, thereby causing skipping, and inability to locate different parts of the disc.

Wobble adjustments—If these are out of alignment, the machine will not be able to read the preformatted blank disc properly, thereby preventing disc identification and reliable recording.

#### Compatibility issues

CD-R record and playback compatibility has improved considerably since the early days of the format. This has been as a result of improvements in CD recorders and the blank media that they use. The more stable 3-beam tracking system is now standard on almost all CD recorders and players. OPC has now become a standard process on all recorders. However, compatibility problems can and do still arise. It is important





## MEET THE BEST DIGITAL AUDIO MULTITRACK MASTER RECORDER MADE.

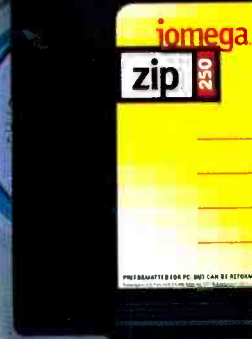

*360 Systems*

360 Systems designed the TCR8 with one goal in mind: To deliver a Master Recorder that faithfully captures the results of your work.

### The Difference is in the Details

To provide the level of sonic accuracy that critical projects demand, you have to sweat the details. TCR's design specifies gold XLR connectors, metal film resistors, no capacitors in the audio path, and a patented low-noise circuit to suppress RF, hum and cable noise. Put all of this on shielded PC boards with double-regulated power, and the result is a 24-bit audio recorder of unprecedented quality.

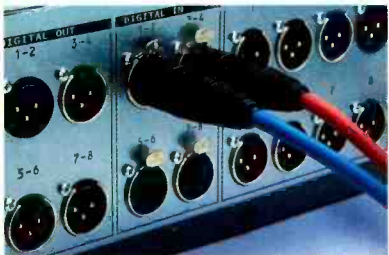

### Defining the Master Recorder

The TCR8 Master Recorder includes the tools you'll need for professional work—solid synchronization, the right connectors, and a feature-set focused on commercial audio production.

Today's high-resolution audio formats need a new generation of recorders that deliver on the promise of 24-bit audio. By actual measurement, the TCR8 Master Recorder far exceeds the specs of competitive machines, and actually approaches the limit of today's art.

Today's "24/7" studio makes very real demands on audio equipment. Which is why 360 Systems designs for reliability, just as we design for audio quality. But then, we also have 30 years experience building equipment for round-the-clock professionals.

From original recording to final mixdown, the new TCR8 Master Recorder delivers performance without compromise. Should you expect anything less?

### Superior Audio Quality

- Measurable improvement of 20-dB in SNR and dynamic range over conventional designs
- Bit-for-bit™ reproduction of 24-bit PCM, Dolby® E and AC-3 recordings
- Record across all tracks, at any sample rate
- Workstation file interchange with SD-II and WAV files
- Complete Cut-Copy-Insert-Erase editing features
- The best digital scrub editing on the market
- Time offsets, track slip, varispeed and audio delays
- Up to 24-hours of recording time in a single file

### Standard Equipment

- DVD-RAM drive for 10 hours of 24-bit audio on low-cost disks
- Internal 9GB SCSI hard disk (up to 50 GB available)
- 250 MB Zip® drive
- A complete set of XLRs for analog and AES/EBU
- Rear panel SCSI port for external drives
- Large display for full length file names
- Multi-machine sync provides up to 64 tracks
- Flex-Format™ drive bay for removable media, such as DVD-RAM (standard), Magneto Optical or removable hard disks
- Complete SMPTE time code features:
  - > Support for all frame rates
  - > VTR emulation with P2 control
  - > Reads LTC or VITC
  - > Hard lock to Digital Betacam® for tight sync during scrub-edits
  - > Reference to Video, AES, Word Clock, or LTC



There is a difference. Click on [www.360systems.com](http://www.360systems.com) for a 20-dB improvement in *your* next project.

*360 Systems*

The pros know the difference.

5321 Sterling Center Drive, Westlake Village CA 91361  
Tel (818) 991-0360 Fax (818) 991-1360 E-mail: [sales@360systems.com](mailto:sales@360systems.com)



## Ad Index

Amek Systems	13
AMS Neve	2
Aphex Systems	80
Audio Ltd	77
Creamware	21
D&R Electronica	60
Digidesign	45
DK Audio	67
DPA Mics	30
Fletcher Electro Acoustics	20
Focusrite	24/25
Genelec	38/39
HHB	50,51,61
JBL	31
Junger Audio	34
Lexicon Inc	11
Location Sound	23
Lydkraft	33
Mackie Designs	79
Manley	17
Marantz	37
MBHO	67
Messe Frankfurt	27
Microboards	62
NAB	77
Richmond Film	67
Sadie	29
Sintefex	49
Soundtracs	19
SSL	5
Steinberg	69
Studer	35
Tascam	41
tc electronic	9,44
TL Audio	54
United Entertainment Media	56/57,75

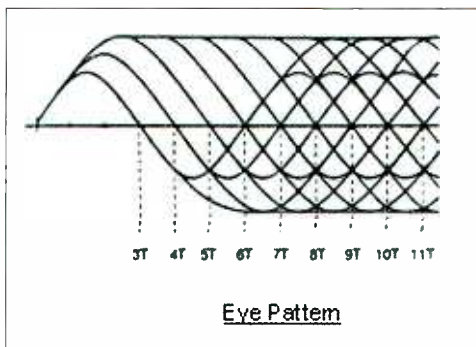

to remember that reliable playback of recorded data is dependant on three elements; the recorder, the CD-R disc and the playback CD machine. If any of these elements do not meet the tight specifications described within the *Orange* and *Red* books then problems can occur.

In some cases, playback problems occur because of additive errors. As an example, consider the situation where a user has a CD-R burner, A, which is only just out of alignment; perhaps the record laser power is slightly too low. In addition, the user plays back his recorded discs on a standard CD player, B, which has



not been serviced for years and its playback laser power is slightly too low. The user experiences problems playing back discs on B, which were recorded on A. He does not have problems playing back commercial CDs or CD-Rs, which were recorded using another burner on B. In addition, the discs burnt using A, play back reliably on another CD player. Here the problems only arise with a particular combination of recorder and player, A+B. The errors created by each alone are fairly innocuous, but when the errors are combined, the error correction systems are unable to cope.

CD-R users should also be aware that there are compatibility issues with CD-R media. In the last 18 months or so, we have seen the emergence of the 80 minute or 700Mb CD-R. [Note: Users may have noted that some 74-minute discs can store 650Mb of data and others can store 680Mb. The difference is due to the way in which the manufacturer defines a megabyte. Some use 1MByte = 1024kbyte and 1kbyte = 1024 bytes, others use 1MByte = 1000kbyte and 1kbyte = 1000 bytes]. The extra storage on an 80-minute disc is achieved by narrowing the track width from 1.6µm to 1.5µm. Some older recorders and players are unable to reliably lock to the narrower tracks and others may not be able to read the data on the disc because of its lower reflectivity. Most recent machines are able to handle the tighter specification

of 80-minute discs.

In the audio CD-R field, there is the added complication of whether to use Professional or Consumer CD-R. The difference has nothing to do with the physical quality of the disc. Consumer CD recorders can only use consumer discs which are more expensive than professional discs. A consumer disc is identified by information in the ATIP. Professional recorders can use both types of disc.

In addition, caution should be exercised when selecting discs with regard to allowable 'write' speeds. Disc packaging usually informs the user of the minimum and maximum write speed specification. Some discs state a minimum write speed of x2. These are obviously not intended for real-time audio burners, but are suitable for computer burners, which are able to write at various speeds. Disc write speed is dependent on type of organic dye, dye layer thickness, reflectivity layer and groove structure, however most discs are manufactured to provide reliable results at a range of write speeds.

Often, CD readers may have problems reading CD-R media but are fine reading commercially pressed discs. Commercial CDs have physical pits and lands rather than an organic dye storage layer. These result in higher reflectivity than a CD-R and thus are easier to read.

The question of media quality and compatibility is a big one beyond the scope of this article, but it should be stated that not all discs meet the same standard of quality. Even the top brand manufacturers are susceptible to occasional batch problems although they are very rare. Considering the fact that hundreds of millions of discs are produced every year, there are bound to be the occasional failures. In general, assume a machine error or alignment problem before blaming the media.

With the proliferation of cheap computer CD burners, this technology is becoming a disposable one. Is it worth having your £100 CD burner serviced to ensure that it is within specification? Probably not. However, is it then reasonable to expect it to give you years of untroubled use? Again, probably not. Five years ago, a CD recorder would set you back thousands of pounds—certainly worth having serviced. Now you can buy 20 or 30 burners for the same price. Even if each one were to last only one year (the warranty period), you have the ability to burn discs reliably for 20 to 30 years. □

### Further information

A FULLER VERSION OF THIS ARTICLE, including explanations of the format is available on our website [www.studio-sound.com](http://www.studio-sound.com)



To place an advertisement contact: Studio Sound (Classified),  
 United Business Media, 8 Montague Close, London SE1 9UR, UK  
 Tel: +44 (0)20 7940 8518 Fax: +44 (0)20 7407 7102  
 All Box numbers reply to the above address  
**RATES:** Recruitment £38 per single column centimetre. (Minimum size 5x2).  
 All other sections £33 (minimum 3cm x 1). Box number £10 extra per insertion. Published monthly

CLASSIFIED

**Equipment for Sale**



# WANTED



**'NEVE  
CONSOLES'**  
 any condition...  
 we will purchase  
 worldwide



**AES**  
**PRO AUDIO**  
A UNITED KINGDOM BASED COMPANY

**THE 'VINTAGE' NEVE SPECIALIST!!**

Telephone: 01932 872672 Fax: 01932 874364 Telephone International: 44 1932 872672  
 Fax: International: 44 1932 874364  
 Website Address: [AESPROAUDIO.COM](http://AESPROAUDIO.COM) Email Address: [aesaudio@intonet.co.uk](mailto:aesaudio@intonet.co.uk)

CRYSTAL PRO AUDIO

new and used  
 AUDIO EQUIPMENT  
 installations and servicing

tel: +44 (0)181 778 3555 fax: +44 (0)181 659 1504  
 Email [peter@crystalpro.demon.co.uk](mailto:peter@crystalpro.demon.co.uk)  
 STOCK LISTING AVAILABLE ONLINE  
<http://www.crystalpro.demon.co.uk>  
 "part exchange welcome"

NEW AND USED VINTAGE EQUIPMENT



180a CENTRAL STREET SAUGUS, MASS 01906  
 Ph: 001 (781) 231-0095 Fax: 001 (781) 231-0295  
[www.harborsound.com](http://www.harborsound.com)

[sales@funky-junk.co.uk](mailto:sales@funky-junk.co.uk)



**New & used  
sales and  
distribution**

[proaudioeurope.com](http://proaudioeurope.com)

London	+44 (0) 20 7609 5479
Paris	+33 (0) 1 4793 0888
Milan	+39 02 6901 6229
Stockholm	+46 (0) 8 749 0939

OMNIRAX

STUDIO FURNITURE SOLUTIONS



A wide range of professional furniture solutions for Mackie, Yamaha, Digidesign, ProTools, ProControl and all other mixers, computer and keyboard workstations.

  
 Tel: 01908 510123  
 Email: [omnirax@audioagency.co.uk](mailto:omnirax@audioagency.co.uk)  
 Full range technical brochure on request



## Product & Brochure Showcase

**FAXBACK**  
+44 20 7407 7102

### Better Audio Quality

Request your copy of the new microphone catalogue from DPA Microphones



**DPA**  
MICROPHONES

Hejrevang 11  
3450 Allerød, Denmark  
Tel: +45 4814 2828  
Fax: +45 4814 2700  
Email: info@dpamicrophones.com  
www.dpamicrophones.com

1

### Analogue Perfection 2



The Father of British EQ - John Oram

For information on John Oram's stunning range of Consoles and Rack equipment, return details or visit our Web site.

[www.oram.co.uk](http://www.oram.co.uk)  
E-mail: sales@oram.co.uk



ORAM PROFESSIONAL AUDIO  
Tel: +44 (0)1474 815300  
Fax: +44 (0)1474 815400

### Advance Entertainment range premiere Advance Tapes has produced a NEW BROCHURE for the entertainment industries 3

Action packed with tapes for stage, screen, studio and set, the new brochure gives a full run down on each of the tapes, what they're used for, tips on where to apply them and what colours and sizes are available. At the back of the brochure there's a glossary of terms, a tape finder and a full technical specification for each of the tapes.

If you thought you knew the Advance product range, you're in for a surprise. There are many new additions including transfer tapes, anti-slip tape and an extended range of double sided and foam tapes, there's also a range of packaging and super strong strapping tapes.

Advance are confident that they can satisfy the tape demands of the entertainment industries with one phone call. Tape samples, expertise on your exact application and the new brochure is all available from Advance, the specialist adhesive tape manufacturer.

For more information contact  
Advance Tapes on 0116 2510191.



### The AMPEX Sound! 4



The Ampex ATR endures as the ultimate quality standard for music mastering. And only ATR Service offers:

- NEW 1-inch 2-track version now available!
- Sales and complete restoration services
- 1/2-inch conversions with Flux Magnetics heads
- Modular tube electronics and transformerless I/O
- Transport upgrades for better-than-new performance
- Complete stock of replacement parts

Call Michael Spitz in the USA at 717-852-7700  
Or visit us on the Web at [www.atrservice.com](http://www.atrservice.com)

**ATR** SERVICE COMPANY  
AMPEX SPECIALISTS

FOR AN IMMEDIATE RESPONSE EITHER: ■ FAXBACK TO +44 (0)20 7407 7102 —OR—

■ MAIL TO: PETER LAWN STUDIO SOUND

Please circle the number(s) you require more information about:

1 2 3 4

NAME:

ADDRESS:

POSTCODE:

### 3M Professional Tape Machines

Service and spares. Secondhand machines available. Studio electronic, acoustic and earthing problems solved. Audio equipment made to measure. Audio Solutions Limited  
9b, Ashbourne Parade, Hanger Lane, Ealing, London W5 3QS  
Tel: +44 (0)20 8998 8127. Fax +44 (0)20 8997 0608

### Lockwood Audio

Authorised **TANNOY** Specialists

SPARES AND REPAIRS  
SPEAKER BARGAINS GALORE

Phone: +44 (0)20 8864 8008  
Fax: +44 (0)20 8864 3064

### JBs records

#### MUSIC and SPEECH

REAL-TIME/HIGHER-SPEED Quality Cassette Duplication and Blank Cassettes from 1-1000. Computer printed labels. Solo, 1/2" real or R-DAT recording. Fast Security Delivery service.

FILTERBOND LTD  
19 SADLERS WAY, HERTFORD, SG14 2DZ  
Tel/Fax: 01992-500101  
E-mail: jbsrecords.filterbondltd@virgin.net

### MAGNETIC TAPE HEADS

STUDER - OTARI - 3M - MCI & OTHERS  
REFURBISHMENT OF ALL TYPES OF WORN HEADS  
AGENTS FOR SONDOR  
PROJECTORS AND MAGNETIC FILM MACHINES  
SUMMERTONE LTD.,

98 Scatterdells Lane, Chipperfield, Herts. WD4 9EZ UK  
Phone: +44(0)1923 263220 Fax: +44(0) 1923 260606  
e-mail: smtone@globalnet.co.uk

### THE STUDIO WIZARD

Will design, supply, build, train, install, debug and save you money!  
So if you want a studio that works like magic call me!  
07803 666789  
From a little advice - to a complete construction project - at the right price!  
email: [info@studiowizard.com](mailto:info@studiowizard.com)  
Web: [www.studiowizard.com](http://www.studiowizard.com)

## Equipment for Sale

SSL - NEUMANN

**K.G.B.**

STUDER - NEVE

[www.killergearbroker.com](http://www.killergearbroker.com)

Professional Audio Specialist

phone++1 (818) 904-9400 fax++1 (818) 904-9444 pgr++1 (818) 999-8970

ANY GEAR NOT LISTED CAN BE FOUND WITHIN 48 HRS!

Neumann U-87s new \$1,850 Studer A-800 MK-3 \$30,000

Neumann U-47s \$ 6,500 original VF-14<sup>99</sup>



1000 CDs with Booklet+Inlay c.£600  
High Quality CDR copies from £1.50  
Real Time Cassette Copying  
CD/CD-ROM Mastering £60ph  
Enhanced CDs, CD-audio, CD-ROM  
Copy Masters, Compilations, Editing

Graphic design  
15 years experience  
Photo quality or litho printing  
Large and small run specialists  
Excellent quality and presentation

**RPM**

Repeat Performance  
Multimedia

6 Grand Union Centre  
West Row  
London W10 5AS

Tel. 020 8960 7222

visit us at  
[www.repeat-performance.co.uk](http://www.repeat-performance.co.uk)

Excellent!

[www.emptystudios.co.uk](http://www.emptystudios.co.uk)

Tel: 020 7263 9989

Mobile: 07946 526 828



## On-line Business Directory



**Contact  
Microphones**  
[www.c-ducer.com](http://www.c-ducer.com)

[www.c-ducer.com](http://www.c-ducer.com)



**"Specialists to the  
Music Industry"**  
Provide a select,  
personally tailored  
Equipment Finance Service  
[www.peachproductions.co.uk](http://www.peachproductions.co.uk)

[www.peachproductions.co.uk](http://www.peachproductions.co.uk)

[recording-equipment.co.uk](http://recording-equipment.co.uk)  
[recording-equipment.co.uk](http://recording-equipment.co.uk)  
[recording-equipment.co.uk](http://recording-equipment.co.uk)  
[recording-equipment.co.uk](http://recording-equipment.co.uk)  
[recording-equipment.co.uk](http://recording-equipment.co.uk)  
[recording-equipment.co.uk](http://recording-equipment.co.uk)  
[www.recordingequipment.co.uk](http://www.recordingequipment.co.uk)

[www.recordingequipment.co.uk](http://www.recordingequipment.co.uk)

### Products & Services

**Superfast Labels Ltd** SELF ADHESIVE  
COMPUTER LABEL  
MANUFACTURERS

**HIGH GLOSS  
INKJET LABELS**  
Instant dry & Rub resistant



L14 118mm CD Labels L03 111mm CD Labels CD label with security tab

**On-line orders**  
<http://www.superfast.co.uk/label/>  
Units 15/16 Church Road Sittingbourne Kent ME10 3RS 

Tel: (01795) 428425 (24 hrs) Fax: (01795) 422365

AKA DESIGN LTD



STUDIO FURNITURE & INTERIORS  
[www.akadesign.co.uk](http://www.akadesign.co.uk)

[www.akadesign.co.uk](http://www.akadesign.co.uk)

A worldwide service for audio manufacturers. Hundreds of Specialist components designed to make your products sound better. Easy on-line ordering with guaranteed fast free delivery throughout the world.



Profusion plc  
Aviation Way  
Southend  
Essex  
SS2 6UN  
UK  
Tel: 01702 543500  
Fax: 01702 543700  
[www.profusionplc.com](http://www.profusionplc.com) Sales@profusionplc.com

[www.profusionplc.com](http://www.profusionplc.com)

Sales@profusionplc.com

### Products & Services



Professional movers of studio equipment within the UK and Europe. Experienced, reliable, fully insured and always on time.  
Call Graham Cook on +44 (0)20 8450 9127 - (mobile: 07785 290754) - e-mail: [audiomoves@easynet.co.uk](mailto:audiomoves@easynet.co.uk)  
134 Cricklewood Lane, London NW2 2DP Fax: +44 (0)20 8208 1979 - Storage facilities also available

**The Digital Village**

Pro Tools and Outboard Specialists  
New G4 in stock.  
Call Gavin Beckwith -  
London's leading Mac guru.

Avalon - Focusrite - Lexicon - Summit -  
TC Electronic - TLA - Eventide -  
Massenberg - Alan Smart -  
Neumann - Oram  
URIE - Cranesong  
Mackie d8b Main Dealer  
Call Niki Melville-Rogers  
+44 (0)20 8440 3440

**AIR CONDITIONING &  
VENTILATION TO SOUND  
STUDIOS IS OUR SPECIALITY**

We provide design only or design and installation for many well known clients. Whether it be for displacement free cooling, V.A.V., V.R.V., split, unitary or centralised call Mike Hardy or

Ambthair Services Ltd on  
+44 (0)1403 250306 or Fax +44 (0)1403 211269  
Web: <http://www.ambthair.com>  
Email: [cool@ambthair.com](mailto:cool@ambthair.com)

**OLD RECORDS  
RESTORATION**



[WWW.TRIARIOS.RU/ARR](http://WWW.TRIARIOS.RU/ARR)

**The AMPEX Sound!**



The Ampex ATR endures as the ultimate quality standard for music mastering. And only ATR Service offers:

- NEW 1-inch 2-track version now available!
- Sales and complete restoration services
- 1/2-inch conversions with Flux Magnetics heads
- Modular tube electronics and transformerless I/O
- Transport upgrades for better-than-new performance
- Complete stock of replacement parts

Call Michael Spitz in the USA at 717-852-7700  
Or visit us on the Web at [www.atrservice.com](http://www.atrservice.com)

**ATR SERVICE COMPANY**  
AMPEX SPECIALISTS

**MUSICAL COCKTAILS**

Digital Editing 25 CD's £ 45  
Compilation 50 CD's £ 77.50  
CD Duplication 100 CD's £ 140  
on-body print and jewel-case included  
**020 8427 5918**



## December

### 5-7 JTSE 2000

Brussels Royal Opera, Brussels, Belgium.  
Contact: RAK Productions.  
Tel: +33 (0)2 40 48 64 40.  
Fax: +33 (0)2 40 48 64 32.  
Email: rak.productions@wanadoo.fr

## 2001

## January

### 18-21 NAMM

Anaheim Convention Center, Anaheim, US.  
Contact: Exhibitions and Events.  
Tel: +1 760 438 8001.  
Fax: +1 760 438 7327.  
Email: namm@namm.com  
Net: www.namm.com

## February

### 3-6 Middle East Broadcast 2001

Bahrain International Exhibition Centre, Bahrain.  
Contact: Overseas Exhibition Services.  
Tel: +44 (0)20 7862 2046.  
Fax: +44 (0)20 7862 2049.  
Email: mebroadcast@montnet.com  
Net: www.aeminfo.com.bh

### 13-16 Memex 2001

Dubai World Trade Centre, United Arab Emirates.  
Contact: Andy Drew, International Conference and Exhibitions.  
Tel: +44 1442 878 222.  
Fax: +44 1442 879998.  
Email: andy@ice-ltd.demon.co.uk

### 22-24 Broadcast Thailand 2001

Queen Sirikit National Convention Centre, Bangkok, Thailand.  
Contact: Adam Ridgway, Overseas Exhibition Services.  
Tel: +44 (0)20 7862 2069.  
Fax: +44 (0)20 7862 2068.  
Email: thailand@montnet.com  
Net: www.besmontnet.com

## March

### 7-11 Frankfurt Musik Messe

Frankfurt, Germany.  
Contact: Messe Frankfurt.  
Tel: +49 69 75750.  
Email: prolightsound@messefrankfurt.com  
Net: www.prolight-sound.com

## 24-27

**Nightwave 2001**  
Rimini Trade Fair Corporation, 47900 Rimini, Via della Fiera 52, Italy.  
Contact: Exhibitions and Events.  
Tel: +39 0541 711 711.  
Fax: +39 0541 786 686.  
Net: www.fierarimini.it

## April 23-26 NAB

Las Vegas Convention Center, Las Vegas, US.  
Contact: Exhibitions and Events.  
Tel: +1 202 429 5300.  
Fax: +1 438 7327.  
Email: Webmaster@nab.org  
Net: www.nab.org

## 28-1 Disma Music Show 2001

Rimini Trade Fair Corporation, 47900 Rimini, Via della Fiera 52, Italy.  
Contact: Exhibitions and Events.  
Tel: +39 0541 711 711.  
Fax: +39 0541 786 686.  
Net: www.fierarimini.it

## May

### 10-13 Showtech 2001

Messe Berlin, Messedamn 22 D-14055 Berlin, Germany.  
Contact: Overseas Trade Show Agencies.  
Tel: +44 20 7886 3106.  
Fax: +44 20 7886 3101.  
Email: james.eliot@montex.co.uk  
Net: www.showtech.de

### 12-15 110th AES

RAI Conference and Exhibition Centre, Amsterdam, The Netherlands.  
Contact: AES.  
Tel: +1 212 661 8528.  
Email: 110th\_exhibits@aes.org  
Net: www.aes.org

## June

**5-7  
AES Brazil 2001**  
International Trade Mart, Centro Textil, Sao Paulo, Brazil.  
Contact: AES.  
Tel: +5511 7291 8188.  
Fax: +5511 7291 0200.  
Email: wcoml@francal.com.br

### 18-22 Broadcast Asia 2001

Singapore Expo, Singapore.  
Contact: Singapore Exhibitions Services Pte Ltd.  
Tel: +65 738 6776.  
Fax: +65 732 6776.  
Email: info@sesmontnet.com  
Net: www.broadcast-asia.com  
UK contact: Overseas Exhibition Services.  
Tel: +44 207 862 2080.  
Fax: +44 207 862 2088.  
Email: broadcastasia@montnet.com

## Character flaws

JUST A LINE to say how much I enjoyed the piece on the Manley 120W Monoblock (*Studio Sound*, August 2000). As a sad soul who comes home to check his stuff out on a classic Quad II valve amp, tearing the roof off the sucker with 15 watts of raw power, it was good to read after all the pure spec that it was great to listen to. I have to say these tube back-ends soften up the digits a treat...

Is anyone else out there listening on gear that is older than they are?

**Bob Ellis, Hope In Hades Productions**

## Praise you

I LOVE THE NEW FORMAT. The whole mag has lifted it's game (I actually thought it was pretty good before)—articles, presentation, even the feel are fantastic. Excellent!

**Mark Walker, ABC TV, Sydney**

JUST A BRIEF NOTE to say that I think the recent makeover of *Studio Sound* is excellent. I've been getting *SS* for over 20 years. I was a little alarmed at the big makeover a few years ago—didn't seem to work at all, but since then it has improved steadily and the recent changes really reflect its status as the best publication of its kind.

Also nice to have photos of the staff and contributors from time to time; helps to put a personal face (literally) on the names we read so often.

**Stuart Tarbuck, Vancouver**

## Contact mag?

I JUST FINISHED reading Rob James' review of Nuendo in the October issue of *Studio Sound* and on the whole we are pleased with the opinions expressed. What I wasn't so pleased about was your 'contact' details not listing us at all, instead you mentioned Steinberg in Germany and USA. I find this a little disappointing especially since I took a whole computer system to Rob's house for review and told him who I was and the company I represent. During the review he also spoke to us about Nuendo, so to leave our contact details out seems unfair.

I would be grateful if you could publish our contact details along with Nuendo's Web address, which is [www.nuendo.com](http://www.nuendo.com).

**Risto Sampola, Steinberg product manager, Arbitrator Group, UK**

As *Studio Sound* enjoys an international circulation, the aim has to be to provide useful contacts for the breadth of readers around the world, Risto. As it is impossible to include a comprehensive list of distributors, it makes sense to include the manufacturer and one or more regional offices or distributors. In the case of an American manufacturer, a European

contact (if available) is important. In the case of a European manufacturer—Steinberg, say—it makes more sense to include American and Far Eastern contacts than further European numbers.

The assistance that you provided to our reviewer is obviously important to us, and is greatly appreciated. In return (in this instance) you can chalk up approaching three pages of publicity for one of your product lines safe in the knowledge that anyone seeking further information will find their way to you either through Steinberg or your advertising.

**Tim Goodyer, editor**

## Bull & other animals

I READ WITH INTEREST Tim Goodyer's delightful leader column (*Studio Sound*, October 2000) and had to point out that surely the phrase 'Now the dogs are off their leash...' is simply wrong or, failing that, involves so many metaphors having been mixed that it's trite balderdash.

I would propose that either the dogs could be let off their 'leashes' or the 'dog' (singular) could be let off its leash, but tying multiple dogs to one leash would be tantamount to cruelty and would almost certainly result in a quick trip to the local animal shelter if not being brought up before the beak! (Note: More animal metaphors creeping in...)

**Joe Bull, MD, SADiE UK**

It's clear to me that you're long overdue a visit to a specialist leather retailer, Joe. Failing that, you might try a reputable pet shop. Had you done so, you would have found that the variety of animal-shelter-approved multiple-dog leashes now available quite defies the imagination, as I did during my research for this editorial. I didn't, however, notice anything resembling a leash intended specifically for use with metaphors, or for mixing them with other breeds of dog. In fact, the metaphor is a breed previously unknown to me, though I shall surely be asking for one for Christmas.

Would it have been better had I referred to 'cats being out of bags', or would this simply have prompted you to expose my ignorance of current the vogue in cats' trouserware—as, no doubt, letting the ferret out of my own would have invited howls of mirth regarding my own dress sense.

Perhaps I should be worried that you have overlooked the concern I was attempting to express over the 'listening test' scenario. Could it be that your eagle eyes missed that part of my missive or is it that your bat-like hearing places you above such concerns (I saw you at the London watermark listening tests...). Then again, you may be as deaf as a skunk behind that knowing grin. It's all water off my back, however you pluck it.

**Tim Goodyer, editor**

Email your event details to Dawn Boulwood: [dboulwood@unitedbusinessmedia.com](mailto:dboulwood@unitedbusinessmedia.com) for prompt inclusion in World Events



# BUILD A FUTURE.

The Entertainment Technology Network is building the world's leading media destination for professionals who create and deliver entertainment and install entertainment systems.

Now's the time to build your future with us.

We are looking for talented individuals to staff senior management positions in:

- >Marketing >Business Development
- >Sales >Content Creation
- >Training/Education >Technology

Experience in and instincts for the business of electronic media and entertainment technology are preferred.

Please send or email your resume and cover letter to:  
resources@uemedia.com or  
Human Resources Director  
Entertainment Technology Network  
460 Park Avenue South, 9th Floor  
New York, NY 10016



**NETWORK WITH US.**

**ENTERTAINMENTTECH.COM**  
**THE ENTERTAINMENT TECHNOLOGY NETWORK**

Pro Sound News >Surround Professional >Systems Contractor News >Residential Systems >EQ  
>Medialine >Videography >Digital Cinema >digital:TV >Government Video >AutoMedia >Car Sound



# THE WISH LIST

< Continued from page 78

or whatever to the Bahamas because it'll die. EAR and DW Fearn, on the other hand, are originators in their own right, and I love them.

'My dream compressor, apart from the EAR, is the LA2A. Also, the LA3A is one of the best vocal compressors that I've ever heard.'

## Console:

'Right now, no one console springs to mind. I want one made. Basically, it should be a monitoring console, with a wealth of outboard mic pres, dynamics, compressors and so on. I'm looking for a console that will faithfully interpret the sound which I'm pointing my microphone at. I want to sit in front of a board that can produce the quietest, cleanest possible translation of that feed, being able to mix it into a stereo bus or separate group assignments for recording purposes. So, I'm looking for a console with multiple inserts across the input and output stages and a very basic monitoring section. Ideally, I would also like to have EQ on each track.

'This is the desk that I would like for the studio I'm designing in the Bahamas. It really is of no concern but of all concern because it's got to be purpose built. So, if anyone's interested in manufacturing it, they should e-mail me at [chris.kimsey@btinternet.com](mailto:chris.kimsey@btinternet.com)—I'm serious about this.

'There again, for this particular setup I don't really need a console. I just need a lot of faders. You see, I'm hopeful that I'm going to be recording musicians because if I'm recording a lot of programmers I'm out of business.'

## Reverbs:

**Lexicon 960L; PCM42; PCM60;**

**MPX100**

**tc electronic M3000 (2)**

**MXR flanger (2); phaser (2)**

**Eventide 4000 (2)**

**Sony DRE S777**

'The DRE S777 is a sampling digital reverberator and it's an amazing unit. They've been around the world and sampled famous rooms—Sony have come up with a device where they have a set of speakers and they pump a collection of special tones into the room. They then measure the sonic depth, frequency, whatever, and the DRE S777 assimilates that room as a reverb. Sony have been to various concert halls and studios, and they've even sampled the Grand Canyon—or at least a piece of it—and so you can use these samples as well as assimilate any room that you wish. You can make a library of your own room sounds, because you don't need any special speakers. It's a unique tool and a wonderful thing, and it's not that expensive either.'

## Microphones:

**Telefunken 251 (2)**

**AKG 414 (2)**

**Shure SM57 (6; pre-1996);**

**SM58 (6; pre-1996)**

**Neumann U47 tube (2); U67 tube (4);**

**TLM170 (6); KM184 (2); M149 (2)**

**Coles ribbon mic (4)**

**B&K 4006 (6)**

**Sennheiser MD421 (6); MD441 (2)**

**AKG D30 (2); D224E (2)**

**Electrovoice RE20 (6)**

**Sony clip-on (8)**

'The 251 is one of the best vocal microphones. There are maybe three vocal

microphones that I would ever consider, and the others are the Shure 57 and AKG 414. The AKG 414s are great piano mics, with a lot of top and bottom, and also good for vocals with certain people. I love Shure microphones but I want the pre-1996 versions because after that there was a manufacturing change of components and I prefer the old sound.

'I use the U47s for drums and electric guitars. All of the guitars on the Stones' *Some Girls* album were recorded with either U47 or U67 tubes. The drums were recorded with one U47 tube over the top and a U67 tube on the side... going into a nice old EMI console, with very short cable runs.

'I use the TLM170 for everything except tambourines. I didn't discover them until two or three years ago, and when I did it was like "Wow!" They're almost like a new U47. M149s for overheads and possibly acoustics. Two of them will make a nice room sound if you're recording, say, three acoustic players together.

'I'm on a quest to find the best tambourine mic, and so far the Coles ribbon mic is the winner. Condensers overload so easily with the bass end pop, whereas the ribbon gracefully accepts it.

'I use the 421s for tom-toms and bass drums. They're a general workhorse. Stick one of these into a Telefunken mic pre, into an EAR EQ and an EAR compressor, it'll sound like a Neumann. That's the beauty; if you match these things up well enough, they can sound quite amazing.

Sony clip-on is like a tom-tom mic and a condenser, and they're really



**THE BALANCE SHEET**  
Total expenditure: <£500,000

This leaves Chris with the necessary funds to purchase his custom console—should anyone volunteer to manufacture it—as well as cabling, racks and sundry items of furniture...

good. I'll take eight just in case I work with Carl Palmer. I put them on the drummer Ian Wallace, who only had four tom-toms, and I didn't use any EQ, and afterwards he said, "What have you done to the tom-toms?" I had to lie, so I said, "Absolutely nothing," and he said, "Well, it sounds the best I've ever heard." □

## ROCK 'N' ROLL ANIMAS

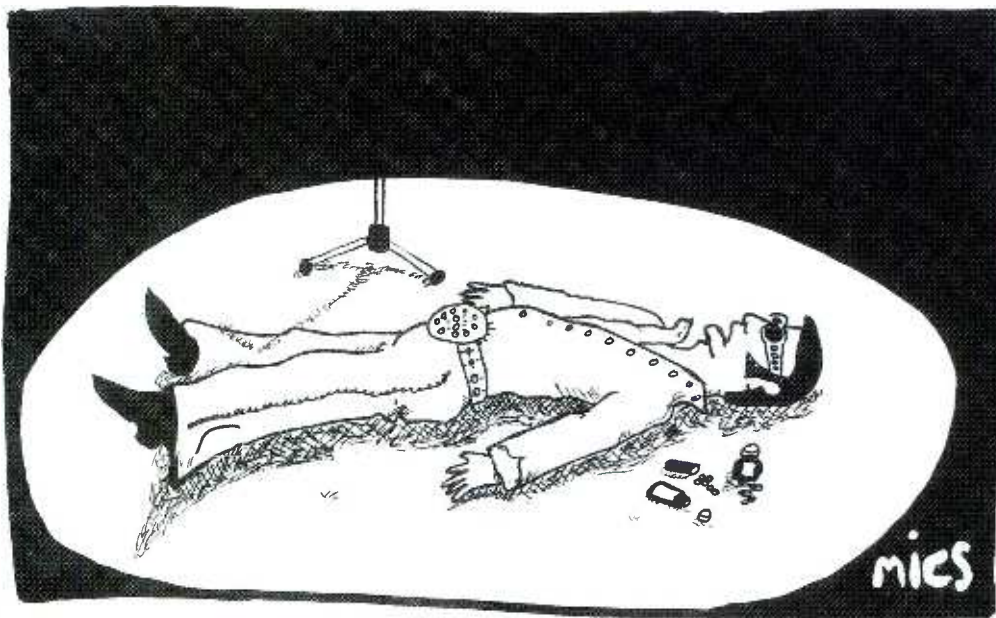

Derek the Elvis clone attempts lie level recording

## LIGGERS TOP 10

- 1 **Blag Sabbath** Ⓢ † † ↑
- 2 **Freebar Furey** \* \* \* ♠ ♠ ↩
- 3 **T-Shirt Burnett** Ⓢ † ↓
- 4 **LWA (Liggers With Attitude)** Ⓢ ↑
- 5 **Free Loader** Ⓢ ♠ ♠ ♠ ↩
- 6 **A Tribe Called Guest** ♠ † ↑
- 7 **Backstage Boys** Ⓢ † † ↑
- 8 **Buffet Saint-Marie** \* \* \* ♠ ↩
- 9 **Shakespeare's Sister... (said I was on the guest list)** ♠ ↩
- 10 **Free B King** \* \* \* ♠ ↓



# HIGH-SPEC HARDWARE. DEPENDABLE DISCS. HHB CD-R DELIVERS.



HHB CD-R. There's no safer place for your recordings. HHB CDR850 and CDR850 PLUS CD recorders are solidly built and fully equipped for professional studio use. And our audio-optimised HHB CD-R and CD-RW discs use advanced recording dyes and protective coatings to ensure consistently high performance and a secure archival life of up to 200 years.



New 80 minute CDR80 Silver  
50 disc 'Cake Pack'

HHB CD-R technology is easy to use, and exceptional sound quality has helped to make it the first choice of leading audio professionals and major studios the world over.

So don't take risks with your own valuable recordings.

Insist on HHB for CD-R technology that delivers.



**HHB CD-R media is developed and manufactured specifically for professional audio use.  
The range includes 74 and 80 minute CD-R, CD-RW, printable and bulk packaged discs.**

HHB Communications Ltd · 73-75 Scrubs Lane, London NW10 6QU, UK  
Tel: 020 8962 5000 · Fax: 020 8962 5050 · E-Mail: sales@hbb.co.uk  
HHB Communications USA LLC · 1410 Centinela Avenue, Los Angeles, CA 90025-2501, USA  
Tel: 310 319 1111 · Fax: 310 319 1311 · E-Mail: sales@hbbusa.com  
HHB Communications Canada Ltd · 260 King Street East, Toronto, Ontario M5A 4L5, Canada  
Tel: 416 867 9000 · Fax: 416 867 1080 · E-Mail: sales@hbbcanada.com

[www.hbb.co.uk](http://www.hbb.co.uk)



**FIRST WE LISTEN**



# CHRIS KIMSEY'S TRACKING STUDIO

Engineers frequently dream about building the perfect studio and what they would put inside it. Chris Kimsey tells **Richard Buskin** about his fantasies

**T**HE PRODUCER AND engineer of artists including The Rolling Stones, The Cult, Killing Joke, The Psychedelic Furs, Marillion and, most recently, The Proclaimers, Chris Kimsey launched his career at Olympic Studios in South London during the late sixties. Starting as a 17-year-old assistant to producer Glyn Johns, he worked on projects with Led Zeppelin, The Eagles and Leon Russell before engineering recordings by Billy Preston, Peter Frampton and Bad Company. His production skills would later come into play on four Rolling Stones albums.

Chris is currently preparing to produce his own material—composed specifically for 5.1—utilising a setup based at London's Sphere Studios, centred around a Pro Tools system and Sony RMX100 console. He is also involving himself in the co-ownership, management and design of a state-of-the-art facility on the island of Abaco in the Bahamas. Accordingly, many of the equipment choices being made for the latter facility are reflected here, for which we'll assume that Chris already has an empty, acoustically treated control room and recording area at his disposal. Thus, he's free to spend the £1m that he's been gifted on a tracking room that can be utilised as a one-off system for a high-profile, long-term project, as well as a moveable system that may be transferred elsewhere at a later stage...

**Recorders:**

**Studer 827 24-track with interchangeable 16-track headblocks (2)**  
**Pro Tools Mixplus 24 (2);**  
**Apogee AD8000 convertors (3);**  
**Digidesign 888 I-O (3)**  
**Sony MDS E11 MD; CDP D11 CD;**  
**PCM 7040 DAT; Sony Super CD Player**  
**Genex GX8500 recorder; Glyph 18Gb hard drives (4)**  
**CD writer**

**Loads of plug-ins**

'I'm not interested in Sony 24 or 48-track, because once you've committed to digital in one form or another you might as well stick with it. Pro Tools is a lot more flexible and everybody has it—well, almost everybody. A lot of people like to record on analogue and then put it on Sony but that involves too much fussing about and it's expensive. So, I'm accommodating people who do or don't want the analogue sound.

'I want two Pro Tools systems, one with Apogees and one with 888s. Some people swear by one, some like the other, although to me it's the same bullshit as people who won't record on an SSL and will only record on a Neve. I'll record on whatever I'm given because I just want to record.'



**Apple Cinema flat panel displays (2)**  
 'These look great. They make everything sound better.'

**Speakers-amps:**

**KRK 15K-A5 main system with KRK amplifiers**  
**KRK 9000 with Bryston 4BSTPRO stereo amp**  
**PRO AC 100 speakers (5) with Bryston 9BST**  
**PRO 5-channel amp**  
**Yamaha NS10m with Quad 404**  
**Genelec 1032AM (5)**  
**PRO AC 100 for studio playback with Omega III**  
**440HC Van Alstine amp**  
**Langevin 8-channel cue stations (6)**  
 'I discovered the big KRKs at Mastermix Studios in Minneapolis and they're the best big monitors I've ever heard. Big speakers normally don't impress me but these KRKs did, as did the setup at the old Ocean Way Studios [in LA].

'I'm using the PRO ACs for 5.1—I've only ever had the opportunity to work with Bryston and Quad, so I'm just sticking with what I know. At the same time, I don't have a sub-woofer because I actually don't believe in sub-woofers. I think it's too complicated for the punter, and it's easier to explain that the sound comes out of just five speakers. The industry is going to try to recreate itself again with 5.1 but it really should make things a lot simpler and define the rules. To me, you don't even need five speakers, you just need four but they can't say "quadrophonic" because that's already died.

'My belief regarding 5.1 or any surround sound system—and this is where a lot of studios screw up—is that it must consist of small speakers. There's no use having huge Genelecs or huge whatever. I've been to studios where they've got three massive Genelecs at the front and then two little ones at the back, but that's not what people will have and it's not what the whole thing is designed for. Each speaker should be the same.'

**EQ, compressors & mic pres:**

**Telefunken V76 (4)**  
**EAR compressors (6); mic pres (4);**  
**EQ (4)**  
**DW Fearn mic pre (2)**  
**dbx 120XP; 160A (2); 902 (2)**  
**Distressor (2)**  
**Joe Meek SC4**  
**Purple Audio MC76 (2)**  
**SSL FX384**  
**LA2A (4); LA3A (4)**  
**Urei 1176 black (2)**  
**Tube Tech compressor with freq selection (2; new);**  
**SMC 2A (2)**

**Avalon VT737SP (2); AD2044 (2); AD2055 EQ (4)**  
**API 225L (4); 512C (12); 550B with 550A**  
**transformers (12); 560B (6)**  
**Neve 1064 (8)**  
**Demeter Tube DI VTDB-2B (6)**

'The secret to recording a great combination of sounds is a great combination of equalisers and mic pres. What I've learned is that they all sound so different. It's shocking. There should be a government health warning on the Neve VR, because its mic pres are the worst I've ever heard. I think the whole world should be put through EARs—put any politician through an EAR and it'll be a lot better at the other end. At least it will make more sense.

'Seriously, my own philosophy is that there's no use buying old equipment anymore. You can't take a lovely old Fairchild—if you can find it—valve amp, limiter

Continued on page 76 >



# "REASONS NOT TO BUY A MACKIE D8B...ZERO."

—Roger Nichols, EQ Magazine

## PLUS 3 MORE REASONS TO GO FOR IT.

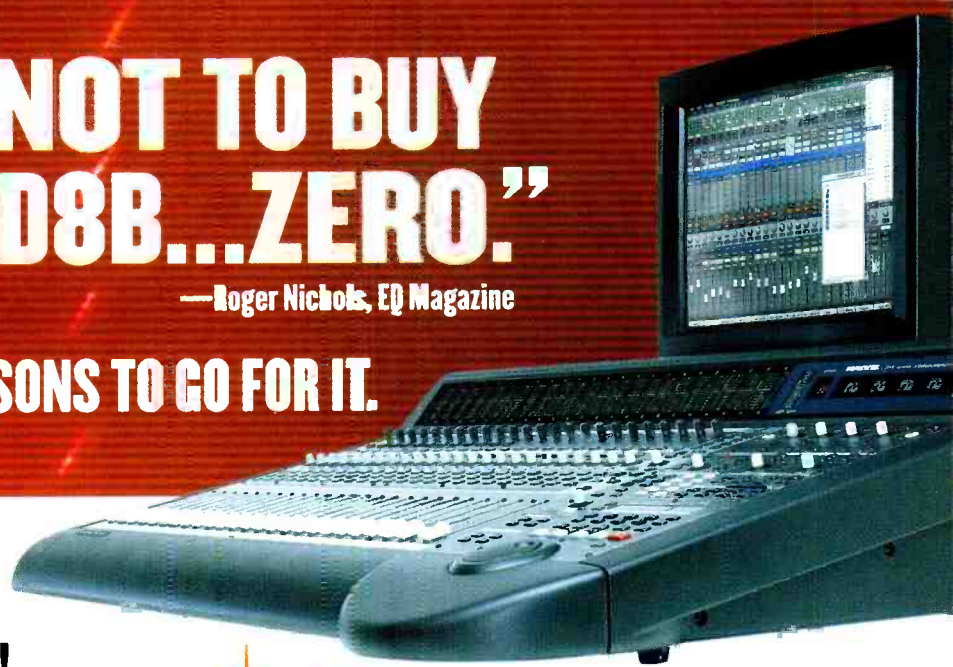

### 1 FREE UPGRADE! NEW OS 3.0 ADDS OVER 30 NEW FEATURES!

Our Programming Department has been chugging the double lattés to create Mackie Realtime OS™ Version 3.0, packed with more new features and enhancements than you can shake a mouse at. Here's just part of what 3.0 adds to the already amazing D8B.

- **New key (sidechain) inputs** for all 48 onboard dynamic processors featuring soft knee architecture and single band 20-20k parametric EQ for frequency dependent processing such as de-essing
- **3rd-party plug-ins** via our new UFX card. Up to 16 simultaneous plug-ins on the first 48 channels, pre or post DSP, pre-fader via up to 4 UFX cards. Each plug-in is available twice — once when tracking, and again at mixdown!
- **Multiple Undo List** — 999 levels!
- **New Snapshot libraries.**
- **Externally or internally accessible inserts across Mains and Buses plus channel inserts pre and post DSP.**
- **Updated GUI** including 48-channel fader bank view screen.
- **Time Offset (delay)** adds a delay of up to 999 samples to the signal at the pre-DSP (dynamics / EQ) point in the signal path.
- **New surround capabilities** including depth-of-center control (LCR mixing with divergence), multiple surround panner window, individual LFE channel level control.
- **Multiple direct outs** per channel.
- **Optional level to tape** fader control.
- **Assignable, bidirectional MIDI control** of all parameters.
- **Cross patching** allows substitution of channels between various banks.



### 2 DSP PLUG-INS!

**Antares' Auto-Tune** for the D8B uses advanced DSP algorithms to detect the incoming pitch of a voice or solo instrument as it's being tracked and instantly pitch-correct it without introducing distortion or artifacts. Fully automatable.



**Massenburg Parametric EQ.** MDW 2x2 High-Resolution Parametric Equalizer plug-in from Grammy-winning engineer/producer George Massenburg. Mono/stereo EQ at 96kHz sample rate for unprecedented clarity and high frequency smoothness.



**Drawmer** offers two dynamics packages for the D8B: ADX100 includes their industry standard frequency conscious gating, plus compression and limiting; ADX200 adds variable "Peak Punch" and further Drawmer innovations.



**IVL Technologies' VocalStudio** provides real time vocal doubling, multi-part harmonies and pitch correction in an easy-to-use interface. A free demo is built-into the Digital 8 • Bus. Just add a second MFX card to own this innovative plug-in from a world leader in vocal processing.



**TC Electronic Reverb** (bundled with the D8B UFX card) provides Reverb 1 and Reverb 2 algorithms from the renowned TC Electronic M2000 Studio Effects Processor. TC FX upgrade package contains an expanded set of M2000 reverbs plus Delay, Chorus, and Pitch. TC 2000 adds the TC M2000's Reverb 3, de-essing, tremolo, phasing, and panning.

### 3 1999 TEC AWARD WINNER!



Normally we don't name competitors in our ads. But in this case, Mix Magazine published the other nominees for the 1999 TEC Award for Outstanding Technical Achievement in Small Format Consoles: Allen & Heath's GS-3000, Digidesign's ProControl, Panasonic's WR-DA7, Spirit's Digital 328 and Yamaha's O1V. Thanks to all who helped us win this prestigious award.

©2000 Mackie Design, Inc. All Rights Reserved. The Mackie logo and the "Running Man" figure are registered trademarks of Mackie Design, Inc. D8B and Mackie Realtime OS are trademarks of Mackie Design, Inc. All other trademarks are the property of their respective companies.



The list of top engineers and producers who use the award-winning Mackie Digital 8 • Bus is growing daily. For info on the D8B, new UFX and Optical • 8 cards, 3rd-party plug-ins and how D8B owners can get their free OS upgrade, visit [www.mackie.com](http://www.mackie.com) or call your local D8B dealer.

**MACKIE**  
Digital Systems™  
www.mackie.com

UK • 44 1768 572172 email: [mackie.uk@ref-uk.com](mailto:mackie.uk@ref-uk.com) • Germany • 49 3572 96042.0 email: [info@mackie.de](mailto:info@mackie.de)  
France • 03.85.46.91.60 email: [ref.commercial@wanadoo.fr](mailto:ref.commercial@wanadoo.fr) • Italy • 39.0522.354111 email: [mackieitaly@ref.it](mailto:mackieitaly@ref.it)



# Who Needs Another Mic Preamp?

"...the finest sounding preamp I've ever used...as close to being the perfect preamplifier as possible. It is made well and it sounds unbelievable."

*Russ Long, Nashville based producer/engineer, Pro Audio Review, June 2000*

"The 1100 is the sweetest, cleanest, warmest, most flattering preamplifier I've ever used."

*Jon Barry, Radio Personality, WMXB (FM), Richmond, VA*

"The Aphex Model 1100 is a good example of something different... A work of art...The results were astonishing, providing an awesome sound that was natural, dynamic and absolutely free of noise."

*George Petersen, Editor - Mix Magazine, April 2000*



**Model 1100**  
Discrete Class A  
2 Channel Tube Mic Preamp  
with 24-Bit 96kHz A to D  
from **Aphex Thermionics**

**Y**es, the Aphex Model 1100 Thermionic Preamp is different - it's a completely new design filled with Aphex proprietary circuitry. These inventions, combined with the absolute highest quality components, provide accuracy, clarity, detail, and depth that have never been available with any preamp, at any price.

The Reflected Plate Amplifier™ tube circuit imparts all the wonderful characteristics of a conventional tube circuit without any of the sonic drawbacks. The MicLim™ provides up to 20dB of limiting on the microphone output- before the preamp gain- allowing hot levels without fear of overloading. And the Drift Stabilized™ 24bit/ 96kHz A to D converters make the transfer into the digital domain at the highest possible resolution. Specs? How about -135dBu EIN! This means that the Model 1100 adds less than 1dB of noise to the output of a microphone!

There are many mic preamps on the market, but if you're looking for something different, with awe-inspiring performance and unique features, **you need another mic preamp—you need the Aphex Model 1100.**

**APHEX**  
SYSTEMS

**Improving the way the world sounds<sup>SM</sup>**

11068 Randall Street, Sun Valley, CA 91352 U.S.A.  
818-767-2929 • Fax: 818-767-2641 • [www.aphex.com](http://www.aphex.com)

Aphex, Aphex Thermionics, Reflected Plate Amplifier, LoCaF, MicLim and Drift Stabilized A/D Circuitry are trademarks of Aphex Systems.  
[www.americanradiohistory.com](http://www.americanradiohistory.com)