



# RECORDING engineer/producer

*relating recording science • to recording art • to recording equipment*



11201PMEBL93DD  
DOUG POMEROY  
COLUMBIA RERDS  
193 BAL TIC ST  
BROOKLYN

NY 11201

ROY HALEE  
ENGINEER OF THE YEAR, 1971

# MOD-N-32



- REMOTE ACCESS AND PROGRAMMABLE SOLID STATE SWITCHING
- DC CONTROL FOR AUTOMATION
- FULL 32 INPUT ASSIGN TO ANY TRACK
- 32 OUTPUT PLUS SIMULTANEOUS QUAD-STEREO-MONO OUTPUTS
- SOLID STATE 32 TRACK PROGRAMMABLE BOARD & MONITOR MASTERS
- AUTOMATIC SYNC SWITCHING
- PREVIEW PUNCH-IN MONITOR CONTROL
- QUAD-PAN ON ALL INPUTS
- SOLO INPUT-SOLO MONITOR-MUTE INPUTS
- SELECTABLE PROGRAMMABLE MUTING
- PEAK OR RMS LEVELITES
- 3 RANGE STEPLESS RECIPROCAL AND SHELVING EQ
- FOUR CUE SYSTEMS
- FULL PLUG-IN CONSTRUCTION
- 68 INCHES WIDE

## DANIEL N. FLICKINGER & ASSOCIATES, INC.

40 SOUTH OVIATT STREET

HUDSON, OHIO 44236

(216) 655-2400

Exclusive West Coast Distributor:

**WESTLAKE AUDIO, INC.**

6311 WILSHIRE BLVD.

LOS ANGELES, CA 90048

655-0303



**RECORDING**  
engineer/producer

—the magazine to exclusively serve the recording studio market... all those whose work involves the recording of commercially marketable sound.

—the magazine produced to relate... RECORDING ART to RECORDING SCIENCE... to RECORDING EQUIPMENT.

Editor/Publisher... MARTIN GALLAY  
Associate Editor... GEORGE KOCH  
Engineering Editors... RON MALO  
WILLIAM ROBINSON  
CHUCK DAVIS  
Business/Circulation  
Manager... V. L. GAFFNEY  
Art Director... GERRY SADOWSKI

RECORDING engineer/producer is published bi-monthly and is sent free to qualified recipients in the United States. Subscriptions for other than qualified individuals or companies may be purchased at \$5.00 per year. (All foreign subscriptions: \$6.00 per year.) Material appearing in Re/p may not be reproduced without written permission of the Publisher. Copyright © by RECORDING engineer/producer 1971.

RECORDING engineer/producer is not responsible for any claim made by any person based upon the publication by RECORDING engineer/producer of material submitted for publication.

Controlled circulation postage paid at Los Angeles, California.  
RECORDING engineer/producer  
6430 Sunset Boulevard  
P.O. Box 2287  
Hollywood, CA 90028  
(213) 461-7907

ROY HALEE ENGINEER OF THE YEAR, 1971	11	George Koch
Poem: "THE ENGINEER"	14	Claude Hill
PHASE AND THE SINGLE MICROPHONE	17	Ron Malo
24 COMES TO L.A.	21	Staff Report
QUAD BROADCASTS AT PHR	23	Staff Report
SOLID STATE SWITCHING	25	Peter J. deBlanc
BOOK REVIEW: "WIDE SCREEN CINEMA AND STEREOPHONIC SOUND"	27	

Letters and Late News	6
FIGHTING MURPHY'S LAW	29
New Products	33
Classified and Advertisers Index	39

CREDITS — cover: TRICI VENOLA  
cartoon: WAYNE YENTIS  
photos: page 23 RICHARD TAUBER  
page 21 LYNN AMES

# Play at 15 i.p.s.

## Yamaha C7 Grand.

When you're laying down the master, you'd better be sure your piano is air quality. That's what the Yamaha C7 Grand is all about. It's a 7'4" concert instrument that ranks among the world's great pianos. Just ask the talent at your next session.

## Yamaha U1-D Upright.

The closest you can come to a grand piano without a grand piano. Four feet high and nearly five feet wide, it has full, rich tone and response crisp enough to please the most finicky talent. It stays that



way through month after month of masters, rehearsals and spilled drinks, too.

## Yamaha Electone

**E-3.** It's a symphony orchestra in a box. With fewer controls, the E-3 gives you more sounds, more music. What's more, it's a regular sound effects machine. Think about *that* the next time you have to synthesize some sounds.

## LETTERS and LATE NEWS

Gentlemen,

Re: the article on page 29 of your Sept/Oct issue [**Fighting Murphy's Law**].

Having just completed the job of causing a few thousand feet of unimproved factory to become a functional eight track studio with little more than a few broken piggy banks, a few grams of sweat and a few determined, albeit seemingly foolhardy psyches, we have probably encountered the phenomenon of which you speak as often as anyone.

We, however, prefer to blame it on Gumperson, whose Law of Inverse Probability states, "The probability of the outcome of an event is inversely proportionate to its desirability".

Gumperson notwithstanding, the studio looks good, sounds even better, and we're looking forward to some good product.

So, with tongue in cheek and my fellows laughing uncontrollably at the idea, I'll cautiously venture that this is what happens when Murphy is on your side. . .

"And look out for Murphy!" indeed! Well, maybe. . .

**Rick Murphy**, studio manager  
FULL COMPASS SOUND STUDIO

Gentlemen:

I just wanted to let you know how much my associates and I enjoyed your recent article on Carol King, et. al.

When an artist becomes as popular as Miss King, hoards of musicians swarm to the studios demanding "that same kind of sound."

While there is certainly more (ie: talent) to getting "that sound" than just microphone selection and placement, information of this type provides a helpful "starting point" to engineers and producers trying to emulate the styles and techniques of the major artists.

I hope you will have more articles of this type in the future, as I think its extremely valuable to learn about the techniques used by major artists, producers, and engineers.

Peace,  
**Mike Wing**



# YAMAHA

YAMAHA INTERNATIONAL CORPORATION  
P.O. Box 6600 • Buena Park, California 90620

Send for complete specifications and dealer information.

- C7 Grand Piano      Name \_\_\_\_\_
- U1-D Upright Piano      Business \_\_\_\_\_
- E-3 Organ      Address \_\_\_\_\_
- Other \_\_\_\_\_      City \_\_\_\_\_ State \_\_\_\_\_ Zip \_\_\_\_\_

Circle No. 102

Gentlemen:

I am presently in the process of remodeling an old building I bought into a recording studio. The structure has the old double-wooden floor—with an eleven inch crawl space underneath that. The building also has all-wood walls . . . Where do I go from here to get the absolute quiet I need . . . ?

I thought perhaps a few of your readers have done this very same thing and found "the perfect solution". Would appreciate your effort! Best Regards,

**Jack DeWaard**  
Sound Ideas Recording Studios  
155 East 16th Street  
Holland, Michigan 49423

### Quad Test Record Available

M. T. Putnam, president of UNITED RECORDING CORPORATION, Hollywood, California, announces the availability of two QUADRIFONIC test records designed for technical evaluation of identical program material encoded in four popular matrix configurations—Sansui, CBS, Electro-Voice (new compatible) Stereo 4, and the Cooper/Nippon Columbia UMX System.

The matrix evaluation set of two 12" LP's demonstrates the four systems using excerpts from the forthcoming "Stan Kenton Live at B.Y.U." albums, selected because they exhibit a variety of quadrifonic recording techniques. All samples were mastered from encoded tapes dubbed directly from the discrete 4-channel tape through the respective encoders.

Each demonstration side opens with a series of bearing localizer tone burst signals, followed by four music tracks. Provided with the test

### From the READERS

*An editorial material rating of the most useful feature article, as gathered from the Reader Service Cards received prior to press time. SEPTEMBER/OCTOBER ISSUE:*

- CAROLE KING .....48.36%
- WITCHDOCTORS .....27.05%
- PHASE CORRELATION .....20.49%
- MURPHY'S LAW ..... 4.10%

discs is an instrument positioning chart indicating where various sound sources were placed in each musical selection. A sixth track demonstrates simulated moving sound sources developed by Professor John Chowning, Stanford University Artificial Intelligence Laboratory.

Distribution is free-of-charge, upon request, to interested members of qualified companies within the industry. Individual requests, on company letterheads, should be addressed to M. T. Putnam, United Recording Corporation, 6050 Sunset Boulevard, Hollywood, California 90028.

### Hall Announces Suit

Attorney E. Fect Hall announced today, with some reluctance, the filing of a suit on behalf of the Greater Electron Movement Association, charging the A.F., I.F., and R.F. Assemblies of Chokes with both narrow and broad-band discrimination. The case is expected to be brought before the circuit court somewhere near its termination.

### Westlake Audio Bows

On October 29, Westlake Audio, a firm specializing in recording studio design and construction, opened the doors of a rather unique sales office on Wilshire Boulevard in Los Angeles. Outside, it seems as if a small chunk of Boston had suddenly been dropped in the midst of L.A.'s highrises.



Westlake's building is an old brownstone, refinished, refurbished, and filled with electronics, including a quad-risonic control room, and featuring Olive, Flickinger, MCI, Crown, and Westlake equipment, among others. It is an interesting place, but short people are cautioned to wear snow shoes, lest they be lost in the new pile carpeting.



- *Highest quality*
- *Independent producer*
- *Available immediately*

Accepted as basic reference tools by major equipment manufacturers, broadcasters, and recording studios throughout the world, STL test tapes are unexcelled for quality.

Available in all audio tape widths—150 mil to 2 inch. Catalog-listed tapes of 1/4" are priced at \$24.00 each.

Supplied to the user promptly on order.

Call or Write:

**TABER MANUFACTURING & ENGINEERING CO.**

2081 EDISON AVE. • SAN LEANDRO, CALIF. 94577 • PHONE: (415) 635-3832

In Los Angeles: Knight-Taber, 1063 Vine St., Hollywood, 467-5121

Contact us for distributor in your area.

Circle No. 103

# STUDIO RECORDERS

by

*Crown*

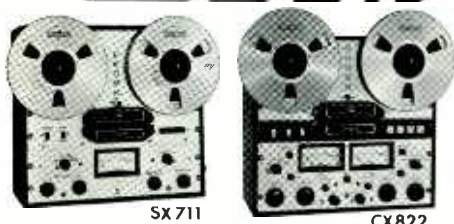

SX711

CX822

## MINIMUM DOWNTIME

Each unit undergoes more than 100 hours cumulative testing ■ Typical parts shipment from factory service department - under 48 hours ■ Easy access plug-in modules for instant servicing ■ Patented electromagnetic brakes never need adjusting ■ Simple transports - only 9 or 10 moving parts, all solenoid operation ■ Superior tape head contact plus light tape tension for low head wear

## MAXIMUM LIFETIME

Design lifetime is 10 years continuous use or 65,000 hours, with three service check-ups ■ Construction "rugged enough to withstand parachute drops" (AUDIO magazine) ■ Top-grade components such as silicon transistors and tantalum capacitors ■ One of the two remaining original American tape recorder manufacturers; still supplying parts and service for broadcast units 15 years and older

## MAXIMUM PERFORMANCE

Computer logic controls provide rapid fool-proof tape handling, safe popless remote control, prevent broken tapes ■ Best frequency response among all recorders, pro or semi-pro, and the only one that's guaranteed ■ Every unit shipped with its hand-entered proof-of-performance report

Speed	Response-Hz	S/N	Wow
15 ips	+2db 40-30K	-60db	0.06%
7½ ips	+2db 20-20K	-60db	0.09%
3¾ ips	+2db 20-10K	-55db	0.18%

## MAXIMUM FLEXIBILITY

Bias metering and adjustment; record and play equalization switching ■ 2 line level inputs per channel and a 600-ohm line output for each channel ■ Third head monitor with A/B switch ■ At-the-head editing plus cue lever ■ Full line of 1, 2 and 4-channel recorders and players ■ From the mono SX711 at \$895 to the stereo CX822 with typical options at \$2300, you can pay less for a semi-pro recorder, and replace it every couple years . . . or pay more for a wide-tape mastering machine, and get no better performance. It's your choice. To help you make it, we'll be glad to send you full technical data with performance graphs.



BOX 1000, ELKHART, INDIANA 46514, U.S.A.

## EV Stereo-4 Announced

BUCHANAN, MICHIGAN—Electro-Voice, Inc., a Gulton subsidiary, recently announced it had developed 4-channel matrix decoding equipment which will decode all presently used or proposed matrixing systems, including CBS SQ, without need for switching by the listener. According to Lawrence LeKashman, E-V's president, both complete decoder units for the consumer and monolithic integrated circuit chips for use by o.e.m. set manufacturers will be available immediately after the first of the year.

The new E-V Stereo-4 system was first demonstrated at a recent meeting of the National Academy of Recording Arts and Sciences in New York.

Also at the NARAS meeting, Electro-Voice unveiled a gain-sensing 4-channel reproduction system developed in conjunction with matrixing pioneer Peter Scheiber. The circuitry further increases separation between channels and will be made available in more sophisticated high fidelity equipment in 1972.

The new Stereo-4 decoder will not obsolete units already in the field. Prices for the new decoders and I.C. chips will be only slightly higher than present models.

## Sony/3M Pact

Sony Corporation, Tokyo, Japan, and 3M Company, St. Paul, Minn. announced today they had entered into a cross patent license agreement involving the manufacture and sale of magnetic tape and recording equipment.

The agreement will permit Sony to manufacture and sell the new 3M "High Energy" magnetic tape and and 3M to manufacture and sell the new Sony ¾-inch "U-Matic" videocassette equipment.

Sony commenced the distribution of its "U-Matic" videocassette equipment in Japan this month and anticipates that it will introduce the same system into the U.S. market in early 1972.

The Sony system is a method of storing and playing pictures and two-track sound on an erasable, magnetic ¾-inch tape for replay on any standard color or black-and-white television set.

With the Sony "U-Matic" videocassette system, the viewer will be able to select exactly what he wants, he can view it when he wants, and always with the options of changing to another cassette instantly.

The recording equipment will be manufactured and sold by 3M through its Mincom division under the Wollensak brand name. Plans for marketing the recorder by 3M are being developed.

## 30,000 Watt Brochure

"Ontario Motor Speedway Incorporates the World's Most Powerful Sound System" is the title of a new 16-page brochure available from the Altec Division of LTV Ling Altec, Inc., of Anaheim, California.

Written by Robert Reim, Systems Engineer with Altec Contractor, Hannon Engineering Company, Los Angeles, California, the brochure details the technical problems and the innovative answers provided for the 30,000 watt system at O.M.S., the largest facility of its kind in the world, covering more than 700 acres of ground, and having seating capacity for 140,000 persons in the grandstands.

To obtain a copy, write to Glenn Malme, Industrial Marketing Dept., Altec, 1515 South Manchester Boulevard, Anaheim, California 92803.

## Wortman to A.E.S. V.P. Post

Leon A. Wortman has been elected western regional vice president of the Audio Engineering Society of America for 1971-72.

Wortman is manager of corporate marketing services for Ampex Corporation, Redwood City, California.

As one of three regional vice-presidents of the AES he is responsible for coordinating society programs in the western states. He also is in charge of arrangements for the AES convention in Los Angeles in May.

A graduate of Brooklyn College, he directed Leon A. Wortman Associates, a New York marketing consultant and marketing services firm, prior to joining Ampex in 1964. He is the author of "Closed Circuit Television Handbook" and numerous articles on business and electronics.

## Audio Courses Offered

The Institute of Audio Research of New York has announced the opening of registration for two Spring Semester courses, *Studio Technology and Practice*, a course offering training in modern studio equipment and techniques, and *Audio Systems Design*, and advanced engineering course and seminar, relating modern electronic developments and technology to audio systems design.

Classes begin in early January. For further information, call or write: Institute of Audio Research, 156 Fifth Avenue, New York, N.Y. 10010. 212-242-1915.

## IEEE Measurement Standard

A new document designed to produce more uniform and reliable results in testing for subjective flutter has just been released by the Institute of Electrical and Electronics Engineers. *IEEE Std 193-1971, Method for Measurement of Weighted Peak Flutter of Sound Recording and Reproducing Equipment* provides a technique for measuring and reporting irregular motion in sound recording and reproducing equipment that is both easier to perform than previous standard methods and also far more likely to produce uniform results when tests are carried out by more than one technician.

### USES WEIGHTED PEAK METER

The new standard makes use of a weighted peak flutter meter of the type called for in German Standard DIN 45 507, 1966. Meters of this type are now readily available in this country, and a series of user tests conducted by the IEEE working group that developed the new IEEE Standard has determined that (1) weighted peak readings agreed with the subjective adjustments of a listening panel, (2) weighted peak meter readings are more easily determined than those made with a Standard Volume Indicator, and (3) recording equipment manufacturers and recording studios in the United States generally expressed a willingness to change to a weighted peak measurement.

Copies of IEEE Std 193-1971 may be ordered from the Institute of Electrical and Electronics Engineers, 345 East 47th Street, New York, N.Y. 10017. The single copy price is \$3.00.

(continued on page 30)



Audiometric-type transducers make our headphones better. Better than any headphone you've ever tried. You can hear the difference; clear, live, distortion-free sound. But even more important, performance and sound are the *same*, all day, every day. Because our audiometric-type elements are absolutely stable to give you consistent performance at all times.

Originally, we developed audiometric elements for clinical hearing tests and measurements. This required elements that remain totally stable even with changes in temperature or humidity. Sensitive elements that respond efficiently to variances in frequencies and power input. Elements capable of sound reproduction at over 130 dB sound pressure level with very low distortion and without burning up.

Now we've modified and adapted this audiometric transducer element to give you a series of thoroughly professional headphones. Headphones you can rely on for stable performance — day in, day out. Clear and undistorted so you can truly monitor sound quality and balance and not just signal presence.

We make two series of professional models to meet your needs Series 1325 for stereo monitoring and series 1320 for communications, with optional noise cancelling boom microphone. Try our better hear muffs at better dealers — or write for free information. You'll hear more from Telex.

PRODUCTS OF SOUND RESEARCH

**TELEX**<sup>®</sup>

COMMUNICATIONS DIVISION

9600 ALDRICH AVENUE SOUTH • MINNEAPOLIS, MINNESOTA 55420

CANADA: DOUBLE DIAMOND ELECTRONICS LTD., Ontario  
EXPORT: ROYAL SOUND COMPANY, INC., 409 North Main Street, Freeport, N.Y. 11520 U.S.A.

Circle No. 105



## Wally Heider and friend.



When Wally Heider, the internationally known master of the art of location recording, talks about recording techniques, we're very frank to admit that we listen! Imagine how pleased we were to hear him talking about our own SM53 unidirectional dynamic microphone in terms such as these: "The loudest guys in the world, screaming into them, won't break them up"; or "They sound good on any assignment"; or "The front-to-back characteristics are excellent"; or "Whenever I'm not locked into a performer's own pet microphone, I prefer to use the SM53." We can tell you about eight provable advantages that can make the SM53 your most effective and reliable recording microphone.

Shure Brothers Inc.  
222 Hartrey Ave., Evanston, Ill. 60204.



Circle No. 106



When a child is learning to walk, he is able to do no more than put one foot in front of the other and shift his weight. He learns quickly (after a couple of falls), that he must master these basics before he can advance to running, skipping, or dancing. His thoughts may not be quite so complex as we seem to imply, but the fact remains that for the time, he can only do one thing, and that without much skill: he can walk.

After several years, he becomes adept to any number of methods of getting himself from place to place. He may walk, skip, run, dance, or whatever. It all depends on the situation he finds himself in. Further, if he's been aware of his learning process, he knows he's gotten beyond his walking stage by experimenting, by playing around with his balance and coordination. *Great dancers are great experimenters.* They've discovered that they have to go beyond just walking in order to fully express themselves, and to respond artfully to the music to which they dance.

We think the analogy is not too strained when we compare the artistry of a great dancer to the artistry of a great recording engineer.

Such an engineer is beyond the elementary repetition of, "It worked then, and it'll work now. Why take chances?," just as the dancer is beyond carefully putting one foot in front of the other and merely walking.

The techniques of the engineer and dancer are always growing, changing, expanding, in order to better express the music and feeling they deal with daily.

# Roy Halee

## Engineer of the Year, 1971

by George Koch

Roy Halee dances with his fingers. For his artistry and technique as an engineer, he was awarded a Grammy and the title Engineer of the Year for 1971 by the National Association of Recording Arts and Sciences. He is the man-behind-the-scenes, engineer, friend, and cohort of Simon and Garfunkel. The classic album "Bridge Over Troubled Water" is the product of his engineering skill combined with the musical genius of Paul Simon and Art Garfunkel. A quick listen to the album will show that its greatness is not music alone.

Columbia has been giving out gold records for only two years, but Halee already has 16 years of them.

His association with Simon and Garfunkel began just as he graduated from Columbia's editing room to the studio. He was starting as a recording engineer when Simon and Garfunkel arrived for their first audition. He engineered, they played, and that first audition became their first album, "Wednesday Morning, 3 A.M." He's been with them ever since.

JUST AS THE DANCER MUST OBEY THE LAW OF GRAVITY, there are certain limits that Halee must work within. But those limits are becoming frayed and dented by his insistent forays against them.

Halee says it succinctly: "I don't like to make hard and fast rules. When experimentation goes out the window, new sounds go out the window."

It's hard to pin the man down on exact and repeatable techniques; he's always changing. We managed however, to get some insight on him, and the contribution he's made to engineering artistry.

It is well known that Halee gets tasteful though unusual sounds from his drums.

He normally mikes them with a U-47 overall, snare *top and bottom* with a salt shaker or RE-20, floor tom often *top and bottom*, a mike over the sock cymbal (high hat), high enough to get some splash from the snare, and the bass drum *front and back*.

The second mike on the snare allows him to get a bit of crack without over equing, a technique that is especially effective on the louder rock dates. Double miking of the other drums allows similar effects to be employed. Phasing seems generally not to be a problem, but readers are cautioned when employing such a technique to be certain that any double miking done is constructive, both electrically and acoustically. Halee is

**ANY WAY YOU  
LOOK AT IT OR  
ANY WAY  
YOU USE IT  
YOU CAN'T  
BEAT IT!**



**OTARI  
MX 7000**



**See the dynamic  
4-channel MX 7000QX!**

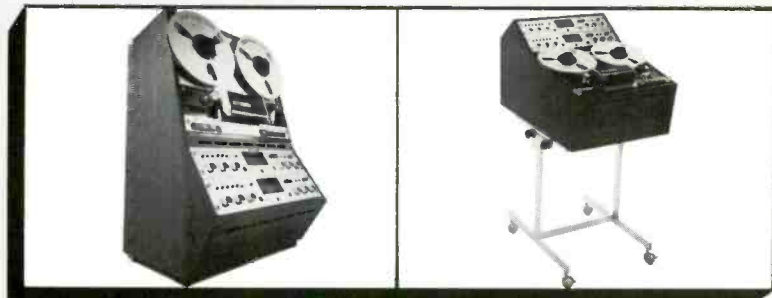

**THE OTARI MX 7000 PROFESSIONAL TAPE DECK** is designed with you, the professional, in mind. Built with the same rugged dependability of the OTARI 32:1 Duplicator and Q.C. Monitors, this outstanding unit has these exclusive features:

- **Three speed hysteresis synchronous motor (3 $\frac{3}{4}$ , 7 $\frac{1}{2}$  and 15 IPS). (Adapter kit available for 30 IPS).**
- **Convenient built-in test oscillator at 700 Hz and 10 KHz.**
- **Plug-in head assemblies for changing from one to four channels.**
- **Push button controls**
- **Sound with sound; sound on sound.**
- **Automatic equalization in all 3 speeds.**
- **10 $\frac{1}{2}$ " reel capacity**
- **Can be used in vertical or horizontal position by merely reversing the modules within cabinet.**
- **Prices start at under \$2000.00**

*For more details, specifications or a representative, Phone, write, TWX or wire*

**OTARI**

**OTARI OF AMERICA, LTD.**

8295 South La Cienega Blvd., Inglewood, Cal. 90301  
Telephone: (213) 678-1442 ■ TWX 910-328-6184

OTARI ELECTRIC CO. LTD., SUGINAMIKU, TOKYO, JAPAN

Circle No. 107

[www.americanradiohistory.com](http://www.americanradiohistory.com)

**“There was the day Halee put a drummer next to the elevator shaft.”**

unhappy with copying for the sake of copying. As he puts it:

“Some people think, ‘That record was successful, so I’ll always mike drums the way I did [or Halee did] on that date.’ But that was *that* day, *that* temperature, *that* studio, and it was Hal Blaine’s set of drums. Tomorrow you’ve got another drummer coming in with his set of drums and the humidity is 80%.”

The point is well-taken. Creativity is most productive when one first recognizes exactly what he is dealing with, and then builds from there.

The creative building of tracks takes strange forms on occasion. There was the day Halee put a drummer next to an elevator shaft,

“We wanted to get an explosion effect, so I put the guy out in the hall next to an elevator at 49 East 52nd street in New York. The hallway itself was extremely live, so I put mikes in the shaft and in the hall, and limited the hell out of them. And we got an explosion sound. It’s in ‘The Boxer.’”

In “Bridge Over Troubled Water” there is a snapping sound, like a whip in the distance. *It* was created by physically placing the drummer *inside* an echo chamber.

THE WILLINGNESS TO SEEK UNUSUAL METHODS AND SOUNDS is certainly worthwhile, but to be effective, it must be coupled with a more gut feeling for the effect of music on a listener.

When we asked Halee about his use of stereo spread on drum and piano mikes, his response was typically non-committal, but at the same time clear.

“The degree of stereo spread I use depends on the piece. If it’s disconcerting to the song and music, I won’t do it. A lot of times I put drums on one track. It depends. If you’re doing a thing like “Cecilia”, where you want it to dance around, it adds to the arrangement.”

“And generally, when I mike the drums and split them into stereo, I won’t split them extreme left and right. I’ll split them left-center, right-center, and center.”

**“If . . . the tune elevates itself, or picks up, I will sometimes pan the drums extreme left and right to give it more motion.”**

“If a tune calls for a lift, as when it goes into the waltz section, or some such thing where the tune elevates itself or picks up, I will sometimes pan the drums extreme left and right, to give it more motion. You won’t even be aware that it happened unless you have headphones on. But it does create the effect of lifting that particular section of the tune. Then I’ll bring it back again.”

SIMON AND GARFUNKEL’S FIRST ALBUM WAS GUITAR AND VOICE. To this day, though other instruments overwhelm the guitar in much of their music, it is still given as much attention as ever, particularly in terms of how it is miked. The exact configuration is dependent on what kind of guitar it is, how it is being played, and whether it is being finger picked, strummed, or flat picked. When a flat pick is used, Halee likes to stay



away from a condenser mike, and uses a dynamic mike instead. Otherwise, one, two, or three condensers are often employed.

Normally, two is the number, one at an angle over the hole (to prevent the hand coming between the hole and the mike), and one down over the guitarist’s right side, behind the hand.

WHEN HALEE DOES OTHER STRINGED INSTRUMENTS, he invariably uses condensers, notably a U-87, 67, or M-49. He’s made the comment that he likes a “wall” of strings. How does he accomplish this?

“I try to use more than one track, like for violins, so I can spread, and the same for low strings. Instead of putting all the violins on one track, and viola and cello on another, I try to use a lot of tracks.”

“For eight violins I’d use two mikes. Again it depends on what you’re doing. If it’s a hard rock date, where you can’t get far away because of leakage problems, I’ll mike every two players. But on overdubs, I use an average of two mikes; with eight violins, one on the front four and one on the back four. If there are two violas and two celli, I’ll put a mike on the violas and a mike on the celli.”

“That’s why I got them to put this mixer in this console [A small mixer, independent of the standard console inputs, is mounted on the right hand side of the console]. If I had strings on a hard rock date, I might mike every two violinists, as I said, to get a lot of presence on the strings, bring them up and mix them on this mixer, and take them all in on one channel. All eight mikes.”

“Then again, there’ve been occasions where I’ve used one mike on twelve violins, and I’d put it far away. But in a room where the air conditioning and rumble weren’t ridiculous.”

## **"I like to create a lot of crazy rhythms."**

"I mult the strings, and I usually use a little tape reverb. Just a little bit. Then afterwards in the mix. It depends, again, on what the mix is, what the tune is, what the arrangement is, whether they're going to have echo or be dry, whether they're going to have delayed echo. But I always put a little tape reverb on strings."

PIANO IS APPROACHED ACCORDING TO THE NATURE OF THE PIECE. In "Bridge Over Troubled Water" (the song), the piano was miked as would be a classical piano solo. Three mikes were placed high and back, about six feet horizontally and six feet vertically. Condenser microphones were employed.

On a rock date however, the dynamics and presence of the piano are altered considerably, and dynamic microphones, with an occasional condenser, are placed in tight.

Listening to tracks Halee has done immediately impresses the listener that considerable innovation and work have gone into their making. Technique follows technique, building a complex stereo matte of interweaving and overlaid effects.

"Through the years I've put guitars in bathrooms, drums in bathrooms. Sometimes I phase the echo. You don't know it's being phased, but it is. I did that on "At The Zoo." I've put a couple of choruses of voices inside a bathroom or an echo chamber. Sometimes I put Dolbies in when I record and then take them out when I mix. I use a lot of tape reverb. Sometimes we use it to create our own rhythms. When I say "our", I mean Simon and Garfunkel. We create our own rhythms in the mix."

"That happened, for instance, on "Bridge Over Troubled Water" Hal Blaine is playing the bass drum, but he's not playing the part you hear. There's tape reverb on that bass drum. Oddly enough, when we did it, we found that it would only work with a Scully four track. If we used another machine, because of the head distance, it was out of rhythm."

"When you hear 'Ba da Ba da da da da', that's not what he's playing. He's playing something like 'Ba . . . da da'. Something like that. I'd have to listen to the original tape to get the exact figure he plays, but what you hear is different."

"I do an awfully lot of that. I like to create a lot of crazy rhythms. A lot of times it's out of rhythm, and you strike out. But I like to fool around and find out when it's in rhythm, and then if it's good, I'll use it. I'll flip it in for a couple of bars, and take it out. Sometimes I'll program it to another track, so it'll answer itself."

HALEE HAS BEEN ASKED TO REMIX "BRIDGE OVER TROUBLED WATERS" FOR QUAD, but so far he has been reluctant to do so. This might seem out of character for a man so willing to experiment and try new techniques, but Halee feels the quality of quad is not up to par yet.

Further, he says he's like to get into miking and recording in quad, rather than just remixing.

"I don't care for drums in back of me, or swishing around. There are phasing problems."

"It seems to me the direction everybody is going now is to have completely isolated tracks, so you can place things in definite positions. I'd like to get into room

sound—dimension rather than directon. I feel a lot more experimentation is in order. Until I've done it, I'm not going to get into remixing old Simon and Garfunkel tunes. I want it to be good."

What about the controversy over more tracks, 24, 32, or more?

"The more the merrier," says Halee.

The technology doesn't seem to frighten him. He plays with it until he knows it well enough to master it. Like a dancer, he finds new movements through experimentation, and learns them well before performing them for the public.

The spirit, coordination, and balance are all there. The engineer is an artist. Roy Halee dances with his fingers.

END

# The Engineer

by Claude Hill

Chief Engineer  
Glaser Sound Studios  
Nashville

*The Engineer, it would appear*

*Must never, ever fail*

*To get the "take", or just one bar*

*Of the incessant wail*

*With all the flashing lights and knobs*

*His miracles perform*

*And with his wits, into Stars*

*These "Common Folk" transform.*

*I echo all your voices*

*And "overdub" the rest*

*And record for all posterity*

*The talent with which you're blessed*

*I "EQ" out shortcomings*

*And at the end of all the jive*

*I have to sit and hear you ask*

*"How'll we ever do it live?"*

# KEPEX AND GAIN-BRAIN AND THE CONCEITED CREEPIE-CRAWLIE

HEY, G & B, YOU'RE REALLY CATCHING ON!! PEOPLE ARE SAYING YOU REALLY TAKE CONTROL WHEN YOU WORK!!

AW... SURE I'M GOOD, BUT WHEW!! SOME OF THE THINGS YOU'VE DONE!!

EVERYWHERE I GO IT'S KEPEX! KEPEX! KEPEX!

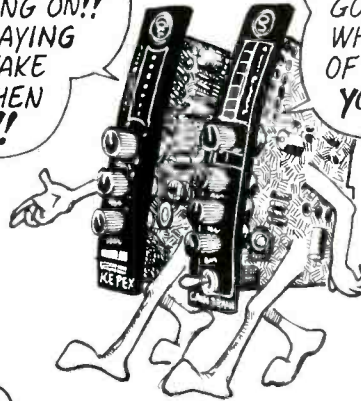

*Wanna (Kant)*

LOOK OUT!! IT'S A TARANTULA!!!

EEK!!!

HI FELLAS! I'M NEW! MY NAME IS VCA-1! I'M JUST WHAT THE WORLD HAS BEEN WAITING FOR! I'M A LOW NOISE, LOW DISTORTION VOLTAGE CONTROLLED AMPLIFIER!!

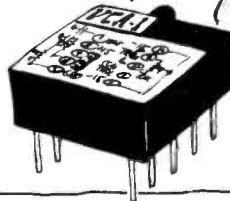

YOU WOULDN'T BELIEVE THE THINGS I CAN DO IN A RECORDING STUDIO! I'M ACCURATE TO WITHIN 1dB OVER A 60dB RANGE, MY NOISE IS AS MUCH AS 108dB BELOW MY +18dBm OUTPUT, MY RESPONSE IS FLAT TO BEYOND 100KHz...

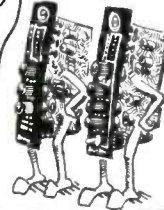

\* As seen in Good Housekeeping

WAIT A MINUTE! I'VE SEEN THAT L'L CRITTER IN ACTION! HE IS GOOD! XYZ STUDIOS ARE PUTTING IN A VOLTAGE CONTROLLED "QUAD" BOARD AND THEY GOT THEM VCA-1s ALL OVER TARNATION! SEEMS THEY'RE FIXIN' TO GO

COMPUTER MEMORY MIXDOWN SOON! MEANTIME THEY'RE DOIN' ALL KINDS OF HI-FALUTIN THINGS WITH VCA-1s! WHY, THEY'VE EVEN ONE KNOB THAT CONTROLS ALL THE LEVELS IN THE ENTIRE BOARD! KIND OF LIKE A 32 GANG SLIDER!!

ALAX RECORDING

THAT GUY SURE BRAGS A LOT FOR SUCH A LITTLE SQUIRT!

YEAH! DOES HE REALLY THINK ANYONE WILL BELIEVE THAT BUNK?

MY DISTORTION IS .1%, MY CONTROL SIGNAL REJECTION IS GREATER THAN 65dB, I CAN ATTENUATE OVER 100dB...



MY SUPPLY IS (AHEM) BI-POLAR

AND I DRAW ONLY 15mA



HEY KID... YOU WANNA BE A STAR? I MEAN REALLY BIG?

YEAH, TAG ALONG WITH US, WE'LL GET YOU INTO ALL THE BEST PLACES!!!

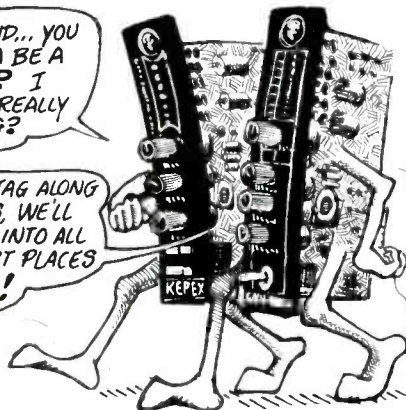

I'M HIGHLY RELIABLE, TEMPERATURE STABLE, I'M ONLY AN INCH SQUARE, AND MY LEGS ARE GOLD-PLATED!!

I COST ONLY \$50.00 (AS LOW AS \$27.99 IN QUANTITIES)

I'M REALLY WUNNAFULL!

BONA-FIDE AUDIO EQUIPMENT MANUFACTURERS ARE INVITED TO ORDER THEIR EVALUATION SAMPLE VCA-1 AT THE SPECIAL PRICE OF 20 BUCKS! (SORRY, AT THIS PRICE ONLY ONE TO A CUSTOMER. OFFER GOOD UNTIL DECEMBER 31, 1971. END OF FINE PRINT) WRITE FOR DETAILS TO EVERLOVIN!



ALLISON RESEARCH, INC.  
7120 SUNSET BOULEVARD  
HOLLYWOOD, CALIF. 90046

(213) 874-6615

Exclusive export agent:  
GOTHAM AUDIO DEVELOPMENT  
CORP., NEW YORK, N.Y.

Using a Bruel & Kjaer Type 3347 Real-Time 1/3-octave Analyzer, we plotted room response in some of the busiest recording studios in the country.

# Real proof, in real time, that a new order of quality is here.

Then we repeated the response measurements substituting a new Electro-Voice SENTRY IV speaker system for the existing studio monitor.

In every case the SENTRY IV was measurably flatter. Measurably wider range. Even where broad-band equalization had been attempted and was in use (versus the SENTRY IV unequaled).

But perhaps most impressive, the working studio engineers judged the SENTRY IV subjectively better sounding than the speaker systems they had been using for years. In every single studio!

There are a host of good reasons why, including lower distortion and outstandingly uniform dispersion from the first new sectoral horn design in 25 years. With response at 60° off-axis that is identical to on-axis performance.

Plus three new drivers, full-range horn loading, and a computer-aided design that led to more efficiency and higher power handling than any of the standard monitors.

You can read about SENTRY IV design in an AES paper reprint we'll send you. It was written by our Ray Newman (left) the man behind the SENTRY IV. We can also show you curves and specs that make impressive reading. And even better listening.

But we know you won't be truly convinced until you hear the SENTRY IV. That's why we're scheduling studio demonstrations now all across the country.

You can arrange an audition through your E-V sound specialist. Or write us today. But be prepared to accept a new standard in sound.

The Electro-Voice SENTRY IV monitor speaker system.



## Sentry IV Professional Monitor and Sound Reinforcement Loud Speaker

Response: 50 — 18,000 Hz. Dispersion: 60° x 120° from 600 to 15,000 Hz. Sound Pressure Level: 117 dB at 4' on axis, with 50 watt input. Dimensions: 27-3/4" w. x 20-5/8" d. x 50-3/4" h. as shown. Weight: 148 lbs. \$495.00 suggested professional retail net.

ELECTRO-VOICE, INC., Dept. 1111RP, 672 Cecil Street, Buchanan, Michigan 49107  
In Canada: EV of Canada, Ltd., 345 Herbert Street, Gananoque, Ontario  
In Europe: Electro-Voice, S.A., Lyss-Strasse 55, 2560 Nidau, Switzerland

**Electro-Voice®**

a GULTON subsidiary

# PHASE and the

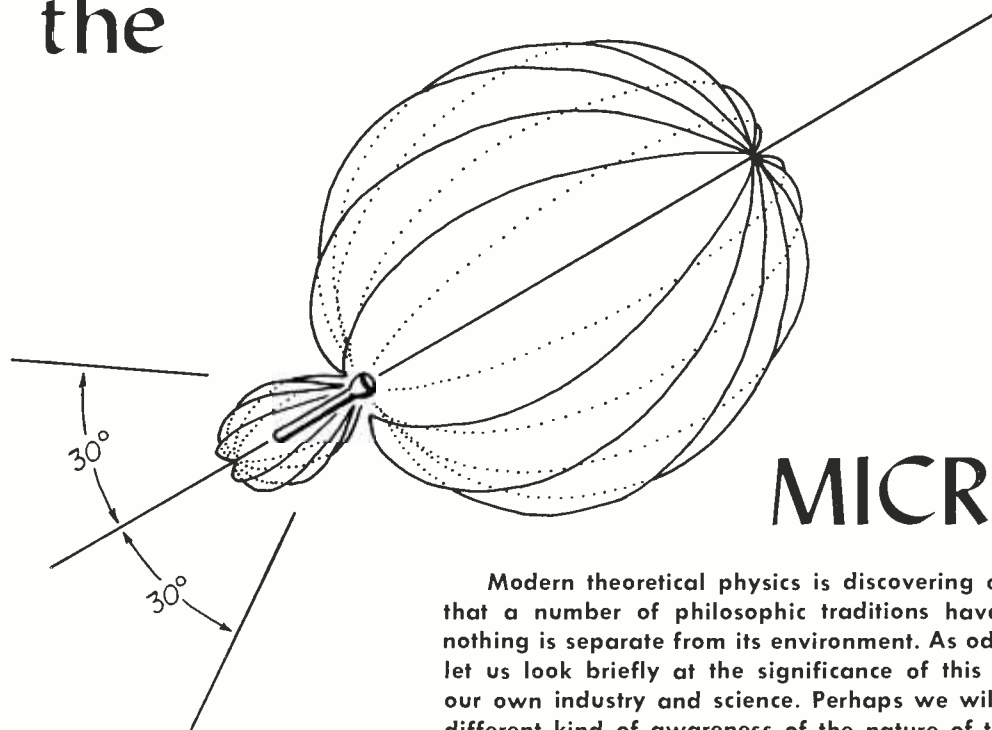

# SINGLE MICROPHONE

by Ron Malo

An electron, in a vastly oversimplified description, is a particle or wave-packet with a field that grows weaker as the distance from its "center" increases. This field, though it weakens quickly, is said to extend to infinity. Hence, every movement of an electron has an effect on everything else in the universe. In theory and in practice, there is no real difference between an electron and its field. Distinguishing between the two is merely a verbal convenience. An electron is its field.

What is true of the electron in this instance, is also true of the other constituents of matter.

The point of this brief discussion of elementary physical field theory is to show that, at a certain level of awareness, it is not possible to separate anything from its environment.

Why have we mentioned these things in an attempt to discuss something as comparatively mundane as microphones?

Modern theoretical physics is discovering over and over again something that a number of philosophic traditions have said for thousands of years: nothing is separate from its environment. As odd an approach as it may seem, let us look briefly at the significance of this principle, and then apply it to our own industry and science. Perhaps we will discover in such a principle a different kind of awareness of the nature of the complex device known as a microphone, and be able to use this new awareness to increase the quality of our recording. We are not going to produce any new facts about the nature of the microphone, though we may uncover a few little-known ones. We want simply to look in a new way.

The fact is that a microphone is not separate from its environment. In fact, it can be considered as carrying with it a field of receptivity, or sensitivity, that extends far beyond the apparent physical bounds of the microphone itself. Without an awareness of this "aura," or field, a microphone can only by chance be used to its best advantage. We call this aura a "pickup pattern," something we are all cognizant of whenever we use a microphone. Still, when we use one of these remarkable devices, we think of it as a solid, physical object, with a definite size and shape. Where the metal ends, the microphone ends. Yet this is true only in the most limited of senses.

If we can conceive of the microphone as a field, both in terms of its nature as energy, and in terms of its field of sensitivity, or pickup pattern, then perhaps we will not only be wiser in our use of it, but also more appreciative of the incredible nature of

the device itself.

Sound is one of many forms of energy, and consists essentially of the movement of atoms and molecules toward and away from each other. Just as pressure moves in waves in a tightly packed crowd of people, so sound moves through the air by passing energy on from atom to atom. The space in which these changes of pressure and energy take place is called a sound-field. The sound field expands at a rate of approximately 1100 feet per second, until it reaches the diaphragm of a microphone, at which point some of this energy is converted to its electrical equivalent. The field, of course, continues to expand past the microphone, but at the diaphragm a transfer of energy takes place.

If there happens to be more than one sound source, then a corresponding number of sound fields exist (reflections are considered sources). A microphone's characteristics are a

function of how it responds to sound fields, and to how it responds when placed at different positions in a sound field. If the sound field is unobstructed, such as in an anechoic (meaning *no echo*, or *no reflection*) chamber, its response characteristics will probably conform reasonably well to its published specifications. However, with the introduction into the sound field of the floor, walls, partitions, music stands, and the like, reflections begin to occur which cause phasing boosts and cancellations. Figure 1 shows a graphic representation of the effect of an obstruction in the sound field. Sound leaving the source S not only reaches the microphone directly, but also reaches it after having been reflected off of the nearby partition. This sound, having traveled a greater distance, is later in arriving at the microphone, and causes boosts and cancellations with sound having left the source somewhat later, but arriving at the diaphragm at the same time.

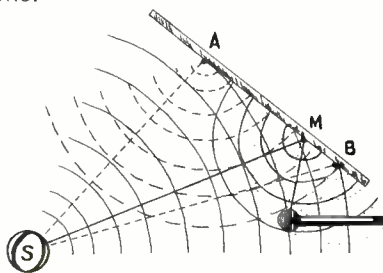

The problem of a partition: Sound source S produces a sound field. Reflections off the partition at A and B act as weak point sources, causing phasing effects when these sounds reach the microphone diaphragm after the sounds directly from the source. Maximum phase cancellations occur from the point M on the partition where the angle of incidence equals the angle of reflection.

To make this all a bit more practical, let's look at the use of certain types of microphones, the cardioid and super-cardioid, and see how they are affected by certain unwise techniques.

The drawing on the first page of this discussion shows the relative pickup pattern of a typical super-cardioid. Maximum sound rejection is  $\sim 150^\circ$  off axis, or  $30^\circ$  measured from the rear of the diaphragm.

Figure 2 shows three methods of miking a vocalist singing with a music stand. A number of recent studies have shown that very significant phase cancellations occur as a result of either of the first two methods, with the microphone at an angle from



Figure 2. Example A Example B Example C

the top or side. The stand is slicing through the microphone's pickup pattern or aura, causing degraded response. Reflections from the stand cause boosts and cancellations at many points between 20 and 20K Hertz of 20 db and more! These points shift back and forth every time the singer moves so much as a quarter of an inch. Perhaps the best way to describe the effect of this phasing is to describe it as giving a certain filtered effect to the sound quality. A good way to demonstrate this effect very clearly is with the use of a pink noise sound source (such as the tape available from Studio Engineering Consultants, 19123 Castlebay Lane, Northridge, Calif. 91324) played through a speaker placed where the singer would normally be. Moving the stand, microphone, or source will produce a swishing, filtering sound. This technique may be used with walls, stands, partitions, or any other similar obstruction. Perhaps a better method for miking a singer with a stand is shown in the third photograph. Placing the microphone just under the stand, and at right angles to the plane of the stand is also effective. The microphone used here is of the front-fire type (an Re-20). Of course, an even more ideal solution is to move the stand away a number of feet from the singer and microphone.

A similar problem exists in miking horn players. Often it is hard for them to hear themselves during a take with other instruments playing, and as a result they blow harder and less skillfully. A common solution is to have them blow into the hard side of a moveable partition, or even the control room window. While this is an advantage in some respects, it can be a disadvantage in others. If the microphone used is not placed exactly at a right angle to the plane of the partition or window, phasing degradation will again occur, and negate any advantage gained by placing the musicians in front of such a surface.

It should be noted here that all partitions can cause phasing distortions regardless of their padding. In fact the degree of boost and cancellation is almost exactly the same for padded and unpadded surfaces, the only major difference being in the absorption of high end information.

Consider again the field, the "aura" of a microphone. If anything is placed within this field, the response of the microphone is altered. If a plane, such as that of a wall or partition, slices through this field, particularly at an angle that destroys the symmetry of the field, significant degradation is going to take place.

The field of sensitivity shown around the microphone at the beginning of this article is of relative size, and purely conceptual. It shows only the response of the microphone to sound from various directions. The top lobe and bottom lobe have no definite size, although they do have relative sizes to each other. They are as meaningful at six feet as they are at ten inches. The full, undistorted sensitivity is, in fact, only valid in an anechoic chamber. Once out in the real world, the anechoic chamber immediately disappears with the existence of the ground, which alters the space around a microphone from the effective sphere of the anechoic chamber to the effective hemisphere of the air above the ground.



(continued on page 31)



# Seatrain session:

Marblehead, Mass. August 1971



**Producer George Martin: Engineer Bill Price**

**A 16-track Dolby recording**

 **Dolby Laboratories Inc.**

333 Avenue of the  
Americas  
New York NY10014

346 Clapham Road  
London SW9

Tiger Building  
30-7 4-chome Kuramae  
Taito-ku Tokyo

"Dolby" and  are registered trademarks of Dolby Laboratories Inc.

Circle No. 110

Re/p 19

# Altec introduces a 4-foot control console with up to 28 inputs and 16 outputs.

It's built to your specs...delivered ready to use.

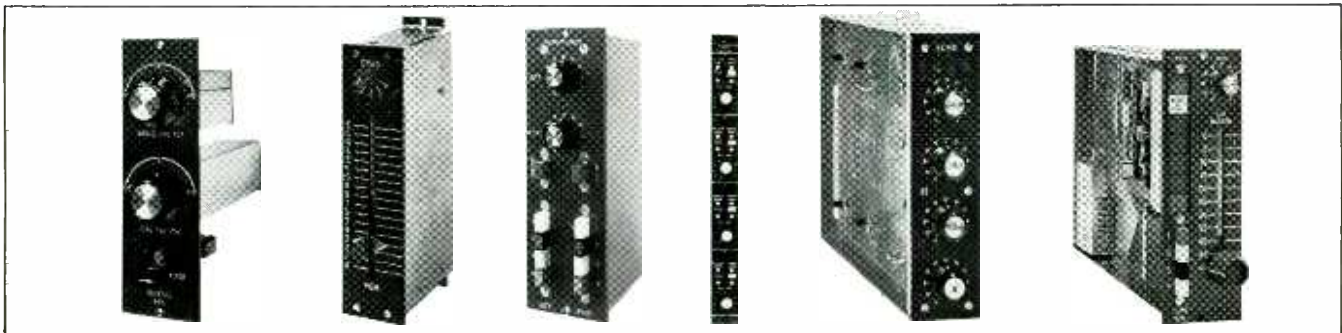

It's the all-new, all-solid-state Altec 9300A control console. Only 51½ inches long, it features direct-plug-in modular construction that lets you custom tailor your own board by simply selecting the specific modules you need.

The new Altec 9300A gives you up to 28 inputs and up to 16 outputs. And any input may be connected to any output by means of a switching matrix on each input channel.

Here are some exclusive features designed into the new Altec 9300A.

- Channel Check provides an individual instant check of all input lines without interrupting the program.
- A Pre Cue pushbutton transfers signals from the output buss to the cue buss.
- A Modulite<sup>®</sup> Visual Volume Level Indicator on each module tells exactly how much level is being fed to tape machines.
- Echo Facilities permit selection of internal or external reverb devices and a bright or soft timbre.
- Color-coded knobs enable fast and easy matching of input channels with correct output selector modules.
- 22 dB of headroom.

Mail this coupon for all the details on the new Altec 9300A console.

To: Altec Lansing, 1515 South Manchester Ave.  
Anaheim, California 92803.

Please send me all the details on the all-new Altec 9300A control console—including information on how its unique modular design will let me simply plug in different modules as I need them.

I'd like to hear more. Please get in touch with me.

Name \_\_\_\_\_ Phone \_\_\_\_\_

Position \_\_\_\_\_ Studio \_\_\_\_\_

Address \_\_\_\_\_

City \_\_\_\_\_ State \_\_\_\_\_ Zip \_\_\_\_\_



A QUALITY COMPANY OF LTV LING ALTEC, INC.

Hallelujah!

# 24 COMES TO L.A.

A great brooding hulk sits silently in the rear of the control room, awaiting the electronic command of Captain Nemo. A button is pressed at the control console, and two wide steel fingers slip quietly up from their repose beneath the surface of the now awakened beast. Another button is pressed; the nerve center is roused; colored lights flash on, and wave after wave of cosmic melodies flood the atmosphere.

Jules Verne would welcome the scene, but it is not his spirit that guides this event today, but that of George Fredrick Handel. The event is the recording of Handel's Messiah, and it is momentous in many respects. It is the premier appearance of MCI's 24 track recorder/reproducer on the west coast. It incorporates a 54 piece orchestra, a 32 voice choir, rhythm and solo instrumentalists, and a massive pipe organ in a Baptist church 22 miles from the studio. Further, this session is another in a growing genre of religious music: It is rock and roll.

Studio A at United Recording in Hollywood is the location, and at the controls is Michael Shields ("Captain Nemo" to friends and others alike), head of Nemo Productions. Shields, the owner of the MCI, is co-producing the session with Red Shepard, former star of the Los Angeles production of HAIR, and partner in Revelation Records



with HAIR producer Michael Butler.

The undertaking was a large one, both musically and technically. A total of 28 microphones were utilized in recording the fifty-four piece orchestra in the studio. A Class B telephone line carried the signal from the pipe organ at the Pasadena First Baptist Church. (Both Class A and B telephone lines are rated for 5K bandwidth audio transmission, the difference being in length of use. Class A is intended for full time use, while Class B is for occasional use.) The Class B line used, although rated at 100-5K Hertz, plus or minus 1 dB, had excellent response far beyond its stated limits, 10K Hertz being down only 2½ dB. Dolbies were used on both ends of the line to assure greater signal to noise characteristics. Phase shifts due to telephone company repeat coils, fortunately, were minimal.

The organist was provided with both a headphone mix of the orchestra as they played, and an open line intercom to Andrew Belling, the arranger and conductor.

Belling, seeming at times as good a stand-up comedian as he was a conductor, continually cracked the control room populace and the organist up with remarks (to the organist) such as, "You've got to get your part down — these are message units!" and, "Jim, we've got to stop meeting like this!"

(continued on page 31)

- ① BASS
- ② DRUMS, LEFT
- ③ DRUMS, RIGHT
- ④ DRUMS, KICK
- ⑤ GUITAR
- ⑥ PERCUSSION
- ⑦ TIMPANI
- ⑧ TUBA
- ⑨ TROMBONES
- ⑩ TRUMPETS
- ⑪ FRENCH HORNS
- ⑫ BASSOONS
- ⑬ CLARINETS
- ⑭ OBOES
- ⑮ FLUTES
- ⑯ QUAD AMBN. (R)
- ⑰ QUAD AMBN. (L)
- ⑱ ARCO BASSES
- ⑲ CELLI
- ⑳ VIOLAS
- ㉑ 1st VIOLINS
- ㉒ " "
- ㉓ 2nd VIOLINS
- ㉔ " "

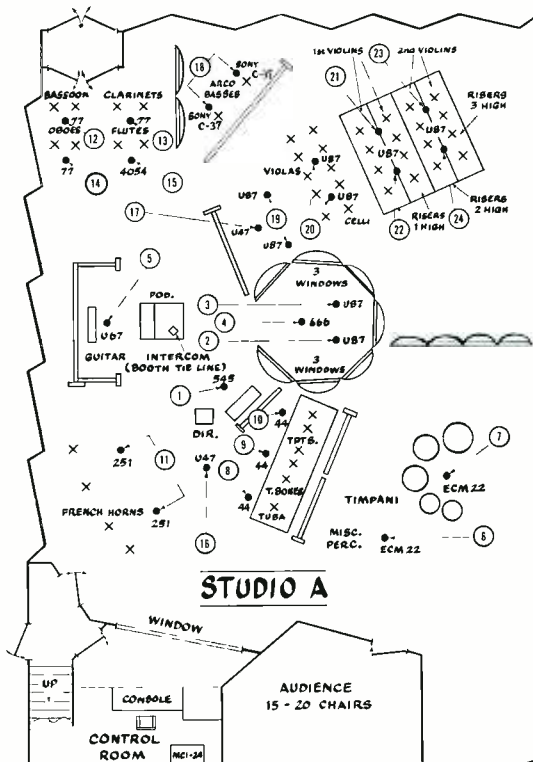

# Sony makes a case for its professional microphones.

Sony has six professionals ready to go to work for you. And each one is unqualifiedly the best microphone money can buy. Contact your nearest Sony/Superscope Special Applications Dealer or write: Sony/Superscope, 8132 Sunland Blvd., Sun Valley, Calif. 91352.

**SONY** SUPERSCOPE

A. ECM-53 CARDIOID CONDENSER: 40-16k Hz  $\pm 3$ dB; MAX. SPL: 126dB @ 1% THD; -53.2dB SENS. @ 250 $\Omega$  IMP. \$149.50.

D. \*C-500 CARDIOID CONDENSER: 20-20k Hz  $\pm 3$ dB; MAX. SPL: 154dB @ 1% THD; -50dB SENS. @ 250 $\Omega$  IMP. \$395.

B. \*ECM-377 CARDIOID CONDENSER: 20-20k Hz  $\pm 3$ dB; MAX. SPL: 140dB @ 1% THD; -49dB SENS. @ 250 $\Omega$  IMP. \$195.

E. ECM-50 OMNI LAPEL CONDENSER: 30-16k Hz; MAX. SPL: 126dB @ 1% THD; -53.2dB SENS. @ 250 $\Omega$  IMP. \$129.95.

C. \*C-37P OMNI/CARDIOID CONDENSER: 30-16k Hz  $\pm 2.5$ dB; MAX. SPL: 154dB @ 1% THD; -49dB SENS. @ 250 $\Omega$  IMP. \$325.

F. ECM-5\* TELESCOPIC OMN. CONDENSER: 50-16k Hz; MAX. SPL: 126dB @ 1% THD; -53.2dB SENS. @ 250 $\Omega$  IMP. \$129.95.

\*AC-148A PHANTOM POWER SUPPLY: 49 V.D.C.  $\pm 1$  VOLT, BUILT-IN CONNECTORS FOR 2 MICROPHONES. UP TO 10 ADDITIONAL MICS WITH EXTERNAL ADAPTORS. \$99.95.



Circle No. 112

©1971 Superscope, Inc. Prices subject to change without notice.

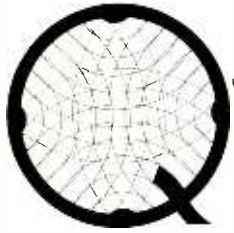

## SAN FRANCISCO:

# QUAD BROADCASTS AT PHR

At the board Phil Sawyer and Bob Shumaker are doing all the things recording engineers do during recording sessions. They are turning knobs, pushing sliders, adding echo, and listening carefully to the mix. Inside the studio, a group is wailing away. They're doing something live, an event which often occurs in recording studios, but there's a difference: three hundred people are in the studio with them, and another 30,000 are listening in their homes. The event takes place every Sunday night from six until nine p.m. at Pacific High Recorders, 60 Brady Street, San Francisco. An Electro-Voice encoder puts the whole event into Quad, and a stereo phone line carries the event to KSAN radio, where it is broadcast.

The broadcasts are the brainchild of Richard Olsen, general manager of PHR. He first started talking to people about his idea two years ago, but no one seemed very interested. His first contacts were with non-profit stations, but they seemed very tight-knit and none of the disk jockeys were particularly anxious to be pre-empted by a weekly concert. Olsen set the idea aside and pursued the task of running a recording studio. Then, a little over a year later, KSAN began doing occasional live concerts from their studios. Olsen gave them a call and invited them to use PHR's facilities, pointing out that they had a room 2500 feet square and an 18 foot stage. KSAN turned the offer down, saying they couldn't see the advantage of such a move. Again Olsen returned to other pursuits. Six months later, KSAN called Olsen, and without reference to Olsen's earlier call, said, "Why don't we do a show down at your place?"

Olsen, remembering the conversation, grins and says "Sometimes it happens like that. You suggest something, and they don't want to do it, then they come back at you and it's their idea."

Did the turn around bother him? "No," says Olsen, "As long as it happens."

It's been happening since the week after the Fillmore closed its doors. All the major groups have been coming by and playing, but thus far a great deal of the energy put into the project has gone uncompensated.

PHR pays ten people during the set up and broadcast, but receives no compensation from KSAN. Sponsors are still being sought, and until the show's popularity spreads a bit further, the income is minimal.

However, PHR's reputation is spreading. Groups that haven't known about PHR before find out about them when they play there. Several groups have recorded portions of albums during the broadcast. The cuts have all of the flavor of live concert albums: the audience re-

sponse, the spontaneity, the energy. The quality of the recording however, can be much more closely controlled than in a concert hall event. PHR gets \$300 per hour for 16 track recording of groups recorded live during these broadcasts, so there is money to be made in such a venture. It is hardly something out of the reach of any number of studios, large and small alike, across the nation. Quad is perhaps a bit of a luxury, but broadcast by a local station of mini-concerts originating in the studio of a recording studio is certainly feasible, offering advantages to both the studio and station, even if no money changes hands between the two.

PHR is now looking toward quadrasonic broadcast with video or film. They are also planning to cut the program down to about an hour, or perhaps change the format of the present one to include interviews. Olsen says he would like to see a "Rolling Stone of the air."

"You're entertaining when you're going over the air. The people in the studio might be feeling good, but you've got to make the people at home pick up on it. They've got to feel like they're right in it."

"The kind of thing you'd want to do is prepare the groups each week, beforehand. Get together with them and figure out what tunes they would play, and what questions the people would like to ask them. Open it up to more of an interview, where you can get more of a picture of what's happening."

"I think this would be really good for the artist, because here they are getting the kind of 'NOW' exposure that they can get on a record. A record is done and six months later it comes out. The group has already changed. Now they might have a whole new idea of

*(continued on page 27)*



# to all recording and broadcast studios

## THE SANSUI QSE-1 IS ALL YOU NEED TO ENCODE 4 FULL-FIDELITY CHANNELS — AND NOTHING ELSE.

Just add it to your existing equipment for instant conversion and here's what you have going for you:

(1) It yields **accurate** sound-source location in every direction for startling live-sound ambience.

(2) It's in broadcast and recording use **today** with outstanding results.

(3) A **complete** line of complementary Sansui home hardware is available now. In fact, thousands of Sansui decoders are in users' homes already.

(4) It's compatible with 2-channel stereo and other four-channel matrix systems.

To be more specific:

Its ingenious  $\pm$ "J" phase shifters completely eliminate the signal dropouts and shifts in sound-source location that plague other matrix systems. Its symmetrical treatment of all four channels can **accurately** pick up **and relocate in reproduction** any sound source over a full range of 360°—so there are no limits to total free-

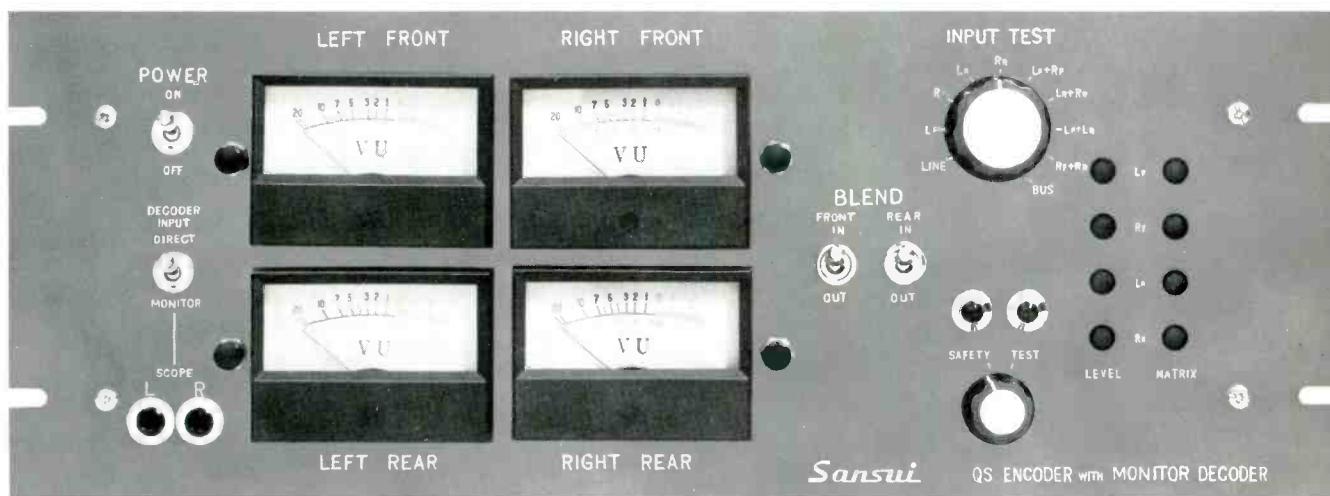

The Symbol of Sansui 4-Channel Sound.

dom and flexibility in using creative studio and psycho-acoustic techniques. And present standards of frequency response, signal/noise ratio and dynamic range are maintained.

It reproduces flawlessly on present two-channel stereo and monophonic equipment. And it will produce four-channel output not only through matching Sansui hardware, but through all other available decoders—and there are 600,000 of them world-wide today.

Thousands of them are Sansui QS-1 Synthesizer/Decoders that will decode it flawlessly. So will any of the full line of matching Sansui 4-channel receivers and converters for existing two-channel systems—made by the most respected name in stereo today throughout the world, and a recognized pioneer in four-channel sound.

Can you afford **not** to make this simple addition? Experiment with one right now. Learn what other recording and broadcast studios everywhere, now working with the QSE-1 Encoder, are finding out for themselves. Confirm their astonished conclusions.



For full details,  
contact your nearest Sansui office now.

### SANSUI ELECTRONICS CORP.

Sansui Electronics Corp.

New York

32-17, 61st Street, Woodside, N.Y. 11377. Tel.: (212) 721-4408. Cable: SANSUILEC NEW YORK. Telex: 422633 SEC U1.

Sansui Electric Co., Ltd.

Los Angeles  
Tokyo

333 West Alondra Blvd. Gardena, Calif. 90247. Tel.: (212) 532-7670.  
14-1, 2-chome, Izumi Suginami-ku, Tokyo 168, Japan. Tel.: (03) 323-1111. Cable: SANSUIELEC. Telex: 232-2076.

Sansui Audio Europe S.A.

Belgium

Diacem Building Vestingstraat 53-55. 2000 Antwerp. Tel.: 315663-5. Cable: SANSUIEURO ANTWERP. Telex: ANTWERP 33538.

Vernitron Ltd.

Germany, W.  
U.K.

6 Frankfurt am Main, Reuterweg 93. Tel.: 33538.  
Thornhill Southampton S09 5QF. Southampton 44811. Cable: VERNITRON SOTON. Telex: 47138.

Circle No. 114

Recording engineers must dream a lot. Visions of ever expanding systems that will make the studio work more smoothly are not often translated into tangible hardware because of cost, time, or space limitations in the overall studio operation. There is always a burden on the shoulders of proponents of any new additions of new hardware to somehow justify the increased cost and technical complexity of that hardware, especially when it does not relate directly to increased revenue. This discussion describes the advantages of converting to solid state switching systems, and a few possible methods of implementing that conversion.

# SOLID STATE SWITCHING

**Peter J. deBlanc**  
**Chief Engineer**  
**dB Associates**  
**San Francisco**

Solid state switching as applied to a recording studio will eliminate entirely the pops, clicks, noise, and contact problems that somehow always occur in even the best studios with the most sophisticated mechanical switches in their boards. Increased versatility is another factor, as the solid state switching and patching network can be controlled from several locations or consoles, as well as by a preset programming device, such as a punched card reader. Switching can take place while tape is running, with no danger of introducing annoying noise. Economically speaking, the inclusion of solid state switching into a system can be done at low cost (ranging from seven to twelve dollars per toggle function) and guarantees to increase client satisfaction dramatically both in terms of increased versatility and better noise characteristics during a session.

Recent developments in microcircuit technology combining with a general downturn in sales for several semiconductor houses have caused the necessary integrated circuits to become available at reasonable commercial prices. The development of the packaged monolithic integrated analog switch, or commutator, is of particular interest to today's recording engineer.

The circuit of figure 1 shows a standard J-FET circuit used in analog switching. The diode allows the gate drive signal to drive the gate negative and turn off the J-FET switch. When the gate drive signal goes positive the diode decouples the drive from the gate and resistor  $R_g$  discharges the gate/source capacitance.  $R_g$  must be large so it doesn't load the analog signal. Its value is usually between 100K and 1 Meg.

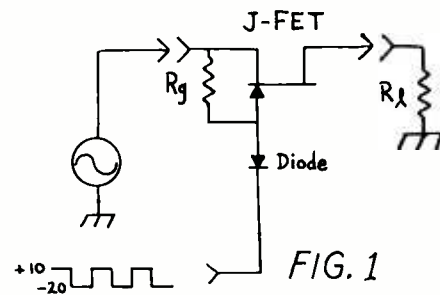
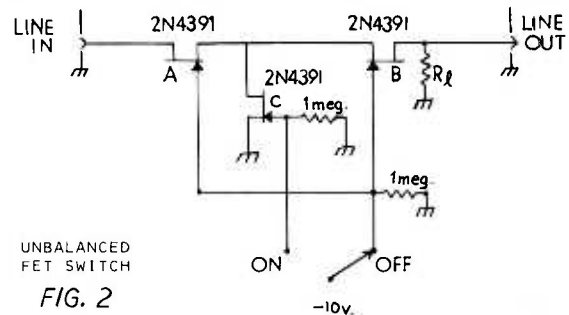

Figure 2 shows an actual discrete FET switch for unbalanced audio lines. FETs A and B act as series pass elements when turned on. FET C acts a shunt element when turned on. **On** resistance of the devices is about thirty ohms. This ratio will yield up to 100 dB of isolation with no tricky adjustments. The circuits can be built up on printed circuit cards and integrated into a system with little difficulty. Assuming size is not a problem, it will cost less to go with discrete components.



(cont'd)

Advancing the state of the art one step further results in the MOSFET circuit of figure 3. Here the FETS have been placed in a dual differential configuration. This is the method of switching balanced lines, especially at low levels, such as tape head inputs, sel sync systems, etc. Isolation is better than the possible dynamic range of any existing recording system in use today. Diode logic and additional biasing networks must be added to make this system operational. Some of the semiconductor houses are now supplying the complete switch module

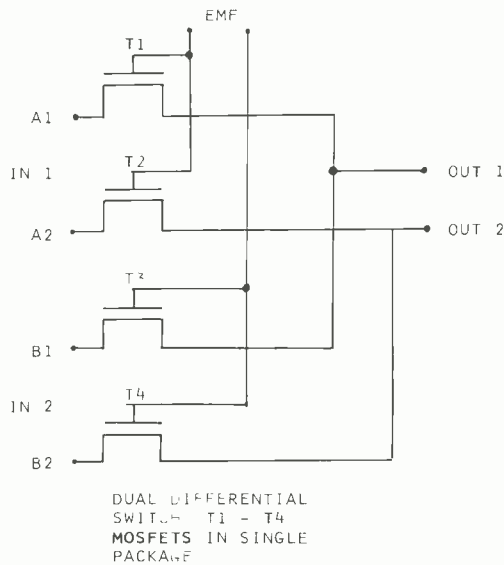

FIG. 3

with the necessary diode gating and dc biasing included in the same dual in-line or T O type header.

Figure 4 shows a completely packaged subsystem with all necessary biasing and gating. The particular circuit shown is the National Semiconductor NH 0014. The NH designation indicates that the device is a hybrid incorporating discrete chip transistors, resistors, etc., bonded to a single monolithic substrate. The devices are available in 14 pin dual in-line packages.

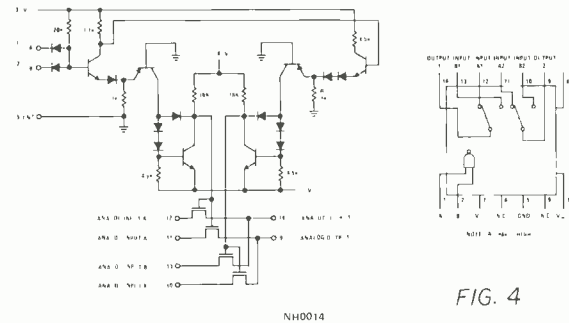
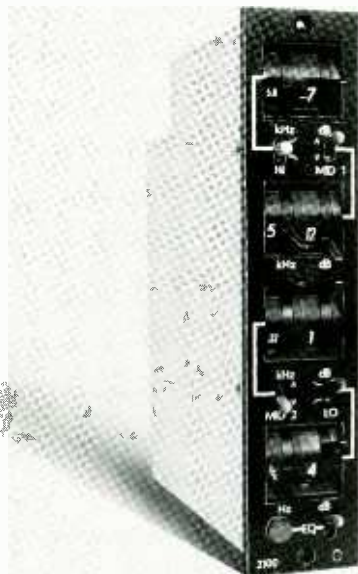

FIG. 4

The advantages of using the integrated MOSFET analog switches become more apparent as one considers the design flexibility of using diode matrices, digital logic, or programmed preset control of standard patching setups. The designing engineer need only configure the system as a finite series of single pole double throw toggles controllable by external application of power. In principal the MOSFET analog switch approaches the perfect relay: *high off* resistance, *low on* resistance, and consumes little power. The integrated circuit modules are then



## Whenever there is a need.

This is the Olive "motto". We live up to it in our constant attempts to push back the accepted frontiers of audio technology. In fact, Olive products represent a whole new concept in audio engineering excellence. Take a close look at our Series 2100 Equalizer for example. Notice the 4 sections. All capable of independent action. There are two mid ranges and a total of 48 frequencies to choose from. Just wait until you experience the speed of set up and feel the smoothness of lever actuated switching. There's no need

to compromise when the natural frequency range of any instrument can be located and brought out where you can really get at it. Quickly. Using only 1 section you can create 300 separate effects. Imagine how many effects you can get with all 4. Designed to answer any need, the 2100 Equalizer is available as you see it here or as a very important part of the Olive Console. Before you are sold on just any equalizer try the Olive 2100. We'll let the product sell itself. Specifications are available on request.



Olive Electro Dynamics Inc  
2670 Paulus  
Montréal 386, Québec  
Canada  
(514) 332-0331  
Cable OliveI, Montréal

Westlake Audio Inc  
6311 Wilshire Blvd  
Los Angeles, California  
90048  
(213) 655-0303

Harvey Radio Company  
444 Madison Avenue  
New York, N.Y.  
10022  
(212) 582-1500

Studio-Technique  
4 avenue Claude  
Vellefaux  
Paris (10e) France  
206-15-60/208-40-99



inserted into the system, and control is handled in any convenient manner. Duplicate control consoles operating the same patch or mixdown switching systems can exist side by side or in different rooms. The use of DC controlled switches makes this system state of the art. Flexibility rules out obsolescence, and technical excellence increases client respect. Simplicity of application enables any engineer to "get his feet wet" in solid state switching immediately. Try it. END

(continued from page 23)

what they want to be saying, and it might not agree with what they said then. This is the opportunity to get up on the speaker's platform and talk to 30,000 people."

Such is Olsen's perspective on the broadcasts. PHR offers a valuable outlet for performers' ideas and music.

Their biggest problem seems to be in getting performers to show and set up on time. They don't seem to realize that even though they are in a recording studio where time usually isn't that important, there is a broadcast scheduled for a specific time, and they must be ready.

The programs are receiving increasingly enthusiastic reviews, and the broadcast quality measures up to album standards.

No one knows yet where the ongoing fusion of the many communications arts will end, if indeed it ever will. In San Francisco, quadrasonic broadcasts of live concerts is a reality. Since the broadcasts are compatible with stereo and mono receiving systems, everybody benefits from the energy PHR and KSAN toss into the air. Perhaps their enthusiasm will be contagious. END

## Book Review

**Wide Screen Cinema And Stereophonic Sound**, Michael Z. Wysotsky, Communications Arts Press, 282 pages, \$15.00.

Remember the days before stereo, when everything was done in mono? Well, technology marches on, and before long, we may even extend stereo to the stage and public address systems. Perhaps even the opera would consent!

It's been done before, you say? Right you are! The first time (that we know of) was in 1881, by a Frenchman, Clement Ader. He set 12 microphones near the footlights at the opera, with headphones provided for the audience, the left earphone connected to the left hand microphones, and the right earphone to the right hand microphones. Stereo opera in 1881! It's enough to make a grizzled gray-haired engineer feel like he's still wet behind the ears!

That little fact, and a wealth of others, as well as a detailed, excellent discussion of American, Russian, and world wide film and recording techniques, are part of a marvelous new book titled **WIDE SCREEN CINEMA AND STEREOPHONIC SOUND**. It's authored by Michael Z. Wysotsky, Deputy Chief Engineer of the Mosfilm Studios in Moscow. Its 282 pages are well worth its price tag of \$15. Copies may be ordered through Re/p. Send check or money order for \$15.00 plus 35¢ postage (\$15.35) to: Recording Engineer/Producer, Dept. M, p.o. box 2287, Hollywood, California, 90028. This same publisher has some other promising titles in the works. We'll keep you posted.

# \$249<sup>00</sup> KIT

## 6 CHANNEL STEREO MIXER—MODEL SM-6

A professional 6 channel stereo mixer at a price everyone can afford. Noise—127 dbm. Output +20 dbm into 600 ohms. Integral VU meters. Switchable mic preamp gain. IC circuitry. 117 VAC or battery operation. Rack mount or table top. Stack for additional inputs. Switchable low frequency rolloff. Allen Bradley pots. UTC and Triad transformers. Centralab switches. COMING SOON: companion plug-in 6 channel equalizer and plug-in echo unit. Available prewired @ \$499.00. See your dealer or order direct postpaid from Prokit.

PROKIT DIVISION, GATELY ELECTRONICS

57 WEST HILLCREST AVE. • HAVERTOWN, PA. 19083 • 215-446-1415

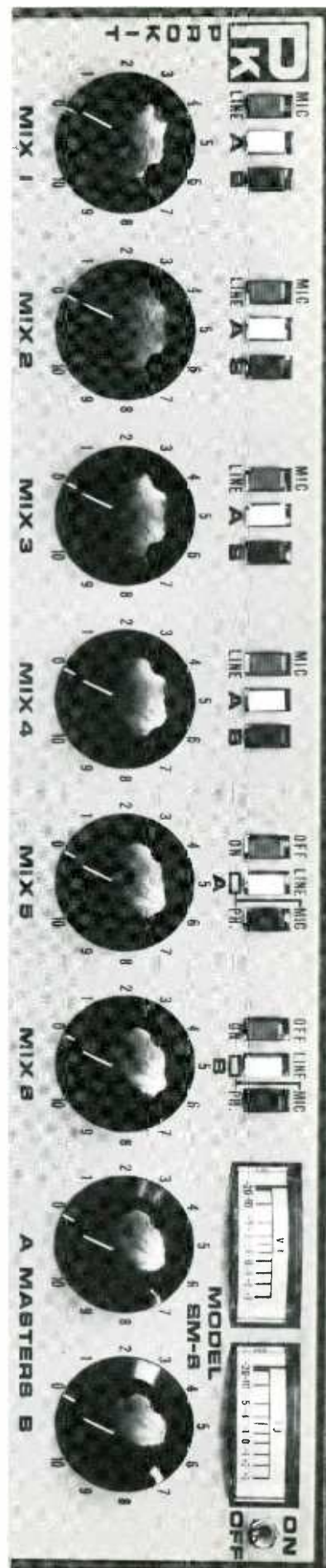

# total tape duplicating with "BUILDING BLOCK" simplicity

## CASSETTE TO CASSETTE, REEL TO CASSETTE, REEL TO REEL

The Telex series 235-1 is more than just another tape duplicating system. It is a concept based on modular "building blocks" which complement each other and provide total flexibility for tape duplicating. It solves the problems of interfacing between open reels and cassettes. It is a system designed for future expansion. Engineered to make tapes of true, professional quality. And it's priced within your budget.

The Telex system consists of only five basic units.

1. Solid state modular electronics containing amplifiers, meters and controls. This unit works with any combination of ten cassette or reel slaves.
2. Cassette master play transport.
3. Open-reel master play transport.
4. Cassette slave record transport. Records three cassettes simultaneously.
5. Open-reel slave record transport.

The five units are totally compatible. Intermix cassette and open-reel master or slave transports to suit your duplicating requirements; cassette to cassette, reel to cassette, reel to reel, or even cassette to reel. All units fit into table top consoles of uniform size so when your requirements change, you just add more units. It's that simple. Telex series 235-1 is heavy duty equipment with hysteresis synchronous motor tape drives, momentary push button controls and time delay circuits for smooth, positive tape handling. Selected premium grade duplicator heads provide long life and excellent frequency response. And fail safe, automatic features enable non-technical personnel to operate the system efficiently. Telex "building blocks" make a totally flexible and complete duplicating system. It's the sensible approach, designed to meet your needs today, next month and in the years to come. Made in the U.S. to professional standards.

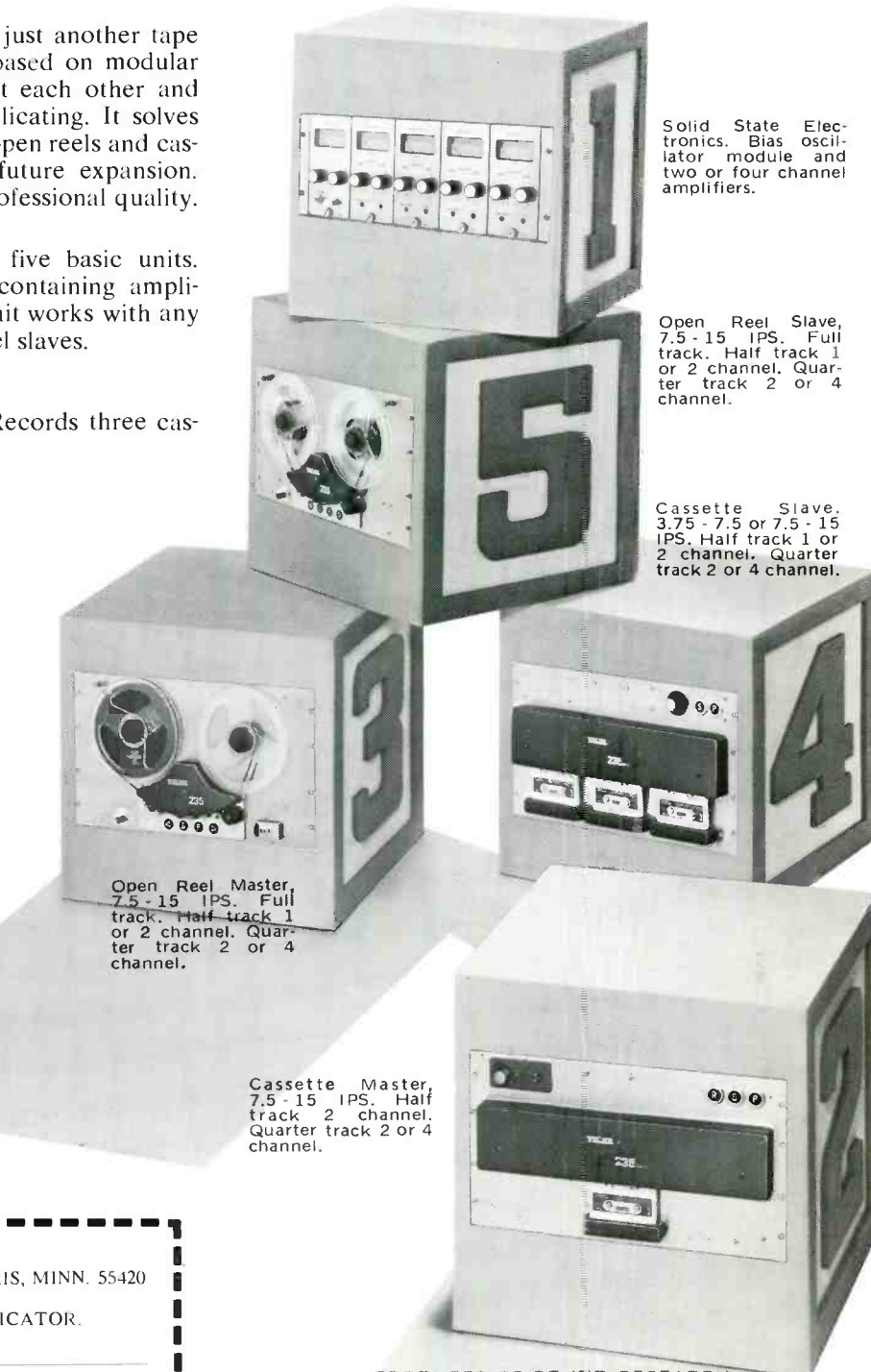

Solid State Electronics. Bias oscillator module and two or four channel amplifiers.

Open Reel Slave, 7.5 - 15 IPS. Full track. Half track 1 or 2 channel. Quarter track 2 or 4 channel.

Cassette Slave. 3.75 - 7.5 or 7.5 - 15 IPS. Half track 1 or 2 channel. Quarter track 2 or 4 channel.

Open Reel Master, 7.5 - 15 IPS. Full track. Half track 1 or 2 channel. Quarter track 2 or 4 channel.

Cassette Master, 7.5 - 15 IPS. Half track 2 channel. Quarter track 2 or 4 channel.

TELEX COMMUNICATIONS DIVISION  
9600 ALDRICH AVE. SO. • MINNEAPOLIS, MINN. 55420  
REP  
PLEASE SEND INFORMATION ON DUPLICATOR.

NAME \_\_\_\_\_

TITLE \_\_\_\_\_

INSTITUTION \_\_\_\_\_

ADDRESS \_\_\_\_\_

CITY \_\_\_\_\_ STATE \_\_\_\_\_ ZIP \_\_\_\_\_

PRODUCTS OF SOUND RESEARCH  
**TELEX**<sup>®</sup>  
COMMUNICATIONS DIVISION

9600 ALDRICH AVENUE SOUTH • MINNEAPOLIS, MINNESOTA 55420

CANADA: DOUBLE DIAMOND ELECTRONICS, LTD., 34 Progress Avenue, Scarborough 4, Ontario  
EXPORT: ROYAL SOUND COMPANY, INC., 409 North Main Street, Freeport, N.Y. 11520

# FIGHTING MURPHY'S LAW

**A column of tips and techniques to aid in the struggle against the physical principle, "If anything can go wrong, it will." (Murphy's Law)**

*(The second in a continuing series of articles conceived and executed in the ever-growing quest to bring the great whiskey-drinking Irish demi-god down from his throne of cosmic practical jokery, and thus ease the tensions and anxieties of a world plagued by a myriad of presently unavoidable petty annoyances.)*

MURPHY HAS MANY AGENTS IN THE RECORDING INDUSTRY WHO OBEDIENTLY CARRY OUT HIS EVIL WILL. Foremost among these are a strange band of men known commonly as MUSICIANS. One thing musicians do best when they are working in studios is STEAL HEADPHONES. One could always assign a bodyguard (phoneguard?) to each headset, but this could run into dollars and union difficulties. There is another solution which is rather elegant in its simplicity. It comes to us from the folks at CRYSTAL INDUSTRIES in Hollywood:

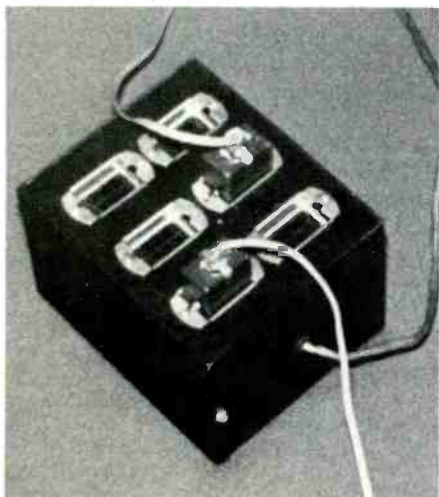

Remove the standard phone plug used with earphones, and replace it with an off-beat connector, such as an 8-prong Ilco. Use its female counterpart for your junction boxes. This is the primary solution. A secondary

one, which may be used in conjunction with the first, is to equip each headset with a label reading: "CAUTION: VOLTAGE STABILIZED — USE ONLY WITH SELF-REGULATING TRANSVERSE CURRENT SOURCE".



Both of the elements will combine to convince the potentially crooked musician that this headset is a strange and unusual beast, unsuited for home use. A sample of the label is included. Cut it out, take it to a nearby "Instant Printer", and have 40 or 50 printed from it. It should then look very official, and cost only about \$5. One caution however: don't leave this article lying around for the eyes of idle musicians to gaze upon. If someone should ask the meaning of the sign, mumble almost incoherently that it has to do with impedance matching of large numbers of headsets being used simultaneously, and the modification to the Voltage Stabilized mode cost *all* too much, and of course made the headsets utterly unusable for anything else.

Also, if you have the time and a little energy, two of the extra pins on that 8-prong plug could be used as part of a continuity system to set off a buzzer whenever a headset was unplugged from its junction box. (Use spare plugs to fill sockets that are unused).

AVOIDING THE UNDERFOOT JUNCTION BOX CRUNCHING SYNDROME: Ever notice how remarkably accurate

a musician's foot can be at stepping on an earphone, microphone, or other junction box on the floor? There's an easy and relatively inexpensive solution, which may even help avoid a nuisance suit if that same musician falls on his nose. It comes to us from the gentlemen at MYSTIC SOUND STUDIOS in Hollywood:

Mount the junction box on the upright of a small microphone stand. This sets it up off of the ground and makes it next to impossible to be crushed. Someone will undoubtedly try, but this will at least make it difficult.

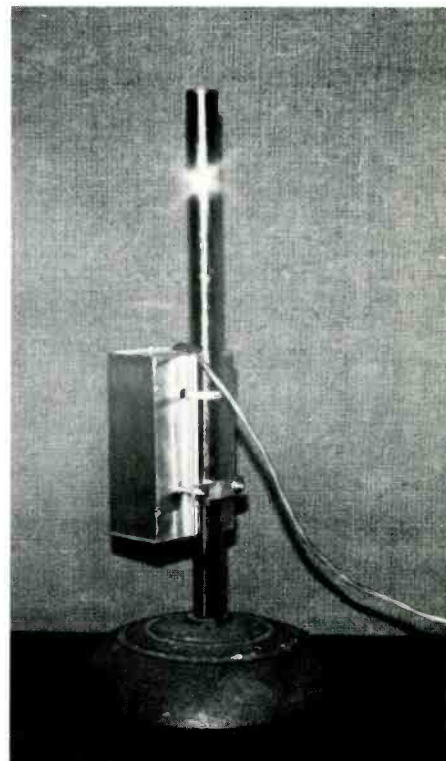

A further hint to spruce it up a bit, might be to mount a 10" circle of 1/2" wood on the top of the stand, (to prevent anyone's being impaled), and paint the whole affair a bright color that contrasts with the floor.

*(cont'd)*

EVER HAVE THE DESIRE TO BACK TIME A TUNE FOR EDITING PURPOSES? Here's a handy little hint from GLOBE MUSIC in Hollywood (Hollywood again! Are the rest of you guys going to let Hollywood show you up on tips and techniques? Let's hear from you, America!). It is familiar to many engineers in the radio biz, but is less well known in the recording industry:

A tape on a tape recorder will go backwards if you thread it past the heads as usual, than on the OUTSIDE of the capstan, around the TOP of the pinch wheel, and then to the pick up reel. When you press the play button, PRESTO!, it goes backwards. A drawing is included below:

HAVE YOU DONE YOUR PART YET in the never ending battle against the forces of the infamous Murphy? Now is the time for all good men to send us their tips and techniques. Help your fellow engineers and producers as they struggle daily against incompetence and cruel fate. If you have a trick or two to offer in the cause, send it along to us, and include a picture or diagram if you can. We'll even pay \$10 apiece for every one we print, and mention who it came from (Just think! A chance to be famous!) Write: FIGHTING MURPHY'S LAW, c/o RECORDING ENGINEER/PRODUCER, P.O. Box 2287, Hollywood, California, 90028. FIGHT ON!

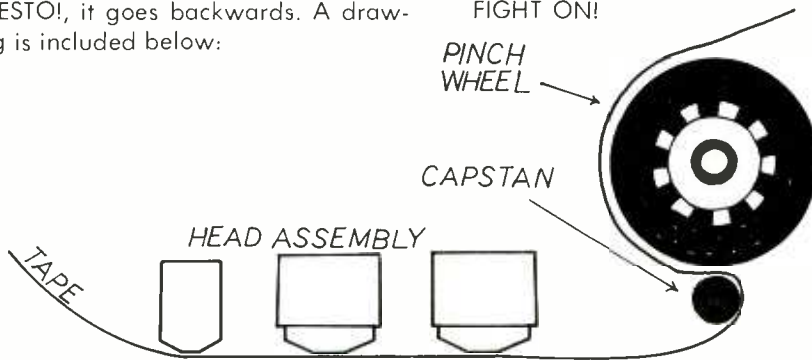

(Continued from page 9)

FOR YOUR INFORMATION . . . The Department of Music Education at the University of Miami offers a Music Merchandising degree Program leading to a Bachelor of Music in Music Merchandising (B.M.M.M.). The program includes courses in general education, music, business, and music merchandising, and offers an "interning" program during the second semester of the senior year, in which the student goes to work for a firm in the field.

The ten areas of the business studied in major course are: 1) U.S. Copyright Law, 2) Published Music, 3) Books and Magazines dealing with music, 4) Teaching of music, 5) Recorded Music, 6) Performed music, 7) Musical instruments, 8) Musical reproducing instruments 9) The music store, 10) Non-commercial music and music promotion.

The University of Miami is the only institution of higher learning to offer this degree. For further information write Dr. Alfred Reed, Director, Music Merchandising Program, School of Music, University of Miami, P.O. Box 8165, Coral Gables, Florida, 33124.

Even the simplest synthesizer can produce sophisticated modulation of amplitude. Now you can expand the capabilities of your synthesizer to include modulation of time, frequency and phase. The Type 968 delays an audio signal in time. This time delay can be continuously varied from 50  $\mu$ S to 3 mS manually or with a control voltage from your synthesizer.

**TYPE 968 PHASE SHIFTER**

CONTROL SENSITIVITY: NORMAL, ZERO, MAX

VOLTAJE (CONTROL VOLTAGE)

DELAY (MS)

POWER: ON, OFF

COUNTRYMAN ASSOCIATES  
AN INDEPENDENT OIL-IMPREGATED CARBON

Isn't it time you asked for complete information on the Type 968?

**COUNTRYMAN ASSOCIATES**  
424 University Avenue  
Palo Alto, California 94301

Circle No. 118

**MORLEY KAHN HEADS DOLBY NEW YORK OFFICE.** Dolby Laboratories has appointed Mr. Morley Kahn to the position of Vice President and Manager of U.S. Operations. Mr. Kahn will be the main contact in the U.S. for all of the company's customers, licensees, and the press, although his primary responsibility will be the sale and distribution of Dolby professional products. Mr. Kahn will be supported in his new post by Mr. Marc Aubort, Vice President and Technical Manager for the U.S. office.

The addition of Mr. Kahn to the staff of Dolby Laboratories is expected to increase the effectiveness of the company's services to manufacturers in the consumer audio field, many of whom are based in the U.S. Although the largest part of the company's activities continues to concern the manufacture and sale of professional products, the number of Dolby licensees in the consumer field now exceeds 70 names.

In the professional field, the U.S. market is to be further developed in the area of multi-track recording and in new applications of the Dolby Noise Reduction System in FM broadcasting and the motion picture industry.



Example A

Example B

Example C

Add to this automatic difficulty that of the walls and ceiling of the studio, plus any interfering planes of partitions or music stands, and some significant problems appear. Front to back isolation, such as in a cardioid, may drop from 20 dB to 6 dB or less. Further, once one has reached the final stage of the mix, the aberrations of microphones add to each other electrically.

Referring once again to the drawing on page 17, we may, keeping in mind the "aura" of the super-cardioid, see a reasonable solution to the age old problem of miking a singing guitarist, and retaining separation.

For the purpose of separating voice from guitar, example A above is the worst possible method of miking. The guitar mike hears almost as much voice as it does guitar, and vice-versa. Examples B and C are equally good solutions to each other. In B, neither voice nor guitar are exactly on the 150° rejection line of the opposite mike, but both are right on the axis of their own. In example C, neither voice nor guitar are exactly on their own axis, but **are** on the rejection line of the opposing mike.

No ultimate solution exists. However, the knowledge that recording requires a great awareness of *environment* is certainly a good beginning.

A microphone is not separate from its environment. It does not end where the metal ends. It is a good and valuable thing to seek out and discuss the practical difficulties of recording and recording techniques. Yet it is the continually broadening awareness of the interrelatedness of all things that moves any science forward.

END

*Continued from page 21*

The accompanying studio layout shows the positions of the various instruments in the orchestra, as well as the microphones used, and their console assignment. It will be observed that a room within a room was built for Hal Blaine and his drums. "Hal's Place," as it was called, was constructed from seven moveable partitions, six of which had windows, allowing him to see and be seen. Stereo, rather than close miking, was employed.

After the orchestral portions of *The Messiah* were recorded, various solo instruments and percussion were added. Finally, the choir, under the direction of UCLA's choral director Donn Weiss, put the vocals on tape, and the entirety was mixed down.

The track assignments, which of course were different from the console assignments, were as follows:

- 1) Fender bass
- 2) Top drum left

- 3) Top drum right
- 4) Bass drum
- 5) Guitar (overdub)
- 6) Percussion
- 7) Trombones & Tuba
- 8) Double reeds
- 9) Violins
- 10) Violas
- 11) Celli
- 12) Arco basses
- 13) Trumpets
- 14) Misc. overdubs
- 15) French horns
- 16) Flutes
- 17) Rear ambience left
- 18) Rear ambience right
- 19) Pipe organ left
- 20) Pipe organ right
- 21) Choir left
- 22) Choir right
- 23) Soul choir
- 24) Choir left & right

The entire project was completed in one month, and Revelation expects to have the album available shortly. Meanwhile, Nemo, the one man floating recording studio, has taken himself and his machine on to other projects.

END

1971 Brigham Young University

### AUDIO RECORDING SEMINAR COURSE OUTLINES

Limited Number Available — 30

250 pages, plus binder

**\$16.50 post paid**

Send check or money order to:

DEPT. BYU,  
RECORDING engineer/producer  
BOX 2287  
HOLLYWOOD, CA. 90028

### Available Now: PINK NOISE TAPE

Make frequency response measurements under actual operating conditions. 28 1/3-octave bands from 40 Hz to 15 KHz.



\$9.95 plus 50¢ mailing and handling  
California residents add 5% tax

STUDIO ENGINEERING CONSULTANTS

19123 Castlebay Lane  
Northridge, CA 91324

Enclosed is payment for: PNNT 1 1/4" Full  
Track 15 ips Tapes

Name:

Address:

City

State

Zip

for that heavy studio sound!

## LA-3A leveling amplifier

The great one with the  
Electro-Optical attenuator

- Half rack size
- High output (+25 dBm)
- Low price (under \$400.00)

See your dealer or write for complete specifications

11922 Valero Street, No. Hollywood, California 91605  
(213) 764-1500  
Exclusive agent:  
GOTTING ALLOY DEVELOPMENT CORP. NEW YORK, NY  
Telex # 335333 GADC GR

Circle No. 119

Re/p 31

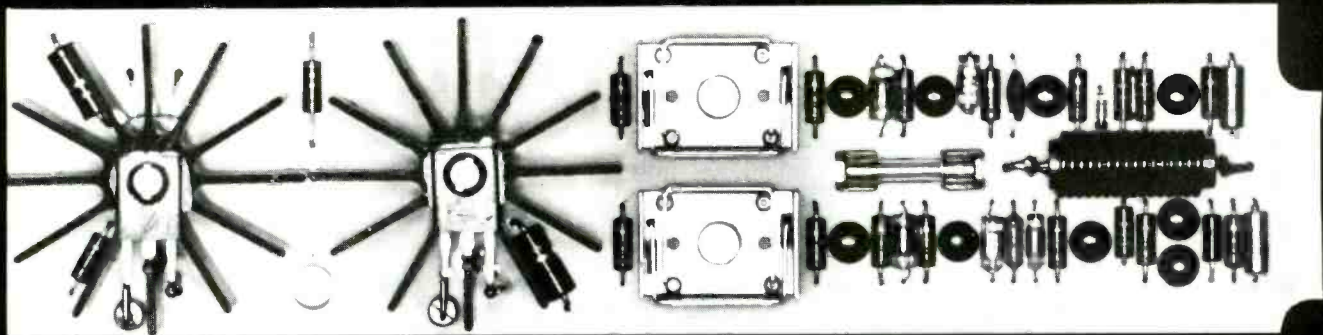

Today's requirement for hi-power/hi-intensity sound cannot be accomplished with yesterday's amplifier. Today you will need the amplifier of today!

The all new SPECTRA SONICS Model 700 Amplifier is . . . . **Beyond the State of the Art**

- **New Specifications . . .**
  - Continuous Power Output . .** 60 watts RMS delivered to a load
  - Bridged Configuration . . . .** (2 amplifiers) 120 watts RMS delivered to a load
  - Power Response . . . . .** Within  $\pm .1$ dB, DC to 20kHz into 8 ohms at full output
  - Total Harmonic Distortion . .** Unmeasurable—less than 1/100th of 1% DC to 20kHz at full output
  - Signal-to-Noise . . . . .** Better than 100dB below 30 watt unweighted, 20Hz to 20kHz typically better than 120dB
  
- **New Flexibility . . . . .** A modular design concept, the SPECTRA SONICS Model 202PC Card Holder offers flexibility of design for bi-amp, tri-amp, quad-amp or multiple speaker installations. Modular additions in the field can be accomplished with ease for upgrading to higher power requirements. Less mounting space is required. Eight Model 700 Amplifiers mount in 3½" of rack space. The total result is less cost per unit and overall savings.
  
- **New Crossovers . . . . .** The SPECTRA SONICS Model 505 Electronic Filter improves the damping factor and eliminates inductive and capacitive reactance loading on power amplifiers. An additional bonus of the Model 505 Filter is reduced weight, no iron core inductor, and no power loss. More power is transferred directly to the voice coil. Each Model 505 Filter has two inputs and four individual outputs, and is available in all standard crossover frequencies.
  
- **Outstanding Results . . .** In just a few short months the list of satisfied users of SPECTRA SONICS sound has grown. It now includes many of the leaders in recording studio, and performing art centers around the world. London Decca, Vienna — Toronto Pavilion, Canada — Blossom Center, Ohio — Hollywood Bowl, California — National Public Radio, Washington, D.C. — Denver Symphony, Colorado — Motown Record and Larrabee Sound, Hollywood, California.

To obtain additional information contact SPECTRA SONICS at 770 Wall Avenue, Ogden, Utah. 84404 or 6430 Sunset Blvd., Suite 1117, Hollywood, California 90028

**SPECTRA SONICS**

LEADER IN ADVANCED TECHNOLOGY



# NEW PRODUCT

## NEWS



CROWN ANNOUNCES 150-WATT STUDIO MONITOR AMPLIFIER. DUAL-CHANNEL MODEL D-150. Guaranteed minimum-performance specifications: 150 watts r.m.s. both channels at rated distortion with 8-ohm load (typically 100 watts per channel at 8 ohms, 180 watts per channel at 4 ohms). Frequency response:  $\pm 0.1$ dB, 20-20,000Hz at 1 watt. Phase response:  $\pm 15^\circ$ , 20-20,000Hz at 1 watt. Power bandwidth:  $\pm 1$ dB, 5-20,000Hz

at 75 watts. Distortion: IM—less than 0.05%, 0.01 watt to 75 watts harmonic—less than 0.05% at 75 watts. S/N: 100dB below 75 watts r.m.s. output. Separation: better than 90dB, 20-20,000Hz. Damping factor: greater than 200, zero to 1000Hz. Input: impedance 25K ohm adjustable, sensitivity 1.2V for full output,  $\frac{1}{4}$ -inch phone jack input. Protection against shorts, mismatching and open circuits, safe with all loads. Construction:

100% American-made to professional standards for continuous commercial use. Warranty: 3 years on all parts, labor and round-trip shipping. Weight: 20 lbs., rack mount 24 lbs. Dimensions: 17" w x 5 $\frac{1}{4}$ " h x 9" d with front panel (rack mount for standard 19" rack).

Price: \$399 without panel, \$429 rack mount. CROWN INTERNATIONAL, BOX 1000, ELKHART, INDIANA 46514.

Circle No. 121



GATELY ELECTRONICS ANNOUNCES THE PROKIT SM-6 STEREO MIXER KIT, the first of a series of professional audio products to be made available in kit form. The latest state of the art Integrated Circuit technology has been utilized throughout. All components are of American manufacture and professional quality. Pots are by Allen Bradley, transformers by UTL or Triad, XLR connectors by Switchcraft, and push button switches by Centralab. The printed circuit card is of the G-10 glass epoxy type.

The kit has been designed for ease of assembly. The very latest kit techniques have been utilized. All integrated circuits are plug in mounted to minimize servicing and trouble shooting problems. Kit and factory

wired units have identical performance specifications.

The SM-6 Stereo Mixed Kit is intended to serve as a professional system for remote or studio recording, and sound reinforcement mixing. Its low price tag however, will put it within the reach of many advance audiophiles.

The SM-6 Stereo Mixer Kit will mix up to six signals simultaneously. Any input can be switched between line or microphone function. In addition inputs 5 and 6 can be switched to function as RIAA phono preamps. Input 5 is permanently assigned to output A, input 6 to output B; however, the other four inputs can be switch assigned to either output A, output B,

or both outputs A and B simultaneously. Provision is incorporated to switch the microphone preamps into either high or low gain mode to accommodate all types of microphones. To minimize room rumble and feedback effects, a low cut filter may be switched into any input circuit by means of a rear panel mounted switch.

If more than 6 inputs are required in a particular application, then two or more APROKIT SM-6 Mixers may be stacked by plugging them together to yield 12, 18 or even more inputs. Kit \$299.00—wired \$499.00.

Additional information can be obtained by contacting Al Klase, PROKIT DIVISION, GATELY ELECTRONICS, 57 W. HILLCREST AVENUE, HAVER-TOWN, PA. 19083, 215-446-1415.

Circle No. 122

← Circle No. 120

# Put an AKG on the job.



**D-58E**

Differential Noise-cancelling,  
Dynamic Microphone  
\$43.00 Net

## It will sound better!

AKG-192

For complete information  
on **AKG** performance  
write to:



**MICROPHONES • HEADPHONES**

DISTRIBUTED BY  
NORTH AMERICAN PHILIPS CORPORATION  
100 EAST 42ND STREET, NEW YORK, NEW YORK 10017

AKG CANADA • DIVISION OF DOUBLE DIAMOND ELECTRONICS • SCARBOROUGH, ONTARIO

Circle No. 123

Re/p 34

QUAD-EIGHT ANNOUNCES A NEW VARIABLE LOW AND HIGH FREQUENCY CUT-OFF FILTER. New frequencies have been carefully selected to provide an extended range of control not previously available in a single filter unit.

**SPECIFICATIONS:** Low Frequency Filter: 3 db points are 40, 55, 70, 85, 100, 150, 200, 250, 350, & 500 Hz. High Frequency Filter: 3 db points are 15, 12.5, 10, 8.5, 7, 6, 5, 4, 3, & 2 kHz. Slope: 18 db per octave. Impedance: 600 ohms in and out. Insertion Loss: 0 db in the pass band. In/out Switch: heavy duty lever key. Escutcheon Panel: engraved formica & luminous paint filled. Size: 3 1/2" x 19" x 6" deep.

Accurate frequency calibration is provided by the use of precision com-



ponents ( $\pm 2\%$ ). Error factors have been included in the design to compensate for the limited finite value of Q in the inductors. This results in very accurate 3 db points and impedance matching for all frequency selections. Use of toroidal inductors provides excellent hum rejection.

The high and low frequency filters are available separately for custom panel mounting.

Price is: \$325.00.

Available: December 1, 1971, QUAD-EIGHT ELECTRONICS, 11810 VOSE STREET, NORTH HOLLYWOOD, CALIF. 91605, 213-764-1516.

Circle No. 124

CAPPS & COMPANY, INC. INTRODUCES FOR THE FIRST TIME AN AMERICAN-DESIGNED AND MANUFACTURED COMPUTER FOR VARIABLE PITCH DISC MASTERING. Its unique signal processing technique is different from any other presently available. The CAPPS VARI-PITCH COMPUTER adds precise variable pitch operation to any Scully recording lathe in a matter of hours. Accurate control and a linear read-out from 50 to 1000 grooves per inch is possible at all turntable speeds. Pre- and post-echo expansion as well as banding



and finishing are completely automatic. Overriding feature for manual operation is included. Expansion and banding times are panel-adjustable ranging from 0 to 5 seconds. High operational reliability is provided by state of the art circuitry and the utilization of a single motor feedscrew drive. The motor employed utilizes a flat low inertia nonferrous armature which assures accurate control at all speeds. CAPPS & CO., INC., 20 ADDISON PLACE, VALLEY STREAM, L. I., NEW YORK.

Circle No. 125

ALLISON RESEARCH IS PLEASED TO ANNOUNCE ANOTHER ITEM IN THEIR GROWING LINE OF GAIN CONTROL GOODIES: THE VCA-1. A potted module of voltage controllable gain, the VCA-1 is intended for use by equipment manufacturers in their forthcoming automated control boards. Allison says the VCA-1 solves the performance problems of conventional multiplier circuits such as poor signal to noise ratio, rising distortion as gain is reduced, control signal rejection and low gain tracking accuracy. Priced

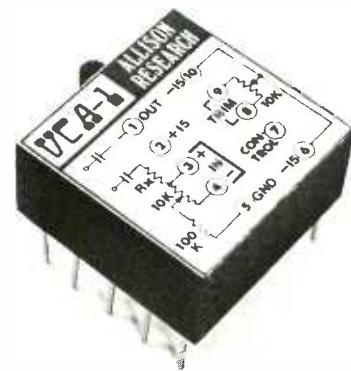

at \$50.00 per unit (\$27.50 in OEM quantities), a manufacturer's evaluation sample is available for \$20.00 (and each only to bona fide audio equipment manufacturers). ALLISON RESEARCH, 7120 SUNSET BLVD., HOLLYWOOD, CALIF. 90046. 213-874-6615.

Circle No. 126



A NEW MICROPHONE ISOLATION STAND BY SHURE BROTHERS INC., reduces the problem of "hollow" sound quality often associated with attempts at distant sound pickup.

These so-called "hollow" sounds are caused by direct sound waves and reflected sound waves cancelling each other. This phenomenon can be effectively counteracted by locating the microphone as close to the floor as possible without actually touching. In this way, the two paths of direct



and reflected waves coincide.  
The Shure Models S53P and S55P  
Circle No. 127

Distant Pickup Microphone Isolation Stands put this principle to work while at the same time providing excellent shock isolation from floor vibrations. They suspend a microphone approximately 1/8-inch above floor level. The Model S53P is specifically designed for the Shure SM53 Microphone. The S55P is designed for use with Models 545, 548, and SM57.

List price for both models is \$28.00.  
SHURE BROTHERS INC., 222 HARTREY AVENUE, EVANSTON, ILLINOIS 60204.

THE PARAMETRIC EQUALIZER M-230 FROM ITI AUDIO PRODUCTS is an active stereo equalizer utilizing new signal processing techniques to replace the functions of several conventional equalizers, while dramatically increasing flexibility and performance. Each channel provides both hi and low frequency shelving equalizers as well as a 3-section parametric control group. Each section includes the following infinitely variable controls: frequency, level  $\pm 12$  db, and shape (Q). The frequency ranges of the three sections are 10-800 HZ, 100-8,000 HZ, and 400-25,600 HZ, each accurately calibrated. Shape is variable from 4 to 14 db/octave and does not affect amount of equalization. No inductors are used in the parametric sections and ringing on transients is virtually non-existent.

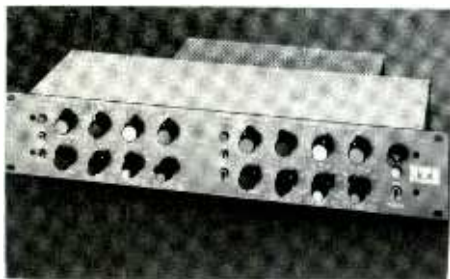

Since the system has unity gain, it may be inserted in a line without program quality degradation—transient-free switching permits use as needed.

Typical uses include remix and transfer rooms, wave shaping in electronic music labs, environmental compensation, and all forms of audio spectrum control.

The same basic equalizer is available on input modules of ITI Programmable Consoles. ITI, McCORMICK ROAD AND SCHILLING CIRCLE, HUNT VALLEY, MARYLAND, 21030.

Circle No. 128

WHO'LL  
GET THE  
NEXT  
ONE?



MCI DISTRIBUTORS: Tom Hidley, Westlake Audio, 6311 Wilshire Blvd., Los Angeles, Calif. 90048 • Dan Flickinger Associates, P.O. Box 628, Hudson, Ohio 44236 • Dave Harrison, Studio Supply Co., 112 Cloverdale Court, Hendersonville, Tenn. 37075 • Paul Kelly, Kelly's Audio Engineers, 704 Elmhurst, Muscle Shoals, Ala. 35660.

Circle No. 129

MULTI-TRACK OF HOLLYWOOD CALIFORNIA INTRODUCES A PORTABLE EIGHT TRACK MIXING CONSOLE for the studio or live performance. The console has 12 input channels with 11 output busses providing simultaneous 8 track, stereo, and mono mix down. Each channel contains slide attenuation, 20HZ + 20KHZ active sloping equalization  $\pm 20\text{db}$ , stereo and echo panpots for stereo buss selection, built-in spring stereo, mute switch, mike gain feedback trim, echo



send, monitor level, earphone level, line mike switch, and 8 position rotary buss selection.

Circle No. 130

REVOX INTRODUCES DOLBYIZED RECORDER. The Revox A77 is now available with the Dolby B Noise Reduction Unit as an integral part of the recorder.

The unit is equipped with four additional Dolby-Processors, two compressors and two expanders, one for each of the two record and reproduce channels. Thus, the recorder can record and play on each channel individually or on both together, with or without the Doby system being in effect.



Circle No. 131

8 buss output masters control the gain of each output buss. Slide attenuators are used for stereo masters. Levels are provided by 10 lighted V U meters. The over-all design contains low noise op-amp integrated circuit amplification, low impedance active combining networks, all plug in circuit card electronics, and a transistor regulated power supply.

Price \$7,255.00.

Mfr: MULTI-TRACK INC., P.O. BOX 3187, HOLLYWOOD, CALIF. 90028.

The Revox A77 Dolby version has an additional on-off switch to bring the Dolby electronics into the circuit. The built-in calibration controls and reference oscillator allow calibration of such a high degree of accuracy that the frequency response remains the same, regardless of whether the Dolby electronics are in or out of the circuit. The built-in multiplex filter protects the Dolby electronics from interferences.

REVOX CORP.,  
155 MICHAEL DRIVE, SYOSETT, N.Y.  
11791, 516-364-1900.



COMMUNICATIONS COMPANY, INC. ANNOUNCES A NEW PRECISION INSTRUMENT FOR THE MEASUREMENT OF REVERBERATION TIME IN REAL TIME which does not require a chart recorder for analysis.

The RT 60 has one third octave band pass filter with frequency centers on 250, 500, 1,000, 2,000 and 4,000 Hz. Digital readout is provided.



To obtain an engineering data sheet write: VICTOR HALL, COMMUNICATIONS COMPANY, INC., 3490 NOELL STREET, SAN DIEGO, CALIFORNIA 92110.

Circle No. 132

# CLASSIFIED

Send for FREE Catalog  
and Audio Applications



**OPAMP LABS**  
172 S. Alta Vista Blvd.  
Los Angeles, Calif. 90036  
(213) 934-3566



Circle No. 138

**SOON**  
**A VSO/MOTOR DRIVER**

**Autec, Inc.**

4222 SERNA AVENUE SUITE 218  
HOLLYWOOD, CALIFORNIA 90028  
(213) 407-4704

## EQUIPMENT AVAILABLE

America's Largest Selection of New and Used  
RECORDING EQUIPMENT

Bought, Sold, Traded — Write for Free Listing

**THE MAZE CORPORATION**

P. O. Box 6636, Birmingham, Alabama 35210

ONE STOP FOR ALL YOUR PROFESSIONAL  
AUDIO REQUIREMENTS.  
BOTTOM LINE ORIENTED.

**F. T. C. BREWER COMPANY**

P. O. Box 8057, Pensacola, Florida, 32505

PROFESSIONAL NATIONWIDE STUDIO  
DESIGN, INSTALLATION, AND SERVICING.

**PLAN BEFORE YOU SPEND!**  
**THE MAZE CORPORATION**

P. O. Box 6636, Birmingham, Alabama 35210

**RENT/LEASE: Professional Audio Equipment**

Mono to 16tk Recorders, Consoles,  
Mics, Monitor Sys, PA Sys, Etc.

**INTERNATIONAL RECORDING CORPORATION**

4214 Lankershim Blvd. North Hollywood  
Calif. 91602 (213) 769-6644

**CHOICE PREOWNED EQUIPMENT**

Ampex MR-70 1/2" 4trk and a Langevin 14  
in 4 out AM4A console mixer, ideal for basic  
new studio. \$10,850.00 package price. North-  
west Audio Development, Inc., Highland  
Park, Illinois 60035, 312-831-5380.

**22 NEW GOTHAM FADERS**  
**K600/85 MT**  
all or part . . . \$60 each

**SUN-WEST RECORDING**  
5539 Sunset Boulevard  
Hollywood, California 90028  
(213) 463-5631

## EMPLOYMENT OPPORTUNITIES

### Tape Recorder Field Service Technicians

Openings now available for quali-  
fied field technicians with a major  
manufacturer of tape recording  
equipment. Background in profes-  
sional audio recorders preferred.  
Extensive travel may be required.  
Locations in L.A., Nashville, Chi-  
cago, and Bridgeport (N.Y. area).  
Send resume to R. Berliner, Mgr.  
Engineering Services.

### ▶ **Scully**

Scully Recording Instruments Co.  
A Division of Dictaphone Corp.  
480 Bunnell Street, Bridgeport,  
Connecticut 06607

*An equal opportunity employer*

### NOTICE

INDIVIDUALS seeking employment in  
the recording industry may submit their  
qualifications for FREE publication in  
*RECORDING engineer/producer.*

Listings will be limited to 30 words,  
and will be limited by available space.  
Listings will be selected for publication  
on the basis of earliest postmark. Listings  
will not be automatically repeated or  
carried over to the succeeding issue.

Young Engineer/Producer with Music  
Background Seeks Four or Eight Track  
Studio. Ambitious and Hungry for Cre-  
ative Learning. Contact Greg Young-  
man, Sound Sync Studios, 3507 N.  
Howard, Fresno, Calif. 93726. (209)  
229-5352.

### USED RECORDING EQUIPMENT

Wide range of recording equipment including  
recorders, amplifiers, speakers, microphones,  
etc. All items in good used condition, most at  
50% off new prices. For complete detailed  
listing with prices, drop a card to:

P.O. Box 2646 Hollywood, Calif. 90028

## Quad Eight **RV10**

The best reverberation  
system can still be . . .

- Small • Rugged
  - Portable
- and also have
- Variable decay
  - Low frequency  
cutoff filter

and . . . produce a clean,  
live room, kind of sound!



**Medium priced at \$795**  
CASE EXTRA



**QUAD-EIGHT  
ELECTRONICS**

11810 Vose Street, North Hollywood,  
California 91605 (213) 764-1516

Circle No. 133

## our "little dipper" cleans up sound pollution

for less than \$300!

The Universal Audio Model 565 "Little Dipper"  
Filter Set cleans up problem tracks made  
under adverse conditions: Whistles, he ero-  
dynes, hum, camera noise, and general  
background noise.

Also, the versatile 565 can be used for:

- "Phasing" and other unique effects
- Sharp enhancement of any audio frequency
- Simultaneous elimination of any two audio frequencies
- Harmonic distortion filtering
- Wave analysis

**FEATURES** • Two variable width notch/pass filters,  
lo-pass filter, hi-pass filter, all continuously tunable  
• Zero insertion loss or 20 dB gain • Extremely low  
noise and distortion

See your dealer or write for complete specifications.



11922 Valerio Street, No. Hollywood, Calif. 9 605  
(213) 764-1500

Circle No. 134

## ADVERTISERS INDEX

AKG	34
ALLISON RESEARCH	15
ALTEC-LANSING	20
COUNTRYMAN ASSOC.	30
CROWN INTERNATIONAL	8
DOLBY LABORATORIES	19
ELECTRO-VOICE	16
FLICKINGER ASSOC.	COVER 2
GATELY-PROKIT	27
MCI	35
OLIVE ELECTRODYNAMICS	26
OTARI OF AMERICA	12

QUAD-8 ELECTRONICS	39
SANSUI CORPORATION	24
SHURE BROTHERS	10
SPECTRA SONICS	32
STUDIO ENGINEERING	31
SUPERSCOPE INC.	22
TABER MANUFACTURING	7
TELEX	9-28
3M - MINCOM DIV.	COVER 4
UREI	31-39
YAMAHA INTERNATIONAL	6

# There was only one thing left to improve:



When we introduced our 8-Track and 16-Track Recorder/Reproducers, they rounded out the most advanced line of professional audio recorders made.

And, with engineering changes and improvements, we've kept our lead.

But with another AES Show coming up, we felt that we had to do something special. So we've come up with the ultimate change: new, improved price tags.

Check the tags, then drop by Booths 46-48 at the Show.

You'll find the same 3M Brand Professional Audio

Equipment that's in major recording studios across the country. Equipment with the most precise tape handling and the highest tape speed accuracy of any recorder made. With the lowest flutter and wow in the industry. With signal-to-noise specs that are still state-of-the-art.

You'll find the finest professional audio equipment made. But you'll never find a better value.

PROFESSIONAL AUDIO PRODUCTS

**Mincom Division** **3M**  
COMPANY

300 SO. LEWIS RD., CAMARILLO, CALIF. 93010 • TEL. (805) 482-1911