

MAY/JUNE 1971

VOLUME 2 — NUMBER 3

\$1.00

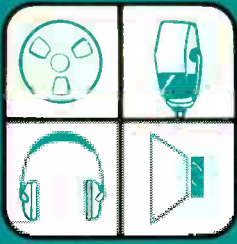

RECORDING engineer/producer

relating recording science • to recording art • to recording equipment

11201PMEBL93DD0
 DOUG POMEROY
 COLUMBIA PERDS
 193 BAL TIC ST
 BROOKLYN
 NY 11201

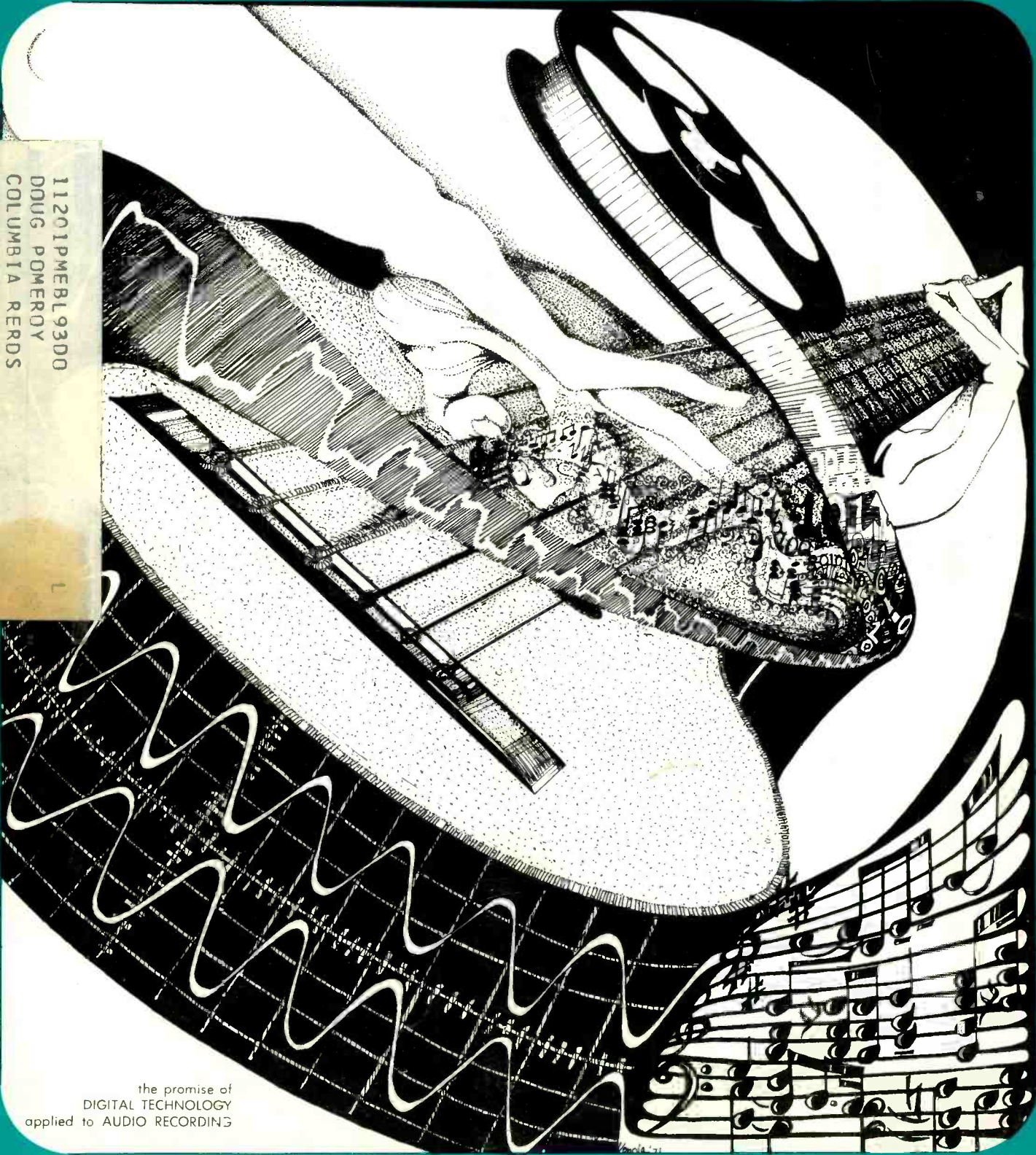

the promise of
 DIGITAL TECHNOLOGY
 applied to AUDIO RECORDING

JOIN THE HITMAKERS

JOHNNY CASH
RAY STEVENS
TONY JO WHITE
JOE SIMON
JERRY LEE LEWIS
ROGER MILLER
KRIS KRISTOFFERSON
BOOTS RANDOLPH

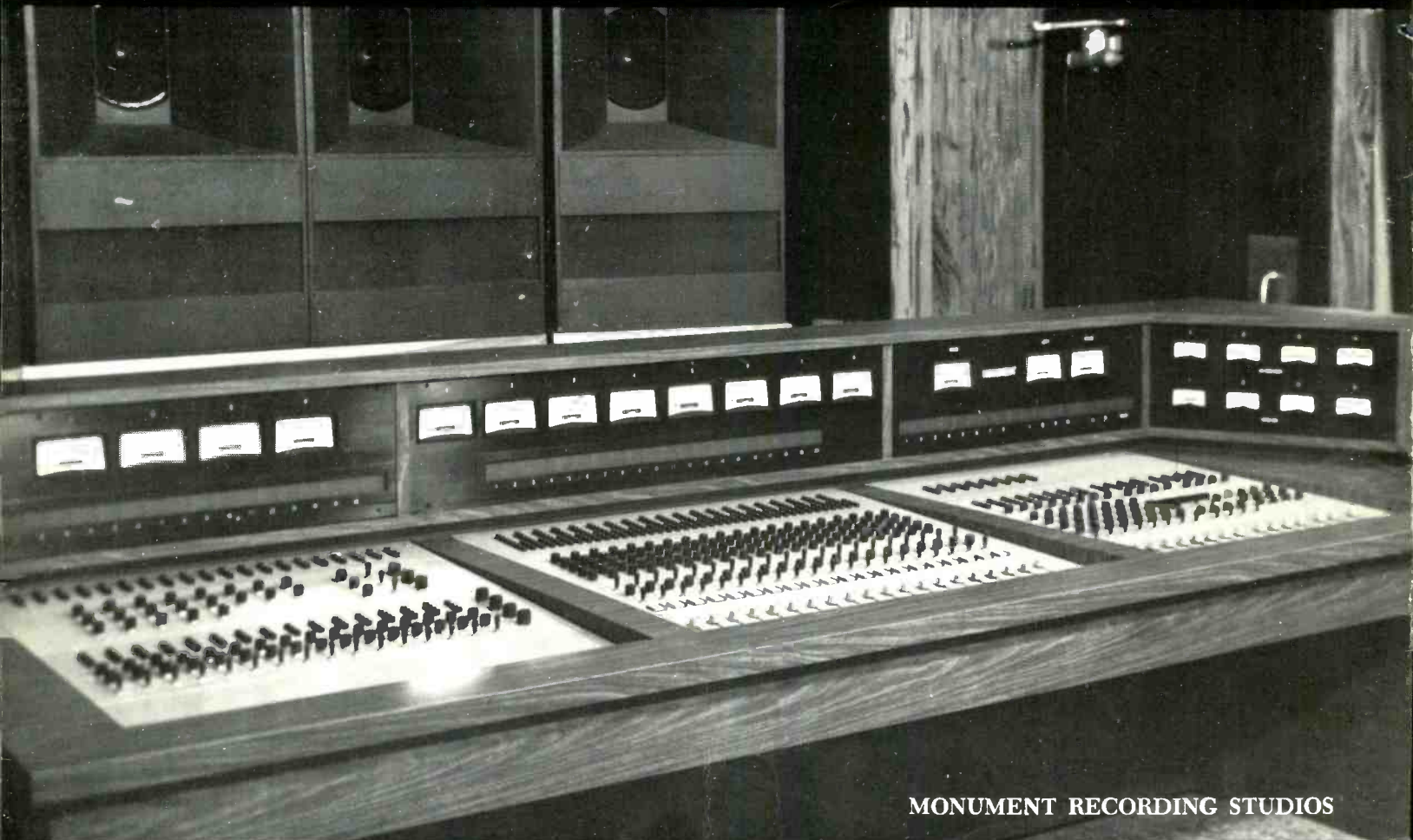

MONUMENT RECORDING STUDIOS

CONSOLES & ACOUSTICS

..... by



DANIEL N. FLICKINGER & ASSOCIATES, INC.

40 SOUTH OVIATT STREET

HUDSON, OHIO 44236

(216) 655-2400

 **RECORDING**
engineer/producer

—the magazine to exclusively serve the recording studio market... all those whose work involves the recording of commercially marketable sound.

—the magazine produced to relate... RECORDING ART to RECORDING SCIENCE... to RECORDING EQUIPMENT.

Editor/Publisher... MARTIN GALLAY
Engineering Editors... RON MALO
WILLIAM ROBINSON
CHUCK DAVIS
Business/Circulation
Manager... V. L. GAFFNEY
Art Director... GERRY SADOWSKI

RECORDING engineer/producer is published bi-monthly and is sent free to qualified recipients in the United States. Subscriptions for other than qualified individuals or companies may be purchased at \$5.00 per year. (All foreign subscriptions: \$6.00 per year.) Material appearing in Re/p may not be reproduced without written permission of the Publisher. Copyright © by RECORDING engineer/producer 1971.

RECORDING engineer/producer is not responsible for any claim made by any person based upon the publication by RECORDING engineer/producer of material submitted for publication.

Controlled circulation postage paid at Los Angeles, California.
RECORDING engineer/producer
6430 Sunset Boulevard
P.O. Box 2287
Hollywood, CA 90028
(213) 461-7907

the promise of
DIGITAL TECHNOLOGY
applied to AUDIO RECORDING 9 William Cara

an active
BAND PASS FILTER
DESIGN TECHNIQUE 21 Charles Davis

MONITORING
you can't hardly believe
what you hear! 23 Ron Malo

QUAD RECORDING
in GRACE CATHEDRAL 27 Robert Orben

Letters 6

Academy Award
to B. J. Losmandy 7

New Products 30

E-V, Sennheiser
Sign Patent Exchange 38

Cartoon 39

Classified 39

credits — cover: TRICI VENOLA
cartoon: WAYNE YENTIS
Allison Research

Play at 15 i.p.s.

Yamaha C7 Grand.

When you're laying down the master, you'd better be sure your piano is air quality. That's what the Yamaha C7 Grand is all about. It's a 7'4" concert instrument that ranks among the world's great pianos. Just ask the talent at your next session.

Yamaha U1-D Upright.

The closest you can come to a grand piano without a grand piano. Four feet high and nearly five feet wide, it has full, rich tone and response crisp enough to please the most finicky talent. It stays that



way through month after month of masters, rehearsals and spilled drinks, too.

Yamaha Electone E-3.

It's a symphony orchestra in a box. With fewer controls, the E-3 gives you more sounds, more music. What's more, it's a regular sound effects machine. Think about *that* the next time you have to synthesize some sounds.

Letters

From: A. V. Siniscal
Spectra Sonics

To answer those who have commented on the recent article "Bi and Tri Amplification" in your March/April 1971 Re/p issue, perhaps the following additional information will summarize some of the views.

All commenting readers confirmed that "Bi- or Tri- Amplification" provided a major increase in available peak power level and dynamic range! Their verifications were based primarily on audible "A-B" testing and included some supporting analysis.

It might be helpful to look at the mathematical solution from a current viewpoint, rather than voltage. Using the same examples, the mid/high and low frequency loudspeakers require $14.14V/8 \text{ ohms} = 1.77A$ and $28.28/8 \text{ ohms} = 3.53A$, respectively. In the single amplification case (figure 1), all the current $1.77A + 3.53A = 5.30A$ must be applied by the one amplifier (Kirchhoff's Current Law). Its peak power capability, P , must therefore $= I^2R = (5.30)^2 8 = 225 \text{ WRMS}$. However, in the bi-amplification case (figure 2), all the current is supplied by two separate amplifiers. The peak power capability, P , of the mid/high frequency amplifier need only be $= I^2R = (1.77)^2 8 = 25 \text{ WRMS}$. Similarly, for the low frequency amplifier $P = (3.53)^2 8 = 100 \text{ WRMS}$.

Therefore, we again conclude, a 25 WRMS and a 100 WRMS amplifier in the bi-amplification configuration can provide the equivalent peak power capability of a 225 WRMS amplifier in the single configuration! This is the reason for the dramatic (approx. 2 to 1) peak power increase provided by bi-amplification. Similarly, an even greater improvement is provided by tri-amplification.

Many thanks all those who have taken the time to write or telephone.



YAMAHA

YAMAHA INTERNATIONAL CORPORATION
P.O. Box 6600 • Buena Park, California 90620

Send for complete specifications and dealer information.

- C7 Grand Piano Name _____
- U1-D Upright Piano Business _____
- E-3 Organ Address _____
- Other _____ City _____ State _____ Zip _____

From: Bill Lobb
Synchron Sound Studios
Wallingford, Conn.

I agree with Owen Bradley's comment in your article on piano recording that the piano needs "room to range in". I doubt that Mr. Steinway designed his masterpiece with his ear six inches from the sounding board. Of course once we start to move a normal cardioid mic back from the point we begin to lose presence and isolation.

Lack of presence, however, is not caused by the increasing distance per se but more by the early reflections from the room and other ambience problems which begin to enter and cause coloration and haziness of the otherwise direct sound. If we could have a microphone with a ten degree acceptance angle we could do our 'close micing' from 25 feet away.

One way to give the piano, or any instrument for that matter, room to range in is to back up and use a shotgun. We have found that recordings made with a shotgun (the AKG CK-9) placed at 3 to 6 times the distance normally used tend to have the same presence and isolation as a close in cardioid or omni but with one important difference. From this distance the shotgun is able to look at the entire radiating surface of the instrument not just a portion of it. Put another way, the close in cardioid differentiates, the backed off shotgun integrates. The resulting pickup has an energy and fullness that can't be heard at close range.

In the case of the piano we place a shotgun 6 to 8 feet over the center of the open top angled slightly toward the hammers. The sound has a foreshortened, almost compressed quality, somewhat analogous to a scene viewed through a telephoto lens and is particularly effective when the final product is to be mono or when the instrument is assigned to a single track in a multi-track situation.

After trying the shotgun technique on guitar amplifiers, Leslie cabinets, drums, acoustic guitars, brass sec-

tions, etc. one gets the feeling that a cinematographer's viewfinder would be helpful in locating the microphone.

The shotgun should preferably be of the condenser type with as smooth an on axis response as possible. The AKG CK-9 seems to be particularly well suited to this application.



An extension of the idea can be applied to bands performing live on stage with often amazing results. A well placed CK-9 (two for stereo) can come up in one shot with the exact sound we would be looking for had we had 20 mics, 16 tracks and 8 hours to fiddle around with balance, compression and reverb.

Our feeling is that the shotgun mic deserves some serious consideration as a basic studio recording instrument.

— — — — —
**"ACADEMY AWARD" TO
OPAMP LABS'
B. J. LOSMANDY**

At "Oscar" ceremonies on April 15, 1971 the Society of Motion Picture Arts and Sciences honored OPAMP LABS President Bela Losmandy with its Class III technical award.

Mr. Losmandy's award recognized his contribution of concepts and designs for improved motion picture recording equipment, through the application of micro-miniature solid state amplifier modules.



Macdonald Carey

B. J. Losmandy

The GREAT Equalizer

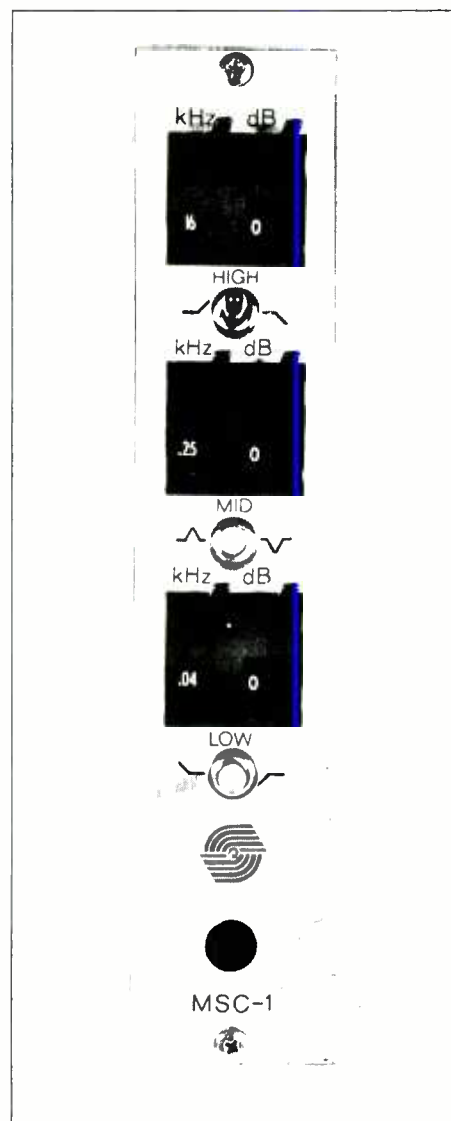

- * 60 AVAILABLE CURVES
- * RECIPROCAL BOOST/CUT
- * LED INDICATOR
- * CUSTOM FOR YOU
WITH YOUR LOGO!

AUDIO
Tempo INDUSTRIES
LIMITED

2 THORNCLIFFE PARK DRIVE
TORONTO 354, ONTARIO, CANADA
AREA CODE 416-425-9229

our superstars*



***ELECTRODYNE, GAUSS and LANGEVIN**

are widely known for their professional performance. Critics have praised the equipment and quality of sound. That's why you will find it in places like New York, Tokyo, London and Moscow. We can help you get it all together, from the smallest switch or component to complete custom recording studio systems.



mca tech
an mca inc. company

Corporate Offices
Gauss, Electrodyne, Langevin
13035 Saticoy Street
No. Hollywood, Calif. 91605
U.S.A.
Telephone (213) 875-1900

Professional magnetic tape recorders available today have serious limitations to record and reproduce musical sounds. Despite the fact that most people in the recording industry have learned to live with its inadequacies, it is time for a radical improvement in the art of magnetic sound recording. Today's *digital* technology has made it possible to achieve this needed advancement.

the promise of

DIGITAL TECHNOLOGY applied to AUDIO RECORDING

**by William Cara
Samuels Engineering
Northridge, CA.**

Digital recording techniques are widely used in computer and instrumentation recorders where high information packing densities and extreme accuracy is required. While there are many kinds of digital recording techniques, most use the principle of magnetizing the tape to a fully saturated condition at certain intervals with respect to time, or at all times but with changing orientations. There is no partially magnetized state since the tape is essentially magnetized in one orientation or oppositely, or is left in its natural state. Digital recording may be considered analogous to throwing a switch on or off at selected intervals. These changing states of magnetization can be termed flux reversals, and it is these flux reversals which generate current in the magnetic reproduce head as the tape is moved across the head.

To record sound by the digital process, the incoming sound signals are encoded in a unique way to preserve all information concerning the exact amplitudes and frequencies throughout the desired bandpass. This coded information then becomes a series of pulses which are recorded on the magnetic tape to a fully saturated condition. In playback, these coded pulses cause current

reversals in the reproduce head which are then decoded to faithfully recreate the original input signals. In this way the non-linearities of both the magnetic tape and heads are bypassed.

The audio recording techniques with which we have traditionally worked are commonly described as 'analog' (synonymous with analogy). Ideally, analog recording should reproduce signals from the tape medium in a direct (linear) proportion to the input signal voltage, but, in practice, this is not possible for two main reasons; (1) the magnetic oxide itself, due to its characteristics, cannot be magnetized linearly in relation to the input signal amplitudes, (2) the record and reproduce heads are inherently non-linear with respect to amplitude and frequency. These fundamental limitations result in most of the distortions found in the analog recording process, and they are those which limit the maximum signal levels which can be recorded and reproduced. Finally, even a hypothetically perfect analog tape recording system would still be plagued by its present problems of crosstalk, print through, tape copying losses and demagnetization losses in storage. The theoretically perfect analog system, further, cannot achieve the wide dynamic range possible with the digital process.

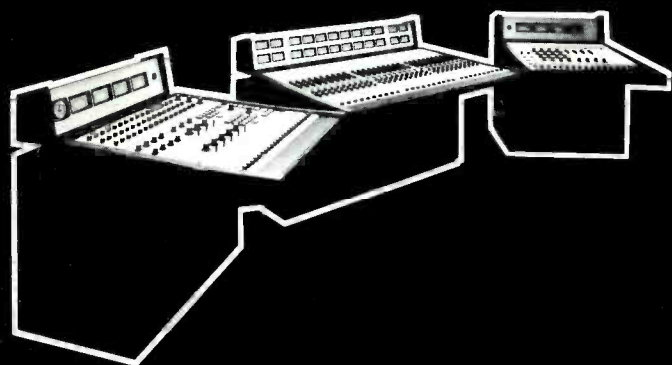
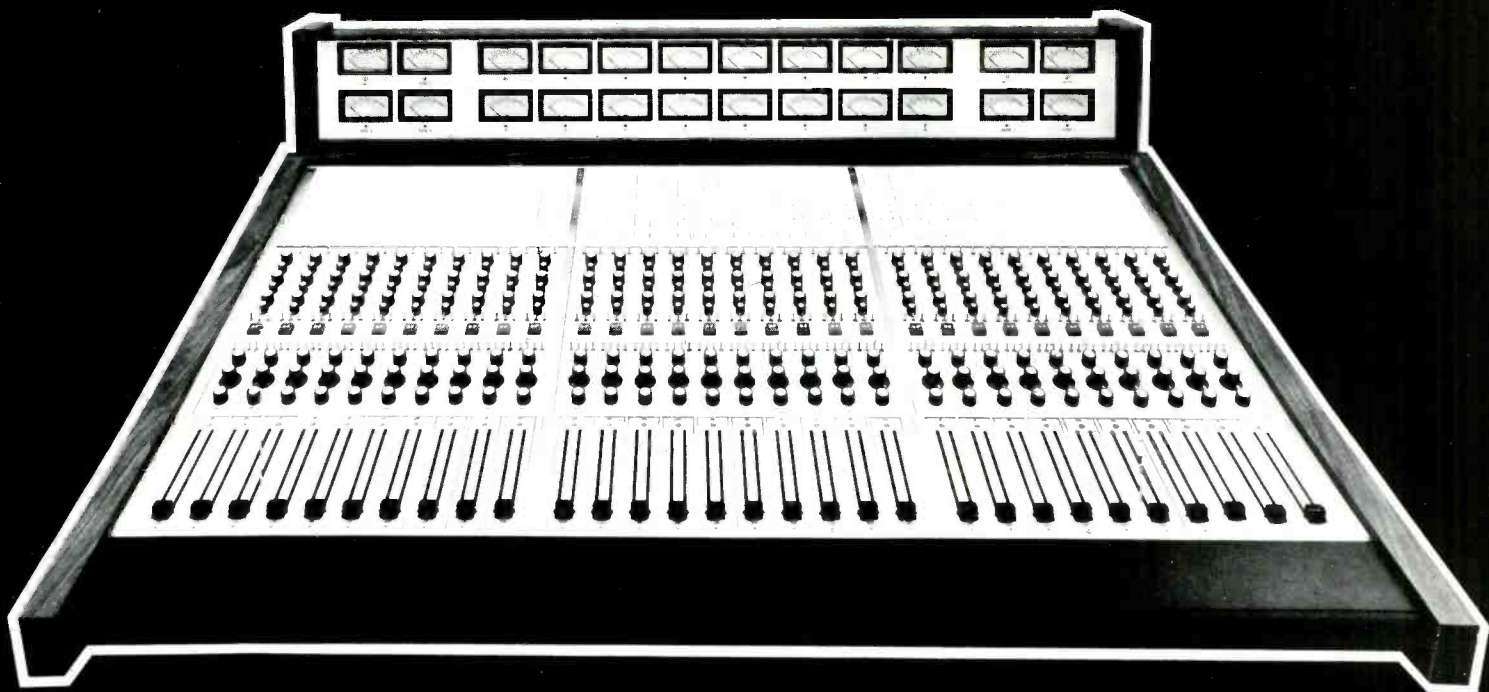

Latest addition to the ever increasing number of "Beyond the State of the Art" audio control consoles, this custom system was designed, fabricated, and installed by SPECTRA SONICS for RECORD PLANT in New York. Representing the ultimate in sophistication, three separate consoles perform the individual functions of: input control, master output control, and monitor control. Designs of advanced flexibility and performance, such as these, are the only guarantee against obsolescence with the passage of time.

For information on custom or production consoles that are both functionally and measurably "Beyond the State of the Art", contact SPECTRA SONICS at 770 Wall Avenue, Ogden, Utah 84404 (801-392-7531) or at 6430 Sunset Blvd., Hollywood, California 90028 (213-461-4321).

SPECTRA SONICS

LEADER IN ADVANCED TECHNOLOGY



Clearly, a better way to record sound should be found if we are to reproduce a true facsimile of the original sound. That way research indicates is by the digital recording process.

The digital sound recording process does not require the use of record bias current, nor pre or post equalization, nor even an erase head. The record playback electronics adjustments are simplified over conventional analog systems, and standardization of signal levels and sound quality can be more readily assured.

The main advantages of digital magnetic sound recording over present analog techniques are shown in Figure 1. Actually, digital sound recording is virtually unlimited in its capabilities. For practical and economic reasons the digital technique developed by Samuels Engineering provides a wide margin of quality beyond the limits of human perceptibility in all known parameters, still without approaching the maximum potential of the process. If, in the future, a dynamic range of, say 120dB from DC to 200 kHz is desired, the present digital state of the art can achieve it.

Most digital recording techniques require the use of very high precision tape transport mechanisms to minimize possible errors which can be caused by flutter and wow, dynamic skew, dropouts, etc. However, sound recording studios cannot tolerate either the complexity nor the high cost of such a tape transport system. Therefore, it is essential that the digital sound recording process will not require the use of a tape transport any more sophisticated than present professional analog tape transports. Samuels Engineering has achieved that goal with its ADAmag process. The methods employed to attain the broad range of technical performance parameters outlined here are a unique state of the art development and will be discussed in a future paper after applicable patents have been issued.

In order to better understand the reasons for initiating a "quantum jump" in the sound recording arts, a brief historical review of man's pursuit of the knowledge of sound is appropriate.

From Helmholtz (1821-1894) and Lord Rayleigh (1842-1919), we began to have a better understanding of the nature of sound and music. In the late 1920's, the search for high fidelity sound reproduction began in earnest spurred by advancements in the emerging field of electronics. The Bell Telephone Laboratories classical studies around 1930 have given us substantial data on the physical properties of musical sounds. The work of Sivian, Dunn and White¹ measured the absolute amplitudes of live musical instruments and orchestras.

FACSIMILE VS. HIGH FIDELITY

In 1933, the Bell Labs succeeded in demonstrating "facsimile" sound reproduction with a highly refined three channel stereophonic sound system.² This remarkable feat paved the way for "high fidelity" sound systems which found their way into movie theaters and eventually into the home in the late 1940's.

Ross Snyder³ in 1953 stated that "facsimile may be said to have been achieved when subjective judgment by a significant number of persons of normal hearing gives no better than chance distribution—50%—of correct distinctions between the live, original sound and the

reproduced sound." He goes on to say, "However acceptable as a substitute for the real thing, reproduction which is distinguishable from the original by a significant proportion of listeners must be accorded no higher rank than high fidelity." This definition still stands today. Most professional sound recording systems do render "high fidelity" sound reproduction, but, by the proposed definition, are not facsimile.

In 1942, Dr. Harvey Fletcher⁴ laid down parameters for facsimile, i.e. reproduction substantially indistinguishable from the original. In substance they were, (1) transmission noise significantly below the ambient noise in the receiving location, (2) dynamic range sufficient to reproduce a level upward of 100 acoustic dB (re: 10^{-16} watts/cm²) peak at the listening chamber, in the case of symphonic music, (3) non-linear distortion due to transmission characteristics below the level of detectability, (4) frequency range equal to or exceeding that of the human hearing apparatus, which is limited by peak listening level, and (5) preservation of spatial orientations.

During the last twenty-five years, a great wealth of research has delved deeply into the subjective aspects of the musical experience. Several studies were concerned with the listeners preference for wide or narrow frequency range. Other studies injected many kinds of distortions into the reproduced sounds in order to determine the listeners threshold of detectability versus his threshold of annoyance. From this wealth of data our present sound recording and reproducing systems have gradually evolved to today's high quality. Yet, there is much to learn about musical sounds, and there is considerable room for improvement in our equipment.

Facsimile sound reproduction for the home consumer, rather than just high fidelity, must begin with the original master tape recording equipment in the recording studio. The entire original recording system must have quality exceeding that required for facsimile. The master recording system should render sound reproduction so faithful to the original performance that even the most exceptional ear, auditioning under the most ideal conditions, cannot distinguish a difference between the monitored live sound and the recorded sound when A-B comparison is made over the same "ideal" monitor system. With such quality retained in the original recorded medium, the product which ultimately finds its way to the consumer can be modified to fit more exactly the conditions imposed by the listener's environment; home, auto, plane, business or public place.

The scope of this paper includes only a discussion of the second weakest link in the sound recording and reproducing chain, the professional studio master tape recorder. (It is acknowledged that the loudspeaker is the weakest link.)

More specifically, we shall examine the tape recorder as it relates to some critical musical values. To quote Dr. Fletcher,⁵ "there are six physical aspects of a musical tone: (1) Intensity, (2) fundamental frequency, (3) overtone structure, (4) duration, (5) growth and decay time pattern, and (6) vibrato." Presently used magnetic tape recording techniques can alter and distort any one, or all of these six physical aspects, and occasionally, all of them at once. Our present analog tape recording equip-

Crown

PROFESSIONAL STUDIO EQUIPMENT

Specs	15ips	7 1/2ips
w. & fl.	0.06%	0.09%
f. resp. +2dB	40Hz to 30kHz	20Hz to 20kHz
S/N	-60dB	-60dB

3 speeds - 15, 7 1/2 & 3 3/4ips; hysteresis synchronous drive motor

computer logic controls for safe, rapid tape handling and editing; full remote control optional

torque reel motors
"capable of providing the most faithful reproduction of sound through the magnetic recording medium... to date" -Audio magazine, 4/68

optional Trac-Sync
individual channel equalizers

third head monitor with A/B switch; meter monitoring of source, tape, output and source+tape; sound-with-sound, sound-on-sound and echo

2 mixing inputs per channel

individual channel bias adjust

"construction rugged enough to withstand parachute drops" -Audio magazine, 4/68

\$1790 for basic rack-mount half-track stereo deck, about \$2300 with typical accessories; Formica floor console \$295, rugged portable case - \$69

modular construction with easy access to all 10 moving parts and plug-in circuit boards; deck rotates 360° in console, locks at any angle

CX822

RECORDERS & REPRODUCERS

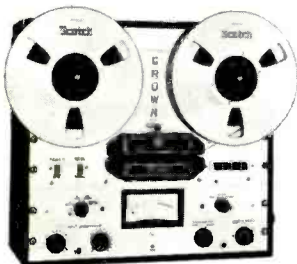

SX711 Claimed by its pro audio owners to be the finest professional tape recorder value on the market today - price versus performance
 ■ Frequency response at 7 1/2ips ±2dB 20Hz-20kHz, at 3 3/4ips ±2dB 20Hz-10kHz
 ■ Wow & flutter at 7 1/2ips 0.09%, at 3 3/4ips 0.18%
 ■ S/N at 7 1/2ips -60dB, at 3 3/4ips -55dB
 ■ Facilities: bias metering and adjustment, third head monitor with A/B switch, sound-with-sound, two mic or line inputs, meter monitoring same as CX822, 600Ω output
 ■ Remote start/stop optional, automatic stop in play mode
 ■ \$895 for full-track mono deck as shown, \$995 for half-track stereo deck

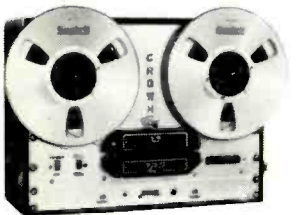

SP722 Ideal reproducer for automation systems
 ■ Meets or exceeds all NAB standards
 ■ Remote start/stop optional, automatic stop in play mode
 ■ \$595 for half-track stereo reproducer

Crown tape recorders and reproducers are available in 42 models with almost any head configuration, including 4 channels in-line. Patented electro-magnetic brakes maintain ultra-light tape tension and never need adjusting. They are made by American craftsmen to professional quality standards, with industrial-grade construction for years of heavy use.

All Crown amplifiers are warranted three years for parts and labor. They are 100% American-made to professional quality standards. All are fully protected against shorts, mismatch and open circuits. Construction is industrial-grade for years of continuous operation.

For more information, write CROWN, Box 1000, Elkhart, Indiana 46514

STUDIO MONITOR AMPLIFIERS



D40

Delivers 40 watts RMS per channel at 4Ω
 ■ Takes only 1 3/4" rack space, weighs 8 1/2 lbs.
 ■ IM distortion less than 0.3% from 1/10w to 30w at 8Ω
 ■ S/N 100dB below 30w output
 ■ \$229 rack mount



D150

Delivers 75 watts RMS both channels at 8Ω
 ■ IM distortion less than 0.1% from 1/10w to 75w at 8Ω
 ■ S/N 100dB below 75w output
 ■ Takes 5 1/4" rack space, weighs 20 lbs.
 ■ \$429 rack mount



DC300

Delivers 300 watts RMS per channel at 4Ω
 ■ IM distortion less than 0.1% 1/10w-150w at 8Ω
 ■ S/N 100dB below 150w output at 8Ω
 ■ Lab Standard performance and reliability
 ■ "As close to absolute perfection as any amplifier we have ever seen" - Audio magazine, 10/69
 ■ \$685 rack mount

ment has made it necessary for us to compromise our values.

The need for compromise is past since a digital sound recording process now exists which will provide a dramatic improvement in the commonly applied technical parameters, and also some which are only beginning to be adequately appreciated such as transient response and phase related distortions.

A digital master tape recording system should not in any perceptible way alter the quality of musical signals recorded and reproduced. Further, the magnetic tape medium should not degrade the reproduced signal quality in any perceptible way through long term tape storage, nor by normal use. Here then, are the levels of technical performance to which we may reasonably aspire today with the use of digital audio recordings.

Reconstructed digital data reproduced at 15 ips (3M 203 tape).

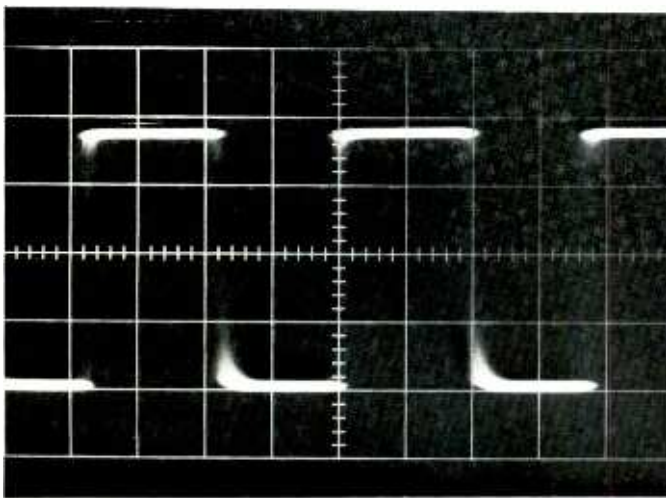

FREQUENCY RESPONSE —

The majority of musical instruments generate fundamental frequencies and overtones falling within the range from 40 Hz to 15 kHz. However, some instruments can generate overtones in the ultrasonic region⁶ (mechanical reed organ, cymbal and harmonica). The pipe organ can generate a fundamental frequency as low as 16 Hz, though it may not be perceived by the human ear. Electronic musical devices can generate sub-audible frequencies, and with modification, can extend into the ultrasonic region.

The limits of human hearing are well established over approximately a ten octave band from about 20 Hz to 20 kHz. Almost any analog tape recorder is capable of handling this range, but most equipment manufacturers specify the range of 30 Hz to 15 kHz. This limitation is necessitated by compromises to obtain the best specifications in noise versus distortion, and allows for some variations in types of magnetic tapes used. The digital recording process eliminates the magnetic tape and heads as a cause of noise and distortion in the reproduced signals.

A professional master tape recorder might usefully have a band-pass exceeding that of human hearing, so

that subsequent degradation in band-pass, with copying and processing, need not result in audible degradation of the consumer product. A reasonable range might be ten and one-quarter octaves from 15 Hz to 20 kHz. The entire frequency band should be able to be recorded at peak recording level, and do so without degrading any other parameter, if all elements of the original performance are to be preserved in the archival, or original recording. The digital technique fulfills these parameters without compromise.

SIGNAL-TO-NOISE RATIO AND DYNAMIC RANGE —

In the late 1930's, the accepted dynamic range for recording a symphony orchestra was about 45 dB. This figure has continued to be used for several reasons. Seventy-eight rpm phonograph records with their inherently high background noise levels could not be made better on a commercial scale. In the 1950's pre-recorded tapes had a signal-to-noise ratio of about 52 dB. Today's cassette tapes with their still lower tape speeds have this same limitation. With the Dolby "B" parameter equalization, a noise level of about -60 dB can be attained on commercially duplicated cassettes. The best long playing stereo phonograph records average about 62 dB S/N today because of the limitation imposed by the master tape which is used to "cut" the lacquer disc. The lacquer disc alone is capable of about 80 dB signal-to-noise ratio. All recorded music today is, in the first place, limited in S/N by the original master tape and the subsequent steps in the studio, and dynamic range is squeezed.

The very best first generation master tapes with NAB equalization measure about 64 dB in signal-to-noise ratio referred to a recording level which corresponds to about 1% third harmonic distortion. This 64 dB S/N is measured at a mid-frequency usually between about 400 Hz and 1 kHz, but at higher frequencies, due to the record equalization, the high frequency dynamic range is reduced by 10 to 15 dB. Because of this, the attack transients and overtones of many instruments cannot be recorded in their original perspective at nominal zero level without severe distortion. This partly accounts for the "muddiness" and lack of presence in many recordings.

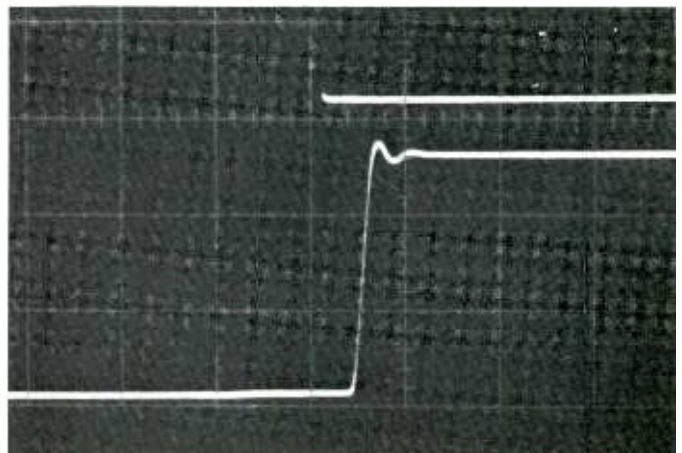

ADAMAG System response for 1 kHz square wave.

PROTECT NOTES

DESIGN THE "IDEAL" LIMITER

PROBLEM — CONVENTIONAL PEAK LIMITERS DON'T RECOGNIZE APPARENT LEVEL

SOLUTION — CREATE A UNIQUE QUASI-RMS ACTIVATED LIMITER TO YIELD PRECISE APPARENT LEVEL CONTROL. — THIS CREATES ANOTHER PROBLEM —

RMS LIMITING CANNOT CONTROL ELECTRICAL WAVEFORM PEAKS

SOLUTION — ADD A SECOND LIMITER WHICH IS PEAK ACTIVATED...

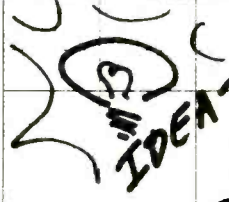

MAKE 2 COORDINATED THRESHOLDS, ONE PEAK ACTIVATED, ONE QUASI-RMS ACTIVATED, WITH VARIABLE SEPARATION OF THRESHOLD LEVELS!

— PERHAPS SEPARATE INDICATOR FOR EACH THRESHOLD —

PROBLEM — MECHANICAL AIRTIGHT FAST LIMITING ACTION

SOLUTION —

air limiting to you find most
Higher frequencies usually require limiting and are more transient. Short duration produced by percussion instruments and pops to be controlled require fast reaction time limiting device.
Low frequencies because of the inherent delay as well as the slow release times. With limiters normally exist in a natural way (a function purely of attack time). In the lowest reproducible frequency. In the most inconspicuous release time of a The most conspicuous release time of a limiter causes interaction and lack of audible degradation stated as the best-time-possible.
One would think the most inconspicuous after limiting would be instantaneous. But problems of producing harmonic distortion but preserve the quality of the sound, dynamic low distortion, the release time is varied a second to several seconds depending on of limiting action. The more severe the

HEY!
THEY ALREADY MAKE ONE!

GAIN-BRAIN™

knows what you want to hear. It's activated by both the peak and the RMS content of the input waveform. The result is a really accurate control of the output level, for all the instruments, plus an absolute control of peaks. Depending upon your needs, the GAIN BRAIN may be adjusted to act only as a peak limiter, or only as an RMS limiter or anywhere in between.

Light emitting diodes sequentially indicate the gain reduction and the mode of limiting.

This is only the beginning. Contact your nearest Allison distributor or the factory for GAIN BRAIN's astonishing spec sheet.



ALLISON RESEARCH, INC.
7120 SUNSET BOULEVARD
HOLLYWOOD, CALIF. 90046

(213) 874-6615

Exclusive export agent: GOTHAM AUDIO DEVELOPMENT CORP., NEW YORK, N.Y.

POWERING
ATTACK TIME $\leq 1 \mu\text{SEC}$, SNR $> 80 \text{ dB}$, THD $< 0.3\%$
EVEN AT LOW FREQUENCIES, +24 dBm OUTPUT CAPABILITY, STEREO INTERCONNECT CAPABILITY, ULTRA-SMALL SIZE & PRICE

In any event, since master tapes must be copied, even with tape copying equal in quality in every way to that of the original master, the second generation tape copy loses 3 dB S/N. Two more generations can degrade the S/N by another 3 dB, so that on the fourth generation 6 dB in S/N may be lost.

In multi-channel master tape mixdowns, for example, mixing a 6-channel master to a 2-channel sub-master could result in a loss of about 9 dB S/N due to rms addition of tape noise. This, of course, presumes that the electronics noise is well below the basic tape noise.

With the ADAmag digital recording process it is possible to make an identical tape copy on the digital-to-digital level (D to D) without loss in S/N, transient response or other important musical qualities.

One can ask, "Isn't 64 dB S/N on the master tape good enough?" The answer is an unequivocal NO! Not if we are to preserve music in its true perspective. To put it another way, a wider dynamic range is needed if we are to have lower amounts of distortion on peak signals, and still have no annoying noise in the background.

Hard rock music typically approaches dynamic level peaks bordering the threshold of pain (120 dB sound pressure level) but has a rather narrow dynamic range of about 30 dB. There are encouraging signs of a change to lower overall sound pressure levels in our popular music, but with greater contrasting dynamic ranges.

Virtually every musical instrument can produce dynamic intensity ranges of at least 35 dB (from ppp to fff markings). The instruments with the widest dynamic ranges are: pipe organ, kettle drum and bass drum at 80 dB; snare drum and cymbal at 55 and 65 dB respectively; and the human singing voice can generate a 65 dB dynamic range from its softest "sotto voce" to its loudest triple forte. These intensity levels are all referenced to 0.002 dynes/cm² at ten feet.⁶

The symphony orchestra provides a better guide to the dynamic range needed for lifelike musical reproduction since it attains a range of about 75 dB. A solo violin playing a triple pianissimo passage generates a sound pressure level of about 40 dB. A triple fortissimo crescendo of the full orchestra generates 115 dB SPL in the same hall. These sound pressure levels were measured by the author in the San Francisco Opera House in 1956 with Enrique Jorda conducting the San Francisco Symphony Orchestra in rehearsal. The absolute sound level in the opera house when empty was about 30 acoustic dB. In other fine auditoriums it has been reported that ambient noise levels may be as low as 20 dB.

Now, if we accept a 75 dB dynamic range for the orchestra, we shall need an additional margin above this intensity range to protect against accidental mis-settings of the gain controls, and to provide for unexpected peak signals. We shall also need a margin below the solo violin playing a triple piano passage, and for pauses between musical phrases so that the background noise level will not be annoying, and preferably, not perceptible. Further, we should be able to record and reproduce the maximum dynamic range with total distortion well below the level of detectability.

Therefore, to encompass the original range of real musical sounds, the professional magnetic tape recorder

should provide a true unweighted signal-to-noise ratio of 80 dB over the audible spectrum, and do so with total harmonic distortion less than 0.5% at peak recording level. And further, this should allow for gentle overload characteristics above the 80 dB intensity range. *This simply cannot be done with any known analog recording system, while the digital process easily accommodates these requirements.*

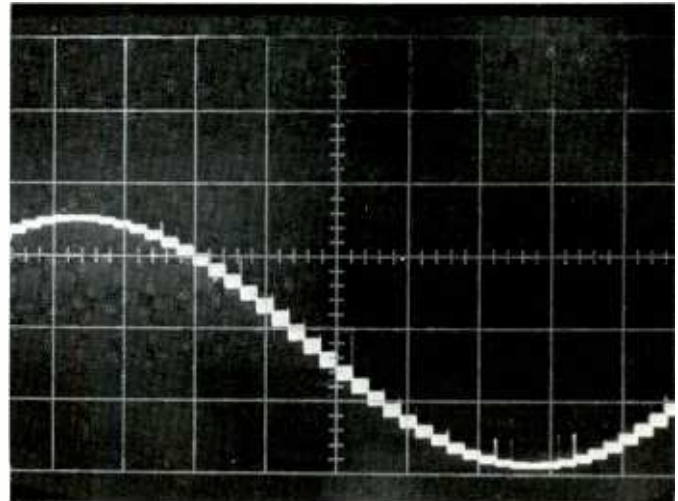

Output directly from Digital to Analog Converter prior to output processing (Arbitrary Scale).

HARMONIC AND INTERMODULATION DISTORTION —

Only a few years ago distortion figures of 3% third harmonic and 5% intermodulation on peak signals were acceptable values for audio power amplifiers. Today's higher quality amplifiers have typically less than 0.5% third harmonic and 0.5% intermodulation distortion at full rated power.

With analog recording techniques the magnetic tape itself is the limiting factor in defining harmonic distortion. It is inherent in magnetic tape that as the flux density is increased so is the harmonic distortion. Professional tape recorder manufacturers therefore specify signal-to-noise ratio from a recorded tape flux level which produces 1% third harmonic distortion of a 400 Hz or 700 Hz sine wave. At peak recording levels of, for example, 10 dB higher than a recommended 1% level, the third harmonic distortion will be about 20%, depending upon the type of oxide formulation of the tape. Because it is perceptible, we should assume that any distortion greater than 0.5% at peak recording level is not acceptable. This figure should be maintained throughout the entire audible spectrum. And further, the magnetic tape itself should not contribute to distortion. This quality is achieved by means of the ADAmag digital recording process.

TRANSIENT RESPONSE —

The transient attacks of musical instruments such as the guitar, harpsichord and piano are extremely sharp and contain spectral energy during the initial attack which is considerably different than the following "steady state" tone a few milliseconds later. Also, peak sound energy during the first few milliseconds of the attack transients on these instruments can be 10 to 15 dB greater than the steady state tone some 200 milliseconds later. All instruments, even non-percussive instruments such as the violin and clarinet, also exhibit these char-

If you've ever been to A&M Records, Columbia, Universal/Decca, MGM, Paramount, United Artists, Walt Disney Productions, Caesars Palace, or the International Hotel, then you've undoubtedly heard Altec filters and equalizers at work.

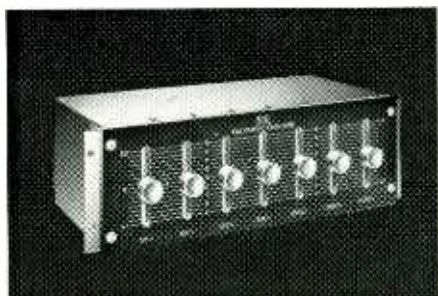

Altec's 9062A Graphic Equalizer. As the "work-horse" of the industry, Altec's Graphic Equalizer provides immediate equalization to attenuate vocal or instrumental soloists or to change the overall frequency curve if desired. This compact unit allows 7 separate frequency segments to be simultaneously tailored. For noise-free operation and maintenance-free reliability, the 9062A features passive circuitry and a proven brush design with gold-tipped dual contacts on each brush.

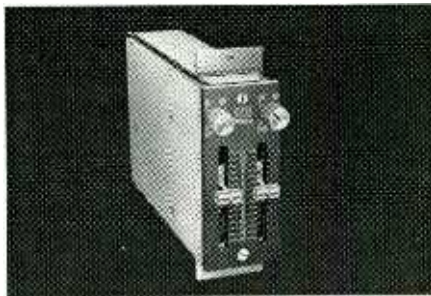

Altec's 9061A Program Equalizer. Providing continuously variable equalization or attenuation, the 9061A is ideal for tailoring and reshaping sounds during mixing and re-mixing as well as for creating your own sound and special effects. The passive 9061A features silent operation (with no external power source required, absolutely no noise is inserted) and includes its own mounting frame that permits the unit to be plugged into or removed from the console as desired. Altec's 9063B is identical in circuitry and is designed for easy mounting in a standard 19" rack. Both models operate at extremely low levels.

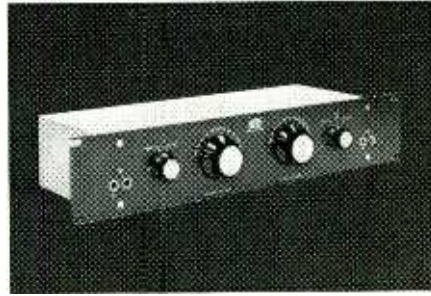

Altec's 9067B Variable High & Low Pass Filter. Handling sonic effects is just one of the many useful functions of this easy-to-operate unit. Some features of this passive network include zero insertion loss, completely silent control action, no distortion, no hum pickup—even in low-level circuits, immediate selection of either or both filters into the circuit and standard rack mounting. The 9067B also features 10 positions of LF and HF cutoff and 18 dB per octave attenuation at any selected frequency.

Send for more information.

To Altec Lansing,
1515 South Manchester Avenue,
Anaheim, California 92803

Please send me details on the following Altec filters and equalizers.

- 9062A Graphic Equalizer
- 9061A & 9063B Program Equalizers
- 9067B Variable High & Low Pass Filter
- Brochure on Altec recording studio installations.

NAME _____

COMPANY AND/OR TITLE _____

ADDRESS _____

CITY/STATE _____ ZIP _____



A QUALITY COMPANY OF THE LING ALTEC INC

acteristics to a certain degree.

Attack transients not only tell the listener which instrument is playing, but add to the total dynamics and excitement of music. Without attack transients, music lacks all distinction.

Research studies by Luce and Clark⁷ found that the duration of attack transients of non-percussive orchestral instruments range from 14 milliseconds to 85 milliseconds. Their previous work in collaboration with others⁸ indicate that our ability to identify musical instruments correctly is greatly impaired if the initial attack transients are removed and only the steady state tones are heard.

Relatively little research has been published concerning the peak energy and spectral distribution of attack transients of musical instruments. We have generally accepted as fact that any noise of a duration shorter than about 13 microseconds is not perceived by the ear. Most professional tape recorders respond to transients within about 15 microseconds, but 'overshoot' and 'ringing' distort the transient response drastically. Moreover, subsequent tape generations (tape copying) compound this distortion of the transient response. *The ADAmag digital recording process bypasses this degenerative problem.*

Another limitation of analog magnetic tape recording is loss of presence ("presence edge smear") thought to be due to bending of the tape as it passes around tape guides. This bending loss, and those transient overshoot and ringing distortions, are compounded by multiple generation losses, with the result that severe transient distortion is demonstrable on commercially duplicated tapes and on phonograph records.

Many recording engineers have observed that a master tape never sounds as good as the day it was recorded. Tape storage evidently produces degradation and it is thought to be caused by "edge smear." These losses are not easily measured on complex musical signals, but the human ear can recognize them. Dr. Harvey Fletcher⁹ in a recent address concerning "The Ear As A Measuring Instrument" summarized by saying, "Don't discount the ear as one of our finest acoustical instruments for measuring sound."

With this in mind then, the master tape system should have transient response better than 13 microseconds without overshoot, and the recording process should permit tape copying through at least five generations without compounding distortions. *The digital process achieves these objectives.*

PHASE SHIFT DISTORTION —

Phase shift in a tape recorder can be caused by the electronics, by tape stretch or skew, misalignment of heads, gap scatter, and other less obvious factors. Some professional tape recorders have as much as 90° phase shift at short wavelengths in the electronics alone, and when measured off-the-tape, errors between two channels can be large enough to cancel high frequencies. In very high quality machines, phase shift can be minimized by careful adjustment of the system.

With a machine in proper adjustment, the largest contributor to phase shift is gap scatter in the head assembly. Phase shift is particularly noticeable when two

channels are combined to monophonic program as in radio broadcasting, or in multi-channel master tape mixdowns.

Large amounts of phase shift affect stereophonic localization and can result in monophonic incompatibility; smaller amounts affect the transient response. More deleterious to musical quality is thought to be the resultant lack of clarity of the reproduced sounds in the 500 Hz to 2 kHz band. Phase shift errors, accompanied by harmonic and other distortions cause "muddiness" in the reproduced sounds.

Maximum phase shift values between any two channels, off-the-tape, should not exceed 50° at 20 kHz. The ADAmag digital process, by use of proper coding techniques, maintains this low phase shift value.

CROSSTALK—

Crosstalk interference might only occur in the electronics, but more commonly is caused by inductive coupling of adjacent tracks in the reproduce head. Crosstalk is a serious problem in multi-channel master recording where high isolation of each new recorded track is desired as in overdubbing. Occasionally, new voice tracks in another language may be needed, or a different instrumental solo may be inserted. Present tape recording equipment imposes limitations in overdubbing of this kind.

In reproduce mode, crosstalk levels as low as -60 dB can be annoying if they occur in the 2 kHz to 5 kHz band. In overdub mode, analog tape recorders can not provide sufficient isolation between adjacent channels in this band, and are still more deficient at higher frequencies.

To really eliminate its effect, crosstalk between any two channels from any cause, including overdub mode, should be down more than 80 dB throughout the entire band from 20 Hz to 20 kHz. *The digital process is inherently immune to crosstalk in any mode of operation and fulfills this specification.*

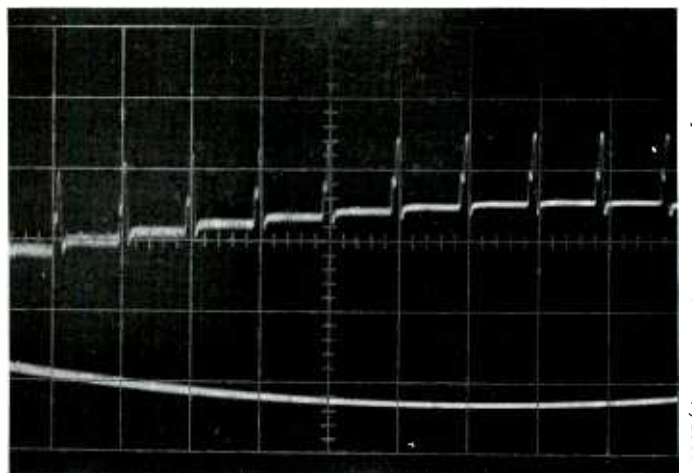

Sampled input into Analog-Digital converter. Acquisition time less than 1 μ /sec.

FLUTTER AND WOW

It is generally agreed that flutter and wow are more readily perceived in piano music than in any other. In a recent study by H. Sakai,¹⁰ the threshold of perceptibility for piano music was 0.14% rms weighted, but on complex tones at 5 kHz, the threshold values were as low

as 0.062% \pm 0.03% rms. Mr. Sakai states, "it may be inferred that a threshold value of 0.06% rms for complex tones may be taken as the most severe criterion in assessing wow . . .".

Flutter and wow, including scrape flutter, result in distortion of the wave shape by frequency and/or amplitude modulation which brings undesirable effects at all frequencies. Most manufacturers specify flutter and wow in rms values which is meaningful only if the disturbance is periodic. But this is not true for high frequency scrape flutter. It would be more meaningful to define flutter and wow in peak values over a given bandpass. There is a need for better industry standards to define flutter and wow in a professional tape recording system. The temptation to show low numbers should be resisted in favor of more meaning.

The record/playback tape system should tolerate reasonable amounts of flutter and wow without their appearing significantly in the output signal. With the ADAmag digital technique, flutter and wow in the tap transport reproduce the same as in analog tape machines, *thus the digital process places no more stringent tape motion requirements than in analog sound recording.*

PRINT THROUGH AND OTHER TAPE STORAGE PROBLEMS

Analog recording techniques require great care in controlling maximum recording levels and in storing the recorded tapes in order to minimize print through effects. Pre and post echo caused by magnetic interaction between adjacent layers of tape often spoils a master tape. If a recorded tape is stored for a few hours, print through can become a problem.

Other tape storage problems such as demagnetization loss of overall signal level can reduce the signal-to-noise ratio by 3 or 4 dB. High frequency losses may also occur. Less understood effects such as loss of transient response or "presence edge smear" may be caused by tape storage, poor tape handling, and possibly other reasons.

The recording process should eliminate any perceptible print through effects even if tapes are stored for several years. Even partial loss of signal should have no observable effect on the reproduced sound, nor on the signal-to-noise ratio. Analog recording techniques cannot overcome these degradation losses to which the digital process is inherently immune.

OTHER PARAMETERS —

So far we have discussed the professional tape recorder as it relates to our traditional musical instruments. But, what about our new electronic musical instruments with their capacity to create highly complex masses of sounds? Synthesized sounds, either alone, or in combination with traditional instruments is rapidly growing in popularity, and this "new" music holds promise to achieve new heights of musical experience. What will be the demands placed upon our recording system then? Certainly they will not be less than with our traditional instruments, and perhaps more.

The design of a professional magnetic tape recorder must, of course, include relative immunity to tape drop-outs and permit the use of a wide variety of tapes now available, and those which may come in the future. The system must contain all of the features and flexibility demanded by recording engineers, and yet, the cost must not be prohibitive.

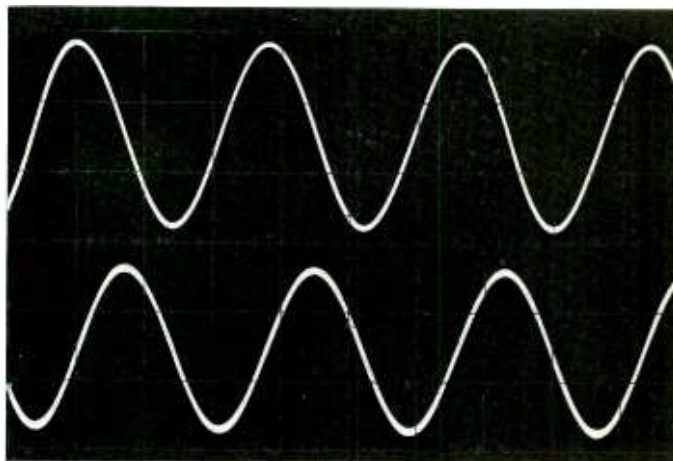

System response for 20 kHz sine wave.

CONCLUSION —

Admittedly there is disparity of opinion as to which musical/technical parameters are important. Even if some people agree, there will be argument over the value of such an improvement.

The recording industry now uses a variety of extra devices to control dynamic range, improve signal-to-noise ratio and reduce distortion; e.g. limiting amplifiers, compression amplifiers, signal processors, automatic gain controls, and so on. Some of these devices can be removed from the master recording and copying process with consequent reduction in complication and inconvenience if the original recording technique possesses the characteristics recommended here.

With a more faithful master tape recording, the consumer product can then be more ideally adapted to the conditions of its intended use, and the final quality can be improved as well. For reproduction in the auto or other places of high ambient noise, the industry can compress the dynamic range as they do now, to 20 or 30 dB. For rock and other popular music at home we might standardize on 55 dB intensity range; for symphonic music, perhaps 65 dB. And, for the extravagant music enthusiast, a premium priced recording might be released with a true 75 dB dynamic range. Regardless of what dynamic ranges are released on the end consumer product, the other vital parameters such as frequency range, distortion and transient response can be clearly superior in quality to the recorded music now available. But, this can only be fully realized by employing the digital sound recording process on the original master taping session, and on subsequent steps in the studio.

In the final analysis, the recording industry can only do what it wants and needs to do to the end product if the archival recording is true to the original performance in every perceptible way.

Figure 1.

(Standard high quality tape @ 15 ips.)

BASIC PARAMETER	DIGITAL ADAmag	PRESENT BEST ANALOG
SIGNAL-TO-NOISE RATIO	better than 80 dB, unweighted, from 0.5% third*.	about 64 dB, ASA weighted, from 1.0% third*.
DYNAMIC RANGE	better than 80 dB from 20 Hz to 20 kHz with less than 0.5% third*.	64 dB mid-band only from 1.0% third*, or 70 dB mid-band only from 3.0% third*.
HARMONIC DISTORTION	function of electronics only, not of tape.	limited by tape and electronics.
FREQUENCY RESPONSE AT NOMINAL ZERO LEVEL	± 1 dB, 20 Hz to 20 kHz, no equalization required.	± 1 dB, 30 Hz to 15 kHz. NAB equalization.
CROSSTALK REJECTION (overdub mode between adjacent channels)	better than 80 dB from 20 Hz to 20 kHz.	less than 35 dB mid-band, worse at higher frequencies.
TRANSIENT RESPONSE AT NOMINAL ZERO LEVEL	better than 13 μ /secs. without overshoot.	very bad, with ringing and overshoot.
PHASE SHIFT ERROR (between any two channels of tape)	controlled to less than 50° at 20 kHz.	Typically worse than 90° at 15 kHz.
PRINT THROUGH EFFECT	no effect on reproduced signal.	causes "echo" in reproduced signal.
MULTIPLE TAPE GENERATION LOSSES (tape copying)	when copied on digital level, no significant effect through five generations.	loss of signal-to-noise ratio, and compounding of all distortions.
TAPE STORAGE LOSSES (demagnetization loss)	no perceptible effect on reproduced signal.	loss of signal-to-noise ratio, and possible "presence edge smear."

*—denotes third harmonic distortion.

REFERENCES

1. L. J. Sivian, H. K. Dunn and S. D. White, Absolute Amplitudes and Spectra of Certain Musical Instruments and Orchestra, J. Acous. Soc. Amer., 1, 172 (1931); 2, 330-371 (1931).
2. Bell Telephone System, Monograph B-784, Auditory Perspective, Symposium of Six Papers, 1934.
3. R. H. Snyder, History and Development of Stereophonic Sound Reproduction, J. Audio Eng. Soc., 1, No. 2, p. 176, (1953).
4. H. Fletcher, Hearing, the Determining Factor for High Fidelity Transmission, Proc. IRE, 30, 266-277, (1942).
5. H. Fletcher, Pitch, Loudness and Quality of Musical Tones, Amer. J. of Physics, 14, 4, (1946).
6. H. F. Olson, Musical Engineering, p. 222-231, McGraw-Hill, 1952.
7. D. Luce and M. Clark, Jr., Duration of Attack Transients of Non-Percussive Orchestral Instruments, J. AES, 13, 3, p. 194-199, (1965).
8. M. Clark, Jr., D. Luce, H. Schlossberg, J. Rice, Preliminary Experiments on the Aural Significance of Parts of Tones of Orchestral Instruments and on Choral Tones, J. AES, 11, 1, p. 45-57, (1963).
9. H. Fletcher, The Ear As A Measuring Instrument, J. AES, 17, 5, p. 532-534, (1969).
10. H. Sakai, Perceptibility of Wow and Flutter, J. AES, 18, 3, p. 290-298, (1970).

END

THE PHASER



Would you use phasing and flanging effects more often if they were less difficult to obtain? Now you can produce these effects without tape machines, reproducibly and with complete control.

The Type 967 Phase Shifter electronically delays an input signal and then mixes the delayed and undelayed versions together. It allows you to add the striking "turning inside out" effect of Phase cancellation to any audio signal live or recorded, in the studio or in performance, in minutes instead of hours.



COUNTRYMAN ASSOCIATES

424 University Avenue
Palo Alto, Calif. 94302
Phone 415-326-6980

Circle No. 109

Good 16-track masters don't just happen.

Unless the Dolby System is used, the final stereo master may be only marginally quieter than an 8-track stereo cartridge.



New sixteen-track recorders are essentially limited in performance by tape noise. No matter what tape is used, noise increases by about 9 dB when the sixteen-track original is mixed down to a two-channel stereo master. This is equivalent to cutting track width down to that of an 8-track cartridge and reducing tape speed to $7\frac{1}{2}$ ips. What a waste of time, money, and effort.

The Dolby System eliminates all this. The noise level of a Dolby recording, even when it is reduced to stereo from sixteen tracks, can easily be better than that of a two-track original recording on the same kind of tape without the Dolby System. At the same time, print-through and cross-talk are also reduced by 10 dB, keeping stereo placement exact and silent passages velvet quiet. Sessions move faster because setting up pre-equalization is unnecessary. Instead, equalization can be worked out during mixdown without affecting the sixteen-track original and without watching the second hand of the clock as session time ticks away. Nor is there need to ride gain on dead channels during mixdown to keep out noise; the Dolby System takes care of that.

The Dolby System makes recording and reduction easier and faster, with time for more attention to creative values, less to technical problems. It makes good engineering 10 dB better.

A mixdown at John Mosely's Command Studios, London. Command, like every other London 16-track studio, is Dolby equipped on every track.

Prices, delivery information and complete specifications are available from



DOLBY LABORATORIES INC

333 Avenue of the Americas New York NY 10014
(212) 243-2525 cables: Dolbylabs New York

UK and International
346 Clapham Road London SW9
(01) 720-1111 telex: 919109 cables: Dolbylabs London

One of the most up-to-date and effective equalizing techniques in use today utilizes a series of active band pass filters. Spaced in octaves, or 1/3 octave band widths for boosting or attenuating fundamental and harmonic frequencies, they are used, for example, in graphic equalizers.

The design technique described here illustrates construction of Band Pass Filters using low cost, readily available IC's along with ordinary resistors and capacitors.

AN ACTIVE BAND PASS FILTER DESIGN TECHNIQUE

by CHARLES DAVIS

This multiple feedback approach uses fewer components than the single feedback 'Twin-T' approach. Too, sensitivity to component values is not critical. 10% components can be used without degradation in performance. The multiple feedback approach does not use the relatively expensive toroidal inductors.

For the sake of completeness, it is made much more simple later in the article, the transfer function for the circuit pictured below is:

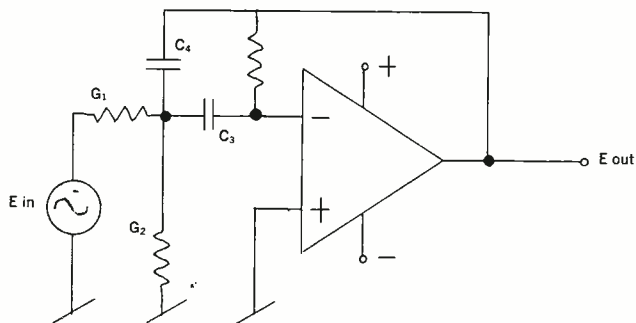

$$\frac{E_0}{E_{1N}} = \frac{-SG_1 C_3}{S^2 C_3 C_4 + SG_5 (C_3 + C_4) + G_5 (G_1 + G_2)}$$

The same multiple feedback scheme can be used to implement hi-lo-pass filters.

Rewriting in terms of R instead of G

$$\frac{E_2}{E_1} = \frac{-S \left(\frac{C_1}{R_1} \right)}{S^2 C_1 C_2 + S \frac{C_1 + C_2}{R_3} + \frac{1}{R_3} \left(\frac{1}{R_1} + \frac{1}{R_2} \right)}$$

Separating the equation, we find:

$$S = j\Omega = 2\pi f$$

A = Midband or Center Frequency Gain

Q = Q of Response (Band Width)

$$\frac{\text{Center Frequency}}{\text{Band Width}} = \frac{f}{\Delta f}$$

$$\omega = 2\pi f$$

From which we find:

that C1 and C2 are independent variables for an ideal operational amplifier from which we find:

$$R_1 = \frac{Q}{A_0 \omega_0 C} = \frac{Q}{A_0 2\pi f \cdot C}$$

$$R_2 = \frac{1}{\left(2Q - \frac{A}{Q}\right) \omega C} = \frac{1}{\left(2Q - \frac{A}{Q}\right) 2\pi f C}$$

$$R_3 = \frac{2Q}{\omega_0 C} = \frac{2Q}{2\pi f C}$$

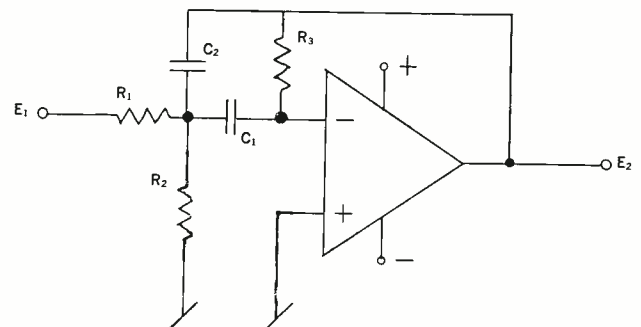

It's MCI's new total-logic JH10.

The logic is so total, not even a power failure (much less an engineer failure) can break or spill the tape.

"Sudden" is the most accurate word we can find for JH10's acceleration from "Stop" to any commanded tape function.

And for its conversion time from one- to two-inch, and vice versa.

Practically everything is plug-in for fantastically simplified maintenance and expansion from, say, 8 to 24 tracks.

Constant, electronic (not mechanical) tension control sensing reduces head wear, wow, flutter and speed variations.

Prices start at \$3,500.

Write: MCI, 1140 N. Flagler Dr.,
Ft. Lauderdale, Fla. 33304 • 305/524-3318.
Distributed West of Rockies: Westlake Audio,
1047 Twinfoot Court, Westlake Village, Cali-
fornia 91361 • 805/497-7924

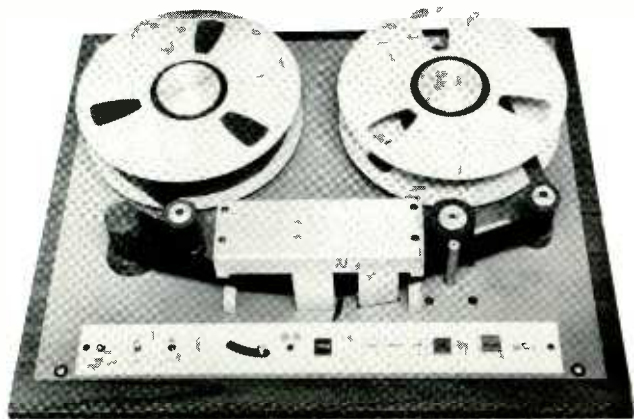

Circle No. 111

Here, then, only a gain of one or unity is needed. And, if the Q is kept to 1 the equations become the simple and familiar:

$$R_1 = R_2 = \frac{1}{\omega_0 C} = \frac{1}{2\pi f C}$$

$$R_3 = \frac{2}{\omega_0 C} = \frac{2}{2\pi f C}$$

if A_0 & $Q = 1$

To prove the design of the filter we shall construct one with the following design goals:

$$A_0 = 1$$

$$\omega = 2500 = 398 \text{ Hz}$$

$$\text{Choose } C = .5 \mu\text{f}$$

$$Q = 1$$

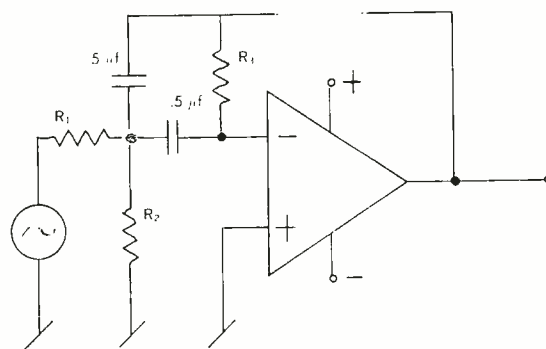

from which, with a reactance chart,

$$R_1 = 910 \Omega$$

$$R_2 = 910 \Omega$$

$$\text{and } R_3 = \frac{2}{\omega_0 C} = \frac{2}{1.25 \times 10^{-6}} = 8\text{K}$$

As another exercise, let's try changing the parameter to increase the gain and narrow the band width:

$$|A| = 10 = 20 \text{ dB}$$

$$\omega = 2500 \text{ (398 Hz)}$$

$$\text{Choose } C = .5 \mu\text{f}$$

$$Q = 25 \text{ (16 Hz - 3 dB Bandwidth)}$$

from which:

$$R_1 = 2\text{K}$$

$$R_2 = 16\text{K}$$

$$R_3 = 40\text{K}$$

For unity gain:

$$R_1 = 20\text{K}$$

$$R_2 = 16\text{K}$$

$$R_3 = 40\text{K}$$

Continued on Page 36

The incredible progress made in electronic technology of these past years has allowed us to create the near ultimate, as we know it today, in recording studio monitor systems. We now have monitor amplifiers with over 150 w/rms output, wide range speakers with bi- and tri-amplification, room equalization that has given us the cleanest, flattest reproduction imaginable. Yet, the most uncontrollable factor in the system seems to have been relegated to the comparative background: THE HUMAN EAR.

MONITORING . . .

you can't hardly believe what you hear!

by **RON MALO**

The questions: "What level do I monitor at?" and "What level will the end user of the material listen to the play-back at?" or, more generally, "How will the human ear react to the recorded material?" These questions need to be considered much more thoroughly. Much of the problem stems from the fact that the ear is not a linear reproducer.

The basic work on "perceived loudness" for various levels of hearing culminated in the Fletcher-Munson equal loudness contour curves. (Figure 1.)

It can be seen, for example, that a difference of 32dB would be required to correct a 50 Hz tone equal loudness if the level is decreased from +80 dB to +40dB.

It is not uncommon for monitor levels in many control rooms to reach 120dB. However, a good average seems to be about 100dB.

Thus, it seems obvious that a mix made at 120dB, the threshold of feeling, and played back at 70dB cannot sound the same. To show just what the change in sound is likely to be, the Fletcher-Munson curve will have to be re-drawn. The graph as shown is really upside down. By inverting the curves the response of the ear can be determined at a particular level. The low points in Figure 1 are actually the most sensitive points. They are the peaks in the hearing response.

In the case of the 120dB mixing level, assuming that the balance of the mix is correct to the ear, the balance will represent a straight line on a frequency response graph (Figure 2A). The question now becomes, "What will that 120dB balance represent to an ear listening at lower, more normal playback volumes?" At 110dB (Fig. 2B), at 100dB (Fig. 2C), at 90dB (Fig. 2D), at 80dB (Fig. 2E), at 70dB (Fig. 2F) you can easily see that you "can't hardly believe what you hear."

At 120dB the ear is at saturation. The ear hears quite differently at, say, 70dB.

By lowering the monitor level a loss of over 10dB at 5KHz occurs. The mix at this lower level will obviously, on the basis of the curve, lack presence and brilliance.

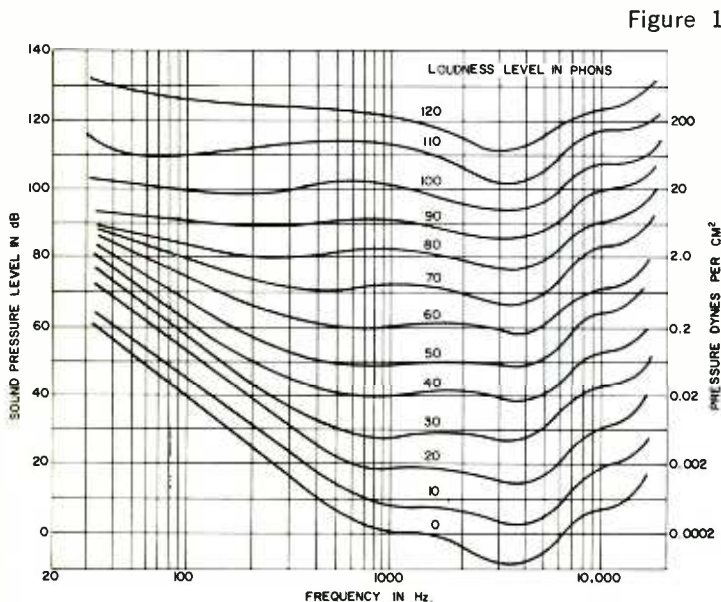

Figure 2. 120dB

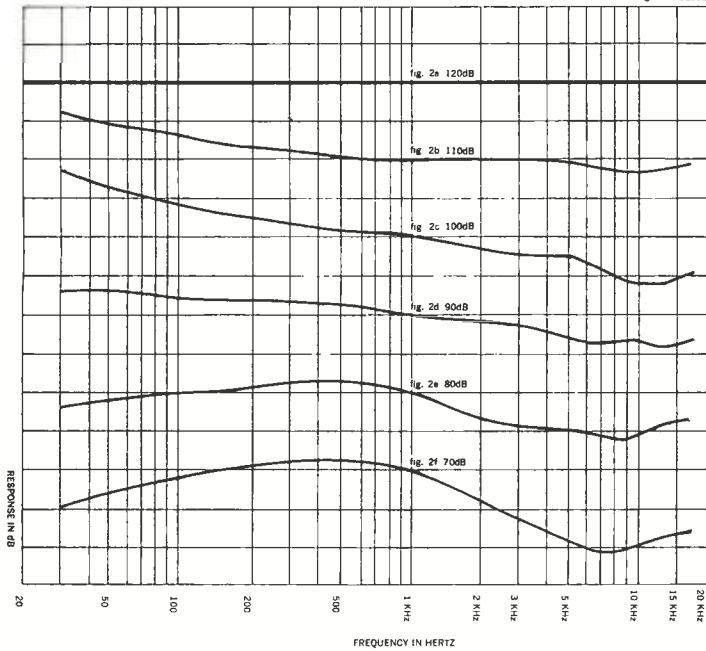

Figure 3. 100dB

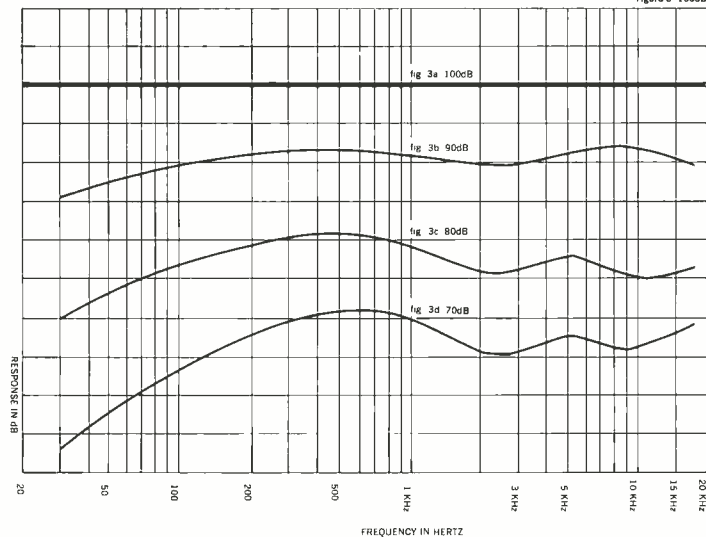
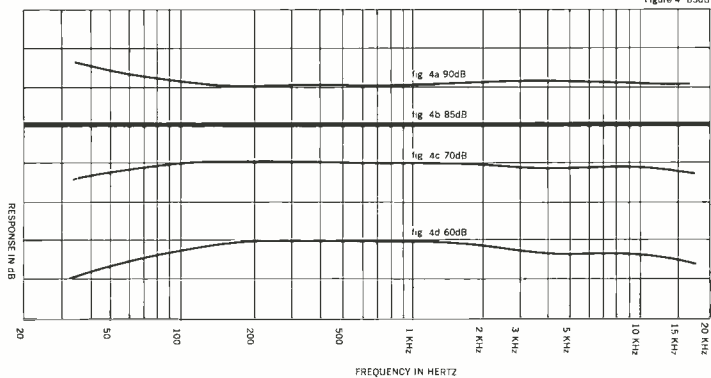

Figure 4. 85dB



Consider, too, the equalization at the 50Hz point. As the level lowered the bass first increases, then falls off as the monitoring volume is further reduced.

Figure 3 represents the same response changes when monitoring and mixing at 100dB. At this level the changes occurring at the bottom end seem to be the problems.

In the field of loudness perception response, a good deal of research has been done to establish the average listening level of music in the home. A fair average would be about 85dB. It seems obvious that material to be marketed and played back at 85dB must be mixed and equalized at 85dB.

Figure 4 graphically displays the conditions for a monitor and mixing level of 85dB.

One method to establish a standard reference monitor level involves using a tape with a 0 level 3rd octave noise centered at 1KHz. With the tape being played through the system at 0 VU the monitor gain is set so that 85dB is measured at the listening position with a sound level meter. The monitor level control can then be marked as 0 level with increases as +dB above the standard and decreases as -dB below the standard level.

The average monitor level will depend on how many speakers are used: 1, 2, or 4. A correction for each configuration will have to be made. Probably the best way to maintain the correct level would be to have a sound meter on the console at all times.

To make a 1KHz noise tape about all you need is some old "high noise" tape, a high-low pass filter, and some extra gain. Record about five (5) minutes of bias noise on the length of tape. Play the tape back through the filter, set as close as possible to pass only the 1KHz component of the noise. Then bring the level to 0 VU and record a new tape on a full track recorder. With this 1KHz noise tape you can also set the levels of your echo chambers, as well.

To set up a two-speaker stereo system, the tape is played and levels are set so that the console VU meters read 0dB. The sound level meter is placed where the mixer's head will be when mixing. The monitor amplifier gain is adjusted so that the sound pressure meter will read 85dB.

A more permanent installation to monitor the loudness level in the control room would be to mount a small omni-directional microphone at the console and connect it to a pre-amp and VU meter which is calibrated to read 0 VU at a loudness level of 85dB. The console talkback microphone and its preamp could be used. It is usually always on at the output of its pre-amp. All you need is an extra VU meter.

Once a standard, be it 85dB or other, has been established, you will probably find less use for a small speaker playback system . . . except to see how a mix will sound on a limited range system. It is important to calibrate the small speakers to the standard level, too.

Now that you've set the monitor level, how would you like to check the frequency response of the speaker system in your control room without special, expensive equipment? You would? Well, we're out of space in this issue, so you'll just have to wait until next time.

END

**If performance
turns you on
turn on the Scully 100**



**Then
to really blow your mind
look at the price tag**

It's a fact. Scully *has* put it all together. A 16-track, professional studio recorder/reproducer that actually out-performs recorders costing at least twice the 100's \$13,700.

The big secret? Like simple. Take the same Scully engineers that design the studio equipment that's been the standard of the business for years. Let them come up with the first really modular unit that lets you buy *only* what you need. Forget all the factory-loaded accessories and extras if you already have them on your consoles. Add them if (and when) you need them.

Then let Scully offer a totally new combined record/playback head, spill-proof silent switching, and a completely new solid-state electronics package. The result? The 100 Series. Half the size and half the cost of available equipment. And performance specs that are outta' sight!

For a demo that'll let you see and hear what we're talking about, write Scully, 480 Bunnell St., Bridgeport, Conn. 06607 (203 335-5146). We'll send you complete 100 specs, and the name of your nearest friendly Scully distributor or Sales/Service office. (There's probably one a dime phone call away.)

What can you lose . . . except all your ideas about how big and how expensive professional recorders really are?

▶ Dictaphone

Scully Division

Listen: we're handing you a line.

The most complete and advanced line of professional audio recorders made.

16-, 8-, 4-, 2- and full-track units to cover just about any audio recording requirements that you'll ever have. All with the same consistent quality and convenience because they're all built with the same transport and electronics.

And the transport is our own unique Isoloop[®], with performance like nothing you've ever seen before: Just 3½" of unsupported tape length. Automatic tape tension control. And the lowest flutter spec in the industry.

The major recording studios agree that it's the finest equipment made, but check it out for yourself. Listen.

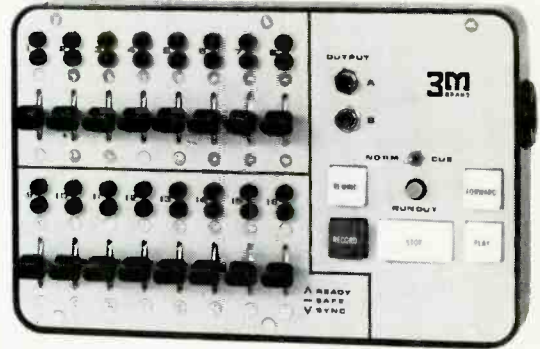

Remote overdub unit for full remote console operation.



Pre-selectable counter for rapid relocation of material.

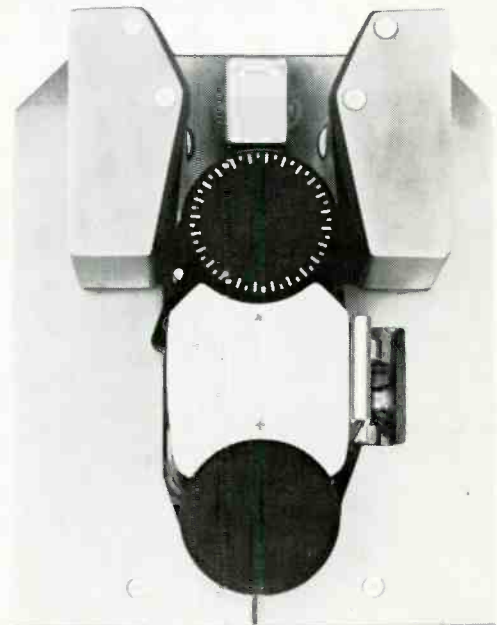

Our unique Isoloop[®] differential capstan tape drive for convenient tape threading and editing and uniform tape speed no matter where you are on the tape. (Isoloop photo)



Our 2-track and 16-track units: they look and sound the same because they're built the same.



This is what the major studios are choosing.

The pitfalls and rewards, musical and otherwise, of recording in the world's largest echo chamber.

QUAD IN GRACE CATHEDRAL

by ROBERT ORBAN

On the nights of February 16 and 17, 1971, the first commercial quad recording sessions ever were held in San Francisco's Grace Cathedral. This monumental edifice to God's glory and Episcopalian financial acumen is blessed with a fine pipe organ, a 90 foot ceiling, and a 7 second reverber-

ation time. The latter, in particular, put some stringent limitations on both the recording technique and musical style involved.

The session was for side 2 of Paul Beaver and Bernard Krause's new Warner Bros. album, **Gandharva**. **Gandharva** is a Sanskrit word, which,

roughly translated, means "the celestial musicians." Since these are not available through the A.F. of M. (contractual limitations being what they are), we imported the nearest counterfeits from Los Angeles: Gerry Mulligan, Gail Laughton, Howard Roberts, and Bud Shank—old timers and all consummate professionals. The music ranged from pure jazz to shades of Webern to more than a hint of Charles Ives. In most cases, the harmonic movement was very slow to avoid muddiness caused by reverberation.

The music was recorded on a 3-M 16-track machine, through six Dolby A-301 units. We recorded a maximum of 12 tracks, leaving 3 open for possible overdubs, and using one for 60 Hz for a film sync track, as the session was being simultaneously filmed in 16mm color. A wild assortment of small mixers were used to handle the mikes, including a custom 8-track Spectra-Sonics and assorted homebrew jobs. Monitoring was through 4 Rectilinear III's, driven by a pair of Harman-Kardon Citation 11 power amps. The speakers were located on the corners of a 9' x 9' square; it was necessary to get them as close as possible to the mixer to overcome the wretchedly echoey acoustics of the vestry that we had commandeered as our control room. The monitor system was fed by a custom 12 in to 4 out high level mixer which served to pan each of the mikes into roughly the same place in which they were scheduled to go in the final mix.

The basic intent of the recording was to use the space in the Cathedral itself in a dramatic and musically effective way. The musicians would often stroll around the building, interacting with the acoustics as well as each other. This provided a special sort of problem for the recording engineer, because the highly reverberant acoustics of the Cathedral necessitated fairly close miking in order to

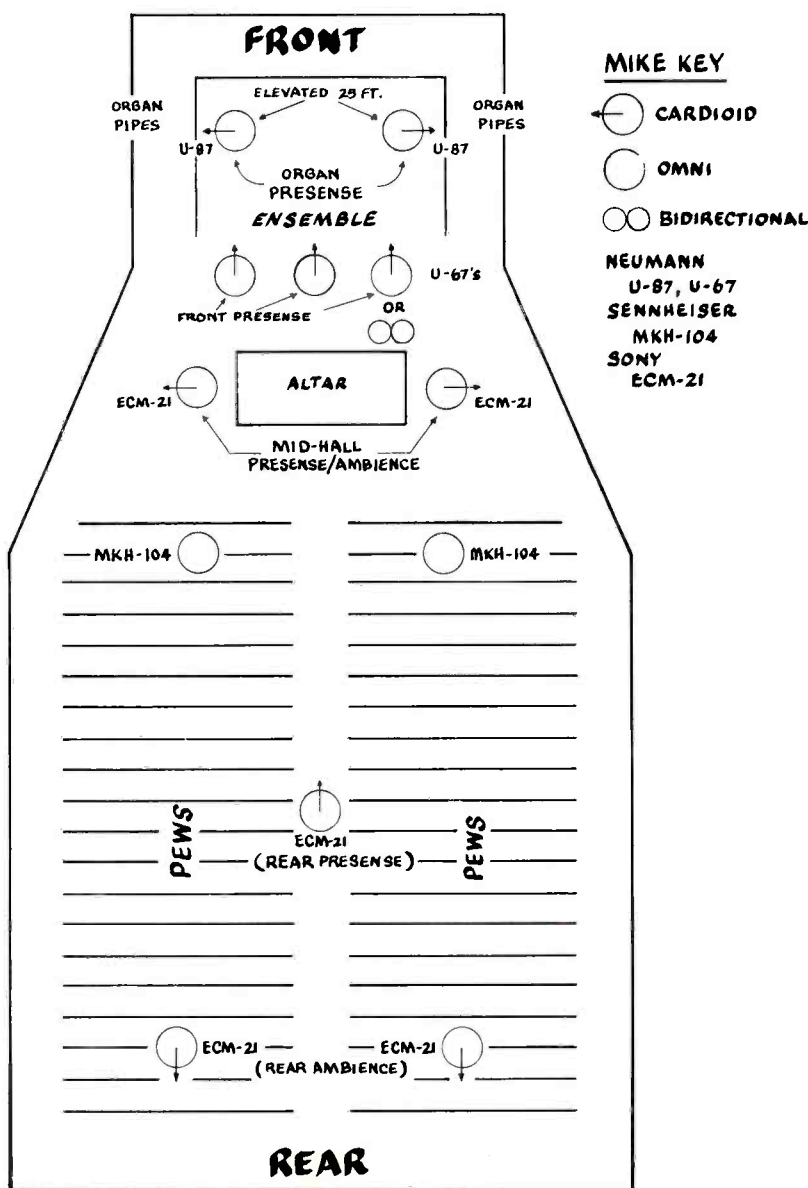

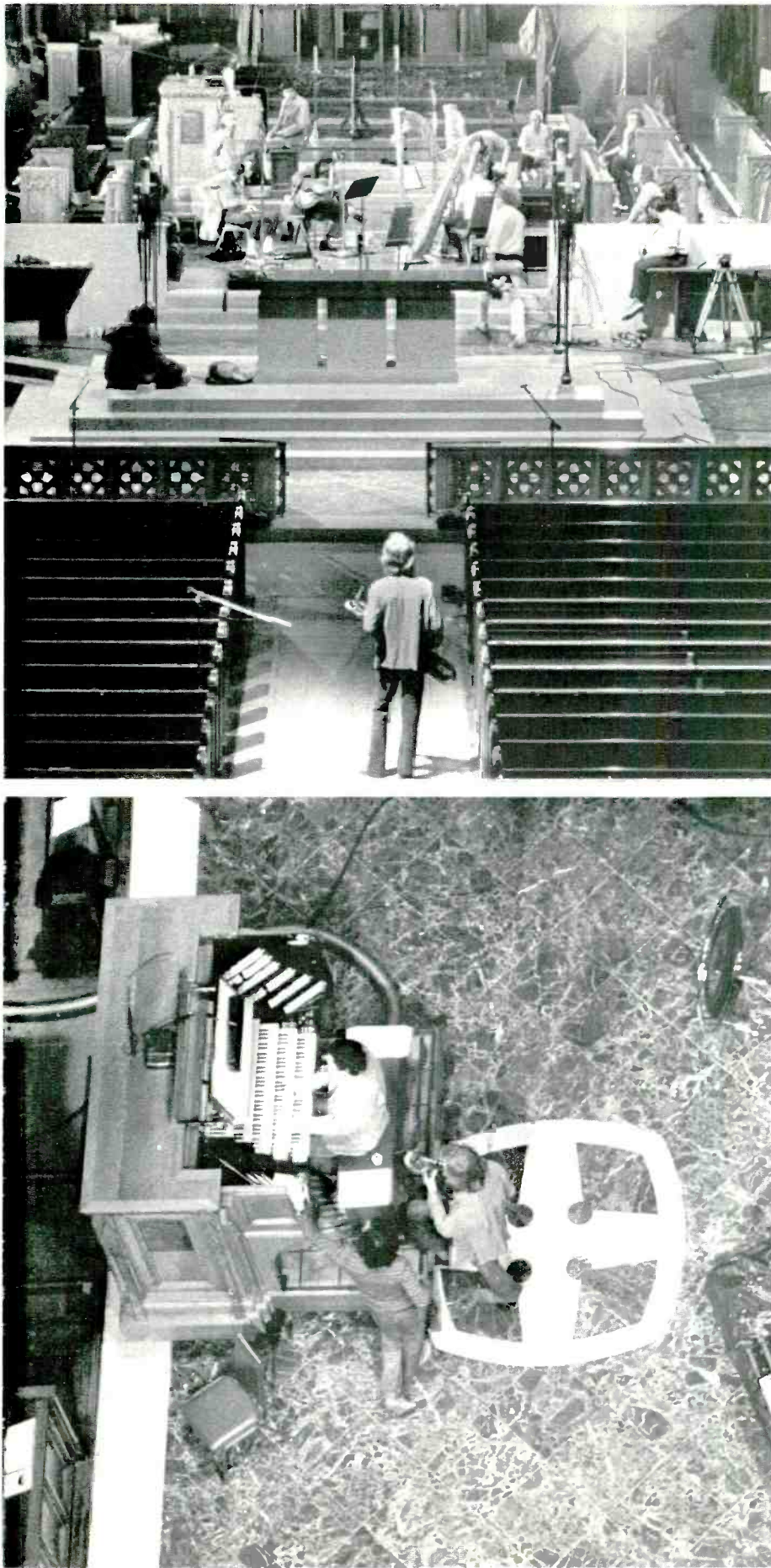

obtain satisfactory presence. Our final solution lay in the use of a number of pairs of mikes, spaced front to back in the Cathedral, as shown in figure 1. These mikes were panned from the front to the rear speakers in the same spatial relationship as existed in the hall, with the rear pair of pure ambience mikes fully in the rear channels, and the front presence mikes fully in the front channels. This gave a somewhat exaggerated, but highly dramatic sense of space, with the entire Cathedral being compressed inside the quad listening field. This was not a classical recording, striving for maximum accuracy, but rather a pop recording exploring the possibilities of the space in a creative manner.

Condenser mikes were used throughout. This may have been a mistake, since we had substantial problems with noise from the ambience microphones due to the very low SPL's involved (imagine recording a flute with a microphone 100' away from the instrument!). I suspect that the use of high-output dynamics for the ambience mikes would have helped the noise problem somewhat. In any event, we managed to keep the noise below the level of a typical stereo LP or reel-to-reel tape, let alone cassette! The spectral content of the noise was closer to "1/f" (3 db/oct low-pass) than gaussian, and this helped reduce its obviousness.

The music could be divided into two basic types. The first involved musicians walking around while they were playing, usually with the pipe organ accompanying. The second involved ensemble playing with the musicians staying in fixed positions near the pipe organ in the front of the church.

The first situation was taken care of with the mikes distributed throughout the hall, plus two presence mikes for the organ: one U-87 for each side of the pipe ranks. The second, surprisingly, caused more problems than the first. The ensemble consisted of guitar (acoustic or electric), flute or alto sax, baritone sax, and **two** harps, played by one harpist. At first, we tried a classic left/center/right stereo pickup for the ensemble. However, this failed due to gross imbalances in the various instruments' acoustic levels. It was finally decided that it was necessary to close-mike each instru-

ment, although this ran counter to our stated goal of using the acoustics of the Cathedral to the greatest possible extent. After extensive experimentation, we finally got sufficient separation to permit a musically balanced mix. Even so, the harp was very marginal, and required extensive equalization in the mix in order to bring it out sufficiently. Unfortunately, it was impossible to baffle the harp because of the time limitations and communications problems between the musicians. Final harp pickup was a Neumann U-67, bidirectional with one harp on each side. The mike was placed maximally close to the sound-ing board.

In the mix, we used the Orban/Parasound Stereo Matrix on the close-miked tracks only in order to regain some of the space which we had lost by essentially mono-miking each of the instruments. In one of the cuts ("Short Film for David"), it was necessary to overdub the harp later in the studio, since it simply couldn't compete with two saxes, electric guitar, and Moog. In the overdubbed material, use of the Stereo Matrix was particularly important, since these tracks had no Cathedral reverberation connected with them, and as mono-miked tracks, they would have come out as incongruous point sources in the live quad sound field.

The musicians were very pleased with the product as it was played in the vestry control room. The last piece in particular ("Bright Shadows") had a magical quality, with the pipe organ permeating the quad space, the harp in front, and baritone sax and flute moving all around the space, calling and answering atiphonally. This piece, in particular, works much better in quad than in stereo—in stereo, everything flattens out, and becomes two-dimensional and non-involving when compared to the quad effect of being in the middle of the space. The stereo mix for all the music recorded at this session was derived from the quad mix by mixing left front and left rear to get the left stereo channel, and by mixing right front and right rear to get the right channel. This procedure required changing the front-to-rear balance for each cut, which is in itself a comment on the essential futility of coming up with a completely satisfactory quad/

stereo compatible disc. In any event, the quad effect was so far superior to the stereo that Beaver and Krause are determined to do all of their future recording quadraphonically.

The mix itself was quite easy. The tracks were panned in the quad space the same way they had been when they were originally monitored. We monitored with JBL 4320's in a square about 5' off the control room floor. The board was a modified Quad-Eight 16-track at the Village Recorder in Los Angeles. We used very little equalization—at the most ± 2 db at 10 kHz or 100 Hz, except for the close-miked instruments, which were equalized more radically. This illustrates the desirability of recording in a hall with good natural acoustics with mikes a reasonable distance from the instruments if a natural, realistic sound (as opposed to super-presence larger-than-life multitrack sound) is desired. No compression or limiting was employed, and Dolby A-361 units were used throughout. My personal feeling is that pop music recording can benefit greatly from the use of Dolby, as their use creates more freedom to post-

equalize, as well as to create musically effective dynamics in the mix. And if American pressing plants could maintain the quality standards routinely maintained by such European firms as Deutsche Grammophon and Phillips, we could even get these dynamics unmarred to the home listener. (This is a somewhat bitter and extremely unsubtle plea to the people responsible for quality control of American discs.)

It is interesting to mention in passing that the other side of the disc was recorded using the usual 16-track studio mono-miking techniques. We used a pair of Parasound Stereo Matrices for front and back to generate the quad space. The spatial sense was quite impressive, and the ability to place musical material front, back, and at both sides greatly aided in separating complex musical textures. Nevertheless, the artificial space was not as real or as effective as the natural sound of Grace Cathedral, and it was the unanimous conclusion of everyone involved in the remote that the money and effort had been well-spent.

END

YOU- SHAPED SOUND...

with Automated Processes Quadrasonic Stereo Panner Model 480

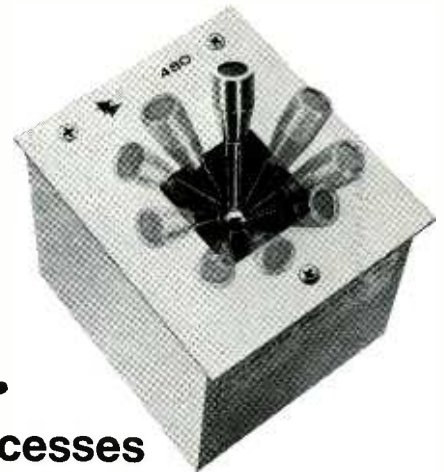

Precise, finger-tip, 360° control of a sound source into 4-channels is yours with the Model 480 Quadrasonic Stereo Panner. It lets you create any type of motion pattern; sequeways between stereo programs; reverb sound combinations; or static positioning (if that's all you want).

The single-knob "joystick" provides infinite resolution . . . stepless movement, noiseless and accurate. It also acts as a visual indicator for the phantom sound source.

We designed the Model 480 to meet the demanding requirements of 4-channel sound positioning...low noise conductive plastic elements, precious metal contacts, connections for splitting 1 channel into 4, or simultaneous 2 into 2.

No power supply required. Occupies only 3" x 3½" of panel space, 3⅞" deep.

To put "you" in the 4-channel driver's seat, contact us at once for technical literature.

AUTOMATED PROCESSES, INC.
35 CENTRAL DRIVE, FARMINGDALE, NEW YORK 11735-516-694-9212
In Canada: PERCEPTION INDUSTRIES, INC.

Circle No. 114

Re/p 29

The best
microphone buy
for the money.



Recently Sony engineers measured the distortion* of the ECM-377 (\$195) and its most prestigious (i.e. expensive) competitor. Here's what they found:

SPL	Sony ECM-377	Most Prestigious Competitor
100dB	< .05%	.8%
110dB	.05%	2.3%
120dB	.08%	>10 %
130dB	.2%	>10 %
140dB	1.2%	>10 %
150dB	>10 %	>10 %

If you think the most prestigious competitor sounds good up close, imagine how the Sony ECM-377 sounds! Better yet — see your nearest Sony / Superscope Special Applications Products Dealer. Or write: Sony / Superscope, 8132 Sunland Blvd., Sun Valley, Calif. 91352.

SONY SUPERSCOPE

*Intermodulation Distortion. 70Hz and 7kHz; 4:1 ratio; applied to input of impedance translator at level which is equivalent to capsule output at specified SPL.
©Superscope, Inc.

Circle No. 115

Re/p 30

NEW PRODUCT NEWS

ELECTRO-VOICE "STEREO-4" FOUR-TO-TWO CHANNEL ENCODER NOW AVAILABLE. The Encoder, model 7445, is standard 19-inch rack-mounted and takes only 5 1/4-inches of space. Input and output lines are 600 ohm with zero insertion loss. The Encoder causes virtually no degradation of signal response, distortion or noise level.

The E-V Stereo-4 system makes possible and practical the manufacture of compatible four-channel records and the broadcasting of four-channel sound by FM stereo stations by encoding any original 4-channel program (from tape, live source, etc.) into a 2-channel signal which contains both two- and four-channel material. Records are then cut and manufactured in the identical way and with the same equipment now in regular use for standard two-channel discs. Broadcasters can be on the air immediately with four-channel stereo information as existing stereo transmission equipment is used. No change in bandwidth or standards is required, and blanket approval has been received from the F.C.C. for the system to be used by any station. Compatible 2/4-channel tape cartridges and cassettes are easier to produce using the Stereo-4 system than separate tracks, and playback equipment is less complicated and not as expensive.

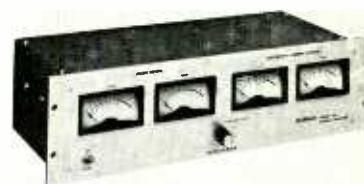

In the home, Stereo-4 records are played on regular stereo record-playing equipment and broadcasts are received on a standard stereo-FM tuner. To reproduce the program in 4-channel sound, an Electro-Voice EVX-4 Decoder and two additional amplifier channels and speakers are added to the present stereo system. Without these additions, the listener hears regular 2-channel stereo sound.

Electro-Voice's home Decoder, EVX-4, is now being widely distributed for sale by local dealers at a suggested retail price of \$59.95.

The Model 7445 E-V Stereo-4 Encoder is priced at a professional net of \$795.00.

ELECTRO-VOICE, INC., 600 CECIL STREET, BUCHANAN, MICHIGAN 49107

Circle No. 116

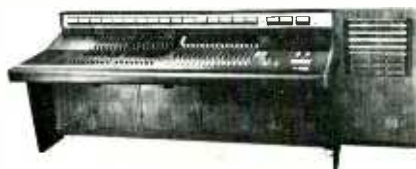

ELECTRODYNE, a division of MCA Technology, has introduced an audio control console, model ACC-2416.

The basic ACC-2416 console uses solid-state circuit amplifier modules throughout and makes use of a newly developed line of modular channel select switches which provide complete 16-track output selection.

The console is outfitted with a wide selection of options.

ELECTRODYNE, 13035 SATICOY STREET, NORTH HOLLYWOOD, CALIFORNIA 91605.

Circle No. 117

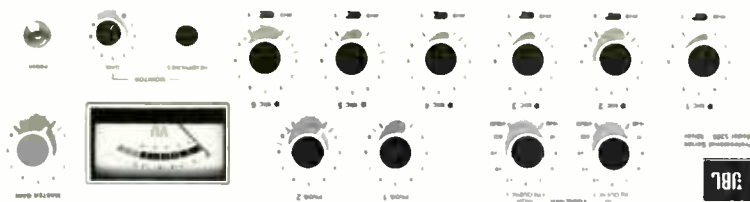

NEW JBL 5306 MIXER. JBL announces its newest Professional Equipment Division product, the model 5306 Mixer/Preamplifier. The unit is capable of mixing six microphone preamps and two high level program channels. Inputs and outputs are designed for a high degree of flexibility enabling use in a variety of professional applications. The unit features all solid state silicon transistor circuitry, low noise microphone preamplifiers, VU meter, headphone

monitor jack, monitor level control, and 3dB/step bass and treble controls. The program inputs accept tape, tuner or other similar sources and are convertible to 600 ohm impedances. All microphone inputs are equipped with integral transformers. Total output goes to +18 dBm at less than .15% THD, 30 - 20 kHz.

JAMES B. LANSING SOUND, INC.,
3249 CASITAS AVENUE, LOS ANGELES, CALIF. 90039.

Circle No. 118

OPAMP LABS 10 STATION PORTABLE MIC-MIXDOWN CONSOLE KIT. Offered in kit form the new Opamp mixer may be assembled to provide for any combination of microphone/line inputs to any number of outputs depending on the number of stations (10 per panel) used.

Typical 8 input—2 output, full EQ mixer in kit form is approximately \$1800.00.

OPAMP LABS INC., 172 S. ALTA VISTA BLVD., LOS ANGELES, CA. 90036.



Circle No. 119

AKG INTRODUCES OMNI-DIRECTIONAL DYNAMIC MICROPHONE. The Model AKG D-160E is the latest professional

omni-directional dynamic microphone which will find application for in-studio use and on-location pick-up work.

The D-160E features a removable, rugged wire mesh windscreen which, when mounted, locks securely to the microphone body. Without the windscreen the microphone has an absolute linear frequency response; with the windscreen, the unit has a presence rise of 4-5 dB between 3,000-12,000 Hz.

The D-160E's response characteristics are maintained uniformly over the entire polar range of 360° and it has an above average output level of -55 dB. Price: \$60.00 net.

AKG, 100 EAST 42nd STREET, NEW YORK, N.Y. 10017.



Circle No. 120

NEW!

PANNING AND SLIDERS ON A BUDGET

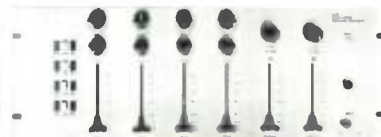

EM-7S Four Input Stereo Echo Mixer

All features of our regular EM-7 Mixer plus slide pots, panning active mixing and IC circuitry. Duplicates all big board effects when used with ES-7 echo unit and PEQ-7 equalizer.

FOUR CHANNEL ACTIVE PEAKING TYPE EQUALIZER



PEQ-7 Four Channel Equalizer

Update your EM-7 system or use with new EM-7S Mixer. Five Hi freq. peaking type curves, 1.5, 3, 5, 10, and 20 kHz. Boost or cut in steps of 2, 4, 6, 9, or 12 dB. EQ in-out switch. Zero insertion loss.

GATELY ELECTRONICS

57 WEST HILLCREST AVENUE
HAVERTOWN, PENNA. 19083
AREA CODE 215 • HI 6-1415
...have you checked Gately lately?

Circle No. 121

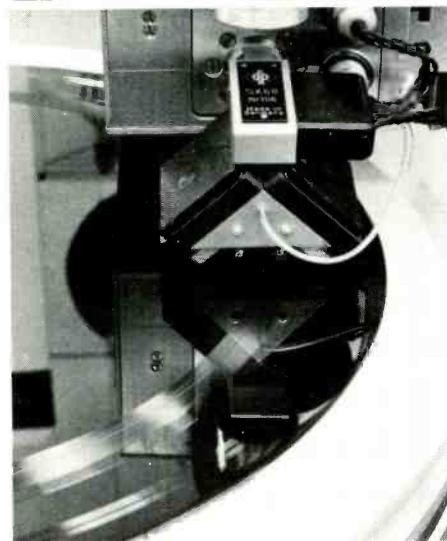

We do it all at our place

We invite you to use all or any part of Capitol's unlimited know-how and modern facilities to express your musical statement.

We offer you our creative engineers, the finest equipment, including our partially computerized marvel, the new Quad 8, 16-Track Console, remix and SX-68 disc-cutting facilities. And if you wish, Capitol will even wrap up your entire sound package, from recording to jacketing. So for the most professional and complete deal anywhere... bring your sound to Capitol.

Circle this ad number on the reader service card and we'll send you our rate card.

CAPITOL CUSTOM SERVICES, A Department of the Special Markets Division.



Hollywood: 1750 N. Vine
Hollywood, Calif. 90028
(213) 462-6252

New York: 151 W. 46th
New York, New York 10036
(212) 582-8040

37

Circle No. 122

Re/p 32

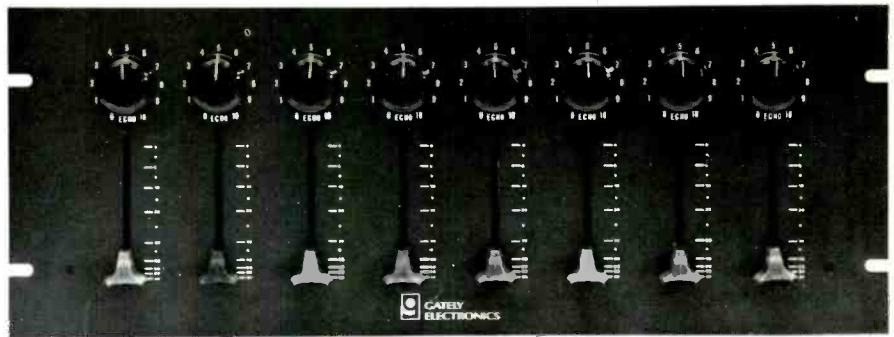

GATELY ELECTRONICS ANNOUNCES THE INTRODUCTION OF ITS NEW SM-8 AND SM-8E SUBMASTER MODULES. This new addition to the Gately Series 8 line of professional audio equipment is intended for submastering between the mixing busses and the multichannel recorder. It features IC operational amplifiers on each channel and has an overgain of 15 db. Output is rated at +22 dBm into 600

ohms and noise at -80 dBm. The unit is available with Penny & Giles, Langevin or Kuhlman slide attenuators.

The SM-8 and SM-8E differ in that the SM-8E has additional rotary controls for mixing echo signals into the program signals so that "WET" recording can be accomplished.

GATELY ELECTRONICS, 57 WEST HILLCREST AVENUE, HAVERTOWN, PA.,

Circle No. 123

NEW BEYER "M-101-N" DYNAMIC MOVING COIL MICROPHONE. The new M-101-N is an extremely small omni-directional microphone. Weighing only 95 grams, it is impervious to body noise and claims an absolutely flat frequency response curve. Accepting speech modulated voltages up to 2 V, the M-101-N can also be used as a talk back microphone.

Frequency Response: 40-20,000 Hz \pm 2.5 dB.

The microphone has had excellent results on bass drum and piano recordings.



BEYER/REVOX CORPORATION, 155 MICHAEL DRIVE, SYOSSET, NEW YORK 11791.

Circle No. 124

OTARI OF AMERICA ANNOUNCES PROFESSIONAL TAPE DECK. First of a family of Professional Recorder Decks by Otari, the MX7000 Series is designed for hard and continuous operation. This professional equipment features three-speed hysteresis syn-



chronization motor; automatic equalization in 3 $\frac{3}{4}$, 7 $\frac{1}{2}$ and 15 ips; built-in test oscillator at 700 Hz and 10 KHz; plug-in head assemblies from full track to four track quad stereo; multi-track synchronization; two to six-pole reel motors for superior winding and 10 $\frac{1}{2}$ -inch NAB reel capacity. Built into this tape deck series are the years of experience of Otari, world renowned as a manufacturer of high-speed 32 to 1 Tape Duplicators. Price: \$1,980. OTARI OF AMERICA, 8295 S. LA CIENEGA BLVD., INGLEWOOD, CA. 90301.

Circle No. 125

3M PROFESSIONAL RECORDER COUNTER-LOCATOR AVAILABLE. A counter locator which will search and automatically locate a pre-selected tape position, has been developed for 8- and 16-track 3M brand professional recorders.

The 3M brand Selectake is used during a recording session to automatically search the tape and to locate previously logged takes. The Selector stops the tape at the pre-selected location with ± 2 counts of the readout counter. It can be overridden manually.

The accessory has four digital display tubes to indicate recorder tape position. Controls include the "pre-selector" which sets the location of a predetermined tape position on the recorder, a "count enable" which al-

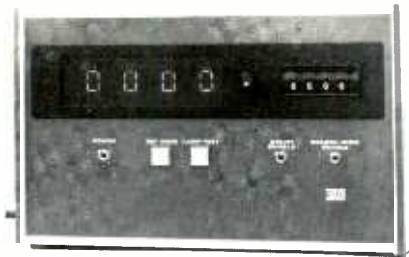

lows the operator to maintain a registered count during such modes as editing, and a "search-stop enable" which inhibits automatic search operation.

The Selectake is priced at \$895.00.

Further information may be obtained from 3M COMPANY, PROFESSIONAL AUDIO PRODUCTS, 300 SOUTH LEWIS ROAD, CAMARILLO, CALIFORNIA 93010.

Circle No. 126

MINIATURE, TRANSISTORIZED SINE/SQUARE WAVE GENERATOR Model DF-24 is designed especially for exacting electronic work where high frequency accuracy is required. Nevertheless, it is priced very modestly, at only \$65.00.

Frequency range, in three bands, is 10 Hz to 166.5 KHz for sine wave . . . 20 Hz to 20.0 KHz for square wave. Frequency accuracy for sine wave and square wave is 1% ± 1 Hz, assured by the use of solid state components and accurate calibration. Output signal amplitude is controlled by a variable attenuator with high resolution.

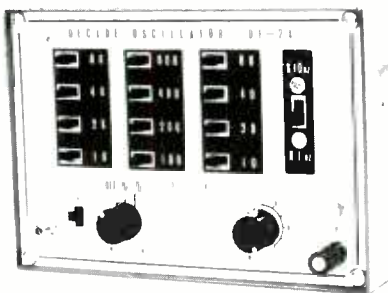

Sine/Square Wave Generator Model DF-24 is available from the ELECTRONIC TOOLS DIVISION OF H. C. MITCHELL CO., 14614 RAYMER STREET, VAN NUYS, CALIFORNIA 91405.

Circle No. 127

TONUS ANNOUNCES THE INTRODUCTION OF THE ARP 2600 PORTABLE SYNTHESIZER. This synthesizer, recently made available in a rugged "suitcase," can be used as an additional keyboard sitting atop any existing organ or piano, or as a solo instrument.

Sold at retail for \$2490, it is aimed primarily at those interested in creating realistic and expressive instrumental voices, supplementing the tone resources of organs, electric pianos, and other conventional instruments. Since the performer controls every aspect of the sound, not just volume and pitch, he is also free to "invent" his own "fantasy" instru-



ments with an endless range of strange and wonderful sounds. And the ARP 2600 Portable synthesizer is human-engineered for performers—sounds can be changed simply and quickly using slide controls.

TONUS INC., 45 KENNETH STREET, NEWTON HIGHLANDS, MA. 02161.

Circle No. 128

The best
microphone
money can buy.



Recently Sony engineers measured the distortion* of the Sony C-500 and its most prestigious competitor. Here's what they found:

SPL	Most Prestigious Competitor	
	Sony C-500	
100dB	<.05%	.8%
110dB	<.05%	2.3%
120dB	<.05%	>10 %
130dB	<.05%	>10 %
140dB	.05%	>10 %
150dB	.97%	>10 %

If you think the most prestigious competitor sounds good up close, imagine how the Sony C-500 sounds! Better yet — see your nearest Sony / Superscope Special Application Products Dealer. Or write: Sony / Superscope, 8132 Surland Blvd., Sun Valley, Calif. 91352.

SONY SUPERSCOPE

*Intermodulation Distortion: 70Hz and 7kHz, 4:1 ratio, applied to input of impedance transformer at level which is equivalent to capsule output at specified SPL.

© Superscope, Inc.

Circle No. 129

Re/p 33

NEW TEAC "SL" SERIES PROFESSIONAL TAPE DECKS. Identified as Models 6010 SL, 7010 SL, and 7030 SL, these decks incorporate more than 50 modifications including all plug-in relays, advanced power supply design, increased dynamic range, reduced distortion and improved signal to noise ratio, bias switching changes, bias and record equalization. The machines accommodate both standard and low noise/high output tapes.



The "SL" suffix identifies these decks as belonging to this new generation of superior sound/low noise line.

Models 7010SL and 7030SL accept reels up to and including 10½ inches.

The Model 6010SL accepts 7" reels only. TEAC CORP OF AMERICA, 2000 COLORADO AVENUE, SANTA MONICA, CA 90404.

Circle No. 130

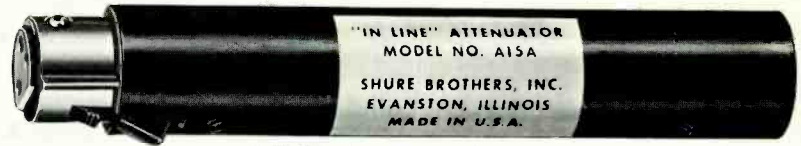

SHURE INTRODUCES SERIES OF VERSATILE "IN LINE" COMPONENTS. A series of seven "IN LINE" microphone attenuators, equalizers, and adapters have been announced by Shure Brothers Inc., Evanston, Illinois.

The small (4½" long, ¾" diameter) plug-in components are designed to provide permanent modification of an existing system as well as last minute modification of a portable system during assembly. The series includes (1) the A15A Microphone Attenuator, ideal for use by a rock group to prevent input overload; (2) the A15PR Phase Reverser, created to reverse the phase of a balanced line without modification of the equipment; (3) the A15HP High Pass Filter, which reduces low-frequency mechanical noises through a low-

frequency cut-off; and (4) the A15LP Low Pass Filter, which reduces high-frequency noises through a high-frequency cut-off.

Other components in the group are (5) the A15PA Presence Adapter, designed to add vocal or instrumental "presence" in recording, broadcast and P.A. applications; (6) the A15RS Response Shaper, for flattening response from an overly "bright" system; and (7) the A15LA Line Input Adapter, which converts a balanced low impedance microphone input to a line level input.

List price of each component in the A15 Series is \$25.00. Components can be purchased individually or in a set. SHURE BROTHERS INC., 222 HARTREY AVENUE, EVANSTON, ILLINOIS 60204.

Circle No. 131

NEW OPAMP MEDIUM VOLTAGE D.C. OPERATIONAL AMPLIFIER FOR AUDIO CONSOLE AND INDUSTRIAL APPLICATIONS. The Model 425 Differential D.C. Operational Amplifier features a matched pair of low noise input transistors coupled to an Opamp 4009 D.C. Operational Amplifier with a Class AB power output stage. It has less than 0.05% THD. at a gain of 100 and has a high output voltage (±22V) and current (±100MA) capability. The amplifier may be used at any supply voltage from ±6V to ±25V.



OPAMP LABS., 172 S. ALTA VISTA BLVD., LOS ANGELES, CA. 90036.

Circle No. 132

From TELEVISION EQUIPMENT ASSOCIATES FNORK, the compact 16-channel portable mike mixer. Integrated circuit technology offers a complete audio console in a rugged executive-styled attaché case. FNORK is everything you need to do an on-location recording or broadcast. Sixteen low-impedance mike inputs, miniature straight-line faders, left-center-right mike channel switching, two 20-watt monitor amps. larae professional VU

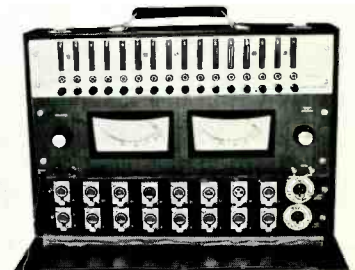

eters, 16-6-4-2-1 channel output, 16 switchable 20 dB input pads for high-level miking, built-in test oscillator. PRICE . . . \$1,600. Available from: TELEVISION EQUIPMENT ASSOCIATES, BOX 1391, BAYVILLE, NEW YORK 11709.

Circle No. 133

NEW PREAMPLIFIERS FROM SHURE SOLVE VARIETY OF AUDIO PROBLEMS. Two new stereo preamplifiers that provide the voltage gain, equalization, and choice of impedances necessary to operate magnetic phono cartridges and tape playback heads have been announced by Shure Brothers Inc., Evanston, Illinois.

The preamplifiers, the Model M64 and the Model M64-2E, provide complete freedom from microphonics, extremely low noise, and the ability to use 50 feet or more of output cable when used as an impedance converter and buffer amplifier. Both models have a single slide switch for selecting equalization for phono, tape, or flat. Positions provide RIAA for magnetic stereo cartridges, NAB for tape head equalization, and flat for microphone or for use as a buffer amplifier. Both models offer high level, high impedance outputs and low level, low impedance outputs plus a minimum of 50 db isolation



between channels.

The Model M64 operates on 120 volts, 50/60 Hz power line, or from an auxiliary 24 to 36-volt DC supply such as the Shure Model A67B Battery Power Supply. The M64-2E is identical to the M64 except that it operates on a line voltage of 240 volts, 50/60 Hz.

Suggested retail price of each model is \$34.00. SHURE BROTHERS INCORPORATED, 222 HARTREY AVENUE, EVANSTON, ILLINOIS 60204.

Circle No. 134

'HERN' A NEW LOW-COST AUTOMATIC SYNTHESIZER. Recording studios and broadcasters can create, embellish and reproduce musical jingles and tags easily and automatically without expensive electronic synthesizers or costly recording sessions. It's simple to tune and operate and is capable of infinite variations around a single tune or a variation of the tune itself.

HERN produces a series of sixteen notes. Each note can be tuned over a three-octave range. After tuning each note and arriving at a satisfactory tune, the entire melody can be adjusted over an additional three-octave range. Tremolo and/or vibrato can be added in varying amounts. The harmonic content can be varied to produce a deep bass accompaniment or a thin, reedy sound. The length of each note and the tempo of the melody are independently adjustable over a



wide range. Attack and decay are individually adjustable for realistic musical effects.

The unit has a built-in cue speaker and a 'phone jack. A noiseless switch converts the unit from a tuning mode to "on line" operation, with a variable output level up to +8dbm. -600 Ω.

For tapes demonstrating HERN's versatility, 'phone TELEVISION EQUIPMENT ASSOCIATES, BAYVILLE, NEW YORK: (516) 628-8068.

Circle No. 135

Please include a Recording engineer/producer address label whenever you write to us about your subscription. The numbers on your address label are essential to insure prompt and accurate service.

(attach label here)

MAIL TO: Recording engineer/producer
Box 2287 hollywood, calif. 90028

Put an AKG on the job.



D-58E

Differential Noise-cancelling,
Dynamic Microphone
\$43.00 Net

It will sound better!

AKG 122

For complete information
on AKG performance
write to:



MICROPHONES • HEADPHONES

13157-464279-13 897
NORTH AMERICAN PHILIPS CORPORATION
100 EAST 42ND STREET, NEW YORK, NEW YORK 10017

AKG CANADA • DIVISION OF DOUBLE DIAMOND ELECTRONICS • SCARBOROUGH, ONTARIO

Circle No. 136 Re/p 35

For comparison purposes, the following table represents values for 398 Hz filters of various Q (Band Width) values.

Note: $C_1 = C_2 = .5 \mu f$ $|A_0| = 10$

Q	R	R	R
5	400Ω	80Ω	8K
10	800Ω	40Ω	16K
25	2K	16Ω	40K
50	4K	8Ω	80K
100	8K	4Ω	160K

In most applications, a pot is used at the output of each filter and thence to an active combining network (summing amplifier).

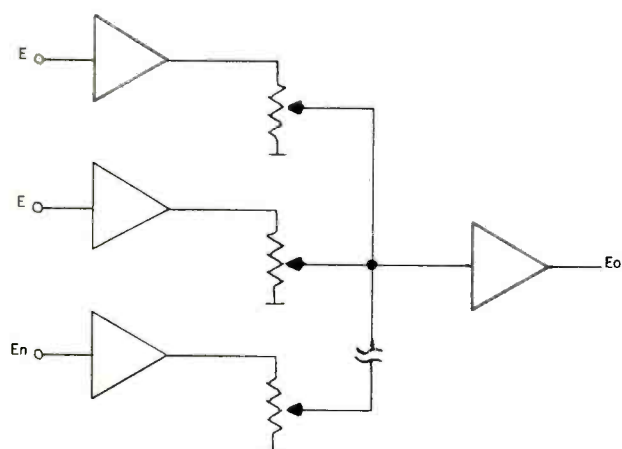

For the circuit, as finally built, an OPAMP LABS 4009 and a FAIRCHILD μa 741 were used interchangeably with equally good results.

Caution: Pin assignments for the amplifiers are different. Further usefulness of these circuits can only be left to the imagination of the users. **END**

**DIRECTOR OF RECORDING
and
CHIEF ENGINEER**

Desires position and long term alliance with major recording studio. Top professional, mature engineering executive and administrator. Highly experienced in all phases of the recording industry. Responsible for design and development of recording systems, acoustical design, financial budgeting, administrator of studio operations and management. Willing to accept any responsibility.

Resumé on request:

Recording engineer/producer
Dept. DR
Box 2287
Hollywood, Calif. 90028

**ELECTRO-VOICE AND SENNHEISER
SIGN PATENT EXCHANGE AGREEMENT**

An announcement has been made that two internationally reputed microphone manufacturers, Electro-Voice, Inc., a subsidiary of Gulton Industries, and Sennheiser Electronic of Wennebostel, West Germany, concluded a far-reaching agreement that provides for a broad exchange of patents relating to microphones. This agreement, signed in Wennebostel by Lawrence LeKashman, president of Electro-Voice and Professor Dr. -Ing Fritz Sennheiser, sole owner of Sennheiser Electronic Company, aims at the mutual endeavor to produce products of the highest quality standards and precludes possible adverse effects resulting from contrasting patents of the parties involved.

The autonomy of both companies will not be impaired by this agreement.

ADVERTISERS INDEX

AKG	35
ALLISON RESEARCH	14
ALTEC-LANSING	16
AUTOMATED PROCESSES	29
BEYER/REVOX	39
CAPITOL RECORDS	32
CROWN INTERNATIONAL	12
DOLBY LABS	20
ELECTRO-VOICE	BACK COVER
FLICKINGER ASSOCIATES	COVER 2
GATELY ELECTRONICS	30
MCA TECHNOLOGY	8
MCI	22
OPAMP LABS	39
SCULLY RECORDING EQUIP	25
SPECTRA SONICS	10
SUPERSCOPE	31, 33
TEMPO AUDIO	7
3-M COMPANY	26
YAMAHA INTERNATIONAL	6

CLASSIFIED

Send for **FREE** Catalog
and Audio Applications



OPAMP LABS

172 S. Alta Vista Blvd.
Los Angeles, Calif. 90036
(213) 934-3566



Circle No. 137

EQUIPMENT AVAILABLE

FOR SALE: Established and prosperous recording studios in N.Y.C. Consisting of two floors, fully equipped and air conditioned. Includes luxurious five room apartment with fireplace and terrace. Extremely low rent. Tom, 212 OX-1-6661.

FOR SALE — 8 track 1" transport and head assembly — 100% NEW — Also new tape transports from 1/4" to 1" — willing to talk prices - contact:

ROGER TOLCES
213-467-7890

or write c/o Dept. RT R-E/P Hollywood

America's Largest Selection of New and Used
RECORDING EQUIPMENT

Bought, Sold, Traded — Write for Free Listing

THE MAZE CORPORATION

P. O. Box 6636, Birmingham, Alabama 35210

ONE STOP FOR ALL YOUR PROFESSIONAL
AUDIO REQUIREMENTS.
BOTTOM LINE ORIENTED.

F. T. C. BREWER COMPANY

P. O. Box 8057, Pensacola, Florida, 32505

PROFESSIONAL NATIONWIDE STUDIO
DESIGN, INSTALLATION, AND SERVICING.
PLAN BEFORE YOU SPEND!

THE MAZE CORPORATION

P. O. Box 6636, Birmingham, Alabama 35210

NOTICE

INDIVIDUALS seeking employment in the recording industry may submit their qualifications for **FREE** publication in *RECORDING engineer/producer*.

Listings will be limited to 30 words, and will be limited by available space. Listings will be selected for publication on the basis of earliest postmark. Listings will not be automatically repeated or carried over to the succeeding issue.

CREATIVE STUDIO ENGINEER

Three years experience as: Mixer, Design consultant, construction, and all around studio operation. Seeking opportunity to further my ability and experience.

Complete resume & references sent upon request. David Huston (216) 371-1695
P. O. Box 18126, Cleveland Hts., Ohio 44118

FAMOUS IN EUROPE* FOR MICROPHONES FOR OVER 40 YEARS

BEYER



* TELL EVERYONE WE'VE ARRIVED!

Revox Corporation • 155 Michael Drive • Syosset, N. Y. 11791

Circle No. 138

USED RECORDING EQUIPMENT SALE

Trade-ins, surplus, in good used condition.

Sample Items	New	Sale Price
Altec 1590 Power Amps	\$ 369.00	\$ 200.00
Altec 290E Drivers & Horns	\$ 294.00	\$ 150.00
Altec Console Electronics package for 8- or 16-Track Console, like new condition	\$12,400.00	\$3,500.00
Ampex AG-440-4B Recorders	\$ 5,150.00	\$3,500.00
Ampex AG-440-2 Recorders	\$ 3,120.00	\$1,800.00
Crown DC-300 Power Amps	\$ 685.00	\$ 400.00
Electro-Voice 666 Microphones	\$ 162.00	\$ 75.00
Langevin EQ251A Equalizers	\$ 270.00	\$ 160.00
RCA 77DX Microphones	\$ 225.00	\$ 100.00
RCA BK-5 Microphones	\$ 162.00	\$ 95.00
Sennheiser 804 Condenser Microphone Systems	\$ 322.00	\$ 130.00
Sennheiser 404 Condenser Microphone Systems	\$ 409.00	\$ 170.00

For complete detailed listing with price information, and for your specific needs, drop a card to:
P.O. BOX 2646 • HOLLYWOOD, CA. 90028

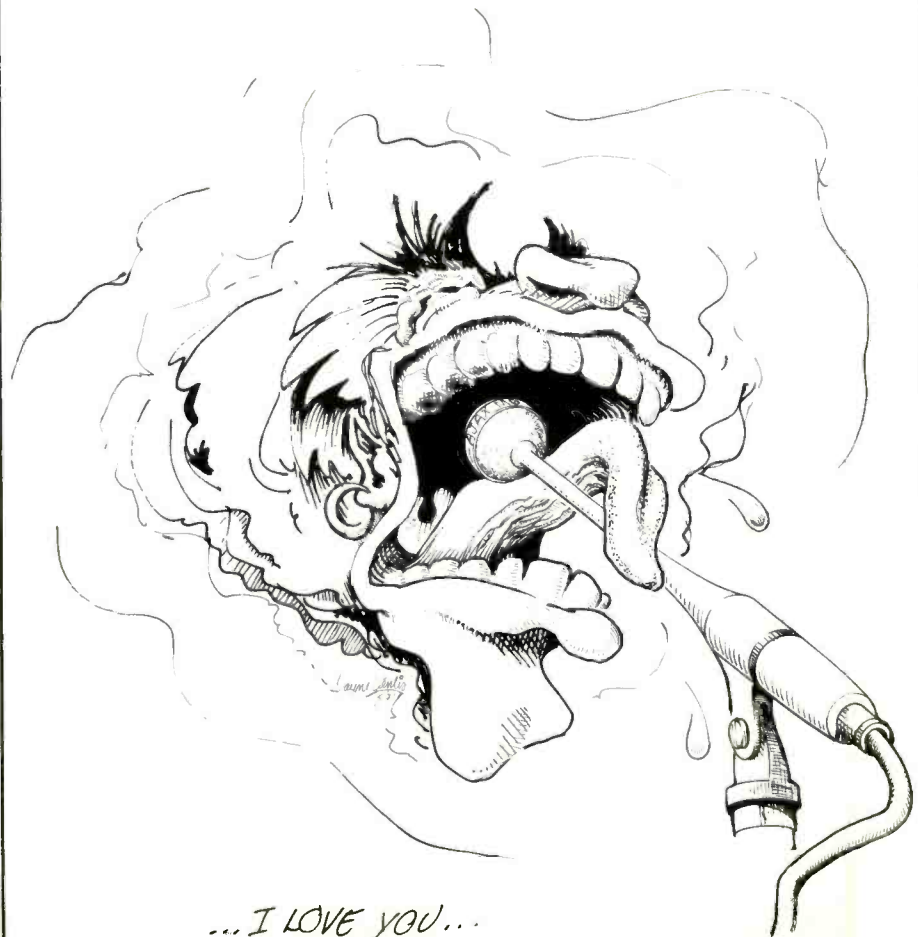

EV STEREO-4™
compatible four channel

4-CHANNEL SOUND

Electro-Voice is making it happen for you...today!

(Being more a progress report than an advertisement.)

The Promise

Thousands of people have heard 4-channel stereo reproduction at hi-fi shows and special demonstrations in the last few years. Others have read about this fascinating and rewarding technique that promises more faithful reproduction of musical performances. Early experiments have also shown 4-channel to be an effective tool in creating new sonic environments for both serious and popular musical forms. The concept has met with almost universal critical acclaim, and strong general approval.

The Problem

But alas only a handful of enthusiasts are actually enjoying this advance today. Because only a few 4-channel tapes have been produced for sale. The problem is simple, but basic: 4-channel means just that—four separate signals. And to reproduce it properly demands four of everything, right down the line.

It's possible (albeit expensive) with reel-to-reel and cartridge tape. But the stumbling block has been to put four completely independent signals in a record groove, or to broadcast them over a standard stereo FM station.

And if you can't make 4-channel discs, or play them on FM, the market is limited to a precious few 4-channel tape owners. But their numbers are so small that the record industry just can't afford to release four channel material. So the industry continues to produce 2-channel stereo that anyone *can* play (and that can be sold in volume).

The Way Out

Now Electro-Voice has moved to break the impasse. With a system that can offer the significant advantages of discrete 4-channel, yet is compatible with present record manufacturing and playback equipment and present FM broadcasting. It is called STEREO-4.

STEREO-4 is a system that encodes four channels into a stereo signal that CAN be transmitted over FM or recorded on a disc, stereo cassette or cartridge. The home listener adds a STEREO-4 decoder, plus another stereo amplifier and a pair of rear speakers. The result is reproduction that closely rivals the original 4-channel sound. Four different signals from the speakers, with a feeling of depth and ambiance you have never before heard from any record.

Admittedly, STEREO-4 is not quite the equal of 4 discrete signals. But while there is some loss of stereo separation, there is no reduction in frequency response or overall fidelity. We might note that this reduced separation actually seems to aid the psycho-acoustic effect for many listeners in normal listening situations. And on the plus side, STEREO-4 offers an advantage that even discrete 4-channel cannot provide.

The Remarkable Bonus

Playback of almost all present 2-channel stereo discs and tapes is greatly enhanced when fed through the STEREO-4 decoder. It's the result of multi-microphone recording techniques that include a remarkable amount of 4-channel information on ordinary stereo discs and tapes. Adding STEREO-4 releases this hidden information for all to enjoy.



Model EVX-4
STEREO-4
decoder

The Decoder

A STEREO-4 Model EVX-4 Decoder costs just \$59.95. And with it, plus 4 speakers and dual stereo amplifiers, the listener is equipped for almost any kind of sound available. Encoded 4-channel, enhanced stereo, regular stereo, and discrete 4-channel (assuming suit-

able source equipment). Even mono. So STEREO-4 is the one system that is compatible with the past, present, and foreseeable future.

The Present

And what about encoded 4-channel discs and broadcasts? Well, that's where you come in. Already recording companies have started mastering STEREO-4 records, and their ranks are growing. And STEREO-4 is now being broadcast in many major cities around the country.

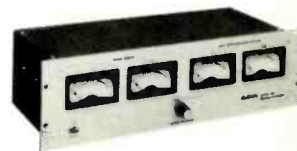

Model 7445
Professional
STEREO-4
Encoder

The Encoder

All that is needed is a Model 7445 Professional STEREO-4 Encoder \$795.00 net, direct from the factory. The encoder is patched into your console. No other changes in equipment or handling, whether broadcasting or recording (except that you'll want to add 4-channel monitoring, of course). No increase in costs. And your performance standards are unaffected. The encoder doesn't add noise, distortion, or limitations on response. And listeners without a decoder still enjoy all the music in conventional 2-channel stereo. Some record producers even feel that the STEREO-4 encoder results in better 2-channel stereo than conventional mix-down techniques.

The Future

Like you, we hope for the day when discrete 4-channel sound will be commonplace on records and FM, and when STEREO-4 decoders will be relegated to enhancing present libraries. But that day will have to wait until some very knotty design problems are solved. And probably after a host of new FCC regulations define an utterly new system. Indeed, there is serious question whether these problems can be solved at all.

In the meantime, the STEREO-4 system is getting 4-channel recordings into the marketplace in increasing numbers, in a form that people can enjoy. EVX-4 STEREO-4 decoders are now on the market in quantity. And STEREO-4 decoder circuits are being designed into mass-produced stereo phonos and receivers. Even STEREO-4 juke boxes are now in use!

What Can You Do?

Write us today for all of the technical details, plus up-to-date news of STEREO-4. Make news yourself by adding compatible STEREO-4 for your audience. It's not too soon to start planning for tomorrow!

ELECTRO-VOICE, INC., Dept. 514RP
674 Cecil Street, Buchanan, Michigan 49107
In Europe: Electro-Voice, S.A., Lyss-Strasse 55,
2560 Nidau, Switzerland

Electro-Voice®
a GULTON subsidiary