

Stereo Review

APRIL 1973 • 60 CENTS

“...AND LYRICS BY COMDEN AND GREEN”

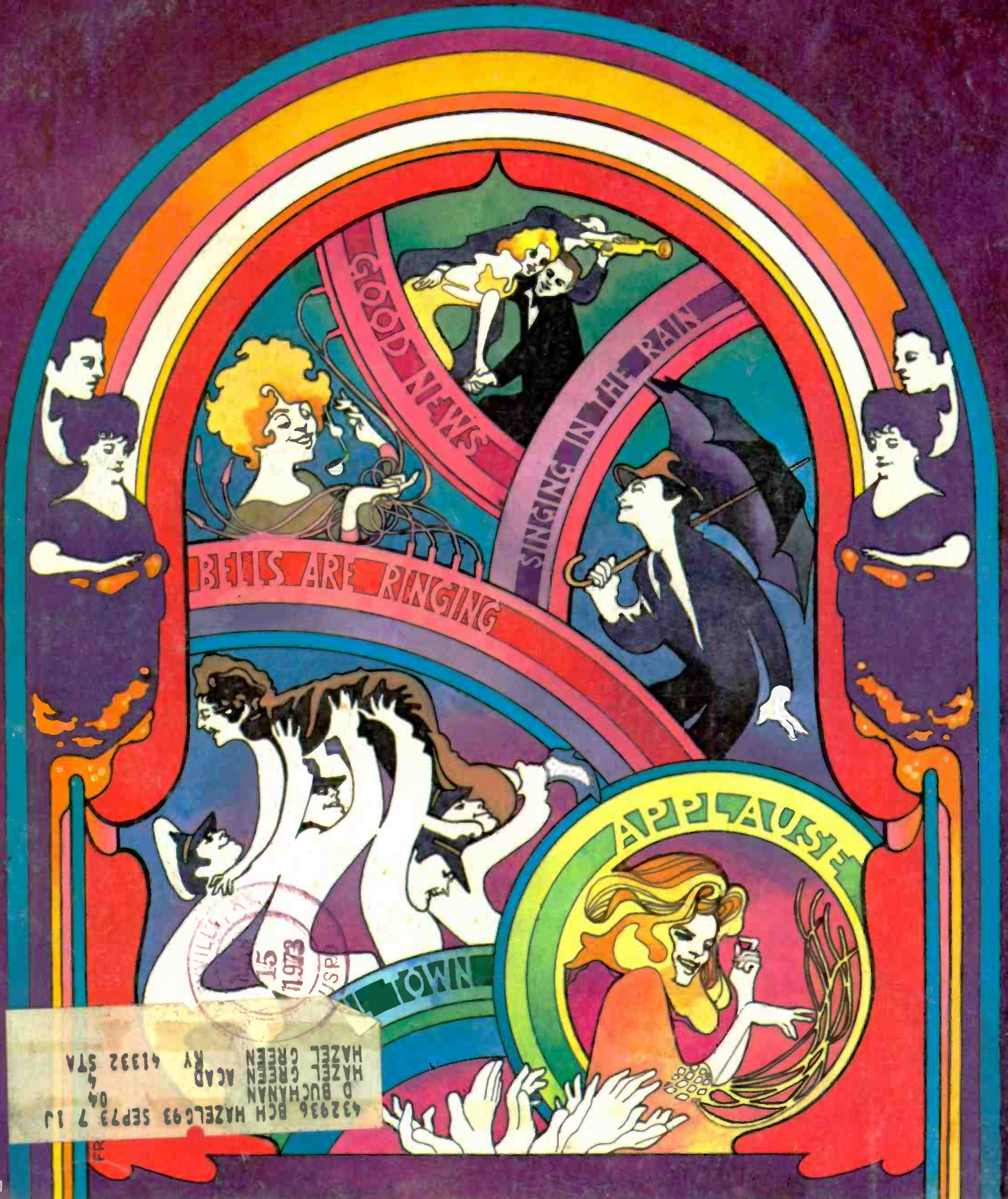

432936 BCH HAZELG93 SEP73 7 1J
D BUCHANAN
HAZEL GREEN
ACAD KY 41332 57A
15 11.973
USP

Pioneer's new and



phase distortion, plus substantially better stability with four double tuned phase linear ceramic filters and four monolithic IC's in the IF section.

6-stage limiters

The IF section includes 6-stage limiter circuits. Used in conjunction with differential amplifiers in monolithic IC's, noise interference is completely eliminated with a signal to noise ratio of 75dB.

Exclusive Phase Lock Loop (PLL) IC circuitry in the TX-9100 multiplex section

Developed and used for the first time by Pioneer, the Phase Lock Loop (PLL) circuit is actually an electronic servomechanism. It maintains continuous and precise phasing between the pilot signal and the subcarrier, supplying optimum channel separation. Completely drift free, no alignment is ever required.

The PLL cannot be affected by humidity or temperature since there are no coils or capacitors to be detuned. This provides complete stability and reliability.

New pulse noise suppressor in the TX-9100 operates with computer control

This circuit operates automatically when it is switched on. It effectively blocks radiated noise from airplane and auto ignition systems, neon and traffic lights, etc. It does not interfere with frequency response and stereo separation. Whether the signal is weak or strong, this automatic 'brain' decides when the PNS gate circuit is to operate.

Unique muting control

A 2-position variable muting control uses electronic switching as well as reed relay switching. This eliminates interstation noise and the popping noise of tuning and detuning.

Complete command with a wide variety of controls

Whether it's for AM, FM or headset output levels, Pioneer provides greater operating precision with three independently operated output level controls. A headset may be used without a following power amplifier. Precision tuning is achieved with the aid of signal strength and tuning meters.

AM section highlights IC's

The entire AM section, following the front end, is a unitized IC. A monolithic IC replaces 84 individual components plus a ceramic filter. By using a differential amp circuit and a balanced mixing circuit, there are better spurious characteristics and special AGC amplification.

Great specs for great performance

	TX-9100	TX-8100	TX-7100
FM Sensitivity (IHF)	1.5uV	1.8uV	1.9uV
Selectivity	90dB	80dB	60dB
Capture Ratio	1dB	1dB	1dB
S/N Ratio	75dB	70dB	70dB
Image Rejection	110dB	100dB	85dB
Stereo Separation	40dB	40dB	40dB
Distortion (THD)			
Mono	0.2%	0.2%	0.2%
Stereo	0.3%	0.4%	0.4%
Spurious Response	110dB	100dB	100dB

The Amplifiers: SA-9100, SA-8100, SA-7100

Two separate power supplies utilize 30,000 uF total capacitance

You read it right. The power supply in the SA-9100 uses a total capacitance of 30,000 uF. 15,000 uF each for the balanced positive and negative power supplies. This completely eclipses anything now available in integrated amplifiers. This super high capacitance results in an absolutely pure DC voltage supply. There's constant DC voltage regulation regardless

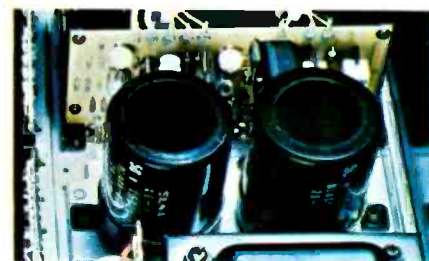

Two 15,000uF power supplies eclipse anything now available in integrated amplifiers.

of line voltage changes and signal input. Even at extremely low frequencies there's stable power output, excellent transient response and minimum distortion — only 0.1% at any frequency between 20-20,000Hz for 60 watts output per channel.

These positive and negative power supplies provide absolute stability in all stages, even in the equalizer amp and proceeding to the control and power amps. Therefore, the signal lines become zero potential to completely eliminate the usual (and annoying) click noise of operating controls and switches.

Stability is increased even further by the differential amplifier used in the first stages of the equalizer and control amplifiers (also the power amp.) 100% DC negative feedback supplies excellent stability and transient response; it also eliminates distortion. To further increase

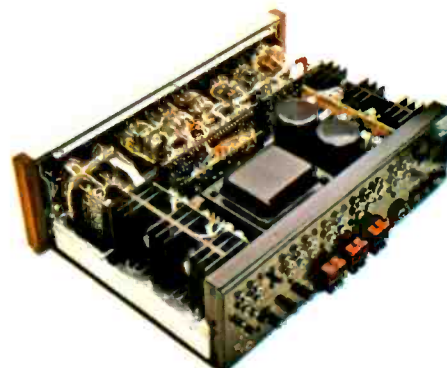

Interior view. SA-9100

Announcing a major breakthrough
that will have universal impact
on all future high fidelity
components and their
performance.

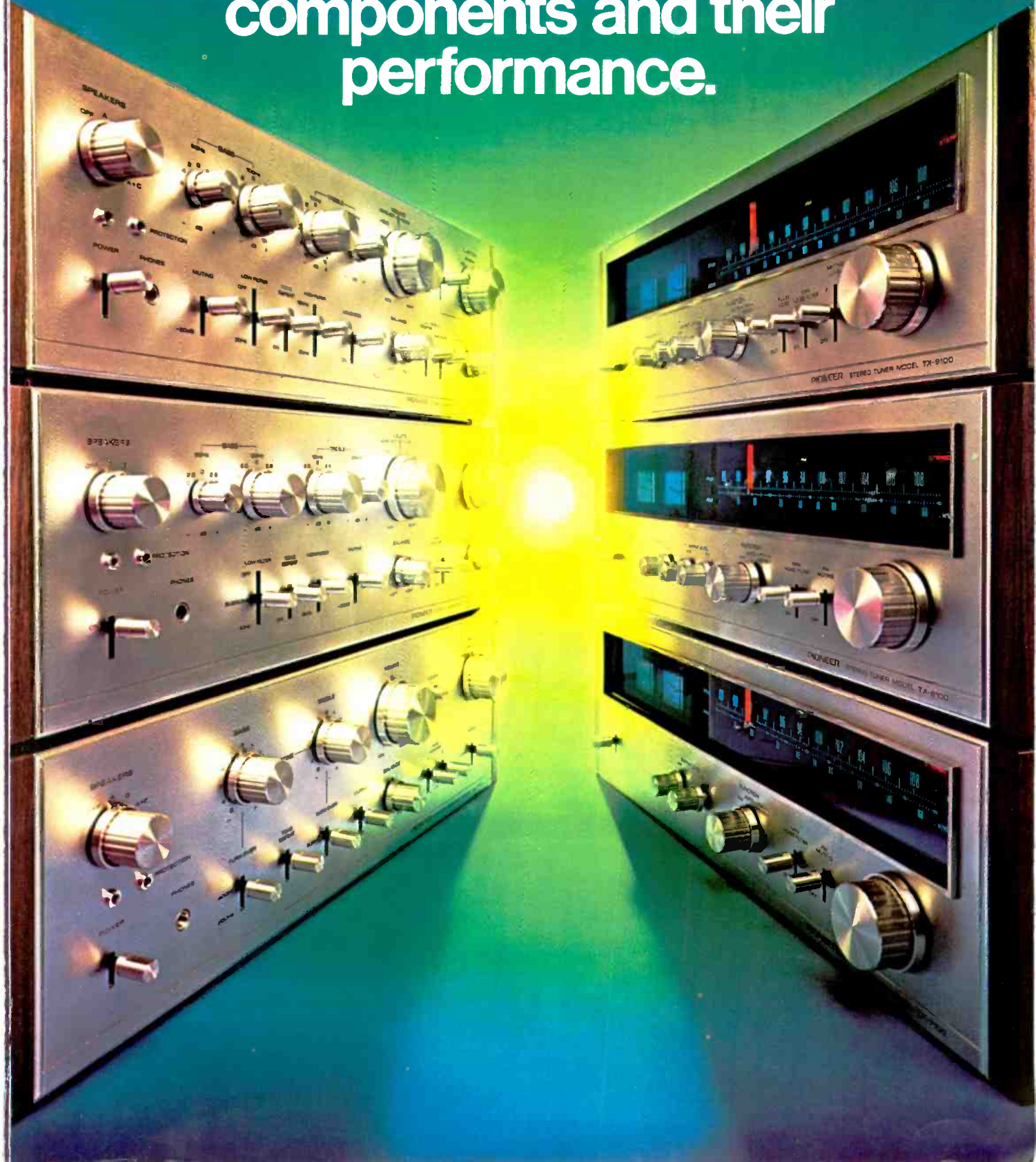

Introducing Pioneer series of tuners and amplifiers.



The time has come to completely re-evaluate the standard you now use to judge high fidelity performance.

With this new line of tuners and amplifiers, Pioneer presents many ingenious innovations in circuitry that are being used for the first time. However, this exclusiveness is only secondary. While each new circuit can be considered revolutionary by itself, what is even more important is that their combined capabilities achieve precision and performance heretofore unattainable.

The Tuners: TX-9100, TX-8100, TX-7100

FM front end — an engineering triumph
The height of sophistication, the TX-9100's stabilized, drift-free front end replaces printed circuit boards with completely metallized construction. The same used in high precision communications equipment.

Employing three dual gate MOS FET's and a buffer circuit in the local oscillator,



Exclusive heavy gauge die cast aluminum housing assures uncanny stability.

there's exceptionally high gain with extremely low noise. Two tuned RF stages with a 5-gang variable tuning capacitor contribute to the highest selectivity (90dB) and astonishing FM sensitivity (1.5uV). The exclusive use of a heavy gauge die cast aluminum housing assures uncanny stability.

IF section — the epitome of advanced research

In the pursuit of excellence, significant new IF section technology was developed. The result is optimum selectivity with minimum

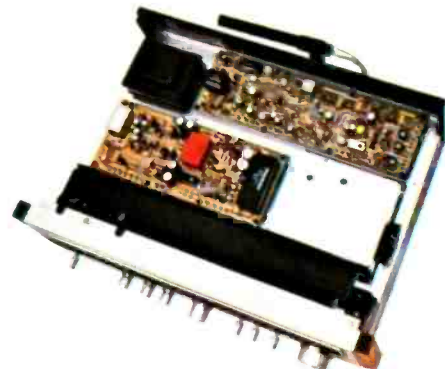

TX-9100 interior view. Chrome plated shielded front end housing and multiplex section.

stabilization, special electronic regulator circuits are used. Transient response is also improved with a superb damping factor of 70.

The unique equalizer amplifier

To make certain that extraneous signals do not interfere with the input signal, the equalizer amp is totally enclosed and sealed to shield it against leakage.

There's also extra assurance of precision with special low noise metal film resistors and styrol capacitors. Both are manufactured under continuous computer control to highest laboratory test equipment tolerances: $\pm 1\%$ for resistors; $\pm 2\%$ for capacitors. Until now such precision has been unheard of in hi-fi equipment. Deviation from the ideal RIAA curve is only $\pm 0.2\text{dB}$.

Since a direct-coupled SEPP complementary circuit is used in the equalizer amplifier, virtually any dynamic phono cartridge can be accommodated without overloading or distortion. For example, with 2.5 mV sensitivity, the overload at 1KHz is an unbelievable 250mV, and 1200mV at 10KHz!

The power amplifier

To sustain the ultra sophistication of the equalizer and control amp sections, the power amp has a direct-coupled pure complementary SEPP circuit, double differential amplifiers and two constant current loads. The combined effect is the achievement of wide power frequency range and excellent transient response. 100% negative DC feedback is supplemented by 66dB dynamic negative feedback for minimum distortion and absolute stability. The pre and power amps can be used independently with a separation switch.

Exclusive direct-coupling in all stages

Until now direct-coupling has been used only with the power amplifier. Pioneer takes it a dramatic step further in the SA-9100 and SA-8100. Direct-coupling in all stages from the equalizer amp to the control amp to the power amp. More effective? Absolutely. It achieves the finest transient response, wider dynamic range, THD and IM distortion of only 0.04% (1 watt). It's an incredible achievement.

Level set, volume and loudness contour controls adjust to listening preference

Three controls working together adjust to any degree of loudness. The level set control is the primary volume control. Its maximum loudness setting is 0dB.

Successive settings of -15dB and -30dB result in lower gain. Once the desired volume is obtained, the volume control is used for fine adjustments within the given

range. While the loudness contour boosts bass and treble, it may also be used with the level set control. The more advanced the position of the level set control, the lower the effective range of the loudness contour.

The original and positive speaker protector circuit

Since the signal is fed directly to the speakers because of direct-coupling, an automatic electronic trigger relay system is incorporated into the power amplifier. This protects the speakers against damage from DC leakage which can also cause distortion. It also prevents short circuits in the power transistors.

Maximum convenience for program source selection

While there is a multiple function rotary switch for microphone, phono 2 and two auxiliaries, Pioneer has included an

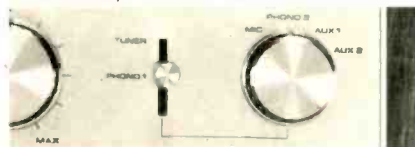

Convenient program source selection switch & control lever.

PIONEER
when you want something better

additional convenience. A separate flip type lever control for instant switching between the more widely used tuner and phono 1 and any other single program source. Incidentally, both switches are shielded to protect the input against undesirable extraneous signal pickups.

Two-way tape duplicating and monitoring

There are two separate flip type switches on the front panel of the SA-9100 for tape-to-tape duplicating and monitoring. Two tape decks can be connected for recording, playback and duplicating in either direction, with simultaneous monitoring.

Level controls for phono 2, aux 2

In order to match the level of various inputs, individual level controls are provided for phono 2 and aux 2.

Speaker B control

This special control helps in the use of two pairs of speaker systems of different efficiencies. There is no sacrifice of damping or distortion when switching from one pair to the other.

Impedance selector for phono 2

An easy-to-use switch allows you to employ any phono cartridge input (25K, 50K, 100K ohms).

Two-position high & low filters

The low filter switch on the SA-9100 and SA-8100 has subsonic (below 8Hz) and 30Hz positions. The high filter switch has 12KHz and 8KHz positions.

Maximum versatility in program sources

	SA-9100	SA-8100	SA-7100
Inputs			
Tape monitor—S/N	2-90dB	2-90dB	2-90dB
Phono—S/N	2-80dB	2-80dB	2-80dB
Auxiliary—S/N	2-90dB	2-90dB	2-90dB
Microphone—S/N	2-70dB	2-70dB	1-70dB
Tuner—S/N	1-90dB	1-90dB	1-90dB
Outputs			
Speakers	3	2	2
Headsets	1	1	1
Tape Rec.	2	2	2

Consistent power for every requirement

	RMS power both channels driven 20-20KHz	RMS @ 8 ohms both channels driven @ 1KHz	RMS @ 4 ohms single channel driven @ 1KHz
SA-9100	60+60 watts	65+65 watts	100+100 watts
SA-8100	40+40 watts	44+44 watts	60+60 watts
SA-7100	20+20 watts	22+22 watts	36+36 watts

This new lineup of Pioneer tuners and amplifiers is unquestionably the most advanced available today. Yet despite this overwhelming sophistication, they're sensibly priced.

See your Pioneer dealer. He'll show you how this series of fine instruments can outperform any units in their price range. All prices include walnut cabinets. SA-9100—\$399.95; SA-8100—\$299.95; SA-7100—\$229.95; TX-9100—\$299.95; TX-8100—\$229.95; TX-7100—\$179.95.

While not discussed here, Pioneer is also introducing the SA-5200 stereo amplifier and the TX-6200 stereo tuner for high quality hi-fi on a low budget. Only \$129.95 each, with walnut cabinet.

U.S. Pioneer Electronics Corp., 178 Commerce Rd., Carlstadt, New Jersey 07072

West: 13300 S. Estrella, Los Angeles 90248 / Midwest: 1500 Greenleaf, Elk Grove Village, Ill. 60007 / Canada: S. H. Parker Co., Ont.

Twin stepped tone controls.

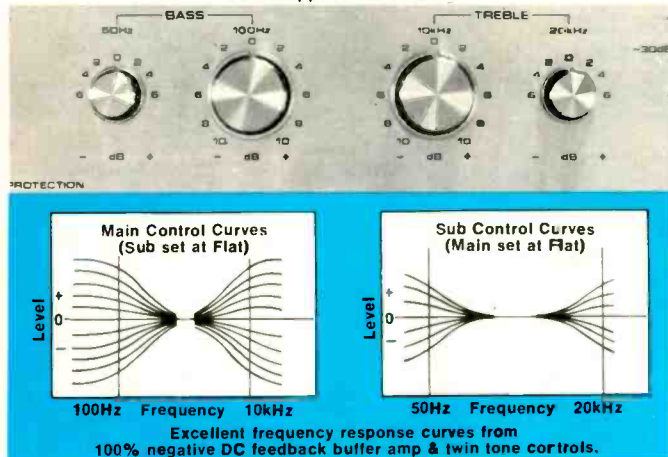

Excellent frequency response curves from 100% negative DC feedback buffer amp & twin tone controls.

The control amplifier: Twin stepped tone controls custom tailor your listening.

Now you can make the most critical bass and treble adjustments with supreme ease. In fact, there are 5,929 tonal combinations to suit your listening room acoustics and to compare or compensate for component frequency response.

On the SA-9100 and SA-8100 four tone controls (two for bass, two for treble) make 2dB (2.5dB with SA-8100) step adjustments for the entire audio spectrum. Working together with the tone controls is a buffer amplifier with 100% negative DC feedback. The main bass control governs $\pm 10\text{dB}$ at 100 Hz; the sub-bass, $\pm 6\text{dB}$ at 50 Hz. The main treble control governs $\pm 10\text{dB}$ at 10KHz and the sub-treble, $\pm 6\text{dB}$ at 20 KHz. This, plus the tone defeat control (described in the next paragraph) makes the SA-9100 the most exciting-to-use amplifier that has ever powered any hi-fi system.

New tone defeat switch

Because of the extremely wide variety (5,929) of frequency adjustments made possible by the twin tone controls, the tone defeat switch adds extra flexibility. Adjusting the tone controls to your satisfaction, you can flip the tone defeat switch. Bass and treble responses instantly become flat. When it is switched off you return to the original tone control settings.



It's here!

The **BOSE 1801™**
solid state dual channel
power amplifier

One page cannot begin to tell the story of this unique new amplifier.

A *sixteen page* illustrated color brochure and a dramatic listening experience await you at your local franchised BOSE dealer.

BOSE®

Framingham, Massachusetts 01701

FORMERLY HI FI/STEREO REVIEW

Stereo Review

APRIL 1973 • VOLUME 30 • NUMBER 4

THE MUSIC

THE BASIC REPERTOIRE

Hindemith's Mathis der Maler Symphony MARTIN BOOKSPAN 53

BETTY COMDEN & ADOLPH GREEN

Their words make the music more memorable PAUL KRESH 54

CAROLE BOGARD

An "accidental" specialist talks about her kind of Baroque STEPHEN E. RUBIN 64

A BASIC LIBRARY OF THE CLASSICAL GUITAR

The harvest may be lean, but it's very nourishing FRED GRUNFELD 66

JONATHAN EDWARDS

A young troubadour shuns the chords of fame SUSAN LARABEE 72

THE BEACH BOYS REGROUP

A Sixties pop group comes up with a Seventies album LESTER BANGS 88

THE MOVE

A timely retrospective of a group on the verge GREG SHAW 104

A MONSTER CONCERT

There's no such thing as "too many pianos" ROBERT OFFERGELD 108

THE EQUIPMENT

NEW PRODUCTS

A roundup of the latest high-fidelity equipment 14

AUDIO QUESTIONS AND ANSWERS

Advice on readers' technical questions LARRY KLEIN 18

AUDIO BASICS

The Frequency of Sounds RALPH HODGES 24

TECHNICAL TALK

Continuous Power Problems; Hirsch-Houck Laboratories reports on the Lafayette LR-4000 receiver, the Magnum Opus 7 speaker system, the Rotel RA-1210 stereo amplifier, and the Pickering V-15 Micro IV cartridges JULIAN D. HIRSCH 31

AMPLIFIER POWER SPECIFICATIONS

The FTC moves to protect consumers from misleading specs WILLIAM D. DIXON 74

TAPE HORIZONS

Setting Up to Record CRAIG STARK 134

THE REVIEWS

BEST RECORDINGS OF THE MONTH 79

POPULAR DISCS AND TAPES 85

CLASSICAL DISCS AND TAPES 107

THE REGULARS

EDITORIALLY SPEAKING WILLIAM ANDERSON 6

LETTERS TO THE EDITOR 8

GOING ON RECORD JAMES GOODFRIEND 46

ADVERTISERS' INDEX 134

COVER: GOUACHE BY FREDERIC MARVIN

Copyright © 1973 by Ziff-Davis Publishing Company. All rights reserved. Stereo Review, April 1973, Volume 30, Number 4. Published monthly by Ziff-Davis Publishing Company; Editorial and Executive Offices at One Park Avenue, New York, N.Y. 10016; Telephone: 212 679-7200. William Ziff, President; W. Bradford Briggs, Executive Vice President; Hershel B. Sarbin, Senior Vice President and Secretary; Philip Sine, Financial Vice President and Treasurer. Also the publishers of Boating, Car and Driver, Cycle, Flying, Modern Bride, Popular Electronics Including Electronics World, Popular Photography, and Skiing. One year subscription rate for U.S., U.S. possessions, and Canada, \$7.00; all other countries, \$8.00. Second class postage paid at New York, N.Y. and at additional mailing offices. Authorized as second class mail by the Post Office Department, Ottawa, Canada, and for payment of postage in cash. SUBSCRIPTION SERVICE: Forms 3579 and all subscription correspondence should be addressed to Stereo Review, Circulation Department, P.O. Box 2771, Boulder, Colorado 80302. Please allow at least six weeks for change of address. Include your old address, as well as new - enclosing if possible an address label from a recent issue.



NOT AN OMNI. NOT A STRAIGHT SHOOTER. BETTER THAN EITHER.

Fisher ST-550 Studio Standard Speaker System

Drivers	15" woofer, two 1 1/2" midrange domes, two 2" cone tweeters, two 1 1/2" side-dispersion domes (total of 7)
Dispersion	"Controlled" type (neither omni nor directional)
Power-handling capacity, rms	300 watts for 2 sec. 100 watts for 60 sec. 50 watts long-term average

A solo guitar that appears to stretch from wall to wall. A singer whose mouth seems fifteen feet wide. If you like that sort of thing, you can have it with omnidirectional speakers that use reflected sound for dispersion.

You can also have shrunken orchestras and choral groups with narrow-dispersion speakers that use straight-firing drivers only.

Or you can have *controlled dispersion*. The new alternative developed by Fisher and available in the new ST-550 speaker as well as other systems in the Studio Standard series.

Controlled dispersion gives you the big sound of an omni combined with the correctly focused solo details of a "straight shooter." The best of both worlds.

Prices start at \$199.95. The top-of-the-line ST-550 shown here is \$349.50.* For detailed technical literature, write to Fisher Radio, SR-4, 11-40 45th Road, Long Island City, N.Y. 11101.

FISHER
Studio - Standard

*Fair trade prices where applicable.
Prices slightly higher in the Far West and Southwest.

Stereo Review

PUBLISHER
EDGAR W. HOPPER

EDITOR
WILLIAM ANDERSON

MANAGING EDITOR
WILLIAM LIVINGSTONE

MUSIC EDITOR
JAMES GOODFRIEND

TECHNICAL EDITOR
LARRY KLEIN

ART DIRECTOR
BORYS PATCHOWSKY

COPY EDITOR
LOUISE GOOCH BOUNDAS

ASSOCIATE TECHNICAL EDITOR
RALPH HODGES

POPULAR MUSIC EDITOR
STEVE SIMELS

ASSISTANT MUSIC EDITOR
VIVIANNE WINTERRY GOODMAN

PRODUCTION EDITOR
PAULETTE WEISS

CONTRIBUTING EDITORS

CHRIS ALBERTSON
MARTIN BOOKSPAN
ROBERT S. CLARK
NOEL COPPAGE
DAVID HALL
JULIAN D. HIRSCH
BERNARD JACOBSON
GEORGE JELLINEK
IGOR KIPNIS
PAUL KRESH
REX REED
PETER REILLY
STEPHEN E. RUBIN
ERIC SALZMAN
CRAIG STARK
LESTER TRIMBLE
JOEL VANCE
ROBERT WINDELER

LONDON EDITOR
HENRY PLEASANTS

ADVERTISING MANAGER
JAMES J. SULLIVAN

ADVERTISING SERVICE MANAGER
MADELEINE LITTMAN

GROUP VICE PRESIDENT
ELECTRONICS & PHOTOGRAPHIC
FURMAN HEBB

ASSOCIATE PUBLISHER
STANLEY NEUFELD

Editorial and Executive Offices
Ziff-Davis Publishing Company
One Park Avenue, New York, New York 10016
212 679-7200
Eastern Advertising Manager: Richard J. Halpern
Midwestern Office: The Patten Group
4761 West Touhy Ave., Lincolnwood, Ill. 60466
312-679-1100
Arnold S. Hoffman

Western Office
9025 Wilshire Boulevard
Beverly Hills, California 90211
213 273-9050, 272-1161
Western Advertising Manager: Bud Dean
Japan: James Yagi
Oji Palace Aoyama, 6-25, Minami Aoyama
6-Chome, Minato-ku, Tokyo, Japan
Telephone: 407-1930/6821

Circulation Office
P.O. Box 2771, Boulder, Colorado 80302
EDITORIAL CONTRIBUTIONS must be accompanied by return postage and will be handled with reasonable care; however, publisher assumes no responsibility for return or safety of art work, photography or manuscripts.

Member Audit Bureau of Circulations



ZIFF-DAVIS PUBLISHING COMPANY
William Ziff, President
W. Bradford Briggs, Executive Vice President
Hershel B. Sarbin, Senior Vice President and Secretary
Philip Sine, Financial Vice President and Treasurer
Phillip T. Heffernan, Vice President, Marketing
Frank Pomerantz, Vice President, Creative Services
Arthur W. Butzow, Vice President, Production
Edward D. Muhfeld, Vice President, Advertising Division
Irwin Robinson, Vice President, Travel Division
George Morrissey, Vice President
Sydney H. Rogers, Vice President
Sidney Holtz, Vice President
Lawrence Sporn, Circulation Director



EDITORIALLY SPEAKING

By WILLIAM ANDERSON

INTERESTING TIMES

CULTURAL fashions appear, like everything else, to move in cycles, so it should not surprise us, political considerations quite aside, that things Chinese are once again very much front and center in this country. The manifestations are everywhere—in dress, decor, cuisine, sport (does not the name alone betray ping-pong's true origin?), medicine, and even the acrobatical outskirts of show-biz. A more arresting example of popular sinology to me at the moment, however, is the rapid spread and now-apparent ubiquity of an old, inscrutably benevolent (or benevolently inscrutable) Chinese curse: *May you live in interesting times*. I think there can be little doubt that we do, indeed, live in interesting times, and (the curse works, apparently) that many regret that fact heartily.

Since psychic energy is, for most of us, hardly ever in oversupply, and since there are so many "interesting" things contending for our regret, it is almost inevitable that we will, in time, concentrate our baleful attentions on just one thing. That one, for some people, is popular music, seen to be, if not the actual cause, at least the powerful symbol of all the rest. I think that this is not simply a coincidental, fortuitous choice, but a wonderful conjunction and fulfillment of the ambiguities of the paradoxical curse: if popular music can be said to be, for the Malvolios of the older generation, the perfect noisy proof that we are going to hell in a handbasket, it is also, for the younger, an equally eloquent guarantee that there will be no repeal of the Age of Aquarius. The generational dispute is, quite simply, not really a musical one, even though the air may be thick with flying phonograph records shied up by one side to be shot down by the other. The "interesting times" we live in, perhaps following some other mysterious cycle, are "revolutionary" ones, expressed not in the vulgar romantic clichés of barricades, bullets, and bomb blasts so dear to the hearts of old bolsheviks, but in a (comparatively!) quiet, peaceful, and already strikingly effective effort to redefine in various ways our expectations of what life in these United States can and should be for all our people. We are fast approaching our two-hundredth birthday as a nation, and it may just be that we are unconsciously ashamed and disappointed to realize that we have fecklessly wasted our best years, that we have failed to carve a new Eden out of the wilderness, not taken full advantage of the richest opportunity ever handed to any people. Perhaps, too, the rest of the world shares that disappointment and expresses it in their anti-Americanism.

Now all that, I admit, sounds just a little heavy, and I will immediately, therefore, answer what I expect will be an immediate objection. No, although I give a great deal of credit to the younger generation for its candor and its conventional youthful idealism, I do not believe that its members have thought through their motives and their actions to the same extent, that they really realize, say, that their music is more a means to them than an end. But then neither, apparently, do their critical elders. The most invisible and unexamined of all our activities are those that might be called "do-in" what comes naturally." What comes naturally to the young is the search for heroes, for those whose manner, style, and deportment is, at least temporarily, an attractive "way to go," the basis for a tentative effort to establish an identity; those models are found today in the rock-music culture. The best proof of this can be discovered by examining the level on which most young people choose to encounter their music—that of personality. They "adopt" a group or separate members thereof, follow their travels, chart their discographical progress, and, in short, become encyclopedias of biographical trivia. If their elders are honest, they will have to confess to much the same youthful crimes: traipsing as best they could in the eventful wake of Bix Beiderbecke and other jazz greats, memorizing the horn sections of the big bands, the starting lineups and the batting averages of favorite ball teams. Anybody out there remember when Joe Hauser sent his last homer over the fence for the Millers?

AVOID 4-CHANNEL CONFUSION



Quality Quad Sound Now At Low Dynaco Prices

Dynaco's \$20 Quadaptor decoder delivers full 4-Dimensional sound now from encoded records in any of the compatible matrix formats. More important, it recaptures the elusive ambience, or realism, which has always been a part of your present stereo records too, but which you've never been able to hear before.

No phase shifting gimmicks; zero distortion; all the sound that's always been there, with correct placement and proportion. It's Dynaco's simpler way to fully decode (U.S. Patent #3697692)—at the output of your present amplifier. You don't need a new amplifier. Use your stereo system to the fullest while the 4 channel hassle settles down.

Superior audio performance is a Dynaco tradition. Fine craftsmanship is evident in even our least expensive speaker. The compact A-10 (8½" x 15" x 8") nearly duplicates the famous A-25's sonics. It uses the same woofer magnet and the identical tweeter in an oiled-walnut wood (not plastic) cabinet at a fraction of the A-25's price. The A-10 fits in any bookshelf, or is easily hung on the wall with brackets supplied.

The best buy A-10 is the first choice for inconspicuous back speakers in quad systems, perfectly complementing your present larger Dynaco (or other

similar-sounding) designs. Smooth, articulate, wide-range clarity; near-perfect transient response for precise delineation. Verbatim reproduction with prodigious power handling capability makes the A-10 the obvious choice for main speakers, too, where space is at a premium.

Dynaco never rips you off. To prove it, a diagram on our demo record (from your dealer, or send coupon) shows you how to try 4-D sound without even the Quadaptor if you have 4 similar speakers.

SPECIAL DIRECT OFFER ON 4-DIMENSIONAL DEMO RECORD

DYNACO INC.

3060 Jefferson Street, Philadelphia, Pa. 19121

Enclosed is my check or money order for \$2.95. Please send me the new Dynaco/Vanguard 4-D demo record post-paid. Limited to USA residents only.

Name _____

Address _____

City _____

State _____

Zip _____

DYNACO INC. Division Tyco

3060 JEFFERSON ST., PHILADELPHIA, PA. 19121

In Canada write: DYNACO OF CANADA LTD., Montreal, 760, Quebec, Canada



LETTERS TO THE EDITOR

Beatlemania

● That was a rather interesting article on the Beatles ("Nine Ways of Looking at the Beatles," February), but you only touched on their recording for Apple/Capitol and the one LP each for Polydor and United Artists. There's a lot of Beatles lore that wasn't covered in your otherwise informative article. First off, there are a few 45's that never made it onto a Beatles album. Why they weren't included in "Hey Jude (The Beatles Again)" is beyond me. These selections are: *The Inner Light* (on the flip side of *Lady Madonna*), a Harrison tune written when his Indian influences apparently were still strong; *I'm Down* (flip side of *Help!*); and *You Know My Name* (*Look Up the Number*) on the flip side of *Let It Be*. This last is a strange tune that must be heard; the only way to describe it is as comedy/burlesque.

Then there are the LPs. "This Is Where It Started" on Metro is one that was overlooked. "Sgt. Pepper" in the monaural version is mastered noticeably differently from the stereo version. The 45 *I Am the Walrus* differs from the LP version (play them back to back and you'll see), and there is still a third version of *I Am the Walrus*, which appears on the double album "Magical Mystery Tour" on English Parlophone. *Let It Be* is mixed differently on the 45, and all the songs on "Hey Jude" are longer in their 45 versions. Two more conspicuously absent LPs are "Introducing the Beatles" on Vee-Jay, and their first double LP on Capitol, "The Beatles' Story," which contains thirty seconds of live material (wow!). Also, there is a completely different version of *Across the Universe* on "No One's Gonna Change Our World," an England-only LP which contains various other artists and is on the Starline label. Then there are the several interview LPs that have Ed Rudy on them. The Beatles have also released 45's on the Swan, Tollie, and MGM labels, and a few on Atco.

A very rare Beatles LP that few own, called "Get Back," is an official Apple release. It was sent to various radio stations, but then the whole LP was changed and retitled "Let It Be." "Get Back" is essentially "Let It Be" with no strings, horns, or choirs. In short, it wasn't tampered with by Phil Spector. It also has one exclusive song on it, called *Teddy Boy* (which appeared on McCartney's solo LP "McCartney," but on "Get Back" it's a

Beatles number, with all four of the Beatles rather than just the talented McCartney playing the instruments).

There are innumerable bootlegs, some quite good, and a few that compare with anything available in the stores today. Most of the material is, however, of dubious quality (but we Beatles fans don't mind a bit—and there are a lot of Beatles fans). What most of the bootlegs provide is a side of the Beatles that Apple never let anyone see: the Beatles *live*. They weren't all that good live, actually, but there are high points. You can get recordings of the Beatles live at Shea Stadium, Carnegie Hall, Philadelphia, and bunches of unnamed places. You can hear their recorded appearances on *Top of the Pops*, *Shindig*, and the *Smothers Brothers Show*. And there are many unreleased tunes, both studio and live, that appear on bootlegs: *Shout*, *People Say*, *Mary Jane*, *Teddy Boy*, *Lucille*, *Hippy Hippy Shake*, *I'm Walking*, *I Got a Woman*, *Glad All Over*, and lots more.

Just thought I'd update your Beatles collection a bit. Anyone interested in more Beatles trivia can contact me at the address below. Include a self-addressed, stamped envelope and I'll reply to all questions.

RICHARD J. KUNKEL
730 Hatch Road
Wadsworth, Ohio 44281

When may we expect the publication of a fat volume containing the complete Beatles canon systematized according to the proper Kunkel numbers?

Schlagoper

● As a long-time operetta freak I was of course delighted to find a feature article on the subject in *STEREO REVIEW* ("Schlagoper," February). I was slightly stunned, however, to find no mention of Leo Fall, in his heyday the peer of Lehár, Kálmán, and Straus—and in my view their superior in some respects, particularly in the generally high level of his output. A conservatory-trained, frustrated opera composer like the above-mentioned trio, Fall was unlucky enough to write some of his best operettas for strictly topical librettos: *Der fidele Bauer* (*The Jolly Farmer*) documented a sort of German "country-folks" craze of the day; *Die Rose von Stamboul* satirized the beginning emancipation of women in the Moslem countries; *Die ge-*

schiedene Frau (*The Divorcee*) applied the light touch to a subject socially touchy at the time; and *Die Dollarprinzessin* (*The Dollar Princess*)—a hit on Broadway in translation—exploited the ever-popular European notion that the streets of New York were paved with gold.

Leo Fall had a way with the Viennese waltz second only to that of Johann II, and wrote for the voice and orchestra with versatility and taste second to none of his contemporaries. Operetta lovers who have never heard such Viennese evergreens as *Ein Walzer muss es sein* (*It Just Has to Be a Waltz*), *Kind, Du kannst tanzen* (*Baby, You Dance Just Like My Wife*), or *Und der Himmel hängt voller Geigen* (*A Heaven Full of Fiddles*) have a treat in store. Highlights of Fall's greatest successes are available from the German catalog on the various EMI labels; modern complete recordings of *Mariza*, *Walzertraum*, *Fledermaus*, *Eine Nacht in Venedig*, and others are also available on Electrola, Eurodisc, etc. Note to fellow freaks: these are sometimes available from large record stores or mail-order houses. If not, it's relatively simple to import direct—I'll be happy to supply details.

JOSEPH LUGAR
7535 Hunley Road
Cincinnati, Ohio 45244

Reader Lugar has himself answered the question he raises: the "strictly topical librettos" of Leo Fall are precisely what did him in; so much for "relevance."

Domingo/Milnes

● I thought Stephen Rubin's article on Plácido Domingo and Sherrill Milnes (February) was outstanding. Perhaps the realization by more people that most opera stars are down-to-earth, fun-loving individuals who happen to be very talented musically will help eliminate the stuffy image opera and its singers seem to have. Certainly articles such as this will move things in that direction.

CAROLYN D. WILLIAMS
Bethesda, Md.

Locating Kipnis' Missing Cantata

● Igor Kipnis is a very knowledgeable performer and critic who must simply have been nodding when he asked in his review of the Bach cantatas (February) "what happened to Cantata No. 15, a longish, very early example of Bach's writing in this form?" The answer is really quite simple: the cantata is *not* by J. S. Bach. It has been known for a dozen years or so that the cantata is actually by Johann Ludwig Bach. The confusion arose because J. S. Bach himself copied the works of his relative, and the manuscript passed as a work of his own when studied by later scholars. Details are available in an article by Angela Maria Owen, "The Authorship of Bach's Cantata No. 15," in *Music and Letters* for 1960.

I might also recommend as an extraordinarily useful quick-reference guide to the Bach cantatas Werner Neumann's *Handbuch der Kantaten Johann Sebastian Bachs* (Leipzig, Breitkopf & Hartel, third edition, 1967). The revolution in Bach research has come so fast that any edition older than the third is totally out of date. Neumann's book lists each cantata, tells its placement in the liturgical year, the date of composition and of later performances, author(s) of the text, and where it is published in the old or new Bach editions as

(Continued on page 10)

The ADC-XLM "...in a class by itself."



That's the way Stereo Review described our XLM. High Fidelity headlined their review, "Superb new pickup from ADC" and went on to say, "...must be counted among the state of the art contenders." And Audio echoed them with, "The ADC-XLM appears to be state of the art."

With the critics so lavish in their praise of the XLM, there's hardly any necessity to add anything. Far better to let the experts continue to speak for us.

Frequency response The CBS STR-100 test record showed less than ± 1.5 dB variation up to 20,000 Hz. *Stereo Review*
...response is within ± 2 dB over the entire range. *Audio*
Frequency response is exceptionally flat. *High Fidelity*

Tracking This is the only cartridge we have seen that is really capable of tracking almost all stereo discs at 0.4 grams. *Stereo Review*
The XLM went through the usual torture test at 0.4 grams (some top models require more than a gram). *High Fidelity*
The XLM is capable of reproducing anything found on a phonograph record. *Audio*

Distortion Distortion readings... are almost without exception better than those for any other model we've tested. *High Fidelity*

The XLM has remarkably low distortion in comparison with others. *Audio*
At 0.6 grams the distortion was low (under 1.5 per cent). *Stereo Review*

Hum and noise The XLM could be instrumental in lowering the input noise from the first stage of a modern transistor amplifier. *Audio*
The cartridge had very good shielding against induced hum. *Stereo Review*

Price This would be a very hard cartridge to surpass at any price. *Stereo Review*
We found it impossible to attribute superior sound to costlier competing models. *High Fidelity*
Priced as it is, it is a real bargain in cartridges. *Audio*

The Pritchard *High Definition*
ADC-XLM \$50.

TALL or BIG? SPORTSWEAR THAT FITS

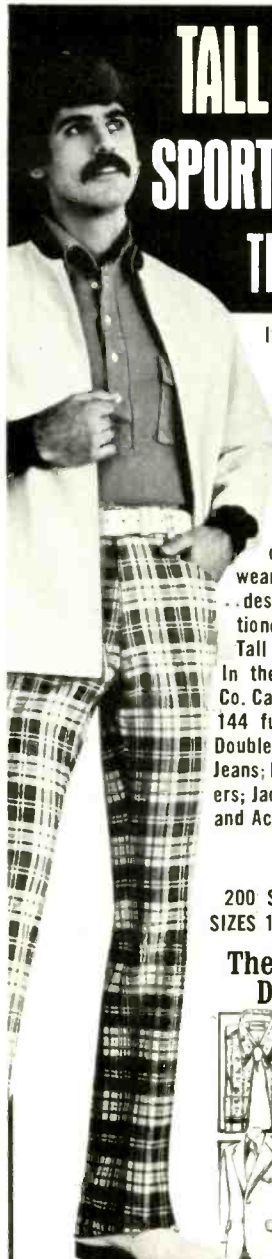

If you're 6'3" or taller; need Sleeves to 38", Waists to 60", or Shoes to 16 EEE — The KING-SIZE Co. guarantees to fit you in today's exciting new sportswear, ready for action designed and proportioned exclusively for Tall and Big Men only! In the FREE KING-SIZE Co. Catalog choose from 144 full-color pages of Double-Knit Slacks and Jeans; Knit Shirts, Sweaters; Jackets; Sport Coats, and Accessories.

PLUS

200 SHOES & BOOTS
SIZES 10 to 16, AAA-EEE

The KING-SIZE Difference

SHIRTS
Collars — 15" to 22"
Chests — Full Cut
Sleeves — 33" to 38"
Lengths — 4" Longer

JACKETS
Chest — 40" to 60"
Sleeves — 33" to 38"
Pockets — Oversized
Length — 4" Longer

SLACKS
Waist — 32" to 60"
Rise — Higher Cut
Inseams — Up to 42"
Bottoms — Proportioned

SHOES
Sizes — 10 to 16
Widths — AAA-EEE
Styles — Over 200
Shoes & Boots



The KING-SIZE Co. GUARANTEE

You must be Completely Satisfied
Both Before and After Wearing.

SEND FOR FREE CATALOG

Please rush me your new 144 page, FULL-COLOR KING-SIZE catalog of Action apparel and footwear for tall and big men.

Name _____
Address _____
City _____ State _____ Zip _____

The KING-SIZE Co. 2183 KING-SIZE BLDG.
BROCKTON, MASS.

well as in such series as the Eulenburg miniature scores, and lists references to the cantata in the Bach literature. It then lists each individual movement, specifies its form and instrumentation, key, vocal ranges for solo parts, and other works of Bach that use the same musical material. All this is followed by a series of appendices that list the cantatas according to date of composition, use in the liturgical year, poet, chorale melodies employed, parodies, and location of the original sources. The true devotee of the Bach cantatas—even one who knows little or no German, can get a great deal of information out of this handbook, inasmuch as the lists are in tabular form.

I am by no means a Bach scholar, but I was able to answer Igor Kipnis' question simply by looking up No. 15 in the numerical listing of Neumann and finding that it had been removed to the section labeled "Ausgeschiedene Kantaten" (cantatas no longer attributed to Bach): there I also found the reference to the Owen article and several other citations.

STEVEN LEDBETTER
Norwich, Vt.

Kipnis nodded, the editors slept; we've ordered the book.

Contemporary Cacophony

● In his letter to the Editor (February), David Dolan finds contemporary classical music lacking in melody, and thus unsatisfying. I sympathize with him. I find most modern music by composers under fifty lacking in musical invention, cliché-ridden, and devoid of character. Most post-Webern and electronic stuff sounds alike, and nearly all of it, I would guess, is evanescent. The same is true of ninety-nine per cent of rock and pop stuff, but then rock seems to live for the moment and doesn't pretend to be anything but commercial. Even so, I find it tedious. I would like to have a list of about ten rock records on which there is general accord that these represent the very best and deserve to be "rock classics," a list for which I would be willing to wait ten years or more, for it takes time for a piece to be deemed a classic. Until such a list comes along, I plan to continue listening to Bach, Beethoven, Mozart, Wagner, Verdi, and the like. These I am sure of, and I have but one life to give to my phonograph.

ROBERT REIFF
Middlebury, Vt.

Ready to Move

● Steve Simels and I must come out of the same mold if his article in the January issue is any criterion. I too have conducted "lonely vigils" for the Kinks, and while they are moving up, they still need our support. I also agree that Procol Harum is indeed the "best rock band in Christendom," yet their success leaves me with mixed emotions: happy that now they are accepted by a greater audience, yet sorry to see them go as my personal favorites (along with about 150,000 other cult members!). A few examples of other English groups that should be discovered by this continent, either again or on a larger scale, are Pink Floyd, Family, and the Move offshoots (Electric Light Orchestra, Wizzard): all are ready for acceptance and certainly worthwhile.

HOWARD CHRISTIE
Windsor, Ont., Canada

Agreed; see page 104.

Coppage's "Confessions"

● All the intellectuals in my neighborhood are aghast at Noel Coppage's confession in your January issue ("Confessions of an Ex-Liner-Note Writer"). One particularly effete snob in my building immediately vowed not to buy any more Columbia records until Mr. Coppage renounces his pledge to abjure writing liner notes forever. "After all," he said, "you should get something for your money." Or words to that effect. He is, however, an emotional sort of fellow, given to extremes; the kind of left-wing weirdo who won't buy nonreturnable bottles or give his seat on the subway to pregnant gnomes.

But it is an ill wind that doesn't blow a piece of dirt in a blind man's eye, as it were. A demand for albums with Mr. Coppage's liner notes has suddenly been created. Already a group down the block has been working long into the afternoon mimeographing the backs of records. Unusually unreliable sources say that they have even obtained copies of his unpublished Dylan and Freedomburger liner notes. They hope to have a thin volume out by spring entitled *The Best of Noel Coppage or Noel Coppage's Greatest Hits, Volume One*. The first copies will be sent to the good folks at Columbia records, along with someone to read the harder words for them. The rest of us must be content perusing the backs of Wheaties packages. But it's getting harder to tell where the box ends and the liner notes begin.

FRED BINKLEY
New York, N.Y.

"Radio Opera"

● I would like to congratulate STEREO REVIEW on January's feature article "Radio Opera," detailing the history of the Metropolitan Opera radio broadcasts. I, like thousands of other rural Americans, am a faithful Saturday listener to the Met broadcasts, and especially enjoy the regular intermission features. While I don't suit up in a floor-length gown for the broadcasts like the lady mentioned in Stephen Rubin's article, on Saturday afternoons all activity in my house stops while we settle down for three or so hours of music enhanced by the wonderfully friendly and familiar voices of Milton Cross, Edward Downes, and other regulars of the intermission features.

WENDY A. BIE
Colton, Wash.

Procol Harum

● Hats off to Steve Simels for his retrospective look at Procol Harum (January)—a truly inspired review! Mr. Simels is the first writer to give an accurate assessment of these motley musicians. I look forward to STEREO REVIEW's critique of their forthcoming "Grand Hotel" album, a future must.

NORMAN W. HOEY
Edison, N.J.

"Hall of Obscurity"

● I read your mag mainly for the lab tests and record reviews, but the December issue really freaked me! J Marks' "Hall of Obscurity" was really down-to-earth. I never would have thought that anyone on the STEREO REVIEW staff knew that good rock does exist. In fact, I thought I was the only one who realized that the group Strawbs was any good, and that I was the only one who knew that the United States of America was more than a country. J Marks has even given credit to Family, Zephyr, and Moby Grape. Wow! His (Continued on page 12)

When they start to jam, your BASF Cassette won't.



Ever lose the most exciting moment of a performance because your cassette jammed?

At BASF we've done something to our cassettes to keep that from ever happening again. We've added Special Mechanics™. The first jam-proof system that really works.

Not just some times. *All* the time.

Inside each BASF Cassette, two precision guide arms feed the tape smoothly from reel to reel. So there's never a rough wind, never a snag.

These unique guide arms also eliminate those annoying distortions like wow and flutter that seem to be "built-in" to most ordinary cassettes.

Combine our Special Mechanics with the super sensitivity of BASF tape and the result is a fidelity and range



you'll have to hear to believe.

Sound reproduction so good, it's made BASF the best selling Cassettes in all of Europe.

Here in the states, people who really know superior tape quality are turning on to BASF too. You'll know why the minute you hear one of our SK, LH or Chromdioxide cassettes.

Ask your dealer to play one for you. For more information on BASF's complete line of Audio Products including cassette recorders and reel-to-reel

tape, write
BASF SYSTEMS,
Crosby Dr., Bedford,
Massachusetts
01730.

BASF SYSTEMS
Division of BASF Wyandotte Corporation



Maxell is happy to announce that the little pad that takes all the pressure has finally gotten a grip on itself.

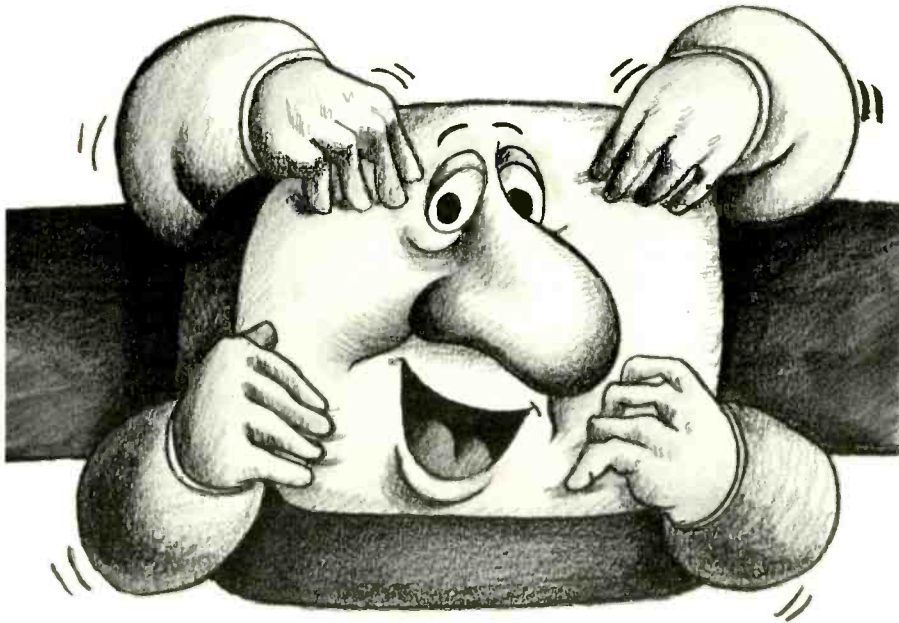

We wanted to make some really big improvements to our Ultra Dynamic cassette. But there just weren't any big improvements left to make. So we made a lot of little improvements.

Our little pad won't come unstuck.

Other cassettes keep their pressure pads in place with glue—or rather don't keep their pressure pads in place with glue. So we've designed a little metal frame that holds the pad in a grip of steel. With the result that you don't need to worry about signal fluctuations or loss of response any more.

More hertzies.

We've also improved our tape. We've increased the frequency response to 22,000 Hz so you get even higher highs. The signal-to-noise ratio's now 8dB more than ordinary cassettes—which means you get less noise and cleaner sound. And the dynamic range is wider so you can turn the sound up loud enough to disturb the neighbors without worrying about distortion.

An improvement you can see but can't hear.

The first five seconds of our new UD cassette is a timing leader. And we've marked the place where it starts with three little arrows so you'll always know exactly where you are.

Amazing new miracle ingredient fights dirt fast!!!

But the leader's also a head-cleaner and what's amazing, new and miraculous about it is that it doesn't rub as it scrubs as it cleans. Because it's nonabrasive. So it keeps your tape heads clean without wearing them down.

Our new long-playing cassette is shorter.

Our new UDC-46 is twenty-three minutes per side. Which very conveniently just happens to be the approximate playing time of your average long-playing record. (Our other cassettes are 60, 90 and 120.)

And that's our new improved Ultra Dynamic cassette.

And its ultra dynamic new improvements.



maxell.

The answer to all your tape needs.

Maxell Corporation of America, 501 Fifth Avenue, New York, New York 10017

CIRCLE NO. 31 ON READER SERVICE CARD

article was indeed glorious, for it tries to give credit where it is due.

MICHAEL MICHALOWSKI
Mt. Home AFB, Idaho

● My compliments to J Marks for his excellent article "Hall of Obscurity" (December). He brings to light some of the best that popular music has to offer. I would like to point out that Ian Matthews, in particular, has a slew of other albums all as good as those mentioned. He has been around a lot longer than "Tigers Will Survive" and "If You Saw Through My Eyes." His three albums with Matthews Southern Comfort are masterpieces, and so were his early albums with Fairport Convention, with whom he made his debut. Also, a rather rare one on Elektra, with a group called Plainsong, can be considered in the usual Matthews style. This type of article helps reassure me that I am not the only "fool" who appreciates these fine musicians.

DANIEL LORD
Syosset, N. Y.

Buzz, Off and On

● Peter Sutheim's article on radio-frequency interference in audio systems in your November issue brought to mind a recent problem I encountered with my audio system. I feel the problem may not really be rare and will undoubtedly increase, and since Mr. Sutheim did not mention it, I would like to bring it to your readers' attention.

After installing a new high-power integrated amplifier, I heard an intermittent buzz in one channel. The repair station spent two weeks testing the unit, but nobody ever heard the buzz, so I took the unit home. As soon as I reinstalled it, BUZZZZZ! Finally I discovered the source of my problem: some months before, I had installed a solid-state light dimmer in another room but on the same electrical circuit; when the dimmer was set to a fairly dim position, the buzz became audible.

Solid-state dimmers are wonderful interference generators, with the RFI level increasing as the light is dimmed more and more. Most, if not all, dimmers incorporate filters, but evidently the filters do not always eliminate the possibility of interference. What fluke in my unit causes the hum in only *one* channel I have not been able to discover.

KENNETH WORKMAN
Menlo Park, Cal.

Pop Protest

● I would like to take issue with Allen Watson III's letter which appeared in the November issue. It is an outrageous insult to all fans of pop music to assume that we do not read record reviews. The popular section of the reviews is one of the main reasons for my subscribing to STEREO REVIEW. Record reviews are just as important to popular listeners as they are to classical listeners, for without reviews how are any of us to know what is happening in the world of music?

Furthermore, to say "how important is high-fidelity reproduction to most of the people who buy pop records?" shows little or no cognizance of pop music on the part of Mr. Watson. I advise him to pick up a copy of "Abbey Road" by the Beatles, or any similar album, and to listen to it on a low-quality system and on a high-quality system. Then maybe he will see just how important high-fidelity reproduction is to pop music.

THOMAS U. MEDANICH
White Plains, N. Y.

STEREO REVIEW

IMPROVE YOUR HEARING FOR \$200.

Sometimes high fidelity people lose sight of what it's all about: Sound.

The ultimate test of any piece of high fidelity equipment is what you hear.

That's why, of all the statements made by equipment reviewers about our Garrard Zero 100, the most significant were these:

"Using identical virgin records, and virgin styli in identical good cartridges, the Zero 100 on occasion sounded markedly 'crisper' than other turntables." *Rolling Stone*.

"A listening test proves to bring new life to many records, noticeably reducing distortion on the inner grooves." *Radio Electronics*.

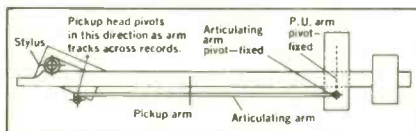

"From about 7 in. diameter to runout, the Zero 100 delivers considerably less distortion and greater definition than with the same pickup mounted in a standard arm. The improvement in sound quality is notably impressive."

Elementary Electronics.

"The articulated arm of the Zero 100 produced less distortion, and therefore greater definition, on high-level, musically complex passages, from the inner grooves."

Hi-Fi Stereo Buyers' Guide.

That's what reviewers actually

heard when they tested the first automatic turntable with Zero Tracking Error. This is, to our knowledge, the first time a turntable has been given credit for making records sound better.

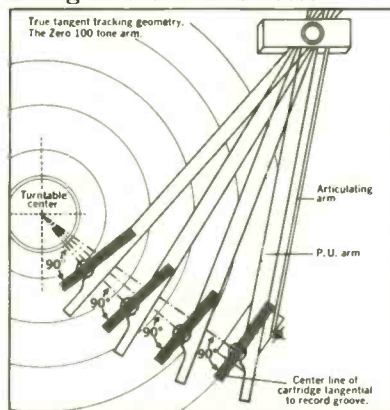

Cartridges and other components, yes. But never a turntable — until the Zero 100.

By this time you probably know how we achieve Zero Tracking Error. The principle of the articulating arm, continually adjusting the angle of the cartridge so it is always at a 90° tangent to the grooves, is a simple one. But the ingenious engineering and the development of the precision pivots to make the principle work, took several years.

But enough from us. Let's go back to what the reviewers say about the Zero 100.

"It probably is the best arm yet

offered as an integral part of an automatic player." *High Fidelity*.

"All of these features combined into one automatic turntable make news, even though some are found on other units. Only in the Zero 100 are they all put together." *Audio*.

When *Audio* talks about "all of these features" they're referring to such things as our magnetic anti-skating, variable speed control, illuminated strobe, viscous-damped cueing, 15° vertical tracking adjustment, patented Garrard Synchro-Lab synchronous motor and our exclusive two-point record support in automatic play.

But all of this gets back to our original point. It is the sound that makes the difference. After all, a \$200 record player should give you a really meaningful difference. And the high fidelity experts agree that people who own a Zero 100 will hear better than people who don't.

If you'd like to read the reviews in full detail, we'll send them to you along with a complete brochure on the Zero 100 and the Garrard line. Write to: British Industries Company, Dept. D33, Westbury, N.Y. 11590.

GARRARD ZERO 100

The only automatic turntable with Zero Tracking Error.

Mfg. by Plessey Ltd. Dist. by British Industries Company

NEW PRODUCTS

THE LATEST IN
HIGH-FIDELITY
EQUIPMENT

Audio-Technica Phono Cartridges



● AUDIO-TECHNICA's line of moving-magnet stereo phono cartridges comprises eight models, all of which use the company's dual-magnet configuration (two magnets, one for each channel, oriented 90 degrees apart and 45 degrees from the vertical). The two least expensive models, AT10 (\$24.95) and AT11 (\$34.95), have 0.7-mil conical (spherical) diamond styli and outputs of 4.8 millivolts for a recorded velocity of 5 cm/sec (centimeters per second). Frequency response and tracking-force range for

the AT10 are 20 to 20,000 Hz and 2½ to 4 grams; for the AT11 model, 15 to 25,000 Hz and 2 to 3 grams. The outputs of the two channels are matched within 2 dB. The models AT11E (\$44.95) and AT12E (\$54.95) have 0.4 x 0.7-mil elliptical styli. The AT12E, rated for tracking forces of 1¼ to 2 grams, has an output of 3.5 millivolts and a low-mass stylus cantilever. Frequency response is 15 to 30,000 Hz. The AT11E has specifications similar to those of the AT11. The Model AT13E (shown, \$64.95) has a 0.2 x 0.7-mil elliptical stylus, a frequency response of 10 to 45,000 Hz, and a tracking-force range of 1 to 2 grams.

The three Audio-Technica top-of-the-line cartridges, the AT14S (\$75), AT15S (\$100), and AT20SL (\$150), all have the Shibata stylus, which is particularly effective with "discrete" four-channel

discs. The frequency response of the AT14S and AT15S is 5 to 45,000 Hz; output is 2.7 millivolts, matched within 1.5 dB between channels. Stereo separation is 25 dB. The AT20SL, a specially selected AT15S, is required to meet frequency-response tolerances of 5 to 50,000 Hz and pass various other special performance tests. All three Shibata-stylus cartridges have tapered low-mass stylus cantilevers and tracking-force ranges of 1½ to 2 grams (it is said that, because of the larger contact area of the Shibata stylus, these tracking forces will produce tracking pressures much lower than would be the case with conventional styli). The four top models of the Audio Technica line have flip-down stylus guards, and all have user-replaceable styli ranging in price from \$12.95 to \$75.

Circle 115 on reader service card

Elac/Miracord Model 625 Automatic Turntable



● BENJAMIN'S new Elac/Miracord Model 625 automatic turntable is a low-

price (\$99.50) unit that will accommodate a stack of up to ten records of any size and speed—78, 45, 33⅓, or 16⅔ rpm. Pushbuttons initiate automatic cycling for any disc diameter selected. There is also a cueing lever for manual operation. The Model 625's tone arm is a tubular metal design with anti-skating compensation and a stylus-force adjustment in the form of a calibrated counterweight. Adjustment is accurate to within 0.1 gram, and it is continuously variable from 0 to 6½ grams. Rumble is -38 dB,

and wow and flutter are 0.07 and 0.03 per cent, respectively. The turntable employs a four-pole motor, and speed accuracy is within at least 1 per cent under any playing conditions. Without base or cover the turntable's motorboard is approximately 13¾ x 11¾ inches, with about 5¾ inches of clearance required above and 2¾ inches below. Bases are available in plastic (\$6.50) or, as shown, in oiled walnut (\$15). A dust cover costs \$5.95.

Circle 116 on reader service card

Pickering PST-1 Stylus Timer



● PICKERING'S PST-1 stylus timer automatically keeps track of the number of hours a phono-cartridge stylus has been in use, so that a regular schedule of inspections for stylus wear can be estab-

lished. The device is calibrated in 100-hour increments up to 1,000 hours. It is meant for installation on the turntable motorboard between the tone-arm pivot assembly and the arm rest. When the arm leaves its rest a plunger is released that activates the timing operation; the return of the arm depresses the plunger and shuts the timer off. The elapsed-time indicator on the timer is a tiny marker in a mercury-filled capillary tube that moves through the tube at a constant rate when a small electrical current is

applied. The current comes from a miniature mercury battery built into the device. When 1,000 hours have passed the timer is reset to zero by repositioning the calibrated scale, which is free to slide along its channel. After the marker has completely traversed the length of the tube, the tube itself is rotated 180 degrees, repositioning the marker at the beginning of the scale. The PST-1 timer is 27/8 x 1 x 1 inches; its plunger switch is adjustable in height. Price: \$13.95.

Circle 117 on reader service card

Sony TA-1055 Integrated Amplifier; ST-5055 AM/Stereo FM Tuner



TA-1055 Amplifier

● SONY'S new TA-1055 integrated stereo amplifier and ST-5055 AM/stereo

FM tuner are compatibly priced and styled to go together in an installation of moderate cost. The TA-1055 provides 23 watts per channel continuous power (both channels driven into 8-ohm loads) with harmonic and intermodulation distortion both under 0.5 per cent. Signal-to-noise ratios for the phono and high-level inputs are 70 and 90 dB, respectively. The amplifier's power bandwidth is 8 to 40,000 Hz. The ST-5055 tuner has an IHF sensitivity of 2.2 microvolts,

and a 4-microvolt input signal is sufficient for 50-dB quieting. The capture ratio is 1 dB, and alternate-channel selectivity is 70 dB. Other specifications include: stereo separation, better than 35 dB at 400 Hz; AM suppression, 45 dB; i.f. rejection, 95 dB; harmonic distortion, 0.6 per cent for stereo reception.

The TA-1055 amplifier has full facilities for the connection of two tape machines, with three tape-monitor pushbut-

(Continued on page 16)

The right Pickering cartridge for your equipment is the best cartridge money can buy.

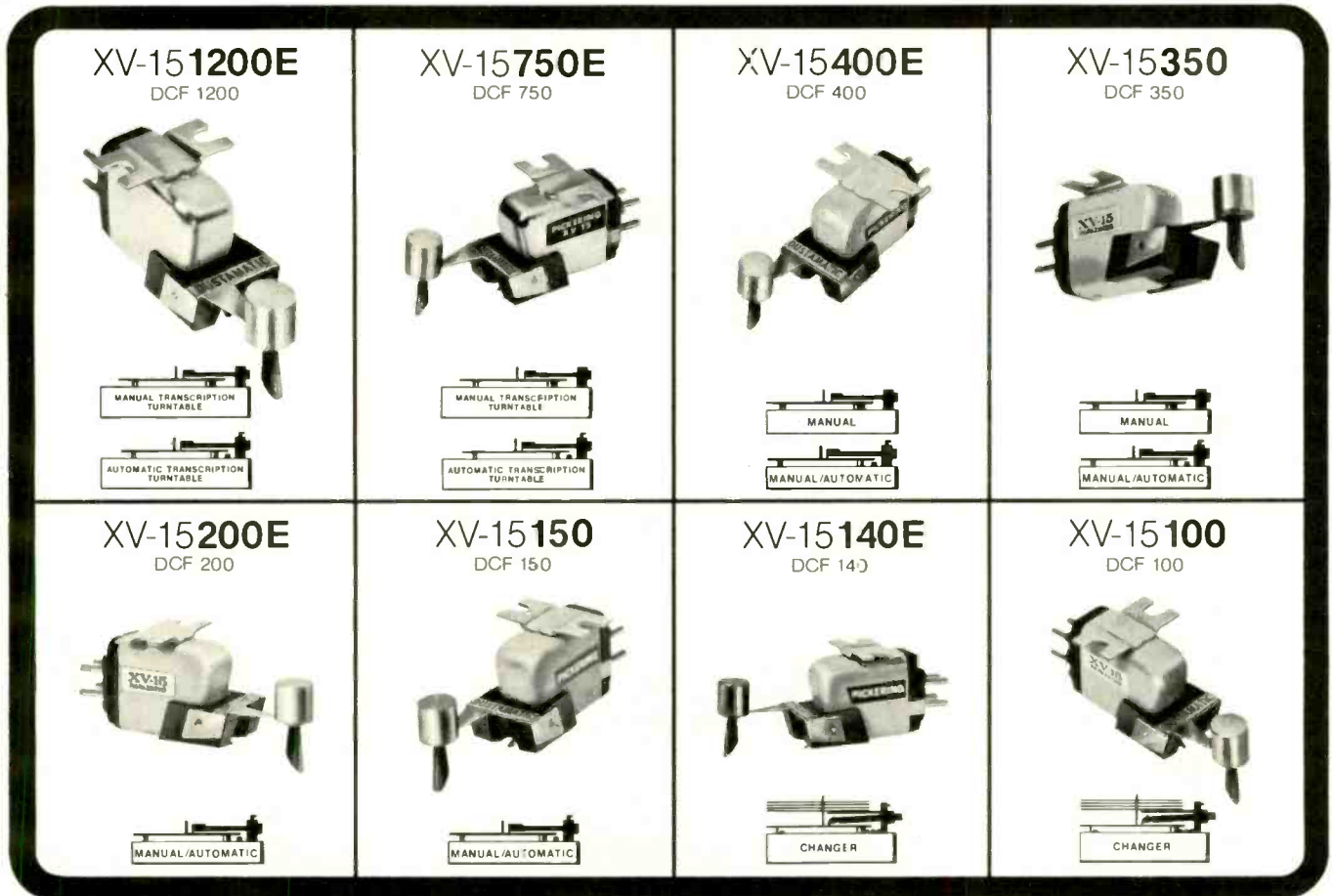

There's a "right" Pickering cartridge for every record player, and only Pickering has developed a way for you to be absolutely certain you select the "right" cartridge for your high fidelity music system.

It is a simple way for you to precisely match one of our XV-15 (100% Music Power) cartridges to whatever kind of record player you have or plan to buy. It's called Dynamic Coupling Factor — DCF for short.

We have taken virtually every record player and pre-analyzed the vital variables affecting cartridge design and those related to the engineering features of the various turntables and changers. So, no matter what

equipment you own or plan to purchase, there is a Pickering XV-15 cartridge exactly "right" for it. The DCF number enables you to select the proper Pickering XV-15 cartridge in relation to a particular type of playback equipment to achieve maximum performance.

If you're ready to buy your next cartridge, be certain you end up with the Pickering XV-15 cartridge that's best for your system. *Have your Pickering high fidelity dealer show you our DCF Chart, or write Pickering & Co., Inc., Dept. V, 101 Sunnyside Boulevard, Plainview, N. Y. 11803.*

 **PICKERING**

"for those who can hear the difference"

The **100%** Music Power Cartridges

All Pickering cartridges are designed for use with all two and four-channel matrix derived compatible systems.

NEW PRODUCTS

THE LATEST IN
HIGH-FIDELITY
EQUIPMENT



ST-5055 Tuner

tons permitting the transfer of material from either one to the other. The volume and tone controls are vertical sliders; inputs are pushbutton-selected for pho-

no, tuner, auxiliary, and microphone, for which there are two jacks on the front panel (there are also front-panel phone jacks for stereo headphones and for a stereo AUX source, duplicating the connectors in the rear).

Additional pushbutton controls introduce loudness compensation, stereo or mono mode, and high-cut filter; others switch the main and remote speaker pairs. The ST-5055 tuner's operating

features include switchable interstation-noise muting on FM, high-frequency blend for stereo-noise reduction, and mono/stereo mode. A signal-strength tuning meter is provided. The TA-1055 amplifier and the ST-5055 tuner are identical in size— $16\frac{1}{8}$ x $4\frac{3}{4}$ x $11\frac{1}{8}$ inches—and come with walnut-finish cabinets. Prices: TA-1055, \$149.50; ST-5055, \$159.50.

Circle 118 on reader service card

Yamaha YP-700 Record Player



● YAMAHA'S finest record player, the Model YP-700, is a 33 $\frac{1}{3}$ - and 45-rpm design with a belt-driven 12-inch platter of cast aluminum. Speed change is accomplished mechanically through a

rocker switch on the motorboard that shifts the belt on the stepped drive-shaft pulley. The tone arm and platter-bearing well are installed on a unitized sub-assembly that is floated on shock-isolating springs within the turntable base. The outer-rotor synchronous motor has its own spring suspension. The YP-700's tone arm has an S-shaped metal tube with a low-mass plug-in cartridge shell. Counterweights are used to balance the arm in all planes, apply anti-skating compensation, and set tracking force, the adjustment for which is calibrated from 0 to 4 grams. The lever-operated cueing mechanism is damped in both directions of travel. Wow and flutter for

the YP-700 are specified as less than 0.05 per cent. Rumble is -50 dB. The tonearm output is muted until the stylus is in the groove, and at the end of a record the arm returns automatically to its rest.

The YP-700 record player is supplied with the Yamaha CG-7000 phono cartridge, a moving-magnet design with 0.7-mil conical (spherical) stylus and a rated tracking force of 1.5 grams. Frequency response is 10 to 25,000 Hz, and stereo separation is 30 dB. Overall the YP-700 measures $17\frac{1}{4}$ x $15\frac{1}{4}$ x $6\frac{1}{2}$ inches. Price: \$189, which includes wood base and hinged dust cover.

Circle 119 on reader service card

Celestion Ditton Speaker Systems



● HERVIC ELECTRONICS is importing the Ditton series of speaker systems manufactured in England by Celestion. The seven systems available are all either two- or three-way designs, and four of them employ an "auxiliary bass radiator"—a passive radiator equal in size to

the woofer cone that reinforces the low-frequency performance. None of the systems employ driver level controls. The top-of-the-line Ditton 66 has a $\frac{3}{4}$ -inch dome tweeter, $2\frac{1}{2}$ -inch dome mid-range, and 12-inch woofer, along with a 12-inch passive radiator. Usable frequency response exceeds 20 to 30,000 Hz, and the power-handling capability is 80 watts; minimum power required is said to be 5 watts per channel. The Ditton 25 uses the same tweeter as well as two $1\frac{1}{2}$ -inch dome high-frequency units and a 12-inch woofer and passive radiator. Frequency response is essentially the same as that for the Ditton 66; power-handling capability is 60 watts. The Ditton 44, with a 44-watt power-handling capability and a frequency response of 30 to 30,000 Hz, uses the same $\frac{3}{4}$ -inch tweeter, a 5-inch cone mid-range, and a 12-inch woofer without pas-

sive radiator. The remaining four Ditton models all have the $1\frac{1}{2}$ -inch dome tweeter of the Ditton 25 together with an 8-inch or 6-inch woofer with or without passive radiator. Their frequency responses extend up to 15,000 Hz and down to 35, 40, and 45 Hz, depending on the model. Power-handling capabilities range from 30 to 20 watts. The Ditton systems are all proportioned similarly to the Ditton 44 shown, and vary in size from 40 x 15 x $11\frac{1}{2}$ inches (Ditton 66) to $12\frac{3}{4}$ x $6\frac{3}{4}$ x $8\frac{1}{4}$ inches (Ditton 10 Mk II) in regularly decreasing increments. Impedances are 4 to 8 ohms, and all models are available in natural teak or walnut. Prices: Ditton 66, \$450; Ditton 25, \$308; Ditton 44, \$252; Ditton 15, \$141.50; Ditton 120, \$115.95; Celestion "County," \$95.95; Ditton 10 Mk II, \$79.95.

Circle 120 on reader service card

Sams 1973 Technical Book Catalog

● HOWARD W. SAMS & Co. has prepared an 83-page indexed catalog that gives capsule descriptions of over 400 hardbound and paperback books published by the company on scientific and technical subjects, including fifteen titles specifically on audio and high-fidelity

topics. Among these are basic books for the beginner; texts on tape-machine principles, installation, and servicing; and on the construction of speaker enclosures: the theory and practice of stereo FM broadcasting; electronic organs and guitars; and several comprehensive reference volumes, including Howard Tremaine's *Audio Cyclopaedia*. The

Sams catalog also lists texts on subjects as diverse as amateur radio, servicing and test equipment, mathematics, and sheet-metal fabrication. It is available free through the Reader Service Card or by writing Robert W. Soel, Howard W. Sams & Co., Inc., 4300 W. 62nd Street, Indianapolis, Indiana 46268.

Circle 121 on reader service card

ELAC MIRACORD: 4 GREAT REASONS TO BUY 'NOTHING'

We believe each of these automatic turntables comes closer to "NOTHING" than any other in its price class. ("NOTHING", of course, is the elimination of anything that interferes with the perfect reproduction of stereo sound. And in automatic turntables, "NOTHING" is everything.)

Only other question is—how automatic do you want it? All four Elac/Miracord turntables feature advanced push button operation that lowers the tone arm so gently you can't tell when the stylus touches the groove.

And many other standard hallmarks of Elac/Miracord greatness.

1. **770H.** Top-rated in 1972 report. Superb performance and unique features such as digital readout of speed and built-in elapsed time stylus use indicator. There's "NOTHING" else in its class.
2. **50H MARK II.** World's standard for automatic record playing instruments. Quality of performance beyond any other in its price range.
3. **650.** Offers the opportunity to enjoy Elac performance

and quality at significantly lower price.

4. And if you'll settle for "NOTHING" less but want to spend under \$100, the 625 is the best automatic turntable buy around.

4 great reasons to buy "NOTHING"—send for the spectacular details today. They're free.

Elac Div., Benjamin Electronic Sound Corp. Farmingdale, N.Y. 11735
A division of Instrument Systems Corp. Available in Canada.



ELAC DIVISION

BENJAMIN

We put more engineering in... so you get more music out.

TOKYO SHAPIRO
WORLD WIDE
STEREO WHOLESALERS
THE BEST OF BOTH
WORLDS... DIRECTLY
TO YOU

WHO ARE THESE GUYS?

We're a group of young people that are well informed about the Hi-Fi world. We're no ripoff. We give you the best value for your money, plus honest practical advice. Every major brand is in our line, we have stock for immediate delivery and you get factory sealed cartons with full warranty. Write your needs to us today and if it's an entire system, we'll save you even more. Send for free catalog, current mig. specials and price list.

WE'RE OFFERING YOU ALL THE FAMOUS NAMES IN STEREO COMPONENTS BELOW NORMAL DISTRIBUTORS' PRICES

TOKYO SHAPIRO

12770 Chillicothe Rd.
(Mayfield Rd. at Ohio 306)
Chesterland, Ohio 44026
Phone 216/729-4903

ATTENTION:
Midwest Residents: Buy from us,
save excessive freight charges.

CIRCLE NO. 53 ON READER SERVICE CARD

DIXIE SAVES YOU MORE BY MAIL!

ON NATIONALLY ADVERTISED BRANDS • HI-FI COMPONENTS!

 Master Charge / BankAmericard Honored on Mail Orders.			
			

Write Today for Our FREE 36-page Wholesale Audio Catalog

Dixie Hi-Fi really sells name-brand stereo gear at Wholesale prices. Prices even LOWER than the "discounters". Call or write for our newest 36-page Wholesale Catalog. Write for quotes too. Choose from the tops in stereo systems & components. Your orders filled promptly and shipped factory sealed and guaranteed.

DIXIE HI-FI WHOLESALERS
10140 Bacon Drive • Beltsville, Md. 20705

DIXIE HI-FI WHOLESALERS
10140 Bacon Drive • Beltsville, Md. 20705
Please rush me FREE 36 pg. Wholesale Audio Catalog and complete information. I understand there is no obligation.

Name _____
Address _____
City _____ State _____ Zip _____
Phone: 1-301-937-3090 SR-4

CIRCLE NO. 12 ON READER SERVICE CARD

AUDIO QUESTIONS and ANSWERS

By LARRY KLEIN *Technical Editor*



Shibata Stylus-force Paradox?

Q. *I don't understand how a stylus can be used at a higher tracking force and yet put less pressure on the groove walls, as is claimed for the Shibata stylus. Can you explain this for me?*

GEORGE REYNOLDS
Hollywood, Ca.

A. The question arises probably because of a confusion between tracking force and stylus pressure. Although related, the two are entirely different physical concepts. An example will be helpful here. Not too long ago fashion dictated that young women teeter about on sharply spiked heels—which produced enormous damage to the plastic flooring in public places and

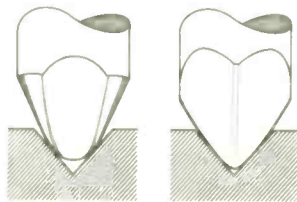

private homes. Obviously the *total* downward force applied by a young lady wearing spike heels is no greater than if she were walking barefoot, but since so much of her body weight is concentrated and applied to a very small floor area by the heel, the pressure per square inch is raised enormously.

Now let's look at the record. The force applied to the walls of a record groove is the total downward "push" of the stylus as determined by the gram setting on your tone arm. But the pressure is determined by how much of the stylus tip area is actually in contact with the groove walls. Obviously the smaller the contact area (remember the spike heels), the greater the pressure per unit of surface area.

All cartridge designers agree that (all other things being equal) the smaller the contact radius of the stylus, the better it will trace the small, rapid high-frequency groove undulations. However, the

smaller the contact area, the greater the pressure and risk of stylus and groove wear. Shibata's answer to the apparently conflicting demands of minimum contact area and minimum pressure is to shape the stylus tip so that it more closely approximates the groove cross section. In other words, while we still have the thin rounded "edges" of the styli resting on the two groove walls (which provides the same advantage as an elliptical stylus), with the Shibata stylus (see illustration, right) there is a longer section of the edge resting on the groove wall than with an elliptical (illustration, left). This distributes the force over a greater area and thereby reduces the pressure per unit of surface area to a more desirable level.

Although the above discussion is theoretically correct, it is certainly not complete, since I've avoided such complex matters as indentation effects and vinyl resonance. There is some evidence that the Shibata stylus is advantageous for playing conventional stereo discs, but time and research are needed before we will have the full story. It should be made clear that the Shibata-shape stylus tip can be used with *any* cartridge design and is, of course, not limited to use at the higher tracking forces.

Testing and Lily-gilditis

Q. *I have noticed that in some recent Hirsch-Houck lab reports, the equipment doesn't meet the manufacturer's "rated" specifications, yet Julian Hirsch nevertheless seems to be praising and recommending it. Isn't there a contradiction of some kind involved?*

VINNIE FICARA
New York, N.Y.

A. There are a few manufacturers who seem to suffer from a spec-writing disease known (at least to me) as "lily-gilditis." The symptoms are these: although the manufacturer produces a good, highly competitive product, he is unable to repress a tendency toward

(Continued on page 20)

AN EXTRAORDINARY OFFER

from

ONKYO®

Take It Home and Live With It for 10 Days . . .

Discover the quality of an Onkyo receiver on your own . . . in your own home!

If it's not what we say it is, or more . . . return it to your participating dealer for a full refund. Ask for a demonstration of our outstanding Model TX-666, Solid State AM/FM Receiver (\$429.95). Or the equally unique TX-555 Solid State AM/FM Receiver (\$349.95). Compare them with others . . . in any price class. Check the performance and specifications. Decide. Then, when you purchase your Onkyo Receiver — take it home for 10 days and live with it! You'll quickly discover that Onkyo's superior performance goes well beyond sterile written specifications — that it delivers dynamically live sound quality through an ingenious blend of superb performance characteristics. To explore the full impact of Onkyo's "Artistry in Sound" audition any of our remarkable Scepter Speaker Systems (\$149.95 to \$495.95). Match any of them to your new Onkyo Receiver. This offer is limited, but our quality isn't!

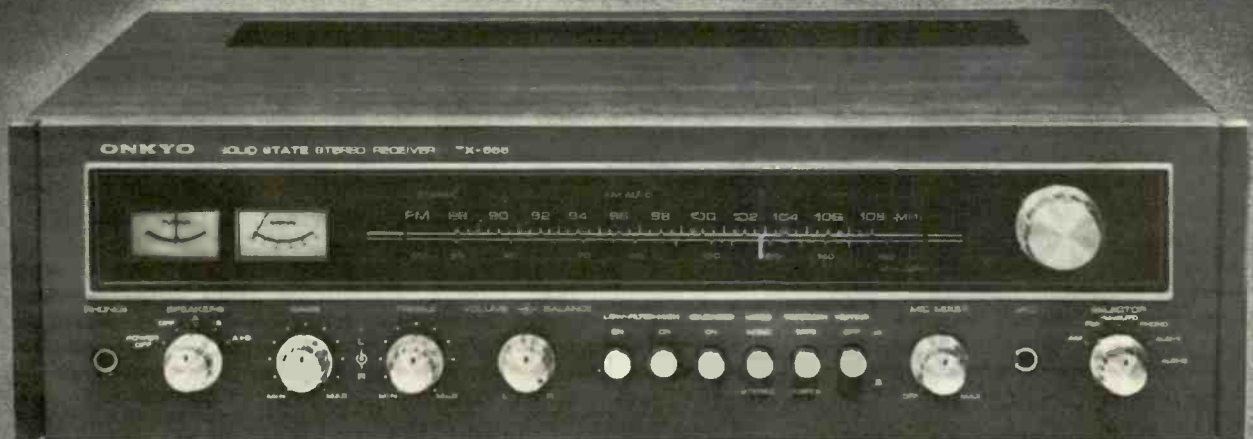

ONKYO® Artistry in Sound

Mitsubishi International Corp./Onkyo Sales Section 25-19 43rd Avenue, Long Island City, N.Y. 11101 / (212) 739-2323

Feel what you hear on Superex Stereophones

Try on a pair of Superex PRO-B VI stereophones and see what happens to your body. It's a physical sensation you can't get with other stereophones. With the PRO-B VI, each earcup contains its own woofer and tweeter, plus a full crossover network.

This permits a glorious rush of music to enter each of your ears and travel right to your toes. The dynamic woofer has double chamber acoustic suspension and damping. So you feel a drum roll down your neck. The coaxially mounted tweeter lets a flute send shivers up your spine. And in each ear, you feel the range and purity of a 15-22,500 Hz frequency response. 4-16 Ohm impedance.

Feeling comfortable is another part of the PRO-B VI. This comes from replaceable Con-Form ear cushions and a completely adjustable headband. Plus 15 generous feet of coil cord, with a clip that attaches the cord to you, and eliminates any tug on your head. In case you feel like dancing.

For \$60.00, you can feel more than you've ever heard. Superex guarantees it for two years. Have a good listen. You'll hear why Superex is the best sound investment around.

PRO-B VI The Professional
Dynamic Woofer/Tweeter
Stereophones
Sugg. Retail Price \$60.00



**Superex
Stereophones**
Feel what you hear

Superex Electronics Corp., 151 Ludlow St., Yonkers, N. Y. 10705
In Canada, Superior Electronics Inc., Montreal.

CIRCLE NO. 49 ON READER SERVICE CARD

hyperbole when writing the specifications for it. For example, FM tuner sensitivity of 2.5 microvolts may become 1.5 microvolts, amplifier power (under a given condition) of 30 watts becomes 40 watts—and so forth. When we test a product, however, we find it most valuable to the readers to consider each component from the viewpoint of its actual performance in comparison with that of other similar-price units, irrespective of the manufacturer's claims. Our comments in the final paragraphs of our reports attempt to place the product in the perspective of its value to consumers.

Frequently our tests reveal no clear-cut significant difference in specifications among a group of competing components, and then the best we can do is spell out our subjective reactions to the features, human-engineering aspects, and (sometimes) the physical appearance of the component under test. But we don't write at any length about our reactions to these matters, simply because we are aware that there can be legitimate differences of opinion in all three of these areas.

Speakers with Equalizers

Q. *It seems to me that there's an increasing number of speaker systems that employ active equalizers as part of their design. Is this a good idea, and how do such speakers compare in performance with conventional systems without electronic equalization?*

L. FRIEDBERG
Toronto, Canada

A. Before I address myself directly to the question, I'd like to submit the following thoughts: In most human endeavors there are likely to be several alternative paths leading to the same general goal. Some approaches will get you there easier, quicker, cheaper, or more reliably than others—but human beings being what they are, you'll usually find disagreement as to which will and which won't. And if, in addition, there's no agreement as to the precise goal, there can never be a consensus as to the best way of achieving it.

Perhaps the astute reader can see where this is leading. As far as I can tell there are legitimate theoretical arguments for and against designing speakers with equalization. And these arguments, if presented in full, would provide more than enough material for a feature article rather than a simple Q and A. My own view, based on listening experience and our test reports, is that it is possible to achieve excellent results either way. The question then comes down to the standard and legitimate matters of size, price, amplifier power requirements, etc.—all of which are factors that can and should be considered separately from the pros and cons of equalization.



FREE INFORMATION SERVICE

- a** Here's an easy and convenient way for you to get additional information about products advertised or mentioned editorially in this issue. Just follow the directions below ... and the literature will be sent to you promptly and free of charge.
- b** Tear out one of the perforated postage-free cards. Please print or type your name and address where indicated.
- c** Circle the number on the card that corresponds to the key number at the bottom of the advertisement or editorial mention that interests you. (Key numbers for advertised products also appear in the Advertisers' Index.)
- d** Simply mail the card. No postage is required.
- e** This address is for our "Free Information Service" only. All other inquiries are to be directed to, Stereo Review, One Park Ave., New York, N.Y. 10016.



1	2	3	4	5	6	7	8	9	10	11	12	13	14	15
16	17	18	19	20	21	22	23	24	25	26	27	28	29	30
31	32	33	34	35	36	37	38	39	40	41	42	43	44	45
46	47	48	49	50	51	52	53	54	55	56	57	58	59	60
61	62	63	64	65	66	67	68	69	70	71	72	73	74	75
76	77	78	79	80	81	82	83	84	85	86	87	88	89	90
91	92	93	94	95	96	97	98	99	100	101	102	103	104	105
106	107	108	109	110	111	112	113	114	115	116	117	118	119	120
121	122	123	124	125	126	127	128	129	130	131	132	133	134	135
136	137	138	139	140	141	142	143	144	145	146	147	148	149	150

SR4733

NAME _____
PLEASE PRINT

ADDRESS _____

CITY _____ STATE _____ ZIP CODE _____
(Zip Code must be included to insure delivery) (Void 90 days after date of issue)

1	2	3	4	5	6	7	8	9	10	11	12	13	14	15
16	17	18	19	20	21	22	23	24	25	26	27	28	29	30
31	32	33	34	35	36	37	38	39	40	41	42	43	44	45
46	47	48	49	50	51	52	53	54	55	56	57	58	59	60
61	62	63	64	65	66	67	68	69	70	71	72	73	74	75
76	77	78	79	80	81	82	83	84	85	86	87	88	89	90
91	92	93	94	95	96	97	98	99	100	101	102	103	104	105
106	107	108	109	110	111	112	113	114	115	116	117	118	119	120
121	122	123	124	125	126	127	128	129	130	131	132	133	134	135
136	137	138	139	140	141	142	143	144	145	146	147	148	149	150

SR4732

NAME _____
PLEASE PRINT

ADDRESS _____

CITY _____ STATE _____ ZIP CODE _____
(Zip Code must be included to insure delivery) (Void 90 days after date of issue)

1	2	3	4	5	6	7	8	9	10	11	12	13	14	15
16	17	18	19	20	21	22	23	24	25	26	27	28	29	30
31	32	33	34	35	36	37	38	39	40	41	42	43	44	45
46	47	48	49	50	51	52	53	54	55	56	57	58	59	60
61	62	63	64	65	66	67	68	69	70	71	72	73	74	75
76	77	78	79	80	81	82	83	84	85	86	87	88	89	90
91	92	93	94	95	96	97	98	99	100	101	102	103	104	105
106	107	108	109	110	111	112	113	114	115	116	117	118	119	120
121	122	123	124	125	126	127	128	129	130	131	132	133	134	135
136	137	138	139	140	141	142	143	144	145	146	147	148	149	150

SR4731

NAME _____
PLEASE PRINT

ADDRESS _____

CITY _____ STATE _____ ZIP CODE _____
(Zip Code must be included to insure delivery) (Void 90 days after date of issue)

FREE INFORMATION SERVICE

(SEE REVERSE SIDE)

FIRST CLASS
PERMIT NO. 217
CLINTON, IOWA

BUSINESS REPLY MAIL

NO POSTAGE NECESSARY IF MAILED IN THE UNITED STATES

POSTAGE WILL BE PAID BY—

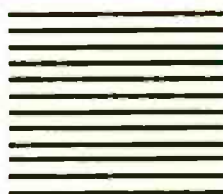

Stereo Review
P.O. BOX 2908
CLINTON, IOWA 52732

FIRST CLASS
PERMIT NO. 217
CLINTON, IOWA

BUSINESS REPLY MAIL

NO POSTAGE NECESSARY IF MAILED IN THE UNITED STATES

POSTAGE WILL BE PAID BY—

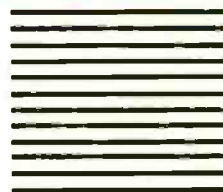

Stereo Review
P.O. BOX 2908
CLINTON, IOWA 52732

FIRST CLASS
PERMIT NO. 217
CLINTON, IOWA

BUSINESS REPLY MAIL

NO POSTAGE NECESSARY IF MAILED IN THE UNITED STATES

POSTAGE WILL BE PAID BY—



Stereo Review
P.O. BOX 2908
CLINTON, IOWA 52732

THE MOST IMPORTANT DISCS IN YOUR ENTIRE COLLECTION!

Stereo Testing! Spectacular Sound!

The New Standard In Stereo Testing!

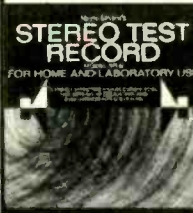

Model SR12 Stereo Test Record

The most complete . . . most sophisticated . . . most versatile test disc available today. Whether you're an avid audiophile who'll settle for nothing but peak performance from his stereo components . . . a casual listener who'd like more insight into the challenging world of stereo reproduction . . . or a professional technician who needs precise standards for lab testing . . . the SR12 is a must for your record collection.

Make These Important Stereo Checks By Ear . . . Frequency response. Separation. Cartridge tracking. Channel balance. Hum and rumble. Flutter. Cartridge. Anti-skating adjustment. "Gun shot test" for stereo musician's "A." Equal-tempered Chromatic octave. Guitar-tuning notes.

and speaker phasing. speed. Multi-purpose.

7 Critical Professional Test Equipment Checks. The SR12 is also a highly efficient design and measurement tool. Recorded levels, frequencies, etc., have been controlled to laboratory tolerances for use with oscilloscope chart recorder, output meter, intermodulation-distortion meter and flutter meter.

The Most Spectacular Sound Exhibition Of Stereo Fidelity Ever Available On One Disc And Cassette!



Stereo Demonstration Record And Cassette

The result of two years of intensive research in the sound libraries of Deutsche Grammophon Gesellschaft, Connoisseur Society, Westminster and Cambridge. The editors of Stereo Review have selected those excerpts that best demonstrate the many aspects of the stereo reproduction of music. It's the greatest variety of sound ever included on a single disc or cassette.

Electrifying Experience In Listening. A series of independent demonstrations designed to show many aspects of musical sound and its reproduction. Self-sufficient capsule presentations are arranged in a contrasting and pleasing order, isolated and pointed up to give you a basis for future critical listening.

Wide Range of Demonstrations. Techniques of separation and multiple sound sources. Acoustic depth. The ambiance of a concert hall. Sharp contrasts of dynamics. Crescendo and diminuendo. Very high and very low pitched musical sounds. Polyphony (two or more melodies going on at once) with both similar and contrasting instruments. Tonal qualities of wind, string and percussion instruments. Sounds of ancient instruments. Sounds of oriental instruments. The singing voice both classically trained and untrained. Plus a large sampling of finger snapping, hand clapping, foot stamping and other musical and percussive sounds.

Booklet discusses and describes each selection.

A Remarkable Listening Experience For Stereo Headphone Owners!



Binaural Demonstration Record

Binaural recording recreates the directions, distances, and even the elevations of sounds better than any other recording method. The super-realism of binaural recording is accomplished by recording the acoustical input for each ear separately, and then playing it back through stereo headphones. Thus the sound intended for the left ear cannot mix with the sound for the right ear, and vice versa. The sound reaching each ear is exactly the same as would have been heard at the live scene.

"Max"—Genie of Binaural Recording. A specially constructed jummy head duplicates the human head as an acoustical absorber and reflector of sound. Super-precision capacitor microphones installed in Max's ears picked up exactly what each human ear would hear. The result is a demonstration of phenomenal recorded sound. 45 minutes of sound and music of startling reality. You'll marvel at the eerie accuracy with which direction and elevation are recreated as you embark on a street tour in binaural sounds—Sounds of the City, Trains, Planes and Ships . . . a Basketball game, a Street Parade, a Steel Fabrication Plant, The Bird House at the Zoo—all demonstrating the incredible realism of binaural sound reproduction. Then, musical performances transport you to the concert hall for a demonstration of a wide variety of music. Selections total 23 minutes, and include examples of jazz, organ and chamber music.

**RECORDS ARE \$5.98 EACH —
CASSETTES \$6.98, POSTPAID**

HERE'S HOW TO ORDER

Send your order to Records, Ziff Davis Service Division, 595 Broadway, N.Y., N.Y. 10012. Be sure to specify the names of the items being ordered, print your name and address clearly and enclose \$5.98 for each record, \$6.98 for the cassette—which includes all postage and handling charges. Outside U.S.A. records and cassette are \$8.00 each.

FOR THOSE THAT CAN UNDERSTAND IT, THE SECRET OF EPI'S LINEAR SOUND:

Most people would have neither the understanding nor the inclination to read an ad like this.

But that doesn't make it a waste of our money. Because the few people that *would* read it are, by definition, the best prospects for our EPI loudspeakers.

The subject is linearity.

On a frequency response graph, an EPI speaker records a remarkably linear curve, measured from both on-axis and off-axis (60°) positions.

Why is that?

It has a lot to do with the kind of tweeter that goes into an EPI speaker.

EPI'S 1-INCH "AIR SPRING" TWEETER.

If you've never heard of an "air spring" tweeter, there's a very good reason for that: We made the name up.

We had to. EPI's tweeter is unlike any other made.

Our air spring tweeter has a concave diaphragm which is driven around its full circumference by a 1-inch voice coil. This is coupled with a 14,000-gauss magnetic field contained in a 9-ounce, permanently charged magnet and suspended in a conically-structured, air-sealed acoustic chamber, designed to create an equi-dispersed recoil effect.

The 1-inch diameter permits

radiation of a nearly perfect hemispherical sound pattern throughout the tweeter's entire frequency range, from 1800 to 18,000hz ± 3 db. And as

Stereo Review Magazine points out, wide dispersion at all levels is the major factor separating an excellent speaker from a merely good one. (*Stereo Review* placed our EPI 400 in the "superb" category.)

So, now that you know the secret of EPI's Linear Sound, all you need to know is where it comes from:

Out of eight great speakers, from \$55 to \$1000, made only by Epicure Products Inc., Newburyport, Mass. 01950.

**THE LINEAR SOUND
OF EPI.** 



DO YOU REALLY KNOW THE LOWEST PRICE?

Receivers, tuners, amplifiers,
speakers, tape recorders, decks,
compact & packaged stereo systems
... appliances & T.V., too!

CHOOSE THE EQUIPMENT YOU
WANT! PRICE IT! THEN GET
STEREO WORLD'S LOWEST PRICE!

Write for our lower than low instant quote!
Our warehouse prices are too low to give
over phone. Join the thousands of satisfied
customers who have found out how much
they save by writing! Your order will be
shipped immediately, in factory sealed car-
tons. Our warehouse has over \$2,000,000.00
worth of merchandise in stock. Franchised
distributors for 78 brands, so you get Full
Factory Warranty, too!

STEREO WORLD

A Division of EBA Associates Inc.
2329 Nostrand Ave. • Brooklyn, N.Y. 11210
PHONE: (212) 252-3400 • (516) 433-8989

TV & APPLIANCE BARGAINS, TOO!
Most any brand of Color or Black & White TV,
Air Conditioners, Washing Machines, Dryers,
Refrigerators, Dish Washers, Freezers or Stoves
at warehouse prices, too! WRITE!

CIRCLE NO. 48 ON READER SERVICE CARD

RECEIVERS
TUNERS
AMPLIFIERS

TAPE
RECORDERS
DECKS

LOW PRICES

ON FAMOUS BRAND
NATIONALLY ADVERTISED

STEREO COMPONENTS

FAST DELIVERY

FACTORY SEALED CARTONS

WRITE TODAY FOR OUR QUOTE

A. D. R. AUDIO

6200 CHILLUM PLACE N.W.
WASH., D.C. 20011
(202)
723-6060

SEND FOR
OUR FREE
CATALOG

SPEAKERS
CARTRIDGES
COMPACTS

ALL
STEREO
SYSTEMS

CIRCLE NO. 1 ON READER SERVICE CARD



AUDIO BASICS

By RALPH HODGES

THE FREQUENCY OF SOUNDS

WAY back when the concept of high fidelity was new, a major fault that its proponents found with the conventional "phonograph" of the day was its severe limitations in reproducing the full frequency range of musical sounds. This is still a shortcoming of many lesser reproducers today, but it may be, as some believe, that frequency-response specifications receive far too much attention from the performance-minded equipment buyer. To understand how much attention they deserve, let us try to establish a few general ground rules about sound and frequency.

Sound as we normally encounter it is the result of a vibrating object—a taut string, a column of air, *etc.*—imposing its vibrations on the surrounding air in the form of rapid fluctuations in atmospheric pressure. These fluctuations are launched outward at a speed of approximately 1,128 feet per second, and if, in passing, they should happen to agitate a human ear drum at a rate somewhere between the arbitrary limits of 20 and 20,000 cycles per second (now abbreviated Hz for hertz), a sound will theoretically be heard. I say "arbitrary," because a young child may clearly perceive sounds considerably "higher" than 20,000 Hz, while under the right conditions many of us might "hear" a tone as low as 16 Hz or so. Furthermore, it is not in the nature of the normal ear to hear sounds up to (or down to) a certain frequency and then cut off abruptly. Instead, the ear's sensitivity usually tapers off gradually, and the perception of sound close to or at an individual's "tapering-off" points depends in large measure on how *strong* the sounds are.

For reproducing music, we're obviously interested in knowing what frequencies musical instruments produce that are loud enough to be perceived and therefore to constitute a part of the listening experience. Since they're intended to be heard, most musical instruments make sounds whose *fundamental* pitches (the notes indicated in the score) are close to the center of the audio-frequency range. However, vibrating objects are apt to vibrate complexly. In other words, they simultaneously produce many frequencies of various strengths—specifically, the basic *fundamental* frequency and a composite of higher frequencies or *overtones*. When the overtones are whole multiples of the fundamental frequency (as is the case with most musical sounds), they are called the *upper harmonics* (the *first harmonic* is the fundamental itself). When they bear no special relationship to the fundamental, they are called, together with the fundamental, "noise"—at least for the purposes of this discussion.

The overtone structure of an instrument is unique to it and an important part of its sonic character. Bereft of their overtones, many musical instruments could not be told apart when playing the same note. We've all heard enough lo-fi to know that an instrument can be recognized even if *all* its overtones are not faithfully reproduced. However, the important overtones—and usually the fundamental—must be there at the right strength for *realistic* reproduction. Next month we'll see what this involves.

SONY® 1055 and 5055

One good Sony deserves another



Sony offers you eleven individual choices in tuners, amplifiers and preamps, plus an infinite variety of combinations. For every listening requirement in every price range. We're going to tell you about two new low-priced models that offer all the traditional Sony performance and value.

The Sony TA-1055 delivers 23+23W RMS continuous power into 8 ohms per channel, from 20Hz to 20kHz. The power you pay for is the power you get, at every frequency from low, low bass (where you really need it) right up to the highest highs. And these Sony circuit features keep that power

clean and quiet—direct coupled differential output and wide range, integrated circuit phono preamp. It has all the operating features, including such luxury touches as two sets of tape output and monitor connections (use one for an SQ decoder) with direct dubbing, front panel Aux and MIC inputs and slide controls. \$149.50.

The deserving tuner for the TA-1055 is Sony's ST-5055. Its sensitivity is 2.2µV IHF, moderate by today's standards, but when you combine it with a capture ratio of 1 dB, performance is outstanding. There's a high blend switch for quiet stereo reception of

weak signals, built in AFC, signal-strength meter and switchable muting. The price, including walnut finish cabinet, \$159.50.

Each is the lowest priced tuner and amplifier offered by Sony. Imagine the performance and value offered by the nine other models. Sony's wide selection of deserving amplifiers and tuners goes right on up to the ultimate combination of the super-powered 3200F, deluxe 2000F preamp, and 5130 tuner at \$1238. Visit your dealer and audition these Sonys. You deserve it. Sony Corporation of America, 47-47 Van Dam St., L. I. City, N. Y. 11101.

All prices suggested retail.

CIRCLE NO. 45 ON READER SERVICE CARD

Sony Tuners and Amplifiers now start at \$149.50.

You were born smart.



Make it pay off in the Navy.

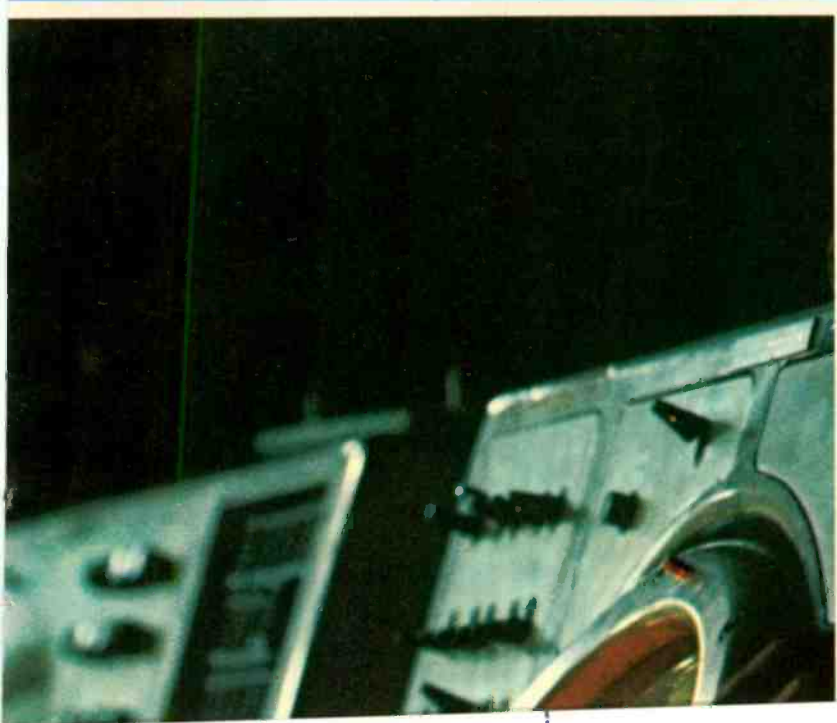

Get College Level Training In Nuclear Power, Advanced Electronics And Many Other Stimulating Jobs.

Let's start with our Nuclear and Advanced Electronics programs. If you can meet our qualifications, the Navy will offer you up to \$20,000 worth of advanced technical training.

But don't kid yourself. These are very special programs, and the academic schedule will be tough . . . calling for

**Use your brain
in the New Navy.
Send in this
postcard today.**

If someone got
to the postcard before you,

**call
800-841-8000
toll free**

(24 hours a day, seven days a week)
(In Georgia, call 800-342-5855.)

Yes, I'd like to know about using my
brain in the new Navy. Send me
information on:

- Nuclear Field Program
- Advanced Electronics Field Program
- Navy training in over 70 different
career fields with over 300 skilled
jobs to choose from.

If it sounds too good to wait, call us
toll free (24 hours a day, seven days
a week) right now at: **800-841-8000**.
In Georgia, call 800-342-5855.

Name _____

Age _____

Address _____

City _____

State _____ Zip _____

Phone _____

258

and honest effort. But it
a good mind to make it.
strong desire to want to
ve. And will it all be worth
inks so. In fact, at the
hitch, you may
000 bonus to re-enlist.
the new Navy is in the
ive modernization
cludes sophisticated
ms and nuclear power
man who can operate or
ic tools of tomorrow
self a firm foothold in the
are just two of the many
g programs in today's
e more brain power
er.
etails on any of these
s, and the opportunities
a, send in the coupon.
ocal Navy recruiter. Or,
toll free (24 hours a day,
k) at 800-841-8000.

Special in The New Navy



This new Wollensak 8-track keeps track of the exact recording and playback time



The Precision Digital Elapsed-Time Counter in the new Wollensak 8055 8-track preamp deck takes the guesswork out of timing recordings. It tells you the exact minutes and seconds that are available on a cartridge so you always know how much time is remaining. And you never have to waste time looking for a particular selection. Just list its time right on the cartridge and find it right away with the fast-forward control.

The Wollensak 8055 records from any sound source for playing back through your home stereo system or for the 8-track unit in your car. Its Logic Control Circuitry contains a "cuing" control that guarantees the

tape is always at the beginning when recording. It's easy to create superb recordings with the 8055's dual illuminated VU meters with switchable automatic record level. Previously recorded programs will be protected from accidental erasure while in the recording mode because of the 8055's built-in automatic eject system. And the Wollensak 8055 also offers a pause control with lock and dual recording level slide controls.

Nobody knows more about sound-on-tape or has more experience in tape recording than 3M Company. Find out why at your nearest Wollensak dealer.

Special Offer from Wollensak

When you audition Wollensak, your dealer will give you a certificate that entitles you to an attractive, high-quality Director's Chair by Telescope valued at \$19.95. Yours for only \$12.95 plus handling and shipping. No purchase necessary. Details at your dealer's.



Audition the new dimensions in spirited sound

Wollensak

3M CENTER • SAINT PAUL, MINNESOTA 55101
CIRCLE NO. 33 ON READER SERVICE CARD

3M COMPANY

STEREO REVIEW



TECHNICAL TALK

By JULIAN D. HIRSCH

● **CONTINUOUS POWER PROBLEMS:** Judging from our mail, there is still some consumer confusion over the rating of amplifier power output. Given the spurious "IPP" (instantaneous peak power) ratings still used by many "brown goods" manufacturers, and the nonsensical ± 1 -dB ratings still used by a few component manufacturers, it's no wonder that the consumer is frequently misled. So let us dispose of the notion of "peak power" once and for all: *any* power measurement based on the use of a single sine-wave signal can be converted to a "peak" figure by simply doubling it. Mathematically valid, perhaps, but nonsense nonetheless!

A reasonably valid argument can be made for an "instantaneous" short-term power rating, such as the "music" ("dynamic") power as defined by the IHF measurement standard. Unlike simple test signals, music waveforms are complex and frequently have momentary peaks many times greater than their average values. Distortion, or clipping, occurs at these peak levels, so why not rate an amplifier in terms of the maximum output it can deliver for, say, 30 milliseconds? Proponents of continuous (or steady-state) power ratings counter by pointing out that music consists of more than a series of momentary pulses or bursts. Some instruments, such as the organ, can generate high levels for extended periods. An amplifier that is able to cope with the transients of a guitar or harpsichord might be severely overloaded by an organ or a full orchestra. In the case of hard rock, with its compressed dynamic range, the gap between peak and average becomes still narrower.

The technical arguments are fueled by the competitive marketing need to claim ever higher power output for new amplifiers and receivers. A large continuous power rating that is honest necessitates large and costly power transformers, heavy-duty output transistors, and adequate cooling via heat-sink fins to protect the transistors from thermal

damage. A good look at any of the really powerful amplifiers, such as those made by Crown, Marantz, Phase Linear, and others, clearly reveals how they differ physically from lower-power amplifiers or receivers.

The large capacitors normally used in an amplifier's power supply serve to store energy, and this can be used (while it lasts) to sustain high power levels for a very short time. Also, larger and costlier capacitors can be used to extend the duration of this short-term power-output capability. But no amount of additional capacity can improve the amplifier's *continuous* power rating—which is based on the output's being available for at least 30 seconds.

Although a legitimate case can be made for having a high dynamic (music) power rating in addition to a large continuous power rating, we have always used continuous power as the basis of our wattage-output measurements. We think it is the fairest and most rigorous method of rating. Fortunately, there are signs that the high-fidelity equipment manufacturers are coming to the same conclusion. In addition, the IHF has instituted a number of technical committees to look into the revision and updating of standards. These include an amplifier standards committee chaired by STEREO REVIEW's Technical Editor Larry Klein.

TESTED THIS MONTH



Lafayette LR-4000 Receiver
Magnum Opus 7 Speaker System
Rotel RA-1210 Stereo Amplifier
Pickering V-15 Micro IV Cartridges

are signs that the high-fidelity equipment manufacturers are coming to the same conclusion. In addition, the IHF has instituted a number of technical committees to look into the revision and updating of standards. These include an amplifier standards committee chaired by STEREO REVIEW's Technical Editor Larry Klein.

We may see some positive developments in this particular area in the next year or so.

Recently, there has been a tendency to refer to the continuous power output as "r.m.s." power. There is surely no intent here to confuse the issue, but the term "r.m.s." (root-mean-square) simply does not apply to the type of measurements involved in measuring amplifier output. We actually measure the *average* power, which is the mathematical product of the sinusoidal r.m.s. voltage and r.m.s. current ($W = EI$) delivered by the amplifier to a resistive load. In fact, we are also talk-

ing about *average* power when referring to dynamic power output, but in this case the averaging time is a small fraction of a second. When interpreting amplifier ratings, one should read "r.m.s." as "continuous," bearing in mind that continuous in this case does not mean forever, but merely 30 seconds or so.

Current standards call for *all* channels of an amplifier to be driven simultaneously when measuring continuous power, and Hirsch-Houck Labs tries to adhere to that practice. Since both stereo channels will rarely carry exactly the same program material, this might seem to be an unfair testing mode. However, a mono signal *does* appear in both channels at the same level, so the requirement is not unrealistic. But we do run into a snag with four-channel amplifiers. Regardless of the conservatism of its ratings, no four-channel amplifier we know of is really meant to carry the same signal at full power on all channels. Many will be overloaded when so operated, and when 4-ohm loads are used, a fuse will usually blow before the rated power is reached. Our

solution to this has been to make most measurements with only two channels driven. This can be justified on other than pragmatic grounds, since no quadraphonic decoder supplies equal-amplitude, in-phase signals to all four outputs with *any* practical input signal. Even a mono signal appears with full strength only at the front outputs, and it is usually absent or greatly attenuated in the rear channels. Some quadraphonic amplifiers can be adjusted to load all four channels equally with a mono input, but this is an artificial situation.

The curves of power output *versus* distortion derived from our two-channel measurements apply equally to a four-channel situation, except that the maximum power output will be somewhat less. If the amplifier design permits, we do make a brief check of four-channel clipping power into 8-ohm loads. The ratio of four-channel power to two-channel power can be used as a basis for modifying the two-channel distortion curves if anyone feels the need to do so.

EQUIPMENT TEST REPORTS

By Hirsch-Houck Laboratories

Lafayette LR-4000 Quadraphonic Receiver



● THE Lafayette LR-4000 is the first, and at this time the only, AM/FM quadraphonic receiver with a built-in, full-logic, SQ decoder. As we pointed out in *STEREO REVIEW* for December 1972, this rather complex decoder can often produce virtually discrete-sounding quadraphonic programs from many SQ records. The front panel of the LR-4000 presents a deceptively simple, uncluttered appearance. Below the FM and AM dial scales is a row of function indicators that light up to identify stereo or mono operation, the selected program source, use of the tape-monitoring mode, and whether or not one of the two sets of speaker outputs is energized. To the left of the dial are the signal-strength and zero-center tuning meters, which are illuminated only when the tuners are in use.

Above the meters are five pushbuttons for selecting the MIC, PHONO, TUNER, AUX 1, or AUX 2 inputs. Directly below the meters is the tuner-mode switch, selecting either FM, FM with noise filter, or AM. To the left of this knob are stereo phone jacks for the microphone inputs and tape-recording outputs (the latter in parallel with the tape outputs in the rear).

To the right of the dial scales are a large tuning knob and three pushbutton switches. These activate either the main or remote speakers, and control the power to the receiver. Below them are two jacks for front and rear

headphone outputs. Six pushbutton switches provide separate tape-monitoring functions for a two-channel and four-channel recorder, stereo/mono mode selection, loudness compensation, a high-cut filter, and FM interstation-noise muting.

The other controls are six knobs along the lower portion of the panel below the dial. The FUNCTION switch has settings for 2 CH, COMPOSER A, COMPOSER B, SQ, DISCRETE, and REVERSE (discrete) modes of operation. In the 2 CH mode, the rear speakers carry the same programs as the front speakers, with a 6-dB level reduction. The two "composer" modes synthesize the rear-channel information from stereo programs, or decode records made with matrices other than SQ. The discrete inputs can be used with a tape-cartridge player or an external CD-4 disc demodulator.

A dual concentric master volume control adjusts the front and rear volume separately. Both sections of the knob must be turned simultaneously for overall volume adjustment. The BALANCE control is also concentric, with one section controlling the left-right balance in the front speakers, and other controlling the rear speakers. There are three dual-concentric tone controls (BASS, MID, TREBLE) that can adjust the front and rear channels (as a pair) independently.

In the rear of the LR-4000 are the main speaker outputs (barrier-strip screw terminals) and phono jacks for the remote speaker outputs. Each output is fused, and a line fuse protects the entire receiver. There are two a.c. outlets, one of them switched. A pivoted ferrite-rod antenna is used for AM, and a jumper link makes possible the use of the line cord as an FM antenna for local recep-

(Continued on page 34)

The world's most distinguished musicians have chosen Acoustic Research high fidelity components for use in their homes.



The reason is accuracy. Professional musicians appreciate a stereo system that reproduces the musical performances of their colleagues and themselves while adding no coloration of its own. For applications where accuracy is the standard, AR components are the only logical choice.

Erich Leinsdorf
 Don Ellis
 Herbert von Karajan
 Virgil Thomson
 Woody Herman
 Zubin Mehta

Karl Böhm
 Seiji Ozawa
 Miles Davis
 Arthur Fiedler
 Evelyn Lear
 Thomas Stewart

Claudio Abbado
 Aksel Schiøtz
 Judy Collins
 Dizzy Gillespie
 Rafael Kubelik
 Dietrich Fischer-Dieskau



Acoustic Research, Inc.

24 Thorndike Street
 Cambridge, Massachusetts 02141

Please send information on the complete line of AR stereo components to

NAME _____

ADDRESS _____

SR-4

CIRCLE NO. 2 ON READER SERVICE CARD

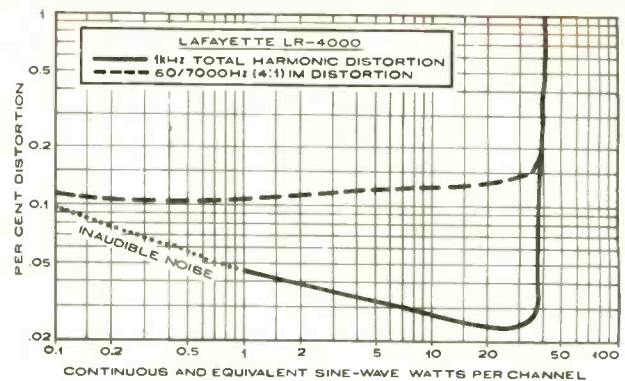
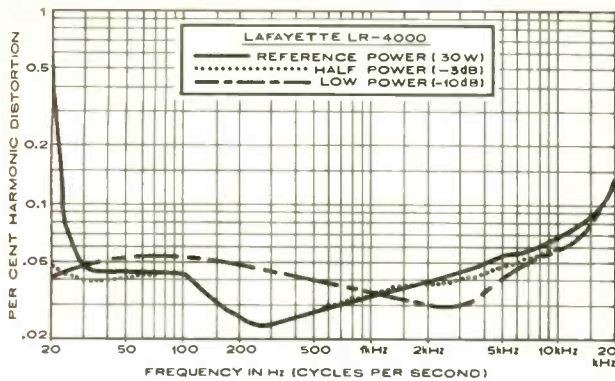

tion. Terminals are provided for external FM and AM antennas. There are the expected signal inputs and outputs, plus an FM DET OUTPUT jack for possible use with a future FM quadraphonic decoder. A slide switch sets up the phono inputs for either a magnetic or a ceramic cartridge. The LR-4000 is supplied in an oiled walnut wood-cabinet and has a two-year guarantee. Overall dimensions are 21 inches wide, 5 $\frac{1}{4}$ inches high, and 15 $\frac{3}{4}$ inches deep; weight, 30 pounds. Price: \$499.95.

● **Laboratory Measurements.** With all four channels driven in phase at 1,000 Hz, the output into 8-ohm loads was 32 watts per channel at the waveform-clipping point. Full-power measurements could not be made with 4-ohm loads since the line fuse blew before full power was reached. Our subsequent measurements were made with only two channels driven. At 1,000 Hz, the outputs clipped at 37.5 watts per channel into 8 ohms, 55.5 watts into 4 ohms, and 24 watts into 16 ohms. The harmonic distortion was between 0.02 and 0.05 per cent from 1 watt to the clipping point, and was below the noise level at lower powers. Intermodulation (IM) distortion was quite uniform over the full power range: between 0.1 and 0.2 per cent from 30 milliwatts to more than 35 watts.

The highest power that could be delivered at the frequency extremes was about 30 watts per channel. Using this as a reference "full-power" output, the distortion was under 0.1 per cent from about 23 to 18,000 Hz, rising to 0.6 per cent at 20 Hz and 0.13 per cent at 20,000 Hz. The typical full-power distortion was a low 0.05 per cent. At half power or less, the distortion level was essentially the same, except at 20 Hz, where it was under 0.05 per cent.

The sensitivity, for a 10-watt output, was 92 millivolts through the AUX inputs, 1.5 millivolts at the PHONO (magnetic) input, and 2.9 millivolts at the MIC input. The corresponding overload levels were 4.4 volts, 72 millivolts, and 135 millivolts. Noise was a very low -80 dB below 10 watts at the AUX inputs, -76 dB at PHONO.

The high-cut filter had a gradual 6-dB-per-octave slope, with its -3-dB point at about 3,200 Hz. The loudness

The LR-4000's input facilities include jacks for two four-channel auxiliary sources and two- and four-channel tape decks. Phono inputs will take either ceramic or magnetic cartridges.

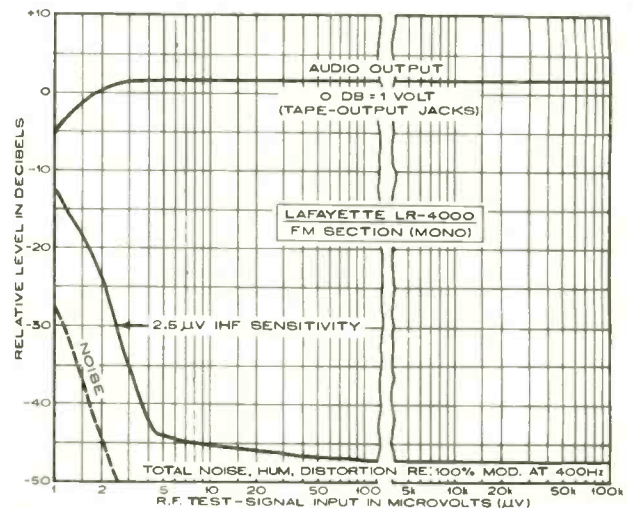
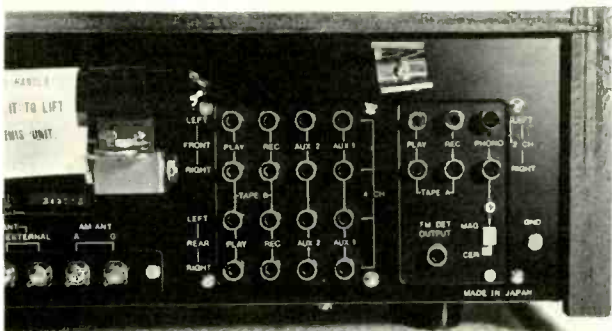

The dashed curve labeled "noise" shows how random noise (principally hiss) drops below the audio output with increasing signal strength. Ultimate quieting level achieved was -69.3 dB.

compensation boosted both high and low frequencies. The RIAA phono equalization was very accurate, within ± 1 dB over the full audio-frequency range. The MIC frequency response was within ± 1 dB from 40 to 20,000 Hz. The bass and treble tone-control characteristics were good, with moderate range and a bass turnover frequency that varied from below 100 to about 400 Hz. The mid-range control provided ± 10 dB of range centered at about 1,200 Hz, but with some effect at frequencies as far removed as 200 and 6,000 Hz.

The FM tuner sensitivity was 2.5 microvolts (rated 1.65 microvolts), but a useful 50-dB signal-to-noise ratio was achieved at only 2.7 microvolts input. The ultimate quieting matched its rated 70 dB. Capture ratio was 2.2 dB (rated 1.5 dB) at 1,000 microvolts input, and 6 dB at 10 microvolts. AM rejection was a good 52 dB. We measured the image rejection at 74 dB (rated 75 dB), and alternate-channel selectivity at 64 dB (rated 60 dB). The FM distortion, which is rated at 0.1 per cent, was measured almost exactly at the 0.5 per cent residual level of our signal generator, which would seem to confirm the receiver's ratings.

The FM frequency response was unusually flat—with ± 0.25 dB from 30 to 15,000 Hz. Even though flat response was maintained to 15,000 Hz, the LR-4000 has a very effective low-pass filter in its multiplex section that reduced the 19-kHz leakage in its output to -64 dB. Stereo channel separation was also noteworthy, possibly because of the use of a phase-locked loop multiplex circuit. It was about 40 dB from 300 to 8,000 Hz, and better than 22.5 dB from 30 to 15,000 Hz. The AM tuner, which produced good if undistinguished quality, had a frequency response of ± 3 dB from 20 to 4,000 Hz.

(Continued on page 36)

Albeit an expensive bargain, but a bargain nevertheless. For the Model Fifty-Four is without question the finest stereo receiver we have ever made. Indeed, it may well be the finest stereo receiver anyone has ever made. And if that wasn't enough, the Fifty-Four is also an absolutely incredible four-channel receiver. With 60 watts (RMS) per side in the two channel mode and 25 watts (RMS) per side in the four-channel mode, the Fifty-Four is an extraordinary power package. It's considerably more compact and sleeker than competitive models, yet it will outperform the biggest and bulkiest of

them with ease.

And it's so very easy to use.

All the controls are clearly indicated and conveniently located on the front panel. You can change from one format to another—two channel, Stereo 4, SQ, etc.—with the simple flip of a switch. In addition, there's a neat "joy stick" for absolutely perfect balance control.

The Fifty-Four also features an exclusive automatic power control circuit (patent pending) that turns the receiver on and off to coincide with the operation of your automatic turntable.

All in all, we think the Fifty-Four is

quite in a class by itself.

But don't take our word for it. Not for \$525.† Go listen for yourself. And if the price still seems a bit rich, consider this: Buy the Fifty-Four and you'll never have to buy another receiver again.

Now *that's* a bargain!

For more technical information, write to KLH Research and Development, 30 Cross Street, Cambridge, Mass. 02139. Or visit your KLH dealer.



KLH RESEARCH DEVELOPMENT CORP.
30 Cross Street, Cambridge, Mass. 02139

†Suggested retail price—slightly higher in the South and West.



**The
new
KLH-Model
Fifty-Four
Stereophonic/Quadraphonic
Dual Function Receiver.
Our \$525 bargain.**

● *Comment.* As our test data show, the general performance of the Lafayette LR-4000 would qualify it for inclusion in any group of fine stereo receivers. The only nits we could pick concerned the control knobs, which lacked clearly visible indexing marks (although a marking pen with a thin tip could rectify that problem easily). Also, the concentric volume-control knobs should have been designed like the tone controls, with slip clutches, since considerable care is required when changing volume settings if front-rear balance is not to be disturbed. (Lafayette has corrected both problems in later production.)

The LR-4000 is a lot more than just another good stereo receiver. All told, it uses one hundred transistors and eight IC's—a formidable semiconductor complement! Many of these are in the full-logic SQ decoder. Recalling that the only other SQ decoder with comparable performance we have seen is a separate component that sells for \$300 by itself, we wondered if the LR-4000's built-in SQ decoder could really achieve the same results.

Our judgment of its quadraphonic performance was based on careful listening to many of the commercial record releases we used during our recent tests of separate quadraphonic decoders (December 1972), and we can state unequivocally that the LR-4000 decodes SQ records with results subjectively identical to those produced

by the \$300 Sony SQD-2000 decoder. Of course the SQD-2000 is far more flexible and has about as many transistors in its decoder section alone as the entire LR-4000 receiver. However, it is evident that the designers of the LR-4000 have done a remarkable job of producing the "most" SQ receiver for the money we have yet seen.

When listening to other quadraphonic records made with the Sansui QS system (also called RM or Regular Matrix) or the old Electro-Voice matrix, we found that the LR-4000's COMPOSER A mode did the same fine job of decoding the material that had so impressed us during our tests of the Lafayette SQ-L decoder.

In summary, we find that the LR-4000 is a better-than-average stereo FM tuner and amplifier, with sufficient power (32 to 40 watts per channel, depending on drive conditions) for most home requirements. Except for our criticisms of the knobs, we were impressed also with its human-engineering aspects: the controls are laid out in a simple and functional manner, without sacrifice of flexibility. Its quadraphonic performance, with the matrixed records available to us, was outstanding, as was its overall sound quality and general ease of operation. All in all, the LR-4000 is a most impressive achievement—especially so considering its price.

For more information, circle 105 on reader service card

Magnum Opus 7 Speaker System

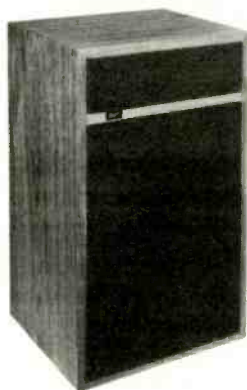

● **MAGNUM OPUS**, a relatively new loudspeaker manufacturer, offers a broad line of speaker systems, from the Opus 2 at \$129 to the Opus 24-T, which has twenty-four drivers and a \$795 price tag. Representative of the company's principles of loudspeaker design is the Opus 7, which we tested for this report.

The Opus 7 uses two 10-inch woofers driven in phase. One faces forward in the enclosure, which has a ducted port opening to the rear; the other faces upward into an acoustically damped cavity measuring approximately 12 x 13 x 3 inches and opening both to the front and rear of the cabinet. At about 750 Hz there is a crossover to a 5-inch mid-range cone driver, and at 3,000 Hz there is a second crossover to three 2-inch cone tweeters and a small dome tweeter. Except for the upward-facing woofer, all drivers face forward and are on the same plane. At the rear of the enclosure are continuously adjustable level controls for the mid-range and high-frequency drivers. Recommended settings are marked. The Magnum Opus 7 is nominally a 4-ohm system, rated for use with amplifiers delivering from 10 to 100 watts. Its oiled walnut cabinet, intended for floor mounting, is 25¼ inches high, 15¼ inches wide, and 13¼ inches deep; the system weighs about 55 pounds. Price: \$279.

● *Laboratory Measurements.* Our integrated frequency-response measurement, using the factory-recommended level-control settings, produced a very flat and uniform response curve through the middle and high frequency ranges. It varied only ± 1.5 dB from 1,200 to 15,000 Hz. In the lower mid-range we found a slight rise at 800 Hz and a dip of several decibels at 500 Hz.

Our normal measuring procedure for low frequencies was complicated by the fact that lows are radiated from several parts of the system (the front woofer cone, the rear port, and the top woofer through its front and rear openings). Normally, we use a close microphone spacing to minimize room effects, but when we placed the test microphone near the front woofer, the measured output fell off rapidly below 60 Hz. This, as it turned out, was not a valid measurement, and we eventually had to rely on subjective comparison to other speakers we have measured for evaluation of low-frequency response. We would say that the Magnum Opus 7 is capable of a strong clean output all the way down to about 30 Hz, which we consider to be its useful lower limit.

The low-frequency distortion, measured close to the front woofer, was low at frequencies above 60 Hz; it

(Continued on page 38)



The Magnum Opus 7 employs cone and dome drivers in a three-way configuration. A second 10-inch woofer is mounted facing upward into a separate, acoustically treated cavity.

The Sound Starts Here.



You're looking at one of the crossover networks for a Quadraflex Model 66 speaker. It may seem a small detail to emphasize when the ultimate concern, your and ours, is how good the completed system sounds. But the "details" have a great deal of effect on the sound, and that's why at Quadraflex we design and build all our own crossovers.

We also test every crossover network and every driver before it goes into a speaker. Quadraflex production facilities are equipped with the same B&K testing equipment used in our design labs. And finally, every single completed system is tested again before it can be sold.

For the Model 66, we designed a 3" cone-and-dome treble speaker, a 6" acoustically isolated midrange, and a 12" acoustic suspension bass speaker. Together, they're capable of flat response (± 3 dB) from 50 to 20,000 Hz — because we don't take chances with the "details."

The Quadraflex Model 66 sells for \$139.95 in a walnut-veneered cabinet. Other Quadraflex models are priced from \$24.95 (a six-inch system) to \$99.95 (a three-way ten-inch system).

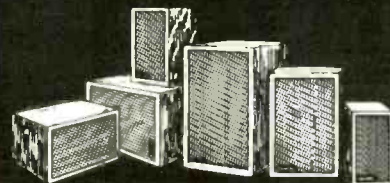

Quadraflex

For more information, just write: Quadraflex Industries, 1301 65th St., Emeryville, CA 94608

CIRCLE NO. 54 ON READER SERVICE CARD

Oscilloscope photos show the Opus 7's good tone-burst performance at (left to right) 80, 1,000, and 9,000 Hz.

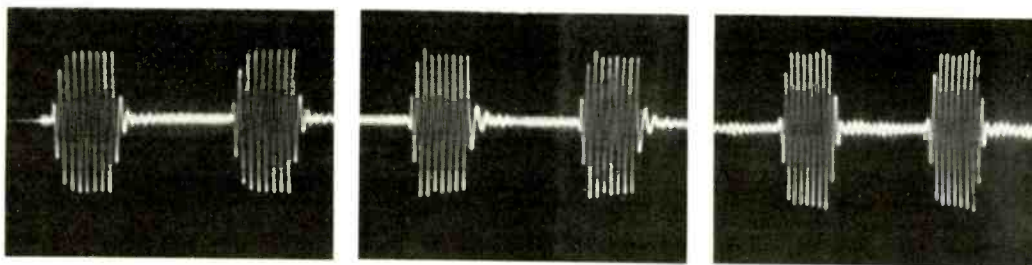

reached 5 per cent at about 55 Hz, 10 per cent at 50 Hz, and 20 per cent at 40 Hz. The measured distortion was about the same at drive levels of 2 and 20 watts. Like our response measurement, these figures do not accurately reflect the true behavior of the system. Our ears told us that the 30-Hz output, at levels sufficient to rattle objects in the room, had very low distortion. The efficiency of the Opus 7 was moderate (somewhat higher than that of most acoustic-suspension systems), and it could be driven to a 90-dB sound-pressure level at mid frequencies with an input of about 0.75 watt.

The impedance of the system was 4 to 5 ohms at most low and mid frequencies, with a peak of 8 ohms at 80 Hz, a dip to about 2.5 ohms at 1,800 Hz, and a gradual rise to about 9 ohms at the very high frequencies. The very low impedance in the upper mid-range will probably not cause problems with most amplifiers, but it should rule out the simultaneous operation of other speakers in parallel with the Opus 7. The tone-burst response was good at all frequencies. A two- or three-cycle build-up time was evident in most of the bursts, but the decay was more rapid. There was no evidence of ringing or spurious outputs.

● *Comment.* Our initial listening impression from the Opus 7 was of a warm, bass-heavy character. Highs were reproduced well, but the balance of the speaker favored the lower mids and deep bass. Using our simulated live-*vs.*-recorded comparison test as a basis for judgment, we experimented with different control settings on the

Opus 7 level adjustments. When the tweeter level was at a maximum and the mid-range level was set midway between the recommended setting and maximum, there was a dramatic change in the sound quality. The upper mids and highs then matched those of the original "live" sound almost perfectly—an "A" rating, by our criteria. Overall, the sound was still warm rather than crisp or dry, but it had a solid, all-there quality that left no doubt of the excellence of the Opus 7. We were frequently made aware of the system's low-bass performance by the almost inaudible sense of physical pressure that comes with a powerful, undistorted output in the octave between 30 and 60 Hz.

The polar dispersion of the Opus 7 was good, without obvious "beaming" of highs. With a white-noise test signal a change of sound character could be heard when passing in front of the speaker, but this is true of almost all speakers without special wide-dispersion or omnidirectional properties.

The Magnum Opus 7 is priced competitively with several other fine systems we have tested. Our tests show that its performance, insofar as we could measure it, is altogether comparable to that of its competitors. Nevertheless, most speaker systems have a special sound quality or tonal balance that may appeal to some people more than to others. We believe that anyone who favors the lower frequencies in his listening will find the Opus 7 especially to his liking.

For more information, circle 106 on reader service card

Rotel RA-1210 Integrated Stereo Amplifier

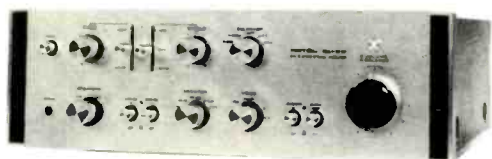

● ROTEL components have generally offered a high degree of flexibility and better-than-average specifications in a medium-to-low price range. With the introduction of their new RA-1210 integrated stereo amplifier, Rotel now competes directly with several of the higher-price deluxe models of other manufacturers. Each channel of the new RA-1210 amplifier has its own individual power supply with separate power transformer. Therefore, the available power output per channel is unaffected by tests made with both channels driven. The amplifiers also use direct-coupled circuitry.

The satin-gold panel is dominated on the right by a large black volume-control knob, surrounded by a metal ring that operates the balance control. Across the top left side of the panel are the bass and treble tone controls, each of which operates in 2-dB steps. Between them are two vertical three-position lever switches. In their lowest positions they defeat, or bypass, the tone-control circuits.

The other switch positions provide a choice of turnover frequencies, above or below which the control action becomes effective. For the bass control, these are 200 and 400 Hz; for the treble control they are 2,000 and 4,000 Hz.

To the left of the tone-control group is a push-on, push-off power switch (a small blue light above the volume control glows when the amplifier is on). To the right of the tone controls is the input selector, with positions for PHONO 1, PHONO 2, TUNER, AUX 1, and AUX 2. The PHONO 2 input can be adjusted for a wide range of cartridge characteristics by means of two slide switches in the rear of the amplifier. These provide input sensitivities of 1, 2, or 4 millivolts and several different input impedances. The PHONO 1 input is fixed at 1 millivolt and 100,000 ohms. At the lower left of the panel is the stereo headphone jack, with an adjacent speaker selector that can connect either, both, or neither of two pairs of speakers. Two pushbuttons control the low and high filters. The RA-1210 has an unusually flexible tape-recording and monitoring system, controlled by a separate MONITOR knob. When the knob is in its center position, the source program is heard. At either side of center are tape

(Continued on page 40)

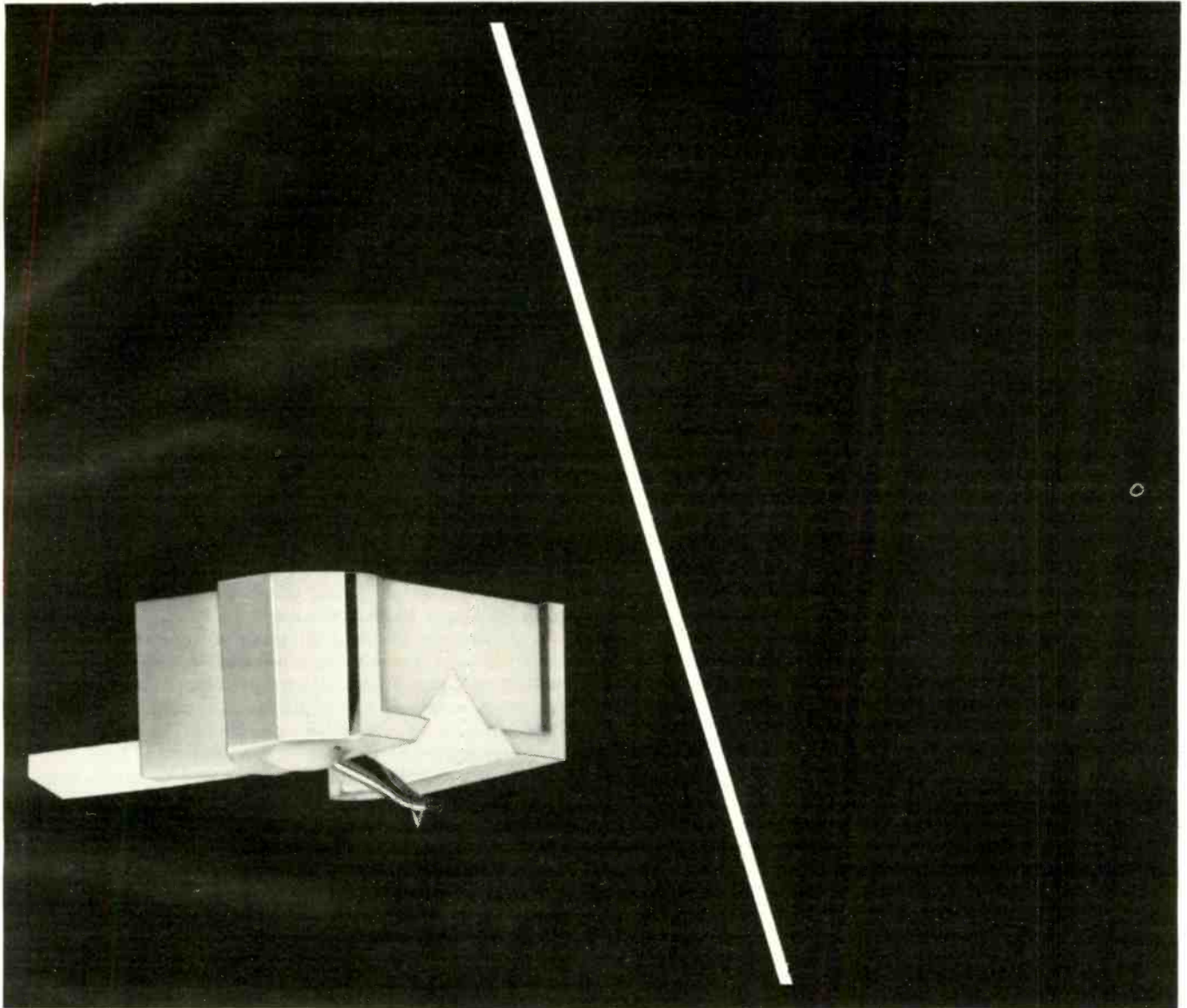

The three-dollar bill.

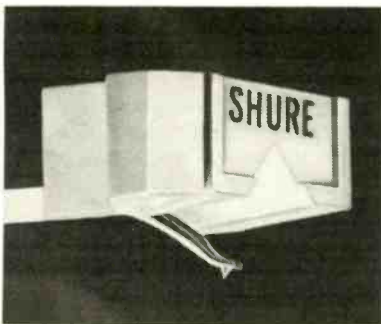

The stylus shown above is phony. It's represented as a replacement stylus for a Shure cartridge, and although it looks somewhat authentic, it is, in fact, a shoddy imitation. It can fool the eye, but the critical ear? Never! The fact is that the Shure Quality Control Specialists have examined many of these imposters and found them, at best, to be woefully lacking in uniform performance — and at worst, to be outright failures that simply do not perform even to minimal trackability specifications. Remember that the performance of your Shure cartridge *depends* upon the stylus, so insist on the real thing. Look for the name SHURE on the stylus grip (as shown in the photo, left) and the words, "This Stereo Dynetic® Stylus is precision manufactured by Shure Brothers Inc." on the box.

Shure Brothers Inc.
222 Hartrey Avenue, Evanston, Illinois 60204



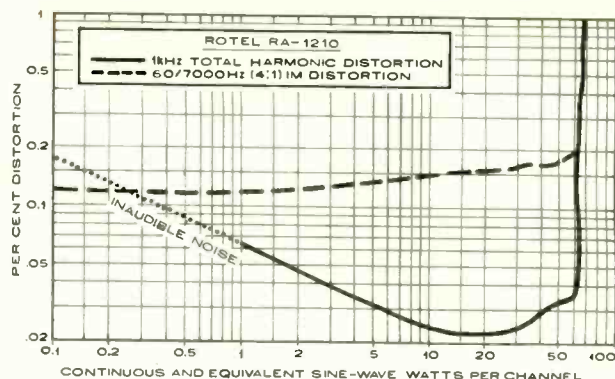
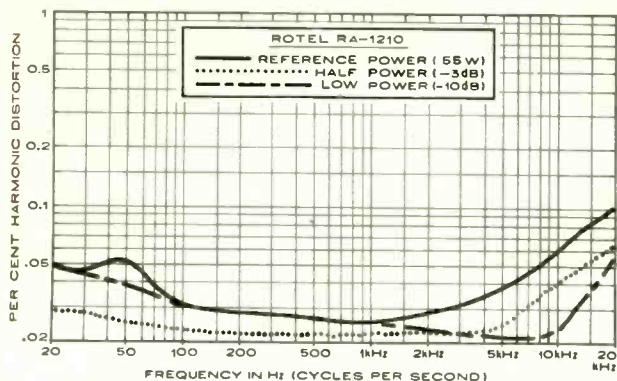

playback (monitor) positions for two independent tape recorders that can be permanently plugged into the amplifier. The two outermost switch settings permit the playback from either tape machine to be recorded on the other. A MODE switch provides normal or reversed stereo, either channel, or the sum of both (mono) played through both speakers. Finally, there are two pushbutton switches, one controlling loudness compensation and the other serving to reduce the output level by 20 dB for brief interruptions such as answering the telephone.

In the rear of the amplifier are the various inputs and outputs (including both DIN and phono jacks for the two tape decks), push-type spring-loaded speaker connectors, and three a.c. outlets, one of which is switched. The preamplifier outputs and main amplifier inputs are brought out to separate jacks, normally joined by jumpers. The Rotel RA-1210 is supplied with a metal dust cover. Its overall dimensions are 16½ inches wide, 5½ inches high, and 12 inches deep, and it weighs 30 pounds. Price: \$299.95.

● **Laboratory Measurements.** With 8-ohm loads, the output waveform of a 1,000-Hz test signal clipped at 66 watts per channel. With 4-ohm loads, the maximum output was 84 watts per channel, and into 16 ohms it was 43 watts per channel. The 1,000-Hz harmonic distortion was between 0.02 and 0.05 per cent at power outputs from 1.5 watts to slightly more than 60 watts. At lower levels, the distortion was below the noise level and hence was unmeasurable. The intermodulation (IM) distortion was almost constant over a wide range of power outputs (typically about 0.1 per cent). It was under 0.17 per cent from the rated 55 watts down to about 50 milliwatts output, rising at very low levels to slightly less than 1 per cent at 2 milliwatts.

The value of the dual power supplies of the RA-1210 showed up in the harmonic-distortion measurements. Distortion was under 0.05 per cent from 20 to 8,000 Hz at full power, rising to only 0.1 per cent at 20,000 Hz. At half power and one-tenth power, the distortion was even

lower—typically from 0.02 to 0.03 per cent over most of the frequency range.

The sensitivity through the high-level inputs was 68 millivolts for a 10-watt output, with a signal-to-noise ratio of 75 dB. The PHONO 2 sensitivity was switchable from 0.35 millivolt to 1.4 millivolts, and had the exceptionally low noise level of -75 dB (referred to a 10-watt output). The phono-input overload level was 115 millivolts at any setting of the phono-sensitivity switch, resulting (in the 1-millivolt position) in the highest phono dynamic range we have yet measured on an amplifier.

The tone controls had a moderate range, up to 10 dB of boost or cut. The selectable turnover frequencies were well chosen, permitting considerable compensation at the frequency extremes with negligible effect on the frequencies that add objectionable coloration. The switchable loudness-compensation circuit boosted both lows and highs, but was rather moderate in its effects and as a result was more listenable than most.

The high- and low-frequency filters had slopes of 6 dB per octave (slopes of 12 dB or better would be preferred in an amplifier of this caliber), with the -3-dB response points at 100 and 3,500 Hz. RIAA phono equalization was accurate within ±1.5 dB from 30 to 15,000 Hz. Although the specifications do not mention it, the RA-1210 has a highly effective subsonic filter permanently incorporated into its phono preamplifier. The filter, which has negligible effect at 20 Hz or above (and is therefore totally inaudible), cuts off abruptly at that frequency and attenuates subsonic noise (including turntable rumble) by 18.5 dB at 10 Hz and 34 dB at 5 Hz.

● **Comment.** Judging by our experience with the RA-1210, Rotel has gotten off to a fine start in the deluxe component field. The controls operate smoothly and positively, giving the RA-1210 a "quality" feel that complements its excellent electrical characteristics. It offers a combination of flexibility, styling, and overall performance that more than justifies its price.

For more information, circle 107 on reader service card

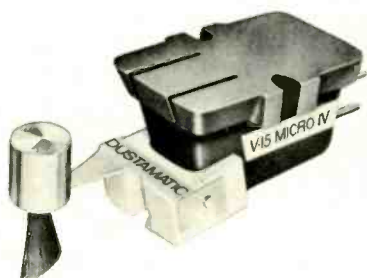

Pickering V-15 Micro IV Phono Cartridges (AME, AM, ATE, AT)

● PICKERING'S V-15 Micro IV line of stereo phono cartridges, which replaces their former Phase IV series, features a unique simplified mounting system and a reduction in effective stylus mass. The hinged "Dustomatic" record brush has been retained in the V-15 Micro IV series. The six models of the V-15 Micro IV line use the same body design and have interchangeable stylus assemblies with characteristics suitable for different types of

(Continued on page 42)

Now that you have more hair, style with more drying power.

[Don't waste time with less powerful stylers, get Schick's Styling Dryer]

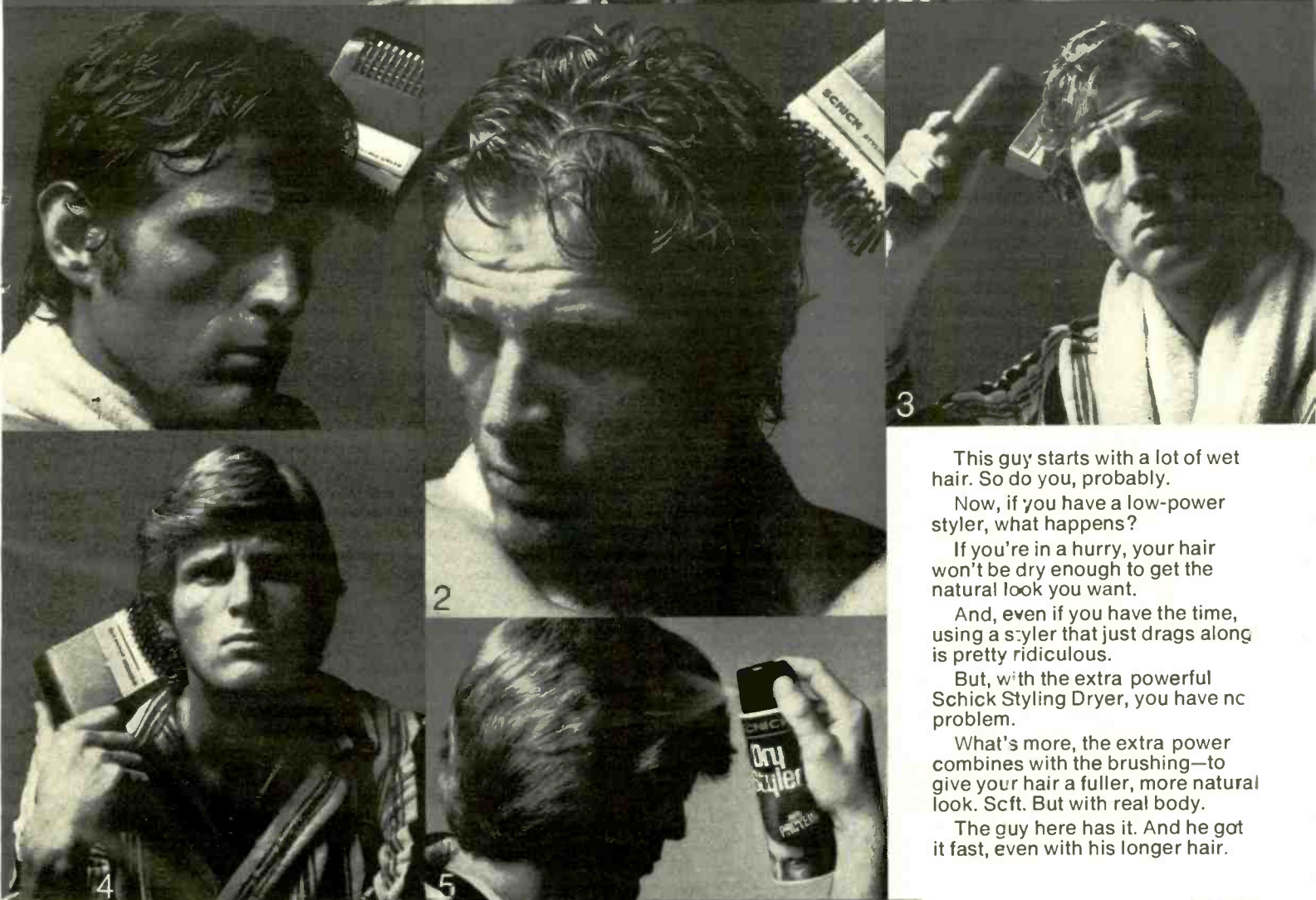

This guy starts with a lot of wet hair. So do you, probably.

Now, if you have a low-power styler, what happens?

If you're in a hurry, your hair won't be dry enough to get the natural look you want.

And, even if you have the time, using a styler that just drags along is pretty ridiculous.

But, with the extra powerful Schick Styling Dryer, you have no problem.

What's more, the extra power combines with the brushing—to give your hair a fuller, more natural look. Soft. But with real body.

The guy here has it. And he got it fast, even with his longer hair.



The Styling Dryer by SCHICK

New Control Spray that doesn't stiffen hair. Don't ruin the whole natural thing with a stiff spray. Get Schick's new Dry Styler. It has protein. Protein is the real key here. It helps give you that good control, without giving you that stiff, strawhead look.



record-playing equipment. The styli differ principally in their compliance and mass relationships and, therefore, in the range of tracking forces over which they can effectively operate.

For use with the better manual tone arms and high-quality automatic turntables, there is the AME, a 0.4 x 0.7-mil elliptical stylus designed to track with between 1 and 2 grams of stylus force. The similarly rated AM stylus has a 0.7-mil spherical tip and tracks between 1 and 3 grams. For lower-price automatic turntables the ATE 0.4 x 0.7-mil stylus operates between 2 and 4 grams, and the AT 0.7-mil spherical stylus is rated for the same range of tracking forces. Finally, the requirements of the least expensive record changers are met by the ACE, with a 0.5 x 0.7-mil stylus for the 3- to 5-gram range, and the AC, whose 0.7-mil spherical stylus is meant to be used between 3 and 7 grams. Other stylus assemblies are available with a 1-mil radius for mono LP's and a 2.7-mil radius for 78-rpm records.

The "Dustomatic" brush, used on all V-15 Micro IV styli, rides on the record just ahead of the stylus and removes surface dust that might otherwise gather on the stylus jewel. The "Keystone" mounting adaptor makes installation in most tone arms a quick and easy job, without even the need for a screwdriver. A plastic plate snaps into the mounting holes or slots in the tone arm's cartridge shell or slide, and the cartridge slides into it. A set of five Keystone plates are supplied with each cartridge, for various BSR, Dual, and Garrard automatic turntables, and one with screw-in slots for conventional installation in arms that won't take the adaptor. The list prices of the Pickering V-15 Micro IV cartridges are: AME, \$49.95; AM, \$34.95; ATE, \$39.95; AT, \$29.95; ACE, \$29.95; and AC, \$24.95.

● **Laboratory Measurements.** We tested the four top models of the Micro IV line (AME, AM, ATE, and AT) in the tone arm of an Empire 598 manual record player. A single cartridge body was used for all tests, so that we could be sure that the stylus assemblies were responsible for any differences observed. The installation was as simple as claimed.



"... The whales and the wolves were bad enough, but those war horses are the last straw!"

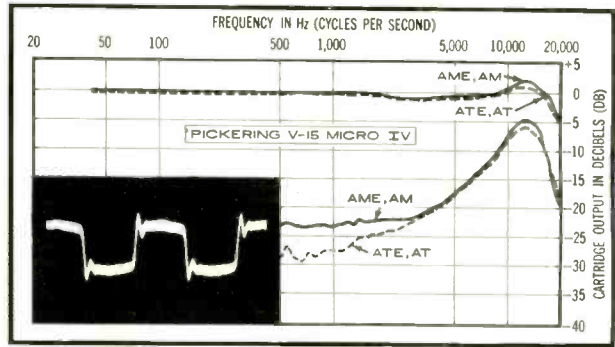

The upper curve represents the averaged frequency response of the cartridges' right and left channels. The distance (calibrated in decibels) between the two curves represents the separation between channels. The oscilloscope photograph of the cartridges' response to a 1,000-Hz square wave is an indication of a cartridge's high- and low-frequency response and resonances. Most program material on discs has velocities well below 15 cm/sec, and it only rarely reaches 25 to 30 cm/sec. Distortion figures shown are therefore not directly comparable with figures obtained on other audio components, but are useful in comparing different cartridges.

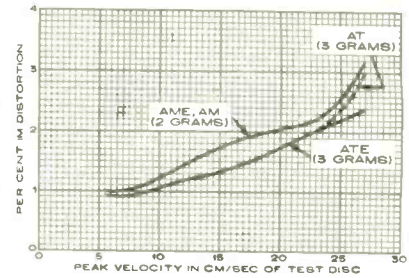

The output voltage, which did not change significantly with different styli, measured between about 5.9 and 6.2 millivolts for a velocity of 3.54 cm/sec (centimeters per second). This is a typical output for cartridges in the price range of the Micro IV series and is enough to drive any amplifier we know of fully, without risk of overloading the phono preamplifier. The tracking force required for optimum tracking of the 30 cm/sec tone bursts on the Fairchild 101 record was 2.5 grams for all the cartridges except the AM, which required only 2 grams. The high-level 32-Hz tones of the Cook 60 record, a severe test of cartridge compliance, were tracked nicely by all the styli at 1.5 grams. For the rest of our measurements, we operated the AME and AM at 2 grams and the ATE and AT at 3 grams.

All the models tested had very similar frequency-response curves with the CBS STR 100 record. In general, the response was within ± 3 dB from the lowest frequencies up to the 20,000-Hz upper limit of the record. There was a slight, broad rise of 2 to 3 dB in the 10,000- to 15,000-Hz region, followed by a smooth rolloff at higher frequencies. The channel separation was 20 to 30 dB at mid frequencies, diminishing slowly with increasing frequency. Between 10,000 and 20,000 Hz, however, the separation was typically between 5 and 10 dB—quite adequate for a full stereo effect. The overall similarity between the four tested models was further confirmed by the 1,000-Hz square-wave response to the CBS STR 111 record, which was identical for all units. Response showed a single overshoot and cycle of "ringing" at the high-frequency resonance point of about 12,000 Hz.

Our measurements were made with a standard cartridge load of 47,000 ohms, shunted by about 250 picofarads. A check with higher circuit capacitance showed only a slight effect for values up to about 500 pF, which slightly elevated the upper mid-range and depressed the extreme highs. The response modification due to the 500-pF load was barely measurable, and certainly was not audible, but we would suggest keeping the cartridge load capacitance below that figure. (Continued on page 44)

“Professional recording studios have all kinds of sophisticated and expensive equipment. With these Realistic® accessories from Radio Shack, you can get many of the same results at home!”



29⁹⁵

PRO-100 13-piece microphone system. Each mike has six accessories for total versatility in “live action” stereo recordings, voice or music, switchable 250 and 10,000 ohm impedance.



Arthur Fiedler, world-famous conductor of the Boston Pops Orchestra and recording artist for Polydor and RCA-Victor.



29⁹⁵

Two-channel solid state mike mixer mixes and blends up to four inputs for recording, group or combo performance. Individual and master volume controls. Stereo phono input is great for background music!

17⁹⁵



8" full-range patio speaker lets you take your favorite music outdoors while relaxing on patio, porch, or at poolside. Easy plug-in connection for radio, TV, phono. Screw terminals. Molded case with slots for mounting.

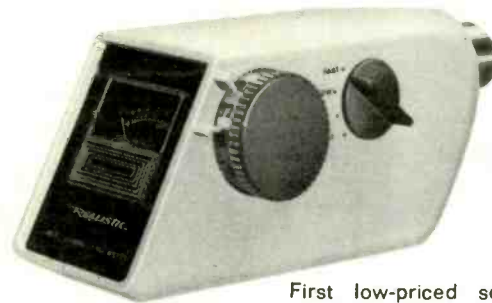

39⁹⁵

First low-priced sound level meter—check music levels, “sound-proof” rooms, stereo balance, more! Reads 60-116 dB in five 16 dB ranges, compares with \$200 meters!

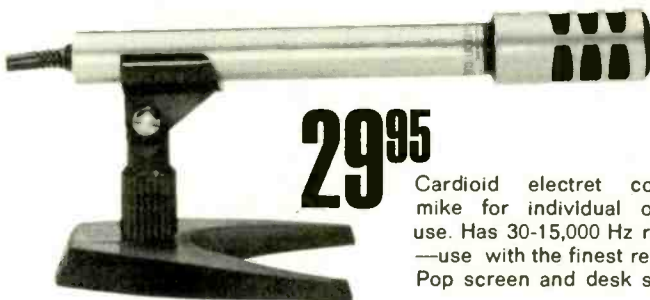

29⁹⁵

Cardioid electret condenser mike for individual or stage use. Has 30-15,000 Hz response—use with the finest recorders! Pop screen and desk stand.



24⁹⁵

Omnidirectional electret condenser mike for group use. Has 30-15,000 Hz response. Can be used with low or high impedance mike inputs. Includes pop screen and desk stand.

RADIO SHACK 172
 2617 W. 7th St., Fort Worth, Texas 76107

Rush me () PRO-100 mike systems, () cardioid mikes or () mike mixers at \$29.95 each; () patio speakers at \$17.95 each; () sound level meters at \$39.95 each; () omnidirectional mikes at \$24.95 each.

Check or money order for \$ _____ is enclosed (add applicable sales tax).

Send FREE Catalog

Please PRINT Clearly:

Name _____ Apt. # _____

Street _____

City _____ State _____ Zip _____

1169

Radio Shack®

and ALLIED RADIO STORES
 A TANDY CORPORATION COMPANY
 P. O. Box 1052, Fort Worth, Texas 76107

The intermodulation (IM) distortion measurements with the RCA 12-5-39 record showed little difference between the various styli over the full recorded velocity range from less than 5 cm/sec to a very high 27.1 cm/sec. The AME and AM were virtually identical on this test, and the other two cartridges also were quite similar, but with slightly less distortion than the more expensive models (which may well have been because of the additional gram of tracking force used). The noteworthy aspect of this test was the fact that all four cartridges were able to track the highest-velocity band with IM distortion levels between only 2.4 and 3.2 per cent. Furthermore, the distortion dropped steadily at lower velocities, to about 1 per cent (possibly near the residual distortion of the record) at the 10 cm/sec levels, which correspond to a moderately loud recorded passage.

The Dustamatic brush had no effect — positive or negative — on the antiskating force adjustment, using our test criterion of equal distortion in both channels. In general, a tone-arm manufacturer's recommendations can be followed, and the accuracy of the adjustments will not be affected by the presence of the brush, which does a fine job of picking up surface lint and dust.

● **Comment.** The Pickering V-15 Micro IV cartridges sounded fine, with no apparent colorations or distortions. In fact, one would not expect cartridges with their wide frequency response and high-level tracking ability to sound otherwise. We were intrigued by the similarity of performance among the models. True, the top-price AME operates at a lower force than the others, but this fact is mitigated somewhat by the ability of all of these cartridges to perform very well at forces somewhat less than those we used in our tests. Except for the highest



velocities, which can tax the abilities of almost any cartridge, we would judge that the AME and the AM can be used as low as 1.5 grams, and the other two at 2 grams. And if your record player requires somewhat heavier tracking forces, these cartridges can serve with distinction. In summary, the Pickering V-15 Micro IV cartridges combine excellent sound, better than average tracking of high recorded velocities, and greatly simplified installation.

For more information, circle 108 on reader service card

**Pierre Boulez
invites you to join him in the
center of Bartók's
"Concerto for Orchestra."**

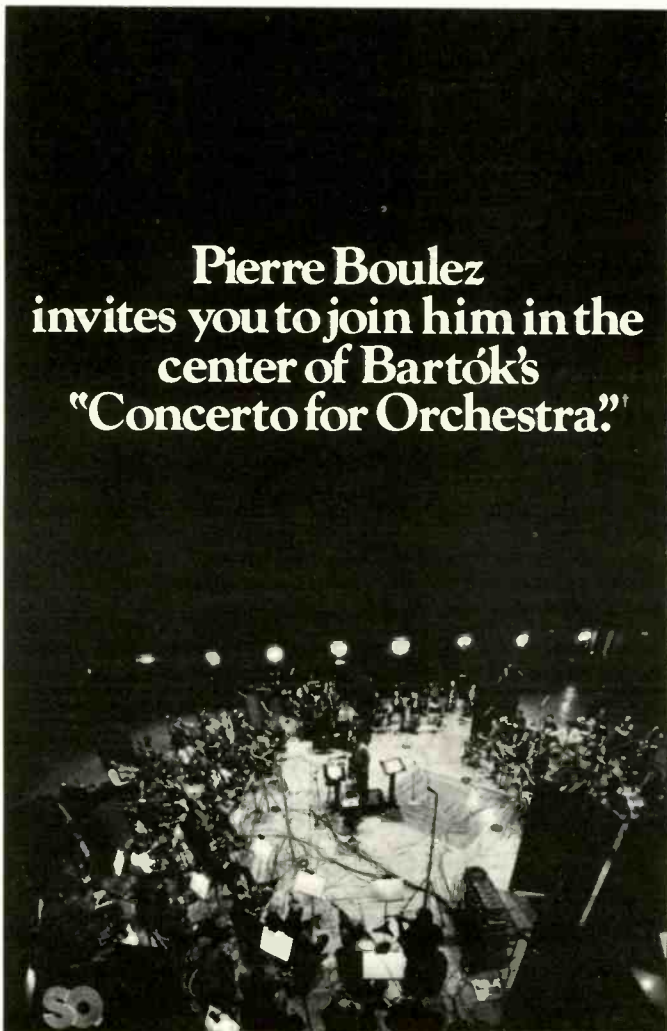

With the help of Columbia SQ quadraphonic recording technique, you can join Boulez at the podium.

Actually, *podia* is more accurate, since Boulez used two, whirling from one to the other to face the orchestra arranged around him.

What's it like to be in the middle of all the action and excitement?

The New York Times used the phrase, "visceral excitement." And certainly the experience is truly fantastic.

But what especially distinguishes this Boulez version of the "Concerto," though, is not the dramatic recording, but the insight the four channels add to the music itself.

We quote Thomas Z. Shepard, the album's producer: "It is Bartók's use of trumpets and trombones that suggested they be placed in right and left rear speakers," he said. And it is also Bartók's use of the percussionists that "virtually dictated their quadraphonic placement in left front, right front, and right rear, respectively."

We at Columbia sincerely feel that if Bartók were alive today, he would take immense pleasure himself, as a listener, in joining Boulez at the podium, in the center of the orchestra.

Even if you don't own SQ quadraphonic equipment, you may play this and any SQ disc on your present stereo systems. The rear channels will "fold" to the front for full stereo display.

**On Columbia SQ Quadraphonic
Records and Q8 Tapes**

Outside the United States and Canada, Columbia Records bear the CBS Records label.

ANRS

Makes Tape Hiss Nonexistent

JVC



stamp out tape noise

And . . . JVC has the brochure to show you how. It explains ANRS (Automatic Noise Reduction System) . . . why it's better for your ears, your audio system and your pocket-book. Now, with JVC Cassette Decks, you can have clean, crisp, "reel-to-reel" fidelity . . . plus cassette features like: 2 Studio-type VU meters accurate enough to be used for studio recording . . . a peak level indicator to signal when distortion reaches critical levels . . . a 3 digit counter with a memory . . . long life Cronios/Ferrite heads . . . a hysteresis synchronous motor . . . automatic eject system with photoelectric cell . . . eject button . . . 100% solid state . . . precision slide controls . . . push button function control panel . . . a frequency response of 30 - 19,000 Hz. . . .

Before you invest in a cassette deck . . . invest in an 8¢ stamp . . . write for this unique, informative brochure on how to make tape hiss nonexistent. **IT'S YOURS FREE!** Just send the coupon below to JVC America, Inc., 50-35B 56th Road, Maspeth, New York 11378.

JVC

Hi-Fi

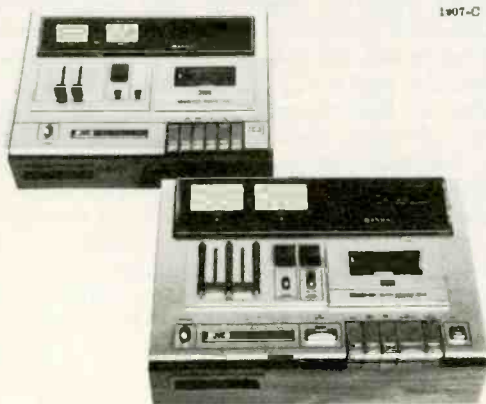

JVC America, Inc.
Advertising Department
50-35B 56th Road
Maspeth, New York 11378

Please send me a FREE copy of the JVC ANRS Brochure.

Name _____

Address _____

City _____

State _____ Zip _____

HUGE SAVINGS ON FAMOUS BRAND STEREO COMPONENTS

DISCOUNTS

ON NATIONALLY ADVERTISED

TURNTABLES • CARTRIDGES

COMPACTS • RECEIVERS

AMPLIFIERS • TAPE RECORDERS

Wholesale Prices! Audio Warehouse Sales, One of the Capitals largest stereo wholesalers will fill and deliver all your mail orders promptly in factory sealed cartons, at prices that will amaze you.

Write for quote on Famous Brand, Stereo Components. Ask about our Special Policy. We guarantee satisfaction.

AUDIO WAREHOUSE SALES
3310 NEW YORK AVE. N.E.
WASHINGTON, D.C. 20002
(202) 832-1616

CIRCLE NO. 5 ON READER SERVICE CARD

THIS

OVER 67 YEARS OF RELIABILITY

IS WHY STEREO & HI-FI BUYERS CAN BE SURE OF

SAVINGS AT RABSONS

At Rabsons Competitive Prices, Reliability and Personal Service have been bywords for over 67 years.

It's so EASY and SAFE to deal with Rabsons. As close as your telephone — as near as your mailbox • Fast Air Mail Response on Quotation Requests • Franchised Distributor for Hi Fi Lines • All merchandise brand new in factory sealed cartons, shipped double-packed, fully insured promptly from our warehouse • Greater savings on complete systems • Export packing • 220 Volts, 50 Cycle merchandising a specialty • Free list of monthly specials.

BEFORE YOU BUY GET A RABSONS QUOTE... YOU'LL BE GLAD YOU DID!

RABSONS 57 ST. INC.
119 West 57th Street, New York, N. Y. 10019
Tel. Area Code 212-338-8555

CIRCLE NO. 38 ON READER SERVICE CARD

GOING ON RECORD

By JAMES GOODFRIEND

Music Editor



SOME FOUR-CHANNEL AESTHETICS

IT is probably no more typical of the record industry than it is of any other field that combines art with business that technical problems seem to get solved before aesthetic ones. We have now, in response to no stated musical need, a number of different systems that permit the recording and reproduction of sound through four more or less distinctly separated channels. The question of the moment is, "What do we do with them?"

That question may be answered in the doing long before the theorizing ever really gets under way, for there are four-channel discs and tapes on the market already, and virtually every record company that has not yet released something in quadrasonic format is committed to doing so in the very near future. It is easy to predict what a certain number of these recordings are likely to be, but the rest defy anticipation. After all, when Adolphe Sax invented the saxophone, jazz had not even come into existence, and it is doubtful that even in his most fantastic dreams he foresaw that sort of future for his baby.

The predictable recordings are mostly of the kind we have heard already: ambient-sound recordings in which the performing group is still assumed to be, as in two-channel stereo, on a platform in front of you, and the rear channels pick up nothing more than the ambient sound of the hall, the more distant wall and ceiling reflections of the music, and, where applicable, the sound of the audience. Such recordings, thus far, have proved to be measurably superior to their two-channel counterparts, but many people find that measure a small one.

Certain other kinds of four-channel recordings are also predictable. Enoch Light has already demonstrated big-band, popular-music recordings in which the arrangements are written in such a way as to take advantage of four distinct sound sources, and there will be others like that. I think it is unquestionable too that some producer, whose taste, per-

haps, leaves a little bit to be desired, will record classical string quartets, one instrument per channel, thus putting the listener in an aural position roughly analogous to that of the music stand.

But none of these methods except the spatially written popular arrangements demonstrate an approach to four-channel recording as a new medium; even Mr. Light's use of the setup is the most obvious one, and it is valid mostly because there is no reason not to arrange pop tunes that way (or any other way, for that matter, the essential substance of pop tunes being confined to melody, harmony, and rhythm). But what about music—classical music, for example (though the field is not confined to that)—whose spatial characteristics are or seem to be fixed?

Starting at the easy end of that question, there are, of course, certain compositions whose proper reproduction almost demands four channels. Beyond this distinct repertoire we can still make a case for musical works involving two separated groups of instrumentalists or vocalists, for the difference in hearing two choirs each spread out between two speakers and hearing them one from each of a pair of speakers (as in stereo) is essentially the same difference as hearing a single choir in stereo rather than through a single speaker. As a matter of fact, the placement of sounds between speakers, particularly between front and rear speakers, rather than in them is likely to be one of the more fruitful courses quadrasonic recording can take.

Another easy aspect of the question concerns rock, jazz, and other contemporary popular music. There is no real problem there because rock and jazz arrangements are created anew for each record. The addition of another two channels of possibility gives the artists and producer merely another tool to work with.

Four-channel recording's real area of
(Continued on page 48)

"A silent giant that's built to last - probably forever..."

Stereo & Hi-Fi Times

and other rave reviews about the Empire 598II Turntable.

"The feel of precision machinery ... rumble was inaudible ..."

Hi-Fi Stereo Buyers Guide

"No acoustic feedback even directly in front of loudspeakers."

Hirsch Houck Laboratories, Stereo Review

"Absolutely no speed error at either 33 $\frac{1}{3}$, 45 or 78 rpm."

High Fidelity

"The turntable suspension is almost impervious to jarring or bumping."

Audio Magazine

"Built to last ... gives great results."

FM Guide

Listening is believing — ask your hi fi dealer for a demonstration. Write for your free "Empire Guide to Sound Design."



EMPIRE Scientific Corp. 1055 Stewart Avenue, Garden City, New York 11530
Canada: 65 Martin Ross Avenue, Downsview, Ontario



CIRCLE NO. 99 ON READER SERVICE CARD

Dokorder 7500

... with Space-Age Sophistication



Enjoy tomorrow's electronics today with the incomparable 7500. Its superb performance makes it the most exciting Stereo Tape Deck of the decade. Bi-Directional Recording/Automatic Repeat Playback • Electronic Tape Transport • Hi-Density MBD Heads • Bias Selector • Solenoid Operation • And More! For complete specifications, write...

Dokorder Inc.® 11264 Playa Court, Culver City, Calif. 90230

CIRCLE NO. 13 ON READER SERVICE CARD

difficulty and controversy is the standard concert-hall repertoire, and, to a lesser extent, opera and theatrical music in general. Here we have a relatively rigid spatial orientation resting upon a long historical tradition: the orchestra, chamber group, singers, or what have you are in front of you. Put them anywhere else and you are fighting history.

So the question *now* is, "Do we junk history, and if so, how?" At least two companies are already in the process of junking it. Columbia has released a recording of Stravinsky's *Le Sacre du printemps*, recorded in England, with nonstandard instrumental deployment, and has recently completed sessions for Bartók's *Music for Strings, Percussion, and Celesta* with the orchestra set up on all four sides of the conductor. Vanguard will release recordings of *Petrouchka*, Handel's *Water Music* and *Fireworks Music*, and Rossini's opera *La Pietra del Paragone*, in which the orchestra was set up normally but the microphone inputs were mixed to a four-channel spatial arrangement of the recorded sound. I have not yet heard the Columbias; I have been much impressed by the master tapes of Vanguard's *Petrouchka*. But a full comment on these can and will be made only when the finished records are available to us.

YES, I think to a certain extent it is time to junk history. By this I don't mean that I want my Beethoven symphonies coming at me from all four sides, nor that I want to be found at the center of an aurally circular keyboard when a Chopin Scherzo is being played on it. But there are a large number of pieces in the repertoire to which four-channel recording can bring a new and musically legitimate view. The crux of the matter, I think, is to get the listener into the *music* rather than into the orchestra.

A record, to repeat the old saw, is not a concert hall. The concert-hall arrangement of things (not the concert-hall *acoustic*, which is a separate thing) is legitimate on a record only if the music sounds best that way. Up to now it almost always has. But I think that the aural deployment of the orchestra in front of and to both sides of the listener can offer, in carefully chosen repertoire and when done with taste, something superior. It is not merely a matter of letting one hear things in the score that were difficult or impossible to hear before—although that is a part of it. It is more a matter of transforming the listener's environment—in somewhat the way that the darkened theater and lighted screen transform his environment in the film-watching experience—so that the omnipresence of the sound blots out even visual distractions, and one hears the music as one has never heard it before. That is the potentiality. Let us pray that it will become the actuality.

FREE McIntosh CATALOG and FM DIRECTORY

Get all the newest and latest information on the new McIntosh Solid State equipment in the McIntosh catalog. In addition you will receive an FM station directory that covers all of North America.



MX 113

FM/FM STEREO - AM TUNER AND PREAMPLIFIER

SEND TODAY!

McIntosh Laboratory, Inc.
East Side Station P.O. Box 96
Binghamton, N.Y. 13904

NAME _____
ADDRESS _____
CITY _____ STATE _____ ZIP _____

If you are in a hurry for your catalog please send the coupon to McIntosh.
For non rush service send the *Reader Service Card* to the magazine.

CIRCLE NO. 30 ON READER SERVICE CARD

STEREO REVIEW

Flip the switch to 4-channel.

The newest thing in sound is the newest Sound of Koss. And it's right at your fingertips.

The switch is on to 4-channel. And only Koss gives you 4 ways to make it. With the big four from Koss. Four exciting Koss Quadrafones that do for 4-channel what Koss Stereophones have done for 2-channel listening.

Four separate Driver Elements.

On the left cup of each Koss Quadrafone is a 2-channel to 4-channel switch. Flip it to 4-channel and four separate Koss dynamic driver elements (two in each cup) surround you with breathtaking, full-dimensional quadraphonic sound from either your matrix or discrete system. If you thought the Sound of Koss was superb in 2-channel, wait until you hear it in 4-channel.

So you haven't made the switch.

There are two plugs on Koss Quadrafones. If you haven't made the switch to 4-channel,



you only use one of them. The black one. Which you insert into your present stereophone jack on your 2-channel system. That automatically connects the two drivers in each ear cup in parallel. So what you'll have is nearly double the bass radiating area and an unbelievable increase in efficiency over the full range. Which should make the switch to Koss Quadrafones worth it even if you haven't made the switch to 4-channel.

Volume-Balance Controls.

Slip on a Koss Quadrafone and you'll slip into any seat in the concert hall. Because Koss

Quadrafones feature volume-balance controls on each ear cup. That puts any seat in the concert hall at your fingertips. From the middle of the concert hall one minute, to front row center the next. And you don't even have to leave the comfort of your own living room.

Hearing is believing.

With all that at your fingertips, it's hard to believe that you can buy Koss Quadrafones from \$39.95 to \$85. But it's true. And while you're on your way to hear them at your Hi-Fi Dealer or favorite Department Store, mail us a request for our full-color catalog, c/o Virginia Lamm, Dept. SR-472. You'll find a lot more from Koss that'll switch you on.



KOSS QUADRAFONES®
from the people who invented Stereophones.

**Are you
playing your records
or ruining them?**



If you're like most music listeners, you never think about your records after putting them on your record player.

You just sit back and enjoy the music.

Chances are you'd be less relaxed, if you knew that your records might be losing something with every play.

Like the high notes.

It's something to think about. Especially when you consider how many hundreds or even thousands of dollars you have invested in your record collection. And will be invested in the future.

What happens during play.

Even the cheapest record changer can bring its tonearm to the record and lift it off again. But what happens during the twenty minutes or so of playing time is something else.

The stylus is responding with incredible speed to the roller-coaster contours of the stereo grooves. This action recreates all the music you hear, whether it's the wall-shaking cacophony of a rock band or the richness of a symphony orchestra.

The higher the frequency of the music, the more rapidly the contours change, and the sharper the peaks the stylus has to trace. If the tonearm bears down too heavily, the diamond-tipped stylus won't go around those soft-vinyl peaks. Instead, it will lop them off. The record will look unchanged, but your piccolos will never sound quite the same again. Nor will Jascha Heifetz.

It's all up to the tonearm.

What does it take for the stylus to travel the obstacle course of the

stereo groove without a trace that it's been there? It takes a precision tonearm. One that can allow today's finest cartridges to track

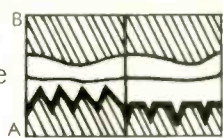

High frequency peaks can be lopped off as in A right. Less fragile low frequency contours are shown in B.

optimally at low pressures of one gram or less. For flawless tracking, the tonearm should be perfectly balanced with the weight of the cartridge, and must maintain the stylus pressure equally on each side wall of the

stereo groove. And in order to maintain this equal pressure during play, the tonearm must not introduce any drag. This requires extremely low friction pivot bearings.

There is much more to the design and engineering of tonearms and turntables. But this should be sufficient to give you the idea.

Dual: the music lovers' preference.

By now you probably understand why serious music lovers won't play their precious records on anything but a precision turntable. And the most serious of these people, the readers of the leading music magazines, buy more Duals than any other make of quality turntable.

If you would like to know more about Dual turntables, we'll send you lots of interesting literature, including an article on how to buy a turntable, and reports by independent test labs. Or better yet, just visit your franchised United Audio dealer and ask for a Dual demonstration. You will never have to worry about your records again.



How Dual protects your records.



Tonearm counterweight is elastically isolated from shaft to absorb any external shock, and is continually adjustable on vernier threads for perfect balance.

Gyroscope gimbal suspension of 1229 and 1218 is best known scientific means for balancing precision instruments that must remain balanced in all planes of motion.

In all Duals, stylus pressure is applied around the pivot - maintaining perfect dynamic balance of tonearm.

1229 tonearm is 8 3/4" from pivot to stylus, essentially eliminating tracking error while maintaining one-piece stability.

Unlike conventional tonearms, the 1218 and 1229 track records at the original cutting angle. The 1229 parallels single records, moves up to parallel changer stack. The 1218 has a similar adjustment in the cartridge housing.

For perfect tracking balance in each wall of the stereo groove, separate anti-skating calibrations for conical and elliptical styli are provided on all Duals.

United Audio Products, Inc., 120 So. Columbus Ave., Mt. Vernon, N.Y. 10553

Exclusive U.S. Distribution Agency for Dual.

CIRCLE NO. 14 ON READER SERVICE CARD

The Quietest Revox

One of the most compelling reasons for buying a Revox is the sounds it doesn't make.

No spurious pops or clicks. No wavering, fluttering tones. No distracting hum. And best of all, virtually noise-free electronics.

Take our new A77 Mk III for example. We manufacture it to such close tolerances and with such exacting attention to detail, that it is generally regarded as one of the quietest tape recorders ever made.

Unfortunately, no matter how quiet our electronics are, there is still the inherent problem of tape hiss.

And that's where our new Revox A77/Dolby B recorder comes in.

By now, the virtues of the Dolby Noise Reduction system are too well known to require any elaboration on our part.

Suffice it to say, for all practical

purposes the last major stumbling block to quality, noise-free recording has finally been eliminated.

Listening to tapes on the new Revox/Dolby B is a revelatory experience. Tape hiss is virtually non-existent. The music seems to emerge from a background of velvety silence. And at 3-3/4 i.p.s. the absence of extraneous noise is truly startling.

But no mere description of the Revox/Dolby B can adequately convey the experience awaiting you the first time you listen to a tape made on this remarkable machine.

Your nearest Revox dealer will be delighted to audition the Quietest Revox

for you. Once you've heard it, you'll understand why we say...

Revox delivers what all the rest only promise.



Hindemith's *Mathis der Maler* Symphony

DURING the years 1932-1934, under the gathering storm clouds of the Nazi holocaust, German composer Paul Hindemith was busily at work on his third opera. For his subject—he wrote the libretto himself—Hindemith chose events from four hundred years earlier in German history: the Peasants' War of 1524, a violent and bloody revolt against state and church that set the stage for a more liberal and responsive hierarchy. Matthias Grünewald (c. 1480-1528), a painter whose sympathies had been with the peasants, became the opera's central figure, through whom Hindemith spoke of his own feelings about political oppression and examined anew the old theme of the artist's role in a society in upheaval.

The Nazi machine was quick to recognize the threat Hindemith's activity posed to its authority; the composer was denounced by Hitler's Minister of Propaganda, Joseph Goebbels, and productions of the opera, *Mathis der Maler* (Matthias the Painter), were banned in Germany. But even before he had completed the opera Hindemith had extracted orchestral sections from the score and fashioned from them a "symphony" of the same title. And the symphony was promptly performed. Wilhelm Furtwängler conducted its first performance at a concert with the Berlin Philharmonic Orchestra in March of 1934 (Otto Klemperer and the New York Philharmonic introduced it to the United States only seven months later). In the face of Hindemith's disfavor in governmental circles, the performance caused a genuine crisis in musical Germany. Furtwängler, defending the freedom of art in general and Hindemith as a German artist in particular, resigned from all his official positions to protest the new governmental repressions (he was "rehabilitated" later, after an apology to Goebbels). Hindemith, for his part, left Germany before the end of 1934, not to return until some twenty years later—well after post-War Germany had begun to recover from the Nazi scourge.

The *Mathis der Maler* Symphony consists of three sections from the opera that are directly inspired by Grünewald's most famous work, a series of paintings commissioned for the altarpiece at St. Anthony's Church in Isenheim, Germany (the

paintings are now in the museum at Colmar near Strasbourg). In the opera, the Isenheim altarpieces take on a special symbolism connected with the dramatic action. The third movement, "The Temptation of St. Anthony," for example, becomes the temptation of Grünewald himself, drawn into the bitter struggles of the Reformation, distracted for the moment from his devotion to his art. The first movement, "The Angelic Concert," is the prelude to the opera; its principal theme, heard first in the trombones and later in the full orchestra, is the old church melody *Es sungen drei Engel* (There sang three angels). The second movement of the symphony, "Entombment," is the intermezzo in the final scene of the opera; it accompanies Grünewald's withdrawal from the world of strife.

AMONG the currently available recordings of the *Mathis der Maler* Symphony, three strike me as having exceptional value: Kletzki's (London CS 6665), Ormandy's (Columbia MS 6562), and Steinberg's (DGG 2530 246). Both Ormandy and Steinberg have recorded the score before, and their current editions represent mature conceptions of music each has lived with for a long time. Ormandy tends to stress the drama of the score, whereas Steinberg makes more of the linear counterpoint in the music. Both conductors work with virtuoso orchestras (the Philadelphia Symphony and the Boston Symphony), and both performances are well reproduced, though Ormandy's is slightly richer in sound. But it is the Kletzki recording that I prefer above all others; this conductor, who is vastly underrated (in the United States, at any rate), brings flaming conviction to his reading of the score, and the Suisse Romande Orchestra outdoes itself for him, playing with a sonority and polish that are not its usual wont. The engineers have captured full-blooded sound in a favorable forward acoustic. The very broad tempo Kletzki adopts at the end of the work, in the *Alleluia* peroration, may seem excessive to some listeners, but to me it is the logical culmination of all that has preceded it. Tape collectors apparently have only one version available to them—Steinberg's (DGG L 3246), which is very well processed in the reel-to-reel medium.

* Mr. Bookspan's 1972 UPDATING OF THE BASIC REPERTOIRE is now available in pamphlet form. *
Send 25¢ to Susan Larabee, Stereo Review, 1 Park Avenue, New York, N.Y. 10016 for your copy.



When the best of Broadway's songwriters
want the best of Broadway's lyricists,
they just naturally send for

Betty Adolph COMDEN & GREEN

A profile by PAUL KRESH

"NEW YORK, New York, a helluva town," I found myself cheerfully humming off key as I stepped aboard the grimy, north-bound Lexington Avenue subway, decorated from floor to ceiling with graffiti, the train that would take me to interview Betty Comden and Adolph Green. How did they get to be New York's brightest team of lyricists, librettists, and library-savers? How did they manage to get so much work done together and still sustain their separate marriages? How and when and where did they invent their rhymed and unrhymed brilliancies?

If the names of Comden and Green were removed from the record, great blank stretches would be left in the history of the Broadway musical. We would lose some of the happiest interludes on Hollywood celluloid as well, and without the words they supplied many of the country's cleverest songs would wind up as mere fodder for Muzak. Without them, there would never have been an *On the Town* or *Wonderful Town* or *Bells Are Ringing* or *Billion Dollar Baby* or *Hallelujah, Baby* or *Two on the Aisle* or *Subways Are for Sleeping* or the musical of *Peter Pan* or the book of *Applause*. The screenplays for such movie musicals as *The Barkleys of Broadway* and *Take Me Out to the Ball Game* and *The Band Wagon* and *It's Always Fair Weather* would probably have turned out not only different but drabber. *Auntie Mame* might have made us yawn instead of laugh. As for *Good News* and *Singin' in the Rain*, for which Comden and Green wrote both the screenplays and the lyrics, we probably would have forgotten them by now instead of remembering them as experiences of unmitigated joy. Surely it would have been a duller world these past thirty years.

Our interview took place in Betty Comden's home, where she lives as Mrs. Steven Kyle on the

upper East Side of Manhattan. We talked in a spacious room furnished generously with handsome objects, and lined from floor to ceiling with books—serious volumes, most of them, they appeared to have been personally selected rather than ordered from a book club or bought by the yard or pound. A Steinway and a Chagall graced an adjoining room. There wasn't a cute or kitschy item on the premises. The chairs and sofas were deep and comfortable.

Betty Comden, who looked as young as I remembered her in *On the Town* during my adolescence, was dispensing an air of what Arthur and Barbara Gelb once described in the *New York Times* as "dignified simplicity." But Adolph Green looked all wound up and as though he might have been happier if the large room were even larger; he's the restless type. Having been up all night with a sick daughter, he'd arrived late and Betty kept apologizing for him. As he once told a reporter, "She is always on time for everything, while I am late for anything." When Green did arrive, though, he exuded good manners all over the place with the breezy, almost marionette-like animation that is his trademark. I tried to thank them both for the many evenings of pleasure they had afforded me as a theater- and movie-goer, at which they both beamed patiently, waiting for the flattery to be over and the inquisition to begin. Then, without a murmur of protest, they launched into the story of their careers for the benefit of my hungry tape recorder.

SINCE they've been writing the books and lyrics of all those musical shows and movies since 1939, the Comden-Green saga takes a bit of telling. When, later that day, I dropped Adolph Green at his apartment on Central Park West, those feverish dark eyes of his looked weary indeed under the jaunty Dutch-boy cap he was wearing to keep up his mo-



Comden and Green in July 1944, together with producer, director, and "play doctor" George Abbott, who directed *On the Town*.

rale (he's always been a flamboyant dresser). I also had been introduced to Steven Kyle, to whom Betty has been married unshakably for as long as she and Adolph have been collaborating. Kyle, a distinguished-looking fellow, was wearing a splendidly conservative, dark, striped suit, and in his patience and self-effacement he reminded me, just a trifle, of Pitkin W. Bridgework, the long-suffering husband in *On the Town* who sings *I Understand*, a number that was dropped from last year's Broadway revival. As practically everybody knows, Adolph Green has been married since 1960 to actress Phyllis Newman, who, in that very same revival, played the part of Claire, the lady anthropologist. (Betty Comden herself originated the role on Broadway in 1940, and Green played Ozzie, the sailor who falls in love with her.) The Kyles have two children, Susanna and Alan. The Greens have two also—Adam and Amanda, who is feeling much better now than she did the day I met her father.

Turn the clock back far enough and you find Adolph Green and Betty Comden entering the world in the same year—1915—she on May 3, he on December 2 (they do not look their age). Set the calendar ahead a bit, and you come upon Adolph attending De Witt Clinton High School and later working as a messenger boy. Meanwhile Betty is "studying dramatics" at New York University. In the next old snapshot they are meeting "through mutual friends" on an evening they both remember as dismal.

Soon afterwards they decided that they were in a "paper bag" with their talents and would have to sing, act, dance, and write their way out of it. Dissolve to the recreation hall of a summer camp. Adolph meets a girl named Judy—Judy Holliday. Fast cut to the N.Y.U. campus, where Betty meets



On the Town opened in December 1944, with Adolph Green himself playing the role of the sailor with the anthropological bent.

"a boy." The next scene is Max Gordon's Village Vanguard in Greenwich Village, New York City, where Comden and Green and their new-found friends have just organized a group of performers. Now, look closely: left to right, Adolph Green, Judy Holliday, Betty Comden, her new-found boyfriend—but who's that fifth one, that frail youngster with the burning eyes and the slightly feverish smile? Oh, *him*. That's only Lenny—Leonard Bernstein, the music counselor with whom Adolph became friends at another summer camp back in 1937, during a production of *The Pirates of Penzance* (in which Green played the Pirate King).

"So we all got together," Betty recounts, "and formed this loose group called the Revuers. We were supposed to perform for one Sunday night only at the Vanguard; instead, we turned into a New York institution."

At first, the Revuers wrote their own material "because we couldn't afford anyone to write it for us." The very first song they wrote was called *The Subway Opening*, a history in rhyme of the Sixth Avenue El, long since torn down. The song was part of a revue called *Where to Go in New York*, with a plot that foreshadowed the one for *On the Town*. Although Bernstein dropped in several nights a week to join the Revuers as accompanist, the tunes were not his; Comden and Green wrote not only the book and lyrics of their first show but the music as well. "There was one boy in the group," Adolph relates, "who played the piano. We used to sing tunes to him and he would play them back for us [the boy was probably Lenny]. Betty had four basic chords which she used with tremendous discipline. You know, some of the melodic inventions of those scores were amazingly good, I think."

“Adolph, of course,” Betty chimes in smoothly, “would just sing melodies — you know, off the top of his head — and they would become the tunes of the songs. And then we would write lyrics.” I was beginning to notice how neatly they spelled each other — just as they do onstage — never interrupting, never bickering, always keeping the ball going and maintaining the amiable air that is their hallmark as a performing team.

The two collaborators wrote a new revue every week for the Revuers. One of these was on the subject of newspapers. Another was a lampoon of Hollywood — the first of many in their repertoire. For the political Thirties, the Revuers’ brand of satire was not particularly political, even though it was topical. It was an approach that must have seemed refreshing to their audience, for pretty soon there were lines around the block at the Vanguard. One of the Revuers’ shows, a half-hour musical called *The Girl with the Two Left Feet*, actually found its way onto the Musicraft label as a record album, but many of their songs never even got written down, much less recorded. Today, when they want to know how one of the old songs went, they have to call Leonard Bernstein. “Leonard always remembers,” Adolph says. “He knows our material better than we do. He seems to have forgotten nothing.”

A few nights after the interview, I was part of an audience at the Juilliard School where Comden and Green restaged their joint careers as lyricists, with the proceeds of the evening going to help save the Lincoln Center Library of the Performing Arts. (One bleak Saturday afternoon in December during

Rosalind Russell as a fledgling reporter tries to interview some Brazilian cadets on leave in Conga (Wonderful Town, 1953).



the previous winter they had been sighted placing Christmas wreaths around the necks of the marble lions in front of the New York Public Library at Fifth Avenue and Forty-second Street. In fact, the lions had been named in their honor for the day — one Comden, the other Green.)

Several of the songs on the program that evening were from the old Revuer days. One was about Joan Crawford, “. . . the epitome/Of what every girl would like to be.” At the end of the *Joan Crawford Fan-Club Song*, however, the fickle fans, with characteristic disloyalty, switch allegiance to Sonja Henie:

I want to be fluffy,
I want to be blond,
My cheeks must be puffy,
I want an ice-pond.
I want to go skating
About on the rink.
I want a slight lisp
And I want to wear pink . . .
I'll learn how to do
Arabesques on the ice,
But I won't be sophisticated,
I won't be hollow,
To hell with Crawford's smartness —
It's you I'll follow. . . †

In its disarming, sheathed-claw approach of seeming innocence as it slinks up to and then suddenly pounces on its target, the song is typical of the style Comden and Green later brought to perfection in the songs they wrote for Broadway.

Another exceptionally bright ditty celebrated the time-saving literary style of the *Reader's Digest*. It offered, for example, a capsule summation of *Gone with the Wind*:

Scarlett O'Hara is a spoiled pet.
She wants everything she can get.
The one thing she can't get is Rhett!
(The end.)†

One stanza was a three-line condensation of the *Complete Works of Sigmund Freud*:

Things you did when just a kid
Are still with you — don't keep them hid.
You love your wife — but oh, you Id!
(The end.)†

As the song continues, the trick trumps itself in a whole series of neat rhymes, disposing in three lines each of *The Story of Mankind*, *War and Peace*, and, in these swift strokes, the entire plot of Victor Hugo's *Les Misérables*:

Jean Valjean, no evil-doer,
Stole some bread 'cause he was poor.
Detectives chased him through a sewer.
(The end.)†

After a while, celebrities of the theater world — Marc Blitzstein, Aaron Copland, Lillian Hellman,

†Quoted permission Betty Comden and Adolph Green.

Paul Bowles—could be glimpsed among those waiting in line at the Vanguard to get in to see the Revuers, who by then were going on five nights a week and beginning to dream of greater glories. At length they were indeed catapulted from the Vanguard basement to the Rainbow Room on top of the RCA Building, but that didn't work out so well. Says Betty, "This was our first experience with people eating with knives and forks and *drinking* during our show instead of *facing* us and really listening and caring. After five weeks of that we were glad to get back to our basement. . . ."

True fame, the kind that has led to Hollywood movie biographies of Rodgers and Hart, George Gershwin, Jerome Kern, and Sammy Kahn, did not come to Comden and Green until their friend Lenny decided in 1943 that it might be a good idea to make a Broadway musical based on the plot of *Fancy Free*, the new Jerome Robbins ballet whose score had just won Lenny fame as a composer (his career as a conductor was already attracting attention). In any old-time movie version of their lives, we would find Comden and Green breaking up at this point in the act, at "the last final terrible gasp in Las Vegas where we were fired from a nightclub on New Year's Eve, right after the first show." We'd see them wandering around the gambling tables, not even allowed to perform for the second show of the evening, feeling that the rooms with the slot machines were thronged with menacing types "who seem to be saying 'get out, get out—or else.'" So Adolph describes it.

By the following New Year's Eve, however, *On the Town* was a hit on Broadway. And it was Bernstein who had insisted that Comden and Green be entrusted with the assignment of creating the book and lyrics for that show. "He was told by people

associated with him," Adolph reminisces, "'But Comden and Green are *satirists*—they do these pastiches, these takeoffs! Can they write a story—write *characters*—write things with *heart*?' " Bernstein stuck with the team.

The work of collaboration on the new musical actually began in a New York hospital, where Bernstein was confined for an operation to correct a deviated septum and Green was scheduled for a tonsillectomy. They arranged to be operated on the same day, and started *On the Town* while they were recuperating in the same room, Bernstein trying out tunes and Green bits of lyrics. Betty Comden came along on daily visits to contribute her share of ideas between gin-rummy games and amid the hospital's traffic hubbub of doctors, nurses, attendants, and assorted well-wishers.

Oliver Smith, who had designed the decor for *Fancy Free*, did the dazzling sets for *On the Town*—an ever-changing New York cityscape, from subway cars and comic-strip cutouts of apartments, to Times Square and the Coney Island midway. George Abbott, known for his high-speed direction, was summoned to stage the production. Robbins did the startling choreography, making *On the Town* a musical that was danced as much as it was sung. The score that Bernstein created had a unity rare indeed for the Broadway stage. Themes were not only reiterated, developed, and expanded, but turned up in various guises and tempos.

The play, which takes three sailors on leave in New York, and the girls they meet, on a whirlwind tour of the city, opened in December, 1944. Though the country was in the midst of World War II, the show rarely referred to the war itself—the occasion was a furlough for the war-weary audience as well as the actors. None of the numbers in it became real

At left, Leslie Uggams, Lillian Hayman, and Robert Hooks belt it all out in Hallelujah, Baby! And at right, beautiful Carol Lawrence gets comfortable and quietly passes out in the "dropout" musical (just a bit ahead of its time) Subways Are for Sleeping.



Friedman-Abeles



Spriner/Bettmann Film Archive



The authors (Comden and Green), composer (Jule Styne) and star (Judy Holliday) of *Bells Are Ringing* together at a rehearsal.

hits, but *Lucky to Be Me* came closest. It starts with what once was known as a “verse”:

I used to think it might be fun to be
Anyone else but me —
I thought that it would be a pleasant surprise
To wake up as a couple of other guys,
But now that I've found you
I've changed my point of view —
And now I wouldn't give a dime to be
Anyone else but me . . . ‡

The chorus has the unstrained, disarming simplicity and open appeal typical of any ballad with words by Comden and Green:

What a day!
Fortune smiled and came my way,
Bringing love I never thought I'd see.
I'm so lucky to be me. . . . ‡

Evidently the team of “satirists” could write lyrics with “heart” after all.

But in *On the Town* they also had all the room in the world to develop satirical pieces in the style that had attracted attention to their talents in the first place. When Chip, one of the sailors in the story, falls into the eager clutches of a lady taxi-driver who keeps trying to get him to “come up to my place” instead of visiting the famous landmarks listed in his out-of-date New York guidebook, they launch into a duet with a patter song that mentions practically every tourist attraction in town—except that every one of them has been torn down and replaced by something else. The Hippodrome is gone (“Aida sang an ‘A’ and blew the place away . . .”). The Woolworth Tower? “You’re just a little late—we’ve got the Empire State.” The Aquarium has moved to the Bronx; the actors in *Tobacco Road* have “washed their feet and called it *Angel*

Street”—and so it goes, in a headlong series of tricky rhymes and local references. It only served to prove the song’s point, when it was performed unretouched during last year’s unsuccessful Broadway revival of *On the Town*, that most of the replacements in the litany, from *Angel Street* to the Aquarium, had themselves been replaced or removed elsewhere since the number was written; even the Empire State Building’s much-vaunted height had been surpassed by the towers of the World Trade Center. *Come Up to My Place* is also a good example of the effortless way the lyrics of a Comden-Green number manage to further the plot of a show even as they entertain; Chip succumbs in the end to the taxi lady’s blandishments, and the next scene is set in “her place.”

Although Comden and Green find the inspiration for most of their songs in “situation and character,” occasionally the music comes first and suggests the theme of a song. During the months they were working on *On the Town* they walked into the theater one day and heard Bernstein playing a tune they thought was so poignant that they told him it ought to be in the show. That song turned out to be *Some Other Time*, the most charming one in the score. It is sung by the principals, all tired out after chasing to Coney Island in search of Miss Subways, as they hang sleepily from subway car straps:

Where has the time all gone to?
Haven't done half the things we want to—
Oh, well, we'll catch up some other time.
This day was just a token,
Too many words are still unspoken—
Oh, well, we'll catch up some other time.*

And so, to ornament the action of *On the Town*, the writers supplied three key numbers: one of loneliness (*Lonely Town*), one of love (*Lucky to Be Me*), and one of parting (*Some Other Time*).

“I must say,” Green has commented, “that Mr. Bernstein inspired us to write in veins we never dreamed we had within us.” For *On the Town*, they also managed to write themselves two big parts in the show—as the sailor Ozzie and the anthropologist Claire. For this couple, a show-stopping number called *Carried Away* was devised:

I try hard to stay controlled
But I get carried away. . . . †

The rhythmic pattern for this, they have disclosed, was cribbed from a number they admired in Richard Rodgers’ and Lorenz Hart’s musical *Pal Joey*: “We never told Leonard this,” Green says. “We just presented him with the first few lines, leaving

‡© 1944 M. Witmark & Sons. Copyright renewed. All rights reserved. Used by permission of Warner Bros. Music.

*© 1945 M. Witmark & Sons. Copyright renewed. All rights reserved. Used by permission of Warner Bros. Music.

†© 1946 M. Witmark & Sons. All rights reserved. Used by permission of Warner Bros. Music.

him oblivious of the hideous thing we'd done. And he immediately conceived a number that was just right for us." Despite its origin, the song turned out to be a spoof duet in the style of Italian *opera buffa*.

It was eight years later when Leonard Bernstein took time off from his career as a "serious" musician to write another musical, based on Ruth McKenney's short stories about her sister Eileen. Neither Betty nor Adolph was optimistic about the chances for *Wonderful Town*, even though it provided them with another New York setting. To Green, the idea seemed "so awfully Thirties-bound, sort of a post-Depression play, full of overexploited plot lines and passé references." Besides, they had been called in only at the last minute to replace Joseph Fields and Jerome Chodorov, who had adapted the story from their own play of *My Sister Eileen*. Comden and Green agreed to do the lyrics only if Bernstein would do the music. And it was Bernstein's enthusiasm that carried the day. He did the score using the forms of the Thirties with comic relish in such numbers as *Swing and Conga!* Once more he brought unity to the music by re-using and ringing variations on his melodies from *What a Waste to Pass that Football!* and *A Quiet Girl*. His orchestrations chaffed the period styles of Eddie Duchin and Glenn Miller. Unusually intricate for a Comden-Green lyric was the number *Conversation Piece*. In that song (or, rather, that scene, since much of the number is talked) five of the characters are attending a party in Greenwich Village on a hot summer evening and trying to keep the conversation going. In the words, which have meaning only in the context of the show, the lyricists were not only inspired by "situation and character" but actually wrote quick miniature character studies.

A major element in the box-office success of *Wonderful Town* was the presence of Rosalind Russell, who, at forty-one, starred in the role of aspiring writer Ruth Sherwood, fresh from Ohio trying to make it in the big town as a journalist. "Rosalind was marvelous," Betty Comden recalls. "She had an idea in her mind—and she kept persisting with it, even though we had already gone through a successful opening in New Haven. She kept saying, 'Look, I need something that I can come on with and establish my character—you know, Lenny, I've got four notes in my voice, and I want a song that goes da-da-da-da-joke, da-da-da-da-joke.' Soon afterward, Rosalind wasn't feeling well, she was in the hospital, and we said, well, we'd better face it because she'll just keep after him until we do. So we met with Leonard in a New Haven hotel room and we wrote *One Hundred Easy Ways to Lose a Man*." The song begins:



A scene from *Applause* (1970) shows Lauren Bacall wielding an axe, surrounded by Brandon Maggart, Ann Williams, Len Cariou, and Lord knows how many other famous people besides.

The first way to lose a man:
You've met a charming fellow and you're out for a spin,
The motor fails, and he just wears a helpless grin.
Don't bat your eyes and say, "What a romantic spot we're
in . . ."
Just leap out, crawl under the car, say it's the gasket
and fix it in two seconds flat with a bobby pin.
That's a good way to lose a man.*

One Hundred Easy Ways goes on through stanza after stanza of similarly vivid situations, never flagging or settling for a second-rate line, right to the bitter end:

Just be as well-informed as he,
You'll never hear *Oh Promise Me*.
Just tell him where his grammar errs
Then mark your towels "Hers and Hers."
Yes, girls, you too can lose your man
If you will use Ruth Sherwood's plan—
One hundred easy ways to lose a man.*

Miss Russell turned out to be right, too. Her song was a show-stopper, and *Wonderful Town* ran for 556 performances on Broadway. There was no Women's Lib at the time; a revival today might well elicit hisses from its members instead of thunderous applause for the hardboiled satire of *One Hundred Easy Ways*. But *Wonderful Town* also had a generous supply of heart in such numbers as *It's Love*; local color in *Christopher Street* and *My Darlin' Eileen* (the quintessential Irish-American ballad and jig); hilarity to spare in *Conga!*, *Wrong Note Rag*, and *Pass that Football!*; and the dreamy nostalgia of *Ohio*, sung by Ruth and her sister Eileen in a wistful duet of homesickness:

Why, oh why, oh why-o
Why did I ever leave Ohio?
Why did I wander
To find what lies yonder
When life was so cozy at home?†

* © 1953 G. Schirmer, Inc. All rights reserved. Used by permission.

† © 1953 G. Schirmer, Inc. All rights reserved. Used by permission.

The song sums up—epitomizes—the entire situation of a scene in a manner that is characteristic of most of the numbers in *Wonderful Town*.

In their collaborations with Bernstein, as in their carefree experiments in satire at the Vanguard, Comden and Green had taken the supposedly rigid thirty-two bars of the popular song and bent it to their lyrical wills in ballads, patter songs, and virtuoso ensemble numbers that not only furthered the plot but, at the same time, like the best of W. S. Gilbert's lyrics, could be lifted out of context and sung for their own sakes. The wit and charm and home truths scattered through their lines are so well matched by Bernstein's sophisticated melodies that it is impossible to separate words from music in our minds—the time-honored test for any genuine song.

Most wordsmiths might have been content to enjoy the hits they had already rung up with Bernstein, but Comden and Green had undertaken other aspects of their career together with equal success. Back in 1951, they had teamed up with another kind of composer—Jule Styne—and adapted their gifts to another way of working on a musical show.

“Leonard thinks of the music of a show more as a single, seamless piece,” Adolph says. “He deals in large concepts. But Julie attacks the situation number by number. Still, Julie's much more than a tunesmith, you know. The show as a whole always matters to him, as it does to Lenny.”

THE first show Comden and Green worked on with Styne was the revue *Two on the Aisle*. “In a revue,” Mr. Green explains, “you don't have to deal with characters and situations. All you have to do is come up with about eighteen sure-fire ideas.”

Adolph Green and Betty Comden check out a take with composer Leonard Bernstein and producer Goddard Lieberson in the control room at sessions for Columbia's *On the Town* recording.



Yet the hit number of *Two on the Aisle* also turned out to be a character study—of a heel named Joe whose girl begins by wailing “There he goes, as usual, my man, breaking my foolish heart.” Suddenly, from this torchy, sentimental opening, she rips out with a series of rapid-fire, tongue-twisting accusations in a catalog of all Joe's rotten ways, and then walks out on him:

If you weren't
If you hadn't
If you didn't
If you weren't
If you hadn't
If you didn't
But you have
And you were
And you went
And you did
And so,—goodbye!‡

Two on the Aisle also had Bert Lahr heading a stylish cast, playing Captain Universe in one of the first take-offs on TV science-fiction and Siegfried in a lampoon of Wagnerian opera in *At the Met*. The show ran for almost a year.

With Styne, Comden and Green went on to write many of the “additional songs” for the 1954 Broadway musical version of *Peter Pan*, remembered more by some of us for Green's Captain Hook song than for Mary Martin's aerial stunts as Peter:

Who's the slimiest rat in the pack?
Captain Hook! Captain Hook!
Who's unlovable? Who's unlivable?
Whose existence is just unforgivable?
Who would stoop to the cheapest and lowest of tricks
In the book?
Blimey! Slimy
Captain Hook!*

Then, in 1956, the team was reunited with an old friend from the Revuers, Judy Holliday, at the pinnacle of her career as a movie comedienne, for the musical *Bells Are Ringing*. Once again the scene was New York. The story dealt with the adventures of a switchboard operator at a telephone answering service, the kind of girl who puts on lipstick before answering the phone. The attempts of Ella Peterson, the heroine, to help her client, playwright Jeff Moss (played by Sidney Chaplin), in his struggles with his play lead her into all kinds of complications. The show was a hit largely because of Judy Holliday's performance, but it also offered such songs as *Drop That Name*, a scathing comment on the practice of name dropping at cocktail parties; *Just in Time*, one of the most appealing ballads in the Comden-Green catalog; and *I'm Going Home* (to the Bonjour Tristesse Brassiere Company), which brought the show's action to a rousing finale.

‡ © 1956 Stratford Music. Used by permission.

* © 1954 Edwin H. Morris & Co., Inc. Used by permission.



Culver Pictures

Gene Kelly singin' in the rain in *Singin' in the Rain*. Comden and Green proved their versatility by writing the screen play.

One touching ballad, *The Party's Over*, has surely outlived the show it graced:

The party's over,
It's time to call it a day,
They've burst your pretty balloon
And taken the moon away. . . †

With Styne, Comden and Green also collaborated on *Say, Darling*, a 1958 musical about a musical. It had nine songs with words by Comden and Green, none of which survived the occasion.

IT should now be about time in our scenario for the standard old-fashioned montage shots of the Santa Fe Super-Chief bearing our hero and heroine on to glory and riches in Hollywood. Actually, they had already gone there 'way back in 1947 to administer artificial respiration to a creaky 1927 musical called *Good News*. They had just enjoyed a success (220 performances) with their second show, *Billion Dollar Baby*, which Miss Comden describes as a "premature look at the Twenties, with bathing beauty processions, a gangster funeral, and even a dance marathon in it." They were invited west to bring the Twenties up to date in *Good News*, originally the boring story of a football player who was forbidden to play in the Big Game unless he passed his astronomy course. "We changed it," Betty Comden recalls, "to a football player who was forbidden to play in the Big Game unless he passed his French course." This little alteration gave the team the opportunity to write one of their most dazzling feats of word-juggling in *The French Lesson*, with its

†© 1956 Stratford Music. Used by permission.

sudden, wild, rather Groucho Marxian ending:

[Madame,] won't you come and join me in a dance?
I am ze Pres-eedent of France!

The team had visited Hollywood once even before 1947, with the sort of results they were to refer to as "Revuers' luck." When they got there that first time, they found that the picture in which the Revuers were supposed to appear had been canceled. Awaiting another break, they accepted an engagement at the Trocadero, appearing there with Judy Holliday. Studio heads would come out to see them, Adolph recalls, but "they were interested only in Judy." At that time, Steven Kyle was in the army, on leave in New York, and Betty went back to join him.

"I went back to New York too," Adolph relates, "to visit my ailing mother. I got to Grand Central feeling miserable and frightened. I walked up that long ramp, the picture of dejection, lugging my bags. And when I got to the top, there was Betty—holding a big sign that read 'The Adolph Green Fan Club.'" Later, Comden and Green used the same kind of sign in their screenplay for *The Band Wagon*, when Fred Astaire, as a performer down on his luck, appears at a railroad station in a downcast state and a whole group of friends are waiting for him waving signs.

In the Sixties, the pair got a chance to use their Hollywood experiences, which involved them in writing the scenarios and lyrics for a dozen films, as a platform for the Broadway satire *Fade Out/Fade In*. During that decade, which kept them busier than ever, they also managed to keep their reputation afloat with *Subways Are for Sleeping*, a musical about a dropout, which was perhaps a bit ahead of its day, and for which they wrote a couple of fat parts for themselves; the Tony-winning *Applause*, for which they wrote a book based on the movie *All About Eve*; and *Do Re Mi*, a musical about songwriters, which brought them together with Jule

June Allyson and Peter Lawford in a scene from *Good News (1947)*, Comden and Green's remake of a Twenties musical.



Culver Pictures

Styne once more but was memorable mainly for one affecting item, *Make Someone Happy*:

Make someone happy,
Make just one someone happy,
Make just one heart the heart you sing to
One smile that cheers you
One face that lights when it nears you
One girl you're everything to. . . ‡

For Styne, they also later supplied both book and lyrics for *Hallelujah, Baby*, the vehicle that launched Leslie Uggams upon a willing world.

Most recently the two have worked on several musical-comedy specials for ABC Television—the sort of hasty efforts in various formats contrived to fill the time slot that was once Dick Cavett's every night. In style, these shows resembled the old free-wheeling satirical approach of the Revuers, but Comden and Green have been crestfallen at the results, which they attribute to a pinch-penny attitude on the part of the network, "trying to put on big revues on a budget of four cents."

I asked the collaborators how—being married to other people (Green, in fact, has been married a number of times) and having children and private lives of their own—they manage to go on making other people happy and still getting so much work done.

"We work here in this house almost every day," Betty said. "We have a room upstairs called the work room. When we're working on a show, Adolph turns up at about one in the afternoon. We map out the day's assignment over sandwiches and coffee. I usually sit at the typewriter with a carbon in the machine for Adolph to take home. Sometimes we just sit staring at each other for hours without saying a word. When we're writing lyrics, of course, there are long sessions with the composer, and then further work periods without him. Then, when we go into rehearsals, it's practically around the clock.

"Every assignment brings its own problems and has to be tackled its own way. When we were working on the book of *Applause* we ran the picture and kept reading the screenplay until we knew it scene by scene. We noticed that the heroine, Margo Channing, isn't in the last reel at all because the final twenty-five minutes of the picture are devoted to what happens to Eve. Well, with Lauren Bacall starring in the Broadway musical we realized that a lot more would have to be said about what happens to *Margo* at the end. This led to a lot of fresh writing on our part. . . . So you see, even when you're doing an adaptation and think it will be easy, you can never just paste up pages and relax. There's always work. . . ."

‡© 1961 Stratford Music. Used by permission.

"My partner," Adolph pointed out, "has a real sense of discipline, built-in. It's a word she hates, but she's stuck with it. She's an unforgivably responsible girl."

In the old days, Betty was a rather maternal figure in Adolph's life. She used to see to it that he had carfare in his pocket, kept appointments, and didn't get run over (he's the sort of fellow who reads a book while crossing Times Square). According to Betty, Adolph stores up everything he has ever read in his "Fernandel-shaped head" and is an incurable game player, his favorite being to recite the first or last line of a play or a book and challenge his victim to identify the quotation. He is also a voracious record collector.

To Adolph, Betty is not only punctual, but exasperatingly efficient: "She invariably appears at, say, a producer's conference with our latest work of dialogue or lyrics neatly typed and arranged in readable form. I ultimately show up with a few blank memo papers and some envelopes covered with hastily scribbled telephone numbers. She also hasn't an enemy of either sex in the world. All her looks and talents are combined with a modesty and feminine shyness that eliminate any trace of competitive feeling around her and inspire friendliness and trust. Pretty repulsive, I must say. . . ."

DESPITE their happy home lives, Betty Comden and Adolph Green did strike out on tour together in 1958 with their own show, *A Party*, a kind of autobiography in song, which they performed in New York off-Broadway at the Cherry Lane Theatre, traveled with across the country, and ultimately made into a phonograph record for a company called Heritage—it's out of print, alas. The jacket contains encomiums from, among other celebrities, Leonard Bernstein, Gene Kelly, and Brooks Atkinson. Mr. Atkinson terms them "extraordinarily inventive." Mr. Kelly states that they "have a style and quality which is unique, and in the difficult field of musical comedy writing, they have carved out their own special niche. . . ." But it is Bernstein, I think, who puts his finger on the heart of the matter: "Their work has a way," he says, "of turning every hearer into a dotting fan." I'm one myself, and I can only agree.



CAROLE BOGARD

“a dazzling amalgam”

By STEPHEN E. RUBIN

“SOME people think they know everything there is to know about early music,” Carole Bogard says, her voice taking on a satiric, didactic tone. “It has to be pinny-pinny neat and pure and square and, oh, *don't* sing it too loud. It must be very, very soft. We don't want to hear any vibrato!” In her normal tone, she continues, “Well, forget it, as far as I'm concerned. That's ridiculous.” And equally ridiculous to the blonde soprano—who looks awfully neat and anything but square in tight black slacks, black sweater, and striking red blazer—are those who like their early music in souped-up, overblown arrangements. Miss Bogard seeks a sane middle ground. “In Monteverdi—especially *The Coronation of Poppaea* and the love songs—there is emotion,” she explains. “You have to use your voice to color phrases and provide variety. It's boring when you sing it neat and pure. I feel



the same way about Bach, which has a beautiful romantic line. I know some people would object to that, but it is romantic to me. It requires a warm, voluptuous line. You can't sell it if you don't convey something.”

The Bogard formula appears to work. Whether performing Bach, Handel, Monteverdi, or another early composer, she is generally applauded—by audiences and critics alike—not only for suave vocalism but for style and feeling. Bernard Jacobson, reviewing one of her records for this magazine, wrote that her singing “is a dazzling amalgam of vocal sureness, musical insight, psychological intensity, and stylish embellishment.”

Oddly enough, Miss Bogard, who is something of a specialist in early music, came to it by accident. As a college student on the West Coast, she seemed destined to meet musicians who did little else but Baroque music.

"Initially, I didn't feel the music as I do now," she recalls. "I liked it, but I'm sure I didn't have a clue to what I was doing. But I did find that it fit my voice very easily."

So easily that she was able—although she is a lyric soprano—to handle the cruelly taxing coloratura passages with consummate ease. "I guess it's because of my early training—lots of scales and things," she says simply. "It came naturally, I think. I don't remember ever struggling too hard . . . although—wait a minute. When I first learned the Bach cantata '*Jauchzet Gott*,' it completely did me in. After the first movement, I had to lie down. But once I learned the trick to it—after about two months—it was fine. Even today, though, there are complicated Handel lines which drive me crazy. Some of them are endlessly long, and there's no time to breathe. But I always feel that there's got to be a way. Somebody sang them once."

Miss Bogard had a thorough early musical indoctrination. Her father sang while studying for the ministry. All three of his daughters took piano lessons, and one of her older sisters also wanted to be a singer. Miss Bogard herself sang alto in a church choir from the age of eleven. "At this point, I got quite taken with the idea of performing," she recalls. "I sang a solo with the harp at my junior high-school graduation. That was a big moment for a little kid. Then, all through high school, I was always in a show of some sort. For a while, I was a blues singer. You know, a mike and lots of cigarette smoke. Oh yes! It's really too funny."

It was the dean of her high school who urged her toward serious music. She began studying with Amy MacMurray, who was a pupil and close associate of Lilli Lehmann. Miss Lehmann had studied with Miss MacMurray's mother, who herself had been taught by an eighteenth-century singer. In a sense, then, Carole Bogard derives her style in a direct line from the musical period in which she excels.

The blues, alas, are in the past. "It just doesn't interest me any more," Miss Bogard says, smiling. "I do enjoy Barbra Streisand—I have since the year one. I think she's marvelous, and I have several of her records. And Frank Sinatra. Ahhh, he's so wonderful. But do it myself? Well . . . I might again someday—it might be a hoot!"

It might also help to eliminate one of her foremost stumbling blocks. "I'm pigeonholed!" she complains. "Nobody hires me to do Sophie in *Rosenkavalier*. I love the role. I guess it's just easier to sell someone who specializes. I also love the Mozart repertoire—Pamina, Susanna, Fiordiligi. I would love to do a Countess, too. These roles lie just right for me. But nobody will hire me—at least nobody recently."

Miss Bogard is not a pusher. "I take it as it comes," she says. "Isn't that awful? But how do you push? I can't push *myself* very well. Records don't necessarily get you on stage. Also, houses in this country are awfully big, and sometimes people feel that my voice is really too light. It's hard to figure. In Europe, they wouldn't think twice before hiring me as Fiordiligi. But they also wouldn't dream of putting me in a soubrette role." And Miss Bogard would not dream of leaving behind her husband, Charles Fisher, president of Cambridge Records, her dogs, and her home in Massachusetts to pursue a European career either—even though she believes it is difficult for native talent to make it at home. "People want the imported product. I rarely get offers to sing in Boston because I'm not an import."

The soprano has sung extensively in California—with the San Francisco Symphony, the San Francisco Spring Opera, and the Oakland Symphony—where she spent her childhood after having moved from her native Cincinnati. She has also appeared with the Boston Symphony and the Opera Company of Boston, at the Smithsonian Institution, and with various organizations in New York. She has made a considerable number of recordings, and can be heard in diverse repertoire on the Cambridge, Desto, and RCA labels.

For the past six years Miss Bogard has managed to keep busy with a career that might be labeled satisfactory. That it has not developed any further might be traced to the soprano's personal outlook. "I like the career aspects of singing," she explains, "but I could never go into it the way Beverly Sills has, for example. I've got a lot of interests and I enjoy many things—art, in particular. I don't want to be a Beverly Sills. Also, there is the problem of funds. You are your own patron in this business. I don't have the money it takes to hire publicity people and things like that. They're terribly expensive."

Miss Bogard was previously married and had two children; then her career began moving up and collided with her family responsibilities. "You really can't have babies and a career both," she says. "My first husband resented my career, and I was getting busier and beginning to sing in the East, and it just didn't work out. My 'now' husband understands. He goes with me every time he can, he's supportive, and it's great—the only way. The career is only going to last so long—a singer's life is short—but my marriage is going to last the whole time, I hope. And if my marriage isn't happy, I'm not happy. I'm not a loner. I've got to have my man. So he comes first."

Miss Bogard's man often acts the role of protective censor, particularly when it comes to the critics. "It's too painful for me if the reviews hit me between the eyes. So I don't read them anymore, my husband does. If there's something I really ought to pay attention to, he tells me about it. Otherwise, the reviews are clipped and go into a scrapbook, and when I'm an old lady I'll weep over them. Of course, I always read the good ones, the raves.

"I don't like what the critics are doing to performances. I feel that they are killing them. For instance, say I'm not a musician, and I really like opera and go to a performance and have a really good time, and the whole audience seems to have a good time, too. The next morning I pick up the paper and somebody lambastes it. Then I wonder if there's something wrong with me—I thought I *liked* it! So I don't go again, maybe. A lot of people feel that way; I meet them all the time. I wish critics would do more reporting and less criticizing. They're like little tin gods. They think they know everything.

"I've had some very good reviews. I've also had some very bad ones. I can't sing in Boston. Michael Steinberg [critic of the *Boston Globe*] can't stand me. He says I'm cold. Or I don't look right. So often it's the way I look—not anything about my voice he doesn't like. He just doesn't like blondes. He likes brunettes. *That's* hardly fair."

Like all performers, Miss Bogard is at her best when she knows she is liked. She is not prone to fits of nerves, except when she is auditioning or in a tense working relationship. "I get nervous if I think the conductor doesn't love me," she says. "But if everybody loves me, I'm fine—not one nerve!"



Portrait of Philaëto Achillini by Marcantonio Maimoni, c. 1500

A BASIC LIBRARY OF THE CLASSICAL GUITAR

Though it suffers from chronic underemployment,
the instrument is well represented on disc

By FRED GRUNFELD

THE guitar has the richest cultural history of any musical instrument: since the Middle Ages it has been producing beautiful sounds in the hands of kings and courtiers, poets and peasants, as well as a long line of professional musicians. Moreover, the guitarist-composers of sixteenth-century Spain were the first composers to create a truly *instrumental* idiom that was not merely translated from the vocal style; thus the guitar possessed a full-fledged music of its own long before the violin or the harpsichord had come of age. Yet today, amid a great guitar renaissance that has produced more virtuosos than ever before, there is a desperate shortage of really first-rate music for guitarists to play. In effect, despite its fascinating past and brilliant present, the guitar is still an instrument in search of a repertoire.

This means that the selection of a basic library of recorded music for the classical guitar confronts the discographer with a series of ticklish dilemmas. Our leading classical guitarists have spent an inordinate amount of time recording pieces of music which, by any but the guitar standard, are almost embarrassingly banal. The argument has been that nothing better was available. Worse yet, until recently the average guitar recording contained a sort of smorgasbord mixture, as though every record had to be a self-contained recital program running the gamut from Baroque to modern. Yes, these included occasional masterpieces for guitar, but they were usually impacted in an assortment of tidbits and hors d'oeuvres. This situation would hardly have been tolerated in any other branch of serious music; what record collector would want to buy his favorite Beethoven sonata bracketed with two *ländler* by Dussek, a set of Thalberg variations, an étude or two by Herz, and a barcarole by Moszkowski? Yet this is what the guitar collector is expected to put up with, on the pretext that it is the *guitarist* who matters, not the music being played.

I realize that this is precisely how many guitar aficionados still approach the subject, and for them my advice is simple: choose your favorite guitarists—Andrés Segovia, Julian Bream, John Williams, *et al.*—and acquire some of their mixed-pickle assortments. My personal choices in this category are Bream's double album, "The Art of the Spanish Guitar" (RCA VCS 7057, two discs), which touches all the bases from Weiss to Ravel; Williams' "More Virtuoso Music for Guitar" (Columbia MS 6939), replete with Bach, Reusner, Giuliani, and Torroba; and an Andrés Segovia record (Decca 710034), a *tour d'horizon* ranging all the way from Roncalli and on through Sor to Granados, Rodrigo, and the like.

Lately, however, it has become apparent, both to performers and to record producers, that the audience's attention span for guitars is no shorter than for other instruments, and the grab-bag recording appears to be on the wane. Instead, we begin to have consistent groupings of (more or less) related material of (again, more or less) equal musical weight and significance. This welcome change enables me to draw up a basic library organized along chronological lines and covering the highlights of the existing literature for guitar, both original and transcribed. I have tried to list both the indispensable items and the most delightful of the optional bagatelles without running into too many duplications. If the result seems to resemble "Through Guitar History with Julian Bream," that is because he has covered virtually the whole field without once producing a clinker, and he has organized his material in the most coherent and listenable fashion. As for Segovia, who is of course the grand old man of the guitar and the man chiefly responsible for the current guitar revival, if I were Decca I would now remaster all of his twenty-odd recordings, unscrambling the tutti-frutti repertoire and putting it all back together again in some logical order: all the early music together, all the Romantics together, and so on. Not only could one then buy just the repertoire one liked, but in the listening one could have a sustained musical experience instead of short bursts of fifty-seven varieties.

THE earliest music for guitar is in many ways the most interesting, though still the most neglected part of the repertoire. No really adequate anthologies of sixteenth- and seventeenth-century Spanish guitar and *vihuela* music (a *vihuela* was an early and aristocratic form of guitar strung with six or seven courses of paired strings) are readily available, and this is a particular pity because this is music that needs time and a congenial environment to make its point; one or two perfunctory pieces by Milán or Mudarra at the start of a recital can hardly get you into the mood. For those who wish to explore the early repertoire properly, I would recommend "*Vihuelistas Españoles*" (Hispanvox HH 5), "*La Guitarra en el Renacimiento i el Barroc espanyol*" (Edigsa AZ 70/03), and "An Anthology of Music for the Guitar: The Sixteenth Century" (Washington WR 411). These discs will be hard to come by, particularly the first two, which are Spanish releases, but your persistence will be rewarded. In the basic list which follows, by the way, I have not included guitar duets. The guitar is pre-eminently a one-man instrument: double the sound and you defeat its very purpose. (Continued overleaf)

BACH: *Lute Suites Nos. 1 and 2.* Julian Bream (guitar). RCA LSC 2896.

BACH: *Chaconne in D Minor; Prelude; Gavotte; Louré.* **SOR:** *Minuets in C and D; Andantino.* **MENDELSSOHN:** *Canzonetta.* **VILLA-LOBOS:** *Prelude.* **RODRIGO:** *Sarabanda.* Andrés Segovia (guitar). DECCA DL 79751.

BACH: *Suite No. 3 (arr. Duarte).* **BOCCHERINI:** *Concerto for Guitar and Orchestra (arr. Cassadó).* Andrés Segovia (guitar); Symphony of the Air, Enrique Jorda cond. DECCA DL 710043.

The Lute Suites are as close as we can come to what Bach might have written for the guitar had he known the instrument. Actually, the chances are that Bach never had occasion to hear a guitar played in earnest. Until the end of the eighteenth century, the lute was so firmly entrenched in German affections that the guitar was simply overlooked. As Johann Mattheson wrote in his 1713 orchestral description, "The flat guitar with its strum, strum, we shall gladly leave to the garlic-eating Spaniards." Even so, Bach's music turns out to



FERNANDO SOR:
not exactly Baroque

need only minimum retouching to become the ideal music for guitar. And Julian Bream is the ideal interpreter for it. He is, of course, also the leading lutenist of our time, but he feels that these lute suites actually sound better on the guitar even if it means transposing; for one thing, the lingering tone of the lute's open bass strings tends to blur the texture of the fast pieces. Both suites consist of a prelude followed by dance movements; the second, originally in C Minor but here transposed to A Minor, also contains a fugue that is a masterpiece of great length and complexity, worthy of being set beside the D Minor Chaconne as an example of Bach's counterpoint at its most breathtaking.

It was Segovia, forty years ago, who first gained acceptance for Bach on the guitar when he won from the French musicologist Marc Pincherle a testimonial to the effect that it was quite permissible to transcribe the Chaconne from the unaccompanied violin to the unaccompanied guitar—especially since it sounded much better that way. Segovia's recording of the Chaconne is still one of his finest;

his marvelous control of relaxed sounds is nowhere more in evidence, and though the whole thing is a masterpiece of understatement, he brings it brilliantly, even triumphantly, to life. Unlike many of the younger crop of guitarists with their steely bravura fingers, Segovia always produces a vibrantly hand-made sound, in which the right hand always knows what the left hand is doing. Along with the Chaconne he has recorded three other Bach pieces to form a sort of suite; the second side is mainly devoted to salon pieces about which the liner notes are unforgivably vague—the Canzonetta is described as being "from Mendelssohn's String Quartet" (actually, Opus 12) and the Villa-Lobos, *sans* key, is identified as belonging to "a series of Preludes." This is, in fact, the famous A Minor Prelude, and it is by far the best thing on the flip side, sounding as though it had been written by a very sexy Brazilian Bach.

Bach's Third Suite for Unaccompanied Cello, in John Duarte's arrangement, receives an elegant performance in a Segovia recording of more recent vintage. Some of the problems and possibilities of this kind of transcription are discussed by Duarte in the liner notes. Bach's problem in writing the solo cello suites was to make the instrument self-sufficient, and he contrived his line in such a way that it implied those basses that the cello was unable to play. "The guitar can apply such basses and, with the aid of Bach's models, the arranger can insert them—he must also know when to refrain from doing so. These basses not only fill out the music but help to compensate for the smaller sonority of the guitar, which nevertheless remains sufficient to preserve the dignity and serenity of the music." The Boccherini-Cassadó Guitar Concerto, which receives top billing, is also derived from a cello original. Luigi Boccherini wrote a lot for guitar obbligato, but he forgot to leave us a concerto for the instrument. Gaspar Cassadó's attempt to rectify the oversight is a pleasantly lyrical pastiche which probably wouldn't appear on my basic list if it weren't for Segovia's stylish playing.

BAROQUE GUITAR. **Sanz:** *Pavanas; Canarios.* **Bach:** *Prelude in D Minor; Fugue in A Minor.* **Sor:** *Fantasy and Minuet.* **Weiss:** *Passacaille; Fantasie; Tombeau sur la mort de M. Comte de Logy.* **Visée:** *Suite in D Minor.* Julian Bream (guitar). RCA LSC 2878.

Bream's Baroque playing is superb because he commands the widest range of timbres of any guitarist I've heard, his tempos are practically infallible, and he has a wonderful instinct for the underlying lilt and playfulness of this music. Here, besides the two Bach pieces, he introduces some of the lesser luminaries of the Baroque galaxy. The great

German lutenist Sylvius Leopold Weiss was an almost exact contemporary of Bach. His elegy on the death of Count Logy is a minor masterpiece, and his *Passacaille* can hold its own with those of Bach and Handel. Robert de Visée belonged to an earlier generation: he was chamber guitarist to the Dauphin of France and is said to have supplied the incidental music when Charles Perrault, author of the classic French fairy tales, gave recitations for his friends. Visée's dance suites are perfect accompaniments to the paintings of Watteau. I can't imagine why Fernando Sor (1778-1839!) is included in a Baroque collection. But let us not cavil at a recording as good as this: what's a century or so between friends?

SCARLATTI, D. (trans. for guitar by Barbosa-Lima): *Nine Harpsichord Sonatas* (Kirkpatrick 11, 391, 32, 462, 322, 481, 431, 309, and 380). Antonio Carlos Barbosa-Lima (guitar). WESTMINSTER WGS 8209.

The harpsichord originals will not be displaced by these guitar transcriptions, which are Barbosa-Lima's own, and as faithful as the change in media will permit: what one misses is the sharp cutting edge of Domenico Scarlatti's percussive keyboard style. Even so, the sonatas on this record sound tailor-made for the guitar—and this raises some interesting questions about the nature of Scarlatti's musical influences. We know that he spent nearly forty years at the courts of Spain and Portugal, and during that time he must have heard a vast amount of guitar music; yet, so far as we know, he never wrote anything for the most Spanish of instruments. On the other hand, as Ralph Kirkpatrick points out in his Scarlatti biography, he often wrote for the harpsichord as *though* it were a guitar. "The very har-

MAURO GIULIANI:
one of the greatest
guitarists of all time



monic structure of many such passages that imitate the guitar seems to be determined by the guitar's open strings and by its propensities for modal Spanish folk music." Here the evidence to support Kirkpatrick's thesis is presented by a young Brazilian guitarist who is on the verge of becoming a star. This is the sort of recording we should have more

of: a consistently beautiful body of material which is allowed to unfold at its own pace for the better part of an hour.

BOCCHERINI: *Guitar Quintet in E Minor*. BOCCHERINI-BREAM: *Introduction and Fandango*. HAYDN: *Guitar Quartet in E, Opus 2, No. 2*. Julian Bream (guitar); members of the Cremona String Quartet; George Malcolm (harpsichord). RCA LSC 3027.

This is easily the most delightful recording of guitar chamber music currently in the catalog. The Boccherini Quintet is a lively, melodious little wonder



JOAQUÍN RODRIGO:
a popular anachronism

by the far-too-neglected composer who succeeded Scarlatti as the representative of Italian Classicism in the palaces of Madrid. It is only one of many works that Boccherini wrote for his guitar-playing patron, the Marquis of Benavente; all of them deserve to be revived. Unlike Scarlatti, Boccherini was never deeply influenced by Spanish folk music, but he found occasion to write a chamber arrangement of "the fandango which was played on the guitar by Padre Basilio," a piece which Bream has now restored to its original instrument, with the addition of a harpsichord accompaniment. As it happens, Padre Basilio was a Cistercian monk who was guitar master to the Queen of Spain and organist of the Escorial. His Fandango owes a great deal to the phenomenal Fandango in D by his Escorial predecessor, Antonio Soler; harpsichordist Rafael Puyana has recorded the Soler Fandango for Philips, and I urge you to compare it with this one. So this is how musical tradition gets handed down from one generation to another in what Indian sitarists call *guruparampara*, the master-to-pupil chain!

The Haydn "guitar quartet" is an arrangement for guitar and strings of an early Haydn string quartet that has been found in a manuscript version for lute and strings (no one knows who wrote the arrangement; it might have been Haydn himself). Bream's playing, as usual, is absolutely on target, and he receives vigorous support from members of the Cremona Quartet: Hugh Maguire, Cecil Aronowitz, and Terence Weil. (Continued overleaf)

CLASSIC GUITAR. Giuliani: *Grand Overture, Op. 61; Sonata in C: Allegro.* Diabelli: *Sonata in A Major.* Mozart: *Larghetto and Allegro (K. Anh. 229).* Sor: *Introduction and Allegro, Op. 14.* Julian Bream (guitar). RCA LSC 3070.

ROMANTIC GUITAR. Paganini: *Grand Sonata in A Major.* Mendelssohn: *Venetian Boat Song; Canzonetta.* Schubert: *Menuetto from Sonata, Op. 78.* Tárrega: *Prelude (Lágrima); Three Mazurkas.* Julian Bream (guitar). RCA LSC 3156.

MASTERS OF THE GUITAR. Sor: *Introduction and Allegro; Two Minuets; Four Studies.* Tárrega: *Estudio Brillante; Three Mazurkas; Two Preludes; Gavota; Capricho Arabe; Recuerdos de la Alhambra.* Andrés Segovia (guitar). DECCA DL 9794.

SPANISH MUSIC. I. Albéniz: *Asturias; Tango; Córdoba.* Sanz: *Canarios.* Rodrigo: *Fandango.* Torroba: *Nocturno.* Granados: *Valses Poéticos; La Maja de Goya.* M. Albéniz: *Sonata in D.* Falla: *Three Excerpts from "The Three Cornered Hat."* Traditional Catalan: *La Nit de Nadal; El Noy de la Mare.* John Williams (guitar). COLUMBIA M 30057.

GIULIANI: Concerto for Guitar and Strings; ARNOLD: Guitar Concerto, Op. 67. Julian Bream (guitar); Melos Ensemble. RCA LSC 2487.

By and large the Romantic era is the silly season for the guitar. Even the best composers of the period — Sor, Giuliani, Paganini, Diabelli — rarely rose above the salon-style commonplaces that make up the bulk of this repertoire. If anyone can bring it to life, however, it is Julian Bream, whose gorgeous palette of tone colors helps dispel the monotony of those eternal tonic-dominant, dominant-tonic harmonies. For some reason, Bream has seen fit to call his Diabelli-Sor-Giuliani collection "Classic Guitar," though the two Mozart fragments are, strictly speaking, the only Classical pieces in the lot. Aside from these, it is the Diabelli work that comes off best in this company. His sonata is actually a composite work, drawn from the most interesting movements of two of his guitar sonatas. And this is the same salon composer, by the way, who provided Beethoven with the "cobbler's patch" of a tune on which the great "Diabelli" Variations are based. The Sor and Giuliani items are historically interesting for students of the guitar, but I suspect that no one would pay much attention to this music had it been written for piano.

Bream's "Romantic Guitar" collection is essentially more of the same. Paganini receives the lion's share of attention in Bream's arrangement for solo guitar of a grand sonata originally written as a guitar and violin duet. The rest are just pleasantly melodious trifles, but the Schubert transcription suggests that he would have been the Romantic guitar composer *par excellence* had he taken the trouble to write some original things for the instrument he

was known to play so often for his own amusement.

Segovia's performances of the Sor and Tárrega pieces are indispensable for serious students of the guitar. Sor was dubbed "the Beethoven of the guitar" by François-Joseph Fétis, the influential music theorist and critic. This is rather high praise, and Sor didn't deserve it. An English critic unwittingly diagnosed the problem when he wrote that Sor was a "man of taste, and . . . always pleasing." In a composer it is a terrible thing to be *always* pleasing, and Sor comes on sounding rather simple-minded. Tárrega suffers from the same syndrome. He was the spiritual father of the modern guitar revival, and spent a lifetime creating a repertoire for it. But, though his devotion and his technique are admirable, he too was cursed with the too-winning smile.

John Williams' anthology of Spanish music has more dash and vitality than such collections are apt to have. The three Falla transcriptions from *The Three Cornered Hat* are a good idea; they have all the tautness and harmonic ingenuity that derive from the best Spanish folk music. The Granados and Albéniz numbers are in a more conventional picture-postcard style, but Williams is a dazzling virtuoso who can turn a number like *Asturias* into a first-rate showpiece.

Which brings us to Mauro Giuliani's Guitar Concerto. In its best moments it has the quaint charm of



ANDRÉS SEGOVIA:
vibrantly hand-made sound

a Weber *Konzertstück*, and some of its themes are freely remembered from Mozart. Giuliani was one of the many supporting characters in Beethoven's Vienna, and one of the greatest guitarists of all time: "In his hands," a contemporary publication declared, "the guitar became gifted with a power of expression at once pure, thrilling and exquisite. He vocalized his adagios to a degree impossible to imagine by those who never heard him. . . ." Bream plays him so singingly, however, that I can well imagine what Giuliani must have had in mind. He also does his best for the Malcolm Arnold concerto on the other side, an unpretentious affair reminiscent of Dukas and Prokofiev. Its finest moment is the slow-movement elegy in memory of the gypsy jazz guitarist Django Reinhardt.

JULIAN BREAM:
wonderful instinct for
the underlying lilt



TWENTIETH CENTURY GUITAR. Brindle: *El Polifemo de Oro*. Britten: *Nocturnal*. Martin: *Quatre pièces brèves*. Henze: *Drei Tentos*. Villa-Lobos: *Two Études*. Julian Bream (guitar). RCA LSC 2964.

RODRIGO: *Concierto de Aranjuez*. **BRITTEN:** *The Courty Dances from "Gloriana."* **VIVALDI:** *Concerto in D for Lute and Strings*. Julian Bream (guitar and lute); Melos Chamber Orchestra, Colin Davis cond.; Julian Bream Consort. RCA LSC 2730.

PONCE: *Concierto del Sur*. **RODRIGO:** *Fantasia para un Gentilhombre*. Andrés Segovia (guitar); Symphony of the Air, Enrique Jorda cond. DECCA DL 710027.

The twentieth-century guitar! What a plethora of unfulfilled promises is contained in those words! Apparently it is terribly difficult to write for the guitar in this day and age without making it sound like the score for a movie about Mexico. The single most powerful piece of modern guitar music is Manuel de Falla's austere *Homenaje* in memory of Debussy; it is the only thing Falla wrote for guitar, but it points the way to what the guitar could and should be in the twentieth century. Frank Martin's *Quatre pièces brèves* come closest to it; he shares some of Falla's gift for manipulating modal harmonies. I wish I could say the same of Henze, whose *Drei Tentos*, supposedly Neapolitan-inspired, have a hermetic sound that is the very antithesis of Mediterranean. Reginald Smith Brindle's *El Polifemo de Oro* takes its title from a guitar-riddle of García Lorca's: "Six maids dancing at a crossroads circle; three of flesh and three of silver. Yesterday's dreams they seek, but they are held in the embraces of a golden polypheme." (The "maids" are the guitar strings, three of gut and three of metal.) Brindle's piece is as experimental and cerebral a work as anything Bream has yet recorded. The Villa-Lobos *Études* are another story: he is the century's most important guitar composer, and Bream plays his work with a relaxed Brazilian elegance. Britten's *Nocturnal*, which Bream (not I) considers the greatest single work written for guitar, is a set of variations on a theme by Dowland, but with an ingenious departure from tradition: the variations lead up to the theme instead of departing from it.

There seems to be an unwritten rule that modern works for guitar are successful only when they are neo-something—i.e., "Yesterday's dream they seek"—and this is particularly true of the concertos. The most popular of all, Rodrigo's *Concierto de Aranjuez*, is almost an anachronism: written in 1940, it combines neo-Classicism and neo-Romanticism in equal parts, as though Albéniz had arranged one of Boccherini's folksier scores. I like both Bream's light-fingered version and Williams' considerably weightier and more *passionato* one with the Philadelphians under Ormandy (Columbia MS 6834), but the deciding factor is the coupling: Williams plays the Castelnuovo-Tedesco Guitar Concerto, a rather cloying piece of late Impressionism, while Bream does the lute dances from Britten's *Gloriana*, which will set your foot to tapping,



JOHN WILLIAMS:
a dazzling virtuoso

together with a Vivaldi concerto. Williams' version, though, is now also available as part of a three-record set of guitar concertos (Columbia M3X 31509), including the Castelnuovo-Tedesco Concerto and those by Vivaldi, Giuliani, and Dodgson, as well as both works for guitar and orchestra by Rodrigo. When all is said and done, I think my favorite work for guitar and orchestra is Rodrigo's *Fantasia para un Gentilhombre* (alias *Son of Aranjuez*), which is based entirely on pieces by Gaspar Sanz. With these sprightly seventeenth-century tunes as a base, how could he go wrong? It was written for Segovia in 1954, and his recording is clearly the one to have. But I doubt if the companion piece, Manuel Ponce's *Concierto del Sur*, will impress you as more than a pleasant "Night in the Gardens of Mexico."

Obviously, there is still ample room for improvement in "twentieth-century guitar." I wonder whether it will ever find a composer to do for it what Bartók did for "twentieth-century piano." Meanwhile, we can always go back and find some more old music to transcribe, and there doesn't seem to be anything wrong with that.

Frederic V. Grunfeld, a long-time contributor to STEREO REVIEW, is the author of *The Art and Times of the Guitar*, a delightful and useful book which might be subtitled "Everything you . . . etc."

JONATHAN EDWARDS

"If I'm having a good time, someone else will too."

By SUSAN LARABEE

JONATHAN EDWARDS has an "I Like Country Music" bumper sticker on the back of his new green Dodge van. He lives on a thirty-acre farm in the Massachusetts countryside. Both of his albums have some country songs on them, but he doesn't consider himself a country singer. "My father said I should call myself a 'wilderness singer,' because I don't sing just country music and I don't sing city music. I don't think you have to label any music, including mine, but 'wilderness music' seems to fit the way I feel now."

What is "wilderness music" and who is this wilderness singer? "I'm living in the wrong century, for sure. I'd like to have lived in America when it was young—when the land was free, anyone could get a homestead, and when a man with guts enough could do what he wanted, grow his own food, make everything he needed, and not have to answer to anyone else for his time. I would have liked being a pioneer or a cowboy—maybe I sing 'pioneer' music."

Jonathan and his lady, Kris, are living in an eight-room Victorian farmhouse surrounded by an apple orchard and open fields. You can't see another house from their property, and that's the way they like it. They live at the end of a dead-end country road, and Jon has posted a sign to that effect to ward off stray cars. Not that they don't like company. "Since we moved out here last spring, we've had lots of guests. Before we got this place, I lived with the band [Orphan, now with its own album on London] in one big house. It got crowded sometimes, but we played every night, every chance we got. I sort of miss that now, not always being able to try out new tunes with a band."

On the day I talked with him, he had almost finished winterproofing a new chicken coop, home for eight Plymouth Rock hens and one rooster ("an Easter chick we raised"). "I never built anything before. Never had a construction job—had a *destruction* job once. We used to go



to construction sites after the workers left, get in the dumptrucks and bulldozers and drive them into each other. Kids everywhere did things like that, I guess." Also in the "family" are sixteen prize beef cattle (one on the way to calving), a pinto named Penny, an Irish setter, and three cats. "Real country living. We grow our own vegetables and bake our own bread, even grind our own flour. I was born in Minnesota and lived there for six years. Then we moved to Alexandria, Virginia. We always lived where there were woods. I didn't like not living in a big exciting place when I was growing up, but now it seems like 'the good old days.' That's what I'm trying to do now—go back to the way things used to be. I guess you can hear that in my music if you listen."

You can indeed trace the nostalgia in his songs—nostalgia not for the Twenties, Thirties, or Forties, but for the nineteenth century. Jon's first album, titled simply "Jonathan Edwards" and released on the Capricorn label, contains a generous sampling of his songwriting and singing. The million-plus-selling single *Sunshine* is delivered in his clear, perfect tenor and is a song about not wanting to be under someone else's thumb, or so it seems. "I got all kinds of letters from all over the country saying 'Ah ha! You tried to be obscure, but we finally figured out the song, and *this* is what it means.' That's why I like the song. It means whatever you want it to." The gold record awarded Jon for *Sunshine* shares space in the bathroom with a homemade ant farm.

There's a lot of variety on the first album—several knee-slapping, hand-clapping crowd pleasers like *Don't Cry Blue*, *Shanty* ("We're gonna lay around the shanty, Mama, and put a good buzz on"), and *Train of Glory*, a white gospel song glorious in its old-fashioned promise of a train ride to the other side. In contrast to these simple straightforward tunes are others—*Jesse*, *Emma*, and *The King*—songs in minor keys, full of complexities both me-

lodic and lyric. My own favorite is *Sometimes*, written by Jonathan's friend Malcolm McKinney. It's a love story, or rather a lost-love story.

"I don't have any 'scientific method' for songwriting," Jon said. "Sometimes the lyric comes to me first, sometimes the melody. I know I've got lots of songs left in me to write, but if I ever dry up temporarily, I've got a lot of friends who write material I like to sing. Malcolm writes great songs and he comes down from New Hampshire every once in a while to drop off a truckload of them."

Jon took a break to bring out his Martin six-string and sit down on the front porch to play a couple of songs Malcolm had just delivered. "I taught myself to play the guitar and the mandolin and the harmonica, and I'm messin' around with the pedal steel guitar and the piano now. I want to be as good as possible on instrumental work, so I won't even try anything in public on the pedal steel for a while. I've been foolin' around with it for about seven months now, and I'm just beginning to get into it. I took voice lessons for a little while, but they didn't have anything to do with what I wanted to sing, so I quit. I don't have perfect pitch, but I have perfect *relative* pitch. I always wondered, though, why my speaking voice was so low and my singing voice so high.

"I've played in bands for a long time. In military high school in Virginia I had a group called the Rivermen. We weren't very good. I went to college in Athens, Ohio, and that's where I met Malcolm. We had a band there we called the St. James Doorknob. We were electric—a typical college-fraternity-party-type band, playing Stones stuff. I was actually an art major—painting—but music was becoming more important to me than painting, so I quit school. I managed to convince the draft board I was crazy, and we left for Boston right after that and changed our name to Headstone Circus. After we'd been in Boston a while, we changed our name again to Sugar Creek and actually made an album. By then, I didn't want to do any more electric stuff. We played some really rough places, places like the Boom Boom Room where guys would get drunk and fight during the set. I decided I wanted to play acoustic guitar and forget all that electric noise."

The result was that Jon went out on his own. He met his current bass man, Stuart Schulman, in Boston when he was still with Headstone Circus and Stu was in a group called Fire and Ice. They liked each other's style and music, made the album "Jonathan Edwards" together, and have now made a second, called "Honky-Tonk Stardust Cowboy," released late last year on Atco. Backup on both albums is by members of Orphan, more Boston-based musicians. "Stuart is just fantastic. He can play anything—violin, bass, piano—and he does some of the arranging." He also harmonizes with Jon in a mystical Art Garfunkel falsetto.

"I really love performing. I'm always a little nervous before a show, but I get off on that, and it makes the set better. One time, though, I was so nervous I almost walked out the door before singing at the Museum of Modern Art in New York. I hate the traveling. Holiday Inns and restaurant food don't do anything for me. If it weren't for the real thrill of feeling an audience that's with you, that's really enjoying a song, I wouldn't travel at all. I still wish people could come out here to hear me."

"Jonathan Edwards" was greeted with critical acclaim, and Jon was immediately compared by several reviewers to James Taylor. "I never compare myself to James Tay-

lor at all. I don't think we're alike in any way except we're both men. I never read reviews, anyway. They don't mean much to me." When I asked about the musicians he likes, he said, "I listened to the usual groups in my youth. [He's twenty-six now.] I guess my favorite groups are the Youngbloods and the Beatles—the technical perfection of the Beatles is really great—I'd like to achieve that perfection. Joni Mitchell, she's just beautiful. I really like Van Morrison too. I've always liked Bluegrass music—used to listen to it every chance I got. The new album has a lot of banjo on it.

"Life's been easier for me since *Sunshine*. I've tried not to change, but you can't help changing, no matter what you do. I've learned a lot, especially about my friends. About the real world. I feel about my music this way: I want to have a good time, to enjoy singing and making records. I figure that if I'm having a good time, someone else will too."

We listened to "Honky-Tonk Stardust Cowboy," his second album, and Jon said, "I heard the title song [by Darrell Statler] on the radio one night, and I knew I wanted to do it and call the album by that title." In content the second album moves on from "Jonathan Edwards" in a more or less logical way. The feel is a little more "country," a little more gospel. There's a hymn on it that Jon wrote, and a driving, frenetic version of *Comin' in on the Mornin' Train*, which he arranged and on which he plays a zealous harmonica. "I'm not a religious person in the church-going sense. Sometimes you just have to stand back in awe of things, in awe of what's been created. I guess you could call that 'God.' I've always liked old-time hymns, always sang in church choirs.

"I think my favorite of my own songs is *Dream Song*, on the second album. It's a waltz." One of the bands is an excerpt from a live radio broadcast Jon and the boys did for an FM station in New York—*Paper Doll*, with Jon doing a great cornet imitation. "I thought we sounded terrible for that show, but when I heard the tape, it wasn't so bad."

THE future? "Another record sometime. More club dates this year. I may be doing a movie—we already have some film from last winter's tour. It may turn out to be a short, or maybe a long. I think I'd like to do film work. The part of being a performer that I *don't* like is the business angle. So, I let my manager do all that, and leave myself free to live out here." Jon's manager, Peter Casperson, also produces his records and is a close friend, so the production aspect of recording has turned out just the way Jon wanted it to.

"I don't feel any responsibility to be a 'contributing' part of the society—not that I don't care what happens, but I don't feel that I have to use my art for social change or whatever. I think the day of the protest song is over, anyway. Just live and let live. Just exist. I have done one benefit already, though—in Kentucky, a thing called 'Toys for Tots.' There were forty thousand people at the two shows, mostly little children. I think they had a good time. I got to meet Colonel Sanders—he was the M.C.!"

"I don't think of my 'career' and my life as being separate—they're the same thing: me. I get as much sense of creativity from making that chicken coop as from painting a picture or writing a song. Picking and singing and making records and living out here, that's my life. By golly, I'm just plain folks. People are always trying to stick the 'star' label on me. Please, lay it off of me."

**U.S.
GOVERNMENT
INSPECTED**

AMPLIFIER

The FTC moves to protect the consumer

WHEN, in pursuance of its responsibilities, the Federal Trade Commission first looked into the amplifier wattage-rating situation in 1970, there seemed to be a general assumption that the manufacturers were divided into two camps, not only with respect to the products they marketed, but also with respect to their ethics. The good guys—the white hats—were the component manufacturers, and their black-hatted opposite numbers were the producers of consoles, “packages,” or “brown goods,” as they are sometimes called. It was at that time urged upon the Commission that if it could simply curb the tendency toward excessive and/or meaningless power claims by the bad guys, the home-entertainment industry as a whole could proceed serenely with the task of selling its products solely on the basis of price and intrinsic merit.

It takes very little experience in an agency such as the Federal Trade Commission to teach the zealous regulator three things: (1) there are no simple solutions to complex problems; (2) relative virtue among competitors is seldom, if ever, involved; and (3) objectivity is rarely, if ever, achieved. The manufacturers of the mass-market brown-goods equipment and the manufacturers of the more expensive components both tend to look at the world from their particular special viewpoints. This fact poses some very peculiar problems for governmental regulators who, unfortunately, may themselves be somewhat less than perfectly objective in their approach to the task.

To illustrate the seriousness of the problem, take as an example a recent brochure advertising an audio component that sells at a moderately high price. The eye is first captured by the graphic announcement “300 WATT RECEIVER” and subsequently diverted by appropriate general assurances of high power and outstanding performance. For those who might contend that this type of equipment is not sold to the consumer *primarily on the basis of power output*, it is interesting to note that the two pages of descriptive text employ the terms “wattage” or “power rating” fifteen times!

For our purposes, we are interested in how the “300 watt” representation of total power output can be substantiated. It is true that component-equipment manufacturers often provide detailed technical specifications—something rarely furnished by sellers of packaged units. In fairness, however, we should acknowledge that packaged-unit producers argue that the consumers to whom their advertising is directed are not interested in complicated technical data, but are instead concerned with the appearance of the equipment and its “tone” in a less discriminating sense. Whether these arguments are valid or not is another subject altogether.

In any event, close examination of the specifications furnished with this particular component receiver indicate that the 300 watts claimed represents “peak power,” perhaps the most discredited method of all by which to rate the power output of sound-amplification equipment. (“Peak power” is a figure that results when a manufacturer simply doubles the power-output numbers obtained by one or more of the other measurement techniques, which will be described below.) And even closer examination indicates that this particular manufacturer has also allowed himself a measurement tolerance of ± 1 dB in the bargain. This 1-dB margin can result in a measured output as much as 20 per cent below or as much as 25 per cent above the nominal output power of the amplifier; experience in such matters indicates that when this ± 1 -dB qualification appears the advertised wattage almost surely represents a 25 per cent exaggeration of the unit’s measured power performance, however derived.

Further study of the specifications in the brochure reveals that the manufacturer’s claimed 300-watt peak-power output was achieved at a 4-ohm speaker-load impedance—despite the fact that most speakers in use today have an impedance of 8 ohms. If the latter impedance figure had been used, the peak power figure itself might easily have dropped down to 220 watts, even allowing for the generous ± 1 dB tolerance.

Before we leave this subject of “peak power” entirely, we should consider still another device for

POWER SPECIFICATIONS

from some misleading, if creative, mathematics

By WILLIAM D. DIXON, Assistant Director, Bureau of Consumer Protection

increasing *advertised* power output without any effect on the *real* power output. The ratings in our example were described as having been achieved "single-channel driven." From this phrase—whose implications may be clear to some engineers, but mean little or nothing to most consumers—it can be discovered that the manufacturer tested only one channel and doubled the test result in order to arrive at the 300-watt rating for stereo. On the face of it, this may seem legitimate—except that most stereo amplifiers usually put out perhaps 10 to 20 per cent *less* power per channel when both channels are being driven than they do when only one channel is working—and stereo, by definition, means simultaneous use of both channels. If a manufacturer chooses simply to *total* the power output available from both channels, as is common practice, he is entitled to do so. But it does seem questionable to specify as *total* power output a figure that is derived from only one driven channel—it is rather like claiming to be able to lift a 200-pound weight because one can lift a 100-pound weight twice.

BUT enough of "peak" power. The specifications go on to tell us that the IHF power (IHF signifies the measurement techniques endorsed by the Institute of High Fidelity) at 4 ohms, one channel driven, is 240 watts, and that it is 175 watts at 8 ohms. Here the manufacturer has chosen to ignore the fact that the existing IHF standard specifies *two* measurement techniques—music (dynamic) power and continuous power—and he hasn't told us which one he means; the standard also specifies that power measurements on multi-channel amplifiers must be made *with both channels driven*.

This brings us down to the third line of the specifications, the one revealing the continuous power figure (frequently referred to as "r.m.s." power). It is given as 150 watts at 4 ohms and 110 watts at 8 ohms. This, of course, translates further into 75 watts per channel at 4 ohms and 55 watts at 8. In other words, the original highly touted "300 watts" has now somehow shrunk to a mere 55 watts per channel.

Once they reach that point in the specifications sheet that gives the "continuous power" figure, many audiophiles think that the mystery of how many watts are *really* available is finally solved. However, the chances are very good (unless there is a statement to the contrary) that the continuous-power rating was obtained using a single-frequency test signal of 1,000 Hz. Most amplifiers will deliver their highest power output at mid frequencies, or, to put it another way, most amplifiers will not deliver the power output available at mid frequencies across the full audio range. And this brings us to the most controversial, and possibly the most misunderstood, point in the Federal Trade Commission's proposed Rule (see the complete text in the accompanying box): the requirement that a manufacturer disclose his power output in terms of *minimum* watts per channel across his rated power bandwidth. The practice of rating equipment at a single-frequency signal of 1,000 Hz is common, and is further sanctioned by certain widely accepted industry standards. It is argued that engineers understand this measurement technique, and that no one would be deceived if *all* manufacturers were required to specify the power output of their amplifiers at this frequency. There are flaws in this argument, however. Two pieces of equipment may have exactly the same mid-frequency power and distortion ratings and still have entirely different performance capabilities at frequencies above and below the measurement frequency. Further, it is plausible to assume that most consumers believe that when equipment has a certain power rating, it can deliver that power over the *entire* audio range. Viewed in this light, the "understanding" of engineers or the sophisticated audiophile becomes slightly irrelevant, since *they* are not the ones who need protection in the first place.

If *no* amplifier were capable of delivering its advertised power over the full audio bandwidth, then the problem would not be so great. But some will and some won't, and the consumer usually has no way of distinguishing between the two by consulting a specification sheet. Bear in mind also the point

at which this discussion began—that amplifiers and receivers are being sold *largely on the basis of relative power* and that the various similar products in any manufacturer's line are generally distinguished from each other by their power-output capabilities.

How much quantitative difference does the FTC requirement of *minimum*-power disclosure create? Simply stated, under existing standards of measurement (specifically, the present IHF Standard on amplifiers), the power bandwidth is determined by those frequencies at which the power output falls to 50 per cent (−3 dB) of what it is at mid frequencies (about 1,000 Hz) without exceeding its rated distortion. Thus, if an amplifier's output is 50 watts at 1,000 Hz and a certain percentage of distortion, the manufacturer's rated power bandwidth will be established at those two points at both ends of the frequency spectrum where the power drops 50 per cent. At these points, the power output would be 25 watts. In the FTC view, if an amplifier is capable of providing only 25 watts (at its rated distortion) at the manufacturer's chosen extremes of the audio-frequency range, then the amplifier is entitled to no more than a 25-watt rating. (In contrast, the present IHF Standard entitles the manufacturer to rate his product on the basis of its *full*-power mid-frequency output—and then establish the power bandwidth points at the frequencies at which it provides *half* power.)

THE question is frequently raised as to what difference all this really makes, since if *all* sound power equipment were rated by the same methods, the higher-quality equipment would still maintain the same relative advantage. It should be clear by now, however, that such is not the case. Power-output ratings that reflect performance only at 1,000 Hz really serve to obscure the difference between high-quality and low-quality products, for it is at the frequency extremes that the former will most dramatically outperform the latter. This involves a serious question of consumer protection, since the uneducated consumer, as distinguished from the knowledgeable audio engineer, will tend to be influenced by a large difference in price for what appears to be a small or non-existent difference in power.

One additional point should also be considered. To his credit, the manufacturer used as a "bad" example here *did* rate his equipment at a very low level of distortion—less than 1 per cent. It is a known fact that many manufacturers outside the component industry will accept distortion as high as 5 per cent—which provides a somewhat higher power rating. This leads naturally to the question of

whether the consumer is not also entitled to be apprised of the reference distortion whenever he is exposed to power-rating claims. It is difficult to support the contention that such information "would only confuse the consumer." Such an attitude of benevolent condescension is somewhat out of place in an age when consumers are demanding *more* rather than less information concerning the products they buy, and when they are displaying an increasing ability to make intelligent use of such information once it is made available.

THE example selected for this discussion is really a very mild sample of what was going on in the audio industry at the time the Commission entered the scene with its proposed Rule in 1971. Equipment selling at half the price was somehow being rated at twice the power. The so-called "wattage war" was truly being waged on all fronts—to the point where power ratings were becoming largely meaningless. Let us look, then, at what the Commission's proposed Rule would do to remedy the situation when it—or something close to it—is finally adopted. (The reader should keep in mind that, as of this writing, the Rule is only *proposed*, and has not been finally adopted by the Commission.)

In brief, the Rule would require certain disclosures whenever *any* claim or representation, direct or indirect, is made about the power output, the power bandwidth, or the distortion characteristics of sound power amplification equipment. It would further require that these disclosures be made clearly, conspicuously, and more prominently than any other representations or disclosures permitted.

Under this general Rule, the manufacturer would have to disclose his rated *minimum* continuous power output in watts per channel and, in addition, three crucial related parameters: (1) the speaker impedances for which the manufacturer intends the equipment to be used, (2) the manufacturer's rated power band or power frequency response, and (3) the manufacturer's rated percentage of maximum total harmonic distortion at his rated power.

The proposed Rule provides for optional disclosure of other operating characteristics and technical specifications—provided that such optional disclosures, if made, are less conspicuous and prominent than the *required* disclosures of continuous power and related parameters.

It is important to note that manufacturers cannot escape the requirements of this proposed Rule by not providing specific power numbers and falling back on such generalized assertions as "high power," "clean power," "distortion free," or other vague circumlocutions. Such general advertising

verbiage would itself be sufficient to trigger the requirements of the Rule and compel disclosure of—at the very least—the rated minimum continuous power and related parameters. It is also important to note that the Commission has so far *not* elected to fix the percentage of distortion at which equipment must be rated, but has instead chosen to require that the manufacturer disclose the percentage at which the rated power was achieved so that the prospective purchaser can judge for himself whether or not to be impressed with an advertised power output that has a high rate of distortion.

Although it has been urged to do so, the Commission has so far not elected to prescribe standardized test conditions. Instead, the Rule would require that no performance characteristic shall be represented if it is not obtainable when the equipment is operated by the consumer in the usual and normal manner without the use of extraneous aids. In this manner, the Rule seeks to forbid the use of artificial and unrealistic test conditions designed solely to inflate the ratings beyond those a consumer could hope to achieve under normal circumstances in the home.

Let us return, then, for a moment, to the example cited in the first portion of this discussion and see how the proposed Rule would affect the advertising of our “300-watt” receiver. We have seen that the *minimum* continuous power output per channel was only approximately 25 watts at the manufacturer’s rated distortion and power band. If this manufacturer then wished to employ any power representations at all, he would have to feature, *more prominently than any other representations*, the fact that this is a “25-watt” product, and state its rated power band at the rated percentage of total harmonic distortion. In addition, he would have to disclose the speaker load impedance at which the equipment was rated. If he still desired to list such ratings as “peak” or “music” power, they would have to be less conspicuous so as not to detract from the principal disclosure, and they would also have to be expressed in minimum watts per channel and without the use of some plus-or-minus decibel figure as a qualification.

Finally, it should in fairness be noted that the various segments of the audio industry, though they disagree on the details, do agree that some common

PROPOSED FTC RULE ON AMPLIFIER POWER-OUTPUT SPECIFICATIONS

FEDERAL TRADE COMMISSION
[16 CFR Part 432]
Power Output of Amplifiers Utilized for
Home Entertainment Products

§ 432.1 Scope.

(a) Except as provided in paragraph (b) of this section, this part shall apply whenever any power output (in watts or otherwise), power band or power frequency response, or distortion capability or characteristic is represented, either expressly or by implication, in connection with the advertising, sale, or offering for sale, in commerce as “commerce” is defined in the Federal Trade Commission Act, of sound power amplification equipment manufactured or sold for home entertainment purposes, such as, for example, radios, record and tape players, radiophonograph and/or tape combinations, component audio amplifiers and the like.

(b) Representations shall be exempt from this part if all representations of performance characteristics referred to in paragraph (a) of this section clearly and conspicuously disclose a manufacturer’s rated power output and that rated output does not exceed two (2) watts (per channel or total).

(c) It is an unfair method of competition and an unfair or deceptive act or practice within the meaning of section 5(a)(1) of the Federal Trade Commission Act (15 U.S.C. section 45(a)(1)) to violate any applicable provision of this part.

§ 432.2 Required disclosures.

Whenever any direct or indirect representation is made of the power output, power band or power frequency response, or distortion characteristics of sound power amplification equipment, the following disclosures shall be made clearly, conspicuously, and more prominently than any other representations or dis-

closures permitted under this part:

(a) The manufacturer’s rated minimum sine wave continuous RMS power output, in watts, per channel (if the equipment is designed to amplify two or more channels simultaneously)—

(1) For each load impedance required to be disclosed in paragraph (b) of this section, when measured with resistive load or loads equal to such (nominal) load impedance or impedances, and

(2) Measured with all associated channels fully driven to rated per channel power;

(b) The load impedance or impedances, in ohms, for which the manufacturer intends the equipment to be used by the consumer;

(c) The manufacturer’s rated power band or power frequency response, in Hertz (Hz), for each rated power output required to be disclosed in paragraph (a)(1) of this section; and

(d) The manufacturer’s rated percentage of maximum total harmonic distortion at any power level from 250 mw. (.25 watts) to the rated power output, for each such rated power output and its corresponding rated power band or power frequency response.

§ 432.3 Optional disclosures.

Other operating characteristics and technical specifications not required in § 432.2 may be disclosed, provided:

(a) Any other power output is rated by the manufacturer, is expressed in minimum watts per channel, and such power output representation(s) comply with the provisions of § 432.2(a)(1) through (d); except that if a peak or other instantaneous power rating, such as music power or peak power, is represented under this section, the maximum percentage of total harmonic distortion (see § 432.2(d)) may be disclosed only at such rated output; and provided further that

(b) All disclosures or representations made under this section are less conspicuously and

prominently made than the disclosures required in § 432.2; and

(c) The rating and testing methods or standards used in determining such representations are disclosed, are well known and generally recognized by the industry at the time the representation or disclosure is made, are neither intended nor likely to deceive or confuse the consumer, and are not otherwise likely to frustrate the purpose of this part.

Note 1: For the purpose of paragraph (b) of this section, optional disclosures will not be considered less prominent if they are either bold faced or are more than two-thirds the height of the disclosures required by § 432.2.

Note 2: Use of the asterisk in effecting any of the disclosures required by § 432.2 and permitted by § 432.3 shall not be deemed conspicuous disclosure.

§ 432.4 Prohibited disclosures.

No performance characteristics to which this part applies shall be represented or disclosed if they are not obtainable as represented or disclosed when the equipment is operated by the consumer in the usual and normal manner without the use of extraneous aids.

§ 432.5 Liability for violation.

If the manufacturer, or, in the case of foreign made products, if the importer or domestic sales representative of a foreign manufacturer of any product covered by this part furnishes the information required or permitted under this part, then any other seller of the product shall not be deemed to be in violation of § 432.4 due to his reliance upon or transmittal of the written representations of the manufacturer or importer if such seller has been furnished, by the manufacturer, importer, or sales representative, a written certification attesting to the accuracy of the representations to which this part applies, and provided further that such seller is without actual knowledge of the violation contained in said written certification.

ground rules are needed. There should be no reluctance to abide by the Rule, for it has already been demonstrated that there is a place in the market for *all* the kinds of equipment now being sold, whatever its audio quality, depending on the interests and resources of the consumers to whom each class of equipment is designed to appeal. The task is simply to assure that none of this equipment is passed off as something it is not, that no consumer is deceived into thinking he is buying a level of performance

that the equipment cannot deliver. All questions of comparative quality will not be resolved by this one step, but the consumer will have the basic information he needs to compare one product with another in at least one vital area: available power output.

William D. Dixon is Assistant Director for Rules and Guides with the Bureau of Consumer Protection, Federal Trade Commission. The views expressed herein are the author's own and do not necessarily reflect those of the Federal Trade Commission.

CAVILS & CAVEATS: Technical Editor Larry Klein comments on the proposed Rule

AT THE present time, it is frequently impossible for an audio consumer to judge on the basis of the furnished power specifications just what his dollar is buying. This is not to say that some few manufacturers do not make every effort to provide comprehensive and unequivocal specifications. The problem is that an uninformed consumer is going to be far more impressed by the inflated wattage ratings produced in some imaginative advertising department than he is by those legitimate, rigorous—and hence far smaller—numbers that honestly describe the power performance of a piece of equipment.

How well will the proposed FTC Rule (see text on page 77) accomplish its aims? Only time will tell. But the Rule does, it seems to me, handicap itself at the outset with a built-in communications problem. As I read it, the language of the proposed Rule is an occasional mish-mash of partly digested audio-engineering jargon, legalese, and (I am sure) inadvertent obfuscation. I can easily envision the engineering, advertising, and legal staffs of any number of companies arguing endlessly over the exact meaning of some of the provisions in the "Required Disclosures" section, and then spending some sleepless nights wondering whether they have accidentally committed a criminal act in publishing their latest specifications sheet. For example, no one could know from the text of the Rule, and without reading Mr. Dixon's article, what, if any, is the relationship between the FTC's "rated power band or power frequency response" and the IHF's "power-bandwidth rating." I could cite several other examples of the use of unexplained new terms—or the use of old terms in a new way—that unnecessarily confuse an already difficult to understand Rule. (In this connection, I have already suggested to Mr. Dixon that a supplementary set of technical definitions and explanatory examples be made a part of the Rule or be made available separately.)

My second area of discontent with the proposed Rule has to do with the options left open to manufacturers when they "disclose" their "minimum" power rating. The disclosure requires qualifications as to: (1) rated "power band" (as redefined by the FTC), (2) rated distortion, and (3) rated load impedance. In case it is not quite clear by now, "rated" translates quite simply into "established by the manufacturer." By adjusting factors 1 and 2, a manufacturer could

easily "disclose" a higher power rating than some other manufacturer who specifies his power over a wider bandwidth and at a lower distortion level. The consumer is then faced with the difficulty of, for example, having to decide whether an amplifier with 40 watts of power at 2 per cent distortion and with a power band of 30 to 10,000 Hz is a better or a worse buy than a competing unit with 30 watts of power at 1 per cent distortion and a power band of 90 to 12,000 Hz. Good luck, Charlie! An audio engineer with access to the manufacturer's curves *might* be able to make such a decision, but it is not the audio engineer who is in need of the FTC's protection.

Among my other objections is the fact that the Rule (Section 432.3) not only *permits* the use of peak power ratings, but then confuses peak power with "instantaneous" or "music" power—they are not the same thing at all! As far as test methods are concerned, the Rule requires the use of "ratings and testing methods . . . that are well known and generally recognized by the industry. . . ." But suppose the "generally recognized" IHF Standard is in conflict (as well it might be) with another "generally recognized" standard—one promulgated by the EIA, for example? The clever manufacturer will then, if he has any sense, choose whichever of these test parameters show off his equipment to best advantage. And the poor consumer is as confused as ever.

In view of these misgivings, I recently suggested to Mr. Dixon that the Rule as it now stands would provide me with a wonderful opportunity to hire out as a consultant to manufacturers who wished to obey the letter of the law while achieving, through hanky-panky, the largest possible power rating. Mr. Dixon cheerfully responded that he would then throw me in jail along with the manufacturers I so advised.

In any case, even if the Rule goes through as it is now constituted, it is not intended to be forevermore fixed and immutable, but is subject to such revision and amendment as experience proves it needs. Aside from our objections to certain approaches and language in the Rule, we at STEREO REVIEW applaud and support fully the intentions of the FTC in regard to setting a standard for amplifier power ratings. Whatever problems arise—and there will certainly be some—we believe that the proposed Rule is a giant step in the right direction.

STEREO REVIEW'S SELECTION OF RECORDINGS OF SPECIAL MERIT
BEST OF THE MONTH



CLASSICAL

VINTAGE PLEASURES FOR LOVERS OF GOOD TUNES & HARMONY

The Western Wind brings all-too-rare sounds from a neglected musical heritage

THE performing talents of a group of New York singers and instrumentalists felicitously named the Western Wind are wonderfully represented in a new Nonesuch release of early American vocal music. It is ironic, standing as we do so close to our two-hundredth birthday as a nation, that the fine relics of the American musical heritage displayed in this program still require an introduction, but they do. Though they have not yet found enough champions to win them their well-deserved place in the national consciousness, this recording is a splendid opportunity to give them a chance with yours.

Music in eighteenth-century New England centered on a unique institution called the singing school. An itinerant singing master would set up for a month or two in some locality, advertise for students, teach them the rudiments of sight-singing, and put them to work mastering a collection of psalms, hymns, anthems, and "fuging tunes" of his own devising—some actually composed, others borrowed, adapted, or otherwise put together. The first native American composers were these singing-school masters, and their strong, archaic, awkward, powerful sort of music has had a lingering, though scarcely acknowledged, influence on the national sensibility.

Just in case you may already have formed some idea in your mind of what this music is like,

basing that idea on conventional (and mistaken) notions of what life was like in stuffy, puritan New England, let me hasten to call your attention to an oft-quoted letter from a Yale undergraduate of the time: "At present I have no inclination for anything, for I am almost sick of the World & were it not for the Hopes of going to the singing-meeting tonight & indulging myself a little in some of the carnal Delights of the Flesh, such as kissing, squeezing &c. &c. I should willingly leave it now." Apparently those Yankee singing masters knew how to keep enrollments up.

The most famous of the New England masters, and the most colorful personality among them, was William Billings (1746-1800), an independent spirit who once announced, "I don't think myself confined to any rules for composition laid down by any that went before me"—and proceeded, like his compatriots, to strew his four- and six-part pieces with rule-breaking parallel fifths and octaves, dissonances, and the like. Broken rules or no, the effect of his music is nearly always that of a sturdy simplicity and a fine, homespun craftsmanship, and these are embodied, above all, in a good tune.

The durability of the tunes of the New England composers was remarkable: their best melodies remained current musical coin for a century or more. They were printed and reprinted, spreading the gospel to the south and west where



New York Public Library

DANIEL READ

Not the least of our American composers

new material — hymns, ballads, and spirituals — were added. One of the most important of the later publications of this sort was the *Repository of Sacred Music, Part Second*, brought out in Pennsylvania in 1813. This volume incorporated the work of Billings and company, but it also included some later revival and spiritual songs of a rather different style. Where Billings, for example — perhaps thinking of all that “kissing, squeezing, &c. &c.” — sets the Bible’s *Song of Songs* in an almost sensuous and certainly colorful manner (*I Am the Rose of Sharon*), the revivalists are more likely to meditate on the march to Canaan’s land, more concerned, in short, with the delights of the next life than of this one.

Among the many fascinating aspects of the Western Wind album, well delineated by the selection of material, are the lines that connect the New England style with the whole hymn-tune, revivalist, gospel tradition. And it also raises the equally fascinating question, one that may possibly never be answered, as to just where and when the black influence came in to cross-fertilize and invigorate the Yankee tradition. Elements of that influence can perhaps already be detected in some of these early songs.

In any case, quite apart from the cultural and historical implications, this is a most vigorous, attractive music, realized, performed, and recorded — without a trace of dutiful historicity, aesthetic preciousness, Liberty Bell ringing, or Old Glory waving — in the most exemplary fashion. The greater part of the performances are *a cappella*, but here and there instruments are added to good effect. The singing is natural, unforced, and extremely beautiful; there is, thank heaven, none of that false, prissy, operatic sound that is the curse of “cultivated” singing, particularly in English. Thus these performances, while pitched at the highest imaginable musical, vocal, and expressive level, remain close to the popular roots of the music — as if, indeed, we were present at the ideal singing-school or revival meeting, a real sing-out, and the best ever held. The “togetherness” of this singing — its “in-tuneness” and ensemble expressivity — is really something to hear. The recording quality itself is glorious, and I want to put the whole thing down right now as my first nomination for a Best of the Year Award.

Eric Salzman

THE WESTERN WIND: *Early American Vocal Music — New England Anthems and Southern Folk Hymns.* Andrew Law: *Bunker Hill.* Daniel Read: *Newport.* Justin Morgan: *Judgment Anthem; Amanda.* William Billings: *I Am Come into My Garden; I Charge You; I Am the Rose of Sharon; An Anthem for Thanksgiving; O Praise the Lord.* Anon.: *Washington; Triumph; Messiah; Canaan; Springhill; Concert; Lonsdale; Animation; Pilgrim’s*



THE WESTERN WIND (l. to r.): William Lyon Lee, Janet Sullivan, William Zukof, Lawrence Bennett, Elliot Levine, Janet Steele.

Farewell. Jeremiah Ingalls: *Northfield.* White: *Power.* Lewer: *Fidelia.* Robison: *Fiducia.* Elkanah Kelsey Dare: *Babylonian Captivity.* Lucius Chapin: *Rockbridge.* The Western Wind (Janet Steele, Janet Sullivan, sopranos; William Zukof, countertenor; William Lyon Lee, Lawrence Bennett, tenors; Elliot Levine, baritone); with Mary Lesnick (mezzo-soprano); Raymond Murcell (bass-baritone); Stuart Schulman (violin); Bonney McDowell (bass viol); Paul Fleischer (piccolo); Allen Herman (snare drum). NONESUCH H 71276 \$2.98.

SOME UNEXPECTED HELP FOR THE “ROMANTIC REVIVAL”

Are three delightful works by Swiss composer Frank Martin just what the doctor ordered?

IT delights me that the music of Swiss composer Frank Martin has been appearing on records more and more frequently in the past three or four years, for he is one of the most distinguished “independents” of the modern Western tradition and far too little known by American music lovers. His concerto for harpsichord and small orchestra is one of the works on a new album of his music just released by Candide, and it is one of the finest pieces of “neo-Classic” art I know. Unlike a great number of works that fall within that stylistic category, it deals not only with manner, but with substance as

well, at great depth and with great originality. There is, in short, flesh on these bones, a humanistic conception far broader in scope than in any other neo-Classical music that comes to mind, including that of Stravinsky and Hindemith. Martin himself conducted for this recording, and this undoubtedly helps the work to sing its song so sweetly and accurately; there is not one lapse in expressive authenticity, balance, stress, or technical perfection at any point in the whole performance.

I was put off slightly by the first few measures of the second work on this program, the *Ballade for Trombone and Orchestra*, because of a rather pedantic formalistic opening by the unaccompanied trombone. What comes afterward, though, at the instant the orchestra enters, is almost as remarkable in its effect as the *Harpsichord Concerto*. Martin's conception of a "ballade" is a little offbeat, and is related, I suspect, to his constructive conception in general. He sees the form as a narrative-dramatic one, and this sends him off in a different direction from that a simple Romantic conception of the ballade would. The trombonist in the work, Armin Rosin, is a musician with not only technique and expressive power, but a stunning tone as well.

The *Ballade for Piano and Orchestra* is a more conventionally Romantic work in both style and pianistic "technology," but it has individualistic ramifications that force you to listen to it on its own terms. I like it least of the three here—but I like it.

I have a sense that this may be a very timely recording: the music is stunning, and so are the performances. It may just be one possible perfect answer to what appears to be a general yearning for a

FRANK MARTIN
A distinguished independent



Candide Records

"Romantic Revival." Who needs chestnuts from the nineteenth century when beautiful works of the twentieth have all the attributes of warmth, melodiousness, and color for which so many seem to be hungering?
Lester Trimble

FRANK MARTIN: *Harpsichord Concerto (1952); Ballade for Trombone and Orchestra (1940); Ballade for Piano and Orchestra (1939)*. Christiane Jaccottet (harpsichord); Armin Rosin (trombone); Sebastian Benda (piano); Chamber Orchestra of Lausanne. Frank Martin cond. CANDIDE CE 31065 \$3.98.

POPULAR

... AND STILL CHAMP: MISS ETHEL MERMAN

Back one more time for some heartwarming reprises of the songs that are uniquely hers

I DON'T know how she does it, but Ethel Merman, at the age of sixty-five, is *still* Merman. I remember watching her as a lad from a stone seat high in the amphitheater at Randall's Island Stadium in New York in the Thirties as she belted out hit after hit in an outdoor revival of *Anything Goes*. Like the rest of her admirers, I was galvanized by her raw energy, her total certainty, her instinctive way with a song—and above all by her unstinting use of a unique ability to get the words all the way back to the last row of the gallery; you never needed a text to follow the lyrics when Merman sang.

I was as stunned as any other of her fans when news came in 1959 that she had burst a blood vessel in the midst of her exacting last-scene epiphany as the Stage Mother in *Gypsy*. I supposed that I would never get to hear her shake the rafters again—and indeed, in a couple of TV appearances following her recovery, she did sound alarmingly subdued, and looked it. Still, I had her old records for consolation, and memories of thrill-packed evenings at the theater as well.

Thus it makes me doubly happy to report that Ethel Merman has evidently recovered her full strength, and the proof is in her new London Phase Four album with the London Festival Orchestra and Chorus. It is a generous program of all the big hits that kept her at the top—five by Cole Porter (who once said that he'd "rather write for Ethel Merman than anyone else in the world"), five by Irving Berlin, one by Stephen Sondheim, one by George Gershwin, and, just in case you didn't already know how far this lady can run with a ballad, the whole (five minutes and forty-one seconds) of



ETHEL MERMAN
You never need a text

Eadie Was a Lady, a low-down tour de force put together, in case you care, by Da Sylva, Brown, and Whiting and immortalized by Merman herself many years ago.

The really remarkable thing about this prize package is that, except for a marked age-betraying quaver (if you want to go looking for flaws), Merman sounds even better here than she did in, well, not the great Columbia original-cast album of *Gypsy*, but such classics as "Ethel Merman Sings Cole Porter" (made some thirty years back) and even Decca's *Annie Get Your Gun*. One of the reasons is the excellent support she gets from Stanley Black and the London Festival Orchestra and Chorus in Eric Rogers' lush arrangements. They were probably ready to catch her when she fell—only, apparently, she never did. So, if you would like to hear the Merm giving her all again to *You're the Top*, *I Got Rhythm*, *It's D'Lovely*, *I Get a Kick Out of You*, *Blow Gabriel Blow*, and *Everything's Coming Up Roses*, try this neat, all-in-one, ultra-hi-fi package. Bonus: following the fashionable new custom, she has unearthed all the wonderful verses that come before the famous refrains, marking the first time I, for one, have ever been able to get all of them straight. This is a must for Mermanites.

Paul Kresh

MERMAN SINGS MERMAN. Ethel Merman (vocals); London Festival Orchestra and Chorus, Stanley Black cond.; various accompanists. *You're the Top*; *I Got Rhythm*; *You're Just in Love*; *Alexander's Ragtime*

Band; *I Got Lost in His Arms*; *Eadie Was a Lady*; *There's No Business like Show Business*; *They Say It's Wonderful*; *It's D'Lovely*; *I Get a Kick Out of You*; *Everything's Coming Up Roses*; *Blow Gabriel Blow*. LONDON XPS 901 \$5.98, Ⓜ 14901 \$6.98, Ⓢ M 84901 \$6.98, Ⓛ L 77901 \$7.98.

SKIP BATTIN HAS SOMETHING TO SAY

A wry troubadour on the Signpost label is a refreshing change from the gloom-and-doom set

SKIP BATTIN, an ex-Byrd, has made a totally fresh, imaginative, and entertaining album for the Signpost label. For it, he and Kim Fowley wrote a collection of ironically wry, frequently witty songs that really have something to say, and they are well performed by Battin—so well that they somehow declare themselves to me immediately as the definitive versions even though this is the first time I've heard them.

Beyond this there is an engaging lack of self-importance and deadly seriousness in all aspects of the recording: arrangements, background vocals (by—welcome back!—Spanky McFarlane), and production. After so many months of listening to the moans and groans, the gloom and doom of so much of today's "personal" music, this bright album is a joy. True, we all live perilously perched atop our own San Andreas faults, but of late there has been a seeming epidemic of Cassandras who are out not only to warn us, but to actively depress us as well.

Some very serious subjects are dealt with nonetheless: *Undercover Man* is about that continuing erosion of privacy that upsets a great many of us, and *Human Being Blues* speaks about the disappearance of simple humanity in ironic rather than bitter terms. Then there's *Central Park*, a bouncy, cheerful number (it saves its lyric punch for the end) about what Fred Olmsted's great big garden was like back in the Twenties when Duchin played the Casino for flappers and their pomaded escorts. There is also a purely hilarious entertainment called *Valentino*, a semi-jug-band arrangement of a song about a man relentlessly pursued by women who swear he reminds them of their Sheik.

Battin's best performance, however, and the best song on the album, is *The Ballad of Dick Clark*, a lament by a refugee from the Fifties pop scene. It is a funny, yet moving, too-long-at-the-fair song about someone—anyone—who can't quite believe the

party's over: "Where has everybody gone? . . . There ain't no rockin' no more." Happily, in Skip Battin's case the parties seem to have just begun; I can't wait for the next one. *Peter Reilly*

SKIP BATTIN. Skip Battin (vocals, guitar, piano, and bass); orchestra. *Undercover Man; The Ballad of Dick Clark; Captain Video; Central Park; Four Legs Are Better Than Two; Valentino; Human Being Blues; The St. Louis Browns; Cobras; My Secret Life.* SIGNPOST SP 8408 \$5.98, Ⓟ TP 8408 \$6.98, © CS 8408 \$6.98.

HAD ENOUGH? VOTE FOR THE MOVE

If there is any justice, their new "Split Ends" for United Artists ought to sell a million

As Greg Shaw makes clear in his excellent account of their tangled history elsewhere in this issue, the Move (Roy Wood, Jeff Lynne, Bev Bevan, and company) have been and continue to be responsible for an inordinate amount of clearly superior rock-and-roll music, and those still unconvinced should find ample evidence to support the claim in their new "Split Ends," just unleashed by United Artists. Made up of seven tracks from their previous "Message from the Country" plus a selection of British chart successes heretofore unavailable on LP, this is probably the Move's best record; certainly it is the most consistent, and therefore the most easily accessible to the neophyte. Without resorting to a detailed description of the individual

SKIP BATTIN
An engaging lack of self-importance

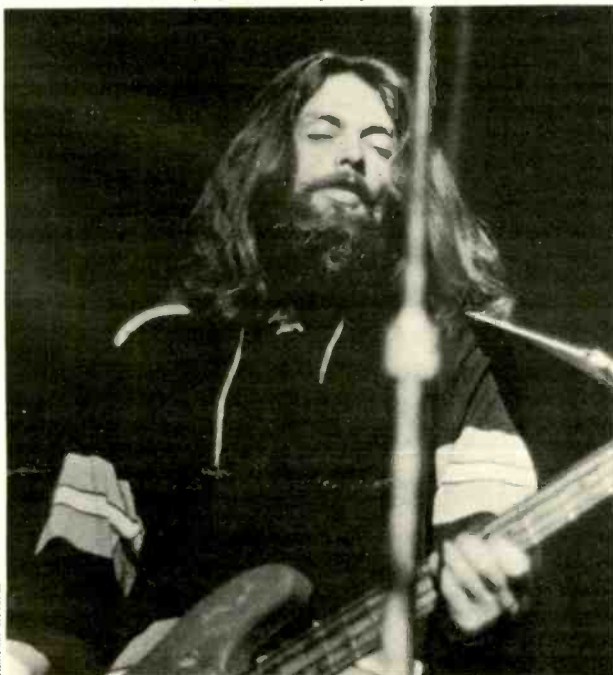

Signpost Records

Capitol Records

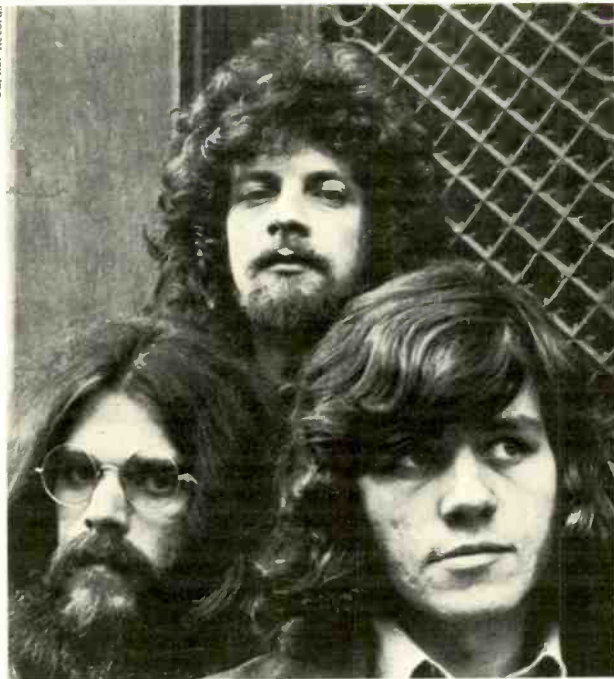

THE MOVE
Left to right: Roy Wood, Jeff Lynne, Bev Bevan

numbers, let me simply observe that the album functions almost as a textbook of the best features of classic British rock—the studio mastery, the melodic eloquence, the wry and winning good humor—and that *Do Ya*, the opener, surpasses even Alice Cooper's *Be My Lover* as an extension of the majestic implications of the Who's *Can't Explain*.

If the thrust of all this is still unclear to you folks, I can only add that "Split Ends" should by rights be the first Move album to sell a million copies, and that anyone even remotely concerned with rock-and-roll should waste no time in availing him- or her-self of its splendors. If, like me, you are surfeited with the endless succession of sensitive folkies who wail inanities about nameless horses in quavering Irish tenors, if you are fed up to the teeth with the naïve grinning optimism and ersatz twang of the country hokum churned out by legions of Hollywood hillbillies, if you want never again to hear excerpts from the Yardbirds' Songbook played at half speed by a quartet of English transvestites, and if David Bowie has as little relevance to your sensibilities as Jim Bowie—then, my friends, I think you may be ready for them. Be the first on your block to become a Move fan. *Steve Simels*

THE MOVE: *Split Ends.* The Move (vocals and instrumentals). *Do Ya; Message from the Country; Chinatown; The Minister; The Words of Aaron; Down on the Bay; California Man; No Time; Ella James; It Wasn't My Idea; Until Your Mama's Gone; Tonight.* UNITED ARTISTS UAS 5666 \$5.98, Ⓟ U 8505 \$6.98.

LAFAYETTE has the world's only 4-channel receiver with Full Logic wave-matching SQ

*Selected as the receiver of choice for
monitoring SQ* Quadraphonic records by CBS
and by other SQ record manufacturers*

Professional record reviewers all over the U.S. and CBS itself, the developer of SQ, are now using the Lafayette LR-4000 receiver to achieve optimum playback of 4-channel records, especially SQ. Why did they choose the LR-4000 over other 4-channel components? Foremost is the "Wave matching" full logic decoder, a Lafayette first in receiver design which provides the listener with the most precise definition of 4-channel SQ records yet developed. This means you get all the spacious surround sound that the SQ engineers built into the recording. A truly thrilling listening experience unequalled by other non logic or semi-logic 4-channel receivers. You can also play other 4-channel records with our exclusive Composer A & B positions and your present stereo records will

sound better when played through the LR-4000 and 4 speakers. Any discrete tape sound source can be used directly with this receiver including an optional CD-4 demodulator. The LR-4000 delivers 228 watts, (57x4) rms of direct-coupled power at 4 ohms. Advanced MOSFET/IC FM circuitry with phase locked multiplex and 1.65 μ V sensitivity brings in each station clearly even in difficult reception areas. Plus all the necessary controls to put you in command of a truly masterful sound system. It's not surprising then when Norman Eisenberg, Executive Editor of High Fidelity said, "Considering all that the LR-4000 offers, its price tag of \$499.95 does not seem unwarranted . . . it is a prime example of a 4-channel receiver". Listen to one and see if you don't agree.

*SQ TM Columbia Broadcasting System, Inc.



LR-4000

Lafayette Radio Electronics P.O. Box 10, Dept. 11043, Syosset, L.I., N.Y. 11791

1973

From LAFAYETTE
Radio Electronics
11043

**Send today!
FREE**

The World's Largest
Consumer Electronics Catalog

Your One Complete Buying Guide For
"Everything In Electronics"

11043

Send my FREE LAFAYETTE 1973 Catalog 730 to:

Name _____

Address _____

City _____ State _____ Zip _____

CIRCLE NO. 28 ON READER SERVICE CARD



POPULAR DISCS AND TAPES

Reviewed by CHRIS ALBERTSON • NOEL COPPAGE • PAUL KRESH
PETER REILLY • JOEL VANCE

ATOMIC ROOSTER: *Made in England.* Atomic Rooster (vocals and instrumentals). *Time Take My Life; Stand by Me; Little Bit of Inner Air; Don't Know What Went Wrong; Never to Lose; Breathless;* and five others. ELEKTRA EKS 75039 \$5.98.

Performance: **Rock rehash**
Recording: **Good**

The group name, sound, and album title smack of England in the Sixties, when much of English rock was new and refreshing. This is, in effect, a rehash, an attempt to call back the emotions of that departed decade. The songs are pretty consistently poor and when not poor are pompous. As a demonstration record of what the band sounds like, it's not bad; the next logical step would be to get them some decent material. But we mustn't do that, you know, because that would infringe on their artistic territory. Sometimes I think that rock music would have been better off if the Beatles had not printed their "Sergeant Pepper" lyrics on the album cover, a ploy that has inspired a lot of hooey from capable but unquestionably mediocre groups ever since. J.V.

AZTEC TWO-STEP. Aztec Two-Step (vocals, guitars); instrumental accompaniment. *Baking; Killing Me; The Persecution and Restoration of Dean Moriarty; The Infidel; So Easy; Prisoner; Strangers;* and four others.

Explanation of symbols:

- Ⓜ = reel-to-reel stereo tape
- Ⓢ = eight-track stereo cartridge
- Ⓒ = stereo cassette
- Ⓚ = quadraphonic disc
- Ⓜ = reel-to-reel quadraphonic tape
- Ⓢ = eight-track quadraphonic tape
- Ⓒ = quadraphonic cassette

Monophonic recordings are indicated by the symbol Ⓜ

The first listing is the one reviewed; other formats, if available, follow it.

ELEKTRA EKS 75031 \$4.98, Ⓢ 85031 \$6.95, Ⓒ 55301 \$6.95.

Performance: **Nice try**
Recording: **Very good**

If you charted the appeal of recordings on a graph, this one would show the familiar bell-



RY COODER

Gets the grit of history in your ears

shape curve where I'm concerned. I didn't like it much at first, then decided I liked it more and more, and then, as I continued playing it, decided I really didn't like it that much after all. Perhaps everyone goes through that sort of thing with every album, but I wished the peak had lasted longer. Aztec Two-Step is two folkie types, Rex Fowler and Neal Shulman, who play acoustic guitars and harmonize something like you-know-who. Fowler writes most of the songs, and Shulman does most of the impressive finger-picking. *Almost Apocalypse* is probably Fowler's best song, though it shows too many undisguised Neil Young influences, and the cliché-riddled *Highway Song* has the most congenial moments. Mostly, Fowler's lyrics are too glib, and the melodies—although they give the guitars some in-

teresting things to do—don't keep their promises. The lads make a nice sound together; seasoning as songwriters is what they need most. N.C.

SKIP BATTIN: *Skip Battin* (see Best of the Month, page 82)

BIG BLACK: *Big Black & the Blues.* Big Black (vocals); instrumental accompaniment. *Shu-Be-Du; I Care; Mm-Baby; Blues of Love; People Are Talkin'; Long Black Sally;* and four others. UNI 73134 \$4.98.

Performance: **Koolaid**
Recording: **Okay**

Well, now, this is pretty silly. Big Black trying to sing blues—it's truly daft. It's as though someone had played him a blues record and Big Black had said, "Oh, I see; you sing certain notes *this way*." Tony Bennett studiously trying to sound like Joe Cocker would give the same effect as this album. It is embarrassingly mechanical, totally empty of feeling. B.B. sounds like he's reading out of a school primer. There is some acceptable guitar playing by Big Black's nephew, but the whole album is such a clumsy amateur job—how did this thing get recorded? Big Black wrote most of the—ahem—"blues tunes" in the album, and his idea of what a blues is—I swear by the buttons of Blind Lemon Jefferson's chauffeur—sounds like Robert Goulet moanin' and groanin' because his orange juice is warm. J.V.

RECORDING OF SPECIAL MERIT

RY COODER: *Boomer's Story.* Ry Cooder (vocals, guitars, mandolin); unidentified accompaniment. *Boomer's Story; Cherry Ball Blues; Crow Black Chicken; Ax Sweet Mama; Good Morning Mr. Railroad Man; Dark End of the Street; Rally 'Round the Flag; President Kennedy; Maria Elena; Comin' in on a Wing and a Prayer.* REPRISE MS 2117 \$5.98.

Performance: **Excellent**
Recording: **Very good**

A boomer is, or was, a hobo, and Ry Cooder,

a confirmed Americana buff, is becoming a faithful and capable heritage revisionist. I admit that at first I didn't know what he was up to, his reputation in rock—as accompanist to the Rolling Stones, *etc.*—having clouded the issue (then, too, Pete Seeger never took a turn as a hot studio musician). But for this album he not only resurrects some choice artifacts, he interprets them with a sort of raw-boned, loose-jointed grace that suits them perfectly. He specializes in that old blues instrument, the bottleneck guitar, and that old mountain instrument, the mandolin, and his singing style, like his picture on the album jacket, seems to have a three-day growth of stubble on it. His guitar style is varied and complex but often comes down to a series of spasmodic attacks, very outdoorsy, very American. He may not sing well, technically, but he sings knowingly—as in his uncanny interpretation of *Rally 'Round the Flag*, for instance, in which he purposely sounds preoccupied, working some present-day irony into the song and also superimposing the image of the bedraggled Yankee corporal distractedly mumbling through the anthem one last time while bedding down. The title cut, which keys the album, shows what Ry is trying to do sonically—get the grit and cinders of our special, informal history into loudspeakers. He does that, and still manages to keep it personal and, yes, relevant. Pretty secure fellow. N.C.

CRAZY HORSE: *At Crooked Lake.* Crazy Horse (vocals and instrumentals). *Lady Soul; We Ride; Outside Lookin' In; 85 El Paso's; Your Song;* and five others. EPIC KE 31710 \$5.98, Ⓢ EA 31710 \$6.98, © ET 31710 \$6.98.

Performance: **Fair**
Recording: **Good**

It takes quite a while for something to happen on this album. In fact, nothing much does until *Don't Look Back*, which is the next-to-last track. Until then, Crazy Horse is notable only for some flashy guitar playing with a sound that seems a cross between c-&-w and Hawaiian. *Don't Look Back*, however, is a very strong piece, and the group performs it with sharpness and gusto.

One track out of ten isn't much. But it is something, and it is, I hope, a guideline performance that the group will follow. P.R.

RECORDING OF SPECIAL MERIT

SANDY DENNY: *Sandy.* Sandy Denny (vocals, guitar, piano); Richard Thompson (guitar, mandolin); Pat Donaldson (bass); "Sneaky" Pete Kleinow (pedal steel); other musicians. *It'll Take a Long Time; Sweet Rosemary; For Nobody to Hear; Tomorrow Is a Long Time; Quiet Joys of Brotherhood; Listen, Listen; The Lady; Bushes & Briars; It Suits Me Well; The Music Weaver.* A & M SP 4371 \$5.98.

Performance: **Lovely**
Recording: **Excellent**

I like to be out ahead of the pack, but this is getting ridiculous. I've been praising Sandy Denny for years now at parties, weddings and funerals, and in print—and it isn't easy to work praise of an English folk singer into an analysis of weed killers for *National Grange Monthly*—but there's still no sign of the pack. Sandy is fairly popular in England, but Americans didn't even notice when she split from Fairport Convention. Maybe this time. Any-

way, here I go again: Sandy Denny has one of the purest, most naturally beautiful voices in pop music, a magnificent reedy soprano with no weak areas within its considerable range. She is a stylized writer, limiting herself mostly to good, old English folk treatments of good, old English folk subjects. The Elizabethan flavor of her songs is a vehicle for patrician beauty. She is a lady; no matter what word is in vogue at the moment, only "lady" fits her. She can pull off a mild surprise, though, as she does with her swinging country approach to Bob Dylan's *Tomorrow Is a Long Time*. Let's just say that Linda Ronstadt will never come within a mile of a performance like this. In her own songs, Sandy generally works down to a slightly enriched folk sound, or rocks aristocratically as one of her groups, Fotheringay (whose bass player, Pat Donaldson, appears here), used to do. The weakness in this album is that its arrangements tend to get out of hand sometimes; only occasionally are they as tight as Fotheringay usually was.



SANDY DENNY

A pure, beautiful voice for English folk

But a slightly tipsy arrangement (plus Sandy's flawless vocal) turns *Listen, Listen*, basically a thin and slightly monotonous song, into an experience, and then everyone gets a grip on himself to fashion a tight, just-right arrangement for the album's masterpiece, *It Suits Me Well*. Wake up, America. N.C.

NEIL DIAMOND: *Hot August Night.* Neil Diamond (vocals and guitar); orchestra. *Sweet Caroline; Soggy Pretzels; Shilo; Play Me; Canta Libre; Holly Holy;* and sixteen others. MCA MCA2 2800 two discs \$9.98, Ⓢ MCAT2 8000 \$10.98, © MCAC2 8000 \$10.98.

Performance: **Kandy karats**
Recording: **Live and entranced**

Knocking Neil Diamond appears to be the major leisure-time activity of most reviewers. I agree with them on artistic grounds; but what seems to infuriate them—although not me—the most is his ability to play to S.R.O. audiences no matter where he appears. Packing the Winter Garden on Broadway, as he did during a recent run, immediately sent the critical arrows flying, with no noticeable effect at the box office. This live album is taken from another Diamond concert during his run at the Greek Theatre in Los Angeles. His audience of 4,500 is obviously rapturous as he

sings and plays his way through more than twenty songs, and the evening builds to a real personal triumph. I'd like to say that I was as swept up by the recording, but no way.

It's pointless to nit-pick about a popular phenomenon on the scale of Neil Diamond. My only explanation for his success is that he functions more as a transmitter of several current musical styles, sifted through a fudgelike mass-cult sentimentality, than as a creator. Granted, he writes very listenable songs and his performances are well crafted, but they lack the spark of truly contemporary musical reality. They come across in much the same way that *Hair* did as it explained what the counter-culture was supposedly about in palatable commercial terms; it didn't particularly matter to the delighted audiences that the era *Hair* described had already long passed—they were satisfied that at last they were getting with it. Neil Diamond is essentially a middle-brow, mass-cult entertainer, and he has succeeded in amassing an enormous number of fans who aren't ready, willing, or able to take the Alice Coopers and David Bowies. P.R.

FIVE DOLLAR SHOES. Five Dollar Shoes (vocals and instrumentals). *Love Song; Can't Do That Anymore; Bare Mattress; Rain Train; Chemical Lover; Bad Dream;* and four others. NEIGHBORHOOD NRS 47002 \$5.98.

Performance: **Impressions time**
Recording: **Okay**

First the lead vocalist tries to sound like Mitch Ryder; then the band tries to sound like, oh, say the Flamin' Groovies, or Canned Heat, or any boogie band that only knows one song, one chord progression, one guitar solo, and one riff. Then they all try to sound like the Rolling Stones. On the last cut—with gooey strings—the vocalist tries to sound like Bob Dylan, from that period when Dylan was goofing. There is a photo of the group, all looking suitably hostile and contemptuous. Fooyey! This is discotheque music and there's no reason to pay list price for it. The sound is commercial, but why buy imitations when you can also buy the "real" thing? J.V.

AL GREEN: *I'm Still in Love with You.* Al Green (vocals); Charles Hodges (keyboards); Leroy Hodges (bass); Tennie Hodges (guitar); other musicians. *I'm Still in Love with You; I'm Glad You're Mine; Love and Happiness; What a Wonderful Thing Love Is; Simply Beautiful; Oh, Pretty Woman; For the Good Times; Look What You Done for Me; One of These Good Old Days.* Hi XSHL 32074 \$4.98.

Performance: **Good**
Recording: **Good**

I like the way Al Green sings here. He doesn't make me like the blaring horns, lame string arrangements, and other production excesses, but I like the way he uses his voice. He plays it off against the rhythm section and backing vocals in a style something like Aretha Franklin's—which is certainly more than one remove from the cottonfields or even the Baptist church, but which is also capable of its own dynamic. A good, tight rhythm section and fine organ work by Charles Hodges cancel out some of the tired elements of the production. Green-composed songs don't have much melody in them, nor much relevance to anything but "luv," but it's nice hearing the vocal doodlings he weaves from a skimpy lit-

tle outline like *Simply Beautiful*. He hits a fresh, personal interpretation of Roy Orbison's old *Oh, Pretty Woman*, but then seems to be on a fishing expedition with Kristofferson's *For the Good Times*. The singing is generally better than the arrangements. *N.C.*

GUNHILL ROAD. Glenn Leopold (vocals, guitar); Steven Goldrich (vocals, keyboards); Gil Roman (vocals, twelve-string guitar); other musicians. *Sailing; She Made a Man Out of Me; Madness; Waiting; 42nd Street; Sag Harbor; My Antoinette*; and three others. KAMA SUTRA KSBS 2061 \$4.98, © M 82061 \$6.95, © M 52061 \$6.95.

Performance: **Dull-normal**
Recording: **Good**

Kenny Rogers of First Edition fame produced this album, and he has a sure instinct for cranking the public's arm down, lining up the fruit, and walking off with the jackpot. Nevertheless, to me Gunhill Road's vocal harmonies seem unpleasantly grainy, their arrangements not too coherent, and their songs dreadfully dull. Sometimes I think that's an unbeatable combination in America. But then again, sometimes I don't. *N.C.*

RECORDING OF SPECIAL MERIT

LANI HALL: *Sun Down Lady*. Lani Hall (vocals); instrumental accompaniment. *Love Song; Tiny Dancer; How Can I Tell You; You; Ocean Song*; and five others. A & M SP 4359 \$5.98.

Performance: **Smooth and sweet**
Recording: **Excellent**

Lani Hall has in her dark voice the rare quality of deep repose, an asset she uses to immense advantage on this record. Miss Hall has recorded before, as the lead singer with Brazil '66, but here she comes into her own, singing smoothly of drifting "with a friend to the end of the ocean," of soaring through the sky under "a new kind of light" on a shining spring day, of meeting a lover in the moonlight, and of other wistful, romantic situations. The songs, by Lesley Duncan, Cat Stevens, Elton John and Bernie Taupin, have in common a floating, dreamy serenity. Particularly pleasant is the easy sensuality of *Sun Down Lady*, and I was more impressed than I expected to be by the ballad *Vincent*, Don McLean's tribute to Van Gogh, which draws on the painter's own palette for its imagery of vibrant landscapes and blazing skies reflected in "Vincent's eyes of china blue." These lyrics, culminating in word pictures about "Portraits hung in empty halls" unseen by the self-preoccupied patrons of museums, struck me as uncommonly fine, as did both the words and tunes of Paul Simon's *Wherever I May Find Him* and the singer's own unaffected *You*. In all, this is an unusual and moving album, beautifully tailored to Lani Hall's special talents. *P.K.*

MICHAEL JARRETT: *We're All Goin' Down Together*. Michael Jarrett (vocals, guitar, piano); various other musicians. *I'm Leavin'; Goin' Down; It's All Uncertain; The Road; Sunday in L. A.; Go Where You Go; Sweet Emily*; and three others. PLAYBOY PB 104 \$5.98.

Performance: **Safe**
Recording: **Very good**

(Continued on page 89)

IT'S FREEBIE TIME

Columbia has a great new blank tape and we want you to start using it.

That's why we're offering a freebie.

Until the end of April, we will give you, absolutely free, one of Columbia's new **FAIL-SAFE** 40-minute blank cassettes when you buy two Columbia blank cassettes of any length.

Just tear off the perforated "NOTICE" paragraph from two Columbia blank cassette labels, write your name and address on the backs, and send them to us. The mailman does all the work.



(One Freebie to a customer!)

COLUMBIA Blank Recording Tape



Columbia Magnetics, Dept. 51/09, CBS, Inc., 51 West 52nd Street, New York, N.Y. 10019

CIRCLE NO. 10 ON READER SERVICE CARD



a name known
around the world for
quality.

Introduces a new standard of turntable
performance.

See the feature loaded GA212, electronic turntable and marvel at the
price.

© N. V. Philips of Holland

DISTRIBUTED BY
NORTH AMERICAN PHILIPS CORPORATION
100 EAST 42nd STREET, NEW YORK, NEW YORK 10017

CIRCLE NO. 34 ON READER SERVICE CARD

THE BEACH BOYS REGROUP

Lester Bangs reviews their latest release



Left to right, Carl Wilson, Brian Wilson, Alan Jardine, Ricky Fataar, Dennis Wilson, Blondie Chaplin, and Mike Love.

NOBODY making music in the Sixties distilled the myths and frustrations of teenage America better than Brian Wilson and the Beach Boys. Customized cars, California girls, cruising for burgers—they caught it best, because they *were* it. But the times changed, and the ante with them; the Beach Boys' popularity, and the quality of their music as well, have waned slightly in the past few years. Beginning with the brilliant "Pet Sounds," they made a concerted effort to be "relevant" and "innovative"—in any case, to transcend their roots—but this made them erratic and awkward just as often as it made them stunningly, eloquently melodic. Brian retreated more and more from active participation in the band, and last year they picked up two South Africans—Ricky Fataar and Blondie Chaplin—who succeeded mainly in making their last album, "Carl and the Passions," one of the most uneven of their career.

All of which makes it a special pleasure to say that "Holland," their newest release, is a moving, finely crafted record. It is not only musically strong, it also achieves a comfortable compromise with the odd-man-out stigma that has dogged them ever since they traded in all their surfing gear for acid and meditation.

Don't retch and run when I tell you that much of this album is concerned with ecology. The Beach Boys' music is uniquely suited to such by-now mundane themes as the preservation of forests. Brian Wilson's arrangements, with their symphonic depth and Phil Spector-like waves of looming sound, always had a vivid, breathtaking quality that was nearly cinematic; you got the impression he could write brilliant movie sound-

tracks. The music on "Holland" is at once strong, stirring, worthy of a Dimitri Tiomkin, and as lulling as supermarket Muzak—perfect aural Valium. It's a subtle, tender, often lavishly programmatic record that comes as close as anything yet has to transcending the banality of the conservationist-polemic-as-art line.

It's also cornball as hell, particularly at the core of the album, the three-part *California Saga*. Art rock, 1968-style, is not dead as long as there's music like this around; the instrumental background could be the Moody Blues performing excerpts from *King of Kings*. It is sheer brocade, framed with such profundities as "Lenin has lived and Jehovah died, while the mother-eagle hunts her same hills," and "A whisper of the world will let you soar with your soul." The poet Robinson Jeffers is also back in there somewhere—not that it matters, for it is the highly individual pretensions of Mike Love that shine through each cliché.

Even better is *Sail On Sailor*, a beautiful mixture of old New Orleans r-&-b balladry and classic Beach Boys harmonies, with a taste of the Band in the vocals and instrumental fills. It's an obvious AM hit, too. Many of these songs seem almost like some weird meeting of Stephen Foster and Charles Reich, and the miracle is that even old reactionaries like me find it pure balm. Both Foster and the Band show up again in *Steamboat*, although Beach Boys manager Jack Reiley's lyrics weaken the effect—lines like "Banks of thirsty lies" are better left to Jethro Tull.

The rest of the material isn't quite as strong, but all of it is palatable, moody, borderline middle-of-the-road. *Leavin' This*

Town is a pleasant, Beatlish ballad; *Only with You* sounds almost like a "Pet Sounds" outtake; and *Funky Pretty* even manages to make the customary astrological banalities bearable. *Mount Vernon and Fairway*, which occupies the bonus EP enclosed, is a little fairy tale by Brian, and it sounds vaguely like a Francis Lai score for some French soap opera. It's all about a young prince in a tinsel kingdom who has a magic transistor radio, and cosmic four-year-olds of all ages will find it a delight.

IF much of this review's praise sounds somewhat backhanded, it's only because I find the Beach Boys themselves trapped by their style; they were most significant and profound when they weren't trying to be—that is, when they were writing about high school and cars—and all their attempts to "move with the times" have only resulted in more self-consciousness. But if Brian Wilson's art is often uncomfortably close to Muzak, so is much of the finest pop music being produced today (Curtis Mayfield's "Super Fly," Marvin Gaye's albums, even Miles Davis' recent work). You can swim in its lush images or just let it fan you from the background; either way, it's really nice to have around.

BEACH BOYS: *Holland*, Beach Boys (vocals and instrumentals). *Sail On Sailor*; *Steamboat*; *California Saga: Part One—Big Sur*; *Part Two—The Beaks of Eagles*; *Part Three—California: The Trader*; *Leavin' This Town*; *Only with You*; *Funky Pretty*; *Mount Vernon and Fairway*. BROTHER/REPRISE MS 2118 \$5.98. © M8 2118 \$6.98. © M5 2118 \$6.98.

Sorry, but it's easy for me to stereotype Michael Jarrett as the act likely to precede Johnny Mathis at one of the larger Playboy Clubs. It is probably unfair, and it probably would not have occurred to me if this album weren't on the new Playboy label. Then again, it might have: the same kind of manufactured style I associate with Playboy Clubs is stamped on the record. Jarrett is a modern version of the supper-club singer, in whose vocals idiosyncrasy passes for style. The arrangements are safe approximations of what's being done practically everywhere else at the moment, and so are most of the songs. *I'm Leavin'* easily outclasses the other songs, although *It's All Uncertain*, showing country influences, is catchy and should be commercial. Most of the album is as far from being offensive as it is from being original. I actually fell asleep twice trying to listen to it. But it isn't that bad; I'd had a rough week. N.C.

MASON PROFFIT: *Rockfish Crossing*. Mason Proffit (vocals and instrumentals). *Jesse: You Win Again; Better Find Jesus; Summer Side of Love; Breakin' Down; Were You There?; Hobo*; and six others. WARNER BROS. BS 2657 \$5.98. © M 82657 \$6.98. © M 52657 \$6.98.

Performance: **Perky**
Recording: **Very good**

Mason Proffit is a very good urban "country" band. Measured against the Flying Burrito Brothers, who were masters of the form, the group stands up well; the vocals are clean and relaxed, the instrumental support is calm and assured. The result is a very pleasant album, but one with some excesses. Urban country bands tend to look upon country music the way rock musicians once looked upon the Maharishi Yogi: as a means to spiritual bliss and an excuse for disdaining worldly things. But authentic country music is very much of this world. Yet, sometimes. Mason Proffit, especially on the second side of the album, recorded live in that terribly down-home place, Huntington Beach, California, seems to be transported to a spiritual plane far beyond the reach of mortal men. This is an annoying stance that mars the music of too many people, including George Harrison in his more monkish moments.

There is a lot of this ideological mush and gush about country music among its urban and suburban advocates. The Burritos managed to avoid most of it. Mason Proffit avoids some of it, and has turned in a generally solid album. J.V.

RECORDING OF SPECIAL MERIT

DON McLEAN. Don McLean (vocals, guitar); Bob Rothstein (bass); Neil Larsen (piano); Buzzy Feiten (guitar); others. *Dreidel; Bronco Bill's Lament; If We Try; Narcissism; Birthday Song; The Pride Parade; The More You Pay (The More It's Worth); Falling Through Time; On the Amazon; Oh My What a Shame*. UNITED ARTISTS UAS 5651 \$5.98.

Performance: **Marvelous**
Recording: **Very good**

American Pie was no fluke, and Don McLean is a major writing and performing talent. His second United Artists album, "Don McLean," not only confirms that, but suggests still better things will issue. McLean gives you flashes of not-quite-harnessed brilliance that are pretty damned dazzling. A writ-

er tuned up on old-fashioned craftsmanship, he handles a wide variety of melodic and rhythmic ideas with ease and plays the English language like a pinball machine. Nor is there ever a lapse in his vocals; he's so well equipped, such a natural, that technique takes care of itself while he concentrates on the interpretation.

Bronco Bill's Lament, the plaint of a "singing" (turns out his vocals were dubbed) show-biz cowboy, is probably my favorite song, although it is difficult to single out only one. McLean brings in such helpers as a cello, a hammered dulcimer, a Motown chorus, and a tap dancer at times, and yet the arrangements are clean and forthright, his vocals and his acoustic guitar always up front as they should be. *On the Amazon*, a song I bet Nilsson wishes he wrote, illustrates McLean's fascination with language by kidding some of our five-dollar words, turning them into fearsome creatures in a Rousseau-type (or maybe a Robert Crumb-type) jungle. *Narcissism*



DON McLEAN
Not-quite-harnessed brilliance

has McLean rocking with style and humor, and *Oh My What a Shame* indicates he can Eleanor a Rigby with the best of them when it comes to cello pop. Drive your Chevy right on down to the record store: the music's still alive. N.C.

MELANIE: *Stoneground Words*. Melanie Safka (vocals and guitar); orchestra. *Together Alone; Summer Weaving; Do You Believe?; Here I Am; My Rainbow Race*; and five others. NEIGHBORHOOD NRS 47005 \$5.98. © 8151 47005 \$6.95, © 5151 47005 \$6.95.

Performance: **Sentimental**
Recording: **Typically lush**

Here's another trip to Sensitivity Land led by the mealy-mouthed Melanie, who probably has as large a personal following as, say, Neil Diamond. Melanie's lyrics are on the palpitatingly mauve level of a boarding-school girl's confidences to her diary. As an example, this is from *My Rainbow Race*: "One blue sky above us/One ocean, lapping all our shores/One earth so green and round/Who could ask for more?" In the matter of song writing, I certainly could. *Together Alone* is another example of Melanie's agonized Sensitivity. Her sentimentality permeates every-

thing like sachet, and it can blur even something like *Between the Road Signs*, a song about the arduousness of touring.

The trouble with Melanie's albums is that all of her heroines seem to be herself. On the other hand, she's a real pro, all right, and occasionally a hard, true edge surfaces. As an added treat the album features extremely lavish packaging, with five enormous color photos of Melanie in different stages of contemplative repose. P.R.

ETHEL MERMAN: *Merman Sings Merman* (see Best of the Month, page 81)

BETTE MIDLER: *The Divine Miss M*. Bette Midler (vocals); orchestra. *Superstar; Am I Blue; Friends; Hello in There; Delta Dawn*; and six others. ATLANTIC SD 7238 \$5.98. © TP 7238 \$6.98. © CS 7238 \$6.98.

Performance: **Overdone**
Recording: **Preentious**

Bette Midler is a biggie on the Old Camp Trail of the New York social scene. She dresses and makes up to look like a surreal Andrews Sister in a 1940's low-budget musical. In the beginning that was pretty much her act: parodies of songs and styles of that era. Now, with this recording, she is taking herself much more seriously. Excessively so—I haven't heard such an overproduced, overdramatized, overung album since Yma Sumac sent out her last bird calls. The bad news is that Miss Midler (who, regardless of the Warhol-style getups and the super-camp manner, is, I think, very serious about her profession) remains more an accurate parodist than an original entertainer. *Do You Want to Dance?* sounds enough like Peggy Lee for that lady to sue, and while *Daytime Hustler* undoubtedly projects excitement, it borrows almost everything from early Streisand. *Superstar* is a chunk of Lee-Franklin territory that runs over five minutes, which is two-and-a-half minutes too long. Midler comes closest to hitting her own stride on *Am I Blue*, again much too long—and I had to fight my own memories of Ethel Waters' classic recording of it—but still a strong and sensitive performance. However, by far my favorite track is the only one of her straight-on parodies, the Andrews Sisters' unlamented hit *The Boogie Woogie Bugle Boy*. It is very funny and very expert.

Nevertheless, the album as a whole is an example of precisely what camp is supposed to deflate and satirize: commercial and theatrical pretentiousness. But maybe things have come full-circle again. P.R.

RECORDING OF SPECIAL MERIT

JONI MITCHELL: *For the Roses*. Joni Mitchell (vocals, guitar, piano); Wilton Felder (bass); Tommy Scott (woodwinds, reeds); Russ Kunkel (drums); Graham Nash (harmonica). *Baranrigill; Lesson in Survival; Let the Wind Carry Me; For the Roses; You Turn Me On I'm a Radio; Blonde in the Bleachers*; and six others. ASYLUM SD 5057 \$5.98, © TP 5057 \$6.98, © CS 5057 \$6.98.

Performance: **Excellent**
Recording: **Very good**

The workout Joni Mitchell's psyche underwent to produce the radical growth album "Blue" has changed her. "For the Roses" has little of the old, easy-going country fluidity of *Both Sides Now*, nothing of instantly recognizable beauty like *Rainy Night House*, no

trace of the pristine bemusement of *Ladies of the Canyon*. Neither is it just another shade of "Blue." Some of the old art-song grace is here, some of the intricate insights, and also some of the pessimism and vulnerability that have crept up on her lately.

It is a *working* album. I had to listen to it five or six times to bank enough memories to follow the melodies easily. There's real beauty in them, and a fair amount of variety, but the beauty is not quite staggering enough, coming from Joni, and the variety will never be apparent to slow learners. The lyrics, as usual, are brilliantly written, but I wish she would graduate from the youth-cult imagery—a couple of these songs seem, and may be, addressed directly to ex-boyfriend James Taylor. The best songs, in my judgment, are *Woman of Heart and Mind*, *Cold Blue Steel* and *Sweet Fire, Banquet*, and *For the Roses*, in that order. Of course there are no really weak songs, but the one about the radio is not very strong.

The album takes a lot of listener energy. Its beauty is fragile, its toughness is all but hidden. It is transitional in some way. Be patient with it, and you will be rewarded. N.C.

RECORDING OF SPECIAL MERIT

THE MOODY BLUES: *Seventh Sojourn*. The Moody Blues (vocals and instrumentals). *New Horizons; You and Me; For My Lady*; and four others. THRESHOLD THS 7 \$5.98. Ⓜ M 24007 \$6.98, Ⓜ M 24807 \$6.98. Ⓞ M 24607 \$6.98.

Performance: **Excellent**
Recording: **Excellent**

This is one of the best Moody Blues albums so far. As usual, the instrumental work is lithe and responsive, and, also as usual, the performances have clarity and true musicianship. What makes this album stand out is the quality of the songs; almost without exception they are poetic without straining and convey a directness of communication that I haven't heard from the group before. The opening song, *Lost in a Lost World*, immediately sets the quietly reflective tone of what's going on here. Perhaps the best track is *Isn't Life Strange*, which conveys what seem to be deep personal feelings through an ironic and wistful lyric. The album ends with *I'm Just a Singer (in a Rock and Roll Band)*, which is saved from bleakness by the hopeful streak of optimism that runs all through this group's work. Tony Clarke's production is splendid, perfectly capturing the intimate atmosphere of a rap session between people of sense and sensitivity. This is a recording worthy of your full attention. P.R.

THE MOVE: *Split Ends* (see Best of the Month, page 83)

RECORDING OF SPECIAL MERIT

RICK NELSON: *Garden Party*. Rick Nelson (guitar and vocals); Stone Canyon Band. *Let It Bring You Along; Garden Party; So Long Mama; I Wanna Be with You; Are You Really Real?*; and five others. DECCA DL 7 5391 \$5.98, Ⓞ 6 5391 \$6.98, Ⓞ 73 5391 \$6.98.

Performance: **Honest**
Recording: **Very good**

I admire Rick Nelson for several reasons; he has bravely and consistently rejected a popular rock-and-roll past that he was probably un-

happy about even at the time it was taking place; he has studiously and conscientiously bettered himself as a musician; he has kept his own faith when almost everyone has consigned him to the dead letter office of rock fan mail; and with all this he grew to physical manhood and musical manhood and refused to compromise on either. For years he put out good products, and he has had the quiet patience to wait for the world to wake up and catch up with him.

It is heartening to see him cheered now for a single called *Garden Party*, which has to do with his appearance at a rock-and-roll revival concert where, along with his old hits, he attempted to present his manhood and his manly music—which the audience rejected. Yet *Garden Party* is gentle but firm, philosophical but intensely personal. The single was (is) a tremendous hit and the world is finally realizing that R. Nelson is going to do musical things on R. Nelson's own terms.



RICK NELSON

Fine musicianship, taste, and honesty

With all this, though, the question still remains: granted his moral fiber, maturity, and professional showbiz background, does Nelson have any real talent? If so, does he have enough to get excited about?

It is difficult to say. Nelson seems to have focused on his music as the proof of his life. He did not have to make that decision; his recording success in the Fifties and early Sixties was enough to put him into rock history, albeit minor rock history—and there are several performers who cling ferociously to their minor place in rock history as the proof of their life. Nelson could have invested his earnings in California real estate and lived a comfortable life thereafter. But he chose to go against everything that had made his name a household word, to expect and quietly demand recognition as his own man, on his own time, on his own talent. And that—as any performer knows—is always entirely subject to the whims of the public. If you are really good, it still may take years before you get any respect.

Well, Rick Nelson deserves the respect he has held out for. His new album is honest and pleasing; high marks for musicianship and taste go to all concerned. Nelson has also turned into a pretty good songwriter; *Palace*

Guard, the outstanding song on the album, and *A Flower Opens Gently By* are really impressive. He don't mess around, man. J.V.

NITZINGER. Nitzinger (vocals and instrumentals). *L.A. Texas Boy; Ticklelick; No Sun; Louisiana Cock Fight; Boogie Queen; Witness to the Truth; The Nature of Your Taste; My Last Good-Bye; Enigma; Hero of the War*. CAPITOL SMAS 11091 \$5.98, Ⓞ 8XT 11091 \$6.98, Ⓞ 4XT 11091 \$6.98.

Performance: **Promising**
Recording: **Good**

This is a very peppy rock trio with lead guitar, vocals, and songs by John Nitzinger, a sad-eyed girl named Linda Waring listed as "percussion section," and a bass player named Curly. The group sometimes veers toward clang-bang rock-and-roll, but always manages to snatch itself back in time. Nitzinger's solo guitar is youthfully energetic; he plays some nice riffs and figures and has some pleasant chord progressions (*Boogie Queen*). He also has some imagination as a songwriter: *Louisiana Cock Fight* is the best number on the album, followed by *Witness to the Truth*. His lyrics—at their best—are so good that I wish the melodies were better, but strong melodies aren't required in blues-based rock-and-roll (or, for that matter, blues). The group seems tight enough (Linda plays a swell "percussion section"), and since they are young, there is room and time for development. If Nitzinger can amplify his talent for descriptive lyrics (and drop the sappy stuff like *Hero of the War*) he will turn out something really fine. The group may be mistaken for Grand Funk Railroad, and may become enormously popular and rake in a lot of cash. If the latter, they should keep the cash. But I hope they defend their identity until they have it nailed down. J.V.

JACK NITZSCHE: *St. Giles Cripplegate*. London Symphony Orchestra, David Measham cond. Jack Nitzsche, composer and arranger. #6; #4 (for Mori); #2; #3; #1; #5. REPRIS MS 2092 \$5.98.

Performance: **Excellent**
Recording: **Excellent**

Jack Nitzsche had a happy habit of showing up at early/middle period Rolling Stones sessions, playing wonderful piano and an instrument known as "Nitzsche-phone." I don't know of him beyond that, but here he pops up with a semi-symphonic work, flawlessly played by the London Symphony Orchestra. It takes quite a bit from Stravinsky, as many contemporary composers do, have done, and will do. Some of it sounds like movie music; some of it practically demands that a dramatic voice say dramatic things over it (anyone from Sir Laurence Olivier to the Shadow will do). Some of it is impressive; some of it is padding and pudding. Reprise seems to be promoting the "symphonic sound" these days; maybe there's a carefully demographed or artistic reason behind it, or maybe the Burbank sun and smog is getting to the guys at the main office. But it can't hurt to hear this. I'm keeping my copy so I can ham up the "Ay, Edward will use women honorably" speech from *Richard III*, à la John Barrymore, over its portentous sounds. Anyway, congratulations, Jack Nitzsche. I'm not quite sure what you did, but you've done something. J.V.

(Continued on page 92)

STEREO REVIEW



Bill Wertz, VP of WQLR, checks the chronometer, as Dennis Weidler is poised to put the station on the air. Pat Dyszkiewicz and Eric Toll watch.

Stanton. Brings on the new.

A new Station, and a new sound hits the air in Kalamazoo, Michigan. WQLR STEREO starts serving the market in June, 1972 with all new equipment and new programming. Every cartridge on every tonearm at WQLR is a Stanton. Vice President, Bill Wertz states, "We chose Stanton because we were starting fresh and we needed to impress the community with the quality of our sound from the very first on-the-air minute. Naturally, the well-documented reliability of Stanton's 500 series cartridges helped influence our choice."



Artie Altro makes the WOR-FM sound, while Eric Small, Sebastian Stone and Promotion Director, Kim Olian look over a new album.

Radio stations all over the nation specify Stanton.

For on-the-air use, Stanton 500 series cartridges have the ability to withstand rugged handling without any lessening of audio quality. They meet all standards for reliability and sound quality. Stanton's Model 681EE cartridge is the choice of many stations for auditioning original recordings and making transfers. Its incredible low mass moving magnetic system (1/5 to 1/10 that of ordinary pickups) and its 10 Hz to 20,000 Hz response, contribute to its exceptional audio quality.



Engineer Brian Morgan of WDRC AM/FM, gets ready for on-air playback.

You can enjoy the professional audio quality of Stanton Products whether your purpose involves broadcasting or home entertainment.

Write today for further information to Stanton Magnetics Inc., Terminal Drive, Plainview, New York 11803.



Scott Muni, WNEW-FM, cues in on a new release.



All Stanton cartridges are designed for use with all two and four-channel matrix derived compatible systems.

THE OSMONDS: *Crazy Horses*. The Osmonds (vocals and instrumentals); orchestra. *Utah; Julie; Big Finish; Girl; Hold Her Tight; Hey, Mr. Taxi;* and six others. MGM SE 4851 \$5.98, Ⓢ 8130 4851 \$6.98, © 5130 4851 \$6.98.

Performance: ". . . with jelly, please"
Recording: **Good**

The release of a new Osmonds recording fills me with the same awe and wonder as the introduction of a new brand of peanut butter. When I was a child, peanut butter represented nirvana, paradise gained, and manna delivered. The last time I ate the stuff (by mistake) I damned near choked. So I guess I can understand, from a long distance, what the Osmonds mean to their preadolescent fans: their music is the ultimate peanut butter! That they are more clean-cut than Yul Brynner's pate, that they have a "Campbell's Kid" cuteness about them, and that they project an air of being credit-to-us-all young people—who wouldn't go beyond "petting" with my daughter—undoubtedly endear them to Mom and Dad. The Osmonds have it made, on several important levels, so why quibble? *P.R.*

SHAWN PHILLIPS: *Faces*. Shawn Phillips (vocals, guitar, sitar); orchestra. *Landscape; Chorale; We; Parisian Plight II;* and four others. A & M SP 4363 \$5.98.

Performance: **Self-indulgent**
Recording: **Orgiastic**

One seven-minute track here, 'L' *Ballade*, is noted as having been recorded at two studios from "September 1971 to April 1972." I believe it. If there were kitchen sinks at recording studios I'm sure Shawn Phillips would have thrown the sound of one of them in. Phillips still plays a fine guitar, though; that is, I think he does—it's hard to tell from these mammoth, Byzantine arrangements. His vocals are often buried too, but perhaps that isn't a bad idea. This is an album that is pretentious and dull almost beyond belief. *P.R.*

POCO: *A Good Feelin' to Know*. Poco (vocals and instrumentals). *And Settlin' Down; Ride the Country; I Can See Everything; Go and Say Goodbye; Keeper of the Fire; Early Times; A Good Feelin' to Know; Restrain; Sweet Lovin'.* Epic KE 31601 \$5.98, Ⓢ EA 31601 \$6.98, © ET 31601 \$6.98.

Performance: **Good**
Recording: **Very good**

Poco is a minor cult band; they may or may not be responsible for the situation they find themselves in, for sometimes the audience makes these things up out of the whole cloth. I tend to be wary, though, of a band that lives in its own world or lets the audience impose one on them. The result is, nearly always, that the music becomes more and more narrow in scope and pedantic in content.

Instrumentally Poco is good, especially in the guitar work, but the songwriting is unexceptional. It is very difficult to express simple things simply when you're going after a Big Statement on the joys of life, love, and Colorado (where most of the band lives). Their musical aspirations may aspire to Teton heights, but most of the songs here end up in the Grand Bland Canyon.

Another problem with Poco is stylistic intermarriage. Part of the band was once part of the Buffalo Springfield, which included Neil Young and Stephen Stills (he wrote one of the

songs on the album), who went on to form Crosby, Stills, Nash & Young and their endless offshoots. At times Poco sounds like all of them—even Graham Nash and David Crosby, who weren't in Buffalo Springfield in the first place. This kind of incestuous carrying-on drove even the Russian Czars crazy; maybe that's why Poco would rather be in Colorado. *J.V.*

RAMATAM. Ramatam (vocals and instrumentals). *Whiskey Place; Heart Song; Ask Brother Ask; What I Dream I Am; Wayso; Changing Days; Strange Place; Wild Like Wine; Can't Sit Still.* ATLANTIC SD 7236 \$5.98, Ⓢ TP 7236 \$6.98, © CS 7236 \$6.98.

Performance: **Forget it**
Recording: **Good**

Many many grunts and screams here, signifying nothing. A lot of ten-lessons-and-you're-a-star guitar licks with the volume turned 'way,



HELEN REDDY
Friedan-Steinem-Millett heartwarmer

'way up. Plus some phony jazz flute solos, plus mediocre material, plus a lot of heavy breathing. Plus a lot of finger-popping guff. So many pluses equal minus.

Don't worry. Every label has a group like this. The reasons for their getting a record out are mostly political: i.e., if manager X once brought you a hit group (which has since left manager X), you as the label must make nice on manager X and record that manager's new, clumpy group just to fulfill your contractual obligations. Or maybe you're sentimental. Or maybe you really think you've got a hit on your hands.

All these considerations should be the problems of record companies, not of listeners and buyers. Let everybody take care of their own problems and not foist them on someone else. *J.V.*

KENNY RANKIN: *Like a Seed*. Kenny Rankin (vocals and guitar); orchestra. *Peaceful; Earthheart; I Was Born; Sometimes; Stringman;* and six others. LITTLE DAVID LD 1003 \$5.98.

Performance: **Sincere but ragged**
Recording: **Good**

This album often sounds as if it were recorded

during an encounter-group session, except that someone misplaced the group. All of the songs are by Kenny and Yvonne Rankin, and more often than not they deal with problems of the drug culture. A patent sincerity of purpose characterizes such things as *Comin' Down* and *Bad Times Make You Strong*, but Rankin's reedy vocals and barely adequate guitar playing don't make the best of them as songs. Nothing much ever seems to happen, musically or emotionally. Perhaps I wasn't truly tuned in on what's going on here; perhaps others could extract more from it. The whole effort struck me as depressing. *P.R.*

RASPBERRIES: *Fresh*. Raspberries (vocals and instrumentals). *I Wanna Be with You; Gain' Nowhere Tonight; Let's Pretend; Every Way I Can; I Reach for the Light;* and five others. CAPITOL ST 11123 \$5.98, Ⓢ 8XT 11123 \$6.98, © 4XT 11123 \$6.98.

Performance: **Time-warped**
Recording: **Good**

It is one thing to have a top-forty, teenage supercommercial hit single like *I Wanna Be with You* and follow it up with an album containing the single. But the Raspberries get to be quite another thing: their music sounds very much like the early Beatles; they wear band uniforms vaguely reminiscent of the lapel-less jackets JPG&R used to wear; they record for the same label; there are four in the group, one each for the girls to pick and adore for their own special appeal. And I am suddenly getting the feeling it is 1963.

The music here is pleasant and harmless, well done and well produced, and no messing about with any of that Art nonsense. Repeated playings of the album and intense staring at the album jacket is liable to convince foolish old men like myself that the generation who were microboppers when the Beatles first appeared have now passed puberty and are determined to bring rock-and-roll back to its senses. If this is a turn of the wheel of life, it is reassuring. It is also a bit scary. I don't want to go back. *J.V.*

HELEN REDDY: *I Am Woman*. Helen Reddy (vocals); orchestra. *Where Is My Friend; The Last Blues Song; I Am Woman; Hit the Road Jack;* and six others. CAPITOL ST 11068 \$5.98, Ⓢ 8XT 11068 \$6.98, © 4XT 11068 \$6.98.

Performance: **Good**
Recording: **Good**

Helen Reddy has made a big splash with the title song here, and with the help of her husband-manager she has managed to parlay its success into a number of TV shots and magazine interviews. It is a song that must warm the cockles of the Friedan-Steinem-Millett Axis' hearts. "I am woman, hear me roar/In numbers too big to ignore./And I know too much to go back to pretend/'Cause I've heard it all before/And I've been down there on the floor./No one's ever gonna keep me down again." Contrary to the lyric, Ms. Reddy doesn't roar when she sings; she sounds like a sedate cross between Anne Murray and Lana Cantrell. She is backed up by a wailing chorus, which repeats after her such ominous phrases as "I am strong, I am invincible." As a Women's Lib anthem, I suppose, this song will do as well as any, and since I am in sympathy with practically all the movement's aims I don't mean that as a put-down.

(Continued on page 94)



I sell them all... these are the best!

That's what knowledgeable stereo dealers everywhere are saying.

Because AKAI offers everything in stereo cassette recorders—GX (Glass and Crystal Ferrite) Heads... Dolby®... ADRS*... Invert-O-Matic... *Everything!*

And you can select from a complete range of models. So you get *exactly* what you want.

Take AKAI's GXC-36D Stereo Cassette Tape Deck. It's superbly engineered with an exclusive GX Head. For wear-free performance. Plus Pause Control... Tape Selector Switch... Induction Motor... and Automatic Stop.

If that sounds good, but you want to add Dolby®, you'll find it in the GXC-38D. Great features, huh? But we went one

giant step further and combined them all in the GXC-46D with AKAI's exclusive ADRS* which eliminates *almost all* high frequency distortion above 8000Hz. (Nobody has it but us!) Then we added a unique Over-Level Switch for high volume recording.

For the ultimate in stereo cassette performance there's the GXC-65D. You'll find *all* the features found in our GXC series plus Invert-O-Matic for automatic repeat/reverse. And the Invert-O-Matic mechanism is unconditionally guaranteed for two years—parts and labor.

Stop wondering where to go to find the cassette recorder that's perfect for you. It's at your AKAI dealer.

"Dolby" is a Trade Mark of Dolby Laboratories, Inc.
*Automatic Distortion Reduction System

AKAI™

AKAI America, Ltd./P. O. Box 55055, Los Angeles, California 90055

CIRCLE NO. 3 ON READER SERVICE CARD

The remainder of the album is fairly mild stuff, with only *The Last Blues Song* approaching anything that could be called musical excitement. P.R.

MALVINA REYNOLDS: *Malvina*. Malvina Reynolds (vocals and guitar); orchestra. *Little Boxes; The Albatross; No Room; The Money Crop; Green Shadows*; and seven others. CASSANDRA CFS 2807 \$5.98 (available in stores and from Cassandra Records, 2027 Parker St., Berkeley, Cal. 94704).

Performance: **Sincere**
Recording: **Good**

Malvina Reynolds will soon be seventy-three years old, but she shows no signs of diminishing her recording activity or of limiting her personal appearances. She began to write songs twenty-five years ago as a result of her friendship with Woody Guthrie and Pete Seeger and Alan Lomax, and at least two of her songs, *Little Boxes* and *Turn Around*, can safely be called modern classics. Although firmly committed to many of the same causes as militant youth (or at least so some might label her), her songs and performances all possess a gentle and translucent wisdom. How good it is to listen to someone who has lived all those years and still seems eager to learn and equally eager to pass on what she has learned, who still has the courage to fight but sees living as a positive engagement, who most of all speaks to people in human and understandable terms without patronization or hypocrisy. I'm afraid that I can't really recommend the album as entertainment, since Malvina's voice is by now a wavery shadow.

But as a document of a human being who dignifies the meaning of existence, it is simply superb. P.R.

HARRY RICHMAN AND SOPHIE TUCKER: *His Broadway and Hers. Your Broadway and My Broadway; Broken-Hearted Clown; You're What's the Matter with Me; They All Laughed; Weep and You Dance Alone; Pennies from Heaven*. Harry Richman (vocals); instrumental accompaniment. *Conversational Man; There's a Blue Ridge 'Round My Heart; If You Can't Sing It You'll Have to Swing It; Foolin' with the Other Woman's Man; I Know that My Baby is Cheatin' on Me; Is He My Boy Friend?* Sophie Tucker (vocals); instrumental accompaniment. MONMOUTH-EVERGREEN MES 7048 \$5.98.

Performance: **Restrained**
Recording: **Good**

When Harry Richman died last November at the age of seventy-seven, a *New York Times* obituary reported that during his last days he sometimes complained that other comedians were paid more to imitate him than he was able to earn himself. But Richman, with his top hat, his dinner jacket, his cane, and his minstrel strut, was eminently imitable. He sounded, much of the time, as though he himself were imitating Ted Lewis ("Is everybody happy?") or Al Jolson. His life was in some ways more entertaining than his act, and he was a press agent's dream. And so was Sophie Tucker (1884-1966), who could bring down the house just by sailing on stage, stout as a brigantine, swathed in white furs over a gown encrusted with jewels. Both of them fought

their way to success in a manner dear to those movie biographies about show business: starting in vaudeville, working up to revue and musical comedy and on to international nightclub appearances.

This album is a worthy memoir of them. It is just as well that they have been relegated to separate sides, for in 1954 Sophie, who up to then had been "Mom" to Harry, made the mistake of interrupting one of his numbers and they never spoke again. The collection finds them both in almost disappointingly restrained moods, perhaps because the recording sessions were done in the inhibiting atmosphere of British studios. Mr. Richman sings songs by people like Arthur Freed and Nacio Herb Brown about Broadway, half-speaks his way through *Weep and You Dance Alone*, tosses in a line from Al Jolson's personal hit *April Showers* to dress up *Pennies from Heaven*, and appropriates *They All Laughed at Christopher Columbus* from the Fred Astaire collection with something—for Richman—suspiciously resembling understatement. He doesn't sing his own hit *Laugh Clown Laugh*, but substitutes another tear-jerker on the topic, *Broken-Hearted Clown*, which gives him a chance to spread a little of the homely philosophy that was essential to his corniest routines. Miss Tucker doesn't sing *Some of These Days*, either (or any of the other songs that were her trademarks), but she does dispense generous quantities of advice to her "girls," along with sardonic dissertations on male potency and the lack of it, in *Conversational Man*, *I Know that My Baby is Cheatin' on Me*, and *Foolin' with the Other Woman's Man*.

Sony's Ferrite and Ferrite recording heads let you record all of the baritone flute. All of the tenor sax. That's because this unique Sony development controls the width of the gap over which your tape passes during recording to the exact tolerance necessary for truly fine sound reproduction. When you record with Sony quality engineered Ferrite and Ferrite heads, your playbacks have all the high and low frequencies of the original sound.

What's more Sony's Ferrite and Ferrite heads are cleaner, stronger and more durable than ordinary heads. The edges of Sony's Ferrite and Ferrite heads are virtually chip resistant. No pits and cracks to distort the sound and collect dust. And Sony's Ferrite and Ferrite heads reduce eddy-current losses to the very minimum.

Experience the performance breakthrough of Sony's Ferrite and Ferrite head tape recorders with exclusive closed-loop dual capstan tape drive system in both reel-to-reel

Don't lose your



Mr. Richman's songs cover the years 1936 to 1938; Miss Tucker is heard over a bit longer a stretch of her career's trajectory, from 1929 to 1934. The recordings must have been good, clean ones in the first place, and the dubbings are satisfactory. *P.K.*

ROWAN BROTHERS. Christopher Rowan (vocals, guitars, piano); Lorin Rowan (vocals, guitars, mandolin); David Diadem (mandolin, keyboards); Bill Wolf (bass, synthesizer); John Douglas (drums). *Hickory Day; All Together; The Best You Can; One More Time; Lay Me Down; The Wizard; Gold; Move on Down;* and four others. COLUMBIA KC 31297 \$5.98. © CA 31297 \$6.98. © CT 31297 \$6.98.

Performance: **Good detail**
Recording: **Excellent**

There's quality workmanship here—not so much as a flicker of genius, but solid workmanship. Lorin and Christopher Rowan, who play both kinds of guitar and other things, don't stick to the straight and narrow (and clearly marked) path that, say, Brewer and Shipley tread. The sound is a sort of futuristic projection of the folk-rock merger—a conglomerate. It's hard to make much sense of it sometimes, just as it's difficult to make sense of ITT sometimes, but all the activity does keep me curious. The production, by two of the players, Bill Wolf and David Diadem, is choice, quality stuff, resulting in such neat effects as the delicate balances between acoustic guitar and organ and between multiple vocal dubs, bass, and strings. Cassette owners will miss one of the slicker tidbits, a locked

and recycling "Mbwa-ha-ha-ha-ha" laugh groove at the very end of side one; it could play forever on a manual turntable.

The songs? Well, you won't wake up in the middle of the night haunted by them, but neither would they embarrass you if Brian Wilson and Van Dyke Parks should drop in while you're listening. My favorite, *Love Will Conquer*, doesn't do much in itself, but on a secondary level it allows for some zonky acoustic guitar chords. A good first effort. *N.C.*

ROXY MUSIC. Roxy Music (vocals and instrumentals). *Re-Make/Re-Model; Ladytron; If There Is Something; Virginia Plain; 2 H.B.; The Bob (Medley);* and four others. REPRISE MS 2114 \$5.98.

Performance: **Yeah, yeah, we know**
Recording: **Good**

Roxy Music is supposed to be killing 'em in England, where I presume they share top honors with the plodding boogie and mincing vocals of T. Rex. Kee-ripes! Remember when England sent us *good music*?

Visually, Roxy Music apes Sha-Na-Na, with greased D.A. haircuts and leopard-skin lapels on their jackets. Aurally, they combine standard rock with wonks, tweets, and snickers on a variety of instruments, à la Pink Floyd, topped off with deliberately overdone vocals featuring an out-of-control vibrato. It sounds as though the singer, when going for a high note, clutches his privates and gives them a twenty-degree turn to the left. *J.V.*

SANTANA: *Caravanserai.* Santana (vocals and instrumentals). *Eternal Caravan of Rein-*

carnation; Waves Within; Look Up (to See What's Coming Down); Just in Time to See the Sun; Song of the Wind; and five others. COLUMBIA KC 31610 \$5.98. © CA 31610 \$6.98. © CT 31610 \$6.98.

Performance: **Boring**
Recording: **Good**

I'm sorry, folks. I just can't take Santana seriously. To me they are to rock-and-Latin as Herb Alpert was to jazz-and-Latin.

Santana's latest album is all about Eastern spiritual philosophy, the kind peddled by a string of giggly gurus over the last ten years (actually, it goes back to *The Prophet* by Khalil Gibran). Santana's musical treatment of his discovery of spiritual discovery—which he apparently discovered through something called the Self Realization Fellowship (whatever happened to the Baptists?)—is full of the direst pomposity. It's the same old Santana story: rattle-boom stuff on the percussion, meandering vocals, and an endless guitar solo which is like all the others he's played.

The opening selection, *Endless Caravan of Reincarnation* (the title should warn you), begins with almost a minute of chirping crickets followed by saxophone honkings that sound as if the saxophonist is trying to take the instrument apart and play it at the same time. Things go downhill from there. The cover illustration shows a caravan at sunset (or is it sunrise?). I can hear one camel driver saying to another: "I wish that Self-Realization guy would stop following us. He's making my camel nervous." *J.V.*

(Continued on next page)

©1973 Superscope, Inc., 8146 Vineland Ave., Sun Valley, Calif. 91352. Prices and models subject to change without notice. Send for free catalog.

flute in the gap!

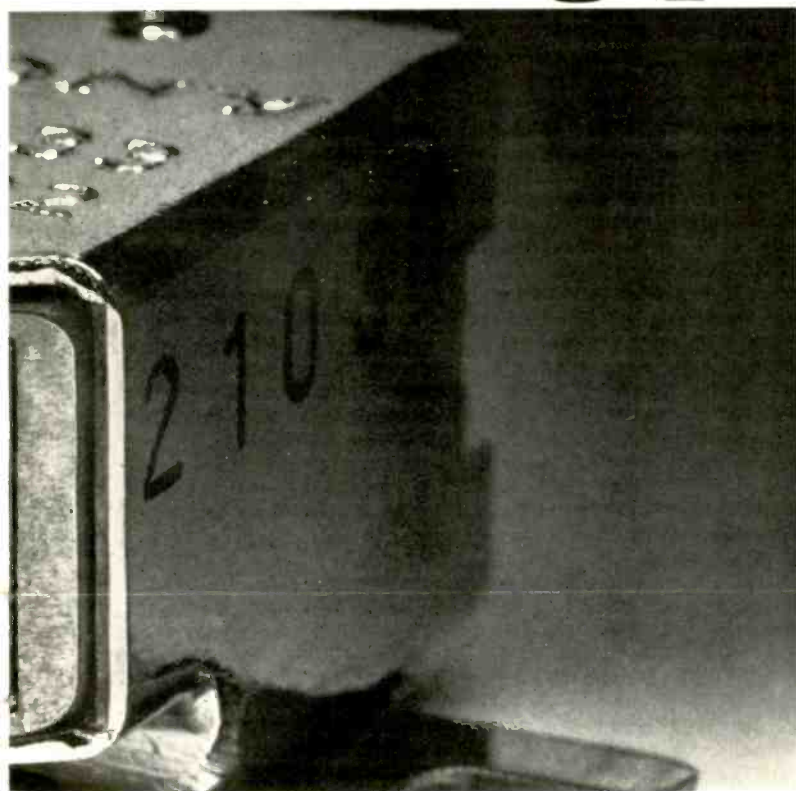

and cassette deck models. In reel-to-reel choose either the TC-280 at \$199.95 or the TC-377 at \$299.95. If a stereo cassette deck is what you're looking for, there's the TC-134 at \$239.95 or the TC-161SD at just \$299.95. Get the clear crisp sound of Sony with Ferrite and Ferrite in the model that best meets your recording needs. They're just part of a full line of superior Sony recording equipment starting as low as \$99.95 at your nearest Sony/Superscope dealer. He's in the yellow pages.



Sony Tape Recorders
A Product from **SUPERSCOPE**

BOZ SCAGGS: *My Time*. Boz Scaggs (vocals, guitar); instrumental accompaniment. *Dinah Flo; Slowly in the West; Full-Lock Power Slide; Old Time Lovin'; Might Have to Cry; Hello My Lover; Freedom for the Stallion; He's a Fool for You; We're Gonna Roll; My Time*. COLUMBIA KC 31384 \$5.98, © CA 31384 \$6.98, © CT 31384 \$6.98.

Performance: **Good**
Recording: **Good**

Boz Scaggs is one of those late-night rockers who sing better than most people realize. He also leads a tight band—no matter who its members are. This album was recorded in two different studios, with different backing groups at each, but distinctions tend to blur in the mellow, after-midnight ambiance Scaggs creates. His best work here is in *Slowly in the West*, recorded at Muscle Shoals, and *Old Time Lovin'*, recorded in San Francisco (the cassette version has *Freedom for the Stallion* sandwiched between those two, and it doesn't work as well as the harder *Full-Lock Power Slide*, which appears in that slot on the disc). But these cuts are only slightly more noticeable than several others. The album's problem, in fact, is that it lacks contrasts, and that's no doubt related to Scaggs' tendency to integrate the hell out of everything—his vocals often seem to exist because the arrangement needs a vocal track, not because the words need to be heard; his guitar (well played) is generally heard neither more nor less than any other instrument. Everything is appealing and mellow, but there must be a way of preserving these qualities and sneaking in an occasional eye-opener too. *N.C.*

RECORDING OF SPECIAL MERIT

THE SECTION: *The Section*. Craig Doerge (keyboards); Danny Kortchmar (guitar); Russ Kunkel (drums); Lee Sklar (bass). *Second; Holy Frijoles; Swan Song; Zippo Dippo*; and six others. WARNER BROS. 0598 \$5.98.

Performance: **Excellent**
Recording: **Excellent**

The Section is a group of musicians who have specialized in being "session musicians," which means they are called upon to back up or augment other artists (primarily James Taylor and Jackson Browne) in recording sessions. But here they are striking out on their own, and their album is a delight: sophisticated, light, and deftly expert. Their playing is individually distinguished and collectively superb. Essentially it is mood music—on an extremely high level. They toy with a jazz technique but actually create something quite apart from it. The album is easy listening, in the best sense, and it is meticulously and beautifully engineered. *P.R.*

BOB SEGER: *Smokin' O.P.'s*. Bob Seger (vocals, guitar, piano); Skip "Van Winkle" Knappe (organ, piano); David Teegarden (drums); Michael Bruce (guitar); other musicians. *Bo Diddley; Love the One You're With; If I Were a Carpenter; Hummin' Bird; Let It Rock*; and four others. PALLADIUM MS 2109 \$4.98, © M8 2109 \$6.95, © M5 2109 \$6.95.

Performance: **Tired**
Recording: **Good**

Bob Seger—as Dave Marsh says in the reprint of a *Creem* article that appears here instead of liner notes—has been a fabulous success in Detroit and a flop most other places;

Marsh says (as of May 1972) that Seger has never had a record played on the radio in New York, San Francisco, or Los Angeles. Reading Marsh's article and then listening to this disc might convince you that Detroit's taste is hopelessly warped—but that would be playing leapfrog with logic. It will prove to be the case only if Detroit likes *this* Seger album. Seger wrote only two of the songs, the excellent *Someday* and the old, tired, childish *Heavy Music* (ironically about radio's role in pop), and he does lame, distracted interpretations of overrecorded biggies and not-so-biggies to fill it out. It was, you learn from reading the article, an interim album, made when Seger was in the process of separating from Teegarden and "Van Winkle" to form yet another band of his own. Aside from *Someday* and some good moments with Leon Russell's *Hummin' Bird*, this album only suggests what Seger can do. Right, Detroit? *N.C.*

SILVERBIRD: *Getting Together*. Silverbird (vocals and instrumentals); orchestra. *Getting*



THE SECTION
Light, sophisticated, deftly expert

Together; You're Too Young; The Summer's Gone; Meet Me After School; She's Gone; Always by My Side; Gotta Get Crackin'; and four others. COLUMBIA KC 31570 \$5.98.

Performance: **High-school**
Recording: **Very good**

A long time ago, Stan Freberg lampooned early rock-and-roll by playing the part of a record producer who stood behind a talentless but ambitious kid and prompted him—with a sharp stick, to help him get the high notes—to sing the word "High-school!" over and over. Maybe Silverbird's producer took his cue from this, I don't know. But take a look at the titles above, and you can imagine what the lyrics are like (I guarantee you'll be one hundred per cent accurate). Still, if the Partridge Family and Donny Osmond (and Bobby Sherman, who's older than I am, for chrissake) can get away with it, I don't see why Silverbird can't too. They've written some catchy tunes to go with those lyrics, and their voices blend pleasantly. And they look like a nice, safe family—they're a bunch of fathers, mothers, brothers, cousins, and so forth from New Mexico. So sail on, Silverbird! Sail through the window of the Choklit Shop and into the hearts of Archie and Veronica and

the rest of Young America. Myself, I gotta get outa here before I go bonkers. *N.C.*

SILVERHEAD: *Silverhead* (vocals and instrumentals). *Underneath the Light; Ace Supreme; Wounded Heart; Silver Boogie; In Your Eyes*; and five others. SIGNPOST SP 8407 \$5.98, © TP 8407 \$6.98, © CS 8407 \$6.98.

Performance: **Min. entertainment, Max Factor**
Recording: **Fair**

Even before Kubrick stuck that false eyelash on Malcolm MacDowell in *Clockwork Orange*, English and American rock musicians had been going to strenuous lengths to outdo each other at being kinky, particularly in the matter of makeup. Mick Jagger, on his last tour, looked like your Avon Lady on a heavy speed trip; David Bowie stalks around androgynously and could be mistaken for Lauren Bacall with a hangover; our very own Alice Cooper is intent upon creating the image of a fifty-year-old hooker with an unsuccessful home permanent working her beat in an Edsel convertible. Silverhead is the newest addition to the androgyne line. "Pinhead" might be a more accurate name when it comes to the entertainment they provide. The album is a bore, from the campy cover photo of Michael Des Barres, the lead vocalist (he can't sing), to the songs, which are below reproach, to the musicianship of the group, which I imagine is something like what you would expect of Ronald Reagan playing the clavichord.

It seems you can't open a closet door these days without someone jumping out. But, please, let us not confuse sexual abnormality, if that's what it is, with talent. *P.R.*

NANCY SINATRA: *Woman*. Nancy Sinatra (vocals); orchestra. *One More Time; Flowers; We Can Make It; I Call It Love; Kind of a Woman*; and five others. RCA LSP 4774 \$5.98.

Performance: **Good**
Recording: **Excellent**

It must take extraordinary strength of character and determination to withstand the critical trouncing that Nancy Sinatra has taken over the years, both from people in her profession and from reviewers. Unfortunately, if those qualities are there, and I think they are, they aren't very apparent in this album. It is so calculated, so super-smooth, so lush, and in some odd way so unreal that it might as well be a page from *Vogue*. The recording is immaculately produced, and Miss Sinatra sounds her studied best on every track. She has a pleasant, unremarkable voice, and she sings a lot of pleasant, unremarkable songs. Only once does she loosen up, on *There's a Party Goin' On*, a rowdy c-&-w song in which she projects an amusing, ironic detachment. It shows that there is a sense of humor buried underneath all the gloss, and I wish that she would display it more often. *P.R.*

SPIRIT: *The Family that Plays Together*. Spirit (vocals and instrumentals). *I Got a Line on You; It Shall Be; Poor Richard; Silky Sam; Drunkard; Darlin' If; Jewish*; and four others. EPIC KE 31461 \$5.98, © EA 31461 \$6.98, © ET 31461 \$6.98.

Performance: **Dependable**
Recording: **Excellent**

Spirit is a Los Angeles band that does every-

thing reasonably well and keeps knocking on the door with one song after another that's almost good enough. It may not be anyone's favorite band (a statement almost sure to get us up to our watch fobs in letters), but it is capable of surviving as long as rock survives, or longer, because it doesn't seem likely to make any enemies. Spirit can rock hard, turn gentle, mouth pretentious lyrics with as straight a face as anybody—but it doesn't trick its audience. It sticks to the basics. *Darlin' If* by Randy California is my favorite cut here, but several others can provide your essential, run-of-the-mill good time and your basic, garden-variety jollies. *N.C.*

T. REX: *The Slider*. Marc Bolan (guitar, vocals), Mickey Finn (percussion, vocals), Steve Currie (bass), Bill Legend (drums). Howard Kaylan and Mark Volman (backing vocals). *Metal Guru; Mystic Lady; Rock On; The Slider; Baby Boomerang; Spaceball Ricochet; Buick Mackane*; and six others. RE-PRICE MS 2095 \$5.98.

Performance: **Lisp! leer!**
Recording: **Okay**

Ah, there's good news in Burbank, for Reprise Records has gotten another master tape from England, and can release another T. Rex album which will sell simply oodles of copies. The little teenies who buy David Cassidy records enter a new dimension when they buy a T. Rex record, for huggy-kissy Marc Bolan peddles that old walla-walla stuff (sex!). Complete with a sibilant "s." We lucky folk who have passed through puberty (God knows it's a lot more fun relaxing comfortably in mid-stream than unsurely plunging in)—well, we kinda hafta laugh. Like their audience, T. Rex seems to think they have invented sex and/or the sexy rock-and-roll record. My dears, my dears, it's all been done before, and so long ago (I well remember that night in 1956, when, with *Susie Q.* coming over the car radio, I lunged for . . . oh, well). Backing vocals on this record are supplied by those rock-and-roll yuksters, Mark Volman and Howard Kaylan, formerly of the Turtles and Frank Zappa. Perhaps I have missed the Social Significance of this and all past (and future) T. Rex albums. Perhaps . . . yes, it's coming! . . . perhaps it's a colossal joke. Jackboot English rock meets Southern California slow-motion fingerpop. But who's the joke on? *J.V.*

ALLEN TOUSSAINT: *Life, Love and Faith*. Allen Toussaint (piano, vocals, guitar); instrumental accompaniment. *Victims of the Darkness; Am I Expecting Too Much?; My Baby Is the Real Thing; Goin' Down; She Once Belonged to Me; Soul Sister*; and six others. WARNER BROS. MS 2062 \$5.98.

Performance: **Disappointing**
Recording: **Good**

Allen Toussaint is one of the shapers, shakers, and movers of the New Orleans Sound, that wonderful musical melting pot that flourished on its own for more than twenty years and has recently, sadly, thrown itself away by moving out of the city and into the sunny, lobotomized climes of Burbank, California, and points (shudder) East.

Toussaint wrote, produced, arranged, and played on a long list of hits by many artists, most of whom recorded in New Orleans. He is a partner of Marshall Sehorn, a rotund, bewhiskered, "double Jack Black" (Johnnie

Walker Black Label) drinking man who thinks, quite rightly, that Allen Toussaint is a major talent. I've never met Toussaint, but I have met Sehorn, and his enthusiasm is genuine. So is mine.

That's why I'm disappointed with this album. I think Toussaint's real genius applies itself almost everywhere except to his performing. He's not bad; he just doesn't move me. The whole album could be sent out as a music publisher's promo record to get other artists to cut Toussaint's songs. Maybe that's the rationale behind this record. I say again and again that Toussaint is a brilliant songwriter, arranger, pianist, and producer, but it just doesn't come through here. More discouraging, he seems to be utilizing other people's styles; *Am I Expecting Too Much* could as

easily have been written by a Motown hack, even down to its Junior Walker-sounding sax. It could be renamed: *Mr. Gordy, Why Don't You Give Me a Call?*

More distressing is that this album was cut in New Orleans, using the Meters (for whom Toussaint and Sehorn produced a string of delightfully funky singles) as a rhythm section, much as Stax/Volt used to use Booker T. & the MG's as their house rhythm section—and believe it or not, the album *still* falls flat. *J.V.*

RECORDING OF SPECIAL MERIT

MAE WEST: *Great Balls of Fire*. Mae West (vocals); Mike Curb Congregation (chorus); Hot Rockers Orchestra. *Great Balls of Fire*;



The difference between 400 watts and 100 watts is more than 300 watts.

This is the New Math suggested by the Phase Linear 400 watt RMS Direct Coupled Stereo Power Amplifier. The difference is dramatic — and it's in the listening. You might be startled to hear your stereo deliver the life-size sound of a musical instrument for instance, free from clipping and distortion.

In this regard Julian Hirsch said in *Stereo Review*, "The Phase Linear. . . was in a class by itself." Hear the 400 at your dealers now—it makes a powerful difference. Price \$499.00

Phase Linear
CORPORATION
405 Howell Way
Edmonds, Washington 98020
206-774-3571

CIRCLE NO. 36 ON READER SERVICE CARD

Men: The Naked Ape; The Grizzly Bear; Whole Lotta Shakin' Goin' On; and five others. MGM SE 4869 \$5.98.

Performance: **Feast**
Recording: **Good**

Now past eighty, Mae West seems to have no intention of relinquishing her role as the mighty mistress of sexual travesty. I don't know how she does it, but she still has no rival in sight. And now she turns her sexy, satirical attention to the world of rock. Until this lady commands you to "light my fire," you simply can't imagine what such an invitation can suggest. Even more devastatingly urgent is her insistence in *Great Balls of Fire* to "Come on baby—drive me crazy." She uses primitive animal noises to great effect; rouses a helpless and apparently impotent history professor to incredible amatory feats; confides that she likes men "in all colors" as well as "straight or on the rocks"; advises some escort or other to "blow out the candles, big boy, or I'll do it for you."

By the time she tackled *Rock Around the Clock* I feared for the chastity of every transistor in my hi-fi system. Then there's *Whole Lotta Shakin' Goin' On*, a title that exaggerates the situation not at all, and a remarkable ballad in which the heroine, on an unscheduled appearance in the halls of the United Nations, turns into a kind of female Kissing and single-handedly achieves world peace in the course of one brief but exhausting international session. Accompanied by an orchestra called the Hot Rockers and that devout chorus called the Mike Curb Congregation, Miss West is every bit as irresistible as she claims to be, as well as ageless—indeed, for all I know, she may very well be immortal.

P.K.

YES: Close to the Edge. Yes (vocals and instrumentals). *Close to the Edge; And You and I; Siberian Khairu.* ATLANTIC SD7244 \$5.98. © TP 7244 \$6.98. © CS 7244 \$6.98.

Performance: **Close**
Recording: **Fine**

Yes is a good rock band, but it may yet be done in by its own ambition. The band's strength is in conventional but solidly based instrumentals and better-than-average vocal arrangements, but such an undertaking as this album calls, first of all, for writers—and Yes is not exactly a hotbed of poets.

The album contains three long songs, each consisting of several "sub-songs" that not only relate to the central theme but refer to each other. The longest, *Close to the Edge*, is musically inept, rambling, and boring, the sort of cant that confuses obscurity with significance. The brightest spot is the "I Get Up I Get Down" segment—a full-fledged song in the usual sense of the word, but also the bridge for the sub-songs of the larger piece—and it is the only place where any real hard-eyed editing has been done on either lyrics or music. Most of the remainder could have been made up on the spot by your average street poet and a band that could jam. *And You and I* has some of these excesses, but is somewhat more musical than the title tune, and the arrangement is also a little more musical. Through it all, Jon Anderson's vocals are better than average and the instruments, especially Steve Howe's guitars, are well played. The album jacket, by Roger Dean, is very neat indeed. Yes has taste and talent; let us hope it becomes a harsher self-critic. N.C.



SAVINA CATTIVA: Savina and All That Gentle Jazz. Savina Cattiva (vocals): Nat Pierce, Don Abney, Hank Jones, and Mal Waldron (piano); Joe Wilder (trumpet); Jimmy Scara (saxophone, flute); Vince Nerlino (vibes); Mike Nerlino (clarinet, saxophone, celeste); Mundell Lowe, Jimmy Raney, and Barry Galbraith (guitar); George Duvivier, Addison Farmer, Oscar Pettiford, Wilbur Ware, and Milt Hinton (bass); Kenny Clarke, Bobby Donaldson, Max Roach, Ed Shaughnessy, and Osie Johnson (drums). *The Man I Love; In My Solitude; It Don't Mean a Thing; Can't We Be Friends; You Go to My Head; Body and Soul; Too Marvelous for Words; I Cover the Waterfront; Mood Indigo.* RAVE LPS 502 \$4.98.

Performance: **An outrage**
Recording: **Transparent**

From producer Alan Hartwell's notes:

"She sings jazz more warmly, more wisely, and perhaps more wonderfully than anyone ever has. . . . Along with Ella Fitzgerald, Sarah Vaughn [sic] and especially Billie Holiday, this album solidly establishes Savina as one of the most innovative and captivating jazz singers of all time. . . . The relationship between the musicians and Savina was almost spiritual or magical—the interplay between them was unbelievable—they just borrowed from each other picking up on each other's vibrations and laying down a solid groove on each number."

I don't believe this record. In fact, it is a lie from beginning to end. The truth is that echo-chambered Savina sings like a wet face towel which, if wrung, would not produce a drop to compare with the worst of Billie in those final, stumbling months. As for the rapport between singer and musicians, it is indeed magical, for Ms. Cattiva and three hopelessly amateurish musicians (Jimmy Scara, Vince Nerlino, and Mike Nerlino) are accompanied by Music Minus One records, which were made in the late Fifties! The whole album is a consumer fraud: bassists Addison Farmer and Oscar Pettiford and drummer Osie Johnson are not given credit ("artist's name may not be used," says the cover), but they happen to be the three accompanying artists who are no longer living, and their names would reveal the age of the accompaniment; Milt Hinton is listed as "Milt Hamilton," etc.

I don't know if Music Minus One consented to the use of their recordings, or whether any of the fine musicians involved were asked for their permission to be used as part of this hoax, but they have been done a great injustice. I truly hope no one buys this album. C.A.

RECORDING OF SPECIAL MERIT

LARRY CORYELL: Offering. Larry Coryell (guitar); Steve Marcus (soprano sax); Mike

Mandel (piano); Mervin Bronson (bass); Harry Wilkerson (drums). *Foreplay; Ruminations; Scotland; Offering; The Meditation of November 8th; Beggar's Chant.* VANGUARD VSD 79319 \$5.98.

Performance: **The best**
Recording: **Excellent**

For some years now Larry Coryell has stood at the top of his profession. He deserves it. He is the most consistently inventive and interesting instrumentalist in pop, and his new album might just be one of the Brandenburg Concertos of its day. The amount of sheer music produced by Coryell and his group is, and in any time would be, astonishing. Coryell doesn't just play the guitar, he seems to *be* the guitar. In album after album he has expanded the possibilities, often beyond probability, of the instrument itself. His always incredible control of the moment and his out-front intelligence have made his recordings a credit to the entire pop scene. He's into several new things here. I probably got only about half, but *Foreplay* has got to be the essential Coryell: fastidious, but never fussy, musicianship; the ability to speak palpably through the instrument; and probably the least garrulous approach to improvisation since God knows when. In all, an album of fine music by one of our finest musicians. P.R.

RECORDING OF SPECIAL MERIT

CLAUDE HOPKINS: Soliloquy. Claude Hopkins (piano). *Indiana; If I Could Be with You One Hour Tonight; Crazy Fingers; You Took Advantage of Me; Late Evening Blues; Safari Stomp; New Orleans; You're Driving Me Crazy; Memphis Blues; Who's Sorry Now.* SACKVILLE 3004 \$5.00 (available by mail from Sackville, 893 Yonge St., Toronto 5, Ontario, Canada).

Performance: **Formidable**
Recording: **Good, but low**

Claude Hopkins has been active as a musician/arranger for over fifty years. He toured Europe as Josephine Baker's musical director in the mid-Twenties and achieved enormous popularity as a band leader in Harlem during the Thirties, broadcasting regularly on coast-to-coast hookups. Hopkins remained active during the Fifties and Sixties, mainly functioning as pianist with various Dixieland bands and recording groups, but his talent as a solo pianist has been overlooked until now.

"Soliloquy" is a thoroughly delightful album, one that is long overdue. And even at seventy Claude Hopkins plays faultlessly. He strides with the greatest of swing and ease through such numbers as *Indiana*, his own *Crazy Fingers*, and *Safari Stomp* (originally recorded with a quintet for Prestige in 1961); he handles *If I Could Be with You*, *Sugar*, and his own *Late Evening Blues* with tenderness and imagination.

The album has been mastered at an uncomfortably low volume, but that is its only fault. C.A.

RECORDING OF SPECIAL MERIT

MODERN JAZZ QUARTET: The Legendary Profile. John Lewis (piano); Milt Jackson (vibraharp); Percy Heath (bass); Connie Kay (drums). *The Legendary Profile; Valeria; Misty Roses; The Martyr; What Now My Love (Et Maintenant); Romance.* ATLANTIC

STEREO REVIEW

SD 1623 \$5.98, © TP 1623 \$6.98, © CS 1623 \$6.98.

Performance: **Timeless excellence**
Recording: **Very good**

The Modern Jazz Quartet grew out of Dizzy Gillespie's big band in 1951. With only one change in personnel—Connie Kay replaced Kenny Clarke in 1955—this group of star performers, by consistently combining exquisite taste with superb musicianship, has survived two decades of rock development and new jazz trends. Maintaining the certain sound that sets them apart from other groups, the MJQ avoids stagnancy by steadily developing a new repertoire (Jackson and Lewis are prolific composers) and by keeping their ears open to what is happening around them. John Lewis, for instance, plays electric piano on Tim Hardin's *Misty Roses* and *The Martyr*, a Milt Jackson original.

Timeless is a hackneyed word, but the fact remains that, even when applied to their earliest recordings, the *modern* in Modern Jazz Quartet is as relevant today as it was in the early Fifties. This album contains no surprises—it is simply excellent. C.A.

BUDDY RICH: *Stick It*. Buddy Rich (drums); Lin Biviano, Wayne Naus, Greg Hopkins, and John DeFlon (trumpets); Eric Culver and Alan Kaplan (trombones); William Reichenbach (bass trombone); Pat LaBarbera (tenor and soprano saxophones, flute); Don Englert (tenor saxophone and flute); Joe Romano and Brian A. Grivna (alto saxophones and flutes); Richard Centalozza (baritone saxophone); George McFetridge (piano); Walt Namuth (guitar); Joel Di Bartolo (bass); Pat LaBarbera arr. *Space Shuttle*; *God Bless the Child*; *Best Coast*; *Wave*; and four others. RCA LSP 4802 \$5.98, © P&S 2089 \$6.98, © PK 2089 \$6.98.

Performance: **Forgettable**
Recording: **Abysmal**

Someone once said that RCA was behind every innovation in sound—*'way* behind. Unkind, but this album does seem rather to back up those words: far better recordings have come out of a Woodstock garage. As it happens, no great harm has been done in this case, for the music simply isn't interesting enough to worry about: a very ordinary big-band date with some very ordinary arrangements played with extraordinary lack of feeling. Buddy Rich is an interesting drummer, but he is no Watusi—as claimed by the album's tin-eared annotator—nor can he sing anything worth preserving on a record. In this set he does sing on one track, Kermit the Frog's *Bein' Green* from "Sesame Street." This odd choice ended the set—and persuaded this reviewer to consign the album to the gifts-for-nonmusical-friends shelf. C.A.

RECORDING OF SPECIAL MERIT

BILLY STRAYHORN & HIS ORCHESTRA: *Cue for Saxophone*. Billy Strayhorn (piano); Harold Baker (trumpet); Quentin Jackson (trombone); Johnny Hodges (alto saxophone); Russell Procope (clarinet); Al Hall (bass); Oliver Jackson (drums). *Cue's Blue Now*; *Gone with the Wind*; *Cherry*; *Watch Your Cue*; *You Brought a New Kind of Love to Me*; *When I Dream of You*; *Rose Room*. MASTER JAZZ RECORDINGS MJR 8116 \$5.98.

Performance: **First-rate jazz**
Recording: **Two-dimensional stereo**

This album was originally released in 1959 as part of London's Felsted series, recordings of generally excellent mainstream sessions assembled and supervised by Stanley Dance. The current reissue of this series by Master Jazz Recordings should be welcomed by all who value good, unpretentious small-band jazz, and no jazz collector should be without this particular album.

The title, "Cue for Saxophone," comes from Johnny Hodges' having to use the pseudonym "Cue Porter" on the original release (he was under contract to Verve at the time), but the alias fooled hardly anyone, for the late alto star of the Ellington band shines brilliantly in his inimitable way from first to last track. Other highlights are Russell Procope's throaty, low-register clarinet and Quentin

"Butter" Jackson's growling trombone, carrying on the traditions of Barney Bigard and Joe "Tricky Sam" Nanton of an earlier Ellington era. Jackson's trombone and Strayhorn's piano, an extension of Ellington himself, inevitably give the session the same kind of feeling that prevailed in Duke's small-band dates of the late Thirties and early Forties, a feeling of relaxed swing with the utmost rapport between the participating players.

Stereo recording was still suffering growing pains in 1959, and herein lies the album's only fault: everything seems to be either to the left or to the right. You can always switch your amplifier to monophonic if that bothers you. The music compensates for everything. C.A.

(Continued on next page)

The first purr in speakers.

We've introduced you to our unique woofers and tweeters. Now meet our purring mid-range speakers.

They purr like a kitten over the whole middle ground, as well as the lower mid-ranges that woofers have to stretch for.

In fact, it's our purring mid-range speaker that makes Jensen

Model 4 such an outstanding three way system.

Model 4 features a 10" woofer, that 5" direct radiating mid-range (purring like crazy), and a Sonodome® ultra-tweeter—all in a walnut cabinet.

We use Total Energy Response design for a fuller, richer sound. Flexair® suspension for clarity. A crossover network for exceptional tonal blend.

And the best 5-year warranty around.

Specifications: Power rating—50 watts Frequency Range—36-30,000 Hz. Crossover—500/4,000 Hz. Dispersion—170°. Two balance controls.

Introduce yourself to the purring mid-range on Model 4. And don't miss the woofer and tweeter either. All together they're a tough act to follow.

Model 4
Speaker
System

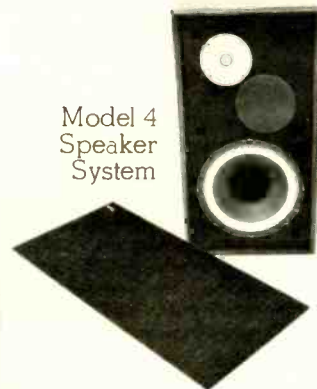

JENSEN SOUND LABORATORIES

DIVISION OF PEMCOR, INC. SCHILLER PARK, ILLINOIS 60176

CIRCLE NO. 23 ON READER SERVICE CARD



THEATER • FILMS

CARMILLA (Ben Johnston-Wilford Leach). Original-cast recording. Margaret Benczak, Donald Harrington, Camille Tibaldeo, Sandra Johnson, Murrell Gehman, and John Braswell (vocals); orchestra, Zizi Mueller cond. VANGUARD VSD 79322 \$5.98.

Performance: **Scary**
Recording: **Excellent**

If your taste runs to morbid decadence and the musical equivalent of green light on wan faces, this weird one-act opera, which created a sensation when the ETC Company of La Mama/New York performed it at their Greenwich Village headquarters, should serve as the perfect prelude to a sleepless night. Called *Carmilla—A Vampire Tale*, with a script by Wilford Leach based on a novella by J. S. LeFanu and with music by Ben Johnston, this story of a girl's venture into a dream-cosmos of phantasmagorical evil and passion is as fascinating from the first as a good horror movie.

The heroine, or victim, of the piece is a blonde girl called Laura. At the age of six, her night candle blows out and she sees, or thinks she sees, a raven-haired companion named Carmilla. Carmilla might only have been a black cat hiding under Laura's bed, or a vampire creature with needle-sharp teeth disguised as the beautiful Carmilla—or even Laura herself. Anyhow, when Laura is eighteen, Carmilla returns, and they huddle together on a couch, into the wooden frame of which are carved the faces of the other figures in Laura's life—her nurse, her father, and a woman named Mlle. de la Fontaine who is apparently a female "assistant" to him and about as cozy a character to encounter as the housekeeper in *Rebecca*. Laura and Carmilla—or the vampire masquerading as Carmilla, or Laura's alter-ego Carmilla—fall rapidly in love. A metronome begins to tick away. Time passes. Laura fades, and at last her passion for Carmilla kills her.

On the stage, as it has been performed at a number of European music festivals (as well as in Los Angeles, Detroit, Santa Barbara, Berkeley, and New York), *Carmilla* makes use of an elaborate series of projections to maintain its Poe-ish atmosphere; only the music for a psychedelic sequence has been cut from the present recording; the rest is pretty much intact. I found it a remarkable score, drenched in the atmosphere of morbidity and inventive in evoking through the orchestra the envelope of horror through which the vocal elements emerge. (But they don't, always. The album sorely needs a libretto, for much of its English text drowns amid the foaming instrumental tides.) At its worst, it is mere sickly-sweet Menotti out of *The Medium* masquerading in the robes of Schoenberg, but at its best *Carmilla* touches musical depths that promise much from the talented Mr. Johnston. What it has to say, finally, is

that "love cannot be helped," and that there are no answers to the ultimate questions which come prowling around in the night to disturb our sleep. As Laura, Margaret Benczak is superb, and Sandra Johnston as Carmilla matches her mood for mood through every vocal nuance accorded to that fat part. Donald Harrington as the hovering father and Camille Tibaldeo as his creepy "assistant" also are splendid. Incidentally, Vanguard promises a quadraphonic version (VSQ 40017) soon. I, for one, would love to hear it, preferably close to a roaring fire some stormy night, menacing me from every direction out of four loudspeakers draped in shrouds. P.K.

RECORDING OF SPECIAL MERIT

GROUCHO MARX: *An Evening With Groucho Marx*. Groucho Marx (vocals and monologues); Marvin Hamlisch (piano). *Overture; Medley from Marx Bros. Films; Introduction by Dick Cavett; Hello, I Must Be Going; My Family, How We Got Our Names; Strange Relatives; Uncle Julius; Chico at Klauber Horn Co.; Uncle Herman, Chiropodist; Timbuctoo*; and thirty-seven

At seventy-eight, Groucho is pleased to describe himself as a "dirty old man," but in reality he remains the *enfant terrible* he always was. Breaking a violin over his knee so as not to be confused with Jack Benny, he launches into a patter of affectionate and splendidly outrageous reminiscences complete with thumbnail portraits of his brothers Harpo, Chico, Zeppo, and Gummo, and brief tales of his New York boyhood, family *schlemiels* such as his four-foot-high sponging Uncle Julius and another uncle who gave up a thriving career as a chiropodist for the more lucrative job of setting fire to hotels, as well as a piquant description of his own first attempt to break into show business by placing an ad in the old New York *World* ("It doesn't exist anymore," he points out, "and hardly do I."). He then breaks into a rendition of *Timbuctoo*, one of those anarchic items in the Groucho repertoire hand-tailored for him by his friend Harry Ruby, and that's the end of side one.

There are still three delectable rounds to go, rife with such nuggets as a description of an evening spent in adolescence during the Depression with a girl who blew on a bag of sauerkraut candy the nickel subway fare he



Margaret Benczak as Laura and Sandra Johnston as Carmilla in a scene from *Carmilla—A Vampire Tale*.

others. A & M SP 3515 two discs \$9.98, ⑧ 8T 3515 \$6.98, © CS 3515 \$6.98.

Performance: **Sustained lunacy**
Recording: **Good**

They haven't yet found a satisfactory way to squeeze a spurious black moustache, an ogling pair of lascivious eyes, and the simian walk of a duplicitous, cigar-smoking chimpanzee into the microgrooves of a phonograph record, though I'm told they're working on it. Meanwhile, A & M Records has done the next best thing. They have packaged four unflagging sides of Groucho's comedy into an album containing a double-track spread of stills revealing the master in his many transparent confidence-man disguises as Rufus T. Firefly, J. Cheever Loophole, Dr. Hugo Z. Quackenbush, and Captain Geoffrey Spalding, along with several pages of encomiums from fellow performers ranging from Greta Garbo and Candice Bergen to Woody Allen, who compares him for genius to Picasso and Stravinsky. Producer Phil Ramone has assembled his program from material recorded during Groucho's one-man show last year in Carnegie Hall with sections snipped from tapes made at his appearances at Iowa State University and the Masonic Auditorium in San Francisco. The star himself comes on after the kind of buildup Katherine Cornell used to get in one of those plays where the first half-hour was calculated to send the audience into a frenzy of anticipation over her first entrance.

had held out for her return from an outing at the theater (she had to walk home forty blocks on a freezing winter afternoon); an Irving Berlin song the composer denies he ever wrote ("It's better to run to Toronto/Than to live in a place you don't want to"); the story of a Polish officer who informs a hooker he has picked up that she doesn't have to pay him ("A Polish officer doesn't accept money"); anecdotes of encounters with George S. Kaufman, Fanny Brice, and Harry Houdini; and a report on the time at T. S. Eliot's funeral when our hero ended up sitting on critic Kenneth Tynan's lap. The whole treat ends, as it properly should, with Groucho's very own incendiary version of *Lydia, The Tattooed Lady*, a ballad for which Yip Harburg and Harold Arlen deserve immortality even if every other hit they ever wrote vanished from memory.

But if you want to know more about Groucho, and follow him on his loping peregrinations around New York, Hollywood, Montreal, London, and Rome, why go on getting it second-hand from me? I suggest flatly that you storm your local record store for a copy of "An Evening with Groucho" and settle down as soon as possible to the pleasure of hearing it all straight from the source. Master of timing, of the telling incongruity, and of self-portraiture as the world's most disarming scallawag, the near-octogenarian Groucho, though a little milder than he used to be, remains top banana in a society that needs more than ever to remember how to laugh. P.K.



New Heathkit Deck. Dolby Circuit. Made for each other...by you.

About five evenings does it. Following famous Heathkit check-by-step instructions written for first-time kitbuilders, you build up the modular plug in circuit boards. Wire in the factory assembled top-quality American-made tape transport mechanism. Install it in the handsome walnut-veneer cabinet. And you're in the Dolby stereo cassette business to stay... at a price designed to please. All controls are interlocked to prevent tape breaking or accidental erasing of prerecorded cassettes. An automatic shut-off returns the transport to STOP when tape ends in PLAY or RECORD mode. "Piano"-keys give you fingertip control of PLAY, RECORD, and STOP functions. Lever controls offer FAST-FORWARD REWIND and EJECT functions. Lever switches are also provided for STEREO or MONO input; DOLBY ON/OFF; tape-type REGULAR (iron oxide) or CrO₂ (chromium dioxide). In the CrO₂ position, both the bias and audio levels of the deck are increased to make full use of the greater fidelity and dynamic range of chromium dioxide tape. Other features are individual record level controls with separate VU meters; large three-digit

resettable counter for reliable indexing of selections within a tape; input selector switch for either microphone or high-level source input (any low impedance microphone with standard 1/4" phone jack can be used). For the life-like fidelity of low-noise cassette recording and playback at its finest, put together the Heathkit AD-1530 Deluxe Stereo Cassette Tape Deck next week.

Kit AD-1530, 21 lbs. 249.95*
ADA-1530-1, dust cover, 1 lb. 4.95*

AD-1530 SPECIFICATIONS: Frequency Response: Regular (iron oxide) tape; ± 3 dB from 40 Hz to 12 kHz typical. CrO₂ (chromium dioxide) tape; ± 3 dB from 40 Hz to 14 kHz typical. Distortion: Tape dependent; electronics less than 0.2%. Hum and Noise: Dolby Switch OFF, -48 dB. Dolby Switch ON-Provides Additional Noise Reduction as Follows: -10 dB @ 4000 Hz and up. -9dB @ 2400 Hz. -6 dB @ 1200 Hz. -3 dB @ 600 Hz. Wow and Flutter: Less than 0.25% RMS. Inputs: Microphone: Lo-Z, 0.2 mV to 10 mV. Auxiliary: Hi-Z, 50 mV to 10V. Bias Oscillator Frequency: Approximately 100 kHz. Tape: Any good quality iron oxide or chromium dioxide tape cassette may be used. Tape Speed: 1 7/8 in/s or 4.76 cm/s. Fast Forward/Rewind Time: Approximately 45 sec. for C-60 cassette. Solid State Devices: 37 transistors and 2 JFET's. Output: Greater than 0.5 volts from low impedance source. Dimensions: 5 1/2" H x 9 1/2" D x 14" W. Power Requirements: 120 volts, 60 Hz, 15 W.

HEATHKIT ELECTRONIC CENTERS — ARIZ.: Phoenix, 2727 W. Indian School Rd.; CALIF.: Anaheim, 330 E. Ball Rd.; El Cerrito, 6000 Potrero Ave.; Los Angeles, 2309 S. Flower St.; Pomona, 1555 Orange Grove Ave. N.; Redwood City, 2001 Middlefield Rd.; San Diego (La Mesa), 8363 Center Dr.; Woodland Hills, 22504 Ventura Blvd.; COLO.: Denver, 5940 W. 38th Ave.; CONN.: Hartford (Avon), 395 W. Main St. (Rte. 44); FLA.: Miami (Hialeah), 4705 W. 16th Ave.; GA.: Atlanta, 5285 Roswell Rd.; ILL.: Chicago, 3462-66 W. Devon Ave.; Downers Grove, 224 Ogden Ave.; IND.: Indianapolis, 2112 E. 62nd Ave.; KANSAS: Kansas City (Mission), 5960 Lamar Ave.; MO.: Baltimore, 1713 E. Joppa Rd.; Rockville, 5542 Nicholson Lane; MASS.: Boston (Wellesley), 165 Worcester St.; MICH.: Detroit, 18645 W. Eight Mile Rd. & 18149 E. Eight Mile Rd.; MINN.: Minneapolis (Hopkins), 101 Shady Oak Rd.; MO.: St. Louis, 9296 Gravois Ave.; N.J.: Fair Lawn, 35-07 Broadway (Rte. 4); N.Y.: Buffalo (Amherst), 3476 Sheridan Dr.; New York City, 35 W. 45th St.; Jericho, L.I., 15 Jericho Turnpike; Rochester, Long Ridge Plaza; OHIO: Cincinnati (Woodlawn), 10133 Springfield Pike; Cleveland, 5444 Pearl Rd.; PA.: Philadelphia, 6318 Roosevelt Blvd.; Pittsburgh, 3482 Wm. Penn Hwy.; TEXAS: Dallas, 2715 Ross Ave.; Houston, 3705 Westheimer; WASH.: Seattle, 221 Third Ave.; WIS.: Milwaukee, 5215 Fond du Lac.



Over 350
Easy-To-Build Kits
SEND FOR
FREE CATALOG

HEATH
Schlumberger

HEATH COMPANY, Dept. 40-4
Benton Harbor, Michigan 49022

Please send FREE Heathkit Catalog.

Enclosed is \$ _____, plus shipping.
Please send model AD-1530.

Name _____

Address _____

City _____ State _____ Zip _____

Prices & Specifications subject to change without notice.

*Mail order prices; F.O.B. factory.

HF-269

In my more than eighteen years as a rock fan, I have never encountered a musical group with a history more confused, more singular, than that of the Move. They are unique. Their sound is the essence of the Seventies—a dense, molten mixture, bursting with trace elements of every stylistic ingredient in popular music's last fifteen years, the whole poured over a foundation of timeless rock archetypes. They are the ultimate synthesis of commercial pop, heavy metal, underground rock, and experimental engineering technology, the perfect setting for two endlessly inventive musical geniuses, and it's not hard to see why those who have followed their career are picking the Move as possibly the most exciting thing to happen to rock-and-roll since the Beatles.

Their story begins in Birmingham, England, where in late 1965 the Move was formed by five of the city's most talented

musicians. From Mike Sheridan and the Nightriders came guitarist Roy Wood, and from Carl Wayne and the Vikings came drummer Bev Bevan, guitarist Chris "Ace" Kefford, and vocalist Carl Wayne. Trevor Burton, from the Mayfair Set, filled out the group.

During the ensuing months they were to be seen as one of the resident house bands at the Marquee Club, dressed to the hilt in paisleys and Day-Glo. They were one of the first groups to be signed to the Decca label's new psychedelic subsidiary Deram (the first was Cat Stevens), but by the time their first album appeared, in early 1968, they were working for another new label, Regal-Zonophone. Produced by Denny Cordell and titled simply "The Move," the LP included most of their early singles plus cover versions of songs by Moby Grape, Eddie Cochran, and the Coasters, but it was never released in the U.S. All their records had made the English charts up to this point, and because of this success they began losing respect in the hipper circles—which is iron-

duplicate the sound of anybody they want to (as they proved in *California Man*, a dead ringer for a Jerry Lee Lewis song), but prefer to synthesize their own in songs that, for all their eclectic influences, can only be, unmistakably and unforgettably, products of the Move.

But in 1968 the trend was to wear torn Levis and play the blues for FM radio consumption. By then the Move had almost two years of solid accomplishment behind them, but they didn't fit this new image; they seemed to be looking ahead to 1972, when heavy rock and pop singles would again join hands without shame. So, for a couple of years in there, the Move had a rather bad time of it. An abortive tour of the States (where they were still virtually unknown) was followed by numerous and complicated personnel changes, resulting eventually in the departure of Carl Wayne, Ace Kefford,

THE MOVE

A well-timed (with any luck at all) retrospective by GREG SHAW

Left to right: Bev Bevan, Jeff Lynne, and Roy Wood



musicians. From Mike Sheridan and the Nightriders came guitarist Roy Wood, and from Carl Wayne and the Vikings came drummer Bev Bevan, guitarist Chris "Ace" Kefford, and vocalist Carl Wayne. Trevor Burton, from the Mayfair Set, filled out the group.

The Merseybeat thing had been going on for nearly four years, and the lads had been through most of it. They felt it was time now for a new approach. They had some far-out ideas, but they needed access to recording studios, exposure to audiences, and, above all, a successful image. So in 1966 they went to London and engaged the services of Tony Secunda, an outrageous manager/publicist who tried every gimmick imaginable in an effort to make the Move trendy. He had them demolishing television sets and cars on stage, dressing in Al Capone outfits, and sending all kinds of ridiculous messages to the media. He finally succeeded in bringing them to worldwide notice through a postcard depicting Prime Minister Harold Wilson in compromising circumstances with a young lady resembling a secretary with whom Wilson was rumored to be having an affair. The card was mailed to the press as an ad for the Move's third single, *Flowers in the Rain*. There was a lawsuit, and the enor-

ous publicity which followed succeeded in making the Move heroes of the emerging London underground.

Even then, the Move were masters of the exacting art of making pop singles. Their melodies and arrangements were consistently fascinating, and they understood completely how tension and excitement can be built and maneuvered through chorus and bridge for maximum effect. This is not to say that they sounded like Neil Diamond, however. Instrumentally they were as crisp, heavy, and inventive as any band around. Their early singles, such as *I Can Hear the Grass Grow*, *Blackberry Way*, and *Curly*, still sound fresh and modern today, unlike most other records of the period.

From the very start, the Move were guided by a concept, one that has changed only as it became more refined with their increasing ability to realize it. This concept, the product of Roy Wood's single-minded direction (and, later, Jeff Lynne's similar vision) involves the deft manipulation of vocal and instrumental riffs lifted with precision from a thousand half-remembered old songs and dropped (if only for the moment it takes to create the desired effect) here and there in songs already structured around themes basic to rock but never fully developed until the Move got hold of them. They can easily

and Trevor Burton, and the addition of Jeff Lynne, an old mate of Wood's from the Nightriders (which had evolved into the Idle Race and been responsible for two very Move-like albums).

Before leaving, Wayne had sung on the Move's second album, "Shazam," which has been widely hailed as one of the landmarks of late-Sixties rock. Its six songs range from such heavy rockers as *Hello Susie* through raga-rock, folk-rock, and other kinds of rock—the whole array of styles that had come to be the Move's trademark.

"Shazam" was released here (on A&M) to glowing reviews, but it failed to sell. Shortly thereafter Lynne joined the group, and plans were announced for a new experiment designed, oddly enough, to make the Move musically obsolete. But first the group put out a great single called *Brontosaurus* (which stomped from a ponderous opening riff to an all-out raving finish), followed by "Looking On," a somewhat less remarkable album that was issued here on the Capitol label. The group was now down to three members, one of whom had just joined (which perhaps explains the album's general sloppiness).

The next album vindicated those patient listeners who had given them the benefit of

the doubt. "Message from the Country" was their most advanced statement yet, making heavy use of multi-tracked instruments (including brass, keyboards, and many kinds of woodwinds), and an ever-developing skill in song construction. At this point the American public was finally starting to pay attention, and it seemed the Move was on the verge of recognition.

But it was time for a change. Roy Wood had always been fascinated with the possibility of fashioning his songs around classical motifs and using classical instrumentation in a purely rock-and-roll context. *Night of Fear*, for instance, the Move's very first single, had been constructed around a motif from Tchaikovsky's *1812 Overture*, and *When Alice Comes Back to the Farm* (from "Looking On") had startled many with its rather *outré* oboe solo. So, following *Tonight*, their most marvelous single yet (and a

What's great about it is that while Roy is singing some "sincere" lyric the like of which you've heard a million times ("Miss Clark. Miss Clark, don't take my heart away"), he's making no attempt whatever to convince you that he gives the slightest damn about *what* he's saying. He's more interested in the total *effect*—the layers of sound that get more dense with each verse, the choirs painstakingly laid down at varying speeds, the harpsichord and banjo parts stuck in here and there, and the la-las and shoop-doo-by-dobbies that fill every available space. Far from giving the abstract, unreal effect you might imagine, the overall result is really quite warm because of the underlying sense of whimsy and absurdity. Who, after all, *could* take seriously a ballad of unrequited love in which the rhythm is provided by the sound of large teardrops dripping noisily into a bucket?

"Boulders" was recorded in early 1972 and not released until just recently. Wood meanwhile was drifting further from the ELO camp and soon came up with his own new group, Wizzard. While organizing his new venture, he collaborated with Lynne and Bevan on two final Move singles. *Chinatown*, a delightful pop tune in the same vein as *Tonight*, made the charts in England, and so did the follow-up *California Man*, a nice Jerry Lee Lewis take-off and a treat for oldies fans. For some reason, though, weeks went by before anyone bothered to flip *California Man* and uncover *Do Ya*, one of the monumental rock classics of all time. Employing a metal-heavy riff out of the Who's *Can't Explain* and a pounding beat reminiscent of *Time* by the Chambers Brothers, the Move wove bizarre lyrics—"I've seen babies dancing in the midnight sun"—through two verses and a stratospheric bridge, culminating in a blinding chorus of "do ya, do ya want my love," which brought it all down to pop reality and left the listener stunned. *Do Ya* should have been a number one record, by any standards. It did make the Top Ten in Boston and several other areas, and United Artists was deluged with requests for the record, which was not on sale in many places. While it never reached the top of the charts, *Do Ya* sold a couple of hundred thousand copies and indicated the readiness of America to accept the Move as superstars at last.

BUT there was a small problem. As 1973 dawned, it was plain that the Move no longer existed as a group. To be sure, they *said* the group still existed for recordings, but there were no more live appearances, and Wood and Lynne were clearly more interested in their own projects.

Roy Wood and Wizzard completed an album ("Wizzard's Brew") that included *Ball Park Incident* (sounding suspiciously like Lloyd Price's *Stagger Lee*), and it went high on the British charts. In reaction to what he saw as ELO's overuse of chamber-music effects, Wood made the music purposely rough and rockish; the album even includes an Elvis takeoff. The Wood genius is there, especially in *Carlsberg Special*, featuring Pianos Demolished (Wizzard's pianist, who hammers at the keyboard until his fingers are bloody and then takes an axe to the piano for the finale). But the album is less satisfying than what Lynn was working on.

The second ELO album ("ELO II") was released around the same time as Wizzard's LP, and even the staunchest fans were surprised by how far the concept had evolved. Two long numbers, *Jeff's Boogie #1* and *Jeff's Boogie #2*, are showcases for Lynne's ideas, moving naturally from stately marches out of Mozart through Ferrante and Teicher right into B. Bumble and the Stingers, reaching new levels of madness with each ensuing verse. Demented horn sections playing the part of electric guitars, violins gone wild, a freaked-out Jerry Lee Lewis at the piano, atonal oboes following slashing guitar solos as the drums pound on—it is an astonishingly smooth and effective realization of an unprecedented approach to rock-and-roll.

That would be enough, but the album's virtues don't end there. Aside from being a milestone of technical and conceptual sorcery, the album is honestly pleasant, unpretentious, and often moving in its beautiful melodies and superb vocals. It's a *funny* record too, if you can take the kind of musical joke that adds themes from Beethoven to Chuck Berry's *Roll Over Beethoven*, and manages to overcome the mere cleverness of that idea and turn into the wildest, most rocking version since Chuck's original.

THIS is not the best vantage point from which to predict a future for the Move. They exist as a group only in the studio, if at all, and the two splinter groups still have so much in common that further changes seem inevitable. There are, however, certain inescapable facts. Wood, Lynne, and company are responsible for an approach to rock that is just beginning to be widely imitated and may well dominate the early years of the hard-rock/heavy-pop single resurgence that is now taking shape. I mentioned the Beatles at the start of this piece, and the parallel here is obvious, but there are others as well. At the time of their demise (or at least the last time they worked together on anything) the Beatles were experimenting with the kind of studio-built music the Move specializes in. "Abbey Road" was a totally synthetic album, and a rather poor one compared to "Boulders," or the latest ELO, or any recent Move recordings. The Beatles' sound then was sterile and pretentious (just compare a ballad like *Something* with ELO's *Mama*, or the *Bathroom Window* medley with Wood's *Rock Medley*), and it was vastly less imaginative than the Move's. I don't want to carry the comparison too far, but the point I'm making is that the direction the Beatles were moving in is precisely that in which the Move is striking out with such brilliance. Attach whatever importance to that you like; I only know that the Beatles used to be the one group I could always count on to come up with something original, to shatter my expectations with each new record, and nobody since has done that except the Move. Nobody who can make a record like *Do Ya* or "Boulders" could, I'm convinced, do anything they wanted. Whether they will work together again, or continue separately, or splinter themselves even further, can't be guessed and doesn't really matter. Each of them is his own four Beatles (as it were), with all the inventiveness (and the ability to implement it) he'll ever need to transform popular music.



song so commercial that it was stripped of its tongue-in-cheek overtones and made into a minor hit by the New Seekers), they moved to the United Artists label in the U.S. and soon released an album as the Electric Light Orchestra, which was really the Move augmented with oboes, violins, cellos, French horns, etc. It was moderately successful, both in sales and as an experiment, but they still weren't satisfied.

Roy Wood, feeling that ELO was essentially Jeff Lynne's group, left to record a solo album. "Boulders," as it was called, is an astonishing work. Every note on all sixty-four tracks was played by Wood, except for those he edited in, one snippet at a time, when he came to an instrument he couldn't play but wanted the sound of. He sings three- and four-part harmony with himself, and is backed up by choruses (of himself) that sound like a speeded-up Chipmunks on one channel and a slowed-down Jan & Dean on the other—or the Mormon Tabernacle Choir, or the Everly Brothers, and on through endless permutations. The songs are exquisite masterpieces of British pop—light, catchy numbers with adorable melodies, crammed with bits of every musical cliché around, but all twisted to sound completely new.

The easiest way to become an Audiophile:

CHOOSE FROM THE BEST OF KENWOOD.

KENWOOD introduces three masterful new stereo components that will elevate your standards of stereo excellence to a new plateau. You may or may not understand the esoterics of KENWOOD's exclusive DSD circuitry, the advanced engineering of all-stage direct coupling, or the complexities of recreating 4-channel concert-hall ambience. What you will understand instantly is that the top KENWOOD stereo components give you the finest stereo reproduction you've ever listened to. Visit your nearest Authorized KENWOOD Dealer soon... and become an audiophile.

KT-8005 AM/FM-Stereo Tuner... 8-ganged air-core variable capacitor (5-FM, 3-AM); floating oscillator circuit for highest stability; selectivity, 100 dB; capture ratio, 1.0 dB; exclusive Double-Switching Demodulator (DSD) for exceptional separation.

KA-8004 Direct-Coupling 300-Watt (IHF) Stereo Amplifier... Powerful differential amplifier for ultra-low equalization and Phono input of 700 mV; all-stage direct coupling for superior phase accuracy, superb tonal quality even at lowest volume; 2 large electrolytic capacitors (10,000 μ F x 2) to eliminate transient distortion.

KR-6140A, 4-Channel, 320-Watt (IHF) AM/FM-Stereo Receiver... Full 4-channel flexibility (Discrete, SQ, Other Matrix, Synthesized) plus 2-channel; two full 4-channel tape systems with A/B Tape Monitor; mike mixing; special remote 4-channel volume control and more.

For complete information, write...

 **KENWOOD**

15777 So. Broadway, Gardena, Calif. 90248 ■ 72-02 Fifty-first Ave., Woodside, N.Y. 11377

CIRCLE NO. 25 ON READER SERVICE CARD



CLASSICAL DISCS AND TAPES

Reviewed by DAVID HALL • BERNARD JACOBSON • GEORGE JELLINEK • IGOR KIPNIS
PAUL KRESH • ERIC SALZMAN • LESTER TRIMBLE

AUBER (orch. Gamley): *Cello Concerto No. 1, in A Minor*. **POPPER**: *Cello Concerto No. 2, in E Minor, Op. 24*. **MASSENET**: *Fantasy for Cello and Orchestra*. Jascha Silberstein (cello); L'Orchestre de la Suisse Romande, Richard Bonyngé cond. LONDON CS 6750 \$5.98.

Performance: **Stylish**
Recording: **Good**

Here's a pleasing and eminently listenable bouquet of little-known Romantic cello fare ably put together and presented by Met Opera solo cellist Jascha Silberstein with the expert collaboration of conductor Richard Bonyngé, who has something of a flair for unearthing out-of-the-way repertoire.

Daniel François Esprit Auber, whom we think of in terms of his lively operatic overtures, turned out four cello concertos for a cellist friend, but he evidently never troubled to orchestrate them. Douglas Gamley has done an able job on the first of them for this recording. The warmly melodious slow movement and the really brilliant tarantella-style finale are for me the high points of this piece.

David Popper, a Czech who spent most of his life in Vienna and Budapest, was one of the most celebrated cellists of the late nineteenth century and a prolific composer whose encore pieces were a fixture of every respectable solo cello recital during the 1920's. The E Minor Concerto is agreeable stuff. In much the same style as the Vieuxtemps and Wieniawski violin concertos, it is perhaps endowed with somewhat less personality except

in its mildly gypsy-flavored finale and the gorgeously lush slow movement.

Few of us think of Jules Massenet as the composer of anything but operas—*Manon*, *Werther*, *Le Cid*, and *Thaïs*—and such pleas-

BARTOK: *Music for Strings, Percussion and Celesta*. **STRAVINSKY**: *Apollon musagète*. Berlin Philharmonic Orchestra, Herbert von Karajan cond. DEUTSCHE GRAMMOPHON 2530 065 \$6.98.

Performance: **Not good**
Recording: **A bit distant**

It is not often nowadays that one comes across a recording of a well-known work by a famous conductor and an admired orchestra on a major label that can be easily characterized in a word. The word on this new recording of the Bartók *Music for Strings, Percussion and Celesta* is "bad."

These distinguished musicians seem to have not the slightest idea of what this piece is about. The performance sounds almost like the kind of new-music sight-reading agonies we used to suffer through in the name of contemporary musical uplift.

The Stravinsky *Apollon musagète* apparently connects better with the kinds of musical traditions with which these musicians are familiar—in particular, the solo string playing is impressive. But even here the musicians don't quite catch that combination of strength, wit, and elegance which is the Apollonian essence of mid-Stravinsky. Neither does the recording. If this music interests you, look elsewhere. *E.S.*



London Records

JASCHA SILBERSTEIN

Expert style and considerable panache

antly colorful suites and incidental music as *Scènes alsaciennes* and *Scènes pittoresques*. Record collectors with good memories, however, may recall the Massenet piano concerto MGM issued in the 1950's. The *Fantasy for Cello and Orchestra* was written in 1897, after the most famous operas, and is cut out of much the same cloth as the orchestral suites—expertly orchestrated accompaniment, highly effective writing for the solo instrument, and a rhythmic-harmonic scheme that lends it a mildly exotic flavor.

All told, then, this fifty-minute program falls pleasingly on the ear. Jascha Silberstein sets forth the decidedly demanding solo cello parts with expert style—and in the finales with considerable *panache*. Richard Bonyngé's orchestral collaboration is of the very best, as is the recorded sound. *D.H.*

BEETHOVEN: *Grosse Fuge in B-flat Major, Op. 133* (see MOZART)

BERIO: *Sincronie*. Lenox String Quartet. **LADERMAN**: *Stanzas*. Chamber Orchestra, Jorge Mester cond. DESTO DC7129 \$5.98.

Performance: **Very good**
Recording: **Very good**

The string quartet, the most unified of the traditional musical media, has been used by composers in essentially three different ways. In spite of the conventional wisdom, a true contrapuntal treatment is the rarest approach: it was used occasionally by Haydn and by Beethoven near the end of his life, but was in vogue principally in the late nineteenth and early twentieth centuries. The most popular approach has always been melody-and-

(Continued on page 112)

Explanation of symbols:

- Ⓜ = reel-to-reel stereo tape
- Ⓢ = eight-track stereo cartridge
- Ⓒ = stereo cassette
- = quadraphonic disc
- Ⓡ = reel-to-reel quadraphonic tape
- Ⓟ = eight-track quadraphonic tape
- Ⓒ = quadraphonic cassette

Monophonic recordings are indicated by the symbol Ⓜ

The first listing is the one reviewed; other formats, if available, follow it.



A MONSTER CONCERT

In the Great American Tradition

Reviewed by ROBERT OFFERGELD

YOU CAN have but little idea of what the "forte" in pianoforte means unless you have heard Columbia's new release called "Monster Concert." In my time I have made a respectable lot of noise on the piano myself (on one inglorious occasion busting a concert-grand bass string in a Chopin *Polonaise*). Faced with this outrageously uninhibited blockbuster of a recording, however, I now retire from the contest, noting that it took *ten* pianos and *sixteen* pianists (plus two alternates) to put me down. The "Monster Concert" ensemble is conducted valorously by Samuel Adler and the piano players are headed up by Eugene List and Frank Glazer, these in turn supported to the death by Barry Snyder, Maria Luisa Faini, and fourteen additional pianists, all of them Eastman School of Music faculty members or graduates.

In an era notably lacking in musical levity (it would be hard to say whether the pop or the classical scene has been glummer of late), this premeditated dam-burst of piano sound is an altogether unlikely release. But even if it were less amusing as a sort of sociological happening, it would recommend itself for other reasons, some of which may interest people who are still trying to figure out what *did* hit our once flourishing concert life.

The album's opening "turn," to use an appropriate music-hall expression, is composer Russell Riepe's ten-piano arrangement of Morton Gould's six-piano-and-orchestra arrangement of Sousa's *Stars and Stripes Forever*. It is distinguished by some volcanic upward whooshes of piano noise that would have recurled Sousa's mustache, and the general effect is that of a McKinley-era parade marching with banners through a Cape Kennedy blastoff—the most candid kind of warning to hold on to your hat in the pianistic fun and games to follow.

Hearing it—or, for that matter, ducking it, depending on your nerves—you understand instantly why the nineteenth century

loved to hear (and watch) dozens of pianists attacking large herds of pianos with military precision. Louis Gottschalk, America's somewhat legendary expert at monster piano concerts, actually did march his battalions of uniformed pianists onto the stages of South American opera houses in a sort of close-order drill, and considering the sorry state of most real armies in his vicinity at the time, this may have been the nearest thing to West Point elegance that the citizenry ever got to see.

The second, fifth, and sixth turns, however, are the real news of this Columbia release. These are, respectively, the Rossini-Gottschalk *William Tell* Overture, the Rossini-Czerny *Semiramide* Overture, and the Strauss-Schultz-Evler-Chasins *Blue Danube Waltzes*, and they illustrate the surprising effectiveness of an unfamiliar instrumental context in reviving concert warhorses that were venerable long before this century dawned.

When did most of us last listen to the Rossini Overtures straight through? These versions deserve that attention if only as fascinating examples of nineteenth-century transcription practice realized in two historically divergent piano styles. Rossini commissioned the *Semiramide* arrangement from Carl Czerny in 1830, and it is a first-rate "Classical" treatment (calling, as you might expect, for plenty of immaculate Czernian finger dexterity) of an equally "Classical," or pre-*William Tell*, Rossini Overture. Its great moment is of course the grandly kinetic "Rossini crescendo," admirably negotiated here by conductor Adler and his disciplined forces, though it is anybody's guess just what internal connection this superbly lively preface was thought to have had with the *melodramma tragica* that followed it.

In the *William Tell* Overture we hear a different Rossini and a different piano style, for the Romantics have obviously got to both of them. It was long ago remarked that this piece is less an overture than a tone

poem, and Gottschalk's elegant piano version does something more than mere justice to precisely that sense of it. Gottschalk wrote it as a sensitively balanced two-piano piece, supported by additional pianos (as it is here) only in the bravura storm and *galop* passages.

Also conceived as a two-piano piece with extra support in the climaxes is *The Blue Danube*, and here the distinct layers of nostalgia are positively geological. Underneath is the Viennese opulence of the Strauss original, this being topped by the gorgeous fireworks of the Schultz-Evler two-hand transcription beloved of the post-Edwardian virtuosos. In the more recent foreground, meanwhile, is the Abram Chasins two-piano updating for early moderns of all the foregoing, a development that displeased some who felt that Chasins abridged and reharmonized it with rather too free a hand. Be that as it may, the piece as here performed discloses more shades of blue in the Danube than you would have thought possible (the liquid sonorities of the List-Glazer two-piano passages, by the way, could not be lovelier tonally), and together with the *William Tell* Overture it brings into focus the real issue raised by the album.

BETWEEN the wars, persons concerned with the idiomatic purification of the piano as a concert instrument waged a highly successful revolt against the admittedly lush taste of the Late Romantic virtuosos, particularly in the matters of dynamic extremes and "unpianistic" coloration. We consequently abjured both the gnomic whippers of a de Pachmann and the cataclysmic thunderings of a Paderewski; we also learned to look with suspicion on the richly somber nightscapes of a Rachmaninoff and the delicate Fragonard coloring of a Giesecking. We made fashionable a severely defoliated piano style that is clinically pure in much the same doctrinaire sense that Corbusier's architecture is. Unfortunately, in

practice this style has proved to be disappointingly monochromatic—and, in all but the most masterly hands, emotionally dull to boot.

Whatever else "Monster Concert" may be, dull it is not. While listening to the balance of the album (which raises no issue at all, being simply good clean fun in the great American tradition of irrational excess that produced Barnum and Bailey, Texas, Macy's Thanksgiving Day parade, rock bands, and New York's World Trade Center), we can do worse than ask ourselves if our puritan taste-makers may not have thrown out most of the baby with the bath water. The background music for these reflections will be Strauss' *Thunder and Lightning Polka*, arranged by Russell Riepe with startling spatial effects, and two once-famous Cuban dances composed by Gottschalk for multiple pianos unlimited, *Ojos Criollos* and *La Gallina*. The latter is a five-story, rubber-balloon Macy's hen if there ever was one.

COLUMBIA has made this recording available in both stereo and four-channel modes. Checking them out on several turntables, a number of differences are noticeable. The two-channel recording, for example, is slightly brighter and more reverberant, but it is also a little bass-shy. The four-channel version, when played in only two, sounds slightly veiled, less reverberant, but heavy in the bass. Playing this same disc in the quadraphonic mode "opens it up," of course, but it is still somewhat less reverberant than the two-channel version. What is more to the point is the lack of directionality in the four-channel version. Whether it was programmed that way (the placement of those many pianos in relation to the microphones), whether it results from the post-recording mixing process, or whether it reflects the characteristics of Columbia's SQ matrix, the listener's impression is one of being surrounded by sound without being able to do much pinpointing as to what is coming from where. (But quadraphonics, whatever the format, is not yet, of course, a finished art.) The two-channel version, however, plays some nice—and nicely musical—tricks with directionality, particularly on *Maple Leaf Rag*, in which the arranger, aided and abetted by the recording technicians, exploits very profitably the available variety of stereo effects—particularly a charming "call-and-response" technique.

MONSTER CONCERT: 10 Pianos/16 Pianists. Sousa-Gould-Riepe: *Stars and Stripes Forever*. Rossini-Gottschalk: *William Tell Overture*. J. Strauss, Jr.-Riepe: *Thunder and Lightning Polka*. Joplin-Riepe: *Maple Leaf Rag*. Strauss-Schultz-Evler-Chasins: *Blue Danube Waltzes*. Rossini-Czerny: *Semiramide Overture*. Gottschalk: *La Gallina (The Hen)*; *Ojos Criollos (Creole Eyes)*. Nancy Bachus, Gregory Butler, Blair Cosman, Edward Easley, Maria Luisa Faini, Frank Glazer, Wallace Gray, Michael Guiltinan, Neal Larrabee, Gladys Leventon, Eugene List, Elizabeth Riepe, Russell Riepe, Mary Jo Santuccio, Kimberly Schmidt, Barry Snyder, Joe Stuessy, and Joseph Werner (pianos); Samuel Adler cond. COLUMBIA M 31726 \$5.98, □ MQ 31726 \$6.98.

New Releases

on
LONDON[®]
RECORDS

MOZART OPERA FESTIVAL

Excerpts from *Le Nozze di Figaro*, *Idomeneo*, *Die Entführung aus dem Serail*, *Die Zauberflöte*, *Zaide*, *Così fan tutte*, *Il Re Pastore*, *Don Giovanni* *Lucia Popp*, *Brigitte Fassbender*, *Werner Krenn*, *Tom Krause*, *Manfred Jungwirth*—*The Vienna Haydn Orchestra*—*Istvan Kertesz*

OSA-1297

Offenbach: LE PAPILLON

The London Symphony Orchestra—Richard Bonyngé

CS-6812

Tchaikovsky: SYMPHONY NO. 4 IN F MINOR

The National Symphony Orchestra—Antal Dorati

CS-6793

Handel: MESSIAH— Highlights

Joan Sutherland, Huguette Tourangeau, Werner Krenn, Tom Krause—The Ambrosian Singers—The English Chamber Orchestra—Richard Bonyngé

OS-26254

Varèse: ARCANA; INTÉGRALES; IONISATION

The Los Angeles Philharmonic Orchestra—Zubin Mehta

CS-6752

MARILYN HORNE SINGS ROSSINI

Excerpts from *The Siege of Corinth* and *La donna del lago*—The Royal Philharmonic Orchestra—Henry Lewis

OS-26005

Shostakovich: SYMPHONY NO. 1 IN F MINOR SYMPHONY NO. 9 IN E FLAT

L'Orchestre de la Suisse Romande—Walter Weller

CS-6787

Meyerbeer: LES HUGUENOTS— Highlights

Joan Sutherland, Martina Arroyo, Huguette Tourangeau, Anastasios Vrenios, Gabriel Bacquier, Dominic Cossa, Nico'a Ghiuselev—The New Philharmonia Orchestra—Richard Bonyngé

OS-26239

All quadraphonic are not Sansui has created

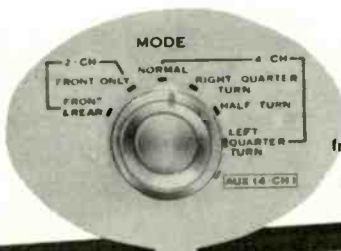

Sound-field rotation and mode selector provides front only, front and rear, normal four-channel, right quarter-turn, half turn, left quarter-turn and discrete aux.

Up-front balance control—
slider adjusts
left/right front channels.

Rear balance control—
slider adjusts
left/right rear channels.

Main balance control—
slider adjusts
front-to-back balance.

QRX-6500

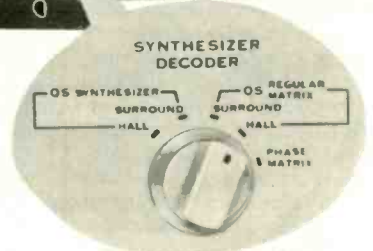

Decoder selector provides two-positions of QS Regular Matrix decoding, two synthesizer positions, and "Phase Matrix" for other types of encoded records.



systems created equal... the QS vario matrix.

Here at last is the development that once and for all will lay to rest the dispute over discrete vs. encoded recordings. The Sansui QS vario matrix — a technological extension of the QS Regular Matrix — provides unbelievable front-to-back separation, to a degree never before possible with matrix technology.

Two new units in the Sansui four-channel lineup have this outstanding vario matrix decoder.

Treading closely in the superlative footsteps of the QR-6500 and QR-4500 four-channel receivers, the new QRX-6500 and QRX-4500 retain all the important features of their predecessors — the generous power output, sensitive FM and AM reception, unitized, easy-to-use controls, and sound-field rotation.

In addition to all these features, the new QRX-series has front-panel matrix switching, selecting between the QS Regular Matrix (vario matrix) and Phase Matrix decoding — which permits accurate decoding and playback of any current matrix record made, while handling up to ten loudspeaker systems.

The result is that these new QRX-series receivers represent the most advanced 4-channel technology available today, with total flexibility and adaptability built-in for tomorrow's needs.

Included with the decoder are two synthesizer positions for creating four-channel sound from two-channel recordings. Both the synthesizer and the QS Regular Matrix decoder have "Hall" and "Surround" positions for varying the quadraphonic effect to suit your particular needs, making this the most versatile decoding system on the market today.

The QRX-6500 has a power output of 280 watts IHF, or 37 watts continuous (RMS) per channel at 8 ohms. Total harmonic distortion is less than 0.5% at rated output; power bandwidth (IHF) is 20 to 30,000 Hz.

The FM tuner section uses three dual-gated MOSFETs and a super-precision four-gang tuning capacitor for exceptional sensitivity (1.8 microvolts IHF) and very low IM distortion. The IF section combines a six-resonator ceramic filter, IC three-stage limiter for exceptional selectivity and capture ratio.

But an in-person demonstration is the real clincher. You really have to hear the QRX receivers to believe that matrix 4-channel can sound this good. Why not drop in at your Sansui dealer showroom today and treat your ears to both the QRX-6500 (Price: \$699.95) and the

somewhat lower-powered QRX-4500 (\$599.95). They're both full-featured quadraphonic receivers in the finest tradition of Sansui craftsmanship.



SANSUI ELECTRONICS CORP.

Woodside, New York 11377 • Gardena, California 90247
ELECTRONIC DISTRIBUTORS (Canada), Vancouver 9, B.C.
SANSUI ELECTRIC CO., LTD., Tokyo, Japan • Sansui Audio Europe S. A., Antwerp, Belgium

accompaniment. The third way, currently in fashion, is to treat the quartet as a totally homogeneous field of sound, a single large instrument within which individual instrumental roles are subordinated.

A good example of the third way is the Berio *Sincronie*—"simultaneities" might be a good translation of the title—with its play of sound densities across a single, unified field. Unlike Ligeti and Xenakis, Berio concentrates on isolated attacks and fields of pulse, largely omitting the sliding, overlapping glissandos that have become almost a cliché of this kind of string music. Within its rather limited intention, *Sincronie* is attractive and sonically inventive, and it is brilliantly played by the Lenox Quartet.

Ezra Laderman's *Stanzas*, written in 1959 for large chamber orchestra, is a different sort of piece—freely serial, linear, and contrapuntal, rather intensely dramatic. Stylistically, its brand of "neo-Classical Expressionism"—horrible term, but reasonably descriptive—is very much out of fashion. The problem with this sort of music is that of sustaining a line over long stretches with musical ideas that hover between tonality and atonality, Classicism and serialism, concreteness and abstraction. I feel that Laderman has managed this immensely difficult tight-rope walk with only partial success, and partial success in a tight-rope walk is not generally accounted as much success at all. Nevertheless, one must admire the considerable amount of skill and imagination involved; anyone whose ears are open enough to ignore the unfashionableness of the sound of this music will find much to enjoy. The performance is impressive—I had no score, but the results are musically convincing—and the recording is clear and attractive.

E.S.

CASADESUS: *Sonata for Cello and Piano; Trois Berceuses for Solo Piano* (see HINDEMITH)

CHERUBINI: *Missa Solemnis in D Minor*. Patricia Wells (soprano); Maureen Forrester (contralto); George Shirley (tenor); Justino Diaz (bass); Clarion Concerts Orchestra and Chorus, Newell Jenkins cond. VANGUARD VCS 10110/11 two discs \$7.96.

Performance: **Very good**
Recording: **Good**

This is a large-scale work, composed in 1811 by one of the most influential musical figures of the era at the height of his powers. The writing for both vocal ensemble (there are no extended solo parts) and orchestra is skillful, clearly organized, and rich in sound. But the spark of true inspiration flickers only intermittently: the "Qui tollis" portion of the *Gloria*, the "Et incarnatus est" with its alternating *a cappella* and accompanied vocal portions, and the *Benedictus* reveal noteworthy inventiveness. Unfortunately, the rest of this lengthy (almost eighty minutes) Mass offers a reasonably good explanation of why posterity has found so little to value in the enormous output of Luigi Cherubini.

Newell Jenkins presides over a presentation that shows the signs of painstaking preparation. The four singers are excellent, and the recording is clear and well-balanced except for some distortion in the massed choral passages.

G.J.

CHOPIN: *Fantasia in F Minor, Op. 49* (see SCHUMANN)

DEBUSSY: *Estampes; Pour le piano; Images, Sets I and II*. Michel Beroff (piano). ANGEL S 36874 \$5.98.

Performance: **Classical**
Recording: **Strong**

Michel Beroff is a young French pianist who has, in just a few years, made a substantial European reputation and will undoubtedly make an equal impression on this continent. This disc is one of his two first recorded appearances here, and it is a pretty impressive debut: strong, controlled, musical, well articulated. One thinks immediately of that other Frenchman prominent on the scene these days: Pierre Boulez. Beroff has the same incisive clarity in his playing, and similar qualities of musicality and intelligence.

Oddly enough, the result here is a very classical view of Debussy. Whereas Boulez connects Debussy, the tremendous innovator,



PIERRE MONTEUX

A very special Dvořák Seventh Symphony

with his own music and our own times, Beroff seems to locate traditional pianistic and formal qualities—or, in the case of an early Classicized work like *Pour le piano*, brings them out strongly. Obviously this is not an Impressionist-Romantic sort of Debussy, and it will not be to everyone's taste. But Debussy was a Frenchman, and in fact very French in his combination of the elliptical, the allusive, and the indirect on the one hand with clarity and symmetry on the other. With this in mind, I think Beroff's interpretations hold up. Indeed, it is in the *Images* (along with the Preludes the least Classical and the most evocative of his piano works) that his playing is most effective. The piano sound is strong, though not especially beautiful.

E.S.

D'INDY: *Le Camp de Wallenstein, Op. 12, No. 1* (see ROUSSEL)

DONIZETTI: *Operatic Arias* (see Collections—Mattia Battistini)

DVOŘÁK: *Symphony No. 7, in D Minor, Op. 70*. Berlin Philharmonic Orchestra, Rafael Kubelik cond. DEUTSCHE GRAMMOPHON 2530 127 \$6.98. © L 3127 \$7.95, © 3300 224 \$6.98.

DVOŘÁK: *Symphony No. 7, in D Minor, Op. 70; Overture—My Home, Op. 62*. London

Symphony Orchestra, Witold Rowicki cond. PHILIPS 6500287 \$6.98.

DVOŘÁK: *Symphony No. 7, in D Minor, Op. 70*. London Symphony Orchestra, Pierre Monteux cond. LONDON STS 15157 \$2.98.

Performance: **Kubelik and Monteux tops**
Recording: **I like Monteux**

The impassioned and somewhat Brahmsian D Minor Symphony of Dvořák has not suffered for lack of distinguished recorded performances since that of Václav Talich and the Czech Philharmonic back in the 78-rpm era.

Of the three readings under consideration here, the Kubelik and the 1960-vintage Monteux (now in its third incarnation after earlier issues on RCA and Victrola) fall definitely into the "distinguished" category. Kubelik goes all out for the subjective and impassioned elements of the score, bringing home in no uncertain terms his conviction that this is Dvořák's real *Sturm und Drang* Symphony. The Berlin players respond magnificently here, but I wish the sound were as rich in the low register as on most other DGG discs I've heard; this one seems to suffer from a bit of excessive mid-range pre-emphasis.

London has done a wonderful job in reprocessing Pierre Monteux's fine 1960 performance—no lack of rich sonics here—and the woodwinds sound gorgeous throughout. In contrast to Kubelik, Monteux treats the music as a work in the great Classical-Romantic tradition, emphasizing in his own special Gallic way the proportion, the balance, the *mésure* that make the most coherent and telling whole of the work. The developmental sections of the first and last movements are particular examples in point.

I wish I could say as much for Witold Rowicki's recorded performance, but for me it has neither Kubelik's passion nor Monteux's structural command of the whole. The performance and recording are not bad; Rowicki is simply outclassed by the competition. The bonus of the *My Home* Overture adds little to the balance for me, since it is minor Dvořák and can also be heard in the excellent Kertész reading as a filler to the *New World* Symphony on London.

Put the Monteux recording down as the best buy.

D.H.

ENESCO: *Prelude for Solo Violin, Op. 9* (see JOACHIM)

FIELD: *Nocturnes: E-flat Major, C Minor, A-flat Major, A Major, B-flat Major, C Major, C Major, F Major, A Major, E-flat Major, E Minor, E-flat Major, G Major; Berceuse in F Major; Malinconia in D Minor; Reverie-Nocturne in C Major; Nocturne Pastorale in E Major; Nocturne caractéristique "Midi" en forme de Rondo in E Major; Reviens Cavatine*. Hans Kann (piano). MUSICAL HERITAGE SOCIETY MHS 1450/51 two discs \$2.98 each (plus 65¢ handling charge from Musical Heritage Society, Inc., 1991 Broadway, New York, N.Y. 10023).

Performance: **Perfunctory**
Recording: **So-so**

Poor John Field. His languid, dreamy playing enraptured Europe and set the tone of poetic melancholy and introspection that was to play such an important role in Romantic sensibility. He developed a new piano style, and, years after his death, his nocturnes and

(Continued on page 114)

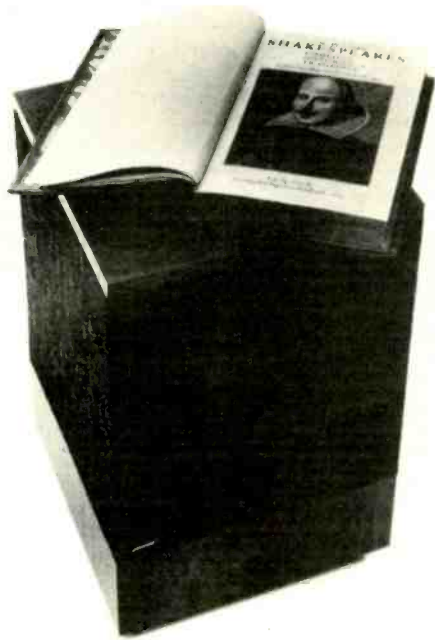

“If music be the food of love, play on.”

TWELFTH NIGHT, Act I, Scene i, Line 1

In past articles we have discussed the research and the technology behind the Bose Direct/Reflecting® speakers. It would indeed be misleading for us to imply that the unprecedented series of rave reviews and the worldwide acceptance of these speakers is the result of only the research and technology that gave birth to their new design¹. While these factors are absolutely necessary, they are far from sufficient to provide the performance for which these speakers are famous.

The more accurate the performance of any instrument or loudspeaker, the more apparent are small imperfections. Variation in the responses of individual speaker drivers, that might be masked by performance limitations inherent in the basic design of conventional speakers, can become annoyingly apparent with the accuracy of music reproduction associated with Direct/Reflecting speakers. The realization of this fact has led us to develop *quality control* measures that we think have no close second anywhere in our industry.

Here are some of the items we check:

1. Acoustical properties of the cone material
2. Annulus material and doping
3. Thickness and bond of the critical glue joints where the cone joins the voice coil bobbin. Errors in either direction can cause audible coloration
4. Density of voice coil winding
5. Flux density in the magnetic circuit
6. Sixteen mechanical parameters are checked ranging from the length of the flexible voice coil leads to the centering tolerance of the voice coil
7. Power tests to check for possible thermal problems
8. Accelerated humidity tests
9. Power sweeps after complete assembly in cabinet to check for any extraneous noises
10. Extensive computer checking of all parameters in the 901 active equalizer

Some of the items in this list cannot be directly tested after the speaker is assembled. For example, we can't see the glue joints or the voice coil. These tests and many others are made by our newly developed Syncom™ speaker testing computer. In addition, this computer selects matched drivers for each 901; and it matches the woofers and tweeters in each 501. One of the significant achievements of this computer is that its measurements are directly related to audible effects rather than to typical specifications whose correlation to audible performance has not been established. When the Syncom computer rejects a speaker, it means that a critical listener could hear the difference between that particular speaker and our standard of quality – more on this in a later issue.

When you couple this unique *quality control* system with all the technology behind the Direct/Reflecting speaker systems, you can appreciate our confidence in asking you to A-B the 901 with any speaker regardless of size or price. And while you're at it, audition the 501 against direct radiating speakers costing several times as much.

*Photograph of Shakespeare First Folio
courtesy of Harvard College Library*



¹For copies of the reviews, circle our number(s) on your reader service card.

²Copies of the Audio Engineering Society paper, ON THE DESIGN, MEASUREMENT AND EVALUATION OF LOUDSPEAKERS, by Dr. A. G. Bose, are available from the Bose Corporation for fifty cents.

You can hear the difference now.

BOSE®

Framingham, Massachusetts 01701

the memory of his playing could evoke the highest praise from no less a devotee than Franz Liszt.

But Field's magic powers have long since been dispelled. Now and again, a pianist or an enterprising record company gives Field a trial, but to no avail. No one listening to these dutiful performances, for example, could figure out very much about the spell that the melancholy Irishman cast over the nineteenth century. For one thing, this music was very much tied to the social situation that produced it. Field's nocturnes were written for the salon and the parlor. They were meant to be played for oneself or, at the most, an intimate circle of friends. They were to create reverie and gentle moods, to caress the emotions. The source of the music is to be found, not in earlier keyboard literature, but in the elegant and romantic cavatins of the Italian opera—a point that all concerned with this recording seem to have missed. This music is meant to be played at least as freely as an expressive aria might be sung—indeed, *more* freely, for in privacy the pianist is confiding in his piano, and all manner of dreamy rubato, pearly embellishment, and sighing ritardando are possible. And nothing less will do. But what we get here is earnestness and good intentions. Well, maybe some day. *E.S.*

GUTCHÉ: *Genghis Khan, Op. 37* (see PENDERECKI)

HARBISON: *Parody-Fantasia* (see PLESKOW)

HINDEMITH: *Sonata for Cello and Piano (1948)*. **CASADESUS:** *Sonata for Cello and Piano (1936)*; *Trois Berceuses for Solo Piano*. Zara Nelsova (cello); Grant Johannesen (piano). GOLDEN CREST □ CRS 4099 \$5.98.

Performance: **Superb**
Recording: **Superb**

Here are two top-flight artists playing music with which, judging by their stunning performances, they are thoroughly *en rapport*. The sonatas of both Hindemith and Robert Casadesus (yes, this is the late *pianist*) are lyrical works, well wrought in line, texture, and form, and handsomely representative of the decades in which they were composed.

Nelsova has one of the great cello tones of our era, and it is a delight to hear her instrument singing chastely or passionately the melodies of the two works, one so thoroughly German neo-Classical and the other so French neo-Romantic. Grant Johannesen provides a piano collaboration that is brilliantly virtuosic and at the same time a model of chamber music subtlety. This is a compatible quadraphonic recording, and I am listening to it in stereo. It makes a splendid sound; in SQ four-channel stereo it may be even more impressive.

The three Casadesus *Berceuses* for solo piano (1931) are piquant, sometimes "blue-sexy" lullabies with an amiable Romantic disposition. No revelations, but nice. *L.T.*

HONEGGER: *Symphony No. 2 for String Orchestra and Trumpet*; *Symphony No. 3, Liturgique*. Berlin Philharmonic, Herbert von Karajan cond. DEUTSCHE GRAMMOPHON 2530 068 \$6.98.

Performance: **Poor**
Recording: **Excellent**

On this recording of Honegger's *Symphonie Liturgique*. Herbert von Karajan does a

remarkable job of missing every point. If I had not known in advance that this was a piece by Honegger, I would have had a hard time guessing who wrote it, so completely have both style and substance been misrepresented. The first movement has become a pastiche of gestures befitting such composers as Strauss and Prokofiev; the second (when it is not meaninglessly vague) might be by Delius abetted by a drunken copyist. The third revokes Prokofiev and adds a little Shostakovich. It is hard to understand how Karajan could so thoroughly evade the true character of this music. In doing so, he has created the illusion of weakness where, in fact, none exists, and he has negated every one of the symphony's strengths.

His performance of *Symphony No. 2* is so obviously painstaking and sincere that I regret having to say that it, too, largely misses the particularity of Honegger's style. Here,



Golden Crest

ZARA NELSOVA

One of the great cello tones of our era

for much of the distance, Wagner seems to have been the stereotype in Karajan's closet. Textures and melodic lines of the flowing movements are given a smooth, almost oily patina that simply is not appropriate to Honegger, who always mixed sandy grit into his sweetness. Without it, the music's intimacies become uncomfortable. *L.T.*

HUBAY: *Hejre Kati for Violin and Orchestra* (see JOACHIM)

HURNÍK: *Musica da Camera (Komorní Hudba)*. Prague Chamber Soloists, Eduard Fischer cond. **KORTE:** *Říběh Fléten ("The Story of the Flutes")*. Géza Novák and František Čech (flutes); Zdeněk Jílek (piano); Czech Philharmonic, Lovro von Matačić cond. SUPRAPHON 1 10 0964 \$5.98.

Performance: **Okay**
Recording: **Good**

These are two middle-generation Czech composers of essentially local reputation. Although the liner notes insist that Hurník's "chamber music" for strings does not resort to "neo-Classicism," it is hard not to associate it with that widespread international movement—even to the point of being reminded of Stravinsky now and then in the midst of a basically heavier, more dissonant

style. One should not deny the music its share of individuality and invention, particularly in the last movement, with its striking use of sustained notes held through a series of violent *sforzando* attacks.

In contrast to this rather sophisticated and engaging music, Korte's symphonic drama *The Story of the Flutes* is a rather naïve piece of tardy Romanticism. Czechoslovakia produced a great deal of musical cross during the difficult post-war years, and I'm afraid this piece isn't even good escapism. *E.S.*

HUSA: *Music for Prague 1968* (see PENDERECKI)

RECORDING OF SPECIAL MERIT

JOACHIM: *Concerto for Violin and Orchestra, Op. 11 ("Hungarian")*. **HUBAY:** *Hejre Kati for Violin and Orchestra, Op. 32*. **ENESCO:** *Prelude for Solo Violin, Op. 9*. Aaron Rosand (violin); Orchestra of Radio Luxembourg, Siegfried Köhler (in Joachim) and Louis de Froment cond. CANDIDE CE 31064 \$3.98.

Performance: **Excellent**
Recording: **Favors fiddle**

Joseph Joachim's reputation as a great fiddler has survived the vicissitudes of time, but his works have not. Of his three violin concertos, the once-famous "Hungarian" surely deserves a small corner of the repertoire. Good violin concertos are in notably short supply, and it is probably safe to predict that good new ones are not likely to turn up in any quantity in the near future. The age of the fiddle has passed, alas, and guitars, drums, and synthesizers are more representative of the modern temperament.

Still, the Joachim Concerto has as much right to our attention as the Wieniawski. No, *more* right; it's a much better work! The surprise here is the seriousness, imagination, and craftsmanship that easily take the measure of Bruch, Glazounov, Vieuxtemps, or any number of other composers on the violinistic fringes.

What the work needs, of course, is champions. Fortunately, it has found a couple in violinists like Charles Treger and Aaron Rosand. I have not heard Treger play this work, but I find Rosand a very impressive and persuasive advocate of the kind of old-fashioned fiddle playing that is necessary to make anything out of this music. If schmaltzy string playing is to come back, let us hope it continues to be presented with as much taste, skill, and musicality as it is here.

The Joachim Concerto, a substantial piece of work in more ways than one, has in fact been slightly cut down in this version—probably an unnecessary caution. This does offer Rosand a chance to show off his skill in the Hubay *Hejre Kati*—in the kind of gypsy creampuff style that Joachim entirely avoids—and the serious, spare Enesco Prelude. But, after all, no one is going to buy this recording for the encores, and it could certainly not have been too difficult to fit in the entire concerto. The recorded sound is very good, allowing for a substantial bias in favor of the soloist—but then that was the point of the recording in the first place. *E.S.*

JOHNSON: *Woodwind Quintet* (see PLESKOW)

(Continued on page 116)

Tandberg tops Tandberg three ways

With the new 9000X 3-motor tape deck,
the new 3300X medium-price deck.
And the new TCD-300 stereo cassette deck.

At Tandberg we aim for just one level of quality . . . the highest. Now we've topped ourselves. With three new tape machines unmatched in sound and specifications.

Our new top-of-the-line is the three motor 9000X with the most sophisticated logic control system in tape recorder history. 15 integrated circuits do the work of almost 700 transistors to assure flawless, fingertip operation and proper sequential functions. True one hand tape threading.

And a rugged new remote controllable transport, with servo brakes, tape tension arms for maximum stability and gentle tape handling.

We have even improved our unexcelled Crossfield recording technique, that provides startlingly true full frequency response and noise free recording at 3³/₄ ips. In fact, the 9000X is limited only by the quality of tape you record with. Linear motion input/output potentiometers, sound on sound, echo, mono mixing, monitoring, front panel 8 ohm headphone output.

The 9000X is a professional quality machine for home use. Just \$649.50

Tandberg's brilliant new 3300X will set a new standard of excellence in the medium price field. A slightly less sophisticated version of the 9000X, it features a rugged new transport, with improved Tandberg Crossfield recording. Its record/playback response and signal/noise ratio are better at 3³/₄ ips than most other recorders at twice the price and at twice the speed. The 3300X features easy to use illuminated peak reading meters to eliminate guesswork, slide potentiometers, echo, sound on sound, mixing, front panel headphone jack and monitoring facilities with photoelectric end-stop. All for just \$399.80

And now—the world's first three motor, dual capstan, ferrite head, dolbyized cassette recording deck—The Tandberg TCD-300.

That's right—three motors. One precise hysteresis synchronous drive motor for constant tape speed. Two D.C. reel motors which let you wind or rewind a C-60 in 40 seconds. Dual capstans to provide maximum stability and minimum wow and flutter—even with poor cassette tapes. Hard pressed ferrite head so tough it can be guaranteed against wear for the life of the machine. Dolby, CrO₂ tape switches to optimize performance and produce an incredible 63 dB s/n ratio. Real head room to minimize distortion.

Dual Peak Reading meters, electronic push button control, servo-controlled wind, rewind and autostop, built in microphone preamplifiers, and a recording/playback quality equal to many reel-to-reel recorders.

At last a true music fidelity cassette recorder. Sound exciting? You bet, and only \$350.00

So there you have them—a Tandberg trio of newsmakers. And they're made the only way we know how . . . better.

At last a true music fidelity cassette recorder. Sound exciting? You bet, and only \$350.00

So there you have them—a Tandberg trio of newsmakers. And they're made the only way we know how . . . better.

So there you have them—a Tandberg trio of newsmakers. And they're made the only way we know how . . . better.

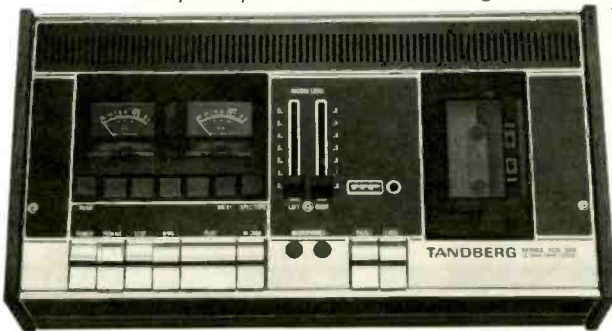

TANDBERG

We're our only competitor.

TANDBERG OF AMERICA, 8 THIRD AVENUE, PELHAM, NEW YORK 10803
A. Allen Pringle Ltd., Ontario, Canada

KILPINEN: *Eight Songs* (see SCHUMANN)

RECORDING OF SPECIAL MERIT

KODÁLY: *Orchestral Songs: Two Songs, Op. 5; Mónár Anna.* György Melis (baritone). *Three Songs, Op. 14.* József Simándy (tenor). *Kadár Kata.* Márta Szirmai (contralto). Hungarian Radio and Television Orchestra, György Lehel cond. HUNGAROTON LPX 11450 \$5.95.

Performance: **Superb**

Recording: **Superb**

I have no doubt these orchestral songs will be as unfamiliar to most people as they are to me. But they are fascinating. Not only do they illustrate the extent of Debussy's influence on Kodály, but they also show the intimate connection between the rhythms of the Hungarian language and the rhythms of both Kodály's and Bartók's music, instrumental and vocal alike. In these songs Kodály's melodic lines are gracefully designed for the human voice, and he surrounds them with rich tapestries of orchestral sound, replete with telling little woodwind gestures and modal scales that link his Hungarian folk-music background and Debussy's French-exotic style. Coming to my ears late, the music sounds a bit dated, and certainly none of these works match the intensity of vocal utterance Bartók achieved in *Bluebeard's Castle*. But they are handsome works, luxuriant, moody, and well worth knowing. The performances by everybody on this recording are exemplary. And, like all the Hungaroton discs I have reviewed, this one sounds gorgeous. *L.T.*

KODÁLY: *The Spinning Room.* Erzsébet Komlóssy (contralto), Hostess; György Melis (baritone), Sutor; József Simándy (tenor), Young Man; Zsuzsa Barlay (contralto), Neighbor; Eva Andor (soprano), Girl; Sándor Palcsó (tenor), "The Flea." Chorus of Hungarian Radio and Television; Budapest Philharmonic Orchestra, János Ferencsik cond. HUNGAROTON LPX 11504/5 two discs \$11.90.

Performance: **Good**

Recording: **Very good**

Like *Háry János*, which preceded it by six years, *The Spinning Room* (1932) grew out of Zoltán Kodály's folklore research. It is a work for the stage—and a lively and very colorful one, at that—but not an opera. Songs and dances of Transylvanian Hungarians are woven into a dramatic sequence of sorts, with scenes following in diversified and clever continuity. But the music's the thing: not only the engaging material itself, but Kodály's endlessly inventive and beautifully harmonized treatment of it.

When the previous mono recording of *The Spinning Room* appeared (December 1961), I deplored its "limited dynamic range and lack of resonance." No such reservations apply here. The sound is rich and spacious; Kodály's fanciful orchestration and intricate choral arrangements are brilliantly served. János Ferencsik, the best Hungarian conductor working in Hungary today, is again at the helm. His pacing is considerably more deliberate than it was a decade ago, and details are lovingly brought out in a treatment of absolute authority.

I was not happy about the singing ten years ago and I am not particularly happy about it now. There are some good voices here

(particularly Komlóssy, Barlay, and Palcsó), but their heavy vibrato has a grating effect. The singing is not really bad, but not as good as the music deserves. The album, on the other hand, is richly annotated and illustrated, and the text is given in four languages. *G.J.*

KORTE: *Příběh Fléten* (see HURNÍK)

LADERMAN: *Stanzas* (see BERIO)

LISZT: *Hungarian Rhapsodies (complete): Nos. 1, 7, 11* (Erika Lux, piano); *Nos. 2, 9, 15, 16; Spanish Rhapsody* (Kornél Zempléni, piano); *Nos. 3, 10, 17, 18, 19* (Erzsébet Tusa, piano); *Nos. 4, 5, 14* (Gabriella Torma, piano); *Nos. 6, 8, 12, 13* (Gábor Gabos, piano). HUNGAROTON LPX 11488/89/90 three discs \$17.94.

Performances: **Good, not great**

Recording: **All right**

Until this record arrived, frankly, I didn't even know that Franz Liszt wrote nineteen



ZOLTÁN KODÁLY
Inventive folklorist/composer

Hungarian Rhapsodies; not more than two or three are familiar. Most of them grew out of arrangements of folk, popular Hungarian, and gypsy tunes that Liszt originally adapted as showpieces and that later evolved into the more highly elaborated form of the Rhapsodies. Mostly they follow the well-known slow-fast pattern, but there's plenty of variation within that outline. Most of them have strong virtuoso elements with free, schmaltzy first sections, faster things to come, plenty of cadenzas along the way, and slam-bang finishes. Nineteen—or any sizable fraction thereof—is a lot to take at one sitting, but amid the endless stream of pianistic *espressivo*, ornament, wit, passion, color, vivacity, and power, there's plenty of music, too.

The first eight are relatively standardized in form; it is in the next group—the *Carnival of Pest* through the *Rakoczy March* and the *Rhapsodie Espagnole*—that Liszt really hits his stride. Of the last four Rhapsodies, dating from the very end of his life, only No. 19, a really beautiful and striking work, is like the earlier ones; the others are cold, dissonant, and eccentric.

The five pianists, all well known in Hungary, are little known outside that country. The

performances here are good, though not really outstanding: everyone handles the music well enough but again and again falls just short of the top in strength and passion. Perhaps Erzsébet Tusa's performance of No. 10 is the musical high point, but it is just a cut above the rest.

It seems to me that the performances suffer from inferior pianos; the poor quality of the instruments, not the recordings *per se*, is the major shortcoming of the sound. The recordings vary somewhat in quality, and some of them have a small but distinct quaver in the piano tone—faulty recording equipment, no doubt. None of this is overwhelmingly serious if you are really determined to have *all* the Hungarian Rhapsodies. Since no other recording even comes close, this has to be it. *E.S.*

MARTIN: *Harpsichord Concerto; Ballade for Trombone and Orchestra; Ballade for Piano and Orchestra* (see Best of the Month, page 80)

MASSENET: *Fantasy for Cello and Orchestra* (see AUBER)

ILHAN MIMAROGLU: *Wings of the Desirious Demon; Anacolutha: Encounter and Episode II; Interlude II; Prelude No. 8; Provocations; White Cockatoo; Hyperboles.* Columbia-Princeton Electronic Music Center. FINNADAR (ATLANTIC) SR 9001 \$5.98.

Performance: **Electronic**

Recording: **Original tape pieces**

Ilhan Mimaroglu, a Turkish composer active in this country for a number of years, is one of the most adroit tape composers around. Most of his pieces manipulate recorded sounds of instruments and voices, and, as usual, I find the combination of tape sounds with the unaltered (that is, recognizable) human voice to be an effective form.

Many of these pieces are based on instrumental transformations which, as they gain in color, seem to lose in recognizable content. Thus, the short instrumental pieces—a prelude based on celesta and harpsichord sounds, and *Provocation* with still-recognizable clarinet sounds—are effective because they work out of recognizable entities, starting from known quantities and working out towards the unknown. Similarly, *Hyperboles*, in a sense the "pop" piece on the album, is fully realized because it generates its tensions and alienations out of pulsation and obsessiveness—also recognizable departure points. On the other hand, the two big pieces on side one of this disc seem to me less successful, for they are symphonically composed out of highly abstracted material. At any rate, all of it is skillful and well worth listening to. Indeed, good new electronic recordings, so common just a short time ago, are now coming out so infrequently that an album like this is something of an event. *E.S.*

MOZART: *Adagio and Fugue in C Minor (K. 546).* **BEETHOVEN: *Grosse Fuge in B-flat Major, Op. 133*** (orchestral version). **R. STRAUSS: *Metamorphosen—Study for 23 Solo Strings*** (1945). Berlin Philharmonic Orchestra, Herbert von Karajan cond. DEUTSCHE GRAMMOPHON 253 0066 \$6.98.

Performance: **Lush**

Recording: **Likewise**

A somber and heavyweight string orchestra
(Continued on page 118)



if you are
serious about
music
use the tape
of the pro.
TDK

When it comes to tape, do like the pros do — use TDK.

TDK, renowned among artists and producers the world over for unrivaled purity and fidelity, gives you greater dynamic range and maximum output levels for "real life" sound.

TDK offers the widest choice of formulations and lengths in cassettes, 8-track cartridges and open-reel tape.

If you're into music, use the tape that's in with the pros — TDK.



Purity in Sound

Make recordings like a pro. Get TDK's Better Recording Kit FREE when you buy any 5 TDK cassettes:

- Free "Guide to Better Recordings"
 - Free TDK C-60SD Super Dynamic cassette
- See your TDK dealer for details.



CIRCLE NO. 50 ON READER SERVICE CARD



TDK ELECTRONICS CORP
23-73 48TH STREET, LONG ISLAND CITY, N.Y. 11101 • 212-721-6881
In Canada, contact: SUPERIOR ELECTRONICS INC Montreal



program this, but in ideal concert or recorded performance each one of these works can be a profoundly moving experience. Adolf Busch, Otto Klemperer, and Bruno Walter are three conductors who quickly come to my mind in this connection; and happily, I had the Klemperer recordings of all three works on hand for direct comparison.

By no stretch of the imagination does Karajan match the fierce and sinewy strength that Klemperer brings to the Mozart and the Beethoven (Klemperer's *Grosse Fuge* recording is no longer available, but Ansermet's London Stereo Treasury disc is a good alternate choice). I am especially unhappy with Karajan's Beethoven reading. It emphasizes dynamic variety rather than structural cohesiveness and momentum: Karajan needs a full twenty minutes for the *Grosse Fuge* whereas even Furtwängler (Heliodor HS 25078) required only eighteen minutes and twelve seconds—and Furtwängler was not averse to dwelling on detail. That this is an orchestral version, by the way, has nothing to do with my unhappiness with it—to me the *Grosse Fuge* can be just as impressive and terrifying in a string orchestra performance as in a string quartet performance (the Yale Quartet's Vanguard version runs fourteen minutes and fifty-eight seconds).

Karajan conducted the Vienna Philharmonic for the first recording of the Strauss *Metamorphosen* on English Columbia shortly after World War II, and I had every hope that his new DGG recording would match the excellence of his original. But here I find that the church-like ambiance of the recording plays both him and Strauss false. Among other things, the acoustic makes it impossible to tell whether there are twenty-three or forty-six players participating, let alone to follow in detail Strauss' cunning tonal fabric. Klemperer's Angel recording sets the standard here, for not only are the individual instruments distinctly perceptible from the very beginning but, more important, there is a sense of inevitable growth, of true metamorphosis.

I regret having so little positive to say about what should have been a series of great recorded performances by an eminent conductor. I am deeply disappointed in this disc, but the repertoire is so fine that I am glad good alternate versions are available. *D.H.*

MOZART: Operatic Arias (see Collections—Mattia Battistini)

MOZART: Piano Concerto in F Major (K. 459); Piano Concerto in A Major (K. 488). Alfred Brendel (piano): Academy of St. Martin-in-the-Fields, Neville Marriner, cond. PHILIPS 6500 283 \$6.98.

Performance: **Excellent**
Recording: **Excellent**

Pianist Alfred Brendel and the orchestra of the Academy of St. Martin-in-the-Fields give beautifully musical and sensible performances of these two Mozart piano concertos. They are so "comfortable" that one has almost a sense of casualness throughout, despite the fact that almost everything is in the neatest possible order. Nothing in the liner notes indicates that this is a tape from a live performance, but it sounds very much like that. The lack of tension and the equal lack of that super-high styling that can usually be achieved only with editing assistance seem to point in that direction. In any event, both concertos receive fine, warm performances, sure to liven

the atmosphere of any household on a rainy afternoon. *L.T.*

PENDERECKI: De Natura Sonoris No. 2. GUTCHE: Genghis Kahn, Op. 37. HUSA: Music for Prague 1968. Louisville Symphony Orchestra, Jorge Mester cond. LOUISVILLE FIRST EDITION LS 722 \$5.95.

Performance: **Superb**
Recording: **Superb**

This new recording by the Louisville Orchestra under Jorge Mester's direction sets a new high point for the series. The orchestra sounds more precise, luxurious, and sentient than it ever has; it has gone into an entirely new world of orchestral excellence. In addition, the music on the disc is interesting (even when you don't agree with it), and in the case of Karel Husa's *Music for Prague* it is just masterly.

BMI Archives



KAREL HUSA, Pulitzer Prize winner. His *Music for Prague* is imaginative, well-composed, and heartfelt.

Husa was awarded a Pulitzer Prize for his Third String Quartet a couple of years ago, and I could not understand why that particular work, all by itself, called forth such commendation. But I myself, if I could, would award a Pulitzer Prize to his *Music for Prague*, which is one of the most imaginative, well-composed, and heartfelt works I have heard in a long time. Husa composed it to express his thoughts about his birthplace (he left Prague in the Forties), and it makes his point compellingly. To my mind, the percussion "Interlude" is a weak spot in the composition and the performance, but with this exception I say *bravo* five times over to both Husa and Mester.

Krzysztof Penderecki I consider a clever musical fraud, so my reaction to his *De Natura Sonoris No. 2* will have to be understood within that frame of reference. In terms of presentation, Mester and the Louisville Orchestra do the piece up proud. Indeed, I'm glad the thing was on this record—for it provides a chance to compare its depressing charlatanry and vacuousness with Husa's deep honesty, and with the good heart and mind of Gene Gutché.

The Gutché *Genghis Khan* was not a work I expected to admire, but I ended up doing so, thanks to the music's own virtues and those of the Louisville Orchestra. What the work has to do with *Genghis Khan* I can't imagine, but, though it is somewhat bombastic and certainly does end without discernable warning, it is a sturdy orchestral utterance and good to hear. *L.T.*

PERGOLESI: La Serva padrona. Reiner Süss (bass), Uberto; Olivera Miljakovic (soprano), Serpina. Staatskapelle Berlin, Helmut Koch cond. TELEFUNKEN SLT 43126 \$5.98.

Performance: **Lacks sparkle**
Recording: **Good**

This is a well-prepared and meticulous performance of Pergolesi's little gem of a comic opera, but it lacks the zestfulness interpreters born to the style can bring to it. Though Reiner Süss is a seasoned buffo, his Germanic Italian mangles the text, and his dry voice is no help. Olivera Miljakovic sings her part well enough but without realizing the comedy in the recitatives. The conducting, adequate most of the time, is plodding in some scenes, particularly in the basso's "*Son imbrogliato io già.*"

There is an outstanding performance of this opera available on Everest 455, which fea-

tures Renata Scotto and Sesto Bruscantini and is conducted by Renato Fasano. *That* is highly recommended. *G.J.*

PLESKOW: Movement for Nine Players. Contemporary Chamber Ensemble, Arthur Weisberg cond. *Bagatelles No. 3.* Lewis Kaplan (violin). *Per Vege Viene.* Lewis Kaplan (violin); Walter Ponce (piano). **HARBISON: Parody-Fantasia.** Robert Miller (piano). **JOHNSON: Woodwind Quintet.** Dorian Quintet. COMPOSERS RECORDINGS INC. CRI SD 293 \$5.95.

Performances: **Outstanding**
Recording: **One side dry**

This is one of that endless series of worthy CRI releases whose purpose in the eternal scheme of things is obscure. All of the works are well written in solid modern idioms, all are excellently performed, and everything is respectable and artful. Few people will hear this music, and fewer still will buy this record. And yet these are all artists, and their work is as serious, imaginative, and talented as, say, most of what passes for art in the Madison Avenue galleries. What, one may ask, is the point of it all? What is art in late twentieth-century America anyway?

These are very disturbing and perplexing questions, and not entirely irrelevant to the music at hand. However, in fairness, a few more specific comments are required. Raoul Pleskow's lively and inventive music—in the tradition of his teacher Stefan Wolpe, but with considerable individuality—provides the strongest impression, though the three pieces

sound like movements of a single work. John Harbison's and Roger Johnson's works are very well recorded, but the record side is noisy. Pleskow's works receive a somewhat dryish recording but a much cleaner surfaces. *E.S.*

POPPER: *Cello Concerto No. 2, in E Minor, Op. 24* (see **AUBER**)

RAFF: *Ode to Spring, for Piano and Orchestra, Op. 76.* Michael Ponti (piano); Hamburg Symphony, Richard Kapp cond. *Symphony No. 3 ("Im Walde"), Op. 153.* Westphalian Symphony Orchestra, Recklinghausen, Richard Kapp cond. **CANDIDE CE 31063 \$3.98.**

Performance: **Commendable**
Recording: **Good**

The fate of Joachim Raff (1822-1882) is an excellent reminder of how a once-admired composer can quickly be almost completely forgotten—though Raff's violin *Cavatina*, which was a favorite encore piece earlier in this century, is still occasionally performed. The composer received encouragement early in his career from both Mendelssohn and Liszt. His principal occupation seems to have been teaching, but he wrote operas, orchestral and chamber pieces, and a large number of piano compositions, all of which eventually made him an established figure in Germany. Most of Raff's symphonies have a typically late-nineteenth-century program, and his Third Symphony, subtitled "In the Forest," is no exception, as a glance at the movement headings shows—(1) Daytime: impressions and feelings; (2) In the Twilight; (3) Dance of the Dryads; (4) At night: gently weaving silently through the woods, entry and exodus of the wild hunt, daybreak.

What does the music sound like? Well, there's some Mendelssohn (a little *Midsummer Night's Dream* in the first movement), some Liszt (the bombast of the last-movement hunt), some echoes of Schumann and Brahms (especially the horns), long build-ups à la Bruckner, a sampling of Smetana and Wagner, and, in the theme of the finale and its reliance on sequences, a foretaste of the third movement of Tchaikovsky's "*Pathétique*." It's certainly not great music, but its atmosphere and German-Romantic mien are worth a brief acquaintance. What really brought poor Raff to his present pass, I think, is the utter lack of distinction of his themes; everything is well put together in the style typical of his period, but there is hardly a theme worth whistling.

I did find the symphony interesting, but I am afraid that the somewhat earlier *Ode to Spring* is a waste of time and record space. If you enjoy empty music, lots of noise and piano figuration, endless sequences, and themes of no character whatsoever, this is your thing!

The performances are highly competent; though the orchestral playing is not overly refined, Richard Kapp, whose work in some Rameau operatic excerpts I have admired in the past, shapes the music quite effectively and elicits some sensitive phrasing from his wind players. He is, I think, a conductor to watch. Michael Ponti copes brilliantly with the solo in *Ode to Spring*, but I wonder why anybody would want to bother. Sonically, the disc is quite good; the end of the second side, however, is distorted, and the orchestra is rather too distant for much detail to stand out. *I.K.*

REGER: *Variations and Fugue in B-flat Major, Op. 86; Introduction, Passacaglia and Fugue in B Minor, Op. 96.* Alfons Kontarsky and Aloys Kontarsky (pianos). **MUSICAL HERITAGE SOCIETY MHS 1292 \$2.98** (plus 65¢ handling charge from Musical Heritage Society, Inc., 1991 Broadway, New York, N.Y. 10023).

Performance: **Very good**
Recording: **Distant**

There are, no doubt, many good things to be said in Reger's behalf, but, after all is said, this is still morose, long-faced music, absolutely infested with chromatic creeper-crawlers. What for Beethoven was a bagatelle (literally—Op. 119, No. 11) is here subject for a massive set of two-piano musings. The "Diabelli" Variations are one model, no doubt, but Reger lacks Beethoven's wit and incisiveness. Brahms provides a better point of comparison, and in some detailed respects—individual variations of great beauty—Reger's work stands up to such a comparison surprisingly well. But the sheer dimensions, the endless seriousness (culture with a capital K), and the contrapuntal wimble-wamble—two pianos can manage an awful lot of notes! finally do the composer and his listeners in. What Reger lacked was a larger sense of proportion and timing. This defect shows up particularly in the Introduction and Passacaglia. The lively, clockwork Fugue of Opus 96 is almost a relief; indeed, both fugues provide sprightly, comic relief where humor is least expected.

Except for a moment or two of what seems like non-togetherness, these are good performances, but I found the piano sound somewhat lacking in presence. *E.S.*

ROUSSEL: *Le Festin de Paraignée, Op. 17.* Unidentified symphony orchestra, Albert Roussel cond. **D'INDY:** *Le Camp de Wallenstein, Op. 12, No. 1.* Unidentified symphony orchestra, Vincent d'Indy cond. **SCHMITT:** *La Tragédie de Salomé, Op. 50.* L'Orchestre des Concerts Straram, Florent Schmitt cond. **PERENNIAL 2006 \$6.00** (available from Perennial Records, P.O. Box 437, New York, N.Y. 10023).

Performance: **Real documentary value**
Recording: **Early Thirties vintage**

Even in the heyday of electrical 78's these recorded performances were rarities. At the beginning of the Thirties the French Pathé firm evidently planned a documentary series of composers not only conducting their own works but also adding short "vocal autographs" to their recorded performances. Apparently only two parts of the series ever saw the light of day: a pair of discs (Pathé X8806/7) with Vincent d'Indy conducting the first part of his Wallenstein Trilogy (after Schiller) and three discs (Pathé X8829/30/31) with Roussel doing his delightful insect ballet score, *The Spider's Feast*.

The d'Indy Wallenstein Trilogy has not been recorded since, though part three, *La Mort de Wallenstein*, appeared briefly on a Crossroads disc with Zoltan Fekete conducting the Prague Symphony Orchestra. Surprisingly, there is no performance currently listed in Schwann for the lovely Roussel music, despite the excellent recordings that were made in the not too distant past by Ernest Ansermet and Paul Paray.

Florent Schmitt originally conducted this performance of his richly colorful *La Tragédie-*

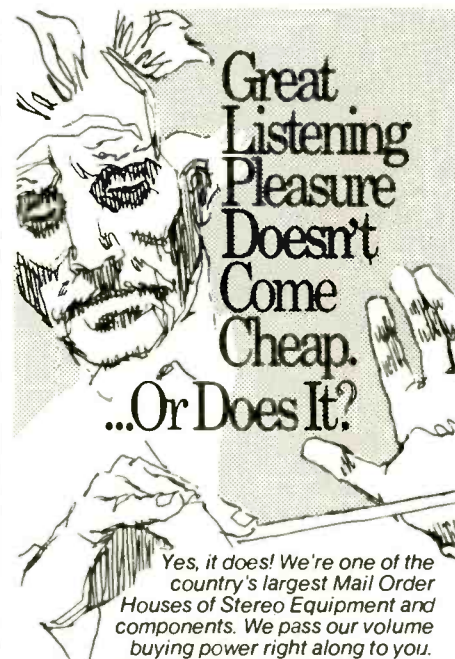

Great Listening Pleasure Doesn't Come Cheap. ...Or Does It?

Yes, it does! We're one of the country's largest Mail Order Houses of Stereo Equipment and components. We pass our volume buying power right along to you.

BALTIMORE
Stereo Wholesalers
*WRITE FOR QUOTATIONS AND OUR LATEST FREE CATALOG!
7A Aylesbury Road
Timonium, Md. 21093 • 301,252-6880
CIRCLE NO. 7 ON READER SERVICE CARD

Planning to move?

Let us know 6 to 8 weeks in advance so that you won't miss a single issue of **STEREO REVIEW**.

Attach old label where indicated and print new address in space provided. Also include your mailing label whenever you write concerning your subscription. It helps us serve you promptly. Write to: P.O. Box 2771, Boulder, Colo. 80302, giving the following information.

- Change address only.
 Extend subscription. Enter new subscription.
 5 years \$26 3 years \$18 1 year \$7
 Payment enclosed (1 extra issue per yr. as a BONUS) Bill me later.

← AFFIX LABEL →

If you have no label handy, print OLD address here.

name	please print	zip code
address		0879
city		
state		

name	please print	zip code
address		
city		
state		

Add'l postage: \$1 per year outside U.S., its poss. & Can.

die de Salomé (1907) for the French Columbia label; it was available over here for a brief period on the American Columbia label (M157 four discs). There is a fine currently available recording of *La Tragédie de Salomé* on RCA LSC 3151.

This Perennial reissue includes the "vocal autographs" by d'Indy and Roussel—for me a really special attraction. The d'Indy music is rather pallid—at least compared with Smetana's treatment of the same subject—and the recorded performance is rather faint and uncommunicative. The Roussel, on the other hand, thanks to its transparent scoring, comes through remarkably well and conveys a decent idea of what the composer was trying to achieve in tempo and nuance.

The Schmitt recording, decidedly superior in quality to the Pathé products, emerges in respectable sound in its LP reincarnation. The vigor and color of the composer's own performance are conveyed quite effectively here.

For the rest, let me say that Perennial is performing a genuine service in transferring these documents of the 78-rpm era to LP format. It is remarkable that so many good qualities of the original recordings have been retained, especially in the Schmitt and Roussel works. *D.H.*

SCHMITT: *La Tragédie de Salomé, Op. 50* (see ROUSSEL)

SCHUBERT: *The Complete Piano Sonatas, Vol. I, The Three Posthumous Sonatas: C Minor (D. 958); A Major (D. 959); B-flat Major (D. 960). Vol. II, Seven Early Sonatas: E Major (D. 157); C Major (D. 279/346); E Major (D. 459); A Minor, Op. 164 (D. 537); A-flat Major (D. 557); E Minor (D. 566/506); E-flat Major, Op. 122 (D. 568). Vol. III, Six Sonatas: F-sharp Minor (D. 571/604/570); B Major, Op. 147 (D. 575); C Major (D. 613/612); F Minor (D. 625/505); A Major, Op. 120 (D. 664); A Minor, Op. 143 (D. 784). Vol. IV, Four Sonatas: A Minor, Op. 42 (D. 845); C Major ("Unfinished," D. 840); D Major, Op. 53 (D. 850); G Major, Op. 78 (D. 894). Paul Badura-Skoda (piano). RCA VICTROLA VICS 6128, 6129, 6130, and 6131 three discs each \$8.94 each.*

Performance: **Levelheaded, knowledgeable**
Recording: **Good**

This set of albums represents about the most complete survey possible (and certainly as complete as any yet recorded) of Franz Schubert's solo piano sonatas. Although the Deutsch thematic catalog lists twenty-two Schubert sonatas, one is a sketch for a sonata's first movement and another is a first version of the Sonata in E-flat, D. 568. That leaves twenty sonatas, which is precisely what Paul Badura-Skoda gives us. In a number of the sonatas (D. 279/346; D. 571/604/570; D. 613/612; D. 625/505; D. 840) the pianist has completed unfinished works, and with great stylistic understanding (as, for example, in the Sonata in C, D. 840, where the score is complete for only two out of four movements). In the sense of comprehensiveness, then, this is a valuable issue. Friedrich Wührer's and Wilhelm Kempff's recordings of the Schubert sonatas contained only eighteen each. It is worth noting, however, that in Europe both Noël Lee and Gilbert Schuchter have recorded sets of Schubert sonatas that fairly well match the present albums. And

substantial collections of the more familiar sonatas have been recorded by several pianists, including Ingrid Haebler. (There is also talk of Alfred Brendel's commencing a Schubert series for Philips.)

What of the Badura-Skoda performances? Well, I wish I could be as enthusiastic about his interpretations as I am about the music itself. Nowhere, it should be pointed out immediately, is the Viennese pianist ever less than thorough, technically adroit, and stylistically knowing. In the earlier sonatas in particular, his understanding of the Classical form is most impressive. To a large extent the same is true of the middle sonatas, though there are moments when a certain felicitous turn of phrase or a magical lilt eludes Badura-Skoda. He plays the final, great posthumous sonatas with understanding and proper emphasis, fine tempos, and warmth of tone—but the music lacks the ecstatic, moody, otherworldly glow



JAKOB GIMPEL
Musicianship of the very highest order

that is so effective in such performances as, for example, Schnabel's of the last B-flat sonata. In short, though the playing is everywhere commendable, it tends, especially in the last works, toward the prosaic.

It could well be, however, that others will find Badura-Skoda's readings to their liking. Among the many features to be admired in this set are its comprehensiveness, as I pointed out, and the pianist's sense of Classical structure; there are also such felicities as Badura-Skoda's use of the piano's soft pedal as a coloristic device. Definitely not a plus, however, are the wafer-thin pressings, the warping of which (at least in my review copy) caused a number of tracking difficulties and uneven piano tone. *I.K.*

SCHUBERT: *Symphony No. 4, in C Minor (D. 417, "Tragic"); Symphony No. 6, in C Major (D. 589, "Little").* Philadelphia Orchestra, Eugene Ormandy cond. COLUMBIA M 31365 \$5.98.

Performance: **Polished**
Recording: **Good**

Eugene Ormandy proffers a rather low-pressure account of the C Minor Symphony, music which I feel carries with it considerably more rhythmic tautness and implicit drama

than comes through here. On the other hand, his treatment of the "Little" C Major has ample energy, lilt, and brilliance—though slightly easier pacing in the finale might have been preferable.

The sound is full-bodied, with ample but not excessive room resonance. *D.H.*

RECORDING OF SPECIAL MERIT

SCHUMANN: *Fantasia in C Major, Op. 17.*
CHOPIN: *Fantasia in F Minor, Op. 49.* Jakob Gimpel (piano). GENESIS GS 1030 \$5.98.

Performance: **Superb!**
Recording: **Good**

Here is what I call a dream packaging of high-Romantic piano repertoire: the two greatest masterpieces of the age in the so-called "fantasia" format. The big problem in such programming, of course, is to have available a pianist who can do total justice to the musical marvels of these works. For my particular taste in these things, Genesis Records has hit the jackpot with sixty-six-year-old Jakob Gimpel, born in Poland, trained in Vienna under Eduard Steuermann and Alban Berg, and for many years a resident of Los Angeles. Save for a few 78-rpm discs of Szymanowski and Debussy done for Columbia in the early 1940's, Mr. Gimpel's recording activities have been confined mainly to Europe (Genesis has previously issued his readings of the Beethoven Fourth and Emperor concertos done for Eurocord in Berlin). Mr. Gimpel's younger brother, Bronislaw, incidentally, has been a well-known recording artist for some decades, both as soloist and as part of the Mannes-Gimpel-Da Silva Trio.

The present performances are the first I have heard to equal the standards set for me back in the 1930's by Wilhelm Backhaus for the Schumann (there is an LP transfer from the Victor/HMV originals available on Parnassus 3) and by Cutner Solomon for the Chopin (recorded on the English Columbia label); both readings always strike just the right combination of romantic ardor and command of tonal architecture. Musicianship of the very highest order is the *sine qua non* of these fantasias, for the slightest misjudgment of tempo relationships and phrasing can result either in a totally heartless performance on the one hand or an excessively fussy one on the other.

Mr. Gimpel has here found the right combination both for the tremendous scale of the Schumann and for the more tautly molded Chopin. For me, the big test in the Schumann comes at the very beginning: unremitting sustenance of line and momentum through the whole of the exposition is a necessity. Maintenance of proper dynamic balances between right and left hands is absolutely crucial as well, for a miscalculation can cause the whole to sag beyond redemption. Another big test is the heroic central movement: does one establish an all-out grand manner at the very beginning—as Backhaus and Gimpel do—or does one save the thunder for the end, in the manner of Richter? It takes a brave and strong artist to essay the first course and get away with it. For me Gimpel comes through with flying colors.

In the Chopin the essential interpretive problem is managing transitions in matters of tempo and key change so that the seams don't show, yet being flexible enough in matters of phrasing and *rubato* so that the performance

(Continued on page 122)

When you make a better cartridge the world beats a path to your door.

From the U.S.

"Separation was tops... square wave response outstanding. We tracked it as low as 1/4 gram."

Audio Magazine

"Among the very best. The sound is superb. Frequency response was flat within $\pm 1\frac{1}{2}$ dB from 20-20,000Hz. Compliance measured 35×10^{-6} cm/dyne."

High Fidelity

"The I.M. distortion at high velocities ranks among the lowest we have measured. A true non-fatiguing cartridge."

Stereo Review

From Great Britain

"A real hi-fi masterpiece. A remarkable cartridge unlikely to wear out discs any more rapidly than a feather held lightly against the scorching groove."

Hi-Fi Sound

"A design that encourages the hi-fi purist to clap his hands with joy."

Records and Recording Magazine

From Canada

"One of the world's greatest cartridges." Dealer's Choice Society's Stereo.

Sound Magazine

From Japan

Grand Prize for cartridges in first all Japan Stereo Component competition.

Radio Gijutsu Magazine



Write for your free
"Empire Guide to Sound Design."

EMPIRE Scientific Corp. 1055 Stewart Avenue, Garden City, New York 11530
Canada: 65 Martin Ross Avenue, Downsview, Ontario



Circle No. 85 on Reader Service Card

doesn't sound like a mere run-through. Gimpel is rather deliberate in his treatment of the opening pages, and he chooses not to overemphasize dynamic differentiation. He saves his powers in this department for the main body of the piece, which he traverses with enormous impetus and dramatic power.

Those who prefer their Schumann and Chopin readings with maximum differentiation of dynamics, coloration, and tempo may find the Gimpel performances too "straight." But speaking for myself, I feel that I at long last have found recorded performances of these fantasias that I can live with for many years to come.

The piano sound is not quite as rich as I would like—whether due to the instrument or the recording locale, I can't say for sure—but it is otherwise clean, bright, and reasonably full-bodied.

Quite candidly, this is the most enjoyable solo piano disc of concert repertoire to have come my way since Abby Simon's of the Chopin B-flat Minor Sonata. I am more than a little interested in hearing Mr. Gimpel again.
D.H.

RECORDING OF SPECIAL MERIT

SCHUMANN: *Lieder, Op. 35 (on poems by Justus Kerner)*. **KILPINEN:** *Eight Songs*. Martti Talvela (bass); Irwin Gage (piano). LONDON OS 26240 \$5.98.

Performance: **Excellent**

Recording: **Excellent**

With this, his first recording of songs, Martti Talvela, heretofore admired as an operatic basso, takes a giant step (the only kind of step his natural endowments allow him to take) toward the top hierarchy of song recitalists. Such a firm, solid, opulent bass sound has not been raised in the service of lieder since the heyday of Alexander Kipnis, and what Talvela achieves here makes me hope he will explore such Kipnis specialties as Wolf's Michelangelo Songs, the Brahms repertoire, and Schubert's *Winterreise*.

Talvela wisely avoids capitalizing on the sheer volume and power of his voice. He uses it with flexibility, with subtle dynamic gradations, judiciously employing *mezza-voce* and even falsetto effects. Though his voice has little variety of color, it is the kind of voice that leaves a listener pleased and satisfied, in no need of looking for things to criticize. There is warmth here as well as power and an imposing range.

The choice of the songs in this collection also calls for praise: this seems to be the only currently available version of the full cycle of the twelve Kerner songs, a worthy group containing at least six songs from Schumann's top drawer. Kilpinen is Finland's foremost composer of songs; his concise, stark, atmospheric evocations are welcome additions to the repertoire. Irwin Gage's accompaniments are outstanding.
G.J.

SHOSTAKOVICH: *Song of the Forests, Op. 81 (1949)*. Ivan Petrov (bass); Vladimir Ivanovsky (tenor); Boys' Chorus of the Moscow Choral School; USSR Russian Chorus; Moscow Philharmonic Symphony Orchestra, Aleksander Yurlov cond. MELODIYA/ANGEL SR 40214 \$5.98.

Performance: **Good**

Recording: **Good**

In the bad old days immediately preceding

Stalin's death, cultural directives made life miserable for artists of strong individualist bent. Writers put their energies into translation work; painters worked with theatrical scenery and posters; and composer Dmitri Shostakovich concentrated his efforts on film scores and withheld from performance—until the more relaxed Khrushchev era—some of his newly completed and headier stuff, such as the Violin Concerto, the Fourth String Quartet, and the *Jewish Folk Poetry* song cycle. His one major concert work of this time was a massive oratorio, *Song of the Forests*, on the theme of postwar reconstruction and reforestation. The music sounded bland and banal to me when I heard the recording issued by Vanguard in 1952. Now, despite the American preoccupation with ecology that makes us more receptive to its theme, *Song of the Forests* still leaves me unenthusiastic. But, as I have mentioned in other reviews, compara-



MARTTI TALVELA
Not since Kipnis

tively few epic choral works on nonreligious themes travel very well from one country to another.

Song of the Forests is well-crafted in terms of its own level of discourse, but I find the choral writing not nearly as interesting as that of Shostakovich's pupil, Georgii Sviridov, in such works as *Little Wooden Russia* or the *Kursk* songs, neither of which is available on records in this country.

The recorded performance is suitably large-scale, with basso Ivan Petrov the star of the proceedings so far as I am concerned. (I wish, by the way, that Melodiya would issue the complete recording of *Boris Godounov* with Petrov in the lead role—it's the best version I know, with by far the best sonics.) The sound, then, is quite impressive, but the music still doesn't move me.
D.H.

STARER: *Ariel, Visions of Isaiah*. Roberta Peters (soprano); Julian Patrick (baritone). *Concerto a Tre*. Joseph Rabbai (clarinet); Gerard Schwarz (trumpet); Per Brevig (trombone); Camerata Singers and Orchestra, Abraham Kaplan cond. DESTO DC 7135 \$5.98.

Performance: **Superb**

Recording: **Mediocre**

Robert Starer was born in Vienna in 1924 and studied in Jerusalem, but he has long been an American citizen. He is best known for his dance pieces—among them several for Mar-

tha Graham—but he has also worked in various instrumental and vocal forms. His are essentially conservative, Romantic compositions, many of them characterized by an Eastern quality. *Ariel*, written in 1959-1960, is a large-scale composition for soloists, chorus, and orchestra based on the prophecies—mostly dire—of Isaiah. The *Concerto a Tre*, for clarinet, trumpet, trombone, and orchestra, was written in 1954 as an abstract piece of music and later used by Martha Graham for her dance "Secular Games." All of this music is fluent and somewhat affecting in its slow movements, but generally less convincing in its faster sections. It is very well performed here by an excellent group of solo and ensemble singers and instrumentalists under the very careful direction of Abraham Kaplan. The recorded sound is badly constricted, however, which is particularly unfortunate in *Ariel*, where spaciousness is needed.
E.S.

STOCKHAUSEN: *Aus den sieben Tagen: Es; Aufwärts; Kommunion; Intensität*. Johannes Fritsch (viola); Jean-François Jenny-Clark (bass); Michel Portal (saxophone, flute, piano); Aloys Kontarsky and Carlos Roqué Alsina (keyboards); Harald Bojé (elektronium); Vinko Globokar (trombone); Alfred Alings, Rolf Gehlhaar, Jean Pierre Drouet (percussion); Karlheinz Stockhausen (voice, percussion, electronics, direction). DEUTSCHE GRAMMOPHON 2530 255/6 two discs \$13.96.

Performance: **Es ist . . .**

Recording: **Unglaublich**

When the latest Stockhausen or Kagel extravaganza arrives for review, I often suppress my natural tendency to read the program notes first—the explanations that make it all so clear—and try to listen naïvely to the sound itself. The sound spectrum in many of Stockhausen's recent works is distinctive in its combination of ugliness, evocation, electronic transformation, vocalise, meditativeness, funk, and junk, all set forth on a huge scale. The infinite variety of this cosmic emptiness can be quite fascinating if, as they say, you can get into it. But it takes a lot of getting into—an hour and three-quarters worth, if you please. And these four segments are, indeed, only part of a much longer event—as suggested by the "seven days" of the title. God rested on the seventh day—but not Karlheinz.

It would be inaccurate to suggest that all of this is cut from the same cloth. *Aufwärts* achieves a certain meditative, reflective quality, while, at the other extreme, *Intensität* comes close to concreteness, a certain loopy, speaking character, which is rare in Stockhausen's music: these are easily the best of the disc. For the rest . . . well, it's Karlheinz and the universe. And Deutsche Grammophon—faithful to a fault—puts you right there if you want to be there.
E.S.

STRAUSS, R.: *Metamorphosen—Study for Twenty-three Solo Strings* (see MOZART)

STRAVINSKY: *Apollon musagète* (see BARTÓK)

STRAVINSKY: *Capriccio; Mouvements; Concerto for Piano and Wind Orchestra*. Michel Beroff (piano); Orchestre de Paris, Seiji Ozawa cond. ANGEL S 36875 \$5.98.

Performance: **Generally good**

Recording: **Moderately poor**

This is an interesting recording, both for the

music on it, and for the playing of twenty-two-year-old Michel Beroff, who is presented here (and in a Debussy program) in what the album bills as his "American Recording Debut"—presumably his "American market debut," since there is nothing else American involved. Beroff is an exceedingly gifted pianist—not more so than many others, but at the age of twenty-two an artist of this caliber certainly merits one's respect. He has lots of technique, a rhythmic sense which serves him in good stead in Stravinsky's quirkier moments, and the ability to produce a firm tone without becoming percussive. He plays like a very civilized young man, and sometimes a vivacious one as well. One could occasionally wish for a bit more incisiveness. But, of course, that might bring on the steely tone of which we are all so tired. Also, it has to be said that the sonics of this record are far less than ideal, and one cannot be entirely sure what the real Beroff may sound like.

As taped in the Salle Wagram in Paris, the engineers' efforts here seem to be a recording in which the listener "overhears" the music, rather than one in which the music projects with immediacy. Busy Stravinsky textures in the Concerto (where the orchestra is not always rhythmically tidy) tend to get blurred. Beroff often seems to be the one absolutely steady element in the proceedings, but in the odd sonics of this "*disque engloutie*" it's hard to be sure. The performance level is identical in the Capriccio for Piano and Orchestra, where Béroff brings out Stravinsky's wit with amiable steadiness. In *Mouvements* for Piano and Orchestra, where the textures are clearer and more transparent than elsewhere, one could wish for a little more intensity, dramatic concentration, and projection from the pianist. To some extent, Beroff's playing in this piece (and Ozawa's as well) could come under the heading of what Virgil Thomson once described in another context as a "soft egg." But, since the Orchestre de Paris does not seem to be overly well disciplined, and the sonics of the recording may be trying to disguise that fact, it's difficult to know for sure just who or what is the "soft egg." L.T.

VERDI: *Operatic Arias* (see Collections—Mattia Battistini)

WAGNER: *Tristan und Isolde*. Jon Vickers (tenor), Tristan; Helga Dernesch (soprano), Isolde; Christa Ludwig (mezzo-soprano), Brangäne; Karl Ridderbusch (bass), King Marke; Walter Berry (baritone), Kurwenal; Bernd Weikl (tenor), Melot; Peter Schreier (tenor), Young Sailor, Shepherd; Martin Vantin (baritone), Helmsman; Chorus of the German Opera; Berlin Philharmonic Orchestra, Herbert von Karajan cond. ANGEL SEL 3777 five discs \$29.90.

Performance: **Very good, with reservations**

Recording: **Overrich**

Well, here's *Tristan* again, that pivot-point of Romantic-modern music, that retreat into sex and the psyche that prefigured everything from Freud to the inner traumas of expressionism and the alienation of the modern artist. How extraordinary that after more than a century this opera continues to astonish and enthrall!

This new version is the first since the live Bayreuth recording of the middle Sixties and the first without Birgit Nilsson since Flagstad-Fürtwängler. *Tristan und Birgit* has become



THE SUPERIOR COMBINATION

You have carefully selected your fine play back equipment. Now complete the system with Discwasher; the record cleaning system that safely removes fingerprints, dust particles,



and cigarette smoke which gradually degrade your record collection.

Discwasher: superior record care for daily use. \$12.95 from your audio specialist.

Discwasher Inc., Suite 316, 909 University, Columbia, Mo. 65201

CIRCLE NO. 55 ON READER SERVICE CARD

ABOUT YOUR SUBSCRIPTION

Your subscription to STEREO REVIEW is maintained on one of the world's most modern, efficient computer systems, and if you're like 99% of our subscribers, you'll never have any reason to complain about your subscription service.

We have found that when complaints do arise, the majority of them occur because people have written their names or addresses differently at different times. For example, if your subscription were listed under "William Jones, Cedar Lane, Middletown, Arizona," and you were to renew it as "Bill Jones, Cedar Lane, Middletown, Arizona," our computer would think that two separate subscriptions were involved, and it would

start sending you two copies of STEREO REVIEW each month. Other examples of combinations of names that would confuse the computer would include: John Henry Smith and Henry Smith; and Mrs. Joseph Jones and Mary Jones. Minor differences in addresses can also lead to difficulties. For example, to the computer, 100 Second St. is not the same as 100 2nd St.

So, please, when you write us about your subscription, be sure to enclose the mailing label from the cover of the magazine—or else copy your name and address exactly as they appear on the mailing label. This will greatly reduce any chance of error, and we will be able to service your request much more quickly.

Lowest of the LOW!

Shamelessly Low Prices...

As one of America's largest wholesale distributors, we're guilty of shamelessly low prices. Our buying volume has made our prices the lowest. We seriously doubt you can find one lower... and that we're proud of. What's more, at S.C.A. you can select from hundreds of NEW, Factory Sealed, Full Warrantee, Brand name, Hi-Fi Stereo components. If its in the Hi-Fi, Audio field... we have it!

Write for a lowest of the low quote... we're not ashamed.



STEREO CORPORATION OF AMERICA



2122 UTICA AVENUE, BROOKLYN, NEW YORK 11234 (212) 338-8555

DISCWASHER

such a staple of the international repertoire that it is hard to imagine this music drama without its leading female interpreter—perhaps the best Isolde who ever lived. But it must be said right off that Helga Dernesch makes a very respectable and moving impression in this most massive of all soprano roles. Indeed, the shortcomings of this recording are elsewhere—notably in the impressionistic recorded sound that, in my opinion, serves Wagner very poorly.

Not the least of Wagner's gifts was his combination of highly articulated detail—a linear, contrapuntal skill in the Bach tradition—with effective harmonic and orchestral color. These qualities, integrated properly with the voices (always as the dominant lines), are admittedly very difficult to bring out in the theater; indeed, I have heard them properly achieved only in the Bayreuth Festspielhaus, which Wagner himself designed for his special acoustical needs. But Wagner's ideal is achievable through the genius of recording, and it is really unfortunate that it was not even attempted here. The overall sound is too rich and resonant (I understand the recording was made in a large church), constantly obscuring the orchestral lines, and the relationship of the voices to the orchestra is inconsistent throughout. Often the solo voices are pale and watery, barely emerging from the haze of reverberant orchestral sound. No, no, a thousand times no.

It really is a pity, for there is much to hear. Besides the commendable Helga Dernesch, there is Jon Vickers; though I often find his singing too mannered, he is unquestionably the most impressive Heldentenor around these days, and this is one of his strongest performances. I was particularly moved by Walter Berry's Kurwenal. Christa Ludwig has recorded Brangäne once before: her portrayal has lost a bit of its vocal bloom but has many musical virtues. The smaller parts are well handled, and the orchestra, from all I can tell, is excellent. The chorus, perhaps because of the way it was recorded, does not make a strong impression.

I have been avoiding the problem of Herbert von Karajan, and I am tempted to use the politician's answer: "No comment." Karajan is a "great" conductor, and Karl Böhm is only a good, competent *Generalmusikdirektor*. Nevertheless, Karajan subordinates detail to overall conception, while Böhm realizes the whole through bringing the parts together. And, to me, the excellent Böhm/Bayreuth version—Nilsson, Windgassen, Ludwig, Talvela, *et al.*—is still the most satisfactory recording. Fürtwängler, anyone? *E.S.*

COLLECTIONS

MATTIA BATTISTINI: Program I, 18th and Early 19th Century Arias. Gluck: *Paride ed Elena: O del mio dolce ardor*. Mozart: *Le Nozze di Figaro: Non più andrai. Don Giovanni: Finch' han dal vino; Deh vieni alla finestra (3 versions); Là ci darem la mano (with Emilia Corsi, soprano)*. Bellini: *I Puritani: Ah, per sempre*. Rossini: *Guglielmo Tell: Resta immobile. Il Barbiere di Siviglia: Largo al factotum*. Berlioz: *La Damnation de Faust: Su queste rose*. Carissimi: *Vittoria mio core*. Giordani: *Caro mio ben*. PERENNIAL Ⓜ 3001 \$6.00 (available by mail from Perennial Records, Box 437, New York, N.Y. 10023).

MATTIA BATTISTINI: Program II. Donizetti: La Favorita: Vien, Leonora (2 versions); Ah!

Palto ardor (with E. Cartonini, mezzo-soprano); A tanto amor (2 versions). Lucia di Lammermoor: Cruda funesta smania; Don Sebastiano: O Lisbona. Linda di Chamounix: Ambo nati; Un buon servo (with Maria Moscisca, soprano). Maria di Rohan: Bella e di sol vestite; Voce fatale di morte. Maria di Rudenz: Ah, non avea più. PERENNIAL Ⓜ 3002 \$6.00 (available by mail from Perennial Records, Box 437, New York, N.Y. 10023).

MATTIA BATTISTINI: Program III. Verdi: Un Ballo in Maschera: Alla vita che t'arride (2 versions); Ve' se di notte (with Elena Barbieri, soprano, and Vincenzo Bettoni, bass); Eri tu (2 versions). Ernani: Da quel dì; Vieni meco (with Emilia Corsi); Vedi come il buon (with Elena Barbieri, Gasteno Tommasini, and Vincenzo Bettoni); Lo vedremo (with Aristodemo Sillich, bass); O de' verdi anni



HELGA DERNESCH AND JON VICKERS
A moving Isolde, an impressive Tristan

miei; O sommo Carlo (2 versions). PERENNIAL Ⓜ 3003 \$6.00 (available by mail from Perennial Records, Box 437, New York, N.Y. 10023).

Performance: **Highly individual**
Recording: **1903 to 1924**

These are the first three discs in a projected eight-part collection of the complete recordings of the celebrated "king of baritones." Mattia Battistini (1856-1928), an enterprise apparently pursued in a serious and well-organized manner by Perennial's producer, Steven Smolian. Battistini, who enjoyed making records, left a legacy of some one hundred sides. His youth preceded the era of the phonograph: he began recording in early 1903, his forty-seventh year, and continued until 1924. The juxtaposition of early and later recordings of the same arias show that his basic approach remained virtually unchanged during those twenty-one years. Even more astonishing is the ease with which he met the musical challenges in the later versions, some recorded when he was sixty-eight years old.

Battistini made his debut in 1878, right around the time De Luca, Ruffo, Stracciari, and Amato were born. He was of an earlier era; not only was his singing style different, but his performing attitude was more self-serving and autocratic. However objectionable the excesses of that era may seem to us

today, they were accepted—even encouraged as the eccentricities to be expected of great artists—by the public that idolized Mattia Battistini.

I have always found Battistini an impressive artist without being able to develop a genuine fondness for his singing. Aside from his questionable musicianship, his mannerisms surrounded his performances with an aura of predictability. But there is no denying his gifts. The voice was a high, tenor-like baritone more commonly found among French singers than among Italians. It was clear, ringing, smoothly produced, superbly effective in the high register—and somewhat unsupported at the low extreme. He had a spectacular technique, and a command of graceful *fioriture* to match that of the most accomplished soprano. As a dramatic interpreter, he could be convincing inside a character who elicited his sympathies (kings, aristocrats, leaders of men); in other situations he would sing gloriously but display utter detachment from the drama.

Program I of this collection is to be approached with caution. Battistini's singing of Mozart was careless of note values, erratic in rhythm, casual toward enunciation—in short, totally unacceptable. The arias from *I Puritani* and *William Tell* are topflight *bel canto* staples, and the 1924 recordings reveal an almost unbelievably well-preserved tone and technique; otherwise, the disc has only curio value to present-day listeners.

Program II is far more enjoyable. Battistini was an inspired interpreter of Donizetti's music. The excerpts from *La Favorita* are delivered with great authority and flourish. There is little audible difference here between "early" and "late" Battistini. In fact, the *caballetta* to the 1921 "Vien, Leonora" is astounding in its virtuosity. The disc also offers music from some really obscure Donizetti operas.

Program III is the first of the two projected all-Verdi discs. Battistini rewrote Verdi's melodic line for "Alla vita che t'arride." The two versions here are virtually identical, though they were recorded seventeen years apart (1907 and 1924); at the age of sixty-eight, Battistini still sang a clarion high G. Except for a fanciful cadenza, his "Eri tu" is faithful to Verdi's writing; it is solidly and effectively sung in both versions. The rare excerpt from Act Two of *Un Ballo* is spiritedly sung but badly recorded. The *Ernani* excerpts have always been considered among the best examples of Battistini's art (evidently, there was something in his makeup that contributed to such a convincing and effective portrait of the haughty king), and, allowing for the primitive recordings, they still rank with the greatest performances the music has ever received.

In general, the technical reproduction in all three discs is highly satisfactory. *G.J.*

RECORDING OF SPECIAL MERIT

THE CONSORT OF MUSICK: *The Leaves Be Greene.* Anon: *The Leaves be Greene; Mother Watkins Ale; Heaven and Earth Pavan; Bara Faustus' Dreame; Duncombes Galliard; La Bergerax.* Elway Bevin: *The Leaves be Greene.* Anthony Holborne: *The Teares of the Muses; The Fairy Round; Mux Linda.* Robert Jones: *Will said to his mammy; As I lay lately in a dreame.* Tobias Hume: *The Passion of Musick; Cease leaden Slumber.* Francis Pilkington: *Echo for two lutes.* John Johnson: *A Dump.* The Consort of Musicke:

James Tyler (lute, tenor viol, cittern, flute); Anthony Rooley (lute); Catherine Mackintosh (treble viol, violin, rebec, cittern); Trevor Jones (bass viol); Martyn Hill (tenor); Peter Bale (reader). L'OISEAU-LYRE SOL 338 \$5.95.

Performance: **Excellent**
Recording: **Lovely**

JULIAN BREAM: *The Woods So Wild*. Byrd-Cutting: *The Woods so Wild*. Francesco da Milano: *Eight Fantasias*. Anon.-Cutting: *Packington's Pound*; *Greensleeves*. Dowland: *Walsingham*; *Go from My Window*; *Bonnie Sweet Robin*; *Loth to Depart*. Holborne: *The Fairy Round*; *Heigh Ho Holiday*; *Heart's Ease*. Julian Bream (lute). RCA LSC 3331 \$5.98.

Performance: **Colorful**
Recording: **Not ideal**

The tastes of the late Renaissance ran to what art historians call "mannerism," combining a love of artifice and drama, a certain anxiety and straining for effect, with a cultivated taste for "natural" things—wild woods, green leaves, expressive music, folklore, and sex. Their tastes were something like our own, then. Many of the works on these recordings are based on folk sources—songs and dances that came out of the popular imagination. The material is treated in two different ways: as a mixed program of Elizabethan consort music for voices (singing and speaking) and instruments, mostly string; and as a lute recital combining English music with a series of mid-sixteenth-century fantasias by a great, if still little-known, Italian lute master.

The Consort of Musicke is a fresh-sounding group of exquisite skill and expression. Their charmingly varied program includes sung and instrumental versions of the old song *The Leaves be Green*, a gorgeous array of instrumental settings, a couple of bawdy ballads, and some bits of suitable Elizabethan poetry. *Everything*—singing, playing, reading, recording—is done to perfection: taste and passion, style and poetry, are mixed in just the right proportions. This is an outstanding recording in every respect.

Bream's album is less satisfying, in large part because of the not very subtle recording—the lute is blown up to giant and quite undelicate proportions—and because of the less than ideal disc quality. However, the eight *Fantasias* of Francesco Canova da Milano constitute a real contribution to the recorded repertoire of early music; these are real masterpieces, and they are very well played here. Bream alternates these very "classical" pieces with a pleasant group of Elizabethan folk settings that includes *Greensleeves* in a very plain early version as well as Francis Cutting's lively and elaborate arrangement. All of this material is given very colorful treatment by Bream. Question: why does his lute sound consistently out-of-tune? If he is using an old tuning, it should be specified; it doesn't sound at all right to my ears.

E.S.

ELIZABETHAN LUTE SONGS AND SOLOS. Dowland: *Fine knacks for ladies*; *Shall I sue*; *Away with these self-loving lads*; *In darkness let me dwell*; *Tarletones risurrectione* (lute solo); *Galliard in D* (lute solo); *Come again: sweet love doth now invite*; *What if I never speed?*; *I saw my lady weep*; *Awake, sweet love thou art return'd*. Campian: *It fell on a summer's day*; *The cypress curtain of the*

night; *Shall I come, sweet love, to thee?* Rosseter: *Whether men do laugh or weep*; *Sweet, come again*; *What then is love but mourning*. Cutting: *Galliard in G Minor* (lute solo). Morley: *Thyrsis and Milla*; *Come, Sorrow, come*; *It was a lover and his lass*. Frank Patterson (tenor); Robert Spencer (lute). PHILIPS 6500 282 \$6.98.

Performance: **Agreeable**
Recording: **Excellent**

This is a well-selected anthology of lute songs, a genre that in England flowered during the last decade of the sixteenth century and died away just twenty-five years later. The album quite rightly devotes a full side to John Dowland, the most profound and subtlest of these composers. Included are several of

Dowland's best-known songs, as well as a good cross-section of the works of other Elizabethan composers. The three brief lute solos are well played by Robert Spencer, who accompanies the Irish tenor Frank Patterson in the songs with excellent style. Patterson has a very pretty, typically light Irish sound; he enunciates clearly, and he is a pleasure to listen to.

Both Patterson and Spencer, however, are up against some formidable competition in most of the repertoire, especially in the Dowland, for Peter Pears and Julian Bream have made three discs of Elizabethan lute songs and solos: "Julian Bream in Concert" (RCA LSC 2819), "Elizabethan Lute Songs" (RCA LSC 3131), and "Recital of Lute Songs" (London OS 25896). Nowhere does



Announcing the **NEW STANDARD**
in Stereo Testing!

The All-New Model SR12
STEREO TEST RECORD

The most complete... most sophisticated...
most versatile Test Disc available today...

For Just
\$5⁹⁸!

Whether you're an avid audiophile, a casual listener or a professional technician... the new MODEL SR12 will be the most important disc in your entire collection.

MODEL SR12 has been produced by Stereo Review Magazine for music lovers who want immediate answers to questions about the performance of their stereo systems and how to get the best possible sound reproduction.

It is the most complete test record of its kind — containing the widest range of checks ever included on one test disc.

Make these important stereo checks **BY EAR...**
(no test instruments required)

- ▶ Frequency response—a direct warble-tone check of nineteen sections of the frequency spectrum, from 20 to 20,840 Hz, which will pinpoint any frequency response defects in your system.
- ▶ Separation—an ingenious test which indicates whether you have adequate separation for good stereo.
- ▶ Cartridge tracking—the most sophisticated tests ever devised for checking the performance of your cartridge, stylus and tone arm.
- ▶ Channel balance—two broad-band, random-noise signals which permit you to eliminate any imbalances originating in cartridge, amplifier, speakers or room acoustics.
- ▶ Hum and rumble—foolproof tests that help you evaluate the actual audible levels of rumble and hum in your system.
- ▶ Flutter—a sensitive "musical" test to check whether your turntable's flutter is low, moderate, or high.

PLUS! ● Cartridge and Speaker Phasing ● Anti-Skating Adjustment ● "Gun Shot Test" for Stereo Spread ● Multi-purpose Musician's "A" ● Equal-tempered Chromatic Octave ● Guitar-tuning Tones.

Attention Professionals Model SR12 is also designed to be used as a highly efficient design and measurement tool. Tests below have been controlled to laboratory tolerances—affording accurate numerical evaluation when used with oscilloscope, chart recorder, output meter, intermodulation-distortion meter and flutter meter.

- 1,000-Hz square waves to test transient and high-frequency response of phono pickups.
- 500 to 20,000 Hz frequency-response sweep.
- Sine-wave tone-bursts to test transient response of pickup.
- Intermodulation test using simultaneous 400-Hz and 4,000-Hz signals.
- Intermodulation sweep to show distortion caused by excessive resonances in tone arm and cartridge.
- 1,000-Hz reference tones to determine groove velocity.
- 3,000-Hz tone for flutter and speed tests.

Sample waveforms—illustrating both accurate and faulty responses are provided in the Instruction Manual for comparison with the patterns appearing on your own oscilloscope screen.

FREE
Instruction
Manual
Includes
Detailed
Instructions,
Charts,
Tables
and
Diagrams

RECORDS • Ziff-Davis Service Division
595 Broadway • New York, N.Y. 10012

Please send _____ test records at \$5.98 each, **postpaid**.

My check (or money order) for \$ _____ is enclosed.
(Outside U.S.A. please send \$8.00 per record ordered.) N. Y. State residents please add local sales tax. **SR 473**

Print Name _____

Address _____

City _____

State _____

Zip _____

PAYMENT MUST BE ENCLOSED WITH ORDER

Pears display the freshness of voice that Patterson does, but in other respects Pears and Bream are clearly superior. For example, when Pears and Bream perform Dowland's *In darkness let me dwell* (on "Julian Bream in Concert"), they evoke the emotional essence of the music and present an object lesson in the flexible, poignant way such a song should be sung and accompanied. In comparison with this artistry, the rendition by Patterson and Spencer is a bit like a Shakespeare soliloquy read off in the style of the television weather report. It's all perfectly proper, but one longs for meaning and depth.

The Philips album features excellent sound and sensibly provides complete texts of the songs. *I.K.*

KATHLEEN FERRIER: *The Art of Kathleen Ferrier.* Purcell: *Sound the trumpet; Let us wander; Shepherd, leave decoying.* Handel: *Ottone: Spring is coming; Come to me, soothing sleep.* Green: *O praise the Lord; I will lay me down in peace.* Mendelssohn: *I would that my love; Greeting.* Kathleen Ferrier (contralto); Isobel Baillie (soprano, in Purcell and Mendelssohn); Gerald Moore (piano). Mahler: *Kindertotenlieder.* Kathleen Ferrier (contralto); Vienna Philharmonic Orchestra, Bruno Walter cond. SERAPHIM 60203 \$2.98.

Performance: **Very good**
Recording: **Good for its age**

Kathleen Ferrier's professional career was so brief and her recorded legacy so small that one can only applaud such a collection as this one. She embarked on a singing career relatively late, and the songs contained on this disc, though dating from the earliest stage of her career, capture her as an already poised and mature artist. This repertoire is quite unusual in itself and makes delightful listening in Ferrier's winning projection, supported by Gerald Moore's masterly pianism and the finely blending soprano of Isobel Baillie.

The Ferrier in the classic recording of Mahler's *Kindertotenlieder* (1949) was already the celebrated artist much sought after by conductors, particularly by the late Bruno Walter, for whom she was the ideal Mahler interpreter. For many years, this was the recording of the cycle. Today, there are sonically superior versions by Christa Ludwig and Janet Baker that offer comparable artistic virtues, but there still seems to be a special poignancy in Ferrier's projection of this tragic music, especially in the way her creamy tone caresses the low-lying phrases. Some sonic assistance in the engineering to add resonance is noticeable, but the sound is good, and Walter's mastery of the score's orchestral felicities is still to be savored. *G.J.*

NICOLAI GHIAUROV: *Russian Songs.* Tchaikovsky: *None but the lonely heart; Not a word, oh my love; Don Juan's Serenade; It was in the early spring; Mid the noisy stir of a ball; I bless you, woods.* Borodin: *For the shore of your far-off native land.* Glinka: *The Midnight Review.* Rubinstein: *Melody.* Dargomizhsky: *The Worm; Nocturnal Breeze; The Old Corporal.* Nicolai Ghiaurov (bass); Zlatina Ghiaurov (piano). LONDON OS 26249 \$5.98.

Performance: **Dramatically understated**
Recording: **Good**

Despite his Russian training, Nicolai Ghiaurov is essentially an Italianate singer, and the

smoothness of his *cantabile* line is a rarity considering the Slavic timbre of his voice. As his recordings amply testify, the Ghiaurov sound and style work remarkably well in Italian opera, and have also produced an unusually lyrical Boris Godounov. In the realm of Russian songs, however, the singer appears somewhat wanting in earthy expressiveness. There are many lovely vocal moments in this well-chosen program—some of the Tchaikovsky songs and the moving Borodin selection—but the Glinka and Dargomizhsky songs fall below expectations. (Dargomizhsky was a pioneer in Russian declamatory writing, a model for Moussorgsky.) Those familiar with Boris Gmirya's rendition of the shattering *Old Corporal* (on MK 1566) will find Ghiaurov's vocally more lustrous treatment quite unexciting by comparison. In sum, the vocal production is admirable, but the recital as a whole is somewhat disappointing, and it is not helped by the colorless accompaniment. *G.J.*



KATHLEEN FERRIER
A small but excellent recorded legacy

RECORDING OF SPECIAL MERIT

DALE MOORE: *Favorite American Concert Songs.* Barber: *The Daisies; With Rue My Heart Is Laden; Three Songs to Poems from Chamber Music (by James Joyce); Sure on this Shining Night; Nocturne; Monks and Raisins.* Rogers: *The Time for Making Songs Has Come.* Homer: *The Sick Rose.* Kelley: *Eldorado.* Hageman: *Do Not Go, My Love.* Charles: *My Lady Walks in Loveliness.* Griffes: *The Lament of Ian the Proud.* Duke: *Luke Havergal.* Speaks: *On the Road to Mandalay.* Dale Moore (baritone); Betty Ruth Tomfohrde (piano). CAMBRIDGE CRS 2715 \$5.98.

Performance: **Quite good**
Recording: **Good**

In this period of nostalgia and revivals, it seems not only appropriate but rather charming that baritone Dale Moore should remind us of our heritage in the field of art song. Judging only by the ones he has recorded, it doesn't sound like a very impressive heritage. But, to save our egos, we can remember that there are many fine American songs not presented here.

It's interesting from a historical point of view to hear some of the flowery, provincial

attempts of twentieth-century Americans to follow in the footsteps of 19th-century German and French composers, and to provide a music for the audiences of their own place and time. Predictably, the Samuel Barber songs (which I do not include with the "provincial" essays) are the most important on this disc, and Moore devotes a whole side to them. They are early Barber works, the first being Opus 2, No. 1, which he wrote when he was fourteen. On the other side—the "nostalgia" side—Oley Speaks' *On the Road to Mandalay* takes top honors. Moore sings well, with fine intelligence, though he is not a brilliant interpreter. His accompanist is good, and so is the recorded sound. *L.T.*

HARVEY PHILLIPS: *Tuba Recital.* Hartley: *Suite for Flute and Tuba.* J. S. Bach: *Two-Part Invention No. 1.* Handel: *Sonatas Nos. 4, 5, 7 for Flute (excerpts).* Wilder: *Song for Carol; Suite No. 1 for Tuba and Piano (Effie Suite); Suite No. 2 (Jesse Suite); Suite No. 3 (Little Harvey Suite); Suite No. 4 (Thomas Suite); Suite No. 5 (Ethan Ayer Suite).* Harvey Phillips (tuba); Arthur Harris (piano in Suite No. 1); Bradley Spinney and Bernie Leighton (percussion and piano in Suites 2, 3, 4, 5; *Song for Carol*); Andrew J. Lolya (flute). GOLDEN CREST RE 7054 \$4.98.

Performance: **Mostly for relatives**
Recording: **Very good**

This album, subtitled "For Family and Friends," is such a cozy affair that its design alone makes any listener who is not a member of the Harvey Phillips family feel practically like an intruder. Mr. Phillips, a celebrated tuba player who has taught music at the New England Conservatory, has fathered three almost unbearably delightful children. I come to this conclusion after seeing the pictures of Tommy, Jesse, and Harvey Jr. on the album cover, and after listening to Alec Wilder's self-consciously charming little tributes to them in the form of suites for tuba and piano. Now Mr. Phillips, understandably public-relations-minded about his instrument, objects to its being cast always in the role of a clown (as in George Kleinsinger's *Tubby the Tuba*), but when it is deprived of its humor I must say that it is also an instrument of almost pathetic limitations. And if I hadn't thought so before, Mr. Wilder's respectful settings would have confirmed this suspicion. Yet the pieces are all diverting miniatures which, for all I know, are as faithful to the characters of their subjects as Mr. Phillips says they are. Anyhow, Alec Wilder, we are told, is the tuba player's "dearest friend" and shares a "deep affection" for Mr. Phillips' children and for his wife Carol as well, so we also are treated here to an admiring piano piece by way of a *Song for Carol*.

I found less deliberately ingratiating than any of these a more carefree suite for tuba and piano called the *Effie Suite*. This one is about an elephant named Effie (apparently not a blood relative of the Phillips family) and her adventures in chasing a monkey, falling in love, taking a dancing lesson, joining a carnival, and so forth. It is entertaining stuff most children probably would find bearable, and Effie's vague resemblance to Debussy's Jimbo, particularly in the concluding lullaby, does it little harm. Besides Wilder, the collection contains a pretty suite for flute and tuba by Walter S. Hartley and arrangements for the same combination of sturdy works by Handel
(Continued on page 128)

LEONARD BERNSTEIN

MARILYN HORNE JAMES McCracken

The critically-acclaimed Metropolitan Opera production

CARMEN



2709 043 3 LP's Boxed
with full color brochure.

Deutsche Grammophon Records, MusiCassettes and 8-Track Stereo Cartridges
are distributed in the USA by Polydor Incorporated; in Canada by Polydor Canada Ltd.

DISCOUNTS
WASH. D.C.
HAS NO FAIR
TRADE
LAWS!

ON
STEREO
COMPONENTS

PLEASE REQUEST
 Prices for your choice of
 Changers, Receivers, Tape
 Recorders, Speakers, etc.

PROMPT DELIVERY
 IN FACTORY
 SEALED
 CARTONS.

DISTRICT
SOUND INC.
 2316 Rhode Island Ave. N.E.
 Washington, D.C. 20018
 202-832-1900

CIRCLE NO. 11 ON READER SERVICE CARD

BIG
DISCOUNTS

STEREO COMPONENTS

Largest selection of top name
 brands... try us and see...

It's worth a call
(301)488-9600

INTERNATIONAL
HI-FI
DISTRIBUTORS

6330 Frankford Ave.
Baltimore, Md. 21206

All mail answered within 24 hours
 Phone Daily 9 AM to 9 PM
 Saturday 9 AM to 4 PM
 Phone (301) 488-9600

CIRCLE NO. 22 ON READER SERVICE CARD

and Bach—like his first two-part invention—which I am sure could survive *anything*, even a transcription for Jew's-harp and kazoo. *P.K.*

HERBERT ROGERS; Piano Recital. Talma: *Piano Sonata No. 2.* Sessions: *From My Diary.* Cowell: *Episode; Invention, Six Ings Plus One.* Lybbert: *Sonata Brevis.* Herbert Rogers (piano). COMPOSERS RECORDINGS INC. CRI SD 281 \$5.95.

Performance: **Very good**
 Recording: **Nothing special**

This record represents some of the activity in the Music Department of Hunter College in New York. Ms. Talma and Mr. Lybbert, as well as Mr. Rogers, teach there, and the two sonatas form a major *raison d'être* for this disc. On the other hand, it is undoubtedly the Sessions and Cowell works that will generate the most interest.

Sessions' *From My Diary* are four keyboard sketches of considerable intensity, each dedicated to one of the composer's pupils. Even more unusual are the Cowell pieces: a pair of delicately neo-classical inventions, one from 1916, the other from 1950, and seven "Ings"—Floating, Frisking, Fleeting, Scooting, Wafting, Seething, and Whisking. This set, which appeared in 1922, belongs with Cowell's remarkable series of keyboard inventions; the extent of Cowell's contribution in these works has still to be properly evaluated. At any rate these are fine little studies, full of character and pizzaz, and very well played by Mr. Rogers.

Ms. Talma's Sonata is a pleasant piece of neo-Classicism with serial elements. Mr. Lybbert's Sonata Brevis is a more intense work, more abstract and serial than neo-Classical, although similarly combining elements. All the performances are excellent; the recording is just fair, with peculiar cracklings throughout the pressing. *E.S.*

SONIC ARTS UNION. Lucier: *Vespers.* Ashley: *Purposeful Lady Slow Afternoon.* Behrman: *Runthrough.* Mumma: *Hornpipe.* Sonic Arts Union. MAINSTREAM MS 5010 \$5.98.

Performance: **Composers' own**
 Recording: **Good**

This recording illustrates two notable facets of recent new music in this country. One is the movement by composers to organize their own performance groups rather than depend on existing institutions to diffuse their ideas. The other is the tendency, in music as well as the other arts, toward concept art, and a performance situation in which the ideas are as important as—and sometimes more interesting than—the realization.

The Sonic Arts was founded in 1966 by the four composers represented on this record; in spite of the seemingly hermetic qualities of their activities, the members of the group have toured and performed rather extensively. The *Vespers* of Alvin Lucier—perhaps the most inventive "idea man" in American music today—equips the performers with echo-location devices and directs them to find their way around in darkness: the "music" of the piece consists of the pulse clicks emitted by these bat-men during their rambles. David Behrman's *Runthrough* is a kind of do-it-yourself electronic-music piece freely produced by flicking switches, turning knobs, and shining flashlights on photocells. Gordon Mumma's *Hornpipe* is a piece for modified French horn and a "cybersonic" console which monitors

the horn and the resonances of the hall and responds on its own.

The obvious problem with concept pieces is that they tend to remain in the realm of ideas—more interesting in the telling than in the doing. Beyond its idea, Alvin Lucier's bat piece functions as a kind of environmental object; although Lucier doesn't say it, I imagine it should be listened to in the dark (as in a "live" performance). It just is; no more, no less musical than, say, a visit to a bat cave. It must be added, however, that a visit to a bat cave is for me a more enthralling and aesthetic experience than the electronic clicks which constitute the recording of Lucier's tribute to our flying mammal friends.

Some of the same objections might be made to the Behrman *Runthrough*. Understanding why this performance is made the way it is made and participating in a "live" performance may be meaningful, but a record is a record, and one can only deal with what comes out of the grooves. The sound here is impressive, unvaried, and not able to convey the sense of how the piece was made. Mumma's *Hornpipe* is the most successful of these three works purely as sound; "cybersonic" or no, it makes quite a good piece.

Robert Ashley's *Purposeful Lady Slow Afternoon* is described as a solo song for female vocalist from something called "The Wolfman Motorcity Revue"—"a theater work for amplified voices and tape which has as its subject matter the melodrama and song structures of the nightclub entertainment situation." Now that description interests me a lot, but the solo song is only a toneless bit of pop-porn recited by a bored-sounding young lady to an inconsequential background of bell-like sounds and growls.

The recordings were made by the composers themselves, apparently during performances, at the Rose Art Museum of Brandeis University. As might be expected from the high level of technical competence of this group, the recordings are excellent. This release documents some important current ideas in new music but it also illustrates a surprising lack of understanding about media. The composers' ideas would certainly have been better served if they had been realized expressly for recording, a medium whose requirements and meanings are vastly different from those of "live" performance. *E.S.*

BERTRAM TURETZKY; Music for Contrabass. Erb: *Basspiece.* Ogdon: *By the Isar.* Mestres-Quadreny: *Divertimento.* "La Ricarda." Simons: *Silver Thaw; Design Groups #1 & #2.* Bertram Turetzky (contrabass); assisting artists. DESTO DC 7128 \$5.98.

Performance: **Unbeatable**
 Recording: **Good**

Bertram Turetzky, superbass, goes his merry way, helping create and realize the most extraordinary new repertoire for his musical behemoth. Superbass, because contrabass is already far too limiting a concept for the enormous repertoire of sounds and ideas that Turetzky puts together with the aid of his composer friends. With performers like Turetzky, music is a real activity, and in the process of getting performer and composer together, the whole is something more than the sum of the parts.

The geographical range here is wide: San Diego (Will Ogdon, Turetzky's colleague at the University of California at San Diego).

(Continued on page 130)

the sound way to better sound

The soundest words you'll ever see for the best sounds you'll ever hear are all in the 1973 Stereo Directory & Buying Guide.

All the latest information on stereo systems and components —

- 4-Channel Components
- Amplifiers • Tuners
- Receivers • Hi-Fi Compacts
- Changers & Turntables
- Speaker Systems
- Phono Cartridges & Arms
- Cassette, Cartridge & Reel-to-Reel Tape Machines
- Headphones, microphones and raw tape

More than 1500 products in all! All listed by manufacturer, each with model number, complete specifications, description and price.

PLUS — FEATURE ARTICLES: A Shoppers Guide To Stereo ■ A Report In 4-Channel Trends

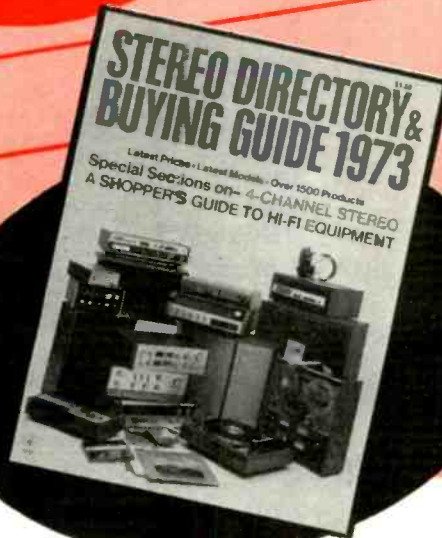

the quiet way to better listening.

You can make a pre-store purchasing decision at home. The silent hours you spend with the Directory will assure you many hours of the purest, most perfect listening pleasure.

The Directory tells you what to look for, what to avoid, how to decide what's best for *you* at a price you can afford. Now you can know what you want *before* you visit the dealer—and what to listen for when you get there.

Whether you're shopping for your very first stereo system, or trading up components on a sophisticated rig, you'll get happier results if you shop first in the 1973 Stereo Directory & Buying Guide. Only \$1.50. Use the convenient coupon below to order your copy today.

Bring your reference library up-to-date!

If you've missed any of the current and previously published Annuals, a wide selection is still available. To place your order, circle the corresponding numbers on the coupon on this page.

Electronic Experimenter's Handbook—Exciting electronics construction projects—all laboratory tested by the Editors, complete with parts list and easy "How-To-Do-It, How-It-Works" instructions.
1973—#88 1972 Winter—#40 1971 Winter—#33 1971 Spring—#26
1970 Spring—#14

Communications Handbook—Here is one single package, the combined knowledge and experience of the top men in each field, tunes you in on everything you need to know about CB, SWL and HAM.
1973—#80 1972—#70 1971—#37 1970—#10 1969—#86

Tape Recorder Guide—The complete guide to what's available—how to choose what's best for you and how to get the best use and pleasure from your tape recorder.
1973 Winter—#78 1972 Spring—#51 1971 Winter—#56 1971—#19



ZIFF-DAVIS SERVICE DIV. • Dept. SD SR-473
595 Broadway, N.Y., N.Y. 10012

Please send me _____ copies of the 1973 edition of Stereo Directory and Buying Guide at \$1.50 each plus 35¢ each for postage and handling. (\$2.50 postpaid for orders outside the U.S.A.)

Also, I have circled the numbers below of the additional annuals I wish to receive:

40	70	80	88	10	86	14	19	26	30	33
\$1.25 each				\$1.35 each		\$1.50 each				

I am enclosing a total of \$_____ for the annuals ordered above. I have enclosed an additional 35¢ per copy for postage and handling. (For orders outside the U.S.A., all annuals are \$2.50 per copy, postpaid.)

print name _____

address _____

city _____ state _____ zip _____

Payment Must be Enclosed with Order

SAVE!

MONEY • TIME • FREIGHT

QUALITY STEREO EQUIPMENT
AT LOWEST PRICES.

YOUR REQUEST FOR QUOTA-
TION RETURNED SAME DAY.

FACTORY SEALED CARTONS—
GUARANTEED AND INSURED.

SAVE ON NAME BRANDS LIKE:
A.D.C. KLH
A.R. SHURE
DYNACO KOSS
SONY FISHER

AND MORE THAN 50 OTHERS

BUY THE MODERN WAY

BY MAIL—FROM

illinois audio

Department 217S

1019 North Dearborn Street

Chicago, Illinois 60610

312-664-0020

CIRCLE NO. 21 ON READER SERVICE CARD

check with the
East-Coast Stereo
Discounters...
...then BUY from

**MIDWEST
HI-FI
WHOLESALE**

Box 567

Ellsworth Industrial Park
Downers Grove, Ill. 60515

(312) 852-5885

Write for our new
WHOLESALE price list
& catalog. You'll
be glad you did!

OVER 50 NAME BRANDS
FACTORY - SEALED CARTONS
WHOLESALE PRICES
SAVE ON TIME
& FREIGHT CHARGES

CIRCLE NO. 32 ON READER SERVICE CARD

Cleveland (the inventive Donald Erb), New York (Netty Simons), and Barcelona (Josep Maria Mestres-Quadreny). The Erb and the first Simons piece are multi-track realizations for the bass. Ms. Simons' *Design Groups #1* is for one to three percussionists—in this instance one percussionist (Ron George) on three tracks (and no contrabass at all!); *Design Groups #2*, also a graphic piece, is for high and low instruments—here, flutes and basses multi-tracked by Turetzky and his wife Nancy. The Mestres-Quadreny is a bit of a theater piece for flute, clarinet, and bass; unfortunately, the theater idea, which must be effective in the concert hall, is not really very well reflected in sound alone. Ogdon's *By the Isar* is a setting of D. H. Lawrence for soprano, alto flute, and bass. Unfortunately, texts are not given and neither soprano nor flute are identified; indeed, the "assisting artists" on the other tracks are barely mentioned somewhere in the liner notes.

Aside from these production problems, the recordings are good, and the pieces, whatever their ultimate value, have that continual fascination with sound that is the trademark of a Turetzky production. E.S.

LEOPOLD STOKOWSKI: Sixtieth Anniversary Concert. Wagner: *Prelude to Die Meistersinger*. Debussy: *Prélude à l'après-midi d'un faune*. Glazounov: *Violin Concerto in A Minor, Op. 82*. Brahms: *Symphony No. 1, in C Minor, Op. 68*. Tchaikovsky: *Marche Slave, Op. 31*. Silvia Marcovici (violin, in Concerto); London Symphony Orchestra, Leopold Stokowski cond. LONDON SPC 21090/1 two discs \$11.96.

Performance: **In-the-flesh**

Recording: **On-the-spot**

Not since the celebrated Schoenberg *Gurre-Lieder* performances with the Philadelphia Orchestra in 1932 has there been a commercial recording of Leopold Stokowski in live concert. Maestro Stokowski's celebration of his sixtieth anniversary as a conductor in London provided the occasion for this particular recording, London's Festival Hall was the setting for the concert, on June 14, 1972, and the program was the same as the one with which Stokowski made his British debut in 1912 with the London Symphony Orchestra. Yet there are a couple of Stokowski "firsts" here: his first recording ever of the Glazounov Violin Concerto, as well as his first stereo recordings of the *Meistersinger* Prelude and the Brahms First Symphony.

The Wagner prelude gets a handsome, broad treatment, much like Stokowski's only previous recording of it, which he made with the Philadelphia Orchestra on 78's. The Debussy prelude is as lush as can be with its gorgeous solo flute; Stokowski's reading is over two lavish minutes longer than Boulez's. The Glazounov concerto—an unjustly neglected piece—also gets an excellent performance here with topflight solo and orchestral work (I wish the elaborate album booklet had given some information about Miss Marcovici). The Brahms First—long a Stokowski staple—is played straightforwardly and with enormous power, the best Stokowski reading I have heard on records since he made the original Victor M-15 with the Philadelphia Orchestra in 1927 or thereabouts. And a delightful Stokowskian anniversary speech precedes the lollipop closer: Tchaikovsky's *Marche Slave*.

Phase-4 sonics or no, this album is essentially a documentary package, and a most en-

joyable one. But the recording is quite far removed from that of a Stokowski studio session. In general, the woodwinds in the Festival Hall recording sound decidedly forward (probably a function of Stokowskian orchestral seating rather than mixing by the engineers), and the strings sound just a bit out of focus compared to what one hears under controlled recording conditions.

It is good to have this album both as document and as musical performance—a great conductor still full of pizzazz at ninety! Even so, I still feel that the finest tribute to Maestro Stokowski's career would be a comprehensive anthology from RCA of the finest Stokowski Philadelphia Orchestra recordings, which stand alongside those of Beecham and the London Philharmonic as landmarks of the finest days of 78's. RCA has made a start with four LP Philadelphia sides ranging in time from 1927 through 1940 (VCM 7101). Let's hope for more. D.H.

JEAN AND KENNETH WENTWORTH: Music for Piano, Four Hands. Sydemann: *Concerto for Piano Four Hands and Chamber Orchestra* (with Contemporary Music Ensemble, Arthur Weisberg cond.). Spiegelman: *Kousochki*. Moss: *Omaggio*. Wuorinen: *Making Ends Meet*. Jean and Kenneth Wentworth (piano, four hands). DESTO DC 7131 \$5.98.

Performance: **Apparently excellent**

Recording: **Good**

This is a program of music written especially for the Wentworths, who specialize in that distinct genre of four-hand music confined to a single piano. Nowadays, two-piano teams are more familiar, but once upon a time four hands on the family parlor grand was the most familiar form of do-it-yourself ensemble music. Not only was there an original literature by the masters—Mozart and Schubert, in particular—but nearly everything from symphonies to string quartets was arranged for such performance.

Recordings and radio changed all that, of course, and now piano for four hands is a quaint pastime practiced in semi-secret by a few amateurs, literati, and the occasional musician who actually still plays for his or her own enjoyment. In fact, I even know a supposedly avant-garde composer who likes nothing better than to rattle through the Schubert *Lebenstürme* with a friend and who once actually composed a "Haydn Symphony No. 105 for piano, four hands" as a birthday present to his wife. Shhhhhh!

So the Wentworths are keeping something of a tradition alive. All these pieces were composed between 1966 and 1967, and, except for the typically craggy Wuorinen work (the title is a purely technical reference and not at all evocative), they are in attractive, modern-music idioms. The biggest and most dramatic of them is the Sydemann Concerto. Like the Spiegelman *Kousochki* (Russian for "morsels") and the Moss *Omaggio* (which actually quotes Mozart four-hand music), it explores keyboard sonorities to good effect. I don't think too much of this music is going to appeal to the performing amateur for his own use. But it should appeal to the listening keyboard connoisseur. Even without the scores, I think it is safe to describe the performances as good to excellent, and the recordings are very good. E.S.

THE WESTERN WIND: Early American Vocal Music (see Best of the Month, page 79)

THE 'STORAGE PROBLEM' SOLVERS

DELUXE MATCHING STORAGE CASES FOR YOUR 12" RECORDS,
7" REELS, CASSETTES AND 8-TRACK CARTRIDGES.

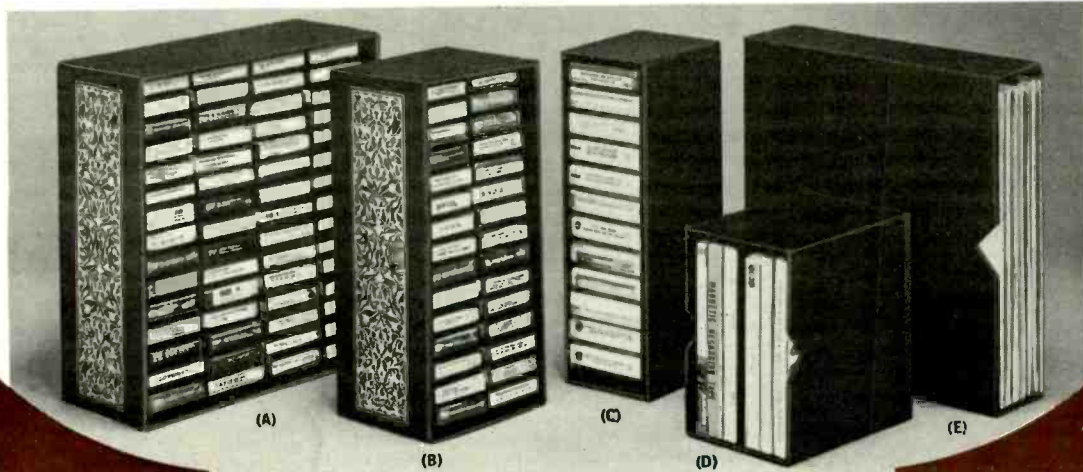

(A) 60-unit cassette case. 13½" h. x 12¾" d. x 5½" w. Compartments are tilted back to prevent spillage. Includes pressure-sensitive labels for titling. \$14.75 each. 3 for \$42.00.

(B) 30-unit cassette case. 13½" high x 6½" deep x 5½" wide. Tilted compartments, labels included. \$8.40 each. 3 for \$24.00.

(C) 12-unit cartridge case. 13¼" high x 6½" deep x 4¼" wide. Tilted compartments, labels included. \$5.25 each. 3 for \$13.75.

(D) 6-unit 7" reel case. 8" high x 7½" deep x 5" wide. Holds reels in original boxes. \$4.75 each. 3 for \$12.65.

(E) 20-unit 12" record case. 13¼" high x 12½" deep x 3½" wide. Holds records in original jackets. \$5.25 each. 3 for \$13.75.

Here's the ideal solution to the problem of keeping all your records and tapes stored neatly, safely, conveniently and attractively. A complete set of matched storage cases, designed by the editors of STEREO REVIEW magazine, for your records and all your tapes: cassette, cartridge and 7" reel. Now you can keep them side-by-side on your bookshelf or cabinet, easy to identify and readily available.

These cases are sturdily constructed and covered in a handsome leatherette. The outer case is elegantly embossed in gold and comes in your

choice of three popular decorator colors—black, brown and green—so that they lend themselves readily to the decor of any room.

STEREO REVIEW large capacity storage cases are just what you've been looking for—they're the ideal solution to keeping your records and tapes neatly stored for easy use.



**AN EXTRA SERVICE FOR YOU—
CHARGE YOUR STORAGE CASE ORDER
TO YOUR AMERICAN EXPRESS
OR BANKAMERICARD ACCOUNT.**

ZIFF-DAVIS PUBLISHING COMPANY, Dept. 23,
One Park Avenue, New York 10016

My remittance in the amount of \$ _____
is enclosed for the cases indicated. SR-473

Charge my American Express Card Account # _____

Charge my BankAmericard Account # _____

Signature _____

Print name _____

Address _____

City _____

- _____ 60-unit Cassette Cases @ \$14.75 each;
3 for \$42.00.
- _____ 30-unit Cassette Cases @ \$8.40 each; 3 for
\$24.00.
- _____ 12-unit 8-Track Cartridge Cases @ \$5.25 each;
3 for \$13.75.
- _____ 6-unit 7" Reel Cases @ \$4.75 each; 3 for \$12.65.
- _____ 20-unit 12" Record Cases @ \$5.25 each; 3 for \$13.75.

Add 50c per unit ordered for postage and handling. Outside U.S.A. add \$1.00 per unit ordered. Payment must be enclosed with order if not charged.

Check color choice for back of case (sides in black only):

Brown Green Black

State _____ Zip _____

STEREO REVIEW MARKET PLACE

NON-DISPLAY CLASSIFIED: COMMERCIAL RATES: For firms or individuals offering commercial products or services, \$1.60 per word (including name and address). Minimum order \$16.00. Payment must accompany copy except when ads are placed by accredited advertising agencies. Frequency discount: 5% for 6 months; 10% for 12 months paid in advance.

READER RATE: For individuals with a personal item to buy or sell, \$1.00 per word (including name and address). No minimum! Payment must accompany copy. **DISPLAY CLASSIFIED:** One inch by one column, \$215.00. Two inches by one column, \$430.00. Column width 2-1/4". Advertiser to supply film positives. Please write or phone for frequency rates.

GENERAL INFORMATION: First word in all ads set in bold caps at no extra charge. All copy subject to publisher's approval. All advertisers using Post Office Boxes in their addresses MUST supply publisher with permanent address and telephone number before ad can be run. Closing Date: 5th of the 2nd month preceding cover date (for example, March issue closes January 5th). Send order and remittance to: Hal Cymes, STEREO REVIEW, One Park Avenue, New York, New York 10016.

EQUIPMENT

WRITE for quotation on any Hi-Fi components: Sound Reproduction Inc., 460 Central Avenue, East Orange, N.J. 07018. 201-673-0600.

NO fair trade laws in D.C. Write for discount prices on your choice of components. District Sound, Inc., 2316 R.I. Ave., N.E., Wash., D.C. 20018. (202) 832-1900.

DIAMOND NEEDLES and Stereo Cartridges at Discount prices for Shure, Pickering, Stanton, Empire, Grado and ADC. Send for free catalog. All merchandise brand new and factory sealed. **LYLE CARTRIDGES**, Dept. S. Box 69, Kensington Station, Brooklyn, New York 11218.

DISCOUNT PRICES on Stereo Components and Systems. For lowest cost, fastest service, write for our quote and order form. West Coast customers: Save on shipping costs and time. Redwood Stereo Co., P.O. Box 2794, San Rafael, Calif. 94902. (415) 472-2255.

LOW, LOW prices, on audio equipment. All factory fresh, 1st quality items. Trained personnel at your disposal for audio consultation. For free catalogs or information write to: Mr. A. Dept. AMS at SMG Distributors, Inc., 46-35 54th Road, Maspeth, New York 11378.

AUDIO FURNITURE? Ask for Jerry Joseph of Toujay Designs at Hi-Fi Expo, 443 Park Avenue South, NYC 10016. Tues.-Fri. 11-5, Sat. 11-4. Full line brochure 25 cents.

**TEST
FREE COMPARISONS**

Comparisons by Pittsburgh's Audio experts of over 100 speakers, receivers, changers, and cartridges included in the most informative catalog of its kind. Complete with lowest wholesale prices.

Wholesale Audio Inc
3916 SAW MILL RUN BLVD., D-4
PITTS., PA. 25527 (412) 884-8797

HI-FI STEREO SALE. Shop by mail and save. America's wildest discountor offers the lowest prices on famous brand stereo systems. Write for prices. Nedco Distributors, 68-01 Watertown Street, Watertown, Mass. 02172.

SAN FRANCISCO'S oldest Hi-Fi dealer goes mail order. Lowest Prices, Prompt Delivery. The Listening Post, Dept. M. 2222 Fillmore, San Francisco, CA 94115.

8-TRACK tapes \$2.99 ea. Boman Astrosonix electronic sound systems, speakers, and accessories. Special WHOLESALE PRICES. No obligations. Write for FREE INFORMATION!! JHS Enterprises, XD7, Point Clear, Alabama 36564.

AR, KLH, ADVENT, DYNACO, ADC, RECTILINEAR OWNERS—low cost electronic equalization for your particular speakers overcomes limitations of bookshelf enclosures, provides full-range performance. Complete specifications, test reports, from Norman Laboratories, 520 Highland Parkway, Norman, Oklahoma 73069.

FOR SALE

JAPAN HONG KONG Directory. World products information. \$1.00 today. Sekai Shogyo Annai, Hillyard, Wash. 99207.

JAPANESE ELECTRONICS DIRECTORY. 350 brands, addresses, tips, \$1.00. Yunyuhin Sankosho, 601 S. Dodson Dr., Urbana, Illinois 61801.

RECORDS

SHOW ALBUMS. Rare. Out-of-Print LP's. Large list. 16 cents. Broadway/Hollywood Recordings, Georgetown, Conn. 06829.

"HARD To Get" records—all speeds. Record Exchange, 842 Seventh Avenue, New York, N.Y. 10019.

PROTECT your records—Poly sleeves for Jackets 5 cents; Inner sleeves 5 cents; Poly lined paper sleeves 11 cents; white jackets 25 cents. Postage \$1.00. Record House, Hillburn, N.Y. 10931.

THOUSANDS of like new LP's and prerecorded tapes. Catalogue \$1.00. Records, Hillburn, New York 10931.

FREE 162-PAGE CATALOG offers over 1,000 fine recordings of Renaissance, Baroque, Classical, Romantic and Modern music. All late stereo recordings. Highest quality at budget label prices. Available only by mail from MUSICAL HERITAGE SOCIETY, Box 932 HS, New York, N.Y. 10023.

ANY RECORD. ANY TAPE AT LOWEST DISCOUNT PRICES. Enroll in Saturnian Record Club. \$1 Lifetime membership fee brings you a Free Schwann catalogue and forms for immediate ordering of any record at unmatchably low prices. No minimum, no limit. Write Saturnian Record Club, 136 Walker Street, Lenox, Mass. 01240. Box STR.

OPERA RECORDS. Rare live performances now available for the first time on top quality LP recordings. Ed Rosen, Box 97, Freeport, NY 11520.

SOUNDTRACKS. Large Free Catalog. STAR-19, Route 2, Box 1944R, Escondido, CA 92025.

FREE CATALOGS—broadcasts. Sound Tracks of Thirties. ARG, 341 Cooper Station, New York City 10003.

RARE SOUNDTRACKS—SHOWS. Extraordinary list. Write to: Film Music, Box 1195, Beverly Hills, California 90213.

SOUNDTRACKS, casts, personalities list 16 cents. Don, 2914 Westerland, Houston, 77042

AUCTION of 78 and LP Jazz, Big Band, Show, Soundtrack. Over 100 new 78 sets. Send large envelope with 16 cents postage for list. Don Larson, 117 Dillon Ave., Mankato, Minn. 56001.

RARE SOUNDTRACKS—SHOWS. Extraordinary list. Write to: Film Music, Box 1195, Beverly Hills, Calif. 90213

FREE monthly stereo record bargain list. Al Roseman, P.O. Box 16083, Phila., Pa. 19114.

TAPE AND RECORDERS

SCOTCH RECORDING TAPE, lowest prices. TAPE CENTER, Box 4305, Washington, D.C. 20012.

OLD Time radio programs—all your old favorites, 50 cents for catalog. Robert Mussehl, R. 1, Brooklyn, Wisc. 53521.

RENT stereo tapes \$1.50 week postpaid—NEW catalog 25 cents. Tape Library, Box 8126, Washington, D.C. 20024.

RENT 4-track open reel tapes—all major labels—3,000 different—free brochure. Stereo-Parti, 55 St. James Drive, Santa Rosa, California 95401.

OLD Radio Programs Catalog. \$1.00 (refundable). The Radio Vault, Box 9032SR, Wyoming, Michigan 49509.

LIVE OPERA PERFORMANCES on reel-to-reel tapes. Incredible performances dating back 40 years. From Ponselle-Callias. Catalog: Mr. Tape, Box 138, Murray Hill Station, N.Y.C. 10016.

OPERA tapes—historical performances of past 40 years. Unbelievable treasures and rarities. Free catalog. Ed Rosen, Box 97, Freeport, N.Y. 11520.

1930-1962 radio programs on tape. Huge catalog! Sample recordings! \$1.00, refundable!! AM Treasures, Box 192, Babylon, N.Y. 11702.

CASSETTES—Blanks, spoken-word and language, plus novel accessories. Send 10 cents in stamp or coin for Brand New 1973 Catalog. Cassettes Unlimited, P.O. Box 13119S, Pittsburgh, Pa. 15243.

OLD Radio Show Monthly Special Club—TBOR, Box 1692B, F.D.R. Station, New York 10022.

OPEN REEL STEREO TAPE BUYERS!

At last! An open reel compilation, including titles, songs, etc., of 95 long play, 1 1/2-3 hour albums by American Airlines, Continental Airlines, and Ampex 4 track stereo tapes (includes a group of "sound effects" tapes by Audio Fidelity). Send \$1.00 — and we will also mail you a 140-page Harrison stereo tape catalog — so you'll get both for \$1.00 — and this \$1.00 is refundable on your first \$10.00 purchase of open reel stereo tapes at our 30% discount!



SCOTCH MAGNETIC TAPE (USED)
#150, 1 MIL POLYESTER, 3600 FT. ON 10 1/2 IN. FIBERGLASS REELS, USED ONCE, \$1.99/1800 FT., 7 IN. REELS, 99¢ — GUARANTEED TO PERFORM AS GOOD AS NEW OR MONEY REFUNDED. (BULK, NO BOX). USED 10% IN. FIBERGLASS REELS (SMALL HOLE) 50¢ NEW HINGED BOXES: 10 1/2 IN., 39¢, 7 IN., 9¢ ALL PLUS POSTAGE BY WEIGHT & ZONE!



SAXITONE TAPE SALES
1776 Columbia Rd., N.W. Washington, D.C. 20009

OPEN REEL TAPES from Rental Library 67% off list. Pre-recorded Stereo and Scotch recording tapes. Lowest Prices Anywhere. Alan Enterprises, 5023 Lee, Skokie, Illinois 60076.

1800' NEW MYLAR TAPE on 7" reel in box. 12 for \$15.00 POSTPAID. Free price list. WIDE RESPONSE, 2926 Bentley Ave., Los Angeles, Calif. 90064.

MEMOREX & BASF audio and video recording tape. BSC, Inc., P.O. Box 1181SR, Melrose Park, Ill. 60161.

OPERA TAPE catalog free. Opera Recorder, 862 East 51 Street, Brooklyn, N.Y. 11203.

TDK, BASF, Memorex. Scotch cassettes, reels, 8-tracks. THE LOWEST PRICES. S&S Audio, Box 523-D, Skokie, Illinois 60076.

HEATHKIT AD110 cassette deck. Mody, 3320 Old Forest Road, Lynchburg, Virginia 24501.

10-1/2" RECORDER Users. Excellent used metal reels, \$2.00; Single 12, \$1.75 each. "REELS," Box 338, Dunwoody, GA 30338.

MUSICAL Theatre Tapes. New York, Hollywood, London. European. Excellent Sound. Over One Thousand Shows. Catalogue \$1 (refundable). ARL, Box 8096, Station F, Edmonton, Alberta.

1/2" VIDEO TAPE. \$6.00 per hour. Free information. OREGON MAGNETICS, Box 13374, Portland, Oregon 97213.

TUBES

TV and Radio Tubes 36 cents. Free 48 page color catalog. Cornell, 4215-H University, San Diego, California 92105.

INSTRUCTION

LEARN Electronics Organ Servicing at home. All makes. Including transistors. Experimental kit—trouble-shooting. Accredited NHSC. Free Booklet. Niles Bryant School, 3631 Stockton, Dept. A, Sacramento, Calif. 95820.

LOGIC trainers catalogs 50 cents. UTI, POB 252, Waldwick, N.J. 07463.

ASSOCIATE DEGREE IN ELECTRONICS through correspondence instruction. G.I. Bill approved. Free catalog. Grantham, 1509 N. Western, Hollywood, Calif. 90027.

TAPE RECORDING COURSE: Taught by studio engineers. Free information. NNA, Box 721A, Rye, New York 10580.

MUSICAL INSTRUMENTS

30% DISCOUNT name brand musical instruments. Free catalog. Freeport Music, 455Q, Route 110, Melville, N.Y. 11746.

WANTED

QUICKSILVER, Platinum, Silver, Gold, Ores Analyzed. Free Circular. Mercury Terminal, Norwood, Mass. 02062.
 WANTED: Any recordings of the Kolisch Quartet or Rudolf Kolisch. Send description and price. David Satz, 16 Ellsworth Park, Cambridge, Mass. 02139.

GOVERNMENT SURPLUS

JEEPS Typically From \$53.90... Trucks From \$78.40... Boats, Typewriters, Knives, Airplanes, Clothing, Multi-meters, Oscilloscopes, Transceivers, Photographic, Electronics Equipment, Wide Variety, Condition, 100,000 Bid Bargains Direct From Government Nationwide. Complete Sales Directory and Surplus Categories Catalog \$1.00 (Deductible on Orders From Separate Included Catalog). Surplus Service, Box 820-L, Holland, Michigan 49423.

HYPNOTISM

Free Hypnotism, Self-Hypnosis, Sleep Learning Catalog! Drawer H400, Ruidoso, New Mexico 88345.
 SLEEP LEARNING, Hypnotic Method, 92% effective. Details free. ASR Foundation, Box 7566 EG, Fort Lauderdale, Florida 33304.

PERSONALS

MAKE FRIENDS WORLDWIDE through international correspondence. Illustrated brochure free. Hermes, Berlin 11, Germany.

RUBBER STAMPS

RUBBER address stamps. Free catalog, 45 type styles. Jackson's, Box 443G, Franklin Park, Ill. 60131.

EMPLOYMENT OPPORTUNITIES

EPICURE PRODUCTS, INC. is seeking quality applicants to meet expansion needs. Applicants must be willing to travel extensively four or five days per week; be knowledgeable of, or willing to learn, all aspects of the hi fi industry—products, policies, and future developments. Position requires a professional approach to sales, and a person interested in rapid advancement into a growing management team. Base salary and monthly incentive. Epicure Products, Inc., Newburyport, Mass. 01950. Call: Robert Fuller, Personnel (617) 462-8191.

BUSINESS OPPORTUNITIES

I MADE \$40,000.00 Year by mailorder! Helped others make money! Start with \$10.00—Free Proof. Torrey, Box 318-N, Ypsilanti, Michigan 48197.
 \$200.00 Dally In Your Mailbox! Your Opportunity To Do What Mailorder Experts Do. Free Details. Associates, Box 136-SR, Holland, Michigan 49423.
 MAILORDER MILLIONAIRE helps beginners make \$500 weekly. Free report reveals secret plan! Executive (1K4), 333 North Michigan, Chicago 60601.
 FREE SECRET BOOK "2042 Unique, Proven Enterprises." Beat inflation with fabulous, successful "Little Knowns." Work home! Haylings-B8, Carlsbad, Calif. 92008.
 FREE BOOK "999 Successful, Little-known Businesses." Work home! Plymouth-Q4, Brooklyn, New York 11218.

MOVIE FILMS

16mm SOUND Features, Shorts, New, Used for Sale. Free Catalog. National Cinema, 333 W. 57th St., N.Y., N.Y. 10019.

EDUCATIONAL OPPORTUNITIES

LEARN WHILE ASLEEP, Hypnotize! Strange catalog free Autosuggestion, Box 24-ZD, Olympia, Washington 98501.

EMPLOYMENT INFORMATION

EXCITING Overseas Jobs. Directory \$1.00. Research Associates, Box 889-E, Belmont, California 94002.

BOOKS

BEST Hi-Fi Books! "4-Channel Stereo" only \$3.95. Free Catalog. TAB BOOKS, B.R.S., Pa. 17214.

MISCELLANEOUS

WINEMAKERS. Free illustrated catalog of yeasts, equip-ment. Semplex, Box 12276Q, Minneapolis, Minn. 55412.
 OLD RADIO PROGRAMS ON CASSETTES OR REELS. Thousands of your favorites live again. Low prices, high quality. Catalog 50 cents. Remember Radio, Box 2513-I, Norman, Oklahoma 73069.

CLASSIFIED ADVERTISING ORDER FORM

Please refer to heading on first page of this section for complete data concerning terms, frequency discounts, closing dates, etc.

1	2	3	4	5
6	7	8	9	10
11	12	13	14	15
16	17	18	19	20
21	22	23	24	25
26	27	28	29	30
31	32	33	34	35

_____ Words @ \$1.00 (Reader Rate) \$ _____
 @ \$1.60 (Commercial Rate) \$ _____

Insert _____ time(s) Total Enclosed \$ _____

NAME _____
 ADDRESS _____
 CITY _____ STATE _____ ZIP _____

Signature _____

WORD COUNT: Include name and address. Name of city (Des Moines) or of state (New York) counts as one word each. Zip Code numbers not counted. (Publisher reserves right to omit Zip Code if space does not permit.) Count each abbreviation, initial, single figure or group of figures or letters as a word. Symbols such as 35mm, COO, PO, AC, etc., count as one word. Hyphenated words count as two words.

SR 473

The Most Spectacular Sound Exhibition of STEREO FIDELITY Ever Available on one Disc.

Stereo Review STEREO DEMONSTRATION RECORD

A sparkling series of demonstrations, each designed to show off one or more aspects of stereo sound.

NOW AVAILABLE ON STEREO CASSETTE

THESE EXCITING SOUNDS ARE NOW AVAILABLE ON STEREO CASSETTE!

Place your order by using coupon below.

ONLY \$6.98 POSTPAID

This record is the result of two years of intensive research in the sound libraries of Deutsche Grammophon Gesellschaft, Connoisseur Society, Westminster Recording Company and Cambridge Records Incorporated. The Editors of Stereo Review have selected and edited those excerpts that best demonstrate each of the many aspects of the stereo reproduction of music. The record offers you a greater variety of sound than has ever before been included on a single disc.

It is a series of independent demonstrations, each designed to show off one or more aspects of musical sound and its reproduction. Entirely music, the Record has been edited to provide self-sufficient capsule presentations of an enormous variety of music arranged in a contrasting and pleasing order. It includes all the basic musical and acoustical sounds that you hear when you listen to records, isolated and pointed up to give you a basis for future critical listening.

WIDE RANGE OF DEMONSTRATIONS

- Techniques of Separation & Multiple Sound Sources
- Acoustic Depth
- Ambiance of Concert Hall
- Sharp Contrasts of Dynamics
- Crescendo & Diminuendo
- Very High & Very Low Pitched Musical Sounds
- Polyphony (2 or more melodies at once) With Both Similar & Contrasting Instruments
- Tonal Qualities of Wind, String & Percussion Instruments
- Sounds of Ancient Instruments
- Sounds of Oriental Instruments
- Sound of Singing Voice, Both Classically Trained and Untrained
- Plus a Large Sampling of Finger Snapping, Hand Clapping, Foot Stamping & Other Musical & Percussive Sounds.

13 SUPERB SELECTIONS

- STRAUSS: Festive Prelude, Op. 61 (excerpt) DGG.
- DEBUSSY: Feux d'artifice (excerpt), Connoisseur Society.
- BEETHOVEN: Wellington's Victory (Battle Symphony) (excerpt from the first movement) Westminster Records.
- MARCELLO: (arr. King): Psalm XVII "The Heavens are Telling" (complete) Connoisseur Society.
- CORRETTE: Concerto Comique Op. 8, No. 6, "Le Plaisir des Dames" (third movement) Connoisseur Society.
- KHAN: Raga Chandranandan (excerpt) Connoisseur Society.
- RODRIGO: Concert-Serenade for Harp and Orchestra (excerpt from the first movement) DGG.
- MANITAS DE PLATA: Gypsy Rhumba (complete) Conn. Soc.
- MARCELLO: (arr. King): Psalm XVII "The Heavens are Telling" (complete) Connoisseur Society.
- PRAETORIUS: Terpsichore: La Bourrée XXXII (complete) DGG Archive.
- BERG: Wozzeck (excerpt from Act III) DGG.
- BARTOK: Sonata for two pianos and Percussion (excerpt from the first movement) Cambridge Records.
- BEETHOVEN: Wellington's Victory (Battle Victory) (excerpt from the first movement) Westminster.

AVAILABLE IN YOUR CHOICE OF 33 1/3 RPM OR 45 RPM

The Stereo Demonstration Record is processed and pressed on a newly developed, improved vinyl. It is permanently anti-static, repels dust and dirt and promotes longer stylus wear. The use of this material is conducive to low surface noise and contributes to the production of full dynamics and frequency range. The record continually looks new, sounds new and wears longer.

FREE Descriptive Booklet Enclosed includes discussion of the selections on the record, plus a complete description of each selection and the purpose behind its demonstration.

RECORDS • Ziff-Davis Service Division
 595 Broadway • New York, N.Y. 10012

My check (or money order) for _____ is enclosed.

Please send the following: **SR 473**

_____ Stereo Review Stereo Demonstration Record Albums @ \$5.98 each postpaid.

Check one: 33 1/3 RPM 45 RPM

_____ Stereo Review Stereo Demonstration Cassettes @ \$6.98 each postpaid.

(Outside U. S. A. please send \$8.00 for each record or cassette ordered.) New York State residents please include local sales tax.

Print name _____
 Address _____
 City _____ State _____ Zip _____

PAYMENT MUST BE ENCLOSED WITH ORDER

TAPE HORIZONS

By CRAIG STARK



SETTING UP TO RECORD

LAST month I talked about some of the basic equipment you ought to take along when you're suddenly asked to tape the concert of a local music group. More often than not you won't have the professional's luxury of experimenting with various microphones and placements. Instead, you'll have about an hour to set up before the audience arrives, and you'll have to infer where the performers will be from the chairs, risers, piano, *etc.* on the stage. Don't be discouraged; chances are you can *still* get a tape to be proud of.

Your first move when you get to the auditorium is, of course, to find a place (preferably with a table) to set up your recorder. Make it as unobtrusive as possible, for neither performers nor audience want *you* to be the focus of attention. And when you're considering locations, *don't* automatically assume that an electrical outlet backstage or on the stage apron will work; check it, for often it will be controlled by a switch somewhere that you can't find, so you'll need a long extension cord instead.

Next, walk around the performing area briefly, clapping your hands hard. A sharp "crack" means a reasonably "live" hall, where moderately close microphone placement will still pick up enough of the room's natural reverberation to give your tape a spacious, concert-hall sound. On the other hand, if your claps produce a dull thud, this indicates a rather "dead" acoustical environment. In that case you'll want to put your mikes farther away from the performers, or the sound will be dry and lifeless. Good recordings demand a balance between the sound waves that reach the microphone directly from the musicians and those that reach it after being reflected around the room: the closer the mikes, the less reverberation you'll get, and *vice versa*. As a rule, the presence of the audience (when it arrives) damps some of the reverberation, but experience will help you to compensate for this in advance. One special situation should be mentioned. If you hear any distinct echoes or if your claps seem to take a very long time to die away—often the case in large churches—the room is over-reverberant and you should place your microphones closer to avoid a "muddy" sound that lacks definition.

When possible, you'll want your microphones somewhat closer to soloists than to their supporting instruments, for this gives the principals a more intimate and forward-sounding perspective. Beware, however, of operatic sopranos, tenors, and brass instruments! Never aim a microphone directly at them; aim slightly above them instead. This way you'll capture all the feeling of power on the high hard notes without losing the orchestral or choral background, but you won't be helplessly watching your VU meters indicate an intolerable distortion level. With small string ensembles, if you can, you should place a microphone higher than the violins, even if this means aiming down on them from a height; these instruments project upward, and this way you'll get that "rosin on the bow" sound. Cellos and double basses project outward, however, dictating lower placement.

Next month, we'll consider some specific microphone types.

STEREO REVIEW APRIL 1973 ADVERTISERS INDEX

READER SERVICE NO.	ADVERTISER	PAGE NUMBER
1	A.D.R. Audio	24
2	Acoustic Research, Inc.	33
3	AKAI America, Ltd.	93
4	Audio Dynamics Corporation	9
5	Audio Warehouse Sales	46
6	BASF Systems	11
7	Baltimore Stereo Wholesalers	119
	Bose	2
9	Bose	113
103	British Industries Co.—Garrard	13
10	Columbia Magnetics	87
	Columbia Records	44
37	Deutsche Grammophon	127
55	Discwasher Inc.	123
11	District Sound Inc.	128
12	Dixie Hi-Fi Wholesalers	18
13	Dokorder Inc.	48
14	Dual	50, 51
15	Dynaco Inc.	7
16	Elac Div., Benjamin Electronic Sound Corp.	17
17	Electro-Voice, Inc.	4th Cover
19	Electro-Voice, Inc.	4th Cover
99	Empire Scientific Corp.	47
85	Empire Scientific Corp.	121
18	Epicure Products Inc.	23
	Fisher Radio	4, 5
20	Heath Company	101, 102, 103
21	Illinois Audio	130
22	International Hi-Fi Distributors	128
	JVC America, Inc.	45
23	Jensen Sound Laboratories	99
24	KLH Research Development Corp.	35
25	Kenwood	106
26	King-Size Co., The	10
27	Koss Corporation	49
28	Lafayette Radio Electronics	84
29	London Records	109
30	McIntosh Laboratory Inc.	48
31	Maxell Corporation of America	12
32	Midwest Hi-Fi Wholesalers	130
34	North American Philips Corporation	87
35	Onkyo	19
36	Phase Linear Corporation	97
41	Pickering & Co., Inc.	15
54	Quadriflex Industries	37
38	Rabsons 57th St. Inc.	46
39	Radio Shack	43
40	Revox Corporation	52
42	Sansui Electronics Corp.	110, 111
	Schick	41
44	Shure Brothers Inc.	39
45	Sony Corporation of America	25
63	Sony/Superscope	94, 95
46	Stanton Magnetics Inc.	91
47	Stereo Corporation of America	123
48	Stereo World	24
49	Suporex Electronics Corp.	20
50	TDK Electronics Corp.	117
51	Tandberg of America	115
52	TEAC	3rd Cover
53	Tokyo Shapiro	18
	U.S. Navy	26, 27, 28, 29
	U.S. Pioneer Electronics Corp.	2nd Cover, 1
14	United Audio Products, Inc.	50, 51
33	Wollensak—3M Company	30

Printed in the U.S.A.

STEREO REVIEW

Meet the creator.

Today, the musical artist has a new instrument at his command—the recording studio. It's an instrument that can capture sound, manipulate it and mold it, stack it and scramble it, equalize and echo it—a contemporary creative tool with possibilities confined only by the borders of imagination.

Some might call this musical soundfoolery, an adulteration of the pure musical art form. But throughout history, the truly creative artist has always used whatever instruments were available to reproduce the music he heard in his mind. The artist is no different today—but the instruments he uses are. And this has resulted in a dynamic new range of musical experiences for us all.

The creator— a 4-channel studio that fits on a shelf



With the needs of the contemporary artist in mind, TEAC tape technologists set out to design a precision musical instrument that would provide studio electronic flexibility and studio performance accuracy—yet be compact enough for home use and priced within the bounds of reason. The result: the creator, TEAC's amazing Model 3340 4-Channel Simul-Sync[®] Tape Deck—a recording studio that fits on a shelf.

The 3340, backed by TEAC's exclusive two-year Warranty of Confidence,* is carefully crafted in the TEAC tradition of professional quality. 10½" studio reels; a quick and gentle three-motor transport; four studio-calibrated VU meters; eight input controls for complete mic/line mixing; dual bias selection; 7½ and 15 ips studio-accurate speeds. And Simul-Sync.

Simul-Sync: what it does and how it works

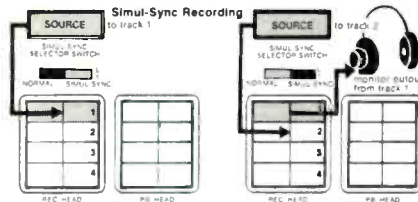

Overdubbing has become a familiar term to every knowledgeable musician. Simply, it means a) recording a voice or instrument on one track of a multi-track tape machine, b) adding another voice or instrument to a different track at a different time, and c) matching the two tracks so it sounds as if they were recorded simultaneously when played back. To overdub properly, the artist recording on the second track has to listen to the material recorded on the first track while performing in perfect synchronization to it.

That's where the problem occurs with most tape recorders. Conventional record/playback monitoring systems only let you listen to the previously recorded material off the playback head. That means a time delay between the track being recorded and the track being monitored. A small delay, to be sure, but large enough to make perfect synchronization virtually impossible.

TEAC engineers solved the problem with Simul-Sync. They designed a studio-tolerance 4-channel record head, then added electronics that allow each track on that head to be switched independently to either record or playback modes. By doing so, they completely eliminated the time lag and permitted the artist to add track after track—all in absolute synchronization with each other.

The TEAC Simul-Sync head, operating in conjunction with a 4-channel erase head and a hyperbolic playback head capable of reproducing either stereo or 4-channel material, served as the foundation for the TEAC 3340 concept. It also opened the door to a whole new realm of musical creativity and enjoyment.

Exploring the realm

Here are just a few of the sonic effects possible with the TEAC 3340:

1. Unlimited overdubbing. Up to nine individual instruments or voices can be recorded at different times without any track being used beyond

second generation. Sensational signal-to-noise ratio is the result.

2. Professional quality mixdown. All four channels to a single track or ¼-track stereo masters. The optional TEAC AX-20 Mixdown Panel makes it a quick and easy process. Individual controls also allow for desired mixing level for each channel.



3. Special effects. Enter the world of psycho-acoustic phenomenon where the creative juices can really start flowing. Things like echo, cross echo, 4-channel rotating echo and pan pot effects (with AX-20 Mixdown Panels). You can put echo on some instruments and not on others. One-man group arrangements, with a single artist playing all instruments and singing all vocal parts. Backwards recording, an effect that gives any instrument a totally new sound. Dual speed recording, mixed down in perfect sync. With all these effects at his disposal, the professional musician can quickly save the cost of a 3340 in reduced studio experimental time alone.

4. Pseudo-quad recording through ambient delay to the rear channels. And, of course, full discrete 4-channel record and playback.

5. Are you creatively curious? If so drop TEAC a line, and ask for the "Meet the creator" booklet. It describes all of the 3340 effects in detail and explains how each is done. And it's free.

If creative involvement is what you're after, meet the creator—the TEAC 3340 4-Channel Simul-Sync Tape Deck. (or the 7" reel, 3¾ – 7½ ips version, the 2340).

When it comes to creative recording, they perform miracles.

*TEAC or one of its authorized service stations will make all necessary repairs to any TEAC tape deck resulting from defects in workmanship or material for two full years from the date of purchase, free of charge to the original purchaser.

The TEAC 2340 and 3340 are priced at \$759.50 and \$849.50, respectively. For complete information, please write to TEAC, 7733 Telegraph Road, Montebello, California 90640. In Canada: White Electronic Development Corp., Ltd., Toronto. TEAC Corporation, 1-8-1 Nishi-shinjuku-ku, Shinjuku, Tokyo, Japan. TEAC EUROPE N.V., Kabelweg 45-47, Amsterdam—W.2, Holland. Hi-Fi, S.A. Alta Fidelidad Hidalgo 1679, Guadalajara, Jal., Mexico.

TEAC[®]

The sound of a new generation

Dreaming
about a pair
of \$300
condenser
microphones?

Think
seriously
about these:
\$39.75* each!

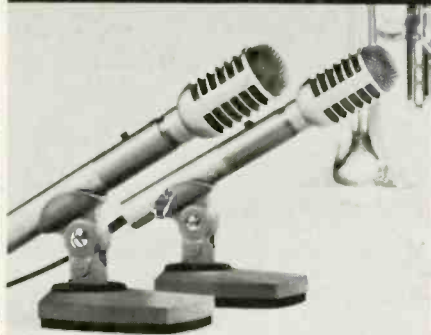

Model 1710 Electret Condenser
Omnidirectional Microphone

All of the great condenser advantages are here without compromise. Flat, extended range, excellent transient response, high output, low noise, and ultra-clean sound. But the new E-V electret condenser microphones need no high voltage power supply. Just an AA penlite battery to operate the built-in FET impedance converter. The result is studio performance without complications and at a dramatically lower price.

There are 4 new E-V electret microphones, including cardioid models, from \$39.75 to just \$75.00, audiophile net. Second-generation designs with unusually high resistance to heat and humidity. Hear them today at your nearby Electro-Voice soundroom. Or write for details.

More U. S. recording studios use Electro-Voice microphones than any other brand.

*Suggested retail price. Microphones shown on Model 421 Desk Stand. \$12.00 each.

CIRCLE NO. 17 ON READER SERVICE CARD

a Gulton
COMPANY

ELECTRO-VOICE, INC., Dept. 434F, 616 Cecll Street, Buchanan, Mich. 49107
In Europe: Electro-Voice, S. A., Römersstrasse 49, 2560 Nidau, Switzerland
In Canada: EV of Canada, Ltd., Gananoque, Ontario



Whatever happened to woofers and tweeters?

Nowadays it seems almost impossible to see or touch a hi-fi speaker. All that you are shown is grille cloth and walnut. And the inside of the system is a mystery reserved only for engineers.

It need not be so. Because there's another way to select a speaker system, starting with the actual components themselves. There's a whole world of E-V custom loudspeakers waiting. Woofers, tweeters, and full-range speakers to suit every plan and need.

The rewards are two-fold. Not only do you create a system that perfectly mirrors your taste in sound, you also have free rein to express your taste in enclosures.

You can build component speakers into walls or shelves to save space and reduce clutter. Or install them in existing or custom furniture that is a positive asset to your living room rather than an intrusion.

If the flexibility of the custom speaker idea engages your interest and challenges your creativity, send for our catalog today. It will put you back in touch with the basic elements of high fidelity. Write for your free copy or visit your nearby Electro-Voice salesroom soon.

CIRCLE NO. 19 ON READER SERVICE CARD

Electro-Voice[®]