

MA 98407  
TACOMA  
4617 N FRACE  
T M DENBROCK  
A98407DENB1461NFRIO 0682 9999

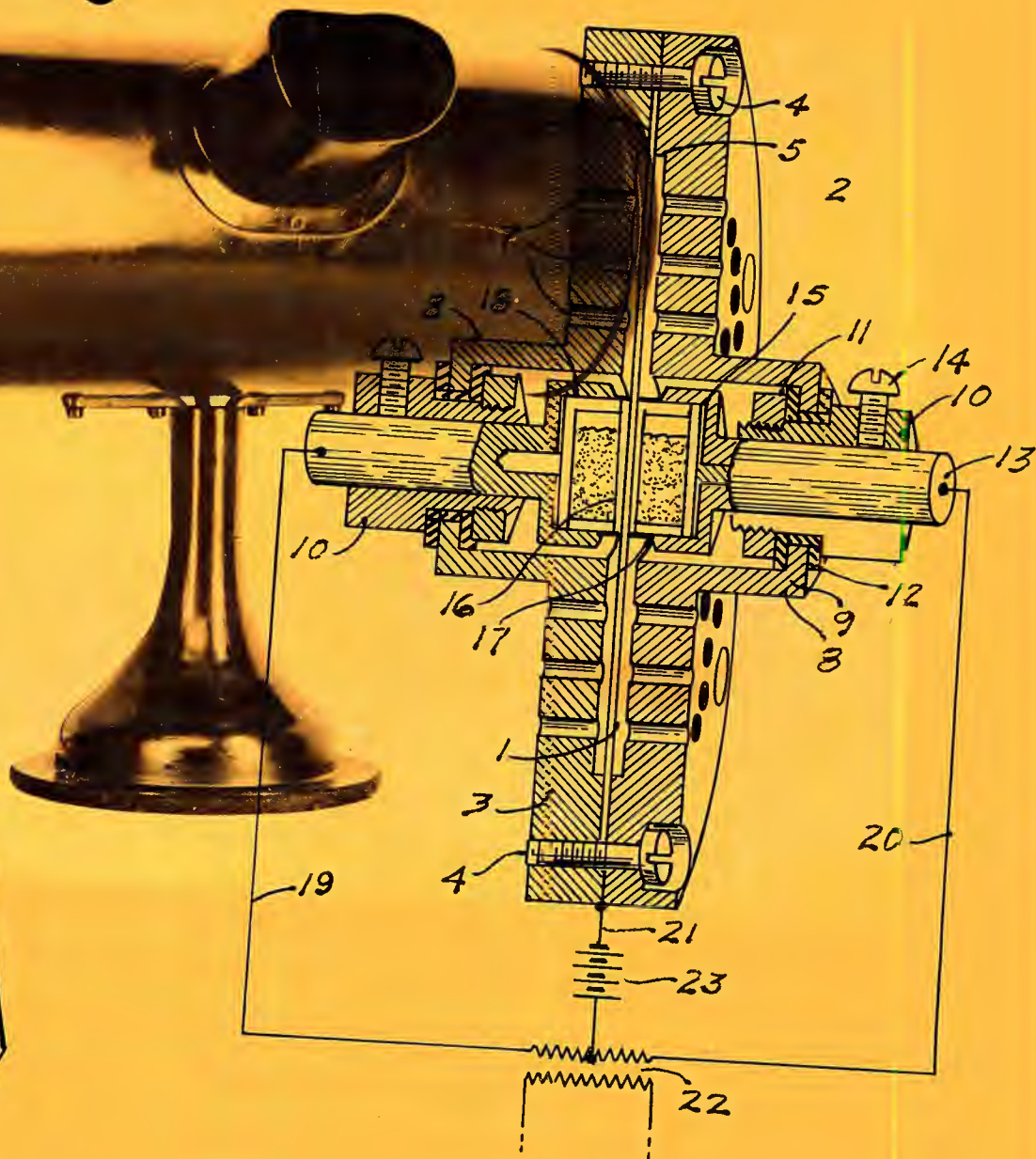
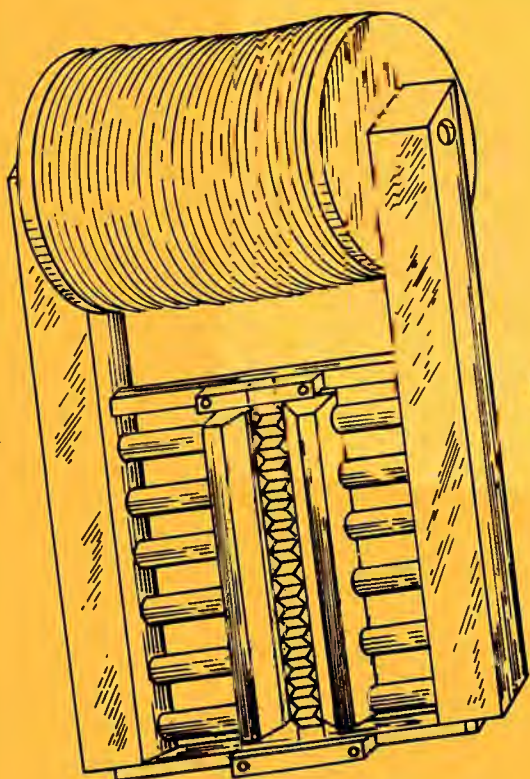

# The Needle Knows

Even when your ears can't tell the difference, your VU meters can.

Which is why we test every reel of our 2" Grand Master® 456 Studio Mastering Tape end-to-end and edge-to-edge. To make certain you get a rock-solid readout with virtually

no tape-induced level variations from one reel of 456 to another or within a single reel.

No other brand of tape undergoes such rigorous testing. And as a result no other brand offers you the reliable consistency of Ampex Tape.

A consistency that lets you forget the tape and concentrate on the job.

Ampex Corporation, Magnetic Tape Division  
401 Broadway, Redwood City, CA 94063  
(415) 367-4463

## AMPEX

Ampex Corporation • One of The Signal Companies 

**4 out of 5 Professionals Master on Ampex Tape.\***



\*1981-1982 Billboard Magazine  
Brand Usage Survey

Circle 10 on Reader Service Card

www.americanradiohistory.com

# MICROPHONES!

At long last, all the questions you ever asked... all the problems you ever grappled with... are answered clearly and definitively!

## The Microphone Handbook

In 256 fact-filled pages, liberally sprinkled with over 500 illuminating photographs, drawings and diagrams, John Eargle covers virtually every practical aspect of microphone design and usage.

Completely up to date, this vital new handbook is a must for any professional whose work involves microphones. Here are just a few of the topics that are thoroughly covered:

- Directional characteristics—the basic patterns.
- Using patterns effectively.
- Microphone sensitivity ratings.
- Remote powering of capacitors.
- Proximity and distance effects.
- Multi-microphone interference problems.
- Stereo microphone techniques.
- Speech and music reinforcement.
- Studio microphone techniques.
- Microphone accessories.
- And much, much more!

**THE MICROPHONE HANDBOOK. You'll find yourself reaching for it every time a new or unusual problem crops up. Order your copy now!**



### JOHN EARGLE.

noted author, lecturer and audio expert, is vice-president, market planning for James B. Lansing Sound. He has also served as chief engineer with Mercury Records, and is a member of SMPTE, IEEE and AES, for which he served as president in 1974-75. Listed in *Engineers of Distinction*, he has over 30 published articles and record reviews to his credit, and is the author of another important book, *Sound Recording*.

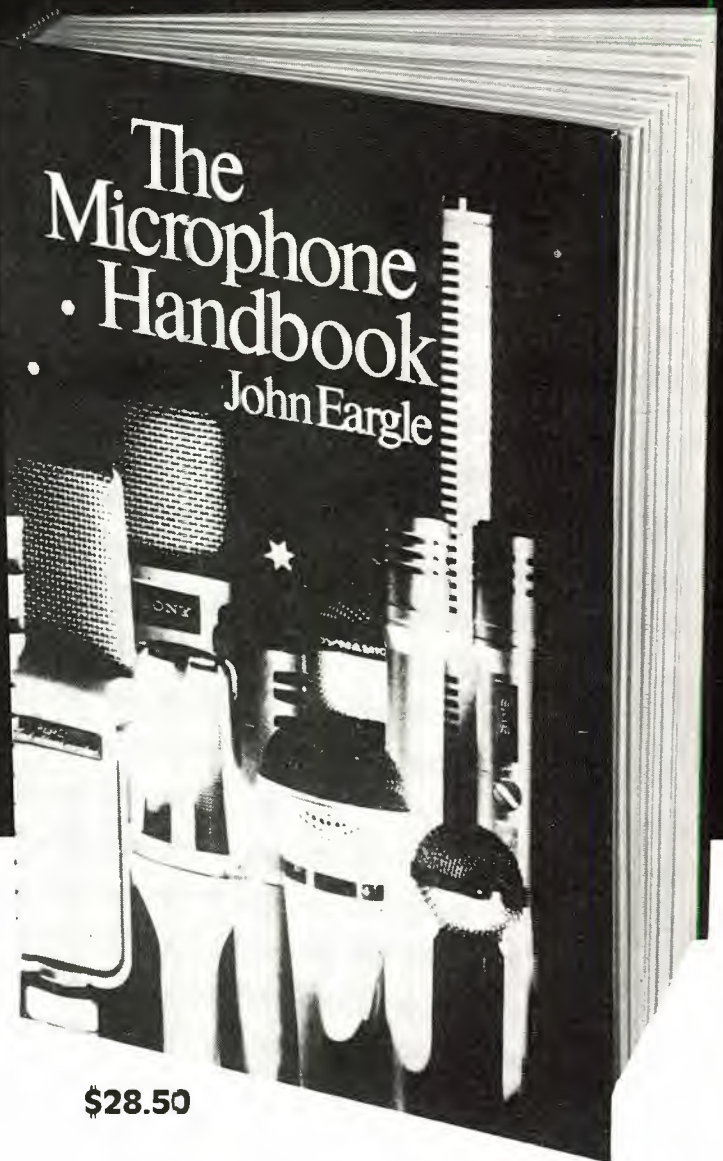

**\$28.50**

### ELAR PUBLISHING CO., INC.

1120 Old Country Road, Plainview, NY 11803

**Yes!** Please send \_\_\_\_\_ copies of **The Microphone Handbook** @ \$28.50 per copy. (New York State residents add appropriate sales tax.)

Payment enclosed.

Or charge my  MasterCard  Visa

Acct. # \_\_\_\_\_ Exp. Date \_\_\_\_\_

Name \_\_\_\_\_  
(please print)

Address \_\_\_\_\_

City \_\_\_\_\_

State/Zip \_\_\_\_\_

Signature \_\_\_\_\_

Outside U.S.A. add \$2.00 for postage. Checks must be in U.S. funds drawn on a U.S. bank.

**If you aren't completely satisfied, you may return your copy in good condition within 15 days for full refund or credit.**

# db Bookcase

Please indicate the number of copies of each title you want and enclose check or money order for the total amount. In New York State, add applicable sales tax. Outside U.S.A. add \$1.00 per book. Allow several weeks for delivery. Address your order to:	Quan.	Quan.	Quan.	Quan.	Quan.
	— 1	— 10	— 19	— 28	— 37
	— 2	— 11	— 20	— 29	— 38
	— 3	— 12	— 21	— 30	— 39
	— 4	— 13	— 22	— 31	— 40
	— 5	— 14	— 23	— 32	— 41
	— 6	— 15	— 24	— 33	— 42
	— 7	— 16	— 25	— 34	— 43
	— 8	— 17	— 26	— 35	— 44
	— 9	— 18	— 27	— 36	— 45

**Sagamore Publishing Co.**  
**1120 Old Country Road**  
**Plainview, New York 11803**

Total payment enclosed \$ \_\_\_\_\_ (Include N.Y.S. sales tax if applicable, or \$1.00 per book foreign.)

Name \_\_\_\_\_

Address \_\_\_\_\_

City, State, Zip \_\_\_\_\_

Check must be in U.S. funds drawn on a U.S. bank.

**2. Sound Recording. (2nd ed.)**

*John M. Eargle.* A graphic, non-mathematical treatment of recording devices, systems and techniques, and their applications. Covers psychoacoustics, physical acoustics; console automation; signal processing; monitor loudspeakers; basic microphone types; audio control systems; stereophonic and quadraphonic sound; magnetic and disk recording; and devices used to modify basic recorded sounds. 320 pages. **\$21.95**

**3. Acoustic Design, M. Rettinger.**

New, THIRD edition completely revised. Covers room acoustics and room design, with many practical examples. 1977. 287 pages. **\$24.50**

**38. Television Broadcasting: Equipment, Systems, and Operating Fundamentals. Harold E. Ennes.**

An extensive text covering fundamentals of the entire television broadcasting system. Discusses NTSC color systems, camera chains, sync generators, recording systems, mobile and remote telecasts, tv antenna systems. Excellent for new technicians and operators as a source of valuable reference data for practicing technicians. Tables, glossary, exercises and answers. 656 pages. **\$22.95**

**39. Reference Data for Radio Engineers. ITT Staff. 5th Ed.**

The latest edition of one of the most popular reference books for radio and electronics engineers, as well as for libraries and schools. Complete, comprehensive reference material with tables, formulas, standards and circuit information. 45 chapters, 1,196 pages with hundreds of charts, nomographs, diagrams, curves, tables and illustrations. Covers new data on micro-miniature electronics, switching networks, quantum electronics, etc. **\$34.95**

**1. The Technique of the Sound Studio. Alec Nisbett.**

A handbook on radio and recording techniques whose described principles are equally applicable to film and television sound. 60 diagrams, glossary, index. 264 pages. Cloth, **\$27.50**

**4. Noise Control. M. Rettinger.**

Revised and enlarged into a separate volume. Covers noise and noise reduction, measurement and control. Several graphs and charts. 1977. App. 400 pages. **\$28.50**

**20. The Audio Cyclopedia (2nd ed.). Dr. Howard M. Tremaine.**

Here is the complete audio reference library in a single, updated volume. This revised edition provides the most comprehensive information on every aspect of the audio art. It covers the latest audio developments, including the most recent solid-state systems and integrated circuits, and spans all subjects in the field of acoustics, recording, and reproduction with more than 3,400 related topics. Each topic can be instantly located by a unique index and reference system. More than 1,600 illustrations and schematics help make complicated topics masterpieces of clarity. 1,760 pages. Hardbound. **\$44.95**

**25. Operational Amplifiers-Design and Applications. Burr-Brown Research Corp.**

A comprehensive new work devoted entirely to every aspect of selection, use, and design of op amps—from basic theory to specific applications. Circuit design techniques include i.c. op amps. Applications cover linear and non-linear circuits, A/D conversion techniques, active filters, signal generation, modulation and demodulation. Complete test circuits and methods. 474 pages. **\$33.50**

**31. Solid-State Electronics. Hibbard.**

A basic course for engineers and technicians, and an extremely practical reference book for anyone who wants to acquire a good, general understanding of semi-conductor principles. Features questions and answers, problems to solve. 1968. 169 pages. **\$32.50**

**32. Circuit Design for Audio AM / FM, and TV. Texas Instruments.**

Texas Instruments Electronics Series. Emphasizing time- and cost-saving procedures, this book discusses advances in design and application as researched and developed by TI communications applications engineers. 1967. 352 pages. **\$34.50**

**37. Television Broadcasting: Systems Maintenance (2nd ed.). Harold E. Ennes.**

A thorough treatment of modern television maintenance practice, covering maintenance of the tv broadcasting system from switcher inputs to antenna. Discusses theory and operation of systems, tests and measurements, including proof of performance for both visual and aural portions of the installation. 624 pages. **\$22.95**

**6. Sound System Engineering. Don and Carolyn Davis.**

The first of its kind, this book is the one source of sound information you can rely on to give you everything you must know to design, install, and service commercial sound systems. The book covers acoustics environments, design applications, equalizing, installations, and interfacing. Hundreds of drawings, photos, charts, and graphs are supplied. 1975. 296 pages. Hardbound. **\$21.95**

**28. Environmental Acoustics. Leslie L. Doelle.**

Applied acoustics for people in environmental noise control who lack specialized acoustical training, with basic, comprehensible, practical information for solving straightforward problems. Explains fundamental concepts with a minimum of theory. Practical applications are stressed, acoustical properties of materials and construction are listed, actual installations with photos and drawings are included. Appendixes illustrate details of 53 wall types and 32 floor plans, and other useful data. 246 pages. **\$42.50**

**36. The Handbook of Noise Control (2nd ed.). Cyril M. Harris.**

Leading noise control authorities share their strategies and know-how in this in-depth treatment of all aspects of noise control. Tables facilitate rapid solutions to practical problems, and illustrations show noise control techniques for a range of common problems. Coverage includes the social, psychological, physiological, and legal aspects of noise and noise control. Hardbound. **\$47.50**

**40. Studio Acoustics. M. Rettinger.**

The author provides those first design principles of sound recording studios that are required for satisfactory vocal and instrumental recording conditions. All equations are presented in both English and MKS systems of measurement. Metric equivalents follow in parentheses when the studio descriptions include linear dimensions. The book is divided into three sections: Basics, Studios and Electroacoustics. 241 pages. **\$35.00**

OUT OF PRINT

Publisher  
**Larry Zide**

Editor  
**John M. Woram**

European Editor  
**John Borwick**

Associate Editor  
**Mark B. Waldstein**

Advertising Production & Layout  
**Karen Cohn**

Classified Advertising  
**Carol Vitelli**

Book Sales  
**Lydia Calogrides**

Circulation Manager  
**Eloise Beach**

Art Director  
**Bob Laurie**

Graphics  
**K&S Graphics**

Typography  
**Spartan Phototype Co.**

sales offices

**Roy McDonald Associates, Inc.**  
**Dallas, Texas 75207**

First Continental Bank Bldg.  
5801 Marvin D. Love Freeway  
Suite 303  
(214) 941-4461

**Denver, Colorado Area**  
**Englewood, Colorado 80112**

14 Inverness Dr. East  
Bldg. 1—Penthouse  
(303) 771-8181

**Houston, Texas 77036**

6901 Corporate Drive  
Suite 210  
(713) 988-5005

**Los Angeles Area**  
**Glendale, California 91204**

424 West Colorado Street  
Suite 201  
(213) 244-8176

**Portland Area**  
**Hillsboro, Oregon 97123**

510 South First  
P.O. Box 696  
(503) 640-2011

**San Francisco Area**  
**Emeryville, California 94608**

265 Baybridge Office Plaza  
5801 Christie Avenue  
(415) 653-2122

**Sagamore Publishing Co.**

**New York**  
**Plainview, NY 11803**  
1120 Old Country Rd.  
(516) 433-6530



JUNE 1982 VOLUME 16, NO. 6

## DEPARTMENTS

LETTERS	CALENDAR	EDITORIAL	CLASSIFIED
6	8	22	56
SOUND WITH IMAGES			Len Feldman
10			
DIGITAL AUDIO			Barry Blesser
12			
SOUND REINFORCEMENT			John Eargle
16			
THEORY AND PRACTICE			Ken Pohlmann
20			
NEW PRODUCTS AND SERVICES			
52			
NEW LITERATURE			
55			
PEOPLE, PLACES, HAPPENINGS			
58			

## FEATURES

THE 71st AES CONVENTION	John Borwick
24	
THE MIC MUSEUM	
28	
NOTES ON MICROPHONES	
36-41	
36 MS WITHOUT PAIN	John Phelan
38 AN ADVANCED MICROPHONE EVALUATION TECHNIQUE IN USE AT ELECTRO-VOICE	Alan Watson
39 THE RIBBON MICROPHONE REVISITED	Robert Lowig
41 THE CALREC SOUNDFIELD MICROPHONE	Nigel Branwell
THE NAB CONVENTION	John M. Woram
42	
MICROPHONE ROUNDUP	Mark B. Waldstein
46	

## About The Cover

• This month's cover features a montage of patent drawings and photos from Bob Paquette's Microphone Museum. For more on this fascinating museum, turn to page 28.

db, the Sound Engineering Magazine (ISSN 0011-7145) is published monthly by Sagamore Publishing Company, Inc. Entire contents copyright © 1982 by Sagamore Publishing Co., 1120 Old Country Road, Plainview, L.I., N.Y. 11803. Telephone (516) 433-6530. db is published for those individuals and firms in professional audio-recording, broadcast, audio-visual, sound reinforcement, consultants, video recording, film sound, etc. Application should be made on the subscription form in the rear of each issue. Subscriptions are \$15.00 per year (\$28.00 per year outside U.S. Possessions; \$16.00 per year Canada) in U.S. funds. Single copies are \$1.95 each. Editorial, Publishing and Sales Offices: 1120 Old Country Road, Plainview, New York 11803. Controlled circulation postage paid at Plainview, NY 11803 and an additional mailing office.

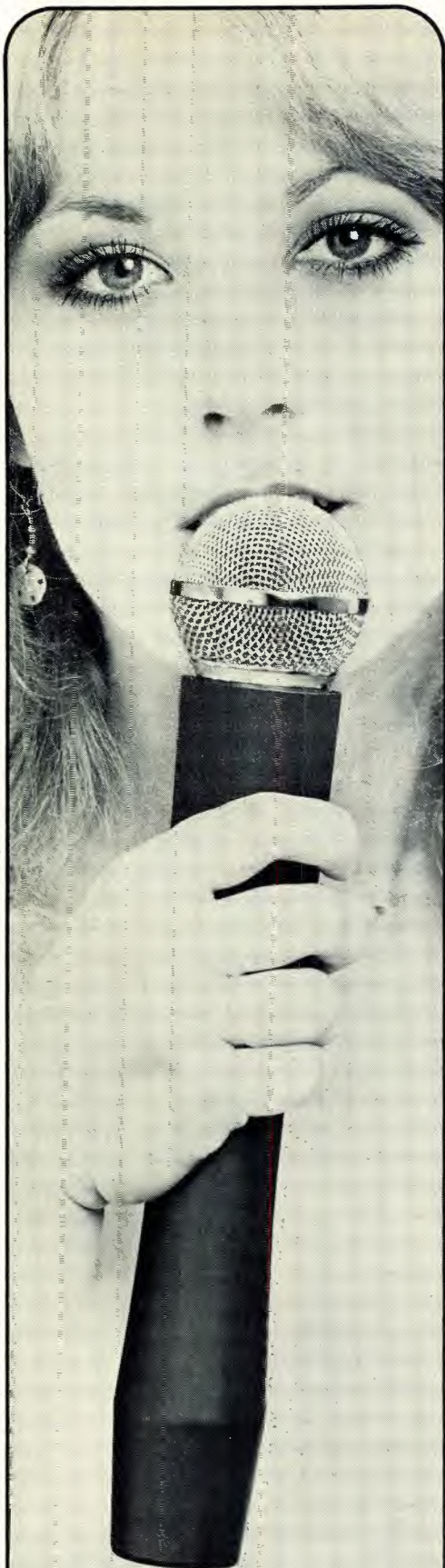

**The Professional's Choice  
in Wireless Microphones**

- Wide frequency response
- Low noise and distortion
- Latest companded technology
- Built-in level indicator
- VHF high band for less interference
- Attractive, non reflective finish



Division of Cetec Corporation

P.O. Box 5348 • El Monte, CA 91731  
(213) 442-0782 • TWX: 910-587-3539

**db Letters**

**WHO ARE THOSE GUYS?**

TO THE EDITOR:

At first I was delighted, and then puzzled, as I read the report covering the 70th AES convention in the February, 1982 edition of **db**. On page 55, under the heading "Electronic Music," it appears that two different systems, the McLeyvier Electronic Music System and the Con Brio ADS 200 Scorewriter System, have been developed for the production of hard copies of musical scores. No further information concerning commercial availability, price or how to contact the manufacturers was given.

Would it be possible to provide me with addresses of persons representing these products? I would appreciate this valuable gesture.

EDWARD MCCUE

**db replies:**

*We'll try to persuade McLeyvier and Con Brio to come out of hiding (that is, to advertise in **db**). In the meantime, you can find them at the addresses listed below. Tell 'em **db** sent you. McLeyvier: c/o Jame Robertson, Hazelcom Ind. Ltd., 39 Hazelton Ave., Toronto, Ontario M5R/2E3. Tel: (416) 961-7090. Con Brio: 975 San Pasqual St., Suite 313, Pasadena, CA 91106. Tel: (213) 795-2192.*

**FLOPPY DISC FLOP**

TO THE EDITOR:

Thank you for mentioning our new Studer A810 recorder in the "Broadcast Manufacturer's Survey" in the April issue of **db**. However, the article's statement that the A810 "...is laid out in floppy disc, based on the SMPTE code" is somewhat misleading.

True, the A810 does introduce a new system for placing both an SMPTE time code and a stereo audio-signal on 1/4" tape. In addition, the A810 offers an unprecedented level of micro-processor control for both the transport functions and the audio electronics alignment. Data storage for these functions is primarily via EPROMs; *no floppy disc* capability is contained within the A810 unit. However, through the optional RS232 bus, the A810 may be controlled

**Index of  
Advertisers**

Ampex ..... Cover 11  
 Atlas Sound..... 49  
 Beyer..... 11  
 Bose ..... 47  
 Cetec Vega..... 6  
 Crown..... 19  
 Emilar..... 54  
 Fitzco ..... 20  
 Garner ..... 53  
 Hewlett Packard..... 7  
 Klark-Teknik ..... 9  
 Knowles ..... 31  
 Lexicon ..... 29  
 Linear & Digital Systems, Inc. .... 8  
 Maxell ..... Cover IV  
 Microtran..... 16  
 Panasonic..... 33  
 Polyline ..... 8  
 Sescum ..... 52  
 Standard Tape Labs..... 43  
 Swintek ..... 14  
 Tascam Div./Teac Corp. .... Cover III  
 Telex ..... 51  
 3M ..... 35  
 TOA ..... 23  
 White ..... 12

**Coming  
Next  
Month**

• In July, we'll be featuring articles dealing with various aspects of Signal Processing. Ralph Hodges checks in with a piece informing us on where the manufacturers of noise reduction equipment stand today, while John Woram brings us a mini-survey on the latest in NR hardware. In addition, we'll have Part II of our NAB wrap-up, our brand new Happenings section and, of course, our regular roster of columnists. All this—and more—in **db**—**The Sound Engineering Magazine**.

db June 1982

6

Circle 13 on Reader Service Card

# Now hear this!



## HP's 8903A now makes audio testing easier than ever before.

Now a single microprocessor-controlled instrument offers you the versatility of an extremely wide range of audio measurements with just a few keystrokes. Manual or HP-IB programmable, the HP 8903A Audio Analyzer is ideal for testing 20 Hz to 100 kHz characteristics of stereo amplifiers, pre- and line amplifiers, tape decks, cassettes, and other high performance audio equipment.

The 8903A measures such basics as distortion, gain and frequency response,

power, AC or DC volts, and frequency; as well as more complex parameters like signal-to-noise and SINAD. It includes a sweepable low distortion audio source and drives an X-Y recorder directly. It's an automatic test system all in one box, yet is priced at only \$6200\*.

For more information, contact your nearby HP sales office, or write to Hewlett-Packard Co., 1820 Embarcadero Road, Palo Alto, CA 94303.

\*Domestic US price only.

04105



**HEWLETT  
PACKARD**



Circle 14 on Reader Service Card

# Audio Tape for professionals



## REEL TO REEL TAPE

Ampex, 3M. All grades.  
On reels or hubs.

## CASSETTES, C-10—C-90

With Agfa, TDK tape.

## LEADER & SPLICING TAPE

## EMPTY REELS & BOXES

All widths, sizes.

**Competitive!**  
**Shipped from Stock!**

Ask for our recording supplies catalog.

**Polyline**  
Corp. 312/298-5300

1233 Rand Rd. • Des Plaines, IL 60016

15

Circle 15 on Reader Service Card

## Noise Suppression & Power Protection



## Model PS-1

The PS-1 is a power line conditioning unit designed to protect audio equipment from high voltage transients and RF interference. Three neon lamps indicate relative phasing of the line, neutral and ground connections. A latching relay helps to avoid amp/speaker damage due to power up transients generated after a temporary loss of power. Ask your local music dealer for more details.



**Linear & Digital  
Systems, Inc.**

46 Marco Lane, Centerville, OH  
45459 (513) 439-1758

Circle 16 on Reader Service Card

by external computer systems, including those with floppy disc storage capability.

I hope this clears up any possible confusion, and readers with further questions should feel free to contact me at any time.

DOUGLAS N. BEARD  
National Service Manager  
Studer Division

## STUDENT DAZE

TO THE EDITOR:

A good friend of mine is a student at the University of Miami and I think he is developing a problem. Ever since he changed his academic program to Music Engineering, he has become overly verbose and he speaks in terms I just can't understand. Here's a portion of a letter he wrote me last week:

"So go on, Dan, tell me all about your wild women—make me jealous. At least I haven't lost my morality in the remix, although I must admit that I wouldn't turn down an occasional punch-in. I mean I have no bias, all things being equalized, but it seems that so many women have been giving me the same tape loop for so long that I'm even having imaging problems. Face it: sync-ing up with women these days is an infinite baffle; it seems as though all of them are afraid of having their headroom stepped on. While maintaining that they'll catch it on the next pass, they just don't seem to realize that their blank stock is being spooled off at 30 ips. If only they'd analyze their positions (in real time) they'd realize that, while holding out for optimum fidelity, they're clipping short their chances of finding lasting friendships in this expanding universe.

"I sense that my dynamics on this subject have reached a limit. Rather than pushing the threshold, I'll fade here. I hope I have left you with some quantifiable data. Thanks for listening in repro."

I really hope that this problem doesn't afflict all Audio Engineering students. If you or any of your readers know how I can help him, please let me know. Thanks for your cooperation.

DANIEL A. WEINSTEIN

## db replies:

*We're afraid your friend's mind may already be too bulk-erased to be re-wound. Try to get a copy of The Recording Studio Handbook, and drop it on his head. If that doesn't reduce his noise level, he can always get a job as an instructor. That way, the real world won't notice his out-of-phase condition. As for his problem with women, try reversing polarity.*

# db Calendar

## JUNE

28- Aug. 6 **Summer Program in Sound Recording.** State University College at Fredonia. For more information contact: The Dept. of Music, SUNY, Fredonia 14063. Tel: (716) 673-3151.

## JULY

25-27 **Midwest Music Exchange — A National Music/Record Industry Convention.** Bismarck Hotel, Chicago, IL. For more information contact: Midwest Music Exchange, 704 N. Wells St., Chicago, IL 60610. Tel: (312) 440-0860.

## AUGUST

29- Sept. 1 **NAB's 1982 Radio Programming Conference.** New Orleans Hyatt Regency Hotel, New Orleans, LA. For more information contact: The National Association of Broadcasters, 1771 N Street, N.W., Washington, DC 20036. Tel: (202) 293-3570.

## SEPTEMBER

12-15 **NRBA '82 Convention and Exposition.** MGM Grand Hotel, Reno, NV. For more information contact: NRBA, 1705 DeSales St., N.W., Suite 500, Washington, DC 20036. Tel: (202) 466-2030.

28 **7th Sound Broadcasting Equipment Show.** Sponsored by Audio & Design (Recording) Ltd. Albany Hotel, Birmingham, England. For more information contact: Audio & Design (Recording) Ltd., North St., Reading, Berks, RG1 4DA, England.



# Better than all measures of delightful sound.

(Shelley 1792-1822)

For further information on our complete range of professional audio equipment and application details telephone (516) 249-3660

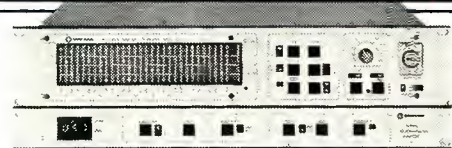

## DN60 REAL TIME SPECTRUM ANALYSER

The DN60 Real Time Spectrum Analyser is a new audio measurement system. It is capable of performance checks on virtually any audio equipment, and is especially well suited for aligning audio tape recorders. On site performance verification, whether of a 10,000 seat arena, or a studio control room, is easily effected with the DN60.

The microprocessor based circuitry makes the DN60 very cost effective and with the inclusion of Three Memories, and a Peak-Hold function, you can expand the scope of your sound check and provide that extra edge of excellence.

## RT60 REVERBERATION ANALYSER

The optional RT60 unit further extends the capabilities of the DN60, facilitating accurate and comprehensive reverberation time analysis. RT60 figure is displayed for any one of 30 1/3rd octave frequencies or 'wide band' and the reverberation decay curve is automatically plotted on the DN60 L.E.D. matrix display.

The RT60 features a variable decay window, three memories, selectable display times and curve accumulate function. Both impulse and gated noise methods are automatically recognised.

An XY plotter and hard copy printer is available for the DN60 and RT60.



**KLARK TEKNIK**  
*sound science*

**Klark-Teknik Electronics Inc.**  
2E2a Eastern Parkway, Farmingdale,  
NY 11735, USA. Telephone: (516) 249-3660

**Klark-Teknik Research Limited**  
Coppice Trading Estate, Kidderminster, DY11 7HJ,  
England. Telephone: (0562) 741515 Telex: 339321

**Omnimedia Corporation Limited**  
9653 Côte de Liesse/Dorval, Quebec H9P 1A3,  
Canada. Telephone: (514) 636 9971

Circle 33 on Reader Service Card

[www.americanradiohistory.com](http://www.americanradiohistory.com)

# db Sound With Images

## AM Stereo—The Beginning Or The End

• Although AM stereo has no direct bearing on Sound With Images, we'll get to an indirect relationship a bit later. As you've probably heard by now, the Federal Communications Commission, after years of deliberations, gave the industry a "false start" in 1980, when it gave the nod to a system proposed by Magnavox and then rescinded that decision. More recently, it has managed to come up with *no decision* at all. In other words, the FCC has decreed that after April 26, 1982, any station may go on the air using any one of the *five* systems which have been under investigation for several years! (This is aside from setting general guidelines for monophonic receiver compatibility, emission limitations, adherence to international rules, adjacent channel interference and stereo compatibility.) Presumably, if additional systems are developed, these too could be used by broadcasters, providing they conform to the general rules and guidelines mentioned in the 44-page Report and Order adopted by the FCC on March 4, 1982 and released two weeks later.

### WHY AM STEREO IN THE FIRST PLACE?

With FM Stereo firmly established as a broadcast system throughout the world, why worry about stereo sound on AM stations? After all, stereo belongs with a high fidelity transmission medium and, as everyone knows (or thinks they know), AM is definitely "low-fi." Well, for one thing, AM need not be low-fi! Some AM stations currently on the air can exhibit proof-of-performance results that show them to be flat in frequency response to well beyond 10 kHz. Our low-fi perception of AM arises primarily from one of those "vicious circle" situations. Broadcasters, using low-grade phone lines with no more than 5,000 Hz of bandwidth, usually don't worry about wide-band program sources; receiver manufacturers, knowing that broadcasters aren't too concerned with frequency response, don't bother to build AM tuner circuits that can handle wide frequency response. All of that *could* change, of course, if there was a good reason to have it change, and AM stereo was thought to be a good reason. From a purely economic point of view, AM broadcasters were extremely interested in having stereo capability because, in recent years, FM station profits have generally outpaced the longer-established AM radio stations.

From the consumer's point of view, FM stereo, the darling of audiophiles at home, is not all that well received in moving vehicles—where most of us do most of our *radio* listening. FM stereo signals are particularly susceptible to multipath interference caused by signal reflections as we move from place to place in a car, and even in the absence of such interference, FM remains a "line-of-sight" transmission medium, so that on long trips, listeners are subjected to fading and loss of signal every few miles.

### BACKGROUND OF THE NON-DECISION

In 1980, when the FCC announced that it was about to give the nod to the Magnavox AM Stereo system, many objections were raised by broadcasters and, of course, by the other four proponents. Broadcasters opposed the system largely because its use would have meant a light backing-off of modulation levels. (Every station wants to be "the loudest guy on the block" for maximum coverage and attention-getting.) Proponents of other systems, of course, felt that *their* systems had greater merit and some threatened to sue in court if a Magnavox decision was handed down. The FCC backed off and decided to take another look at the mass of data that had previously been compiled. They even invited further comments from interested parties. That was two years ago. And now, the FCC concludes that it cannot make up its mind with respect to a single system. This would not be too serious if the systems differed only in minor details. In that case, conceivably, receiver manufacturers could come up with a single circuit that, with slight modifications, could be switched (manually or automatically) from one broadcast system to another. Unfortunately, such is not the case. The systems differ substantially, as you will see from the following brief descriptions taken directly from the FCC.

### HOW THE FIVE SYSTEMS WORK

The **Belar** system frequency modulates the RF carrier with a preemphasized, 400 microsecond (L-R) signal. Maximum frequency deviation of the carrier varies from 312.5 Hz at low frequencies to 6250 Hz at the higher audio frequencies. The L + R signal *amplitude* modulates the frequency-modulated RF carrier. This system is called an AM-FM system. The Belar system also uses an identifying pilot tone having a frequency of 10 Hz.

The **Harris** system modulates two

carriers that are separated in phase by 90 degrees. These two carriers are referred to as the in-phase carrier and the quadrature carrier. The two modulated carriers are then combined into one signal whose phase and amplitude are used to modulate the phase and amplitude of the transmitted signal. Quadrature modulation level is reduced by varying amounts ranging from 1/1.00 to 1/3.73, depending upon relative strengths of the L - R and L + R modulations. A pilot tone accompanying the other signals varies in frequency from 55 to 96 Hz depending upon instantaneous gain reduction of the L - R channel and serves as a control signal for the decoder in the receiver. Harris calls its system V-CM, for Variable Compatible phase Multiplex.

The **Kahn/Hazeltine** system phase modulates the RF carrier with the L - R signal in such a way that amplitude modulation of the carrier will place most of the left channel stereo information in the lower sideband and most of the right channel stereo information in the upper sideband. Kahn/Hazeltine call their system an independent sideband system. Kahn/Hazeltine uses a pilot tone at 15 Hz which angle-modulates the carrier by approximately 0.1 radian.

The **Magnavox** system uses the L - R signal to phase modulate the RF carrier and the L + R signal to amplitude modulate the phase modulated RF carrier. This type of system is referred to as an AM-PM system. Magnavox also phase-modulates the RF carrier with a 5 Hz pilot tone of 4 radians peak deviation.

The **Motorola** system amplitude modulates two RF carriers that are separated in phase by 90 degrees. The L + R signal modulates one of the carriers and the L - R signal modulates the other. The two modulated carriers are then added together. The amplitude of the resultant signal, however, would not be compatible with monophonic envelope detector receivers (high levels of distortion would occur). To achieve a better degree of compatibility, the combined signal is first hard-limited and then remodulated with the L + R signal. Motorola calls its system C-QUAM, for Compatible Quadrature Amplitude Modulation. The Motorola system uses a 25 Hz pilot tone.

### IS A UNIVERSAL RECEIVER POSSIBLE?

National Semiconductor, who jumped the gun two years ago and developed a chip for use with the Magnavox system, now suggests that this same chip, with

different external parts switched in, would also work for the Motorola and Belar Systems. They further hint that the chip might even be useful (again, with new external parts) for the Kahn/Hazeltine and Harris Systems, but they don't give details. Clearly, even if such a "universal" switchable circuit is possible, it will add greatly to the cost of receivers and, if manual switching is required, many car manufacturers feel that drivers simply won't stand for it—and won't buy it! Not all of the FCC Commissioners agreed with the so-called "marketplace" decision. Commissioner Abbott Washburn summed up the feeling of many industry people when he said:

"I submit that this type of marketplace referendum is not the way to make an informed choice, if indeed it results in a choice at all. (The sad possibility of no service coming into being is recognized in paragraph 55 of the Order.) The data before us shows that the performance characteristics of the five systems are so close that consumers of AM stereo will be able to detect little if any difference among the systems... In actuality, therefore, whichever system or systems evolve will be based not on true consumer preference resulting from comparison of the five systems, but rather on the size of promotion and merchandising expenditures and like factors... I continue to believe that it is in the public interest for the Commission to choose a single system... I dissent to the majority's unwillingness to make the choice which would have assured a national standard."

At the recently-held NAB convention in Dallas, an attempt was made on the part of broadcasters to finish the job that the FCC failed to complete. With so many diverse interests represented, not to mention the fact that some stations had already made up their minds which system was superior, it is no surprise that the seminars held in Dallas didn't even come close to achieving unanimity.

#### TV STEREO COULD BE EVEN WORSE

With the ever increasing tendency of the FCC to toss its "non-decisions" into the marketplace, we come to the question of TV stereo, which will soon be before the FCC. (See, I told you we'd get to sound with images before the end of this column.) Here, the FCC is faced with having to choose between three totally different and incompatible systems. Here, the market for stereo, and its impact on the American public, will be far greater than the potential market and influence of AM stereo. A similar marketplace decision by the FCC might well stifle the development of stereo TV completely, or at least for several years. Meanwhile other industrialized nations, such as Japan and West

Germany, go merrily along supplying their citizens with this vastly improved form of home entertainment.

In an effort to forestall such an outcome, the Multi-channel TV Sound Committee, under the aegis of the Electronic Industry Association, hopes to depart from its previous practice with regard to supplying information to the FCC. In the past, such test and evaluation committees have simply supplied necessary *data* to the FCC, without any specific recommendations in favor of any system. Now, fearful that the FCC might throw the decision open to the

marketplace, as they did with AM stereo, the Committee, after sifting through all the data, plans to poll many industry groups (broadcasters, networks, engineering societies, etc.) in the hope that they can present to the FCC a recommendation for a specific standard for TV stereo/multi-channel sound. Even then, of course, the FCC might elect to leave it up to the public. In that event, not only AM stereo but TV stereo may well suffer the fate of quadraphonic sound which, as you may recall, was also "left up to the public" who, in their total confusion, rejected the whole ball of wax. ■

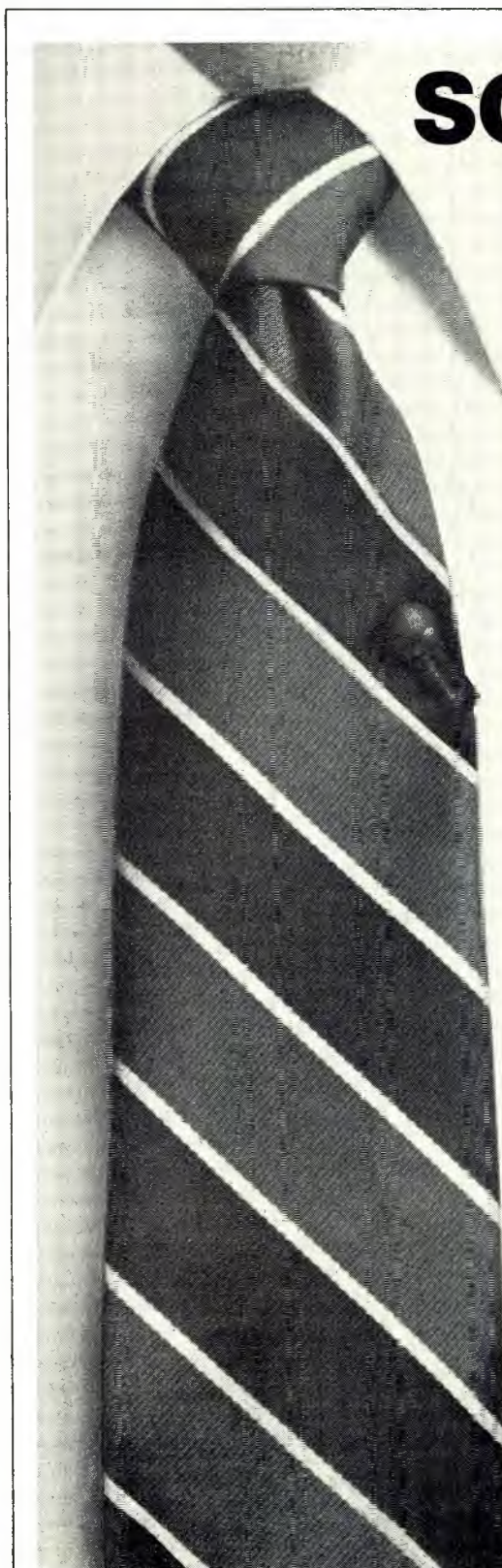

## SOUND UNSEEN

### THE BEYER MCE 5

Voice and appearance are key to a news announcer's success. Beyer benefits both with its MCE 5 electret condenser mic. A matte-black omni so tiny it's virtually invisible. Full 20-20,000Hz range projects the vital presence of the speaker, uncolored, undistorted. Unique floating element eliminates clothing noise. Removable windscreen for outdoors. 62dB S/N. 116dB overload. 700-ohm balanced output for professional performance. Phantom or self-powered, also available in a variety of connector configurations to meet every application requirement, including wireless.

Visit your local Beyer dealer today.



beyer dynamic 

BEYER DYNAMIC, INC.  
5-05 Burns Avenue, Hicksville,  
NY 11801 • (516) 935-8000

## Digital Signal Processing: a Beginning

Figure 1. When the delay time is an integer multiple of the sampling period, the sampler may be moved from input to output without changing the final result.

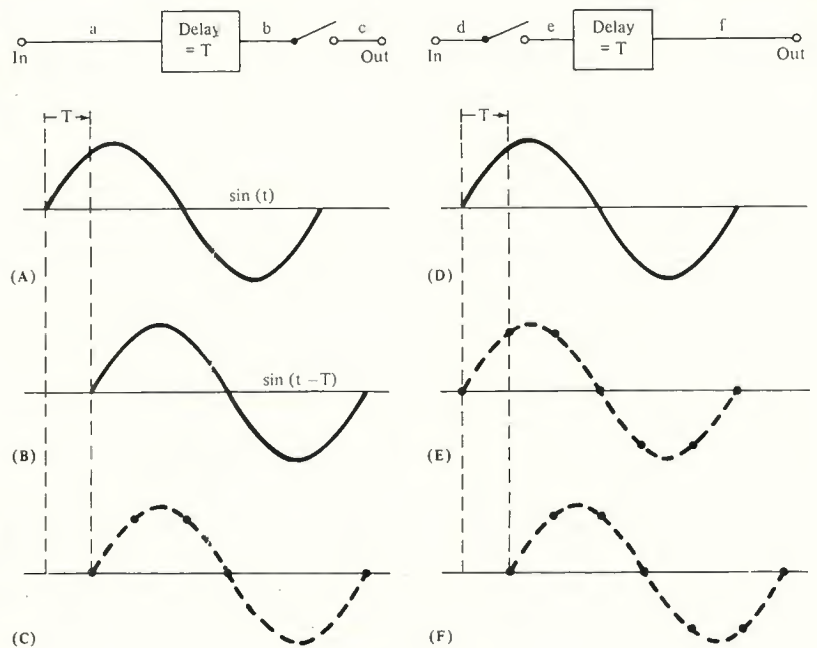

• Digital signal processing is really little more than the “number-crunching” of digital signals. The name may be somewhat of a misnomer though, since some of the crunching may have nothing to do with a signal in the digital domain! In fact, the identical processing might have been done with analog circuits, and most of the technology was actually done in this classic format. Thus, digital signal processing may be nothing more than

analog signal processing using digital hardware.

### SIGNAL PROCESSING IN GENERAL

In our earlier discussion of digital logic, we divided the world into two classes: combinatorial and memory logic. Combinatorial logic is nothing more than a non-linear combination of signals, whereas memory logic uses information about the past. This distinction also

exists in analog non-linear and filter circuits. A non-linear circuit produces an output which is based on its present input(s), with no regard for memory. A box which produces the logarithm of a signal is a no-memory device. Notice that this class is fundamentally different from a filter, which must use history in order to process a signal. A filter cannot produce an output on the basis of its present value alone. For example, an input of 2.23 volts could be from a DC signal, a 50 kHz sinewave, or white noise. In order for a filter to separate signals on the basis of frequency, the nature of the past signal must be available to the circuit. Thus, to implement such a filter we commonly use capacitors and inductors because they have a memory of past events. The voltage on a capacitor or the current in an inductor comes from the past average voltage or current, and is not related to the present voltage or current. Another kind of memory device is a delay line such as might be implemented by a length of transmission cable (0.7 nanoseconds per foot), a length of pipe for acoustic filters (1 millisecond per foot), or any other such circuit. The delay lines contain past information because the output is related to the signal that had entered the input in the past.

The reason that capacitors and inductors are preferred over other devices is that they are much easier to build at audio frequencies. At microwaves however, these devices are difficult to implement, and one uses pieces of transmission line for storage elements. With the advent of digital technology, one has yet another type of storage element: a register. This device can store the signal indefinitely, but the information must be in the form of a digital word. A capacitor (ideally) is similar except that the information must be in analog form. Printed text on paper is also a storage element, but the format must be that of differential light reflectivity. We can thus see a uniform aspect to

## THE EXPANDABLE SYSTEM 200

Advanced Microprocessor Controlled Real Time Analyzer.

<p>Featuring:</p> <ul style="list-style-type: none"> <li>• Interchangeable Filters</li> <li>• 45 dB Dynamic Range</li> <li>• 16 × 31 High Intensity LED Display</li> <li>• 8 Non-volatile Memories</li> </ul>	<ul style="list-style-type: none"> <li>• 3 Smoothing Time Constants</li> <li>• Simultaneous Peak and Average Processing</li> <li>• 0.5 dB Precision</li> <li>• T<sub>60</sub> Measurements</li> </ul>	<ul style="list-style-type: none"> <li>• 3 dB, 2 dB or 1 dB Resolution</li> <li>• Built-in Pink Noise Generator</li> <li>• 15 V Microphone Power</li> <li>• Oscilloscope and Plotter Drive</li> <li>• Optional Function Generator</li> </ul>
---	---	--

All Functions Microprocessor Controlled. Plug-in Options Available

**White instruments, inc.**  
P. O. Box 698, Austin, Texas 78767 • 512/892-0752 • TELEX 776409 WHITE INST AUS

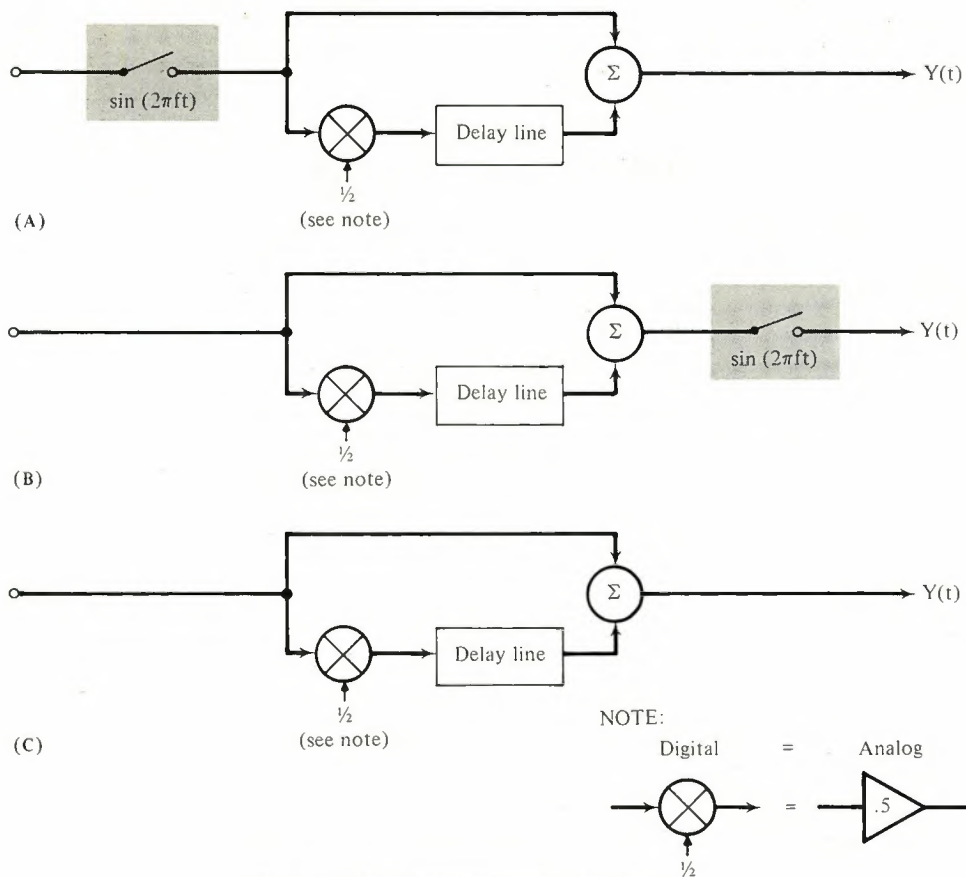

Figure 2. The transformation of a sampled-data filter to a continuous filter.

all filtering namely, the past must be available in the present.

In the discussion of digital signal processing, we should not always refer to "digital," since the same processing might be implemented in analog form. When we think of digital signal processing, we are actually thinking of discrete time representations of the signal. Using 1000 capacitors, we can store 1000 digital discrete samples of an audio signal. With 1000 digital storage registers, we can also store the same information, but we must re-label the topic of discussion as discrete time-sample filtering. The category includes analog bucket-brigade shift registers and switched-capacitor filters, and digital filtering. The math is not just similar, it is identical.

Since most of us know how to build filtering systems using capacitors and inductors, we will now focus on using delay and storage elements instead. Since these memory elements are not the same as capacitors and inductors, we should not expect to be able to build the identical filters: similar, yes, but not identical. Delay elements can be either discrete, like our 1000 capacitors, or continuous, like our acoustic pipe. In almost all analysis, the difference is often irrelevant except for a certain transform.

Consider the two delay systems represented in FIGURE 1. In one case, the input signal feeds a delay line and then a sampler. In the other, the signal is sampled first, and then enters the delay line. When are these two cases identical, such that the final output is the same for both?

To seek the answer, let's consider a specific example in which samples are taken every second (or millisecond, or microsecond). Now, assume we have an audio signal of the form  $\sin(t)$ . In the former case, the entire signal enters the delay line, and the output of the line is  $\sin(t - T)$ , where  $T$  is the length of the delay line. Before continuing, let's look at our notation for time. The symbol  $t$  is the time you observe on your clock. At  $t = 3$ , the signal entering the delay line is  $\sin(3)$ , but the signal leaving is that which entered earlier. If the delay line is  $T = 2$ , then the signal leaving it is that which entered at  $t = 1$ . Hence,  $\sin(t - T)$  is  $\sin(3 - 2)$ , or  $\sin(1)$ .

Actually, the signal leaving the delay line has meaningful values for every possible value of  $t$ , since it is a continuous delay. However, the sampler at the output discards all information except that at  $t = 0, 1, 2, 3, 4, 5$ , etc. If  $T = 2.1$ , then the signal at the sample time  $t = 5$  is the signal which entered at  $t = 2.9$ .

Now consider what happens when the sampler is located before the delay line, so that the samples entering it are  $\sin(0), \sin(1), \sin(2)$ , etc. These samples may still be delayed by 2.1 seconds, yet now there is no component of the input signal present except at multiples of 1 second.

Thus, the two cases do not lead to the same result, except for the special case of an integer value of  $T$ . When  $T = 6$ , then in either case the output samples will be  $\sin(0), \sin(1), \sin(2)$ , etc. The delay means that the output at  $t = 7$  will be that part of the signal corresponding to  $t = 1$ . The con-

clusion is simple: when the delay line has a length which is an integer multiple of the sampling period, we can move the sampler from input to output without changing the final result.

This apparently trivial demonstration is very important because it means that we can even ignore the sample nature of discrete-time signal processing when we analyze a filter! The filter can be thought of as an ordinary analog filter, without digitization and without sampling. The effect of sampling can be added later on. Moreover, as we demonstrated much earlier in this series of monthly columns, sampling has no effect on those parts of the spectrum which are below half the sampling rate. It only effects higher frequencies which are moved to new frequencies. Since our first assumption in digital audio is that the process contains an anti-aliasing filter to remove components that are beyond the Nyquist frequency, spectral transformation cannot occur. To restate the conclusion:

The sampling process has no effect, since there are no high-frequency components;

The input sampler for a digital filter can be moved to the output of the structure and ignored;

The remaining part of the filter is merely a structure made up of delay lines.

The only condition on this conclusion is that the delay line must have a length which is a multiple of the sampling frequency's period. Thus, there are certain



... a brief bikini or skimpy costume pose NO problems for the mini-VHF/UHF SWINTEK MARK 50A wireless microphone transmitter  
Write for full details

**Swintek**

TELECOMMUNICATIONS DIVISION  
1180 Aster Avenue, Unit J, Sunnyvale, CA 94086  
(408) 249-5594 TELEX #172-15J SLVL SWINTEK



... the wireless microphone system small enough to be hidden in a brief bikini.

SWINTEK MARK 0/50A-dBS® Pocket Sized mini VHF system featuring compandor audio; RELIABILITY that meets the demands of EEP/ENG production facilities ENGINEERED to accept any microphone, including the "CROWN PZM"  
Write for full details.

**Swintek**

TELECOMMUNICATIONS DIVISION  
1180 Aster Avenue, Unit J, Sunnyvale, CA 94086  
(408) 249-5594 TELEX #172-15J SUVL SWINTEK

kinds of filters made up of delay lines which could not be built in the digital domain without using very high sampling rates. Let us consider a filter containing delays of 1.2, 3.9 and 7.45. These would all be multiples of the sampling period if that period was 0.05 time units. The first delay line would be 24 units long, the second, 78, and the third, 149.

#### AN EXAMPLE

To illustrate this process, we may begin with the digital filter shown in FIGURE 2A. We represent the sampler at the beginning as corresponding to the sample-and-hold found just before an A/D converter. The delay line is implemented with shift registers, or a ring memory (see the April Digital Audio column), and it is two sampling periods long. Our task is to determine the spectral characteristics of this filter. We begin the process by observing that the sampler can be moved to the output (FIGURE 2B), and finally ignored if we only consider frequencies below the Nyquist frequency (FIGURE 2C). This structure can be analyzed without any higher mathematics by just considering the filter's effect on a sinewave at frequency  $f$ . The output  $Y(t)$  is equal to the input, plus half the delayed input. This gives us

$$Y(t) = \sin(2\pi ft) + 0.5 \sin(2\pi f[t - T])$$

where  $T$  = twice the sampling period.

Using a little trigonometry, and then combining terms, we can rewrite this as

$$Y(t) = \sin(2\pi ft) [1 + 0.5 \cos(2\pi fT)] + \cos(2\pi ft) [-0.5 \sin(2\pi fT)]$$

Notice that the parts of the expression in the brackets are just the numbers for any given  $f$  and  $T$ ; only the  $\sin(2\pi ft)$  and the  $\cos(2\pi ft)$  are actual time signals.

When we have a sinewave with a sine and cosine part, the magnitude is just the square root of the sum of the squares. For those more inclined to trigonometric manipulations, we can represent the above as

$$Y(t) = \sin(2\pi ft + \theta), \text{ where}$$

$$M = \sqrt{1.5 + \cos(2\pi fT)}, \text{ and}$$

$$\theta = -\arctan[\sin(2\pi fT) / (2 + \cos(2\pi fT))]$$

$M$  is nothing more than the ratio of the output to the input for different frequencies. Thus, it is the frequency response, and it will vary between  $\sqrt{2.5}$  and  $\sqrt{0.5}$ .

The term  $\theta$  is the phase response. Both  $M$  and  $\theta$  are a function of frequency. We should observe that both the amplitude and phase response always contain the  $f$  multiplied by  $T$ . The reason is clear. Both the sampling rate and the signal frequency use the same time scale. The actual physical samples which enter the system are the same for a 10 kHz signal sampled at 100 kHz as they are for a 1 kHz signal sampled at 10 kHz. In both cases, the samples occur at  $0^\circ$ ,  $36^\circ$ ,  $72^\circ$ ,  $108^\circ$ , etc. We can see now that sampling makes our frequency notation become a phase notation. So, the Nyquist sampling theorem can be restated:

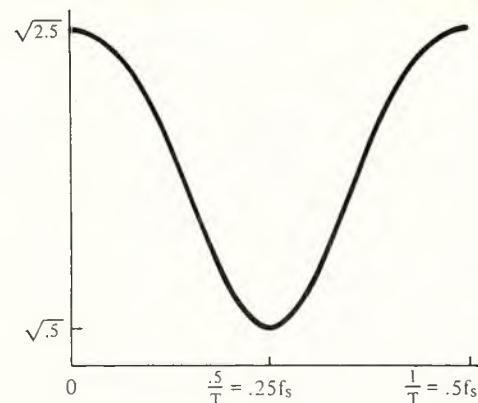

Figure 3. The frequency response of our digital filter.

*There must be at least two samples per period, or,*

*No sample can be more than 180 degrees from the previous sample.*

Remember that a sampling system only operates on successive samples, and its response depends only on the relationship between successive samples. There is no concept of time in processing; rather, there is a concept of bookkeeping successive samples. Thus, we speak of Sample 134, 135, 301, etc. It doesn't matter if these are microseconds, milliseconds, or hours.

Of course, the outside world is concerned with absolute time, and an audio system would now work very well with samples taken just every minute. However, the digital filter only cares about the sample counting. The conversion between count index and real frequency is only relevant at the sample-hold. When we really begin to deal with digital filters, we will note that the notion of time is replaced with counting, and the concept of frequency becomes a normalized phase. A sine wave will be referred to in terms of the numbers of counts per cycle, or phase per period.

The digital filter we have just analyzed has a frequency response which is plotted in FIGURE 3. This curve is just as real as any frequency response which would be found in an analog filter. We should also note that this characteristic is just as meaningful when the input data are the temperatures of successive days as it is for audio. If we feed temperature data in as samples, we will get filtered temperature data out. The curve gives us the increase and decrease in temperature behavior. In other words, oscillatory weather will be emphasized if the oscillatory rate matches one of the peaks but it will be de-emphasized at other rates. Finally, we should note that the earliest work on digital filters was actually done in the 19th century by statisticians trying to deal with data points.

We will show that averaging, as a way of making data smoother, is actually a well-defined digital low-pass filter. But, we'll leave that until next month. ■

# 25,000 copies in print

## The Recording Studio Handbook



John M. Woram

**8 clearly-defined sections**  
**18 information-packed chapters**

### I. The Basics

The Decibel  
Sound

### II. Transducers: Microphones and Loudspeakers

Microphone Design  
Microphone Technique  
Loudspeakers

### III. Signal Processing Devices

Echo and Reverberation  
Equalizers  
Compressors, Limiters and Expanders  
Flanging and Phasing

### IV. Magnetic Recording

Tape and Tape Recorder  
Fundamentals  
Magnetic Recording Tape  
The Tape Recorder

### V. Noise and Noise Reduction

Noise and Noise Reduction  
Principles  
Studio Noise Reduction Systems

### VI. Recording Consoles

The Modern Recording  
Studio Console

### VII. Recording Techniques

The Recording Session  
The Mixdown Session

### VIII. Appendices

Table of Logarithms  
Power, Voltage, Ratios and Decibels  
Frequency, Period and Wavelength of Sound  
Conversion Factors  
NAB Standard  
Bibliography  
Glossary

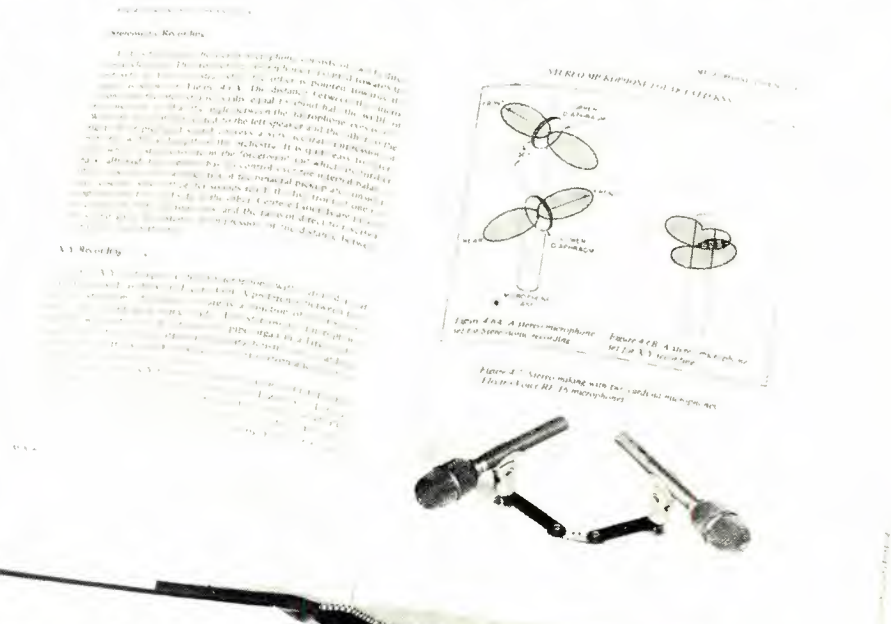

## Fifth big printing of the definitive manual of recording technology!

"John Woram has filled a gaping hole in the audio literature. This is a very fine book . . . I recommend it highly."

— **High Fidelity**. And the **Journal of the Audio Engineering Society** said, "A very useful guide for anyone seriously concerned with the magnetic recording of sound."

So widely read . . . so much in demand . . . that we've had to go into a fifth printing of this all-encompassing guide to every important aspect of recording technology. An indispensable guide with something in it for everybody to learn, it is the audio industry's first complete handbook on the subject. It is a clear, practical, and often witty approach to understanding what makes a recording studio work. In covering all aspects, Woram, editor of *db Magazine*, has provided an excellent basics section, as well as more in-depth explanations of common situations and problems encountered by the professional engineer.

It's a "must" for every working professional . . . for every student . . . for every audio enthusiast.

**ELAR PUBLISHING COMPANY, INC.**  
1120 Old Country Road, Plainview, N.Y. 11803

Yes! Please send \_\_\_\_\_ copies of THE RECORDING STUDIO HANDBOOK. \$37.50. On 15-day approval.

Name \_\_\_\_\_

Address \_\_\_\_\_

City/State/Zip \_\_\_\_\_

Total payment enclosed \$ \_\_\_\_\_  
(In N.Y.S. add appropriate sales tax)

Please charge my  Master Charge  
 BankAmericard/Visa

Account # \_\_\_\_\_ Exp. date \_\_\_\_\_

Signature \_\_\_\_\_  
(charges not valid unless signed)

Outside U.S.A. add \$2.00 for postage.  
Checks must be in U.S. funds drawn on a U.S. bank.

**Use the coupon to order your copies today at \$37.50 each. And there's a 15-day money-back guarantee.**

## Low-Frequency Systems, Part I

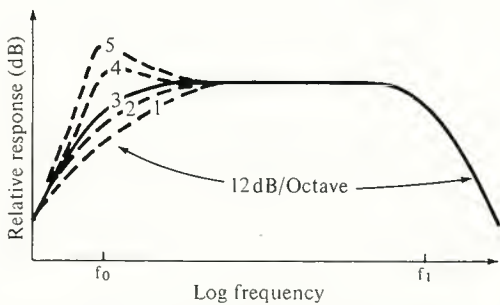

Figure 1. Power response of a cone loudspeaker mounted in a large flat baffle.

• In this, and next month's columns, we will examine the three basic low-frequency systems used in sound reinforcement: horn, horn-reflex, and ported systems. Historically, horns were first introduced into high-level sound work because of their relatively high efficiencies. Later, as more electrical power became readily available, horn-reflex systems permitted some reduction in size with little or no sacrifice of low-frequency bandwidth.

In recent years, both high-powered amplifiers and ruggedized transducers have made ported systems attractive in a field traditionally dominated by some degree of low-frequency horn loading.

### PERFORMANCE OF A SIMPLE DIRECT-RADIATOR LOUDSPEAKER

If a direct-radiator loudspeaker is mounted on a large flat baffle, its region

## LOW LEVEL INPUT TRANSFORMERS

**For Microphones/Transducers**



Control and Instrument Amplifier Applications  
Excellent magnetic ESS shielding  
Response 30-20 KHz +1db  
Turns Ratio 1:1 thru 1:20



7-Pin PC Mounted

Single Threaded Stud Mounting      Equivalent to Imported European Studio Grade Transformers

COMPLETE SPECIFICATIONS AND PRICE SHEET AVAILABLE

Complete Catalog line of

### AUDIO-POWER COMMERCIAL-MIL TRANSFORMERS

IMMEDIATE DELIVERY FROM DISTRIBUTORS





## MICROTRAN COMPANY, INC.

145 E. Mineola Ave., Box 236, Valley Stream, N. Y. 11582

Figure 2. Directional characteristics of a circular-piston source, mounted in an infinite baffle, as a function of diameter and wavelength.

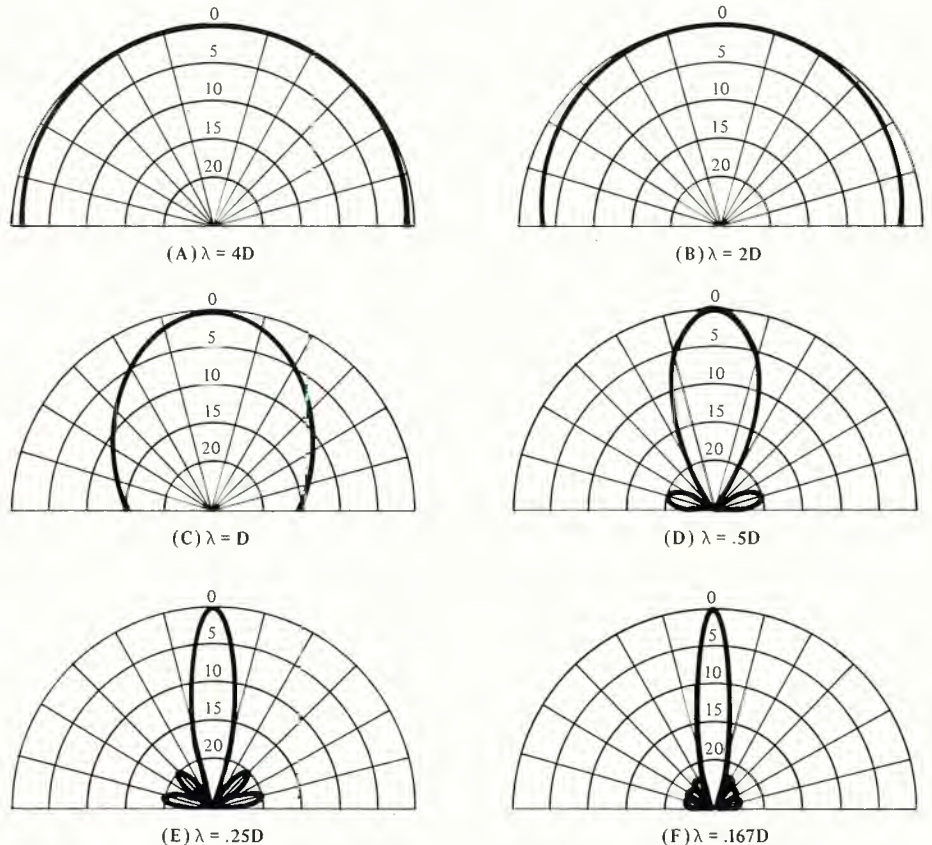



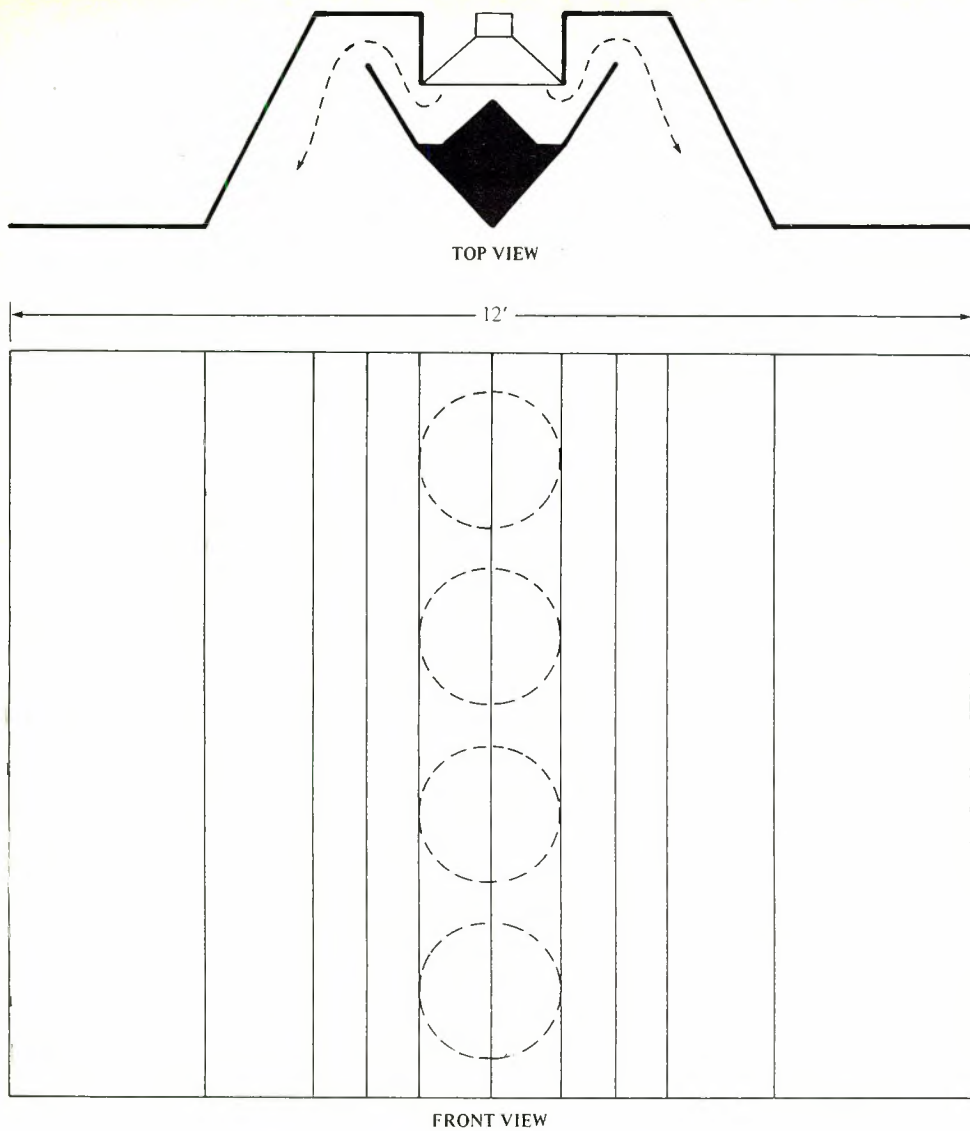

Figure 3. Top and front view of a "W" horn designed for motion picture sound reproduction.

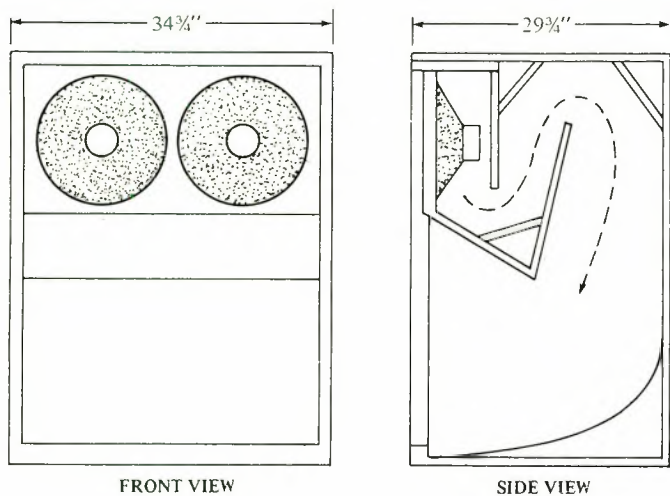

Figure 4. A back-loading horn.

of flat power output will be bounded at the low end by the resonance frequency,  $f_0$ , of the moving system. The high-frequency boundary may be determined by the equation

$$f_1 = c/2.5a,$$

where  $f_1$  = the upper frequency boundary,

$c$  = the velocity of sound, and  
 $a$  = the effective radiating diameter of the cone.

For most transducers used in sound reinforcement,  $f_0$  will range from about 330 Hz for an 18-inch transducer, up to about 670 Hz for a 10-inch transducer.

FIGURE 1 shows these relationships, along with the effects which damping will have on the response in the region of  $f_0$ . Consider what happens if the transducer is heavily damped, either through mechanical losses or through the effect of electro-magnetic damping. As the back EMF of the transducer is shorted out through the low source impedance of the driving amplifier, its low-frequency response will be rolled off, as shown by curves 1 and 2 in the figure. However, if there is insufficient damping (normally the result of a small magnet), then the response will be peaked at  $f_0$ , as shown by curves 4 and 5. For the most part, the class of low-frequency transducers used in sound reinforcement work will exhibit curves like 1 and 2 when mounted under the conditions of FIGURE 1.

### EFFECTS OF DIRECTIVITY

The useful on-axis output of a loudspeaker can easily extend beyond the limits of flat power response described above, and the reason for this is shown in FIGURE 2, where the wavelength is compared to the effective cone diameter. Note that as the wavelength gets progressively smaller, the polar response of the device begins to sharpen, or "beam," on axis. This effectively maintains the on-axis response of a low-frequency transducer one octave above the point where the power response begins to roll off. The effects of directivity will also be apparent when transducers are loaded into horns or other enclosures.

### LOW-FREQUENCY HORNS

Low-frequency horns were developed for the motion picture industry in the early thirties. FIGURE 3 shows details of a typical "W" horn, as used in the early MGM system developed by Shearer, Lansing and Hilliard. Note that the back of the system opened directly into the stage house behind the screen. These systems typically used two or four 15-inch drivers, and the flare rate for these horns gave a cut-off frequency of about 40 Hz.

In later years, Klipsch refined low-frequency horn design through ingenious folding to allow better use of space. The

Klipsch corner-horn design maximizes loading by coupling the horn's flare to the trihedral corner which exists where the floor and two walls come together at right angles. Klipsch's design also makes use of *reactance annulling*. This involves the use of a properly sized back air chamber behind the low-frequency transducer which cancels some of the horn throat reactance, which is quite high in the region of cut-off. This allows the resistive component of the horn's acoustical impedance to remain higher than it normally would, resulting in more acoustical output in the cut-off region. FIGURE 4 shows a later horn design of the *back-loading* type. Above about 300 Hz, the direct radiating low-frequency transducers will provide useful output up to 500-800 Hz.

### SENSITIVITY AND POWER RESPONSE OF HORN SYSTEMS

The sensitivity of a typical horn system is quite high. Many can produce outputs of 103-107 dB-SPL, 1-Watt at 1-meter. Just as we observed in our study of high-frequency horn drivers in the March column, the low-frequency horn system will be limited at high frequencies by the mass of the moving system. The frequency of this break point in power response is given by

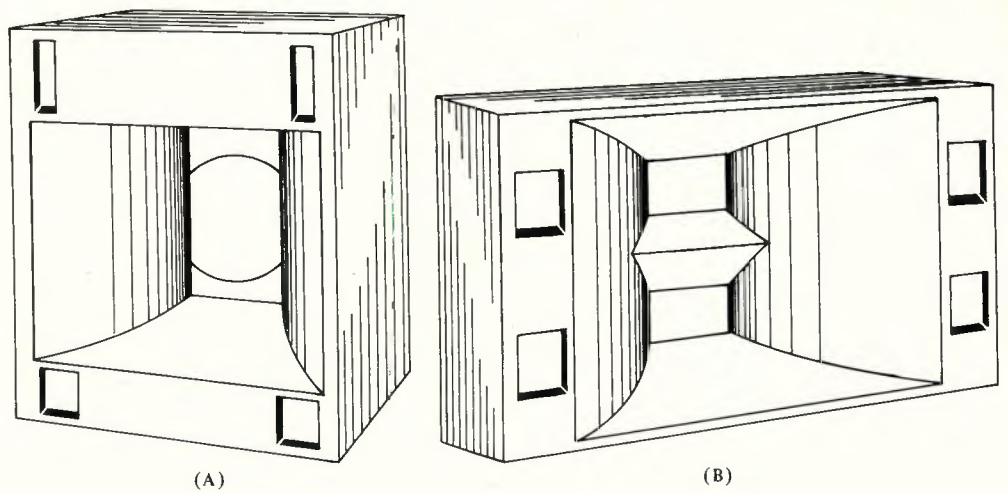

Figure 5. Two horn-reflex systems with (A) single and (B) dual low-frequency drivers.

which work best in horns have light cone/voice coil assemblies, high free-air resonance frequencies and large magnet structures. When mounted on a flat baffle, as shown in FIGURE 1, a typical low-frequency horn driver would exhibit response similar to Curve 1 in that figure. The fact that many low-frequency horns exhibit extended on-axis response above the mass break point is due, as we have seen before, to the inevitable increase in directivity with rising frequency.

Later designs of horn-reflex systems have, in general, employed enclosure-port resonances in the 40 Hz range, thus yielding more useful output in the region just below horn cut-off. FIGURES 5A and B show two horn-reflex enclosures (single and double) which are typical of those made by many manufacturers and users in the field. The on-axis response of systems such as these exhibit the characteristic responses shown in FIGURE 6A and B. For the single low-frequency

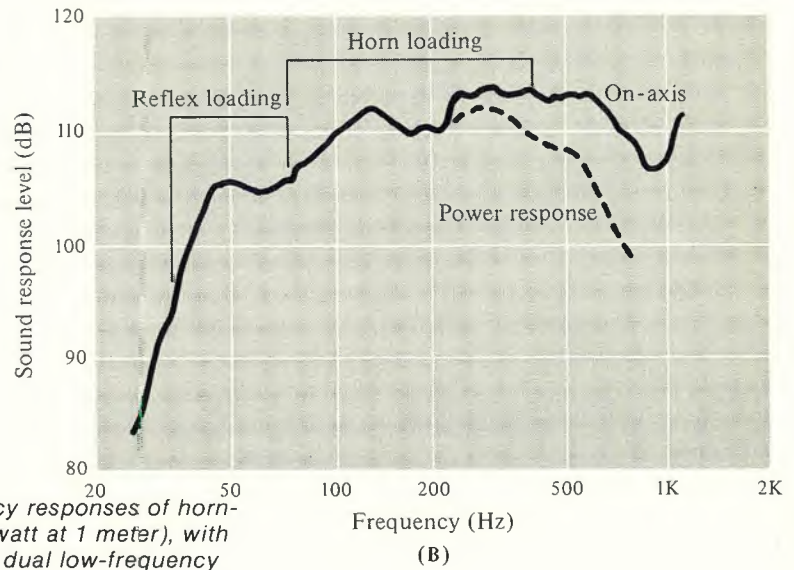
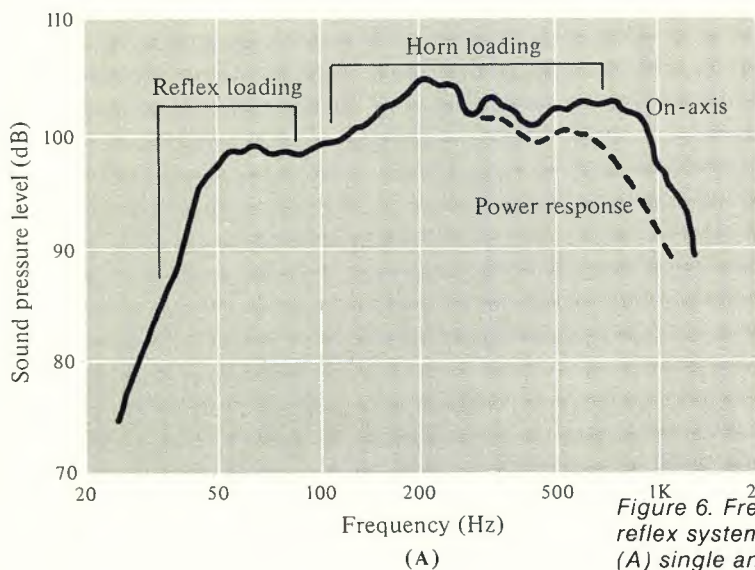

Figure 6. Frequency responses of horn-reflex systems (1 watt at 1 meter), with (A) single and (B) dual low-frequency drivers.

$$f_{HM} = (\beta l)^2 / \pi R_E M_{MS}$$

where  $B$  = the flux density in teslas,  
 $l$  = the length of the voice coil in meters,  
 $R_E$  = the DC resistance of the voice coil, and  
 $M_{MS}$  = the mass of the moving coil in kilograms.

For a typical low-frequency transducer which might be used in a horn system, we would normally expect values of  $f_{HM}$  in the 400-450 Hz range. The low-frequency response of the horn would be determined by the cut-off frequency and the mouth size of the horn.

Those low-frequency transducers

### HORN-LOADED REFLEX SYSTEMS

Beginning with the Altec A-4 theater system in the mid-forties, Hilliard and Lansing enclosed the traditionally open-backed low-frequency theater horns and brought the sound to the front via ports in the lower part of the enclosure. This accomplished two things: it kept sound from echoing around in the stage house, and it increased the useful acoustical output below about 80 Hz into the theater itself. The porting of these large enclosures was arrived at empirically, and it produced an enclosure-port resonance of about 25 Hz.

system, the horn-loaded region begins at about 100 Hz and is about 6 dB more sensitive than the reflex region, which extends down to the 40 Hz enclosure-port resonance frequency. The dual low-frequency system has a larger horn, so the horn-loaded region extends down to about 70 Hz. As before, the enclosure-port resonance is at 40 Hz, and response falls off sharply below that frequency.

Next month, we will continue our discussion of low-frequency systems with a survey of ported systems designed using the Thield-Small parameters for low-frequency transducers. ■

# POWER. PRECISION. CHOICE.

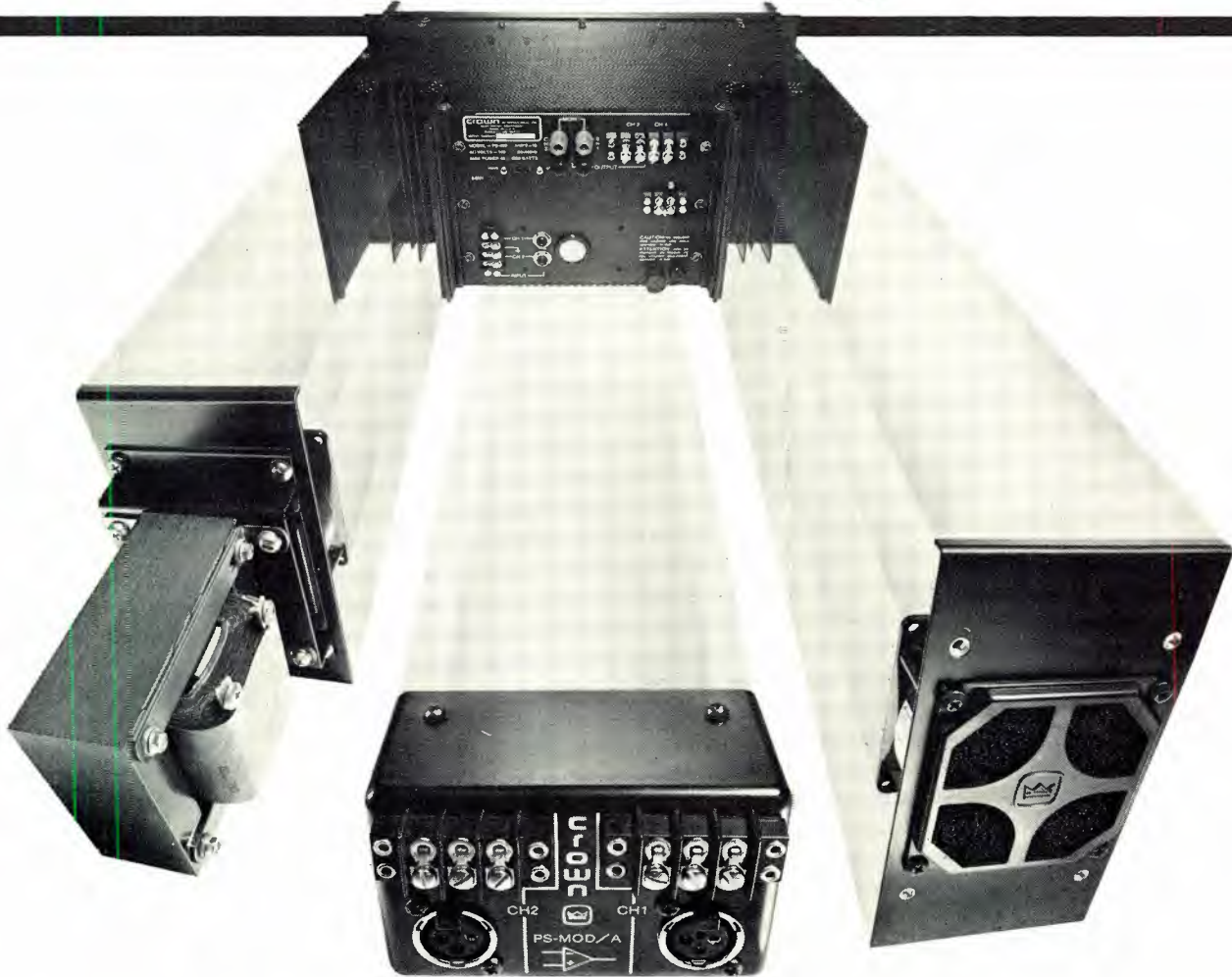

Build yourself a stronger reputation by selecting the unique flexibility and professional performance of two new Crown power amps: the PS-400 or the PS-200.

Choose only the special, low-cost options you need: plug-in balanced input, active or passive; 70-volt transformer; dual fans. Install them easily, quickly, anytime, in any combination – thanks to the fresh, innovative design of these amps.

Built-in features make these amps the first choice of professionals: instant mono/stereo conversion, terminal strip connectors plus phone jacks, IOC™ and signal-present indicators, low-frequency protection, and much more.

Select the power level you need. For full-time, reliable performance, both amps are built in the best Crown tradition. PS-200 rated (FTC) at 135 watts per channel into

4 ohms, PS-400 at 260. Mono ratings into 8 ohms are 270 watts (PS-200) and 520 (PS-400).

Introduce yourself to the new Crown MULTI-MODE™ output circuit, a new, three-deep design that eliminates audible distortion, and introduces a degree of precision sound reproduction that will delight performers and audiences.

Complete information on specifications and prices, for the amps and the optional accessories, is now available from Crown. For quick action, simply fill in the blanks below and send this corner of the ad to Crown.

Name \_\_\_\_\_

Address \_\_\_\_\_

City \_\_\_\_\_ State \_\_\_\_\_ Zip \_\_\_\_\_



PS-200



...WHEN YOU'RE READY FOR REAL!  
1718 W. Mishawaka Rd., Elkhart, IN 46517, (219) 294-5571



PS-400

db June 1982

19

Circle 22 on Reader Service Card

AAE "Concept One"  
Automation

AKG

AMPEX

AMPEX TAPE

AUDIOARTS ENGINEERING

BGW TANNOY

HANNAY  
(Cable Reels)

EVENTIDE

IVIE

LEXICON

SENNHEISER

TECHNICS

VEGA

WIREWORKS



204 N. Midkiff

Midland, Texas 79701

(915) 684-0861

## Doppelgangers Again

• My power amplifier is fixed (why is it always burned resistors and fried drivers?), and so my experiment with monaural is over. A single speaker is as restricted as one ear; we want two loudspeakers, one for each ear. Now I'm enjoying stereo again, and anxious, like everyone else, to make it sound even better. That's where we left off last month. But first, a quick review.

A pair of loudspeakers can simulate a phantom sound image by playing into the ear-brain's system for sound localization. Of several different cues, and a complex interaction among them all, the two most important are amplitude and time of incidence. Along an arc between two loudspeakers, an image is fixed toward the louder source, or toward the earlier source. And with either one of those cues, or using the cues together, a lateral image width can be created between two loudspeakers. An image panorama is created which helps to recreate the original panorama—an important step towards realism. But we are limited to a flat panorama along a line between the loudspeakers. That is unnatural—an orchestra has both width and depth. We perceive sound from the violins on the left and the double basses on the right, and the cellos up front and the percussion in the back. That entire sound mass is presented before us, and to our sides, and behind us—all around. We need that reality of localization in recordings (sound from all around us) and two loudspeakers can, to a large degree, accomplish that.

### TIME AND AMPLITUDE CUES

To learn how to decode that kind of information, let's first look at one way to encode it—at the microphone itself. A coincident microphone technique makes use of amplitude cues. Consider the example of crossed cardioids (a coinci-

dent technique could never use omni—right?). A sound source equidistant between them produces identical amplitudes at each capsule. A sound source to one side will be on-axis to one capsule, and off-axis to the other. Depending on the polar pattern, the off-axis capsule will yield an attenuated output. The on-axis capsule, and its associated playback channel, will have higher amplitude, and thus the phantom image will be placed toward that channel. So, the ensemble between the crossed-cardioid capsules will be recreated through amplitude cues on the playback system. Both variations of this technique, X-Y and M-S, use amplitude information for their panorama. And the technique is good; placement of the microphones is essentially impartial to distance away from the sound source, and angular information is consistent.

A spaced-apart microphone pair makes use of time differences. Whether it be omnidirectional or cardioid capsules spaced apart by several feet, or separated by only a few inches, any off-axis signal will arrive at one capsule a short time before it reaches the other capsule. For example, if two capsules are a foot apart, a sound source 45 degrees to the left will arrive at the nearer capsule half a millisecond earlier, resulting in a mild pan toward the left playback channel. A separation of three feet would yield a time difference of 2 milliseconds and give us a hard pan to the left. Furthermore, the sound arriving at the nearer capsule will be louder, resulting in an additional amplitude-pan to that channel. As mentioned last month, the use of time delays to provide localization cues is a touchy aspect of stereo. The resulting images can radically break from the middle with only a slight time difference. Any source far enough off-center to yield a time difference more than about 2 milli-

seconds will be hard-panned. As the capsules are further separated, sources only slightly off-center will yield too-long delays, again resulting in an exaggerated effect. Also, any spaced-apart technique with its uneven path lengths is vulnerable to cancellation when the signals are added either acoustically or electrically. A special problem is a low-frequency source located to either extreme side—disc masters beware.

As mentioned above, a combination of time and amplitude cues can be employed, and a near-coincident technique illustrates this. For example, angled cardioid capsules spaced a few inches apart would yield both amplitude cues because of the cardioid properties of the capsules, and the physical distance between the capsules provides a time difference. The DIN and ORTF arrangements are examples of this technique.

### AMBIENCE

Thus far we have only described time and amplitude cues, and clearly the kind of realism these techniques provide indicates that more information than that is being encoded. That extra information is essentially ambience. Not the stuff you get from your echo returns, but a genuine environment pattern, correct in the totality of the phase and polarity that made it unique and live in the first place. Each performance is an environment of surrounded sound, and a well-placed stereo microphone arrangement provides the means to encode that information, and in fact encodes more information than two loudspeakers can use.

The classic arrangement of two bi-directional coincident capsules crossed at 90 degrees is perhaps the best example of an encoder getting absolutely everything. The Blumlein technique encodes a pair of voltages for every slice of the 360-degree sound pie. Direct sound, ambient sound—everything present in the space is recorded. Playback through two loudspeakers recreates that space remarkably—the lateral image is there of course, and so are all of the depth cues; it can be a brilliant recording technique, if your recording space is up to it. But still, all of the space information is still up front. Sure, it's ambience, but it's still flat. Yes, I know I could wire up some rear loudspeakers, but I want two speakers to create a full panorama. Besides, I can't Blumlein *everything*. I want a pan pot that can do it for me, from my multi-track...

Let's set up our pair of loudspeakers. We can place an image in one or the other, in the middle, or along the line. Now how about this. Place a signal at one speaker, and then feed a small amount of the same signal 180 degrees out of phase to the other speaker. The resultant phantom phase relationship produces an image angle greater than that subtended by the speaker arc; the phantom image is placed outside of that arc. Well,



*Prototype version of a Ramsa localization processor.*

in theory that sounds great, but in practice (introducing out-of-phase signals?)—no, I'd rather not.

### DOUBLE PHANTOMS

Let's set up the loudspeakers again. Amplitude information is the first and the best localization cue, and coincident microphones are essentially amplitude-encoding systems. Let's observe listening conditions, and plug our results into a simulation computer to explain how acoustic information behaves at the ears. Given a free sound field (and two ears), the signals are characterized by acoustic transfer functions. The computer simulations show that there are two functions, one a sound pressure ratio of signals between the two channels, and the other a sound pressure signal common to both channels. We build hard-wired circuits which duplicate the signal processing indicated by the simulations and feed in our signal, and suddenly we can produce a sound image at any selected location. Let's place those phantoms on each side, one to our right and one to our left. Now, using good old amplitude controllers, we control the pan between them. Instead of panning between two real loudspeakers 60 degrees apart, we are panning between phantoms 180 degrees apart. It's beautiful—two loudspeakers placed as usual, but they are there only to create our super phantoms. Now our pan pots operate over a 180-degree arc, and

that whole frontal half plane—all of that nice curved space—is available, as enjoyable as free parking.

There's more: we can pan a sound closer—we can control sound depth by differentiating the sound pressure between the actual loudspeakers and the phantom sound lateralized inside the head created—not by the real loudspeakers, but the phantom loudspeakers. Get it? We're working not with ordinary phantom images—but phantom loudspeakers. *Doppelgangers*, literally translated, means double phantoms. And that is the RAMSA Localization Processor. It is a new creative tool used to control sound placement and distance within the entire frontal half plane. It operates through two ordinary loudspeakers and its localization is encoded for playback from any record and tape, just like any other panning.

Oh, there's more. It controls the ratio between direct and early sound reflections to fully control distance, and reverberation to control spaciousness. It allows the engineer to intelligently place the source in its proper sonic environment in which lateral position, distance and the ambience envelope all collectively make sense. Sure—sales pitch—I've used the RAMSA with some good results, but more importantly, it's the first step in a new direction of products to better utilize localization information. It's about time too. ■

## Micsmanship

**W**HEN IT COMES TO buying control-room hardware, we've often noticed that there is a certain amount of what advertisers would call "brand loyalty." Thus, one studio will have nothing but Brand X consoles in all its control rooms, while another insists on Brand Y. The tape recorders probably all come from the same manufacturer, and the power amps certainly do. Even the speakers are apt to be from the same company, because everyone likes their "sound."

This definitely makes life easier for the spare parts buyer, and there is also a certain amount of efficiency in whatever interchangeability results from this practice. Yet, that's generally not what influences the studio in making its purchases. Most often, it's because *everyone* (that is, the chief engineer) likes the performance—or sound, price, styling, or whatever.

But then, we get into the studio, and sneak a look into the mic closet. There's two from here, three from there, a couple from elsewhere, and one or two from the other place. In fact, there is rarely anything even approaching a consensus towards a particular manufacturer. And surely, no studio anywhere employs *only* the model XX made by the folks at Brand Y.

Why not? Wouldn't it make a lot more sense to establish a "standard" microphone for the studio that already has its in-house standard consoles, recorders, amplifiers, and probably even cables?

Nope; why even editors know that would be a pretty dumb idea! Microphones are supposed to have "personalities," and these are a lot more important than published specs. So, there can be no standard microphone. Everyone knows that the best piano microphone is lousy on vocals. The XM-93 sounds great on gut-string acoustic, while the QE-2 does a much better job on kick drum. On the other hand, the H<sub>2</sub>-SO<sub>4</sub> is *the* mike for strings, unless there's only a few of them, in which case the . . . .

And so it goes. Well then, why doesn't some smart manufacturer introduce a line of microphones that are

tailored for specific musical instruments? That's another dumb idea. For besides death and taxes, there is one more little reality in this life that every recording engineer (and microphone manufacturer) can depend on: an opinion about the best microphone for the you-name-it is something best kept to oneself. Mentioning it in public will only cause your friends to wonder how anyone in the business so long could be so stupid. Why, *everyone knows that the best microphone is really the . . . .*

And so it goes. Oops, we said that already. But you know what we mean. The fine art of microphone selection—and placement—is just that: a fine art. It helps to know the rules, but after that it's up to you.

Speaking of rules, we think one of them should be—Check out the off-axis response before going any further. Maybe it should even be Rule #1. We all know what our favorite guitar microphone sounds like—on guitar. But, what does it sound like on the "everything else" that's leaking in from the off-axis sides and rear?

At least one frequently-seen mic has an off-axis response that's not very good at all. All things considered, we'd say it's over-priced. Put a handful of them up in the studio and you've got a guaranteed concerto for mud-bath going on. But many of us make our mic judgments out-of-context. Sure, the mic sounds great on the instrument. But we don't get around to listening to that just-mentioned everything else. Later on, during mixdown, it's too late. (Fortunately, editors have no such problems. On paper, *everything* sounds great.)

In closing, we'd like to pass on three other rules that we've just discovered. Unfortunately, these rules are so new, John Eargle didn't even know about them in time to put them into his just-published *Microphone Handbook*:

1. Do not use a condenser microphone as a hammer.
2. Ribbon microphones are not happy in kick drums.
3. When miking vocalists, it is probably not a good idea to go direct.

Remember, you read it here first.

JMW

# THE RUGGED, COMPACT TOA MONITORS

## DESIGNED TO PERFORM WHERE YOU NEED THEM THE MOST.

For the stage, the powerful SM-60 stage monitor speaker system. For the studio or stage, the equally powerful RS-21M reference mini-monitor. Both as small and as rugged as we could engineer them—without compromising the performance you need for accuracy and higher power-handling. They're everything you've always wanted in smaller, high quality monitors. And less. Less bulk and less set-up hassles.

Our SM-60 is a full-range, dual transducer speaker system with a rated input of 70 watts\*. It features a sensitivity of 90 dB SPL—for operation at levels that really cut through. The frequency response is 110Hz to 16kHz—extended top and bottom to cover a broad musical range. And instead of cheap plastic or flimsy wooden boxes, we enclose the SM-60 in a tough, extruded aluminum shell with solid cast end panels.

When you make your set-ups with an SM-60 you've got options too. The adjustable mounting bracket will securely attach the monitor to the top of the mic stand or anywhere along the stand itself. And when a speaker cable is stepped on, you're not going to lose the show because the connections are terminated with our exclusive positive-locking, 1/4" phone jack.

The RS-21M is a closed enclosure, full-range reference monitor that can handle a rated input of 35 watts\*\*. It gives you a sensitivity of 88 dB SPL (1W@1m) and a frequency response of 100Hz to 17kHz. The RS-21M is designed to fit right where you usually need it the most—right on top of the meter bridge of our RX Series boards.

Both new monitors can take the toughest, continuous high power use on stage or in studio. They're companion

systems that join our compact RX Series consoles and the extension of our philosophy that professional sound gear doesn't have to be bulky, unsightly and a drag to set up.

The SM-60, the RS-21M and our RX Series consoles—they're big on performance and stingy on space, the kind of studio equipment designed to perform where you need it the most.

\*16 ohms \*\*8 ohms



*Crafted in Japan  
Proven in the States.*

**TOA Electronics, Inc.**

480 Carlton Court  
South San Francisco, Ca. 94080  
(415) 588-2538 Telex: 331-332

In Canada:

**TOA Electronics, Inc.**

10712-181 Street  
Edmonton, Alberta T5S 1K8  
(403) 489-5511 Telex: 037-43255

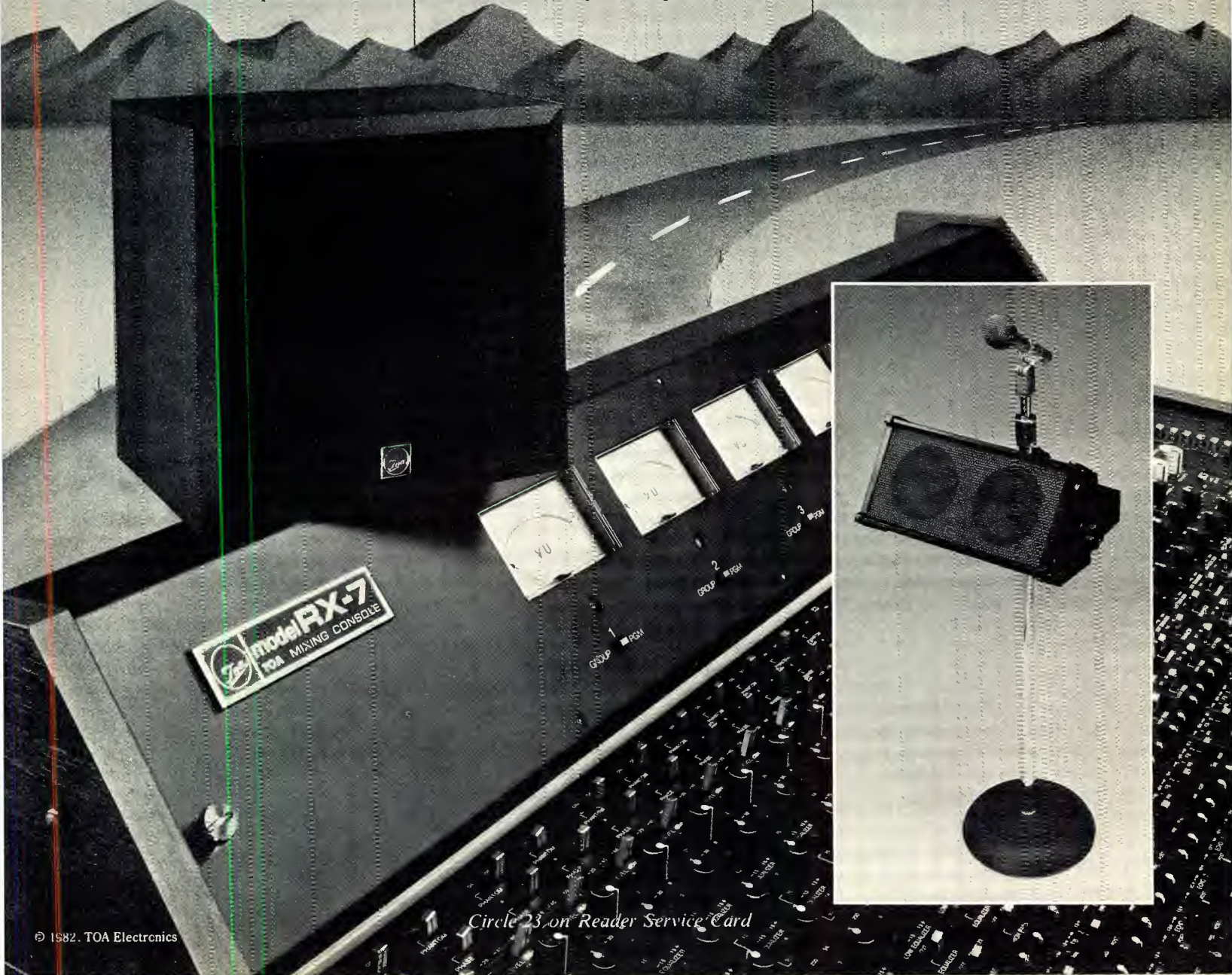

Circle 23 on Reader Service Card



The Enertec Schlumberger F462 Super Stereo analog recorder.

transient control, in either mono or stereo/dual mono versions. They also featured their Transdynamic Processor which splits the signal into three frequency bands before compressing and recombining at the broadband limiter and clipper stages. *Audio Developments* (UK) specialize in miniature portable mixers and showed new models aimed at the film industry and ENG (electronic news gathering) such as the four-into-one ADO49 weighing only 7.15 lb. *Audio Kinetics* (UK) listed a score of tape and film recorder brands which their Q-Lock time-code synchronizer can control.

*Beyer* (West Germany) were demonstrating a radio microphone system with built-in compander. *Bruel & Kjaer* (Denmark) introduced a Type 3360 sound intensity analyzing system using two microphones to give real time display of incident direction as well as level. *Calrec* (UK) have developed what they call a Rolling RAM video post-production automation system cueing either to footage count or time code. The storage medium is 32K bytes of Random Access Memory arranged in a circular form so that the first data is eventually replaced by later signals. *Court Acoustics* (UK) had combined new Proflex amplifiers and loudspeakers into a powerful rig which could occasionally be heard in the distant lecture hall and made some nervous individuals wish they could don ear-defenders. A convenient package, though, for high acoustic levels in large auditoria.

*Domain Magnetics* (Israel) must be the first AES exhibitor from that country. They operate a three-shift 24-hour day to keep up with export orders for their giant rolls of coated and polished recording tape, or can slit to standard widths if required. *EMT-Franz* (West Germany) showed a new EMT 938 direct-drive broadcast disc reproducer with fantastic quick-



The Enertec Schlumberger UPS5000 series mixer.

start and remote control. Their clever 19-inch rack EMT 245 digital reverberator, giving reverberation times from 0.4 to 4.5 seconds, pre-delay and variable early-reflection amplitudes, was made even more versatile by the addition of a new EMT 245S remote control unit. The latter carries displays of all settings, and uses serial digital transmission over a single AF cable with no risk of crosstalk. It can also store up to 10 reverberation programmes. *Enertec Schlumberger* (France) were demonstrating their F462 Super Stereo 1/2-inch analog recorder claiming 50-25,000 Hz,  $\pm 2$  dB and 80 dB signal-to-noise at 30 ips. They also showed their UPS5000 series mixers and a prototype digital mixer.

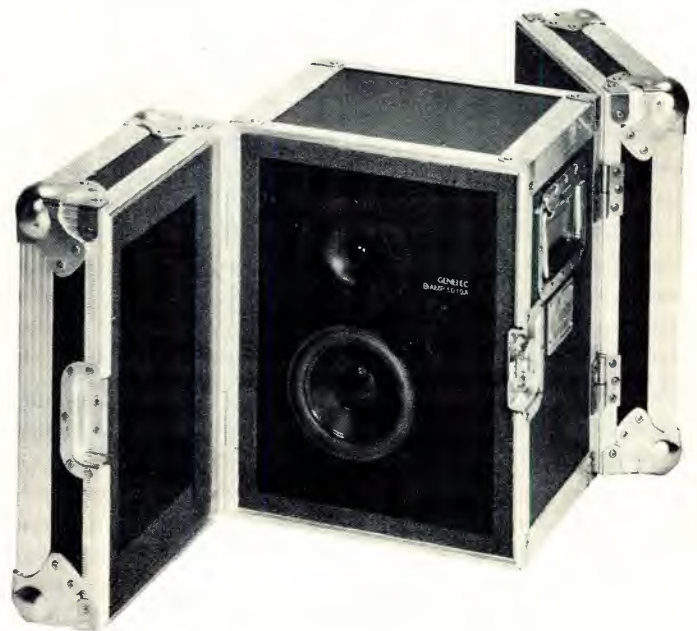

The Genelec Oy Biamp 1019A monitor loudspeaker.

*FM Acoustics* (Switzerland) had a range of power amplifiers featuring 10 different protection systems per channel, a dual-speed fan and delayed turn-on. *Genelec Oy* (Finland) demonstrated active biamp and triamp monitor loudspeakers, including versions built into robust transit cases. *JVC* (Japan) took a large demonstration room to show off their professional digital audio recorder and editor, but attracted just as much attention with a compact cassette digital machine running at 2.8 ips, with 33.6 kHz sampling frequency and 14-bit equivalent quantization. *Klark-Teknik* (UK) demonstrated to me their DN772 digital stereo profanity delay line (which was on its way



to the British Houses of Parliament for use on the Budget broadcast) and can provide up to 7.15 seconds delay in 7 ms increments. Their DN60 real time spectrum analyser was also working in conjunction with the RT60 reverberation analyser to display decay curves for "wide-band" or any one of 30 third-octave bands.

*Nagra-Kudelski* (Switzerland) finally unveiled their new baby, the Nagra T-Audio "transportable studio" tape recorder. This is not so miniscule as the traditional Nagra battery portables, but is still amazingly compact at 16.7 by 16.5 by 10 inches. The performance and features list is formidable: it will take up to 11.8-inch reels, runs at four speeds with  $\pm 6$  percent variation, has three skip speeds in both directions, twin-capstan open-loop drive, detachable remote control and a frequency response of 30-20,000 Hz  $\pm 1$  dB and wow-and-flutter of  $\pm 0.02$  percent at 15 ips (see my visit report at the end of this survey). *Neumann* (West Germany) featured their latest VMS80 automated disc-mastering lathe and full range of microphones. But their new line was a Type N20 modular mixing console system based on 0.8-inch wide channel strips.

*Neve* (UK) had decided not to transport their DSP (Digital Signal Processing) console to Montreux since it is in continual demand for demonstration to clients back in England. Even so, their large demonstration room allowed hands-on trials of at least three examples of different analogue mixer ranges—a 32-channel version of the Neve 8128 multi-track music console, a 24-track 36-channel version of the Neve 51 series of broadcast consoles, and a new Neve 5322 on-air broadcast stereo production console. *Sennheiser* (West Germany) had added a new SKM 4031 wireless microphone to their range, and built-in noise reduction circuitry was demonstrated. Solid State Logic (UK) continue to expand the versatility of their 4000E computer-controlled console, with new single-word keys like PRESET, SEQUENCE and EVENT added to their keyboard. The dynamic mixing system has a real-time memory for fader levels and can simultaneously control up to 40 external voltage-controlled devices. *Soundcraft* (UK) had a new flagship console, the automation-ready Series 2400, in 25/16 and 28/24 versions with bargraph metering to include a 27-band 1/3-octave spectrum analyzer. *Stellavox* (Switzerland) are best known for their tiny SP-8 battery-operated recorder weighing just 17½ lb, but they also showed the TD88 modular studio machine having top-quality specifications and facilities.

*Studer* (Switzerland) were giving impressive demonstrations of their prototype digital tape recorder and SFC 16 digital sampling frequency converter. Analog was not forgotten, however, and they attracted a good deal of attention with their 'super analog' ½-inch version of the A80 recorder and new A810 programmable machine giving the ultimate in remote control of all functions.

## A VISIT TO NAGRA

The programme of technical tours at Montreux included visits to Studer-Revox and Nagra-Kudelski. Since I had recently been to the Studer plants (see my report in the January issue), I joined the coach-ride up into the mountains above Lake Geneva where the four small Nagra factories are located.

Two points of similarity with the Studer operation became obvious. First, both companies were founded and are still dominated by a visionary perfectionist who demands precision and reliability in his products—and who shuns publicity. Both Willi Studer and Stephan Kudelski are famous for avoiding public occasions, and on each of my visits the "boss" appeared (almost reluctantly) dressed in a lab coat. Of course they could not ignore an AES Convention on their doorstep, and both attended the Awards Banquet where Willi Studer was presented with the AES Gold Medal.

The other point of similarity was in the decidedly old-fashioned approach to hand assembly of recorders in very small quantities—though the most sophisticated data-controlled multiple metal-working machines were in use everywhere. Nagra make practically everything except electronic components in-house, from nuts to tape-heads. Every product



*The new Nagra T-Audio tape recorder.*

is under continuous update and I was shown how to interpret the batch and revision codes included in the serial numbers. Computers not only control the presses and store all data: they also perform very complex text programmes on each machine. I was handed the computer printout at the end of one test sequence on a Nagra 4.2 recorder. It shows a frequency plot easily within 50-20,000 Hz,  $\pm 0.5$  dB and is almost dead centred between the tolerance tram-lines. Distortion is shown as 0.18 and 0.12 percent for second and third harmonics respectively—again well below the tolerance limits.

Stephan Kudelski is of Polish emigrant parentage (Nagra means "recorded" in Polish) and was a student in Switzerland in 1948-50 when he designed and built a small, battery-operated tape recorder of high quality as part of his university thesis. Reporters and other users were immediately interested and the company was formed shortly afterwards. By 1953 the Nagra II was in production, followed by the fully-transistorised Nagra III in 1958 and the Nagra IV in 1968. The annual production of recorders rose from 240 in 1958 to 1,500 in 1962 and is now about twice that figure. Amazingly, most of the Nagra recorders since the Mk. III are still in use, and spare parts are still available to provide the Nagra "rebuild" service to customers. I saw a bench of motors on "whole life" test, in which they are run continuously until they fail: the oldest date I could decipher was 1971—and still running 24 hours a day!

One aspect of Nagra diversification since 1977 has been Nagrafax, a data recorder capable of sophisticated electronic facsimile display or hard-copy printouts. One model was in continuous use in the factory reception hall producing printouts of weather satellite photographs and contour diagrams on a map of Europe. We were told that the results were so good that, if a cloud was shown in the Geneva area, you could walk outside and see it for yourself.

I was intrigued as I walked around the plant to see capstans and tape-head carriers that I could not recognise as being part of the trusty Nagra IV audio recorder. Then it slowly dawned on me that I was seeing the component parts of some videotape development not yet announced. Of course Stephan Kudelski has always devoted a large part of his inventive genius to meeting the needs of the film industry—his Neopilot synchroniser system is an industry standard, and Nagra recorders are to be seen on very many location filming sessions. In whatever direction the film-versus-video power struggles develop or video fashions change, I am certain that the Nagra-Kudelski talents for inventive design and traditional Swiss precision will be in there playing a vital role. On the subject of digital recording, Mr. Kudelski told me, "We have demonstrated digital to some of our customers, but for some reason they seem to prefer our analog quality—up to now." ■

# The Microphone Museum

*The following photo-essay features patent drawings and photos from Bob Paquette's renowned Microphone Museum....*

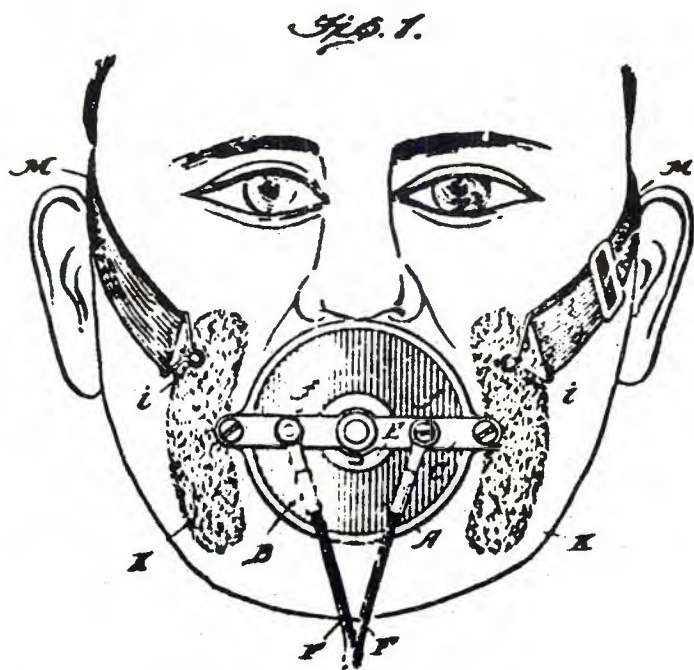

Figure 1. Patent drawing and photo of a Magnavox close-talking microphone.

"...a telephone transmitter designed and adapted for use in situations where it is subjected to extraneous sound waves as contradistinguished from vocal sound waves...The transmitter is adapted to be held close to the face of the user with the diaphragm spaced a suitable distance in front of the user's mouth by...face-engaging pads resting against the user's face at each side of the mouth only... Figure 1 is an elevation showing a transmitter embodying the present improvement held in place by a strap or band passing around the head." (excerpted from patent 1,332,873 — March 2, 1920.)

**I**N MILWAUKEE, WISCONSIN, Select Sound Service offers sales, service, installation and rental of pro audio hardware. Included in the product line are the latest microphones from Shure, Electro-Voice and others.

Also on hand—but definitely *not* for sale—are more than 600 microphones built during the first 50 years of this century. For the Select Sound Service building is also the home of owner Bob Paquette's Microphone Museum. The Paquette collection is a frequently-tapped resource for exhibits at the Smithsonian Institution in Washington, and other museums throughout the country. Some 30 of his microphones are currently on display at New York's Museum of Broadcasting, and countless others have been seen in movies set in the pre-'50's era. In addition, Paquette is a frequent guest at SBE and amateur radio club meetings, where he presents a 140-slide show on the history and evolution of the microphone.

It all began more than 30 years ago, when Bob Paquette was

working for Western Sound & Electric Laboratories—a Milwaukee sound contracting outfit. At the time, the company was frequently called upon to update sound systems that had been installed during pre-World War II days. What with wartime parts shortages, many of the microphones that the company removed from service were good for little more than the junk heap. Nevertheless, Paquette held onto a few of the more intriguing models, and thus his collecting began. Today, his Microphone Museum probably houses the largest collection of early microphones in the country.

On the following pages, we present some representative examples from the collection. Needless to say, Paquette is always on the lookout for additions to the museum, and would be delighted to hear from **db** readers with old mics in the closet. Of particular interest are old high-power microphones, and early Western Electric cylindrical condenser microphones. ■

# "Lexicon's PCM 41 digital delay

gives a crisp sound that I can't get with my regular tape echo." "The chorus effect alone makes it worth sharing on stage." "PCM 41 and Model 224 Digital Reverb enhance the sounds I can obtain from my instrument as well as providing a multitude of special effects on stage and in studios." "They've become an integral part of my sound." Thanks Lexicon!

**Steve Morse**  
songwriter, producer, artist  
"The Dregs"



If you'd like to learn more about Lexicon digital delay products for all musicians contact Lexicon, 60 Turner Street, Waltham, MA 02154 (617) 891-6790 TELEX 923468

## lexicon

Circle 24 on Reader Service Card

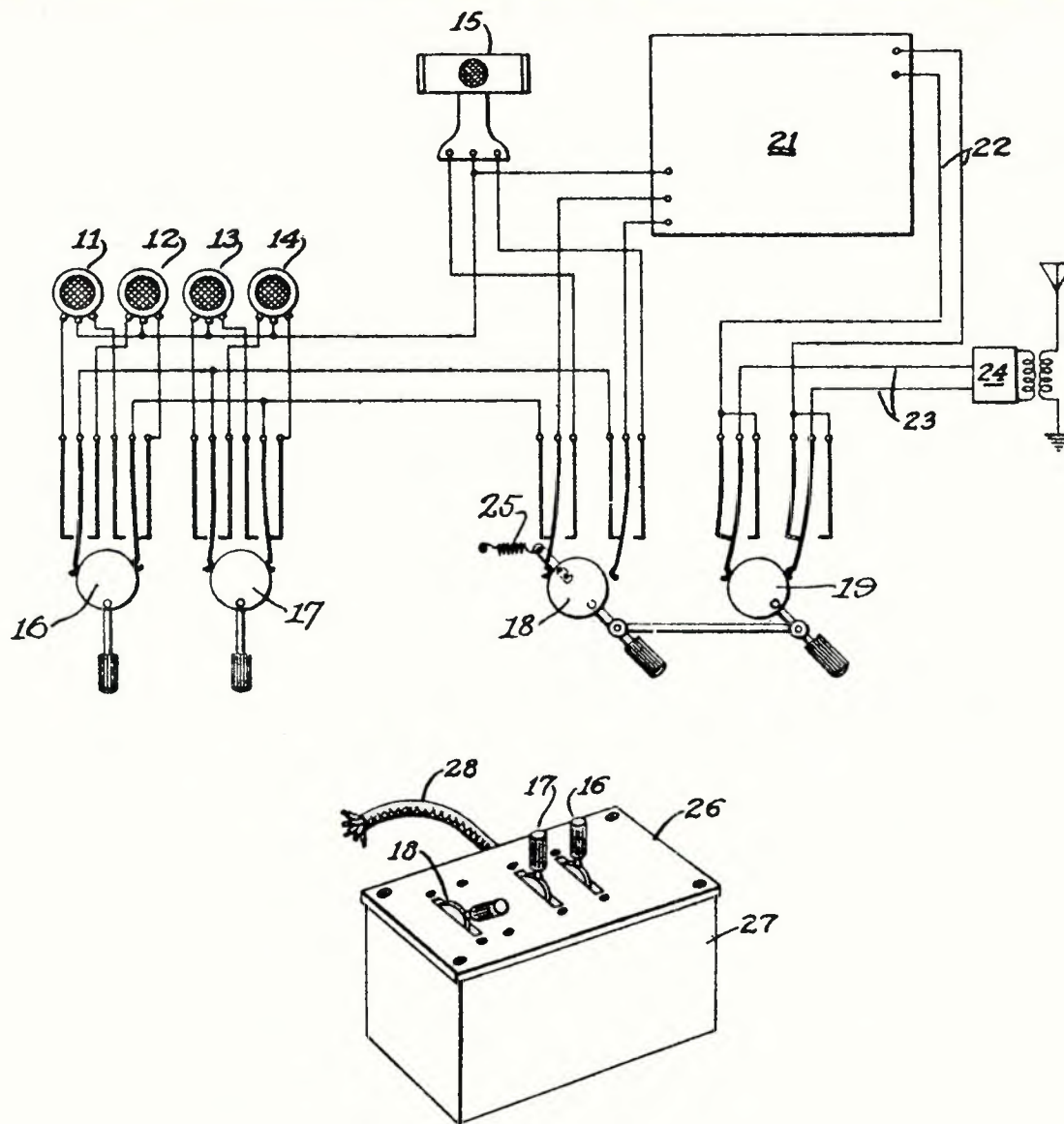

Figure 2. An early console?

"My invention relates to sound reception systems, and more particularly to sound reception systems for response to a variety of sounds in which several different types of microphones are used for response to the different types of sounds.

"An object of my invention is to provide a sound reception system adapted for use with a plurality of microphones of different characteristics and a thermionic amplifier.

"Another object of my invention is to provide a sound reception system suitable for use in locations where it is desirable to obtain a sound translation of diffused sounds and at intervals to obtain a sound translation of the voice of a speaker only in the midst of such diffused sounds." (from patent 1,696,897, issued to Joseph E. Aiken and assigned to Westinghouse, January 1, 1929.)



Figure 3. An improved "Acoustic Aparatus"; the Western Electric double-button carbon transmitter.

"In its preferred embodiment, the diaphragm is made of an aluminum alloy, such as duralumin, having a thickness of approximately .0017" and tuned by stretching it to a period of about 6000 cycles per second. The transmitter...will deliver 25 times the energy to an output circuit of given impedance that one having a steel diaphragm .003" in thickness will deliver." (from patent 1,611, 370, issued December 28, 1926.)

Around the world,  
the choice of  
professionals is the

# AUDIO SIGNAL DELAY.

From Westminster Abbey to performing arts centers such as Wolf Trap Park and Ravinia Festival, the Superdome and the Contemporary Hotel, Disney World, the digital AUDIO SIGNAL DELAY from Industrial Research Products has meant *PERFORMANCE* in these demanding facilities and many more!

## ANNOUNCING . . . DF-4015

The NEW DF-4015 Digital Delay has the performance, reliability and flexibility that made the Audio Signal Delay the standard since the early 1970's, and is the most versatile model yet with even lower noise and distortion.

Check these outstanding features:

- 1, 2, 3 or 4 outputs
- 192 ms in 3 ms increments
- Thumbwheel delay setting
- Greater than 90 db dynamic range
- Compact 1 3/4" x 19" rack mount chassis
- Security panel
- Transformer isolated in and out



Contemporary Hotel,  
Disney World



Westminster Abbey



Ravinia Festival



The Superdome



Model DF-4015



Wolf Trap Park

For more information,  
CALL OR WRITE TODAY

**INDUSTRIAL  
RESEARCH  
PRODUCTS, INC.**

A Knowles COMPANY

321 Bond Street  
Elk Grove Village, IL 60007  
312-439-3600

Circle 25 on Reader Service Card



Figure 4. The W. E. Kellogg model 501 double-button carbon microphone.



Figure 5. A collection of early Westinghouse microphones. From left to right: glow discharge, push-pull condenser, standard condenser, double-button "tomato can," and a double-button carbon mic in a special desk stand.



Figure 7. An RCA prototype ribbon microphone, circa 1931.



Figure 6. Condenser microphones, circa 1928. A General Electric microphone built for RCA and the Westinghouse model 47A.



Figure 8. A Western Electric Shotgun microphone, circa 1937.



## Now Technics lets you hear nothing but the sound of the source. Introducing the SV-P100 Digital Cassette Recorder.

No tape hiss. No wow and flutter. Not even head contact distortion. With Technics new SV-P100, they no longer exist. The result—*אין שום דבר* you listen to the actual music... the source, not the tape or the tape player.

Utilizing the Pulse Code Modulation (PCM) digital process, the SV-P100 instantaneously translates musical notes into an exact numerical code, stores them on any standard VHS cassette, then "translates" them back into music on playback. Duplicate tapes are exactly the same as the original. Thus, every recording and every copy is a "master."

The revolutionary size of the new Technics SV-P100 recorder (17" x 11" x 10") is the result of state-of-the-art semiconductor technology. The built-in videotape transport mechanism brings the convenience normally associated with conventional front-loading cassette

decks to a digital application. Tape loading is now fully automatic. And, frequently used controls are grouped together on a slanted panel with LED's to confirm operating status.

Despite its compact size, the SV-P100 recorder offers performance beyond even professional open reel decks. Since the digital signal is recorded on the video track, the space usually available for audio can therefore be used for editing "jump" and "search" marks. The unit employs the EIAJ standard for PCM recording. And, in addition, editing and purely digital dubbing are easily accomplished with any videotape deck employing the NTSC format.

Technics new SV-P100 is available at select audio dealers. To say that it must be heard to be appreciated is an incredible understatement.

**Technics**  
The science of sound.

Circle 26 on Reader Service Card

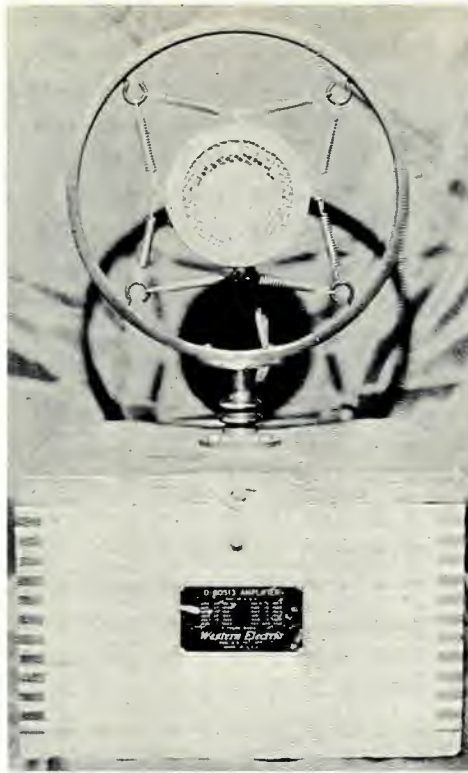

Figure 9. A 1924-vintage Western Electric condenser microphone, spring-mounted within a ring on top of the microphone preamplifier.



Figure 10. Part of Bob Paquette's microphone collection, on display at Select Sound Service in Milwaukee.



Figure 11. "...An improved microphone for use in connection with the transmission of announcements of public events." (from patent 1,678,842 issued to Joseph E. Aiken.)



*John Stronach started out as a classical pianist and a rock 'n roll drummer. Today, he's a producer/engineer. In fact, he's been a part of the record business since he was sixteen years old. His sixteen years of experience have included work with Diana Ross, The Supremes, the Jackson Five, Bobby Darin, Sammy Davis, Sarah Vaughn, Canned Heat, Alvin Lee, Three Dog Night, John Mayall, Rufus, Jo Jo Gunn, Dan Fogelberg, Joe Walsh, REO Speedwagon and more.*

### **ON BREAKING IN**

"As far as recording engineering schools, those things are great for teaching you fundamentals, but don't be spending a lot of money on that. There are people who spend thousands of dollars learning how to be a recording engineer, and they still start as a go-for, which is the same way everybody starts. It's nice to have that behind you, but I don't know. I don't know that it does all that much good. The best way to learn is by doing."

### **ON REPETITION OF STYLE**

"I've seen it ruin people's careers. You can't use the same production style all the time. What works for one group of songs won't necessarily work for another. You have to remain flexible enough to change your production techniques as the music changes."

### **ON TECHNOLOGY**

"A lot of producers and engineers are real spoiled with all this technical gadgetry and wizardry and all the things we can do now. They forget about the music, and the music is the thing we are here for. That's what you have to keep in mind all the time."

### **ON TAKING OVER**

"The producer is there to help. It is not a dictatorial thing. A lot of producers get into a situation such as 'You are going to do it this way,' and it turns out to be the producer's album, not the band's. And I don't think that's fair to the band. It's their music. The act must be able to retain their identity and not just be a vehicle for the producer."

### **ON PLAYING AROUND**

"In today's world, you have to be real businesslike. It's not like the early 70's, where everybody comes in and has a big party. You have to work within budgets, and you have to show up on time. I bring that consistency, and I try to bring a stability to the bands, so they know that they can be as creative as they want, but yet know that they can get a lot of work done and relate with the labels and management and just tie everything together."

### **ON TAPE**

"I used another tape for a time and switched to 3M, because I would make twenty passes and all of a sudden, you would be able to see through the other stuff. They had a bad shedding problem. I just couldn't trust it any more."

"Here at the Record Plant, we give our clients any brand they want. But I recommend to people that they use the 3M, and especially the 226. Their consistency and quality is better. It just doesn't get real good and then drop to bad. You just know that it's going to be okay all the time. You don't have to worry about it. Which is important when you're out there and you're trying to get that magic take."

**SCOTCH 226  
WHEN YOU LISTEN FOR A LIVING.**

# JOHN STRONACH ON TAPE.

Magnetic A/V Products Division/3M  
"Scotch" is a registered trademark of 3M.

3M hears you...

# 3M

Circle 27 on Reader Service Card

# Notes on Microphones

Presenting a number of "selected short subjects," in which some prominent microphone manufacturers bring us up-to-date on work in progress, and some old and new approaches to mic usage.

JOHN PHELAN

## MS Without Pain

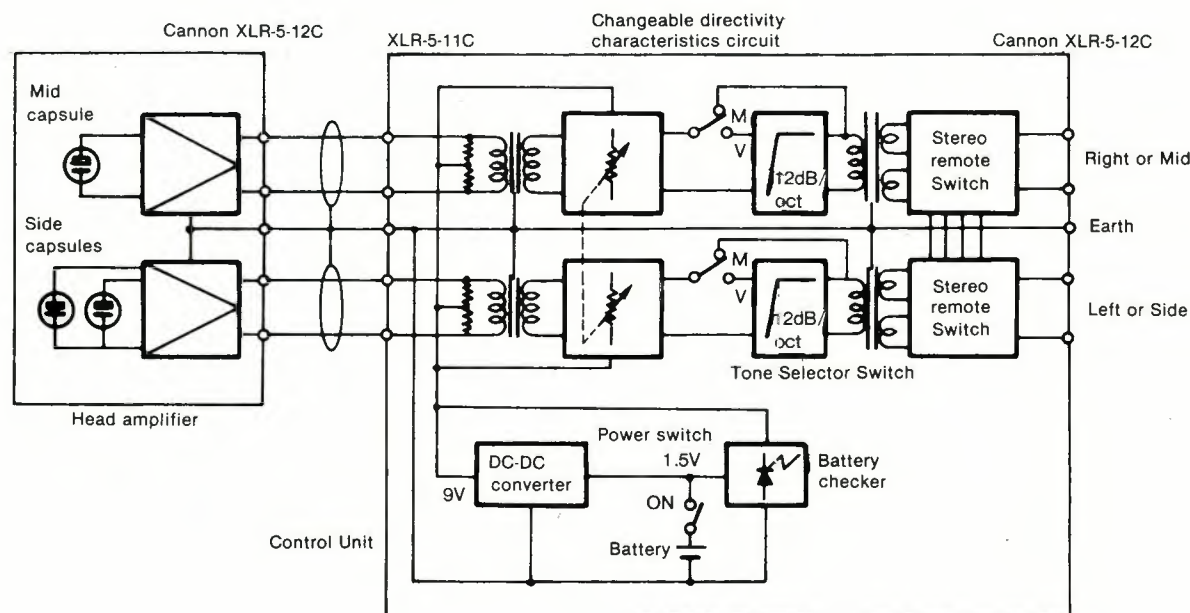

Block diagram of the ECM-989.

**M**AKING TOP-QUALITY location recordings has always been the ideal of recording engineers, particularly those who want to expand their work beyond the confines of a small studio. But how to make professional stereo recordings with minimal equipment and set-up can be a problem.

One of the easiest ways of making a good location stereo recording is to use one of the following two-microphone setups:

- X-Y—two cardioid microphones at an angle of 135 degrees; coincident spacing.
- ORTF—two cardioid microphones at an angle of 110 degrees; 7 inch spacing.
- NOS—two cardioid microphones at an angle of 90 degrees; 12 inch spacing.
- Stereosonic—two bi-directional microphones at an angle of 90 degrees; coincident spacing.

- MS (Mid-Side)—one cardioid and one bi-directional microphone; the cardioid faces forward; the bi-directional faces left/right; coincident spacing.

Of these, the X-Y and MS are the most popular. The MS is gaining in popularity for two reasons: manufacturers are now making MS (Mid-Side) equipment at reasonable prices; and the MS stereo effect tends to give a more even stereo image. The "hole-in-the-middle" phenomenon does not crop up in the MS stereo.

As with any set-up that has more than one part, repeatability is a major factor. To get the same stereo image—time after time—the exact angle and spacing must be achieved at every use. With two microphones on a stereo stand, this can at best be tricky. A better way to achieve repeatability is to use a single microphone that's only purpose in life is to allow repeatable MS stereo setups.

The stereo MS mic is a remarkably versatile device which can be used in a wide variety of recording situations. In combination with a good portable recorder, it becomes a miniature

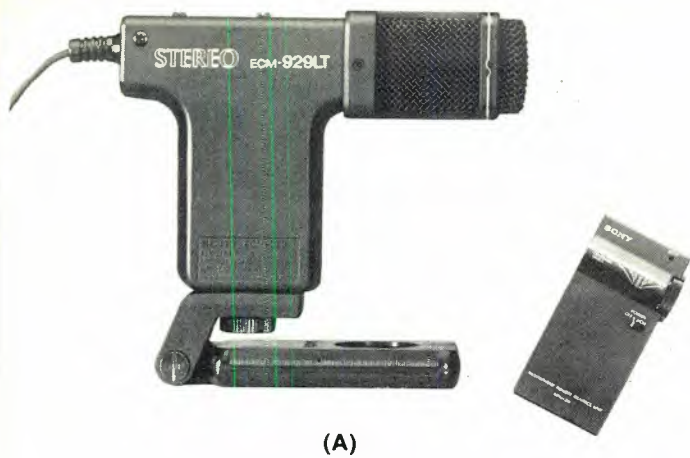

(A)

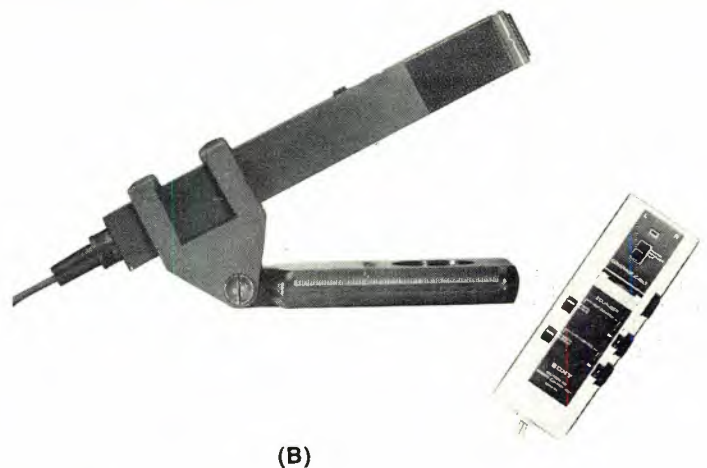

(B)

Three recently introduced microphones from Sony; A) the ECM-929LT MS microphone and MRU-60 remote control unit; B) the ECM-939T MS microphone and MRU-90 remote control unit; C) the ECM-989 MS stereo microphone.

studio for location work, from the recording of a small musical combo to choral groups and large orchestras. The microphone is also useful for studio work where the variable stereo characteristics allow convenient changes in the image and ambience.

Sony has recently introduced three low-to-medium priced MS microphones which should make it easy for studios without unlimited budgets to begin using this increasingly popular recording format. At the top-of-the-line, the lightweight ECM-989 features a two-part docking design enabling the capsule unit to be separated from the power supply and directivity controls by up to 100 meters, to achieve even lighter weight and greater mobility.

The capsule system contains three identical cardioid elements; one facing forward for the mid (M) position and the remaining two operating back-to-back as a bi-directional

### THE BLACK ELECTRET ELEMENT

In the Sixties, Sony began to employ electret properties in practical microphone configurations. Further research led to the development of the back electret design which is employed in these microphones. In conventional condenser microphones, a thin polyester film, four to six microns in thickness is used. This thin film often cannot be used in electret condensers, because it has rather poor characteristics as an electret material. A technique was developed to adhere the electret material to the backplate of the microphone, eliminating the need for the electret material to vibrate. Instead, a gold-evaporated polyester film (thinner than the electret film) vibrates, and the electret material adhering to the backplate of the microphone converts the sound vibration to electrical energy in the same manner as in ordinary electret condenser microphones.



(C)

capsule for the side (S) pickup. This obviates the need to try to match the characteristics of differing cardioid and bi-directional microphone elements. The matrix circuitry takes the bi-directional S signal and combines it with the uni-directional M signal to produce the separate left and right channels. The signals are combined through the matrix, buffers, and a potentiometer varies the amount of signal coming from the mid-capsule and the bi-directional capsule configuration.

The directivity control adjusts the relative gain of the mid and side capsules so that the pattern characteristics can be adjusted to suit the width of the sound source. A detent is provided at 120 degrees, which is generally considered the optimum stereo pattern.

The advantages of back-electret design include improvement of low frequency response, better directivity, and less mass which improves transient response over the entire frequency range. Additionally, the electret characteristics become more stable, since the surface charge of the electret material is completely shielded by the metal layer of the diaphragm.

The versatility of MS stereo makes it a wise choice for the person who is presented with constantly changing recording situations. Perfect for the studio that is also involved with location work, the college program where experimentation is encouraged, or for the individual who requires a highly portable and professional stereo microphone, the MS microphone is indeed a microphone for many jobs. ■

# An Advanced Microphone Evaluation Technique In Use at Electro-Voice

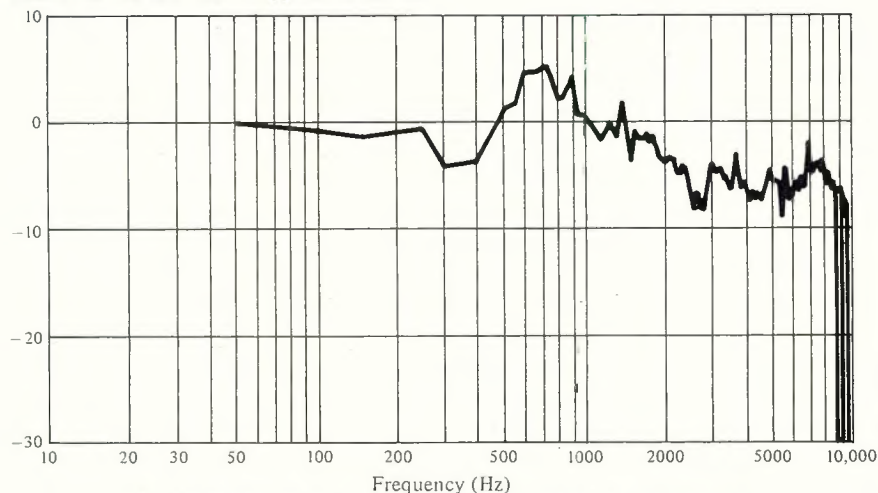

*An FFT-generated frequency response of a quarter-inch windscreen-protected B&K microphone in classic "lavalier" position (off chest), referenced to its on-axis response with the same vocal input.*

**T**HE HUMAN EAR/BRAIN combination can resolve differences in microphone performance far beyond the resolution of conventional testing techniques. In order for a conventional testing method to produce a meaningful response, the response of the test source must be known, and repeatable. For example, to determine a microphone's frequency response in the laboratory, a swept sinewave is used to drive some sort of speaker system. By comparison, the human ear uses a musical signal, or other suitable acoustic input, for its evaluation. The swept sinewave test evaluates a microphone's response to a swept sinewave from the test speaker system; on the other hand, the human ear establishes how the microphone responds in an actual use situation. Since these listening tests often disagree with conventional laboratory evaluation techniques, a means has been sought to establish a repeatable testing approach that will supply detailed comparative data that is consistent with listening-based tests.

## FFT

The Fast Fourier Transform analyzer (often called an FFT) is a relatively recent technological development which removes the restrictive requirement of a repeatable simple source, thereby eliminating the primary weakness common to virtually all conventional techniques. An FFT can take a complex input consisting of a series of spoken words, a musical passage, a gun blast, the tap of a finger, etc., and via an electronically-made mathematical calculation produce a frequency response consisting of the relative amount of each frequency present in the input. For example, consider two microphones exposed to the same input. One is a small calibrated condenser reference microphone and the other is a microphone under test. A frequency response of the test microphone can be obtained by charting the difference between the resulting FFT-generated response curves. In this case, the reference microphone is assumed to be perfect, so an absolute duplication of its response by the test mic would yield a straight-line frequency response.

By employing a microcomputer to chart the difference in response produced by a two-channel FFT, Electro-Voice has been able to document microphone performance with a resolution approaching that of a trained human while providing far greater useable information. For example, for years the proximity effect has been measured by employing an

artificial voice and swept sinewave excitation. While this technique clearly displays the proximity effect, listening tests have suggested that the results are incorrect. The FFT test is based on human-generated speech and produces results that agree with listening-test data. It is felt that the primary weakness of the artificial voice is its inability to duplicate the complexity of the human vocal system. For example, the artificial voice generates all of its sonic energy at the same distance from the microphone, while a human generates lower frequencies at the vocal cords and higher frequencies via air flow in the forward part of the mouth.

Electro-Voice is currently employing FFT-based testing in a variety of ways to establish a data base that can be used to develop totally optimized microphone designs. The following is a sample of the tests currently being employed to improve our understanding of microphone operation:

1. Human-generated frequency response relative to a standard condenser microphone.
2. Comparison response of two microphones using human or musical inputs.
3. Positional response of microphones; for example, analysis of the "lavalier effect" and the effect of close-versus-distant miking.
4. Relative handling noise response to evaluate shock-mount effectiveness.
5. Relative "P-POP" and wind noise response to evaluate wind screen effectiveness.
6. Miking technique comparison tests; for example, simple-versus-multiple microphones.
7. Evaluation of microphone coloration phenomena; for example, the microphone-generated phantom "S" sound resulting from the interaction of air flow and metal microphone screens.
8. A categorization of human vocal characteristics with regard to primary vocal resonance points and the complex harmonic patterns that differentiated voices.

## CONCLUSION

In the past, a significant improvement in measurement technology has usually spurred a wave of equally significant product advances. Future microphone designs will undoubtedly be improved in a similar fashion as the wealth of microphone performance data obtainable via the intelligent use of an FFT is acted upon by microphone designers and users. ■

*Alan Watson is chief product engineer/microphones at Electro-Voice, Inc.*

# The Ribbon Microphone Revisited

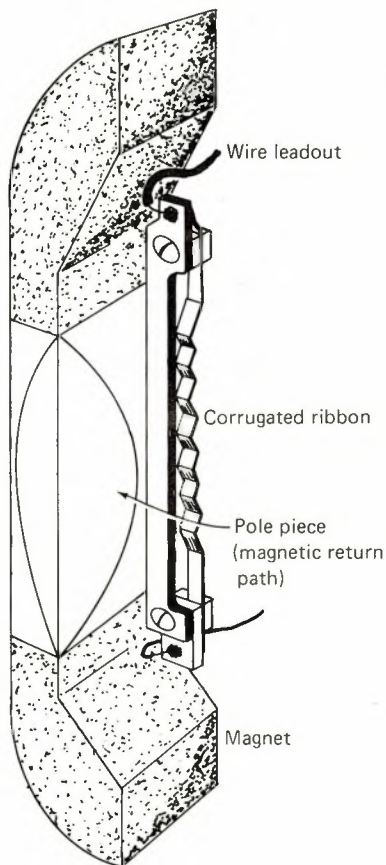

Figure 1. Cutaway view of a dynamic ribbon microphone. (reprinted from *The Microphone Handbook* by John Eargle.)

**T**HE RIBBON MICROPHONE operates by suspending a strip of aluminum between two permanent magnets. When an air-pressure differential occurs between the front and rear of the microphone, the ribbon moves within the magnetic field, generating a low-level alternating current flow across it.

Since its introduction in the early 1930s, the structural design of the ribbon microphone has been improved greatly. Yet, the basic technology remains very much the same.

The early advantages of the ribbon design were: accurate sound reproduction, uniform extended frequency response, and an excellent polar response throughout the frequency range. Since the ribbon element was (and still is) extremely

light, it was able to overcome inertia and track transients better than its moving-coil counterpart. The resulting sound was extremely clear and transparent, with a crisp mid- to high-end, and a warm, natural low-end, making it a popular choice for studio recording and broadcasting.

However, inherent in the early ribbon designs were some disadvantages that prevented its use as an on-location or hand-held microphone.

First, the ribbon was extremely delicate and had a tendency to become deformed at the slightest burst of wind. Vocalists generating those problematic "P popping" sounds would quickly put the microphone out of commission. Hence its long-time reputation as a fragile microphone, to be used *only* in a controlled studio environment. Most live applications were out-of-the-question.

*Robert Lowig is a sales engineer with Beyer Dynamic.*



*The ribbon mic has played a prominent role in the history of microphone design. Note the four ribbon microphones among these six early RCA mics. Top row, left: an early condenser type—1928; Center: an early modern ribbon microphone (velocity type)—1930; Right: The 44-BX velocity mic—1932. Bottom row, left: the model 50-A pressure type mic, first in the line of induction mics—1933; Center: the type 77-A universal (ribbon) microphone, forerunner of the present day 77-D—1936; Right: the 88-A pressure type mic.*

Secondly, in order to generate a usable output level, the ribbon and its accompanying magnetic structure were of a size and dimension that necessitated a large and bulky enclosure—making it unwieldy as a hand-held microphone. The early designs also lacked a system to isolate the ribbon element from the casing, and so the noise of handling the microphone was reproduced through the transducer at undesirable levels.

With the development of more reliable and rugged moving-coil microphones, the early ribbon designs were seen less and less in the contemporary recording studio. However, there have recently been advancements made in ribbon technology and design that have solved most, if not all, of the limitations of the original ribbon design.

Advances made in magnetic materials have enabled engineers to decrease the size of the microphone's magnet structure and yet still maintain a very high magnetic flux density level. This was the first step in decreasing the bulky size of the original designs. The second step was to reduce the size of the ribbon itself. Since the new magnets had a higher flux density, the size of the ribbon could be decreased without adversely affecting the output level. In fact, the newer ribbon designs, although smaller, actually generate higher output levels. This system could now be placed in a ball-type microphone with a cylindrical barrel, as seen in FIGURE 1.

Thirdly, the smaller ribbon is more durable, and in conjunction with an integral blast and pop-filter, is better able to withstand high-SPL "P popping" and the rigors of the road.

Lastly, a suspension system, isolating the ribbon and magnetic structure from the barrel and casing is now possible, cutting down the hand-held noise to a bare minimum.

In another advancement, a double-ribbon system has been developed and is now in commercial use. Engineers have found that by suspending two strips of aluminum, one on top of another and a fraction of an inch apart, non-linear distortion is decreased considerably. This particular design is now widely used in studio applications where the demands for accurate reproduction are paramount.

These advances in design have re-established the ribbon microphone as an integral part of the audio reproduction chain in our industry today.

Recently, newer microphones have been designed that embody the best features of both the ribbon and moving-coil elements. Such microphones utilize new polycarbonate materials as diaphragm elements. They are extremely light in weight, flexible, and yet uncommonly durable. This polycarbonate material, coupled with hair-thin coil wire, is able to track transients much like that of a ribbon, but being a moving coil, its durability surpasses even the strongest ribbon microphones.

Even so, whatever technological advancements are made in microphones, ribbons will always be an integral part of the audio reproduction chain. They are loved by many for that unique "ribbon sound" property, and have earned their place as a great microphone in the electronic industry. ■

# The Calrec Soundfield Microphone System

The Soundfield capsule array provides four supercardioid outputs (the A-format signals) and these are used to derive the B-format signals, W, X, Y, & Z. These represent:  
 W—Omni-directional pattern,  
 X—Bi-directional pattern (front-to-back),  
 Y—Bi-directional pattern (side-to-side),  
 Z—Bi-directional pattern (up-and-down).

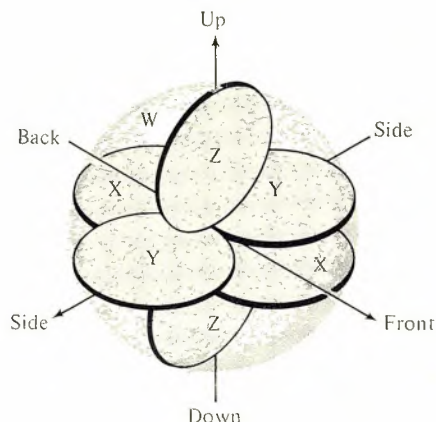

**T**HE CALREC CM 4050 Soundfield Microphone consists of four hypercardioid capacitor capsules arranged in a regular tetrahedron so as to detect the soundfield at the surface of the sphere. The signals derived from the four capsules are known as A Format signals.

The capsules are mounted as close together as possible while subsequent electronics located in the A/B matrix module of the control unit produce truly coincident signals up to 11 kHz with limited divergence above this frequency.

A 12-wire single-screened cable is used to connect the microphone to the input module of the control unit. The input module has a switchable 10 dB attenuator for use in very high sound levels while four capsule mute buttons allow capsule checking.

Within the A/B Matrix Module, various combinations of the A Format signals are used to produce the four B Format outputs which are available to the user for recording and/or further processing. The B Format outputs are shown in FIGURE 1.

The B Gain Module follows: this is a four-gang level control of the B format signals, both to the main set of B Format outputs and to the subsequent modules.

The B Monitor Module receives the B Format signals from the B Gain Module and feeds them without active circuitry to the Tape Record Outputs. A Test pushbutton substitutes a line-up tone. The B Format signals are also passed to the subsequent Control Unit Modules, except when the Tape button is pressed. In this case, B Format signals are recorded directly on tape. Later on, these B Format replay signals are passed on to the subsequent modules for Post-Session processing.

## B-FORMAT PROCESSING

The Soundfield 1 Module allows the Azimuth and Elevation controls to process direct or taped signals.

The Soundfield 2 Module allows the appropriate Dominance to be chosen via the Up/Down or Front/Back switches. The dominance control modifies the effective directions or arrival of sounds and also their loudness. Compensation is provided such that the ratio of the energy in the velocity of the signals to the energy in the pressure signal remains unchanged, although a use of the control is to emphasize a particular direction and/or to de-emphasize others so that an apparent change in program level is usually heard.

The Mono/Stereo/Quadruple Module selects the microphone type to be synthesized from the B Format signal in Stereo/Mono and into Quadruple. The angle between the synthesized stereo pair or quad pair can be varied from zero (pointing in the same direction) to 180 degrees (back-to-back).

*Nigel Branwell is vice president of Audio + Design Recording, Inc.*

The Polar Pattern can be varied from omni-directional to figure-eight and *all* intermediate cardioid positions.

The Output Module contains a Level Control, Output Selector, and Loudspeaker Layout Control for the Ambisonic Decode Positions and fields the X (LB), W (LF), Y (RF) and Z (RB) output sockets.

In the Stereo/Mono mode, the LF and RF outputs are only used for "double" Mono or Stereo, both with Azimuth, Elevation, Pattern and Angle control facilities available. In the Quadruple, four cardioid microphones are synthesized for LB, LF, RF, and RB.

The Ambisonic Decode processes B Format signals from the microphone or Tape Replay inputs to produce loudspeaker feeds for horizontal surround sound—azimuth, elevation, dominance are operative, but capsule angle and pattern are inoperative. The decoder has shelving filters to optimize psycho-acoustic performance, and is designed for four loudspeakers two to three meters from the listening position in a rectangular layout.

The LS Layout control varies the signal to suit rectangular layouts of various aspect ratios. In the B Format mode, a full B Format output is available with the extra facilities of Azimuth, Elevation, and Dominance. This B Format output can be used in dubbing already-recorded B Format material where modification is needed, or while recording if it is felt necessary to use the Azimuth, Elevation and Dominance controls in this condition. The Level knob controls all four output signals in all modes and tracks accurately over a 30 dB range.

In summary, the Soundfield Microphone consisting of four capsules in a tetrahedral array with electronic compensation to remove the effects of capsule spacing, is designed to accurately capture the sounds that exist at a point in space. It may be used for mono and stereo as well as surround sound; its directional characteristics can be steered electronically from a remote location. By storing the Soundfield Microphone's signals in B Format, optimum recordings may be issued not only in Mono and Stereo, but in Surround sound, or later, even Periphonically (with height).

A fuller discussion of Ambisonic Recording and Reproduction will follow at a later date, but suffice it to say here that its supporters feel the process is far superior to discrete Quadraphony. It is hoped that Ambisonics will be of particular interest for the new media of digital discs and digital satellite broadcasting. These new media are able to handle four periphonic signals of full audio bandwidths. In the case of AM/FM broadcasting, a 3-channel Ambisonic (surround sound) signal can be transmitted with the additional third channel carried in a stereo multiplex signal by an additional modulation of the sub-carrier. Whether reproduced in Mono, Stereo, 3-Channel, or even 4-Channels, all are compatible.

# The NAB Convention

*Our intrepid editor journeyed to the NAB Convention looking for answers, but instead returned with a lot of questions.*

**F**OR NAB CONVENTION WATCHERS (and the industry in general), the good news is that high-quality audio is attracting more and more of the broadcasters' attention. In fact, even the video folks are beginning to acknowledge that there may be life below 20k.

Of course, there were some notable hold-outs. At the Kodak booth, a sophisticated A/V display featured spectacular color slides, a cleverly-executed "live" computer-automated interactive video cartoon character, and possibly the worst mono audio sound track this reporter has heard in a very long time. Unfortunately, the Kodak folks didn't seem to notice, although at least some of the audience was seen to be squirming.

The bad news is the Federal Communications Commission. A convention panel discussion of AM stereo reveals that the Commission's recent non-decision isn't doing much to bring about a fast resolution of the five-sided systems argument. (For more about the non-decision, see Len Feldman's Sound With Images column, in this issue.)

In fairness, we really can't blame the entire situation on the Commission (but it's tempting), since there is the usual industry problem of almost-simultaneous development of rival (and of course, non-compatible) systems, all vying for a share of the marketplace.

Marketplace skirmishes are nothing new. Remember the almost-coincident births of the 33 $\frac{1}{3}$  and 45 rpm records some years ago? After an initial period of confusion, the slower speed was reserved for albums, while singles were cut at 45. The marketplace preferred its albums on one 12-inch (33 $\frac{1}{3}$  rpm) record, and simply didn't accept those early multiple-disc (45 rpm) album sets.

VHS and Beta format videocassettes are another obvious example of rival non-compatible systems competing for acceptance. Eventually, one of these may fade from the scene, depending on the wishes expressed in the marketplace.

Would we all have been better off with just one system—right from the start? Well, it certainly would have been less confusing, but we probably profit in the long run by having rival manufacturers slug it out in the marketplace. Each tries to come out on top, by building a better product than the competition. Eventually, the truly superior product is identified, and the





Figure 1. Ampeg UNISYN can lock up to 16 transports in sync, with one synchronizer required for each recorder.

consumer is the long-term winner. (We can't help wondering if word of this little fact of life will ever reach the boardrooms of Detroit.)

Closer to home, we have the confusion of digital audio standards. While studio owners seek a universal standard, our Justice Department does its best to prevent manufacturers from collaborating on such a standard, for fear of stifling competition. Although bureaucratic implementation of antitrust matters is generally not distinguished for its clarity of thought, the basic concept is valid: if manufacturers are permitted to collaborate (or if you like, collude) on standards-setting, there is little doubt we would be saddled with many instantly-obsolete devices—recording, broadcast and otherwise.

For example, some critics hail American television as being "first with the worst," and they're *not* referring to program content. Of course, one can't wait around forever for a better system to emerge: after more than a quarter-century of mass acceptance of a lower quality medium, high-resolution color television is only just now attracting some serious attention. It would have been a shame to have to wait this long for a television standard.

But now, with the present system so firmly established, will it ever be possible to enjoy the improvements of a newer, non-compatible, system? On the other hand, should TV have been kept off the air until now, in the hopes that the ultimate system would get itself discovered? But then, would anyone bother looking for an ultimate system, if there weren't a less-than-ultimate system that needed to be improved? Notice there are no answers here—just lots of questions.

#### AM STEREO AND THE FCC

And that brings us 'round to AM stereo and the FCC. As with all our previous examples, rival non-compatible systems were brought to the industry's attention some five years ago. However, none of these systems were brought to the attention of the marketplace. In order to do so, the various contending systems were each required to petition the FCC for acceptance. At no time did the Commission encourage—or even permit—any system to present itself to the consumer. In time, five rivals were petitioning the FCC—rather than the marketplace—for its blessing.

Understandably, hardware manufacturers were not so keen on building AM stereo receivers for any of the systems, for fear of putting a sizeable start-up investment behind a system that might get shot down by the Commission. Many of them remember the beating they took on FM quad, which the learned Commissioners *still* can't figure out. And so, we have the well-known "wait-and-see" attitude. Given the circumstances, and past history, manufacturers would have been foolish to do otherwise.

Technologically, no system stands head-and-shoulders above its rivals. Each has its good and bad points. So why not get

together and combine the best of two or more systems? Simple: remember the Justice Department?

And so the lines of battle were drawn. Each contender bombarded the FCC (and anyone else who would listen) with charts, graphs, surveys, petitions, and whatever else was lying about. Meanwhile, the marketplace couldn't hear any of the systems, since none were approved for transmission, despite the fact that the Commission's own Broadcast Bureau had already proposed that this be permitted.

Eventually (April, 1980), the Commission determined that the Magnavox system was the most satisfactory. The reaction was predictable: other contenders raised an uproar, and the Commissioners went scurrying back to the office to review the situation. They discovered that they really didn't have sufficient data after all.

Two more years passed, and then the Commission had an inspired idea: Let's let the marketplace decide!

Great ideas are always so simple, one marvels that no one thought up this one years ago. That is, no one in the Commissioners' offices.

So, it has taken the Federal Communications Commission until 1982 to discover that it has no idea which system is truly superior. Since this more-or-less goes along with the prevailing industry attitude, we surely can't blame the Commission for not choosing the premier system if there isn't one. However, we *can* blame the Commission for wasting all these years of our time. Of course, things could be worse: the same Commission has already wasted more than ten years on FM Quad.

On the off-chance that the Commission is bright enough to learn from past mistakes, we'd suggest that in the future it allow marketplace decisions to be made in the marketplace immediately. There is really no need to paralyze the industry for years (or even for months), and then come out with a non-decision. In other words dear Commissioners: if you have nothing to say, why take five years to not say it?

# STL

## PRECISION



## MAGNETIC TEST TAPES

**STANDARD TAPE LABORATORY, INC.**

26120 EDEN LANDING ROAD #5, HAYWARD, CALIFORNIA 94545 • (415) 786-3546

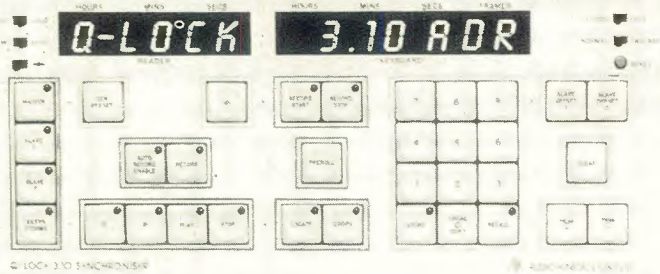

Figure 2. The Audio Kinetics Q-Lock 3.10 Synchronizer.

Well then, what's next, now that the Commission has finally not made up its mind? Don't look for any overnight action. Many manufacturers are not that excited about AM stereo in the first place, since it may not create a new market for them. The market for stereo radios, receivers and tuners is already well-saturated by FM sets, and these manufacturers will now have to add an AM chip or three to an existing product, just to stay competitive.

So, while the AM broadcaster gets a chance to compete with FM stereo, there isn't likely to be a brand new receiver market to entice the consumer products manufacturer into full-scale production, especially in the absence of a clearly-defined single-system standard.

And now, let's consider the dilemma of the manufacturer who may decide to give it a try anyway, and produce some AM stereo hardware. Presumably, he will pick the system which his marketing people think is most likely to succeed. Presumably, several manufacturers will reach similar conclusions. In any case, one or two big companies will make their decisions, and others will follow the example, for fear of losing out on the momentum.

Proponents of the system(s) not chosen will cry "foul play," and the Justice Department will get into the act. In other words, pick the system that seems to be winning, and you may be liable for an anti-trust suit: if you pick the system that seems to be losing, you're not very bright. Or to put it still another way: "either way, you lose."

Given the above scenario, it's reasonable to assume that AM stereo will not come bursting onto the scene overnight. Manufacturers will proceed with caution, just as they might have done five years ago when this all began. At that time, the Commission said, in effect, "No, you may not proceed. You must wait for directions from us." Now the Commission says, "Proceed as you wish. Don't wait for us to figure out what's going on." And the Justice Department says, "But big brother is watching." And the public says, "I wonder what ever happened to AM stereo?"

Oh yes, about that convention panel discussion... In a *deja vu* presentation, various AM stereo proponents argued (hopefully, for the last time) the merits of their favorite systems. Receiver manufacturers tried to explain why a multi-system receiver was impractical. National Semiconductor representative Dan Shockey argued that Magnavox is the *de facto* standard. According to Shockey, the company's LM 1981 chip was designed and optimized for the Magnavox system. But according to a National Semiconductor news release, the chip is universal to all AM stereo systems. But according to a National Semiconductor application note, the chip *may* be usable with the Harris and *perhaps* with the Kahn system. (Apparently the Commission is not the only organization that's a little confused these days.)

Will the AM stereo question finally be answered for us by Japan, Inc.? Could happen. Some industry observers feel the marketplace mostly responds to advertising and promotion packages, and is unlikely to choose a system based on its technical merit. Therefore, the first manufacturer to show up with an ad campaign and a receiver for sale will be the one to establish the real *de facto* standard.

With the FCC out of the picture, and no clearly-superior system on the horizon, the ball may be passed (or fumbled) onto the manufacturers' court. After all, the marketplace needs those receivers in order to hear *any* stereo broadcast. And the broadcaster is not apt to be very enthusiastic about beginning transmissions over a system for which there are no available receivers.

During the convention, Pioneer announced its preference for the Magnavox system, as "...one of the best and most effective" (our italics). However, the same news release noted that although the company has "...no specific development plans in that area, we feel it is vital that one system be adopted as an industry-wide standard..."

Reading between the lines, the LM 1981 chip is already available, and if a few other Japanese manufacturers issue similar systems-reference statements, the world may be on its way to a standard, with or without U.S. participation.

Japanese manufacturers have patiently waited five years for the FCC to make a ruling—*any* ruling. Now that they officially haven't ruled, it's reasonable to assume that some overseas suppliers may do it for them, thus placing their U.S. subsidiaries in an uncomfortable position with the Justice Department, if enough companies support the same system.

What if some company was to petition the Justice Department for relief from the no-win situation in which the FCC's inaction has entrapped it?

We close this chapter with an excerpt from a concurring statement by FCC Commissioner James H. Quello: "...there are many things that government doesn't do well."

## THE EXHIBITS

Not so many years ago, the exhibit area at an NAB convention was no place to go to look for professional-quality audio hardware. Broadcast and audio seemed to have little to do with each other, although us *db*-types always wondered just

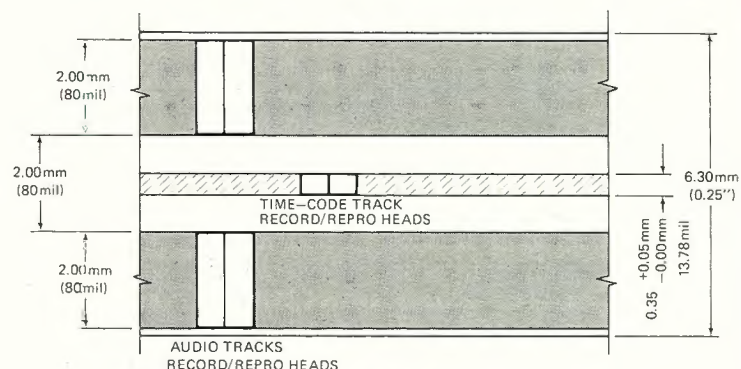

Figure 3. Studer's Time-Code record/repro format.

what it was that the broadcasters thought they were transmitting.

Times are changing. It remains a broadcast show, but now some 15 percent of the exhibits (that is, about 80) might be considered as being pro audio. That's still less than half the number that exhibited at the Fall AES show in New York. However, with no Spring AES convention scheduled in the U.S. for 1983, we suspect that next year's NAB will have an even greater audio turn-out.

Generally, most of the AES regulars seemed pleased with the reception they were getting from the broadcasters, and the timing couldn't be better. The broadcasters seem to be in relatively good financial health, and ready, willing and able to spend money on audio.

With more and more video production looking for high-class audio, that brings us to...

## SYNCHRONIZERS

The Ampex UNISYN synchronizer is a modular system which can lock up to 16 transports in sync, in any combination of NTSC, PAL, SECAM or film standards. It is designed with a

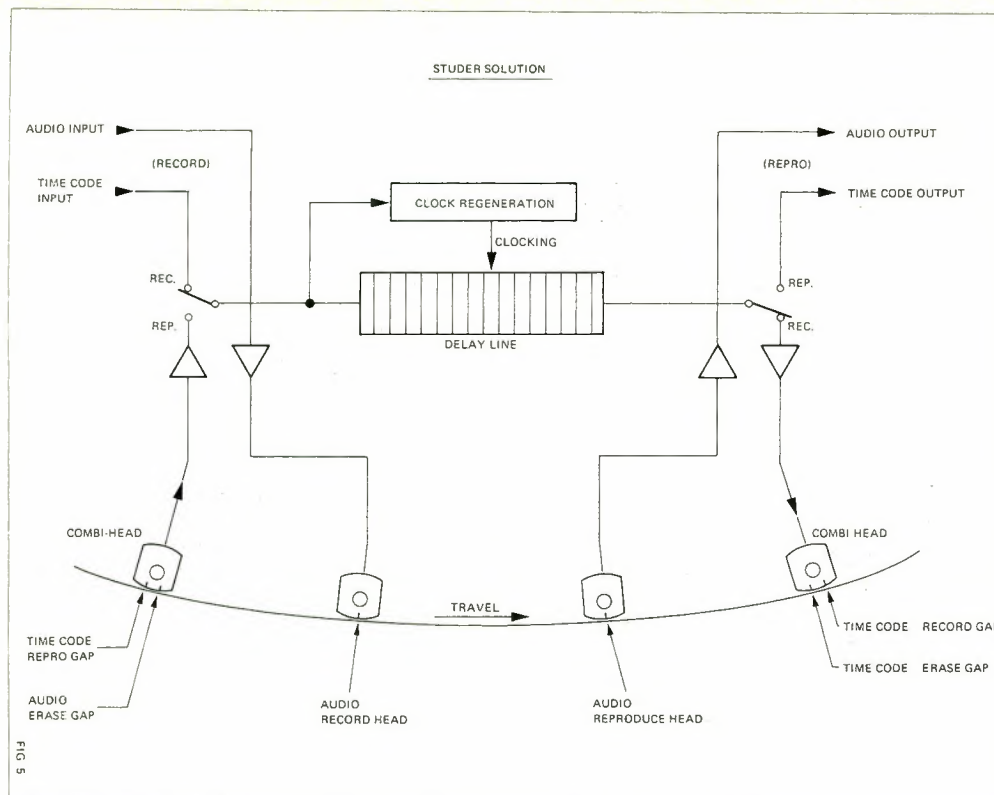

Figure 4. Head layout and related signal paths for the Studer time-code format.

digital serial communication port that interfaces with any standard mini- or micro-computer. Slave recorders will lock to the master recorder even when the master speed varies dynamically from one-quarter to double speed. Each slave recorder can locate and synchronize ten separate segments in one continuous pass of tape on the master recorder.

Audio-Kinetics' Q-Lock 3.10 is an SMPTE/EBU time code synchronizer capable of controlling three machines, with capability for linking additional synchronizers to provide a multi-slave facility.

The Q-Lock CCU (Central Control Unit) brings together machine remotes, time-code generator controls and the Q-Lock 3.10 programming keys on a single keyboard panel. The Q-Lock's computer is compatible with Melquist, Neve and Solid-State Logic's computers, via mutual software adaptations.

Audio-Kinetics has also developed an ADR (Automatic Dialogue Replacement) software package for applications which require the recording or replacement of dialogue in sync with picture. The "Q-Soft" program is optimized to require the minimum number of keystrokes during looping sessions.

For applications involving VITC (Vertical Interval Time Code), EECO, Inc. introduced a VITC Generator/Reader and a Reader-only. Both are capable of recovering, decoding, and displaying code from video at tape speeds from freeze-frame to 45 times normal play speed. VITC provides the advantage of freeing an audio track for other uses (maybe even for audio).

For more information about VITC, EECO has published a 32-page tutorial booklet, "SMPTE/EBU Longitudinal and Vertical Interval Time Code." The text provides an introduction to time code, and then describes the familiar longitudinal SMPTE format. Next, the problems of reading time code on helical-scan VTRs are discussed, and it is shown how VITC overcomes them.

For a more-detailed view of the subject, Datametrics publishes the 110-page (plus index) "Time Code Handbook," which covers history, applications, setup for time code operation, text and diagrams for the SMPTE standard, technical guidelines and problem solving. The Handbook price is \$5.00, or \$3.50 when ordered in quantities of five or more.

#### TIME CODE RECORDING ON 1/4-INCH TAPE

On multi-channel tape recorders, the allocation of an audio channel for time code recording is more-or-less taken for granted these days. It's a small price (in space, if not in money)

for gaining lots of extra channels on another machine.

Obviously, the users of two-channel recorders cannot afford to be so generous, yet there are at least a few two-channel applications in which it would be nice to have time code available.

Studer proposes a time-code track format for two channel machines that is illustrated in FIGURE 3. The system uses standard audio record and repro heads, plus two combination heads (time-code repro/audio erase, and time-code erase/time-code record). The head layout and related signal flow diagram is seen in FIGURE 4.

Note the dual-purpose delay time, and that the spacing between the audio and time-code record head gaps is the same as the spacing between the time-code and audio repro heads. Therefore, the time code is recorded or reproduced with zero offset from the audio. However, if an offset is required, the delay line may be adjusted as required.

The time-code system is available as an option on Studer's new A810 recorder, which was introduced at the convention. The NAB wrap-up will continue in the July issue. ■

#### MANUFACTURERS' ADDRESSES

##### Ampex Corporation

401 Broadway  
Redwood City, California 94063  
(415) 368-4151

##### Audio Kinetics

4721 Laurel Canyon Blvd., Suite 209  
North Hollywood, California 91607  
(213) 980-5717, (800) 423-3666

##### EECO, Inc.

1601 East Chestnut Avenue  
P.O. Box 659  
Santa Clara, California 92702  
(714) 835-6000

##### Datametrics-Dresser Industries, Inc.

340 Fordham Road  
Wilmington, Massachusetts 01887  
(617) 658-5410

##### Studer Revox America, Inc.

1425 Elm Hill Pike  
Nashville, Tennessee 37210  
(615) 254-5651

# Microphone Roundup

*Presenting our annual (first actually, but who's counting) roundup of new and/or recently introduced microphone products.*

**A**S A SERVICE TO OUR READERS, the staff of **db** has compiled a sampling of new and/or recently introduced microphone products now available. For more information on the products mentioned below, circle the reader service numbers given for the manufacturers of the products you are interested in. All information has been provided to **db** by the manufacturers themselves, and as such, the specifications and descriptions given are theirs.

From **Beyer Dynamic** (circle 45 on reader service card) comes the new M 300 cardioid microphone. Featuring a frequency response of 50-15,000 Hz and a nominal output impedance of 250 ohms, the Beyer M 300 is designed for young musicians looking for a professional-quality mic at a price they can afford. As a result, Beyer has placed the M 300 on sale for the price of \$124.95.

A fairly new name in microphones for us at **db** is **Wright Microphones** (circle 46 on reader service card). Wright currently offers two microphones, designed primarily for studio applications: the SR-1, featuring a conventional transformer output utilizing a nickel core transformer, and the TSR-2, a transformerless version. Both Shaped Response™ models exhibit a rising high-end characteristic with a response peak of 6 dB at 16 kHz. Tying all the design criteria together is a fast responding 3/8-in. gold foil diaphragm mounted in acoustical foam to prevent low-frequency rumble pick-up. The SR-1 and TSR-2 are designed to operate on phantom power supplies ranging from 12-48 volts DC. Each microphone is hand-made.



*The Sony ECM-939T MS microphone and MRU-90 remote control unit.*

From **Sony** (circle 47 on reader service card) comes the "Sound Crew" MS microphones designed for on-location recording. The model ECM-939T, Sony's top of the line Sound Crew MS, combines a bi-directional, back electret capsule with a cardioid capsule. The frequency response of the ECM-939T is 50-15,000 Hz, the output level -57.6 dBm. It comes complete with left and right Unimatch plugs (threaded plugs with 1/4-in. phone plug sleeves). The suggested price of the ECM-939T is \$115.00.

The model MRU-90 is the remote control unit for the ECM-939T. It features directionality control that varies the recording image from cardioid mono to a stereo image. The MRU-90 control unit allows for remote control of the stereo panorama of the microphone and includes bass and treble equalization. Major specifications include a coverage angle of 1-150 degrees, a frequency response of 20-20,000 Hz and a dynamic range of more than 96 dB.

*Mark Waldstein is the associate editor of db magazine.*



*The Green Bullet 520D microphone.*

Among the new microphone products from **Shure Bros.** (circle 48 on reader service card) is one item that doesn't actually qualify as "new." Shure has announced the return of the "Green Bullet" 520 microphone, but not as the dispatcher model of years gone by. Rather, the Green Bullet, now designated the 520D, is back in a limited edition due to its popularity among harmonica players. The Green Bullet 520D is a dual impedance microphone, and is available as the hand assembly only. The unit has a frequency response of 100 to 5,000 Hz and carries a price tag of \$80.00.

100 to 5,000 Hz and carries a price tag of \$80.00.



*The Shure SM63-CN.*

Shure Bros. has also recently come out with the SM63-CN dynamic, omnidirectional microphone featuring an output that is, according to the manufacturer, about 6 dB higher than comparable units. Designed basically for on-camera or on-stage use, the SM63-CN features a controlled low-frequency rolloff to insure natural sounding voice and music pickup as well as smooth high frequency response. It also features a hum-bucking coil and a mechanical-elastomer isolation system that makes it resistant to handling noise. The price of \$100.00 includes a swivel adapter windscreen and professional 3-pin audio connectors on both ends of the cable.

The **Bruel & Kjaer** (circle 49 on reader service card) 1/2-inch prepolarized condenser microphones Types 4155 and 4175 are Free-field microphones designed to complement the already

# Introducing the Bose® 402 Loudspeaker.

**N**ow Bose brings the advanced technology of the Articulated Array™ system to a speaker designed specifically for high-quality reinforcement of vocals and acoustic instruments. The 402 Professional Loudspeaker. An affordable and truly portable alternative to the traditional small-group P.A. speaker.

Each 402 enclosure contains four 4½" high-sensitivity drivers mounted on a faceted 3-dimensional baffle. This unique Articulated Array™ system works together with a special Acoustic Diffractor and built-in Directivity Control circuitry to deliver exceptionally uniform room coverage, without the penetrating shrillness of horns or the muffled sound of columns.

Tuned Reactive Radiator slots allow the 402 speaker to produce surprisingly high output levels with low distortion. The matched 402-E Active Equalizer assures smooth, accurate spectral response across the entire operating range of the system. And the TK-4 Transit Kit lets you clamp a pair of 402 speakers (with equalizer) together into a compact unit light enough to carry in one hand!

The 402 Loudspeaker makes it easy for anyone to

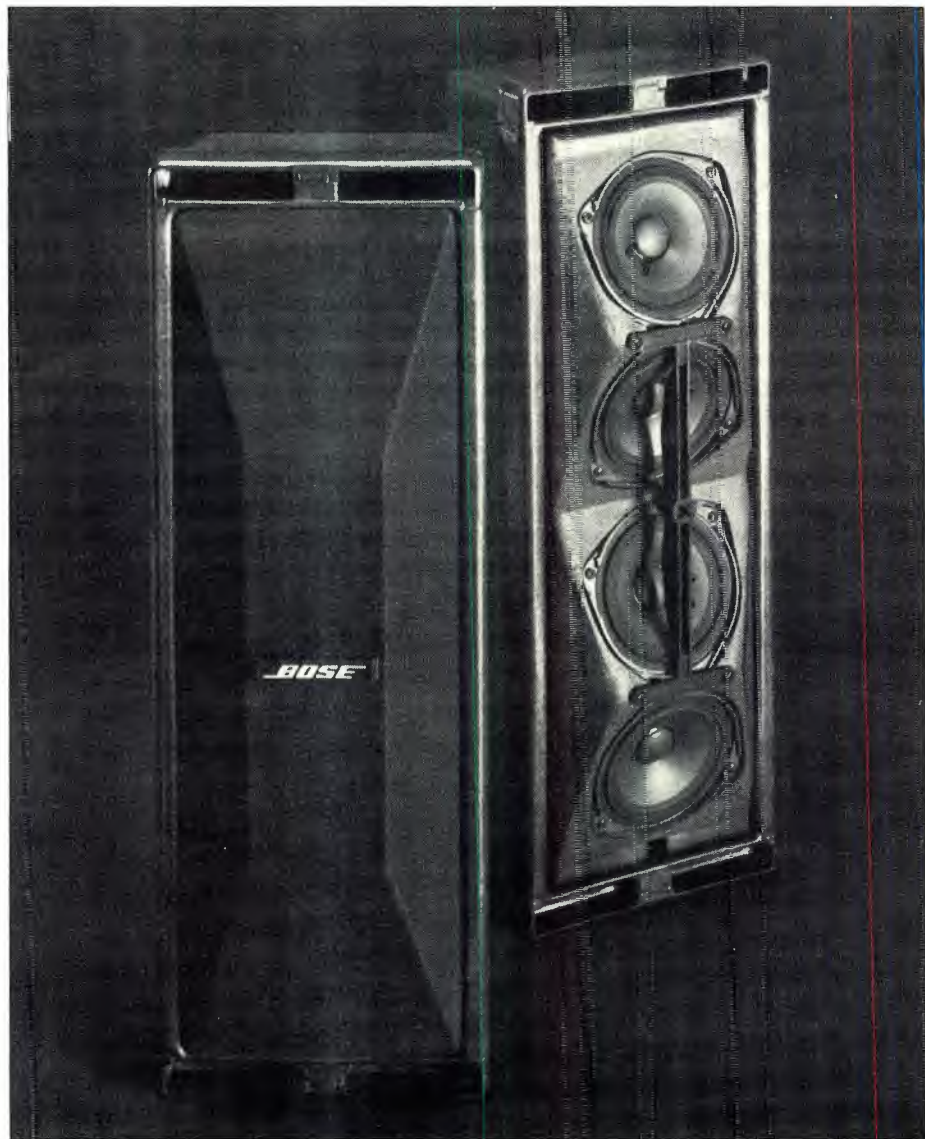

obtain the outstanding performance of Bose's Articulated Array™ system. Ask for a live demonstration at your authorized Bose Professional Products dealer.

402 Speaker on SS-4 Speaker Stand.



402 System Set in TK-4 Transit Kit.

Bose Corporation, Dept. SE  
The Mountain  
Framingham, Massachusetts 01701

Please send me the Bose Professional Products Catalog and your technical data.

Name \_\_\_\_\_

Firm \_\_\_\_\_

Address \_\_\_\_\_

City \_\_\_\_\_

State \_\_\_\_\_ Zip \_\_\_\_\_

Telephone ( ) \_\_\_\_\_

**BOSE®**  
Better sound through research.

Covered by patent rights issued and/or pending  
402 speaker design is a trademark of Bose Corporation  
© Copyright 1982 Bose Corporation.

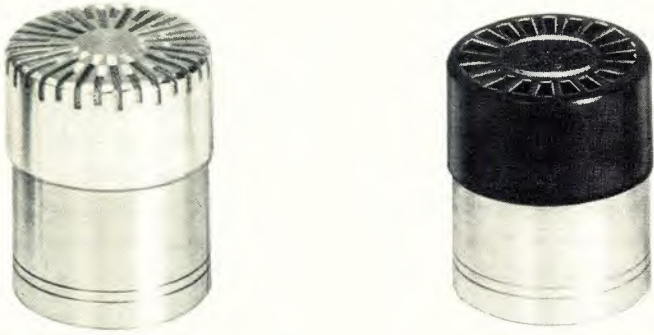

The Bruel & Kjaer prepolarized condenser microphone cartridges Types 4155 and 4175.

existing range of condenser mics. The Type 4155 is a precision microphone which is acoustically equivalent to the externalized Type 4165 and is intended for sound measurements to IEC 651 Type 1. The Type 4175 is acoustically equivalent to the externally polarized Type 4125, although of higher sensitivity, and is intended for measurements to IEC 651 Type 2 and ANSI S1.4—1971 Type 2. Both have the same mechanical properties as their equivalents, but are polarized via a charge-carrying (electret) layer. To minimize its influence on the moving diaphragm, this is placed on the backplate. Features of the 4155 include a Free-field frequency range from 4 Hz to 20 kHz and a dynamic range from 14 dB(A) noise floor to 146 dB (3 percent distortion). The 4175 features a Free-field frequency range from 5 Hz to 12.5 kHz and a dynamic range from 14 dB(A) noise floor to 144 dB (3 percent distortion).



The Astatic model 1070 Spectrum low profile, dynamic cardioid mic.

The Astatic (circle 50 on reader service card) 920 series mics are omnidirectional dynamics designed especially for the entertainment and recording and broadcast industry. The 920s feature a smooth, wide band frequency response, built-in multi-stage blast filter, professionally designed cartridge shockmount system and 15 feet of permanently attached cable. The 920 series is available in low impedance (920L) and high impedance (920H).

Also new from Astatic is the model 1070 "Spectrum" low profile, dynamic cardioid microphone specifically designed for conference recordings. According to the manufacturer, the 1070 can replace up to four mics. Internally, a hum-bucking coil minimizes hum pickup. The 1070's low profile and vertical orientation keeps off-axis tone quality consistent by being omnidirectional at all frequencies in a horizontal plane.

Phillips (circle 51 on reader service card), a North American Phillips company, has recently introduced the new Model 7401 dynamic cardioid mic, specifically designed for vocalists. The 7401 has an internal, locking on-off switch and is available with a detachable cable in any one of three variations: as the 7401E with XLR-XLR cable, the 7401P with XLR-to-phone plug, or the 7401T with XLR-to-Hi-Z phone plug.



The Milab LC-25 transformerless line level condenser mic.

New from Milab (circle 52 on reader service card) is the LC-25 transformerless line level condenser mic, designed for operation on a 48 volt Mipow™ system. The pre-amplifier and line driver amplifier are contained within the body of the microphone. An electronically balanced output signal level (0.775 volts) into a standard k-ohm microphone input permits direct connection to consoles or tape machines which are equipped with input pads in the range of 20 to 40 dB. Tape machines with line input sensitivity of -15 to -20 may directly accept the LC-25 signal output. Line inputs may easily be wired for 48 volt powering. The microphone may be used unbalanced with a signal loss of 6 dB. No transformers are employed in any part of the signal path. Basic specifications of the LC-25 include a frequency response of 20-20,000 Hz, a directivity index of 25 dB at 1000 Hz and a dynamic range of 110 dB.



The Calrec 2156 mic.

The Calrec (circle 54 on reader service card) 2100 series microphones are phantom powered from 7.5 to 50 volts 0.5mA and feature detachable capsules. All Calrec microphones operate on conventional balance line cables and produce a positive-going output for an increase in sound pressure on pin 3 of a standard 3-pin XLR plug. Basic specifications include: frequency range—40-20,000 Hz; EIA rating Gm—135 dEm; recommended local impedance—1000 ohms; source impedance—200 ohms.

Calrec Condenser Microphones are now being distributed by Audio + Design Recording, Inc., of Bremerton, Washington.



The Audio-Technica model AT803R lapel mic.



The Countryman Isomax Pro directional lavalier mic.

## LAPEL AND LAVALIER MICS

**Audio-Technica** (circle 55 on reader service card) has recently introduced the AT803R, an electret condenser omnidirectional lapel microphone intended to be worn on the clothing of performers. The wide-range capability of the AT803R insures accurate reproduction with high intelligibility for lecturers, singers, etc. A built-in switch on the belt module allows the frequency response (20-20,000 Hz) to be adjusted for voice or music applications. AT803R performance is achieved with a very thin (5 microns) polymer diaphragm whose low mass moves readily in response to changing sound pressure. The AT803R is intended for use in applications where remote powering is available and will accommodate an external power source supplying from 9 to 52 volts DC. This lapel mic is unique in that the belt (output) module can be worn on the person or operated at distances up to 10 feet. This is accomplished through the use of a miniature 3-pin connector terminating the 28-inch cable from the microphone capsule to the

mating jack of the output modules. The AT803R response curve is tailored to provide natural voice characteristics when worn in the usual position.

From **Countryman Associates Inc.** (circle 56 on reader service card) comes the Isomax Pro, a new directional lavalier mic which, according to the manufacturer, offers up to 20 dB better rejection of feedback and unwanted sound when compared to other lavaliers. The Isomax Pro operates on either phantom power or internal batteries. Standard features include switch selectable low frequency rolloff and presence peaking, making the Isomax Pro equally at home in voice or music

# PROVEN PERFORMERS FOR STAGE AND STUDIO

## SB-36W

The preference for recording studios. Triangular cast-iron base with rubber casters for heavy duty stability. Adjustable counterweight, gyromatic swivel for microphone positioning. Boom length: 62". Height range: 48"-72".



## MS-12S

The favorite of professional entertainers. Automatic clutch with touch-control sleeve action makes it possible to position microphone height to any level without the usual rotary adjustment. Low silhouette, charcoal finish, 10-lb. cast-iron base for maximum stability. Height range: 39"-62".

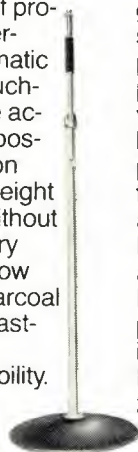

## PS-C3

The ideal for music groups. Instant set-up, and compactness for transportation. Base and vertical tube combine in a single portable unit and feature spring-action telescoping legs. Extra low adjustment flexibility for seated performer or instrument-miking. Height Range: 26"-66".

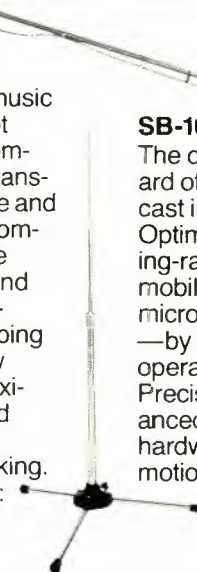

## SB-100W

The quality standard of the broadcast industry. Optimum positioning-range and mobility. 350° radius microphone-follower —by single knob operator-control. Precision balanced, oversized hardware for motion-functions,

heavy duty wheels. Boom length: 110" —Height range: 61.5"-92.5".



ATLAS SOUND, DIVISION OF AMERICAN TRADING AND PRODUCTION CORPORATION  
10 POMEROY ROAD, PARSIPPANY, NJ 07054 (201) 887-7800



The Crown 3LV tie-bar lavalier PZMicrophone.

applications. Its ability to handle 150 dB sound levels without distortion enables it to be used on horns or amplified instruments without fear of overload. The Isomax Pro, complete with case and tie clip, lists for \$269.00. An optional tie clip that holds two mics is also available.

**Crown** (circle 57 on reader service card) has recently introduced the 3LV tie-bar lavalier PZMicrophone. The 3LV, because of its small size, can be used in areas where other mics might be considered obtrusive. Musical instrument pickup is also possible with the 3LV. As with all Crown PZMicrophones, the operation of the 3LV is based on the Pressure Recording Process,<sup>™</sup> exhibiting a hemisphere response. Because of this, face-to-face interviews may be conducted using only one 3LV mic. General specifications include a frequency response of 50 Hz to 15 kHz, a normal loading impedance of 1000 ohms, total harmonic distortion of 3 percent at 150 dB-SP, and a signal to noise ratio of less than 26 dB-SPL (equivalent acoustic input).



The Edcor E Com System and PM/ST System of wireless mics.

## WIRELESS MICS

**Edcor** (circle 58 on reader service card) has recently announced their new high and low band wireless microphone systems. The E Com Systems operate on the high VHF frequency band (typically 150-210 MHz). These systems feature an RF carrier frequency of 150-216 MHz standard, and an operating range of 100 feet under adverse conditions and 1500 feet line of sight. Basic specifications include a signal to noise ratio of better than 65 dB and a frequency response of 200 to 16,000 Hz,  $\pm 2$  dB.



The Telex WHM-400 and WHM-300 transmitter mics.

The PM/ST Systems operate on the low frequency band (typically 30-50 MHz). These Systems feature receiver signal strength indicator and operate reliably up to 200 feet. Basic specifications include a frequency response of 200-1600 Hz and a signal to noise ratio of better than 55 dB.

**Telex** (circle 59 on reader service card) has recently added two handheld VHF transmitter microphones to its line of wireless microphone equipment. In both models the transmitter and the compressor circuits are built into the microphone housing. This housing also serves as the omnidirectional transmitting antenna. A 30 dB compression circuit provides maximal signal to noise ratio and dynamic range and also prevents over-modulation. Frequency response for either model is given as 50-15,000 Hz.



The Swintek Mark Q-AC/50A-DB-S wireless microphone system.

The model WHM-300 is a cardioid electret mic with flat response and is well suited for the speaking voice. This model is equipped with separate switches for RF and audio so that the audio can be turned off without losing control of the RF carrier.

The model WHM-400 is a cardioid dynamic microphone with slight emphasis in the lower audio frequencies. No switches are provided on this model, preventing the user from inadvertently turning the mic off. RF power is shut off by removal of the batteries. Both transmitter microphones work with alkaline or Nicad batteries.

From **Swintek** (circle 60 on reader service card) comes the Mark Q-AC/50A-DB-S wireless microphone system. This



system utilizes the high VHF FM band to reduce the possibility of interference generated by citizen band radios, fluorescent lights, etc. The Mark Q-AC receiver plugs into any standard 3-pin XLR sound system. Switchable low-level or hi-level balanced audio outputs are provided with an adjustable squelch and LED indicator showing proper power or audio levels at all times. The receiver can be powered from any external 14 to 18 VDC power-pad or a standard 110 VAC power module, which is provided. The Mark Q-AC receiver can utilize many of the Swintek transmitters.

#### MICROPHONE CAPSULES AND STANDS

Two new products have recently been added to the Schoeps (circle 61 on reader service card) line of professional condenser microphones. A new capsule, designated the MK 8, has been added to the Colette system of interchangeable capsules, fitting the standard 12 or 48V-powered amplifiers already being produced, as well as the 12V parallel-feed version. Its characteristic is bi-directional, employing a single, low-mass small diaphragm for even polar and frequency response. Radially-oriented in its pickup, it is especially well suited for coincident (Blumlein) stereo miking as well as mid-side (M-S) stereophony, in conjunction with cardioid and hypercardioid capsules.

An accessory swivel mount, the GVC, allows any capsule of the Colette series to be angled through 120 degrees relative to the mic body, allowing offset of the pickup characteristic to simplify special mounting applications. The MK 8 bi-directional capsule is priced at \$440.00 and the GVC swivel adapter at \$155.00.



The Veloured Chrome tube finish is featured on the Atlas Omni-Series mic stands.

Atlas Sound (circle 62 on reader service card) now features the option of a new "Veloured Chrome" finish for several of its microphone stand models specifically designed for use in stage performance and studio conditions where bright, high intensity lighting can cause annoying glare and camera reflections off conventional polished chrome tubing. The Velour Chrome finish from Atlas reduces the specular reflective effects of high intensity stage and studio lighting. It is standard on the recently introduced Atlas Sound Omni-Series of angulated floor and desk microphone stands and boom attachments. 7/8-in. diameter assemblies for other Atlas stand models can be purchased individually. ■

# MAGNECORD MC-II

Compare Quality at this Price

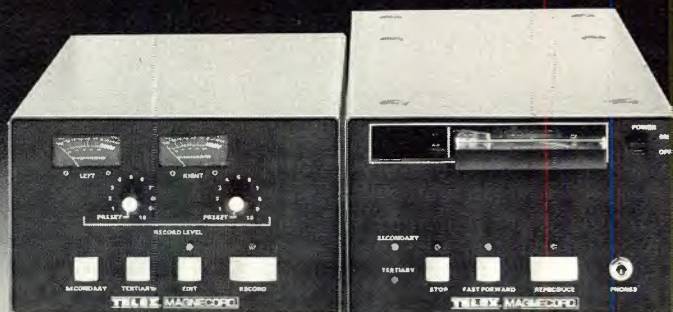

Incomparable  
from \$1100.00\*

- Meets or exceeds NAB standards, with IEC equalization on request.
- DC servo, flutter-filter drive runs true regardless of line voltage fluctuation.
- Cool operation; no ventilation required.
- Full remote capability.
- Long life heads and phase locked tape guides.
- Mono or stereo play models field convertible to record.
- Automation cue tones (stop, secondary, tertiary) with LED's and external switching contacts.
- Cue track access for FSK logging.
- Universal mic/line input.
- Immune to RFI and EMI.
- Rugged design in the Magnecord tradition —made in USA.

\*Suggested Pro Net Price

Quality Products for the Audio Professional

**TELEX MAGNECORD**

TELEX COMMUNICATIONS, INC.

9600 Aldrich Ave. So. Minneapolis, MN 55420 U.S.A.  
Europe: Le Bonaparte - Office 711 Centre Affaires Paris-Nord 93153 Le Blanc-Mesnil France

Circle 30 on Reader Service Card

## TEST INSTRUMENT

• The Model LSW-115 is an Audio Sweep/Marker Generator with Response Curve Storage. The combined sweep generator and detector provides a stable display by using digital storage technology. The unit is designed primarily for use in observing the frequency response characteristics of a wide range of audio equipment. It uses a digital waveform storage system to provide stable displays at single or slow sweep rates eliminating CRT blooming problems often associated with high persistence phosphors. Response curves may be reproduced on an X-Y recorder, where hard copy is required, or on any X-Y module.

Mfr: Leader Instruments Corp.

Circle 35 on Reader Service Card

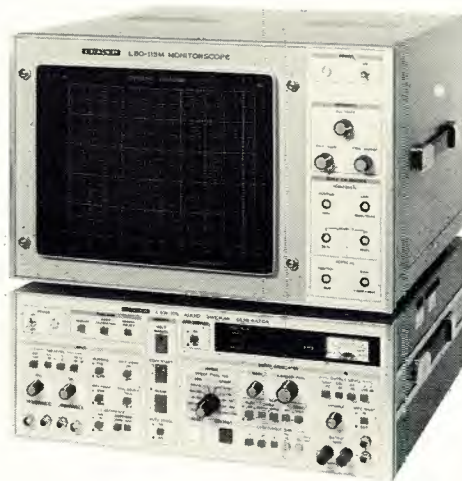

## HORN CABINET

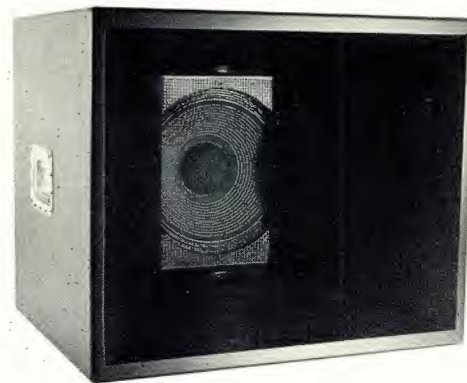

• Equipped with a single 15-in. speaker, the E-560 can supply the low end in a small PA system or the upper base/mid-range in larger concert systems. Designed for high efficiency and fidelity, the E-560 has a usable response down to 50 Hz, and its pattern control gives driver sensitivity a 6 dB boost above 200 Hz. The recommended crossover point is from 500 to 800 Hz depending on the total system configuration. The horn dispersion is 90 degrees horizontal and 60 degrees vertical at 800 Hz.

Mfr: Borge Systems Ltd.

Circle 36 on Reader Service Card

AUDIO COMPONENTS FOR PA, RECORDING, & LIVE PERFORMANCE

★ SH-1  
STEREO HEADPHONE BOX



★ SHB-1  
COMPANION TO SH-1



HOLDS UP TO SIX HEADPHONES

★ SC-1  
STEREO COMBINER



SEND FOR YOUR FREE COPY OF OUR CATALOG



**SESCOM, INC.**  
Professional Sound Division  
1111 Las Vegas Blvd. North  
Las Vegas, NV 89101 U.S.A.

(702) 384-0993  
(800) 634-3457  
TWX 910-397-6996

Circle 18 on Reader Service Card

## PROPRIETARY FEEDBACK SUPPRESSOR



• The patented 1620A Acoustic Feedback Suppressor is, according to its manufacturer, the first feedback eliminator that automatically detects and corrects oscillating signal feedback caused by microphone/loudspeaker interaction. Sensing the initial signal oscillation, the 1620A automatically reduces the sound system gain by 3 dB steps until the feedback is eliminated. The device then readjusts the system volume, increasing the gain by 3 dB steps to the maximum feedback-free level. Standard features on the 1620A include LED attenuator displays (at 3, 9, 15 and 28 dB) clipping indicator light, direct hardware/by-pass switch, remote-capable reset switch, and set-up level indicator light. The feedback eliminator requires only 1 3/4-ins. of vertical rack space.

Mfr: Altec Lansing

Price: \$1190.00

Circle 37 on Reader Service Card

## MIXING BOARDS



• The CX and SX mixer line is available in Mono and Stereo models featuring optional 200 and 300 watt power amps. Popular features include: phantom power supply, 3 band active EQ, Solo monitoring, 2 bus sends, professional 3-spring reverb system, A & B sub grouping, two 9-band graphic equalizers, talk-back system and professional analog meters.

Mfr: Carvin Manufacturing Co.

Price: \$599.00 for mono;

\$699.00 for stereo

Circle 38 on Reader Service Card

**SOUND REINFORCEMENT**



• The Model S-1 and S-2 3-in-1 units are designed specifically to meet the multi-faceted sound requirements presented to today's churches and synagogues. The units contain a low noise microphone mixer, a 60 watt low distortion amplifier and a high efficiency full range speaker system. Variable crossover tone controls provide individual adjustment of bass and treble without interaction, while mic and line inputs with individual controls enable singing with sound tracks. The S-1 models feature two 4½-in. speakers and a tweeter while the S-2 models have four 4½-in. speakers and a tweeter. An optional mic stand bracket provides flexibility.  
 Mfr: Manke Instruments  
 Circle 39 on Reader Service Card

**RACK-MOUNTED VCA**



• The 668VCA is designed to fill the demand for a self-contained VCA without the necessity of wiring in a power supply. The 668VCA rack-mounted unit is available in 2, 3, or 4 channel versions, with or without balanced 600 ohm, transformer isolated outputs. Back panel terminals are provided for audio in, control pot, and audio out on each channel. Channels may be strapped for single element control of multiple channels. The 668VCA is designed to provide 100 dB of attenuation. Maximum input is +20 dBv, maximum output +18 dBv.  
 Mfr: ProTech Audio Corp.  
 Circle 40 on Reader Service Card

**16-BIT DAC**

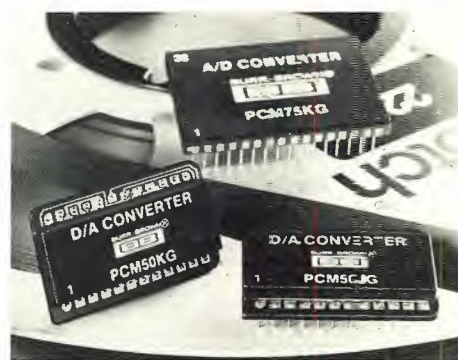

• Burr-Brown now offers a 16-bit DAC designed and specified for audio applications. PCM50 offers 16-bit resolution with a 96 dB dynamic range. Typical total harmonic distortion is 0.003 percent and settling time is 5 μsec typical, fast enough to handle high frequency audio demands. Differential linearity error is 0.0015 percent of FSR typical. PCM50 can also be operated as a 14-bit converter for less demanding applications and is compatible with EIAJ STC-007 specifications. Pin compatible with DAC71-COB-V, PCM50's ceramic 24-pin dual-in-line package also contains an internal voltage reference and an output operational amplifier.  
 Mfr: Burr-Brown  
 Price: \$49.75 in hundreds  
 Circle 41 on Reader Service Card

**Now you hear it...**

**Now you don't.**

Garner tape erasers have a reputation we're proud of, and we've earned it.

Garner audio tape erasers are designed to meet your most exacting standards. Just drop the reel, cassette or cartridge onto the belt, and, four seconds later, you have a completely erased tape...free of any noise.

Whatever your requirements, Garner has an audio tape eraser designed for you...the machines of the '80's.

Left to right:  
 Model 70  
 Model 105  
 Model 1-4  
 Model 116

Ask about Garner video tape erasers, too.

Dependability... Guaranteed  
**Garner Industries**  
 4200 N. 48th Street  
 Lincoln, NE 68504  
 402/464-5911

Circle 31 on Reader Service Card

## TIME CODE SYSTEM



- The Cypher™ system of time code products simultaneously reads, generates and character inserts SMPTE/EBU/VITC time code. The system is based on an intelligent micromputer that allows a full range of functions. Modular design allows functionality to be increased by the addition of plug-in boards that can be installed in the field. The system is fully compatible with both NTSC and PAL video standards in both longitudinal and VITC formats. Size, position, brightness and background intensity of characters inserted into video are available from the front panel of the unit. Complete RS232 interface makes the Cypher system compatible with all editing computers. An optional relay board allows frame accurate triggering of sixteen events.

*Mfr: BTX Corporation  
Circle 42 on Reader Service Card*

- Compression Drivers
- Cone Drivers
- Horns
- Crossovers

# EMILAIR

For complete information call  
714-632-8500 — 800-854-7181

**EMILAIR CORPORATION**  
1365 N. McCan St.  
Anaheim, CA 92806

*Circle 19 on Reader Service Card*

## DIRECT BOX TRANSFORMER

- A Direct Box Transformer must exhibit the proper impedance at its input and output in order to preserve correct frequency and phase response in the guitar and mixer. In addition, an extremely important criterion is immunity from hum and noise. According to its manufacturer, the JE-DB-E meets these criteria. The JE-DB-E has independent Faraday shields (electrostatic screens) for the primary and the secondary, permitting complete isolation of the guitar or other instrument from the amplifier or mixer. The JE-DB-E handles up to +19 dBv at 20 Hz and +30 dBv at 50 Hz before saturation. Below saturation, distortion is cut to less than 0.1 percent at 20 Hz, and decreases by 1/2 for each octave higher, measuring less than 0.005 percent at 1 kHz. The JE-DB-E has a high bandwidth (-3 dB at 80 kHz), which results in a clear top end.

*Mfr: Reichenbach Engineering  
Price: \$43.04  
Circle 43 on Reader Service Card*



## CASSETTE COPIER

- The Sony model CCP-100 audio tape cassette copier, which operates at 16 times normal play speed (30 ips), is a monaural 2-track/2-channel system which will copy both sides of the tape at a single pass. Features include a built-in erase head, automatic rewind and stop, and 50 or 60 Hz AC operation without cycle conversion. Other features include ferrite heads which, according to the manufacturer, will last more than 200 times longer than conventional heads, and linear BSL motors to assure speed accuracy.

*Mfr: Educational Electronics Corp.  
Circle 44 on Reader Service Card*



## TACHOMETER

- The RT-100 electronic tachometer system is designed for easy installation on reel to reel tape machines which don't have tachometers and are required to operate with a SMPTE controller for chase-lock and auto-locate. The RT-100 is made in two parts: the tape drive module and the electronics module. The tape drive module is mounted on the deck of the reel to reel tape recorder in the tape drive path. A template is provided with mounting location for various model recorders. The tape drive module incorporates a precision wheel mounted with jewel bearings. The wheel is in constant contact with the tape while infrared light is used to accurately count revolutions and direction of the wheel. The RT-100 operates from its own power supply.

*Mfr: Regent Engineering Co.  
Price: \$700.00 for 1/4 and 1/2 inch;  
\$800.00 for 1 and 2 inch tape machines  
Circle 64 on Reader Service Card*



## LOUDSPEAKERS



• The 802-W loudspeaker, designed for full-range reinforcement and reproduction of voices and music in permanent indoor sound installations, employs eight Bose D-11A full-range drivers mounted in vertical pairs on a faceted 3-dimensional baffle. This Articulated Array™ system works with a built-in Directivity Control circuit to deliver excellent uniform side-by-side and front-to-back room coverage. Twin reactive air columns reduce distortion by controlling the cone excursion required to reproduce deep bass frequencies. A matched active electronic equalizer, the 802-E, assures smooth spectral response across the entire operating range of the system.

*Mfr: Bose Corp.*

*Price: \$648.00*

*Circle 65 on Reader Service Card*

## PRECISION DELAY LINE



• A precision delay line, the DLY-1 provides accurate delay, or recirculation, of acoustic, audio, and instrumentation signals having bandwidths up to 30 kHz and dynamic range of 72 dB. Front panel thumbwheel switches permit specification of sample rate and delay. The DLY-1 digitizes an incoming signal via an internal memory and reconstructs the delayed analog signal. When switched to the recirculate mode, the signal currently stored in memory is output in a continuous-loop fashion. Sample intervals are adjusted in steps of 1 microsecond from 15 to 9999 microseconds (corresponding to a sample rate of 67 kHz to 100 Hz). Delay is adjustable in steps of one sample delay up to a maximum of 65,536 delays. The total signal delay is specified by the product of the sample interval and number of delays. For very low bandwidth signals, delays in excess of 10 minutes may be achieved. For voice bandwidths, up to 10 seconds delay is achieved.

*Mfr: Digital Audio Corporation*

*Price: \$2,350.00*

*Circle 66 on Reader Service Card*

# db New Literature

## MICROPHONE AND CIRCUITRY PRODUCTS CATALOG

• Shure Bros. Inc. has announced the release of their Microphone and Circuitry Products Catalog. For ease of product selection, the catalog explains in detail the meaning of microphone specifications, and also has an easy-to-use selection guide offering suggestions for application. The catalog also implements a new indexing style that cross references each product by model and contains a data sheet reference guide for easy ordering. The 72-page catalog describes over 150 microphones including professional, general purpose, communication and special purpose models. The catalog also covers microphone accessories, circuitry products and their corresponding accessories. **Mfr: Shure Brothers Inc., 222 Hartrey Ave., Evanston, IL 60204.**

## ACOUSTIC SILENCER BROCHURE

• A new brochure describing acoustic splitter silencers is now available from AeroAcoustic Corp. These devices are used to block the flow of sound while allowing air to flow through. Their applications are described in the bulletin. Called splitter silencers because they are designed with an array of parallel acoustic baffles, the acoustic performance for a given air flow is determined by the thickness and spacing of the baffles. Statistical information on selecting splitter silencer sizes and dimensions as well as acoustical and aerodynamic performance figures are also featured in the brochure. **Mfr: AeroAcoustic Corp., 4876 Victor St., Jacksonville, FL 32207.**

## AUDIOVISUAL REFERENCE BOOK

• The 12th edition of Audiovisual Market Place 1982 groups 22 sections under three broad areas: Audiovisual Software, Audiovisual Hardware, and Reference. The individual listings within each section contain firm names, addresses, telephone numbers, key personnel, along with product lines, services, activities, and other related details. The AVMP 1982 concludes with a yellow pages section, which provides an alphabetical listing of more than 12,000 individual and firm names from the main text. **Mfr: R. R. Bowker Co., 1180 Avenue of the Americas, New York, NY 10036.**

## TV/VIDEO SYNC PRIMER

• A 16-page primer on the fundamentals of video and associated waveforms has recently been published. The booklet features 13 drawings and three photographs, and includes information on U.S. NTSC broadcast standards and nomenclature, a discussion of PAL, NTSC and SECAM systems of color transmission and a glossary of TV and video terms. Other sections cover theory of operation, typical set-up, specifications and the features and applications possible when a TV/video sync option is added to any currently manufactured HP 1700-series oscilloscope. **Mfr: Hewlett-Packard Company, 1820 Embarcadero Rd., Palo Alto, CA 94303.**

## AUDIO MICROCOMPUTER BOOKLET

• A full color brochure and a 20 page flip chart detailing the operation and features of the Crown BDP-2 audio microcomputer have recently been made available. The brochure provides six pages of text and color illustrations describing the BDP-2 and its features. The flip chart, which is provided free with each unit, provides step by step instructions for set-up and use of the BDP-2 for real time analysis of room frequency response and RT-60 programs. **Mfr: Crown International, 1718 W. Mishawaka Rd., Elkhart, IN 46517.**

**Closing date is the fifteenth of the second month preceding the date of issue.**  
**Send copies to: Classified Ad Dept.**  
**db THE SOUND ENGINEERING MAGAZINE**  
**1120 Old Country Road, Plainview, New York 11803**

**Minimum order accepted: \$25.00**  
**Rates: \$1.00 a word**  
**Boxed Ads: \$40.00 per column inch**  
**db Box Number: \$8.50 for wording "Dept. XX," etc.**  
**Plus \$1.50 to cover postage**

**Frequency Discounts: 6 times, 15%; 12 times, 30%**

**ALL CLASSIFIED ADS MUST BE PREPAID.**

REELS AND BOXES 5" and 7" large and small hubs, heavy duty white boxes.  
**W-M Sales, 1118 Dula Circle, Duncanville, Texas 75116 (214) 296-2773.**

MICROPHONES BY UPS. Quicker. You'll save more with us. All popular models for immediate delivery. **UAR Professional Systems. (512) 690-8888.**

FIRST TIME AVAILABLE. Only from RPM Sound. For rent: Lexicon Super Prime Time Model 97. Fully loaded memory, all options, cassette storage of unlimited programs. **Call (212) 242-2100.**

DISC CUTTING SYSTEM for sale. Gram- pian monaural cutterhead and amplifier, RCA lathe, heated stylus, and vacuum. Excellent condition, \$1,000.00, **call (212) 882-0723.**

ORBAN and LEXICON. All products in stock. FOR IMMEDIATE DELIVERY. **UAR Professional Systems, 8535 Fairhaven, San Antonio, TX 78229. 512-690-8888.**



**ACOUSTIC TEST INSTRUMENTS**  
 USE TO ADJUST EQUALIZERS, OPTIMIZE SPEAKER PLACEMENT, ETC.

- Complete Test Set.....\$449
  - Calibrated Sound Level Meter.....\$199
  - Fractional Octave Pink Noise Generator.....\$339
  - Handbook on Acoustic Testing.....\$10
- Free broch: HALL ENGINEERING, Dept. E5  
 P.O. Box 506, Martinsville, NJ 08836  
 (201) 647-0377

**FOR SALE**

**FREE 32pg Catalog & 50 Audio/Video Applic.**

PWR SUPP. EQ.  
 PHONO. MIC.  
 TRANS. ACN.  
 TAPE, VIDEO,  
 LINE, OSC

Stereo/Mono Pwr Ampl.

8-in/2-out, 12-in/4-out, 16-in/4-out  
 Video & Audio Dist Ampl. TV Audio & Recd Prod Consoles

**OPAMP LABS INC (213) 934-3566**  
 1033 N Sycamore Av LOS ANGELES CA, 90038

AMPEX, OTARI, SCULLY—In stock, all major professional lines; top dollar trad- ins; write or call for prices. **Professional Audio Video Corporation, 384 Grand Street, Paterson, New Jersey 07505. (201) 523-3333.**

USED RECORDING equipment for sale. **Dan (415) 441-8934.**

**PROFESSIONAL AUDIO EQUIPMENT**

Shop for pro audio from N.Y.'s leader, no matter where you live! Use the Harvey Pro Hot Line (800) 223-2642 (except N.Y., Ak. & Hi.). Expert advice, in-depth parts dept., 3/4" video systems available. Broadest selection such as Otari, Quad Eight, Soundcraft, Tascam and more. Write or call for price or product info:

**Harvey Professional Products Division**  
 25 W. 45th Street  
 New York, NY 10036  
 (212) 921-5920

BLANK AUDIO AND VIDEO CASSETTES direct from manufacturer, below whole- sale, any length cassettes: 4 different qualities to choose from. Bulk and reel mastertape—from 1/4-inch to 2-inch. Cas- sette duplication also available. Brochure. **Andol Audio Products, Inc., Dept. db, 42-12 14th Ave., Brooklyn, NY 11219. Toll free 1-800-221-6578, ext. 1, NY residents (212) 435-7322.**

FOR SALE: SCULLY 280 1/2-inch 4-track, mint condition. **RPM Sound Studios, 12 East 12th St., New York City, NY 10003. (212) 242-2100.**

FOR SALE AKG C-24 and other tube type condenser mics. **(415) 441-8934 or 527-6167.**

NEUMANN DISC CUTTING system for sale. SX-74 and SAL-74. Also Neumann AMT-32B Lathe without preview. Make offer to: **Crystal Clear Records, P.O. Box 3864, San Francisco, CA 94119. (415) 824-0225.**

AUDIOHOUSE SELLS, Ecoplate, Valley People, MicMix, Symetrix, **(303) 751-2268.**

FOR SALE—Scully 280 1" 8 Trk. tape machine. No remote or synchmaster. Presently in operation in our tape master- ing facility. \$4,300.00. **Call Chas. at Disk- makers (215) 627-2277.**

QUALITY STEREO CASSETTE duplica- tion in real time. **G.G. Productions, Box 24164, Denver, CO 80231. (303) 751-2268.**

LEXICON, dbx, & UREI. Most items for im- mediate delivery. **UAR Professional Sys- tems, 8535 Fairhaven, San Antonio, TX 78229. (512) 690-8888.**

THE LIBRARY... Sound effects recorded in STEREO using Dolby throughout. Over 350 effects on ten discs. \$100.00. Write **The Library, P.O. Box 18145, Denver, Colo. 80218.**

TECHNICS, BGW, EVENTIDE, AKG, Scully, and many more IN STOCK. FOR IMMEDIATE DELIVERY: **UAR Professional Systems, 8535 Fairhaven, San Antonio, TX 78229. (512) 690-8888.**

ROCKET STUDIOS—All inventory, Teac 90-16, Pioneer 4-2 track, Allen-Heath modified 16 x 8 x 16, Neumann, Ecoplate, AKG, much more, complete studio \$50,000. **(303) 567-2965, (303) 526-1881.**

BRUEL & KJAER Model 2211 Noise Limit Indicator. 12.5 Hz-20 kHz, full set 1/3 and 1 octave filters. Like new condition \$1,750.00.

**Fabrication/Update Industries**  
 6701 Seybold Road  
 Madison, Wisc. 53719  
 (608) 274-6960

Electrodyne 16 x 8 complete: 5000.00  
 dbx 187: 750.00; dbx 154: 350.00  
 Ampex 440 1/2 track 7.5 ips: 2000.00.  
 MCI 16 track JH 100: 14500.00.  
**(513) 258-2463**

**SURPLUS JBL TWEETERS. NEW.** Ideal for disco tweeter arrays or improving sound reinforcement and home loud-speaker systems. Specify choice of bullet or slot lens type. \$80 plus \$2 shipping each. Add sales tax if in NY. **Rosner Custom Sound, 11-38 31 Ave., L.I. City, NY 11106. (212) 726-5600.**

**USED/NEW CONDITION:** MCI JH-110A-8 track, Ampex 456 tape for above. **Paul (816) 753-7388.**

**MASTER THE RECORDING SCIENCE.** Sherman Keene's "Practical Techniques for the Recording Engineer" is a book about the real world of studio recording. Acclaimed by magazines, reviewers, college teachers, studio owners and engineers. 381 pages, 28 chapters (4 on computer mixing). To order send \$29.75 plus 6% (Calif. only) and \$2.75 shipping to: **Sherman Keene Pub., 1626 N. Wilcox No. 677-D, Hollywood, CA 90028.**

**EMPLOYMENT**

**CHIEF ELECTRONICS ENGINEER for leading Intercom Manufacturer located in San Francisco**

Clear-Com is looking for an electronics engineer to assist in the design of new products and be responsible for the management of product development, from prototype to production.

Required qualifications include:

E.E. degree, minimum of 5 years experience in working for a manufacturing company preferably in professional audio products. Must have design experience in linear audio, packaging and P.C. board layout.

Excellent growth opportunity and benefits. Salary open. Send resume or call:

**Robert Cohen**  
 **Clear-Com**  
 intercom systems  
 1111 17th Street  
 San Francisco, CA 94107  
**415-861-6788**

**KHNS WANTS THAT rare bird:** audio engineer with programming/production skills. 3KW public station serving pop. 3,000 has construction/maintenance load for 1/2 engineer w/knowledge of satellite down-linking systems. Now advertising full-time position; placement depends on other radio skills offered. Salary: 19-22M. Interested in relocating to Southeast Alaska? Send resume to: **KHNS, Box O, Haines, Alaska 99827.** If part-time or contract desired, send resume; describe your situation.

**WANTED**

**WANTED: TRANSCRIPTION** discs, any size, speed. Radio shows, music. **P.O. BOX 724—db, Redmond, WA 98052.**

**SERVICES**

**CUSTOM RECORDING SERVICE:** Tapes, discs and cassettes; stereo and mono; live recording and copies; editing, masters. High quality at reasonable rates. **Audio-Tech Laboratories, 1158 Stewart Avenue, Bethpage, NY 11714. (516) 433-0171.**

**ACOUSTIC CONSULTATION—**Specializing in studios, control rooms, discos. Qualified personnel, reasonable rates. Acoustilog, Bruel & Kjaer, HP, Tektronix, Ivie, equipment calibrated on premises. Reverberation timer and RTA rentals. **Acoustilog, 19 Mercer Street, New York, NY 10013 (212) 925-1365.**

**MAGNETIC HEAD** relapping—24 hour service. Replacement heads for professional recorders. **IEM, 350 N. Eric Drive, Palatine, IL 60067. (312) 358-4622.**

**VIF INTERNATIONAL** will remanufacture your Ampex or Scully (Ashland/Bodine) direct drive capstan motor for \$200. Average turn around time—2-3 weeks. For details write **PO Box 1555, Mtn. View, CA 94042, or phone (408) 739-9740.**

**CUTTERHEAD REPAIR SERVICE** for all models Westrex, HAECO, Grampian. Modifications done on Westrex. Quick turnaround. New and used cutterheads for sale. Send for free brochure: **International Cutterhead Repair, 194 Kings Ct., Teaneck, N.J. 07666. (201) 837-1289.**

**INSTRUCTION**

**SHERMAN KEENE CORRESPONDENCE** course. Author of acclaimed textbook "Practical Techniques for the Recording Engineer" invites you to study recording at home. Course includes reading and homework assignments in two textbooks with personal dialog via cassette. Eight lessons per level, 3 levels. \$250 per level. For info write: **Correspondence Course, 1626 N. Wilcox No. 677D, Hollywood, CA 90028.**

**UH-OH!**

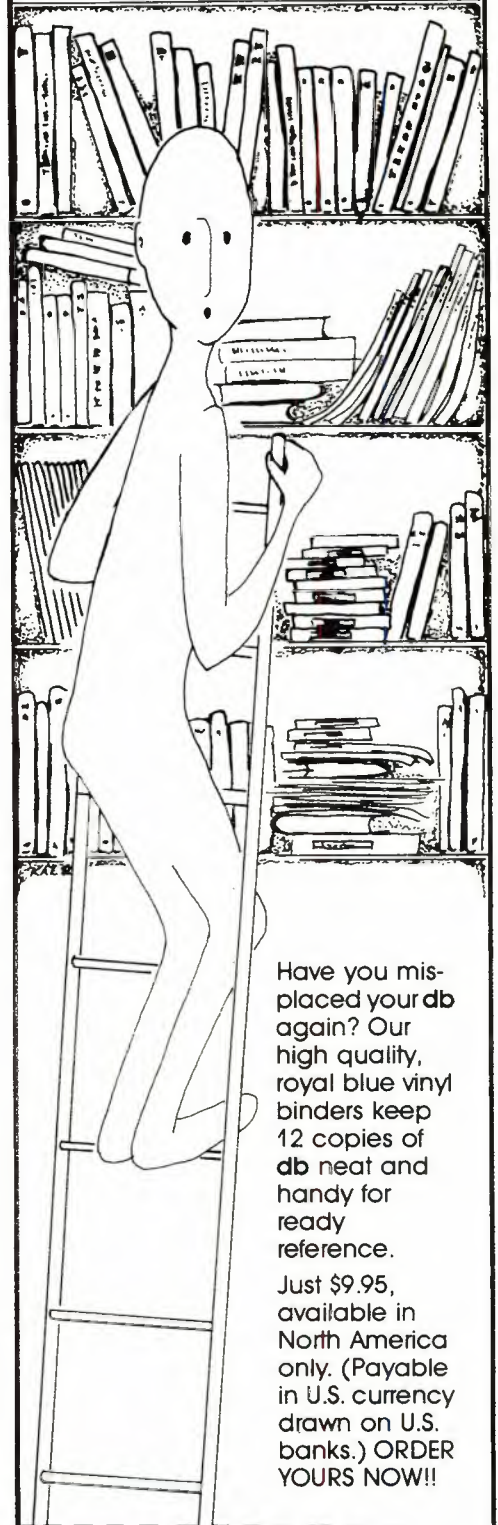

Have you misplaced your db again? Our high quality, royal blue vinyl binders keep 12 copies of db neat and handy for ready reference.

Just \$9.95, available in North America only. (Payable in U.S. currency drawn on U.S. banks.) **ORDER YOURS NOW!!**

**Sagamore Publishing Co., Inc.**

1120 Old Country Road  
 Plainview, NY 11803

**YES!** Please send \_\_\_\_\_ db binders @ \$9.95 each, plus applicable sales tax. Total amount enclosed \$ \_\_\_\_\_

Name \_\_\_\_\_

Company \_\_\_\_\_

Address \_\_\_\_\_

City \_\_\_\_\_

State/Zip \_\_\_\_\_

# People..Places..

• **Geoffrey Langdon** has recently joined the staff of **Sennheiser Electronic Corporation** in the capacity of technical manager. Mr. Langdon had previously been the technical manager for **AKG Acoustics, Inc.**

• **Steve Waldman, Charles "CJ" Flynn** and **Rodney Pearson** have announced the formation of **Audio Kinetics Inc.**, to import and distribute the Audio Kinetics "Q-Lock" synchronizer to the United States and Central and South America.

The new company is the result of the merger between **Quintek**, the former importer and distributor, and **Screen Sound**, which held a software license to write specialized operating software for the film and video business. These programs and other new developments will continue to be available from Audio Kinetics. Latest installations for these systems have been to **Lucasfilms, Zoetrope** in Northern California, **Warner Bros., Lion's Gate** in Southern California, **Teletronics** and **National Recording & Video Center** in New York.

• **William W. Weston** has been named Eastern area sales supervisor for **3M's Professional Audio/Video Equipment** line. Weston will supervise sales activities of five East Coast account representatives for the company's digital audio systems, graphics generators and video tape recorders. Previously, he was senior account representative for the video line in the mid-Atlantic states region. Weston continues to work out of 3M's Gaithersburg (Maryland) office.

• **Robert Hecht** has been appointed eastern regional sales manager for **Sony Professional Audio Products**. The announcement was made by **Nick Morris**, general manager of the division. Mr. Hecht will oversee all Sony Professional Audio Product eastern regional sales and the marketing of all professional products, reporting directly to national sales manager **Jim Guthrie**. Mr. Hecht has spent eleven years in electronic marketing and sales, founding his own company to manufacture and distribute loudspeakers. He has also directed wholesale and retail operations for **Stereo Components Systems** and **Tech Hi Fi**.

• **Stanley W. Faught**, general manager of the **Magnetic Tape Division (MTD)**, has been elected vice president of the corporation by **Ampex Corporation's** board of directors. "This promotion recognizes his contributions to the continuing success of Ampex's magnetic tape products," said **Arthur H. Hausman**, chairman of the board, president, and chief executive officer of Ampex. Faught was named general manager of MTD in March 1981 after a six-year career at Ampex's Colorado Springs, Colorado, facility. During the last four years he was responsible for the manufacture of audio-video products in Juarez, Taiwan, and Cupertino, California.

• **Bengt O. Orhall**, president, **AB Film-Teknik**, Solna, Sweden, is the first international governor of the **SMPTE**, it was announced by SMPTE president **Charles E. Anderson, Ampex Corp.** Orhall's presence on the SMPTE Board of Governors is the first time that SMPTE's international members are represented by their own governor on the Board. It demonstrates SMPTE's interest in recognizing its international membership and broadening its international representation. Anderson said that Orhall has been asked to work with SMPTE's Chairman of the International Relations Committee **William Connolly, CBS**, to establish a permanent method of nominating and electing international governors. Anderson pointed out that the international governorship is one of the most significant developments in recent SMPTE history.

• **Walter Sear** of **Sear Sound**, 235 West 46th Street is pleased to announce the appointment of **Chuck Irwin** to the position of director of recording. Mr. Irwin is well known in the industry. His extensive background includes a wide range of experience in all aspects of the recording arts. His credits include the films "Prince of the City," "Fame," "Hair," "Rhinoceros," and "Angel and Big Joe." His record credits include work with such artists as **Chuck Mangione, Mike Seeger, Liza Minnelli, Galt Macdermot, Morgana King** and many others. Sear Sound is the only major recording studio that features the "Vacuum Tube Sound," created by using authentic vacuum tubes in microphones and console.

• **Shure Brothers Inc.** has announced the appointment of **M. Travis Ludwig** to the position of technical coordinator, distributor microphone products. His responsibilities include field research, product development, market planning, and product sales training. Ludwig previously worked as a commercial sound products specialist for the **Electro-Voice Division of Gulton Industries**.

• **Chris Ware** has been appointed a sales engineer and assigned to head the new Dallas office of **Studer Revox America**. According to the firm's president, **Bruno Hochstrasser**, Ware will assume primary responsibility for sales and service of Studer professional products in Texas, New Mexico, Oklahoma, Arkansas, and Louisiana. Ware previously served in a variety of broadcast engineering capacities, gaining experience in maintenance, facilities design, installation, and audio mixing. His two most recent positions, at **WFAA-TV** and **Southwest Producers Service**, both of Dallas, have given him a strong background in both audio and video technologies.

• **JRF Company** has recently moved to new and larger quarters in Hopatcong, NJ. The firm specializes in selling and servicing magnetic recording heads and assemblies. By moving to larger quarters, JRF will now be able to stock a wide variety of new heads required for direct replacement. Its expanded laboratory will also enable the firm to offer superior relapping and optical alignment service. Even worn, unserviceable heads will be restored to original performance specifications. Generally, re-conditioned replacement heads as well as a large stock of new heads from mono to 24-track will be available for immediate delivery; 24-hour repair service is also available for prior arrangement.

• **Lew Barrett**, principal of Seattle, Washington-based **North Shore Marketing**, has been named **James B. Lansing Sound, Inc.'s** "Pro Rep of the Year." Making the presentation, held during JBL's recent national sales meeting in Anaheim, California, was Professional Division manager **Ron Means**. Barrett has represented JBL since the establishment of North Shore Marketing three years ago. The territory he covers for the company includes the states of Alaska, Washington, Oregon and Montana.



# ... & Happenings

## What's HAPPENINGS?

• No, our copy editor is not asleep. "Happenings" is (are)? an expanded version of our long-running "People, Places, Happenings."

What's it all about? Glad you asked. We get lots of "over the transom" stuff delivered almost every day; new product announcements, new literature, personnel changes, you-name-it. Most of it goes into clearly-marked categories, such as those just named. Some of it goes into the circular file (we seem to be on everyone's list these days).

But some of it just doesn't fit into our neatly-ordered Department of Clearly-marked Categories. So, we're opening up another category, in which we can pass along some of the more-intriguing items that refuse to be catalogued elsewhere. Some of these may be little more than an editorial post-script on a new product. Others

may be an extended comment about something in the news. There may even be a letter or two that needs some additional comment. And who knows what else?

We probably won't have much to say about who's recording in what studio this month. Those announcements come in by the ton, and in order to be fair, we should really print all of them. It could easily take up the entire magazine, and with the exception of your studio, it's about as exciting as reading the yellow pages. Besides, as G and S (an early British production company) once said, "When everyone is somebody, then no one's anybody."

So, here's our first installment of "Happenings." Let us know what you think. If it's printable, we'll try to fit it into a future Happenings. If it's not, we might do it anyway.

## '...More and More Japanese Influence'

• In our March issue, **Almon Clegg** noted that pro audio will be seeing more Japanese influence in the future. Almost as he wrote (that is, on February 3), **Sony Corporation** announced the acquisition of **MCI, Inc.** And so, the largest manufacturer of multi-track recorders and consoles in the U.S. has become "MCI/Sony."

The contributions of MCI and Sony certainly don't need recounting here. Separately, they enjoy favorable positions within the industry. Together, MCI/Sony will certainly prove to be a formidable influence on future audio/video recording technology. In fact, the new operation is already exploring stereophonic AM and TV as a major new market for professional audio hardware.

In the meantime, **Universal Studios** and **Disney Productions** are continuing their war against Sony and—it seems—the world in general. Based on an appeal by Universal and Disney, the courts ruled that non-commercial home videotaping off-the-air is against the law. Late last year, Universal filed a second suit, this time against 42 VCR and blank tape manufacturers. According to an article in *New York* magazine (March 15, 1982), Disney did not join this suit, and won't say why not. (The two had earlier sued Sony, as our April editorial pointed out.)

The *New York* article speculates that the Disney tactics may be throwing a little too much mud on Mickey's image, and it quotes EIA vice-president Jack Wayman as saying, "The whole issue is not copyright protection, but pure and simple greed." In other words, the plaintiffs are looking for more royalties.

This position is given further credence by a Sony Petition for Review to the Supreme Court that points out that Universal and Disney have already admitted that they have suffered no damages, and cannot show that home recording reduces the potential market for their productions. Needless to say, Universal and Disney are opposing a review by the Supreme Court. Meanwhile, film industry lobbyists are now urging Congress to impose substantial royalties on all home videotape recorders and on all tape.

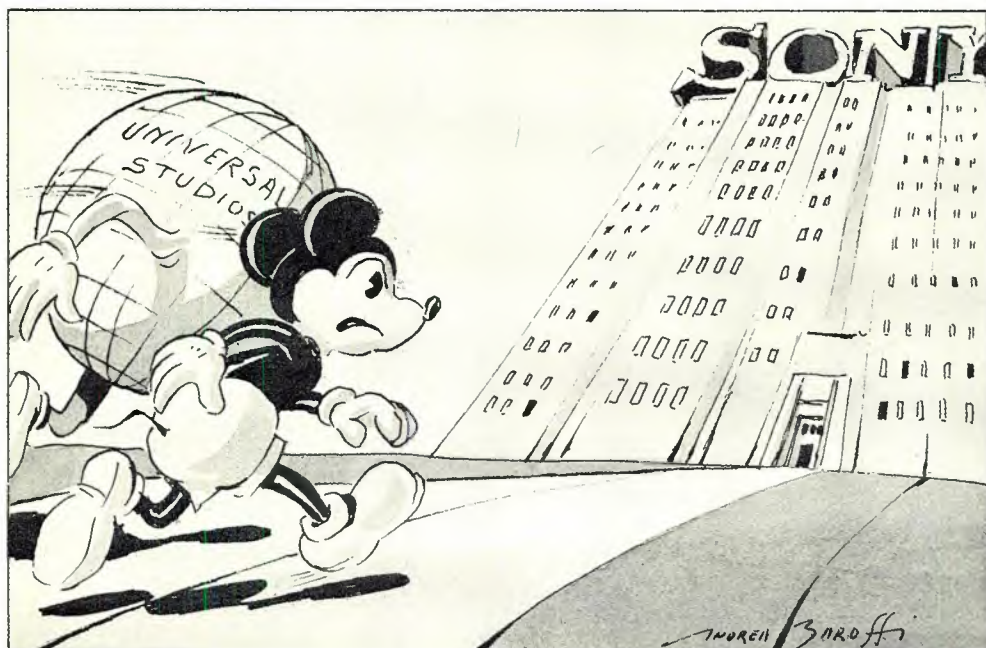

continued on next page

# ..More Happenings

Joining the fray, the **Home Recording Rights Coalition** has retained former FCC chairman **Charles D. Ferris** as its counsel. (For the sake of the Coalition, let's hope he'll move a little faster than he did at the Commission.) The Coalition opposes the imposition of a royalty "tax" on the grounds that it would be unfair to consumers, harmful to small businesses, and is not justified by either law or the economics of the recording industry.

Although all of the above is directed at the videotape industry, it's reasonable to assume that the outcome will have a ripple effect which will eventually make its presence felt in the audio-only industry as well. Maybe it's time to start choosing up sides?

In the meantime, no one can accuse Sony of being asleep at the switch (although one may wonder where the rest of the industry is). **WNET** (Channel 13) president **John Jay Iselin** recently announced that Sony will donate as many as 100 Betamax video cassette recorders to the top supporters of the public TV station. Presumably, Channel 13 contributors will not be tempted to tune in "The Wonderful World of Disney."

## AES News

• After much discussion, the future convention schedule for the **AES** has been announced. As most readers know by now, the Society's schedule of three conventions a year has been trimmed. The last convention was in Montreux, in March, and the next one will not take place until next fall. It will be held at the Disneyland Hotel (will Sony be there?) in Anaheim, California, October 22-25, 1982. The 1983 conventions will be in Eindhoven, Holland (March), and New York City (September or October). Dates and locations will be announced shortly.

To fill in the convention gap, the **AES** has just concluded its first 3-day Technical Conference on "The New World of Digital Audio." Attendance was limited to 300 participants, who heard presentations on the digital disc, high-density recording, data protection and preservation, and other topics in the digital domain. The conference took place at the Rye Town Hilton (Rye, New York) early this month. We'll be back later with a full report.

## Computer Programs

• Way back in February, 1971, **db** published a feature article by **Charles W. King** on "Attenuation Pads." Later on (March, May, October, 1980), a series of **db** Application Notes presented some BASIC computer programs for calculating T and H pad values.

And still more recently, reader **John L. Forbes** wrote in to describe his "APAD" program, which calculates the resistance values for T, PI, H and O pads. Written in Applesoft Floating-point BASIC, the program does all calculations for the four forms of pad, checks for minimum insertion loss, and then presents a CRO display of each schematic, with all resistors labelled.

An optional "APAD.2" version of the program includes instructions for generating a hard-copy printout (on an Epson MX-80 printer). The programs are too long to be reprinted here, but we can report that our sample (cassette) copy worked quite well—and on the first try! Mr. Forbes is willing to supply cassette or diskette copies, with documentation, at \$7.00 (cassette) and \$15.00 (diskette) each. Write to him at 21832 99th Avenue, Snohomish, Washington 98290.

Apparently, **Eventide Clockworks** has come to the conclusion that not enough **Apple Computer** owners have bought their Real-time Audio Spectrum Analyzer. To make further stalling even more difficult, Eventide has devised a sinister plot: just send them a blank 5¼" diskette, and they will fill it full of enticing 2- and 3-D color graphics simulations and send it back to you.

## Want to Buy a Stolen Microphone?

• Probably not, and especially if it was stolen from *you!* But that's just what happened to an **APRS** member who rediscovered a long-lost microphone. When the microphone turned up at the manufacturer for repair, the owner found he could not legally claim it, since he had neglected to report its loss in the first place. The studio in possession of the microphone disclaimed any knowledge of its history, and the true owner wound up buying his own mic, for the second time.

To help avoid this sort of unpleasantness, here are some suggestions from the **APRS** (Association of Professional Recording Studios): Don't rely entirely on the manufacturer's serial number, especially if that number appears only on an easily-replaceable part of the microphone. Approach engraving your own number with extreme care, since this could be seen as disfiguring the microphone and reducing its resale value. On the other hand, outside engraving services are expensive, and potentially dangerous on delicate equipment. Report missing, lost and stolen equipment as soon as possible, so that if the equipment eventually comes to light, a proper claim can be made.

The **APRS** is preparing a leaflet with further notes on keeping track of disappearing microphones, and giving advice on how lost microphones might be recovered.

Eventide's Spectrum Analyzer plug-in card and optional Specsystem software perform all sorts of neat tricks, including displays of reverberation time (3-D), spectral surface modes, real-time spectrum analysis, etc. All of these are demonstrated on the diskette, and you Apple owners can get hooked by sending a blank diskette to Eventide Clockworks, 265 West 54th Street, New York, NY 10019.

EVENTIDE SPECTRAL SURFACE PLOTTER

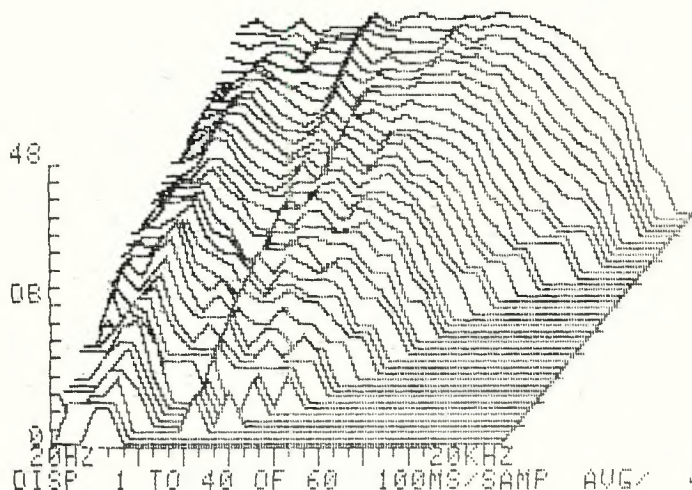

# ONE-INCH THE NEW STANDARD.



In the world of SMPTE there are no excuses. Get it now and get it right, in sync, on time. No matter how smart your SMPTE controller/editor is, you can't work fast if the recorder can't keep up. Our one-inch 85-16B has the high motor torque and Tach rate (30 pulses per second) you need to achieve fast "lookup" and stable operation with today's new editing systems. It will "park" where your controller tells it to, on the cue, every time. With the 85-16B you only lose one track to code. Our superior control of crosstalk gives you 15 fully usable tracks for Audio! No need to waste a track as a guard band to keep code out of the mix! You get everything from the wheels to the reels: the console, the built-in dbx\* and TASCAM full function record controls. With TASCAM, you can always get what you want without paying for extras you don't need.

In Video production you have to think big, but if you think **Hard** you'll see that TASCAM means business—Multitrack, Multi-image and much more. Talk to your dealer to get our equipment working on your bottom line.

**TASCAM**

TEAC Production Products

Circle 11 on Reader Service Card

\*dbx is a trademark of dbx, Inc.  
Newton, MA.  
Copyright 1982, TEAC Corporation of  
America, 7733 Telegraph Rd.,  
Montebello, CA 91640

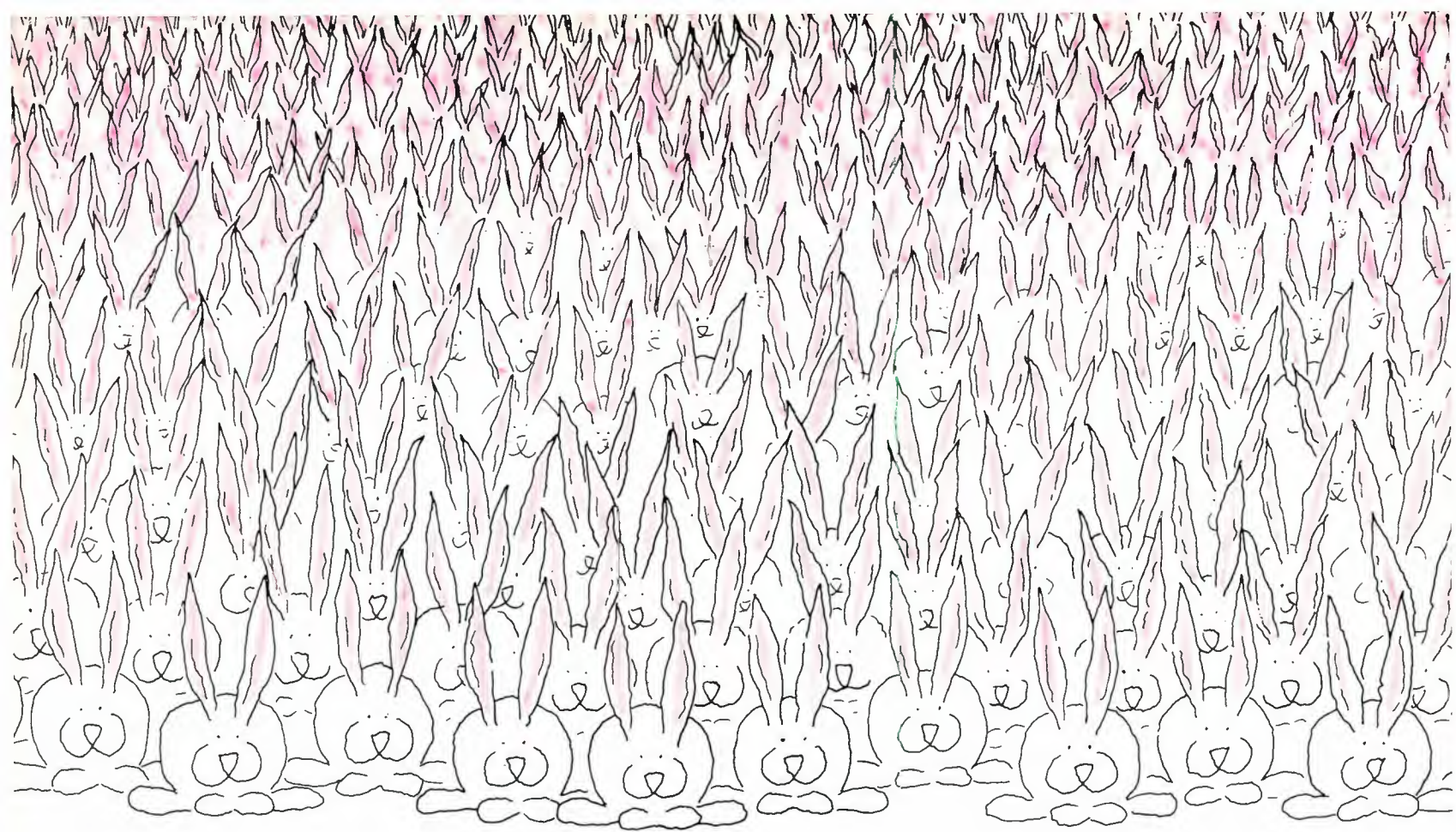

## We're going to share our expertise in duplication.

We know a lot about duplication. After all, millions of our cassettes and open reel tapes are duped every day under conditions that can make you hopping mad. So, we had to learn how to make cassettes that sound terrific, last, and are as trouble free as possible.

Maxell gives you the cassettes you need, with the quality you must have. Tape ends stay anchored. Our shells have a five screw construction to eliminate warping. Maxell devel-

oped a four-function leader with A/B side indications, directional arrows, non-abrasive head cleaner and five-second cue to set timing and level. In performance, highs are clear and lows are solid and pleasing. On the business side, supplies are delivered when you need them. What more do you need to know about duplicating cassettes? Call us, we'll give you the name of your nearest Maxell distributor, quick as a bunny.



**maxell**<sup>®</sup>

PROFESSIONAL / INDUSTRIAL DIVISION

**Our success is magnetic.**

Maxell Corporation of America, 60 Oxford Dr., Moonachie, N.J. 07074 (201) 440-8020

Circle 12 on Reader Service Card

[www.americanradiohistory.com](http://www.americanradiohistory.com)