

JANUARY 1958 • 35 CENTS

audiocraft

for the **HI-FI** hobbyist

How to use
mixers for
recording

Handy switch
box for test
instruments

Report on
Argos speaker
enclosure kit

Perfectionist's Power Amplifier

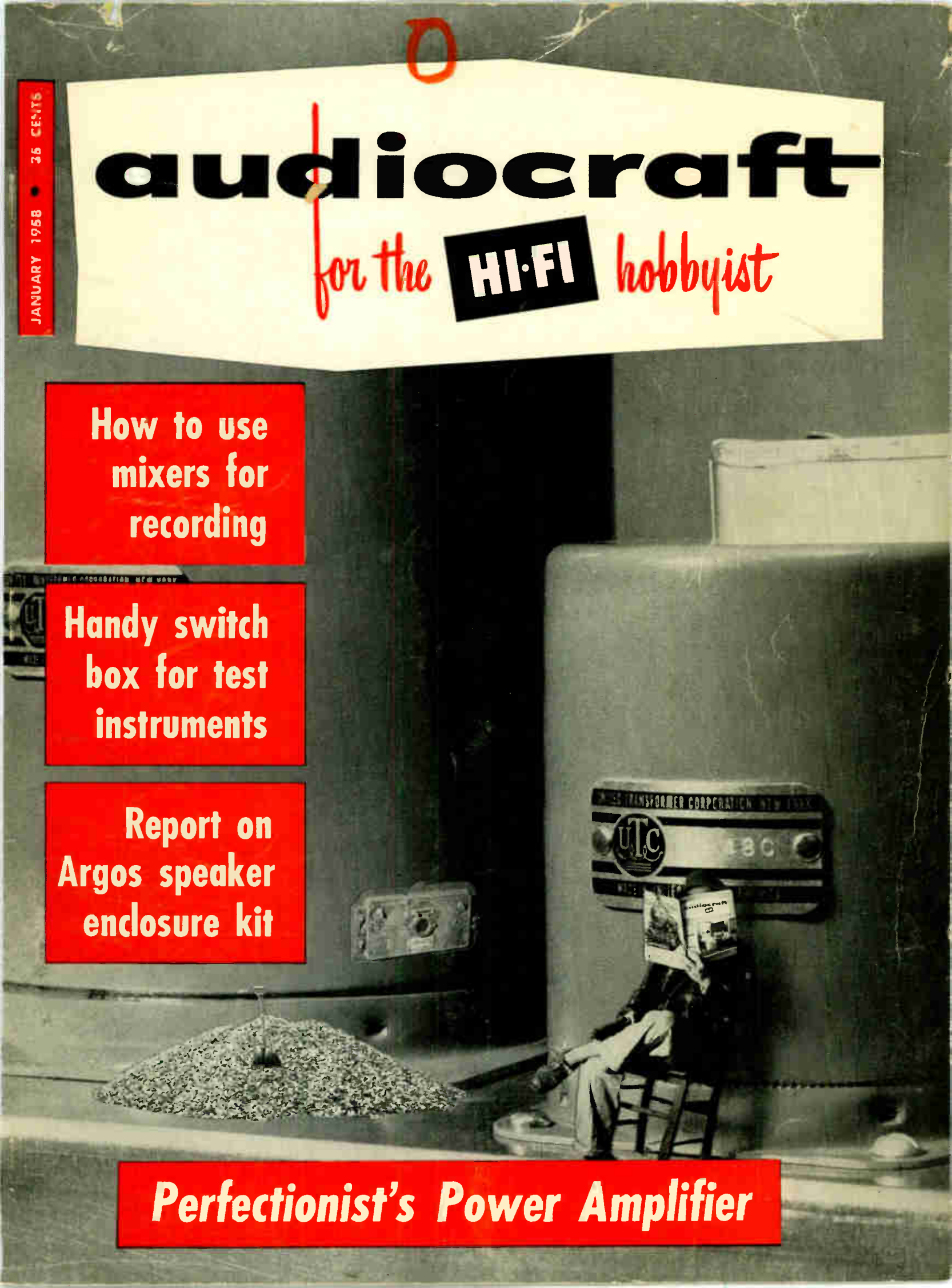

He who is fortunate enough to own the Garrard 301 Transcription Turntable and the Garrard TPA/10 Tone Arm can enjoy the unique pleasure of knowing that *bis* is the finest... the handsomest... record-playing combination in the entire high fidelity galaxy. A pair of great products... great because they reflect 35 years of skill and the standards of leadership. No gadgets... no compromises... only the time-proven features which guarantee continuing, undeviating excellence.

Garrard

**WORLD'S FINEST
RECORD PLAYING
EQUIPMENT**



*There's a Garrard
for every
high fidelity system*



**Model 301 PROFESSIONAL
TRANSCRIPTION TURNTABLE**
Each speed variable!
Each unit with its own
performance test report. \$89.00



**Model RC98 4-SPEED SUPER
AUTO-MANUAL CHANGER**
Continuous + or - variable
control on all speeds. \$67.50



Model TPA/10 TRANSCRIPTION TONE ARM
—Professional performance,
jewel-like construction
and exceptional
versatility. \$24.50



**Model RC88 4-SPEED DELUXE
AUTO-MANUAL CHANGER**
Exclusive pusher platform
protects your records. \$94.50



**Model T Mark II
4-SPEED MANUAL PLAYER**
A superior unit for quality
budget systems. \$32.50



**Model RC121 4-SPEED MIXER
AUTO-MANUAL CHANGER**
Fine performance with economy
and compactness. \$42.50

For information, write: Dept. GA-98.

GARRARD SALES CORPORATION, PORT WASHINGTON, N. Y.

FREE... ANY 3

of these superb High-Fidelity

12" COLUMBIA LP RECORDS

if you join the Columbia Record Club now—and agree to purchase 4 selections during the coming 12 months



Two delightful and romantic ballet scores by Offenbach and Chopin



Definitive performances of three best-loved Beethoven sonatas



Johnny Mathis sings 12 favorites — Day In Day Out, Old Black Magic, etc.

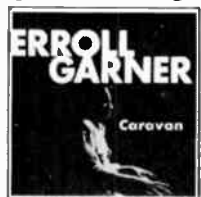

Erroll Garner plays Caravan, No Greater Love, Memories of You, etc.



Tenderly, Deep Purple, Soon, Laura, September In The Rain, 7 others



Complete score! I Could Have Danced All Night, The Rain In Spain, etc.



7 exciting new jazz improvisations by two great modern combos



Duchin plays The Man I Love, April Showers, Am I Blue?, Brazil—11 more



Suave arrangements of Embraceable You, Somebody Loves Me—12 more



The Moon of Manakoora, Lotus Land, Poinciana, Jamaican Rumba, etc.



Armstrong and his All-Stars. 10 numbers from triumphant tour abroad



Stunning hi-fi performances of the "Firebird" and "Romeo and Juliet"



Doris Day sings The Song Is You, But Not For Me, Autumn Leaves—9 more



Emperor Waltz, Blue Danube, Vienna Life, Gypsy Baron Overture—2 more



12 Sinatra favorites — Mad About You, Love Me, Nevertheless, etc.

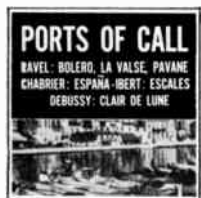

A romantic musical tour —Ormandy and The Philadelphia Orchestra



Rodgers & Hammerstein's fabulous hit, with Nelson Eddy as Curly



3 Gershwin works—Concerto in F, Rhapsody in Blue, American in Paris



12 inimitable Elgart arrangements — ideal for listening or dancing



Eight of the best-loved melodies of all time — magnificently performed



America's favorite quartet sings Love Walked In and 11 others



Benny Goodman and his Original Orchestra, Trio and Quartet. 11 numbers



6 works: Symphony No. 3, Academic Festival Overture, 4 Hungarian Dances



The complete score of Lehár's operetta—Vilja, Maxim's, Women, etc.

- ★ You receive, at once, any 3 of these records—FREE. One is your gift for joining, and the other two are your Bonus records "in advance"
- ★ After you have purchased only four records, you receive a 12" Columbia Bonus record of your choice FREE for every two additional selections you purchase from the Club
- ★ You enroll in any one of the four Club Divisions: Classical; Jazz; Listening and Dancing; Broadway, Movies, Television and Musical Comedies
- ★ Every month you receive, FREE, a new issue of the Columbia Record Club Magazine — which describes all forthcoming selections
- ★ You may accept or reject the selection for your Division, take records from other Divisions or take NO records in any particular month
- ★ Your only membership obligation is to buy four selections from the more than 100 to be offered in the coming 12 months. You may cancel membership any time thereafter
- ★ The records you want are mailed and billed to you at only \$3.98 (original cast Musical Shows somewhat higher), plus small mailing charge
- ★ You must be delighted with membership or you may cancel it by returning the free records within 10 days

COLUMBIA LP RECORD CLUB
TERRE HAUTE, INDIANA

FREE—ANY 3—VALUE UP TO \$12.94—MAIL ENTIRE COUPON NOW!

COLUMBIA LP RECORD CLUB, Dept. 456
TERRE HAUTE, INDIANA

Please send me as my FREE gift the 3 records whose numbers I have circled at the right — and enroll me in the following Division of the Club:

(check one box only)

- Classical Listening and Dancing Jazz
 Broadway, Movies, Television and Musical Comedies

I agree to purchase four selections from the more than 100 to be offered during the coming 12 months . . . at regular list price, plus small mailing charge. For every two additional selections I accept, I am to receive a 12" Columbia Bonus record of my choice FREE.

Name..... (Please Print)

Address.....

City..... Zone..... State.....

CANADA: Prices slightly higher, address 11-13 Soho St., Toronto 2B
If you wish to have this membership credited to an established Columbia Records dealer, authorized to accept subscriptions, please fill in the following information:

Dealer's Name.....

Dealer's Address.....

© Columbia Records Sales Corp., 1967 "Columbia" "LP" "Mercury Pop"

CIRCLE 3 NUMBERS BELOW:

1. Eddy Duchin Story
2. Beethoven: 3 piano sonatas
3. Erroll Garner ("Caravan")
4. Gaité Parisienne; Les Sylphides
5. Easy To Remember—Luboff Choir
6. My Fair Lady—Orig. Broadway Cast
7. Brubeck and Jay & Kai
8. Gershwin Hits—Percy Faith
9. Sinatra—Adventures of the Heart
10. Ambassador Satch
11. Firebird; Romeo and Juliet
12. Day By Day—Doris Day
13. Johann Strauss—Waltzes
14. Lure of the Tropics—Kostelanetz
15. Ports Of Call
16. Oklahoma!
17. Levant Plays Gershwin
18. The Elgart Touch
19. The Great Melodies of Tchaikovsky
20. Suddenly It's the Hi-Lo's
21. King of Swing—Benny Goodman
22. Brahms: Symphony No. 3
23. The Merry Widow
24. Wonderful, Wonderful—Mathis PE-1

something wonderful has happened in high fidelity



a record changer with turntable quality performance

The new Glaser-Steers GS Seventy Seven made its debut at the 1957 New York High Fidelity Show. Thousands of people filed through the demonstration rooms to see and hear it perform.

Response was sensational. Listeners were astounded at the quality of the sound — the absence of wow and flutter, and — the absence of rumble, even with the bass sharply boosted.

Three GS-77 features received the most comment: Speedminder, Turntable Pause, and the Tone Arm.

SPEEDMINDER is the super automatic setting on the speed selector knob at which the user has virtually nothing to do but place the records on the spindle and select the correct stylus.

With the standard groove stylus in position, the changer automatically plays at 78rpm. With the microgroove stylus in position the changer automatically operates at 33 $\frac{1}{3}$ and 45rpm, playing both speed records intermixed in any sequence.

SPEEDMINDER also protects both stylus and record, for you can detect immediately if you are using the incorrect stylus.

The changer can also be 'dialed' to play 16 $\frac{2}{3}$, 33 $\frac{1}{3}$, 45 or 78rpm, automatically or manually.

TURNTABLE PAUSE brings to the automatic GS-77 all the gentleness of record handling associated with manual turntables. In the GS-77 — and only in the GS-77 — the turntable pauses during the change cycle and resumes motion only after the stylus is in the run-in groove of the next record.

This eliminates the surface grinding which takes place in conventional changers where the record drops onto a rotating record. Turntable Pause protects your records, and adds many, many plays to their useful life.

The **TONE ARM** of the GS-77 is another example of precision engineering — evident from the very moment you lift and handle it. Movement, laterally as well as

vertically, is as smooth and free from friction drag as you'd expect in a high quality transcription arm.

Fundamental resonance of the arm is well below the audio band, and of extremely low amplitude. Acoustical isolation is also used to prevent vibration feedback through the arm pivot.

Dynamically balanced on hardened steel pin bearings, the arm will track at low stylus pressures recommended for modern cartridges. And stylus pressure between the first and tenth record in a stack will not vary beyond 0.9 gram.

... and there is much, much more!

See *all* the GS-77 features! See the advanced, years-ahead styling. See why music lovers everywhere hail this American contribution to high fidelity.

\$59.50 less cartridge

For descriptive literature, write: AU-1
GLASER-STEERS CORPORATION
20 Main Street, Belleville 9, New Jersey
In Canada: Glaser-Steers of Canada, Ltd., Trenton, Ont.
Export: M. Simons & Sons Co., Inc., N. Y. 7.

audiocraft

THIS MONTH'S COVER: Just to prove that everything need not be deep and ponderous in audio, we begin a fanciful photographic journey into the sometimes strange and intricately mysterious realm of audiophilia. This month we unveil the usually unseen engineer who kindles the tubes in our "Perfectionist's Power Amplifier." Photo by Phil Geraci.

Roy F. Allison
Editor
Eleanore B. Wright
Assistant to the Editor
Philip C. Geraci
Associate Editor
Ruth M. Martin
Production Editor
Roy Lindstrom
Art Director
Eleanor Gilchrist
Art Assistant
R. D. Darrell
J. Gordon Holt
Joseph Marshall
Contributing Editors

Charles Fowler
Publisher
Warren B. Syer
Associate Publisher
Claire Eddings
Advertising Sales Manager
Frank R. Wright
Office Manager
Arthur J. Griffin
Circulation Manager
Frances A. Newbury
Manager, Book Division



THE MAGAZINE FOR THE HI-FI HOBBYIST

JANUARY 1958

Volume 3 Number 1

The Grounded Ear <i>What's new in sound reproduction</i>	4	Joseph Marshall
Book Reviews	6	Richard D. Keller
Audionews	12	
Editorial <i>Forecast for stereo discs</i>	15	
Readers' Forum	15	
Perfectionist's Power Amplifier <i>Complete instructions for a performance-guaranteed instrument</i>	16	Ben Zale
The Argos Californian, Jr., Speaker Kit <i>An AUDIOCRAFT kit report</i>	20	
Practical Gadget for Gadgeteers <i>Solve test-lead problems with this switching box</i>	22	George K. Marshalsea
Puzzlements <i>A discussion of loudspeaker problems</i>	24	Norman H. Crowhurst
Using Test Instruments <i>How RF signal generators work</i>	26	Donald Carl Hoefler
Transistors in Audio Circuits <i>Part VIIIb: Volume controls, mixers, equalizers, and tone controls</i>	28	Paul Penfield, Jr.
Tape News and Views <i>Simple circuits for easy-to-build mixers</i>	30	J. Gordon Holt
Basic Electronics <i>Chapter XXI: Output impedance matching in down-to-earth language</i>	32	Roy F. Allison
Sound-Fanciers' Guide <i>Reviews of exceptional disc and tape records</i>	34	R. D. Darrell
Audio Aids <i>Short-cuts for the experimenter</i>	36	
A Simplified "Phantom Channel"	37	
Professional Directory	46	
Advertising Index	48	

ADVERTISING

Main Office — Claire Eddings, The Publishing House, Great Barrington, Mass. Telephone: Great Barrington 1300.

New York — Frederick H. Wallin, 280 Madison Ave., New York 17, N.Y. Telephone: Murray Hill 3-4449, 3-4450.

Chicago — John R. Rutherford & Associates, Inc., 230 East Ohio St., Chicago 11, Ill. Telephone Whitehall 4-6715.

Los Angeles — Brand & Brand, Inc., 6314 San Vicente Blvd., Los Angeles 48, Calif. Telephone Webster 8-3971.

Audiocraft Magazine is published monthly by Audiocom, Inc., in Great Barrington, Mass. Telephone: Great Barrington 1300. Editorial, publication, and circulation offices at: The Publishing House, Great Barrington, Mass. Subscriptions: \$4.00 per year in the United States and Canada. Single copies: 35 cents each. Editorial contributions will be welcomed by the editor. Payment for articles accepted will be arranged prior to publication. Unsolicited manuscripts should be accompanied by return postage. Entered as second-class matter October 1, 1955, at the post office, Great Barrington, Mass., under the act of March 3, 1879. Additional entry at the post office, Pittsfield, Mass. Printed in the U. S. A. by the Ben Franklin Press, Pittsfield, Mass. Copyright 1958 by Audiocom, Inc. The cover design and contents of Audiocraft Magazine are fully protected by copyrights and must not be reproduced in any manner.

The Grounded Ear

by Joseph Marshall

Stereo Growing Up

This season's high-fidelity shows make clear that the industry is looking forward to a boom in stereo in the next few years. Stereo sound was so commonly demonstrated that, after the first few moments, one took it for granted.

The long-heralded stereo discs¹ were demonstrated in two different forms, by London Records and Westrex (of California); there was talk of commercial production in about a year. Fairchild had a stereo version of its cartridge. Pilot had trial models of deluxe stereo preamps, with twin VU meters and twin phono channels for stereo discs; other equipment makers also showed two-channel equipment. Not many record companies were exhibiting, but virtually all of those present had stereo tapes.

Two trends seemed significant to me: first, exploitation of stereo's greatest virtue, and second, correction of its biggest shortcoming. The feature of stereo that is acknowledged by everybody is its capacity for making a 50¢ investment more spectacular to most ears than a dollar investment in monaural. Especially is this true of speaker systems. Two small speakers in a stereo pair, even if they don't cover the final octaves at the top and bottom at all, and lack purity and cleanness at the extremes of their range, may nevertheless impress the ear more at first hearing than a superb single-channel system costing several times as much and capable of covering the full range far more faithfully. Similarly, two medium-quality, low-power amplifiers, in a stereo system, may approach the performance (especially in definition) of a single superb high-power amplifier.

Clearly, the industry is ready to exploit this virtue. It is encouraging to note, however, that there is little tendency so far to use this virtue as an excuse for inferior design and performance. There has been, for example, a considerable improvement in the quality of sound produced by the small compact speaker systems, and I refer not only to the acoustic-suspension types which deliberately exploit compactness to produce extremely high quality, but

to those using bass-reflex and horn principles as well. There were many bass-reflex systems of small size which produced an impressive sound. EICO, for example, was showing a pair of very small horns designed by Stuart Hegeman which also were very impressive.

More significant to me, however, because it promises greater progress toward the ideals of sound reproduction, was the evidence of some success in the effort to correct stereo's deficiency—the "hole-in-the-middle" effect. This and the exaggerated directionality, which is partly the result of the hole in the middle, have been the principal faults preventing complete acceptance of stereo by some of the most critical listeners. Several different approaches are being taken to correct this fault. The first is by the recording companies, who are generally forsaking the tendency to emphasize and exaggerate directionality in the recording process. Mike placement and the arrangement of orchestras are receiving more thought, and a great effort is evident in mixing and balancing to produce a more homogeneous sound. Some companies record on three channels: right, left, and middle. In making two-channel tapes, the middle-channel component is mixed into the right and left channels in proportions varying with the need. In effect, this results in a mixture of stereo and two-channel monaural sound. The center-channel com-



ponent is radiated by both channels as a spaced monaural pair; in addition, each channel radiates its own half of the two stereo channels. One result of this is that the ear always hears part of the middle channel regardless of its position; in the precise center it hears the balanced output of both speakers; and to either side it hears the output of whichever is the closer. This helps considerably in removing the "hole," and in producing a greater leeway in the position of the

listening ear; it also yields an improved depth and some correction for the tendency of two-channel stereo to stretch an orchestra into a long line one instrument or voice deep.

Paul Klipsch works on much the same principle, but on the reproducing rather than the recording end. Instead of three recording channels and two reproducing, he uses two recording and three reproducing channels. The third channel is simply a third speaker in the middle fed by both stereophonic channels.² Klipsch co-ordinates recording and reproducing setups, and his tapes will probably work best with the reproducing system for which they were designed. However, it strikes me that this might well be experimented with in systems using other tapes and speakers. If you now have a two-channel stereo system with 16-ohm speakers, you might try a third central speaker connected between the 4-ohm or 8-ohm taps of the amplifiers, depending on its relative efficiency. There will be a problem of impedance matching and amplifier loading as well as of acoustic balance, but modern amplifiers can operate with wide departures from optimum loading, and balance can be varied by changing to lower and higher taps on the amplifiers.

There is another theory proposing that the hole-in-the-middle effect can be minimized if either the recording or the reproducing channel is narrow-spaced. The B&O microphone people have a rig for narrow spacing of microphones in recording stereo. I made some comments about this some months ago and reported that it does reduce the hole in the middle, as well as the exaggerated directionality when wide-spaced speakers are used in reproduction. There was considerable evidence at the show of a move to narrow spacing at the speaker end. Bozak, of course, has had a narrow-spaced stereo system for some time; Ampex also has introduced a narrow-spaced console. Pro-Plane has a narrow-spaced stereo system, and several manufacturers were demonstrating stereo with independent speakers closely spaced.

Continued on page 40

¹Paul W. Klipsch, "Two-Track Three-Channel Stereo," *AUDIOCRAFT*, II (Nov. 1957), p. 26. See also "A Simplified 'Phantom Channel,'" this issue, p. 37.

²See p. 15, this issue.



*build with
the best...*



JBL signature loudspeakers!

The careful work you do in building your high fidelity sound system will be shown off to best advantage if you use precision-made JBL SIGNATURE Loudspeakers. These are the most efficient units to be found anywhere, made with the most exacting care, meticulous attention to detail. Remember, it takes no more effort on your part to build with the best.



MODEL D130
15" Extended
Range
Loudspeaker

The only 15" extended range speaker made with a 4" voice coil is the world-famous JBL Signature D130. The large voice coil stiffens the cone for crisp, clean bass; smooth, extended highs. Your basic speaker, the D130 works alone at first, later becomes a low frequency driver when you add a JBL Signature high frequency unit and dividing network to achieve the ultimate excellence of a JBL Signature two-way system.



MODEL D208
8" Extended Range
Loudspeaker

A precision transducer in every sense of the word, the famed JBL Signature 8" D208 is made with the same care and precision as the larger units in the James B. Lansing Sound, Inc. line. If space and cost are major considerations, the D208, properly enclosed, provides the most lastingly satisfactory sound you can get. It is widely used in top quality systems where extension speakers are desired for areas other than the main listening room.

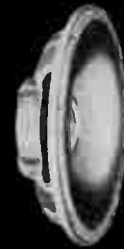

MODEL D123
12" Extended
Range
Loudspeaker

With outstanding "presence" and clean response throughout the entire audio spectrum, the D123 features an unusual shallow construction. Only 3 1/4" deep, it is designed to mount flush with the wall, between studding, in any standard wall or partition. Frequently, the D123 is used in multiples in "infinite baffle" wall installations. In this case the JBL Signature 075 is a logical high frequency unit to add when you advance to a two-way system.



MODEL 075
High
Frequency Unit

Another exclusive for James B. Lansing Sound, Inc., is the ring radiator in the JBL Signature 075 high frequency unit. A ring, rather than a diaphragm, radiates into the annular throat of an exponential horn. The result is high frequency reproduction of unmatched smoothness and clarity, absolutely free of resonances and strident peaks. The horn is beautifully machined from aluminum, the entire unit a gratifying, solid piece of fine craftsmanship. Designed for crossover at 2500 cycles with the JBL Signature N2500 Network.



MODEL 1750-H High Frequency Assembly

The acoustical lens is only available on JBL Signature high frequency units. The 14 element lens on the 175DLH disperses sound within the listening area over a 90° solid angle smoothly, with equal intensity regardless of frequency. The acoustical lens is the greatest contribution to life-like high frequency reproduction in 20 years, and it was developed for use with high fidelity equipment by James B. Lansing Sound, Inc. In addition to the lens the 175DLH consists of a high precision driver with complex phasing plug and a machined aluminum exponential horn. Designed for crossover at 1200 cycles with the JBL Signature N1200 Network.



**JBL Signature
Two-way
Systems Are
Available
As Kits**

086 KIT This two-way system is made up of units which have been acclaimed by impartial authorities as the finest available anywhere today. Included in the kit are the 150-4C Low Frequency Driver, N500H Network, 375 High Frequency Driver, 537-509 Horn-Lens Assembly. These are the same units—including the serpentine acoustical lens—which are used in The Hartfield... units designed originally for installation in the most modern theaters in the world.

There are many more kits and loudspeakers in the JBL Signature line. Whatever your needs, you will find exactly the right unit or system in the complete JBL Signature catalog. Send for your free copy. A limited number of technical bulletins are also available. Please ask only for those in which you are vitally interested.



James B. Lansing Sound, Inc.

JAMES B. LANSING SOUND, INC., 2439 Fletcher Dr. • Los Angeles 39, Calif.
Please send me the following:

- Free Catalog of JBL Signature Products Name and address of Authorized JBL Signature Audio Specialist in my community

TECHNICAL BULLETINS ON:

- D130 D123 D208 175DLH 075 375 150-4C

Name _____

Address _____

City _____ Zone _____ State _____

by RICHARD D. KELLER



book reviews

Transistor Circuits

Rufus P. Turner; pub. by Gernsback Library, Inc., New York; 160 pages; \$2.75, paper-bound.

In his second published book in the transistor field, the author has assembled a great variety of circuit diagrams ranging from simple audio preamps to oscillators, multivibrators, and Geiger counters.

There is practically no theory given in this book; there are only circuit diagrams, more than 150 of them, mostly quite simple and basic. They have all been tried and tested by the author and should offer good starting points for further design embellishments. No precautions have been taken in most of them for temperature stabilization or interchangeability, since the object here has been to achieve maximum simplicity.

I believe that Turner's previous book, *Transistors, Theory and Practice*, although somewhat outdated by now, is a better introduction to transistors because it delves into the "why" of transistor operation in an easily understood manner.

Transistor Manual

2nd ed., pub. by General Electric Co., Syracuse, N.Y.; 112 pages; \$.50, paper-bound.

Right on the heels of the excellent little manual introduced by GE last February is this new and enlarged edition, with almost twice as much material.

This handy volume is to the transistor what the *Tube Manual* has been to the electronics industry for years; an indispensable companion for everyone interested in working with these amazing tiny devices.

It contains nearly 50 pages on basic transistor theory and construction techniques, with their applications to audio, radio, and switching circuits. This is followed by detailed ratings of over 45 GE transistors, and condensed ratings of all registered JETEC (Joint Electronic

Tube Engineering Council) transistors produced by the 17 major transistor manufacturers. The latter table includes outline drawings, dimensions, and full cross references to GE types. Transistors made by different manufacturers are not, unlike tubes, exactly alike either physically or electrically. Consequently, such cross references are necessarily limited to showing the most nearly similar types.

The circuit-diagram section shows the latest and most up-to-date circuit ideas, such as transformerless hi-fi power amplifiers, transistor-regulated power sup-

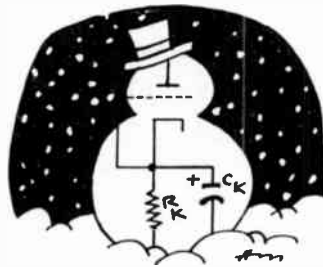

plies, and reflex superhet radio receivers.

Finally, to round out the manual's coverage, there is a table of the transistor complements of some 38 commercially manufactured transistor portable radios, and an up-to-date reading list of the best current books in this field.

Basic Mathematics for Radio and Electronics

F. M. Colebrook and J. W. Head; pub. by Philosophical Library, New York; 359 pages; \$6.00.

Here is a book that presents mathematical concepts in a very human sort of way. It covers all the basic matters from algebra through logarithms, complex numbers, trigonometry, geometry, and differential and integral calculus, leading finally to the application of mathematics to radio.

Surprisingly enough, it is enjoyable reading all the way, with concepts such

as the duality of square roots being described as "a sort of Dr. Jekyll and Mr. Hyde" (since the square root of 25, for instance, is both +5 and -5). Such examples, along with a liberal sprinkling of British wit, tend to bring this rather coldly analytical subject to life, clarifying and emphasizing major points in a most disarming manner.

Still, the author has been precise in his symbology and proofs; even the graduate engineer may find that this book will clear up points which continue to elude him in the mathematical sphere.

Arithmetic for Engineers

Charles B. Clapham; pub. by John F. Rider Publisher, Inc., New York; 540 pages; \$6.50.

A large book, this volume is slanted toward those who work on mechanical problems, and it provides a good background in mathematics for shop machinists, draftsmen, and tool and die makers.

In addition to chapters on fractions, algebra, logarithms, graphs, and trigonometry, it contains material on slide rules, verniers, and micrometers. Hundreds of examples are given as the text progresses, along with nearly 2,000 problems to be worked by the student (and to which answers are given in the back of the book).

Originally published in 1916, the book has been brought up to date by its English author. It has been long accepted as a fine home-study course for those to whom it is slanted.

Electricity and Magnetism

J. Newton; pub. by Philosophical Library, New York; 612 pages; \$10.00.

This book delves quite deeply into the history as well as the mathematics of electricity, electrostatics, and magnetism.

Problems are given at the end of each chapter, and the book would be useful as an elementary text.

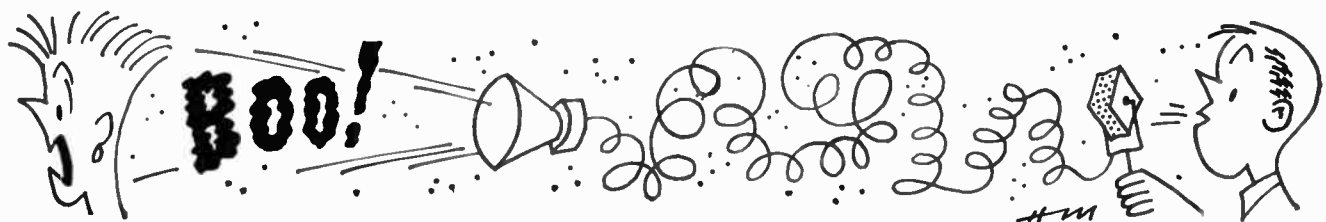

Save yourself time and trouble
by ordering your books directly from us.
Just fill in the coupon below.



audiophile's bookshelf

Suggestions for your library

THAT CRAZY AMERICAN MUSIC

By ELLIOT PAUL

An informed, witty, unorthodox, highly opinionated, always fascinating account of the development of American music — from pre-Revolutionary days to jazz, boogie, and rock 'n' roll, by the author of *The Last Time I Saw Paris*. What he says carries weight. How he says it makes vigorous, illuminating, sometimes searing reading. Not only for music lovers, but for all who enjoy good, lively writing. \$4.00 259

UNDERSTANDING HI-FI CIRCUITS

By NORMAN H. CROWHURST

Here the audiophile will find the answers to questions often confusing. The chapters are: special output stages, feedback, damping, inverter and driver stages, input stages, matching, equalization, speaker distribution and crossovers, loudness and volume controls, tone controls.

Hard cover, \$5.00 254 Soft cover, \$2.90 255

HIGH FIDELITY: A PRACTICAL GUIDE

By CHARLES FOWLER, Publisher, AUDIOCRAFT Magazine

Here at last is *the* book for the beginner — one that neither under- nor overrates his knowledge or ability to understand high fidelity. With unusual clarity and in just the right amount of detail it explains the principles involved and their application. Thus the reader is able to exercise an informed and reasoned judgment as to what would best suit his own taste, his available space, and his purse — in building, in buying, or in adding to his high-fidelity system. In short — a complete, intelligible, and literate exposition for the novice high fidelitarian. \$4.95 234

MAINTAINING HI-FI EQUIPMENT

By JOSEPH MARSHALL

A much needed book on the specialized approach necessary to service high-fidelity equipment. The author discusses not only electronic faults, but the mechanical and acoustical defects which cause a hi-fi system to function less than perfectly. The book is clearly written and well indexed.

Hard cover, \$5.00 232 Soft cover, \$2.90 233

HANDBOOK OF SOUND REPRODUCTION

By EDGAR VILLCHUR, inventor of AR loudspeaker systems and president of Acoustic Research, Inc.

Here is A-1 information about all aspects of sound reproduction, acoustics, and the necessary components. Written by one of the foremost authorities in the field, the book is organized in a way similar to home training courses. It fully covers a difficult technical subject in a manner which will provide pleasure and profit to the high-fidelity enthusiast. \$6.50 249

JAZZ: ITS EVOLUTION AND ESSENCE

By ANDRE HODEIR

"I think I've read about everything on jazz and there's nothing like this book. . . . It is the first and only treatment of the aesthetics of jazz. Secondly, it was written by a practicing musician in both the jazz and academic fields who is also a musicologist. And finally, it's a balanced treatment which grinds no axe and will stand up over the years." — Marshall Stearns. Paper, \$1.45 262

Just published

Records in Review-1957

The Third High Fidelity Annual

Edited by Joan Griffiths

Associate Editor, HIGH FIDELITY Magazine

Here, between the covers of a single volume, is the expert guidance needed by everyone who would make intelligent purchases of LPs and tapes.

This book, the only one of its kind, contains over 900 reviews of classical and semiclassical music, and the spoken word which have appeared in HIGH FIDELITY Magazine from July 1956 through June 1957. Written by some of this country's distinguished music critics and intended for both instruction and pleasure, the material is arranged for convenient use. Reviews cover both the merits of performance and the quality of recording. An index of performers is included.

RECORDS IN REVIEW is published by The Wyeth Press, an affiliate of HIGH FIDELITY Magazine. The book is printed in clear type on fine quality paper, attractively bound and jacketed. \$4.95 257

ORDER TODAY

FM Stations Up-to-Date

Here, in convenient booklet form, is a complete geographical listing of FM stations in the United States and Canada. The list was compiled by Bruce G. Cramer directly from FCC records, and originally appeared in AUDIOCRAFT Magazine. With additional changes and corrections to bring it up-to-date, it has just been reprinted as a booklet.

Only a limited number of copies of *FM Stations Up-to-Date* are available, so, to be sure of getting one, place your order soon. The price is only 50¢. 264

Book Department

AUDIOCRAFT Magazine

Great Barrington, Mass.

I enclose \$..... for which please send me, postpaid, the books indicated by circled numbers below. (No C. O. D.'s or charge orders, please.) Foreign orders sent at buyer's risk. Add 55¢ per book for postage on foreign orders except Canadian.

Binder 1 (holds 14 issues)	223	\$3.50	
Binder 2 (holds 12 issues)	245	\$3.00	254
Unmarked binders	265	\$2.75 ea.	223 255
			232 257
NAME			233 259
ADDRESS			234 262
			245 264
			249 265

*treat your family
to all the fun and enjoyment
of fine high fidelity at
one-half the price you
would expect to pay*

HERE'S ALL YOU NEED

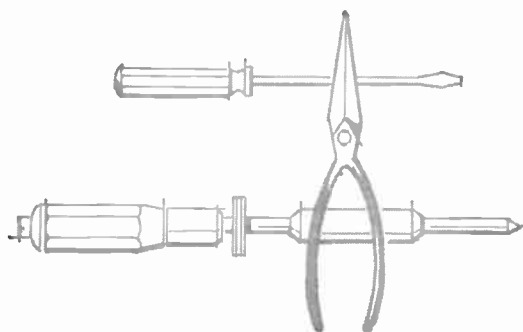

to build your own



HI-FI

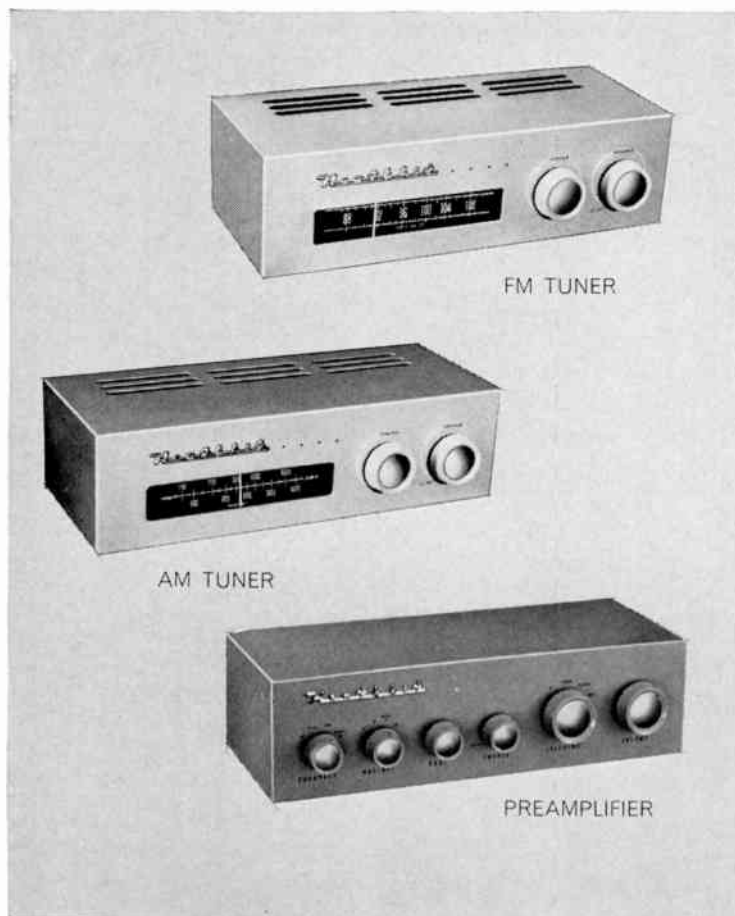

FM TUNER

AM TUNER

PREAMPLIFIER

**HEATHKIT
HIGH FIDELITY FM TUNER KIT**

This FM tuner is your least expensive source of high fidelity material! Stabilized oscillator circuit assures negligible drift after initial warmup. Broadband IF circuits assure full fidelity, and 10 microvolt sensitivity pulls in stations with full volume. High-gain cascode RF amplifier, and automatic gain control. Ratio detector gives high-efficiency demodulation. All tunable components prealigned. Edge-illuminated dial for easy tuning. Here is FM for your home at a price you can afford. Shpg. Wt. 7 lbs.

MODEL FM-3A \$25.95 (with cabinet)

**HEATHKIT
BROADBAND AM TUNER KIT**

This tuner differs from an ordinary AM radio in that it has been designed especially for high fidelity. The detector uses crystal diodes, and the IF circuits are "broadbanded" for low signal distortion. Sensitivity and selectivity are excellent. Quiet performance is assured by 6 db signal-to-noise ratio at 2.5 uv. All tunable components prealigned. Incorporates AVC, two outputs, and two antenna inputs. Edge-lighted glass slide rule dial for easy tuning. Your "best buy" in an AM tuner. Shpg. Wt. 8 lbs.

MODEL BC-1A \$25.95 (with cabinet)

**HEATHKIT "MASTER CONTROL"
PREAMPLIFIER KIT**

This unit is designed to operate as the "master control" for any of the Heathkit Williamson-type amplifiers, and includes features that will do justice to the finest program material. Frequency response within $\pm 1\frac{1}{2}$ db from 15 to 35,000 CPS. Full equalization for LP, RIAA, AES, and early 78's. Five switch-selected inputs with separate level controls. Bass and treble control, and volume control, on front panel. Very attractively styled, and an exceptional dollar value. Shpg. Wt. 7 lbs.

MODEL WA-P2 \$19.75 (with cabinet)

**HEATHKIT "BASIC RANGE"
HIGH FIDELITY SPEAKER SYSTEM KIT**

The very popular model SS-1 Speaker System provides amazing high fidelity performance for its size because it uses high-quality speakers, in an enclosure especially designed to receive them.

It features an 8" mid-range-woofer to cover from 50 to 1600 CPS, and a compression-type tweeter with flared horn to cover from 1600 to 12,000 CPS. Both speakers are by Jensen. The enclosure itself is a ducted-port bass-reflex unit, measuring 11½" H x 23" W x 11¾" D and is constructed of veneer-surfaced plywood, ½" thick. All parts are precut and predrilled for quick assembly.

Total frequency range is 50 to 12,000 CPS, within ±5 db. Impedance is 16 ohms. Operates with the "Range Extending" (SS-1B) speaker system kit later, if greater frequency range is desired. Shpg. Wt. 30 lbs. **MODEL SS-1 \$39.95**

**HEATHKIT "RANGE EXTENDING"
HIGH FIDELITY SPEAKER SYSTEM KIT**

The SS-1B uses a 15" woofer and a small super-tweeter to supply very high and very low frequencies and fill out the response of the "Basic" (SS-1) speaker system at each end of the audio spectrum. The SS-1 and SS-1B, combined, provide an overall response of ±5 db from 35 to 16,000 CPS. Kit includes circuit for crossover at 600, 1600 and 4000 CPS. Impedance is 16 ohms, and power rating is 35 watts. Measures 29" H x 23" W x 17½" D, and is constructed of veneer-surfaced plywood, ¾" thick. Easy to build! Shpg. Wt. 80 lbs.

MODEL SS-1B \$99.95

...and save!

**HEATHKIT "LEGATO"
HIGH FIDELITY SPEAKER SYSTEM KIT**

The fine quality of the Legato Speaker System Kit is matched only in the most expensive speaker systems available. The listening experience it can bring to you approaches the ultimate in esthetic satisfaction.

Frequency response is ±5 db 25 to 20,000 CPS. Two 15" theater-type Altec Lansing speakers cover 25 to 500 CPS, and an Altec Lansing high frequency driver with sectoral horn covers 500 to 20,000 CPS. A precise amount of phase shift in the crossover network brings the high-frequency channel into phase with the low-frequency channel to eliminate peaks or valleys at the crossover point. This is one reason for the mid-range "presence" so evident in this system design.

The attractively styled "contemporary" enclosure emphasizes simplicity of line and form to blend with all furnishings. Cabinet parts are precut and predrilled from ¾" veneer-surfaced plywood for easy assembly at home. Impedance is 16 ohms. Power rating is 50 watts for program material. Full, smooth frequency response assures you of outstanding high fidelity performance, and an unforgettable listening experience. Order HH-1-C (birch) for light finishes, or HH-1-CM (mahogany) for dark finishes. Shpg. Wt. 195 lbs.

MODELS HH-1-C or HH-1-CM \$325.00 each

*Pioneer in
"do-it-yourself"
electronics*

HEATH COMPANY

A subsidiary of Daystrom, Inc.
Benton Harbor 18, Mich.



"BASIC" SPEAKER SYSTEM

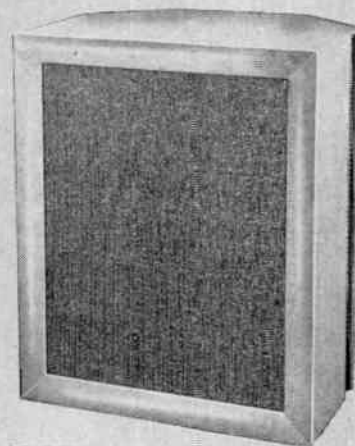

RANGE EXTENDER

HEATHKITS

*World's finest
electronic equipment
in kit form...*



"LEGATO" SPEAKER SYSTEM



70-WATT AMPLIFIER



25-WATT AMPLIFIER

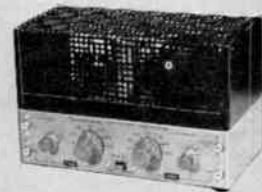

ELECTRONIC CROSS-OVER

easy-to-build designs by **HEATH** *insure*

You get more comprehensive assembly instructions, higher quality circuit components, and more advanced design features, when you buy HEATH hi-fi!

HEATHKIT 70-WATT HIGH FIDELITY AMPLIFIER KIT

This new amplifier features extra power reserve, metered balance circuit, variable damping, and silicon-diode rectifiers, replacing vacuum tube rectifiers. A pair of 6550 tubes produce full 70-watt output with a special-design Peerless output transformer. A quick-change plug selects 4, 8 and 16 ohm or 70 volt output, and the correct feedback resistance. Variable damping optimizes performance for the speaker system of your choice. Frequency response at 1 watt is ± 1 db from 5 CPS to 80 KC with controlled HF rolloff above 100 KC. Harmonic distortion at full output less than 2%, 20 to 20,000 CPS, and intermodulation distortion below 1% at this same level. Hum and noise are 88 db below full output. Variable damping from .5 to 10. Designed to use WA-P2 preamplifier. Express only. Shpg. Wt. 50 lbs. **MODEL W-6M \$109.95**

HEATHKIT 25-WATT HIGH FIDELITY AMPLIFIER KIT

The 25-watt Heathkit model W-5M is rated "best buy" in its power class by independent critics! Faithful sound reproduction is assured with response of ± 1 db from 5 to 160,000 CPS at 1 watt, and harmonic distortion below 1% at 25 watts, and IM distortion below 1% at 20 watts. Hum and noise are 99 db below rated output, assuring quiet, hum-free operation. Output taps are 4, 8 and 16 ohms. Employs KT66 tubes and Peerless output transformer. Designed to use WA-P2 preamplifier. Express only. Shpg. Wt. 31 lbs. **MODEL W-5M \$59.75**

HEATHKIT ELECTRONIC CROSS-OVER KIT

This device separates high and low frequencies electronically, so they may be fed through two separate amplifiers driving separate speakers. The XO-1 is used between the preamplifier and the main amplifiers. Separate amplification of high and low frequencies minimizes IM distortion. Crossover frequencies are selectable at 100, 200, 400, 700, 1200, 2000, and 3500 CPS. Separate level controls for high and low frequency channels. Attenuation is 12 db per octave. Shpg. Wt. 6 lbs. **MODEL XO-1 \$18.95**

HEATHKIT W-3AM HIGH FIDELITY AMPLIFIER KIT

Features of this fine Williamson-type amplifier include the famous Acrosound model TO-300 "ultralinear" transformer, and 5881 tubes for broad frequency response, low distortion, and low hum level. Response is ± 1 db from 6 CPS to 150 KC at 1 watt. Harmonic distortion is below 1% and IM distortion below 1.3% at 20 watts. Hum and noise are 88 db below 20 watts. Provides output taps of 4, 8 or 16 ohms impedance. Designed to use WA-P2 preamplifier. Shpg. Wt. 29 lbs. **MODEL W-3AM \$49.75**

HEATHKIT W-4AM HIGH FIDELITY AMPLIFIER KIT

A true Williamson-type circuit, featuring extended frequency response, low distortion, and low hum levels, this amplifier can give you fine listening enjoyment with a minimum investment. Uses 5881 tubes and a Chicago-standard output transformer. Frequency response is ± 1 db from 10 CPS to 100 KC at 1 watt. Less than 1.5% harmonic distortion and 2.7% intermodulation at full 20 watt output. Hum and noise are 95 db below full output. Transformer tapped at 4, 8 or 16 ohms. Designed to use WA-P2 preamplifier. Shipped express only. Shpg. Wt. 28 lbs. **MODEL W-4AM \$39.75**

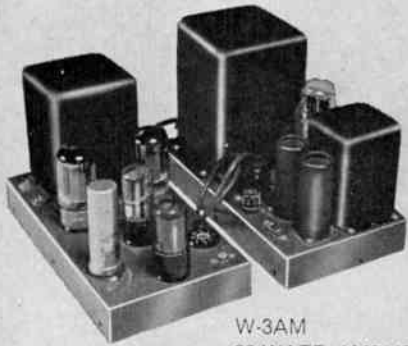

W-3AM
20-WATT AMPLIFIER



W-4AM
20-WATT AMPLIFIER

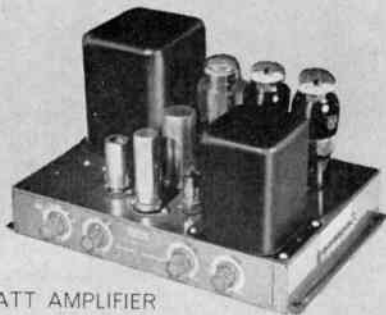

A-9C
20-WATT AMPLIFIER



A-7D
7-WATT AMPLIFIER

HEATHKITS

*World's finest
electronic equipment
in kit form...*

...top HI-FI performance

HEATHKIT A-9C HIGH FIDELITY AMPLIFIER KIT

This amplifier incorporates its own preamplifier for self-contained operation. Provides 20 watt output using push-pull 6L6 tubes. True high fidelity for the home, or for PA applications. Four separate inputs—separate bass and treble controls—and volume control. Covers 20 to 20,000 CPS within ± 1 db. Output transformer tapped at 4, 8, 16 and 500 ohms. Harmonic distortion less than 1% at 3 db below rated output. High quality sound at low cost! Shpg. Wt. 23 lbs. **MODEL A-9C \$35.50**

HEATHKIT A-7D HIGH FIDELITY AMPLIFIER KIT

This is a true high fidelity amplifier even though its power is somewhat limited. Built-in preamplifier has separate bass and treble controls, and volume control. Frequency response is $\pm 1\frac{1}{2}$ db from 20 to 20,000 CPS, and distortion is held to surprisingly low level. Output transformer tapped at 4, 8 or 16 ohms. Easy to build, and a fine 7-watt performer for one just becoming interested in high fidelity. Shpg. Wt. 10 lbs. **MODEL A-7D \$17.95**

Model A-7E: Same as the above except with extra tube stage for added preamplification. Two switch-selected inputs, RIAA compensation, and plenty of gain for low-level cartridges. Shpg. Wt. 10 lbs. **\$19.95**

HOW TO ORDER...

Just identify the kit you desire by its model number and send check or money order to address below. Don't hesitate to ask about HEATH TIME PAYMENT PLAN.

Pioneer in
"do-it-yourself"
electronics

HEATH COMPANY

A subsidiary of Daystrom, Inc.
Benton Harbor 18, Mich.

FREE
CATALOG



NAME _____

ADDRESS _____

CITY & STATE _____

Please send **FREE** Heathkit Catalog



Audionews

FOUR-SPEED RECORD CHANGER

The *GS Seventy-Seven*, a new four-speed record changer, is being offered by Glaser-Steers. The change cycle of the unit is only 5 seconds, during which the turntable pauses, resuming motion only after the next record is in play position and the stylus is in the lead-in groove. A four-pole, hum-shielded motor with dynamically balanced rotor and highly cushioned motor mounts reduces rumble, according to the manufacturer. A newly designed idler assembly that disengages completely in OFF position, and a precision four-speed turret capstan drive are said to virtually eliminate wow and flutter. Specs state that the arm has no resonant points within the audio range, and that variation of stylus pressure between the first and tenth record is less than one gram. A special feature, the Speedminder, automatically



GS Seventy-Seven with Speedminder.

operates the changer at 78 rpm when the standard 3-mil stylus is in position and, with the microgroove stylus in play position, intermixes and plays 3 $\frac{1}{3}$ - and 45-rpm records without regard to size or sequence. The changer shuts off automatically after the last record and may be wired to shut off the amplifier as well. The *GS Seventy-Seven* sells for about \$60.

SERVO-SPEAKER-AMPLIFIER

A new development from Integrand Corporation is the *Integrand Servo-Speaker-Amplifier* system, an integrated system of loudspeakers and transistorized amplifiers. Three specially designed loudspeakers (including a 15-inch woofer) are constructed so as to be coaxial and



Speaker has transistorized amplifiers.

coplanar. They are driven by three separate transistor amplifiers, each with a feedback loop from the driven speaker's voice coil which gives speaker-performance information to the amplifiers. According to the manufacturer, this enables the system to operate independent of room acoustics. Both stereo and monaural models, housed in contemporary-style furniture, are available.

KNIGHT STEREO-MONAUROAL PREAMPLIFIER

With the advent of stereo broadcasting a semiaccomplished fact, Allied Radio Corporation has introduced the *Knight KN-700* stereo-monaural preamp, providing control facilities for stereo tapes and broadcasts, and monaural tapes, broadcasts, and records. Special features include equalized tape-head playback preamps for stereo playback; a control for switching between stereo and monaural, and for reversing channels; independent gain controls for each channel; and master volume control regulating both channels simultaneously.

Stereo tuner has reversible channels.



Inputs are provided for GE and Pickering magnetic cartridges, ceramic phono cartridge, two tape heads, two auxiliary sources, microphone, tuner, and tape preamp or crystal cartridge. Cathode-follower outputs and two auxiliary AC outlets are also included. Frequency response is said to be ± 1 db, 20 to 20,000 cps; hum level, 50 db below full output on tape channels, and 70 db below full output on high-level input. All tube filaments run on DC.

The stock number for ordering the *KN-700* is 92 SX 406; price is \$79.50.

GENERAL ELECTRIC CARTRIDGE

General Electric recently announced the introduction of the *VR-II* series of moderate-price magnetic variable-reluctance cartridges. The new cartridges are said to have a frequency response of from 20 to 20,000 cps at 4-gram tracking force.

Compared with GE's RPX types, the new *VR-II* cartridges have a narrower



GE VR-II is a variable-reluctance unit.

body with a 27% weight reduction and a 10%-lighter stylus. They also incorporate a new electrostatic shield.

The company has ended production of RPX-type cartridges, but will continue to make replacement styli for them.

Further information about the *VR-II* cartridge is available on request.

JENSEN CONDENSED CATALOGUE

Recently announced by Jensen Manufacturing Company is their data sheet, *165-B*, which may be obtained free on request. This condensed catalogue features Jensen's new Unax, Duax, and Triax lines of reproducers. Other Jensen products are also included.

SWITCHCRAFT PHONE PLUGS

Added to the Switchcraft line of components are standard *Switchcraft Phone*

Plugs molded directly to two-conductor shielded cable. These are assembled in standard cable assemblies of the type often used in high-fidelity and audio equipment for interconnecting ampli-



Angle- and straight-type phone plugs.

fiers, microphones, etc. They are available in straight or angle types, as illustrated.

Full details are available on request.

UNIVERSITY SPEAKER CATALOGUE

A new loudspeaker catalogue available from University Loudspeakers, Incorporated, includes full product descriptions, specs, application information, and prices of University products. There are speaker systems, enclosures, and enclosure kits, as well as paging and talk-back speakers, heavy-duty trumpets and driver units, submergence-proof speakers, portable soundcasting systems, and super-power projectors.

LUSTRAPHONE MIKE

The first of a new line of British Lustraphone quality transducers, the *Ribbonette* ribbon-velocity microphone, is now available through Fen-tone Corporation.

It is a bidirectional, high-impedance unit which may be plugged into any tape recorder accommodating a crystal microphone without the addition of an



The *Ribbonette* mike is bidirectional.

input transformer. According to the manufacturer, frequency response is substantially uniform from 30 to 14,000

cps, ± 2 db, with output rated at -54 db (about 6 mv).

The *Ribbonette* is mounted on a chrome swivel-table base and is said to resist heat and humidity.

Complete with 11 ft. of cable, it sells for \$55.50, audiophile net; if purchased before February 1, 1958, a special introductory price of \$49.95 with trade-in is being offered by Fen-tone.

JANSZEN CONE WOOFER

The *JansZen Dynamic* cone woofer is a low-frequency direct radiator in a $2\frac{1}{2}$ -cubic-foot enclosure and is designed to complement the *JansZen Model 130* electrostatic tweeter. Bass frequencies are said to be reproduced in proper perspective, without hangover or boom. The upper frequency response has been extended in order to blend well with the tweeter without employing a crossover network. Each speaker is tested by the

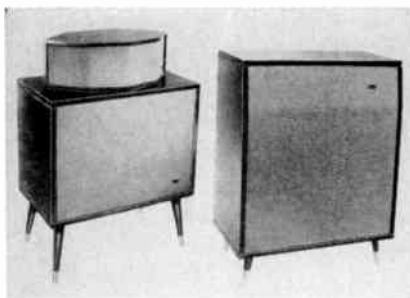

Woofer available singly or with tweeter.

manufacturer. The *Dynamic* is available singly or in combination with the tweeter.

A 4-page folder describing both units may be obtained gratis from Neshaminy Electronic Corp., Neshaminy, Pa.

DYNAKIT 60-WATT AMPLIFIER

Dynaco, Incorporated, has announced the introduction of the *Mark III* 60-watt amplifier kit utilizing the new heavy-duty KT-88 tubes in the output stage. All audio portions of the circuit are premounted at the factory on a printed-circuit assembly.

For more information about any of the products mentioned in *Audio-News*, we suggest that you make use of the Product Information Cards bound in at the back of the magazine. Simply fill out the card, giving the name of the product in which you're interested, the manufacturer's name, and the page reference. Be sure to put down your name and address too. Send the cards to us and we'll send them along to the manufacturers. Make use of this special service; save postage and the trouble of making individual inquiries to a number of different addresses.

Additional features of the *Mark III* include choke filtering which, with low-noise circuitry, is stated to reduce hum to 96 db below 60 watts. Continuous power of 60 watts is obtained at less



Mark III amplifier has choke filtering.

than 1% IM distortion, and short duration peaks of up to 140 watts are handled without clipping, according to the manufacturer. Frequency response is said to be ± 0.1 db from 16 cps to 24,000 cps at full power.

A detailed brochure on the *Mark III* is available on request.

LAFAYETTE'S 1958 CATALOGUE

Lafayette Radio's 1958 general catalogue No. 305 is now available free on request. The 180-page book contains a complete listing of all Lafayette's own component and kit lines as well as the newest items from major manufacturers. Featured is a comprehensive listing of stereophonic equipment and prerecorded stereo tapes. Miniaturized components and other parts are also listed.

TELECTRO TWO-SPEED TAPE RECORDER

A new two-speed tape recorder with simple push-button speed-change control has been introduced by Telectrosonic Corporation. The unit is designated the *Model 1960*, and is priced at \$79.95.



The *Telectro Model 1960* tape recorder.

The recorder weighs 15 pounds. It operates at speeds of $3\frac{3}{4}$ and $7\frac{1}{2}$ ips. A patch cord is available for use with the unit for direct recording from radio, TV, or other source.

Fleetwood[®] CUSTOM TELEVISION

A New HIGH In FIDELITY...

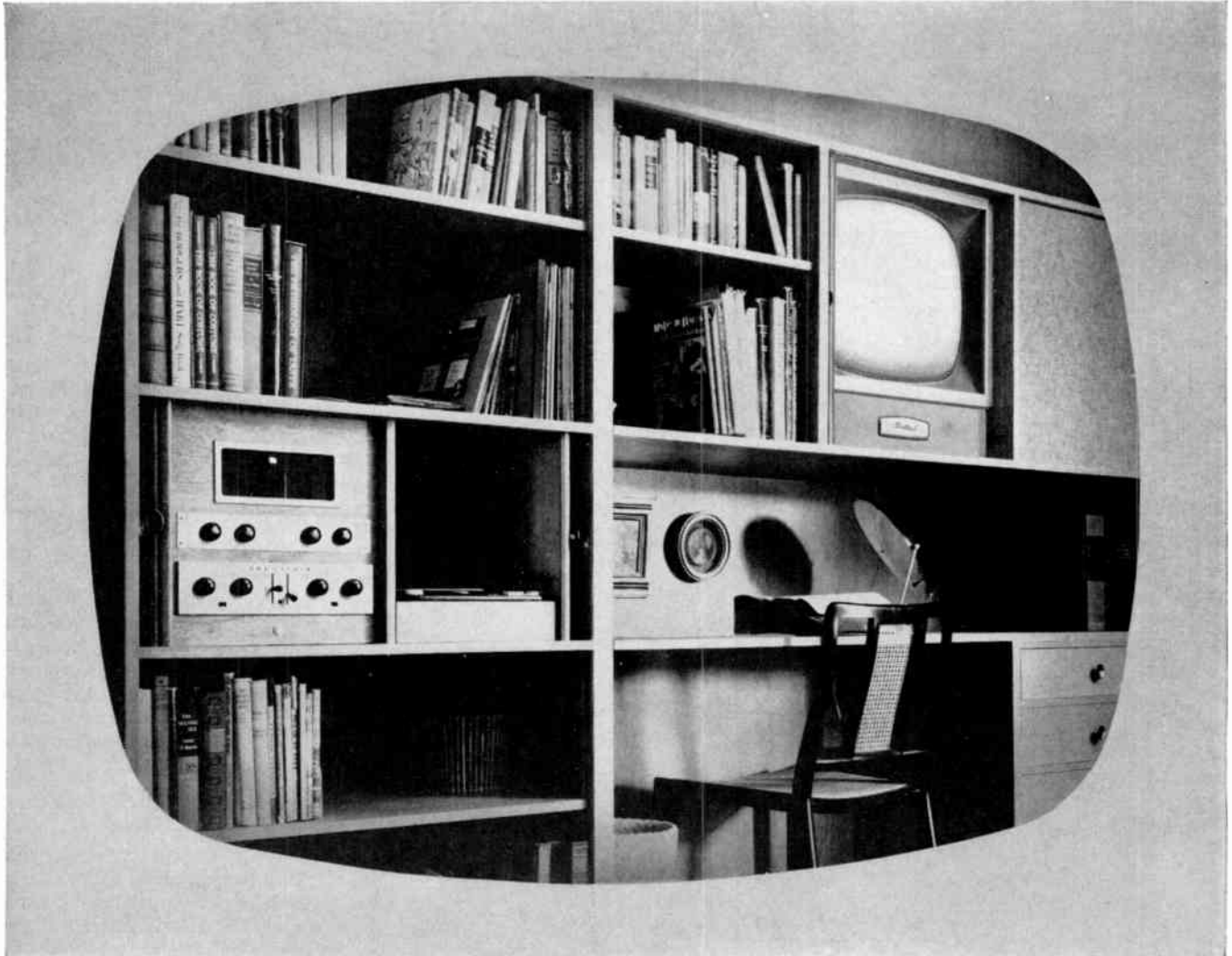

FLEETWOOD is the *monitor-standard* television system. Made to the same exacting standards as the professional telecast monitors Fleetwood makes for the major networks — Fleetwood is the television professional's choice for his home!

Fleetwood's fully electronic remote control provides not just channel selection and volume control — but contrast, brightness, volume, channel selection, fine tuning and the exclusive Definition Control that tailors picture texture to suit individual taste. Non-remote Fleetwoods are also

available. The Fleetwood receiver has four I.F. stages for full four megacycle bandpass — employs 27 tubes exclusive of the picture tube and will mount a 21", 24" or 27" rectangular picture tube. Fleetwood provides high and low impedance audio outputs that furnish your high fidelity system with distortion-free sound.

Wherever you want Fleetwood — *it belongs beautifully!* In a wall, room divider, bookcase, piece of valued heirloom furniture — in the living room, den, kitchen, bedroom, recreation room . . . installations are unlimited!

For a free booklet of installation ideas, complete information and the name of your nearest dealer, write:

Fleetwood[®] CUSTOM TELEVISION

Crafted by CONRAC, INC. • Department G, Glendora, California

Export Division: Frazar & Hansen, Ltd., 301 Clay St., San Francisco, Calif.

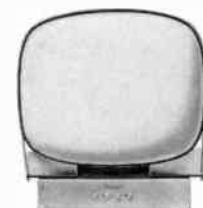

© Conrac, Inc. 1957



Forecast for stereo discs

Gentlemen:

Until now I have not written to comment on any articles or the selection thereof for the extremely simple reason that I had no cause to disfavor any of them. Your taste in selecting articles as well as authors and experts on the various subjects has, to my taste, always been beyond reproach.

However, the recent abrupt conclusion of the series "Tips for the Woodcrafter" took me completely by surprise. Today, more than ever before, speaker cabinets are appearing on the market in quantities to make the do-it-yourselfer really concentrate his efforts in order to choose one best suited to his purpose. Other types of kits also involving woodwork and a working knowledge of grains, paints, stains, power tools, hand tools, etc., are essential. Surely, your series hasn't covered every facet of working with wood or working with tools—or has it?

As a "charter" subscriber, I think you made a serious mistake in dropping this interesting and necessary feature. Many of my fellow workers share my sentiments.

Burt Zimmer
San Francisco, Calif.

When George Bowe was appointed Program Director of WTIC-TV, the new television station in Hartford, Connecticut, he found it impossible to continue as author of our "Tips for the Woodcrafter" column. We didn't look for a replacement because we had previously received many letters stating, in essence, that, while the column was a good one, it had no place in AUDIOCRAFT.

If enough other readers who share Mr. Zimmer's opinion will tell us about it, we'll be glad to renew "Tips for the Woodcrafter." — ED.

Gentlemen:

I agree with Mr. Wright's statement that an organ kit is not the best starting point for the amateur builder [see "Rumble Seat," AUDIOCRAFT, December 1957, pp. 36, 38-39]. Although we have sold hundreds of kits to novices, they have had to learn such things as how to solder, how to read color codes and how to test their work. Had they known basic kit-building techniques, the organ would have been easier to as-

Continued on page 43

WHAT about stereo discs?

Here, in a nutshell, is the present status. At the recent New York High Fidelity Show, held concurrently with the AES Convention, not one but *two* distinct methods of stereo-disc production were demonstrated.

London Records broke the ice first. Specialists from England arrived with examples of their latest vertical-lateral discs and magnetic pickups, and demonstrated to a steady flow of visitors in their New York offices. The London method represented the most modern adaptation of an idea which has been in the works for years—the combination of standard side-to-side (lateral) recording for one channel with up-and-down (sometimes called "hill-and-dale" or vertical) recording for the second channel. The stereo effect was unmistakable. Apparently a great many problems inherent in cutter as well as pickup design have bowed before the diligent persistence of engineers.

But there is yet another hat in the ring, and it was thrown hard and far enough to secure industry-wide adoption as *the* stereo disc system of the future. In this, the Westrex system, a cutting head with *two* coils positioned at right angles to each other (and at 45° relative to the record) drives the cutting stylus. In simple terms, one channel is inscribed on one groove wall, and the other channel on the opposite wall. It's as elementary (in theory, at least) as that. A groove, of course, has but two walls, and what could be more logical than planting one microphone's output in one wall, and the second mike's signal in the other.

Of course, this simplicity fails to traverse the span between the record itself and the means of producing it. The problems of designing a cutting head which will accurately feed two signals to a single cutting stylus are not easily surmounted. Obviously, a great deal of experimentation has gone into this intricate Westrex device, and—in line with progress everywhere—it won't end here.

But if a steady breeze of research must continue toward perfecting the ultimate cutter, a veritable hurricane of effort will be needed to devise a pickup which will faithfully reproduce those two sister channels as well as current cartridges reproduce monaural sound.

What are these problems? Basically, they boil down to this.

1) The stereo playback pickup must contain *two* moving magnets or coils, or *two* crystals, or *two* variable-reluctance armatures, and these must be driven by a single stylus. Obviously, doubling most of the weighty components of a pickup will increase both mass and weight, and the march toward miniaturization must continue if gentle-to-record stylus forces are to be maintained.

2) Perhaps more difficult to solve is a second disadvantage not often mentioned: since both sides of the cartridge must be sensitive to vertical motion of the stylus, harmonic distortion will increase in both channels due to pinch effect when playing old LP records. Since one of the proclaimed advantages of the Westrex system is its ability to produce high-quality monaural sound from standard microgroove records, and thus be usable on *all* records, stereo and monaural alike, this problem assumes an importance of major degree.

Undoubtedly it will be solved, whether by rephasing the output of the two coils and installing a STEREO-MONAURO switch, or by some other means. Heretofore seemingly insurmountable audio problems have succumbed to persistence, and there is no reason to believe the stereo-disc dilemma will be anything but consistent.

In fact, the future for the new medium looms so bright that some of the larger record companies plan stereo-disc releases as early as next summer, and some plan to cease production of monaural records as soon as their stereo wheels are in motion.

This is, indeed, exciting news, and we don't intend to leave our readers in the dark. By next issue, we hope to have a major article explaining the Westrex system and interpreting the status of playback facilities for you, the consumer.

ANOTHER news-worthy item came in the mail recently from Acoustic Research, Inc., manufacturers of the AR-1 and AR-2 speaker systems. The company has scheduled an open house at the factory, at 24 Thorndike Street, in Cambridge, Mass., for three days beginning January 20, 1958. Guides will show visitors through the plant where they may witness many phases of loudspeaker production, testing, and assembly. Drop over if you can—it should be interesting.

—P.G.

Build this super-deluxe 36 watter and say good-bye to power-amplifier troubles for years and years and years . . .

Perfectionist's Power Amplifier

by BEN ZALE

THERE is nothing quite like the quality of excitement generated by a new power amplifier. Others may talk of preamplifiers, speakers, enclosures, or what-have-you. But start discussing a new and improved power-amplifier circuit, and the ears of the true audiophile prick up, a fever flashes like lightning through his mind, and he is on his way to the parts distributor for the necessary components.

I experienced the same reaction recently when I came across a booklet¹ in which the Mullard 520 power-amplifier circuit is described. The specs of the new circuit were extremely impressive: 36

watts power output from 30 to 20,000 cps; frequency response within 1 db from 20 to 20,000 cps at 36 watts; IM distortion, using 40 and 10,000 cps in a 4:1 ratio, a low 0.8% at 36 watts; hum and noise 89 db below 36 watts; and a damping factor of 50.

For me, however, the most exciting specification of all was the sensitivity: only 0.3-volt input for a full 36-watt power output! This extremely high sensitivity meant that the power amplifier, in normal use, would be driven at a tiny fraction of a volt. The reduction in the amount of drive signal needed for the power amplifier would enable me to use

my preamplifier at much lower operating levels, where distortion would be significantly diminished.

Aside from its excellent specifications, the circuit itself seemed simple and inviting from every point of view. It consists of a low-noise, high- μ pentode as a voltage amplifier feeding a dual-triode phase-inverter driver, which in turn drives two of the new EL34 power pentodes in an Ultra-Linear configuration.² Fig. 1 shows the completed amplifier, and Fig. 2 the under-chassis view.

I had already used the internally shielded EF86 miniature-pentode voltage amplifier in my preamplifier circuit, and found it to be extremely low in noise and lacking in microphonics. Its high gain, combined with the low noise figure, made it an excellent choice for the voltage amplifier in the Mullard 520 circuit.

The cathode-coupled phase inverter (or long-tailed pair, as it is also called) made use of the ECC83, a dual triode corresponding to the 12AX7 but with guaranteed low noise and microphonics. The virtue of this phase inverter is its extreme simplicity of construction combined with its fine balancing qualities in supplying push-pull signals to the output tubes.³

EL34 (or 6CA7) power pentodes, now appearing in many new commercially manufactured amplifiers, are small and sturdy and are capable of delivering up to 100 watts in push-pull with 800 volts on the plates. This indicated operation well within maximum ratings in an Ultra-Linear circuit with only 440 volts on the plates and a 36-watt power output. It also suggested very low distortion.

The power supply (Fig. 3) was simple and straightforward as could be, consisting of a 200-ma transformer operating into a capacitor-input filter system, from which emerged 440 volts for the plates of the EL34 output tubes. Two decoupling stages followed, supplying power for the EF86 and ECC83 tubes. In essence, the same power supply as that in my UTC Williamson-type amplifier could have been used. Since the EL34's required about 40 ma more cur-

Fig. 1. This is the perfectionist's dream come true—our model of the power amplifier described by Mr. Zale, built solely from data contained in the article.

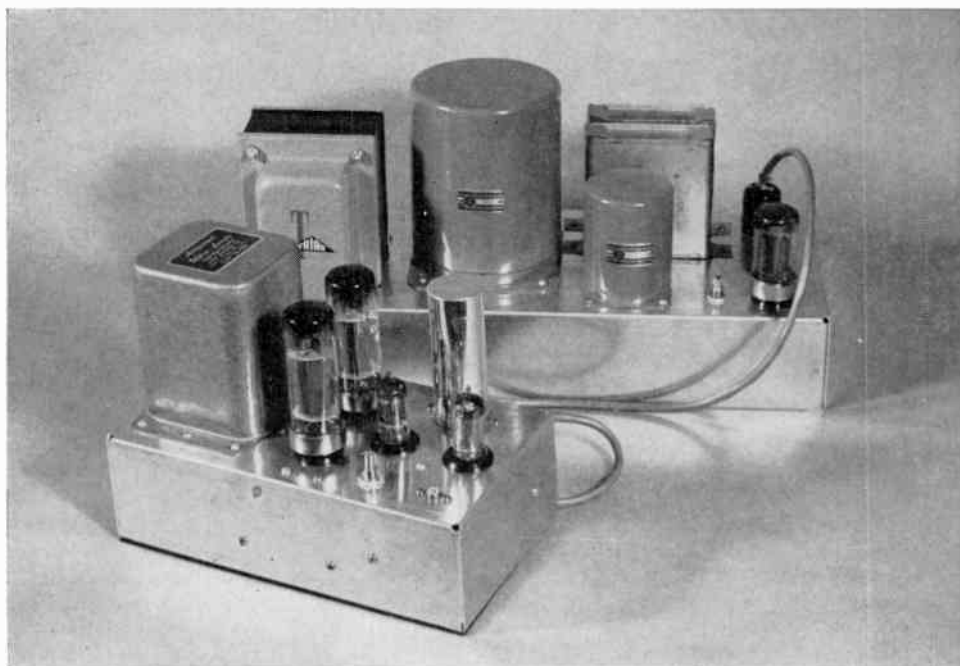

¹W. A. Ferguson, "Design for a 20-Watt High Quality Amplifier," *High Quality Sound Reproduction* (booklet of articles reprinted from *Wireless World*), Mullard Ltd., London, England. Available in the USA from International Electronics Corp., New York, N.Y. Also see: E. J. Porto, "High Fidelity Performance with Mullard's 520 Circuit," *Radio & Television News*, LV (Apr. 1956), pp. 66-68, 139.

²Herbert I. Keroes, *Theory and Operation of the Ultra-Linear Circuit*, monograph available from Keroes Enterprises, Philadelphia, Pa.

³Joseph Marshall, "The Grounded Ear", *AUDIOCRAFT*, I (Nov. 1955), p. 10. See also: Norman H. Crowhurst, "Designing Your Own Amplifier," *AUDIOCRAFT*, I (May 1956), pp. 21-23, 40-41.

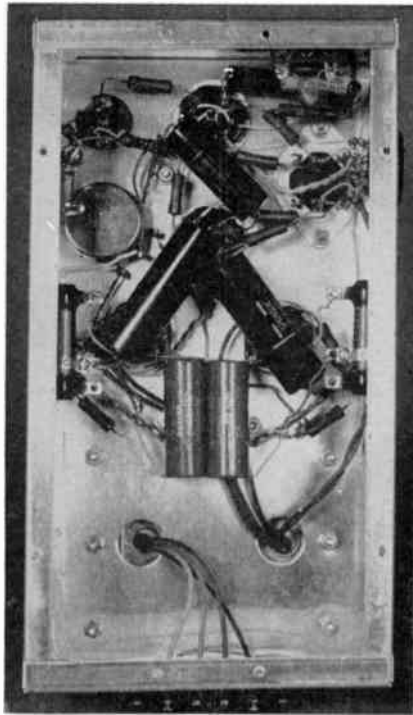

Fig. 2. View inside amplifier chassis. Note symmetrical layout of components.

rent than KT66's, I switched to GZ34's in parallel, instead of a single 5V4G. The GZ34 is a pantam-type tube rated at 250 ma. A pair of these would provide lower impedance in the power supply, although one is actually sufficient.

Component Selection

An analysis of the parts list was the next step.

All resistors, except for a pair of wire-wounds in the cathode legs of the output tubes, were rated at 1/2 watt or less. Two pairs of resistors were matched within 5%, and the feedback resistor was limited to a 5% tolerance. For most purposes 1/2-watt, ±10% carbon re-

sistors, except for the matched pairs, would be satisfactory. Building preamplifiers, oscillators, and other equipment has taught me that 1-watt resistors prove to be a good deal more satisfactory than 1/2-watt units, and that even better than 1-watt molded carbon resistors are the high-stability, low-noise, deposited-carbon resistors which, in addition, are supplied in 1% tolerances.

Deposited-carbon resistors have a number of decided advantages over ordinary molded or compound resistors. For audio purposes, the main advantages are greater stability and low noise ratings. Greater stability means less shift of value, as time goes by, in bias, feedback, and other networks; sometimes a shift of some 10% in value can cause deterioration in an amplifier's specifications. In cases of marginally stable circuits, oscillation, noise, and other types of deterioration might arise after an amplifier has been used for a while. And I wanted an amplifier that I could depend on to stay in peak condition year after year.

An improvement of 6 db in noise level over the compound carbon resistor is general with the deposited-carbon resistor. And when such resistors are used throughout an amplifier, as one author reports,⁴ the noise figure is so low that it is impossible to reduce it further except with the development of new and better tubes for the input portion of the amplifier!

Combining the use of deposited-carbon resistors throughout the amplifier with the inherently low noise of the EF86 input tube (less than 5 microvolts total noise in terms of input to the grid, according to the manufacturer), seemed to present the most feasible approach to high and reliable quality. The

⁴L. B. Keim, "The Deposited Carbon Resistor: An Essential Component of Good Audio Design Practice," *Journal of the Audio Engineering Society*, 1 (Jan. 1953).

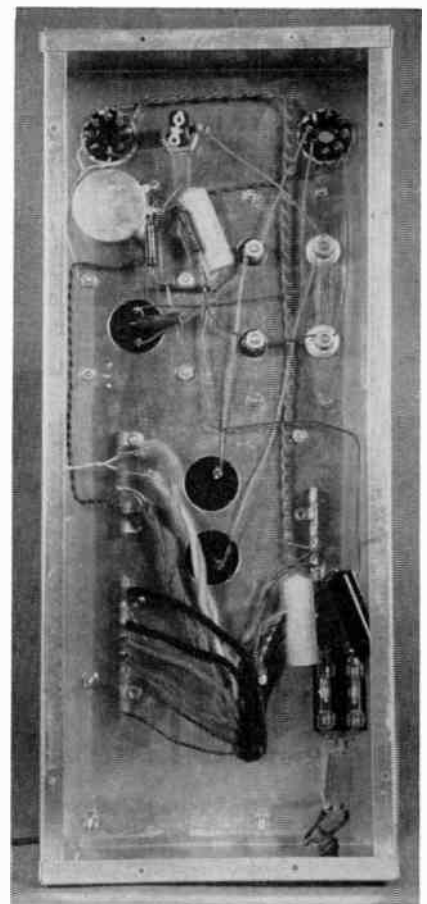
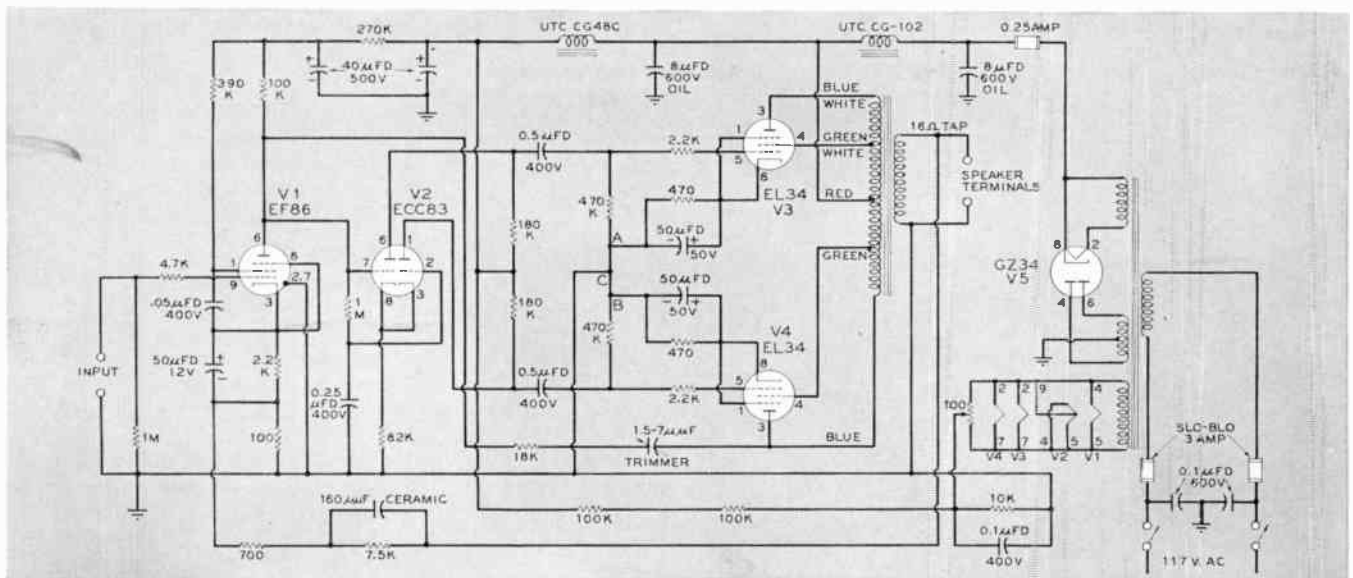

Fig. 3. Power-supply chassis. Unused transformer leads appear near bottom.

only drawback appeared to be the additional expense involved in the cost of the deposited-carbon resistors. A little arithmetic, however, showed that the exact difference in cost amounted to only \$4.60. I settled for the deposited-carbon units.

The Mullard 520 circuit calls for two 3-watt 470-ohm wire-wound resistors in the cathode legs of the EL34's (Fig. 4). The closest values commercially available

Fig. 4. Schematic diagram of the perfectionist's amplifier. Points A, B, and C (near center) indicate connections to balancing pot.



are 5-watt units with 450-ohm ratings. But 5-watt wire-wound adjustable resistors of 500 ohms can be used to provide the exact 470-ohm value needed. The adjustment is made with an ohmmeter, thus providing a 1% tolerance range for all resistors in the circuit.

Coupling capacitors between the phase inverter and the power output tubes, in a push-pull circuit, should be matched if best results at the low end are to be obtained.⁵ Two of the proper value were selected, using a capacitance bridge, for use in the circuit. The other capacitors in the circuit included two ceramic types, two molded-paper types and a number of electrolytics. Instead of the 8- μ fd electrolytics called for in the parts list for decoupling, two 40- μ fd units were chosen, because use of the larger units helps to increase the margin of stability of a feedback amplifier.⁶ The filters used on either side of the filter choke are oil-filled units rated for a lifetime of use. The oil-filled input capacitor is to be preferred for a smoother ripple and the ability to withstand high peak starting voltages when the amplifier is switched on. Swift surges of starting current often wreak havoc with ordinary electrolytics when power supplies are operated at high voltages.

Finally, I came to the most important component consideration in the entire amplifier: my choice of output transformer. Here, the author of the article describing the Mullard 520 circuit was quite explicit on the need of a first-class unit: "The use of distributed load conditions does not modify the essential features of a first-class component — on the contrary, the output transformer may be a more critical component, since precise balance of primary windings must be maintained."⁷ Williamson also sees this

⁵Milton S. Kiver, "How to Improve Your Hi-Fi Amplifier," *Radio & Television News*, LIV (Sept. 1955), pp. 50-51, 128.

⁶M. V. Kiebert, "The 'Williamson Type' Amplifier Brought Up To Date," *Audio Engineering*, XXXVI (Aug. 1952), pp. 18-19, 35-36.

⁷Ferguson, *op. cit.*

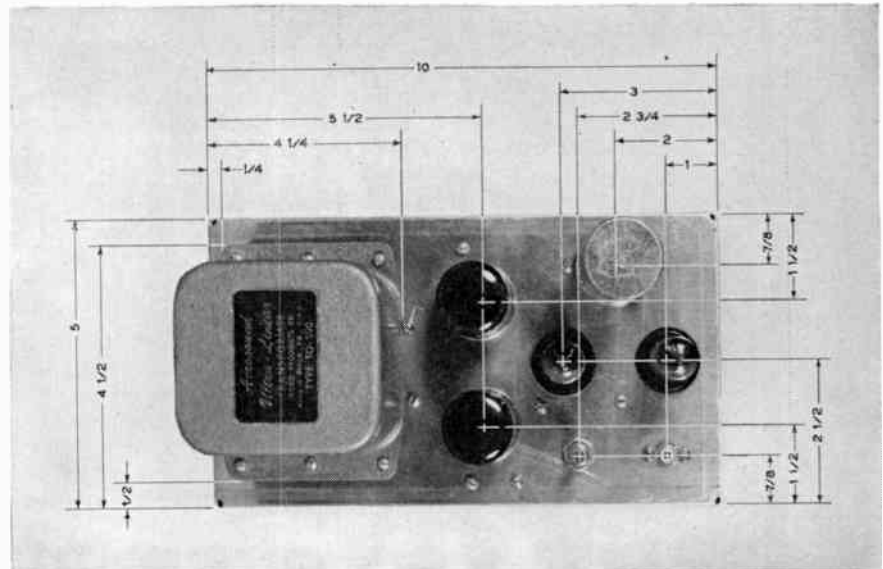

Fig. 5. Mounting guide for amplifier chassis; dimensions are expressed in inches.

component as a source of potential difficulty: "The constructor with limited facilities cannot be too strongly advised to keep to proved circuits which are inherently trouble-free. In particular, he should keep to designs requiring the minimum number of coupled circuits in the output transformer, since the possibility of pitfalls is greatest in this component and increases rapidly with the number of windings when all these must be closely coupled."⁸

It seemed quite clear at this point that only a reputable output transformer of the highest quality should be considered if the performance detailed in the specifications were to be obtained. The Acrosound TO-300 output transformer was chosen because the Mullard 520 is a tapped-screen circuit, and it seemed quite logical to suppose that the company responsible for the Ultra-Linear circuit and Ultra-Linear output transformer would produce an ideal component for this type of service. The unit itself is compact, makes use of grain-oriented

steel, and features a guarantee that AC primary balance is 1% or better.

Parts List

Resistors

- 2 1-megohm, 1/2-watt
- 1 4,700-ohm, 1/2-watt
- 3 2,200-ohm, 1/2-watt
- 1 100-ohm, 1/2-watt
- 1 100,000-ohm, 1/2-watt
- 1 390,000-ohm, 1/2-watt
- 1 82,000-ohm, 1/2-watt
- 1 270,000-ohm, 1/2-watt
- 2 180,000-ohm, 1/2-watt (matched)
- 2 470,000-ohm, 1/2-watt (matched)
- 2 470-ohm. Use 500-ohm 5-watt adjustable wire-wounds (see text)
- 1 680-ohm, 1/2-watt
- 1 7,500-ohm, 1/2-watt (critical value)
- 2 100,000-ohm, 1-watt
- 1 10,000-ohm, 1-watt
- 1 100-ohm wire-wound potentiometer
- 1 18,000-ohm, 1/2-watt

Capacitors

- 1 .05- μ fd, 400-volt
- 1 50- μ fd, 12-volt electrolytic
- 1 0.25- μ fd, 400-volt
- 2 40- μ fd, 500-volt electrolytic
- 2 0.5- μ fd, 400-volt (matched)
- 1 160- μ fd ceramic (for 16-ohm load)
- 2 50- μ fd, 50-volt electrolytic
- 2 8- μ fd, oil-filled, 600 working volts
- 1 0.1- μ fd, 400-volt
- 2 0.1- μ fd, 600-volt
- 1 1.5- to 7- μ fd trimmer

Other Parts

- 1 choke, 12 henries at 250 ma, UTC CG-102 or equivalent
- 1 choke, 75 henries at 50 ma, UTC CG-48C or equivalent
- 2 3-amp, slo-blo fuses
- 1 1/4-amp fuse
- 1 DPST switch
- 1 power transformer, 440 volts at 200 ma, UTC H-86 or equivalent
- 1 output transformer, 6,600 ohms plate-to-plate, 4-8-16-ohm secondary, Acrosound TO-300 or equivalent

Fig. 6. Guide for mounting power-supply components. We used 17-inch chassis base.

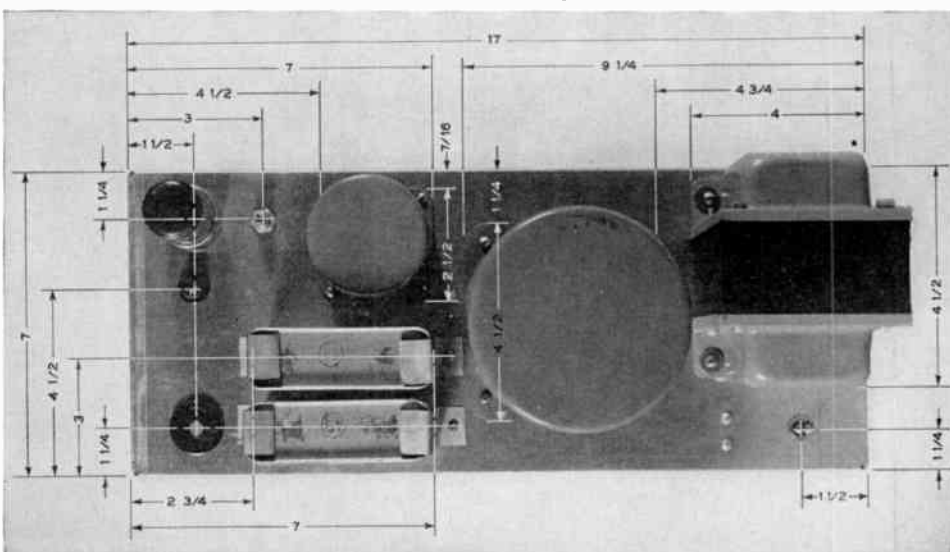

- 1 EF86 tube
- 1 ECC83 tube
- 2 EL34 (matched pair)
- 1 GZ34 tube
- 1 Amphenol type 80-PC2F input connector (another type if preferred)
- Chassis, hardware, sockets

Construction

So much for choice of components. The rest was construction and care, to make sure that a top-drawer choice of components would not be rendered worthless by slipshod layout or craftsmanship.

It is good practice to avoid unnecessary difficulties in amplifier construction. A common annoyance in placing everything on a single chassis, including the power supply, is the danger of hum contamination. It's just as easy to use a separate chassis for the power supply, and to build the amplifier part of the circuit on another chassis. Two chassis are used, therefore, in this version of the amplifier. Placement photos are reproduced in Figs. 5 and 6.

The classical, professional approach is to lay out the circuit in a line, from one end of the chassis to the other, using a heavy ground bus connected to the chassis only at the input end, and with all circuit grounds connected to the bus in ascending order. The best approach in this case is the familiar T-formation, used by Sarser and Sprinkle in the layout of the "Musician's Amplifier."⁹

Wiring is point-to-point, with leads, especially plate and grid leads, kept as short as practicable. Wiring and parts layout are made as physically symmetrical as possible, in order to maintain circuit balance at the high end.¹⁰

The power supply chassis is laid out conveniently, since placement of parts is not critical.

In working with deposited-carbon resistors, it is wise to apply a minimum of heat to leads during soldering, since excessive heat will cause resistors of this type to change value. An excellent method of handling this problem is to attach some heat-conducting vehicle between the body of the resistor and the point where the resistor lead is being

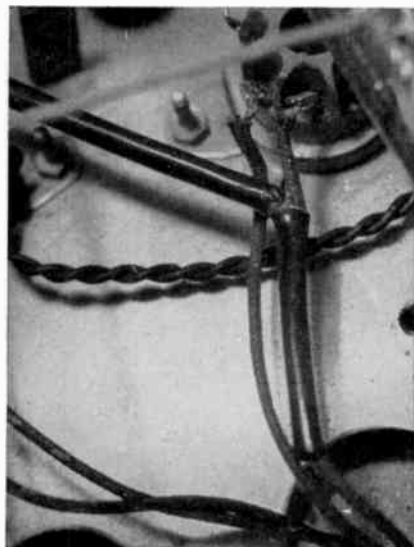

Fig. 7. "Glitch" circuit as used on original amplifier built by Mr. Zale.

soldered. The best tool I've yet come across for this purpose is one used by surgeons during operations, a surgical pliers called a hemostat. Alternatively, you can use alligator clips, needle-nose pliers, or any other handy device.

Use good-quality mica-filled sockets for best results. While RCA-type phono input sockets might be used, I prefer microphone connectors, since they are stronger and will not come apart, and make a better permanent connection.

A number of circuit changes were made on the recommendation of Herbert L. Keroes, of Acro Products Company. The changes were designed to optimize circuit values for this transformer, since the original circuit, as described in the Mullard booklet, made use of a Partridge output transformer.

It is true, in general, that the use of different output transformers will require the use of different types of networks or values of compensating resistors and capacitors for maximum stability and best transient response. This is because the frequency and phase characteristics of the circuit and transformer must be adjusted to complement each other for optimum results. The type of compensation worked out for this circuit, while somewhat unorthodox, produced excellent results, as seen in the oscillograms of square-wave response. There is very little overshoot and practically critical damping of the flat top of the wave. Moreover, the amplifier is stable on open and short-circuit output and over a wide range of capacitive loads, making it perfectly suitable for use with the new electrostatic speakers if desired.

The original circuit had a phase-shift network consisting of a 47- μmfd disc ceramic capacitor in series with a 4,700-ohm resistor strapped across the 100,000-ohm plate resistor of the EF86 tube. This circuit was eliminated in favor of a "glitch" circuit, made up of a very small capacitor in series with an 18,000-ohm resistor connected to the EF86 plate and one output tube plate,

the one to which the blue lead of the output transformer is connected. This capacitor may be a standard 1.5- to 7- μmfd trimmer set for best square-wave response, which should occur about midway in the range. A less easily duplicated, but equally effective capacitor was built into the amplifier described by paralleling within a spaghetti sheath about 1/2 in. of insulated hookup wire adjacent to the blue transformer lead (see Fig. 7 for detail).

The capacitor-resistor combination rolls off high-frequency response above 60 Kc gradually and smoothly. This approach is to be preferred, according to Mr. Keroes, over the more usual one of striving for a maximum flat bandwidth of 100 Kc and better, which usually results in a sharp cutoff at the upper end. In such an amplifier, there is generally less stability and considerable ringing on high-frequency square-waves.

Splitting the feed-back resistor into two sections (the original Mullard 520 circuit calls for a single 8,200-ohm resistor), with one section bridged by a compensating capacitor, contributed to improved stability. The 1,000-ohm stabilizing resistors connected in series with the output tube screens in the original circuit are not required with the TO-300 and were eliminated, since they would serve no useful purpose and would limit output power.

The capacitor used to bridge the feed-back resistor in the original circuit was a 220- μmfd unit. Recommended change is to 160 μmfd across the 7,500-ohm feed-back resistor *only*.

Here are the specifications I obtained for this version of the circuit: power output at 20 cps was 32 watts clean, with overload at 36.8 watts. This is notable in view of the fact that the Acrosound TO-300 is rated at 20 watts at 20 cps, and attests to the conservative specifications for this item. Clean power output at 1 Kc was 38.5 watts; at 20 Kc, 32.3 watts.

Frequency response was flat from 20 to 20,000 cps, being down 1/2 db at 20 Kc, 3/4 db at 50 Kc, 1 db at 60 Kc, 6 db at 100 Kc, and 10 db at 200 Kc, all at 36 watts. The rolloff at the high end was clean and gradual. Square-wave response was excellent even at 20 Kc, with

Continued on page 46

⁹David Sarser and Melvin C. Sprinkle, "Musician's Amplifier," *Audio Engineering*, XXXIII, (Nov. 1949), pp. 11-13, 53-55. See also: Glen Southworth, "Chassis Layout and Wiring," *AUDIOCRAFT*, I (Dec. 1955), pp. 21-23, 43.

¹⁰Kiver, *op. cit.*

Fig. 8. Curve showing intermodulation distortion with respect to power output.

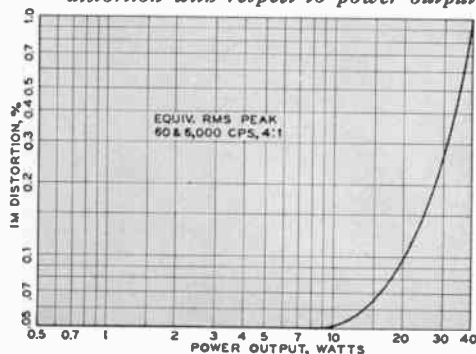
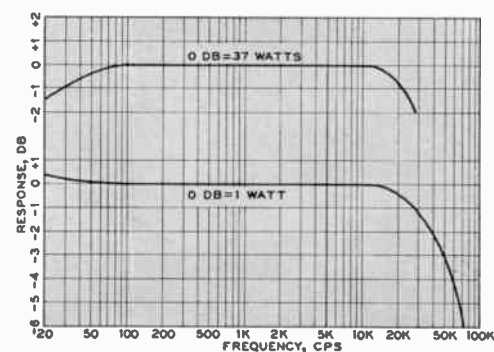

Fig. 9. Power response (top curve) and frequency response of model built here.



Deceptively small size doesn't mar this enclosure's performance. It's one of the easiest-to-build kits on the market — and one of the prettiest.

WE looked upon the construction of the Argos Californian, Jr., as something of a lark. The small, light-weight package which arrived with the parts for the enclosure no doubt contributed to this happy-go-lucky frame of mind, and with the package tucked complacently under one (ONE) arm, we whistled homeward for a relaxed evening of kit building, and merrily anticipated results before bedtime.

The unusual outcome of this anticipatory light-heartedness was that we were correct in every respect. The Argos speaker kit *is* a lark to build. There are no parts to saw, no holes to drill, no fussy angles to measure — in fact, the entire job from start to finish can be done with a single Phillips-head screw driver and a hammer. If your screw driver has a heavy handle you might dispense with the hammer since only two nails must be driven, and they go through soft wood and don't have to be driven all the way in.

Although most of the pieces are held together with glue as well as with screws, the thoughtful Argos folks have provided two easy-to-use pliable tubes of ready-mixed, sticky white glue which spreads like tooth paste. They suggest keeping a damp rag handy to wipe off the excess, but we found it unnecessary; spreading the glue is such a foolproof process that we simply didn't goof.

When finally finished and put into operation (as we expected, before bedtime), the lark came to an unequivocal end. The Californian, Jr., is an enclosure which speaks with conviction. It's no toy, despite its deceptively compact size. We have heard small speaker enclosures rattle the floor, but not often. The night we finished the Argos Cali-

Fig. 1. The kit shown before assembly. Envelopes hold screws, bolts, and tacks.

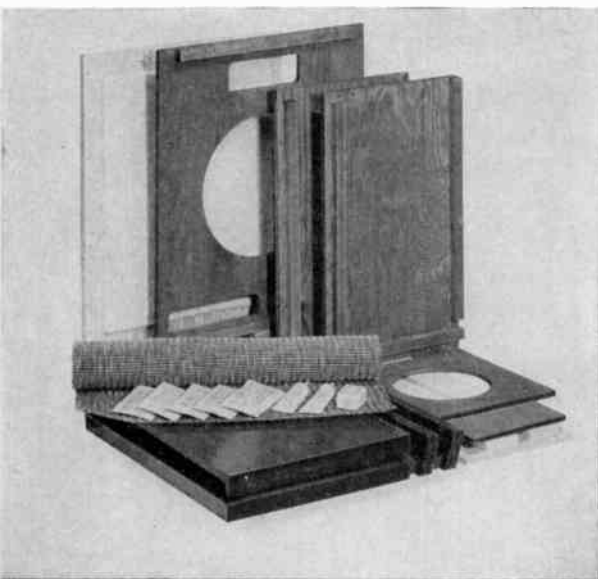

The ARGOS

Californian,

An audiocraft kit report

fornian, Jr., was one of those occasions.

Licensed by Jensen Manufacturing Company, the Californian, Jr., makes use of the ducted-port Bass Ultraflex principle developed by Jensen. By using tunnels or ducts rather than a simple bass-reflex port, the enclosure resonance is broadened and damped; moreover, a smaller enclosure volume can be used. Principles of the Bass Ultraflex design are given in more detail in a previous kit report.*

There are two Argos kits of this type. The Californian DSE-1K, at \$40.50, is for 15- or 12-inch speakers. Our kit, the Californian, Jr., DSE-2K, sells for \$32.50. It is designed for 12- or 8-inch speakers. Both models are available in prefinished blond or mahogany.

Construction Notes

While unpacking the box, we spread the parts over the living-room rug as kit

*"Jensen-Cabinart Concerto Speaker System," *Audiocraft*, II (June 1957), p. 26.

builders are always pictured doing. See Fig. 1 for our version. The prefinished top and bottom pieces came as a surprise. Not only is the top all finished, but it is covered with a diamond-hard, simulated-wood, shiny material (St. Regis Panelyte) which is impervious to just

Fig. 2. Squaring board is in place where it must stay until glue hardens.

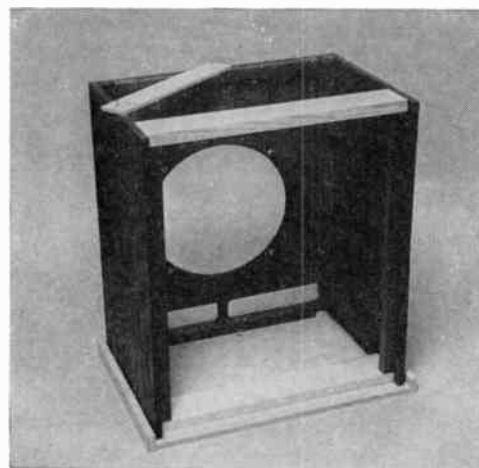

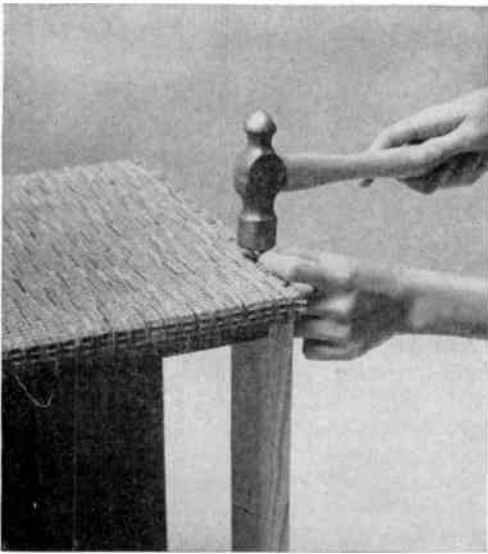

Fig. 3. Grille cloth is attached to the enclosure with tacks every inch or so.

Ir.

Speaker Kit

about anything you might have around the house. Our kit was the blond model, with light-colored top and bottom panels and golden grille cloth. Even the wife thought it was pretty.

The first step listed on a four-page instruction sheet was to smear glue all over the edges of the side panels and screw them to the front piece. Nothing tricky here, except to line up all edges so that they were flush with each other. Then the cross bars were glued and screwed to the top and bottom.

The instructions say not to turn the screws all the way in until the box has been squared, and here's where the hammer comes in. After the cross bars are added, the box is lifted onto either the top or bottom panel (they're both the same size, so either will do) and the whole thing shoved around until it looks square with respect to the panel. Then a spare piece of plywood (sup-

plied) is tacked diagonally to the edges with two nails (also supplied). All the screws are firmly tightened, and the whole assembly left for an hour or so until the glue sets (Fig. 2). Our timing was perfect—we were called to dinner at almost the exact instant we finished tightening the screws, and when we had finished eating, the joints were tight and we could proceed to the following steps.

Speaker bolts were installed next. There were only four, since we planned to use a 12-inch speaker. A reducing panel for an 8-inch speaker is included in the kit, however, and four additional mounting bolts are provided so that if you should install an 8-inch speaker now, when the time comes to broaden your horizons to include a genuine 12-incher, the bolts will be in place already and the

bottom panels. Two sides are smeared with glue, and they are slid (that's right) into place. The glue is sticky enough to hold them in position, without nails or screws, until it hardens and makes the bond permanent.

The instructions advise another wait of 15 minutes at this point, to allow the glue on the triangular braces to set, so we readied the speaker and attached the terminal strip to the back panel. This terminal strip is a handy gadget. It permits you to connect the wires from your amplifier directly to the speaker cabinet on the outside, without having to open the back or string a loose wire through a hole. For best results, the wires which go to the speaker itself should be soldered to lugs on the inside of the back panel, but a tight wire-

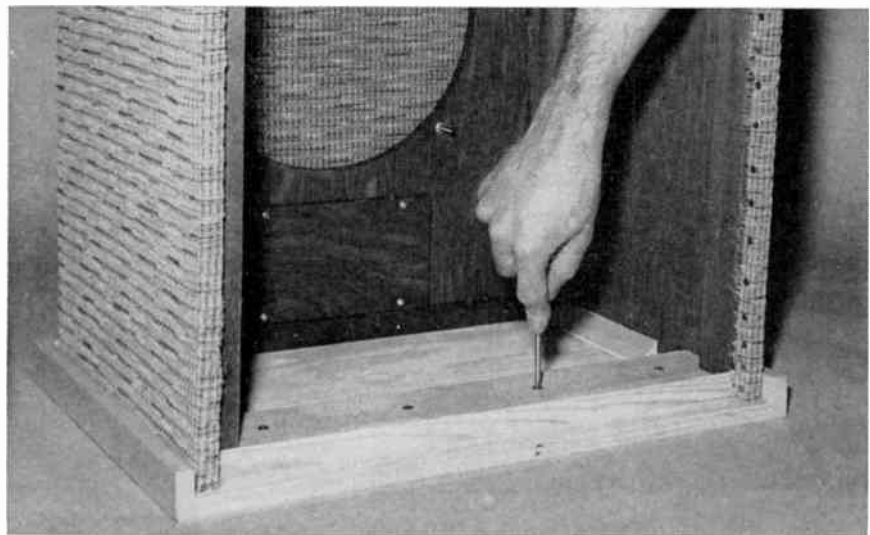

Fig. 4. The enclosure shell is placed on prefinished top and bottom panels and screws inserted from the inside. Note triangular braces to right of screwdriver.

grille cloth won't have to come off to insert new ones.

Tacking on this luxurious golden grille cloth was the next operation, and following the instructions was a breeze. The enclosure was laid on one side, the grille cloth tacked, then rolled around and tacked on the other side. Its positioning was checked to make sure the straight lines of the cloth were not being contrary (they were, but it was easy to pull them back into line). Then the whole piece was tacked around its periphery (Fig. 3). This was the most exacting task in the entire project—but even this arduous effort consumed only 15 minutes or so.

At this point we were ready to attach the top and bottom panels. The glue tube was squeezed once more, all around the flat areas of one end of the enclosure. Then the bottom panel was laid on the floor, and the enclosure, glue and all, lowered into place and the screws inserted. The top panel was attached in the same way (Fig. 4). Four triangular pieces of wood are supplied which function as additional braces for the top and

wrapping job probably would suffice in an emergency.

When the 15 minutes had elapsed we installed the tunnel plate. It is the only piece of interior construction in the enclosure, and helps adjust the tuning of the front-panel reflex ports. This was a simple operation, involving one final

Continued on page 44

Fig. 5. Completed enclosure from rear. Insert shows closer view of tunnel port.

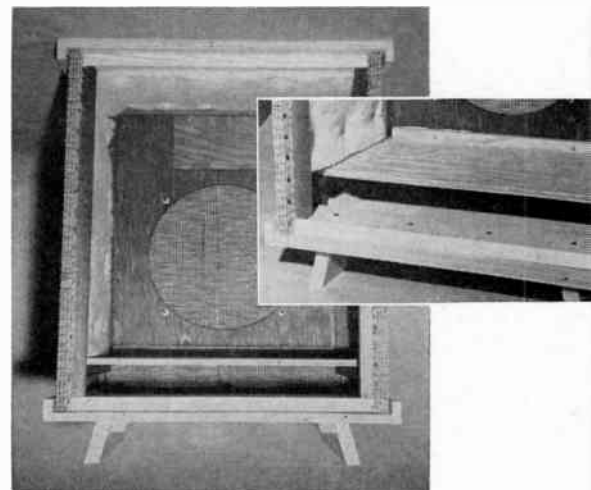

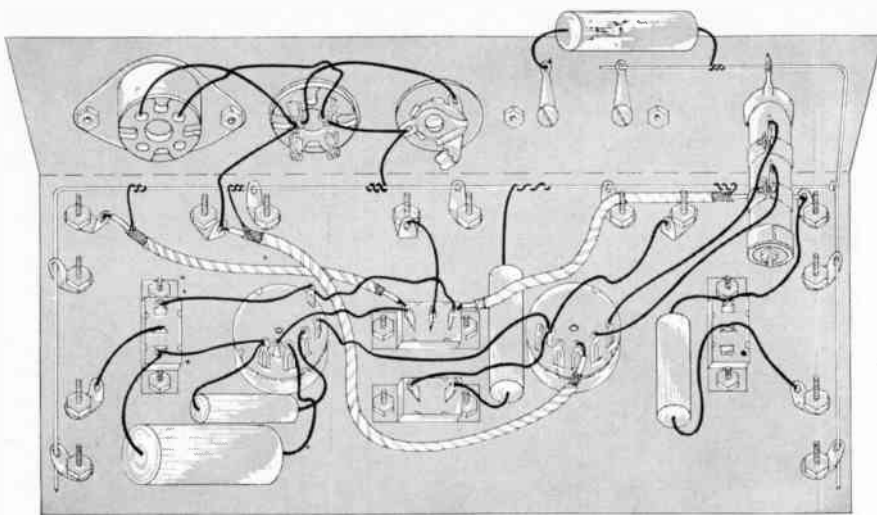

Fig. 1. Pictorial drawing of the gadget box shows parts layout.

HIGH-FIDELITY enthusiasts, audiophiles, hams, and experimenters in general are often rudely reminded of the fact that their world is a realm of gadgetry. Herein is explained another gadget. It is indeed a gadget, if by definition of the term we mean that it is not a kit, not a completely assembled mechanism, nor anything at all which, until now, has existed anywhere but in the mind of its creator.

At the same time, it is a most handy gadget, as anyone who has tinkered with electronic paraphernalia with a bent to testing it will comprehend. Nothing is more frustrating than a tangled maze of wires connecting several test devices to an amplifier and to themselves again, and so on ad infinitum. A gadget is often the only vehicle on which to traverse the route to ultimate freedom from this confusion. This particular gadget was designed and built by George K. Marshalsea, a merchant seaman whose hobby is high fidelity. Not having any room to spare in his quarters to spread

PRACTICAL GADGET FOR GADGETEERS



Fig. 2. View of the completed gadget.

Fig. 3. Follow this block diagram when installing jacks and switches.

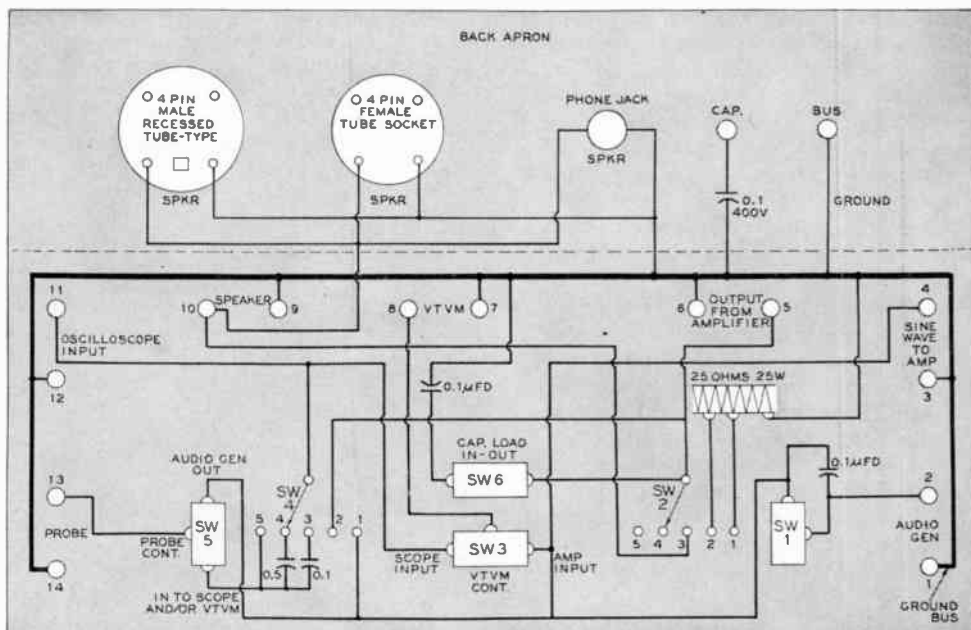

out a tangle of test leads, Mr. Marshalsea was forced to invent the gadget in self-defense. The "Gadget," which we shall term it for lack of a more appropriate name, is designed to serve as a connecting link between an amplifier, sine- or square-wave generator, VTVM, speaker, and oscilloscope. Once basic connections have been made, nothing is required in the way of switching more complicated or nerve jangling than the touch of your finger tips to one of six knobs. Connections are made, via switches, inside the box. The pictorial diagram (Fig. 1) shows the wiring.

The output of an amplifier can be routed to a speaker or a variety of dummy loads by rotating Switch 2 through its four positions. The VTVM can be connected to the amplifier input (which at the same time is the generator output) or to the scope input (which is concurrently the amplifier output or probe) by pushing Switch 3 right or left as indicated. The oscilloscope input (which can also be the VTVM input if the VTVM switch is in the right position) can be selected by Switch 4 to contact the amplifier input, amplifier out-

put, generator output, or probe. Note the position of switches and jacks in Fig. 2.

Four types of speaker connections are furnished: recessed male and flush-mounted female four-prong tube types, a standard phone jack, and banana jacks. Two insulated ground connections are provided, in addition to the banana jacks, one of which is a direct tap to the ground bus. The other is connected to the bus through a 0.1- μ fd capacitor.

Banana jacks are provided on the front panel for all connections to amplifier, VTVM, scope, and signal generator. A gadget builder would be wise to make up several sets of shielded connecting cords with banana plugs on one end and fittings to match test equipment or amplifiers to be tested on the other end.

For signal tracing, the probe can be connected through either a 0.1- μ fd or 0.5- μ fd capacitor to the scope input, or to the scope and VTVM inputs at the same time (Fig. 3). For signal injection, the output of the signal generator can be connected to the probe either directly or through a 0.1- μ fd capacitor. There is also a sine-wave output to the amplifier under test. Although this output is not switchable, the convenience of having the generator output in the box for scope or VTVM analysis will not be disputed.

This gadget is built into a standard, 2½-by-10-by-4-inch channel-lock box. Using the template (Fig. 4), mark drill positions carefully. Patience and skill at this point will be rewarded in the end with a beautiful instrument which will be a pleasure to look at as well as to use.

A ground bus made of heavy wire is attached to the solder lugs under all ground inputs. No ground connection is made to the chassis at any point.

In wiring, use shielded wire for all scope, VTVM, and probe connections. Ground one end of each shield to the ground bus.

The appearance of the gadget can be further enhanced by using decals to identify all switch positions and input connections. After the decals have dried overnight, the front of the box can be painted with lacquer, varnish, or clear enamel for protection.

Parts List

1 channel-lock box, gray hammertone finish, 2½ × 10 × 4 in.

2 switches, Mallory type 3215-J or equivalent: single-pole, 5-position, non-shorting.

3 switches, slide, SPDT.

1 switch, slide, SPST.

14 binding posts, 7 red, 7 black, to fit banana plugs.

4 capacitors, 0.1 μ fd, 400 volts.

1 capacitor, 0.5 μ fd, 400 volts.

1 resistor, 25 ohms, 50 watts, adjustable with slider.

2 knobs, with pointer.

Estimated cost: \$8.34.

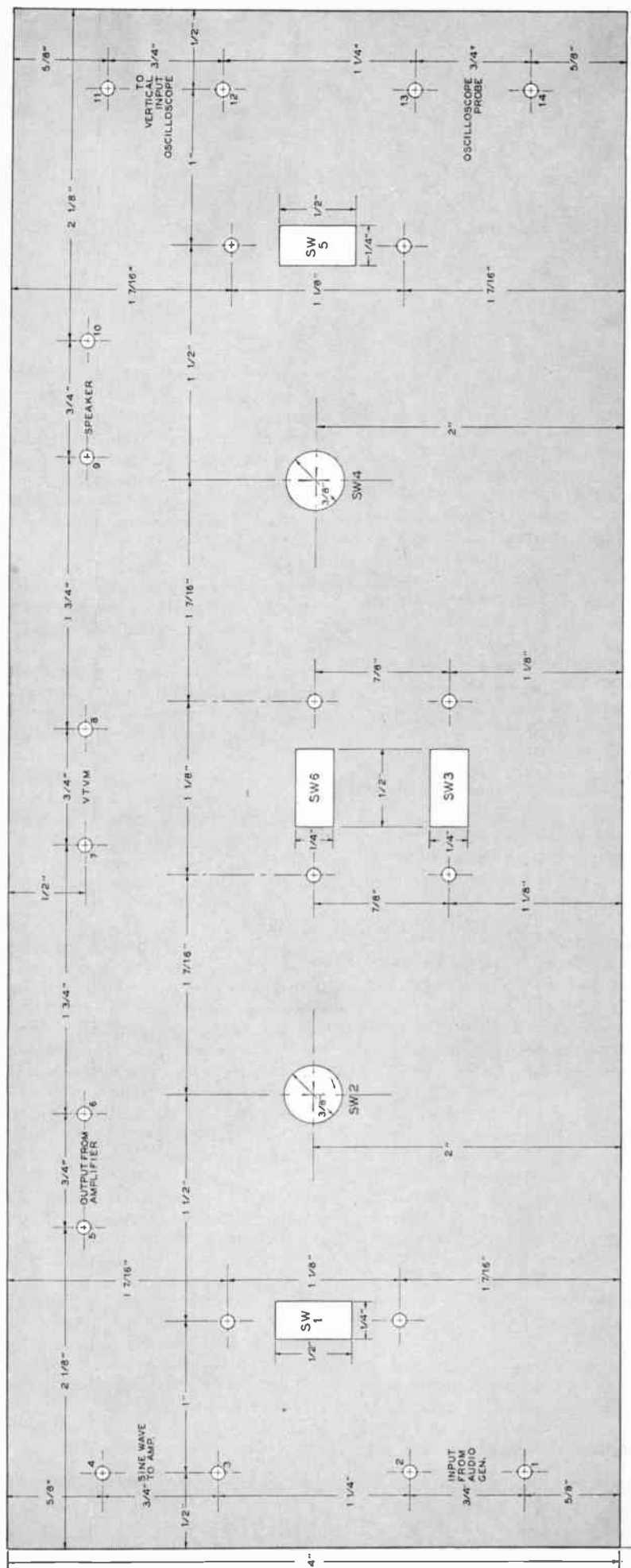

Fig. 4. This template has been drawn to the exact size of the channel-lock box used by Mr. Marshalsea. Place this page over a box of similar size, and punch through paper with a sharp instrument, observing center lines. Use the marks thus made on your chassis box as guides for hole drilling. Square holes can be made with a file or coping saw, after drilling pilot hole.



by NORMAN H. CROWHURST

Enclosure Practicalities

"There are times I almost think / I am not sure of what I absolutely know." In no part of high fidelity do these two lines more often find appropriate application than with reference to loudspeaker systems. This is well illustrated in a recent incident: a friend called me the other day, quite disconcerted because he found that a bass-reflex loudspeaker sounded as good or better in his living room than the back-loading horn he had been using. His education in sound reproduction had led him to believe that some kind of horn was essential for good performance; and that a bass-reflex or any other kind of loudspeaker enclosure must of necessity give inferior performance; in fact, that they should only be used as a matter of economy, either in cost or in space.

In this particular case my friend had built a bass-reflex speaker for his dining room, where he did not have room for a horn-loaded corner type. Quite casually he tried it out in his living room, with the results stated. The way he sounded over the telephone suggested he would not be surprised if I told him to go trade in his ears for a new pair. He sounded as if he thought he deserved this treatment for liking the bass reflex better than a corner horn!

As usual, of course, there is a reasonable explanation. In most instances the theory behind an academic preference for one particular loudspeaker type is based upon an idealization that is never fully realized in practice, usually some very basic acoustic theory. This postulates at the beginning that the sound source is radiating into a semi-infinite medium, or the same thing with some other name.

Well, this "semi-infinite medium" is an academic way of saying the loudspeaker is (or should be) mounted in the center of an infinitely large flat wall, the sound being radiated on one side of this wall. In the case of a corner horn this theory is modified by idealizing that

the radiation takes the form of a spherical wave "into" the one-eighth of a sphere bounded by the three right angles at the corner of the room, between the two walls and the floor (or, if it's mounted at the top of the room, the two walls and the ceiling). This would be described as radiating into one-eighth of an infinite medium.

The theory that postulates this as correct acoustic loading for the loudspeaker unit assumes that this is the *only* corner in the room—that the walls and also the floor extend upward and outward to infinity. The whole universe could contain only eight such corners, but most rooms have an average of eight corners: four at the floor and four at the ceiling. Stated another way, the theory is based upon the sound wave's being radiated from the sound source, in this case the loudspeaker with its horn, and keeping on going without ever being reflected.

In living rooms standing waves are always produced, because the sound waves quickly encounter the opposite wall and are reflected as pressure waves which eventually get back to the mouth of the loudspeaker. This, unfortunately, is just as true with a horn loudspeaker as with any other type. The difference is that the loudspeaker diaphragm is (in theory, at least) better matched with the acoustic air load at the mouth of the horn than with other types. This is an academic way of saying the diaphragm does not have to work so hard to radiate the same sound wave.

But this better matching works as much in the reverse as it does in the forward direction. So a standing wave coming back to the mouth of the horn will exert as much *relative* influence on the diaphragm movement as it does with any other loudspeaker.

One big claim in favor of horn loading is that it allows reasonable power to be radiated at the extreme low frequencies without the necessity for excessive excursion of the diaphragm. This enables it to avoid the much-discussed Doppler effect, i.e., the cone's having to

radiate higher frequencies while it's going back and forth a considerable distance at the lower frequencies, which amounts to frequency modulation of the higher frequencies by the lower frequencies. Horn loading is one way of reducing the effective amount of frequency modulation the loudspeaker can produce in this way.

One question is whether this frequency modulation amounts to anything that can be *heard*. The argument put forward by the anti-Dopplerites is that, if the loudspeaker excursion is one-eighth of an inch or more, the corresponding amount of frequency modulation, in the form of flutter or wow, for example, is quite audible.

But this seems to overlook a fairly important distinction: that flutter or wow is not part of the program to which we want to listen, whereas the low frequency, that may be frequency-modulating middle and higher frequencies, is. If we consider this form of interference or modulation to be somewhat like the vibrato and tremolo in music, we find its importance may have been rather exaggerated.

It requires careful listening to tell the difference between vibrato and tremolo, one of which is a modulation of intensity, while the other is a modulation in pitch or frequency. So the Doppler frequency modulation will have an aural effect almost indistinguishable from other forms of intermodulation of the middle and higher frequencies by the low frequencies present.

Viewed this way, an analysis makes it quite evident that the so-called Doppler, or frequency-modulation, effect will be of negligible order compared with other intermodulation effects invariably present in loudspeaker units employing the same low-frequency excursion. This does not argue that it is not a good thing to keep the magnitude of diaphragm movement down. It certainly is, because this will minimize both of these forms of distortion.

But let's take the matter a step fur-



ther. Does horn loading prove any more beneficial in restricting diaphragm movement than, for example, the bass-reflex loudspeaker? Taking an average condition, if both kinds of enclosure utilize the same kind of loudspeaker unit and produce the same resultant loudness in the room at their lowest frequency, the excursion of the diaphragm will also be the same.

It is true that the limitation, or loading, is effected by different means (according to theory, at least), but the result is of the same order. In the case of the bass-reflex loudspeaker, the enclosure with its port (which may be just a simple hole, or one that is extended so as to provide air loading of the port) reverses the phase of the wave radiated from the back of the loudspeaker unit. This means that, when the diaphragm is moving forward, the air in the port is also moving forward, so radiation from both places produces a pressure wave on the front of the loudspeaker. This is equivalent to putting two diaphragms in the same enclosure, each of which increases the air loading on the other, because both are trying to move the same total body of air. So, in fact, one diaphragm is coupled in such a way that it moves twice its normal area of air in the same direction.

This is precisely what happens, perhaps in a somewhat smoother manner (again according to theory), in using horn loading. But in both instances this idealized theory is modified by the fact that the wave does not come out of the loudspeaker *and keep on going*. The reflected waves from the room also affect the loudspeaker diaphragm movement.

Taking a room, for example, in the region of 20 ft. square by 10 ft. high, the dimensions of the room represent a wave length of frequency in the region of 40 to 50 cps. In any reflection from a surface a pressure build-up occurs at the surface where the wave gets reflected. If the distance from the wall surface back to the loudspeaker is one wave length or an integral number of wave lengths, there must also be increased pressure at the loudspeaker tending to restrict the diaphragm's movement. At intermediate frequencies the reflected wave will have the opposite effect, causing increased diaphragm movement. This will be equally true whether the loudspeaker is a bass-reflex or a horn-loaded unit.

Let's pursue the matter a little further and see how important enclosure shape can be. Most theory on this subject says that, to reproduce down to a certain frequency, with a specified size of loudspeaker unit, one needs a certain enclosure *volume*, according to whether the enclosure is a bass reflex, a so-called infinite baffle, or what-have-you. Some schools would have us believe it is relatively unimportant what shape this vol-

ume takes, so long as we have the requisite number of cubic feet.

As far as the low-frequency end is concerned, this is quite true. The theory states that the air inside the enclosure merely acts as a compliance by being compressed or expanded, all at once. This may be true for the extremely low frequencies, but it does not remain true for the middle frequencies. In this region the sound waves have time to be radiated from the back of the loudspeaker diaphragm to various surfaces of the enclosure's interior and back to the diaphragm again. These radiations can also build up standing waves.

Just by way of example, let's assume we put a loudspeaker in a box 10 ft. long and 1 ft. square, to obtain a volume of 10 cu. ft. This is one-quarter of a wave length at 25 cps, one-half a wave length at 50 cps, a full wave length at 100 cps, and so on up. Because of the propagation of sound waves inside the box, the diaphragm movement will tend to be exaggerated at 25 cps, 75 cps, 125 cps, and so on up the scale, while its movement will be minimized at 50 cps, 100 cps, 150 cps, and so on. This par-

ticular box shape will produce quite an irregular frequency response.

A good shape for an enclosure for rear-loading a loudspeaker diaphragm is the three-corner construction normally used for corner enclosures, which avoids any specific dimension between the rear of the diaphragm and the back of the box. The distance is different at all points; consequently, it will have no specific frequency pattern as just discussed.

Alternatively, a rectangular cabinet in the form of a comparatively shallow box, with the unit mounted in such a position that the distance from the back of the diaphragm to the two sides and top and bottom is different in all directions, will achieve a similar effect. This is achieved in practice by the average bass-reflex loudspeaker. Just to smooth off the irregularities which the definite flatness of the side surfaces can produce, a certain amount of acoustic lining with suitable material can be used on the inside of the box.

Don't be guided by pseudotheory in loudspeaker choice. The important factor is which performs best in your living room. And human ears are, after all, the final judge of what it sounds like.



USING TEST INSTRUMENTS

by DONALD CARL HOEFLER



The Signal Generator

PART I: How it works

THE RF signal generator is useful not only for trouble shooting, but also for routine maintenance and testing of hi-fi tuners. Remember that, if your radio equipment came off someone's assembly line a long while ago, or if it was built by you from kits, it is almost a certainty that right now its performance could be improved by some touch-up adjustments with the aid of accurate test equipment.

Not so long ago the idea of a hobbyist maintaining his own audio laboratory was a ridiculous one, but this is fortunately no longer the case. In fact, the basic instrument is presently available in kit form for less than \$20.

Operation of the RF generator is fairly simple, and almost anyone can do a passable job at it without actually knowing how it works. But to get the most out of it, the user should understand its

operating principles. These aren't very complex, so let's spend a little time discussing them.

The schematic diagram in Fig. 1 is that of the completed generator shown in Fig. 2. Actual generation of RF energy occurs in the right-hand half of the 12AU7. This is a Colpitts oscillator which covers five bands of frequencies by means of switching coils *BF* and *BR*. The five bands are: A—160 to 500 Kc; B—500 to 1,650 Kc; C—1.65 to 6.5 Mc; D—6.5 to 25 Mc; and E—25 to 110 Mc.

Standard coils on forms are used for bands A through D, but a little trickery is employed for the E-band coil. This is the heavy bus wire that forms the connections between the band switch and tuning capacitor for the first four channels. When the switch is in the E position, a short is put

across the ends of this bus wire, which makes it a loop inductance to tune the highest band.

The feedback necessary for oscillation in the Colpitts circuit is obtained from a capacitive-reactance divider across the inductor of the tuned circuit. In most textbook versions of this circuit the capacitors in this divider are fixed in value, while the coil is either tapped or in the form of a variometer. In this circuit rough tuning is accomplished through selection of the proper inductor by the band switch, while fine tuning is by adjustment of a split-stator variable capacitor in the divider. This is seen between plate and grid of the oscillator section of the 12AU7.

The advantage of this arrangement becomes apparent when we consider what would happen if the capacitors were fixed in value. As the frequency

Fig. 1. Schematic diagram of signal generator shown in Fig. 2. This instrument produces frequencies from 160 Kc to 110 Mc.

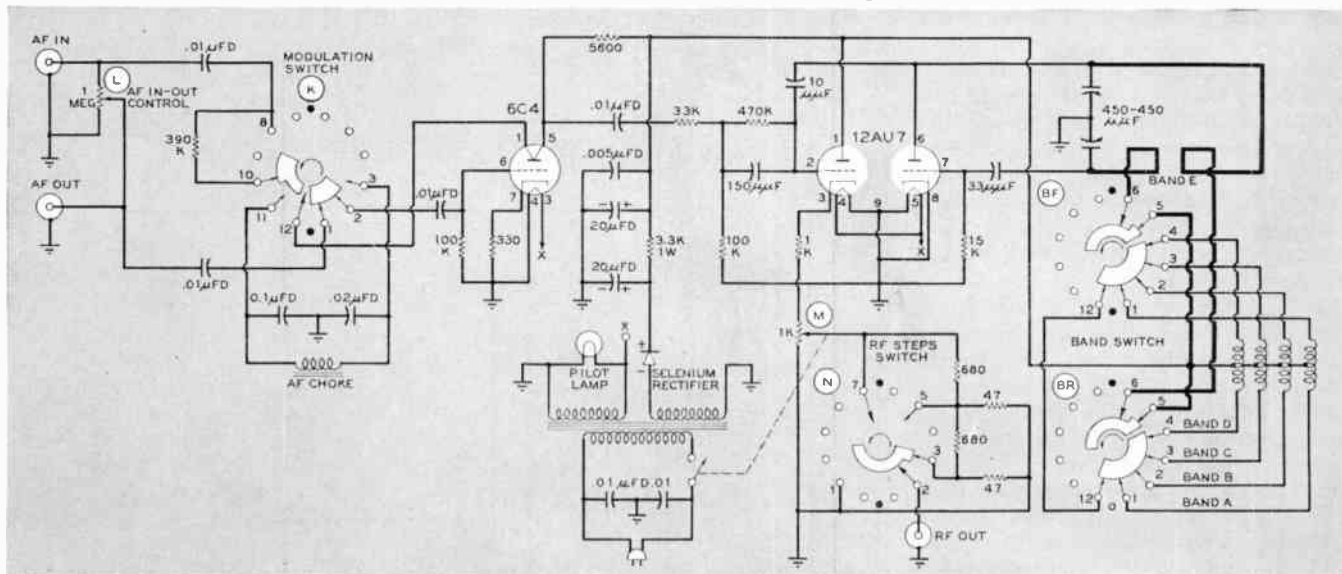

rose the reactance of the capacitors would decrease; the capacitive-reactance formula tells us that reactance is inversely proportional to frequency. Ultimately, a point would be reached at which the reactance would be so low that oscillations could no longer be sustained.

In this circuit the split variable capacitor is both divider and tuner, and the capacitance decreases as frequency increases. Since capacitive reactance is also inversely proportional to capacitance, we now have a situation wherein increasing frequency tends to decrease reactance, while at the same time the decreasing capacitance is pulling in the opposite direction, tending to raise the reactance. The result is that these two actions more or less cancel each other; the reactance of the network remains fairly constant, and oscillation over a wide frequency range is made possible.

The left-hand section of the 12AU7 acts as a buffer or isolation stage between the oscillator and the output circuit. It is connected as a cathode follower, with the signal coming off pin 3. The characteristics of the cathode follower are ideally suited to this purpose. Its extremely high input impedance produces little or no loading effect on the oscillator, and its very low output impedance makes it tolerant of changing loads.

The cathode follower also incorporates the signal-level controls, consisting of potentiometer *M* and step switch *N*. The switch, in combination with the resistance network, provides a coarse output level control. Continuously variable fine control is then achieved through the potentiometer marked RF OUTPUT in Fig. 2.

This generator also has an internal audio oscillator which is fixed in frequency at 400 cps. A 6C4 is used as the oscillator tube. It too is in a Colpitts circuit, with an AF choke and two fixed capacitors in the divider shunted across it.

The output of the audio oscillator is controlled by a two-position selector switch *K*. When this switch is in the INT position, the audio is applied through a resistance network to the grid of the cathode follower, from pin 5 of the 6C4 to pin 2 of the 12AU7. The buffer is thus effectively control-grid modulated, and the output becomes the selected radio frequency modulated with an AM note of 400 cps. At the same time the tone appears at the AF OUT jack, from which it can be picked up as an audio source for testing. The level is controlled by potentiometer *L*.

When the modulation switch is set at the EXT position, any external audio source may be used to modulate the RF output of the generator. This arrangement permits the flexibility of using a variable-frequency audio generator for a frequency run of the entire system, or



Fig. 2. Heathkit RF Signal Generator combines versatility with moderate cost.

test signals from a record, or even program material from disc or tape.

Under these circumstances two interesting changes take place. The 12AU7 is a dual-purpose tube, for in the INT position it is oscillator and modulator, while in the EXT position it acts as a straight amplifier of the external source as well as a modulator. Similarly, AF IN-OUT control *L* is in one case an output-level control between oscillator and external load, while in the other it is an input-level control between the external source and the 12AU7 amplifier.

The power supply is simple and straightforward. Filaments are AC operated from one winding, while the plate winding drives the half-wave selenium rectifier. An RC network filters the

pulsating DC to a fairly steady DC. Isolation to prevent the RF signal from feeding back into the power line is accomplished by the power transformer, which, as a further precaution, has both sides of the primary bypassed to ground through small capacitors.

As a comparison with the basic economy-model generator depicted in Figs. 1 and 2, let us consider briefly a professional type shown in Fig. 3. The oscillators are similar, being Colpitts in both cases, but there are refinements in the more expensive model. The oscillator is a separate triode, type 6AF4, using split-stator tuning but with a conventional coil for each of the five bands. Ranges covered are: A—100 to 290 Kc; B—280

Continued on page 38

Fig. 3. Laboratory generator has refinements which adapt it to precision use.



TRANSISTORS

by PAUL PENFIELD, Jr.

in audio circuits

Part VIIIb: Volume controls, mixers, equalizers, tone controls

Volume Controls

Many audio amplifiers require volume controls, and with transistors this can be a problem. Turning the control should not affect the DC bias in any part of the circuit. Some horrible examples appear in Fig. 10. In 10A, the base bias is changed by turning the control, and in 10B the collector current changes.

Some better ideas are shown in Fig. 11. The first is a variation of the usual vacuum-tube setup. The second uses the control as a current divider. These circuits have one remaining fault, though: turning the control forces the DC voltage across the capacitor *C* to change. This cannot change suddenly; instead, it takes a short time, depending on the size of the capacitor and the various resistors. This time may run up to a second in

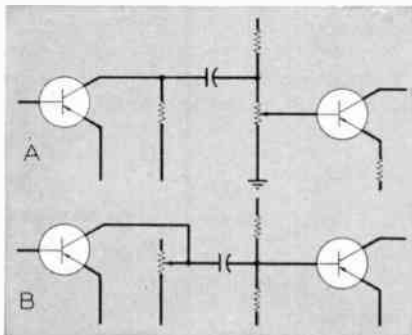

Fig. 10. Poor volume-control usage.

extreme cases. During that time the transistor biases will change, and merely turning the control fast may be enough to push one of the stages into cutoff or saturation for a short time.

Fig. 12 shows two control circuits that do not have this fault. The first uses a large series resistor to cut down the signal strength. The sound cannot be turned off completely, but, by using a high enough resistor, such a control can be made very satisfactory. Fig. 12B shows a satisfactory control circuit for transformer coupling.

Either of the circuits shown in Fig. 11 can be made satisfactory by isolating

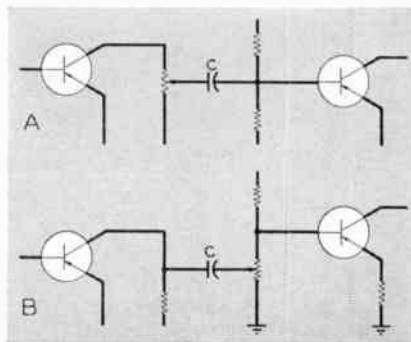

Fig. 11. Capacitors will cause trouble.

the variable resistor from both bias networks. This will mean using two coupling capacitors, with the control between the two.

Loudness Controls

Because transistors have not been used for long in high-fidelity equipment, practical designs for loudness controls are not generally available now.

The purpose of a loudness control, of course, is to provide tone equalization automatically as the volume is changed, so as to counteract the tendency of normal ears to be less sensitive to bass frequencies at lower volume levels. Only a relatively complicated array of resistors and capacitors can do this well, and all so far made are for use in vacuum-tube circuits — where they will not be loaded down by the following stage.

Loading these controls with a low-impedance transistor input circuit will change their characteristics. So far none has been designed for transistor circuits,

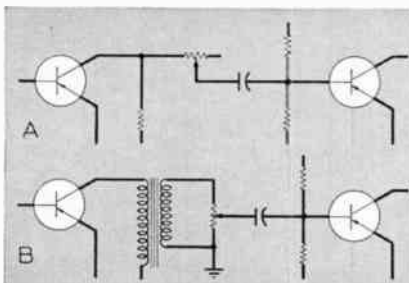

Fig. 12. Two usable control circuits.

although undoubtedly some will be in the future.

Mixing Circuits

If two or more signals are combined to give one output, some sort of mixer is needed. Usually the sources will have separate gain controls, and customarily these are placed at the point of mixing.

We want to be able to turn any one control and not have it affect the other channels at all. Merely combining the outputs of several potentiometers is not enough, since turning one of them all the way off will affect all the other channels. Strictly speaking, we should use T-pads or L-pads to keep the resistance presented by each pad constant.

In many practical cases, however, this

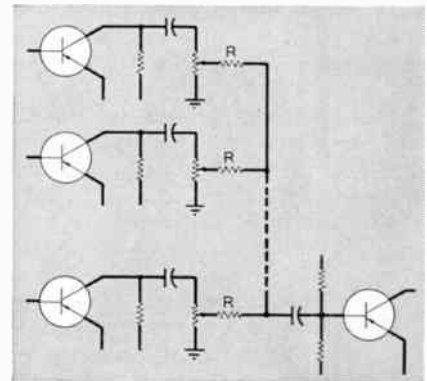

Fig. 13. Mixer provides good isolation.

costly method is not necessary. Simpler circuits using plain potentiometers are available; one of them is shown in Fig. 13. Here the value of *R*, the series resistor, is made several times the input impedance of the following transistor, and for practical purposes the channels are isolated.

Another solution is presented in Fig. 14. It is important to make sure that the input resistance of the following stage is much smaller than the output impedance of each previous stage. The value of the potentiometers is chosen so as to lie between these two resistances. If the isolation here is not good enough, you can add series resistors in each branch.

When no volume control is needed at the mixing point, even simpler methods can be used. Two channels feeding into a single stage are drawn in Fig. 15 as an illustration of simple mixing. No isolation is necessary, and both collectors can be tied together, if they operate at the same DC voltage.

Equalization

In Part VIIb (AUDIOCRAFT, Nov. 1957, p. 19) we discussed the kind of equalization

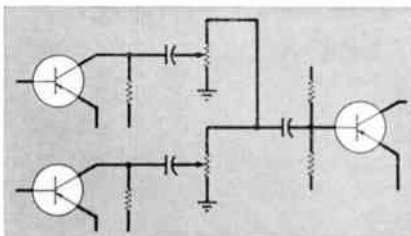

Fig. 14. Alternative mixing circuit.

needed for magnetic and crystal cartridges. For crystal cartridges, the typical transistor amplifier looks like a short circuit, and the normal RIAA equalization (Fig. 16) is needed. Magnetic cartridges open-circuited also require this equalization, although by terminating the cartridge properly we can automatically produce the treble rolloff.

To provide bass boost, several circuits are possible. The simplest one is that shown in Fig. 17. The RC shunt attenuates the middle and high frequencies,

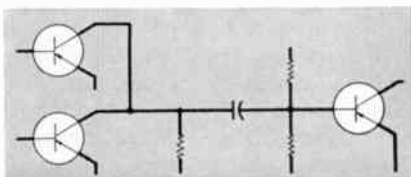

Fig. 15. A very simple mixing circuit.

leaving the bass intact. For proper operation, compute the effective resistance in parallel with the series RC circuit. This will be the parallel combination of the bias resistors, the input resistance of the second stage, and the output resistance of the preceding stage. Make R equal to one-ninth of this value, and make C equal to the turnover time constant divided by R . Since the most important consideration is the turnover (the frequency f_1 is not critical), we may adjust

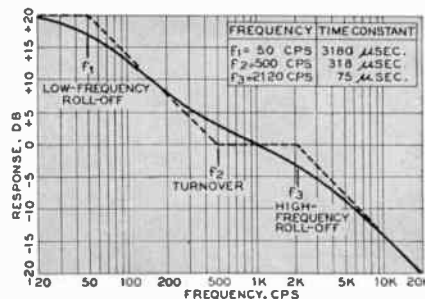

Fig. 16. Standard RIAA equalization.

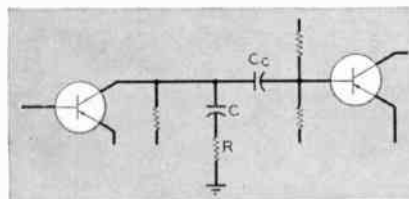

Fig. 17. A simple bass-boost equalizer.

the value of C slightly to a convenient value, and then choose R so that the product RC still equals the turnover time constant of 318×10^{-6} seconds. For instance, if the parallel combination of circuit resistances is 1,000 ohms, we would make $R=110$ ohms, and $C=2.9 \mu$ fd. We would normally adjust C to 3.0μ fd, and then make $R=106$ ohms. A 110-ohm, 5% resistor would be adequate.

The coupling capacitor C_c should be several microfarads, so that its effects will be negligible.

Remember when making these calculations that if the time constant is expressed in seconds, and the resistance in

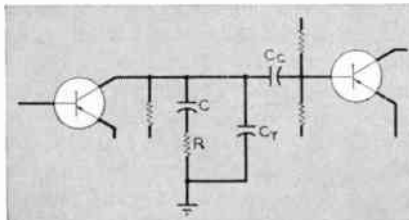

Fig. 18. Capacitor provides rolloff.

ohms, the capacitance will be in farads. Multiply the answer by 10^6 to get it in μ fd. Alternatively, if the time constant is in microseconds, and the resistance in ohms, C will come out in μ fd.

If high-frequency rolloff is desired also, this can be added easily with one more capacitor: C_r , diagrammed in Fig. 18. Make the product of this capacitance and the resistance of R equal to the roll-off time constant of 75×10^{-9} seconds

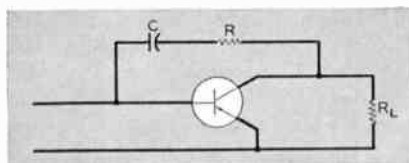

Fig. 19. Feedback bass-boost network.

(for the RIAA curve). Thus in our example, $C_r = 75/110 = 0.68 \mu$ fd.

Another way to apply equalization is by means of a feedback network. The circuit shown in Fig. 19 will give bass boost if the transistor normally has more than 20 db gain. Make R one-ninth of R_L for magnetic cartridges, and one-ninth of $R_L(1+\beta)$ for crystal cartridges. Then make the product RC equal to the turnover time constant of 318×10^{-6} seconds, again adjusting C and R if necessary to fit convenient values of C .

It may be easier to determine the exact value of C and R experimentally in any

of these circuits. This is done by setting up the circuit involved and adjusting R until the output drops to one-tenth its original voltage. Then find C from the formula $C = t/R$, where t is the turnover time constant, 318×10^{-6} seconds, for the RIAA curve. Again C and R can be adjusted to convenient values while keeping the product RC constant.

Tone Controls

Transistor tone-control circuits are harder to design and build than corresponding vacuum-tube circuits, because

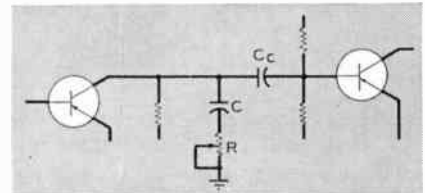

Fig. 20. Adjustable treble-loss network.

of the low impedances encountered. For optimum results special tapers are necessary on the controls, and more complicated circuits are required. To this writer's knowledge, no really good high-fidelity tone controls have been designed for transistorized circuits.

Several control circuits are known, however, which may be satisfactory. Among these are treble-loss and treble-boost, and bass-loss and -boost controls.

Treble Loss. Common low-priced tone controls are usually simply treble-loss controls, of the type given in Fig. 20. In designing this circuit, lump all resistances that the combination RC cir-

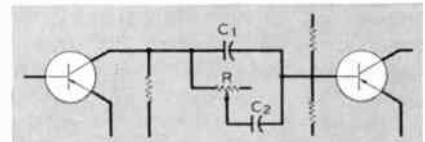

Fig. 21. Circuit for bass attenuation.

cuit "sees" into one resistance, and call it R_1 . This control will then start to roll off at the frequency whose time constant is $C/(R+R_1)$, and will provide an output at high frequencies of $R/(R+R_1)$ of the low-frequency output. As the control is turned, of course, R varies the treble loss.

Bass Loss. One circuit is shown in Fig. 21. The smaller capacitor C_1 , about $.05 \mu$ fd, passes the middle and high frequencies. The large capacitor C_2 , which will pass the low frequencies, is brought in and out of the circuit by means of the variable resistor R .

Treble Boost. Fig. 22 shows one cir-

Continued on page 45

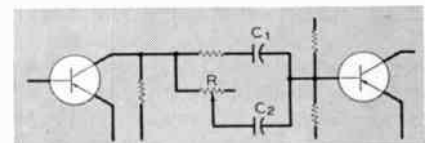

Fig. 22. A useful treble-boosting circuit.

MIXERS, wet and dry

PROBLEM: take a 75-piece orchestra, a chorus of 150, a narrator, and four soloists. Arrange these in orderly and conventional fashion across the stage of a large auditorium, and then try to record the whole thing with a single microphone while maintaining proper balance, perspective, timbre, blending, and reverberation.

To make this a little bit stickier, let's say that soloist A has a feeble voice, soloists B and C can fill a moderate-sized hall with a minimum of strain, while soloist D is a real bull roarer, fully capable of generating half an acoustic watt without batting a bronchus. Finally, the narrator is a nice old gentleman with years of radio experience, who is accustomed to speaking softly and carrying a big microphone so he can be heard.

Now see what happens with a single-mike pickup. The soloists are out of balance and are too distant, unless we move the microphone closer to them and lose the other side of the orchestra. The narrator, whom the theater management has thoughtfully supplied with a public-address system and an aura of acoustic feedback, sounds fine to the patrons sitting in the auditorium, but his voice is not much more than a series of ghostly echoes by the time it has bounced off the loges and come back to our single recording microphone.

I am not claiming that a good recording cannot be made by a single mike before a performing group like this, but I wouldn't want to tackle it. There are too many factors involved to make a musical carnival of this kind easily recorded with a one-mike pickup arrangement.

Without speculating further about this hypothetical headache, let's go home and dust off the old movie projector, and load up the film of Aunt Agatha throwing stones into the Grand Canyon. Now attempt to tape a sound track for it, using nothing more than a plain, ordinary home tape recorder, a microphone, and a phono player. The result might be something like this: opening fanfare (10 sec.), and fadeout. Several seconds of silence while phono is unplugged from recorder and microphone is plugged in-

to recorder. "And now, Feckless Films presents number one of the series, 'Living With Topography' . . . the story of Mankind in his eternal struggle to undo the wonders of nature." Several seconds of silence while microphone is unplugged, phono is plugged in, needle is shoved across into the appropriate groove, and volume control is faded in to predetermined setting. Then come the opening bars of something appropriate to Grand Canyon, such as the *Grand Canyon Suite* or *Rock Around the Clock*. Several hours later begin the editing, clipping out the dead air spots and joining the cut ends, then re-running the film and the tape and finding the tape to be two minutes short because of the missing silences.

It would greatly simplify the recording of the orchestra and chorus if you had some means of using more than one microphone, just as it would simplify the film sound-track dubbing if you could feed both the microphone and the phonograph into the same input, controlling them independently. You can do such things with an input mixer. Every serious recordist should own one of these handy devices.

An input mixer—also redundantly called a mixer-fader—is a gadget that provides independent control of the volume levels of several different input sources which are feeding a single program channel. It may be as simple as a pair of audio-taper volume-control pots with isolating resistors (Fig. 1), or it may be as complex and costly as the monster consoles operated by broadcast-studio engineers behind glass windows.

The basic requirements for a mixer are few but stringent. It should provide complete control of the volume of each incoming signal. There should be no interaction between controls; that is, the manipulation of one or several of the controls should have no effect on the level of the other channels. There should be no tendency for the signal in one channel, when shut off, to spill over into the other channels, which is to say there should be no interchannel cross-

talk. And finally, there are the traditional requirements of wide frequency range, linear response, low distortion, and adequate input and output voltage-handling capability.

If we want to be a little more critical about things, we may add that a mixer should provide correct or optimum matching for input and output sources, and that a given setting of each channel's level control should give about equal volume from each channel.

Now let's look at a few typical mixers and see how they stack up against our list of desirable qualities.

Fig. 1 shows the simplest and least expensive mixer circuit. This is what is known as a "dry" mixer, because no tubes are involved in the mixing process. R_1 and R_2 are a couple of audio-taper volume controls, each fed by a separate high-impedance input (they could just as well be low-impedance inputs, as long as the sources will operate properly with a noncritical high-impedance load). As is reasonably obvious, these controls are variable voltage dividers, connected in the usual manner so as to avoid changing the load presented to the input source. However, since their output will vary from zero ohms to almost the full resistance of each control, R_3 and R_4 have been added to isolate the controls from one another and to prevent one from grounding out the other in its full-off setting. Resistors R_3 and R_4 should be as low in resistance as possible, with the minimum values being determined by the loading requirements of their respective input sources. A value of be-

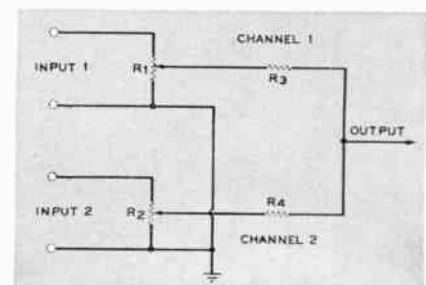

Fig. 1. Dry mixer is simplest of all.

tween 250 K and 100 K will be optimum for most tuners, preamp-control units, etc. Resistors R_1 and R_2 , on the other hand, should be as high as possible, because the greater the difference between them and the input controls, the less control interaction there will be. The upper limit of these is set by the capacity between the mixer output and ground. For any given length of shielded cable (or for a given tube's input capacitance), the greater the source resistance, the worse the high-frequency loss. A resistance of 250 K to 500 K is about the maximum for a 50- μmfd shunt capacity. This will give a 3-db loss at between 13,000 and 28,000 cps, depending upon the resistor values; the lower the isolating resistance, the better the high-frequency response. And 50 μmfd is quite a low value of shunt capacity.

There is another limitation in this circuit, too. Each input source works into what amounts to a voltage divider between the mixer's input and output. The two-channel circuit shown introduces a nominal 6-db insertion loss; it automatically drops the signal level by half, even at the highest volume-control setting. Adding a third such channel creates a 9.6-db insertion loss, a fourth costs 12 db, and so on. Also, the more channels there are, the more interaction there is between channels, so that this circuit is best used in its basic two-channel form, unless of course we find a better way of isolating the controls from one another and whooping up the gain a little bit.

Thus we come to the more elaborate "wet-dry" mixer, Fig. 2. Here we have taken a pair of the original two-channel dry mixers, and fed each of these to half of a dual-triode amplifying tube. The two pairs of channels are then wet-mixed at the common plate connection from the tube sections. No isolating resis-

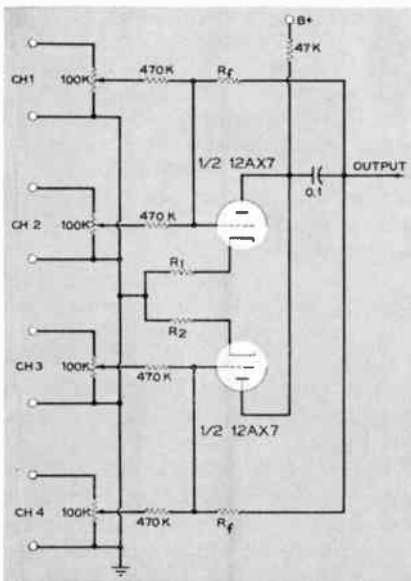

Fig. 2. "Wet-dry" mixer uses dual triode.

tors need be used at the tube plates unless the mixer is intended to produce several volts output. There is still an effective loss of about 6 db from the mixing action, however, because each triode section is working into a load impedance equal to or slightly less than its own output impedance. The gain in each tube will more than make up for this loss, though, and the feedback resistors R_f may be adjusted as desired to produce unity gain or slightly more or less than unity gain from the entire mixer system (at the same time reducing distortion). The cathode-bias-resistor values (R_1 , R_2) will depend on the available B+ supply voltage to the tubes. Output impedance of this mixer is fairly low, so it may pass through several feet of shielded cable on its way to the recorder input without incurring high-frequency losses.

It is obvious by now that we have been overlooking something in this discussion. What about microphones? If

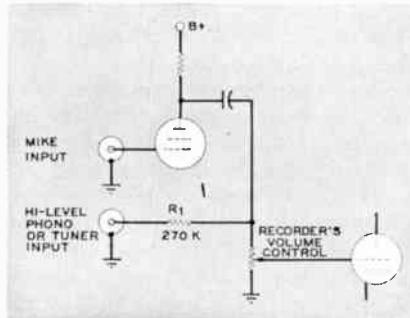

Fig. 3. R_1 prevents mike-preamp loading.

we were to use the circuit shown in Fig. 1 for a microphone and a high-level phono source, we would find *a*) that the output from the mixer would have to go into the preamplifier stage of the tape recorder, *b*) that the resistance of the volume controls would be too low to match some high-impedance microphones, and *c*) that in order to mix the mike and the phono, the mike's control would have to be operated at or near its full-up setting, while the phono control would have to be nearly all the way off. This makes for awkward handling. What we need, then, is a way of equalizing the volume levels coming into the mixer circuit.

The logical solution is a microphone preamplifier, installed ahead of the mixer's mike channel. Perhaps the major objection to this is that it leads to complications, multiple-tube arrangements, low-noise components, and hum-free circuitry. Mike preamps are a topic unto themselves, but I'm not going to get involved in that at this time.

There are several ways to avoid using a separate mike preamp. One alternative is to use the preamplifier in the tape recorder, as shown in Fig. 3, and the other is to install an attenuator between the high-level input and its mixer con-

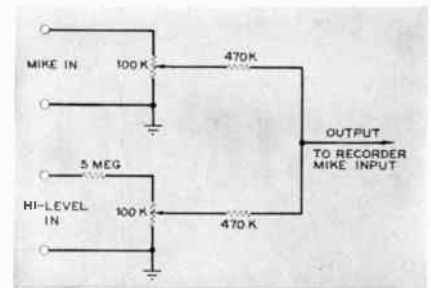

Fig. 4. 5-megohm resistor balances level.

trol, Fig. 4. Neither of these ideas is particularly red-hot, but they are good stopgap measures for anyone who does not demand the most flexible setup. The modified recorder circuit (Fig. 3) leaves the recorder's volume control effective on both input channels, but the isolation resistor R_1 allows the phono preamp to be plugged in across the mike line without unduly loading the mike preamp. A volume control on the external control unit permits balancing the phono against the mike, and also provides a means of fading the phono in and out while the mike remains at a fixed level, determined by the recorder's volume-control setting.

Fig. 4 is a simpler way of achieving phono-mike mixing; here a 5-megohm resistor has been inserted in series with one channel of our basic two-channel dry mixer, to cut the level in that channel down to a point comparable to that from a microphone. This arrangement has one disadvantage: since the mixer must be connected to the recorder's microphone input, turning down the mixer's controls does not cut down the hiss or hum that may be originating in the recorder's preamplifier stage. Optimum results are obtained, however, by turning the mixer's mike control up full, setting the record level by means of the recorder's volume control, and then adding phono level as desired by adjustment of the mixer's phono control. The recorder's volume control then serves as the master gain control, varying both inputs simultaneously. The master control should not be used at a higher setting than that established as correct with the mixer's microphone control in its full-up position.

The circuit in Fig. 1 may be used for two dynamic microphones if desired, although in this application it shares the faults of the mike-phono mixer just described. Consequently, it should be used in much the same way, with the recorder's volume control adjusted to the setting required with the lowest-level mike's input control wide open.

Another form of dry mixer, suitable for use with two or more low-impedance microphones having the same impedance ratings, is shown in Fig. 5. R is the nominal impedance of the microphones (50, 125, or 250 ohms) and of the

Continued on page 42

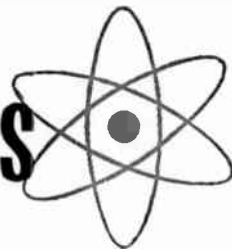

XXIa: Output stages

Impedance Transformation

Vacuum tubes are high-impedance devices. As pointed out in preceding chapters of this series, the plate resistance of a voltage-amplifier triode is many thousands of ohms, and that of a corresponding pentode may be a megohm or more. In tubes designed specifically to furnish much heavier plate currents (*power-amplifier* or *output* tubes), plate resistances are far lower in value: they range from less than 300 ohms upward for power-amplifier triodes, and from 10,000 to 100,000 ohms for typical power pentodes and beam-power tubes.

It is true that, given a fixed signal voltage available, maximum power will be developed in the load when the source impedance and the load impedance are equal (matched). It is equally true that the function of an output stage is to deliver undistorted power to its load — in this case, a loudspeaker. But it is *not* true that maximum undistorted power can be obtained under practical conditions from an output stage when the source impedance, or plate resistance, is matched in value to the load. If there were no practical limitations on plate voltage and plate current, then for any given input signal the matched condition would produce most power in the load. There are limitations, however: the voltage and current ratings of the tube must not be exceeded if the tube is to stand up in service. Under these restrictions maximum power output in Class-A operation is usually obtainable when the load resistance is from two to three times the plate resistance of a power-amplifier triode, and from 1/10 to 1/20 the plate resistance of a beam-power tube or power pentode. The disadvantage of this "unmatched" condition is not a severe one; it is simply that, for any given output power, a larger signal input to the stage is needed.

An effort is made to design power tubes so that minimum distortion occurs with a load value corresponding to that at which the most power output is obtainable. Ordinarily these two values do

not correspond precisely, and the tube manufacturer establishes recommended load values for various typical operating conditions that represent optimal compromises between maximum obtainable power and minimum distortion. Such recommended load values are published in tube data sheets and in tube manuals. They range from 2,500 to over 10,000 ohms for single output tubes.

These recommended load values are a long way from typical loudspeaker impedances, however; most high-quality units are of 8 or 16 ohms rated impedance, or of some similar impedance. A few speakers are made with 500-ohm impedance ratings, but these are quite rare. Problem: how to make a 16-ohm speaker appear to an output stage as the recommended load of, say, 5,000 ohms. Solution: use an output transformer as the tube's load, as shown in Fig. 1.

The output transformer serves two purposes here. First, it couples the signal in the tube's plate circuit to the loudspeaker load, while preventing the DC plate current from reaching the load. Second, it "matches" the load to the tube by transforming the 16-ohm impedance across the secondary winding to the required 5,000-ohm impedance on the primary side.

It is easy to see how this impedance transformation can occur if we recall the characteristics of transformers. Voltage developed across the secondary winding is in the same ratio to the primary voltage as the relative numbers of turns in the two windings; currents are in inverse proportion to the relative numbers of turns. In Fig. 1 let us say that the pri-

mary winding has 17.7 times as many turns as the secondary winding, and that at a given time there exists an AC signal voltage of 16 v across the secondary. Because the speaker impedance is 16 ohms, there must exist a current of 1 amp in the secondary circuit. And since the primary has 17.7 times as many turns as the secondary, the AC voltage across the primary must be 17.7 times 16 v, or 283 v. The primary AC current is 1 amp/17.7, or 56.7 ma. If 283 v AC exists across the primary, and the current through it is 56.7 ma AC, then its impedance must be $283/.0567$, or 5,000 ohms.

Note that this is a reflected impedance; if a loudspeaker of a different impedance had been connected to the secondary, the primary winding would have presented a different load impedance to the tube. For example, suppose an 8-ohm speaker were used. The secondary current would then have been 2 amps and the primary current, correspondingly, 113.4 ma. This would represent an impedance at the primary of $283/0.1134$, or 2,500 ohms. With this particular transformer the impedance step-up from secondary to primary is always 312.5 (5,000/16, or 2,500/8, etc.). The impedance ratio is the square of the turns ratio: $17.7 \times 17.7 = 312.5$ (approx.). And that too is logical enough, for the turns ratio affects both the current ratio and the voltage ratio, but in opposite manner; so it multiplies the impedance ratio twice. To sum up: the impedance ratio is equal to the turns ratio squared, or the turns ratio is equal to the square root of the desired impedance ratio.

Output transformers are usually made with multiple or tapped secondary windings, so that the proper primary impedance can be obtained with two or more secondary loads. Typical secondary impedance taps are at 4 and 8 ohms, with 16 ohms utilizing the entire secondary winding. Suppose that a 5,000-ohm transformer had 2,000 turns in the primary. The turns ratio for the entire secondary winding, at 16 ohms, would be the square root of 5,000/16, or 17.7. The number of turns in the

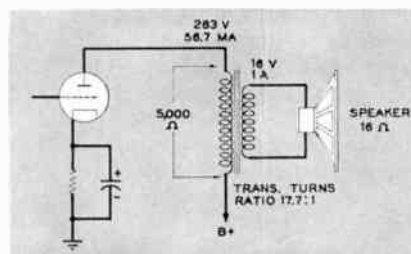

Fig. 1. Typical single-ended output stage.

secondary would be $2,000/17.7$, or 113. The 8-ohm tap would require a turns ratio of the square root of $5,000/8$, or 25, so the 8-ohm tap would be taken at the number of turns found by dividing 25 into 2,000: 80 turns. A 4-ohm tap would require a turns ratio of the square

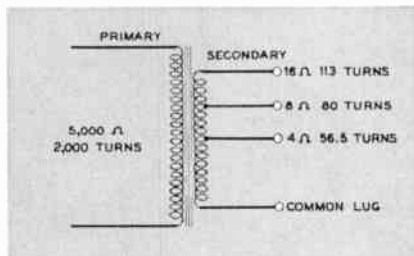

Fig. 2. Taps provide impedance choice.

root of $5,000/4$, or 35.4. Thus, the 4-ohm tap would be taken at $2,000/35.4$, or 56.5 turns—one half of the winding. This is illustrated in Fig. 2. Often the primary winding is tapped to obtain various primary impedances as well.

Push-Pull Operation

Despite the best efforts of designers, a *single-ended* output stage such as that shown in Fig. 1 has two severe limitations for high-fidelity applications: inadequate maximum power, and too much distortion. The power limitation can be overcome simply by adding more tubes in parallel, of course, but there is a better way to operate a pair of tubes that also reduces distortion. This is in a push-pull circuit, shown in Fig. 3.

A push-pull output circuit consists of two tubes (or, sometimes, two pairs of parallel tubes) driven by oppositely phased input signals so that, when the current in one side increases, current in the other side decreases, and vice versa. Both sides of the stage have a common load: in this case, the center-tapped primary winding of an output transformer. The center tap is connected to $B+$, so that DC plate current of the lower tube flows through the lower half of the primary and DC plate current for the upper tube flows through the upper half. For AC signals, however, the two halves of the primary are closely coupled. If at any given instant a negative input signal to the upper tube makes the upper half of the primary positive with respect to the center tap, it simultaneously makes the lower half negative with respect to the center tap because of this coupling. At the same time the lower tube is being driven by an oppositely phased positive signal, which makes the lower section of the primary negative with respect to the center tap, and the upper half positive. In this way one tube "pushes" while the other "pulls," and when the signal reverses polarity the first "pulls" while the other "pushes."

Push-pull action refers only to the AC signal component of plate current, since

—as with a single-ended stage—plate current can only decrease below the quiescent value and increase above it, in response to the grid signal. This is shown in Fig. 4. The plate current can never be less than zero. But so far as the output transformer is concerned, a decrease in current below quiescent (no-signal) value is the same as a negative current. Note that in Fig. 4 one tube's E_g-I_p curve is shown inverted below the other's with the quiescent operating points aligned vertically. This was done because the plate currents flow through the primary in opposite directions; but with oppositely phased drive signals, the currents are complementary. The straight line between the two curves is the resultant of the two, more linear than either.

This increased linearity is one of the more important advantages of push-pull operation, because it indicates reduced distortion. Now, all manifestations of distortion arising from nonlinear am-

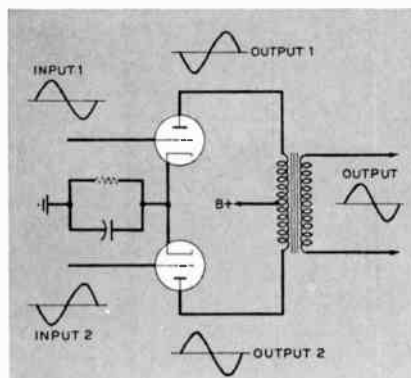

Fig. 3. Push-pull circuit increases power.

plitude response are correlative, if only roughly; and the type of distortion easiest to predict quantitatively for vacuum-tube stages is harmonic generation. When harmonics are added to a sine wave the odd-order components—third, fifth, and so on—affect both halves of the sine wave symmetrically. But the even-order harmonics—second, fourth, and so on—produce asymmetrical deformation. In a single-ended stage the lower half of the input signal encounters a different curvature in the E_g-I_p curve than does the upper half; this is clearly visible in Fig. 4, considering the upper curve only. As a result the lower half of the input signal is amplified less than the upper half, producing asymmetrical or even-order harmonic distortion. But in a push-pull stage one side of the input-signal wave form operates on the lower part of one tube's E_g-I_p curve and simultaneously on the upper part of the other tube's E_g-I_p curve; the second side of the input wave form operates on the *upper* part of the first tube's curve and the *lower* part of the other tube's curve. Fig. 4 shows this to be true. So long as the tubes have similar curves (as they would normally), the total amplification

for each side of the input signal is the same. Accordingly, no asymmetry is introduced, and even-order harmonic distortion is canceled or eliminated with push-pull amplification. The odd-order harmonic distortion is not affected, but the *total* distortion is reduced.

If the same $B+$ voltage, bias, and input-signal excursion were retained for a push-pull stage, and the plate-to-plate primary impedance were doubled, then the power output of a push-pull stage would be exactly double that of the corresponding single-ended stage. It is generally true for single-ended triodes, however, that the recommended compromise load value is significantly higher than that giving maximum obtainable power output. Further, most of a single-ended triode's distortion is second harmonic, which is eliminated in a push-pull circuit. It follows that so much compromise isn't necessary when triodes are used in a push-pull circuit, and the plate-to-plate primary impedance can be reduced to far less than twice the recommended single-ended value. In this way a maximum power output can be obtained that is significantly more than twice the maximum undistorted single-ended output, even while retaining completely Class-A operation.

There are other advantages of push-pull operation as well. One of the most important in high-fidelity applications is that the DC tube currents, flowing in the transformer core in opposite directions, produce a resultant DC flux of zero. As a result the core is much further from saturation than it is in a single-ended stage; thus, the transformer can handle a great deal more power without danger of core distortion. Another really practical advantage is that hum voltages in the power supply are canceled because they are applied to the two tubes *in phase*. Filtering for the output stage's $B+$ supply, accordingly, can be less elaborate and expensive. Many amplifiers now do not have a choke

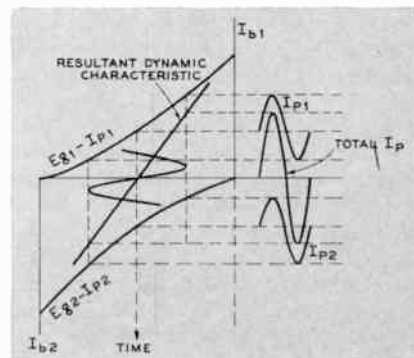
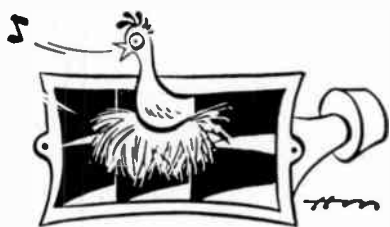

Fig. 4. Curves illustrate push-pull action.

in the power supply, depending on good output-stage balance to cancel hum.

Pentodes and beam-power tubes are always used in a push-pull arrangement

Continued on page 37



Sound-Fanciers' Guide

by R. D. DARRELL

New Year's Resolutions

My No. 1 personal resolve for 1958 is to quit tucking organ discs and tapes into a future-attention corner and give them an immediate chance to be heard as sympathetically as my admittedly not-unprejudiced ears permit. High time, too, since I see that I haven't ventured into these controversial domains since last May. Meanwhile, a considerable batch of pertinent materials has been accumulating, fortunately including some which prove to be immensely enjoyable, as well as others which arouse all my aural antagonisms.

Robert Elmore's *Boardwalk Pipes* (Mercury stereo MDS 5-5; also on LP as MG 50109), for example, presents intriguing mixtures of theater- and "serious"-organ characteristics, both in the instrument itself (that of the Atlantic City Ballroom) and the program. The latter is mostly light stuff, starring several Kreisler encores and Elmore's *Nursery Fantasy*, with a Boex March and Clarke Trumpet Voluntary for more distinguished fare. But the registrations and use of effects are discreetly handled, while the recording itself is remarkable in its retention of clarity and warmth in what should sound like—but doesn't—an echoing and chilly acoustical ambience.

More frankly pops materials and theatrical qualities characterize Buddy Cole's *Pipes, Pedals and Fidelity* (Columbia stereo JCB 2; no LP as yet) and Guy Kibbee's *High Fidelity Show Pieces* and *Mighty Wurlitzer Vol. 1* (Omegatape stereo ST 7007 & 7009; no LP's). The first is not too fancily registered, but tends to be mighty thick and thobby, and is recorded with scant reverberance. So are Kibbee's two reels, for that matter, but their recording is more brilliant, and, although the stereo effect is not particularly marked, it does make the performances somewhat easier for a non-theater-organ fancier to take. Yet with all due respect to the estimable artist, I still find his playing labored, "swoopy," and far too mannered for my taste.

If I sound harsh myself, let me assure you that none of these strictly mass-appeal pops works rasped my sensibilities a fraction as much as two technically

impeccable Robert Owen stereo Sonotapes. One of these aesthetic monstrosities is a *Wedding Music* program, in which Robert Locksmith on a Stromberg-Carlson electronic carillon (almost never in tune to my ears) embellishes—or perhaps I should say "bejangles"—Owen's ecstatically throbbing performances of *Ob, Promise Me*, etc., on the Rochester, New York, First Baptist Church organ (SWB 8019; or Westminster LP WP 6043). The other is the more pretentious *Toccatas for Organ* on an instrument with the most repulsive tone I've ever heard and which, mercifully, I won't identify here (SWB 8004; or Westminster LP, XWN 18363). The former can easily be forgotten (unless you're a prospective bridegroom doomed to start married life on a wrong note), but the latter warrants analytical and philosophical study as an example of the horrors of technological "progress." For the superb hi-fi and stereo techniques here unashamedly expose the most elephantine, most tonally unfocused, and "rumbly" pedal tones you've ever encountered in either recordings or life.

Baroque and Symphonic Organs

For what results when the same engineering skills are matched to true artistry and an instrument of infinitely more expressive tonal characteristics, be sure to hear Alf Linder's first stereo Buxtehude and Carl Weinrich's second stereo Bach programs (Sonotape SWB 8022 and SWB 8025; the latter repre-

sented in part on Westminster LP's, XWN 18427 and 18499). Even if you're not a baroque-organ connoisseur by either instinct or training, you can't help but be mightily impressed—if only as a connoisseur of distinctive timbres—by the bitter-sweet tonal diversity and exquisitely contoured sonorities of the Vårfrukyrka instrument, captured here so vividly in the warmest of spaciouly reverberant acoustics. Since Weinrich plays rather too precisely for many listeners' tastes, although not for mine, the Linder tape can be more unreservedly recommended, both for its more relaxed and sensitive playing and for the inexhaustible zest of Buxtehude's somewhat episodic but exhilaratingly jubilant music.

I can't wax so enthusiastic about the final three organ programs at hand, but each has considerable (especially technical) merits. The compositions in *Organ Music of France* leave me lukewarm, except for a lovely Langlois *Nazard* and a terrible Maleingreau *Tumult in the Praetorium*; but Robert Nohren's performances are mildly attractive and—in an exceptionally bright and crystalline recording—the warm, natural qualities of the Toledo, Ohio, Collingwood Presbyterian Church organ are much more markedly so (Audiophile LP, AP 42). The main feature of *Bach on the Biggest* is not so much Robert Elmore's competent performances of familiar masterpieces as it is the tremendous Atlantic City Convention Hall organ itself, the world's largest, boasting even a 64-foot (8-cps) subterranean C. Neither my ears nor my speakers can prove that it is actually recorded here, although they do reproduce plenty of ultraponderous low pedal tones and gigantic full-organ sonorities. All this doesn't help Bach's polyphony, but it certainly does give the Mercury engineers a supreme test in dealing with the longest hall-reverberation period I've ever met on records (Mercury LP, MG 50127).

There is more genuinely big, reverberant pipe sound in Austin Lovelace's *Organ Concert* on the Evanston, Illinois, First Methodist Church Austin instrument. And if not so gargantuan, it is aesthetically far better suited to some of its musical materials, the symphonic

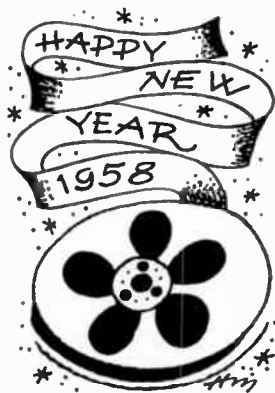

pieces by Hermann Schroeder and Flor Peeters, for example. These are artistically dwarfed, of course, by the more substantial works of Bach, Pachelbel, and D'Aquin, but here Lovelace's performances are prosaic at best. Yet for the sheer sound fancier, the only moderately attractive instrument and definitely dull playing are more than redeemed by the solidity, brilliance, and magnificent breadth of the recording, surely the most impressive example of modern-organ sound reproduction we have yet had in the stereo medium (Concertapes stereo 24-3; no LP).

Midwinter Housecleaning

My second New Year's resolution is also to stop shilly-shallying over some other (nonorgan) recordings I've been shuffling aside while I tried to think of something to say about them, at least as far as technical points of interest go. They well may please many listeners, but personally I just can't (with the exceptions to be noted and the alternative recommendations added in parentheses) work up any real enthusiasm or dislike for them. So I might just as well admit it and hope that some readers react more spiritedly, at least within the categories with which they're most concerned.

Folksingers: John Allison (with a small chorus) picks some fine old ballads for *Heroes, Heroines and Mishaps* (Ficker LP, C 10001); sings them deftly, if with little authenticity and some preciousness; and is cleanly and openly recorded, but with uncomfortably close miking. . . . *The Weavers at Carnegie Hall*, an actual performance recording (Vanguard LP, VRS 9010), is both an infectiously entertaining show and very effectively recorded; but even if the horseplay doesn't bother you, the frenzied crowd applause and laughter are sure to become mighty tiresome. . . . (For something closer to my personal taste in folkballadeering, try Bob Gibson's wholly delightful stereo tape of *I Come for to Sing* [Riverside, via Livingston, RT 7-11; also on an LP, 12-806].)

Popsingers: Maybe I'm antiquated, but when *Sarah Vaughan Sings Gershwin* (Mercury MGP 2-101, two LP's) ultraslowly, with apparent echo-chamber expansion of close miking, and sentimental orchestral accompaniments, it just doesn't sound like the George I once knew and still revere. Lots of personality, though, and a very handsome album. . . . Dinah Washington in *The Swinging Miss "D"* (EmArcy MG 361-04) flaunts even more of a tremolo, which even hot-blues accompaniments can't compensate for. . . . (But, happily, my faith in ex-jazz gal vocalists is restored by the incomparable Ella Fitzgerald, who still sings as if she could never forget Louis Armstrong's finest trumpet playing, and who is given worthily solid, driving accompaniments in *The Rodgers*

& Hart Song Book on no less than four stereo reels [Verve VST 10001-4; or two LP's 4002-2]. I've heard only one of the tapes so far, but that's absolutely tops—in sonics as well as musicianship.)

Standard classics: The Brahms First Piano Concerto with Rudolf Firkušny and Steinberg (Capitol P 8356) is recorded with good detail despite some empty-hall hollowness, and has plenty of power and eloquence, but for me just lacks something (heroism, warmth, gusto?) intangible. . . . But Scherchen's Brahms First Symphony (Westminster XWN 18448) seems definitely shocking, with excruciatingly screaming highs as well as oversluggish or jerkily frantic mannerisms, until one realizes that the recording isn't current at all, but is an ill-advised reissue dating back to 1953. . . . (For a better example of Capitol's Pittsburgh recordings, try the Milstein/Steinberg Dvorák and Glazounov Violin Concertos [P 8382], sonically less reverberant but far more transparent and pure, and played with relaxed and supreme virtuosity. And for Scherchen and Westminster-Sonotape engineers in their best present-day form, hear the stereo taping of Khachaturian's *Gayne Ballet Suite* [SWB 7008].)

Easy moderns: The notion of combining the delectably sprightly Françaix and Honegger Piano Concertinos with Richard Strauss's early *Burleske* was sheer inspiration, but unhappily Margit Weber, for all her glassy sparkle, just isn't a skilled and communicative enough pianist, and Fricsay's rather routine accompaniments are recorded without much acoustical glow (Decca DL 99-00). . . . (For more assured and eloquent performances, as well as more luminous sonics, I recommend Steinberg's superbly rich and warm *Enigma Variations* by Elgar and the *Tallis Fantasia* by Vaughn Williams [Capitol P 8383].)

Cream of the Late-Season Crop

But if these scattered notes conveniently clean up some of my stockpiled odds and ends, they provide too scant, or ambiguous, attractions for the hi-fi fan seeking fully satisfactory or even electrifying new sonic experiences. Luckily, there are plenty of these, too, and you hardly can do better than to start off with Galliera's Tchaikovsky *Romeo and*



William Steinberg

Juliet and Richard Strauss *Death and Transfiguration* (Angel 35410), two familiar war horses, to be sure, and not the most interpretatively dramatic version of either. But what recorded sound! The big climaxes in *Romeo* especially are louder and more searing than anything I think I have ever heard from discs before. Yet, if your pickup can track such power-packed grooves and your speakers don't blow themselves clean off their moorings, they are impeccably clean and symphonically authentic. Almost as outstanding for its dynamic range and overwhelming sonorities is Howard Hanson's *Fiesta in Hi-Fi* program (Mercury MG 50134) of less substantial but far more zestfully jaunty Mexican and hillbilly flavored *divertissements* by the young American composers, Robert McBride, Ron Nelson, Lyndol Mitchell, and Charles Vardell—lusty musical fun as well as high-fidelity sound *in excelsis*.

For equally piquant, if less full-blooded, sonics and even more novel musical materials, it'll be well worth your while to strike far off the beaten paths, first to rediscover Vivaldi's fascinating concerto experiments with maverick solo instruments, and then to time-travel in the parallel worlds of medieval Byzantium and modernistic today which are simultaneously spanned by Alan Hovhaness. The former's Concerto for Two Mandolins and three Concertos for Piccolo are played with brisk verve and delicate lyricism by soloists and orchestra of the Accademia dell'Orso under Newell Jenkins, and in this vibrantly sparkling recording all of them are a spicy joy to every odd-sound fancier's ears (Period SPL 733). Hovhaness's *Saint Vartan* Symphony is much stranger at first encounter, but its irregular meters, intricate canonical writings and solemn ecclesiastical chants alternating with rustically pounding dances have in-

Continued on page 41





Monitor Speaker

If a loudspeaker system is on one side of the room and the FM tuner on the other, it is sometimes hard to tell when a distant station is tuned in exactly. If you have a monitor speaker right by your ear, the job is made easier.

In my own outfit, I installed an inexpensive, 8-inch, 8-ohm speaker at the

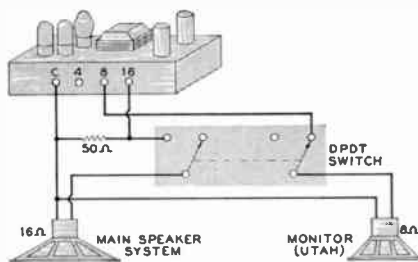

Hookup for 8-inch monitor speaker.

control console and connected it to a double-pole, double-throw switch as shown in the drawing.

The 50-ohm resistor is for the protection of the output transformer during the switching operation.

The diagram shows the hookup for an 8-ohm monitor speaker, but a 3.2-ohm speaker could be used instead with appropriate connections to the 4-ohm tap.

L. E. Johnston
Madison, Wis.

Acoustic Lining

A substance called *Styrofoam*, I have found, makes excellent acoustic insulation for lining the interiors of speaker enclosures. Styrofoam is a white plastic material that looks something like bread. It is very light in weight, and is easily cut to any shape. The material is available from a number of sources, including the five-and-ten, which sells it for Christmas decorations. I got my supply from a dealer in store-window decorations and supplies. Styrofoam comes in thicknesses of 1/2 in. and up, and in panel sizes up to 1 ft. by 3 ft. With its fine absorbency, I believe that a thickness of 1 in. should be adequate, although 1 1/2 in. or 2 in. will allow a greater margin of safety.

To cut the material, I used an old hacksaw blade. A knife, even a very

sharp one, was found to be inadequate because of the structure of the plastic. Fine shaping can be done with sandpaper.

The one serious problem encountered in using Styrofoam was fastening the material to the inside of the enclosure. I found that the solvents in many adhesives dissolved the plastic; this was true even of adhesives made especially for use with plastics. I finally found that an adhesive called *Black Magic*, manufactured by the Miracle Adhesive Corporation, did the job satisfactorily.

Howard H. Rice
Coral Gables, Fla.

Temporary Tape Splicing

For tape splices between selections with several seconds of quiet background on each side of the splice, almost any kind of splice can get by. For careful work, however, some kind of splicing jig is a



Procedure for temporary tape splicing.

necessity. I use both a Cousino jig with precut tapes and a Robins Gibson Girl Jr. splicer-trimmer with tape on a dispenser.

For the tricky "substitution" splice, in which a portion of a rehearsal tape, say, is to be substituted for a passage of the performance tape in which an error or noise occurred, exact timing is essential, and some form of temporary splice is of great help in achieving an undetectable final splice.

The procedure I use is illustrated in the photograph. The first part of the material to be spliced is allowed to run past the heads and is progressively trimmed down until almost all of the unwanted material has been removed. It pays to use one of the jigs for these cuts, so that an accidental overshoot can be

repaired. Then the tape to be added is cut several inches ahead of the point corresponding to the cut on the first part and the two are overlapped as shown, using one of the precut splicing tapes, with the second part overlapping the first on the back. The composite tape can then be run past the heads repeatedly, and small displacements made until the "virtual" splice is undetectable. This may take a number of tries, since it is often difficult to understand what you heard the first time through!

A final splice can be made at any point in the overlap, although it is best to make it as close as possible to the end of the first part, since that was the part actually auditioned.

John D. Seagrave
Los Alamos, N. Mex.

Transformer Voltage Booster

In converting my audio amplifier to a new high-power circuit, I was faced with the alternatives of buying a new power transformer or operating the output tubes at lower than required voltages. The amplifier's original transformer could handle the amperage, but was of a lower voltage rating than that required by the new circuit.

I had on hand a 110-to-24-volt open-frame transformer rated at 1 amp. By connecting the secondary of this small transformer, between the high-voltage center tap of the power transformer and ground, I was able to boost the voltage

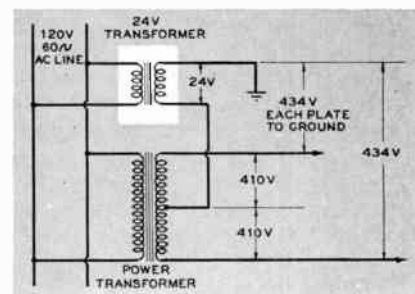

Transformer with voltage modification.

output to a suitable value. The connection must be made with voltages additive, but it is a simple matter to check this with a voltmeter.

Alan M. Palmer
Brooklyn, N.Y.

BASIC ELECTRONICS

Continued from page 33

also in hi-fi amplifiers, with the same advantages as for triodes. Usually, however, distortion cancellation is not so complete because harmonic distortion of these tubes is relatively higher in odd-order content than that of triodes. But

equivalent to R_p divided by the impedance transformation ratio of the transformer. If the tube is a triode, R_p may be about 1,500 ohms. Such a source would appear to the speaker as 1,500/312.5, or 4.8 ohms, as Fig. 5C illustrates. If the tube is a pentode or beam-power tube, on the other hand, R_p may be 50,000 ohms or so. In that case the effec-

And that, as we have seen before, is one basic difference between a triode and pentode stage.

This difference accounts for another important dissimilarity in effect on a speaker. Loudspeakers, as we all know, are not perfect transducers. They do not always follow the applied signal faithfully, particularly at the bass resonance

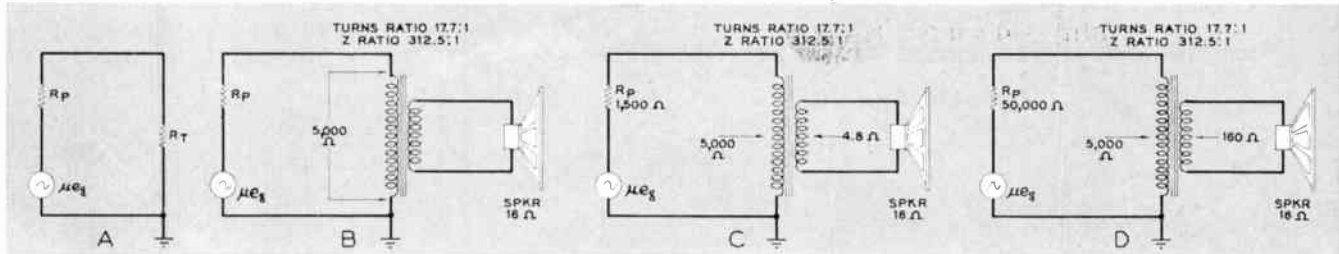

Fig. 5. These diagrams illustrate relationship between speaker impedance and reflected primary impedance for triodes and pentode.

it is still significant and worth while.

The advantages and disadvantages of power pentodes and beam-power tubes relative to triodes are carried over to the push-pull circuit. They require much lower signal input voltages to drive them than do triodes, have higher efficiency, and generally are capable of greater output. Unfortunately, they are less tolerant of load variations from optimum. Since a loudspeaker's impedance actually does very widely, increasing far above its rated value at its bass resonance frequency and at the high end also, triodes have a real advantage in this respect. As the load value increases above optimum for a triode stage, power output decreases and distortion decreases too. As the load increases above optimum value for a pentode or beam-power stage, distortion increases quickly, and power output also increases until the overload point is reached. With a large impedance increase this point is reached at low actual power, and the result is then even more distressing.

If a transformer can reflect an impedance one way, it can do so in the opposite direction as well. Recall that the basic equivalent circuit for an amplifying stage is that shown in Fig. 5A: the entire amplified signal, which is the product of the input signal and the tube's amplification factor, is developed across the plate resistance and the total AC load in series. In a power output stage, the load for the tube is the loudspeaker impedance (say, 16 ohms) multiplied by the impedance step-up ratio of the output transformer. If this impedance step-up ratio is 312.5, as in our previous example, then the reflected impedance at the primary is 5,000 ohms. This is shown in Fig. 5B.

The source impedance on the primary side of the transformer is the value of the tube's plate resistance (R_p). But the actual load is on the secondary side of the transformer; so far as the speaker is concerned, it is being fed power from a source with an impedance that is

itive source impedance for the speaker load would be 50,000/312.5, or 160 ohms. Fig. 5D shows this equivalent circuit. This source impedance at the transformer secondary is called the output impedance of the amplifier.

Figs. 5C and 5D can be simplified even further if we are only interested in the speaker circuit. For a triode, Fig. 6A is the result: the transformed source impedance of 4.8 ohms (the output impedance) is in series with the speaker load across a signal generator. Fig. 6B shows the corresponding circuit for a beam-power output tube; it is identical with Fig. 6A except that the effective impedance of the signal source is 160 ohms. It is easy to see why increasing the load value in the first case results in a mild decrease in output power, and why increasing the load value in the second case produces a marked increase in power output. The first source approaches a constant-voltage generator; the second, a constant-current generator.

frequency. If a sudden surge of power is applied to a speaker and then suddenly removed, the cone is likely to continue moving (because of its inertia) after the applied signal has stopped. When it does, the voice coil moving in the magnetic field, acting as a generator, induces a current in the circuit of such direction as to oppose the motion. If the total impedance in the circuit is small this current is high, so that the spurious cone motion is held to a minimum; it is highly damped. If the total circuit impedance is high, the induced current is not very large and it cannot supply much opposition to the spurious cone motion.

With the speaker impedance fixed in value, the determining factor in the total amount of voice-coil circuit impedance is the amplifier's output impedance. The triode's output impedance is quite low; therefore, the current induced by unauthorized speaker-cone mo-

Continued on next page

A Simplified "Phantom Channel"

Too late for the preceding issue, Paul Klipsch sent us details of a greatly simplified method of driving the center speaker in a two-track, three-channel stereo system.* It's simply connected between the 4-ohm "hot" terminals of the amplifiers driving the outer-channel speakers, as shown in the diagram herewith.

Since the two stereo-amplifier output signals have a common reference potential (ground, or the "common" output terminals), then a speaker connected between the two 16-ohm terminals would receive power proportional to the difference between the two stereo signals. Connected between the two 4-ohm terminals, the power received by such a center-channel speaker would be

half this difference, $\pm \frac{1}{2}(A - B)$. And according to Mr. Klipsch, this gives an audible effect equivalent to that produced by a mixing circuit and an extra amplifier.

It is evident that the two amplifiers used should be similar and that the efficiencies of all three speaker systems should be the same, if this system is to work properly.

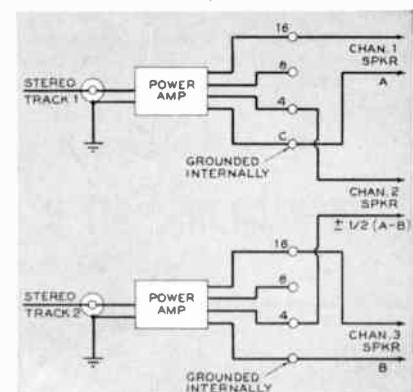

*Klipsch, Paul W., "Two-Track, Three-Channel Stereo", AUDIOCRAFT, II (November 1957), p. 26.

DYNAKIT PREAMPLIFIER

An Outstanding Companion Kit to the World Famous
Dynakit Amplifiers



This handsome new control unit gives crystal clear, noise-free reproduction from *any* modern program source. Its unique all feedback design by David Hafler sets a new standard of preamplifier performance. The design of the Dynakit preamplifier is a synthesis of outstanding features which produce smoother, more natural sound. Compare these features with any other units regardless of price.

★ Unequaled performance

Actually less than .1% distortion under all normal operating conditions. Response ± 5 db 6 cps to over 60 kc. Distortion and response unaffected by settings of volume control. Superlative square wave performance, and complete damping on any pulse or transient test.

★ Easiest assembly

All critical parts supplied factory-mounted on XXXP printed circuit board. Eyeleted construction prevents damage to printed wiring. This type of construction cuts wiring time by 50% and eliminates errors of assembly. Open simplified layout offers complete accessibility to all parts.

★ Lowest noise

Integral dc heater supply plus low noise components and circuitry bring noise to less than 3 microvolt equivalent noise input on RIAA phono position. This is better than 70 db below level of 10 millivolt magnetic cartridge.

★ Finest parts

1% components in equalization circuits to insure accurate compensation of recording characteristics. Long life electrolytic capacitors and other premium grade components for long trouble-free service.

★ High Flexibility

Six inputs with option of extra phono, tape head, or mike input. Four ac outlets. Controls include tape AB monitor switch, loudness with disabling switch, full range feedback tone controls. Takes power from Dynakit, Heathkit, or any amplifier with octal power socket.

★ Outstanding appearance

Choice of bone white or charcoal brown decorator colors to blend with any decor. Finished in indestructible vinyl coating with solid brass escutcheon.

★ Best Buy

Available from your Hi-Fi dealer at only \$34.95 net (slightly higher in the West), and yet the quality of performance and parts is unexcelled at any price.

Descriptive brochure available on request.

Pat. Pending

DYNACO INC., 617 N. 41st ST., PHILADELPHIA, PA.

Export Division: 25 Warren St., New York 7, N. Y.

BASIC ELECTRONICS

Continued from preceding page

tion is high, the damping is high, and the spurious motion is minimized. But the beam-power tube's output impedance is high, 160 ohms; accordingly the induced current is low, damping is nil, and the cone is relatively free to boom away.

A useful measure of damping efficacy is provided in a figure for *damping factor*. It is defined as the ratio of load

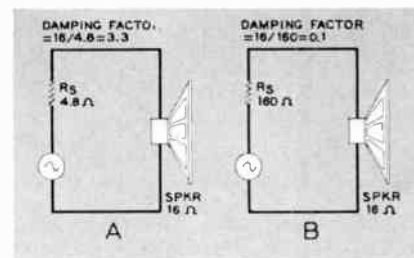

Fig. 6. Diagram of output stage shows method of determining damping factor.

impedance to source impedance. For the triode, Fig. 6A, the damping factor is $16/4.8$, or 3.3. For the beam-power tube, Fig. 6B, it is $16/160$, or 0.1. A damping factor of 1 would indicate, of course, that the output or source impedance matched the load impedance precisely.

Most of the disadvantages of power pentodes and beam-power tubes can be minimized through simple circuit techniques, such as feedback, while their advantages over triodes remain. The subject of output stages will be continued in the next article of this series.

SIGNAL GENERATOR

Continued from page 27

to 1,000 Kc; C—0.95 to 3.1 Mc; D—2.9 to 9.5 Mc; E—9 to 31 Mc.

The Colpitts audio oscillator is one half-section of a 12AU7, fixed in frequency at 400 cps. Following it is a separate cathode-follower modulator, the other half of the 12AU7. When the function switch is in the CW position, the grid of the modulator is grounded and the RF signal remains unmodulated.

With the switch in the MCW position, the output of the audio oscillator is applied through the modulator to provide an amplitude-modulated output signal. In the EXT position any external audio source may be used to amplitude-modulate the generator's output. Whenever modulation is applied, its level is set by the MODULATION level potentiometer in the grid circuit of the modulator.

A control-grid-modulated buffer amplifier tube, type 6AV5, feeds the output attenuator. The signal from the RF generator is fed to the buffer grid through an RC equalizing network to maintain

a constant level throughout the operating range.

Audio modulation is taken off the cathode of the modulator and resistance-coupled to the control grid of the output amplifier. This signal is rather large and therefore shifts the operating point, transconductance, and stage gain of the amplifier at an audio rate.

At the plate of the amplifier is not only the resulting modulated RF, but also the audio alone. This audio is immediately blocked, however, by a relatively small coupling capacitor, so that only the modulated RF appears at the output jack. With this type of modulation system the percentage of modulation depends entirely upon the transconductance variation and, hence, upon the audio level, but it is entirely independent of the RF level.

The output control consists of a step attenuator plus a continuously variable fine level control. The degree of attenuation is rather high because of a large signal output from the amplifier; hence, very elaborate shielding is used. The coils and step attenuator each have their own shielding. Then a second shield surrounds the RF section. Finally, the entire unit is shielded.

A metering section is used to determine the level of the RF output and the percentage of modulation. When the meter switch is in the RF CARRIER position, the output of a crystal diode rectifier following the fine attenuator is connected to an internal-carrier calibration control. Initially this meter is calibrated with the assistance of an external VTVM or scope.

When the meter switch is in the MOD position, it is fed through its own calibration control from a half-bridge circuit using two crystal diodes across the cathode resistor of the modulator. This DC signal indicates the audio level fed to the amplifier grid. Since the modulation percentage is independent of the RF signal level, it can be adjusted once to the desired level and then left there. This level is often 30%, for reasons which we'll discuss in a subsequent part of this series. Once calibration is completed and the modulation level set, the meter may then remain semipermanently in the RF position.

The power supply is a half-wave rectifier with AC filaments, as in the basic model, but is otherwise considerably more elaborate. The primary of the power transformer has not only three bypass capacitors to avoid signal radiation through the line cord, but also an RF choke in series with either side of the line.

A combination of LC and RC filtering is used, built around a three-section electrolytic capacitor. A voltage-regulator tube is included as well, to stabilize the voltage applied to the several tubes.

Continued on next page

Excerpts from **PRESS COMMENT** on the

AR-2

High Fidelity *(Tested in the Home)*

"... With the (tweeter) control set to suit my taste (best described as row-M-oriented), oscillator tests indicated that bass was smooth and very clean to below 40 cycles, was audibly enfeeblished but still there at 35, and dropped out somewhere around 30 cycles. No doubling was audible at any frequency.

From 1,000 to 4,000 cycles there was a slight, broad dip in the response (averaging perhaps 2 db down), a gradual rise to original level at 8,000 cycles, and some minor discontinuities from there out to 12,000 cycles. Then there was a slow droop to 14,000 cycles, with rapid cutoff above that.

Because of its slightly depressed 'presence' range, the AR-2 has what is to me a refreshingly sweet, smooth, and highly listenable sound. Music is reproduced transparently, and with very good detail. Its high end is unobtrusive, but its ability to reproduce the guttiness of string tone and the tearing transients of a trumpet indicate that it is, indeed, contributing highs when needed. This, I feel, is as it should be.

Its low end is remarkably clean and, like the AR-1, prompts disbelief that such deep bass could emanate from such a small box.

"... Like the AR-1, the AR-2 should be judged purely on its sonic merits... not on the theoretical basis of its 'restrictive' cabinet size. When so judged, it can stand comparison with many speakers of considerably greater dimension and price.—J.G.H."

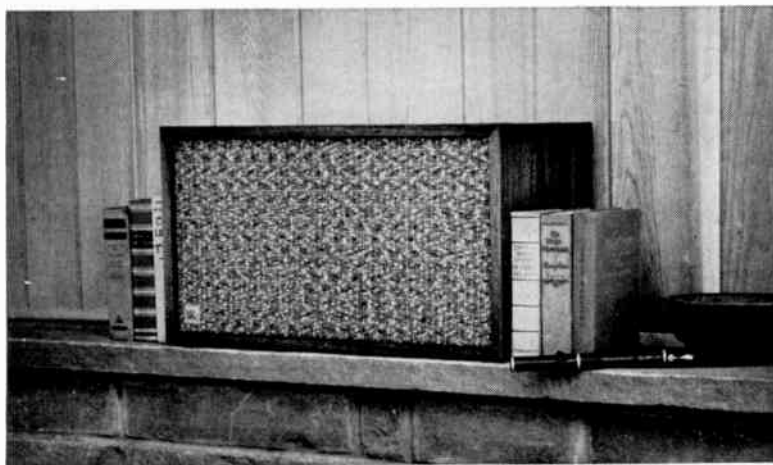

AUDIO ETC.

Charles Townsend's Column

"... I find the AR-2 remarkably like the AR-1 in over-all sound coloration. Its cone tweeter is not the same, but there isn't much difference in sound. (It costs less, but that doesn't prove much.) On direct comparison, given a signal with plenty of bass component in the very bottom, you can tell the difference between the two in bass response. Most of the time, in ordinary listening, I am not aware of it at all.

"... I find AR-2, as with AR-1, remarkably clean and unobtrusive in its sound, easy on the ears for long-period listening, easy also to ignore in favor of the music itself. Either speaker has a way of simply fading into the surroundings (the size helps) leaving the music unattached and disembodied in the room. Excellent illusion!..."

Prices for Acoustic Research speaker systems, complete with cabinets, (AR-1 and AR-2) are \$89.00 to \$194.00. Size is "bookshelf." Literature is available from your local sound equipment dealer, or on request from:

ACOUSTIC RESEARCH, INC. 24 Thorndike St., Cambridge 41, Mass.

SIGNAL GENERATOR

Continued from preceding page

Finally, the function switch has a **STANDBY** position which keeps the filaments lit without the necessity of applying high voltage. This allows the equipment to be kept constantly near full working temperature with minimum use of power or reduction of tube life.

Now that we are acquainted with RF signal generators and their function, we'll next discuss some practical applications of the instrument as they apply to the audiophile.

GROUNDED EAR

Continued from page 4

An interesting variant was provided by the most remarkable design at the show: James B. Lansing Sound's big \$1,700 stereo speaker system. From a visual point of view this is easily the most "different" speaker yet produced for hi fi. It looks a lot more like a futuristic fountain or garden bench than a speaker system, though this is the result not of any peculiarity of the designer but of the acoustic function. Like the appearance or not, it represented a most

interesting design approach to stereo. The speakers of each channel, and especially the midrange and the tweeter, are inclined so that a large part of their radiation is reflected off a big curved wooden surface in the middle. This reflection reduces the directional effects by diffusion, but it also produces a certain mixing of the two channels both directly and by reflection. And the system did produce a good homogeneity of sound while preserving enough directionality to give a stereophonic effect.

I cannot say that anybody has yet arrived at a completely acceptable solution of the problem; but obviously, there is not only an awareness of the problem but a concerted effort in every promising direction to try to solve it. It is evident that stereo is growing up, just as hi fi did a few years ago. In the beginning there was a tendency to exaggerate the most spectacular aspects of high fidelity—the awesome bass and brilliant highs—both in recording and reproducing. Today the stress is on a more natural balance. Similarly, the tendency at first to stress the most spectacular differences between stereo and monaural sound—namely, its directionality—is moderating, and instead the effort is again in the direction of a natural perspective. It is a fact that the more stereo moves in this direction, the more it sounds like a very fine monaural system; but there is left a residue of enhancement of the sound which, despite everything, is probably impossible for the best single-channel systems to equal.

Gray Stylus-Force Balance

The dramatic things get most attention at the shows, and often the things which yield the greatest immediate satisfaction are overlooked. Such is the new stylus-force balance introduced by Gray. It is a genuine balance, using a single weight, which has a range from 1 to 11 grams. Although it is formed of aluminum stampings and has no special bearings, it achieves excellent accuracy and tolerances by spreading the balance out to a relatively long 4 in., so that any small irregularities in manufacture or assembly have an insignificant effect



on its accuracy. It is simple, very easy, and convenient to use, and inexpensive; the accuracy, even in the 1-gram range, is more than sufficient for the purpose of setting stylus force on a hi-fi system. I suspect that it will be my best-remembered souvenir of this year's audio-show season.

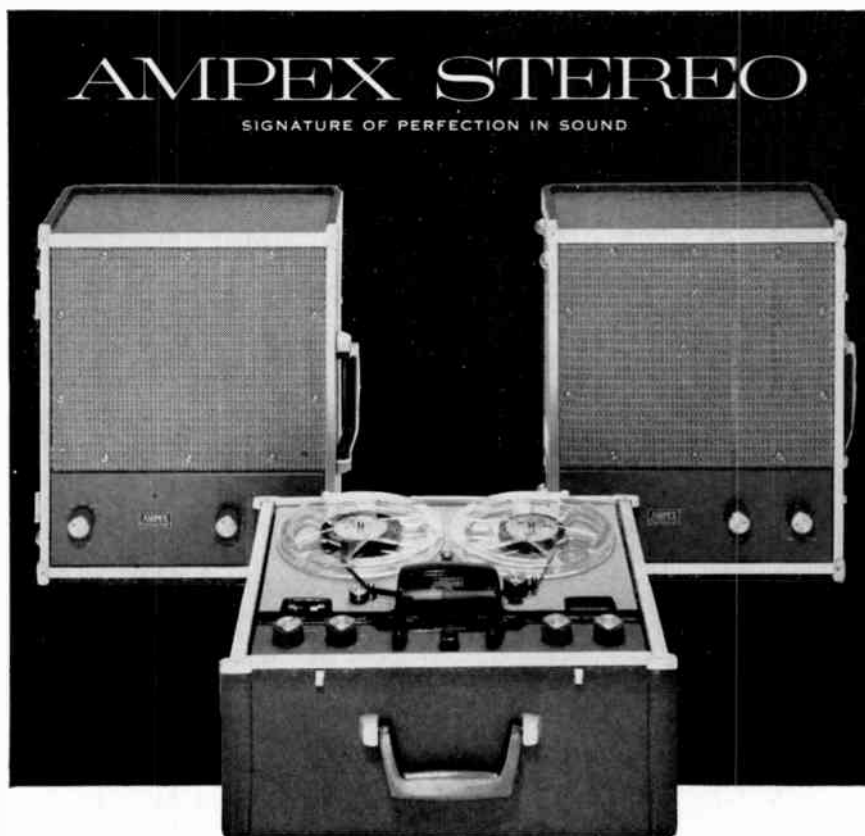

An audio system is like a chain. For optimum performance, all the links must be equally strong... there can be no compromise with "weak-link" components in the system.

It was on this premise that the Ampex A122-SP Portable Stereophonic System was designed. Each link in the chain—from recording and playback heads to speaker—was forged to the same exacting standards and precision tolerances which guide the manufacture of world-famous Ampex professional recording and playback equipment.

Heads—Facing surfaces of head gaps lapped to an optical flatness so precise they reflect a single light band ($\frac{1}{2}$ micron) on flatness gage. This, plus initial surface polish of 6-8 micro-inches, insures sustained frequency response with negligible change in characteristics over many thousands of hours of operation—many times longer than with ordinary heads.

Amplifier-Speakers—Ampex-designed, Ampex-built as an integral part of system... yet may be used separately with other units of your system (has front-panel input switching for Tape, Tuner, TV, or Phono). Amplifier sensitivity 0.25 v for maximum power output; 20-20,000 cps \pm $\frac{1}{2}$ db output with well under 1% harmonic distortion. Speaker features unusually high total gap energy, converts a maximum of output power into sound energy, with smooth, peak-free response.

Complete Specifications—Write today for free new full-color brochure containing complete specification sheet and description of full line of unmounted units, consoles, modular table-tops and portables.

AMPEX AUDIO, INC.

1038 KIFER ROAD,
SUNNYVALE, CALIFORNIA

Please send free color brochure to:

NAME _____

ADDRESS _____

CITY _____



SOUND FANCIER

Continued from page 35

exhaustible fascination. If the slightly dry recording is a bit unkind to the M-G-M Chamber Orchestra's high strings, it does full justice to the imaginative scoring for timpani, trumpet, trombone, and saxophone soloists, as well as to Carlos Surinach's superbly disciplined performance and the kaleidoscopically blended and differentiated timbres (M-G-M E 3453).

To top aural delights and titillations like these (or the wondrously rich and open wind sonorities in Morton Gould's *Hi-Fi Band Concert* on Columbia CL 954, which, however, is musically less interesting in its incongruous mixing of pops materials with the *Italian in Algiers* and *Hänsel und Gretel* Overtures in summer-bandstand fashion), stereo is the only conceivable medium. And even there it isn't always possible to surpass certain outstanding LP masterpieces. Thanks to an English Columbia stereosonic tape of the Scots Guards Band, Vol. 1 (BTC 502), kindly lent to me by A. E. Foster, I was able to discover that two channels aren't inevitably—or in this case, significantly—better than one; for, fine as this tape is, it can't dim one's admiration of the superb LP version (Angel 35271, reviewed here in July 1956). Ditto for the Audio Fidelity stereo taping (AFST 1833) of *Port Said* reviewed here so enthusiastically, in its LP version, just last month.

But these are surely rare exceptions to the general rule. Much more typical are the stereos of the Dukes of Dixieland's Vol. 3, *Marching Along* (Audio Fidelity AFST 1851; reviewed in LP last October), and Monteux's latest edition of Stravinsky's *Rite of Spring* (RCA Victor ECS 67, first released on LP as LM 2085). In both these disparate but equally electrifying works something new and miraculous definitely has been added in stereo. The LP's did sound incomparable by themselves—but how much more musical drama and sonic vitality existed *in potentia* in the original performances is revealed only when one hears them in the acoustical spaciousness and magical immediacy of stereo. Hearing isn't always believing—but stereo experience (which at its best is no less feeling than hearing) can be an irrefutably convincing illusion of complete belief.

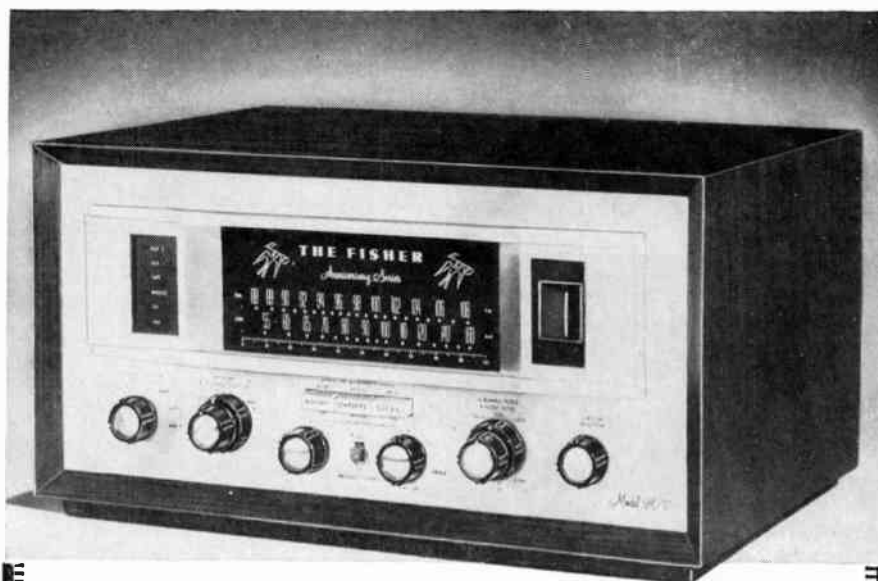
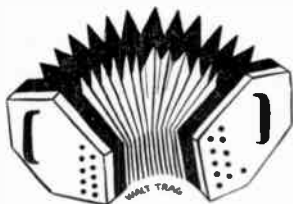

New! And the Best Yet!

THE FABULOUS

FISHER

90-T

FM-AM TUNER

ELEVEN momentous features now available for the first time—plus TWENTY other terrific features. The 90-T reflects engineering excellence without equal. It incorporates the celebrated FISHER GOLD CASCADE RF amplifier and widest-band circuitry, to provide astonishing one-microvolt FM sensitivity. The new FISHER MICROBEAM TUNING INDICATOR is more accurate on weak signals than conventional meters or tuning eyes. At fingertip-touch, the exclusive, three-position FISHER PUSH-BUTTON FM MUTING/AM BANDWIDTH SELECTOR eliminates FM inter-station noise, and assures maximum AM reception with minimum interference. The Audio Control Center includes a new PRESENCE CONTROL and three-position, sharp-cut-off NOISE and RUMBLE FILTERS. Incomparable in performance and appearance, THE FISHER Model 90-T will meet the critical requirements of even the most particular professional.

\$239⁵⁰

Mahogany or Blonde Cabinet, \$19.95

WRITE TODAY FOR COMPLETE SPECIFICATIONS

FISHER RADIO CORP.
21-31 44th DRIVE
LONG ISLAND CITY 1, N. Y.

FISHER RADIO CORPORATION 31-18
21-31 44th Drive • L. I. City 1, N. Y.
Please send specifications of THE FISHER 90-T

Name _____

Address _____

So simple it's like magic...
Grommes Little Genie HI-FI KITS

LAYER-BUILT • COLOR-GUIDE
 Before you build another kit see this new method of Kit Assembly. Each kit is complete with all parts and the new exclusive "Little Genie" Instruction Book.



NEW LJ-6K \$24⁹⁵

LJ-6K 10 Watt Amplifier (Little Jewel). Highest value in the low priced field, with built-in pre-amplifier and record compensator on phono channel. Freq. Response: $\pm 1\text{DB}$ 20 to 20,000 CPS at 1 watt. Distortion: 2% harmonic or less at 10 watts. In Charcoal and Brass. Shpg. Wt. 10 lbs. Complete Kit and instructions.....Net 24.95

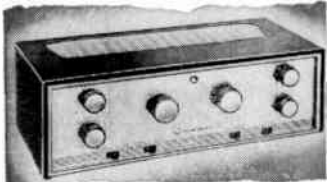

NEW 207AK \$44⁵⁰

207A-K Hi-Fi Preamplifier. The ideal control unit with self-power feature for use with any basic amplifier. True flexibility with 10 separate controls. Feedback throughout for low distortion and wide frequency response. In charcoal gray and brass. Shpg. Wt. 10 lbs. Complete Kit and instructions.....Net 44.50

NEW 250A-K

80 Watt Basic Hi-Fi Amplifier. For use with a preamplifier (such as 207A-K). New advanced circuitry for true high fidelity with exceptional reserve power. Shpg. Wt. 40 lbs. Complete Kit and instructions.....Net 79.50

61PG-K

20 Watt Amplifier. With built-in pre-amplifier and all controls. Modern flat compact design for tabletop or cabinet installation. Shpg. Wt. 20 lbs. In Charcoal and Brass. Complete Kit with instructions.....Net 59.50

See your Hi-Fi Dealer or write . . .

Grommes—A Division of Precision Electronics, Inc. Dept. A-1 9101 King Ave., Franklin Park, Illinois

Send complete Kit details. Send.....Kit. COD (\$5 enclosed). Postpaid. (Full payment enclosed. Enclose name of Dealer. (If any.)

Name.....
 Address.....
 City..... Zone..... State.....
 10-day money back guarantee on all Kits

TAPE NEWS

Continued from page 31

primary winding on the recorder's mike-input matching transformer. The channel level controls are T-pads of the same resistance as the impedance of the microphones. R_1 , R_2 , and R_3 are to maintain proper source impedance from the mixer into the following input transformer. The values of these resistors will depend upon the number of mixing channels, as will the insertion loss. With two channels, as in Fig. 5, R_1 , R_2 , and R_3 will be equal to $\frac{1}{3}$ the value of R (the nominal microphone impedance), and the insertion loss will be 6 db. If a third channel is added, the resistor values will be $\frac{1}{2} R$, and the insertion loss, 9.6 db. Four-channel parameters will be $\frac{3}{5} R$ and 12 db respectively, and so on.

This circuit shares most of the advantages and disadvantages of the high-impedance mixer. If it is used for microphones it will increase preamplifier noise in direct proportion to its insertion loss. Some of this loss may be overcome by increasing the values of R_1 and R_2 , by omitting R_3 , and by making the appropriate matching correction at the input

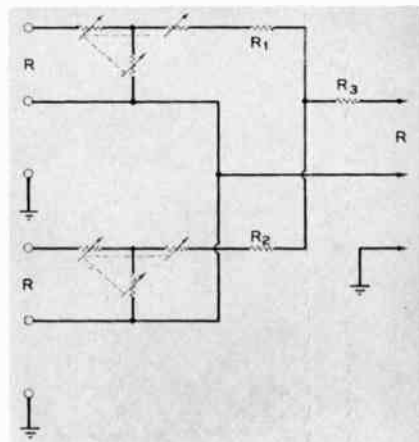

Fig. 5. Dry mixer uses few parts, but may decrease signal-to-noise ratio.

transformer. The resulting reduction in insertion loss is negligible in the case of a two-channel mixer, but there is some advantage to this method when using a three- or four-channel arrangement, as long as the input transformer provides enough flexibility to permit restrapping for the new output impedance from the mixer. Thus, for a three-channel mixer, R_1 and R_2 should be $\frac{3}{8} R$, the input transformer should be strapped for $\frac{1}{2} R$, and the insertion loss will be 7 db (as opposed to 9.6 db for the original circuit). A four-channel arrangement should have R_1 and R_2 equal to $\frac{3}{4} R$, the input transformer wired for $\frac{1}{2} R$, and the insertion loss will be 8.5 db.

Further information about all of these mixer circuits, as well as a few I have



ENJOY ALL THAT HIGH-FIDELITY CAN GIVE YOU— WITH CENTRALAB COMPENTROL®



You bought your hi-fi to enjoy concert-hall realism. Are you actually getting it? You are for sure, if you use a Centralab Compentrol.

When an ordinary volume control is turned down, it not only lowers the sound—but cuts down both the high and low frequencies, leaving only the uninteresting middle range.

That's when you need a special control that bolsters frequencies otherwise lost.

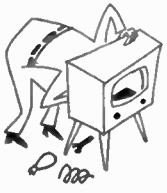

THAT'S WHERE COMPENTROL COMES IN with do-it-yourself fun!

Compentrol is a COMPensated CONTROL that provides tonal balance of the lows and highs—and does it automatically at any volume level. You hear the pleasing full range of the orchestral score.

It's easy to replace an ordinary volume control with Centralab Compentrol—in amplifiers, pre-amplifiers, radios, TV, tuners, tape recorders, and record players.

Buy a Compentrol from your Centralab distributor today.

Remember, only Centralab makes Compentrol

6 models from \$2.50 suggested net price



Send for Compentrol Booklet. Write Centralab, Dept. 923A Milwaukee 1, Wis.

Centralab

not mentioned, may be found in the *Radiotron Designer's Handbook*, by F. Langford-Smith (RCA Publication). I have specifically avoided getting embroiled in the more complicated and versatile mixer systems that can be built up, but if readers are interested in assembling a good three-channel mike mixer, I might suggest the unit that was described in the December 1955 issue of *Audiocraft* [J. Gordon Holt, "A High-Quality Microphone Mixer," pp. 24-27, 42].

READER'S FORUM

Continued from page 15

semble. Our instructions, however, are written for either experienced or non-experienced.

As for a discussion on ensemble tone, all authorities agree that the more sound sources the better. Even firms producing locked-oscillator organs go to great expense to overcome their shortcoming. Even this year Baldwin has introduced a pitch-change device to break up this locked-tuning condition. For years Hammond owners have added Leslie (spinning) speakers to create pitch change. Random phase difference between pipes of a pipe organ or between instruments of an orchestra are responsible for the superior ensemble tone of a large organ or orchestra as compared to a small one.

Robert L. Eby, President
Electronic Organ Arts
Los Angeles, Calif.

Gentlemen:

Although many of your readers have been praising *Audiocraft*, some of the material is useless. As an engineer—and an audio fan—Mr. Marshall's article in the October issue [Joseph Marshall, "The Grounded Ear," p. 4.] is an insult to my intelligence. I am enclosing a copy of a portion of a paragraph from his discussion of the Fairchild elliptical cartridge. My impression is that Mr. Marshall would have me believe that the stylus will track a square wave on a record. I have one question: how does Mr. Marshall get the stylus to track a square wave? It must be quite a feat to change the direction of the stylus 90° and keep it in the groove.

R. G. Chaplick
Silver Spring, Md.

The physical shape of a square wave, when translated by a velocity-responsive device, is a triangular wave. This is possible to cut on a record, and it is possible for a very good pickup to reproduce a square wave from it with little wave-form distortion. As a matter of fact, RCA has just put on the market a test record with "square-wave" bands.

—ED.

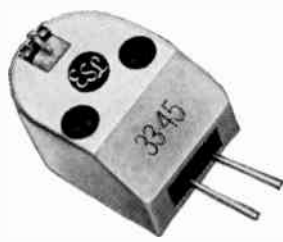

fabulous!

Would you like the greatest possible improvement in your hi-fi system at the lowest possible cost? Would you like to hear all the music on your records, the instruments and sounds you've been missing? Would you like to prolong the life of your valuable records and styli?

All this can be yours with the fabulous new ESL C-60 electrodynamic cartridge, as advanced as tomorrow's jet airliner and musical as a rare Stradivarius. Yet, the C-60 will easily drive all modern preamplifiers, and is ruggedly suitable for any record changer or arm. Only the C-60 has all these advantages:

- ▶ Frequency response flat within 1 db 18 cps to 20,000 cps (Elektra 35 test record)
- ▶ Response extends beyond 30,000 cps
- ▶ Minimum output 10 mv at 10 cm/sec
- ▶ Minimum compliance 6.8×10^{-6} cm/dyne
- ▶ Dynamic mass 1 mg
- ▶ IM distortion almost immeasurably small
- ▶ Vertical stylus force 2-6 gms
- ▶ Output impedance 40 ohms at all audio frequencies
- ▶ No transformer nor transistor amplifier ordinarily required
- ▶ Performance unaffected by load resistance
- ▶ Only \$39.50 net at your audio dealer's

After a single hearing, no other make of pickup can ever again satisfy. Be among the first to own the ESL C-60—the cartridge of tomorrow.

magnificent!



Microphone users are spreading the good news about ESL's new line of magnificent moving coil microphones at sensible prices. For every application, ESL has a low impedance microphone specifically designed to provide the highest quality of performance.

An example is the ESL MC-1 pictured above. This superb omnidirectional microphone will easily meet the most exacting professional requirements for music and speech, yet it lists for only \$80 complete with base.

- ▶ Frequency range 50 cps to 15,000 cps ± 3 db
- ▶ Internal impedance 200 ohms
- ▶ Output level -47 db re 1 mw/10 dynes/cm²
- ▶ Size $4\frac{3}{4}$ " x $1\frac{1}{16}$ " x $1\frac{1}{16}$ "
- ▶ Weight 8 oz.

A catalog of the entire line of ESL moving coil microphones and accessories may be obtained free upon request.



FOR LISTENING AT ITS BEST

Electro-Sonic Laboratories, Inc.

Dept. C-35-54 Thirty-sixth Street • Long Island City 6, N.Y.

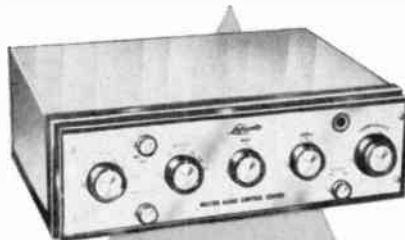
LAFAYETTE'S**Exclusive High-Fidelity Values****ARGOS KIT***Continued from page 21***LAFAYETTE MASTER AUDIO CONTROL CENTER with BINAURAL CHANNEL AND DUAL VOLUME CONTROL.**

- Self-Powered • DC On All Filaments
- 24 Positions of Equalization
- Tape Head Input, High Impedance
- Dual Cathode Follower Output Stages

This is not only the finest hi-fi preamp characterized by unmatched features, but it has been functionally designed to keep pace with the conversion of your present hi-fi system to binaural (Stereophonic) sound. Incorporates an extra channel and dual volume control for binaural reproduction. Features include DC on all tube filaments, negative feedback in every stage, dual cathode follower output stages and latest printed circuit construction. Less than 0.09% IM distortion and less than 0.07 harmonic distortion at 1V. Hum and noise level better than 80 db below 3V. Uniformly flat frequency response over entire audible spectrum. 7 inputs for every type of phono, tuner or tape. Tasteful styling, brilliantly executed. Size 12 $\frac{3}{4}$ " x 9 $\frac{1}{8}$ " x 3 $\frac{3}{4}$ ". Shpg. wt., 10 $\frac{1}{2}$ lbs.

KT-300—Lafayette Master Audio Control Kit Complete with cage and detailed assembly instructions. Net **39.50**

LT-30—Same as above completely wired and tested with cage and instruction manual. Net **59.50**

DELUXE 70 WATT BASIC AMPLIFIER

Here's ultra-stability in a 70 watt basic power amplifier employing highest quality components conservatively rated to insure performance and long life. Features matched pair KT 88's and wire range linear Chicago output transformer, variable damping control, meter for bias and balance and gold finish chassis. Frequency response 10-100,000 cps \pm 1db. Hum and noise 90db below full output. IM distortion less than 1 $\frac{1}{2}$ % at 70 watts, less than 0.3% below 30 watts. Harmonic distortion less than 2% at 70 watts from 20 to 20,000 cps \pm 1db. Output impedance 4, 8 and 16 ohms. Handsome decorative cage perforated for proper ventilation. Size 14 $\frac{1}{2}$ " x 10" x 7 $\frac{3}{8}$ " including cage and knobs. Shpg. wt., 40 lbs.

KT-400—Lafayette 70 watt Deluxe Basic Amplifier Kit complete with cage and detailed assembly instructions. Net **69.50**

LA-70—Same as above completely wired and tested with cage and instruction manual. Net **94.50**

- Conservatively Rated At 70 Watts
- Metered Balance And Bias Adjust Controls
- Inverse Feedback • Variable Damping
- Available In Kit And Wired Form

Lafayette Radio 165-08 Liberty Ave
JAMAICA 33, N. Y.
Dept. AC-A Include postage with order.

NEW YORK: 100 SIXTH AVE
NEWARK, N. J.: 24 CENTRAL AVE
PLAINFIELD, N. J.: 137 WEST 2nd ST
BRONX, N. Y.: 542 E. FORDHAM RD
BOSTON, MASS.: 110 FEDERAL ST

COMING to your city

HIGH FIDELITY MUSIC SHOWS

*See and hear the latest in HIGH FIDELITY
from leading high fidelity manufacturers . . .*

Don't miss these public showings of Hi-Fi Equipment . . . from the most economical units for the budget-minded to spectacular home music theatres . . . compare and enjoy them all. Components and complete systems will be displayed.

THREE DAYS OF CONTINUOUS DEMONSTRATIONS

1 P.M. to 10 P.M.

SPRING 1958

January 10-12	Minneapolis	Hotel Dyckman
January 17-19	Indianapolis	Hotel Antlers
January 24-26	Buffalo	Hotel Statler
February 7-9	Denver	Hotel Cosmopolitan
March 7-9	Pittsburgh	Hotel Penn-Sheraton
March 21-23	Newark	Hotel Robert Treat

Rigo Enterprises, Inc. 500 North Dearborn Street, Chicago 10, Illinois

glue spreading and the insertion of six screws.

Our job was practically complete. We put on the feet (three screws each), and put sound-proofing material (supplied) on two inner sides of the cabinet with tacks (also supplied). Fig. 5 shows the completed enclosure from the back. Then we mounted the speaker. Only one operation remained—to attach the back panel. It is, of course, not glued since it must be removable for speaker servicing or later replacement.

With the back panel in place, we beheld our completed Californian, Jr., a scant three hours—not all of which was actual working time—from the time it was unpacked.

AUDIOCRAFT Test Results

The performance characteristics of a speaker enclosure depend to a large degree on the speaker used in it. Rather than confuse the issue by installing a speaker which we didn't know, we removed one we had been using in a corner enclosure and put it in the Californian, Jr. Since our ear was familiar with the sound of the speaker while it was in the corner enclosure, any changes in the sound produced by the Californian, Jr., would be immediately evident. This was a 12-inch Jensen wide-range unit, which might be expected to work well in a Jensen-designed enclosure.

As it turned out, the result exceeded our hopes. The bass surged forth in full and apparently deep flavor. There seemed to be no unusual coloration of the sound whatsoever. Nicest of all, when the Californian, Jr., was moved out of the corner and along a wall, the bass pretty much stayed put and this we could never do with the corner enclosure.

For a more critical test, we turned on an oscillator and swept the audio band. No pronounced resonances showed up that could not be directly attributed either to the speaker or the listening room. The Californian, Jr., although built of modestly thin plywood, is amazingly rigid, and our oscillator test showed that it's solidity withstands any impulse to sing duets with the speaker.

At this point we rested, satisfied with the night's work, and wondered how *two* Californian, Jr.s, would sound in stereo, since their petite size makes them uniquely suited to almost any room arrangement. If one sounds so nice, we reasoned, two must be breathtaking in a stereo setup. We must try it sometime. The task would be easy—we have proof of that.



TRANSISTORS

Continued from page 29

cuit. With the control R all the way to the right, the large capacitor C_1 passes all frequencies. By turning the control, however, the small capacitor C_2 is brought into action, passing only the higher frequencies.

Bass Boost. The circuit given in Fig. 23 attenuates all frequencies when the resistance R is made zero. But as R is

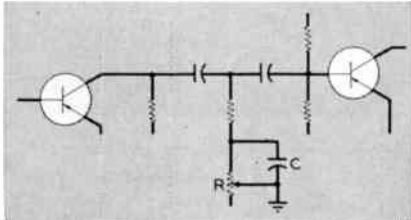

Fig. 23. Bass-boost circuit cuts highs.

increased, only the high frequencies are attenuated, and the effect is a bass boost.

It is possible to combine boost and loss circuits with some success, but as mentioned before the ideal transistor tone control has not yet been invented.

Further Reading

Transistor Circuits of This Type

Garner, L. E., Jr. *Transistor Circuit Handbook*. Chicago: Coyne, 1956, pp. 49-64.

Hunter, L. P. *Handbook of Semiconductor Electronics*. New York: McGraw-Hill, 1956, pp. 11-63 — 11-65.

Kiver, M. S. *Transistors in Radio and Television*. New York: McGraw-Hill, 1956, pp. 100-121.

Lo, A. W., Endres, R. O., Zawels, J., Waldhauer, F. D., and Cheng, C. C. *Transistor Electronics*, Englewood Cliffs, N.J.: Prentice-Hall, 1955, pp. 185-195.

Shea, R. F. *Transistor Audio Amplifiers*. New York: Wiley, 1955, pp. 101-144.

Shea, R. F. *Transistor Circuit Engineering*. New York: Wiley, 1957, pp. 96-105.

Corresponding Vacuum-Tube Circuits
Langford-Smith, F. *Radiotron Designer's Handbook*. Harrison, N.J.: RCA, 1953 (4th ed.), pp. 481-542, and 635-677.

Horowitz, M. "Phase Inverters for Hi-Fi Amplifiers." *Radio & TV News*, LVII (May, 1957), pp. 92-97.

Crowhurst, N. H. "Choosing the Phase Inverter." *Radio-Electronics*, XXVIII (Aug. 1957), pp. 49-51, and (Sept. 1957), pp. 40-41.

Augsburger, G. L. "Are Loudness Controls Necessary?" *AUDIOCRAFT*, II (June 1957), pp. 30-31, 39-40.

Holt, J. G. "Pro and Con for Contour Controls." *AUDIOCRAFT*, II (Sept. 1957), pp. 22-23, 44-46.

Crowhurst, N. H. "Why Loudness Control?" *Radio & TV News*, LVII (April 1957), pp. 42-44, 111-113.

Look over the BEST BUYS in HI-FI ... from EICO®

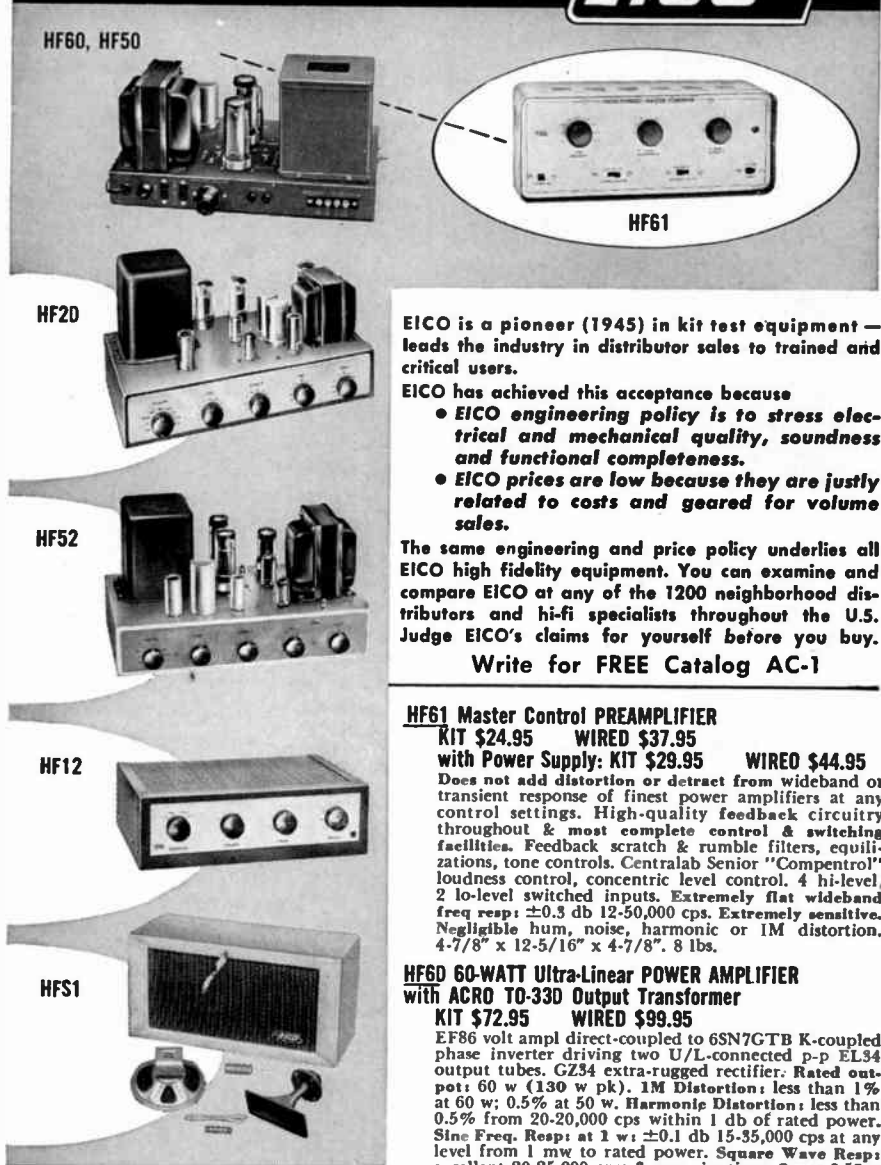

EICO is a pioneer (1945) in kit test equipment — leads the industry in distributor sales to trained and critical users.

- EICO has achieved this acceptance because
- EICO engineering policy is to stress electrical and mechanical quality, soundness and functional completeness.
 - EICO prices are low because they are justly related to costs and geared for volume sales.

The same engineering and price policy underlies all EICO high fidelity equipment. You can examine and compare EICO at any of the 1200 neighborhood distributors and hi-fi specialists throughout the U.S. Judge EICO's claims for yourself before you buy.

Write for FREE Catalog AC-1

HF61 Master Control PREAMPLIFIER
KIT \$24.95 WIRED \$37.95
with Power Supply: KIT \$29.95 WIRED \$44.95
Does not add distortion or detract from wideband or transient response of finest power amplifiers at any control settings. High-quality feedback circuitry throughout & most complete control & switching facilities. Feedback scratch & rumble filters, equalizations, tone controls. Centralab Senior "Compentrol" loudness control, concentric level control. 4 hi-level, 2 lo-level switched inputs. Extremely flat wideband freq resp: ± 0.3 db 12-50,000 cps. Extremely sensitive. Negligible hum, noise, harmonic or IM distortion. 4-7/8" x 12-5/16" x 4-7/8". 8 lbs.

HF6D 60-WATT Ultra-Linear POWER AMPLIFIER
with ACRO TO-33D Output Transformer
KIT \$72.95 WIRED \$99.95
EF86 volt ampl direct-coupled to 6SN7GTB K-coupled phase inverter driving two U/L-connected p-p EL34 output tubes. GZ34 extra-rugged rectifier. Rated output: 60 w (130 w pk). 1M Distortion: less than 1% at 60 w; 0.5% at 50 w. Harmonic Distortion: less than 0.5% from 20-20,000 cps within 1 db of rated power. Sine Freq. Resp: at 1 w: ± 0.1 db 15-35,000 cps at any level from 1 mw to rated power. Square Wave Resp: excellent 20-25,000 cps; 3 usec rise-time; Sens: 0.52 v for 60 w. 7" x 14" x 8". 30 lbs. Matchlog Cover E-2, \$4.50.

HF5D 5D-WATT Ultra-Linear POWER AMPLIFIER
KIT \$57.95 WIRED \$87.95
Extremely high quality output transformer with extensively interleaved windings, 4, 8, and 16-ohm speaker taps, grain-oriented steel, fully potted in seamless steel case. All other specs equivalent to HF6D but on 50 w level. Matching cover E-2, \$4.50.

HF2D 2D-WATT Ultra-Linear Williamson-type INTEGRATED AMPLIFIER complete with Preamplifier, Equalizer & Control Section
KIT \$49.95 WIRED \$79.95
Sets a new standard of performance at the price, kit or wired. Rated Power Output: 20 w (34 w peak). 1M Distortion: 1.5%. Max Harmonic Distortion: below 1%, 20-20,000 cps. within 1 db of 20 w. Power Resp (20 w): ± 0.5 db 20-20,000 cps; Freq Resp (1/4 w): ± 0.5 db 15-35,000 cps. 5 feedback equalizations. Low-distortion feedback tone controls. 4 hi-level & 2 lo-level inputs. Conservatively rated, fully potted output transformer: grain-oriented steel, interleaved windings. 8 1/2" x 15" x 10". 24 lbs. Matchlog Cover E-1, \$4.50.

HF52 5D-WATT Ultra-Linear INTEGRATED AMPLIFIER complete with Preamplifier, Equalizer & Control Section
KIT \$69.95 WIRED \$109.95
Power amplifier section essentially identical to HF5D, including output transformer, GZ34 rectifier, etc. Includes all-feedback equalizations (5 pos.) & tone controls. Centralab loudness control & separate level control that does not affect response at any setting. Cathode follower output to tape. Correct input loading for new ceramics. Zero cross-talk. Biamplification input & output facilities. 8 1/2" x 15" x 10". Matching Cover E-1, \$4.50.

HF12 12-WATT Williamson-type INTEGRATED AMPLIFIER KIT \$34.95 WIRED \$57.95
Complete with Preamplifier, Equalizer & Control Section. Equalized direct tape head & magnetic phono inputs. Power Output: 12 w cont., 25 w pk. 1M Dist.: 1.3% @ 12 w. Freq. Resp.: 1 w: ± 0.5 db 12-75,000 cps; 12 w: ± 0.5 db 25-20,000 cps. 2-EL84, 3-ECC83/12AX7. 1-EZ81.

HFS1 TWO-WAY SPEAKER SYSTEM \$39.95 complete with FACTORY-BUILT CABINET
Jensen heavy-duty 8" woofer & matching Jensen compression-driver exponential horn tweeter. Smooth clean bass & crisp, extended natural highs. Overall response: ± 6 db 70-12,000 cps. Power-handling capacity: 25 w. Impedance: 8 ohms. Bookshelf size: 23" x 11" x 9". 25 lbs. Wiring Time: 15 min.

EICO® 33-00 Northern Blvd., L.I.C. 1, N. Y. AC-1
Please send FREE catalog & name of neighborhood distributor or hi-fi specialist.
NAME.....
ADDRESS.....
CITY..... ZONE..... STATE.....
Prices 5% higher on West Coast

IMPROVE your AMPLIFIER in 5 ways



with the
Amperex
GZ34/5AR4
RECTIFIER

A LOW-IMPEDANCE, INDIRECTLY HEATED, FULL-WAVE RECTIFIER WITH 250 MA OUTPUT CAPACITY

The unique AMPEREX GZ34 replaces without circuit changes, in the majority of amplifier circuits, an entire line of popular, heavy-duty 5-volt rectifiers—5U4G, 5V4G, 5T4, etc.

— with the following benefits:

- Better voltage regulation due to lowered power supply impedance;
- Higher power supply output voltage for more power;
- Added filter condenser protection due to reduced surge;
- Cooler operation due to lower voltage drop;
- Protection of costly power output tubes through delayed warm-up.

OTHER **Amperex** TUBES FOR HIGH-FIDELITY AUDIO APPLICATIONS:

EL84/6BQ5	9-pin power pentode; 17 W PP
6CA7/EL34	High-power pentode; 100 W PP
EF86/6Z67	Low-noise high- μ pentode
ECC81/12AT7	Low-noise medium- μ dual triode
ECC82/12AU7	Low-noise low- μ dual triode
ECC83/12AX7	Low-noise high- μ dual triode
ECC85/8AQ8	High- μ dual triode for FM tuners
EZ80/6V4	9-pin rectifier; cathode; 90 ma.
EZ81/6CA4	9-pin rectifier; cathode; 150 ma.

At All Leading Electronic Parts Distributors

Amperex
ELECTRONIC CORP.
230 Duffy Ave., Hicksville, Long Island, N.Y.

POWER AMPLIFIER

Continued from page 19

a practical minimum of high-frequency ripple.

Hum and noise measured 85 db below 36 watts. Changing the input tube to another EF86 improved this figure to 86.5 db below 36 watts. (This was before the installation of the hum balancing network including positive bias, with which the hum and noise level has been further improved to measure more than 90 db down at 36 watts.) The British version measured 89 db below 36 watts. It was felt that an optimum choice, by selection of input tube, would have given an even better figure. Also, the line voltage, during measurement, tended to run low, thereby reducing my figures somewhat. At any rate, my measurements equalled those of the original version.

Intermodulation using 60 and 3,000 cps in 4:1 ratio, was 0.55% at 34.5 watts and 0.75% at 35.4 watts. With 60 and 7,000 cps, IM read 0.8% at 36.3 watts, which was somewhat better than the original version. Sensitivity was measured at 300 millivolts input for full 36-watt power output, and the damping factor was measured at better than 50.

A higher line voltage at the time the measurements were taken might have served to improve the figures significantly. As it is, they justified the assertions of the designers of the Mullard 520 circuit completely. Such differences as did occur were more than likely the result of differences in test equipment and measurement setups, and line voltage at time of testing. A more carefully matched pair of output tubes would also have provided improved IM figures.

The changes that have been made in this version of the Mullard circuit are small, but in my opinion are important and fully justified. In stability and square-wave response I believe the amplifier equals or exceeds the performance of anything available at this date. I would like to express my sincere thanks to Herbert I. Keroes, of the Acro Products Company, for his many suggestions and his personal interest and help; and to E. J. Porto, International Electronics Corporation, for his kindness in reviewing this article and for clarification of points of material interest.

AUDIOCRAFT Test Results

We encountered very little difficulty in building our unit. We followed Mr. Zale's instructions closely, and found that they are comprehensive and complete in almost every detail. For the sake of building ease we chose to order the 17-inch chassis base for the power supply, and heartily recommend this approach to anyone for whom space is not a problem.

We used an electric hand drill for pilot holes for our chassis punches, and

PROFESSIONAL DIRECTORY

SIX BRANDENBURG CONCERTOS

BACH'S
greatest works
in distinctive
performances
conducted by
HERMANN SCHERCHEN
exclusively
on tape

Omegatape

4 Highlights of Concertape,
Livingston, Omegatape
and Replica libraries
plus maximum
savings on all Stereo
Tapes from most
complete stock
anywhere! All for \$9
full year membership

**STEREO
TAPES
FREE**

**STEREOPHONIC
MUSIC SOCIETY, INC.**
303 Grand Ave., Palisades Pk., N.J.

TAPE RECORDERS
EXCEPTIONAL VALUES
HI-FI COMPONENTS
NATIONAL BRANDS
WRITE FOR FREE CATALOGUE

CARSTON
215 VV E. 88 ST.
NEW YORK 28, N.Y.

**UNHAPPY
WITH
"HI"
HI-FI
PRICES?**

Write us your HI-FI Needs.

KEY ELECTRONICS CO.
120 LIBERTY ST.
NEW YORK 6, N.Y.

TRADERS' MARKETPLACE

UNHAPPY WITH "HI" hi-fi prices? So alright already... Write already. Key Electronics Co., 120 Liberty St., New York 6, N.Y. Evergreen 4-6071.

TAPE RECORDERS, hi-fi components, tapes, Unusual values. Free catalog. Dressner, 69-02D 174 St., Flushing 65, N.Y.

TAPE RECORDERS: hi-fi components, tapes at wholesale prices! Free catalogue. Carston, 215-V, E. 88 St., N.Y.C. 28.

"WE BUY AND SELL tape recorders — new and used — tell us what you want or what you have — raw tape — pre-recorded tape; recording supplies". Tape Recorder Sales Company, 433 S. Wabash Ave., Chicago 5, Ill.

ELECTRIC ORGAN FOR SALE: used with piano; or parts are excellent for organ builder; 65 tubes; cost \$700; sacrifice \$200. Organist Box 2, Great Barrington, Mass.

the Magnificent *Ferrograph*



Model 3A/N
(portable)
with built in
speaker.
3 3/4-7 1/2 ips
\$379.50

The world's finest hi-fi tape recorder

The ultimate in high-fidelity tape recorders for home and professional use. Dual-speed, dual-track FERROGRAPH recorders are also available in custom models (tape decks available, from \$195.) and with 7 1/2 and 15 ips speeds. Independent field performance tests rate Frequency Response at ± 2 db between 50 and 10,000 cycles with wow and flutter less than 0.2% at 7 1/2 ips.

Quality standards have restricted our production and unforeseen demand may delay delivery, write TODAY for literature.

ERCONA CORPORATION (Electronic Division)

551 Fifth Ave., Dept. 30, New York 17, N. Y.
In Canada: Astral Electric Co. Ltd.
44 Danforth Road, Toronto 13

AR^{INC}

QUOTATION from The Audio League Report*

"We are now using the AR-1W as our reference speaker.

"As a result of extensive listening and laboratory tests, we are of the opinion that the AR-1W is one of the outstanding low-frequency reproducers available to-day. It may well be the most outstanding. At any rate, we do not specifically know of any other speaker system which is truly comparable to it from the standpoint of extended low frequency response, flatness of response, and most of all, low distortion."

*Authorized quotation #255. For the complete technical and subjective report on the AR-1 consult Vol. 1, No. 11 of the independent consumer periodical THE AUDIO LEAGUE REPORT, Mount Vernon, N. Y.

Prices for Acoustic Research speaker systems, complete with cabinets, (AR-1 and AR-2) are \$89.00 to \$194.00. Size is "bookshelf." Literature is available from your local sound equipment dealer, or on request from:

ACOUSTIC RESEARCH, INC.
24 Thorndike St., Cambridge 41, Mass.

for screw mounting holes. Every component of the amplifier can be mounted with round holes—even the transformers and oil-filled capacitors—which makes the mechanical construction extremely simple.

We did not choose to follow Mr. Zale's method of making the "glitch" circuit since we felt the average home constructor could more readily duplicate results by using the 1.5- to 7-micro-microfarad trimmer capacitor. To mount our trimmer, we enlarged the hole in a mounting lug to accommodate the adjustment screw, attached the trimmer, and mounted the lug on the side of the chassis so that the screw would be accessible from underneath the chassis for adjustment. Nor did we use a pair of GZ34's in the power supply, since one is more than adequate.

We also added a 100-ohm potentiometer between the cathodes of the output tubes (Points A and C, Fig. 4) and connected the arm to ground (Point B, Fig. 4), readjusting the cathode resistors to 420 ohms each. Although precise adjustment of the 500-ohm adjustable resistors for minimum distortion can achieve the same effect, the job is tricky, since tightening the adjustment screw without changing its position (and thus its resistance) is difficult. The potentiometer makes precise balancing simple.



because it can be adjusted easily while the amplifier is in operation, while testing for current balance or minimum IM

When assembly was completed it was necessary to balance the output stage and adjust the filament balance for minimum hum. To guarantee the validity of our test results, we used the amplifier in our own system for a while before checking its performance.

When checks finally were made, the results proved the durability of Mr. Zale's design. The use of low-noise resistors throughout the circuit, and the extreme filtering in the power supply, produced a signal-to-noise ratio in our unit of 93 db!

Just as fine were the figures for intermodulation distortion, Fig. 8. Using 60 and 6,000 cps in a four-to-one ratio, our unit measured below the residual of the meter up to about 15 watts, rose slowly to 0.5% at 35 watts, and reached the

Continued on next page

Better Results With
ROBINS' AUDIO ACCESSORIES!

GIBSON GIRL® TAPE SPLICERS		
1. Semi-Pro	SP-4	\$ 3.50
2. Junior	TS-4JR	6.50
3. Standard	TS-4STD	8.50
4. De luxe	TS-4DLX	11.50
5. Industrial (5 sizes to 1")		(net) 55.00

ROBINS PHONO AND TAPE ACCESSORIES		
6. Splicing tape	ST-500	\$.39
7. Jockey Cloth for Tapes	JCT-2	1.00
8. Tape Threader	TT-1	.78
9. AUD-O-FILE	AF-50 (net)	23.99
10. Changer Covers	CC-1, 2	2.00
11. Turntable Covers	CC-3	2.50
12. DisClosures	E10, 12 (pkg)	1.20
13. Jockey Cloth for Records	JC-1	1.00
14. KleeNeedLE	N8-1	1.50
15. Phono-Cushion, 10", 12"	PC-10, 12	1.50
16. Atomic Jewel	SE-90	5.00

At Dealers Everywhere

ROBINS INDUSTRIES CORP.
BAYSIDE 51, NEW YORK

MAGNETIC TAPE ERASER



Erases recorded signals and noise from magnetic tape without rewinding. Spindle mounting of reel permits rapid coverage without missed spots. Noise level reduced below level of standard erase heads. Restores tape to like new condition or better. Reel size range 5", 7", 10 1/2". May also be used for demagnetizing record—playback—erase heads.

Model HD-11 Price \$27⁵⁰

TELEPHONE PICK-UP COIL

For transcribing telephone conversations with recorder or making messages audible on amplifier. May also be used as probe for locating sources of hum. More constant signal level than base mounted units. Suction-cup mounting on any telephone receiver. Supplied with 68" shielded cable, terminated with standard phone plug for recorder or amplifier.



Model HP-61

Price \$7⁹⁵

MATCHING TRANSFORMER

A precision transformer developed to enable the audiophile to modify, enlarge, redesign, or rearrange his speaker systems. Permits use of additional speakers of different impedance ratings with present amplifier, or crossover networks, without impedance mismatch. Delivers equal, or 3 db, adjustable power, to all speakers. Power 50 watts, 100 watts peak. Frequency response 15 to 30,000 cycles. Matching range: any combination of 1 to 3 speakers of 16, 8, 4 Ω .

Model HM-80 Price \$21⁷⁵



Available from Electronic and Audio Distributors

MICROTRAN COMPANY
Inc.
Valley Stream, L. I., N. Y.

...the ultimate goal
of the
critical listener

marantz

Audio Console
preamplifier, complete \$171*

Power Amplifier
\$198*

Electronic Crossover
\$90*

*slightly higher west of
the Mississippi

write for literature

marantz company
25-14 Broadway Long Island City 6, N. Y.

POWER AMPLIFIER

Continued from preceding page

1% point at 38 watts. These figures follow very closely those obtained by Mr. Zale, further confirming the reliability of the circuit when 1% components are used.

Although our unit did appear to roll off beyond 20,000 cps a bit faster than Mr. Zale's, Fig. 9, we attributed this fact to stray wiring capacitances introduced by the slight changes we made in parts placement and component layout. The differences are minute, and do not degrade the audible performance of the amplifier in the slightest.

Low-frequency stability was excellent, and high-frequency square waves closely approximated those photographed by Mr. Zale, (Figs. 10, 11, and 12).

Although this is a rather expensive amplifier (it cost us about \$110 to

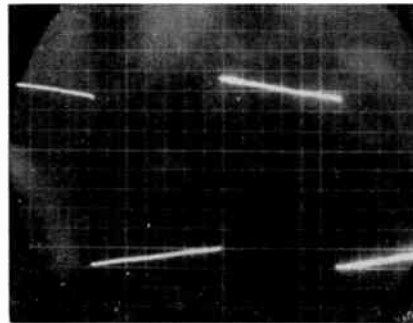

Fig. 10. Response to 30-cps square wave.

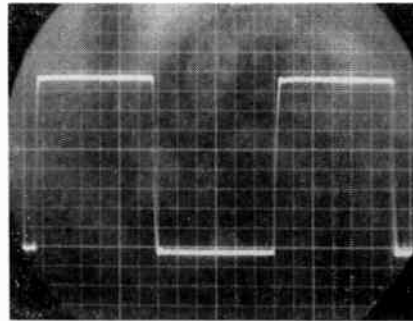

Fig. 11. Response to 3-kc square wave.

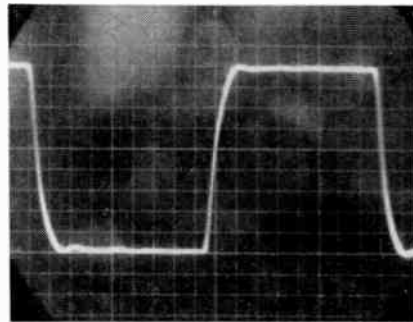

Fig. 12. Response to 11-kc square wave.

build), the extra cost has gone into tried-and-true, work-horse parts which should retain their efficiency over a great many years. The amplifier is indeed a perfectionist's dream and one which we can recommend without reserve.

ADVERTISING INDEX

Key No.	Advertiser	Page
1...	Acoustic Research, Inc.	39, 47
2...	Allied Radio Corp.	48
3...	Amperex Electronic Corp.	46
4...	Ampex Corp.	40
5...	Audio Fidelity Records	Back Cover
6...	Audiophile's Bookshelf	7
7...	British Industries Corp.	Inside Front Cover
8...	Carston Studios	46
9...	Centralab	42
10...	Columbia LP Record Club	1
11...	Conrac, Inc.	14
12...	Dynaco Inc.	38
12...	EICO	45
14...	Electro-Sonic Laboratories	43
15...	Ercona Corp.	47
15...	Ferroglyph	47
16...	Fisher Radio Corp.	41
11...	Fleetwood	14
7...	Garrard Sales Corp.	Inside Front Cover
17...	Glaser-Steers Corp.	2
18...	Grommes	42
19...	Heath Co.	8-11
20...	International Pacific Recording Corp.	46
21...	Key Electronics Co.	46
22...	Lafayette Radio	44
23...	Lansing, James B., Sound, Inc.	5
24...	Marantz Co.	48
25...	Microtran Co.	47
20...	Omegatape	46
18...	Precision Electronics, Inc.	42
	Professional Directory	46
26...	Rigo Enterprises, Inc.	44
27...	Robins Industries Corp.	47
28...	Stereophonic Music Society	46
	Traders' Marketplace	46
29...	Viking of Minneapolis	Inside Back Cover

for everything in **hi-fi**
GET THE MONEY-SAVING 1958
ALLIED CATALOG



featuring the
world's largest
stocks of systems
& components

free!
SEND FOR IT

Here's your complete money-saving guide to Hi-Fi. Own a fine custom quality Hi-Fi music system at no more than the cost of an ordinary phonograph. See dozens of ALLIED-Recommended complete Hi-Fi systems, plus the world's largest selection of components (amplifiers, tuners, changers, speakers, enclosures and accessories). Want to build-your-own?—see our exclusive Hi-Fi KNIGHT-KITS. For everything in Hi-Fi—for everything in Electronics, get the FREE 1958 ALLIED Catalog.

ALLIED RADIO AMERICA'S
HI-FI CENTER

ALLIED RADIO CORP. Dept. 89-A8
100 N. Western Ave., Chicago 80, Ill.

Send FREE 1958 ALLIED Catalog

Name _____

Address _____

City _____ Zone _____ State _____

SPECIFICATIONS

ALL VIKING DECKS

frequency response: 30 to 14,000 cps plus, at 7½ ips; 40 to 7,000 cps plus, at 3¾ ips.

signal-to-noise: 55 db or better.

flutter: 0.2 percent average.

long term speed regulation: ½ of 1.0 percent.

tape speed: 7½ ips (3¾ ips available by changing belt to smaller groove on motor pulley).

maximum reel size: 7"

record/playback head characteristics: track width .082 inch. Gap width .00016 inch. Impedance 2000 ohms at 1000 cycles. Double coil hum bucking winding. Mu-metal shielded. Output 2.5 mv.

recommended bias current: .8 ma. at 68 kc.

in-line head characteristics (VIKING'S own in-line head) same as above.

erase head characteristics: track width .125 inch, double gap (each .045 inch), inductance 23 mh. at 1 kc, erase 60 db at 68 kc.

MORE PERFORMANCE PER DOLLAR

THESE ARE THE REASONS WHY:



Ultra-linear transport . . . flutter and wow completely below audibility.

Short-gap record and/or playback heads for extended range . . . Double-coil (hum-bucking) record and playback heads for minimum hum. Double-gap erase heads for *dead quiet* erase.

The finest of bearings, and the ultimate in machining tolerances in capstan and drive members — *where precision counts.*

Rugged simplicity for enduring performance.

Physically independent amplifier components for increased flexibility and minimized hum pick-up

Very high erase-bias oscillator frequency permits extended range recording without bias intermodulation.

NARTB equalization. Physical separation of mechanical and amplifier components, plus clean design, eliminates need for roll-off of lower (*hum*) frequencies.

SPECIFICATIONS

RP61 SERIES PREAMPLIFIERS

frequency response, playback: 30 to 14,000 cps \pm 2 db.

frequency response, record-playback cycle: 30 to 12,000 cps \pm 3 db.

distortion (tapes recorded 12 db below saturation): less than 2% within specified frequency range.

internal signal-to-noise ratio: 60 db minimum all units.

equalization: modified NARTB



⊗ Ask your dealer for a Viking recording and playback demonstration before you buy any other recorder.

recording channel gain: low level input. Requires .002 volt rms at 400 cycles for recording level 8 db below saturation. (High level input, .3 volts rms.)

playback channel gain: 55 db.

recording inputs: high impedance microphone (62 db overall gain) and high impedance radio or phono input (32 db gain).

bias frequency: 68 kc.

output: 1 volt, high impedance.

tube complement: 1-12AX7, 1-12AU7A, 1-12AV7, 1-6X4, 1-6E5 Indicator.



Viking OF MINNEAPOLIS

9600 Aldrich Avenue South, Minneapolis 20, Minnesota

EXPORT DIVISION: 23 Warren Street, New York City 7, New York
Cable: SIMONTRICE, NEW YORK (All Codes)

C
O
M
P
O
N
E
N
T
S
W
I
T
H
T
H
E
H
I
G
H
R
P
F
A
C
T
O
R*

the ultimate in high fidelity listening pleasure...



AUDIO FIDELITY

TOTAL FREQUENCY

RANGE RECORDINGS*

TFRR*

reg. opp.

In the strictest sense of the word
only **AUDIO FIDELITY RECORDS**
are **HIGH FIDELITY RECORDS!**
Engineering tests prove a frequency range
of 16 to 25,000 cycles and more!

Hear, for the first time, because of
marvelous microphone techniques,
a brilliance and clarity of each
and every element in the recording —
whether it be a vocalist, a shimmering
trumpet or a steam locomotive.



AUDIO FIDELITY, INC.

770 Eleventh Avenue · New York 19, N. Y.

Please Write for Free Catalog



TM