

AUGUST
1952
35c

AUDIO ENGINEERING



 *California West Coast Issue* 

THE WORLD OF SOUND



FULL DIMENSIONAL SOUND

Lifts "HI-FI" to a new HIGH

—thanks to the finest in modern sound recording methods and equipment



"FULL DIMENSIONAL SOUND" is an apt description of the tonal perspective that gives these fine records the true balance, depth and full tonal range of the original live performance.

To achieve these outstanding results, Capitol's sound recording methods and equipment include all of the latest technical advances in the audio field. Recording materials—both discs and tape—must measure up to the highest professional standards in every respect. And Capitol—like leading phonograph record manufacturers the country over—has found that Audiodiscs and Audiotape are the ideal combination for meeting these exacting requirements.

Remember—Audiodiscs and Audiotape are made *by* audio engineers, *for* audio engineers. Their consistent uniform quality is the result of more than a decade of experience by the only company in America devoted solely to the manufacture of fine sound recording media—both discs and tape.

AUDIO DEVICES, Inc.

444 MADISON AVE., NEW YORK 22, N. Y.
Export Dept.: 13 East 40th St., New York 16, N. Y., Cables "ARLAB"

...including
audiotape*
for the original sound



...and **audiodiscs***
for the master recording

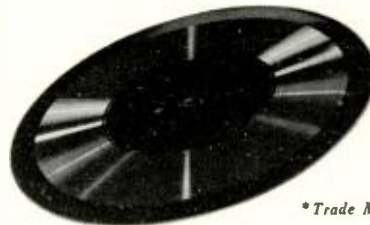

* Trade Mark

Successor to **RADIO** —Established 1917

AUDIO ENGINEERING

INCLUDING



C. G. McProud, Editor and Publisher

Harrie K. Richardson, Associate Editor

Luci Turner, Production Manager

Lucille Carty, Circulation Manager

Edgar M. Villchur, Contributing Editor

S. L. Cahn, Advertising Director

H. N. Reizes, Advertising Manager

Editorial Advisory Board

Howard A. Chinn

John D. Colvin

C. J. LeBel

J. P. Maxfield

George M. Nixon



Representatives

H. Thorpe Covington, Special Representative

677 N. Michigan Ave., Chicago 11, Ill.

Sanford R. Cowan, Mid-West Representative

67 W. 44th St., New York 18, N. Y.

James C. Calloway, Pacific Coast Sales

816 W. 5th St., Los Angeles 17, Calif.

Technical Book & Magazine Co.

297 Swanston St., Melbourne, C. I.

Victoria, Australia

CONTENTS

AUGUST, 1952

Vol. 36, No. 8

Audio Patents— <i>Richard H. Dorf</i>	2
Letters	8
Book Review	9
Editor's Report	10
A Distortionless Oscillator— <i>Dunford A. Kelly</i>	13
Broadcast Audio Wiring Practices— <i>W. Earle Stewart</i>	16
Williamson-Type Amplifier Up-To-Date— <i>M. V. Kiebert, Jr.</i>	18
Handbook of Sound Reproduction— <i>Chapter 3—Edgar M. Villchur</i>	20
Planning and Building a Radio Studio— <i>Part 3—Eugene F. Coriell</i>	22
Audio in the Home— <i>William C. Shrader</i>	24
The Western Electronic Show & Convention	26
Record Revue— <i>Edward Tainall Canby</i>	30
New Literature	37
New Products	38
New Newcomb Line Features New Features	40
Commercial O-T-L Amplifier of Unique Design— <i>Frank H. Gilbert</i>	46
Price and Product Changes— <i>Radio's Master Reports</i>	55
Industry People	55
Advertising Index	56

COVER

Bird's eye view of part of the city of Long Beach, California, showing the Municipal Auditorium on the beach surrounded by the horseshoe pier. This location is important during the month of August because of the annual Western Electronic Show and Convention which holds the boards August 27-28-29. More than 200 exhibitors will show their products to a probable attendance of over 10,000 visitors. Photo by Pacific Air Industries.

RADIO MAGAZINES, INC., 342 MADISON AVE., NEW YORK 17, N. Y.

AUDIO ENGINEERING (title registered U. S. Pat. Off.) is published monthly at 10 McGovern Ave., Lancaster, Pa., by Radio Magazines, Inc., Henry A. Schober, President; C. G. McProud, Secretary. Executive and Editorial Offices: 342 Madison Avenue, New York 17, N. Y. Subscription rates—United States, U. S. Possessions and Canada, \$3.00 for 1 year, \$5.00 for 2 years; elsewhere \$4.00 per year. Single copies 35c. Printed in U. S. A. All rights reserved. Entire contents copyright 1952 by Radio Magazines, Inc. Entered as Second Class Matter February 9, 1950 at the Post Office, Lancaster, Pa. under the Act of March 3, 1879.

AUDIO ENGINEERING • AUGUST, 1952

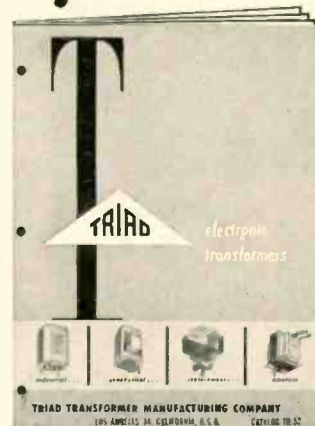

TRIAD CATALOG TR-52 featuring:

- "HS" (hermetically sealed) transformers to MIL-T-27 specifications
- High quality Audio transformers
- 400-cycle Power transformers
- "TRIJET" Miniature transformers.
- Toroids
- General Purpose transformers for television and radio replacement
- Geophysical transformers
- Amplifier Kits

Write for Catalog TR-52 today
or pick up your copy at
BOOTH 1201
**WESTERN ELECTRONIC
SHOW & CONVENTION**
Long Beach, California
August 27-28-29



NEW!

The turntable
that you helped
us design!



Model
B-16H

REK-O-KUT
3-SPEED, 16"
Transcription Turntable
FOR BROADCAST AND
RECORDING STUDIOS

THE new B-16H three-speed, 16" transcription turntable is not a modification of a two-speed machine, but a completely new design, with operational controls suggested by leading engineers. Now you can play all three speeds—33 $\frac{1}{3}$, 78 and the popular 45—with equal facility.

The B-16H can be quickly and easily fitted into your present 2-speed transcription consoles or cabinets. The base is drilled and tapped for mounting Audak, Grey or Pickering arms. Maintenance is simple . . . turntable, motor pulley and idlers are easily accessible.

OUTSTANDING FEATURES:

- 45 RPM Adapter . . . disappearing type, built into hub of turntable.
- Aluminum Base . . . square shape, radial ribbed for utmost rigidity.
- Speed Changes . . . instantaneous for all three speeds—controlled by selector.
- Speed Shift . . . Mastermatic, self-locking. A REK-O-KUT exclusive.
- Speed Variation . . . Meets the N.A.B. standard for speed variation and "wow" content.
- Turntable . . . 16" cast aluminum: lathe turned, with extra heavy rim for balanced flywheel action. Sub-mounted in base.
- Motor . . . Hysteresis Synchronous, 60 cycles AC, 115 volts. Available in other frequencies and voltages at extra cost.
- Dimensions . . . 1 $\frac{1}{2}$ " above base, 6" below. 20" wide x 18 $\frac{3}{4}$ " deep. Shipping weight, 30 lbs.

MODEL B-16H \$250.00 net.

Available at Leading Radio Parts Distributors. Write for detailed literature.

REK-O-KUT CO.

38-01 Queens Blvd., Long Island City, N. Y.
EXPORT DIVISION: 458 Broadway, N. Y. C. U.S.A.
Canada: Atlas Radio Corp., Ltd., Toronto 28, Ont.



AUDIO PATENTS

RICHARD H. DORF*

ALL OUR TECHNICAL LIVES we have been carefully taught that E is equal to I times R, meaning (among other things) that voltage is directly proportional to current. Some of us have been forced to think in somewhat upside down terms by the recent spate of articles in *Æ* on positive current feedback in amplifiers, resulting in negative output resistance, though we may have been somewhat conditioned by previous work with negative-resistance oscillators. It has been known for some time that germanium crystal diodes have a negative resistance characteristic and now a patent has appeared on using the diodes as amplifiers and multivibrators. Diode amplifiers are highly nonlinear and represent no threat to their cousins, the transistors, but they will be useful in many applications where a distortion amplifier is desired.

W. A. Miller is the holder and assignor to RCA of patent No. 2,581,273, covering use of the negative-resistance characteristic of crystal diodes. If you will connect one in a circuit like that of Fig. 1 (using a

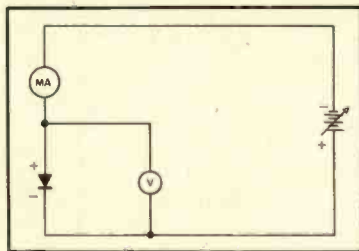

Fig. 1

power supply with poor regulation or placing a resistor in series with it), you will see that the diode is connected "backward." Starting with the voltage of the supply at a low value and gradually raising it, the milliammeter will show a rise in current through the diode, as expected, since semiconductors have a quite finite, not infinite, resistance in the backward direction, and current does flow.

Figure 2 is a rough graph of the experiment, in which the voltage across the diode rises as the current through it is increased by raising the supply voltage. However, just after the diode voltage rises to the value indicated on the curve by X, it will start to decline, even though the supply voltage is raised some more and the milliammeter continues to go up. Effectively, the nonlinear characteristic of the crystal causes its resistance to drop as the current through it increases after the critical X point. This is, of course, "negative resist-

ance," and we would be interested in comments from the late Dr. G. S. Ohm.

Figure 3 shows how a nonlinear ampli-

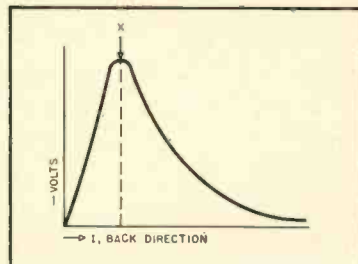

Fig. 2

fier can be made with a germanium diode. The diode is connected as before with the addition of R_1 , the diode load resistor, and R_2 , the input load resistor. The power supply voltage is chosen so that the diode operates on the negative-resistance slope of its characteristic, that is, beyond point X in Fig. 2. The signal will appear, amplified and distorted, at the output terminals.

Figure 4 shows a multivibrator made with a pair of germanium diodes. The two diodes are not quite identical because of unavoidable differences in manufacture, and one conducts slightly before the other. (Again, the supply voltage is chosen to make the diode operate beyond point X.) Let us assume that D_1 conducts first. The voltage at point A goes more positive because the resistance of D_1 has decreased. The positive pulse is coupled by C_1 to point M, the high-voltage end of R_1 , preventing D_2 from conducting until C_1 discharges through D_1 and R_1 . When C_1 has discharged enough to allow point M to go sufficiently negative for D_2 to conduct, D_2 passes current and causes point B to go more positive. As a result the resistance of D_1 increases to a high value and D_1

[Continued on page 4]

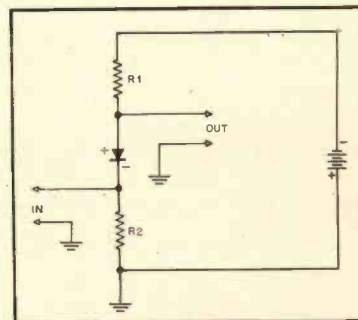
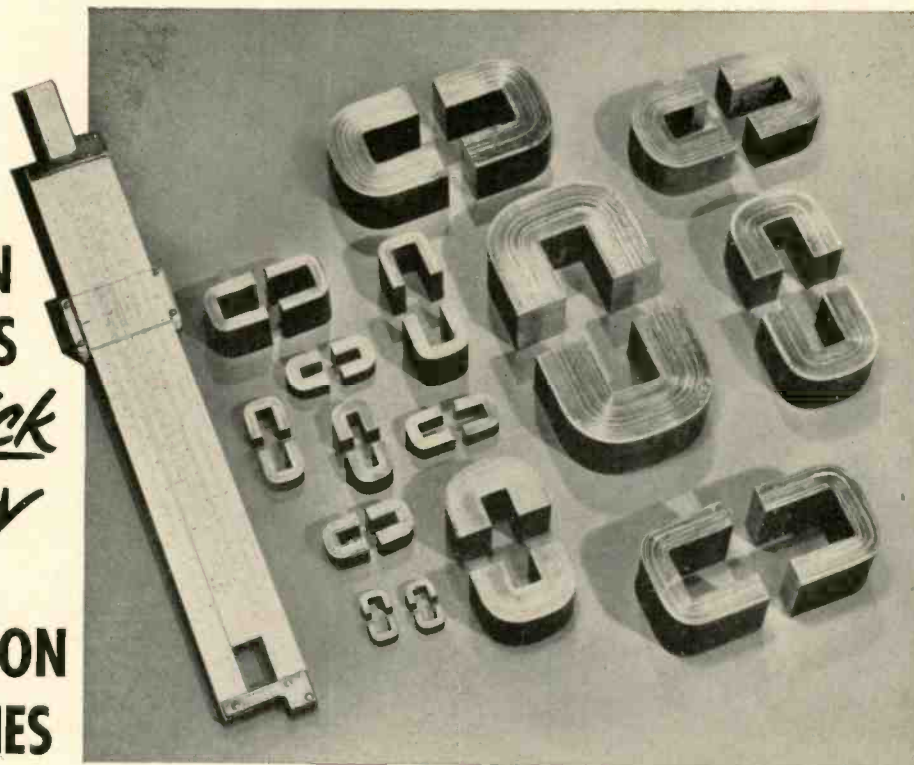

Fig. 3

* 255 W. 84th St., New York 24, N. Y.

**SILETRON
"C" CORES**
*for quick
delivery*
**IN
PRODUCTION
QUANTITIES**



... wound from strip as thin as 0.00025"

*Quality-Tested
and Proved*

- ★ Arnold "C" Cores are made to highly exacting standards of quality and uniformity. Physical dimensions are held to close tolerances, and each core is tested as follows:
- ★ 29-gauge Siletron cut cores are tested for watt loss and excitation volt-amperes at 60 cycles, at a peak flux density of 15 kg.
- ★ 4-mil cores are tested for watt loss and excitation volt-amperes at 400 cycles, at a peak flux density of 15 kg.
- ★ 2-mil cores are tested for pulse permeability at 2 microseconds, 400 pulses per second, at a peak flux density of 10 kg.
- ★ 1-mil cores are tested for pulse permeability at 0.25 microseconds, 1000 pulses per second, at a peak flux density of 2500 gauss.
- ★ ½ and ¼-mil core tests by special arrangement with the customer.

Now available—"C" Cores made from Siletron (oriented silicon steel) thin-gauge strip to the highest standards of quality.

Arnold is now producing these cores in a full range of sizes wound from ¼, ½, 1, 2 and 4-mil strip, also 29-gauge strip, with the entire output scheduled for end use by the U. S. Government. The oriented silicon steel strip from which they are wound is made to a tolerance of plus nothing and minus mill tolerance, to assure designers and users of the lowest core losses and the highest quality in the respective gauges. Butt joints are accurately made to a high standard of preci-

sion, and careful processing of these joints eliminates short-circuiting of the laminations.

Cores with "RIBBED CONSTRUCTION"* can be supplied where desirable.

Ultra thin-gauge oriented silicon steel strip for Arnold "C" Cores is rolled in our own plant on our new micro-gauge 20-high Sendzimir cold-rolling mill. For the cores in current production, standard tests are conducted as noted in the box at left—and special electrical tests may be made to meet specific operating conditions.

● We invite your inquiries.

*Manufactured under license arrangements with Westinghouse Electric Corp.

WAD 4211

THE ARNOLD ENGINEERING COMPANY



SUBSIDIARY OF ALLEGHENY LUDLUM STEEL CORPORATION

General Office & Plant: Marengo, Illinois



To tailor a Circuit
more accurately,
specify

ADVANCE RELAYS!



There are many reasons why the Aircraft Industry specifies **ADVANCE RELAYS**: They meet or surpass Military and Civilian requirements—many types have AN approval—many are hermetically sealed—all are lightweight—small rugged—compact—and all are precision-built for efficient, trouble-free, long life performance.

If you have relay problems involving contact loads, coil resistances, close differential, timing features, input sources, critical environment or any particular requirements involving unusual or accurate circuit behavior. **ADVANCE** can supply the relay.

A complete line of relays for radar, radio, electronic and electrical aircraft equipment applications.

Write for new, descriptive Catalog containing detailed information about **ADVANCE Relays** and facilities.



ADVANCE ELECTRIC AND RELAY COMPANY

2435 NORTH NAOMI STREET, BURBANK, CALIFORNIA
Sales Representatives in Principal Cities of U.S. and Canada

stops conducting. This is because raising the positive potential on point B causes a positive pulse to go through C_2 to point N, making point N more positive.

This cycle repeats itself indefinitely, at a rate determined by the values of C_1 and C_2 , and the resistances. The supply voltage is set so that the diodes will swing from the right of point X in Fig. 2 to the neighborhood of point X for the high-resistance (cutoff) condition and considerably past point X for the low-resistance (on) condition. Output may be taken from point A, B, M, or N into a high-impedance load

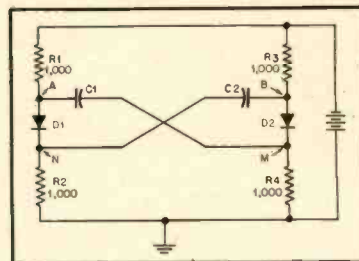

Fig. 4

which will not disturb the capacitor discharge paths. With the 1000-ohm resistors as shown and various values for C_1 and C_2 (both of which should be equal) the inventor produced oscillations at frequencies between 1 and 5,000 cps. Output waveform is approximately square at 1 to 3 cps. Though nothing is said in the patent, it should not be difficult to synchronize the frequency of oscillation with an outside signal.

Voltage Amplifier

Jerre D. Noe of Palo Alto, Calif., is the inventor of a pentode voltage-amplifier circuit which is usable over an exceptionally wide range of audio and video frequencies. It has relatively small bypass capacitors, yet is operable down to dc.; and it has an unbypassed cathode circuit so that feedback may be inserted at the cathode or an output taken from that point.

The circuit appears in Fig. 5, with a sample set of values. At high frequencies the screen is effectively bypassed and there is no screen degeneration. R_1 is bypassed by C_2 , so that R_1 constitutes the entire effective plate load. At low frequencies there

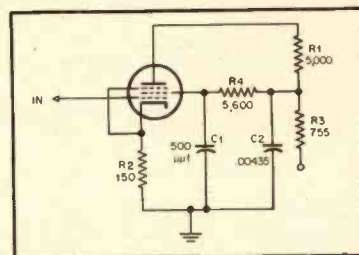
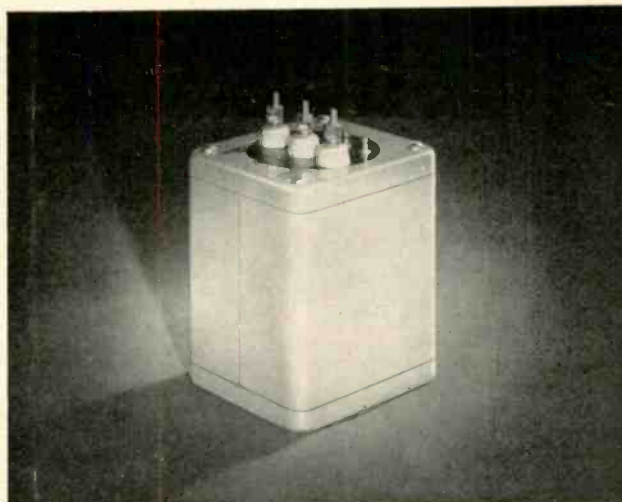
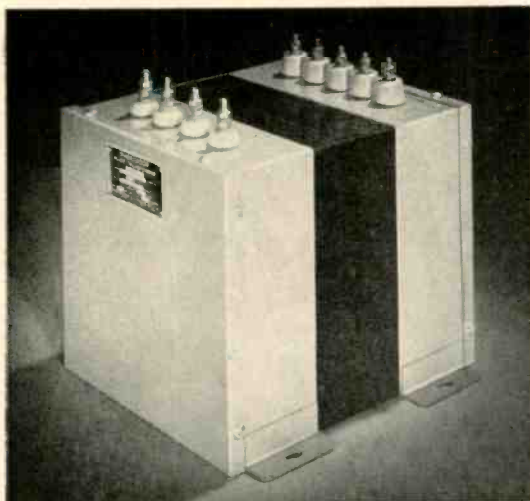

Fig. 5

is screen degeneration but the resulting loss of gain is made up by the fact that R_1 is no longer bypassed and the gain is brought back to the low-frequency value by the consequent increase in total plate load resistance.

The patent specification contains derivations as well as design formulas but the latter are the essentials, so we present them here. When the components are pro-

[Continued on page 53]



A complete new line of transformers from

THERMADOR!

Thermador Electrical Manufacturing Co. has expanded its transformer line to include units for use in amateur, audio, broadcast, aircraft, television, geophysical, radio, and radar applications.

FOR THE WHOLESALER: This new line of standard transformers is now available as a catalog line for stock.

FOR THE ELECTRONICS ENGINEER: Thermador has the technical facilities to design and test transformers for prototype equipment. We are also familiar with JAN specifications and have laboratory equipment that will establish compliance of products with these requirements.

FOR THE MANUFACTURER: In addition to the advantages of a large selection of catalog units and complete design and test facilities, we can manufacture transformers in quantity to meet your production requirements.

Engineered by one of the West's largest manufacturers of electrical products, Thermador transformers have the same precision and quality that have been associated with Thermador Electrical Manufacturing Co. for thirty-five years.

▼
**STOP IN AT OUR BOOTH
(NUMBER 320)
AT THE
WESTERN ELECTRONICS SHOW
AUGUST 27, 28, 29
— IN LONG BEACH**
▲

Write for NEW catalog describing the new Thermador line!

THERMADOR ELECTRICAL MANUFACTURING CO.

5119 District Boulevard ★ Los Angeles 22, California



3-342



NOW...say goodbye to timing error problems!

"SCOTCH" Brand's sensational, NEW 7" plastic professional reel cuts timing error of tape recorded programs up to ONE HALF

If timing problems are the bug-a-boo of your job as a recording engineer, you are no exception. Recording engineers agree that nothing is as distressing as having a tape recorded program run over or under specified time, creating a scheduling problem. But why not relax and breathe easy? You can, you know, because "SCOTCH" Brand, first in sound recording tape, announces its new, exclusive 7" plastic professional reel.

HAILED BY BROADCASTING & RECORDING INDUSTRY LEADERS

Every test on professional recording machines proved conclusively the superiority of "SCOTCH" Brand's exclusive, new 7" reel as contrasted to the standard 7" reel. In every instance the maximum deviation of the recorder speed has been reduced to one-half that experienced using the standard 7" reel.



EXTRA ADVANTAGES OF THE NEW PLASTIC PROFESSIONAL 7" REEL



REDUCTION OF PITCH CHANGES — Pitch changes can be a source of trouble when making continuous long recordings on two machines. Because of the closer speed control made possible by the new plastic professional reel, pitch changes in musical selections are greatly reduced.

MINIMIZED MECHANICAL DISTORTION OF TAPE — On the new professional reel there is only one small threading slot. This minimizes the mechanical distortion of the layers of tape nearest the hub.

MORE UNIFORM WINDING — The new plastic professional reel does not attain as high a rotational speed as the standard 7" reel. This results in less vibration and smoother re-winding.

ORDER TODAY FROM YOUR ELECTRONIC PARTS DISTRIBUTOR

EXCLUSIVE DEVELOPMENT

IN PROFESSIONAL 7" REELS

OLD

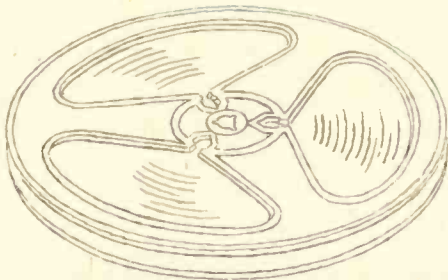

NEW

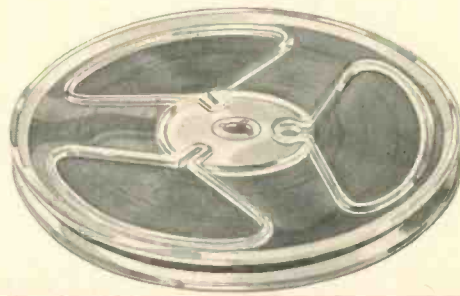

SCOTCH BRAND Sound Recording Tape

"SCOTCH" Brand's new, professional reel has an exclusive, large-sized hub ($2\frac{3}{4}$ " in diameter as compared to the $1\frac{3}{4}$ " diameter hub for the standard 7" reel). This gives "SCOTCH" Brand's new, professional reel the same ratio of outside diameter to hub diameter as that of the standard NAB metal reel.

While timing is also determined by mechanical considerations in recording machines, tape reels play an important part in this problem. With the standard 7" reel, as tape is spooled from the supply reel on to the take-up reel, tension is

constantly varying because of the changes in the effective reel diameters. This change in tension causes slight variations in speed; the tape running faster at the beginning of the reel, and slower at the end. The hub of "SCOTCH" Brand's new plastic professional reel is purposely made large to eliminate tension change while the tape is playing.

More than 1200 feet of "SCOTCH" Brand's exclusive *dry lubricated* Sound Recording Tape is readily stored on the new professional 7" reel.

Quality Guarantee

The Sound Recording Tape supplied on "SCOTCH" Brand's new, professional 7" reel is 100% splice free.

Tape wound on the new 1200 foot reel has an output variation at 1000 cps less than plus or minus $\frac{1}{4}$ db, and is less than plus or minus $\frac{1}{2}$ db from reel to reel.



The term "SCOTCH" and the plaid design are registered trademarks for Sound Recording Tape made in U. S. A. by MINNESOTA MINING & MFG. CO., St. Paul 6, Minn.—also makers of "SCOTCH" Brand Pressure-sensitive Tapes, "Underseal" Rubberized Coating, "Scotchlite" Reflective Sheeting, "Safety-Walk"; Non-Slip Surfacing, "3M" Abrasives, "3M" Adhesives. General Export: 270 Park Avenue, New York 17, N.Y. In Canada: London, Ont., Can.

CANNON PLUG ACCESSORIES

for the "AN" Series



Here is the answer to a frequent question we receive from people everywhere. Yes, Cannon *does* make a complete line of accessories to be used in conjunction with the AN Series of connectors. Complete engineering data on each of these is given in the Cannon AN Bulletin, available on request.

CANNON ELECTRIC

Since 1915 

Factories in Los Angeles, Toronto, New Haven, Benton Harbor. Representatives in principal cities. Address inquiries to Cannon Electric Company, Dept. H 109, P. O. Box 75, Lincoln Heights Station, Los Angeles 31, California.

LETTERS

Ultra-Linear Williamson

Sir:

The article in the June issue on converting the Musician's Amplifier to the Ultra-Linear version prompts me to tell users of Partridge WWFB transformers that they can make the required changes quite easily.

I tapped the screens of my 807's at the 16 per cent step-down impedance point (instead of the idealized 18.5 per cent point) by tapping the outer winding of my WWFB transformer. This is quite easily done—this series of transformers has five primary windings and tapping at the junction of windings #2 and #3 from the plate end gives (2/5)² or 4/25 or 16 per cent stepdown impedance to the screens.

The only other change is the use of a 12,000-ohm feedback resistor. I have used this arrangement since last December and it definitely sounds better and gives the advantages claimed by the authors of the Ultra-Linear articles.

Homer P. Foerster
2619 West 3rd Ave.,
Vancouver 8, B. C.

(We believe that this tap should have been made at the junction of windings #3 and #4 from the plate end, thus offering the screens an impedance of 16 per cent of that offered to the plates. This is in accordance with the recommendations of Hafner and Keroes. However, if the performance is satisfactory, this connection may be the best one to use. As presently connected by Mr. Foerster, the impedance offered to the screens is 36 per cent of that offered to the plates. Ed.)

FM Quality

Sir:

Having read and mulled over the letter of H. F. Ellwood in the April issue relating to the apparent poor quality of some FM stations, I am of the opinion that the trouble may not be at the station at all. Unlike AM receivers, which can deliver good quality even though somewhat out of adjustment, an FM receiver must be critically adjusted to give even passable quality. Therefore, if some stations sound distorted, it may be that the receiver is somewhat out of alignment, and thus is not producing the best linearity on stations which may be modulating close to or above the FCC's 100 per cent figure. Also, a bypass capacitor which is slightly "sour" may be causing enough regeneration to narrow the pass band of the receiver considerably. A good way of checking this is to see if the side responses on each side of the main response are approximately equal in amplitude. If one side response is very much stronger than the other, this is a sign that the set is way out of alignment, even though the quality may be reasonable. Another possible cause of distortion is that the signal level may not be sufficient to obtain good AM rejection from the detector. This also may be a factor in a complaint of noise.

Hum, however, is not likely to be present in a receiver, unless a stage before the detector is putting hum modulation on a weak signal which cannot be removed by the detector due to the low level. This, however, is a remote possibility. Even so, hum is the least annoying of all complaints. I know of only one Chicago station which hums, and its hum level is so low that it is only heard during periods of no modulation.

In summary, I wish to state that a person who is ready to berate an FM station for poor quality should check his own receiver first—including all points mentioned above—before picking up his pen. As an illustration of this, a Chicago station which has a poor reputation for quality among local hi-fi fans sounds quite tolerable on my home-built receiver, which has been accurately aligned. Therefore it is unfair to add to the present troubles of an FM broadcaster a worry which is completely out of his control.

Charles Erwin Cohn,
7720 Marquette Ave.,
Chicago 49, Ill.

Loudness Controls, Again

Sir:

I have read both Mr. Pile's letter in the May issue and your comments regarding compensated controls. As an ex-bass-viol player, I beseech you—"What am I to do?"

Albert L. Peterson,
5723 W. Superior St.,
Chicago 44, Ill.

Book Review

Musical Engineering, by Harry F. Olson.
New York: McGraw-Hill Book Co.,
1952, 347 pp. \$6.50.

The type of sound with which most audio engineers are basically concerned is musical. In this book the field of music is covered from an engineering viewpoint, by an engineer and author to whom the audio profession is already indebted for two texts which have become standards.

The construction, mode of operation, and output characteristics of musical instruments, from bagpipes to zithers, are discussed in physical terms and illustrated profusely and well. Although the approach is descriptive, those who are interested in quantitative analysis will find analogous circuit diagrams of the mechanical and acoustical systems involved and mathematical treatments of the basic types of sound generators.

In addition to the analysis of musical instruments, Dr. Olson has written chapters on the nature of sound waves (also with fine illustrations), on musical terminology and notation, on the theory and construction of musical scales, on hearing, and on sound reproduction. This book will serve musicians and laymen as a bridge to the field of acoustics, and conversely, engineers will use it as a bridge to the field of music.

The concluding chapter expresses the author's conviction that modern acoustical and electronic techniques, aside from their function in the reproduction of music, will make inroads on the design of all types of musical instruments, and will free composers and musicians from present limitations for higher musical achievements. This reviewer, noting that artistic achievement does not necessarily follow technological refinements in the artistic medium (many painters and sculptors have purposely discarded more refined media in favor of less tractable material), does not find himself in agreement. This is irrelevant, of course, to the fact that *Musical Engineering* belongs on the bookshelves of audio engineers, professional musicians, and hobbyists in between the two.

—EMV



Precision Now Offers Unmatched Facilities For 16mm Processing!

Here at Precision, we are constantly revising our film processing technique; utilizing new engineering principles and new machinery which enable us to offer 16mm producers the finest processing service they will be able to find *anywhere*.

Here are some of the new types of equipment that make Precision a leader among film processing laboratories:

New 16mm Developing Machines automatically operated—Maurer-designed to handle the complete range of 16mm work—negative or positive promptly and efficiently.

Automatic Temperature and Air Control built to a Maurer design. Rigidly maintain every technical condition necessary to the finest 16mm processing.

Electrically Heated and Controlled Drying Cabinets on each new developing machine turn out high quality film, waxed and ready for immediate projection.

New Electronic Printer: For the reproduction of magnetic sound to 16mm either independently or in combination with picture prints.

New Control Strip Printers operate without notching original—produce fades and dissolves from A & B rolls—incorporate filter changes between scenes.

Precision Film Laboratories—a division of J. A. Maurer, Inc., has 14 years of specialization in the 16mm field, consistently meets the latest demands for higher quality and speed.

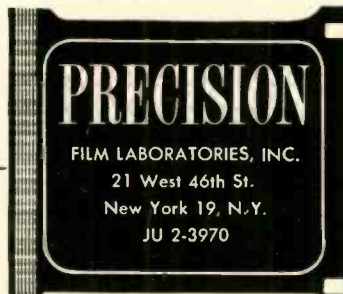

EDITOR'S REPORT

WESTERN SHOW AND CONVENTION

WHEN AUGUST rolls around again, it is time to look to the West—the fast-growing and already third largest electronic market in the country. In the space of the last ten years, growth in electronics in the Far West has surpassed that of any other region in the United States—and that means in the world.

And not only in electronics, but in aviation, shipbuilding, fashions, and in practically every other field the West's growth has been little short of fantastic. No matter in what industry the college graduate wishes to work, he is sure to find openings out on the Pacific Coast. In our own field—audio—the West is noteworthy for its speaker manufacturers, its amplifier manufacturers, its transformer manufacturers, and for components of various other types which are competing strongly with long established companies of the East and the Midwest.

We salute the West, on this occasion of its annual Electronic Show and Convention, for its advances, its consistent high quality of products, and for its aggressiveness in telling the world about itself. For our own part, we shall attend the Show and the too-few Audio papers at the Convention to learn more for ourselves about the equipment that “goes East”—the reverse of the usual trend. And to the West Coast Electronic Manufacturers Association a special salute for choosing August as the month for their show—New York is generally pretty hot during August.

MOVING DAY

Speaking about the heat in New York reminds us that *Æ* is moving. In the interests of better service to our readers, to more comfortable office quarters, and to greater convenience to the majority of the staff, *Æ* is moving to Mineola, Long Island about the first of September. While admittedly less accessible than the midtown Manhattan location, the new offices are just across the street from the Long Island Rail Road station in Mineola, which is only 35 minutes from Broadway.

We believe that the remote location will be more conducive to the work involved in putting a magazine together every month, and we hope our personal services to the readers will be improved as a result of this move. In any case, even though we are to be in the City no longer, we are told that they do have telephones in Mineola, so we shall not be completely out of touch with the Audio world.

RECORD CLEANING

How best to clean phonograph records is one of the controversial issues of the season, it appears. One authority says one thing, and yet another of presumed equal reliability says another. Which one should we believe?

From this observer's viewpoint—and experience—

records are most effectively cleaned if given the same sort of treatment as that given a photographic plate. The conditions are similar, although the plate is never permitted to accumulate the dirt and grit that gets on the surface of a record. The main similarity is in the fragility of the surface, which should be protected at all costs. We do not feel that it is necessary to clean a record each time it is played, but when it does become necessary we favor the following process:

Wash the record thoroughly, using lukewarm water and a mild soap or detergent. Rinse under running water until all soap is flowed off the surface, and dip in a pan containing warm water and a teaspoonful of wetting agent (such as Photo-Flo, obtainable from photographic suppliers) and stand upright in one of those dust-collecting record racks, allowing the record to dry in air. Needless to say, the records should be placed in a location where there is little dust during the drying process.

There are some static-reducing agents available which do not leave a greasy or waxy scum, others which do. A medium of the former type may be used to neutralize static in those locations where trouble is encountered with it, thus reducing the natural propensity of the record to attract dust and lint. Once the record is so treated, the surfaces can be wiped free of dust with a dry, lintless cloth until such time as another washing is deemed necessary. A minimum of contact with the record surface with anything but the stylus is preferred, and it may be possible to blow any accumulated dust from the surface, once the record is treated so as to be static-free.

A trial of this method will be the best proof of its effectiveness. We do not agree that the record surfaces should *never* be wiped with a damp cloth because of the tendency to form a “mud” in the bottom of the grooves.

CANBY MOVES, TOO

But not out of the pages of *Æ*.

Edward Tatnall Canby, who has been reviewing records for *Æ* since the first issue, will now appear in *Harper's Magazine* in addition to *AUDIO ENGINEERING* commencing with the September issue. The new department in *Harper's* will provide both current and cumulative information on recorded music as viewed from his early training and experience in music, and from his more recently acquired technical competence as a reviewer.

Since we are not losing Mr. Canby because of this move—another magazine is the loser—we congratulate him and wish him the best of success in this new medium. His last few months have been spent in preparing a new book—*Home Music Systems: How to Build and Enjoy Them*—which should be in the bookstores by Christmas.

they're different
 they're improved
 they're better than ever!

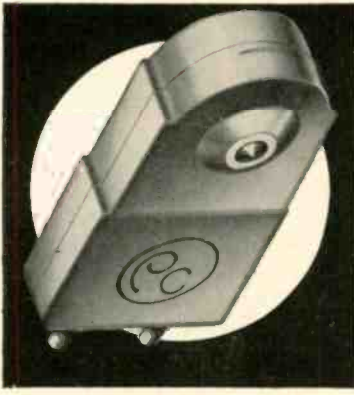
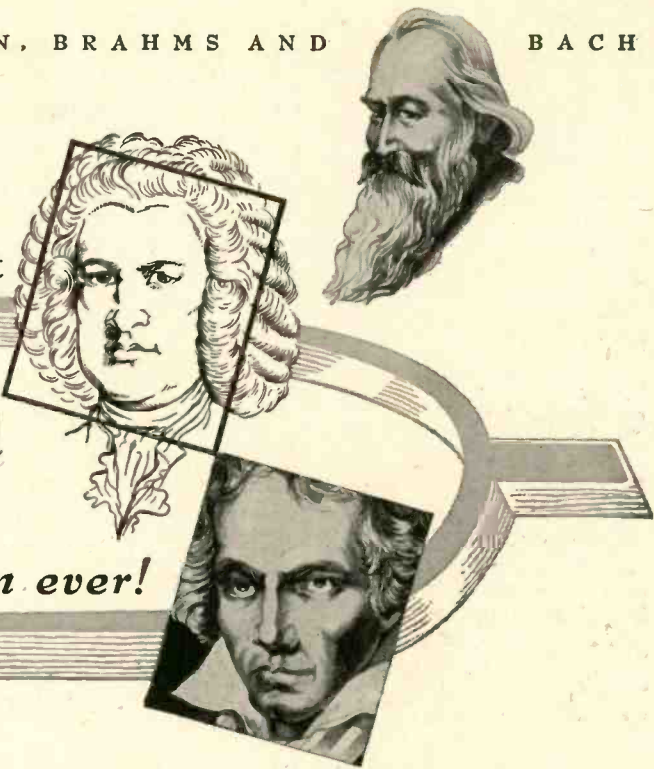

*Y*es, Bach, Beethoven and Brahms are now better than ever—we don't mean we've improved their music, but we do mean we've improved the reproduction of their recorded music.

It's the new, improved Pickering Cartridges that give credence to this claim. Yes, Pickering Cartridges are *different*. They're *improved*. They're *better* than ever. Pickering patented Cartridges with Dynamic Coupling* are superior in every way, by providing . . .

HIGHER FREQUENCY RESPONSE • NEGLIGIBLE INTERMODULATION DISTORTION • BETTER TRACKING CHARACTERISTICS

REMEMBER Pickering engineers and designers have but one objective . . . to produce products that will please the music lovers' insatiable appetite for the flawless recreation of recorded music . . . for the utmost in quality insist upon Pickering Audio Components. . . . Pickering diamond stylus cartridges . . . not only wear longer but, *more important*, they preserve the musical quality and prolong the life of your record library.

* *dynamic coupling assures*

- constant stylus contact with the record grooves over the entire audio spectrum (20-20,000 cps)
- full frequency response • full transient response
- NO RESONANCES • NO MISTRACKING • NO GRINDING OF GROOVE WALLS

PICKERING and company, incorporated



• Pickering High Fidelity Components are available through leading Radio Parts distributors everywhere; detailed literature sent upon request. Address Department A



Oceanside, L. I., New York



Radio-relay station at Evanston, Wyoming

a **W**atcher for lonesome places

Many of the Bell System's 107 radio stations connecting New York and San Francisco by microwave radio-relay stand on hills and mountains far from towns. Day after day, the apparatus does its duty; no man need be there to watch it. But when trouble threatens, an alarm system developed by Bell Telephone Laboratories alerts a testman in a town perhaps a hundred miles away.

A bell rings. The testman sends a signal which asks what is wrong. A pattern of lights gives the answer—a power interruption, an overheated tube, a blown fuse, a drop in pressure of the dry air which

keeps moisture out of the wave-guide. At intervals the testman puts the system through its paces to be sure it is on guard.

Sometimes the testman can correct a trouble condition through remote control, or the station may cure itself—for example, by switching in an emergency power supply. Sometimes the trouble can await the next visit of a maintenance man—sometimes he is dispatched at once.

This is one of the newest examples of the way Bell Laboratories adds value to your telephone system by reducing maintenance costs and increasing reliability.



Alarm-receiving bay in town. Lights on a chart report on 42 separate conditions affecting service. Telephone is to communicate with maintenance crews. Eleven alarm centers across the country cover all 107 radio-relay stations. Stations too far off the beaten trail for wire connections signal by very high frequency radio.



BELL TELEPHONE LABORATORIES

IMPROVING TELEPHONE SERVICE FOR AMERICA PROVIDES CAREERS FOR CREATIVE MEN IN SCIENTIFIC AND TECHNICAL FIELDS.

A Distortionless Oscillator

DUNFORD A. KELLY*

Designed to provide an unusually pure sine-wave source for testing purposes, this oscillator surpasses previous models, but involves meticulous construction details.

THE NEED FOR A PURE SINE WAVE has been apparent since the first distortion measurements were made. Intermodulation tests have partially supplanted harmonic tests, but when a pure signal is available, harmonic measurements have some important advantages. The oscillator to be described has a distortion level below 1/1000 of 1 per cent or 100 db below the fundamental. Thus, for the first time, oscillator distortion can be eliminated as a source of error in harmonic measurements.

Circuit Operation

Figure 1 is a block diagram of this oscillator. It contains the three elements

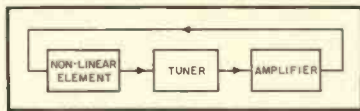

Fig. 1. Block schematic of the low-distortion oscillator.

required for sustained oscillation. Figure 2 is a simplified schematic, useful for tracing circuit functions and Fig. 3 is the complete schematic. Usual oscillator practice involves the fewest possible amplifier stages to minimize phase shift. Conversely, the gain of this amplifier was made so great that the negative feedback largely controls the over-all phase shift. In addition, direct coupling provides excellent low-frequency linear-

* Better Audio Co., 4638 10th Ave., Los Angeles 43, Calif.

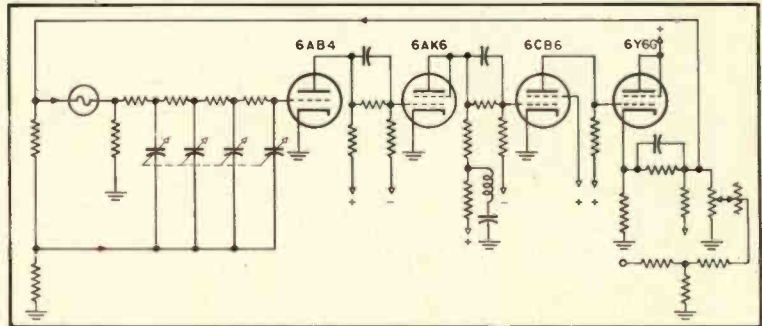

Fig. 2. Functional schematic to indicate circuit operation.

ity, while low plate resistances and low circuit capacitances minimize the high-frequency phase shift. These measures are so effective that 10 volts change in a.c. line voltage shifts the frequency less than one cycle at 20 kc. This is unusual for an R-C oscillator, especially when no plate supply regulation is used. A regulator would have increased the oscillator temperature and therefore the frequency drift.

The four stage amplifier voltage gains are, respectively, 40, 8, 125, and 0.75, totaling 30,000. A large part of this amplification is available for negative feedback. This makes it possible to operate the final stage at full power output, generating about 10 per cent of harmonic distortion, yet reducing this by negative feedback to less than 1/1000 of 1 per cent at the output terminals. The ar-

angement is novel and is properly protected by patents now pending.

Triodes are unusual in such applications, but three of these four stages are triode in function because screen supply is difficult in a direct-coupled amplifier. With a wide pass band and large feedback factor, very careful control of phase and gain margins is required for stability. The second plate circuit incorporates a major part of the required correction, which must be effective to about 25 megacycles.

Like almost all oscillators, L-C or R-C, this one oscillates at such a frequency that the phase shift around the oscillating loop approaches 0 deg. The four-stage amplifier inverts the signal, or introduces 180 deg. of phase shift. At the frequency where the four-section R-C ladder network also adds 180 deg., the total phase shift is zero. The tuning arrangement is the one usually found in R-C oscillators, with variable capacitors and switched resistors. The total frequency range is from 20 to 20,000 cps in three decade ranges.

Frequency Stability

The frequency stability of an oscillator can be no better than the stability of the tuner. In an R-C oscillator the tuning resistors are commonly the least stable elements. This oscillator uses precision film resistors, which are the most suitable yet developed because of their very low temperature coefficients. In addition, the oscillator has a perforated cover and back, with directed ventilation through the chassis and sides, plus internal heat shielding. The temperature of the tuning resistors is therefore much lower than would be possible with a closed cabinet. Unusually good long-term stability and freedom from drift are the results.

An oscillator requires a non-linear

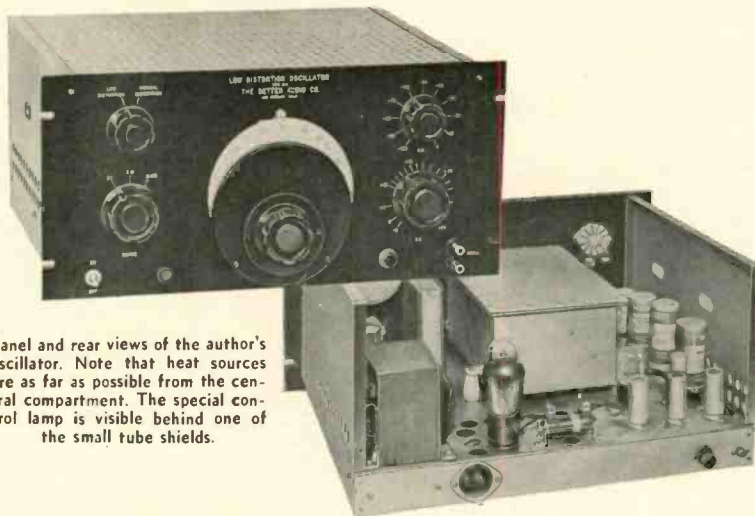

Panel and rear views of the author's oscillator. Note that heat sources are as far as possible from the central compartment. The special control lamp is visible behind one of the small tube shields.

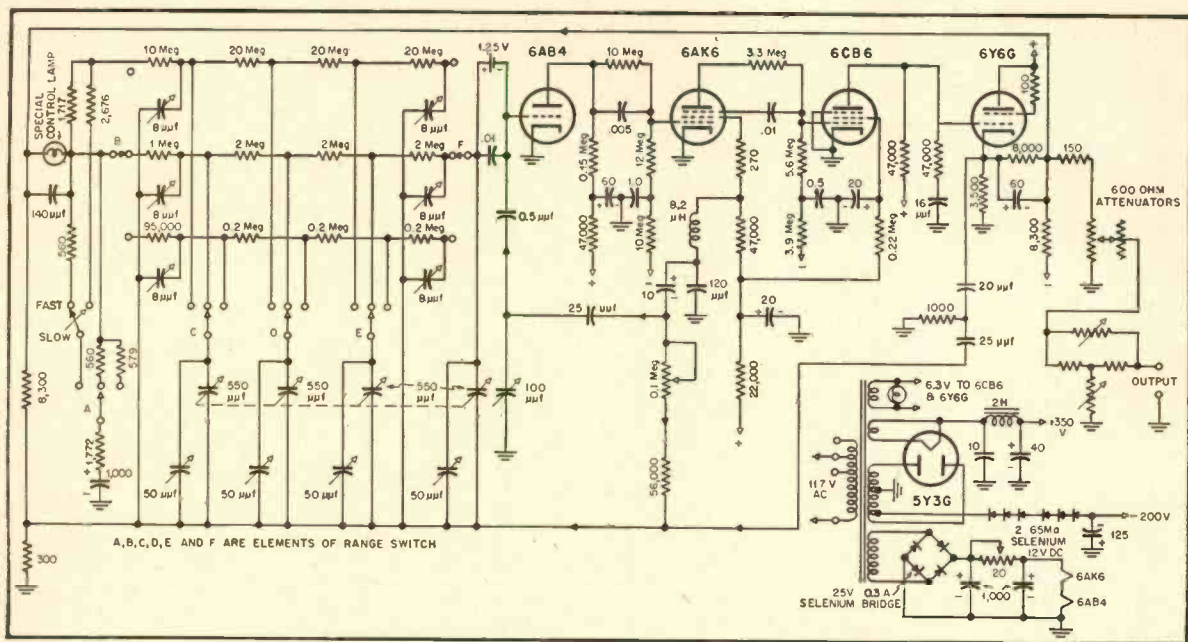

Fig. 3. Complete schematic of the low-distortion oscillator.

element for amplitude control. The simplest suitable regulators are thermistors and lamp filaments. Lamp control is used in this case because it is relatively immune to ambient temperature changes. The lamp must heat with very little current and generate no noise. The 3-watt, 120-volt lamps often used in R-C oscillators are most unsatisfactory. They are economical of heating power but exhibit an erratic resistance, because the filament is loosely suspended in a series of wire loops. Motion of the filament, from mechanical shock or current variation, alters the heat conduction through the points of contact. This in turn affects the filament resistance and therefore the oscillator amplitude. Oscillators using such lamps are usually microphonic, and often have poor amplitude stability.

Pilot lights, vacuum fuses, telephone switchboard lamps, radio tube filaments, power measurement lamps, and many commercial lamps were measured in the ten-year search for a suitable lamp. Several types are non-microphonic, and some are sufficiently sensitive, but unfortunately not the same ones. It was necessary to design a lamp and have it produced by an expert glass-blower. This lamp uses a coiled filament. The fewest possible filament supports are used and these are rigid. To obviate contact noise, the electrical connections to the filament are welded, rather than crimped.

It might be assumed that the principal difference between this and other R-C oscillators is the special control lamp. This is not the case. The use of this lamp in other R-C oscillators yields no spectacular improvement except in regard to microphonics. An oscillator must have a very large feedback factor and most stable components to maintain a

constant amplitude, even with a suitable control lamp.

Design Features

Components used in the oscillator—especially those in the feedback loop—must generate very little distortion. Wire-wound resistors with crimped connections are unsuitable. Precision wire resistors made of the several alloys that cannot be truly soldered, such as the popular nickel-chromium alloys, are suspect. Because almost all capacitors produce harmonics, it is necessary to test each type in each specific application. Magnetic core materials of all kinds are avoided, because a basic characteristic of ferromagnetic substances is harmonic generation.

With harmonics 100 db below the fundamental, other spurious signals must also be reduced. Hum voltages, random noise, microphonics, and low-frequency surges caused by supply voltage fluctuations must be far below ordinary levels. Well filtered d.c. is supplied to the heaters of the first two stages, eliminating the source of hum that is usually most troublesome. The power transformer is placed as far as possible from the input tube to avoid modulation of the electron stream by the alternating magnetic field. The power transformer is oriented for minimum induced voltage in the continuously variable output attenuator. Ground loops are carefully avoided, as the induced hum voltage between opposite sides of the chassis is many times as great as the allowable hum voltage in the oscillator output. These several measures result in a hum level at least 100 db below the signal.

Circuit noise is minimized by choice of low level tube types and operating conditions, as well as the quietest types of resistors. Signal level in the first stage

is as high as possible, as this is also effective.

The most troublesome microphonics result from chassis vibration at hum frequencies. By using a non-magnetic chassis, thoroughly impregnating power transformer coil and core, and choosing a low power-transformer flux density, this source of trouble has been controlled.

Surges due to line voltage changes are minimized by the large amount of negative feedback, which is effective even at zero frequency. Long time constants in the supply circuits are also helpful.

The load circuit is connected directly to the oscillator, without the buffer amplifier generally used for isolation. This is necessary to preserve the full signal-to-noise ratio at low levels. Connecting a variable load to an oscillator poses new problems. The amplitude of an oscillator is usually subject to load. However, by reducing the internal impedance of this oscillator to a very small value, this effect has been eliminated. It is not possible to detect any change of voltage to, not from, the attenuators due to load change.

It is impossible to attenuate a signal while maintaining zero internal resistance. Accordingly, the terminal impedance has been increased to 600 ohms by the addition of series resistance. This value is maintained within moderate limits at all positions of the level controls.

The other part of the problem is frequency shift due to load change. Fortunately this is also minimized by a negligible internal impedance. It is even possible to connect another oscillator to the output terminals, supplying several milliamperes of a slightly different frequency, without appreciably changing

the frequency of the low distortion oscillator.

An often-neglected point in oscillator design is the desirability of a stable output voltage, unaffected by warmup or any other variables. The large feedback factor in this instrument made it possible to limit the output voltage drift to 1 per cent despite oscillator heating, room temperature changes, and line voltage changes.

The output voltage is nearly constant over the entire frequency range. This fact and the previously mentioned stability, make it unnecessary to measure the oscillator output voltage except for very critical measurements.

Oscillator Distortion

Figure 4 shows the variation of oscillator distortion with frequency. At low frequencies the distortion is almost inversely proportional to frequency. It is caused by cyclic heating of the control lamp filament, which accounts for the -1 slope. The distortion originating in the amplifier stages approximates that shown by the curve at 1000 cps and higher. The amplifier distortion is not greatly affected by frequency except above the range of the wave analyzer. Here the distortion increases with frequency but is below 1/1000 of 1 per cent at 20 kilocycles.

With the lamp at normal temperature, the distortion is about 1/200 of 1 per cent at 20 cps. At this temperature the transient recovery time, after range switching, is approximately three seconds. To reduce the low-frequency distortion below the 1/1000 of 1 per cent specification, it is necessary to reduce the lamp temperature. This increases the recovery time to about 15 seconds, but reduces the 20 cps distortion by a factor of 10.

This slow transient recovery is the same effect found in other R-C oscillators, but more severe. It precludes exact measurements while the frequency is changing, but the need for these is rarely encountered.

The lamp distortion is practically pure third harmonic, so at low frequencies the total distortion is largely third. The amplifier produces both second and third harmonics. Higher order harmonics cannot usually be detected except at harmonic frequencies of 100 kc and

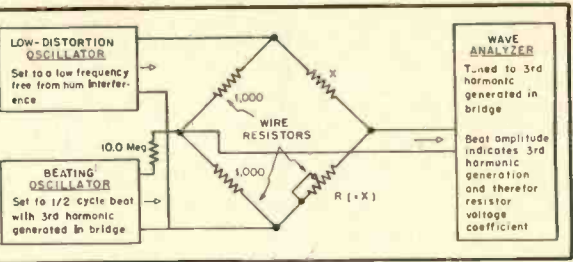
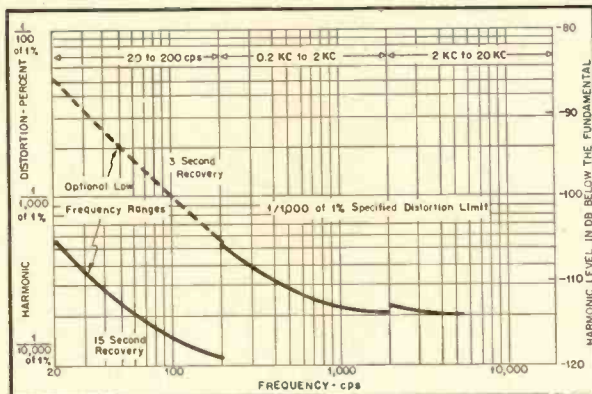

Fig. 6. Method of measuring resistor voltage coefficient.

higher when the fundamental frequency is near the top of the range and the load current is nearly maximum. At lower frequencies the load has little effect, excepting actual overload.

Very Sensitive Tests

These distortion levels were measured with a Wien bridge and wave analyzer as shown in Fig. 5. By eliminating the fundamental frequency with the bridge, the wave analyzer can be used at maximum sensitivity. Corrections must be made, of course, for bridge attenuation. Using a second oscillator to produce a

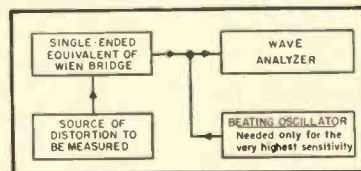

Fig. 5. Arrangement used to measure distortion of very low percentage.

beat with the voltage in question yields even greater sensitivity. If the noise level is low, measurements to two or three microvolts are possible. Such voltages are about 140 db below a 25-volt signal.

Intermodulation tests of equivalent sensitivity are practically impossible because of the difficulty in eliminating both test signals without losing low level modulation products.

It should not be assumed that involved procedures are required with this oscillator. At the distortion levels commonly encountered, the usual measuring devices are satisfactory. The wave analyzer is adequate without preselection, while

distortion measuring sets with low residual distortion are also suitable.

Measurement Limitations

Harmonic tests have been so limited by oscillator distortion that the availability of a pure sine wave places the harmonic test in a substantially improved position. It is therefore desirable to re-examine the limitations of the several test methods.

The SMPTE intermodulation test¹ utilizes two signals, such as 40 and 1000 cps. The new frequencies generated in transmitting these signals are intermodulation, and are measured *en masse*. This is undesirable because the higher-order components, which are most objectionable to the ear, contribute little to the voltmeter reading because their magnitudes are usually somewhat below those of the lower order components. Thus the results do not correspond to audible distortion.

In measuring high-frequency distortion by the SMPTE method, a moderate and a high frequency are employed. It has recently been demonstrated² that serious high frequency distortion may be undetected by this test. Therefore other methods are often used to determine high-frequency distortion.

The CCIF intermodulation test³ employs two adjustable frequencies differing by a fixed number of cycles, such as 400, for example. A wave analyzer tuned to this frequency, which is a lowest order modulation product, will indicate continuously without readjustment while the test signals are set anywhere in the spectrum. Being easy to measure, this difference term is sometimes used to indicate amplifier quality. However it is equivalent to second harmonic and may be negligible though severe higher order distortion is present. Consequently this measurement may be highly misleading.

For a satisfactory CCIF test, all sizeable modulation products should be measured. If an amplifier generates harmonics as high as the fifth—a common condition—intermodulation components may be found at ten or more frequen-

[Continued on page 42]

Fig. 4. Curves showing distortion for two positions of the high-low distortion switch.

¹ J. K. Hilliard, "Distortion tests by the intermodulation method," *Proc. IRE*, Vol. 29, No. 12, December 1941, pp. 614-620.

² A. P. G. Peterson, *The General Radio Experimenter*, Vol. XXV, No. 3, August 1950, p. 6.

³ International Telephonic Consultative Committee (CCIF), Document No. 11 of the "Commission Mixte." CCIF/UIR, March 2 and 3, 1937.

Broadcast Audio Wiring Practice

W. E. STEWART*

Basically a reprint of an article previously appearing in RCA's *Broadcast News*, yet considered of sufficient general interest to warrant reprinting, this article gives the answer to some of the problems encountered in wiring an audio installation—large or small.

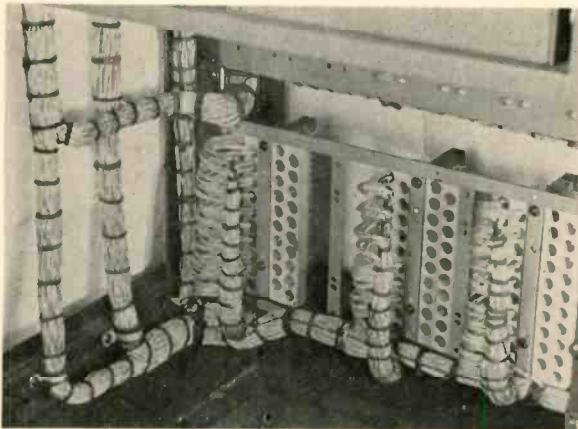

Fig. 1. Cable forming at audio terminals in typical rack installation. Note length of loops between formed cable and holes in fanning strips.

ALMOST EVERY STUDIO INSTALLATION undergoes minor modifications from time to time, and the subject of proper installation practice is raised. Modern standards require careful elimination of noise and crosstalk from the program circuits. It is not uncommon to spend many hours wiring in new components, only to find their performance reduced by the wiring itself. A tested and proven standard practice can avoid much wasted time.

There are two basic philosophies employed in practical approaches to the noise problem. In one system every circuit shield is carefully isolated from its neighbors and grounded at one point only. In the other, all the shields of one unit (such as a rack) are put in such close contact that a brute-force ground is provided for any stray currents that might be present. This latter approach is taken in RCA equipment with modifications as follows: Every rack, cabinet or desk is wired as a unit to terminal boards. The terminal boards are placed as near as possible, consistent with accessibility, to the point where the external circuits enter the unit. See Fig. 1 for examples.

In a rack, as viewed from the back, all audio cables are run on the right side of the rack; and all d.c. power cables and all signal a.c. cables are run on the left side. All audio circuits are twisted pair conductors shielded with a tinned copper braid. Separate cables are formed for:

(a) Microphone outputs, preamplifier

outputs, and other audio circuits with levels below -20 VU.

(b) Mixer, line, and channel circuits up to $+30$ VU.

(c) Loudspeaker and other lines above $+30$ VU.

(d) At times further subdivisions are made for convenience in bulk or because levels are widely separated.

Each cable is bound with lacing cord so the shields are in tight contact for their entire length, as shown in Figs. 2 and 3. Where two audio cables cross or join, they should either be definitely insulated or bound together. It is better to have tight contact than to risk an intermittent noise source made by casual contact.

The ends of the individual shields are

terminated either with "wedge-on" collars or with plastic tape, as in Fig. 4. The shields are grounded to a main ground bus near the terminal block. A shielded ground lead is run from each amplifier chassis to the ground bus.

Single, solid conductors are more compact, easier to form into a neat cable, and allow the use of enamel insulation where desired. However, enamelled wire is harder to clean and solder, and if the single conductor is accidentally nicked, it may break later. Tinned, stranded conductors are less likely to break and are easier to solder. Loose strands must all be tied down to prevent shorts to adjacent terminals.

All wire ends should be looped or formed in such a manner that there is sufficient length for a new connection if the old one is broken. Preferably, they should be placed in a position that allows inspection of the solder joint.

Jack Panel Wiring

Several practices are followed for jack panel connections. In general, there are three points to consider.

(a) Space and flexibility to the cable so the jack may be thoroughly inspected while in place and wired.

(b) Space and lead length to remove a jack without disturbing other jacks and without disconnecting the wires. (This rule is usually ignored for short jumpers to adjacent jacks.) Note insert on Fig. 4 for details.

(c) Sufficient lead length to allow a

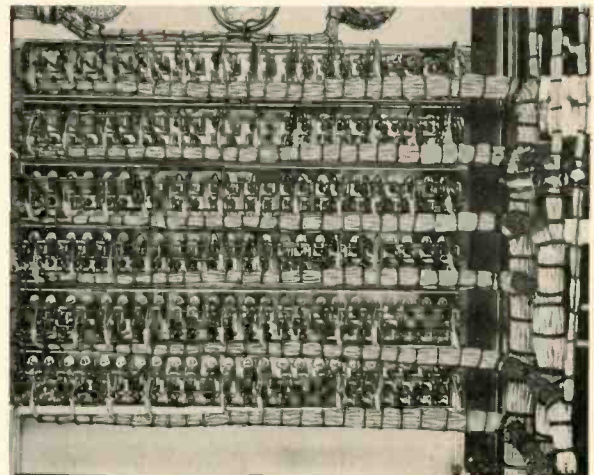

Fig. 2. Detail of jack wiring showing laced cables, forming to jack rows, and general arrangement.

* Manager, Broadcast Audio Engineering, RCA Victor Division, Camden, N. J.

new end to be made if the wire breaks at the solder joint.

Similar practice is applied to lever keys and other items mounted on panels.

There are several types of tape and binders on the market for helping form a neat cable. However, by far the most common practice uses a waxed cord for binding. The cable is formed with temporary ties and adjusted to bends and wire exit points. Sometimes a steel strap or a taut wire is used as a guide and support. The cable is then laced with a self-locking stitch. The frequency of loops around the cable varies with the size of the cable, position of wire exits,

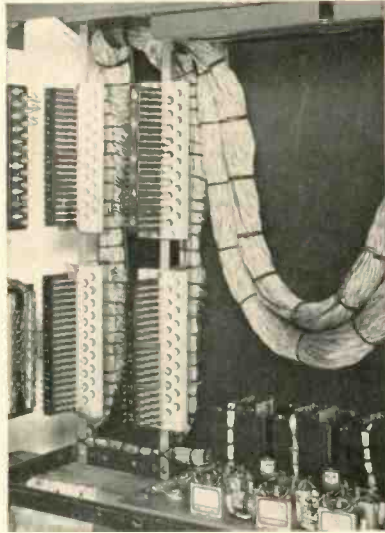

Fig. 3. Cables and terminals in leg of desk-type console.

etc., but averages about 1 in. per loop.

The a.c. and d.c. power circuits are handled similarly. All a.c. circuits should be in twisted pair, shielded cable. The a.c. current should be balanced in each pair. That is, one pair should not be used for one side of a circuit and a second pair for the other side. If more than one pair is needed for the load, two or more pairs should be used with part of the load on each.

Plus and minus plate potentials should be carried in single conductor shielded cable. Shields are tied off and grounded the same as the audio circuits. Signal circuits do not require shielded wire. The frames of jacks should be tied together and grounded with a shielded wire the same as amplifier chassis.

General Rules

In installing the equipment in a studio or control room, the following rules have been found useful: The pairs run in conduits should be grouped in the same general way as the cables in the racks. The audio conduits should be kept free from grounds to power conduits or power circuits. Low level audio circuits (less than -30 VU) should have the shields insulated from the conduits and from each other. Splices should be avoided. Low level conduits should be

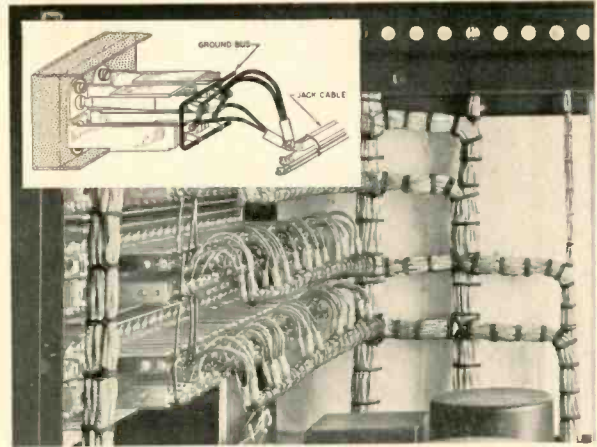

Fig. 4. Side view of jack wiring to show loops between cable form and jacks. Insert shows detail of loop.

well spaced from power conduits.

Signal and telephone circuits should not be run in the same conduit with program or power circuits. Telephone leads should be twisted pair. Power and audio grounds should consist of separate, heavy, shielded leads to the main station ground. Shields should be insulated from ground and the audio circuit and shield grounded only at the point of lowest level.

Typical good practice for microphones

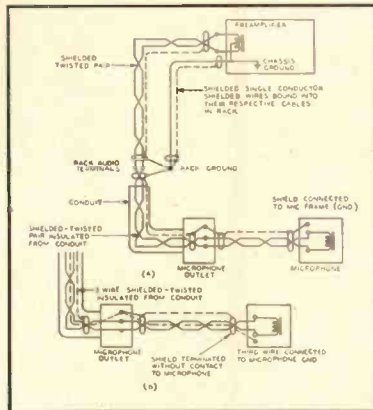

Fig. 5. Typical wiring diagram to show microphone grounding practices.

is shown at (A) in Fig. 5. In this case two-conductor shielded wire, with insulation over the shield, is used for the conduit run and the microphone cord. The arrangement of (B) shows somewhat better practice in which three-conductor shielded, insulated cable is used for the conduit run and microphone cord. This latter practice removes any ground current from the field.

Turntable pickup circuits should be handled like microphones with particular care being taken to keep the motor power circuits and their shields away from the audio circuits. The input to mixer circuits is usually at comparatively high level, but the output is frequently very close to microphone level and the circuits should be treated in the same way. Figure 6 shows typical good grounding practice in this respect. Unbalanced circuits may be used but are usually more difficult to handle if there is noise present. It will be noted that the only ground to this part of the system is at the point of lowest level and that all the circuits are balanced to ground. The center taps of the mixer attenuators are only tied to ground if special noise difficulty is encountered and tests indicate improvement. This occasionally happens on circuits which connect to remote lines or studio equipment with separate ground systems.

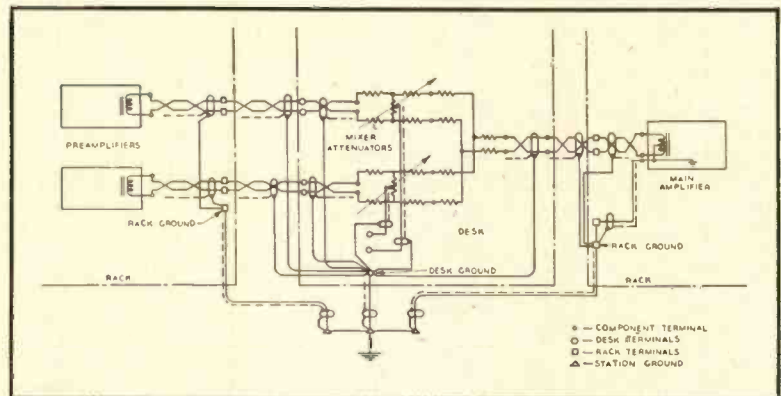

Fig. 6. Diagram showing good grounding practices for interconnections of preamplifier and mixer circuits.

The "Williamson Type" Amplifier Brought Up to Date

M. V. KIEBERT*

Attention to detail in the construction of the Williamson-type amplifier, as well as in the choice of components and tube types, results in an amplifier with low noise level and a minimum of "bugs."

WHILE BUILDING a new "super" amplifier, it became necessary to provide an interim power amplifier for use with the pre-amplifier-equalizer unit to be described by the author next month.

The unit was to be rack mounted on a standard 19-inch assembly with a chassis 17 by 10½ inches. The power supply was to be integral with the amplifier with the provision for self-contained output-stage metering and plate-current balancing.

Electrically, it was required that the unit have a 16-ohm output; a calibrated input attenuator, a 600-ohm input or an unbalanced high impedance input of 100,000 ohms; a power output level of approximately 15 watts with negligible intermodulation distortion; a relatively flat power-frequency characteristic, a

high output damping factor; a gain of 60 to 80 db, and a noise and hum level held to at least 80 db below a one-half watt nominal output level. Combined with these specifications was the requirement that the unit have excellent transient response not only when working into a resistive load but also under the condition of driving a speaker load. To cross-check the latter requirement, square-wave tests were to be made under both conditions of operation—resistive load and speaker—and these measurements were to be compared with the speaker output as sampled by a calibrated microphone.

Preliminary Design

A number of circuits were investigated and checked. The basic Williamson design looked like a good starting place, and accordingly a rather comprehensive investigation was made of the

various circuit literature published on this general type of circuit.

Initial tests soon indicated that four major sources of noise, distortion, and poor transient performance limited the optimum capabilities of the generally used circuit. The difficulties were found to be as follows:

1. The input stage was too noisy, had hum, and required careful selection of plate and coupling resistances in order to provide a balanced, "clean" output from the second half of the tube.
2. The driving power to the 807's was marginal at peak levels.
3. Typical coupling capacitor tolerances and variation of distributed capacitances tended to cause circuit unbalance at both high and low frequencies with attendant transient difficulties.
4. Composition resistors as normally used in the feedback circuit gave distortion from the frequently overloaded voltage co-efficient characteristics of the

* Eclipse-Pioneer Division, Bendix Aviation Corp., Teterboro, N. J.

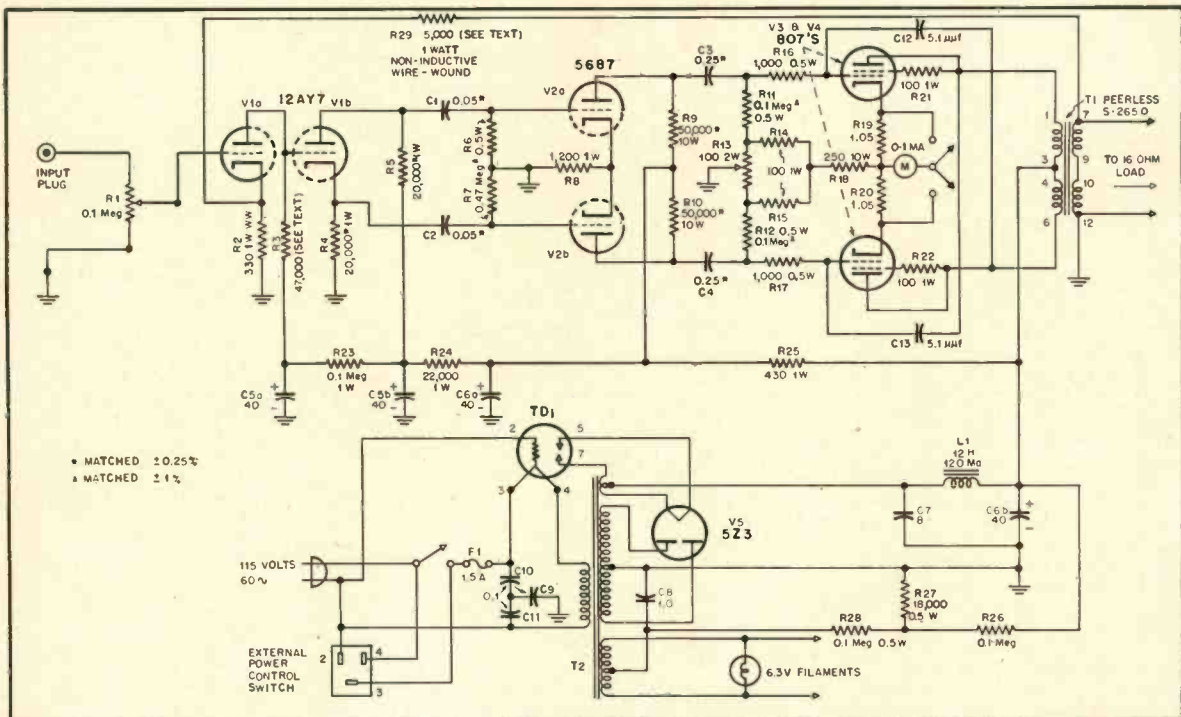

Fig. 1. Over-all schematic of the author's up-to-date version of the Williamson amplifier. Note use of tube types which differ from those originally chosen for use in the Musician's Amplifier—the most popular American version to date.

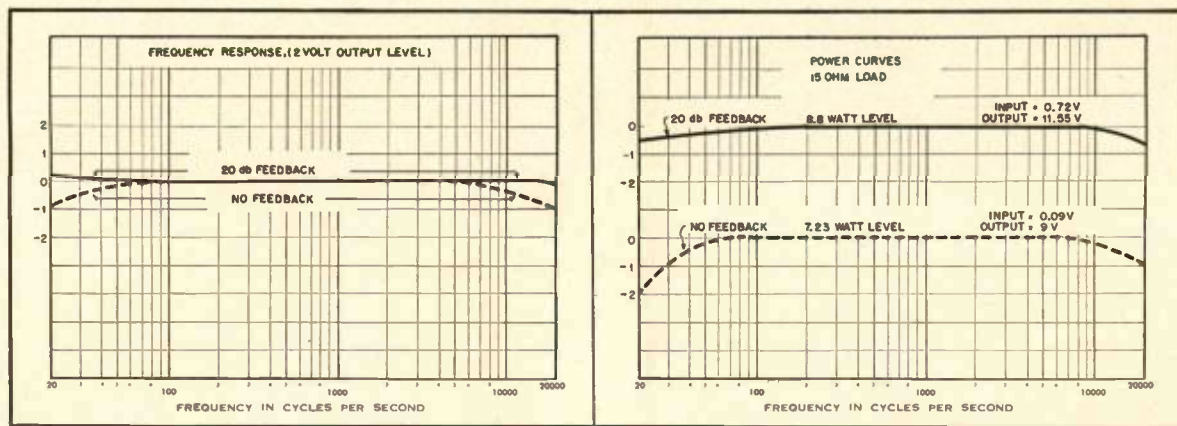

Fig. 2 (left). Frequency-response curves with and without feedback. Fig. 3 (right). Power output curves for 1 per cent distortion, with and without feedback.

units generally specified for use in this position.

It was also believed to be desirable to have a time delay provision so that plate voltage would not be applied to the system until after cathodes had reached a satisfactory operating temperature. Either an Edison or Amperite thermal relay tube would do the job in a satisfactory manner.

Initial tests also disclosed that the use of 10- or 20- μ f decoupling capacitors were inadequate at low frequencies if good transient characteristics were to be maintained down to 5 or 10 cps when a considerable amount of feedback was used. Accordingly, 40- μ f units were used in this position, which then provided fairly good frequency and phase characteristics well down into the lower audio frequencies.

Study of the complete schematic, Fig. 1, will show the differences in detail from the standard design. In order to avoid the four major difficulties observed in basic Williamson circuits, all stages were carefully checked and tested as individual elements and the optimum configuration found prior to inclusion in the final assembly. Likewise, the entire amplifier was carefully tested and rechecked prior to inclusion of any feedback loops—that is, care was taken to assure a good triode design and performance even before feedback was incorporated in the final circuit. Tests indicated that this was a sound design procedure any way you listened to it—or looked at it on an oscilloscope.

First Stage Improvements

In order to circumvent the first listed difficulty—hum due to cathode-heater leakage, and noise arising in the first stage—it was necessary to take two corrective measures. First, a 12AY7 tube which was specifically designed for low-noise-level audio service, was used to replace the conventionally employed 6SN7 and care was taken to follow carefully the manufacturers' recommendation as to input grid resistance, heater connections, and voltage. By-passed and isolated heater bias was then employed with circuit parameters selected to pro-

vide minimum hum when an unbypassed first-stage cathode resistor was utilized as required when feedback is connected in at this point. Second, it was found that the 47,000-ohm plate-load resistor did, as would be expected, cause increased noise unless wire-wound or low noise level units were used.

With respect to noise level in the first-stage load resistor, a number of resistive elements were checked in order to secure a relative evaluation of each type and value. The following were tested:

- 1) $\frac{1}{2}$ watt composition resistor
- 2) 1 watt composition resistor
- 3) 2 watt composition resistor
- 4) 1 watt deposited film resistor
- 5) 1 watt S.S. White low-noise-type resistor
- 6) 1 watt non-inductive, wire-wound resistor

The use of a 1-watt composition resistor in lieu of a $\frac{1}{2}$ -watt unit improved the noise level by approximately 3 db with a like improvement occurring when a 2-watt unit was substituted for the 1-watt unit. The 1-watt S.S. White unit was about 6 db better than the 2-watt composition resistor. The 1-watt deposited film resistor was slightly inferior to the S.S. White unit while the 1-watt non-inductive wire-wound resistor was about 6 db better than the 2-watt composition unit. Substitution of the 1-watt non-inductive wire-wound resistor for the generally specified $\frac{1}{2}$ watt carbon unit thus provided about 12 db improvement in noise level, while the 12AY7 with a biased and properly by-passed heater circuit also cleans up the hum level by about 12 db and accordingly helps to meet the original design requirement.

Phase Splitter Improvements

Following the clean-up of the first stage, the inverter was investigated. Resistors matched to ± 0.25 per cent were utilized. Both S. S. White units and 1- and 2-watt carbon units were checked as regards to noise level. As might be expected, however, the noise level was fixed by the first stage and no significant improvement was found when changing from one type of resistor to another. The

relatively low resistance of these units, 20,000 ohms, minimizes the problems of high-frequency roll-off and asymmetrical phase characteristics sometimes found in this type of inverter circuit. The splitload, cathodyne circuit was found to be superior to all other circuits tested for possible use in this application.

The driver stage was next considered and a number of tube types were evaluated and tested for use in this position. Tubes tested and considered were the 6SN7, 6N7, 6K6's and 6V6's operated both as triodes and as pentodes, 6AG7's, 2C21, 6J6, 12AU7, and the 5687. It was soon evident that the 5687 was considerably superior to other driver configurations although pentode connected 6K6's were also excellent except for the fact that the considerable variation in tube characteristics between tubes required a careful balancing of tubes and a re-adjustment of the screen voltage each time a tube was changed. This was not the case with the 5687 (a dual triode) and accordingly this tube was selected as the driver. It is also obvious that the use of a single tube considerably simplifies the circuit layout and saves on both components and space.

After going through the preceding studies, a preliminary circuit was set up on an experimental chassis, and frequency and phase characteristics were run with the feedback loop left open. It was soon noted that rather peculiar things were happening at low frequencies. ± 20 -per cent coupling capacitors had been used (without actually checking to see what they were) while the grid coupling resistors had been held to ± 10 per cent. The coupling capacitors were then tested and found to have a wide capacitance spread. As soon as matched units were employed, the sides of the push-pull circuits maintained balance and the frequency and phase characteristics smoothed out the way theory said they should.

The use of cross-neutralization or phase correction in the output stage materially helped to extend and smooth out the high-frequency end of the spectrum but again, watch out for balanced capa-

[Continued on page 35]

Handbook of Sound

Reproduction

EDGAR M. VILLCHUR*

The reader is introduced to acoustic resistance, mass, and stiffness—which correspond respectively to electrical resistance, inductance, and the inverse of capacitance.

THE LIFE CYCLE of sound energy involves generation, transmission, and finally, dissipation in the form of heat. One of the most useful tools in the analysis of these stages, and of devices associated with them, is the concept of acoustic impedance.

Impedance is a general term which may be used in connection with electrical, mechanical, acoustical, or other types of oscillatory energy. It is the opposition offered by a transmission medium to an applied force-like stimulus. Specifically, in the case of acoustic impedance, it is the opposition offered by an acoustic medium to having its par-

elements it can only store not absorb, energy, all of which it must ultimately release. The contribution of acoustic stiffness to the total impedance, as in the case of the electrical analogy, is called reactance, and varies inversely with frequency.

Acoustic stiffness may be calculated by the following expression:

$$S = \frac{\rho c^2}{V}$$

where S = acoustic stiffness¹

ρ = density of the medium

c = velocity of sound

V = volume of enclosed medium

For a given medium, then, the enclosed volume alone determines the stiffness; the smaller the volume, the greater the stiffness.

Acoustic Mass (Inertance)

The property of an acoustic medium associated with its inertia, opposing any change in the velocity of its particles, is called inertance. It is comparable to inductance in an electrical circuit and to mass in a mechanical system. Like both of these, it cannot absorb energy, but can only store it in kinetic form in the momentum of the medium particles. The contribution of inertance to the total impedance, as in the case of inductance and of mass, is called reactance and varies directly with frequency.

Although the inertial effect of the acoustic mass is the same as that of mass in a mechanical system, the two are not measured in the same units. The mass of a rigid body is a complete index of its inertial impedance at a given frequency. This must also be true of a single vibrating particle in an acoustical medium, but it is not true of the medium as a whole, because the total momentum imparted to the molecules will be partly dependent upon the area receiving the pressure. This is illustrated by Fig. 3-1. The force applied to each of the pistons is the same, but the pressure per cross-sectional area and per molecule is greater in the smaller radius pipe, whose molecules will therefore have a higher acceleration and momentum imparted to them. Since the number of molecules in each pipe is the same, the piston "sees" a greater effective mass from the point of view of inertia.

Inertance varies directly as the volume of

¹ S is usually used in acoustics to denote surface (area) and the reciprocal of stiffness (acoustic capacitance = C) is the generally used form. Ed.

the medium and inversely as the square of the area to which pressure is applied:

$$M = \frac{V\rho}{S^2} = \frac{m}{S^2}$$

where M = inertance

V = volume of medium

ρ = density of medium

S = cross-sectional area over which medium receives pressure

m = mass of medium

Acoustical or mechanical impedances are treated mathematically in the same way as units of electrical impedance; complex algebra is used for adding reactive components, and acoustic impedance, whether resistive, reactive, or complex, is measured in a unit called the acoustical ohm. Ohm's law and electrical resonance formulas may be applied to mechanical or acoustical systems, where mechanical *force* and acoustical *pressure* is substituted for voltage, and mechanical *velocity* or acoustical *volume velocity*² (the rate of flow of the acoustical medium) is substituted for electrical current. Figure 3-2 is a chart showing the various elements used in connection with the generalized concept of impedance. Rigorous analysis of the behavior of the sound wave and of mechanical-acoustical systems is greatly facilitated by the use of these dynamical analogies, and design for predictable results may be substituted for pure cut-and-try work methods.

Acoustical Transformers

Contact between a source of sound and the air into which it radiates energy may be entirely direct, as in the case of the cymbal, or the coupling may be achieved through a device which increases the efficiency of the transfer from mechanical to acoustical energy. The sounding board and the horn are two such devices, serving as acoustical transformers between a relatively small source and a large volume of air into which the source radiates.

A sounding board, which vibrates in sympathy with the source of sound, increases the radiating area of the source and allows it to get a better "bite" of its load, setting a greater number of air molecules into motion. A horn accomplishes the same result in a different way. Because of the fact that each cross-

² Also referred to as *volume current*.

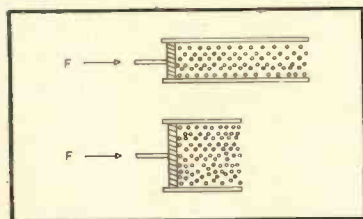

Fig. 3-1. Two pipes of the same volume but different lengths. The acoustic medium in the narrow pipe has greater inertance (acoustic mass).

ticles pressed together and spread apart. This opposition takes three forms: acoustic resistance, reactance due to acoustic stiffness, and reactance due to acoustic mass.

Acoustic Resistance

This is the part of the acoustic load which absorbs the power of the sound and turns it into heat. It is associated with friction between medium particles or between these particles and other surfaces. Like electrical resistance, its effect is independent of frequency.

Acoustic Stiffness

Acoustic stiffness, the reciprocal of acoustic compliance, is a measure of the elasticity exhibited by an enclosed acoustic medium. It is analogous to the reciprocal of electrical capacitance and equivalent to the mechanical stiffness possessed by a spring. Like both of these

* Contributing Editor, AUDIO ENGINEERING.

sectional layer of air in the horn is intimately associated with its adjacent layers, a vibrating reed or diaphragm at the throat is tightly engaged to and moves all of the air in the horn instead of cutting a swath through the middle. The result is to increase the effective sound radiating surface approximately to that of the mouth of the horn. Both of these coupling devices are ancient, and appear in various types of musical instruments all over the world.

It will be noted that the original source applies a large force to a limited number of medium particles, producing a condition of high pressure and low volume velocity. The coupling device distributes the force over a larger area, decreasing the pressure per unit area but increasing the volume velocity, and the transducing action is directly comparable to that of a voltage step-down electrical transformer.

Types of Wave Behavior

A sound wave travels in a straight line along the direction in which it was radiated unless it is absorbed, reflected, refracted, or diffracted.

Absorption

The acoustic medium which transmits a sound wave, and all surfaces with which the wave comes into contact, will absorb and dissipate some of the sound energy. Dissipation is in the form of heat produced by friction between the vibrating particles.







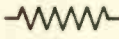

Reflection

Reflection, to a greater or lesser degree, will take place when the wave encounters a medium which presents a change of impedance to its passage.

Reflection from a medium of higher impedance is familiar in common experience. When a group of air particles are impeded from moving past the plane of a wall, they pile up at the wall and then spring back, creating a pressure area travelling in the opposite direction. If the wave meets a gaseous medium which, like the wall, offers a greater resistance to having its particles compressed and rarefied, reflection will also occur, although not as completely. In both cases the compressed particles are reflected as a pressure area, and there is no reversal of phase.

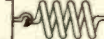
An example of the reflection of sound from a medium of lower impedance is provided by the open end of a small diameter pipe. The impedance of the air surrounded by the pipe walls is greater than that of the outside air due to increased viscosity and inertia. This increased impedance is accompanied by lower acoustical volume velocity but greater pressure swings per unit area, since all of the pressure is confined to the cross-sectional area defined by the pipe's diameter. Thus a sound pressure front leaving the pipe does not compress the air on the outside as much, and the end of the pipe is in contact with an area of lower pressure. Extra particles will therefore be drawn from the direction of the pipe, producing a rarefaction impulse

Fig. 3-2. Electrical, Mechanical, and Acoustical impedance units.

ELECTRICAL (VOLTAGE) IMPEDANCE (CURRENT)	MECHANICAL (FORCE) IMPEDANCE (VELOCITY)	ACOUSTICAL (PRESSURE) IMPEDANCE (VOLUME VELOCITY)
ELECTRICAL RESISTANCE 	MECHANICAL RESISTANCE 	ACOUSTIC RESISTANCE 
ELECTRICAL CAPACITANCE 	MECHANICAL COMPLIANCE 	ACOUSTIC COMPLIANCE 
ELECTRICAL INDUCTANCE 	MASS 	ACOUSTIC MASS or INERTANCE 

travelling back towards the source. Since a pressure impulse has been reflected as a rarefaction impulse, we say that the reflection has suffered a 180-deg phase reversal.

The same reversal occurs when a rarefaction front reaches the "impedance discontinuity" at the end of the pipe; the air inside is in contact with a less rarefied area on the outside, and extra particles are drawn into the pipe, starting a reflected pressure impulse.

Refraction

A sound wave will be refracted when it encounters, at an oblique angle, a medium in which its velocity is changed. That part of the wave which meets the new conditions first is slowed up or accelerated while other parts of the wave front are continuing at their old velocity. Hence the wave front, or contour connecting the most advanced points of the wave, is swung around to a new direction. (See Fig. 3-3). The behavior is the same as that exhibited by light waves.

An analogy often used to represent refraction is that of a line of men marching abreast who enter a ploughed field at an angle. As each man walks into the loose earth he is slowed up in turn, until the entire line has been swung around to face a new direction.

Diffraction

Diffraction is the change of direction of a sound wave which is caused by travel around an obstacle. This effect influences the performance of microphones

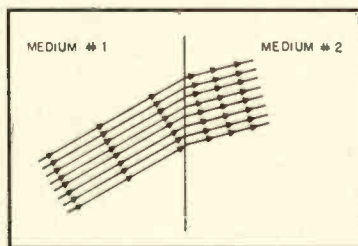

Fig. 3-3. Wave refraction: the distance between arrows represents the distance travelled in a given unit of time. The velocity of sound in medium 2 is greater than that in medium 1.

and loudspeakers, and certain types of acoustic lenses make use of the principle of diffraction.

Interference

When a point in space receives sound energy from more than one source, interference occurs. The interference is said to be constructive if the relative phase of the waves is such that the total energy at the point is increased, and is called destructive if the relative phase causes cancellation of energy and a decrease of sound level. There may be various degrees of constructive and destructive interference, depending upon how close the phase relationship is to zero or 180 deg.

Radiation Patterns

If the source of a sound wave were a pulsating sphere in free space, swelling and contracting symmetrically, energy would be radiated equally in all directions. Such a source is, of course, unusual, and different types of vibrating systems radiate sound into definite patterns. The type of source with which we are especially concerned is that physically similar to the vibrating element of most loudspeakers in use today—the cone.

A ring may be considered as the basic element making up a conical form. In turn, the ring is composed of an infinite number of point sources. A listener will receive sound energy from all of the point sources, but there will be a difference of path length from each point, and so if the wave length of the sound is comparable in size to this difference in path length, destructive interference may take place.

In Fig. 3-4 the energy received at A from all points on the ring must be in the same phase. The sound received at B, however, will not all be in the same phase, and some destructive interference will occur, lowering the total sound intensity. Thus certain conclusions may be drawn about a vibrating ring source:

1. If the ring is subjected to vibrations there will be a non-uniform radiation pattern at the higher frequencies, with greatest intensity at the center.

[Continued on page 54]

Planning and Building a Radio Studio

EUGENE F. CORIELL*
Major, USAF

Part 3. Continuing the series with a few helpful hints about public relations with the builder before discussing practical methods of laying out block diagrams, cable runs, and jack arrangements.

THE PRECEDING INSTALLMENT dealt with air-conditioning, heating and ventilating systems, and the means of minimizing resulting noise. Various construction features were discussed, such as sound-isolated walls, floors, ceilings, doors, and windows. Also, electric light and power considerations were outlined, along with means to avoid sound leakage through outlet boxes and conduits. This completes the material on the structural design and building construction aspects of studio planning. However, before going on to the audio phases of the work, there are a few things to be said about a very important intangible;

Relations with Contractor

Give some thought to the highly important matter of getting along with the people who will do the actual building. No matter how carefully you plan the acoustics, the structural details and the electrical and ventilation systems, they won't be a bit better than the care taken to build them. Studio work is one of the most expensive types of construction, and management, which includes the station chief engineer, should realize this fact and be willing to pay for it. The contract with the general contractor, and all the job specifications, should clearly spell out the quality of the work required.

That hurdle passed, the next thing to do is to put a resident inspector on the job during construction as the station representative. This poor chap generally turns out to be the chief engineer. It's up to him to see to it that the studio is built according to drawings and specifications, and to catch errors before they are safely sealed up in concrete. It's amazing how many items a wide-awake inspector can catch—it's also amazing how unpopular he can become—and so quickly, too.

His first job, therefore, should be to win the confidence and goodwill of the contractor, his subcontractors, and their cousins and aunts. This is often a big order and is always a matter of public relations. He'll be taking a big step in that direction if he can sincerely convince the construction personnel that

he's there to assist them by helping them to avoid mistakes. The station representative should also be able to put over tactfully to the various foremen and supervisors that studio work is touchy, and that the success of the installation will depend largely on how well they conform to the specifications. Most construction people are not familiar with the requirements for studio jobs. They will turn out an honest day's work, unless they know why their ordinary commercially-accepted standards won't do, those are the standards you are likely to get, no matter what the contract says. There will also be some mistakes and occasional instances of poor workmanship, as on every job. It's difficult, of course, to be diplomatic when you see slipshod work. Nevertheless, don't correct the mechanic yourself. Make your pitch to his boss. This public relations approach also works both ways. There are times when a minor departure from the blueprints will greatly simplify a contractor's problems. In such cases, give way cheerfully and promptly.

There is one practice guaranteed to lose the builder's goodwill and to increase costs and confusion: the business of changing dimensions and floor plans during construction. Make sure your designs are well thought out before the contract is let, and discourage well-meaning colleagues who descend on you as the concrete is being poured, with the

battle-cry—"Why dontcha . . ." If changes must be made, make them through the architect or the general contractor who will coordinate the various trades affected, thereby holding disruption to a minimum.

Audio Facilities

Turning now to the actual layout and interconnection of the various items of equipment, this is not particularly difficult if the job is broken down into a series of logically-ordered steps. Here is one such order: 1. Decide as to the exact facilities needed, including the choice between custom-built and manufacturers' stock consoles. An example of the latter is shown during installation in Fig. 1. Then prepare a list of specific equipment and accessories needed. 2. Draw the block diagram. 3. Lay out the jack fields and enter the assigned jack numbers on the block diagram. 4. Lay out the racks in detail. 5. Draw the complete two-wire wiring diagram of the various relay systems. 6. Draw pictorially the internal cable layout diagram for each rack. 7. Draw pictorially the layout diagram of the interconnection or cross-connection cables between racks, turntables, console, etc. 8. Prepare the conduit list, and, when necessary, the cable make-up sheets for each cable, including relay and power cables. 9. Draw the audio conduit diagram, if any. 10. Draw complete grounding diagram of the entire in-

Fig. 1. Stock console in course of installation (RCA Type 76B5). Control room "A" Armed Forces Information School, Fort Slocum, New York. Official Defense Dept. Photo.



* Radio Technical Officer, Armed Forces Information School, Fort Slocum, New York.

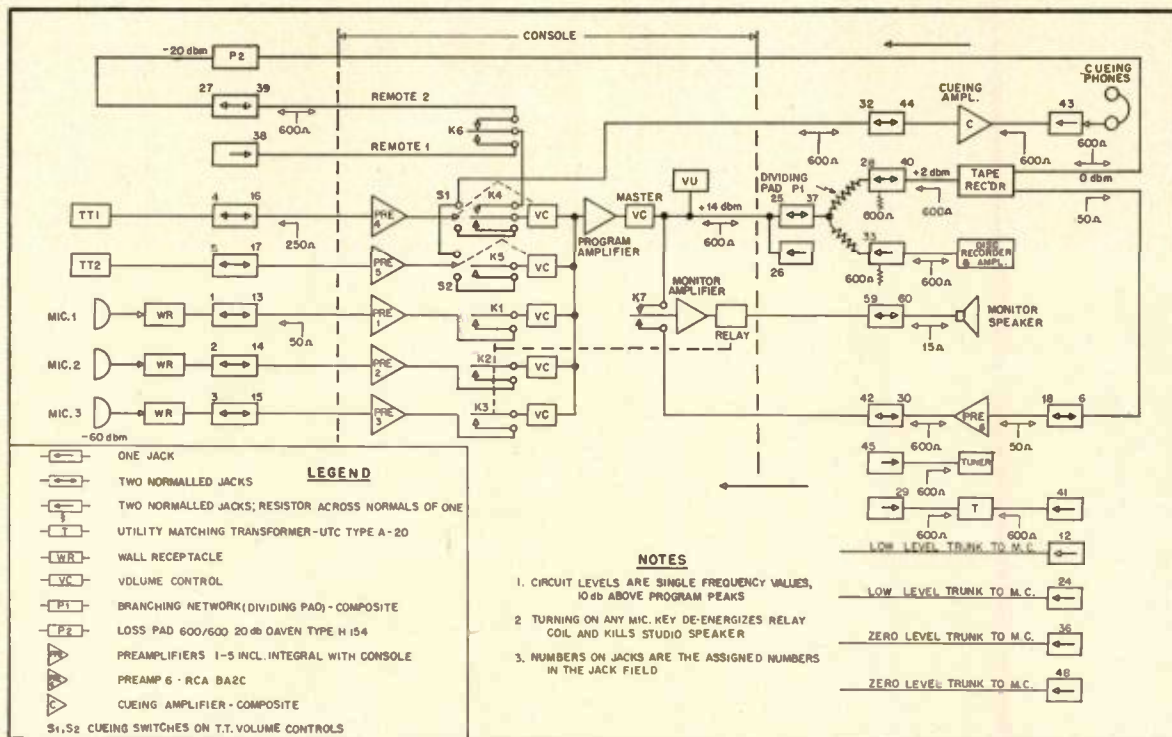

Fig. 2. Block diagram of small audition and recording studio. Note simplification of internal circuits of modified stock-type console. A disadvantage of this particular unit is that its construction does facilitate extension of all amplifier inputs and outputs to the jack field. Direction of signal travel is from left to right unless otherwise indicated by heavy arrows.

stallation. 11. Prepare complete running sheets for each rack. 12. Prepare interconnection or cross-connection sheets. 13. Prepare list of construction materials needed, such as lacing cord, cable clamps, wire, etc.

Regarding the first of these steps, the kind and quantity of specific equipment items needed, these would depend on the programming policies of the station. A reasonably complete list of studio audio equipment and accessories is shown in Appendix A. As to the choice between stock and custom-built consoles, here are some of the factors influencing the selection: Single versus dual channel; number of microphones, preamplifiers, and turntable and remote inputs, and their apportionment between studios; emergency facilities; relay arrangements; need for channel indicator lights; space available; console height limitations; special cueing features; need for sub-master control; necessity for having patching facilities integral with console; talkback to studio and remotes; remote call-in over-ride facilities; simultaneous availability of on-the-air and auditioning facilities; appearance; ease of operation and maintenance; likelihood of future use in some other studio having different requirements; spare facilities for foreseeable expansion; and time and care needed to build a custom console.

The objections to stock consoles include the complaint that they contain too many of some facilities, not enough of others, and none at all of still others. Also they sometimes present more controls to the operator than he needs for

the type of programming involved, and they take up more space than necessary. These objections are met by the custom job which is tailored to measure, but this very fact reduces the flexibility of the installation and reduces the possible value of the console for later use in some other studio. The writer designed and built one console and has come, via the hard way, to this conclusion: Unless the stock model falls seriously short of requirements, or cannot be fitted into the space available, don't build your own. Console construction to present standards of frequency response, distortion, noise and hum, and the inclusion of feedback-proof relay systems and quiet, dependable switching facilities is no light matter—particularly if you have never done it before.

However, if the choice must be a custom-built console, the following points are suggested: 1. Put nothing on the panel not needed for present or contemplated programming. 2. Put nothing in the console cabinet except line coils, pads, matching transformers and terminal blocks; amplifiers and power supplies go in racks or wall cabinets. 3. Group related elements on the panel, and space the other components such as master gain and monitor volume controls so they won't be operated accidentally. 4. Keep overall height to a minimum. 36 inches is suggested as a maximum height of the console cabinet top above the floor. 5. Slope the panel at least ten degrees, and slope the cabinet top downward to the rear as required for appearance and visibility into the studio. 6. De-

sign the controls and relay systems for expected future needs as well as present requirements. 7. Use top quality components throughout and insist on first-grade workmanship in construction . . . the console is no place to cut corners.

Block Diagram

Step two in the foregoing list of planning steps is the block diagram. This is the heart of the whole design and it cannot be laid out the first time in its final form—not even if you manage to withdraw during its preparation to a place where the phone doesn't ring and your number two man can't find you to ask about the changes in the operators' night schedule at the transmitter. In this connection, some degree of undisturbed privacy is absolutely necessary during planning, if you are to avoid such boners as running the master control trunks to the microphone terminal block. You may very well find yourself doing your designing at home in the evenings—a practice which, incidentally, may create more problems than it solves.

Make your preliminary block diagram layout on cross-section paper until the design is firmed up. Try to keep the direction of signal progress in a straight line from left to right. When this cannot be done, or when the circuit divides, use heavy arrows to indicate direction. Make the diagram large enough to show, without crowding, everything you want to include. Show all keys, volume controls, switches, patch panel jacks, and

[Continued on page 51]

Audio in the Home

William C. Shrader*

The constant search for better and cleaner bass response has progressed through a long list of cabinet types. The author reviews the most common of them and describes their performance characteristics.

WHILE IT IS FAIRLY SIMPLE to obtain satisfactory response throughout the audio spectrum from 200 to 6000 cps, reproduction of the extremes of the range is increasingly difficult. Every radio listener is well aware of the deficiencies in low notes in the smaller sets, and to overcome this lack, designers have utilized acoustic principles quite effectively.

In spaces of 4 to 10 cubic feet, the bass reflex type of cabinet is by far the most popular and, at the same time, one of the most abused in design. The port must be the proper size for the cone resonance of the speaker used with it. A port that is too large will cause boomy response, and one that is too small will give no bass reinforcement at all. Many manufacturers design this type of cabinet for use with their own speakers, but a customer will buy another make of speaker with a different cone resonance and put it into such a cabinet and then wonder why the results are worse than having no port at all.

One method for determining the size of the port is to take an audio oscillator or test record, place a 50-100 ohm 10-watt resistor in series with one of the speaker leads and an AC voltmeter directly across the speaker terminals, as in Fig. 1, and read the voltage changes as the pitch of the audio tone from the oscillator or test record varies. When the port is properly tuned, there will be two slight peaks of equal amplitude

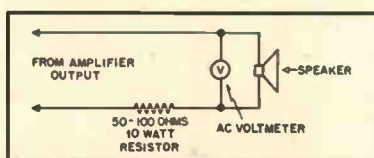

Fig. 1. Showing the method of testing the resonance of the bass-reflex port.

about an octave apart, and a properly tuned port can extend output as much as an octave. Some designs extend the port into the cabinet by means of a duct (Fig. 2). Because this method seems to have a slight advantage over ordinary bass-reflex cabinets, it has become quite popular in the last few years.

The materials of the cabinet should be rigid. Otherwise, the sides will vibrate and any unbraced plywood panels in the cabinet will give rise to a series of peaks and variations in the mid frequencies. It is, therefore, essential to embrace the cabinet to reduce chestiness and barrel-like sounds. These defects are not necessarily characteristic of the bass-reflex cabinet or its port—although an improperly tuned port can cause similar shortcomings. I have heard speakers in several cabinets, one of which was a complete brick enclosure based on the suggestions of G. A. Briggs of Wharfedale Wireless Works in Great Britain, and I must say that I was completely surprised that the material of this cabinet had so much effect upon the reproduction. The care and expense involved seemed to me altogether justified. This idea would, of course, be impractical for apartments, but people building their own homes might consider it. The shape of the cabinet must also be considered for best results. It is not advisable to make it very tall or long at the expense of width and depth since this can produce the resonances of an air column as in an organ pipe. And speakers are the reproducers of sound—not its originators.

It has been very popular to make bass reflex into corner cabinets, and they are perfectly satisfactory as long as they are braced, rigid, and sufficiently padded. They should have no vibrating walls or panels which is the case when they are made of $\frac{3}{8}$ " plywood or less. Probably because of cost, padding is inadequate in many commercially available cabinets. The generally accepted method is to pad one of each of the opposing walls (such as top, back, and one side). Ozite

or felt similar to that used under rugs, or Kimsul—a paper-packing used for house insulation—is acceptable, but the most effective, and also more difficult to use, are rockwool and Fibreglas. These latter, however, should not be used with speakers that are not dust proof.

The Labyrinth Principle

Another type of baffle that has been used a lot is the acoustic labyrinth, Fig. 3, which is merely a series of passages that extend the length of the air column between the front and the rear of the speaker cone to prevent cancellation. The length of the labyrinth is related to the wavelength of the speaker cone resonance so that the peak produced by this resonance is removed. Also, the back radiation from the speaker is absorbed by lining the labyrinth with absorbent material. Due to this absorption, most baffles of this type are generally inefficient. However, if the passage is of the right length, extended bass response without a peak is possible. There have been several variations of the labyrinth principle, the most outstanding of which has been the expansion of the ducts in an exponential taper by progressively increasing the area of the duct. In this way the efficiency of the speaker is increased at lower frequencies. The series of passages then becomes a horn.

Since the diaphragm of a speaker moves in two directions, it can be seen that a means to couple the energy produced at the rear of the cone to the air

[Continued on page 48]

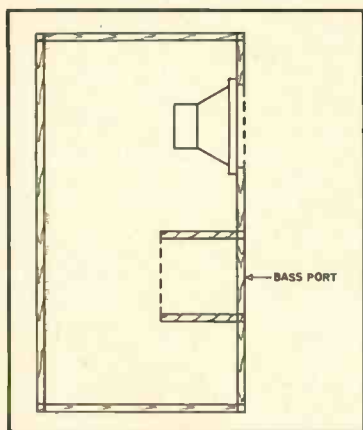

Fig. 2. Cross section of bass-reflex cabinet showing port extended into cabinet by means of a duct.

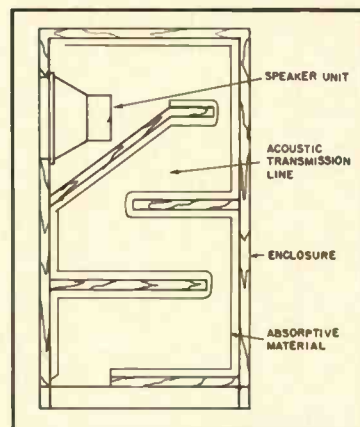
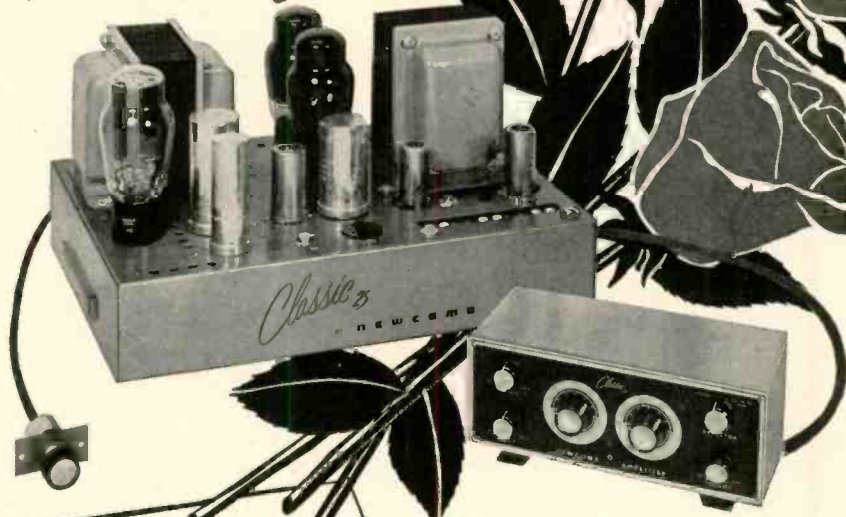

Fig. 3. Labyrinth type of transmission-line speaker.

Thanks for the bouquets



"Unquestionably
the Greatest Contribution
in years to reproduced
record enjoyment."

Everybody who has seen these completely new home music amplifiers has had a good word for them. We are proud to quote some of the things they had to say at the Chicago Show and Audio Fair.

... "the first really new amplifiers in years"
... "the best record reproduction I've ever heard"
... "they solve many of our toughest installation problems"
... "they really make installation easier"
... "here are some real improvements"
... "this Audi-balance feature really does away with tube balancing problems"
... "the Adjusta-panel makes cabinet mounting a breeze"
... "I've never seen anything in the field so beautifully designed for the home"
... "women will love them"
... "I find the A.E.S. response position very pleasing"
... "I want the Classic 25 for myself"
... "the finest coverage yet, there's something here for everyone" ...

On and on like that it went, and naturally we loved it. Those of you who missed the show will want to see this complete line at once. Illustrated above is only one of these Newcomb hi-fidelity custom home music amplifiers designed for thrillingly better listening and much easier installation.

★
Send for Catalog C-20M
8 completely new amplifiers priced
\$39.50 to \$269.50, audiophile not

15 years of quality leadership

★
Newcomb

NEWCOMB AUDIO PRODUCTS CO.
Dept. T, 6824 Lexington Ave.
Hollywood, California



New Records Promised By 1952 West Coast Electronics Show

ASCENT of the Pacific Coast into the upper firmament of the electronics manufacturing industry will receive full verification with the opening of the annual Western Electronic Show and Convention on August 27. Conducted as a joint activity by the West Coast Electronic Manufacturers' Association and the I.R.E., the event alternates yearly between Northern and Southern California. The 1952 WESCON will be a three-day affair held in the Long Beach Municipal Auditorium.

Since its inception seven years ago the event has displayed great strides in stimulation of both technical and commercial interest—today it ranks among the country's top three technical gatherings, the others being the national convention of the I.R.E. and The Audio Fair. Preliminary information indicates that the commercial exhibits this year will number more than 200. More than 100 engineering papers will be presented during 27 technical sessions, some of which are devoted to high-quality audio.

Presented at the show will be the largest display of electronic equipment ever as-

sembled in the West. So intense was the desire of manufacturers to participate that a large number who applied for space could not be accommodated.

In addition to the "business" aspect of the event, WESCON officials have arranged a diversified social program, including many functions of particular intrigue to feminine visitors. Unique among the latter is a "Get-Acquainted Tea" scheduled for the opening day, during which hostesses will greet the ladies and perform introductions. Other distaff attractions which should create more than casual interest are the Fashion Show Luncheon and the Movie Studio Tour on August 28th and 29th respectively.

The one formal social event during the 1952 WESCON will be a luncheon held in the Marine Room of the Wilton Hotel. Scheduled for noon on Friday, August 29, this will be the occasion for presentation of the Pacific Region I.R.E. award to that member of the 7th Region adjudged by a committee to have contributed most to electronics in the West during the past

year. Presentation will be made by Donald E. Sinclair, national I.R.E. president. The formal lunch will also be the scene of the keynote address to be delivered by a prominent industry leader.

Officers of the WESCON, representing WCEMA and I.R.E., are: Richard G. Leitner, *Packard-Bell Co.*, Los Angeles; Howard G. Grove, *West Coast Electronics Co.*, Los Angeles; Leon B. Ungar, *Ungar Electric Tools, Inc.*, Los Angeles; Richard A. Huggins, *Huggins Laboratories, Inc.*, Menlo Park, Calif.; W. D. Hershberger, *University of California*, Los Angeles; Joseph H. Landells, *Westinghouse Electric Corp.*, San Francisco; Noel E. Porter, *Hewlett-Packard Co.*, Palo Alto, Calif.; Leonard J. Black, Berkeley, Calif. Business manager of the show, as in previous years, is Heckert Parker.

Sponsoring organizations and members of the various committees have labored long and diligently to make the 1952 WESCON a memorable and profitable event. Their only reward will be your attendance—if you can make it, BE THERE!

ADAM ELECTRONICS, INC. 300 North Lake Ave., Pasadena 4, California <i>Manufacturer</i> Products: Wave filters, radio range filters, magnetic amplifiers, delay lines, radar components, solar components, cam, quartz elements, thermal indicators and transformers, RF and I/O coils	ADAMSON ELECTRONICS and BELLET COMPANY 2435 North Miami St., Burbank, California <i>Manufacturer</i> Products: Electrical relays	ADDOPPE CORPORATION 740 Belleville Ave., New Bedford, Massachusetts <i>Manufacturer</i> Products: Electronic capacitors and resistors, capacitor checker	ADRIAN ELECTRONIC PRODUCTS, INC. 2105 Parkton St., Harrisburg, Pennsylvania <i>Manufacturer</i> Products: Solderless terminals and connectors	ADVENT, INC. 101 East Elizabeth Ave., Linden, New Jersey <i>Manufacturer</i> Products: Microwave phantoms (ferrite and rigid), waveguide switches, quartz elements	ALPHA WIRE CORPORATION 430 Broadway, New York 10, N.Y. <i>Manufacturer</i> Products: Radio and TV parts and accessories	ALTA LAMINO CORPORATION 9356 Santa Monica Blvd., Beverly Hills, California <i>Manufacturer</i> Products: Amplifiers, remote control pre-amplifier, speech input console, AM-FM tuner, limiter amplifier, intermediate ion test equipment, Phoenix Divisor, transformer	AMERICAN ELECTRON BYTES, INC. 4811 Telegraph Road, Los Angeles 22, California <i>Manufacturer</i> Products: Miniature and sub-miniature AC 60 & 400 V. motors and blowers, relay high-frequency power supplies, precision instruments, remote control pre-amplifier, motor, induction potentiometer, tachometers	AMERICAN ELECTRONIC COMPANY Chemise Blvd. & Wilks Road, Chattanooga 5, Tennessee <i>Manufacturer</i> Products: Ceramic inductors for radio, TV, radar, electronic components, wave communications, control equipment	AMERICAN ELECTRONIC COMPANY 370 South Fair Oaks Ave., Pasadena 1, California <i>Manufacturer</i> Products: Microphones, microphone stands and accessories	AMERICAN FREEDOM SHOP 1830 So. 54th Ave., Chicago, Illinois <i>Manufacturer</i> Products: Radio parts, cable, electrical connectors, antennas, resistors, conduct fittings, Teflon cable, sockets, shops	AMRAY CORPORATION 363 East 75th St., Chicago 19, Illinois <i>Manufacturer</i> Products: Cassette television sets for TV and communications, antennas, directional and non-directional, dry air equipment, tower lighting equipment, manufacturing and engineering facilities	THE ARDOL ENGINEERING COMPANY P. O. Box 6, Marquette, Michigan <i>Manufacturer</i> Products: Permanent magnet materials, cast Alnico magnets, sintered magnets, Vitroloy, Permalloy, Canite, Canite, cast cobalt magnet steel, high-permeability materials, Delmox, supermalloy, non-permalloy and non-radiation tube-wound cores, tin-ferromagnetic powder cores, Permalloy	ARADITE PRODUCTS, INC. Chicago 17, Illinois <i>Manufacturer</i> Products: API panel meters, Sanyolux pyrometers (indicating & controlling), contact meter relays, loop action relays, amplifier drives	ARMO ELECTRON, INC. 444 Madison Ave., New York 22, N. Y. 1000 Mc. Farlin, Hollywood 46, California <i>Manufacturer</i> Products: Lacquer recording blanks, audiophiles, magnetic recording tape, audio tape, magnetic recording film, audiophile	AUDIO PRODUCTS CORPORATION 2265 Westwood Blvd., Los Angeles 64, California <i>Manufacturer</i> Products: Computer components, packaged circuitry	AUTOMATIC ELECTRON SALES CORPORATION 1033 W. Van Buren St., Chicago 7, Illinois <i>Manufacturer</i> Products: Telephone type relays and switches for industrial and aircraft use	AVERY ABBOTT LABEL SHOP 1636 So. California Ave., Alhambra, California <i>Manufacturer</i> Products: Precision-sensitive labels and labeling methods for product identification: printed circuits, trademarks, industrial line instructions, warning & inspection markers, electrical Avery electric label dispenser	BALLANTINE LABORATORIES, INC. Fanny Road, Boston, New Jersey <i>Manufacturer</i> Products: Small-size electronic voltmeters and accessories	BARTON & BOGAN 1406 So. Grand Ave., Los Angeles 13, California <i>Manufacturer</i> Products: Radio and electronic parts and accessories	BIRD ENGINEERING COMPANY 1140 Crenshaw Blvd., Los Angeles 19, California <i>Manufacturer</i> Products: "Elastic" transmitting and TV tubes; "National" HF & VHF communication receivers, radio and VHF components; "Universal" resistors, multimeters and rheostats; "Sanyolux" flood mica, paper, electrolytic and mica button capacitors; "Sanyo" quartz switches; "Mars" transformers and chokes; "Viking" quartz crystals; "Mars" relays; "Harvey-Walker" transmitters	BIRNBY AVIATION CORPORATION 401 N. Bondin Drive, South Bend 20, Indiana <i>Manufacturer</i> Products: Dynamometers, tubes, aircraft radio, telemetry equipment, electronic measuring devices	BLACKLEY IDENTIFIX CORPORATION 2200 Wright Ave., Richmond, California <i>Manufacturer</i> Products: Electronic instrumentation	BETA ELECTRONIC CORPORATION 333 East 109th St., New York 29, N. Y. <i>Manufacturer</i> Products: Electronic instruments, power supplies, etc.	BIRD ELECTRONIC SHOP 1800 E. 31st St., Cleveland 14, Ohio <i>Manufacturer</i> Products: Electronic laboratory equipment	THE WILLIAM BEARD and CO., INC. North & Valley Sts., Wilmette, Connecticut <i>Manufacturer</i> Products: Wire, cable, insulating materials	BROWN ELECTRIC MEASUREMENT SHOP 4415 S. E. Hawthorne Blvd., Portland 15, Oregon <i>Manufacturer</i> Products: Impedance bridges & accessory null amplifiers, precision decade boxes	THE BROWN DEVELOPMENT COMPANY 3405 Perkins Ave., Cleveland 14, Ohio <i>Manufacturer</i> Products: Industrial & research electronic instruments for measurements and permanent recording of electrical phenomena, mechanical strain, pressure, torque, surface analysis and acoustic phenomena	BURLINGTON INSTRUMENT COMPANY 203 North 3rd Street, Burlington, Iowa <i>Manufacturer</i> Products: AC & DC electrical indicating instruments	CAUTION ELECTRONIC MANUFACTURING COMPANY 2353 Colburn Ave., Los Angeles 64, California <i>Manufacturer</i> Products: Precision wire-wound potentiometers, special electro-mechanical devices	CHURCHMAN OPT. CO. University at Jefferson, St. Louis 7, Missouri <i>Manufacturer</i> Products: All type foils for protection of electronic circuits	CAMBRIDGE THERMOFORM CORPORATION 445 Concord Ave., Cambridge 38, Massachusetts <i>Manufacturer</i> Products: Electronic components and hardware	CANNON ELECTRON COMPANY 3209 Humboldt St., Los Angeles 31, California <i>Manufacturer</i> Products: Electrical and electronic connectors	CASTELLAS Division of Elenco-Beacon, Inc. 900 E. Korte Ave., Milwaukee 1, Wisconsin <i>Manufacturer</i> Products: Ceramic capacitors, printed electronic circuits, controls, switches, special ceramics, components	CHINMAN TRANSFORMER DIVISION Eaton Wire Corporation 3501 W. Addison St., Chicago 18, Illinois <i>Manufacturer</i> Products: Transformers and filter reactors	CIENGA COMMERCIAL COMPANY 1510 West Venice Ave., Burbank, California <i>Manufacturer</i> Products: Precision wire-wound resistors, equalizers; magnetic recording components, amplifiers; communication equipment, audio attenuators, instrument switches, resistance decoders	CLAY MULTIPLEX CORPORATION 400 Juniper St., San Gabriel, California <i>Manufacturer</i> Products: Electronic counters, read-out printing machines for electronic counters, computers and data reduction devices, analogue to digital converters	CLASH BEAM TV ANTENNAS 100 Prospect Ave., Burbank, California <i>Manufacturer</i> Products: TV antennas, accessories, mounts, open and lead wire	COLE INSTRUMENT COMPANY 1320 So. Grand St., Los Angeles 15, California <i>Manufacturer</i> Products: Electrical and electronic instruments and components	COLLINS RADIO COMPANY—Western Division 2700 West Olive St., Burbank, California <i>Manufacturer</i> Products: Electronic equipment, aircraft navigation and communication transmitters and receivers, special non-electronic devices	COMPTON RESEARCH CORPORATION 3348 W. El Segundo Blvd., Hawthorne, California <i>Manufacturer</i> Products: Ferrite-core film-tape, miniature magnetic recording heads, magnetic memory wheels; decade counters	CONSOLIDATED ENGINEERING CORPORATION 300 North Sierra Madre Villa, Pasadena 6, California <i>Manufacturer</i> Products: Computing and data handling equipment, recording oscilloscope and associated equipment	CORRELL-DUBOIS ELECTRON CORPORATION 333 Hamilton Blvd., South Plainfield, New Jersey <i>Manufacturer</i> Products: Capacitors	COORING GLASS WORKS Corning, New York <i>Manufacturer</i> Products: TV, power and radio tube bulbs, x-ray and radar tube bulbs; glass for all types of glass to metal seals; multiform glassware and specialty shapes for electronic industry requirements	JOE DAVIS and ASSOCIATES 2903 Los Flores Blvd., Lynwood, California <i>Manufacturer</i> <i>Repair center</i> Products: 400 V. AC motors, DC motors and control systems; vibrators, relay solenoids, precision instruments. Servo motors and systems, specialty transformers, sound systems, precision crystals, variable frequency generators, regulated power supplies, potentiometers, tachometers, laboratory equipment	GEORGE BAYNE SALES COMPANY 5259 E. Beverly Blvd., Los Angeles, California <i>Manufacturer</i> <i>Representative</i> Products: "Adams" relays, "Standard Call" products and tuners, "California" chassis, "Pertron" tape recorders, "Peerless" transformers, "Pioneer" switches	DELTECH LABORATORIES, INC. 1275 Riverside Drive, Los Angeles 31, California <i>Manufacturer</i> Products: Radio noise filters and component parts	DISTRIBUTION PRODUCTS INDUSTRIES Div. of Eastman Kodak Company 755 Ridge Road West, Rochester 3, New York <i>Manufacturer</i> Products: High vacuum pumps, valves and gauges	ALLER & DE NORT LABORATORIES, INC. Guthrie-Bay Tube Division 730 Blountfield Ave., Chilton, New Jersey <i>Manufacturer</i> Products: Cathode ray picture tubes	ALLER & DE NORT LABORATORIES, INC. Infrared Division 1500 Main Ave., Chilton, New Jersey <i>Manufacturer</i> Products: Cathode ray equipment, oscilloscope cameras and industrial cathode-ray tubes	JACKSON EDWARDS & CO. 6247 Hollywood Blvd., Los Angeles 28, California <i>Manufacturer</i> <i>Representative</i> Products: Electronic equipment, small physical size precious metal contacts and hermetic seals, terminals, solderless emitters, relays, fuses, instruments	ETEL-SUBCULON, INC. 790 San Mateo Ave., San Bruno, California <i>Manufacturer</i> Products: Transmitting 1000 vacuum tubes including tubes for public and Co. service VHF and UHF TV, rocket set rods, periscopes, klystrons, high vacuum products & apparatus	ELECTRO-SAF, INC. 1269 Riverside Drive, Los Angeles 31, California <i>Manufacturer</i> Products: Conventional, metallized paper and special capacitors, both temperature and moisture condensers	ELECTRO-SELECTION WORKS 6221 College Ave., Oakland 18, California <i>Manufacturer</i> Products: Electronic power, aircraft and hermetically sealed transformers, voltage normalizers & stabilizers, variable reactors	ELECTRON ASSOCIATES, INC. Long Beach, New Jersey <i>Manufacturer</i> Products: Variable photo boards; digital to analog converter for comparing 1000 card data to DC voltage; general purpose "Econ" analog computer	ELECTRON ENGINEERING ASSOCIATES 1040 Bixham Ave., San Carlos, California <i>Manufacturer</i> Products: Dynamic pressure transducers, instrumentation carrier amplifiers	ELECTRON ENGINEERING COMPANY OF CALIFORNIA 180 South Alvarado St., Los Angeles 4, California <i>Manufacturer</i> Products: Components for electronic computers and electronic digital equipment	ELECTRON INSTRUMENT CO. 84 Wilshire St., Brooklyn 11, New York <i>Manufacturer</i> Products: Vacuum tube wall meters, oscilloscopes, generators, signal tracers, multimeters, tube testers, decade boxes, test equipment kits and instruments	ELECTRO-VISOR, INC. Cock and Curlew Sts., Buchanan, Michigan <i>Manufacturer</i> Products: Microphones and accessories; photograph cartridges; headphones, loudspeaker enclosures; high-fidelity components; TV testers and TV distribution systems	EDGE ELECTRON CORPORATION 644 West 12th St., Erie, Pennsylvania <i>Manufacturer</i> Products: Erie components, electronic trimmers, button silver mica condensers, electronic sub-components
---	--	--	---	--	---	--	--	--	---	--	--	--	--	---	--	--	--	---	---	--	--	--	---	---	--	---	---	--	--	--	---	--	--	---	--	---	--	---	--	--	--	---	--	---	---	---	---	---	--	--	--	--	---	--	---	---	---	---	--

HOPKINSON RADIO CORPORATION 6200 South Azusa Blvd., Los Angeles 3, California <i>Manufacturer</i> Products: Air-line vacuum equipment; amplifiers, direction finders, instruments, radio receivers and TV radio transmitters, radio scope, counter-measures & frequency shift equipment	301	FAIRCHILD RADIO AND INSTRUMENT CORPORATION 88-06 Van Wyck Blvd., Jamaica 1, New York <i>Manufacturer</i> Products: Precision linear and non-linear potentiometers, oscilloscope recording circuits	1313	THE JAMES BRIGGS CO. 101 E. Church St., Sandechee, Illinois <i>Manufacturer</i> Products: Quartz crystals and holders, quartz oscillator plate, filters and adaptors, quartz piezoelectric, hermetic sealed holders, beams of all sizes and capacities; tourmaline and quartz crystal, custom cut and ground frequency standard	1304	MASTER MOBILE MOUNTS, INC. P. O. Box 1817, Los Angeles 36, California <i>Manufacturer</i> Products: Antennas; body and bumper mounts	107
HYCO COMPANY, INC. 11423 Vanowen St., North Hollywood, California <i>Manufacturer</i> Products: Tapped coil wave filters, precision wire-wound resistors	412	HERAY FELDMAN COMPANY 400 W. Pico Blvd., Los Angeles 13, California <i>Manufacturers' Representative</i> Products: Electronic test equipment, TV replacement parts	1812	LABORATORY FOR ELECTRONICS 43 Leon St., Boston, Massachusetts <i>Manufacturer</i> Products: Oscilloscopes; nuclear resonance microwave measure delay lines	7154	MEASUREMENTS CORPORATION Bonton, New Jersey Products: Electronic test equipment	1074
HTTORG RADIO ELECTRIC COMPANY A Division of CBS 76 Lafayette St., Salem, Massachusetts <i>Manufacturer</i> Products: Radio tubes	1394	THE FILTER SALES CORPORATION 131-05 Fowler Ave., Flushing, Long Island, New York <i>Manufacturer</i> Products: Radio noise filters	1933A	JAMES A. LASSING SOUND, INC. 2439 Fischer Drive, Los Angeles 39, California <i>Manufacturer</i> Products: Sound equipment; loudspeakers and systems	1110	MERTY TRANSFORMER COOP. 4427 Hill Clark St., Chicago 40, Illinois <i>Manufacturer</i> Products: Transformers and coils	1217
THE INDIANA STEEL PRODUCTS COMPANY Valparaiso, Indiana <i>Manufacturer</i> Products: Radio tubes	428	FUSITE CORPORATION 6028 Fernow Ave., Cincinnati 13, Ohio <i>Manufacturer</i> Products: Glass-to-metal hermetic sealing terminals, terminals for electronic instruments, switches, transformers, etc.	1818	MARTY A. LAYNE COMPANY 2216 West 11th St., Los Angeles 4, California <i>Manufacturers' Representative</i> Products: "Astro" capacitors, "Astro" microphones and cartridges, "Ball" tape recorder, "Thomas" cathode-ray tubes, "Clem" speakers, "G. E." TV accessories	810 811	MEAD & WILLEN COMPANY 1540 North Highland Ave., Hollywood 28, California <i>Manufacturer</i> Products: Industrial and research instruments; components	214 217
INDUSTRIAL DEVELOPMENT ENGINEERING ASSOCIATES, INC. 55 No. New Jersey St., Indianapolis, Indiana <i>Manufacturer</i> Products: Regency TV boosters, electronic components	396	BARBARO SALES CORPORATION 164 Duane St., New York 13, N. Y. <i>Manufacturer</i> Products: General record changers	812	LEACH RELAY CO. 5915 Avalon Blvd., Los Angeles 3, California <i>Manufacturer</i> Products: Electrical relays, open, hermetically sealed, radio and high frequency type	800	MIDWESTERN OPTICAL LABORATORY 3401 South Harvard St., Tulsa, Oklahoma <i>Manufacturer</i> Products: Oculographs, galvanometers and strain measure-ment equipment	1100
THE INSTITUTE OF RADIO ENGINEERS, INC. Advertising Department 303 West 42nd St., New York 18, N. Y. <i>Publisher</i> Products: Proceedings of the IRE (an Engineering Journal), IRE Directory, IRE Emblem Film, Standards, Membership Applications, and IRE information	105	GENERAL CERAMICS AND TREATMENT CORP. Plant Three Kearny, New Jersey <i>Manufacturer</i> Products: Radio and TV parts and accessories	326A	LEHNEY ELECTRIC CO., INC. 1105 County Road, San Carlos, California <i>Manufacturer</i> Products: Telephone Center equipment and component parts	422	NATIONAL CARBON COMPANY A Division of Union Carbide and Carbon Corporation 22 Battery St., San Francisco 6, California <i>Manufacturer</i> Products: "Essorady" radio batteries, dry cells, flashlights	1017
INTERNATIONAL RECTIFIER CORP. 1521 E. Grand Ave., El Segundo, California <i>Manufacturer</i> Products: Selenium rectifiers and photo-cells	501	GENERAL ELECTRIC COMPANY Electronics Division Electronics Park, Syracuse, New York <i>Manufacturer</i> Products: Electronic tubes, test equipment, and component parts	700	LEWIS COMPANY 1952 West 55th St., Los Angeles 17, California <i>Manufacturers' Representative</i> Products: "Alloy" relay, "Damp" miniature resistors, "Diamond" RF connectors, "General Control" switches, "T.T.E." resistors, "Insom" communication equipment, "ULAN" sockets and transformers	1000	NATIONAL ELECTRON PRODUCTS CORPORATION Chamber of Commerce Bldg., Pittsburgh 19, Pennsylvania 400 Pioreiro Ave., San Francisco 10, California <i>Manufacturer</i> Products: TV antenna mounting accessories, and wires	319
INTERNATIONAL RESISTANCE CO. 401 North Broad St., Philadelphia, Pennsylvania <i>Manufacturer</i> Products: Volume controls, resistors, TV controls and kits	403	GENERAL ELECTRIC COMPANY 275 Massachusetts Ave., Cambridge 39, Mass. 1000 North Seward St., Los Angeles 38, California <i>Manufacturer</i> Products: Electronic laboratory apparatus	1401 1404	LYON ELECTRONIC RELEASE COMPANY 228 W. Palm Ave., Burbank, California <i>Manufacturer</i> Products: Terminal lugs, terminal boards, electronic hardware	310	NEELY ENTERPRISES 7422 Monroe Ave., Hollywood 46, California <i>Manufacturers' Representative</i> Products: Electronic laboratory test equipment, sound proof meat bins	1405 1406
JERRICO RADIO MANUFACTURING COMPANY 970 McLaughlin Ave., San Jose, California <i>Manufacturer</i> Products: Vacuum capacitors, fixed and variable vacuum switches, miscellaneous vacuum items	509	GEORGESON PRODUCTS, INC. 11846 Washburn Ave., Los Angeles 25, California <i>Manufacturer</i> Products: Electronic test equipment	1210	DAW MICROFILM, INC. 3700 W. Roosevelt Road, Chicago 24, Illinois <i>Manufacturer</i> Products: Sound equipment; amplifiers, speakers, baffles, carrying cases, microphones and automatic phonographs	410	NEWCOB AUDIO PRODUCTS COMPANY 6824 Levington Ave., Van Nuys, California <i>Manufacturer</i> Products: General purpose audio, mobile, phonograph and musical instrument amplifiers, portable phonographs and portable transcription players, radios, sets and panel equipment	306
J. F. W. MFG. CO. 6103 16th Ave., Brooklyn 4, New York <i>Manufacturer</i> Products: TV, FM and mobile external antenna systems, accessories, ballast tubes, boosters, Teletypes, TV accessories; radio parts; dial belts	810	GIBARD-HOPKINS 1000 40th Ave., Oakland, California <i>Manufacturer</i> Products: Capacitors, resistors	383	WESTERN LABORATORY, INC. 300 Water St., Binghamton, New York <i>Manufacturer</i> Products: Audio equipment	1811	THE J. M. HET COMPANY 71 Elm St., Hartford, Connecticut <i>Manufacturer</i> Products: Precious metal alloys for electronic instruments	518
KEAD ENGINEERING COMPANY 2995 Middlefield Road, Palo Alto, California <i>Manufacturer</i> Products: Mobile and marine radio-phones, radio direction finders, echo dupli-sonder, communication transmitters and receivers	408	ROBERT W. HADLEY COMPANY 707 East 61st St., Los Angeles, California <i>Manufacturer</i> Products: Transformers, chokes, filters, electronic chassis and sheet metal cabinets	208	MAJMA ELECTRONICS COMPANY 9810 Anza Blvd., Inglewood, California <i>Manufacturer</i> Products: Public address amplifiers, speaker baffles, retard and transcription players, TV accessories, phonograph oscillators, radios	413	BAE MFG. CO. 1260 Cloydman Ave., Chicago 10, Illinois <i>Manufacturer</i> Products: Rotary, push-button & slide switches, vibrators, variable condensers and tuners	783
KALFREL LABORATORIES, INC. 1090 Alhambra Blvd., P. O. Box 1578, San Diego 10, Calif. <i>Manufacturer</i> Products: Electronic laboratory test equipment	388	HEWEMANN ELECTRIC COMPANY PO Box 299, Trenton, New Jersey <i>Manufacturer</i> Products: Circuit breakers, time delay relays	100	WASBERG, INC. 360 North Michigan Ave., Chicago 1, Illinois <i>Manufacturer</i> Products: Professional tape recorders	1113	WHITE MANUFACTURING COMPANY 4835 W. Flournoy St., Chicago 44, Illinois <i>Manufacturer</i> Products: Resistors and resistors	1218
KEAP METAL PRODUCTS CO., INC. 211 63rd St., Brooklyn 20, New York <i>Manufacturer</i> Products: Cabinets and enclosures for electronic devices	423	HELIPAY CORPORATION 916 Meridian Ave., So. Pasadena, California <i>Manufacturer</i> Products: Precision linear and non-linear potentiometers, helical (multi-turn) and single turn, turn counting, indicating dials	1382	P. B. WALLACE & CO., INC. 3029 E. Washington St., Indianapolis, Indiana <i>Manufacturer</i> Products: Capacitors, resistors, resistors, control switches, vibrators, power supplies	500	LEE H. SWANSON COMPANY 2331 West Washington Blvd., Los Angeles 18, California <i>Manufacturers' Representative</i> Products: Electronic parts and equipment	1114
KEARL & KITTLESON COMPANY 7614 Metro Ave., Los Angeles 46, California <i>Manufacturers' Representative</i> Products: Electronic test equipment, tape recording, measure and precision instruments, microwave plumbing components (through and rigid)	323 324	HERMETIC SEAL PRODUCTS COMPANY 29-37 South 54th St., Newark 7, New Jersey <i>Manufacturer</i> Products: Hermetic spray, glass-metal hermetically sealed terminals, bushings, headers, plugs and bases, in single or multi-leads for the electronic industry	418	MARCONI INSTRUMENTS LTD. 23-25 Beaver St., New York 4, N. Y. <i>Manufacturer</i> Products: Radio communication and industrial electronic equipment	407	M/V PALMER, INC. Electronics Division 4002 Fruit Valley Road, Vancouver, Washington U.S.A. <i>Manufacturer</i> Products: Dial telephone switchboards, telephones, telephone components, stepping switches and relays	1067
KEWITT-JACOBO CORP. 395 Page Mill Road, Palo Alto, California <i>Manufacturer</i> Products: Electronic test equipment	1205 1206	HEWLETT-PACKARD COMPANY 3000 Sand Hill Road, Menlo Park, California <i>Manufacturer</i> Products: Cathode-ray oscilloscopes & electronic laboratory instruments	415	MARION ELECTRICAL INSTRUMENT CO. Stam Street, Gales, Manchester, New Hampshire <i>Manufacturer</i> Products: Indicating meters	1389	PERM ENGINEERING CORPORATION 385 Kansas St., El Segundo, California <i>Manufacturer</i> Products: DC power supplies, laboratory test equipment	111
W. REIT EIGHT CO. 10373 W. Pico Blvd., Los Angeles 64, California <i>Manufacturers' Representative</i> Products: Radio components	1750	J. T. HILL BALLE CO. 800 W. 31st St., Los Angeles 18, California <i>Manufacturers' Representative</i> Products: Cathode-ray oscilloscopes & electronic laboratory instruments	414 415	G. J. MARSHALL COMPANY 40 South Los Robles, Pasadena 1, California <i>Manufacturers' Representative</i> Products: Radio noise filters, germanium silicon diodes, electrical ceramics, precision wire-wound resistors, terminals and terminal boards, moisture and sub-miniature wire	1301	PERMUTH SWANSON AND ASSOCIATES 1335 So. Flower St., Los Angeles 15, California <i>Manufacturers' Representative</i> Products: Radio and TV parts and accessories	327 328

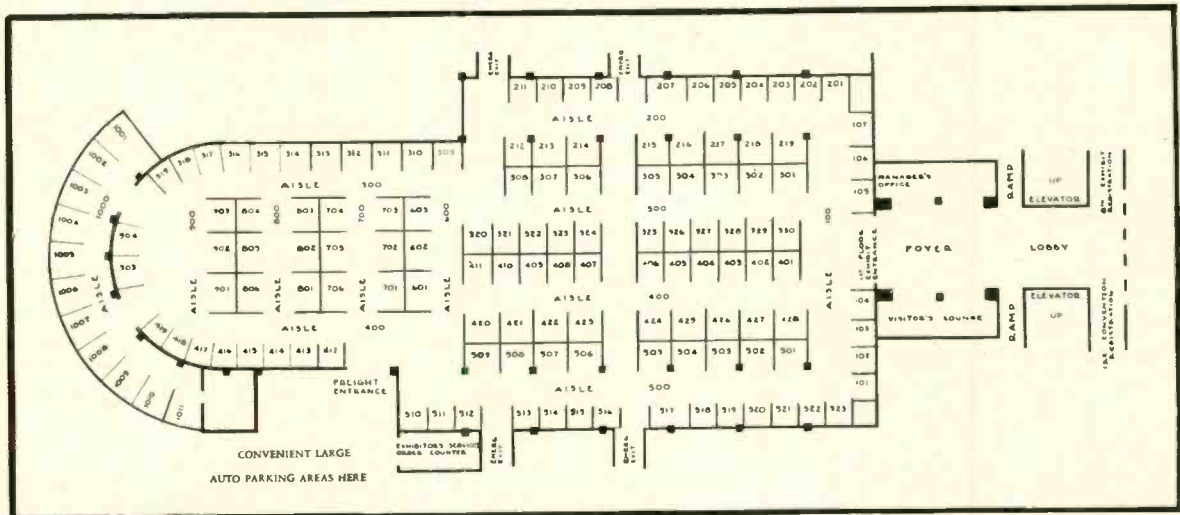

Floor plan of the Municipal Auditorium, Long Beach, California, scene of the 1952 Western Electronic Show and Convention, August 27-28-29. AE's booth is located just inside the hall at the left of the entrance from the foyer—Booth 104.

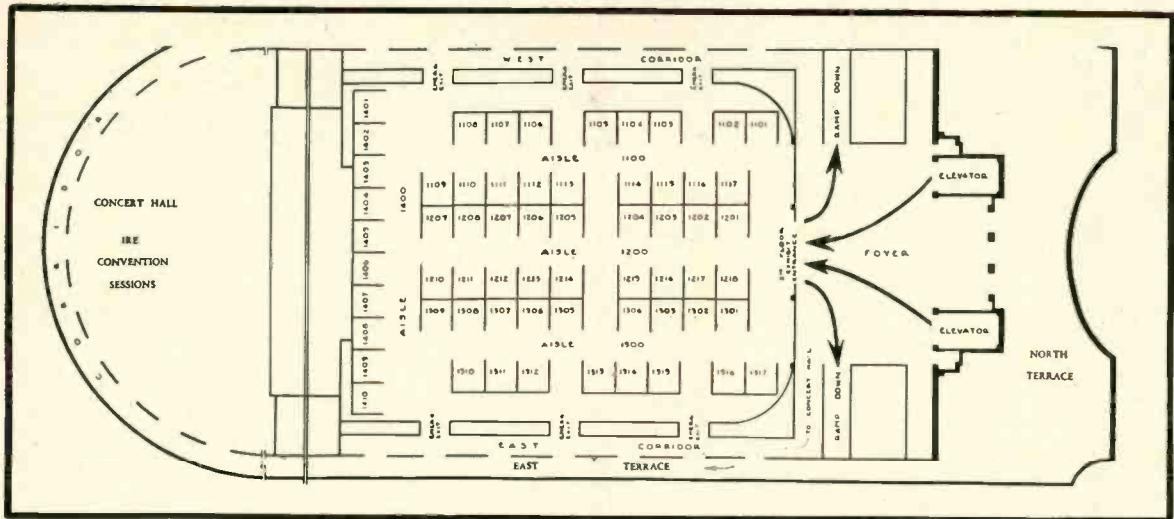

Second floor plan of the Long Beach Municipal Auditorium. Technical sessions of the IRE convention will be held on this floor.

MANUFACTURING COMPANY 151 Pasadena Ave., San Pasadena, California <i>Manufacturer</i> Products: Electronic indicating instruments (suppressed), deposited carbon & fluorescent resistors, relays, antennas, multimeters	LARGAN ELECTRIC EQUIPMENT 1116 E. Colton Ave., Springfield, Illinois <i>Manufacturer</i> Products: Mica, paper and electrolytic capacitors	SARL & STONE ASSOCIATES 3102 S. Western Ave., Los Angeles 6, California <i>Manufacturers' Representative</i> Products: Electronic laboratory test equipment and components	TUO-SO SALES CORPORATION 8575 Washington Blvd., Culver City, California <i>Manufacturer</i> Products: Electronic tubes
PEREE ELECTRONICS CORPORATION 2232 Broadway, Santa Monica, California <i>Manufacturer</i> Products: TV picture tubes, vacuum switches cover and special purpose tubes	WALTER L. SHURTZ CO. 3725 Exposition Place, Los Angeles 18, California <i>Manufacturer</i> Products: Electronic hardware, tools & service specialties, TV antennas and installation hardware	CORRAD & STRASSER CO. 1865 N. Western Ave., Los Angeles 27, California <i>Manufacturers' Representative</i> Products: Electronic transformers (tube conductors), hardware, relays, switches, test equipment and baffles, nuclear instruments	UDAGAN ELECTRONIC TOOL, INC. 615 Occidental St., Los Angeles 54, California <i>Manufacturer</i> Products: Soldering pencil and tin (USAF-MIL)
POLYTECHNIC RESEARCH AND DEVELOPMENT CORPORATION, INC. 55 Johnson St., Brooklyn 1, New York <i>Manufacturer</i> Products: Microwave, VHF & UHF & TV test equipment	SCIENTILLA MAGNETIC DIVISION Renda Aviation Corporation Shepherd Ave., Sycamore, New York <i>Manufacturer</i> Products: Magnetrons for industrial, outboard & marine engines, aircraft reaction systems, electrical connectors, quantum analyzer demonstrator, built-test and other components	THE SUPERIOR ELECTRIC COMPANY 83 Laurel St., Bristol, Connecticut <i>Manufacturer</i> Products: VOLTRON AC power adapters, STABLELINE automatic voltage regulators, SUPERIOR S-type binding posts, WAREDELL DC power supplies, POWERSTAT light dimming equipment and variable transformers	UNITED CATALON PUBLISHERS, INC. 106-110 Lafayette St., New York 13, N. Y. <i>Publisher</i> Products: Specimen samplers of books published and pricing service
POTTER & SAUNDFIELD Franklin, Indiana <i>Manufacturer</i> Products: Relays	SENSITIVE RESEARCH INSTRUMENT CORP. 9-11 Elm Ave., Mt. Vernon, New York <i>Manufacturer</i> Products: Laboratory meters	SUPPLEMENT OPTIC COMPANY Clinton, Massachusetts 2929 W. Third St., Los Angeles 36, California <i>Manufacturer</i> Products: Plastic wire, tape & tubing	H. E. SONGER BY STANDARDS Washington, D. C. and Corona, California <i>Governmental</i> Exhibiting: Recent developments in computer components, new reference standards of radio activity, Progression developments in telemetering equipment
POTTER INSTRUMENT COMPANY, INC. 115 Colver Mill Road, Great Neck, New York <i>Manufacturer</i> Products: Counters, chronographs, frequency-time counters, high-speed digital computer components	STUBBIA PRODUCTS CORPORATION 894 Douglas Ave., Redwood City, California <i>Manufacturer</i> Products: Plastic insulated wire products	SYLVANIA ELECTRIC PRODUCTS, INC. 1740 Broadway, New York 19, N. Y. 2936 East 46th St., Los Angeles 58, California <i>Manufacturer</i> Products: Radio TV and subminiature tubes, silicon and germanium diodes, microwave components, special electronic products	B. S. BAYT ELECTRONIC LABORATORY San Diego, California <i>Governmental</i> Exhibiting: Radar signal and propeller beat signal simulators, information acquisition displays, miscellaneous static discharges, recent developments
RADIART PUBLICATIONS 25 West Broadway, New York 7, New York <i>Publisher</i> Products: Radio Electronic Magazine, technical radio and TV books	SHORE RESEARCH, INCORPORATED 225 West Huron St., Chicago 10, Illinois <i>Manufacturer</i> Products: Microphones, phonograph pickup cartridges, wire and tape recording heads	TAPE MASTER, INC. 13 West Hubbard St., Chicago 10, Illinois <i>Manufacturer</i> Products: Portable recorder, transport mechanism and pre-amplifier, portable amplifier-speaker combination	U. S. ENGINEERING CO. 521 Commercial St., Garden 3, California <i>Manufacturer</i> Products: Electronic hardware, terminal test, terminal boards, shafts, belts, stand off, etc.
RADIO MAGAZINE, INC. 342 Madison Ave., New York 17, N. Y. <i>Publisher</i> Products: AUDIO ENGINEERING (Technical Publication), AUDIO ANTHOLOGY (Compilation of reprints from early issue of AUDIO ENGINEERING)	RADIOLA ELECTRONIC CORPORATION 1050 Brittan Ave., San Carlos, California <i>Manufacturer</i> Products: Radio transmitters, electronic test equipment and instrumentation	TAYLOR-STOLLE ELECTRONIC, INC. 3709 South Grand Ave., Los Angeles 37, California <i>Manufacturer</i> Products: Transformers, coils, and hi-temp bearing pot.	A. G. VAN BROSSE 1436 N. Serrano Ave., Hollywood 27, California <i>Manufacturer</i> Products: Powerline voltage regulators, signal generators, test equipment
RADIO TELEVISION NEWS and RADIO-ELECTRIC ENGINEERING 360 Madison Ave., New York 17, N. Y. 815 So. Hill St., Los Angeles 14, California <i>Publisher</i> Products: Radio & TV tube magazines	SIEMENS ELECTRIC COMPANY 3200 W. Maple St., Chicago 64, Illinois <i>Manufacturer</i> Products: Panel instruments, radio, radar & TV test equipment	SABER TUBES, INC. 529 S. Walnut Street, Bloomington, Indiana <i>Manufacturer</i> Products: Radio and TV tube accessories	VARIAN ASSOCIATES 990 Varian St., San Carlos, California <i>Manufacturer</i> Products: Microwave electron tubes, nuclear resonance apparatus
RADIOWAY INC. COMPANY 55 Chapel St., Newton, Massachusetts <i>Manufacturer</i> Products: Radio and TV parts and accessories	SOLA ELECTRIC COMPANY 4633 W. 164th St., Chicago 50, Illinois <i>Manufacturer</i> Products: Sola constant voltage transformers & related products	TECHNOLOGY INSTRUMENT LABORATORY 531 Main St., Acton, Massachusetts <i>Manufacturer</i> Products: Electronic laboratory instruments, precision potentiometers and component	VEETO ELECTRONIC COMPANY 3352 San Fernando Road, Los Angeles 65, California <i>Manufacturer</i> Products: Vacuum tubes, socket currets, plug-in units
SEA VICTOR DIVISION Radio Corporation of America Front & Cooper Sts., Camden 2, New Jersey 11814 W. Olympic Blvd., Los Angeles, California <i>Manufacturer</i> Products: Electron tubes, components & test equipment	SOLA ELECTRIC COMPANY 4633 W. 164th St., Chicago 50, Illinois <i>Manufacturer</i> Products: Sola constant voltage transformers & related products	TECHNOLOGY INSTRUMENT LABORATORY 531 Main St., Acton, Massachusetts <i>Manufacturer</i> Products: Electronic laboratory instruments, precision potentiometers and component	WALIS ENGINEERING, INC. 47-18 67th Place, Long Island City 3, N. Y. <i>Manufacturer</i> Products: Complete line Wadley track retaining rings, Wadley track grooving tool, Customer assemblies incorporating track rings illustrating function and application
SEVTECH INSTRUMENT CORPORATION 215 East 91st St., New York 28, N. Y. <i>Manufacturer</i> Products: Instrumentation, breadboard parts, precision resistors	SOLA ELECTRIC COMPANY 4633 W. 164th St., Chicago 50, Illinois <i>Manufacturer</i> Products: Sola constant voltage transformers & related products	TECHNOLOGY INSTRUMENT LABORATORY 531 Main St., Acton, Massachusetts <i>Manufacturer</i> Products: Electronic laboratory instruments, precision potentiometers and component	THE WALKLET CO. 5808 Marilyn Ave., Culver City, California <i>Manufacturer</i> Products: Pure dielectric, plug-in units, "Trombone" tube
SHULER COMPANY, LTD. 2101 Bryant St., San Francisco 10, California <i>Manufacturer</i> Products: Military electronic equipment fabricated components	SOLA ELECTRIC COMPANY 4633 W. 164th St., Chicago 50, Illinois <i>Manufacturer</i> Products: Sola constant voltage transformers & related products	TECHNOLOGY INSTRUMENT LABORATORY 531 Main St., Acton, Massachusetts <i>Manufacturer</i> Products: Electronic laboratory instruments, precision potentiometers and component	OH & WALLACE & WILLIAM M. WALLACE 1206 Maple Ave., Los Angeles 15, California <i>Manufacturers' Representative</i> Products: "E. F. Johnson," "Amperite," "Gordon" pairs, "Vibrostat," "Vite-Dr," "Trimmer," "Jawyer," "UTL" accessories, "Fenton" wire, "Duck-Egg" tools, "Control," "Feed rail" vacuum tubes, "L'Arc," "RIM" transmitting and receiving equipment, "E.M.C.," "Oregon Electronics," test equipment, "Radio Receiver," "Blaster," "Cannon," "Stator," "Ratona" 1500 "Duo-tone" components
S. B. ROBERTS & ASSOCIATES 5068 West Washington Blvd., Los Angeles 10, California <i>Manufacturers' Representative</i> Products: Electronic components hardware & instruments	SOLA ELECTRIC COMPANY 4633 W. 164th St., Chicago 50, Illinois <i>Manufacturer</i> Products: Sola constant voltage transformers & related products	TECHNOLOGY INSTRUMENT LABORATORY 531 Main St., Acton, Massachusetts <i>Manufacturer</i> Products: Electronic laboratory instruments, precision potentiometers and component	WEINER-ENGLEDORF CORPORATION 5610 W. Bloomington Ave., Chicago 39, Illinois <i>Manufacturer</i> Products: Electronic memory tape and wire recorders, photographs, disk-changers
STANDARD BOND ENGINEERING PRODUCTS, INC. 32nd and Walnut Sts., Philadelphia & Pennsylvania <i>Manufacturer</i> Products: Telemetering equipment	SOLA ELECTRIC COMPANY 4633 W. 164th St., Chicago 50, Illinois <i>Manufacturer</i> Products: Sola constant voltage transformers & related products	TECHNOLOGY INSTRUMENT LABORATORY 531 Main St., Acton, Massachusetts <i>Manufacturer</i> Products: Electronic laboratory instruments, precision potentiometers and component	WESTERN LITHOGRAPH COMPANY 600 E. Second St., Los Angeles 54, California <i>Manufacturer</i> Products: E-2 Code wire markers, Westline pressure sensitive identification
V. T. SAMP COMPANY 2230 W. 11th St., Los Angeles 6, California <i>Manufacturers' Representative</i> Products: "Ardex" choppers, inverters & vibrator, "Alloy" sound equipment, "Barker & Williamson" coils & test equipment, "Buntins" batteries, "Carwell" condensers, "Ez Mence" mica condensers, "Daper" connectors, "Goldard" diaphragm & converters, "Planet" condensers	SOLA ELECTRIC COMPANY 4633 W. 164th St., Chicago 50, Illinois <i>Manufacturer</i> Products: Sola constant voltage transformers & related products	TECHNOLOGY INSTRUMENT LABORATORY 531 Main St., Acton, Massachusetts <i>Manufacturer</i> Products: Electronic laboratory instruments, precision potentiometers and component	WETWOODS ELECTRIC CORPORATION 410 Bush St., San Francisco 6, California <i>Manufacturer</i> Products: Electronic equipment
WATERFORD ELECTRONIC INC. 3707 So. Robertson Blvd., Culver City, California <i>Manufacturer</i> Products: Electronic test equipment, particularly dealing with timing and pulse circuitry	SOLA ELECTRIC COMPANY 4633 W. 164th St., Chicago 50, Illinois <i>Manufacturer</i> Products: Sola constant voltage transformers & related products	TECHNOLOGY INSTRUMENT LABORATORY 531 Main St., Acton, Massachusetts <i>Manufacturer</i> Products: Electronic laboratory instruments, precision potentiometers and component	WOLFE INCORPORATED 2787 Park Metairie Ct., Inc. 2-78 Bana St., Orchard Park, New York <i>Manufacturer</i> Products: Mechanics hand tools, screwdrivers, nutdrivers, pliers, wrenches

AT HARVEY You can Hear Them All and Choose the Finest

McINTOSH

Model C104

PHONO PREAMPLIFIER and EQUALIZER



An extremely flexible unit designed for the most discriminating and acute listener. Provided with five inputs and selector switch, it accommodates crystal pickup, FM-AM tuner, low level microphone, as well as high level and low level magnetic pickups. A 3-position switch selects the correct compensation to match the three recording characteristics most often used. In addition, the C104 features treble and bass boost and attenuation, each with separate controls. Connectors are furnished for obtaining power from the main amplifier. A master power switch and volume control completes the attractive brown hammetone panel. Supplied complete with tubes and connectors.

In Mahogany-finish Cabinet \$57.50
Less Cabinet 49.50

HARVEY SALUTES . . .

The Western Electronic Show & Convention

This is one of the few occasions we have to address our many friends on the West Coast. Naturally, we are grateful for the many opportunities given us throughout the year to serve you in connection with your Audio and general electronic requirements. We wish, of course, it were possible for you to avail yourselves of all our facilities. It would be wonderful if we could install a direct TV line to the show so that you could actually see and hear our famous AUDIOTorium. The HARVEY AUDIOTorium has become the talk-of-the-town . . . It is a congenial meeting place for Hi Fi enthusiasts . . . a place to see and hear the widest selection of Audio equipment in any number of combinations.

Some day you will visit our town, and when you do, put Harvey on your itinerary. We shall be delighted to meet you and chat about Audio.

WILLIAMSON HR-15 AMPLIFIER KIT

The famous, original Williamson HR-15 . . . still acclaimed the leader . . . in kit form, with the original Partridge output Transformer.

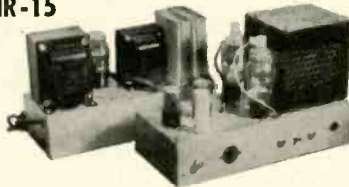

Assemble this kit, and in 3 hours or less, enjoy the finest sound you ever heard. Operates from a tuner, phono-preamp, crystal pick-up, or other signal source. Absolute gain is 70.8 db with 20 db of feedback. Frequency response: $\pm .5$ db, from 10 to 100,000 cps. Output impedances to match all speakers from 1.7 to 109 ohms. Kit is complete with 5 tubes (1-5Y4, 2-6SN7, and 2-5881 (or 807 if requested), 2-Punched Chassis, 2-Resistor Mounting Strips, Sockets, Partridge WWFB Output Transformer, Assembly Instructions, and All Other Necessary Parts for Amplifier and Power Supply. \$76.50

HR-15, as above, but with Partridge CFB Output Transformer (Hermetically Sealed) \$90.00

PARTRIDGE OUTPUT TRANSFORMERS — Available Separately. WWFB.....\$26.00 CFB.....\$40.00

HR-15T WILLIAMSON KIT—Furnished as above, with TRIAD Transformers and Chokes \$69.50

NOTE: HR-15 and HR-15T Kits may be had with British KT-66 Output tubes for \$3.00 additional.

ELECTRO-VOICE "Baronet"

FOLDED HORN CORNER ENCLOSURE FOR 8 INCH SPEAKERS



Licensed under Klipsch patents, the "Baronet" will reproduce frequencies as low as 35 cycles. Although designed originally for the EV SP8-B speaker, it will enhance the performance of any good quality 8 inch driver. High frequencies are direct-radiated. Enclosure measures 23 1/2" high x 14 1/2" wide x 10 1/2" deep at the top and 14" deep at the bottom. Solidly built and handsomely finished. Weight is 15 pounds.

Mahogany \$34.98
Blonde 37.34

Everybody is Talking About . . .

"The Saturday Review Home Book of Recorded Music"

by Edward Tatnall Canby
C. G. Burke Irving Kolodin

312 pages jammed full of information.

\$4.50 per copy



THE NEW R-J SPEAKER ENCLOSURE

The Sensational 'Hit' of the New York and Chicago Audio Fairs

Designed for use with ANY 12 or 15 inch speaker, this new sensation in high-fidelity has no counterpart in anything available today. The R-J is a new concept.

Large enough only to accommodate the speaker, it reproduces tones to the lowest limits of audibility, cleanly and without hang-over. The R-J is the amazing solution to the problem of space versus quality.

Now Available for Immediate Delivery. Specify for 12 or 15 Inch speaker.

Model FM (Mahogany) \$49.95
Model FB (Blonde) 54.50



PICKERING

Model 410
AUDIO INPUT SYSTEM

A versatile, self-contained, self-powered, and complete pre-amplifier-control unit with three input channels and selector switch for phono, TV, and FM-AM tuner. A 3-position equalizing selector permits matching to the characteristics of most recordings. Separate step type controls provide bass boost as well as treble boost and attenuation. Phono input channel will accommodate any modern magnetic cartridge. Three AC outlets on chassis permit main amplifier and other units to be controlled by master 'on-off' switch on Model 410. Cathode follower circuit allows long transmission line without high frequency loss. Supplied complete with tubes: 1-6AU6, 3-6AB4, 1-6X4

\$99.00

VISIT HARVEY'S AUDIOTORIUM — Come in and visit our new Sound Department... all these items and many more on working display at all times.

Telephone  LUzemburg 2-1500

HARVEY

RADIO COMPANY, INC.

103 West 43rd St., New York 18, N. Y.

NOTE: In view of the rapidly changing price situation in both complete units and components we wish to emphasize that all prices are subject to change without notice, and are Net, F.O.B., N.Y.C.

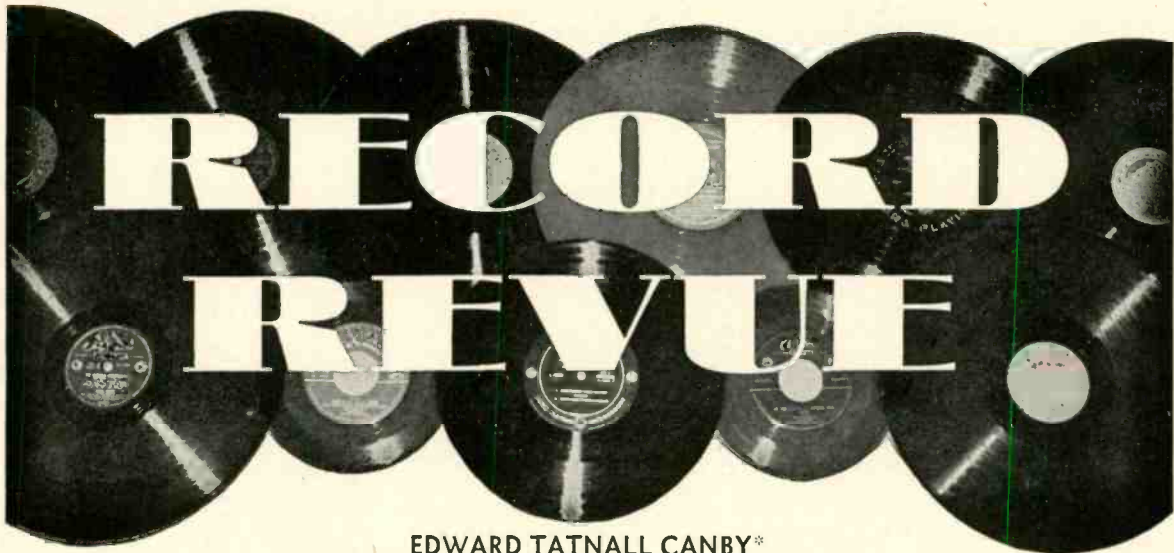

EDWARD TATNALL CANBY*

AUDIO is a quickly growing field, in spite of the poor business that has plagued it, along with plenty of others, these last months. Changes come fast; trends are important. Today's eccentricity, in some manufacturer's line or store's sales effort, is tomorrow's boom—perhaps. It is in the nature of most of us to pooh-pooh these novel efforts, until success shuts us up; very few novelties establish themselves without running a heavy fire of quite sincere doubt or scorn from all sides. The arguments always prove that the new thing is quite impractical, won't work, won't sell, not of interest, can't be built, doesn't do what it says it will, etc. etc.

The trouble is that they're usually right. Most new ideas are punk and deserve extinction. But *all* new ideas get the Treatment when they're small and unimposing. That's why we launch new things with Big Publicity if we can, with cocktail parties at the Waldorf or the Conrad Hilton, full-page ads, impressive press releases, etc. Then the thing won't look small and people will sit up and take notice.

Nevertheless, the Treatment will be applied. Big Publicity merely cuts down its impact a bit. The thing *probably* won't work, people say. It doesn't look too hot. It won't sell. And by the law of averages it won't. Quite right.

And yet—look at the changes in audio over a year or so. Some of those new ideas, new gadgets, new ways of doing things, obviously do work. They survive the Treatment. The chorus of negatives dies gently away. Nobody takes anything back. People merely jump adroitly and silently on the bandwagon. Sharp and violent tussles go on, but not out in the open. People are bruised and shocked and pushed aside before they know what's happened. All is sweetness and light on the outside—and suddenly where there was one small voice, there are a dozen smiling competitors (the winners), all acting as though there was nothing new under the sun; nothing has changed. Business strictly as usual.

That's the way new things get started. We do our best to make every new idea look like an old one.

Luckily, this column can afford to stick its long, familiar neck out and ignore this fine system in favor of a bit of risky prop-

Hi-Fi for Aunt Minnie

hecy. What are some of the items now in the small-voice category that could conceivably be tomorrow's "old stuff?"

Non-Separate Separate-Unit System

I'd say an item to look at right now is that utter paradox and contradiction, the non-separate separate-unit system. The complete, ready-made, ready-to-play phonograph or home music system, one-piece, but assembled at the manufacturing level from standard-make audio components.

It looks like an old fashioned "console" model, in modern costume. It isn't a "system" at all, to the customer. Aunt Minnie can run it and so can three-year-old sister Jane. You don't have to assemble it, there aren't any bare wires, and you won't get shocks. No worries about impedances, inputs, and outputs. Not a trace of solder, no holes to be cut, no screws to be screwed. Not even a plug to be plugged. Just one, into the 117-volt a.c. socket. Hi-fi for Aunt Minnie.

And yet, inside, it is a system. It has all, or almost, every advantage of the now familiar separate-unit hi-fi outfit (so-called). Good quality at low cost, net prices. Flexibility, adaptability. Separate units, separately replaceable; and therefore low obsolescence, maximum ease of access for repair. Above all, sound quality that beats the usual commercial home machine, as "hi-fi" equipment has been doing right along since the war.

No, I wouldn't have one of these myself. Me, I'm a hi-fi man of sorts and I want my stuff really separate. I *like* bare wires and I enjoy hooking things up. I can stand solder, if necessary. I dislike having my loudspeaker in the same place as my record player—I want my speaker away from me, across the room. I like to look at my amplifier and wouldn't put it in a fancy box for love or money. Same with the record player. The separate-unit system is the thing for me and for many a reader of this magazine, from professional to amateur. That is the present feature attraction of the audio business. Here is where the expansion has occurred, here is where the money has been made.

But it's not a new idea any more. Nor is it one that pleases everybody—only a few

hundreds of thousands, audio's present customers. Millions perhaps. There are still other people.

Look at the trend in the past, as audio has gone through its phenomenal expansion. Audio or "hi-fi" (we have still to find an official front-office name for it) began more or less with the engineer and the advanced hobbyist; it came out of P.A., thrived on the wholesale radio store, hasn't yet broken its ties with the professional world, nor with the gadgeteer. It isn't yet a retail business. It's still a parts business. (In a very strict sense, since there is an excise tax on "wholes.")

But the trend has been, as all can see, in a large circle. At first a sort of unvoiced protest to the commercial phonograph, "hi-fi" began at the opposite extreme. It has been coming back. And as it has more closely approached the commercial machine its market has expanded. Certain vital steps along the way mark that progress.

Pre-wiring, the fitting of plugs and sockets so that separate units could be "assembled" at home without so much as a soldering iron; that was a big step in widening the appeal of the system.

After pre-wiring (recommended in this column in audio's Stone Age, about 1947), came a significant step, the "package." Pre-wired, pre-chosen groups of units sold as a system, with or without fancy title. True, the package was and still is extremely flexible; you can more or less make your own substitutions to taste. But the idea was different. "They"—the separate units—were beginning once more to revert to "it"—the system, the thing-as-a-whole. True again, the need was merely practical; people who didn't know how to choose had to be given a helping hand. But the importance was still that here was an expansion into wider fields, where people really *didn't want* gadgets, separate units, components; they wanted an "it." A machine.

And what next? Bring in the timid souls who buy a package, a pre-chosen system, and before you know it you'll have more customers, who want more. Not only pre-chosen, pre-wired components, but a box to put them in—and, as quick as a double-take, a box with them already inside, installed. Ready to play.

No matter that a pre-assembled machine is expensive to ship, the assembling clumsy

[Continued on page 32]

* 279 W. 4th St., New York 14, N. Y.



"... In music, listening quality is everything. My AUDAX CHROMATIC has it to a degree that I never thought possible. Using it with the new AUDAX arm, I am now able, for the first time, to test-play a soft master-disk without damaging the groove-walls. I am thrilled with its performance. . . ." So says

Dave Sarser, the violinist (Toscanini's NBC Symphony) of "Musician's Amplifier" fame.
AUDAX Compass-Pivoted arms (3 models) are unquestionably the simplest and most efficient yet devised.

Only 3 parts: no restraint to stylus travel; frontal oscillation nil; no springs; no fatigue; maintains original point-pressure permanently, regardless of climatic changes. AUDAX pickups also available for record changers. New AUDAX literature describes the now world-famous CHROMATIC Diamond POLYPHASE—send for it. Be sure to ask for a copy of ELECTRONIC PHONO FACTS at your distributor's.

AUDAK COMPANY

500 Fifth Avenue

New York 36

Creators of Fine Electro-Acoustical apparatus for over 25 years.

The Standard by Which Others Are Judged and Valued.

kima
CBS YAKIMA
[WASHINGTON]
OPERATES

dependable
AMPEX
RECORDERS

4

The COMPLETE DEPENDABILITY of Ampex is repaying many a radio broadcasting station with real dollar savings! Such savings result from greatly reduced maintenance, elimination of mechanical breakdowns, and negligible out-of-service periods. Ask for an Ampex demonstration in your studio . . .



Completely Reliable
on TIME SAVING, MONEY SAVING
REMOTE CONTROL

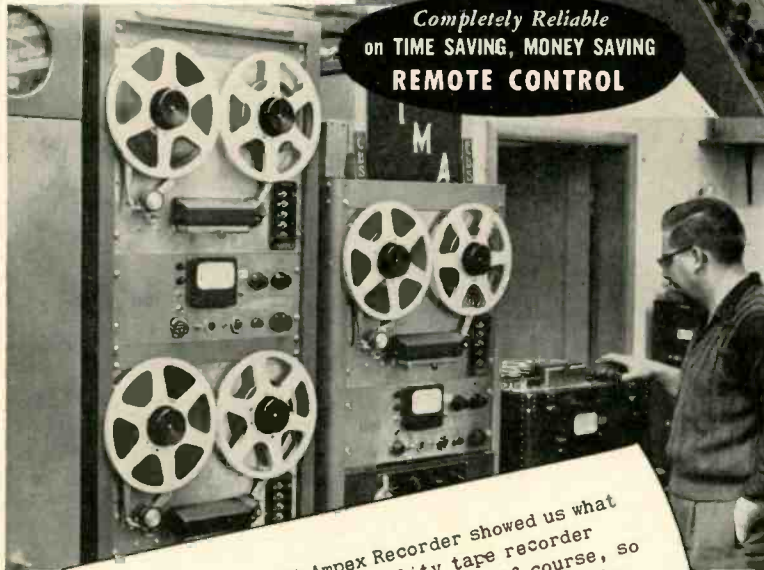

"... our first Ampex Recorder showed us what a real professional quality tape recorder could be. The reproduction is, of course, nearly perfect that no detection is possible. In addition, the remote control facilities allow an announcer-operator to completely control our four units, even to cue-ing up tapes while reading an announcement on the air. Mechanically, the Ampex is the first we have seen that is built to "broadcast" standards of quality."

J. Barry Watkinson
Chief Engineer

AMPEX

Magnetic Tape Recorders

AMPEX ELECTRIC CORPORATION

Redwood City • California

RECORD REVUE

[from page 30]

and slow and a job that no sales store wants. No matter that a one-piece machine is less flexible and less of a value than a freely adaptable system, to be disposed as one wishes, in the home living room. There is a large slice of our population that is immovably anti-gadget. For these people, we invented the automobile starter, the push-button radio tuner, the pop-up toaster (which is no gadget but a basic necessity, human nature being given to toast-burning). These people will trade better value for greater convenience, if they can't get both in one. They'll turn in the gadget that requires thinking on their part for the one that thinks for itself, if imperfectly. They'll swap the device that requires skill in the operating for the one which requires none—though results are not guaranteed.

These people are now hearing about "hi-fi." They want what it has, but they won't give what it takes—as of now. No wires, no packages, no components. Just a machine. They'll take the knobs and switches, as long as they don't have to use them too often. As long as the thing will play reasonably well no matter where they set the controls. Don't make them too effective. They'll like everything they get—if it's effortless, mentally and physically.

If you'll think for a brief second of the old-fashioned, tried-and-true home radiophonograph in all its glory, you'll see a commercially sound answer to this need that has sold machines for a quarter century. It'll sell more, too.

Hitting the Home Market

The "hi-fi" audio business is up against a real paradox, then, in that it is making ready to gobble up its old enemy—if it can—and absorb that enemy's huge following. Audio is going to hit the home phonograph market head-on. If it has its way, it will necessarily gobble up the enemy's tactics too. The larger public will have its cake and it—or else.

How? The product that will sell to this larger audience for music and yet will maintain the basic advantages of the present hi-fi movement will have to be a compromise—but it can be a clever one. The assembling will be done at manufacturer's level, from separate-unit components on special bulk order. Quite a standard business procedure. To cut more essential economic corners, the machines will have to sell on a fairly large scale, at the "net" level or less, one step above the assembler; that means, if not a parts dealer or mail order house, then a chain of department stores, a large-scale "discount" record dealer, etc. If the intervening jobber is included in, the price will go up to something a bit above net for the parts—but still a bargain for the buyer.

Of course flexibility will be lost. The components will be fixed, with only a few models, standardized. Of course quality will not be that of some of the better-known names at their best. It will be sub-normal from the hi-fi enthusiast's viewpoint. But it will far surpass the quality of equivalent commercial one-piece machines. That's what matters.

Separate-unit? Definitely. We can assume that the coming one-piece machines will in every case be made up of the kind of flexible units that are now on the market, perhaps somewhat modified for the special job but essentially in the usual audio forms. At first, anyhow. This is a step in

audio expansion, not to replace but to complement the present set-up.

What will happen after that—when the home phonograph and the hi-fi home phonograph get to be so much alike we can't tell them apart? Perhaps then the circle will be complete. But that, my friends, is a long way off.

If you'd like to take a look at the prototype (and inspiration for this article) you'll find it already on sale, at Sam Goody's, the New York record dealer, and perhaps elsewhere by the time this is out. It isn't the machine you or I might buy. It's just a phonograph, an old-fashioned "it" like any home machine. But its insides are straight out of audio, via the most familiar parentage—Webcor, GE, Grommes, Cabinet, Jensen. Sounds that way, too.

AN AUGUST CONCERT

Charles Munch conducts French Music. (Ravel: Rapsodie Espagnole; La Valse. St. Saëns: La Princesse Jaune. Berlioz: Ov. to Beatrice and Benedict. Lalo: Ov. to Le Roi d'Ys.) Boston Symphony, Munch.

RCA Victor LM 1700

This excellent French pot-pourri puts the Boston Symphony at the forefront of recording, in spite of a few flaws. The playing has a lightness and flexibility that is new for Boston, after many a year of the somewhat heavy Koussevitsky touch; transparent, imaginative, delicate performance of music that often gets stodgy, overdone war-horse treatment. Only "La Valse" suffers—it is extremely fast and the climaxes are raucous. (Perhaps because it is squeezed on a side with the complete "Rapsodie"). Technically the recording is marvelous except again for "La Valse," where percussion has a false thump, climaxes are not steady and clear. (Side 1 on my copy has cutting stylus trouble—a constant whispering in background. May have been re-cut since.)

Bruckner, Symphony #6. Linz Bruckner Symphony Orch., L. G. Jochum.

Urania URLP 7041

One more definitive recording of the confused and much-tampered-with Bruckner symphonies—this is probably the first hearing for most Americans of the original score. Long-winded, but more fluent, considerably less weighty in style than the familiar 5th symphony and others. Beautifully carried forward in a sensitive, lightly paced performance by the expert Jochum. On LP this lengthy music is easy to take—just sit back and let it play. No hard-backed concert seats, no coughs to choke back, no cigarettes to miss! The recording is well miked, lovely in the soft parts, coarse and tending to break up in the loud passages. Radio lines again?

Organ Music of Bach. (Passacaglia and Fugue in C minor; 4 Chorale Preludes.) Catharine Crozier, organ. Kendall LP 2551
Julius Reubke, Organ Sonata on the 94th Psalm. Catharine Crozier. Kendall LP 2552

An extraordinarily forceful and versatile woman organist here plays extremes in music outstandingly well. Her Bach has that deliberate sense for harmony and phrase that Schweitzer has, but the nervous intensity of Biggs; excellent playing on an eclectic organ with useful Bach-period stops. Though she's not a Bach specialist, the sense of the music is decidedly there.

Julius Reubke died in 1858, age 24—his only work of importance was this tremendous Romantic sonata, which hurls great masses of organ sound, climax after climax, in a style that for the 1950's was remarkably futuristic—César Franck's late work is anticipated, not to mention Strauss. Reubke was a pupil of Liszt and it is Liszt's tremendous piano, reconstituted in organ terms, that we hear principally. A recording for the biggest speaker systems—this music cries for volume and for big spaces.

TINY-TRIM and TERRIFIC

THE TURNER 80

THIS is the new Turner 80 — a crystal microphone so tiny it hides in the palm of your hand, yet so strikingly designed it is the very picture of scintillating symmetry. Weighs less than 5 ounces, yet its high output and unusually fine response characteristics make it a natural for announcing and mobile public address systems, for home recording, dictating machines, amateur communications, portable recorders and dozens of other applications. Finished in beautiful satin chrome. Level: Approximately 58 db below 1 volt/dyne/sq. cm. Response: 80 — 7000 c.p.s. 7 foot attached single conductor shielded cable.

List Price.....\$15.95

ACTUAL
SIZE



The Model 80 is pictured with the C-2 desk stand—a good combination for paging, dictaphone, home recording, etc.

C-2 stand. List Price \$2.75



Model 83 — Same technical specifications as Model 80. Ideal for use wherever a hand microphone is required.

List Price\$15.95

Model 81 — smaller than Model 80. Same technical specifications, but with a PC1M Amphenol connector attached.

List Price\$13.95

Model 82-3H — Same technical specifications as Model 80. Furnished with famous Turner "Third Hand" and 20 foot attached single conductor shielded cable.

List Price\$22.75

THE TURNER COMPANY 929 17th St., N. E. Cedar Rapids, Iowa

IN CANADA:
Canadian Marconi Co., Ltd. Toronto, Ont., and Branches

EXPORT:
Ad. Auriema, Inc. 89 Broad Street, New York 4



Crystals licensed under patents of the Brush Development Company

the **AUDIO "BUGS"** know best



they're using

CHICAGO

for quality



Audio Amplifier with "Presence"
Described in Radio News, Nov. 1951. Heart of the amplifier is the CHICAGO full-frequency BO-6 output unit, with other "Sealed-in-Steel" transformers incorporated in the separate power supply chassis for top audio results.



An Unusual P.A. Amplifier
An unusually compact 20-watt P.A. amplifier of exceptional audio fidelity. CHICAGO full-frequency range transformers are used exclusively for exceptional audio quality coupled with small size and light weight.



Audio Modulator
Described in Radio News, June 1951. An efficient audio testing instrument suitable for precise lab analysis or for subjective quality tests. CHICAGO "Sealed-in-Steel" input, output and power transformers are incorporated.

Wherever audio quality is a "must"—the experts specify and use
CHICAGO "Sealed-in-Steel" Transformers



talk about full frequency—
CHICAGO Output Transformers
really deliver for you...
.2 db 30-20,000 cps

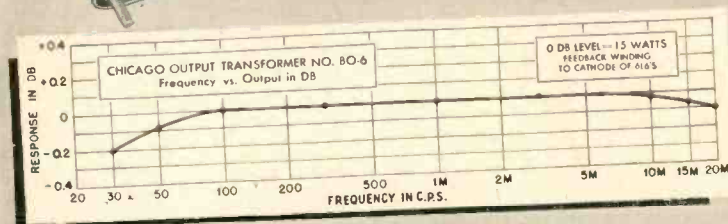

No. BO-6

For use in high fidelity amplifiers. Couples push-pull 6L6's (7500 ohms, C.T.) to 6/8 or 16/20-ohm voice coil. Center-tapped tertiary winding provides 15% inverse feed-back to reduce harmonic distortion to a minimum. In drawn steel case, 4 1/4" x 3 3/4" x 3 1/4", with mounting studs and convenient pin-type terminals.

No. BO-7

For matching 600 or 150-ohm line to a 6/8 or 16/20-ohm voice coil. Frequency response within plus or minus 1 db. of full rated output—maximum power level, 30 watts. Mounted in compound-filited drawn steel case, 4 3/4" x 3 3/4" x 3 1/4". Mounting studs and pin-type terminals same as No. BO-6 illustrated above.

There's a **CHICAGO** Transformer for Every Audio Application

CHICAGO "Sealed-in-Steel" Transformers (the world's toughest) are available in 3 complete ranges for every type of audio requirement: Full Frequency, Public Address, and Communications. Whatever the application, it's wise to choose **CHICAGO** audio transformers for that extra margin of dependability under all operating conditions.



Free "New Equipment" Catalog

Get the full details on **CHICAGO's** New Equipment Line—including "Sealed-in-Steel" transformers designed for every modern audio application. Write for your Free copy of this important catalog today, or get it from your electronic parts distributor.

CHICAGO TRANSFORMER

DIVISION OF ESSEX WIRE CORPORATION

3501 ADDISON STREET • CHICAGO 18, ILLINOIS



Villa Lobos, Mass of Saint Sebastian. Chorus of Univ. of California at Berkeley, Janssen. Columbia ML 4516

An interesting if eccentric work and a stunning job of choral recording—130 voices, as close as your hand and yet in a big, wide liveness. The music tries to be classical; its three parts are doubled in octaves throughout, filling up what otherwise would be thin writing, and its fugal limitations are clumsy and forced. The best parts of it, however, are sultry and atmospheric, strongly suggesting the well known Bachianas Brasileiras number 5 with its soprano and nine cello. Like much Villa Lobos, this is a loose, improvisatory work, substituting momentary brilliance and effect for over-all strength.

R. Strauss, Taillefer (1903); Divertimento after Couperin (1940). Radio Berlin Symphony, Rudolf Lami Choir, Rother. Cebotari, Ludwig, Hotter. Urania URLP 7042

An unexpectedly interesting work, this Taillefer, and beautifully recorded (far less trouble with loud passages than other recent Uranias). A major Strauss work, between the great tone poems and the operas—Salome came immediately after—Taillefer, written for three solos, chorus and huge orchestra, is too big for frequent performance and is seldom heard. It's about the Battle of Hastings (Strauss and the recording's annotator put in anachronistic rifles and cannons), yet it is lyrical more than pompous or noisy. Tantalizing foreshadowings of Elektra, Rosenkavalier.

In 1940, sprang in the middle of the war, the redoubtable old German took it into his head to orchestrate a group of 18th-century harpsichord works by Couperin—French to the core, and the essential Frenchness of style beautifully realized! The Divertimento transcends the usual orchestration, as one might expect from a man of Strauss' stature, a transparent, light-footedly lyric piece for small orchestra glowing with bright, delicate colors. The music is considerably expanded by Strauss whenever he felt called upon to luxuriate in Couperin's wealth of musical ideas, yet not for a moment is it out of taste. A most attractive recording.

Copland: Children's Suite from "The Red Pony". V. Thomson: Acadian Songs and Dances ("Louisiana Story"). Little Orch. Society, Thomas Scherman. Decca DL 9616
Copland: Our Town. Thomson: The Plow that Broke the Plains. Little Orch. Society, Thomas Scherman. Decca DL 7527 (10")

Four film scores in suite form by the two contemporary leaders Virgil Thomson and Aaron Copland, played by the enterprising Little Orchestra from New York that has brought novelties such as are rarely heard in concert to its subscription audiences. All of these have the saucy, brassy twang, jaunty, a bit cowboy, a bit jazzy, sentimental, romantic, but never elegant—American's answer to the need for combining "classical" and folk styles. Nice on records and these are superb recordings on ultra-noiseless surfaces. Playing shows some of the roughness of ensemble that Mr. Scherman never quite conquers but the spirit is good, the intention right.

Florida Bird Songs. Recorded in natural habitat. Lab. of Ornithology, Cornell Univ. (Comstock Press, 124 Roberts Pl. Ithaca, N. Y.)

A brief successor—10-inch 78-rpm—to the extraordinary second volume of Cornell Bird Songs, a fat volume of 12-inch 78's issued a year or so back. Top quality recording, mostly from tape now, pressed on red vinylite and noiseless. This disc, done (I hear) with a parabolic reflector, is similar to the earlier release; short excerpts, remarkably realistic, with spoken commentary interludes. Cornell still resists pressure towards issuing all of these in LP form, at greatly reduced cost. The last stronghold of the 78 record seems to be the university foundation. Harvard has just issued a set of Indian music on 10-inch breakable 78's. Eventually—why not now? LP is here to stay!

WILLIAMSON

[from page 19]

citors and a symmetrical circuit layout which is most important in this part of the circuit because this is one of the limiting points in the high-frequency end of the spectrum.

At this point, the amplifier, even without feedback, "listened" good and would appear to satisfy even the most discriminating user. In order to find out what was available, a series of characteristics were measured. The frequency response, gain, noise level, mid-range output impedance and power characteristics were measured.

With something already good to work with and an available 20 db of gain to utilize, the feedback loop was closed. Initial steady-state measurements were made and it looked as though the arithmetic were right. It being early in the morning and we being anxious to test the listening quality of this new unit, the

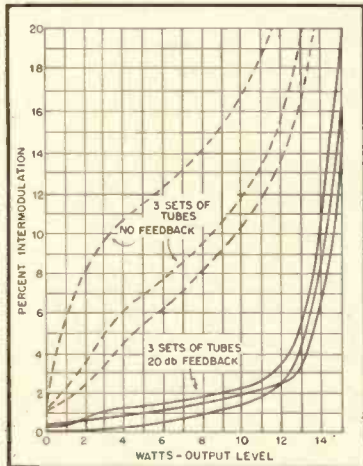

Fig. 4. Intermodulation distortion curves, with and without feedback, taken with three sets of tubes in each condition.

system was set up and a test tape of known excellence fed into the system. And was it terrible!

Additional tests were now made. The feedback loop was opened, and a square-wave generator was fed into the amplifier. The transient performance looked good under this condition of operation. The feedback loop was closed, the circuit again checked and curves and bumps appeared where and when they shouldn't. The input cathode resistor was a 1/2-watt carbon unit as was the feedback resistor—so remembering a bit about voltage coefficients of composition resistors, 2-watt carbon units were substituted for the 1/2-watt units and an immediate improvement was noted. The transient performance, however, did not completely clean up until these two resistors were replaced by non-inductive 1-watt wire-wound units. The performance of the amplifier was now remeasured and is compared—with and without feedback—in Figs. 2, 3, and 4.

HEAR THIS!

500 CYCLE X-0 POINT

28~BASS
COMPLETE
\$244⁹⁵ NET F.O.B.
Los Angeles
UNFINISHED



Altec High Fidelity Speakers!
Smooth Response to 28 Cycles!
500 Cycle Crossover Point!
Calif. Sound Toroid Crossover!
Altec 730A Hi-Freq. Driver!
Altec 803B L.F. Driver!
Calif. Sound L.F. Horn!
Needs No Corner for Full Bass!
Fits into Small Rooms Easily!
Adjustable Hi-Freq. Balance!
34" H x 30" W x 24" D

L.F. HORN \$68.50 Unfinished.
MAHOGAN Y OR BLONDE
\$45.00 Add.

F.O.B. Factory, Los Angeles.

Calif. Sound Prod. 2way Speaker

500 CYCLE TOROID X-0

- Latest Design Using Toroid Chokes
- Full 1/2 Section — 40 Watt Cont. Power
- .4 DB Insertion Loss — Compact Design
- Crossover Point Down Only 2.75 DB
- Hi-Freq. Attn. Available — .1% Distortion

\$44⁹⁵ NET

This Network is guaranteed the equal or better of any 500 Cycle network commercially available at any price. Dimensions: 5 x 4 x 2 3/8".



500 Cy. Hi-Freq. Horn

W. E. Exponential Sectoral Horn Designed to be used with Altec, E-V, Lansing, Stephens or any quality high frequency driver utilizing flange-type mounting and with response down to 500 cycles. Freq. range up to 15,000 c.p.s. Hor. Coverage 80° Vert. angle 40° 19" long 23 21/32" wide, 6 3/8" high IDEAL FOR USE WITH KLIPSCH OR SIMILAR L. F. HORNS OR CABINETS—state driver used when ordering.

\$3600 NET

new ALTEC HI-FREQ. DRIVER

This New Altec-Lansing Hi-Freq. Driver is far and away the best thing we have heard at anywhere near this price. Has a very smooth response within its frequency range out to 8000 cycles. Will satisfy the requirements of 90% of all listeners. Guaranteed to handle 40 Watts continuous power or 80 Watt peaks. Used in the above system by many critical music lovers. Specify Altec 730A.

\$2950 NET



WRITE FOR DESCRIPTIVE LITERATURE ON ABOVE

WEST COAST HIGH FIDELITY CENTER HOLLYWOOD ELECTRONICS

"ON THE AUDIO MILE"

7462 MELROSE AVENUE • HOLLYWOOD, CALIFORNIA

A.I. Nationally Advertised High Fidelity Components in Stock . . . Large Listening and Comparison Rooms . . . Liberal Terms . . . Quality Service since 1939.

With the final version of the improved and up-to-date Williamson unit connected into the complete system, it appears as though this new amplifier may become more than the "interim" amplifier that it started out to be.

At this point attention is invited to Fig. 4 which presents the IM tests on the circuits both before and after closing of the feedback loop. In each case a family of curves has been presented. These families of curves represent measurements made with eight 807's, four of which were new, two of which had over 1000 hours of operation, and two of which had over 3000 hours of operation in a voltage regulator. The best curves in each case resulted from optimum tube selection, the poorest curves were made

with the poorest combination of tubes.

Tests with various combinations of 12AY7's and 5687's indicated that the IM was negligibly influenced by these stages but rather was almost entirely determined by the characteristics of the particular type 807 tubes used in the output stage.

Past experience has indicated that all too often the proud parent of a circuit presents the brain child in Sunday-go-to-meeting clothes rather than in the day-to-day attire and environment of run-of-the-mill tubes which are generally the only ones normally available to the average experimenter or the unsuspecting public. In this instance it is believed that a representative and fair evaluation of the circuit has been made.

Construction

Care was taken in construction to avoid circulating ground currents and accordingly, an electrical connection is made to the chassis at only the one point next to the input. Twisted and capacitively shielded filament leads and as balanced and symmetrical physical and electrical layout as possible with this circuit further simplifies wiring and assembly while keeping capacitances as they should be.

PARTS LIST

C_1, C_2	.05 μ f, 600-v. paper, matched $\pm 1/4\%$
C_3, C_4	0.25 μ f, 600-v. paper, matched $\pm 1/4\%$
C_5, C_6	40-40/450-v. electrolytic
C_7	8 μ f, 600-v. oil filled
C_8	1.0 μ f, 400-v. paper
C_9, C_{10}, C_{11}	0.1 μ f, 600-v. paper
C_{12}, C_{13}	5.1 μ f, 600-v. mica
L_1	12-H, 120-ma filter choke
M_1	1-ma meter, 100-ohm resistance
R_1	0.1 meg audio taper pot
R_2	330 ohms, 1 watt, wirewound, non-inductive
R_3	47,000 ohms, 1 watt, wirewound, non-inductive
R_4, R_5	20,000 ohms, 1-watt, wirewound, non-inductive, matched $\pm 1/4\%$
R_6, R_7	0.47 meg, $1/2$ -watt, matched $\pm 1/4\%$
R_8	1200 ohms, 1-watt, composition
R_9, R_{10}	50,000 ohms, 10-watt, wirewound, matched $\pm 1/4\%$
R_{11}, R_{12}	0.1 meg, $1/2$ -watt, composition, matched 1%
R_{13}	100 ohms, 2-watt pot, wirewound, linear
$R_{14}, R_{15}, R_{16}, R_{17}$	100 ohms, 1-watt, composition
R_{18}, R_{19}	1000 ohms, $1/2$ -watt, composition
R_{20}	250 ohms, 10-watt, wirewound
R_{21}, R_{22}	1.05 ohms, wirewound shunt for meter
R_{23}, R_{24}, R_{25}	0.1 meg, 1-watt, composition
R_{26}	22,000 ohms, 1-watt, composition
R_{27}	430 ohms, 1-watt, composition
R_{28}	18,000 ohms, $1/2$ -watt, composition
R_{29}	5000 ohms, 1-watt, wirewound, non-inductive
T_1	Output transformer, 10,000 ohms plate-to-plate/4-8-16 ohm secondary Peerless S-265Q (Similar transformers of other makes are: Acro—TO-290; Triad—HSM-89 or S-48A; UTC—LS-6L1. Suitable results should be obtained, although author has not made measurements with these types.)
T_2	Power transformer—400-0-400 v. at 200 ma; 5 v. at 3 a.; 6.3 v. at 6 a.
TD_1	Amperite thermal time-delay switch
V_1	12AY7
V_2	5687 (Tung-Sol)
V_3, V_4	807
V_5	5U4G (or 5V4G)



U/L LISTED

Rauland High-Fidelity 1825 Phonograph Amplifier

TOPS FOR CUSTOM INSTALLATIONS!

EXCLUSIVE! Detachable Remote Preamplifier

Here's unlimited flexibility for custom installations! Preamplifier is detachable; has universal mounting features permitting positioning to meet mechanical requirements of any installation. Mounts horizontally, vertically, inverted, etc. Compact; only 2 3/4 x 2 3/4 x 11".

± 1 DB, 40 TO 20,000 CPS

25 Watts Output.....5% harmonic distortion
20 Watts Output.....2% harmonic distortion
15 Watts Output.....1% harmonic distortion
(Measured at 100, 400 and 5000 CPS)

- 5-Position Frequency Cut-off (Noise and Scratch Suppression 12 db per octave)
- Boost Type Tone Controls
- Dual Volume Controls
- Dual Input Selector
- Plug-In Equalizer

Percentage Intermodulation Distortion taken at 60 and 7,000 cycles with 4 to 1 ratio:
2 Watts—.54% (home level); 10 Watts—2%; 15 Watts—3.2%.

The RAULAND Model 1825 High-Fidelity Phono Amplifier puts you on top in the custom-installation market. Outstanding in its mechanical advantages—amazing in its performance—there's nothing on the market comparable for features and value. Available for immediate delivery from stock. Get the full details today!

See your RAULAND-BORG Distributor for full information on the RAULAND 1825 High-Fidelity Phono Amplifier. Compare its features and price! Get your profitable share of the big market for quality custom installations with this fast-selling amplifier. It's tops for the advanced features and value custom-builders appreciate and want.

SOUND
EQUIPMENT

INTER-
COMMUNICATION

RAULAND-BORG CORPORATION • 3523-L Addison St., Chicago 18, ILL.

NEW LITERATURE

● **Cannon Electric Company**, P. O. Box 75, Lincoln Heights Station, Los Angeles 31, Calif., will mail on request a newly revised 32-page Audio-Type Connector Bulletin which covers all engineering data on Type P, O, X, XK, XL, BRS, BG, and UA Cannon connectors. This is by far one of the finer examples of cataloging in the electronics industry. Excellent illustrations, accurate mechanical drawings, and lucid descriptive material combine to answer every conceivable question of prospective buyers. There should be more industrial catalogs like this one. In writing, address Advertising Department and ask for Bulletin PO-4-1952.

● **Ohmite Manufacturing Company**, 4876 W. Flournoy St., Chicago 44, Ill., describes the complete line of Ohmite resistors, rheostats, tap switches, and chokes in a new Stock Catalog No. 24. A 20-page two-color publication, the catalog illustrates and provides complete data, including prices, on all items manufactured by Ohmite. Copy may be obtained by writing the company.

● **Electro-Voice, Inc.**, Buchanan, Mich., is now distributing Catalog No. 113, a condensed listing of the Electro-Voice line of microphones, phono cartridges, high-quality loudspeakers, TV boosters, and distribution systems for multiple TV installations. Here at a glance is pertinent data which is entirely sufficient for comparative analysis of all Electro-Voice products. Copy will be mailed free on request.

● **Jensen Manufacturing Company**, 6601 S. Laramie St., Chicago, Ill. is releasing a new 20-page high-fidelity catalog to coincide with announcement of the new Jensen Silver Anniversary line of speakers. The booklet contains introductory material for music lovers and audio hobbyists, and includes special sections on the selection of speakers, how to evaluate a speaker demonstration, choosing enclosures, and other worthwhile data for the layman. This is one of the finest publications of its kind. Available to distributors upon request for Brochure 1020.

● **Prestole Corporation**, Toledo, Ohio, is releasing a catalog sheet giving full information on Prestole fasteners for spacer assemblies. The bulletin includes application and engineering information which will be helpful in the selection of spacers for most any requirement. Ask for Bulletin 215-A-5M.

● **Aircraft-Marine Products, Inc.**, 2100 Paxton St., Harrisburg, Pa., is publishing a book titled "A-MP Quality Control," a treatise on the solderless wire termination process. Of special interest to engineers, designers, and manufacturers in the electrical and allied fields, the book will be mailed on request.

● **Jensen Industries, Inc.**, 329 S. Wood St., Chicago 12, Ill. gives full information on every known modern needle replacement in its new Catalog No. 52. Requiring more than a year in preparation, the 16-page brochure is cross-referenced according to phonograph manufacturer, cartridge manufacturer, and competitive stylus sources. Copy may be obtained from Jensen distributors or by writing direct to the company.

● **Advance Electric and Relay Company**, 2435 N. Naomi St., Burbank, Calif. is now distributing one of the finer catalogs to make its appearance in the industrial field in many forms. Included are electrical and mechanical characteristics of the company's extensive line of relays and associated equipment. Both striking in appearance and easy to read, the new Advance catalog should be in the hands of everyone whose job calls for use of relays.

● **Harvey Radio Company**, 103 W. 43rd St., New York 36, N. Y. is issuing the season's first new high-fidelity catalog. Completely unique in styling, the new Harvey catalog contains larger pictures than have ever been used in a book of this type before, and descriptive copy is slanted to reach non-technical readers. Considerable care was taken, however, to include sufficient data for technical evaluation of all equipment shown. Requests for free copy should specify Catalog No. 54.

Electronic Components



Series E PRECISION Wire-Wound RESISTORS
Miniature and Jan R-93 types



Toroid INDUCTORS and TRANSFORMERS
Stock types available
and Custom Windings to specifications



Precision WAVE FILTERS and EQUALIZERS
Custom built to Military Specifications



Series 1600
Plug-In AUDIO FILTERS and EQUALIZERS
Economically priced for general purpose use



Series 700 DECADE-INDUCTOR Units
Indispensable for
Audio Network design and Experimental work



SOUND EFFECTS FILTER Model 4200
Features wide range of
Pass-Band combinations and Low Hum pickup

HYCOR COMPANY, INC. specializes in the manufacture of high grade components and accessories involving audio and carrier network designs. This field requires specialization since the problems encountered often require unorthodox approaches to their solution. Our Engineering Department has acquired a wealth of experience during the past years and our files contain thousands of designs.

Send for bulletins on our stock lines. Individual attention given to special requirements. Performance to meet specifications guaranteed.

HYCOR

Company, Inc.

11423 VANOWEN STREET, NORTH HOLLYWOOD, CALIFORNIA • SUNset 3-3860

NEW PRODUCTS

• **Distortionless Audio Oscillator.** Less than one-thousandth of one per cent distortion at any frequency from 20 to 20,000 cps is the principal feature of the new Model 10A audio oscillator recently introduced by Better Audio Co., 4638 10th Ave., Los Angeles 43, Calif. (See page 13.) Especially suited for waveform analysis



and distortion measurements, the oscillator affords frequency and amplitude stability of a similar high standard. Maximum output is 0.25 watt into 600 ohms, with more than 100 db of attenuation available when needed.

• **Audio Input System.** Designed for use with high-quality basic amplifiers, the new Pickering 410 equalizer-preamplifier provides complete audio control facilities. Self-powered, the 410 contains three input channels, two for high-level signals from AM, FM, or TV tuner, and one for magnetic-type pickups. The pickup input has 40 db gain at 1000 cps and 6-db-per-octave



of bass boost below the low-frequency turnover. A three-position record compensator correctly matches the characteristics of all popular types of recordings. Step-type tone controls permit extreme flexibility in adjustment of bass and treble response. Intermodulation and harmonic distortion are lower than established engineering practice calls for in professional equipment. Three a.c. outlets on the rear of the chassis are controlled by the ON-OFF switch on the front panel, thus permitting control of other system components such as tuner, record player, etc. Extremely compact, the 410 may be conveniently mounted in any cabinet. Tubes are externally mounted for easy test and replacement. Complete technical specifications will be supplied without charge by Pickering and Company, Inc., Oceanside, Long Island, N. Y.

• **All-Purpose Tool Kit.** Servicemen and experimenters alike will find the new Tele-Tool kit a saver of time, also an economy in both space and money. Compactly designed, it is a 17-unit tool kit that does the work of more than 50 individual tools. Consisting of a wide variety of screw-driver blades and deep-wall socket

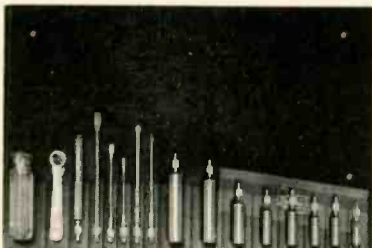

wrenches, together with interchangeable handles, the Tele-Tool kit fits easily into most tube carriers. Manufactured by Tele-Scopic Products, Inc., 111 W. 42nd St., New York 36, N. Y.

• **Program Line Equalizer.** Broadcast stations, as well as users of communications circuits in general, will welcome announcement of the new Daven Type 286 Program Line Equalizer. Designed to improve frequency response of program lines, the unit consists of a parallel network and calibrated step-type series control. The network is tuned to the frequency of equalization. The attenuator connected in series with the network controls the degree of equalization. Four points of equalization, 5, 7.5, 10, and 12.5 kc, are readily available by selection of designated terminals. In operation the Type 286 is simply connected across the program line, with the calibrated control adjusted to give the amount of equalization required. Desired data will be supplied without cost by The Daven Company, Dept. P., 191 Central Ave., Newark 4, N. J.



• **Folded-Horn Corner Speaker Enclosure.** The Super Horn is a new type baffle employing a horn load on the back side of the speaker it encloses for improved low-frequency response, at the same time permitting unimpeded direct radiation of the high frequencies. Described as a non-resonant cabinet, the enclosure employs a total fold of only 180 degrees, yet permits the advantages of horn loading in a cabinet of practical size. Dimensions of the 15-in. model, for example, are 17" deep at center, 21½" wide, and 37" high. Construction of the Super Horn includes a number of features on which patents are pending. Stressed in the manufacturer's announcement are the enclosure's ability to im-

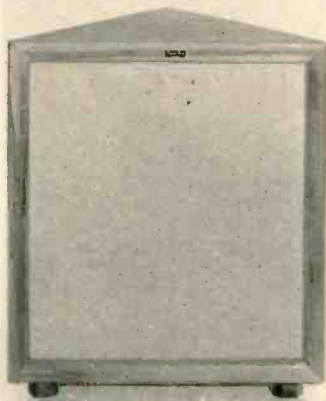

prove speaker efficiency, reduce distortion for given output, lower resonant frequency, and give remarkable damping. Technical brochure will be mailed on request. The Gately Development Laboratory, Box No. 2, Clifton Heights, Pa.

• **"Walkie" Tape Recorder.** Completely independent of a.c. lines, the new Tapak portable tape recorder operates at standard 7½ in./sec. recording speed, and incorporates facilities for turning out finished program material ready for airing. In addition to recording, it erases, monitors, plays back at headset level, and is equipped with a built-in editing fixture. A unique spring-powered tape drive eliminates clutches or belts and drives tape

and take-up reel simultaneously through a rubber idler. The Tapak records continuously for 15 minutes on a 6-in. reel of tape, runs 5 to 6 minutes per winding, and may be rewound while running. Indicators warn when winding is necessary.



Drive mechanism is shiftable to fast reverse without rethreading. Microphone, headset, spare reel, and splicing tape fit inside carrying case. Amplifier is powered with two standard flashlight cells and one 67½-volt B battery, accessible through outside door. Built-in battery tester is provided. Filament battery life is 20 hours; B battery life is 40 to 80 hours. Brochure available on request. Broadcast Equipment Specialties Corp., 135-01 Liberty Ave., Richmond Hill 19, N. Y.

• **Wide Range 8-inch Speaker.** Similar in appearance and construction to the well-known Diffusicone-12, the new University Diffusicone-3 is intended to fill the need for a low-priced extended-range speaker for general high-fidelity application, and for use as a mid-range reproducer in multiple-speaker systems. Exceptionally shallow in depth, the speaker is well suited for flush mounting in walls or ceilings. Dual-concentric horn loading of the apex extends the high-frequency response beyond 13,000 cps, also affords uniform



dispersion over a wide area. Efficiency is exceptionally high. Descriptive folder will be mailed on request. University Loudspeakers, Inc., 80 S. Kensico Ave., White Plains, N. Y.

• **Portable Power Amplifier.** Designed as a companion unit to the Model PT-125 tapeMaster tape recorder, the new SA-13 power amplifier combines in one assembly a 7½-in. accordion-type speaker, a power amplifier, and an effective baffle. Together

the PT-125 and the SA-13 comprise a complete tape-recorder-and-playback assembly. Amplifier response is within 1 db from 30 to 15,000 cps. Peak output is 8 watts. Hum level is below audibility at



normal listening level. Dimensions are 12 x 9½ x 18½ in. high. Complete data is included in Bulletin No. 102, which may be obtained by writing to tapeMaster, Inc., 13 W. Hubbard St., Chicago 10, Ill.

• **High-Fidelity Amplifier.** Needs of custom builders were given foremost consideration in design of the new Craftsmen 400 audio amplifier. Circuit features a direct-coupled split-load triode phase inverter driving push-pull 6V6 power output



tubes. Power output is 10 watts within +db from 15 to 20,000 cps. Harmonic distortion is less than one per cent and intermodulation is less than five per cent, both measured at full rated output. Noise level is -80 vu. Overall dimensions of the 400's streamlined chassis are 14 x 4½ x 5½ in. high. The Radio Craftsmen, Inc., 4401 Ravenswood Ave., Chicago 40, Ill.

• **First 8-mm Sound-On-Film Projector.** Bringing the advantages of magnetic recording to the 8-mm movie field for the first time, the new Movie Sound Eight is a complete projector-recorder weighing

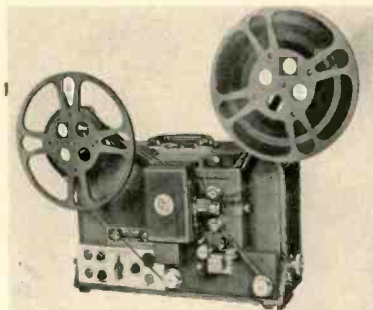

only 35 lbs. Two separate recording channels are provided, thus permitting simultaneous recording of narration and background music. Flutter is reduced to a minimum by a newly patented method of stabilizing the film as it passes the record-playback head. Movie-Mite Corporation, 1116 Truman Road, Kansas City 6, Mo.

[Continued on page 41]

Look to **LEONARD** for Hi-Fi!



Bozak Two-Way Speaker System B200X Dual Tweeters

Completely free from the usual shrill tones of other high-fidelity systems . . . the Bozak Tweeter gives you a thrilling new listening experience! The perfect complement for the B-199 Woofer, it requires only a 4 MFD series condenser for crossover. It has exceptionally smooth response, ± 3 db 2 to 20 KC, with slow roll off down 12 db at 20 KC. Can be equalized for uniform response to 20 KC.

SPECIFICATIONS: Coverage 120° at 10 KC; 100° at 13 KC; crossover 2 KC; input 6 watts; 8 ohm impedance; weight, 2¾ pounds.

\$22.72 net

B199 Woofer

Here's a 12" Woofer that gives an exciting new orchestral fullness to the lower registers! This low frequency unit has a high-edge compliance damped cone . . . large displacement for minimum low frequency distortion . . . exceptionally smooth response throughout its working range.

SPECIFICATIONS: Response 40-4500 cycles; resonance 40 cycles ± 10% input 12 watts; 8 ohm impedance; weight, 8 pounds.

Woofer & Dual Tweeters \$38.72 net
\$61.44 net



Pickering Audio Input System Model 410



Designed to enhance your listening pleasure and satisfaction, the 410 is a self-powered central control station for the home music system, with special emphasis on record reproduction. It provides an accurately equalized pre-amplifier for all magnetic pickups, with a 3-position record compensator. Separate high and low frequency tone controls have 5 positions of bass boost, 4 positions of high frequency roll-off, and one position of high frequency boost. Flat response positions are clearly marked. Three switched inputs for Phono, TV and Radio. Completely shock mounted.

SPECIFICATIONS: 3 AC outlets on back controlled by switch on front panel. Tubes: 1-6AU6, 3-6AB4, 1-6X4. Size: 3" x 13½" x 6¾". 117 volts 50-60 cycle AC. Weight: 5½ pounds.

\$99.50 net

Bogen AM-FM Tuner Model #R604

You're sure of a continuously excellent signal with this all new superheterodyne AM-FM tuner. Ten micro-volt input produces more than 20 db noise reduction on both AM and FM. Automatic frequency control and stabilized oscillator prevent drift and eliminate warm-up period. Controlled power receptacle built in for switching on remote units. Separate TV and Phono jacks.

SPECIFICATIONS: Frequency response: FM, 50-15000 cps ± 1 db; frequency range: FM, 8E-108 MC, AM 530-1650 KC; Tubes: 1-6CB6, 1-6AB4, 2-6BA6, 2-6AU6, 1-6T8, 1-6BE6, 1-6X4, 1-12AT7. Size: 10" x 11½" x 7"; weight: 14 pounds.

\$97.35 net



ACROSOUND Williamson-type output transformer, 20 watt, TO-300 \$24.75
CABINART 12" folded horn kit #61 \$19.95
WEATHERS one gram capacitance pick-up cartridge \$37.50
DUOTONE 14 power needle-checking microscope . . \$.50

Mail and phone orders filled (25% deposit)

LEONARD RADIO INC.
69 CORTLANDT ST., NEW YORK 7, N.Y.
Cortlandt 7-0315 - 9
The House Built On Service
Send for FREE 48 page Hi-Fi Catalog!

IT'S NEW!



**10-POUND PORTABLE
BATTERY-OPERATED
TAPE RECORDER**

THE MAGNEMITE*

NEW DRY BATTERIES

Inexpensive flashlight-type cells that last 100 operating hours.

NEW SPRING MOTOR

Governor-controlled constant speed motor runs 15 minutes per winding.

NEW PLAYBACK & MONITORING

Feeds directly into headphones or external amplifier and speaker.

NEW SENSITIVITY

Crystal-clear recordings up to 100 feet from the microphone.



Field recording is now as easy as studio recording, with the Magnemite* Portable series. There's a midget battery-powered spring-motor Magnemite* model for every recording need — speech, music and sound effects. Write today for descriptive literature and direct factory prices.

*Trade Mark Reg.

AMPLIFIER CORP. of AMERICA

398 Broadway New York 13, N. Y.

Naturally,

Newcomb

**PRODUCTS ARE
HANDLED BY
KIERULFF & CO.**

LOS ANGELES
820 W. Olympic Blvd. • RI 7-0271

SAN DIEGO
2426 Fourth Ave. • Woodcrest 6275

FRESNO
725 "L" Street • Fresno 24108

New Newcomb Line Features New Features

West Coast manufacturer introduces a new line which includes models for every price range and listening requirement.

AMONG THE MORE impressive equipment which will attract music lovers and audio hobbyists when they visit their preferred Sound departments this Fall are the new high-quality amplifiers introduced only recently by Newcomb Audio Products Company of Hollywood. Striking in appearance and meeting the highest standards of performance, the new line is complete in every respect, consisting of both single-chassis and remote-control models which range in power from 10 to 25 watts. Previewed in May at the Chicago Audio Fair, the amplifiers were acclaimed by visiting dealers as well as by prospective users.

Spearheading the new line is the Classic 25, a 25-watt remote-control model with frequency response from 10 to 100,000 cps and distortion reduced to less than 0.5 per cent at 20-watts, remaining under 2 per cent at full rated output. Frequency and distortion measurements apply to the entire system, including both power amplifier, pre-amplifier, and remote-control unit.

There are six input connections, all of which are made at the power amplifier, which in turn is connected to the remote-control chassis by means of a single cable which may go up to 100 feet in length without measurable effect on electrical characteristics. Individual jacks are appropriately loaded and frequency-compensated for all types of input accessories.

To insure minimum distortion at all times, Newcomb engineers have evolved a feature known as "Audi-Balance"—for which patent has been applied—that permits persons without technical knowledge and with no access to instruments, to

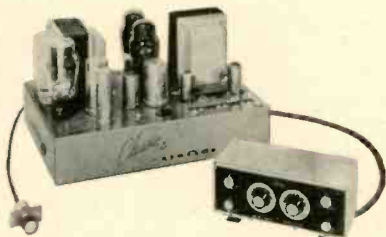

The leader of the Newcomb line—the Classic 25—with remote control and all the other new features.

achieve perfect balance of output tubes in a matter of seconds.

Another feature on which patent is pending is known as the "Adjusta-Panel." This is a unique means of extending control shafts to accommodate any panel thickness up to ¾ in., particularly useful where remote-control units are to be mounted in a cabinet rather than used externally. "Adjusta-Panel" is included with all of the amplifiers in the new Newcomb line.

The Classic 15 is similar in all respects to the Classic 25, except for lower power rating. Both amplifiers are equipped with low-distortion tone-control systems which provide a wide range of boost and droop on both treble and bass, with flat positions clearly indicated. Volume controls are fully compensated in accord with Fletcher-Mun-

son specifications in the Classic 25 and Classic 15, as well as in all of the more moderately-priced models.

Other models in the new line recently announced by Newcomb include the Series 104 12-watt amplifiers, and the Series 10 units with 10-watt rating. Both groups fall into the moderate- to low-price range and are available as either single-chassis or remote-control units.

Important to music lovers is inclusion in all models of an AES roll-off tone position, use of which results in a marked reduction of surface noise, at the same time preserving full-range response. In the Classic 25 and 15, this position is included on the control for selection of record crossover frequencies.

Even the more inexpensive models include separate bass and treble controls, multi-stage inverse feedback, a.c. receptacle for accessories controlled by amplifier power switch, and built-in compensated pre-amplifier. All are Underwriters approved.



12-Watt single-chassis Model 104, with "Adjusta-Panel" feature, details of which are apparent.

Newcomb provides a distinct service to the audio industry with the manner in which the new amplifiers are being introduced to prospective users. This is being done largely through a tastefully prepared booklet titled "Modern Classics in Sound," which is being distributed through jobbers and dealers. Incorporating in its pages the theme, "It's Easy to Install the Finest Home Music System," this booklet over and above describing Newcomb amplifiers, brings home the ease, economy, and convenience with which fine music can be the heritage of every living room.



Model AM-10R, the 10-watt remote control amplifier for the more modest budgets.

• **End-Table Radio-Phono Cabinet.** Needs of music lovers and audio hobbyists will be well-served by the new end-table equipment enclosure being manufactured by Jeff Markell Associates, 108 W. 14th St., New York 11, N. Y. Housing changer, tuner, and amplifier in a compact, attrac-



tive piece of furniture, the Markell cabinet is ideal for the preferred arrangement of a music system—the speaker and equipment in separate enclosures. External measurements are: length 30", width 18", height of upper step 27½", height of lower step 17". Available through dealers and jobbers in birch, mahogany, korina, oak, or walnut.

• **Hermetically Sealed Relays.** Designed for critical requirements, the new Advance Series 000-A1A relays are compact, light in weight, and capable of withstanding 10 G's vibration with a minimum operating power of 500 mw. They are available with coil resistances up to 5000 ohms, and with either SPDT or DPDT contacts of silver rated at 1.5 amps, or of palladium rated at 3 amps. Weighing only 1.3 ounces, these relays are ¾" x 15/16" x 1-13/32" high. Complete information may be secured by writing Advance Electric and Relay Co., 2435 N. Naomi St., Burbank, California.



• **Single-Frequency T. R. F. Strip Tuner.** Professional engineers faced with the problem of high-quality audio monitoring, or recording AM broadcasts off the air, as well as perfectionists among hobbyist groups, will discover many useful applications for this fixed-frequency r.f.

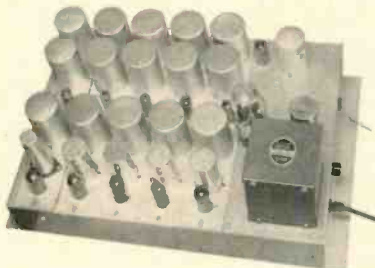

tuner. High "Q" transformers in a band-pass circuit afford band width of approximately 20 kc at standard AM broadcast frequencies. Full technical information will be supplied by the manufacturer, California Sound Products, Inc., 7264 Melrose Ave., Hollywood 48, Calif.

CINEMA

TYPE B-13

PRECISION WIRE-WOUND RESISTORS



NON-INDUCTIVE: Accuracies 1% to 1/20%. ¼ to 10 Watt power ratings. Several impregnation treatments to fit your specific requirements. 42 different styles. Sub-miniature and laboratory instrument types. Characteristics to best commercial tolerances; temperature coefficients; and wire alloys. Orders accepted for special controlled, calibrated resistors, and ratio sets. Cinema resistors are finding nation-wide acceptance from proto-type to production. For complete technical data, write for Catalogue 14-R.

TYPE 992-A

PRECISION VARIABLE ATTENUATORS



ROTARY TAP CONTROLS: Precision and general purpose types. Resistance accuracies 5% to 1/20%. Nickel silver contacts and brushes. Low, constant contact resistance with stutter-free performance. "Multi-brush" design assures positive wiping action and quiet operation. Fine decibel accuracy and accurate voltage ratios. Mixer and detented action. Special ratio and resistance steps. (Specials are our largest business.) Write for Catalogue 18-A.

TYPE CES

INSTRUMENT SWITCHES

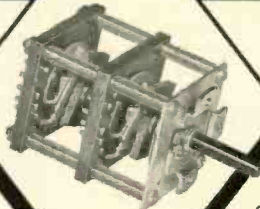

ROTARY TAP TYPE: Low contact resistance and long life are features of the CES design. Complete with integral detent action with stops or 360 degree rotation. Nickel silver contacts and brushes. Phenolic insulation. Especially designed for dc and audio instrument applications. Custom built in jig-time from basic production parts. Speedy service is the key-note of this design. Catalogue provides formula by which literally hundreds of switch circuit possibilities may be selected to fit your specific needs. Request Catalogue 17-S.



CINEMA ENGINEERING COMPANY

1510 WEST VERDUGO AVENUE, BURBANK, CALIFORNIA

Export Agents: Frazar & Hansen, Ltd. • 301 Clay St. • San Francisco, Calif., U.S.A.

New
**WILLIAMSON
TYPE**

**Heathkit
AMPLIFIER
KIT**

AMPLIFIER Features

- First Williamson Type Amplifier supplied with matching preamplifier
- Uses Altec Lansing Peerless output transformer.
- Practically distortionless — Harmonic and intermodulation distortion both less than 1/2 of 1% at 5 watts output.
- Frequency response
21 db from 10 cycles to 100 kc.
- Output impedance 4, 8, or 16 ohms.

The new Heathkit Williamson Type Amplifier kit is the best obtainable in amplifiers today — the choice of the really discerning listener. You can hear the difference and measurements actually bear out the superb performance. Frequency response 21 db from 10 cycles to 100 kc allow you to hear the highs and lows with equal crispness and clarity. Harmonic and intermodulation distortion both less than 1/2 of 1% at 5 watts output eliminate the harsh and unpleasant qualities which contribute to listening fatigue.

The circuit is similar to the one published in Audio Engineering Magazine for November, 1949, and is considered by engineers throughout the audio field as one of the best ever developed. The Main Amplifier (which may be purchased separately) consists of a voltage amplifier and phase splitter using a 6SN7, a driver stage using a 6X4, and a push-pull output stage using a pair of 807 tubes. The output transformer is manufactured by the Peerless Division of Altec Lansing and is built to their highest standards. Output impedances of 4, 8, and 16 ohms are available. The power supply uses a separate chassis with husky Chicago Transformer power transformer and choke, and 700V Mallory filters for long burn-in operation. A 5V4G rectifier is used.

The main amplifier and power supply are each on a chassis measuring 7" high by 5 1/2" wide by 11" long.

PREAMPLIFIER AND TONE CONTROL UNIT KIT

The preamplifier kit consists of: a 12AX7 (or 12AV7) dual triode first amplifier stage with a turn-over control for LP or 78 record types, and a 12AU7 amplifier stage with individual bass and treble tone controls which each provide up to 15db of boost or attenuation. A switch on panel selects either magnetic, crystal, or tuner inputs. Preamplifier also is well suited to custom installations — it will operate in either vertical or horizontal position, and special notched shafts of the controls and switches allow a variety of shaft lengths to be selected. Dimensions: 2 1/4" high by 10 1/4" wide by 7 1/4" deep.

WRITE FOR FREE CATALOG

**The
HEATH COMPANY**
BENTON HARBOR 25,
MICHIGAN

WA-PI Amplifier kit — Combination 1 — (Main Amplifier and Power Supply) complete with WA-PI Preamplifier kit. Total Ship. Wgt., 34 lbs. (Shipped Express only) \$69.50

WA-PI Amplifier kit only — Combination 4 — (Main Amplifier and Power Supply). Less WA-PI Preamplifier. Total Ship. Wgt., 29 lbs. (Shipped Express only) \$49.75

WA-PI Preamplifier Kit only. (Less power supply tubes included). Total Ship. Wgt., 7 lbs. (Shipped Express or Parcel Post) \$19.75

SAVE BY ORDERING DIRECT

By Popular Demand... A Leonard Repeat!

**A Professional Type Tape Recorder
PREMIER No. 70
TAPE-SONIC***

Price: \$298.50 net
CASE INCLUDED

CHECK THESE FEATURES:

- ✓ 3 speeds; 3 1/4", 7 1/2", 15" per second . . . 2500 ft. per min. rewind and forward
- ✓ Dual track . . . 4 hrs. on one reel; accommodates 10 1/2" NAB . . . 7" . . . 5" reels
- ✓ Three dynamically balanced motors with electro-dynamic braking
- ✓ 9 tube push-pull amplifier...12 watt undistorted output...8 inch extended range speaker
- ✓ 4 inch calibrated V. U. meter
- ✓ Controls: Separate bass & treble; special pad for controlling speaker level while recording; mixer-fader arrangement for external input
- ✓ 2 outputs: 8 ohm for external speaker; Hi impedance for external amplifier
- ✓ 2 inputs: Hi impedance mike w/mixing control; external hi impedance w/separate mixing controls
- ✓ Completely fused for added safety
- ✓ Frequency response: 3 1/4" . . . 40 to 7,000 cps; 7 1/2" . . . 40 to 12,000 cps; 15" . . . 40 to 15,000 cps

MAIL AND PHONE ORDERS FILLED . . . 25% DEPOSIT . . . BALANCE C. O. D.

*Reg.

LEONARD RADIO INC.
69 CORTLANDT ST., NEW YORK 7, N.Y.
COrtlandt 7-0315 - 9
The House Built On Service



OSCILLATOR

[from page 15]

cies. Add the harmonics from the test oscillators and the oscillator in the wave analyzer. Include the fact that the wave analyzer is a super-heterodyne with nearly equal response to the image frequency. Together these add many spurious responses to the large number of real ones. Therefore deciphering the results may be an arduous task.

Not only are SMPTE and CCIF tests both in use, but variations in frequency choice and amplitude ratio make it difficult to find two pieces of equipment measured in identical fashion, permitting valid comparison.

It appears that a serious limitation of the harmonic test method has been the lack of a wholly suitable sine-wave oscillator. When this limitation is removed, the harmonic test has desirable features not shared by intermodulation tests, including simplicity of measurement, simple sets of data, and the straightforward comparisons which can be made between any two sets of distortion figures.

In a few cases harmonic tests are difficult to make or interpret. In sound recording, irregular mechanical motion causes frequency modulation, which if severe, makes harmonic tests difficult. With very non-uniform frequency response, as in hearing aids, harmonic measurements can be misleading unless allowance is made for the variations in gain. In such cases, intermodulation tests may be expedient.

W. J. Warren and Wm. R. Hewlett compared intermodulation and harmonic tests* in both mathematical and physical investigations of very high calibre. Their results indicated that predictable ratios correlate harmonic and intermodulation levels, so that harmonic tests supply the desired information.

Better Oscillators Needed

As in other fields where standards are required, it is found desirable in distortion work to have a much better standard of waveform than would appear necessary. Actual distortion in an audio unit may have any value between the measured amount minus the oscillator distortion and the measured amount plus the oscillator distortion. Therefore accurate measurements require a good oscillator.

Data for equipment specifications should be accurate beyond question, and free from the ambiguity of included oscillator distortion.

For curves of distortion versus signal level, allowable oscillator distortion is much lower than for other uses, because distortion approaches zero as the signal approaches zero. At low levels the meas-

*W. J. Warren and Wm. R. Hewlett, "An analysis of the intermodulation method of distortion measurement." *Proc. IRE*, April 1948.

ured distortion thus becomes the oscillator distortion.

In designing low-distortion equipment, adjustments that yield minimum measured distortion in the presence of oscillator distortion, actually produce as nearly as possible the same distortion found in the oscillator, but of opposite sign.

Excellent evidence indicates that present distortion limits are too high. Harry F. Olson established the permissible levels of distortion for complete sound systems.⁵ His data shows that $\frac{3}{4}$ of 1 per cent of even the least audible harmonic, the second, can be detected in a wide-range system. Considering all of the elements in a sound system, from sound input to sound output, as many as ten elements are often involved. These may be radio-frequency or audio-frequency amplifiers, level indicators, modulators, detectors, microphones, or loud speakers, as well as other units. With $\frac{3}{4}$ of 1 per cent to be apportioned between the several units, $\frac{1}{10}$ of 1 per cent or less would be allowable in a single audio unit of high quality. Accurate measurement of such harmonic levels requires a very pure signal.

General Usefulness

In addition to being distortionless, this unit was designed to be a better general purpose instrument than any now available, thus distributing the high cost over more territory. To this end, the power output is fairly substantial, about 0.25 watt to a matching load of 600 ohms, or 25 volts on open circuit. The combination of a step attenuator and a continuous attenuator is more flexible than gain sets using several step attenuators, and provides more than 100 db of precise attenuation without frequency discrimination. A continuously variable frequency is provided, rather than step frequencies, for flexibility. The amplitude stability and freedom from frequency drift establish new standards of performance.

Special Uses

Several applications for a very pure sine wave are apparent.

The transmission of high-attenuation band-pass and high-pass audio filters can be measured by a vacuum tube voltmeter. Oscillator harmonics usually obscure the attenuation.

The voltage coefficient of resistors can be readily determined by measurement of third harmonic generation. Even precision film resistors with extremely low voltage coefficients have been compared in this manner. By placing the resistor in a bridge the fundamental voltage can be eliminated, permitting maximum wave analyzer sensitivity, as in Fig. 6.

Measurements of the properties of magnetic materials at very low flux densities are rather difficult. It seems likely that harmonic distortion measure-

ments would add useful information not readily obtainable otherwise.

Solid dielectric capacitors of some types generate harmonics. This is not surprising in the case of electrolytic and ceramic capacitors, but some paper and mica capacitors also exhibit this phenomenon. It seems reasonable to assume that all such capacitors have a voltage coefficient of capacitance.

If analog computers of highest numerical accuracy are designed, they will probably require very pure sine waves. Phase angles must sometimes be determined with great precision. The accuracy of such measurements is limited

by the waveform distortion. Wave analyzers have a distortion level an order of magnitude better than conventional oscillators. This oscillator is an order of magnitude better than the wave analyzers. It thus greatly increases the scope and accuracy of waveform analysis.

This oscillator was used in developing an audio amplifier that produces 60 watts of 20-cps signal at a distortion level of 1/100 of 1 per cent. This is obviously better than necessary for sound reproduction, but a striking example of the value of accurate measurements in reducing distortion.

Smooth Continuity of Sound

... Over the Full Range

BARKER

DUODE

SOUND UNIT

LOW COST—HIGH FIDELITY
LOUDSPEAKER

- Dual Drive, with Built-In Crossover and Feedback
- Highs and Lows in Realistic Balance
- Amazing Reproduction, Clarity and Detail



Now hear crisp, smooth bass . . . true, natural highs . . . dead-beat transients . . . without audible resonances. The DUODE NATURAL SOUND UNIT provides unbelievable clarity, even in the most complex orchestral passages—reproduces all audio at its natural best. Unique, patented high-frequency design of voice coil and diaphragm provides perfect crossover balance plus response, attack and clarity of sound that far surpasses most multiple units. Hear it to believe it at your distributor's now Or write for full details.

BARKER

DUODE

BEAM INSTRUMENTS CORPORATION
350 FIFTH AVENUE



Response, below 40 to above 15,000 C.P.S. Overall diameter, 12 1/4 in.
A dual drive consisting of a very light metal tube on which is wound a coil of fine wire over a skin of pure long life latex.
A cone impregnated with a new cellulose and molded with logarithmically graded corrugations from apex to rim.

NEW YORK 1, N. Y.

⁵ Harry F. Olson, "Elements of Acoustical Engineering," 2nd ed., pp. 488-491. D. Van Nostrand Co., Inc., 1947.



ELECTRO

presents

**Modulation
Transformers
of Revolutionary
Design
for Commercial
Transmitters,**

*featuring the
compact, exclusive*

**Electro Seal
Construction**

See them at the

**WESCON
SHOW,**

with other "Electro"
audio components
for commercial
and military
applications

ELECTRO ENGINEERING WORKS
6019 Colledge Ave., Oakland 18, Calif.



IF YOU ARE MOVING

Please notify our Circulation Department at least 5 weeks in advance. The Post Office does not forward magazines sent to wrong destinations unless you pay additional postage, and we can NOT duplicate copies sent to you once. To save yourself, us, and the Post Office a headache, won't you please cooperate? When notifying us, please give your old address and your new address.

Circulation Department

RADIO MAGAZINES, INC.
342 Madison Avenue
New York 17, N. Y.

Magnetic Tape in Southwestern Monuments

(From time time, E receives a letter which goes far beyond the usual subject matter contained in a normal month's mail. Although hardly of feature status, the following letter was of sufficient interest to us that we thought *all* our readers might enjoy it. Since this issue is devoted to California and the West Coast throughout most of its pages, we trust readers from that area will not begrudge a little space set aside for the Great Southwest. This letter is therefore published in full and without further comment. ED.)

WE ARE WITHOUT BIAS or prejudice. Personal knowledge of and acquaintance with the men doing the work in the dusty digs and among the Indians in the Southwest have served to build certain convictions that are reasonable beyond argument. Any opinion that differs from this has to be based upon ignorance or something equally sour.

The anthropologic sciences include archeology, ethnology, ethno-botany, and a fist full of other latin derivatives that include the physical structure of ancient man, his many tribal relationships, his social and political development, and just about all that can be thought to deal with the pre-history of ancient man as well as the history, mythology, legends, ceremonials, and folklore of living Indians. Excellently qualified men of these sciences have done remarkable work here in our Southwest—as well as others have done in ancient Egypt. But most of what they have found or done along the line of restoration can be found only in the dusty mounds of mimeograph files in our museum basements. If even there.

Who among us is not interested in Mound Builders, Cliff Dwellers, Folsom Man, or the man of Sandia Cave? Answer: only those who have not *heard* of them. By and large few have read of all of them. The average citizen has a latent interest in the work and findings of the men of the sciences; so much so that many have waded through the hydrocephalic ponderosity of anthropologic classification and nomenclature in order to know something about these early Americans.

With the advent of high-fidelity sound recording, a man's voice can be identified, his shaded meanings caught exactly, and his current convictions and enthusiasms captured on the spot. The little personal details of his experiences can be captured alive. The color of his interpretations need not be forgotten or erased in later effort of writing a report.

What We Have Begun

On more than just this brief list of reasons we have begun the collection of recordings from among the active men in the National Monuments, Region 3, National Park Service. The aim is to build a contribution to the future that may function in at least two ways. It may serve as a supply of material for playback over sound systems in National Monuments and Parks for visiting Dudes. It may be a source, through loan of copy tapes, to organizations or per-

sons for their use in satisfying that perpetual appetite of noonday programs for lunching Americans. These in addition to a real scientific value that cannot be computed.

Through private subscription we have now in use a series of machines; a Stancil-Hoffman Minitape for use where there is no power available; a Magnecorder battery converter for power supply for other machines in the field; an Ekotape 102; two Eicors. At Indianapolis, somewhat outside the playing field, several Magnecorders in a copy set-up permit copies to be made that are not distinguishable from the originals. On these, and mostly on the free time of the men working, we are collecting for copy at 7½ inches speed, half-hour tape reels that include everything from the story of the excavation of Tse-ta-a, through Navaho chants and Hopi Kachina songs, to reminiscences of unbelievable happenings.

One of the early demonstration recordings was a reel describing the significance and discoveries of Tse-ta-a (Navaho for "rock leaning over"). This is the extensive stratigraphic dig by Charlie Steen, archeologist supreme, in Canyon DeChelly.

After the work had advanced through many important rooms, burials, and an ancient murder, Charlie agreed to make a recording. Two weeks of daily needling led to the fateful night with an Eicor and its crystal mike. The power supply was a Diesel generator at Canyon DeChelly Monument Headquarters.

Family dispersed, house and office emptied, and all dudes bedded down, Charlie entered. Accustomed to writing scientific reports, Charlie had ordered his notes and was ready. He began.

Our First Experience

He spoke slowly and without effort or artificiality. He put periods at the end of sentences—by slamming the mike up against his shirt. All hi-fi fans know what sound effect he created, but he didn't until we played back the first five minutes, to be done over.

He worked well into his preamble when there came an increasingly audible rhythmic thumping. DeHarport, Harvard archeologist, wore heavy boots and did not want to appear to be sneaking up on anything. Charlie backtracked.

A few more minutes of good recording and the phone rang. A useful screw-driver, and Charlie began anew.

Going good once more, and Meredith's

Diane came in skipping and singing, "Daddy, Vi wants more flour. They are making a cake. Oh, watcha doing?"

Quiet again, Charlie's ruffled feathers smooth again, and inspired words began to come out from hiding as Tse-ta-a took understandable shape through Charlie's descriptive powers.

All light and power went off, and out. The Diesel was dead. It was just that Etsitty, a Navaho, had decided to grease the motor and had pulled the switch. If you know Navahos, you know that we waited until he finished, un-hurried, and very thorough.

When the Eicor ran again at long last, Charlie resumed. In Burmese, for he was in that theater; in Indo-Chinese, for he was in that theater, too; and in pungent Americanese, Charlie (the Serene) described tape recorders and those who use them. He ended, "You can leave that or erase it. Suit yourself." He felt better and continued.

In five hectic hours we made a 30-minute reel. Charlie says it would be easier to read from manuscript. Pioneering has not come easy to any generation.

To mention the work being done by Earl Morris, Harmon Maxson, Dale King, Rogers Young, Eric Reed, Meredith Guillet, Platt Cline, and many others would be to catalogue a very serious effort, and this is not the place for that.

For hi-fi-fans, we have the equipment to record, dub in, copy from or to any type of tape, wire, or disc recording. We hope to standardize on tape at 7½ inches per second—simply because that seems the most economical speed and material for best reproducing of the human spoken or chanted voice; and a 7-inch reel plays thirty minutes, which is about the right time for good listening.

This outlay has come from private source, most of the work is done in spare time, and it represents the sincerest dedication to conservation, which is the way of life of these men of science in the Park Service.

The Editor of AUDIO ENGINEERING wrote a paragraph about tape exchange. That should be the route to honest complete expression and to a new world of expanding knowledge. The printed page is relatively dead as compared to the living voice on tape: and this puts Æ right on the spot, obviously. But there is no competition—only comparison and different service.

In a better day, when men spend to conserve the good and need not be dedicated to destruction, we may have an appropriation for this catching of the moment of history rediscovered and recreated. In the meantime, magnetic tape has proven to be the instrument with which the present can be preserved without loss of single facet or inspiration.

Platt Cline,
Editor, Arizona Daily Sun,
Flagstaff, Arizona
Meredith Guillet,
Supt. Walnut Canyon
National Monument
Flagstaff, Arizona
Tom Noble, M.D.
Indianapolis, Ind.



ANOTHER PENTRON EXCLUSIVE



NEW

MULTI-SPEED
PENTRON
TAPE RECORDER

10 1/2" REEL ADAPTER attaches in 1 Minute

Visit Us At The
Long Beach Show

Designed for standard N.A.B. reels. Converts Pentron recorder and players . . . doubles normal playing time for professional needs. Reel adapter can also be used for smaller size reels without detaching from recorder or player.

X302
Reel Extension Kit
List \$30.00

THE PENTRON CORPORATION

221-Ar E. Cullerton St., Chicago 16, Ill.
In Canada: Atlas Radio Corp., Ltd., Toronto

What is Your Musical Preference?

*Classic symphonies—Chamber Music
Red-Hot Jazz Band?*
*Enjoy . . . one or all in natural,
lifelike reproduction with a*

Available in 10 or 30 watt models, featuring:

- All triodes.
- Attractive, remote-control pre-amplifier with inputs for tuner, TV and phono; or single-chassis units.
- Exclusive BROOK 8-position stepped bass & treble control circuits.
- BROOK-designed transformers and "transient peak" circuits.
- Harmonic distortion and intermodulation reduced to vanishing point.

BROOK
ALL TRIODE HIGH QUALITY
AUDIO AMPLIFIER

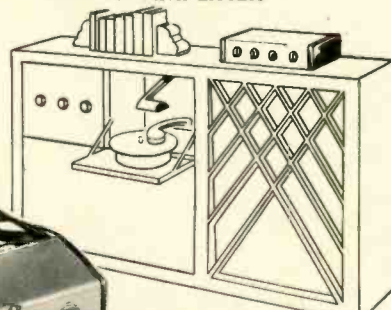

Write for technical data, free booklet, "Better Listening" and name of local dealer. Dept. AH-2.



BROOK ELECTRONICS, INC.
34 DeHART PLACE, ELIZABETH 2, N.J.

Magnetic Recorders Co.

OFFERS YOU THE MOST COMPLETE LINES OF ALL TAPE RECORDERS PRICED FROM \$84.50 TO \$1164.00

The West's Largest Recorder Distributors
Choose from such famous lines as:



Illustrated
The NEW Berlant
Network Recorder

AMPEX
AMPRO
BELL
BRUSH
CONCERTONE
CRESTWOOD
DU KANE
EICOR
EKOTAPE
MAGNASYNC
PENTRON
PRESTO
REVERE
SOUNDMIRROR
STENO
SCRIBE
WEB-COR
WILCOX-GAY

MAGNASYNC—The lightest weight, lowest priced synchronous 16-mm tape recorder—yet offering fidelity comparable to the highest priced units.

Also—the West's most complete service facilities by trained recorder specialists. Call for free home demonstration.

Magnetic Recorders Company
7170 MELROSE AVENUE
LOS ANGELES 46, CALIF.
Telephone WEhster 3-5545

Naturally,

STEPHENS

TRU-SONIC

MANUFACTURING CORPORATION

PRODUCTS ARE
HANDLED BY
KIERULFF & CO.

LOS ANGELES
820 W. Olympic Blvd. • RI 7-0271

SAN DIEGO
2426 Fourth Ave. • Woodcrest 6275

FRESNO
725 "L" Street • Fresno 24108

Commercial O-T-L Amplifier of Unique Design

FRANK H. GILBERT*

First practical design of an O-T-L amplifier designed to feed 500-ohm speakers is presented by Stephens—a speaker manufacturer.

CONSIDERABLE CREDIT must be given to Robert L. Stephens, president of Stephens Manufacturing Corporation, for the design work involved in producing a line of loudspeakers with voice-coil impedances of 500 ohms so as to use output-transformer-less amplifiers to drive them. The high impedance voice coils are wound with extremely fine wire in a multilayer construction which has been sufficiently field tested so that these speakers carry the same one-year warranty as others of conventional voice-coil impedances. Then, too, a line of dividing networks had to be developed for use with these speakers in two- and three-way systems.

Not content with the development of high-impedance speakers, considerably more work was done to produce an amplifier for use with these speakers—one which achieves the desired ideal, without an output transformer.

The Stephens 500D amplifier, shown in Fig. 1, makes use of four 2A3's in a series-parallel output tube arrangement to provide a low driving impedance in a system free of the reactance effects found in conventional amplifiers. Figure 2 shows the final three stages in simplified form. It will be noted that the drive to the power stage is single-ended and is applied between the grid of the lower tubes and ground.

The circuit embodies several unique features which contribute to the excellent performance of the amplifier as a whole. The driving system consists of one section of a 12AX7 directly coupled to the grid of a 6K6 triode-connected cathode follower. The grids of the lower 2A3's are tied directly through parasitic suppression resistors to the cathode of the 6K6. The resistor *A* provides 25 db of d.c. feedback from the output to the cathode of the 12AX7 section. This feedback stabilizes the bias on the 2A3's and minimizes its shift with changes in line voltage. The circuit is adjusted by means of a potentiometer in the grid return circuit of the 12AX7 so that approximately one-



Fig. 1. External appearance of Stephens 500D output-transformer-less amplifier.

half the positive voltage is applied across the plate and cathode of the bottom power tubes while the remaining half is applied across the top power tubes. To prevent direct current from flowing in the load, an 80- μ f 450-volt electrolytic capacitor is employed, and to compensate for its effect—as well as to linearize further the input voltage amplifier stages—a second feedback loop is taken from the load side of this capacitor. Distortion with 100 volts r.m.s. across a 500-ohm load for this final section of the amplifier is 0.16 per cent second harmonic, 0.39 per cent third harmonic, and all other harmonics are less than .02 per cent.

The input voltage amplifier consists of two sections of a 12AU7 connected in a conventional cascade circuit. The addition of these does not increase the third harmonic distortion, but brings the second harmonic to 0.36 per cent with the same output voltage. Power and distortion measurements indicate that the amplifier will develop 97 per cent of full output voltage at 20 cps with an increase of less than 0.2 per cent in harmonic content.

The Power Supply

The power supply consists of a special transformer incorporating a 230-volt

* Chief Electronic Engineer, Stephens Mfg. Corp., Culver City, California.

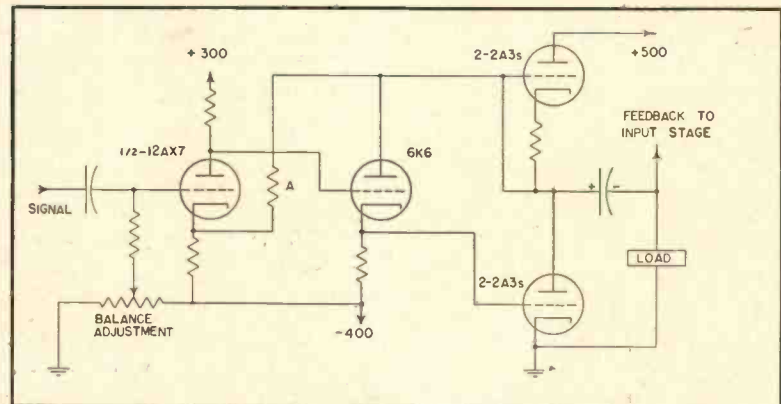

Fig. 2. Simplified schematic of o-t-l amplifier to show circuit operation. Output stage consists of four 2A3's in series parallel arrangement.

500-ma winding for the plate supply, which uses two voltage-doubling selenium rectifier systems—one to furnish 520 volts positive and one to furnish 420 volts negative from ground. Two separate 2½-volt windings provide filament current for the top and bottom pairs of output tubes, and three separate 6.3-volt windings feed the 12AX7, the 6K6, and the 12AU7. The pilot light is also fed from the latter winding. Because of the audio potentials involved, the cathode and heater of the 12AX7 are connected together, as are those of the 6K6, and each heater winding must be electrostatically shielded from the others. Furthermore, capacitance to ground must be kept as low as possible. Although flat performance to 200 kc has been obtained with this circuit, stability and r.f. field discrimination have been improved intentionally by providing a 27- μ f capacitor across the d.c. feedback resistor *A* and by utilizing the case capacitance of the coupling capacitor between the 12AU7 and the 12AX7 as a high-frequency-attenuating element. In final form, the amplifier gives essentially perfect square-wave performance at 10,000 cps, while at 20 cps square-wave tests show a phase shift of approximately 10 deg.

To prevent excessive voltage from being applied to the output coupling capacitor during warm-up, a protective relay effectively removes the input filter capacitor from the high-voltage supply until the 6K6 is drawing normal current. This relay also shorts the output terminals during warm-up



Fig. 3. 103LX woofer and two high-frequency drivers—P-35 and 108A—all available with 500-ohm voice-coils.

to prevent excessive hum and d.c. disturbances from being applied to the loudspeaker.

With the feedback circuits employed, the apparent output impedance is approximately 3 ohms. This provides excellent speaker damping which results in reduced hangover usually encountered with reflex-type cabinets. The excellent damping provided also improves the performance of high-frequency drivers by reducing the amount of distortion which is contributed by phase shifts in the output transformer and by a low damping factor at the extremely high audio frequencies. The total power drawn from the line by this amplifier is 150 watts.

Figure 3 shows three typical speakers from the Stephens line which may be employed with the 500D amplifier.

Chalk up another hit for BELL . . . the **NEW** BELL 2200



High Fidelity Amplifier

puts the breath of life into reproduced music

OUTPUT: 20 watts at less than .3%—Peak power 35 w.
FREQ. RES: 0.5 db 20 to 20,000 cycles (flat)
INPUTS: (7) Radio, Crystal, Mag 1, Mag 2, TV, Tape, Micro
HUM LEVEL: 80 db below rated output
OUTPUT IMPEDANCE: 4, 8, 16 ohms
POWER CONS: 150 watts; 117 volts; 50-60 cycles
SIZE: 8¾" deep; 7½" high; 16" long
NET WEIGHT: 24 pounds

A truly great amplifier that catches the "middle-price" market—and a proud addition to Bell's unsurpassed line of high fidelity units. The Model 2200 delivers 20 watts at less than .3% distortion. Its faithful clarity and response please the most discerning listener. Peak power 35 watts. Built for the utmost in convenience, it has six accurate controls: five-position equalizer switch, five-position selector (TV, Mag, Radio, Crystal, Tape), volume with compensation, separate bass and treble (with boost and cut), and a rotary AC power switch. Write for complete details.



BELL SOUND SYSTEMS, Inc.

559 Marion Rd., Columbus 7, Ohio
 Export Office: 401 Broadway, New York 13, N. Y.

BACK ISSUES

1949 June September December
 1950 August
 1951 March April May June October
 1952 March May

1949—\$1.00 each
 1950—50 each
 1951, 1952—.35 each
AUDIO ENGINEERING 342 Madison Avenue New York 17, N. Y.

DC to AC Converters

Dynamotors

Genemotors

DEPENDABLE . . . COMPACT . . . EFFICIENT

Carter Rotary Power

Carter DC to AC Converters, Dynamotors, Genemotors, Magmotors, and Inductor Alternators (inverters) are made in a wide variety of types and capacities adaptable to communications, laboratory, and industrial applications, of many kinds. Widely used in aircraft, marine, and mobile radio, geophysical instruments, laboratory work, ignition, timing and many other uses.

Carter Motor Co.

2648 N. Maplewood Ave., Chicago 47
 Sales Offices in Principal Cities

Recorder Converters

Inductor Alternators

Magmotors



MAIL COUPON FOR CATALOGS

Please send catalogs containing complete information on Carter Rotary Power Supplies.

Name _____
 Address _____
 City _____ State _____

*Trade Mark Registered

AMPERITE

Studio Microphones
at P.A. Prices

Ideal for
BROADCASTING
RECORDING
PUBLIC ADDRESS

"The ultimate in microphone quality," says Even Rushing, sound engineer of the Hotel New Yorker.

• Shout right into the new Amperite Microphone—or stand 2 feet away—reproduction is always perfect.

• Not affected by any climatic conditions.
• Guaranteed to withstand severe "knocking around."



Models
RBLG—200 ohms
RBHG—Hi-imp.
List \$42.00



"Kontak" Mikes
Model SKH, list \$12.00
Model KKH, list \$18.00

Special Offer: Write for Special Introductory Offer, and 4-page illustrated folder.

AMPERITE Company, Inc.

561 BROADWAY • NEW YORK 12, N. Y.

Canada: Atlas Radio Corp., Ltd., 560 King St. W., Toronto

Naturally,

ALTEC
LANSING CORPORATION

PRODUCTS ARE
HANDLED BY
KIERULFF & CO.

LOS ANGELES
820 W. Olympic Blvd. • RI 7-0271

SAN DIEGO
2426 Fourth Ave. • Woodcrest 6275

FRESNO
725 "L" Street • Fresno 24108

AUDIO IN THE HOME

[from page 24]

could make a 15-in. speaker as effective at low frequencies as speakers of more than 36 in. in diameter. With an expanding labyrinth coupled to the rear of the cone, a reasonable sized cabinet can be used and still retain advantages of direct radiation. This principle has already been used by C. G. McProud and Eugene

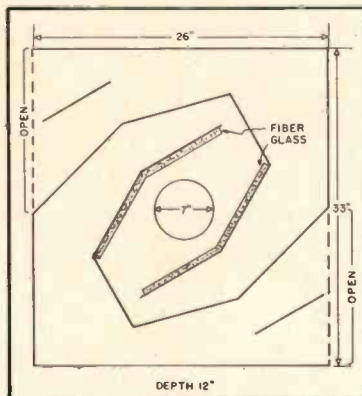

Fig. 4. An efficient cabinet design by Capozio for an 8-in. speaker. In this design, it will outperform many larger cones on a comparison test. With alterations in over-all dimensions, this design can be used with 12- or 15-in. speakers, and, being rectangular in shape, lends itself admirably to straight walls.

R. Capozio in their corner horns, by Paul Klipsch in the Rebel, and by Electro-Voice in the Aristocrat. The point must be made that high frequencies are attenuated in horns of the folded type and that low crossover frequencies must be used in horns where there is no direct radiation, such as in the Klipschorn. Where back loaded horns are used, the high frequencies must be attenuated purposely by the use of Fibreglas or equal thus preventing the higher bass tones from bouncing around in the labyrinth itself and cancelling the front radiation. It is the writer's feeling that this back-loaded principle is one means of retaining efficiency while extending the range to a lower octave and eliminating the feeling that the sound is coming from behind a panel. Direct radiation with horn loading on the front of the cone requires a rather long horn if low frequencies are to be reproduced efficiently. However, by using two 15-in. speakers a short horn can load uniformly down to 50 cps. An example of this design is the Altec Lansing 820A Speaker System.

Horn Enclosures

A horn, when properly matched to a speaker diaphragm, acts as an acoustic transformer between the diaphragm and the air into which the mouth of the horn radiates. It effectively makes the area

of the speaker diaphragm equal to the mouth opening of the horn and, therefore, the speaker is, in effect, able to act upon a larger air surface indirectly with a consequent extension of low frequency response. The horn presents more of an acoustic load to the speaker diaphragm than would be the case if the speaker were directly radiating from a panel. The effect is very similar to reinforcing speech by the use of a megaphone. By choosing the characteristics of the horn, such as the area of the opening (which is called the throat), the rate of flare, or its length, different portions of the audio range may be more efficiently reproduced. In order to maintain an efficiency in the bass which is equal to that in the mid-range, as well as to extend the low-frequency response, the rate of increase in area of the horn between the throat and the mouth, as well as the area of the mouth, are established by certain physical laws. Generally, the lower the rate of expansion and the larger the mouth, the lower is the frequency response obtainable. For horns of practical dimensions, it has been found that, for suitable results, the throat opening of the horn should be comparable in area to that of the diaphragm (approximately 120 square inches for a 15 in. speaker). A length of from three to five feet is satisfactory. From our own experience, it has been found that the optimum results from a standpoint of over-all balance and realism are obtained when a speaker is mounted for direct radiation from the front of the cone and the rear of the cone is terminated by a horn which

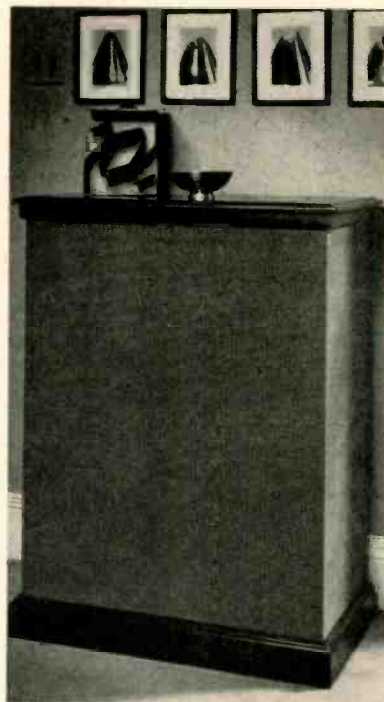

Fig. 5. Rectangular Capozio Horn with a model on top showing its internal construction.



Fig. 6. Corner cabinet design employing two-path rear loading and direct-radiation from front of cone.

reinforces the extreme low frequencies. Such direct radiation may be supplemented with a high-quality tweeter, which may be coaxial with or separate from the low-frequency speaker.

The length of the horn, as well as the volume of the cavity behind the diaphragm, are so chosen as to minimize undesirable cancellation effects. These effects are further reduced to a negligible amount by the use of proper padding within the horn chamber. In addition to extending the low-frequency response, a horn reduces the resonant peak of the speaker and speaker "hang-over" effects. Since the excursions or movements of the speaker diaphragm are proportionately reduced by the increased loading provided by the horn for a given acoustic output in the range of the horn's effectiveness, distortion effects which result from large movements of the cone are reduced accordingly. Likewise, the reduction in the motion of the diaphragm for a given acoustic output reduces the tendency of the diaphragm to "break-up," and this results in less irregularity in the response. Two examples of this type of horn are shown in Figs. 4 and 5, the first designed by Eugene R. Capozio, a hobbyist engineer, and the other by the Jensen Mfg. Company.

Horns are effective for both high and low frequencies. However, their characteristics differ. Generally, high-frequency horns are of the exponential type and have many cells—thus the name multicellular horns. There are other variations of the high-frequency horn, like the acoustic lens by Jim Lansing, which spreads sound evenly with slight attenuation of the high frequencies. The low-frequency horns are generally of the folded type because of the extremely

long wavelengths they must reproduce; these have been used in the theatres for a good many years. Paul Klipsch adapted this type of horn to a corner cabinet of reasonable size and made reproduction of the bottom octave possible for the first time in home systems. The theatres, however, due to continuous research, found that the upper frequencies passed through the bass horn were attenuated and that speech sounded like it was coming from a closet. They then adapted a large direct radiating horn with multiple speakers for the throat. This method made it possible to have a relatively short horn and, since the crossover was 500 cps or less and the nearest seat was more than 20 feet away, it offered no problems.

The labyrinth principle may also be applied to corner cabinets. It then enlists the walls of the room to extend the low-frequency range of the cabinet even beyond the length of the cabinet itself. This type was first made popular back in 1948 and 1949 by Capozio and McProud. The basic differences in their designs are as follows: McProud's has a single passage in the rear "horn" that is relatively short and also has a short horn in the front of the speaker. This, however, makes phasing of the high- and low-frequency speakers in two-way systems very simple. Capozio's has the speaker mounted flush on the front panel and offers one extra passage of about two feet, which in turn allows a slower expansion and extends the low-frequency range almost another octave. The McProud design would adapt itself quite well to two bass speakers to increase the area of the throat, whereas the throat opening would have to be made somewhat different in the Capozio design for two bass speakers.

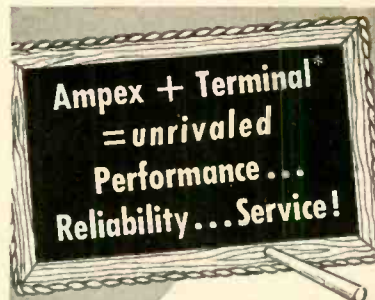

***Terminal**

DIRECT FACTORY DISTRIBUTOR
FOR ALL
AMPEX RECORDING EQUIPMENT
presents

the **NEW**

AMPEX **'403' CONSOLE** **TAPE RECORDER**



Here is the "standard setting"
400A in a beautifully designed
gray modern console cabinet.
Dimensions: 23 1/4" wide, 30 1/4"
high, 25 3/4" front to back. **\$995**

- Available in full-track or half-track models.
- Remote control assembly optional at extra cost.

Brochures and engineering data
on all AMPEX equipment
available on request.

Visit our audio department
for a recording and play-
back demonstration.



Terminal **Radio Corp.**

85 Cortlandt St., New York 7, N. Y.
WO 4-3311

SYLVANIA
PRECISION

FREE!

The following manufacturers' products are cataloged in the 128 page Instrument & Test Equipment Section.



EMICO

JACKSON

Chicago

ELECTRONIC MEASUREMENTS

SUPERIOR

SUPREME

BROWNING

BARKER & WILLIAMSON



marion

STERLING

Industrial Instruments

precise

HICKOX

RADIO CITY PRODUCTS

JAMES MILLEN

Berlington

Weston

FREED

Shurite

BOUNTON RADIO

TRIPLET

BEAM



SHALLCROSS' MEASUREMENTS CORPORATION

EICO

JBT

Simpson

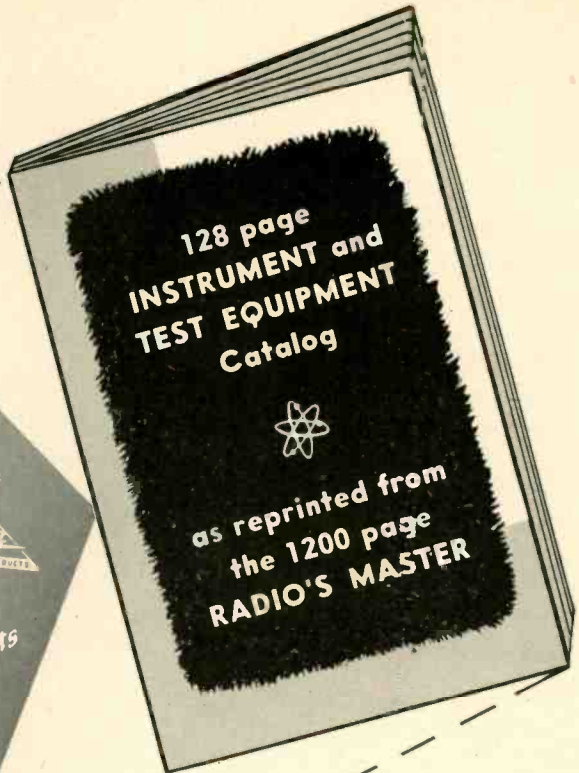

AUDIO ENGINEERING subscribers can receive, without cost or obligation, a complete 128 page catalog section on Test Equipment and Instruments, as reprinted from the 1200 page RADIO'S MASTER, the Industry's Official Buying Guide.

This section catalogs in detail the products of the leading Instrument and Test Equipment manufacturers—all in 1 handy booklet. It is complete with descriptions, specifications and illustrations as written by each manufacturer. You will find this large catalog section extremely helpful and a handy reference.

This FREE offer is made possible by a special arrangement between AUDIO ENGINEERING MAGAZINE and the publishers of RADIO'S MASTER. Be sure to get your copy . . . just mail coupon NOW.

GET YOUR FREE 128-page CATALOG

AUDIO ENGINEERING MAGAZINE
342 MADISON AVENUE, N. Y. 17, N. Y.

Please send, without cost or obligation, the 128 page Instrument and Test Equipment Catalog as reprinted from Radio's Master.

Name.....
Address.....
City..... Zone..... State.....

These manufacturers do not catalog test equipment in Radio's Master. Separate catalog sheets will accompany each booklet.

Audio Instruments Corp.
Ballantine Laboratories
General Radio Corp.
Heath Company
Hewlett-Packard Corp.

RADIO STUDIO

[from page 23]

other components. There are standard audio symbols for use on block diagrams. Some of these are used in the circuit of Fig. 2 which will be referred to again later in this article. The reader is referred to the literature¹ for a detailed discussion and tabulation of these symbols.

Show all impedances, and the audio levels at each point. In this connection, it would seem desirable to show circuit levels as single-frequency values expressed in dbm, ten db above expected VU meter program peaks.² Levels so indicated allow for the peak factor in program waves and are the levels to which the system will be adjusted during initial performance measurements with oscillator and gain set. (2) When figuring levels, remember that ladder attenuators sometimes used for individual channel volume controls have a minimum insertion loss of 6 db; the insertion loss of some other types varies with the degree of rotation. Also bear in mind the losses in fixed pads used for isolation, impedance matching, and circuit branching. If the loss occasioned by any circuit element drops the single-frequency level below microphone level (approximately -60 dbm), be sure to add amplification ahead of that element. Otherwise, it will be impossible to maintain the desirable 60-db ratio between the signal and the residual noise. The latter has a theoretical minimum value of -129 dbm and a somewhat higher actual value.³

The amount of information which it is desirable to show on the block diagram probably varies with the experience of the designer. A highly detailed layout may contain so much information that it tends to confuse rather than clarify. For example, the complete grounding diagram of the studio is probably best shown on a separate grounding diagram. For the same reason, avoid cluttering up the layout with all the circuits of a stock console. Put in only the main input and output circuits, as indicated in Fig. 2. You can always refer to the manufacturer's instruction book for the data on remote cueing circuits and the various talkback arrangements—or did you decide to build your own console, after all?

Don't attempt to show complete relay system operation on the block diagram, except perhaps for simple audio contact arrangements on speaker relays, etc. As Colvin pointed out,³ the block diagram can only serve as a reminder of the relay operations involved, and a two-wire

schematic is required to show the complete relay layout. Even then, notes are often required to fully detail the operation of the system. In this connection, notes are helpful for all features of a block diagram not completely describable by a simple one-line drawing—for example, special switching arrangements—and such notes should be made a part of the block diagram, which brings us to the preparation of its final draft.

Don't limit yourself to one painfully-drawn and liberally smudged copy of the block diagram. The wireman should have one so he can see where his racks fit into the over-all picture; the same is true of the boys doing the bench work on amplifier modifications, switching panels, etc. You'll also want an extra copy on which to mark up a grounding diagram. So draw up the block diagram on regular draftsman's tracing paper, that is, after it has reached what you hope is its final form. This should include the numbers assigned to the jacks. It should also include a table or legend clearly identifying each component by manufacturer's name and model number. Type up the notes double-spaced on the same kind of paper, backed by a sheet of carbon paper with the carbon side in contact with the tracing paper. This increases the density of the typed characters and assures good reproduction. Fasten the notes to the main tracing with scotch tape and have the architect or the local blueprint firm run off the required number of copies on an Ozalid or other type of black-on-white printing machine. The advantage of this type of print over blueprints is that it is much easier to make notes and corrections on the resulting white background. One caution: Don't go overboard on the number of copies. Make no more than you need and register them serially so that the inevitable changes and corrections will get to all who received the original edition.

Figure 2, referred to earlier, shows the block diagram of a small audition and recording studio at Fort Slocum. Note that the console elements have been grouped together, and that the console elements have been considerably simplified. There are three microphone and two turntable inputs. There are also two remote inputs, either of which is selected by the key K_6 . The remote line so selected can be substituted for number one turntable by throwing turntable key K_4 to the remote position. Cueing switches S_1 and S_2 on the turntable volume controls transfer the turntable preamplifier outputs to a rack-mounted cueing amplifier feeding a pair of phones.

The console line-out is split into two circuits through the dividing pad P_1 to feed the tape and disc recorder channels. The load for the console is this pad when both outputs are terminated in 600 ohms. The second output of the dividing pad is so terminated when the input of the Presto 85E disc recorder amplifier is patched into the pad output jack. A 600-ohm resistor maintains this load when the patch-cord is withdrawn. (This is the only patch-cord used in this

¹ Howard S. Chinn, "Audio system design fundamentals." AUDIO ENGINEERING, Nov. 1948.

² Howard A. Chinn, "DBM vs. VU." AUDIO ENGINEERING, March 1948.

³ John D. Colvin, "Planning a studio installation." AUDIO ENGINEERING, August 1947.



SAVE
33 1/3%

This is our

GROUP SUBSCRIPTION PLAN

You and your friends and co-workers can now save up to \$1.00 on each subscription to AUDIO ENGINEERING. The more men in a Group, the more each saves. If you send 6 or more subscriptions for the U.S.A. and Canada, they will cost each subscriber \$2.00, 1/3 less than the price of a regular 1-year subscription. Present subscriptions may be renewed or extended as part of a Group.

AUDIO ENGINEERING is still

- The only publication devoted entirely to Audio—
- Recording
- Broadcasting equipment
- Acoustics
- Home reproduction systems
- PA systems
- Psychoacoustics

(Please print)

Name

Address

Position Company

Name

Address

Position Company

Name

Address

Position Company

Name

Address

Position Company

Name

Address

Position Company

Name

Address

Position Company

Add \$.50 to each Foreign subscription ordered

RADIO MAGAZINES, INC.

342 Madison Ave., N. Y. 17, N. Y.

Naturally,

Magnecord INC.

**PRODUCTS ARE
HANDLED BY
KIERULFF & CO.**

LOS ANGELES
820 W. Olympic Blvd. • RI 7-0271

SAN DIEGO
2426 Fourth Ave. • Woodcrest 6275

FRESNO
725 "L" Street • Fresno 24108

Miller
BUILERS OF QUALITY RADIO INDUCTANCES SINCE 1924

**THE SENSATIONAL
NEW MILLER BAND-PASS TRF
TUNER USING A GERMANIUM DIODE
DETECTOR**

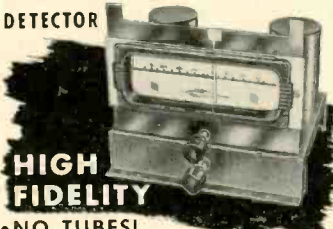

**HIGH
FIDELITY**

- NO TUBES!
- NO POWER SUPPLY! • NO HUM!
- A SIMPLE 2 TUNED CIRCUIT NEGATIVE MUTUAL COUPLED BAND PASS TUNER
- EASY TO ASSEMBLE & WIRE!

In spite of its simplicity, low cost, # 585 kit is not a toy: — It is a carefully designed High Fidelity Broadcast band tuner. Use it with your amplifier and speaker system for truly high quality reception.

The audio output of the tuner is proportional to the input signal and will vary from .05V to .5V for stations within a 20-25 mile radius when used with a good antenna of from 75 to 100 feet in length. A good antenna is absolutely essential to the proper operation of the # 585 tuner.

The net price of the Miller # 585 TRF tuner kit, including chassis, dial, and tuning condenser, is only \$11.40. The additional parts required make it possible to build the complete tuner at a net cost of less than \$15.00.

Order yours now — ask for the new MILLER — Cat. No. 585 Crystal Detector Tuner — Net \$11.40



SEE YOUR LOCAL RADIO PARTS SUPPLIER FOR THE MILLER #585 KIT AND OTHER MILLER PRODUCTS

J. W. MILLER COMPANY
5917 S. MAIN ST. LOS ANGELES, CALIF.

studio, and is required by physical considerations; all other ties are made through the jack normals.) The first output of the dividing pad feeds—through an added isolation transformer—into the unbalanced “bridging” input of the Magnecord PT-J-AH tape recorder modified for rack mounting. Since this does not properly terminate the pad, a 600-ohm resistor is shunted across the jack normals of the first output.

Regarding the monitoring facilities, it will be noted that the console monitor amplifier has two alternate inputs. A key K₇ on the console panel selects either the output of the program amplifier or the output of the number six preamplifier associated with the special accessory monitor head of the Magnecord. This permits instantaneous comparison of the live and the recorded signals. The 600-ohm line output of the tape recorder is normalled to number two remote input of the console through a loss pad. This permits listening to the playback over the console monitor facilities and/or piping it to other studios and audition rooms throughout the radio building.

It was mentioned earlier that the unbalanced input of the tape recorder required the use of an isolation transformer. In this connection, the trend today appears to be toward unbalanced components, because of their greater simplicity, smaller size, and lower cost. However, the writer's experience is that less trouble results from cross-talk, patching errors and feedback when using a balanced system, and the greater freedom from these difficulties appears to warrant the station engineer in going to the expense of isolation transformers and associated accessories for balancing the installation.

Jack-Field Design

So much for the block diagram; let's consider the jack field as the next step. As a general rule, bring out to jacks all microphones, turntables, and remote lines, and their corresponding inputs to the console; the inputs and outputs of all amplifiers, preamplifiers, and tape recorders; miscellaneous equipment such as utility keys, pads, equalizers, filters, etc. The jacks referred to are the so-called “normal” jacks which have auxiliary contact springs through which circuits ordinarily tied together are connected—for example, a microphone and

its preamplifier. Under “normal” conditions, that is, with no patch-cords inserted, the two circuits are connected together. Where operating requirements are sufficiently stable to warrant it, it is considered good practice to make all connections through jack normals so that patch-cords need be used only for special set-ups or emergencies.

In so far as practicable, try to put in their own rows all jacks of a given level group. This is a group of circuits whose levels do not differ by more than (roughly) 30 db³. Additional data will be given in the next installment on the grouping of circuit levels. Place the “outs” directly above the “ins.” For example, “MIC. 1” would be directly above “PREAMP 1 IN.” At points where it is desirable to pick up a bridging feed or a test signal, as for example at the outputs of preamplifiers and the program amplifier, assign two jacks in multiple. In such cases, only the tips and rings are multipled. High-level jacks such as those for speakers, cutter heads, and monitor amplifier outputs should be located at the extreme right of the field as seen from the front—or, in the case of large fields, in a row of their own at the bottom. In the latter case, the takeoff bundle running across the field should be spaced well back from those of lower circuit levels to reduce the likelihood of cross-talk. For the same reason, the high-level cable should run down the right side of the rack, far removed from the other level groups which run down the left side.

It's also a good idea to include one or two “parallel gangs” of three or four jacks each, with their tips and rings in multiple. This makes it possible to patch up two or three feeds from one jack, thereby providing multiples for circuits which do not have their own.

It is helpful in designing a jack field to use a chart laid out to simulate the field itself, as shown in Fig. 3. This illustrates the conventional double-jacks, twelve to a row; the same scheme would of course apply to single jacks. The use of the latter was proposed by Chinn and Monroe,⁴ and saves a great deal of space. The writer has successfully used single jacks in standard double-jack strips, although it's quite a problem to squeeze two intelligible but highly-ab-

⁴ Howard A. Chinn and Robert Monroe, “Single jacks for broadcast application.” AUDIO ENGINEERING, July 1947.

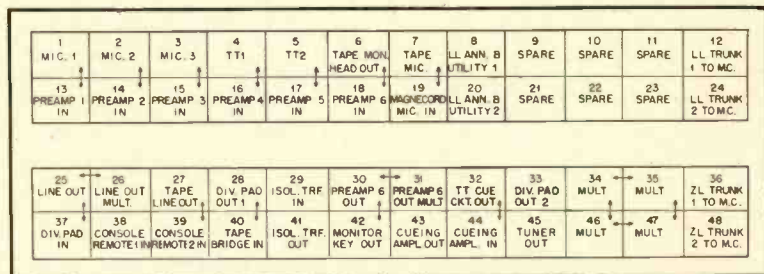

Fig. 3. Portion of jack field layout for the audition and recording studio diagrammed in Fig. 2. Note use of arrows to indicate jacks to be mutually normalled and/or multipled.

breviated titles in a label window meant for one. One solution is to make them on a Varityper. Getting back to the jack field chart, use arrows to indicate jacks to be normal and/or multiplied. As each jack is assigned on the chart, it should be checked off on the block diagram and the finished chart should be rigidly rechecked. The jack numbers should then be marked on the block diagram. As soon as all jacks are assigned, the total jack field panel space can be figured and the rack panel space available for other elements can be determined.

APPENDIX A

Microphones—velocity, dynamic, cardioid	Piano
Booms, floor stands and table stands	Organ
Turntables for transcriptions and sound effects	Music stands
Console and desk switching console	Racks
Preamplifiers	VU meters
Line amplifiers	Rack panels
Monitor amplifiers	Jack strips
Cueing amplifiers	Patch-cords
Talkback amplifiers	Relays
Limiter amplifiers	Repeat coils
Remote amplifiers	Matching transformers
Disc recorder amplifiers	Bridging transformers
Tape recorders	Fixed pads
Disc recorders	Variable attenuators
Filters	Elapsed time meters
Equalizers	Wall clocks
Reverberation generators	Program stop timers
Recorder suction gear	Tape bulk eraser
Sound effects gear	Assorted plugs and receptacles
AM/FM Tuner	Assorted cable
Power supplies	Signs — On-the-air, Rehearsal, etc.
Loudspeakers	Work bench
Earphones	Hand tools
Monitor dial systems	Test equipment—oscillator, gain set, tube tester, noise and distortion meter, intermodulation analyzer, volt-ohmmeter, vacuum-tube voltmeter
Intercoms	
Ring-down facilities	
Field telephones	

AUDIO PATENTS

[from page 4]

portioned as shown below the gain is constant from the normal high-frequency cut-off down to d.c.:

$$R_1 = R_s \left[\frac{G_{sg}}{G_m + G_{sg}} \right] \times \left[\frac{G_m R_1}{\mu_{sg} - G_m R_1 + R_s (G_m + G_{sg}) (\mu_{sg} + 1)} \right]$$

$$C_1 = C_s \left[\frac{G_{sg} R_1}{\mu_{sg} + R_s (G_m + G_{sg}) (\mu_{sg} + 1)} \right]$$

The inventor notes that the values of C_1 and C_s are not particularly critical. Gain of a stage designed in accordance with the patent is:

$$\frac{G_m R_1}{1 + (G_m + G_{sg}) R_s}$$

For the values shown in Fig. 5 mutual conductance G_m is 4,000 micromhos, mutual conductance of control grid with respect to screen current G_{sg} is 1300 micromhos, and amplification factor of the screen with respect to the control grid μ_{sg} is 31.

A copy of any patent may be had for 25¢ from the Commissioner of Patents, Washington 25, D. C.

Announcing The Hallmark Williamson Amplifier

This superlative amplifier is the first production model of the famous Williamson circuit planned and endorsed by the designer and is hallmarked:

D. S. N. Williamson.

The hallmark is your guarantee that this production amplifier, based upon the authentic Williamson prototype, meets with the high standards set by Mr. Williamson.

It is being built in England with the highest quality components and to exacting engineering standards established by Mr. Williamson himself.

A companion pre-amplifier/control unit, designed to the same standards, is in production.

Orders are now being accepted for early September delivery. For information, specifications and address of nearest dealer, please write:

BRITISH RADIO ELECTRONICS LTD.
ONE THOMAS CIRCLE, WASHINGTON 5, D. C.



Double installation of Gramplan Amplifier with Power Supply

NOW AVAILABLE The GRAMPAN Feedback Disk Recording Cutterhead Unit

Engineers and musicians now realize a perfect transient response of any recording system is of paramount importance—the Gramplan cutterhead with its precision-made true balanced armature and flux correcting feedback loop obtains this ideal.

Used by the BBC and other international broadcast networks where fidelity is of primary importance, you too, can be assured of the highest fidelity disk recording.

Many outstanding recordings, such as the LP Mercury Olympian Series, were recently produced with the Gramplan.

For more information, write to



REEVES EQUIPMENT CORP.
10 EAST 52nd STREET • NEW YORK 22, N. Y., U. S. A.
CABLE: REEVESQUIP, N. Y.

Wide frequency range
30 cps to 20 kc
Low Distortion
Superior transient response

audio anthology

Paper cover . . . \$2.00 *Distributors write for quantity discount*

The long awaited compilation of reprints from early issues of AUDIO ENGINEERING, most of which are unobtainable. The ANTHOLOGY contains 37 articles, covering • amplifiers • speakers • noise suppressors • phonograph equipment • tone and loudness controls • dividing networks. Together, they comprise the most authoritative reference work for the audio hobbyist.

—CUT OUT—MAIL TODAY—

Book Division, Dept. A9
Radio Magazines, Inc.
342 Madison Ave., New York 17, N. Y.

Sirs: Enclosed is my check money order for _____ copies of the Audio Anthology.

Name (print carefully) _____
Address _____
City _____ Zone _____ State _____

CLASSIFIED

Rates: 10c per word per insertion for noncommercial advertisements; 25c per word for commercial advertisements. Rates are net, and no discounts will be allowed. Copy must be accompanied by remittance in full, and must reach the New York office by the first of the month preceding the date of issue.

THE AUDIO EXCHANGE, INC. buys and sells quality high-fidelity sound systems and components. Guaranteed used and new equipment. Catalogue, Dept. 3, 159-19 Illihside Ave., Jamaica 32, N. Y. Telephone OL 8-0445.

Williamson Amplifier—flat from 20 to 20,000 cps, essentially distortionless, loudness control, \$50.00. Long Island Sound Co., 19 Bennett Place, Amityville, N. Y.

SACRIFICE several conventional Williams-sons with TO-280 \$75, immediate delivery, 30-watt Williams-sons with Peerless S-265-Q and Peerless power transformers, all oil filters and couplers, \$99.50. Dr. Nicely, Kenton, Ohio.

TAPE RECORDER wanted, Concertone or equivalent. Mr. Lee, Ivy Way, Port Washington, N. Y. Telephone PO 7-3536-J (Business: EX 6-5100, ext. 3488.)

FOR SALE: Stephens 612 Mahogany bass-reflex cabinet. Like new. \$40. R. Forbes, 3 Mohawk Road, Marblehead, Mass. Phone 2488W.

FOR SALE: Altec 802B Driver with H-808 Horn, unused, \$100. Bogen 16-in. two-speed turntable, \$65. Want 804B, Henry Dzewit, 12236 Arlington, Detroit 12, Mich.

FOR SALE: McIntosh 20W-2 Amplifier with AE-2 Preamplifier, like new, \$175. Pickering 250H Preamplifier, new with 132E Record Compensator, \$13. Browning BJ-10A FM Tuner, brand new, \$85. Gray SP-100 Transcription Arm, new, \$25. Garrard RC-20 Changer, new, with Audak Polyphase, \$35. Clarkstan 12-in. Quick-Change Arm with RV cartridge and stylus, like new, \$15. Two Livingston Universal Arms, perfect, \$4 each. Livingston Loudness Control, new, \$5. Cardax Mike, new, \$12. McIntosh Self-powered Preamp AE-2, perfect condition, \$30. Platz, Phone HOllis 8-6952 after 6 p.m.

SOUND REPRODUCTION

[from page 21]

2. The pattern will become sharper as the frequency is raised, and broader as the frequency is lowered.

3. The pattern will become sharper as the diameter of the ring is increased, and broader as the diameter is decreased. When the diameter is equal to one fourth the wave length or less, the pattern will not be appreciably affected by interference from different points on the ring.

Cone radiation patterns are determined by the total effect of all the ring

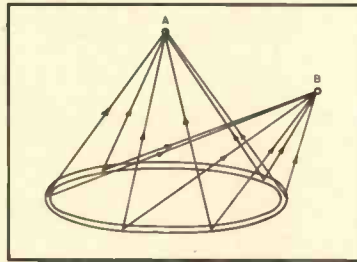

Fig. 3-4. Wave energy radiated by a vibrating ring, at two points of reception.

elements. They follow the principles listed above, and in addition are modified by the material of the cone and by the angle and curve of the flare, as will be seen when loudspeakers are studied. The curved surface formed by the mouths of a multicellular horn group act somewhat like a section of a radially pulsating sphere.

Concentration and Diffusion of Sound

Sometimes it is desirable to control the radiation pattern by concentrating the sound at a point or by diffusing it over a larger area than the vibrating source would of itself cover. The medieval "whispering gallery" is an example of sound concentration. Reflections from a curved surface met in phase at a specified distant point, reinforcing each other to the extent that whispers could be heard from a distance.

Sound diffusion rather than concentration is of greater interest to the audio technician, as one of the problems of reproduction is the avoidance of narrow speaker radiation patterns at the higher frequencies, an effect which takes place for the reasons discussed above. Both acoustic lenses and curved reflecting surfaces have been used for sound diffusion.

Beats

The phase relationship between interfering waves may be affected independently of distances from the sources by slight differences of frequency. If the number of cycles of difference is below the frequency at which tonal fusion will take place (the frequency at which instantaneous amplitude changes are no

longer perceived individually but as the pitch of a continuous tone), distinct amplitude pulsations or beats, at the difference frequency, will be heard. A beat is not a tone, but a periodic variation of the sound at some low frequency. Figure 3-5 shows diagrammatically how two waves differing in frequency by one cycle alternately aid and oppose each other to produce a throbbing effect at one cycle per second. The resultant is equivalent to a wave whose fundamental frequency is that of the greater of the two components, phase and amplitude modulated by the difference frequency.

The frequency of two notes may be compared by listening for beats and by counting their rate, a procedure followed by piano tuners. Since beats are formed by harmonics as well as by fundamentals, their use is not restricted to comparing notes whose fundamental frequencies come close to coinciding. An octave interval, for instance, will be known to be out of tune if it produces beats.

A clear distinction must be made between beats and sum and difference tones. The latter, which are distinct tones with an existence of their own, are produced only when two or more waves of different frequency are passed through a non-linear or distorting transmission device. (The human ear is non-linear for loud tones.) Sum and difference frequencies are also referred to as intermodulation products.

Doppler Effect

All sources and points of reception considered so far have been stationary. If the source of sound and point of reception are moving with respect to one another, the frequency detected by the

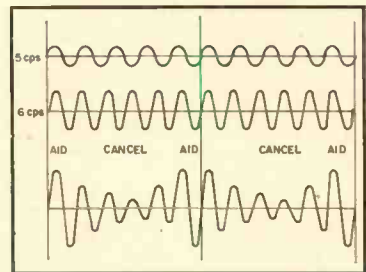

Fig. 3-5. 1-cycle amplitude pulsation, or beat, created by mixing 5-cycle waves with 6-cycle waves.

listener will not be that of the vibrating source. Suppose, for example, that the listener is approaching the source. Since he is moving towards each wave impulse at the same time that it is moving towards him, he meets it a little sooner than if he had merely waited for it, and the perceived period between impulses is shortened, which is to say the perceived frequency is higher. When source and listener are moving apart, the effect is the opposite, that of lowering pitch. Motion which does not change the dis-

1st choice

STEPHENS FINE COMPONENTS FOR 2-WAY SYSTEMS



Those who demand the finest in sound reproduction... who want true-to-life tones, specify Stephens Tru-Sonic high fidelity components in their two-way systems. Custom set builders, manufacturers of fine sets and theatres rely on Stephens because there's such a wide selection of components to fit every space requirement and price range. Stephens Tru-Sonic components are available in crossover frequency ranges from 400 to 3500 cps. The low frequency driver, high frequency driver, crossover network and 2x5 horn shown here are only a few representative items available under the Stephens brand.

Write for catalog K-1 and installation instructions.

STEPHENS MANUFACTURING CORPORATION
TRU-SONIC
 Pioneer name in high fidelity reproducing equipment

8538 WARNER DRIVE, CULVER CITY, CALIFORNIA

tance between source and listener has no effect on pitch.

This change of pitch with motion relative to the source is called the Doppler effect. It may be noticed dramatically in the sound of a crossing signal bell as you pass it on a rapidly moving train. A less dramatic example of Doppler effect occurs when a speaker cone reproducing a high-frequency note undergoes a large excursion at some low frequency. The pitch of the high-frequency note is changed at the regular rate of the low frequency, or to put it another way, the high-frequency note is frequency modulated.



A MONTHLY SUMMARY of product developments and price changes of radio electronic-television parts and equipment, supplied by United Catalog Publishers, Inc. 110 Lafayette Street, New York City, publishers of Radio's Master.

These REPORTS will keep you up-to-date in this ever-changing industry. They will also help you to buy and specify to best advantage. A complete description of most products will be found in the Official Buying Guide, Radio's Master—available through local radio parts wholesalers.

Miscellaneous Radio, TV and Electronic Parts

AMERICAN TELEVISION & RADIO CO. Added 28-HSF, super-heavy-duty radio inverter . . . 28T-HSF, 32BT-RHD, 110AT-RHD, television inverters . . . 28-RSC, 32B-RHD, standard and heavy-duty radio inverters . . . 12 new standard and heavy-duty industrial inverters (with built-in filter) . . . and 28-L1D, low-power inverter.

ASTRON CORP. Decreased prices on type "E" screw base dry electrolytic capacitors E-8-6000 to \$1.89 net and E-16-9000 to \$2.25 net.

CLAROSTAT MFG. CO. Added constant impedance controls CIL 4 (wire wound L-pads) at \$2.25 net and CIT 4 (cure wound L-pads) at \$2.55 net.

INDUSTRIAL CONDENSER CORP. Added 5 new type GA oil filled capacitors. The case is a one-piece metal extrusion with a locked in molded neck.

MALLORY & CO. Added 8 mercury-type batteries for instrument and industrial use.

POTTER & BRUMFIELD. Added SM series of super midjet relays . . . AP series of ratchet or impulse relays . . . LK series of latching relays.

Recording Equipment, Tuners, Speakers, Amplifiers, Needles, Tape, etc.

CLEVELAND ELECTRONICS. Added PM-5CR Tweeter at \$2.87 net . . . PM-8FR high-fidelity speaker at \$5.10 net . . . PM-8JR public address speaker at \$7.26 net . . . PM-12LR public address speaker at \$11.97 net . . . PM-12JR coaxial at \$16.59 net. Also in-car speaker unit for outdoor theaters at \$6.12 net and model 19, automobile rear seat speaker 5 1/2" at \$5.37 net.

DUOTONE CO., INC. Added "Duoscope" at \$30 net, a 14-power pocket microscope to observe needle wear . . . "Electro-Wipe" at \$7.75 net, a chemically treated record cloth to remove record static charges, etc.

ELECTRO-VOICE. Added model 715 microphone at \$6.75 net—moisture-proof ceramic generating element—ac-d.c. insulated—15-7500 cps—output 55 db—weight 6 oz.—7 1/2-ft. cable, high impedance.

MASCO ELECTRONIC SALES. Reduced the price of model MC-25N to \$129.00 net—mobile amplifier plain cover without phono-top but with tubes.

MILWAUKEE RECORD CHANGER. Reduced prices on the 3-speed automatic record changer No. 12300 to \$25.25 net . . . No. 12300 DE to \$26.50 net . . . metal base to \$2.75 net.

ORRADIO INDUSTRIES. Added Irish sound recording tape No. 220RPA (red oxide, plastic base, coating wound inside) in 600, 1200 and 2400 foot reels.

PRESTO RECORDING CORP. Increased prices on Presto double-sided Master No. 621-A to \$1.53 net . . . No. 623-B to \$1.95 net . . . Presto single-sided Master No. 821-B to \$1.20 net . . . No. 823-B to \$1.44 net.

QUAM-NICHOLS CO. Added high-range-fidelity speakers 8A10X, 8-in. PM seamless, molded, curvilinear cone, 10-oz. Alnico V magnet, freq. response 40-12,000 cps. flat \pm 5 db., max. input 10 watts voice-coil impedance 8 ohms, voice-coil diameter 1 in., depth 3/8" at \$11.18 net . . . 10A10X, 10-in. PM as above only maximum input is 12 watts, voice-coil impedance 8 ohms, voice-coil diameter 1 in., with dust cover, depth 5 5/8" at \$14.40 net . . . 12A10X, 12" PM as above only maximum input is 15 watts, voice-coil impedance 8 ohms, voice coil diameter 1 in., with dust cover, depth 8 1/4" at \$15.60 net.

RADIO CRAFTSMEN INC. Added C10 FM-AM tuner, compensated pre-amplifier for variable-reluctance phono cartridge, rathode-follower output, bass and treble controls (provide either boost or cut) all use low-distortion triode tubes. Includes AM whistle filter, FM-AM antenna, 11 tubes plus rectifier at \$131.50 net. . . Also added C300 equalizer-preamplifier for remote control of all tone compensation, phono equalization, and audio channel switching. Self-powered unit can be used up to 50 ft. from other chassis, features continuously variable loudness control, multi-position record equalization, four-position noise-reducing filter, five separate inputs each with level adjustment 4 dual-triode tubes plus rectifiers at \$89.50 net . . . C400 high-fidelity amplifier 10 watts output at less than 1 per cent har. or 5 per cent I.M. distortion. Pres. response: 10 to 30,000 cps \pm 1 db. Hum: \rightarrow 70 db. Damping factor: 4 : 1. Tubes: 6J5, 6SN7GT, push-pull 6V6GT's, 5Y3GT rect. at \$42.90 net.

Test Equipment

APPROVED ELECTRONIC INSTR. CO. Withdrew A220K, vacuum-tube volt-ohmmeter kit . . . A410K, push-pull 5 in. oscilloscope . . . A450, marker generator . . . A610, 4-watt a.c. amplifier.

G.E. Added ST-2B2 oscilloscope (uses 5U7 CR tube) at \$497.50 Sug'd user and ST-2B3 oscilloscope (uses 5U7P CR tube) at \$499.25 Sug'd user.

PRECISE DEV. CORP. Introduced signal generators K-610 at \$22.95 net . . . KA-610 at \$27.95 net . . . W-610 at \$38.95 net. Prices are East Coast.

SUPERIOR INSTR. CO. Model 670A, a combination volt-ohm-milliammeter, plus capacitance, reactance, Inductance, and decibel measurements at \$28.40 net—replaces model 670.

SUPREME INC. Withdrew model 660, deluxe wide range TV oscilloscope.

TRIPLETT ELECTRICAL INSTR. CO. Added model 3434-A, a sweep signal generator with ranges (1) 0-60 MC (2) 60-120 MC (3) 120-240 MC at \$199.50 net . . . withdrew battery tester 698 and volt-ohm-milliammeter 2405-A.

Tubes—Receiving, Television, Special Purpose, etc.

G.E. Added radio receiving tubes 6V3 at \$3.55 list and 12AV7 at \$2.90 list which are currently being used by some VHF set mfrs.

R.C.A. Added 6V6-Y, beam power amplifier tube with micanoal base at \$4.25 Sug'd user.

RAYTHEON. Added receiving tube 6BK5, a nine-pin miniature beam power amplifier tube designed for use as a power output tube in radio and TV receiver at \$2.45 list.

Industry People...

Charles M. Ray, newly-appointed manager of Arrow Electronics' sound division, joined with **Maurice Goldberg**, company president, in entertaining the press July 22 at special showing of Arrow's spacious new Audio Center in downtown New York.

E. C. "Chet" Wharfield is newly-appointed coordinator for sales of sound equipment by Allied Radio Corporation, Chicago, according to announcement of **Alex Brodsky**, Allied sales manager.

Bob Penfield, formerly editor of "Sylvania News," has been named to executive advertising post by Sylvania Electric Products Inc.—takes place formerly occupied by **Fred Harvey**, who has joined Fuller & Ross, Inc., advertising agency, to become account executive for Westinghouse Electronic Tube Division.

Harry N. Reizes, manager of The Audio Fair, happily announcing that the 1952 event will be bigger and last longer—four days instead of three—than any preceding one.

GREENE IN NEW COMPANY

Irving Greene, co-author of the book *Make Music Live*, who resigned recently as Sound Department director of Sun Radio & Electronics Co., Inc. New York, is forming a new company in association with one of the industry's major distributors. As yet unnamed, the new firm will be located in New York City's midtown section, and will be devoted solely to the sale of audio equipment for both home and industry. Formal opening is scheduled for fall.

Naturally,

Jim Lansing

SIGNATURE
Speakers

ARE HANDLED BY

KIERULFF & CO.

LOS ANGELES
820 W. Olympic Blvd. • RI 7-0271

SAN DIEGO
2426 Fourth Ave. • Woodcrest 6275

FRESNO
725 "L" Street • Fresno 24108

PROFESSIONAL DIRECTORY

Custom-Built Equipment

U. S. Recording Co.

1121 Vermont Ave., Washington 5, D. C.
Lincoln 3-2705

Tape duplicating

Prices per 7" reel, any quantity, \$1.00 if we use your tape, or \$3.50 if we supply new plastic base Audiotape.

EMPIRE RECORDING CO.
3221 S. Acoma St., Denver, Colorado

CALIFORNIA SOUND PRODUCTS INC.

7264 Melrose Blvd., Hollywood 46, Calif.
"In The Audio Mile"

Manufacturers of Quality Audio Products
Distributor Inquiries Invited
Write for Descriptive Literature



WE ALSO MAKE GOOD AMPLIFIERS

Our main job in life is making the 215 speaker, and speakers have always been our chief interest. Yet because speakers deserve good amplifiers, we were, quite early in our career, asked to make those good amplifiers. It is just twenty years ago this month since the first high-fidelity amplifier in the world appeared—designed and produced by us. Believe it or not, it was a push-pull amplifier with negative feed-back. It had a flat response from 30 to 12,000 cps, and a power output of 10 watts, because even in those early days we believed in having a reserve of undistorted output power.

Today our 20 watt amplifier is still outstanding. With distortion of less than 1% at a power output of 20 watts, it is +1 db at 20 cps, -1 db at 60,000 cps, and dead flat from 30 to 50,000 cps. Hum level is -90 db. (that is, virtually non-existent), and it is absolutely free from incipient motor-boating or rf oscillation. These defects are frequently shown up with a scope and square-wave generator, and many amplifiers thought perfect may not pass this extreme test. Our amplifiers have to pass the test before they are sent out. Additionally, all our products are now comprehensively tested with white-noise.

Our tone-control preamplifier has won many friends in the U.S.A., as it has throughout the world. It has continuous control of treble and bass, and was designed to be the perfect corrector for LP records, taking everything else—78's, tape and radio—in its stride. There is no distortion at all in any position of the controls. Used with the 20 watt amplifier, it is as near perfect as you can ever hope to get an audio amplifying system.

BUT LOOK AT THE PRICE.

The 20 watt amplifier complete except for tubes (standard American types used) costs only \$110.00 (plus 12½% import duty) all freight charges paid. The Tone-control preamplifier similarly costs \$25.00. The legendary 215 speaker added to these at a cost of \$48.00 will give you an audio outfit which, to quote the words of our American visitors who have called to see us this summer, ends the search for many years to come, at a price level which on the face of it seems ridiculous. The best is not always the dearest.



Illustrated catalogue free on request, AND we shall be with you again at the Audio Fair in New York.

H. A. HARTLEY CO. LTD.
152, Hammersmith Road
London W.6, England

ADVERTISING INDEX

Advance Electric & Relay Co.	4
Amperite Co., Inc.	48
Ampex Electric Corp.	32
Amplifier Corp. of America	40
Arnold Engineering Co., The	3
Audak Co.	31
Audio Devices, Inc.	Cover 2
Beam Instruments Corp.	43
Bell Sound Systems, Inc.	47
Bell Telephone Laboratories	12
British Radio Electronics Ltd.	53
Brook Electronics, Inc.	45
California Sound Products, Inc.	55
Cannon Electric Co.	8
Carter Motor Co.	47
Chicago Transformer Co.	34
Cinema Engineering Co.	41
Classified Ads	54
Daven Co., The	Cover 3
Electro Engineering Works	44
Empire Recording Co.	55
Hartley, H. A., Co. Ltd.	56
Harvey Radio Co., Inc.	29
Heath Co., The	42
Hollywood Electronics	35
Hycor Co., Inc.	37
Kierulff & Co.	40, 46, 48, 52, 55, 56
Leonard Radio, Inc.	39, 42
Magnetic Recorders Co.	46
Miller, J. W., Co.	52
Minnesota Mining & Manufacturing Co. 6, 7	
Newcomb Audio Products Co.	25
Partridge Transformers Ltd.	56
Pentron Corp., The	45
Pickering & Co., Inc.	11
Precision Film Laboratories, Inc.	9
Professional Directory	55
Rauland-Borg Corp.	36
Reeves Equipment Corp.	53
Rek-O-Kut Co.	2
Stephens Manufacturing Corp.	54
Terminal Radio Corp.	49
Thermador Electrical Manufacturing Co. 5	
Triad Transformer Manufacturing Co. 1	
Turner Co., The	33
U. S. Recording Co.	55
United Transformer Corp.	Cover 4

PARTRIDGE WILLIAMSON OUTPUT TRANSFORMER

**Built to the
original specification**

De-luxe model now available from stock from all important Radio Stores throughout the U.S.A. (Price \$26.00 duty paid)

This transformer is now accepted as the most efficient in the world. According to "Audio Engineering" (Nov. 1949), there is no U.S. equivalent. Thousands already sold in the U.S.A. Partridge P.1292 16 watt Output Transformer now available is intended for use in equipment reproducing the full audio frequency range with the lowest possible distortion. Series leakage inductance .10 mh. (Price \$21.00 duty paid.)

The Following Stores are among those now Stocking Partridge Transformers.

Harvey Radio Co. Inc. 103 West 43rd Street, New York 18.	Electronic Wholesalers Inc. 2345 Sherman Ave., Washington, D. C.
Sun Radio Corp., 938 F Street, N.W., Washington, D. C.	Gates Radio Company, 2700 Polk Avenue, Houston, Texas.
Quincy, Illinois.	Wholesale Radio Parts Co. Inc. 311 W. Baltimore St., Baltimore 1, Maryland.
Terminal Radio Corp., 85 Cortlandt Street, New York 7.	

Sole Agents in Canada: Atlas Radio Corporation, 560 King Street West, Toronto 2-B.

If you are unable to purchase Partridge transformers in your city, write to us and mention the name of your dealer.

Fullest data, including square-wave tests, distortion curves, etc., together with list of U. S. stockists rushed Air Mail to you.

PARTRIDGE TRANSFORMERS LTD.
TOLWORTH, SURREY, ENGLAND

Naturally,

Concertone

MAGNETIC TAPE
RECORDER

BERLANT ASSOCIATES

IS
HANDLED BY
KIERULFF & CO.

LOS ANGELES
820 W. Olympic Blvd. • RI 7-0271

•
SAN DIEGO
2426 Fourth Ave. • Woodcrest 6275

•
FRESNO
725 "L" Street • Fresno 24108

PRODUCTS OF WORLD-FAMOUS

DAVEN

CREATIVE - ENGINEERING



TYPE T-330

DAVEN
ATTENUATORS

Exclusive Features:

- 1. "Knee-Action" Blade**
 - Tamper proof
 - Uniform contact pressure and low contact resistance over the life of every unit.
 - Each rotor blade individually supported to give positive contact in operation under all types of conditions.
- 2. Brass Case of 2-Piece Construction**
 - Greatly reduces clearance space required for removal of cover in rear of unit.
- 3. "Lock-Tite" Dust Cover**
 - Held by positive, bayonet-type lock which prevents cover from falling off under stress of vibration.
- 4. Enclosed Roller-Type Detent Mechanism**
 - For extra long life and positive indexing.
 - Addition of detent does not increase depth of unit.
- 5. Low-Loss Molded Terminal Board**
 - For high resistance to leakage.
- 6. Rigidly Supported Resistor Strips**
 - With air insulation.

YEARS AHEAD, CREATIVE-ENGINEERING

has always characterized Daven's efforts in the production of electronic components and equipment.

The unit illustrated above is only one in a complete line of Daven's world-famous attenuators. Because this Company has pioneered and created so many worth-while improvements in units of this type, you can do no better than to specify Daven Attenuators.

Daven's skilled staff of specialist-engineers is at your "beck and call" to help with your problems in the selection of the right attenuators for the equipment you are designing.

Write for complete catalog data.

THE **DAVEN** CO.

185 CENTRAL AVENUE
NEWARK 4, NEW JERSEY





for Stock Hermetically Sealed Components

For over fifteen years UTC has been the largest supplier of transformer components for military applications, to customer specifications. Listed below are a number of types, to latest military specifications, which are now catalogued as UTC stock items.



RCOF CASE

Length 1 25/64
 Width 61/64
 Height 1 13/32
 Mounting 1 1/8
 Screws 4-40 FIL.
 Cutout 7/8 Dia.
 Unit Weight 1.5 oz.

MINIATURE AUDIO UNITS...RCOF CASE

Type No.	Application	MIL Type	Pri. Imp. Ohms	Sec. Imp. Ohms	DC in Pri., MA	Response \pm 2db. (Cyc.)	Max. level dbm	List Price
H-1	Mike, pickup, line to grid	TF1A10YY	50,200 CT, 500 CT*	50,000	0	50-10,000	+ 5	\$16.50
H-2	Mike to grid	TF1A11YY	82	135,000	50	250-8,000	+21	16.00
H-3	Single plate to single grid	TF1A15YY	15,000	60,000	0	50-10,000	+ 6	13.50
H-4	Single plate to single grid, DC in Pri.	TF1A15YY	15,000	60,000	4	200-10,000	+14	13.50
H-5	Single plate to P.P. grids	TF1A15YY	15,000	95,000 CT	0	50-10,000	+ 5	15.50
H-6	Single plate to P.P. grids, DC in Pri.	TF1A15YY	15,000	95,000 split	4	200-10,000	+11	16.00
H-7	Single or P.P. plates to line	TF1A13YY	20,000 CT	150/600	4	200-10,000	+21	16.50
H-8	Mixing and matching	TF1A16YY	150/600	600 CT	0	50-10,000	+ 8	15.50
H-9	82/41:1 input to grid	TF1A10YY	150/600	1 meg.	0	200-3,000 (4db.)	+10	16.50
H-10	10:1 single plate to single grid	TF1A15YY	10,000	1 meg.	0	200-3,000 (4db.)	+10	15.00
H-11	Reactor	TF1A20YY	300 Henries-0 DC, 50 Henries-3 Ma. DC,	6,000 Ohms.				12.00



RC-50 CASE

Length 1 5/8
 Width 1 5/8
 Height 2 5/16
 Mounting 1 5/16
 Screws #6-32
 Cutout 1 1/2 Dia.
 Unit Weight 8 oz.

COMPACT AUDIO UNITS...RC-50 CASE

Type No.	Application	MIL Type	Pri. Imp. Ohms	Sec. Imp. Ohms	DC in Pri., MA	Response \pm 2db. (Cyc.)	Max. level dbm	List Price
H-20	Single plate to 2 grids, can also be used for P.P. plates	TF1A15YY	15,000 split	80,000 split	0	30-20,000	+12	\$20.00
H-21	Single plate to P.P. grids, DC in Pri.	TF1A15YY	15,000	80,000 split	8	100-20,000	+23	23.00
H-22	Single plate to multiple line	TF1A13YY	15,000	50/200, 125/500**	8	50-20,000	+23	21.00
H-23	P.P. plates to multiple line	TF1A13YY	30,000 split	50/200, 125/500**	8	30-20,000 BAL.	+19	20.00
H-24	Reactor	TF1A20YY	450 Hys.-0 DC, 250 Hys.-5 Ma. DC,	6,000 ohms ...				15.00
			65 Hys.-10 Ma. DC, 1500 ohms.					



SM CASE

Length 11/16
 Width 1/2
 Height 29/32
 Screw 4-40 FIL.
 Unit Weight 8 oz.

SUBMINIATURE AUDIO UNITS...SM CASE

Type No.	Application	MIL Type	Pri. Imp. Ohms	Sec. Imp. Ohms	DC in Pri., MA	Response \pm 2db. (Cyc.)	Max. level dbm	List Price
H-30	Input to grid	TF1A10YY	50***	62,500	0	150-10,000	+13	\$13.00
H-31	Single plate to single grid, 3:1	TF1A15YY	10,000	90,000	0	300-10,000	+13	13.00
H-32	Single plate to line	TF1A13YY	10,000****	200	3	300-10,000	+13	13.00
H-33	Single plate to low impedance	TF1A13YY	30,000	50	1	300-10,000	+15	13.00
H-34	Single plate to low impedance	TF1A13YY	100,000	60	.5	300-10,000	+ 6	13.00
H-35	Reactor	TF1A20YY	100 Henries-0 DC, 50 Henries-1 Ma. DC,	4,400 of ms.				11.00

The impedance ratings are listed in standard manner. Obviously, a transformer with a 15,000 ohm primary impedance can operate from a tube representing a source impedance of 7700 ohms, etc. In addition, transformers can be used for applications differing considerably from those shown, keeping in mind that impedance ratio is constant. Lower source impedance will improve response and level ratings... higher source impedance will reduce frequency range and level rating.

- * 200 ohm termination can be used for 150 ohms or 250 ohms, 500 ohm termination can be used for 600 ohms.
- ** 200 ohm termination can be used for 150 ohms or 250 ohms, 125/500 ohm termination can be used for 150/600 ohms.
- *** can be used with higher source impedances, with corresponding reduction in frequency range. With 200 ohm source, secondary impedance becomes 250,000 ohms... loaded response is -4 db. at 300 cycles.
- **** can be used for 500 ohm load... 25,000 ohm primary impedance... 1.5 Ma. DC.

United Transformer Corp.
 150 VARICK STREET NEW YORK 13, N.Y.

EXPORT DIVISION: 13 EAST 40th STREET, NEW YORK 16, N.Y. CABLES: "ARLAB"