

**THE**

**INTERNATIONAL**

**Audio**

**FESTIVAL**

**&**

**Fair**

**APRIL 1964**

# ***Ferroglyph***



**We shall be pleased to see you at  
BOOTH 67  
DEMONSTRATION ROOM 337  
OFFICE 339**

*or write for full details to :*

**THE FERROGRAPH COMPANY LIMITED**

84 BLACKFRIARS ROAD, LONDON, S.E.1. Telephone : WATerloo 1981

see **QUAD**  
on stand no. 58  
and hear  
**QUAD** in  
demonstration  
room 422



for the closest approach to the original sound

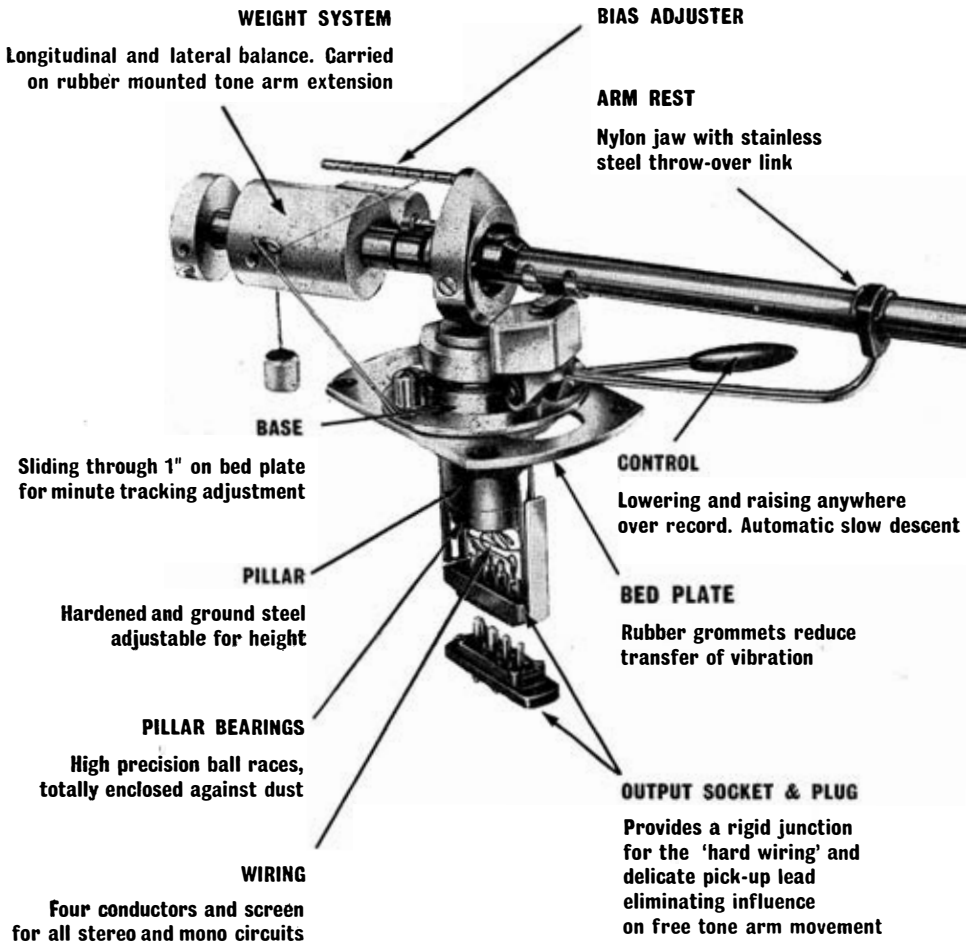



**TONE ARM**

Carried on virtually frictionless knife edges  
Resonance damped by wood lining

**SHELL**

Suitable for all standard cartridges  
Screw fixings at  $\frac{1}{2}$ " centres

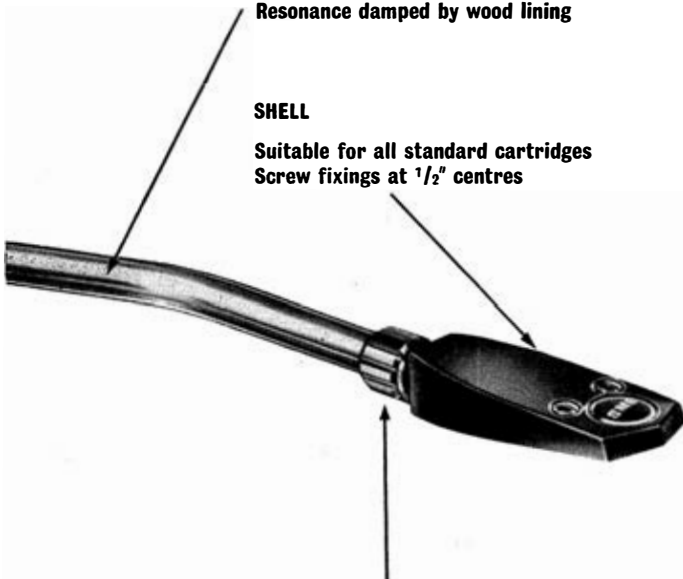

International standard 4-pin socket  
(Suitable for Ortofon etc.)  
Also Decca with S.M.E. adaptor D.2.

*The best pick-up arm in the world*

# New Reslo Pencil Dynamics



Pencil  
Dynamic  
Type PD



Mini  
Pencil  
Dynamic  
Type MPD

*Reslo* Reslosound has specialised for more than 30 years in the manufacture of ribbon and moving coil microphones which are in great demand for use with high quality tape recorders and in the entertainment industry generally.

---

## CHAPMAN domestic high fidelity equipment



306  
INTEGRATED  
STEREO  
AMPLIFIER

**DERRITRON RADIO LTD. (Chapman Division)** produce the widest range of British tuners from VHF.FM only, to 6 stage AM bandspread and high-gain FM. Illustrated is the "new look" 306 — integrated 8 + 8 W Stereo Amplifier.

*Full technical details and price information on the complete matching range of Chapman equipment and Reslo microphones is available from:*

**DERRITRON LTD.**

24, Upper Brook Street, London, W.1. HYDe Park 2291





Model STB1

# NO COMPROMISE ... for the best in Audio

Every link in the chain is as vital as the next when it comes to getting the best in High Fidelity and the tape recorder is no exception.

The Brenell range of three basic machines, which covers practically every requirement, has an enviable reputation for quality of performance, ease of operation, versatility and solid dependability.



Mark 5  
Type M



Mark 5  
Series 2

see and hear  
for yourself

**STAND No28**  
Demonstration Room 342

or write for full details to the sole manufacturer :-

**Brenell**

**BRENELL ENGINEERING CO. LTD.,**  
1a DOUGHTY STREET, LONDON, W.C.1  
Telephone : HOLborn 7356 (3 lines)

# The shapes of sound

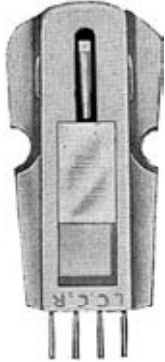
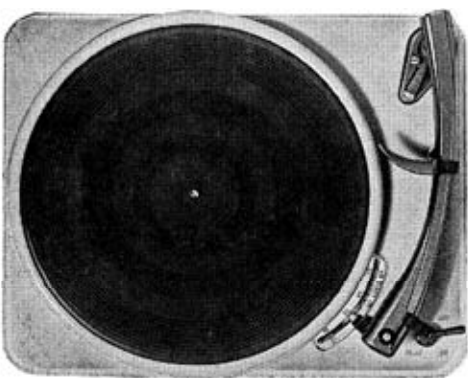
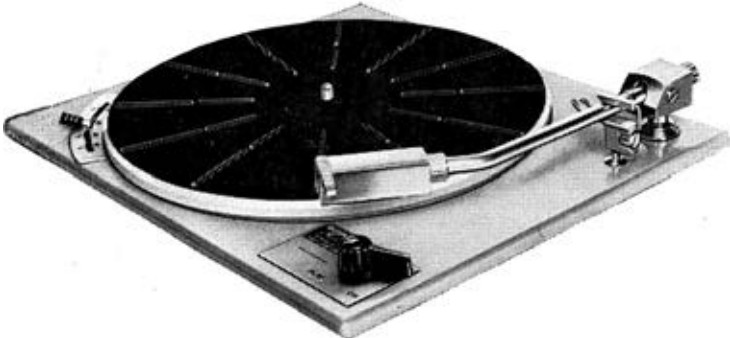
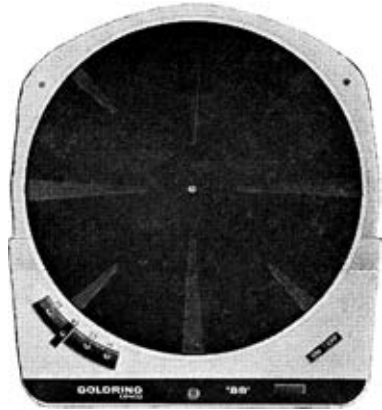

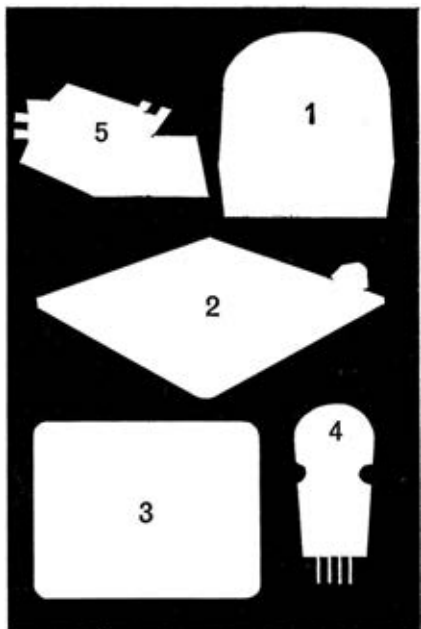

### Goldring-Lenco Transcription Units

All Goldring-Lenco transcription units are powered by the now famous Lenco 4-pole constant velocity motor and have the unique vertical drive system which permits continuously variable speed from above 80 r.p.m. to below 30 r.p.m. and from 15 to 18 r.p.m. with adjustable click-stops for the four standard speeds. There is less than 1% speed change for 13% mains voltage change. Wow and flutter—0.2% maximum. Rumble and hum are negligible.

**1. The '88'** For use with separately mounted transcription arms. 8 lb. die-cast, accurately machined non-magnetic turntable. The press-button on/off switch, linked to a neon pilot light, also engages and disengages the drive. Price £16.5.6 (plus P.T. £2.12.11).

**2. G.L.70** Incorporating the superb Swiss-engineered L.70 transcription arm with interchangeable shell which will house virtually any hi-fi cartridge. Wired for stereo and/or mono. Machined die cast 8 lb. non-magnetic turntable. The on/off switch is linked to a pick-up lowering device. Price £23.12.6 (plus P.T. £3.16.10) or, mounted on box-type base, £26.12.6 (plus P.T. £4.6.7).

**3. G.L.58** The much-praised 'budget' transcription unit, with integral transcription arm taking virtually any hi-fi cartridge on an ingenious and interchangeable nylon slide-in 'platform'. Wired for stereo or mono. Turntable weighs 3 $\frac{3}{4}$  lbs. The on/off switch is linked to a pick-up lowering device. Price £14.14.0 (plus P.T. £2.7.9) or, mounted on box-type base, £17.4.0 ( plus £2.15.11).

**4. C.S.90 Stereo Ceramic Special** A ceramic cartridge with the characteristics of a top quality magnetic! Can be loaded straight into an amplifier with a sensitivity of 100mV or more. Tracks at 1 $\frac{1}{2}$ –3 grammes. Fitted with .0005" replaceable diamond stylus. Price £4.4.0 (plus P.T. 13/8d.).

**5. Pickering 380A Cartridge** One of the most acclaimed stereo cartridges in the world. The moving magnet 380A, of hermetically sealed construction, features the exclusive "V-Guard" push-in diamond stylus assembly and tracks at 2 grammes giving faultless reproduction from even the most exacting recorded material. Price £12.12.0 (plus P.T. £2.0.11).

**Other Goldring Cartridges include** the well-known variable reluctance "600" (mono) and "700" (stereo).

---

. . . and, of course, there is a Goldring guaranteed replacement stylus—diamond or sapphire—for virtually every modern pick-up cartridge.

---

## HI-FI EQUIPMENT BY **GOLDRING**

STAND  
**20**



GOLDRING MANUFACTURING CO. (G.B.) LTD  
486-488 High Road, Leytonstone London E11 Phone: LEYtonstone 8343



**BOOTH NO. 5  
DEMONSTRATION  
ROOM 402**

**LET THE  
EXPERTS  
GUIDE YOUR  
SELECTION**



**MAGNETOPHON STEREO 97 and 98.** Stereo from Telefunken! These recorders were news when first released and live up to their great promises. The 97 and 98 are the same price, but the 97 is a quarter-track recorder. Both have a high signal-to-noise ratio, wide frequency range and three speeds. 95 gns

**MAGNETOPHON 85 de luxe.** Two-speed half-track with excellent frequency response. New-styled case and plenty of exciting new features and refinements, including built-in splicing groove, remote control connection, new-style magic eye recording level indicator. 83 gns

**MAGNETOPHON 96** Quarter-track perfected! Wide frequency range, 3-speeds. Full inter-track transcription offering ideal effects for cine enthusiasts. No limit to trick effects that can be achieved with this machine. Can be used for stereo playback utilising stereo amplifier or radio. 62 gns



**AND NOW . . . A PORTABLE BATTERY TELEFUNKEN,  
THE BRAND NEW MAGNETOPHON 300**

The new 300, on show for the first time in this country. It operates in any position, powered by five 1.5 volt batteries (or a rechargeable battery, if preferred), uses 5 in. spools at 3½ i.p.s. The microphone has a built-in level control, with a pause button and combined recording level/playback volume control in the handle. Is completely push-button operated and introduces high-quality Telefunken electronics into the fully portable field. 59 gns (inc. TD7 mic)



**T**OP sound-studios everywhere use Telefunken recording equipment exclusively. Reason why? Telefunken made the world's first tape recorder, and with that head start they've been way ahead in research and development for years. Telefunken's wide range gives you a superb choice of equipment that integrates perfectly with your set-up, yet sounds great on its own. Whatever model you buy you'll know you bought the best. . . . Telefunken, the machine the professionals use at home! Telefunken has sound quality taped.

**MAGNETOPHON 55**  
The machine which brings high-quality tape recording into a lower-priced field. Elegantly styled, the smart wooden case ensures good sound reproduction. Two-speed half-track performance gives amazing frequency range for a machine in this class. 43 gns (inc. TD7 mic).



*For further details and illustrated catalogue giving details of Telefunken tape-recorders and accessories write to:*  
**WELMEC CORPORATION LTD.**  
27 Chancery Lane  
London WC2

**TELEFUNKEN**

# THE AIREDALE

*The "move-anywhere"*  
**FREE STANDING SPEAKER  
 ASSEMBLY**

For many years the Wharfedale omni-directional 3-speaker Corner System has been recognised as a superbly natural reproducer, and has frequently stood the difficult test of comparison with live musical performances. The AIREDALE is a free standing version of this speaker, suitable for corner or along the wall location. Cabinet resonance is avoided by sand filling the front panel and fitting ceramic tiles to rear side panels. Some idea of the solid construction is given by the fact that the total weight exceeds  $\frac{1}{4}$ -cwt. Fitted with castors for ease of movement.

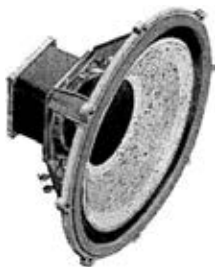
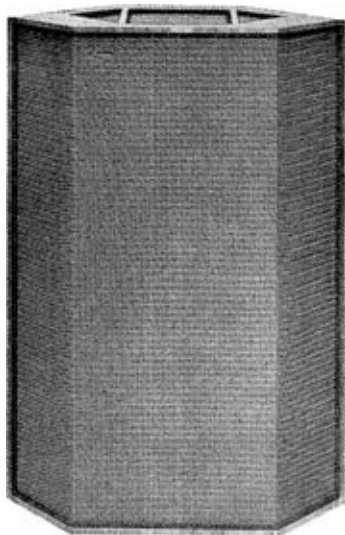

## In the Airedale

*L.F. output is produced by a 15in. unit type W15/RS, fitted with heavy cone and impregnated cloth roll surround for minimum distortion.*

## THE AIREDALE

*SIZE: 39in. x 28½in. x 14in.  
 WEIGHT: 91 lb. complete.  
 IMPEDANCE: 12/15 ohms only.  
 MAX. INPUT: 20 watts.  
 Individual controls for middle and treble response are located in the rear panel.  
 £65 fully finished with a choice of polished walnut or mahogany veneers, or oiled teak.  
 Oak finish available to special order.  
 £64 unfinished.  
 Fully descriptive literature free on request.*

**Wharfedale**

**WHARFEDEALE WIRELESS WORKS LTD.**

Idle • Bradford • Yorkshire

Tel.: Idle 1235/6

Grams: 'Wharfedel' Bradford



*This*

This advertisement appeared in the March issues of the leading technical press. We now give you the answers.

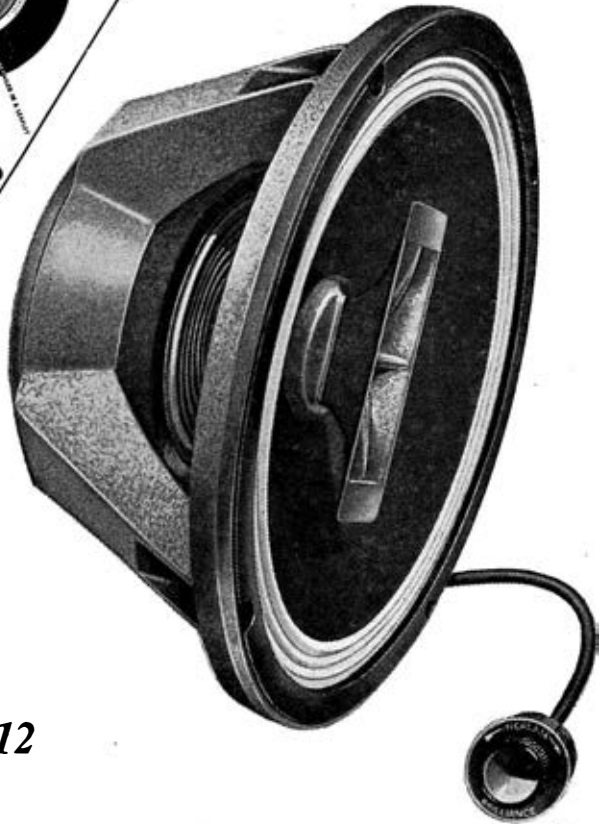

**12"/20w**  
*De Luxe*

*Model CX 2012*

Overall Frequency Response	30-18,000 c/s
Power Handling Capacity	20 watts
Fundamental Resonance	35 c/s
Cross-over Frequency	4 kc/s
Impedance	15/16 ohms

**BRILLIANCE CONTROL**  
provides adjustment of high-frequency level to suit room conditions.

**Celestion** **STUDIO SERIES**

**CELESTION LTD. Ferry Works, Thames Ditton, Surrey. Telephone: EMBerbrook 3402**



# IS IT!

---

*...an  
entirely  
new range of  
'professional'  
loudspeakers*

**12"/15w**  
**Standard**

*Model CX 1512*

Overall Frequency Response	30-15,000 c/s
Power Handling Capacity	15 watts
Fundamental Resonance	35 c/s
Cross-over Frequency	4 kc/s
Impedance	15/16 ohms

**SEE**  
**and HEAR**  
**for yourself on—**

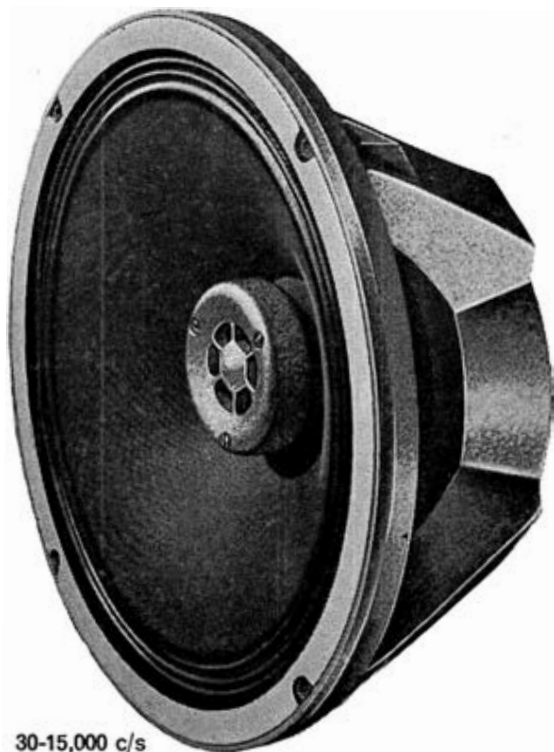

**STAND No. 8**  
and in Demonstration Room 149

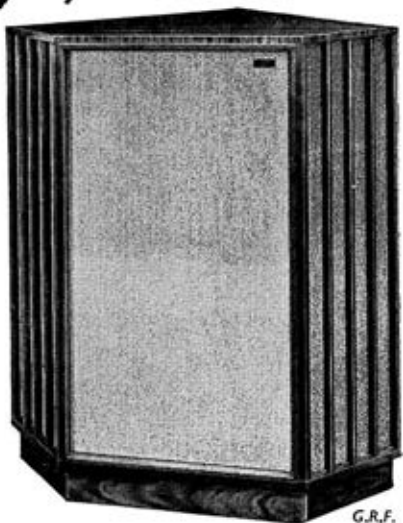

G.R.F.  
enclosure

It's  
the sound  
that counts  
... not the  
size!

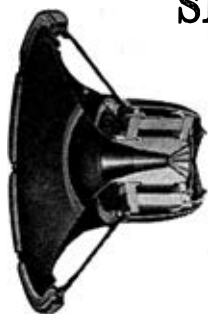

There is a growing tendency for the compactness of a Loudspeaker to be regarded as a prime criterion of its excellence; this is most misleading. Generally speaking, the larger the Loudspeaker and its associated Enclosure, the better it sounds. For this reason professional users choose, where possible, Loudspeakers of high power handling capacity, used in conjunction with generously proportioned Enclosures. The necessity occasionally arises for choosing small Loudspeakers due to lack of space, but remember, a large Loudspeaker System can accurately recreate a small intimate sound, but a small Loudspeaker System can never accurately recreate the sound of a large combination of instruments or voices, even with Stereo!

The Dual Concentric Loudspeaker System in its various forms has been in continuous production for 17 years. This fact, together with its increasing adoption as a quality Monitor by Professional users throughout the World, is an indication of the exceptionally high standard of this original design.

**TANNOY**

*the BIG*

*name in Quality Loudspeakers*

**SEE US AT STAND 23 & ROOM 447**

## Other things we do....

Fundamental Electro-acoustic research together with specialised test and measurement equipment for stringent quality control, are among the many activities of our research company—

### TANNOY LIMITED



*Houses of Parliament, Westminster*

Highly developed specialist manufacturing facilities, catering for all types of Audio and Electronic equipment, together with our main sales organisation are provided by—

### TANNOY PRODUCTS LIMITED



*Sound & Control Systems for Factories*

Rental, long and short term hire of Electro-acoustic equipment, ranging from simple inter-communication to complex industrial control systems, and multi-language interpretation systems throughout the World—

### TANNOY RENTALS LIMITED



*Multi-Language Interpretation for Conferences*

The distribution, manufacture and servicing of the complete range of Tannoy Equipment throughout the U.S.A.—

### TANNOY (AMERICA) LIMITED



*Monitor Dual Concentrics*

The distribution of Electro-acoustic equipment, together with the renting and operation of many important systems such as the Canadian House of Commons—

### TANNOY (CANADA) LIMITED



*House of Commons, Ottawa*

A wide range of Marine Instruments including Inflammable Vapour Detectors, Bilge Level Indicators and complete Ventilating systems are provided by the youngest company in the Group—

### TANNOY MARINE LIMITED



*Marine Instruments*

# Ortofon

## THE WORLDS TWO

## TO give to you TOO superb

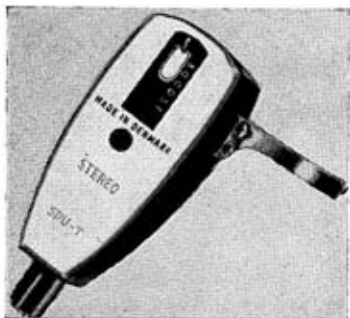

### SPU-GT STEREO CARTRIDGE

The Hi-Fi stereo cartridge with built-in transformers, will match into virtually all equipment without pre-amplifier, or other stages.

★ Channel Separation	20-25 dB
★ Frequency Response	20-20,000 c/s
★ Stylus Pressure	Below 2 gms
★ Compliance	10 cm/dyne
★ Fitted Low Mass (1 mg)	Diamond Stylus

Price £23.4.2 incl. P/T.

Now—The sensational Elliptical Diamond Stylus  
The Elliptical diamond will give better tracking of the most difficult recorded passages, and a superb brilliance in reproduction.

### SMG 212 Pick-up Arm

For exchangeable heads. Due to the special shape of the Pick-up Arm, turntable levelling is unnecessary. Precision engineered and statically balanced. Ball-bearings are applied for both horizontal and vertical action assuring trouble-free performance, even at the lowest possible stylus force. Height over mounting plate is adjustable.

Price £11.12.1 incl. P/T.

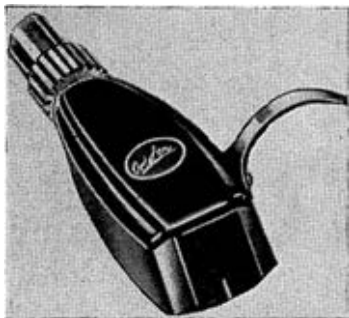

### CG (MONO) CARTRIDGE

STILL THE WORLD'S FINEST MONAURAL CARTRIDGE

Now available in the type "G" shell for use with ORTOFON Pick-up Arm SMG212. All ORTOFON Cartridges in type "G" shell are suitable for use with SME Arm.

Price £16.4.10 incl. P/T.

SPECIAL DEMONSTRATIONS OF ALL ORTOFON

Distributors for the U.K. New Service Department.

HEAR for  
YOURSELF!  
Booth No. 2A  
Demonstration Room  
336

# METRO SOUND SALES

*finest components  
sound reproduction  
to miss!*

# THORENS



## MODEL TD 124

The incomparable turntable which exceeds the most stringent requirements of broadcasting studios. The only turntable possessing all these outstanding features: ★ In-built levelling device. ★ Inertia - controlled drive system. ★ 4-pole motor. ★ 2 step speed reduction. ★ Four speeds — with variable control ( $\pm 3\%$ ) acting on all four speeds. ★ Integral stroboscope. ★ Turntable with clutch action. ★ Spring suspension.

Price, with SMG212 Pick-up Arm and SPU-GT Stereo Cartridge £71.8.5 incl. P/T.

★ THORENS TURNTABLES EXCEED BROADCAST STUDIO EQUIPMENT SPECIFICATIONS

**Introducing the Thorens Masterpiece TD 234. Details on application**

Model TD 135 complete with BTB 12S pick-up Arm

Here is surely the finest value for the budget-minded Hi-Fi enthusiast. THORENS professional quality turntables are outstanding examples of Swiss precision engineering. No other turntable approaches the operating efficiency of THORENS.

- ★ Spring suspension.
- ★ Special in-built levelling device.
- ★ Precision built 4-pole motor.
- ★ Variable speed control ( $\pm 3\%$ ).
- ★ Acting on four speeds.
- ★ Precisely machined non-magnetic turntable.

Price £35.8.4 incl. P/T.



## BTB. 12S Professional Pick-up Arm

Statistically balanced. Precision ball-bearings. Stylus force adjustment. INTEGRATED RAISE/LOWER CONTROL.

## AND THORENS EQUIPMENT

Nation-wide distribution. Write today for full descriptive literature.

**METRO-SOUND SALES LTD.,**  
Bridge Works, Wallace Road, N.1.

CANonbury 8641/4

HEAR for  
YOURSELF!  
Booth No. 3A  
Demonstration Room  
335

# COMPLETE AUDIO REALISM

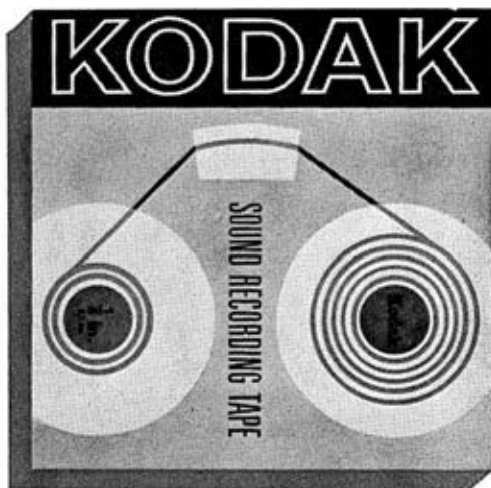

## —from new Kodak Sound Recording Tape

*There's never been a tape so sensitive as new Kodak Sound Recording Tape. For the first time you can capture complete audio realism. Sound so true you'll hardly believe it's recorded.*

- ▶ High output sensitivity
- ▶ Low noise performance
- ▶ Full audio frequency range response
- ▶ Double-lubricated for smooth transport
- ▶ Low bias adjustment

New Kodak Sound Recording Tape is manufactured to the same super-critical standards as Kodak film. Standards that have never been excelled in any coating process. Standards that give a coating uniformity that never varies more than plus or minus 20 millionths of an inch.

There are four types of new Kodak Sound Recording Tape to suit all requirements: standard, long play, double play and triple play—the extra strong tape with the extra long playing time.

Each reel is wrapped in a polythene bag and packed in a sturdy box. A form for recording data is printed on the back of the box. Each reel incorporates a special clip which eliminates tape spillage.

Write for further details of this new tape, to Dept. T6A, Kodak Ltd., Kodak House, Kingsway, London, W.C.2.

## Hear the Kodak demonstration now!

KODAK LIMITED, DEPT. T6A,  
KODAK HOUSE, KINGSWAY, LONDON, W.C.2.

Another  
BRILLIANT RECORDING  
on

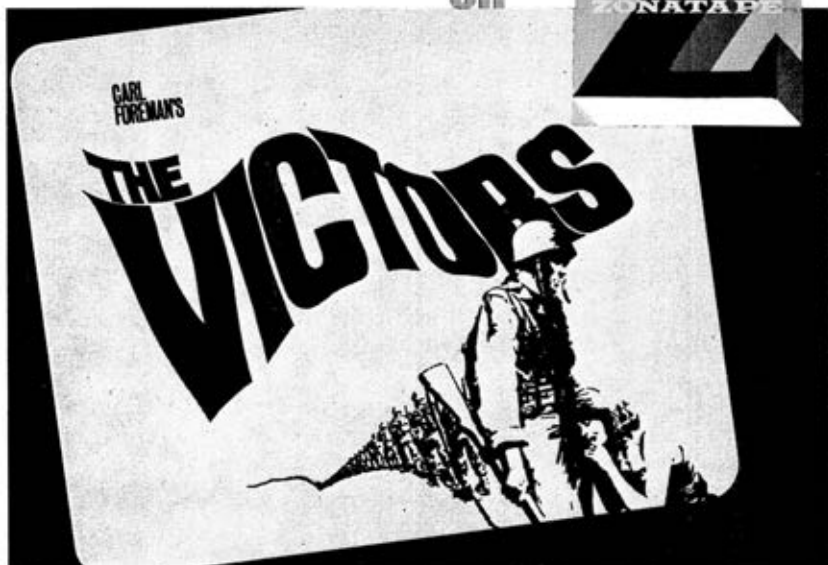

The same quality magnetic coating used for the magnificent sound recording of "THE VICTORS" is available to you . . . offers you a fidelity in recording limited only by the capability of your tape recorder. Choose from 4 types ; Diacetate or PVC Standard Play, Polyester Extra Play and—just released—Polyester Double Play. Wound on distinctive coloured spools, clear, red, green and blue for easier identification. Supplied in attractive, durable book-type containers. Stocked by all the best hi-fi and radio shops.

New—a comprehensive range of Zonatape accessories, including coloured printed leader and timing tapes . . . multi-purpose coloured leaders . . . and metallic stop and sensing foil.

BRIEF SPECIFICATION OF ZONATAPE  
TYPE 700 POLYESTER EXTRA PLAY

Intrinsic Coercivity Hci	310 Oersteds (high)
Rententivity Br.	1200 Gauss
Bias	6.3 milliamps
Peak signal to basic noise ratio	- 71 dB
Reel to reel variations	± 1 dB at 1000 cycles
Ultimate tensile stress	8 lb.

SEE US ON STAND 40  
**ZONATAPE**

CLEARLY THE BEST FOR RECORDING SOUND



**ZONAL FILM (MAGNETIC COATINGS) LTD**

ZONAL HOUSE, WESTFIELDS ROAD, ACTON, W.3. ACORN 6841

Introducing the new . . .

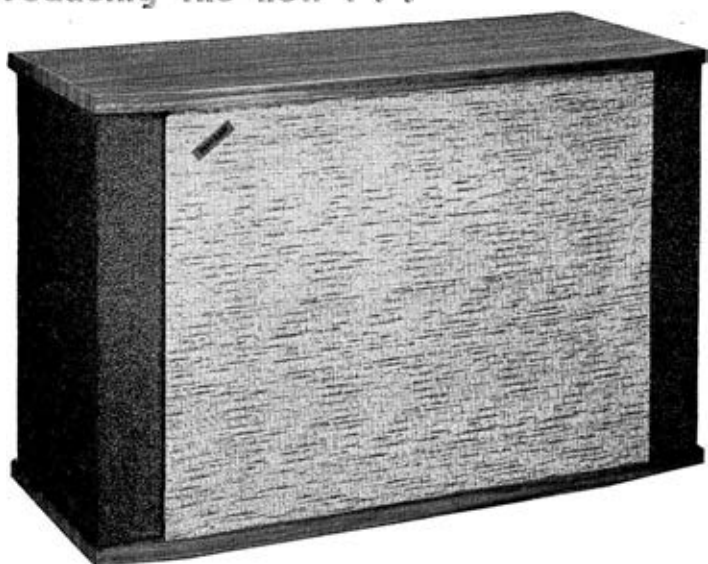

# MINI-CADET

## COMPACT SPEAKER SYSTEM

This latest addition to the range of ROGERS Speakers has been developed to cater for the listener requiring an extremely compact speaker system suitable for shelf or wall mounting. Despite its small size the performance is quite outstanding and belies the modest price.

Two speaker units are employed in an infinite baffle enclosure. The bass unit is a heavy duty 12in. unit on die-cast chassis; the treble unit a high flux 3 $\frac{3}{8}$ in. unit. An effective damping technique minimises bass resonance and distortion.

Styling features panels in Teak finish, plastic laminate and two-tone "Vynair" fabric.

### SPECIFICATION

Impedance :	10—16 ohms.
Power Rating :	10 watts.
Frequency Range :	40—18,000 cps.
Bass Unit :	Heavy Duty 12in. unit on die-cast chassis. Cambric treated core suspension. Gap Flux 14000 Gauss.
Treble Unit :	3 $\frac{3}{8}$ in. unit. Plastic core suspension. Gap Flux 13000 Gauss.
Cross-Over :	$\frac{1}{2}$ Section. Frequency 2200 cps.
Overall Dimensions :	20in. wide x 8 $\frac{1}{2}$ in. deep x 13 $\frac{1}{2}$ in. high.

RETAIL PRICE **£21.10.0**

DEMONSTRATION ROOM 449

BOOTH 43

ROGERS DEVELOPMENTS (ELECTRONICS) LTD.

"RODEVCO WORKS" • 4-14 BARMESTON ROAD • CATFORD • LONDON S.E.6

Tel.: Hither Green, 7424/4340.

Grams : RODEVCO LONDON S.E.6



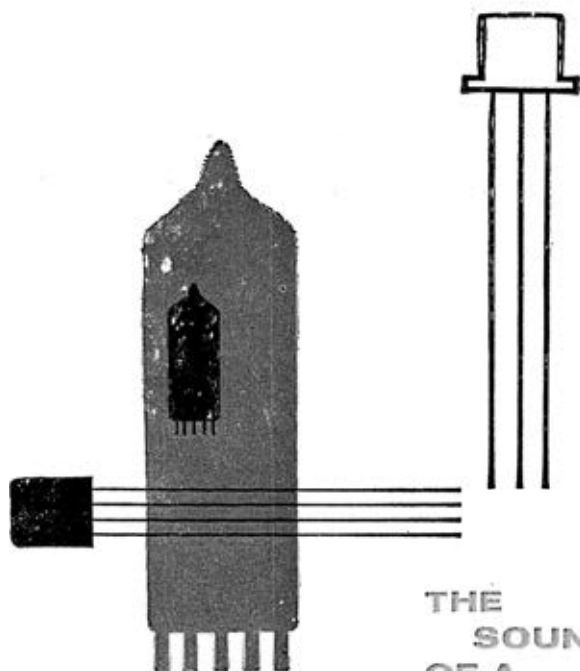

THE  
SOUND  
OF A  
NEW ERA

A few years ago nobody would have believed that a transistor amplifier could compare in quality with its valve counterpart. But at a recent test carried out by Mullard, 20 experts confirmed that transistor amplifiers now provide sound reproduction which is comparable with their valve equivalents.

Here's proof that a new era in high fidelity sound is already upon us and that once again Mullard is leading the way.

For further information about Mullard audio transistors visit Stand No. 50.



MULLARD LTD  
STAND No. 50  
AUDIO FESTIVAL

**4113****4114****4118****STEREO  
HEADSET**

## FROM THE STC HIGH PERFORMANCE RANGE

Among the range of **acoustic** equipment shown at the Audio Fair by Standard Telephones and Cables Limited will be:-

**4113.** A new uni-directional microphone of distinctive appearance which combines small size with good performance. The full audio frequency range is covered. In sound reinforcement systems feedback is greatly reduced. Response to breath noises and mechanical vibrations is reduced to a minimum.

**4114.** A new omni-directional microphone introduced at an extremely low price. It is eminently suitable for sound reinforcement and announcing systems, tape recorders, etc.

**4118.** A **light-weight** tubular omni-directional moving coil microphone offering a good performance at a very moderate price. Ideal for sound reinforcement, speech and music reproduction.

**Stereo Headset.** These are **dynamic** earphones having a wide frequency range and low distortion at high sound levels. A robust moving coil system incorporating a plastic diaphragm is housed in light-weight shock-proof moulded enclosures. The earphones are correctly matched and phased and are ideal for sound monitoring and stereo and high fidelity listening.

Details of the complete range are available from Standard Telephones and Cables Limited, Electro-Mechanical Division, West Road, Harlow, Essex. Telephone Harlow 21341. Telex 81184.



## Is this the best tape in the exhibition?

Opinion varies, of course, but we know for a fact that Gevasonor tape is regarded by many people as the nearest thing to perfection in sound reproduction.



GEVAERT LIMITED · GREAT WEST ROAD · BRENTFORD · MIDDX · Tel: ISLeworth2131

# microphones



of Vienna has specialised in the development and manufacture of high quality microphones of the dynamic and condenser types and headphones. In broadcasting, recording, and film studios, as well as for semi-professional applications you will find AKG microphones in use the world over.

16 anechoic chambers with the associated expensive measuring equipment, AKG's own analog computers for research and development, a new demonstration polaroscope equipment for instant pattern and many other highly scientific facilities ascertain that AKG products are the most advanced in their field.

## D 12

The D 12 dynamic microphone with cardioid characteristics has less tendency for developing feedback when loudspeakers are located near the microphone. And if you want more brilliancy, fuller bass, crystal clear transparency and higher volume ask for the D 12. Excellent sensitivity and magnetic shielding. Frequency response 40-15,000 cps. 18 db front back ratio.



## D 24B

The dynamic cardioid microphone D 24B has been designed for use in professional BC, television, and sound film studios as well as in electro-acoustic installations. It combines very wide frequency response (30-16,000 cps) with excellent front - to - back ratio (20 db).



## C 60

The C 60 miniature condenser microphone is a breakthrough in price and sound. It combines highest professional quality with light weight and small dimension. No peaks between 20 and 20,000 cycles. No instability, performs in all climates, with full 25 db front-back ratio at all frequencies. No residual noise, 19 db spl or better.



Vienna State Opera

Microphones  
pioneered  
in Vienna

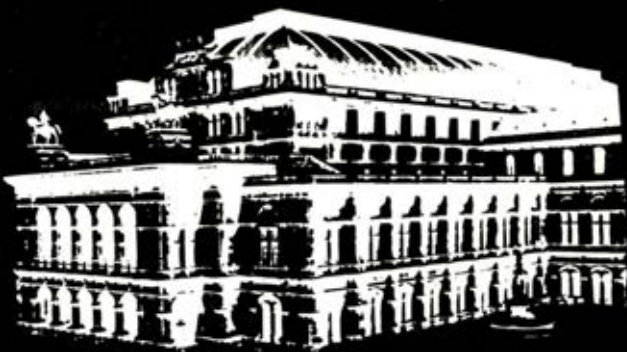

AKG microphones are shipped all over the world. Here, in the "Home Town of Music" scientists and designers work together to meet the challenge of the world's most critical audience.

## C 12 A

The C 12 A is the latest AKG Condenser microphone. The stabilised power supply has built-in remote control for the 9 polar patterns, controllable during actual programme pick-up. The exceptionally flat frequency response (30-20,000 cps) extends beyond the limits of audibility. Microphone C 12 A and power supply N 12 A are extremely small. No tubes are used, only 1 Nuvistor and 1 Transistor.



This is the  
sign  
to look  
for in  
microphones



## POLITECHNA (LONDON) LTD.

3 PERCY STREET LONDON W.1  
Telephone: Langham 6236 Telex: 23894 Cables: Polindust London

Amalgated Wireless (Australasia) Ltd., Sydney, Wellington — Soundrite Ltd., Singapore, Penang, Kuala Lumpur — The China Engineers Ltd., Hong Kong — Caldwell A-V Equipment Co. Ltd., Toronto 5, Ont., Canada — International Aeradio (East Africa) Ltd., Nairobi — David Pollock (Pty) Ltd., Johannesburg.

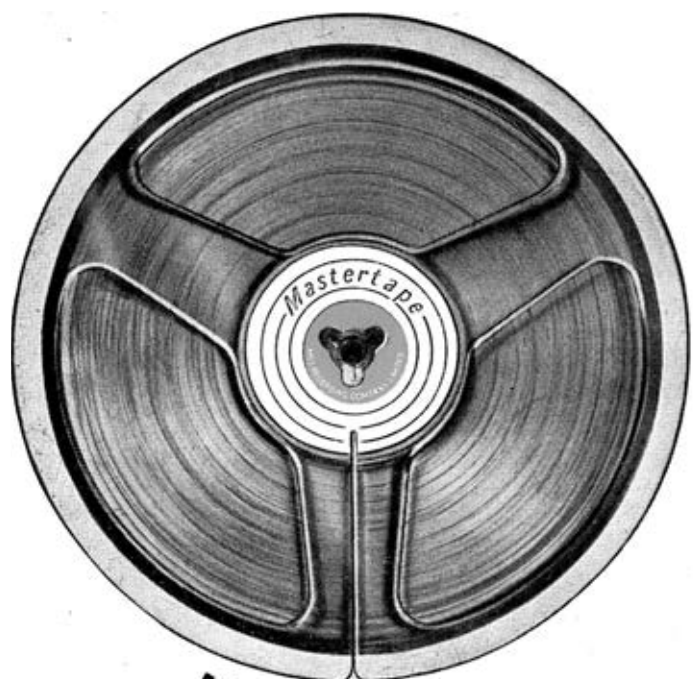

MSS MASTERTAPE

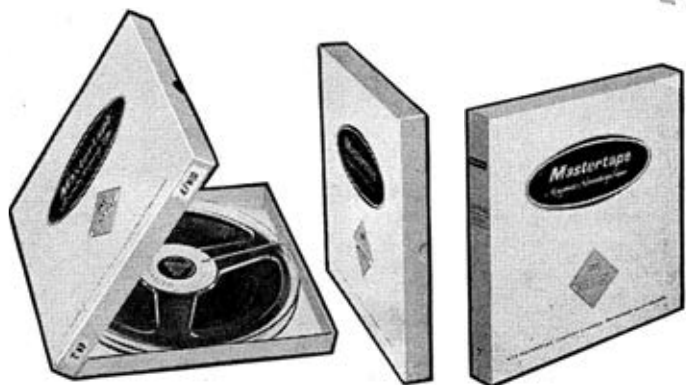

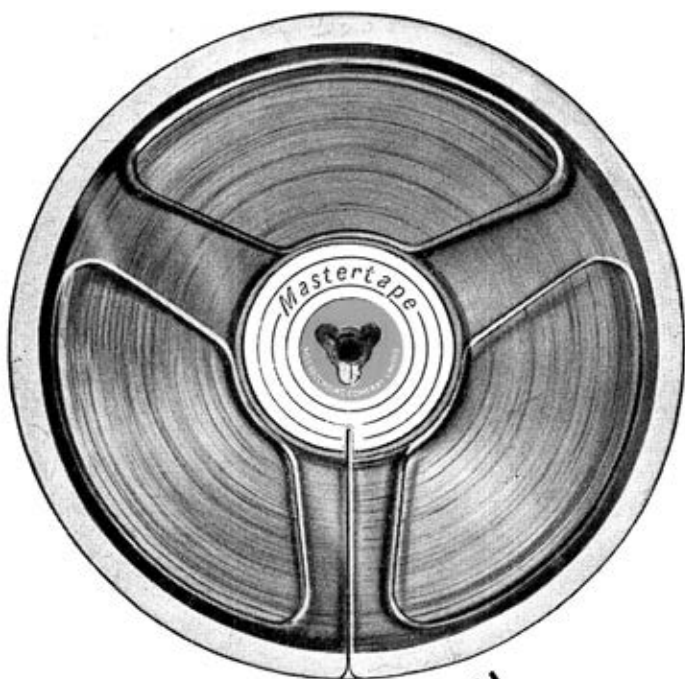

**FOR TRUE LIFE REPRODUCTION**

Come and see the full MASTERTAPE range of outstanding quality Magnetic Recording Tape and accessories on

**STAND NO. 51**

For your interest and enjoyment we are presenting throughout the duration of the Fair in

**DEMONSTRATION ROOM 217**

our full colour film entitled "A Journey into Tape"

*"We look forward to seeing you"*



**M.S.S. RECORDING COMPANY LTD.,**  
Colnbrook, Slough, Bucks. Telephone Colnbrook 2431 (8 lines)





**YOU CAN SELECT FROM**

**A RANGE OF TOPICS**

**AND LISTEN TO A SHORT TALK ON**

**THE SUBJECT IN WHICH YOU ARE INTERESTED.**

**WHILST YOU ARE LISTENING**

**A COPY WILL BE MADE AUTOMATICALLY FOR YOU**

**TO TAKE AWAY FREE OF CHARGE.**



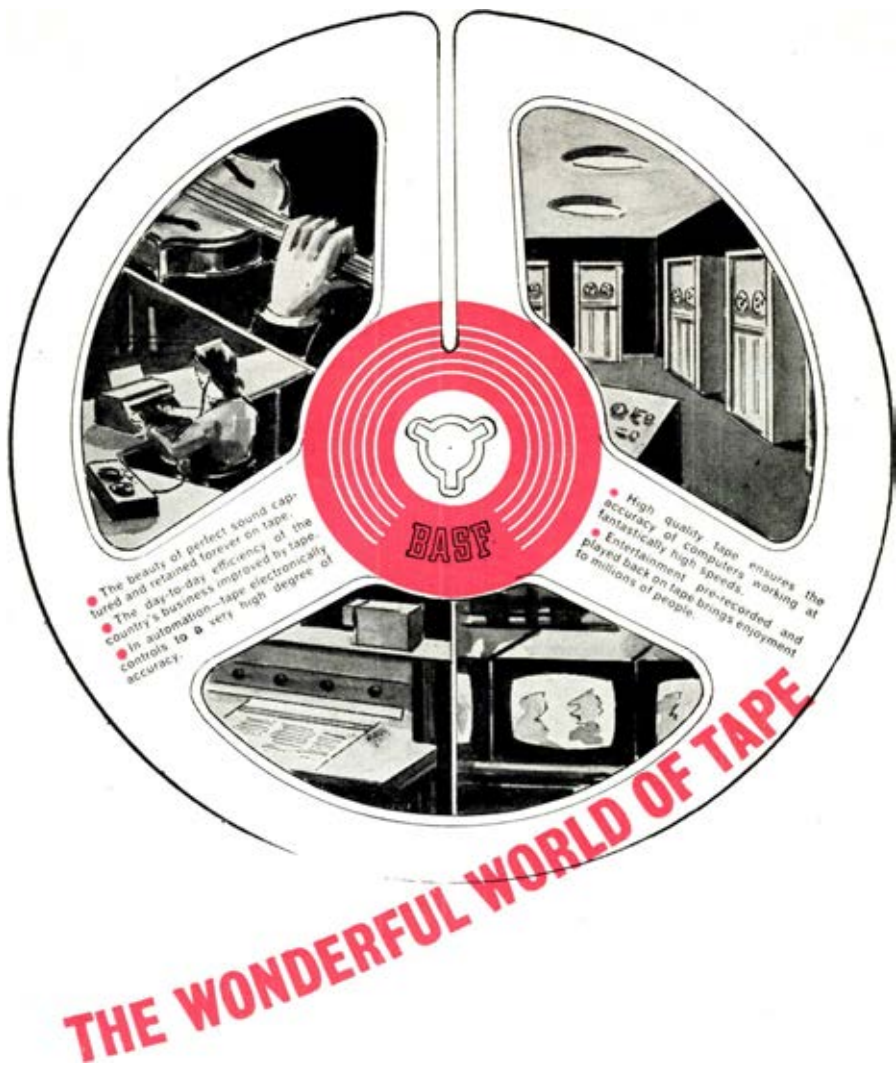

- The beauty of perfect sound captured and retained forever on tape.
- The day-to-day efficiency of the country's business improved by tape controls to a very high degree of accuracy.

- High quality tape ensures the accuracy of computers working at fantastically high speeds.
- Entertainment pre-recorded and played back on tape brings enjoyment to millions of people.

BASF—first to produce magnetic recording tape, so opening up channels which affect every one of us. Today, the imagination, initiative and craftsmanship which made this possible are invested in maintaining BASF tapes at a standard of technical perfection unequalled throughout the world. BASF magnetic recording tapes are recognized for qualities of dimensional and magnetic stability, full frequency response, negligible print through and mirror finish surface. The wide range ensures that there's a BASF tape for every type of machine and every possible requirement—INCLUDING YOURS.



—**SYMBOL OF AUTHENTIC SOUND**

**BASF CHEMICALS LIMITED**

5a Gillespie Road, London N.5. TEL : CANonbury 2011

# S. G. Brown's

# NEW

MODERN STYLING

ATTRACTIVE PRESENTATION

## The **NEW** Princess

*A lightweight headset using a new non-magnetic capsule of high impedance. Excellent reproduction and low price (£1 16s. 0d.) makes this attractive new model admirably suitable to amateur radio and tape enthusiasts.*



*A Hawker Siddeley Company*



**3C.600/1  
PRINCESS  
HEADSET**  
High Impedance  
£1 16s. 0d.



**5C.600/1  
STETHOSCOPE  
HEADSET**  
High Impedance  
£3 6s. 0d.  
(Low Impedance  
Model 5C.100/2,  
same price)



**3C.402/1  
HOSPITAL  
HEADPHONES**  
High Impedance  
£1 1s. 0d.



**3C.400/1  
STANDARD 'F'  
HEADPHONES**  
High Impedance  
£3 4s. 0d.  
(Low Impedance  
Model 3C.400/4  
same price)

**S. G. BROWN LTD., Communications Division,  
King George's Avenue, Watford, Herts.**

Telephone: Watford 23301. Grams: Radiolink,  
Watford. Telex: 23412 Radiolink, Wtfd.

# RANGE

A NEW APPROACH TO HEADSET DESIGN

ADVANCED TECHNICAL FEATURES



**6C.101/1  
PILLOWPHONES  
SPONGE**  
Type M/C  
High Impedance  
£3 19s. 0d.



**3C.501/1  
SUPER 'K'  
HEADPHONES**  
Stereo  
Low Impedance  
£6 17s. 0d.



**6C.102/1  
PILLOWPHONES  
M/I Immersible**  
High Impedance  
£2 8s. 0d.

**6C.104/1  
PILLOWPHONES  
M/C**  
Immersible  
High Impedance  
£3 14s. 0d.

Make a point of seeing and trying the new developments in Headset design on the S. G. Brown Stand. This restyled range, with outstanding features of design and presentation, includes the exciting new Diplomat Headset introduced at this year's Fair.

STAND No. 27  
DEM. ROOM 421

**If you are  
a Dealer . . .**

Call in at our office at the Fair, Room 426, and have a chat about the new range and current distribution facilities.



A Hawker Siddeley Company

**S. G. BROWN LTD., Communications Division,  
King George's Avenue, Watford, Herts.**

Telephone: Watford 23301. Grams: Radiolink,  
Watford. Telex: 23412 Radiolink, Wtfd.

# **garrard**

Seeing—and hearing—is believing. And you can do both on the Garrard stand. See and hear the new Model 3000LM automatic record changer with low-mass pick-up arm.

Judge for yourself the outstanding performance obtainable. Feather-light tracking reduces record wear to the minimum; absence of resonance marks up the performance to the highest of standards.

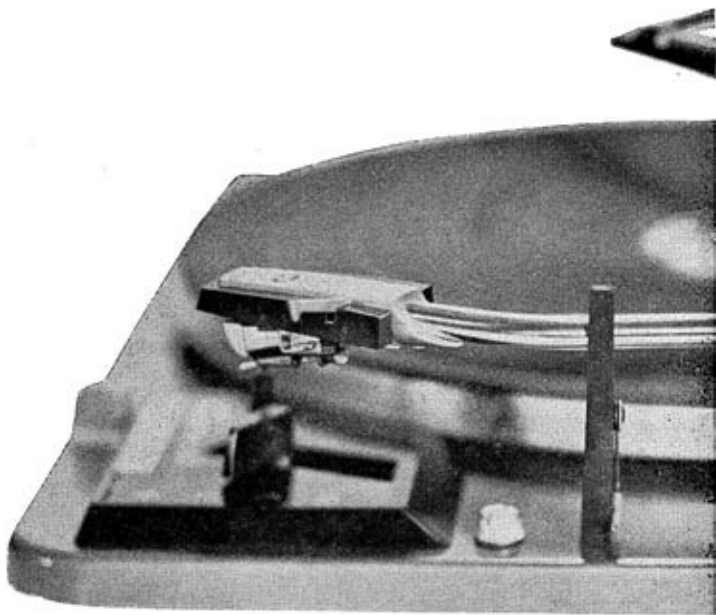

# 1st again!

Specifically designed for use with the very highest quality stereophonic pick-up cartridges having low tip mass and high stylus compliance. Garrard have the widest range of record playing units to suit Hi-Fi enthusiasts or music lovers—manufacturers, too.

**Garrard Engineering Ltd · (Dept. AF) · Swindon · Wiltshire**



Come along and see us at Booth 29, Room 145—  
and find out for yourself just how much Garrard can offer  
in the way of sound reproduction.

 G20

**YOUR NEXT TAPE RECORDER  
MAY BE ON**



**PHILIPS**

**STAND**

**54**

*Demonstration  
Rooms: 109 & 111*

Whatever Philips tape recorder you care to examine on Stand 54, you'll be impressed by its styling, its faithful reproduction and its overall outstanding performance. From smart, portable battery model to full-scale stereo machine, Philips tape recorder range offers you a wide selection of styles and prices.

**See the Philips tape recorder range on Stand 54, and in  
Demonstration Rooms 109 and 111**

# This new KEF speaker *MUST be heard*

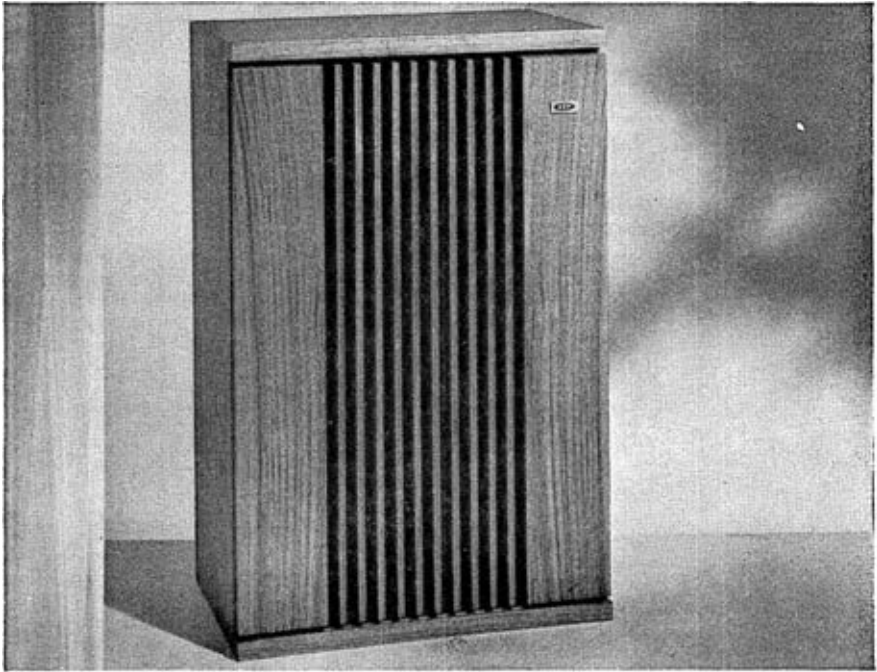

There is only one way to discover the outstanding qualities of the KEF Duette: hear it. This recently introduced speaker stands alone among today's compact systems, because its superb performance and standard of manufacture are in the KEF tradition. What specification in cold print can do justice to its exceptional transient response and freedom from colouration? Let *your ears* judge how fine a speaker this is . . . put the Duette through its paces at your hi-fi centre tomorrow.

**Abridged specification:**

Speakers: B139 rectangular bass unit, 13" x 9"

T15 spherical dome tweeter, 1½" diameter.

Size: 24" x 15" x 9½". Weight: 48 lb.

Max. power: 15 watts. Fundamental resonance: 48 c/s

**Price: £39.19.0**

## Duette

the compact speaker by KEF



SEND COUPON FOR FREE LITERATURE  
To KEF Electronics Ltd., Tovil, Maidstone, Kent.  
Please send me full details of the Duette  
and information on other KEF products.

Name

Address



# ELCOM

---

## SOUND MIXING

---

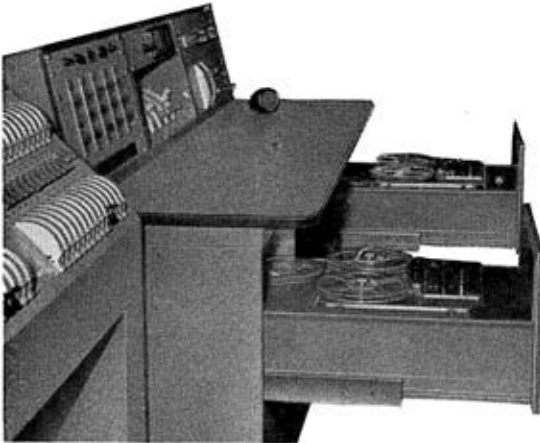

Elcom Sound Mixing Equipments, based on the revolutionary Electronic Fader which was perfected by Elcom, after years of research and development, are used by leading Radio and Television authorities and major Recording Studios. Elcom Sound Mixing Equipment extends from Four Channel Units, to Multi-Channel Consoles and can incorporate any combination of a vast range of facilities, from the bare minimum necessary, to the most sophisticated arrangement demanded by modern techniques.



**Booth  
No. 60  
Room 213**

Elcom Equipment Modules and components available are:—  
Compensating, Microphone, Line and Talk-back Amplifiers, P.P.M. Units, Faders, Attenuators, Vitreous and Precision Wire-wound Resistors, Sine/Cosine Potentiometers. Terminal Boards, Plugs, Sockets, Rotary Stud Switches, Chokes, In-line and P.C. Connectors and Edge Controls.

---

**ELCOM (Northampton) LTD.,**

Weedon Road Industrial Estate, Northampton.  
Telephone: Northampton 51873-5.

---



# IF YOU ARE INTERESTED IN EQUIPMENT

HAVING : SUPERB FINISH

HIGHEST ATTAINABLE RELIABILITY

WORLD'S FINEST PERFORMANCE

SPECIFICATION—

Then visit Stand No. 11 and Room 417 and see and hear for yourself

**PREAMPLIFIERS**



SC 2  
SC 5  
SC 6

**FM TUNER**



FMT 1

**INTEGRATED  
TRANSISTOR  
AMPLIFIER**



SC4-10

**MONO POWER  
AMPLIFIERS**

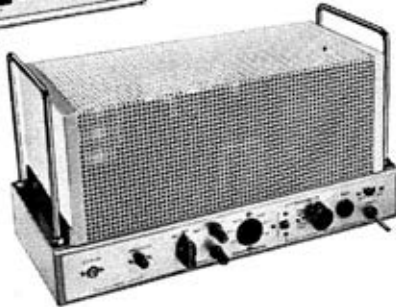

IMA 15  
IMA 25

**DUAL  
POWER  
AMPLIFIERS**

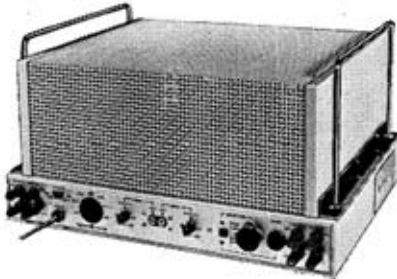

STA 15  
ISTA 15  
ISTA 30  
ISTA 60

AND OTHER INTERESTING ITEMS

**RADFORD ELECTRONICS LTD.**

ASHTON VALE ESTATE, BRISTOL 3 Tel. : 662301/2

# SONY SOUND

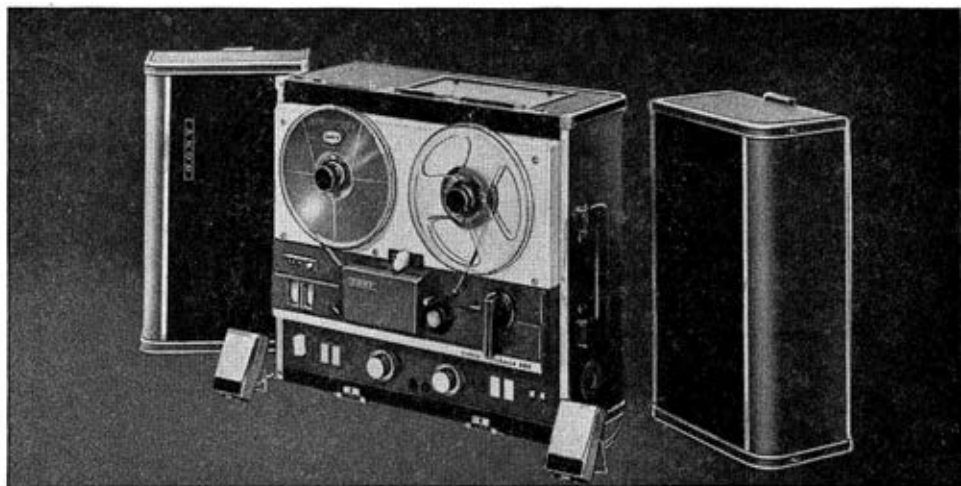

▲  
**SONY TC500.** A magnificent Recorder offering 4-track 2-speed Stereo-Mono facilities. 2 VU meters Twin Dynamic Microphones. Frequency Response 30-18000 C.P.S. Separate level controls. Complete with 2 Full Range Satellite Speakers with all accessories 106 gns.

**SONY TC464.** Beautifully engineered —4-track 2-speed with facilities for Stereophonic, Sound on Sound or Parallel Track recording. Used extensively in Language Labs. throughout the world. Complete with Dynamic Microphone 64 gns.

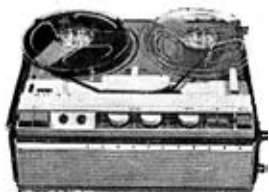

**SONY TC777A.** Professional 2-track 2-speed machine, fully transistorised, incorporating remote control giving instant start, stop, forward and reversing facilities. Frequency response 30-18000 C.P.S. 3-head system giving tape monitor through separate internal amplifier. Complete with microphone and all accessories 159 gns.

◀ **SONY TC200**  
 The outstanding Recorder of the year, this instrument offers a fully packaged 4-track 2-speed Stereo-Mono system with first-class specifications, complete with 2 dynamic microphones and 2 satellite speakers. Inclusive of all accessories 79 gns.



Hear the Sony sound—

**Demonstration Room 311 (Booth No. 73)**

*Sole Concessionaires for the Sony Range*

---

## SONY®

---

RESEARCH MAKES THE DIFFERENCE

---

**TELLUX LIMITED**

HIGH FIDELITY DIVISION, GALLOW'S CORNER,  
 ROMFORD, ESSEX. TELEPHONE: INGREBOURNE 43971

# -SUPREME



# introducing the **TRUVOX 90**

**A NEW THOROUGHbred SERIES FROM A FAMOUS BRITISH MARQUE**



**R.922-track recorder  
R.944-track recorder  
Each 69 gns. (U.K. only)**

**Complete with moving coil  
microphone and first-class  
reel of tape.**

*We'll be happy to see  
you at the Audio Fair.  
Booth 41 and  
Demonstration room 442.*

Clinically professional in every line. Crisply precise in operation. Full and faithful in reproducing sound... this sums up the new Series 90—the finest yet from Truvox. No concessions here to mass-market 'styling'. No fancy plastic moulding; no pretty-pretty cover fabrics. No 'cosmetics' at all. Instead—clean, rugged and functionally austere, the new Truvox looks every inch what it is... a thoroughbred instrument for the enthusiast. For the man who wants a *real* tape recorder; not a gilded toy on the one hand, nor a status symbol on the other.

*Among the outstanding features of the Series 90 are:*

- 'Piano' Key operation.
- A cathode follower output.
- Recording level meter.
- Positive lock reel carriers.
- 4 digit counter — instant reset button.
- Hinged editing panel.
- 'No-tape' autostop.
- Mixing facilities.
- Superimposition.
- Forward facing Rola-Celestion loudspeaker.
- 3 tape speeds —  $7\frac{1}{2}$   $3\frac{1}{2}$   $1\frac{1}{2}$  ips.
- 3 motor drive—Papst capstan motor.

also  
PD.932-track mono tape unit.  
PD.954-track mono tape unit.  
Each 59 gns. (U.K. only)

and  
PD.972-track stereo tape unit.  
PD.994-track stereo tape unit.  
Each 79 gns. (U.K. only).

**TRUVOXLTD. Neasden Lane, London NW10. Tel: DOLLis Hill 8011**

# SHERWOOD

BOOTH No. 42

DEMONSTRATION ROOM 122

*Sherwood is the fastest growing manufacturers of Stereo High Fidelity components in the United States and has received more unsolicited honours from independent research organisations than any other component manufacturer.*

## THE NEW S - 9300 36 WATT TRANSISTOR INTEGRATED STEREO AMPLIFIER

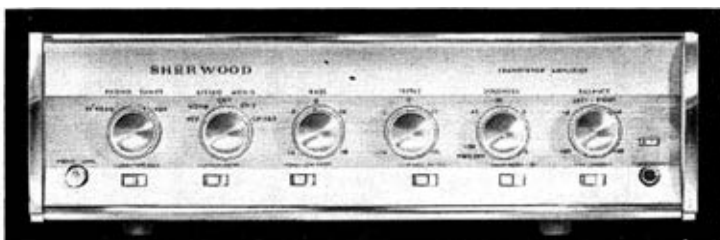

A quality-engineered transistor amplifier offering cooler operation, instant warm-up, extremely low hum and noise and much lower power consumption than a comparable tube amplifier. Six high-level and four low-level inputs are provided for phono, tape play-back, tuner and tape recorder monitoring. All pre-amp and control amplifier stages feature silicon transistors mounted on epoxy circuit boards. Large black anodized aluminium heat dissipators for the output transistors permit continuous operation without overheating. Music power output: 17 watts per channel at 8 and 4 ohms. Continuous power output: 15 watts per channel at 8 or 4 ohms at 1.5% distortion. Utilizes 20 transistors, 2 diodes and 2 rectifiers.

### THE S - 5500 III 80 WATT INTEGRATED STEREO AMPLIFIER

This is a more powerful version of the S - 5500 II stereo amplifier which gained such tremendous popularity since its introduction at the 1963 Audio Fair.

Other equipment demonstrated will include :

S - 3000 III FM TUNER  
S - 8000 FM-MX INTEGRATED  
STEREO RECEIVER  
S - 7700 AM-FM-MX INTEGRATED  
STEREO RECEIVER

★ *Demonstrations of disc reproduction will utilise the Grado Laboratory Series Turntable, Tonearm and Grado Imperial Stereo Cartridge.*

U.K. Distributors :

**AUDIOSON LTD • ORCHARD HOUSE • ORCHARD STREET • LONDON W1**  
telephone **MAYfair 5431**

---

# Five break-throughs that revolutionized the recording world!

- 1947** Three years after it is founded, Ampex announces the first broadcast quality magnetic tape recorder.
- 1951** To meet the exacting demands of the challenging new field of data recording, Ampex introduces the first multi-track recorders.
- 1956** A step ahead of the rest of the world, Ampex brings out their Videotape\* recorder.
- 1960** Ampex merges with Telemeter Magnetics Inc., and adds core memories to its range.
- 1961** Ampex develops an advanced multi-purpose theatre sound system. For this difficult achievement, is awarded a technical "Oscar".

The shattering of these technical barriers adds up to twenty years of solid Ampex achievement. Twenty years of breathtaking leadership in the recording field.

Ampex magnetic tape recorders are used in hundreds of capacities in thousands of key places all over the world. Our FR.1400's record data from satellites in a dozen locations. Our VR.1000's record, reproduce television pictures for entertainment and industry.

Whether your recording need is for a high speed computer, or a home hi-fi, there is an Ampex to meet it.

In order to meet your recording needs, Ampex now has offices or representatives in all parts of the world, and manufacturing facilities in the United States, Great Britain and Hong Kong.

*\*Ampex Trade Mark*



## See Ampex on stand 17

---

WHY

*Agfa*

high definition

RECORDING  
TAPES are  
FIRST CHOICE  
FOR PROFESSIONAL  
RECORDING and  
BROADCASTING -  
mono, stereo  
and video

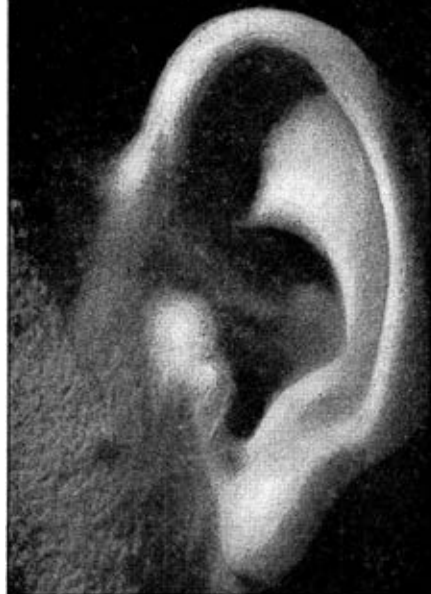

- ✎ CONSISTENT, HIGH DEFINITION RECORDINGS—FROM START TO FINISH. Special Agfa process deposits *even* thickness of magnetic emulsion and arranges unusually small needle oxides in consistent, parallel alignment.
- ✎ SUPERFLEXIBLE, NON-STRETCH POLYESTER BASE ·stays *flat* preserves 100% contact with recorder heads and ensures balanced recordings on *all* tracks (absolutely essential for stereo realism).
- ✎ AGFA TAPES ARE VIRTUALLY EVERLASTING. Agfa magnetic emulsion is *bonded* to the polyester base—and stays there. Even after 1,000 playings, wear is still undetectable!

Now available in beautiful, shatter-proof,  
EASY ACCESS LIBRARY CASSETTES.

(5 $\frac{3}{4}$ " and 7" spools only)

P.E.31 Long-play, P.E.41 Double-play and

P.E.65 Triple-play.

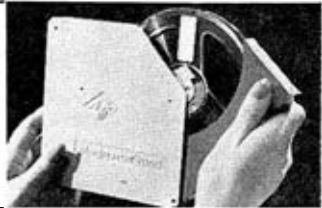

AUDIO FAIR BOOTH No.2 · DEMONSTRATION ROOM 114 (First Floor)

AGFA LTD · DEER PARK ROAD · WIMBLEDON · LONDON S.W.19 · CHerrywood 1121



*Armstrong*

## TUNERS

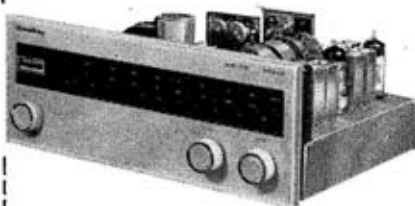

## AMPLIFIERS



## TUNER-AMPLIFIERS



"A new range of tuners, amplifiers and tuner-amplifiers designed to meet every requirement of the music-lover in his own home. A superb performance, combined with elegance of styling, gives you a high fidelity system of enduring quality whether mounted in a cabinet with other equipment or in one of the optional shelf-mounting cases, illustrated above, which are available for all models."

**ARMSTRONG AUDIO LTD.** Warlters Road, London, N.7. Telephone: NORTH 3213





**Craftsman II**  
2 speed transcription turntable  
complete with plinth and  
SAUI pickup arm.  
Items also sold separately.

**Craftsman III**  
Variable 3 speed transcription turntable  
can also be supplied complete  
with plinth and  
SAUI pickup arm.



# *Connoisseur*



**Craftsman Speaker Series**  
**MAJOR & MINOR**  
supplied complete  
with Drive Units.



**MK II Speaker Series**  
**MK II MAJOR**  
**MK II MINOR**  
supplied complete  
with Drive Unit.



**Stereo Cartridge**  
Type SCUI  
Mono type also available



**SAUI Pickup Arm & Shell**  
Supplied with or  
without lifting device.

See classified section for specifications and prices Free leaflets available on request  
(state product) *A. R. Sugden & Co. (Engineers) Ltd.*, Market Street, Brighouse, Yorks.

AMPLIFIERS · TUNERS · DRIVE UNITS · ENCLOSURES



# BRITISH AUDIO AT ITS BEST

See it on  
**STAND No. 12**

Hear it in  
**SUITE No. 411**

Overseas Office  
**ROOM 409**

# LOWTHER

THE LOWTHER MANUFACTURING COMPANY

LOWTHER HOUSE · ST. MARK'S ROAD · BROMLEY · KENT · TELEPHONE RAVENSBORNE 5225

IMPROVED TRANSIENT  
RESPONSE INCREASED  
RELIABILITY STYLED  
FOR COMPACTNESS

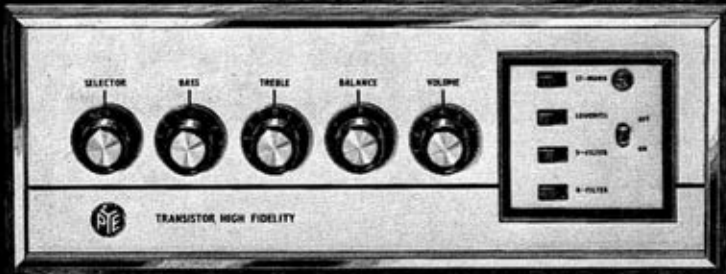

**PYE CALL THEIR NEW TRANSISTORISED AMPLIFIER THE BRAHMS HFS30T**

## YOU'LL CALL IT BRILLIANT

ITS DESIGNERS CALL IT A MAJOR BREAKTHROUGH

Pye's new Brahms transistorised amplifier is one of the first transformerless stereo high fidelity amplifiers in production in Great Britain. Behind its supremely functional construction lie years of research into transistors and high fidelity reproduction by technicians and scientists of Pye's High-Fidelity Division. During this time the technical controllers of this special Division have had at their disposal the vast and diverse resources of the Pye Group. A Group with the brains that built the precisely accurate Pye spectrophotometer, the minds that mastered the complexities of digital computers and the scientists who schemed many hundreds of precision instruments in guided missiles—the result?—the finest amplifier yet produced.

The Brahms HFS30T has many advanced new features. Big improvements in transient response over normal valve amplifiers, thus giving distortion-free reproduction at both very low and high frequencies. Hum and noise is inaudible and there is a minimum of heat dissipation. But the HFS30T's supremacy is not restricted to performance alone. The ingenious design combines preamp, power amplifier, power unit and controls into a single case—lightweight, compact and very tough. There's a rather luxurious rosewood case version too. Write and we'll give you any more information you want. Or see your Hi-Fi dealer—you'll find him as equally enthusiastic about this new amplifier as Pye are themselves.

**BRIEF SPECIFICATION** • Main amplifier • Power output: 15 watts per channel • Frequency response 20—35,000 c/s  $\pm 1\frac{1}{2}$  dB • Signal to noise: -90 dB • Damping factor: better than 50 • Crosstalk: better than -50 dB • Distortion: typically less than 0.5% at 1,000 c/s.

**AUDIO FAIR • PYE ARE AT STAND 13 • DEMONSTRATION ROOM 318**

**PYE LIMITED HIGH-FIDELITY**



**DIVISION P.O. BOX 49 CAMBRIDGE**

**THE 1964  
INTERNATIONAL**

**AUDIO  
FESTIVAL & FAIR**

*Festival Director:*

C. Rex-Hassan

**APRIL**

**2nd, 3rd, 4th, 5th.**

**Hotel Russell**

**London, W.C.2**



*Catalogue 2/6*

# ... for the guidance of visitors

**This International Audio Festival is divided into two distinct Sections.**

In the **First Section** on the ground floor in the Exhibition Halls are Booths on which Exhibitors are displaying their Products. These Booths are manned by expert personnel who are able to discuss any aspect of their equipment.

The **Second Section**, and the one which is considered the most important, is on the **First, Second, Third and Fourth** floors of the Hotel. On these floors the manufacturers who are exhibiting are giving live demonstrations. The way up to their demonstration rooms is by means of the main Hotel staircase, situated straight on through the Halls. There are other staircases for visitors to circulate around and down to visit any room, and there is a special staircase from the demonstration room floors allowing re-entry into the Main Halls.

## **How to use this Catalogue**

On the following Blue pages of this Catalogue will be found a complete Guide to the 1964 International Audio Festival and Fair.

Overleaf are Plans showing the layout of the Exhibition. The first is of the Ground Floor Halls giving the positions of the booths and their number. It shows how to progress through these Halls to the main stairway which leads to the demonstration room floors. There is a large Indicator Board in the Main Hall, on which is shown, floor by floor, the numbers of the Exhibitors demonstration rooms.

The next plan shows the general situation of the demonstration rooms on each floor and where the stairways up and down are to be found. It also shows the special Re-Entry staircase back down to the Exhibition Halls.

On the Corridor Walls this plan is repeated separately for each floor, with the names of Exhibitors written on it. These can be spotted quite easily because of their red frames.

### **Who is Exhibiting . . . and where**

Then again, there is the index of Exhibitors. Exhibitors are placed in this alphabetically by their Trade Name. Their booth numbers and demonstration room numbers follow. The initial number of the room denotes the floor, i.e., the 300s are the third floor, the 100s the first floor and so on.

### **Type and style of Products and Manufacturers names**

The remainder is made up of a Magazine Section, containing full details, both technical and explanatory, in article form on the Products of each Manufacturer. Each page is headed by the Trade name and beneath is the full title and address. Under this is their type or style of goods.

In the main, Exhibitors in this 1964 International Audio Festival and Fair are Manufacturers and they are entered as from the country of origin of their goods.

If they are Overseas Manufacturers, the U.K. Agent or Company and address is shown in bold type at the end of the article.

### **AMENITIES**

There are ample cloakroom facilities in the Hotel for visitors who would like to leave their hats, coats and parcels.

### **LIFTS**

There are express lifts operating up to fourth floor only. They are at front of Hotel.

### **Where to eat and relax**

A large bar is situated near the front Hotel entrance, and there are also spacious lounges. There are excellent restaurants adjacent to the centre Exhibition Hall, where either *Table d'hôte* or *à la carte* meals can be obtained. Light refreshments are also available in the Hotel lounges throughout the opening times of the Exhibition, and there is an extension of licence for alcohol during the afternoon hours. A luxurious Bar and Restaurant is to be found on the first floor next to the staircase.

### **Where to find out**

An Information Bureau is situated in the Glass Hall with courteous staff who will be pleased to answer any queries and offer any guidance required. Next to this is a special lounge for the benefit of Overseas Visitors. Interpreters are available.

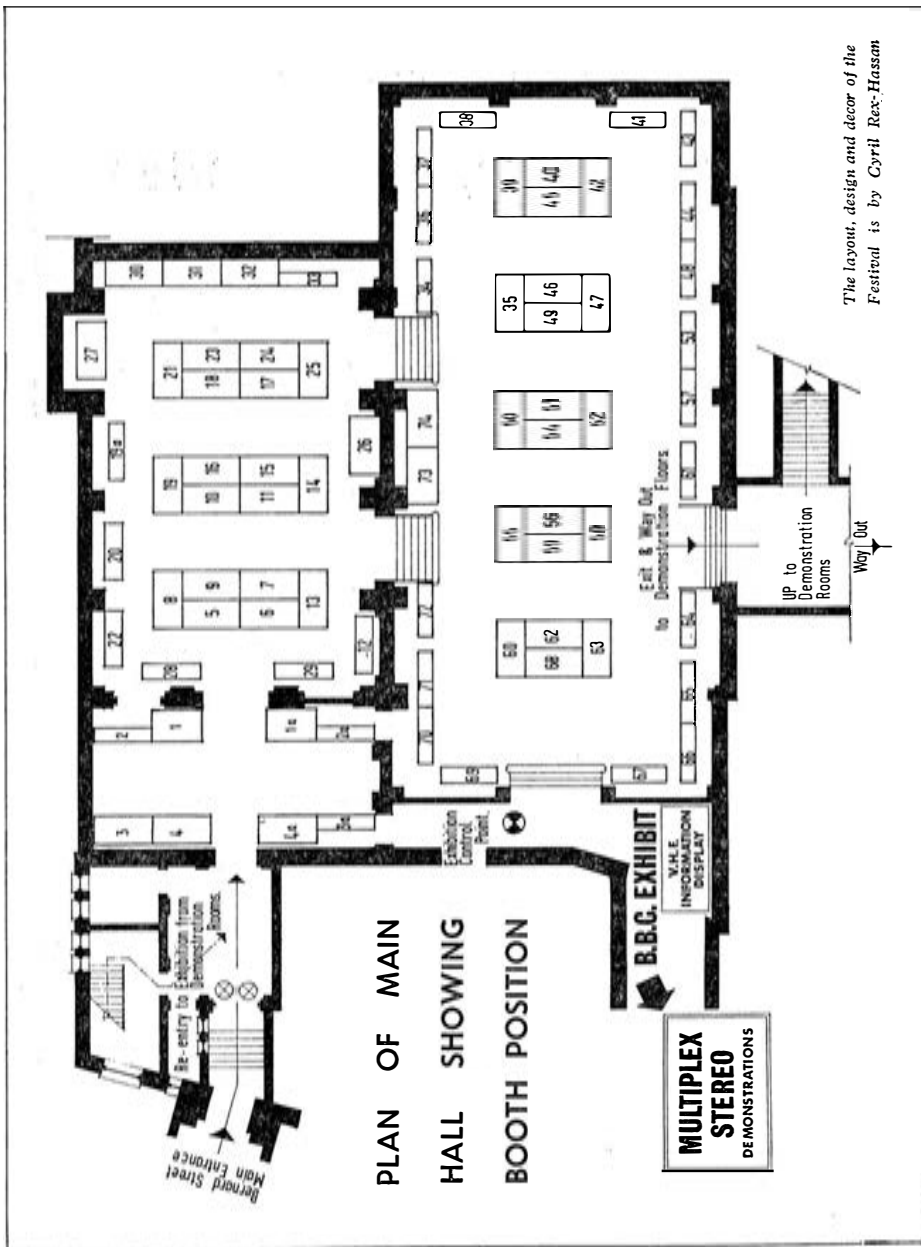

FIRST ANNOUNCEMENT

# British Amateur Tape Recording Contest, 1964

Firms marketing magnetic recording tape in the United Kingdom jointly sponsor the annual British Amateur Tape Recording Contest, in which valuable prizes are awarded for the best tape productions entered.

Almost any type of recording—from a couple of minutes of bird-song to a fifteen-minute production of a play—may be submitted.

Newcomers to the hobby have as much chance of winning a prize as the long-experienced enthusiast, provided the choice of subject is related to the equipment available.

The judges give due weight to the resources available to entrants and to their experience when assessing the entries.

The best tapes in the British Contest are automatically entered in an International Amateur Recording Contest, where they stand a chance of winning further valuable prizes.

There is a cash prize of fifty guineas for the best tape entered in the Contest and many other prizes of cups and trophies and reels of tape.

*Apply at Information Desk for your entry form or write for fuller information about the event. . . . Send a stamped addressed envelope to **British Amateur Tape Recording Contest, 7 Tudor Street, London, E.C.4.***

**THE CLOSING DATE IS JULY 31st, 1964.**



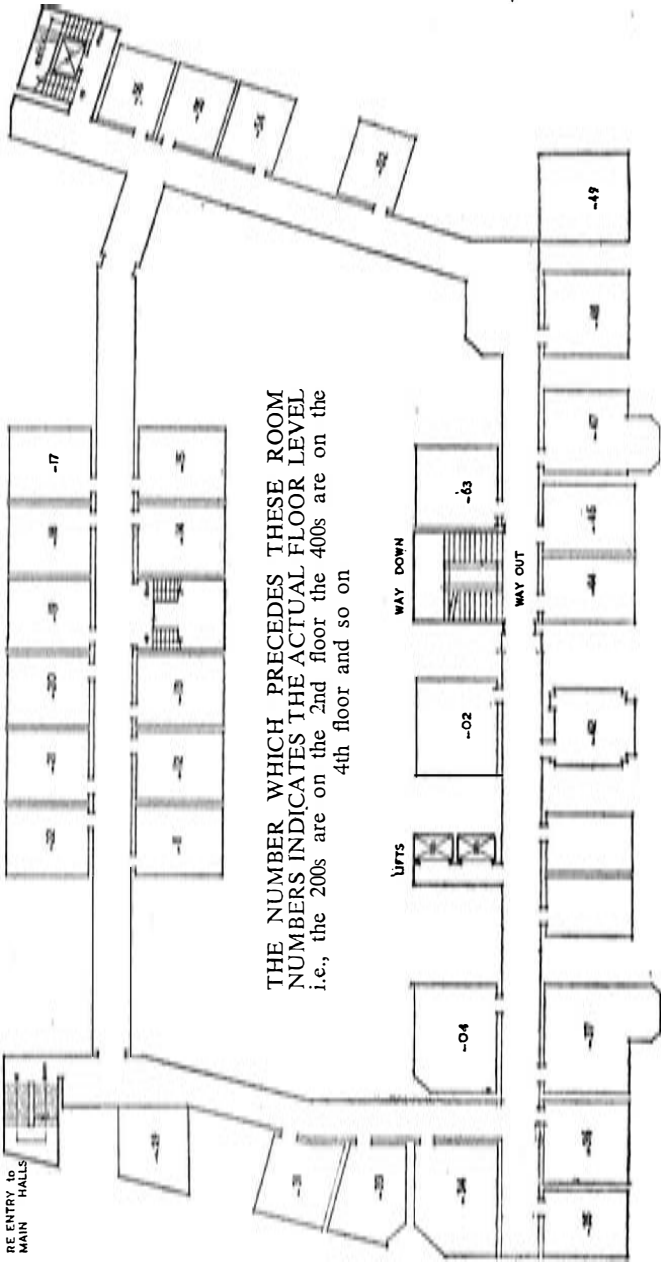

THE NUMBER WHICH PRECEDES THESE ROOM NUMBERS INDICATES THE ACTUAL FLOOR LEVEL i.e., the 200s are on the 2nd floor the 400s are on the 4th floor and so on

INDICATION PLAN OF THE DEMONSTRATION FLOORS

# **SPECIAL EXHIBIT**

## **. . . GROUND FLOOR**

**First time at the Audio Festival.**

**BBC Stereo Multiplex Broadcast direct from  
Wrotham to 1964 AUDIO FESTIVAL**

This will be received throughout the Exhibition, and can be heard by visitors in the rooms of any exhibitor showing the multiplex equipment. The BBC themselves are giving their own demonstrations on the ground floor next to their Display Exhibit. This is situated at the entrance end of the Glass Hall.

It will include a demonstration of stereophonic broadcast transmission and reception using the Zenith-GE system. The programme items will be broadcast by the Third Programme VHF transmitter at Wrotham outside its normal programme hours and will be received "over the air" at the Hotel Russell. The equipment used for the demonstration will be of BBC design.

The Zenith-GE system is one of a number of systems that have been proposed for the broadcasting of stereophonic signals from a single transmitter. The system is compatible, i.e., the transmission can be received monophonically by a conventional VHF receiver. International agreement has not yet been reached on a common standard for stereophonic broadcasting in Europe and it is unlikely that a decision to start a regular stereophonic service in the United Kingdom can be taken for some time. Meanwhile the BBC will continue with its experimental transmissions and to study the technical problems affecting the introduction of a stereophonic service.

Sound broadcasting and the VHF sound broadcasting service will be featured at the BBC Engineering Information bureau. The VHF service provides greatly improved reception to many millions of listeners who have VHF receivers, the transmissions being virtually free from the interference from foreign stations which plagues reception in the medium-waveband and also capable of giving, with suitable receiving equipment, better quality sound reproduction. So far, 21 main VHF sound stations have been brought into operation. These are being supplemented by 39 relay stations of which 13 are already in operation. The BBC's VHF service, transmitting the Home, Light, and Third Programme with Network Three is now available to nearly 99 per cent. of the population of the United Kingdom and when the remaining 26 projected relay stations are completed the service will be available to about 99.5 per cent. of the population. The building of a further group of VHF sound relay stations is under consideration.

## INDEX of EXHIBITORS

Against each Trade name below, is the Booth number and the Demonstration Room number. The initial number of each Room indicates the floor.

All demonstration rooms are clearly numbered and also have a pennant protruding out from the doorway on which is written the Exhibitor's Trade name. This is readily viewable as you walk along the corridors.

*Note that in some instances Exhibitors only have Booths and are not themselves demonstrating, although their goods may be heard in conjunction with the demonstrations of other Exhibitors. In the same manner some of the Press merely have lounges where, in comfort, visitors may meet the Editor, staff and contributors. There are also some trade lounges.*

NAME	BOOTH	ROOM NO. OR LOUNGE
AGFA - - - - -	2	114
AKAI - - - - -	47	412
AKG - - - - -	46	204
AMATEUR TAPE RECORDING - - - - -	34	—
AMPEX - - - - -	17	247
ARMSTRONG - - - - -	19	404
AUDIO & RECORD REVIEW - - - - -	—	344
BASF - - - - -	22	320
BEYER - - - - -	36	415
BRAUN - - - - -	9	214
BRENNELL - - - - -	28	342
BROWN - - - - -	27	421
BUTOBA - - - - -	68	234
CELESTION - - - - -	8	149
CHAPMAN - - - - -	70	448
CLAIRTONE - - - - -	7	215
CLARKE & SMITH - - - - -	24	321
CONNOISSEUR - - - - -	25	242
DECCA - - - - -	66	235
DECCA - - - - -	65	236
DESIGN FURNITURE - - - - -	59	117

<i>NAME</i>	<i>BOOTH</i>	<i>ROOM NO. OR LOUNGE</i>
DUAL - - - - -	33	158
ELCOM - - - - -	60	213
E.M.I. - - - - -	63	322
FANE - - - - -	19a	221
FED. OF BRITISH T/R CLUB - - - - -	—	154
FERROGRAPH - - - - -	67	337
FI-CORD - - - - -	37	414
GARRARD - - - - -	29	145
GEVAERT - - - - -	6	—
GKD - - - - -	45	319
GOLDRING - - - - -	20	118
GOODMANS - - - - -	31	347
THE GRAMOPHONE - - - - -	—	244
GRAMPIAN - - - - -	32	237
GRUNDIG - - - - -	35	147
HI-FI NEWS - - - - -	72	—
JORDAN-WATTS - - - - -	56	420
KEF - - - - -	38	212
KELLY - - - - -	—	232/3
KODAK - - - - -	49	312
LANSING - - - - -	21	112
LEAK - - - - -	64	334
LOEWE-OPTA - - - - -	10	413
LOWTHER - - - - -	12	411
L/P RECORD LIBRARY - - - - -	—	153
LUSTRAPHONE - - - - -	4	220
LUXOR - - - - -	30	218
METRO-SOUND - - - - -	4a	335
MSS - - - - -	51	217
MULLARD - - - - -	50	211
ORTOFON - - - - -	2a	336
PETO-SCOTT - - - - -	—	152
PIONEER - - - - -	16	314

<i>NAME</i>	<i>BOOTH</i>	<i>ROOM NO. OR LOUNGE</i>
PLANET - - - - -	57	418
PHILIPS - - - - -	54	111
PYE - - - - -	13	318
QUAD - - - - -	58	422
QUALITONE - - - - -	61	113
RADFORD - - - - -	11	417
RECORD HOUSING - - - - -	52	302
RECORDS and RECORDING - - - - -	1a	—
RESOSOUND - - - - -	71	—
REVOX - - - - -	15	315
RICHARD ALLAN - - - - -	39	120
ROGERS - - - - -	43	449
SCOTCH - - - - -	55	349
SHERWOOD - - - - -	42	122
SHURE - - - - -	48	249
S.M.E. - - - - -	44	—
SONY - - - - -	73	311
S.T.C. - - - - -	3	—
STUZZI - - - - -	14	115
TANDBERG - - - - -	69	248
TANNOY - - - - -	23	447
TAPE RECORDING MAG - - - - -	—	346
TELEFUNKEN. - - - - -	5	402
THORENS - - - - -	3a	—
TRIO - - - - -	62	121
TRUVOX - - - - -	41	442
VITAVOX - - - - -	18	348
VORTEXION - - - - -	74	202
WHARFEDALE - - - - -	53	222
WHITELEY - - - - -	26	304
WILLINAN EXPORT - - - - -	—	246
WILSON STEREO LIBRARY - - - - -	—	155
WIRELESS WORLD - - - - -	1	—
WORDEN - - - - -	—	313
ZONAL - - - - -	40	—

## **AGFA**

**Agfa Aktiengesellschaft,**  
Leverkusen-Bayerwerk, Germany

**Booth 2**

**Demonstration  
Room 114**

### *Tape*

Agfa will be showing the range of Recording Tapes and accessories generally available in this country, especially the wonderful new Novudur Library Cassette in which many Agfa tapes are now marketed. In addition, following a progressive policy, they will be showing subject to certain production factors and time permitting, a unique electronic keyboard musical instrument known as the Mellotron.

This instrument places an almost infinite range of musical sound at the command of anyone who has "ear" enough to hum a tune. The first of its kind in the world, it looks like a modern electronic organ of the type intended for the home but is fundamentally different in that it can produce "pure" music, free from what might be called the characteristic oscillator tone of electronics.

Musical "data" in the form of 1,260 recordings of notes and phrases are stored on 72 three-track magnetic tapes. By simple "programming," with the use of push button selection any of these recordings can be played, either singly or with others, using the piano-type keyboard. There are 16 rhythms, from a Viennese waltz to a Samba, 16 lead instruments and many added sounds to choose from.

Selection puts the basic rhythm and backing under the control of the left hand in such a way that the most complex and rapid figures can be executed without any great dexterity or musical knowledge. Touching a key in the bass produces a rhythmic pattern, with appropriate backing, which instantly repeats if the key is depressed.

The treble has a similar arrangements of buttons for selecting the lead instruments, which by combination can be made to give out a full orchestral sound.

A system of numbers on the keyboard, and the fact that the instrument can be played with two fingers and a thumb only, make it easy even for the inexperienced to master the basic technique in a day or so.

**U.K. Address: Agfa Limited, 27, Regent Street, S.W.1. Telephone REGent 8581.**

## AKAI

**Akai Electric Co. Ltd.,**

883, 3-Chome,

Kojiya-Cho,

Ohta-Ku,

Tokyo, Japan

**Booth 47**

**Demonstration**

**Room 412**

### *Tape Recorders and Accessories*

“AKAI” are taking part in the Audio Fair for the first time. They are displaying a full range of tape recorders and accessories currently available in the United Kingdom.

Well known in America, the AKAI tape recorders sold under the name “Roberts” are rated as being big sellers in the U.S.A.

Four models are on show, and the best known one, the model M-7 is a four track, High Fidelity Stereo machine fitted with Akai's exclusive Cross-Field recording head which allows the machine to give first class stereo sound at only  $1\frac{7}{8}$  i.p.s. At this speed the response is from 40 to 13,000 c.p.s. rising to 40 to 20,000 c.p.s. at  $3\frac{3}{4}$  i.p.s. When operated at  $7\frac{1}{2}$  i.p.s. the M-7 gives a response of 30 to 23,000 c.p.s. and this model will allow recording to be made on four-track monaural, full-track monaural, as well as both two- and four-track stereo. Supplied with two dynamic microphones, reel caps, radio cables, tape and spools, splicing tape and a  $1\frac{3}{4}$  i.p.s. stereo demonstration tape, the M-7 also has a choice of three speaker systems.

Most advanced of the AKAI machines on show is the Model 345 which is a truly professional tape recorder fitted with three heads and with three motors. Twin speeds of  $3\frac{3}{4}$  i.p.s. and  $7\frac{1}{2}$  i.p.s. are offered on this magnificent stereo recorder and a feature of it is the completely automatic function which is offered. Additionally, the transistorised circuit is fully protected from damage caused by excessive heat or mains fluctuation by having incorporated the AKAI IRAP device. (Instantaneous Resettable Automatic Protection). With a massive output of a full 10 watts per channel, this recorder is extremely powerful and the quality of sound is quite magnificent. This machine also has the unique “repeat” mechanism.

A smaller two-track monaural recorder is the Model 707 which offers top quality monaural sound with a single touch speed selector for the two available speeds of  $3\frac{3}{4}$  i.p.s. and  $7\frac{1}{2}$  i.p.s. Automatic shut-off, 6 watt output, 7 in. reel capacity, instant stop mechanism, and a professional VU meter are included in this fine recorder from AKAI.

The Model 903 tape recorder is a High Fidelity monaural machine with dual channel mixing facilities; monitoring is by means of the built-in speaker and incorporated “Monitor” switch. The recorder is fitted with a VU meter and speeds of  $7\frac{1}{2}$  i.p.s. and  $3\frac{3}{4}$  i.p.s. are available. Various accessories are available such as telephone pick-up, monitoring headphone, endless tape magazine, bulk tape eraser and a head de-magnetizer.

Speaker systems are all supplied in pairs and range from the SS-50 speaker system consisting of two 8 inch mechanical Two-way speakers with a maximum power capacity of 8 watts to the SS-100 speaker system which consists of a pair of 10 inch co-axial speakers with  $2\frac{1}{2}$  inch built in tweeters taking a maximum of 10 watts.

Other speakers available are the SS-70 speaker system consisting of twin 8 inch co-axial speakers with built-in 3 inch tweeters and with tone control, and the SS-55 speaker system which is made up of a pair of 8 in. woofers and a pair of built-in  $2\frac{1}{2}$  in. tweeters taking a maximum of 5 watts each.

**Sole Distributors: Pullin Optical Co. Ltd., Ellis House, Aintree Road, Perivale, Middlesex. ALP 1541.**

**AKG**

**Akustische u. Kinogeräte GmbH,**  
Vienna, Austria

**Booth 46**

**Demonstration  
Room 204**

*Microphones, Headphones*

AKG of Vienna is one of the world's leaders in the research and development of dynamic and condenser microphones and of dynamic headphones.

AKG owns hundreds of patents. Among these are many basic patents covering new principles of obtaining cardioid patterns, extended frequency range, low distortion and new designs. Every microphone undergoes at least two full-scale tests in anechoic rooms of the most up-to-date design, where frequency response, front-to-back ratio, etc., is measured and recorded.

Approximately half a million microphones per year for broadcast, T.V. and film studios, for theatres and recording studios, for P.A. installations, for tape recorders and for many other purposes are shipped to destinations all over the world.

AKG manufacture a large proportion of microphones used in the most successful tape recorders.

AKG studio microphones (condenser and dynamic types) are used by leading broadcasting organisations, film studios and recording companies, where they meet the exacting specifications demanded by such users.

Here are some types from the extensive AKG range :

D7A omni-directional dynamic microphone. Rugged, yet inexpensive. Frequency range : 80-11,000 cps.

D9C dynamic microphone, has been developed for use with tape recorders of fairly slow tape speed, for mains or battery operation.

D11C dynamic cardioid microphone allows echo-free speech and music recordings to be made in acoustically unsuitable locations.

D12 dynamic directional microphone with extremely flat frequency response curve (30-15,000 c.p.s.). Greatly reduces the tendency for developing feedback when loudspeakers are located near the microphone.

D19C dynamic cardioid microphone designed for semi-professional applications. Bass attenuation switch. Shielded against magnetic stray fields.

D24B. The studio version of the D19C with built-in wind screen. Frequency response 30-16,000 c.p.s.

D25B dynamic cardioid studio microphone specially designed for boom operation. Used by leading T.V. and film studios.

D58 dynamic anti-noise microphone, has been developed for close-talking applications in noisy surroundings. Due to its good frequency response in the close-talking model it is very useful as a reporter microphone. Suitable for work even in iron dust atmosphere.

C12 studio condenser microphone of highest professional quality. Accepted as a standard by many famous broadcasting organisations.

C24 Stereo version of the C12. Suitable for M-S and X-Y stereophony.

C28/29/30. A condenser microphone system for the highest professional requirements. Cardioid and omni-directional patterns.

C60 miniature condenser microphone. Weight only 2.1 ounces.

Please refer to the AKG advertisement in this catalogue.

**Sole Distribution : Politechna (London) Ltd., 3, Percy Street, London, W.1. Telephone : LANgham 6236.**



## **AMATEUR TAPE RECORDING, VIDEO & HI-FI** Booth 34

**Plant News Ltd.,**  
Room 532, Ulster Chambers,  
168, Regent Street, London, W.1

### *Publishers*

**NOVICE?** You're new to tape recording and want to learn how to get the best out of your equipment? Then easy-to-understand guidance, advice and information are yours via the pages of ATR.

**PROFICIENT?** You've attained a reasonable standard of recording but want to join the ranks of the experts? ATR is your stepping stone. Expert technical articles and construction circuits and our unique, personal readers' enquiry service are free to readers of ATR.

**CLUBMAN?** You've joined a club, or want to run one? Only ATR offers the added incentive with club competitions and extensive monthly reports. Exclusive to ATR, too, is the specimen club constitution specially designed as a guide to club organisers.

**EXPERT?** You know your electronics inside out and want to keep abreast of the latest technical developments? ATR is first in its field, with exclusive articles on chromasonics, video recording and radiophonics.

Newcomer or old-stager, whoever you are, ATR is the recording magazine you can't afford to miss. From your local newsagent, 2s. per month, or by subscription.

**AMPEX**

**Ampex Great Britain Ltd.,**  
72, Berkeley Avenue,  
Reading, Berkshire  
Reading 55341

**17**

**Demonstration  
Room 247**

*Precision Magnetic Tape Recorders*

Ampex Magnetic Tape Recorders being featured at this year's Audio Festival and Fair include two new, outstanding advances in tape recorder design: the E 65 and the all-new UST 4. These recorders are designed to supplement the full range of Ampex professional and audio recorders. While Ampex Great Britain Ltd., Reading, is producing some of the Ampex line of tape recorders, the UST 4 will be imported from the new Chicago facilities of Ampex Corporation.

Ampex Corporation concentrated its efforts in the specialised field of broadcast quality tape recording and consequently has carried this standard of excellence over into its line of domestic recorders. Beyond the broadcast field, Ampex scientists have established Ampex as the leader in demetry recording, computer memory devices and wherever the need for sophisticated recording techniques exist.

The E 65 is designed with the educational field in mind. It is simple in operation yet with the ultimate in fidelity of reproduction. It is sturdy and designed to stand up under long hours of steady usage, but is "compact" for easy movement. Ampex has built in solid reliability with this recorder and backs it up with a three year warranty.

The new star in the Ampex line is the UST 4, the answer to the problem of the enthusiast who want the highest quality and performance but at a competitive price. The new recorder gives full dynamic stereo recording and reproduction with self-contained, dual amplifiers and speaker system—all mounted in an attractive carrying case. The UST 4 adds a new dimension to home portables by allowing either vertical or horizontal mounting to meet the requirements of all home systems. What is more: the UST 4 is fully portable.

These new additions to the Ampex recorder line, are backed by the Universal 351 (the standard in broadcast tape recorders), the PR 10 professional portable studio quality recorder, and the ultimate in home recorders, the F 44. Ampex is also showing its full range of magnetic recording tape with the unique signature binding the 500 series.

## ARMSTRONG

Armstrong Audio Ltd.,  
Warlters Road,  
Holloway, London, N.7  
NORth 3213

Booth 19

Demonstration  
Room 404

*Tuners, Amplifiers, Tuner-Amplifiers*

One of the main features of this year's demonstration will be our new **222 Integrated Stereo Amplifier** with the Decca Deram pick-up. We shall be showing the excellent results which can be obtained from the new high quality ceramic pickups when used with a high performance, yet moderately priced, amplifier.

In addition we shall be demonstrating Stereo Radio, using a prototype **Armstrong Stereo Multiplex Decoder**, during those times when the B.B.C. are transmitting stereo broadcasts from Wrotham. A series of these transmissions has been specially arranged for the period of the Audio Fair.

In general, all models are displayed in the shelf-mounting cases of teak and vinyl-hide which are available as optional extras. These cases enable any unit to be used free-standing on shelf, sideboard or table, but when fitted in a cabinet with other equipment the case would not be required.

The new range includes :

<b>Tuners</b>	224 FM TUNER	... ..	£22.10.0
	223 AM-FM TUNER	... ..	£28.15.0
<b>Amplifiers</b>	222 INTEGRATED STEREO AMPLIFIER	...	£27.10.0
	220 STEREO POWER AMPLIFIER	...	£24.18.0
	225 STEREO-PRE-AMPLIFIER	... ..	£22.12.0
<b>Tuner-Amplifiers</b>	226 STEREO TUNER-AMPLIFIER	...	£56. 0.0
	227 STEREO TUNER-AMPLIFIER	...	£48.15.0
	227M MONO TUNER-AMPLIFIER	... ..	£33.18.0

Since we shall be giving demonstrations of Stereo Radio during the Fair we would like to emphasise the ease with which the new Tuners and Tuner-Amplifiers can be made suitable for the reception of FM stereo radio broadcasts. On the assumption that the B.B.C. will follow the present experimental transmissions with a regular stereo service at some time in the future, complete provision has been made for an **Armstrong Stereo Multiplex Decoder** to be added. This will be available as soon as regular broadcasts begin and will only be required to be fixed in the space provided and plugged into the socket on the tuner or tuner-amplifier.

## **AUDIO & RECORD REVIEW**

**Hanover Press Ltd.,**

4, Mill Street, Hanover Square,  
London, W.1  
HYDe Park 3936

**Press**

**Lounge 344**

*Monthly magazine of record and  
equipment reviews, audio topics  
and specialist features*

Better hi-fi listening—this is the ambition *Audio & Record Review* shares with its many readers. The fine arts of records, recording and appreciation are expertly covered every month by writers who really know their subjects. In the current Audio Festival and Fair issue, for example, the technical panel of commentators, headed by Donald Aldous, provides a comprehensive survey of what's new and where to find it at the Festival, plus some glimpses of future trends.

*Audio & Record Review* is an established, well-respected journal, but *new* in concept and outlook. Visitors are cordially invited to see the magazine for themselves at Room No. 344, where special subscription terms are being offered without obligation.

## **BASF**

**Badische Anilin-& Soda-Fabrik AG.**

Ludwigshafen am Rhein,  
Western Germany

**Booth 22**

**Demonstration  
Room 320**

*Tape, Library Boxes and Accessories*

Each year BASF have presented an original demonstration at the International Audio Festival and Fair, and this year is no exception !

In order that you may obtain the maximum benefit from your recording tapes and equipment, come and listen to some expertly prepared pre-recorded talks on a number of topics designed to be of interest and assistance to tape-recording enthusiasts. Choose the subject in which you are interested and whilst you are listening to the talk a copy-tape will be automatically prepared and will be ready for you to take away free of charge.

The talks cover the following topics :—

- Recordings of Historical Interest
- Sound Exploration
- Sound Effects
- Slide Synchronisation.

Details and prices of the full range of BASF tapes, library boxes and accessories will be available and BASF's recording experts will be pleased to assist you and answer any queries which you may care to discuss with them.

The full range of our products is on display at our booth.

**U.K. address : BASF Chemicals Limited, 5a Gillespie Road, London, N.5.  
Telephone : CANonbury 2011.**

## **BEYER**

**Eugen Beyer Elektrotechnische Fabrik,**

71, Heilbronn/Neckar,

West Germany

**Booth 36**

**Demonstration**

**Room 415**

*Microphones, Headsets, Stands, Booms, etc.*

The sound coming out of top quality recording and amplifying equipment is only as good as the microphone allows. This first stage in the process is vitally important and has long been studied by Beyer. The result is a range of directional and omni-directional microphones second to none, both moving coil and ribbon. Used in large numbers by radio and T.V. broadcasting companies, recording studios, instrumental and vocal groups around the world, a wide variety of Beyer microphones is on display for your inspection.

Examples are :

**M119 Dynamic moving coil omni-directional microphone.** High performance general purpose, with frequency response 50-16,000 c.p.s.  $\pm 3$ dB, output level 0.22 mV/ $\mu$ b/ -73dB. Plastic sleeve reduces noise of finger rubbing.

**M61 Dynamic moving coil directional microphone.** Compact, lightweight, 70-12,000 c.p.s.  $\pm 3$ dB, strong cardioid characteristics with minimum susceptibility to feedback.

**M100 Dynamic moving coil microphone — non-directional.** Studio quality 40-18,000 c.p.s.  $\pm 2.5$  dB, output level 0.1 mV/ $\mu$ b/80 dB at 1Kc.

**M160 Dynamic Double Ribbon microphone, cardioid.** For top quality musical reproduction, 40-18,000 c.p.s.  $\mp 2.5$  dB, output level 0.07 mV/ $\mu$ b/ -83dB at 1Kc., imperceptible non-linear distortion, very compact and perfect for serious studio work.

**M260 Dynamic ribbon microphone, cardioid.** 120° dampening up to 20 dB, minimising feedback, frequency response of 50-18,000 c.p.s.  $\pm 2.5$  dB, at 1Kc. output level is 0.08 mV/ $\mu$ b/ -82dB. Excellent reproduction of speech and music.

Dynamic headphones for acoustical testing and monitoring, both mono and stereo are on show together with table and floor stands, booms, goose necks, etc. Full demonstration facilities available for all equipment in Room 415.

**Sole U.K. distributors : Fi-Cord International, 40a, Dover Street, London, W.1. HYDe Park 3448.**

## **BRAUN**

**Braun A.G.,**  
Russelsheimer Strasse 22,  
Frankfurt/Main,  
Western Germany

**Booth 9**

**Demonstration  
Room 214**

*Hi-Fi, Stereo, Tuners, Amplifiers, Record Players, Speakers.*

### **Audio 1**

A mains-energised fully transistorised feeder unit of outstanding quality. Short, medium, long and VHF wavebands. 11 FM and 8 AM tuned circuits. AVC on FM and 2 AM stages. Output 2 x 14 watts. Distortion under 1% at 1 Kc/s. Frequency response 30 to 30,000 c/s. FM multiplex adaptor. PC45 deck. Dimensions : 25½ in. x 11 in. x 4½ in.

### **TC 20**

Similar in design to the Audio 1. Fully transistorised feeder unit. Medium, long and VHF wavebands. 12 FM and 11 AM tuned circuits. Output 4.5 watts per channel. Frequency response 30 to 25,000 c/s. New P2 record player. FM multiplex adaptor. Dimensions : 20½ in. x 9¾ in. x 5½ in.

### **PC 5 Hi-Fi Stereo Record Player**

Spring suspended hysteresis synchronous motor. Friction wheel and belt drive. Synchronous oscillation under 0.15%. Rumble free. Signal to noise ratio greater than 52 decibels. Matching dimensions to CSV 13 and 60 Hi-Fi Stereo Amplifier.

### **CSV 10 Hi-Fi Stereo Amplifier**

Fully transistorised. Output 2 x 14 W. Frequency response 20 to 30,000 c/s. Built in preamplifier for electro magnetic cartridge, controlled by separate panel selector switch. Dimensions 11 in. x 11 in. x 4 in.

### **L.46 Speaker Unit**

Slim line—can be wall mounted. Frequency response 40 to 20,000 c/s. Matching impedance 4 to 6 ohms. 1 woofer 8 in. diameter, 1 tweeter 4¼ in. diameter. Dimensions : 26 in. x 14½ in. x 4½ in.

### **L.80 Speaker Unit**

Superb stereo listening. "Leak Sandwich" woofer 13¼ in., mid-range speaker (specially designed) 4 in. and "Kelly Ribbon" tweeter. Frequency range 25 to 25,000 c/s. Capacity 10 watts.

**U.K. distributors : Argelane Ltd., 251, Brompton Road, London, S.W.3.  
Tel.: KEN 9611.**

## **BRENELL**

**Brenell Engineering Co. Ltd.,**

1a, Doughty Street,  
London, W.C.1  
HOLborn 7356

**Booth 28**

**Demonstration  
Room 342**

### *Tape Recording Equipment*

The Brenell range includes Mono conventional, Mono with separate record and playback amplifier, Stereo Units for use with external Hi-Fi amplifiers and decks to accommodate spools up to 10½ in. in diameter.

An examination of the MK5 Series 2 Deck reveals the reasons for its popularity. Such features as the synchronous capstan motor with an outer rotor having the action of a flywheel — the robust, cleanly designed linkage mechanism—the three-motor system with interlocking mechanism which prevents accidental erasure and physical damage to the tape—the facilities of four tape speeds, accommodation of up to four heads and larger spools than most decks.

### **SPECIFICATIONS :**

#### **Brenell Mk. 5 Series 2 Deck**

Three motors (synchronous type of capstan drive). Large flywheel (statically and dynamically balanced). Four tape speeds (15, 7½, 3½, 1¾ i.p.s.). LOW WOW and Flutter less than 0.05% at 15 i.p.s.; 0.1% at 7½ i.p.s.; 0.15% at 3½ i.p.s.; 0.25% at 1¾ i.p.s. Spool sizes up to 8¼ in. Accommodation for four heads—mono or stereo. Digital counter.

#### **Brenell Mk. 5 Series 2 Amplifier**

Designed to match the ½-track Erase and Record/Playback heads fitted to the standard two-headed mono deck.

For use as: (a) Recording Amplifier. (b) Replay pre-amp. into external Hi-Fi equipment. (c) Replay into 15-ohm speaker. (d) "Straight" amplifier, featuring: Switched frequency correction for four speeds, Microphone and Radio input sockets, monitoring of input signals on headphones, plug and socket coupling to associated equipment. Available with magic eye or meter.

#### **Brenell Mk. 5 Series 2 Tape Recorder**

High quality Mono (½ track) recorder incorporating above deck and amplifier. Wooden cabinet, 9 in. x 5 in. internal speaker.

#### **Brenell Mk. 5 Type M Tape Recorder**

Special Mono (½ track) recorder fitted with SEPARATE RECORD AND PLAYBACK HEADS and AMPLIFIERS. Four tape speeds—Low Wow and Flutter (to above deck specification). Mixable inputs, Bass and Treble controls, outputs to headphones, external amplifier and external speaker.

#### **Brenell STB1/5/2 Stereo Unit**

A first-class stereo unit incorporating SEPARATE RECORD AND PLAYBACK PRE-AMPLIFIERS.

Designed for the Hi-Fi enthusiast desirous of adding really high quality Mono/Stereo recording facilities to his present installation.

Four-speed deck, four heads, Replay facilities for 1/4, 2/4, 1/2 and 2/2 track tapes and recording facilities for 1/2 and 2/2 track.

Variable bias. Mixing of input signals. "A.B." switching enables recorded signals to be compared with input signals, two edgewise scaled meters, variable output to suit any external amplifier.

#### **Brenell Mk. 510 Series 2 Deck**

A special deck designed to accommodate reels up to 10½ in. diameter, otherwise to MK5 Series 2 deck specification.



## BROWN

S. G. Brown Ltd.,  
King George's Avenue,  
Watford, Herts.  
Watford 23301

Booth 27

Demonstration

Room 421

### Headsets

#### DIPLOMAT HEADSET—3C.604

We announce the release of a new lightweight headset of high fidelity and performance. It incorporates ceramic piezo-electric transducers which are designed to withstand severe environmental conditions and which possess excellent response characteristics over a wide range of audio frequencies.

The wire guides in matt chrome and the terminal caps in polished aluminium anodised natural finish, the headband wires are plastic coated in black P.V.C.

The Headgear assembly is designed to fit both children and adults. It has two insulated spring wires passing over the head and terminating in plastic discs which embody wire guides carrying the earpieces. The adjustment of these is by virtue of a spring roller mechanism.

A 4 ft. 6 in. length of lightweight twin flat cable is attached to one side of the Headset; this cable has its conductors individually screened and the circuit connections to each of the transducers of the equipment are brought out via a conductor and a screen of the cable; this configuration enables stereophonic or monophonic operation according to choice and also has the advantage when used for stereophonic reproduction the fact that each channel is separately screened will reduce the possibility of mutual interference. The insulated spring wires of the Headband form part of the circuit connections to one of the transducers.

**PERFORMANCE—HEADSET.** Frequency Response: 30-1,200 c/s. Normal Input Signal: 3.5 volts RMB for 95 dBs. SL for less than 1 per cent. distortion. Maximum Undistorted Level: 80Vs. RMB produces 120 dBs. SL for less than 3 per cent. distortion. Impedance: Predominantly capacitive at 0.00 mFd per earpiece, which can be regarded as 150 K ohms at 1 Kcs. Weight: 3.5 ozs. (98 grams.)

**DIPLOMAT CONTROL UNIT 12C.100.** The unit is complementary to the Diplomat Headset, and it provides control of parameters which are of prime importance when using headphones and for stereophonic equipment.

Housed in a lightweight zip-topped case, together with the Diplomat Headphones, the Control Unit is intended to operate directly from low-impedance output circuits which are normal to most commercially available disc and tape reproducers, and it provides the following control facilities:—

- (a) Independent control of sound level for each earpiece, thus providing balance and level adjustment on stereophonic and monophonic listening.
- (b) Channel mixing on stereophonic, which is essential when listening on headphones if the full potentialities of such recordings are to be realised. The mixing control has a very wide range of adjustment and will give monophonic, true stereophonic, or two-channel listening, as desired. The mixing control is operative only on stereophonic systems.
- (c) Switched selection of input impedance, giving matching to 15 ohms or 600 ohms per channel on stereophonic or 7.5, 30, 300 or 1,200 ohms on monophonic depending upon method of connection, since the two channels can be wired in series or parallel when connected to monophonic equipment.

## **BUTOBA**

**Butoba Uhrwerke K.G.,**

Schonach,

Western Germany

**Booth 68**

**Demonstration**

**Room 234**

*Portable Transistor Tape Recorders at reduced prices.*

Butoba has been the leading name in portable tape recorder design for over 10 years. Two current models which re-emphasise their superiority in design and "value for money" are now available.

The MT5 model is an established favourite with discriminating tape recorder users throughout the world. From missionaries in the tropics to broadcasting companies in the U.S., they all praise the reliability, economy and outstanding performance of the MT5.

Powered by 8 U2 batteries, a car battery or A.C. mains (either 50 or 60 cycles) it is very economical and flexible in use. 5 in. tape spools, two motors, 1.2 watts output, a 7 in. x 5 in. loudspeaker, a clock-type tape counter, two input and two output sockets, a pause and instant start control, two speeds, magiceye and headphone monitoring, together with a wide frequency response of 50-13,000 cycles. These features combine to make the Butoba MT5 a portable recorder without equal among other machines costing up to twice as much.

Retail price now 59 gns. Accessories available include a range of microphones, a mains converter unit and carrying cases.

The Butoba MT7 model has recently been reduced in price to 38 gns., complete with microphone and tape, making it the ideal recorder for those who demand excellent recording quality in a machine that is smaller, lighter and more economically priced than the MT5.

Powered by 4 U2 batteries, a car battery, A.C. mains (50 or 60 cycles) or a rechargeable battery, and weighing only 7 lb., the MT7 has facilities normally only found in far larger machines.

With sockets for external battery or battery charger, extension speaker, preamplifier output and monitoring headphones, two speeds, a 6 in. x 2½ in. speaker, a frequency response of 100-12,000 cycles ± 3dB. 1 watt output, pause and instant start controls, a record safety lock button and 2 speeds; the MT7 gives true Hi-Fi performance at a price comparable with ordinary mass produced domestic mains-operated machines.

A remote control version, the MT7R is also available (43 guineas) together with a wide range of accessories for both these models.

The great strides that have been recently taken in the design of transistor recorders have been pioneered by the Butoba company earning them a reputation for advanced design, quality, reliability and service that is the envy of other manufacturers. Comprehensive stocks of spare parts are available from the U.K., concessionaires and from agents throughout the world.

**U.K. Agents : Denham & Morley Limited, 173-175, Cleveland Street, London, W.1. Telephone: EUSton 3656.**

# CELESTION

**Celestion Ltd.,**

Ferry Works,

Thames Ditton,

Surrey

EMBerbrook 3402/6

**Booth 8**

**Demonstration**

**Room 149**

## Loudspeakers

The year 1964 heralds the introduction of a new range of loudspeakers by Celestion Ltd., to be known as the Studio Series. The first of the range to be introduced are the CX1512 (standard model) and the CX2012 (de luxe model); both are full-range co-axial units of 12 in. diameter and capable of handling 15 and 20 watts respectively. The crossover frequency is 4 Kc/s and impedance 15/16 ohms.

The principle features of the Standard Model CX1512 are as follows:—

**PLASTAFLEX SURROUND** ensuring maximum damping of standing waves and surround resonances.

**TWO VOICE COILS** giving full coverage of the audio spectrum.

**COMPRESSION TREBLE UNIT** axially mounted ensures uniform high-frequency distribution.

**PURE ELECTRICAL CROSS-OVER** provides smooth frequency transition and feed to appropriate voice coil.

**HIGH FLUX CERAMIC MAGNETS** ensuring high input/output ratio.

**RIGID DIE-CAST CHASSIS** giving permanent precision alignment.

### Specification :

Frequency response	...	...	30—15,000 c/s
Power Handling capacity	...	...	15 watts British 30 watts American
Fundamental Resonance	...	...	35 c/s
Ceramic Magnet			
Flux density	...	...	13,000 Gauss
Total flux	...	...	88,000 Maxwells

and the features of the De Luxe Model CX2012 are:—

**HI-FLEX "FREE" SURROUND** provides high compliance, eliminates standing waves and surround resonance. Guaranteed moisture resistant.

**TWO VOICE COILS**, extra-long bass voice coil and precision mounted H.F. coil, to ensure clean extended frequency coverage.

**PURE ELECTRICAL CROSS-OVER** provides smooth frequency transition and feed to the appropriate voice coil.

**HIGH FLUX CERAMIC MAGNETS** ensuring high input/output ratio.

**COMPRESSION HORN LOADED TREBLE UNIT** for linear and wide-angle distribution of the high frequencies.

**RIGID DIE-CAST CHASSIS** giving permanent precision alignment.

**HIGH FREQUENCY LEVEL CONTROL** or "brilliance" control allows adjustment of high-frequency level to suit room conditions. Complete with 30 in. of cable, escutcheon and control knob.

### Specification :

Frequency response	...	...	30—18,000 c/s
Power Handling capacity	...	...	20 watts British 40 watts American
Fundamental Resonance	...	...	35 c/s
Ceramic Magnet			
Flux density	...	...	17,000 Gauss
Total flux	...	...	180,000 Maxwells

## CHAPMAN

**Derritron Radio Ltd.,**  
24, Upper Brook Street,  
London, W.1  
HYDe Park 2291

**Booth 70**

**Demonstration  
Room 448**

### *Amplifiers and Radio Tuners.*

The range of Chapman domestic high fidelity equipment on view and being demonstrated is as follows:

#### **FM.1000 V.H.F./F.M. Tuner**

With a range of 87.5—108 mcs.—High sensitivity—Low consumption and an output almost constant at 250 mv.

#### **FM.1005 A.M./F.M. Tuner**

With a range of A.M.-16.50m.; 50-195m.; 195-550m.; 800-2,000m. F.M.-875-108 mc/s.—Output F.M. and A.M. 250 mv. approx.—3 watts approx. consumption—This tuner has a sensitivity better than 2 microvolts for 20 dB quieting. A.M. better than 4 microvolts for 20 dB signal/noise ratio.

#### **S6BS/F.M. Mk. II**

A six-stage A.M. Bandsread and high gain F.M. Tuner—This tuner has an output of 500 mv. approximately into 100,000/500,000 ohms—A sensitivity of A.M. 2 microvolts for 20 dB signal/noise ratio. F.M. 2 microvolts for 20 dB quieting—Wave range of A.M. 11m., 13m., 16m., 19m., 25m. and 31m. in six bandsread ranges. 13-43m., 43-140m., 175-570m. F.M. 88-108 mcs.

#### **S6BS Mk. II**

A six-stage A.M. Bandsread Tuner, with an output of 500 mv. approx. in 100,000/500,000 ohms—A sensitivity of 2 microvolts for 20 dB signal/noise ratio—Wave range of 11m., 13m., 16m., 19m., 25m. and 31m. bands in six bandsread ranges 13-43m., 43-140m., 175-570m. displayed on a large scale.

#### **305 Mk. II**

Stereo Control Unit—Gram Input of 5 mv. at 100 k. ohms RIAA curve; tape 50 m.v. at 100 k. ohms flat; Radio and Aux. 100 m.v. at 250 k. ohms. Frequency response within 0.2 dB 30-20,000 c/s without filters—Distortion less than 1.0% total.

#### **205 Amplifier**

This has a power output of 30 watts from 20 c/s to 20,000 c/s—Power response with 0.5 dB of 1 Kc. level at 20 watts from 20 c/s—20 Kc.—Sensitivity of this amplifier is 220 m.v. for 20 watts output—Hum and noise down 90 dB relative to 20 watts—Harmonic distortion of 0.05% at 20 watts, 0.1% at 30 watts—intermodulation distortion 0.7% at 20 watts, 1% at 30 watts.

#### **305 Stereo Main Amplifier**

This amplifier has a power output of 8 watts over the range 30-20,000 c/s input sensitivity of 350 m/V RMS for 8 watts output—Frequency response within 0.2 dB 30-20,000 c/s—Distortion, harmonic at 8 watts less than 1% at 1 Kc/s, Intermodulation at 8 watts less than 1% with mixed frequencies.

#### **306 Integrated Stereo Amplifier**

Frequency range of  $\pm 0.5$  dB 36 c/s—20 Kc. including filters at 1 watt level (25 c/s-25 Kc. without filters)—Treble and Bass Controls are fully variable—Input is Gram, 5 mv. at 100 K. ohms RIAA curve, 50 mv. at 100 K. ohms flat (Tape)—Radio and Aux 100 mv. at 250 K. ohms.—Distortion, Harmonic at 8 watts less than 0.1% at 1 Kc. Intermodulation less than 1% with mixed frequencies—Hum and Noise, Main Amps-75 dB Radio tape and aux.—60 dB, gram—50 dB.

## **CLAIRTONE**

**Clairtone Sound Corporation Ltd.,**  
Toronto, Canada

**Booth 7**

**Demonstration  
Room 215**

### *Stereophonic Hi-Fidelity Reproducers*

#### **Project "G"**

The new shape in sound—a completely new concept in stereophonic sound systems. Visually and acoustically, PROJECT "G" represents a departure in self-contained stereo units in that its twin "sound globes," 18 in. in diameter and made of spun aluminium, rotate freely outside the console through 340-degree arcs. The globes are sealed and represent the ultimate in sound baffling. They can be adjusted to any type of music being played, thus simulating faithfully the conditions of the recording studio.

There are two other major innovations. By isolating the "sound globes" from the cabinet all traces of feedback speaker vibrations which affect record player and amplifier have been eliminated.

The shock-mounted ball-bearings, on which the spheres turn, provide further insulation.

A patented motional velocity feedback circuit eliminates distortion electronically. This circuit derives its voltage from the proportional movements of the "sound globes" and carries this signal back to the amplifier, where it is pitted against the input signal to cancel out distorting frequencies. PROJECT "G" is completely transistorised and the cabinet, made of rosewood, rests on an extruded aluminium undercarriage.

Solid state tuner, three I.F. stages, F.M. sensitivity 2.5 mv., channel separation 25 dB, A.M. frequency response 20—8,000 cps  $\pm$  1 dB. Solid state amplifier, 20 watts per channel output at less than 0.5% distortion. Frequency response 14 to 40,000 cps  $\pm$  1 dB, hum and noise ratio 65 dB below rated output. Four-speed record changer with precision tone arm, Elac variable reluctance cartridge, tracking force 2.5 grams, separation 35 dB at 7,000 cps.

#### **Clairtone Model 603, Empress**

Equipped with a socket for stereo earphone "Silent Listening." Fully transistorised TC4 chassis. Amplification: Latest in engineering achievement. High-fidelity push-pull balanced dual amplifiers with total instantaneous musical power of 15 watts per channel. Frequency response: 20—22,000 cps. Channel separation: 50 dB. Hum and noise: 68 dB below rated output. Available in hand-rubbed oiled walnut or teak.

#### **The Regency Stowaway**

The Regency console radiogram now in its Stowaway form incorporates additional space for T.V., tape recorder or records concealed behind smooth sliding doors.

Lab "A" Garrard record changer with Acos Cartridge.

Two 11 in. x 6 in. E.M.I. aluminium cone woofers, and four 2½ in. tweeters.

Equipped with "Silent Listening." F.M., A.M. and Long wavebands. Fully transistorised TC4 chassis, with low-level fidelity. Automatic shut-off after last record. Finished in oiled walnut.

**U.K. Distributors: Argelane Ltd., 251, Brompton Road, London, S.W.3.**  
**Telephone: KENsington 9611**

## **CLARKE & SMITH**

**Clarke & Smith Mfg. Co. Ltd.,**  
Melbourne Road, Wallington,  
Surrey  
Wallington 9252/7

**Booth 24**  
**Demonstration**  
**Room 321**

*High Fidelity Equipment, Pick-ups, Tape Recorders,  
P.A. Equipment.*

Under the trade mark "C.S.I. Sound," Clark and Smith continue their policy of offering a complete matched range of domestic audio components.

Two new additions to the range are a self-powered AM/FM Tuner (Model 658 Mk II) with a much improved specification over its Mark I predecessor, and a compact loudspeaker system — model 619 — giving reproduction remarkably free from colouration and an even response from 50 to 18,000 cycles. This model has a cabinet constructed from  $\frac{3}{4}$  in. Blockboard and finished in matt polished Walnut Veneers. A flush fitted Tygan front in neutral colours enables the speaker to blend with most furnishing schemes, traditional or contemporary.

Also being shown, are the integrated stereo amplifier—Model 655, Stereo Control Centre—Model 656, and Stereo Power Amplifier—Model 657. These remain unchanged from last year and provide the user with the alternative of a compact integrated unit or separate control unit and power amplifier. All will be demonstrated together with the E.M.I. Pick-up (EP11/100) throughout the period of the exhibition in Room 321 where you are invited to listen in peace and comparative quiet !

Since their introduction last year, the transistorised Tape Recorders models 634 and 635 have enjoyed enormous success in the Education market. We are happy to announce that enquiries from the public through retail channels can now be entertained.

Both models employ a fully transistorised 10 watt amplifier incorporating facilities for mixing, superimposition, "straight through" and monitoring via the separate replay circuitry. The model 634 employs a Wright and Weaire deck and the model 635, a Truvox deck.

A selection of interesting units produced by the Sound Equipment Division, are exhibited on the main stand in the Exhibition Hall. (Booth 24.) These include a range of the now "well used and tried" transistor microphone and music input stages with their associated power supply unit. A cabinet, containing an assembled panel of these pre-amplifier "bricks," is also on display. Also to be seen are the three-station VHF/FM crystal-controlled radio tuners and a low power general purpose amplifier.

## CONNOISSEUR

A. R. Sugden & Co. (Engineers) Ltd.,  
Market Street,  
Brighouse, Yorks.

Booth 25  
Demonstration  
Room 242

*Stereo Cartridge, Transcription Turntables,  
Pickups and Arms, Speaker Enclosures*

Showing for the first time the **Connoisseur** transcription pickup arm and shell Type SAU1 designed to meet the demand for a quality arm at a competitive price. The SAU1, besides accommodating the SCU1 stereo cartridge, will also accommodate the majority of cartridges having the universal  $\frac{1}{2}$  in. -  $\frac{7}{16}$  in. fixings. Features: Single  $\frac{3}{8}$  in. hole fixing, single unipivot bearing for both vertical and lateral movement, detachable head-shell, lever height adjustment, offset sliding counter balance weight, unique method of setting stylus pressure by calibrated weights supplied, optional lift-and-lower device, integral arm rest.

**Connoisseur** Stereo cartridge Type SCU1: This ceramic stereo cartridge having international  $\frac{1}{2}$  in. fixing centres will satisfy the most discerning audiophile and can be accommodated in the majority of arms. The channel separation is well maintained to both ends of the frequency spectrum resulting in a well defined stereo image in correct perspective. The high compliance and low mass of the stylus system in conjunction with a well designed arm allow extremely low downward pressures to be accomplished. The versatility of the cartridge is such that it may be used under both magnetic conditions of loading and also under conditions of loading normally associated with crystal/ceramic type of cartridges, thus giving correct compensation for the RIAA playback standard without the need for complex equalisation networks.

**Connoisseur Craftsman III.** Three-speed transcription turntable for stereophonic and monaural records. Requires minimum mounting space. Styled in black and satin silver. Heavy non-ferrous 12 in. lathe-turned turntable. Speeds 78, 45 and 33 $\frac{1}{3}$  r.p.m. 4 per cent. variation on all speeds. Large stroboscope fitted beneath turntable viewed through mirror illuminated by neon light source. Synchronous motor balanced dynamically and electrically, runs at constant speed irrespective of large variation in supply voltage. No braking action employed to obtain change of speed. Precision ground large diameter idler wheel retracted in "off" position. Shafts lapped to mirror finish, fitted with adjustable bearings.

**Connoisseur Craftsman** two-speed transcription turntable has been designed specifically to answer the stringent requirements of stereo disc playback and, in addition, provides superior performance for monaural reproduction. Speeds 33 $\frac{1}{3}$  and 45 r.p.m. Synchronous motor, 12 in. lathe-turned turntable; all shafts precision ground running in adjustable bearings.

Plinth mounted **Connoisseur** transcription units as above with SAU1 arm.

**Connoisseur** Speaker enclosures are entirely new concepts in speaker design and construction and make the most effective use of new materials. They provide the maximum performance in the minimum of required space and are equally suitable for monaural and stereophonic reproduction. **Craftsman Major** and **Major II** enclosures accommodate 8 in. speakers and 2 $\frac{1}{2}$  in. HF units. Range 30/15,000 cycles. **Craftsman Minor** and **Minor II** enclosures accommodate 8 in. units. Range 40/12,000 cycles. **Junior** speaker accommodates 6 $\frac{1}{2}$  in. unit 3 or 15 ohms. Finished in attractive "Vynair" plastic.

**DECCA**

**Decca Radio and Television,**

Ingate Place, Queenstown Road,  
London, S.W.8  
MACaulay 6677

**Booth 66**

**Demonstration**

**Room 235**

*Sound Reproduction Equipment and Records*

Decca Radio and Television will be demonstrating the Decca ffss III pick-up. The new 2-gram magnetic pick-up head with the Decca "Professional" arm and the Decca Stereo Decola Separates.

On show only, there will be the Mark I "Super" arm and a new magnetic mono LP head.



## **DECCA**

**The Decca Record Company Ltd.,**  
Decca House, Albert Embankment,  
London, S.E.1  
RELIance 8111

**Booth 65**

**Demonstration  
Room 236**

*Records and Record Players*

In this room Decca will be demonstrating their records on new equipment comprising :

A transistorised stereo amplifier.

Playing desk equipped with the Decadec turntable and Deram cartridge

And compact speaker systems.

Also a multiplex stereo radio unit

And the Deccalian Mark 4E.

## **DESIGN FURNITURE**

**Design Furniture Ltd.,**

Calthorpe Manor,  
Banbury, Oxon.  
Banbury 4341

**Booth 59**

**Demonstration  
Room 117**

### *Cabinets*

The Design Furniture range consists of a selection of cabinets constructed to meet the practical demands of the Hi-Fi enthusiast and, at the same time, to become a part of home furnishing which the owner may be proud to possess.

The range of equipment cabinets embraces sizes varying to accommodate the minimum or the maximum amount of equipment required. (The enclosed top shelves vary from approximately 20 in. x 16 in. to 42 in. x 19 in. and the control panels from 20 in. x 14 in. to 42 in. x 13 in.). Some incorporate record and tape storage space.

The speaker cabinets include several which have been tested and approved by a leading speaker manufacturer. They vary in size for 8 in., 10 in. or 12 in. speakers, the largest one being suitable for stage building.

Record and tape storage cabinets and television tables and trolleys are also available.

The cabinets are made to a very high standard and are finished in one or other of the following woods, namely, Natural Oiled Teak, Polished Natural Rosewood and Polished Medium Walnut or Mahogany.

## **DUAL**

**Gebr. Steidinger,**  
St. Georgen,  
Western Germany

**Booth 33**  
**Demonstration**  
**Room 158**

*Stereo Systems and Accessories, Transcription Turntables,  
Tape Recorders.*

Very few audio components approach the goal of the term "High Fidelity" and convey the true sound of music but outstanding amongst those that do is the name DUAL from one of Western Germany's largest manufacturers.

**DUAL 1009.** This unit, now shown in England for the first time, establishes a new concept of design and incorporates some of the most advanced knowledge of record reproduction techniques, satisfying the most stringent technical requirements at the present state of the art. The DUAL 1009 is the first record playing instrument to combine professional standards of reproduction with automatic changer operation—the very first to offer automatic operation at a tracking force of only  $\frac{1}{2}$  gram.—the normal requiring up to 10 times this force in order to function with any degree of reliability. This unique tracking ability of the DUAL 1009 makes it the first automatic unit able to accommodate cartridges of even the highest compliance—absolutely no compromise whatever need be made for the convenience of automatic operation either in fidelity or performance or record wear. The dynamically balanced Pick-Up arm is stable in all planes and extremely simple, but positive to balance. It has a continuous variable tracking force of from 0.7 grams and provides flawless tracking as low as  $\frac{1}{2}$  gram with automatic stop and shut-off. Perhaps the greatest tribute to this unit lies in the fact that almost all the leading European and American manufacturers incorporate the DUAL 1009 into their top quality models.

**DUAL Tape Recorder TG 12A.** This four track high fidelity stereo tape recorder with separate twin speakers is another product of professional quality from this company. The built-in low noise tube amplifier provides all facilities for various recording methods and stereo playback. A power stage for High Fidelity play back through the two acoustically identical speaker systems is also incorporated. Any mistakes in operation are eliminated by the interlocking design of the controls and the operator will immediately appreciate that the controls will automatically return to play-back position after each tape rewinding. Only by seeing and experiencing the reproduction these magnificent products offer, can you judge their real quality.

**U.K. Distributors : CELSA Electric Company Limited, Celsa House, Kelway Place, London, W.14. Telephone: FULham 9761-2.**

## **ELCOM**

**Elcom (Northampton) Ltd.,**  
Weedon Road, Industrial Estate,  
Northampton  
Northampton 51873/4/5

**Booth 60**

**Demonstration  
Room 213**

### *Audio Equipment*

For the first time at the International Audio Festival and Fair, "ELCOM" are exhibiting a range of fully transistorised Audio Equipment.

This equipment, after many years of research and development, has been designed to cover the exacting requirements of Broadcasting, Theatre, Studio and the connoisseur. Particular attention has been paid to overall design grouping of controls, together with the facilities required by the operating engineer. The simplicity of the module constructional design, both mechanically and electronically, allows the final requirements to meet most specifications from standard units.

The "ELCOM" system of audio mixing is based primarily on the Electronic Fader. This fader being of unity gain (no insertion loss) means that line level is maintained and further amplifiers to make up such losses usually associated with stud-type faders, are no longer required. Other advantages are that the fader gives completely stepless balancing, and patching networks are dispensed with.

The range of Audio Equipments available as standard units are :—

**Four Channel Transportable Mixer** with equalisation on all channels, giving tone correction of  $\pm 9\text{dB}$ s of cut and boost on treble and bass. This unit also incorporates a pre-set gain control with an overall range of 0—40dBs.

**Ten Channel Mono/Stereo Mixer**, which is available either in table-top form or as a twin pedestal desk, featuring all the facilities required for the recording studio, i.e., input switching, equalisation on all channels, group and master fading, visual monitoring by P.P.M. unit, together with various optional facilities.

Other items available as standard units are : Two types of Microphone Amplifiers, Compensating Amplifiers, Electronic Faders, Line Amplifiers, Talk-back Amplifiers, P.P.M. units, together with the well-known range of "Elcom" components, which include Attenuators, Switches, Connectors and Plugs and Sockets.

The range of our equipment can be fully appreciated by a visit to Room 213, where our aim is to show the wide application of our equipment

## **E.M.I.**

**E.M.I. Ltd.,**

Blyth Road, Hayes, Middlesex

HAYes 3888

**Booth 63**

**Demonstration**

**Room 322**

*Magnetic Recording Tape and Film; Lacquer Recording Discs ; Tape Accessories ; Professional Tape Recorders.*

At Booth No. 63, E.M.I. Tape Limited will be showing a range of Magnetic Recording Tapes:

Emitape 100 — Double Play

Emitape 99 — Long Play

Emitape 88 — Standard Play

Emitape 44 — Acetate Standard Play.

Also on display will be EMIFILM (Magnetic Recording Film); EMIDISCS (Lacquer Recording Discs); tape accessories and aids to better recording—notably EMIGUIDES (6 pre-recorded instructional tapes) and the EMITAPE GUIDE TO BETTER RECORDING—a 64-page booklet by John Borwick. Copies of the latter can be purchased direct from Booth 63, price 2/6 each.

At Demonstration Room 322, E.M.I. Electronics Limited will be demonstrating the Type 311, RE 301 and TR 52 professional tape recorders.

The Tape Recorder Type 311 is a high-quality magnetic sound tape recorder which can be used in broadcasting studios, recording studios, and for scientific and industrial research applications. It can be supplied for full track, half track or twin track stereo recording on 0.25 in. (6.3mm) tape, and three or four track recording on 0.5 in. (12.6mm) tape. The recorder will be in console, transportable, trolley-mounted and rack-mounted versions. Tape speeds are 15/7.5 inches/second (38/19 cm/sec) or 7.5/3.75 inches/second (19/9.5 cm/sec). The deck will be available for sale separately with or without heads.

The RE 301 is intended to provide an extremely flexible two-channel recorder in transportable form, for the specialised needs of the communication field, audio analysis, noise measurement and comparison tests. A trolley is available with this model.

The TR 52 portable stereophonic tape recorder is designed for professional use on those occasions when it is necessary to leave the studio and can be employed not only for formal recordings such as actual performances but also whenever critical assessment and judgment of performance is of paramount importance. In addition it finds wide use in scientific and industrial research establishments. A trolley is also available with this model.

## **FANE**

**Fane Acoustics Ltd.,**  
Hick Lane, Batley,  
Yorkshire  
Batley 1578

**Booth 19a**  
**Demonstration**  
**Room 221**

### *Loudspeakers*

On display in our Booth No. 19A are samples of our very large range of 12 in., 15 in. and 18 in. heavy duty loudspeaker units which can be supplied either with low resonance cones for use as bass reproducers in Hi-Fi systems, or with high resonance cones for use with electric guitars.

On show for the first time is our Model 851 mid-range unit, which, together with our Model 301 high frequency unit and 3 x 1 crossover unit, completes our range of Hi-Fi loudspeakers.

In our Demonstration Room No. 221 may be seen and heard our new slim and very elegant three-speaker enclosure, the "SYLPHIDE." This employs a 12 in. bass unit, an 851 mid-range unit and a 301 H.F. unit, together with a new cross-over network. It will be demonstrated on both single channel and stereo programmes.

We shall also be demonstrating for the first time our new four-speaker enclosure, the "FANFARE." This is in the very highest class of reproducers and employs rear horn-loading for the bass unit effective down to 17 cycles per second. It will appeal to all who are looking for the ultimate in high fidelity reproduction.

## **FEDERATION OF BRITISH TAPE RECORDING CLUBS**

Lounge 154

1007a, Finchley Road,  
N.W.11  
WATERloo 2345 Ext. 201

### **Federation of British Tape Recording Clubs**

In the Federation Lounge amateur recording enthusiasts may listen in comfort to a selection from our Library of British and International Prize-winning Tapes. Whatever your particular interest, there is sure to be something for you—Orchestral Music from Venezuela—Technical Experiment from Switzerland—Documentary from Africa—there are tapes to suit all tastes in this fascinating programme.

### **Federation of British Tape Recording Clubs**

Amateur recordists are assured of a warm welcome in the Federation Lounge. Members of the Committee are on duty to explain the objects of the Federation, to describe its activities and to answer your questions. Have you a tape recording problem? If we can't give you the answer right away, we will find it for you. That (amongst other things) is what we are here for.

### **Federation of British Tape Recording Clubs**

The Federation was formed in 1958 to represent on a national scale the interests of local Tape Recording Clubs. This it does by maintaining close links with the Press, with industry and with the retailer. In addition, the Federation is in close touch with amateur recording activities throughout the world through its membership of Federation Internationale des Chasseurs de Son. Any club, society or individual interested in amateur tape recording is eligible for membership of the Federation. Amongst our activities are the following :

**Information Bureau.** The Bureau will answer any query connected with the art and science of tape recording. Nothing is too much trouble. Details of professional recording and disc-dubbing services are available. In the latter case reduced rates for Member Clubs are obtainable.

**Competitions.** The Federation takes part in the judging each year of the British Amateur Tape Recording Contest organised by *Tape Recording Magazine*. The Amphlett Trophy is awarded by the Federation to the winning entry in the Club Section of this contest. The Federation also sends delegates to the Annual Congress of Federation Internationale des Chasseurs de Son and judges to the international contest.

**Annual Congress.** In order to provide an opportunity for an exchange of views between local Clubs, the Federation organises an Annual Congress of British Tape Recording Clubs to which all Clubs are invited to send delegates.

**Library.** The Federation maintains a library of winning tapes from the British and international contests. Copies of these tapes are available on loan, free to Member Clubs and on payment of a copying fee to non-members.

### **Federation of British Tape Recording Clubs**

Address for correspondence : **E. R. Aslin, Hon. Secretary, 1007a, Finchley Road, London, N.W.11.**

## **FERROGRAPH**

**The Ferrograph Co. Ltd.,**  
84, Blackfriars Road,  
London, S.E.1.  
WATERloo 1981

**Booth 67**  
**Demonstration**  
**Room 337**

*Magnetic Sound Recorders*

The complete Ferrograph range of instruments will be on view on the Stand in the General Exhibition Hall and demonstrations will take place as usual in the room allocated to the Company upstairs.

This year we are taking a special room also wherein visitors with problems are invited to call in order to obtain technical assistance and advice which would not easily be possible to be given in the Demonstration Room or in the Hall. This room has the number 339 and is to be found on the third floor.

No innovations are planned or are being disclosed as far as the Ferrograph instruments are concerned, but there are, of course, modifications made from year to year whereby improvements are introduced both in the mechanical and in the electronics specification senses.

The demonstration in room 337 will be of stereophonic recording and reproduction and will follow the pattern usually employed in the past years.



## **FI-CORD**

**Fi-Cord International,**  
40a, Dover Street,  
London, W.1  
HYDe Park 3448

**Booth 37**  
**Demonstration**  
**Room 414**

### *Portable High Fidelity Tape Recorder*

A new accessory being shown by Fi-Cord International will further add to the exceptional versatility of the FI-CORD 202. This new accessory, a rechargeable battery unit, added to the existing range of power units now enables the FI-CORD 202 to be used from the following power sources :

- (1) 105-240 volts A.C. mains
- (2) 12-volt D.C. car battery
- (3) Rechargeable accumulators
- (4) Mercury batteries

The FI-CORD 202, designed for the user requiring professional standards, has achieved wide popularity as a result of its combination of high fidelity, portability and extreme versatility.

Vital statistics of the FI-CORD 202 are as follows : Two speeds— $7\frac{1}{2}$  and  $3\frac{3}{4}$  i.p.s. : 50-12,000 c.p.s.  $\mp$  3dB : Standard 4 in. spools : Fast forward and back wind : Resettable counter : Vu meter with volume and recording level control : Built-in speaker : Sockets for extension speaker, low and medium inputs, remote control and mains input ; weighs only  $6\frac{1}{4}$  lb. including batteries : measures 9 in. x  $6\frac{1}{2}$  in. x  $4\frac{1}{2}$  in.

Also on display will be two recent FI-CORD releases—a portable, battery-powered amplifier speaker and a transistorised mixed unit with high and low impedance outputs (also battery-powered).

Live demonstrations of the FI-CORD 202 system will be given in Demonstration Room No. 414.

## **GARRARD**

**Garrard Engineering Ltd.,**  
Newcastle Street, Swindon  
Swindon 5381

**Booth 29**

**Demonstration  
Room 145**

### *Sound Reproducing Equipment*

#### **Laboratory Series Auto Turntable Type A**

A transcription motor with Garrard's exclusive pusher platform record changing mechanism to give automatic play if required. Incorporates a sandwich-constructed heavy turntable and a fully counter-balanced pick-up arm with inbuilt pressure gauge.

#### **AT.6 Auto Turntable**

This high quality unit has a large diameter turntable and counter weighted balanced tubular pick-up arm, with plug-in pick-up head. Fitted with the Garrard calibrated stylus pressure adjustment. Ideal for manual playing or automatic selection as required.

#### **AT.5 LM Automatic Record Changer**

This new Garrard auto-changer incorporates, for the first time by a British manufacturer, the technique of the low-mass pick-up arm. Designed for use with the very highest quality high compliance pick-up cartridges.

#### **Autoslim**

An extremely compact, elegant and low-priced automatic changer with provision for manual play. Pick-up arm with plug-in head available.

#### **301 Transcription Motor**

The world-famous unit as used by the B.B.C. and many other broadcasting stations. Designed for top performance, high fidelity systems.

#### **SRP.10**

A compact unit with modern styling, this inexpensive single record player possesses all the features associated with larger unit and will play all sizes of records.

#### **Battery Tape Deck**

Designed to give a compact, portable unit capable of high quality performance. Weighs only 3 lb.

#### **Pick-ups**

Model GC.2 Turnover Crystal Monophonic has a wide frequency range and gives good quality reproduction for long playing and 78 r.p.m. records.

Model GC.8 Turnover Crystal Monophonic with a higher compliance than the GC.2.

EV.26a Turnunder Stereophonic Ceramic gives smooth response, with a high compliance. Virtually unaffected by climatic conditions. Plays stereophonic and monophonic records including 78 r.p.m.

#### **Stylus Pressure Gauge Model SPG.3**

A useful accessory to ensure correct stylus pressure. Accurate through the entire scale, 1-12 grammes. Supplied with 5 gramme checking weight.

#### **Styli**

The complete range of sapphire or diamond replacement styli is available for all Garrard Pick-ups.

## **GEVAERT**

**Booth 6**

**Gevaert Photo-Producten N.V.,**  
Mortsel, Antwerp, Belgium

### *Magnetic Tapes*

This year Gevaert will again be exhibiting their comprehensive range of GEVASONOR magnetic recording tapes, which are among the finest in the world. They are produced by the largest manufacturer of sensitized materials in Europe. From the following list of types and sizes it can be seen that there is a tape to meet the professional or domestic need :

**Gevasonor Type M.** Standard play tape on cellulose triacetate base. An inexpensive tape of high quality, suitable for all general purposes. Minimum elongation at breaking point. In spool sizes 3 in., 4 in., 5 in., 5½ in., 7 in., 8¼ in. and 10 in. Also 2,400ft. lengths on NAB spools for professional use.

**Gevasonor Type LR.** Long play tape on a cellulose triacetate base. Minimum elongation at breaking point. Particularly suitable for editing work. Supplied in spool sizes 3 in., 4 in., 5 in., 5½ in., 7 in., 8¼ in. and 10 in.

**Gevasonor Type LRP.** An exceptionally strong long play tape on a tensilised polyester base. Particularly useful for 4-track recording. Available in spool sizes 3 in., 4 in., 5½ in., 7 in., 8¼ in. and 10 in.

**Gevasonor Type DP.** Double play tape on a tensilised polyester base, with high breaking resistance. Equally suitable for 4-track recording. In spool sizes 3 in., 4 in., 5 in., 5½ in. and 7 in.

**Gevasonor Type TrP.** Extremely thin tape for triple playing-time, on a tensilised polyester base. Recommended for portable machines, and for 4-track recording. Supplied in spool sizes 3 in., 4 in. and 5 in.

**Gevasonor Magnetic Film.** For the motion picture and television industries.

**U.K. Sales : Gevasonor Tape Division, Gevaert Limited, Great West Road, Brentford, Middlesex (Isleworth 2131).**

**GKD**

**GKD Ltd.,**  
King Street,  
Houghton Regis, Beds.  
Dunstable 63300

**Booth 45**

**Demonstration  
Room 319**

*High Fidelity Equipment Cabinets*

GKD have gained an impressive reputation for design, quality and workmanship of their range of High Fidelity Equipment Cabinets and, in fact, all designs have been developed in the closest collaboration with leading manufacturers of Hi-Fi equipment, such as Messrs. H. J. Leak & Co. Ltd., and The Acoustical Manufacturing Co. Ltd.

This year we have decided to modify certain of our cabinets in order to keep up to date with all the latest technical developments and trends, but at the same time retain the same style, which combines graceful, pleasing design with absolute conformity to the very exact standards required for housing audio equipment.

Come and see for yourself this superb range on Booth No. 45, and hear your favourite equipment demonstrated in Room No. 319.

## **GOLDRING**

**The Goldring Manufacturing Co.  
(Great Britain), Ltd.,**  
486-488, High Road, Leytonstone,  
London, E.11  
LEYtonstone 8343-4-5

**Booth 20**  
**Demonstration**  
**Room 118**

*Transcription Units, Pick-up Arms, Cartridges, Stylus Replacements*

### **Transcription Units**

Three Goldring "Lenco" Transcription Units will be exhibited, all featuring the unique vertical drive system which offers infinitely variable speed adjustment from below 35 r.p.m. to above 80 r.p.m. and from 15 to 18 r.p.m.

**G.88 :** This Unit, which is designed for use with any pick-up arm, has an 8 lb. non-ferrous turntable and neon indicator light.

**GL.70 :** An 8 lb. die-cast non-ferrous turntable is also fitted to this Unit, which incorporates the L.70 pick-up arm. By means of the automatic lifting and lowering device, this arm can be placed on any pre-determined part of the record.

**GL.58 :** This Unit also incorporates a lifting and lowering device and is fitted with a heavy-duty motor and improved centre spindle bearing.

All these Units have extremely good wow and flutter figures and are all supplied with stroboscopes.

### **Pick-up Arms**

An exciting new arm which can be balanced in all planes, irrespective of which cartridge is fitted will be introduced. In addition, the G.60, with its unique slide-in platform, and the L.70 Arm will also be shown.

### **Pick-up Cartridges**

In addition to the well-known 580 and 600 Variable Reluctance Monaural Cartridges, the 700 Mk II Variable Reluctance Stereo Cartridge will be shown and the 380 A moving magnet Stereophonic Cartridge, which has separation of 30 dB at 1 Kc, and never less than 15 dB throughout its entire frequency range.

**The CS.90** is a Stereo Ceramic Cartridge with the characteristics of a magnetic cartridge. Its frequency response extends to 20,000 cycles and its separation at 1 Kc exceeds 20 dB. With its compliance of not less than  $6 \times 10^{-6}$  cms/dyne, it will happily track records at two grammes.

**The CS.80** is a turnover Ceramic Cartridge with an output of 200 mv and yet high compliance. In addition a wide range of mono and stereo Crystal Cartridges will be shown.

### **Replacement Styli**

The range of replacement Sapphire and Diamond Styli has again been increased to include all the known makes recently introduced in this country.

## GOODMANS

Goodmans Industries, Ltd.,  
Axiom Works, Wembley,  
England  
WEMbley 1200

Booth 31

Demonstration  
Room 347

*High Fidelity Loudspeakers, Pressure Units and Components, High Fidelity Loudspeaker Systems complete in enclosures, High Fidelity special Loudspeakers for Stage and Theatre work, Guitar amplification, etc.*

**Eleganzia** was introduced at last year's Audio Festival. Since then it has become the most sought-after slim-style High Fidelity Loudspeaker System. The Mark II Eleganzia now increases this lead still further by providing a smoother overall performance than ever before—still with no increase in size of the elegant super-slim Enclosure, only 6½ in. deep. Range 35-15,000 c/s. Power 15 Watts. Impedance 15 ohms. Price £27 10s. (Walnut or Teak to order).

**Maxim.** New for this year's Show—the New Goodmans Maxim. A true High Fidelity System with a range of 45-20,000 cycles within dimensions of 10½ in. × 5½ in. × 7¼ in. Its largest dimension is dwarfed by an ordinary 12 in. rule !

The Maxim contains two special precision-built direct radiators with most unusual capabilities. Developed exclusively for this sized enclosure these "mighty midget" drivers cover the frequency range with less deviation from level response than almost any other High Fidelity Loudspeaker. Range 45-20,000 c/s. Power 8 Watts. Impedance 15 ohms. Price £15 + £2 10s. 6d. Purchase Tax. (Walnut or Teak to order). Both loudspeaker systems are on display on Booth 31, on the ground floor and demonstrations in Stereo are being given in Demonstration Room 347, third floor.

On Booth 31 a representative selection of Goodmans' world-famous High Fidelity range is on display. This includes the 8 in. Axiette 8-6 Watts, the 10 in. Axiom 10-10 Watts for the slightly larger High Fidelity installations, the 12 in. 20 Watt twin cone Axiom 301 and its slightly less powerful brother the 12 in. 15 Watt twin cone Axiom 201, together with Trebax, Midax, Attenuators and Crossovers so much in demand for the famous stage-built High Fidelity Loudspeaker Systems. The new Triaxiom 1220C will also be on show. This 12 in. 20 Watt three-element reproducer incorporates a precision High Frequency pressure unit with its own electrical crossover and attenuator, greatly facilitating baffle mounting—only one aperture for the loudspeaker and one for the treble control. Triaxiom 1220C, 30-20,000 c/s. Power 20 Watts, Impedance 15 ohms. Price £18 10s.

The Audiom range of single cone loudspeakers is also represented ; these sturdy hard-working units are available in a choice of diaphragms and are suitable (depending upon the cone specified) for use as the Bass unit in High Fidelity Systems or in their Standard versions for top quality reproduction for Guitar Groups, etc. NEW in the Audiom range is the Audiom 91, the newly designed sleek yet rugged 18 in. Handling 50 Watts, available in two versions, Standard or Bass (no extra charge) and replacing the Audiom 90.

Free copies of the Goodmans' High Fidelity Loudspeaker Manual are available upon request from Booth 31.

## **THE GRAMOPHONE**

**General Gramophone Publications Ltd.,**  
379, Kenton Road, Kenton,  
Harrow, Middlesex  
Wordsworth 2010

**Press  
Lounge  
244**

*Publishers of "The Gramophone" and "The Gramophone"  
Classical LP Catalogue and "The Gramophone" Popular  
Record Catalogue*

*The Gramophone* is Britain's oldest and most widely read gramophone record journal. It was founded in 1923 by Sir Compton Mackenzie and Christopher Stone and today has a circulation in excess of 73,000 copies per month, circulating to very nearly every country in the world.

Record reviews, in conjunction with a comprehensive technical section, form the basis of the journal. In the technical field the team of experienced writers is led by Percy Wilson. The team of record reviewers is necessarily larger and includes such well-known critics as Alec Robertson, Lionel Salter, Andrew Porter, Philip Hope-Wallace, Deryck Cooke, Roger Fiske, John Freestone, Edward Greenfield, Trevor Harvey, Malcolm Macdonald, Jeremy Noble, Stephen Plaistow, Denis Stevens, Roger Wimbush and W. A. Chislett. On the lighter side, and in the field of Jazz and Swing, further reviews are contributed by Charles Fox, Alun Morgan, Brian Rust, Nigel Hunter, William Gilman and Michael Cox. Quarterly retrospective articles are contributed by Desmond Shawe-Taylor and John Warrack (Music Critics to the *Sunday Times* and the *Sunday Telegraph* respectively).

*The Gramophone* is published on the 1st of the month, price 2s. Annual subscriptions (home and overseas) 30s. per annum.

In addition the Company publishes two quarterly record Catalogues—one related to Classical music and the other to Popular music.

## **GRAMPIAN**

**Grampian Reproducers Ltd.,**  
The Hanworth Trading Estate,  
Feltham, Middlesex  
Feltham 2657

**Booth 32**  
**Demonstration**  
**Room 237**

*Microphones, Amplifiers*

Although by no means new to regular visitors to the Audio Fair, the Grampian DP4, DP6 and Ribbon microphones are again featured. The DP4 range, which has so justifiably received World wide praise, is still being used in steadily increasing numbers for many purposes. Unusual applications which have recently been brought to our notice are as aircraft marker beacons, in radioactive cells in atomic research and in pressure leakage equipment in deep tunnel construction work.

The DP6 and the parabolic reflector are also finding many other applications apart from the more generally known "bird song recording" use.

Grampian Ribbon microphones types GR1 and GR2 are also steadily gaining ground, particularly in cases where high fidelity is required and acoustic conditions render the use of an omni-directional microphone unsuitable. A full range of accessories, stands, matching units, etc., are displayed, together with an entirely new microphone, to complete the range.

The "Mike 3" all transistor pre-amplifier mixer is now available in three types and is suitable for use with tape and other amplifiers. It is unique in this particular field in having variable bass and treble controls and being battery operated is independent of mains supply.

The Grampian reverberation unit is also on show and the effects can be heard in the demonstration room. A mains power unit is now available for this unit.

Of special interest to the Public Address Engineer are new amplifiers and column line source loudspeakers, while for the Dance bands and Clubs there are the new "Ensa" outfits and other special amplifiers.



## GRUNDIG

Grundig (Great Britain) Ltd.,

Newlands Park,  
Sydenham, S.E.26  
SYDenham 2211

Booth 35

Demonstration  
Room 147

### *Hi-Fidelity Units*

The Grundig SV 50 Stereo Amplifier and RT 50 Tuner Unit on show for the first time are sure to prove of exceptional interest.

Although supplied ready for use in slim walnut cases the units can be removed and installed with other auxiliary equipment in cabinets to suit individual tastes.

**SV 50 Stereo Power and Control Amplifier.** This instrument is fully transistorised with 27 transistors and 2 rectifiers. The built-in microphone pre-amplifier feeds 7 audio amplifiers and correction stages to load the driver stage and the push-pull transformerless output stage. A full complement of filters and tone controls provide wide compensation of the input signal and printed circuits are used throughout.

#### **Abridged Specification**

Circuit Type (each channel): Two-stage microphone Pre-amplifier and correction Network for magnetic pick-ups. Seven stage Main Amplifier. Four stage Push/Pull Driver and Power Amplifier in cascade with transformerless Output Stage.

Transistors: 27 Transistors including 4 power transistors are used plus 2 Selenium rectifiers.

Output Power: 2 × 20 watts (sine wave input), 2 × 25 watts (music power).

Distortion Factor at 1,000 c/s: Less than 0.1% at 20 watts per channel.

Frequency Response: 20 – 20,000 c/s ± 1 dB.

Signal to Noise Ratio: 60 dB referred to 50 mW output power. 85 dB referred to 20 W output power.

Press Buttons: 1, On/Off. 2, Pick-up. 3, Microphone. 4, Tape Recorder. 5, Radio Tuner (I). 6, Radio Tuner (II). 7, Mono/Stereo Selector. 8, Noise Filter. 9, Rumble Filter. 10, Linear Frequency Response. 11, Presence Control.

Connecting Sockets: 1, Pick-up (magnetic or crystal system). 2, Microphone. 3, Tape Recorder (Recording and playback). 4, Radio Tuner (I). 5, Radio Tuner (II). 6, Grundig Reverberation Unit.

Dimensions: 11½ × 10½ × 6 in.

**The Grundig RT 50 Hi-Fi Tuner** matches the SV 50 Stereo Amplifier in every respect. Equipped to receive VHF and Medium Wave Stations, this instrument provides outstanding reproduction in any condition. Star features are the switchable automatic frequency control on FM, switchable FM noise suppression and Stereo Decoder stage for Stereo FM reception. The AM stage is provided with a switchable Ferrite aerial and switchable bandwidth selection. The FM and AM sections are separated throughout the unit.

**Hi-Fi Loudspeaker Combinations, Type Nos. Box 70 and Box 100.** These speakers are made specially for use with the RT 50 Tuner and SV 50 Amplifier. Box 70 has a volume of 2.8 cubic feet and is equipped with four loudspeakers, one bass, and three mid range/treble, and Box 100 has a volume of 3.9 cubic feet with nine loudspeakers, one bass, two mid range, and six treble.

Also shown in the Grundig Demonstration Room is the HF 10 and NF 2 Units, together with the TM 45 tape deck, incorporated in the Grundig MS 100 Radiogram.

## HI-FI NEWS

Booth 72

Miles Henslow Publications Ltd.,

99, Mortimer Street, W.1

MUSEum 3967

*Magazines and Books*

*Hi-Fi News* first appeared on the bookstalls in the Spring of 1956, to serve the interests of Audio Enthusiasts—users, dealers and manufacturers. Since then its scope has been considerably widened, and its readership has steadily increased from an initial 5,000 to over 24,000—which must be its own best recommendation. *Hi-Fi News* is held in high esteem for its reliable reviews, its informative articles, and its lively but well balanced interest in all audio matters. (Published Monthly, 2s.).

*The Tape Recorder* serves the tape recording enthusiast, the manufacturer and the dealer on parallel lines with its sister journal, *Hi-Fi News*, *The Tape Recorder* is a well-balanced publication for the newcomer, the hardened enthusiast, and the experimenter. Its reviews of equipment and accessories are the finest to be found anywhere—reliable, readable and well presented. Its editorial features are always well illustrated and full of information. *The Tape Recorder* is read in all parts of the world, and is regarded by the user and the Trade alike as the leading journal in its field. At 2s. monthly it is a monthly “must” for everyone who is seriously interested in “Tape.”

## HI-FI BOOKS

**Hi-Fi Year Book** was founded in 1956 for the purpose of collecting and presenting all the usefully available data on Audio Equipment. Year by year since, it has reliably filled this need, increasing its directory sections to follow the expanding and changing market. This year, the 1964 edition provides a remarkably large summary of audio products. **Hi-Fi Year Book** is the buyers' guide for all things audio, and is referred to annually in more than 8,000 homes, shops and laboratories. (Annually, 10s. 6d., posted 11s. 6d.).

**Cine Year Book.** A similar publication to the *Hi-Fi Year Book*, contains complete details and specifications of all available cine products. Price 10s. 6d.

**Hi-Fi for Beginners.** This book has been welcomed as the ideal introduction to High Fidelity, easy to understand and profusely illustrated. Price 7s. 6d.

**Stereo for Beginners**, by B. J. Webb. Stereo by disc, tape and radio are all covered in this new book. “The foremost handbook on the subject.” Price 7s. 6d.

**Sound and Cine for Beginners**, an up to date guide covering all aspects of adding sound to film. Written by Richard Golding. Price 7s. 6d.

**Cabinet Making.** An indispensable book by Wheeler Smith on cabinet making, whether for the home or for Hi-Fi applications. Many special illustrations and drawings. Price 7s. 6d.

**Experimental Recording.** Twenty practical experiments and the full details on how to make a clockwork portable recorder of exceptional performance. Price 5s.

## **JORDAN-WATTS**

**Boosey & Hawkes (Sales) Ltd.,**

Sonorous Works,  
Deansbrook Road,  
Edgware, Middlesex  
EDGware 5581

**Booth 56**

**Demonstration  
Room 420**

### *Hi-Fidelity Loudspeakers and Loudspeaker Systems*

Boosey & Hawkes, the largest manufacturers of musical instruments in Europe, make their entry into the Audio field with what is probably the most fundamentally correct and versatile High Fidelity loudspeaker ever designed.

This is the Jordan-Watts "building brick" loudspeaker, a principle that outdates and outperforms all complex multi-speaker systems—and at a fraction of their size and cost.

The Jordan-Watts loudspeaker originated from a purely theoretical exercise that set out to determine in the light of most advanced knowledge available, the perfect conditions necessary for completely accurate conversion of electrical energy into sound, regardless of convention, cost or size. Translating this exercise into physical terms by an experimental loudspeaker fully confirmed the theories, producing a quality of sound reproduction outstandingly superior to anything previously heard.

There is one basic loudspeaker of revolutionary design, which can be used either singly or in an enclosure, or in any multiples to suit whatever amplifier power is required. It is, in fact, the smallest or the largest, and the most perfect sound reproducer in existence, and owes its incredible performance to unique design features and the use of new materials to loudspeaker construction.

This unique High Fidelity Loudspeaker is built with watchmaker precision and main features are :—

Constant efficiency throughout entire frequency range.

Low intermodulation distortion.

Metal cone, unaffected by water, damp, temperature or insects.

Excellent polar response.

Frequency response, on axis 35-17,000 c/s  $\pm$  3 dB.

Frequency range 20-20,000 c/s  $\pm$  6 dB.

Amplifier Power Handling 12 watts (rms) per unit.

24 watts (U.S.A.) per unit.

Amplifier impedance matching 8-16 ohms.

## **KEF**

**KEF Electronics Ltd.,**  
Tovil, Maidstone, Kent  
Maidstone 55761

**Booth 38**

**Demonstration  
Room 212**

### *Loudspeakers*

KEF now manufacture a complete range of loudspeaker systems covering all Hi-Fi requirements from the world-famous diminutive Celeste to the big professional Monitor. These speakers will be demonstrated continuously throughout the Festival in Room 212 and will include the highly successful Duette, which is now available both in a de-luxe version, featuring the sophisticated cabinet designed by Robert Heritage, and in the big standard version.

Separate units are also available for those wishing to construct their own cabinets and a booklet of detailed drawings is available to assist in getting optimum results. Those with only moderate cabinet-making facilities will favour the baffle systems which are easily fitted into existing cabinets, room recesses or cavity walls. Here again, published designs are available on request.

The programme in Room 212 will conclude each session with a demonstration of artificial reverberation allied with stereophonic sound. This will take the audience a step nearer reality producing the effect of actually being inside the auditorium instead of listening through a hole in the wall.

A new departure for KEF is the construction of broadcast quality Monitor loudspeakers to designs by the British Broadcasting Corporation. These speakers which are manufactured strictly to B.B.C. acceptance tests are now being adopted by I.T.V. and film companies as standard listening equipment. Floor standing and suspended versions will be available for inspection in Room 224 by arrangement.

## **KELLY**

**Kelly Acoustics Ltd.,**  
Romagna, Bycullah Avenue,  
Enfield, Middlesex  
ENField 7890

**Demonstration  
Rooms**

**232/3**

*Electro-Acoustic Engineers*

Kelly Acoustics Ltd. will be showing an extended range of high fidelity loudspeakers. These will include the following items :

Mk. II Ribbon Loudspeaker

CO/1/15 Multi-section Dividing Network

Mk. III 12-inch L.F. Drive Unit (14,000 gauss, 1½-inch voice coil)

Mk. IV 12-inch L.F. Drive Unit (10,000 gauss, 1½-inch voice coil)

Mk. V 12-inch L.F. Drive Unit (14,000 gauss, 2-inch voice coil)

Mk. VI 12-inch L.F. Drive Unit (17,000 gauss, 2-inch voice coil)

Mk. VIII 15-inch L.F. Drive Unit (17,000 gauss, 2-inch voice coil)

Although these units have been designed specifically for high fidelity use, because of their exceptionally rugged construction they are being used in increasing quantities by industrial and musical instrument manufacturers. All units are fully tropicalised and suitable for pan-climatic conditions.

## **KODAK**

**Kodak Ltd.,**  
Kingsway, W.C.2  
HOLborn 7841

**Booth 49**

**Demonstration  
Room 312**

### *Sound Recording Tape*

A cordial welcome awaits all visitors to the Kodak demonstration rooms, where they can hear for themselves the remarkable new "Kodak" Sound Recording Tape. This high-fidelity, high quality  $\frac{1}{4}$  in. wide tape is now available in four types to meet the needs of both amateur and professional users. These new tapes have high output sensitivity, low noise performance, full audio frequency range response, and double lubrication for smooth transport. They resist scratching, tearing and stretching and are made to exactly the same high standards that have always been associated with "Kodak" Films.

"Kodak" Sound Recording Tape Standard Play, designed for the amateur tape recording enthusiast, is a low-cost, general purpose recording tape. It has an oxide coating 10 microns thick on a 37 micron triacetate base.

"Kodak" Sound Recording Tape Long-Play gives one and a half times the playing time of Standard Tape on the same size reel. The 25 micron base is of strong flexible PVC and the oxide coating is the same as that of the Standard Play.

"Kodak" Sound Recording Tape Double-Play, for equal reel size and tape speed, gives twice the playing time of standard tape. The pre-stretched polyester base ensures that good head contact is maintained even at very low tape speeds. The base is 18 microns thick; the oxide coating is 9 microns thick.

"Kodak" Sound Recording Tape Triple-Play. This gives three times as much tape on the same size reel. The oxide coating is 6 microns and is coated on a 12 microns pre-stretched polyester base. Being extremely thin with extremely high tensile strength, this tape records high notes at low tape speeds with remarkable fidelity, which makes it very suitable for use with portable and miniature tape recorders.

Each "Kodak" Sound Recording Tape is enclosed in a polythene bag and attractively packaged in a box or carton, according to reel size. Boxes and cartons have printed rulings on the back to provide an index of contents. Each type of tape has a different coloured label for rapid identification.

An informative booklet *Kodak Sound Recording Tape* will be available free of charge at the Booth, and Kodak experts will be on hand to answer questions.

## **ORTOFON**

**Ortofon A/S,**  
5, Trommesalen,  
Copenhagen V,  
Denmark

**Booth 2a**

**Demonstration**

**Room 336**

*Pick-up Cartridges, Arms, Amplifiers, Speakers and Pick-up Arm Controls*

Since the last Audio Fair, Ortofon have introduced the now world-famous Stereophonic SPU/GT cartridge with an elliptical diamond, and this has introduced a new standard in sound reproduction. In recent weeks the Consumers Union in the United States issued a report on Hi-Fi pick-up cartridges and classified this particular one as the best of all those tested. Recent technical reviews in publications in this country have confirmed this opinion.

Ortofon Stereo Cartridges are supplied with built-in Micro Transformers (SPU/GT) or without these Micro Transformers (SPU/G)—both types being available for either stereo/mono or stereo only. Frequency response of the SPU/GT and SPU/G ranges from 20—20,000 c.p.s. with channel separation better than 20—25 dB.

The many high fidelity enthusiasts still preferring monaural systems can have the Ortofon C Cartridge, still unsurpassed as the finest of all single channel heads, with a flat frequency characteristic from 20—20,000 c.p.s.—even when reproducing a very high level amplitude the distortion factor of the dynamic system is less than 0.2 per cent.

The superb range of the Ortofon Pick-up Arms cater for all possible requirements, from the low-priced SKG212 which brings Ortofon quality and craftsmanship to the enthusiast on a very limited budget through to the SMG212 and the RMG309 (16 in. arm for studio, broadcast and professional use), statically balanced for both horizontal and vertical actions.

An interesting addition to the Ortofon Pick-up Arm is RMG212 supplied with the Ortofon Hi-Jack which is a shorter version of the RMG309.

The Ortofon KS601 stereo amplifier has been designed for music lovers. It has two push/pull outputs each of 15 watts giving ample volume for undistorted reproduction. Five stereo inputs for tape, f/m, microphone, etc., 20—80 c/s continuously variable rumble filter. Crosstalk figures are better than 30 dB at 10 Kc/s.

The Ortofon loudspeaker system is being demonstrated in Room No. 336 and is outstanding in the quality of reproduction.

The Ortofon Hi-Jack which now attracts special interest is of all-metal, chromium-plated construction with a special spring-loaded friction system giving "air cushion" lowering at an adjustable speed. Easy to fit—only one  $\frac{1}{8}$  in. hole needed. The Ortofon Hi-Jack is the ideal pick-up arm control for safeguarding records and stylus against accidental damage.

**Sole Distributors for the United Kingdom : Metro-Sound (Sales) Limited,  
Bridge Works, Wallace Road, Canonbury, London, N.1.  
Telephone : CANonbury 8641/2/3.**

## **PETO SCOTT**

**Peto Scott Electrical Instruments Ltd.,**  
Addlestone Road,  
Weybridge, Surrey

**Demonstration  
Room 152**

*Philips Sound Studio Equipment*

A comprehensive range of Philips Sound Studio Equipment is exhibited, including :

EL3566 Transportable Tape Recorder, mono and stereo versions (as widely used by the B.B.C.). And the following new equipment :

EL3564 Heavy-duty Console Tape Recorder.

EL3624 Console Record Player (based on B.B.C. R.P.2/1 design).

Microphone channel from the transistorised Mixing Desk.

Components from Multi-channel and Message-repeater Tape Recorders.

Professional buyers are welcome to demonstrations in Room 152—tickets available from the stand.



## **PIONEER**

**Pioneer Electronic Corporation,**  
5 Otowacho,  
6 Chome, Bunkyoku,  
Toyko, Japan

**Booth 16**

**Demonstration  
Room 314**

### *Radio Tuner Units and Audio Amplifiers*

A completely new range of high-quality radio tuner units and audio amplifiers are being introduced this year, manufactured in Japan by the Pioneer Electronic Corporation.

The most interesting item is probably the SM-G 205 integrated stereophonic tuner-amplifier, containing its own FM multiplex circuits for the reception of the B.B.C. stereophonic broadcasts. The radio section employs a superhet tuner with a frequency range of 535 to 1605 Kc. in the medium waveband, and 88 to 108 Mc. in the F.M. band. There is also an automatic frequency control circuit on the F.M. band to prevent drifting of the tuning point, and this can be switched in or out at will. The I.F. bandwidth is variable from  $\pm 8$  Kc. to  $\pm 2$  Kc. to obtain the best possible listening conditions. The built-in ferrite aerial provides excellent reception, due to the high sensitivity of the receiver.

The stereo audio amplifier of the SM-G 205 contains volume, loudness, bass, treble, and balance controls, in addition to switchable high and low pass filter elements. Sockets are provided for simultaneous tape recording, independent of the amplifier tone and volume settings. **Price 85 gns.**

The SM-Q 300B is an all-purpose tuner-amplifier with 3 A.M. bands, short, medium, and long, and an F.M. tuner. No multiplex circuit is incorporated, although output jacks are provided for connection to the Pioneer multiplex adaptor, type MXA-1A (**price 16 gns.**). The audio section is fully stereophonic, and contains scratch, rumble and whistle filters. It also has the unusual feature of a centre channel output for 3-dimensional listening through an additional power amplifier. **Price 85 gns.**

Other items being exhibited include the TX-5 A.M.-F.M. tuner unit containing its own multiplex circuit. Main features of this tuner are high sensitivity, good signal-to-noise ratio, and an outstanding channel separation. The SM-500 integrated stereo amplifier has an extremely wide frequency range ( $\pm 1$  dB. from 5 to 100,000 cycles) with less than one per cent. harmonic distortion. It is equipped with six inputs per channel for maximum versatility, and will accept a signal direct from tape heads, magnetic or crystal pick-up, microphone, tuner, and tape recorder. Tape equalisation is NARTB, and gramophone RIAA. Another unusual item is the SR-101 reverberation amplifier, which provides excellent reverberation characteristics with a low distortion performance. It may be used with the complete range of Pioneer stereophonic amplifiers.

All the above units are being demonstrated, using B.B.C. stereo broadcasts where possible. A pair of high-quality moving coil headphones by Pioneer are also being shown. **Price 8 gns.**

**Sole Distributors : C. E. Hammond & Co. Ltd., 90, High Street, Eton, Windsor, Berks.**

## PLANET

Planet Projects Ltd.,

Goodman Works, Belvue Road,  
Northolt, Middlesex  
VIKING 1775

Booth 57

Demonstration

Room 418

### *Tape Transport Mechanisms*

**Planet U.1 Tape Deck.** The specification of the first quality British tape transport has been further improved. The most modern manufacturing and testing facilities in our new factory now enable us to meet the demand which discerning buyers have shown for a really high-quality deck.

The design and quality control produce the lowest possible **wow and flutter**: better than 0.08% R.M.S. at  $7\frac{1}{2}$  i/s., 0.12% R.M.S. at  $3\frac{3}{4}$  i/s., 0.18% R.M.S. at  $1\frac{7}{8}$  i/s. Frequency response obtainable is, at  $7\frac{1}{2}$  i/s., 30-18,000 c/s.;  $3\frac{3}{4}$  i/s., 30-16,000 c/s.;  $1\frac{7}{8}$  i/s., 30-9,000 c/s. Every deck passes our specification before leaving the factory. The performance we require is higher than that of some professional decks costing very much more.

**Controls** are by a fully interlocked push-button system; record with interlock to eliminate accidental erasure, pause with lock, fast rewind, fast wind on, and stop, manual or automatic solenoid operated by metal foil on the tape. This removes all idler and pinchwheel pressures. When operated, the leader tape does not wind off the empty reel, thus rethreading is unnecessary.

Pressure pads are not used. Adjustable stainless steel pins wrap the tape around the face of the heads, making both heads and tape last longer.

A four-digit **tape position indicator** makes accuracy easy.

A four-pole changeover switch operated by the record lock-lever is provided for switching the erase circuit.

Head to amplifier **connections** are made through coaxial sockets provided on the baseplate so that the deck can be easily removed and replaced

A variable speed magnetic **clutch** gives smooth take-up and tight, even, rewind (90 seconds for 1,200 feet.)

**Balanced drag** ensures even tape tension throughout, with wow and flutter the same at the beginning and end of the tape.

**Spools** up to 7 in. diameter can be used.

**Dimensions** are: Top Mask: 14 in. x 12 in. (15 in. x  $12\frac{1}{2}$  in. with spools). Body:  $11\frac{1}{2}$  in. x  $10\frac{3}{4}$  in. x 2 in. below mask. Motor protrudes  $2\frac{1}{4}$  in.

**Planet U.1 15 Tape Deck.** This deck has been produced especially for those who require to record or reproduce at speeds up to 15 i/s., and gives also speeds of  $7\frac{1}{2}$  i/s., and  $3\frac{3}{4}$  i/s.; its specification is otherwise equal to the U.1.

**Semi and Fully Remote Operated Decks.** Semi-remote—standard push-button control with facilities for electrical remote control of stop-start functions. Fully remote—has one button on deck for emergency stop. The remote control box controls the main solenoid-operated stop, start, rewind left or rewind right functions. There is a space left for amplifier switching on this panel.

*The Tape Recorder*, June, 1962: "A very fine deck which shows evidence of careful design and vigorous inspection . . . . If you want the best you must be prepared to pay for it and, so far, this is the best British deck I have handled."—A. TUTCHINGS.

**PHILIPS**

**Philips Electrical Ltd.,**  
Century House, Shaftesbury Avenue,  
London, W.C.2

**Booth 54**

**Demonstration**

**Room 111**

*Tape Recorders and Tapes*

Exhibition and demonstration of the latest range of Philips tape and tape recording equipment and accessories. In addition to the existing well-known range of Philips tape recorders model EL3548 is being displayed for the first time. This is a two-speed, four-track quality family tape recorder available at a competitive price. Demonstrations of latest tape recording techniques continues daily.

**PYE**

**Pye Ltd.,**

P.O. Box 49, Cambridge  
Cantab 58985

**Booth 13**

**Demonstration  
Room 318**

*Amplifiers, Tuners and Loudspeakers*

Although the famous Mozart range of equipment will continue to be marketed, the skeleton of the new Brahms range is shown this year. The Brahms HFS30T, shown last year in prototype, is now in production with a rated output of 15 watts per channel. Available in an elegant rosewood cabinet as well as in chassis form, this amplifier is already hailed as a major breakthrough. A monaural version of this amplifier will be shown in prototype together with a fully transistorised A.M./F.M. stereo multiplex tuner in a matching design, as a pre-production model.

In the speaker range, is shown the universally popular Mozart Minor HF9BS matt finished, together with pre-production models of a book case speaker in the new Brahms series.

Demonstrations, using commercially available associated equipment as a signal source, are given approximately every quarter hour in Room 318. Staff on Booth 13 will be pleased to discuss any aspect of Pye's high fidelity range.

## **QUAD**

**Acoustical Manufacturing Co. Ltd.,**  
Huntingdon,  
Hunts  
Huntingdon 361 & 574

**Booth 58**

**Demonstration  
Room 422**

*Amplifiers, Tuners and Loudspeakers*

The most important and interesting development in the field of high quality reproduction of music in the home today is stereo broadcasting. Now that the superficialities of stereo have given way to a more mature appreciation of its true value the potentially superior quality of stereo broadcasts of V.H.F./F.M. will find a ready response from everyone interested in this field. The pilot tone (Zenith-G.E.) system has proved itself as an acceptable system compatible with both mono and stereo reception, and used judiciously on programmes which would benefit from stereophony, would now greatly enlarge the enjoyment of listening to broadcast music, and indeed plays or other suitable programme material.

Since no insuperable technical difficulties appear to be involved in the introduction of these broadcasts, it is to be hoped that the comparatively small enthusiast audience in this country (which nevertheless runs into tens of thousands) will be given the benefit of this medium in the not too distant future.

Acoustical have decided to commence production of the QUAD multiplex decoder which has been exhibited at various European audio exhibitions during the past year. This will enable the standard QUAD F.M. Tuner to be used for these broadcasts with only slight modification comprising the removal of the de-emphasis network, which can be carried out in a matter of minutes.

Switching from mono to stereo, as with other programme sources, is a function of the pushbuttons on the QUAD 22 control unit, and the decoder may be mounted inside the cabinet separately or attached to the rear of the tuner itself, since it carries no controls and needs no adjustment in use.

Further details may be obtained from Stand 58 where our staff will be pleased to answer any queries regarding this or other units in the QUAD range.

Demonstrations in Room 422 will follow our usual pattern of separate complete sessions of about 15 minutes each, but during the B.B.C. stereo broadcasts these will be incorporated in the demonstration.

## **QUALITON**

**Electroacoustical Factory, Budapest  
Elektroimpex Hungarian Trading Company  
For Telecommunication and Precision Goods**

Budapest P.O.B. 296,  
Hungary

**Booth 61**

**Demonstration  
Room 113**

### *Stereo Amplifier*

Showing for the first time at the International Audio Festival.

The Electroacoustical Factory has 15 years experience in the production of different kinds of electroacoustical apparatus, such as amplifiers, loudspeakers, microphones and the whole range of broadcasting studio equipments.

The Qualiton integrated stereo amplifier type AE 211 was conceived after a comparatively long developing period thus enabling a throughout high-standard performance.

The amplifier has an adequate power output: 2x14 VA by continuous sine wave for 15 Ohm loudspeakers. The frequency coverage range is 20—20,000 cps. with either 15 dB boost or cut at the bass and treble ends of the range. The distortion of the mid-band frequencies is less than 0.5 per cent. taken at 11 V output level. With a six position selector may be chosen the actual active input channel among four 250 mV level and two 7 mV level ones. One 7 mV channel has a built-in equalisation at 100 cps + 10 dB, at 10,000 cps—7 dB for dynamic and reluctance pickups.

Input impedance is 0.68 Mohm for each of the inputs. The noise level is better than -75 dB at the high-level inputs and less than 10 uV at the microphone input respectively 20 uV at the 7 mV sensitive pickup input referred to the input level.

Tubes : 4x ECL 86, 2x ECC 82, 2x EF86 and 4x SIEG 7 silicone diodes.  
The amplifier works from a 110/220 V 50-60 cps mains.  
Dimensions : Width 15¼ in., height 5½ in., depth 13 in.

**U.K. Agent: David and Co. Shipping Ltd., 70, Brewer Street, London,  
W.1. Telephone: GERrard 7300.**

## **RADFORD**

**Radford Electronics Ltd.,**  
Ashton Vale Estate,  
Bristol, 3  
Bristol 662301/2

**Booth 11**

**Demonstration  
Room 417**

*Amplifiers, Tuner, Loudspeakers, Gramophone Equipment*

**PERFORMANCE — FINISH — RELIABILITY** are the specification highlights of RADFORD equipment.

**PERFORMANCE** can be assessed by studying the technical sales leaflets available on all Radford items. These leaflets are written by engineers and do not contain meaningless sales slogans. The quoted specifications are not exaggerated or ambiguous and are believed to be correct. Radford products have exceptional characteristics, as the following examples will show.

### **REFERENCE STANDARD AMPLIFIERS**

These are the only valve power amplifiers in the world having a distortion of less than 0.1% at all frequencies from 20 c/s—20,000 c/s at the rated power output. They are unconditionally stable, and can be driven into pure capacity of any value (no resistance load) without instability.

### **INTEGRATED TRANSISTOR AMPLIFIER SC4-10**

The only transistor amplifier made in Europe, and one of only a few in the world, which will deliver full r.m.s. power at the rated output from 20 c/s to 20,000 c/s at less than 0.1% distortion.

### **F.M. TUNER**

One of only a few tuners in the world with a distortion less than 0.2% at full modulation. Has variable interstation quieting, wide bandwidth at all input levels, yet high selectivity and capture ratio due to progressively limited multi-tuned circuits. Designed and provided for multiplex inclusion.

**FINISH** is easily checked by visiting Stand No. 11.

**RELIABILITY.** The same intensity of effort is applied to reliability as to finish and performance. Only the finest materials and components available are used, such as high-stability carbon and metal oxide resistors, polyester and polystyrene capacitors, and pure foil, heat aged, telephone quality electrolytics. Metalwork and finishing, transformers, and printed wiring boards are manufactured in Radford factories.

## **RECORD HOUSING**

**N. & S. B. Field & Co. Ltd.,**  
Brook Road, N.22  
BOWes Park 7487

**Booth 52**  
**Demonstration**  
**Room 302**

*Hi-Fi Furniture, Record Storage*

Record Housing products have long been familiar to audio enthusiasts. Indeed, we were the first firm in this country to cater exclusively for the needs of the audio and record trades, and our reputation has grown with the years. When you consider what Record Housing has to offer, you will understand why we are acknowledged to be pre-eminent in our particular field.

1. **Variety.** There is a choice of over **twenty** different cabinets capable of housing turntable, amplifiers, tuner, records, tapes, speakers, tape deck or even a complete tape recorder. Our smallest cabinet is 20 ins. wide, our largest nearly 7 feet; so whatever your set-up Record Housing should be able to help you.
2. **Matching.** All these different cabinets match each other for style and finish, avoiding the "hotch-potch" look so many installations suffer from. There is a choice of three wood grains: straight-grained walnut; sapele mahogany, and now—at long last—teak.
3. **Quality.** Construction and finish are to the highest standards of British workmanship, as any dealer will confirm.
4. **Know-how.** Our designers are enthusiasts themselves, with years of experience and a detailed knowledge of all the equipment on the market.
5. **Value for Money.** Although ours is a "specialist" market, we do not charge "specialist" prices. Thanks to a consistently high demand, we can employ large-scale production methods which keep prices down to a sensible level.

This year's exhibit concentrates on the Lowline Range. Introduced last autumn, the Lowlines "Three," "Four" and "Five" were an immediate success—embarrassingly so, since it has taken us months to catch up with the demand. Now on show for the first time are two smaller versions: **Lowline "One"** and **Lowline "Two."**

Matching the Lowline Range is perhaps our most exciting newcomer: the **Lowline Folded Horn Enclosure**. Small and slim, it produces a superb bass and bright clean response when used with either the Wharfedale Super "8" or the Goodman's "8" Axiette. Moreover, it is the only Folded Horn Enclosure in the country available without loudspeaker. It will be demonstrated in comparison with established models like the Viking and Strauss. This is one demonstration you cannot afford to miss.

**Free Advisory Service:** Several of Record Housing's designers will be in attendance; you can consult them on your housing problems.



## **RECORDS AND RECORDING**

**Booth 1a**

**Hansom Books,**  
16, Buckingham Palace Road,  
London, S.W.1  
BELgravia 5346

### *Magazine Publishers*

*Records and Recording*, now in its seventh year of publication, is the only illustrated magazine devoted entirely to reviewing all recorded classical music issued in Britain and giving, in addition to more than 100 extended record reviews each month, articles on the artists, music and background to recordings.

A comprehensive Audio section each month reports on new technical advances. Clement Brown and Thomas Heinitz examine the latest equipment and give frank advice on its suitability for home listening.

Visitors to the Audio Festival who visit our Booth 1a will be able to see copies of current and past issues and talk with the editor and staff of the magazine.

Feature articles in recent issues include Britten's War Requiem by Noel Goodwin; Age of Transistors, by Clement Brown; Sutherland's Command Performance by Mark Lubbock; Listening Booths in Your Living Room by Joan Abel; The Elliptical Stylus by Clement Brown; England's Golden Age by Charles Cudworth; The Unfamiliar 18th Century by John Lade; The Mini Age of Loudspeakers by Thomas Heinitz; Ancient Instruments and Stereo by Dr. Hans Hickmann; Prokofiev's Fiery Angel by Bernard Jacobson; The Unfamiliar Schoenberg by Peter Heyworth; Verdi by Harold Rosenthal and Audio Problem Page.

Inside each issue of *Records and Recording* is a 24-page Record Guide reviewing all new classical releases at length. *Records and Recording* has the finest illustrations and the most stimulating and satisfying musical articles for the intelligent reader.

Please ask at Booth 1a for free sample back copies of *Records and Recording* (the current Audio Fair issue is on sale at 2s. 6d.) or you can write to us at : 16, Buckingham Palace Road, London, S.W.1, for a free back issue. *Records and Recording* can be obtained through any news-agent by giving a firm order for regular delivery, or a trial six months subscription is only 18s. to any address in the world.

## **RESLO**

**Booth 71**

**Reslosound Ltd.,**

24, Upper Brook Street,

London, W.1

HYDe Park 2291

### *Microphones*

This year Reslo have two new additions to their wide range of microphones. The Pencil Dynamic (Type P.D.) and the Mini Pencil Dynamic (Type M.P.D.).

**Pencil Dynamic (Type P.D.).**—This new Reslo microphone incorporates a miniature dynamic insert together with a lightweight tapered cylindrical housing which is designed to give the appropriate air loading to the rear of the diaphragm with the result that the microphone has a level and wide frequency characteristic and good transient response. With its smooth overall response extending well into the bass region, this microphone is extremely suitable for high quality music recording and relay purposes. The construction is such that reasonable bass cut in the associated amplifier the microphone can also be used for high level realistic close speaking or singing purposes, without any additional acoustic filters.

**Mini Pencil Dynamic (Type M.P.D.).**—This new Reslo microphone incorporates the same dynamic insert as the new P.D. microphone in a much smaller body and is very suitable for all high quality voice reproduction and recording. The microphone is so constructed that additional filters are not required for every close singing or announcement use and the plastic diaphragm reduces the possibility of breath condensation causing failure of the microphone. It is supplied as Lavalier, complete with neck attachments.

**Miniature Ribbon (Type R.B./T).**—This is one of the most versatile and robust microphones that can be used for general sound reinforcement and recording purposes. It is particularly suitable for realistic semi-professional recordings.

**Broadcasting Miniature Ribbon (Type V.R.T.).**—This microphone is a special version of the Type R.B. and has been developed to meet the very high standards insisted upon by various broadcasting authorities, including the B.B.C.

**Cardioid Ribbon (Type C.R.).**—A high quality miniature ribbon microphone with cardioid characteristics particularly suitable for announcing and general public address purposes.

**Pencil Ribbon (Type P.R.).**—This ribbon microphone is specially designed for amateur use with tape recorders, and for professional multi-microphone conference installation use where the low price is an attraction.

**Ribbon Lavalier (Type R.L.1).**—This "Lavalier" microphone is a miniature high quality lightweight unit, designed for suspension from the user's neck by means of an adjustable cord.

**Studio Ribbon (Type S.R.1).**—A new professional type ribbon microphone specially developed by Reslo for use by broadcasting authorities and professional recording studios; it follows the tradition set by the world-famous R.B. miniature ribbon series.

**Accessories.**—Also on show will be: floor stands, table stands, microphone mounts and other accessories, including transistorised couplers, transformer couplers, adaptors, plugs and sockets, stand dampers, suspension mounting and quick-release adaptors.

## **REVOX**

**Revox-Studer,**

c/o C. E. Hammond and Co. Ltd.,  
90, High Street, Eton,  
Windsor, Berks.

**Booth 15**

**Demonstration  
Room 315**

### *Tape Recorders*

#### **Revox Tape Recorder**

The latest REVOX tape recorder, model 736, is being exhibited for the first time. It contains many new and important features, including accommodation for 10½ in. diameter spools (not N.A.B. fitting), two V.U. meters calibrated from 3 to -20 v.u.s, and a reel size selector switch to ensure even tape tension on either small or large spools.

The REVOX tape recorder is a precision-made mono/stereo machine, available in twin-track or four-track versions. Recording speeds are 3¼ and 7½ i.p.s., and the record/replay characteristic is accurate to the latest C.C.I.R. (or DIN 45113) standard of 70 and 140 μ/seconds. The REVOX contains separate record and replay heads, six audio pre-amplifiers, and a single 6 watt power amplifier with push-pull output stage. This has been designed especially for monitoring purposes, and can be switched to either channel input, to either tape replay amplifier, or to sample a combined tape replay. Cathode follower outputs are provided on each channel for feeding existing stereo amplifier installations, or for transcription purposes.

The entire tape transport system is solenoid operated by push buttons, either on the machine or at a remote position. A large Papst Hysteresis motor with external rotor provides the main drive, and is directly coupled to a dynamically balanced flywheel and capstan assembly. Two smaller Papst motors are employed for fast winding and rewinding.

The overall frequency response at 7½ i.p.s. is 40 to 15,000 cycles (+2 to -3 dB), and the price is 119 gns. in chassis form, or 124 gns. fitted in a substantial carrying case with a completely detachable lid.

Due to comprehensive switching arrangements, all forms of duoplay and multiplay are possible on both twin-track and four-track models, in addition to mixing facilities when used as a mono recorder.

The REVOX model 736 is being demonstrated in both mono and stereo modes, using original orchestral material. Made in Switzerland.

**U.K. agents: C. E. Hammond and Co. Ltd., 90, High Street, Eton, Windsor, BERKSHIRE.**

## **RICHARD ALLAN**

**Richard Allan Radio Ltd.,**

Taylor Street, Batley,

Yorks.

Batley 1123, 1308 and 4033

**Booth 39**

**Demonstration**

**Room 120**

### *High Fidelity Loudspeakers and Enclosures*

Richard Allan are exhibiting a new range of high fidelity loudspeakers utilising the latest advances in ceramic magnet techniques, these techniques and the use of shallow cones in the units result in a great reduction in overall depth in comparison with loudspeakers using conventional magnet steels. The units also incorporate a specially doped cambric surround providing linear movement and adequately damped termination. The reduction in overall depth makes the units admirably suitable for use in the slim enclosures which have become very popular in this "space-saving" age. Three new enclosures of this type are exhibited and demonstrated.

Loudspeaker drive units from the new range which are exhibited include the following :—

Type CG15. 15 in. Bass unit 2 in. voice coil, 17 Kilogauss magnet, 25 cps, 20 watt power handling.

Type CG12 Super. 12 in. Bass unit 2 in. voice coil, 14 Kilogauss magnet, 30 cps, 15 watt power handling.

Type CG12. 12 in. Bass unit 1½ in. voice coil, 14 Kilogauss magnet, 30 cps, 10 watts power handling.

Type CG12T. Twin cone, wide range version of CG12.

Type CB12. 12 in. Bass unit 1½ in. voice coil, 12 Kilogauss magnet, 30 cps, 8 watt power handling.

Type CB12T. Twin cone, wide range version of CB12.

Type CG10. 10 in. Bass unit 1½ in. voice coil, 14 Kilogauss magnet, 45 cps, 10 watts power handling.

Type CG10T. Twin cone, wide range version of CG10.

Type CB10. 10 in. Bass unit 1½ in. voice coil, 12 Kilogauss magnet, 45 cps, 8 watts power handling.

Type CB10T. Twin cone, wide range version of CB10.

Type CG8. 8 in. Bass and mid range 1 in. voice coil, 14 Kilogauss magnet, 55 cps, 6 watts power handling.

Type CG8T. Twin cone, wide range version of CG8.

Type CB8. 8 in. Bass and mid range 1 in. voice coil, 12 Kilogauss magnet, 55 cps, 5 watts power handling.

Type CB8T. Twin cone, wide range version of CB8.

Type 812F. 8 in. Mid range unit 1 in. voice coil, 12 Kilogauss magnet.

Type CT4. Horn loaded tweeter 1 in. voice coil, 12 Kilogauss magnet.

Type 410T. Economy tweeter 4 in. cone ¾ in. voice coil, 10 Kilogauss magnet.

The three cabinets demonstrated are all solidly constructed, heavily lagged, "sealed box" enclosures.

**Enclosure S.C.12.** Three-way system using CG12 Super as woofer, 812F as mid range and CT4 or 410T tweeter.

**Enclosure S.C.10.** Two-way system using CG10 as woofer and mid range with either CT4 or 410T tweeter.

**Enclosure S.G.8.** Two-way system using CG8 as woofer and mid range with either CT4 or 410T tweeter.

## **ROGERS**

**Rogers Developments (Electronics) Ltd.,**  
"Rodevco Works," 4-14, Barmeston Road,  
Catford, London, S.E.6  
HIT 4340

**Booth 43**

**Demonstration  
Room 449**

### *Sound Equipment*

Two entirely new Speaker Systems will be introduced at this year's Fair.

The extremely successful **Cadet II** Horn-Loaded Speaker System first introduced at last year's Fair is now joined by the **Mini-Cadet**, a compact speaker system designed for shelf or wall mounting where space is at a premium.

Two Speaker Units are employed in an infinite baffle enclosure. The bass unit is a heavy-duty 12 in. unit on die-cast chassis. The treble unit is a high-flux  $3\frac{3}{8}$  in. unit. An effective damping technique minimises bass resonance and distortion. Styling follows that adopted for the **Cadet II** Horn-Loaded Speaker System and features panels in teak finish plastic laminate and fabric in contrasting "Vynair."

The second Speaker System to be introduced is the **Eighty-Eight**, which provides a higher standard of performance and a greater power handling capacity than our other two designs.

The **Eighty-Eight** speaker is particularly suitable for use in conjunction with the HG 88 II Integrated Stereo Amplifier.

The external appearance of the speaker is identical to the **Cadet II** Horn-Loaded Speaker System but employs a heavy-duty 12 in. bass and four 3 in. tweeter units in an infinite baffle enclosure.

Our range of Amplifiers and Control Units, including the **Cadet Mk. II** Stereo Amplifier and Control Unit and the HG 88 Mk. II Integrated Stereo Amplifier, continues unchanged while a completely self-powered Mk. II version of the Switched FM Receiver is now available.

Demonstrations will feature the two new Speaker Systems together with two representative groups of equipment housed in standard Lowline Equipment Cabinets.

The units used for demonstration and static displays are standard production models in every respect and have not in any way been modified or specially prepared for exhibition purposes. This applies particularly to the standard of wiring to be seen on the equipment used for Static Display.

## **SCOTCH**

**Minnesota Mining and Manufacturing Co. Ltd.,**

3M House, Wigmore Street,

London, W.1

HUN 5522

**Booth 55**

**Demonstration**

**Room 349**

*Magnetic Tape and Accessories*

*Scotch Magnetic Tape at the Audio Fair, 1964*

At this year's International Audio Festival and Fair, the 3M Company is showing the full range of "SCOTCH" Magnetic Tapes and Accessory Items.

The range includes two standard play tapes. No. 111 acetate all-purpose tape which enjoys a world-wide reputation for high fidelity and clarity of reproduction. No. 175, with a tough polyester base manufactured to the same critical standards as the high-grade "SCOTCH" Instrumentation Tapes used in space projects.

No. 150 is the long play tape of the range with a tough polyester base of similar characteristics to No. 175.

No. 200 Double-Play Tape, with its super thin yet tough polyester base, gives an improved signal to print-through ratio, excellent reproduction and double the playing time of standard play tapes.

Accessory items include No. 24 coloured leader and timing tape in five colours, No. 41 pressure-sensitive splicing tape, No. 51 sensing tape, tape clips and an accessory kit which includes a tape splicer.

Copies of the popular "How to do it Booklet of Tape Recording" and the "SCOTCH" Playing Time Calculator will be freely available on the ground-floor stand No. 55 and in the 3M Demonstration Room—No. 349.

## **SHERWOOD**

**Sherwood Electronic Laboratories Inc.**

4300, North California Avenue,  
Chicago, 18. Illinois, U.S.A.

**Booth 42**

**Demonstration**

**Room 122**

*Amplifiers, Tuners, Receivers*

Sherwood is the fastest-growing manufacturer of Stereo High Fidelity components in the United States and has received more unsolicited honours from independent research organisations than any other component manufacturer.

Sherwood stereo amplifier and tuner designs have been recognised as being pre-eminent for their outstanding performance. New models being demonstrated in Room 122 will include: The S-9300 36-WATT (15 watts RMS per channel) TRANSISTOR INTEGRATED STEREO AMPLIFIER. This quality engineered amplifier features SILICON TRANSISTORS throughout the preamp and control stages. Special circuitry prevents damage to costly transistor components from shorted output or overheating. A switched headphone jack is mounted on the front panel; demonstrations of stereophone listening can be heard with Koss Stereophones.

The S-5500 III 80-WATT (28 watts RMS per channel) INTEGRATED STEREO AMPLIFIER is a new more powerful version of the S-5500 II stereo amplifier which has gained widespread popularity in this country since its introduction at the 1963 Audio Fair.

Other Sherwood equipment demonstrated will include the S-3000 III FM TUNER; S-8000 FM-MX INTEGRATED STEREO RECEIVER; S-7700 AM-FM-MX INTEGRATED STEREO RECEIVER.

Demonstrations of disc reproduction will utilise the Grado Laboratory Series Turntable, Tonearm and Grado Imperial Stereo Cartridge.

**U.K. Distributors: Audioson Ltd., Orchard House, Orchard Street, London, W.1. MAYfair 5431.**

## SHURE

Shure Brother Inc.,  
222, Hatrey Avenue,  
Evanston, Illinois, U.S.A.

Booth 48

Demonstration  
Room 249

*Pickups, Pickup Cartridges, Transcription Arms, Microphones*

Highlight of the Shure display and demonstration is the new M44 Series Stereo Dynetic Cartridges specifically designed to conform with the proposed industry standard effective cutting angle of 15° already adopted by major recording companies. The M44 Cartridges provide a significant audible improvement in brilliance, clarity, transparency, smoothness and fullness of sound. Harmonic and intermodulation distortion have been reduced to negligible proportions and channel cross-talk in the critical low and mid frequency ranges effectively eliminated, providing superior separation throughout the audible spectrum.

M44 Cartridges incorporate a totally efficient retractile stylus that momentarily withdraws whenever an excessive pressure is applied, protecting both records and stylus.

Stylus Assemblies are easily replaced by the user without the necessity even of removing the cartridge from the shell. M44 Cartridges are fully compatible and will give excellent results from both stereo and mono L.P. records. The use of an M44 will enable owners of mono systems to obtain first-rate mono reproduction from stereo records until such a time as they add a second reproducing channel.

Additional Stylus Assemblies are available for playing 78 and early mono L.P. discs, making the M44 Series fully comprehensive in its application. All stylus assemblies are colour coded and interchangeable one with the other.

The range is as follows :

**Model M44-5.**—Cartridge for use with precision transcription arms tracking at between 3-1½ grammes. 0.0005 in. diamond stylus.

**Model M44-7.**—Cartridge for use with arms and playing units tracking at between 1½ and 3 grammes. 0.007 in. diamond stylus.

**Model N44-1.**—Stylus Assembly for playing mono L.P. records. 0.001 in. diamond stylus. Colour—Blue.

**Model N44-3.**—Stylus assembly for playing 78 records. 0.0025 in. diamond stylus. Colour Code—Green.

**Model N44-5.**—Replaceable stylus assembly for M44-5. 0.0005 in. diamond stylus. Colour Code—Red.

**Model N44-7.**—Replaceable stylus assembly for M44-7. 0.0007 in. diamond stylus. Colour Code—White.

For budget stereo systems the M7D-M Cartridge provides excellent reproduction at a most modest cost. The M7D-M is fully compatible and is suitable for use at playing weights of 4-6 grammes. It is fitted with a 0.0007 in. replaceable diamond stylus.

Professional Transcription Arms Model M232 and M236 enable cartridges of any make to be used to the best advantage.

The Shure Studio Dynetic Integrated Pickups Model M212 and M216 are the supreme result of treating design of arm and cartridge as complementary and provide unequalled performance for the connoisseur.

Shure microphones cover broadcast, recording, public address and communications grades, the range including moving-coil, ribbon, controlled magnetic, ceramic, crystal and carbon types with directional characteristics to suit any application.

**U.K. Distributors: Shure Electronics Limited, 84, Blackfriars Road, London, S.E.1. WATerloo 6361.**



## **S.M.E.**

**Booth 44**

**S.M.E. Ltd.,**

Steyping, Sussex

Steyping 2228

*Precision Pick-up Arms*

Our Series II precision pick-up arms are unchanged, but presented this year with the amplifier connecting lead as standard equipment in an attractive new pack.

The range now comprises the following items:—

Model 3012 Series II Precision Pick-up Arm

Model 3009 Series II Precision Pick-up Arm

S.3 Standard Shell

S.2.W/12 Ultra light-weight perforated aluminium shell for high compliance cartridges (Shure, ADC, etc.), with companion balance weight for model 3012 Series II

S.2.W/9 Ultra light-weight shell with companion balance weight for model 3009 Series II

S.2 Ultra light-weight shell

W/12 Companion Balance Weight for Model 3012 Series II

W/9 Companion Balance Weight for Model 3009 Series II

D.2 Adaptor for mounting Decca heads on S.M.E. arm

P.1 Plinth to increase height of pick-up when used with deep turntable units

TD124/3012 Mounting Board to fit model 3012 on Thorens TD124

We extend a cordial welcome to Booth 44 where we shall be pleased to deal with technical and commercial enquiries.

**SONY**

**Sony Corporation of Tokyo,**  
Tokyo, Japan

**Booth 73**

**Demonstration  
Room 311**

*Tape Recorders, Tapes, Microphones*

The Sony Corporation of Tokyo is an internationally known manufacturer of high-quality electronic equipment, distributed in nearly seventy countries throughout the world. They have an unparalleled reputation of leadership in their field, producing a very comprehensive range of Transistor Radio, precision engineered Tape Recorders and specialised Data Recording Instruments.

The 1964 Audio Fair is a particularly exciting one for Tellux, coinciding as it does with the release of a completely new range of Sony Tape Recorders—all having arrived in this country over the past few months. Recorders on show will be :—

**Sony TC777A.** Professional 2-track 2-speed machine, fully transistorised, incorporating remote control giving instant start, stop, forward and reversing facilities. Frequency response 30-17,000 c.p.s 3-head system giving tape monitor through separate internal amplifier. Complete with microphone, etc. **Price: 159 gns.**

**Sony 600.** 4-track 2-speed Stereo-Mono Recorder. 3-head system to permit tape monitoring. Hysteresis Synchronous drive motor. Transistorised pre-amplifiers for hum-free operation. Cathode follower output. Frequency response 30-18,000 c.p.s. **Price 106 gns.**

**Sony 500.** 4-track 2-speed Stereo-Mono Recorder. V.U. Meters. Dynamic Microphones. Frequency response 30-18,000 c.p.s. Complete with two full-range satellite speakers. **Price 106 gns.**

**Sony TC200.** This outstanding Recorder has undoubtedly stolen the limelight this year. Similar to the Model 500 in appearance, this machine offers a fully packaged 4-track 2-speed Stereo-Mono system with first-class specification, complete with two dynamic microphones and two satellite speakers. **Inclusive Price of 79 gns.**

**Sony TC272.** 2-speed 2-track Recorder incorporating all the unique Sony quality features ; complete with microphones, tape, etc. **Price : 56 gns.**

**Sony TC464.** 4-track 2-speed with facilities for Stereophonic, Sound on Sound or Parallel Track recording. Used extensively in language laboratories throughout the world. Complete with dynamic microphone. **Price : 64 gns.**

**Sony 263D/SR2L.** Stereophonic Tape Deck and Amplifier unit offered to the enthusiast constructor for the first time. Complete in every meticulous detail. 3-head system, etc. **39½ gns. and 34 gns. respectively.**

Also on display will be the outstanding fully transistorised Bryan Amplifiers and a complete range of Tape Recorder Accessories.

**Sole Distributors and Importers : Tellux Ltd., Romford, Essex.**  
**Tel. : Ingrebourne 43971.**

**S.T.C.**

**Booth 3**

**Standard Telephones & Cables Ltd.,**

Electro-mechanical Division,  
Edinburgh Way,  
Harlow, Essex  
Harlow 26811

*Microphones*

Standard Telephones & Cables Ltd., who are the leading manufacturers in the United Kingdom of studio grade microphones, will be exhibiting their complete range of instruments.

4021-J. A moving coil microphone, designed for high quality studio work and particularly suitable for acoustical measurements. Acoustic baffle available to give high frequency directional properties.

4032-G.—A very robust microphone, with pressel switch fitted in the handle, used by commentators and interviewers on the radio and television. An all-weather instrument with full marine and tropical protection. Windshield available.

4033-A. This model incorporates two elements, i.e., moving coil and ribbon. By means of a switch at the rear, these elements may be used separately or in combination to give a cardioid response. For stand or boom mounting.

4037-A and C. Light and unobtrusive omni-directional microphone ideal for television interview work. Can also be stand mounted. A windshield is available.

4038-A. A ribbon instrument which is accepted as one of the world's best microphones. It is widely used by the British Broadcasting Corporation and other leading broadcasting authorities. The frequency response is substantially flat from 30-15,000 c/s. It has excellent transient response and extremely low (non-linear) distortion.

4104-B and C. Noise-cancelling microphones for use by broadcast commentators where the highest quality and signal to noise ratio are required.

4105-A. A small, moving coil microphone with a cardioid characteristic. For use in high quality sound reinforcement systems where a high degree of intelligibility and a good feed back margin are required.

4108. A high quality electrostatic microphone for studio use. It has an extended frequency response and an accurately maintained cardioid directional response. A special power supply unit with connecting cable is available.

4113. A new uni-directional microphone of distinctive appearance which combines small size with good performance. The full audio frequency range is covered. In sound reinforcement systems feed back is greatly reduced. Response to breath noises and mechanical vibrations is reduced to a minimum.

4114. A new omni-directional microphone introduced at an extremely moderate price. It is eminently suitable for sound reinforcement and announcing systems, tape recorders, etc.

4115. A new ribbon microphone designed for close talking applications where good quality speech is required to be reproduced from conditions of high ambient background noise, e.g., motor cycle meetings, etc.

4118. A light-weight tubular omni-directional moving coil microphone offering a good performance at a very moderate price. Ideal for sound reinforcement, speech and music reproduction.

Accessories. A range of accessories and cables for use with STC microphones will be shown.

## **STUZZI**

**Stuzzi Radiotechnischer Betrieb,**  
28/30, Stattermayergasse, Vienna 15,  
Austria

**Booth 14**

**Demonstration**

**Room 115**

### *Tape Recorders*

At this year's Audio Fair we shall be showing a number of very interesting new departures in tape recording. To make recognition easy we will refer to them in the following by model names and numbers.

#### **The 802FM**

This is a high fidelity 2 speeds, i.e.  $7\frac{1}{2}$  and  $3\frac{3}{4}$  recorder equipped with Papst motor and featuring a built-in FM tuner. The recorder facilities are in line with the established requirements of the discerning amateur and the FM tuner is capable of the highest quality. The machine can be used either for just listening to FM when the motor is switched off or for recording from FM when the listening volume can be regulated separately. The frequency response is from 40 to 20,000 cycles at  $7\frac{1}{2}$  in. **List price 75 gns., including P.T.**

#### **The 602**

This same machine is, of course, available without the FM tuner, executed in the same contemporary style cabinet, two-tone grey. **List price 50 gns.**

#### **The 502**

Again similar in conception to the 802FM and the 602 in general appearance but in place of the built-in FM tuner there is a built-in AM medium and long wave superhet receiver of considerable sensitivity and performance. **List price 66 gns., including P.T.**

#### **The Stuzzi Disc-Corder**

Another completely new machine from the Stuzzi stable the Disc-Corder is a battery operated portable with HF controlled motor speed regulator and a row of push buttons selects an amazing range of facilities. It can be used as an ordinary battery operated tape recorder weighing only  $8\frac{1}{2}$  lb., and in its very smartly designed contemporary housing is a "truly take everywhere" machine. At a recording speed of  $1\frac{1}{8}$  the frequency response is up to 9,000 cycles and the playing time on the  $4\frac{1}{4}$  in. spool is over two hours on each track. At the touch of a button a built-in radio unit comes into operation and you can select from the medium wave band in the same way as on any other high grade transistor portable. Turn the machine over and a record player is exposed that will play 45 r.p.m. records at the touch of yet another button. It is possible to make tape recordings from the radio or from the record player and there are, of course, separate monitoring facilities, yet the list price for this amazing machine is only **59 gns., including P.T.**, and this must be the most compact entertainment unit yet devised. For use in the home mains adaptors are available to save batteries, and there is a whole host of accessories.

Also on show will be the Stuzzi Tricorder again, by now quite famous for its fantastic performance at any of the three speeds, including  $\frac{3}{8}$  in., still good enough to record piano music. It is by now an established fact that many other manufacturers have tried to copy this but have never succeeded in approaching the same performance.

## **LANSING**

**J.B. Lansing Sound Inc.,**  
3249, Casitas Avenue,  
Los Angeles 39,  
California, U.S.A.

**Booth 21**  
**Demonstration**  
**Room 112**

*Loudspeakers, Amplifiers and Control Units*

In the United States, loudspeakers manufactured by James B. Lansing Sound Inc., have long enjoyed the reputation of being the choice of professional musicians. A wide variety of JBL precision transducers is shown here for the first time in England.

JBL high efficiency loudspeakers with their characteristic "bright," incisive qualities as well as Linear Efficiency transducers for use in infinite baffle enclosures.

JBL units employ highly sophisticated magnetic structures and large diameter edge-wound ribbon voice coils to achieve greatest possible dynamic range and precise delineation of complicated transient sounds. JBL has pioneered numerous other design features such as the acoustic lens, the ring diaphragm, and the passive radiator, all of which may be seen in the various units on display.

Also on show will be complete loudspeaker systems including the new JBL Ranger Paragon stereo reproducers.

**Sole U.K. Agents : Ad. Auriema Ltd., 125, Gunnersbury Road, Acton, W.3.**

## **LEAK**

**H. J. Leak & Co. Ltd.,**

Brunel Road, Westway Factory Estate.

London, W.3

SHEpherds Bush 1173

**Booth 64**

**Demonstration**

**Room 334**

*Amplifiers, Loudspeakers, FM Tuners, Pickups*

For 30 years the Company has been engaged exclusively on research, development and the manufacture of audio frequency equipment of the highest quality. Leak gave the world the first very-low-distortion amplifier in 1945, and the amazingly low distortion content of the first Point One amplifier, one-tenth of one per cent., is still an accepted world-wide standard.

In recent years the firm has been working intensively on the use of transistors in high-fidelity amplifiers. "The imminent obsolescence of the valve in home high-fidelity equipment" was the major subject of H. J. Leak's presidential address to the B.S.R.A. in the autumn of 1962 when he also demonstrated a prototype transistor amplifier whose performance was described in a *Wireless World* editorial as being indistinguishable in quality from the Leak valve amplifier.

The Company is now in production with the "Stereo 30" transistor integrated amplifier which gives results that are indistinguishable from the equivalent valve amplifier and which offers these important advantages: it is 43 per cent. of the volume, it is 48 per cent. of the weight, it is 89 per cent. of the price, it has greater reliability (estimated to be 500 per cent. better) because the heat rise within the case is negligible (12°F.) and because the maximum voltage is less than 50. The "Stereo 30" is built to the same standards as Leak amplifiers supplied to the B.B.C., I.T.V. and many Commonwealth and overseas broadcasting authorities who use them for monitoring (quality checking) the transmissions.

The Company has been granted a U.S. Patent for the revolutionary loudspeaker cone of sandwich construction which weighs the same as conventional cones of plastic, paper or aluminium construction, but is hundreds of times stiffer and thus overcomes the major weakness of the moving-coil system—lack of diaphragm rigidity with its attendant distortions. With its very low distortion content, the "Sandwich" loudspeaker has set a new standard for moving-coil loudspeaker systems: it has gained acceptance by professional audio engineers throughout the world and it is used in many broadcasting studios for monitoring (quality checking).

It is appropriate to mention that the comparative low price of Leak studio quality equipment is made possible by our being kept fully and efficiently employed by the world-wide demand which resulted from the lead we established in this field.

The "Stereo 30" and "Sandwich" loudspeaker will be demonstrated throughout the day in Room 334. All enquiries on these and other Leak products should be made at Booth 64 where a cross-sectional view of the "Sandwich" loudspeaker system may be seen.

## **LOEWE-OPTA**

**Loewe-Opta,**  
Kronach, West Germany

**Booth 10**

**Demonstration  
Room 413**

*Tape Recorders and Radiograms*

Loewe-Opta—the leading name in radio, television and tape recorders in Western Germany—now bring to you the results of our 40 years' experience, and the backing of our 8,000 employees, in the shape of our Tape Recorders, Radios and Radiograms available in this country through our appointed agents—Highgate Acoustics. All our products are built to the highest engineering standards as well as being attractively styled. Below are brief descriptions of our range of Tape Recorders and Radiograms.

**Optacord 414.** One of the most versatile portable tape recorders available in the world, beautifully styled in brief case shape in light metal frame. Two-track transistorised tape recorder, single speed  $3\frac{3}{4}$  i.p.s. For use on batteries, motor-car batteries or A.C. mains without alterations or adaptations. Up to  $1\frac{1}{2}$  hours playing time. Maximum spool size  $4\frac{1}{4}$  in. Will operate on any angular position. Push-button controls for recording, playback, fast forward/reverse, pause, input selection and stop. Rim wheel-drive controls for volume and tone. 1 watt power output.

**Optacord 414 DIA.** This is exactly the same machine as the 414 described above with a built-in synchroniser to couple to any automatic slide projector. It has an additional two press-buttons for impressing and erasing impulses on the second track to change the slides on the automatic slide projectors. Dimensions :  $14\frac{1}{4}$  in. wide, 9 in. deep,  $4\frac{1}{8}$  in. high. Approximate weight :  $8\frac{3}{4}$  lb.

**Radios and Radiograms.** We are the manufacturers of the biggest range and variety of radios and radiograms with the finest stereo chassis and a superb cabinet design and finish. It is impossible to describe the 24 different radiograms and 20 different radio receivers in three different veneers on this one page. Please ask for our catalogue and view our products on our stand or at our demonstration rooms.

**U.K. Distributors : Highgate Acoustics, 71-73, Great Portland Street, W.1.**

## **LOWTHER**

**Lowther Manufacturing Co. Ltd.,**  
Lowther House, St. Marks Road,  
Bromley, Kent  
Ravensbourne 5225

**Booth 12**

**Demonstration  
Room 411**

### *Electronic and Electro-Acoustic Reproducing Equipment*

The Lowther Stand will display all Lowther Products, excluding Enclosures. It will be seen that each and every article has been advanced, in either electronic technique or mechanical design, to keep this world-famous range among the foremost throughout the world. Each and every modification is the result of painstaking effort towards perfection by Lowther engineers since the last London exhibition.

Personnel at the Stand will endeavour to deal with all problems relating to Lowther equipment in preference to points being asked in the Demonstration Room.

In the Demonstration Room we are pleased to present the entire Lowther range "in sound" and, here again, extreme points of finesse which have been even more highly developed will be manifest.

Lowther engineers are probably the foremost in the world in the development of Drive Units of very high flux density and the associated folded horns to be used in conjunction with them. The efficiency of these combined systems is of a very high order, which has made them so famous in recent years as a means of monitoring in both broadcast, television and recording studios; the T.P.1 Reproducer, in particular, still ranking in the top three throughout the world.

The Acousta Enclosure and the Corner Acousta Enclosure represent the best possible performance, both in balance and definition, at their price range. When used as an extension speaker to a tape recorder, it is often surprising to hear the quality which has been recorded.

A radical departure from the hitherto Lowther policy is by the introduction of a high-quality broadcast receiver covering Band 2 (F.M.), with all its attendant fidelity, Transistorised Tuner and pre-amplifying stage, full bass, treble and filter controls suitable for dynetic type pick-ups, push-pull valve output stage of 12 Watts, the overall performance of which places it in a class all by itself for those still requiring the best possible monaural reproduction.

We extend a cordial welcome to all music lovers and, for those unable to attend, our latest brochure will gladly be sent upon request.



## L/P RECORD LIBRARY

The Long Playing Record Library, Ltd.,

Squires Gate Station Approach,  
Blackpool, Lancs.

Lounge

153

*"A Guide to the Bargain Classics"; Library Catalogue; "The Stereo Record Guide," Volumes I, II and III*

It is as publisher that the L/P Record Library Ltd., participate at the Festival. Its selective Classical Catalogue has long been world-renowned, and a new edition of this is available at the Fair. In 1960 the Library followed up with a publication which was an even greater success: *The Stereo Record Guide*. Beautifully produced and luxuriously bound, this book was a comprehensive review of all stereo LP's, and included a section on light music. The co-authors were Edward Greenfield, Denis Stevens and Ivan March. Later in 1960, Volume I of *The Stereo Record Guide* was published in America, and during the year reached readers in nearly every other country (including Russia!). Volumes II and III of *The Stereo Record Guide*, which are supplementary to Volume I, were published in 1961 and 1963 respectively, and the other L.P.R.L. publication speaks for itself. It is the same authors' *Guide to the Bargain Classics* for which a supplementary volume is currently in preparation.

Since its inauguration in 1954, the Long Playing Record Library, Ltd., has built up a nation-wide (indeed, one might say world-wide) reputation for its postal record lending library service. The Library Catalogue is completely comprehensive, and in the mono field, includes every LP of classical music of any merit. Since the very first stereo release, the Stereo Section of the Library has maintained a complete coverage, and as a new venture, light music was included as well as serious issues. Poetry, plays and the spoken word are included in both mediums.

Moderate hiring charges and the simplest possible form of permanent packing (the member has merely to reverse an address card and re-secure the outer casing—an operation taking about 45 seconds—and records are ready to return), have attracted the Library service not only to thousands of private borrowers all over the British Isles, including the Shetlands and Western Isles of Scotland, but also to universities and educational organisations and educational institutions of all kinds. A special *Society Subscription* enables such organisations, together with Gramophone Societies and Music Clubs (of whom there are over a hundred permanent members) to reserve records in advance for specific recitals.

Besides its loaning service, the Library also operates a superior Factory-Fresh Sales Service, enabling customers to obtain guaranteed unplayed and blemish-free copies of new records to order, such records also being Parastated without charge. This service is used extensively by public libraries, as well as by private purchasers.

During 1960, the Library extended its operations to begin the first of a planned chain of branches where members can change records personally, rather than by post, and such branches were opened at Blackpool and Manchester. In 1961, a further branch was opened in central London, to be followed in 1962 and 1963 by agencies in Bristol and Bath.

## LUSTRAPHONE

Lustraphone, Ltd.,  
St. George's Works,  
Regent's Park Road,  
London, N.W.1  
PRImrose 8844/6

Booth 4  
Demonstration  
Room 220

*Microphones, Transistor Equipment, "Radiomic" Systems, Stands, Booms, Accessories*

**Lustraphone** Exhibits at this International Audio Festival have been grouped to show the numerous Microphones, "Radiomic" Systems, Transistor Amplifiers, Mixer Units, Matching Transformers, Floor and Table Stands, Microphone Booms, as well as many convenient accessories available for:— Educational Services, Public Address, Broadcasting, Recording Studios, Tape Recorder Users and Social Services.

The Microphones which cover a very wide range—from the well-known "**Stereomic**" (dual head) Stereo Microphones, Studio Ribbon Velocity Microphones, Moving Coil Microphones, all of which offer a unique selection for every Tape Recorder user desirous of obtaining the best possible reproduction of Music and Voice.

Two "**Lavalier**" Microphones have been designed to giving full freedom of hands and movement; Model LV/59 Moving Coil and Model VR/70L Ribbon.

For those who favour Ribbon microphones, the inexpensive yet quality proven, Model VR/64, complete on its swivel and base, is available.

The well favoured "**Stereolus**" dual head Stereo Microphone is in substantial demand, and the cost of this high quality instrument makes it available to wide semi, and non-professional circles interested in Stereo recording.

The "**Radiomic**" System, since it received the G.P.O. Type and Specification approval, is now in very considerable demand. An entirely new Radio Microphone Cum Transmitter, conforming to G.P.O. specification is now introduced for the first time, together with Valve/Mains Single and Multi-channel Receivers.

There is a wide selection of Floor Stands—Heavy base and Folding, Table Stands of varying heights and Table Bases, that allow for every requirement. Microphone Booms as supplied to the B.B.C. are now available and a new Folding Mobile Floor Stand is shortly being introduced.

Additionally, there are available many useful accessories, such as:—

1. Flexible "Stayput" positioning tubes of various lengths.
2. Cable exit bushes and plug and socket releases enabling Microphones to be lifted from Stands, used as a Roving or Hand Microphone, and just as readily replaced without interfering with any of the cable connections. All most valuable to orchestral and singing groups and individual Recordists.

The equipment described can be seen at the Booth or in the Demonstration Room, where descriptive leaflets are available.

All equipment is of British design and manufactured in Britain, of British materials.

## LUXOR

Luxor Industr, Aktiebolag,  
Motala, Sweden  
Motala 16200

Booth 30

Demonstration  
Room 218

### *Tape Recorders, Record Players and Loudspeakers*

For more than 40 years Luxor has been one of the leading Swedish companies in its field. In accordance with its slogan "Always in pace with development—often a step ahead" Luxor has during the years presented news which has received wide-spread acclaim. Here are some milestones in Luxor development and progress :

1934—first with automatic record changer on the European continent.

1949—first with Swedish-built recorder for private use.

1963—first with Swedish-built transistor TV.

Luxor is now one of the few firms in the world that from its own production lines can offer a complete range of TV, radio, tape recorders, record players and loudspeakers.

Five different Luxor tape recorders with Stereo, Mono, 2-track and 4-track are shown at the Audio Fair. Many leading trade magazines throughout the world are praising Luxor's tape recorders for their excellent sound reproduction, easy operation and splendid design. The British "*Audio and Record Review*" wrote in their September 1963 issue the following about Luxor MP 423: "An admirable compact Stereo Tape Recorder of robust construction that many enthusiasts will find is just the job for their hobby."

**Luxor MP-423** and **Luxor MP-424** are Stereo tape recorders with internationally approved 4-track standard and exported to several countries including Great Britain and U.S.A.

**Luxor MP-433** is the monaural version of the above recorder.

**Luxor MP-233** is the 2-track monaural version.

**Luxor MP-404** is a low-priced 4-track monaural tape recorder.

Luxor's record players have always been admired for their excellent performance. At the Audio Fair you will find two models, Luxor ES-515 and Luxor ESL-514. ES-515 is a plug-in type with four speeds, Stereo pick-up, spring-mounted motor and automatic stop. ESL-514 is battery-operated with built-in transistor amplifier, loudspeaker and is in fact a complete gramophone—reproduces Stereo records if connected to an external amplifier or radio.

Luxor's loudspeaker programme includes loudspeaker systems as well as speakers for building-in purposes.

**SH-105** with four Luxor Brilljant speakers (one 10 in., one 5 in. and two 2 in.) for perfect tonal quality.

**SH-107** excellent sound-reproduction through the built-in 7 in. x 10 in. Luxor Brilljant speaker.

**SH-314** top-quality 3½ in. x 14 in. loudspeaker in compact cabinet.

**VH-57** and **VH-4**, handy speaker-boxes with 6 in. and 4 in. speakers respectively.

Luxor also offers a complete range of speakers for building-in purposes from 2 in. to 14 in.

Further information on our products at our booth No. 30 at the Audio Fair.

**U.K. Distributors: Britimpex Limited, 16/22 Great Russell Street, London, W.C.1. Telephone: MUSeum 7600.**

## **METRO-SOUND**

**Metro-Sound Manufacturing Co. Ltd.,**

Bridge Works,  
Wallace Road,  
Canonbury, N.1  
CANonbury 8641/2/3

**Booth 3a**

**Demonstration  
Room 335**

*Hi-Fidelity Speakers, Integrated Stereo Record Players, Tape Recorder Accessories and Replacement Sapphire and Diamond Styli*

This Company, well known for its ranges of replacement styli and exclusive tape and disc accessories has now introduced the MI compact speaker, the MII bookshelf speakers and the Classic Stereo Reproducers which are already receiving wide acclaim.

The MI speaker is available in single units or matching pairs and contains a 12 in. bass unit of special design by Wharfedale. The Tweeter unit is a 5 in. Wharfedale SP5, cross over is at 1,000 cycles and the frequency response is 30 cycles to 18,000 Kc. A unique addition is the Cor-Reflex system developed and patented by Metro-Sound technicians.

The MII speaker is the smaller version but with a 13 x 8 Elliptical and 3 in. treble unit. The frequency response of this enclosure is 40 to 18 Kc/s.

The Classic reproducer comprises an attractive centre cabinet finished in sapele mahogany and two separate bookshelf speakers. The motor unit is the Garrard type AT6, the pick-up cartridge is the new Sonotone 9TA with diamond stylus, an integrated stereo amplifier with an output of 8 watts ensures sufficient volume for the larger than average living room and the frequency response is from 50-15,000 c/s.

This unit is designed for the individual who requires more than the average listening than that catered for by commercial record players and can be classified in the Hi-Fidelity group.

Other products manufactured by Metro-Sound are Klenzatape, the only acceptable and safe way of removing oxide and dust deposits from the magnetic heads of tape recorders.

Metro-Stop, a colloidal silver for applying to tape to use on all tape recorders with an electronic auto-stop device and ideal for synchronising with film.

A range of Hi-Jack lowering devices and a complete range of replacement sapphire and diamond styli.

Many other items manufactured by Metro-Sound which are not listed above are shown at their stand.

**M.S.S.**

**M.S.S. Recording Company Limited,**  
Prescot Road,  
Poyle Trading Estate,  
Colnbrook,  
Nr. Slough, Bucks.  
CN8 2431

**Booth 51**  
**Demonstration**  
**Room 217**

*Magnetic Recording Tape and Recording Heads*

The full range of M.S.S. "Mastertape" will be on display at Booth 51. Four grades are available in all the usual spool sizes :

Standard Play  
Long Play  
Double Play  
Triple Play

Each grade is colour coded. Accessory items include empty spools, coloured leaders and a kit which includes a tape splicer.

In the Demonstration Room you can see a coloured film—"Journey into Tape." This shows the production of "Mastertape" from the raw oxide to the fully boxed state, emphasising the great care taken in the manufacture of this product.

## **MULLARD**

**Mullard Ltd.,**  
Mullard House,  
Torrington Place,  
London, W.C.1  
LANgham 6633

**Booth 50**

**Demonstration  
Room 211**

### *Valves and Semi-Conductors for Audio Applications*

Once again we at Mullard welcome this annual audio event to show you our latest array of valves and transistors in the very latest applications. Our staff is ready to help you on your audio problems and to see which of the Mullard technical publications will be of most use to you.

#### **Audio Transistors**

On the Mullard stand you will find examples of equipment incorporating transistors as used in the recently published Mullard transistorised Hi-Fi designs. Among the power junction transistors displayed are the AD140 and OC81 (the latter being intended for use in driver stages of amplifiers), and the pre-amplifier devices include the OC44, OC71 and AC107, the last mentioned being a low noise transistor for the input stages of audio amplifiers.

#### **Audio Valves**

Among the range of audio valves displayed, two are particularly worthy of mention. They are the ECL86, a high  $\mu$  triode, high slope pentode—particularly suitable for stereophonic applications—the EM87, a short grid-base (10V) electron beam tube for use as a recording level indicator in tape recorders.

#### **Design Information**

In addition to design information and performance figures for a wide range of Mullard audio circuits, the Mullard Technical Information Service provides, on request, full data on current valves, transistors and specialised components for audio applications.

Various leaflets are available and two in particular give details of Mullard publications which will be of interest to audio designers. These are "Circuits for Audio Amplifiers" and "Reference Manual of Transistor Circuits." Other leaflets available are:—

Twin Three Stereophonic Amplifier—TP422

10 + 10W Stereophonic Amplifier—TP456

3W Tape Amplifier for Modern Tape Deck—TP421

Circuits for Audio Servicing Equipment TP500

Circuit for Serviceman's Oscilloscope—TP496

World Series Valves for Audio Equipment—2354

Valves and Semi-conductors for the Radio Amateur—2366

## **TANDBERG**

**Tandbergs Radiofabrikk A/S,**  
Kjelsasveien 16, Oslo, Norway

**Booth 69**

**Demonstration  
Room 248**

### *Tape Recorders and Language Laboratory Equipment*

The name **Tandberg** commands respect throughout the entire world of tape recording. Fourteen years ago when the first Tandberg Tape Recorder appeared it was immediately recognised to be an outstanding example of mechanical and electronic engineering. Although primarily designed for domestic use its outstanding merit quickly made it popular with most Scandinavian countries for government departments, armed forces, post offices, industry, education, etc.

It is unlikely that any tape recorder manufacturer has a larger, more forward-looking, experienced team of clever design engineers. In 1961/2 a new nine-storey research and development building, costing £500,000, was built adjoining the main Oslo factory.

With the advent of "Stereo" Tandberg took a major step forward, being one of the first to recognise the potentialities of this new development. The original **Tandberg Model 3 Stereo** made a big impression and firmly established **Tandberg** as a top name with American, and later British, High Fidelity enthusiasts. Most of these machines continue to give excellent service to-day, after many years of continuous use.

Stereo models 4 and 5 followed, achieving a standard of four-track performance never previously thought possible with a domestic tape recorder; as a result Tandberg began to be asked for a really fine 4-track deck specially for use in high-quality Hi-Fi installations. The world-famous **Tandberg Series 6** was produced to meet the demand of this most critical and fastidious market.

In the United States and Great Britain **Tandberg 64** (4-track) was immediately recognised as a "world-beater," but Hi-Fi enthusiasts in other countries quickly followed. To-day the Tandberg factory is sold out for many months ahead supplying the demands of Tandberg distributors in U.S.A., Norway, Sweden, Great Britain, France, Germany, Switzerland, South America, Canada, Denmark, Finland, Holland, Iceland, Belgium, Italy, Spain, Greece, South Africa, Australia, New Zealand, Hong Kong, Singapore, Lebanon, Syria, Jordan, Iraq, Thailand, Japan.

At your special request, to cater for 2-track preferences, Tandberg produced **Tandberg Model 62**. This version of Series 6 is normally available only in the U.K.

In the autumn of 1962 **Tandberg Series 7** was released with 4-track and 2-track models. Due to its unusual versatility, complete stereo facilities, portability, and the usual Tandberg quality, Series 7 rapidly proceeded to outsell its famous companion. Note: Series 7 is additional to, and does not supersede, Series 6.

We are exhibiting and demonstrating **Tandberg Series 6** and **Tandberg Series 7**, also **Tandberg Electronic Teaching Systems**.

**Sole distributors: Elstone Electronics Ltd., Edward Street, Templar Street, Leeds 2. Phone 35111.**

## **TANNOY**

**Tannoy Products Ltd.,**  
West Norwood,  
London, S.E.27  
GIPsy Hill 1131

**Booth 23**  
**Demonstration**  
**Room 447**

### *High Fidelity Systems*

For more than 30 years the Tannoy Organisation has been one of the few offering a complete range of High Quality Audio Equipment for domestic and professional use. The policy of perfection, rather than price consideration, remains unaltered and, as always, all products are designed and manufactured entirely within the Tannoy Group, thus enabling the most stringent quality control to be exercised at all times.

The **Tannoy 12 in., 15 in. and IILZ Monitor Dual Concentrics**: These dual systems continue to set the standard for high-quality loudspeakers. The adoption of these units as listening standards by broadcasting, television, and recording companies throughout the world, is an indication of their supremacy.

**Tannoy Loudspeaker Enclosures.** The Guy R. Fountain Autograph Enclosure provides both front and rear horn loading for the 15 in. Dual Concentric unit. It makes use of the exclusive Tannoy expanding source principle and gives reproduction of the highest quality where space is not an important consideration.

The G.R.F. Enclosure has many of the advantages of the Autograph, but is of smaller size, thus increasing its appeal. This enclosure provides horn loading and is fitted with a 15 in. Dual Concentric, being used by many leading British record manufacturers and television companies as a quality standard.

The introduction last year of a rectangular free-standing version still further increased the versatility of this unit.

The York and Canterbury are dual ported, bass reflex, enclosures, of simple design, suitable for home construction and give excellent results.

The Chatworth Enclosure is a critically damped infinite baffle, suitable for either 12 in. Monitor or the IILZ Monitor, it is available as a corner cabinet or a rectangular free-standing cabinet.

The IILZ Enclosure is designed specifically for the IILZ Monitor Unit. It is sufficiently small to be placed on a shelf or small table, but nevertheless, provides outstanding reproduction over the entire audio frequency range, extending to well below 40 cycles in the bass.

The **Tannoy Varilutance Mono Cartridge, Mark II**, is well established as a standard with many companies manufacturing television and broadcasting studio equipment, and is selected for use in quantity by the B.B.C.

The **Tannoy Vari-Twin Stereo Cartridge, Mark II**, is designed for the reproduction of stereophonic records in conjunction with equipment of the highest grade. The frequency response extends beyond 16 K/cs and channel separation is in excess of 20 Db.



## **TAPE RECORDING MAGAZINE**

**Press**

**Print & Press Services Ltd.,**

**Lounge 346**

7 Tudor Street,  
London, E.C.4  
FLE 1455

*Publishers*

The Editor and Staff of *Tape Recording Magazine* look forward to meeting again the countless friends made during the eight years since the magazine was founded.

It is, of course, the oldest established magazine on the subject in Europe and the unique team of contributors which it has built up gives it recognised authority in this field.

The Editor is Douglas Brown, who for several years has been the regular compere of the B.B.C. "Sound" programme and a judge of both the British and the International Amateur Tape Recording Contests.

Its distinguished contributors include names like James Moir. John Borwick, H. Burrell Hadden, Edward Greenfield.

*Tape Recording Magazine* caters for every type of enthusiast: its regular features cover creative tape recording, "do-it-yourself" construction, tape in education, drama recording, test reviews of equipment, notices of all new tape records and news of the clubs.

Its news service is unsurpassed and it regularly brings news of new products and of new developments here and abroad before they are reported elsewhere.

The personal columns written regularly by the Editor, by John Borwick and by Alan Edward Beeby are among the most readable features published in any magazine.

Associated publications include *Tape Recording Yearbook* and a series of popularly priced handbooks under the following titles: "Sound Effects on Tape," "Advice on Buying a Tape Recorder," "Introduction to the Tape Recorder," "Tape and Cine," "Hi-Fi for the Music Lover" and "How to Record Weddings."

## **TELEFUNKEN**

**Telefunken G.M.B.H.,**

Hanover Linden, Göttinger Chaussee 76,  
West Germany

**Booth 5**

**Demonstration**

**Room 402**

### *Tape Recorders*

#### **Telefunken Covers the Whole Tape-Recording Range**

Looking in at Booth No. 5, Demonstration Room 402, you'll see the largest display of Telefunken Tape Recorders ever shown in Great Britain. Everything is there, from the Christmas 1963 smash-hit, Magnetophon 55, to the latest model: Magnetophon 300. Telefunken have a machine for every tape-recording interest, from newly initiated amateur to professional.

**And now . . . .**

#### **A Portable Battery Telefunken, the Brand New Magnetophon 300**

The new 300 is on show for the first time in this country. It operates in any position powered by five 1.5-volt batteries (or a rechargeable battery can be supplied if preferred), and uses 5 in. spools at  $3\frac{3}{4}$  i.p.s. The microphone has a built-in level control indicator and there is a pause button and combined recording level/playback volume control built into the handle (ideal for one-handed operation). The machine is completely push-button operated and introduces high-quality Telefunken electronics into the fully portable field.

#### **The Success of 1963 . . . Magnetophon 55**

Telefunken launched this machine into the lower-priced market last year and judging by the public's response, it was eagerly awaited. Although the price is lower than the usual range, its quality is still high, worthy of the company that manufactured the world's first tape recorder. Its handsome case contains a host of new features, including a specially designed new speaker which accounts for the high-quality reproduction.

#### **Home Movie Fans go for 96**

Four-track, three-speed Magnetophon 96 is the ideal home-movie machine which has a special feature for specialised recording addicts: Inter-track transposition. Language laboratories have found this highly useful as well and its wide frequency response will fit into the most sophisticated set-up.

#### **Stereo 97 puts you in the Full Recording Picture (98 has the same effect)**

Stereo from Telefunken! This recorder was news when first released, and lives up to its great promises. The 97 and 98 are the same price, but the 97 is a quarter-track recorder. Both have a high signal to noise ratio, wide frequency range and three speeds.

#### **Magnetophon 85 de luxe is Mid-Priced for Quality**

Built to last, built to blend in with the highest quality sound set-up, yet sounds excellent by itself. Two speeds:  $7\frac{1}{2}$  and  $3\frac{3}{4}$  i.p.s. with a frequency response of 30—20,000 cps and 30—15,000 cps. The 6-watt push/pull amplifier gives this machine plenty of power on its own.

#### **The Studio-Quality M26KL and the M24KL**

Here are two machines that bridge the gap between the home machine and studio-quality tape recorders. At the lowest running speeds the wow and flutter are so low as to be almost unmeasurable. These two machines are identical in appearance, the only difference being in a choice of speeds between the two. Every possible feature is built into this high-quality equipment, truly the finest tape recorders in their price range.

**U.K. Agent: Welmec Corporation Ltd., 27, Chancery Lane, London, W.C.  
Telephone: CHAncery 9944**

## **THORENS**

**Booth 3a**

**Thorens S.A.,**  
Ste-Croix,  
Switzerland

*Transcription Motors, Turntables, Units and Pick-up Arms*

The Thorens TD224 "Masterpiece" Transcription Changer Unit is being shown for the first time in this country. An outstanding product it makes possible a unit which can automatically place the record on the turntable and then individually remove them without in any way affecting the uncompromising transcription quality for which all Thorens Swiss precision engineering products are justly renowned.

The superb Thorne TD124 is also being shown on the booth, and in use in the Ortofon demonstration room No. 336 as well as being chosen by many other exhibitors for their demonstrations. The TD124 has many features found in no other transcription turntable and these include the inertia control drive system with two step speed reductions. The double turntable with clutch action, built-in illuminated stroboscope and many features unique to this model.

Introduced at last year's Audio Fair the Thorens TD135 Transcription Unit incorporating the professional tone arm BTD12S has continued the Thorens success story and the integrated unit makes possible at a price anyone can afford a high quality turntable and arm.

The BTD12S arm is also available separately and is of the highest professional quality. It has been specially adapted to take cartridges of the highest lateral and vertical compliance therefore the lowest possible inertia in both the horizontal and vertical planes has been the primary objective. Precision ball bearing throughout, simultaneous longitudinal and lateral balance and an integrated Raise/Lower control are just a few of its many features.

Transcription Units based on the TD124 and TD135 incorporating Ortofon Pick-up Arms and Cartridges are also available. These composite units have been costed to show a price reduction to the consumer.

**Distributors throughout the United Kingdom: Metro-Sound (Sales) Limited, Bridge Works, Wallace Road, Canonbury, London, N.1. (Telephone: CANonbury 8641/2/3.)**

## **TRIO**

**TRIO Corporation,**  
7, Chidori-Cho, Chofu, Ohta-Ku,  
Tokyo

**Booth 62**

**Demonstration  
Room 121**

### *High Fidelity Amplifiers and Tuners*

The main feature of this display will be devoted to the **Trio** range of FM, FM/AM-AM Tuners, and Tuner Amplifiers. The following brief descriptions of some of the models will indicate the wide field of interests catered for in this attractive range of outstanding equipment.

#### **“Trio” Model FM-105. High Fidelity FM Tuner.**

Armstrong circuit with Dual Limiters and Foster-Seeley Discriminator. Low Noise Front End with tuned triode grounded grid amplifier and triode mixer. Transformer operated power supply with full wave rectification. Tuning Meter for quick and accurate tuning. Sufficient signal voltage to operate a conventional amplifier. Provision for connection with an FM multiplex adapter. Tuning Range : 80-108 Mc. **Retail Price 31 guineas.**

#### **“Trio” Model W-38. High Fidelity Tuner Amplifier.**

A general purpose stereo amplifier for disc playback, and all types of broadcast reception such as AM-AM stereo, FM, SW, and, if an FM multiplex adapter used additionally, FM multiplex stereo. Audio output of 14 watts per channel or 28 watts total. Hum eliminated by Direct Current Filament Heating System in the equalizer circuit. Rumble Filter eliminates low level disturbance. Magic Eyes. Foster-Seeley FM Detector brings you stable and superb high fidelity reception. **Retail Price 79½ guineas.**

#### **“Trio” Model AFX3U. AM-FM Stereo Multiplex Tuner.**

Extra wide band tuner and special circuitry ensure finest possible reception. 14 valves plus 9 diodes. FM ; 80-108 Mc., AM ; 535-1605 Kc. **Retail Price 59 guineas.**

#### **“Trio” Model TW30. All-Transistor Stereo Pre-Main Amplifier.**

22 Transistors plus 2 diodes. No special speakers required. Size only 12 in. x 7½ in. x 3½ in. high. Undistorted output 5 watts per channel (U.S.A. 10 watts per channel). **Retail Price 59 guineas.**

#### **“Trio” Model AD-5U. FM Multiplex Stereo Adapter.**

Designed for reception of FM Stereo broadcasts with an FM Tuner or FM radio. 3 valves and 5 diodes. Operates on AC Mains. Special Stereo Monitor, Noise Filter and Dimension Controls. **Retail Price 19 guineas.**

#### **“Trio” Model WX-400U. AM-FM Stereo Multiplex Receiver.**

21 valves and 7 diodes. Frequency range FM ; 80-108 Mc., AM ; 535-1605 Kc. Output 10 watts per channel (U.S.A. 20 watts). Tape Monitor Switch. Personal listening jack. **Retail Price 99 guineas.**

**Sole Distributors: Winter Trading Co. Ltd., 95/99, Ladbroke Grove, London, W.11. PARK 1341.**

## TRUVOX

Truvox Ltd.,  
Neasden Lane,  
London, N.W.10  
DOLLIS Hill 8011

Booth 41  
Demonstration  
Room 442

### Tape Recording and Audio Equipment

#### “SERIES 90”

Fabulous success has attended the latest range of Truvox Recorders and Tape Units since its release to the public last November. Now shown at the Audio Festival for the first time, these models are certain to make a deep impression owing to their discreet but modern styling, ease of operation and near-professional standards of performance. Reviewers have been indulging in superlatives usually reserved only for foreign competition if used at all.

During the recent confusion regarding Retail Price Maintenance, we experienced no difficulty in persuading the Trade to observe our published prices, for the principal reason that our price structure is extremely reasonable, and our methods of trading intensely fair. We manufacture in quantity and in quality, thereby offering the purchaser the finest value on the market in its class.

“Series 90” models are as follows :

R92	Half-track Monaural Recorder	69 gns.
R94	Quarter-track Monaural Recorder	69 gns.
PD93	Half-track Mono Tape Unit	59 gns.
PD95	Quarter-track Mono Tape Unit	59 gns.
PD97	Half-track Stereo Tape Unit	79 gns.
PD99	Quarter-track Stereo Tape Unit	79 gns.

Truvox, of course, pioneered the Tape Unit idea which has been taken up by other companies and is now an accepted product category in the Trade.

Full technical details are available in our leaflet, and we would point out that certain models in the successful “Series 80” are still current in a rather lower price bracket.

#### ADVANCE INFORMATION

##### TSA 100 Transistorised Stereo Amplifier

This is a real breakthrough by Truvox, a firm renowned for tape recorders, into the field of Audio equipment, where time-honoured names and designs prevail.

The TSA 100 is a complete integrated transistorised stereo amplifier capable of extremely fine performance and designed specifically for the tape disc enthusiast with a custom-built installation. A perfect match in appearance and specification for the “Series 90” models, this amplifier can be used with any reputable equipment on the market, and can be built in or left free-standing in its attractive Afrormosia plinth. Transformerless output, 10 watts per channel into 15 ohm loads, two inputs for all known pick-ups, three inputs for Tape, Radio and Auxiliary, output for recording. Controls are as follows : selector, bass, treble, balance and volume/on-off ; low and high pass filters and a stereo/mono switch. All sockets are at the rear. No matching problems—perfect compatibility !

To complete the TRUVOX TAPE SYSTEM—

we are hoping to release at the same time twin loudspeaker enclosures of similar elegance and compatibility, thereby taking full responsibility for *all* the (hi-fi) sounds to be heard in *our* demonstration room—and soon, we hope, in *your* home.

Full information from our technical staff at the Show, or write to us for leaflets.

## **VITAVOX**

**Vitavox Ltd.,**  
Westmoreland Road,  
London, N.W.9.

**Booth 18**  
**Demonstration**  
**Room 348**

### *Loudspeakers and Microphones*

The term "High Fidelity" is probably one of the most misused in existence. It is often used out of context in that it does not refer particularly to the required need. For example, in public address installations where speech only is required to be broadcast then the equipment must be designed to produce true high fidelity speech. Such equipment would not, however, for obvious reasons, give high fidelity music. The location of the equipment must also be taken into account; in the confined space of a submarine, for instance, high fidelity speech is exceedingly important so that commands and instructions are clearly heard throughout the vessel. It is perhaps no exaggeration to say that the highest fidelity of all is that that is demanded in the cinema. This is why Vitavox this year have equipped their Demonstration Room with a Base Bin Loudspeaker installation of the type that is fitted to cinemas throughout the world. In addition, there will be an "Effects" Loudspeaker of the type that is used for multi-channel sound distribution in the cinema. Vitavox will also exhibit typical equipment designed and made by them in the form of microphones, loudspeakers, loud hailer used in industry, in public address installations, as monitoring equipment in film and TV studios and by all the three Services as well as the types of loudspeakers you may use with advantage in your home.

Enquiries can be dealt with in the Office Room No. 362, from where literature can also be obtained.

## **VORTEXION**

**Vortexion Ltd.,**

257/263, The Broadway, Wimbledon,

London, S.W.19

LIBerty 2814

**Booth 74**

**Demonstration**

**Room 202**

### *Audio Equipment*

THE VORTEXION C.B.L. is capable of making and replaying the very highest quality recordings of either monaural or stereo whether "live" or transcript. This instrument, however, is intended to be more than a straightforward tape recorder in that provision is made not only to mix inputs on each side but also to feed the playback from the other track into the new recording. Each input is separately controllable and measured on the two meters. "Before and After" monitoring is employed and the echo facilities are more extensive than the W.V.B. The track-to-track cross-mixing function may be switched out when not needed as, for instance, listening to cues from one track whilst recording on the other.

THE VORTEXION W.V.B. is a highly quality monaural machine with "Before and After" monitoring. The recording inputs are a high sensitivity socket for moving coil or ribbon microphones and a high impedance socket for radio, etc., either of which can be selected by a switch. Superimposing and echo work can be done and the playback has reserve gain for abnormal requirements. This model cannot be converted for stereo P.B., but is a thoroughly reliable machine for the engineer specialising on monaural work.

THE VORTEXION W.V.A. is a monaural machine which has a performance equal in sound and quality to the other models. It possesses all the features of the W.V.B. except for "Before and After" monitoring, Dubbing and Echoes. The recording being made can be heard on the internal loudspeaker as in the W.V.B. and C.B.L. The controls are uncomplicated.

All tape recorders have adjustable bias controls, low impedance microphone inputs for unlimited lengths of cable, highly accurate position indicators and meters to measure recording level and bias.

ELECTRONIC MIXERS. A variety of mixers are available, 3-channel with accurate within 1 dB Peak Programme Meter, 4-channel, 12-channel and 2 x 5 channel Stereo. All feature long life without attention tropical controls, built in screened supplies, balanced line mic. inputs and .5 volt or alternative 1 m.w. 600 ohm balanced, unbalanced or floating outputs. A version is available which has recording erase and bias, play back and echo facilities with metering of bias signal.

## **WHARFEDALE**

**Wharfedale Wireless Works Ltd.,**

Idle, Bradford,  
Yorks.

Idle 1235/6

**Booth 53**

**Demonstration**

**Room 222**

### *Loudspeakers*

The quality sound for which Wharfedale has long been famous is maintained in the range of speaker systems offered. The Airedale, SFB/3, W4 and W3 models give that clean, open sound with adequate bass response, as yet unparalleled by smaller systems, and represent the best available for sound reproduction to-day.

The newest addition to the Wharfedale range of cabinet models—the Bookshelf 2—is an ultra-compact two-speaker system, with an exceptionally good response consistent with its small size. The use of a special 10 in. bass unit with polystyrene diaphragm, combined with an efficient 5 in. speaker, has enabled this to be achieved in a cabinet only  $\frac{1}{2}$  cu. ft. in volume.

Still deservedly popular in the smaller speaker range is the well-proved Super 8/RS/DD, which gives a smooth response over the full frequency scale and is capable of an excellent performance in an enclosure only 1 cu. ft. in volume. It is considered the best 8 in. unit yet produced by Wharfedale.

The entire selection of crossover units has been replaced by two new types which cater for most requirements. These are the HS/400/3 and QS/800, being 3-way and 2-way separators respectively. The use of newer and smaller components in these crossovers has enabled reductions to be made in size, weight and price.



## **WHITELEY**

**Whiteley Electrical Radio Co. Ltd.,**

Victoria Street,  
Mansfield, Notts.  
Mansfield 1762/5

**Booth 26**

**Demonstration**

**Room 304**

*Loudspeakers, V.H.F. Tuners, Amplifiers and Ready-to-Assemble Cabinets*

The wide range of Whiteley High Fidelity products comprises loud-speaker units, enclosures and matching equipment cabinets, stereophonic and single-channel amplifiers and radio tuners. The whole range of sound-reproducing equipment is thus manufactured within the Whiteley organisation and close control is exercised at every stage of manufacture.

### **Stentorian Loudspeakers**

The range of loudspeakers varies in size from 1½ in. in diameter up to 18 in. in diameter and these units are available with a variety of cone construction, speech coil impedance and magnet strength to suit all requirements. The universal speech coil is fitted on the 8 in. and 10 in. units and this feature is of great value in providing satisfactory matching to most systems.

The H.F. 1216 and H.F. 1016 Major Loudspeaker units have suspension systems which enable them to be used in the more compact type of cabinet. This enables reproduction of the highest quality to be obtained in a relatively limited space and designs of cabinets are available.

### **Ready-to-Assemble Cabinets**

A range of acoustically designed enclosures suitable for use with various types of loudspeaker will be on display and a selection of items will be demonstrated. These cabinets are of bass reflex design and can be assembled with the aid of a screwdriver. The finishes are in Sapele, Mahogany or Walnut Veneer and the completed items form an attractive piece of furniture.

Where space is limited, two types of enclosures are available. The Thoresby Slimline has been designed to accommodate any of the 8 in. or 10 in. units and provision is made for the fitting of a tweeter unit. The cabinet is substantially constructed and acoustically proportioned to give a balanced reproduction.

The Clumber Compact Loudspeaker system is available as a loudspeaker complete in cabinet and is extremely suitable for stereophonic use as well as forming an ideal bookshelf-type unit for the small, high-quality system.

### **Amplifiers and Tuners**

The Whiteley range of amplifiers and complementary tuners has been redesigned for present-day needs. The heart of the system is the improved W.B.12 Amplifier having the same high standard of performance. A Control Unit with facilities for stereophonic and single-channel reproduction enables either tape, gramophone or radio inputs to be coupled to the main amplifier system. This control unit is suitable for all types of magnetic and crystal pick-up and has a comprehensive system of tone compensation and built-in filters.

To cater for the potential requirements of stereophonic radio reception, a switched V.H.F. tuner has been designed giving instant choice of Third, Home or Light programme. The tuner incorporates comprehensive A.F.C. system ensuring that the station selected is always accurately tuned and an output is available for multiplex stereo.

To cater for users requiring a less complex system, a redesigned integrated 8 watt amplifier is available. This amplifier can be used with most types of crystal pick-up and will accept radio and tape input and form the basis of a high-quality single-channel system.

## **WILLIMAN EXPORT**

**K. H. Williman & Co. Ltd.,**

Blackford House,

Sutton, Surrey

Melville 1491

**Trade**

**Lounge**

**246**

*Exclusive Export Agents for FM/VHF Tuners, Tuner Amplifiers, Stereo Amplifiers and Control Units, Pick-ups, Tape Decks, Loudspeaker Units and Enclosure Systems*

Overseas visitors and manufacturers interested in export of British Audio Equipment are especially invited to visit us on the second floor, where they will be warmly welcomed.

All information and assistance is here available on anything connected with the export sales of British High Fidelity equipment manufactured by the following firms whom we represent.

### **KELLY ACOUSTICS LTD.**

Products include the unique Kelly Ribbon HF (Tweeter) unit and matching range of Kelly LF Driver Loudspeakers from the Mk III 12 in. to the Mk VII 15 in. units, "TALLBOY" and "MINI" loudspeaker enclosure systems.

### **ROGERS DEVELOPMENTS (ELECTRONICS) LTD.**

VHF/FM Tuners, Stereo Amplifiers and Control Units, including the Integrated HG88 Stereo Amplifier, Cadet Stereo Amplifiers and loudspeaker systems.

### **PLANET PROJECTS LTD.**

Tape Decks providing professional standards of performance with domestic user, presentation and facilities.

### **ARMSTRONG AUDIO LTD.**

The new "200" range of VHF/FM Tuners, Tuner Amplifiers, Power Amplifiers with Control Units, and Integrated Stereo Amplifiers designed for world markets.

### **E.M.I. SOUND PRODUCTS LTD.**

EPU 100 Stereo Pick-up, E.M.I. Combined High Performance Loudspeaker units in a size range to cover all High Fidelity requirements.

Our unique experience is freely at the disposal of any manufacturer or importer interested in British Audio Equipment of quality in the export of which we are 100 per cent. engaged, and on which we cover every aspect from start to finish.

## **WILSON STEREO LIBRARY**

**Lounge 155**

**The Wilson Stereo Library Ltd.,**

463, Streatham High Road,

London, S.W.16

POLLards 2910

*"The Stereo Index"*

The Wilson Stereo Library is a complete collection of every worthwhile stereo record available in this country. In this collection are included all Classical, Light, Demonstration, Popular and Jazz stereo records of good quality. Every stereodisc in the Library is maintained in perfect condition.

The W.S.L. Service is unique among libraries and record suppliers in being the only service devoted exclusively to the service of the stereo enthusiast. From its inception, W.S.L. has attracted the informed modern music listener who possesses above average stereo equipment and an understanding of the care needed to protect stereodiscs.

W.S.L. operates from one library centre. The whole library collection being "under one roof" ensures that every member can choose from the complete library catalogue no matter whether he calls personally at the Library Centre or makes use of the Postal Service.

Stereo specialisation has made it possible to offer the most efficient world-wide service to those who wish to buy new stereodiscs. Perfect copies of every new release are received by W.S.L. from the various recording companies for distribution to postal customers who demand the highest quality.

The Library's first publication, *The Stereo Index* (containing over 200 pages), is now recognised to be the most valuable and most comprehensive catalogue offered to the modern listener. Even the recording release dates of every stereo record are quoted.

*The Stereo Index* embraces every worthwhile recording—Classical, Light, Demonstration, Popular and Jazz, and gives a good indication of the Library collection of W.S.L.

Among the many other specialised services offered to the stereo enthusiast are the Stereo Testing and Setting-Up Kit and the supply and maintenance of first-class stereo equipment.

## WIRELESS WORLD

Booth 1

**Wireless & Electrical Trader**  
**Hiffe Electrical Publications Ltd.,**  
Dorset House, Stamford Street,  
London, S.E.1

*Publishers*

*Wireless World* is Britain's leading technical journal in the general field of radio, television and electronics. Providing a complete and accurate survey of the newest British technique in design and manufacture, its articles cover every phase of the radio and allied industries. Contributions by recognised experts deal with design data and circuits for every application. High fidelity receives searching attention. *Wireless World* is published monthly, 2s. 6d.

*Wireless & Electric Trader* is the leading trade journal of the radio, television and light engineering industries, widely read by dealers, service engineers, manufacturers and wholesalers. Obtainable only on subscription basis by bona fide members of the trade, it provides an invaluable weekly survey of trade trends, experienced observers reporting on every development, technical or commercial. "Audiotopics," a regular feature now in its seventh year, presents the latest technical and commercial aspects of the audio field—an invaluable aid to dealers in keeping right up to date in this increasingly important subject. *Wireless & Electrical Trader* costs £3 a year, including postage.

**Technical Books.** Authoritative and up-to-date books on many aspects of radio and television are also on show. Among them is :

**Principles of Feedback Design.** G. Edwin and Thomas Roddam.

The first book to bridge the gap between elementary treatment of feedback in standard textbooks, and advanced works of a highly mathematical nature. It commences with a thorough examination of negative feedback applied in simple amplifiers of both valve and transistor types. The authors show how to determine the response of an amplifier before it is built. The second half of the book deals with more general problems including signal flow diagrams, a discussion of the analytical approach and the use of feedback amplifiers as filters. The authors are both regular contributors to *Wireless World*. 45s. 238 pp. 185 diagrams.

## WORDEN

Demonstration  
Room 313

### Worden Audio Developments Ltd.,

54, Chepstow Road,  
London, W.2  
BAYswater 4996

#### *Sound Reproducing Equipment*

The originators of the world-renowned Worden Articulated Pickup Arm and latterly the Panosonic Reproducers are showing a complete stereophonic sound system of superlative quality at a total cost of £145 only. The components of this system are as follows:— Transistorised Stereo Control Unit with companion (valve) stereo power amplifier; Articulated Pickup Arm fitted with magnetic stereo cartridge to customer's choice (priced around £13-£15); Transcription Motor; two Panosonic Reproducers, and choice of plinth-type playing desk or equipment cabinet.

**TRANSISTORISED STEREO CONTROL UNIT.** Contains all facilities for obtaining high quality stereo and mono reproduction, and will drive a power amplifier of 50-200 mv. input sensitivity from any pickup cartridge, magnetic or ceramic/crystal possessing an output of from 1.2 mv/cm/sec. r.m.s. upwards (per channel). It is also suitable for Radio, Tape and Microphone inputs. Channel separation is better than 55 dB and frequency response is from 15 c/s to 25 Kc/s. Self-powered by easily replaceable 9 v. battery.

**STEREO POWER AMPLIFIER.** Of economic design and high performance, this amplifier is intended to provide superior quality sound for domestic listening, and has a basic sensitivity of 50 mv. for 4 watts output per channel (more than adequate power for the Panosonic speakers and sufficient for many other reasonably sensitive horn and vented types). Channel separation is better than 55 dB and response is substantially linear from 20-20,000 c/s (4 dB down at 40,000 c/s).

The **WORDEN PANOSONIC REPRODUCER** employs a unique application of the horn-loading principle. One only, good quality full-range loudspeaker unit with simple paper cone is used (Wharfedale), and from which maximal efficiency is obtained. This is mounted in the centre of an enclosure and facing to the rear, where it drives two intercommunicating horns; one extending in an upward direction, the other downwards. Frequencies from the face of the unit are thus loaded by the horns, which provide the middle and low frequency range, whilst the upper and high frequencies are freely radiated from the back of the unit.

The sound from this reproducer may be said to possess a most vivid "presence" and realism, and with a stereo pair quite a remarkable illusion of actuality can be created. In addition the sound is directed and spread both horizontally and vertically in a manner which ensures similar and comfortable listening over a large area. As Thomas Heintz remarked in *Records & Recording*, March, 1963:— "I was profoundly impressed by the warmth and spaciousness of the sound, as well as by the naturalness and clarity of the stereo image." And Donald Aldous in *Audio & Record Review*, November, 1963, wrote:— "Perhaps the most notable feature of the design is its ability to give good stereo sound patterns without 'beam' or 'off beam' effects according to the position of the listener."

All of the above equipment is on demonstration in Room 313, where fully descriptive literature is freely available.

## **ZONATAPE**

**Booth 40**

**Zonal Film (Magnetic Coatings) Ltd.,**

Zonal House,

Westfields Road,

Acton, W.3

ACOrn 6841 (10 lines)

*Magnetic Tapes*

ZONATAPE  $\frac{1}{4}$  in. magnetic recording tape is manufactured in Great Britain, and is now used in large quantities by the B.B.C., by recording studios, and by a large number of film and television studios.

ZONATAPE is manufactured to the same high-quality professional standard as the magnetic products supplied to professional users. Each grade of ZONATAPE is easily identified by the colour coded spool and label, and is supplied in handsome case-bound library containers.

An ever increasing number of high class hi-fi, radio and television dealers are now distributing ZONATAPE.

The following popular ZONATAPE accessories have recently been introduced :

Coloured leader and timing tape. 100 foot lengths. White, Red, Green, Blue, Yellow.

Splicing tape.  $\frac{1}{4}$  in. x 108 ft.

Metallic stop foil.  $\frac{1}{4}$  in. x 100 ft.

ZONATAPE is available in the following grades and sizes :

Diacetate. Grade 500. Clear spools.

3, 5,  $5\frac{1}{2}$  and 7 in. spools.

P.V.C. Standard. Grade 600. Red spools.

3,  $3\frac{1}{2}$ , 4, 5,  $5\frac{1}{2}$ , 7,  $8\frac{1}{4}$  and  $10\frac{1}{2}$  in. spools.

Polyester Extra play. Grade 700. Green spools.

3,  $3\frac{1}{2}$ , 4, 5,  $5\frac{1}{2}$ , 7,  $8\frac{1}{4}$  and  $10\frac{1}{2}$  in. spools.

Polyester Double play. Grade 800. Clear spools.

3,  $3\frac{1}{2}$ , 4, 5,  $5\frac{1}{2}$ , 7 and  $8\frac{1}{4}$  in. spools.



see and hear the quality. . . . room B 120  
and stand 39

*. . . A new range of high fidelity loud speaker units from 8" to 15", using the latest ceramic magnet techniques. Suitable enclosures have been designed and styled in close collaboration with our acoustic engineers and by specialists in this field, giving unequalled quality of reproduction . . .*

# Richard Allan

*Radio Limited, Batley, Yorkshire.*

---

*Telephone : Batley 1123, 1308 & 4033. Telegrams : Acoustics, Batley.*

In all types of  
Public Address  
Systems—you'll  
find VITAVOX

*In the ships of the  
Royal Navy—you'll  
find VITAVOX*

# VITAVOX

*In the Film  
Studio and  
in the Cinema  
—You'll find  
VITAVOX*

**MICROPHONES AND  
LOUDSPEAKERS**  
*built for dependable  
service in  
Communications  
and Entertainment*

*In TV Studios  
...in Closed  
Circuits...in  
Monitoring  
— you'll find  
VITAVOX*

**In 'Circlorama'**  
*you'll have VITAVOX  
all round you*

**Demonstration Room 348**  
**Office 362**  
**Booth No. 18**

*and so, naturally you'll  
find VITAVOX in the  
homes of discerning  
music lovers*

VITAVOX LIMITED WESTMORELAND ROAD LONDON NW9

*Close to Queensbury Stn, L.T., Bakerloo Line, Stanmore Branch*

Telephone: COLindale 8671    Telegrams: Vitavox London England





## **THE LANSING ROLLS SPEAKER SYSTEM ...**

is constructed with the same individual care as a Strad Violin would be. Five speakers in all are used, each handling certain Octaves or Frequencies for maximum efficiency. This is brought about by the application of a 3 element cross-over network. The Speakers and Cross-Over Network are enclosed in a special Acoustic Folded Horn Cabinet which allows Frontal and Rear Radiation to be projected. This increases the Acoustic efficiency by as much as 25% to 40% over and above the usual cabinets employed.

Within the control unit are two power amplifiers—each 30 watt output at .1% total distortion, a pre-amplifier, a Connoisseur 3 transcription unit, a Shure pick-up, a professional type tape recorder, a record storage compartment. The heavy shelf lid is supported by two hydraulic gold-plated stays. The L.F. Speakers employed in the system incorporate the best features, such as multi-parameter shaped cone fully tropicalised, with plastic surround, a Super-High Flux Magnet, together with a longer magnet core, built-in centrelling device for perfect gap alignment, heavy duty oversize speech coil, etc. The medium and H.F. Speakers are also of unique design and construction, the cone being of a non-metallic special plastic, completely sealed at the rear of cone by the use of a non-perforated back plate. Cabinets are constructed of  $\frac{3}{4}$  in. timber, finished in Sapele Mahogany, complete with anodised Gilt Grille. All joints and seams of the internal structure are precision cut and assembled, afterwards linen tape is glued over all joints and seams to ensure complete air-tightness.

The entire system is on castors.

The complete Hi-Fi System      **£385. 0.0.**

Lansing Rolls Speaker Systems    **£68.10.0.**

*All Sales Enquiries to : Mr. F. ORPIN, Sales Director—*

**LANSING ROLLS LIMITED,**  
**49 FOXDALE WAY, CHALFONT - ST. - PETER, BUCKS.**

# NOW...

another  
milestone in  
audio engineering  
by

## LEAK



# STEREO 30

## *Transistorised* INTEGRATED AMPLIFIER

... superb styling, faultless performance and a breakthrough in price and reliability by LEAK the First Name in High Fidelity . . .

Reprinted from "WIRELESS WORLD" Editorial, May, 1963.

"... Last autumn, during his presidential address to the British Sound Recording Association, H. J. Leak demonstrated a prototype high-quality transistor amplifier which gave results indistinguishable from those of his valve amplifiers . . ."

"People sometimes ask why there is any necessity to change to transistors. The elimination of the output transformer is, in our view, sufficient reason now that solutions of the problem of linearity in the response of the rest of the transistor circuit have been found. As additional bonuses we get smaller size, cooler running and the prospect of longer life."

Compared with its equivalent valve amplifier the "Stereo 30" gives results which are indistinguishable and it offers these important advantages:—

- It is 48% of the weight.
- It is 43% of the size.
- It is 89% of the price.
- It has greater reliability (estimated to be 500% better) because the heat rise within the case is negligible (12°F) and because the maximum voltage is less than 50.

- ★ How can the valve possibly survive in view of the above comparisons?
- ★ Dimensions: 13" x 4½" x 9" deep. Weight: 14lb. Price £49-10-0d.

Write now for fully illustrated brochure.

## LEAK

### H. J. LEAK & CO. LTD.

BRUNEL ROAD, WESTWAY FACTORY ESTATE,  
LONDON, W.3.

Tel: SHEpherds Bush 1173

Telegrams: Sinusoidal Ealux, London



# First time in England!

The new Dual 1009 automatic turntable with stereo magnetic cartridge

Not until you have seen and heard the magnificent DUAL Stereo System incorporating the new DUAL 1009 automatic changer, will you be able to appreciate the notable advance in the technology of record reproduction that it represents. The DUAL 1009 is designed to suit the needs of both the stereo specialist and enthusiastic amateur.

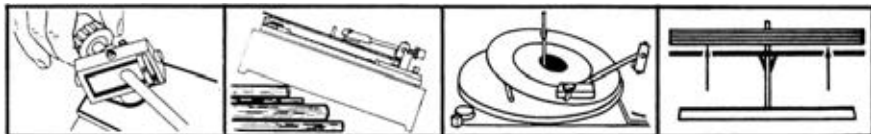

**A.** A simple but positive pick-up arm balancing mechanism with fine adjustment provides a variable tracking force from 0 to 7 grams.

**B.** No levelling necessary before operating the DUAL 1009. At 33 $\frac{1}{3}$  rpm tracking at 1 gram, a standard 12" record can be played up to 45° from the horizontal with complete satisfaction.

**C.** A 7" record with a warped surface is placed off-centre to achieve eccentric tracking. The DUAL 1009 pick-up arm will follow the eccentric movements of the grooves perfectly illustrating its extremely low friction and insensitivity to horizontal vibration.

**D.** When changing, the automatic elevator spindle lifts up all but the bottom record so that there is no weight on it when it drops on to the turntable.

SEE THE DUAL 1009 AND THE DUAL STEREO TAPE RECORDER IN BOOTH 33 AND DEMONSTRATION ROOM 158

A DIVISION OF CELSA ELECTRIC CO. LTD

# Dual

CELSA HOUSE KELWAY PJ. W14. FUL 9761/2

Qualiton STEREO

This is



your

**STEREO**  
*amplifier*

Demonstration  
Room 113, Booth 61

*2x14VA integrated high fidelity stereo amplifier type  
AE 211*



Electroacoustical Factory, Budapest, exported  
by ELEKTROIMPEX Hungarian Trading Company for  
Telecommunication and Precision Goods  
Budapest POB 296. Hungary

# PROFESSIONAL PERFORMANCE

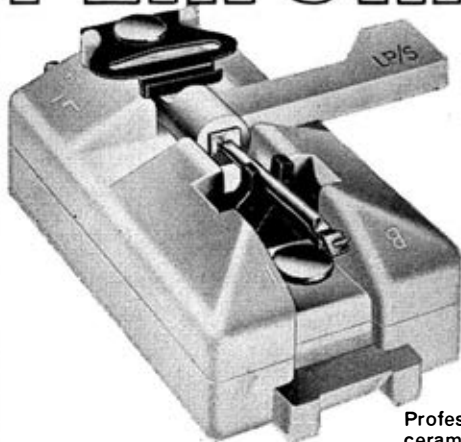

# BSR

## BSR C1 CERAMIC cartridge

Professionals choose the BSR C1 ceramic cartridge because of its outstanding performance and dependability. You, too, can now buy this cartridge with a specification comparable to designs costing twice as much. The C1 plays L.P.'s, mono or stereo and 78's, has a stylus pressure of 2-6 grammes, a high compliance of  $5.2 \times 10^{-6}$  cm/dyne, and channel difference less than 3dB.

**£2 · 6 · 5** inc. tax. Stereo cartridge with double tipped sapphire stylus.

**£3 · 9 · 8** inc. tax with diamond L.P/S tip.



### UA 15 Record Changer

A model of slim elegance . . . automatically plays ten 12", 10" and 7" records mono or stereo. Manual play facility and RMS wow and flutter below 0.3% and 0.06% respectively.

Send for details of the complete range of BSR equipment and the address of your nearest BSR stockist.



**BSR LIMITED, MONARCH WORKS, OLD HILL, STAFFS.**

The world's largest manufacturers of Record Changers & Tape Decks

# Vortexion

## quality equipment

Type C.B.L.

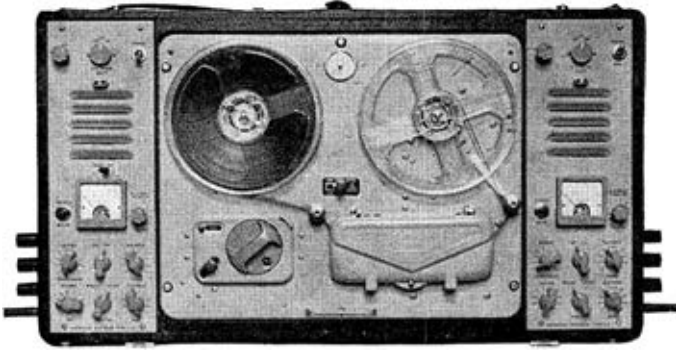

### STAND No. 74, DEMONSTRATION ROOM No. 202

The C.B.L. stereo programme building recorder can transfer signal from one track to the other with two more mixed inputs each time.

The W.V.B. Recorder is suitable for professional use with after record, monitoring and echo facilities.

The W.V.A. Recorder is a semi-professional model of the highest quality.

#### Additional details on Page 137.

The Vortexion 30/50 Amplifier can deliver 50 watts of speech and music or over 30 watts of continuous sine wave and the main amplifier has a response of 30 to 20,000 cps within 1 db at 0.1 per cent. distortion. Outputs for 4, 7.5, 15 ohm and 100 volt line. Models are available with two, three or four mixed inputs which may be low impedance balanced line microphones, P.U. or Guitar inputs.

The 120/200 Watt Amplifier can deliver its full audio power at any frequency in the range of 30 to 20,000 cps for which the response is accurate within 1 db with less than 0.2 per cent. distortion at 1,000 cps. It can be used to drive mechanical devices, i.e. synchronous capstan or projector motors, etc., for which the power is over 140 watts on continuous sine wave. The input is for 1 m.w. 600 ohms, the output for 100-120 volts or 200-240 volts and additional matching transformers for other impedances are available.

Other items of our manufacture are:

- 4 way Mixer with 10 watt output and tone controls.
- Record and Playback Mixer.
- 2 x 5 way Stereo Mixers.
- 12 way Mixers.
- 3 way Mixer and Peak Programme Meter.
- 4 way Mixers.
- 2 way 30/50 ohm in and out stud type Mixers
- Erase Fader unit for our recorders.

## VORTEXION LIMITED

257-263 The Broadway, Wimbledon, London, S.W.19

Telephone: LIBerty 2814 and 6242-3-4. Telegrams: "Vortexion, Wimble, London"





see and hear the quality. . . . room B 120  
and stand 39

*. . . A new range of high fidelity loud speaker units from 8" to 15", using the latest ceramic magnet techniques. Suitable enclosures have been designed and styled in close collaboration with our acoustic engineers and by specialists in this field, giving unequalled quality of reproduction . . .*

# Richard Allan

*Radio Limited, Batley, Yorkshire.*

---

*Telephone : Batley 1123, 1308 & 4033. Telegrams : Acoustics, Batley.*

In all types of  
Public Address  
Systems—you'll  
find VITAVOX

*In the ships of the  
Royal Navy—you'll  
find VITAVOX*

**VITAVOX**

In the Film  
Studio and  
in the Cinema  
—You'll find  
VITAVOX

**MICROPHONES AND  
LOUDSPEAKERS**  
*built for dependable  
service in  
Communications  
and Entertainment*

*In TV Studios  
...in Closed  
Circuits...in  
Monitoring  
—you'll find  
VITAVOX*

**In 'Circlorama'**  
*you'll have VITAVOX  
all round you*

**Demonstration Room 348**  
**Office 362**  
**Booth No. 18**

*and so, naturally you'll  
find VITAVOX in the  
homes of discerning  
music lovers*

VITAVOX LIMITED WESTMORELAND ROAD LONDON NW9

*Close to Queensbury Stn, L.T., Bakerloo Line, Stanmore Branch*

Telephone: COLindale 8671 Telegrams: Vitavox London England





## **THE LANSING ROLLS SPEAKER SYSTEM ...**

is constructed with the same individual care as a Strad Violin would be. Five speakers in all are used, each handling certain Octaves or Frequencies for maximum efficiency. This is brought about by the application of a 3 element cross-over network. The Speakers and Cross-Over Network are enclosed in a special Acoustic Folded Horn Cabinet which allows Frontal and Rear Radiation to be projected. This increases the Acoustic efficiency by as much as 25% to 40% over and above the usual cabinets employed.

Within the control unit are two power amplifiers—each 30 watt output at .1% total distortion, a pre-amplifier, a Connoisseur 3 transcription unit, a Shure pick-up, a professional type tape recorder, a record storage compartment. The heavy shelf lid is supported by two hydraulic gold-plated stays. The L.F. Speakers employed in the system incorporate the best features, such as multi-parameter shaped cone fully tropicalised, with plastic surround, a Super-High Flux Magnet, together with a longer magnet core, built-in centrelling device for perfect gap alignment, heavy duty oversize speech coil, etc. The medium and H.F. Speakers are also of unique design and construction, the cone being of a non-metallic special plastic, completely sealed at the rear of cone by the use of a non-perforated back plate. Cabinets are constructed of  $\frac{3}{4}$  in. timber, finished in Sapele Mahogany, complete with anodised Gilt Grille. All joints and seams of the internal structure are precision cut and assembled, afterwards linen tape is glued over all joints and seams to ensure complete air-tightness.

The entire system is on castors.

The complete Hi-Fi System    £385. 0.0.

Lansing Rolls Speaker Systems   £68.10.0.

All Sales Enquiries to : Mr. F. ORPIN, Sales Director—

**LANSING ROLLS LIMITED,**  
49 FOXDALE WAY, CHALFONT - ST. - PETER, BUCKS.

# NOW...

another  
milestone in  
audio engineering  
by

## LEAK

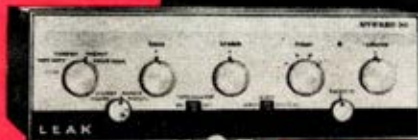

# STEREO 30

## *Transistors* INTEGRATED AMPLIFIER

... superb styling, faultless performance and a breakthrough in price and reliability **LEAK the First Name in High Fidelity** . . .

Reprinted from "WIRELESS WORLD" Editorial, May, 1963.

"... Last autumn, during his presidential address to the British Sound Recording Association, H. J. Leak demonstrated a prototype high-quality transistor amplifier which gave results indistinguishable from those of his valve amplifiers . . ."

"People sometimes ask why there is any necessity to change to transistors. The elimination of the output transformer is, in our view, sufficient reason now that solutions of the problem of linearity in the response of the rest of the transistor circuit have been found. As additional bonuses we get smaller size, cooler running and the prospect of longer life."

Compared with its equivalent valve amplifier the "Stereo 30" gives results which are indistinguishable and it offers these important advantages:—

- It is 48% of the weight.
- It is 43% of the size.
- It is 89% of the price.
- It has greater reliability (estimated to be 500% better) because the heat rise within the case is negligible (12°F) and because the maximum voltage is less than 50.

★ How can the valve possibly survive in view of the above comparisons?

★ Dimensions: 13" x 4 $\frac{1}{4}$ " x 9" deep. Weight: 14lb. Price £49-10-0d.

Write now for fully illustrated brochure.

## LEAK

### H. J. LEAK & CO. LTD.

BRUNEL ROAD, WESTWAY FACTORY ESTATE,  
LONDON, W.3.

Tel: SHEpherds Bush 1173

Telegrams: Sinusoidal Ealux, London



# First time in England!

The new Dual 1009 automatic turntable with stereo magnetic cartridge

Not until you have seen and heard the magnificent DUAL Stereo System incorporating the new DUAL 1009 automatic changer, will you be able to appreciate the notable advance in the technology of record reproduction that it represents. The DUAL 1009 is designed to suit the needs of both the stereo specialist and enthusiastic amateur.

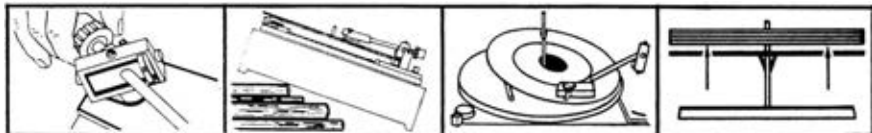

**A.** A simple but positive pick-up arm balancing mechanism with fine adjustment provides a variable tracking force from 0 to 7 grams.

**B.** No levelling necessary before operating the DUAL 1009. At 33 $\frac{1}{3}$  rpm tracking at 1 gram, a standard 12" record can be played up to 45° from the horizontal with complete satisfaction.

**C.** A 7" record with a warped surface is placed off-centre to achieve eccentric tracking. The DUAL 1009 pick-up arm will follow the eccentric movements of the grooves perfectly illustrating its extremely low friction and insensitivity to horizontal vibration.

**D.** When changing, the automatic elevator spindle lifts up all but the bottom record so that there is no weight on it when it drops on to the turntable.

SEE THE DUAL 1009 AND THE DUAL STEREO TAPE RECORDER IN BOOTH 33 AND DEMONSTRATION ROOM 158

A DIVISION OF CELSA ELECTRIC CO. LTD

# Dual

CELSA HOUSE KELWAY PI. W14. FUL 9761/2

Qualiton STEREO

This is



your

**STEREO**  
*amplifier*

Demonstration

Room 113, Booth 61

*2x14 VA integrated high fidelity stereo amplifier type  
AE 211*



Electroacoustical Factory, Budapest, exported  
by ELEKTROIMPEX Hungarian Trading Company for  
Telecommunication and Precision Goods  
Budapest POB 296. Hungary

# PROFESSIONAL PERFORMANCE

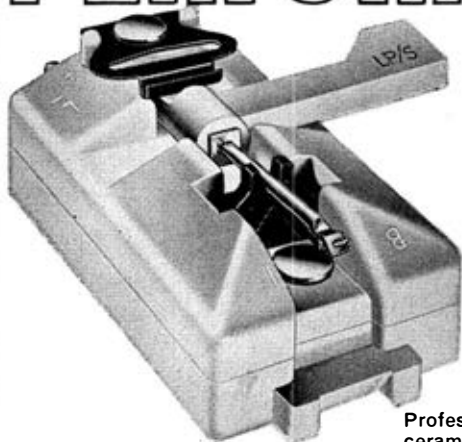

# BSR

## BSR C1 CERAMIC cartridge

£3·9·8 inc. tax with diamond L.P/S tip.

Professionals choose the BSR C1 ceramic cartridge because of its outstanding performance and dependability. You, too, can now buy this cartridge with a specification comparable to designs costing twice as much. The C1 plays L.P.'s, mono or stereo and 78's, has a stylus pressure of 2-6 grammes, a high compliance of  $5.2 \times 10^{-6}$  cm/dyne, and channel difference less than 3dB.

£2·6·5 inc. tax. Stereo cartridge with double tipped sapphire stylus.



### UA 15 Record Changer

A model of slim elegance . . . automatically plays ten 12", 10" and 7" records mono or stereo. Manual play facility and RMS wow and flutter below 0.3% and 0.06% respectively.

Send for details of the complete range of BSR equipment and the address of your nearest BSR stockist.



**BSR LIMITED, MONARCH WORKS, OLD HILL, STAFFS.**

The world's largest manufacturers of Record Changers & Tape Decks

# Vortexion

## quality equipment

Type C.B.L.

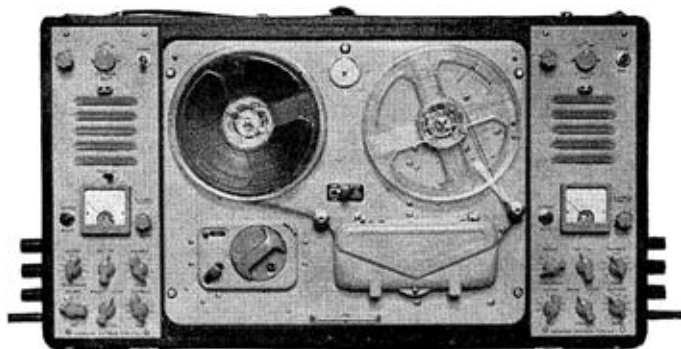

### STAND No. 74, DEMONSTRATION ROOM No. 202

The C.B.L. stereo programme building recorder can transfer signal from one track to the other with two more mixed inputs each time.

The W.V.B. Recorder is suitable for professional use with after record, monitoring and echo facilities.

The W.V.A. Recorder is a semi-professional model of the highest quality.

#### Additional details on Page 137.

The Vortexion 30/50 Amplifier can deliver 50 watts of speech and music or over 30 watts of continuous sine wave and the main amplifier has a response of 30 to 20,000 cps within 1 db at 0.1 per cent. distortion. Outputs for 4, 7.5, 15 ohm and 100 volt line. Models are available with two, three or four mixed inputs which may be low impedance balanced line microphones, P.U. or Guitar inputs.

The 120/200 Watt Amplifier can deliver its full audio power at any frequency in the range of 30 to 20,000 cps for which the response is accurate within 1 db with less than 0.2 per cent. distortion at 1,000 cps. It can be used to drive mechanical devices, i.e. synchronous capstan or projector motors, etc., for which the power is over 140 watts on continuous sine wave. The input is for 1 m.w. 600 ohms, the output for 100-120 volts or 200-240 volts and additional matching transformers for other impedances are available.

Other items of our manufacture are:

- 4 way Mixer with 10 watt output and tone controls.
- Record and Playback Mixer.
- 2 x 5 way Stereo Mixers.
- 12 way Mixers.
- 3 way Mixer and Peak Programme Meter.
- 4 way Mixers.
- 2 way 30/50 ohm in and out stud type Mixers
- Erase Fader unit for our recorders.

## VORTEXION LIMITED

257-263 The Broadway, Wimbledon, London, S.W.19

Telephone: LIBerty 2814 and 6242-3-4. Telegrams: "Vortexion, Wimble, London"



# Stentorian STAND 26

Demonstration Room 304



## MODEL H.F.1012 SPEAKER

10in. die-cast unit, incorporating 12,000 gauss magnet. Fitted with cambric cone and universal impedance speech coil providing instantaneous matching at 3, 7.5 and 15 ohms. Handling capacity 10 watts. Frequency response 30 c.p.s. to 14,000 c.p.s. Bass Resonance 35 c.p.s.

Price: £47.6.

## THORESBY SLIM-LINE CABINET

This enclosure has been designed to accommodate any of the Stentorian range of 8in. or 10in. units. Provision is made for the addition of either pressure or cone type tweeter and a crossover may be used.

The cabinet is substantially constructed and acoustically proportioned to give a balanced reproduction with the chosen units. Available in mahogany or walnut. Height 31in. x Width 20in. x Depth 9½ in.

Price: Mahogany £8.15.0. Walnut £9.0.0.

### BASS REFLEX CONSOLE CABINETS

Height 31in. x Width 19½ in. x Depth 18 in.

Price: Mahogany £12.12.0. Walnut £12.19.6.

### HI-FI EQUIPMENT CONSOLES

Height 31 in. x Width 19½ in. x Depth 18 in.

Price: Mahogany £14.14.0. Walnut £15.4.0.



## T.359 CONE TWEETER

Provides a very high standard of reproduction when used in conjunction with 'Stentorian' 10in. or 12in. units. Incorporates High Sensitivity 9,000 gauss magnet, special cone and lightweight coil. Frequency response: 3,000-15,000 c.p.s. Overall size: 3in. dia x 2in. deep. Voice coil impedance: 15 ohms or 5 ohms. Power handling capacity: 15 watts when used with a 3,000 c.p.s. crossover.

Price: £110.6.

See and hear our wide range of  
**AMPLIFIERS • TUNERS**  
**SPEAKERS & CABINETS**

WHITELEY ELECTRICAL RADIO CO. LTD. • MANSFIELD • NOTTS.

# New products from the **METRO-SOUND** GROUP



## THE "CLASSIC" M1

The Metro-Sound "Classic" M1 loudspeaker has been designed and produced to match high quality amplifiers and pick-ups. This has been achieved by the use of a special 12in. bass unit covering the middle and lower frequency range and incorporates a unique bass reflex system, thus ensuring fuller response from the lower frequency spectrum. A 5in. diameter totally enclosed treble unit brilliantly reproduces the upper frequencies.  
Price: £36 . 0 . 0

## THE "CLASSIC" M2

A further major advance in compact loudspeaker design. Available singly, or in matched pairs for true stereo reproduction. Attractively finished in Sapele Mahogany. The Metro-Sound "Classic" M2 speaker enclosures are designed for bookshelf mounting or for use where space is limited.  
Price £17 . 10 . 0

## METRO-SOUND STEREO PREAMPLIFIER MST/10

Designed and produced for use with low and medium output pick-up cartridges and microphones, and has a performance unequalled within this price category. Frequency Response 30 c/s—30 kc/s substantially Linear Gain 40 db Plus ★ Input Impedance Low and Medium Output Impedance Medium and High ★ Battery Vidor V.T.4 or equivalent.

Price : Standard Model £7 . 10 . 0 ; De luxe £9 . 10 . 0



Look, Listen, Compare the all new

# CLASSIC

HI-FI STEREO REPRODUCER



Sapele Mahogany Cabinet with ebony finished legs. Speakers also in Sapele Mahogany with Vynair fronts. This is the finest Hi-Fi value ever.

Price: £61 . 6 . 10  
incl. Purchase Tax

Look at the price. Listen to the superb reproduction. Compare with any other Stereo Equipment within this price range, and you'll agree that this is today's finest value. Specification: Garrard AT6 Autochange unit, the latest Sonotone 9T Cartridge with Transcription Diamond Stylus, matched speakers each having separate bass and treble unit. Independent treble and bass controls. Stereo Balance control. Amplifier—Integrated amplifier, combined output 6—7 watts.

# METRO-SOUND

METRO-SOUND MANUFACTURING Co. Ltd.,  
Bridge Works, Wallace Road, Canonbury, N.1  
CANonbury 8641/4



no other portable  
tape recorder  
so versatile . . .



## UHER 4000 REPORT-S

Two tracks to international standard ■ reel size :  
up to 5" ■ four tape speeds:  $7\frac{1}{2}$  ips,  $3\frac{3}{4}$  ips,  
 $1\frac{7}{8}$  ips,  $\frac{9}{16}$  ips ■ frequency response ( $\pm 3$  db) :  
40-20,000 cps at  $7\frac{1}{2}$  ips, 40-17,000 cps at  
 $3\frac{3}{4}$  ips, 40-10,000 cps at  $1\frac{7}{8}$  ips, 40-4,500  
cps at  $\frac{9}{16}$  ips ■ contrast ratio : 55db ■ wow  
and flutter:  $\pm 0.15\%$  at  $7\frac{1}{2}$  ips (audible  
frequencies only) ■ output power: 1 watt  
(push-pull power stage) ■ power supply :  
five flashlight cells (1.5 volts each) or  
"dryfit" storage battery model Z 211 or  
model UHER Z 111 mains-operated power  
unit and battery charger or an automobile  
battery via automobile adaptor cable  
■ inputs : Micro 0.1 mV at approx.  $2k\Omega$  ;  
Radio 1 mV at  $47k\Omega$  ; Phono 25 mV at  
1 megohm ■ outputs : 2 volts at 4 ohms :  
1 volt at  $15k\Omega$  ■ operating time : intermittent  
operation of approx. 12 hrs : continuous  
operation and intermittent operation  
respectively from the "dryfit" storage battery  
—approx. 10 hrs. ■ dimensions approximately :  
 $11" \times 8" \times 3"$  ■ weight without batteries  
approximately 6lbs.

PRICE  
**93**  
GUINEAS  
Inc. microphone  
and L.P. Tape

SEE AND  
HEAR IT  
AT OUR  
LONDON  
SHOWROOM



Ask your dealer to demonstrate or write for further information to:  
**BOSCH LIMITED, London Showroom, Domestic Appliance Division**  
**205 Gt. Portland Street, London W.1** Telephone LANgham 1809

MT5



Pick  
of the  
world's  
best

**BLUTOBA**  
FROM WESTERN GERMANY  
**ON STAND 68**  
DEMONSTRATION  
ROOM 234



MT7



## At reduced prices

**MT7** Small and handy—and easy to carry in its elegant leather case—the MT7 is a battery operated recorder with 'mains machine performance.' It operates from four U2 batteries, car battery, rechargeable battery, or A.C. mains. Special features include fast forward and rewind, quick stop push-button, recording level indicator, high performance 6" elliptical loudspeaker, Hi-Fi frequency response (100-12,000 cycles  $\pm$  3 dB) and 1 watt output. A remote control model is also available.

**MT5** A high quality, extremely versatile, battery portable, renowned the world over, the MT5 runs from eight U2 batteries, which give from 20 to 40 hours' use. There is a converter for plug-in mains or car battery, and built-in advantages include 5" spools, two speeds, 7" x 5" loudspeaker, straight-through amplification, and clock tape counter.

*These recorders are backed by ample stocks of spare parts, and a one year guarantee.*

Prices from 38 guineas to 59 guineas.

**DENHAM & MORLEY LIMITED**  
DENMORE HOUSE • 173/175 CLEVELAND STREET • LONDON • W.1 • EUSton 3656

# A NEW SPEAKER SYSTEM OF ASTONISHING PERFORMANCE



the

## JORDAN WATTS

### MODULAR SPEAKER

*THE MOST FUNDAMENTALLY CORRECT  
AND VERSATILE INSTRUMENT EVER MADE*

There is one basic loudspeaker of revolutionary design which can be used as a single loudspeaker, or in multiples to suit whatever amplifier power is required. It is in fact the smallest, or the largest, and most perfect sound reproducer in existence, built with watchmaker precision. Systems range from 12W miniature to 50W compact.

#### A TRIUMPH FOR HI-FI REPRODUCTION

The Jordan-Watts approach lends itself superbly to the problems of domestic Hi-Fi reproduction because there is no size, power, or acoustic conditions that cannot be accommodated.

\* "The Jordan-Watts 'Building Brick' principle outdates all complex Hi-Fidelity loudspeaker systems — and does so at a fraction of their size and cost."

Metal cone, unaffected by water—damp—temperature—insects. Frequency range 20 c/s to 20,000 c/s within  $\pm 6$  dB. Frequency range on axis 35 c/s to 17,000 c/s within  $\pm 3$  dB. Extremely low distortion levels. Polar response superior to any known loudspeaker. Power handling 12 watts RMS per unit (24 watts U.S.A.)

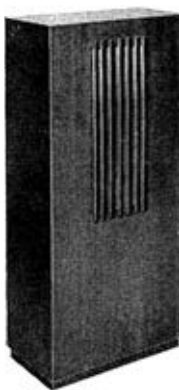

#### SPECIALLY DESIGNED CABINETS

Illustrated is the two-speaker cabinet; matching units are available for 1, 2, or 4, speakers. Enclosure designs available for larger systems.

SEE US AT BOOTH 56 AND DEMONSTRATION ROOM 420, OR SEND FOR FULLY ILLUSTRATED AND DESCRIPTIVE LEAFLETS TO:-

WORLD DISTRIBUTORS:

EDGware 5581

**BOOSEY & HAWKES (SALES) LTD., SONOROUS WORKS,  
DEANSBROOK ROAD, EDGWARE, MIDDLESEX**  
MANUFACTURERS OF THE WORLD'S FINEST MUSICAL INSTRUMENTS

# GOODMANS MAXIM MINI-SYSTEM

## True High Fidelity From The Most Compact Loudspeaker System Ever!

**Incredible?**—that a true full-range High Fidelity Loudspeaker system with a range 45-20,000 c/s can be housed in an enclosure  $10\frac{1}{2}'' \times 5\frac{1}{2}'' \times 7\frac{1}{4}''$  deep.

**See one for yourself.**

**Unbelievable?**—that up to 8 watts of power can be handled by the MAXIM with easy grace.

**Hear one for yourself.**

**Inconceivable?**—that such a tiny enclosure, so meticulously finished (in teak or walnut to order) can give full range High Fidelity and still cost you only £15. 0. 0. + P.T. £2. 10. 6.

**Buy one for yourself** (or two—the Maxim is ideal for stereo).

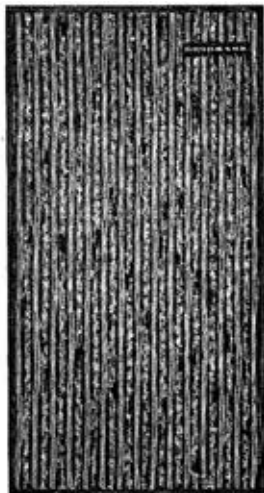

**DEMONSTRATION ROOM 347 TRADE ROOM 363**  
General enquiries and Loudspeaker Display, **STAND 31**



## GOODMANS HIGH FIDELITY MANUAL

### A Guide To Full Listening Enjoyment

The Manual is much more than a catalogue of Goodman's High Fidelity Loudspeakers—it contains informative articles, including advice on stereo, special beginners page, and full cabinet drawings. You'll find it interesting as well as informative. Ask or write for your **FREE** copy.

**GOODMANS**

**GOODMANS INDUSTRIES LIMITED**  
Axiom Works, Wembley, Middlesex.

Telephone: WEMbley 1200

A Member of the Relay Exchanges Group

# TRIPLETONE

---

# Hi-Fi PRODUCTS

“The Tripletone FM tuner represents one of the best ‘value for money’ offers on the Audio market to-day.”

*Audio and Record Review*

“If we were conducting a consumers’ service evaluation, it would be among the ‘best buys.’”

*Hi-Fi News*



TRIPLETONE  
F.M.  
TUNER

Price **£13-19-6** inc. P.T.



TRIPLETONE  
CONTROL  
PRE-AMP

Mono Pre-Amp and Power Amplifier - **£23- 3-6** complete  
Stereo Pre-Amp and Power Amplifiers - **£25-18-9** complete

For a demonstration of these and all Tripletone products go to “Hi-Fi & Components Ltd.”, Surrey’s leading Hi-Fi stockists, 7, Sutton Court Road, Sutton High Street, Sutton, Surrey.

*Other models from £6-19-6. Write for Catalogue.*

**THE TRIPLETONE MANUFACTURING Co., Ltd.**  
**241a, The Broadway, London, S.W.19**  
LIBERTY 1189

# LUXOR

## TAPE- RECORDERS

.... praised by the world's  
leading trade magazines.

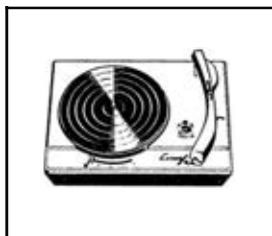

The tape recorder  
**MP 424** is a product  
that has won respect and  
admiration for the name  
Luxor in the international  
market. The finesse of design,  
outstanding quality and per-  
fect sound reproduction charac-  
teristic of these tape recorders  
are leading features of all Luxor equip-  
ment. The renowned Luxor range of  
tape recorders, record players and loud-  
speakers are on display in booth No. 30.

**LUXOR INDUSTRI AB • MOTALA • SWEDEN**

# the record retailer

and music industry news

**PUBLISHED  
THURSDAY**

(subscription  
only)



- classified releases
- top fifty
- american top fifty
- artistes on tour
- radio discs
- shopfitting
- music industry
- record reviews
- people
- technical reviews



## INTERESTED IN MONEY ?

Want the best in Tape Recorders and Hi-Fi equipment without wasting your money ? Object to paying high interest rates ? Object to paying for servicing ? Tried Howard Tape Recorders yet ?

We have the biggest sales in the U.K. Why ? Because we give you the best terms—including **No Interest Charges over 12 & 18 months** ★ 12 months free servicing ★ Special cash terms ★ Free home demonstrations in the London area ★ We specialise in mail order with free delivery anywhere in the British Isles.

*Write or 'phone us for free Brochures on all the best makes and full details of all our offers and terms :*

# HOWARD

TAPE RECORDERS · HI - FI

218 HIGH St. BROMLEY KENT. RAVensbourne 4000.





## ONLY A PILLAR BOX AWAY !

Yes, wherever you live, you are only the nearest pillar-box away from the biggest Tape Recorder and Hi-Fi Specialists in the British Isles.

*Why are we the biggest ?* Because we guarantee you the best terms you can get, that's why. They include :

- ★ FREE H.P. TERMS OVER 12 & 18 MONTHS
- ★ FREE DELIVERY ANYWHERE IN U.K.
- ★ FREE SERVICING FOR 12 MONTHS
- ★ SPECIAL CASH TERMS

. . . and lots more, besides.

Willing to risk 3d. to know whether we are lying or not? Then write or 'phone for free Brochures and full details of all our terms :

# HOWARD

TAPE RECORDERS · HI - FI

218 HIGH St. BROMLEY KENT. RAVensbourne 4000.

# you should read ...

## THE GRAMOPHONE



THE MOST UP-TO-DATE  
GRAMOPHONE JOURNAL  
IN THE WORLD

★ *Authoritative Record Reviews*

★ *Interesting and Informative  
Articles*

★ *Technical Reports*  
by PERCY WILSON and  
JOHN GILBERT

2/-

*Published on the 1st of the month*

A.B.C. average net sale figure July to December 1963, was 73,051 copies.

### ORDER FORM

"THE GRAMOPHONE", 379 KENTON ROAD, KENTON, HARROW, MIDDLESEX.

*I enclose my subscription for 30s. (or 32s. including Index) for one year,  
post paid. Subscription to the U.S.A. and Canada \$5, beginning*

with.....number                      Date.....196.....

MR., MRS., MISS.....

Address.....

*Copies of "The Gramophone" are obtainable from Newsagents,  
Railway Bookstalls and Record Dealers throughout the Country.*

**THINK**  
 “Trade Mark”  
**Scotch**  
 MAGNETIC  
 TAPES

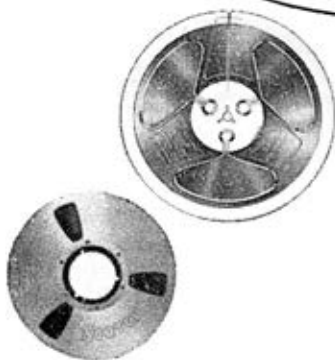

**SEE THEM ON STAND 55 AND IN ROOM 349**

- Watch the clock on Stand 55 for times of live demonstration of Video Tape in Room 349 on the 3rd floor.
- See how Video Tape works and how you look on the Television screen



**3M** MINNESOTA MINING AND MANUFACTURING COMPANY LIMITED  
 3M HOUSE, WIGMORE STREET, LONDON, W.1. TEL.: HUNTER 5522  
 3M and the word SCOTCH are trademarks of Minnesota Mining and Manufacturing Company

People  
 who do  
 find it very  
 profitable.



*be an angel*



*write*<sup>\*</sup> to us for a FREE back  
issue of RECORDS AND RECORDING—  
the only illustrated monthly magazine which  
is *absolutely devoted* to classical records  
and recording equipment

*\*or ask for a copy at our Stand number 1a, Main Hall*

# TRIO

of Japan

## HI-FI and STEREO EQUIPMENT . . . *designed for the connoisseur of fine reproduction*

BOOTH No.

**62**

DEM. ROOM No.

**121**

Model TW30. Stereo ALL-TRANSISTOR pre-main Amplifier	59 gns.
Model AD5U. AM/FM Multiplex Stereo Adaptor	19 gns.
Model F.M. 105 FM Tuner	31 gns.
Model W.E.24 Stereo pre-main Amplifier	45 gns.
Model Fx 2U FM Multiplex Stereo Tuner	49 gns.
Model WX 400U FM-AM Stereo Multiplex Receiver	99 gns.
Model AFX 3U AM-FM Multiplex Stereo Tuner	59 gns.
Model AFE 220 FM., MW., LW. Hi-Fi Tuner	39½ gns.
Model WE 8 S MW., LW., FM., Stereo Tuner Amplifier	59 gns.
Model W 41U Stereo pre-main Amplifier	55 gns.
Model W 38 Hi-Fi Tuner Amplifier	79½ gns.

*Available from all leading HI-FI dealers.*

*Sole Distributors for the U.K.*

**WINTER  
TRADING**

Head Office : 95/99, LADBROKE GROVE, LONDON, W.11



THE FOREMOST NAME IN  
**MICROPHONES**

(MONO & STEREO RIBBON, DYNAMIC)

**PORTABLE P.A. SYSTEMS**  
**RADIO MICROPHONE SYSTEMS**  
**TRANSISTOR AUDIO EQUIPMENT**  
**FLOOR AND TABLE STANDS**  
**MICROPHONE ACCESSORIES**

*See and hear the Equipment that*

**KEEPS FAITH  
WITH SOUND**

AT

**BOOTH 4 AND DEM. ROOM 220**

**LUSTRAPHONE LTD.**

ST. GEORGE'S WORKS,  
REGENTS PARK ROAD, LONDON, N.W.1

Phone : PRImrose 8844

Cables : LUSTRAPHON, LONDON

---

3

magazines  
for the  
price of  
one

**RECORDGUIDE**

reviewing all new  
classical releases

**AUDIOGUIDE**

what's new  
in equipment  
analysed  
every month inside

**records** and recording

plus features  
on the world  
of recorded music

TWO SHILLINGS MONTHLY FROM NEWSAGENTS/by post 2s. 6d. each (6 months 15s.)  
FROM THE PUBLISHERS HANSOM BOOKS 16 BUCKINGHAM PALACE ROAD LONDON SW1

*See us at Booth 1a (Main Hall), or write for free sample back issue*

---



**Every month a special FREE feature in  
AMATEUR TAPE RECORDING 2/-**

*On Sale on booth No. 34. Take out a subscription now.*

**A M A T E U R   T A P E   R E C O R D I N G**

Plant News Limited, c/o Vernon Holding & Partners,  
43/44 Shoe Lane, London, E.C.4.



# **WESTRADIO LIMITED**

24 ST. THOMAS STREET,  
BRISTOL 1

Telephone : 292525  
(3 lines)

17/21/25 PORTSWOOD ROAD,  
SOUTHAMPTON

Telephone : 55633  
(2 lines)

PRESTON PARK CLOSE,  
WESTBOURNE GROVE,  
YEOVIL

Telephone : 3553

YOUR HI-FI WHOLESALE DISTRIBUTORS FOR THE WEST

---

*OFFICIAL  
WHOLESALE  
DISTRIBUTORS*

*for*

## **GARRARD EQUIPMENT**

The world's finest record changer

---

WE SPECIALISE IN ALL LEADING MAKES OF  
TAPES, TAPE RECORDERS, AMPLIFIERS  
AND STYLI.

*HI-FI PRODUCTS :-*

DECCA • GARRARD • GOLDRING  
GOODMANS • GRAMPIAN • LEAK  
LINEAR • QUAD • RESLO • SHURE  
WHARFEDALE • W.B. • Etc.

# new exclusive hi-fi cabinets

Two new designs have now been added to Imhofs already extensive range of exclusive hi-fi cabinets, and bleached pine has been added as a new optional finish. You can see them **ONLY** at Imhofs store in New Oxford Street . . . you can buy them for shipment to anywhere in the world.

## HFU/12

This new handsome cabinet is available in either teak, elm or afrosmosia as standard but can also be supplied in a variety of other finishes to order. It will house transcription motor, tape deck, amplifier and tuner with ample storage space for over 250 records. The centre sliding door conceals the instrument panel. The cabinet is 60" wide by 20" deep and stands 30" high. Price £52.10.0 — equipment extra according to choice. See it **ONLY** at Imhofs.

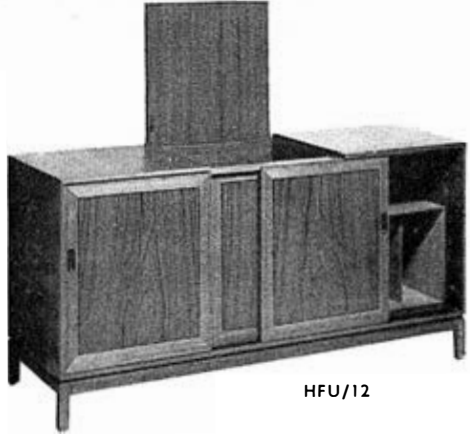

## HFU/1/L

A new enlarged version of the ever popular HFU/1. This elegant cabinet is designed to enable a tuner to be fitted alongside of a transcription motor. Available in a wide choice of finishes including walnut, mahogany and bleached pine. It is 28" wide by 19" deep and is 26" high including 9" legs. Price £23.2.0 — equipment extra according to choice. See it **ONLY** at Imhofs.

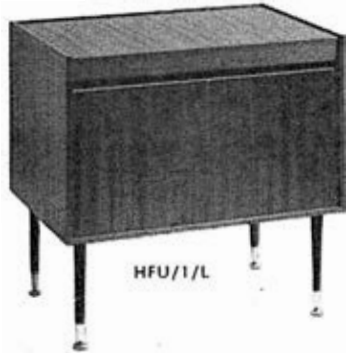

## TROLLEY TYPE L

This is the trolley that was chosen for display at the Design Centre and is shown here in the new bleached pine finish. There is plenty of space for the latest equipment. Dimensions are 24" high (including castors), 18½" deep by 35½" wide. Other standard finishes include walnut, mahogany and rosewood, all light mahogany, all dark mahogany and (at a little extra cost) teak. Price of standard model £30.10.0 — equipment extra according to choice. See it **ONLY** at Imhofs.

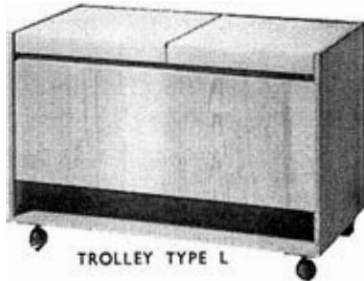

Details of many other exclusive Imhof hi-fi cabinets are shown in "This Year of Hi-Fi 1964"—send for your free copy today.

**IMHOFS**

**ALFRED IMHOF LIMITED**

Dept. AFC, 112-116 New Oxford Street,  
London, W.C.1. Telephone MUSeum 7878

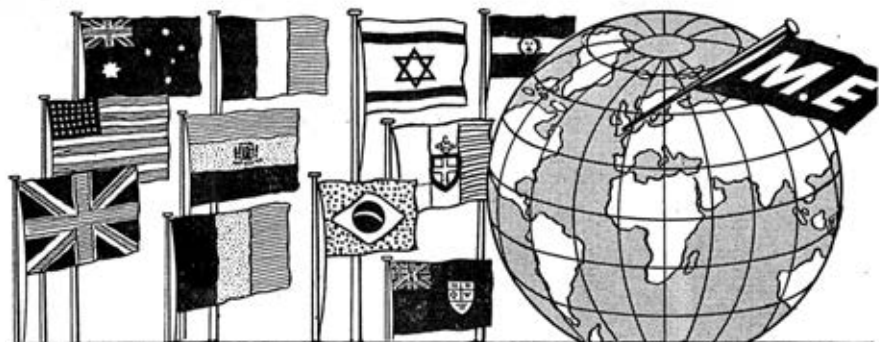

**WE SERVE THE WORLD**

Welcome to London and . . .

Bienvenu à Londres, et . . .

Willkommen in London, und . . .

Benvenuto a Londra, e . . .

Velkommen til London, og . . .

Bienvenido a Londres, y . . .

## **MODERN ELECTRICS**

**STOCKISTS OF EVERYTHING THAT MAKES HI-FI WORTH WHILE**

PERSONAL EXPORT SERVICE WITH MINIMUM OF FUSS AND FORMALITY

**MODERN ELECTRICS LTD.,**

**120 SHAFTESBURY AVENUE, LONDON, W.1**

*(Four minutes from Piccadilly Circus and opposite Columbia Cinema)*

Telephones :  
GER 9692 and TEM 7587

Cables  
MODCHAREX, LONDON

From a cartridge to a complete system!

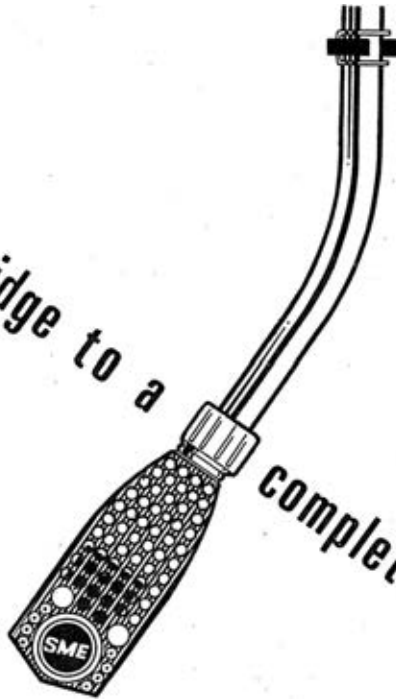

The wide selection of high fidelity equipment at Webb's Radio is supported by an exceptionally comprehensive after-sales service. Our Service Manager personally supervises all installations and you will find our sales staff thoroughly experienced and ready with informed advice if you need it. Hire Purchase Terms can easily be arranged on most equipment. Choose in comfort from an unrivalled selection of Amplifiers, Speakers, FM & AM Radio Units, Pickups and motors by leading makers.

# make a sortie on WEBB'S for all HI-FI equipment

*HOW TO GET THERE: From Tottenham Court Road Tube Station go westward along Oxford Street. Soho Street is the first on the left.*



There's always something **NEW** at **WEBB'S RADIO**

14, SOHO ST., OXFORD ST., LONDON, W.1

Telephone: GERrard 2089/7308

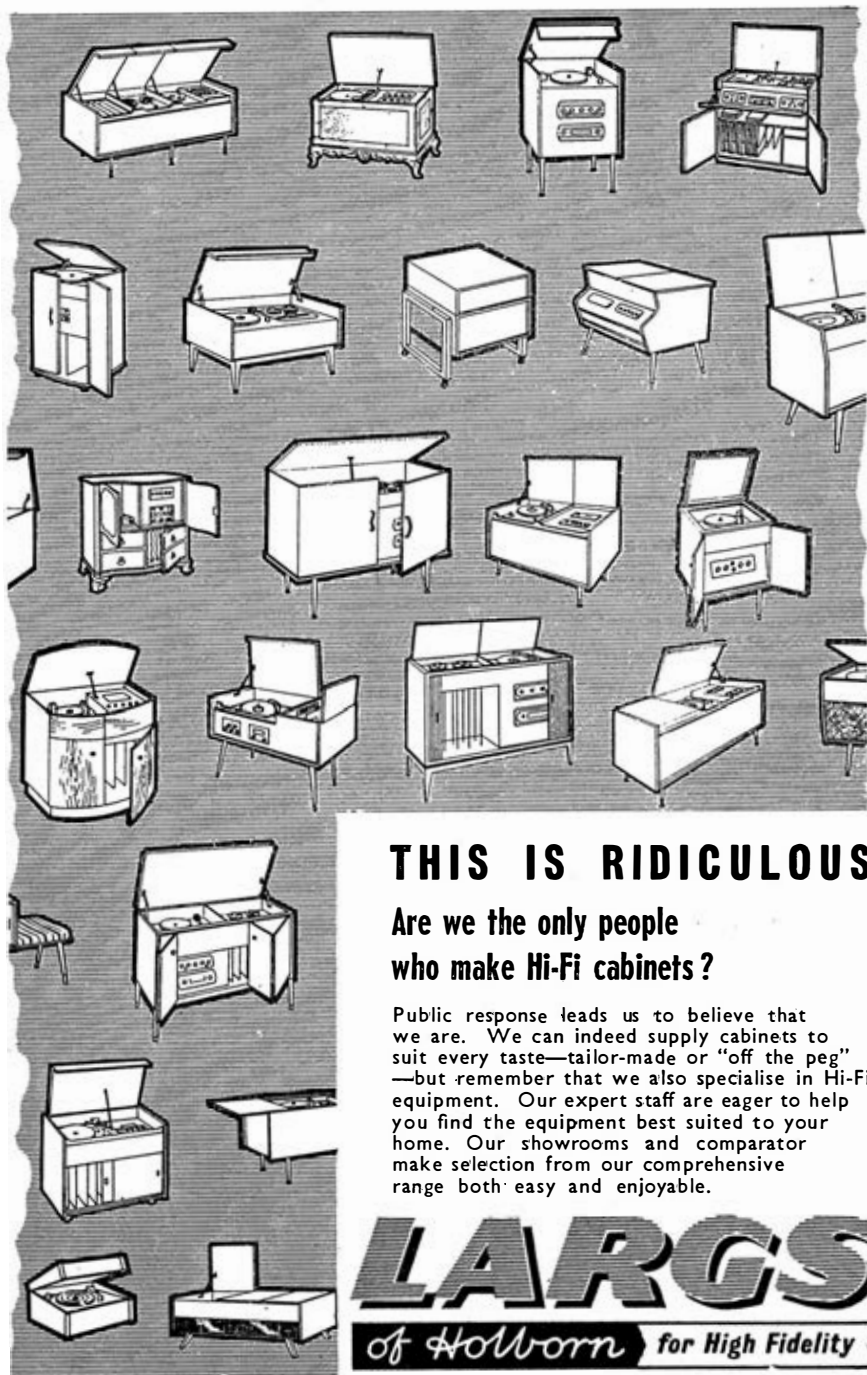

## THIS IS RIDICULOUS

Are we the only people  
who make Hi-Fi cabinets?

Public response leads us to believe that we are. We can indeed supply cabinets to suit every taste—tailor-made or “off the peg”—but remember that we also specialise in Hi-Fi equipment. Our expert staff are eager to help you find the equipment best suited to your home. Our showrooms and comparator make selection from our comprehensive range both easy and enjoyable.

# LARGS

*of Holborn* for High Fidelity

76-77 HIGH HOLBORN : LONDON : W.C.1

Telephone CHAncery 2626 (Private Branch Exchange)

# ALL PRODUCTS

ON SHOW AT THE FAIR

PLUS OUR OWN

MULLARD DESIGN EQUIPMENT

ARE AVAILABLE FROM

## ALL BRANCHES OF

# STERN-CLYNE

(Incorporating STERN RADIO LTD., PREMIER RADIO, CLYNE RADIO LTD.)

## GREAT BRITAIN'S GREATEST ELECTRONIC HOBBIES ORGANISATION

### LONDON

Your nearest branches to the Audio Fair

18, Tottenham Court Road, W.1. MUSEum 5929/0095.

23, Tottenham Court Road, W.1. MUSEum 3451/2.

Half-day Sat.

Half-day Thurs.

Other London Branches :

309, Edgware Road, W.2. PADdington 6963.

109, Fleet Street, E.C.4. FLEet St. 5812/3.

162, Holloway Road, N.7. NORth 8161/5.

9, Camberwell Church St., S.E.5. RODney 2875.

Half-day Thurs.

Half-day Sat.

Half-day Thurs.

Half-day Thurs.

### CROYDON

12, Suffolk House, George St. MUNicipal 3250.

Half-day Weds.

### BRISTOL

26, Merchant Street, Bristol 1. BRistol 20261.

Half-day Weds.

### MANCHESTER

10, Withy Grove, Manchester, 4. BLAck Friars 5379. Open 6 days a week

***NOW OPEN !***

OUR NEW TAPE RECORDER  
DEMONSTRATION SHOWROOM  
AT 23, TOTTENHAM CT. ROAD

# FRANCIS

OF STREATHAM

*invite all*

## HI-FI AND RECORDER

*enthusiasts to their*

*South London Showrooms*

FOR LARGE AND UP-TO-DATE STOCKS  
OF EQUIPMENT BY LEADING  
MANUFACTURERS AS ADVERTISED  
IN ALL LEADING JOURNALS

★ FERROGRAPH  
★ BRENNELL  
★ GRUNDIG  
★ PHILIPS  
★ SONY  
★ TELEFUNKEN  
★ VORTEXION  
★ SHURE  
★ B. & O.  
★ FI-CORD  
★ LEAK  
★ GRAMPIAN

★ QUAD  
★ SME  
★ GARRARD  
★ LENCO  
★ TANDBERG  
★ LUSTRAPHONE  
★ GOODMAN'S  
★ AKG  
★ ARMSTRONG  
★ WHARFEDALE  
★ ORTOFON  
★ THORENS

**NO CHARGES FOR  
CREDIT FACILITIES**

★  
**LARGEST SELECTION  
OF LATEST MODELS**

Personal attention  
to all enquiries  
without obligation.

*Tapes ● Pre-Recorded Tapes ● Accessories*  
*Own Service Department ● No extra for Credit*

**WRITE ★ CALL ★ 'PHONE**

*Please note our ONLY address:*

## FRANCIS OF STREATHAM

196-173 STREATHAM HIGH ROAD, LONDON, S.W.16

Between Streatham Stn. and St. Leonard's Church ★ Phone: STReatham 0466 & 0192

HIGH FIDELITY — SOUTHAMPTON

# HAMILTON ELECTRONICS

HAMPSHIRE'S SPECIALISTS IN THE  
FIELD OF TAPE RECORDERS AND  
HIGH FIDELITY SYSTEMS

---

- Visit our Southampton showrooms to obtain expert advice on selecting the most suited combination of up to date units to suit your budget.
- 

- All recommended units in stock :  
Ampex, Vortexion, Ferrograph, T/R's,  
Thorens, Garrard, Philips turntables.  
Quad, Leak, Rogers amplifiers.  
Tannoy, Leak, Goodman's L/S's  
housed in Record Housing cabinets.

**HAMILTON ELECTRONICS LTD.,**

35 LONDON ROAD • SOUTHAMPTON

*Telephone : Southampton 28622 (3 lines)*



# ALL TRANSISTOR HIGH FIDELITY EQUIPMENT VHF TUNER—MONO AND STEREO AMPLIFIERS

## ● MONO FULL FUNCTION PREAMPLIFIER/CONTROL UNIT

For use with transistor power amplifiers as below or valve amplifiers — Hum Free — High Sensitivity — 8 inputs between 1.5mV and 300mV. For all pick-ups — Microphones, Tuners — Tape Replay. Separate treble and bass with cut and boost — 4 position Low Pass Filter Volume, etc. Overall size 9 x 2½ x 2in. Battery operated (2½mA) or from power supply. Signal to noise ratio 70dB at 10 watts with power amplifier. Supplied built and ready to use. Price **£5.10.0** p.p. 2/-.

\* Dark brown and gold panel plate 8/6d.



## ● INTEGRATED FULL FUNCTION STEREO PREAMPLIFIER

(Available May/June, 1964)

Developed from above preamplifier. Provides 8 Inputs per channel. Controls are treble, bass, volume, input selector, balance, mono/stereo selector. Battery operated (6mA) or from power supply. Overall size 9 x 3½ x 1½in. deep. Supplied built and ready to use. Designed to feed two 10 watt power amplifiers. Price **£10.19.6** p.p. 3/-.

\* Dark brown and gold panel plate 15/-.

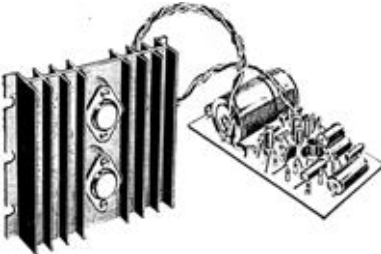

\* Power supply unit for 1 or 2 amplifiers **69/6** p.p. 2/6.

## ● 10 WATT POWER AMPLIFIERS\*

Direct coupled transformerless design. Sensitivity 100mV from 10 K ohm source for 10 watts output. Response  $\pm$  1db 40 c/s to 20 kc/s. 0.25% total distortion at 10 watts. Push-pull class B output. 60db feedback. Two versions available for 3/4 ohm and 15/16 ohm output. Battery or mains supply operation. Supplied built and ready to use.

\* 3 ohm 10 watt **£5.10.0** p.p. 2/6

\* 15 ohm 10 watt **£5.19.6** p.p. 2/6

## ● VHF FM TUNER

To build yourself. A new compact 5-transistor and 4-diode printed circuit design. Full coverage 87 to 105 mc/s. AVC and AFC. Output 30mV for 10 micro volt input. 70mV maximum. Price **£7.19.6** p.p. 2/6.

(Cabinet assembly 20/-)

**FULL DETAILS OF ABOVE  
EQUIPMENT ON REQUEST**

● New 84-page fully illustrated and detailed catalogue, 2/- post free.

**HENRY'S RADIO LTD. PADDINGTON 1008/9  
303 EDGWARE ROAD, LONDON, W.2**

---

# Hear it better at

## *University*

### **AUDIO**

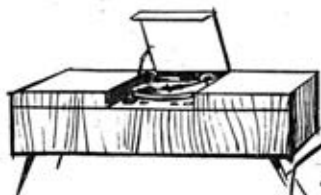

If you're on the track of any piece of hi-fi equipment you must visit University Audio, where you'll find it sooner and hear it better. Find it sooner because everybody at University Audio is a specialist, enthusiastic about hi-fi and able to find quickly the right item at the right price. Hear it better because there's a mono-stereo comparator which enables you to hear and see how any piece of equipment works. Demonstrations can be arranged for you of equipment on show at this year's Audio Festival. Don't you think it's a good idea to pay them a call?

**UNIVERSITY AUDIO** — hi-fi's second home

*University* **AUDIO**

**CAMBRIDGE — SOUTHAMPTON**

1-2, PEAS HILL

12, BARGATE STREET

# WESTWOOD'S

of

## OXFORD

FOR ALL YOUR HI-FI EQUIPMENT—  
TAPE RECORDERS AND ACCESSORIES

46 GEORGE STREET

Telephone Oxford 47783

**HORNS** believe that the purpose of high fidelity is the enjoyment of music.

**HORNS** can demonstrate effectively and discuss intelligently all that is best in the Audio World.

**HORNS** can supply, install and service your equipment with skill and expediency.

**HORNS** are the specialists in high fidelity.

**HORNS**

**SPECIALISTS IN HIGH FIDELITY  
SIX SOUTH PARADE**

Telephone **OXFORD**

**55360**

# HEAR THE EQUIPMENT ON SHOW IN THE

LONDON CENTRAL

*Why not go on from here to*

FOR THE WIDEST RANGE OF HI-FI  
AND STEREO EQUIPMENT IN EUROPE  
Alfred Imhof Ltd., 112-116 New Oxford Street, London, W.C.1  
Nearest Underground Station-Tottenham Court Road

**IMHOFS**

**EUROPE'S  
HI-FI  
CENTRE**

LONDON, E.

Leak, Quad, Rogers, etc.

S.M.E. Decca Ortofon

HI-FI is HERE in HACKNEY AMH 9591

**R.T.M. (Radio & Television) SERVICE LTD.**

387b, MARE STREET, E.8 AMH 3259

Wharfedale, Goodman, Lowther, etc. Garrard, Goldring, etc. Ferrograph,  
Brennell, Sony, Telefunken, Grundig, etc.

LONDON, N.

Disc and Tape Reproducing Equipment and Tape Recorders  
by Leading Manufacturers  
Custom Built Installations

All High Fidelity Requirements and Services Available

*Estimates Free*

*Personal Service*

**CUSTOM HIGH FIDELITY**

371 Green Lanes Palmers Green N.13 PALmers Green 5228

LONDON, N.

● NORTH LONDON'S HI-FI CENTRE

**C. C. GOODWIN**

(SALES) LTD.

**MAIL ORDER SPECIALISTS**

Goods Despatched by Return. Carriage Free (U.K.)

7 THE BROADWAY, WOOD GREEN, N.22

Telephone : BOWES PARK 0077-8

See our monthly advertisement in "Gramophone" and "Hi-Fi News" for comprehensive list of all the best

Amplifiers - Tuners  
Motors - Pick-ups  
Speakers - Cabinets  
Tape Recorders  
**CASH OR TERMS**

LONDON, N.W.

PRI 3314

**NORTHERN RADIO SERVICES**

16, KINGS COLLEGE ROAD, LONDON, N.W.3

MAIN AGENTS FOR RADFORD & SYMPHONY EQUIPMENT

Specialists in complete Stereo Outfits

LONDON, W.

**HENRY'S RADIO LTD.**

303 EDGWARE ROAD, PADDINGTON, LONDON, W.2.  
PADdington 1008 9

Open Monday to Saturday 9 a.m. to 6 p.m. Thursday 1 p.m.

# SHOPS OF THESE AUDIO DEALERS

LONDON, W.

**LASKY'S RADIO,**  
207, EDGWARE ROAD, LONDON, W.2.  
PADdington 3271/2  
33, TOTTENHAM COURT ROAD, LONDON, W.1.  
MUSeum 2605  
152/3, FLEET STREET, LONDON, E.C.4.  
FLEet Street 2533

LONDON, W.

**MASSEY'S CENTRE OF SOUND,**

121-123, HIGH ROAD, CHISWICK, W.4.

"LONDON'S LIVELIEST AUDIO CENTRE"

CHI 2082

9.30 a.m.—6.30 p.m.

LONDON, W.

Established 1910

Telephone : PADdington 5591/7595

**H. L. SMITH & CO. LTD.**

Makers of the "Cooper-Smith" High Fidelity Amplifiers

287-9, EDGWARE ROAD, LONDON, W.2

LONDON, S.W.

PRO 0985

**SHEEN TAPE RECORDER & HI-FI  
CENTRE LTD.**

8, STATION PARADE, SHEEN LANE, S.W.14  
(Opposite Mortlake Station, S.R.)

The CENTRE with the courtesy and "know how."

"THE SMALL CENTRE WITH THE BIG REPUTATION"

BIRMINGHAM

**C.H. (HI-FIDELITY) LTD.,**

HI-FI CENTRE,

167-169, BROMSGROVE STREET, BIRMINGHAM, 5.

Telephone : MID 4282

BOLTON

Telephone : 26623/4

**HARKER & HOWARTH (Music) LTD.,**

THE ARCADE and GOODWIN STREET, BOLTON

ARE EXPANDING —

- ★ New High Fidelity showrooms
- ★ New modern Recording Studios
- ★ Larger and more comprehensive stocks

FOR SOUND ADVICE CONSULT THE HOUSE OF SOUND

# HEAR THE EQUIPMENT ON SHOW IN THE

BOLTON

Phone: 23093

**H. D. KIRK**

*Stereolectrics*  
**LIMITED**

Specialists in High Fidelity

150 HIGHER BRIDGE STREET

BOLTON

BOURNEMOUTH

**BOURNEMOUTH HANTS  
NATIONAL RADIO SUPPLIES**

66-72, HOLDENHURST ROAD

Telephone: 25232

Tape and Hi-Fi

# HOWARD

**TAPE RECORDERS · HI - FI**

218 HIGH ST. BROMLEY KENT. RAVensbourne 4000.

CARDIFF

Telephone: CARDIFF 28473

**GOUGHS (J. Gough & Co. Ltd.)**

148-154, NORTH ROAD.

QUAD and LEAK Main Dealers. Largest range of High Fidelity Equipment  
in Wales. Designers of the "Jabez Gough" Loudspeaker Cabinet. .

COVENTRY

**COVENTRY & DISTRICT  
CO-OPERATIVE SOCIETY LIMITED**

High Fidelity Sound Section, Electrical Department,  
FIRST FLOOR, CENTRAL PREMISES, CORPORATION STREET,  
COVENTRY.

CRAWLEY

**KIRKMAN**

HOME DEMONSTRATIONS

EASY TERMS

40 The Broadway,  
next to Supermarket

**CRAWLEY**

# SHOPS OF THESE AUDIO DEALERS

## DERBY

THE MIDLAND'S HI-FI SPECIALISTS

### BUCKLAND'S of DERBY,

90FT. FRONTAGE! 3 FLOORS OF SOUND! RECORDING STUDIOS  
41-49, LONDON ROAD, DERBY Telephone: 48425/6/7

## FARNHAM

Telephone: 5534

### LLOYD & KEYWORTH LTD.,

26-27, DOWNING STREET, FARNHAM, SURREY

COMPLETE HI-FI STOCKISTS :: COMPARATIVE DEMONSTRATIONS

## GOODMAYES

### UNIQUE RADIO LTD.,

6, THE FACADE, HIGH ROAD,

GOODMAYES, ESSEX.

HI-FI  
&  
PUBLIC  
ADDRESS  
ENGINEERS

## HENLEY

HENLEY-ON-THAMES AND READING DISTRICT

### G. O. MOORHEN HIGH FIDELITY SPECIALIST

190, READING ROAD, HENLEY. Telephone 363

TANDBERG STOCKIST

Ferrograph, Simon, Leak, Quad, Goodman, K.E.F., Mordaunt, Wharfedale, etc.  
Cabinets and complete installations

## LEAMINGTON SPA

Telephone: LEAMINGTON SPA 24935

### TYSONS, SOUND ENGINEERS

41, RUSSELL STREET

We supply the finest Sound Producing Equipment available, plus the  
knowledge and experience gained in more than 30 years work in  
Audio Engineering.

## LEATHERHEAD

Telephone: 2214

RADIO HOUSE, THE CRESCENT, LEATHERHEAD, SURREY

### MAURICE RICHARDS LTD.

THE MID-SURREY "HI-FI" AND "STEREO" SPECIALISTS

Comparator Demonstrations at any time by Appointment using

Quad : Leak : Armstrong : T.S.L. : Tandberg : Tannoy  
Dynatron : Lorenz : Wharfedale : H.M.V.

and other makes of equipment

# HEAR THE EQUIPMENT ON SHOW IN THE

## LEICESTER

### LEICESTER CO-OPERATIVE SOCIETY LTD.

ALL YOUR HI-FI REQUIREMENTS

Speakers: Quad, Tannoy, Rogers, Kef, Goodmans, Wharfedale, Kelly  
Amplifiers: Quad, Leak, Rogers, Armstrong, Kerr McCosh, Dulci, Radford

RECORDS

ALL LABELS

PARASTAT SERVICE

## LIVERPOOL

### LAMBDA RECORD COMPANY LTD.

LIVERPOOL'S SPECIALIST SUPPLIER

95 LIVERPOOL RD., LIVERPOOL 23

PHONE: GRE 4012

## LOUGHTON

### SOUND SUPPLIES (LOUGHTON) CO. LTD.

42, SMARTS LANE, LOUGHTON, ESSEX

Telephone: LOU 1133

ROGERS AMPLIFIERS, TUNERS, SPEAKERS, ETC.

## MAIDENHEAD

TELEPHONE 25630

### GREVILLES of 7 HIGH ST., MAIDENHEAD

*Tape Recorders and Sound Equipment Specialists. Professional Disc and Tape Recording  
Facilities—Mobile Recording Unit—Tape to Disc Service.*

## MANCHESTER

STOCKISTS OF ALL THE STEREO EQUIPMENT WHICH YOU HAVE  
SEEN AND HEARD AT THIS FESTIVAL.

Tape Recorders by Ferrograph, Revox, etc.

### LANCASHIRE HI-FIDELITY LTD., 8, DEANSGATE, MANCHESTER, 3.

## MANCHESTER

MANCHESTER'S LEADING AUDIO DEALER

### RARE RECORDS LTD.,

5-7, BARTON SQUARE (off St. Ann's Square), MANCHESTER, 2.

Telephone: DEA 2265

Daily 9.30—6 p.m. Sat. 9—5.30 p.m.

Early closing Mon. 1.30 p.m.

Late closing Thurs. 7 p.m.



# SHOPS OF THESE AUDIO DEALERS

OXFORD

## WESTWOOD'S

of  
**OXFORD**

46, GEORGE STREET

TELEPHONE : 47783

SALISBURY

SOUTHAMPTON — SALISBURY

Everything connected with Hi-Fi and Records

### J. F. SUTTON

THE HI-FI CENTRES IN THE SOUTH

SOUTHAMPTON

## HAMILTON ELECTRONICS

HIGH FIDELITY AND  
TAPE RECORDER  
SPECIALISTS

TEL. 28622

35 LONDON ROAD

### SOUTHAMPTON

STOURBRIDGE

Tel : 5339

## E. J. BENTON LIMITED

A comprehensive range of hi-fi equipment  
always in stock.

TUNBRIDGE WELLS

Telephone : 30151/2

## GOULDEN AND CURRY LTD.

HI-FI TAPE RECORDERS :: RECORDS

59-61, HIGH STREET

### TUNBRIDGE WELLS

WOLVERHAMPTON

26, CHAPEL ASH, WOLVERHAMPTON

*The Hi-Fi rendezvous of the West Midlands*

All leading makes of High Fidelity and Tape equipment stocked.

## WARNERS AUDIO

Telephone: WOLVERHAMPTON 26581

**WORTHING**  
THE FINEST HI-FI SERVICE IN SUSSEX . . . AND A GOOD DEAL  
FURTHER AFIELD

**BOWERS  WILKINS**

1, BECKET BUILDINGS, LITTLEHAMPTON ROAD  
WORTHING 5142

**WORTHING**



**J. W. MANSFIELD LTD.**  
8—12, LIVERPOOL ROAD, WORTHING

— All leading makes of Audio Equipment stocked —  
Specialists in Custom-built Hi-Fi Installations

Telephone : 305

Telephone : 3229

## INDEX OF ADVERTISERS

	Page		Page
Acoustical Manufacturing Co. Ltd.	1	Lustraphone Ltd.	168
Agfa Ltd.	41	Luxor Industri A.B.	160
Akustische u. Kino-Gerate GMBH	22 & 23	Metro-Sound Manufacturing Ltd.	154
Richard Allan Radio Ltd.	145	Metro-Sound (Sales) Ltd.	14 & 15
Amateur Tape Recording Magazine	170	Minnesota Mining and Manufacturing Co. Ltd.	165
Ampex (Great Britain) Ltd.	40	Modern Electrics Ltd.	173
Armstrong Audio Ltd.	42	M.S.S. Recording Co. Ltd.	24 & 25
B.A.S.F. Chemicals Ltd.	26 & 27	Mullard Ltd.	19
Boosey & Hawkes (Sales) Ltd.	157	Philips Electrical Ltd.	32
Bosch Ltd.	155	Pye Ltd.	45
Brenell Engineering Co. Ltd.	5	Radford Electronics Ltd.	35
S. G. Brown Ltd.	28 & 29	Record Retailer & Music Industry News	161
B.S.R. Ltd.	151	Rogers Developments Ltd.	18
Celso Electric Co.	149	Rola Celestion Ltd.	10 & 11
Denham & Morley Ltd.	156	Sherwood Electronic Laboratories Inc.	39
Derritron Ultrasonics Ltd.	4	Shure Electronics Ltd.	I. Back Cover
Elcom Ltd.	34	S.M.E. Ltd.	2 & 3
Electroimpex	150	Standard Telephones & Cables Ltd.	20
Ferrograph Co. Ltd.	I. Front Cover	Stern-Clyne	176
Francis of Streatham	177	A. R. Sugden & Co.	43
Garrard Engineering Co. Ltd.	30 & 31	Tannoy Products Ltd.	12 & 13
Gevaert Ltd.	21	Tellux Ltd.	36 & 37
Goldring Manufacturing Co. Ltd.	6 & 7	Tripletone Manufacturing Co. Ltd.	159
Goodmans Industries Ltd.	158	Truvox Ltd.	38
The Gramophone	164	University Audio	180
Hamilton Electronics (Southampton) Ltd.	178	Vitavox Ltd.	146
Hansom Books Ltd.	166 & 169	Vortexion Ltd.	152
Henry's Radio Ltd.	179	Webbs Radio Ltd.	174
Horns of Oxford	181	Welmecc Corporation Ltd.	8
Howard Tape Records	162 & 163	Westradio Ltd.	171
Imhofs (Retail) Ltd.	172	Westwood's of Oxford	181
K.E.F. Electronics Ltd.	33	Wharfedale Wireless Works Ltd.	9
Kodak Ltd.	16	Whiteley Electrical Radio Co. Ltd.	153
Lansing Rolls	147	Winter Trading Co. Ltd.	167
Largs of Holborn	175	Zonal Film Ltd.	17
H. J. Leak & Co. Ltd.	148		
Lowther Manufacturing Co. Ltd.	44		

# Connoisseurs of audio equipment eagerly acclaim Shure components



Studio Stereo Dynetic Pickup

Shure audio components and microphones are world acclaimed for sound reproduction and re-creation of the very highest order. They are made only for the discriminating listener with the experienced ear to appreciate their true quality. If you seek nothing but the finest in audio equipment, you will want to write at once for the current Shure catalogue of pick-ups, cartridges or microphones.



Model 545  
Unidyne III

**See us on Stand 48**

**SHURE**

**SETTING THE WORLD'S STANDARD IN SOUND**

SHURE ELECTRONICS LTD.

84 BLACKFRIARS ROAD · LONDON SE1 · Telephone: WATERloo 6361



**HOTEL RUSSELL WC1**