

HOW TO BUILD YOUR OWN
RADIO

and

HI-FI

SETS

By William R. Wellman

Published by

POPULAR SCIENCE PUBLISHING CO., INC.
353 Fourth Avenue • New York 10, N. Y.

Copyright MCMLIV, by
POPULAR SCIENCE PUBLISHING CO., INC.

All Rights Reserved

Printed in the United States of America

INTRODUCTION

WELCOME TO the world of tubes, circuits and frequencies. Whether you are an expert or are just tuning in on this hobby, you will find the complete, step-by-step instructions and diagrams in this book practicable, easy to follow, and, if you wish, profitable.

The basic aim of this book is to give you a variety of projects you can begin to build immediately. These include different kinds of radio receivers, amplifiers, intercommunicators, high fidelity components, test equipment and a frequency modulation tuner.

The difference in the amount of "know-how" between the expert and the beginner has been taken into account in the organization of this book. All the projects are designed to be interesting and worthwhile, but are presented in order of increasing difficulty. A one-tube receiver with a crystal diode detector comes first. Even the experienced constructor should have fun with this. If you're just getting started in this hobby, the one-tube receiver is an ideal project to start with. And you can easily move from it to the three-tube set that follows, then to the five-tube superhet and the six-tube.

If you take the projects in order through the book, you can progress from a novice to a practical, experienced constructor, ready to start off on your own. The author has spent years telling how to do just that.

Another principle of organization used here is to break the over-all circuit down into stages, then complete and test each stage before going on to the next one. Experience shows this method is simple, quick, and as fool proof as can be. Wrong connections, for instance, are practically eliminated. The test of each stage tells you if you made a mistake before locating it becomes a complicated and time-consuming task.

The general scheme for each project goes like this:

Description of over-all circuit

List of parts

Chassis layout and assembly

Wiring and testing of individual circuits

Unless you can really claim to be an expert without boasting, read Chapter 3 before you start to work on any of the sets. The hints and tips given there will save you time, money and headaches. It tells you, among other things, how far you can go in substituting a slightly different part for the precise one called for, when you can rearrange the components of a set, how to overcome oscillation, special information about volume control, wiring, resistors, and so on.

There is also a trouble-shooting chart at the end of Chapter 1 that you will find useful if things don't go as planned. However, you will have little trouble if you read the text and diagrams carefully and in order.

Before you get very far, you're going to need test equipment. A minimum amount of equipment is essential for testing the circuits, aligning the set,

measuring capacitance, determining resistances, and so on. Chapter 7 tells you how to build the basic tools. They will be as good as the less highly priced items you can buy at the supply houses.

Beginners and advanced constructors alike can have concert quality music in their living rooms with high fidelity systems built as directed in Chapter 5. Instructions for hi-fi components that one can build, such as amplifiers and speaker enclosures, are simple and complete. Tips are offered on selecting the components that must be bought, such as speakers and record players, according to the thickness of the wallet.

This book has been prepared with the thought in mind that you may want to tear down one project after you have built it and use the parts for a different one. A special parts section at the end tips you off to wise shopping at the parts stores and suggests how you may find many components you may need right in your own scrap box.

Contents

1. THREE EASY-TO-BUILD RADIO RECEIVERS...	11
One-Tube Receiver Using a Crystal Diode Detector	12
Circuit description	12
Parts list	13
Chassis layout and assembly	14
Wiring	18
Testing	18
Two-Tube Receiver Using Miniature Tubes	18
Circuit description	18
Parts list	19
Layout and assembly.....	20
Wiring	21
Testing	21
Three-Tube TRF Receiver Using Selenium Rectifier	22
Circuit description	23
Parts list	24
Chassis layout and assembly	24
Wiring	27
How to wire the heater circuit	27
How to wire the power supply circuit	28
How to wire the power output circuit	29
How to wire the detector circuit	30
How to wire the r.f. circuit	31
Trouble-shooting chart	33
2. TWO ADVANCED RECEIVERS WITH PHONOGRAPH COMBINATION.....	35
Five-Tube AC/DC Superheterodyne	35
Circuit description	35
Parts list	36
Chassis layout and assembly	38
Assembly	41
Wiring	42
How to wire the heater circuit	43
How to test the heater circuit	44
How to wire the power supply circuit	44
How to test the power supply circuit	45
How to wire the power output circuit	46
How to test the power output circuit	46
How to wire the first audio circuit	47
How to test the first audio circuit	48

CONTENTS

2. TWO ADVANCED RECEIVERS WITH PHONOGRAPH COMBINATION (Cont.)	
How to test the diode detector-AVC circuit	49
How to wire the i.f. amplifier circuit	50
How to test the i.f. amplifier circuit	50
How to wire the mixer circuit	51
How to test the mixer circuit	52
How to wire the oscillator circuit	52
How to test the oscillator and mixer circuits	53
Adding phono input	54
Selenium rectifier conversion	55
Automatic volume control	56
Six-Tube AC-Operated Receiver	57
Circuit description	57
Parts list	59
Layout, drilling, and assembly	62
Wiring	66
Alignment	69
3. TIPS, TRICKS AND SHORTCUTS FOR CONSTRUCTORS	71
Parts Substitutions	71
Resistors	71
Condensers	72
Coils	75
Arrangement of Components	76
Location of Power Supply	77
How to Prevent and Overcome Oscillation	78
Grid and plate lead interaction	78
Coil interaction	80
Screen bypass condenser	80
Unshielded glass tubes	81
Condenser contact	81
Chassis Construction	82
Wiring	85
Volume Control Tips	86
Line Ballast Resistors	88
Flat and tubular resistors	89
Resistor line cords	89
Determining line resistor value	89
Ballast tubes	91
Replacing a ballast tube	92
Pilot Lamps	93
4. HOW TO BUILD AMPLIFIERS AND INTERCOMMUNICATORS	95
Amplifier differences	95
Compact One-Tube Phono Amplifier	96

CONTENTS

4. HOW TO BUILD AMPLIFIERS AND INTERCOMMUNICATORS (Cont.)	
Circuit description	96
Parts list	96
Layout and assembly	97
Wiring	99
Final test	99
Phonograph Oscillator	99
Circuit description	100
Parts list	100
Layout and assembly	101
Wiring	102
Testing	103
Installing the Phono Oscillator in a Table-Model Record Player	103
Assembling a Record Player	105
The motor	105
The pickup	105
Stylus and stylus pressure.....	106
Constructing the cabinet	107
Assembly	108
Installing an Amplifier in a Record Player	110
The speaker opening	110
Three-Tube AC/DC Amplifier	111
Circuit description	111
Parts list	112
Layout and assembly	112
Wiring	113
Wiring the power supply	114
Wiring the output circuit	115
Voltage amplifier circuit	115
Five-Tube AC Amplifier	116
Circuit description	116
Parts list	116
Assembly	119
Wiring	119
Preamplifier for Variable Reluctance Pickup	120
Parts list	121
Assembly	121
Baby Tender: a One-Way Intercommunicator	122
Construction	123
Parts list	124
Assembly	124
Talk-listen switch; multiple stations	124
5. HOW TO BUILD HIGH FIDELITY SYSTEMS.....	127
What is hi fi?	127
Limitations of the units	127
The heart of the system	128

CONTENTS

5. HOW TO BUILD HIGH FIDELITY SYSTEMS (Cont.)

Five-Tube Amplifier	130
Parts list	130
Chassis layout and assembly	133
Wiring	135
Testing	138
Speakers for High Fidelity Systems	139
How to Build a Bass Reflex Speaker Enclosure	142
Construction of the cabinet	143
Calculating the area of the port	145
High Fidelity Amplifier with Bass and Treble Controls	146
Circuit description	146
Parts list	147
Layout and assembly	150
Wiring	151
Testing	154
Record Players for High Fidelity Work	155
Eliminating hum	155
Eliminating variations in speed	156
Pickup arms	157
Stylus pressure	157
Shock-proof mounting	158

6. HOW TO BUILD A FREQUENCY MODULATION TUNER.....

A Six-Tube Tuner	160
Coil construction	160
Parts list	163
Layout and assembly	164
Wiring and testing	166
Heater and power supply circuits	166
Ratio detector circuit	167
Second i.f. amplifier circuit	167
First i.f. amplifier circuit	168
Mixer circuit	168
R. F. amplifier circuit	170
Oscillator circuit	170
FM tuner alignment	171
How to Make Your Own FM Antenna	172

7. HOW TO BUILD YOUR OWN TEST EQUIPMENT.....

DC Milliammeter	175
DC Voltmeter	177
Converting a milliammeter into a voltmeter	178
Determining meter resistance	179

CONTENTS

7. HOW TO BUILD YOUR OWN TEST EQUIPMENT (Cont.)

Ohmmeter	180
Converting a milliammeter into an ohmmeter	181
Shunting the meter	182
AC Voltmeter	183
Combined Volt-Ohm-Milliammeter	183
Parts list	184
The volt-reading circuits	185
The resistance-reading circuits	186
Signal Generator	187
Two methods of isolating trouble	187
Checking the set	188
Parts list	190
Assembly and calibration	190
Condenser Checkers	191
Measuring capacitance	192
Parts list	194
Layout and assembly	195
Power transformer	196
Rewinding a transformer	197
The turns-per-volt ratio	197
Replacing the laminations	199
Visual Alignment Indicator	199
Aligning a set	200

8. BATTERY-TYPE RECEIVERS—PORTABLE, SHORT-WAVE, AUTOMOBILE.....203

Battery-Operated Portable Receiver	203
Circuit description	204
Parts list	206
Layout and assembly	207
Wiring	209
Alignment	214
Battery-Operated Short-Wave Receiver	215
Coil construction	217
Coil-winding table	218
Parts list	220
Layout and assembly	220
Wiring	221
Six-Tube Automobile Radio	225
Circuit description	225
Parts list	229
Layout and assembly	230
Wiring	231
Alignment	237
Ignition interference	237

INDEX	251
-------------	-----



Bedside

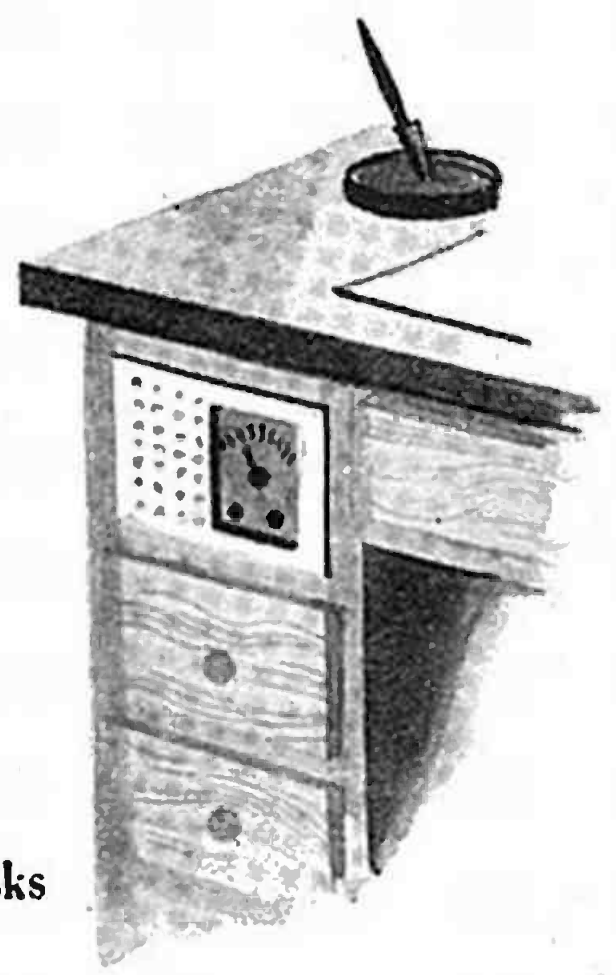

Desks

Home-Built Sets Fit In Wherever You Choose

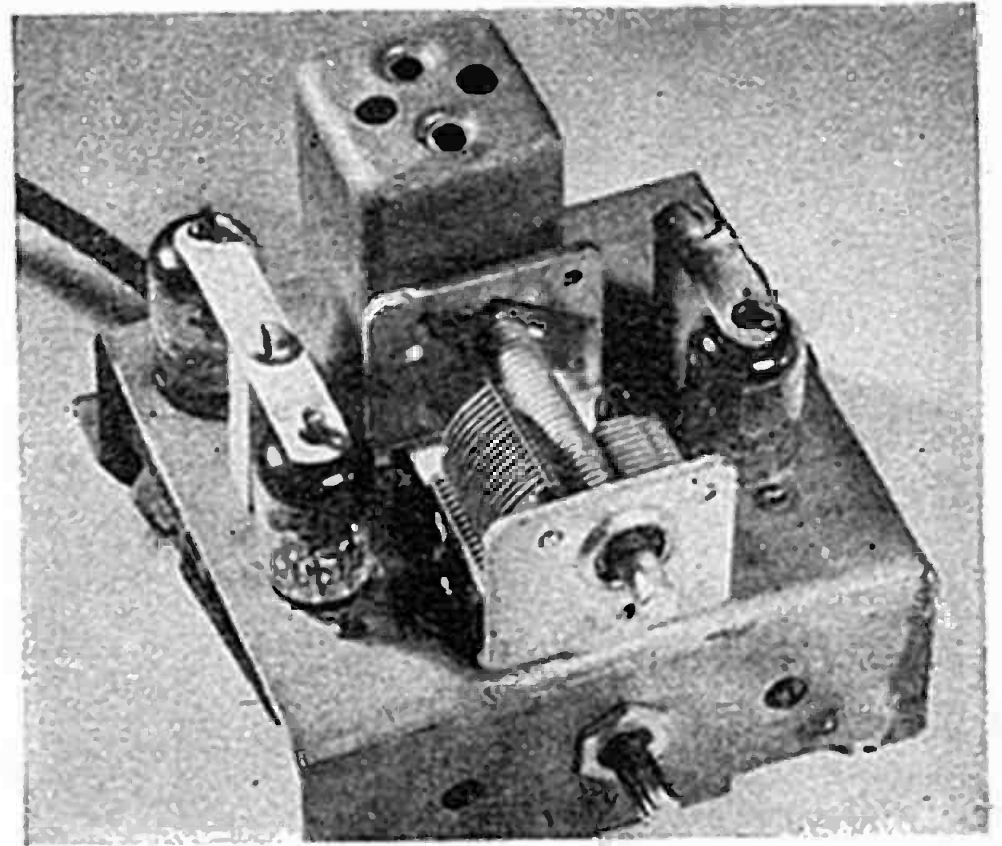

A Three-Tube Receiver

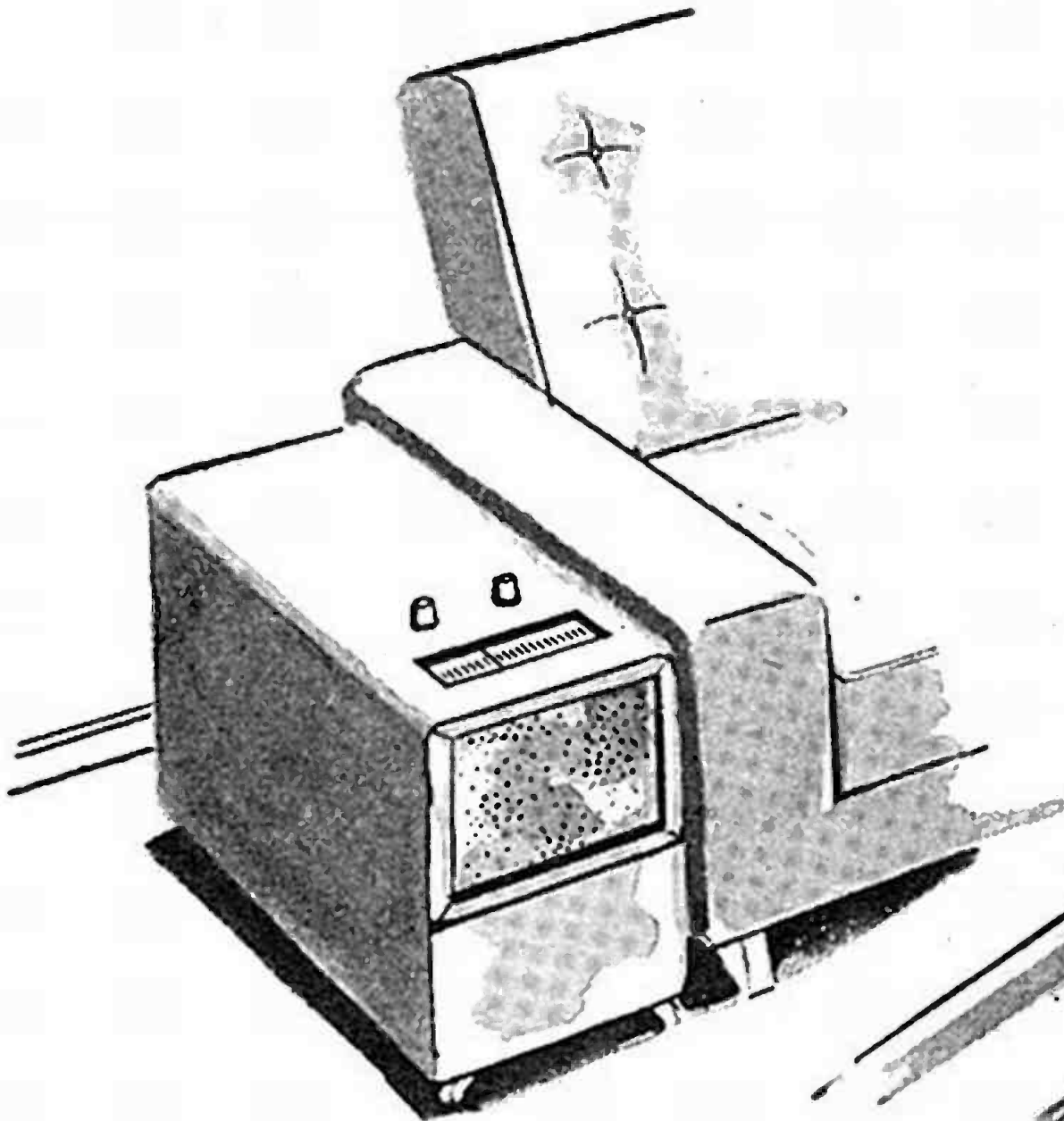

Chair Units

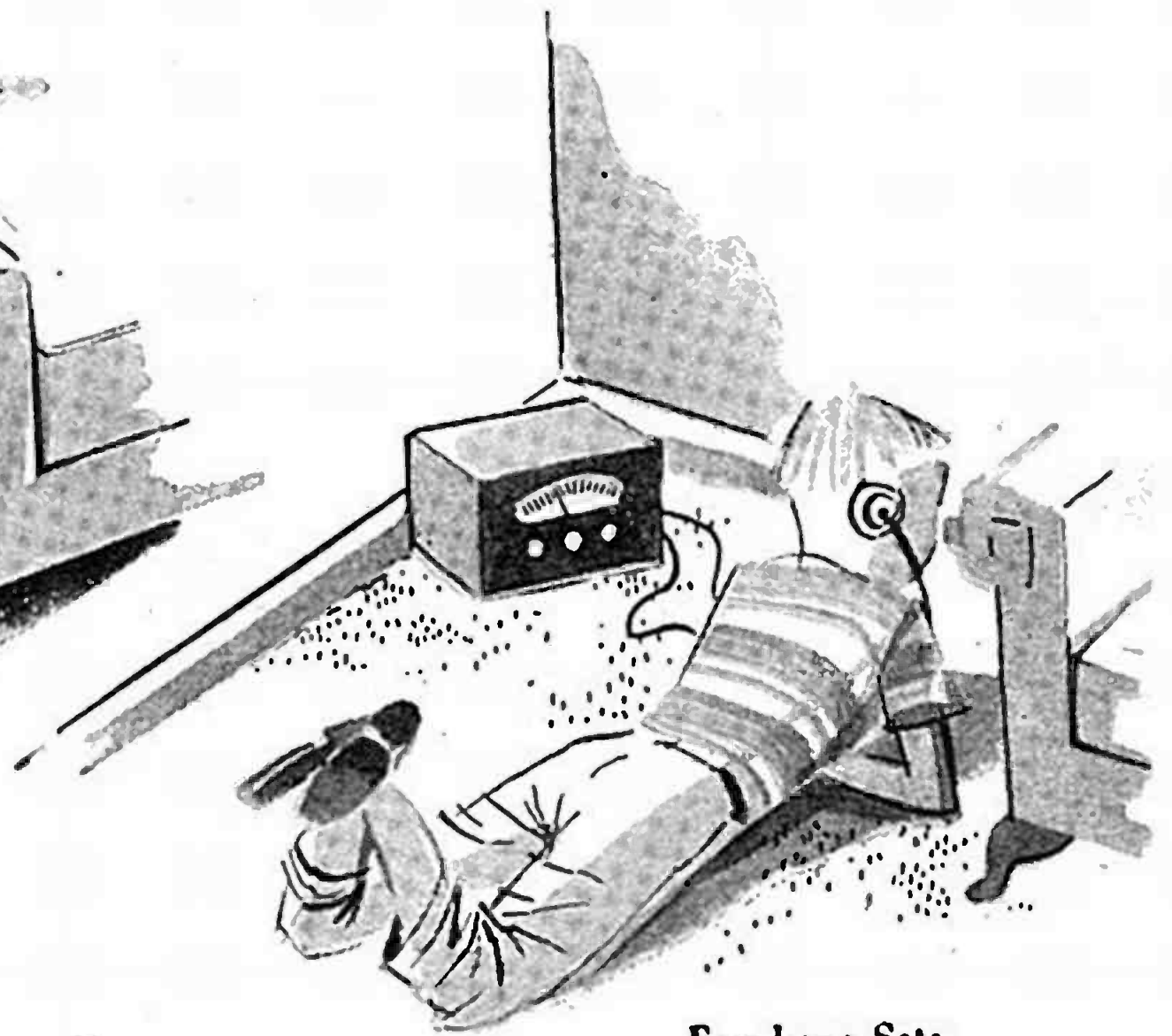

Earphone Sets

Three Easy-to-Build Radio Receivers

IN THE first two chapters we tell you how to build several home radio receivers, ranging from a one tube, ac/dc set to a fairly elaborate project using six tubes and equipped with phonograph input and push-pull output stage.

These projects are explained in the order of their difficulty; in each one a new circuit, device, or principle of construction appears. You can build these sets for fun, experience, or profit, as you like. Even a beginner will find plenty of basic radio information presented in a non-technical manner. More advanced technicians may want to go right to the second or third set. But everyone should read Chapter 3 for its time- and trouble-saving hints on construction, substitution of parts, and other professional practices.

You will find that the description of each project is accompanied by a parts list, and often you will notice that some of the parts specified for use in a particular project are the same as those used in other, earlier projects. This is not an oversight. These sets have been arranged in this way so that, if you wish, you can reuse the parts of one in building the others.

As the projects become more difficult, the descriptions are, of course, longer and more detailed. Unless you

have had a great deal of experience, you will do better to read all the descriptive material carefully. Often this will actually save you time and prevent costly errors.

You will notice that tuning dials are not included in the lists of parts. These items have not yet reached the degree of standardization found in such other radio components as resistors and condensers. And it would be impossible to take into account the wide variety of types available and all individual preferences. However, this will not cause you any difficulty. The installation of a dial of your choice is a simple matter. Complete assemblies, consisting of drive shaft, cord or cable, pulleys, pointer, and scale are available from all large radio-parts distributors. Usually, such assemblies can be fitted to a standard tuning condenser shaft in a matter of minutes because only two or three screws are needed to fasten the dial assembly to the chassis.

Instructions on cabinets for housing your sets are also fairly brief in this book because the man who builds his own set, if he plans to put it in a cabinet, has a specific purpose and a previously selected cabinet in mind and builds the set to fit. This usually happens when the set is to be part of a high fidelity system.

ONE-TUBE RECEIVER USING A CRYSTAL DIODE DETECTOR

For many years, crystal sets enjoyed immense popularity among constructors and students because of their simplicity of construction. The old-time crystal detector, however, had many disadvantages. The chief objection was that it was rather difficult to keep in adjustment. Furthermore, individual specimens of the crystalline material used varied greatly in sensitivity. Recently, the germanium crystal diode has demonstrated its ruggedness and its uniform sensitivity to such a wide degree that it has been accepted as a detector in television receivers, as a rectifier in measuring instruments, and in crystal diode probes for use with electronic measuring devices. Now it seems that the crystal detector has taken a new lease on life.

The receiver described first uses the crystal diode as a detector, and under good reception conditions (especially in metropolitan areas near powerful broadcast stations) fair loud-speaker volume may be expected. Of course, a good antenna is nec-

essary; use an outside antenna if possible. And, as with most crystal sets, a good ground connection is imperative. Nowadays we have become so accustomed to using receivers that operate from a loop antenna that it may be necessary to remind you that a cold water pipe makes an excellent ground connection.

Circuit description

See Figure 1-1 for diagram.

Signals appearing across the tuned circuit consisting of L1 and C1 are applied to the germanium diode, where they are rectified. R.F. impulses are removed by the bypass condenser C2, and the remaining audio signals are then fed to the control grid (pin 4) of the 117L7 tube.

The 117L7 tube consists of two sets of electrodes in one envelope, and, like many other tubes in this category, it can be used in a variety of unusual ways. In this set the diode section of the tube supplies plate and screen voltages for the set, while the remaining electrodes function as a

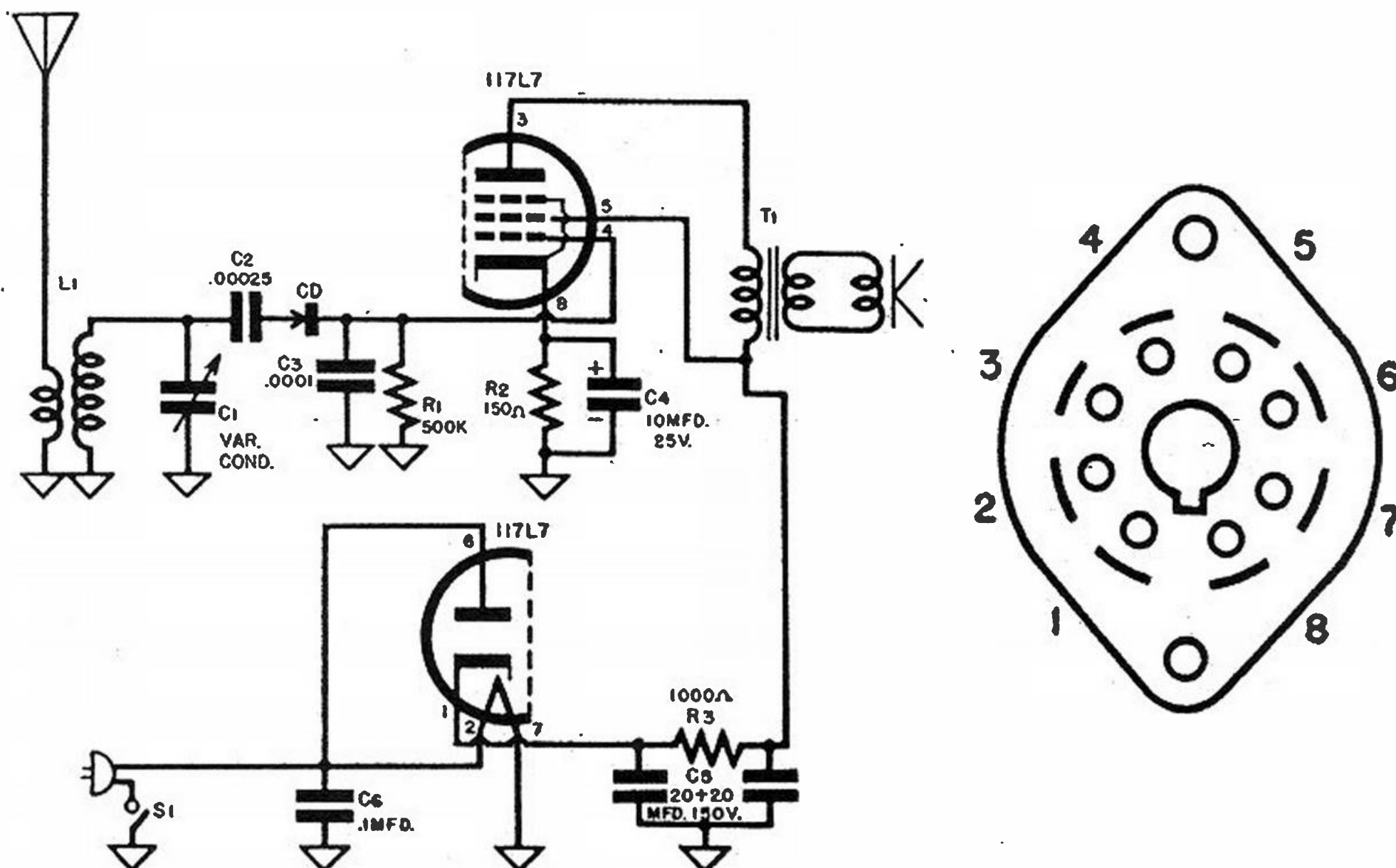

Fig. 1-1. Circuit of one-tube receiver and bottom view of 117L7 socket.

power output amplifier.

Because the tube is designed to operate at a heater voltage of 117, it can be connected directly to the power line; no line ballast resistor is needed. Although a 4-inch speaker is specified in the list of parts, any other size may be substituted, but if a larger diameter is used it cannot be

graphs intended for children's use employ a circuit similar to the amplifier circuit shown here. Be sure that the inner wire of the phono pickup cable is connected to the grid of the tube and the shield is connected to chassis.

Some readers may, perhaps, wonder why condenser C3 has been in-

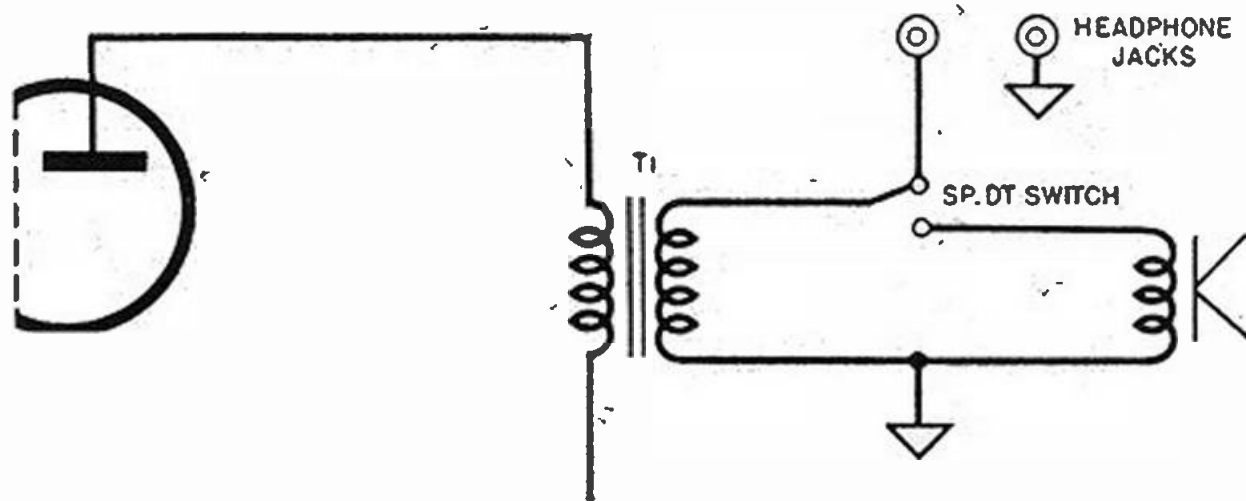

Fig. 1-2. Connecting headphones to one-tube set.

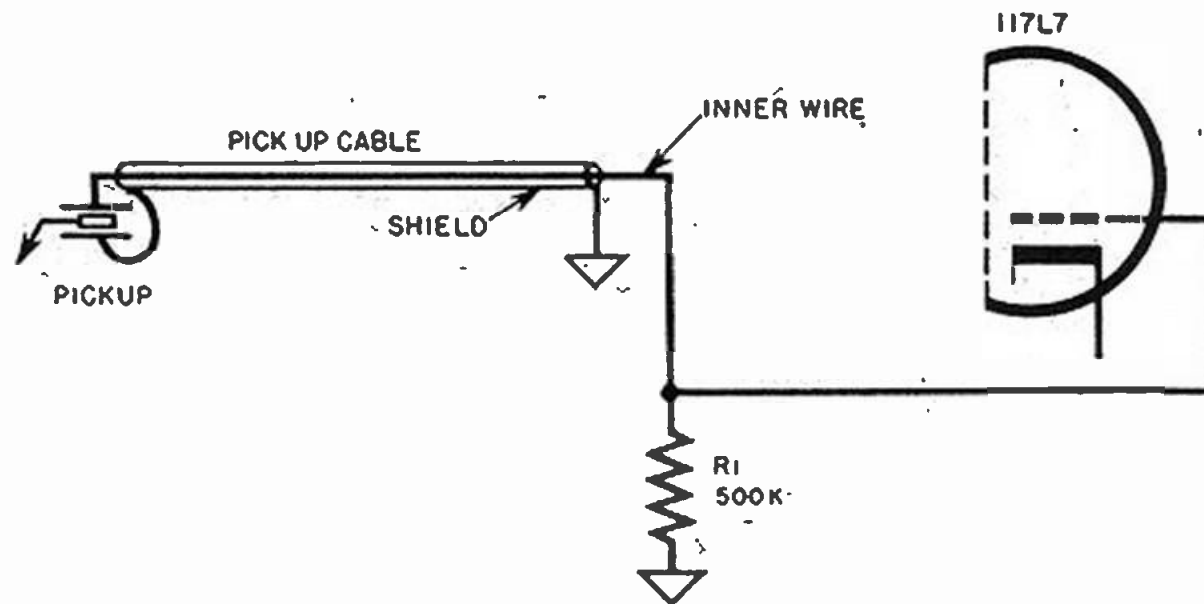

Fig. 1-3. Connecting phonograph pickup leads to set.

mounted directly on the chassis. In any event, if you do make a substitution, be sure that the speaker voice-coil impedance matches that of the output transformer secondary.

With very little additional trouble you can adapt this set for headphone listening under conditions where a speaker might disturb other people. Figure 1-2 shows how to add a single-pole double-throw switch and a pair of pin jacks for headphone listening. Only one of the jacks need be insulated from the chassis; the other one is connected to it.

Another interesting feature is that the set may be used as a phonograph amplifier by connecting the phonograph pickup leads as shown in Figure 1-3. In fact many small phono-

graphs intended for children's use employ a circuit similar to the amplifier circuit shown here. Be sure that the inner wire of the phono pickup cable is connected to the grid of the tube and the shield is connected to chassis.

Some readers may, perhaps, wonder why condenser C3 has been included in the circuit. Careful observation has shown that many germanium diodes have been damaged as a result of incorrect connections that permit considerable amounts of current to flow in the diode circuit. C3 has been used here as a protective measure but may be omitted if you feel certain that no such accident will occur.

Parts list

<i>Resistors</i>	
R1	470K ohms, 1/2-watt carbon
R2	150 ohms, 1/2-watt carbon
R3	47 ohms, 1-watt carbon
R4	1,000 ohms, 1-watt carbon

<i>Condensers</i>	
C1	Midget TRF single gang vari-

- ble, .000365 mfd.
 C2 100 mmfd., mica
 C3 250 mmfd., mica
 C4 25 mfd., .25-volt electrolytic
 C5 40-40 mfd., 150-volt electrolytic
 C6 .1 mfd., 400-volt paper tubular

Coils

- L1 Adjustable iron-core antenna coil, Stanwyck S-409 or equivalent

Transformers

- T1 Output transformer Stancor A-3877, Merit A-2930

Switch

- S1 Single-pole single-throw, rotary; Hart & Hegeman 1561-BS or equivalent

aluminum. (For home-made chassis, sheet aluminum, 20 gauge, 6 x 6-3/4 inches.)

Tube

117L7

Chassis layout and assembly

If you intend to use a ready-made chassis, you may go ahead with the layout, drilling, and assembly. Otherwise, make up the chassis from sheet metal as described in Chapter 3. Figure 1-4 shows the locations of all major parts that are mounted on top of the chassis, while Figure 1-5 is an underside view of the chassis. Exact measurements cannot be given, since parts made by different manufacturers do not always use the same mount-

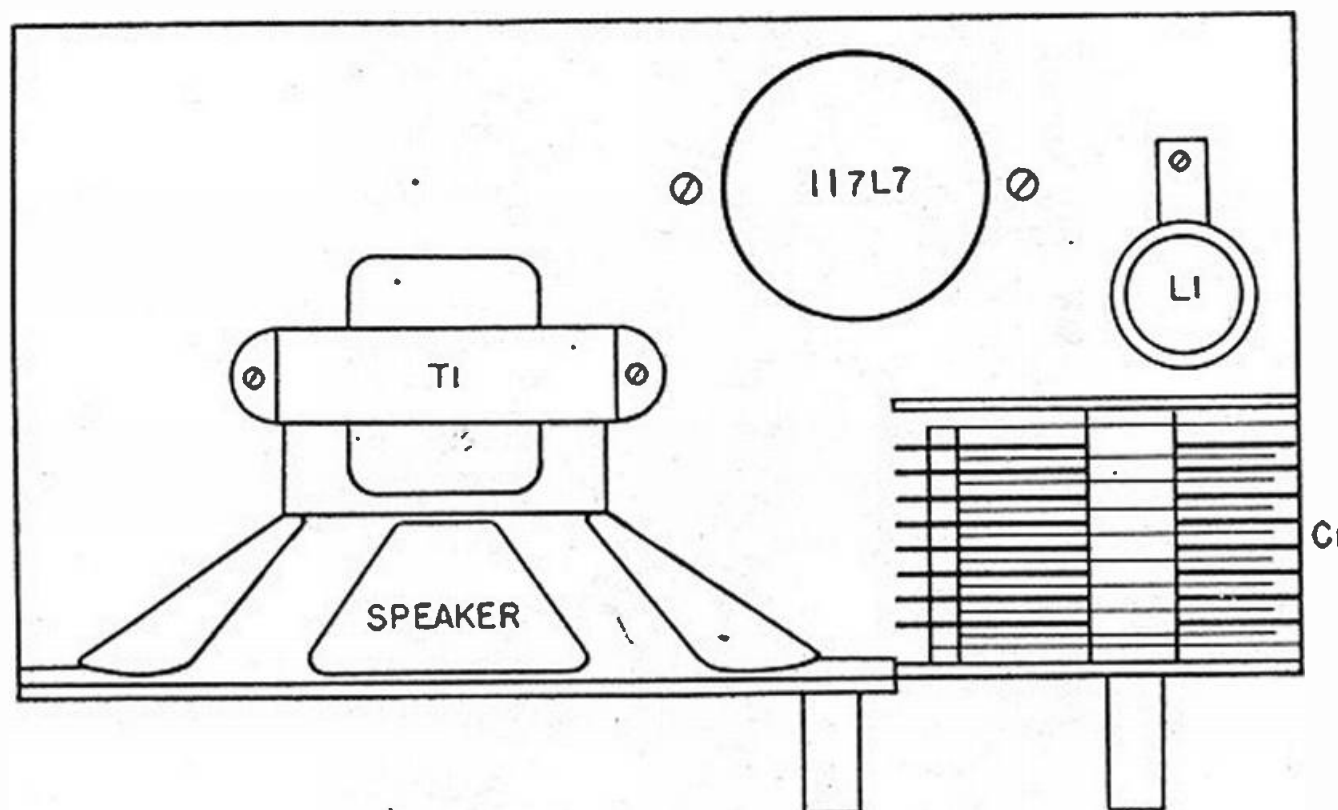

Fig. 1-4. Top View of chassis.

Speaker

4-inch PM dynamic; Jensen P4-X or equivalent

Miscellaneous

1N34 germanium diode (Kemtron or Sylvania)
 Octal wafer-type tube socket
 Line cord and plug
 3-point tie lug strip
 2-point tie lug strip
 6-32 x 1/2 inch r.h. machine screws
 6-32 hexagon nuts
 8-32 x 3/8 inch r.h. machine screws for variable condenser and speaker
 Push-back wire
 Rosin-core solder
 Chassis: 3 x 6 x 1-1/2 inches, steel or

ing arrangement.

The easiest way to locate the screw holes is to use a paper template or pattern. First cut a piece of paper the exact size of the chassis top. Now place each part on the paper template in the position it is to occupy on the chassis. Draw the outline of each part on the paper. Now, by measurement you can determine the locations of the screw holes and transfer these measurements to the pattern. For example, let us suppose that the over-all dimensions of the variable condenser are 1-7/8 by 1-1/4 inches. When the outline of the condenser is drawn on the template you will have a rectangle, as in Figure 1-6. By ac-

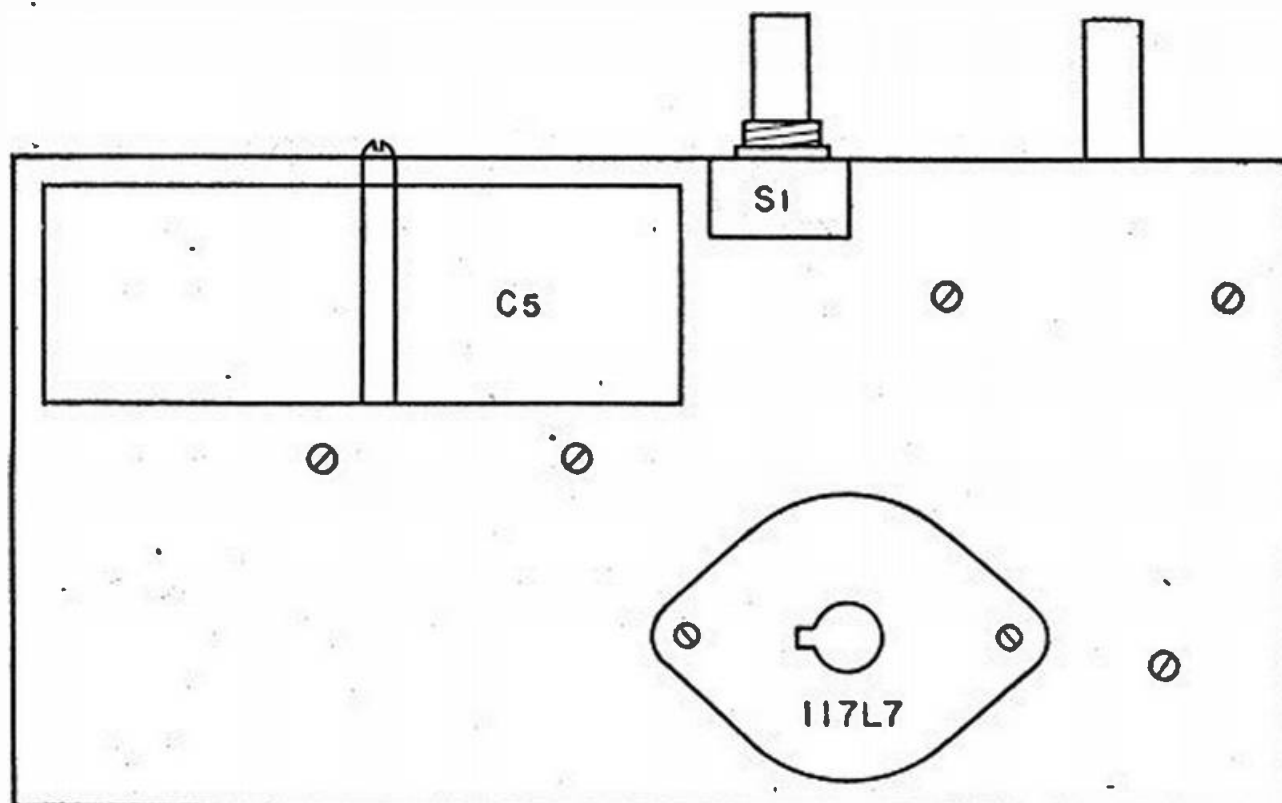

Fig. 1-5. Underside view of chassis.

tual measurement you find that the two screw holes are $5/8$ inch from the front edge of the condenser, and each hole is $3/8$ inch from an end. Transferring these measurements to the pattern, you will now have intersecting lines marking the positions of the screw hole centers. See Figure 1-6. Applying this method to all parts, you will have a complete template showing the locations of all screw holes. Next, fasten the paper to the chassis top with cellulose tape or with a few dabs of rubber cement. By placing a center punch at each of the intersections, you can punch through the paper into the metal.

Unless you are fortunate enough to own a drill press, drilling will have to be done with a hand drill. In that case, it will generally be much easier to drill a small hole and enlarge it later if necessary. Most of the parts are fastened with 6-32 machine screws,

therefore drill all holes with a #25 drill, which provides clearance for this size screw. As a rule, variable condensers use 8-32 screws for mounting, so those holes must be enlarged with a #16 drill. The antenna coil may have a bracket or a single-hole type of mounting. If a bracket is used, there will be no need to enlarge the mounting hole. However, the threaded bushing on a single-hole mount is usually somewhat larger. The size will have to be determined by measurement.

With all holes drilled, you are now ready to punch the socket hole. If you do not have a punch, the hole can be enlarged to $1-1/16$ inches by using a tapered reamer, but this is not recommended as the result is usually a ragged, irregular hole.

The chassis punch (also known as a sheet metal punch or a Greenlee punch) consists of three parts: the

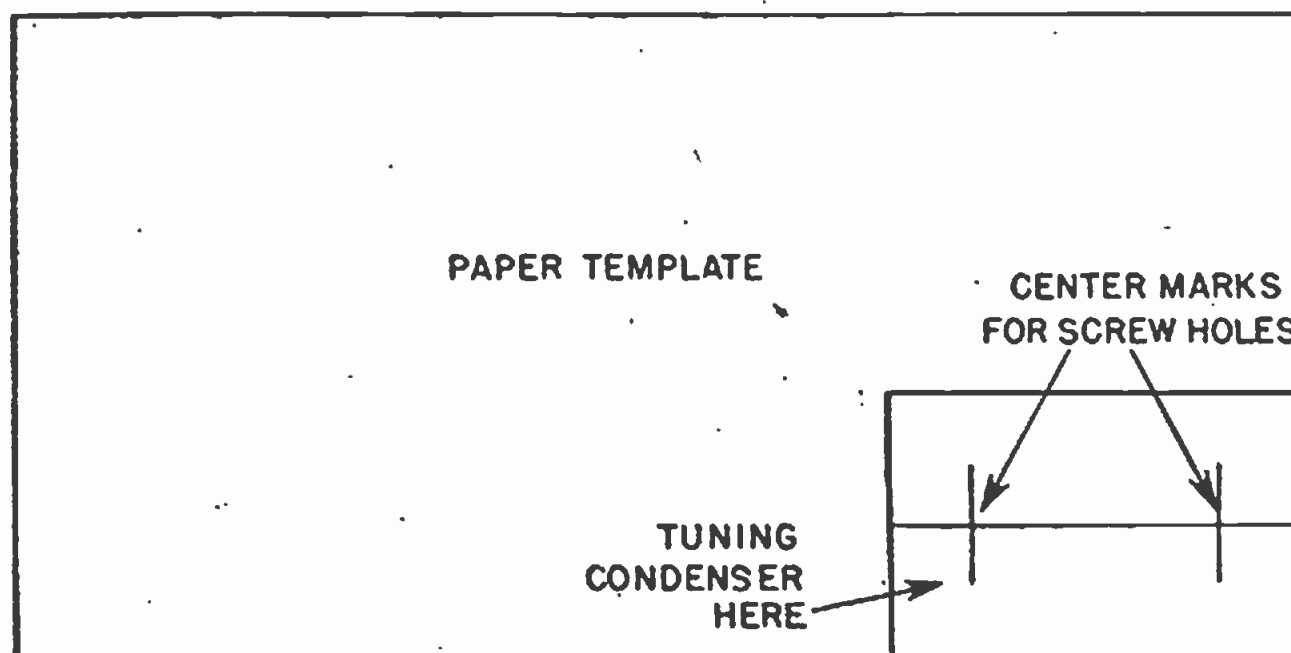

Fig. 1-6. Using a template to lay out chassis.

die, the punch, and the center screw (or capscrew). The correct method of using the tool is illustrated in Figures 1-7A, B, C, and D. The center hole in the chassis must first be enlarged to accommodate the capscrew; use a drill that is 1/32 inch larger than the screw.

Slip the capscrew through the hole in the die, as shown in Figure 1-7A. Now pass the capscrew through the drilled hole in the chassis, as shown in Figure 1-7B, from the underside of the chassis. Be sure that the cup or hollow end of the die is toward the chassis. Apply a few drops of oil to the screw threads, then thread the punch on the screw with the cutter

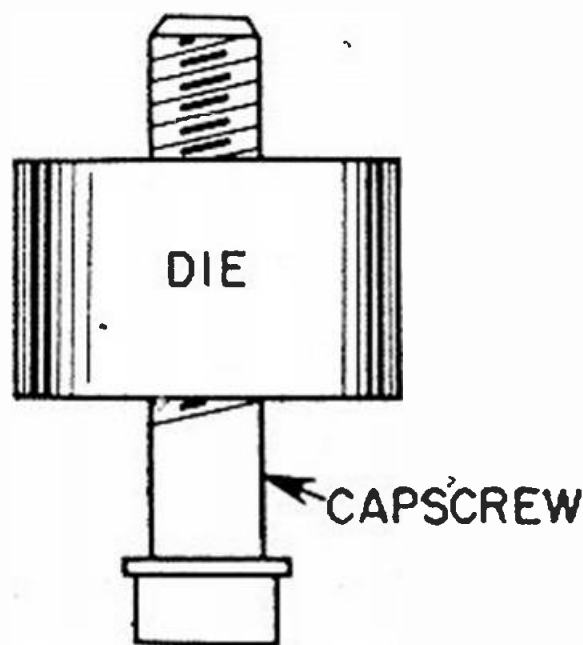

Fig. 1-7A.

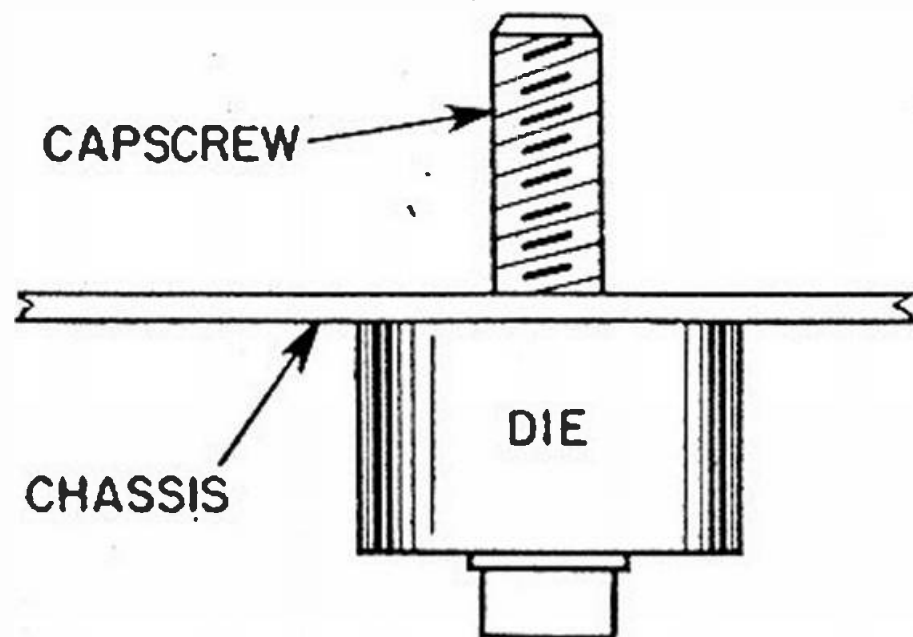

Fig. 1-7B.

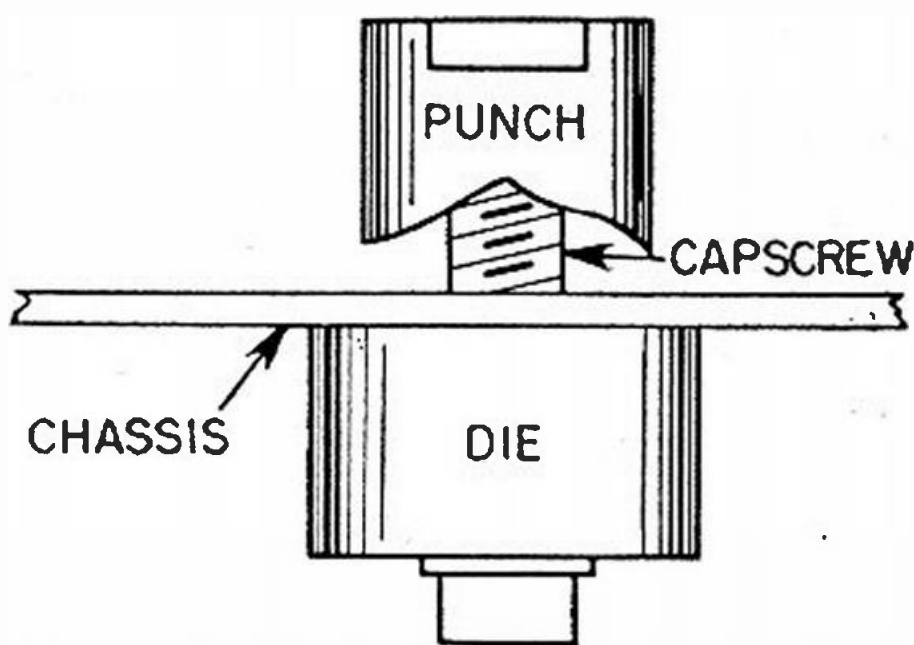

Fig. 1-7C.

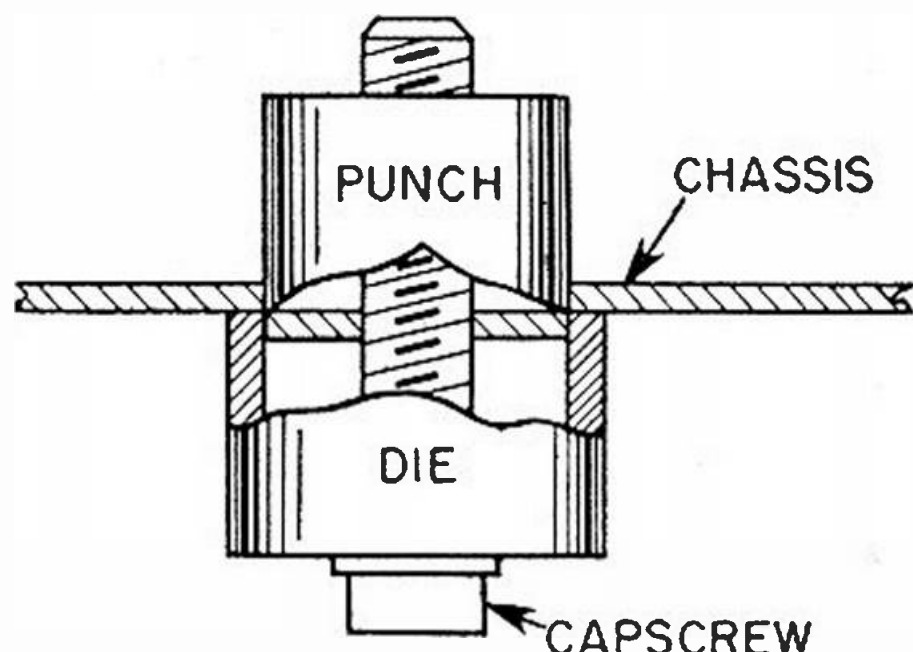

Fig. 1-7D.

end toward the chassis, Figure 1-7C. Continue turning the punch by hand until it makes contact with the metal and can no longer be turned freely. Using an open end or an adjustable wrench, continue tightening until you notice a "click"; the punch will then have cut through the metal as in Figure 1-7D. Unscrew the punch and re-

move the capscrew from the chassis. If the metal disc cut from the chassis does not drop out of the die, remove it by prying with a screw driver. Never allow discs to accumulate in the die or you may find it impossible to remove them.

When the socket hole has been punched out, you may locate and drill the two holes for the socket mounting screws. Of course, if you use the retainer-ring type of socket, no holes are needed. To locate the screw holes, hold the socket against the under side of the chassis so that the pin circle is concentric with the center hole. While holding the socket in this position, mark the locations

with a pencil. Center punch, then drill with a #25 drill.

You are now ready to fasten the speaker and output transformer in place. Before handling the speaker, it is a good idea to cover the cone with a piece of heavy cardboard held to the cone ring with wire; this will prevent possible damage to the cone.

The method of mounting the transformer on the speaker will depend upon the type of speaker you have. Many speakers come with the transformer already mounted, and in that case you will, of course, save a lot of work. If you cannot buy the speaker and transformer already assembled, at least try to get a speaker with a plate for holding the transformer. The plate is located on top of the magnet frame or, sometimes, on the cone frame, and usually has two holes for fastening the transformer, as shown in Figure 1-8A. It is then only necessary to fasten the transformer in place with two 6-32 machine screws and nuts. An alternative method of mounting the transformer, used in cases where the speaker does not have a mounting plate, is shown in Figure 1-8B. Notice that the transformer rests on the magnet frame, as before, but is held in place by a strap passing under the top of the magnet frame. The strap may be made of steel, brass, or very heavy aluminum. It is about 1/2 inch wide and an inch longer than the width of the magnet frame.

When you are ready to fasten the speaker to the chassis, you may find that it is necessary to improvise a bit on account of the variation in speaker construction. Some speakers have L-shaped brackets welded to the magnet frame. This simplifies mounting, for it is quite likely that the brackets are already drilled for machine screws. If the speaker has no brackets, it will have to be held in place with two

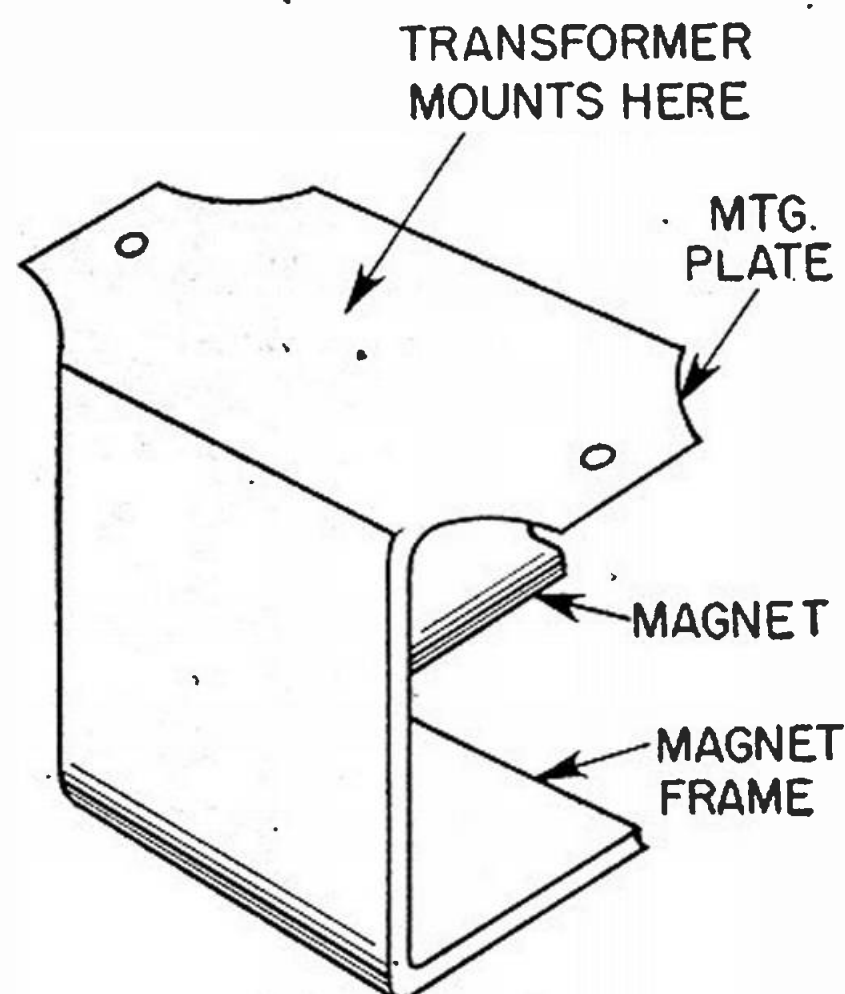

Fig. 1-8A. Speaker magnet frame.

machine screws that either pass through the magnet frame or are threaded into it. The latter method is preferable, if you have an 8-32 tap and a tap holder. After locating the holes, drill them with a #29 drill and follow with an 8-32 tap. If the speaker has no mounting brackets, you may find that when the bottom of the magnet frame rests on the chassis the front of the cone frame projects too far forward. It will then be necessary to raise the magnet frame so that the speaker can be moved back until the cone frame is against the front chassis apron. This can be done by placing a wood block of the required thickness under the magnet frame. Of course, the screws will have to be long enough to pass through holes drilled in the block.

The on-off switch is located on the

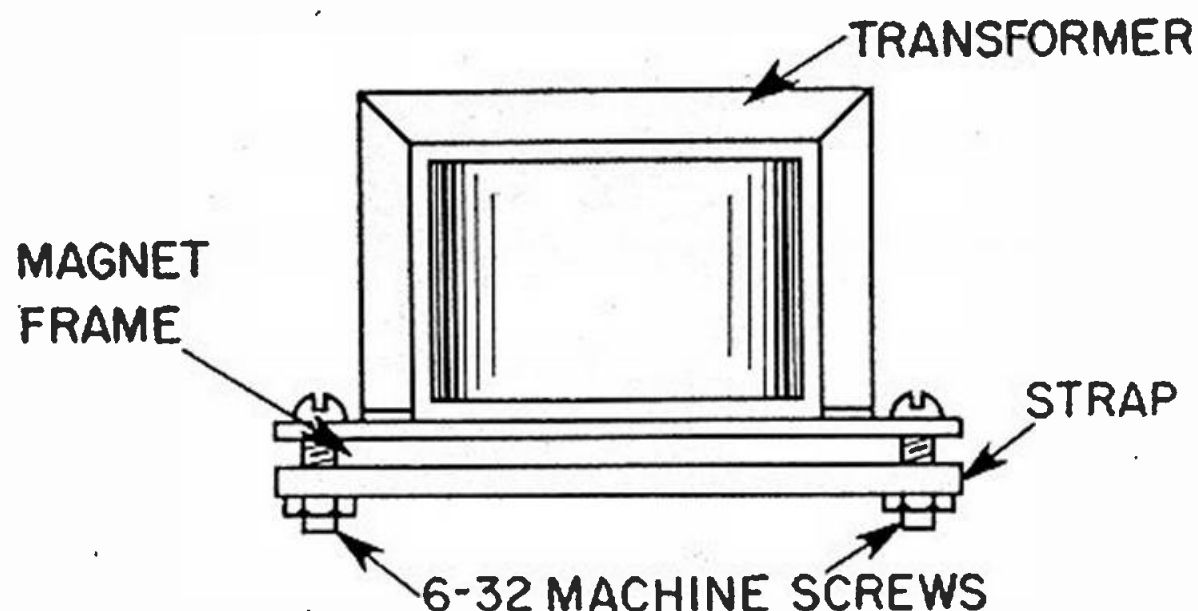

Fig. 1-8B. Fastening transformer to magnet frame.

front apron of the chassis. The center of the switch shaft is 2-3/8 inches from the right-hand end of the chassis and 3/4 inch from the top. Drill the hole with a #25 drill, then enlarge to 15/32 inch with a reamer. When all major parts have been fastened in place, you are ready to begin wiring.

Wiring

Use #22 push-back wire for all connections. The diagram is fairly simple, so that little explanation is needed. Be sure that the terminal wires of parts such as tubular and mica condensers, resistors, and the germanium diode are covered with spaghetti or with insulation removed from push-back wire. If you do not care to do this or if the wires are likely to be rather long, then support such units on terminal strips so that there is no possibility that the bare leads will come in contact with the chassis or other parts. Carefully observe the polarity when connecting electrolytic condensers in the circuit. Negative leads are either marked with a minus sign or are colored black. As you will observe, the negative leads of both the cathode bypass condenser and the filter condenser are connected to chassis. Positive leads of electrolytic condensers are either marked with a plus sign or are colored red. (*Note:* Some filter condensers have one positive

wire colored red, the other blue or green. In such cases, the red positive wire is connected to the end of the filter resistor nearest the rectifier tube.) When connecting the antenna coil, follow the terminal information given on the instruction sheet that accompanies the coil.

Testing

When all connections have been made and carefully checked, insert the tube in its socket. Connect the antenna and the ground to their terminals and insert the line plug in the outlet. Turn the line switch on and allow the tube to warm up. If everything is in order, you will hear one or more of your local stations immediately. The number of stations received and their signal strength will depend upon your location and the efficiency of your antenna and ground system.

Listen to each station long enough to hear an announcement so that you can determine its frequency. Now note whether the station appears to come in at the proper point on the dial. You may find that you are unable to receive stations at the extreme high frequency or low frequency ends of the dial. If this is the case, adjust the tuning screw at the end of the antenna coil until you are able to cover the entire range.

TWO-TUBE RECEIVER USING MINIATURE TUBES

This set uses a twin triode tube—type 12AU7—as detector and audio amplifier. The detector circuit is the grid leak type and, since this is one of the most sensitive types, you can expect that the set will perform better than the crystal diode circuit used in the last project. The complete circuit diagram of the project is shown in Figure 1-9. This project is an example of the many and varied applications of dual unit tubes, and with a little thought you should be able to use tubes belonging to this category in a

variety of unique circuits. Other available combinations include dual diodes, diodes combined with triodes, and triode-pentodes. All have been developed with a view to reducing the number of tubes needed.

Circuit description

One half of the 12AU7 operates as a grid leak detector, and this circuit is unusually sensitive. It does have the disadvantage that it is easily overloaded, and for that reason it is rarely used in sets employing r.f. or i.f.

amplifiers ahead of the detector. In sets of the superheterodyne type we shall find that the diode detector is used almost universally; although less sensitive than the grid leak detector it is not easily overloaded and is less subject to distortion.

The detector half of the tube is coupled to the grid of the amplifier half through the coupling condenser, C3. After amplification, the signals are fed to the speaker. Although a four-inch P.M. speaker is mentioned in the parts list, a speaker of any size may be used provided its voice coil impedance matches the output transformer.

All DC voltages are supplied by the 35W4 rectifier tube. Heater voltages

Parts list

Resistors

- R1 5 megohm, 1/4-watt carbon
- R2 50K ohm, 1/2-watt carbon
- R3 500K ohm volume control, with switch
- R4 2000 ohm, 1-watt carbon
- R5 47 ohm, 1-watt carbon
- R6 480 ohm, 15-watt wire-wound

Condensers

- C1 Midget variable, single gang, .000365 mfd.
- C2 .0001 mfd., mica
- C3 .02 mfd., 400-volt paper tubular
- C4 40-40 mfd., 150-volt electrolytic
- C5 .1 mfd., 400-volt paper tubular

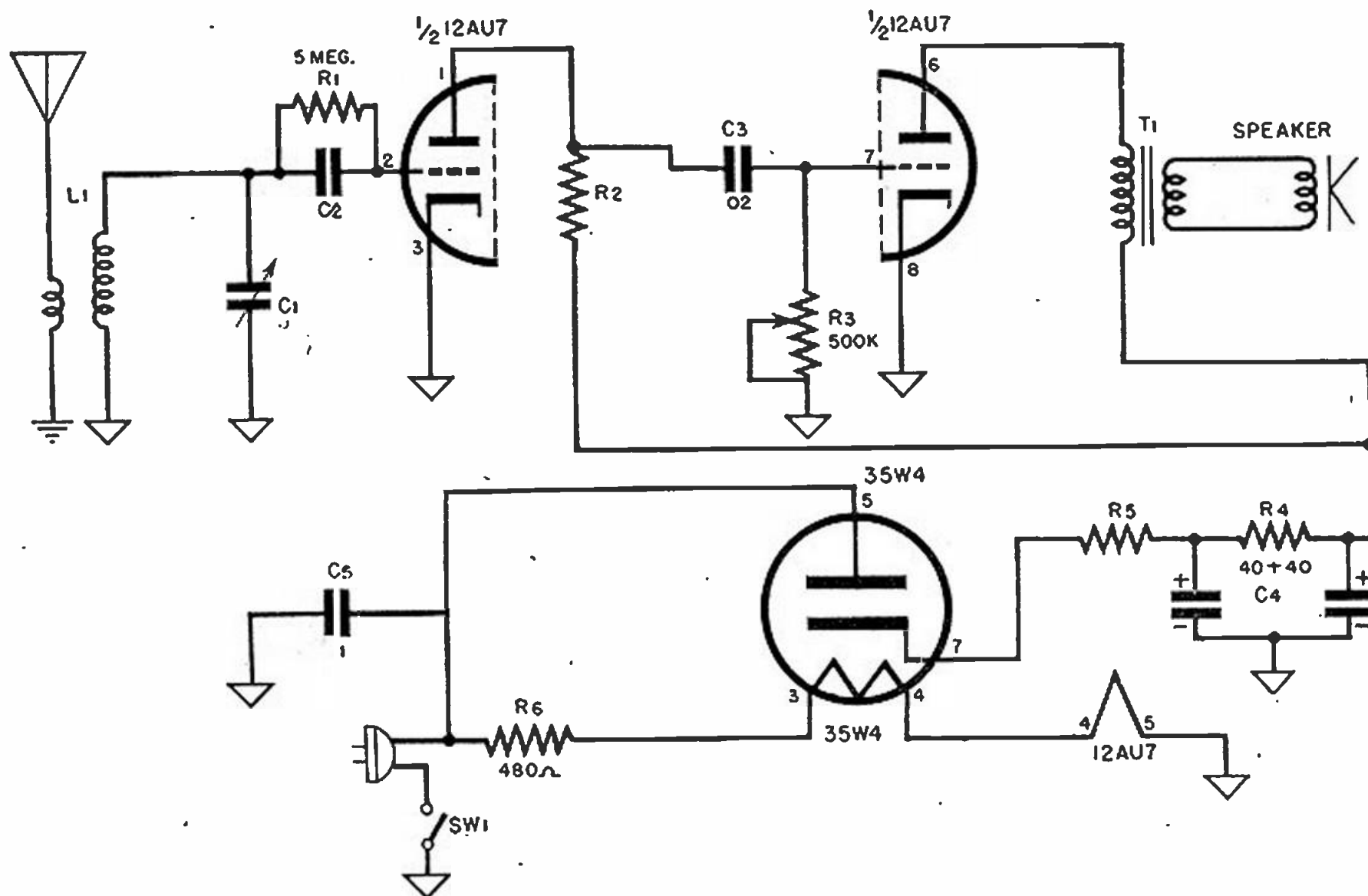

Fig. 1-9. Circuit diagram of two-tube receiver.

are taken directly from the line and are dropped to a value suitable for the tube heaters by the 480-ohm series line resistor, R6. The combination of two miniature tubes results in a set that is small in size but high in performance. When used within the dependable service range of broadcast stations, good speaker volume may be expected, but, of course, a good antenna and ground system must be used.

Transformers

- T1 Output transformer, 4,000 ohms primary impedance, 3.5 ohm secondary impedance

Speaker

4-inch PM dynamic, 3.5 ohm voice-coil impedance; Jensen P4-X or equivalent

Miscellaneous

Chassis: steel or aluminum, 3 x 6 x

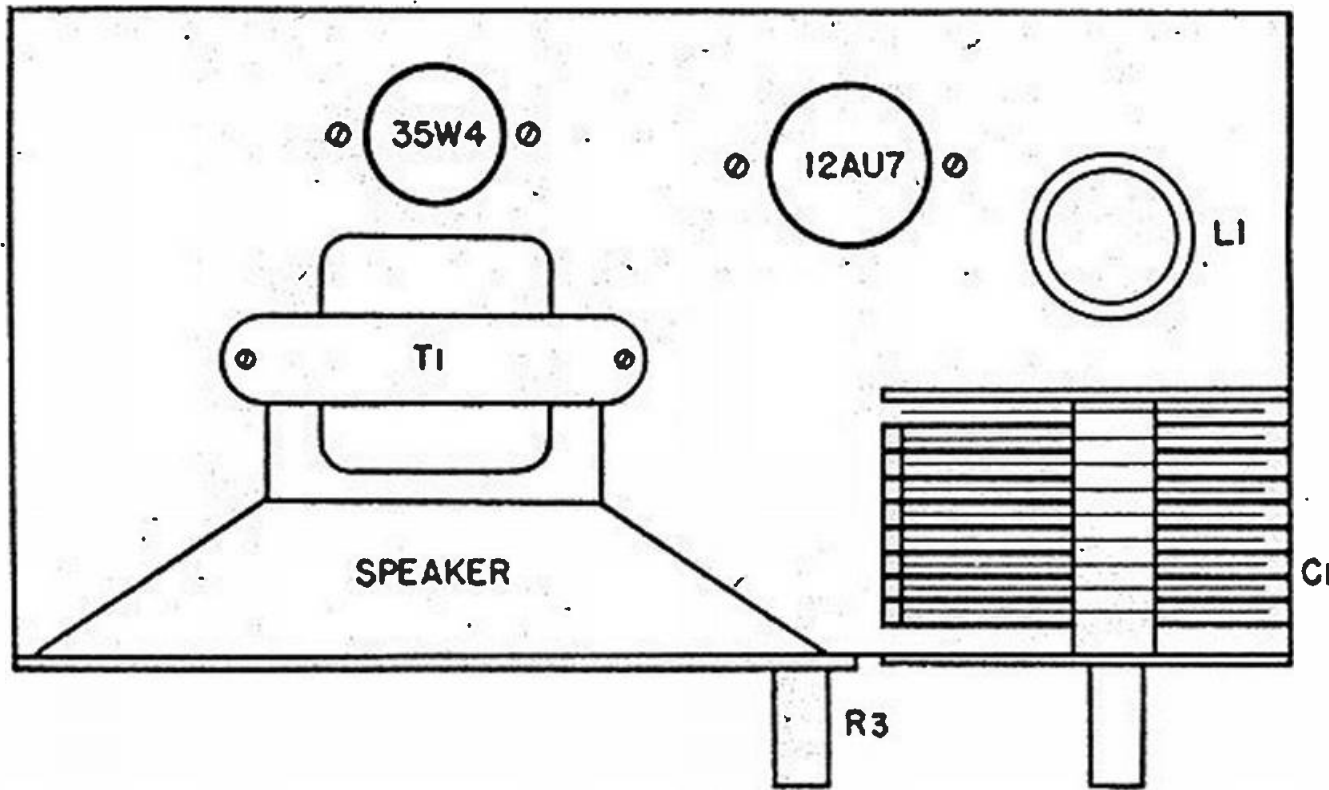

Fig. 1-10. Top view of chassis.

1-1/2 inches (or 20 gauge sheet aluminum 6 x 6-3/4 inches)
 Miniature 7-pin tube socket,
 Noval 9-pin tube socket
 Line cord and plug
 6-32 x 3/8 inch machine screws
 6-32 hexagon nuts
 Push-back wire
 Rosin-core solder

Tubes

12AU7
 35W4

Layout and assembly

Figure 1-10 shows the arrangement of all principal parts to be mounted on top of the chassis, while Figure 1-11A is an underside view. Actual measurements and detailed locations of screw holes are not given, since this would limit you to the selection of specific makes of parts, which in some

cases may not be obtainable. However, the lack of exact dimensions should not place any obstacle in your way if you use the template method of layout used in connection with the one-tube set previously described.

The 3 x 6 inch chassis used on the last project may be reused for this one if you wish. The speaker, variable condenser, and certain other parts may also be used again. It is true that the chassis has a hole punched in it for a large tube socket, but with a little care this can be covered to make a neat-looking job. To do this you will need a piece of 20 gauge sheet aluminum 2 inches square. In the exact center of this piece, punch a hole to accommodate the noval tube socket used for the 12AU7. Remove the octal tube socket from the chassis and place the aluminum over the hole. Scribe

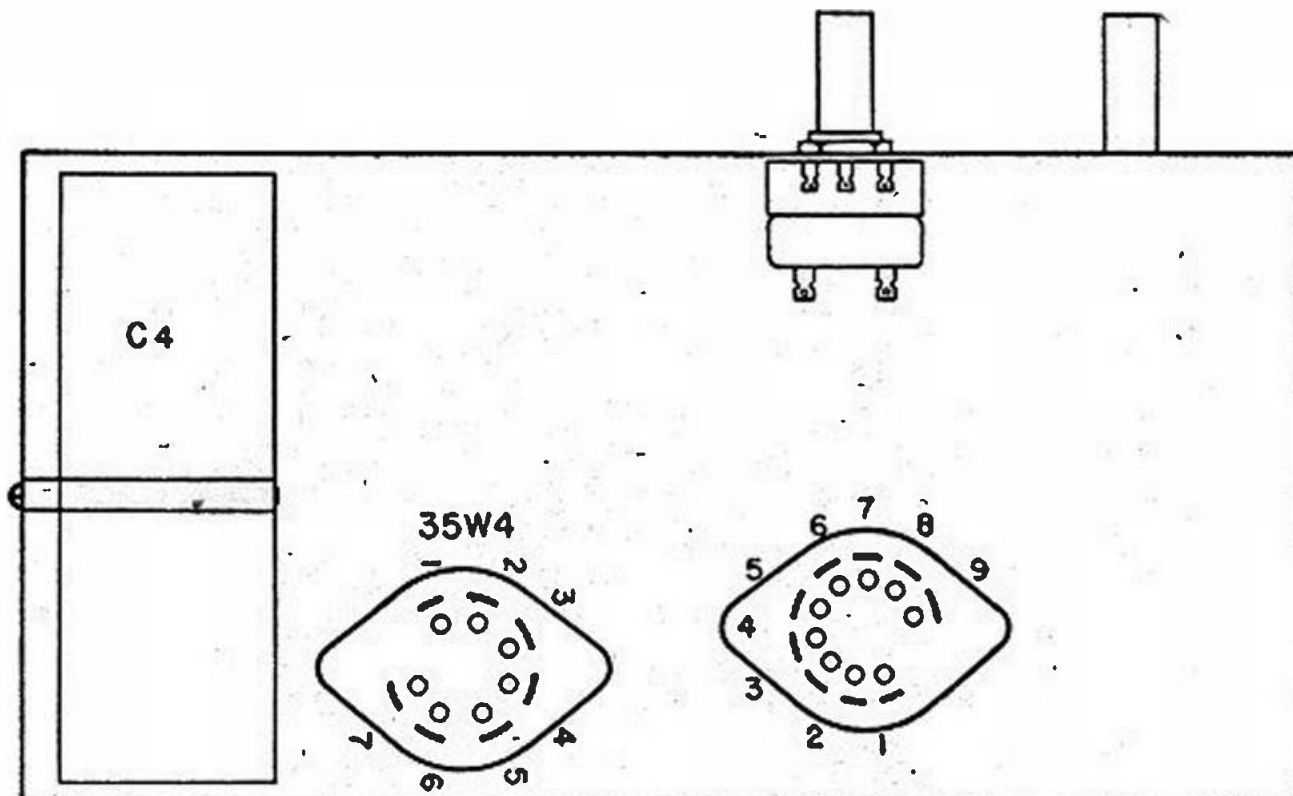

Fig. 1-11A. Underside view of chassis.

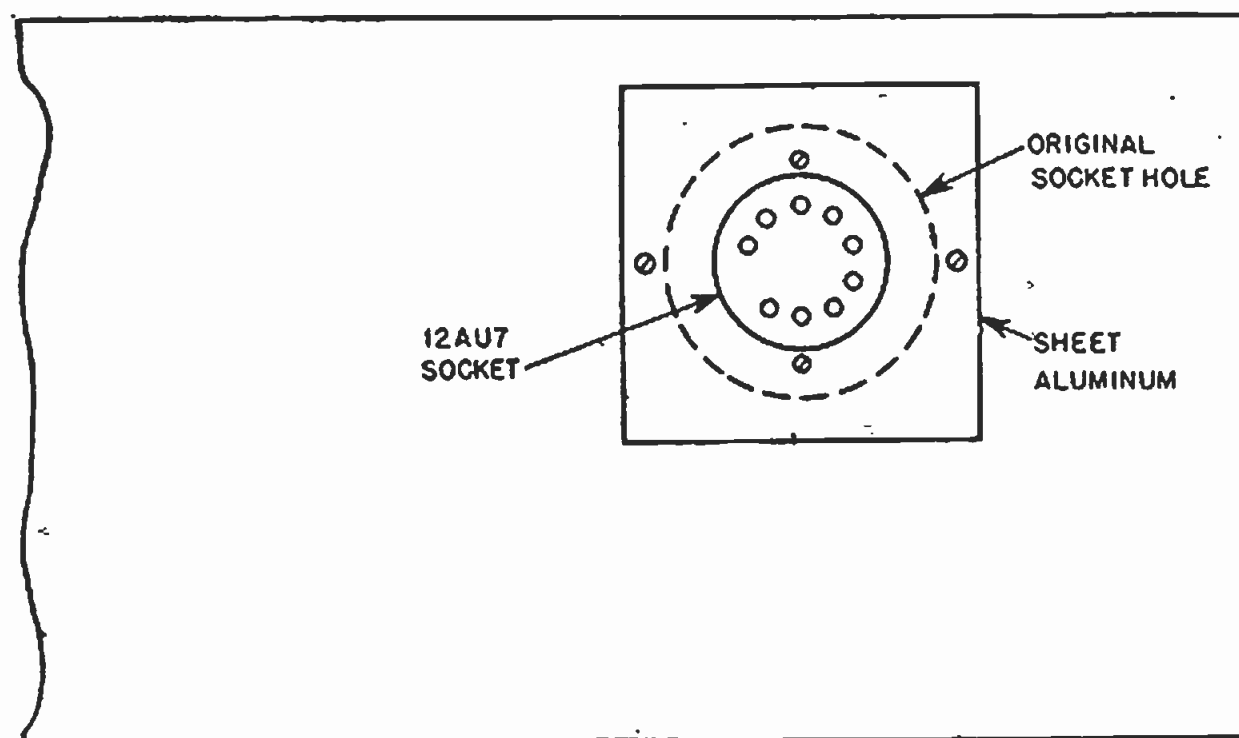

Fig. 1-11B. Fastening miniature tube plate to chassis.

the locations of the two socket mounting holes on the sheet aluminum. Drill corresponding holes in the square of aluminum, using a #25 drill. Fasten the noval socket in place, then fasten the aluminum square to the chassis, as shown in Figure 1-11B, using two short 6-32 machine screws and nuts.

After drilling all small holes, punch or cut the holes for the tube sockets. The 35W4 socket requires a hole $\frac{5}{8}$ inch in diameter. The average 9-pin socket (the type used for the 12AU7) fits into a $\frac{3}{4}$ inch hole. Enlarge the hole for the volume-control-shaft bushing to $\frac{7}{16}$ inch with a drill or a reamer. The location of the volume control is shown in the detail sketch, Figure 1-12. For details on mounting the variable condenser and the speaker, refer to the information given in the preceding, one-tube project. When all major parts have been fastened in place, you are ready to begin wiring.

Wiring

The wiring may be done in any desired order or sequence, but it is suggested that you follow some systematic plan to avoid overlooking one

or more connections. One such plan is to wire the set in sections, perhaps beginning with the series heater circuit, consisting of the 12AU7 and 35W4 heaters, the 480-ohm line resistor, the cord and plug, and the on-off switch, in that order. The next step, after completing the heater circuit, might be to wire all of the cathodes, then the grids, and finally the plates. The actual procedure is unimportant, just as long as a system is used. Some constructors prepare a diagram of the complete set before wiring is begun. As each wire is put in place, it is marked in colored pencil on the diagram. This trick will help you make a quick check to determine whether any connections have been overlooked.

Testing

When the wiring has been completed and carefully checked, connect the set to a good antenna and ground. Insert the tubes in their sockets, connect the line plug to an outlet, and turn the switch on. Advance the volume control to the full on position.

Tune over the entire range in order to locate all local stations and note

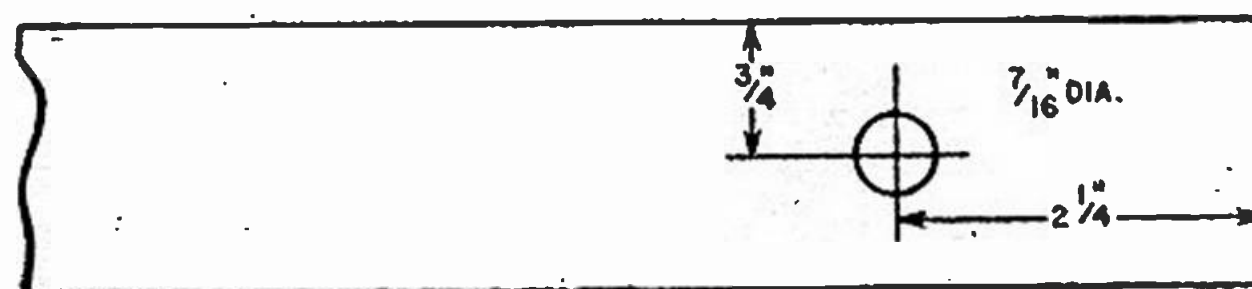

Fig. 1-12. Location of volume control.

their positions with respect to the tuning condenser settings. If you find that the set does not cover the full

broadcast range, adjust the screw located at one end of the antenna coil until all frequencies are received.

THREE-TUBE TRF RECEIVER USING SELENIUM RECTIFIER

This tuned radio frequency receiver using metal tubes in the r.f. and detector stages is quite popular among constructors because of its simplicity and the fact that it will give good volume and fair sensitivity under average receiving conditions. In most locations it will perform well on an indoor antenna. An antenna "hank" is suggested; this is a coil (usually about 25 feet) of very flexible, stranded wire wound on a flat fibre form or spool. It may easily be unwound and strung around a room.

With a few changes, tubes other than those shown in the circuit diagram, Figure 1-13, may be used. The reasons for offering an alternative plan of construction are simply those of economy. Perhaps you have some of the substitute types of tubes on hand, or perhaps you have looked ahead to the five-tube superheterodyne described later in this book. Some of the tubes used in that set might well be used first in this one, thus resulting

in a substantial saving.

A type 12BA6 may be substituted for the 12SK7, a 12AU6 for the 12SJ7, and a 50B5 for the 50L6. Of course, the glass equivalents of the 12SK7 and 12SJ7 may also be substituted, provided that tube shields are used. For your convenience, diagrams showing the differences in basing arrangements between the 12SK7 and the 12BA6 (Figure 1-14A, 1-14B), the 12SJ7 and 12AU6 (Figures 1-15A and 1-15B), and the 50L6 and 50B5 (Figures 1-16A and 1-16B) are given here. When using the wiring diagrams with the substitute tubes, refer to these base diagrams. It is only necessary to note, for example, that the schematic diagram calls for the heater wires of the 12SK7 to be connected to pins 2 and 7, but when using the 12BA6 these wires are to be connected to pins 3 and 4 instead.

Of course there will be a few mechanical changes to accommodate the miniature tubes. All three use the

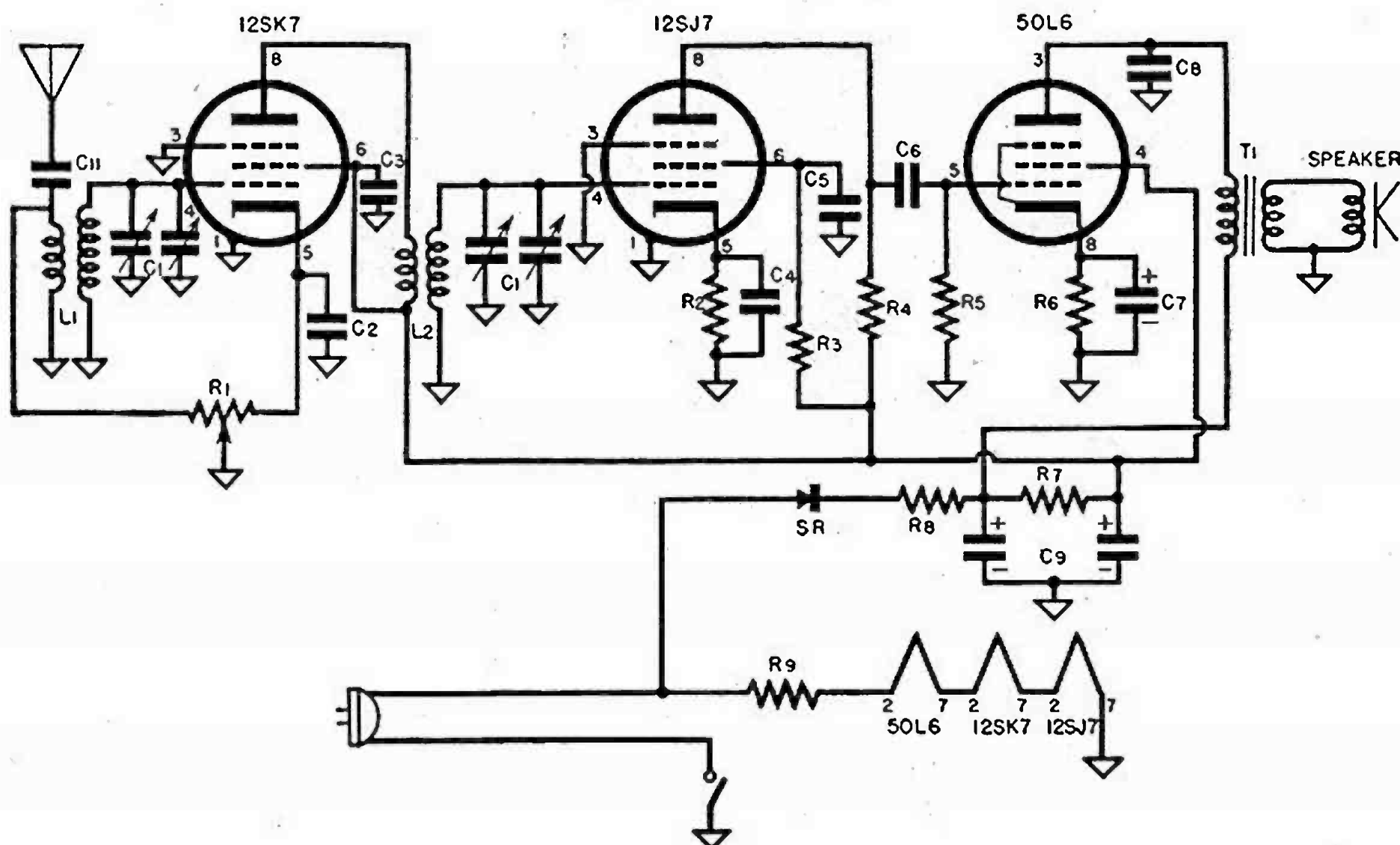
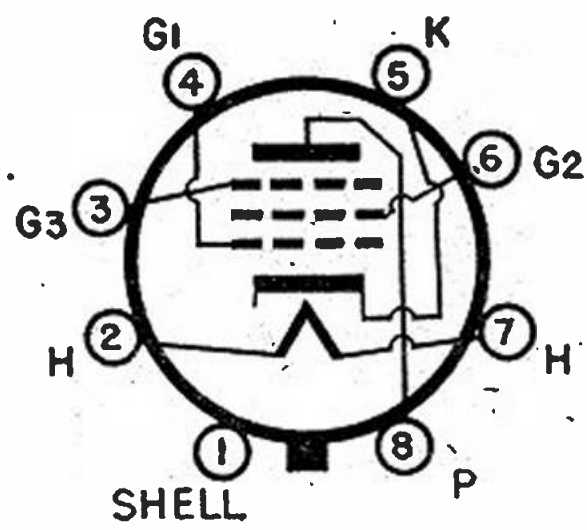
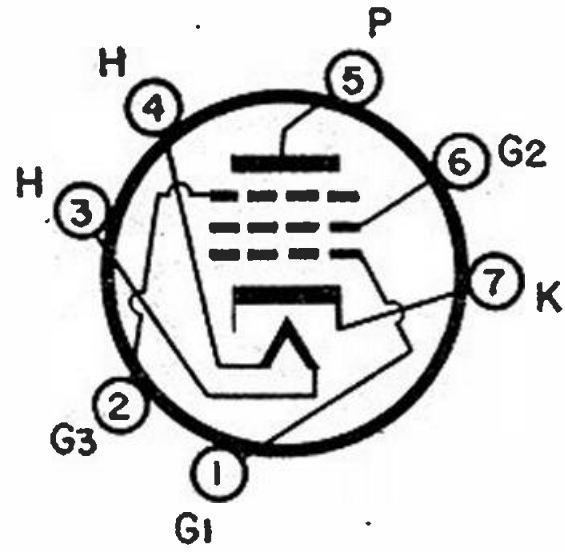

Fig. 1-13. Schematic diagram of a three-tube TRF receiver.



12SK7
Fig. 1-14A.



12BA6
Fig. 1-14B.

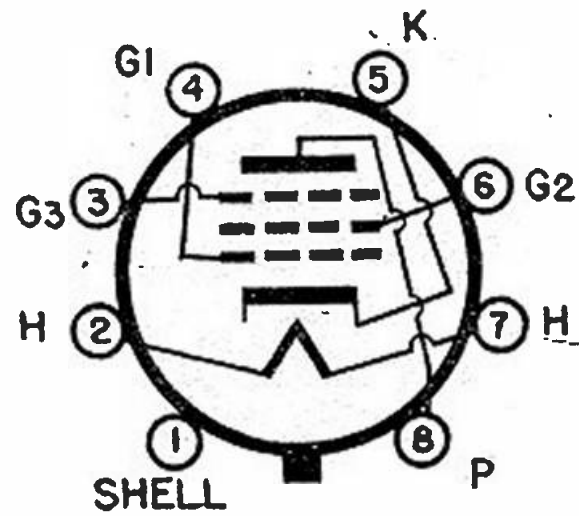

12SJ7
Fig. 1-15A.

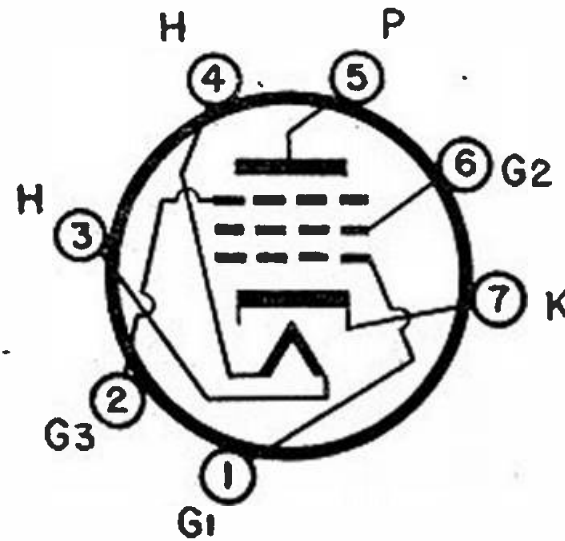

12AU6
Fig. 1-15B.

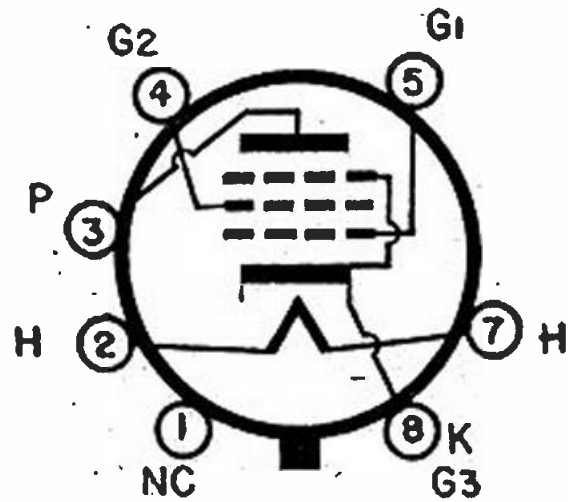

50L6
Fig. 1-16A.

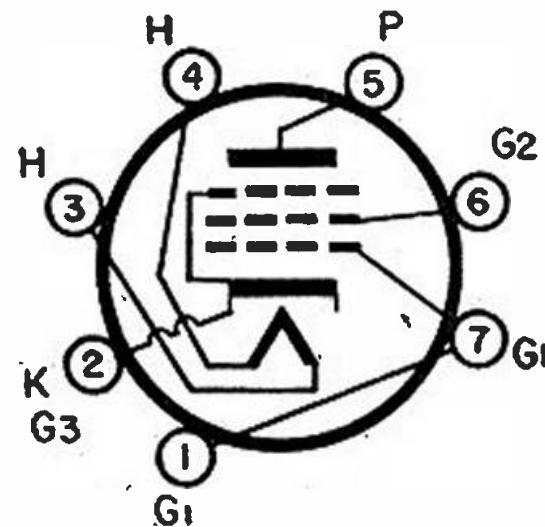

50B5
Fig. 1-16B.

7-pin miniature socket; the r.f. tube and detector tube sockets must be of the type fitted with bases for tube shields. Attempting to use unshielded glass tubes in a TRF receiver can easily result in oscillation.

Circuit description

Signals picked up by the antenna appear across the tuned circuit consisting of the tuning condenser (antenna section) and the secondary of L1. These signals are then applied to the control grid of the 12SK7 r.f. amplifier tube. Note that this tube

has a screen electrode; this reduces the capacitance existing between the control grid and the plate and thus makes possible high gain without danger of oscillation due to coupling within the tube itself. Amplified signals appearing in the plate circuit of the tube are induced in the secondary of L2 and fed to the grid of the detector tube. The second tuned circuit (tuning condenser and secondary of L2), like the first one, rejects unwanted signals and builds up the desired signal. After rectification by the detector, the audio signal is fed to the

grid of the 50L6 power output stage, amplified and passed on to the speaker. Plate and screen voltages for all the tubes are supplied by the selenium rectifier, SR. Such rectifiers are now widely used in radio and television receivers, probably because they require no heater voltage and are reputed to outlast tube rectifiers. Heater voltages for the set are taken directly from the line through the series dropping resistor, R9.

Parts list

Resistors

R1	25K ohm volume control with switch
R2	50K ohm, 1/2-watt carbon
R3	1 megohm, 1/2-watt carbon
R4	270K ohm, 1/2-watt carbon
R5	470K ohm, 1/2-watt carbon
R6	150 ohm, 1-watt carbon
R7	2K ohm, 1-watt carbon
R8	47 ohm, 1-watt carbon
R9	280 ohm, 15-watt wire-wound line resistor

Condensers

C1	Variable condenser, 2-gang, .000365 mfd. each section (with trimmers)
C2	.1 mfd., 200-volt paper tubular
C3	.1 mfd., 400-volt paper tubular
C4	.1 mfd., 200-volt paper tubular
C5	.1 mfd., 400-volt paper tubular
C6	.02 mfd., 400-volt paper tubular
C7	50 mfd., 50-volt electrolytic
C8	.002 mica
C9	20-20 mfd., 150-volt electrolytic
C10	.1 mfd., 400-volt paper tubular
C11	.006 mfd., 200-volt paper tubular

Transformers

T1	Output transformer, Stancor A-3876 or equivalent
----	--

Coils

L1	Antenna coil
L2	R.F. coil (Note: Buy in matched pairs; you will then be sure to get coils having similar inductances)

Rectifier

SR	Selenium rectifier, 50 milliamperere output
----	---

Speaker

	4-inch PM dynamic, Jensen P4-X or equivalent
--	--

Miscellaneous

	Line cord and plug
	3 octal tube sockets (or miniature 7-pin sockets)
	Chassis: 5 x 9 x 1-1/2 inches
	6-32 x 3/8 inch r.h. machine screws
	6-32 hexagon nuts
	Single-point tie strip
	2 3-point tie strips
	Soldering lugs
	Push-back wire
	Rosin-core solder
	Antenna "hank"

Tubes

	12SJ7, 12SK7, 50L6 (or 12BA6, 12AU6, 50B5)
--	--

Chassis layout and assembly

If a speaker no larger than 4-inch is used, the set can be built on a chassis measuring 5 by 9 by 1-1/2, inches. Using octal sockets (to accommodate the larger tubes) you will have ample space. If you elect to use the miniature tubes, you will have some wasted space, which is no particular disadvantage. Figure 1-17 is a plan view of the chassis, arranged for the large tubes. An underside view is given in Figure 1-18, and a front view in Figure 1-19.

For information on mounting the speaker and output transformer, refer to Figures 1-8A and 1-8B, as well as the accompanying text. With the speaker mounting holes marked and center punched, draw a line parallel to the rear edge of the chassis and 1-1/2 inches distant from it. All three tube sockets will be centered along this line. Measure along this line 2-1/4 inches from the left-hand end of the chassis and make a center punch mark. This is the center of the 12SK7 tube socket. Now, 2-3/8 inches to the

right of this mark (still measuring along the center line of the sockets), make a second mark to indicate the position of the 12SJ7 socket. A distance of 2 inches to the right of this point, mark the position of the 50L6 socket. After locating the centers of the tube sockets, proceed to locate the socket screw holes in this way: Place the socket on the chassis with the top face of the socket down. Center the guide pin hole over the punch mark. While holding the socket in this position, mark the hole locations with a pencil. Remove the socket and make a punch mark at the center of each of the small penciled circles.

The selenium rectifier is located to the left of the speaker, about an inch from the left end of the chassis and two inches from the front. The exact position is not too important, as there is ample space here. The line resistor is located under the chassis; the exact position is not critical, as long as it is not placed close to a coil or condenser. Notice that the filter condenser (see Figure 1-18) is at the front center of the chassis, so that the best position for the line resistor will be along the left end of the chassis.

Next to be located is the variable

condenser. It is placed at the right front corner of the chassis, as in the drawing, Figure 1-17. If your condenser has spade bolt mountings, it will have to be placed on edge. In this case, you will be unable to place it exactly as shown in the drawing. If the plates open to the left, make a trial location to be sure that the rotor plates, when open, are clear of the speaker. If the plates open to the right, position the condenser so that the rotor plates, when fully open, do not extend beyond the end of the chassis. Regardless of the method of mounting the condenser, two small holes will have to be drilled in the chassis for the grid wires that run from the condenser stator plates to the underside of the chassis. Assuming that the condenser is mounted as shown in Figure 1-17, these holes will be located just to the left of the condenser. Each hole will be opposite a stator terminal lug. For edge mounting, drill the holes so that they will be under the condenser when it is in position and so that the wires will be as short as possible.

The antenna coil is to be mounted just to the rear of the variable condenser. The coil will, in all probab-

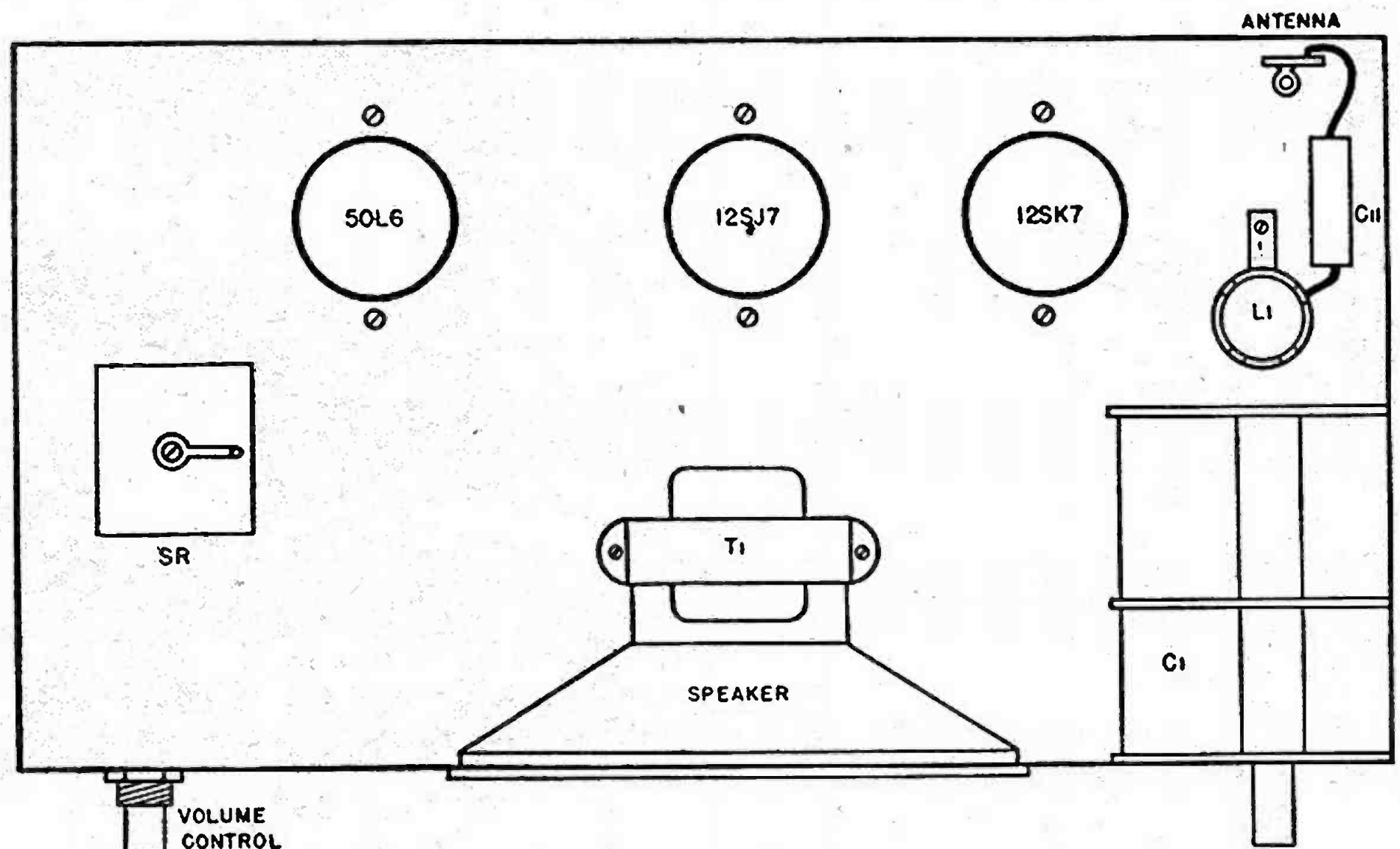

Fig. 1-17. Top view of three-tube TRF receiver chassis.

ity, have a mounting bracket that requires only one screw for fastening. Near the rear edge of the chassis there is a single-point tie strip that is used as an antenna terminal. It is also used as a junction point for the antenna wire and the antenna series condenser, C11. Alongside the antenna coil, mark the location of a hole to admit a wire that runs from the antenna coil primary to the volume control.

Referring again to the underside view, Figure 1-18, notice that the r.f. coil is located between the 12SK7 and 12SJ7 tube sockets so the connecting wires are as short as possible. The best position for the volume control would be at the right of the chassis, just under the tuning condenser; wiring will

marked and center punched, drill them, using a #25 drill. Enlarge the volume control and line cord holes to $7/16$ inch with a drill or reamer. Enlarge the socket center holes with a $3/8$ -inch drill. Punch the socket holes with a sheet metal punch, referring to Figures 1-7A, B, C, and D and the accompanying text, if necessary. Enlarge the variable condenser screw holes with a #16 drill if the condenser is intended to be fastened with 8-32 screws.

You are now ready to begin the work of assembly. Mount the tube sockets first, using 6-32 by $3/8$ inch machine screws and nuts. While the sockets are being fastened in place it is a good idea to slip a soldering lug

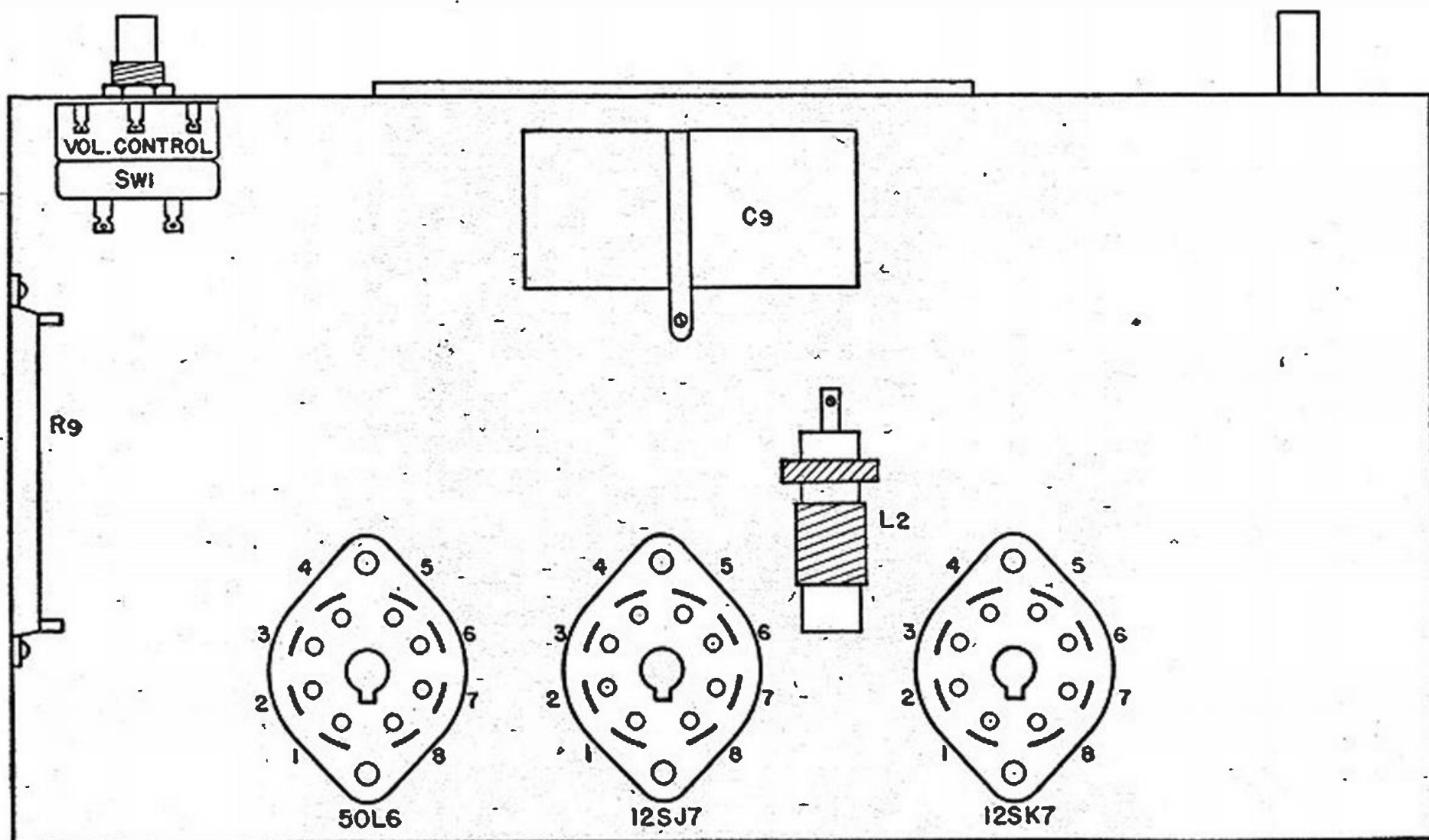

Fig. 1-18. Underside view of three-tube receiver chassis.

then be more direct. If the wiring is done carefully, you will encounter no particular difficulty and the appearance of the set will be more symmetrical with the control at the right.

On the rear apron of the chassis, about 1-1/2 inches from the left end, there is to be a hole to accommodate the line cord; this, of course, is not shown in any of the drawings, since there is no great need for a rear view of the set.

When all hole locations have been

over one of the mounting screws on each socket; this will later be a convenient ground terminal. Fasten the selenium rectifier, line ballast resistor, and filter condenser in place next. Resistors R7 and R8 may now be mounted on a three-point tie strip and fastened in place at the left end of the chassis; see Figure 1-19. The other three-point tie strip is to be used for the 12SJ7 plate and screen resistors. These may now be mounted on the strip and the strip fastened in place

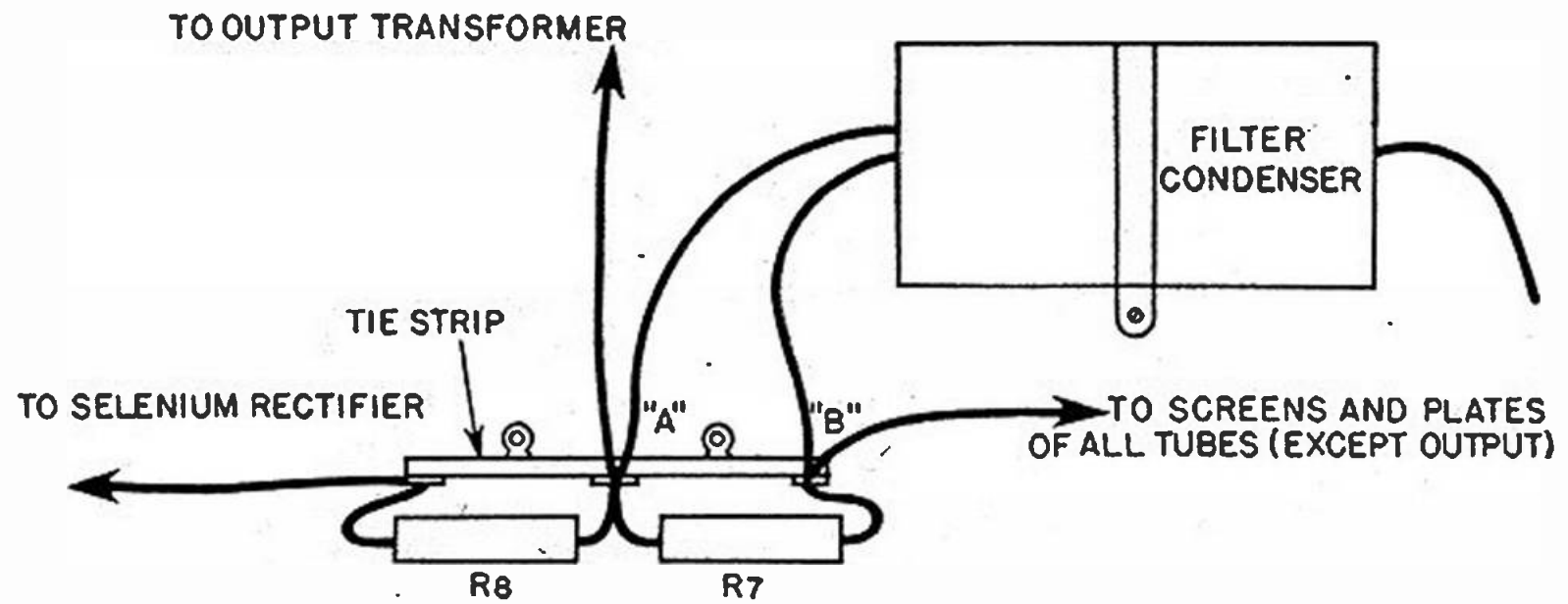

Fig. 1-19. Assembly of R7 and R8 on tie strip.

close to the tube socket. Fasten the r.f. coil to the underside of the chassis and the antenna coil on the top. Place the variable condenser in position but, before fastening it down, run the grid wires through the holes drilled for them. Finally, fasten the speaker in position. (*Note:* Unless the speaker and output transformer were purchased assembled as a unit, mount the transformer in place before fastening the speaker to the chassis.)

Wiring

Experience in the radio industry and in teaching radio has led the writer to the conclusion that the wiring of a multi-tube set is best done in sections. No matter how experienced the builder may be, there is always the danger of omitting a wire if he attempts to follow a complete schematic diagram. The more tubes used, the more likely this is to happen. The principal cause of such errors or omissions is a lack of systematic wiring procedure. Even if you have had considerable experience, we suggest that you use the sectional wiring method to be described.

The entire schematic diagram has

been divided into five sections. Each comprises those components that are closely related. As each section is wired the connections can quickly be checked and any errors or omissions detected much more rapidly than if the set were to be wired as a unit. Furthermore, this method offers a systematic procedure and you will find that it is not only simpler but often saves time.

How to wire the heater circuit

The heater circuit, Figure 1-20, includes the line cord and plug, on-off switch, line ballast resistor, and the heaters of the three tubes. Begin by passing the free end of the line cord through the hole in the rear apron of the chassis. (*Note:* Before doing this, we suggest that you install a rubber grommet in the hole. This will prevent abrasion of the cord.) Measure the length of cord you will need to reach to the line ballast resistor and to the on-off switch. Tie a single knot in the cord just inside the chassis; this will take up any strain on the cord and prevent breakage of terminals. Split the line cord into its two component wires as far back as necessary. Cut the wires to length and connect

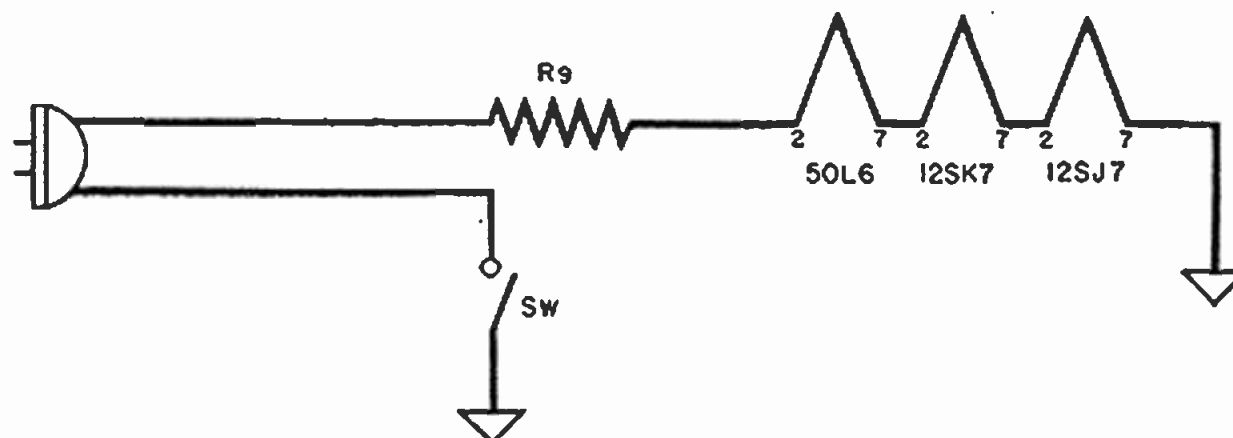

Fig. 1-20. The heater circuit.

one to the line resistor, the other to the switch. Now connect the free end of the line resistor to terminal 2 of the 50L6 socket (if a 50B5 tube is used, this will be terminal 3 instead). Connect the heaters in series, as shown in the diagram, by wiring pin 7 of the 50L6 to pin 2 of the 12SK7, pin 7 of the 12SK7 to pin 2 of the 12SJ7, and by connecting pin 7 of the 12SJ7 to chassis. If you use miniature tubes the wiring will be as follows: Pin 4 of the 50B5 to pin 3 of the 12BA6, pin 4 of the 12BA6 to pin 3 of the 12AU6, and pin 4 of the 12AU6 to chassis. Finally, connect the remaining ter-

to be mounted on a three-point tie strip located in the power supply corner of the chassis. This detail is illustrated in the sketch, Figure 1-20. With the resistors in place on the strip, the left-hand end of R8 is to be connected to the plus terminal of the rectifier. This connection is clearly marked in the drawing. R7 and R8 join at the center lug on the tie strip; this lug is marked "A" in the drawing. Later on, when the rest of the set is wired, the B plus wire of the output transformer will be connected to point "A," so that the resistor connections need not be soldered at this time. However, one

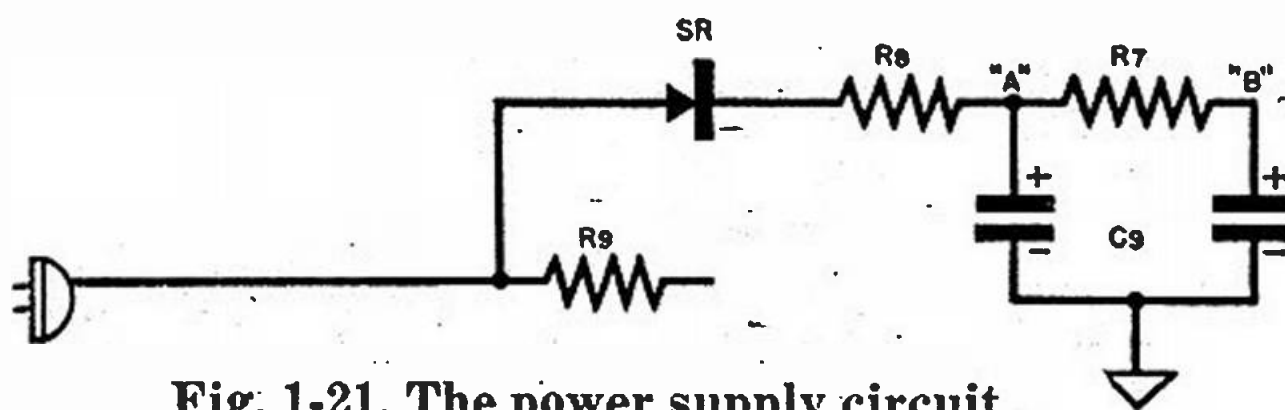

Fig. 1-21. The power supply circuit.

minal of the switch to chassis. This completes the heater circuit wiring. The circuit may be tested by installing the tubes in their respective sockets, inserting the line plug in an outlet, turning the switch on, and noting whether the tubes light to normal brilliance. If they do not light at all, check for a missing connection, a defective tube, or defective line resistor. If the tubes light up much more brightly than normal, or if one of the tubes fails to light and the others light very brightly, turn the switch off immediately and check the circuit. It is possible that one of the tube heater terminals has been grounded to the chassis by excess solder, or perhaps one or more of the connections has been made incorrectly.

How to wire the power supply circuit

This circuit, as seen in Figure 1-21, includes the selenium rectifier, resistors R7 and R8, and the filter condenser, C9. As mentioned in the assembly instructions, R7 and R8 are

of the positive wires of the filter condenser must also be connected to "A." The remaining filter-condenser positive wire is now connected to point "B" on the tie strip, to which the free end of R7 is already connected. When the remainder of the set is wired, the B supply for all plates and screens (except the plate of the 50L6) will be taken from point "B." Connect the negative (black) wire of the filter condenser to chassis. Connect a wire from the line-cord end of the line resistor to the free terminal of the selenium rectifier and the job is complete. The power supply circuit cannot be properly tested without a DC voltmeter. If you have one, check the voltages from points "A" and "B" on the tie strip to chassis. These voltages should be somewhere between 90 and 120. If you do not have a voltmeter, turn the set on and note whether any parts appear to overheat. If they do not, the power supply circuit is probably working properly. At any sign of overheating, turn the set off at once and check for a ground or for wrong

connections. Things to watch out for include: Rectifier terminal lug grounded to chassis; defective filter condenser; connections to filter condenser reversed.

How to wire the power output circuit

The sectional wiring method may be extended by making the connections to the tube socket terminals in a particular order. You may proceed clockwise or counter-clockwise around the socket, as you choose. If you decide to follow a clockwise direction, you will note first of all that pin 1 is not connected, since the 50L6 has neither an outer metal shell nor an internal shield. Pin 2 has already been wired as part of the heater circuit. Connect the blue wire of the output transformer primary to pin 3, the plate. Before soldering the connection, also connect one end of C8 to this terminal. Solder the connection, then connect the free end of C8 to chassis. If you are using the type of socket that has a metal ring with several terminal

one of them is in contact with the metal frame of the speaker. If it is, then this terminal is already connected to the chassis. If neither of the terminals is fastened directly to the metal, you will have to add the chassis connection shown in Figure 1-22. Before leaving the plate circuit, look at the plate wire of the output transformer. Make sure that it runs directly from tube socket to transformer and is no longer than necessary. See that it does not come near the grid terminal (pin 5) of the 50L6. If you follow the wiring instructions given in Chapter 3, you will not be likely to allow this wire to come near the 12SJ7 socket, but this should be checked nevertheless. Connect the red wire of the output transformer primary to the "A" terminal of the filter resistor strip. All connections at this terminal point may now be soldered. Run a wire from pin 4 of the socket to the "B" terminal of the filter resistor strip. If you have a voltmeter and signal generator and intend to make separate voltage and operation tests on the

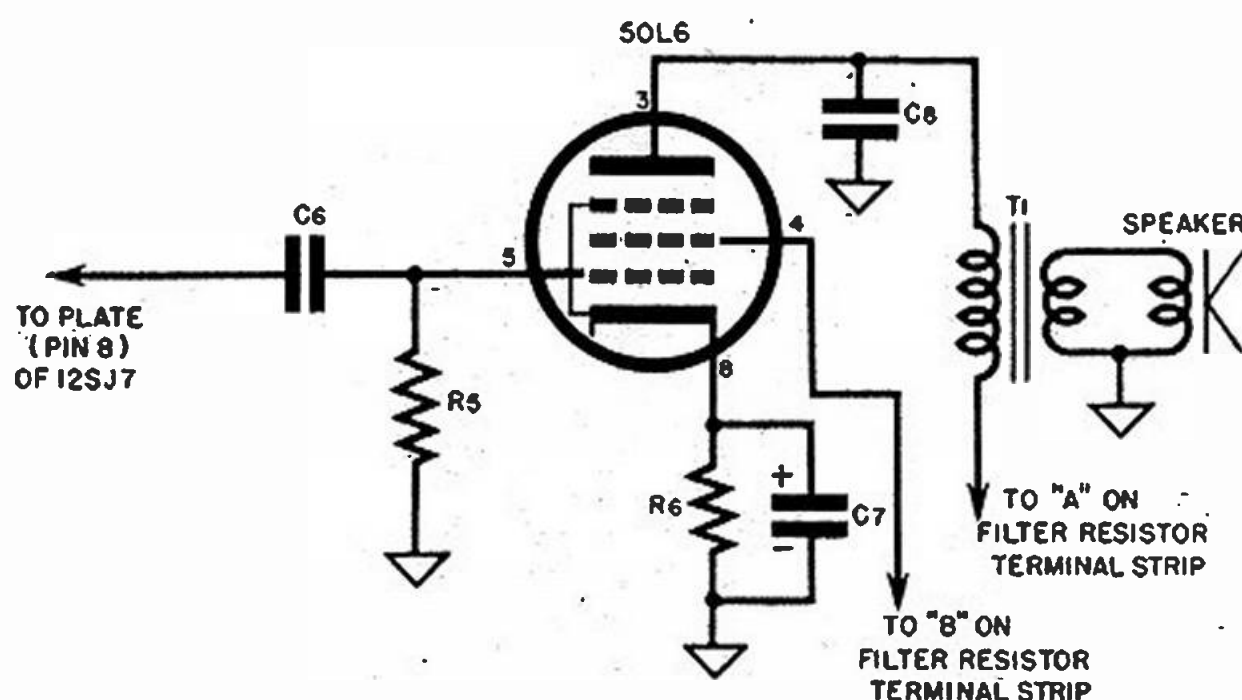

Fig. 1-22. The power output circuit.

lugs, C8 can best be connected to one of these lugs; they are, of course, in contact with the chassis. While working on the plate circuit, connect the secondary wires of the output transformer to the voice coil terminals of the speaker. (The secondary wires are usually enameled wire.) No "polarity" need be observed in connecting these wires. Now examine the speaker voice-coil terminals and note whether

stage, this connection may now be soldered; otherwise it need not be soldered until other wires are added later on. Resistor R5 may now be connected between pin 5 of the socket and the chassis. Here again, ground terminal lugs on the tube sockets will be found convenient. Before soldering the connections at pin 5, add one end of condenser C6. It is advisable to slip a piece of tubing (spaghetti)

over the condenser wire. Notice that the other end of C6 remains unconnected until the next circuit is wired. You will notice that there are no connections made to pin 6 of the socket, and pin 7 was wired during the heater circuit wiring operation. Pin 8, the cathode, carries one end of the cathode resistor, R6, and also one end of the bypass condenser, C7. The remaining ends of these units are to be connected to chassis. The resistor and condenser may either be connected directly between the tube socket and a convenient ground terminal, or they may be supported on an additional two-point tie strip. In the latter case, wires are run from the tie-strip terminals to chassis and to the tube socket. In any case, be sure to observe the polarity of C7; the positive terminal must be connected to the cathode and the negative terminal to chassis. This completes the output stage wiring, and the circuit may now be inspected and checked. Lacking any

a DC voltmeter, you may make a further test by measuring the voltages at the tube socket terminals. Normal voltages are: Pin 3 to chassis 90-110 volts, pin 4 to chassis 80 to 100 volts, pin 8 to chassis 12 to 20 volts.

How to wire the detector circuit

See Figure 1-23.

The detector circuit includes the secondary of the r.f. coil, L2; one section of the variable condenser (this will be the front section in this set); the tube socket; resistors R2, R3, and R4; condensers C4 and C5; and the free end of C6.

Pin 1 of the 12SJ7 is the metal shell of the tube and must be connected to chassis. Pin 2 was connected during the heater circuit wiring operation. Pin 3, the suppressor, is connected directly to chassis. Using the instruction sheet that came with the r.f. coil, locate the grid terminal lug. If you followed the assembly instructions closely, you will have a wire running

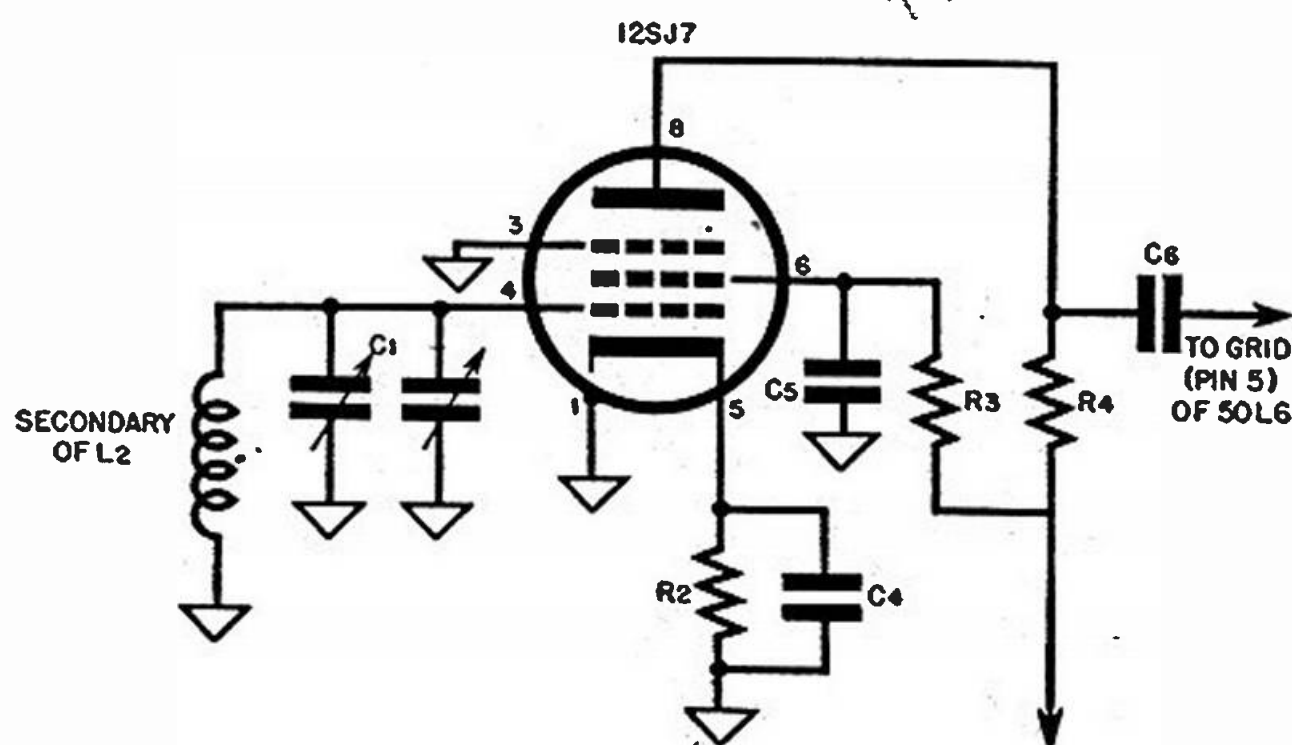

Fig. 1-23. The detector circuit.

test equipment, you may make a very rough operation test of the circuit. With all tubes in their sockets and the set plugged in, turn the switch on and allow the tubes to warm up for a moment. Touching the grid terminal (pin 5) of the tube socket with your finger or with a metal object, such as a screwdriver blade or scribe, should result in a clearly audible buzz in the speaker. In doing this, be careful to touch no other terminals. If you have

from the stator terminal of the variable condenser (front section) down through a hole in the chassis. Connect the free end of this wire to the grid terminal of the r.f. coil. Make sure that this wire is as short and direct as possible and that it is kept well away from parts and from other wires. Before soldering the connection at the coil, add the wire running from the coil terminal to the grid terminal of the tube, pin 4. Solder the connec-

tions, then inspect your wiring to be sure that it is short and direct. Resistor R2 and condenser C4 are added next, connected between the cathode terminal (pin 5) of the socket and chassis. As explained during the output circuit description, these parts may either be connected directly between the socket terminal and chassis or they may be mounted on a tie strip. Be sure that the outside foil connection of the condenser (usually indicated by a stripe on the container) is connected to the chassis. When the set was assembled, resistors R3 and R4 were mounted on a tie strip located near the 12SJ7 socket. This sub-assembly is shown in Figure 1-24, and the connections are clearly indicated. Now, referring to this sketch and to the circuit diagram, Figure 1-23, connect the free end of R3 to the screen terminal of the tube socket, pin 6. Before soldering, connect one end of C5 to this socket terminal. Connect the remaining end of C5 to chassis,

R3 and R4 on the tie strip to point "B" on the filter-resistor tie strip (refer to Figure 1-20 for a drawing of this tie strip and location of point "B"). This completes the detector circuit wiring. As in the case of the output stage, a rough operation test may be applied to this circuit. Touching the grid terminal of the socket, pin 4, should result in a loud buzz in the speaker. Remember that these tests are not fully conclusive. It is possible for trouble to exist in the circuit even though the buzz is of normal loudness. Adequate testing can be done only with suitable test equipment.

How to wire the r.f. circuit

See Figure 1-25.

The r.f. section is the largest unit to be wired, because it includes both the primary and the secondary of the antenna coil, L1, as well as the volume control. These parts are in addition to the 12SK7 tube and its associated

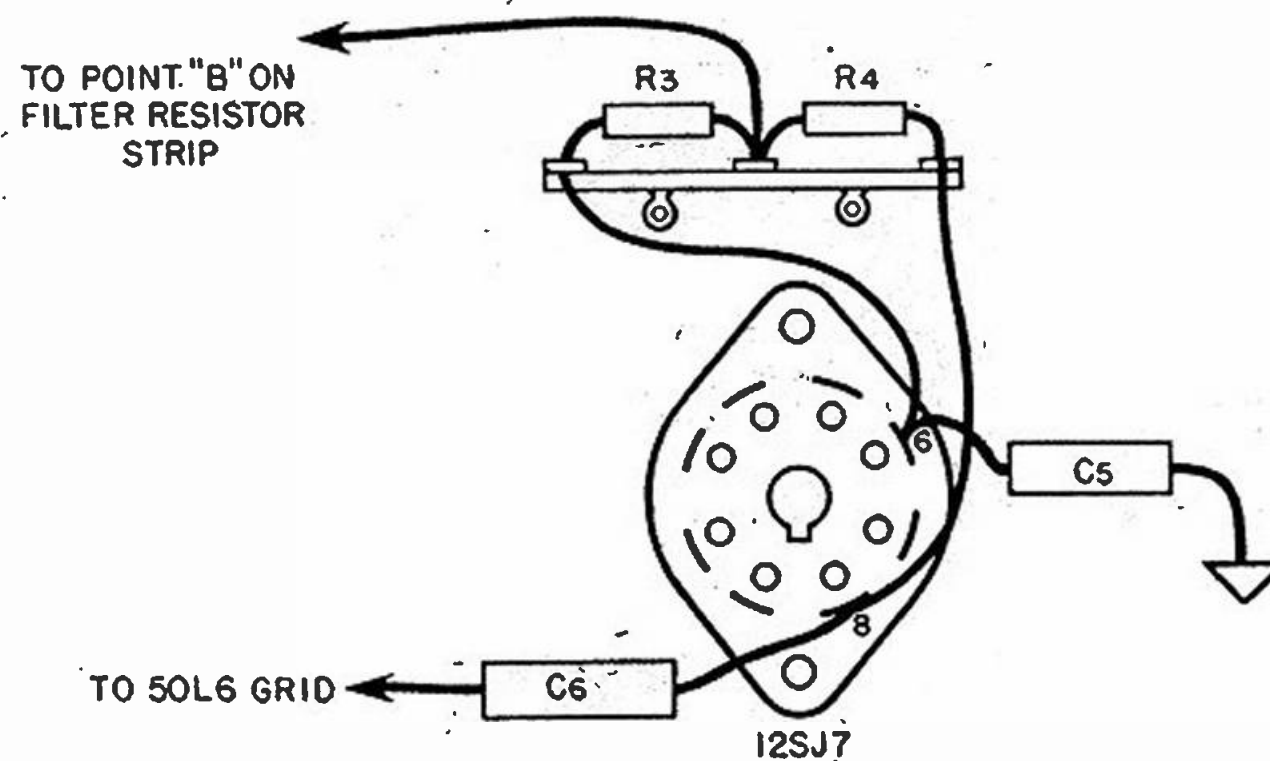

Fig. 1-24. Assembly of R3 and R4.

but be sure that the chassis end is the outside foil. Referring to the detail sketch, Figure 1-24, notice that R3 and R4 join at the center of the three terminal lugs on the tie strip. The free end of R4 (the right-hand end in the sketch) is now connected to the plate terminal of the socket, pin 8. Don't forget to connect the free end of C6 (left unconnected in the previous job) to the plate terminal also. Now run a wire from the junction of

resistors and condensers. Connect pin 1, the shell, to chassis. Pin 2 was wired with the heater circuit, so that you may now proceed to pin 3, the suppressor. This terminal is connected directly to the chassis. The rear, or antenna, section of the variable condenser has a wire connected to its stator lug and this wire runs down through the chassis. Connect it to the grid terminal (pin 4) of the tube socket. This circuit also includes the

secondary of the antenna coil. Locate the grid terminal of the coil by using the instruction sheet that came with the coil. Connect a wire to this terminal; then connect the other end of this wire to the remaining stator lug on the rear section of the variable condenser.

All variable condensers have two terminal connections to each set of stator plates. If the condenser has been mounted flat, as in the chassis top view, the terminal lugs at the left side of the condenser are already occupied. This means that the wire from the antenna coil must be connected to the terminal at the right side. If the condenser is mounted on edge, the terminals at the bottom are already in use and the coil wire is then connected to the top stator terminal. Be sure that both of the grid wires are as short and direct as possible.

be needed to locate the proper terminal. Notice that condenser C11 is also connected to this terminal of the coil. It was suggested that the condenser be installed during assembly; if this has been done, you now need only to solder the connection. The two remaining terminals of the antenna coil are to be connected to chassis. Connect a short jumper wire between the two coil terminals, then run a wire from either one of the terminals to chassis. Ground the center terminal of the volume control to the chassis. Locate the plate terminal of the r.f. coil primary and connect it to the plate terminal of the tube socket, pin 8. Next, run a wire from the screen terminal of the socket, pin 6, to the remaining coil terminal and another wire from this same coil terminal to point B on the filter-resistor terminal strip. Finally, install the

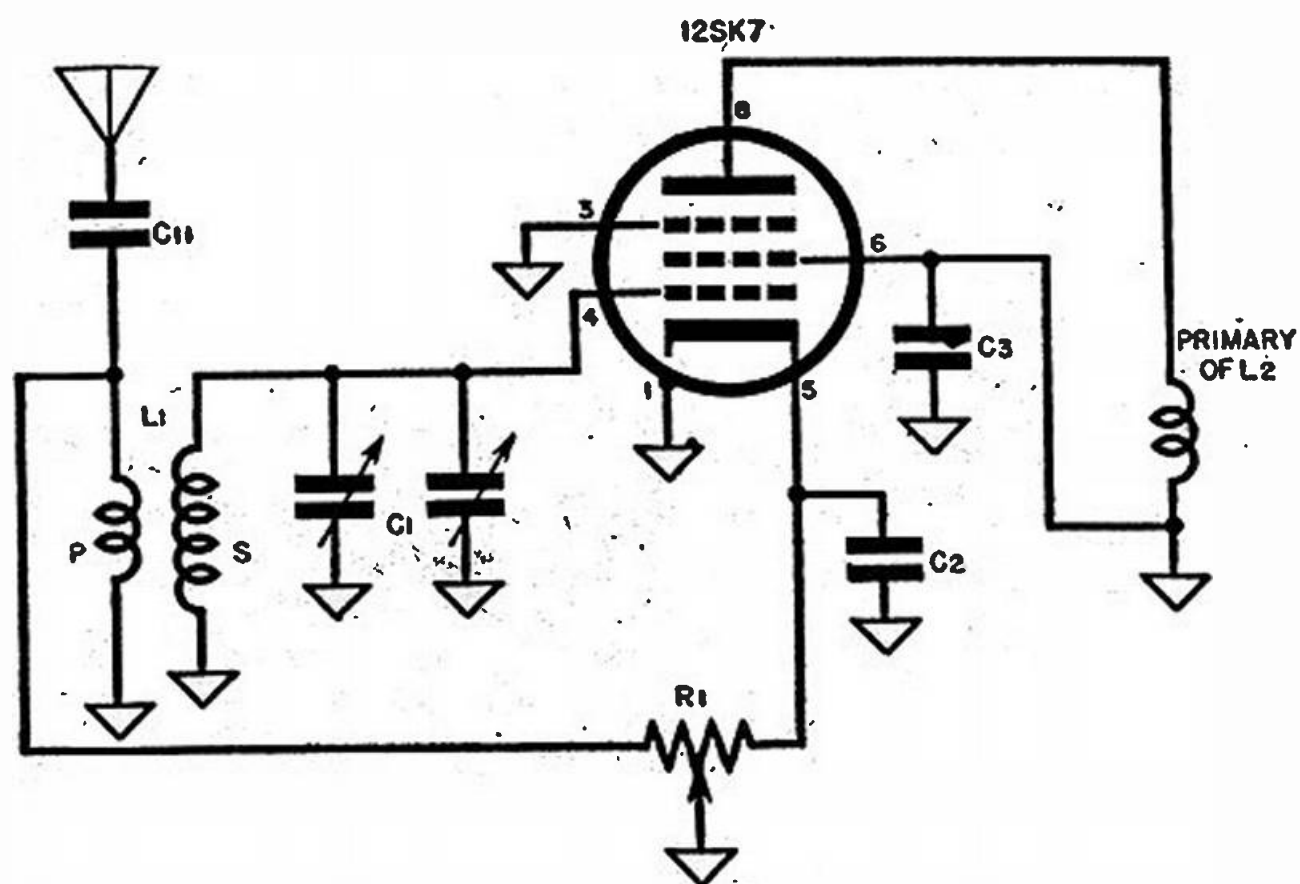

Fig. 1-25. The R. F. amplifier circuit.

Now run a wire from the cathode terminal of the tube socket (pin 5) to the volume control. This wire will be rather long, so be careful to keep it away from other wires. To locate the proper terminal on the control, face the shaft end of the control, with the terminal lugs pointing downward. The proper terminal is the one to your right. Now wire the left-hand terminal lug of the control to the antenna end of the coil primary. Here again, the coil instruction sheet will

screen and cathode condensers, C2 and C3. Be careful to connect both condensers with their outside foil terminals to chassis.

Connect the antenna wire to the antenna terminal, turn the set on, and advance the volume control all the way to the right. You should now hear signals, although they may not be as loud as expected. This is probably due to the fact that some alignment is necessary. If you do not have a signal generator, align the set in the

following manner: Tune in a signal located as near the wide open position of the variable condenser as possible. Without changing the condenser setting, turn each of the trimmer screws so as to obtain the maximum signal strength. If, at the first trial, you were unable to pick up a station quite close to the open position of the variable condenser, try again. You will probably find that, after the preliminary alignment, stations come in over

the entire range. Select one operating on a frequency between 1500 and 1600 kilocycles and repeat the alignment. If you intend to use a tuning dial calibrated in kilocycles, it will be best to use a signal generator for the alignment. Adjust the generator to give a 1500-kilocycle modulated signal and connect the generator cable to the antenna terminal and chassis. Set the receiver tuning dial at 1500 kilocycles. Adjust the two trimmer screws to give maximum signal strength.

TROUBLE-SHOOTING CHART

In constructing any radio receiver the possibilities of defective parts and incorrect wiring are always present. If you wired the set from the sectional diagrams and have made the simple

tests suggested, you have minimized the chance of trouble when the final test is made. However, a list of common troubles and their causes is given here for your convenience.

<i>Trouble</i>	<i>Causes</i>
Tubes do not light.	Defective tube, defective line resistor, defective switch, missing or broken connection in heater circuit.
One tube fails to light, others light brighter than normal.	Heater terminal of tube grounded to chassis. Look for excess solder.
Tubes light, but no signals; touching grid terminal of 50L6 does not give a buzz; R8 overheats, but R7 does not.	Look for shorted filter condenser (first section) or ground in plate circuit of 50L6.
Same as above, but both R7 and R8 overheat.	Shorted section of filter-condenser ground in plate or screen circuits of 12SK7 or 12SJ7 or in screen circuit of 50L6.
No buzz when grid of 50L6 is touched, but neither R7 nor R8 overheat.	Defective output transformer, defective speaker, defective 50L6 tube, R6 not connected or open.
Buzz when 50L6 grid is touched, but none at grid of 12SJ7.	C6 open, R2 open or not connected, defective 12SJ7, R3 or R4 open or not connected.
Set operates, but signals are weak.	Inefficient antenna, open antenna-coil primary, connections to r.f. or antenna coil reversed, set needs alignment.

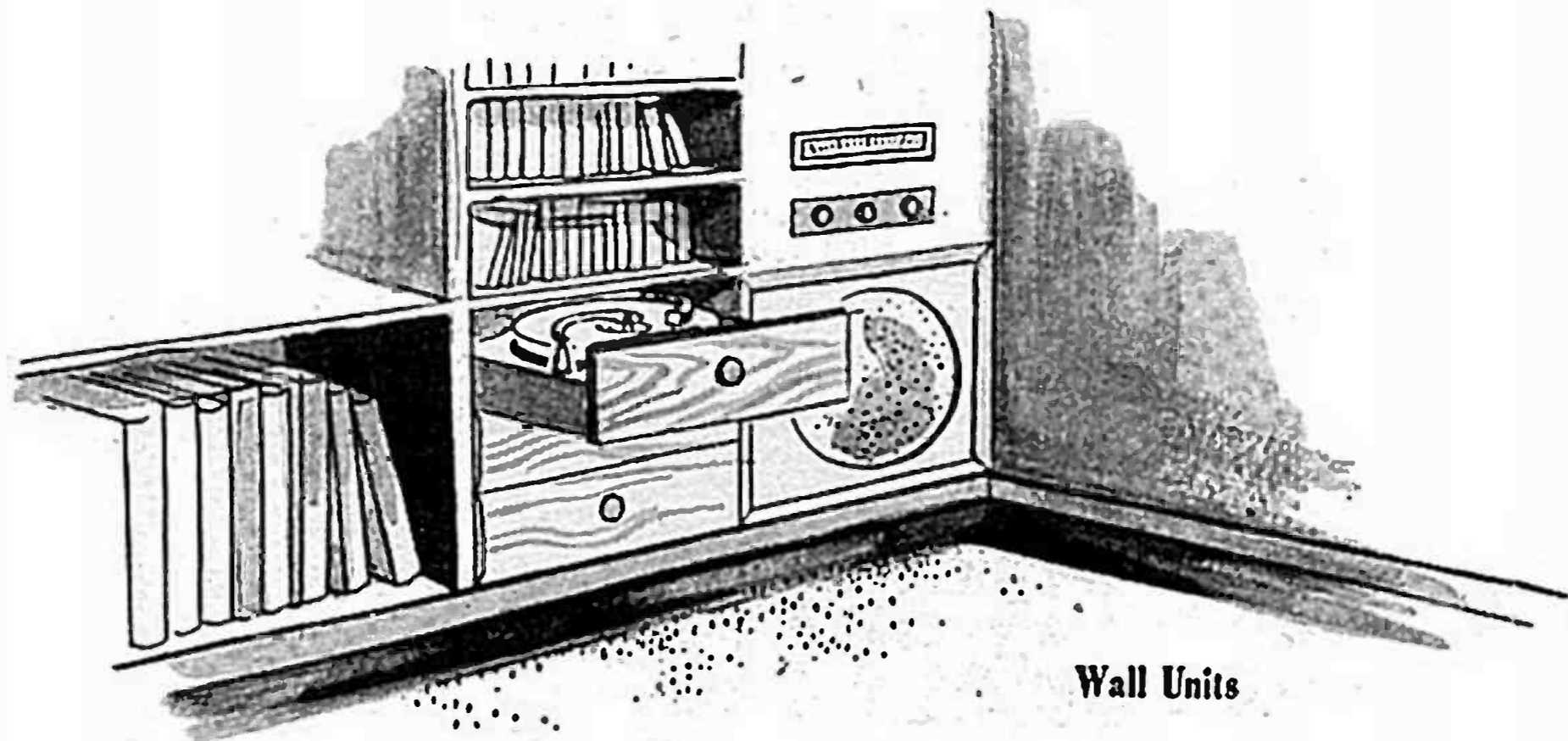

Wall Units

Make Your Radio-Phono an Integrated Part of Your Home

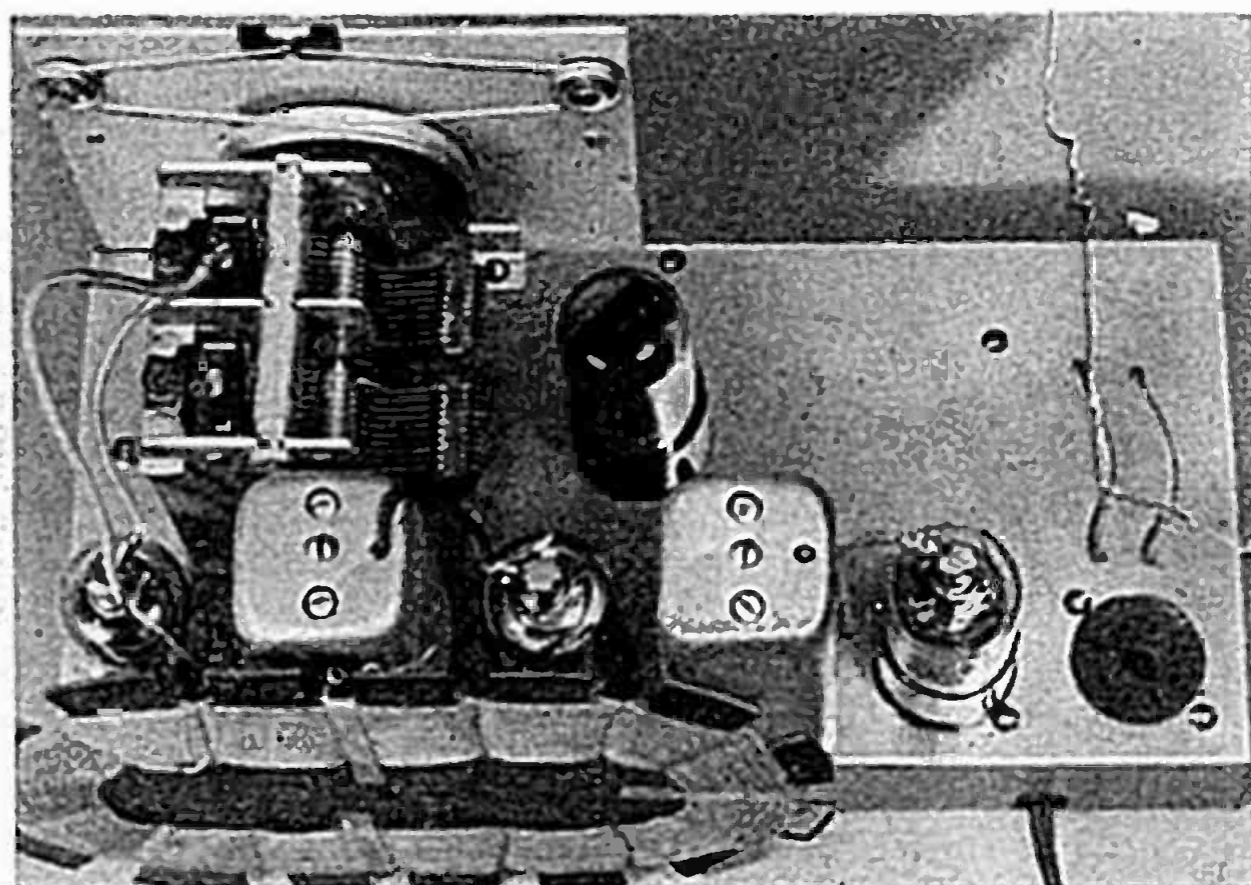

A Five-Tube Radio Receiver

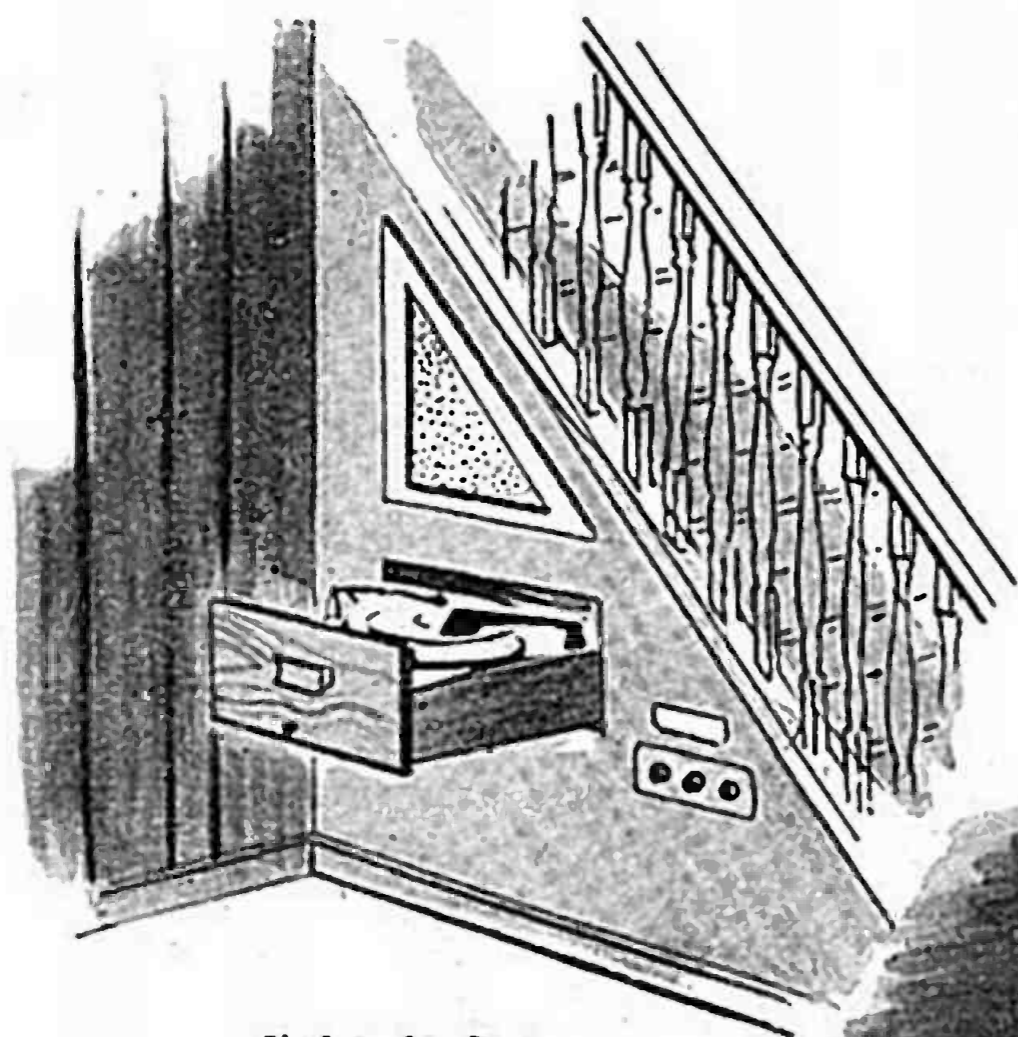

Under the Stairs

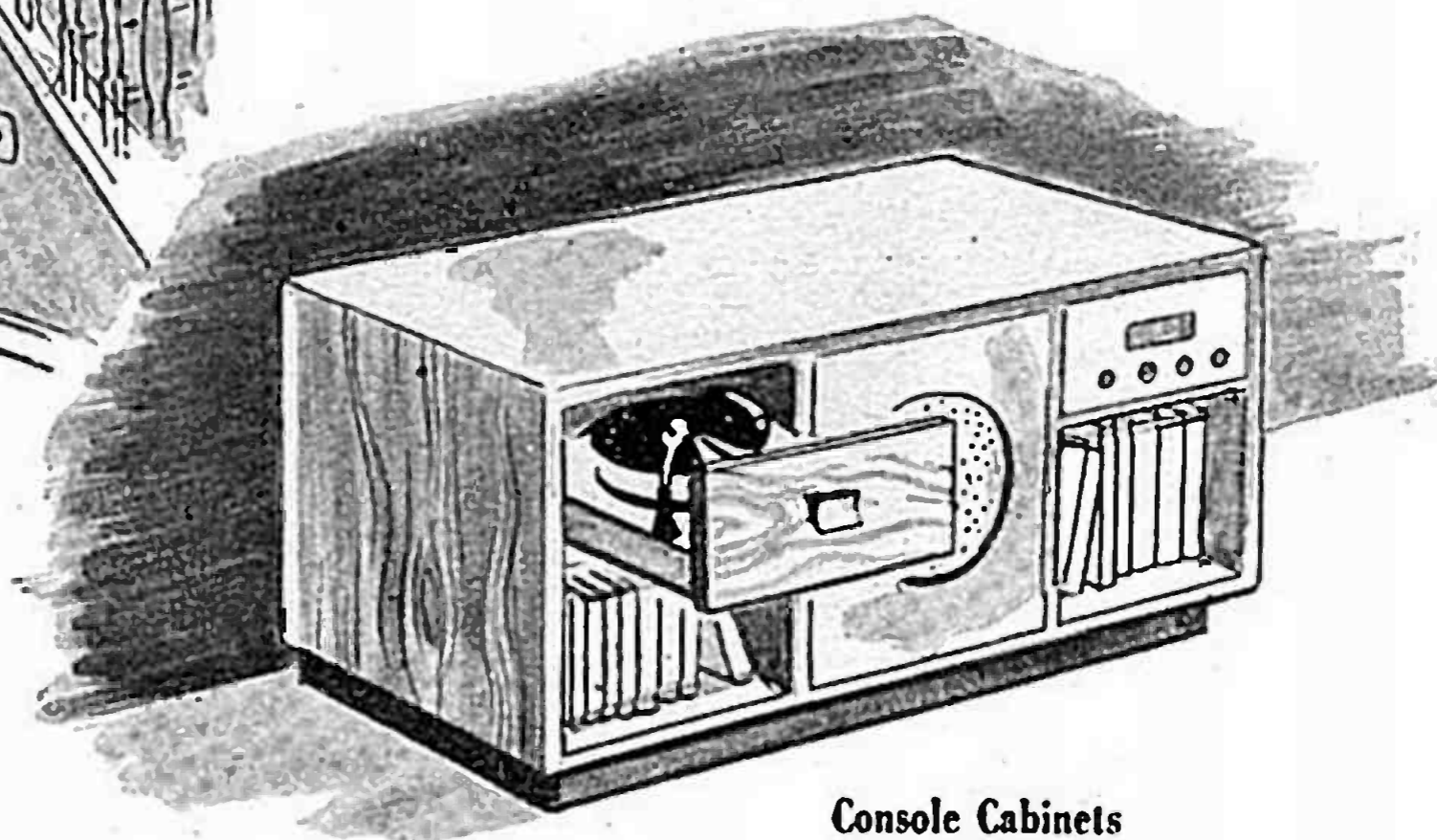

Console Cabinets

Two Advanced Receivers with Phonograph Combination

IN THIS chapter we describe the construction of advanced home radio receivers. These sets will compare favorably with good commercially built sets as well as interesting the experimenter. One is a very compact receiver, the other a living-room set comparable to highly priced commercial products.

The first of these projects is a five-tube superheterodyne for operation from either AC or DC supply. The use of miniature tubes results in a compact unit that is suitable for use as a personal or "second" set—a valuable asset in any household in the bedroom, guest room, or kitchen. It is also easily adapted for use, together with a manual or automatic record player, as a table radio-phonograph combination. The circuit changes required for adapting the set to this purpose are explained after describing the construction.

Continuing to offer alternative methods of construction so you may have as wide a choice of tubes and components as possible, we should like to point out that the GT type tubes, or metal tubes, may be substituted for the miniature tubes if you wish. The

only circuit changes this substitution calls for are in the wiring (changes in tube socket connections). The values of parts remain the same. Whether or not additional chassis space will be needed depends upon your choice of components. If you select midget i.f. transformers and variable condenser and if the speaker is not larger than the size suggested, it is entirely possible to build the set, using the larger tubes, on the 3 by 10 inch chassis originally specified, although some rearrangement of parts may be required.

Another variation described for this set is the substitution of a selenium rectifier for the tube rectifier.

The second project in this chapter is a six-tube a.c. superheterodyne. This set is equipped with a push-pull output stage and phono input, and in all respects—volume, tone, and sensitivity—compared with manufactured sets in upper price brackets. If carefully built it can serve as the principal, or living room, set in any home. Following the description of the assembly and wiring of this set, you will find instructions for adding a tone control and an electron-ray tuning indicator.

FIVE TUBE AC/DC SUPERHETERODYNE

Circuit description

This project uses the famous and popular "All American Five" superheterodyne circuit. First introduced

commercially almost a score of years ago, it has become the standard of the industry for small, compact sets and has reappeared yearly with improve-

ments and revisions. In addition to vast numbers of these sets turned out each year by the plants, countless numbers have been built by home constructors.

Operating from a loop antenna, it will deliver excellent signal strength over the entire broadcast range in all except the most remote locations. If the loop antenna selected is of the proper dimensions, it will serve also as a back cover for the cabinet and help to keep out dust. Furthermore, if you use a loop having a primary winding, an indoor or outdoor antenna can be connected for additional pickup when the set is operated under adverse conditions. The loop is tuned by the rear section of the variable condenser.

Signals from the tuned circuit just described are passed to the mixer grid (grid no. 3) of the 12BE6 converter tube; see diagram, Figure 2-1. At the same time, locally generated

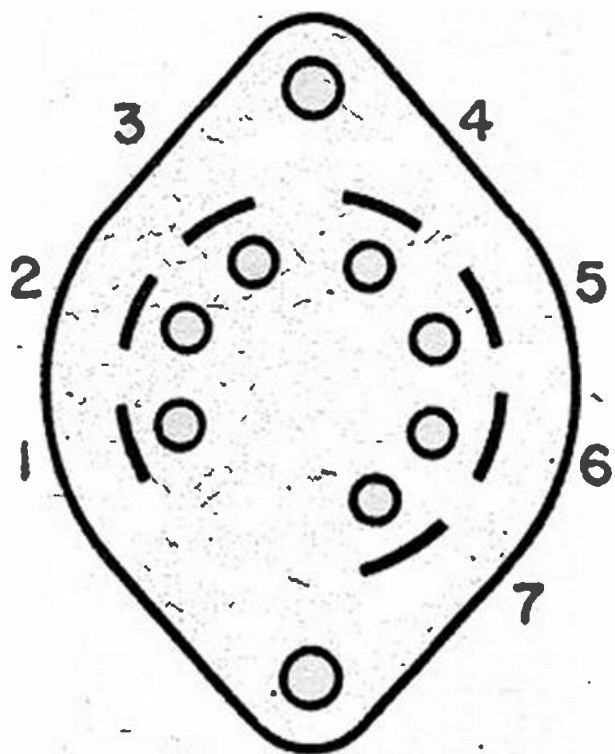

Fig. 2-2. Tube socket layout.

oscillator signals also appear in the mixer circuit. These oscillations are developed in the tuned circuit consisting of the oscillator coil winding and the front section of the variable condenser. The oscillator signals are always 455 kilocycles higher than the signals picked up by the loop.

After mixing of the station signal and the oscillator signal has taken place, the resulting signal (the difference between the station signal and the oscillator signal) passes through

the intermediate frequency transformers, which "screen out" any unwanted signals. At the same time, the 12BA6 i.f. amplifier builds up the wanted signal and passes it on to the diode detector section of the 12AT6 tube. The 12AT6 is a dual purpose tube, serving as detector and first audio amplifier. It also supplies AVC voltages, which we shall neglect for the moment. The diode section of the tube rectifies the signal and the i.f. impulses are removed by the filtering action of the resistor R9 (51,000 ohms), and the two bypass condensers C7 and C8 (150 mmfd. each).

The audio portion of the signal appears across the 500,000-ohm volume control, R8. The desired amount of this signal is taken from the volume control and applied to the grid of the triode section of the 12AT6 through the coupling condenser, C6. The amplified signal passes to the grid of the beam power output tube, 50B5, where it is further amplified and passed to the speaker.

Heater voltages for all tubes are taken directly from the power line through the use of a series heater circuit. Plate and screen voltages for all tubes are supplied by the 35W4 rectifier tube. Although a 5-inch permanent-magnet speaker is shown in the drawings, you may substitute a speaker of any diameter. If a smaller one is used, you can probably rearrange the layout so that a smaller chassis can be used. If the speaker is to be larger than 5 inches, you will have to mount it in some location other than on the chassis.

Parts list

Resistors

R1	150 ohms, 1/2-watt carbon
R2	47 ohms, 1-watt carbon
R3	2,000 ohms, 1-watt carbon
R4	470K ohms, 1/2-watt carbon
R5	150 ohms, 1/2-watt carbon
R6	220K ohms, 1/2-watt carbon
R7	10 megohms, 1/2-watt carbon

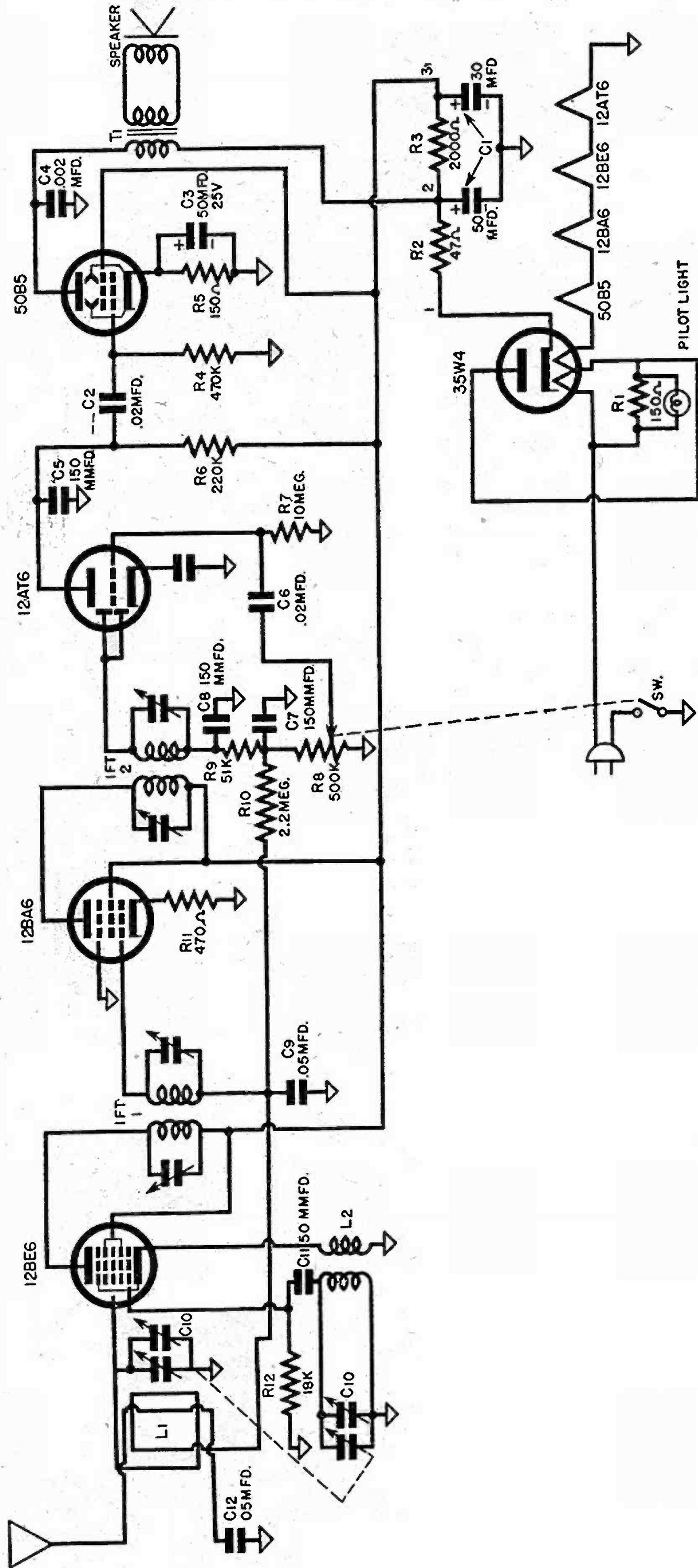

Fig. 2-1. Circuit for the "All American Five" superheterodyne receiver.

- R8 500K ohms, volume control
with switch
R9 51K ohms, 1/2-watt carbon
R10 2.2 megohms, 1/2-watt carbon
R11 470 ohms, 1/2-watt carbon
R12 18K ohms, 1/2-watt carbon

Condensers

- C1 -50-30 mfd., 150-volt electrolytic
C2 .02 mfd., 400-volt paper tubular
C3 50 mfd., 25-volt electrolytic
C4 .002 mfd., 500-volt mica
C5 150 mmfd., mica
C6 .02 mfd., 400-volt paper tubular
C7 150 mmfd., mica
C8 150 mmfd., mica
C9 .05 mfd., 400-volt paper tubular
C10 Two-gang tuning condenser,
30-470 mmfd. and 40-205
mmfd.
C11 50 mmfd., mica
C12 .05 mfd., 200-volt paper tubu-
lar

Coils

- L1 Loop antenna
L2 Oscillator coil, Meissner 14-
1040 or equivalent

Transformers

- T1 Output transformer, primary
impedance 2,000 ohms, sec-
ondary impedance 3.2 ohms
Stancor A-3876, Thordarson
T22S45, or Merit A-2928
IFT1
IFT2 455 K.C. midget iron core
type, Stanwyck

Speaker

- PM dynamic, voice coil impedance 3.2
ohms, Jensen P5-X or Quam 5A15

Miscellaneous

- Line cord and plug
5 tube sockets, 7-pin miniature
2 2-point tie lugs
2 3-point tie lugs
6-32 screws, 3/8 to 1/2 inch long
6-32 hexagon nuts
8-32 x 3/8-inch machine screws for
variable condenser
Chassis: 3 x 10 x 1-1/2 inches steel or
aluminum (or 18 gauge sheet alum-
inum 6 x 11 inches)

- Push-back wire
Rosin-core solder

Tubes

- 12BA6, 12BE6, 12AT6, 50B5, 35W4

Chassis layout and assembly

This project can be built on a chassis measuring 3 by 10 by 1-1/2 inches. It may be either of the pre-formed steel type, zinc plated or with wrinkle black or grey finish, or made of sheet aluminum in the home shop. If you decide to make your own chassis, you will need a piece of 18 gauge soft aluminum stock 6 by 11 inches. As mentioned before, you may want to use a larger or smaller speaker. If a 4-inch speaker is used, the chassis length can be reduced. We do not advise using a speaker smaller than 4 inches. You may want to use a speaker as large as 12 inches and, in that case, it will have to be mounted in the cabinet, or elsewhere, separate from the chassis. It would then be possible to rearrange the layout so that not only the length, but the overall proportions of the chassis conform to a particular cabinet you may have in mind. By locating the 12BE6 converter tube and the first i.f. transformer to the rear of the variable condenser, the chassis can be made shorter and wider; dimensions of about 5 by 7 inches would then be about right. The top view of the chassis is shown in Figure 2-3.

Begin the chassis layout by drawing a light pencil line parallel with the rear edge of the chassis and 1-1/2 inches from it. (We do not advise the marking of layout lines with a scribe or other tool; such marks are difficult to remove, no matter how lightly they are drawn, and will spoil the appearance of the finished job.) The line just drawn marks the centers of the 35W4, 50B5, 12AT6, and 12BA6 sockets. The 12BE6 socket, you will notice, is not located on a line with the others but is well forward of them, with its center about an inch from the

front edge of the chassis. The exact position of the socket, laterally, depends upon the size of variable condenser selected, but with an average-size condenser the center of the socket will be about 2-1/2 inches from the right end of the chassis. Locate the socket by trial, placing it and the variable condenser temporarily in position on the chassis. Now indicate the center of each socket by marking a short intersecting line. Measuring along the pencil line already drawn, make a mark at 3/4 inch from the left end of the chassis. This intersection marks the center of the 35W4 socket. Lay out other intersecting lines at 2 inches, 5-1/4 inches, and 6-3/8 inches from the end of the chassis. Make a center-punch mark at each of the intersections, then mark and center punch the socket screw holes.

The next step is to locate the position of the tuning condenser. The size

coincide and, while holding the paper in position, press firmly over each of the mounting holes. This will mark the positions of the holes on the paper. Then place the paper in position on the chassis and center punch through the paper. If the condenser uses spade lug mountings, it will be best to determine the positions of the holes by measurement.

Once the position of the tuning condenser has been determined, you may proceed to lay out the position of the first i.f. transformer. If you find that you are crowded for space because of the size of the tuning condenser, the transformer may be located close to, or even in contact with, the frame of the condenser. Center punch the positions of the holes to accommodate the spade bolts on the transformer. Midget i.f. transformers are of two varieties: those having the usual wire leads and those having four color-coded termi-

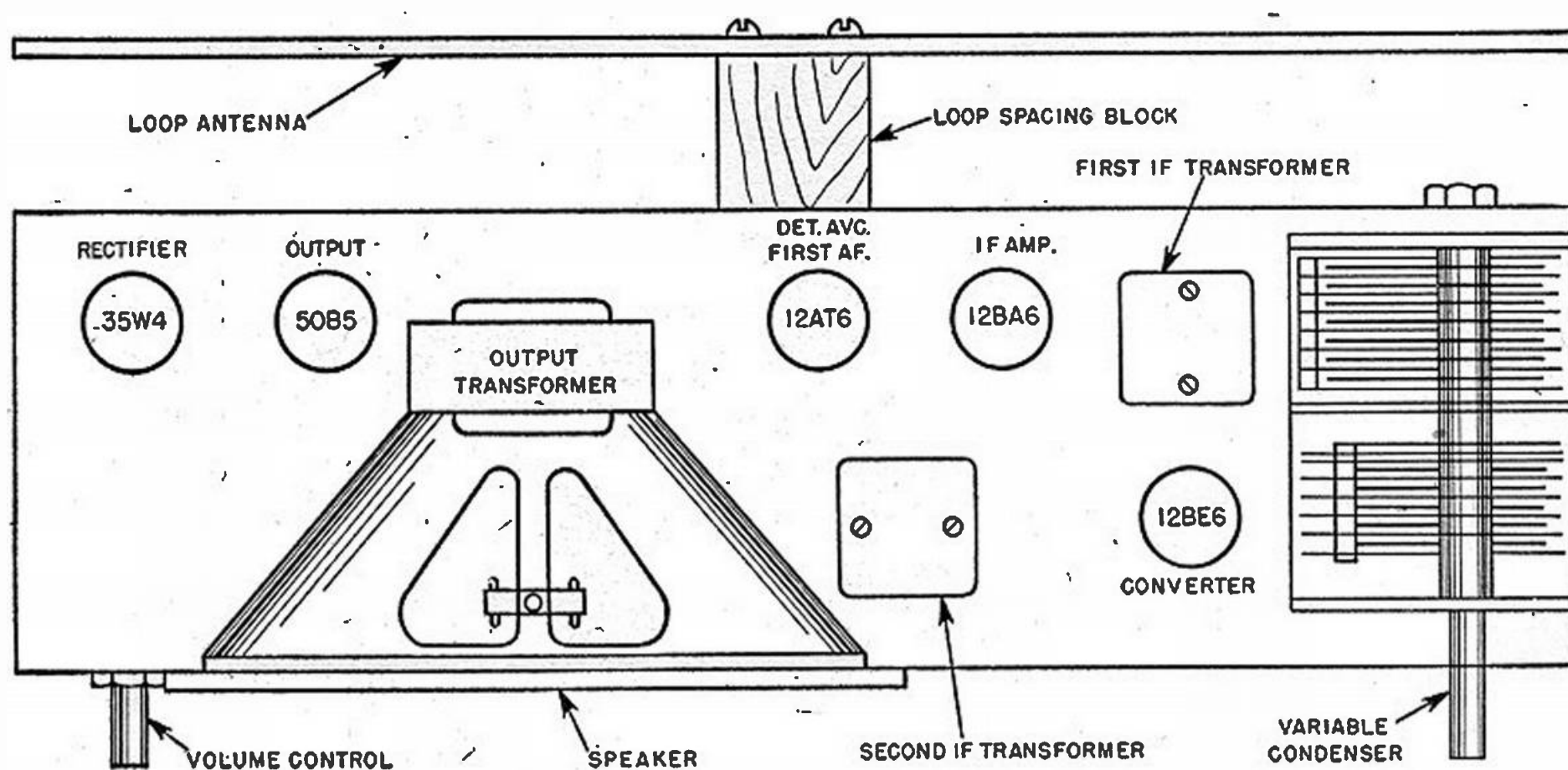

Fig. 2-3. Top view of the chassis.

and shape of the unit you buy will also determine the exact position of the first i.f. transformer. If your condenser has tapped holes in the underside of the frame, you will find that the use of a paper pattern will help to locate the holes in the chassis accurately. Cut a piece of writing paper the exact size of the bottom of the condenser. Position the paper on the bottom of the frame so that all the edges

coincide and, while holding the paper in position, press firmly over each of the mounting holes (for spade bolt or other type of mounting) and then make a center punch mark in the position to be occupied by the center of the transformer. This will later be drilled out to a size large enough to admit the wires. For the second type of transformer, first mark the positions of the mounting holes, then by meas-

urement locate the positions of the four terminal lugs. Make a center punch mark for each. This procedure applies to both transformers. Notice that the second transformer is located with its center about $7/8$ inch from the front edge of the chassis and midway, laterally, between the 12AT6 and 12BA6 sockets.

The exact positions of the speaker mounting holes will depend upon the type of speaker. If you buy a speaker with the output transformer already mounted on the magnet frame, you will save considerable work, but if you cannot get this type, you will have to complete the assembly yourself. Many speakers have a plate for holding the transformer, and in most cases the plate is already drilled for the transformer mounting holes. If your speaker does not have such a plate, you will have to make a clamp or bracket for

with one or more machine screws. The locations of the holes may now be marked. Refer to Chapter 1, Figures 1-8A and 1-8B, for information on the speaker mounting.

Referring to the underside view of the chassis, Figure 2-4, notice that the center of the volume control shaft is about $7/8$ inch from the end of the chassis. This distance may be varied so that the volume control and variable condenser shafts are an equal distance from the chassis ends. The position of the shaft hole should be in the center (vertically) of the front chassis apron. After marking and center punching the position of the shaft hole, note whether the control has a locating pin, or tab, as shown in Figure 2-5. If there is such a pin or tab, its purpose is two-fold: to enable you to quickly locate the control so that the lugs point downward and to prevent the

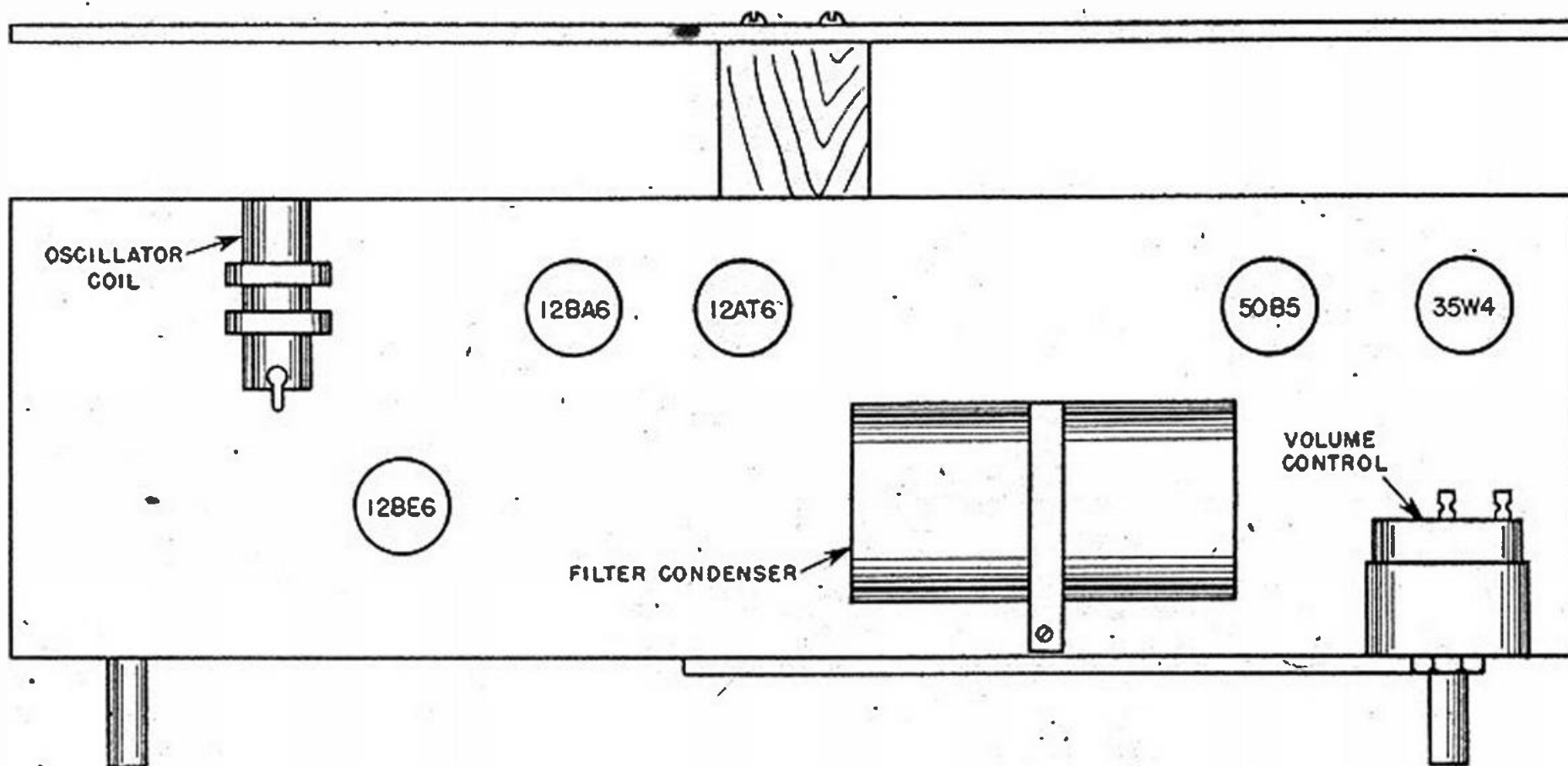

Fig. 2-4. Underside view of the chassis.

holding the transformer to the frame. Chances are, the speaker will have two tapped holes in the underside of the magnet frame or will have two brackets welded to the frame. In either case, layout involves merely marking the positions of the holes on the chassis. When the speaker magnet frame is fastened to the chassis, the rim of the cone frame will project a considerable amount below the top surface of the chassis, and it is a good idea to secure it to the front apron of the chassis

control from turning if the locknut is not fully tightened. This tab or pin may be broken off if you wish, but it is best to use it. Measure the distance from the center of the shaft to the center of the tab and make a punch mark in the proper place.

Locate and mark the positions of the tie strips; their approximate locations are shown in Figure 2-6. They need not be placed exactly as shown in the drawing but should be close to the tube sockets with which they are as-

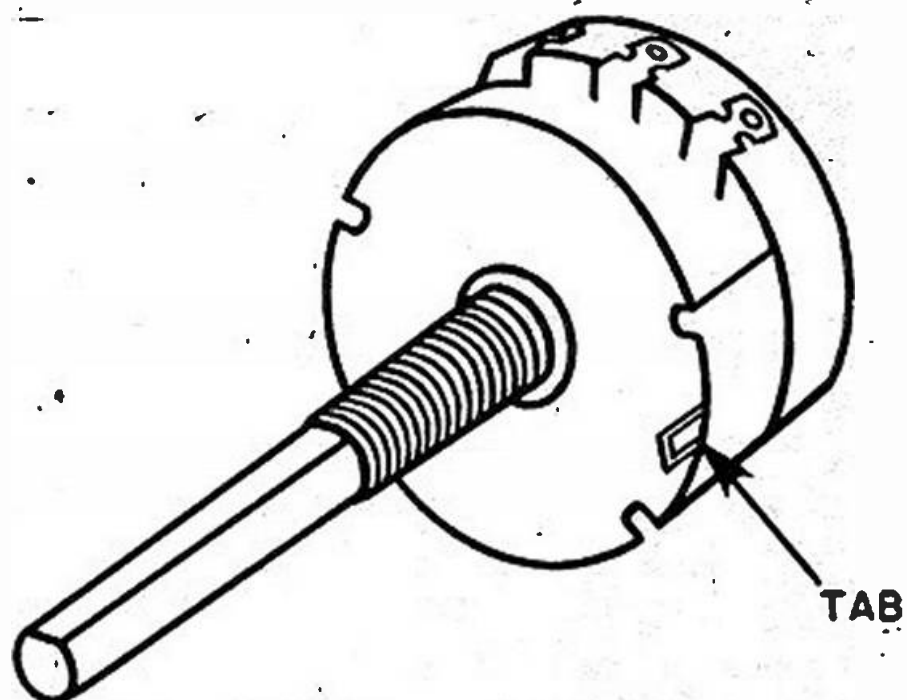

Fig. 2-5. Control locating pin.

sociated. The filter condenser can be held in place with a single screw and nut; locate and mark the position of this screw now. The oscillator coil is located close to the rear apron of the chassis and about 1-3/4 inches from the right end of the chassis. To complete the layout, mark the positions of the two screws used for holding the loop antenna to the chassis.

Begin drilling by using a #25 drill. This size provides clearance for a 6-32 screw, the size used for mounting most of the parts. The next step is to enlarge all of the other holes, either with a larger drill, with a punch or with a reamer. Tube socket center holes are cut by first drilling the center hole with a drill that is 1/32 inch larger than the diameter of the capscrew used with the punch. Follow this by punching out with a Greenlee punch as described and illustrated in Chapter 1. A 5/8-inch punch is the correct size for the sockets used in this set. Incidentally, this size of punch may also be used to punch holes for the i.f.

transformer wires, if the transformers are of that type. If the terminal lug type is used, drill the holes for the lugs 1/4 to 3/8 inch in diameter. The size will depend upon how accurately you have located the centers of the holes. After drilling, be sure to try the transformers in position to make certain that none of the lugs touch the chassis.

You may find that the tuning condenser is intended to be held in place with 8-32 screws. If so, enlarge the holes already drilled with a #16 drill. Drill the hole for the volume control shaft with a 7/16 drill or enlarge to size with a tapered reamer. Notice that the loop antenna is held to the chassis with two screws; these may well be of the self-threading variety. Use #6 screws about 1-1/4 inch long. A wood block slightly under 1 inch thick is used to space the loop from the chassis. Never mount the loop against the chassis. When all the holes mentioned have been drilled and cut, you will be ready to assemble the major components of the set.

Assembly

Fasten the tube sockets in place first. As each socket is installed, you might slip a soldering lug under one of its mounting screws. This will provide a convenient place for connecting resistors and condensers to chassis when the wiring is in progress. Next, install the i.f. transformers. If they have wire leads, be sure to study both possible positions of the transformer

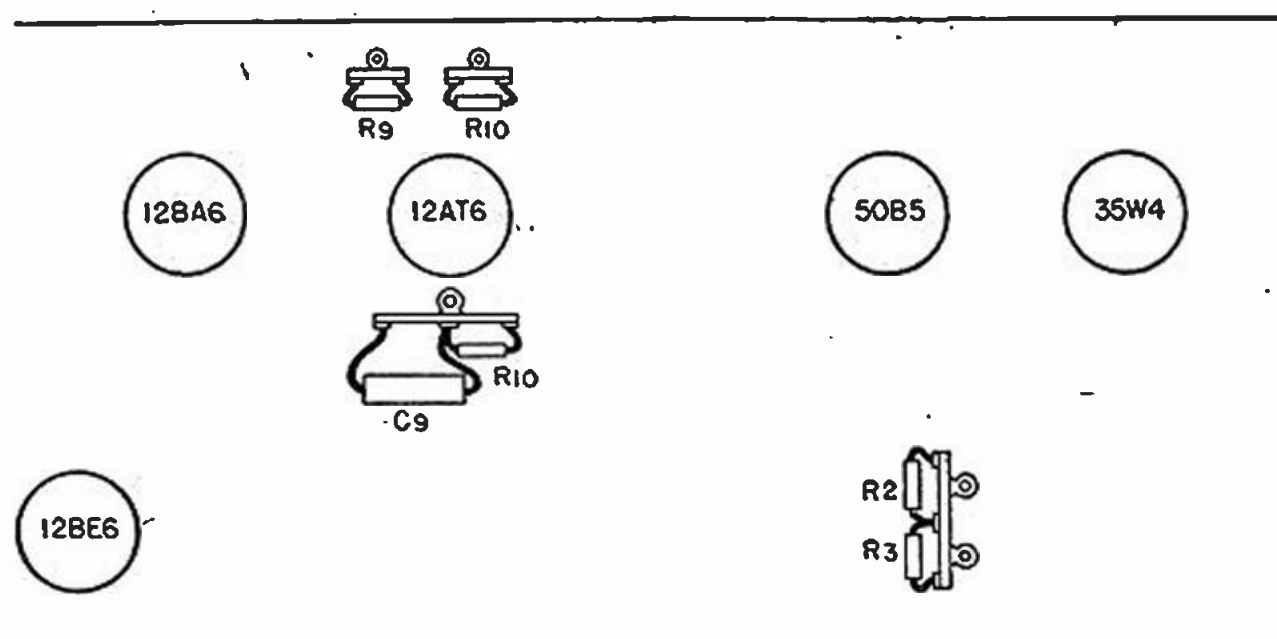

Fig. 2-6. Approximate positions of the tie strips.

before fastening them in place. Since they can be turned through 180 degrees, there will always be one best position in which the grid and plate leads are as short as possible and do not cross.

The variable condenser, volume control, filter condenser, oscillator coil, and speaker may now be fastened in place. There is no need to install the loop antenna until you are ready to wire the converter stage; this will lessen the possibility of damage to it. Mount resistors and condensers on tie strips as shown in Figure 2-6 and fasten tie strips in place.

Wiring

In wiring this project, the "sectional" method has been used. Whether you are a beginner or an experienced constructor, you will find this method helpful, for it provides a systematic procedure. Furthermore, a test procedure is given at the end of each step in the wiring, and by following this you will be able to check on your work as you proceed. This, of course, is a very easy way to locate any troubles that might arise. Instead of referring to the complete diagram, use the sectional diagrams. The complete schematic is needed only for checking and as a final reference.

Using this method, you will proceed to wire the set stage by stage, or circuit by circuit. As the heater circuit is distinct from the rest of the set, it has been regarded as one section, or circuit. The power supply consisting of the rectifier tube, filter resistor, and filter condenser, comprises another circuit.

In further dividing the set into convenient sections, we find that the output stage lends itself to such division with no trouble at all. The detector-first audio-AVC tube, type 12AT6, can conveniently be split into two sections: detector and first audio. Of course, the AVC is a separate function, but it is considered as part of the detector function.

In dividing the set into sections, we have attempted to make each wiring job as complete and as distinct from the balance of the set as possible and, at the same time, to keep it as simple as possible. For instance, the 12BA6 i.f. amplifier cannot be subdivided, and when considered as a complete unit is fairly simple. The 12BE6 converter, on the other hand, seems to divide easily into two jobs: the mixer stage and the oscillator stage.

If you will try this method of wiring, you will find that it is well nigh impossible to make an error in wiring. Then, if you do slip up somewhere, you will find that the simple test procedure will readily locate the mistake.

Here it will be well to note that the power supply has two terminals, marked "HI B plus" and "LOW B plus." This is clearly indicated in the picture wiring diagram of Figure 2-9, which shows the assembly of the filter resistor, R3, resistor R2, and the filter condenser, C1. The use of a tie strip eliminates the unsightly and sometimes risky practice of allowing resistors and condensers to hang by their connecting leads, which may often be quite long. Tie lugs are advised in all cases except when a resistor or condenser may be directly connected, with short leads, from a fixed point such as a socket terminal to another fixed point such as a chassis connection. If you will use this method of construction you will eliminate almost entirely, the possibility of accidental grounds and short circuits and your project will present a neater appearance. Notice that the resistor R2 is connected between points 1 and 2 on the three-point tie strip, while the 2,000-ohm filter resistor, R3, is connected between points 2 and 3. One positive lead of the filter condenser is connected to point 2, while the other runs to point 3.

Point 2 on the tie strip, or terminal strip, has been designated as "HI B plus," and it is to this point that the B-plus wire (usually color-coded blue)

of the output transformer is to be connected. The screen of the output tube (pin 6) is connected directly to point 3 on the tie strip. Also, the plate and screen connections of all other tubes are wired to this point, referred to as "LOW B plus."

By this time you probably have a question: "Why not take all B voltage from one common point, instead of using two separate B-plus connections?" This is a very good question, for the wiring in that case would be a bit simpler. There is an excellent reason, however, for going to the extra trouble, and the answer to the question explains much about present-day set design and construction.

All sets intended to operate from a power line require some kind of filter to smooth out the pulsations produced by the rectifier tube. There are two general types of filter circuit: resistance-condenser and choke-condenser. The latter type uses a choke and usually two filter-condenser sections, while the first (and cheaper) type gets by with an inexpensive resistor in place of the choke. The trou-

the output tube (which takes more current than all the others combined) from such a point in the filter system that the current need not pass through the resistor. "But," you may ask, "doesn't this method allow unfiltered current to reach the output tube plate?" The answer is no, because the output transformer acts as a filter choke. In wiring this set, just be sure that only the B-plus lead of the output transformer is connected to "HI B plus"; all other plate and screen leads go to "LOW B plus."

How to wire the heater circuit

See Figure 2-7.

Before starting to wire, refer to Figure 2-2, which shows the tube-socket layout for this set. All five sockets are alike, so only one diagram is needed. Drill a hole in the rear apron of the chassis to accommodate the line cord. To prevent the possibility that the chassis metal will cut into the cord, fit a rubber grommet into the hole. Pass the line cord through the hole, measure the amount needed to reach the on-off switch and

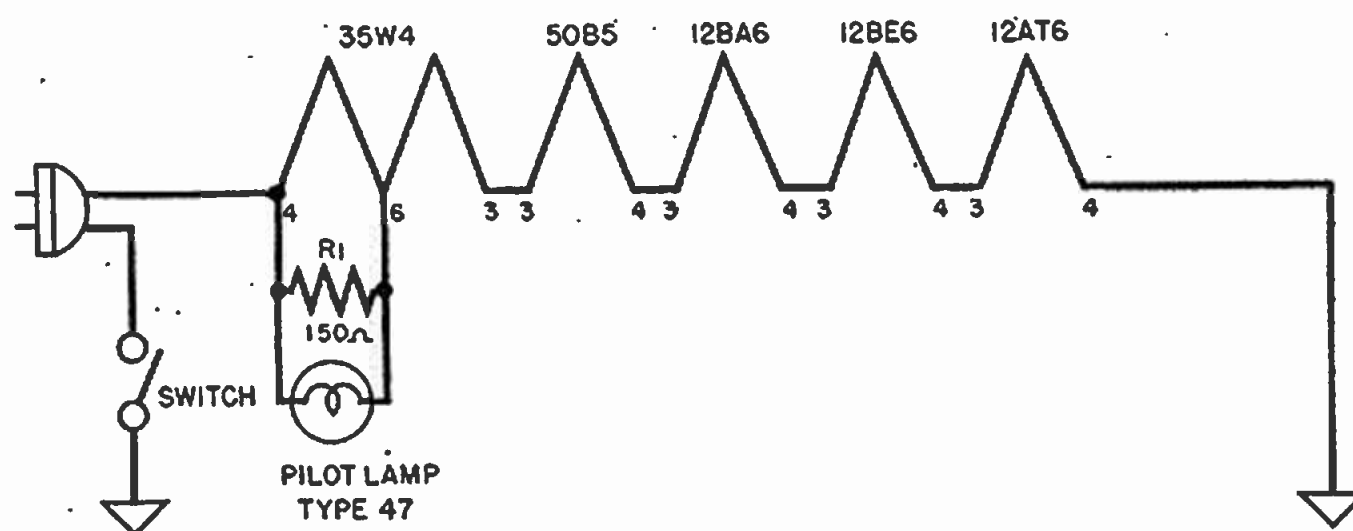

Fig. 2-7. The heater circuit.

ble is that the resistor-condenser filter can be used on limited current only, otherwise there is grave danger of overloading the resistor. Such filters are often used in small sets with one or two tubes. But the resistor-condenser filter is a lot cheaper and takes up much less space than the other type, so, as you might expect, set designers found a way to use it on sets employing up to five tubes. The method is to take current for the plate of

the rectifier socket, then tie a single knot in the cord. This will prevent a strain on the cord from tearing loose any connections. Separate the two wires with a razor blade, connect one to the on-off switch and the other to pin 4 of the 35W4 socket. Wire the heaters in series as shown in the diagram, making sure that the wiring order is as shown. Connect pin 4 of the 12AT6 and the free terminal of the on-off switch to chassis. Connect

R1, 150 ohms, to pins 4 and 6 of the 35W4 socket. Connect the pilot-lamp socket leads to pins 4 and 6 of this socket. Inspect the wiring to be sure that all connections have been made and that all are properly soldered.

How to test the heater circuit

There are two methods of testing the heater circuit. Which one you use will depend upon whether or not you have an AC voltmeter.

Place the tubes in their respective sockets, insert a no. 47 pilot lamp in the lamp socket, connect the line plug to a wall outlet, and turn on the switch. Allow the tubes to warm up for a minute, then note whether they appear to burn at normal brilliancy. If the tubes do not light at all, turn the switch off, remove the line plug from the outlet, and check the entire heater circuit for an open. Perhaps you failed to make one connection or

If the tubes appear to light at normal brilliancy, check the heater voltages with an AC voltmeter. This may be done either by measuring the voltage across each of the heaters in turn or by measuring from heater terminals to chassis. If you choose the latter method, here are the correct voltage readings:

Tube	Socket Terminal	Voltage
12AT6	3	12
12BE6	3	24
12BA6	3	36
50B5	3	86
35W4	4	117

How to wire the power supply circuit

See Figure 2-8.

Connect the plate of the 35W4 (terminal 5) to the heater tap terminal of the same tube (terminal 6). With R2 and R3 mounted on the three-point tie lug, as in Figure 2-9,

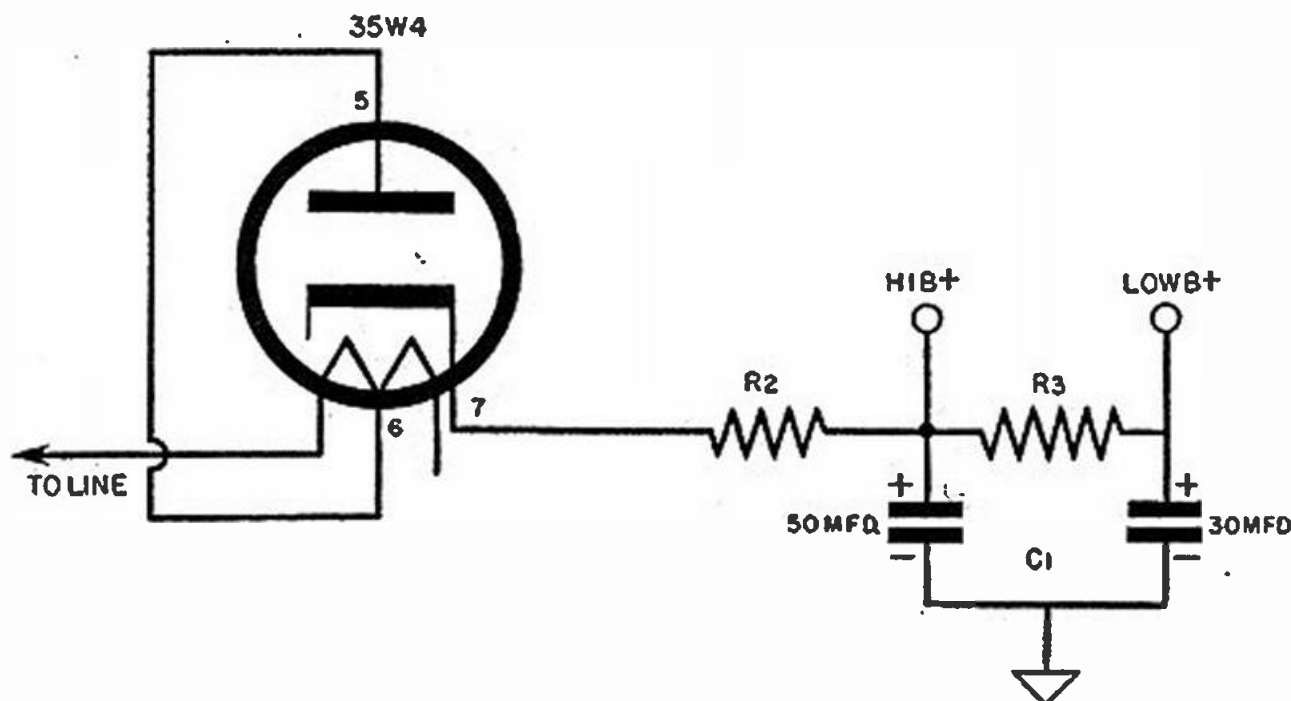

Fig. 2-8. The power supply circuit.

there may be a connection that is not properly soldered. If all connections seem to be in order, check the continuity of the heater of each tube. Even though they may be new tubes, it is possible for an open heater to occur. If one or more tubes fail to light but the others do, or if for some reason the tubes seem to be brighter than normal, turn the set off immediately. Trouble of this kind may be due to an accidental short across the heater terminals of a tube or a ground (usually due to excessive solder) at one of the heater terminals.

these resistors will then be in series. Connect the free end of R2 to the cathode terminal (7) of the rectifier tube socket.

Connect one of the positive leads of the filter condenser to the junction point of R2 and R3. (Note: The positive wires of the filter condenser will usually both be red. Some condensers, however, may have a red wire and a blue wire. If this is the case, connect the red wire to "HI B plus" and the blue wire to "LOW B plus.") The remaining filter condenser positive wire is to be connected to point 3 on the tie

lug, at the free end of R3. Connect the negative lead of the filter condenser to the chassis.

How to test the power supply circuit

a) Resistance Test. With an ohmmeter, measure the resistance from the cathode (pin 7) of the rectifier tube to chassis. You will probably find that the needle of the meter at first swings over to indicate a very low resistance, then drops to a higher value. The final reading, when the needle comes to rest, should be somewhere between 50,000 and 100,000 ohms. Reverse the positions of the test prods and repeat the test. You will most likely get the same effect as before, but in neither case should the final reading be lower than 50,000 ohms. A much lower reading indicates a defective filter condenser. A short circuit reading would indicate a ground at the point under test. Repeat the tests just made at the "HI B plus" and "LOW B plus" terminals. The readings here should be about the same as before. If all readings are normal, the filter condenser is in good condition and there are no grounds in the circuit. Now measure

the resistance between the cathode of the tube socket and the "LOW B plus" terminal. A normal reading is slightly more than 2,000 ohms.

b) Operation Test. With all tubes in their sockets, connect the line plug to outlet, turn the switch on, and allow the tubes to warm up for a moment. If, during the warm-up period or at any other time, you see signs of an overload or that a part is overheating, turn the switch off immediately and check for a ground in the circuit. This may occur at the rectifier cathode or at one of the tie points because of excessive solder or because a strand of wire is touching the chassis. Of course, this cannot happen if the resistance test has been made, but it may develop if you lack a meter or failed to make the test. If a ground develops at the tube socket it is quite likely that the tube will be ruined. Should a ground occur at one of the other points, the life of your rectifier tube will depend upon your ability to turn the switch off quickly.

c) Voltage Test. Allow the set to remain on and make a voltage test. Use a DC voltmeter for this purpose; the range should be not less than 150

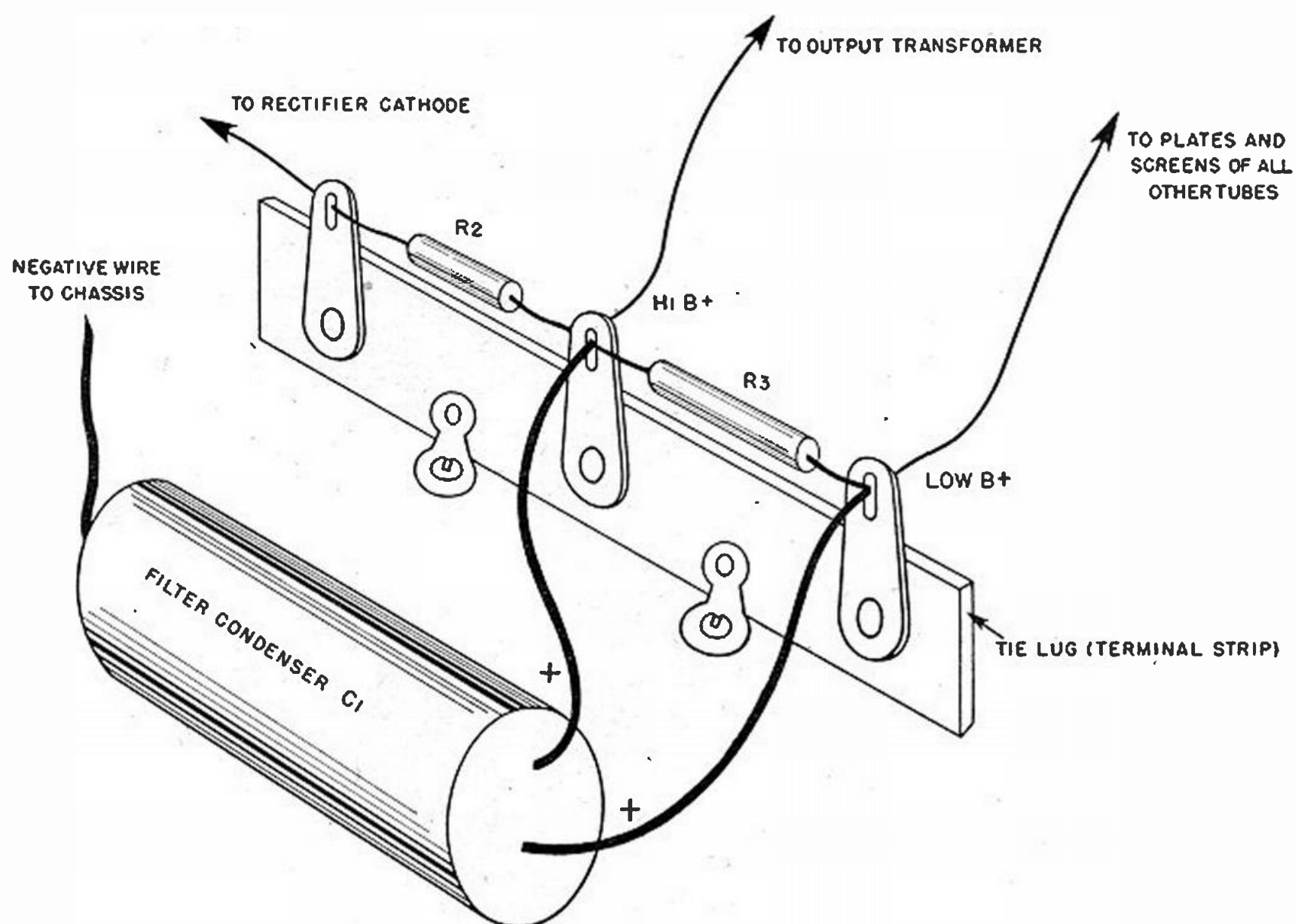

Fig. 2-9. Wiring the power supply circuit.

volts, full scale. Measure the voltages from "HI B plus" to chassis and from "LOW B plus" to chassis. "HI B plus" should show a reading of about 100 volts; the "LOW B plus" voltage should be approximately 90 volts. If all resistance and voltage readings are normal, begin wiring the power output stage.

How to wire the power output circuit

See Figure 2-10.

If you are using a speaker that is complete with output transformer, you will need to make no connections between the transformer and the voice coil of the speaker. If you have purchased the parts separately, you will have to determine the primary and secondary sides of the transformer. Most transformer primary wires are

your speaker does not have such a connection you will have to run a wire from one of the terminals to chassis or to the speaker frame. Connect the blue wire of the transformer to the plate terminal (pin 5) of the tube socket. Before soldering this connection, connect C4 from the plate terminal to chassis. Connect the red transformer wire to "HI B plus" and the screen terminal of the tube socket (pin 6) to "LOW B plus." Twist the wire leads of the resistor R5 and condenser C3 together, making several twists at each end of the units. Now note which end of the combination bears the positive end of the condenser; connect this end to the cathode of the tube (pin 2) and the remaining end to chassis. Connect R4 between the grid of the tube (pin 7) and chassis. Before soldering the grid connection, connect one end

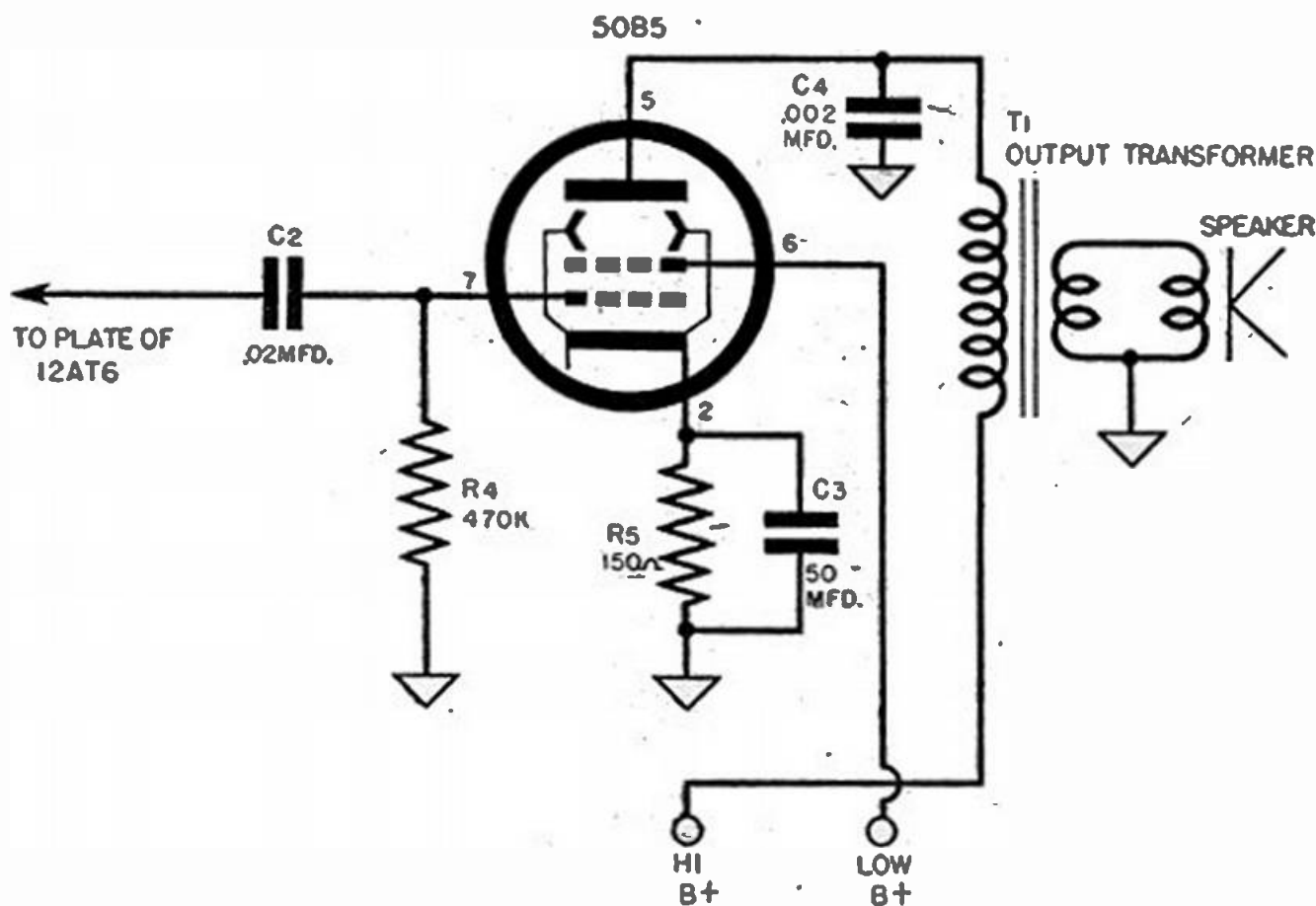

Fig. 2-10. The power output circuit.

color-coded blue for the plate lead and red for the B-plus lead. If you find two such wires, your problem is solved, for it is obvious that the remaining two wires are the secondary and must be connected to the voice coil. Connect the secondary wires (usually having enamel insulation) to the voice coil terminals in the most convenient way; there is no "polarity" to be observed here. On many speakers, one of the voice coil terminals is connected to the frame of the speaker; if

of C2 to the grid terminal. Notice that the remaining end of C2 is not connected; it will remain unconnected until you wire the first audio circuit.

Inspect all wiring. Be sure that all connections are well soldered. Keep the plate lead of the output transformer well away from the grid terminal of the tube.

How to test the power output circuit

a) *Resistance Test.* With the tube

in its socket, measure the resistance from terminals 2, 5, 6, and 7 of the socket to chassis. Also take readings from pin 6 to "LOW B plus" and from pin 5 to "HI B plus." Here are the readings you may expect:

From	To	Reading
pin 2	chassis	150 ohms
pin 5	chassis	not less than 50K
pin 6	chassis	not less than 50K
pin 7	chassis	470K
pin 5	"HI B plus"	approx. 200 ohms
pin 6	"Low B plus"	0 ohms.

b) *Voltage Test.* Connect the plug to outlet and turn the switch on. When the tubes have warmed up, measure DC voltages (using 150-volt range) from plate, screen, and cathode to chassis. Also measure the voltage from grid to cathode. When measuring cathode and grid voltages, a range

terminal of the tube socket, pin 7. In doing this, be careful not to create a short circuit or to touch any terminal connected to the B-plus terminals. If the stage is working, you will hear a moderately loud buzz in the speaker.

A phonograph can be used to give a much better indication of how well the stage is working. Connect the inner wire of the phonograph pickup shielded cable to the grid terminal of the tube socket and the outer shield to the chassis. Start the phonograph and note the volume obtained. It will not be as loud as an average radio set, but should be distinctly audible. A signal generator, if available, may also be used. Connect as before, with the inner wire to the grid and the shield to the chassis. The signal should be clearly audible in any part of a large room.

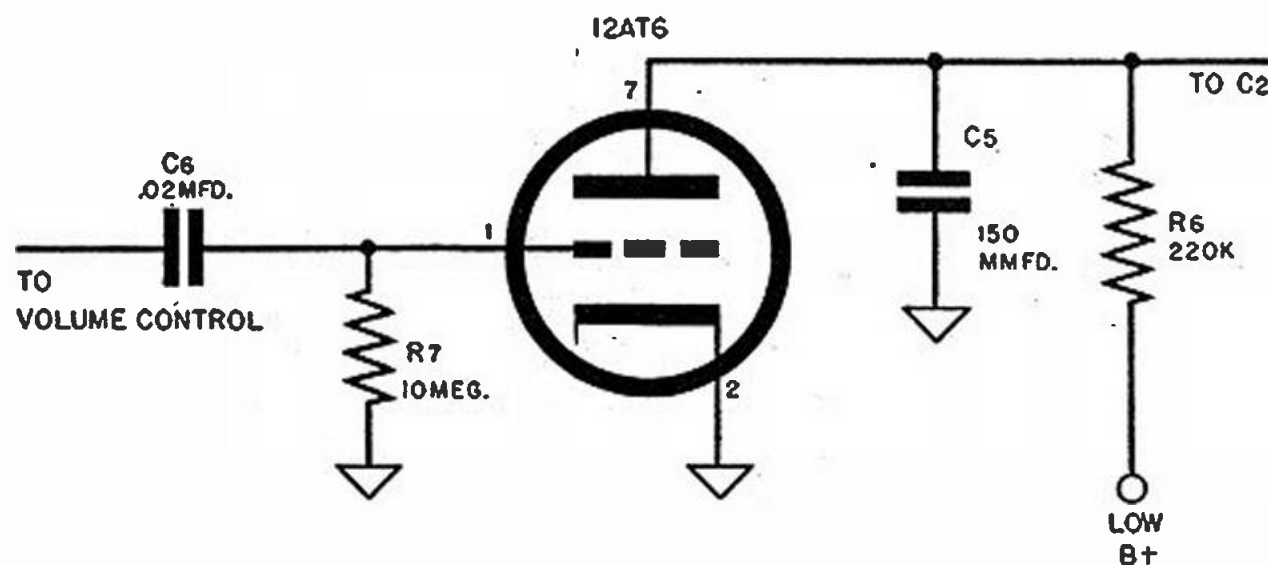

Fig. 2-11. The first audio circuit.

lower than 150 may be used. Note that the reading from grid to cathode will be in the reverse direction compared to the other readings. Normal readings are: Plate 100 volts, screen 90 volts, cathode 6 volts, grid -6 volts.

c) *Operation Test.* If you have no test equipment, this will be the only test made. With all the tubes in place and the set turned on, allow the tubes to warm up for a moment. The purpose of the operation test is to determine whether the stage is functioning as intended. It can be made in several ways. The simplest—but not the most conclusive—method must be used if you have no equipment at all. Holding a short piece of bare wire between your fingers, touch the grid

How to wire the first audio circuit

See Figure 2-11.

As mentioned before, the 12AT6 circuit can conveniently be divided into two sections: the first audio circuit and the detector-AVC circuit.

Resistor R6 should be mounted on a two-point tie lug, as the resistor leads will not be long enough to span the distance between the 12AT6 socket and the B-plus tie point. Connect R6 and C5 to the plate terminal of the socket. You will recall that in wiring the power output circuit one end of C2 was left unconnected; this is now connected to the plate terminal of the 12AT6. Connect the free end of C5 to chassis and the free end of

R6 to the "LOW B plus" terminal. The cathode terminal of the socket is connected directly to the chassis. One end of R7 and one end of C6 may now be connected to the control grid terminal (pin 1). Connect the free end of R7 to chassis; the other end of C6 remains unconnected until the detector circuit is wired.

How to test the first audio circuit

a) *Resistance Test.* This test is quite similar to the one performed on the output circuit. The list of test points and readings to be expected follows:

From	To	Resistance
pin 7	chassis	over 270K ohms
pin 7	"LOW B plus"	220K ohms
pin 2	chassis	0 ohms
pin 1	chassis	infinity (on average low-priced meter)

b) *Voltage Test.* Take readings as

that you have forgotten to complete connections to R6, or that pin 7 of the tube socket is grounded to the chassis by excess solder, or perhaps that C5 is shorted. If all readings are normal, you are ready to proceed with the operation test.

c) *Operation Test.* A rough test can be made by touching the grid terminal with a piece of wire, as described under testing the output stage. In this case, however, the buzz should be very much louder since you now have two stages of amplification. For a more elaborate test, use a signal generator or phonograph as outlined above, connecting the inner wire of the phono or generator cable to the grid terminal of the socket and the shield to chassis. In either case the signal should be as loud as one from a set or small amplifier. If either test fails to produce a signal, the possible causes are a ground at the grid terminal or a defective tube. If you get a fairly loud hum with no external

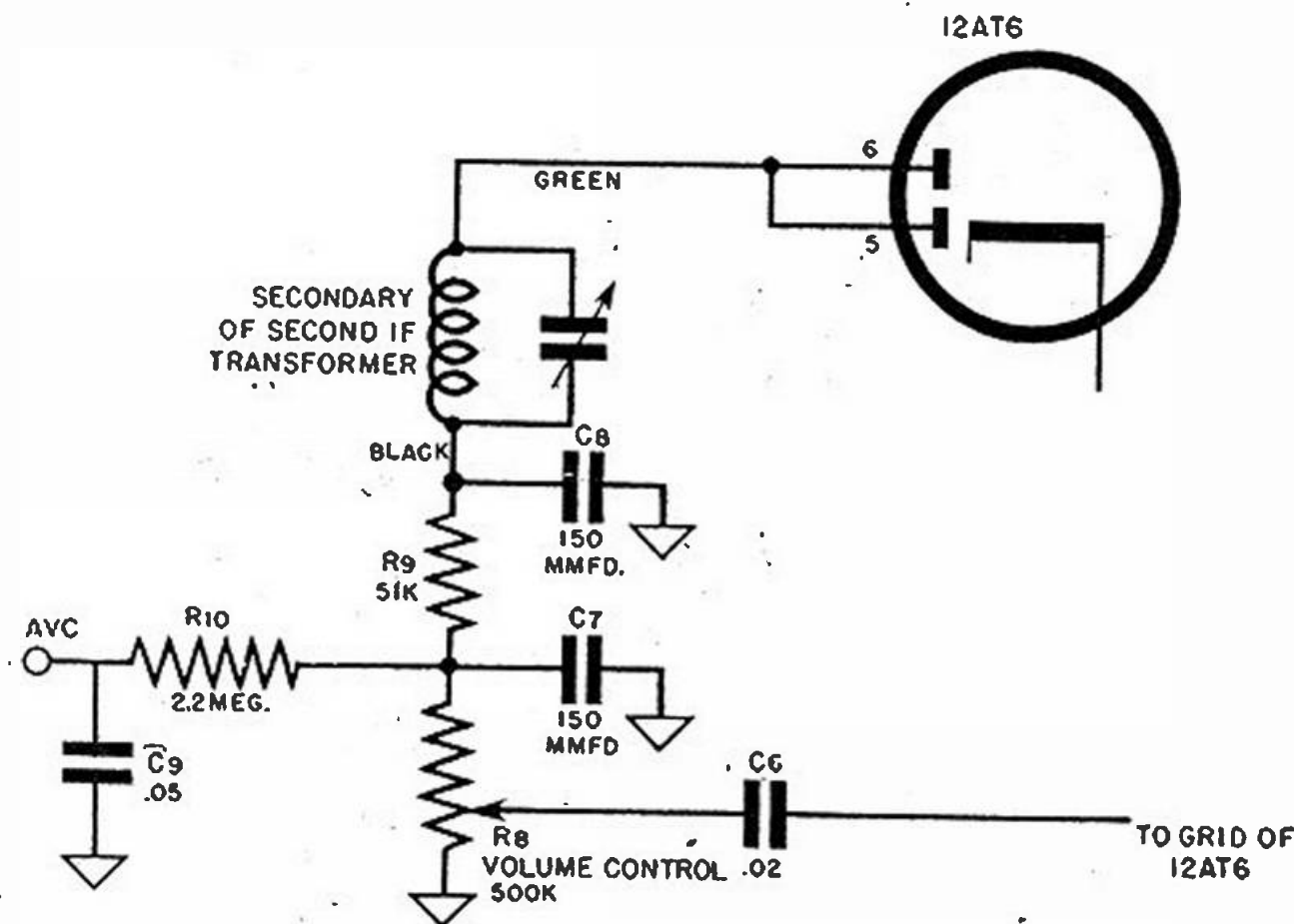

Fig. 2-12. The diode detector and AVC circuit.

described under testing the power output stage. The test points and normal readings are:

From	To	Reading
pin 7	chassis	45 volts
pin 2	chassis	0 volts
pin 1	pin 2	0 volts

Lack of plate voltage usually means

connections to the grid terminal of the tube, look for a missing connection in the grid circuit.

How to wire the diode detector and AVC circuit

See Figure 2-12.

As we have intimated, this circuit comprises two stages: the detector

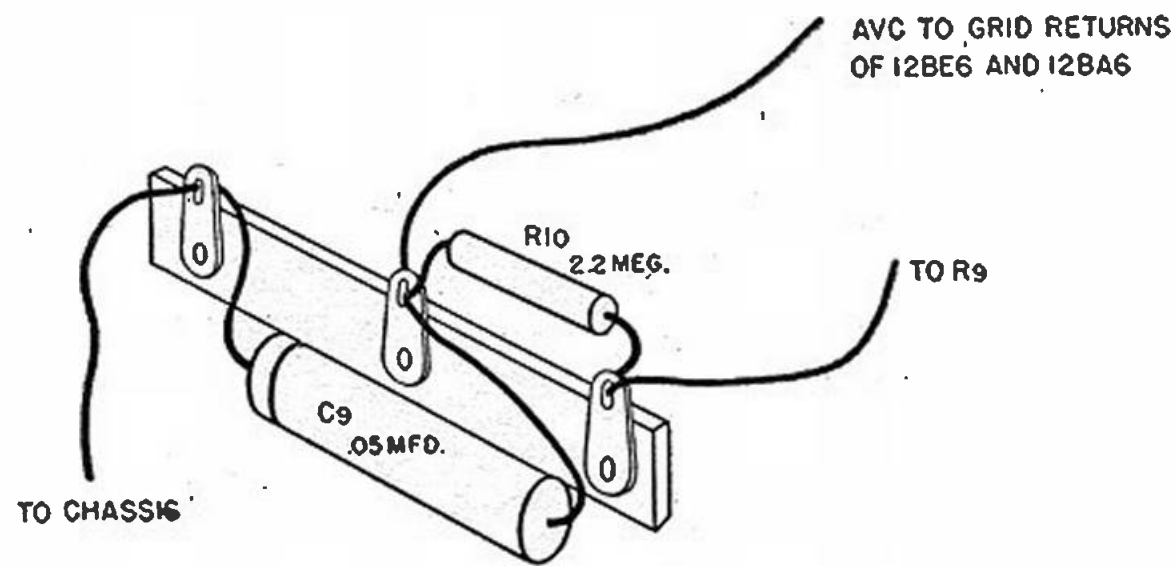

Fig. 2-13. Attaching resistor R10 and condenser C9.

and the AVC, or automatic volume control. The detector, of course, does the work of changing the inaudible signals from the i.f. stage into audible ones. The automatic-volume-control feature will be explained more fully later in this book. Here, it is sufficient to know that this circuit automatically maintains all signals at the same volume level, regardless of how weak or how strong they are when they reach the antenna. The circuit consists of two parts: the resistor R10 and the condenser C9. Mounting and wiring is shown in Figure 2-13.

This little circuit is vital to the proper performance of the project and the values of the parts must be exactly as specified; no substitutions are permissible. Also, be sure to connect the outside foil of C9, (the end of the condenser having a stripe) to chassis. For neatness and ease of wiring, it will be advisable to mount R9 and R10 on tie lugs. C7, C8, and C9 may then be connected from the tie

points to chassis as shown in Figure 2-14. Notice that the two diode plates of the tube (pins 5 and 6, Figure 2-12) are connected together. The cathode of the tube is not shown connected in the diagram, since it was previously connected during the wiring of the first audio stage. For the same reason, one end of C6 is not shown connected in the sketch as it is already connected to the grid of the first audio. If you have any trouble determining the correct volume-control connections, refer to Figure 3-18A, in Chapter 3.

How to test the diode detector-AVC circuit

a) *Resistance Test.* This part of the test is quite simple and consists merely of measuring the resistance from one of the diode plates (pin 5 or 6) to chassis. The reading should be approximately 550,000 ohms. If you get a reading considerably lower than this value, look for a ground

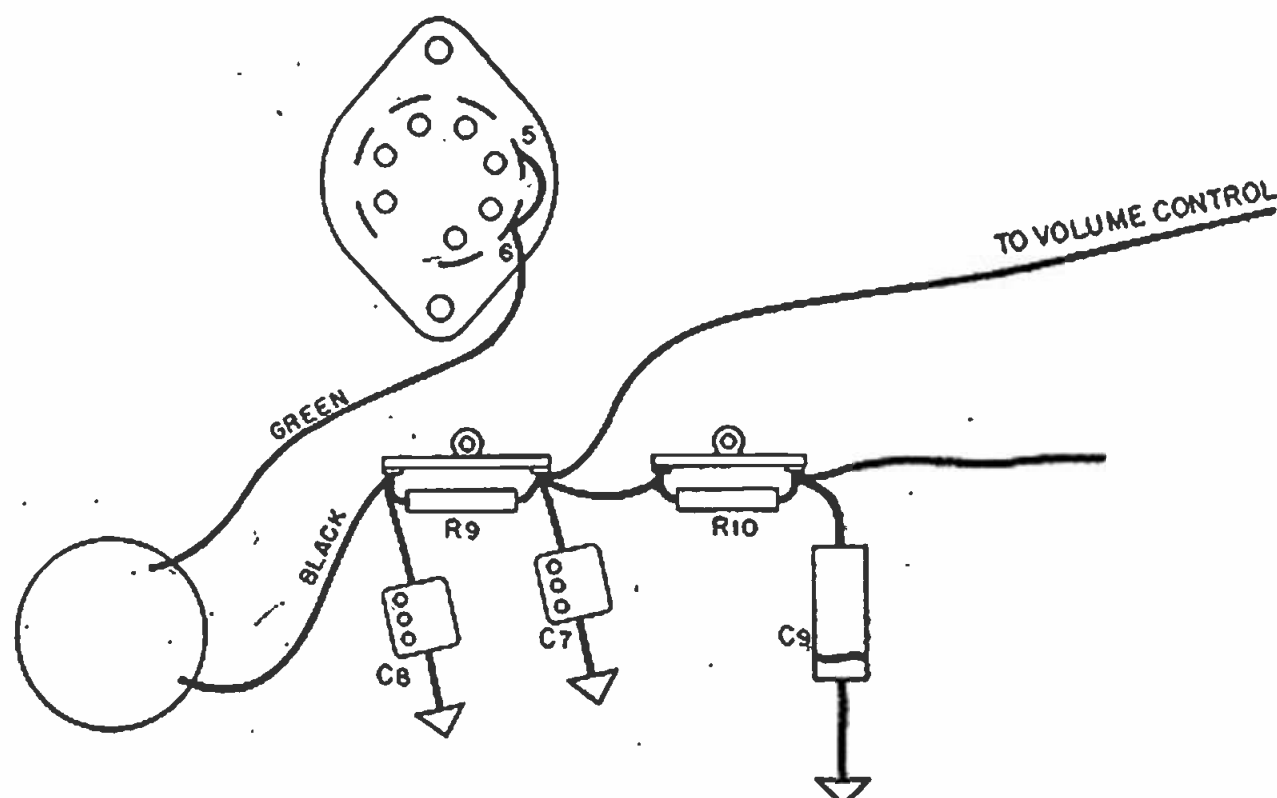

Fig. 2-14. Connecting C7, C8 and C9 from tie points to chassis.

somewhere in the circuit. For instance, if you get a reading of about 50,000 ohms, you have a ground at the point where R8, R9, and R10 meet. A reading of only a few ohms points to a ground at the junction of the i.f. transformer and R9.

b) *Voltage Test.* There are no voltages measurable with ordinary instruments; consequently, no voltage test can be made.

c) *Operation Test.* An operation test cannot be made without a signal generator. If you have a generator, connect the cable leads to the primary wires of the second i.f. transformer (these are the red and the blue wires and are not yet connected). Adjust the generator to deliver a 455-kilocycle modulated signal and turn the attenuator or output control of the generator to maximum. If you do not hear a signal with the generator tuned to 455 kilocycles, sweep the generator tuning dial back and forth slowly. Most i.f. transformers are pre-adjusted

audible note heard in the speaker will probably be about half as loud as the signal heard when testing the first audio stage.

How to wire the i.f. amplifier circuit

See Figure 2-15.

In wiring this circuit, be sure to observe the colors of the i.f. transformer leads and to remember that the primary of the second (or output) i.f. transformer is connected in the plate circuit of the tube, while the secondary of the first (or input) transformer is in the grid circuit. Connect the blue wire of the second transformer to the plate (terminal 5) of the 12BA6 socket, and the red wire to the "LOW B plus" tie point. When wiring the secondary of the input transformer, connect the green wire to the grid terminal of the tube socket (pin 1). The black wire is then connected to the AVC tie point. If you will refer to Figure 2-13, you will see that this

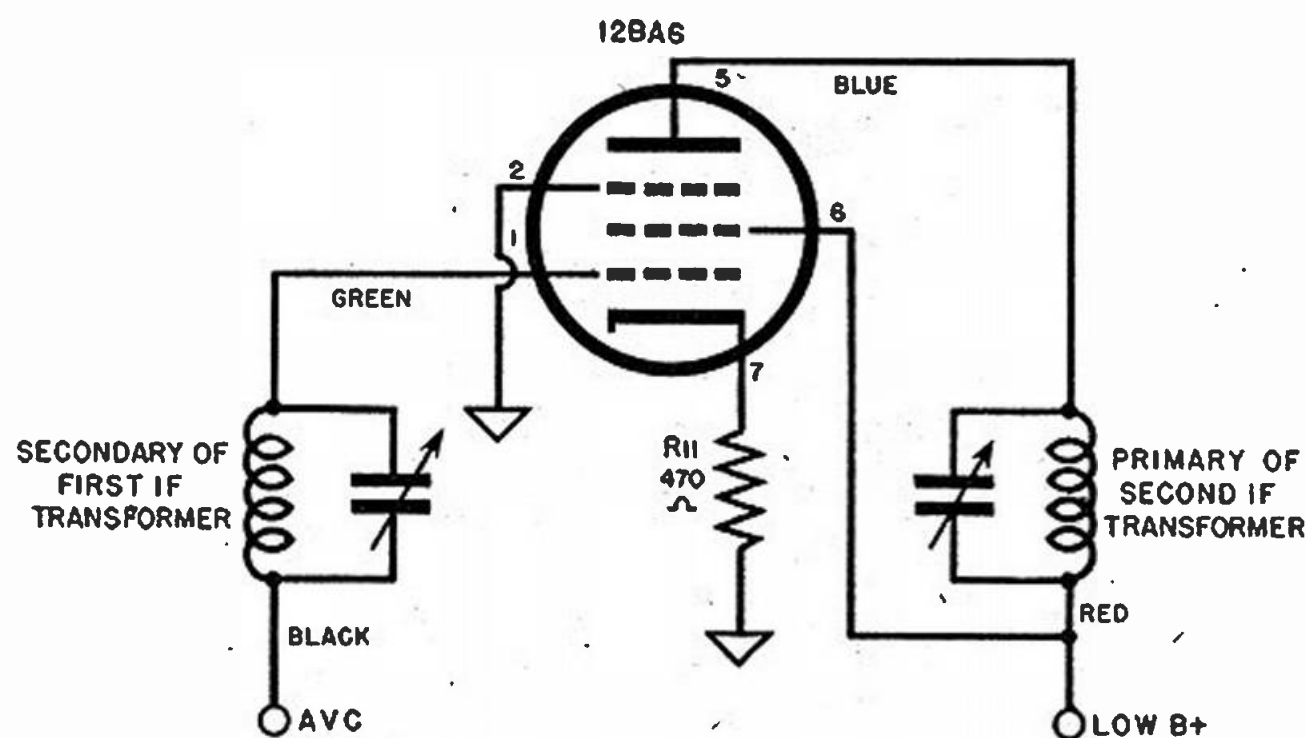

Fig. 2-15. The i.f. amplifier circuit.

at the factory and you should hear a signal somewhere in the vicinity of 455. If you do not, set the generator dial at 455 and allow it to remain there. Now carefully adjust the two trimmer condensers located on the i.f. transformer. On some transformers, both adjustments will be on top of the transformer shield; on other types, one will be located on top and the other underneath. Adjust both so that you get maximum volume. The

is the center terminal on the tie strip which holds R10 and C9. Connect resistor R11 directly from the cathode terminal of the socket (pin 7) to chassis. Complete the wiring by connecting pin 2 (the suppressor grid) to chassis.

How to test the i.f. amplifier circuit

a) *Resistance Test.* Check resistance values as indicated below. Readings from pin 2 to AVC point and

from pin 5 to "LOW B plus" may vary somewhat with the type of i.f. transformer used. The readings given here are average values.

From	To	Reading
pin 7	chassis	470 ohms
pin 1	chassis	2.7 megohms
pin 1	AVC point	50 ohms
pin 2	chassis	0 ohms
pin 5	chassis	over 50K ohms
pin 5	"LOW B plus"	50 ohms
pin 6	chassis	over 50K ohms
pin 6	"LOW B plus"	0 ohms

b) *Voltage Test.* Take readings at points indicated below and compare with the normal readings listed.

From	To	Reading
pin 7	chassis	3 volts
pin 1	chassis	0 volts
pin 2	chassis	0 volts
pin 5	chassis	90 volts
pin 6	chassis	90 volts

How to wire the mixer circuit

See Figure 2-16.

As mentioned before, the wiring of the 12BE6 converter has been divided into two sections: mixer and oscillator. If you will look at Figure 2-16 you will notice that two of the grids and the cathode have been omitted. This is not an error but has been done purposely because these electrodes will not be connected until we come to the oscillator circuit. As you will see, the blue wire of the first i.f. transformer is connected to the plate (pin 5) of the tube socket, while the red wire is connected to "LOW B plus." Pin 6, the screen, is connected directly to "LOW B plus." The stator of the variable condenser (this is the larger of the two sections) is connected to pin 7 of the tube socket. When you examine the diagram you will find that C10 seems to consist of

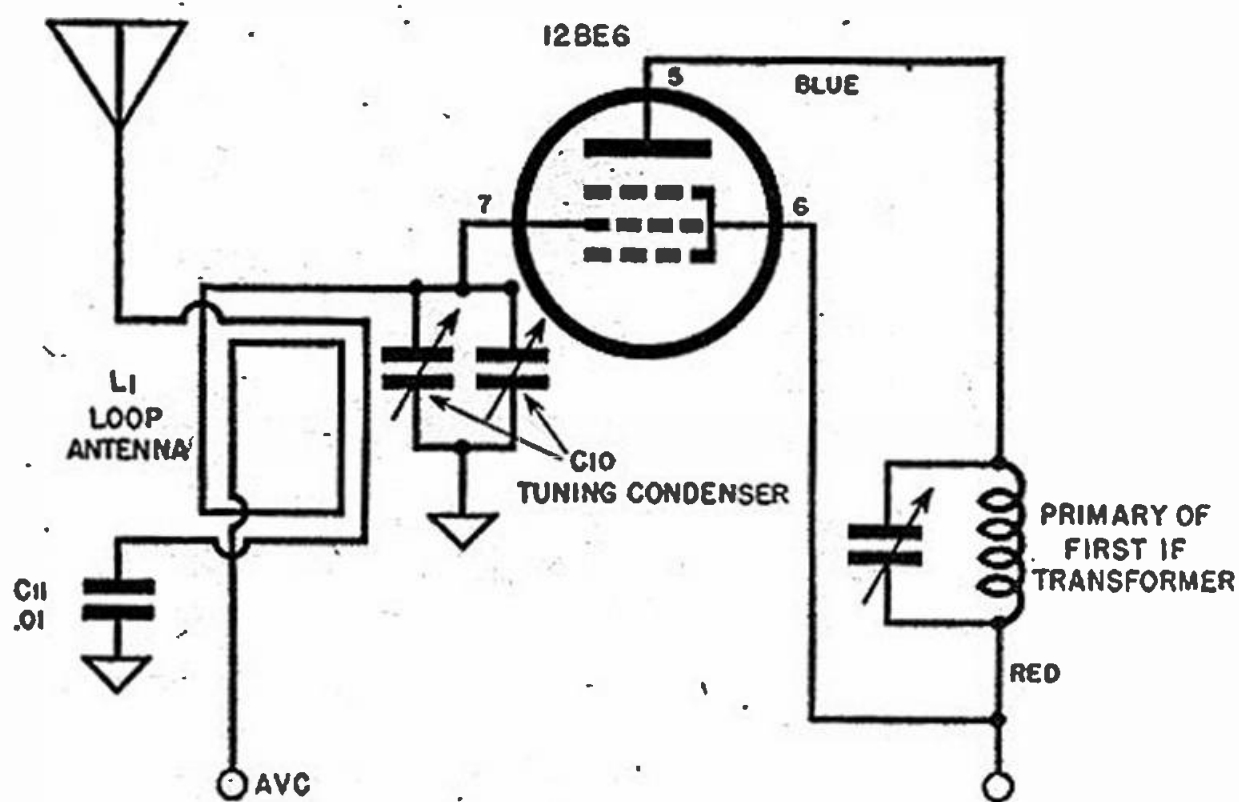

Fig. 2-16. The mixer circuit.

c) *Operation Test.* The operation test is the same as that for the detector circuit and can be made only with a signal generator. The procedure is exactly the same except that the generator leads are to be connected to the red and the blue wires of the first i.f. transformer. With the trimmers correctly adjusted for maximum signal, the note heard in the speaker should be almost as loud as in the first audio test.

two condensers in parallel. You need not worry about this, because one of the condensers is the trimmer and is already connected to the main condenser.

To determine the proper loop antenna connections, refer to Figures 2-17A and 2-17B. (Incidentally, these diagrams apply equally well to loop antennas used with other sets.) First examine the loop, and note whether the primary, or antenna, winding is

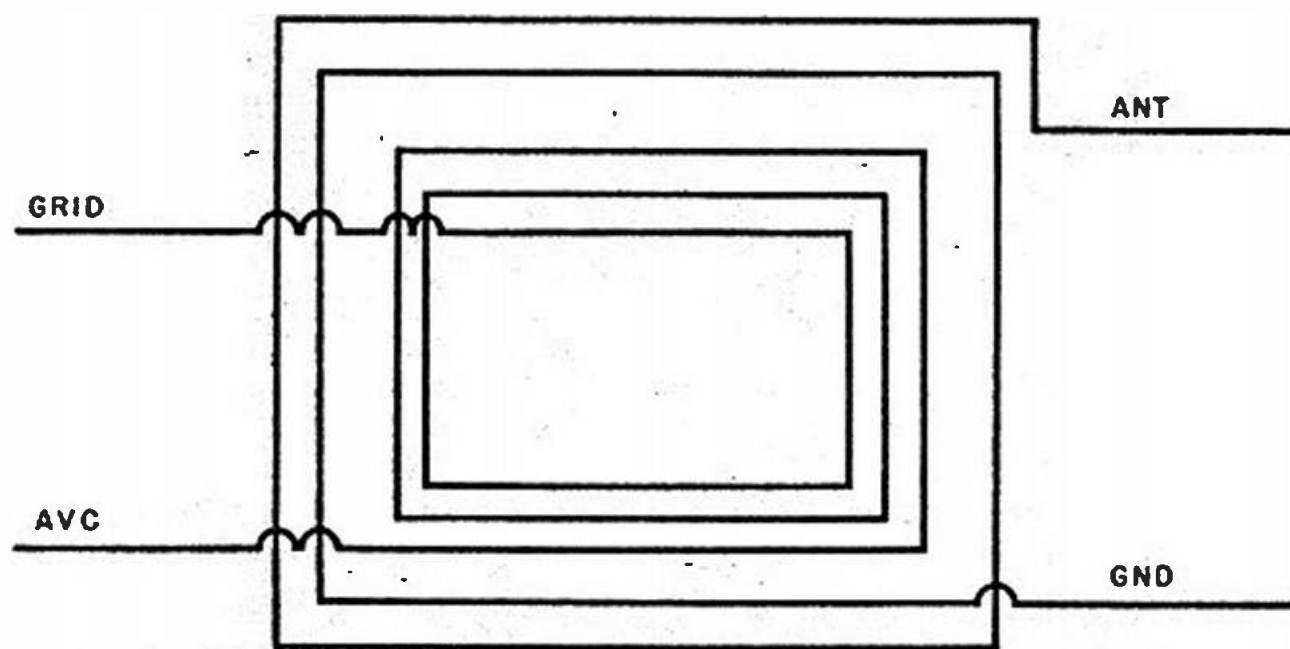

Fig. 2-17A. Loop antenna connections, primary on outside.

on the inside or the outside. The primary winding will be the smaller of the two and will usually consist of two or three turns. If the primary is on the outside, then Figure 2-17A applies to your case. Notice that the beginning (inside wire) of the large winding is to be connected to the grid of the mixer tube, and the end is connected to the AVC point. The start of the small winding is connected to chassis through C12, while the remaining end is to be connected to an external antenna, when used.

If, on the other hand, you find that the small winding (primary) is on the inside of the loop, use Figure 2-17B. In this case, connect the start of the large winding to AVC point and the end to the tube grid. The primary winding connections are then: end of winding to chassis through C12 and beginning to the external antenna.

How to test the mixer circuit

a) *Resistance Test.* Check resist-

ance at points indicated below and compare with the normal values given.

From	To	Reading
pin 5	chassis	over 50K ohms
pin 5	"LOW B plus"	50 ohms
pin 6	chassis	over 50K ohms
pin 6	"LOW B plus"	0 ohms
pin 7	chassis	2.7 megohms
pin 7	AVC point	2 ohms

b) *Voltage Test.* The cathode has not yet been connected, therefore a voltage test cannot be made until the oscillator circuit has been wired.

c) *Operation Test.* For the reason given above, an operation test cannot be made until the oscillator circuit is wired.

How to wire the oscillator circuit

See Figure 2-18.

The oscillator circuit wiring is fairly simple, but there are one or two precautions to be observed. First of all, make sure that the connections to the oscillator coil terminals are correctly made. If you use the type of

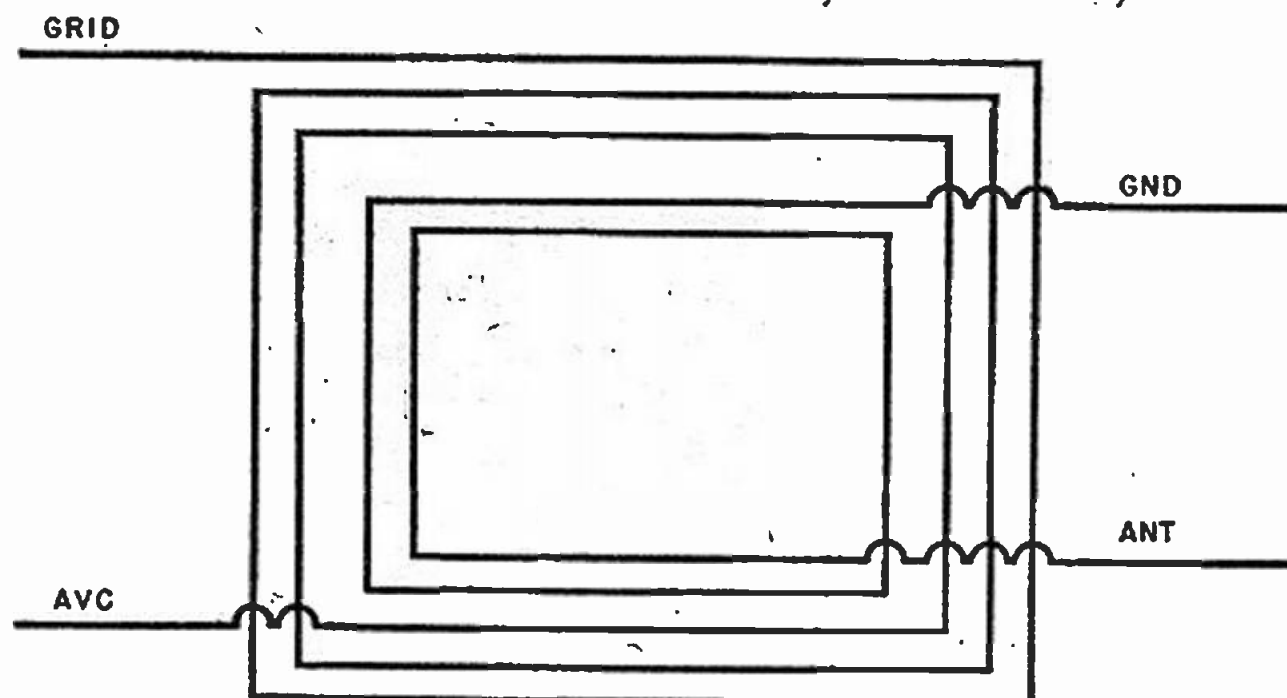

Fig. 2-17B. Loop antenna connections, primary on inside.

coil specified in the parts list, it will be accompanied by an instruction sheet that will show you the right way to wire it. If you buy another type, try to get a connection diagram for it; otherwise you will have the bother of checking continuity and trying to determine the lug arrangement yourself. Using the coil specified in the parts list, a small condenser, C11 in the diagram, is connected from the oscillator grid (pin 1), to the top end of the coil winding. Some makes do not require this condenser, but in such instances the coil will always have an extra terminal lug. In that case, check continuity between all terminals and, if you find one that shows no continuity with any other, that is the extra terminal. In this type of coil a "gimmick" has been used to take the place of C11. Figure 2-19 shows how this works. The gimmick is nothing more than a turn of wire wound around the coil winding proper. One end of the gimmick is connected to a terminal, the other end is free. Capacitance between the gimmick and the coil winding takes the place of C11.

How to test the oscillator and mixer circuits

a) *Resistance Test.* Measure resistances at the points indicated and compare with the normal values.

From	To	Reading.
pin 1	chassis	18K ohms
pin 2	chassis	1 ohm
pin 5	chassis	over 50K ohms
pin 5	"LOW B plus"	50 ohms
pin 6	chassis	over 50K ohms
pin 6	"LOW B plus"	0 ohms
pin 7	chassis	2.7 megohms

b) *Voltage Test.* The normal voltage readings are given below. Note that the voltage at the oscillator grid (pin 1) is negative. This reading cannot be taken unless you have a high resistance instrument, preferably an electronic voltmeter. But if you have such a meter and find that

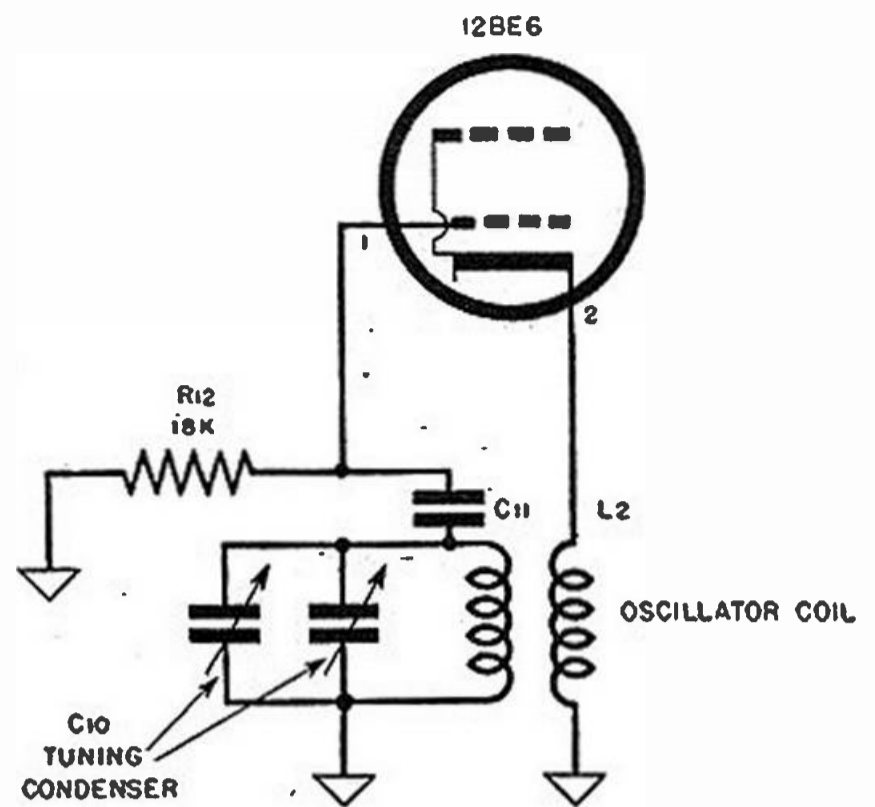

Fig. 2-18. The oscillator circuit.

the negative grid voltage is not present, it is a fairly sure indication that the oscillator circuit is not working. Checking an oscillator circuit is usually difficult, and there is no simple operation test that can be made.

From	To	Reading
pin 1	chassis	-8 volts
pin 2	chassis	0 volts
pin 5	chassis	90 volts
pin 6	chassis	90 volts
pin 7	chassis	0 volts

c) *Operation Test.* With the tubes warmed up, connect the signal generator to pin 7 and to chassis. Adjust the generator to give maximum out-

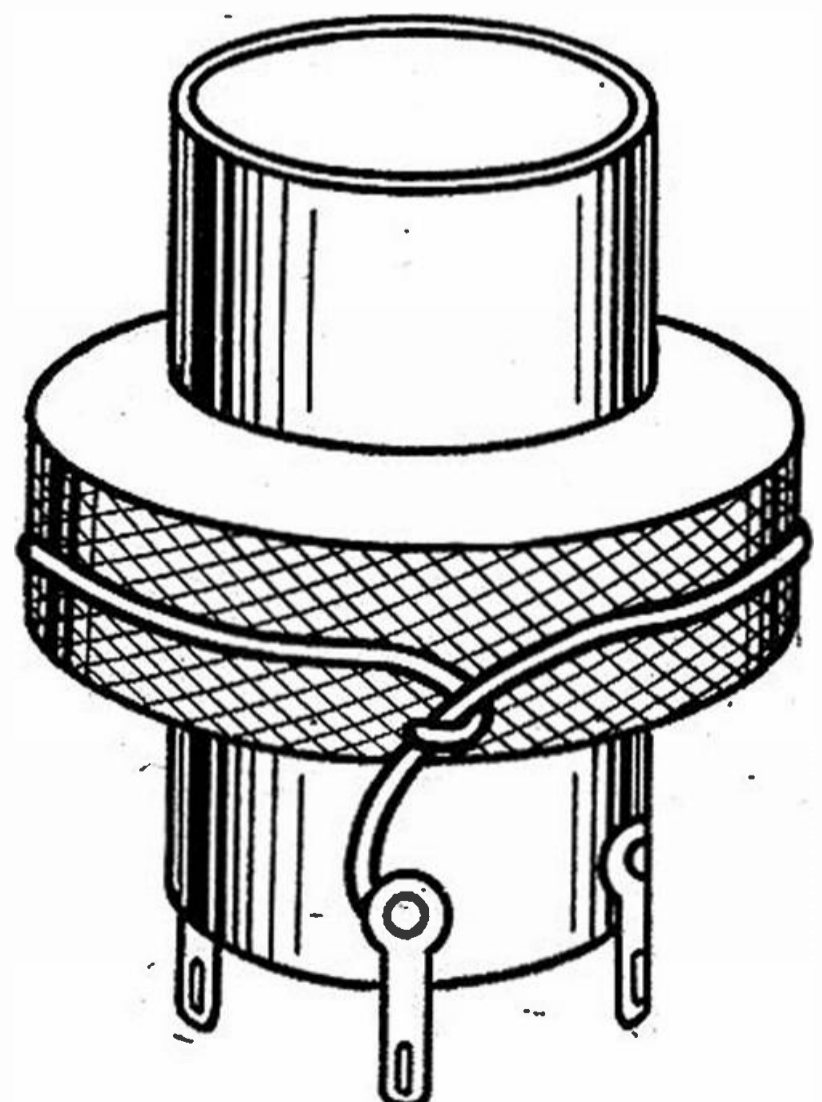

Fig. 2-19. A "gimmick" on a coil.

put at 455 kilocycles, and proceed as in testing the detector and i.f. circuits. If no signals are heard at first, adjust the i.f. trimmers.

When the operation test on the converter has been completed, the set is almost ready to go into operation. In fact, it is more than likely that you will hear broadcast signals at this point. However, for maximum performance, the alignment must be completed. If you made the various operation tests carefully, the i.f. adjustments will probably be close to correct and all that remains is to adjust the antenna and oscillator trimmers located on the tuning condenser.

To make these adjustments, connect the high side of the generator

to the generator cable. Now adjust the generator to deliver a modulated signal at 1620 kilocycles.) Turn the oscillator trimmer (the one located on the smaller section of the tuning condenser) until you get the loudest signal. While making this adjustment, the tuning condenser should be fully open.

Now readjust the generator to give a signal at 1400 kilocycles, and adjust the tuning condenser on the set for maximum signal. Allow the tuning condenser to remain at that setting and adjust the antenna trimmer (located on the larger section of the condenser) until the signal is as loud as possible. This completes the alignment.

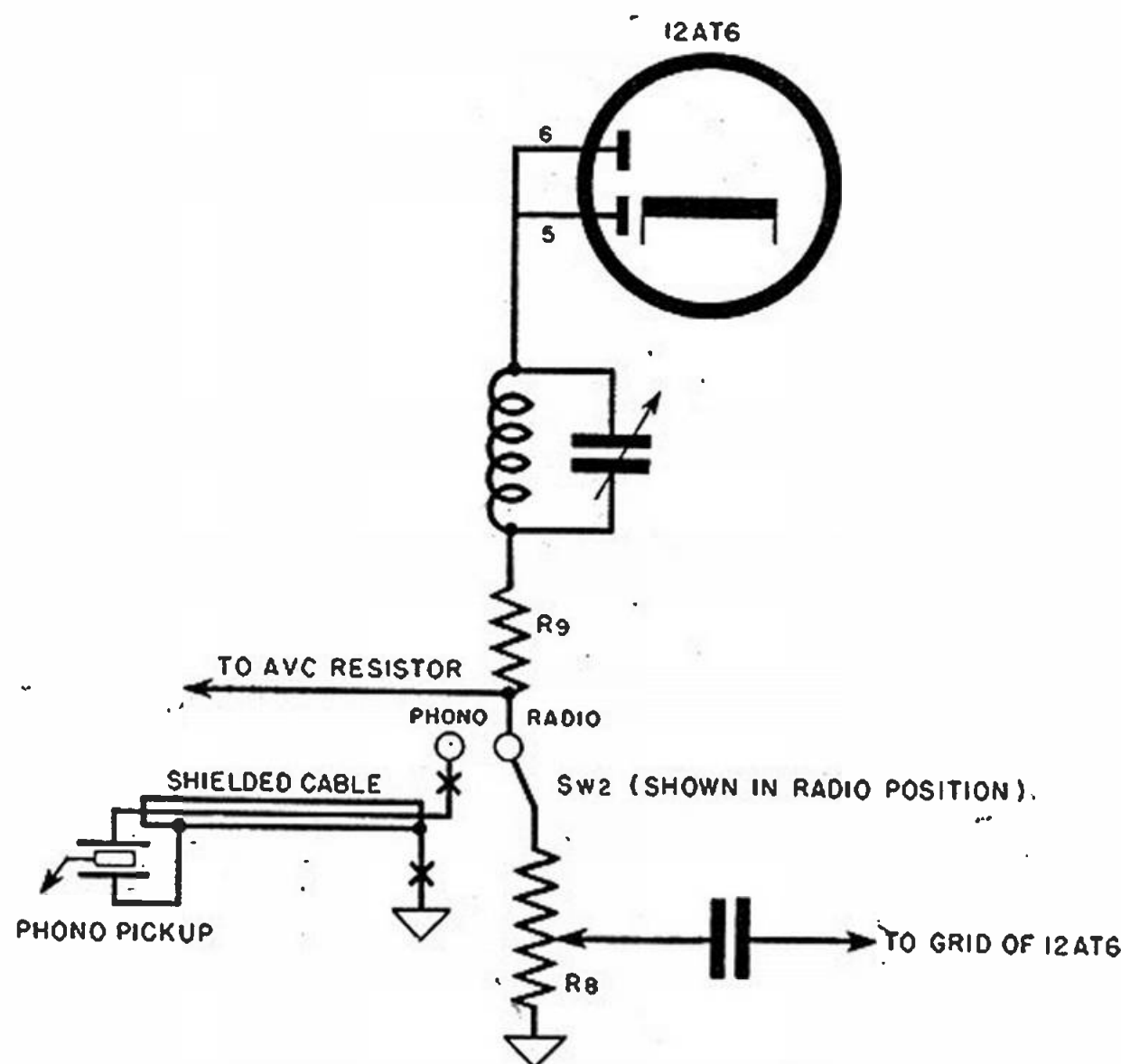

Fig. 2-20. Connecting a phono jack to the receiver.

(the inner wire of the cable) to the free end of the loop-antenna primary winding and the shield to the chassis. (Note: if your loop does not have a primary winding, you will have to use an alternate method of coupling the generator to the set. Make up a coil of wire, using five or six turns. The coil should be about the same size as the loop antenna. Place the coil quite close to the loop and connect its ends

Adding phono input

Connecting a phono input jack and switch to the receiver just described is a simple matter. Aside from the phonograph, the parts needed are: a regulation two-contact phono jack and plug, enough shielded cable to run from the phonograph pickup to the set, and a single-pole double-throw switch. A toggle switch may be used for this purpose, but a rotary switch

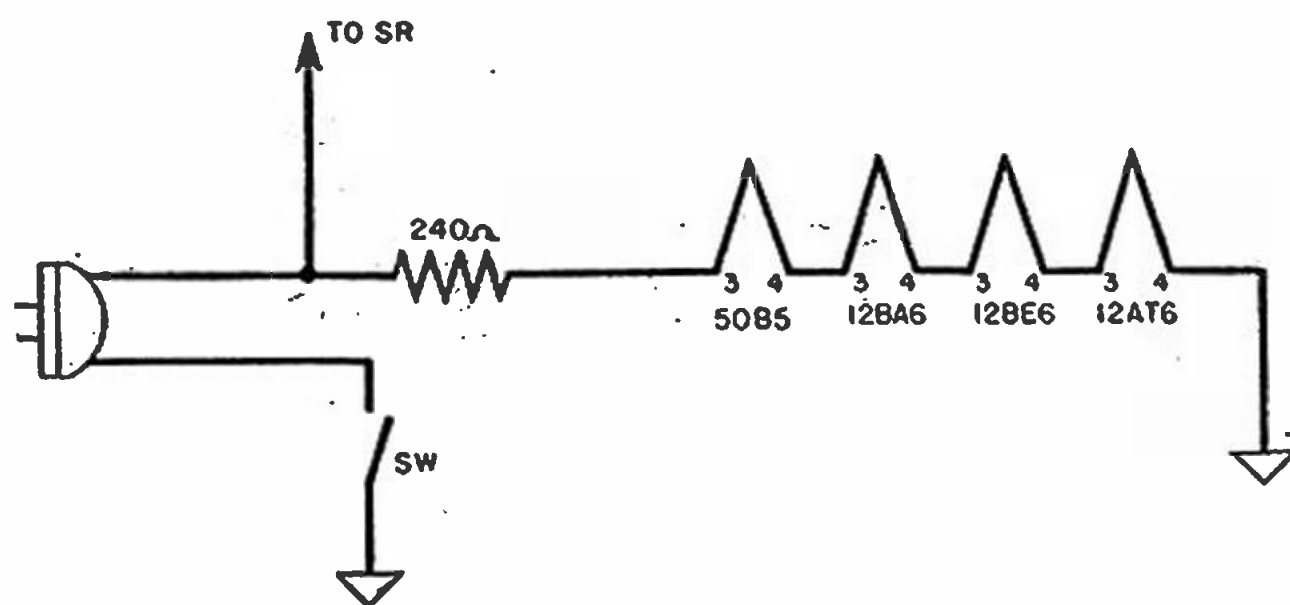

Fig. 2-21. Converting to a selenium rectifier.

is more convenient. Drill a hole in the rear of the chassis opposite the volume control to accommodate the jack, and fasten the jack in place. If a rotary switch is used, drill a hole for it in the front apron of the set. Disconnect the high end of the volume control (this is the right-hand lug when facing the control shaft) from the lower end of R9 (see Figure 2-20), but do not disturb the AVC connection at this point. Run a new wire from the top end of the control to the moving contact of the switch. One fixed terminal of the switch is now connected to the point formerly occupied by the high end of the volume control, while the remaining terminal is wired to the "hot" terminal of the phono jack. The ground-side of the jack is connected directly to chassis. This completes the wiring change in the receiver.

You may find that the phonograph can be placed close enough to the set so that the original pickup leads will be long enough. If this is not the case, add enough shielded cable to reach.

Be sure the outer shield of the cable is connected to the grounded pickup terminal. You will generally find a metal strap at this point. When connecting the plug to the cable, make sure that the outer shield is connected to the outer shell of the plug.

Selenium rectifier conversion

For one reason or another you may wish to use a selenium rectifier in place of the tube rectifier originally specified. To make this change, two parts are required: the selenium rectifier and a 240-ohm line resistor. Figure 2-21 shows the heater-circuit changes necessary. Notice that the heater of the 35W4 tube has been removed from the circuit and the line resistor connected in its place. The pilot lamp and R1 have also been removed.

In the power supply circuit, only two wiring changes are required. After installing the selenium rectifier, disconnect the wire at pin 7 (the cathode) of the tube and connect it to the plus terminal of the selenium rec-

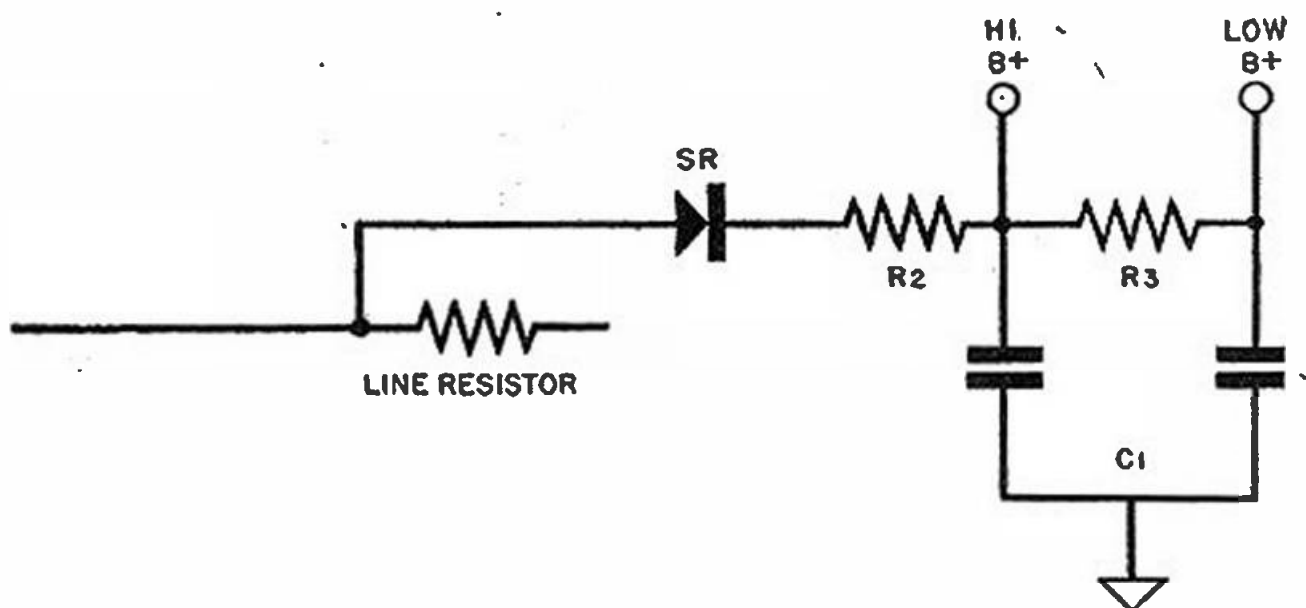

Fig. 2-22. Power supply for selenium rectifier.

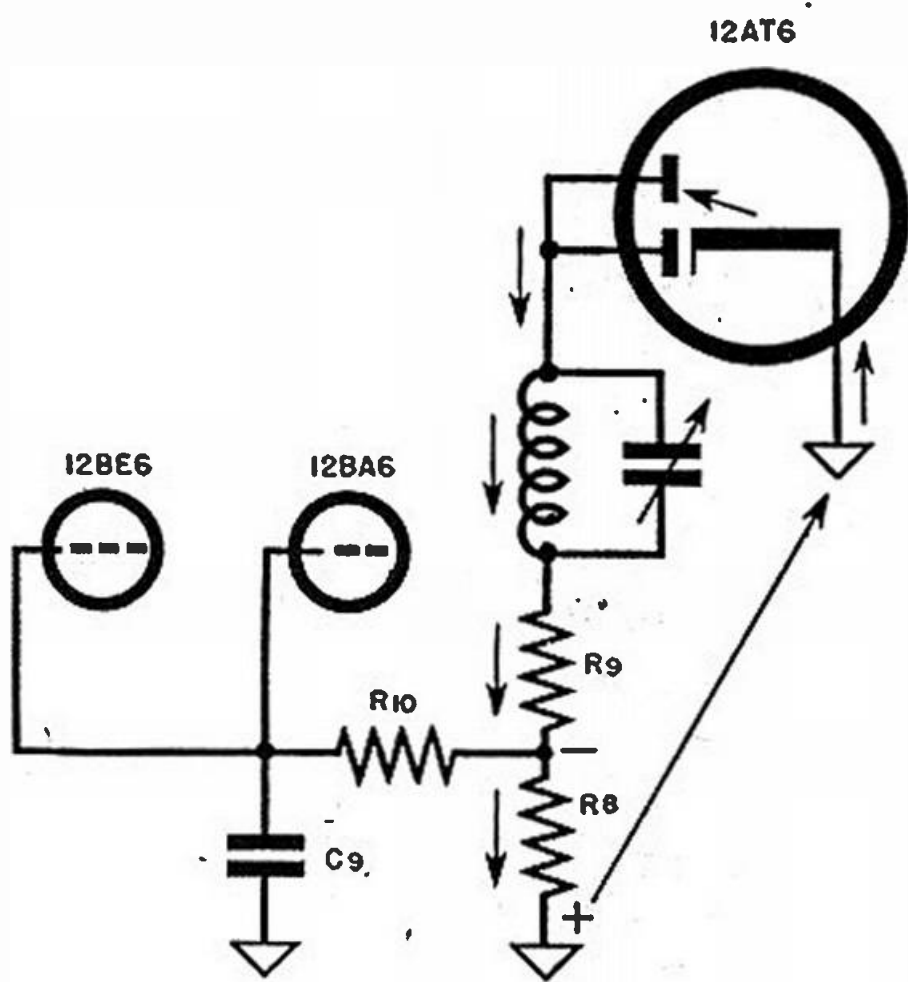

Fig. 2-23. How AVC operates.

tifier. Remove the connection from the plate of the rectifier tube (pin 5) and connect it to the remaining terminal of the selenium rectifier. Disconnect the other end of this wire and reconnect it to the power line end of the 240-ohm resistor.

Automatic volume control

The set just described incorporates automatic volume control. Without this feature we would find that the variations in power and distance of the various broadcast stations would seriously affect the operation of the set. If we happened to be tuned to a weak signal and then retuned to a stronger one without resetting the manual volume control, the stronger signal would cause blasting. On the other hand, tuning from a strong to a weak signal would prove equally objectionable, for then the weaker signal might be entirely too weak for good listening without readjustment of the manual control. This condition is remedied by the use of AVC.

Referring to Figure 2-23, you will see that signals reaching the diode detector are rectified by the tube and caused to flow in one direction. This direction is from cathode to diode plate within the tube, then downward through the i.f. transformer, through

R9 and R8, and to chassis, as indicated by the arrows. Current then flows through the chassis back to the cathode of the tube. The amount of current flowing in this circuit depends upon signal strength.

Current flow through R8 develops a voltage across R8 and, since current always flows from minus to plus, the top end of R8 will be minus compared to chassis. The amount that this point is minus will depend upon the signal strength. Thus we have a variable negative potential at the top end of R8, controlled by signal intensity.

The gain, or amplification, of the 12BA6 and 12BE6 tubes depends upon the negative voltage applied to their grids. And, you will note, the grids are connected to the AVC point in the circuit. If we tune from a weak signal to a stronger one, more negative voltage is developed at R8. This higher negative voltage, applied to the grids of the 12BE6 and 12BA6, reduces the degree to which these tubes amplify the signal, and thus the over-all volume of the set is kept constant. Just the reverse happens when we tune from a weak signal to a stronger one. Not only does this feature compensate for differences in signal strength, but also serves to keep the output of the set constant in the event that fading of signals takes place.

Sometimes it is desirable to separate the functions of the detector and

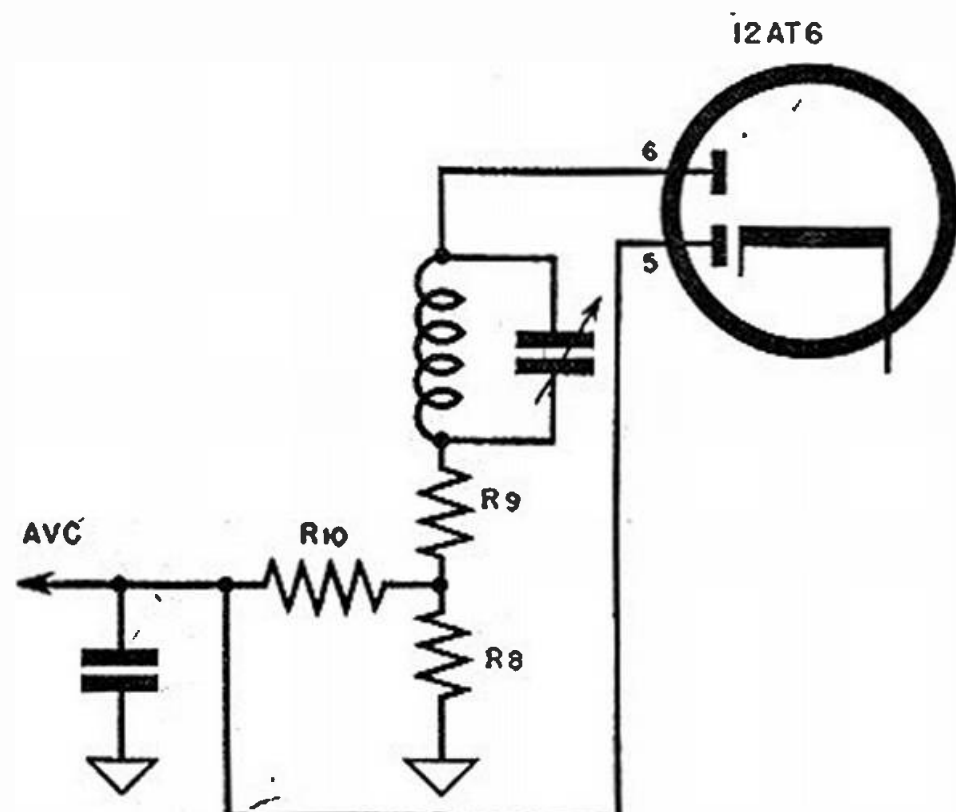

Fig. 2-24. Separate AVC diode.

automatic volume control, and then the circuit shown in Figure 2-24 is used. Here, the diode plates are not connected together, but one (terminal 6 of the tube) is used solely as de-

detector, while the other one performs the function of AVC rectifier. In either circuit, R10 and C9 are used to filter out the i.f. impulses present in the signal.

SIX-TUBE AC-OPERATED RECEIVER

This project is a six-tube superheterodyne, designed for AC operation only. It uses two 6V6GT tubes in the output stage and is capable of delivering a power output of about seven watts. Another feature of the set is the phonograph input jack and radio-phonograph switch. In sensitivity, power output, and tone quality this project is equal to many commercially built sets in the upper price brackets. If well constructed and installed in a suitable cabinet, it may well serve as the living room set in your home. Although metal tubes are specified for the converter, i.f., and detector-first-audio stages and the GT type of tubes in the other sockets, tube type substitutions are possible. GT tubes may be used in place of the metal tubes, but it would then be advisable to fit the i.f. and detector-first audio tubes with metal shields. Miniature tubes may also be used in the first three stages; suitable types are: 6BE6 converter, 6BA6 i.f. amplifier, and 6AT6 detector-first-audio. If you observe the differences among socket terminal connections, you should have no difficulty in making such substitutions, for all part values remain the same and there will be no difference in the performance of the set.

Circuit description

The complete circuit diagram is shown in Figure 2-25. Except for the oscillator circuit, power supply, heater wiring, and output circuit, it resembles the one used in the five tube AC/DC superheterodyne and a complete description of its operation is not necessary.

You will notice that the oscillator

coil used is of the tapped, single-winding variety. Otherwise, the converter circuit is similar to that used in the previous project.

The output stage uses two tubes in a phase inverter circuit. This results in power output about double that from one tube, together with a substantial reduction in distortion. There are many schemes for utilizing two output tubes. The oldest of these is the familiar push-pull circuit, which requires a special input transformer with center-tapped secondary. However, good quality transformers of this type are quite expensive while the results obtained with cheap transformers are not fully satisfactory. Engineers have therefore developed a number of "phase inverter" circuits that eliminate the input transformer. The idea behind all of these circuits is the development of signal voltages (for the grids of the two output tubes) that are opposite in phase. In some such circuits, an additional tube is used to give the desired phase inversion, but in this set the inversion is provided by resistor R4 and condenser C4. Because the signal appearing at the screen of any tube is out of phase with the grid signal voltage, we may use this out-of-phase voltage to provide an inversion at the grid of the opposite tube of the pair.

The power supply circuit in this set differs materially from that used in any of the preceding projects. Line voltage is stepped up to 350 volts by the power transformer, T1. This high voltage is rectified by the full wave rectifier, type 5Y3GT. Filtering is accomplished by means of the resistors R1 and R2 and the three-section filter condenser, C2. Plate voltage for

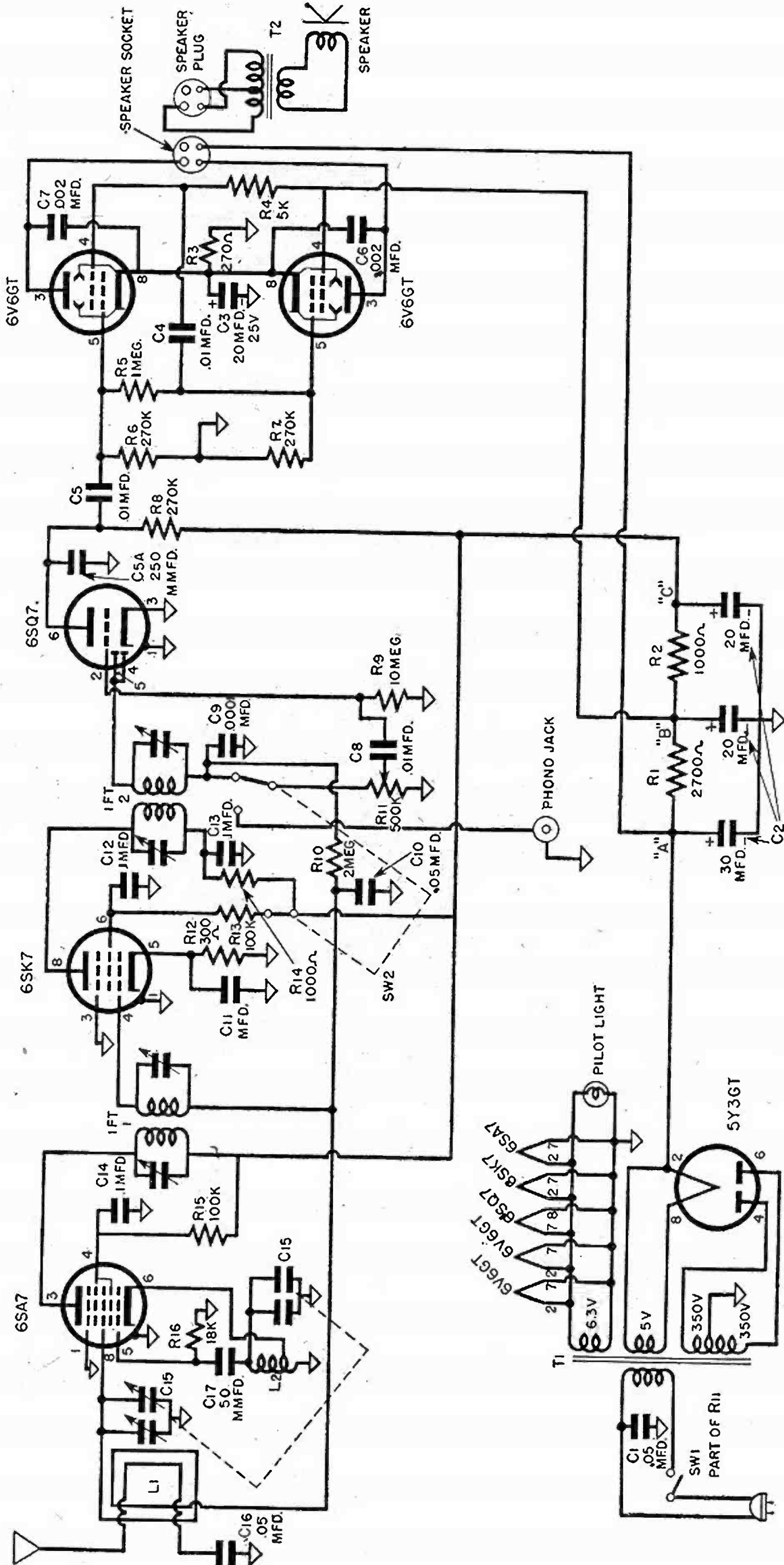

Fig. 2-25. Complete circuit diagram for six tube AC receiver.

the output stage is taken from point *A* on the filter resistor terminal strip; thus the output transformer must take part in the filtering action. Screen voltage for the output circuit is taken from point *B*; this voltage is filtered by R1 and the first two sections of C2. All other plate and screen voltages are taken from point *C* on the resistor terminal strip; these voltages are filtered by both R1 and R2 and all three sections of the filter condenser.

Heater voltages for all tubes except the rectifier are supplied by the 6.3-volt winding of the power transformer. Another low voltage winding, 5 volts in this case, supplies the heater of the 5Y3GT rectifier.

The phonograph circuit comprises the phonograph jack and the double-pole double-throw slide type of switch, SW2. One set of contacts transfers the high side of the volume control from the lower end of the second i.f. transformer to the phonograph jack for record reproduction. At the same time, the remaining set of contacts on SW2 disconnects the screen of the i.f. amplifier from its voltage supply; this effectively prevents radio signals from interfering with recorded music.

Parts list

Resistors

R1	2700 ohms, 1-watt carbon
R2	1,000 ohms, 1-watt carbon
R3	270 ohms, 1-watt carbon
R4	5,000 ohms, 1/2-watt carbon
R5	1 megohm, 1/2-watt carbon
R6	270K ohm, 1/2-watt carbon
R7	270K ohm, 1/2-watt carbon
R8	270K ohm, 1/2-watt carbon
R9	10 megohm, 1/2-watt carbon
R10	2 megohm, 1/2-watt carbon
R11	500K ohm volume control, with switch (SW1)
R12	300 ohm, 1/2-watt carbon
R13	100K ohm, 1/2-watt carbon
R14	1,000 ohm, 1/2-watt carbon
R15	100K ohm, 1/2-watt carbon
R16	18K ohm, 1/2-watt carbon

Condensers

C1	.05mfd., 400-volt, paper tubular
C2	30-20-20 mfd., 450-volt, electrolytic (aluminum can, vertical-mounting type)
C3	20 mfd., 25-volt, electrolytic (tubular type)
C4	.01 mfd., 600-volt, paper tubular
C5	.01 mfd., 600-volt, paper tubular
C6	.002 mfd., 600-volt, mica
C7	.002 mfd., 600-volt, mica
C8	.01 mfd., 400-volt, paper tubular
C9	.0001 mfd., mica
C10	.05 mfd., 400-volt, paper tubular
C11	.1 mfd., 200-volt, paper tubular
C12	.1 mfd., 600-volt, paper tubular
C13	.1 mfd., 600-volt, paper tubular
C14	.1 mfd., 600-volt, paper tubular
C15	Variable condenser, two-gang superheterodyne type (see 5-tube receiver for specifications)
C16	.05 mfd., 400-volt, paper tubular
C17	50 mmfd., mica

Transformers

IFT1	Input i.f. transformer, 455 KC; Stanwyck S-105 or equivalent
IFT2	Output i.f. transformer, 455 KC; Stanwyck S-106 or equivalent
T1	Power transformer: high voltage, 350-0-350 volts at 90 m.a.; heater, 6.3 volts at 3.5 amp.; rectifier, 5 volts at 3 amp. Stancor type P-4079 or equivalent
T2	Output transformer, push-pull type, 8,000 ohm primary, 4 ohm secondary; Stancor type A-3823 or Thordarson type T-2S87

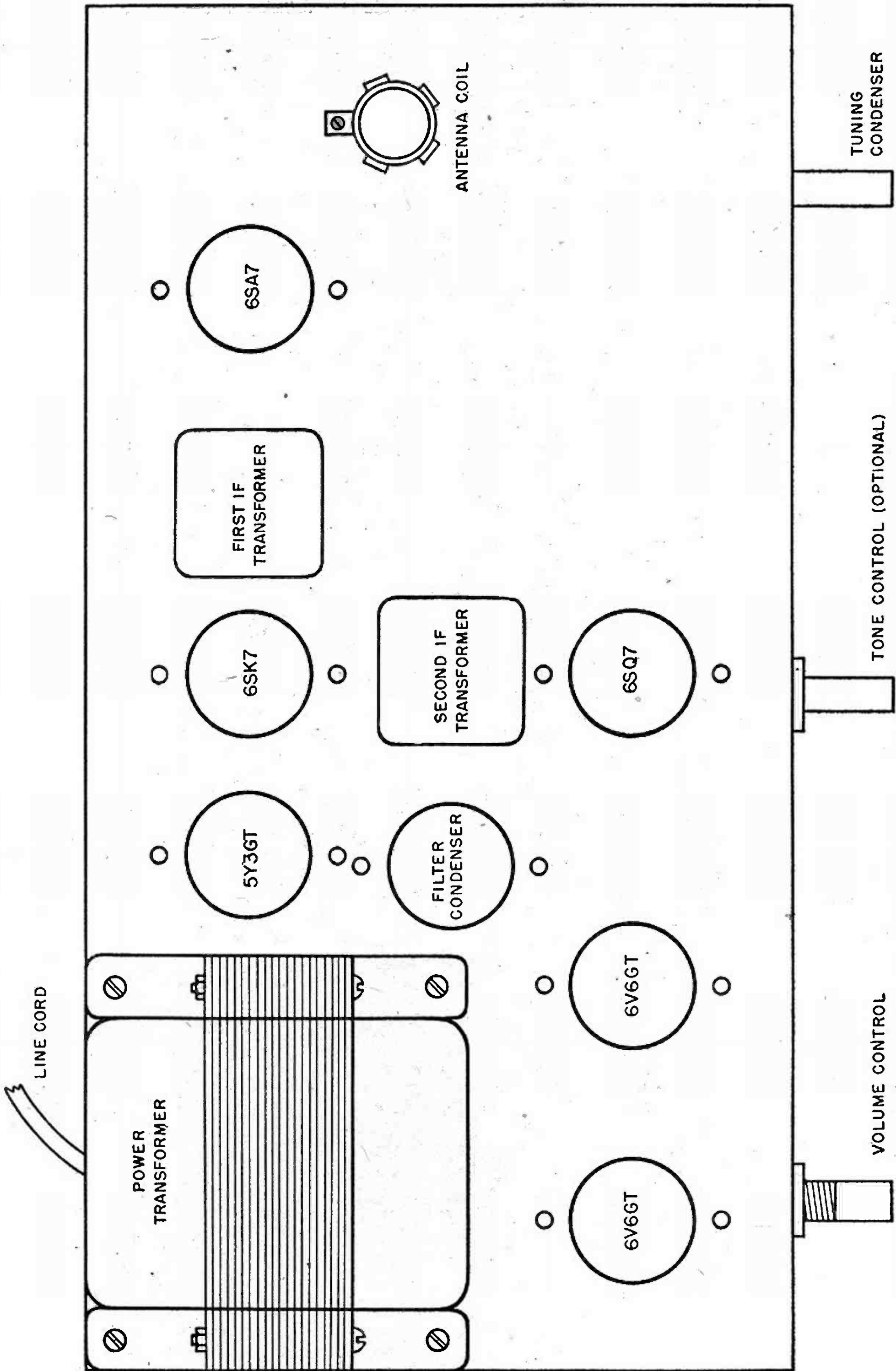

Fig. 2-26. Arrangement of components on top of chassis.

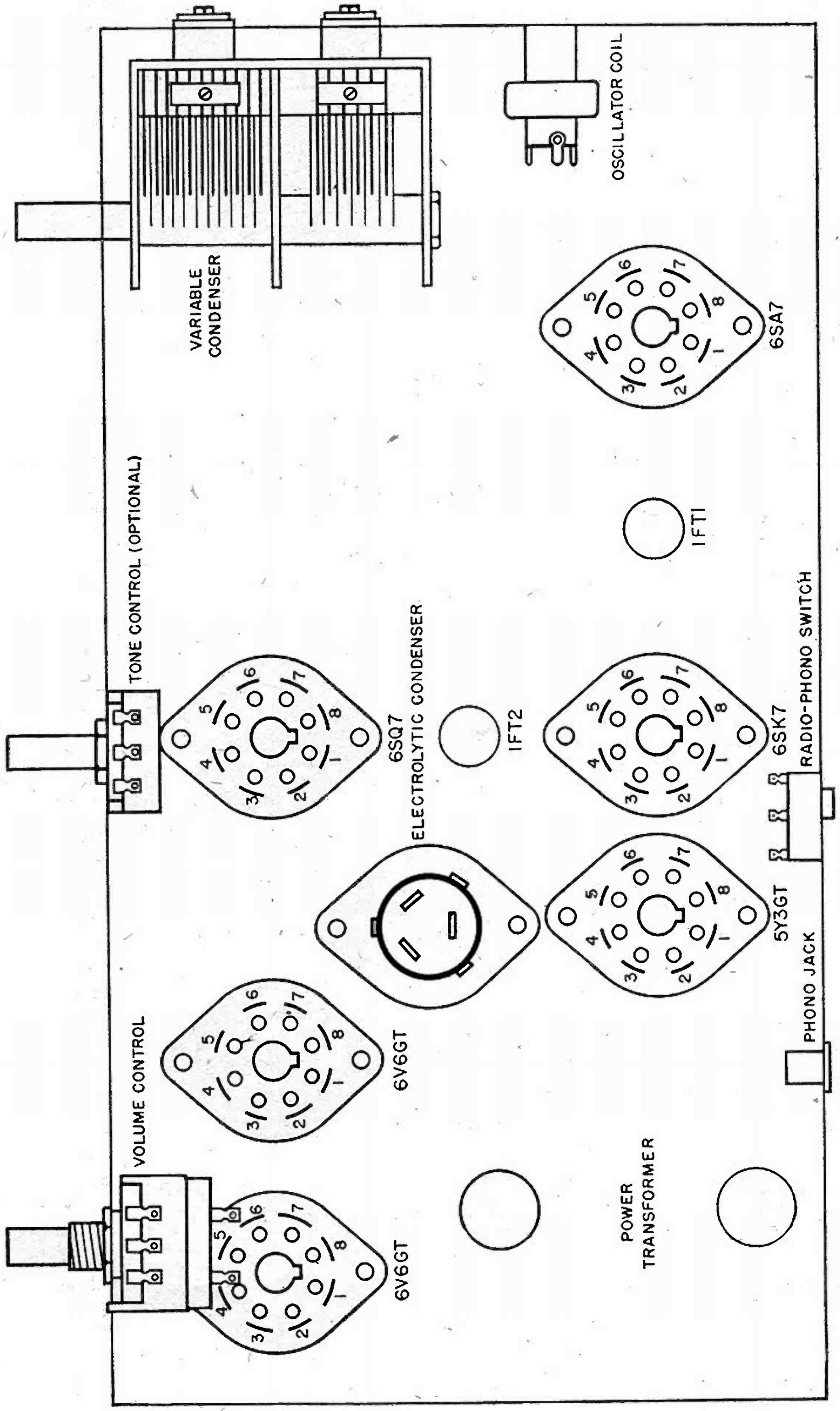

Fig. 2-27A. Underside view of chassis showing terminal arrangements of tube sockets.

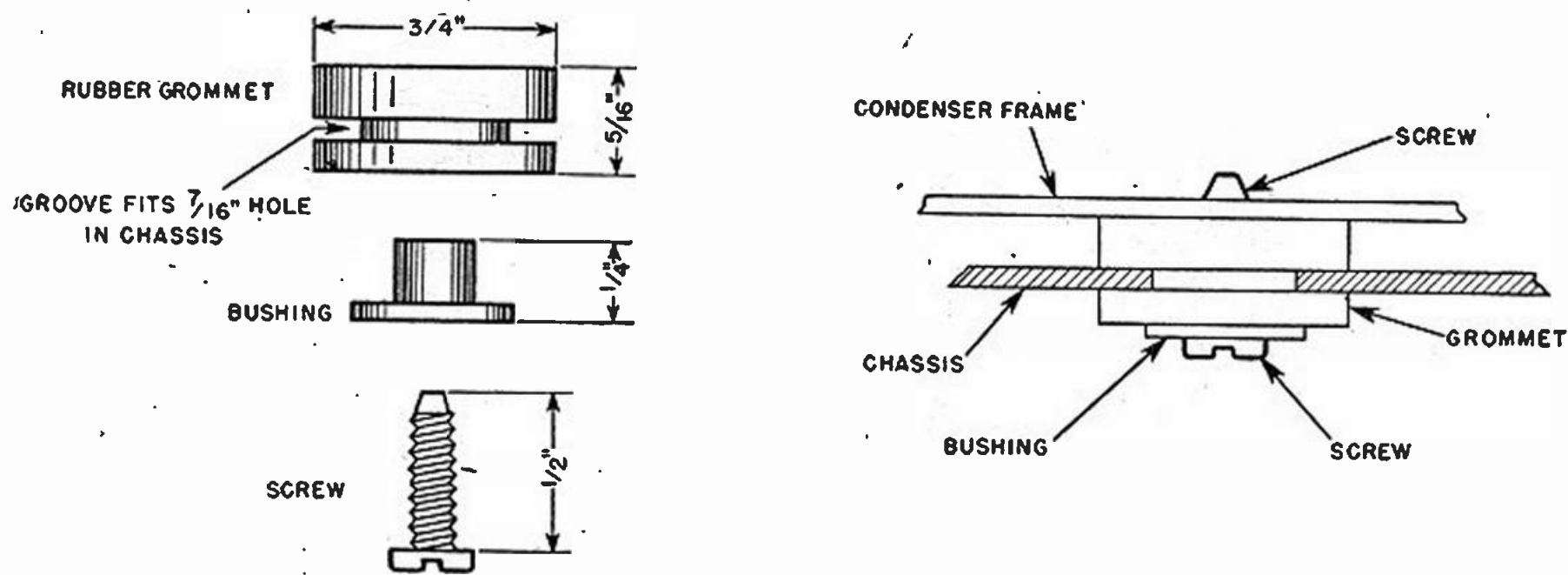

Fig. 2-27B. Cushions for mounting the variable condenser.

Coils

- L1 Loop antenna
 L2 Oscillator coil, tapped single-winding type

Switches

- SW1 On-off switch, part of volume control, R11
 SW2 Double-pole double-throw, slide type

Speaker

Permanent magnet dynamic; any size may be used, since the speaker is not mounted on the chassis; voice coil must have 3-4 ohm impedance.

Miscellaneous

- Chassis 6 x 12 x 3 inches
 6 octal wafer-type tube sockets
 1 4-pin wafer-type socket
 1 speaker plug, 4-pin; Amphenol type 86 PM4 or equivalent
 4 2-point tie strips
 4 3-point tie strips
 6-32 x 3/8 inch r.h. machine screws
 6-32 hexagon nuts
 4 10-24 x 1/2 inch r.h. machine screws (for power transformer)
 4 10-32 hexagon nuts
 Line cord and plug
 Push-back wire

Rosin core solder

Tubes

- 6SA7, 6SK7, 6SQ7, 6V6GT (2), 5Y3GT, and (for tuning indicator) 6U5/6G5

Layout, drilling, and assembly

The arrangement of parts on top of the chassis is shown in Figure 2-26. While minor departures from this arrangement can be made, try to preserve the general layout so that components are as close as possible to the tubes they are associated with.

Perhaps the most logical beginning is the layout of the screw holes for the power transformer, since the size and position of this largest unit of the set will influence, to some degree, the placement of other parts. Locate and punch mark the positions of the sockets, i.f. transformers, antenna coil, and filter condenser next.

The underside view, Figure 2-27A, shows the placement of major parts located beneath the chassis. Screw holes for fastening the variable condenser, oscillator coil, phonograph switch, and phonograph jack should now be located and center punched.

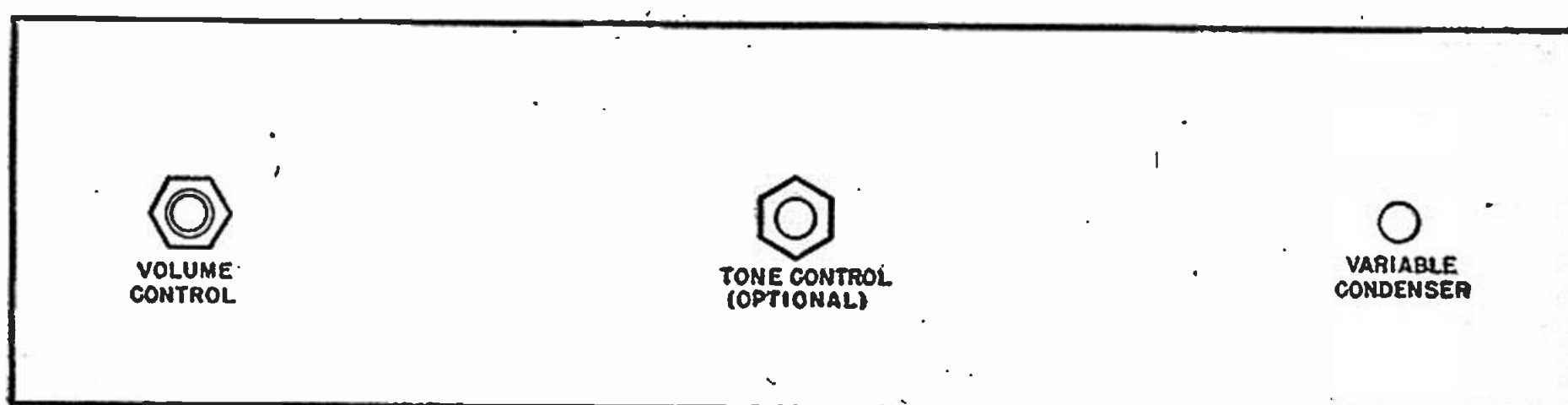

Fig. 2-28. Front apron view of the chassis.

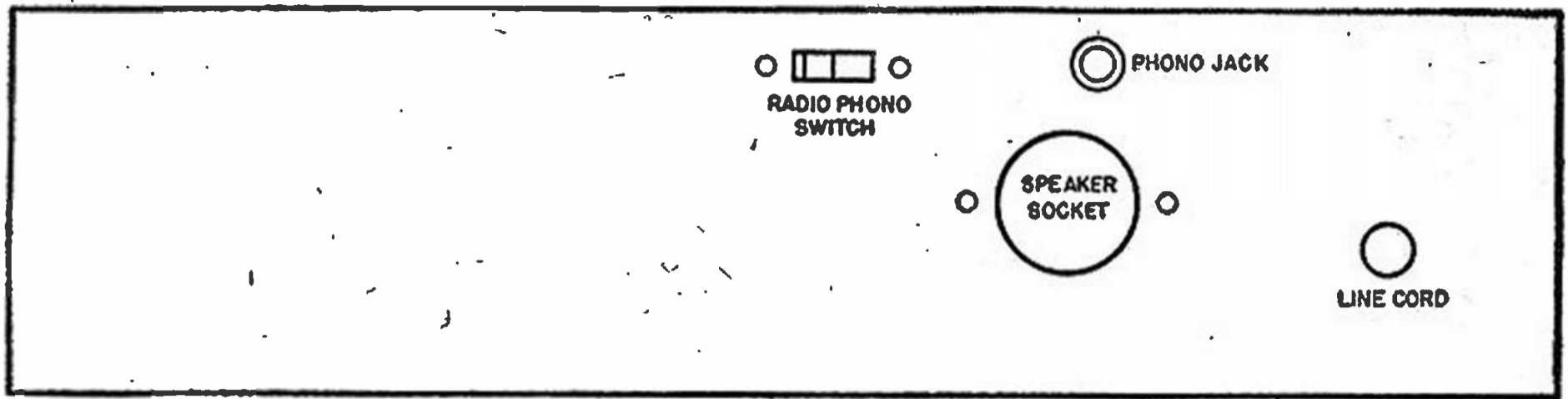

Fig. 2-29A. Rear apron view of the chassis.

Notice that the underside view also shows the terminal arrangements of the tube sockets. You may now locate the two large holes (shown at the left of Figure 2-27A) for the power transformer leads.

The front apron view of the chassis, Figure 2-28, shows the positions of the volume control, variable condenser, and tone control shafts. Note that the tone control is optional. On the rear apron of the chassis, Figure 2-29A, are the speaker socket, phonograph jack, radio-phonograph switch, and the hole for the line cord.

When the layout has been com-

pleted and all the locations center punched, drill, as usual, for clearance of a 6-32 screw. The one exception is the hole for the radio-phonograph switch, which will be considered below. Holes to be enlarged are: tube socket center holes, 1-1/16 inch; holes for i.f. transformer wires, 5/8 inch; holes for power transformer leads, 5/8 to 3/4 inch; volume control, tone control, and variable condenser shafts, 7/16 inch; line cord, 1/2 inch; speaker socket, 1-1/16 inch; variable condenser screw holes, 7/16 inch. The size of hole for the phono jack will depend upon the type of jack to be used. Holes up to

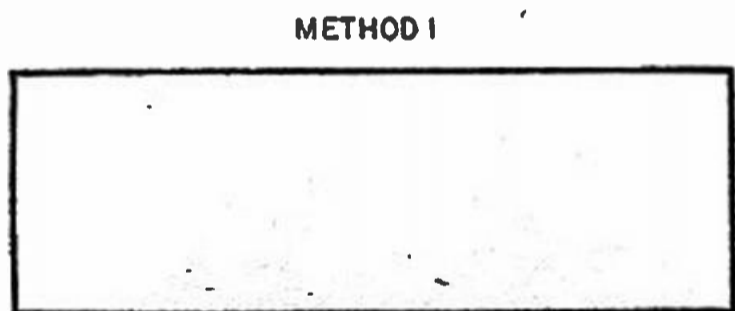

SCRIBE RECTANGLE ON CHASSIS

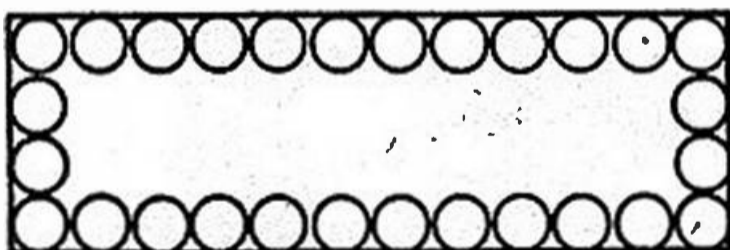

DRILL SMALL HOLES JUST INSIDE BORDERS OF RECTANGLE

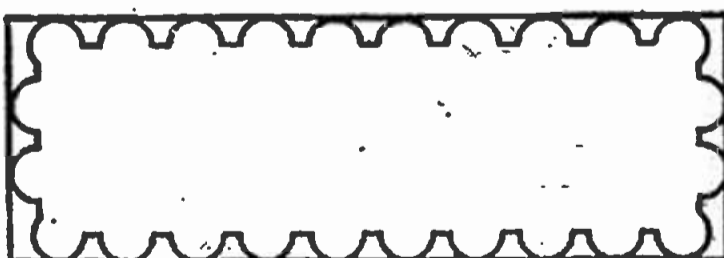

CUT OUT WITH COLD CHISEL



FILE TO SHAPE

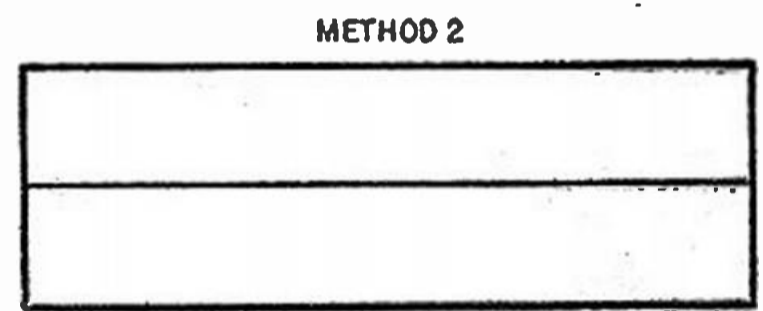

SCRIBE RECTANGLE ON CHASSIS, SCRIBE CENTER LINE

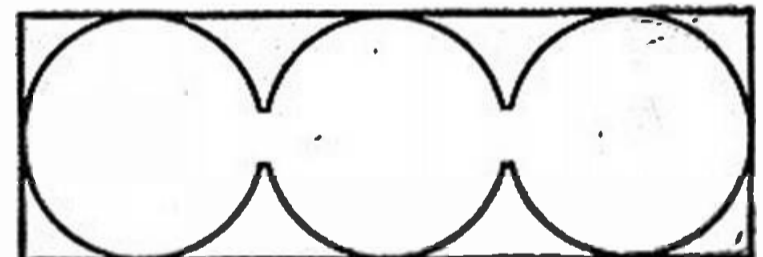

ON CENTER LINE, DRILL HOLES HAVING DIAMETER EQUAL TO SHORT SIDE OF RECTANGLE

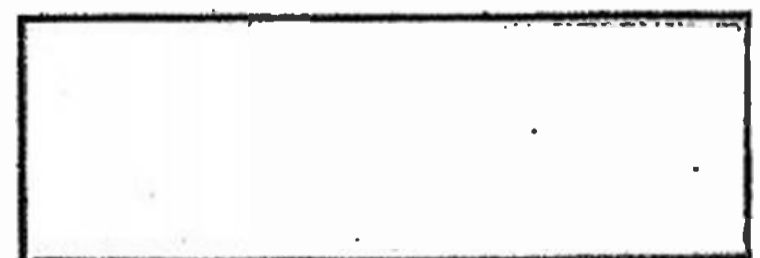

FILE TO SHAPE

Fig. 2-29B. Two methods for cutting rectangular hole in the chassis.

1/2 inch may be enlarged with a reamer or large drill; larger openings should be cut out with a sheet metal punch.

In almost all cases, the slide type of switch will require a rectangular hole in the rear of the chassis. There are two methods of cutting such an opening, both illustrated in Figure 2-29B. For either method, first scribe the outline of the rectangle in the proper place. Ordinarily, pencil marks are recommended for layout, but in this case a more permanent mark is required and furthermore the layout lines will be obliterated when the rectangle is finished. If you prefer to use the first method, drill a series of holes just inside the borders of the rectangle, as in the sketch. The exact size

side) of the rectangle. Carefully centering the drill on the center line, drill as many overlapping holes as will fit into the space. (Three holes are shown in the sketch, but you may need one or more than three.) Finish by filing to the scribed lines with round and flat files.

Mounting parts will proceed in a conventional manner, so no description is needed other than some notes on the mounting of the variable condenser. You have observed that this item is not mounted flush against the end apron of the chassis, but is spaced away from it. The reason for this is that the condenser is mounted on rubber cushions to prevent microphonic action. Whether this is necessary will depend upon where you place the

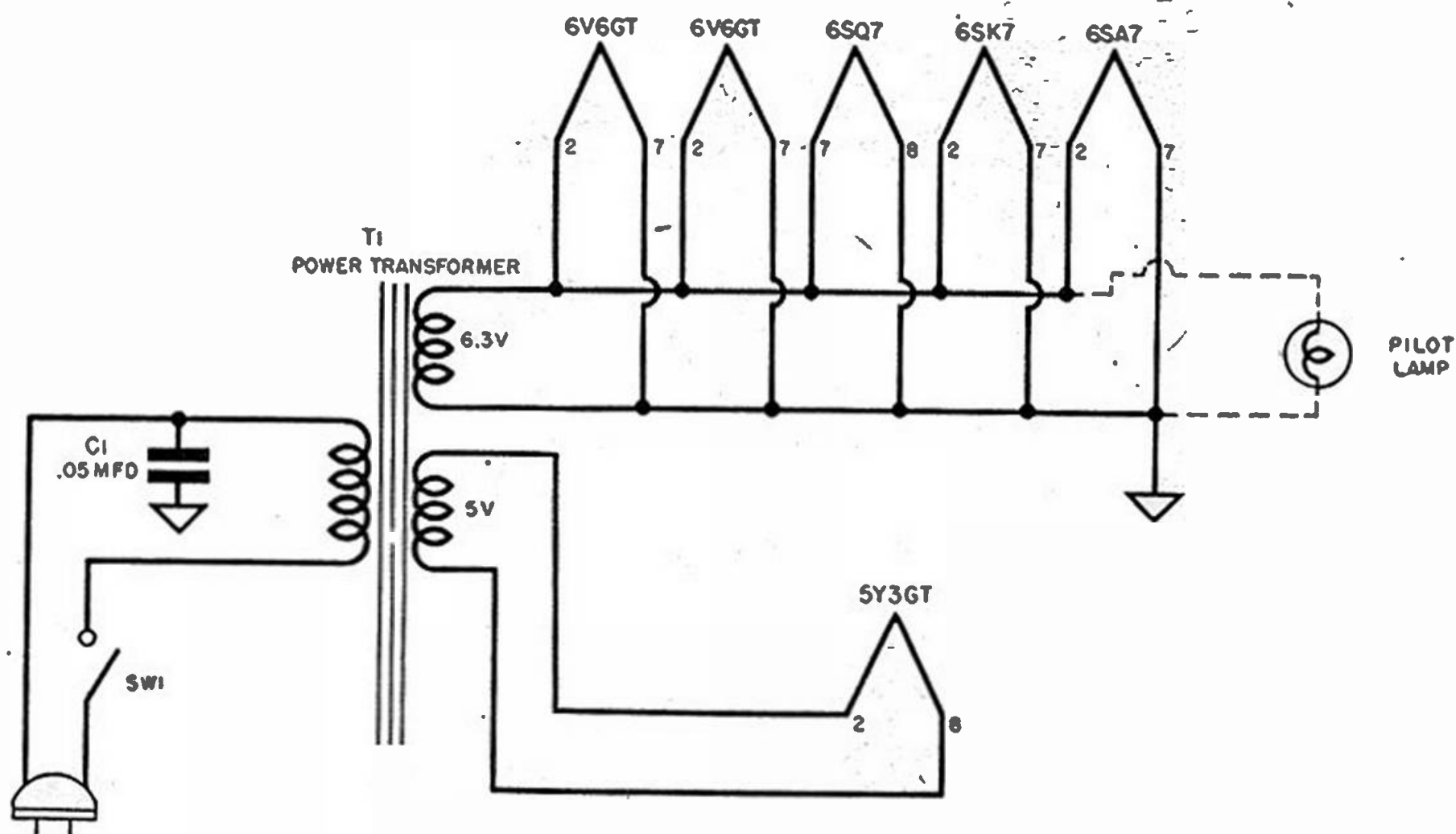

Fig. 2-30. Wiring the heater circuit.

of the drill is not too important; 3/32 inch diameter is about right. After drilling, cut rather close to the scribed outline with a cold chisel. This will leave a cut-out that looks like the third drawing under method 1. Using a small flat file, file away the serrations until you have worked down to the scribed lines. In the second method, a center line must be drawn parallel to the longer sides of the rectangle. Select a drill with a diameter slightly less than the width (short

speaker. If you use a table type of cabinet with the speaker at one end of the cabinet (or in any case, rather close to the chassis), this type of mounting is essential. For a floor-model cabinet (or with speaker in a separate cabinet), it may be dispensed with. In the latter case, fasten the condenser against the right end apron of the chassis, using the ordinary mounting. The mounting holes should then be drilled for 8-32 screws. Of course, this will change the location

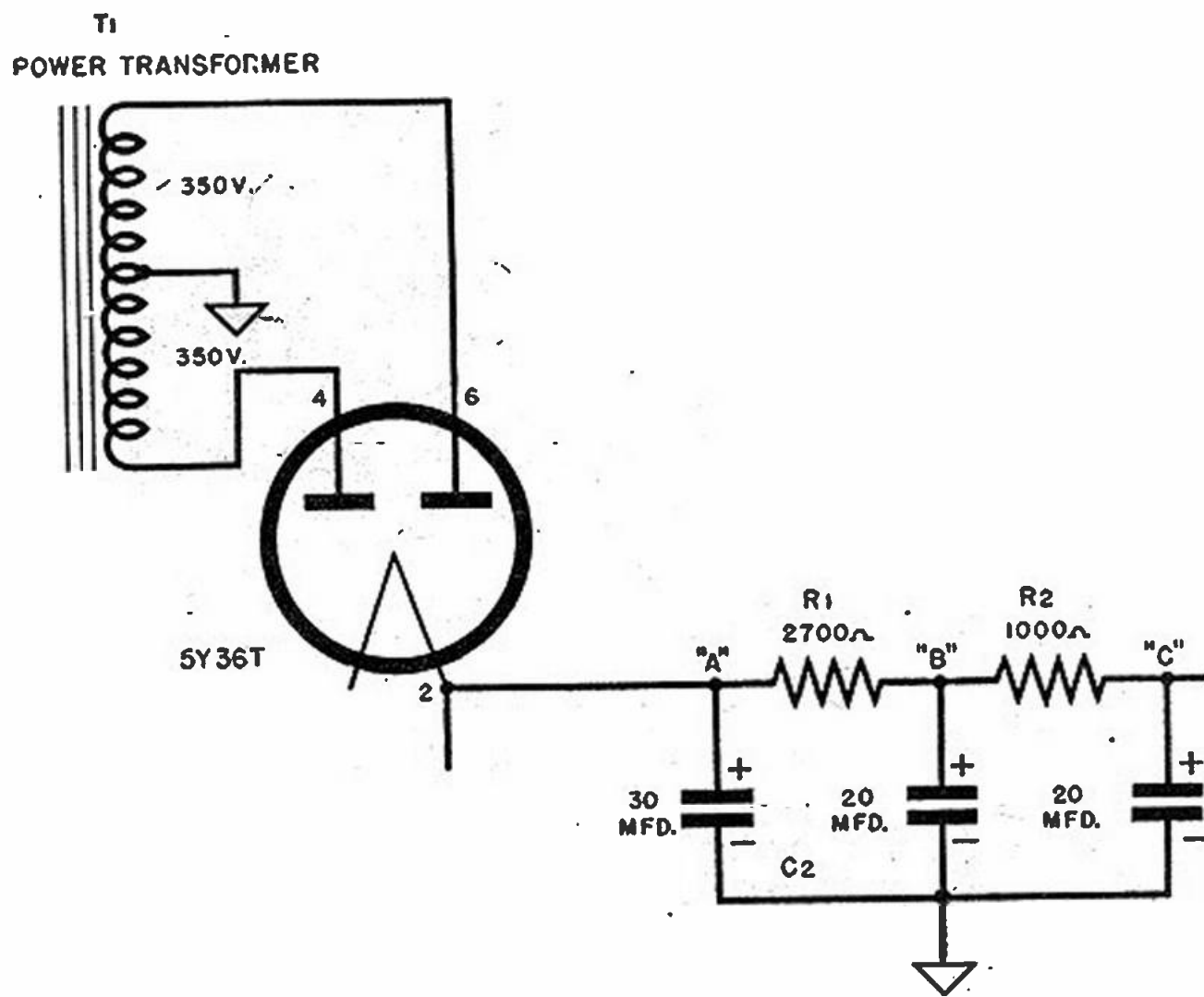

Fig. 2-31. Wiring the power supply.

of the shaft hole and the volume control will also have to be shifted slightly to preserve a symmetrical appearance.

The rubber mountings shown in Figure 2-27B can be obtained from any large radio supply house and consist of three parts: a 1/2 inch screw, a metal bushing with a flat end that serves as a washer, and a rubber grommet 3/4 by 5/16 inch with a deep groove. To assemble, force the grommet into the 7/16 hole in the chassis

with the thicker part of the grommet toward the inside. Push the bushing into the hole in the grommet, place the condenser against the grommet, and then slip the screw through the hole in the bushing and thread it into the tapped hole in the condenser frame. With this type of mounting, a short heavy wire connection is needed between the condenser frame and chassis.

When placing the i.f. transformers, be sure to turn them so the plate and

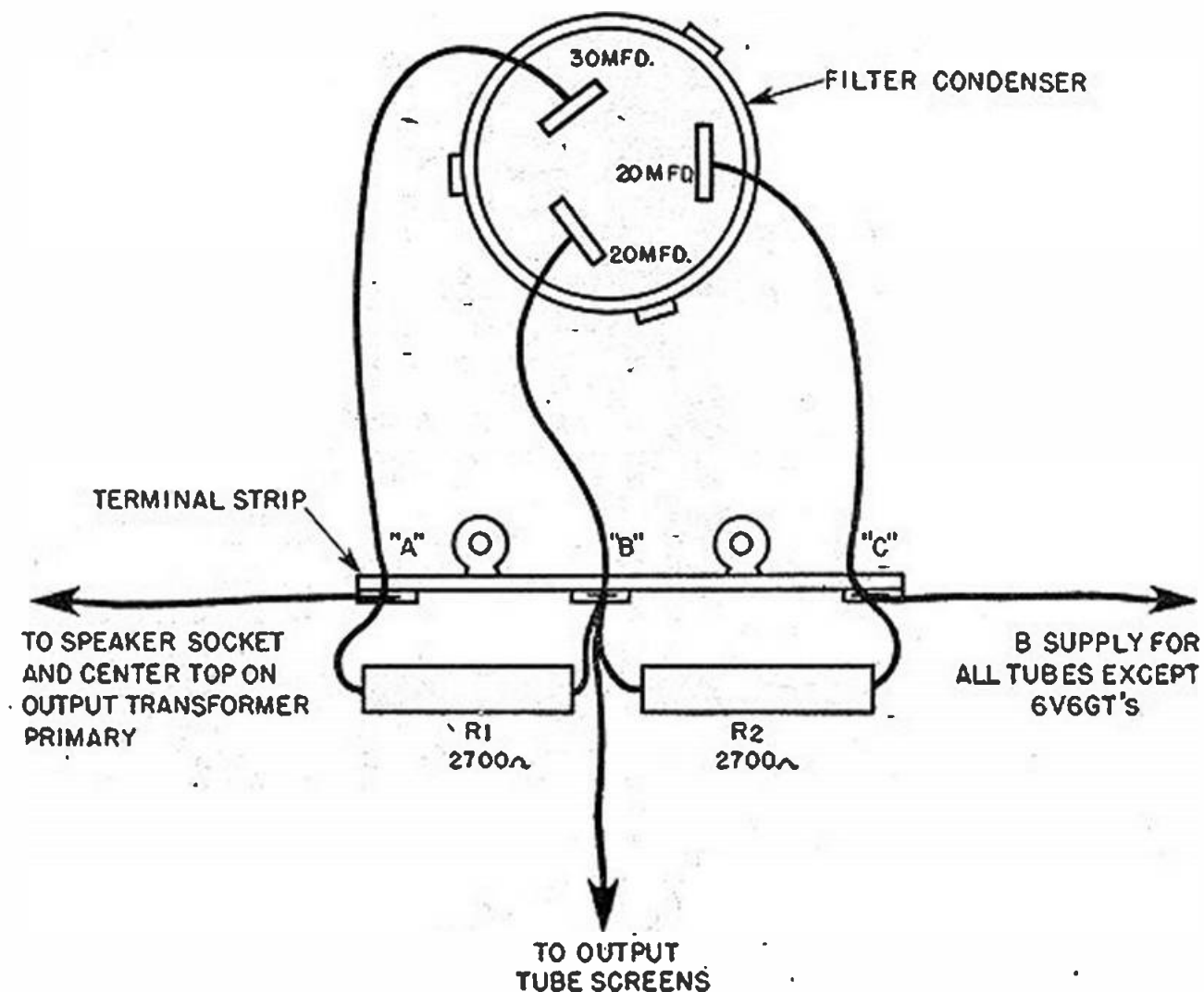

Fig. 2-32. Wiring the filter resistors and condensers.

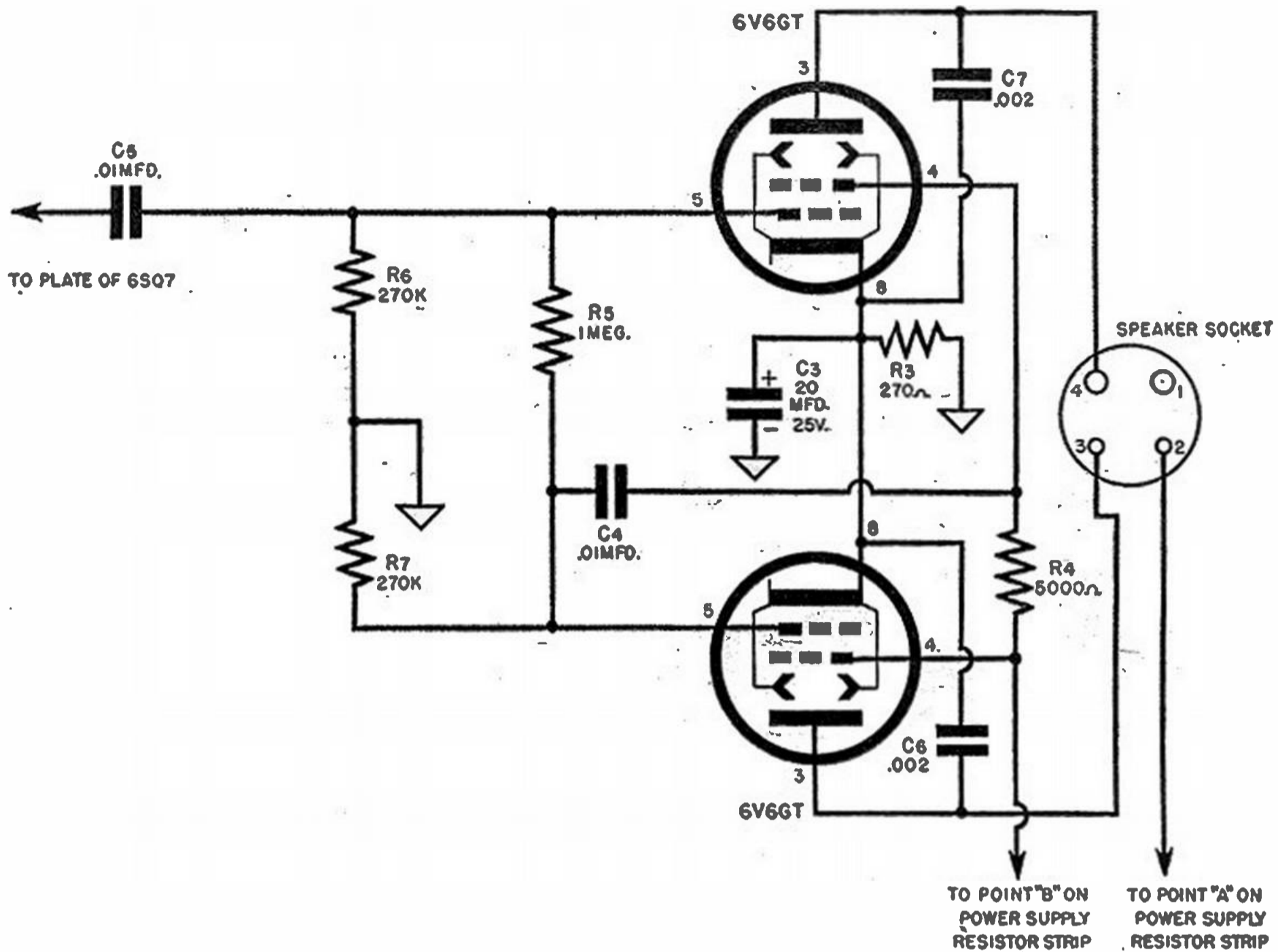

Fig. 2-33. Connections to the 4-pin speaker socket.

grid leads will be as short and direct as possible. Note that it will be necessary to fasten the 6V6GT socket at the extreme left in place before putting the volume control in position, because the socket lies partly under the control. The control may be temporarily removed, if necessary, in order to complete the wiring to the tube socket.

Wiring

a) *Heater Circuit.* Figure 2-30. Note that, as in all transformer types of sets, the tube heaters are wired in parallel. Connect one end of the power transformer 6.3 volt winding (leads are usually green) to pin 2 of the

6V6GT tube at the extreme left; the other end of the winding is connected to pin 7 of the same tube. Ground pin 7 to chassis. Now run a wire from pin 2 of the tube to pin 2 of all other tubes except the 6SQ7 and 5Y3GT. On the 6SQ7, connect to pin 7 instead. Complete this portion of the wiring by connecting the following tube socket pins to chassis: pin 7 on the remaining 6V6GT and on the 6SA7 and 6SK7; pin 8 on the 6SQ7. Connect the line cord to the primary wires (usually black) of the transformer; note that one wire runs to the primary by way of the switch. Connect C1 to one side of the line

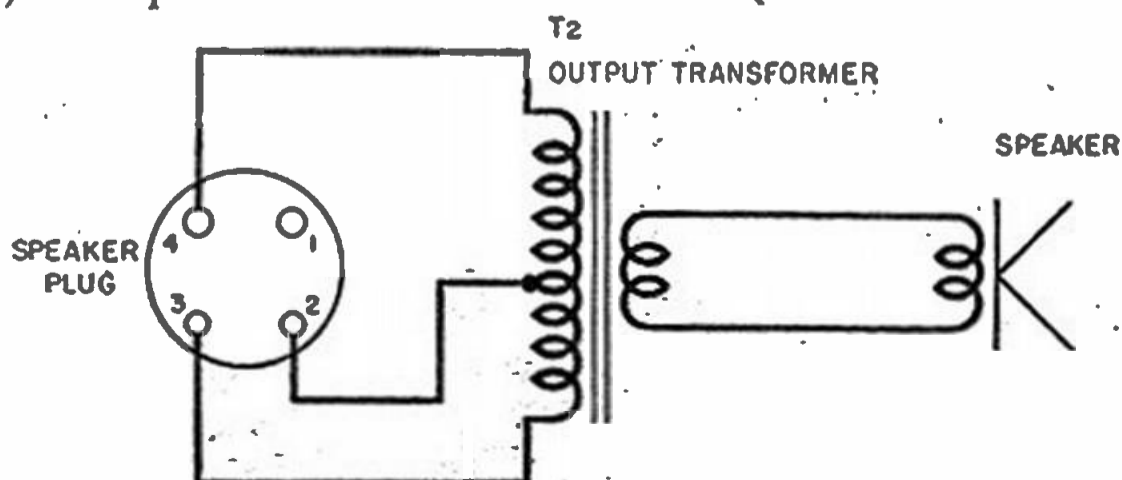

Fig. 2-34. Wiring the speaker plug.

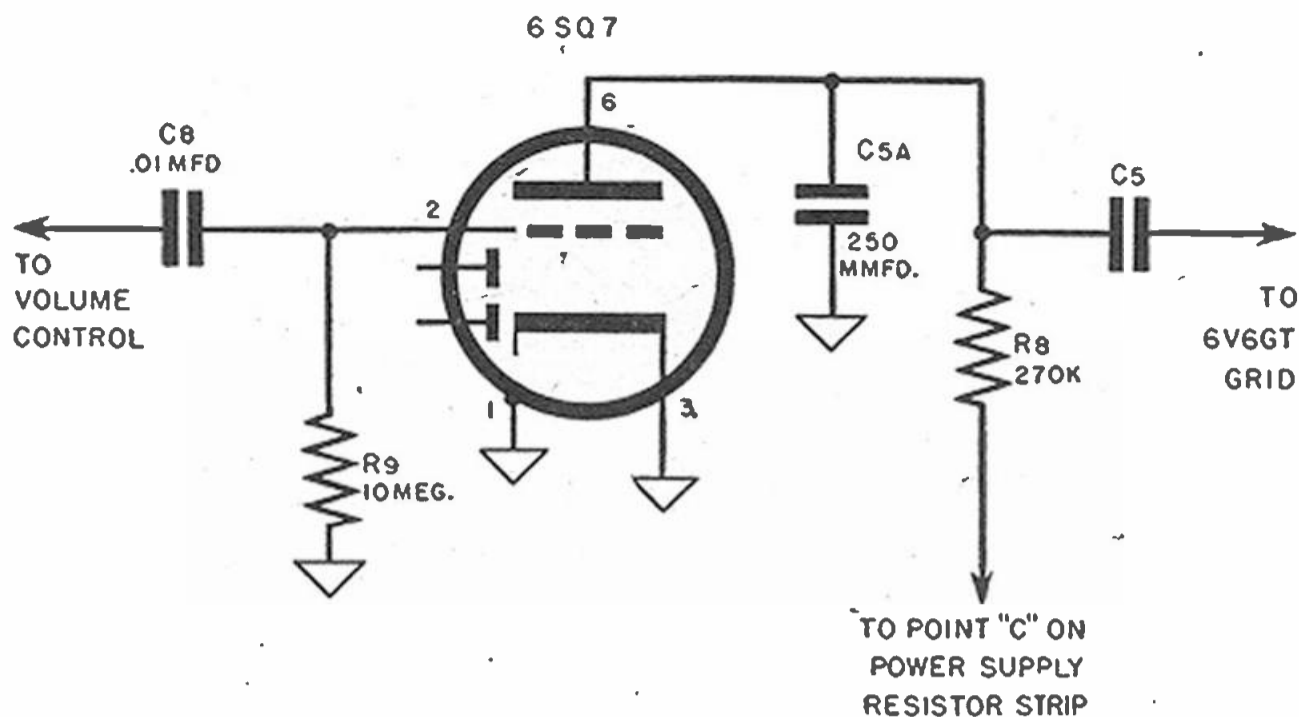

Fig. 2-35. The first A. F. circuit.

and to chassis. Wire the rectifier heater circuit (the transformer leads are usually yellow). Since these leads pass near the phono jack, it is best to twist them together to prevent hum pickup.

b) *Power Supply.* See Figure 2-31. Wire as shown in the sketch. The high voltage leads will probably be red, the center tap red and yellow. Be sure to connect the three units of the filter condenser exactly as shown. The coding of the sections will be marked on the condenser can. Refer to Figure 2-32 for additional details on the wiring of the filter resistors and condensers.

c) *Output Circuit.* The output stage wiring is shown in Figure 2-33. Wire exactly as shown in the drawing, being careful to connect C4 between the screen of the upper 6V6GT and the grid of the lower one. Observe that resistor R4 is between the screen of the upper tube and the B supply, while the screen of the lower tube is connected directly to B supply. These precautions must be observed, otherwise the stage will not function properly. Figure 2-33 shows the connections to the 4-pin speaker socket, while 2-34 illustrates the wiring of the corresponding plug.

d) *First A.F. Circuit.* See Figure 2-35. No special comments are needed here.

e) *Detector-AVC Circuit.* The wiring of the entire circuit is shown in

Figure 2-36. Figure 2-37 is a detailed drawing of the phonograph portion. Notice that the wire from the switch to the volume control must be shielded. Use regular shielded wire or, if this is not available, cover a length of stranded, well-insulated wire with woven shielding. Be sure to ground both ends of the shield to chassis.

f) *I.F. Amplifier Circuit.* This circuit includes one set of contacts on the radio-phono switch. The full i.f. amplifier circuit is shown in Figure 2-38. For further details on the switch wiring, refer back to Figure 2-37.

g) *Mixer Circuit.* This section of the set is illustrated in Figure 2-39. If you have trouble identifying the loop antenna wires, refer back to Figures 2-17A and 2-17B.

h) *Oscillator Circuit.* Refer to Figure 2-40 for a sectional diagram of

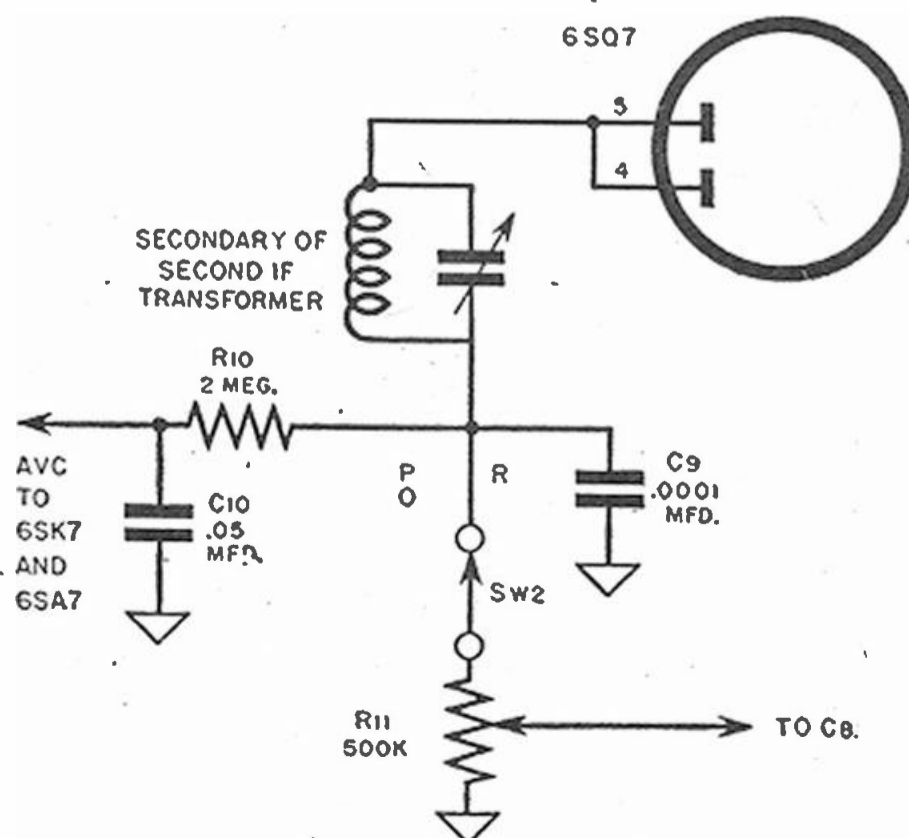

Fig. 2-36. The detector-AVC circuit.

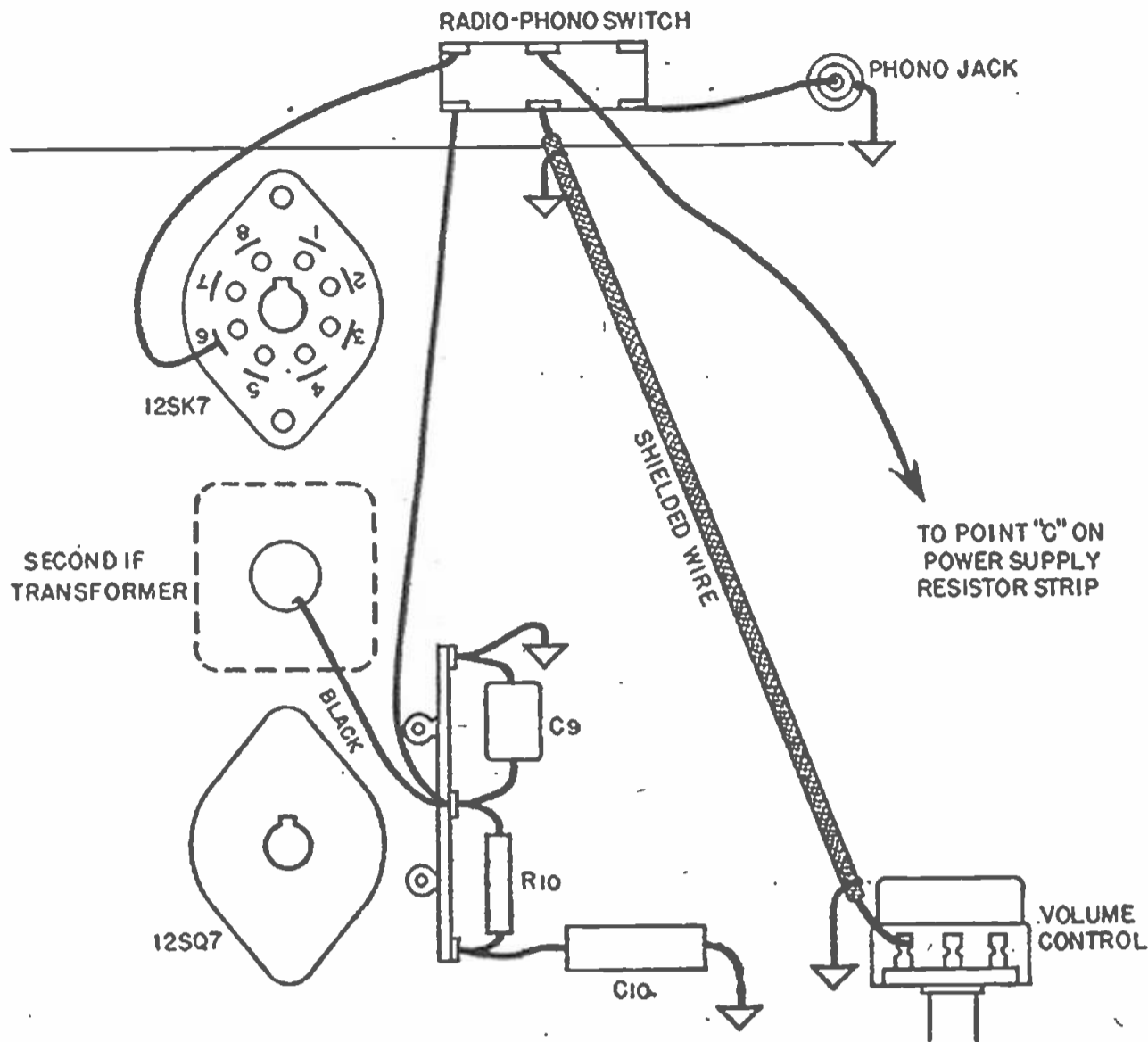

Fig. 2-37. Phono portion of the detector-AVC circuit.

the oscillator circuit. If the coil you have is intended to be used with a coupling condenser between the oscillator grid of the tube and the top end of the coil, use a 50 mmfd. mica for this purpose. If no condenser is needed (gimmick used instead) there will be four, instead of three, terminal lugs. Check the continuity between all terminals; when you find one that has a wire connected to it but checks open, it is the one to which the gimmick is connected and should be connected directly to pin 5 of the tube

socket, with no condenser between.

If you did not receive, or have lost, the connection diagram for your oscillator coil, the terminals can be identified by measuring the resistance with a low-reading ohmmeter. You will get three readings, which we shall refer to as high, medium, and low. The highest reading applies, of course, to the entire winding, from start to end. The medium reading is from the top, or grid end, of the coil to the cathode tap, while the lowest reading is between the cathode tap and the chassis

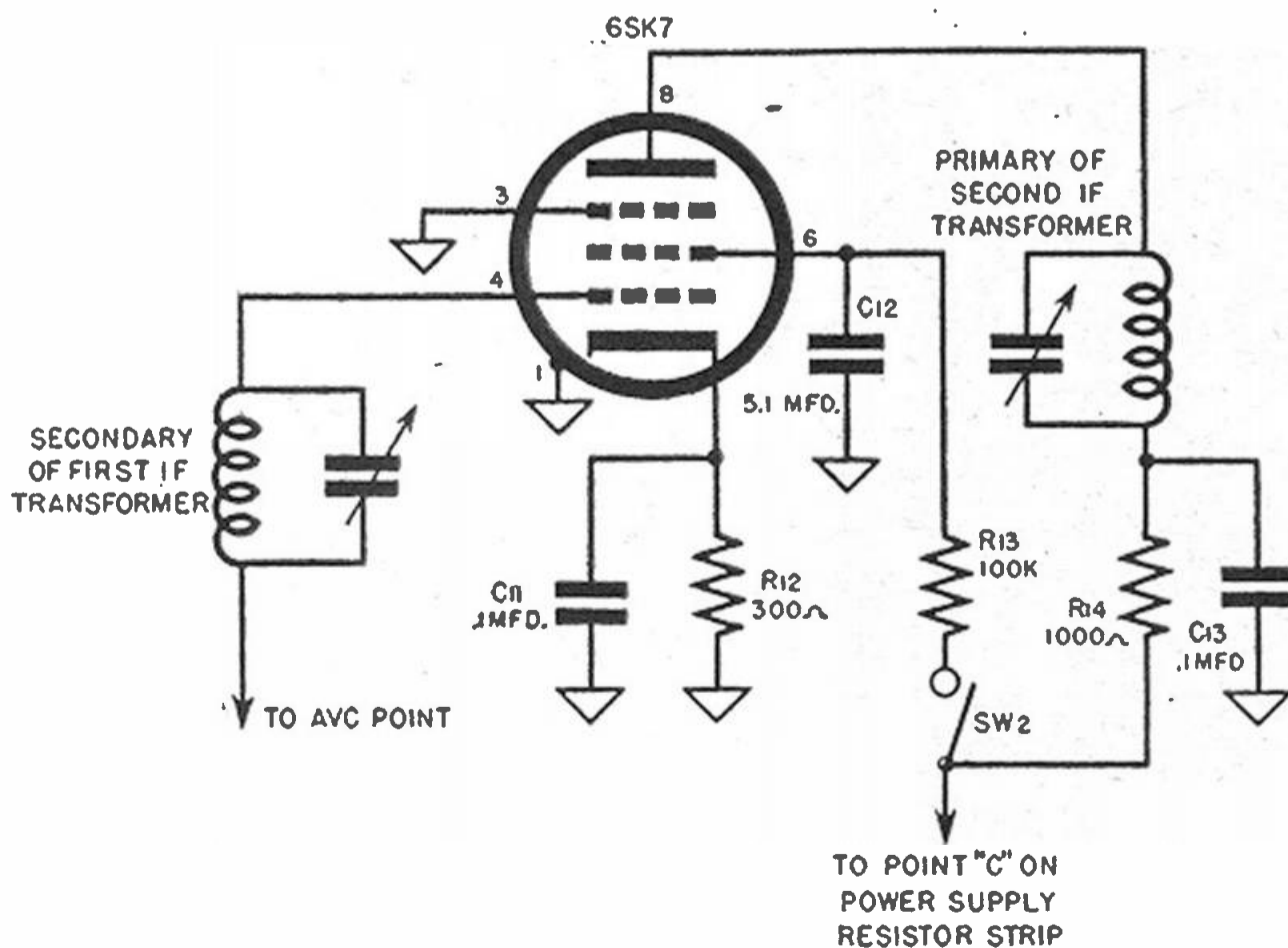

Fig. 2-38. The full i.f. amplifier circuit.

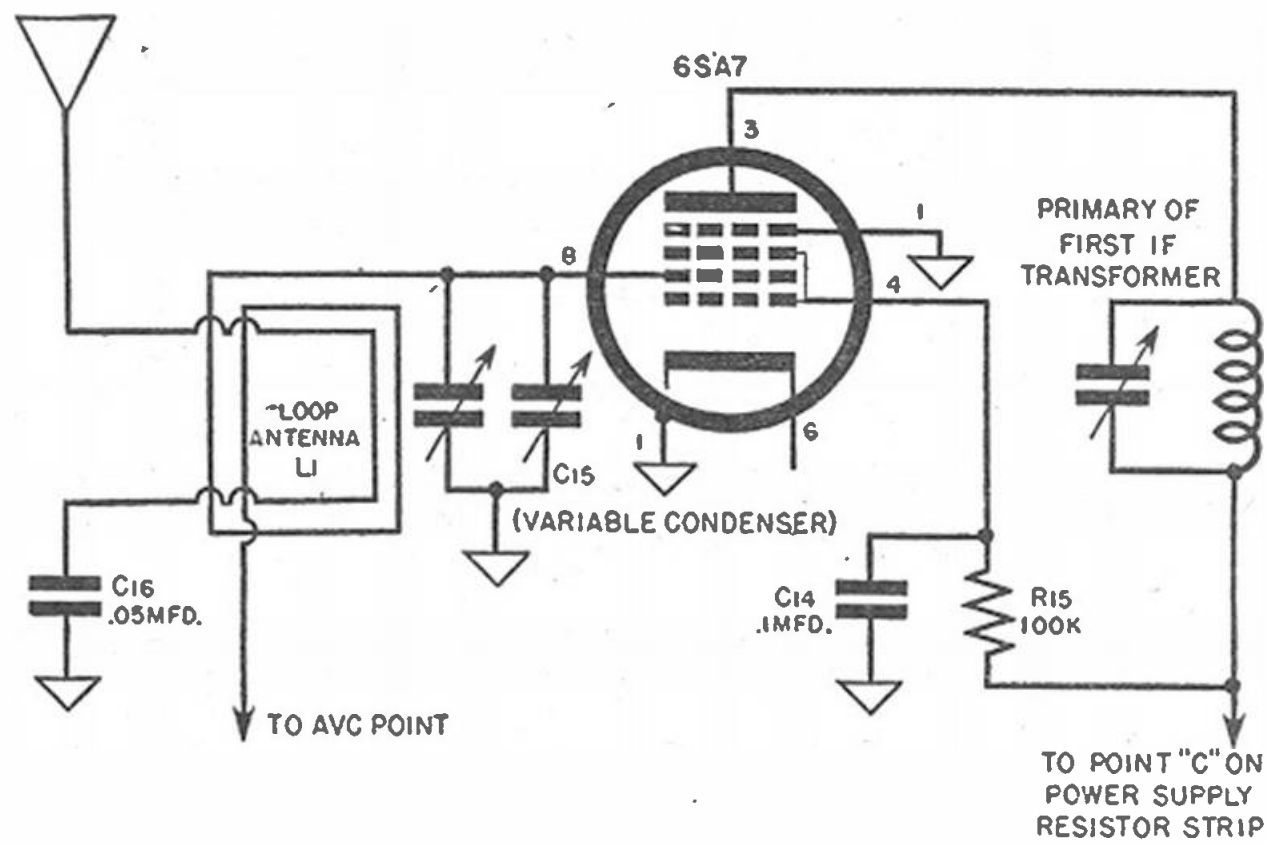

Fig. 2-39. Components of the mixer circuit.

end of the coil.

i) *Tone Control Circuit.* If you intend to add a tone control to the set, refer to Figure 2-41 for the diagram. The connections to be added are indicated by the dotted lines.

j) *Electron-ray Tuning Indicator.* See Figure 2-42. A type 6U5/6G5 tube is used as an indicator. It will not only show when the set is correctly tuned to the desired signal but, since it is in effect a vacuum tube voltmeter, it will also give a rough indication of the relative intensity of station signals. Once you have become accustomed to using it, you will be able to detect quickly any change in the sensitivity of the set due to a faulty tube or other causes. Furthermore, it may also be used as an indicator when aligning the set. Additional parts needed: 6U5G tube, 6 pin socket, 1-megohm 1/4-watt carbon resistor, connecting wires. All of the parts may be pur-

chased in kit form, including a special six-pin molded socket and brackets for mounting. Some kits also include a panel-mounting bezel.

Alignment

When the set is completed, it must be aligned, and this cannot be properly done without a signal generator. With the set and generator turned on and warmed up, connect the inner wire of the generator cable to pin 8 of the 6SA7 tube and the outer shield to chassis. The tuning condenser on the set should be fully meshed. Adjust the generator to deliver a modulated signal at 455 kilocycles. With the receiver volume control turned all the way up, adjust the signal intensity at the generator so that the sound heard in the speaker is barely audible. Now adjust the trimmers on both i.f. transformers for maximum volume; as each adjustment increases the volume, turn

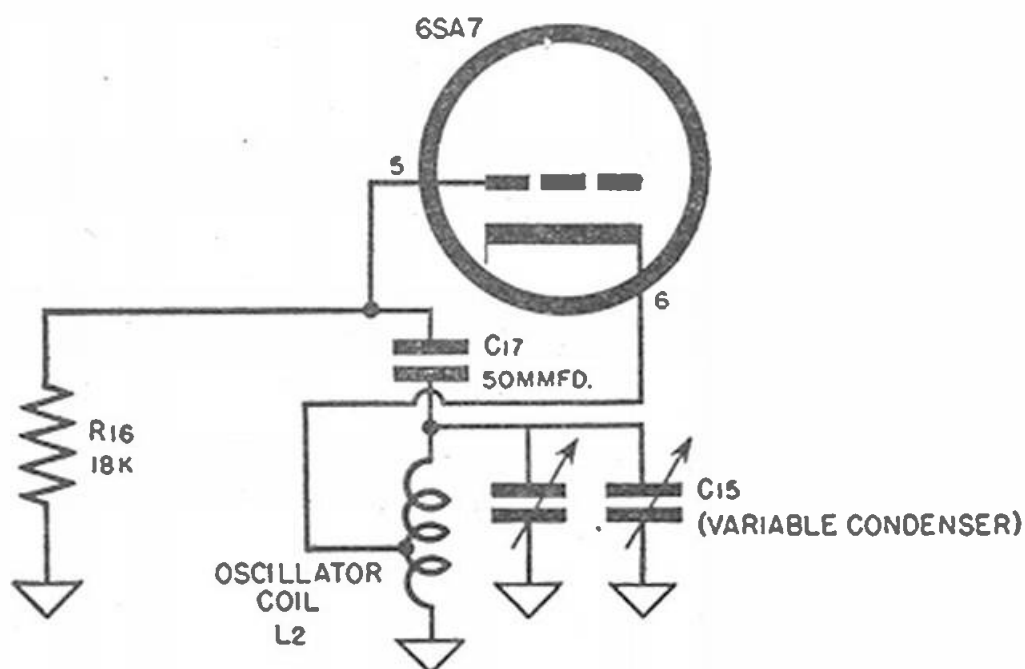

Fig. 2-40. Oscillator circuit.

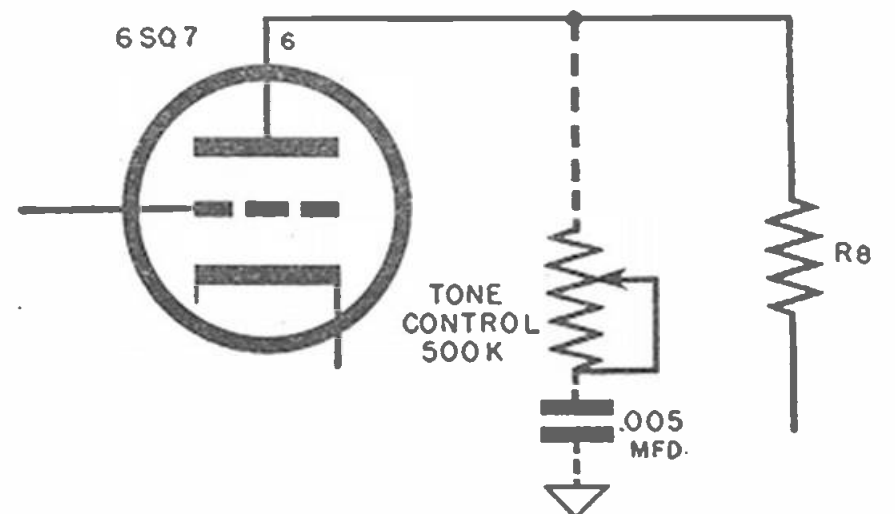

Fig. 2-41. Tone control circuit.

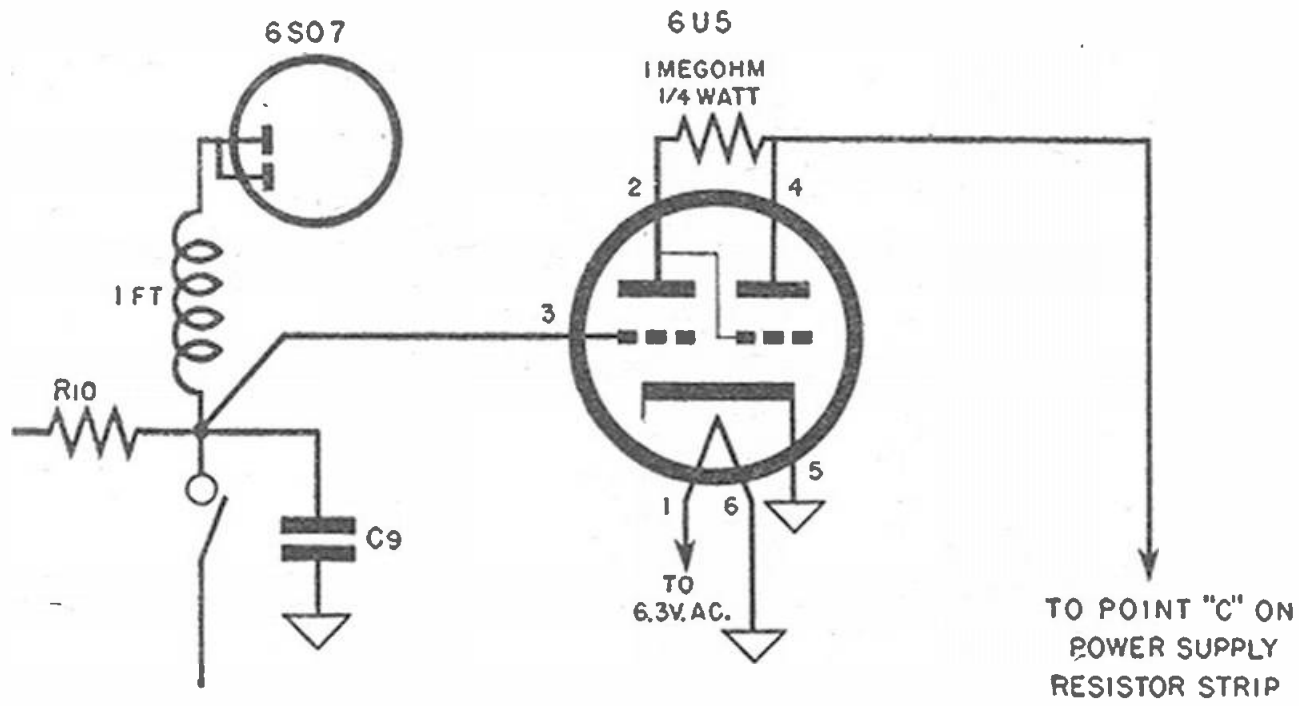

Fig. 2-42. Electron-ray tuning indicator.

down the generator output control to keep volume at a low level. If the set is equipped with the electron-ray tube, you may use it as a visual alignment indicator.

When the i.f. trimmers have been carefully adjusted, disconnect the generator cable from the set. Fashion a coil of a few turns of wire and place it close to the loop antenna. Connect the generator cable to the ends of the coil. Adjust both the receiver variable

condenser and the generator to 1500 kilocycles, and again adjust the generator output control so that the signal is barely audible. Adjust the oscillator trimmer condenser (rear section of the variable condenser) and the antenna trimmer (front section of the variable condenser) for maximum response. Here again, the electron-ray indicator will be useful in visual alignment indication. This completes the alignment.

Chapter 3

Tips, Tricks and Shortcuts for Constructors

THIS chapter will furnish you with information that will enable you to construct any of the projects in this book with a minimum of difficulty and with the assurance that if you follow instructions carefully, the project will perform satisfactorily.

Experienced radio men use techniques in chassis layout, assembly and wiring—call them “tricks of the trade” if you will—that often save time, occasionally save money, and always enable the set builder to turn out a product that has a neater appearance, is more ruggedly constructed, and is less likely to develop “bugs” in operation. Some of these techniques will be discussed here. None of them is espe-

cially new or revolutionary; they are known to professionals, but are all too often neglected by constructors.

In addition to these general guides and helps in construction, this chapter will also discuss the possibilities of parts substitutions—always a pertinent question among set builders. In this connection, remember that the parts list that accompanies each project will list parts by manufacturers’ numbers only when substitutions are unavailable or not desirable. Whenever a specialized part is needed (as in the case of an output transformer, i.f. transformer, or the like) two or more manufacturers’ parts numbers will be given if equivalent parts are available.

PARTS SUBSTITUTIONS

Heading the list of questions most often asked by constructors are those relating to the substitution of a slightly different part for the one mentioned. A typical question is: “Your diagram calls for a .01 audio coupling condenser. Will a .02 condenser work just as well?” Perhaps the material to follow will answer similar questions that may have puzzled you.

Resistors

In almost all radio and electronic equipment a deviation of twenty per cent from the specified value of a carbon resistor is permissible. There are certain exceptions of course; sometimes the circuit will not perform well unless a resistor is within five per cent (or in some instances two per cent)

of the rated value. However, when such exceptions occur in this book, your attention will be directed to them.

Bear in mind that the tolerance of twenty per cent mentioned means twenty per cent either above or below the assigned value. Thus, a 100,000 ohm resistor might be as low as 80,000 or as high as 120,000 ohms and still do the job. In emergencies, it is often possible to install a resistor that deviates as much as fifty per cent from the rated value; this will enable you to complete the job without delay, but you must regard such a substitution as only temporary and replace the resistor with one of correct value as soon as possible, even though the project appears to work moderately well.

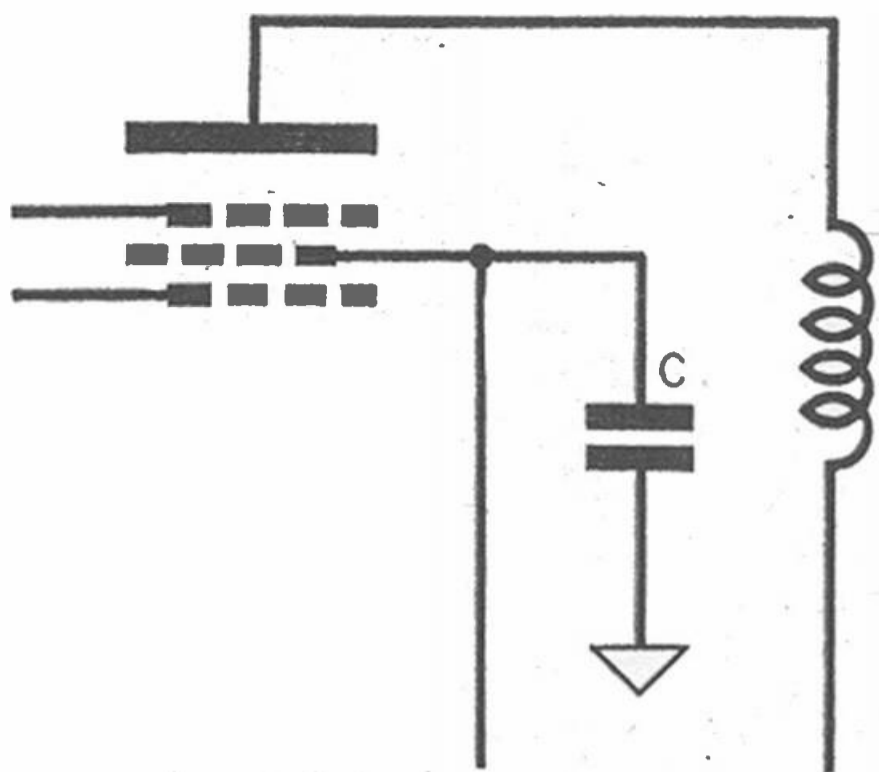

Fig. 3-1A. Screen bypass condenser.

Carbon resistors are made in wattages ranging from 1/16 watt upward; those of higher wattage, as you probably know, are larger physically and thus are better able to throw off heat. A higher-wattage resistor may always be substituted for one of lower wattage, provided, of course, that you have the space for it. In fact, in many applications (output-tube cathode resistors and voltage-divider resistors among them) the use of a higher wattage than specified may be quite beneficial; the larger resistor will dissipate more heat in the event of an overload.

Condensers

Fixed condensers are most often used in coupling, bypass, and filter applications. Neglecting for the moment the audio amplifier cathode bypass condenser, we find that in most cases, r.f., i.f., and converter screen and cathode bypass condensers range in value from .05 to .1 microfarad. This applies to apparatus intended

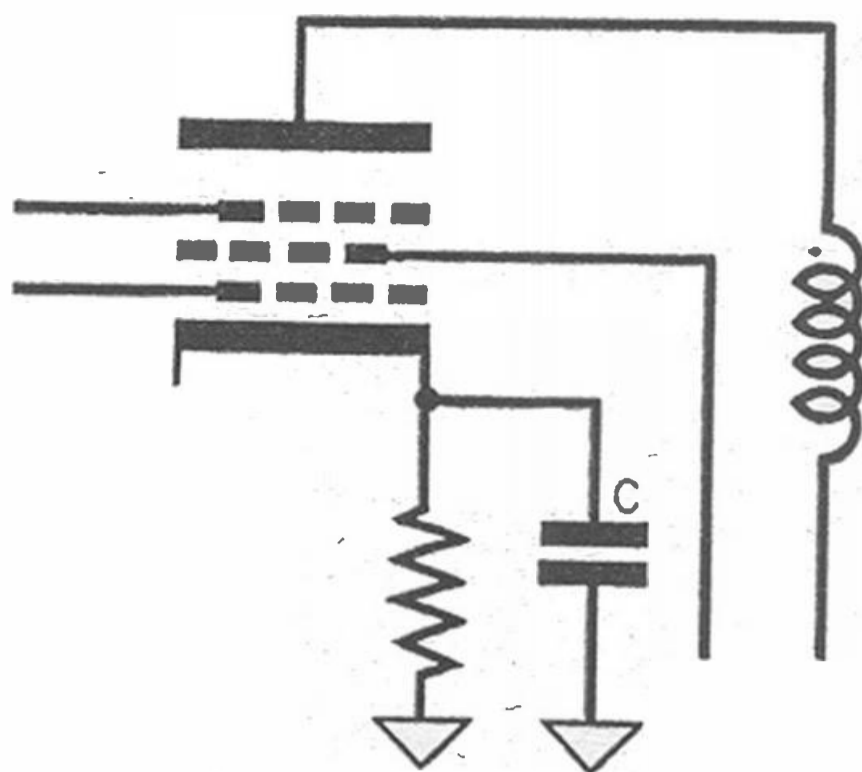

Fig. 3-1B. Cathode bypass condenser.

for the broadcast range; for short-wave work, these values are usually lower. The common application of a screen bypass condenser is shown in Figure 3-1A; 3-1B shows the arrangement of the usual r.f. cathode bypass condenser.

Within reasonable limits, there is no harm in substituting a higher value of screen or cathode bypass condenser for the one specified; fifty per cent would seem to be a reasonable limit. However, under no circumstances is it safe to use a lower value; quite often, this will lead to such undesirable effects as oscillation.

The most common value of audio coupling condenser (see Figure 3-2) is .01 microfarad. (Incidentally, some books and articles refer to this as a blocking condenser.) Here again, substitution of a higher value is possible, although the capacitance should never be greater than .05 microfarad. Use of a lower value is sometimes permissible, although you run the risk of losing some of the bass notes if this is carried too far, since a smaller value

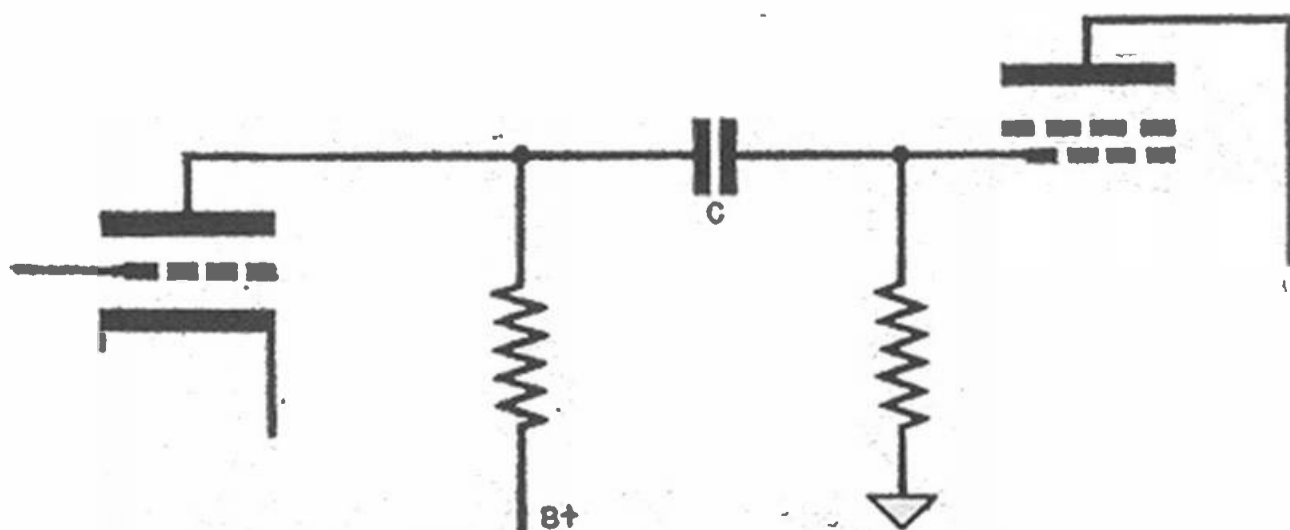

Fig. 3-2. Use of the audio coupling condenser.

of condenser is less able to pass the lower notes.

In selecting electrolytic condensers you have considerable latitude; examination of several small AC/DC sets will prove this to be true, for the filter condensers run from 16 to 50 microfarads. A good rule to follow is to use an 8 to 10 microfarad condenser for AC operated (transformer-type) sets and from 20 to 30 microfarads in universal or AC/DC receivers. You may always use higher values than those just mentioned, if you have such values at hand. However, you will gain little, for doubling the size of a filter condenser (above the values just stated) does not double the filtering effect. Always keep in mind that the use of higher or lower values is not suggested as an improvement but as an expedient when you do not have the value specified but do have some other value.

Some set construction articles may call for the use of a dual electrolytic condenser; of course, two separate units, each of the specified value, will work as well. Figures 3-3A to 3-3D show how such substitutions may be made. Figure 3-3A shows a standard dual condenser, with the internal connections indicated by dotted lines. Figure 3-3B shows how to connect two single units to give the equivalent of the dual. This can also be applied in the event of failure of one section of a dual unit or should you find that you have on hand a dual unit with only one good section or with the connecting lead of one section cut so short that it cannot be used. Simply connect the negative lead of a single unit to the common negative wire (generally black) of the dual unit. Then connect the positive wire of the single unit to the point where the positive lead of the dual unit would ordinarily be connected.

Occasionally a set design (or an existing set) may require what is known as a "common positive" condenser. This means that instead of having

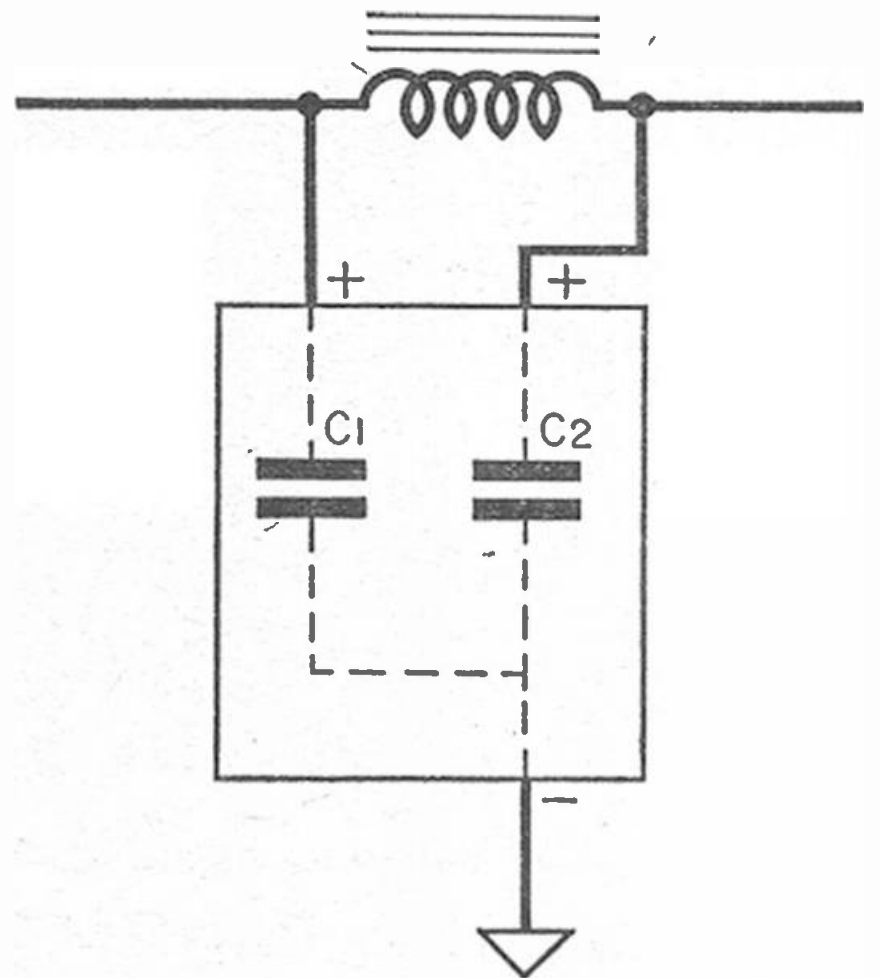

Fig. 3-3A. A dual condenser.

the negative terminals of the two units connected together within the case, as in Figure 3-3A, the two positive wires are connected, as shown in the drawing of Figure 3-3C. An arrangement to give the equivalent of such a condenser, using two single units, is shown in Figure 3-3D. Of course, you must be careful to observe the connections of condensers of this type, for one negative wire of the combination is not connected to ground or to chassis but to some other point.

All paper and electrolytic condensers are marked with the working voltage. You must be careful always to use a condenser having a working voltage as high as or higher than the voltage specified in the parts list or schematic diagram. Failure to observe

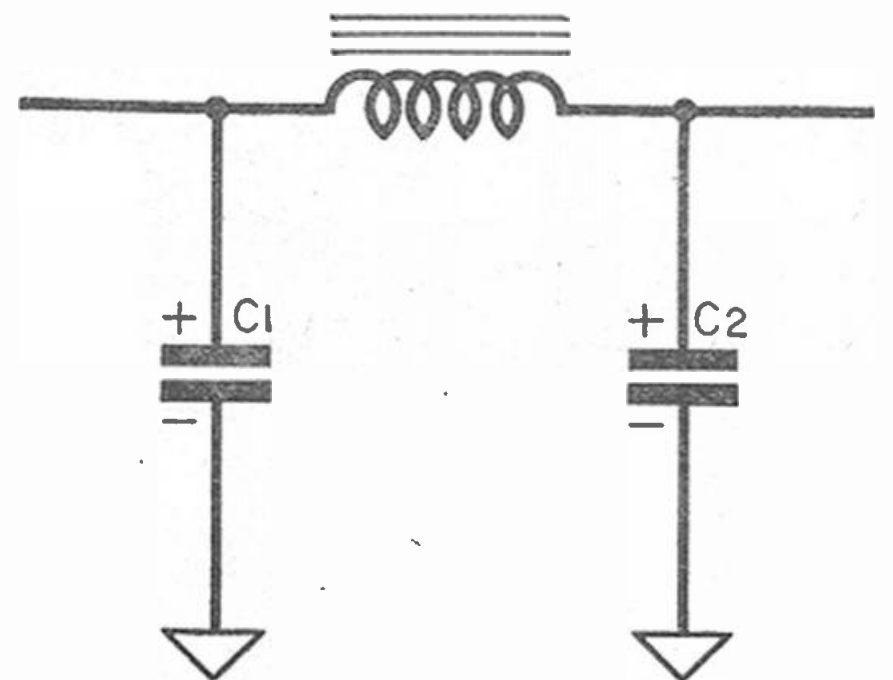

Fig. 3-3B. Two units act as dual.

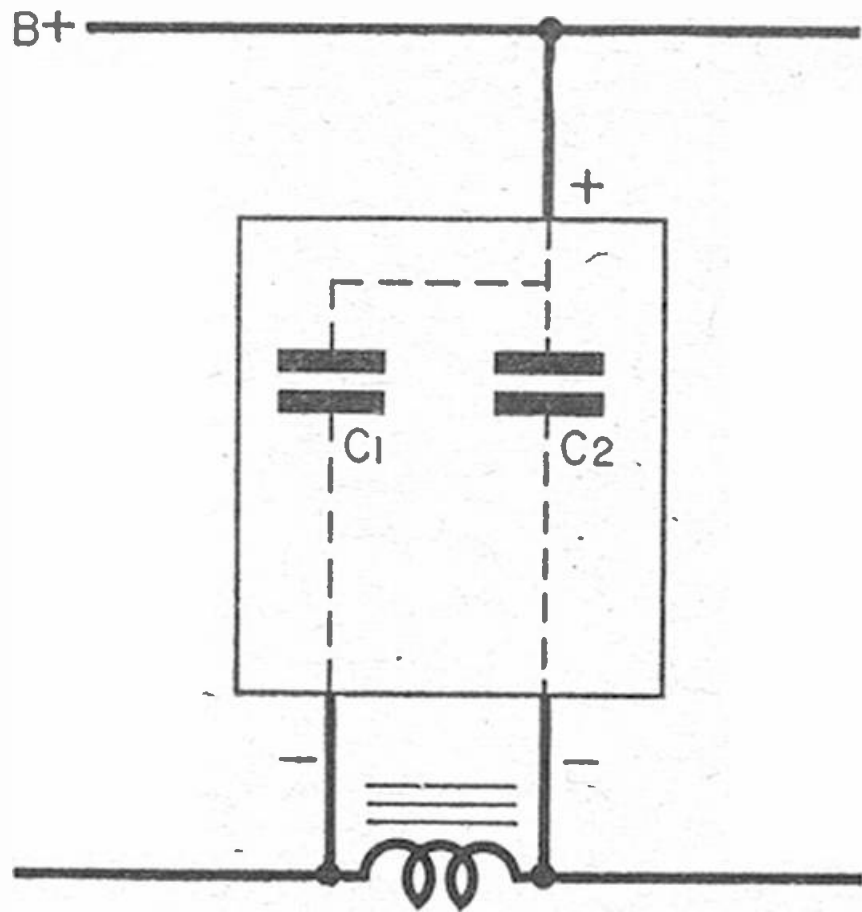

Fig. 3-3C. A "common positive."

this will usually result in damage to the condenser and possibly to other parts in the set. Here is a list of important condenser applications, together with recommended working voltages:

Filter Condensers

AC sets 475 volts
AC/DC sets 150 volts

Screen Bypass Condensers

AC sets 400 volts
AC/DC sets 200 volts

Coupling Condensers

AC sets 400-600 volts
AC/DC sets 200 volts

Antenna Series Condensers

all sets 200 volts

Cathode Bypass Condensers (paper)

all sets 200 volts

Cathode Bypass Condensers (electrolytic)

output stage 50 volts
first a.f. stage 25 volts

In some sets, low voltage electrolytic condensers, listed in the table above, are used for cathode bypassing. Such condensers are commonly made in values ranging from 5 to 50 microfarads. Usual working voltages are 25, 35, and 50. The 25 volt condenser is suitable for use in the early stages of

an audio amplifier, as the cathode voltages developed in such stages are ordinarily well within the 25 volt limit. For most power amplifier stages it is generally safer to use 50 volt condensers. In all such applications, observe the voltage rating recommended in the parts list or diagram; the condenser you use may have a higher voltage rating, but never a lower. Another point to be stressed is polarity. Figure 3-4 shows how to connect an electrolytic bypass, with the positive terminal toward the cathode. This diagram also shows how a dual condenser may be used for cathode bypassing in both the first audio and output stages of a set or amplifier.

In the matter of variable condensers, you have no choice but to use the exact value mentioned in the parts list; if, for example, the design calls for .000365, a .0003 will not do as well. Furthermore, many designs specify both the maximum (fully meshed) and minimum (open) values of the condenser to be used. If you do not follow the recommendations precisely, you may find that the tuning range of the set is narrower than expected and that either the high or the low frequencies cannot be received.

A few words on the two widely differing types of variable condensers available may be helpful. Two- or three-gang condensers for use in TRF receivers are made with the rotor plates in any one section, or gang,

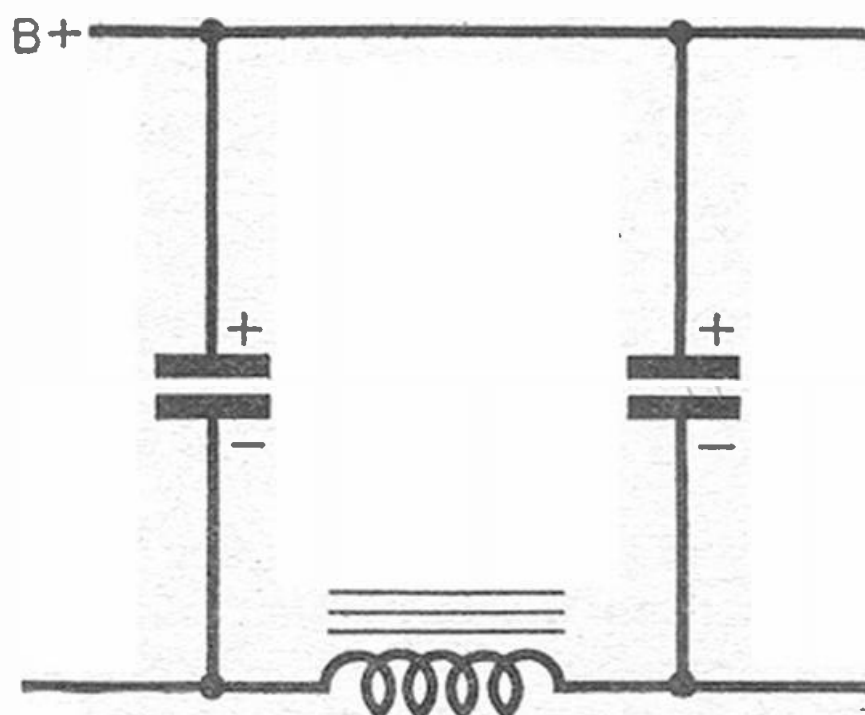

Fig. 3-3D. Two positive units.

of exactly the same size and shape as the rotor plates in the other sections. Most superheterodynes, however, use a condenser in which the plates in one gang (the oscillator section) are smaller and of different shape than those in the other sections. This difference in rotor-plate shaping is used to maintain a frequency difference between the oscillator circuit and the other tuned circuits. This frequency difference is almost always 456 kilocycles; however, there are condensers designed for other frequencies. To be on the safe side, it is well to specify the frequency wanted when you purchase the condenser.

Variable condensers are usually mounted on the chassis in one of two ways (assuming, of course, that the condenser is to be rigidly mounted and not "floating" on rubber). In one method, spade lugs are used. The

will not work, to say nothing of possible irreparable damage to the condenser.

Coils

In more elaborate projects, it is always well to follow instructions given concerning coils. Usually the designer will recommend coils of a specific make, by part numbers. He is not doing this to boost the sales of a manufacturer but because he has found that the items mentioned will definitely do the job. Of course, the variation between coils of different make is sometimes insignificant. For instance, unshielded antenna, r.f., and oscillator coils for use in small AC/DC sets are fairly well standardized. Let us suppose that you are constructing a five tube superheterodyne. The diagram specifies a .000365 two-gang variable condenser, tapped single-winding os-

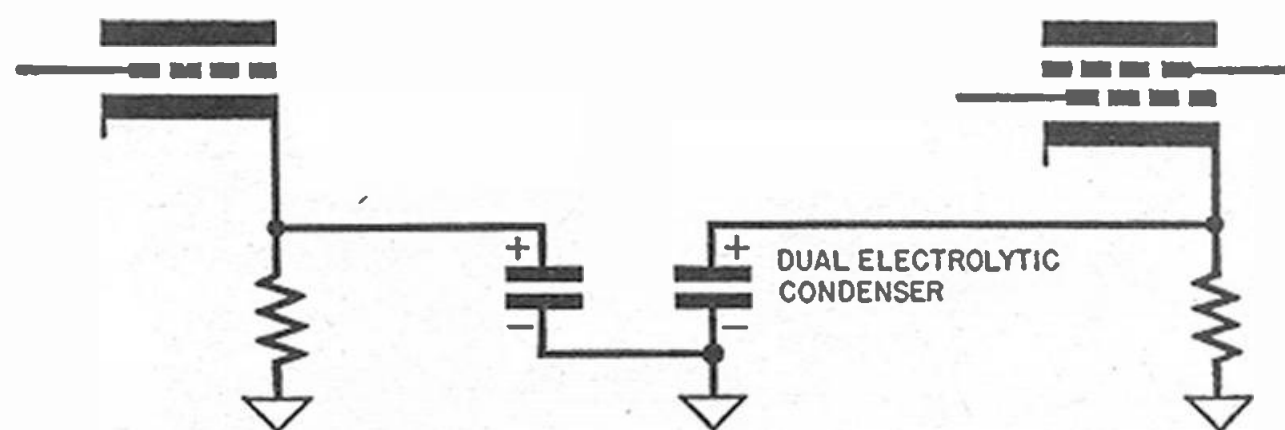

Fig. 3-4. How to connect an electrolytic bypass.

spade lug, which is riveted or otherwise fastened to the condenser frame, passes through a hole in the chassis and carries a hexagon nut on the under side. Where this mounting is used, the condenser usually comes with spade lugs already riveted to the frame. The other method of mounting consists of a machine screw passing up through a hole in the chassis and threaded into a tapped hole in the underside of the condenser frame. In using this method of mounting you must be particularly careful to select machine screws that are not too long; if they are, they may project far enough through the tapped holes so that they touch the stator plates. If this happens, the stator plates will be grounded and, of course, the set

will not work, to say nothing of possible irreparable damage to the condenser.

cillator coil, and an antenna coil. If you buy the coils in a reputable store or supply house and if you specify that they are to be used in the same set, the chances are excellent that you will get a set of coils that will perform well. The same thing applies to TRF receivers—as long as the two coils match, the set will operate satisfactorily. It is possible, of course, that the tuning range might be slightly less than intended, but this is often unimportant.

Before leaving the subject of coils, it is well to mention that substitution of i.f. transformers can only be made under certain conditions. Certainly it is understood that if the writer specifies 456 K.C. transformers, no other frequency will do. No substitu-

tion is possible here unless changes are made in other parts. Be sure to use iron-core transformers whenever the design calls for them.

ARRANGEMENT OF COMPONENTS

While compactness is often desirable in the construction of a piece of radio or electronic equipment, this aim is often carried too far with the result that oscillation, excessive hum, or other unwanted effects appear. There are cases where ultra-compactness is really needed; this is often necessary because the unit must fit into an unusually small space or must be made portable. In such cases, you will probably find that you will have to use more than ordinary care in the arrangement of parts, in the assembly, and in the wiring, if the unit is to work as expected.

If you will examine almost any factory-built radio receiver, you will immediately note three things: the

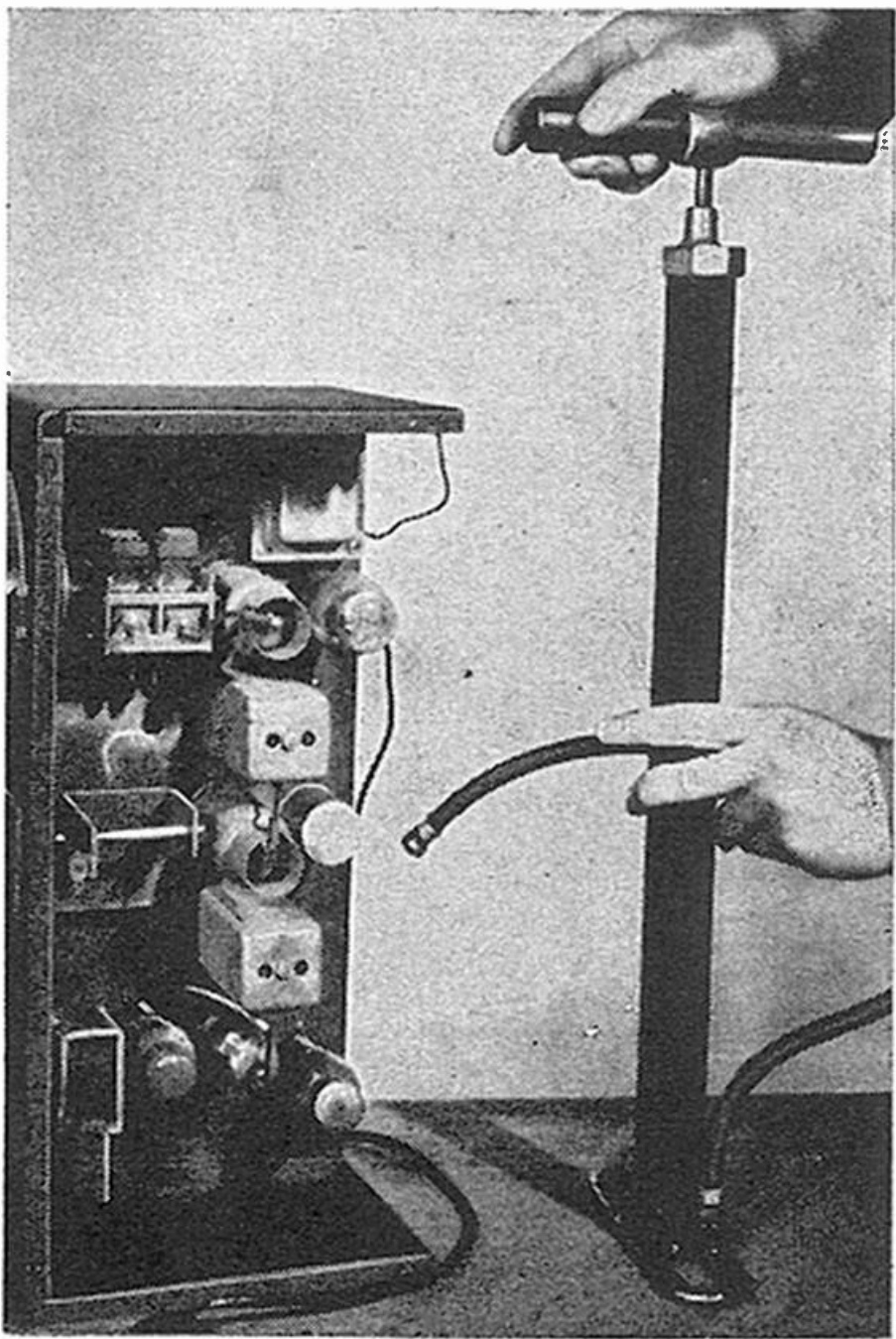

An auto tire pump can be used to clean hard-to-reach parts like tubes and condensers that require occasional dusting.

If these points are carefully observed, substitutions are possible, provided that the substitute parts will fit into the space available.

chassis seems to be larger than necessary, the wiring seems to be rather haphazard, and, most important of all, the signal, in its progress from antenna to speaker, follows what might be called a "straight-line signal path." If we carefully analyze these three characteristics, we find that, first of all, the apparent waste of chassis space is not a waste at all; the designer arranged the parts so signals from one stage would not interfere with another stage. Secondly, what appears to be haphazard wiring is really the result of a carefully planned wiring schedule; the final position and direction of many of the connecting wires have been determined only after considerable thought and, perhaps, a great deal of trial and error.

Our interest at this point centers around the layout and arrangement of the major parts of the set. Figure 3-5 shows the "straight-line signal path" arrangement mentioned before. Notice that in following the arrows representing the progress of the signal, there is nowhere a retracing or doubling back of signals. This is important, because where such retracing occurs there is a much greater chance of oscillation and other unwanted effects. A project planned in this way will generally have a better chance of operating satisfactorily.

Another result of the straight-line construction is that all of the components belonging to any one stage are grouped closely together and the connecting wires are therefore as short as possible. It is a well-known fact that unduly long wires (especially grid and plate wires) are a common cause of oscillation. This, by the way, is one of the most troublesome effects encountered by constructors.

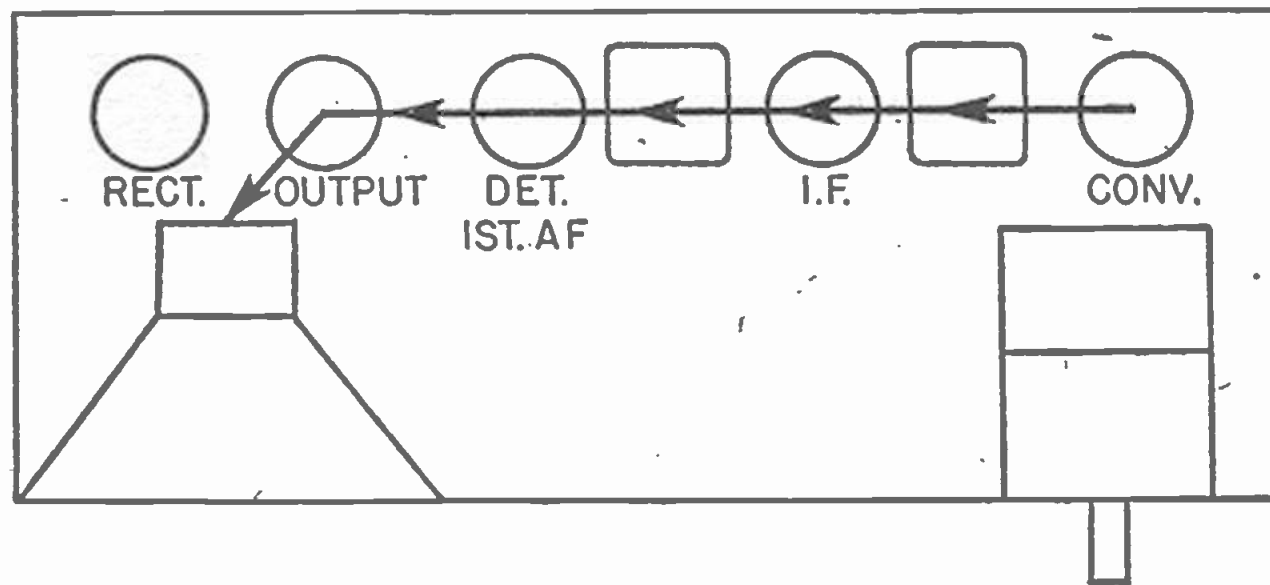

Fig. 3-5. A "straight line signal path" layout.

It follows that better separation between stages results from the straight-line construction. Look at Figure 3-6. Here the chassis has been made considerably smaller and it has been necessary to "bunch up" the various parts. Notice that the signal, in passing from antenna to speaker, traverses a zig-zag path. Not only are critical grid and plate leads made longer, but also it is more likely that they will approach each other too closely or will run parallel for considerable distances. Referring back to the straight-line design of Figure 3-5, you will see that where unshielded glass tubes are used, the i.f. transformers, for example, offer some measure of shielding

between tubes and thus help prevent interaction. This shielding effect may not be possible with the type of construction shown in Figure 3-6. Finally, a set using straight-line construction is usually much easier to wire and presents a neater appearance when completed.

Straight-line layout does not mean that the tubes and parts must be in a single row; the layout can take an L-shape, as shown in Figure 3-7. This is a good arrangement and is often used, particularly in small sets of the "All-American Five" variety. You will notice that the rearrangement has been confined to the audio portion of the set, which is not so critical.

LOCATION OF POWER SUPPLY

While less critical in AC/DC sets, the location of the power supply may become quite important in the transformer type of receivers. This is because some transformers (particularly the unshielded, or open-coil, types) are capable of radiating energy that can be picked up by the grid leads of tubes. A safe procedure is to keep all the power supply components (transformer, rectifier, choke, filter condensers, and voltage dividers) together and as far as possible from other stages. In car radios, it is imperative that the power supply unit be separated from the rest of the set by a partition; in effect, this places the power unit in a separate, shielded compartment. This is not necessary in home receivers, but there should

be some isolation of power supply components. A typical arrangement, used in AC sets, is shown in Figure 3-8.

In considering the power supply, it is well to note that detector and audio

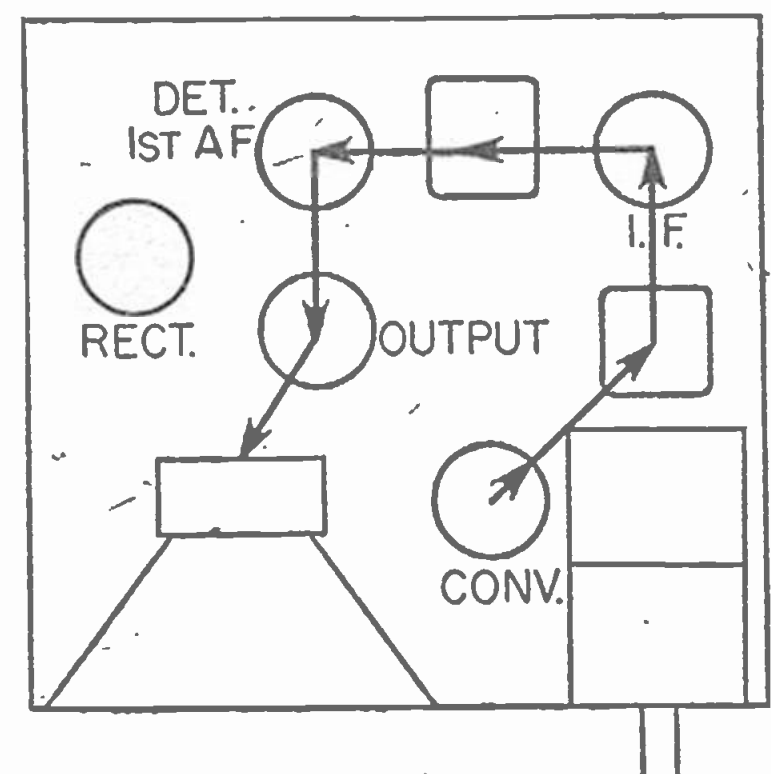

Fig. 3-6. A poor layout.

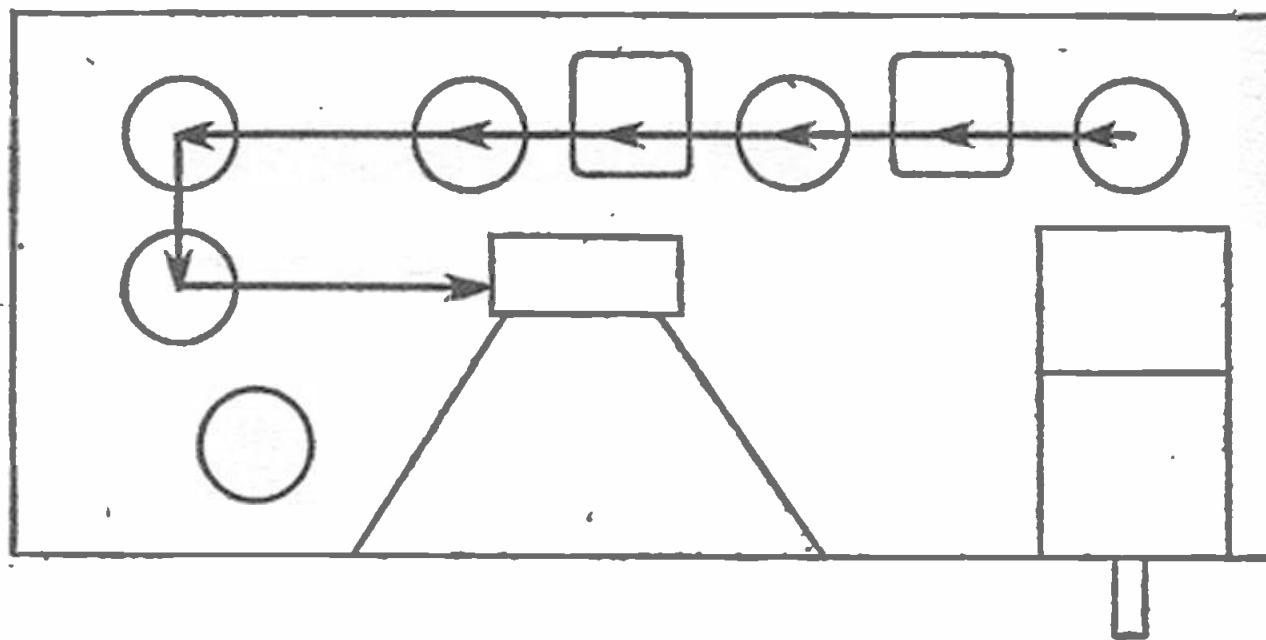

Fig. 3-7. An L-shaped layout.

stages are most easily affected by hum voltages set up by the power unit components. Close observation of a number of factory-built sets will demonstrate this. You will find that in many cases the power unit is placed rather close to an r.f. or converter stage, but because these stages do not operate

at audible frequencies, there is little hum interference. Any hum introduced into the audio system of a set will be noticeable, but it will be more objectionable when picked up by one of the earlier stages, for the hum voltage is then amplified to a greater degree.

HOW TO PREVENT AND OVERCOME OSCILLATION

Oscillation is the result of coupling between the input (grid) and output (plate) circuits of one stage or between the circuits of two neighboring stages. Energy is fed back from the output circuit to the input circuit; this builds up until the stage oscillates. Here are some of the more common causes of oscillation:

- a) Grid and plate leads of one stage are too close together or are parallel for a considerable distance.
- b) Grid or plate leads of one stage

are too close to grid or plate leads of another stage.

- c) Unshielded antenna and r.f. coils are located too close together.

- d) Screen bypass condenser is defective or lacking.

- e) Unshielded glass tubes are located too close to each other.

- f) The shells of metal tubes are not grounded.

- g) There is poor contact between the rotor shaft and the frame of a two- or three-gang variable condenser.

Now, suppose we consider these causes in sequence and take up the remedies for them.

Grid and plate lead interaction

It would seem that once the possibility of interaction between grid and plate leads of a stage is recognized, it should be easy to avoid such trouble. This is not always the case, however, for it is often difficult to spot the focal point of the trouble. Sometimes, just an extremely short length of grid wire brought too close to a plate wire will set up oscillations. The possibility of interaction is increased as the fre-

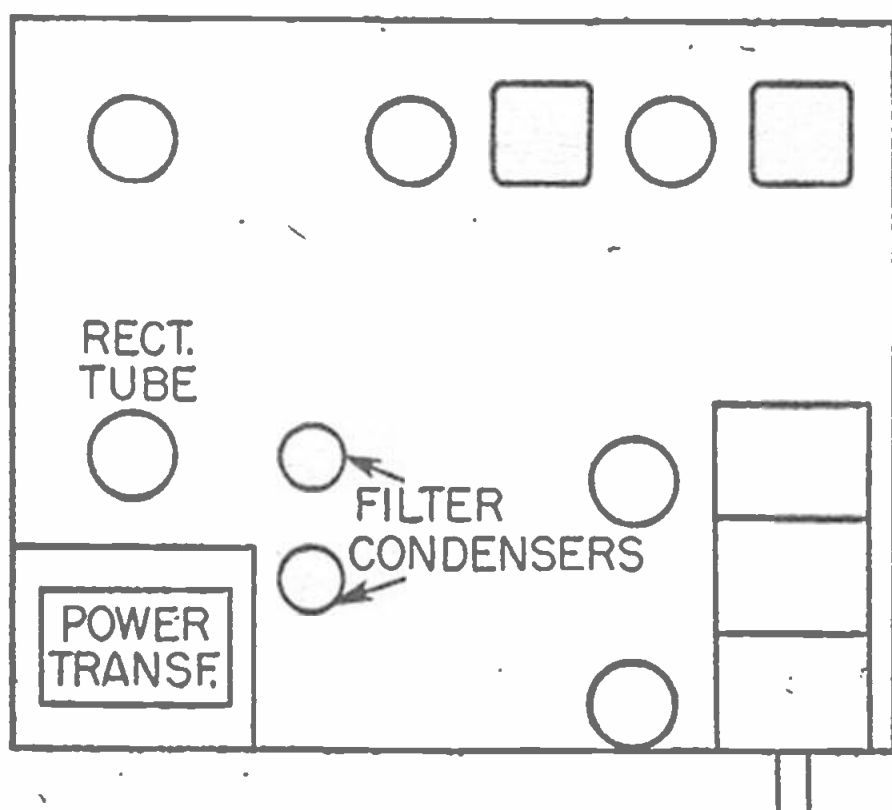
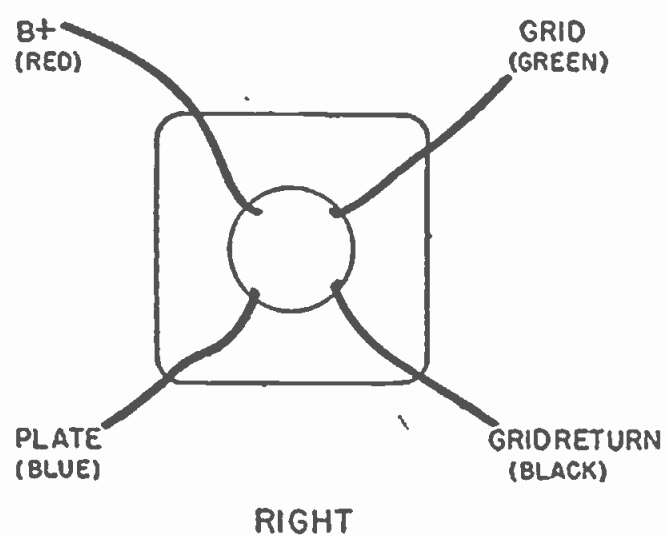

Fig. 3-8. An AC power layout.

quency becomes higher (short-wave fans take notice):

The safest procedure is to keep all grid leads as far as possible from plate wiring, keep leads short, and wherever possible keep them close to the chassis. Be particularly careful regarding the wires leading down from an i.f. transformer. Keep them dressed as shown in Figure 3-9A, never allow them to cross as in 3-9B.

If you encounter a stubborn case of oscillation and feel that it is caused by the arrangement of wiring, there is just one way to locate the trouble—trial and error. You may be able to find the troublesome stage by grounding its grid; if the oscillation stops, it is possible (but by no means certain) that the cause lies in that stage or in one preceding it. Using a tool made



RIGHT

Fig. 3-9A.

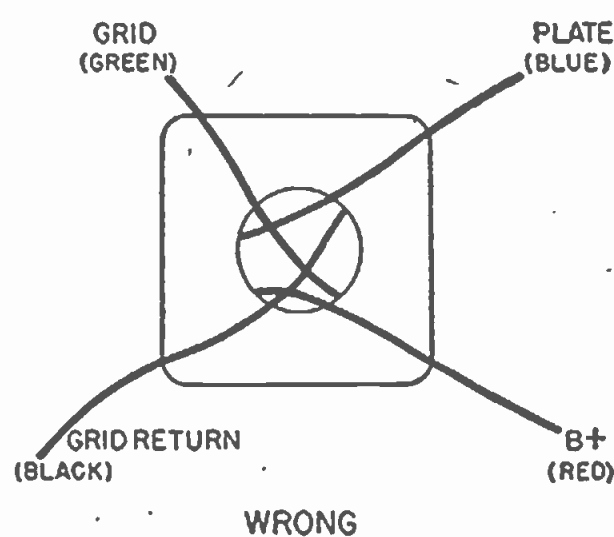

WRONG

Fig. 3-9B.

of insulating material—a lollipop stick or a piece of thin dowel will do very well—try moving grid and plate leads, meanwhile noting the effect. It is always best to adjust the set so that the whistling is just about as strong as you can make it before going ahead.

When you discover that a change in the position of the wire makes a decided difference, try moving the wire to various positions. It may be that you will have to remove the wire and install another length running in an entirely different direction.

One caution should be noted here: you may find that moving some of the oscillator circuit wiring has an effect on the whistling. As a rule, you will find that moving such wiring merely changes the pitch of the whistle, with-

out having any great effect on its intensity. In fact, the possibilities of trouble in this circuit can be neglected.

Concentrate most of your efforts on radio frequency stages, if there are such. Next in line of suspicion comes the intermediate frequency stage, then the detector, and finally the converter.

Of course, we have considered here only oscillations that occur at radio or intermediate frequencies. An audio stage can oscillate too, but then the effect is usually quite different. First of all, the pitch of the whistle is not changed by working the tuning control. Second, although some audio oscillation occurs at a constant pitch, the more usual form is sometimes called “motor-boating”—an excellent

description.

Some constructors clear up oscillation resulting from wiring by shielding the offending wires. This may be done—but as a last resort only and under the following conditions:

a) Exhaust all other possibilities first, by checking the other causes given later in this chapter.

b) Use only as much shielding as is absolutely necessary.

c) Shield grid leads only, never plate leads.

d) Be sure that the shield is well grounded at *both* ends.

e) Recognize the fact that shielding a wire will change the tuning characteristics of the circuit and may make realignment necessary.

f) Never add shielding to a set

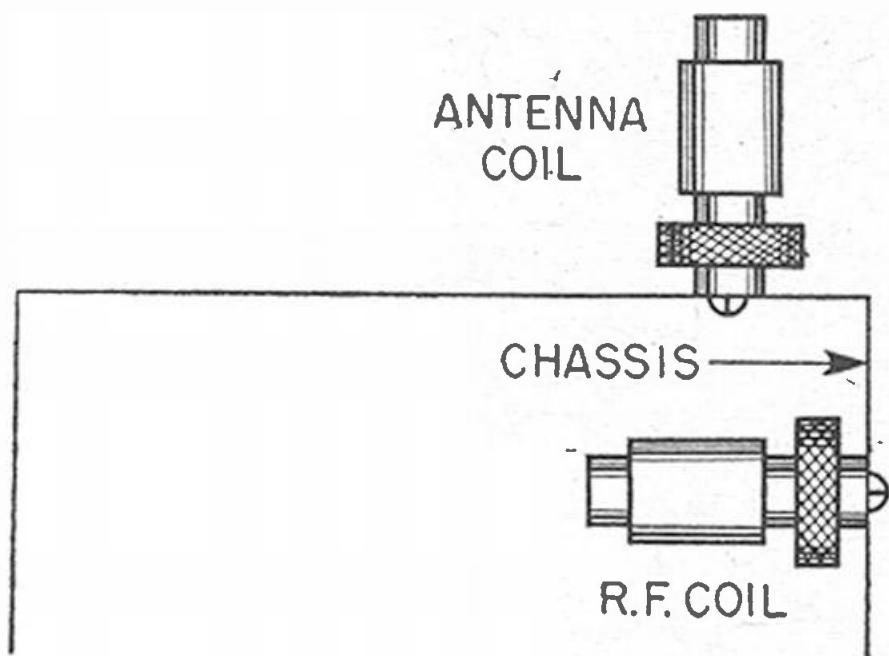

Fig. 3-10. Placement of coils.

that previously worked well. Look for other causes.

Coil interaction

Interaction between coils is a common cause of oscillation, particularly in TRF receivers. You may easily avoid such trouble by placing the coils as shown in Figure 3-10. Notice that not only is the axis of one coil at right angles to that of the other, but also that the placement of the coils—one above the chassis; the other below—places the chassis between the two so that it acts as a shield. It is possible for coupling to exist between an unshielded coil and an unshielded glass tube; this is more likely to happen when the coil belongs to one stage and the tube to another. This can often be detected by placing, temporarily, a grounded metal plate between tube and coil. If the oscillation stops, shield the tube. The metal plate used for making the test must be grounded, otherwise the result might be to make conditions worse.

Furthermore, when you decide that the tube is to be shielded, use a shield that fits the tube rather closely and is well grounded.

Screen bypass condenser

The purpose of a screen bypass condenser is to maintain the screen at ground potential from an r.f. standpoint, although the screen is still kept at a high DC voltage. If the condenser is missing, of too low capacitance, or is defective, oscillation may result. In larger sets having an r.f. stage and one or more i.f. stages, it is well to use a screen bypass condenser for each stage ahead of the detector. As mentioned before, for broadcast-range sets the condenser should be at least .05 microfarads. The condenser should be connected *directly* from the screen terminal of the tube socket to chassis or to B minus; connecting it to some other point farther away from the screen may not give the same result. See Figure 3-11 for a typical connection diagram. Be sure, too, that the end of the condenser having a stripe (or marked "outside foil") is connected to ground or B minus; the outside foil then acts as a shield.

Many small AC/DC sets do not use screen bypass condensers; in such cases, the electrolytic filter condenser is depended upon to do the job. Figure 3-12A shows how this is possible. Radio frequency energy in the converter tube screen-circuit is bypassed through the second section of the filter condenser to the ground and thus

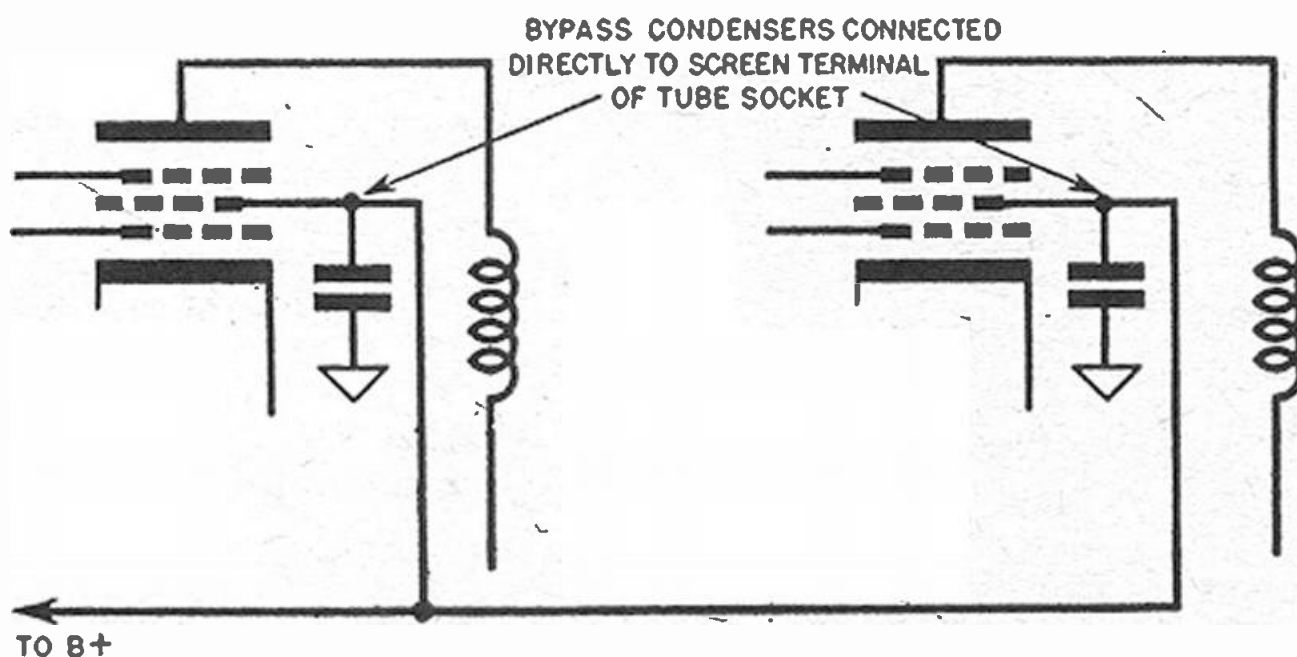

Fig. 3-11. Connecting the screen bypass condenser.

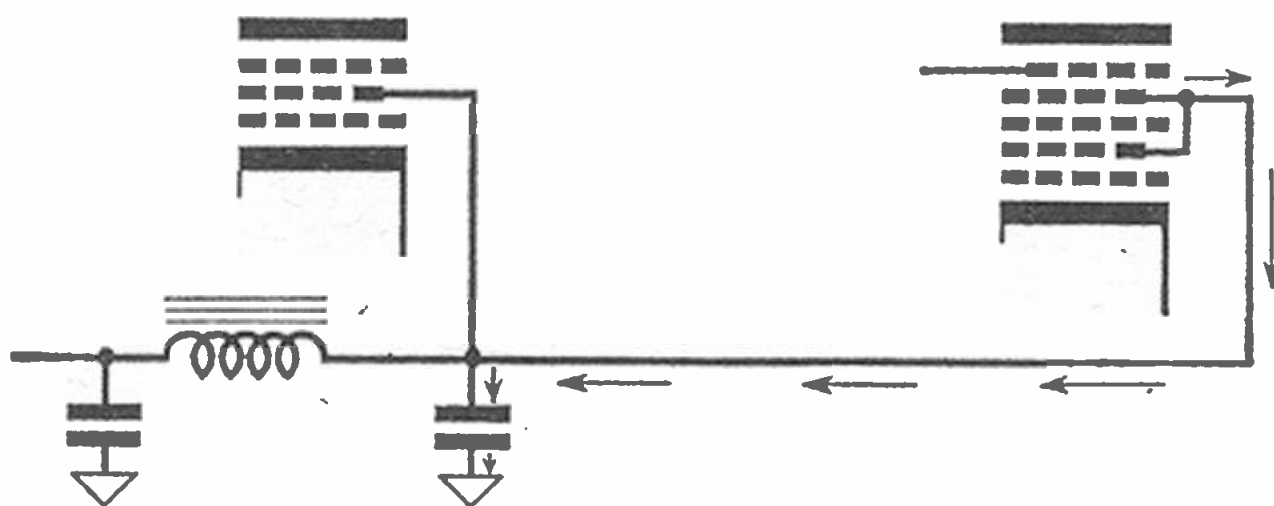

Fig. 3-12A. How filter condenser works on bypass.

is prevented from reaching the intermediate frequency stage. This is all very well. But sometimes the filter condenser fails to work well as a bypass condenser, although still able to do its regular job. You can detect such troubles by connecting a .1 microfarad paper condenser in parallel with the filter condenser, as shown in Figure 3-12B. If the oscillation stops; you need not replace the filter condenser; just connect the paper condenser permanently in place.

Unshielded glass tubes

The matter of oscillation resulting from unshielded glass tubes placed too close together has been covered above. As stated, the remedy is to fit the tube or tubes with close-fitting, grounded shields. Metal tubes can develop similar troubles if you fail to ground the metal outer shells. You will remember it was suggested earlier that an ungrounded shield might be worse than no shield at all; and metal tubes can give you an excellent demonstration of this fact.

Condenser contact

The rotor plates of a variable condenser are connected to chassis (or to B minus) via the rotor shaft and the frame of the condenser. This sometimes becomes a high resistance path due to the fact that the shaft rotates in some type of bearing, usually lubricated during manufacture. The result is that the contact between frame and shaft (poor at best, due to the rotation of the shaft) is made worse by the lubricant. Even ball bearings,

used in most condensers, do not provide a satisfactory contact. To overcome this condition, each rotor section of the condenser is provided with a brass or bronze wiper contact, shaped something like a two-tined fork. Each wiper contact has a soldering terminal. For effective grounding of the condenser, do not depend upon fastening it to the chassis with screws but connect the soldering terminals to chassis or B minus with wire or, better, with woven metallic braid. If the set design calls for mounting the condenser on rubber to eliminate microphonic effects, there will then be no connections to chassis or B minus, unless you make the wire connections just mentioned. One point that is often ignored is that dependence upon a connection through the condenser frame, or connecting only one of the wipers to chassis, may lead to oscillation. Figure 3-13 shows how this may happen. This partial diagram illustrates the r.f. and detector stages of a small set. Notice that neither of the variable condenser sections has a ground or chassis connection; this is about what would happen if you depended upon the condenser frame and shaft for a

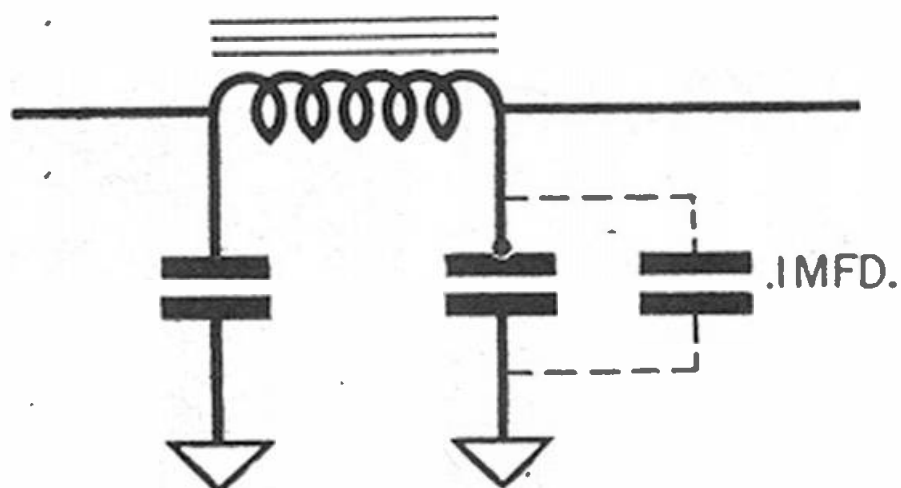

Fig. 3-12B. Checking filter condenser.

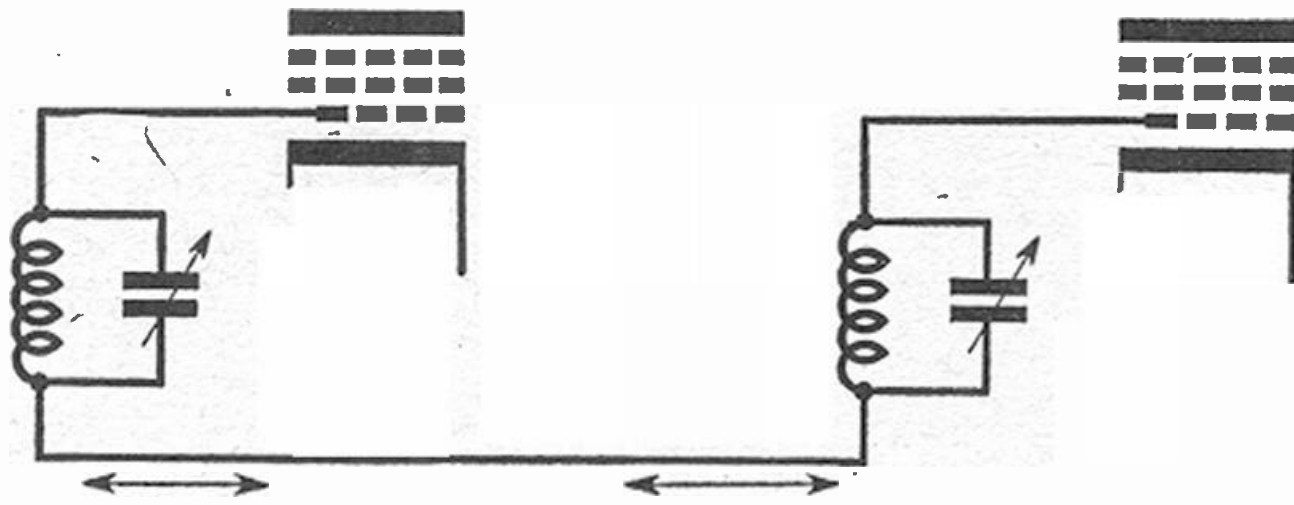

Fig. 3-13. Poor grounding of variable condensers.

connection. Under this condition, you will notice, the two sections are in series; this provides effective coupling between the grids of the two tubes and oscillation will almost certainly result.

Occasionally, even on a new con-

denser, the wipers make poor contact with the shaft. In some types there is an adjustment screw on the wiper that may be tightened to correct the condition; on others it is necessary to bend the wiper spring slightly to increase its tension.

CHASSIS CONSTRUCTION

For any one of a number of reasons, you might want to make your own chassis for a particular project. Perhaps the exact size you have in mind is unavailable, or you may wish to use soft aluminum instead of the usual steel. Aluminum is obviously far easier to work than steel, and on some projects it makes a fair substitute; however, do not use it in very large projects or the result is likely to be rather flimsy. Also, do not use

aluminum alloy; although it is harder and more rigid than soft aluminum, it has a tendency to crack on sharp bends.

Suppose, for instance, your project requires a chassis measuring 5 by 7 by 1-1/2 inches. For this job you will need a piece of 18 or 20 gauge sheet aluminum measuring 8 by 8-1/2 inches. The thickness, or gauge, of the metal will depend upon the size of the chassis to be constructed; 22 gauge

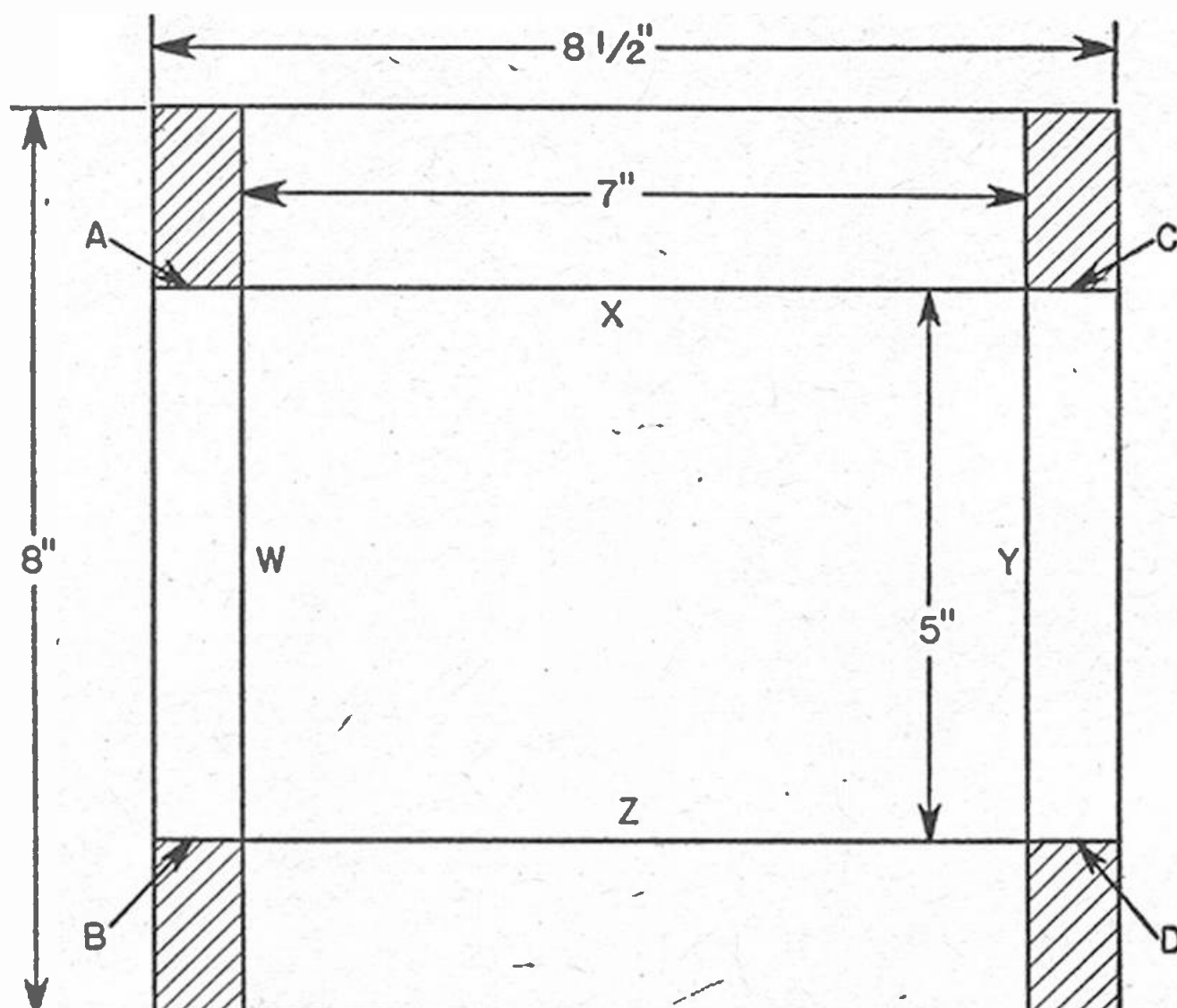

Fig. 3-14. Preparing metal sheet for chassis.

will probably be heavy enough for, say, a small preamplifier chassis measuring 3 by 5 inches. For sizes larger than 7 by 10 inches, use 16 gauge. It is not advisable to use soft aluminum for a chassis larger than about 10 by 12 inches, unless it is reinforced by some kind of partition or brace.

Lay out the chassis as shown in Figure 3-14. With a pair of tin snips, cut out the corner areas, shown cross-hatched in the drawing. Be careful not to cut beyond the intersections of the lines, as this may weaken the chassis at those points. When bent into shape, the two narrow strips ($3/4$ by 5 inches) will form the end aprons of the chassis, while the wider strips ($1-1/2$ by 7) will become the front and rear aprons. Now file the ends (A, B, C, and D in the sketch) of the narrow strips slightly; this will relieve the ends, so that when bent to shape, the end aprons will fit between the front and rear aprons.

For bending the chassis to shape you will need two hard-wood blocks $1/2$ to $3/4$ inch thick. Maple or birch is best, but a soft wood such as pine can be used if the blocks are to be used for only one job. The blocks should measure just a trifle less than 7 inches long by at least 3 inches wide.

If the lines drawn on the metal before cutting have become obliterated, redraw them. Begin by bending the two end aprons. Place one wood block on the upper, or marked surface of the metal so that the edge of the block coincides exactly with the pencil line. Your accuracy in placing and keeping the blocks exactly on the lines during bending will determine the accuracy and neatness of the bends. Now place the second wood block against the under side of the metal, and shift the block around until its edge coincides with the edge of the upper block.

If you intend to use a vise for bending, hold both blocks in place and clamp the entire assembly of metal and blocks in the vise. If the

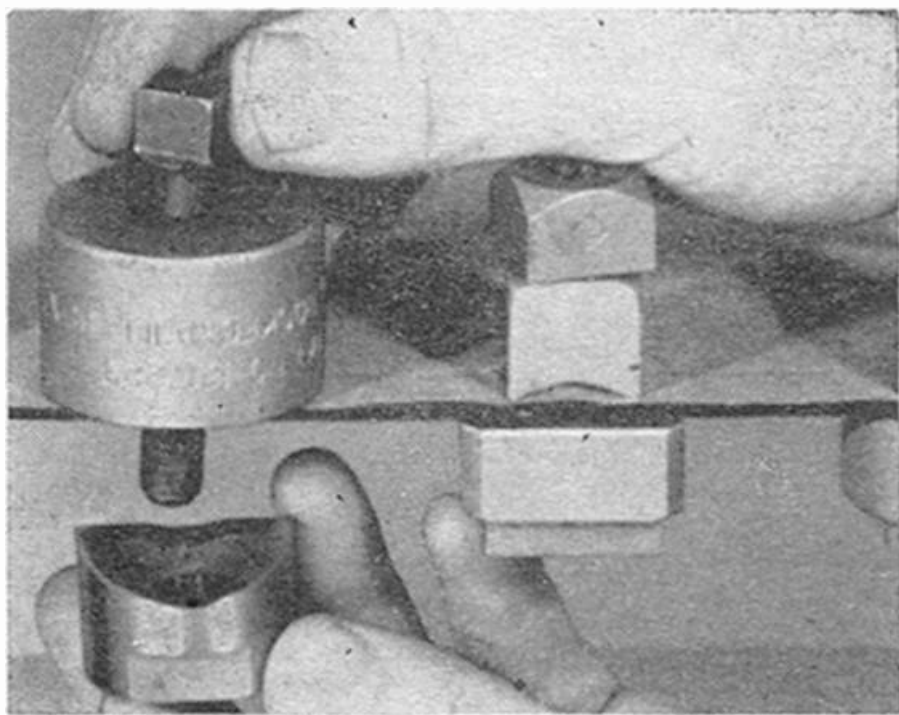

Chassis punches can be used to produce large, cleanly-cut holes. Tightening the bolt pulls the cutter through the metal.

vise is large, you may be able to clamp the work so that the apron strip protrudes above the blocks, but with a smaller vise you will probably have to clamp it so that the main area of the chassis extends above and only the apron strip is clamped between the blocks. In the event that you have no vise, two large iron clamps may be used to hold the metal

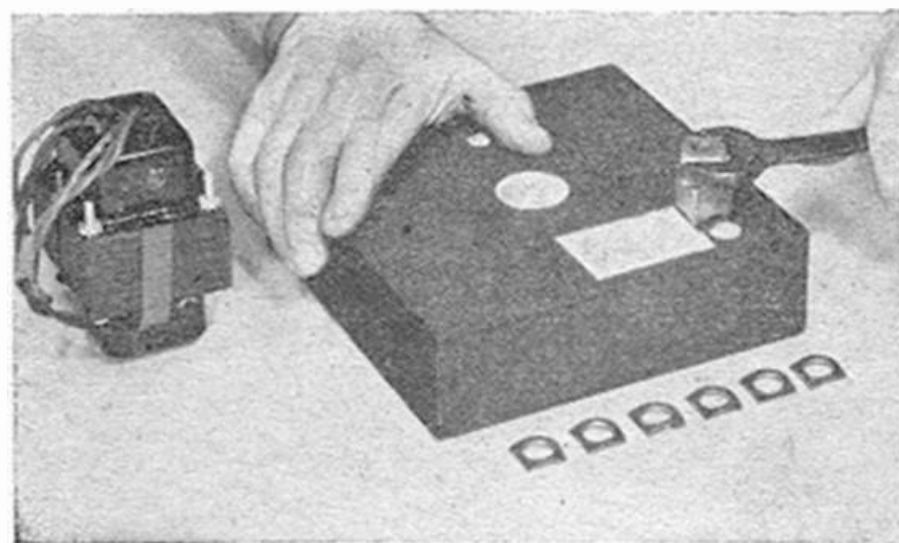

Large square or rectangular openings of any size can be cut out with square die cutters. Overlap several bites as needed.

between the bending blocks. Of course, a vise alone, without the bending blocks, may be used, but it should be fitted with soft metal jaws to avoid marring the work. However, unless the vise has unusually wide jaws, a much better job can be done with the blocks, for then the entire length of the bend is made in one operation. Before bending, recheck the blocks

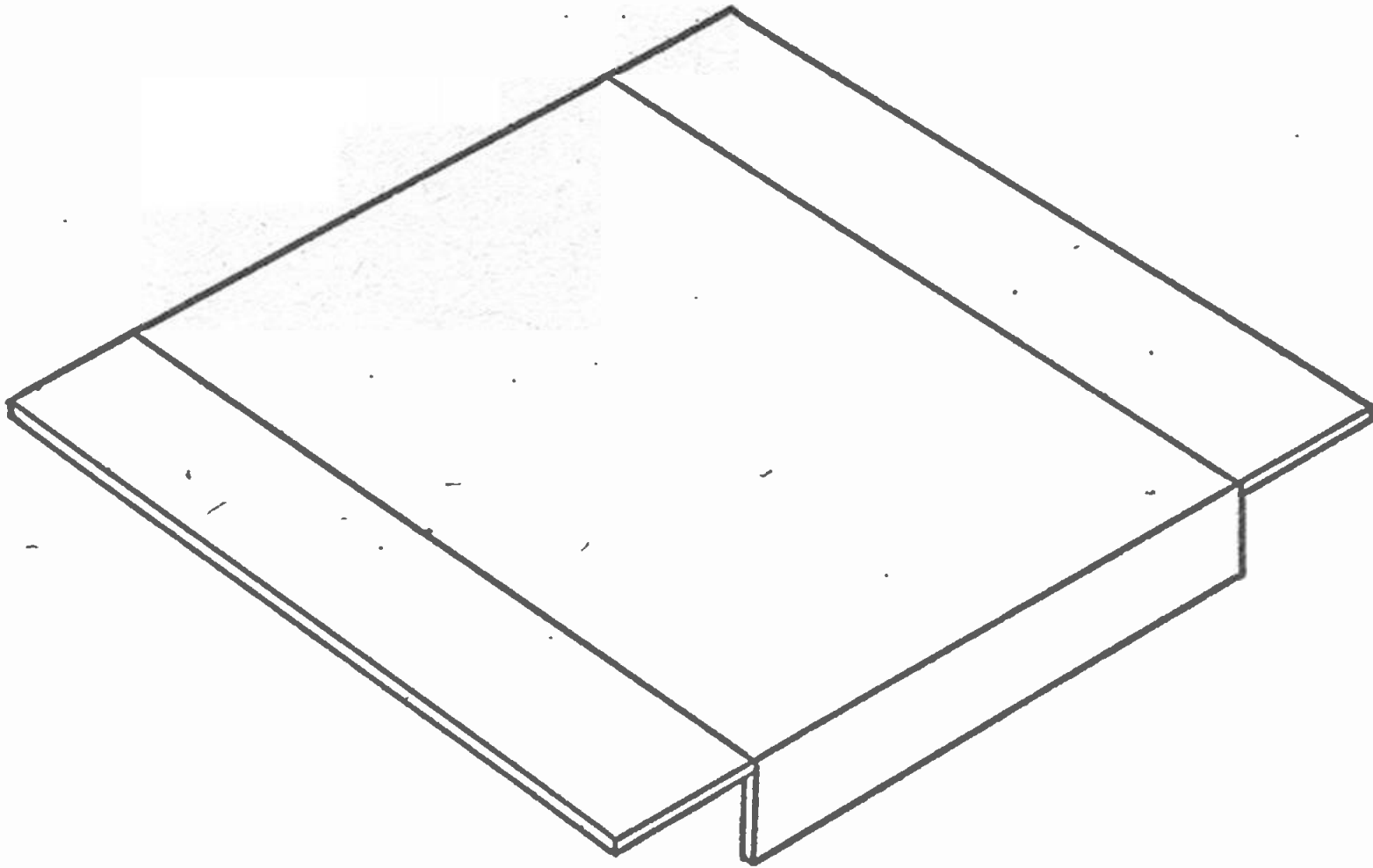

Fig. 3-15. Ends of the metal sheet are bent over blocks first by hand, then with wooden or plastic mallet.

to be sure they have not shifted from the line.

Start the bend by hand, and continue until the bent over area of the metal lies flat against the bending blocks. This will give a bend with a slight radius. Now tap the metal along the bending line with a wooden or plastic mallet until a sharp bend is formed. Never use a hammer for this purpose. If you do not have a mallet, hold a scrap block of wood against the metal and strike the block with a hammer.

When one end apron has been completed, bend the opposite one. The partially finished chassis will now look like Figure 3-15. Bend the wider front and rear aprons, using the process just described, and the job is completed. See Figure 3-16.

For a chassis of moderate size, you will find the type of construction described above remarkably sturdy. The end aprons can be made wider, if you wish, so that space for mounting parts is added. If the chassis is to be mounted in a cabinet, you may want

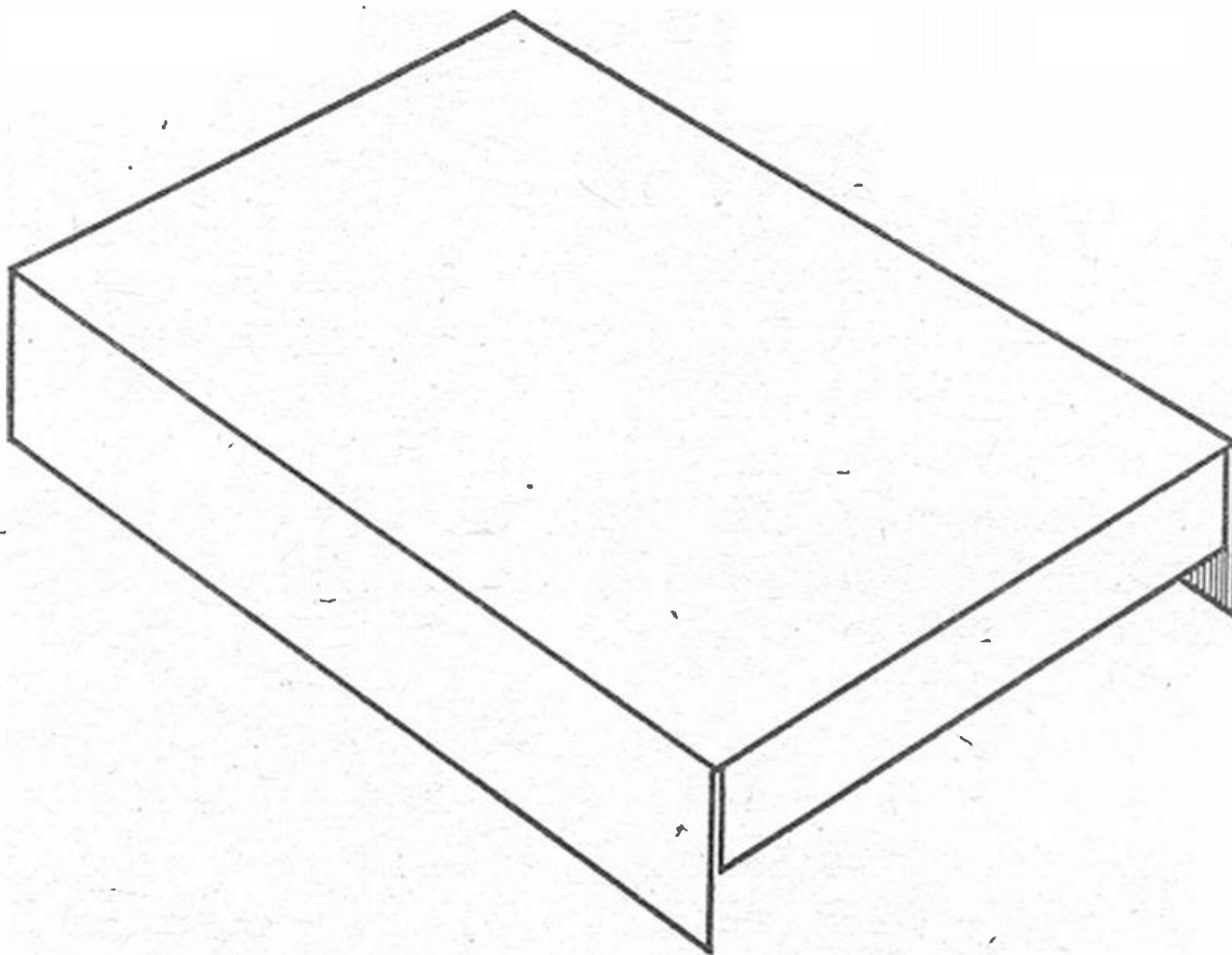

Fig. 3-16. Front and rear aprons are bent next.

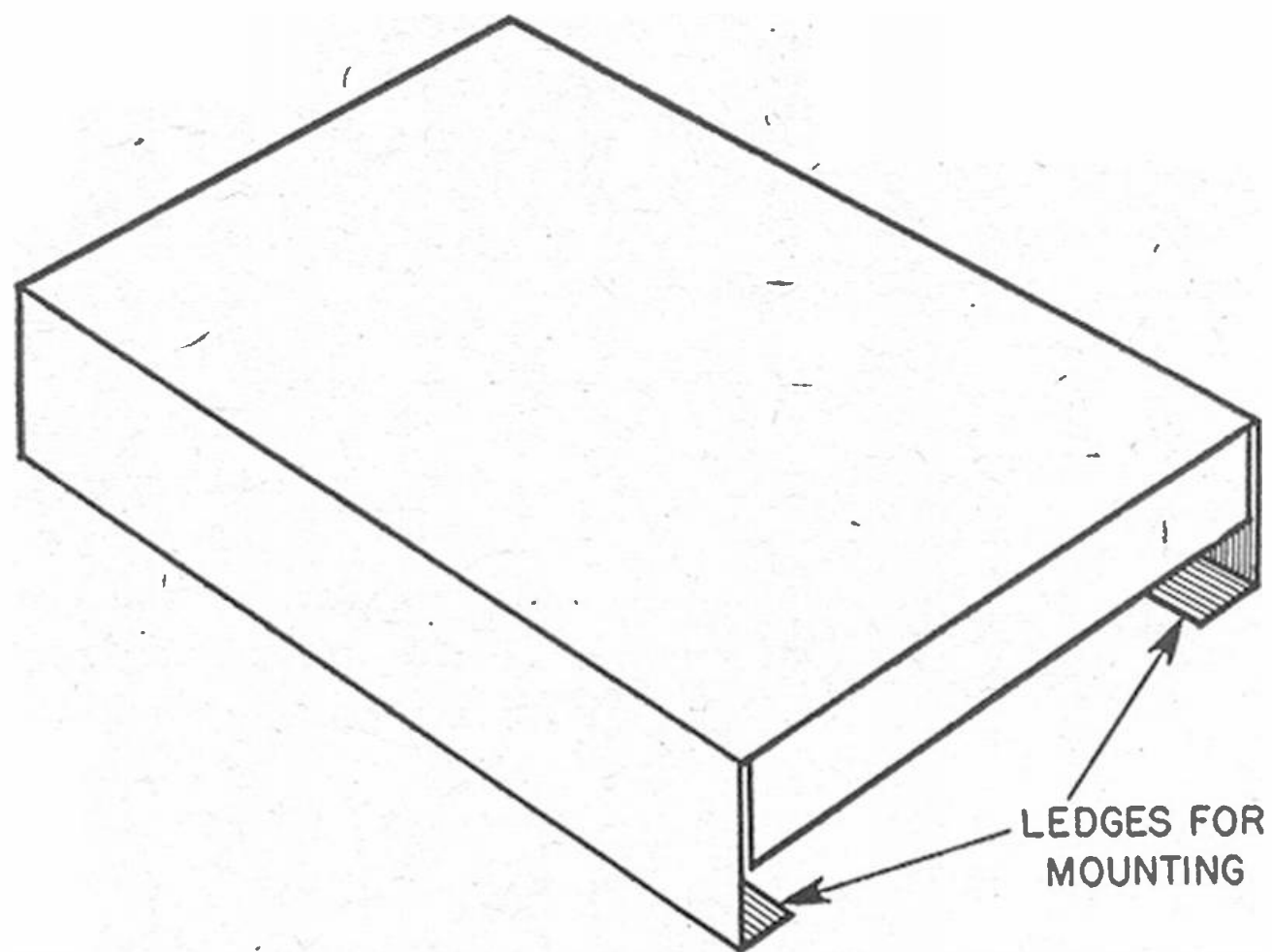

Fig. 3-17. Finished chassis will look like this.

to add ledges for this purpose. Allowing 1/2 inch for each ledge, the metal stock for a 5 by 7 by 1-1/2 inch chassis would measure 9 by 8-1/2 inches. The additional 1/2 inch is turned under the front and rear aprons, as shown in Figure 3-17. To bend a chassis of this type, the bending blocks must be just a trifle smaller than the front

(or rear) apron in both dimensions. The chassis may be fastened in the cabinet by drilling the ledges to take three or four self-threading sheet metal screws. A chassis of this type is considerably more rigid than the first type described on account of the extra reinforcement of the mounting ledges.

WIRING

Practically all present day radio receivers are wired in such a manner that the connections are as short and direct as possible and there is no reason why you should not use this method in wiring your projects. If done haphazardly, of course, it will not present a neat appearance, but if the original parts layout is sound, the wiring, although short and direct, will fall into a pattern that will be fairly neat.

Special attention to ground or chassis connections will contribute a great deal to the performance of a project. One common error is trying to solder wires directly to the chassis. This can be done, but only if you use a soldering iron large enough for the job. Constructors are apt to forget that the chassis is capable of radiating a

considerable amount of heat. Before the metal becomes hot enough to cause solder to flow, the soldering iron has cooled. The result is a "cold soldered" joint. The wire may be "stuck" to the chassis, but is not truly soldered. To make a direct soldered connection to a chassis, you will need a 500-watt electric iron. Lacking this, your next best bet is to avoid soldering to the chassis entirely and make all chassis connections to soldering lugs fastened to the chassis with screws. The one exception is in cases where a pre-formed chassis has stamped ground connections, which are little tongues of metal cut away from the chassis on three sides to form soldering lugs. Since the lugs are more or less isolated from the metal mass of the chassis, the heat of the iron is

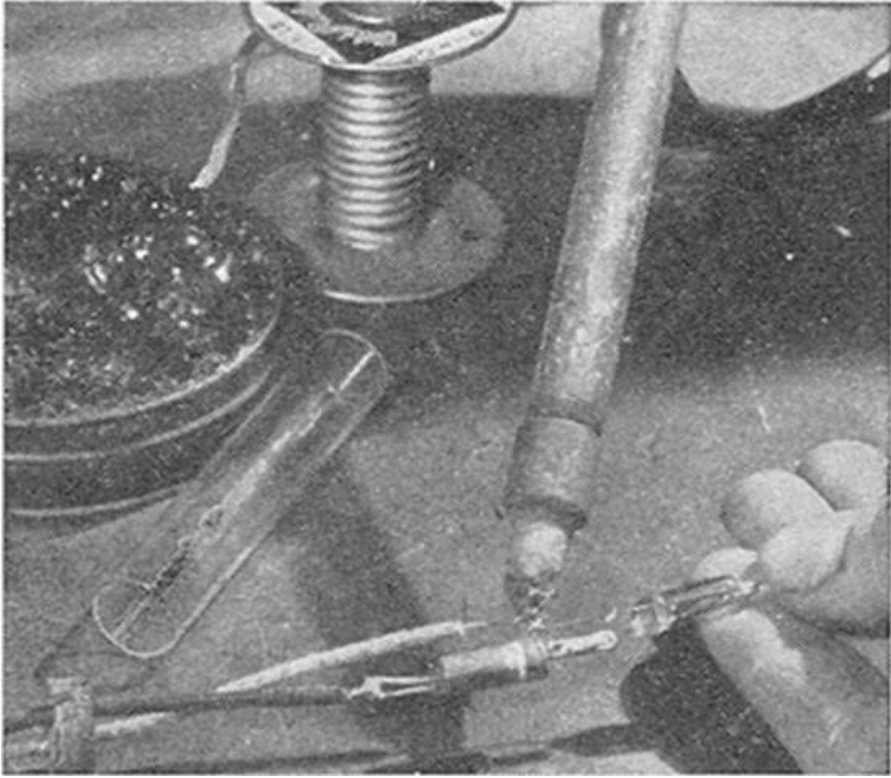

Good soldering requires a clean iron and ample heat.

not dissipated so quickly. Attempting to solder wires to an aluminum chassis is a complete waste of time with ordinary equipment, but the job can be done with special aluminum solder and a very large soldering iron.

Instead of trying to solder to the chassis, make ground connections to convenient screws on the chassis, but don't be satisfied with a connection made by merely winding the end of a wire around a screw and tightening

the nut. It is not neat and the wire is likely to break at the point where the screw head or nut exerts pressure on it. Furthermore, if more than one wire is to be connected to the same screw, you will be courting trouble, for almost certainly one will fail to stay in place. Put the shakeproof type of soldering lugs on the screws, then solder the wires to the lugs.

Although every set constructor knows that only rosin-core solder should be used in radio work, a time arrives when this kind of solder will not work as well as expected. Perhaps the wire to be soldered is untinned copper or perhaps the terminal lug is a bit corroded. Whatever the reason, everyone occasionally cheats a bit and uses a dab of soldering paste. You may do this and keep out of trouble, provided you are very careful. First of all, never use soldering paste, no matter how minute the quantity, on the terminal of a coil. Even though you diligently try to remove all traces of the paste, enough will remain to corrode the fine coil wire in time. When you must use paste, use as little as possible, and, *immediately* after soldering, while the connection is still hot, sponge it thoroughly with a cotton swab dipped in alcohol.

VOLUME CONTROL TIPS

In building radio equipment you will encounter two general types of controls: those used in superheterodyne receivers, amplifiers, and intercommunicators, and those used in TRF receivers. The first type usually has a total resistance of from .5 to 2 megohms, while the latter ordinarily ranges from 10,000 to 50,000 ohms. If you are building a superheterodyne and the diagram specifies a 1 megohm control, you may usually substitute one having a value as low as .5 megohm or as high as 2 megohms. TRF receivers will, as a rule, work well with a control that is anywhere between the values of 10k and 50k.

Beginners sometimes have trouble remembering the terminal connections of controls; the diagrams of Figure 3-18 may help, if you have such trouble. 3-18A shows the diode detector type of control commonly found in superheterodyne receivers. With the shaft of the control pointing toward you and the terminals pointing downward, as shown, the terminal at your left is to be connected to ground (or to B minus). The center terminal is usually connected to the grid of the first audio amplifier (through a coupling condenser). The terminal at the right joins the grid return lead of the second i.f. transformer (this wire is

usually color-coded black).

Figure 3-18B illustrates the connections to the antenna-C bias types of control commonly used in TRF sets. Incidentally, this type of control operates in two ways. It is shunted across the primary of the antenna coil, and thus varies the voltage appearing across the coil. Also, it is connected between the cathode of the r.f. tube and ground. Varying the resistance of the control changes the cathode bias on the grid of the r.f. tube. With the shaft of the control pointing toward you and the terminal lugs pointing downward as before, you will note that the terminal at the left is connected to the top end of the antenna coil primary. The center lug is grounded, while the right-hand lug is connected to the cathode of the r.f. tube.

A few controls have their outer metal case extended so it makes contact with the normally grounded terminal of the control. This is useful, providing the terminal is to be

get one with a plug-in type of removable shaft. To assemble a control of this type, first cut the shaft to the length needed. File the cut end of the shaft to remove burrs. Place the control on a bench or table, with the opening for the shaft facing upward. Plug the notched end of the shaft into the control, and tap the free end of the shaft lightly. Slip the C-washer into the groove in the shaft, and tap into place.

The wire connecting the center terminal of the diode type of control with the grid of the first a.f. tube is rather critical and in some sets may pick up hum. Since this wire is necessarily located close to the switch on the rear of the control, the grid lead may pick up hum from the line connections to the switch. For this reason, on some sets the on-off switch is "divorced" from the volume control and is mounted either separately or on the tone control. If you encounter trouble of this kind, the only remedy is to move the switch to a location away

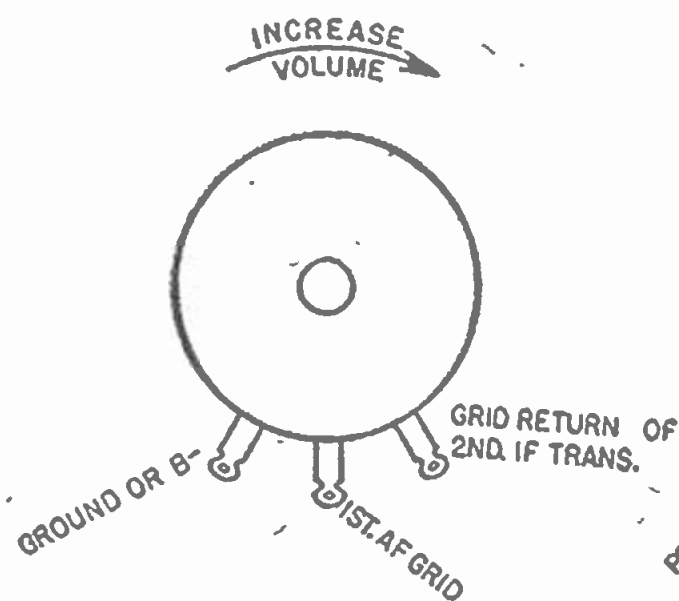

Fig. 3-18A.

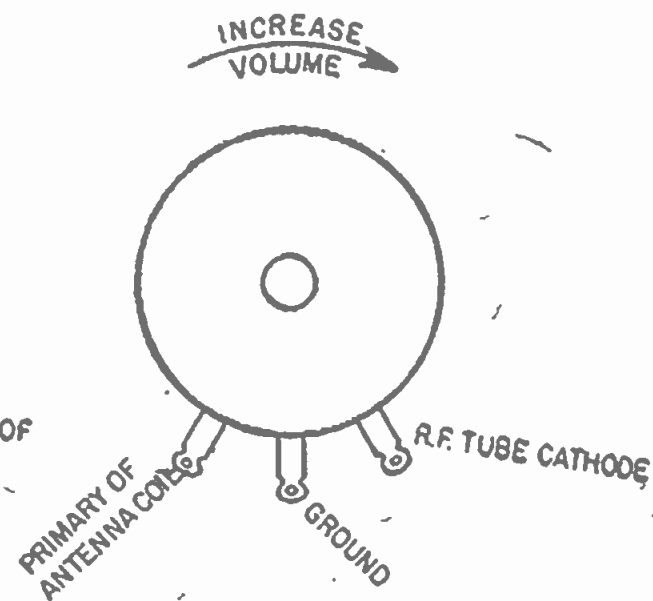

Fig. 3-18B.

connected to ground, for it eliminates one connection. In rare cases, however, this end of the control is intended to be connected to a point *other* than ground. In such cases you will have to avoid a control of this type or else insulate the shaft and body of the control from the chassis, which can be a rather difficult operation.

For the average set-building job you will probably buy one of the general replacement types of control, and there is a good chance that you will

from the volume control, even though this may involve the installation of a separate switch. You can easily verify such trouble by disconnecting the line wires from the switch. Temporarily connect them together and move them as far as possible from the control. Of course, the set will now be on as soon as the line plug is inserted in the outlet. If such an arrangement achieves a noticeable reduction in hum, install a separate on-off switch as far as possible from the control.

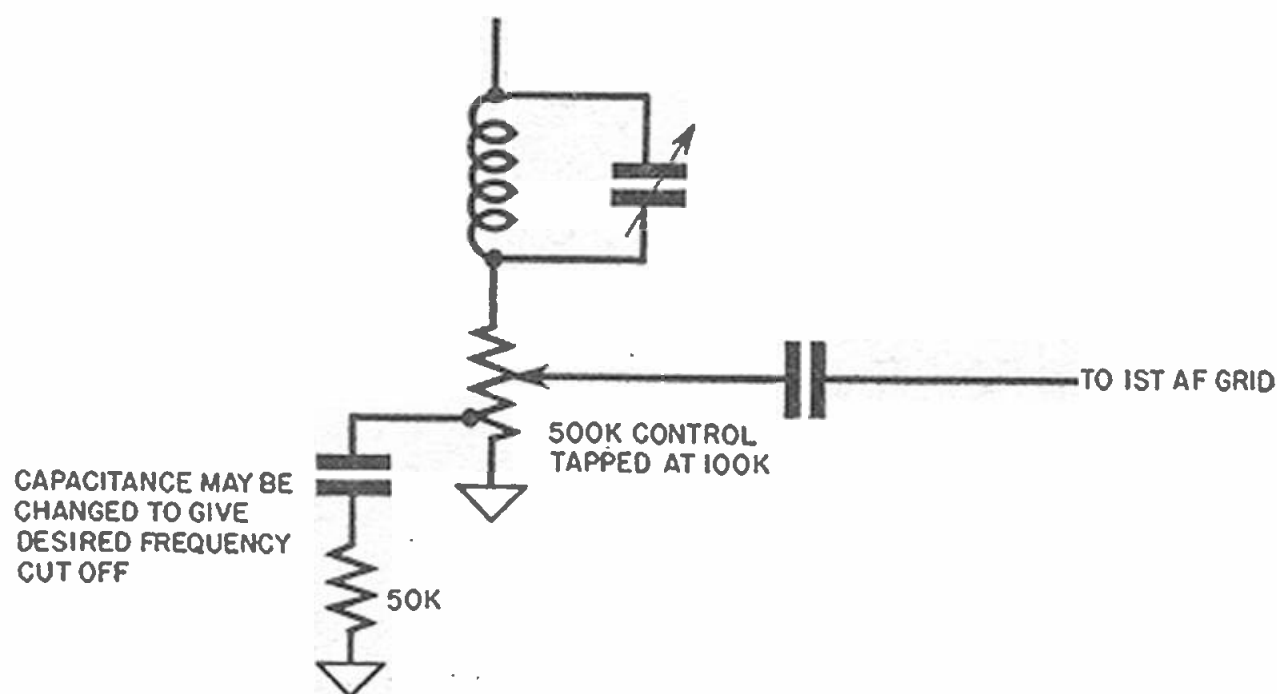

Fig. 3-19. A bass compensation volume control circuit.

Any radio receiver or amplifier has a tendency to sound tinny or high pitched when the volume control is adjusted for a low level. Set manufacturers have compensated for this by installing the bass compensation type of volume control. You may apply the idea to most amplifiers and to any receiver using a diode type of control. Figure 3-19 illustrates the circuit used. Here is how it works: when the control is set at a low level, some of the higher notes are bypassed to ground through the resistor and the condenser. The result is that, with some

of the higher notes eliminated, the music seems to be deeper although no actual increase in the bass has been effected. There is a slight decrease in the over-all volume when using a circuit of this type. Controls are made with the tap at various points but a good general rule when using the ordinary .5 megohm unit is to select one with a tap at 100,000 ohms from the grounded end. The resistor should be about 50,000 ohms. The value of the condenser will determine the amount of high frequency cut off. A good value to begin with is .01 microfarad.

LINE BALLAST RESISTORS

Many AC/DC sets use a resistance connected in series with the tube heaters to drop the line voltage to a value suitable for the tubes used. An exception is found in those sets that have a tube complement in which the tube heater voltages added together equal the line voltage, which is usually 117. An example of such a tube complement is 35W4, 50C5, 12BE6, 12BA6, and 12AV6.

In the construction of smaller units, however, such as 2- and 3-tube amplifiers, intercommunicators, phonograph oscillators, and the like, you will almost always find that some type of line resistor is necessary. In such cases it is helpful to know how to determine the value of resistor to be used and to be aware of the substitu-

tions that can be made.

Line ballasts are available in at least four types:

a) A flat, moulded, wire-wound resistor.

b) A tubular, vitreous, wire-wound resistor.

c) A ballast tube, which is not a true tube at all but merely a resistor within a glass or metal envelope.

d) A resistor line cord. This consists of the usual two-wire cord; one of the wires has an asbestos covering and on this covering the resistance wire is wound.

It should be emphasized at once that, provided the resistance values and current carrying capacities are equal, these units are interchangeable.

Easiest to use, of course, is the flat wire-wound resistor, for it requires only two machine screws and nuts for mounting and lies flat against the underside of the chassis or one of the aprons, taking up very little space.

Flat and tubular resistors

Next comes the tubular wire-wound resistor, which many radio men feel gives less trouble than the flat type. It does have the disadvantage of being difficult to mount and taking up a little more space. It is fastened in place either by a pair of L-shaped brackets with a threaded rod passing through the resistor or by means of two L-shaped clips. The clips are secured to the chassis with screws and nuts; the ends of the clips fit into the center hole of the resistor and hold it in place. It is hardly necessary to say that resistors of either of these two types should never be located close to coils, condensers, or other parts that might be affected by heat.

Resistor line cords

The resistor type of line cord is still rather popular, although some people object to the fact that the entire cord runs quite warm during operation. These cords are made in a wide variety of resistance values, and the value you select will depend upon the number and types of tubes to be used. This brings us to the method used for determining the value needed.

When you have decided to build a particular project, you may want to substitute other types of tubes for those mentioned in the circuit description and schematic diagram. For instance, in almost every case there is a 6-volt tube that is the equivalent of a given type of 12-volt tube. Similarly, there are 25-volt tubes that, except for heater voltage, are interchangeable with 50- or 35-volt types, and so on. In such cases it is important to understand the method of calculating the value of a resistor line cord

or any other type of line resistor.

Determining line resistor value

To determine the line resistor value, you must know two things: the heater voltage of each of the tubes and the heater current of the tubes. You will understand, of course, that in any series heater circuit, the current drain of all the tubes must be the same. Unless special, rather complicated arrangements are made, a tube requiring .3 ampere cannot be used in series with others that require only .15 ampere.

Suppose we take a typical series heater circuit as an example. The set is to use two 25-volt tubes and three 6-volt tubes. (*Note:* the heater voltage of a 6-volt tube is actually 6.3 volts, but 6 volts is close enough for the calculation.) All the tubes take a heater current of .3 ampere. The first step is to add all of the heater voltages; this comes to 68 volts. We

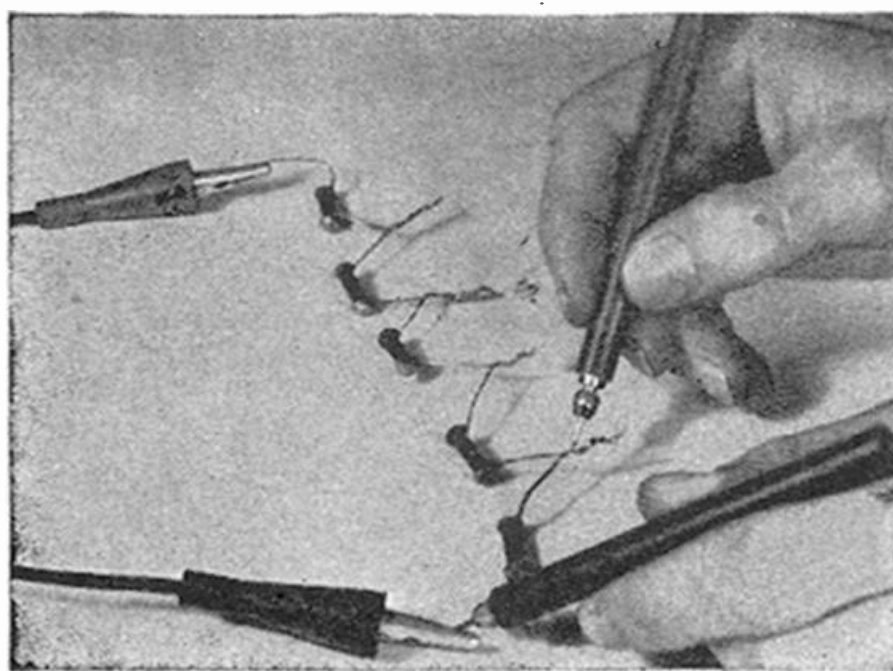

Checking resistors.

next subtract this value from the line voltage (117 volts in most areas of the United States) to find the voltage that must be lost in the resistor. We find that the drop necessary is 49 volts. The value of resistance needed is now found by using Ohm's law: 49 volts divided by .3 ampere equals 163 ohms. Actually, a 160 ohm resistor must be used, since this is the nearest value manufactured.

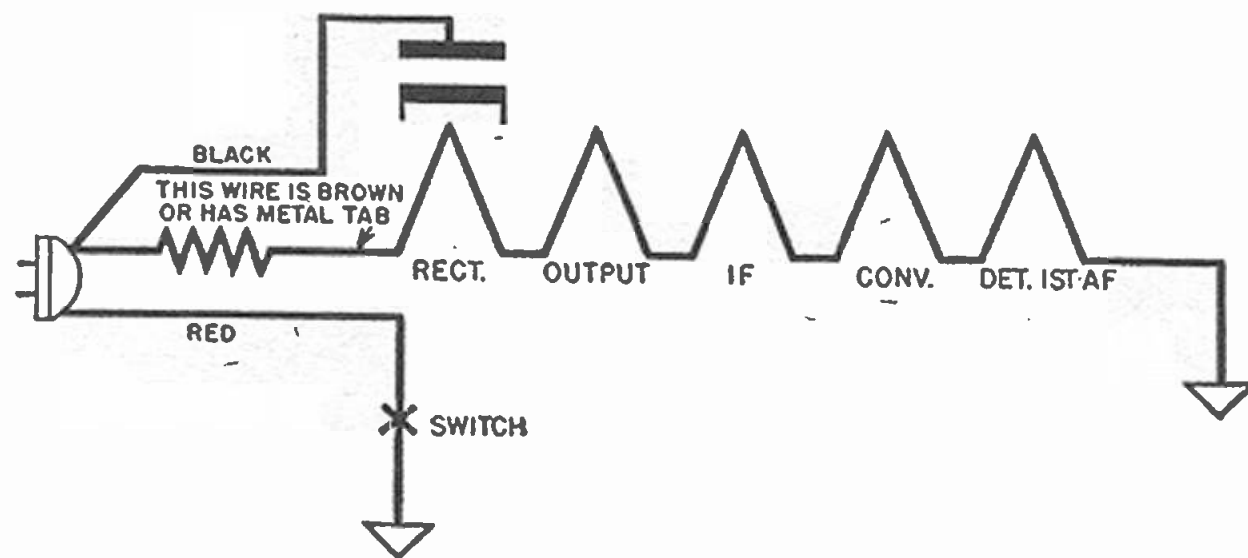

Fig. 3-20A. A series heater circuit with resistor cord.

Constructors are sometimes puzzled by the fact that a resistor cord has three wires instead of two, but there is no mystery to this. It is because a connection must be brought from the line plug to supply voltage to the plate of the rectifier tube. This connection is the third wire. If you were to use a wire-wound resistor mounted on the chassis (with a two-wire cord), you would have to run a wire from the resistor to the plate of the rectifier tube. This is the same connection as before, but in a resistor cord it is brought directly from the line plug. Figure 3-20A illustrates a series heater circuit using a resistor cord. It also shows the color-coding of the wires in the cord. Although a very few cords do depart from this color scheme, you will find it is almost universally used. Figure 3-20A illustrates

still another point sometimes ignored in set building, the correct order of tubes in the heater circuit. Scanning the series circuit from right to left, you can readily see that as you proceed to the left, each succeeding tube has a higher voltage above ground than the one before it. The left-hand heater terminal of the detector-first-audio tube, for example, will be exactly 6.3 volts above ground. Now, it is a fact that the chances of hum pick-up are in proportion to the voltage of the heater above ground. The most sensitive tube in the string is the first audio, therefore it is placed at the ground end of the string. Next come the converter, the i.f. amplifier, the output stage, and last the rectifier, which, having no tendency to introduce hum, is located at the line end of the string.

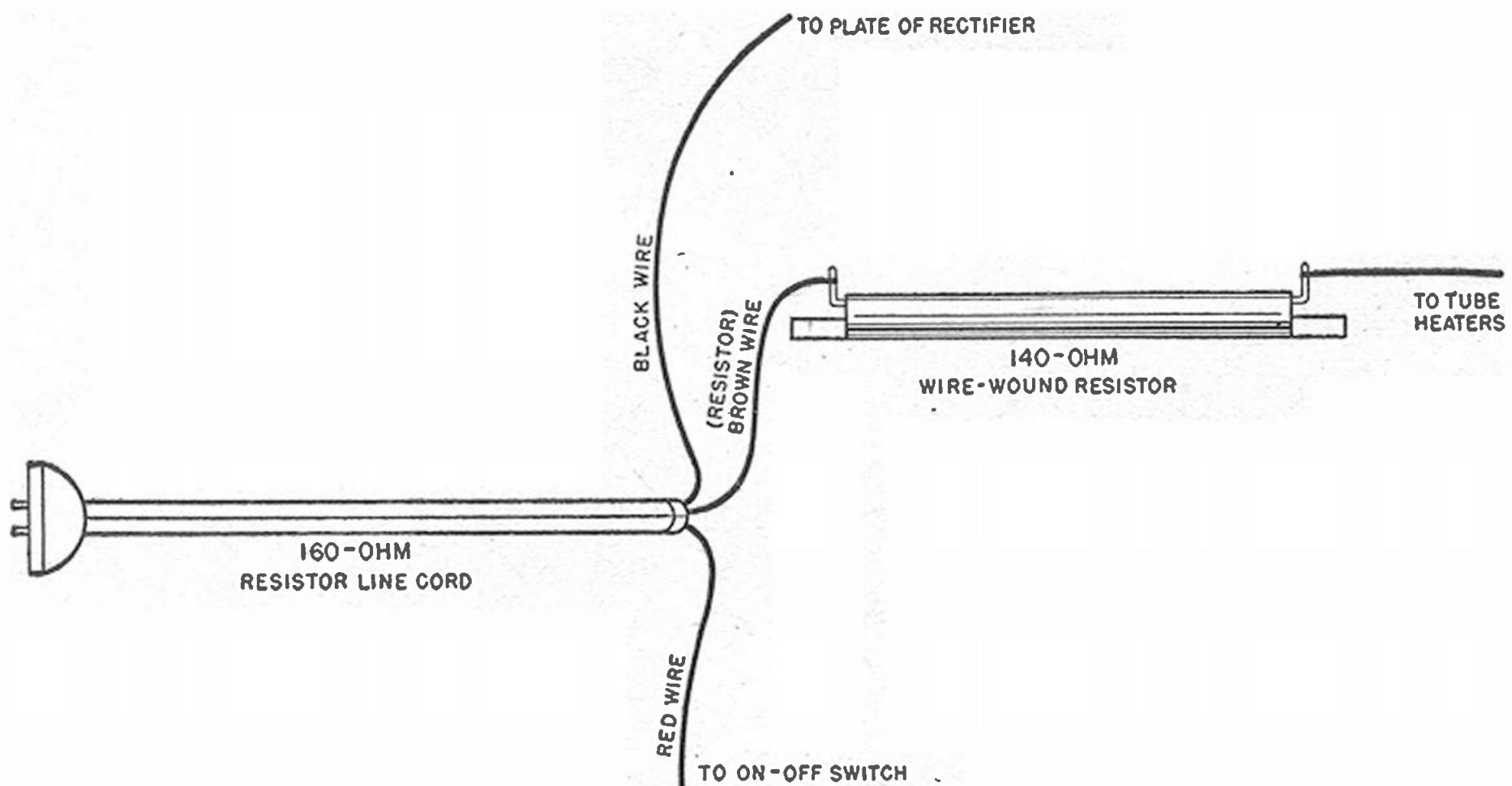

Fig. 3-20B. A resistor line cord with wire-wound resistor.

Before leaving the subject of resistor line cords, it might be well to mention the universal type, which has several resistors built into the cord and can usually be adapted to sets using from one to as many as five or six tubes. Such cords come with an instruction sheet that will show you how to connect together (or tape up, as the case may be) certain wires so as to get the desired resistance value. If you intend to build projects for experience or for fun and expect to dismantle them sooner or later, you are advised to invest in a universal cord for your first project. The additional cost is not too great and you will then be able to reuse the cord in later, more advanced projects. Another point to remember is that when building a project that requires, for example, a 300-ohm line resistor and you find that you have on hand only a 160-ohm line cord, you can always connect a 140-ohm flat or tubular wire-wound resistor in series with the cord in order to make up the needed value, as in Figure 3-20B. This applies to other types of line ballast resistor as well.

Ballast tubes

Although the ballast tube has become practically obsolete, it is possible that you might want to revamp a set using one or you might decide to use the chassis and parts from such a set in building a project. In that case you would want to know something about ballast tubes and how to replace them with other types of line ballasts.

The principal disadvantage of the ballast tube is that an additional tube socket must be used to accommodate it. The extra socket, of course, takes up space on top of the chassis that might well be used for other components. You will probably find that most sets using a ballast tube employ an octal socket for this purpose, although there were a few very early models that used a four-pin socket.

It is fairly obvious that not all the socket connections are used, since in most cases the tube utilizes only two or three base pins. The unused socket terminals made quite convenient tie points for various wires that frequently had no relation to the heater circuit. This is mentioned here because experimenters and set builders are often confused by the fact that the ballast-tube socket has more connections than appear to be necessary. Information on the base-pin connections of ballast tubes is published by the tube manufacturers. Two of the more common types are discussed here.

Ballast-tube types are designated by a combination of numbers and letters that give you information concerning the application of the tube. Suppose

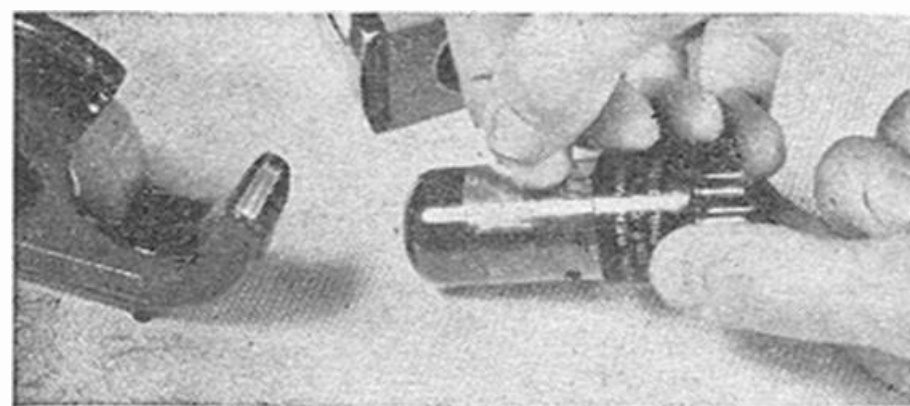

Tube type numbers wear away through handling. Protect them by placing clear tape over them when tubes are new.

we use the designation K49B as an example. The first letter, K, indicates the type of pilot lamp that the tube is intended to be used with. K indicates a 150-milliampere type. If the letter happened to be L, a 250-milliampere lamp should be used; M indicates a 200-milliampere lamp. The figures refer to the voltage drop across the ballast tube. You will recall that when we calculated the value of a line resistor earlier in this chapter, we found that we required a voltage drop of 49, equivalent to 163-ohms resistance in that particular circuit. The ballast tube here used as an example would thus have a voltage drop of 49 or, in other words, a resistance of 163 ohms. The final letter in the

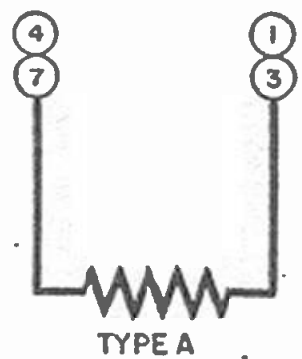

Fig. 3-21A.

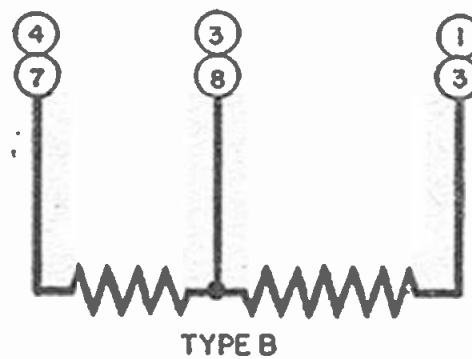

Fig. 3-21B.

designation, B in this case, refers to the circuit, or the base-pin connections. Figure 3-21A shows the A type of circuit, while 3-21B illustrates the B circuit. You will note that in the diagrams each terminal of the ballast tube has two numbered circles. The upper circles apply to tubes using a four-pin socket; the lower are used for tubes intended for an octal socket.

Replacing a ballast tube

Now, let us assume that you have a set using a ballast tube and want to replace the tube with a resistor line cord or some other kind of line ballast resistor. If you still have the original ballast tube, look for the type designation stamped on the tube. Looking this designation up in the tube manufacturers' listing will give you full information. You will then know the value of the replacement resistor to be used and the socket terminals to be used.

If you no longer have the original ballast tube, you can determine its

type by first tracing the wiring, disregarding all socket connections except those running to the line plug, the plate of the rectifier tube, and the tube heaters. If you find a pilot-lamp socket wired to two of the ballast-lamp socket terminals, you will immediately know that a ballast of the type shown in 3-21B has been used. The resistance value of the original ballast can, of course, be determined from the number of tubes used and their heater voltages. If the set did not use a pilot lamp connected across a section of the ballast, your problem is simplified. Assuming that the set originally used a 49A ballast tube, a check of the set reveals that heater circuit wires are connected to socket terminals 3 and 7. Tracing the wiring, you find that there is a wire from the line plug to pin 3 of the ballast socket. Pin 7 of the ballast socket is connected to one heater terminal of the rectifier tube. Connect the resistor wire of the line cord to 7; as shown in the sketch, Figure 3-22B, but do not remove the heater wire already connected there. There is a wire connected between terminal 3 and terminal 5 of the ballast socket, and another wire runs from this point to the plate of the rectifier. Disconnect the original line cord wire. The jumper wire from 3 to 5 need not be removed. Connect the black resistor line-cord wire to terminal 5. The remaining wire of the original line cord was connected to the line switch. Remove this wire, connect the red wire of the resistor line cord in its place, and the job is completed.

If the ballast tube is to be replaced

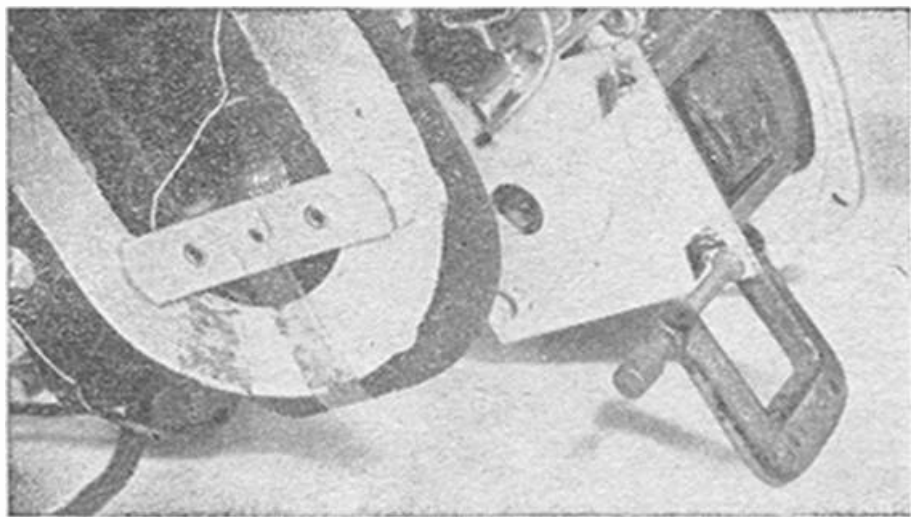

To keep weight off delicate coils and tubes and lessen chance of breakage, attach one or two C-clamps to steady set.

by a wire-wound resistor of the flat or tubular type, the work is still easier. In that case, merely connect

the new line ballast resistor between terminals 3 and 7 of the ballast socket.

PILOT LAMPS

For a number of reasons it is often desirable to install a pilot lamp on a project, although the original circuit diagram did not include one. If the set uses a power transformer, the problem is a simple one indeed. Just connect a pilot-lamp socket in parallel with the tube heaters at any convenient point, insert a lamp in the socket, and you are ready to go.

On series heater jobs there are several ways of adding panel lamps. The simplest method is to connect the lamp in series with the heaters, but this does have disadvantages. You will probably find that the lamp is too dim until the tubes have warmed up and

of 170 ohms, and the pilot-lamp section works out to 35 ohms. You would then use a 135-ohm main section and a 35-ohm pilot-lamp section in series with it, connected as in Figure 3-23.

Sets using tubes whose heater voltages add up to the line voltage generally employ such rectifier tubes as 35Z5 or 35W4. These tubes have built-in provision for a pilot lamp in the form of a tapped heater. The pilot lamp is connected across the smaller section of the heater, as shown in Figure 3-24. On smaller projects using two or three tubes, you can still use this method, provided that a rectifier tube having a tapped heater is

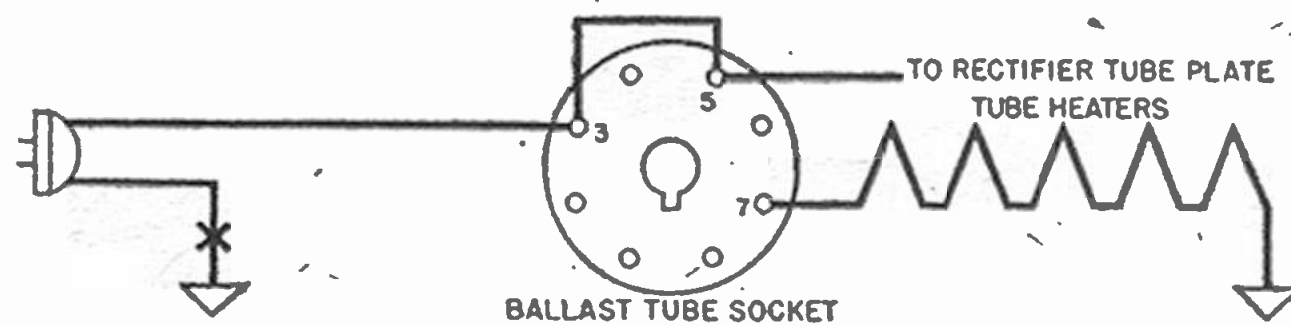

Fig. 3-22A. Original ballast tube circuit.

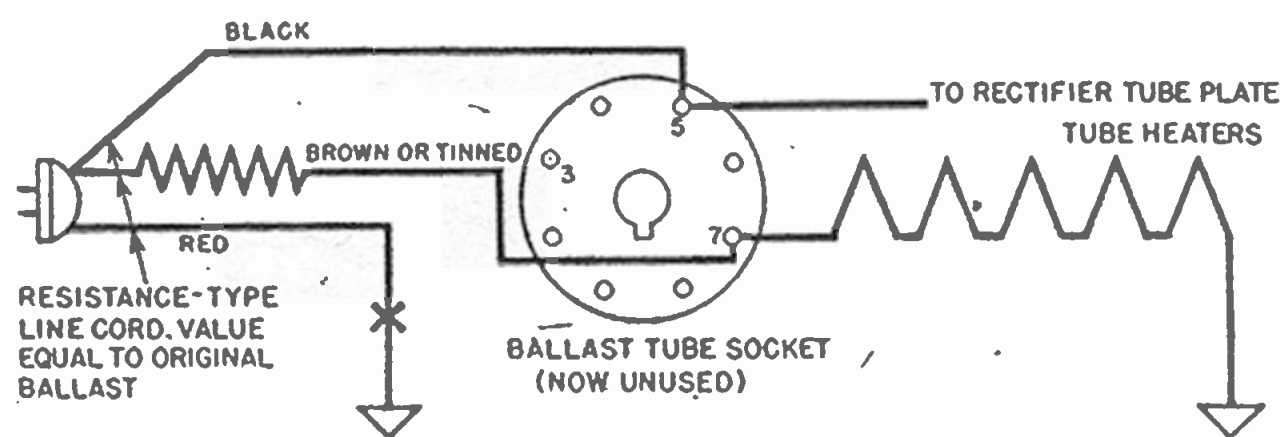

Fig. 3-22B. Ballast tube replaced by line resistor cord.

then becomes too bright. There is also the possibility of frequent burn-out. A much better way is to connect a wire-wound resistor in series with the heaters and connect the lamp in parallel with this resistor. But this method cannot be used if the total of the heater voltages is equal to the full line voltage. Furthermore, you must remember to deduct the value of the pilot-lamp resistor from the total-line-ballast resistance used. Suppose that the set requires a total line resistance

used. You would then add a series line resistor to give the required voltage drop.

Incidentally, it is fairly common for the pilot-lamp section of the heater in such tubes to burn out, leaving the remainder of the heater intact. The tube may still be good and, if so, can still be used. One method is to connect a wire jumper across the pilot-lamp section of the tube. For a type 35Z5, connect the jumper between socket terminals 2 and 3. If the tube

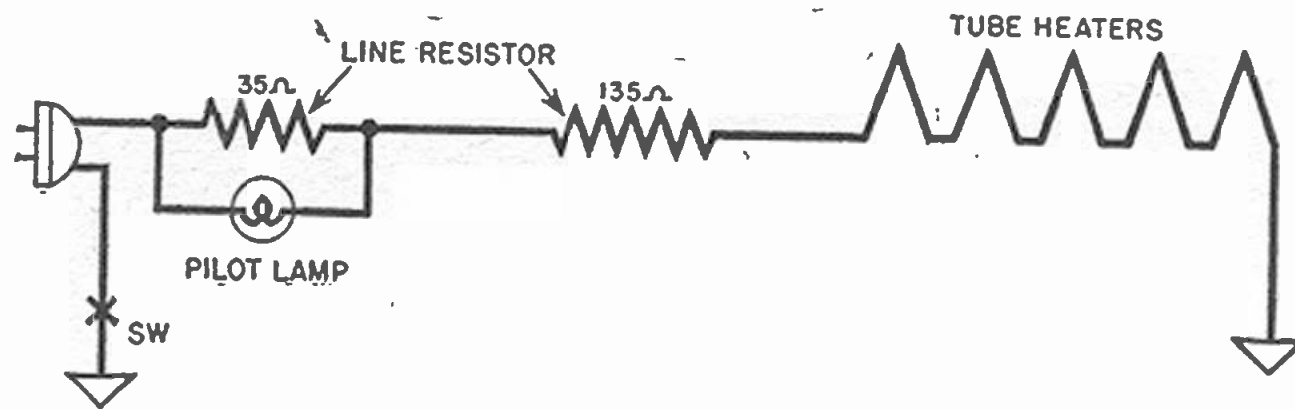

Fig. 3-23. A main section and pilot lamp section in series.

is a 35W4, use terminals 4 and 6 instead. For a 35Y4 terminals, 1 and 4 are the proper ones. This method will increase the voltage applied to the tube heaters by a small, but not serious, amount and, of course, the pilot lamp will no longer light. This is therefore an emergency measure only. A much better plan is to connect a small wire-wound resistor between the proper tube-socket terminals in place of the jumper wire. Not only will the lamp then light, but the tube heater voltages will remain at their original values. The resistor value should be

between 40 and 50 ohms, and a 2-watt resistor should be used for this purpose.

Perhaps the most satisfactory method of connecting a panel lamp is to locate it between the line cord and the plate of the rectifier tube, as shown in Figure 3-25. This scheme is used on the majority of present-day commercially built sets. The lamp operates on the rectified direct current flowing through the rectifier. While this method is very good, it has one slight disadvantage—the lamp may flicker on unusually strong signals.

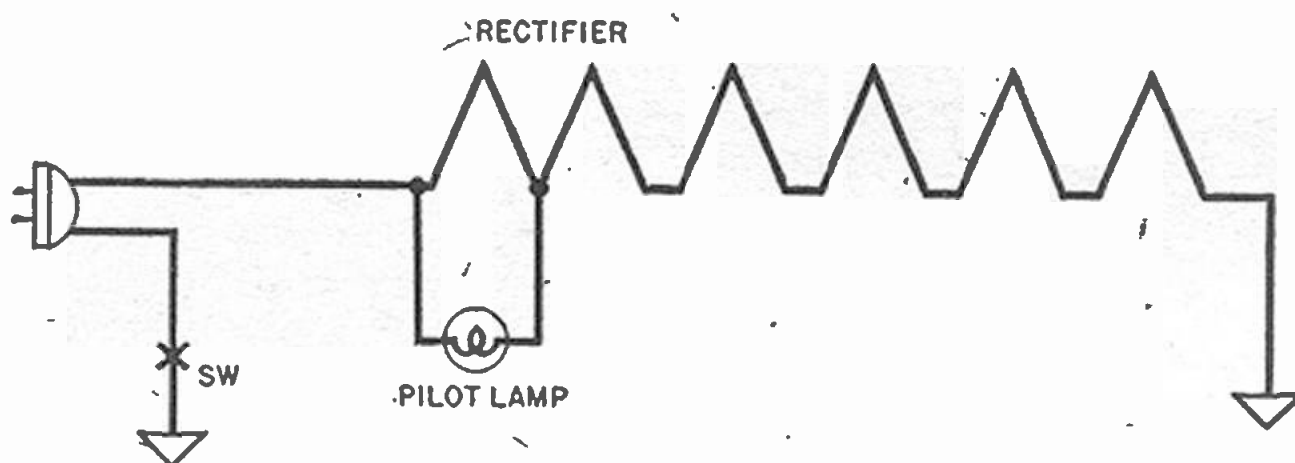

Fig. 3-24. A pilot lamp connected across the heater.

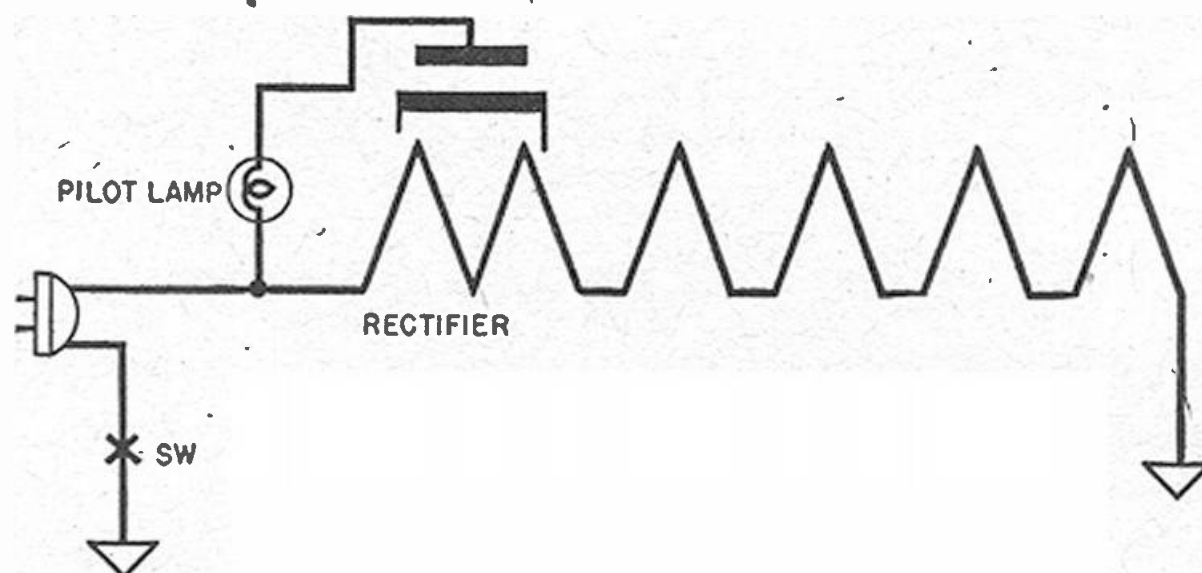

Fig. 3-25. A panel lamp between line cord and rectifier tube.

How to Build Amplifiers and Intercommunicators

THIS branch of radio construction has a particular fascination for many builders. Just why this should be so is not entirely clear. Perhaps the perfectly natural desire to use a microphone has some bearing. Then, too, it is possible that the growing interest in recorded music has had an influence. It is a fact, whatever the reason, that much of the interest among constructors and experimenters centers around the many types of audio amplifier.

In this chapter we present a number of projects, ranging from an extremely simple and inexpensive one-tube phonograph amplifier to a more complex outfit that will deliver considerable power and is suitable for use with phonograph, microphone, or radio tuner. It is perhaps worth mentioning that many constructors who have built amplifiers have profited through rental of their equipment for social gatherings.

In connection with amplifiers, we shall take up the construction of intercommunicating systems, which are really nothing more than rather specialized amplifiers. Within the last few years, intercommunicators have been widely used in all kinds of business establishments, from food markets to large manufacturing plants. Even more recently, they have come into favor in the home, where they have been used in many ways—notifying dad that dinner is ready as he putters in his basement workshop, keeping tabs on Junior asleep in his

room while mother goes about her household tasks or perhaps entertains the bridge club in the living room, listening to baby.

Finally, we consider some of the problems in building equipment for the reproduction of records, including the limitations and the possibilities of records, pickups, and motors, together with circuits for tone compensation and the reduction of record surface noise.

Amplifier differences

It is well to remember that there are one or two essential differences between the amplifier intended for use with phonograph or microphone and one designed to function in an intercommunicating system. First of all, the usual small amplifier designed for phonograph work is called upon to deliver a moderate amount of power with as good a frequency response as possible. Perhaps a 10-watt amplifier for use in the home may never be used at full power, but a ten-to-one reserve is needed to prevent overloading on the louder passages. And, as we are all aware, an amplifier intended for reproduction of music must be capable of handling all frequencies from about 30 to at least 10,000 cycles per second if we expect to get anything like a faithful reproduction of the original music.

Well, how about reproduction of speech? Next time you use the telephone, pay no attention to the con-

versation for a moment and try instead to concentrate on the sounds you hear. You will then become aware of a fact known to engineers for a long time. For intelligible speech the instrument need not be capable of reproducing all the tones the human voice can create. In other words, the telephone transmits a far narrower band of frequencies than most amplifiers. In fact, the range of the usual hand-set instrument is so limited that we often piece together a conversation partly by guesswork, by filling in words we think the party said. If you doubt this, try having someone read to you over the telephone a few familiar paragraphs and see how much of it you actually hear.

Much the same thing applies to an intercommunicator intended for home use. There is no real need for large amounts of power, just as long as the speech is audible and intelligible. We need not be as careful to design the unit with a view to faithful reproduc-

tion of all tones. If the equipment is to be used in a business or industrial application, however, the requirements will probably be somewhat more rigid.

On the other side of the balance sheet, we find that the intercom must meet other specifications not applicable to phono amplifiers. Part of the time the intercom is used with the speaker (connected as a microphone) in the input circuit. For talking in the opposite direction, conditions must be reversed. This introduces a complication: the "talk-listen" switch. An exception is the simple one-way intercom described later. Some intercoms must be designed so the master-station operator can make contact with any one of a number of remote stations without activating the others. We take up the construction of a multi-unit intercom below, but to avoid a complicated switching system, it connects the master station to all remote stations at once.

COMPACT ONE-TUBE PHONO AMPLIFIER

This tiny phonograph amplifier is about as simple and as small as can be built. Tube equipment is kept at a minimum by using a selenium rectifier. This unit cannot, of course, be used as a public address system, nor will it fill a large room with music. It will serve very well as a "personal" type of phonograph and is widely used in portable units designed for children. It will fit inside the cabinet of the average record player or it can be combined with a player in a home-built cabinet like the one described later on in this chapter. One point needs emphasis: the pickup cartridge used with it must deliver a relatively high voltage output. Among the cartridges suitable are: Shure W42H, Electro-Voice H60, Astatic L-82-A.

Circuit description

The circuit diagram is shown in Figure 4-6. A 50C5 tube is used to

drive a 3-inch p.m. dynamic speaker. All voltages for the tube are obtained from the selenium rectifier, SR. Heater voltage for the tube is taken from the line and reduced to a suitable value by the 450-ohm line dropping resistor, R1. Although the amplifier is of the familiar AC/DC type, remember that the ordinary phono motor will operate on alternating current only. Notice the outlet for supplying power to the motor; the supply to this outlet, as well as to the amplifier, is controlled by the on-off switch, a part of the volume control. If you prefer, the outlet may be omitted and the motor is then connected directly to an external outlet.

Parts list

Resistors

- | | |
|----|----------------------------|
| R1 | 450-ohm line cord resistor |
| R2 | 500K ohm volume control, |

- with switch
 R3 150 ohm, 1/2-watt carbon
 R4 47 ohm, 1/2-watt carbon
 R5 5000 ohm, 1/2-watt carbon

Condensers

- C1 .05 mfd., 200-volt midget paper tubular
 C2 10 mfd., 25-volt electrolytic (tubular)
 C3 .01 mfd., 400-volt midget paper tubular
 C4 30-20 mfd., 150-volt electrolytic (tubular)

Transformers

- T1 Output transformer, compact type, 2,000 ohm primary, 3.5 ohm secondary

Speaker

- 3-inch PM dynamic, 3-4 ohm voice coil (square type frame preferred)

Chassis: 3 x 4 x 2 inches

Tube

50C5

Layout and assembly

The entire amplifier, including the speaker and the phono motor receptacle, can be built on a chassis measuring only 3 by 4 by 2 inches, if you use judgment in the selection of parts. Note that the parts list specifies midget condensers in most cases; the volume control, too, must be of the midget type, measuring not more than 15/16 inch in diameter. If the parts specifications are followed closely, you will have space for all components, for besides the volume control, resistor line cord, and filter condenser, only three resistors and three condensers are needed.

If you care to make your own chas-

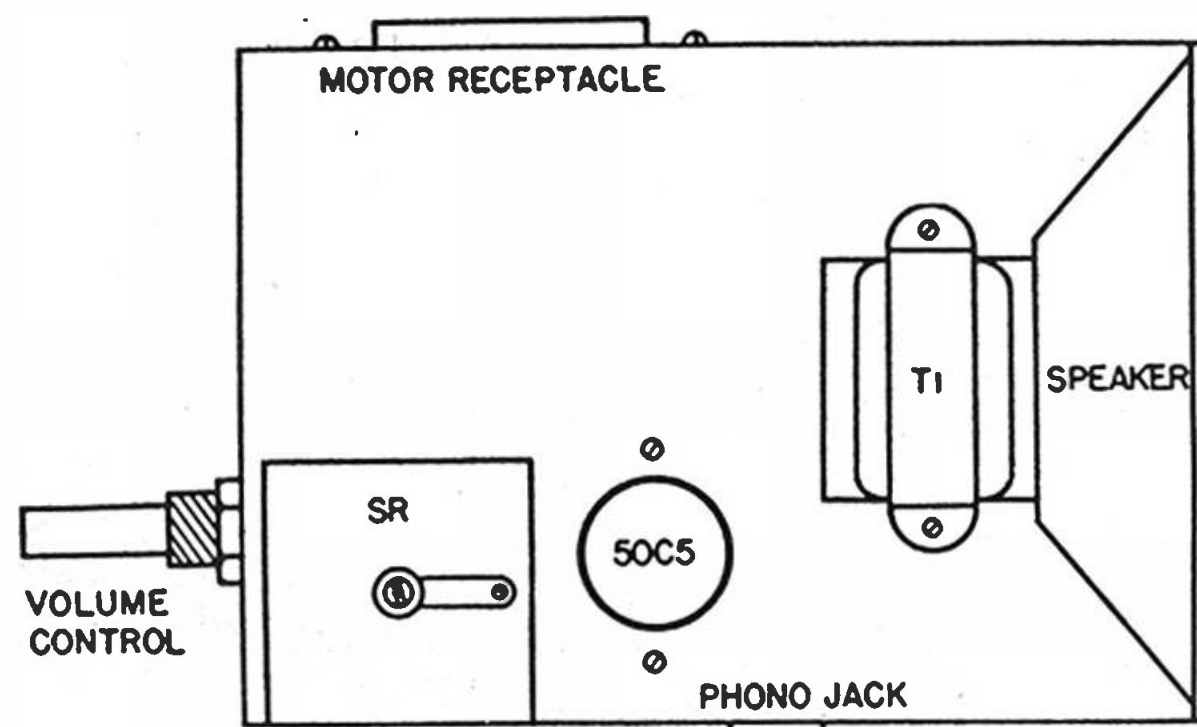

Fig. 4-1. Top view of chassis.

Miscellaneous

- Selenium rectifier, 50 m.a. output
 RCA-type phono jack
 Motor receptacle: 2-pole female receptacle, flush mounting, Amphenol 51-F1 or equivalent
 7-pin miniature tube socket
 2 4-36 x 3/8-inch r.h. machine screws
 2 4-36 hexagon nuts
 6-32 x 3/8-inch r.h. machine screws
 6-32 hexagon nuts
 2-point tie strip
 Push-back wire
 Rosin-core solder

sis, use a piece of 20-gauge aluminum 7 by 8 inches in size. Follow the instructions given in Chapter 3 and you can make a 3 by 4 inch chassis with side and end aprons a full two inches in depth. Although narrow end aprons were used in previous projects, the small size of this amplifier makes the extra apron width necessary.

If you can, select a speaker with a square frame; it can be fastened to the chassis with two screws through the lower corner holes. The speaker, together with the compact output trans-

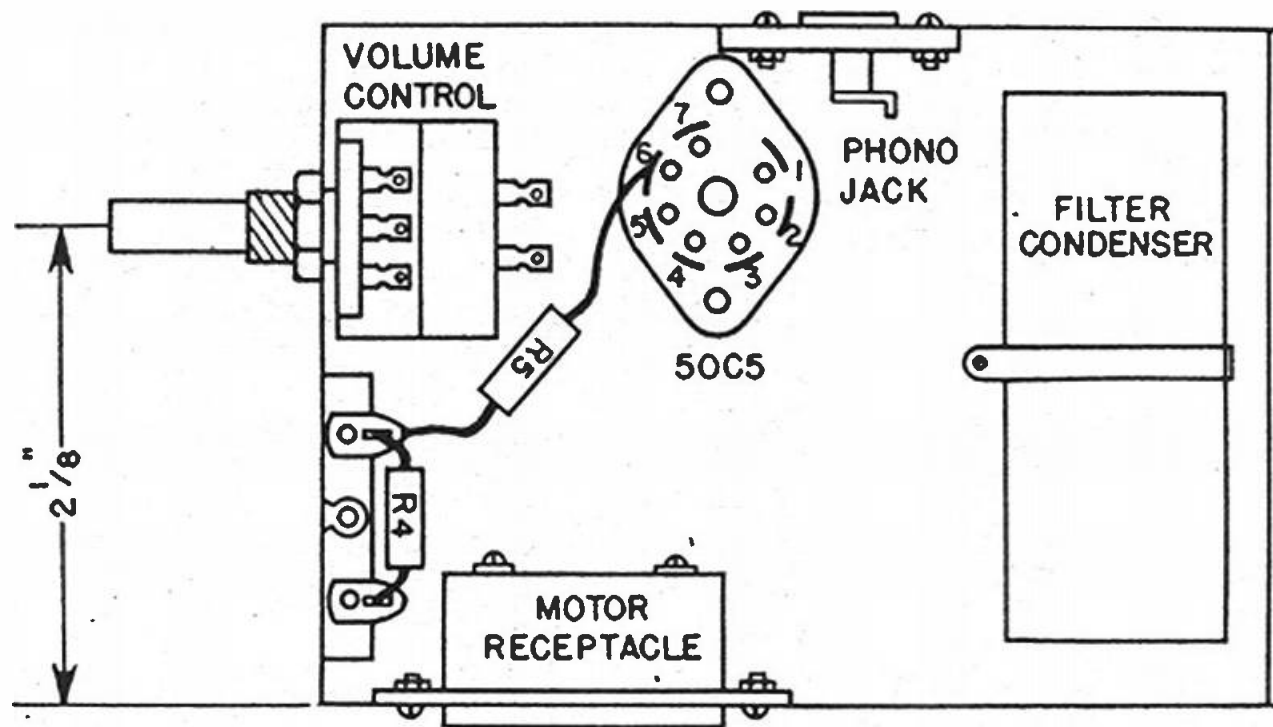

Fig. 4-2. Underside view of chassis.

former, will be light enough so that this kind of mounting will be sufficiently rigid. See Figure 4-1 for a top view of the chassis, showing the speaker in place. Place the selenium rectifier at the left rear corner of the chassis. (*Note:* When facing the speaker cone, the rectifier is considered to be at the rear of the chassis.)

The tube socket is placed between the selenium rectifier and the speaker. Its exact location can be determined after the speaker and rectifier positions have been marked.

When all screw holes for fastening the speaker, rectifier, and tube socket have been marked and center punched, you may lay out the positions of the parts under the chassis. The filter condenser is placed under the speaker. The center of the volume control shaft, as indicated in the underside view, Figure 4-2, is 2-1/8 inches from the right side of the chassis.

The phono jack is placed on the left side of the chassis (see Figure 4-3)

2-1/4 inches from the rear and 11/16 inch from the lower edge of the chassis. On this same sketch you will note the position of the hole for the line cord, 7/16 inch from the front of the chassis and 1/4 inch from the lower edge.

Referring to Figure 4-4, the right side view of the chassis, locate the center of the motor receptacle approximately 1-5/16 inches from the rear and about an inch from the bottom. The exact position of the receptacle will depend upon its size. Figure 4-5 is the rear view of the chassis, showing in greater detail the position of the volume control.

All holes, except those for the tube-socket screws, are to be drilled with a #25 drill, which provides clearance for a 6-32 screw. The socket is fastened with two 4-36 screws; use a #31 drill for these. Drill or ream the volume-control-shaft hole to 3/8 inch, punch out the socket hole with a 5/8-inch sheet metal punch, and punch a hole

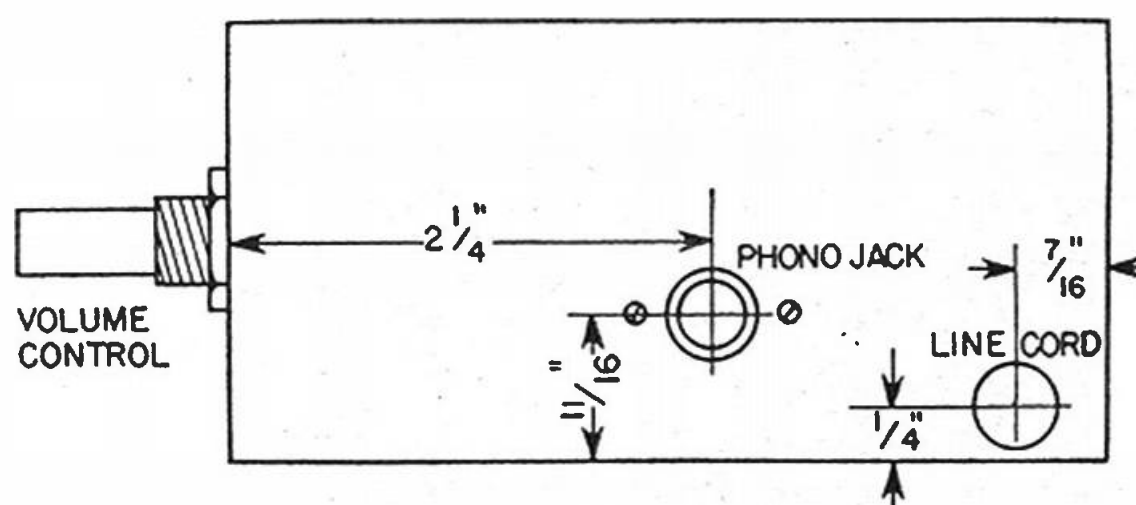

Fig. 4-3. Left side view of chassis.

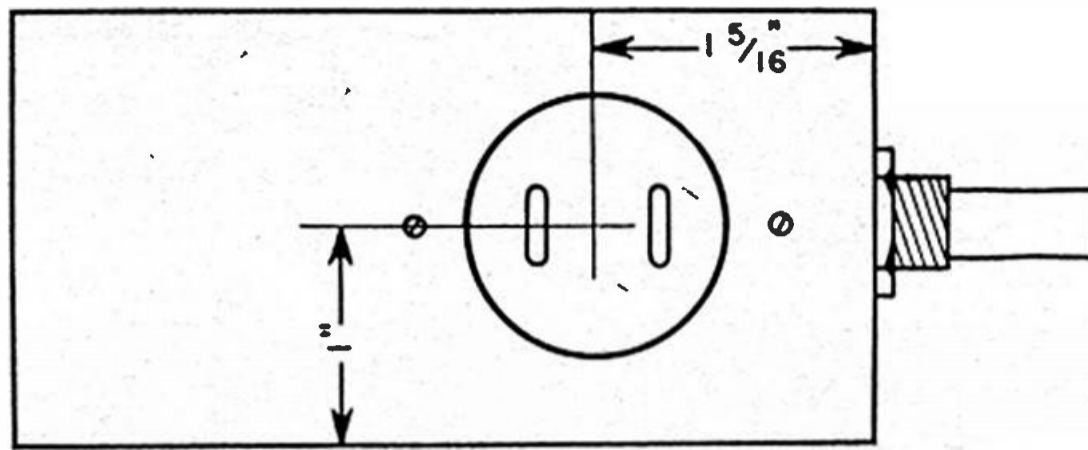

Fig. 4-4. Right side view of chassis.

for the motor receptacle. The size of this last hole will be determined by the dimensions of the particular receptacle, but usually it will be about 1-1/4 inch.

The parts may be mounted in any order, but it will be necessary to remove the filter condenser temporarily when wiring the tube socket.

Wiring •

It will probably be best to wire the heater circuit first. Do not forget to anchor the line cord in place by tying a single knot in it close to the inside of the chassis apron. With the heater circuit wired, place R4 in position on the 2-point tie strip, then connect R5 between the end of R4 and the screen terminal (pin 6) of the tube socket. You may connect the filter condenser to the filter-resistor terminals and later remove it from its position while wiring the tube socket. Wires to the selenium rectifier may be brought through two small holes in the chas-

sis, drilled close to the rectifier terminals. The motor receptacle is connected in the circuit by bringing the black line-cord wire to one of its terminals and connecting the other to chassis.

Final test

If the record player is to be more than a foot or two from the amplifier, be sure to shield the entire length of the connecting wires. With a pickup capable of delivering about two-volts output and a record of average loudness, the amplifier should give ample volume in a small room. If the music is too high-pitched or record surface noise is objectionable, try the compensating circuit used in the three-tube phono amplifier to be described later. As you will see from inspection of Figure 4-21 this circuit consists of a 700K resistor connected across the pickup jack and a 1-megohm resistor connected between the jack and the volume control.

PHONOGRAPH OSCILLATOR

A phonograph oscillator is a miniature broadcast station. It transmits a carrier wave within the broadcast range (the upper, or low-frequency end of the band is usually the better). Signal voltages from the phonograph pickup are used to modulate this carrier and the resulting signals are picked up by the receiver in the usual way. If the record player is within a few feet of the set, the results can be very good. The principal advantage of the device is that no electrical con-

nection between player and set is necessary. This makes it truly portable, for it can be carried about from place

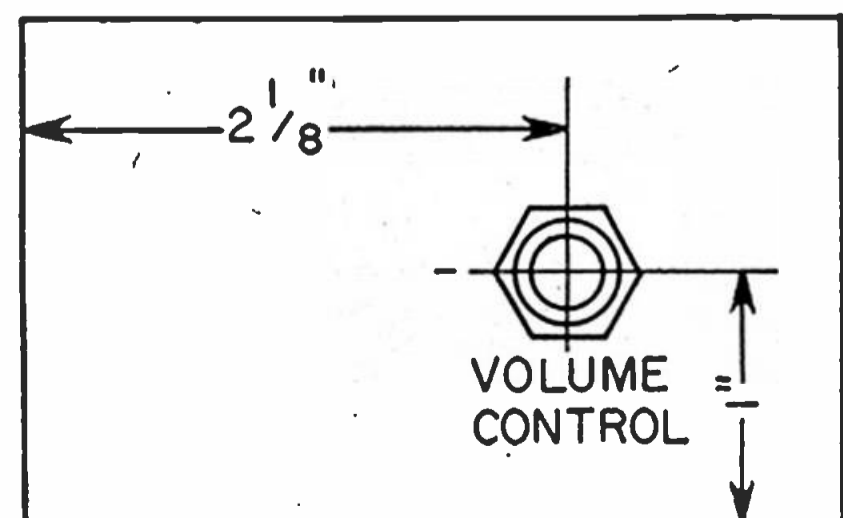

Fig. 4-5. Rear view of chassis.

to place and used with any set on a moment's notice and with no previous preparation. Should you want to take your record collection to a friend's home and you find that he has neither phonograph nor amplifier but does have a radio set, the phono oscillator is the answer. Following this description you will find plans for building your own record player, with the oscillator unit incorporated in it. Phono oscillators conform to Federal Communications Commission rules and regulations, provided the power radiated is limited. Using the tube and the circuit to be described here, you will be within those specifications.

used in the six-tube AC receiver described in Chapter 2. In fact, with one or two changes, you can use such a coil in place of the one specified. Audio voltages from the phonograph pickup are injected into the tube's electron stream by way of grid 3, and the modulated signals are then fed from the plate to the antenna. Plate and screen voltages for the 12BA6 are supplied by the selenium rectifier, SR, while the heater voltage is held at 12 volts by the line resistor, R6.

Parts list

Resistors

R1 500K ohm, 1/2-watt carbon

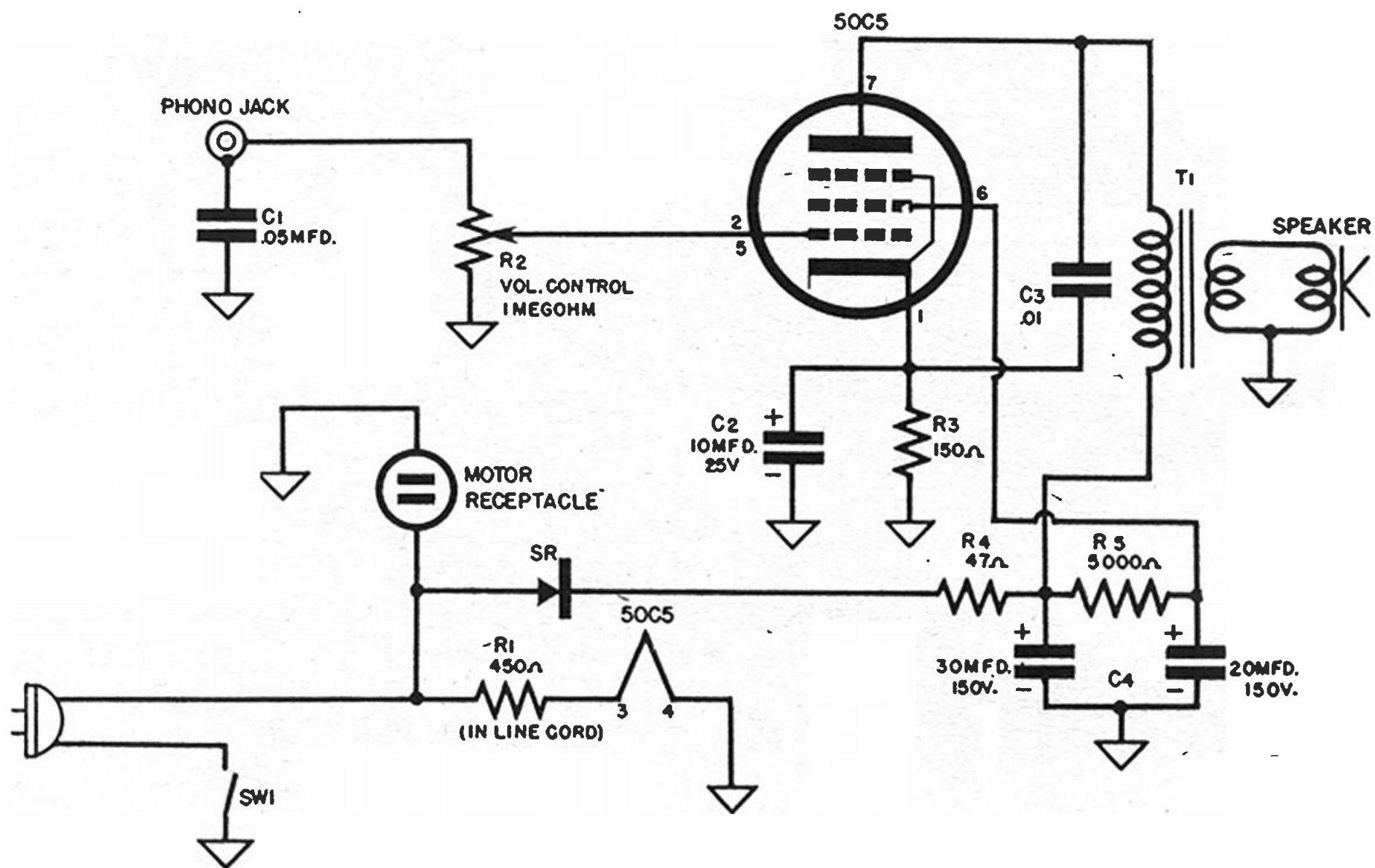

Fig. 4-6. Schematic diagram of a one-tube phono amplifier.

Circuit description

See Figure 4-7.

A 12BA6 tube develops the modulated signals radiated from the unit by way of the antenna, which may consist of a short length of wire. Grid 1 and the cathode are used as the r.f. oscillator electrodes. Note that the oscillator coil is of the tapped, single-winding variety, similar to the one

R2 25K ohm, 1/2-watt carbon
 R3 5K ohm, 1-watt carbon
 R4 5K ohm, 1-watt carbon
 R5 5K ohm, 1/2-watt carbon
 R6 700-ohm, 20-watt wire-wound

Condensers

C1 180 mmfd., mica
 C2 20-20 mfd., 150-volt electrolytic (tubular)
 C3 .1 mfd., 400-volt paper tubular

- C4 250 mfd., mica
- C5 .02 mfd., 400-volt tubular

Coils

- L1 Single winding, tapped phono-oscillator coil with tuning capacitor

Miscellaneous

- Selenium rectifier, 50 m.a. output
- 7-pin miniature tube socket
- Line cord and plug
- SW1: on-off switch, single-pole single-throw, rotary
- 2 3-point tie strips
- RCA-type phono jack
- 2 4-36 x 3/8 inch r.h. machine screws
- 2 4-36 hexagon nuts

Layout and assembly

Few comments are needed concerning this phase of construction, for only a small number of parts are used and there is enough chassis space for all of them without crowding. Figure 4-8A is the top view of the chassis, showing the positions of the tube socket, selenium rectifier, and the tie strip for the wire-wound line dropping resistor. The resistor is located here rather than under the chassis because it radiates an appreciable amount of heat and will run at a lower temperature with improved ventilation. A resistor line cord is not specified for this project since, due to the un-

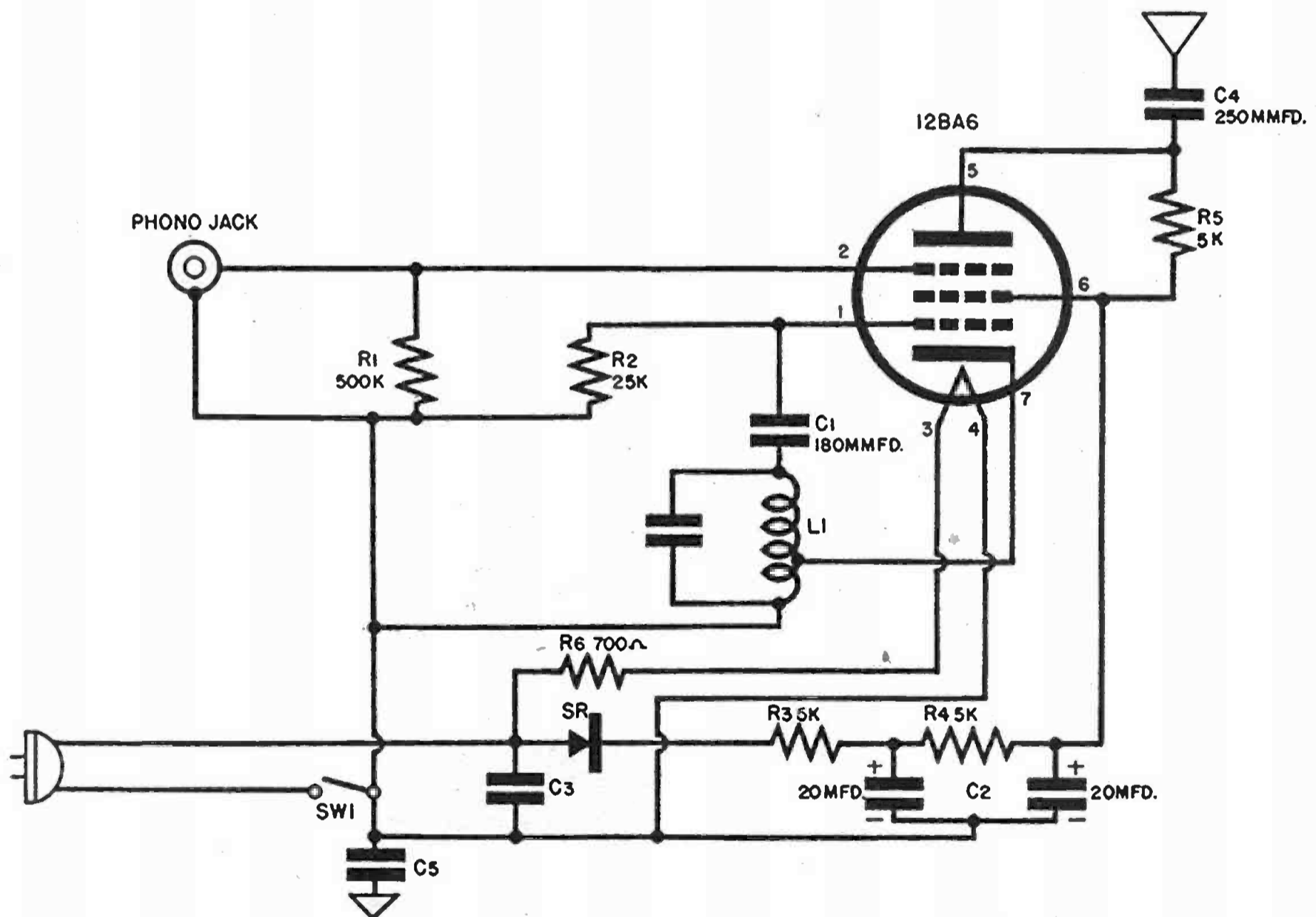

Fig. 4-7. Schematic diagram of a phono oscillator.

- 6-32 x 3/8 inch r.h. machine screws
- 6-32 hexagon nuts
- Chassis: 3 x 3 x 1-1/2 inch, aluminum or steel. If homemade, use 20-gauge sheet aluminum, 6 x 6 inches.
- Push-back wire
- Rosin-core solder

Tube

12BA6

usually high value needed, it may be difficult to buy. If you should prefer to use a resistor cord, you may connect two 350-ohm cords in series and substitute this combination for the wire-wound resistor.

Figure 4-8B is the underside view of the chassis, showing the filter condenser, oscillator coil, and filter-resistor tie-strip positions. The under-

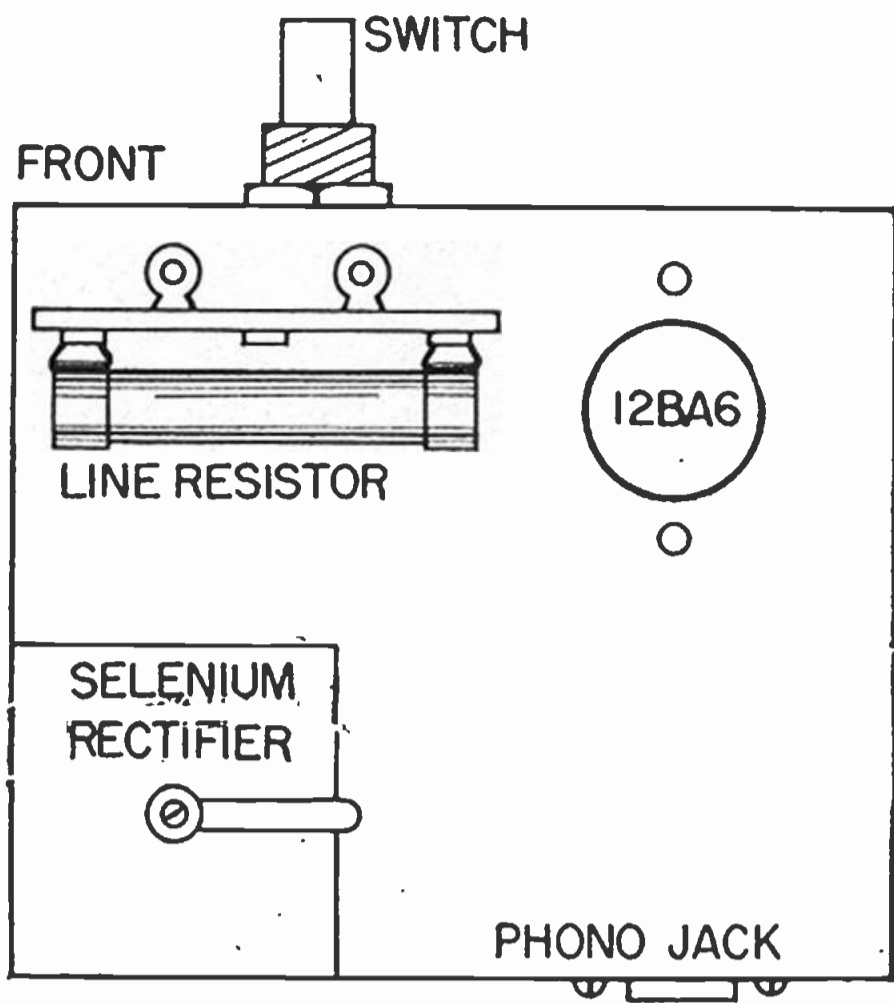

Fig. 4-8A. Top view of chassis.

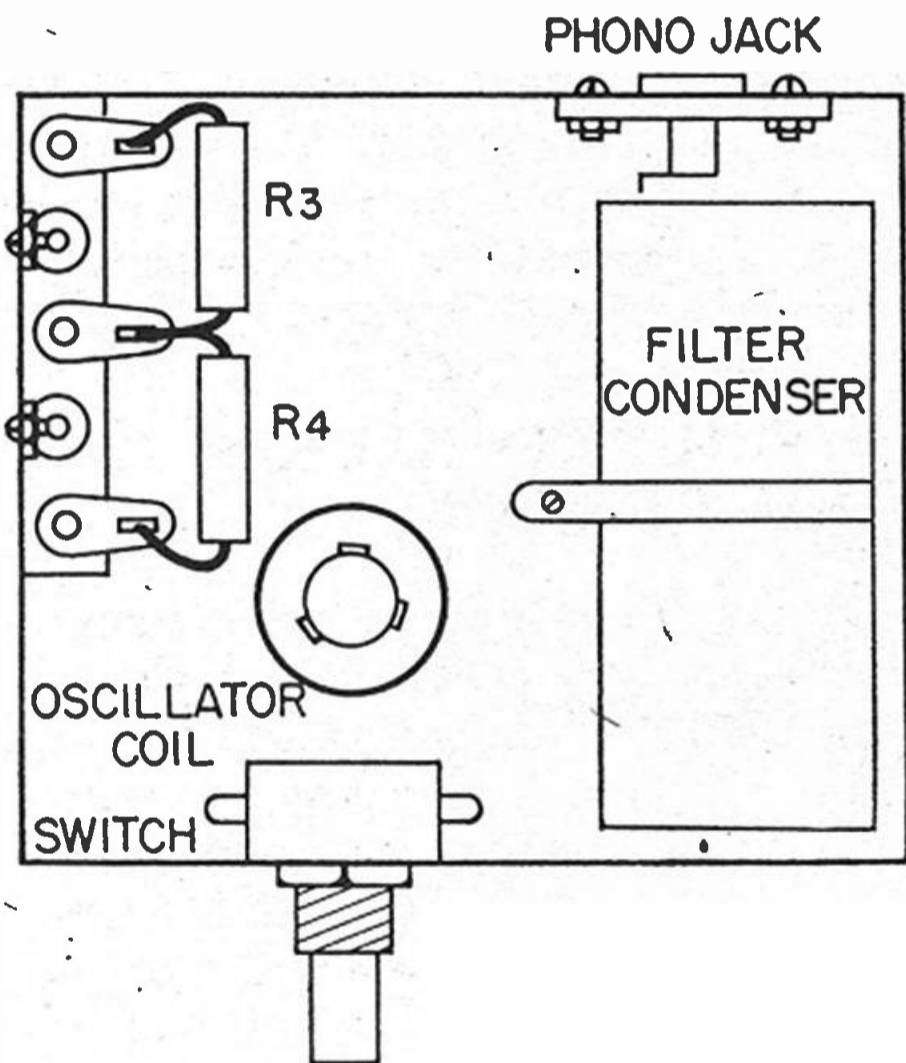

Fig. 4-8B. Underside view of chassis.

side of the tube socket is not visible in this drawing, it is covered by the filter condenser. A separate drawing, Figure 4-9, shows the 12BA6 socket terminal arrangement. Unless you are in an area served by one of the larger radio supply houses, you may have trouble getting just the right type of oscillator coil. But you can use the ordinary single-winding oscillator coil used in superheterodyne receivers by connecting the required capacitance in parallel with it. If you make this

substitution, refer to Figure 4-10 for the connection diagram. The shunt capacitance consists of a 400-mmfd. mica condenser in parallel with a 9-180-mmfd. trimmer. With this arrangement it is possible to shift the operating frequency of the oscillator over a wide portion of the broadcast range.

The location of the phono jack is shown in the chassis rear view, Figure 4-11. Also shown in this sketch is the hole for the line cord.

Besides the screw holes for the parts illustrated (and the socket center hole), you will have to drill several holes not shown in any of the drawings. They are better and more easily located and drilled after the actual physical dimensions and locations of the parts have been determined. Drill two holes close to the line-cord resistor strip for the two wires that lead up to it. Be sure that all burrs are removed from the edges of these holes, as the wires running through them are connected directly to the power line. One more hole for a wire must be drilled close to the selenium rectifier. The same precautions apply here.

Wiring

The circuit diagram is quite simple and few instructions are necessary. Connect R3, R4, and R6 to their respective tie strips before starting the wiring. As the wiring progresses, you will find it necessary to remove the filter condenser, C2, in order to make connections to the tube socket. It is better either to allow ample lead length on that condenser or to connect

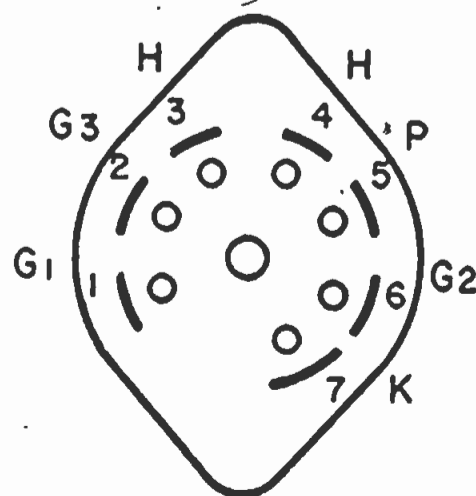

Fig. 4-9. Tube socket arrangement.

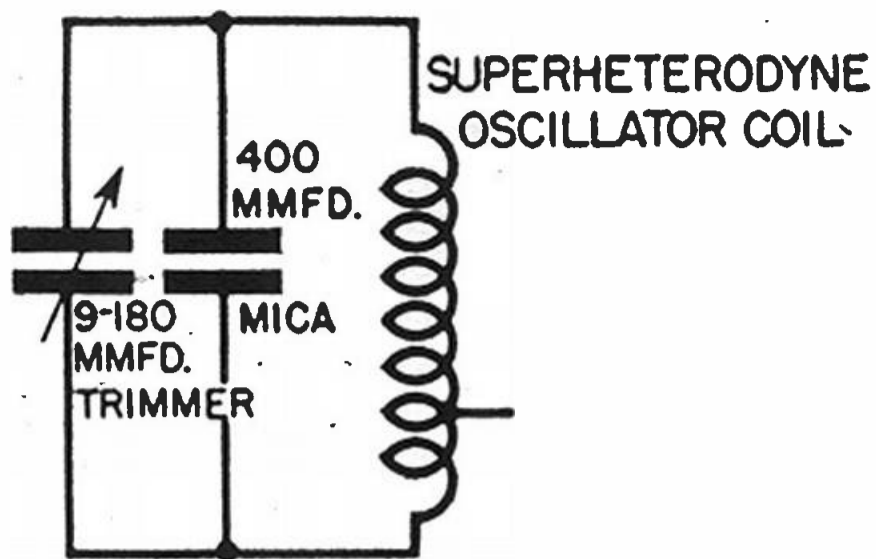

Fig. 4-10. Oscillator coil junction.

it in the circuit after the tube-socket wiring is finished. Be very careful in bringing line-cord wires through the chassis to the line resistor and selenium rectifier. Any burr or sharp edge on the holes through which the wires pass may result in a ground and the blowing of a fuse. Also note that one of these wires (from line resistor to selenium rectifier) may be run above the chassis.

Testing

You may find that, with the oscil-

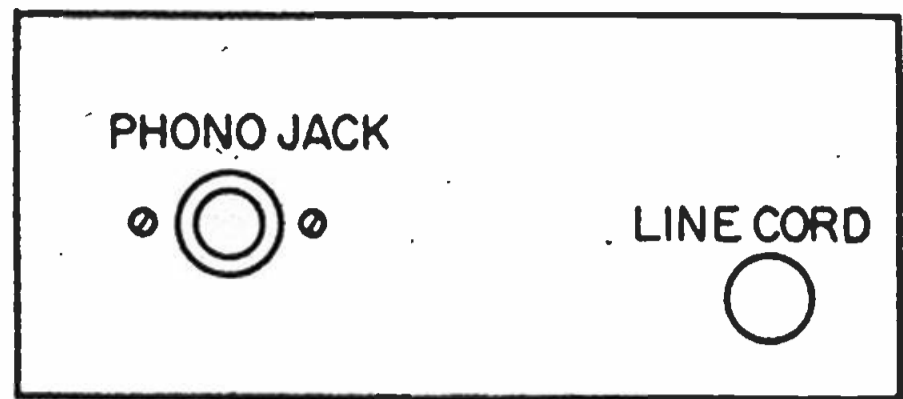

Fig. 4-11. Rear view of chassis.

lator close to the radio receiver, signals are strong enough. If they are not, connect a short length of wire to the free end of C5. With the phonograph in operation and the oscillator tube warmed up, tune the radio receiver until you hear the signals. If you are using an oscillator coil with an adjustable tuning capacitor, tune the set to a spot on the dial where no broadcast signals are heard, then adjust the oscillator trimmer until the oscillator signals are as loud as possible. If the signals do not seem strong enough, try shifting the frequency; the sensitivity of any radio set varies considerably over the entire range.

INSTALLING THE PHONO OSCILLATOR IN A TABLE-MODEL RECORD PLAYER

The cabinets of many table-model record players are large enough to permit the installation of a phonograph oscillator or a small amplifier within the cabinet, thus resulting in a compact, portable unit. If, after careful measurement, you find that your

record-player cabinet is large enough, the installation can be made with very little trouble. The probable position of the oscillator is shown by the dotted lines in Figure 4-12. In manual players there will most likely be ample area, and the principal consideration will

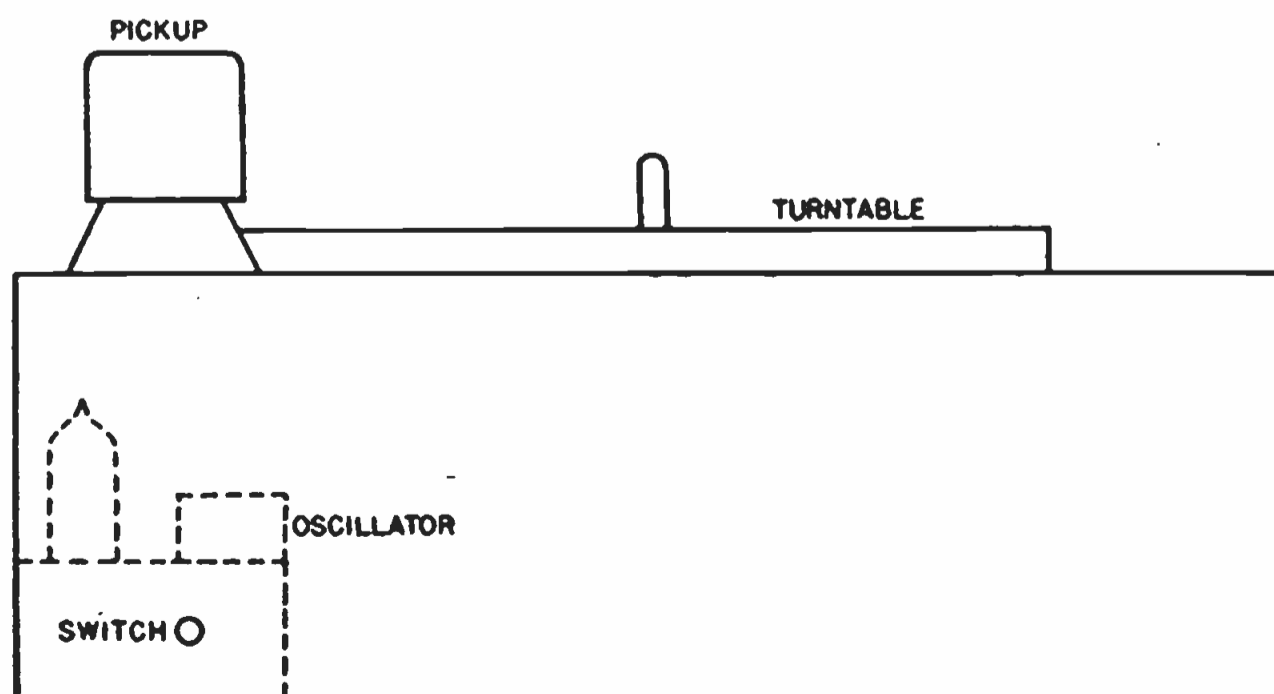

Fig. 4-12. Location of phono oscillator in record player.

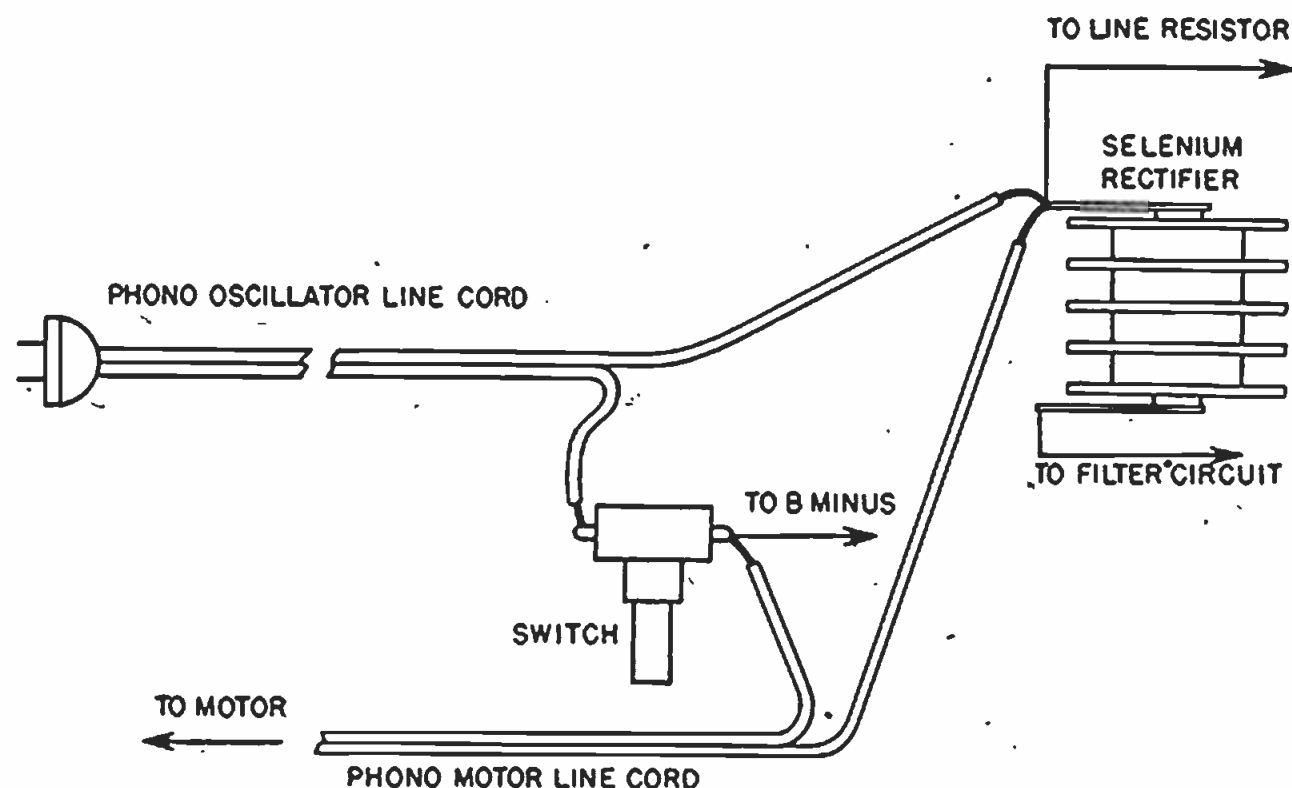

Fig. 4-13A. Connecting phono motor directly to oscillator.

then be the height of the cabinet. Including the tube, the oscillator unit will require a height of something over three inches. It is doubtful whether any of the current models of automatic-changer cabinets will be large enough to take this unit.

Often the bottom of the cabinet is open, and it is necessary to fasten the chassis to the inside wall of the cabinet with two or more screws and nuts. Countersunk-head screws are recommended. If the construction of the player permits you to do so, fasten the oscillator to the rear of the cabinet so that the screws do not show. Of

course, the switch shaft must pass through a hole in the cabinet and this location will put the switch at the rear—not a serious drawback. Drill the holes in the chassis for the supporting screws first. Then, by measurement, determine the position of the hole for the switch shaft and drill that. Hold the oscillator unit in position, slip the screws through the cabinet and the chassis, and then screw the nuts on. It will probably be impossible to use a nut driver; hold the nut with a pair of pliers as you tighten the screw.

One or two electrical connections

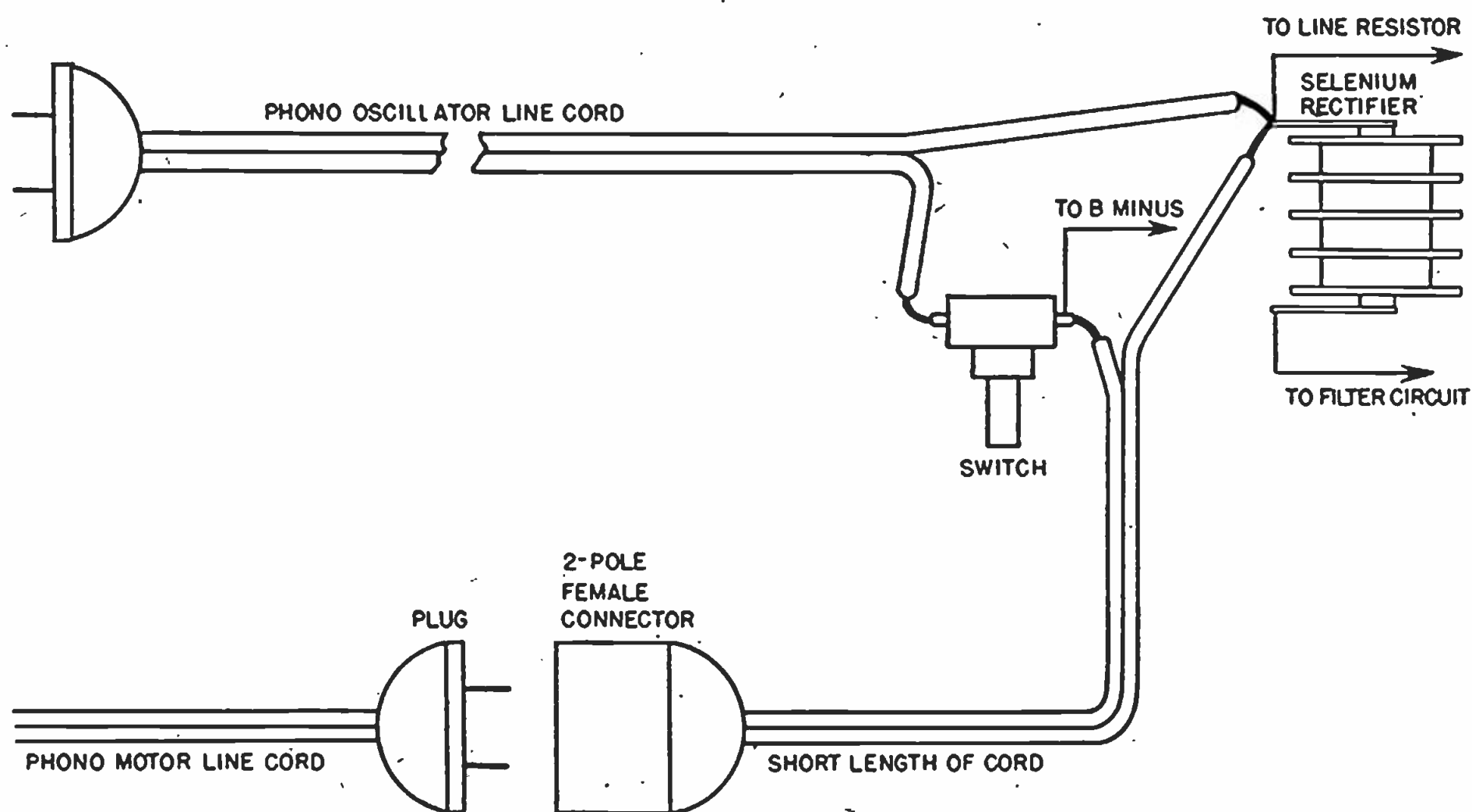

Fig. 4-13B. Connecting phono motor to oscillator using female connector.

are needed to make a finished unit of this project. The pickup must be connected to the amplifier, of course, and it is desirable for one switch to control both phono motor and oscillator. There are two ways to do this. The first method is to connect the record-player line cord directly to the oscillator, as shown in Figure 4-13A. This is the simpler method and no parts are needed, but it has the disadvantage that if it becomes necessary to remove the oscillator unit at any time, the connections must be unsoldered. A much better way to do the job is illustrated in Figure 4-13B. You will need

a two-pole female connector. This is made in two parts and can be separated for making connections by removing two screws. Connect a short length of rubber-covered line cord to the connector; usually, a foot or so will be enough. Referring to the wiring diagram, note that one wire is connected to the line terminal of the selenium rectifier and the other runs to the terminal of the on-off switch farthest from the line. When the record-player line plug is inserted in the connector, the on-off switch will operate both motor and oscillator.

ASSEMBLING A RECORD PLAYER

A simple manual record player may consist of only two main parts—motor and pickup—and as a rule these parts can be purchased separately and assembled at a cost far less than that of a commercially-built player. The lowest-priced motors run from three to four dollars, and a fair pickup can be bought for about the same; this contrasts favorably with even the most inexpensive player. On the other hand, if you want something more deluxe, you can buy a first-rate motor and pickup for less than the cost of an excellent player and, unless you insist upon frills, the cost of the home-made cabinet will be very little.

The first step in assembling a record player is to select the motor and the pickup. When we mention motor, we consider it to include the turntable, which comes with the motor. Motors fall into two broad classifications: governor-controlled and rim-driven. The first is the more expensive but in most cases will maintain a more constant speed. The motor (which may be the same as used in the rim drive) drives the turntable through a worm-and-gear arrangement; speed is controlled by a centrifugal governor. The motor proper may be the same for the rim-drive type, but in this case the motor shaft has a roller of brass or

bronze. This roller bears against a rubber drive-wheel, which rides on the inner flange of the turntable. The main weakness of the rim-drive is that wear of the rubber tire decreases the speed of the turntable. And if the rubber drive-wheel is allowed to rest against the turntable rim for a long inactive period, it is likely to develop a flat spot, which may show up in the music as a "wow," or periodic increase and decrease in pitch. All things considered, however, the rim-drive motor is a rugged, fairly reliable device and is widely used in manual players and automatic changers.

The motor

Three styles of rim-drive motor are presently available: single-speed, for 78 r.p.m. records only; two-speed for 78 and 33-1/3 r.p.m.; and three-speed for 33-1/3, 45, and 78 r.p.m. Which style you choose depends, of course, upon your present record collection and what you intend to buy in the future. You will remember, of course, that one type of pickup is used for 78 r.p.m. records only, while another is needed for playing the 45 and 33-1/3 records.

The pickup

Pickups range in price from three

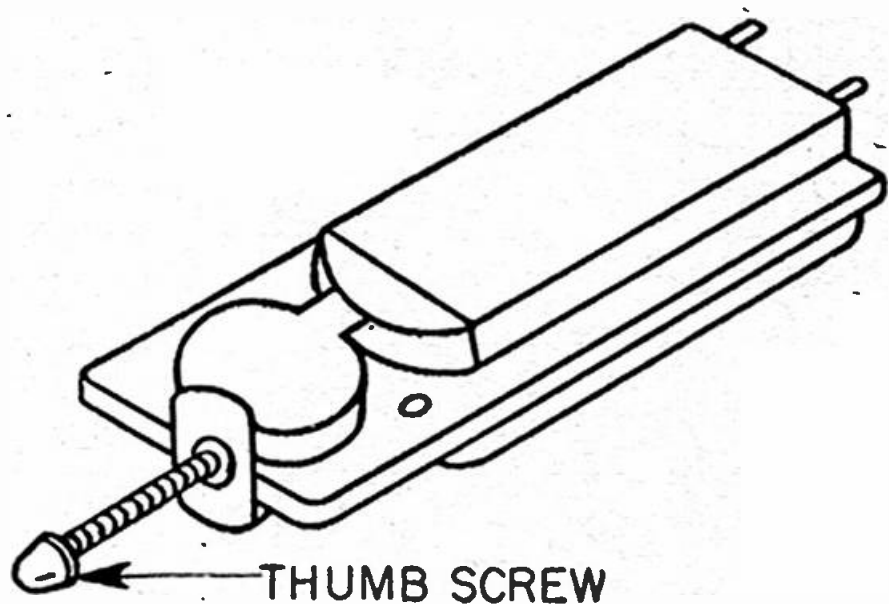

Fig. 4-14. Thumb-screw cartridge.

dollars upward. At first glance there seems to be little difference in their construction. But when we examine them more closely, we find that there are reasons for the difference in price. The cheapest pickups are usually sold without a stylus, or needle; the cartridge usually has a thumb-screw (see Figure 4-14) for holding either the ordinary variety of steel needle or a more expensive "semi-permanent" type that may be used for playing many records. Most of these operate at a fairly heavy stylus pressure—two to three ounces. Next in the price range is the pickup equipped with a "precious" metal stylus capable of playing several thousand records. These pickups are designed for much lighter pressure, usually from one to one-and-a-half ounces. The stylus tip is made of a hard metal, such as osmium, and since replacement is necessary only at infrequent intervals, the stylus-retaining screw generally has a slotted head, as in Figure 4-15, or a recessed head (Allen type). Most expensive of all is the pickup with cartridge equipped with a jewel stylus, usually diamond or sapphire. Because of their hardness and ability to take a fine polish, such points can be used for very long periods without undue record wear. Furthermore, such pickups are designed for extremely light pressure, usually from seven or eight grams to one ounce. In many cases the stylus cannot be replaced, and, if necessary, the entire cartridge must

be changed. In other cases the stylus can be replaced at reasonable cost.

Stylus and stylus pressure

Type of stylus and stylus pressure, among other things, should be taken into consideration when buying a pickup. The lighter the stylus pressure is to be, the more carefully a pickup must be designed and balanced and—it follows—the higher the price will be. But with lighter pressure, better balance, and accurate tracking, it also follows that far less record wear will occur.

Pickup cartridges intended for use with the several different kinds of records (78, 45, and 33-1/3 r.p.m.) must be equipped with two needles. One, having a tip radius of .003 inch, is used for 78 r.p.m. records; the other, with a tip radius of .001 inch, for both 45 and 33-1/3 r.p.m. Two needles are needed because the grooves in the 45 and 33-1/3 records are narrower than in the 78 r.p.m. Any attempt to interchange needles or cartridges will surely result in damage to the record. In players and automatic changers designed for all three types of record, the change-over can be handled in any one of three different ways: a) by using two separate pickups; b) by using a "turn-over" type of cartridge with a stylus at either side; and c) by using a reversible stylus. If your record collection includes 45 and 33-1/3 r.p.m. records and you want to build a manual player at the lowest cost,

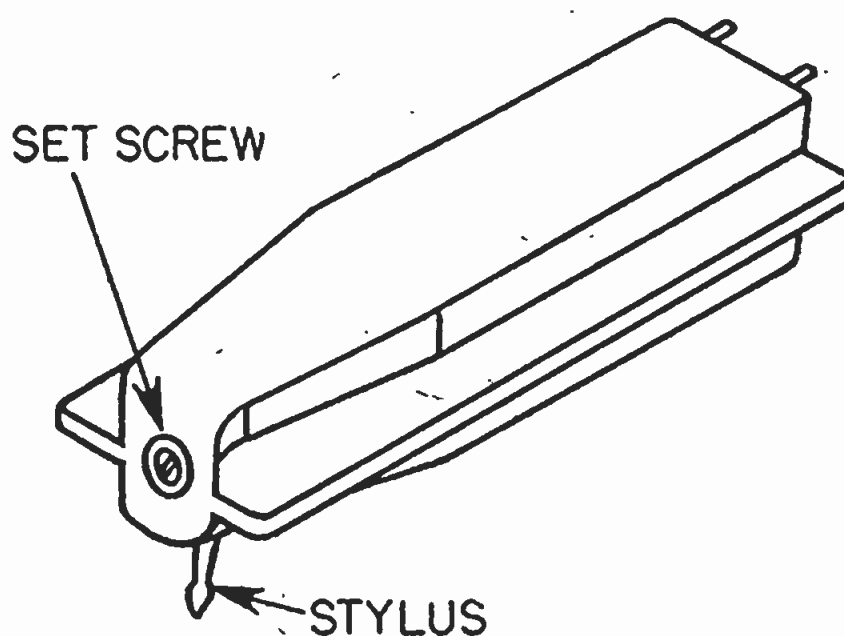

Fig. 4-15. Set-screw type cartridge.

you should be able to buy a three-speed motor for under ten dollars and a pickup equipped with a turn-over cartridge for perhaps seven to eight dollars. (These prices are the lowest to be expected and can be obtained only in large cities through large radio supply houses.)

Constructing the cabinet

When building a manual player, the procedure is the same whether it is designed for single speed or for two or three speeds. There is practically no difference in the proportions of the pickup and very little in the size of the motor.

When you have the pickup and

glue should be used as well. If screws are used, the flat-head type are preferable. If you use nails, set the heads slightly below the surface of the wood with a nail set or a slender punch. Six small wood screws (about $\frac{3}{4}$ inch, number 6) will fasten the top to the sides. Do not use glue on the joints between top and sides as you may want to remove the top at some future time. When the box is completed, sand it well and apply a coat of shellac. Follow with two or more coats of enamel in the desired shade. The finished box is shown in Figure 4-16.

If you prefer a cabinet in a natural wood finish such as walnut or mahogany, the material and the method

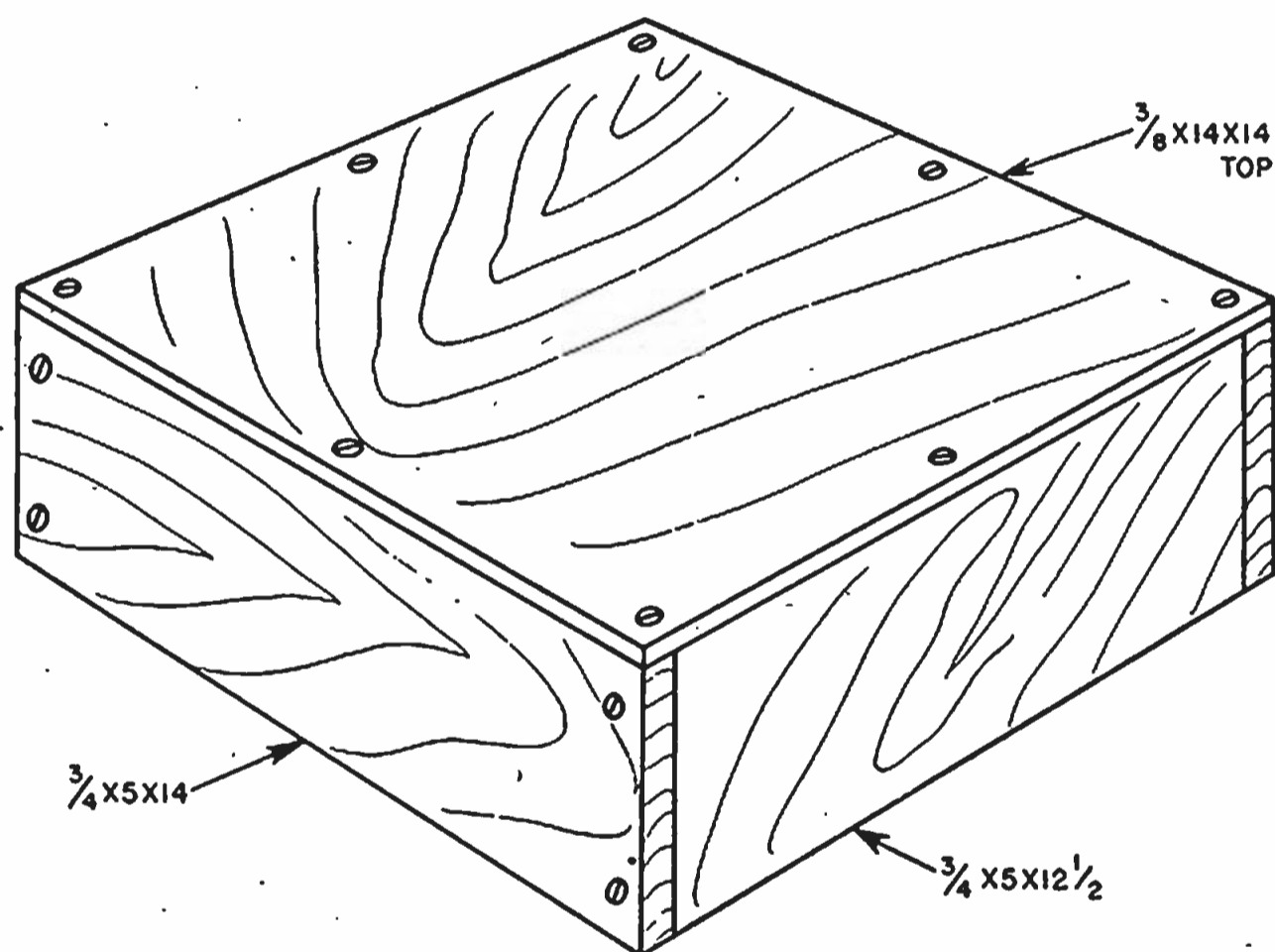

Fig. 4-16. Record player cabinet.

motor, the next step is to construct the cabinet. If it is to be painted, white pine lumber or common plywood will be suitable. You will need about five linear feet of $\frac{3}{4}$ by 5 inch stock for the sides. For the top, or motor board, you will need a piece of $\frac{3}{8}$ -inch plywood, 14 inches square. Cut four pieces from the $\frac{3}{4}$ -inch stock, two 14 inches long and two $12\frac{1}{2}$ inches long. Butt joint the ends of these pieces to form an open box 14 inches square. Either finishing nails or screws may be used for fastening, but in either case

of construction will be somewhat different. For the sides and top, buy plywood that is veneered on one side in the desired wood. For the sides use $\frac{3}{4}$ -inch plywood, and for the top use $\frac{3}{8}$ -inch.

When building a cabinet in natural wood finish, the end grain of the side and end pieces will be unsightly unless the cabinet is built to conceal it. There are many ways of doing this. Figure 4-17 illustrates one method, in which the ends of the pieces are mitered and held together with glue

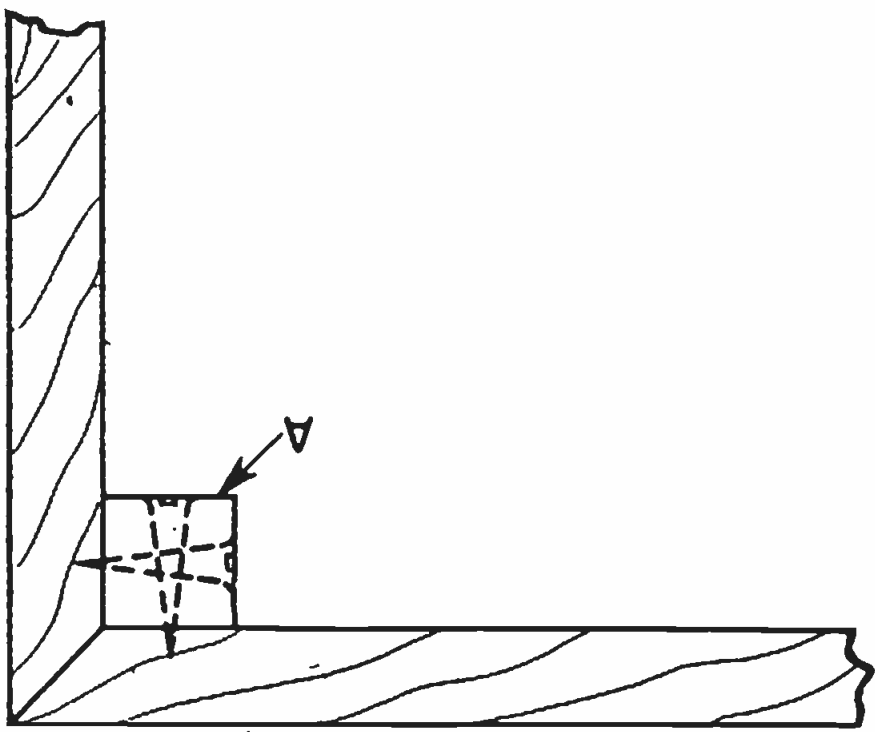

Fig. 4-17. Joining corners (method 1).

and wood screws. The corner block, *A* in the sketch, affords considerable reinforcement. If this joint is used, no end grain at all will be visible, but some skill is needed to make a good miter joint.

An alternative method is shown in Figure 4-18. Here a little of the end grain shows but not enough to be unsightly. For a cabinet of the size suggested, the corner blocks should be a full five inches long and about an inch square. Use #8 or #10 wood screws 1-1/4 inches long. Two screws driven into each side piece (total of four for each corner of the cabinet) will suffice.

When the glue has hardened, you are ready to finish the cabinet. Finish the top at the same time as the sides, and do all finishing work on the top before cutting the opening for the motor. Steps in finishing are: 1) Sand with 4-0 sandpaper. 2) Stain as de-

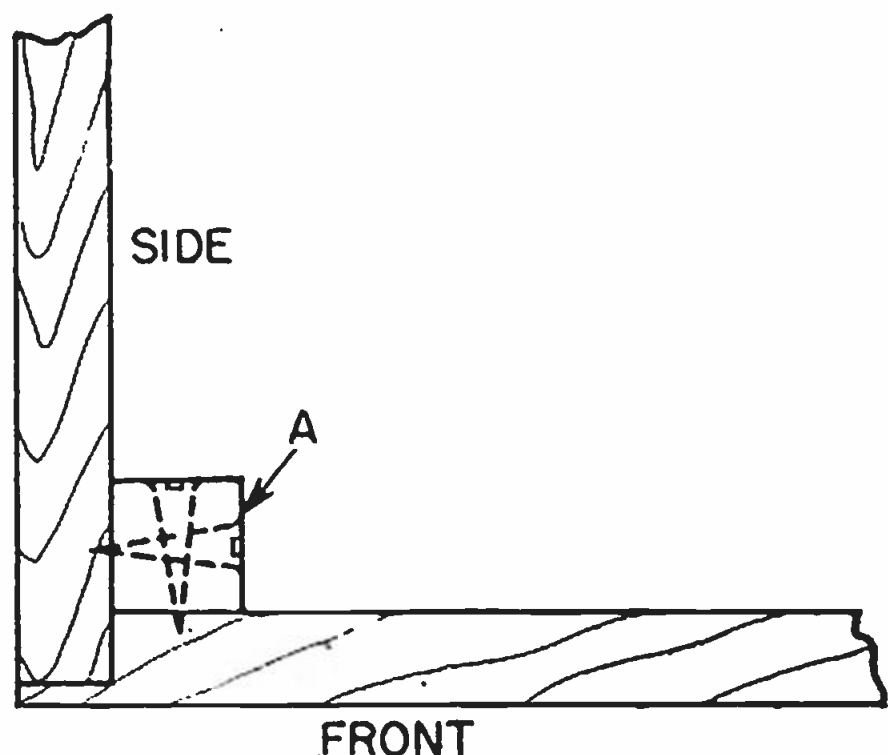

Fig. 4-18. Joining corners (method 2).

sired. 3) For a close-grained finish, apply a coat of wood filler. If an "open-grain" finish will be satisfactory, the filler may be omitted. 4) Apply a thin coat of shellac; when dry, rub to dullness with 6-0 garnet finishing paper. If you prefer a dull finish, apply a second coat of shellac, sand, then apply a coat of paste wax and rub. 5) For a high finish, follow the first coat of shellac with two coats of rubbing varnish (or lacquer, if you prefer), rubbing each coat with 6-0 garnet paper. Rub final coat with very fine pumice powder and water.

Assembly

When the cabinet is finished, drill the screw holes for fastening top to sides. You are then ready to cut a hole in the top for the motor. The motor itself is suspended from a motor plate, which also carries the turntable drive wheel and the center pin. An opening must be cut in the top of the cabinet to admit the motor; then the motor plate is fastened in place with several small wood screws. The cutting of this opening is simplified if you have the instruction sheet that comes with a new motor. The instructions almost always include a template for cutting the motor opening.

Place a sheet of carbon paper face down on the cabinet top. Place the template over the carbon so the mark indicating the record center pin is at the center of the cabinet top. Then, with a fairly hard pencil, trace the lines marking the area to be cut out. Drill several starting holes to admit the saw, then cut with a coping saw or narrow compass blade.

Lacking the original template, you will have to make your own. Cut a piece of cardboard to the same size and shape as the motor plate. Mark the approximate position and area of the cut-out on the cardboard, and cut a small hole. Slip the template over the motor and try it for size. If the cut-out area is too small, trim a bit

until the motor will just fit inside it. Mark the position of the turntable center pin on the cardboard template; then place template in position on the cabinet top and mark the outlines of the cut-out area with a pencil. Cut the wood as described before.

Place the motor in position and fasten to the motor board, or cabinet top, with wood screws. Hold the turntable with both hands and allow the center hole to drop over the record center pin. With one finger, push the rubber drive-wheel inward and, at the same time, lower the turntable until

nearly touches the record center pin. Keep the stylus end in that position, while you swing the support end around until it is in proper position, well clear of the turntable. Be sure that there is slightly more than a 1-1/2-inch clearance between the edge of the turntable and the inner side of the pickup support. If you do not allow this clearance (for a 9-inch turntable) you will be unable to play 12-inch records. If the turntable happens to be 10 inches in diameter, allow slightly more than an inch clearance. When you have located the best posi-

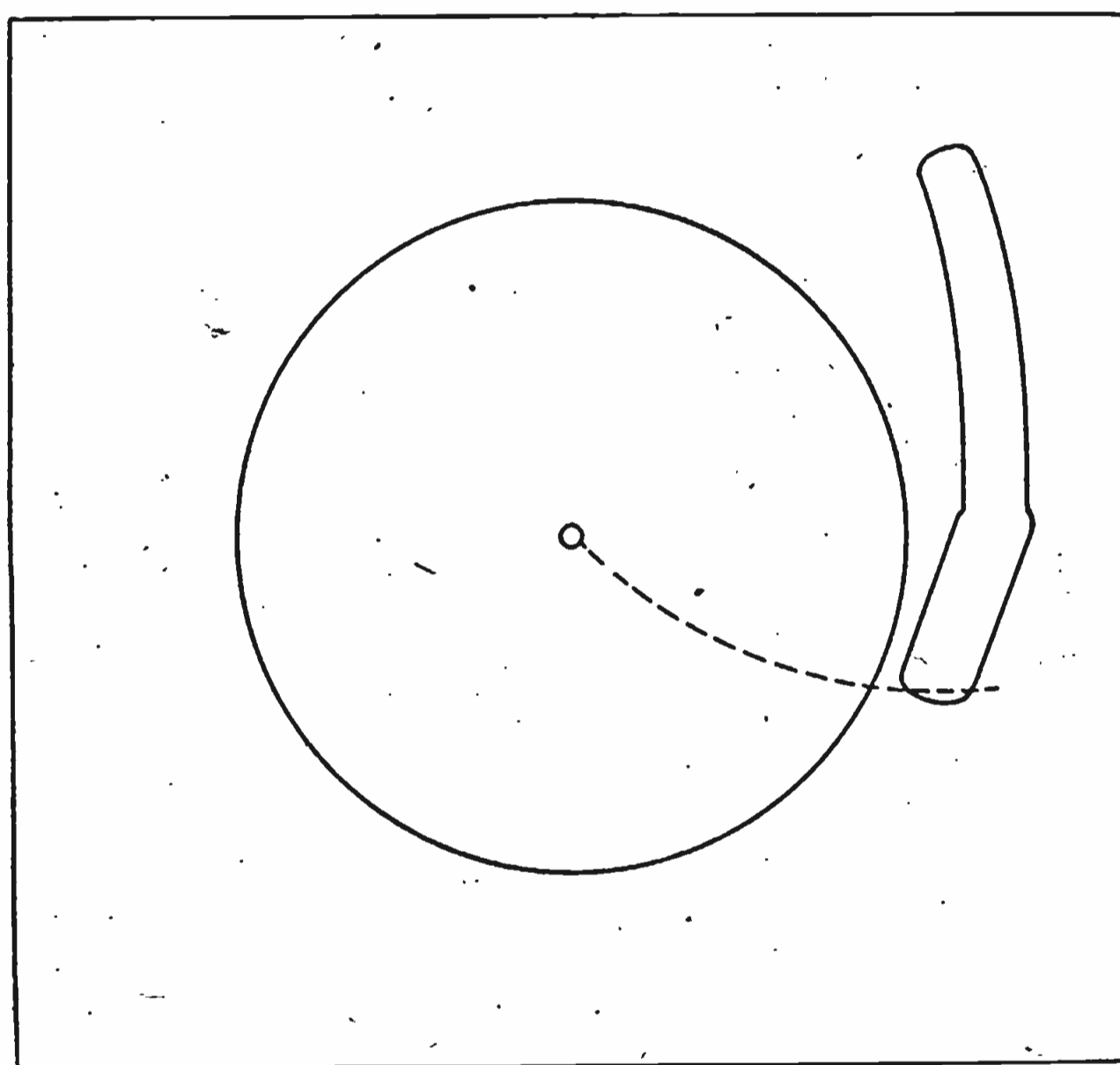

Fig. 4-19. Locating the phono pickup.

the edge of the drive wheel rests against the inner rim of the turntable.

The next step is to locate and fasten the pickup in position. Figure 4-19 shows the position of the ordinary curved-arm pickup. Notice that the stylus in moving inward will describe an arc that crosses the center of the record.

Place the carbon paper face down over the corner of the cabinet top to be occupied by the pickup swivel support. Hold the pickup in both hands and lower it until the stylus point

tion for the pickup support, press the pickup down so it marks through the carbon paper. When the carbon is removed, locate the center of the mark you have made and drill; the diameter of the hole will be, in most cases, from 5/8- to 3/4-inch. When fastening the pickup in position, use both plain and lockwashers on the underside of the motor board. Before tightening the locknut securely, check the pickup side travel to be sure it will swing from the rest position to the center of the turntable. Most pickups are fur-

nished with a rest, which you can now fasten to the cabinet top.

The job is completed by installing

the phono oscillator and connecting the motor and oscillator as described earlier in this chapter.

INSTALLING AN AMPLIFIER IN A RECORD PLAYER

The record player just described may be used in connection with the one-tube amplifier at the beginning of this chapter. If you want to make the cabinet large enough, you may prefer to build and install the three-tube amplifier described later on. In any case, the principal requirement is space for the amplifier.

The steps to be followed in installing any amplifier in a record player cabinet are as follows:

1. Determine position of the amplifier in the cabinet.
2. Drill holes for the volume-control and tone-control shafts.
3. Cut an opening in the cabinet for the speaker.
4. Cover the speaker opening with grille cloth, or other suitable decorative covering.
5. Install the amplifier.
6. Connect the phono pickup and motor to the amplifier.

The first and second steps listed have already been described in this chapter; they differ in no way from the procedure followed in installing the phono oscillator. If you are installing the one-tube amplifier, one or two changes will have to be made. This amplifier was made as small as possible and therefore the volume control and the speaker were mounted at opposite ends of the chassis. Before installation in a cabinet can be made, one of these parts must be relocated. Perhaps the easier way is to remove the speaker from the chassis and fasten it to the inner wall of the cabinet in back of the opening; two wires connect the speaker to the chassis. The volume control can also be moved and relocated directly on the cabinet wall, but then you will have to use five

connecting wires between control and chassis.

The speaker opening

To lay out and cut the speaker opening, first determine where the center of the speaker cone will be in relation to the side (or end) of the cabinet. When you have marked this point, measure the diameter of the speaker cone. From this measurement deduct 1/2 inch for a 3-inch speaker, 5/8 inch for a 4-inch speaker, or 3/4 inch for a 5-inch speaker. Suppose, for example, you have a 5-inch speaker and find that the actual diameter of the cone is 4-1/4 inches. After deducting 3/4 inch, you have 3-1/2 inches as the size of the opening to be made. There will be some variations in the size of the opening, since all 5-inch speakers, for example, do not use cones of the same diameter. With a pair of dividers or a pencil compass, scribe a circle on the cabinet wall. Inside the circumference of this circle drill three or four holes large enough to admit a saw blade. If the cabinet has no bottom, you will probably be able to use a coping saw. If the bottom is enclosed, you will have to use a small compass saw blade. In any case, cut as closely to the scribed circle as you can.

When the circle has been cut out, smooth the circumference with a rasp and a single-cut file. Final smoothing can be done with one or two grades of sandpaper. For a really neat job, you will want to color the wood to match or to contrast with the finish of the cabinet. You will find it much easier to apply a contrasting finish. This is readily done by applying several coats of colored shellac.

Colored shellac is made with ordi-

nary white shellac as a base. Start with a fairly thin mixture. Add to it enough dry spirit-soluble powder stain to give the desired shade. For a walnut cabinet, Vandyke brown will give a good contrast. On mahogany, use Vandyke brown mixed with some red. The exact proportions are unimportant as long as the final product is several shades darker than the cabinet finish. Of course, if the cabinet is to be painted, it is only necessary to finish the inside edge of the opening in the same color.

The next step is to cover the speaker opening with grille cloth. It is possible to simply stretch the cloth over the inside, but this is a little difficult to do. A much better way is to cut a cardboard mask an inch or so larger each way than the opening. In the center of the mask cut a round opening to match the one in the cabinet. Cut the grille cloth a little larger all around than the mask. Apply a little cement (household cement will do) to the front surface of the cardboard mask, but be sure that the cemented areas will not be visible through the opening in the cabinet. Stretch the cloth over the mask and apply weights to it until dry. You now have a neat grille that is easy to put in place; it is only necessary to fasten the cloth and mask to the inside of the cabinet with several very small carpet tacks. Figure 4-20 shows how to install the grille cloth and mask.

When installing the amplifier in the

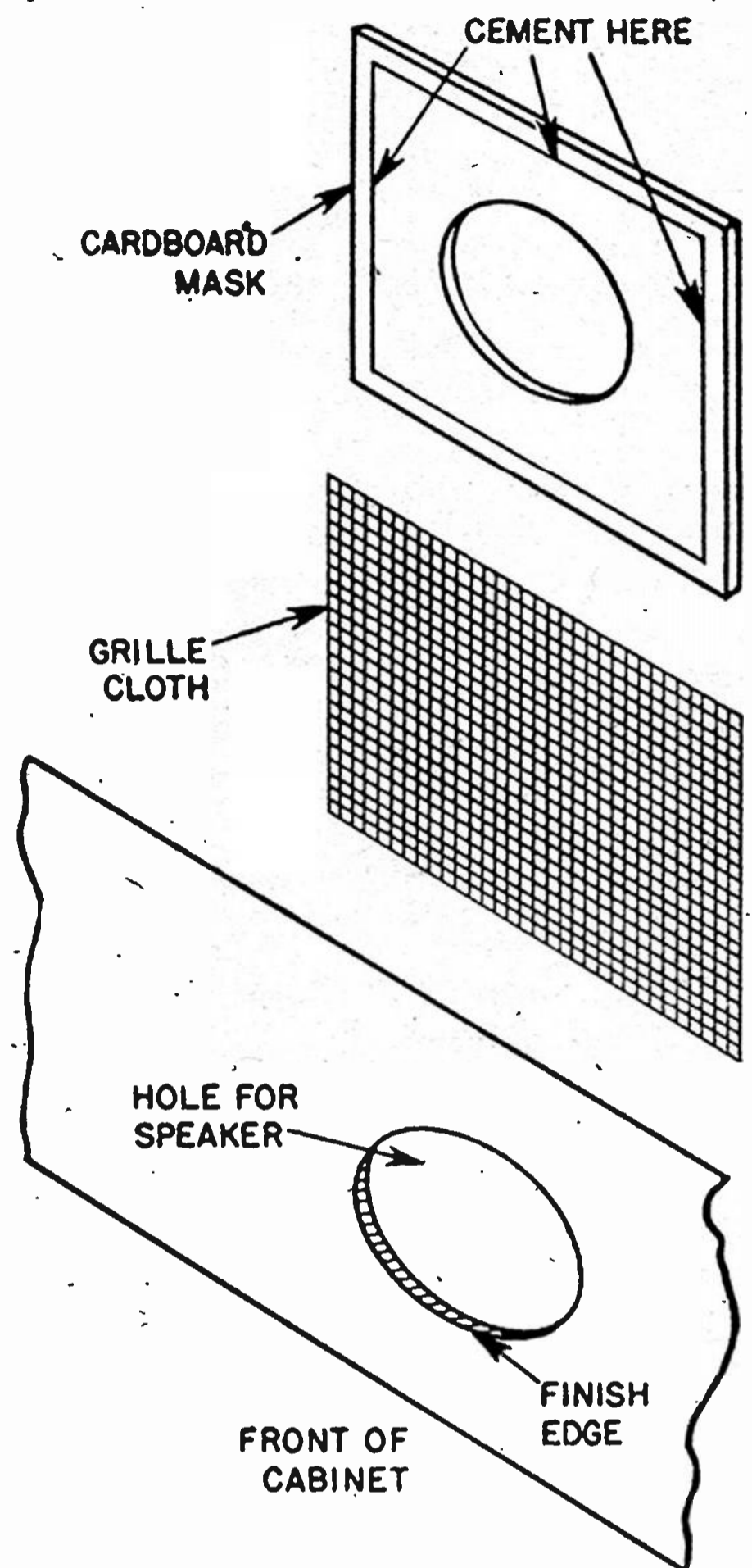

Fig. 4-20. Speaker grille assembly.

cabinet, refer to the instructions given under the phono oscillator. For diagrams showing how to connect the phono motor to the amplifier, refer to Figures 4-13A. and 4-13B.

THREE-TUBE AC/DC AMPLIFIER

This three-tube amplifier using miniature tubes features tone control and a choke-condenser power-supply filter. It is small enough to fit into the suitcase type of portable phonograph.

Circuit description

See Figure 4-21.

A 12AT6 duo-diode-triode tube is used as the voltage amplifier. As the

diode plates are not needed, they are tied together and connected to chassis. A 50C5 tube drives the speaker. Although a 5-inch p.m. speaker is specified in the parts list, a speaker of any diameter may be substituted, but a larger size cannot be mounted on the chassis. An electrodynamic type of speaker may also be used, provided that the field-coil resistance is approxi-

mately 500 ohms. In this case, the field coil is connected in place of the filter choke, and the filter choke may be eliminated.

Parts list

Resistors.

- R1 500 K ohm, volume control
- R2 500K ohm, tone control, with switch, SW1
- R3 700 K ohm, 1/2-watt carbon
- R4 1 megohm, 1/2-watt carbon
- R5 5 megohm, 1/2-watt carbon
- R6 270K ohm, 1/2-watt carbon
- R7 500K ohm, 1/2-watt carbon
- R8 150 ohm, 1/2-watt carbon
- R9 15 ohm, 1/2-watt carbon
- R10 120 ohm, 5-watt wire-wound

Transformers

- T1 output transformer, 3000 ohm primary, 3.5 ohm secondary; Stancor type A-3877 or Merit type A-3018

Speaker

- 5-inch PM dynamic, 3.5-ohm voice coil; Jensen P5-X or equivalent

Miscellaneous

- 3 7-pin miniature tube sockets
- RCA-type phono jack
- 6 4-36 x 3/8-inch r.h. machine screws
- 6 4-36 hexagon nuts
- 4 2-point tie strips
- 6-32 x 3/8-inch r.h. machine screws
- 6-32 hexagon nuts

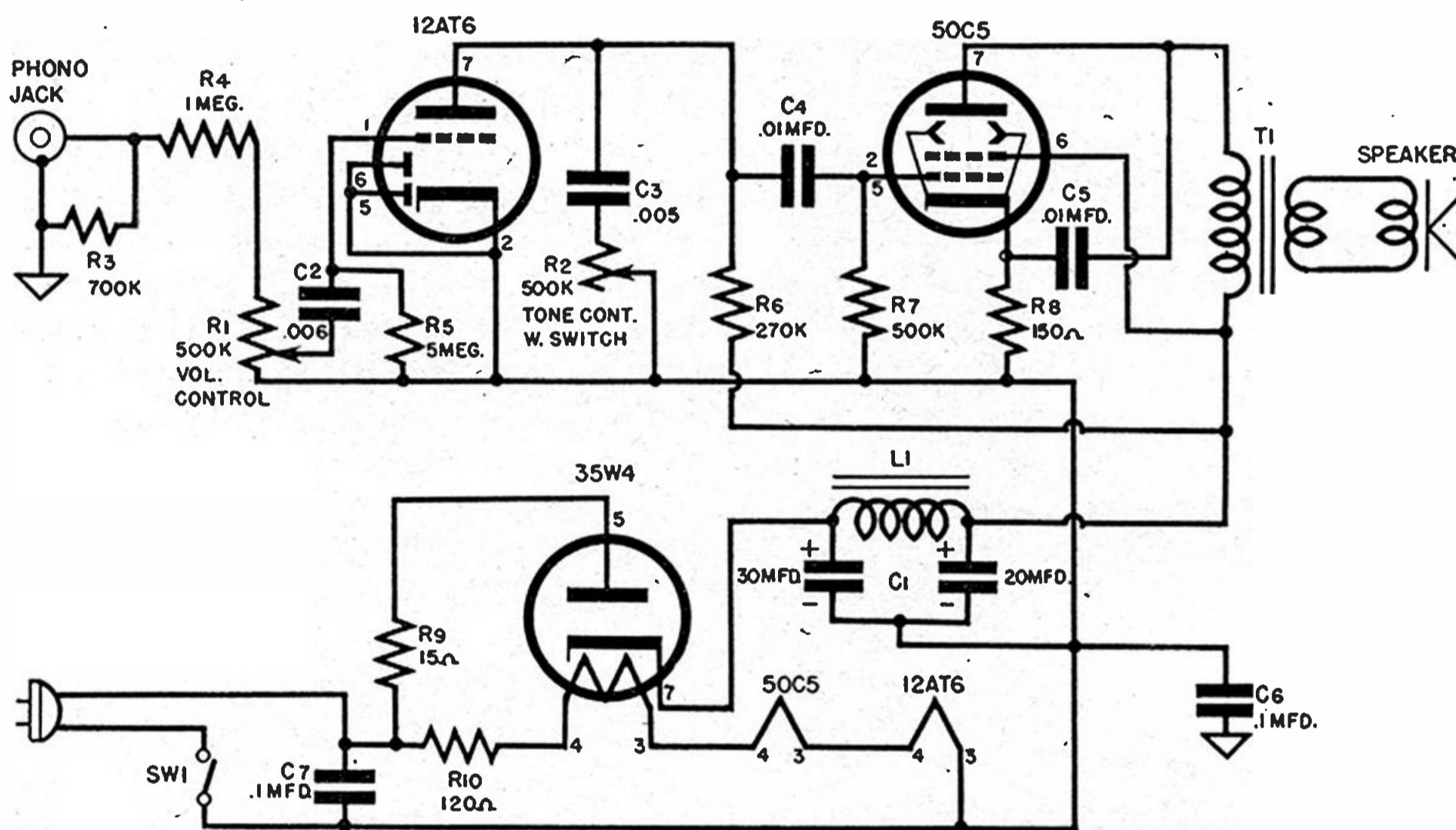

Fig. 4-21. Schematic diagram of a three-tube amplifier.

Condensers.

- C1 30-20 mfd., 150-volt electrolytic (tubular)
- C2 .006 mfd., 400-volt paper tubular
- C3 .005 mfd., 400-volt paper tubular
- C4 .01 mfd., 400-volt paper tubular
- C5 .01 mfd., 400-volt paper tubular
- C6 .1 mfd., 400-volt paper tubular
- C7 .1 mfd., 400-volt paper tubular

Coils

- L1 450-ohm, midset-type filter choke

- Line cord and plug
- Push-back wire
- Rosin-core solder
- Chassis: 4 x 6 x 1-1/2 inches

Tubes

- 12AT6, 50C5, 35W4

Layout and assembly

Figure 4-22 is a top view of the chassis, showing the position of the tube sockets, speaker, output transformer, and volume and tone controls. The filter condenser, filter choke, and

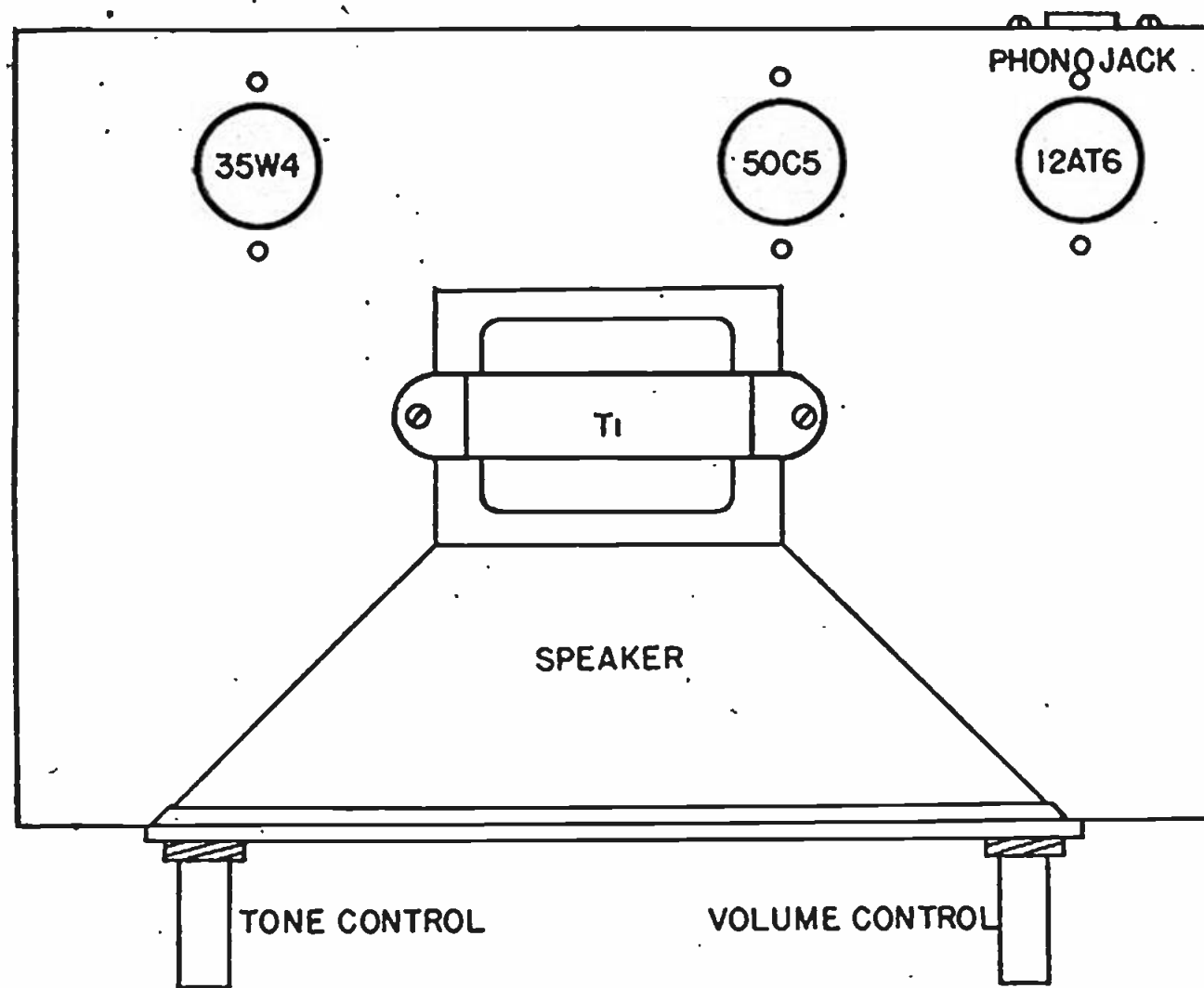

Fig. 4-22. Top view of three-tube chassis.

tube-basing arrangement are clearly shown in Figure 4-23, an underside view of the chassis. When the layout has been completed, drill and punch all holes. Mount parts as shown in the drawings, and you are ready to wire.

Wiring

The wiring of this amplifier differs materially from that used in any other project thus far described. As you will

note from an inspection of Figure 4-21, the chassis is not used as a return connection. This means that all wires that would ordinarily be connected to chassis are connected together and this common B-minus connection is isolated from the chassis. This kind of circuit is often referred to as a "floating chassis." You will notice that only three components are actually connected to chassis: the shell of the

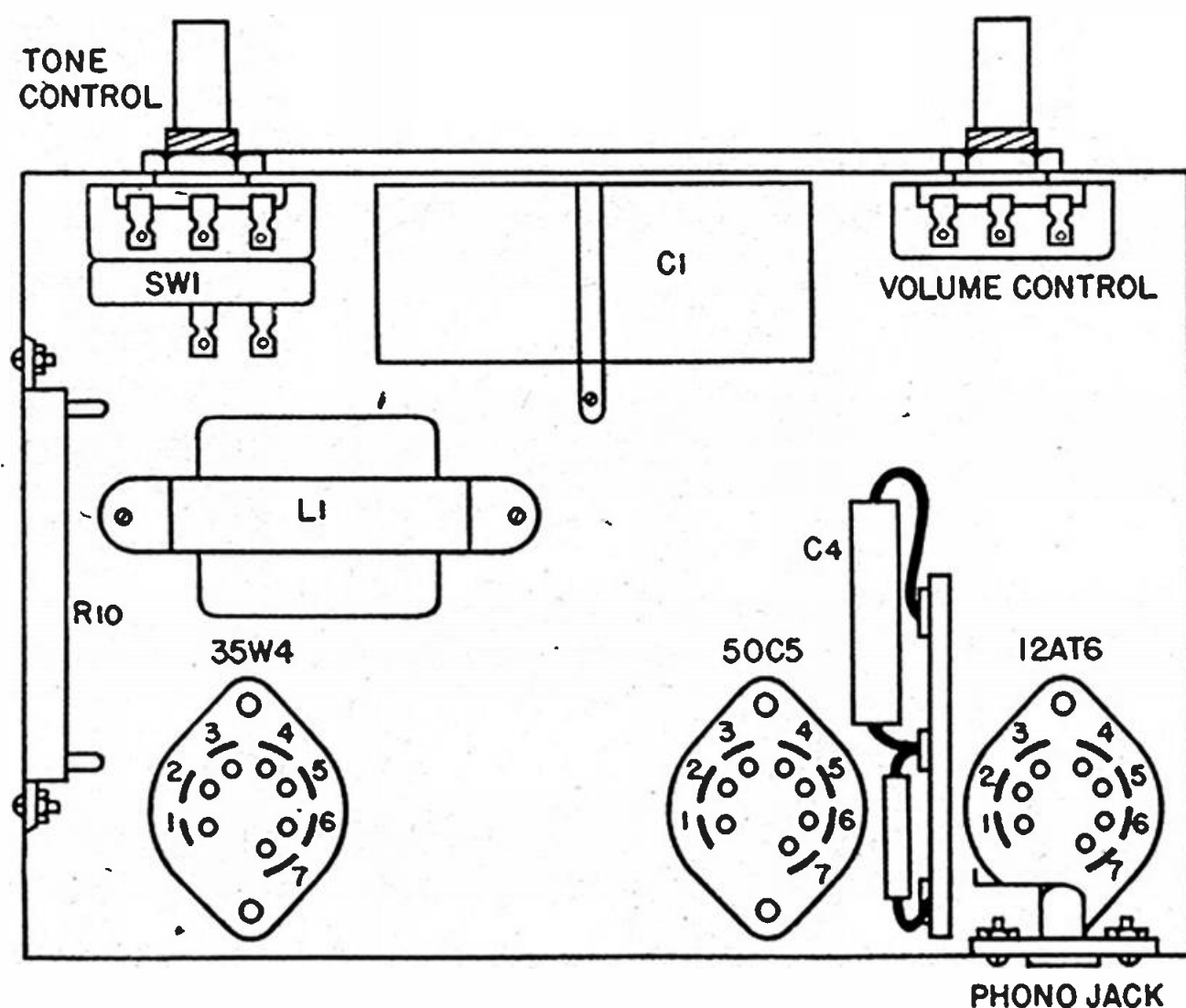

Fig. 4-23. Underside view of three-tube chassis.

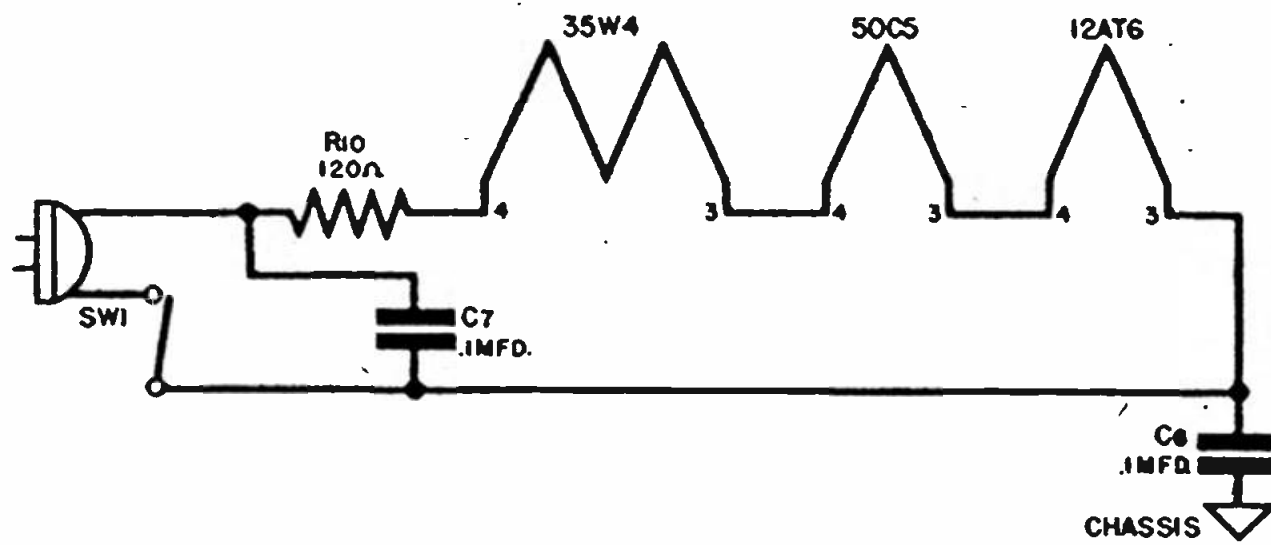

Fig. 4-24. Heater circuit wiring.

phono jack, one end of R3, and one end of C6.

Referring to Figure 4-24, the heater circuit, you will see that, unlike most sets and amplifiers, the switch is not connected to chassis but instead there is a wire connection from it to the #3 terminal of the 12AT6 tube socket. Similarly, in the power supply circuit, Figure 4-25, the negative wire of the filter condenser is connected directly to the switch. Incidentally, this point (as well as the #3 terminal of the 12AT6) is convenient for use as the common negative; all wires that ordinarily would be connected to chassis are connected to it instead.

Heater Circuit: This circuit is shown in Figure 4-24. Be sure to observe the correct wiring order, otherwise there is a possibility of hum. When the heater circuit has been completed, test it by measuring from B minus (not the chassis) to the points listed below, with an AC voltmeter.

<i>Test Point</i>	<i>Voltage</i>
pin 4, 12AT6	12

pin 4, 50C5	62
pin 4, 35W4	97

Wiring the power supply

See Figure 4-25 for a diagram of the power supply circuit. Be sure that the 30-mfd. section of the filter condenser (usually the red lead) is connected to the cathode of the rectifier. The blue (or green) wire is connected to the end of the filter choke farthest from the rectifier.

When the wiring is finished, test the power supply circuit by measuring resistance values as follows:

<i>From</i>	<i>To</i>	<i>Resistance</i>
pin 7, 35W4	B minus	over 50K ohms
plus terminal of 20-mfd. filter condenser		

If either of the readings is much less than 50,000 ohms, check for a shorted filter condenser section or for an accidental ground to B minus at the test points. If the readings are normal,

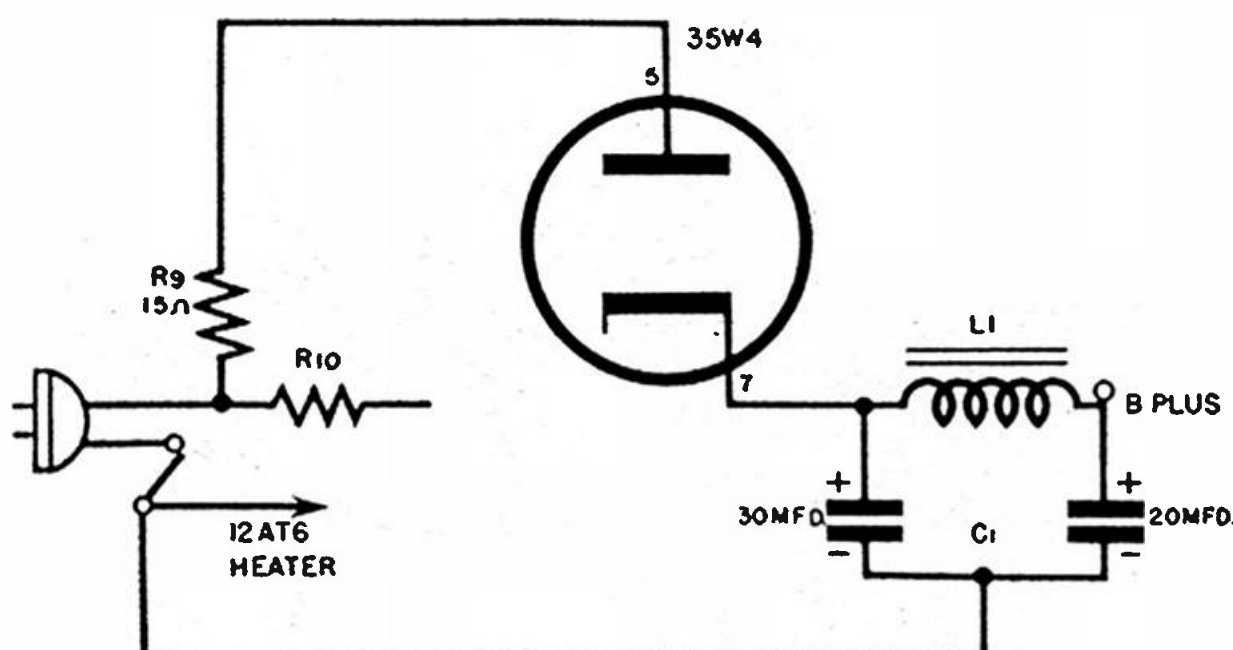

Fig. 4-25. Power supply circuit wiring.

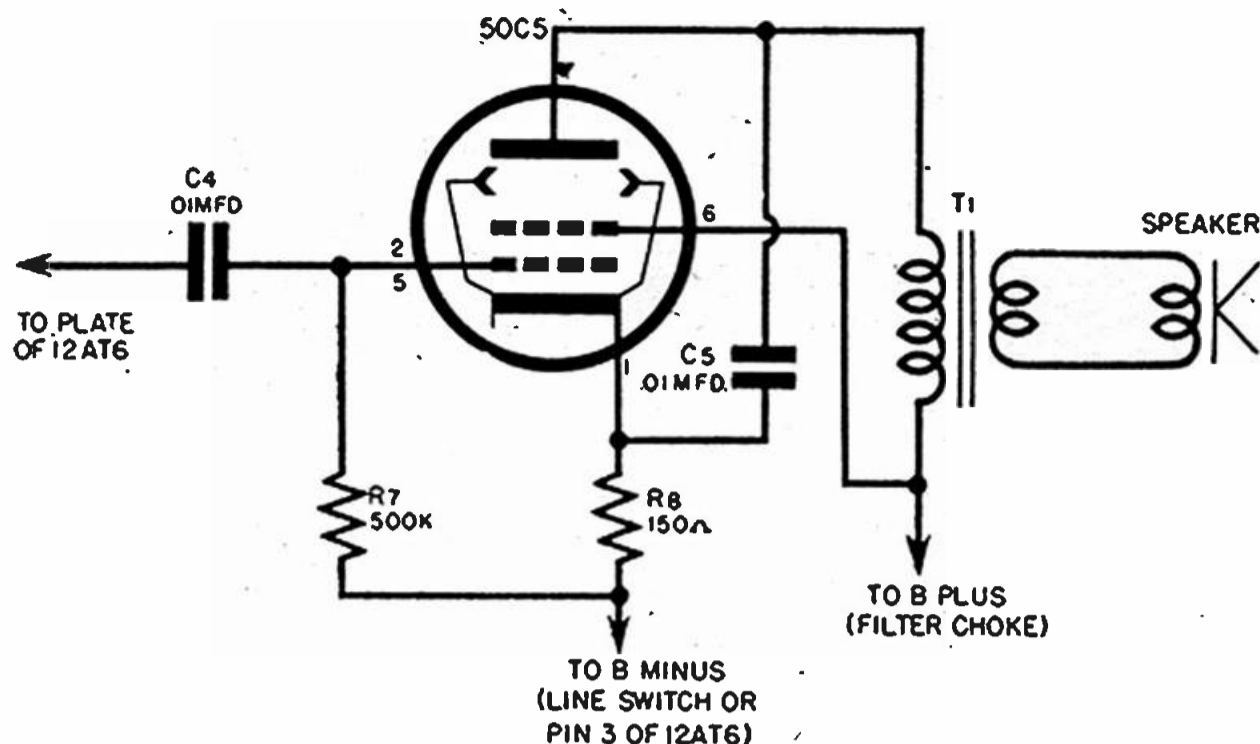

Fig. 4-26. Output circuit wiring.

make a voltage test as follows:

From	To	DC Volts
pin 7, 35W4 positive terminal of 20-mfd. filter condenser	B minus	100-120
	B minus	90-100

Wiring the output circuit

The output circuit is wired according to the diagram of Figure 4-26. Notice that the B-minus ends of R7 and R8 are connected together, then wired to either the line switch or pin 3 of the 12AT6 tube socket. Pin 6 (screen) of the tube socket is connected to the lower end of the output transformer (red wire), then both of these are connected to the B-plus terminal. This terminal is the end of the filter choke farthest from the rectifier-tube cathode.

When the output circuit wiring is complete, make an initial test by measuring resistance values as listed below:

From	To	Resistance
pin 1	B minus	150 ohms
pin 2(or 5)	B minus	500K ohms
pin 7	B minus	over 50K ohms
pin 6	B minus	over 50K ohms

If all resistance values are normal, or near normal, measure voltages and compare with the chart below:

From	To	DC Volts
pin 1	B minus	8-15
pin 7	B minus	90-100
pin 6	B minus	100-120

Voltage amplifier circuit

See Figure 4-27.

In this circuit all the following

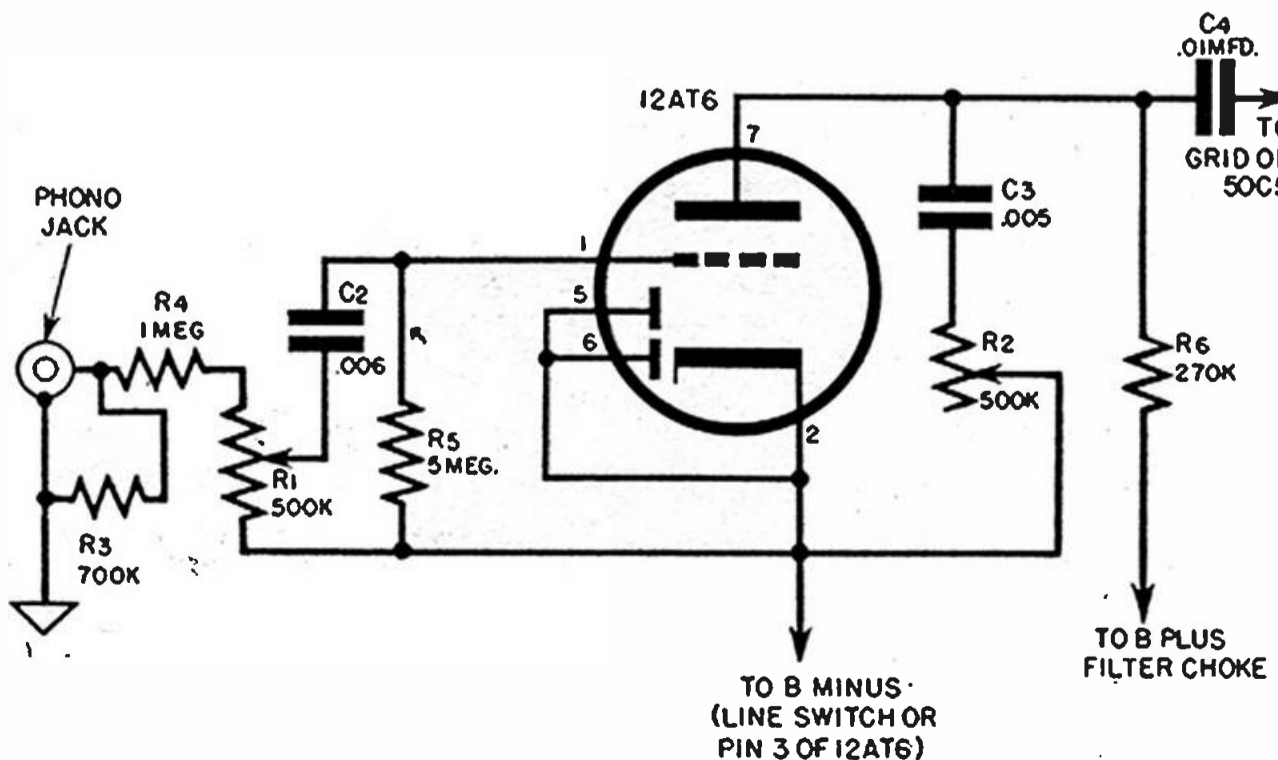

Fig. 4-27. Voltage amplifier circuit wiring.

points are to be connected together and their junction then connected to B minus (either at the line switch or at pin 3 of the 12AT6 socket): lower end of R1; lower end of R5; pins 2, 5, and 6 of tube socket; lower end of R2. Connect the lower end of R6 to the B-plus terminal at the filter choke. Note that the shell of the phono jack and the lower end of R3 are both connected to chassis.

Normal resistance readings for this

circuit are:

<i>From</i>	<i>To</i>	<i>Resistance</i>
High side of phono jack	chassis	700K ohms
High side of phono jack	B minus	1.5 megohms
pin 1	B minus	5 megohms
pin 7	B minus	over 320K ohms

Normal voltage readings are:

<i>From</i>	<i>To</i>	<i>DC Volts</i>
pin 7	B minus	45

FIVE-TUBE AC AMPLIFIER

This is a high gain, medium-power amplifier for use with microphone, phonograph, or radio tuner. With adequate speaker equipment it is well suited for moderate-sized auditoriums, as it delivers about ten watts to the speakers. Separate gain controls for microphone and phonograph are provided, as well as a tone control.

Circuit description

See Figure 4-28.

The output circuit of this amplifier is unusual in consisting of a 6F6G and a 6AD7G. The 6F6G is a pentode and, like most output tubes, may be operated in push-pull to give greater power output. In this particular circuit, however, the opposite tube in the pair is a 6AD7G. This tube comprises a pentode that is similar to the 6F6G and also has a set of triode electrodes, which function as the phase inverter. Signals from the second audio stage (6AU6) are applied to the grid of the triode section of the 6AD7G (as well as to the grid of the pentode section) through C3. As in any tube, the signal appearing at the plate of the triode section is 180 degrees out of phase with the grid signal voltage. The out-of-phase signal is fed to the lower tube in the push-pull circuit (the 6F6G) and thus provides an inversion.

Signal voltages from a phonograph pickup are applied to the grid of the

6AU6 second-audio amplifier. Signal intensity is controlled by R3. When using a microphone, an additional audio stage is employed—the 6AV6. For microphone work, volume is controlled by R2. The tone control circuit consists of C5 and R8.

The power-supply filter circuit consists of R14, R13, C7A, and C8. You will note that plate and screen voltages for the output stage are taken directly from the cathode of the 5Y3GT through R15. All other plate and screen voltages, however, are taken from the end of R14; in addition to the filtering action of R14 and C8, there is also R13, 22,000 ohms, and C7A, a .20-mfd. 250-volt unit. Incidentally, C7 (20 mfd., 25 volts) and C7A are combined in one container, as indicated in the plan view of the chassis. But there is no reason why separate condensers cannot be substituted, if desirable.

Parts list

Resistors

R1	2.2 megohms, 1/2-watt carbon
R2	1 megohm, microphone volume control
R3	1 megohm, phonograph volume control
R4	10 megohm, 1/2-watt carbon
R5	500K ohm, 1/2-watt carbon
R6	330K ohm, 1/2-watt carbon
R7	120K ohm, 1/2-watt carbon

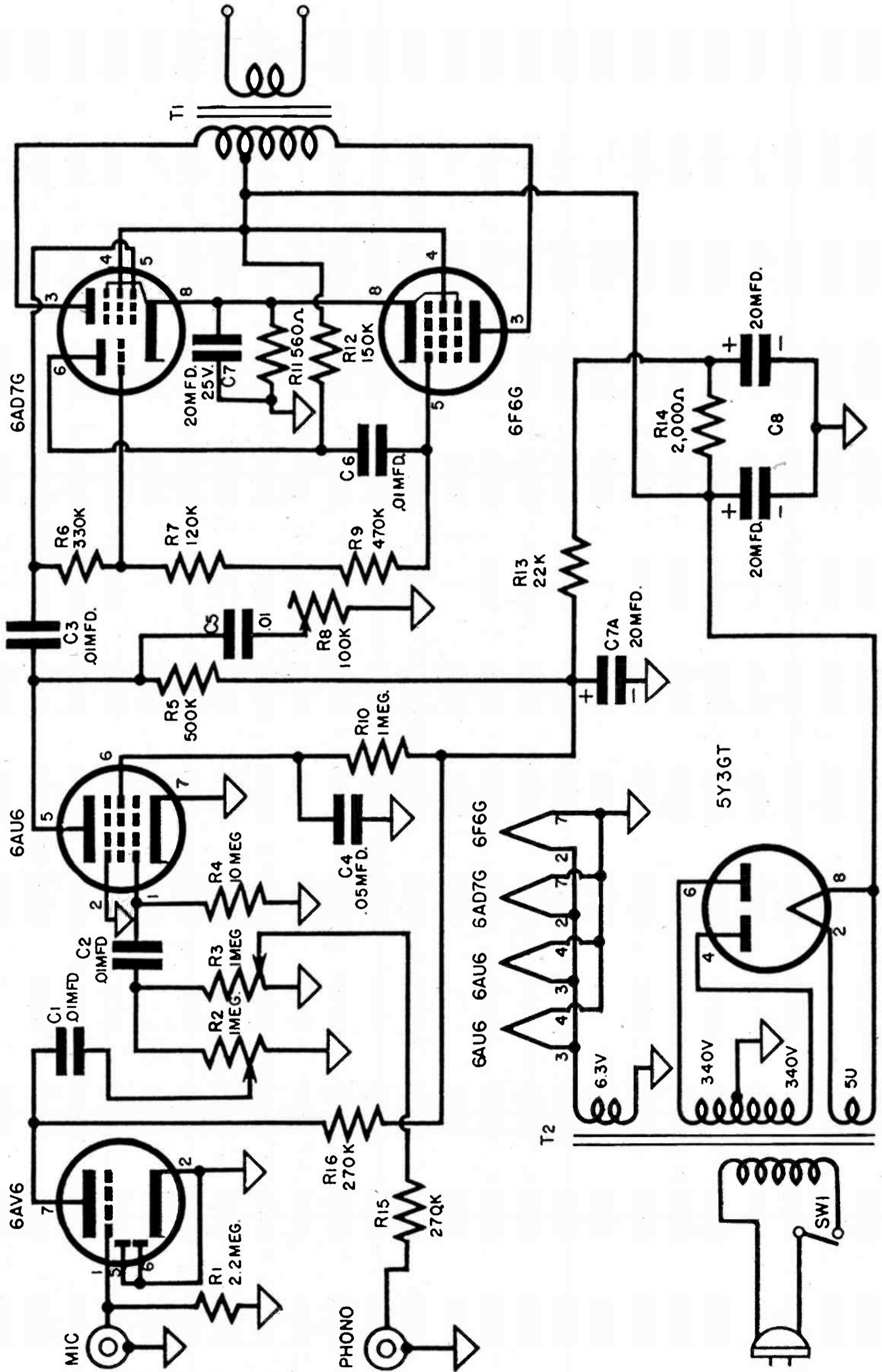
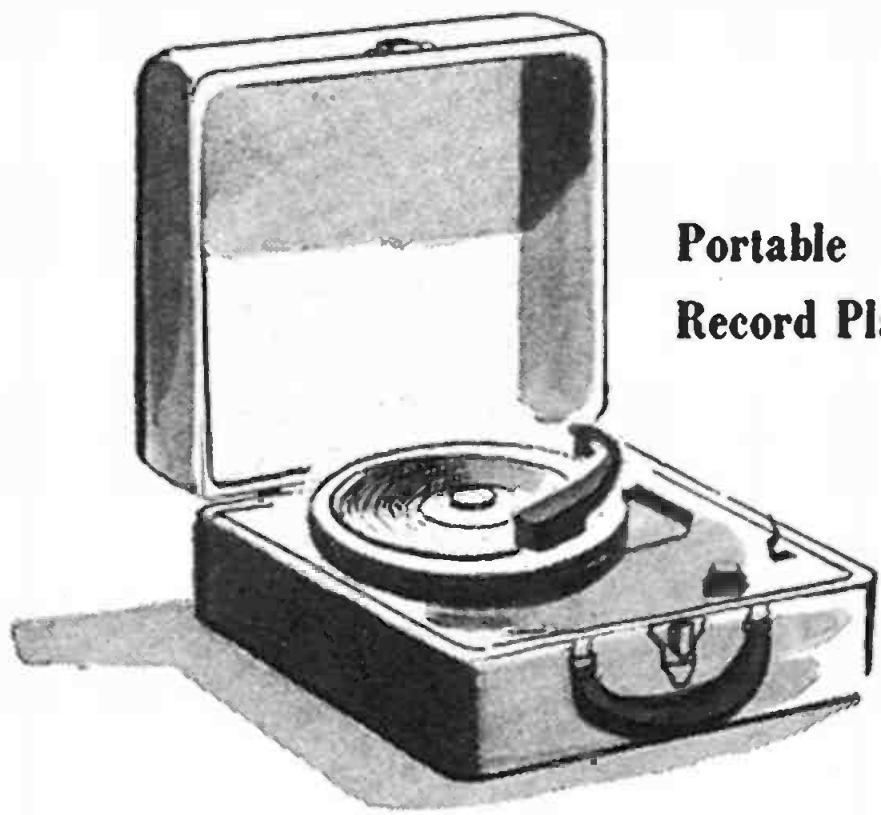
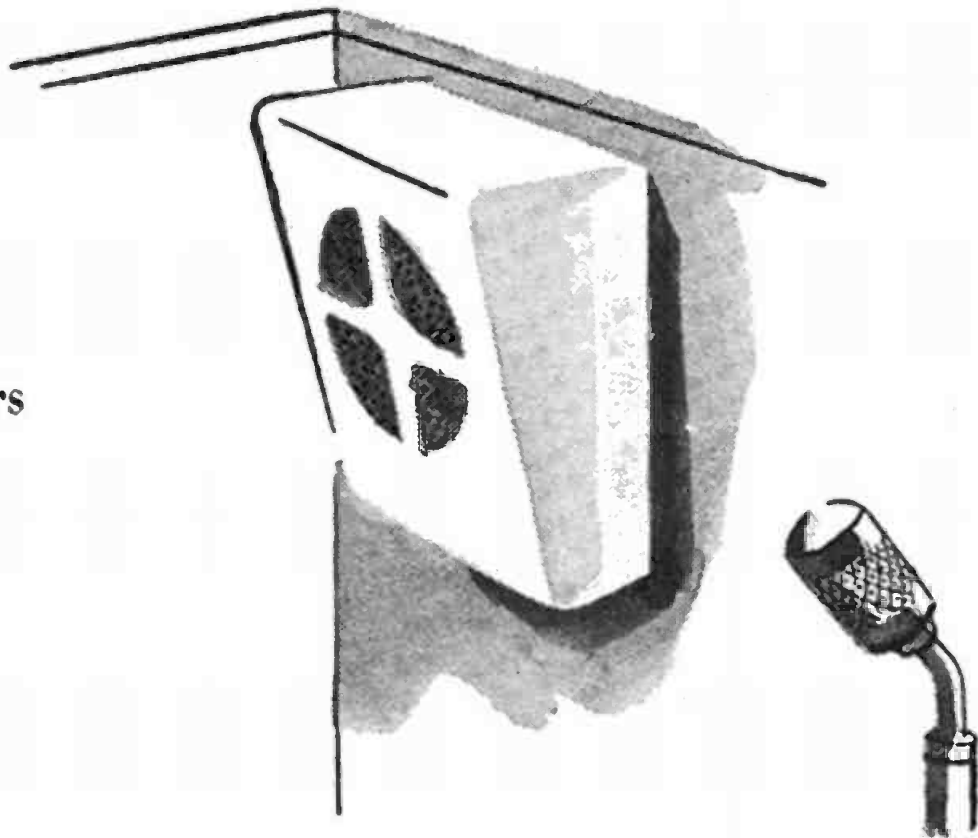

Fig. 4-28. Schematic diagram of a five-tube amplifier.



**Portable
Record Players**



Public Address Systems

Easy-to-Build Amplifiers Provide Fun and Profit

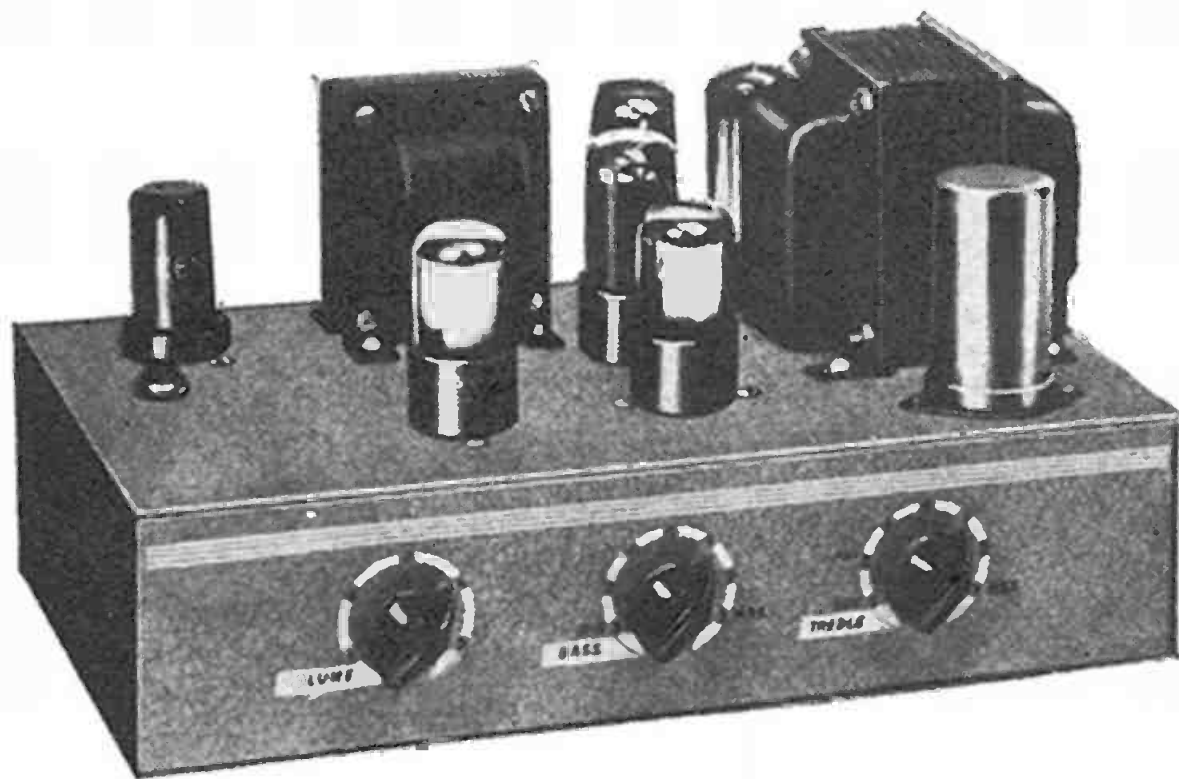

A 10-Watt Amplifier

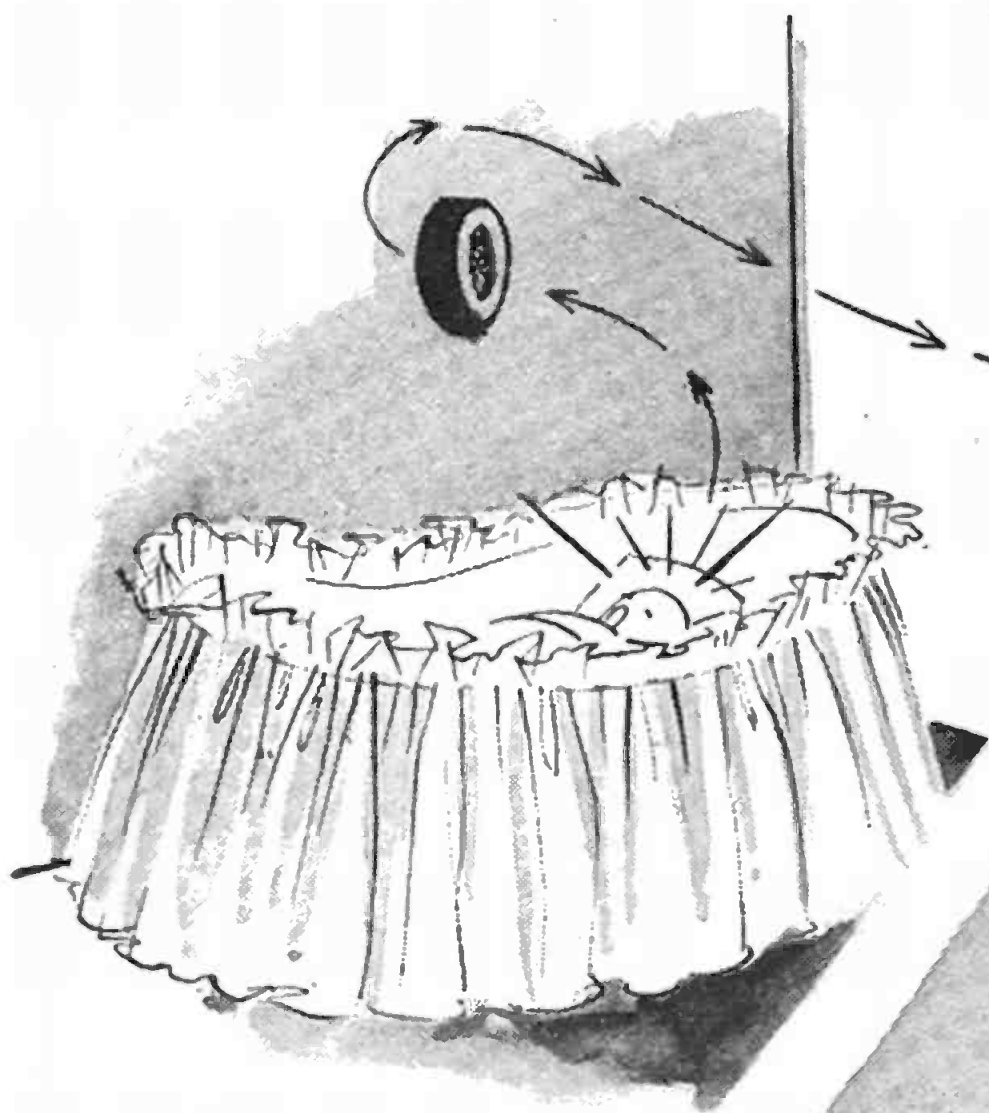

Baby Tenders

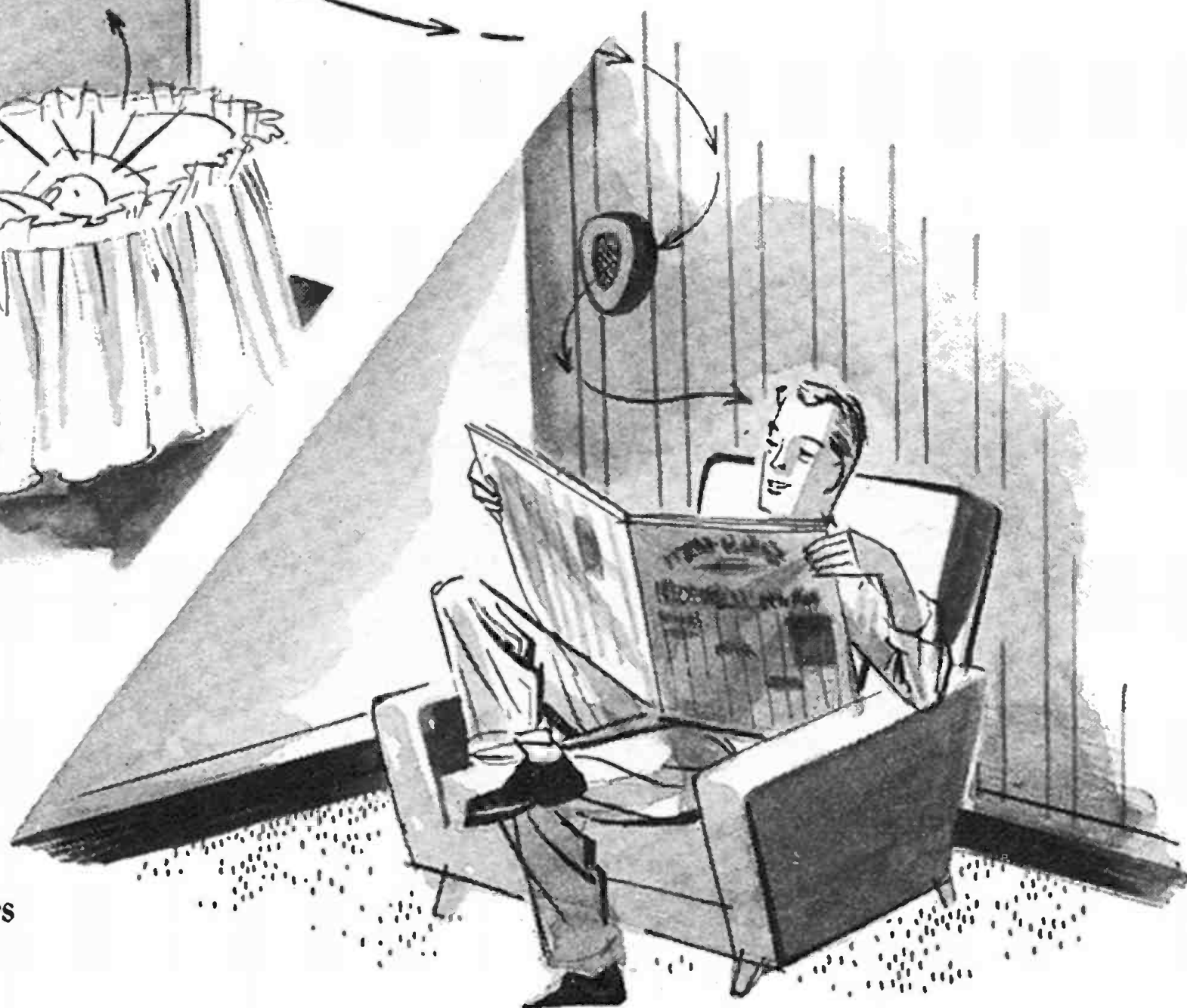

BUILD YOUR OWN RADIO AND HI-FI SETS

R8	100K ohm, tone control with switch, SW1
R9	470K ohm, 1/2-watt carbon
R10	1 megohm, 1/2-watt carbon
R11	560 ohm, 4-watt wire-wound
R12	150K ohm, 1/2-watt carbon
R13	22K ohm, 1-watt carbon
R14	2,000 ohm, 10-watt wire-wound
R15	270K ohm, 1/2-watt carbon
R16	270K ohm, 1/2-watt carbon

Condensers

C1	.01 mfd., 600-volt paper tubular
C2	.01 mfd., 600-volt paper tubular
C3	.01 mfd., 600-volt paper tubular
C4	.05 mfd., 600-volt paper tubular
C5	.01 mfd., 600-volt paper tubular
C6	.01 mfd., 600-volt paper tubular
C7	20 mfd., 25-volt electrolytic
C7A	20 mfd., 250-volt electrolytic (combined with C7, aluminum can type, vertical mounting)
C8	20-20 mfd., 450-volt electrolytic (aluminum can type, vertical mounting)

Transformers

T1	Output transformer, shielded type, 10,000-ohm center-tapped primary, secondary to match desired speaker
T2	Power transformer, high voltage 350-0-350, 150 m.a.; rectifier 5 volts, 3 amp.; heater 6.3 volts, 4 amp.

Miscellaneous

Chassis: 7 x 10 x 2 inches, steel
3 octal tube sockets
2 7-pin miniature tube sockets
RCA-type phono jack
Microphone connector; Amphenol 75-PC1M or equivalent
Line cord and plug
2- and 3-point tie strips
4-36 and 6-32 x 3/8-inch r.h. screws
4-36 and 6-32 hexagon nuts
10-24 r.h. machine screws with nuts (for transformers)
Rosin-core solder
Push-back wire

Tubes

6AD7G, 6F6G, 6AU6, 6AV6, 5Y3GT

Assembly

See Figure 4-29 for a top view of the chassis, showing locations of transformers, controls, tube sockets, and filter condensers. Although the output transformer is shown mounted on the chassis, this may be altered to suit your requirements. If you intend to use a smaller lighter type of transformer, it may be mounted on the speaker itself. In that case, you will have to install a four-pin speaker socket. If the amplifier is to be used with speakers having different voice-coil impedances, the output transformer should then have a tapped secondary with taps at 4, 8, and 16 ohms.

All three controls are mounted on the front chassis apron near the left end of the chassis to keep the wiring short. For the same reason it will be best to locate the phono jack and the microphone receptacle on the left end of the chassis near the 6AV6 tube socket.

Wiring

Little in the way of wiring description is necessary. The gain is moderately high, so be very careful to hold grid and plate leads to minimum length to avoid the possibility of interaction. The problem of adequately connecting all components to chassis will occur here, as in other amplifiers. It is unwise to depend upon the chassis itself as a return connection between parts. Of course, looping a wire from one part to the next may be effective, but is far from neat. For a job that is both efficient and neat, make up a "ground bus." This may be a single heavy wire (#12 or 14 bare, tinned) or may be made of several strands of smaller bare wire twisted together. Stretch the bus the

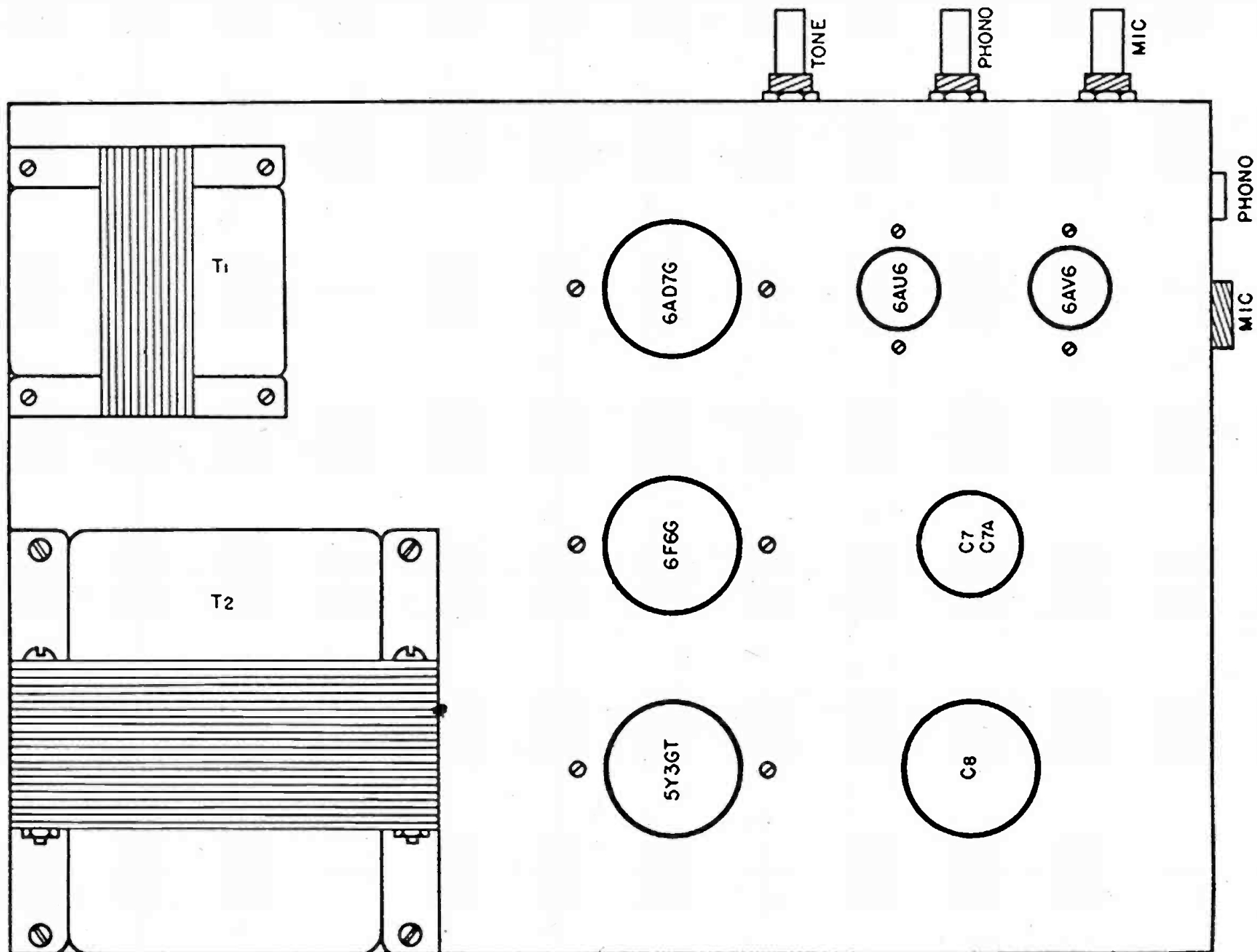

Fig. 4-29. Top view of five-tube chassis.

entire length of the chassis, making sure that there is a good electrical connection to chassis at either end. Resistors, condensers, tube-socket ter-

minals, and all other connection points may now be wired directly to the bus, with the assurance of low-resistance contact.

PREAMPLIFIER FOR VARIABLE RELUCTANCE PICKUP

The variable-reluctance-pickup cartridge is quite popular, particularly among constructors and operators of high fidelity equipment. This is due to the unusual ruggedness of the cartridge, among its many desirable features. It does have one disadvantage, however, rather low voltage output. The output is about 10 millivolts, compared with as high as one volt or more for crystal cartridges. When the variable-reluctance pickup is used with a conventional amplifier, such as the three-tube or five-tube units described in this chapter, it is necessary to employ a preamplifier between the pickup and the main amplifier.

Figure 4-30 is the circuit diagram

of the preamplifier that General Electric recommends for use with their cartridges. No details as to chassis, parts layout, or arrangement are given here, as it is possible to construct the amplifier either as a separate unit or to incorporate the circuit in the main amplifier. If it is to be a separate unit, a small aluminum chassis measuring about 3 x 3 x 1 inch will be large enough.

This is a complete two-stage amplifier, each half of the 6SC7 tube functioning as a stage. R6, R10, and C5 in this unit act as a tone-equalizing circuit, and if the preamplifier is to be used with an amplifier intended for record reproduction, be sure that

any tone-compensating or scratch-filter circuits used in the main amplifier are disconnected. Changing the value of R7 will have a substantial effect on the high frequency response. The value of 15,000 ohms specified in the diagram is the average value, but any value from 5,000 to 50,000 ohms may be used. Higher values will provide higher frequency response; for maximum response, the resistor may be omitted entirely.

Parts list

Resistors

- R1 68K ohms, 1/2-watt carbon
- R2 33K ohms, 1/2-watt carbon
- R3 33K ohms, 1/2-watt carbon
- R4 68K ohms, 1/2-watt carbon
- R5 68K ohms, 1/2-watt carbon

- C4 .05 mfd., 400-volt paper tubular
- C5 .01 mfd., 400-volt paper tubular

Miscellaneous

- Chassis: 3 x 3 x 1 inches, aluminum
- 1 octal tube socket (non-microphonic mounting preferred)
- RCA phono jack
- RCA phono plug
- Shielded wire
- 3-point tie strips
- 2-point tie strips
- 6-32 x 3/8-inch r.h. machine screws
- 6-32 hexagon nuts
- Push-back wire
- Rosin-core solder

Tube

- 6SC7

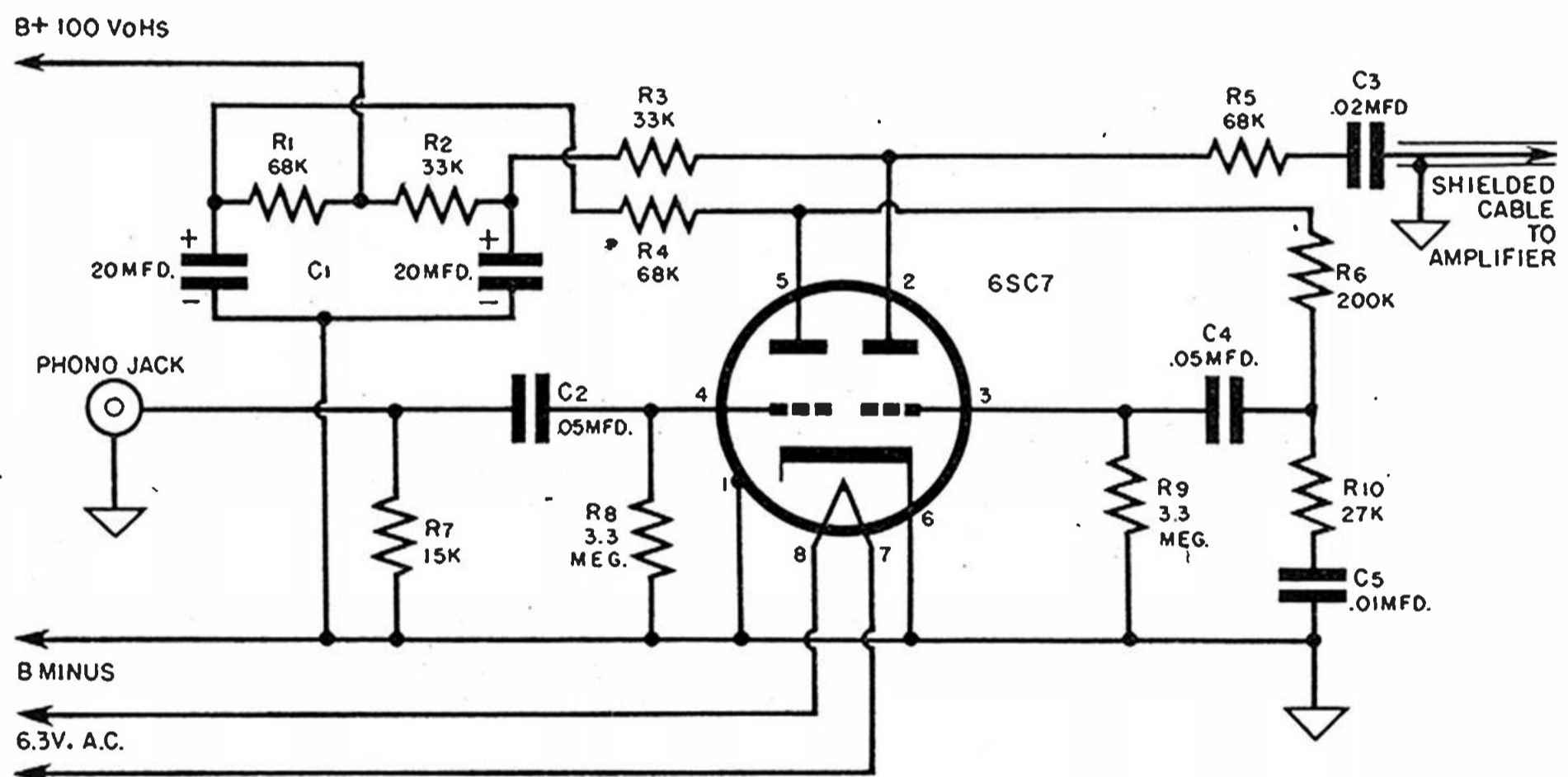

Fig. 4-30. Preamplifier for variable reluctance pickup.

- R6 200K ohms, 1/2-watt carbon
- R7 15K ohms, 1/2-watt carbon
- R8 3.3 megohm, 1/2-watt carbon
- R9 3.3 megohm, 1/2-watt carbon
- R10 27K ohms, 1/2-watt carbon

Condensers

- C1 20-20 mfd., 150-volt electrolytic, tubular
- C2 .05 mfd., 400-volt paper tubular
- C3 .02 mfd., 400-volt paper tubular

Assembly

Aside from the input and output terminals, there are four external connections to the preamplifier: B minus, B plus, and the two heater leads. B supply is to be from 80 to 100 volts. To use this unit with an AC amplifier such as the five-tube unit described earlier, it is necessary to obtain heater supply voltage by connecting the heater wires to the 6.3-volt winding of the power transformer. The B-minus lead may be con-

nected directly to the chassis of the main amplifier. B plus may be taken from the end of R13 farthest from the rectifier tube (see Figure 4-28). If the voltage at this point is still too high, a dropping resistor may be connected in series. Too-high plate voltages may result in microphonic noises. Incidentally, you may find that in some installations, particularly when the preamplifier is confined within a small cabinet, there will be a tendency to microphonic action. To correct the condition, you may have to install a tube socket mounted on rubber supports. Another cure is to "float" the preamplifier chassis on rubber mountings.

For use with AC/DC sets or amplifiers, different connection arrangements are necessary. If the set or amplifier uses .3-amp. tubes (25L6, 25Z6, etc.), the heater of the preamplifier tube can be connected in series with them, not forgetting to reduce the value of the line dropping resistor to compensate for the extra tube. You may assume that the 6SC7 tube has a heater resistance of 21 ohms.

If the set or amplifier uses .15-amp. tubes, the 6SC7 cannot be connected

in series unless a rather complicated system of heater shunts is devised. A much simpler arrangement is to substitute a 12SC7, identical with the 6SC7 except for the heater ratings. Again, it is important to lower the value of the line resistor used; in this case allow 80 ohms for the 12SC7. If the heater voltages of all tubes in the set or amplifier already total 117 volts, the preamplifier tube cannot be connected in series without operating all tubes at reduced heater voltages, which may reduce efficiency and affect the tube life.

On any AC/DC set or amplifier the required B voltage is readily obtained by connecting the preamplifier B-plus wire to the filter resistor or filter choke. Be sure to connect to the end of the resistor or choke farthest from the rectifier-tube cathode. The B-minus connection must be made to chassis or to B minus, depending upon the wiring of the set or amplifier. If the chassis is used as a common connection, connect the wire to it. Should you find that all B-minus connections are isolated from chassis, the wire from the preamplifier may be connected to the on-off switch.

BABY TENDER: A ONE-WAY INTERCOMMUNICATOR

Among the varied applications of the intercommunicator is its new role as electronic nursemaid. With the master station a few feet from the child's crib and the remote speaker, or speakers, in a strategic location, you can be notified of the child's awakening in any part of the home. However, commercially made intercoms are not inexpensive; some are rather elaborate and almost all are designed for two-way operation, a feature that is not at all necessary in this particular service.

Figure 4-31 is the schematic diagram of a simplified one-way intercom that can be built at low cost. It has been trimmed down to perform one specific duty. Multiple remote stations

and a talk-listen switch (making a two-way unit) can be added, if you wish; the procedure is explained at the end of this section.

As you will see from an inspection of the diagram, the circuit is a standard AC/DC amplifier with the addition of an input transformer and a second speaker. In fact, any such amplifier (or the audio portion of a small set) can be adapted to this job by adding the transformer and the speaker.

The input transformer, T1, has a 1 to 20 ratio; its primary impedance matches the speaker voice coil, while the secondary matches the tube impedance. Air waves striking the cone of speaker 1 (now functioning as a

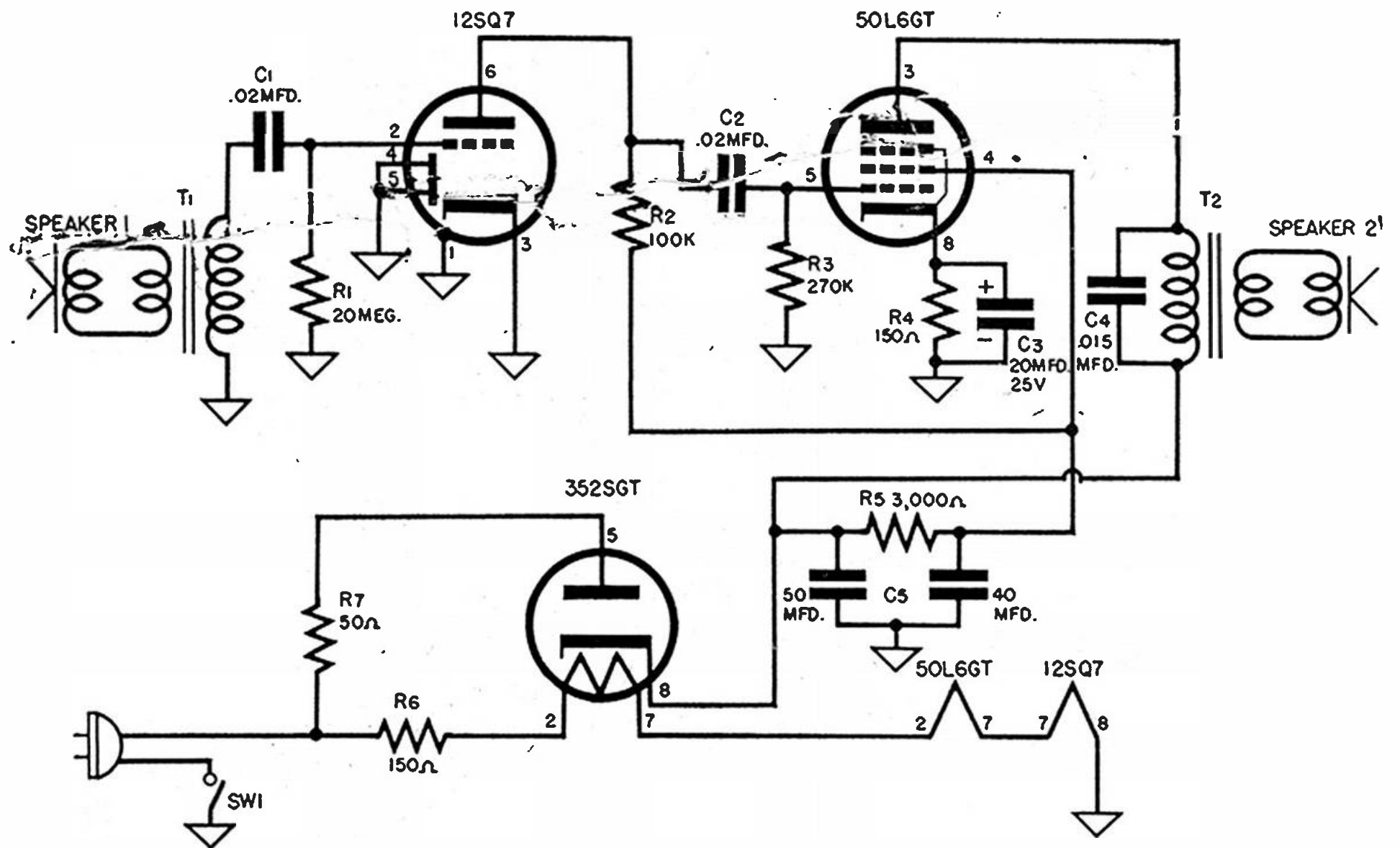

Fig. 4-31. Schematic diagram of intercom system.

microphone) cause the cone and the attached voice coil to move. Motion of the coil through the strong magnetic field of the speaker sets up voltages in the coil; these are applied to the grid of the 12SQ7 through the medium of the transformer. After amplification by the 12SQ7 and 50L6 tubes, signal voltages are applied to speaker 2 through the output transformer. Here the signals are converted back to the original sound waves.

Construction

The entire master unit may be built on a chassis measuring 5 by 7 by 2 inches. The chassis layout is shown in Figure 4-32. T1, the input transformer, is mounted on the speaker, while T2 is located near the rear of the chassis. The remote unit consists merely of a second p.m. speaker and requires no chassis. Simply mount the speaker in a box of suitable size. Four-inch p.m. speakers are recom-

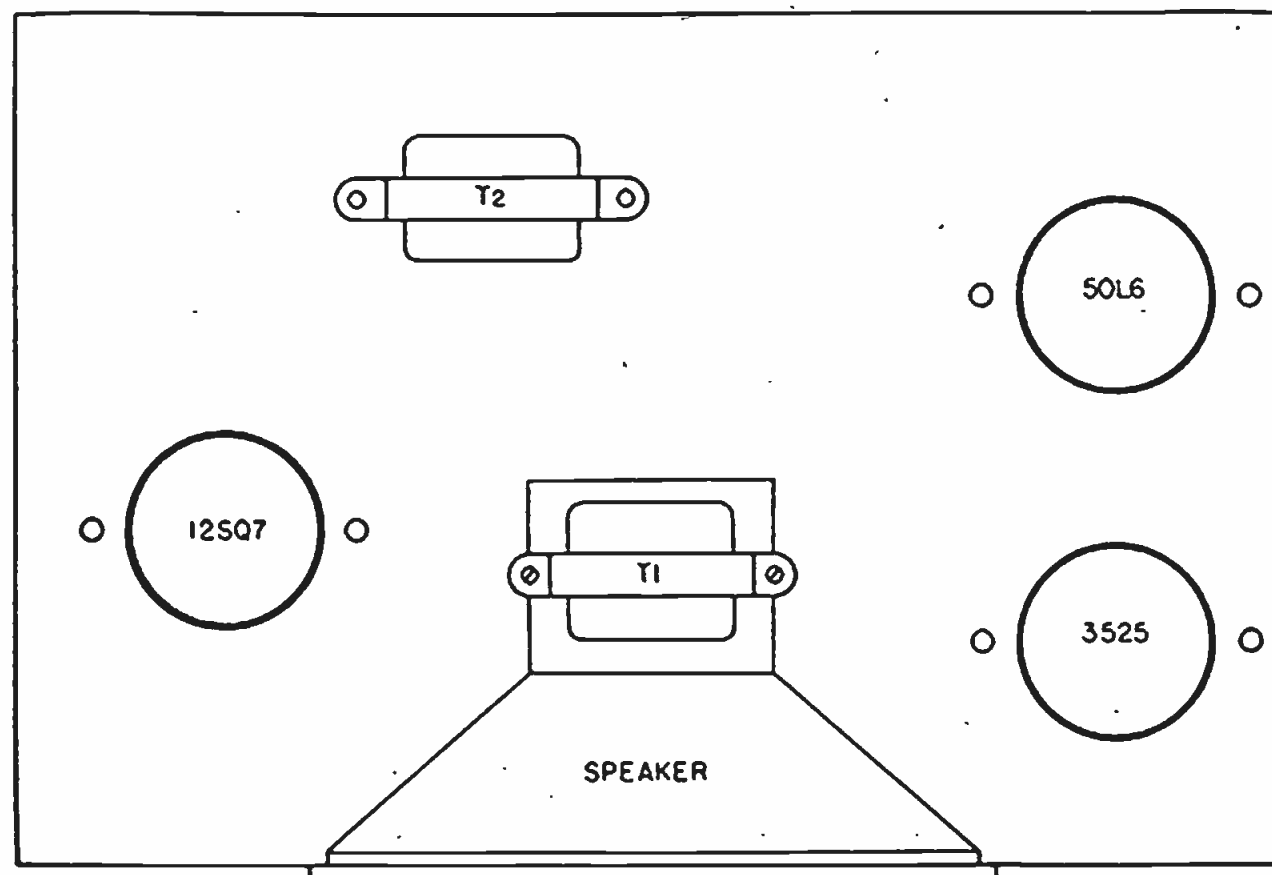

Fig. 4-32. Top view of intercom chassis.

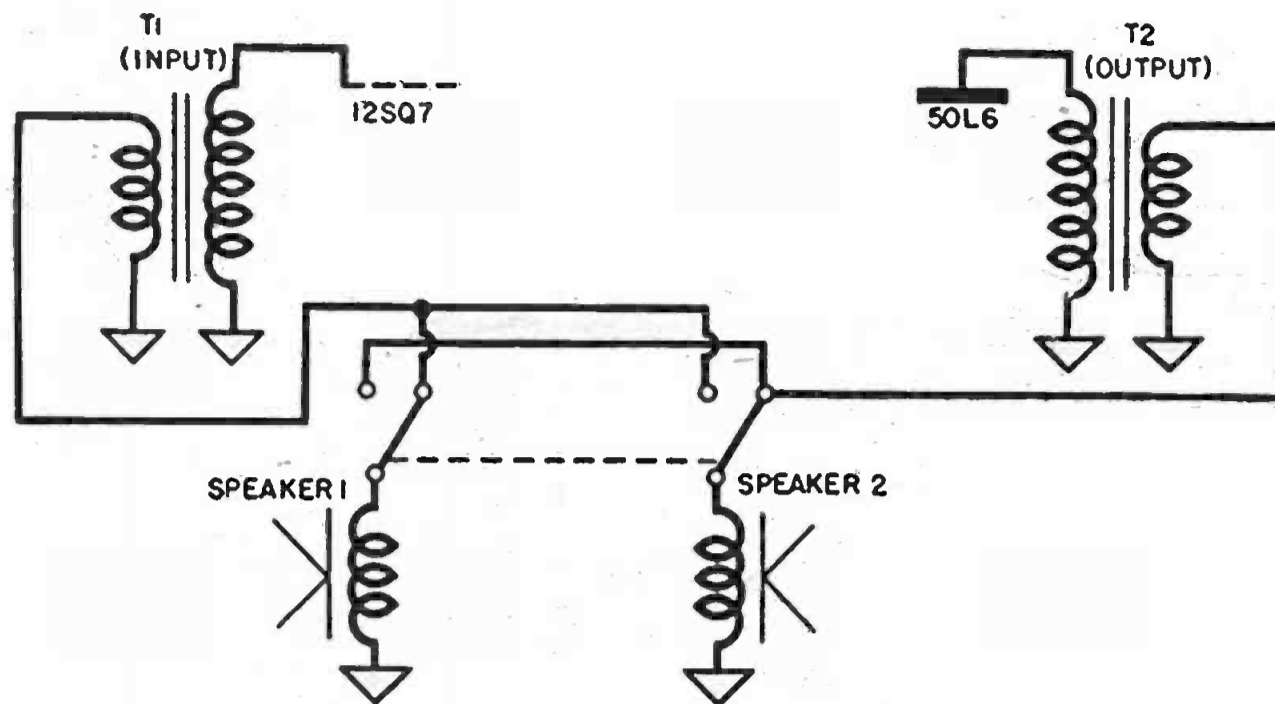

Fig. 4-33. Adding a talk-listen switch.

mended for this purpose, since good low frequency response is not too important. A volume control is not shown in the diagram but can be added by connecting a 500,000-ohm unit in parallel with the secondary of the input transformer. The end of C1, which is shown connected to the top end of the T1 secondary (Figure 4-31), will then be wired to the moving contact of the control.

Parts list

Resistors

R1	20 megohm, 1/2-watt carbon
R2	100K ohm, 1/2-watt carbon
R3	270K ohm, 1/2-watt carbon
R4	150 ohm, 1/2-watt carbon
R5	3000 ohm, 1-watt carbon
R6	150 ohm, 10-watt wire-wound
R7	50 ohm, 1/2-watt carbon

Condensers

C1	.02 mfd., 200-volt paper tubular
C2	.02 mfd., 400-volt paper tubular
C3	20 mfd., 25-volt electrolytic (tubular)
C4	.015 mfd., 400-volt paper tubular
C5	50-40 mfd., 150-volt electrolytic (tubular)

Transformers

T1	1 to 20 turns ratio; Stancor A-4705, Merit A-2919
T2	Output transformer, 2,000-

ohm primary, 3-ohm secondary; Stancor A-3876 or equivalent

Speakers

2 4-inch PM dynamic, 3-ohm voice coil; Jensen P4-X or equivalent

Miscellaneous

3 octal tube sockets
Line cord and plug
Single-pole single-throw rotary switch, SW1
4 2-point tie strips
6-32 x 3/8-inch r.h. machine screws
6-32 hexagon nuts
Rosin-core solder
Push-back wire

Tubes

12SQ7, 50L6GT, 35Z5GT

Assembly

Assembly and wiring procedure are the same as for the three-tube amplifier described earlier in this chapter. No special comments are necessary.

After the unit is built, it is connected to the remote speaker, using any type of twisted-pair wire. The line carries no appreciable voltage, so that particularly good insulation is not required.

Talk-listen switch; multiple stations

Figure 4-33 shows the circuit used when adding the talk-listen switch. In most applications, it is desirable to have the master station normally con-

nected in the listen position. This is accomplished by using a spring-return type of switch, wired so that, with the switch in normal position, the master-unit speaker is connected to the output transformer, T2.

If you wish to add more than one remote speaker and also want to be able to talk to each station individually, the circuit of Figure 4-34 should be used. The remote-station selector may be a set of push button switches

(like those used for station selection on sets a few years ago) or you may use a rotary switch instead. Notice that only one remote station is able to talk to the master station—the one whose switch is left in the depressed position. If all remote stations are to be able to talk to the master station at any time, then the remote speakers must be wired in parallel. In that case, conversation between master and remote will be overheard by all other remote stations.

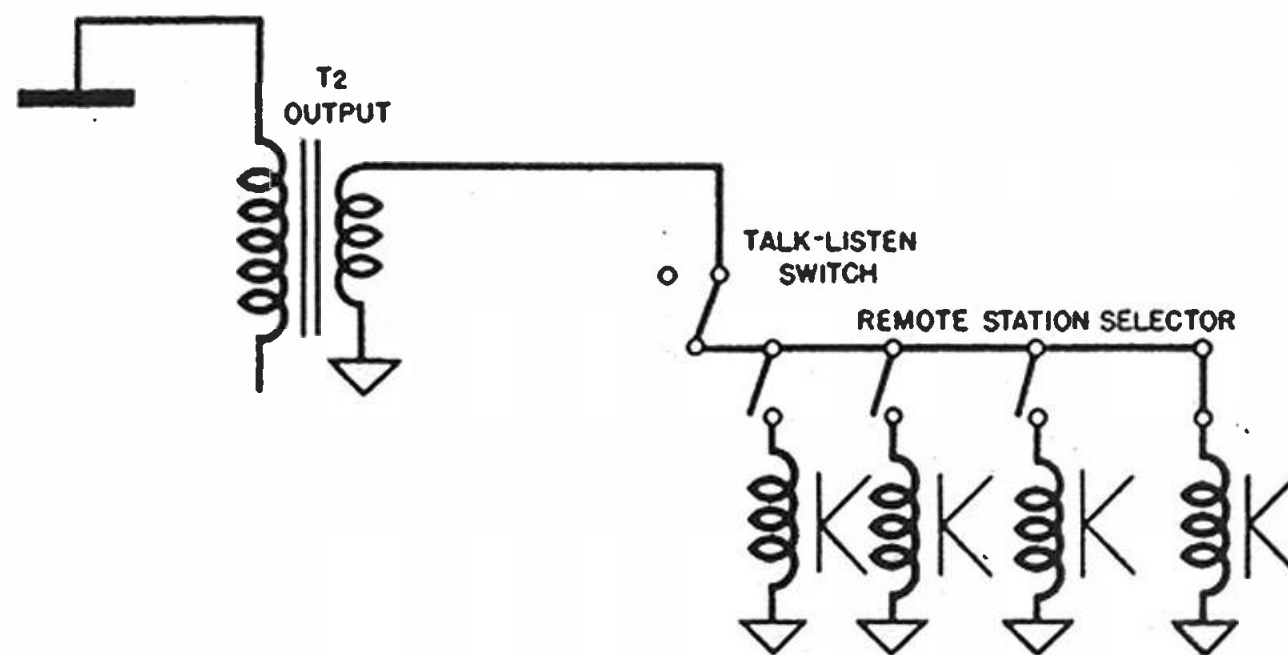
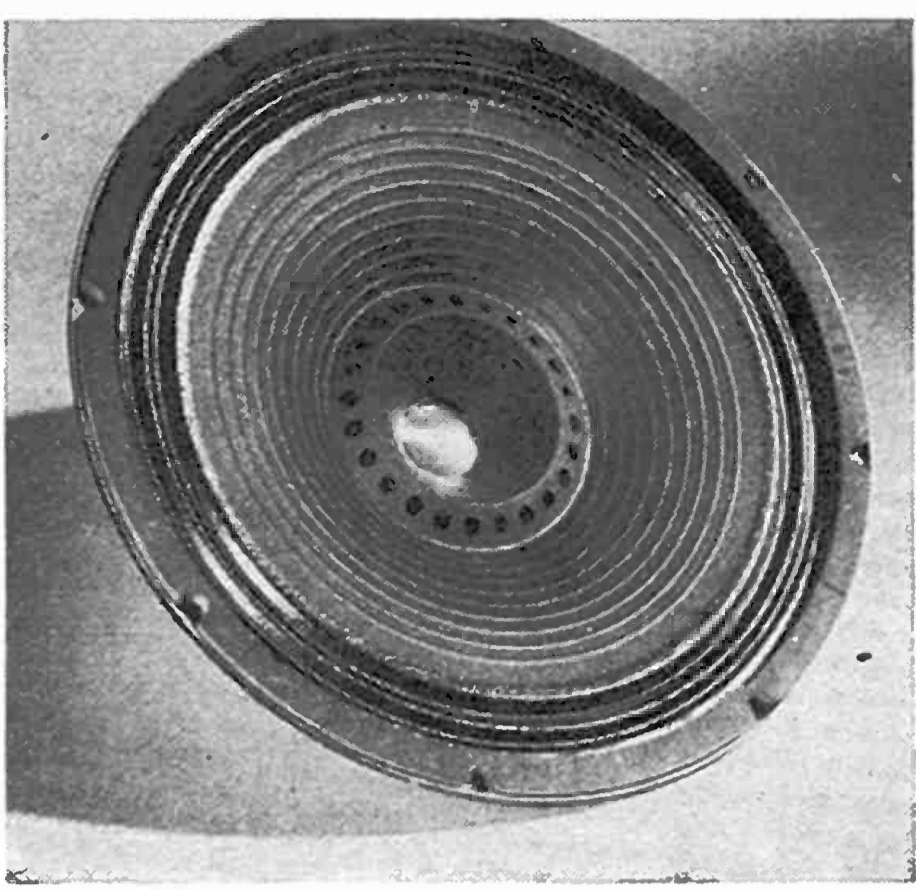
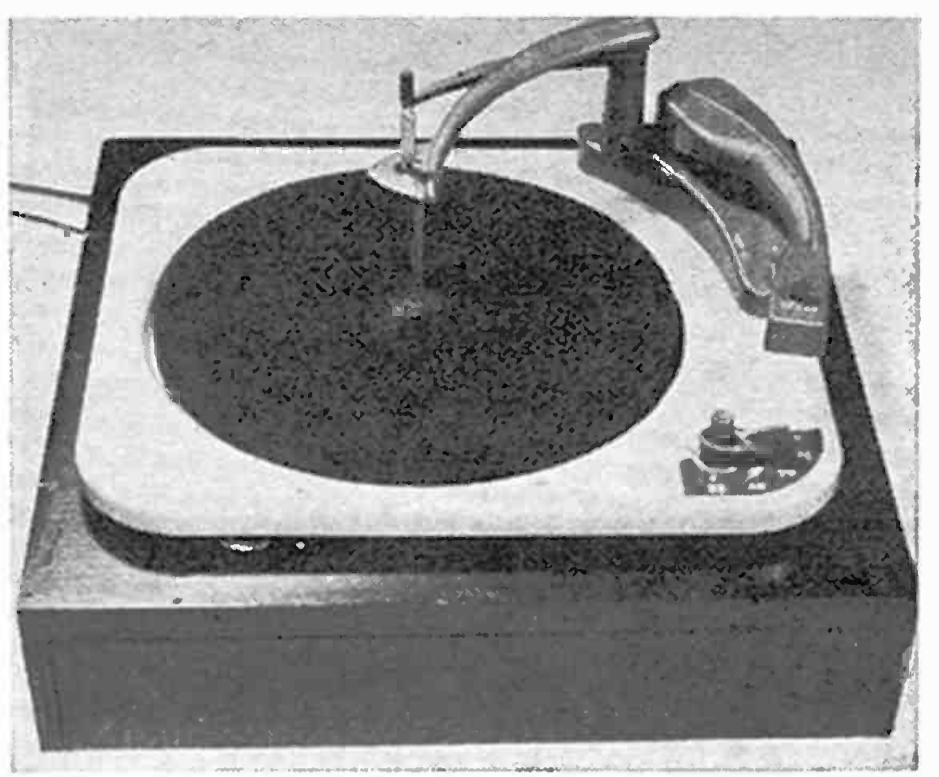

Fig. 4-34. Adding multiple remote stations.



Speaker



Record Player

**These Hi-Fi Components
Bring Concert Quality
Into Your Home**

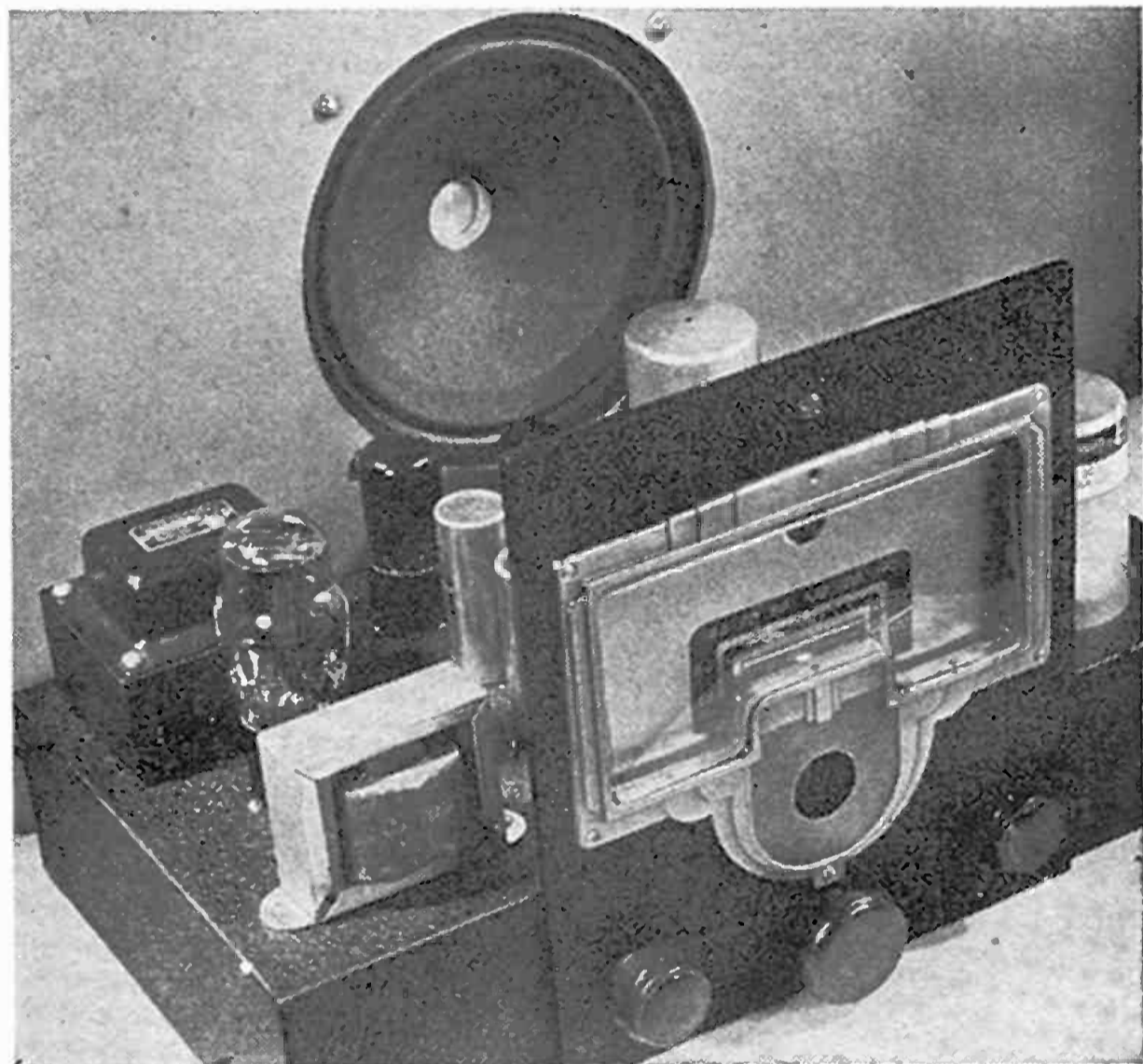

Tuner

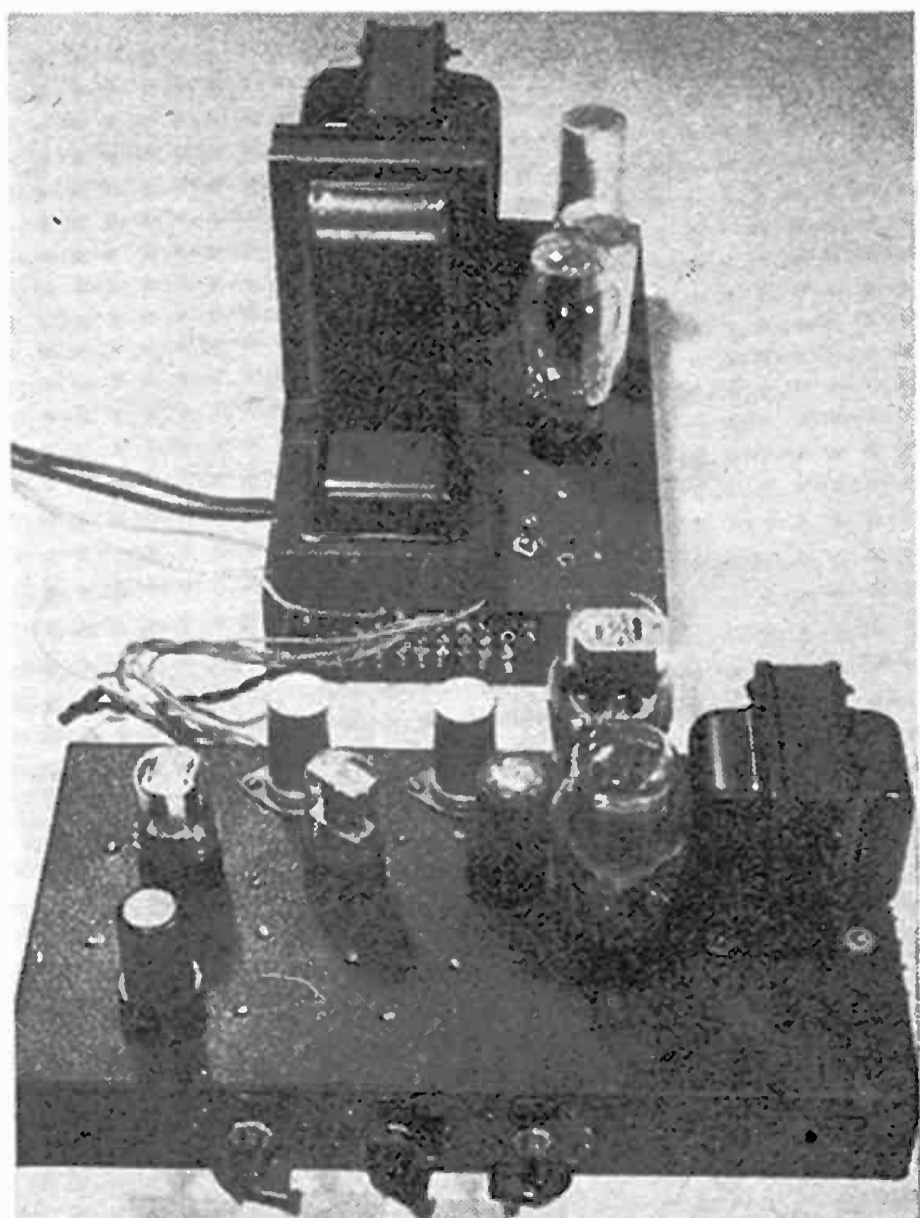

**Amplifier and Separate
Power Supply Unit**

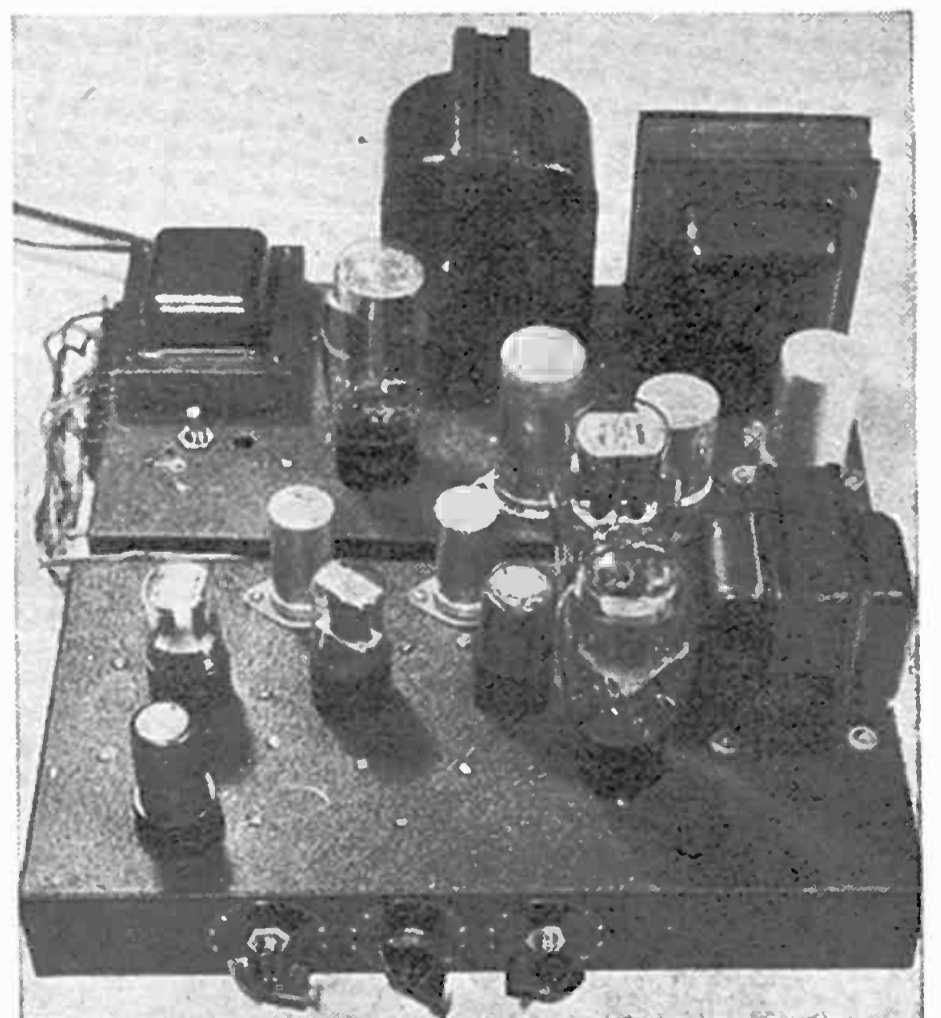

**Amplifier and Power
Supply as One Unit**

How to Build High Fidelity Systems

TODAY there is an ever-widening circle of people, dissatisfied with ordinary, commercially built radios and phonographs, who are turning to more highly specialized—and often individually designed—equipment that can reproduce music more nearly like the original. This group is growing so rapidly, in fact, that it has attracted the attention of receiver manufacturers, who are now beginning to offer high fidelity equipment.

True high fidelity equipment is quite expensive but, as we point out later in this chapter, there are compromises that can be made. While such compromises do not allow the very best results that top-notch high fidelity equipment is capable of, the quality will still be far better than can be obtained from ordinary sets and amplifiers.

What is Hi-Fi?

Perhaps we should clearly define "high fidelity." Basically, high fidelity refers to apparatus for reproducing recorded or broadcast music as faithfully as possible. More technically, it means that all sounds, from the lowest to the highest in pitch, are not only reproduced but reproduced equally well. This may be taken to mean, in the strictest sense, all sounds having frequencies between 15 and 15,000 cycles per second.

Let us assume for the moment that

you are not particularly interested in broadcast reception but that you do want to assemble a unit that will reproduce recorded music that sounds as nearly as possible like the original performance—and that you would like to do this at moderate cost. To find out how far we may deviate from true high fidelity and yet get acceptable results—to discover how much we are willing to sacrifice in order to keep the cost within reason—we must first understand where and how much of the original tonal quality of music may be lost.

In its journey from record to loud speaker, the music is handled by several different units. Each of these can affect the final result either favorably or unfavorably, depending upon the technical perfection of the unit. These units are: (a) the record itself; (b) the record player, comprising motor, pickup, and stylus; (c) the amplifier; (d) the speaker; and (e) the speaker "baffle," or enclosure.

Limitations of the units

Let's take a brief look at each unit and its possible shortcomings. Later on we will go into more detail as we start to use the units.

All the items mentioned can be excellent or sadly deficient. Generally speaking, the deficiencies arise as a result of cutting production costs. If you have not already made the dis-

covery, you will soon learn that true high fidelity can be, and usually is, expensive.

The one exception is the record. Prices are fairly well stabilized among the various manufacturers and both excellent recordings and extremely bad ones have been offered at identical prices. The newer recordings, made at 33-1/3 and 45 r.p.m., are almost always superior to the older 78 r.p.m. in both fidelity and absence of surface noises. And remember, no matter how effective the amplifier and speaker, you cannot get any more from a record than the manufacturer put into it. A scratch filter will remove some of the surface noise but only at the expense of removing some of the higher notes, too.

When we come to the record player we are likely to receive a surprise here and there. We have often compared the rendition of a record on an expensive well-built unit and on a low-priced portable player, only to find that the cheap player appeared to give much better, easier-to-listen-to results than the high fidelity equipment. It is hardly necessary to add that the record was not one of those brilliant, almost flawless gems that are becoming more common today but just an ordinary, run-of-the-mill record. What happens here is, of course, that certain deficiencies in the record player compensate for other shortcomings in the recording. It is quite possible for an amplifier deficient in the higher tones to compensate for distorted highs in a recording, simply because the highs become inaudible. Again, some of the older records, made before electrical recording methods were introduced, usually sound a bit better on an amplifier with booming, exaggerated bass response. Many people have been "unsold" on high fidelity because their first experience consisted of listening to poor recordings. It is true that some low-priced equipment will eliminate much of the surface noise present

in a poor recording, but this does not mean that such a system is good or desirable. High fidelity will instantly disclose such flaws in a recording, which is why high fidelity fans select their records with extreme care and buy only after they have heard a record on their own unit or one of comparable quality.

In building high fidelity equipment you shall find that a record player (or automatic changer) capable of first class results will not be prohibitively expensive. The low cost of today's good crystal and magnetic cartridges has helped to keep down the cost of a first class player or changer. A good record player must be capable of delivering to the amplifier an accurate reproduction of the recording; more than that, it should handle records gently. This means that the pickup arm, cartridge, and stylus should be designed with a view to keeping record wear at a minimum. These requirements can best be met by using a good jewel stylus in a pickup that exerts low stylus pressure and "tracks" properly. Good "tracking" means that the axis of the cartridge is always tangent to the record groove. It is almost impossible to realize perfect tracking on account of the differences in groove diameters from the edge of the record to the center. But tracking error can be kept to a minimum by using a long pickup arm.

The heart of the system

Now we come to the amplifier, heart of the system. Here we find, strangely enough, that almost any well-designed amplifier is capable of near-high-fidelity results. In the ordinary factory-assembled receiver, however, the amplifier is "strangled" by the speaker associated with it.

The speaker is the most discussed and most expensive component in a high fidelity system. Ordinary speakers, like those used in even high-

priced commercial sets, are incapable of reproducing frequencies as high as 15,000 per second; many do not reach even 10,000 cycles.

There are several ways of minimizing this difficulty without purchasing one of the special speakers selling at prices from one hundred to five hundred dollars. The first, simplest, and cheapest way is to buy an "extended range" speaker that is a bit better than the type used in ordinary sets but cannot be classed as high fidelity. Many of these will go to (and a few of them beyond) 12,000 cycles. The average cost is from twenty to thirty dollars.

The next possibility is to use two speakers: one, a large-diameter cone for the low frequencies (a "woofer"); and the other, either a small cone or a horn for the high notes (the "tweeter"). Some constructors use a large cone (up to 15-inch diameter) as a woofer and an array of several small cones (three- to five-inch diameter) for the tweeter section. It is usual to employ a cross-over or frequency-dividing network to direct the lower notes to the woofer and the higher ones to the tweeter, although this is not absolutely essential, as noted later on. (We are not now discussing true high fidelity but a compromise arrangement.)

Finally, you may prefer to use one of the many moderately priced duplex speakers marketed under trade names such as "coaxial" and "cinaxial." This kind consists of a large speaker with a much smaller one mounted concentrically within it. Sometimes the tweeter unit is a small cone, but in other types a multi-cellular horn is used. Some makes require an external cross-over network, while others have the network built in. Prices range from thirty dollars or so for a fair unit to two hundred or more for a really excellent one. Your choice of speaker will depend to some degree on the thickness of your wallet, but

dollar for dollar there is little to choose among different makes.

Getting back to the amplifier, the only component in the system that you can build yourself aside from the speaker enclosure, we give here plans for two different units, each capable of delivering about ten watts to the speaker or speakers. As explained in Chapter 4, this is about the minimum power for home use if the amplifier is to be able to handle large power peaks.

In the output stage of any amplifier we have a choice of triodes or pentodes (beam power tubes). Unless means are taken to reduce it, a beam tube has a plate resistance so high that making a match between it and the output transformer is impracticable, if not impossible. Since inductance drops off with a reduction in frequency, the mismatch between tube and output transformer becomes far more aggravated at the bass end of the register. Of course, this trouble, like many others, can be resolved at a price. There are available output transformers of excellent quality that will adequately match the high impedance of beam tubes, such as the 6V6 and 6L6, but they are quite expensive, and we are after fair to good quality at a reasonable price.

Triodes, on the other hand, have an inherently low plate resistance, which makes it easier to achieve a proper match with an ordinary, lower-priced output transformer. Although the discussion of triode versus beam tube still rages, it is a fact that most high-fidelity enthusiasts prefer triode tubes.

The first high fidelity amplifier project will consist of a pair of triode tubes, a phase inverter stage consisting of a dual triode, and a pentode tube as voltage amplifier. Following this, we shall take up the construction of a much more elaborate, seven-tube amplifier. This will incorporate a built-in preamplifier for magnetic

pickup cartridges, bass and treble controls, phase inverter and driver

stages, and, of course, a push-pull output stage using a pair of triodes.

FIVE-TUBE AMPLIFIER

The complete circuit diagram of this project is shown in Figure 5-1A. It is designed for AC operation. All heater, plate, and screen voltages are supplied by the power transformer, T1. There are two separate heater windings, one for the output tubes, the other for the voltage amplifier and phase inverter. The reason for using two separate windings is that the 6B4G output tubes are of the filament type; biasing is by means of a resistor connected in the center tap of the filament winding. It would be undesirable to apply this bias voltage to the heaters of the other tubes; hence, the separate heater winding.

The 5U4G rectifier tube derives its plate voltage from the center-tapped 740-volt winding of the transformer. After rectification, plate voltage for the output stage is taken from the far end of the filter choke, L1. Plate voltage for the phase inverter stage and plate and screen voltage for the voltage amplifier stage are further filtered by the resistor R13 and the condenser C6.

The voltage amplifier stage is a 6AU6 tube. Signal voltages are taken from the phono jack and their level controlled by the potentiometer, R15. Note the use of the screen dropping resistor, R3, and the screen bypass condenser, C2.

Signals appearing in the plate circuit of the 6AU6 tube are applied to the grid (pin 1) of one section of the 6SN7GT phase inverter. The output of this section of the phase inverter is coupled directly to the grid of one of the 6B4G output tubes. Grid voltages for the remaining section of the 6SN7GT is derived from the tap on the 6B4G grid resistor; this results in a phase displacement of the grid voltage. The output of this second half

of the inverter tube is fed to the grid of the other 6B4G output tube. This is a balanced phase inverter. Notice that the output transformer has a secondary tapped at 4, 8, and 16 ohms, thus providing for speakers of different voice-coil impedances. Such an arrangement is desirable when the amplifier is to be used with a variety of speakers or when series or parallel operation of speakers is required. If you intend to employ the unit with a single speaker at all times, we suggest that you use an output transformer having an untapped secondary winding of the correct impedance to match your speaker.

The 6B4G tube is a filament type of triode with an octal base; it is electrically identical with type 6A3, which has a four-pin base. Although the 6A3 is now manufactured in limited quantities for replacement purposes only, if you happen to have this type on hand there is no reason why a substitution cannot be made. Another possible substitution is type 2A3, which is similar to the 6A3 and 6B4G except for filament voltage, which is 2.5 instead of 6.3. Such a substitution will require the use of a power transformer with 6.3-volt, 5-volt, and 2.5-volt heater windings or of a conventional transformer with 6.3-volt and 5-volt windings, plus a separate 2.5-volt filament transformer. There will be no difference in the performance of the amplifier whichever type of output tube is used.

Parts list

Resistors

R1	270K ohms, 1/2-watt carbon
R2	10 megohm, 1/2-watt carbon
R3	1 megohm, 1/2-watt carbon
R4	500K ohms, 1/2-watt carbon
R5	250K ohms, 1/2-watt carbon

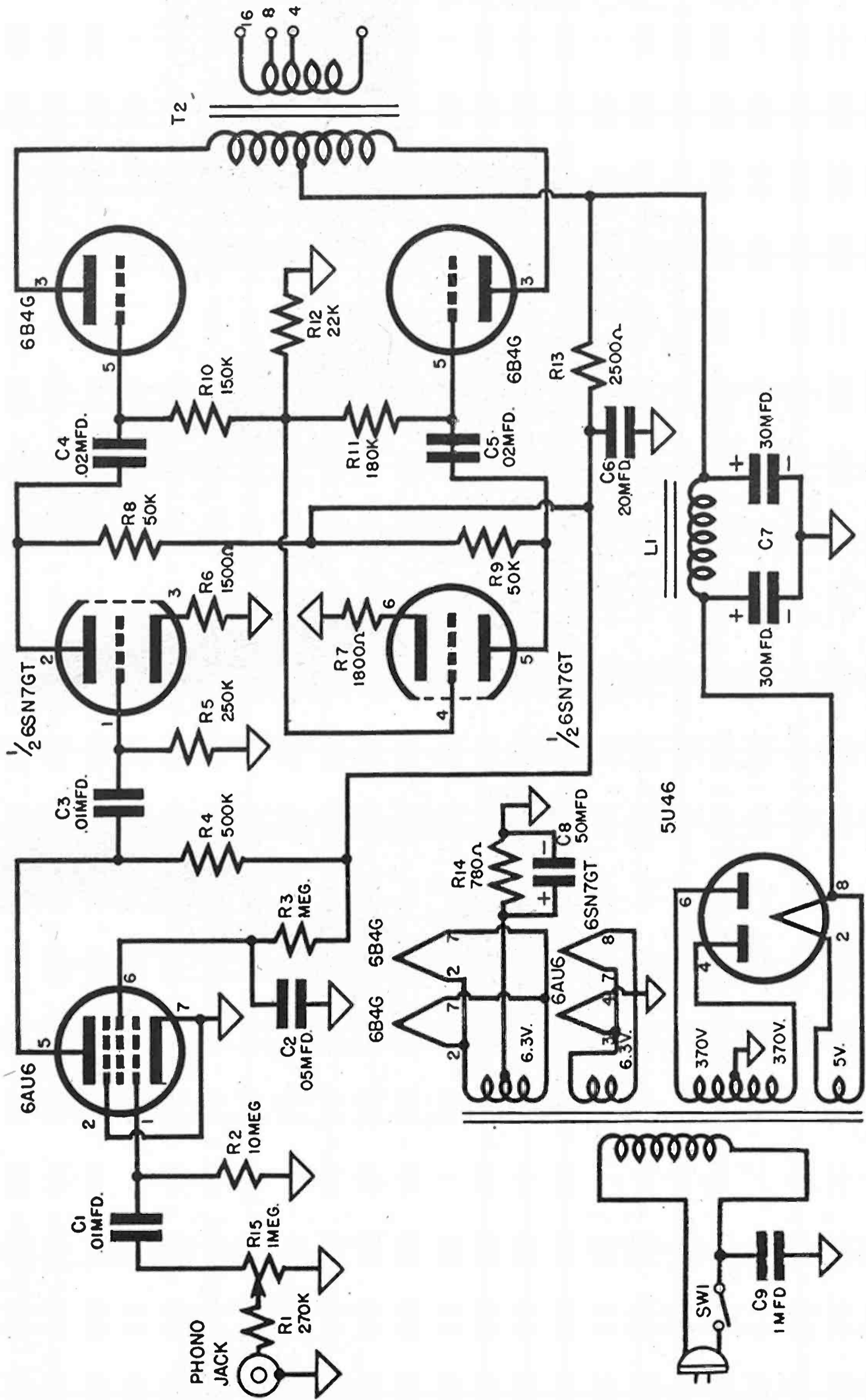

Fig. 5-1A. Schematic diagram of a five-tube hi-fi amplifier.

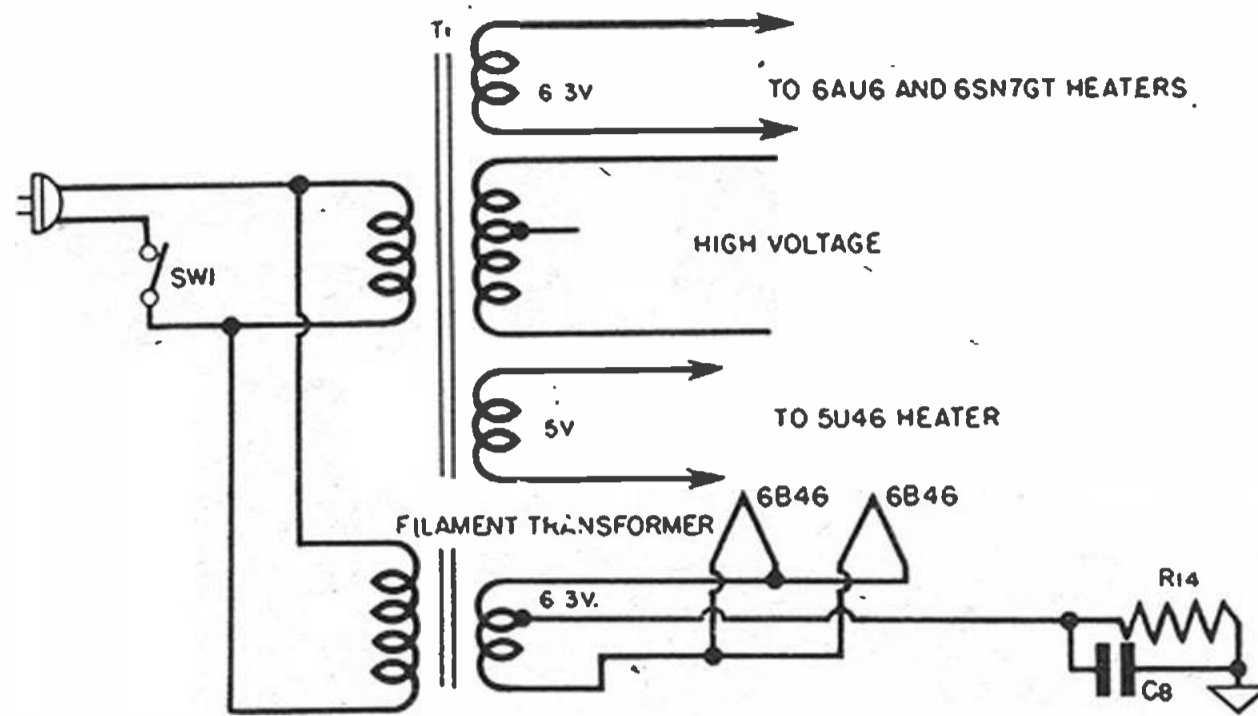

Fig. 5-1B. Use of separate filament transformer.

- R6 1500 ohms, 1/2-watt carbon
- R7 1800 ohms, 1/2-watt carbon
- R8 50K ohms, 1/2-watt carbon
- R9 50K ohms, 1/2-watt carbon
- R10 150K ohms, 1/2-watt carbon
- R11 180K ohms, 1/2-watt carbon
- R12 22K ohms, 1/2-watt carbon
- R13 2500 ohms, 10-watt, wire-wound
- R14 780 ohms, 10-watt, wire-wound
- R15 1 megohm, volume control with switch, SW1

Condensers

- C1 .01 mfd., 600-volt paper tubular
- C2 .05 mfd., 600-volt paper tubular
- C3 .01 mfd., 600-volt paper tubular
- C4 .02 mfd., 600-volt tubular
- C5 .02 mfd., 600-volt paper tubular

- C6 20 mfd., 450-volt electrolytic, aluminum can, vertical mounting
- C7 30-30 mfd., 450-volt electrolytic, aluminum can, vertical mounting
- C8 50 mfd., 100-volt electrolytic, aluminum can, vertical mounting
- C9 .1 mfd., 600-volt paper tubular

Transformers

- T1 Power transformer. For 6B4G or 6A3 tubes: high voltage 370-0-370 volts, 150 m.a.; heater (output) 6.3 volts, 4 amp.; heater 6.3 volts, 1 amp.; rectifier 5 volts, 3 amp. CTC type PCC-150 or equivalent.
For 2A3 tubes: high voltage 375-0-375 volts, 180 m.a.; heater (output) 2.5 volts,

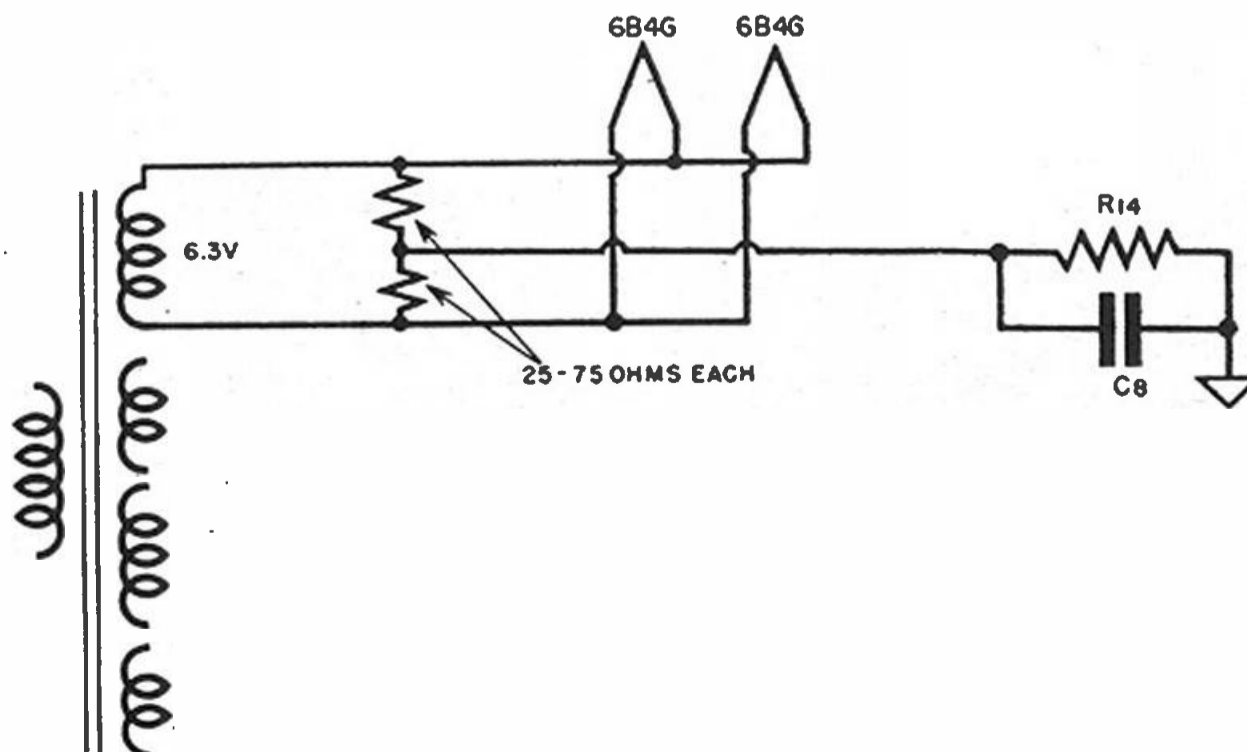

Fig. 5-1C. Use of untapped filament winding.

3.5 amp.; heater 6.3 volts, 3.3 amps.; rectifier 5 volts, 3 amp. Stancor type P-6008 or equivalent.

T2 Output transformer. Push-pull type, primary impedance 5,000 ohms; secondary impedance to match speaker. If a tapped secondary is desired, use Stancor type A3800 or CTC type PCO-80.

Coils

L1 Filter choke 12 henry, 230 ohm, 150 milliamperes

4 8-32 x 1/2-inch r.h. machine screws with nuts

4 10-32 x 1/2-inch r.h. machine screws with nuts

1 output terminal strip, screw type (number of terminals depends upon output transformer used)

Line cord and plug

Chassis: 7 x 10 x 2-1/2 inches, steel

Rosin-core solder

Push-back wire

Tubes

6B4G (2), 5U4G, 6AU6, 6SN7GT

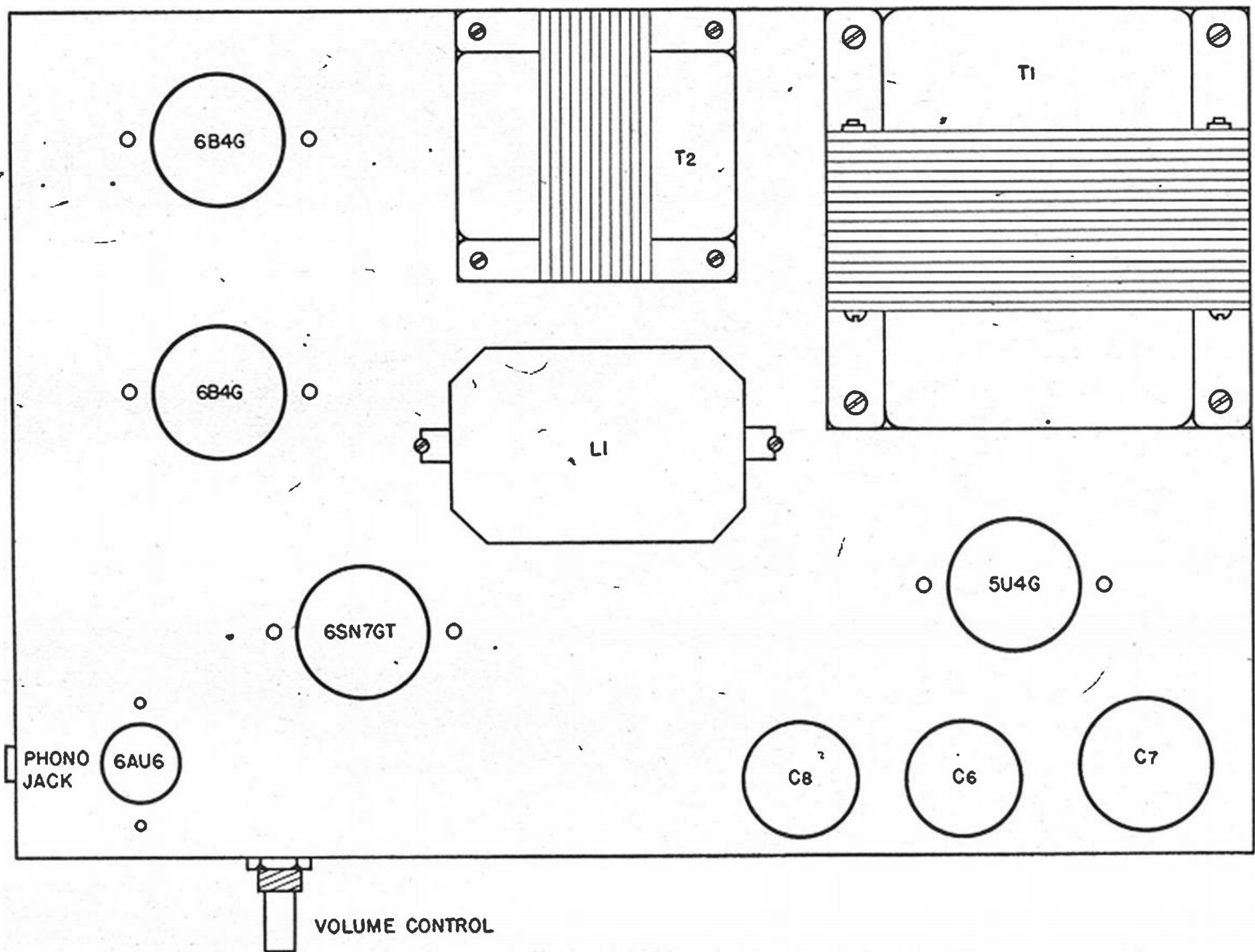

Fig. 5-2. Top view of five-tube amplifier chassis.

Miscellaneous

- 1 RCA-type phono jack
- 4 octal tube sockets
- 1 miniature 7-pin tube socket
- 3 2-point tie strips
- 4 3-point tie strips
- 2 4-36 x 3/8-inch r.h. machine screws
- 2 4-36 hexagon nuts
- 36 6-32 x 3/8-inch r.h. machine screws
- 36 6-32 hexagon nuts

Chassis layout and assembly

See Figure 5-2.

As in most other radio equipment, it is desirable to keep the power supply components, particularly the transformer, as far from the input circuit as possible. Note that the power transformer is mounted at one corner of the chassis and the 6AU6 socket, together with volume control and

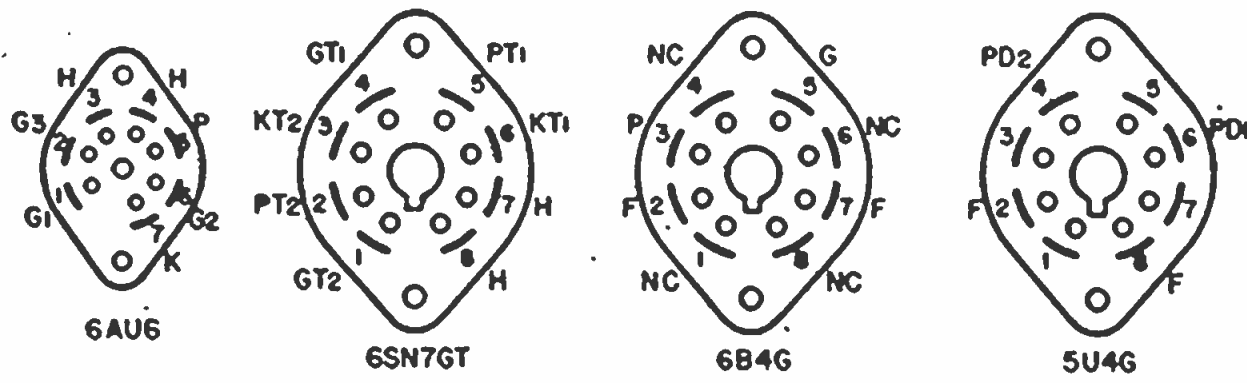

Fig. 5-3. Bottom view of tube sockets.

phono jack, at the diagonally opposite corner. The output transformer is located with its core at right angles to the core of the power transformer, even though both transformers are shielded. The 5U4G rectifier tube and the filter condensers are at the right side of the chassis. The center of the rectifier socket is about 2-1/4 inches from the front edge of the chassis and 2 inches from the right end.

Lay out the positions of the output-tube sockets so that they are at the left rear of the chassis, as shown in the drawing. If the center line is about 1-3/4 inches from the left end of the chassis, you will have ample space. As indicated in the drawing, the two sockets are spaced about 2-1/8 inches between centers, which is rather close but is still enough to prevent the two glass envelopes from touching. If you find by a trial that the tubes will be in contact when thus spaced, the front socket may be moved slightly forward. The center of the 6SN7GT socket is 1-7/8 inches from the front edge of the chassis and 2-7/8 inches from the left side. The center of the 6AU6 socket

may be 3/4 inch from the front edge of the chassis and about one inch from the left. As you will observe in the sketch, the phono jack is located just opposite the 6AU6 socket; its vertical position is midway of the chassis apron. The center of the volume control shaft is approximately 2-1/8 inches from the left end of the chassis and midway between top and bottom on the front apron. The output terminal strip, not shown in the illustration, is mounted on the rear chassis apron, just below the output transformer. You will also need a hole for the line cord, located on the rear apron near the right rear corner. Under the power and output transformers there will be holes to accommodate the transformer leads; their number and positions will depend upon the construction of the individual transformers.

Tie strips required are located as follows: two 2-point (or a single 3-point) for R10 and R11, located between the two output tube sockets; one 3-point near the 6SN7GT socket for R8 and R9; one 3-point for R3

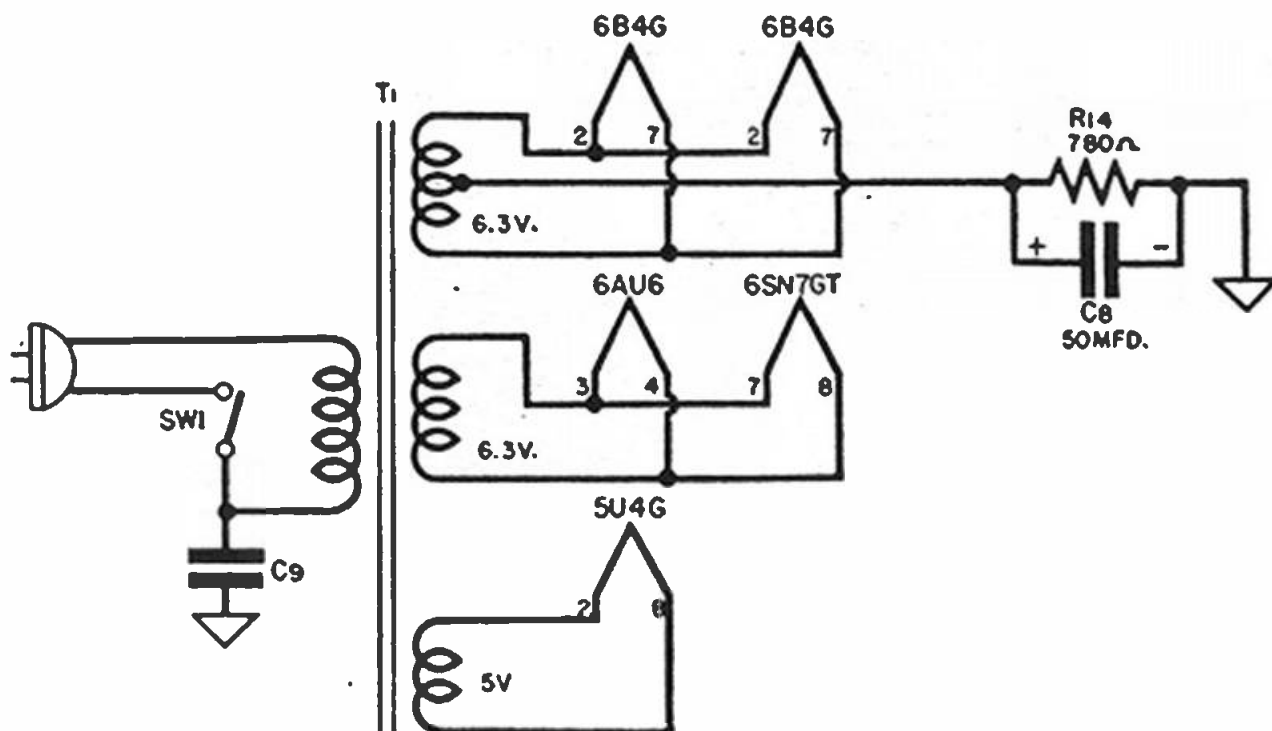

Fig. 5-4. The heater circuit.

and R4, located near the 6AU6 socket; two 2-point near the 6AU6 for R2 and C1; one 3-point for R14; and one 2-point for R13. The 2-point strips ordinarily require one mounting hole and the 3-point need two holes. If tube sockets do not have ground terminals, install such terminals under screws at strategic points.

Wiring

a) *Heater Circuit.* See Figure 5-4.

The transformer primary circuit consists of the line cord and plug, the switch, SW1, and the transformer primary winding. The primary wires are usually color-coded black. Do not omit condenser C9. When wiring the rectifier, heater, and output filament circuits, refer to Figure 5-3 for a bottom view of the tube sockets.

In some localities it may be diffi-

hand a transformer that fills all specifications except for the center-tapped winding. In that case, use the arrangement shown in Figure 5-1B. Notice that a center tap is set up by using the two resistors connected in series across the transformer winding. The resistors may be of any value from about 25 to 70 ohms and should be capable of dissipating about 5 watts. Although this arrangement is a bit bulky, it may save buying a transformer.

b) *Power Supply Circuit.* See Figure 5-5.

As the heater of the rectifier tube is already wired, it is only necessary to connect the high voltage leads (almost always red) to the plates of the rectifier socket and the high voltage center-tap (red and yellow) to chas-

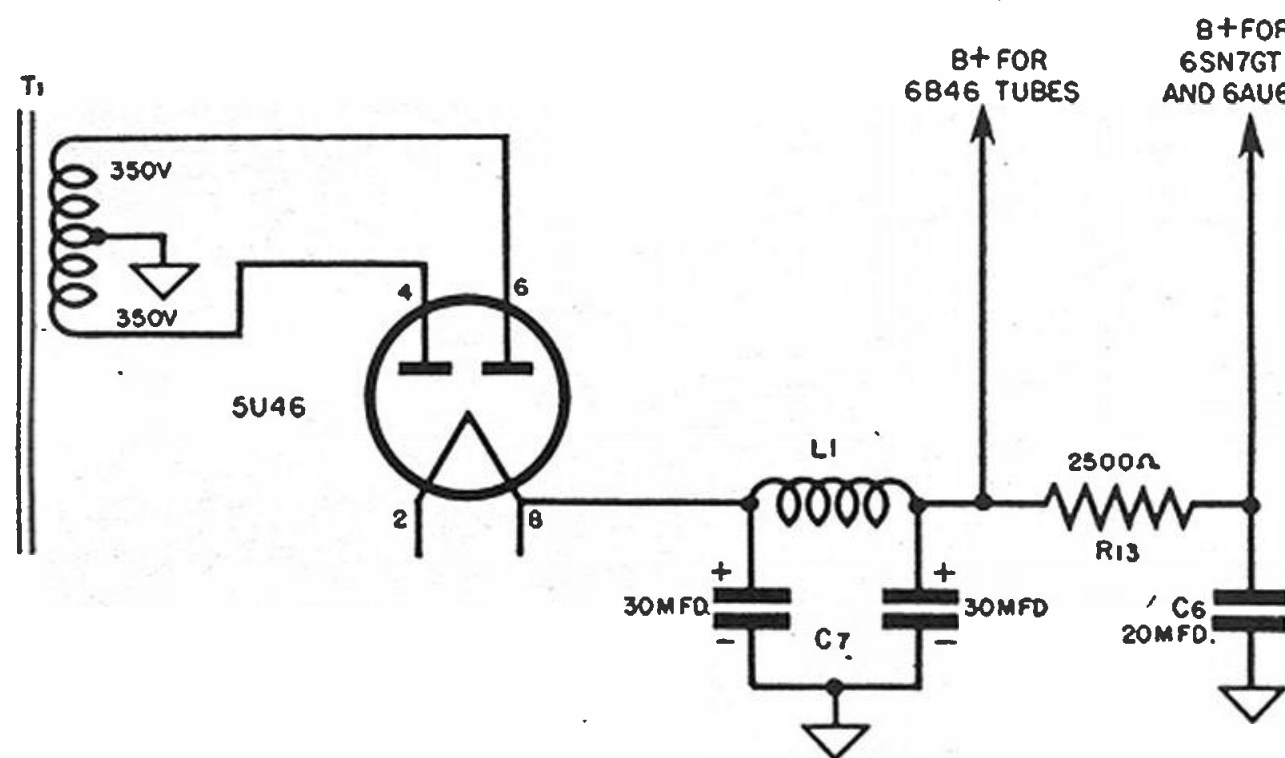

Fig. 5-5. The power supply circuit.

cult to obtain exactly the type of power transformer needed for this amplifier. For that reason, the alternative scheme, shown in Figure 5-1A, is offered. Here a small, separate filament transformer for the 6B4G (or 2A3) output tubes is used; it is wired as shown. If 2A3 tubes are to be used, the filament transformer should, of course, have a 2.5-volt center-tapped secondary winding.

It is possible that, although unable to get a transformer with a center-tapped filament winding (needed for the output tubes), you do have on

sis. B plus may be taken from either pin 2 or pin 8, as in the sketch. Notice that the filter choke and filter resistor are in series. B supply for the output tubes only is taken from the choke. All other plate and screen voltages are taken from the filter resistor, R13.

c) *Output Circuit.* See Figure 5-6.

The secondary terminals of the output transformer are wired to the output terminal strip, located on the rear chassis apron below the transformer. The diagram shows a transformer with secondary taps at 4, 8, and 16

ohms, but the transformer actually used will depend upon the speaker system you intend to purchase.

R10 and R11 should be mounted on a 3-point tie strip located between the two sockets. R12 can be connected from the junction of R10 and R11 to chassis. Incidentally, R12 is actually a part of the grid resistance for the upper 6B4G tube. R10 and R12 together constitute a voltage-divider circuit; the voltage applied to the grid of the 6SN7GT inverter tube depends upon the ratio of R12 and R10. In this case, about 15 per cent of the total voltage is applied to the inverter grid. Note that the connection from

d) *Phase Inverter Circuit.* See Figure 5-7.

Before starting the wiring, R8 and R9 should be mounted on a 3-point tie strip located close to the tube socket. R6 and R7 are connected between the cathode terminals and chassis and therefore need not be supported on strips unless you prefer this arrangement. This also applies to R5 and C3. The junction of R8 and R9 is connected to B plus at the end of the filter resistor, R13. The coupling condensers, C4 and C5, which were left unconnected in the previous circuit, are now wired to the plate terminals 2 and 5. As noted above, be sure

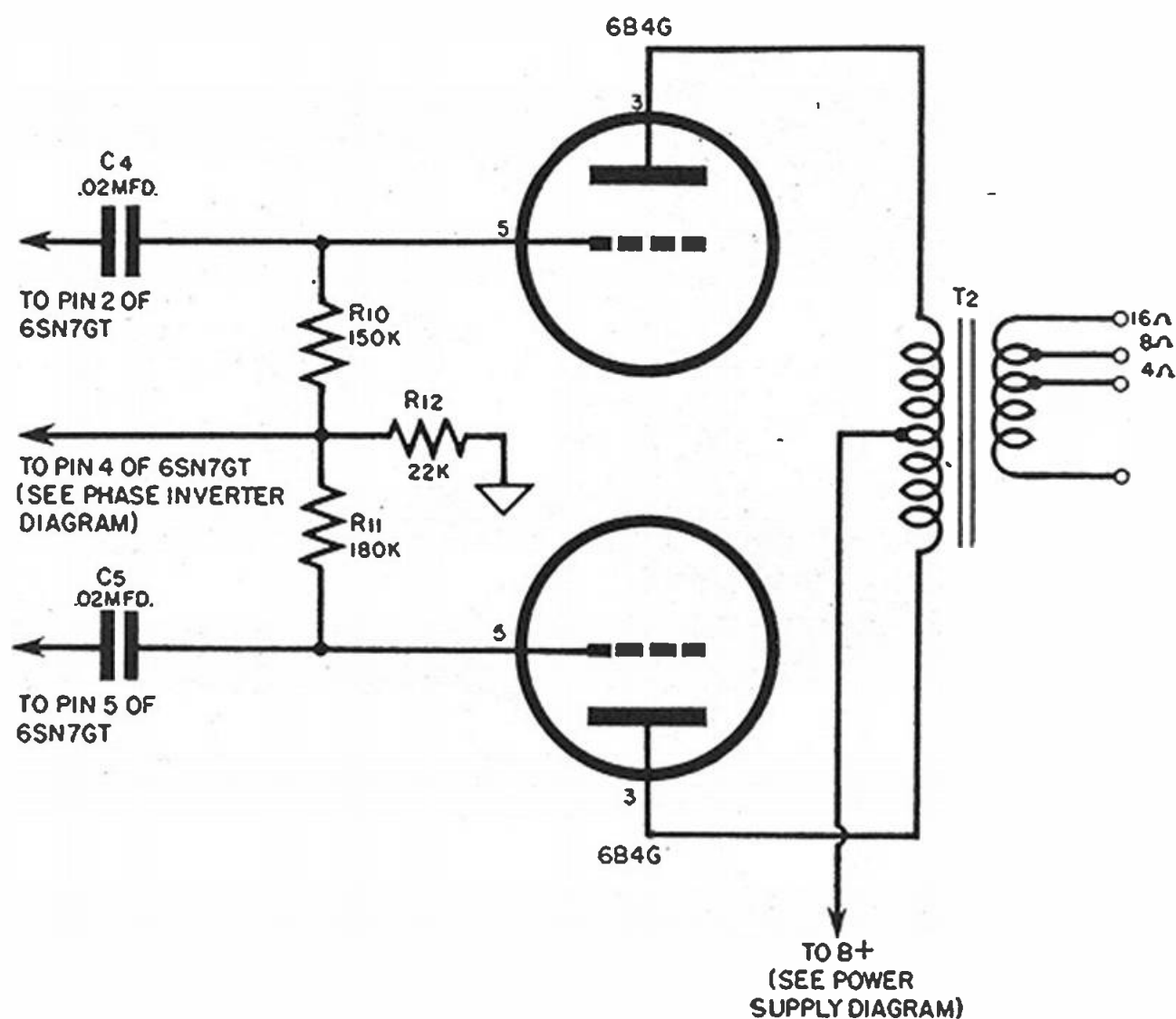

Fig. 5-6. The output circuit.

the junction of R10 and R12 to the grid of the 6SN7GT is not made until the next stage is wired.

C4 and C5 may be connected directly from the output tube grids to pins 2 and 5 of the 6SN7GT, or they may be mounted on tie strips; the latter arrangement is to be preferred. Be careful to observe the connections indicated in the drawing; C4 must be connected to pin 2 of the 6SN7GT, and C5 to pin 5.

to observe the proper connection arrangement here, otherwise the circuit will not work properly. Connect pin 4 to the junction of R10, R11, and R12. R5, the grid resistor, may be connected directly from the socket terminal to chassis, and C3 between the 6AU6 and 6SN7GT tube sockets, or these parts may be supported by tie strips, as you choose. The use of the tie strips is optional in some cases, but in others is mandatory.

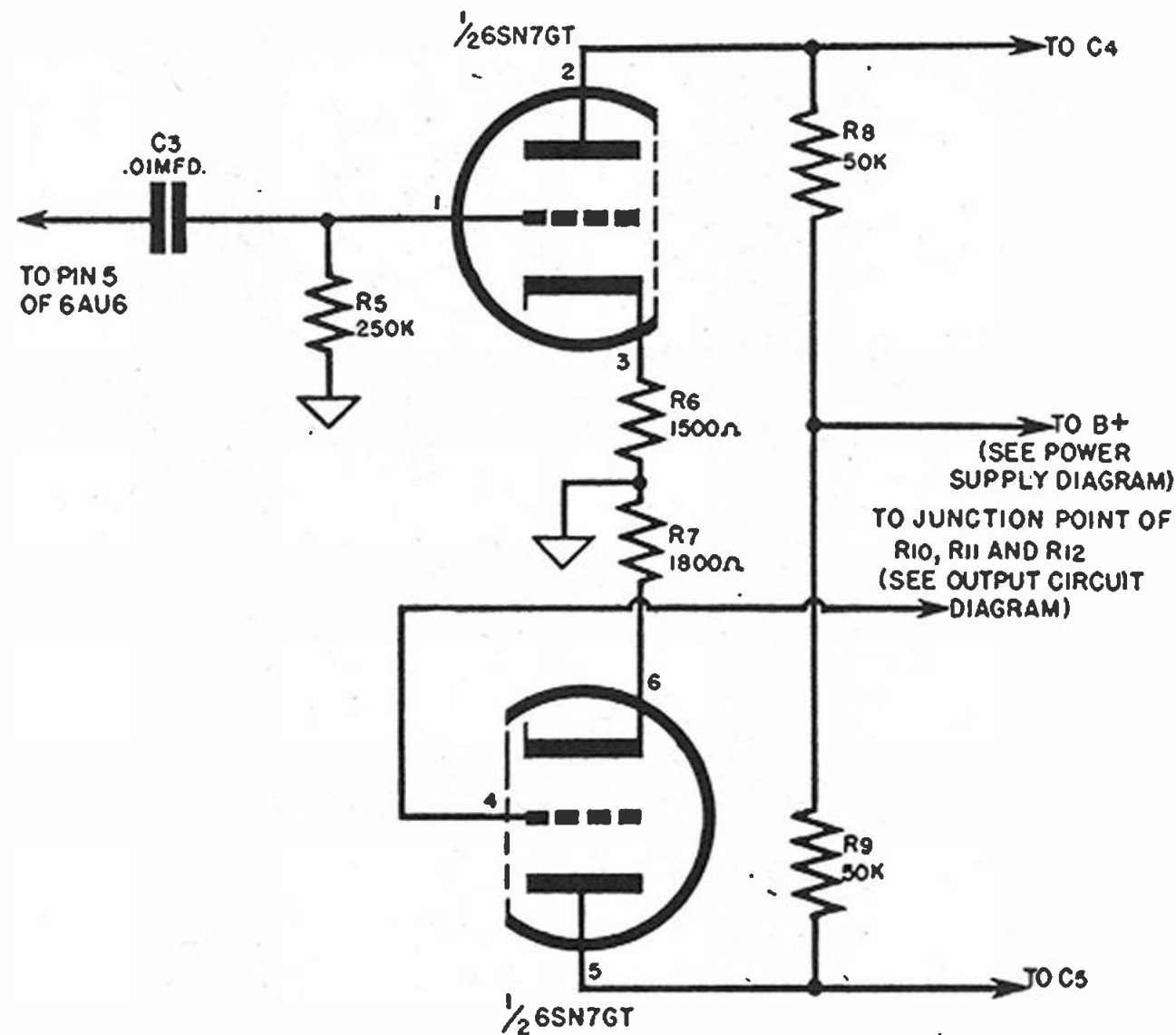

Fig. 5-7. Phase inverter diagram.

e) *First A.F. Circuit (Voltage Amplifier)*. See Figure 5-8.

Since R3, R4, R2, and C1 cannot be supported by socket terminals or other connection points, it is advisable to mount them on tie strips before beginning the actual wiring of the circuit. Use a 3-point strip for R3 and R4, and another for R2 and C1.

Connect a short jumper wire between socket terminals 2 and 7, then connect 7 to chassis. The junction of the plate and screen resistors, R3 and R4, is wired to B plus, at the far end of the filter resistor, R13. Reference back to Figure 5-5 will show the prop-

er point for this connection. C2 may now be connected from the socket terminal (pin 6) to chassis. Connect C3 between pin 5 (the plate terminal) and pin 1 of the next tube, the 6SN7GT.

If the phono input jack and the volume control have been placed quite close to the 6AU6 socket, as indicated in the assembly drawing, the wiring between the jack, the volume control, and the grid of the tube will be short, and there will then be slight possibility of hum pickup. R1 is connected directly between the high side of the phono jack and the movable

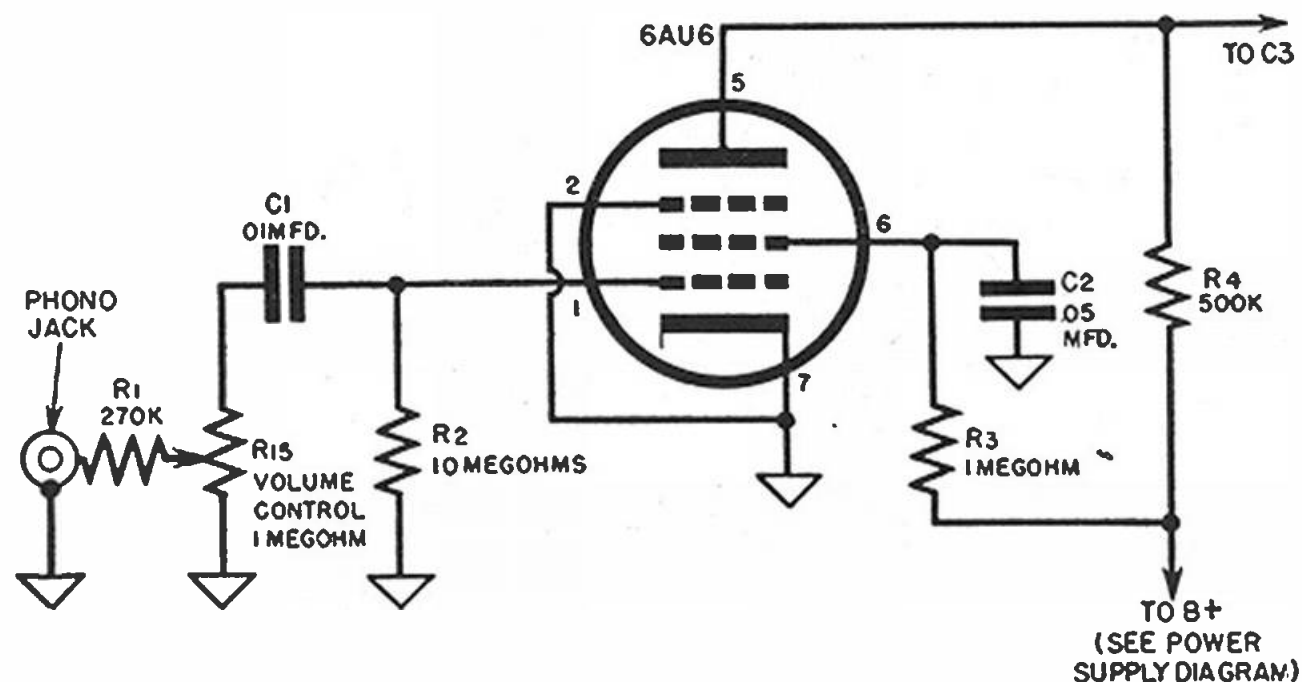

Fig. 5-8. The first A. F. circuit.

contact of the volume control. The high side of the control is connected to the tube grid (pin 1) through condenser C1. R2 is connected from this point to the chassis. This completes the wiring.

Testing

The rough operation test described in connection with other projects in this book—touching the tube grids with a screwdriver—may be used here. Touching the grid of the 6AU6 tube should produce a very loud hum or buzz. A similar check made at the grid of the 6SN7GT tube (pin 1) will be somewhat less effective, as only two stages are then working. At the output-tube grids you should get a noticeable, but not loud, buzz; this is because the gain of this triode stage is quite low.

For your convenience, the normal resistance and voltage measurements are given below, together with some suggestions for diagnosing troubles that may arise.

a) *Output Stage.* All values apply to either tube, unless otherwise noted.

Resistance measurements:

<i>From</i>	<i>To</i>	<i>Ohms</i>
pin 3	chassis	over 100K
pin 2 or 7	chassis	780
pin 5 (upper tube)	chassis	172K
pin 5 (lower tube)	chassis	180K

Voltage measurements:

<i>From</i>	<i>To</i>	<i>DC Volts</i>
pin 2 or 7	pin 3	approx. 300
chassis	pin 3	approx. 360
pin 2 or 7	pin 5	-60
chassis	pin 5	0
pin 2 or 7	chassis	60

A common trouble in push-pull output stages is excessive hum. You may determine whether or not the hum arises in the output stage by removing the 6SN7GT tube from its socket with the set in operation. If

there is no change in hum level with the tube removed, then the trouble is in the output stage. Common causes of hum include: circuit unbalanced due to poorly matched tubes; one-half of output transformer primary winding open. A shorted coupling condenser (C4 or C5) may also cause high hum level, but in that case the grid of the tube connected to the defective condenser will show a positive voltage reading to chassis.

b) *Phase Inverter.*

Resistance measurements:

<i>From</i>	<i>To</i>	<i>Ohms</i>
pin 1	chassis	250K
pin 2	chassis	over 100K
pin 2	B plus	50K
pin 3	chassis	1500
pin 4	chassis	infinity
pin 5	chassis	over 100K
pin 5	B plus	50K
pin 6	chassis	1800

Voltage measurements:

<i>From</i>	<i>To</i>	<i>DC Volts</i>
pin 2	chassis	175
pin 5	chassis	175
pin 3	chassis	4
pin 6	chassis	4
pin 1	chassis	0
pin 4	chassis	4

If this stage appears to be inoperative, look for a shorted or open coupling condenser (C3) or a defective tube. A shorted coupling condenser will become evident by the positive voltage existing between grid and chassis. Aside from these possibilities, and assuming that the circuit is correctly wired and all values as specified, you should encounter no trouble in this stage.

c) *Voltage Amplifier.*

Resistance measurements:

<i>From</i>	<i>To</i>	<i>Ohms</i>
pin 1	chassis	10 meg.

pin 2	chassis	0
pin 5	chassis	over 600K
pin 6	chassis	over 1 meg.
pin 5	B plus	500K
pin 6	B plus	1 meg.

pin 5	chassis	approx. 125
pin 6	chassis	approx. 75
pin 7	chassis	0

Voltage measurements:

From	To	DC Volts
pin 1	chassis	0
pin 2	chassis	0

If screen voltage is lacking, look for open R3 or shorted C2. Low voltage, excessive hum, and no signal indicate an open grid circuit, probably the grid resistor, R2. Normal voltages, hum level normal and no signal may mean that C1, R15, or R1 is open.

SPEAKERS FOR HIGH FIDELITY SYSTEMS

Earlier in this chapter we touched rather lightly on the subject of speakers. At this point, assuming that you have built the amplifier just described, you will probably want additional information.

If you have decided to use one of the single-unit extended-range speak-

of a suitable baffle, or enclosure, for the speaker, which will be taken up later on.

The installation of coaxial or other duplex speakers is not particularly complicated. Some types are furnished with a built-in dividing network for feeding the proper frequencies to the respective speaker units. If the network is not an integral part of the speaker combination, then the manufacturer supplies a suitable network at extra cost. In either case you are assured a cross-over network that is specifically designed for the speakers used.

It is entirely possible that you might want to try making your own combination of speaker units; you will therefore want to know something of the principles involved in designing and constructing cross-over circuits.

It is possible to operate two or more speakers in series or parallel without a cross-over or frequency-dividing network, although with such an arrangement you cannot expect to get the best results. Parallel operation of two speakers is illustrated by the circuit of Figure 5-9. Here two speakers, each having a voice-coil impedance of 8 ohms, are connected to an output-transformer secondary winding of 4-ohm impedance. Impedance matching will be correct, for the total impedance of any two units of equal impedance will be half that of a single unit. This arrangement may be extended to three, four, or more speak-

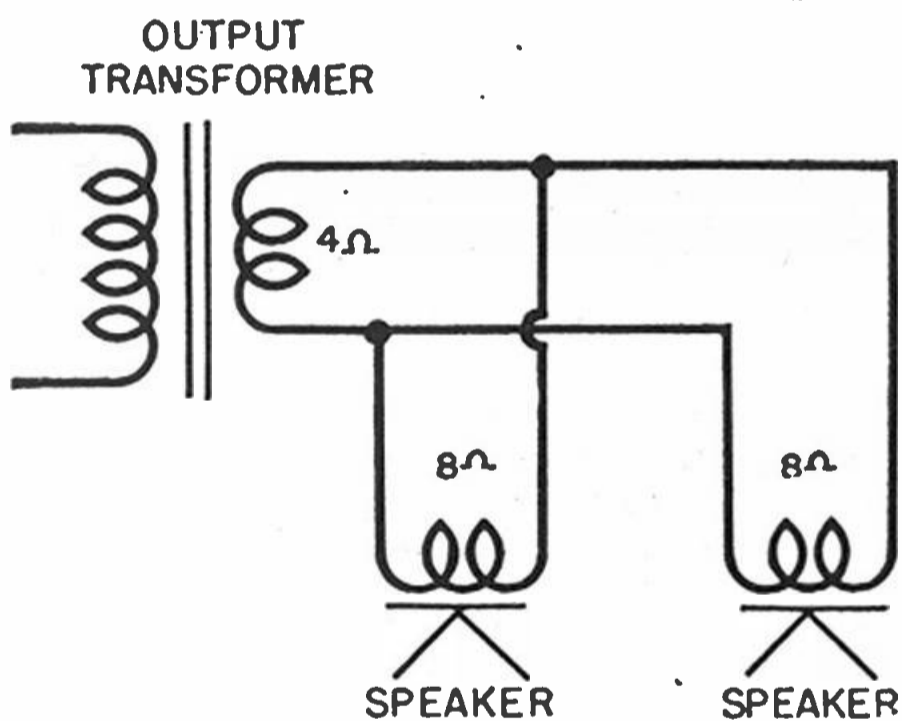

Fig. 5-9. Speakers joined in parallel.

ers, you will have no problem at all except to be sure that the speaker voice-coil impedance matches that of the output transformer secondary winding. Of course there is the matter

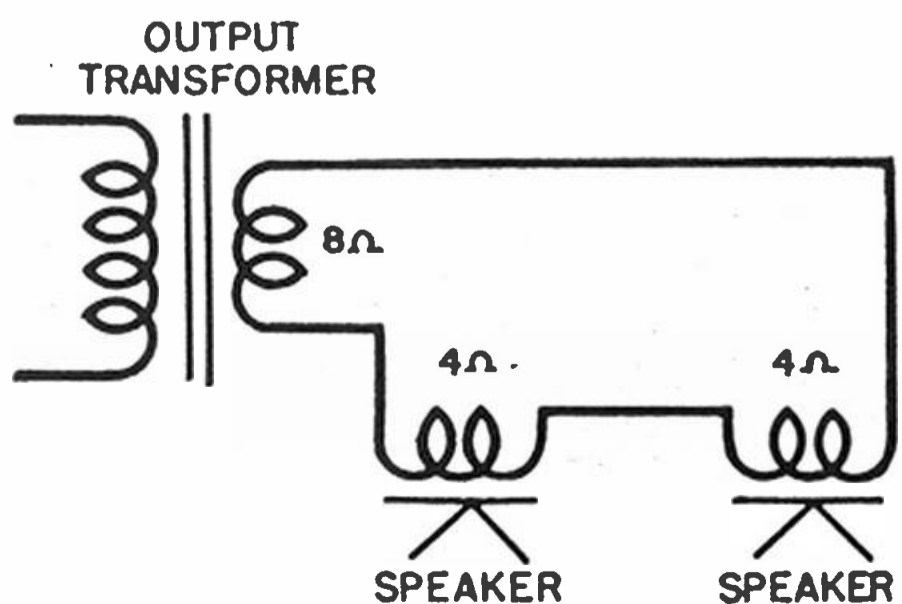

Fig. 5-10. Speakers joined in series.

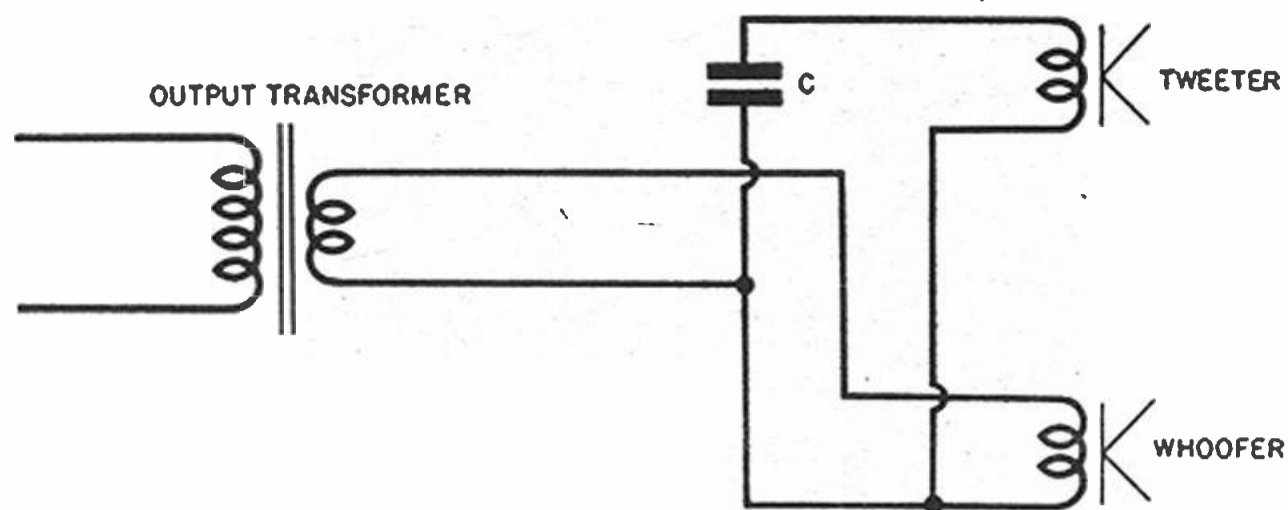

Fig. 5-11. Condenser in series with tweeter.

ers, and the correct transformer impedance is not difficult to calculate, provided that speakers having equal impedances are used. For example, four 16-ohm speakers may be connected in parallel to a 4-ohm transformer secondary.

Figure 5-10 shows two speakers of similar voice-coil impedance connected in series. Since the total impedance of units in series is the sum of the individual impedances, the two 4-ohm speakers require a transformer with an 8-ohm secondary winding. If you wanted to use four such speakers in series, the secondary impedance should be 16 ohms.

Figure 5-11 shows an arrangement that is a definite improvement over the simple series and parallel circuits just discussed, for some provision is made to restrict the low frequencies fed to the tweeter unit. This is done by connecting a condenser in series with the tweeter. The size of the con-

denser will depend upon two factors: (a) the desired cut-off point, and (b) the speaker voice-coil impedance. To determine the cut-off point, you will have to know something of the speaker's characteristics; however, most cross-over networks are designed for a frequency of somewhere between 1,000 and 4,000 cycles, so that we may select a frequency within that range for an example. In this instance we shall assume a cut-off frequency of 2,000 cycles; this is to say, all frequencies lower than 2,000 will be attenuated, so far as the tweeter is concerned. To accomplish this, the reactance of the condenser must be equal to the voice-coil impedance at 2,000 cycles. If the voice-coil impedance is 4 ohms, the condenser must have a capacitance of 20 microfarads. To save you the work of calculating the condenser value, the accompanying table is offered.

Voice-coil-impedance	4-ohms	6-ohms	8-ohms	16-ohms
Cap. for 1,000 cycles	40 mfd.	28 mfd.	20 mfd.	10 mfd.
" " 1,500 "	27 mfd.	18 mfd.	13 mfd.	6.5 mfd.
" " 2,000 "	20 mfd.	13 mfd.	10 mfd.	5.5 mfd.
" " 3,000 "	14 mfd.	9 mfd.	7 mfd.	3.5 mfd.
" " 4,000 "	10 mfd.	7 mfd.	5 mfd.	2.5 mfd.

It is evident that for even a relatively high cut-off point the condenser will be quite large. One difficulty is eliminated immediately, however—the working voltage need not be high since the applied voltages rarely exceed 50. Paper condensers may be

used for the smaller sizes, but it is obvious that for capacitances above 5 microfarads or so, electrolytic condensers must be employed if the physical size is to be kept within reasonable limits. No doubt you are ready with the question: "Since the electrolytic

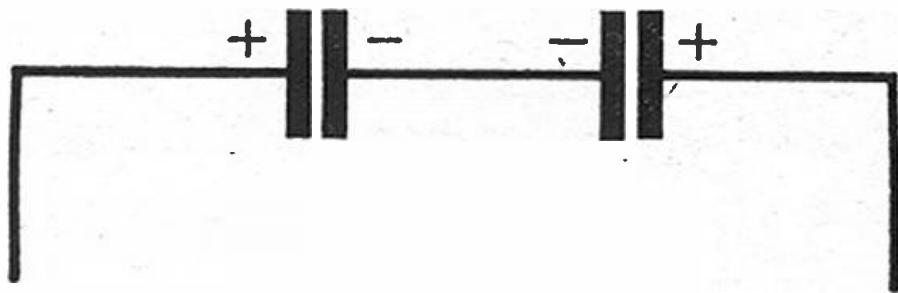

Fig. 5-12. Connecting for AC use.

condenser has polarity, what happens when it is operated on voice-coil voltages, which, of course, are AC?" The answer is found in the electrolytic condensers used in motor starting circuits on such appliances as refrigerators and washing machines. Ordinary electrolytic condensers are used, but two units are connected as shown in Figure 5-12. You will notice that the two units are wired with their negative terminals connected together. Whenever two condensers are connected in series, the total capacitance of the combination will be half the value of either unit, assuming of course that the two are equal in capacitance. Thus, to make up a 20-microfarad combination, two 40 mi-

crofarad condensers must be used.

Improved results will be realized if you use a cross-over network like that of Figure 5-13. This is the arrangement used in many commercially manufactured combinations. The woofer and the tweeter are connected in parallel and there is a condenser in series with the tweeter voice coil as before, but there is also a choke in series with the woofer. When the circuit of Figure 5-11 is used, the lower frequencies are kept out of the tweeter unit, but there is no provision for excluding the high notes from the woofer. This may be undesirable as some large speakers distort on high notes at increased power. The situation may be avoided by using the Figure 5-13, circuit.

The inductance of the choke coil will depend upon the desired cross-over frequency and the voice-coil impedance. Here is a tabulation of the inductance required for various cross-over frequencies and voice-coil impedances.

<i>Voice-coil-impedance</i> Inductance in milli- henries for cross-over at	<i>4-ohms</i>	<i>6-ohms</i>	<i>8-ohms</i>	<i>16-ohms</i>
1,000 cycles	.65	.95	1.3	2.6
1,500 "	.43	.65	.85	1.75
2,000 "	.33	.5	.7	1.3
3,000 "	.23	.35	.45	.9
4,000 "	.17	.25	.35	.65

You have a choice of buying a suitable inductance or winding it yourself. If you decide upon the latter

course, you will need some #17 enameled wire and a wooden form of suitable size. If the inductance is to

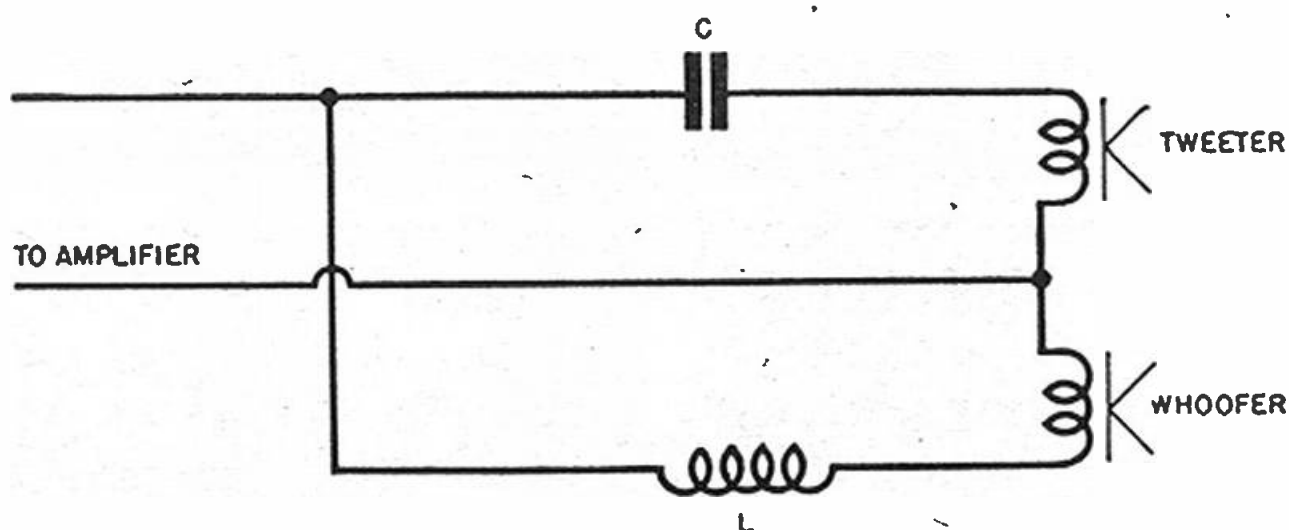

Fig. 5-13. Crossover network for dual speaker.

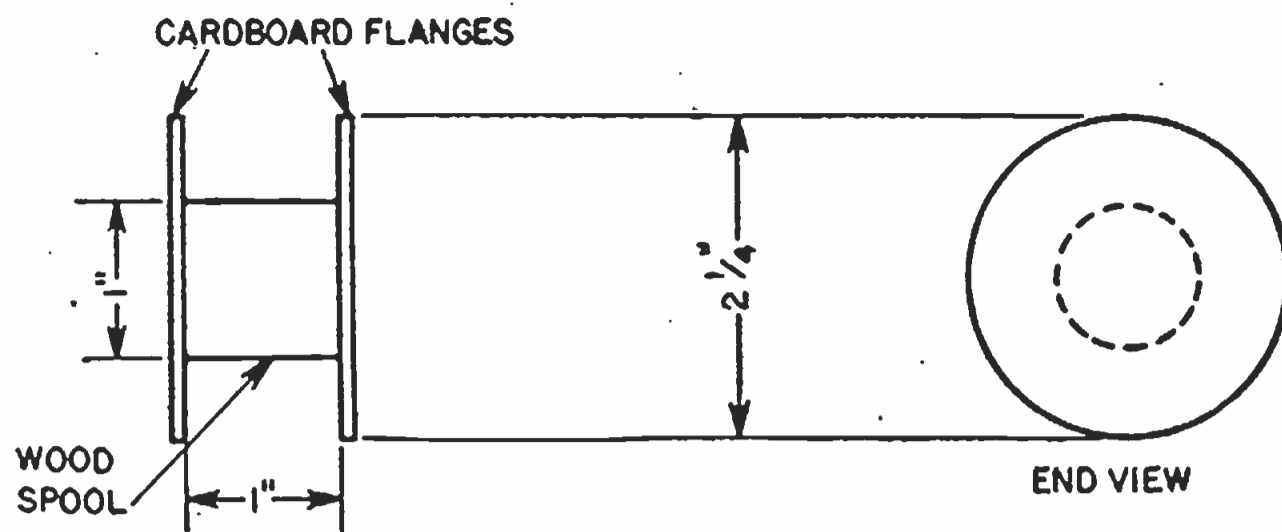

Fig. 5-14A. Form for winding inductances.

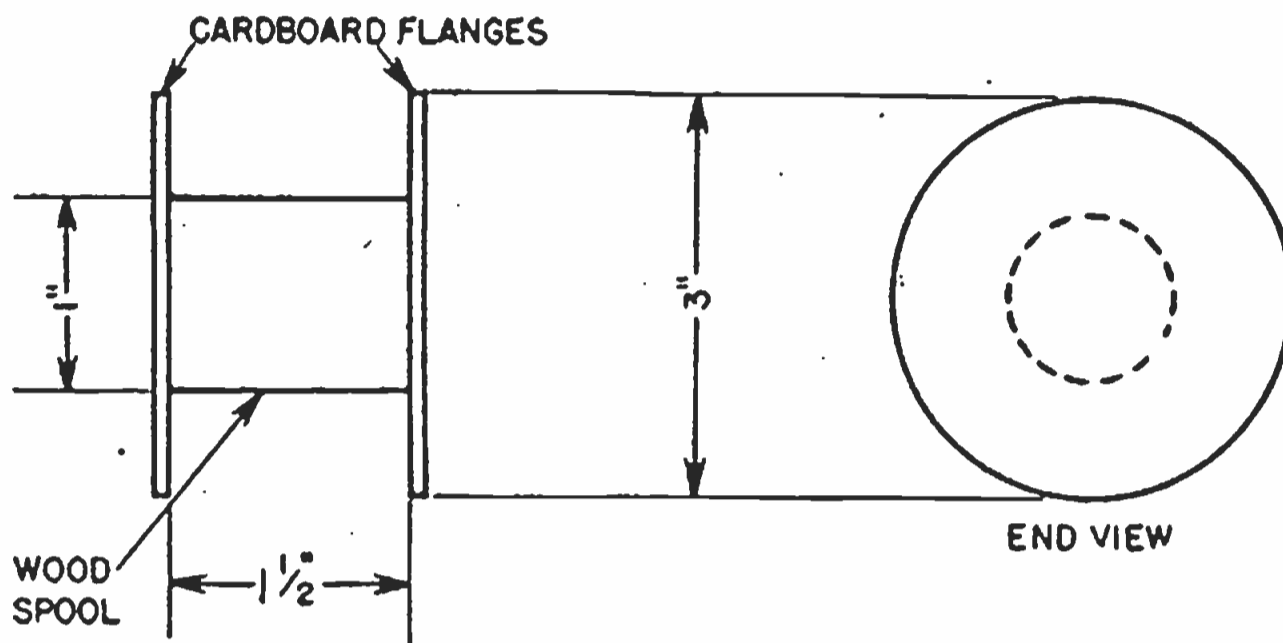

Fig. 5-14B. Larger form for over 1.5 millihenry.

be less than 1.5 millihenry, make a form as shown in Figure 5-14A. For any value above 1.5, the form must be larger, as shown in 5-14B.

The spool for the coil form may be made of a length of 1-inch dowel or broom handle. For a neat job, be sure that the ends of the spool are cut squarely, otherwise the flanges will not be parallel and at right angles to the spool. Use a piece of dowel an inch long for the smaller form (Figure 5-14A) or a 1-1/2 inch length for the larger one, Figure 5-14B.

Make the flanges of heavy cardboard, sheet fibre, or masonite. In fastening the flanges to the spool ends, use brass wood screws. Under no circumstances should iron screws or nails be used. Start the winding by drilling a small hole in one flange, close to the spool. Pass the wire through the hole and then wind on the required num-

ber of turns. The end of the winding is then anchored by passing it through another small hole in the flange. The coil should be layer-wound, not jumble-wound. The number of turns to be wound on the form of Figure 5-14A, together with the desired inductance is given below:

Inductance	Turns	Inductance	Turns
.17	87	.5	141
.23	100	.65	160
.25	108	.7	166
.33	116	.85	180
.35	120	.9	185
.43	128	.95	190
.45	135	1.3	230

If the inductance works out to more than 1.5 millihenry, use the larger form. The number of turns will then be: for a 1.75 millihenry inductance, 310; for a 2.6 millihenry inductance, 360.

BASS REFLEX SPEAKER ENCLOSURE

As you are probably aware, any speaker requires a baffle if it is to operate

efficiently. A speaker suspended in air with no baffle at all will set very little

air in motion and will be quite inefficient. The reason is that the air waves at the front of the cone cancel those at the back.

Theoretically, the larger the baffle, the more efficient the speaker will be, particularly at the lower frequencies. This fact has led high-fidelity fans to adopt one or the other of two baffle systems, referred to as the infinite baffle and the bass reflex enclosure. An infinite baffle is so large that the front and back waves set up by the speaker can never meet and cancel. It is most frequently achieved by building a speaker into one wall of a room. Such an arrangement may be impracticable, if not impossible, in many situations.

This brings us to the bass reflex type of speaker baffle. The basic idea is to eliminate waves caused by the resonance of the cone. This is done by making the resonant frequency of the cabinet equal to that of the cone.

When this is accomplished, a cancellation of waves occurs and the reproduction of bass notes is enhanced. Unlike most radio cabinets, which have the back open, the bass reflex cabinet is completely enclosed. But there is a port, or vent, in the front of the housing below the speaker opening. The size of this port is quite important; it is governed by the size of the speaker.

Construction of the cabinet

A bass reflex cabinet should have a volume of not less than 5 to 6 cubic feet. If the front of the cabinet is to be 2 by 2 feet, the depth will then be about 1-1/2 feet. Figure 5-15 shows an enclosure for use with a 12-inch speaker. This cabinet is 30 inches high, 24 inches wide, and 18 inches deep; the total volume is considerably greater than the minimum—it is 7.5 cubic feet.

In building the enclosure, use ply-

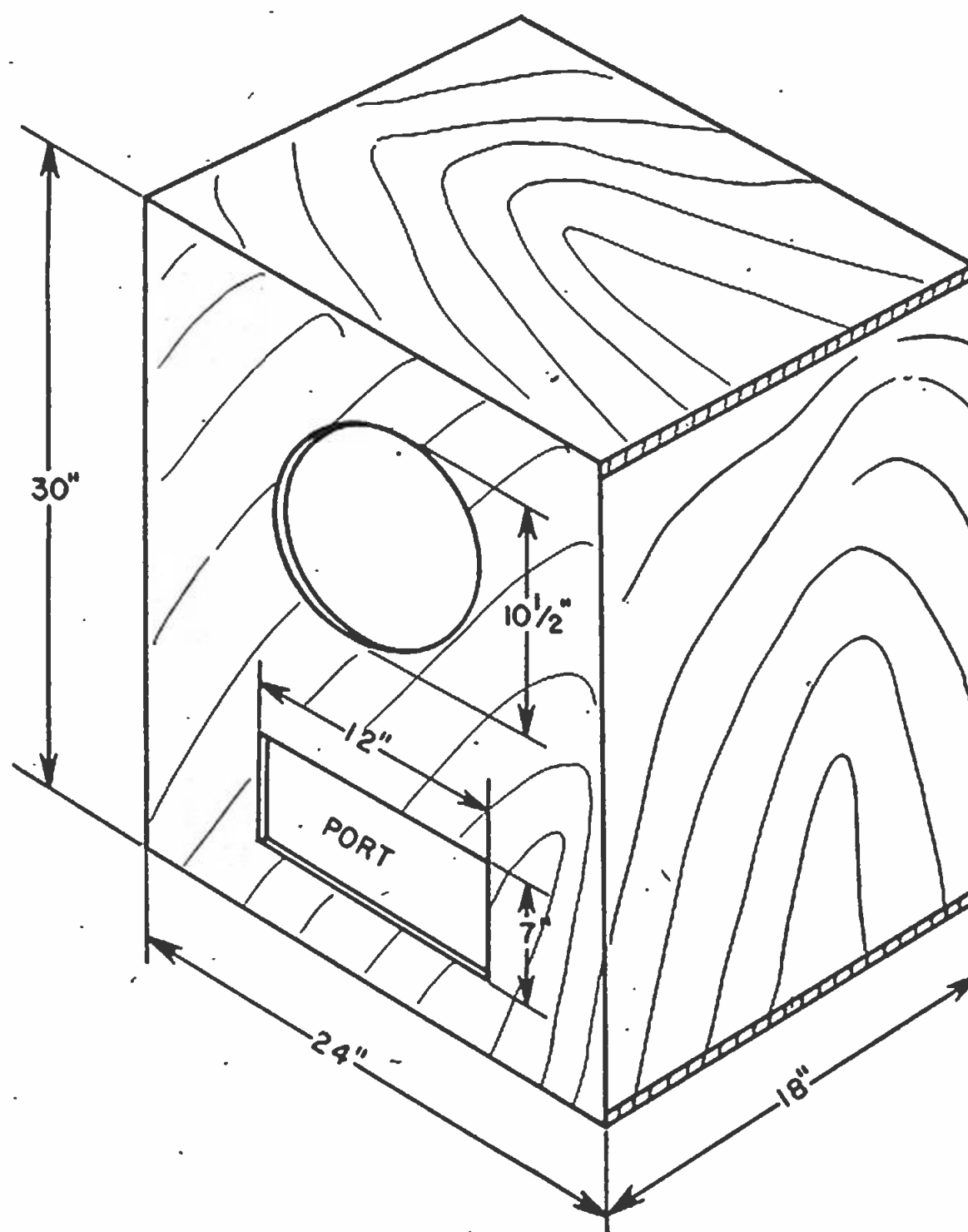

Fig. 5-15. Bass reflex speaker enclosure.

wood or solid lumber at least $\frac{3}{4}$ -inch thick. As plywood is more readily obtainable in widths greater than 12 inches or so, it is better adapted for this kind of construction than solid lumber. Furthermore, there is much less likelihood of warping.

Begin construction by building an open box 30 inches high, 24 inches wide, and 18 inches deep. The type of corner joint used will be governed by the kind of finish you intend to apply and your woodworking skill. If the cabinet is to be painted, there will be no need to conceal the end grain at the joint and a common butt joint can be used. In that case, the two side pieces will be 18 by 28- $\frac{1}{2}$ inches; the top and the bottom will be 18 by 24 inches. When the pieces have been cut to size, assemble as shown in Figure 5-15. As each corner joint is made up, apply glue to the surfaces to be jointed; you can use a prepared liquid glue or one of the powder types, such as Casein, Cascamite, or Weldwood.

Fasten each joint with 1- $\frac{1}{2}$ -inch brads or finishing nails spaced about three inches apart. Set the heads of the brads below the surface of the wood with a small nail set. When all four corner joints are completed, install the corner blocks shown in the sketch. These should be about 1- $\frac{1}{2}$ inches square and should run the full depth of the cabinet. Fasten the corner blocks in place with 2- $\frac{1}{4}$ -inch #10 flathead wood screws, not forgetting to apply glue to the inside surfaces. If you use reasonable care in construction, you will have a cabinet that is remarkably rigid.

The back of the cabinet is a $\frac{3}{4}$ -inch panel measuring 24 by 30 inches. It is not to be fastened permanently to the cabinet, but is held in place with 8 or 10 wood screws so that it may be removed if necessary.

Some builders prefer to use an adjustable port. If this scheme is used, there must be some access to the cabinet interior to permit adjustment.

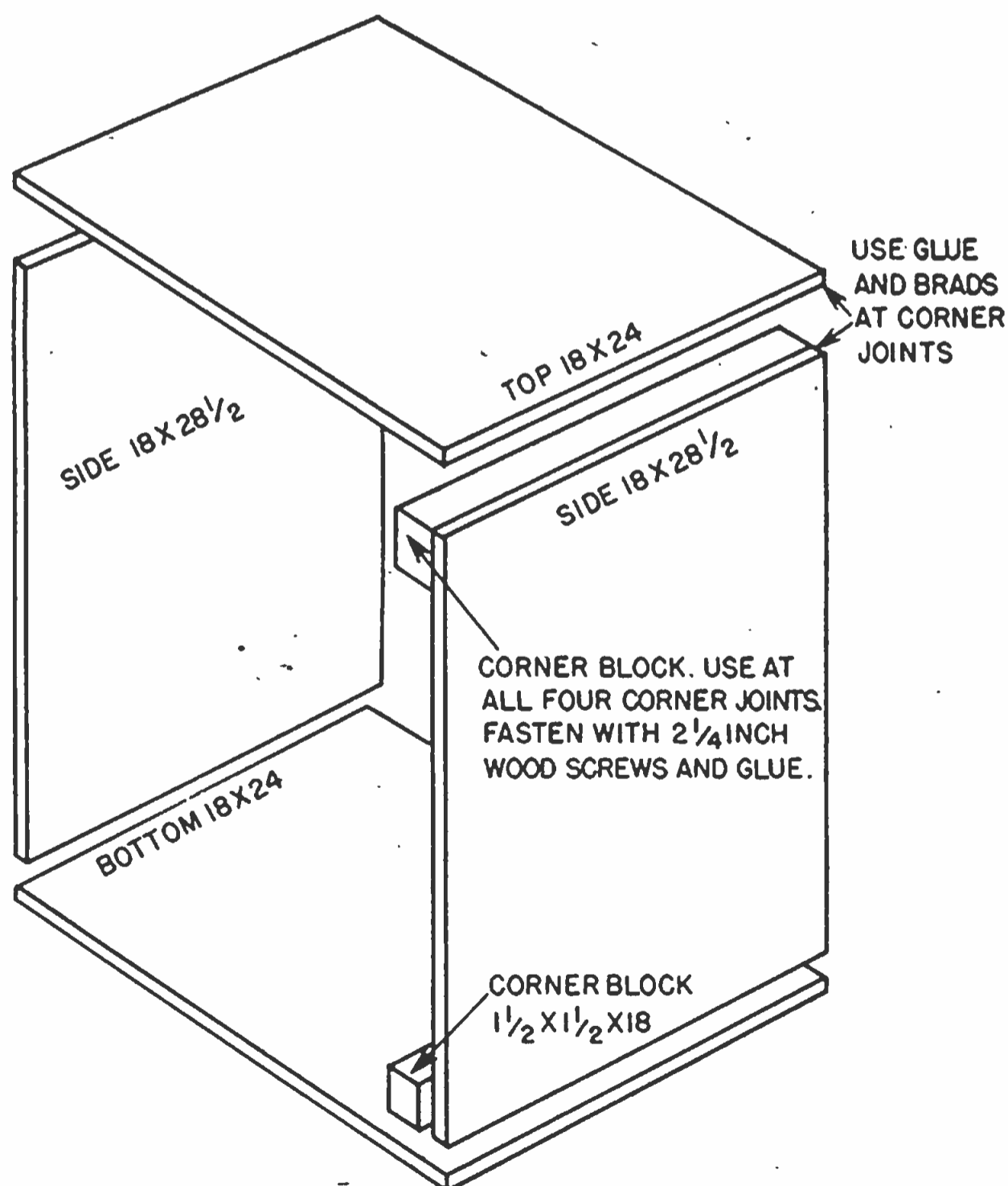

Fig. 5-16. Speaker enclosure construction detail.

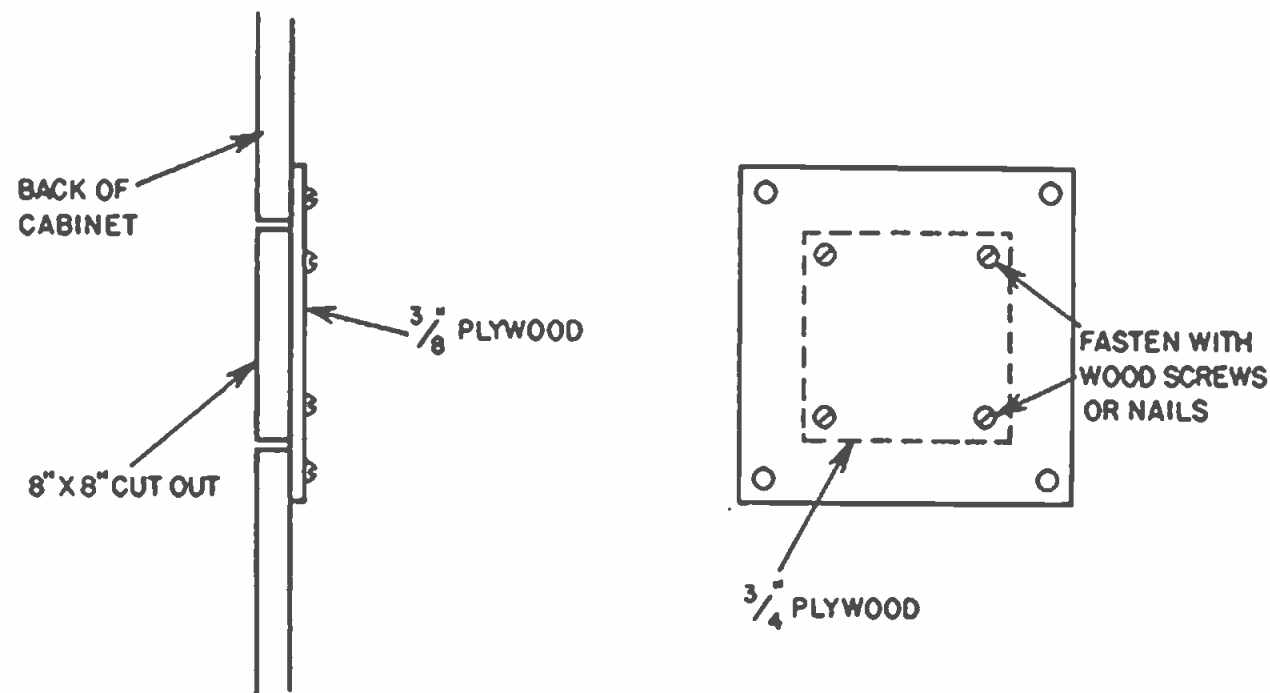

Fig. 5-17. Speaker enclosure access door.

This can best be done by cutting an opening in the back panel and fitting this opening with a removable door, as shown in Figure 5-17. As you will observe, the door consists of the square or rectangular piece cut out of the back. The opening may be as large as desired, but 8-inches square should be ample. To the back of the cut-out section of plywood, fasten a piece of 1/4-inch thick plywood that is three inches or so larger in each dimension than the opening. The 1/4-inch plywood is nailed or screwed to the door. Four or more wood screws located around the edges of the 1/4-inch panel hold it to the back of the cabinet.

Calculating the area of the port

The front panel shown in Figure 5-15 is for use with a 12-inch speaker; the size of the speaker opening and the area of the port will vary with speaker diameter. For a 12-inch speaker the round opening should be 10-1/2 inches in diameter. This hole can be cut with a compass saw. The port is 7 by 12 inches, but these proportions need not be followed precisely since the important thing is the area of the port, not its actual dimensions. For instance, the port shown in the drawing has an area of 84 square inches and measures 7 by 12 inches. The dimensions could just as well be 10 by 8-1/2 inches, which would give a total area of 85 square inches. The precise location of the port opening is unim-

portant, except that for structural reasons it is best not to locate it too close to an edge of the panel. Should you want to calculate the size of the port for a speaker other than one of 12-inch diameter, square the radius of the speaker opening, then multiply this result by 3.14. For example, a 10-inch speaker should have an 8-1/2-inch diameter opening. The radius of this opening would be 4-1/4 inches. 4-1/4 times 4-1/4 times 3.14 equals 56.7 square inches. The port opening for such a speaker, then, would have an area of approximately 56 square inches. The dimensions could be 7 by 8, 10 by 5-3/4, or any other combination.

With the front and back panels completed, the next step is to apply sound-absorbing material to the interior of the cabinet, as shown in Figure 5-18. Many types of insulating material used in home construction are suitable for this purpose, including rock wool, Celotex, and Kimsul. The minimum requirement is to line the top, the back, and one side, although all interior surfaces may be lined if you wish. Some constructors insist that the front panel should be lined.

After the sound-absorbing material has been installed, the front panel may be fastened in place. Use #6 or #8 flathead wood screws that are at least 1-1/4 inches long. For a solid job, the screws should be spaced no more than six inches apart. Don't for-

get to apply glue to the joint. The speaker may now be installed. Unless it is of unusually light construction, you will be unwise to try to mount it in place with wood screws. A much better plan is to use #8 or #10 flat-head machine screws about 1-1/2-inches long. The screws pass through countersunk holes in the front panel and through the speaker frame, and hexagon nuts are used on the inside. Be sure that the frame of the speaker fits tightly against the inside of the front panel with no space between.

The voice-coil leads are brought out through a small hole drilled in the back panel. The method of fastening the back of the cabinet is the same as for the front panel except that glue is not used. This completes the enclosure except for finishing.

The best method of concealing the openings in the front is by covering the entire front of the unit with grille cloth, tacked into place at the edges. A quarter-round or half-round molding may then be applied to finish the job. The cabinet may be painted or stained as you prefer.

Many critical listeners claim that the size of the port or vent is determined not only by the speaker size but by the type as well. Their contention is that no two speakers will both give peak performance with the same

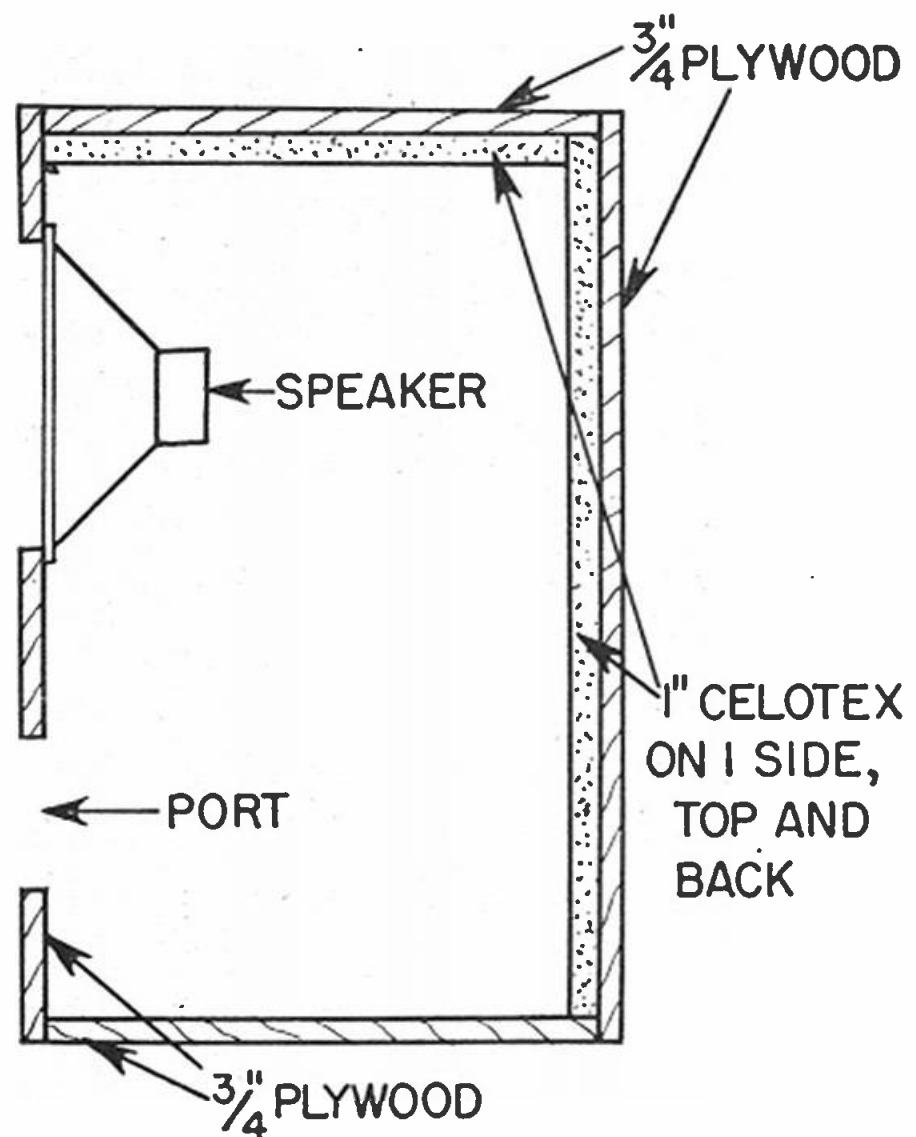

Fig. 5-18. Inside speaker enclosure.

size of vent and that the opening must be adjusted to the individual speaker. This is the reason for the opening in the back panel, described above. If you are inclined to agree with this reasoning (and it does seem to have considerable merit), you will have to devise a means of changing the port size. An easy way is to fit the port with a sliding flap or cover held in place with two screws. The screw holes can be slotted to permit adjustment. Be sure to close the opening in the back panel after making each adjustment.

HIGH FIDELITY AMPLIFIER WITH BASS AND TREBLE CONTROLS

This seven-tube high fidelity amplifier uses the identical output circuit employed in the five-tube project described earlier, but also features a built-in preamplifier for magnetic pickup cartridges and separate bass and treble amplifiers. Since the bass and treble amplifiers have individual controls it is possible to control the degree of boost at either end of the range. With this arrangement, record deficiencies can be compensated for to

some extent.

Circuit description

Magnetic cartridges, which have much lower output voltages than crystal cartridges, are plugged into the standard phono jack. The preamplifier then builds up the low voltage to a value high enough for application to the grid of the voltage amplifier. When a crystal cartridge is used, the preamplifier is not needed. Such car-

tridges are plugged into the closed circuit jack and the opening of the jack contacts cuts the preamplifier out of the circuit. The first 6SN7GT tube performs two separate functions: the lower set of electrodes (as in Figure 5-19) acts as a bass amplifier and the degree of bass boost is controlled by the potentiometer, R26. The upper set of electrodes (pins 4, 5, and 6) functions as a conventional voltage amplifier. Signals enter the lower section by way of the grid (pin 1) and after amplification are fed to the grid of the upper section.

The next 6SN7GT tube is a combined treble amplifier and phase inverter; the lower section (as seen in Figure 5-19) is the inverter and the upper is the treble amplifier. Treble boost is controlled by R15. Following this tube, there is a push-pull driver stage using another 6SN7GT. The output of this stage is applied to the grids of the 6B4G. Incidentally, 2A3 or 6A3 tubes may also be used in the output circuit. If 2A3s are used, the power transformer filament winding must supply 2.5 volts instead of 6.3 volts.

The heater circuit is similar to that of the five-tube amplifier. One 6.3 volt winding supplies the three 6SN7GT and the 6SC7 tubes; another supplies the two 6B4Gs. A two-section filter circuit is employed; the filter choke, L1, filters current for the output and driver stages, while both the choke and the filter resistor, R40, are used for all other tubes.

All resistors and condensers used in this project (especially those in the bass and treble amplifier circuits) should be carefully selected so that they are within ten per cent of the assigned values. If this precaution is taken and if the unit is carefully constructed, the amplifier will afford record reproduction of unusually high quality.

Parts list

Resistors

R1	250K ohms, 1/2-watt carbon
R2	250K ohms, 1/2-watt carbon
R3	47K ohms, 1/2-watt carbon
R4	47K ohms, 1/2-watt carbon
R5	2700 ohms, 1/2-watt carbon
R6	2700 ohms, 1/2-watt carbon
R7	2700 ohms, 1/2-watt carbon
R8	2700 ohms, 1/2-watt carbon
R9	500K ohms, 1/2-watt carbon
R10	500K ohms, 1/2-watt carbon
R11	47K ohms, 1/2-watt carbon
R12	4700 ohms, 1/2-watt carbon
R13	500K ohms, 1/2-watt carbon
R14	47K ohms, 1/2-watt carbon
R15	250K ohms, treble control
R16	33K ohms, 1/2-watt carbon
R17	500K ohms, 1/2-watt carbon
R18	1500 ohms, 1/2-watt carbon
R19	10K ohms, 1/2-watt carbon
R20	47K ohms, 1/2-watt carbon
R21	1500 ohms, 1/2-watt carbon
R22	500K ohms, 1/2-watt carbon
R23	20K ohms, 1/2-watt carbon
R24	47K ohms, 1/2-watt carbon
R25	100K ohms, 1/2-watt carbon
R26	1 megohm, bass control
R27	10K ohms, 1/2-watt carbon
R28	1500 ohms, 1/2-watt carbon
R29	500K ohms, volume control
R30	27K ohms, 1/2-watt carbon
R31	180K ohms, 1/2-watt carbon
R32	3.3 megohm, 1/2-watt carbon
R33	200K ohms, 1/2-watt carbon
R34	3.3 megohm, 1/2-watt carbon
R35	5,000 ohms, 1/2-watt carbon
R36	68K ohms, 1/2-watt carbon
R37	68K ohms, 1/2-watt carbon
R38	33K ohms, 1/2-watt carbon
R39	33K ohms, 1/2-watt carbon
R40	10K ohms, 10-watt wire-wound
R41	780 ohms, 10-watt wire-wound

Condensers

C1	20-20 mfd., 450-volt electrolytic, aluminum can, vertical mounting
C2	10 mfd., 450-volt electrolytic, aluminum can, vertical mounting

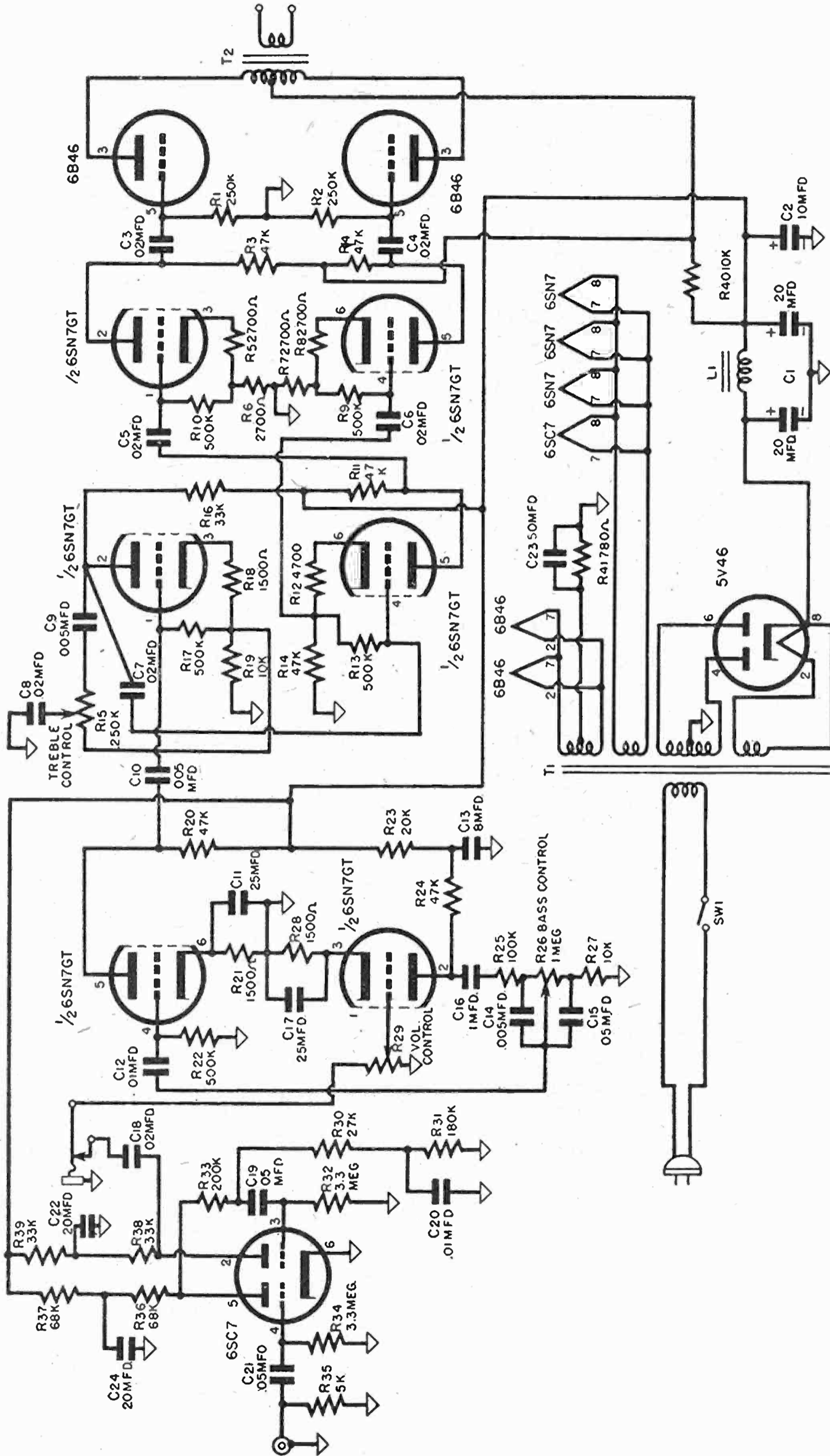

Fig. 5-19. Schematic diagram of a seven-tube hi-fi amplifier.

- C3 .02 mfd., 600-volt paper tubular
- C4 .02 mfd., 600-volt paper tubular
- C5 .02 mfd., 600-volt paper tubular
- C6 .02 mfd., 600-volt paper tubular
- C7 .02 mfd., 600-volt paper tubular
- C8 .02 mfd., 600-volt paper tubular
- C9 .005 mfd., mica
- C10 .005 mfd., 600-volt paper tubular
- C11 25 mfd., 500-volt electrolytic, tubular-cartridge type
- C12 .01 mfd., 600-volt paper tubular

- C20 .01 mfd., 600-volt paper tubular
- C21 .05 mfd., 600-volt paper tubular
- C22 20 mfd., 450-volt electrolytic, aluminum can, vertical mounting (combined with C24)
- C23 50 mfd., 100-volt electrolytic, tubular-cartridge type
- C24 20 mfd., 450-volt electrolytic, aluminum can, vertical mounting (combined with C22)

Transformers

- T1 Power transformer; high voltage 370-0-370 volts, 150 m.a.; heater (output) 6.3 volts, 4

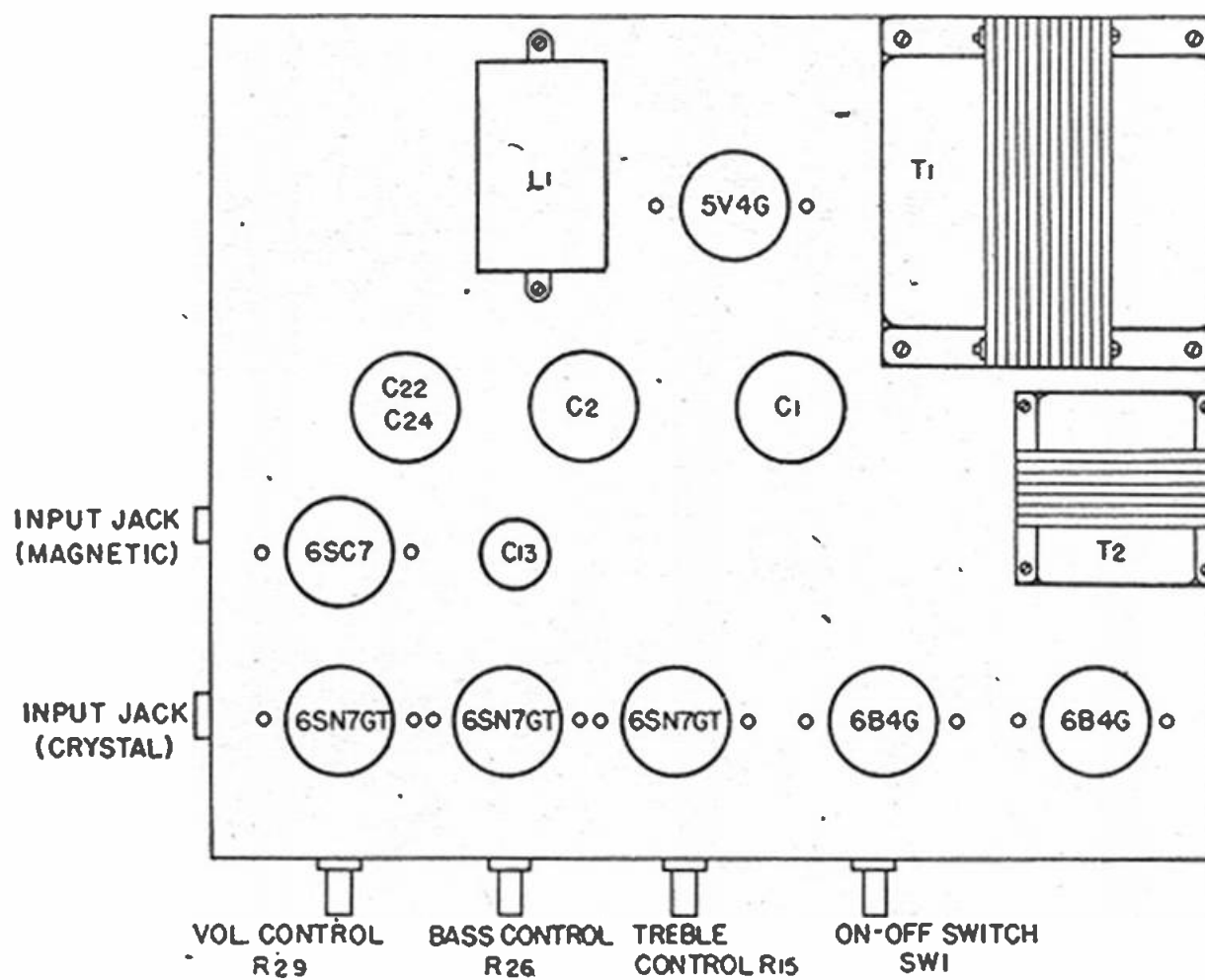

Fig. 5-20. Top view of seven-tube amplifier.

- C13 8 mfd., 450-volt electrolytic, aluminum can, vertical mounting
- C14 .005 mfd., mica
- C15 .05 mfd., 600-volt paper tubular
- C16 .1 mfd., 600-volt paper tubular
- C17 25 mfd., 50-volt electrolytic, tubular-cartridge type
- C18 .02 mfd., 600-volt paper tubular
- C19 .05 mfd., 600-volt paper tubular

- T2 Output transformer, push-pull type, primary impedance 5,000 ohms; secondary impedance to match speaker

Coils

- L1 Filter choke, 12 henry, 230 ohms, 150 milliamperes

Miscellaneous

- 1 RCA-type phono jack
- 1 closed circuit jack
- 7 octal tube sockets

2- and 3-point tie strips
 6-32 x 3/8-inch r.h. machine screws
 6-32 hexagon nuts
 4 8-32 x 1/2-inch r.h. machine screws with nuts
 4 10-32 x 1/2-inch r.h. machine screws with nuts
 1 output terminal strip
 Line cord and plug
 Chassis: 10 x 12 x 3 inches
 Rosin-core solder
 Push-back wire

Tubes

6B4G (2), 6SC7 (2), 6SN7GT (3)

Layout and assembly

The parts required for this project represent a considerable investment. You will therefore be wise to exercise care in the planning, layout, assembly, and wiring. Poor judgment in layout and wiring will not only result in a product that is other than neat but may seriously affect its performance.

The chassis top view, Figure 5-20, shows the approximate positions of all major components. While none of the measurements are at all critical, it will be best to follow the general arrangement as closely as possible.

Before marking the positions of the tube sockets, determine just how much

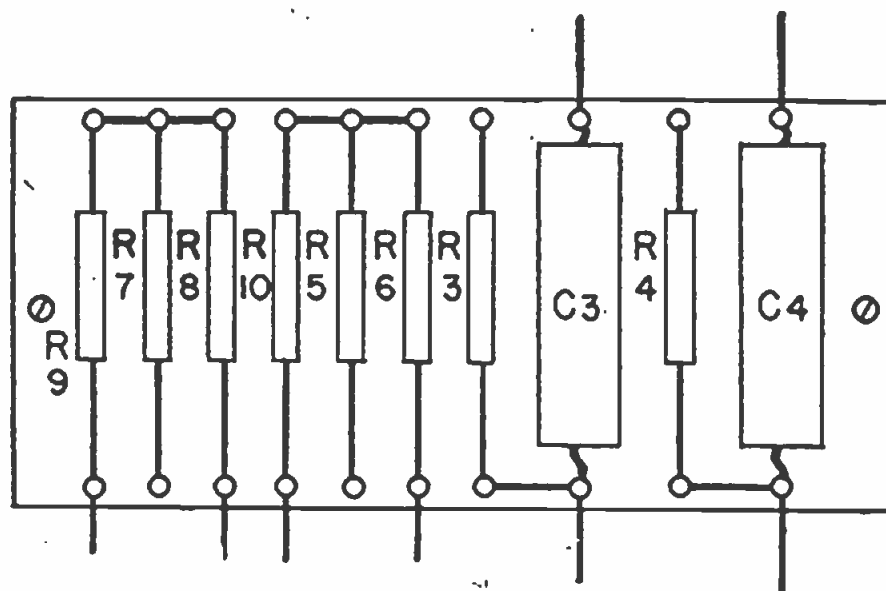

Fig. 5-21. Use of sub-panels.

space will be needed for the power and output transformers. These components are large and their space requirements vary among different makes. When this has been done, make a trial placement of the tubes in approximately the positions shown to be sure that the spacing between them is sufficient.

Be careful to place the input jacks and bass, treble, and volume controls as shown in the drawing. Two minor details are not shown in the chassis top view: the output terminal strip and the hole for the line cord. The terminal strip should be located on the rear apron of the chassis, below the output transformer. The line cord will enter the rear apron at the right-hand corner of the chassis.

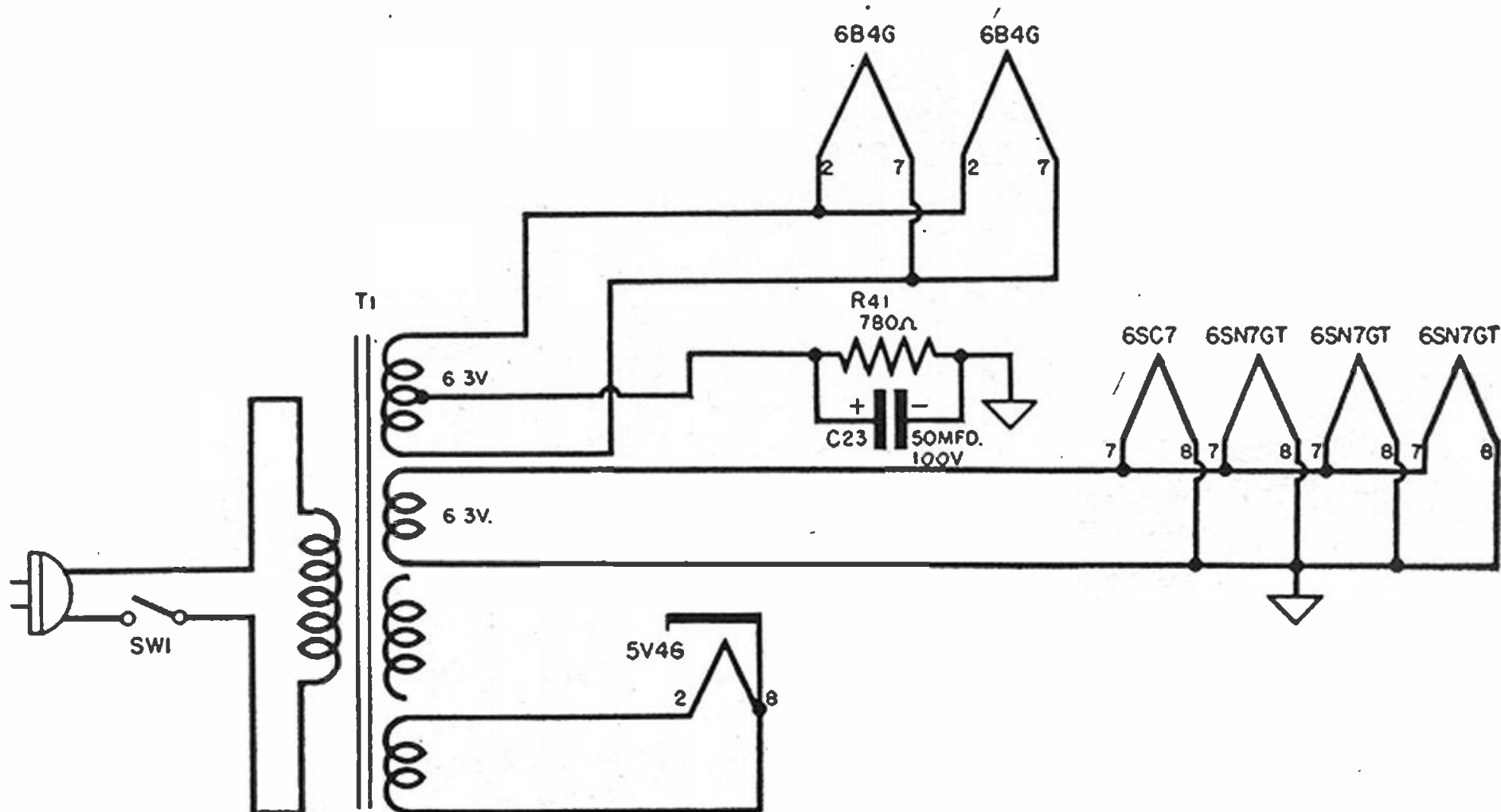

Fig. 5-22. Heater circuit for seven-tube amplifier.

Wiring

The wiring of this project should be planned in advance with as much care as you used in the layout. In consideration of the rather large number of small parts needed (41 resistors and 24 condensers), take time in arranging their positions so that all are as close as possible to the tubes they are associated with. It is best to provide some kind of support for all resistors and condensers instead of allowing them to dangle by their connecting wires. The conventional tie strips may be used, or you might

a) *Heater Circuit.* See Figure 5-22.

This circuit is not at all complicated and should cause you no difficulty. As mentioned in Chapter 4, 2A3 tubes may be substituted for the 6B4Gs, provided that a suitable power transformer is used. Furthermore, a separate filament transformer may be used for the output stage if necessary. Refer to Figures 5-1A and 5-1B with the accompanying text for further information on power transformer substitution.

b) *Power Supply Circuit.* See Figure 5-23.

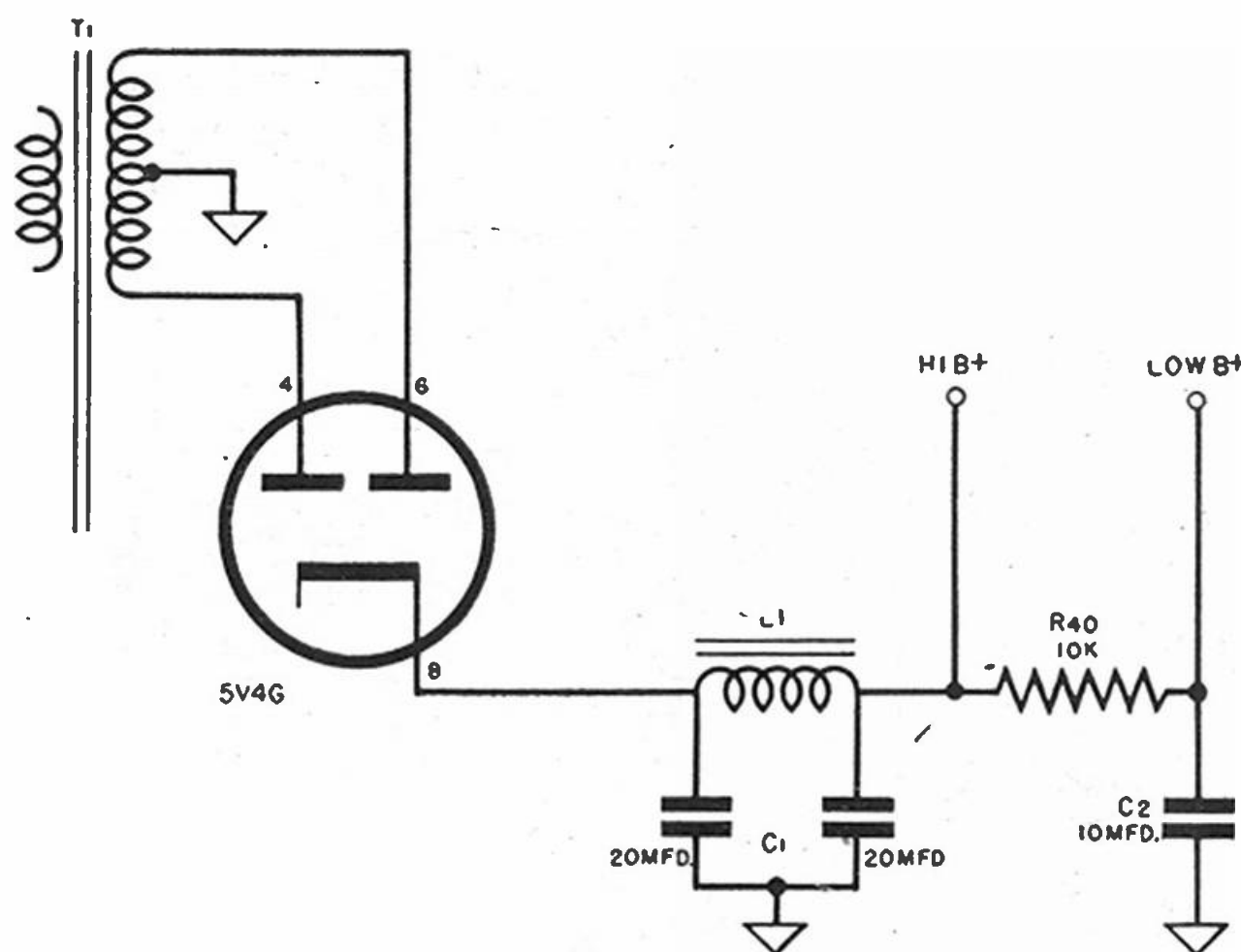

Fig. 5-23. Power supply circuit for seven-tube amplifier.

make up small sub-panels of plastic or thin plywood, as shown in Figure 5-21. The sub-panels can be about two inches wide and as long as required. They may be spaced from the chassis with brackets or by means of short lengths of brass tubing slipped over the mounting screws.

When you plan the actual wiring, you may decide to use the cable method, found in many commercially-made amplifiers. It makes an unusually neat job, but must be carefully planned. Heater, cathode, B plus, and screen wires may be cabled without fear of interaction between wires, but plate and grid leads are best run separately.

Before starting the wiring, be sure that the filter resistor, R40, is adequately supported by one or more tie strips or in some other manner. In wiring the circuit, remember that the B-plus terminal for the output and driver stages is at the junction point of L1 and R40. All other DC voltages are taken from the end of R40 farthest from the choke L1.

c) *Output Circuit.* See Figure 5-24.

Connect the ends of the output-transformer secondary winding to the output terminals. R1 and R2 should be mounted on terminal strips; from their junction, connect R1 to the

chassis. The coupling condensers, C3 and C4, are wired as part of the driver circuit.

d) *Driver Circuit.* See Figure 5-25.

Resistors R3, R4, R5, R6, R7, R8, R9, and R10 should be mounted on tie strips, since it is impossible to support these components properly otherwise. Note that R5 is connected between the cathode of the upper section of the tube (pin 3) and the junction of R6 and R10. Similarly, resistor R8 is connected from the other cathode (pin 6) to the junction of R7 and R9.

The junction point of R6 and R7 is connected to chassis. With R3 and R4 mounted on a tie strip, and with

When wiring this circuit, be careful to observe the socket terminal numbering, otherwise there is a possibility of reversing connections. In other words, while terminals 1, 2, and 3 might be used for the phase inverter instead of for the treble amplifier, be sure that you do not wire, for example, the grid and cathode of one section of the tube and the plate of the other section as one circuit.

The free ends of C5 and C6 (shown unconnected in the drawing) are to be wired to the grid terminals of the driver tube. Pin 1 of the treble amplifier need not be connected to the coupling condenser, C10, until the voltage amplifier circuit is wired.

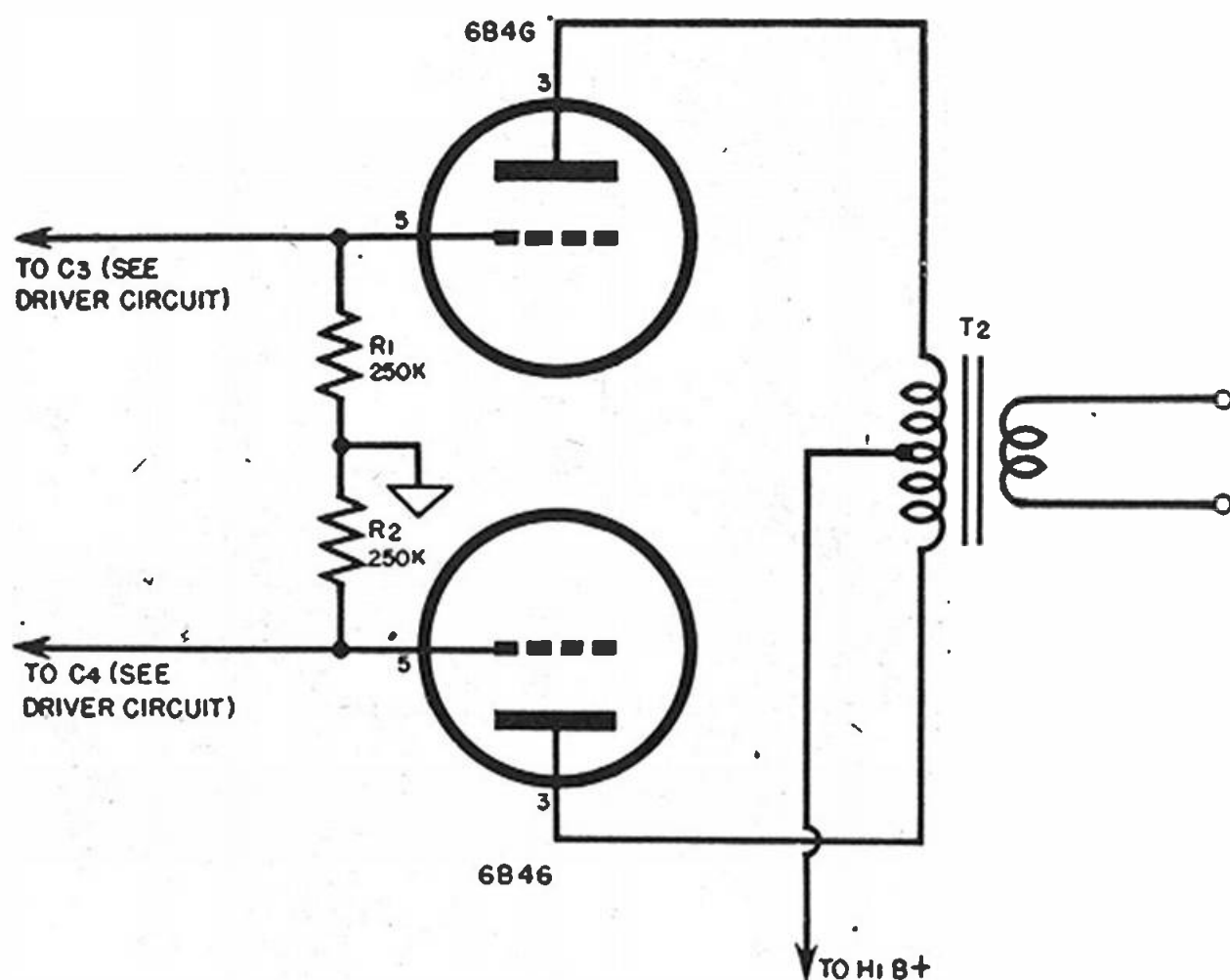

Fig. 5-24. Output circuit for seven-tube amplifier.

one end of each connected respectively to pin 2 and pin 5, their common point is then connected to B plus (see power supply diagram, Figure 5-23). Connect C3 and C4 from the plates of the two tube sections to the grids of the output tubes. Condensers C5 and C6 are not wired in the circuit until the phase inverter stage is completed.

e) *Treble Amplifier-Phase Inverter.* See Figure 5-26.

f) *Bass Amplifier-Voltage Amplifier.* See Figure 5-27.

As in the treble amplifier-phase inverter circuit (and in all other circuits using dual triode tubes), be sure to pay attention to the tube socket terminal numbering, for an error here will render the amplifier inoperative and may cause much loss of time in tracing the trouble later on.

Note, when wiring the bass control circuit, that C16, R25, R26, and R27 are all in series, connected between

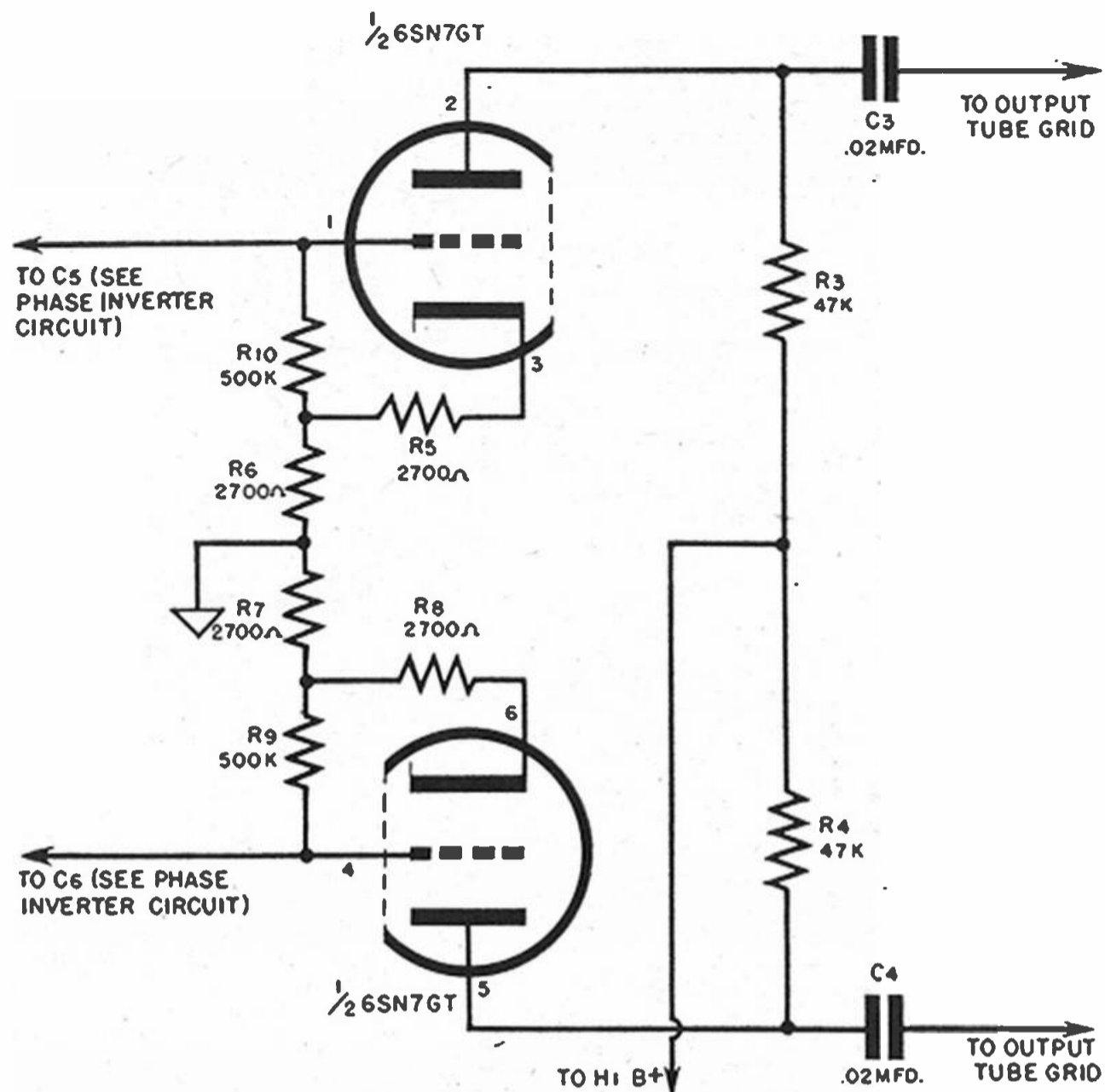

Fig. 5-25. Driver circuit for seven-tube amplifier.

pin 2 of the tube socket and chassis. Also note that C14 and C15 are not in parallel, although at first glance they may appear to be so connected. In the final inspection, be sure that the high side of R29 is wired to the top contact of the crystal pickup jack and that the shell of the jack is connected to chassis. The remaining contact of the jack is connected when the preamplifier circuit is wired. Finally,

be sure that the free end of C10 is wired to the grid of the treble amplifier.

g) *Preamplifier Circuit.* See Figure 5-28.

Mount resistors R30, R31, R33, R35, R36, R37, R38, and R39 and condensers C19, C20, and C21 on tie strips. Other resistors and condensers may be connected directly between

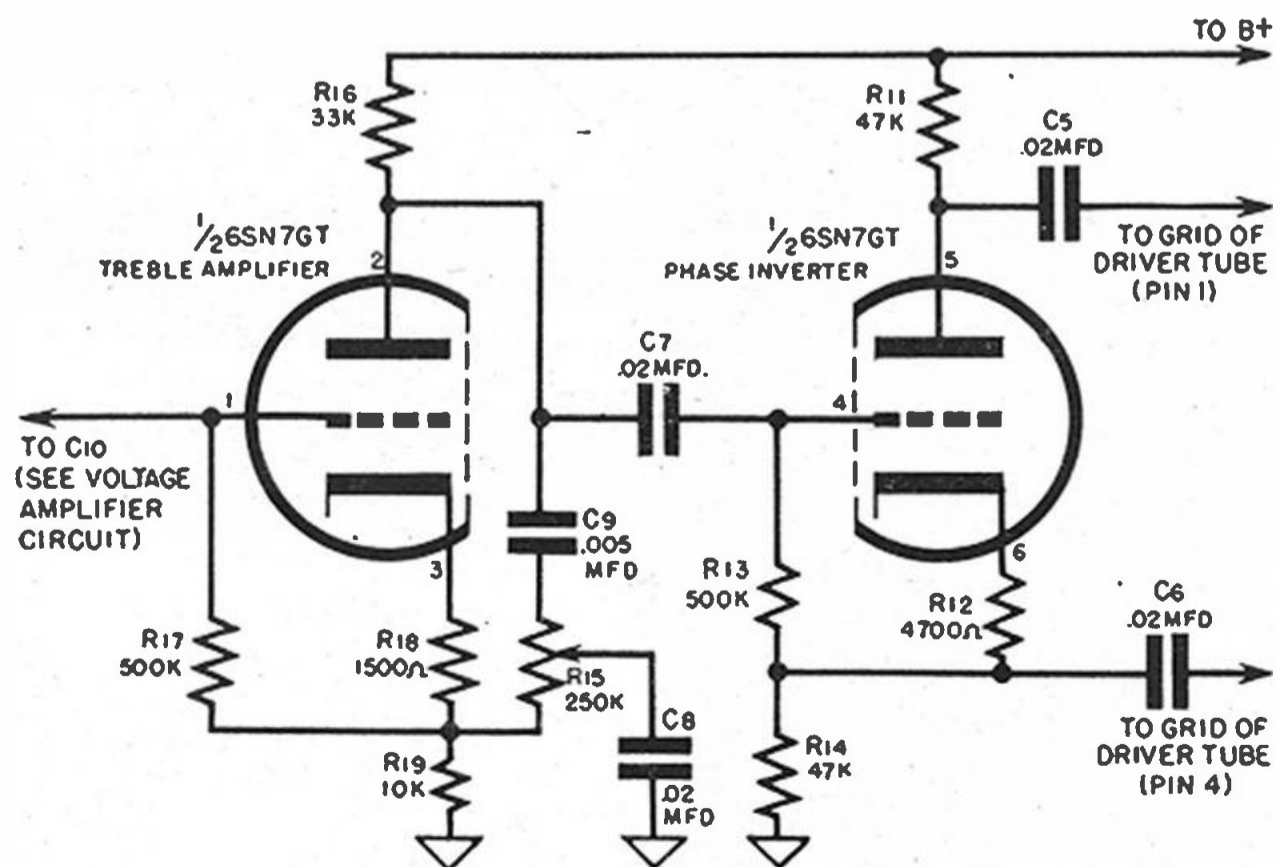

Fig. 5-26. Treble amplifier-phase inverter circuit.

socket terminals and chassis, if desired. Condensers C22 and C24 (combined in a single unit) present no mounting problem since they are enclosed in a vertical-mounting aluminum can, already fastened to the chassis.

Connect R34 from socket terminal 4 to chassis. C21 is then connected from the same terminal of the socket to the high side of the magnetic cartridge jack. R35 may now be connected from the jack to chassis. The shell of the jack is then grounded to chassis.

The filter network, consisting of R36 and R37 in series, is now wired between the #5 socket terminal and B plus. At the same time, connect the filter network for the other half of the tube (consisting of R38 and R39) from the remaining plate (pin 2) to B plus. Connect the lead from C24 to the junction of R36 and R37, and the lead from C22 to the junction of R38 and R39. Be sure that the negative terminal of the C22-C24 combination is connected to chassis.

R32, C19, and R33 (all in series) are now connected from socket terminal 5 to chassis. Connect the junction of C19 and R32 to pin 3 of the tube socket. From the common point of

C19 and R33, connect R30 and R31 to chassis, with R31 at the chassis end of the combination. From the common point of R30 and R31, connect C20 to chassis.

To complete the wiring, connect C18 from pin 2 of the tube socket to the break contact of the crystal phono jack.

Testing

For purposes of checking, the normal voltages to be expected at tube socket terminals are given below:

1) Output stage (voltages apply to either tube):

From	To	DC Volts
pin 2 or 7	chassis	60
pin 2 or 7	pin 3	approx. 320
pin 5	chassis	0
pin 5	pin 2 or 7	60

2) Driver stage:

From	To	DC Volts
pin 2	chassis	approx. 250
pin 3	chassis	10
pin 5	chassis	approx. 250
pin 6	chassis	10

3) Treble amplifier:

From	To	DC Volts
------	----	----------

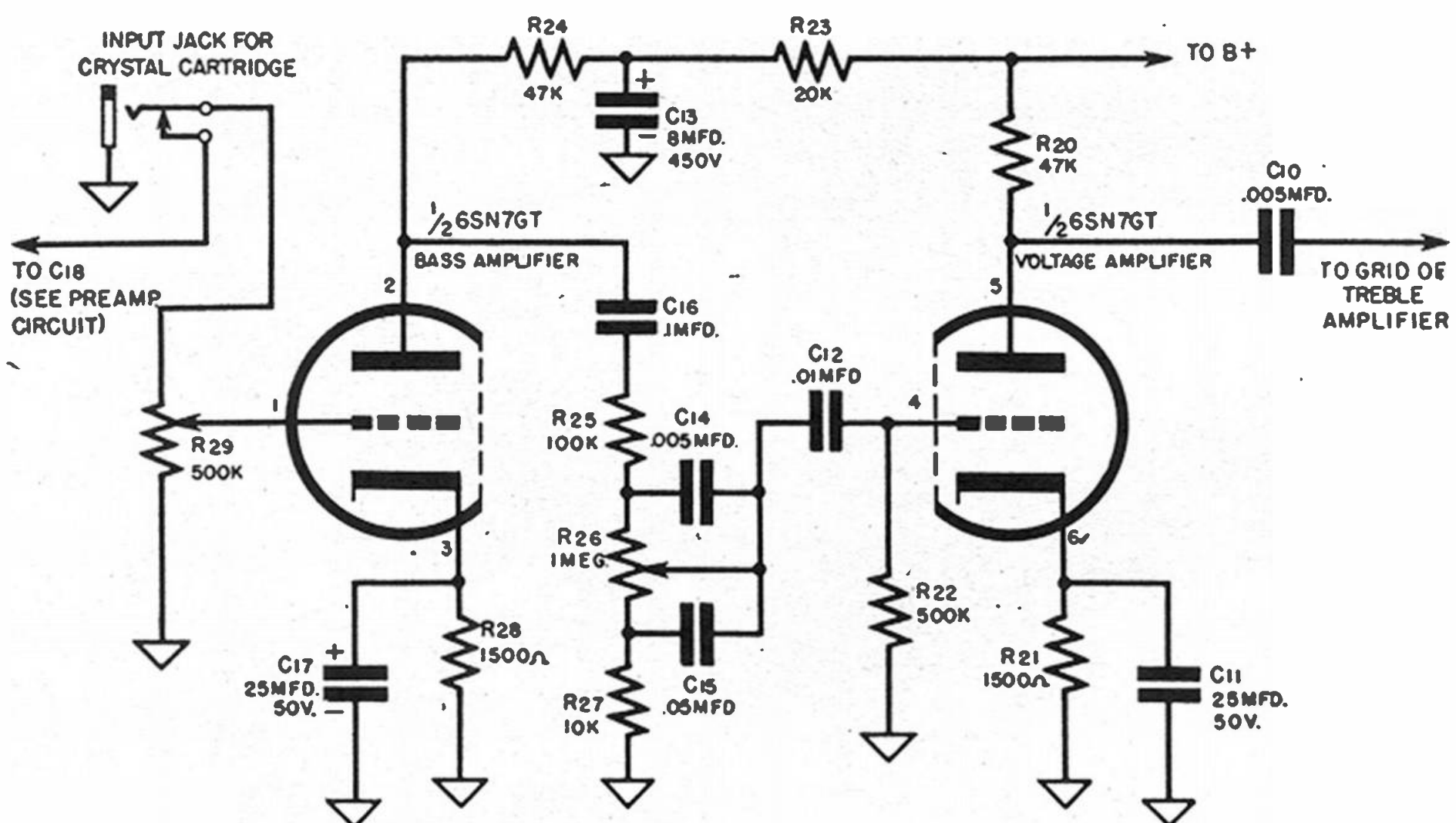

Fig. 5-27. Bass amplifier-voltage amplifier circuit.

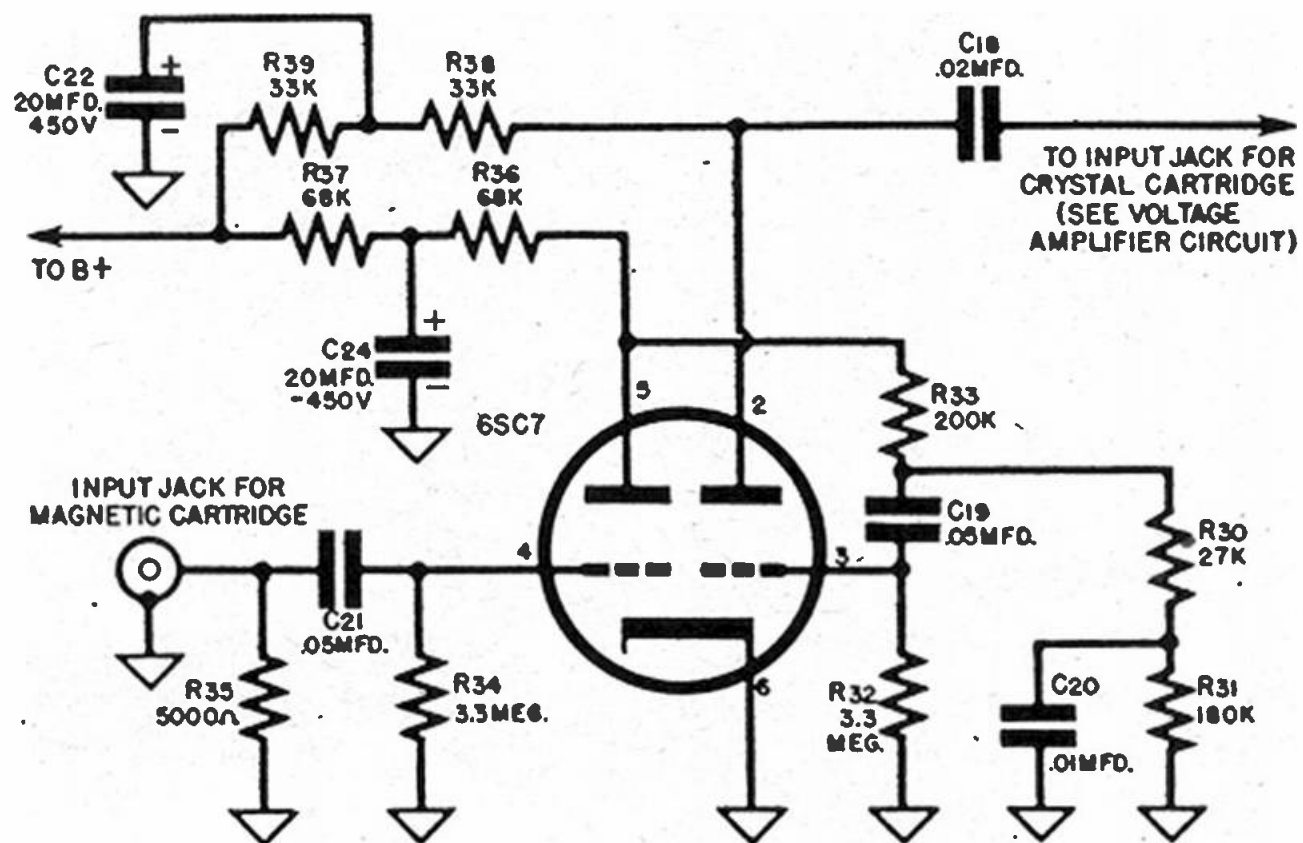

Fig. 5-28. Preamplifier circuit.

pin 2 chassis approx. 175
 pin 3 chassis 6

4) Phase inverter:

<i>From</i>	<i>To</i>	<i>DC Volts</i>
pin 5	chassis	approx. 175
pin 6	chassis	5

5) Bass amplifier:

<i>From</i>	<i>To</i>	<i>DC Volts</i>
pin 2	chassis	approx. 150

pin 3 chassis 10

6) Voltage amplifier:

<i>From</i>	<i>To</i>	<i>DC Volts</i>
pin 5	chassis	approx. 160
pin 6	chassis	10

7) Preamplifier:

<i>From</i>	<i>To</i>	<i>DC Volts</i>
pin 2	chassis	approx. 120
pin 5	chassis	approx. 120
pin 6	chassis	0

RECORD PLAYERS FOR HIGH FIDELITY WORK.

Up to this point we have considered some of the components of a high fidelity system, but have barely touched upon the record player (or record changer). This item is basically no different from the player used in an ordinary phonograph or radio-phono combination, but there are several construction features that require special attention if the player is to be subjected to the critical demands of a high quality system.

Most high-fidelity listeners prefer a manual player to an automatic changer, and there are two principal reasons for this preference. A player is more often assembled from components than purchased as a unit, and in selecting the components of a player you have considerably more lati-

tude in the choice of motor and pick-up than you do in the case of a changer.

Eliminating hum

To be fully satisfactory for high fidelity work, a motor must be as nearly noiseless as possible. This refers not only to noise heard directly in the form of vibration but also disturbances that pass through the amplifier and are radiated from the speaker. When used with a magnetic cartridge—and most especially when LP records are played—the ordinary cheap motor is likely to introduce objectionable hum. This results from the combination of the low output voltage of the magnetic cartridge and the low amplitude recording common

in LP records. The LP grooves are narrower than those in conventional records and the "lands" between the grooves are also narrower. To prevent over-cutting, or breakdown of the walls between grooves, the excursion, or swing, of the cutting stylus must be kept low as compared with that common in cutting 78 r.p.m. records. The net effect is that for LP records played with a magnetic pickup, the volume control must be advanced quite far, which, of course, increases the possibility of picking up extraneous disturbances such as hum voltage induced by the motor. The same condition prevails for 45 r.p.m. records, although to a lesser degree.

If you suspect that an annoying hum emanates from the motor, a positive check can be made in this way:

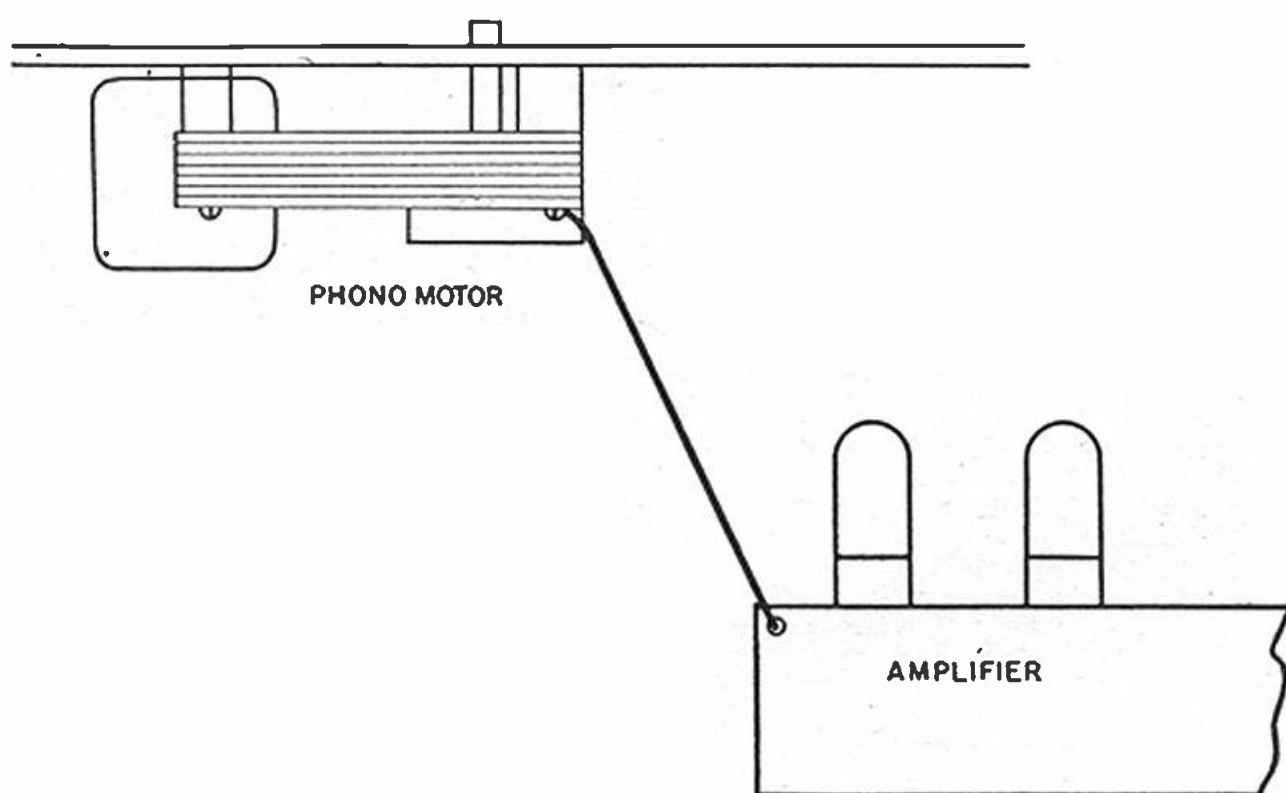

Fig. 5-29. How to ground motor frame.

Advance the volume control to the point where it is ordinarily set for the type of record on the turntable. With the motor running, swing the pickup arm across the record but do not allow the stylus to touch the record. If the hum becomes louder as the stylus passes across the record, the hum is being set up by the motor. Most such troubles arise from using a two-pole motor, and the only remedy is to substitute a four-pole type. If you are selecting a motor for use with LP records, by all means choose one having four poles. Another pos-

sible cause of hum is failure to ground the motor frame to the amplifier chassis. You can easily make the ground by connecting a length of wire from the motor frame to chassis, as illustrated in Figure 5-29. Most phono motors have a convenient soldering lug for this purpose.

Eliminating variations in speed

For any type of record, the motor speed must be as nearly exact as possible. A deviation of as little as one or two revolutions per minute, either higher or lower, may result in a serious change in pitch. This is particularly important in the case of 45 and 33-1/3 r.p.m. records, because a revolution or two then becomes a more considerable proportion of the total number of revolutions. Another difficulty that may show up is a "wow"—

a rise or fall in pitch resulting from a momentary change in turntable speed. One cause of "wows" is a flat spot on the rubber drive-wheel of a rim-drive motor, a point that was touched upon in Chapter 4. The only satisfactory method of overcoming such a condition is replacement of the wheel. Speed changes may also result from slipping of the drive-wheel as it bears against the inside of the turntable; this is frequently caused by over-lubrication. The drive-wheel bearing should be lubricated once in a while, but the oil should be

used very sparingly and care must be taken to get none of it on the rim of the wheel.

Pickup arms

Many of the more expensive record players are equipped with unusually long pickup arms of the "transcription" type. These run to 16 inches or more in length, and their purpose is to reduce "tracking error." In Chapter 4 we mentioned the desirability of always keeping the axis of the pickup head tangent to the record groove. Unless this is done the record wear is increased and the fidelity of reproduction will be affected. It is not possible to achieve absolutely perfect tracking, as you know, because of the variation in record-groove diameter from the outside to the center of the record. However, the use of a curved pickup arm and an offset head, as illustrated in Figure 5-30, helps to reduce the error, which is more evident when a straight arm (Figure 5-31) is used. Even more important is the use of a long pickup arm. Whether you assemble your own player or buy one already assembled, be sure to get a curved-arm pickup with the offset head. And, if you can afford to do so, buy the transcription type of pickup, designed to play records up to 16 inches in diameter. Although you may not play such large records, on ordinary sizes the tracking error will be reduced to a minimum.



Fig. 5-30. Curved pickup arm.

Stylus pressure

You also know that low stylus pressure gives less record wear. However, this statement is often misinterpreted. If a pickup is designed to operate with a stylus pressure of one ounce, for instance, no attempt should be made to reduce the pressure by add-

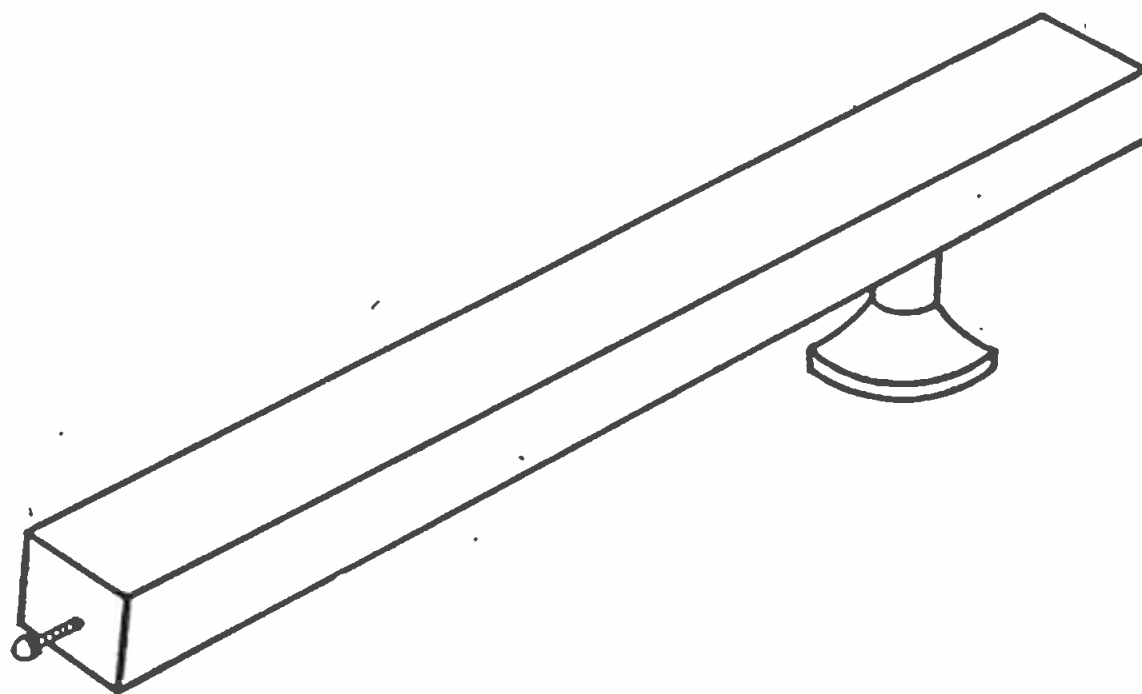

Fig. 5-31. Straight pickup arm.

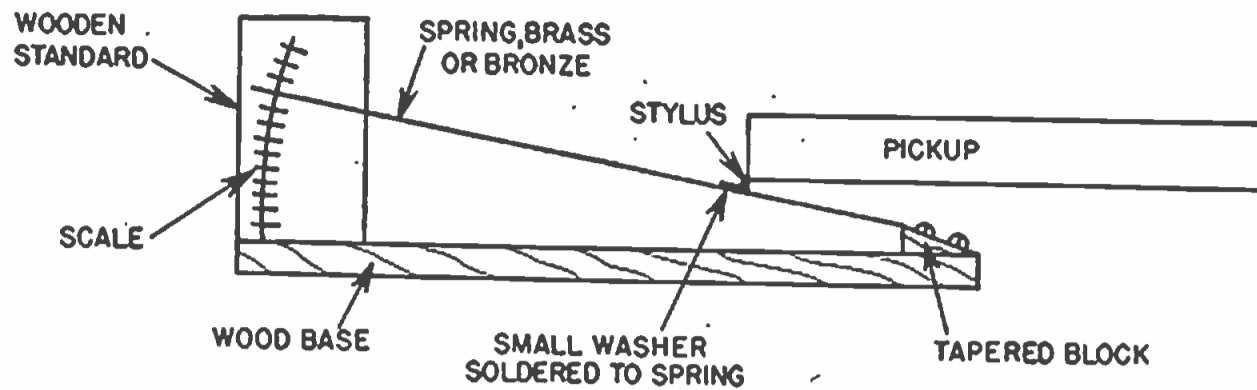

Fig. 5-32. Stylus pressure gauge.

ing a tension spring, weighting the arm, or any other means as long as the original cartridge is being used. Reducing the pressure below the amount specified for a particular cartridge may cause the stylus to skip grooves or even to "skate" across the record. Some high quality pickups are made with a stylus-pressure adjustment, but this feature is added to enable the user to change from one type of cartridge to another. Using a cartridge with the pressure adjusted higher than recommended is equally harmful, for it will result in undue wear of the record and perhaps of the stylus as well.

If at any time you are not sure whether your pickup is adjusted for the correct stylus pressure, use one of the several kinds of pressure gauges on the market. If you care to do so, you can make your own with very little trouble. The general idea is illustrated in Figure 5-32. The strip on which the stylus rests should be made of very light, springy brass or bronze. Make the base and calibrated standard out of wood. To calibrate the gauge you will have to borrow a set of gram weights—perhaps your local druggist will cooperate.

Shock-proof mounting

Whenever a player or changer is to

be installed in the same cabinet with the loud speaker, some kind of shock-proof mounting must be used between the motor and the motor board and between the motor board and the cabinet, otherwise speaker vibrations will be communicated to the motor board, turntable, and pickup. In some cases this will result in a microphonic howl, but it is more likely to create a constant rumbling noise. Usual practice is to float the motor on rubber cushions, and in almost all rim-drive motors such cushions are installed by the manufacturer. If this has not been done, install several soft rubber pads, each at least 1/8-inch thick, between the motor and the board. The best plan is to use springs between the motor board and the cabinet, as shown in Figure 5-33, which also illustrates the method of insulating the motor from the board. Springs of the type shown in the drawing are found at the four corners of almost all automatic record changers; no doubt your local radio supply house will have them in stock. If you prefer or if for some reason the springs are not available, there is no reason why rubber mountings cannot be used. Finally, remember that the best job of shock-mounting a motor board will be rendered useless if the board touches the cabinet at any point.

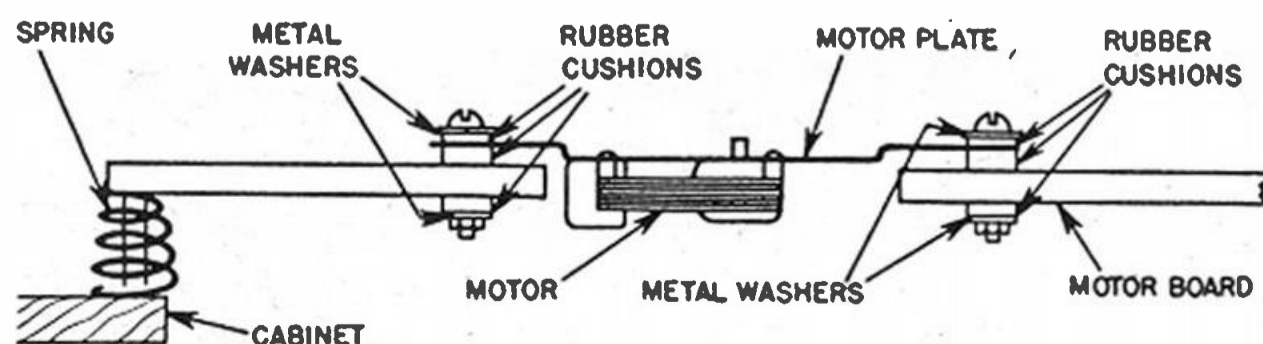

Fig. 5-33. Shock-proof mountings in motor arrangement.

How to Build a Frequency Modulation Tuner

FREQUENCY MODULATION needs no introduction to anyone interested in radio construction, although it has come into wide acceptance only recently. However, it may be well to call attention to a few fundamental ideas for the benefit of those who have little or no experience in this field.

FM differs from AM in that the former is capable of transmitting all the high audible frequencies. This fact alone makes the FM system interesting to high-fidelity enthusiasts; remember that the average AM transmitter is at present limited to about 5,000 cycles. If the capabilities of FM are to be fully realized, however, the tuner must be used with an amplifier and speaker designed to handle the higher frequencies. One reason why FM was not widely accepted in its earliest days was the tendency of manufacturers to offer FM-AM combinations equipped with amplifiers and speakers that were not designed expressly for FM.

Aside from the ability to reproduce the high frequencies, there are other differences between the FM and AM receiving systems that should be discussed, at least briefly. These are:

- 1) FM receivers operate in the range from 88 to 108 megacycles, compared to 1700 to 550 kilocycles for the usual AM broadcast receiver.

- 2) An FM receiver uses an intermediate frequency of 10.7 megacycles compared to (usually) 455 kilocycles for AM.

- 3) Practically all FM sets employ an r.f. stage ahead of the mixer; this stage is used only rarely in the ordinary AM broadcast set.

- 4) Many FM sets use a separate oscillator stage, while most AM sets depend upon a combined oscillator and mixer tube.

- 5) FM intermediate-frequency transformers have much broader selectivity than those used in AM sets. Also, three transformers (two i.f. amplifier tubes) are almost always used in FM sets, compared to the two transformers (one i.f. tube) found in the average AM receiver.

- 6) Detector circuits used in FM tuners differ materially from those used in AM sets, because the FM detector must convert frequency variations into amplitude variations.

To the constructor, these considerations are important. In the r.f., mixer, and oscillator stages, the coils and condensers used will be much smaller than those used in AM sets because of the high carrier frequencies. Proper placement of these units becomes more critical in FM. Further, more than ordinary care must be taken

in wiring. At the high frequencies employed, the effect of coupling between connecting wires is far greater than at broadcast frequencies.

In addition, any wire that is longer than necessary may add sufficient inductance to the circuit to affect the tuning seriously.

A SIX-TUBE TUNER

Circuit description

See Figure 6-1 for the complete circuit diagram.

This is a six-tube tuner, with no audio amplification. If you have built one of the high fidelity amplifiers described in the preceding chapter, you are already familiar with the type of construction and the circuits necessary for amplification of the higher audible frequencies. To those without previous high fidelity experience, attention is directed to the fact that in FM broadcasting, all frequencies up to 15,000 cycles per second are transmitted. The FM tuner is, of course, capable of accepting all these higher frequencies, but if the advantages of FM are to be fully realized, the amplifier and speaker must be capable of handling them too. Building an FM tuner and then using it with an ordinary amplifier and speaker will result in a system that is little better in frequency response than the average mass-produced radio receiver.

A volume control has been included in the circuit so the tuner can be connected to an amplifier that does not have a built-in control. However, if the amplifier you intend to use has a volume control (as all those described in this book have), the one shown in the circuit diagram may be omitted. The output of the tuner will then be taken from condenser C1 and chassis.

A 6BA6 tube is used as the r.f. amplifier. This circuit is conventional except for the coils and condensers used. For example, the antenna-coil secondary consists of only two-and-a-half turns of wire; each section of the three-gang tuning condenser has a capacitance of only 7 to 20 micro-

microfarads.

The 6C4 oscillator tube has its output coupled to the first grid of the 6BE6 mixer tube through condenser C19. The output of the mixer stage is applied to the primary of the first i.f. transformer, T1. As mentioned above, there are three transformers and two i.f. amplifier tubes; both of these are 6BA6. Incidentally, although separate sectional diagrams of the first and second i.f. amplifier circuits are given for the sake of completeness, you will observe that the two are identical.

Most present-day FM tuners use either the discriminator detector or the ratio detector. In this project, the ratio detector has been chosen because this reduces the number of tubes needed by one. In any tuner using the discriminator detector, at least one limiter stage must be used to wipe out any amplitude variations before the signal reaches the detector. Some such sets use two limiter stages. Tuners using the ratio detector require no limiter stage. The ratio detector in the present project is a 6AL5.

Heater voltages for all tubes are derived from the secondary of the heater transformer, T4. All plate and screen voltages are supplied by the selenium rectifier, SR. Filtering is taken care of by the circuit consisting of R25 and C32.

Coil construction

If reasonable care is used, you will have little or no trouble making your own coils for this project. All are wound of #14 enamelled wire on a 3/4-inch-diameter form. The spacing between individual turns is in all cases equal to the diameter of the wire.

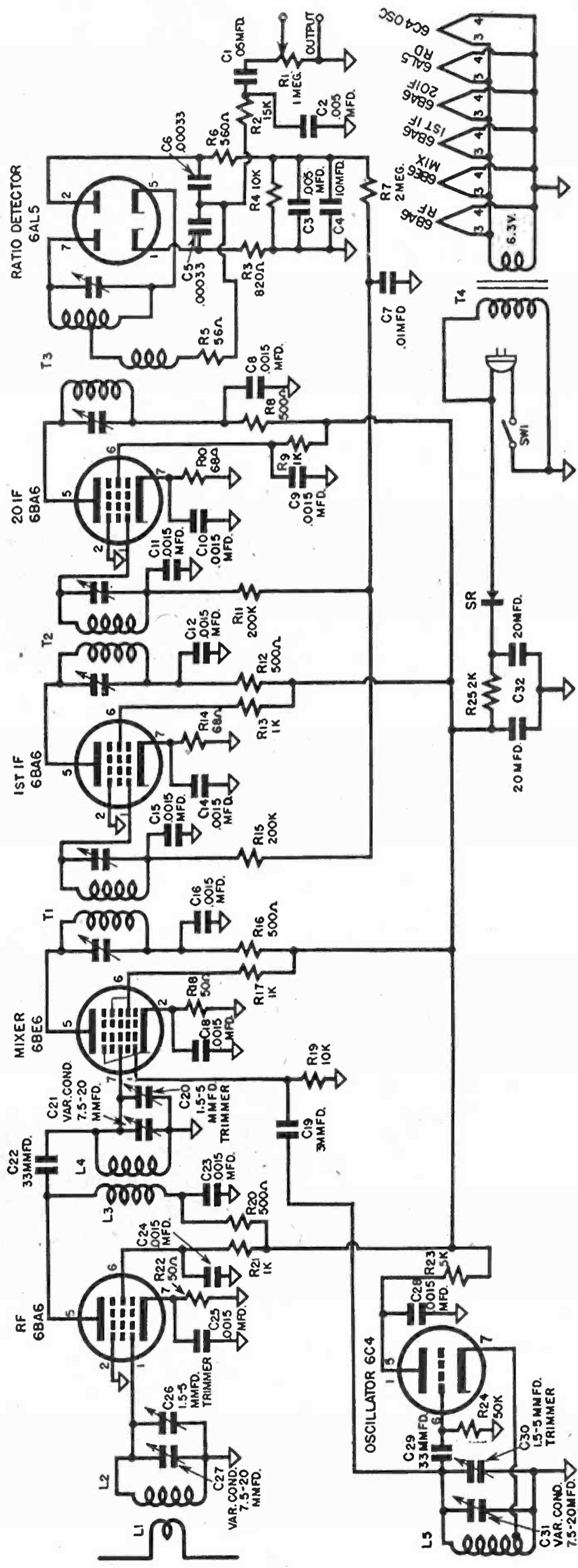

Fig. 6-1. Schematic diagram for a six-tube frequency modulation tuner.

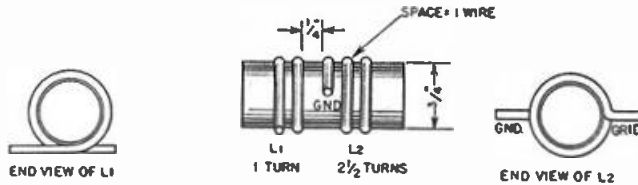

Fig. 6-2. Antenna coil windings.

The turns can be spaced accurately by winding a scrap piece of wire side by side with the wire used for the coil. When the winding has been completed, remove the scrap wire. The principal difficulty you may have is handling the #14 wire, which is rather stiff, but after one or two trials you will soon get the knack of winding a smooth, accurately spaced coil. You will save yourself a lot of trouble if, before starting any of the windings, you make sure that the wire to be used is absolutely straight. If there is the slightest suggestion of kinking or bending you will not be able to wind a neat, accurately spaced coil.

There are several methods of straightening wire, but perhaps the easiest is by stretching. Cut a piece of wire that is a few inches longer than actually needed for the coil. Clamp one end tightly in a vise. Take hold of the free end with a pair of heavy pliers and stretch the wire by pulling away from the vise. The coils may be wound on a permanent form of 3/4-inch-diameter polystyrene rod or tubing, or they may be wound on a temporary wood or metal form, which is removed when the coil is completed; the turns then become self-

supporting. The polystyrene tubing is inexpensive and can be bought at most large radio-supply houses. It is usually sold by the foot; one foot will be more than enough for all the coils. Also available is a special cement that may be used for holding the ends of the windings in place. Whether wound on a permanent form or self-supporting, the coils can be mounted on bases made of narrow polystyrene strips.

The antenna coil, Figure 6-2, consists of two windings. The secondary is 2-1/2 turns, with the turns spaced a distance equal to the diameter of the wire. At a distance of one-quarter inch from one end of the secondary, the one-turn primary is wound. When wired in the circuit, the end of the secondary nearest the primary is connected to ground; the opposite end is connected to grid.

Referring to the complete circuit diagram, Figure 6-1, you will notice that the r.f. unit consists of two windings, L3 and L4. L3 is a choke, wound on the body of a 1/2-watt, 4700-ohm carbon resistor (see Figure 6-3). The winding consists of 25 turns of #24 enamelled wire, close-wound (no spacing between turns). Before starting the winding, solder one end of the wire to one of the resistor leads. Wind on the 25 turns, then connect and solder the remaining end to the other resistor lead. This connects the choke and the resistor in parallel.

Coil L4 consists of 2-1/2 turns of #14 wire wound on a 3/4-inch-diameter form, as shown in Figure 6-4. The spacing between turns is equal to the wire diameter. This winding is quite similar to the secondary of the

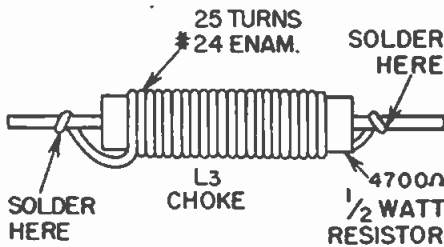

Fig. 6-3. L3 choke winding.

antenna coil. Additional construction information on both L2 and L4 can be gathered from the end view of the coil, Figure 6-2. Notice that the ends of the winding are diametrically opposite.

The oscillator coil, Figure 6-5, is made up of 2 turns of #14 enamelled wire, using the same size of form and the same spacing as for the other coils. However, L5 differs in having a tap located one-third of a turn from one end. After you have determined the location of the tap, scrape away the enamel insulation at that point. Prepare a short length of the wire used for winding the coils, by removing the insulation from one end. Apply a very small amount of soldering paste to both pieces, place in contact, and solder. Finally, remove all traces of soldering paste with alcohol.

Parts list

Resistors

- R1 1 megohm volume control, with switch, SW1
- R2 15K ohms, 1/2-watt carbon
- R3 820 ohms, 1/2-watt carbon
- R4 10K ohms, 1/2-watt carbon
- R5 56 ohms, 1/2-watt carbon
- R6 560 ohms, 1/2-watt carbon
- R7 2 megohms, 1/2-watt carbon
- R8 500 ohms, 1/2-watt carbon
- R9 1K ohms, 1/2-watt carbon
- R10 68 ohms, 1/2-watt carbon
- R11 200K ohms, 1/2-watt carbon
- R12 500 ohms, 1/2-watt carbon
- R13 1K ohms, 1/2-watt carbon
- R14 68 ohms, 1/2-watt carbon
- R15 200K ohms, 1/2-watt carbon
- R16 500 ohms, 1/2-watt carbon
- R17 1K ohms, 1/2-watt carbon
- R18 50 ohms, 1/2-watt carbon
- R19 10K ohms, 1/2-watt carbon
- R20 500 ohms, 1/2-watt carbon
- R21 1K ohms, 1/2-watt carbon
- R22 50 ohms, 1/2-watt carbon
- R23 5K ohms, 1/2-watt carbon
- R24 50K ohms, 1/2-watt carbon
- R25 2K ohms, 1-watt carbon

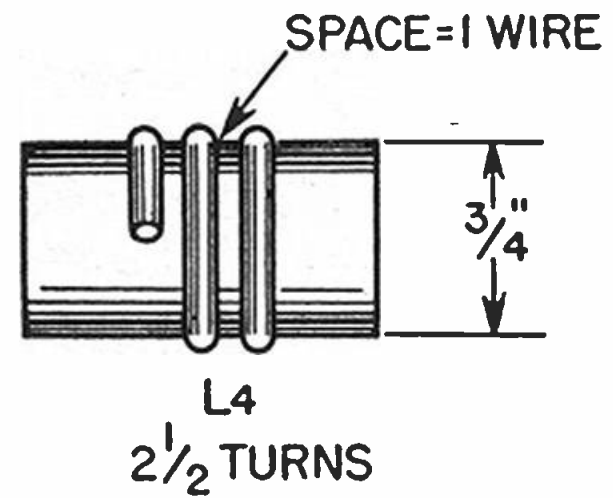

Fig. 6-4. RF coil winding.

Condensers

- C1 .05 mfd., 200-volt paper tubular
- C2 .005 mfd., 200-volt paper tubular
- C3 .005 mfd., 200-volt paper tubular
- C4 10 mfd., 150-volt electrolytic, tubular cartridge
- C5 .00033 mfd., 200-volt mica
- C6 .00033 mfd., 200-volt mica
- C7 .01 mfd., 200-volt paper tubular
- C8 .0015 mfd., 400-volt mica
- C9 .0015 mfd., 400-volt mica
- C10 .0015 mfd., 200-volt mica
- C11 .0015 mfd., 200-volt mica
- C12 .0015 mfd., 400-volt mica
- C13 .0015 mfd., 400-volt mica
- C14 .0015 mfd., 200-volt mica
- C15 .0015 mfd., 200-volt mica
- C16 .0015 mfd., 400-volt mica
- C17 .0015 mfd., 400-volt mica
- C18 .0015 mfd., 200-volt mica
- C19 3 mmfd., 200-volt silver mica
- C20 1.5-5 mmfd., ceramic trimmer
- C21 7.5-20 mmfd., three-gang tuning condenser, with C27 and C31

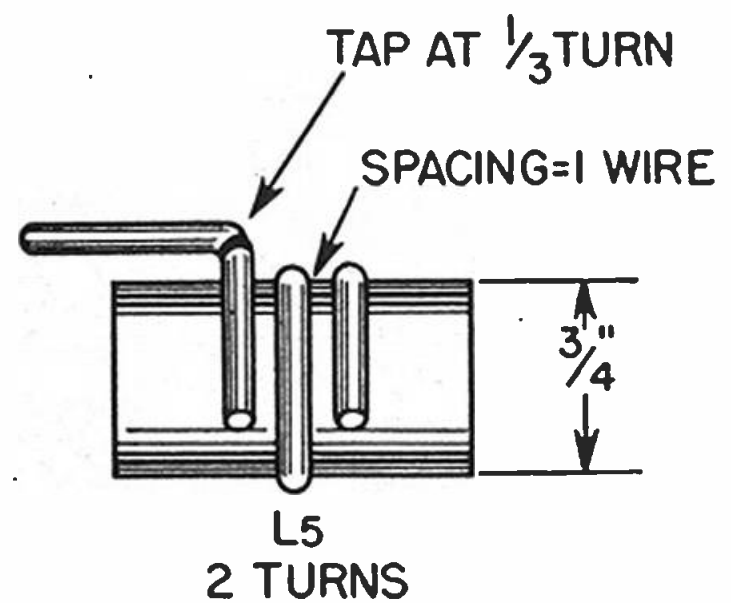

Fig. 6-5. Oscillator coil winding.

C22	22 mmfd., 400-volt mica
C23	.0015 mfd., 400-volt mica
C24	.0015 mfd., 400-volt mica
C25	.0015 mfd., 200-volt mica
C26	1.5-5 mmfd., ceramic trimmer
C27	With C21
C28	.0015 mfd., 400-volt mica
C29	33 mmfd., 400-volt silver mica
C30	1.5-5 mmfd., ceramic trimmer
C31	With C21
C32	20-20 mfd., 150-volt electrolytic, aluminum can, vertical mounting.

Coils

L1	Antenna coil, with L2 (see text)
L2	With L1
L3	Choke (see text)
L4	R.F. coil (see text)
L5	Oscillator coil (see text)

Transformers

T1	10.7 mc. FM i.f. transformer; Stanwyck SFM-614S or equivalent
T2	10.7 mc. FM i.f. transformer; Stanwyck SFM-614S or equivalent
T3	10.7 mc. FM ratio detector transformer; Stanwyck SFM-6133 or equivalent

T4	Heater transformer, primary 117 volts, secondary 6.3 volts 3 amp.; Thordarson T21F10 or equivalent
----	--

Miscellaneous

Chassis: 7-1/2x9x1-1/2 inches
 6 7-pin miniature tube sockets with bases for tube shields
 6 miniature tube shields
 12-inch length 300-ohm twin-lead transmission line
 2-terminal antenna-connection strip
 Line cord and plug
 2- and 3-point tie strips
 4-36x3/8-inch r.h. machine screws
 4-36 hexagon nuts
 6-32x3/8-inch r.h. machine screws
 6-32 hexagon nuts
 Push-back wire
 Rosin-core solder

Tubes

6BA6 (3), 6BE6 (1), 6AL5 (1), 6C4 (1).

Layout and assembly

Figure 6-6 is a top view of the chassis, showing all major components in position with the exception of the antenna, r.f., and oscillator coils. These coils are mounted beneath the

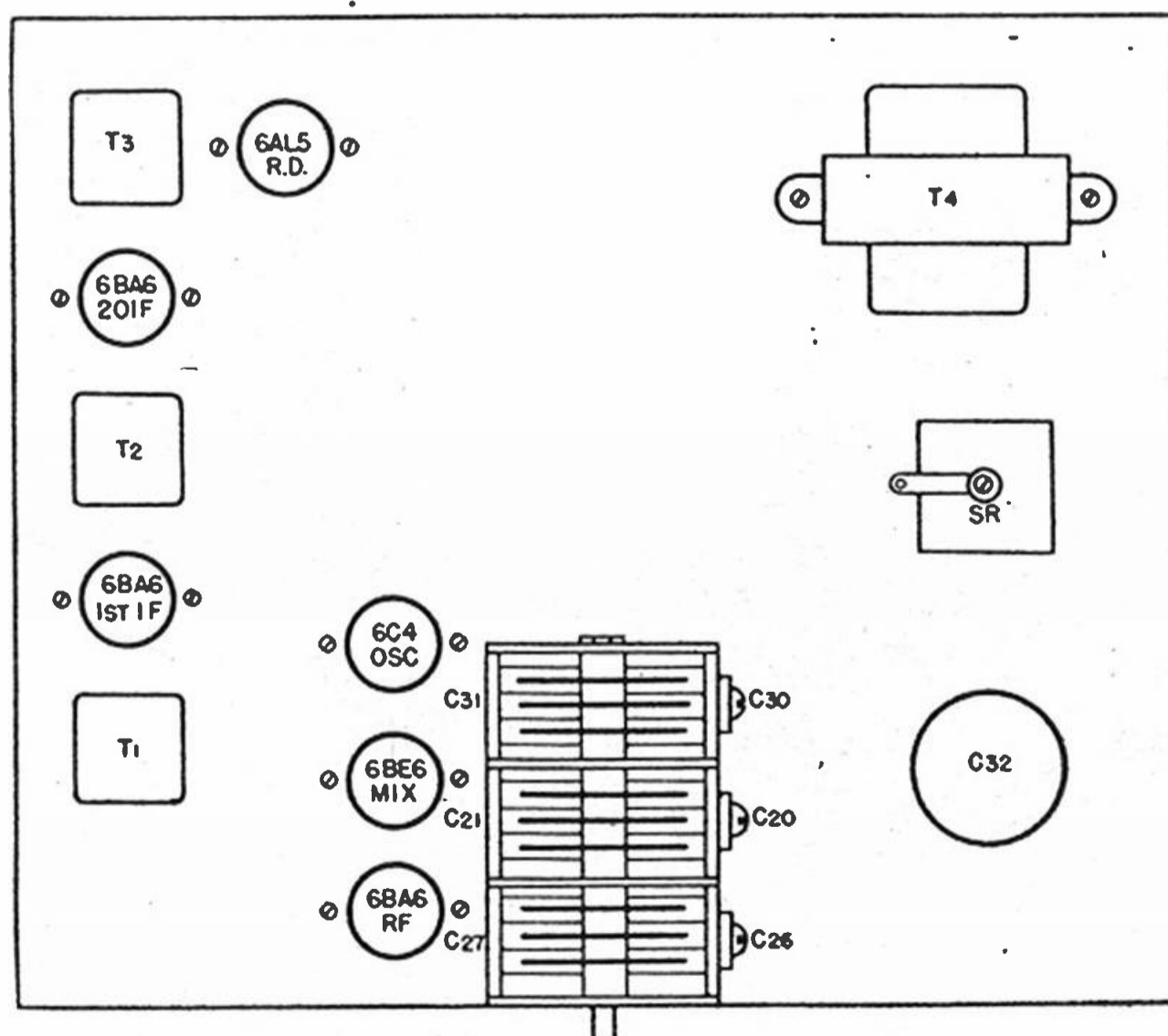

Fig. 6-6. Top view of six-tube FM tuner chassis.

chassis, each immediately below its respective tuning-condenser section. As you will see from the positions of the r.f., mixer, and oscillator tubes, the tuning-condenser sections are as follows, numbering from front to rear: 1, antenna; 2, r.f.; 3, oscillator. Trimmer condensers are mounted directly on the tuning condenser.

The r.f., mixer, and oscillator tubes are located close to the variable-condenser sections they are associated with. Thus the r.f. tube is placed immediately beside the antenna section of the condenser; the mixer tube is close to the middle, or r.f., section of the condenser; and the oscillator tube is to the left of the rear, or oscillator, section of the condenser.

The first i.f. transformer is placed near the left edge of the chassis, just opposite the mixer tube, keeping the connections between tube and transformer short. The first i.f. amplifier tube, second i.f. transformer, second i.f. amplifier tube, and the ratio detector transformer are arranged in a straight line along the left side of the chassis, making short connections between units. The 6AL5 ratio detector tube is to the right of the detector transformer. The output terminals—a 2-terminal antenna-connection strip is used for this purpose—are located on the rear apron of the chassis.

You can substitute a length of shielded wire, terminating in a standard phono plug, for the antenna terminals. The plug is inserted in a corresponding jack located on the amplifier chassis. And this arrangement is preferred to the antenna terminal strip, but of course the tuner was designed so that it is adaptable to a wide variety of situations.

If shielded wire is used and if the volume control is to be located on the tuner chassis, connect the center wire of the shielded cable to the movable contact of the volume control, R1 in the diagram. Connect the shield to chassis.

On the other hand, if the volume control is to be part of the amplifier circuit, R1 in the tuner diagram will be omitted. In this case, connect the center wire of the shielded cable to C1, and the outer shield to chassis. The shielded wire should, of course, be no longer than is absolutely necessary.

The entire right side of the chassis is reserved for the power supply components. The heater transformer is

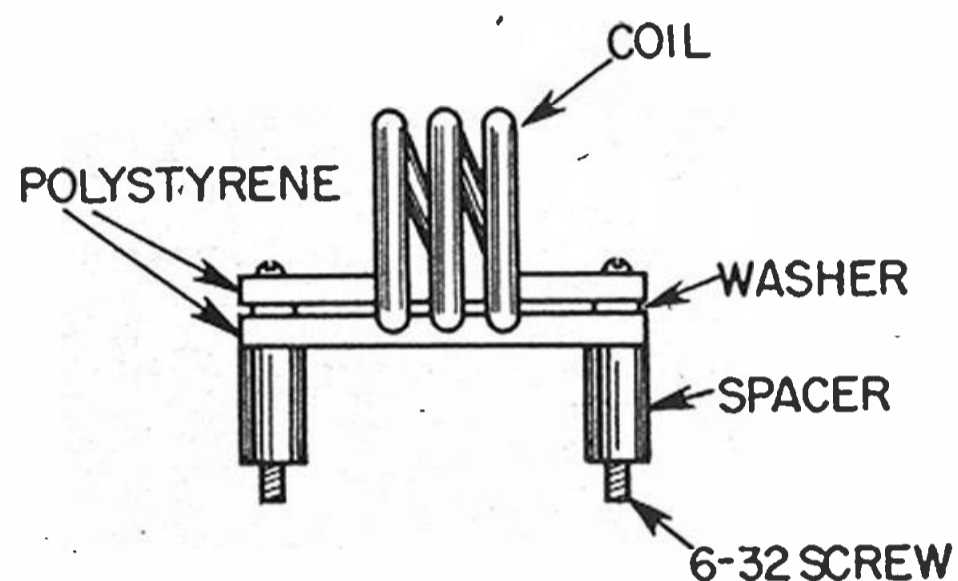

Fig. 6-7. Coil assembly.

located at the right rear corner, with the selenium rectifier and filter condenser forward of it. If a volume control is to be part of the tuner, it may be centrally located on the front apron of the chassis, below the tuning condenser.

A suggested method of mounting the antenna, r.f., and oscillator coils when permanent winding forms are not used is shown in Figure 6-7. If you use this method, you will need the following for each coil:

- 2 pieces of sheet polystyrene, 1/2 inch by 1/8 inch in cross section and about 3/4 inch longer than the coil
- 2 6-32x1 inch r.h. machine screws with nuts
- Several washers to fit over the 6-32 screws
- 2 pieces of 1/8-inch-inside-diameter brass tubing, 1/2-inch long, or brass spacers of equivalent size

The coil is assembled as shown in Figure 6-7. Note that the turns are held between the two polystyrene

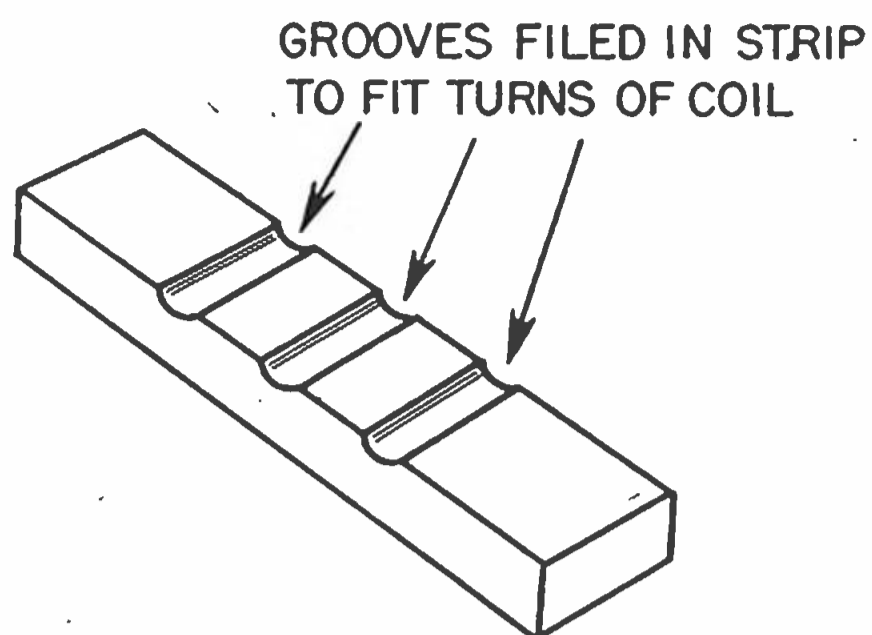

Fig. 6-8. Detail of polystyrene strip.

pieces; any space between the ends of the strips is taken up by washers. The coil, with the insulating strips, is held away from the chassis by means of the spacers or tubing, while the entire assembly is fastened to the chassis with the one-inch screws and nuts. Groove each piece of polystyrene with a round or three-cornered file as shown in Figure 6-8, and drill the ends for 6-32 screws. The grooves accommodate the turns of the coil.

When you arrive at positioning the coils, you will probably have two choices. They may be mounted on the underside of the chassis, each immediately under the tuning-condenser section it is to be connected to. The mounting scheme described in the preceding paragraph is ideal for such an arrangement.

The second possibility is to mount each coil directly on its tuning-condenser section. In some cases, the coil-mounting arrangement already discussed can be used, but in others, another method will have to be worked out, depending upon the construction of the condenser.

Wiring and testing

Wire the project from the sectional diagrams rather than the complete schematic.

Heater and power supply circuits

See Figure 6-9 for circuit diagrams.

Connect one line-cord wire to the

selenium rectifier, the other to one switch terminal. One side of the primary of T4 is also connected to the same rectifier terminal. The remaining primary wire runs to the free switch terminal and thence to chassis. Connect one end of R25 to the free terminal of SR, and the remaining end to a tie-strip terminal; this terminal will be the B-plus connection for all tubes. Wire the two filter-condenser positive leads as shown, and connect the negative lead to chassis.

The tube heaters are connected in parallel to the secondary of T4. Connect all of the #3 socket terminals together, then connect a wire between the secondary of T4 and the #3 terminal on the socket nearest the transformer. Connect all of the #4 pins and the remaining transformer secondary wire to chassis.

The heater circuit may be tested by inserting the tubes in their sockets, connecting the line plug to an outlet, closing the switch, and noting whether the tubes light. If you have an AC voltmeter, you may measure the voltage between pins 3 and 4 of each tube socket. Correct reading is 6.3 volts.

A DC voltmeter is needed to make a check of the power supply circuit. The meter range should be not less than 150 volts. With the negative test lead on chassis, touch the positive lead to the terminal of R25 that is farthest from the selenium rectifier. The reading at this point should be from 90 to 120 volts.

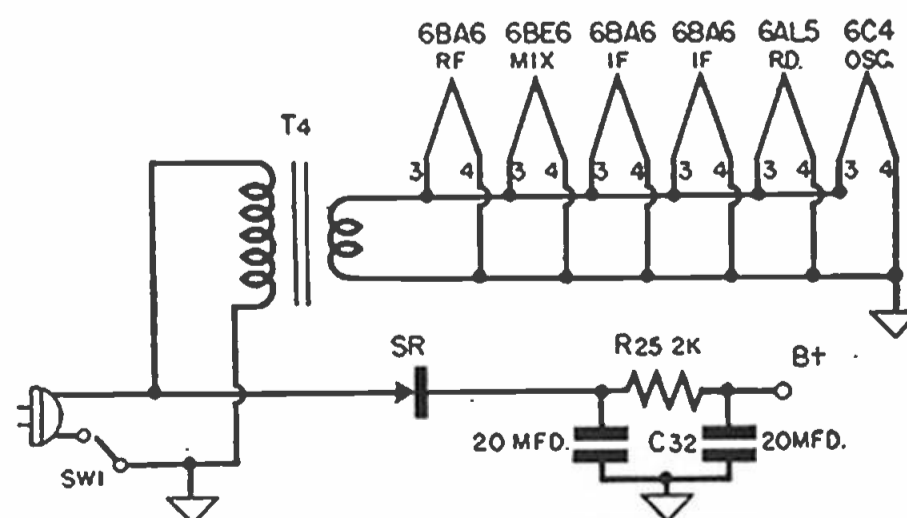

Fig. 6-9. Heater and power supply.

Ratio detector circuit

See Figure 6-10 for the circuit diagram.

Notice that the two diodes are connected series aiding; because of this the outer ends of the transformer secondary winding are not connected to the diode plates, as you might anticipate. Instead, one end of the secondary is connected to a plate (pin 7) while the opposite end of the winding is wired to a cathode (pin 5).

Between the remaining tube-socket

in the middle. Connect C2 between the junction point of R2 and C1 and chassis.

All that remains is to wire the AVC filter, consisting of R7 and C7. They should be mounted on a tie strip and one end of each connected together. Be sure the outside foil of C7 is connected to chassis. The free end of R7 is then connected to the junction of R4 and R6. Note that the grid returns to the two i.f. amplifier stages will be connected to point X, the AVC ter-

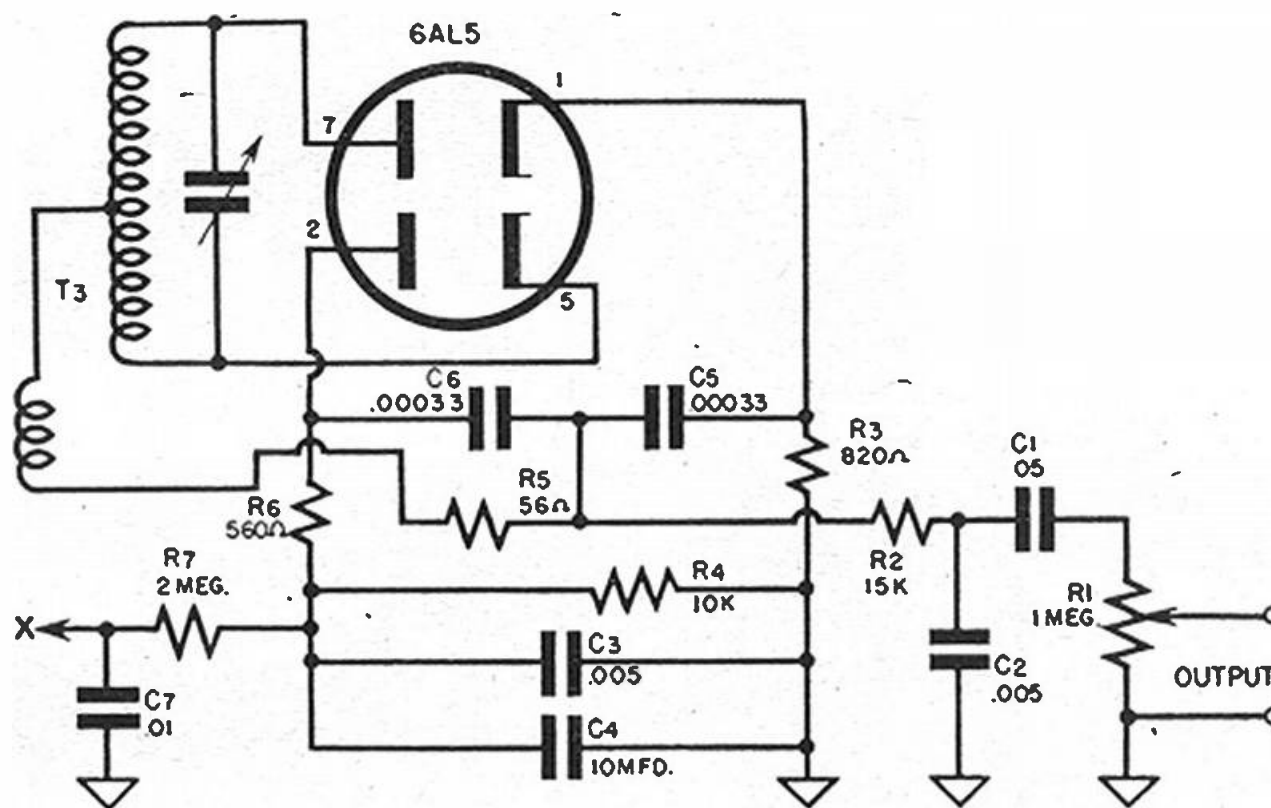

Fig. 6-10. Ratio detector circuit.

terminals (pins 1 and 2) we have a rather complicated circuit consisting of C3, C4, C5, C6, and R3, R4, R5, and R6. Connect C5 and C6 in series, then connect the series combination between socket terminals 1 and 2. R3 is connected from socket terminal 1 to chassis. With R6 mounted on a tie strip, connect one end to pin 2 of the tube socket. Now, from the free end of R6 we have R4, C3, and C4, all in parallel; the free terminal of this parallel combination is to be connected to chassis.

Connect the transformer tertiary winding to the junction of C5 and C6, through R5. From this same point (the junction of C5, C6, and R5) connect the series combination of R1, C1, and R2 to chassis. Notice that R1 (the volume control) is at the chassis end of the series combination, with C1

minal, later on.

There is no simple operation test that can be made on this stage. A voltage analysis cannot be made since, under normal conditions, there will be no DC voltage at any of the tube electrodes, with the exception of the heater terminals. A resistance check can be made, and the test points and normal readings are listed below:

From	To	Ohms
pin 7	chassis	infinity
pin 5	chassis	infinity
pin 7	pin 5	will vary with individual transformer
pin 1	chassis	820
pin 2	chassis	10,560

Second i.f. amplifier circuit

See Figure 6-11 for the circuit diagram.

C8, C11, R8, R9, and R11 are best

supported on tie strips. If R8 and R9 are mounted on a 3-point strip, their common point can conveniently be wired to B plus (see power supply diagram, Figure 6-9). The remaining terminal of R8 may now be connected to the B-plus end of the T3 primary. The opposite end of the primary is connected to the plate of the tube (pin 5). Add the condenser C8 from the junction of R8 and the transformer winding to chassis. The opposite end of the primary is connected to the plate of the tube (pin 5). Add the condenser C8 from the junction of R8 and the transformer winding to chassis.

Complete the screen circuit by connecting the free end of R9 to the screen terminal (pin 6). Before soldering the connection, add the screen bypass condenser, C9.

R10, the cathode resistor, and C10, the cathode bypass condenser, are connected in parallel and the combination connected between socket terminal 7 and chassis. These two components may either be mounted on a tie strip or be connected directly between the socket terminal and chassis.

One end of the T2 secondary winding is connected to the grid of the tube (pin 1). At the same time, connect pin 2, the suppressor, to chassis. R11 is connected from the remaining terminal of T2 to AVC (point X in the ratio detector circuit, Figure 6-10). Add condenser C11 from the junction of the T2 winding to chassis, and the wiring of this stage is completed.

Make a resistance check of the stage and compare the readings with those given:

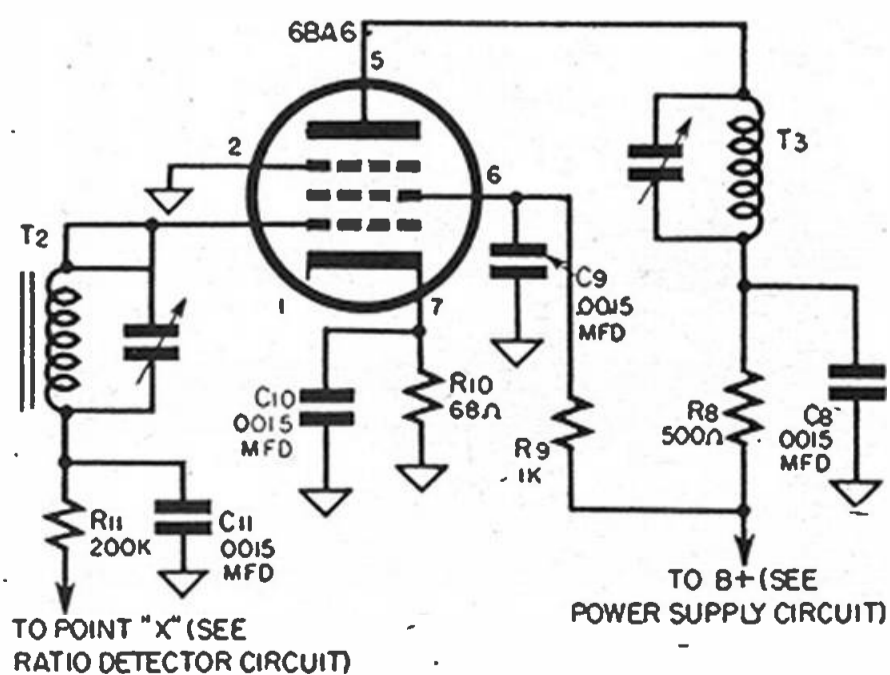

Fig. 6-11. Second IF amplifier.

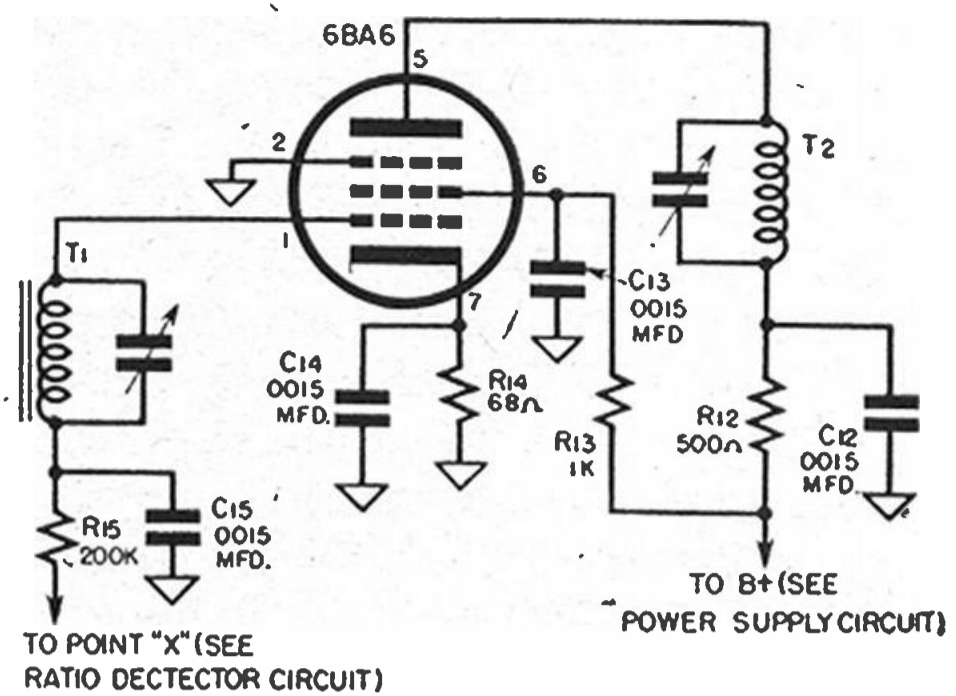

Fig. 6-12. First IF amplifier.

From	To	Ohms
pin 1	chassis	2.2 megohms
pin 1	AVC point	200K
pin 2	chassis	0
pin 5	chassis	over 100K
pin 5	B plus	approx. 500
pin 6	chassis	over 100K
pin 6	B plus	1000
pin 7	chassis	68

Normal voltages for this stage are:

From	To	DC Volts
pin 1	chassis	0
pin 2	chassis	0
pin 5	chassis	90
pin 6	chassis	90
pin 7	chassis	.7

First i.f. amplifier circuit

The circuit diagram for this stage is shown in Figure 6-12. The wiring and test procedures are exactly the same as for the second i.f. amplifier stage.

Mixer circuit

See Figure 6-13 for the circuit diagram.

Mount R16, R17, R19, C16, and C19 on terminal strips before starting the wiring. R18 and C18, in parallel, may be connected directly from the cathode terminal of the tube socket (pin 2) to chassis. Connect the plate terminal of T1 to pin 5 of the tube socket. With R16 and R17 on a 3-point tie strip, connect their common point to B plus (see power supply circuit, Figure 6-9).

Connect the free end of R17 to the screen terminal (pin 6) of the tube socket, but before soldering connect C17 from pin 6 to chassis. To the free end of R16 connect the B-plus terminal of the T1 primary; C16 is then connected from this point to chassis.

Connect R19 from tube-socket terminal #1 to chassis; do not solder until you have connected one terminal of C19 to this point. The remaining terminal of C19 is connected to point Y in the oscillator circuit, but this connection is not made until the oscillator circuit is wired.

The r.f. coil, L4, the r.f. section of the tuning condenser, C21, and the trimmer condenser, C20, are now connected in parallel. The exact procedure

for making the connections will depend upon the location of L4 with respect to C21. If L4 is mounted directly on the tuning condenser, the end of the coil winding itself may be connected directly to the condenser terminal. C20 should be fastened to the frame of the tuning condenser, so that there will be a minimum of wire connection between the two. Don't forget that at the high frequencies appearing in this circuit (88 to 108 megacycles) a half inch of connecting wire can change the inductance of the circuit—and therefore the frequency—to an appreciable degree. With the coil, tuning condenser, and trimmer in parallel, connect the high side of the parallel combination (the stator of the tuning condenser) to the grid (pin 7) of the tube. The opposite end of the combination is connected to chassis. Whether or not an actual wire connection is necessary here depends upon the construction of the tuning condenser; in the average case, the frame of the condenser will take the place of a wire connection to chassis. If a connecting wire must be used, keep it as short as possible; short connections here are just as important as between the coil and the grid of the tube. Complete the wiring of this stage by connecting one end of C22 to the grid of the tube (pin 7). The opposite end of this con-

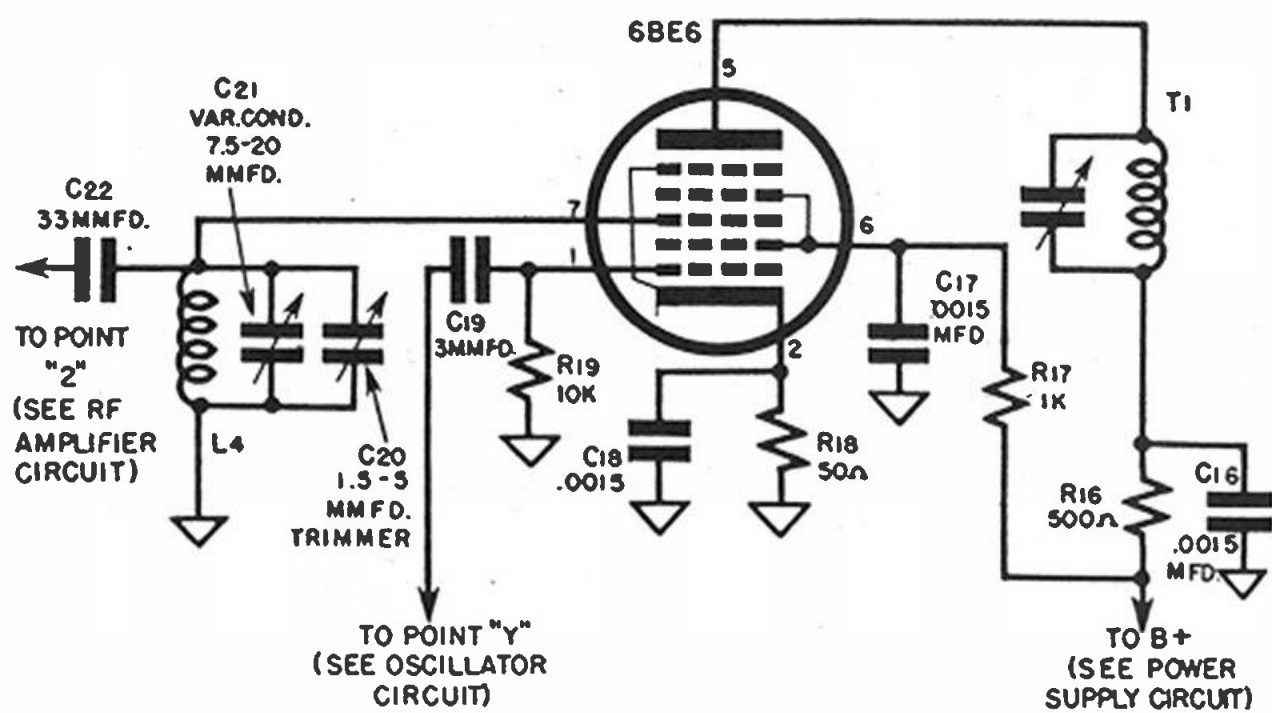

Fig. 6-13. Mixer circuit.

and trimmer in parallel, connect the high side of the parallel combination (the stator of the tuning condenser) to the grid (pin 7) of the tube. The opposite end of the combination is connected to chassis. Whether or not an actual wire connection is necessary here depends upon the construction of the tuning condenser; in the average case, the frame of the condenser will take the place of a wire connection to chassis. If a connecting wire must be used, keep it as short as possible; short connections here are just as important as between the coil and the grid of the tube. Complete the wiring of this stage by connecting one end of C22 to the grid of the tube (pin 7). The opposite end of this con-

denser is connected when the r.f. stage is wired.

Here are the test points and normal readings for a resistance analysis:

Here are the test points and normal readings for a resistance analysis:

From	To	Ohms
pin 1	chassis	10K
pin 2	chassis	50
pin 5	chassis	over 100K
pin 5	B plus	500
pin 6	chassis	over 100K
pin 6	B plus	1000
pin 7	chassis	0

For those who wish to make a voltage check, the test points and normal readings are listed:

From	To	DC Volts
pin 2	chassis	.7
pin 6	chassis	90
pin 5	chassis	90

R.F. amplifier circuit

See Figure 6-14 for the circuit diagram.

As in the case of the mixer circuit, unusual care must be exercised in the wiring. All wires must be as short and direct as possible and all connections should be well soldered.

R20, R21, C23, and the choke, L3, should be mounted on tie strips. Connect the junction of R20 and R21 to B plus. The remaining end of R21 is connected to the screen terminal of the socket (pin 6). Condenser C24 is connected from the screen terminal to chassis. Connect the plate terminal of the tube socket (pin 5) to one terminal of L3. The remaining terminal of

mer condenser, C26, are connected in parallel. Refer to the instructions for wiring the mixer circuit if additional information is wanted. One terminal of L2 is connected to the grid terminal of the tube socket (pin 1) and the opposite terminal to chassis. The ends of the 12-inch length of transmission line are connected to the terminals of the antenna-coil primary, L1, and the free end of the line is brought out at the rear of the chassis.

Make a resistance check at the points listed below:

From	To	Ohms
pin 1	chassis	0
pin 2	chassis	0
pin 5	chassis	over 100K
pin 5	B plus	500
pin 6	chassis	over 100K
pin 6	B plus	1000
pin 7	chassis	50

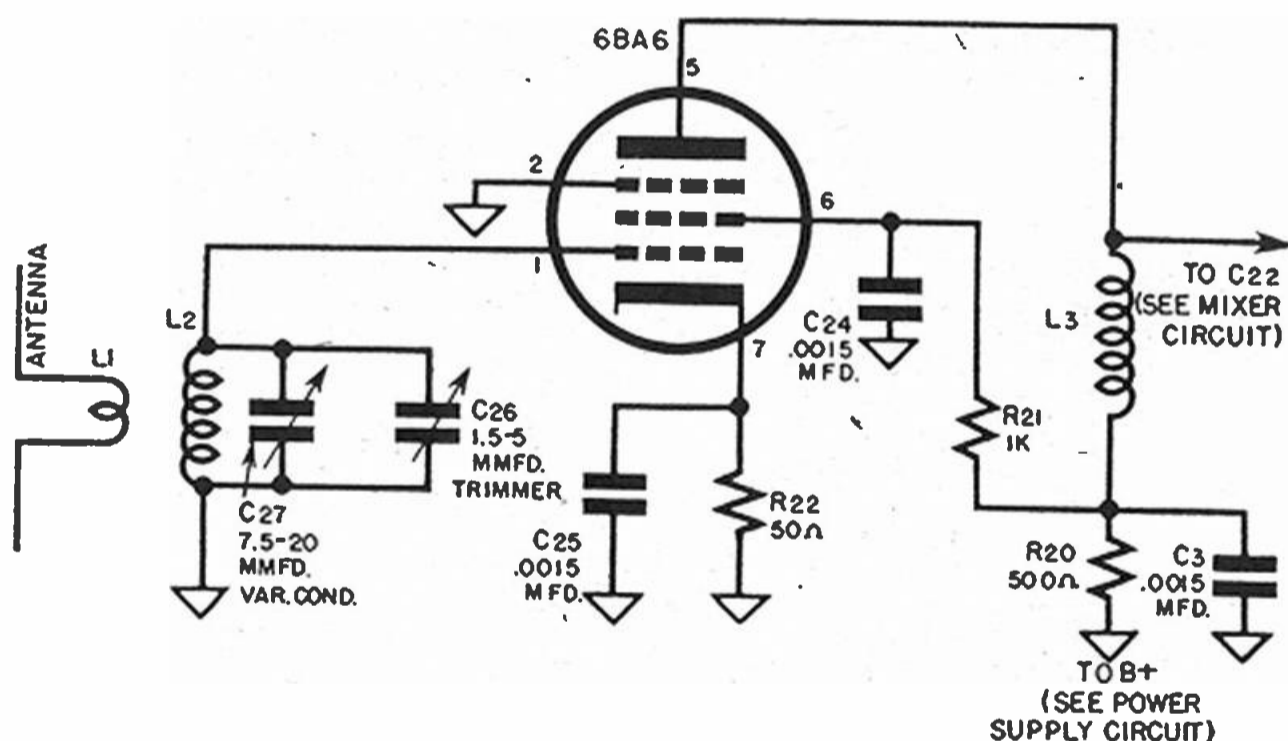

Fig. 6-14. RF amplifier circuit.

L3 joins the free end of R20; from this junction C23 is connected to chassis. Don't forget to connect the free end of C22 (mixer circuit) to the top end of L3 (point Z in the diagram).

R22 and C25, in parallel, may be connected directly from the cathode terminal of the tube socket (pin 7) to chassis. Socket terminal #2 is grounded to chassis.

The antenna-coil secondary winding, L2, the antenna section of the tuning condenser, C27, and the trim-

To make a voltage check, refer to the test points and normal readings listed here:

From	To	DC Volts
pin 7	chassis	.5
pin 6	chassis	90
pin 5	chassis	90

Oscillator circuit

See Figure 6-15 for the circuit diagram.

Connect L5, C31, and C30 in parallel, making sure that all connections

are direct. Note that the end of the winding farthest from the tap is connected to the stator of the tuning condenser. The smaller end of the coil is connected to chassis and the rotor of the tuning condenser. Connect the top end of the coil to the grid terminal of the tube socket through C29. From the grid terminal, connect R24 to chassis. Make the connection between the grid end of the coil and C19 in the mixer stage. Connect the oscillator coil tap to the cathode of the tube socket (pin 7).

R23 should be mounted on a tie strip. One end of this resistor is connected to B plus (see power supply diagram, Figure 6-9). The opposite end of the resistor is connected to the plate terminal of the socket (pin 5). Connect C28 directly from plate to chassis. This completes the wiring of the tuner.

Test points and readings for a resistance check are given in the table below:

From	To	Ohms
pin 5	chassis	over 100K
pin 5	B plus	5K
pin 7	chassis	0
pin 6	chassis	50K

Only one of the socket terminals will show a voltage reading that is measurable with an ordinary instrument—the plate (pin 5). The reading from this terminal to chassis should be about 90 volts.

FM tuner alignment

Unless you have had considerable experience in receiver alignment, we suggest that you have the tuner aligned by an experienced service man. If you feel that you can do the job and have, or can borrow, the necessary equipment, the following instructions will be helpful. You will need a high-frequency signal generator and a vacuum-tube voltmeter.

Connect the vacuum-tube voltmeter across R4 in the ratio detector circuit,

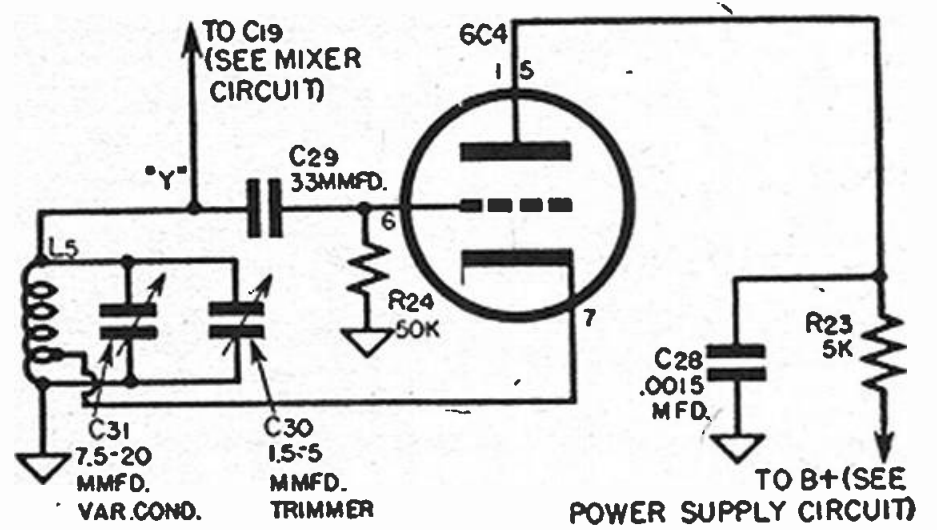

Fig. 6-15. Oscillator circuit.

as illustrated in Figure 6-16. The generator is connected to the grid of the second i.f. stage (pin 1) and adjusted to deliver a 10.7-megacycle signal. Adjust the primary trimmer of the ratio detector transformer, T1, for maximum reading on the meter.

The next step is to tune the secondary of the ratio detector transformer, T1. Disconnect the vacuum-tube voltmeter. Connect two 100,000-ohm resistors in series and connect this combination across R4 in the ratio detector circuit. Connect the meter between the junction of the two 100,000-ohm resistors and the junction of C5 and C6, as shown in the sketch, Figure 6-17. With the generator connected and adjusted as before, adjust the secondary trimmer of the ratio detector transformer until you get a zero reading on the meter. Disconnect the meter and the two 100,000-ohm resistors.

To align the i.f. stages, the meter must again be connected as in the first step, in parallel with R4 in the ratio detector circuit. See Figure 6-16. With the generator connected to the grid (pin 7) of the mixer circuit and adjusted for 10.7 megacycles, tune the i.f.

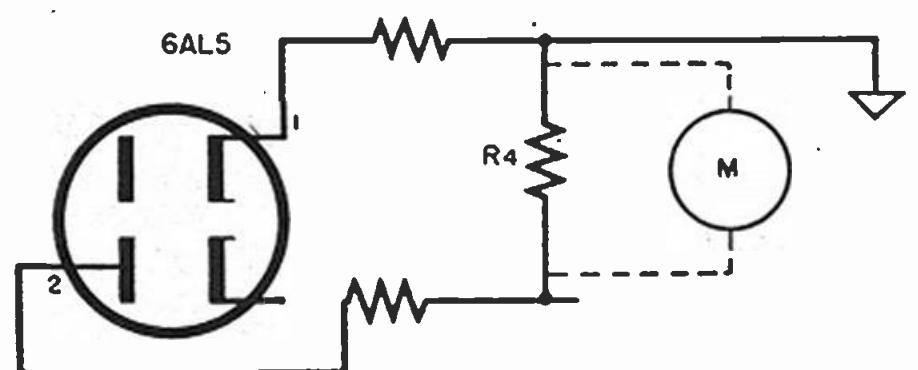

Fig. 6-16. Meter connections for adjusting primary of R.D. transformer.

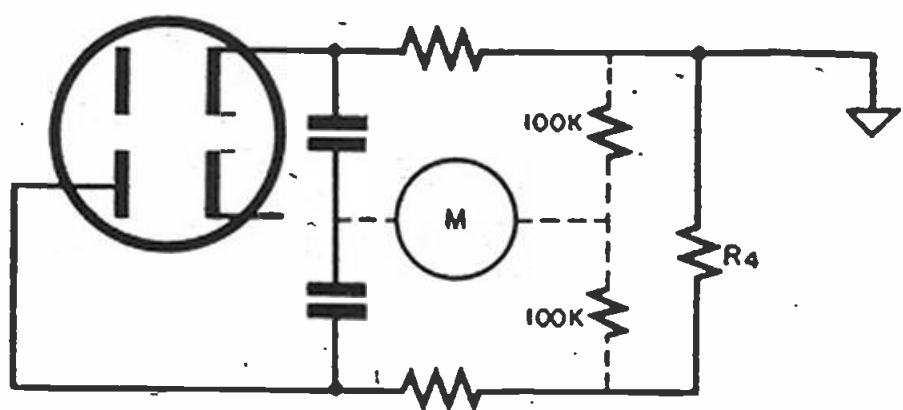

Fig. 6-17. Meter connections for adjusting secondary of R.D.T.

trimmers, starting with the secondary of T1 and working back toward the mixer stage. Adjust each trimmer to give maximum reading on the vacuum-tube voltmeter.

Allow the vacuum-tube voltmeter to remain in its present position for alignment of the r.f. and oscillator circuits. Connect the generator to the

HOW TO MAKE YOUR OWN FM ANTENNA

There is no reason why you cannot build your own FM antenna for either indoor or outdoor service, depending upon your location. In metropolitan areas served by a powerful FM transmitter, an indoor antenna will probably be satisfactory.

Of the simpler types of FM antenna, two are readily adaptable to home construction: the simple dipole and the folded dipole. If you decide to use an indoor antenna, it is simple to make up a folded dipole from the transmission wire ordinarily used to connect the antenna to the set.

You will need a piece of transmission line 58-1/2 inches long. Strip one inch of insulation from both wires at each end of the line. Twist the bared ends of the pairs together, as shown in Figure 6-18. Locate the exact center of the length of the line by measurement.

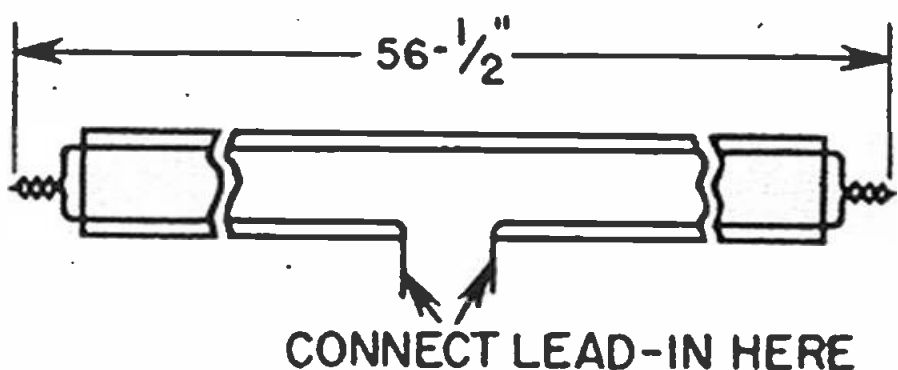

Fig. 6-18. Indoor antenna.

antenna terminals, with a 300-ohm carbon resistor in series. Adjust the generator to deliver a 105-megacycle signal. Tune the receiver to this frequency. Adjust the oscillator trimmer, C30, to give maximum reading on the meter. After the oscillator has been adjusted, vary the r.f. and antenna trimmers, C20 and C26, to give maximum reading. When this has been achieved, rock the tuning condenser slightly on either side of the 105-megacycle position. If the receiver does not tune exactly back to 105 megacycles at the maximum reading of the meter, turn the dial slowly to 105 megacycles and readjust the oscillator trimmer until the 105-megacycle point has been reached.

At the center point, cut through one wire only. Remove the insulation from the two ends thus formed. The line leading to the set is then connected to these points. The completed antenna may be fastened to a wall with tacks or by any other suitable method. Remember, best reception is obtained when the antenna is at right angles to the direction of reception.

A simple dipole for outdoor use may be made of 1/2-inch-diameter aluminum rod or tubing, as illustrated in Figure 6-19. The rod is divided into

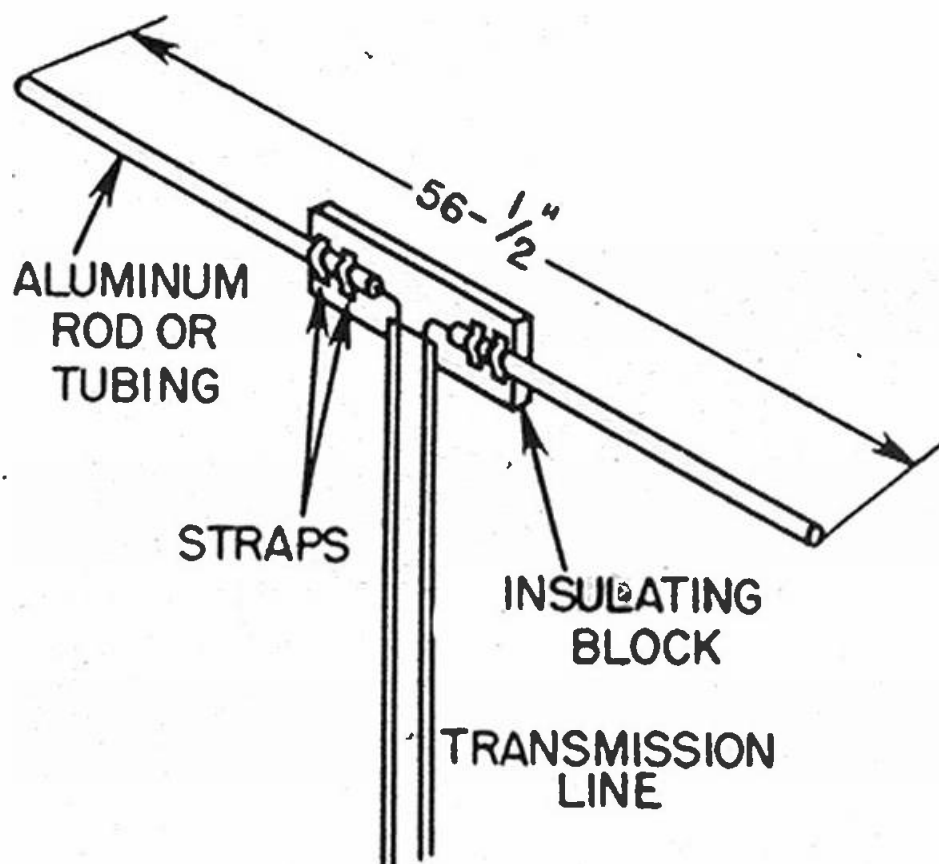

Fig. 6-19. Outdoor dipole antenna.

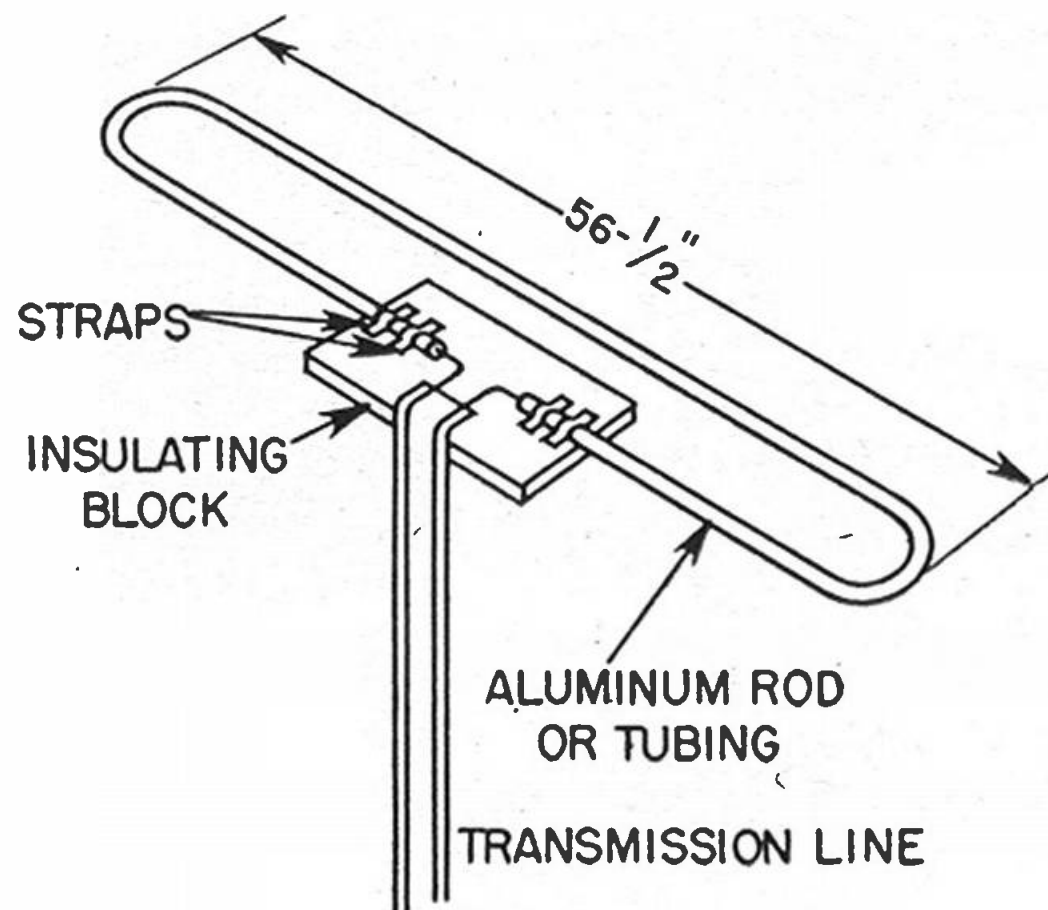

Fig. 6-20. Outdoor folded dipole antenna.

two equal sections and fastened to a block of bakelite or other plastic by means of small metal straps. The end-to-end length of the finished antenna should be 56-1/2 inches. The completed assembly is mounted on a mast, with the antenna facing toward the station. The lead-in, or down lead, is 300-ohm transmission line, connected to the inner ends of the rod.

A folded dipole antenna, Figure 6-20, can be made of 1/2-inch-diameter

aluminum rod or tubing. Here again, the total length of the antenna should be 56-1/2 inches. If you make such an antenna, use soft aluminum rather than aluminum alloy, as it is much easier to bend. Rod is also much easier to bend than tubing on account of the tendency of the latter to kink. This tendency can be circumvented if you use a spring tubing bender as electricians and refrigerator-service men do.

D. C. Milliammeter

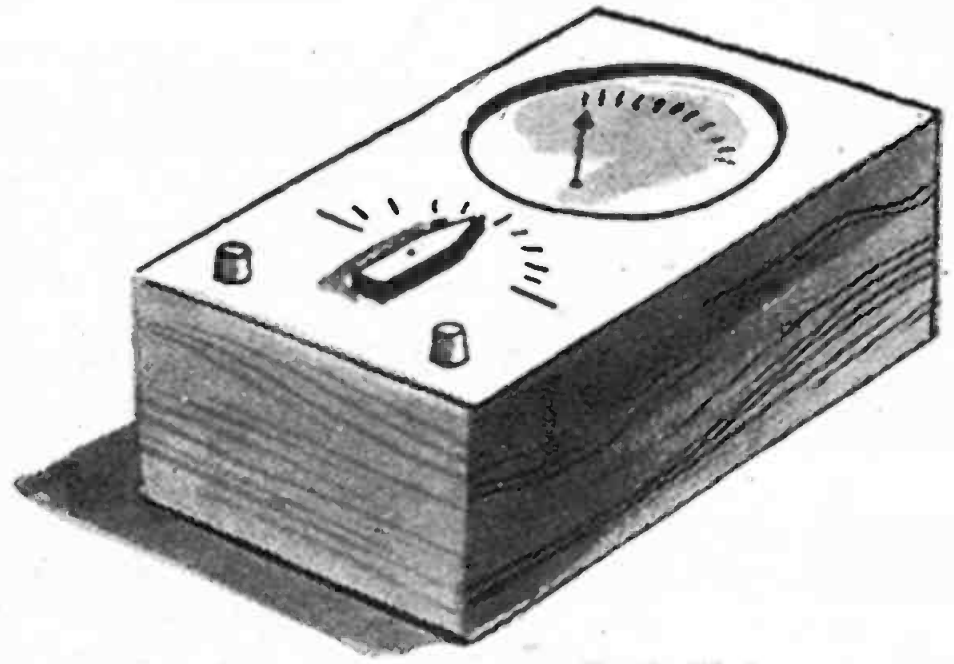
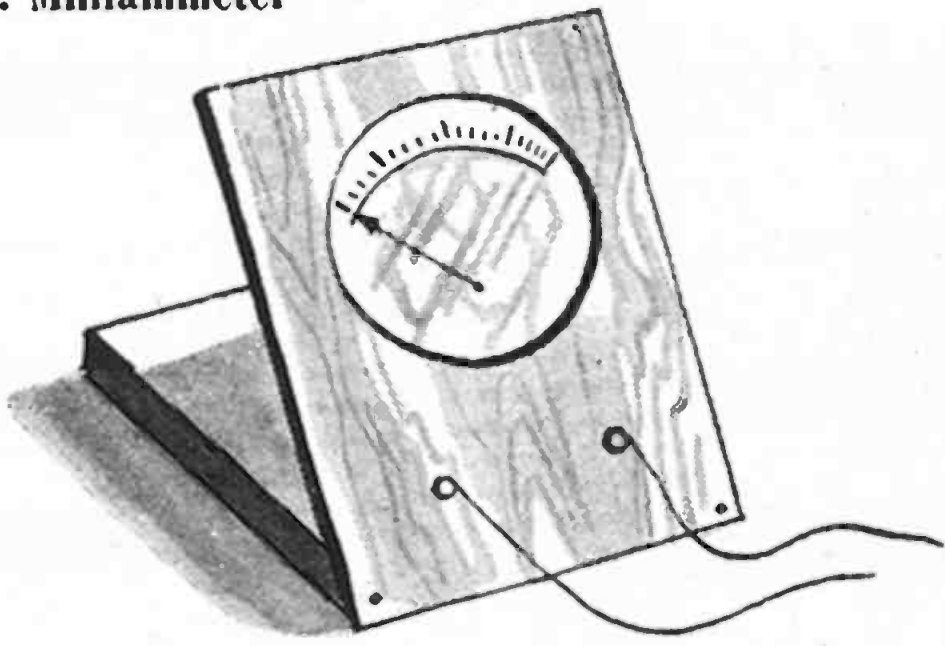

D. C. Voltmeter

Easy-to-Make Testers Simplify Building and Repairs

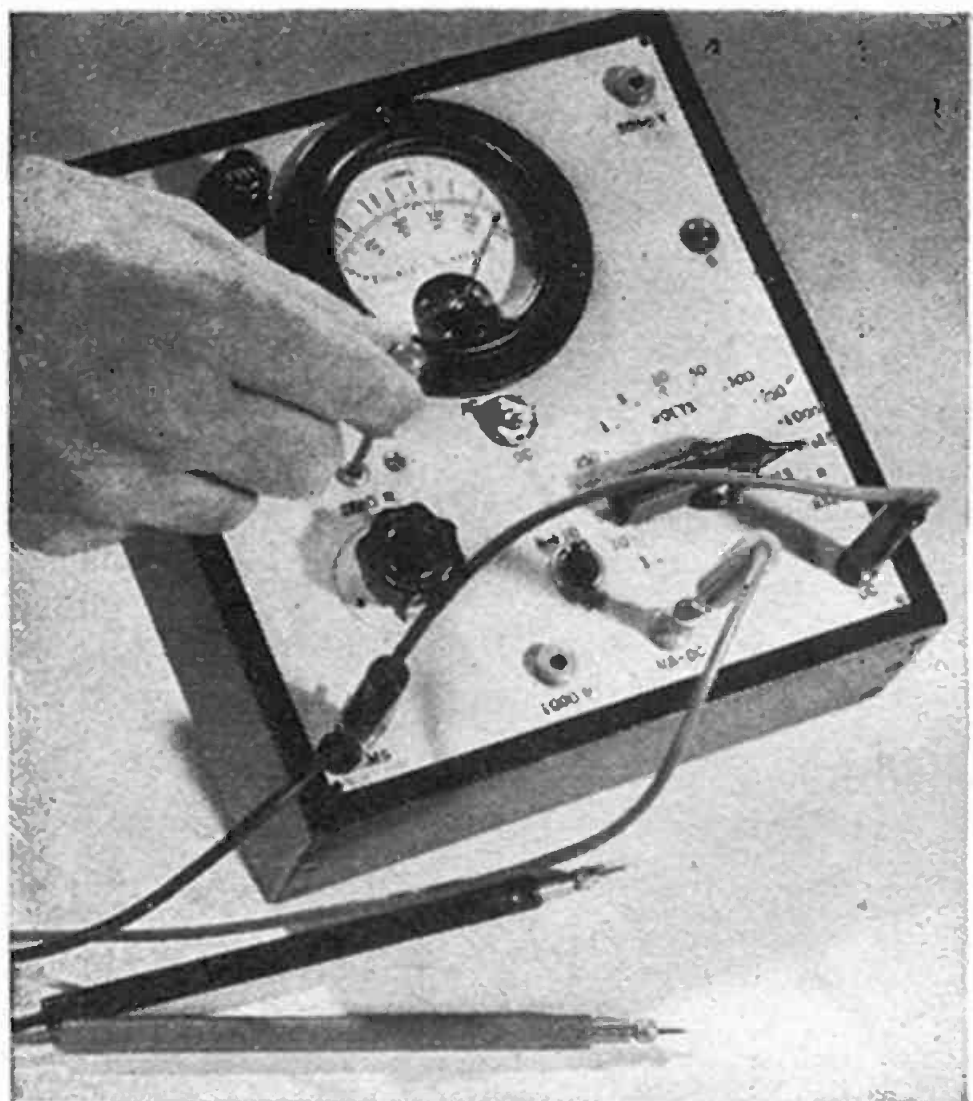

Multitester

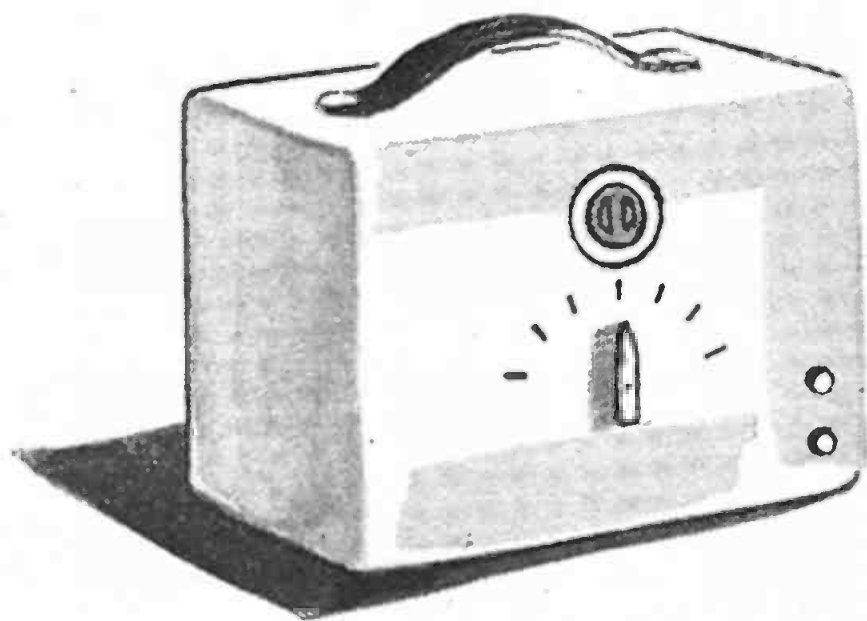

Signal Generator

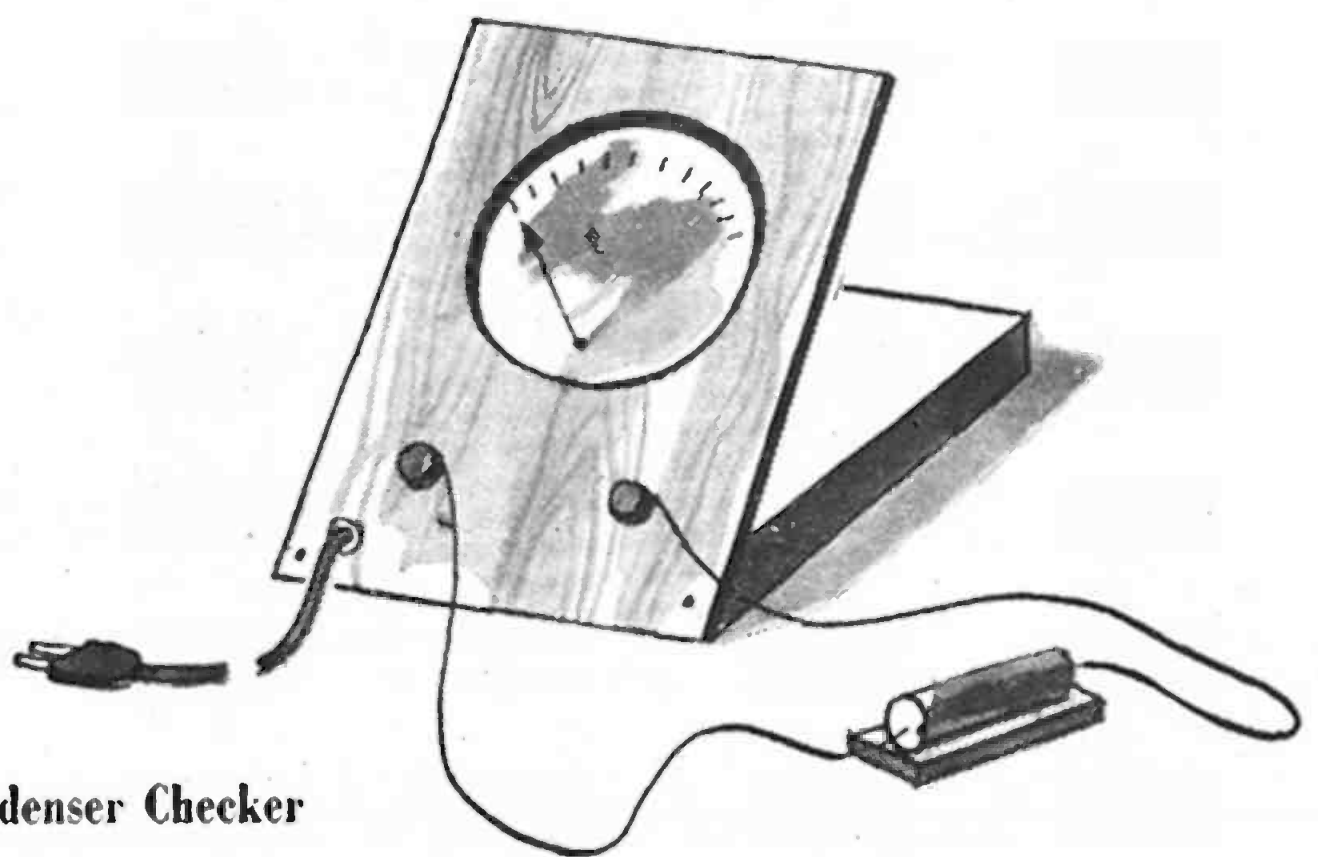

Condenser Checker

How to Build Your Own Test Equipment

EVERYONE who builds radios will sooner or later find that he needs test equipment. Of course, the equipment may be borrowed when needed, but it is always more convenient to have simple test instruments on hand. However careful you may be in your construction work, errors in wiring are bound to occur now and then. And even if you are unusually cautious in wiring and avoid misplaced connections, defects in the parts may show up. The detection of wiring errors and defective parts is almost impossible without test instruments, however crude they may be. Then, too, the more elaborate sets will have to be aligned when completed, which cannot be done without some kind of signal generator. The absolute minimum in test equipment is a volt-ohmmeter and a signal generator.

The instruments needed for alignment and trouble location may be purchased, and there are now available low-priced versions of more elaborate equipment. But you will certainly gain considerable skill and knowledge from the construction of your own apparatus while you are making a substantial saving.

In this chapter we discuss the con-

struction of several instruments, including a simple volt-ohmmeter and a fixed-frequency signal generator. We also consider briefly the basic principles of the equipment, so you will be better able to design and build apparatus to suit your particular needs.

The volt-ohm-milliammeter or multitester widely used by service men is four separate measuring instruments in one, although all four circuits use the same meter movement. The four instruments are: 1) DC voltmeter; 2) DC milliammeter; 3) AC voltmeter; 4) Ohmmeter. The DC voltmeter and the ohmmeter are indispensable for all radio workers, but the AC voltmeter and the milliammeter are absolutely necessary only to the professional serviceman and may be omitted from equipment built for a constructor or experimenter.

Milliammeter circuits are incorporated in the multitester described later in this chapter. Practically all present-day multitesters are single-meter instruments and are based on a DC milliammeter. The DC milliammeter is used for indicating all quantities and, by means of special circuits, is adapted for use as a DC voltmeter, AC voltmeter, or ohmmeter.

DC MILLIAMMETER

Almost every multitester is equipped with more than one milliamperere range. The meter movement found in

current production of such instruments may have a full-scale reading from 1 milliamperere to as low as 50

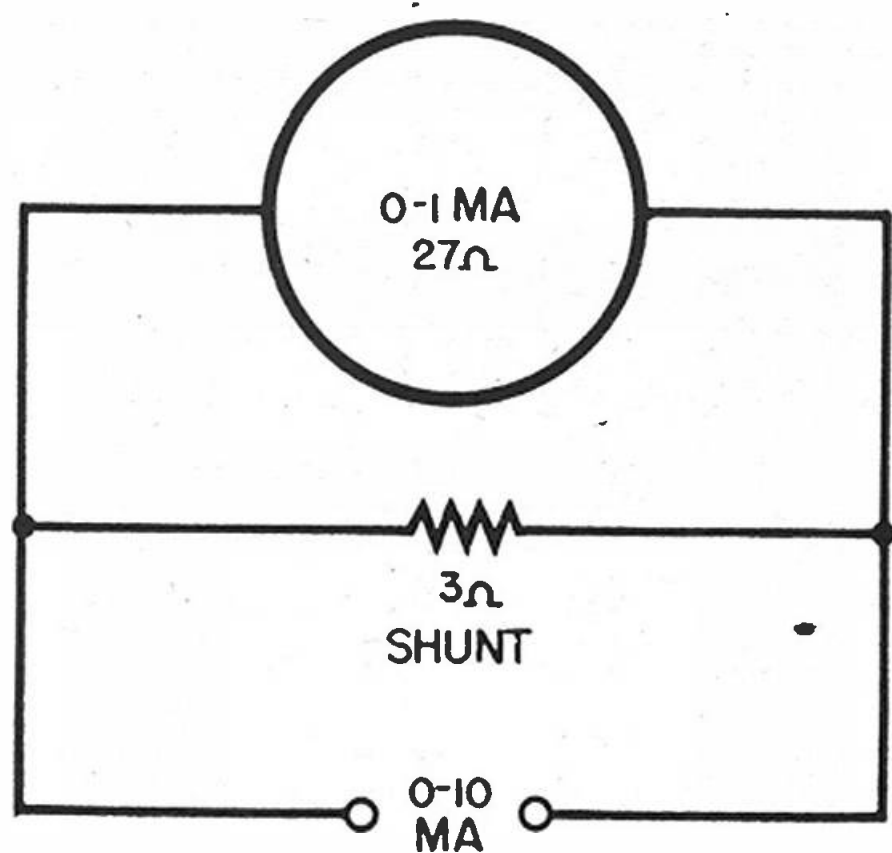

Fig. 7-1. Increasing meter range.

ment, for that is its full current-carrying capacity. The remaining nine-tenths of the total current obviously must pass through the shunt.

To accomplish this, the shunt must have a resistance equal to one-ninth of the meter resistance and, of course, we must therefore know the resistance of the meter. This can be determined by measurement, but usually the manufacturer supplies the information with the instrument. Suppose we find the meter has an internal resistance of 27 ohms. The shunt must have a resistance one-ninth of the value, or 3 ohms.

Use of a shunt may be extended to afford a multiplicity of ranges up to any practicable value. The limit will be reached when the value of the shunt is so low that it is difficult to measure accurately. You can see how the value of the shunt changes if we take another example—using the same meter to measure 20 milliamperes. The maximum that can be handled by the meter is 1 milliampere, so the remainder, 19 milliamperes, must flow through the shunt. The current path through the shunt must be 19 times easier than the one through the meter, therefore the shunt must have a resistance one-ninetcenth that of the

microamperes. The meters having a lower full-scale reading are generally rather expensive since they are much more sensitive. You need not use a meter as sensitive as 1 milliampere. Many milliammeters with full-scale readings of 10 to 50 milliamperes may be found at a fraction of their original cost in surplus stores. But remember, when converting a meter, the scale reading may always be increased to any desired value but usually cannot be decreased without opening the meter case and removing any internally connected shunts. In many cases, there are no internal shunts and the range cannot be decreased.

Suppose we start with a meter having a scale reading from 0 to 1 milliampere; this is considered to be about the minimum in sensitivity for radio work. Should we find it necessary to measure direct currents greater than 1 milliampere, we can do so with the original instrument by using a shunt, as illustrated in Figure 7-1. A shunt is a resistor connected in parallel with the meter; part of the current to be measured passes through the meter itself, the balance flows through the shunt. If, for example, we want to measure currents up to 10 milliamperes only, one-tenth of the total current (one milliampere) must be allowed to pass through the instru-

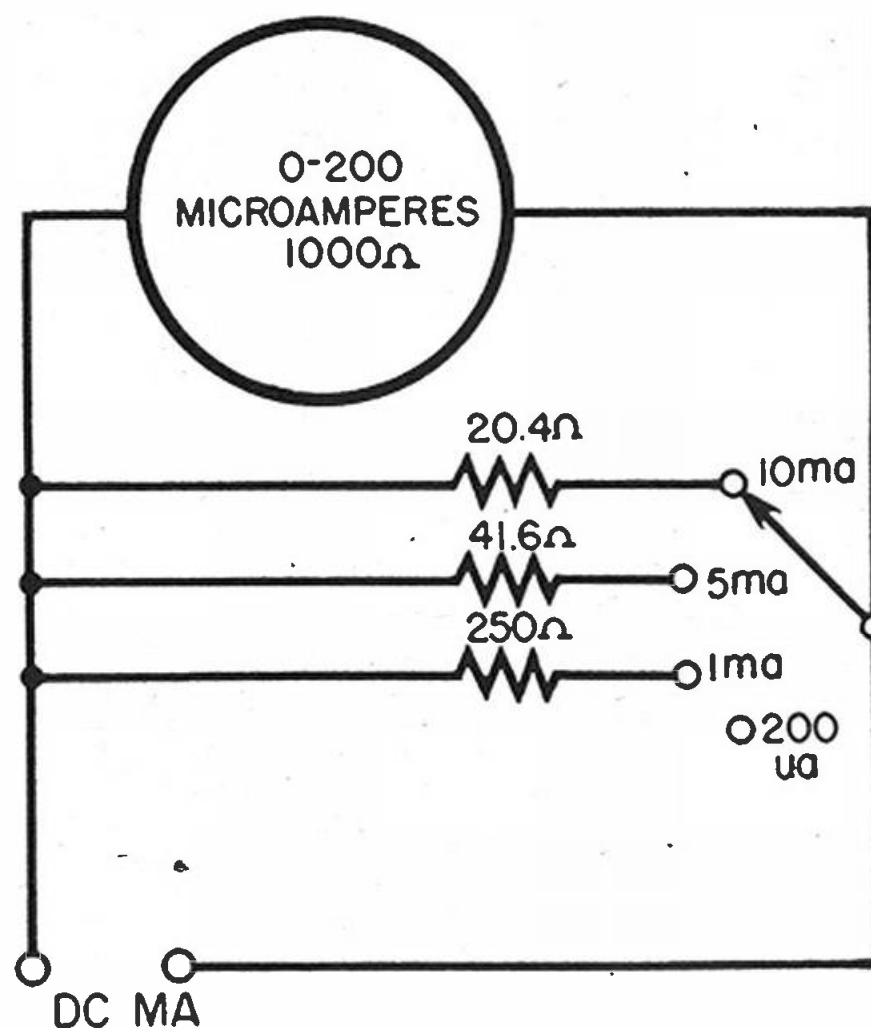

Fig. 7-2. Multi-range milliammeter.

meter, or approximately 1.42 ohms. Notice that as the range increases the value of the shunt decreases, and it must be more precise in value if the accuracy of the instrument is to be maintained.

Multi-range milliammeters can be made from any single instrument by using the circuit shown in Figure 7-2. The circuit consists of a 0-200 microampere instrument with a resistance of 1,000 ohms. Four ranges are used:

0-200 microamperes, 0-1 milliampere, 0-5 milliamperes, and 0-10 milliamperes. Only three shunts are required because on the 200-microampere range the meter is used unshunted. The single-pole four-position switch is used for changing from one range to another. Knowing the resistance of the meter, you may use it in a similar multi-range instrument by calculating the shunt values as described above.

DC VOLTMETER

A DC milliammeter can be used as a direct-current voltmeter by connecting a resistor in series with it, as shown in Figure 7-3. The resistor is then known as a multiplier. Any discarded DC milliammeter can be converted into a voltmeter, provided it is in working order. If, as shown in the sketch, the range of the meter happens to be 0-1 milliampere and we want to use it to measure voltages up to 150 (this range is particularly useful in checking AC/DC projects), then we must connect in series with the meter a resistor whose value is just sufficient to limit the current to 1 milliampere when 150 volts are applied. Using Ohm's law, we find that 150 volts divided by 1 milliampere (.001 ampere) equals 150,000 ohms. You will notice that in this calculation we have neglected the internal resistance of the meter. In the present instance this is of little importance as the meter resistance is only 27 ohms and is negligible when compared to

the multiplier value of 150,000 ohms. On lower voltage ranges the multiplier value will also be lower and the meter resistance must be taken into

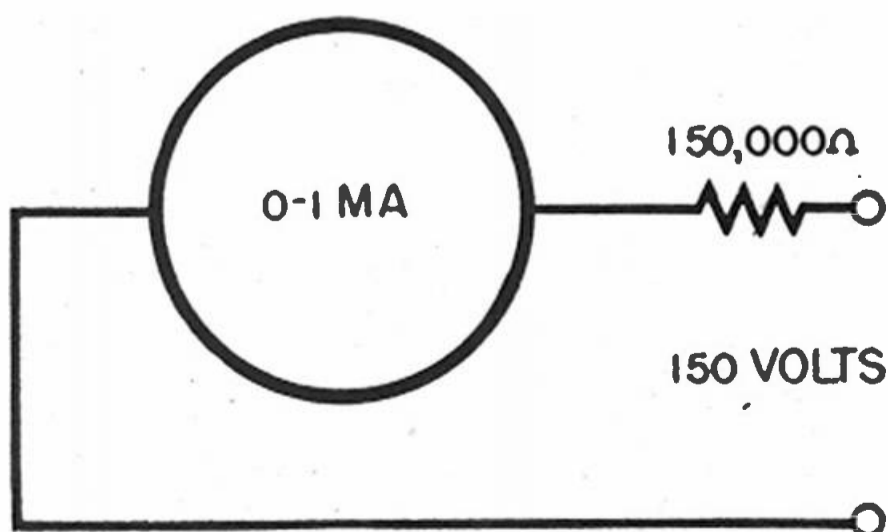

Fig. 7-3. Milliammeter to voltmeter.

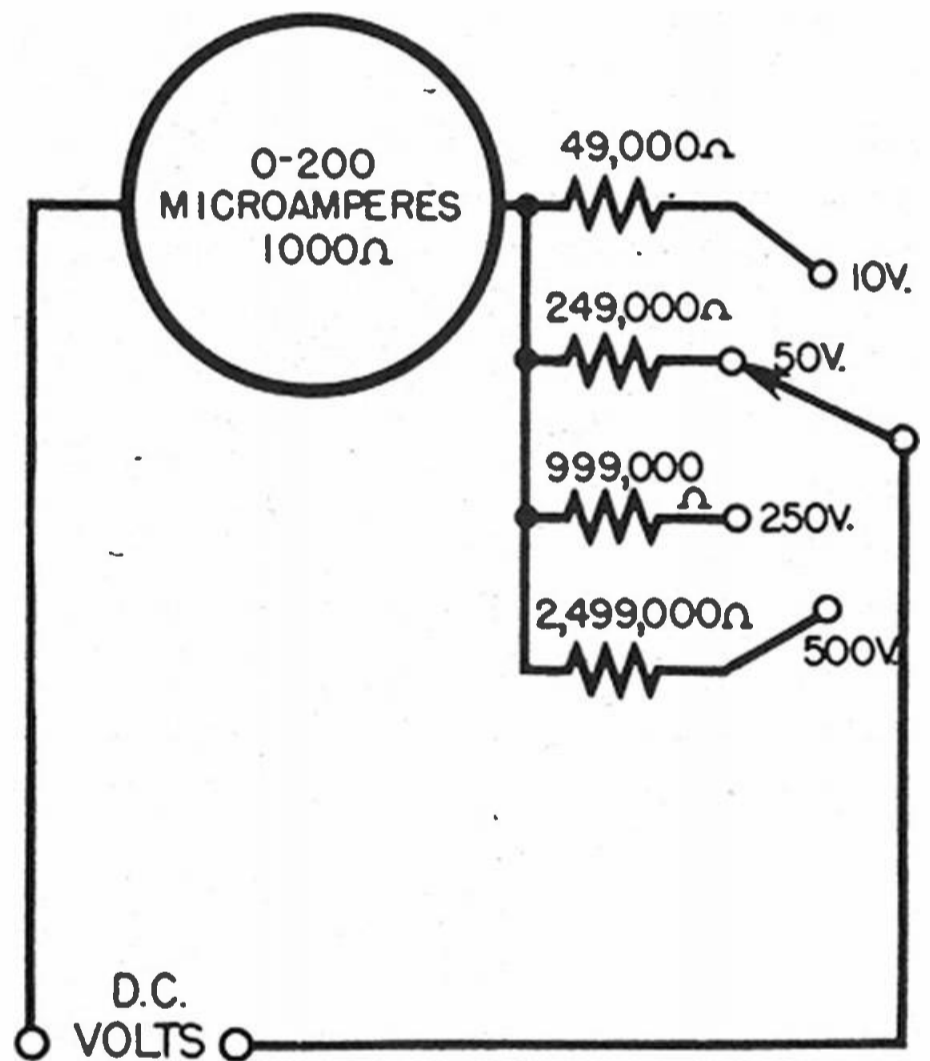

Fig. 7-4A. Multi-range voltmeter.

account. Furthermore, when using meters having a higher internal resistance (for example, a 0-200 microammeter with a resistance of 1,000 ohms, Figure 7-4A) the meter resistance may be a considerable proportion of the total resistance and must be included in the calculation. In all such cases, the meter resistance is merely subtracted from the total value of resistance; this gives the actual value of multiplier needed.

A simple multi-range voltmeter is

shown in Figure 7-4A. Here we have used a 200-microampere meter with a resistance of 1,000 ohms. The ranges are: 0-10, 0-50, 0-200, and 0-500 volts. In each case the value of the multiplier is equal to the computed value minus the meter resistance, which in this case is quite high. A single-pole, four-position switch is used to select ranges.

In studying the diagrams of Figure 7-3 and 7-4A you will observe an important principle of voltmeter design. If we take the value of the multiplier

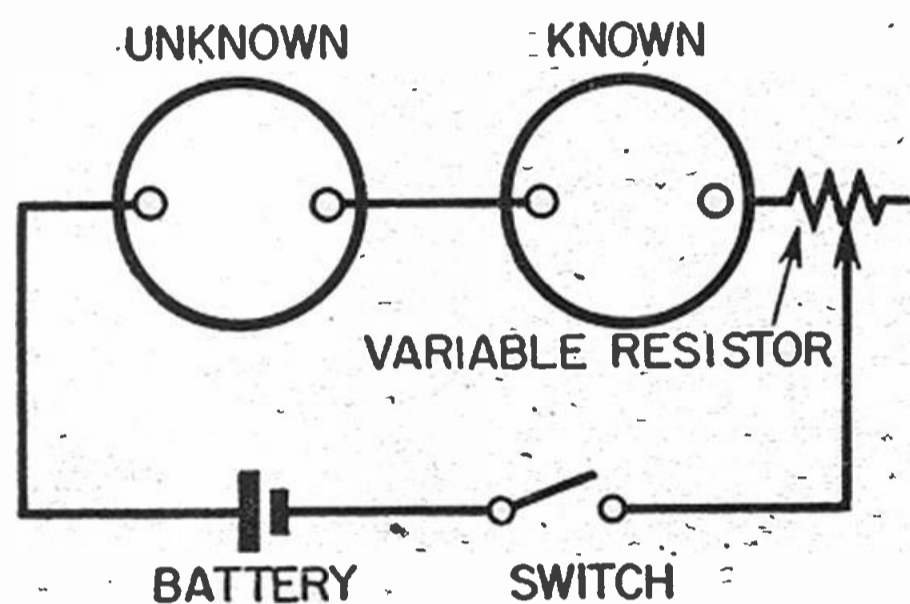

Fig. 7-4B. Testing range of meter.

resistor in Figure 7-3 (150,000 ohms) and divide it by the range (150 volts), we find that for each volt we have a series resistance of 1,000 ohms. This quantity is referred to as "ohms per volt" and is an indication of the sensitivity—and indirectly of the accuracy—of the voltmeter. A higher ohms-per-volt rating means higher sensitivity—the readings will be more accurate as the meter circuit takes very little power from the source to be measured. The 0-200-microampere meter of Figure 7-4A, by contrast, has a sensitivity of 5,000 ohms per volt. A 50,000 ohm resistance is used for a 10-volt range (49,000-ohm multiplier plus meter resistance of 1,000 ohms). This meter thus has a sensitivity five times that of the 0-1 milliamperere meter. This leads to the conclusion that the full-scale reading of a milliammeter will be a direct indication of its sensitivity when used as a voltmeter. For rough measurement, you

will find it possible to use a milliammeter with a full-scale reading of as much as 5 milliamperes, which will give a sensitivity of 200 ohms per volt, although 1,000 ohms per volt is considered the minimum in professional servicing.

Converting a milliammeter into a voltmeter

No doubt you are interested in the procedure necessary for converting any milliammeter into a voltmeter. Suppose you have an old discarded instrument, known to be in working order, but no information concerning its range or internal resistance. Perhaps there are calibrations on the scale, or perhaps the scale has been removed or the markings are defaced. Still another possibility is that the meter was calibrated as a voltmeter, and the calibrations will then give no clue as to the resistance or the current required for full-scale deflection. In that case, bear in mind that all voltmeters are basically milliammeters.

The first step is to determine the current needed to produce a full-scale deflection. You will need a battery, a variable wire-wound resistor, a calibrated milliammeter (which you can probably borrow from another experimenter or a service man), and a single-pole single-throw switch. The value of the variable resistor will depend upon the range of the milliammeter used for comparison and the voltage of the battery. For example, if the standard milliammeter has a range of 0-10 milliamperes, a simple calculation will tell you that a resistance of at least 150 ohms must be connected in series to limit the current to 10 milliamperes. To be on the safe side, we suggest you use a resistor much higher than this value, say 500 ohms.

Now connect the two meters, the dry cell, switch, and variable resistor as shown in Figure 7-4B. Before closing the switch, adjust the variable resistor to maximum value. With the

switch closed, *slowly* turn the shaft of the variable resistor until either the standard meter or the meter under test reads exactly full-scale deflection. If the standard meter shows a full-scale deflection first, you will know the current flowing in the circuit is exactly 10 milliamperes. Now note the deflection of the unknown meter. If the pointer stands at exactly half-scale reading, the full range of the meter is 20 milliamperes. A reading of one-fifth full scale means the full-scale reading is 50 milliamperes, and so forth. The scale may then be calibrated accordingly.

It is equally possible that the unknown meter will reach a full-scale deflection first. In that case, note the reading of the standard meter. A reading of 5 milliamperes, for example, shows the full-scale reading of the unknown meter is 5 milliamperes. The method is really quite simple, and it is only necessary to be sure that one of the two meters shows exactly full-scale deflection.

Determining meter resistance

The next step is to determine the resistance of the meter movement. Of course, there are times when the internal resistance of the meter is unimportant. In a voltmeter circuit, if it is low compared to the resistance of the multiplier resistor, it may be disregarded. In a low-range voltmeter, however, the meter resistance may be a considerable proportion of the multiplier value and must be taken into account. As an example, we may consider a meter whose resistance is 200 ohms and whose full-scale reading is 5 milliamperes. If used as a 0-5-volt DC meter, the multiplier would have to be 1,000 ohms. As 200 ohms is a fairly large part of 1,000 ohms, the meter-resistance must be subtracted from the calculated value of the multiplier, giving an actual value of 800 ohms. Furthermore, the resistance of the meter must be known if shunts are

to be used with it and in some ohmmeter circuits the internal resistance becomes important.

To measure the meter resistance, you will have to borrow an ohmmeter or have someone who owns an ohmmeter do the job for you. The procedure is illustrated in Figure 7-4C. With the ohmmeter adjusted for the lowest range, touch the test prods to

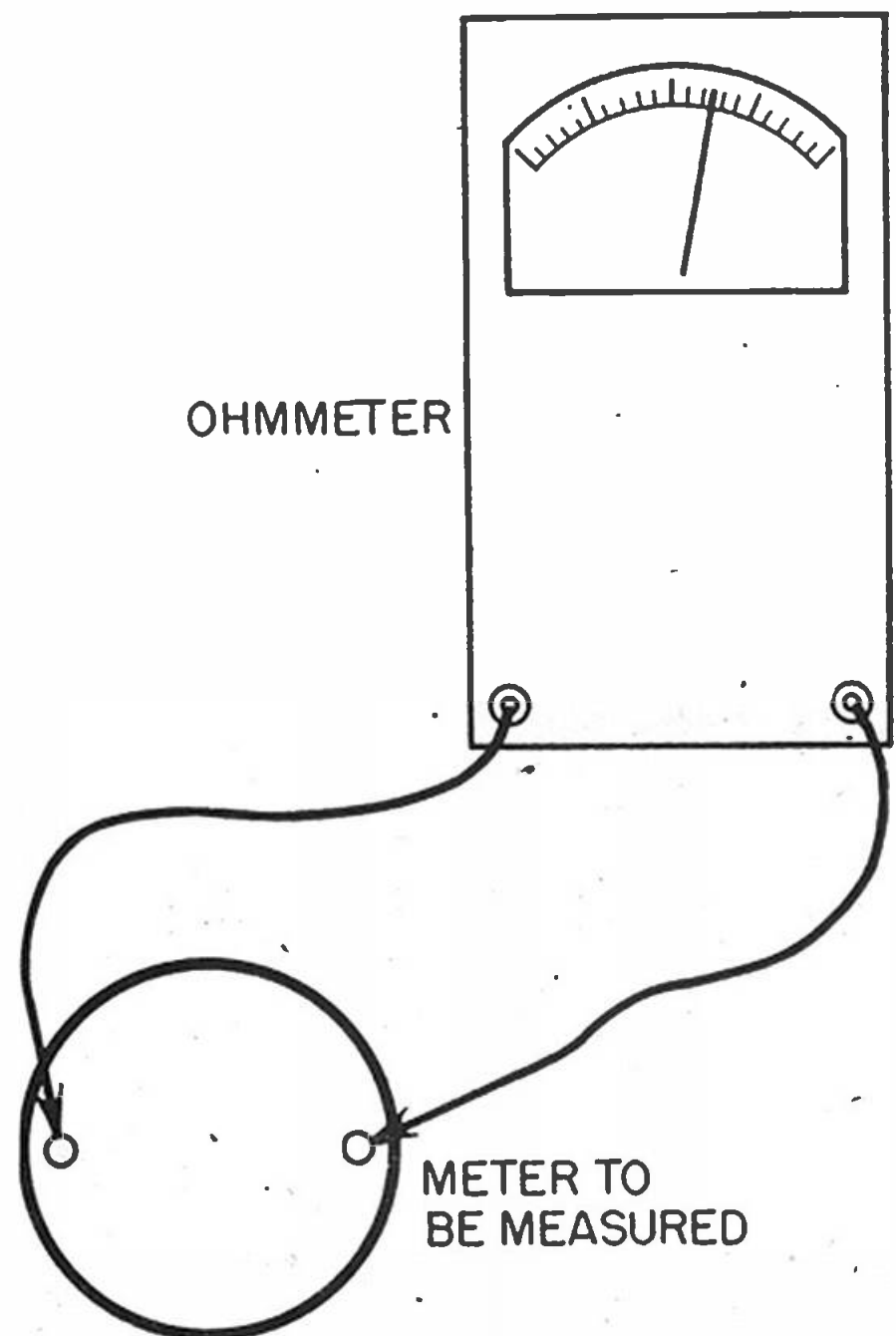

Fig. 7-4C. Measuring resistance.

the terminals on the back of the meter. At the same time be careful to watch the pointer of the meter under test. If the pointer slams over to the right side of the scale, the current needed for the operation of the ohmmeter is greater than the full-scale reading of the meter. Remove the test prods immediately to avoid damage to the meter. If the current needed for the ohmmeter is too great, there are two other methods of measuring the resistance. One is to use a higher ohmmeter range or another ohmmeter. The higher range may, however, make it difficult to get an accurate reading.

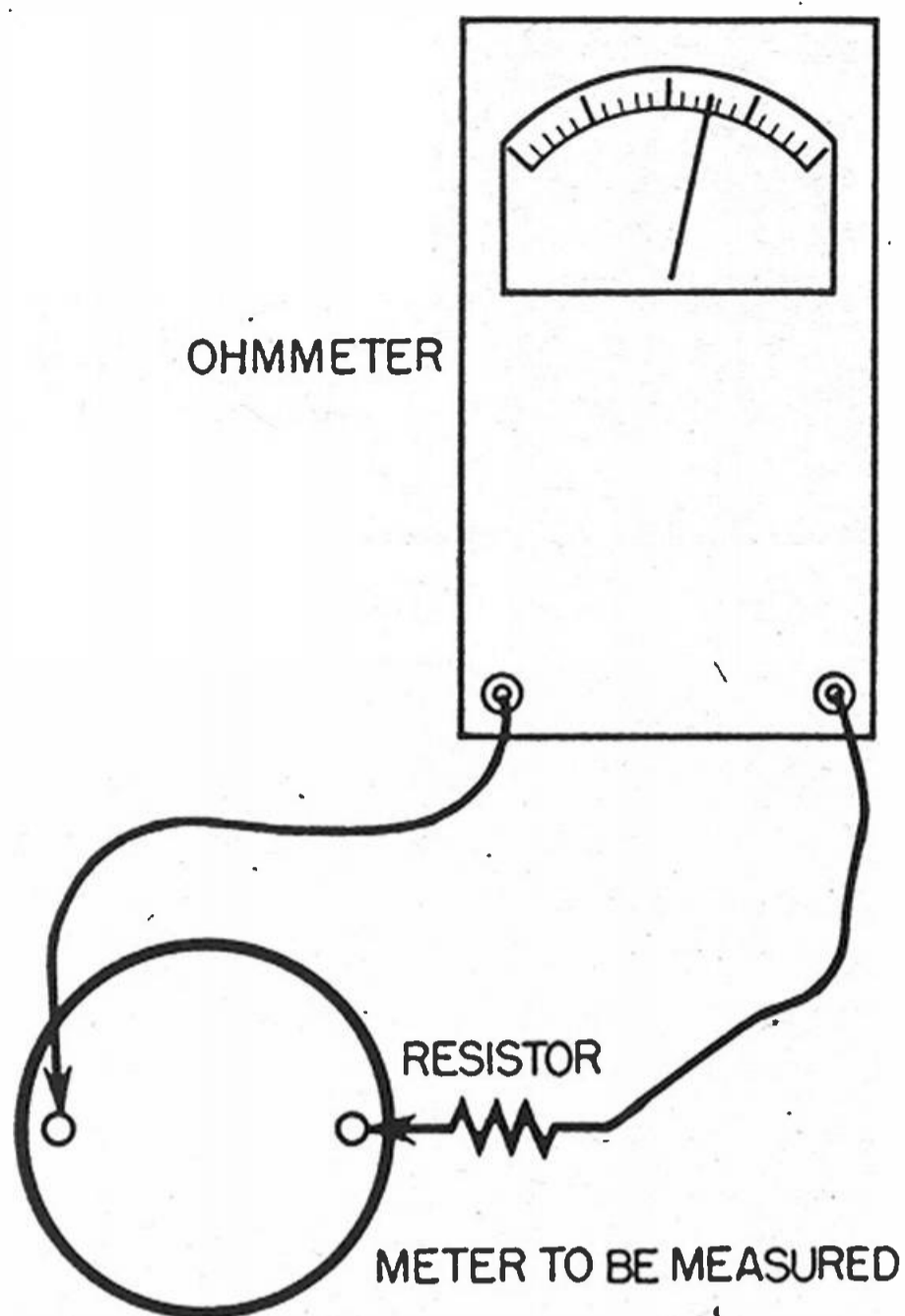

Fig. 7-4D. Using series resistor.

The alternative method is to connect a resistor of known value in series with the meter under test, as shown in Figure 7-4D. Select a value that is well within the range of the ohmmeter used. The resistance of the meter will be the total reading minus the value

of the known resistor. For example, if the total reading is 500 ohms and a known resistor of 300 ohms has been used, the meter resistance is 200 ohms.

Knowing the full-scale reading and the resistance of the meter, you may proceed to convert it into a milliammeter of any desired range or into a DC voltmeter of one or more ranges by using the information given above. Instructions for using a milliammeter as an ohmmeter will be given in the section to follow.

Another method of connecting multiplier resistors is shown in Figure 7-5. Here we have a 0-1-milliamperemeter movement used as a multi-range voltmeter for measuring 25, 50, 100, and 500 volts. The resistor needed for the 25-volt range is, of course, 25,000 ohms. When the range switch is adjusted for the 50-volt range, the 25,000-ohm resistor remains in the circuit, so it is necessary to add only 25,000 ohms to give the total of 50,000. Similarly, when the 100-volt range is used, the multipliers for 25 and 50 volts are also in the circuit and only another 50,000 ohms need be added. Both of the systems described are used in commercially made instruments.

OHMMETER

We now come to the third function of the milliammeter in a multi-tester. There are many different ohmmeter circuits, some more complicated than others. The simplest—and the one most often used—is illustrated in Figure 7-6. It consists of the meter, a battery, and a variable wire-wound resistor, R . If the two test leads are touched together and the resistor is adjusted so the meter gives exactly full-scale reading, we may use the device for measuring resistance values since as we introduce more and more resistance between the test leads, the meter reading will drop to a lower value. Suppose that with 50 ohms in

the circuit the reading is .8 milliamperes, with 100 ohms it is .7 milliamperes, and with 200 ohms it is .65 milliamperes. The next time we use the instrument, if we get a reading of .7 milliamperes, we know this means a resistance of 100 ohms, and so forth. However—and this is very important—the readings will be accurate only if the instrument is first adjusted for full-scale deflection with zero resistance between the test leads. The adjustable wire-wound resistor is referred to as the “ohms adjuster” on most instruments. The ohmmeter may be calibrated either by making a chart of current readings versus resistance

readings or by actually marking the resistance values on the face of the meter.

Converting a milliammeter into an ohmmeter

In converting any milliammeter into an ohmmeter, two things must be considered:

1) The maximum value of resistance that the instrument is capable of reading depends upon the full-scale reading of the instrument as a milliammeter. In other words, a 0-1-milliamperce movement will be capable of reading much higher values of resistance than a 0-5-milliamperce instrument.

2) The maximum value of resistance the instrument can indicate depends upon the voltage of the battery. Increasing the battery voltage will permit the meter to read higher resistance values.

The value of the variable resistor, R in Figure 7-6, must be carefully calculated. It must be high enough to keep the current within the range of the meter. You may want to know why a fixed resistor is not used. The an-

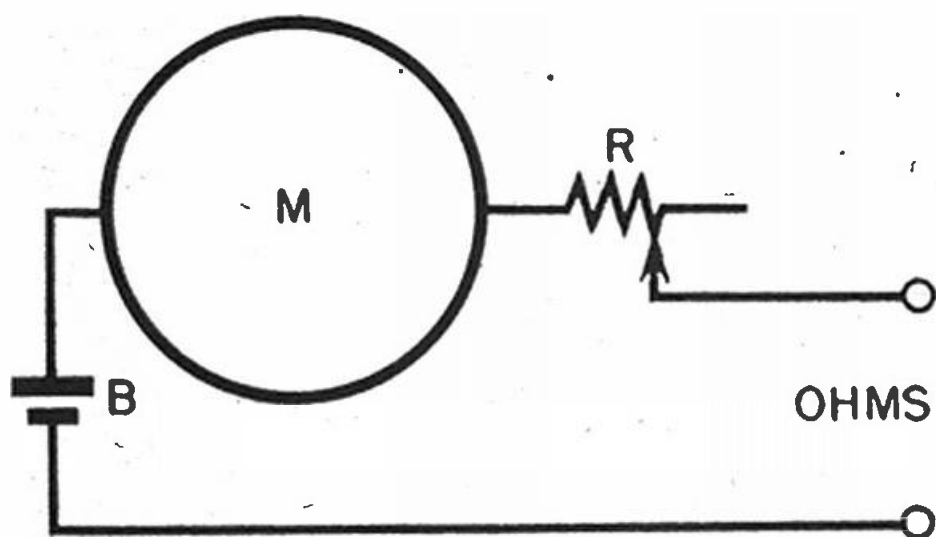

Fig. 7-6. Basic ohmmeter circuit.

swer is that the battery voltage will vary with usage; a variable resistor permits some adjustment as the battery voltage drops off.

To illustrate the method of calculating the value of the variable resistor, suppose we assume a 0-1-milliamperce movement is to be used with a 4.5-volt battery. To find the series resistance, we divide the battery voltage by the maximum allowable current—1 milliamperce. We then have 4.5 divided by .001, which is 4500 ohms. In this case we would use a resistor with a value of 5000 ohms; first because it is the nearest value readily obtainable, and second because the extra 500 ohms afford a safety margin. If we should happen to turn the variable resistor to the minimum resistance setting, however, there would be little or no resistance in series with the meter and it might be damaged. To guard against this, it is usual to include a fixed resistor in series as protection. This resistor in the instance under discussion might be 500 or 1000 ohms. In the diagram, Figure 7-7, 1000 ohms has been used.

Let us find out what resistance values this instrument is capable of measuring. With the ohms adjuster set for maximum current reading, the resistance will, of course, be zero. If we assume that the smallest current indication which can be read accurately is .05 milliamperce (1/20th of full-scale reading), we can calculate the maximum resistance reading. You will remember that 4500 ohms in series,

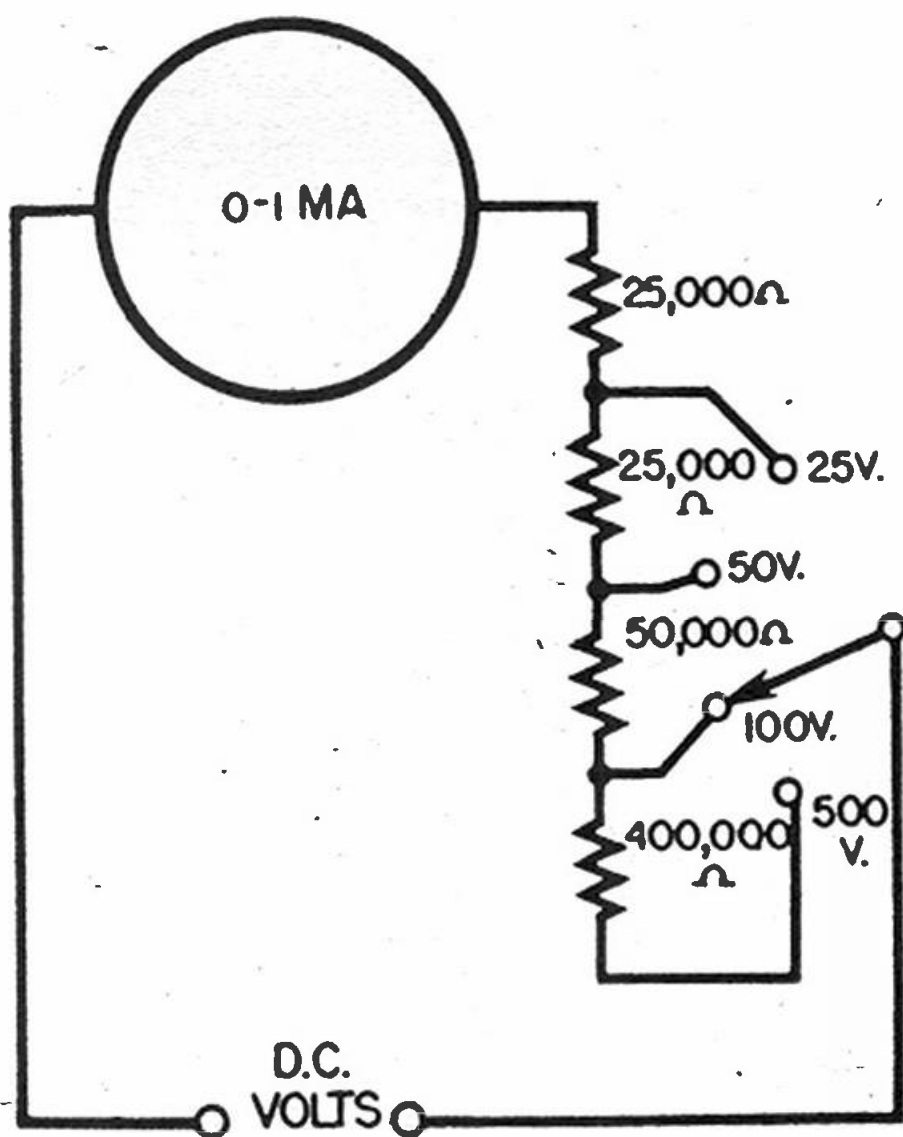

Fig. 7-5. Alternative method of connecting multiplier resistors.

with a fresh battery, will give full-scale deflection. A deflection of .05 milliamperes (or .00005 ampere) at 4.5 volts means there must be 90,000 ohms in series. 90,000 minus the original 4500 ohms gives a value of 85,500 for the resistor under test. Actually, we should be able to use such an instrument for measuring values upward of 100,000 ohms, depending upon our ability to read the scale accurately.

The next step to consider is the effect of a higher battery voltage, as many commercial ohmmeters provide a multiplicity of ohmmeter ranges by using different battery voltages.

If the meter (0-1 milliamperes) of Figure 7-7 is used with a 12-volt battery, a total of 12,000 ohms in series is required to limit the current to 1 milliamperes. A safe procedure is to use a fixed resistor of at least 5000 ohms and a variable resistor of 10,000 ohms, as shown in Figure 7-8A. Again assuming the smallest easily-read indication is .05 milliamperes, we see that this value corresponds to a resistance reading of about 250,000 ohms. We may conclude, then, that for a low-reading ohmmeter range we must use either a high current meter or a low battery voltage or a combination of the two. For the higher resistance ranges a more sensitive meter in combination with a higher battery voltage is necessary.

Using the information just given,

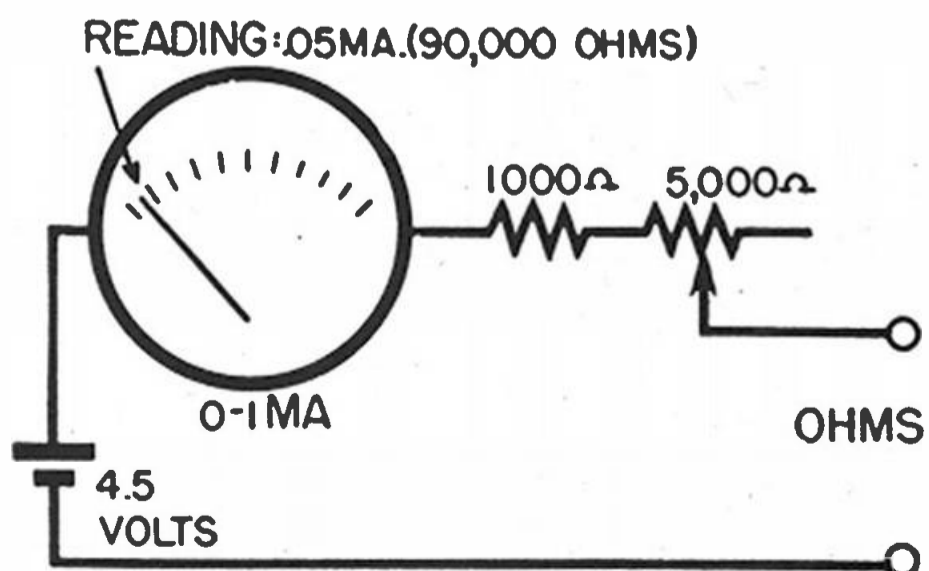

Fig. 7-7. Ohmmeter circuit with fixed current limiting resistor.

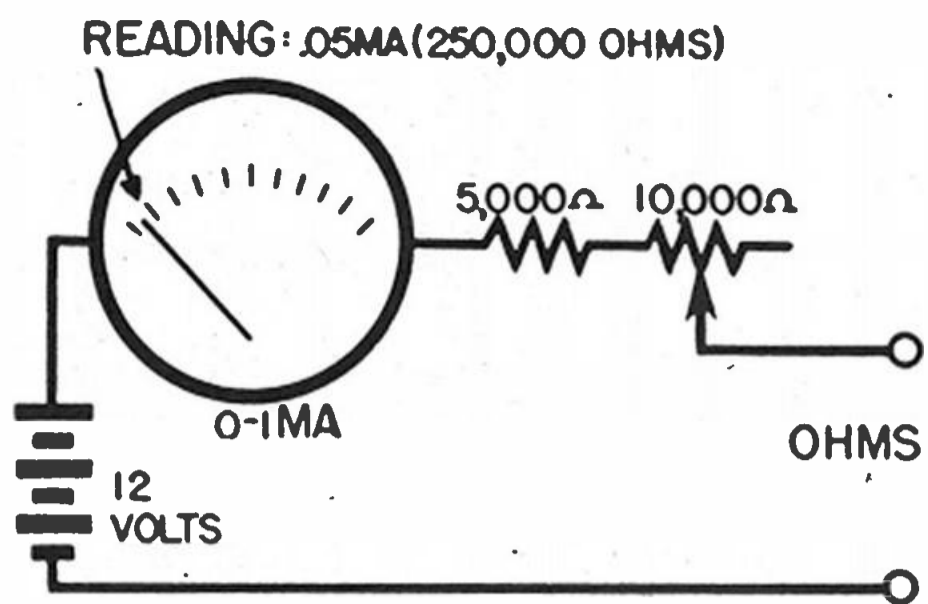

Fig. 7-8A. Increasing ohmmeter range by increasing battery voltage.

you should be able to work out an ohmmeter circuit for almost any milliammeter you happen to have on hand. Don't forget that a discarded voltmeter is converted to a milliammeter by disconnecting the multiplier resistor in series with it. No matter how low the sensitivity of the meter, it can always be used in continuity-checking of coils, transformers, and the like.

Shunting the meter

Another method of obtaining two or more ohmmeter ranges—a method often used in commercial instruments—is to shunt the meter in order to increase the full-scale current. And as you know, an increase in the current range will result in a lower ohms range. Low-reading ohmmeters are useful in measuring low-resistance components such as speaker voice coils, r.f., antennae, and oscillator coil windings, and some kinds of transformer windings. It is often impossible to measure these accurately with a high scale meter.

Figure 7-8B shows how a shunt may be used to lower the range of an ohmmeter. The instrument used has a range of 0-500 microamperes and a resistance of 200 ohms. When such a meter is used with a 4.5-volt battery and without a shunt, resistance values up to at least 200,000 ohms may easily be read. This assumes that the smallest

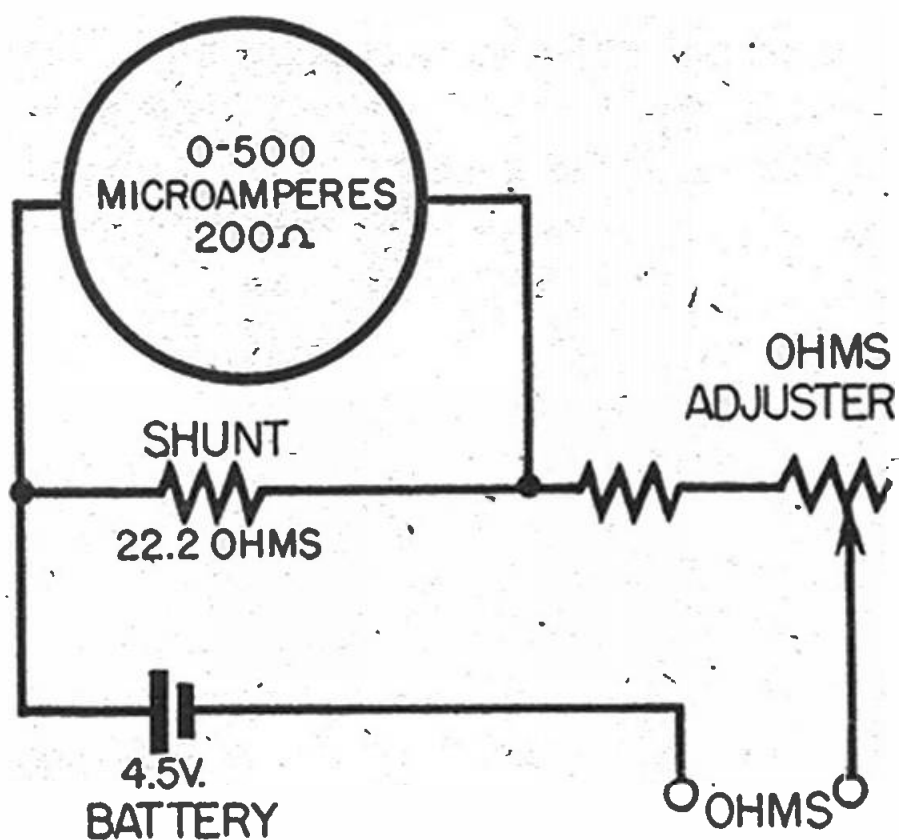

Fig. 7-8B. Shunted ohmmeter.

readable indication of current would be about 25 microamperes.

With the 22.2-ohm shunt connected as shown, the range of the meter as a milliammeter is extended to ten times its former value, or 5 milliamperes. The smallest easily-read current indication will be 250 microamperes, corresponding to a resistance reading of about 20,000 ohms. The current range of the meter may be extended to any

desired value; the higher the full-scale current, the lower will be the top reading on the ohmmeter scale. Commercial instruments commonly use a low-reading ohmmeter scale with a maximum reading of about 1,000 ohms.

When calibrating a home-made ohmmeter, you will realize the ohmmeter scale is not linear—a given distance at the left-hand end of the scale represents a much greater change in resistance than does the same distance at the right-hand end of the scale. For instance, a space equal to one-tenth of the entire range may represent at the right-hand end a change of only 5 ohms while the same space at the other end may represent a change of several hundred ohms. Generally speaking, then, the right half of the scale is more useful than the left half. Naturally, this must be taken into consideration when selecting an ohmmeter range or you may find that the reading falls into the part of the scale where the calibrations are crowded and difficult to read with any degree of accuracy.

AC VOLTMETER

A direct-current meter cannot be used in its original form for measuring alternating current or voltage; however, by using a small rectifier to change the AC to DC a direct-current milliammeter can be made to function as an AC voltmeter. One such circuit is illustrated in Figure 7-9. Here, the meter has a full-scale current reading of 400 microamperes. Most meter rectifiers are of the copper-oxide type and are extremely small, taking little space in the multimeter case. Some, like the one in the

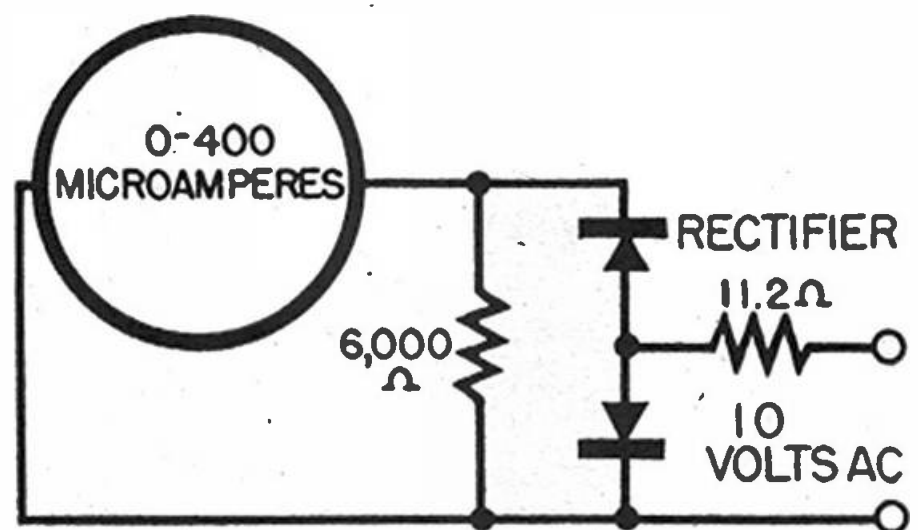

Fig. 7-9. Using a rectifier.

illustration, consist of two rectifier units, others have a single set of discs, and still others use four sets.

COMBINED VOLT-OHM-MILLIAMMETER

If you have followed our discussion this far, you are prepared to build a combination volt-ohm-milliammeter. The project to be described uses a

0-500-microampere meter, which has a sensitivity of 2,000 ohms per volt, sufficient for all measurements a constructor is likely to make. Should you

prefer to build an instrument with higher sensitivity, you may substitute a more sensitive meter movement and calculate the voltmeter multipliers, shunts, and ohmmeter resistances from the information in the preceding pages.

The circuit diagram for the combination is given in Figure 7-10. The DC voltmeter ranges are 10, 50, 250, and 500. There are two ohmmeter ranges. And the current ranges are 0-500 microamperes, 0-10 milliamperes, and 0-100 milliamperes. All shunts, ohmmeter series resistors, DC voltmeter multipliers and the low-range ohmmeter shunt have been calculated on the basis of a meter resist-

a three-deck, single-pole ten-position switch, which may be purchased as a unit or assembled from separate switch sections. If you decide the DC milliampere ranges are not necessary, they may be eliminated, together with the shunts, and a seven-position switch used instead. The 1.0-ohm and 10.5-ohm shunt resistors should be wire-wound. If you are unable to buy them in the values needed, wind them from wire of 1-ohm-per-foot resistance, using a short length of 1/4-inch wood dowel as a form. All such resistors should be wound non-inductively. Begin by doubling the required length of wire and start winding at the center point.

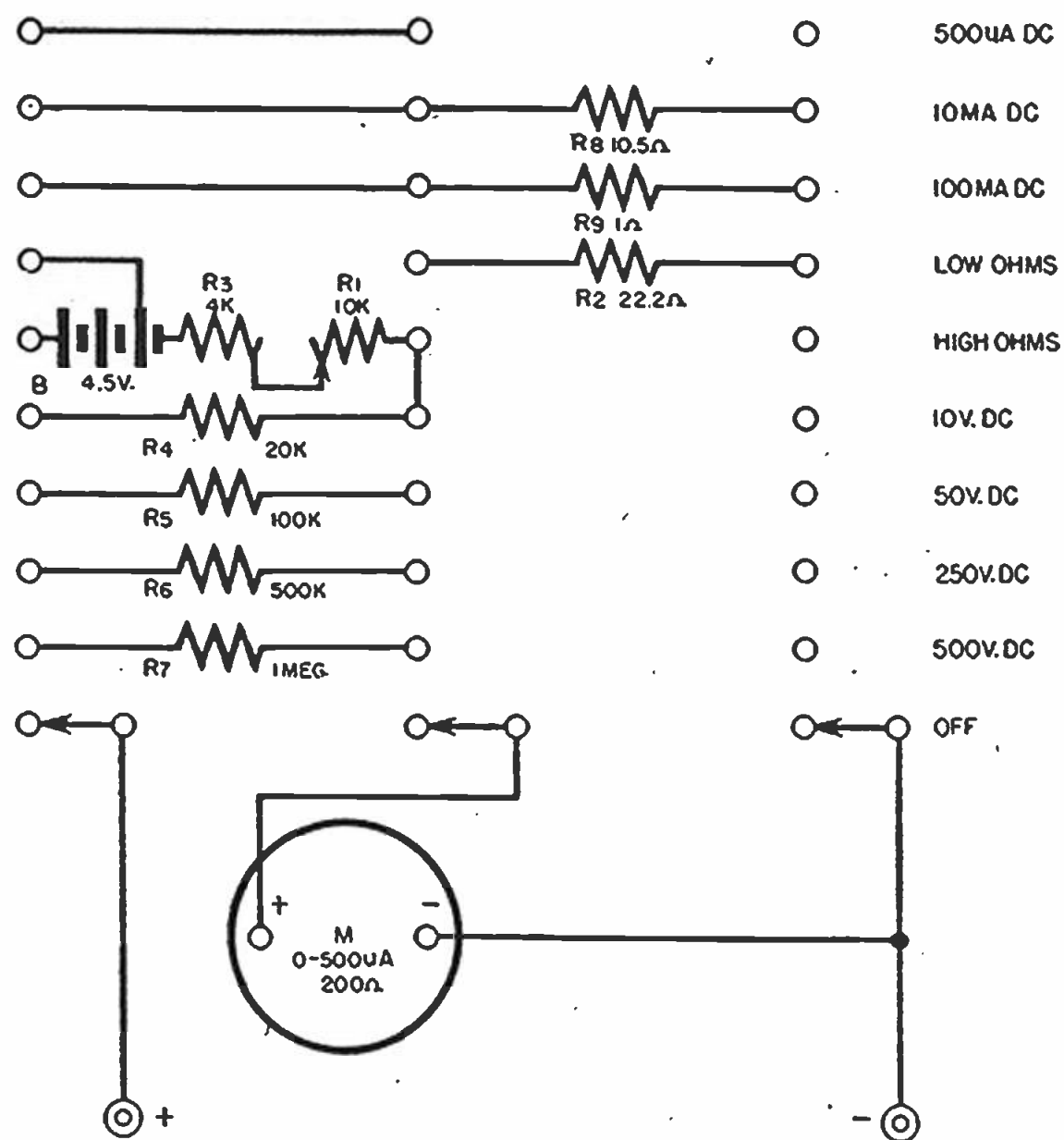

Fig. 7-10. Circuit of a volt-ohm-milliammeter.

ance of 200 ohms. The total cost of the project should not exceed twenty dollars, although this will vary considerably with the price you pay for the meter. If you buy a three-inch-square meter, the entire multitester can be built into a wood, plastic, or metal box measuring about four inches wide, three inches deep, and eight inches long. Shifting from one range to another is done by means of

Parts list

Resistors

- | | |
|----|---|
| R1 | Ohmmeter zero adjuster, 10K wire-wound, variable |
| R2 | Low-ohms shunt, 22.2 ohms, wire-wound |
| R3 | High-ohms series, 4K ohms, 1-watt carbon |
| R4 | 10-volt DC, 20K ohms, 1/2-watt carbon, 5% tolerance |

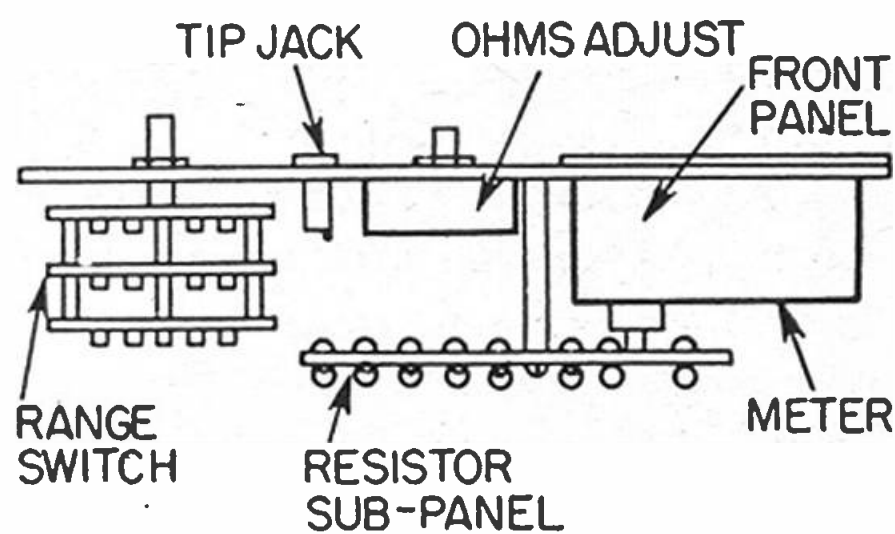

Fig. 7-11. Assembly of multitester.

- R5 50-volt DC, 100K ohms, 1/2-watt carbon, 5% tolerance
- R6 250-volt DC, 500K ohms, 1/2-watt carbon, 5% tolerance
- R7 500-volt DC, 1 megohm, 1/2-watt carbon, 5% tolerance
- R8 10 milliamperes shunt, 10.5 ohms, wire-wound
- R9 100 milliamperes shunt, 1 ohm, wire-wound

Miscellaneous

Meters: 0-500 microamperes, 200 ohms
 Switch: 3-deck, single-pole, 10-position
 Panel: 4 x 8 inches, steel or aluminum
 Case: 4 x 3 x 8 inches, wood, plastic, or steel

- 2 phone tip jacks (insulated)
- Battery: 3 1-1/2-volt penlight cells
- Push-back wire
- Rosin-core solder
- Bar-type knob for switch
- Round knob for ohms adjuster
- Resistor panel: 1/16-inch bakelite, 3 x 4 inches
- 2 angle brackets or spacers for resistor panel
- 6-32 x 3/8-inch r.h. machine screws
- 6-32 hexagon nuts
- Soldering lugs

Figure 7-11 shows the location of all major parts except the dry cells. The cells can be mounted on the sub-panel or in the bottom of the case. If the latter method is used, be sure the connecting wires are long enough to permit removing the instrument from the case without strain on the wires. The resistor sub-panel is illustrated in figure 7-12. Two 6-32 screws, two hexa-

gon nuts, and two soldering lugs will hold each resistor. Resistors need not be arranged in any particular order. A top view of the main panel, showing the positions of the meter, switch, ohms adjuster, and tip jacks is shown in Figure 7-13.

Refer to Figure 7-10 before starting the wiring. Each vertical row of ten small circles in this diagram represents the contacts of one deck of the three-deck ten-position switch. Because the three decks are ganged together on one shaft, all three of the movable contacts will advance simultaneously. In the drawing, the switch is shown in the "off" position; in this position, one of the meter terminals is connected to a tip jack, but the opposite meter terminal is disconnected from the other tip jack because all three of the switch blades are then on open or unused contacts. With the switch in the "off" position, the meter is protected against accidental overloads that might result from tampering with the instrument or from careless handling.

The volt-reading circuits

To understand how the switch functions, imagine that it has been advanced to the "500 Volts DC" position.

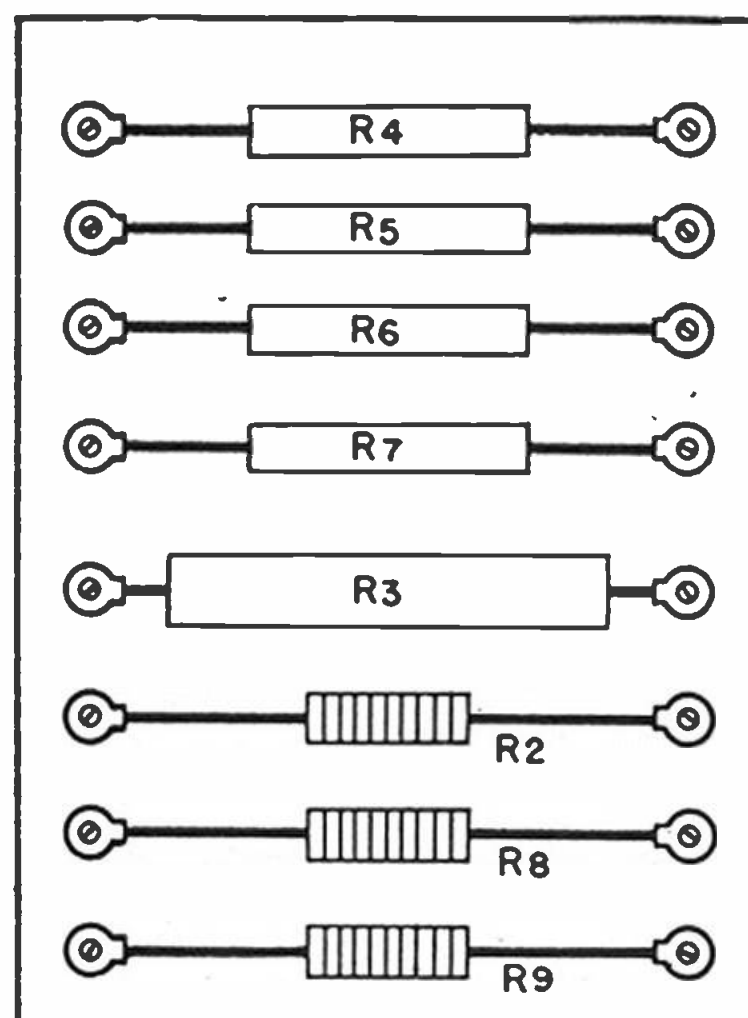

Fig. 7-12. Resistor sub-panel.

We now have a complete circuit from the minus tip jack, through the meter, through the one-megohm multiplier resistor, R7, to the plus tip jack. The meter is set up to read up to 500 volts, with a suitable multiplier resistor in series with it. Exactly the same circuit is used in the other DC volts positions except that in each case the appropriate multiplier resistor is cut into the circuit. When the switch is advanced from the "off" position to the DC voltage ranges, the higher ranges are selected first (an added protection for the meter).

The resistance-reading circuits

In the resistance ranges, the circuits are quite different. Suppose the switch has been advanced to the "high ohms" position. The switch deck at the extreme right is not in use on that range as there is no connection to its contact. Tracing the "high ohms" circuit, we start at the minus tip jack, continue through the meter to the middle switch deck, and on through the ohms adjuster, R1, the current-limiting resistor, R3, and the 4.5-volt battery to the switch deck at the left; from this point the circuit is completed down to the plus tip jack. Thus the circuit includes the meter, battery, ohms adjuster, and current-limiting resistor all in series. It is a conventional ohmmeter circuit, similar to the one of Figure 7-6, and you should have no difficulty measuring resistance values up to 1/4 megohm—or even higher.

When the switch is advanced to the "low ohms" position, an entirely different circuit is in use. The ohmmeter shunt, R8, is now connected in parallel with the meter, since the meter is connected to the middle and right-hand switch decks and R8 is connected between the contacts of those two decks. As there are two parallel branches, the current divides through them. The shunt has a resistance equal to one-ninth that of the meter, consequently nine-tenths of the cur-

rent passes through the shunt and one-tenth through the meter, which, of course, increases the range of the meter to ten times its former value. Tracing the remainder of the circuit (from the contact of the middle switch deck), you will see that the ohms adjuster, R1, and the current-limiting resistor, R3, are in series with the meter as before. However, when you come to the battery you will notice a difference. The three cells are not in the circuit, as they are in the "high ohms" range. Instead, there is a connection from the first cell up to the contact of the left-hand switch deck. As you are aware, the use of a lower battery voltage further reduces the range of the ohmmeter. The full circuit, then, includes the shunted meter, the ohms adjuster, the current-limit-

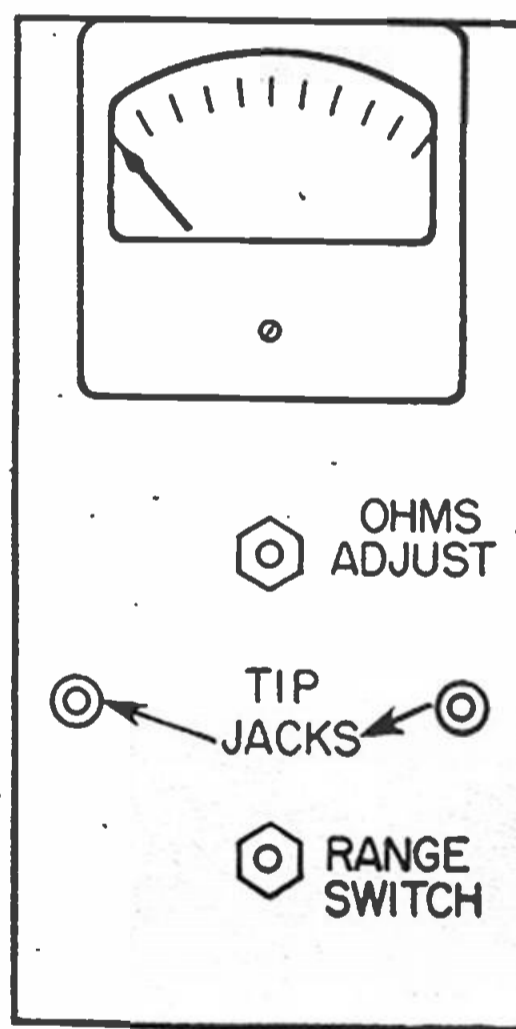

Fig. 7-13. Front panel of multitester.

ing resistor, and a 1.5 volt battery. Except for the battery voltage, this circuit is quite similar to the one shown in Figure 7-8B and will read values from zero to about 6,000 ohms.

When the switch is advanced to the "100 milliamperes DC" position, there are two parallel paths. One may be traced from the minus tip jack through the meter to the contact of

the middle switch deck, then through a wire connection to the left-hand deck contact and down to the plus tip jack. The second path is through the right-hand switch deck, the 1-ohm shunt resistor, R9, and the middle and left switch contacts to the plus tip jack. The 1-ohm shunt is thus in parallel with the meter. The circuit for the "10 milliamperes DC" range is similar except that now the 10.5-ohm shunt, R8, is in parallel with the meter. However, when the switch is set for the "500 microamperes DC" range, there is no shunt in the circuit, which may now be traced from the minus tip jack and through the meter, the contacts of the middle switch deck, and the left-hand deck contacts to the plus tip jack. Notice that in passing from the ohmmeter ranges to the current ranges, the highest current range

is selected first. Furthermore, the various ranges are set up so that in passing from the "off" position to any range, maximum protection is afforded the instrument. Accidental connection of an unprotected milliammeter (without a series resistor) to a source of voltage always results in serious damage to the instrument unless the user is extremely fortunate. If an ohmmeter is so connected, the possibility of damage is less, because there is at least some resistance in series (the ohms adjuster and the current-limiting resistor). Connecting a voltmeter to a source of voltage, even though the range is too low, is not necessarily ruinous to the meter. Unless the connection is maintained for a considerable time, there is a good chance that the coil will not be burned out, although it is likely that the pointer will be bent.

SIGNAL GENERATOR

The utility of a signal generator is not limited to alignment, although that function is quite important to the set constructor as any superheterodyne receiver must be aligned after completion and this cannot be done in a satisfactory way without a generator.

The generator is also almost indispensable in the rapid diagnosis of trouble in sets and amplifiers. Suppose you have just completed the six-tube AC superheterodyne described in Chapter 2. The last wire has been soldered in place, the tubes have been inserted in their sockets, and the power has been turned on. The tubes light up, but the set is absolutely dead. Obviously there is trouble somewhere in the set. To run the trouble down you might follow the haphazard course of checking all the tubes, inspecting all the connections, and, perhaps, eventually testing all the parts. This takes entirely too much time. Using a generator to "isolate" the

trouble is a great deal quicker. "Isolating" means determining which stage the trouble lies in.

Two methods of isolating trouble

There are two methods of isolating troubles with the aid of a generator; one is called signal tracing, the other signal substitution. In the signal substitution method we inject into the grid circuit of a tube the kind of signal that should be there if the stage is working properly. If the signal is heard in the speaker with normal volume, this stage is functioning; if not, there is trouble here. Thus within minutes we are able to restrict our search to one tube and the relatively few parts associated with it, as compared to a search through the entire set with all its parts and tubes.

In signal substitution we must be careful to feed into a stage the exact type of signal that should be there under normal operating conditions. Thus, when checking the audio am-

plifier stages, we feed into the grid an audible signal, usually at 400 or 1,000 cycles, depending upon the generator. And when checking the detector and i.f. stages of most sets, we use a 455-kilocycle modulated signal. A converter is checked with an r.f. signal having a frequency between 550 and 1600 kilocycles.

The signal substitution procedure can best be explained by a "block" diagram of a typical set. Let us take for an example the 6-tube AC project described in Chapter 2. In a block diagram, each block or square represents a stage, consisting of the tube used in that stage together with all the associated parts (resistors, condensers, coils, and so forth). Figure 7-14A shows the 6-tube set in block diagram form. A full block or square

(grid circuit) of the converter there should be r.f. signals in the range between 550 and 1600 kilocycles. At the input of the i.f. amplifier stage and at the detector stage we can expect to find a 455-kilocycle signal. At the input of the first and second a.f. stages there will be audio signals (30 to 15,000 cycles).

A set becomes inoperative because of failure of one or more stages. If we proceed from antenna toward loudspeaker, we will get a normal signal at each stage until we come to the defective one.

Now look at Figure 7-14B. It is the same block diagram as before, but the power supply has been eliminated. The small vertical arrows indicate the test points and the signal to be used. If a signal generator is used to supply

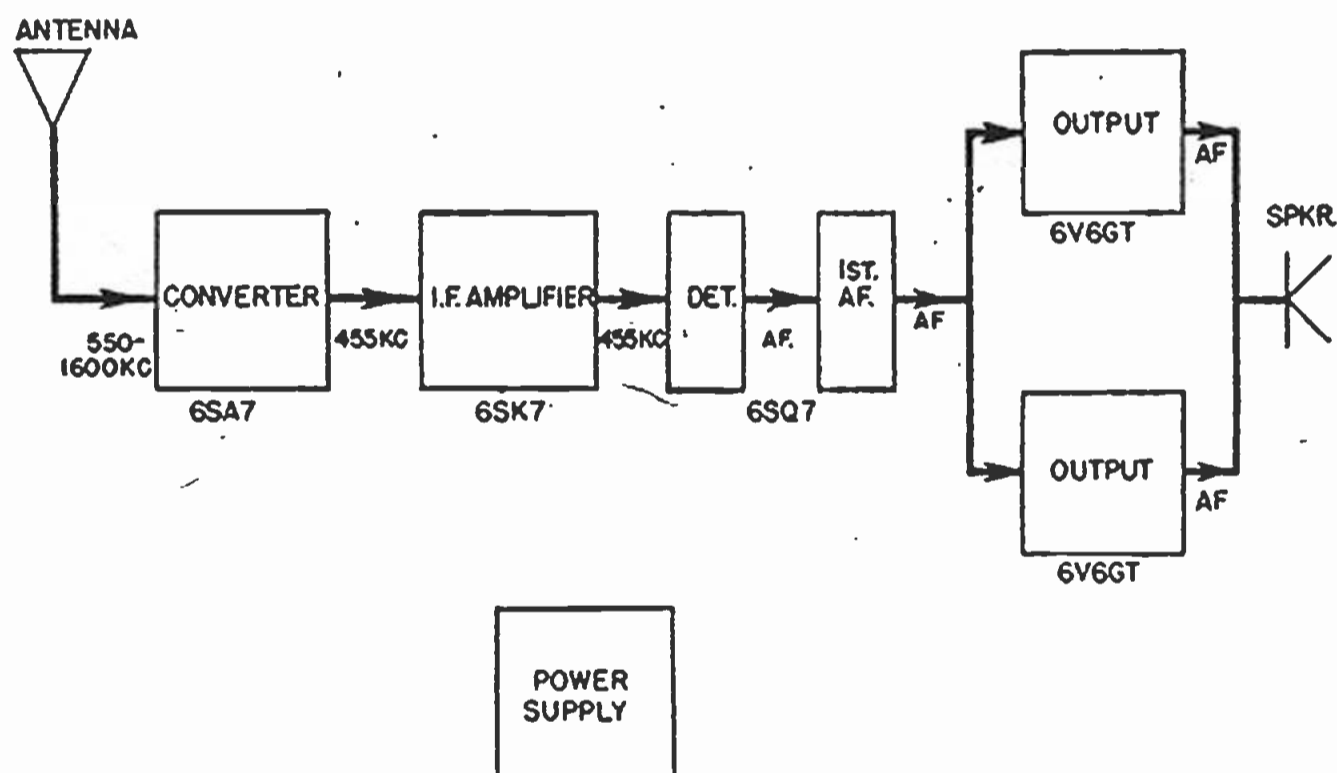

Fig. 7-14A. Block diagram of a six-tube receiver.

is used for each of the stages, with two exceptions. The detector-first-audio stage, which combines two functions in one tube is represented by a divided block, each half pertaining to one of the two functions. The output stage consists of two tubes and has two blocks. The arrowed line connecting the stages shows the signal path from antenna to speaker.

If you examine the drawing, you will see there is a legend for each of the stages that tells us the kind of signal to be found there under normal operating conditions. At the input

the right kind of signal at each of the test points, the result should be heard in the speaker, *if the stage under test is working properly.*

Checking the set

Suppose we start checking the non-operative set by applying an audible signal to the input of the second audio or output stage. If the signal is heard in the speaker with normal volume, we may conclude the trouble is *not* in that stage. Now we have eliminated two tubes and quite a few parts from the search. On the other hand, if we

hear no signal in the speaker, the second a.f. stage is faulty and should be checked thoroughly. The checking includes testing tubes, measuring voltages, and perhaps testing suspected parts. The important thing is that with this or some other method of signal checking it is not necessary to worry about six tubes and maybe fifty or more circuit components. The search is quickly narrowed down to one stage, one tube, and probably no more than eight or ten different parts.

Remember—audio signals are used for checking a.f. stages only. When checking the i.f. or the detector stage, the generator should be adjusted to deliver a modulated signal at the operating frequency of those stages (usually 455 kilocycles). At the antenna, a modulated signal within the

cycles, 1600 kilocycles, and 550 kilocycles. In the project to be described, these three alignment frequencies are available and are selected by a switch.

Referring to the diagram, Figure 7-15, you will see that a 12BA6 tube is used in the r.f. oscillator circuit. The oscillator coil is the standard single-winding, tapped coil of the kind used in superheterodyne receivers. The three preset frequencies are determined by the trimmer condensers, C1, C2, and C3, shunted across the coil. Each is adjusted to one of the three frequencies, and the switch, SW2, controls the selection. Thus we get a choice of 455 kc, 1600 kc, or 550 kc.

The audio signal is generated by a neon-lamp oscillator circuit, and the resulting signal is applied to the third

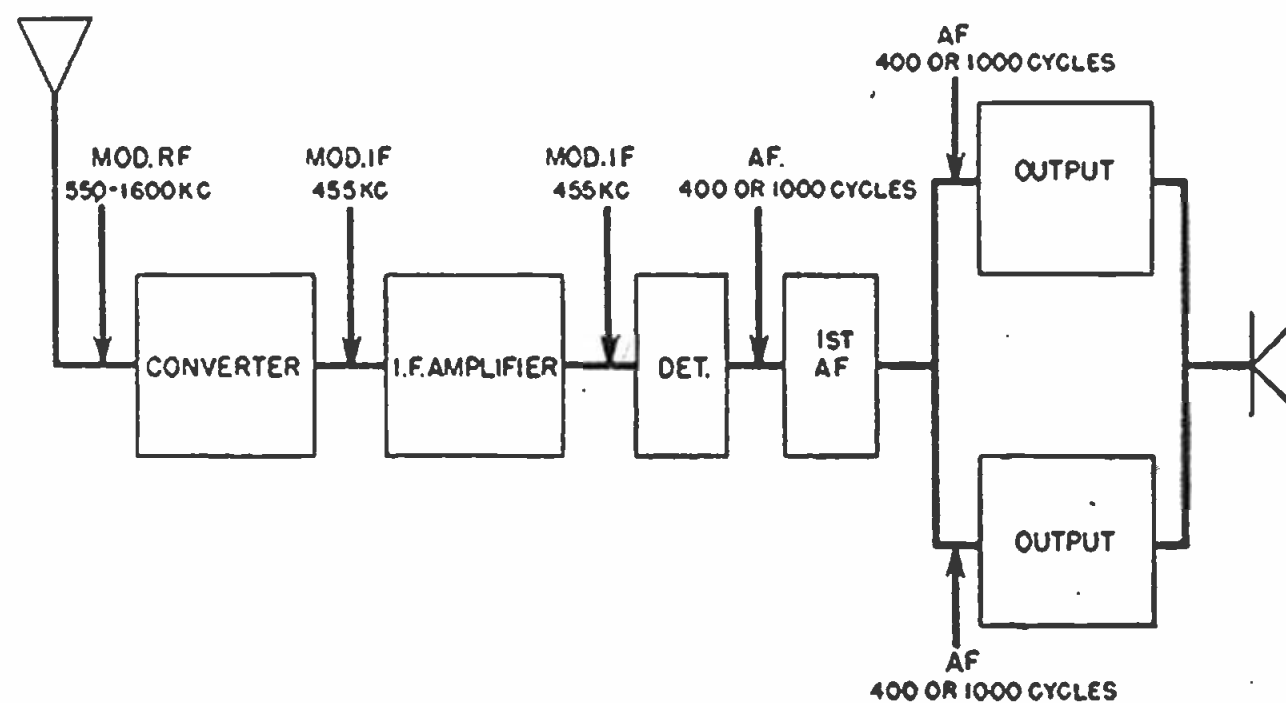

Fig. 7-14B. Block diagram showing signal substitution method.

tuning range of the receiver should be applied and, of course, the set should be tuned to that frequency.

Perhaps this discussion has given you an idea of the requirements a generator must meet. It must operate from the power line, it must supply a sufficiently strong signal for alignment and for signal-substitution work, and its output should be variable. While most generators used for radio servicing have a continuously variable frequency range (usually from about 100 kilocycles to about 20 megacycles), the average constructor finds only three frequencies essential: 455 kilo-

grid of the tube. The modulated r.f. signal is fed to the output terminals and may be controlled by the attenuator, R1. The heater of the tube is operated from the power line; note that the line dropping resistor, R9, is in series with the heater. DC voltages for the tube and for the neon oscillator circuit are applied by the selenium rectifier, SR.

Remember that for best results the generator must be enclosed in a metal case and the front panel must be metal. Otherwise, signal radiation may be so great that the attenuator control will be useless. If desired, the neon

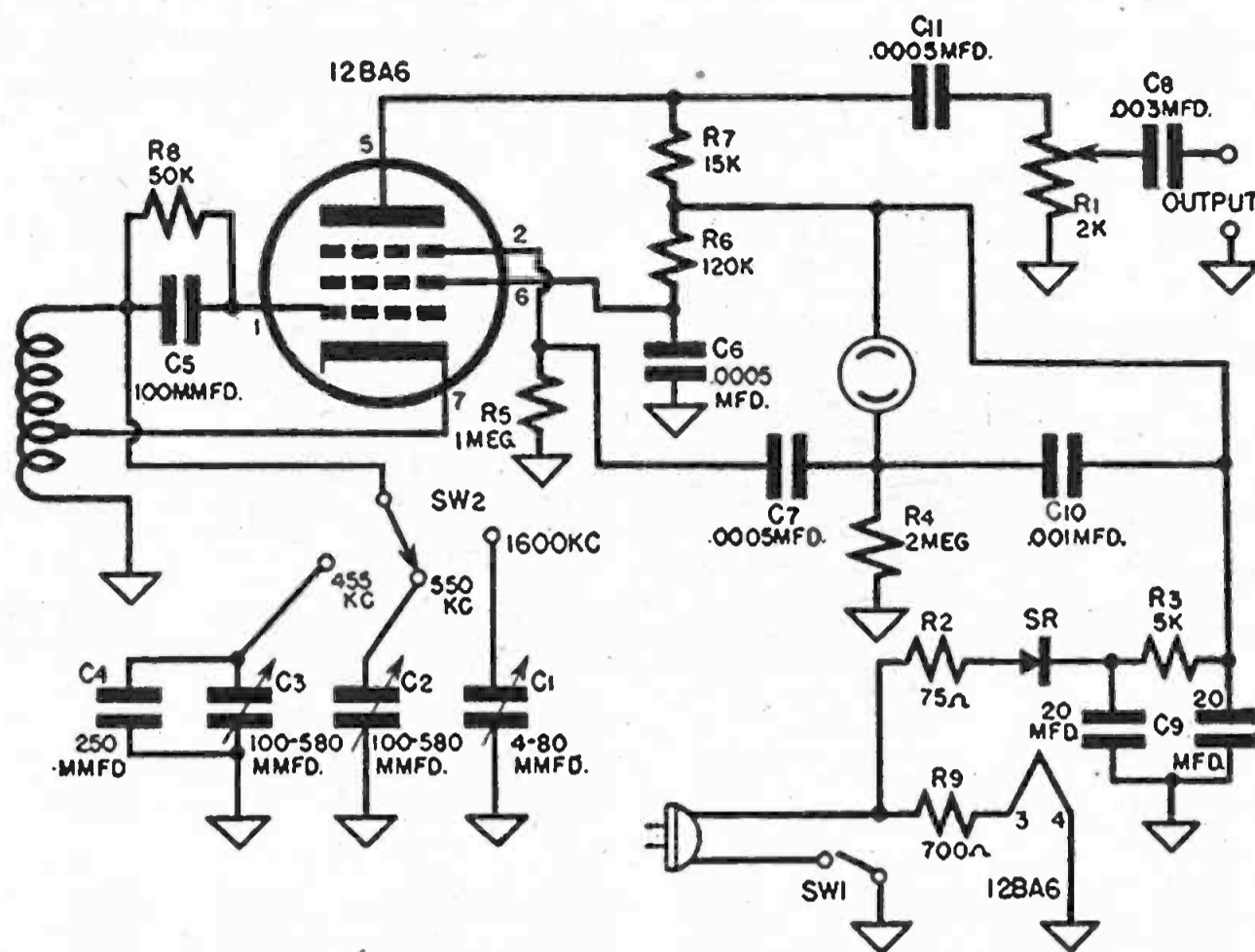

Fig. 7-15. Schematic diagram of a signal generator.

lamp may be mounted in back of an opening in the front panel so it also serves as a means of determining when the equipment is turned on.

Parts list

Resistors

- R1 Attenuator, 2K ohms, wire-wound control with switch, SW1
 R2 75 ohms, 1-watt carbon
 R3 5K ohms, 1-watt carbon
 R4 2 megohms, 1/2-watt carbon
 R5 1 megohm, 1/2-watt carbon
 R6 120K ohms, 1/2-watt carbon
 R7 15 ohms, 1/2-watt carbon
 R8 50K ohms, 1/2-watt carbon
 R9 700 ohms, 10-watt wire-wound

Condensers

- C1 4-80 mmfd., trimmer (1600 kc)
 C2 100-580 mmfd., trimmer (550 kc)
 C3 100-580 mmfd., trimmer (455 kc)
 C4 250 mmfd., mica (455-kc shunt condenser)
 C5 100 mmfd., mica
 C6 .0005 mfd., mica
 C7 .0005 mfd., mica
 C8 .003 mfd., mica
 C9 20-20 mfd., 150-volt electro-

lytic, tubular cartridge

C10 .001 mfd., mica

C11 .0005 mfd., mica

Miscellaneous

- Oscillator coil (L1)
 NE-48 1/4-watt neon lamp
 2-contact bayonet candelabra socket for neon lamp
 Single-pole three-position rotary switch, SW2
 Line cord and plug
 100-milliamperere selenium rectifier
 Miniature 7-pin tube socket
 Female microphone connector
 Male microphone connector, panel-mounting type
 Microphone cable, 24-inch length
 2 alligator clips
 Metal case
 Metal panel

Assembly and calibration

The best method of construction is to mount all the parts, except the attenuator control and the output jack, on a sub-panel fastened to the main panel with brackets. There should be sufficient space between the two panels to accommodate the oscillator tube and socket. The three trimmer condensers should be mounted on the lower side of the sub-panel side by

side. Three holes are then drilled in the back of the case for adjustment of the trimmers without having to remove the generator from its case.

To calibrate the generator you will need a superheterodyne receiver using a 455-kilocycle intermediate frequency. The receiver must be in good operating condition and in accurate alignment. The 455-kilocycle trimmer is adjusted first. With the set and the generator turned on and warmed up for five minutes, connect the high side of the generator cable to the grid of the converter tube and the cable shield to chassis. Using an insulated screwdriver inserted through the hole in the back of the generator case, adjust the 455-kc trimmer until the loudest signal is heard in the speaker. For

most accurate adjustment, set the attenuator for a weak signal and as the volume increases reset the attenuator so the signal is barely audible.

Disconnect the generator lead from the i.f. tube grid and connect it to the antenna terminal of the set. (*Note:* If the set uses a loop antenna, make up a coil of two or three turns of wire and connect it to the generator output leads. Place the coil close to the receiver loop antenna.) Tune the receiver to 1600 kilocycles. Now adjust the 1600 kc trimmer for maximum signal as before.

Without disturbing the generator leads, retune the set to 550 kilocycles. Adjust the 550 kc trimmer for maximum signal as described above. This completes the calibration of the generator.

CONDENSER CHECKERS

The simplest condenser checker is based upon the principle that an alternating current will flow in a circuit containing a condenser. This current will be proportional to the capacitance of the condenser. Figure 7-16 shows the circuit of the checker. The meter is an AC milliammeter (an AC voltmeter may also be used), and the condenser under test is connected in series with the meter and a source of AC power. The supply may be taken directly from the AC line. Some experimentation will be necessary to determine the capacitance range of this device. With a low-current meter, very large condensers may give an off-

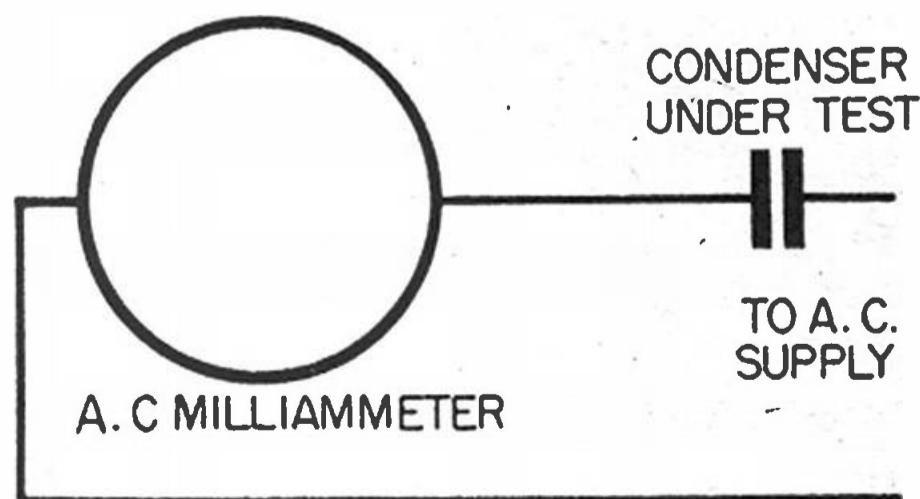

Fig. 7-16. Circuit diagram of a simple condenser checker

scale indication. Very small condensers used with a high-current meter may give little or no indication. Ordinarily, the average AC instrument will have a limited range. There are several methods of solving this difficulty. One is to connect a resistor in series to limit the current, as shown in Figure 7-17. Using a low-current meter, it should be possible to measure values over a wide range by changing the value of the series resistor.

It is well known that any meter having a non-linear scale can be read with greater accuracy if the indication falls within the middle third

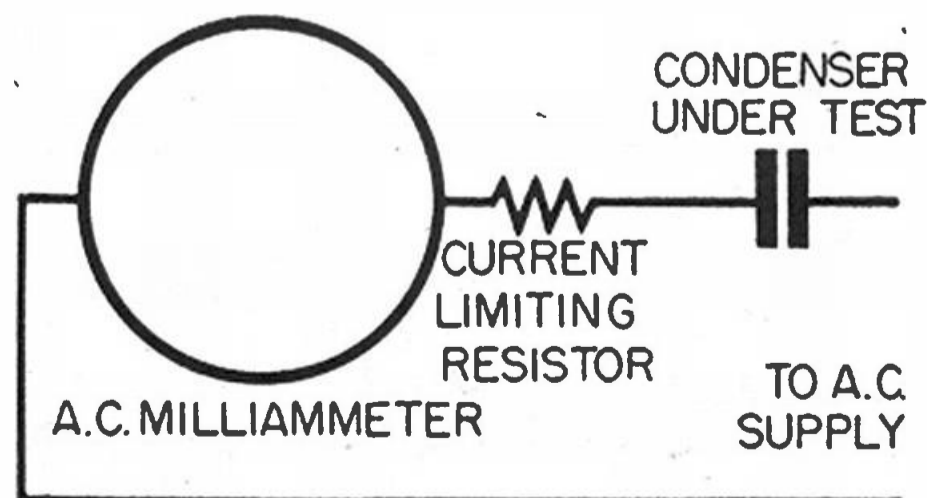

Fig. 7-17. Extending range of the condenser checker.

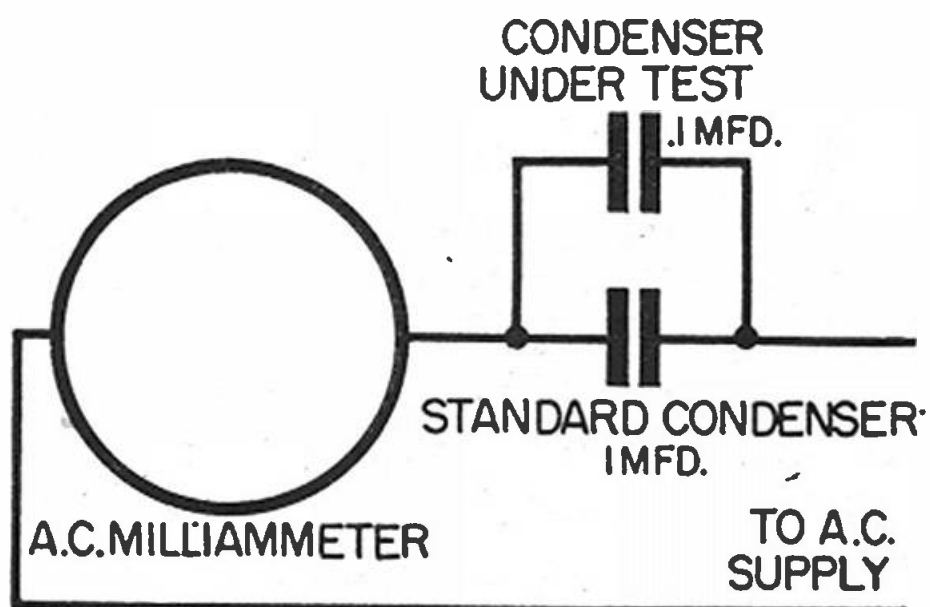

Fig. 7-18. Alternative method of extending the range.

of the scale. By a non-linear scale we mean one with non-uniform calibrations; the calibrations at one end of the scale are worth more than those at the other end. You may take advantage of this fact by using the circuit of Figure 7-18.

Because of the range of this instrument, indications for low-capacitance condensers will fall at the end of the scale where the divisions are crowded and are difficult to read with any degree of accuracy. But you can connect a condenser of known capacitance in series with the meter and bring the reading near the center of the scale. Let us suppose that this "standard" condenser has a value of 1 microfarad, and the one to be measured a value of .1 microfarad. When the condenser under test is connected in parallel with the "standard" condenser, as shown in the sketch, there will be an increase in the reading. The increase will be the same, in microfarads, as it was before the "standard" condenser was used but—and this is important—it is now spread over a greater scale length and is much easier to read.

Reading an instrument of this type is quite simple if the value of the "standard" condenser is known within reasonable limits. If, for instance, the final reading (with the two in parallel) is 1.1 microfarads and the "standard" condenser has a value of 1 microfarad, you subtract 1 micro-

farad from 1.1 microfarad to get a value of .1 microfarad.

There are other variations of the condenser-checker circuits. For any of them the utility of the instrument will depend upon its calibration. The obvious method of calibration is by comparison. You will need a number of "standard" condensers; they may be ordinary condensers whose values have been determined by measurement on an instrument of known accuracy. Perhaps a friend who owns a condenser-checker will measure a set of condensers for you. The values need not be precise, as long as they are definitely known. For example, it is unimportant whether a condenser has a value of .005 or .0045; the most important thing is to establish a set of known values on the scale of the meter. At least ten values should be marked, covering the full range of the instrument. Values between these points may then be estimated.

Before leaving the subject of milliammeter condenser-checkers, we should emphasize one very important precaution. Such instruments should not be used for checking electrolytic condensers. (It is true that in bridge circuits alternating current is used, but the amount of current is so small that the condenser will not be damaged.)

Measuring capacitance

The most accurate and generally

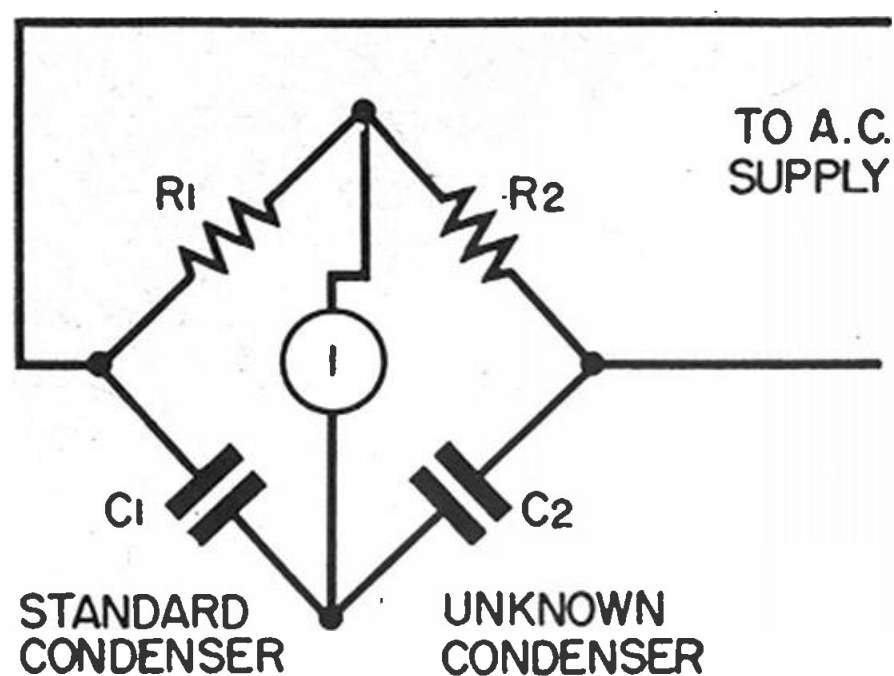

Fig. 7-19. Bridge-type checker.

satisfactory method of measuring capacitance is by means of a bridge circuit. One is illustrated in Figure 7-19. Alternating current applied to the bridge has two paths. One is through the resistance arms, R_1 and R_2 . The second path is through the two condensers, C_1 and C_2 . The bridge is said to be balanced when the terminals of the indicator, M , are at points of equal potential; under this condition, the meter will read zero. If the ratio between the resistance arms is known and if the value of C_1 is known, the value of the unknown condenser can be calculated as follows: C_2 equals C_1 times R_1 divided by R_2 . Suppose the values are: R_1 , 10,000 ohms; R_2 , 5000 ohms; and C_1 , 1 microfarad. Then C_2 is equal to 1 times 10,000 divided by 5,000, or 2 microfarads. By changing the values of R_1 and R_2 and the standard condenser, C_1 , the range of the bridge may be extended until almost any condenser can be measured. The AC may be supplied by an audio signal generator or taken from the AC line. The indicator may be an AC milliammeter of the zero-center type or better yet a pair of headphones. Minimum signal in the phones means the bridge is balanced.

Another version of the bridge method of measuring condensers is illustrated in Figure 7-20. In this case, the two resistors have been combined into one unit, the variable resistor, R . This should be a good-quality wire-wound control. To calibrate the bridge you will need several condensers of known capacitance. As an example of the method used in calibration, assume that you have a standard condenser having a capacitance of .001 microfarad and an "unknown" condenser of .002 microfarad. When the bridge is balanced you find that the ratio between the two resistance arms is two to one. Of course you need not measure this ratio, since the value of the "unknown" condenser is in reality

a known quantity. At this point on the scale mark the value ".002". This indication will be correct as long as the .001 standard condenser is used. Next you remove the .002 "unknown" condenser and substitute another one with, say, a value of .005. The ratio between the two arms of the variable resistor is now five to one, and at that point on the scale mark the value ".005". By following this method through a series of values, the bridge can be calibrated throughout the de-

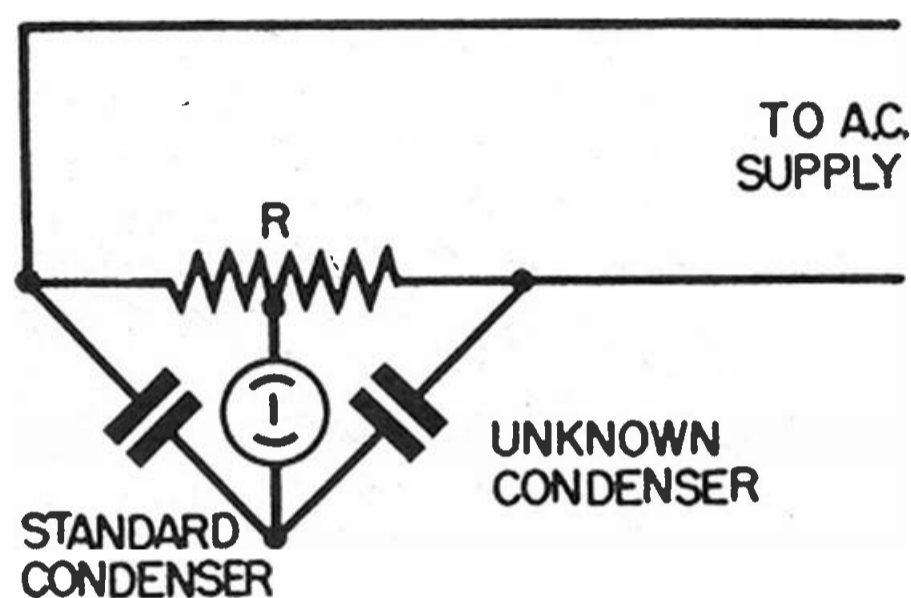

Fig. 7-20. Bridge using potentiometer for resistance arms.

sired range. Although the term "standard" condenser has been used here, it should not be taken to mean one that is of especially high quality or one that has been painstakingly measured for this purpose. For average use the standard condenser may be one whose value is known within reasonable limits. For laboratory purposes the tolerance would be held to within one per cent or less. However, remember that in construction and servicing a deviation of ten per cent in the value of resistors and condensers is permissible.

A more elaborate condenser-checker can be built using the circuit of Figure 7-21. The bridge circuit consists of the secondary winding of the transformer, T_1 , the three standard condensers, C_1 , C_2 , and C_3 , the variable wire-wound resistor, R_1 , and the condenser under test, which is connected to the tip jacks, J_1 and J_2 . Any voltage existing at the bridge terminals

under an unbalanced condition is amplified by the 6K6GT tube and applied to the control electrode of the 6AF6G electron-ray tube. Maximum opening of the visual indicator occurs when the bridge is balanced. The wire-wound potentiometer is fitted with a bar knob and scale, and this scale is calibrated directly in microfarads.

Parts list

Resistors

R1	4K ohms, wire-wound
R2	75 ohms, 1-watt
R3	2K ohms, 1-watt
R4	5 megohm, 1/2-watt
R5	2K ohms, 1/2-watt
R6	1 megohm, 1/2-watt
R7	200K ohms, 1/2-watt
R8	1 megohm, 1/2-watt

Condensers

C1	.0002 mfd., mica
C2	.02 mfd., 400-volt, paper tubular
C3	2 mfd., 400-volt, paper tubular
C4	.00025 mfd., mica
C5	.05 mfd., 400-volt paper tubular
C6	20-20 mfd., electrolytic, tubular cartridge

Transformers

T1	Primary: 117 volts; heater: 6.3 volts, 1 amp.; secondary: 30 volts, 40 ma.
----	--

Miscellaneous

Chassis: 5 x 6 x 1-1/2 inches, steel or aluminum
 Panel: 6-1/2 x 6-1/2 inches, steel or aluminum
 Cabinet: 6-1/2 x 6-1/2 x 6 inches (outside dimensions), wood or metal
 Selenium rectifier, 100 ma. output (SR)
 Single-pole single-throw rotary switch (SW1)
 Single-pole 3-position rotary switch (SW2)
 2 octal tube sockets.
 Magic-eye mounting kit for 6AF6G
 Large bar knob for R1
 Small bar knob for SW2
 Round knob for SW1
 2 insulated tip jacks
 Line cord and plug
 6-32 x 3/8-inch r.h. machine screws
 6-32 hexagon nuts
 1/2-inch #5 r.h. wood screws for panel (if wood cabinet is used)
 3/8-inch #6 self-threading screws for panel (if metal cabinet is used)

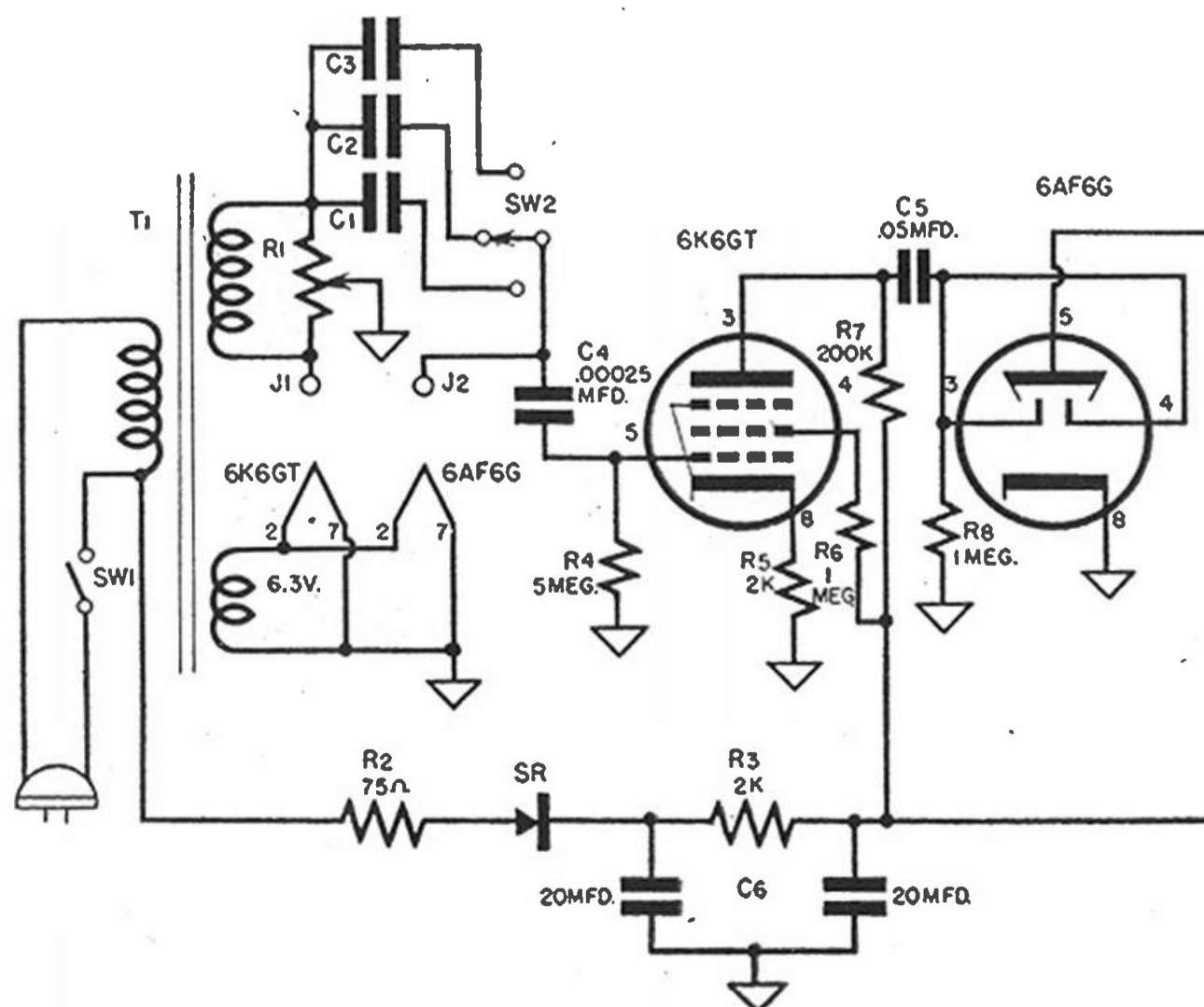

Fig. 7-21. A more elaborate condenser checker.

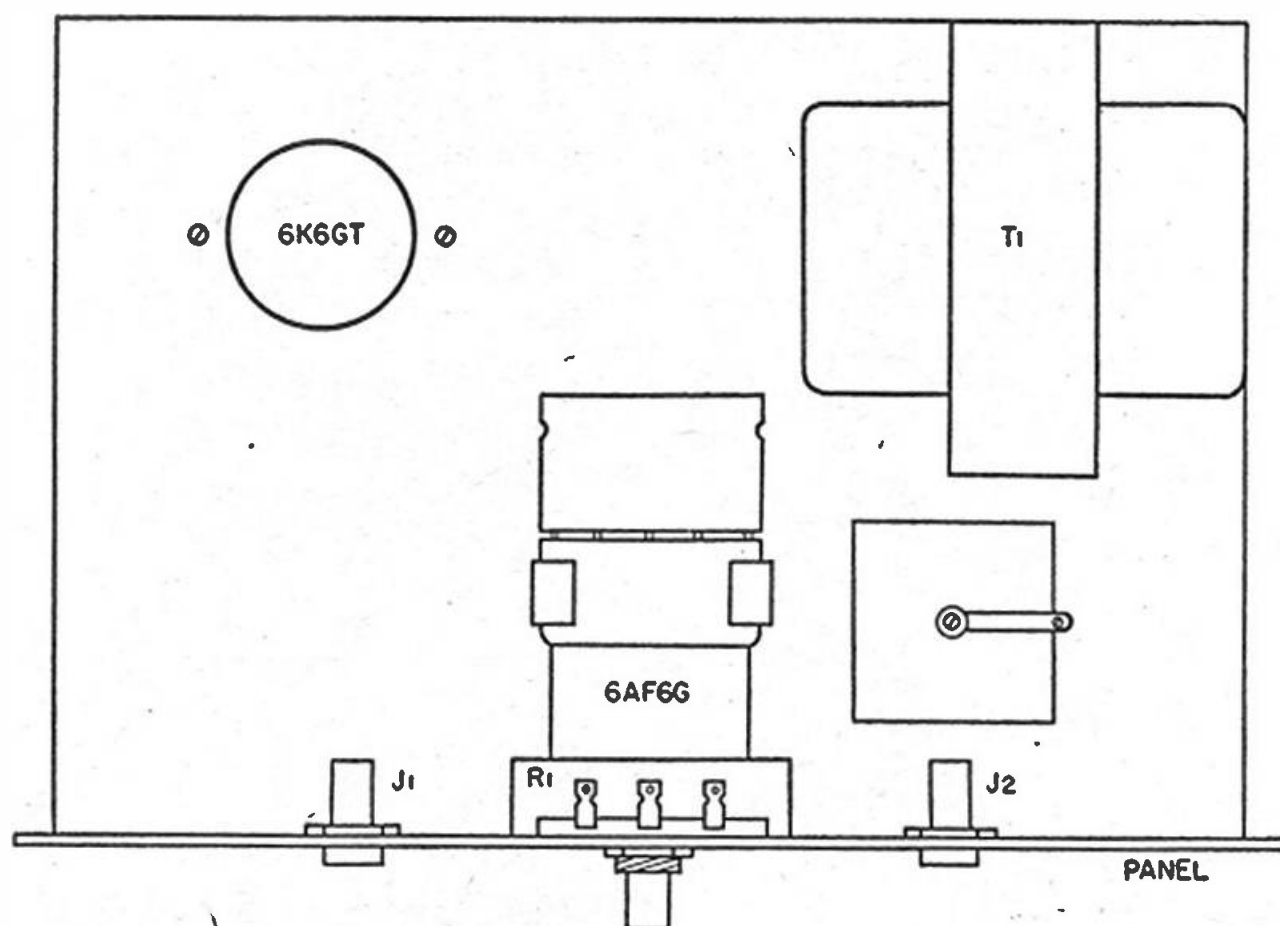

Fig. 7-22. Top view of chassis.

Rosin-core solder

Push-back wire

Tubes

6K6GT, 6AF6G

Layout and assembly

It is assumed that the checker will be built on a chassis measuring 5 by 6 inches, with a front panel 6-1/2 by 6-1/2 inches. It is desirable—and it will be more convenient—to make the front panel of steel or aluminum, although 1/4-inch plywood can be used. Using plywood, all components having ground connections should be interconnected and the common wire run to the chassis. A 6-1/2-by-6-1/2-inch panel will require a cabinet measuring about 6 by 6 inches inside, allowing for a 1/4-inch thick cabinet wall. If a metal cabinet is to be used, the dimensions of the cabinet may be slightly larger or the panel slightly smaller. The best plan is to select the cabinet first and then cut the panel to fit it. For fastening the panel, a metal cabinet should have at least four lips to take the panel screws. If the cabinet walls are thin, it will be best to use self-threading screws for fastening the panel. There is no reason why the chassis, cabinet, and panel

cannot be of other dimensions and proportions to suit your convenience, but the measurements given here represent about the minimum space needed for the convenient placement of parts. Some constructors may want to use a cabinet having a sloping front; but make allowance for the extra space needed.

Lay out the chassis as shown in Figure 7-22. The 6K6GT tube socket, the transformer, the selenium rectifier, and the mounting bracket for the 6AF6GT socket are mounted on the top of the chassis. Place the transformer at the right rear corner. The method of fastening will depend upon the transformer used. The selenium rectifier is located forward of the transformer. You have a choice of locations for the 6K6GT socket; in the drawing it is shown about an inch and a half from the left side of the chassis and an inch and a half from the rear edge. The 6AF6G electron-ray indicator tube is mounted in the exact center of the chassis. Determine its exact position in relation to the front panel by trial; the socket should be so arranged that, with the front panel in place and the tube in the socket, the front of the tube will be almost in contact with the panel.

Most magic-eye mounting kits have provision for some forward adjustment of the tube socket.

Figure 7-23 shows the front-panel arrangement. Notice that the opening for the eye tube is at the center of the panel. The vertical position of the hole will depend upon the height of the tube above the chassis.

Potentiometer R1 is placed midway in the panel. The center of the shaft should be about an inch and a quarter from the top edge of the panel; this will allow space for a scale a little more than two inches in diameter. The length of the bar knob you intend to use must be taken into account here; choose the position of the potentiometer so the end of the

range switch, SW2, are located on a center line about $\frac{3}{4}$ -inch from the lower edge of the panel. This position places the switches below the chassis, and the lock nuts used for fastening the switches can also serve to hold the panel to the chassis. The line cord is brought out through a hole in the rear of the cabinet.

Drill all the holes in the chassis and panel first. Use a $1\frac{1}{16}$ -inch socket punch for the 6K6GT socket hole. This size will do for punching the eye-tube opening, too, although a somewhat larger hole—about $1\frac{1}{4}$ -inch—is desirable. When the drilling and punching have been completed, mount all the major parts on the chassis. Fasten the panel to the chassis as described above, or by use of ma-

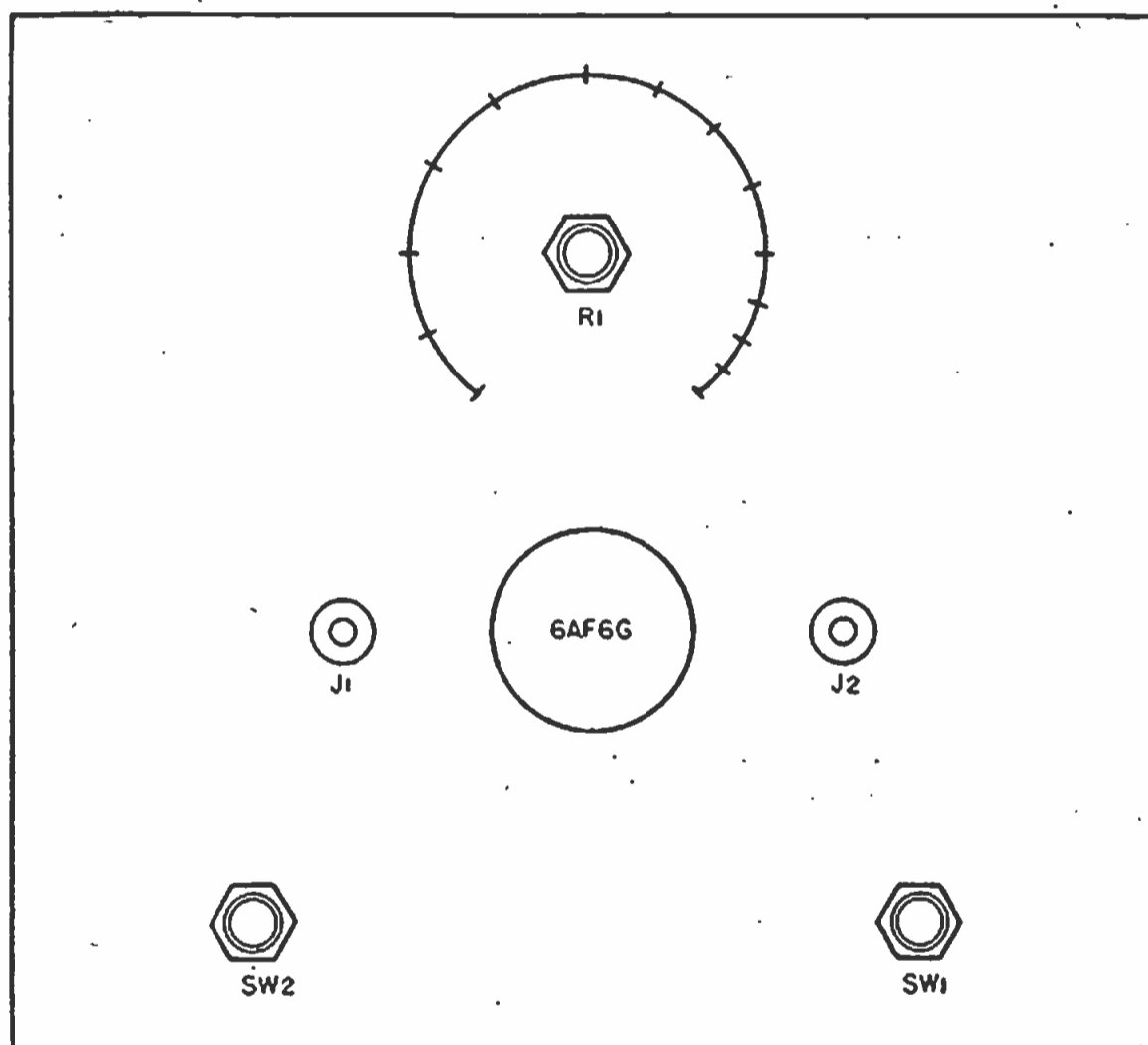

Fig. 7-23. Front panel.

knob does not overlap the top edge of the panel or the edge of the eye-tube opening.

Place the tip jacks as shown, one on each side of the eye-tube opening. If a metal panel is used, insulated tip jacks are necessary, but if plywood is substituted for the metal, ordinary jacks may be used. The precise position of the jacks is unimportant, but they should be placed symmetrically.

The on-off switch, SW1, and the

chine screws and nuts if you prefer, and mount the potentiometer and jacks on it.

Power transformer

You will need a special transformer with a 30-volt secondary for this project. Such transformers are available, but may be difficult to get in areas away from large cities. If you have trouble buying it, you can make one from a very small receiver power trans-

former in good condition.

Rewinding a transformer

Most small power transformers have a primary, a high-voltage winding, a 6.3-volt heater winding; and a 5-volt winding for the rectifier. Usually the primary winding is inside, nearest the iron core, the filament windings on the outside, and the high-voltage winding in between. This arrangement makes things easier, for you need not remove the secondary to get at the heater windings. In some transformers the 5-volt and 6.3-volt windings will be side by side, making one layer of winding. In others, one may be wound on top of the other. Either the 6.3-volt or the 5-volt winding may be outermost.

Before taking the transformer apart you must determine the voltage of each of the windings. Most often this can be done by observing the coding of the leads. The standard RMA color code is: primary, black; high-voltage, red; high-voltage center tap, red and yellow; 6.3-volt, green; and 5-volt, yellow. Transformers taken from Philco receivers may use a different code: primary, white; high-voltage, yellow; high-voltage center tap, yellow and green; 6.3-volt, black; and 5-volt, blue.

If the wires are not color-coded or do not conform to either of the codes given, you will have to determine the voltages by measurement. First find the primary. Locate the pairs of wires by checking continuity with an ohmmeter. Measure the resistances between the pairs. The heater windings will show resistances of less than 1 ohm, the primary will show about 20 ohms, and each half of the high-voltage secondary about 100 ohms.

Keep all wires well separated and connect the primary to an outlet. Avoid touching the high-voltage wires. With an AC voltmeter check the pairs showing the lowest values of resistance to determine which is the 6.3-volt and which the 5-volt winding.

To rebuild the transformer, first remove the core. Several bolts run through the core, and in the shielded variety of transformer these bolts will also hold the case together. Unscrew the nuts and withdraw the bolts from the holes in the core. If the bolts are tight, tap them with a block of wood. Do not use a hammer as that is likely to damage the threads.

When the bolts have been removed, take out the core laminations. The first few laminations are the hardest to get out. Examine the core and coil carefully to determine whether a wedge has been used to hold the coil tightly to the core. The wedge may be made of fibre or, in some older transformers, of thin wood. The technique needed to remove the wedge will depend upon circumstances. It is sometimes possible to remove it by pulling with a pair of pliers. In some cases, it will have to be driven out with a thin tool, a piece of thin metal or the like. Be extremely careful not to damage the coil. When the wedge is out, the first few laminations can be removed by driving them out. After four or five have been taken out, the balance will come out easily.

The outside of the coil will have a covering of heavy paper or similar insulating material. Very carefully remove it by slitting it with a knife and peeling it off. This will expose the outside windings. We shall assume the winding to be removed (the 5-volt winding) is in the outermost layer. Unwind the wire, counting the exact number of turns you remove. If there seems to be a fraction of a turn over an even number, include it in the total.

The turns-per-volt ratio

Suppose the 5-volt winding just removed had a total of 20 turns. By dividing the voltage into the number of turns you will have the turns-per-volt ratio of the transformer. In this case, 20 divided by 5 gives a turns-per-volt

ratio of 4. This ratio is maintained in all the windings. The 117-volt primary should have 468 turns, the 640-volt high-voltage winding 2560 turns, and the 6.3-volt heater winding 25.2 turns. The last case shows the importance of including a fraction of a turn in your count. You now have sufficient information to plan a winding for any desired voltage for the transformer under consideration.

Replace the 5-volt winding with one designed to deliver 30 volts. A simple calculation shows the new winding must have 120 turns of wire. Don't worry about the job of crowding 120 turns of wire into a rather limited space formerly occupied by only 20

care of the current requirements, and in almost every case the 120 turns will fit into the allotted space. If there are two low-voltage windings side by side and the space seems narrow, the winding can consist of two layers with a layer of waxed paper laid between them.

Since #30 wire is rather fragile for use as a connecting wire, splice and solder a 6-inch length of larger wire to the beginning of the coil. Number 22 is sufficiently heavy for this purpose. Be sure to remove all traces of enamel before trying to solder. Now take a 2-inch length of adhesive cellulose tape and double it with the sticky side out. Pass the loop over the

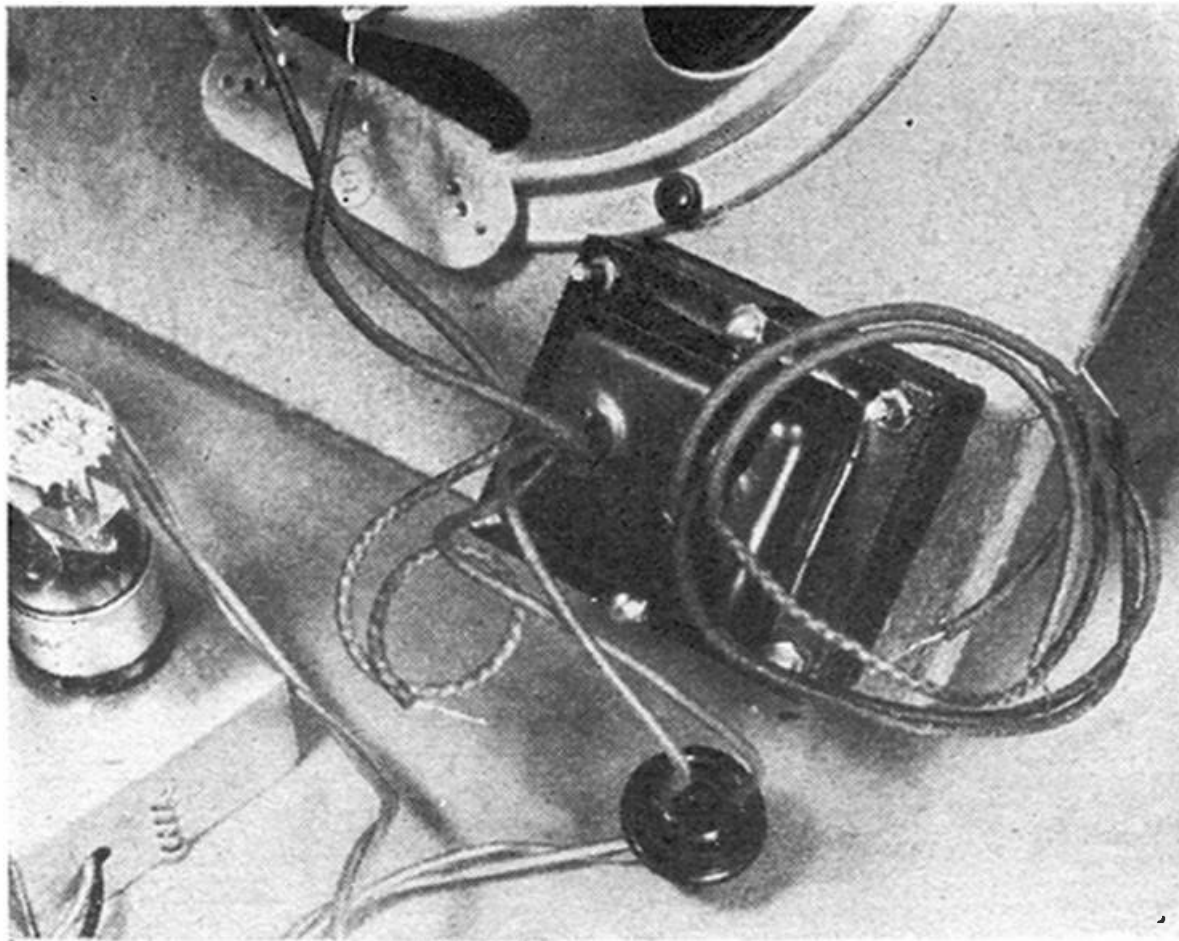

By rebuilding a small power transformer, you can have an efficient, special transformer for your condenser checker.

turns. You probably noticed the winding you removed was made of quite heavy wire—because the winding delivered considerable current (often the current is 2 amperes or more). The new winding, on the other hand, need deliver only a few milliamperes (although in the parts list a conservative rating of 40 milliamperes was given, the drain under ordinary conditions will be only about 10 milliamperes). Consequently, the new winding may be of much smaller wire. Number 30 enamelled wire will take

wire and anchor it in place by sticking the tape to the coil. The heavier lead wire should be anchored in place so there is no danger of breaking the thinner wire of the winding. Now start winding on turns over the tape. Continue until 120 turns have been completed, making sure the turns are close and even. If you allow turns to cross one another you may get an uneven coil that will take up too much space. Solder another length of #22 wire to the end of the winding and anchor with cellulose tape. Finish

the job by covering the coil with at least two layers of waxed paper; the ordinary household variety will do.

If, when you uncover the coil, you find the winding to be removed is under the 6.3-volt heater winding, the job is more complicated. You will have to remove the 6.3-volt winding, strip off the 5-volt winding, wind the new coil, and finally replace the 6.3-volt winding. It won't be as difficult as it sounds, provided care is used. Be sure to count the turns on all windings removed, as a double check. If the 6.3-volt winding was on top originally, don't try to wind it on first, for then you will change the diameter of the winding and the number of turns will not be correct. Should you have to remove both low-voltage windings, it will be well to strip off the high-voltage winding, too, since it is not to be used. You need not unwind the hundreds of turns of wire, however; carefully cut through the wire with a knife or razor blade and peel it off. With the high-voltage winding removed, you will not have to use as much care in rewinding as you will have space to spare. If you do not remove the high-voltage winding, clip the leads off close to the coil.

Replacing the laminations

Replacing the laminations is the next job. Most transformers use E- and I-shaped punchings; when two of these are placed facing each other, they form a hollow rectangle with a cross-bar in the center over which the center of the coil fits. You can stack

the core by reversing the position of every other lamination, or you might have found when you disassembled the transformer that the manufacturer took a short cut that you can follow—stacking three or four laminations together and placing them in the coils so they face in one direction with the next stack of exactly the same number of laminations facing the opposite way. If you have trouble fitting all the laminations into the space provided, try compressing the core in a vise. The vise, plus a clamp or two, will also be useful to compress the core when the wedge is inserted. Replace the core bolts and the cover, if one is used. Replace the nuts and tighten snugly.

If you hear a pronounced hum when the transformer is connected to the line, the coil is loose on the core or the bolts are not tight enough.

The information above can be applied in rebuilding any kind of transformer. For example, you might need an especially heavy transformer for use in an amplifier. As such items are expensive, consider the possibility of using a transformer taken from an old radio set that used 2.5-volt tubes. You will find it well worth while to take the transformer apart, remove the 2.5-volt winding, and install a new one designed for 6.3-volts.

When considerable current is needed, use wire large enough to carry it safely without overheating. Current-carrying capacities of various wire sizes can be found in the wire tables included in all electrician's handbooks.

VISUAL ALIGNMENT INDICATOR

Although all the instructions for receiver alignment given in this book are based on the aural method, many experienced workers claim the visual method is more accurate because the average ear cannot detect very small

changes in sound intensity.

One widely-used visual alignment indicator consists of an AC voltmeter connected across the speaker voice coil or, in some cases, from the plate of the output tube to chassis. If the latter

connection is used, a condenser must be connected in series with the meter to block direct current. If this scheme is used on a set with a push-pull output stage, the meter must be connected from the plate and the series condenser can be omitted.

An electron-ray-tube alignment indicator is much less expensive than a meter and just as accurate. The parts needed for it are: a 6U5G tube; one 6-pin tube socket; a 1-megohm, 1/2-watt carbon resistor; about 8 feet of stranded insulated wire; and 4 alligator clips. The wires can be more readily identified if different colors are used; this means you will need 2 feet of each color. We suggest black for the chassis connection, yellow for the 6.3-volt heater wire, red for B plus, and green for the AVC connection. You may find it more convenient to use one of the magic-eye tuning-indicator kits that come complete with socket, colored leads, and mounting hardware.

Wire the unit as shown in Figure 7-24. Connect the green wire to socket terminal 3, the yellow to terminal 1, and the black wire to terminal 6. Connect a jumper wire between terminals 5 and 6. The 1-megohm resistor is then connected between terminals 2 and 4. Connect the red wire to terminal 4. Solder an alligator clip to the free end of each wire.

Aligning a set

The unit may be used to align any set that uses a power transformer; it cannot be used on a set having a series heater arrangement unless special provisions are made for supplying the heater of the indicator tube without disturbing the heater circuit of the set. Of course, a small heater transformer may be used for this purpose, but this will increase the cost of the device. Another method is to operate the heater of the indicator tube directly from the power line with a suitable dropping resistor in series. If this ar-

angement is used, omit the jumper wire between pins 5 and 6 of the tube socket and connect the heater wires to the AC line instead of to the heater supply of the set being aligned.

To align the average AC set, connect the black wire to the chassis of the set and the yellow wire to the ungrounded terminal of the 6.3-volt heater supply. Connect the red wire to any convenient source of B voltage, such as the screen of an output tube or the end of the filter choke or resistor farthest from the rectifier tube. The voltage should not exceed 300.

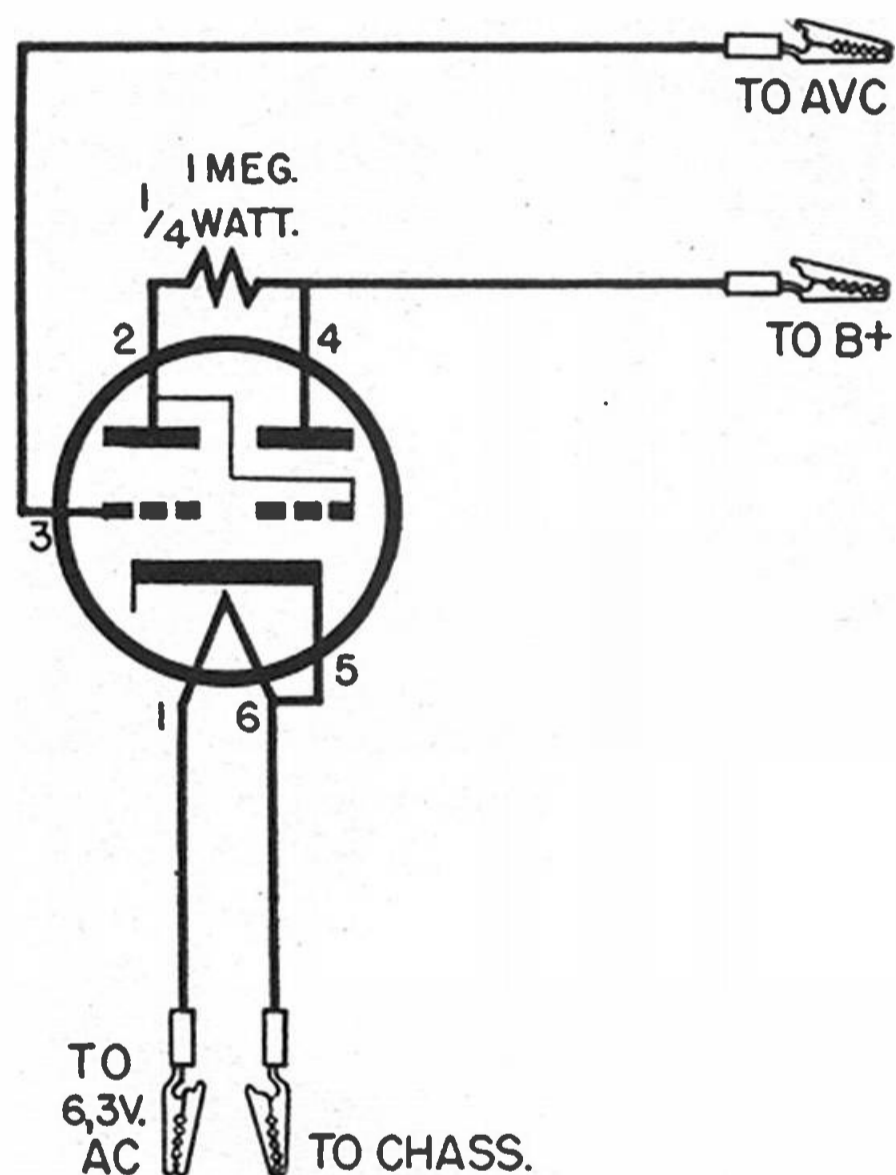

Fig. 7-24. An electron-ray alignment indicator.

Connect the green wire to the AVC supply point. Locate this point by tracing the circuit, starting at the grid return (black wire) of the second i.f. transformer. The wire may run directly to the high side of the volume control or there may be a resistor (about 50,000 ohms) between the two. In any case, at the high side of the volume control there will be an AVC filter resistor; its value will be from 1 to 2 megohms. The end of this resistor that is away from the volume control

is the AVC point.

If the set is in working order, you will probably note some narrowing of the shadow angle in the indicator

tube as soon as the generator signal is applied. Make all adjustments so as to obtain maximum closure of the indicator (minimum shadow angle).

Handy Midget Portables

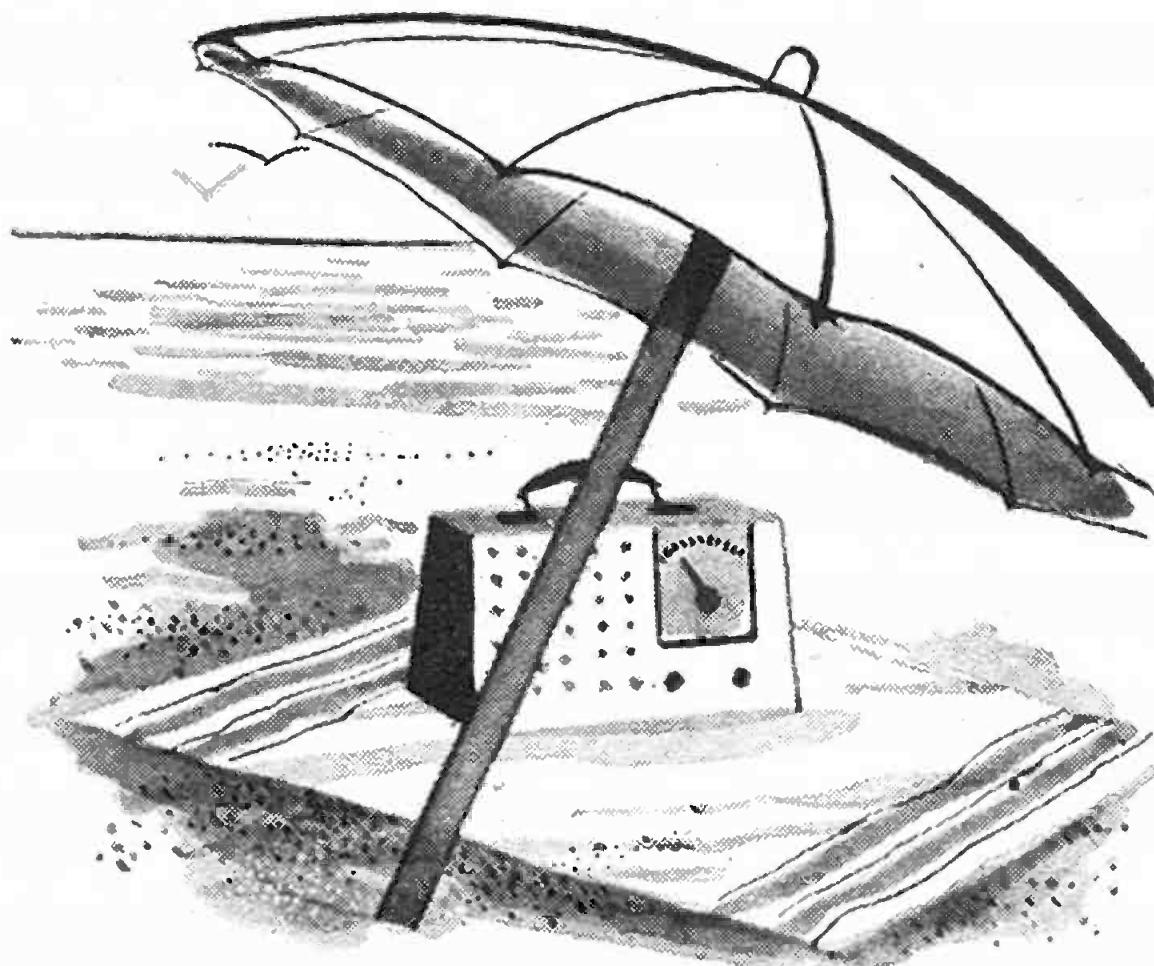
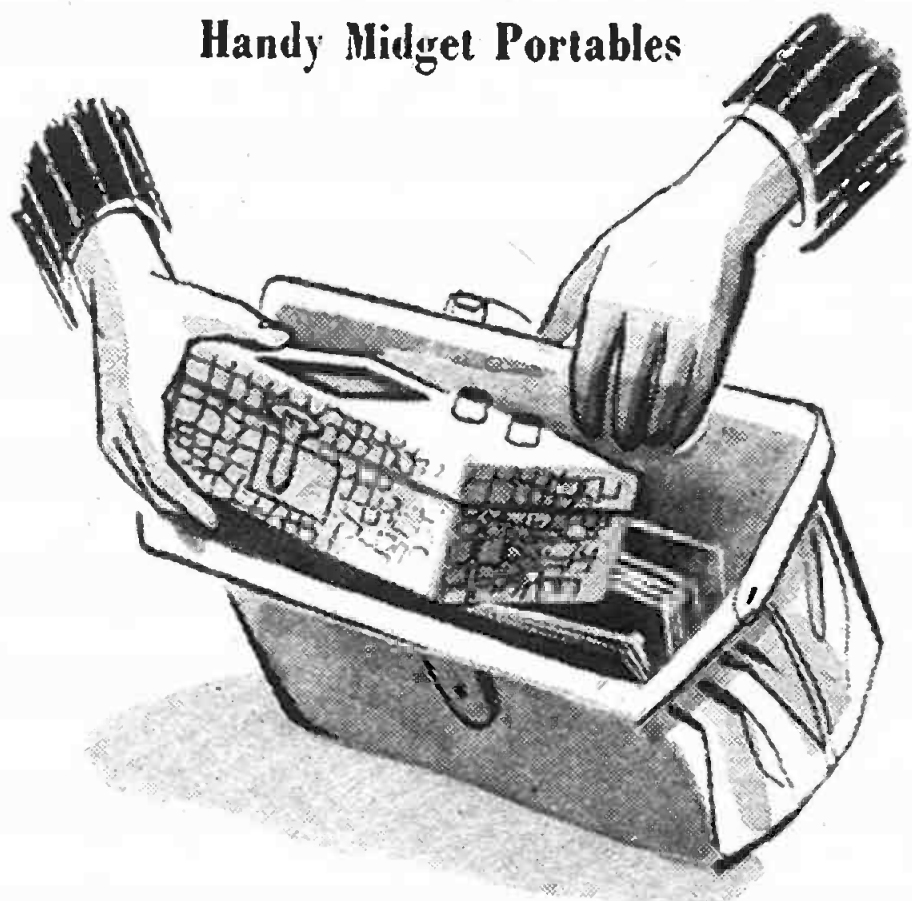

Sets for Beach or Mountains

You Can Have Music Wherever You Go

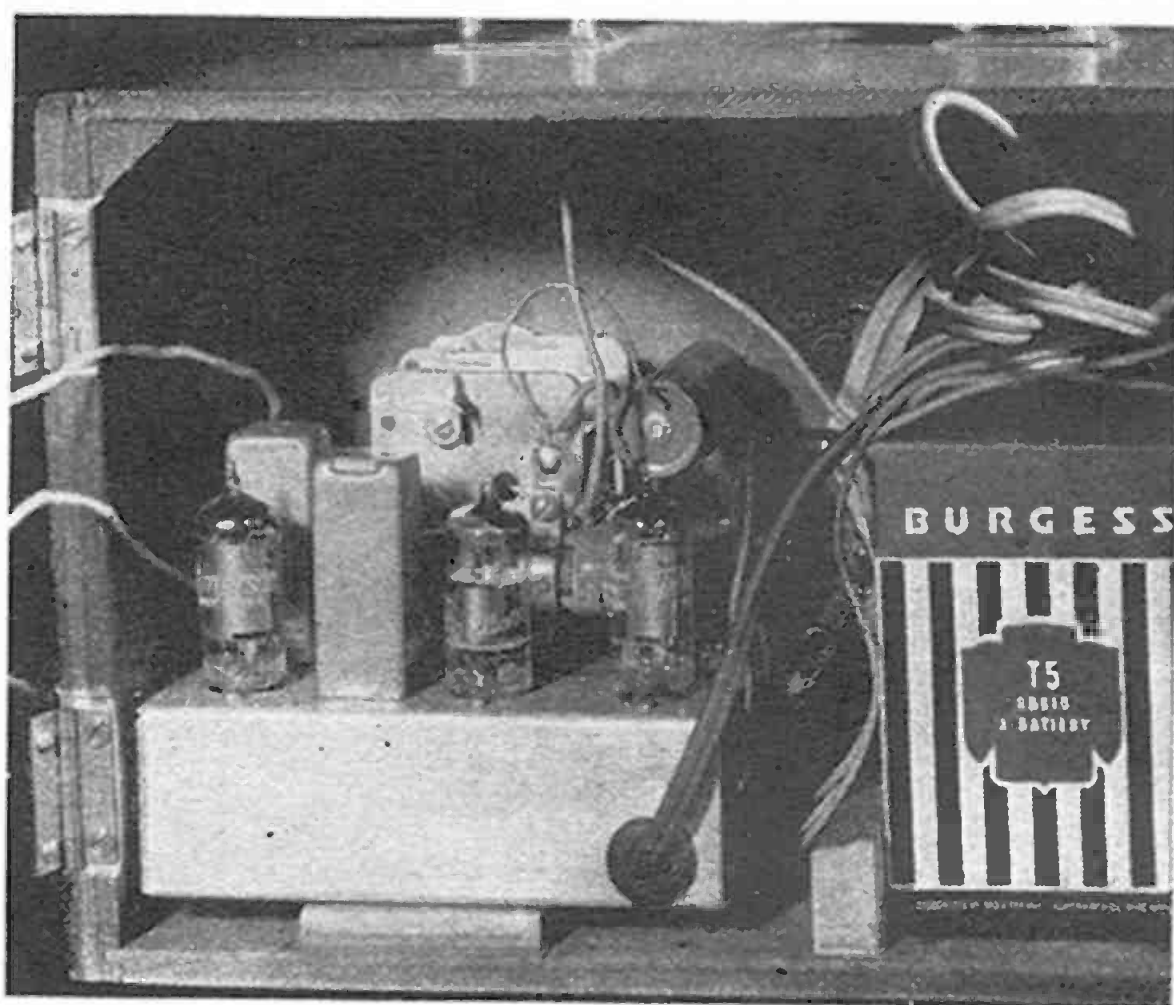

A Portable Receiver

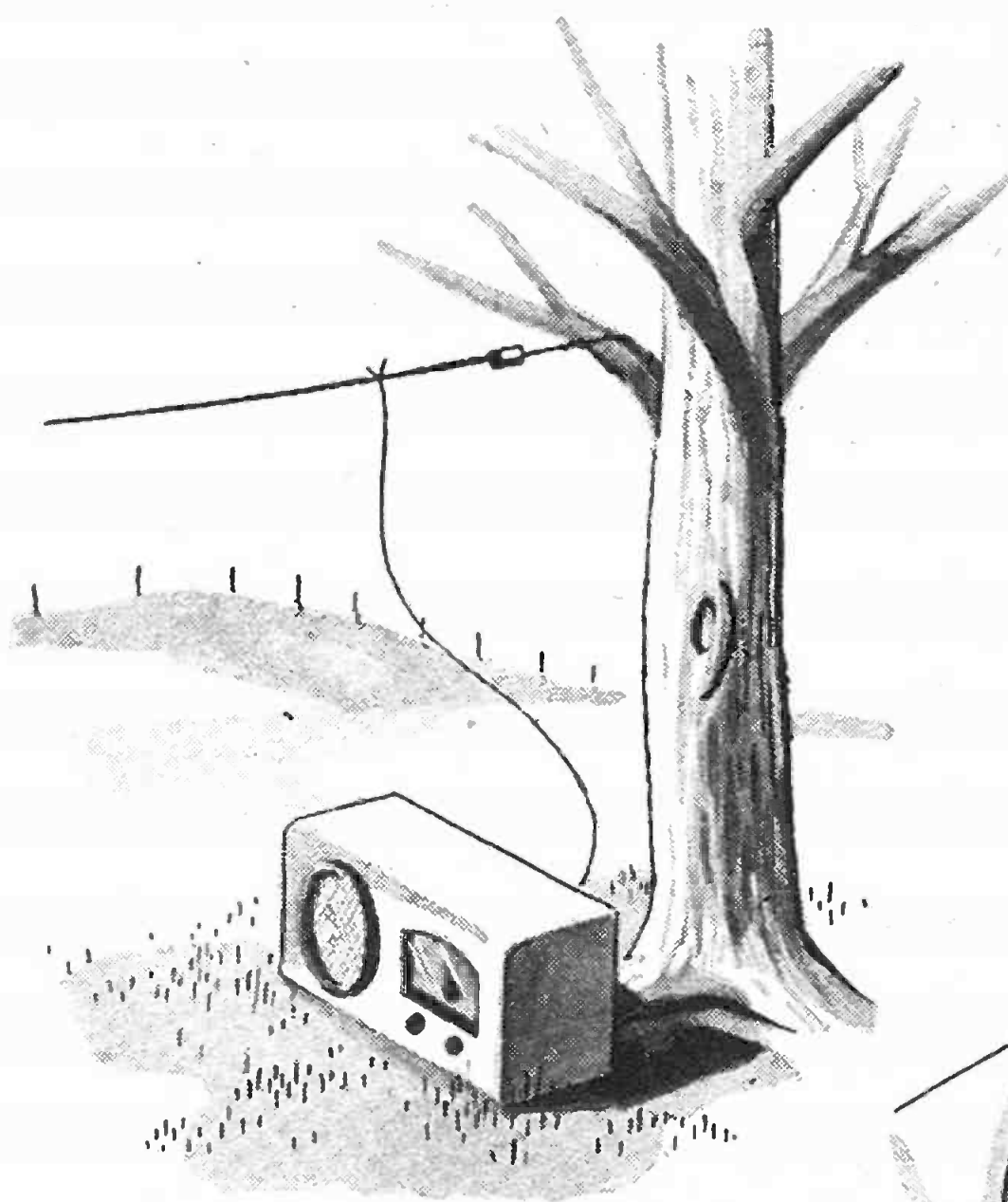

Outdoor Shortwave Portables

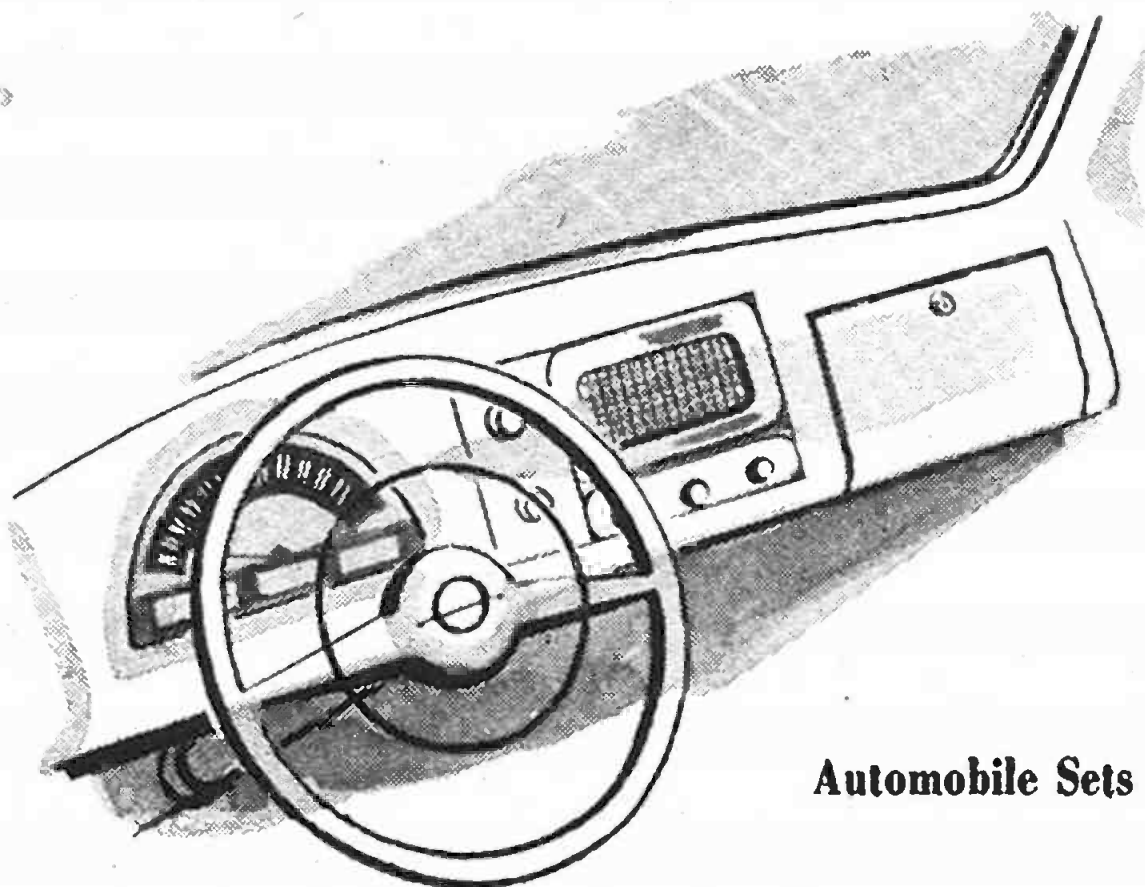

Automobile Sets

Battery-Type Receivers— Portable, Short-Wave, Automobile

SETS that operate from a battery supply may be divided into two categories: those taking filament power and plate power from separate batteries, and automobile receivers that derive power from a single storage battery. The two kinds differ materially in circuitry and tubes employed. Both are discussed in this chapter.

Dry-battery-operated receivers require special design features in order to conserve battery power, which, incidentally, is expensive when compared to power taken from AC or DC supply lines. In the portable type of battery-operated receiver, two other factors must be taken into consideration—physical size and weight. The three requirements are met by using tubes with low filament and plate power consumption, by using the minimum number of tubes, and by using small components. This brings up a point that is too often neglected by purchasers and builders of portable sets. The batteries used in many of these sets—especially sets of the “personal” variety—are quite small. Al-

though this does effectively reduce the size and weight of the set, it is far from economical, for doubling the physical size of a battery will usually more than double its life. It is hardly necessary to add that in all portable sets the use of miniature tubes is a “must.”

When we consider automobile receivers, we find that the problem is somewhat different. There is no longer a need to be extremely frugal in the use of battery power, since today's automobiles are provided with heavier batteries and a charging system fully capable of handling the heavy drain of starter, ignition, horn, lights, heater, radio, and a multitude of other devices. The current requirements of the set should, however, be sufficiently moderate that operation over an extended period is possible without running the engine or discharging the battery too much.

In this chapter we take up the construction of a portable battery set, a short-wave battery set, and an automobile receiver.

BATTERY-OPERATED PORTABLE RECEIVER

This set is designed for operation from a 1.4-volt A battery and a 67.5-volt B battery. The batteries may be

as large or as small as you wish, although we suggest you give due consideration to the matter of economy.

Small, light batteries will allow the set to perform as well as larger, heavier ones but will be less economical. The question you must answer for yourself is whether extreme lightness warrants the increase in the cost of operation.

The approximate dimensions of a carrying case suitable for this set might be about 8 inches long, 7 inches high, and 5 inches deep, which allows space for batteries of medium size. The chassis rests on a shelf so located that the highest point on the chassis clears the inside of the case. Sufficient space remains under the shelf for the installation of batteries.

Examination of Figure 8-2, the chassis top view, shows that the tubes and parts are by no means crowded. In fact, if you care to do so, the spacing between components can be reduced and a smaller chassis used. Remember, however, that placing the parts closer together will increase the difficulty of layout, assembly, and wiring to some degree.

Circuit description

See Figure 8-1 for the complete circuit diagram.

This is a four-tube superheterodyne using miniature tubes requiring filament voltage of 1.4. Except for the filament and power supply circuits, it bears some resemblance to the five-tube AC/DC superheterodyne set described in Chapter 2. As no rectifier is needed, the tube complement is reduced to four.

The set operates from a loop antenna mounted on the back of the chassis. The converter circuit uses a 1R5 tube and is almost identical with the circuit found in the five-tube superheterodyne except for the tube itself. Note that a two-winding oscillator coil is used, with coupling between coil and oscillator grid provided by a "gimmick," or dead-ended turn of wire. The oscillator grid resistor is 100,000 ohms, higher than the

average value in AC/DC receivers.

After frequency conversion, signals are applied to the input grid (pin 6) of the 1T4 intermediate-frequency amplifier tube. Note the use in this stage of the screen dropping resistor, R10, and the screen bypass condenser, C8.

Amplified signals are fed to the second i.f. transformer, 1FT2, and appear at the diode plate of the 1S5 detector-first-audio-AVC tube. The audio component of the signal appears across the volume control, R7, and the desired portion of the signal is passed on to the pentode section of the tube. At the same time, AVC voltage developed in this portion of the circuit is applied to the grids of the 1R5 and 1T4 tubes. The AVC filter circuit consists of the resistor R9 and condenser C10.

You may note a difference between the detector-first-audio tube used in this set and those ordinarily used in AC and AC/DC sets. In most universal sets the detector-first-audio tube is a combination of double diode and high-gain triode or, in some instances, a medium gain triode. The 1S5, however, contains a single diode plate and a pentode unit.

The input circuit of the pentode section includes the coupling condenser, C7, and the 10-megohm resistor, R6. In the screen circuit we find the screen resistor, R5, and the bypass condenser, C4.

Observe that the plate circuit of the 1S5 is more complicated than usual. In addition to the plate resistor, R3, there is a filter, consisting of R4 and C5. Also note the use of the 10-microfarad electrolytic condenser, connected to the junction of R4 and R5.

The output circuit uses a 1S4 power pentode and is a standard type of circuit except for resistor R2, connected between the grid resistor, R1, and chassis.

When the heater circuit is considered, remember that, unlike tubes

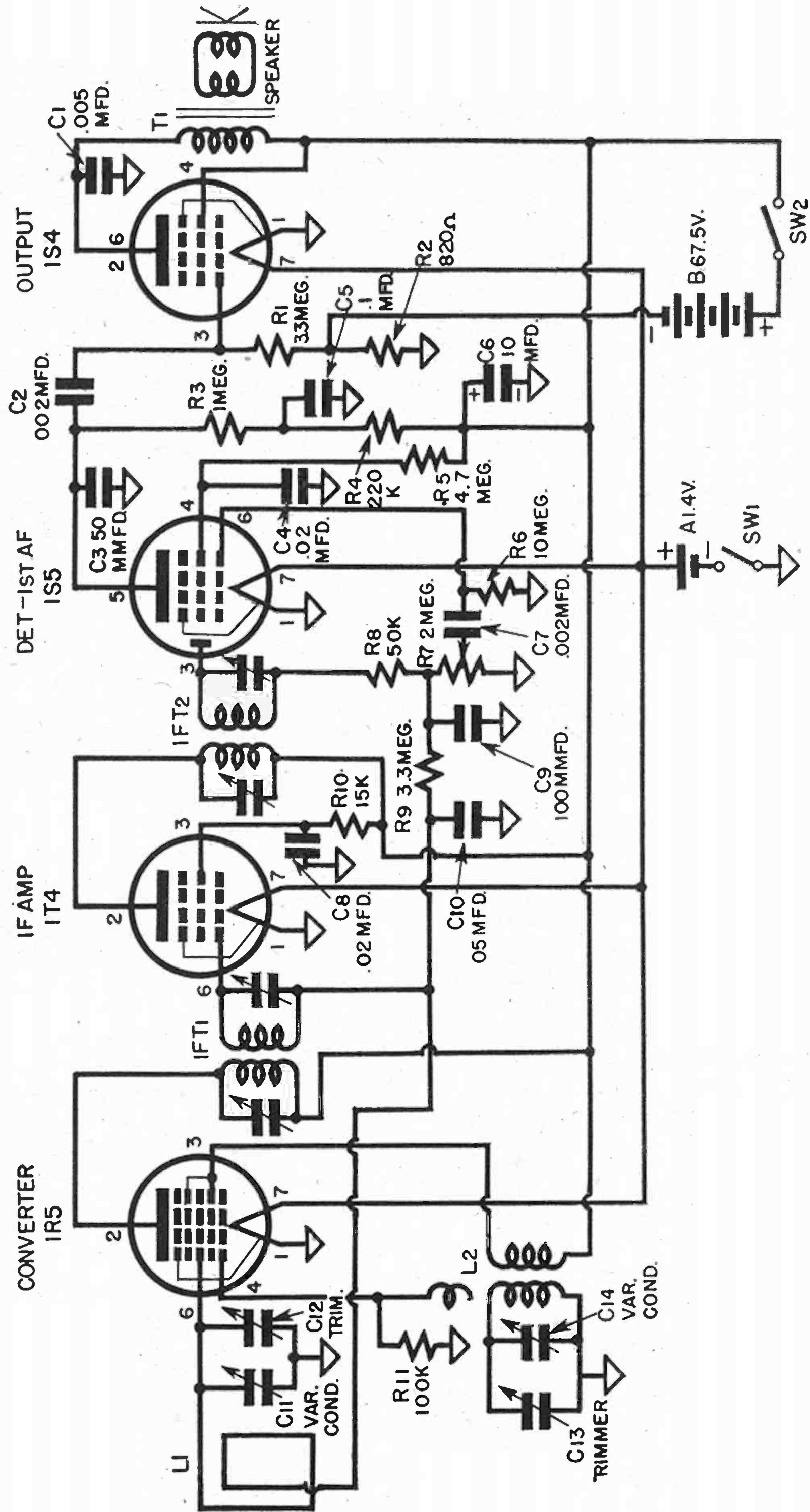

Fig. 8-1. Schematic diagram of a portable receiver.

used in other sets, battery tubes have no separate cathode. The filament serves both as a source of heat and a source of electrons. This construction results in a difference in the method of obtaining grid bias. The usual cathode bias cannot be used because there is no separate cathode. The problem is solved in the output tube circuit by using R2, which is connected between B minus and chassis. Current flowing downward through R2 develops a slight negative bias for the grid of the tube. The pentode section of the 1S5 first-audio tube is, of course, contact-biased by the 10-megohm resistor.

The filaments of all tubes are wired in parallel; one end of each is connected to A plus and the other end to chassis. In each case the #1 pin is grounded, which is necessary because the suppressor grid is connected to that pin inside the tube. If the connections were to be reversed and the #7 pin grounded to chassis, the suppressor grid would then be connected to A plus and would be slightly positive compared to chassis. This is an undesirable condition and would materially affect the operation of the set.

The filaments of all battery tubes are fragile. Most heater-cathode tubes will withstand a heater voltage that is much higher than normal for short periods without serious damage, but this does not apply to battery tubes. Filament voltages higher than normal usually cause instantaneous burnout. This can easily happen if a short circuit occurs or a wrong connection applies the B-battery voltage to the filament.

The relatively fragile filaments of battery tubes are also more likely to be broken by rough treatment than are the heaters of the more rugged heater-cathode tubes.

Parts list

Resistors

R1 3.3 megohms, 1/2-watt

R2 820 ohms, 1-watt
 R3 1 megohm, 1/2-watt
 R4 220K ohms, 1/2-watt
 R5 4.7 megohms, 1/2-watt
 R6 10 megohms, 1/2-watt
 R7 2 megohms, midget volume-control with two S.P.S.T. switches, SW1 and SW2
 R8 50K ohms, 1/2-watt
 R9 3.3 megohms, 1/2-watt
 R10 15K ohms, 1/2-watt
 R11 100K ohms, 1/2-watt

Condensers

C1 .005 mfd., 400-volt mica
 C2 .002 mfd., 400-volt paper tubular
 C3 50 mmfd., 400-volt mica
 C4 .02 mfd., 400-volt paper tubular
 C5 .1 mfd., 400-volt paper tubular
 C6 10 mfd., 150-volt electrolytic, tubular cartridge
 C7 .002 mfd., 200-volt paper tubular
 C8 .02 mfd., 400-volt paper tubular
 C9 100mmfd., 400-volt mica
 C10 .05 mfd., 200-volt paper tubular
 C11 Tuning condenser, 2-gang; antenna section 420 mmfd., oscillator section 163 mmfd. (with C14)
 C12 Trimmer condenser, part of tuning condenser
 C13 Trimmer condenser, part of tuning condenser
 C14 (with C11)

Transformers

T1 Output transformer, 5,000-ohm primary, 3.5-ohm secondary
 IFT1 455-kilocycle midget i.f. transformer, Stanwyck ST-1107-S or equivalent
 IFT2 455-kilocycle midget i.f. transformer, Stanwyck ST-1107-S or equivalent

Speaker

3-inch PM dynamic, 3.5-ohm voice-coil impedance

Coils

- L1- Loop antenna
- L2 Oscillator coil, Meissner type 14-1040 or equivalent

Miscellaneous

- Chassis: 5 x 8 x 1 inches, steel or aluminum
- 2 spacers for loop antenna, 3/4 x 1/2 inch, wood
- 2 3/4-inch #6 self-threading screws for loop
- 4 miniature 7-pin tube sockets
- 8 4-36 x 3/8-inch r.h. machine screws
- 8 4-36 hexagon nuts
- 4-point tie strip
- 3 3-point tie strips

gether. The general arrangement should nevertheless remain close to the diagram.

Begin the layout by drawing a center line 1-3/16 inches from the rear edge of the chassis. The 1R5, 1T4, and 1S5 tube sockets and the two i.f. transformers are to be placed along this line. Measure along the center line a distance of one inch from the right side of the chassis and make a center-punch mark at this point; this is the center of the 1R5 socket. The center of the first i.f. transformer may be located next, at a distance of 1-3/8 inches to the left of the 1R5 socket. Layout of the other i.f. transformer

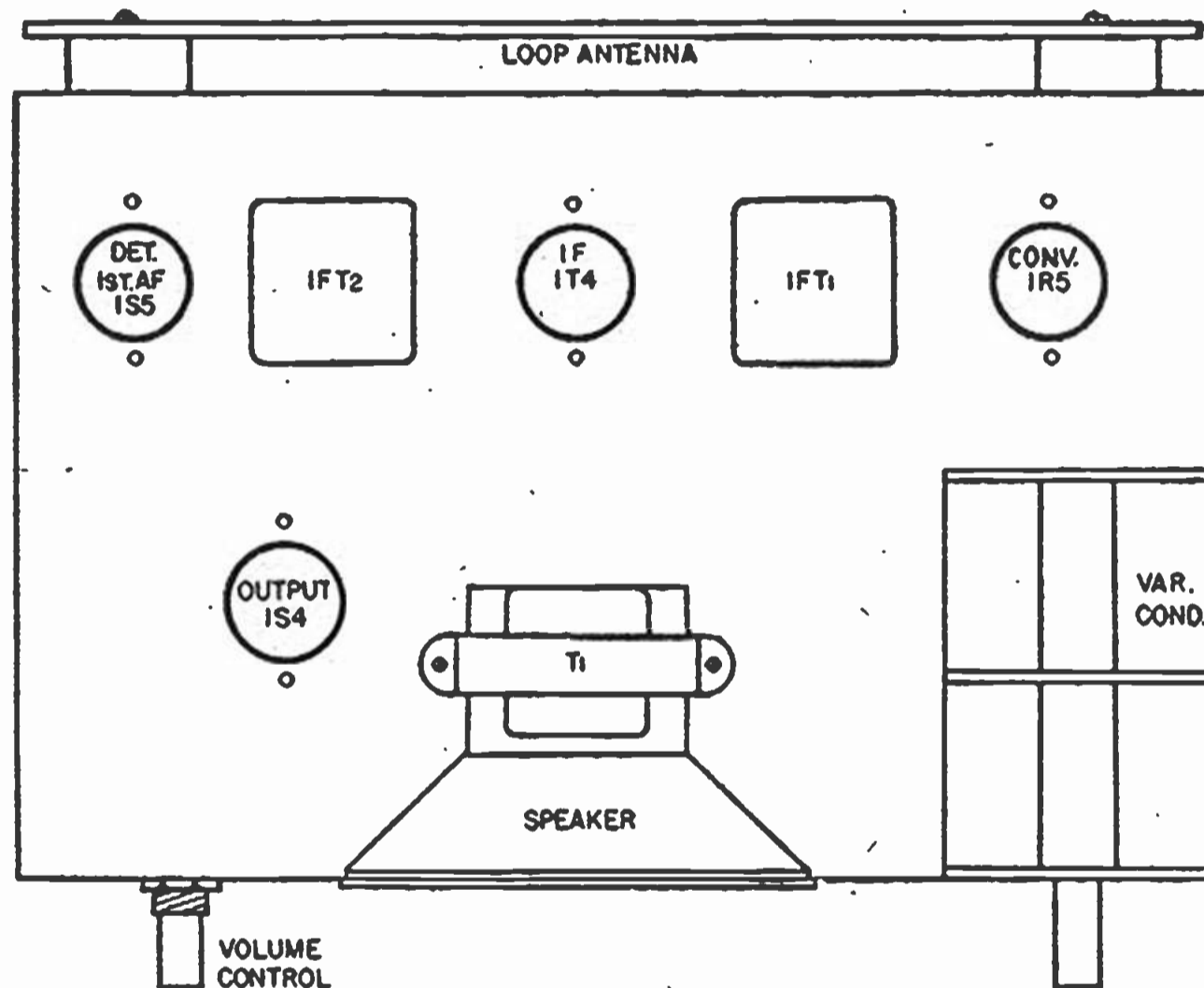

Fig. 8-2. Top view of portable receiver chassis.

- 6-32 x 3/8-inch r.h. machine screws
- 6-32 hexagon nuts

Tubes

- 1R5, 1T4, 1S5, 1S4

Layout and assembly

See Figure 8-2 for a top view of the chassis.

All instructions for layout and assembly are based upon the use of a chassis measuring 5 by 8 inches, but, as mentioned earlier, it is possible to reduce the size of the chassis by placing some of the components closer to-

and the 1T4 and 1S5 sockets is then a matter of scaling off 1-3/8 inch distances along the center line. When the centers of the three sockets have been marked, lay out two mounting holes for each. Place a socket face down on the chassis so the center of the socket coincides with the punch mark, then mark the two screw holes with a pencil. The positions and sizes of the mounting holes for the i.f. transformers will depend upon the construction of the transformers. One with four wire leads will usually require two

holes for spade bolts. Others may use a clip mounting.

The variable condenser is located at the right front corner of the chassis. Again the construction of the individual part will determine the method of mounting and the positions of the screw holes. The average condenser requires three or four 8-32 screws for mounting. The simplest method of marking the positions of the holes is to prepare a paper template the same size as the bottom of the condenser frame. Place the paper on the frame and press down to mark the outlines of the holes on it. Lay the paper template on the chassis in the exact position the condenser will occupy and center-punch the locations through the paper.

The 3-inch speaker is mounted at the center of the chassis. Small speakers are satisfactorily mounted with two or more 6-32 screws through the speaker flange and the front chassis apron. If the flange has no screw holes, they may be drilled with a #25 drill, being very careful not to damage the cone. Protect the cone during construction by covering it with a

ers and output transformers, the use of templates, and other pertinent information are included in Chapters 1 and 2.

The 1S4 output-tube socket is located 2-1/8 inches from the left side of the chassis and 1-3/8 inches from the front. After marking the location of the center, lay out the screw holes as described above.

The volume control is located on the chassis front apron and its center is 1/2 inch from the top of the chassis. The position of the variable-condenser shaft will determine the distance from the left end of the chassis to the center of the control shaft, if a symmetrical arrangement is desired. If you care to go a step further toward symmetry in the arrangement of controls, you may mount the volume control above the chassis on an L-shaped bracket. The bracket is fastened to the chassis with two machine screws and nuts; its upright portion has a hole to accommodate the control-shaft bushing. The vertical distance from the center of the shaft to the chassis should be the same as for the tuning condenser.

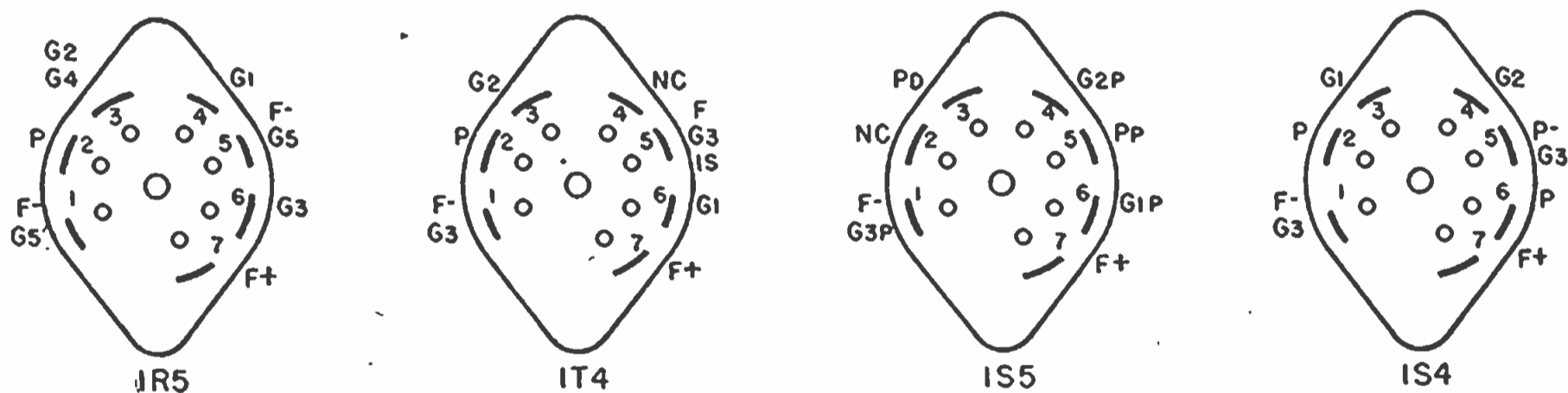

Fig. 8-3. Bottom view of tube sockets.

piece of heavy cardboard. Mount the output transformer on top of the speaker magnet frame, as shown in Figure 8-2, with a metal strap that passes under the top of the magnet frame. The strap has two holes spaced to align with the holes in the transformer mounting tabs. Two 6-32 screws and nuts hold the strap and transformer together. Drawings illustrating methods of mounting speak-

Drill the screw holes for the tube sockets with a #31 drill; use a #25 drill for all other holes except those for the loop-antenna screws and the variable condenser. The latter will usually require 8-32 screws, for which the correct clearance drill is #16. If #6 self-threading screws are used for fastening the loop antenna in place, drill with a #37 drill. Enter the point of the screw in the hole, then force

it in with a socket wrench to cut a thread in the chassis metal. Enlarge the hole for the volume-control-shaft bushing to $\frac{3}{8}$ inch with a drill or reamer. Punch out the holes for the socket with a $\frac{5}{8}$ -inch sheet-metal punch, first enlarging the center hole to $\frac{1}{16}$ -inch larger than the cap-screw diameter.

Fasten all parts in place as shown in the sketch. For convenience in wiring, see that all sockets face in the same direction. Unless you decide to use a chassis smaller than specified, support some of the resistors and condensers on tie strips, particularly those that do not have one end grounded. Place a 3-point strip close to the 1S4 tube socket for R1 and R2; a 4-point strip near the 1S5 socket for R3, R4, and C5; a 3-point strip near the 1S5 socket for R9 and C10; and another 3-point strip near the i.f. amplifier socket to support C8 and R10. When these parts are in place you are ready to start wiring.

Wiring

Refer to Figure 8-3 for the tube-socket terminal arrangement.

a) Heater Circuit. See Figure 8-4.

For a neat and durable job use stranded insulated wire in four colors between the set and the batteries. Green is suitable for the A-minus lead, yellow for A plus, black for B minus, and red for B plus.

Connect the #7 pins of all tube sockets together. To the #7 pin of one of the sockets in the row near the rear of the chassis, connect a piece of the yellow wire long enough to reach from the chassis to the battery compartment. In most cases the battery wires need be no more than a foot or so in length. The wires may leave the set through small holes drilled in the rear apron of the chassis, or you may use a single larger hole fitted with a rubber grommet. Do not neglect to anchor each wire so that a

strain placed on it will not damage a socket or other part. Connect all the #1 socket terminals to chassis; ground each individually or use a single wire looped from socket to socket, as you choose.

On the rear of the volume control you will find four switch terminals. There are two separate single-pole single-throw switches operating from a single cam. One pair of terminals belongs to one switch, the second pair

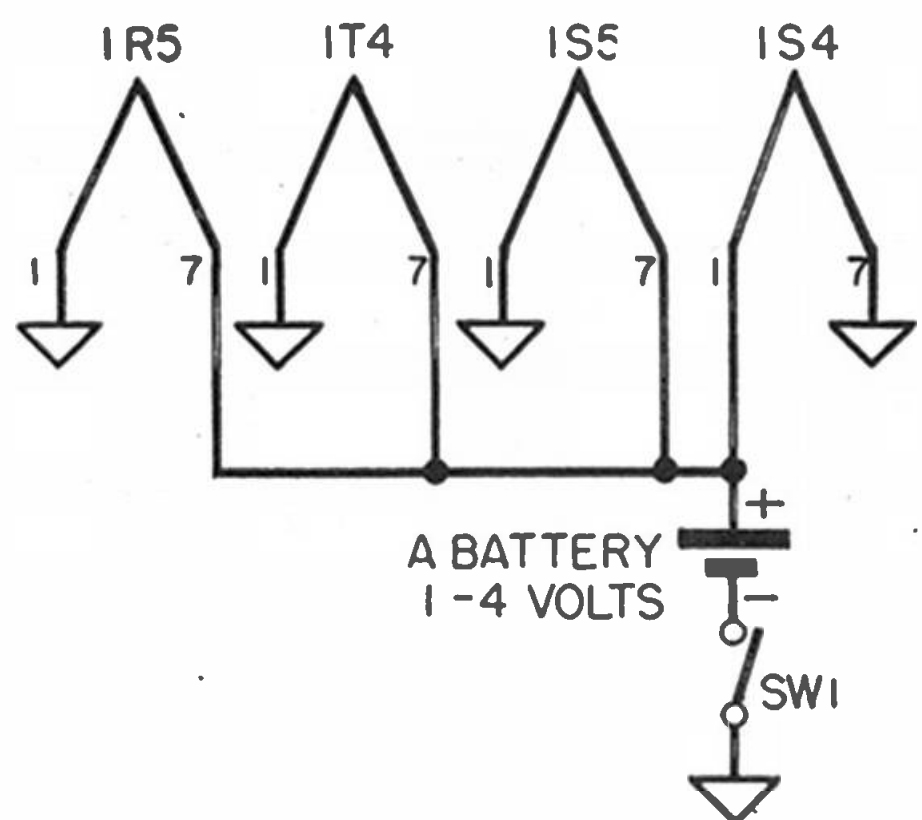

Fig. 8-4. Filament circuit.

to the other. One of the switches closes the A-battery circuit, the other is used for the B battery. If the terminals are unmarked, you will have to find the pairs. This can be done by checking with an ohmmeter while you turn the control shaft to open and close the switches. When you have located the pairs, mark them A and B.

Connect one of the A switch (SW1) terminals to chassis. The green battery wire runs from the other switch terminal to the negative terminal of the A battery. Cut the wire long enough to reach from the set to the battery compartment and be sure to anchor it as mentioned above.

The filament circuit can be tested in the usual way by noting whether the tubes light. Since the filaments of battery-operated tubes do not glow very brightly, you will probably have

to make the test in a partially darkened room. Connect the green wire to the negative terminal of the 1.3-volt A battery and the yellow wire to the positive terminal. If you have not purchased the regular batteries for the set, an ordinary dry cell (a large-size flashlight cell will do) may be used for the test. Insert the tubes in their sockets, turn the switch on, and look for the glow of the filaments. Since this is difficult to see, you may want to make a more conclusive test. With the set turned on, measure the voltage from each of the #7 socket terminals to chassis with a DC voltmeter with a 5-volt range. Then remove each tube from its socket and check filament continuity with an ohmmeter. If each #7 filament terminal shows a 1.4-volt reading to chassis and if all the tube filaments are intact, the filament circuit is in operating condition.

b) *B Supply Circuit.* See Figure 8-5.

Connect one end of R2 to chassis. The black battery wire is now connected to the opposite end of R2 and brought out through the chassis. Cut the wire long enough to reach to the battery compartment in the lower part of the case. Connect the red battery wire to one terminal of the B switch (SW2) on the back of the volume control and bring it out through the rear of the chassis. Cut it to approximately the same length as the other battery wires. The remaining switch terminal will be used later on as a junction point for all of the plate and screen supply wires.

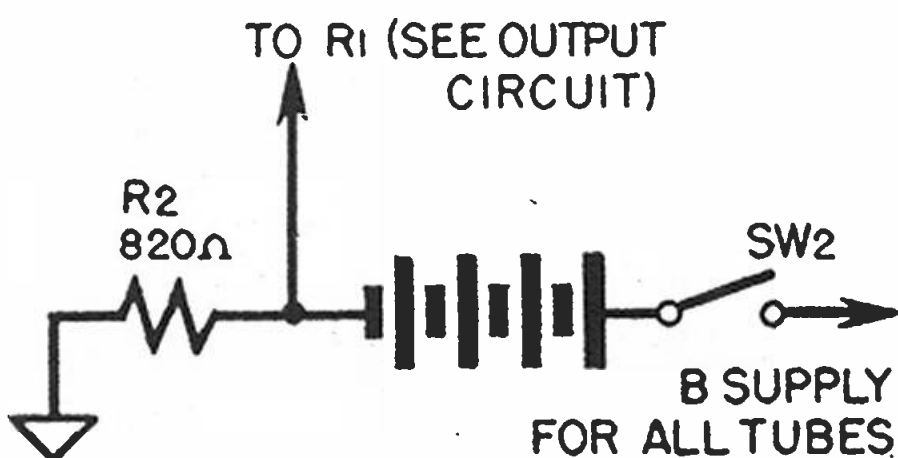

Fig. 8-5. B. supply circuit.

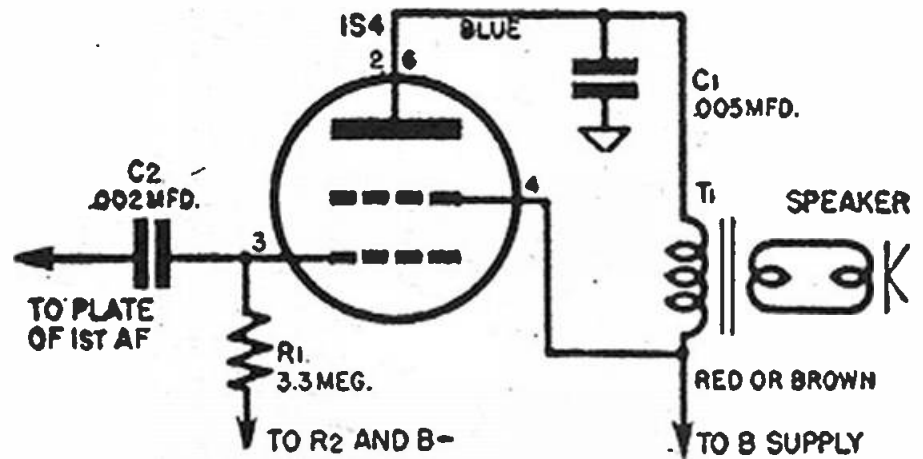

Fig. 8-6. Output circuit.

The junction of R2 and the black B-battery wire will also have an additional connection (to R1) made later.

c) *Output Circuit.* See Figure 8-6.

Connect the output-transformer secondary wires to the voice-coil terminals of the speaker. The blue wire of the output transformer is now connected to the plate (either pin 2 or pin 6 may be used) of the tube socket, but before soldering the connection add one wire of C1. The other wire of C1 is now grounded to chassis. Wire pin 4 (the screen) of the tube socket to B plus, which is the free terminal of SW2 on the volume control. Bring the red wire from the output transformer to the same point on SW2. Connect one end of resistor R1 to pin 3 of the tube socket. The other end of R1 is connected to B minus, not to chassis. The B-minus point is the junction of R2 and the black B-battery wire. Condenser C2 is now connected to the grid terminal of the socket, but the remaining end of C2 is not connected until the first audio circuit is wired. The suppressor grid of the tube is not shown in the drawing as no connection need be made to it; it is already connected to one terminal of the filament, inside the tube.

A resistance test of the output circuit can now be made. When making such a check on any of the stages in this set, it is advisable to disconnect the batteries. Normal resistance readings are as follows:

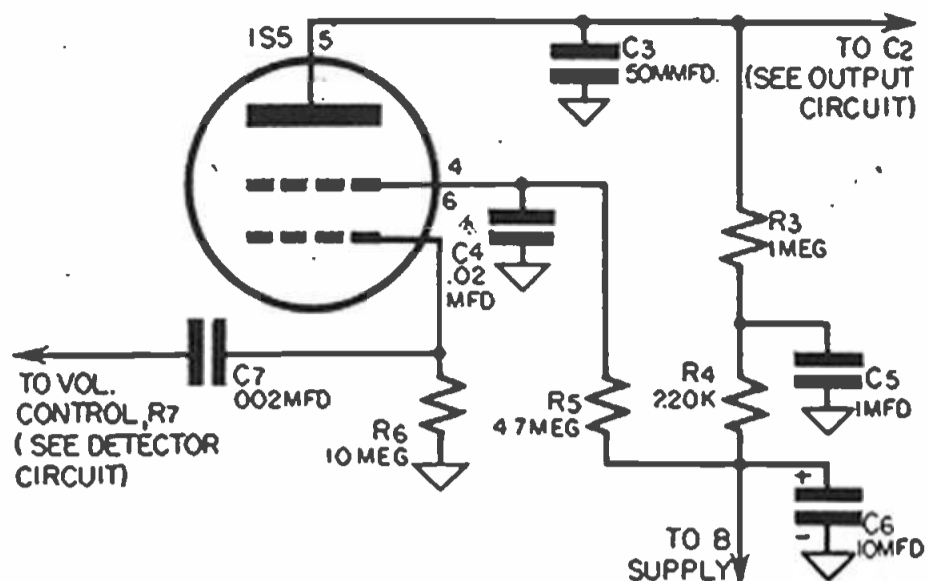

Fig. 8-7. First audio circuit.

From	To	Ohms
pin 3	chassis	3.3 megohms
pin 4	chassis	over 100K
pin 2 (or 6)	chassis	over 100K
pin 4	B plus	0
pin 2 (or 6)	B plus	200

With the batteries connected to the set and the tube in its socket, a voltage check should be made. Normal readings are:

From	To	DC Volts
pin 4	chassis	55
pin 2 (or 6)	chassis	50

When making a voltage test on any battery-operated receiver, remember that the actual voltage readings depend upon the age and condition of the batteries.

d) *First Audio Circuit.* See Figure 8-7.

Mount R3, R4, and R5 on tie strips and connect them in series, with R4 between R3 and R5. Connect the free end of R3 to the plate terminal of the tube socket (pin 5), but before soldering the connection add one terminal of C3. Ground the other end of C3 to chassis.

From the junction of R3 and R4, connect C5 to chassis with the outside foil of the condenser toward the chassis. The junction of R4 and R5 may now be wired to B plus, located on SW2. Connect the positive terminal of C6 to the junction point of R4 and R5. Connect the negative terminal of this condenser to chassis. Now wire

the free terminal of R5 to the screen terminal of the tube socket (pin 4); do not solder the connection until you have added one terminal of C4, the screen bypass condenser. The remaining terminal of C4 may now be grounded. Connect one end of R6 and one end of C7 to the grid of the tube socket (terminal 6). The free end of R6 is connected to chassis but the free end of C7 remains unconnected until the detector circuit is wired.

The normal resistance values for this circuit are:

From	To	Ohms
pin 6	chassis	10 megohm
pin 4	chassis	over 4 megohm
pin 5	chassis	over 1.3 megohm
pin 4	B plus	4.7 megohm
pin 5	B plus	1.2 megohm

Make a voltage test and compare the readings taken with the normal values, given below:

From	To	DC Volts
pin 6	chassis	0
pin 4	chassis	approx. 20
pin 5	chassis	approx. 30

Make an operation test by touching the free end of C7 or the grid-terminal of the tube socket with the finger or with the tip of a screwdriver blade; a fairly loud hum or buzz should be heard.

e) *Detector Circuit.* See Figure 8-8.

Of all the tube electrodes, only the diode plate is shown in the illustration. The others were either wired as

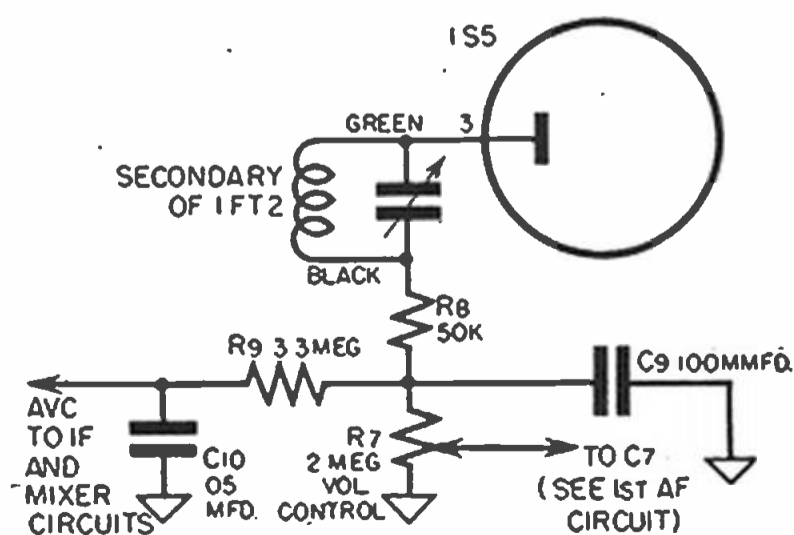

Fig. 8-8. Detector circuit.

part of the previous circuit or are connected inside of the tube.

Start wiring by connecting the green wire of the second i.f. transformer to the diode plate, pin 3 of the tube socket. Now connect the black i.f. transformer wire to one end of R8. R8 should be supported by a tie strip. The remaining end of R8 is connected to the high side of the volume control. As you face the shaft end of the control with the terminal lugs pointing downward, the high terminal is farthest to the right. The opposite terminal of the control (the lug at the extreme left) is connected to chassis. From the junction of R7 and R8, connect C9 to chassis. To the same junction point connect one end of R9, the AVC filter resistor. From the free end of R9, connect C10 to chassis; make sure the chassis connection is the outside foil of the condenser.

Incidentally, the junction of three

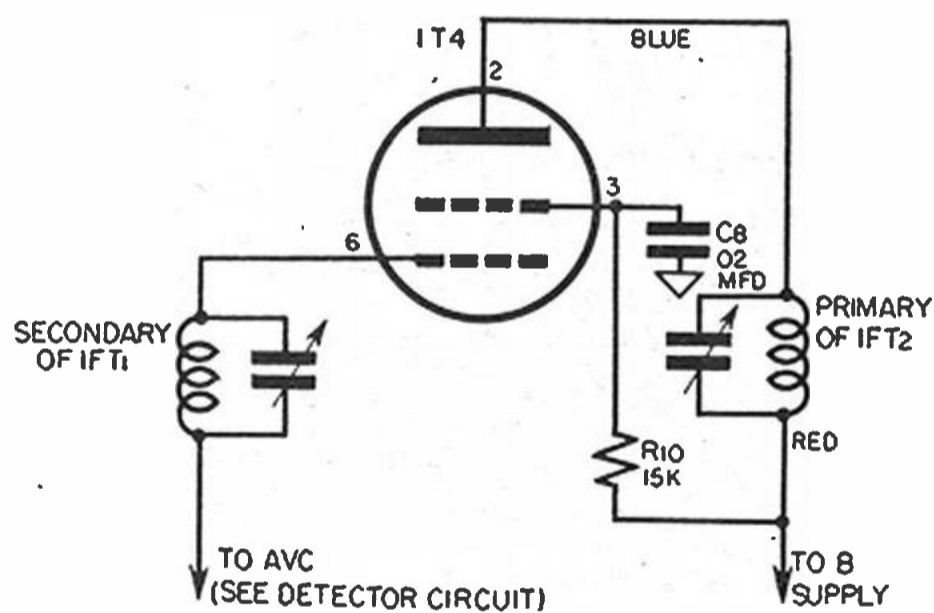

Fig. 8-9. I. F. amplifier circuit.

resistors and a condenser in this circuit offers an excellent argument for the use of tie strips to support small parts. It is obvious that without such support the wiring of this part of the circuit would be rather messy.

The free end of condenser C7 (left unconnected when the first audio circuit was wired) may now be connected to the movable contact of the volume control. This is the center of the three terminals. The junction of R9 and C10 is the AVC supply point for

the i.f. amplifier and mixer circuits; these connections will be made later. The wiring of the detector is now complete.

If you wish to make a resistance check of the stage, use a high-range ohmmeter, measuring between the points listed and comparing your readings with the normal values:

From	To	Ohms
pin 3	chassis	approx. 2 megohm
pin 3	junction of R7, R8, R9, C9	50K
pin 3	AVC point	approx. 3.3 megohm

As no DC voltage is applied to the diode plate, a voltage check cannot be made and an operation test is impracticable without a signal generator. If you have a generator, connect the output cable to the red and the blue wires of the second i.f. transformer. Adjust the generator to deliver a 455-kilocycle modulated signal. When you hear a signal, turn the generator output control down so that the signal is barely audible. If you do not hear a signal immediately, turn the generator tuning control back and forth slowly until it is heard. The signal should be audible but in most cases will be rather weak.

f) *I.F. Amplifier Circuit.* See Figure 8-9.

The suppressor grid and the filament have been omitted from the diagram for the sake of clarity and in accordance with the practice adopted on other circuits.

Connect the plate (blue) wire of the second i.f. transformer to the plate terminal of the tube socket. Then connect the red transformer wire to B plus on the B switch, SW2. Next, one end of R10 may be connected to the screen terminal of the tube socket, but remember to add one wire of C8 to this point before soldering. The

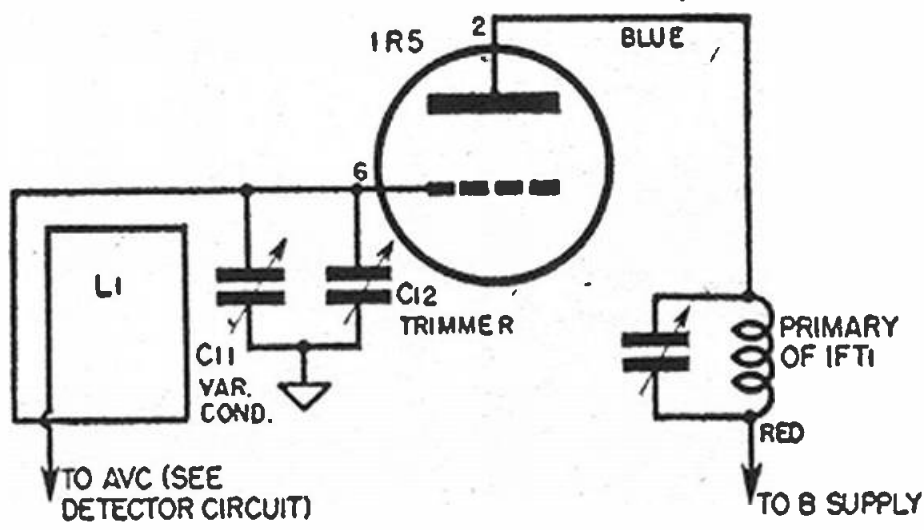

Fig. 8-10. Mixer circuit.

other end of C8 is connected to chassis. The lower end of R10 and the red (B plus) wire of the i.f. transformer are now connected to B plus (see B-supply diagram, Figure 8-5).

Connect the green wire of the first i.f. transformer to the grid terminal of the tube socket. Complete the wiring by connecting the black, or grid return, wire of the i.f. transformer to the AVC point, located at the junction point of resistor R9 and condenser C10 (see detector circuit, Figure 8-8).

Normal resistance readings for the i.f. amplifier circuit, as well as the test points to be used are listed below:

From	To	Ohms
pin 2	chassis	over 100K
pin 2	B plus	approx. 50
pin 3	chassis	over 115K
pin 3	B plus	15K
pin 6	chassis	5.3 megohm
pin 6	AVC	approx. 50

Make a voltage test in the usual way, measuring from the tube socket terminals to chassis. Expect to get the following readings:

From	To	DC Volts
pin 2	chassis	approx. 50
pin 3	chassis	approx. 55

If you have a signal generator and wish to make an operation test, proceed as follows: Connect the generator cable to the plate and B-plus wires (or terminals) of the first i.f. transformer. Adjust the generator to de-

liver a 455-kilocycle modulated signal. Advance the generator output control to the full on position. If you do not hear the signal at once, turn the generator tuning dial slightly to either side of the 455-kilocycle position.

g) *Mixer Circuit.* See Figure 8-10.

The only tube electrodes in this diagram are the signal input grid and the plate. All others have been connected in previous wiring operations or are connected inside the tube.

Connect one wire of the loop antenna to the stator terminal of the tuning condenser. The larger section of the condenser is the one used for this circuit; the smaller section belongs to the oscillator circuit. For information on identifying the loop-antenna wires, refer to Figures 2-17A and 2-17B in Chapter 2. With the loop antenna connected to the tuning condenser, run another wire from the stator of the condenser to the grid terminal of the tube socket (pin 6). Each of the two condenser sections will, in all probability, have two stator terminal lugs, one on each side of the stator plates. Either one may be used for connecting both wires, or one wire may be connected to one lug and the remaining wire to the lug on the opposite side of the stator. Convenience in wiring will indicate the proper procedure. The chassis connection shown in the diagram need not be made, as the frame of the condenser is mounted on the

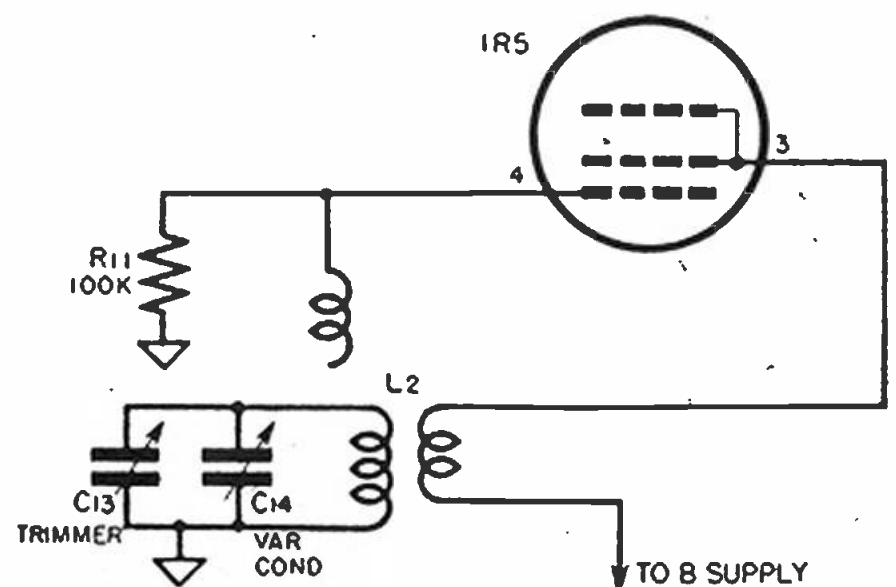

Fig. 8-11. Oscillator circuit.

chassis. And the connections to the trimmer condenser have also been made, as the trimmer is a part of the tuning condenser. The grid portion of this circuit is completed by connecting the remaining loop-antenna wire to AVC. If your loop antenna has a primary winding intended for use with an external antenna, connect one of the primary wires to chassis through a .01 condenser.

To complete the mixer circuit wiring, connect the plate wire or terminal of the first i.f. transformer to the plate terminal of the tube socket and the B-plus wire to the B-plus terminal, located on SW2.

You may expect to get the following resistance readings when you check this stage:

<i>From</i>	<i>To</i>	<i>Ohms</i>
pin 6	chassis	5.3 megohm
pin 6	AVC	approx. 1
pin 2	chassis	over 100K
pin 2	B plus	approx. 50

Normal DC voltage readings are:

<i>From</i>	<i>To</i>	<i>DC Volts</i>
pin 2	chassis	approx. 55

h) Oscillator Circuit. See Figure 8-11.

Only the screen and the oscillator grid electrodes are shown in the diagram. Connect the "gimmick" terminal of the oscillator coil to the oscillator grid (pin 4). To identify the oscillator-coil terminals, refer to the instruction sheet that came with the coil: there is considerable variation in the terminal arrangements used by different manufacturers. If you do not have a coil diagram or instruction sheet, the correct terminal may be located by checking continuity with an ohmmeter. The terminal showing no reading to any of the other lugs is the "gimmick" terminal. From the oscillator-grid terminal, connect R11 to chassis.

Now connect one end of the oscil-

lator-coil plate winding to the screen-terminal of the tube socket (pin 3). The other end of the plate winding is connected to B plus.

In wiring the oscillator secondary, it is only necessary to run a wire from the stator terminal of the tuning condenser (the smaller of the two sections is used here) to one terminal of the coil secondary and to ground the remaining terminal to chassis. No wire connections to the tuning condenser rotor or the trimmer condenser are needed.

Compare the resistance readings you get with the normal values listed here:

<i>From</i>	<i>To</i>	<i>Ohms</i>
pin 3	chassis	over 100K
pin 3	chassis	approx. 2
pin 4	B plus	100K

Voltage and operation tests cannot be made on this stage with the instruments the average constructor is likely to have.

Alignment

1) Connect the inner wire of the signal-generator cable to pin 6 of the converter-tube socket, with a .001 condenser in series. The cable shield is connected to chassis. Adjust the generator to deliver a 455-kilocycle modulated signal. The receiver volume control should be turned full on and allowed to remain in that position during the entire alignment process. Adjust the generator output control so that the signal is barely audible. Adjust the i.f. trimmer condensers to give maximum output. As each adjustment increases the volume, readjust the generator output control to maintain the signal at a low level. Do not reduce output by operating the receiver volume control.

2) Disconnect the signal-generator cable from the set. If the loop antenna has a primary winding, connect the generator leads to the ends of that winding. If there is no primary,

make up a coil of three turns of wire; the coil should be about as large as the loop. Connect the ends of this coil to the generator leads and place the coil close to the loop antenna.

3) Adjust the generator to deliver a 1620-kilocycle modulated signal. Tune the receiver to the same frequency as the generator. Now adjust the oscillator trimmer condenser to give maximum output. If the signal becomes too loud during the adjust-

ment, reduce it by means of the generator output control. Remember, if you are careful to keep the signal no louder than necessary the alignment will be more accurate.

4) Readjust the generator to 1400 kilocycles and retune the receiver to that frequency. Adjust the antenna trimmer for maximum response, as outlined in the previous paragraphs. This completes the alignment.

BATTERY-OPERATED SHORT-WAVE RECEIVER

This three-tube battery-operated short-wave receiver consists of an r.f. amplifier, regenerative detector, and output stage. It is intended primarily for use on the 10-, 20-, 40-, and 80-meter amateur bands, although with additional coils the set can be made to tune over a range extending from about 30 megacycles to 4 megacycles.

Referring to the complete circuit diagram, Figure 8-12, observe that a 1U4 tube is used in the tuned r.f. stage. Grid bias—and consequently the sensitivity of the stage—is controlled by the 50,000-ohm potentiometer, R6. Notice that the .05-microfarad condenser, C12, is used to isolate the lower end of the antenna-coil secondary from chassis so that the variable grid bias may be applied. As mentioned earlier in this chapter, special arrangements such as this have to be made in order to obtain bias on the filament type of tubes.

The r.f. coil consists of three windings: L6, L7, and L8. L6 and L7 are the usual primary and secondary windings, respectively. L8 is a tickler winding and is used to effect regeneration. In this process, a portion of the signal appearing in the plate circuit of the detector tube is induced, by the primary, in the secondary, L7. The feedback produced reinforces the original signal and the sensitivity of the circuit is greatly increased—one reason why a first audio stage is not

used. The tickler winding has a sufficient number of turns to carry the regenerative process to the point where the tube will oscillate. However, when receiving radio-telephone signals, the most desirable operating point is just below the point of oscillation, so some method of control must be added. Control of regeneration is effected by varying the screen voltage applied to the tube. This is accomplished by the potentiometer, R4. With R3 in series, it is connected across the B supply.

The method of transferring signals from the detector to the output stage differs from that in ordinary broadcast receivers. It is commonly referred to as impedance coupling. In the plate circuit of the detector, where we would expect to find a resistor, there is, instead, the audio choke, L2. The output-stage grid resistor is the volume control, R1. Coupling between stages is effected by means of the condenser, C3.

The coils used in this receiver are of the plug-in type and are inserted into ordinary tube sockets. You may wind them on factory-made forms or on forms you build yourself. Instructions for making your own forms and for winding the coils is given below.

The set may be constructed on a chassis measuring 5 by 8 by 1-1/2 inches, provided a speaker no larger than four inches in diameter is used.

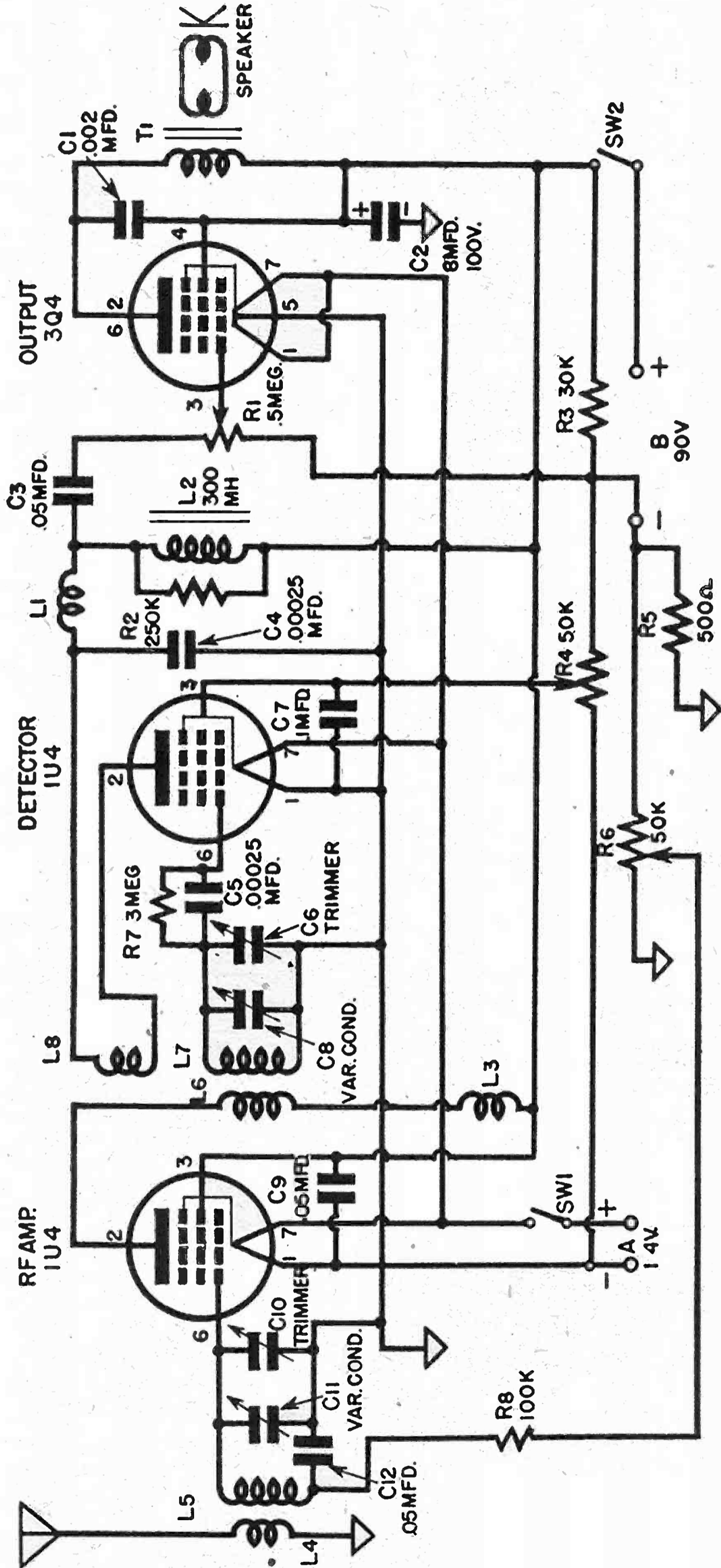

Fig. 8-12. Schematic diagram of a short wave receiver.

A 3-inch speaker is shown in the assembly drawing, Figure 8-13. As all power is derived from a 1.4-volt A battery and a 90-volt B battery, the receiver is adapted to portable use.

Coil construction

If you prefer to use commercially-made coil forms, you have a choice of two types. One consists of a ribbed bakelite tube with a standard four-, five-, or six-pin tube base at its lower end. The ribbed construction is used to keep the windings away from the form as much as possible. The second consists of a polystyrene tube with the same kind of plug-in base. As polystyrene is considered a low-loss material, there is no need for the ribbed construction.

All coil forms must be 1-1/4 inches

If polystyrene tubing of that diameter is available in your particular area, its use is recommended. In making up your own forms, whether of bakelite or polystyrene, take into account that the outside diameter of the tubing is slightly larger than for the commercial form and the winding must therefore have fewer turns. The difference will have to be determined by experiment. Wind each coil with the number of turns specified in the table below, then remove turns as required to adjust it to the band limits.

To make a set of coils for one band you will need: one four-pin tube base, one six-pin tube base, and two 2-1/4-inch lengths of the 1-1/2-inch-diameter tubing. Bases can be removed from tubes without damage if

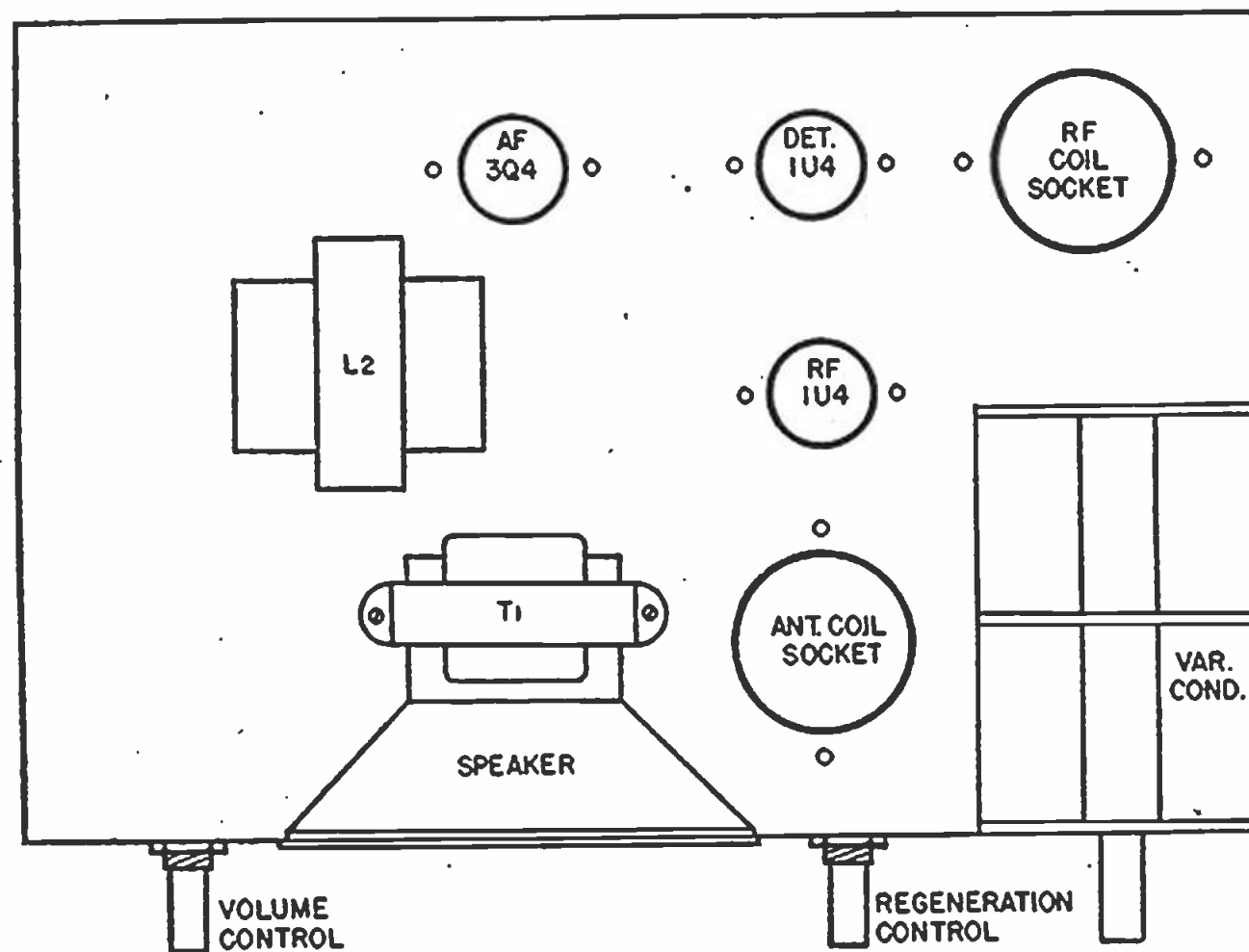

Fig. 8-13. Top view of short wave receiver chassis.

in diameter if the windings are to be as specified. Factory-made forms of both types are readily available, make a neat job, and are inexpensive. You will need one four-pin and one six-pin form for each of the bands to be covered, or a total of eight forms.

You may make your own forms, using bases removed from defective tubes and 1-1/2-inch-outside-diameter bakelite (or other plastic) tubing.

a little care is used. Wrap the tube in a number of layers of cloth or heavy paper and strike it with a hammer. Most all the glass will be broken from the base, and whatever remains can be removed by crushing it with pliers. Scrape away all the cement from the inside of the tube base with a knife. To remove the lead wires from the base prongs, hold each with a pair of long-nose pliers and place

the end of the prong against the tip of a soldering iron. As soon as the solder melts, pull the wire out. To clean all remnants of solder from the prong, reheat it and, while the solder is still soft, tap the base smartly on the workbench or table top.

The method of fastening the tubing to the base is illustrated in Figure 8-14A. Slip the tube over the base, then drill three 1/16-inch holes through both tubing and base. The holes should be equally spaced around the tubing. Remove the form from the tube base, coat the outside of the tube base with household cement, and replace the form, making sure that the holes in the form and the base are aligned properly. Drive short lengths of 1/16-inch dowel into the holes and cut them flush with the surface of

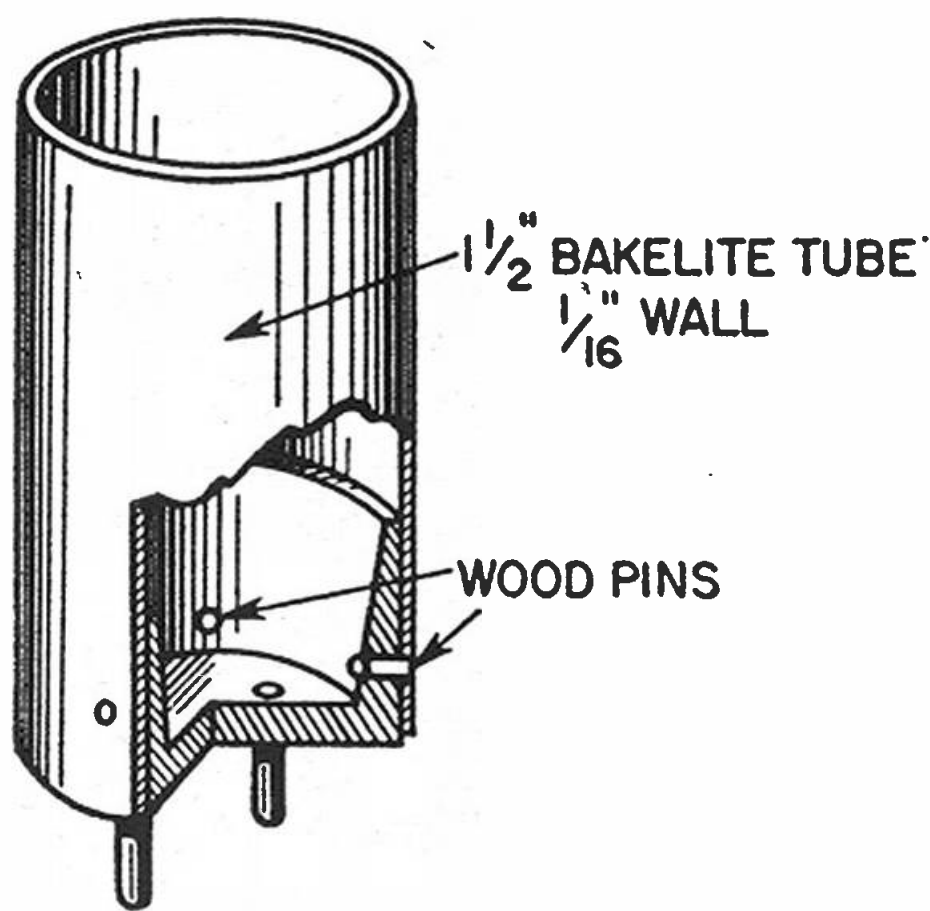

Fig. 8-14A. Coil form.

the tubing.

Wind the coils by using the data given in the table below. When you wind the antenna coil, the primary should be at the lower end of the form and the secondary above it. For the r.f. coil, wind the primary at the lower end of the form, the secondary next, and the tickler at the top. Space all windings 1/8-inch apart. Spacing can be increased later if you find the coupling is too great. Use #22 double-

cotton-covered magnet wire for all coils.

Coil-winding table

80 meters

L4	7 turns, close-wound
L5	42 turns, close-wound
L6	7 turns, close-wound
L7	42 turns, close-wound
L8	12 turns, close-wound

40 meters

L4	6 turns, close-wound
L5	21 turns, spaced to occupy a length of 1-1/2 inches
L6	6 turns, close-wound
L7	21 turns, spaced to occupy a length of 1-1/2 inches
L8	8 turns, close-wound

20 meters

L4	4 turns, close-wound
L5	11 turns, spaced to occupy a length of 1-1/4 inches
L6	4 turns, close-wound
L7	11 turns, spaced to occupy a length of 1-1/4 inches
L8	6 turns, close-wound

10 meters

L4	3 turns, close-wound
L5	6 turns, spaced to occupy a length of 1 inch
L6	3 turns, close-wound
L7	6 turns, spaced to occupy a length of 1 inch
L8	5 turns, close-wound

We shall take the antenna coil as an example of the method used in winding the coils and connecting the ends to the tube-base prongs, and we shall assume that the 80-meter coil is under construction.

Drill a small hole (use a #60 drill) through the form and base at a distance of 1/2 inch from the lower end of the form. Pass the wire through the hole and down inside the #4 pin of the tube base. Solder the wire in place and wind on seven turns of wire. This is the primary, L4, and it is to be close-wound; the turns must lie side by side, each as even and as close as possible to the one next to it. When seven turns have been completed,

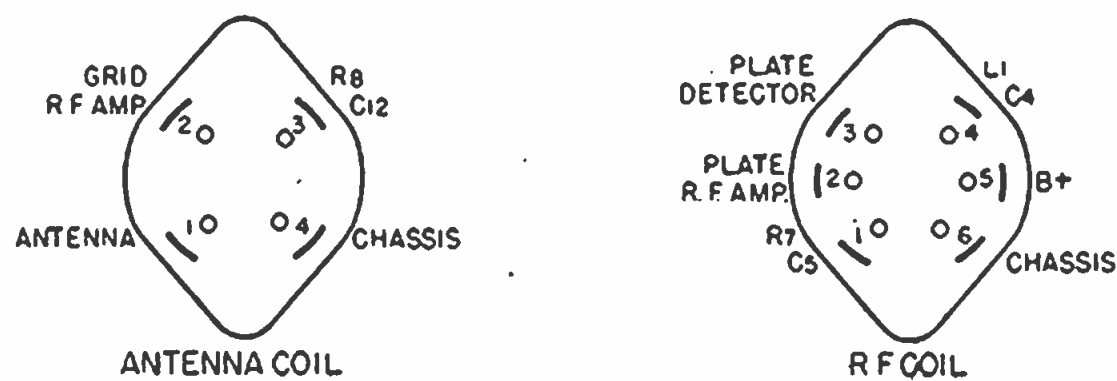

Fig. 8-14B. Bottom view of coil sockets.

hold the wire in place on the form with a bit of cellulose tape while you drill another hole close to the end of the winding. Cut the wire long enough to reach to the base pin. Pass the end through the hole just drilled and down inside the #1 base pin. Solder in place. This completes the primary winding.

Drill another hole in the form 1/8 inch above the primary winding. Slip the wire through and into the #2 base prong, where it is to be soldered in place. Start winding the secondary in the same direction as the primary. When 42 turns, also close-wound, have been completed temporarily anchor the wire in place while you drill another hole. Pass the end of the wire through it and into the #3 base pin. Solder the wire in place.

All antenna coils are wound in exactly the same manner, although the secondaries of the 40-, 20-, and 10-meter coils must be spaced to occupy the prescribed length. An easy way to do this is to wind the specified number of turns on the form experimentally, and cut the wire to a length somewhat greater than necessary to allow for the end connections. Then solder one end to its base pin and start the actual winding, spacing as you wind. You will find that the turns can be shifted to some extent, so the proper spacing will result after one or two trials.

Here are the directions for winding the r.f. coils:

1) All windings must be made in the same direction. Whether the direction is clockwise or counter-clock-

wise makes no difference. The important point is that primary, secondary, and tickler on any one coil must be wound in the same direction and the ends of each winding must be connected to the base pins exactly as specified.

2) Start the primaries about 1/2 inch from the bottom of the forms. Connect the start of the primary winding to base pin #2 and the end to base pin #5.

3) Start the secondary winding 1/8 inch above the primary. Connect the start of the secondary winding to base pin #6 and the end to base pin #1.

4) Allow 1/8-inch space between the end of the secondary and the start of the tickler winding. Connect the beginning of the tickler winding to base pin #3 and the end to pin #4.

Additional information on the coils and the manner of connecting the ends of the windings to the base pins is given in Figure 8-14B, a bottom view of the coil sockets. In this drawing, the socket terminals are not only numbered but are marked with the points in the circuit to which they are to be connected. When looking at these sketches, imagine that you are looking at the bottom of the coil form instead of the socket, which after all

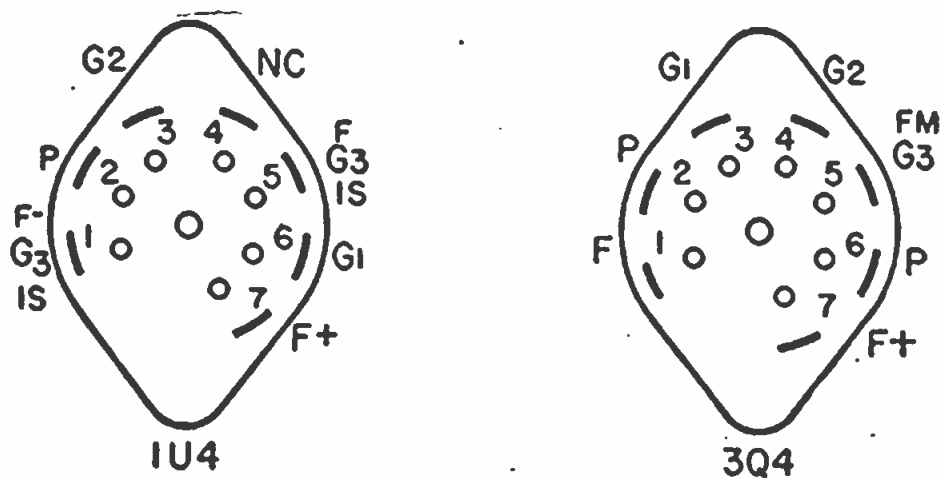

Fig. 8-15. Detail of coil sockets.

amounts to the same thing. In the drawing of the antenna-coil socket, for instance, you will note that the #1 pin is marked "antenna" and the #4 pin is marked "chassis." These are the terminals of the primary winding. Similarly, the #2 pin is labeled "grid of r.f. amplifier" and the #3 pin is marked "R8-C12." We know that the secondary winding is connected to the grid of the r.f. tube and that the lower end of the secondary winding is connected to the junction of R8 and C12. These are the secondary terminals. By referring to the wiring diagram, the coil-winding instructions, and Figure 8-14B from time to time, you will have no difficulty in constructing the set of coils and in correctly wiring the coil sockets.

Parts list

Resistors

- R1 500K ohms, volume control with two single-pole single-throw switches, SW1 and SW2
 R2 250K ohms, 1/2-watt carbon
 R3 30K ohms, 1/2-watt carbon
 R4 50K ohms, regeneration control
 R5 500 ohms, 1/2-watt carbon
 R6 50K ohms, bias control
 R7 3 megohms, 1/2-watt carbon
 R8 100K ohms, 1/2-watt carbon

Condensers

- C1 .002 mfd., 400-volt paper tubular
 C2 8 mfd., 100-volt electrolytic, tubular cartridge
 C3 .05 mfd., 400-volt, paper tubular
 C4 .00025 mfd., 400-volt mica
 C5 .00025 mfd., 400-volt mica
 C6 2-30 mmfd., ceramic trimmer
 C7 .1 mfd., 400-volt paper tubular
 C8 Midget dual 50-mmfd. variable condenser (with C11)
 C9 .05 mfd., 400-volt paper tubular

- C10 2-30 mmfd., ceramic trimmer
 C11 (with C8)
 C12 .05 mfd., 400-volt paper tubular

Coils

- L1 8 millihenry r.f. choke
 L2 300 millihenry audio choke
 L3 8 millihenry r.f. choke
 L4 Antenna coil (see text)
 L5 Antenna coil (see text)
 L6 R.F. coil (see text)
 L7 R.F. coil (see text)
 L8 R.F. coil (see text)

Transformer

- T1 Output transformer, midget type, 9,000-ohm primary impedance, 3.5-ohm secondary impedance

Speaker

- 3-inch PM dynamic, 3.5-ohm voice-coil impedance

Miscellaneous

- Chassis: 5 x 8 x 1-1/2 inches, steel or aluminum
 3 miniature 7-pin sockets
 4-pin tube socket
 6-pin tube socket
 8 1-1/4-inch-diameter plug-in coil forms, or home-made forms
 100 feet (approx.) #22 double-cotton-covered magnet wire
 3-point tie strips
 Push-back wire
 Rosin-core solder
 Hardware

Tubes

- 1U4 r.f., 1U4 detector, 3Q4

Layout and assembly

For a top view of the chassis showing all major parts, refer to Figure 8-13. Dual variable condenser, speaker, coil sockets, and tube sockets are all mounted on top of the chassis. The three controls, R1, R4, and R6, are mounted on the front apron of the chassis. R6 is not visible in the drawing because it is mounted immediately below the variable condenser.

The dual variable condenser is mounted at the front right corner of

the chassis. The fastening of the condenser will be governed by the construction of the particular type you buy. Some condensers may be mounted directly on the top surface of the chassis while others are intended primarily for panel mounting, in which case a special arrangement may have to be worked out.

The speaker is located at the center of the chassis and may be fastened to the front apron. You may have to drill two or more holes in the speaker flange for this purpose. The output transformer is located on top of the speaker magnet frame. If the transformer you buy (or have on hand) is too large for this method of mounting, you will find ample space for it on the chassis to the left of the speaker.

Lay out a center line one inch from the rear edge of the chassis. Along this center line locate the r.f. coil socket, 1U4 socket, and 3Q4 socket.

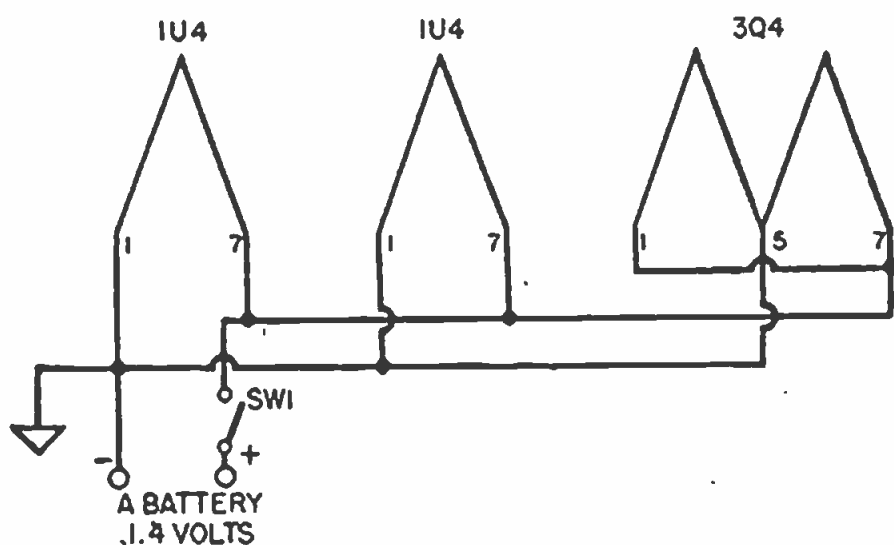

Fig. 8-16. Filament circuit.

Starting at the right end of the chassis and measuring along the center line, lay off a distance of one inch. This marks the center of the r.f. coil socket. To the left of this mark lay off a distance of 1-3/4 inches; the 1U4 detector socket will be located at this point. Another center mark at a distance of 1-3/4 inches to the left of the 1U4 socket marks the position of the 3Q4 tube socket.

Another center line, for the r.f. tube socket and the antenna-coil socket, may now be drawn parallel to the right edge of the chassis and ap-

proximately 2-1/2 inches to the left of it. Starting from the front of the chassis, lay off a distance of 1-1/4 inches; this is the center point of the antenna-coil socket. The center of the r.f. tube socket is located 1-1/2 inches to the rear of the coil socket.

On the front apron of the chassis draw a center line 3/4 inch from the chassis top. From the left side of the chassis measure a distance of 1-1/4 inches along this line and mark the center of the volume-control shaft. Measure 4-1/4 inches to the right of this mark to locate the position of the regeneration-control shaft. The bias control is located 1-1/4 inches from the right side of the chassis along the center line previously established.

Punch-mark all centers, then lay out the positions of the tube socket mounting screws. This may be done by laying the socket face down on the chassis and aligning it so that the center of the socket coincides with the punch mark, then marking the socket mounting holes with pencil.

Drill the screw holes for the tube sockets with a #31 drill. For the coil-socket mounting holes and all other holes use a #25 drill. Enlarge the holes for the control shafts to 3/8 inch with a drill or a reamer. Cut the tube-socket and coil-socket holes with chassis punches, using a 5/8-inch-diameter punch for the tube sockets and a 1-1/16-inch-punch for the coil sockets. When all major parts are in place you are ready to begin wiring.

Wiring

a) *Filament Circuit.* See Figure 8-16.

Notice that the 3Q4 tube has a center-tapped filament. If we were to connect pins 1 and 7 to the A battery, the two sections of the filament would be in series and would require 2.8 volts at 50 milliamperes. In some sets the filament terminals are so connected, but in this set we want all the tubes to operate at a filament voltage of 1.4. Therefore, connect the two

sections of the filament in parallel. The requirements are now 1.4 volts at 100 milliamperes, arrived at by connecting a jumper wire between socket terminals 1 and 7, and then connecting terminals 5 and 7 to the A battery. A bottom view of the tube sockets is shown in Figure 8-14A.

Wire the filaments in parallel by first connecting the #7 terminals of all sockets together. Run a wire from the #7 terminal of any one of the tube sockets to one contact on the A battery switch (SW1 in the diagram). To the remaining contact of SW1, connect the positive A-battery wire. This wire should be brought out through the rear apron of the chassis and anchored to prevent strain on any of the socket terminals.

Now connect the following socket terminals together: terminal 1 of the 1U4 r.f., terminal 1 of the 1U4 detector, and terminal 5 of the 3Q4 output. Connect the negative A-battery wire to any one of these three terminals, observing the precaution, mentioned above, to anchor the battery wire. Ground any one of the three socket terminals to chassis.

With the A battery connected and the tubes in their sockets, turn the switch on and note whether the tube filaments glow. If you care to make a voltage test, use a DC meter with a 5-volt range and check from the positive terminal of each filament to chassis. The normal reading is 1.4 volts.

b) *B Supply Circuit.* See Figure 8-17.

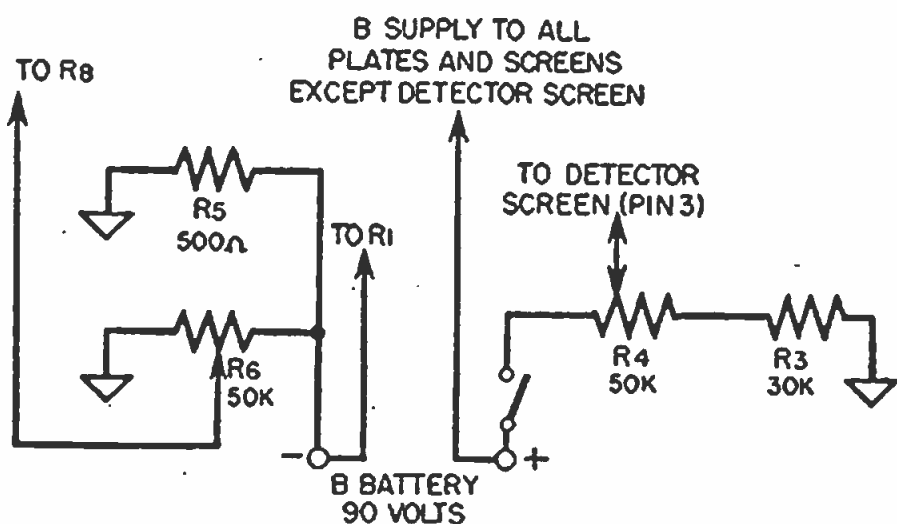

Fig. 8-17. B. supply circuit.

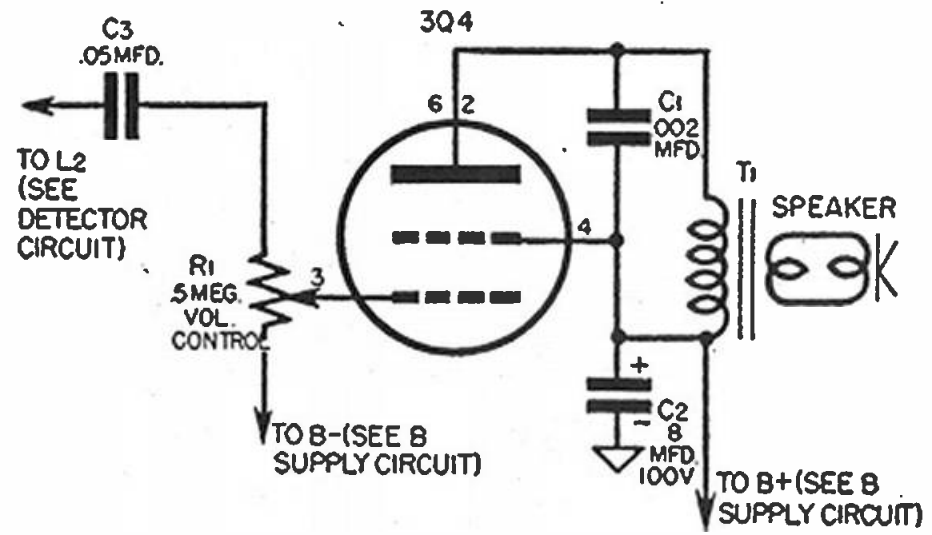

Fig. 8-18. Output circuit.

It is a good idea to use a double tie strip as a connection point for the B-plus and B-minus battery wires.

Connect resistor R5 from the B-minus terminal to chassis. From the same terminal, connect potentiometer R6 to chassis. To insure proper rotation of R6, look at it from the shaft end with the terminal lugs pointing downward; the terminal at your right is connected to B minus, the one at the left to chassis, and the center terminal will be wired to R8 later on. A connection will also be added to the B-minus terminal during a later stage of the wiring.

Connect the right-hand terminal of potentiometer R4 to one end of R3. Ground the other end of R3 to chassis. Run a wire from the left-hand terminal of R4 to one terminal lug of SW2, the B-battery switch. Connect the positive B-battery wire to the other terminal of SW2. As you will observe in the sketch, other wires will be added to the B-plus terminal later, and another connection will be made at the center terminal of R4.

c) *Output Circuit.* See Figure 8-18.

Connect the left-hand terminal of the volume control (as you face the shaft end of the control) to the B-minus terminal (see B-supply diagram, Figure 8-17). Connect one end of the coupling condenser, C3, to the high side of the control (the terminal at the extreme right). The grid terminal of the tube socket is now connected to the center terminal of R1. The blue wire (or plate terminal)

of the output transformer primary is now connected to either pin 2 or pin 6 of the tube socket. The opposite end of the primary winding can next be connected to B plus. Connect C1 between socket terminal 2 (or 6) and chassis. Connect the positive terminal of C2 to socket terminal 4; from this terminal run a wire to B plus and ground the negative terminal of C2. Complete the output-stage wiring by connecting the secondary wires of the output transformer to the voice-coil terminals of the speaker.

To make a resistance check of this circuit, measure values from the tube-socket terminals to chassis, B minus, or B plus, as indicated below:

From	To	Ohms
pin 3	B minus	500K
pin 3	chassis	500K
pin 4	chassis	over 100K
pin 4	B plus	0
pin 2 (or 6)	chassis	over 100K
pin 2 (or 6)	B plus	200

A voltage check from plate and screen to chassis should show values substantially the same as those given below:

From	To	DC Volts
pin 2 (or 6)	chassis	80
pin 4	chassis	85

An operation test can be made on this stage. With the tube in its socket, A and B batteries connected, and the switch turned on, advance the volume control to the full on position and touch the grid (pin 3) with the finger or the tip of a screwdriver. This will result in a hum or buzz in the speaker if the stage is working properly.

d) *Detector Circuit.* Refer to Figure 8-19.

The r.f. choke, L1, and condenser C4 are best mounted on a tie strip. Connect one end of L1 to one end of C4. Run a wire from their common point to pin 4 of the r.f. coil socket. From pin 3 of the r.f. coil socket run

a wire to the tube-socket terminal 2. Connect the free end of C4 to chassis and the free end of L1 to one terminal of L2, the audio choke. If L2 is provided with terminal lugs, one of these may be used as a convenient junction point. The opposite end of L2 may now be connected to B plus (refer to the B-supply diagram, Figure 8-17, when making this connection).

Next, run a wire from the screen terminal of the tube socket (pin 3) to R4 in the B-supply circuit. Before soldering the connection at socket terminal 3, add one end of condenser C7; connect the free end of C7 to chassis.

R7 and C5 should be mounted on a tie strip and connected in parallel. Connect one end of the parallel combination to pin 6 of the tube socket. Now connect the remaining terminal of the R7-C5 combination to pin 1 of the r.f. coil socket. To this same point connect a wire leading to the stator

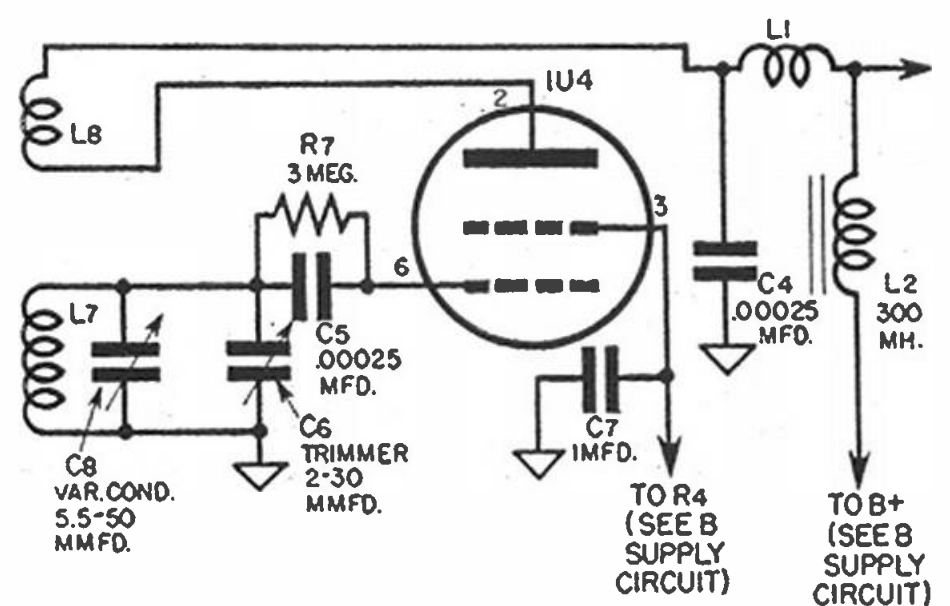

Fig. 8-19. Detector circuit.

terminal of the r.f. section of the tuning condenser. Since the two sections of the condenser are similar, either may be used in this circuit; however, be sure to select the one that will be nearer the coil socket. Terminal 6 of the r.f. coil socket may now be connected to chassis. If the tuning condenser is not fastened to the chassis, you will have to add a wire from the rotor terminal to chassis.

The trimmer condenser, C6, must now be connected in parallel with the main tuning condenser. There are

several ways of supporting the trimmer. It may be possible to mount it on the tuning-condenser frame with machine screws and nuts, or the trimmer-condenser soldering lugs may be soldered directly to the main-tuning-condenser terminals. If neither of these methods can be employed, use short lengths of heavy wire (about #14) to connect the trimmer-condenser terminals with the main-tuning-condenser terminals.

Normal resistance readings for this stage are:

From	To	Ohms
pin 6	chassis	3 megohm
pin 3	chassis	over 100K
pin 3	B plus	0
pin 2	chassis	over 100K
pin 2	B plus	approx. 100

Voltage readings:

From	To	DC Volts
pin 3	chassis	55
pin 2	chassis	52

e) R.F. Amplifier Circuit. See Figure 8-20.

Connect the #4 pin of the antenna-coil socket to chassis; this is the grounded end of the antenna primary in the diagram. The opposite end of this winding (pin 1) is connected to the antenna. Connect a short length of wire to this terminal, if you wish, and lead it out through a small hole in the rear apron of the chassis to serve as a convenient antenna connection.

Run a wire from the stator terminal of the antenna tuning condenser (C11 in the diagram) to the #3 pin of the r.f. coil socket; from this point run another wire to the #6 terminal of the tube socket. At this time you may connect the trimmer condenser, C10, in parallel with the main tuning condenser as described above in section (d) on the detector circuit. The rotor terminal of the tuning condenser and one terminal of the trimmer may now be connected to chassis (unless the tuning condenser is

mounted directly on the chassis).

The lower end of L5 (antenna-coil socket terminal #3) is not grounded directly to chassis, as in most sets, but is grounded through condenser C12. Connect one end of C12 and one end of R8 to the #3 terminal of the coil socket; the other end of C12 is then connected to chassis and the free end of R8 to R6 in the B-supply circuit.

Now run a wire from the screen terminal of the tube socket to B plus. Before soldering the screen connection, add one end of condenser C9. Connect the other end of C9 to chassis.

Connect a wire from the plate terminal of the tube socket (pin 2) to terminal 2 on the r.f. coil socket. R.F. coil socket terminal #5 may then be connected to one end of the r.f. choke, L3. The free end of L3 is next connected to B plus. This completes

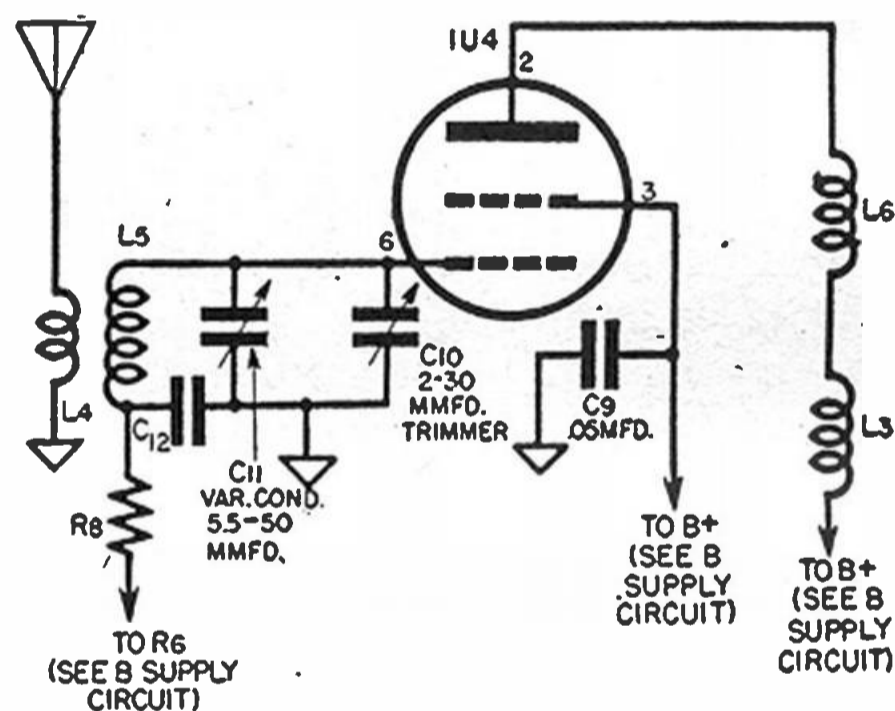

Fig. 8-20. R. F. amplifier.

the wiring of this project.

Resistance measurements on r.f. stage:

Ohms	To	From
1 megohm	R6	pin 6
over 1 megohm	chassis	pin 6
0	B plus	pin 3
over 100K	chassis	pin 3
approx. 20	B plus	pin 2
over 100K	chassis	pin 2

Voltage measurements:

From	To	DC Volts
pin 3	chassis	approx. 55
pin 2	chassis	approx. 50

SIX-TUBE AUTOMOBILE RADIO

The requirements for an auto radio are much less flexible than those for a home receiver. Suppose we consider some of them.

1) A car radio must operate from an antenna of limited size. The most popular antenna is a vertical rod mounted on the cowl of the car.

2) Because of the small antenna size, the set must have higher sensitivity than the average home set. Sensitivity is increased to the desired level by the use of an r.f. stage ahead of the mixer.

3) The set must derive both heater and plate voltages from a 6.3-volt storage battery. The heaters are therefore operated in parallel and connected directly across the battery. In fact, the development of auto receivers and tubes for them led to the standardization of types with 6.3-volt heaters. For supplying plate and screen voltages, a special power supply capable of converting 6.3 volts DC to about 200 volts DC has been developed. It is described in detail below.

4) The ordinary electrodynamic speaker, used in home receivers, cannot be employed on account of the high field resistance. The first answer to this problem was a low-resistance field winding connected directly across the car battery. A few years ago manufacturers began to use permanent-magnet dynamic speakers instead.

5) The car radio with its high sensitivity must operate under unusually severe noise conditions created by the ignition system and some of the accessories. An auto receiver must be completely shielded to prevent noise from reaching the set through the wiring or tubes, and an elaborate filtering system is used to prevent noise from entering via the battery connection. The antenna, however, remains as an entrance point, and, as nothing further can be done to the

set to eliminate noise, suppression devices are often applied to the ignition system of the car.

6) The set must be small enough to mount on the driver's side of the fire wall, either in back of, or just below, the instrument panel.

The set described here conforms to present-day practice. Following a description of the circuit layout, assembly, and wiring, a few suggestions are given for the suppression of ignition interference.

You can use a chassis measuring 6 by 10-1/2 by 1 inches mounted in a metal case just long enough and wide enough to accommodate it and about 5 inches deep. The case should have a removable top and bottom to provide access to the tubes and the parts below the chassis. It must be fitted with a partition to separate the power supply from the rest of the set. The partition should be about 3 inches from one end of the case. The partition is clearly shown in the chassis top view, Figure 8-22. Some rearrangement of parts and changes in chassis proportions may be necessary, but it should be possible to build the set to fit into a large glove compartment.

Circuit description

The complete circuit diagram is shown in Figure 8-21A. In our overall description of this project, we must give special attention to the auto-radio power supply because it is quite different from any circuit considered so far.

Figure 8-21B is a simplified diagram of part of the power supply circuit. Only the car battery, the vibrator (or interrupter), and the primary of the vibrator transformer are included as pertinent to our discussion.

To begin with, let us examine the first function of the power supply, which is to convert a direct current at

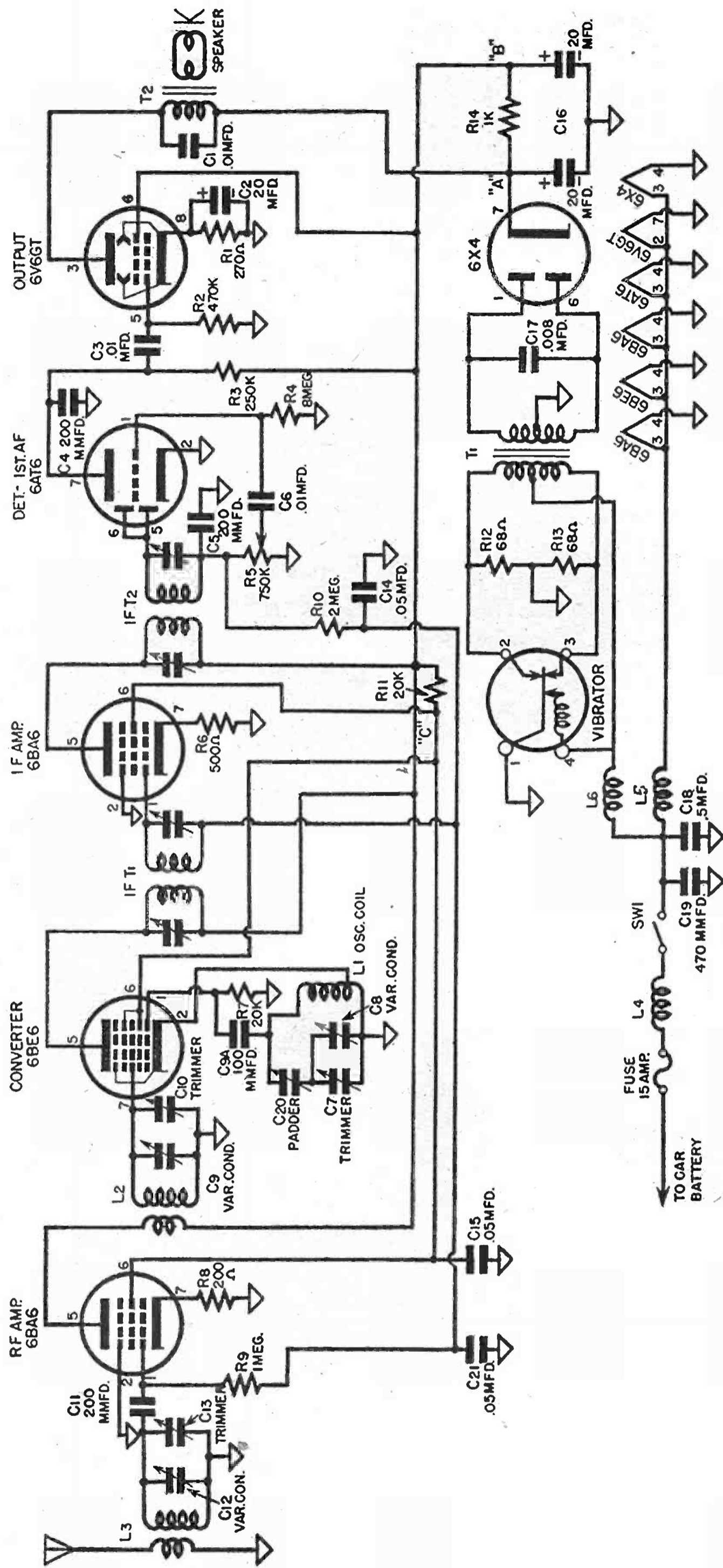

Fig. 8-21 A. Schematic diagram of an automobile receiver.

6.3 volts to an alternating current at about 220 volts. This conversion is performed by the vibrator and transformer. Afterwards the 220-volts alternating current is changed to high-voltage direct current by the rectifier tube, and finally is smoothed out by the filter circuit.

The vibrator in this project consists of a vibrating reed carrying three contact points. The points engage three fixed contacts, one of which is located above the reed, the other two below it, as shown in the illustration. Two of the fixed contacts, one above and one below the reed, are connected to the ends of the transformer primary winding. The third fixed contact is connected to one end of the small coil seen just below the reed. This coil is an electromagnet; it causes the reed to vibrate.

In Figure 8-21B the reed is shown in its normal position before the on-off switch is closed. It is resting against the lower fixed contact, which is connected to the transformer winding. When the switch is closed, current flows from the negative terminal of the car battery through the car frame to the vibrator reed. From this point the current passes through the reed and the lower fixed contact and then *upward* through the lower half of the transformer winding. Current also flows through the winding of the electromagnet, via the third fixed contact, to the positive terminal of the battery.

The magnet is thus energized, and it attracts an iron armature attached to the reed, displacing the reed from its normal position and causing it to move upward and make connection with the upper fixed contact. As the reed leaves its normal position, the connection to the lower half of the transformer winding is broken and current no longer flows through it.

With the reed in its new position, the circuit of Figure 8-21C is established. Current flows from the negative terminal of the battery through

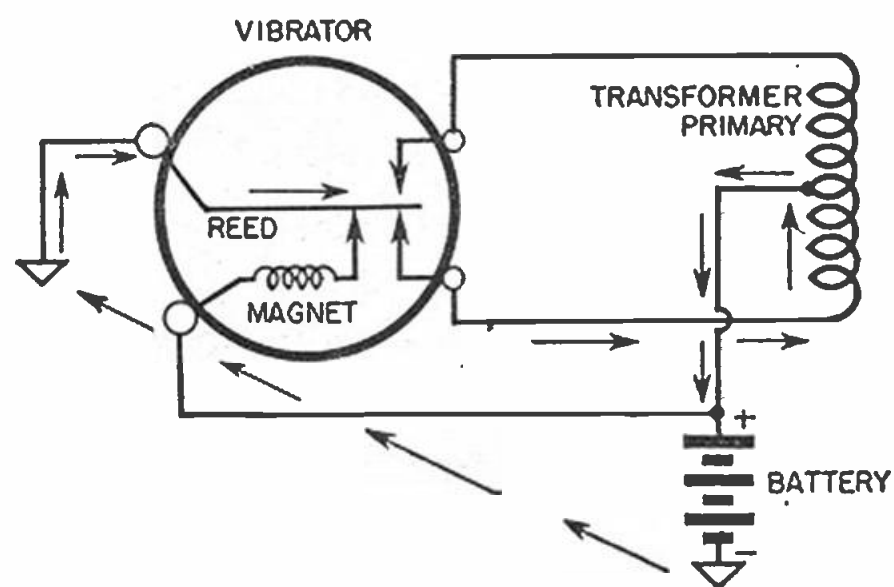

Fig. 8-21B. Vibrator circuit with reed in normal position.

the reed to the upper fixed contact and thence *downward* through the upper half of the transformer winding and back to the battery.

As soon as the reed leaves its normal position, the circuit between it and the electromagnet contact is broken and the magnet is de-energized. The reed snaps back to its original position, the circuit through the lower fixed contact is reestablished, and the cycle begins again.

As long as the switch is closed, the magnet is alternately energized and de-energized and the reed remains in motion. The important point is that the transfer of connections from the lower to the upper halves of the transformer winding causes current pulses to flow in opposing directions through the winding. And this, as we are all aware, produces an alternating current in the transformer secondary winding. Due to the step-up ratio of the windings, the voltage appearing

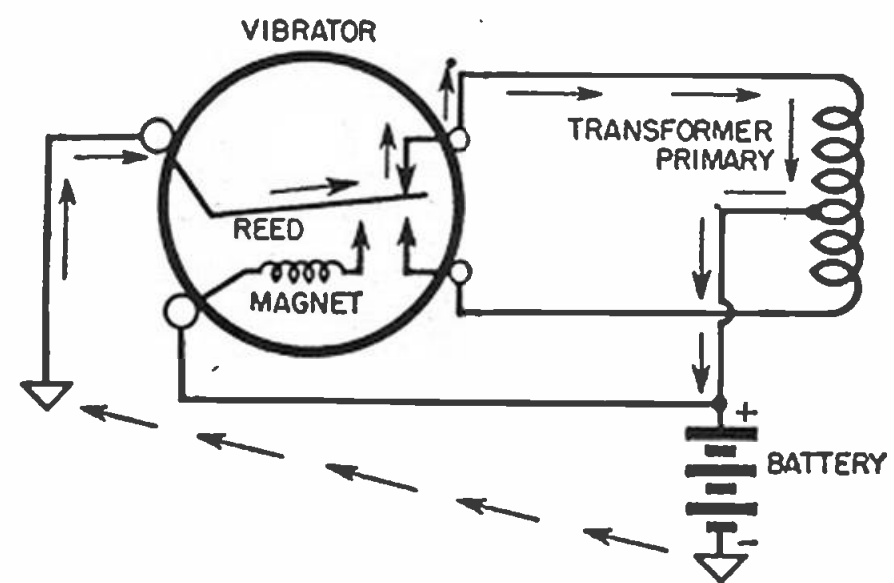

Fig. 8-21C. Vibrator circuit with reed in upper position.

at the secondary is about 215 volts from the center tap to either end of the winding. After rectification and filtering, we have a direct current at something over 200 volts.

Before leaving the power supply, it is worth mentioning that the voltage developed in the transformer windings does not change direction at the usual rate of 60 cycles per second but at 115 cycles. The vibrator reed operates at that particular frequency. For other applications, vibrators are made to function at 60 cycles per second. This type is used principally as an inverter for operating phonographs, radio and television receivers, electric shavers, and other appliances from a DC line. Because the operating frequency of the auto-radio vibrator is higher than usual, the power transformer may be designed with less iron in the core, which gives us a smaller unit.

The r.f. amplifier circuit in this set is conventional and uses a 6BA6 miniature tube. The amplified signals are passed on to the grid of the 6BE6 converter tube. The mixer circuit, too, is no different from that used in home receivers, but the oscillator circuit differs in several ways. Although the oscillator coil is the ordinary tapped variety found in many home-radio sets, notice that the condenser C20 is connected in series with the oscillator tuning condenser. C20 is the padding condenser, or padder. Resembling a trimmer, although with a higher capacitance than the average trimmer, it is variable between a minimum of 70 and a maximum of 480 micro-microfarads. Also note that all three of the variable condenser sections have the same capacitance—365 micro-microfarads. In all previous projects the oscillator section of the tuning condenser had a capacitance about half that of the other sections. When the padder is in series with the main tuning condenser, the total capacitance is reduced to a value lower than

that of either unit, and if the two are equal, then the total capacitance will be exactly half that of either unit. The important point is that the padder is adjustable and therefore the operating frequency of the oscillator may be adjusted, especially at the low-frequency end of the range.

The r.f. amplifier, detector, first audio, and output circuits resemble those used in an AC home receiver. A 6BA6 tube is used in the i.f. stage, a 6AT6 in the detector-first-audio, and a 6V6GT in the output. AVC voltage developed across R5 is applied to the grids of the r.f. and i.f. stages. To permit the application of AVC to the r.f. amplifier, its control grid must be isolated from the chassis—the reason why condenser C11 is used.

Although the speaker is shown in the complete circuit diagram, none is shown in the chassis layout drawing, as you probably observed. Space limitations will generally require you to mount the speaker elsewhere than on the set. But this is no particular problem. It can be located on the dash or on the package shelf at the rear of the car easily enough. Any PM speaker having a voice-coil impedance of 3.5 ohms is suitable.

Now look at condenser C17 in the power supply circuit. It is known as a buffer condenser and must be a high-quality component rated at 1600 volts.

Included in the heater and power supply circuits are the condensers C18 and C19 and the chokes L4, L5, and L6. Their function is to block ignition interference created by the make and break of the vibrator contacts (vibrator "hash") from moving into other parts of the set. The condensers are ordinary, commercially available units of the proper values, but the chokes cannot be bought in radio supply stores. They can be ordered from the distributor of any nationally-known auto receiver, but it is better to make them yourself. Heavy wire—#16 enameled will do—must be

used to carry the heavy current; the heavy wire will also make the chokes self-supporting.

You have a choice between two methods of winding. In the first method, a helical coil is wound on a cylindrical form 1/2 to 5/8 inches in diameter. A dowel will do as the winding form. Wind on about 15 to 20 turns (close wound), remove the form, and mount the choke on a terminal strip or in any other convenient manner. The alternate method involves the use of a pancake-like winding: Drive a large nail into a board and start winding wire around the shank of the nail. Each turn should lie flat against the board and on the outside of the turn preceding it, producing a flat spiral. About 20 turns will be sufficient. When the coil has been completed, remove the nail and bind the coil with string or narrow tape. If you decide to use the first method, wind coil L5 using condenser C18 as a form.

In the parts list reference is made to a fuse holder and to an antenna connector. Both are available at all large radio-supply stores.

The fuse holder is intended for use with the tubular fuse common to auto lighting systems. A 15-ampere fuse should be installed in the battery line leading to the radio receiver. The holder consists of two parts that can be separated for removal and replacement of the fuse. A fuse *must* be used; otherwise failure of the vibrator will damage the transformer or other parts of the set.

The antenna connector is a tubular bayonet connector into which the car antenna lead is plugged. Install it on the rear or side apron of the chassis.

Parts list

Resistors

- R1 270 ohms, 1/2-watt carbon
- R2 470K ohms, 1/2-watt carbon
- R3 250K ohms, 1/2-watt carbon
- R4 8 megohms, 1/2-watt carbon

- R5 750K ohms, volume control with switch, SW1
- R6 500 ohms, 1/2-watt carbon
- R7 20K ohms, 1/2-watt carbon
- R8 200 ohms, 1/2-watt carbon
- R9 1 megohm, 1/2-watt carbon
- R10 2 megohms, 1/2-watt carbon
- R11 20K ohms, 2-watt carbon or wire-wound
- R12 68 ohms, 1/2-watt carbon
- R13 68 ohms, 1/2-watt carbon
- R14 1K ohm, 1-watt carbon

Condensers

- C1 .01 mfd., 600-volt paper tubular
- C2 20 mfd., 25-volt electrolytic, tubular cartridge
- C3 .01 mfd., 600-volt paper tubular
- C4 200 mmfd., 600-volt mica
- C5 200 mmfd., 600-volt mica
- C6 .01 mfd., 400-volt paper tubular
- C7, C10, C13 Trimmer condenser, 5-30 mmfd., part of tuning condenser
- C8 Tuning condenser, 3-gang, 365 mmfd. each section (with C9, C12)
- C9 (with C8)
- C9A 100 mmfd., 400-volt mica
- C10 Trimmer condenser, 5-30 mmfd., part of tuning condenser
- C11 200 mmfd., 400-volt mica
- C12 (with C8)
- C13 Trimmer condenser, 5-30 mmfd., part of tuning condenser
- C14 .05 mfd., 400-volt paper tubular
- C15 .05 mfd., 600-volt paper tubular
- C16 20-20 mfd., 350-volt electrolytic, aluminum can, vertical mounting
- C17 .008 mfd., 1600-volt tubular
- C18 .5 mfd., 50-volt paper tubular
- C19 470 mmfd., 400-volt mica
- C20 Oscillator padder condenser, 70-480 mmfd.

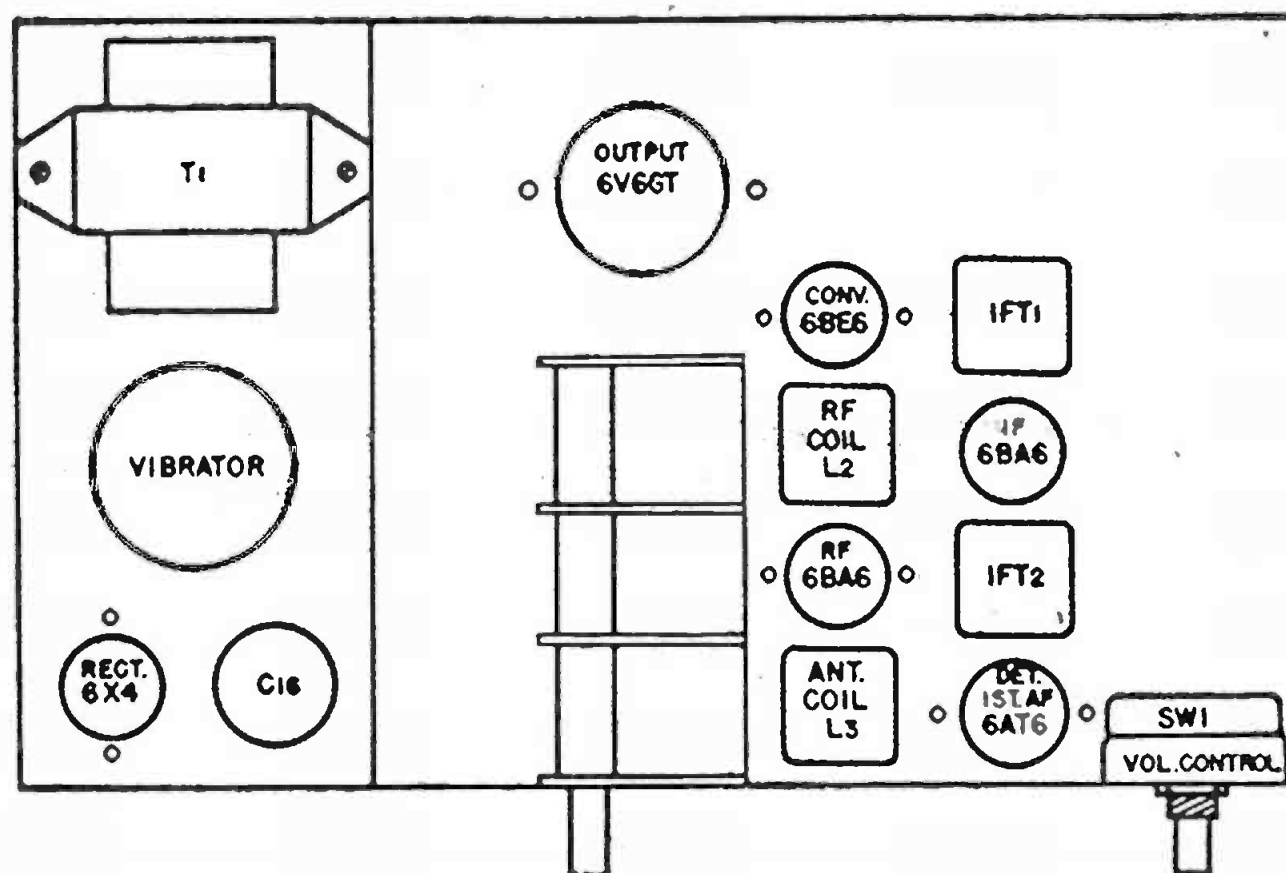

Fig. 8-22. Top view of auto radio chassis.

Coils

- L1 Tapped, single-winding oscillator coil (used with 365 mmfd. tuning condenser)
- L2 R.F. coil, shielded, Meissner 14-2437 or equivalent
- L3 Antenna coil, shielded, Meissner 14-2436 or equivalent
- L4 R.F. choke (see text)
- L5 R.F. choke (see text)
- L6 R.F. choke (see text)

Transformers

- T1 Vibrator transformer, Stancor P-4062 or equivalent
- T2 Output transformer, Stancor A-3877 or equivalent
- IFT1 455-kilocycle input, Merit BC-352 or equivalent
- IFT2 455-kilocycle output, Merit BC-353 or equivalent

Vibrator

Radiart 5301 or equivalent

Miscellaneous

- 5 miniature 7-pin tube sockets
- Octal tube socket
- 4-pin socket for vibrator
- Chassis: 6 x 10-1/4 x 1 inches, steel
- Case: 6 x 10-1/4 x 5 inches, inside dimensions; removable top and bottom, partition 3 inches from one end
- 4-36 x 3/8 inch r.h. machine screws with nuts
- 6-32 x 3/8 inch r.h. machine screws

with nuts

- 2-terminal output strip
- 3/8-inch #6 self-threading screws
- 3- and 4-point tie strips
- Fuse holder
- Bayonet-type antenna connector
- 15-amp. fuse
- Ground-connection soldering lugs
- Push-back wire
- Rosin-core solder

Tubes

6BA6 (2), 6BE6, 6AT6, 6V6GT, 6 x 4

Layout and assembly

Figure 8-22 is a top view of the chassis, showing the locations of the power supply components, tube sockets, tuning condenser, i.f. transformers, antenna and r.f. coils, and the volume control. The spacing of parts may be varied to suit the individual builder if the order of the tubes, coils, and transformers is not changed.

The power supply unit is located in the shielded compartment, separate from the rest of the set to insure that vibrator hash will not be picked up. If the chassis is the size specified, you will have to make your own case, which is not a difficult job. Usually light-gauge sheet metal may be used. If the set is to be installed in the glove compartment, 18 gauge aluminum will be satisfactory, as the case does

not support the weight of the set. On the other hand, if the set is to be bolted to the fire wall, it must be heavier and should be made of steel. For a glove-compartment installation, be sure to establish a good, low-resistance connection between the chassis of the set and the frame of the car. You may have an opportunity to acquire a used or discarded case, and then you can change the size and proportions of the chassis to fit the case. In any event, the chassis may be held to the outer container by means of #6 self-threading screws. A metal container is absolutely essential, otherwise you will be troubled by ignition-noise pickup. Because of the wide latitude in chassis size and proportions, no dimensions are given in the layout and assembly instructions. Figure 8-22 is a suggested layout, but you may vary it to suit your needs. This is possible within a fairly wide range as long as a reasonably direct signal path is maintained.

When the layout is complete, drill all miniature-socket screw holes with a #31 drill. Use a #25 drill for the 6V6GT-socket screws, the centers of all sockets and all other screw holes, for the transformer mounting, the vibrator-socket mounting screws, and the volume-control-shaft bushing. Enlarge the hole for the volume-control bushing with a 3/8-inch drill or a

reamer. Cut out the holes for the miniature-tube sockets with a 5/8-inch sheet-metal punch, first enlarging the center hole to 1/16-inch larger than the cap screw of the punch. Use a 1-1/16-inch-diameter punch for the 6V6GT socket and the vibrator socket. You may have to punch 5/8-inch holes for the i.f. transformers and the antenna and r.f. coils, depending upon their construction. Be sure that the r.f. and converter tubes, as well as the coils associated with them, are close to the tuning condenser, regardless of the layout you use. This will insure the shortest possible grid leads, minimizing the danger of coupling between wires. In the layout illustrated, the front section of the tuning condenser is used for the antenna, the middle one for the r.f., and the rear section for the oscillator.

Wiring

For your convenience, a bottom view of all tube sockets and the vibrator socket is shown in Figure 8-23. You may want to refer to it from time to time as the wiring progresses.

a) *Heater Circuit.* See Figure 8-24.

Connect all #4 terminals of the miniature sockets together; the #7 pin of the output tube socket is also connected to this line. The order of wiring makes no difference.

The battery supply for the set may

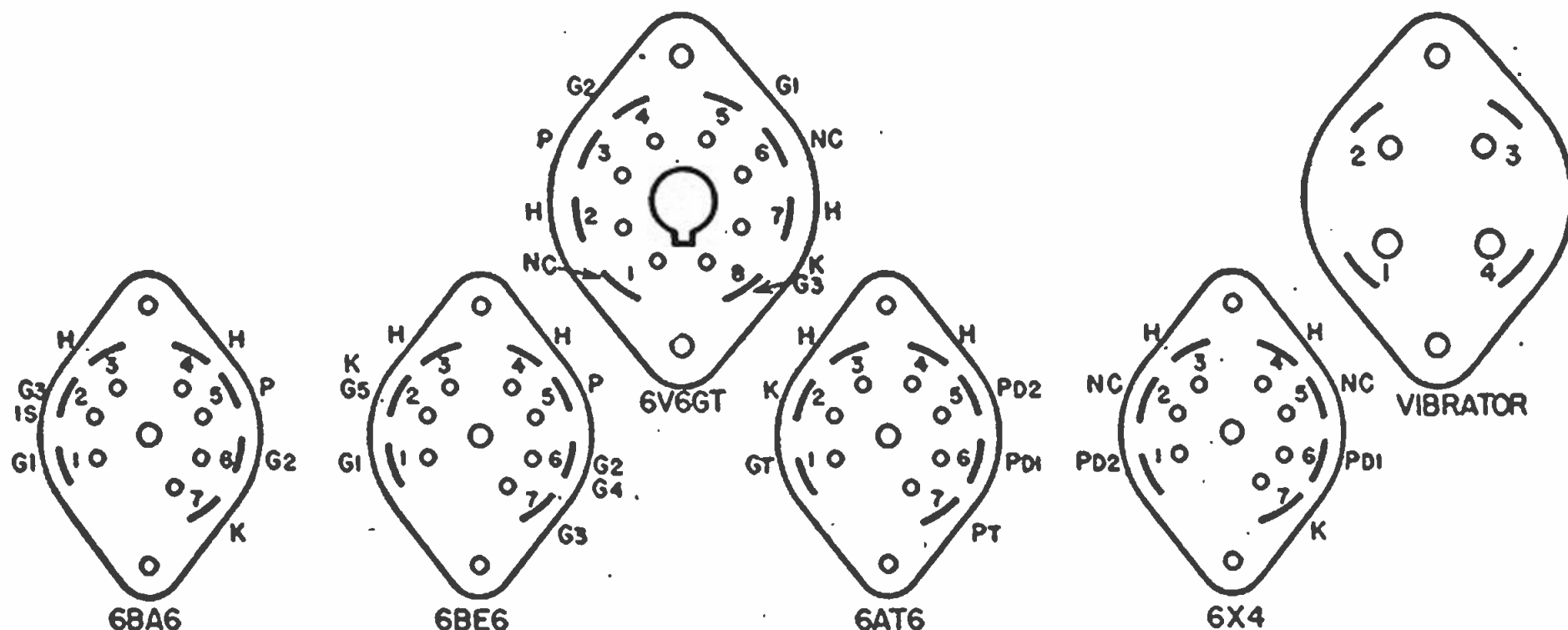

Fig. 8-23. Bottom view of auto radio tube sockets.

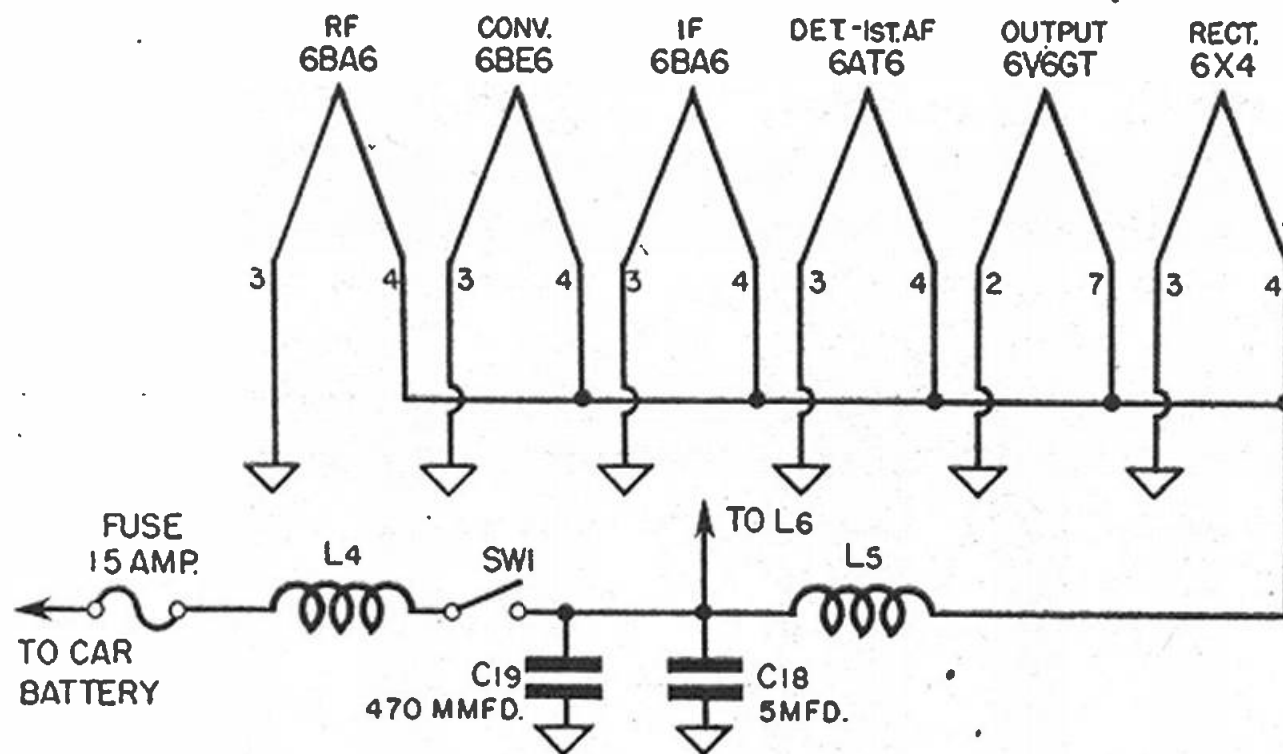

Fig. 8-24. Auto radio heater circuit.

be taken from the battery side of the ammeter (on the instrument panel), or directly from the ungrounded terminal of the battery. In either case, use #14 or #16 rubber-and-cotton-insulated lacquered wire. The wire carries a heavy current and must withstand considerable abuse, especially when connected directly to the battery. The wire from battery to set terminates at the male half of the fuse holder. The female half of the holder has a short length—about a foot—of heavy wire leading into the chassis. This short battery wire is then connected to one end of L4, which is mounted on a terminal strip, and the other end of L4 is connected to one terminal of the switch, SW1. To the other switch terminal connect one end each of C19, C18, and L5. Later this connection point will be used for the battery supply to the vibrator. Now run a wire from the free end of L5 to the most convenient point on the parallel heater circuit, which may be any one of the #4 terminals, or the #7 terminal of the 6V6GT. Connect the #2 terminal of the 6V6GT socket and the #3 terminals of all other tube sockets to chassis, and the heater circuit is completed.

To test the heater circuit, connect the fuse wire to one terminal of the storage battery. If the test is made with a battery already installed in a car, you must use the ungrounded

terminal. Insert a 15-ampere fuse in the holder and connect the two halves of the holder together. Connect the chassis to the other battery terminal, insert the tubes in their respective sockets, and turn on the switch. Observe whether the tubes operate at normal brilliance. If you have a DC voltmeter, check voltage from each ungrounded heater terminal to chassis. You should get a 6.3 volt reading in each case.

b) *Power Supply Circuit.* See Figure 8-25.

Connect one of the ends of the transformer primary winding to the #2 terminal of the vibrator socket and the opposite end of the winding to the #3 terminal. Connect the #1 terminal of the vibrator socket to chassis. Now connect the center tap of the primary winding to the #4 vibrator-socket terminal, and from that point run a wire to one end of the r.f. choke, L6. Connect the remaining end of L6 to the battery supply. This is one terminal of the on-off switch at the junction of L5, C18, and C19. Finally, wire R12 and R13 in series and connect the ends of the series combination between the #2 and #3 vibrator-socket terminals. Connect the common point of R12 and R13 to chassis. The primary section of the power supply circuit, is now completed.

Connect one end of the transformer

secondary winding to pin 1 of the 6x4 socket and the other end of the winding to the #6 socket terminal. Ground the center tap of the winding to chassis. Connect the buffer condenser, C17, between the #1 and #6 terminals of the socket.

The filter circuit consists of R11, R14, C15, and the two sections of C16. Mount R11 and R14 on tie strips and connect them in series. The R14 end of the combination is now connected to the cathode of the tube socket (pin 7). To this socket terminal connect one of the positive terminals of the filter condenser, C16. The other positive terminal of C16 may now be connected to the junction of R11 and R14. Ground the negative terminal of C16 to chassis. Connect C15 from the free end of R11 to chassis, and the power supply wiring is completed.

Three B-voltage supply points are shown in the diagram, marked *A*, *B*, and *C*. Plate voltage for the output tube only is taken from point *A*, the junction of R14 and the rectifier tube cathode. Plate voltages for the first audio, i.f. amplifier, converter, and r.f. amplifier are taken from point *B*, at the junction of R14 and R11. Screen voltage for the output tube is also taken from this point. The re-

maining B-supply point, *C*, furnishes screen voltage for the r.f. amplifier, converter, and i.f. amplifier tubes.

To make a resistance check of this stage, measure from the tube-socket terminals to chassis and compare the readings with those listed below:

<i>From</i>	<i>To</i>	<i>Ohms</i>
pin 1	chassis	240
pin 6	chassis	240
pin 7	chassis	over 100K

Voltages should correspond to those shown in the following table. An AC voltmeter must be used for taking the readings between the rectifier plate terminals and chassis.

<i>From</i>	<i>To</i>	<i>Volts</i>
pin 1	chassis	215 AC
pin 6	chassis	215 AC
pin 7	chassis	230 DC

c) Output Circuit. See Figure 8-26.

The output transformer may be mounted on either the speaker or the chassis. The latter position is more desirable if your particular layout permits. If you use the chassis mounting, connect the output-transformer secondary wires to the output terminal strip, which should be located on the rear of the chassis. Then connect the plate wire of the transformer

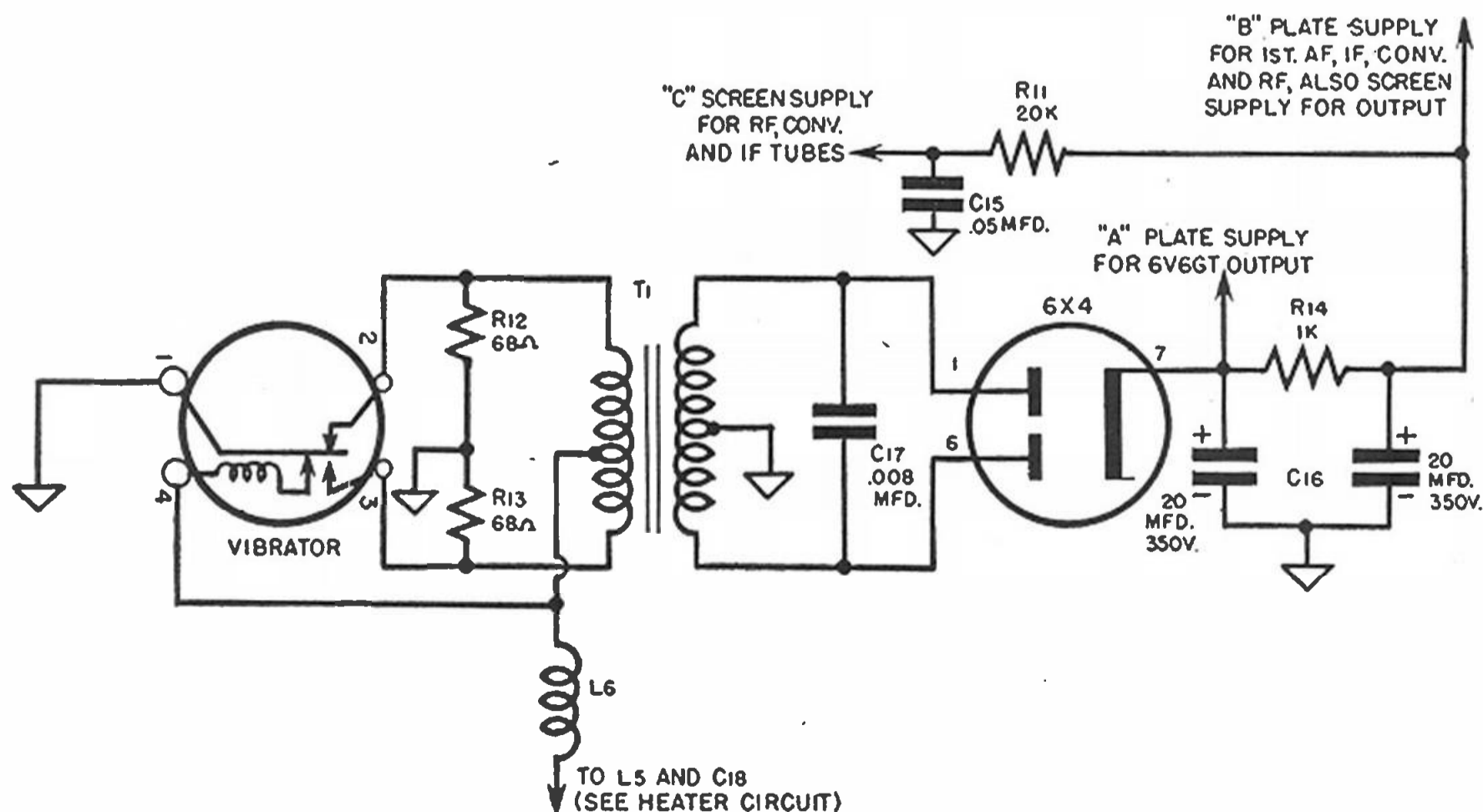

Fig. 8-25. Auto radio power supply circuit.

to the #3 terminal of the tube socket, but before soldering this connection add one end of condenser C1. The other end of the transformer primary may now be connected to point A in the power supply circuit. Connect the free end of C1 to this point, also. Run a wire from the screen terminal of the tube socket (pin 4) to the B-terminal in the power supply circuit.

R1 and C2 are now connected in parallel and one end of the parallel combination is connected to the cathode (pin 8) of the tube socket. The other end of the combination is to be connected to chassis, but be sure that the negative terminal of the condenser is toward chassis. Connect one end of C3 and one end of R2 to the grid terminal of the tube socket. The free end of R2 is now grounded to chassis, but the remaining terminal of C3 is not connected until the first audio circuit is wired.

Resistance check:

From	To	Ohms
pin 3	chassis	over 100K
pin 3	B plus (point A)	approx. 200
pin 4	chassis	over 100K
pin 4	B plus (point B)	0
pin 5	chassis	470K
pin 8	chassis	270

Voltage measurements:

From	To	DC Volts
pin 3	chassis	220
pin 4	chassis	210
pin 8	chassis	12
pin 8	pin 5	-12

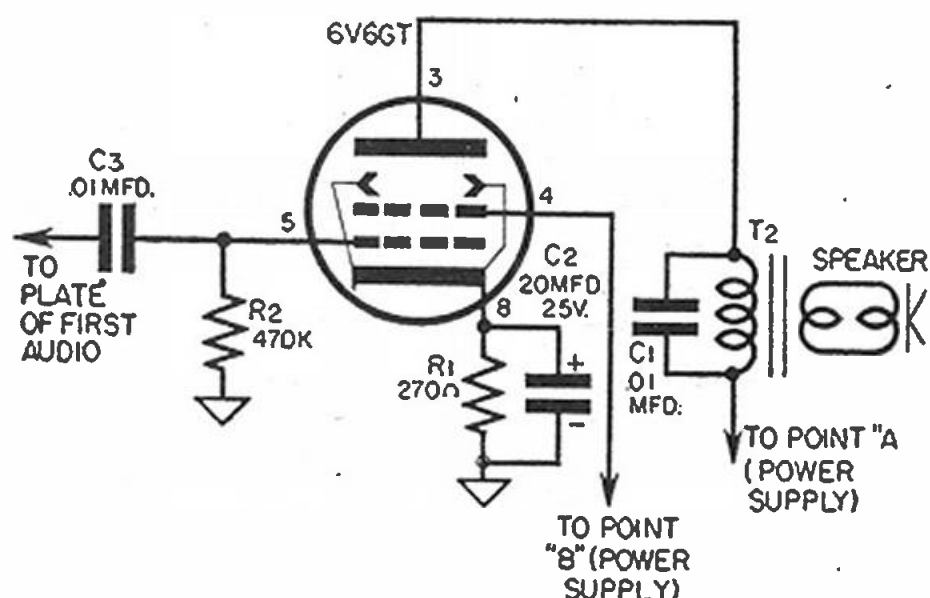

Fig. 8-26. Output circuit.

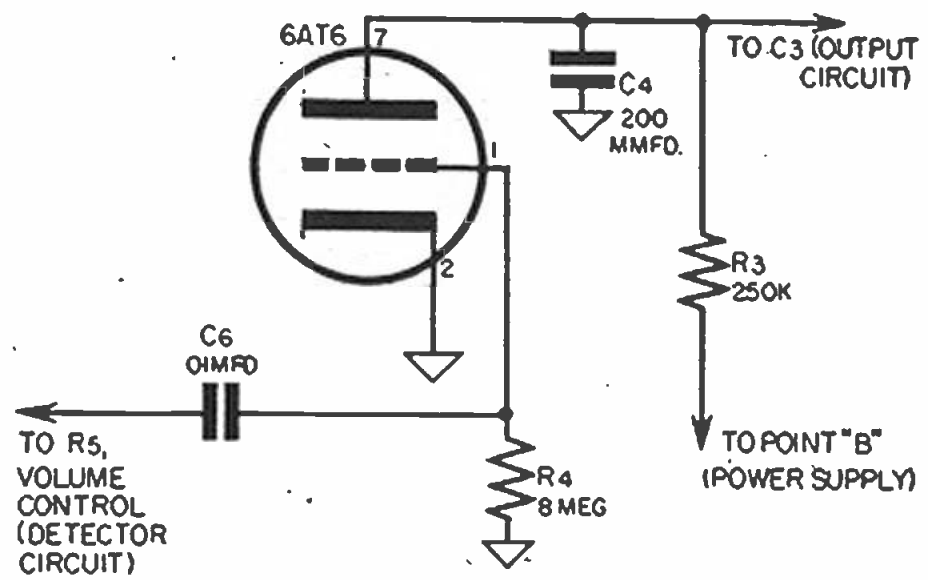

Fig. 8-27. First audio circuit.

An operation test can be made by touching a finger or the tip of a screwdriver to the grid terminal of the socket. A hum or buzz should be heard. A more conclusive test can be made by feeding the audio output of a signal generator into the grid of the tube.

d) First Audio Circuit. See Figure 8-27.

Start by connecting one end of C4, one end of R3, and the free end of C3 (see output circuit) to pin 7 of the tube socket. The other end of C4 may now be grounded to the chassis; and next the lower end of R3 is connected to point B in the power supply circuit.

Connect R4 and C6 to the grid terminal (pin 1) of the tube socket. The other end of R4 is to be grounded, but the free end of C6 remains disconnected until the detector circuit is wired. Connect socket terminal 2 directly to chassis, and the wiring of this circuit is completed.

Make a resistance check by measuring between the points indicated and compare your readings with the normal values given below:

From	To	Ohms
pin 1	chassis	8 megohm
pin 2	chassis	0
pin 7	chassis	over 350K
pin 7	B plus (point B)	250K

Check the voltage between pin 7 and chassis; the normal reading is 80

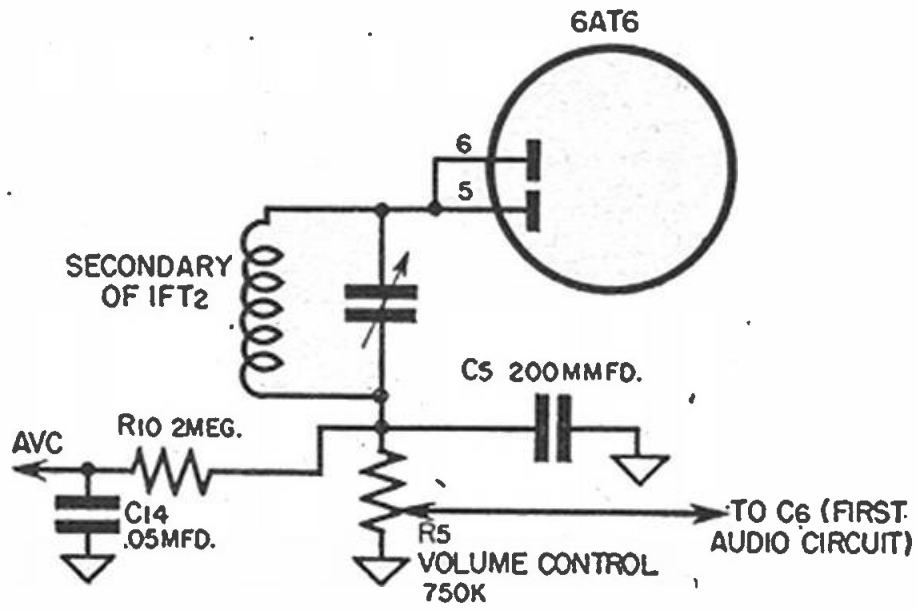

Fig. 8-28. Detector circuit.

volts DC. Make an operation test as described under the output circuit; the results should be similar, although much louder.

e) Detector Circuit. See Figure 8-28.

Connect a jumper wire between socket terminals 5 and 6. To either #5 or #6 connect the grid terminal (or green wire) of the second i.f. transformer. Mount C5, R10, and C14 on terminal strips and connect them in series, with R10 in the center. Now connect the grid-return terminal (or black wire) of the transformer winding to the junction of C5 and R10. Before soldering the connection, add a wire running to the high side of the volume control. (Identify this terminal by looking at the control from the shaft end with the terminal lugs facing downward; the lug at the right is the high side.) Connect the free end of C5 and of C14 to chassis. Now ground the lug at the left of the volume control, and connect the free end of C6 (see first audio circuit) to the center lug. The detector circuit is now ready for testing. Only a resistance check can be made as there are no DC voltages at any of the socket terminals.

Normal resistance values for this stage are:

From	To	Ohms
pin 5 (or 6)	chassis	750K
pin 5 (or 6)	AVC point	2 megohm

Using a signal generator, make an operation test of this stage. Feed a

455-KC modulated signal into the primary of the second i.f. transformer and listen for an audible tone.

f) I.F. Amplifier Circuit. See Figure 8-29.

Begin the wiring by connecting the plate terminal (or blue wire) of the second i.f. transformer to tube-socket pin #5, and the other-end of the winding to point B in the power supply. Connect socket terminal 6 directly to point C in the power supply circuit. Now connect R6 between socket terminal 7 and chassis.

The grid terminal (or green wire) of the first i.f. transformer secondary is now connected to socket terminal 1, and the opposite end of this winding is wired to the AVC point (see detector circuit). Complete the wiring by grounding socket terminal 2.

The resistance values to be expected when testing this stage are:

From	To	Ohms
pin 1	AVC	approx. 20
pin 1	chassis	over 2.7 megohm
pin 5	chassis	over 100K
pin 5	B plus (point B)	approx. 20
pin 6	chassis	over 100K
pin 6	B plus (point C)	0
pin 7	chassis	500

Voltage readings at the socket terminals should be approximately:

From	To	DC Volts
pin 5	chassis	210
pin 6	chassis	75
pin 7	chassis	2

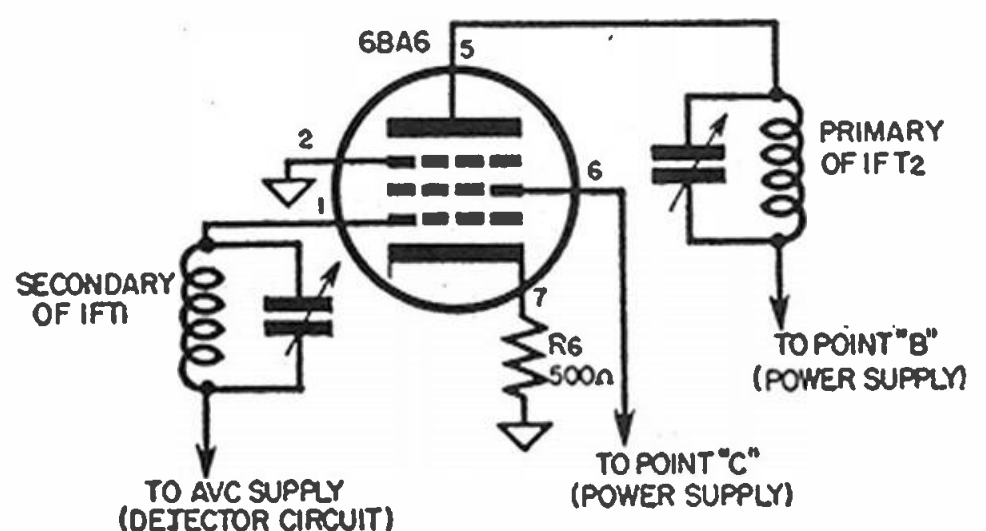

Fig. 8-29. I. F. amplifier circuit.

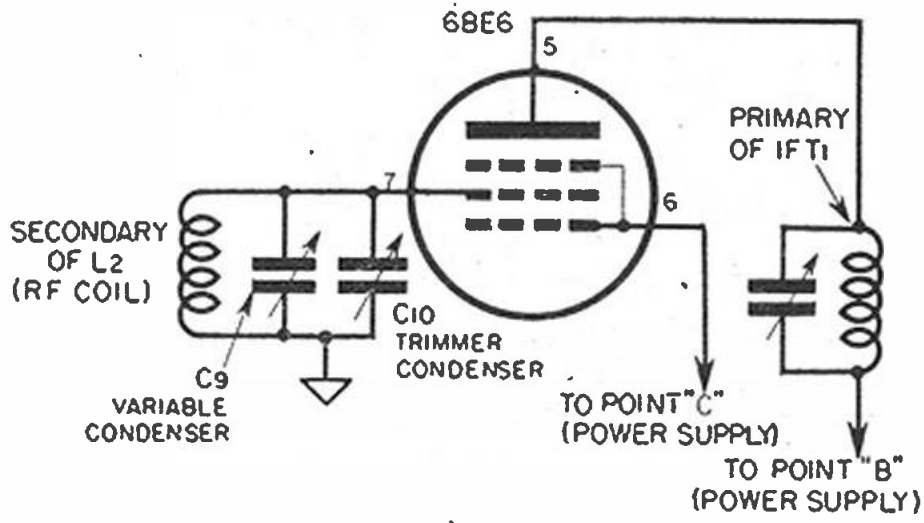

Fig. 8-30. Mixer circuit.

g) *Mixer Circuit.* See Figure 8-30.

Connect the grid end of the r.f. coil secondary to the stator terminal of the tuning condenser (mixer section). From this point run a wire to pin 7 of the tube socket. Ground the opposite end of the r.f. coil secondary winding. The plate terminal (or blue wire) of the i.f.-transformer winding may now be connected to socket terminal 5 and the opposite end of the winding connected to point B in the power supply circuit. To complete the wiring of this stage, connect tube socket terminal 6 to point C in the power supply circuit.

Resistance measurements should be:

From	To	Ohms
pin 5	chassis	over 100K
pin 5	B plus (point B)	approx. 20
pin 6	chassis	over 100K
pin 6	B plus (point C)	0
pin 7	chassis	approx. 5

Do not make a voltage check on this stage until the oscillator circuit wiring has been completed.

h) *Oscillator Circuit.* See Figure 8-31.

Connect the oscillator-coil tap to the cathode of the tube socket (pin 2) and the ground end of the coil to chassis. The top, or grid, end of the coil is connected to one terminal of the padder condenser, C20. The opposite terminal of the padder is connected to the stator terminal of the

oscillator tuning condenser. From the junction of the padder and the oscillator coil, connect C9 to the oscillator grid terminal (pin 1) of the tube socket. Connect R7 between pin 1 and chassis.

Resistance measurements should be:

From	To	Ohms
pin 1	chassis	20K
pin 2	chassis	less than 1 ohm

Make a voltage check of the combined oscillator and mixer stages. The normal values are:

From	To	DC Volts
pin 1	chassis	2
pin 5	chassis	210
pin 6	chassis	75

i) *R.F. Amplifier Circuit.* See Figure 8-32.

Connect the plate end of the r.f. coil primary to socket terminal 5 and the opposite end of the primary to B plus (point B in the power supply circuit). Run a wire from pin 6 to B plus (point C). To socket terminal 1 connect one end of C11 and one end of R9. The free end of R9 may now be wired to the AVC point (see detector circuit). Connect the end of C11 to the stator terminal of the tuning condenser where it joins one end of the r.f. coil secondary. The other end of the secondary is connected to chassis. Ground pin 2 to chassis. Wire one end of the antenna-coil primary to the antenna connector; the oppo-

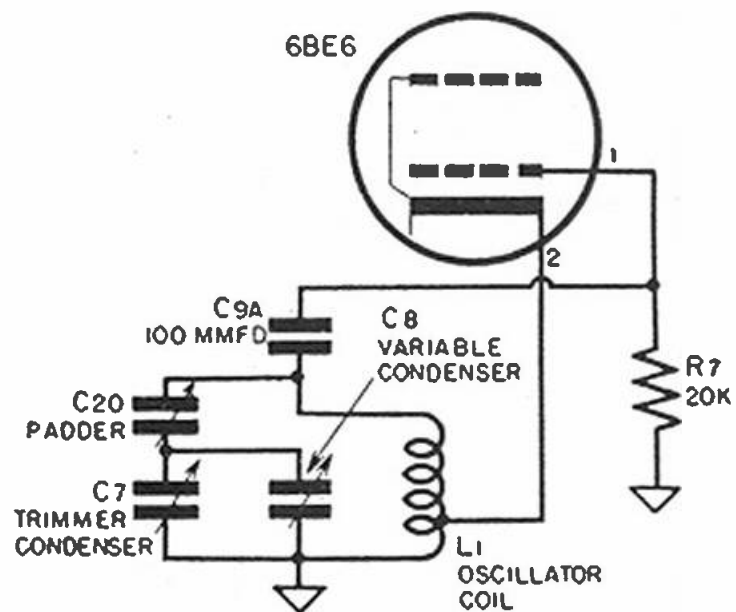

Fig. 8-31. Oscillator circuit.

site end is grounded. Connect C21 between the lower end of R9 and chassis.

R.F. stage resistance measurements are:

From	To	Ohms
pin 1	AVC	1 megohm
pin 5	chassis	over 100K
pin 5	B plus (point B)	approx. 5
pin 6	chassis	over 100K
pin 6	B plus (point C)	0
pin 7	chassis	200

Voltage measurements should be:

From	To	DC Volts
pin 5	chassis	210
pin 6	chassis	75
pin 7	chassis	1

Alignment

The i.f. alignment is made in the usual manner by connecting the generator to the grid of the converter tube (pin 7) and to chassis. With the generator adjusted to deliver a 455-kilocycle modulated signal and the receiver volume control full on, make the i.f. adjustments so as to give maximum output.

Next, connect the generator to the antenna and chassis and tune both set and generator to 1620 kilocycles. Adjust the oscillator trimmer condenser, C7, for maximum output.

Retune the generator and the set to 1400 kilocycles and adjust the antenna and r.f. trimmer condensers, C13 and C10, to give maximum output.

Finally, adjust both set and generator to 600 kilocycles. Make a very slight adjustment of the paddler condenser, C20, and watch whether the adjustment increases or decreases the output. If it decreases the output, retune the receiver very slightly and determine whether the output increases. Continue adjusting the paddler until no adjustment of the variable condenser will result in an increase. Retune the receiver and the

generator to 1400 kilocycles and recheck the adjustment of the r.f., antenna, and oscillator trimmers.

Ignition interference

A few suggestions are offered here for eliminating or reducing interference from the car ignition system. In most cases a suppressor must be installed between the high-tension wire and the center terminal of the distributor cap. Suppressors are available at all large radio-supply stores and plug into the distributor in place of the ignition wire, which is then joined to the top end of the suppressor.

Sometimes it is necessary to connect a condenser between the battery

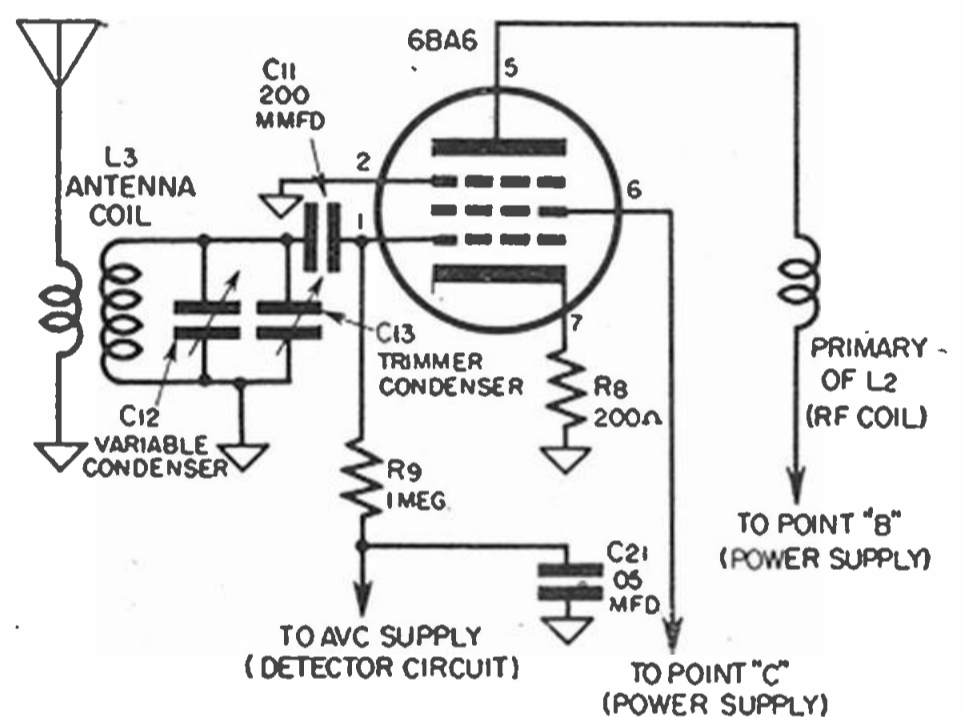

Fig. 8-32. R. F. amplifier circuit.

terminal of the ammeter and ground. Suitable condensers may be purchased at radio and automotive supply stores for a few cents. Another effective method of reducing interference is to install a hood-grounding strap to supplement the rather poor ground connection between the hood and the sheet metal of the car via the hood hinges. In a few instances, grounding all cables, wires, tubes, and rods leading from the engine compartment to the driver's compartment will help.

All items to be grounded must first be cleaned bright for an inch or so. Flexible copper braid is then wrapped tightly around them and connected to a good ground on the frame of the car.

Special Parts Section

How to Buy Radio Parts

Although parts and how to use them are fully discussed throughout this book, here are some money-saving shopping tips to remember.

SHOULD you ask a radio-parts salesman for a "double-o-one-mike condenser," he could put out a counterful of parts—all different, yet all .001-mfd. capacitors. "Which do you want?" he might ask. "Paper, mica, or ceramic—and what voltage and tolerance?"

If your first impulse is to say that it makes no difference so long as the capacity is right, you've probably never seen the wax melt out of a paper condenser used where a mica should have been. Sometimes, to be sure, identically rated parts may be used interchangeably. But don't overlook the many cases where an improper part may cause a short, burnout, or open circuit, or simply become defective in a hurry.

Some of the things that are worth knowing about condensers, coils, resistors, output transformers, and tubes are dealt with in this article. You may find them helpful next time you shop for radio parts.

Condensers—Fixed and Variable

Mica condensers (Fig. 1) are easily recognized by their molded-plastic cases. They are commonly used in by-pass and coupling circuits and as grid condensers in grid-leak detectors. Their working-voltage rating is generally about 500 volts DC but the cases are rarely marked. Mica condensers are used mostly at high frequencies, and therefore capacities are low, ranging from about 50 mmf. to 6,000 mmf. (.006 mfd.). You'll find micas in demand wherever low capacities with

low loss at high frequencies are required.

Incidentally, in case condenser arithmetic has you stumped, the basic unit of capacity is the *farad*. As radio components go, this unit is enormous, so it's divided by a million. This gives the *microfarad* (mfd.) and can be expressed as .000001 farad, (one millionth farad) but would normally be written 1 mfd. Even that's big in radio work, so the microfarad is further divided by a million to give the *micromicrofarad* (mmf.) which can be written .000001 mfd. or, more simply, 1 mmf. To translate mfd. to mmf., simply move the decimal six places to the right (in effect, multiply by a million). Thus .0001 mfd. is the same as 100 mmf., and .005 mfd. becomes 5000 mmf.

One of the war-developed ceramic capacitors will often do when specifications call for mica. Ceramics have high stability and compactness; they come in the form of small disks or tiny cylinders resembling fixed resistors (Fig. 1). They are also primarily for use in radio-frequency (RF) circuits.

Paper condensers can be found in every stage of a modern receiver. They have such varied functions as by-passing stray signal voltages, coupling two stages, bass boosting (in tone-control circuits), and filtering in certain rectifier applications.

Working voltages are usually indicated for paper condensers, and it is important that the rating be adequate. When in doubt always take a larger voltage. In AC-DC or

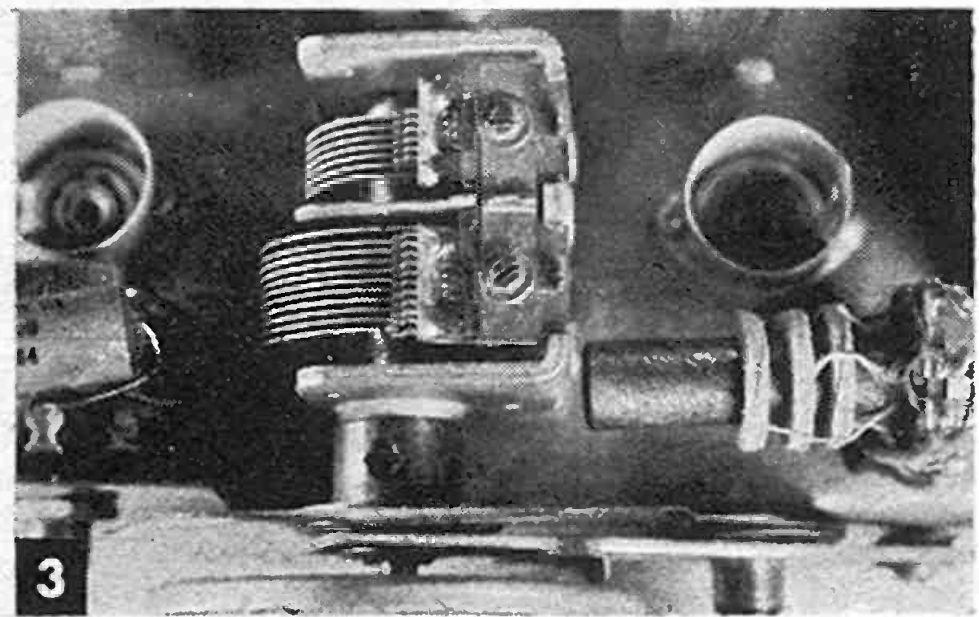
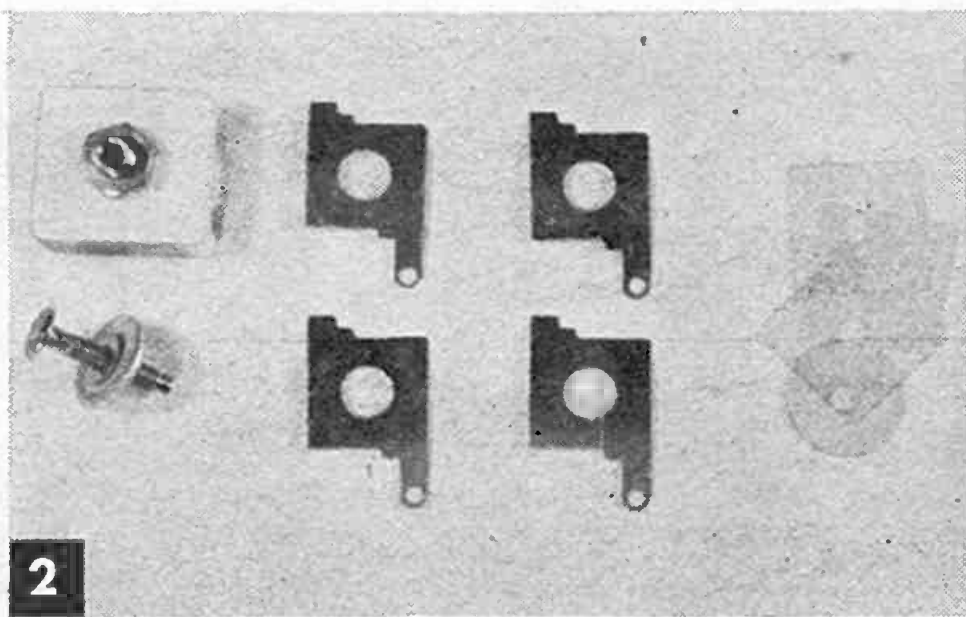
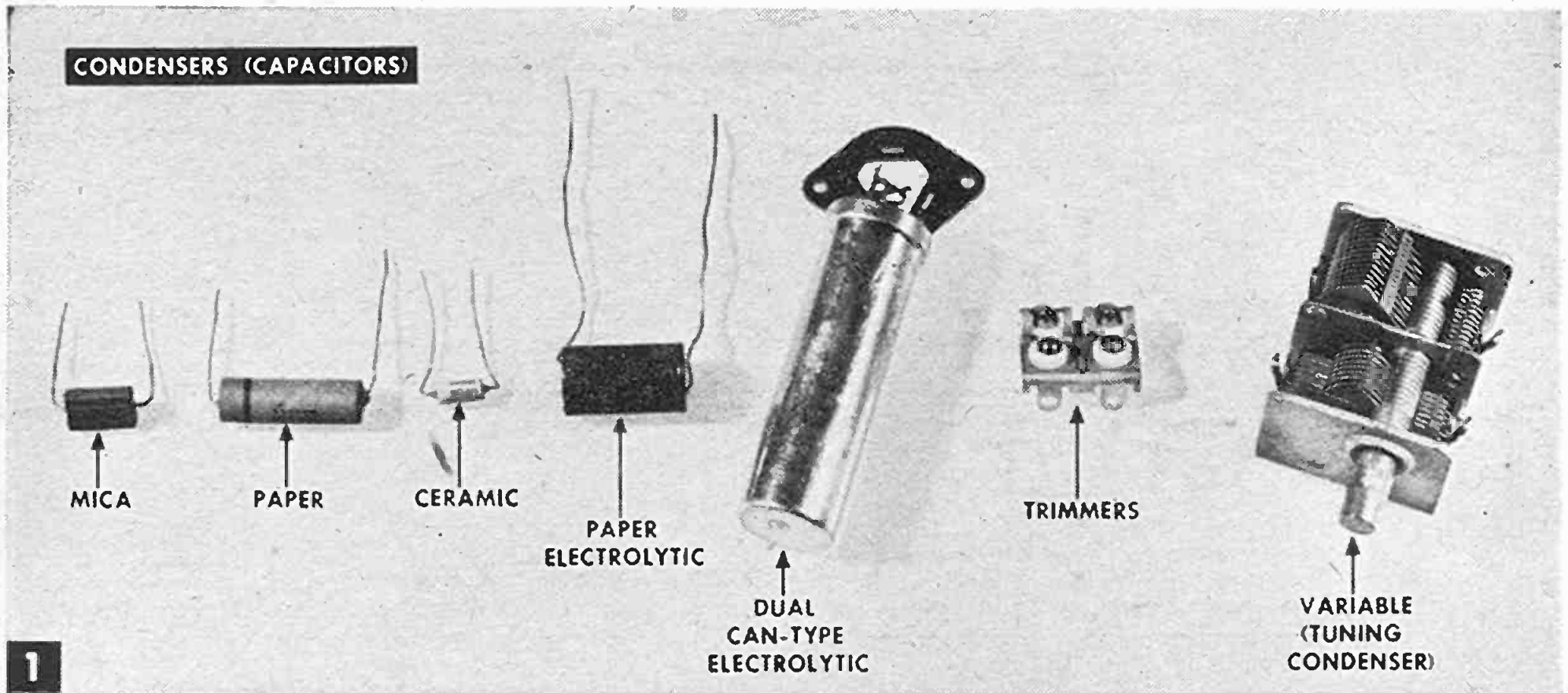

battery-operated receivers a condenser rated at 400 volts allows a safe margin. You might get by with these even in an AC set or amplifier that delivers 250 to 350 volts of B plus, but a few pennies more can buy greater safety in the form of 600-volt condensers. Sometimes heat generated by tubes may melt the wax in which a condenser is sealed. Where this seems likely, try to get capacitors sealed in plastic.

There is still another type of fixed condenser that crops up in practically every

piece of radio or electronic equipment—the electrolytic. This is used in all filter circuits and in many special applications. Electrolytic condensers come in aluminum cans or cardboard containers. In order to save space (and cost), two or more units are often put in one container with separate leads brought out. A single can containing two units is called a dual electrolytic; multiple electrolytics with up to four sections are common. Polarity must be observed for electrolytics, so make sure the leads are color-coded or

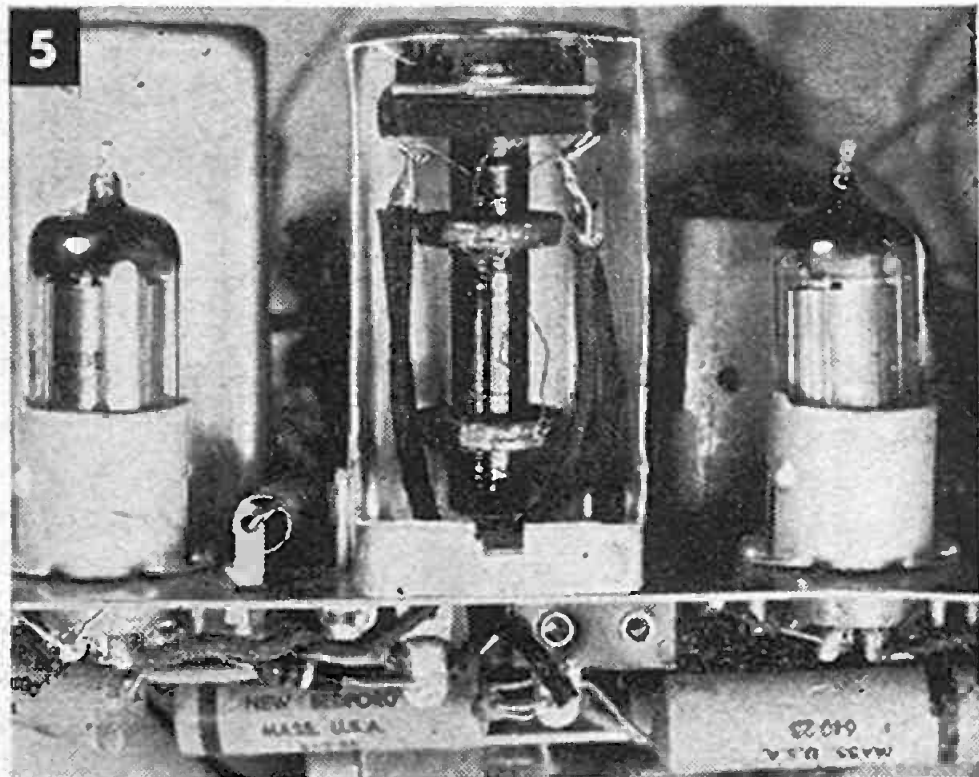
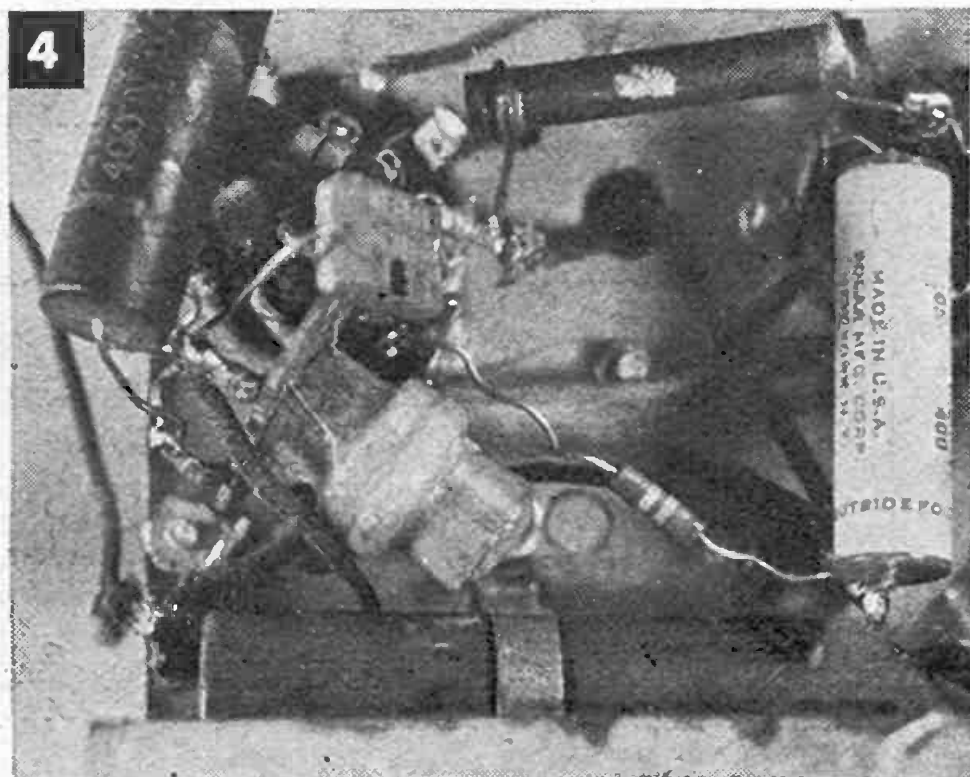

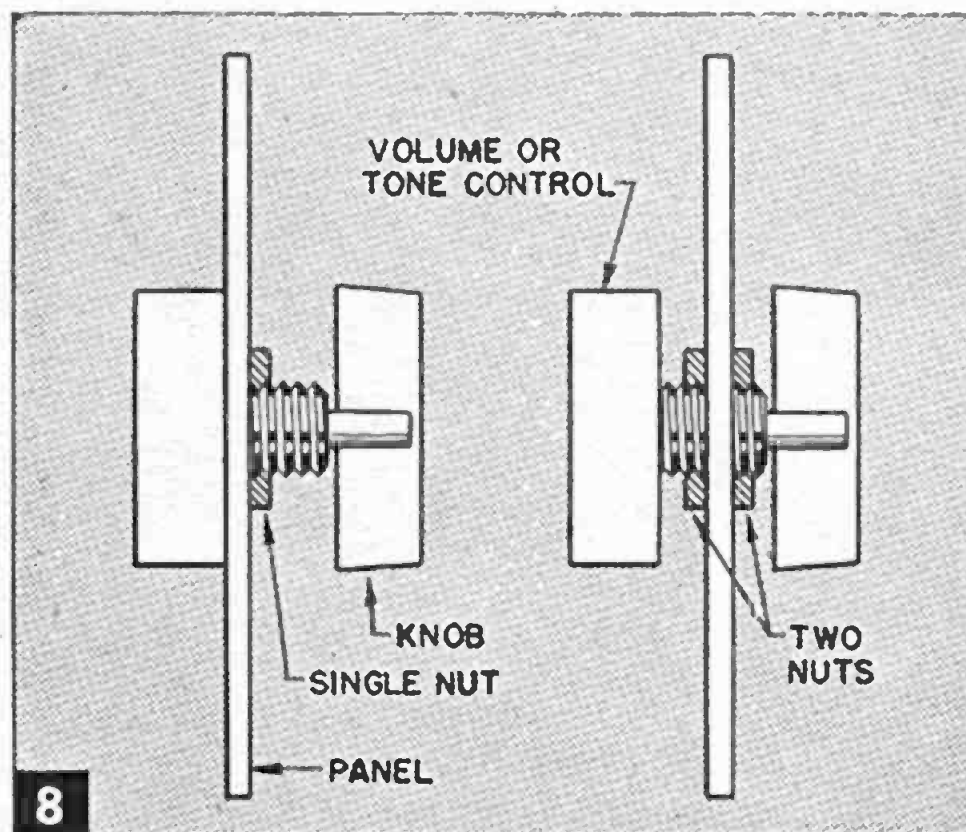
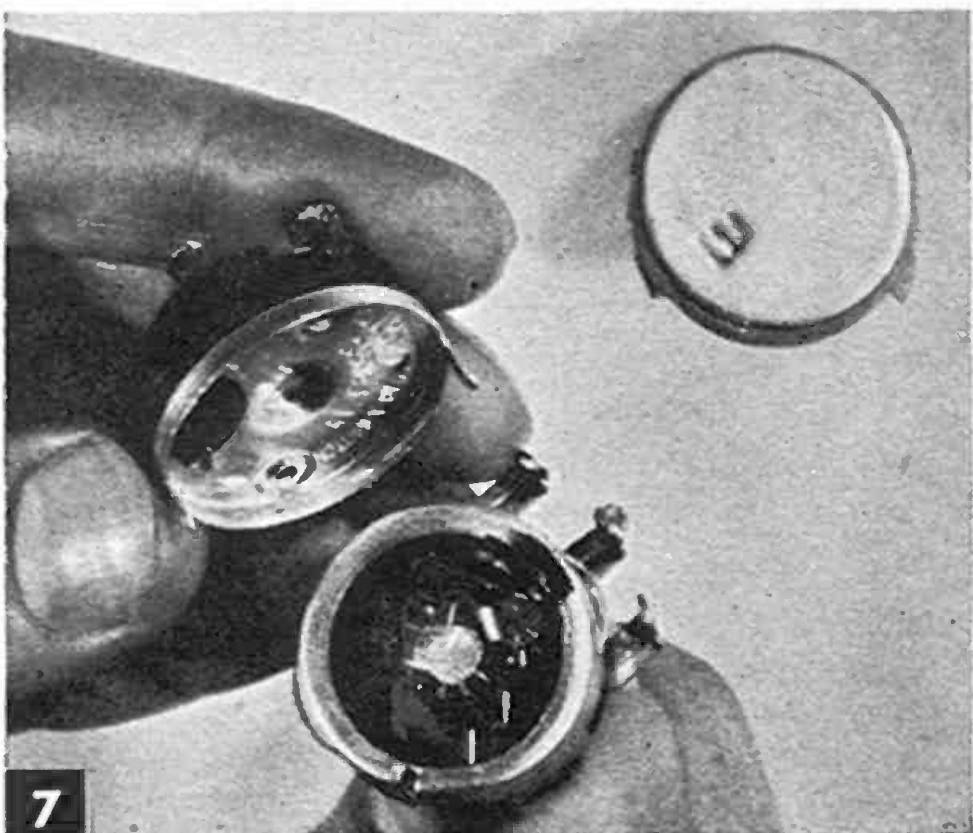
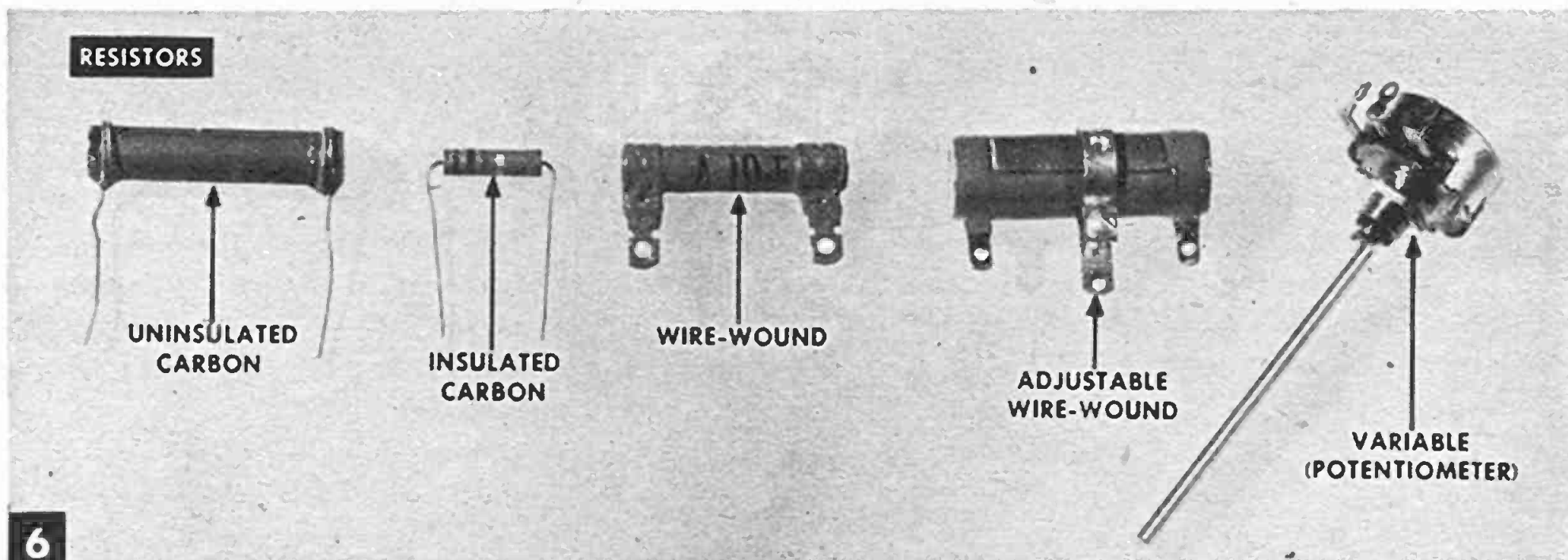

otherwise marked. Standard codes use red for the positive and black for the negative terminals.

Fixed condensers sometimes vary from rated value by as much as 20 percent plus or minus. Except for test equipment or the like you can usually allow an extra margin of up to 20 percent when you can't find a condenser of the right size. If the parts list calls for .005 mfd., you can get by with .006 or .004 mfd. But for very exacting equipment it is frequently wise to pay more for condensers guaranteed within 5 percent of stated capacity.

The variable condensers used for tuning short-wave or broadcast receivers are usually .00014 mfd. (140 mmf.) or .000365 mfd. (365 mmf.). They're available either as single units or ganged into two or three sections. The type to buy depends on the number of tuned circuits in the set. Ganging of two condensers of unequal size is common in superhets to tune the antenna and the oscillator circuits to different frequencies.

Experimenters almost always find it wise to purchase variable condensers with built-in trimmers. These are sandwiches of metal

and mica (Fig. 2). A setscrew squeezes the metal plates more tightly when you have to increase capacity, or relieves the pressure to reduce capacity. Fig. 3 shows trimmers mounted directly above the variable plates.

Trimmers are built into most IF transformers to enable you to make minor adjustments. They also come separately for use in coupling an antenna to an antenna coil, as padders in oscillator circuits, and even as tuning condensers in midget receivers.

Coils

Coils constitute another large and often bewildering category to the man who sets out to buy radio parts. Under this head you will find plug-in, antenna, RF, oscillator, and IF transformer coils. Some are shielded, some aren't.

Plug-in coils, found in simple crystal and regenerative receivers, are generally sold in matched sets to cover broadcast and short-wave bands. In most cases the tuning condenser is of 140-mmf. capacity. Four-prong coils are used when the circuit calls for two windings, while six-prong coils are needed for three windings.

Antenna and RF coils are employed in small TRF receivers. They are available either shielded or unshielded. When using unshielded coils, it is best to mount the antenna coil above the chassis and the RF coil underneath so the chassis will serve as a shield. Wherever it is necessary to mount all coils on one side of the chassis, or where there's more than one tuned RF stage, only shielded units should be used. In buying receiver coils, ask for a matched set. This will assure accurate ganging between coils as well as with the condensers.

Most superheterodyne circuits call for an antenna coil, and they always require an oscillator coil, and at least two intermediate-frequency (IF) transformers. Shielding problems are the same as in the TRF set. In the lower foreground of Fig. 4 an unshielded oscillator coil is mounted underneath the chassis.

The transformers used to couple IF stages are basically coils tuned to a fixed frequency—in broadcast receivers 456 kc. They are in aluminum cans (Fig. 5 shows one cut away) with lugs, clips, or feet by which they can be mounted.

Some IF transformers are brought to peak frequency by trimmers, and some by adjusting an iron core. The latter respond over a much broader tuning range and are therefore easier to align without a signal generator.

One final point to bear in mind when buying coils: If you are building a receiver with only a single stage of RF or IF, you need maximum amplification in each stage. You will get this plus greater selectivity by using coils with iron cores.

Fixed and Variable Resistors

You'd have to look hard for an electronic circuit that doesn't use a fixed or variable

resistor of some kind. Fixed carbon resistors constitute the bulk of all resistance units. They are inexpensive, reasonably accurate, and come in a large variety of sizes and ratings. Some are encased in plastic, which makes them impervious to moisture and less likely to short against other components. Uninsulated resistors (Fig. 6) dissipate heat a little more readily but shouldn't be used in cramped quarters.

All fixed resistors are rated in *ohms* (the unit of resistance) and *watts* (current rating). As with voltage ratings in condensers, a larger wattage is safer when there's doubt.

For AC-DC receivers and amplifiers, ½-watt units are generally adequate in the control-grid circuits of amplifier tubes. Plate and screen circuits should get 1-watt resistors, and cathode and filter circuits 2 watts or more. Battery-operated equipment can generally get by with ratings half as large.

Wire-wound resistors are employed where current drain is high and where stability and accuracy are paramount. On adjustable wire-wound resistors part of the winding is left bare so that a movable metal band can tap off any resistance between zero and the maximum.

Variable resistors, now found chiefly in the form of potentiometers, have a fixed carbon or wire-wound element and a moving contact turned by a shaft. If you want resistance to increase evenly in proportion to shaft movement, specify a linear-taper pot. Because of tube characteristics, nonlinear pots usually give more gradual control over volume, tone, and bias. In logarithmic pots, usually used for tone and volume controls, resistance increases at a definite but uneven rate. In end-tapered pots, used for varying tube bias, resistance "thins out" at one end.

For the convenience of radio builders, the

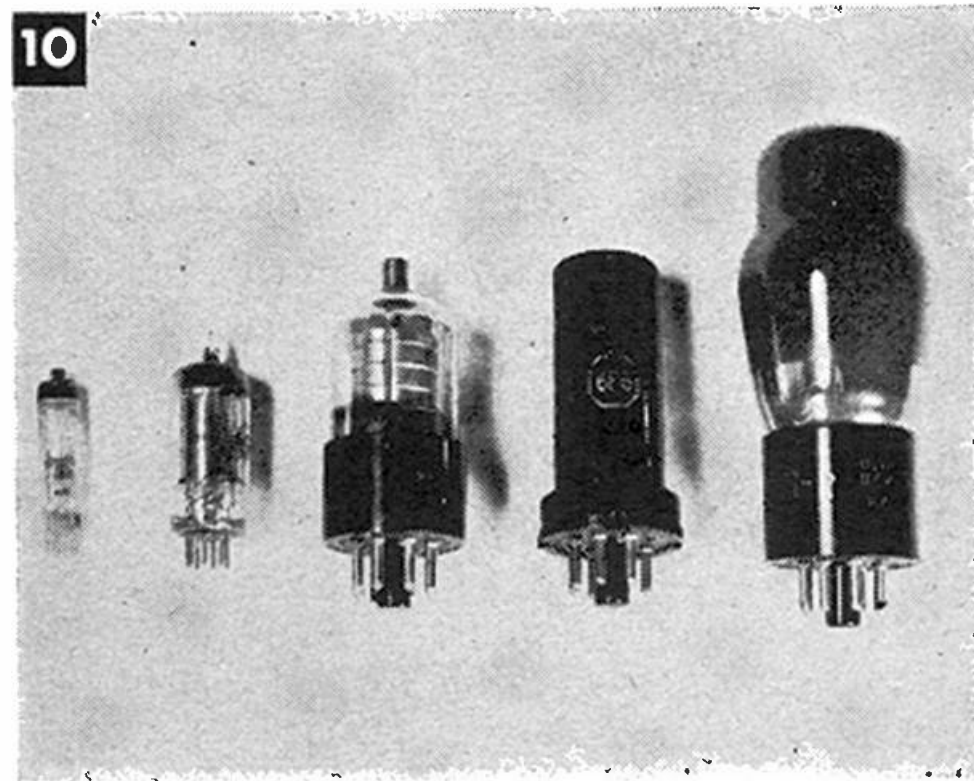
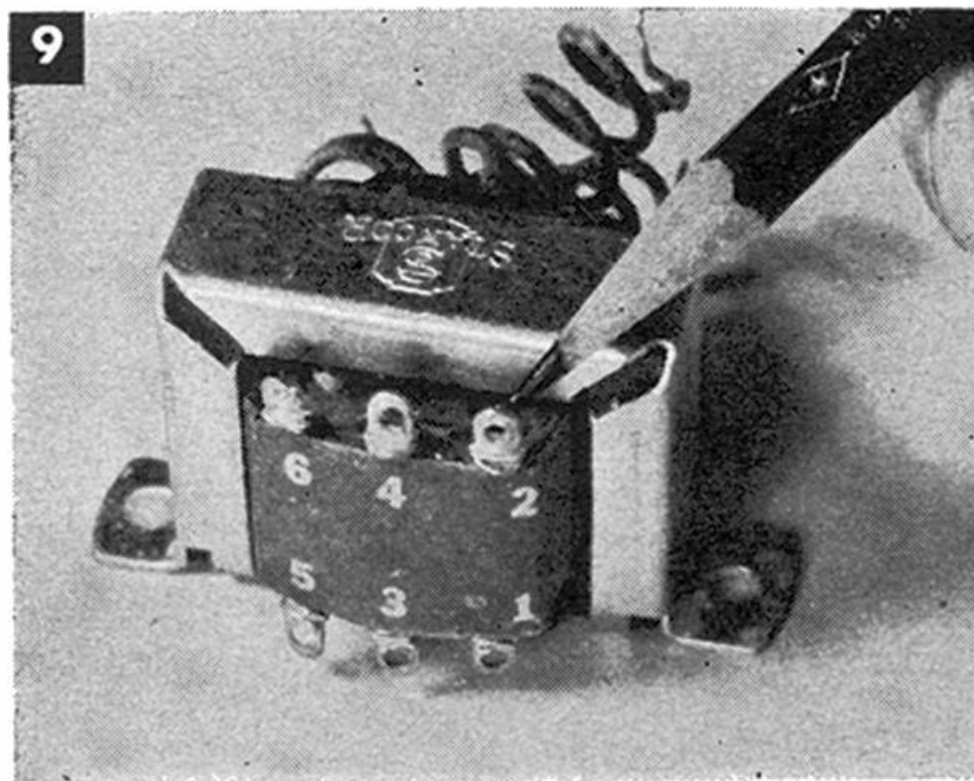

makers of potentiometers provide switches that can be slipped onto the back of the unit (Fig. 7). The switch is actuated by the first few degrees of shaft turn.

A potentiometer is usually fastened to a panel by means of a gripping nut screwed on a threaded shaft. Since there is a good deal of variation in shaft nuts, you can often do yourself a favor by purchasing an extra one at the time you buy the potentiometer. With two nuts you can exactly regulate the projection of the shaft in front of the panel as shown in Fig. 8.

Output Transformers

In purchasing an output transformer for a small set, it is best to look for the universal type. Taps on the secondary winding of the transformer (Fig. 9) allow matching of any tube impedance from 1,500 to 20,000 ohms to any voice-coil impedance from .1 to 24 ohms. These figures vary somewhat with different makes.

Impedance matching is probably the leading consideration in the selection of an output transformer, but there is one other that must never be overlooked. If the transformer can't handle all the plate current that will be delivered to it, it cannot transfer that power to the speaker. Output transformers are rated in watts. For most battery and small AC-DC receivers, 4 to 5 watts is suitable; for AC receivers and high-powered audio amplifiers you will usually want a transformer rated at 8 watts or more.

Tubes and Pilot Lights

Some people feel that radio tubes offer the largest variety of radio components. Several catalogs list upward of 400 types. This, however, need rarely worry the builder who works from a parts list. The specifica-

tions always designate tubes by numbers.

One puzzling element is the lettering that follows the tube number. A metal 6K7, for example, has the same electrical characteristics as the glass-dome 6K7-G or the bantam 6K7-GT (the latter is sometimes listed as GT/G). The only differences are in their physical dimensions (Fig. 10) and in the method of shielding. The first of these tubes is encased in metal, the other two in glass envelopes of different sizes (G being considerably larger than the GT). The 6K7 requires no separate shielding, while the others must be covered with a metal shield (Fig. 11) to suppress undesirable coupling. Only tubes used in the high-frequency circuits—RF, converter, IF, and sometimes detector stages—need shielding; others such as power output tubes and rectifiers don't require it. Fig. 10 shows the most common types of receiving tubes, being, from left to right, subminiature, miniature, bantam (GT), metal, and glass dome (G).

Sometimes you want to duplicate a particular circuit in a smaller size. This is becoming increasingly possible with miniature components. For example, the 50L6 beam-power amplifier can be replaced with a 50B5 miniature.

Dial pilot bulbs become critical in AC-DC sets, because they're in series with the tubes and must match them in current rating, since current is equal in all parts of a series circuit. The bulb ratings are marked by a colored glass bead in the bulb. For example, a set using tubes with heaters drawing .15 amp at 6.3 volts calls for a brown-bead pilot bulb. A white bead means .5 amp. at 2.5 volts, a blue .3 amp. at 6 to 8 volts, and a pink one .06 amp. at 2 volts. All types come with both bayonet and screw bases to suit the two socket types (Fig. 12).

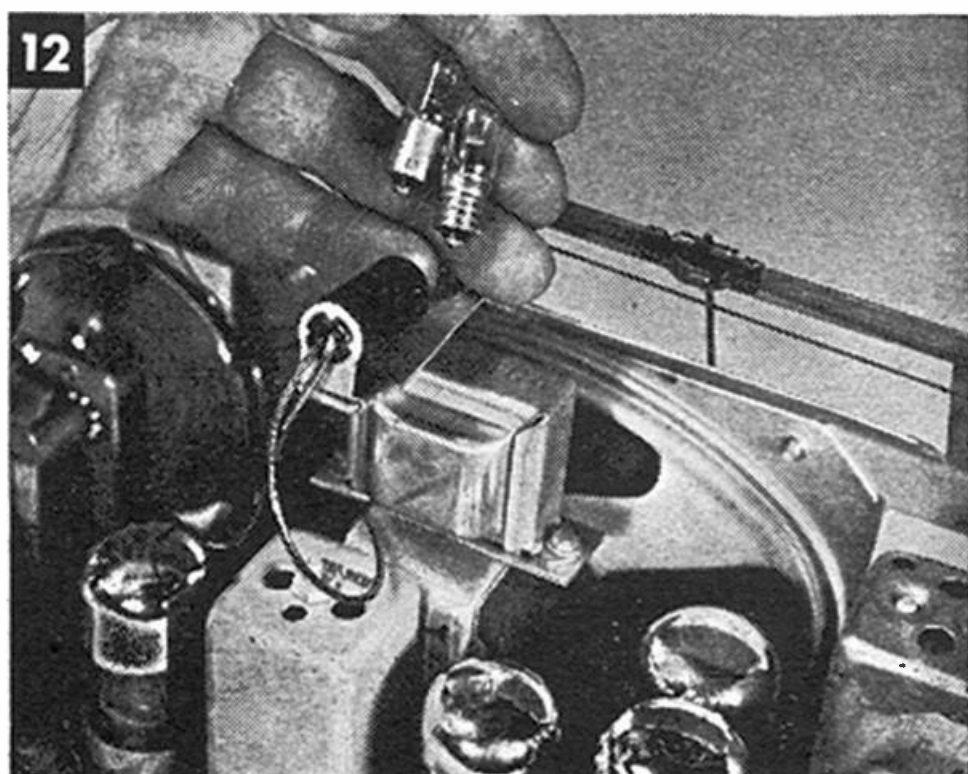

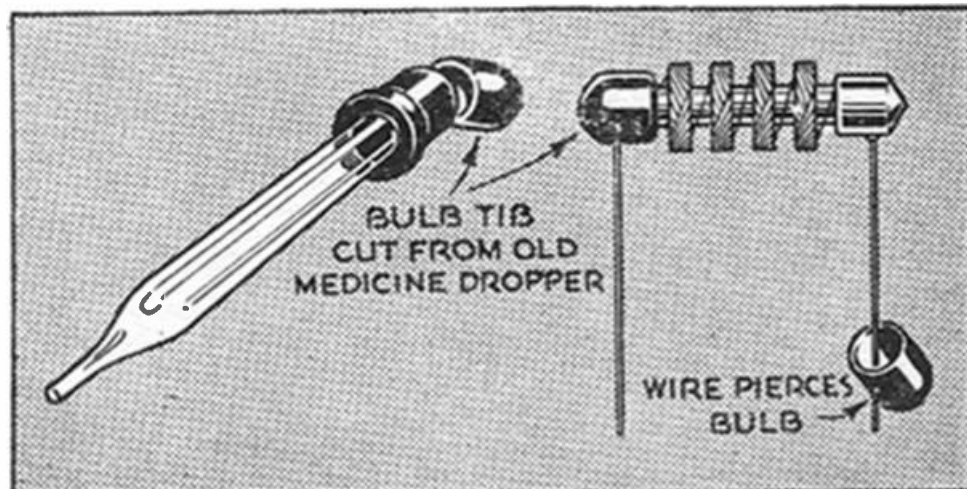

Rubber Tips Insulate Chokes

WHEN crowding radio parts close together to make a compact job, here's a method for protecting the bare metal ends of an RF choke against accidental contacts. For each end, cut the rubber tip from an old medicine dropper and place it over the end as shown.—*Alfred H. Fortier, Orono, Me.*

Vent Holes Prolong Tube Life

A FEW $\frac{1}{8}$ " holes drilled around the socket of the rectifier tube of a large receiver, amplifier, or transmitter will keep the tube cooler and thus help to increase its life. Other nearby components are also benefited because the increased air circulation carries away much of the damaging heat.—*D. J. Bachner, Jackson Heights, N. Y.*

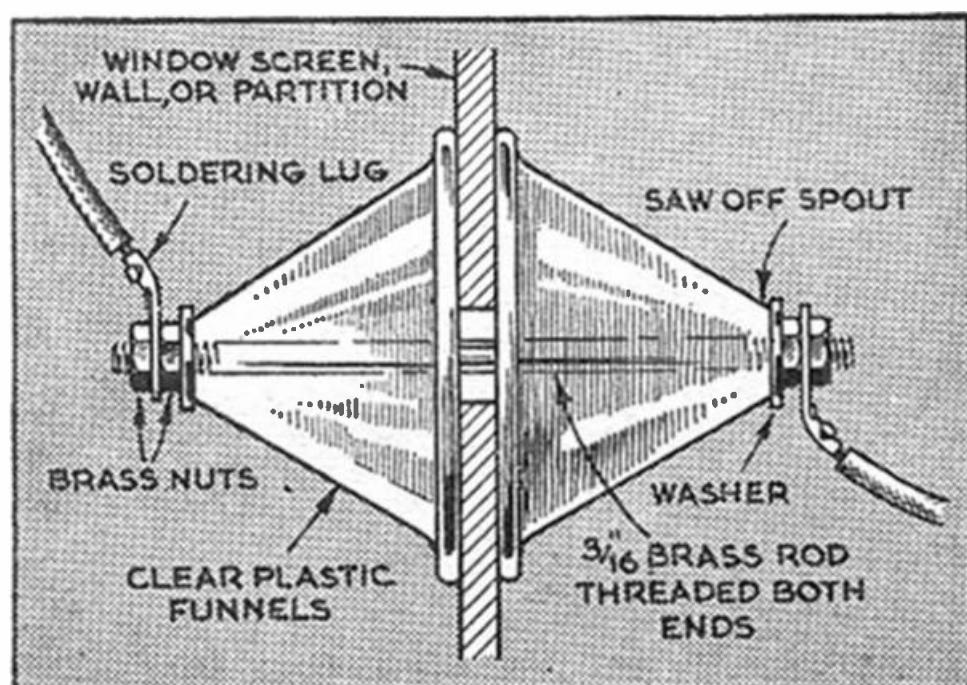

Insulators Made From Funnel

I MADE some swell cone-type feed-through insulators from the small plastic funnels sold in dime stores. Comparable commercial insulators would have cost me a lot more. Two of the funnels, with the tips cut off, are used for each insulator as shown in the sketch above.—*Arthur Trauffer, Council Bluffs, Iowa.*

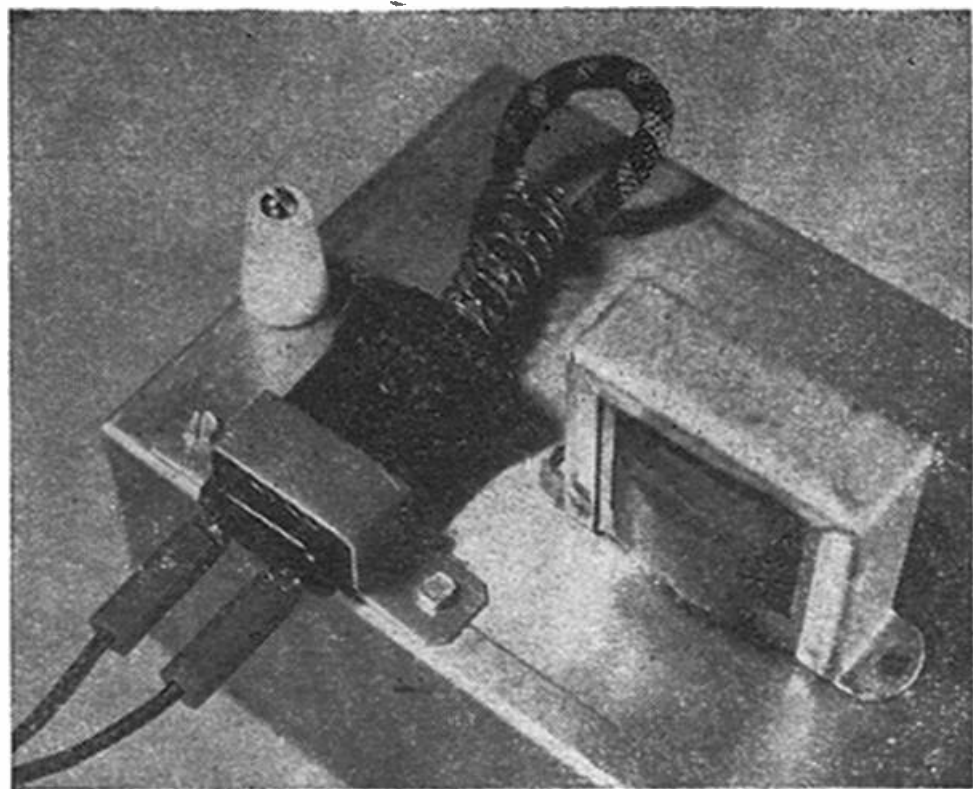

Iron Plug Is Phone Terminal

AN OLD electric-iron plug can be converted into a handy terminal for a mike or phono input or used for an output connection to speaker or phones. Its own cable can be brought under the chassis to the appropriate connections. Incoming leads are fitted with banana plugs, which are in most cases a good fit in the holes. Either bolts and nuts or self-tapping screws can be used to hold the clamp. Being built with heavy-duty insulation, the plugs can be attached directly to the chassis as shown.

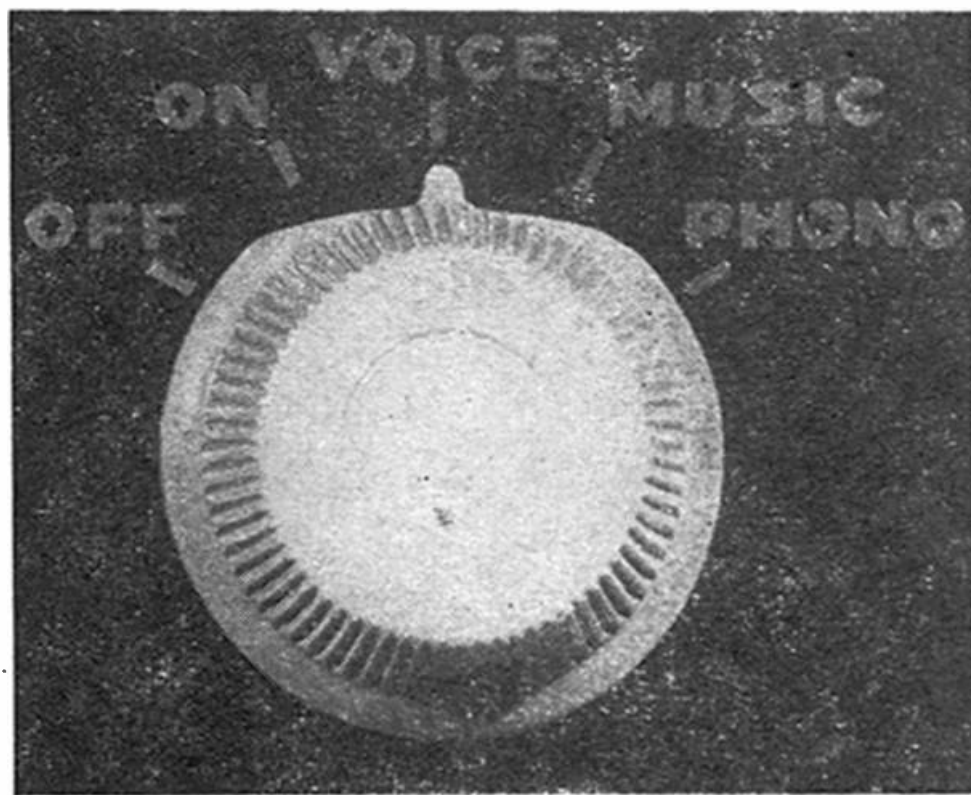

Pointer Filed on Plain Knob

IT IS often convenient to have a reference point on the knob of a volume, tone, or other control so that a setting can be noted for future use. If you don't have a pointer knob on hand or want one that matches the others as closely as possible, you can convert an ordinary round knob to your purposes as shown. File two small flats on the rim, leaving a small portion between them. Then file this portion sharp to form the pointer.

A spot of paint or nail polish on the point will make it easier to read.

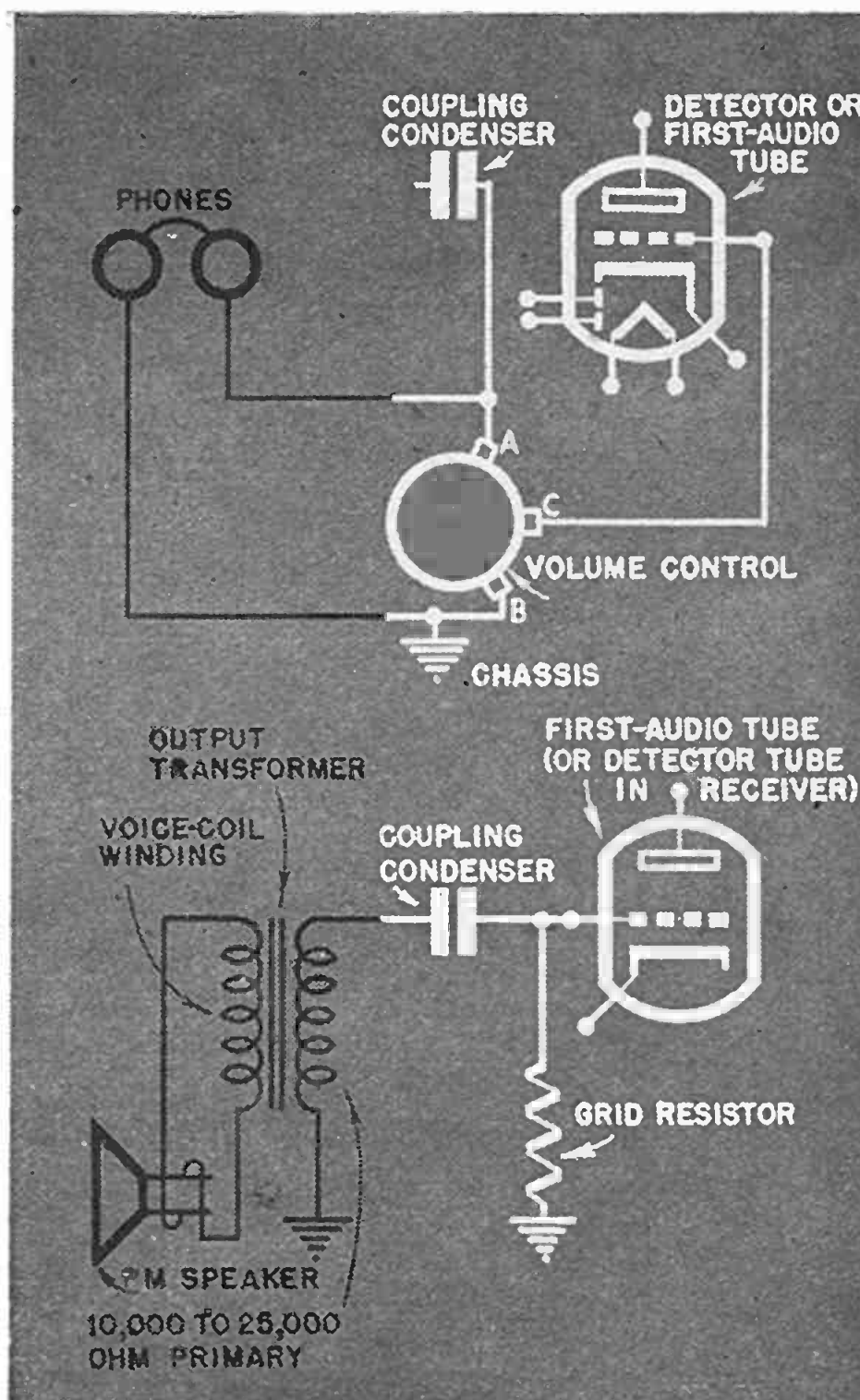

1. Headphones or even a loudspeaker will often replace a crystal microphone. Drawings at

the left show connection to common radio circuits. Above, phone is used to test amplifier.

Radio Parts from Your Scrap Box

Though most components are designed for particular jobs, you can make many of them double up in a pinch.

IF YOU'RE a typical radio experimenter, you know what it means to be stuck for a vital part when the stores are closed. Since many amateurs do their work nights and holidays, it happens to a lot of people. Next time you run into that situation, take a look in your spare-parts box. You may not see what you're looking for, but perhaps you'll find at least a temporary substitute for the part you need.

The first rule for making spare parts work for you is to keep them in good order. Separate components by type and value, and never, never toss in a defective part without marking it. If you know a condenser is shorted or open, throw it away. A transformer with one winding open is worth saving,

however, if you tape on a note that tells what's wrong with it.

With a fair selection of resistors you should never be too badly stuck for a particular value. Connect smaller ones in series to add up to the total you want, or in parallel to get a lower value. The same is true of condensers, but in reverse.

Headphones and loudspeakers are usually thought of as reproducers but they will also operate as microphones in a pinch. A single phone will give fair volume with two stages of amplification, as in an AC-DC receiver; both phones will do even better. For such use, connect it as shown in the upper sketch. In some cases it may be necessary to make the connection at terminal C of the volume control instead of terminal A. If the amplifier has a microphone-input jack, you'll use that, of course. As you can see in the diagram, no special coupling is needed; the condenser and volume control are already in the set.

To use a permanent-magnet speaker as a microphone you need a transformer to match the voice-coil impedance to that of the amplifier grid. The best bet is to use a regular intercom transformer which has a secondary winding in the neighborhood of 70,000 ohms. Lacking this, try an ordinary output transformer, selecting the highest primary impedance available. Wire them as shown in the lower sketch of Fig. 1; black lines represent the parts added to those already in the set.

The humble wafer socket has the makings of a test-point adapter (Fig. 2). The wafer socket must be of the same base type as the tube to be checked. Invert the socket, push in the tube, and plug both tube and test socket into the socket on the chassis. It may be necessary to clip the prong sleeves on the wafer socket to allow the tube pins to extend through. Bend back the soldering lugs.

You may find yourself short of test prods at a bad time. That's nothing to worry about if you have two mechanical pencils around the shop. These pencils make good substitutes for prods (Fig. 3). They should have plastic barrels, or you may find yourself holding a piece of high voltage. Make sure that a good contact exists between the metal ferrule on top of the pencil and the metal tip. Wedge the wire from the meter under the eraser cap or solder it on.

Coil Forms from Spools

An ordinary wooden pencil, by the way, will make a fine core for a high-frequency choke. Such chokes are widely used in FM and TV receivers and in other high-frequency equipment. Leave the graphite in the pencil; it takes the place of a powdered metal core. Saw off a 1" piece and wind the coil around it.

Other substitute coil forms can be salvaged from flashlight batteries or a sewing box (Fig. 4). In the former case, slip the cardboard sleeve off the cell; in the latter, use a wooden spool from which the thread has been removed. Finished coils will stay neat longer if they are coated with liquid coil dope.

Have you ever thought of employing a power transformer as an output transformer? Even a defective unit can be used at times. In Fig. 5 a fairly common transformer type is shown in this unconventional application. Using half the high-voltage winding between the plate and B plus, and em-

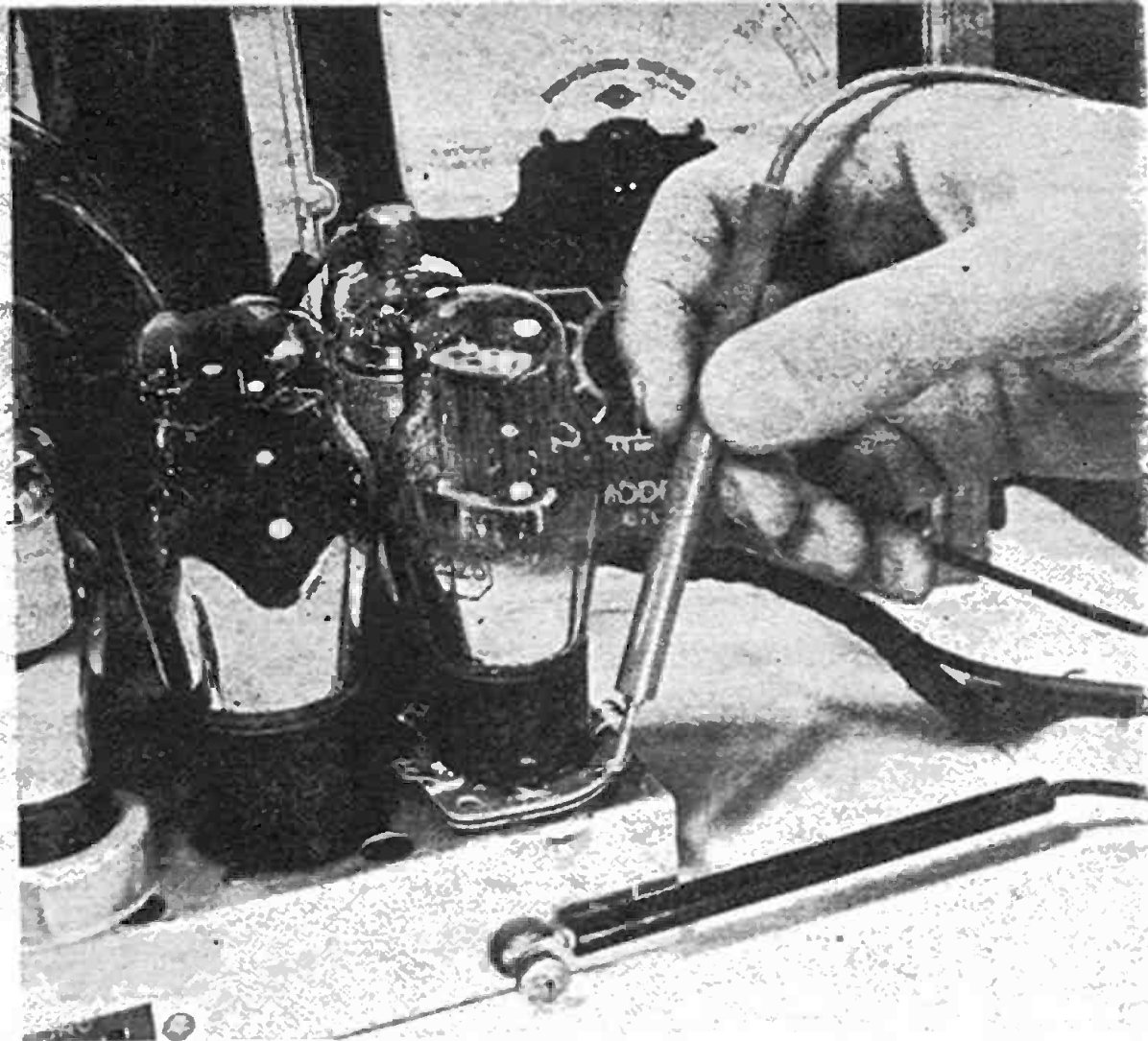

2. Test-point adapter, easily made from wafer tube socket, allows you to check voltages at the tube instead of turning chassis over.

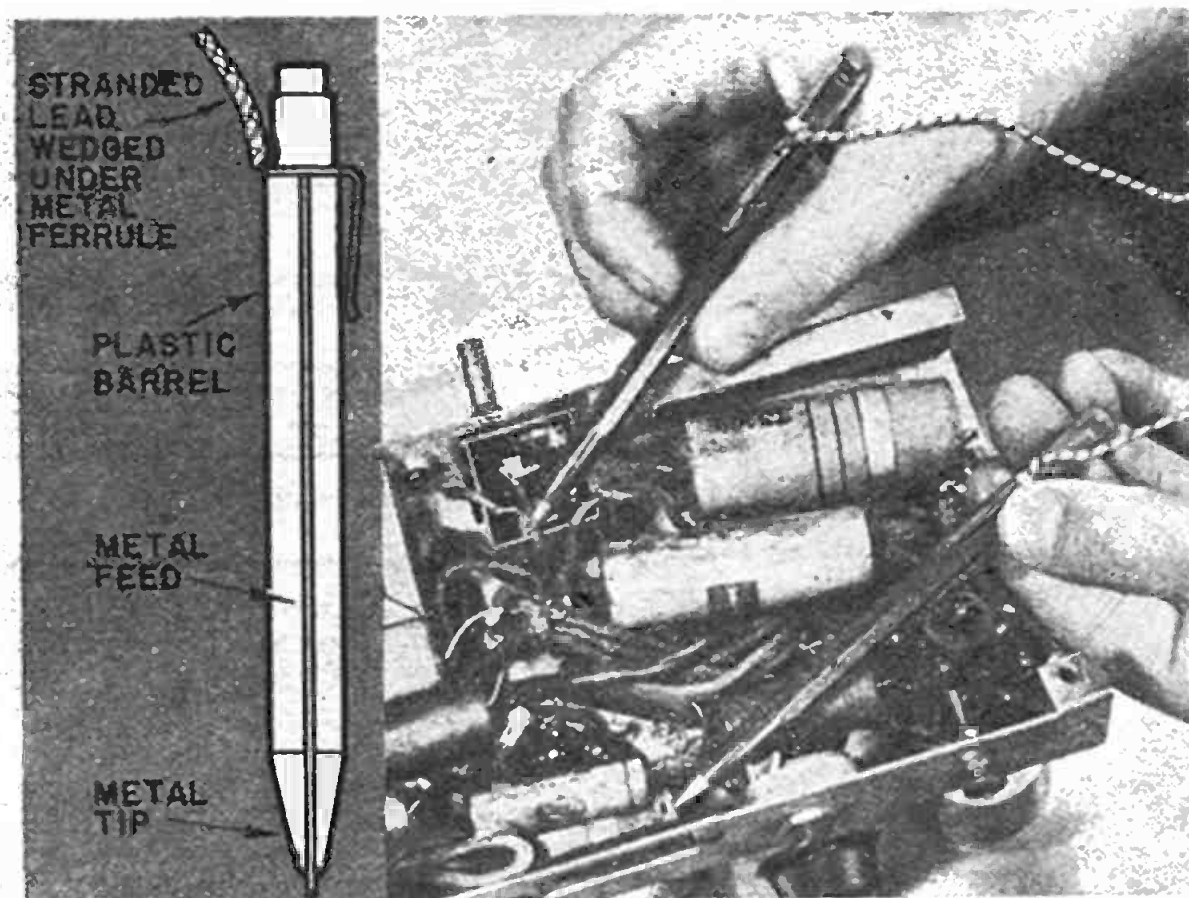

3. Need a pair of test prods? Try using mechanical pencils. Be sure they have plastic barrels, for the metal parts may be "hot."

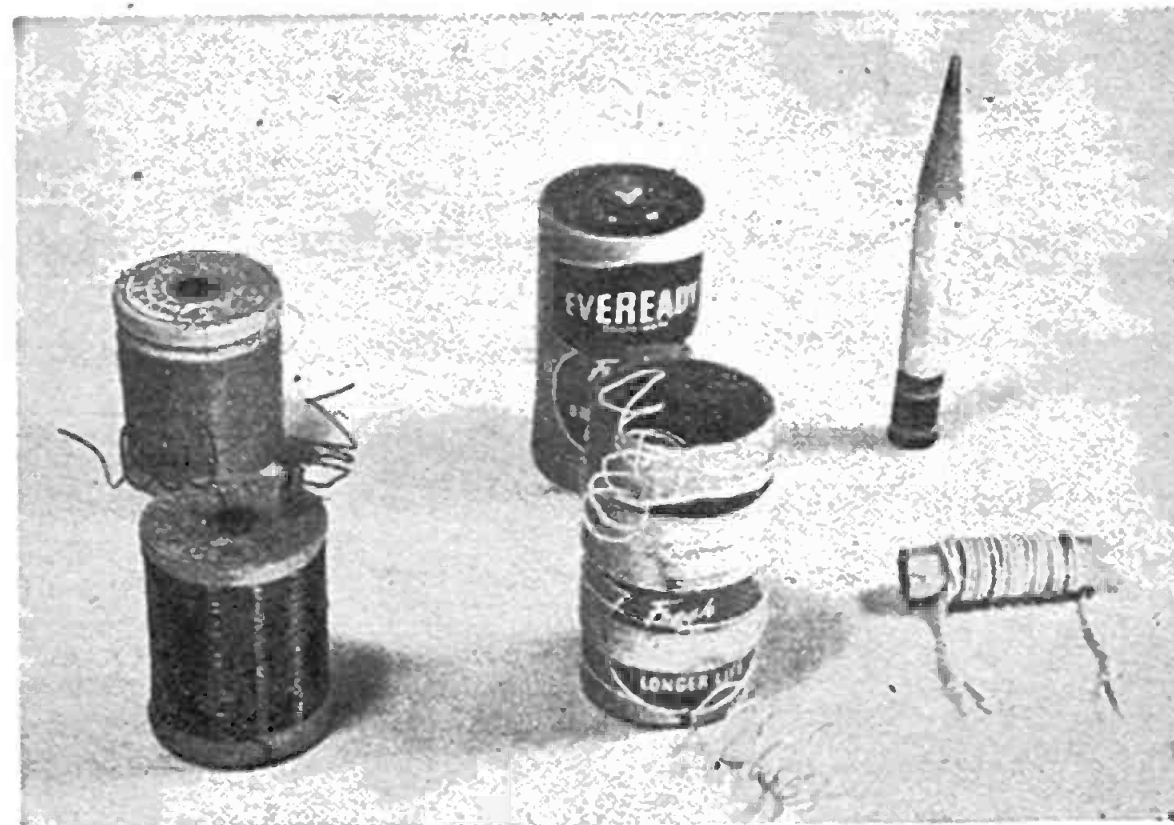

4. Coil forms can be improvised from many common objects. Windings must, of course, be figured in relation to diameter of the form.

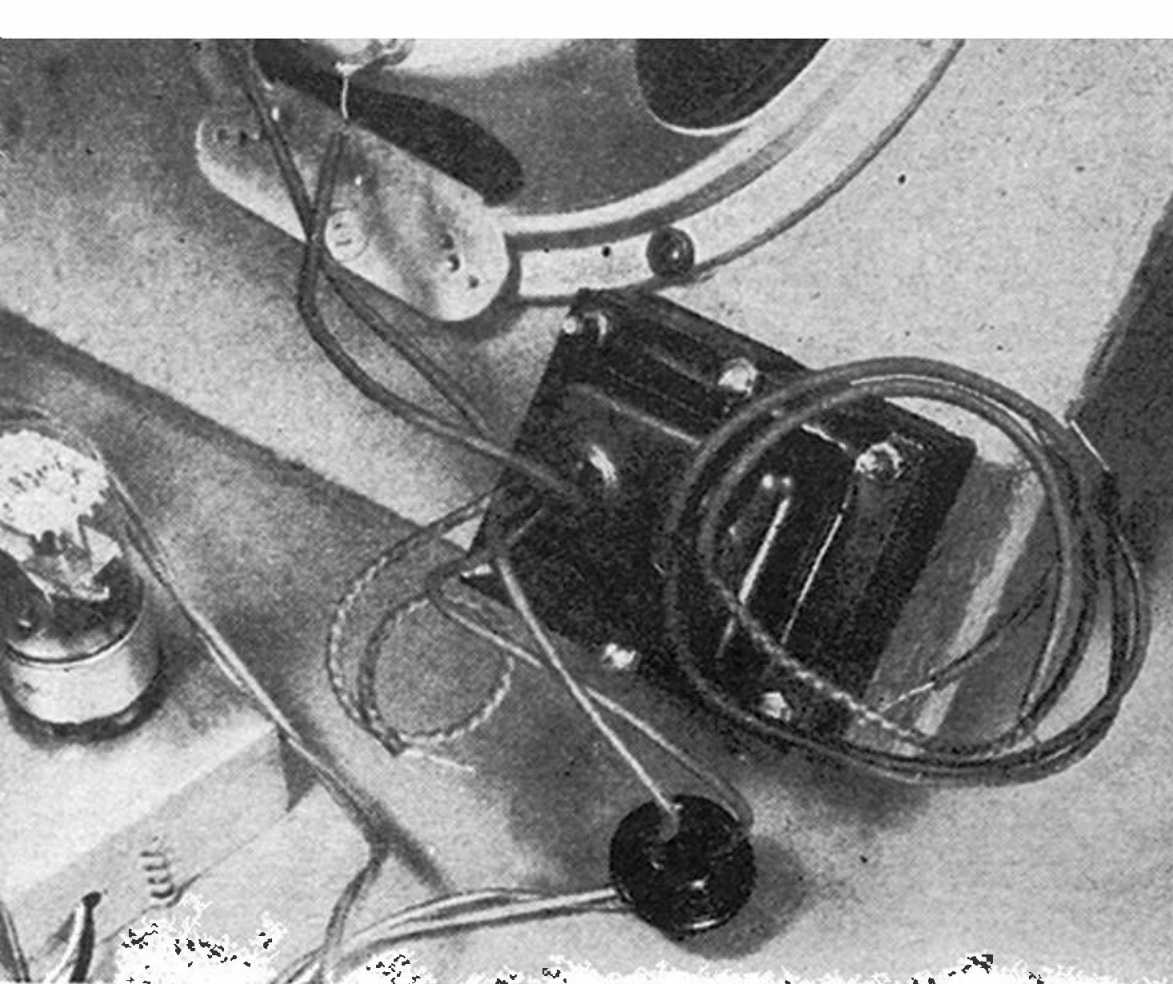

5. A power transformer can be used in place of an output transformer. It's an expensive sub-

stituting the 5-volt rectifier winding for the voice coil gave a surprisingly good match between a 35L6 power tube and the speaker. For other tubes and speakers you can try a number of other combinations. The 6.3-volt secondary, for example may be used in place of the 5-volt one. Also try the entire high-voltage side, or half the 6.3-volt winding.

A push-pull audio transformer can be made from two single-tube transformers if they're wired in series as shown in Fig. 6. First try connecting one grid and one ground lead together at the center tap. This may not be the best arrangement, however, so experiment with others.

By juggling the filament windings on an old power transformer made for 5-volt and 2.5-volt tubes, you can obtain 6.25 volts. This means you can use the transformer in a circuit employing modern 6.3-volt tubes. Note, however, that you no longer have a 5-volt tap for the rectifier, so you'll have to use a 6X5 or similar 6.3-volt rectifier, heating all tubes off one winding.

Subs for Filter Chokes

It often happens that a serviceman or experimenter is stuck for a filter choke. It may occur when you replace a field-coil speaker with a permanent-magnet one, for the field coil frequently doubles up as a choke. In a pinch you'll find a filament transformer is a pretty good substitute. Lacking a filament transformer, try using the primary winding of an output transformer in place of the missing choke. Both applications are pictured in Fig. 8.

Figure 9 illustrates another possible transformer dodge. The photo shows a universal output transformer being used to feed

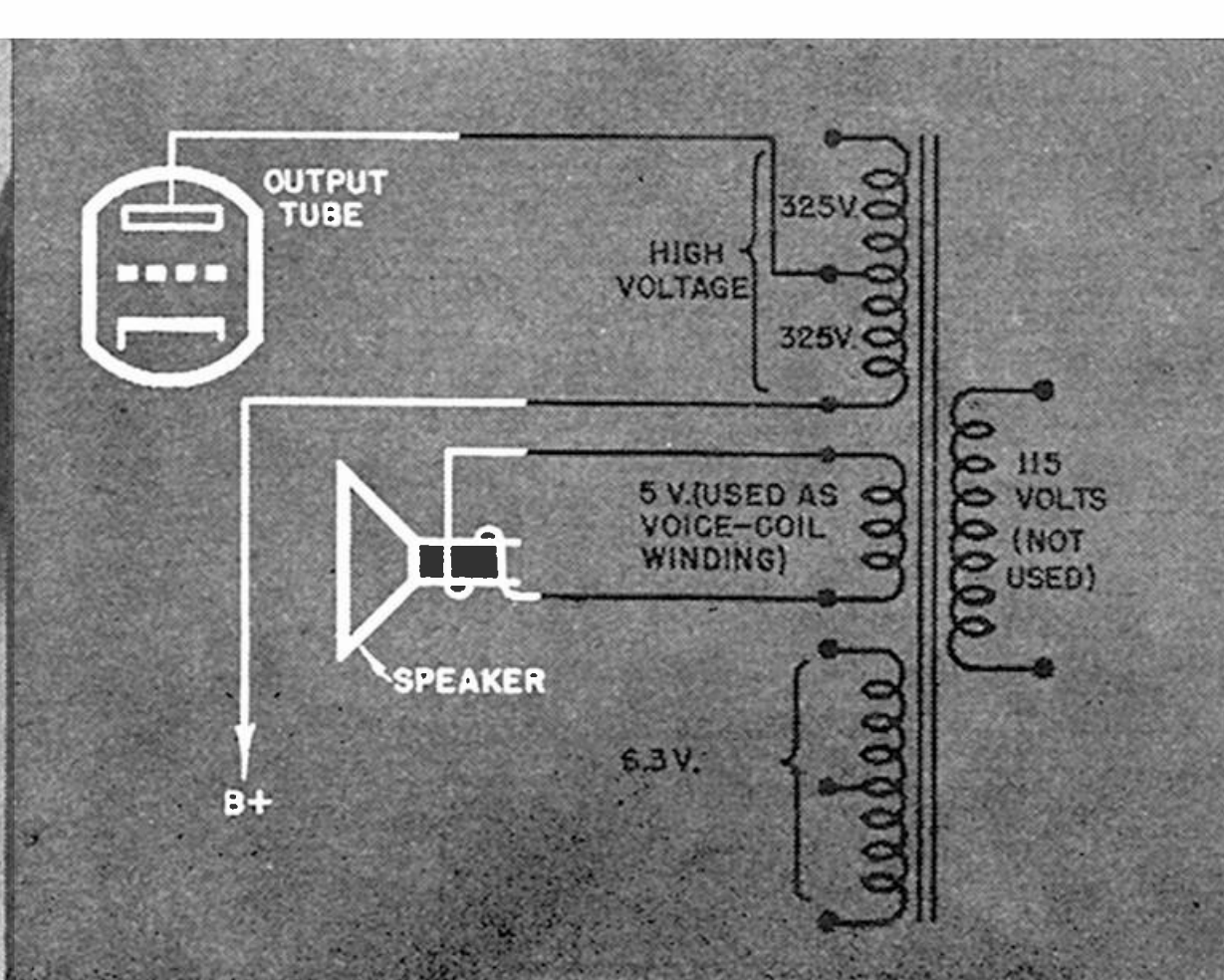

stitute, but it will work nicely until you get a chance to put in the correct replacement unit.

6-3-volt tube heaters. This won't work in all cases, but by trying the various taps on both primary and secondary you may be able to find a combination that steps down 115 volts to a value very close to 6.3. Test the voltage on an AC meter before risking the tubes. The transformer should be rated at 8 to 10 watts or higher; smaller ones will overheat. The voice-coil winding goes to the tube filaments while the primary is connected to the 115-volt line.

Selector Switches

If it's a low-voltage switch you want, you don't have to hunt very far. A few nickel-plated wood or machine screws will do the job nicely, as pictured in Fig. 10. The setup shown is a test circuit in which a universal output transformer is used to feed a number of different speakers. Instead of soldering and unsoldering a number of connections to find the best match, make a selector switch by driving the required number of screws into a scrap of wood. Place them in an arc arrangement so that the moving arm—which can be a flat brass or plated bracket about 1½" long—will make contact with each screw head. A small wooden knob can be attached at the end opposite the pivot screw.

Parts substitution of the kind described above may not save you much money, but it will save a lot of time and energy. Obviously it doesn't make sense to buy a \$3 power transformer in order to replace a filament transformer that costs half as much. But if you happen to have the more expensive unit gathering dust, you won't lose anything by putting it to work. If this makes it possible to finish the building or repair job you're doing, it will often put you ahead of the game.

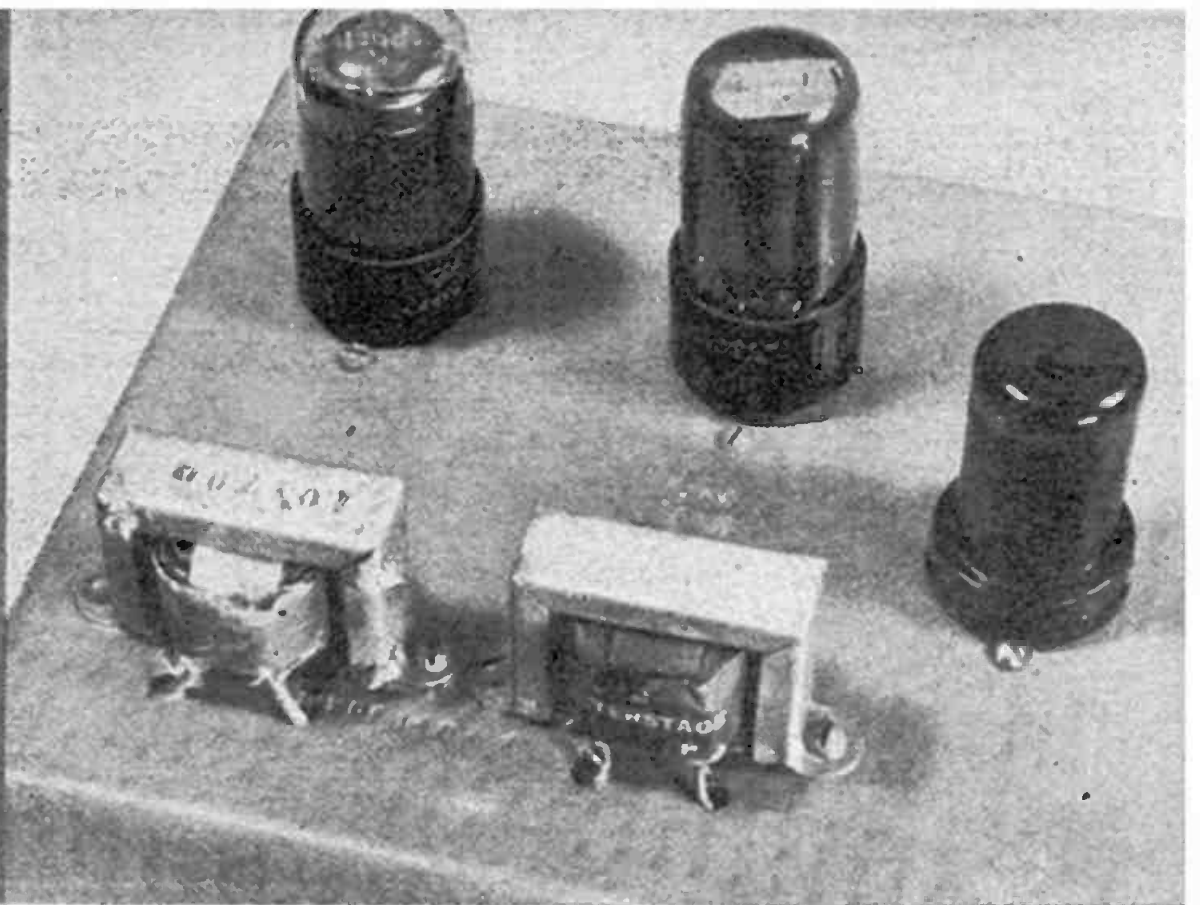
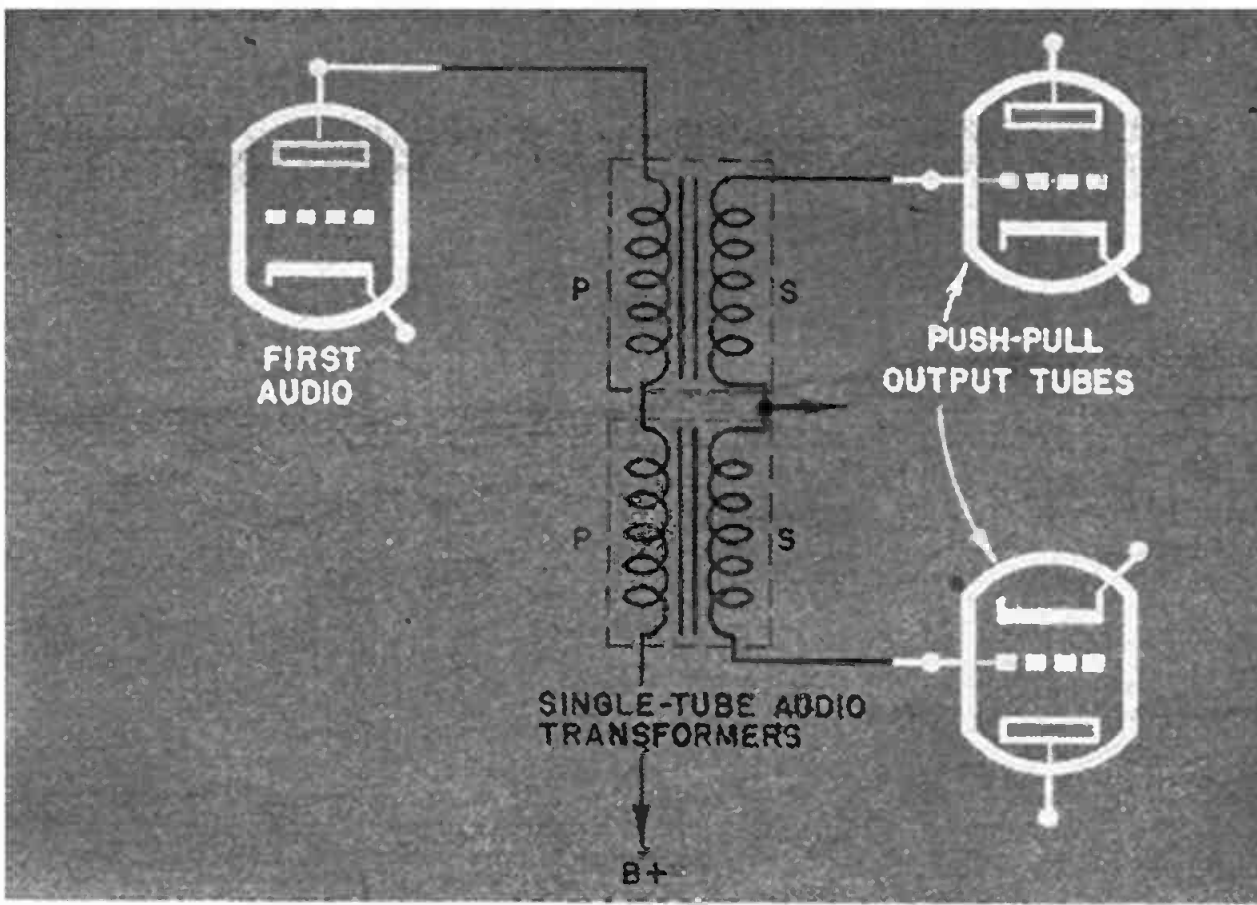

6. Two single-tube audio transformers make a neat replacement for a push-pull transformer.

Depending on transformer make, method of connection may vary; try different combinations.

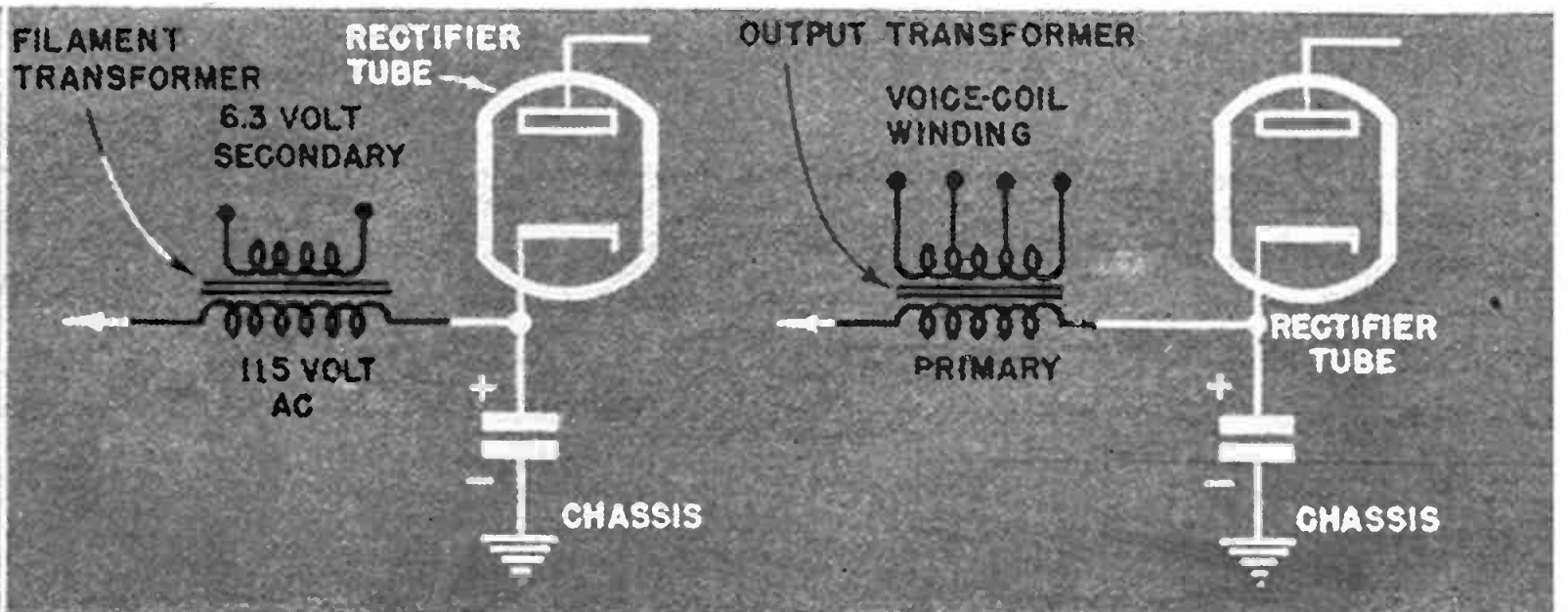
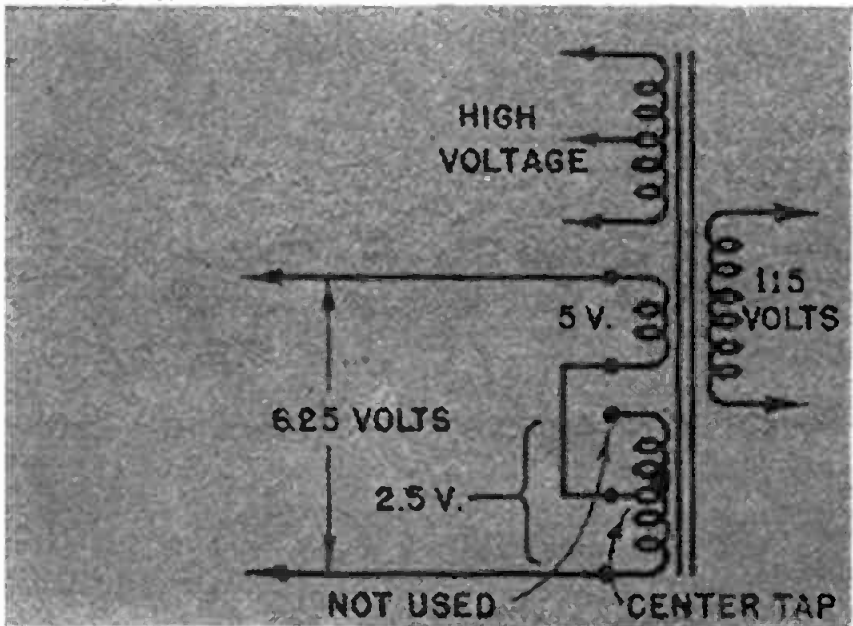

7. Old transformers for 2.5 and 5-volt tubes can be used in modern circuits with 6.3-volt heaters. This arrangement gives 6.25 volts.

8. Filter chokes may be improvised from either filament or output transformers. One winding isn't used; it can even be open or shorted.

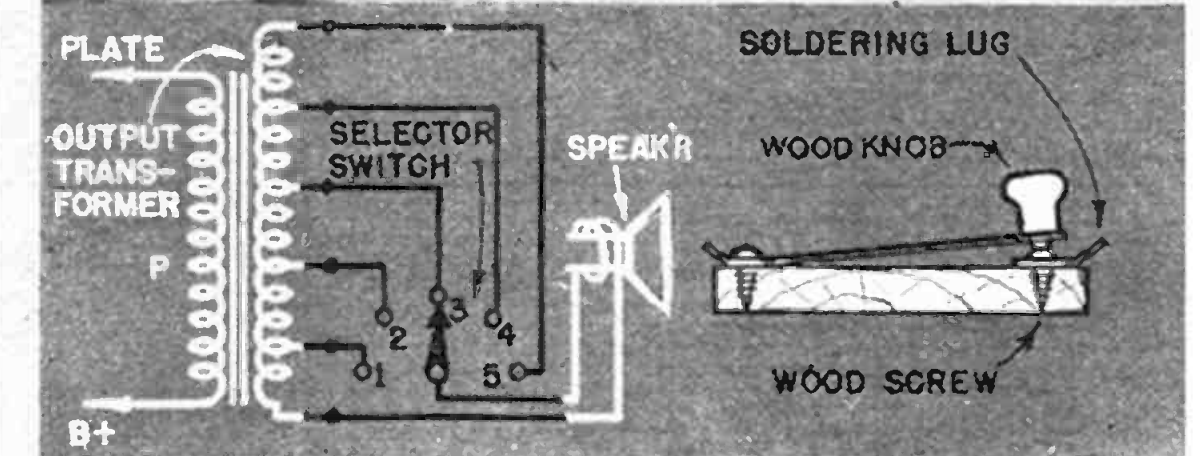
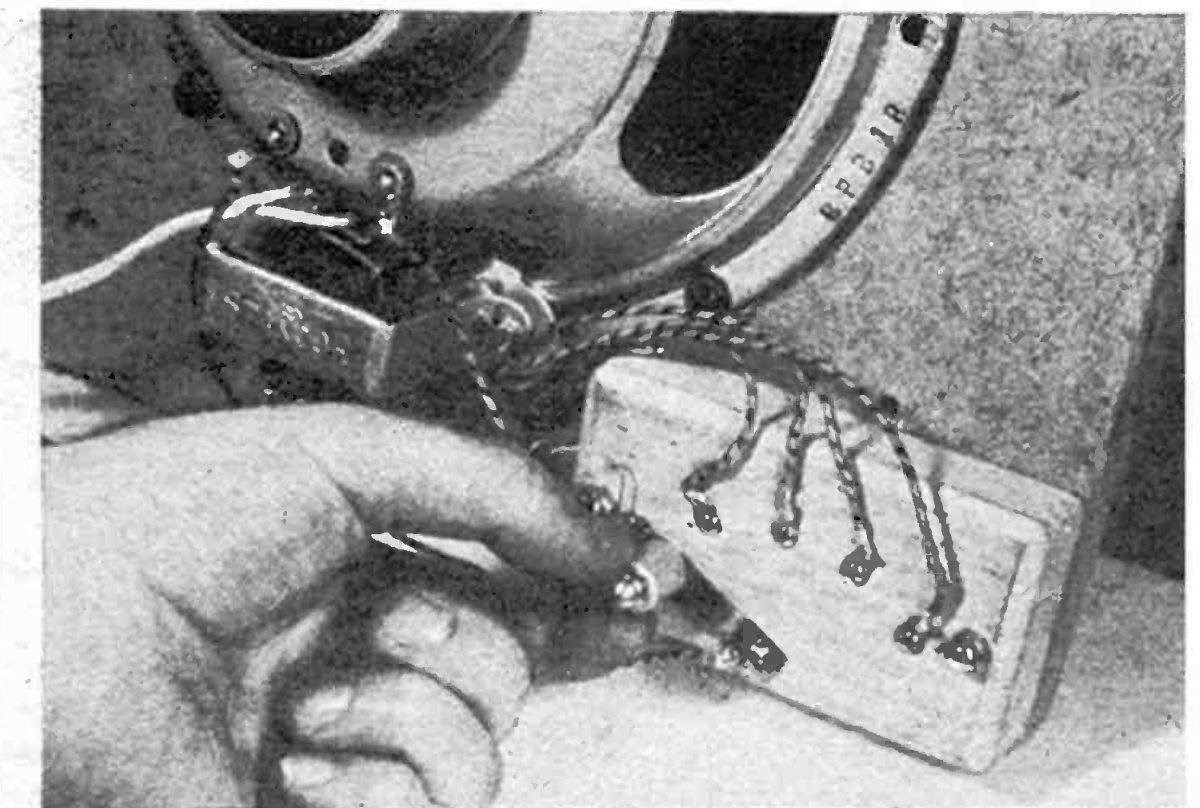
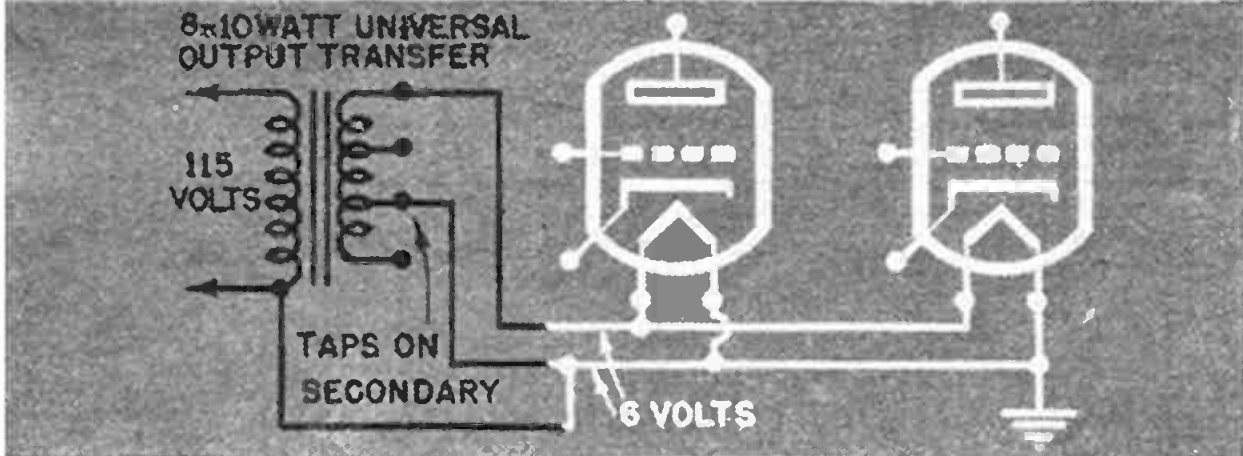
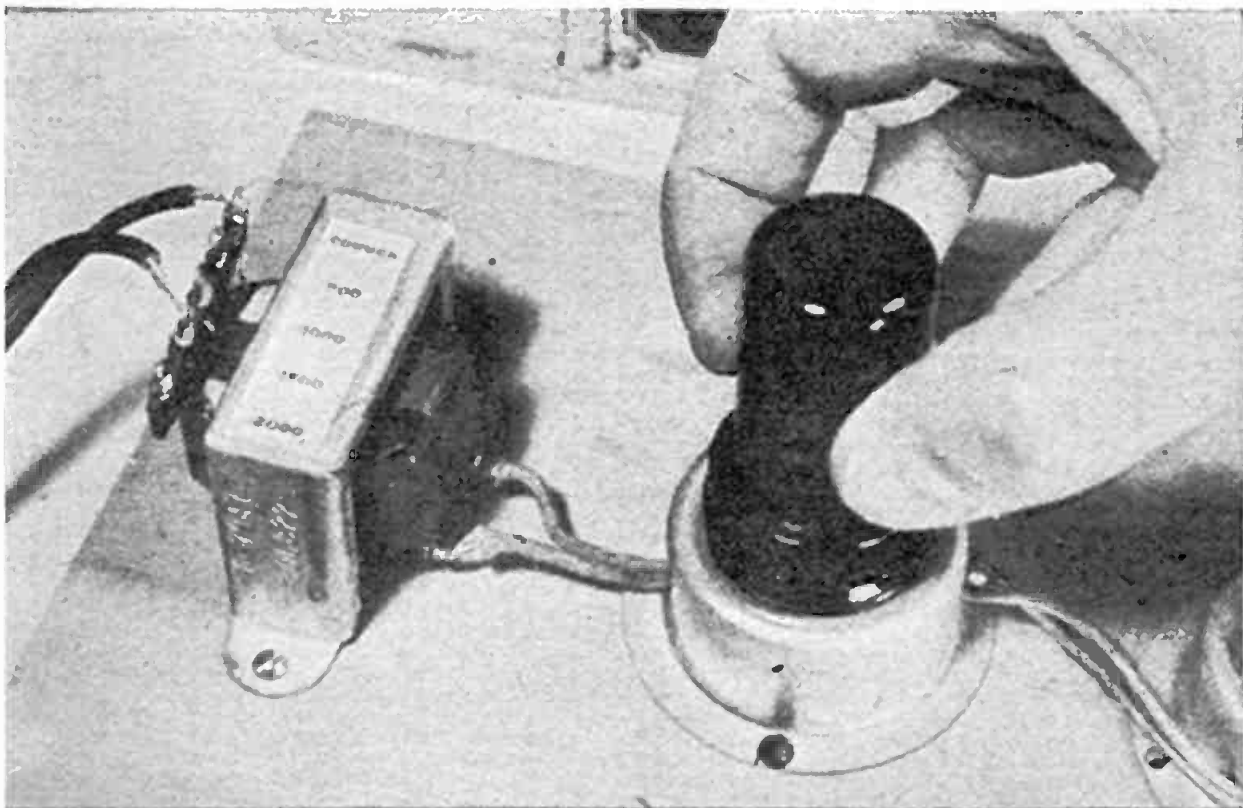

9. Heater voltage can be furnished in many ways; one of the more unusual ones is to use an output transformer. Test tap combinations.

10. Selector switches are a cinch to make. A couple of screws and a flat metal arm do the trick. Use soldering lugs for the contacts.

Index

Index

A

- A.c./d.c. power supply, how to test. 45
- A.c. power supply. 67
- Alignment 33
- Alignment indicator 199
- Amplifier, five-tube 116
- Amplifier, high fidelity. 130
- Amplifier, how to install in record player 110
- Amplifier, one-tube 96
- Amplifier, three-tube 111
- Antenna, FM 172
- Antenna, loop, how to mount. . . . 41
- Antenna, loop, how to identify leads 51
- Automatic volume control. 56
- Auto receiver 225

B

- Ballast resistors 88
- Ballast tubes 91
- Bass compensation volume control. 88
- Bass reflex speaker enclosure. . . . 142
- Battery receivers 203
- Bypass condenser, screen. 80

C

- Cabinet, record player. 107
- Chassis construction 82
- Chassis layout 15
- Chassis punch, how to use. 14
- Coil, oscillator, how to identify windings 52
- Coils, short wave. 218
- Condenser checker 191
- Condenser, electrolytic, common positive 73
- Condenser, electrolytic, dual. 73
- Condensers, working voltage of. . . . 74
- Crossover network 141
- Crystal diode 12

D

- Diode, crystal 12

E

- Electrolytic condenser, common positive 73
- Electrolytic condenser, dual. 73
- Electron-ray indicator 69

F

- Filter, resistor-condenser type. 42
- Five-tube superheterodyne 35
- Five-tube amplifier 116
- FM antennas 172
- FM tuner alignment. 171
- Frequency modulation 159

G

- Generator, signal 187
- "Gimmick" 53

H

- Headphones, how to connect to set. 13
- Heater circuit, parallel. 66
- Heater circuit, series, how to test. . . 44
- Heater circuit, series, how to wire. . . 43
- High Fidelity, cost. 128
- High Fidelity record changers. 128
- High Fidelity systems. 127
- See also Amplifiers, Tuners, Phono pickups, Record players, etc.
- High Fidelity, what it is. 127
- Holes, rectangular, how to cut. 64

I

- Ignition interference: how to overcome 237
- Indicator, electron-ray, how to install 69
- Indicator, visual alignment. 199
- Installing amplifier in record player 110
- Intercommunicator 122
- Interference, ignition, how to overcome 237

L

- Lamps, pilot 93
- Layout of receivers. 76
- Line resistor, how to determine value of 89
- Loop antenna, how to mount. 41
- Loop antenna, how to identify leads 51

M

- Milliammeters 175
- Multiple speakers 139
- Multitester 183

O

Ohmmeters	180
One-tube receiver	12
Oscillation, causes of.....	78
Oscillation, how to prevent.....	78
Oscillator coil, how to identify windings	52
Oscillator, phono	99
Output transformer, how to mount.	40

P

Parallel heater circuit.....	66
Parts from your scrap box.....	246
Parts, how to buy.....	240
Parts substitutions	71
Phono amplifier, one-tube.....	96
Phono cartridge	106
Phonograph, how to connect to set.	13
Phonograph oscillator	99
Phono input, how to add.....	54
Phono motor, how to connect.....	105
Phono oscillator, installing in rec- ord player	103
Phono pickups	157
Pickup, how to mount.....	109
Pilot lamps	93
Portable receiver	203
Power supply	42
Power supply, a.c.	67
Power supply, a.c./d.c., how to test.	45
Power supply, arrangement of com- ponents	77
Power supply, auto radio.....	225
Preamplifier	120
Punch, chassis, how to use.....	14

R

Radios, see receivers	
Receiver, auto	225
Receiver layout	76
Receiver, one-tube	12
Receiver, portable	203
Receiver, battery-operated	203
Receiver, short wave.....	215
Receiver, three-tube	22
Receiver, two-tube	18
Receiver wiring	85
Record changers, high fidelity.....	128
Record player cabinet.....	107
Record player, how to assemble...	105
Record players	155

Rectangular holes, how to cut.....	64
Rectifier, selenium	55
Resistor, ballast	88
Resistor-condenser power supply filter	42
Resistor, line, how to determine value of	89

S

Screen bypass condenser.....	80
Sectional wiring	42
Selenium rectifier	55
Series heater circuit, how to test...	44
Series heater circuit, how to wire...	43
Short wave coils, how to wind.....	218
Short wave receiver.....	215
Signal generator	187
Soldering	85
Speaker enclosures	142
Speaker, how to mount	17
Speakers, multiple	139
Stylus pressure	106
Substitution of parts.....	71
Superheterodyne, five-tube	35
Superheterodyne, six-tube	57

T

Template, how to use.....	75
Test equipment	175
Three-tube amplifier	111
Three-tube receiver	22
Tips, tricks and shortcuts.....	71
Tone control, how to add.....	69
Transformer, output, how to mount	40
Trouble location chart.....	33
Trouble shooting	33
Tubes, ballast	91
Tuner, FM	159
Two-tube receiver	18

V

Voltmeter, a.c.	183
Volume control, automatic.....	56
Volume control, bass compensation type	88
Volume control, how to connect...	87

W

Wiring, sectional method.....	42
Working voltage of condensers....	74