

H. H. ...

JOURNAL OF THE A. I. E. E.

OCTOBER 6 1930



PUBLISHED MONTHLY BY THE
AMERICAN INSTITUTE OF ELECTRICAL ENGINEERS
33 WEST 39TH ST. NEW YORK CITY

MEETINGS

of the

American Institute of Electrical Engineers

MIDDLE EASTERN DISTRICT MEETING, No. 2,
Philadelphia, Pa., October 13-15, 1930

SOUTHERN DISTRICT MEETING, No. 4, Louis-
ville, Kentucky, November 19-22, 1930

ANNUAL WINTER CONVENTION, New York,
N. Y., January 26-30, 1931



MEETINGS OF OTHER SOCIETIES

National Safety Council, Pittsburgh, September 29-October 4,
inclusive, (W. H. Cameron, North Wacker Drive, Chicago)

American Society of Civil Engineers, Fall Meeting, St. Louis,
Missouri, October 1-3, (George T. Seabury, Secretary, Engi-
neering Societies Building, 29 West 39th St., New York)

Illuminating Engineering Society, Hotel John Marshall, Rich-
mond, Va., October 7-10, (E. H. Hobbie, 29 West 39th St.,
New York, N. Y.)

National Electric Light Association

New England Division, New Ocean House, Swampscott,
Mass., September 29-October 1, 1930. (Miss O. A. Bursiel,
20 Providence Street, Boston)

Rocky Mountain Division, Franciscan Hotel Albuquerque,
N. M., October 20-22, (O. H. Weller, Public Service Co. of
Colórado, Denver)

JOURNAL of the A. I. E. E.

PUBLISHED MONTHLY BY THE AMERICAN INSTITUTE OF ELECTRICAL ENGINEERS
33 West 39th Street, New York

PUBLICATION COMMITTEE

W. S. GORSUCH, *Chairman*, H. P. CHARLESWORTH, F. L. HUTCHINSON, A. E. KNOWLTON, E. B. MEYER

GEORGE R. METCALFE, *Editor*

Changes of advertising copy should reach Institute headquarters by the 15th day of the month for the issue of the following month.
Subscription: \$10.00 per year to United States, Mexico, Cuba, Porto Rico, Hawaii and the Philippines, Central America, South America, Haiti, Spain and Colonies, \$10.50 to Canada, and \$11.00 to all other countries.
Single copies \$1.00.

Entered as matter of the second class at the Post Office, New York, N. Y., May 10, 1905, under the Act of Congress, March 3, 1879. Acceptance for mailing at special rate of postage provided for in Section 1103, Act of October 3, 1917, authorized on August 3, 1918.

Vol. XLIX

OCTOBER 1930

Number 10

TABLE OF CONTENTS

Papers, Discussions, Reports, Etc.

Electricity's Part in Open Cut Copper Mining (Abridged), by R. J. Corfield	823	The Calculation of Cable Temperatures (Abridged), by W. B. Kirke	855
New Waldorf Astoria to Have Largest Centralized Radio	825	The Influence of Polarity on High-Voltage Discharges (Abridged), by F. O. McMillan and E. C. Starr	859
Calculation of Mechanical Performance of Oil Circuit Breakers (Abridged), by A. C. Schwager	826	Transmission System Relay Protection—III (Abridged), by W. W. Edson	863
Steam Power Development (Abridged), by R. C. Powell	830	The Effect of Transient Voltages on Dielectrics—IV (Abridged), by F. W. Peek, Jr.	868
New Trends in Mercury Arc Rectifier Developments (Abridged), by O. K. Marti	834	The M. I. T. Network Analyzer (Abridged), by H. L. Hazen, O. R. Schurig and M. F. Gardner	872
Grounding Banks of Transformers with Neutral Impedances (Abridged), by F. J. Vogel and J. K. Hodnette	838	Origin of the Word Electron	875
The East River Generating Station (Abridged), by C. B. Grady, W. H. Lawrence and R. H. Tapscott	842	Ways and Means to Traffic Safety	875
High-Speed Protective Relays (Abridged), by L. N. Crichton	846	Railbonding Practise and Experience on Electrified Steam Railroads (Abridged), by H. F. Brown	876
Arcing Grounds and Effect of Neutral Grounding Impedance (Abridged), by J. E. Clem	850	Illumination Items	
Dropping a Dam in Place	854	Inadequate Wiring of Buildings	877
		Courses in Fundamentals of Architecture Given for Illuminating Engineers	877

Institute and Related Activities

Middle Eastern District Meeting	878	A New Member of Journal Staff	885
Southern District Meeting at Louisville	879	Personal Mention	886
Pacific Coast Convention	880	Obituary	886
New York Section to Hold Three October Meetings	881	Addresses Wanted	887
Nomination of Officers	882	Section Activities	
New Laboratory to be Dedicated at Lehigh	882	Past Section Meetings	888
New Graduate Courses at the Polytechnic Institute of Brooklyn	883	A. I. E. E. Student Activities	
Ninth National Power Show	883	Student Session at Pacific Coast Convention	888
National Research Council		Engineering Societies Library	
Committee on Electrical Insulation	883	Book Notices	889
Industrial Research Laboratory	883	Engineering Societies Employment Service	
International Electrotechnical Commission	883	Positions Open	890
New Test Method for Thermal Conductivities Issued by A. S. T. M.	885	Men Available	890
Luncheon in Honor of Baron Shiba	885	Membership	
A Memorial to George Westinghouse	885	Applications, Elections, Transfers, etc.	892
Airport Drainage and Surfacing Committee Program	885	Officers A. I. E. E. 1930-1931	893
		List of Sections	894
		List of Branches	894
		Order for Reprints of Papers abridged in JOURNAL	895
		Digest of Current Industrial News	896

A REQUEST FOR CHANGE OF ADDRESS must be received at Institute headquarters at least ten days before the date of issue with which it is to take effect. Duplicate copies cannot be sent without charge to replace those issues undelivered through failure to send such advance notice. With your new address, be sure to mention the old one indicating also any changes in business connections.

Copyright 1930. By A. I. E. E.

Printed in U. S. A.

Permission is given to reprint any article after its date of publication, provided proper credit is given.

(The Journal of the A. I. E. E. is indexed in Industrial Arts Index.)

AMERICAN INSTITUTE OF ELECTRICAL ENGINEERS

—Some Activities and Services Open to Members—

Employment Service.—The employment service is a joint activity administered by the Civil, Mining, Mechanical, and Electrical Engineering societies and is available to the membership of these societies. Branches of this Department are located in Chicago and San Francisco, the main office being located at the societies headquarters in New York. The service is designed to be mutually helpful to engineers seeking employment, and concerns desiring to secure the services of engineers. This department is financed by contributions from the societies maintaining it and from beneficiaries of the service. Further details will be furnished on request to the Managers of the Employment Service at the main or branch offices, addresses of which will be found elsewhere in this issue.

Scope of Papers.—Institute papers should present information which adds definitely to the theoretical or practical knowledge of electrical engineering and may be derived from activities in any of its branches. Acceptable subject matter is as follows: New theories or new treatments of existing theories; Mathematical solution of electrical engineering problems; Researches, fundamental or practical; Design of equipment, and of electrical engineering projects; Engineering and economic investigations; Operation and tests of electrical equipment or systems; Measurements of electrical quantities; Electrical measurement of non-electrical quantities; Applications of electricity to industrial or social purposes; Education; Standardization; Cooperative engineering organizations; Ethical and social aspects of the profession.

Attendance at Conventions.—Taking part in the Institute conventions is one of the most useful and helpful activities which membership in the Institute affords. The advantages offered lie in two distinct channels; technical information and personal contacts. The papers presented are largely upon current problems and new developments, and the educational advantages of hearing and taking part in the discussion of these subjects in an open forum cannot but broaden the vision and augment the general knowledge of those who participate. Equally advantageous is the opportunity which conventions afford to extend professional acquaintances and to gain the inspiration which grows out of intimate contact with the leaders in electrical engineering. These conventions draw an attendance of from 1000 to 2000 people and constitute milestones in the development of the electrical art.

To Members Going Abroad.—Members of the Institute who contemplate visiting foreign countries are reminded that since 1912 the Institute has had reciprocal arrangements with a number of foreign engineering societies for the exchange of visiting member privileges, which entitle members of the Institute while abroad to membership privileges in these societies for a period of three months and members of foreign societies visiting the United States to the privileges of Institute membership for a like period of time, upon presentation of proper credentials. A form of certificate which serves as credentials from the Institute to the foreign societies for the use of Institute members desiring to avail themselves of these exchange privileges may be obtained upon application to Institute headquarters, New York. The members should specify which country or countries they expect to visit, so that the proper number of certificates may be provided, one certificate being addressed to only one society.

The societies with which these reciprocal arrangements have been established and are still in effect are: Institution of Electrical Engineers (Great Britain), Societie Francaise des Electriciens (France), Association Suisse des Electriciens (Switzerland), Associazione Elettrotecnica Italiana (Italy), Koninklijk Instituut van Ingenieurs (Holland), Verband Deutscher Elektrotechniker E. V. (Germany), Norsk Elektroteknisk Forening (Norway), Svenska Teknologforeningen (Sweden), Elektrotechnicky Svaz Ceskoslovensky (Czechoslovakia), The Institution of Engineers, Australia (Australia), Denki Gakkwai (Japan), and South African Institute of Electrical Engineers (South Africa).

Library Service.—The Engineering Societies Library is the joint property of the four national societies of Civil, Mining, Mechanical, and Electrical Engineers and comprises one of the most complete technical libraries in existence. Arrangements have been made to place the resources of the library at the disposal of Institute members, wherever located. Books are rented for limited periods, bibliographies prepared on request, copies and translations of articles furnished, etc., at charges which merely cover the cost of the service. The Director of the library will gladly give any information requested as to the scope and cost of any desired service. The library is open from 9 a. m. to 10 p. m. every day except holidays and during July and August, when it closes at 5 p. m.

Abridgment of Electricity's Part in Open Cut Copper Mining

BY R. J. CORFIELD¹

Associate, A. I. E. E.

Synopsis.—This paper describes the electrification of a large open cut copper mine, covering 725 acres, operating 23 modern electric shovels, 39 special type electric locomotives, approximately 50 mi. of overhead trolley construction, and a rather elaborate shovel and locomotive feeder system.

The main power supply and receiving substations for the electrifi-

cation are described, and the method of protecting main line trains between mine and concentrating plants with automatic block signals directed by dispatcher through centralized traffic control, illustrated.

Miscellaneous uses of electricity at the mine and plants are discussed, and operating statistics covering one year's operation are included.

INTRODUCTION

THIS mine, (Fig. 1) is, in reality, a mountain of low-grade copper ore opened in 1906; and even at that early date, mining on a large scale, using railway type steam shovels and standard gage rolling stock, was contemplated. From a small beginning, additional equipment was added until in 1922, there were 23 steam shovels and 50 steam locomotives operating to remove ore and waste at the rate of 100,000 tons per day.

Early in 1922 consideration was given to the econo-

superior to steam shovels, and considerable economy was shown, together with other advantages that could not be capitalized. Tests over a period of several months led to the purchase of more electricity until there are now eight a-c. equipments and fifteen d-c. equipments, and none for steam. Fig. 3 is a view of a modern electric shovel.

SHOVEL CHARACTERISTICS

The electric shovel was primarily designed to replace the steam shovel which, were it not for its poor economy and high maintenance, would be ideal in its control.



FIG. 1—GENERAL VIEW OF MINE

mies which would accrue from electrification. Electric shovels and locomotives were then well developed and preliminary study indicated that electrification was an economical and progressive move.

TYPES OF LOADING EQUIPMENT

At that time considerable diversity of opinion existed regarding the relative merits of direct current and alternating current for shovel drive, and as a large fleet of shovels was to be purchased, it was thought advisable to purchase one of each type, testing them in actual operation. Either of the electric drives proved to be

The electric shovel should therefore be designed with a type of control to duplicate the steam characteristic as nearly as possible. Comparative control characteristics are shown in Fig. 4, and it will be noted that for this class of service, the Ward Leonard system of control is nearly ideal.

Three types of motors are available for d-c. shovel drive; *i. e.*, shunt-wound, compound-wound, and series-wound. Which is best suited to service depends upon speed requirements and the nature of the material to be handled.

Typical graphic charts showing power input, peaks, and general character of the duty cycle, are given in Fig. 5, for d-c. equipment, Fig. 4 illustrates a-c. equipment.

1. Asst. Elec. Engr., Utah Copper Co., Garfield, Utah.

Presented at the Pacific Coast Convention of the A. I. E. E., Portland, Oregon, September 2-5, 1930. Complete copy upon request.

An examination of these charts shows clearly the necessity for sturdy electrical equipment. Torques being greater with the electric drive it is necessary to strengthen the mechanical parts of the shovel. This will result in fewer mechanical delays and prove a contributing factor to electrification economies.

LOADING CAPACITY

As a continuous source of power is available, and electrical delays are generally confined to control



FIG. 3—ELECTRIC SHOVEL

equipment, the electric shovel is capable of loading material more rapidly than its steam competitor. With steam equipment, steam pressures vary over a wide range, and repairs are usually of such a nature as to cause a shut-down.

A railway type of electric shovel with a 4½-cu. yard dipper will load, roughly, 14 tons of material per minute, or 6720 tons per shovel shift; however, the

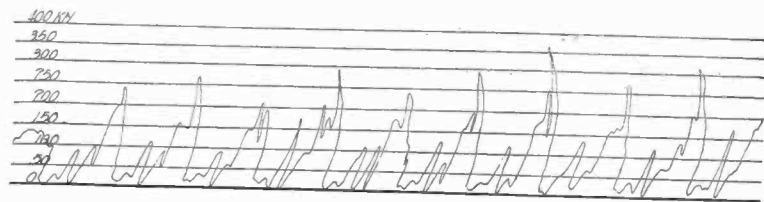

FIG. 5—POWER INPUT CURVE, D-C. EQUIPMENT

operating time factor is about 80 per cent, and as cars are not always available, the maximum tonnage is about 105,000 per day.

MINE TRANSPORTATION

The quality of ore varies from 35,000 to 50,000 tons per day while the waste tonnage varies with the mine development. The ore after being loaded must be transported to various assembly yards, while the waste is dumped in adjacent ravines. This work is performed by 39 electric locomotives of special design. Because of complexity of trackage, these locomotives

are equipped with a standard pantograph, two side-arm trolleys, a cable reel, and, in some cases, a 680-ampere-hour 240-volt storage battery. Fig. 7 shows a standard locomotive, while Table II is a condensed specification. These locomotives will haul a trailing load of 250 tons up a 4 per cent grade at 10 mi. per hour, with a power input of approximately 825 kw.

Motors, totally enclosed, are equipped with anti-friction bearings, have a one-hour rating of 280 amperes, and a continuous rating of 120 amperes. Control is of the conventional electromagnetic type with 22 controller points.

TROLLEY SYSTEM

As no trackage is permanent and temporary trackage

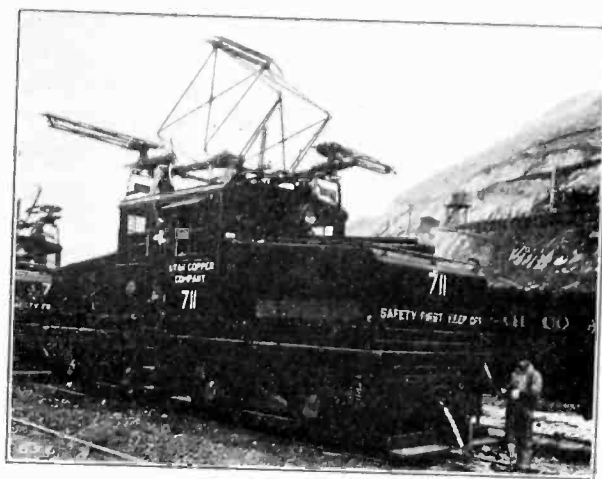

FIG. 7—TYPICAL ELECTRIC LOCOMOTIVE

is laid to curves varying from 0 deg. to 40 deg., an adequate trolley system for supplying this fleet of locomotives presented considerable difficulty.

Various types of structures were devised and have

TABLE II—LOCOMOTIVE SPECIFICATIONS

Rigid Wheel Base.....	8 ft.-0 in.
Total Wheel Base.....	25 ft.-2 in.
Wheel Diameter.....	44 in.
Length Inside Knuckles.....	36 ft.-6 in.
Weight.....	154,000 lb.
Compressor Capacity.....	150 cu. ft.
Motor Rating (One Hour).....	261 Hp. at 105 deg. cent.
Gear Ratio.....	85 : 18
Rail Clearance.....	4 3/8 in.

given excellent service. All trolley construction is direct suspension with the exception of the Bingham Yard, which is catenary on steel structures, spaced 200 ft.

MAIN LINE TRANSPORTATION

The ore cars after being transported to the various assembly yards are consolidated into 50-car trains and hauled to the concentrating plants—a distance of 18 mi. This work is done by seven Mallet locomotives weighing 316 tons each. The railroad, known as the

Bingham & Garfield, is a single-track road with six passing sidings. Complete A. P. B. block signaling is provided, together with remote-controlled electrically-operated switches. Traffic is governed by dispatchers with the aid of a centralized traffic control system.

PLANT OPERATION

Upon arrival at the plants, the 50-car trains are broken up into 10-car cuts which are run over car dumpers, either one or two cars being dumped at one time. The ore is given a preliminary crushing to reduce it from mine size to approximately eight-inch; further crushing and grinding reduces it to minus 100 mesh.

This material is fed to the flotation plant, where the ore and gangue are separated, the concentrated copper going to the dewatering plant to be prepared for initial refining at the smelter.

This work is done by about 3000 motors, varying in size from 1/4 to 850 hp., most of them being of the standard squirrel-cage induction type. Synchronous motors are used wherever possible and all new drives are carefully analyzed with the idea of using synchronous instead of induction motors. All new motors are purchased with anti-friction bearings, and conversion from sleeve to roller bearings has been going on for several years. Motors are started across the line by means of contactors, many of which are designed and built by the company's forces.

Miscellaneous uses about the plant include electric rivet heaters, hot plates, acid and water heating, pipe annealing, floodlighting, etc.

POWER SUPPLY

Power for these operations is furnished by the Utah Power & Light Company, and is received at a central substation at 120,000 volts. Three transformer banks, with a total capacity of 62,000 kv-a., step down from 120 kv. to 44 kv. All 120-kv. apparatus is installed outdoors, while the 44-kv. oil circuit breakers and control equipment is indoors. Fig. 15 is a general view of this station.

Seven 44-kv. feeders are carried to seven substations,—five at the plants and two at the mine. In an industry of this kind continuity of service is the primary consideration; accordingly, duplicate lines are carried to each mill substation and ring busses are used to gain switching flexibility.

Each substation has a spare transformer arranged to spare any other unit with a minimum of delay. Secondary voltage is 440, and is transmitted by means of three-conductor cables to the various mill circuits, each circuit being protected by an automatic oil circuit breaker.

Power is transmitted to Bingham over a two-circuit steel tower line, approximately 14 mi. long, and distributed to two composite shovel and railway substations

(Fig. 19.) These shovel substations, which are of the outdoor type, each contains two banks of transformers rated at 1200-kv-a. each, the secondary voltage being 5500. This energy is transmitted over duplicate wood pole lines arranged to completely encircle the mining area. These trunk lines are tapped at both ends of each bench and carried across the bench on a specially designed portable steel tower.

Railway substations are of the semi-outdoor type, and are automatic. Each station contains four 1000-kw., 750-volt, 1200-rev. per min., shunt-wound converters, all tied to a common bus from which eight 1,000,000-cir. mil feeders are taken. In the majority of cases, these feeders, are carried on the poles supporting the trolley.

The magnitude of these operations may be more easily visualized by consulting the following statistics, representative of one years operation:

Tons of ore loaded.....	16,556,070
Tons of waste loaded.....	14,400,170
Total tons loaded.....	30,956,240
Tons of ore hauled by electric locomotives.....	16,031,728
Tons of waste hauled by electric locomotives.....	5,465,939
Total tons hauled by electric locomotives...	21,497,664
Kilowatt-hours used by electric shovels.....	6,190,136
Kilowatt-hours used by electric locomotives.....	7,536,604
Total kilowatt-hours used by Utah Copper Company.....	323,454,428
Average yearly load (kilowatts).....	36,924
Maximum load for year (kilowatts).....	45,155
Annual load factor (percentage).....	81.8

In an undertaking of this kind, many problems present themselves for solution, and the author wishes at this time to express his appreciation to the mine operators for their fine cooperation.

NEW WALDORF-ASTORIA TO HAVE LARGEST CENTRALIZED RADIO

The largest centralized radio reception system ever designed, capable of intercepting and delivering six selected radio programs to loudspeakers in the 2000 rooms of the new Waldorf-Astoria Hotel in New York City, will be in operation when the building is opened to the public, according to the designer, J. J. Kuhn, of the Bell Telephone Laboratories, New York. The entire installation will cost nearly \$200,000, and besides the speakers in the guest rooms there will be thirty-nine large horn speakers concealed in the walls or ceilings of the fifteen public rooms. The largest power amplifier ever designed, consisting of twenty-one separate panels, larger than any similar broadcasting station equipment in the country, will be used to intensify programs received over the radio or the addresses or music picked up from a function held within the hotel. More than 1,000,000 feet of wire, in the form of strands in metal shielding, will convey the programs from the amplifier to each of the rooms—*Telegraph & Telephone Age*. (Sept. 1930)

Abridgment of Calculation of Mechanical Performance of Oil Circuit Breakers

BY A. C. SCHWAGER¹

Associate, A. I. E. E.

Synopsis.—This paper describes the methods of calculating mechanical performance of a typical rotary type oil circuit breaker, operated by a spring-actuated motor control. For a given spring characteristic, the motion of the breaker is predicted, and time required

to reach any position, and the speed at that position, calculated. General formulas are set up.

A mechanical test is performed on a specific breaker and a comparison made between calculated and tested results.

IN the early days of oil circuit breaker design, when operating speed and time were of no consideration, gravity was the only force relied upon for the opening of a vertical-break breaker. There was no dynamic problem existing; the motion of the blade simply followed the laws of a falling body.

With the requirements of today, which call for shorter operating times and higher speed, the dynamic problem has become of increased importance.

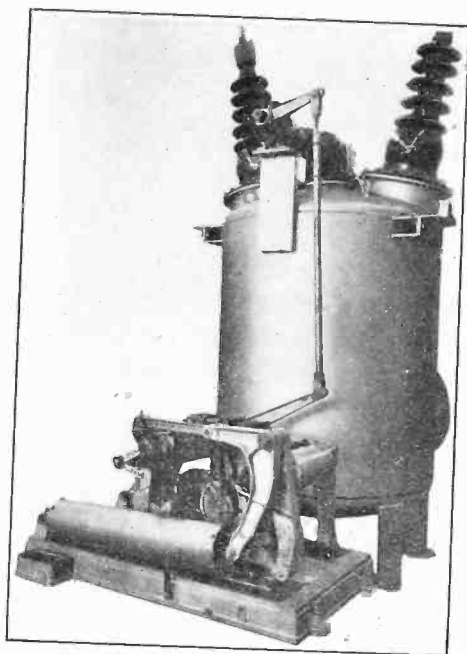

FIG. 1A—OIL CIRCUIT BREAKER WITH CONTROL

A travel-time chart of the moving contact during the stroke is the most direct indication of mechanical performance; from this it is possible to measure the time that is required to reach a certain position,—particularly that of arc length,—and to calculate the velocity at each point.

If the designer has at his disposition a complete line of breakers and controls, and is confronted with the problem of furnishing a breaker to give specified characteristics, the proper control is best selected by a

1. Oil Circuit Breaker Design Engr., Pacific Electric Mfg. Corp., San Francisco, Calif.

Presented at the Pacific Coast Convention of the A. I. E. E., Portland, Oregon, September 2-5, 1930. Complete copy upon request.

test consisting of the determination of the time-travel chart of the combination.

For a given size of operating mechanism, various means are available to change its total energy output as well as the power delivered over the stroke. In the case of a solenoid control mechanism, the ampere-turns of the closing coil may be varied arbitrarily. Adjustment of the motor current in centrifugally-operated breakers provides for the proper energy range, while the springs of a spring-actuated control can be varied as regards pressure and pressure distribution over both opening and closing stroke.

In the most usual case, however, a new type of breaker and control has to be designed and the problem presented is more difficult, the possibility of prediction of the time-travel chart being of marked importance. In the following, the method of its calculation is developed for a typical rotary type oil circuit breaker with spring-actuated motor-wound operating mechanism. For the sake of simplicity, only the opening stroke is considered, the closing stroke calculation being similar.

Fig. 1A shows the first unit of a 115-kv. breaker with control for position during the opening stroke, power being transmitted from the main control shaft through a connecting link to the horizontal shaft of the breaker, and through a set of bevel gears to the rotating unit, (Fig. 1C). The control shaft travel is 40 deg.; that of the horizontal and vertical shaft 90 deg. and 72 deg., respectively.

KINEMATICS OF SYSTEM

The schematic diagram in Fig. 3 shows the breaker and control for position during the opening stroke.

α = Angle at which vertical shaft is out of closed position.

β = Angle at which horizontal shaft is out of closed position.

γ = Angle at which control shaft is out of closed position.

b = Normal distance between connecting link and control shaft.

a = Normal distance between connecting link and horizontal shaft.

ω_v = Angular velocity of vertical shaft in radians per sec.

ω_h = Angular velocity of horizontal shaft in radians per sec.

ω_c = Angular velocity of control shaft in radians per sec.

I_v = Moment of inertia of all parts rotating around the vertical shaft of one unit with reference to the shaft.

I_h = Moment of inertia of all parts rotating around horizontal shaft.

I_c = Moment of inertia of control during opening stroke referred to the main shaft.

The system consists of three main rotating shafts, as follows: (1) Oil circuit breaker vertical shaft; (2) Oil circuit breaker horizontal shaft; and (3) Control operating shaft.

For every position of one shaft, there is one definite position for each of the remaining two shafts. If one shaft is rotating with a certain angular velocity through a certain position, the two other shafts are rotating with different angular velocities through their positions. In considerations for the future, the vertical rotating oil circuit breaker shaft, is chosen for primary reference.

Relation of Horizontal to Vertical Shaft. As stated

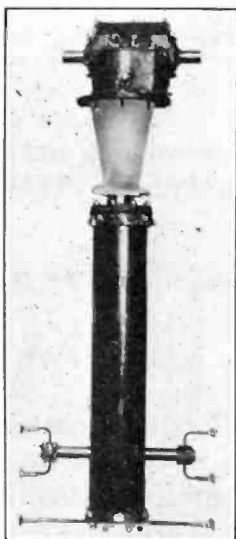

FIG. 1C—VERTICAL ROTATING BLADE UNIT

before, the vertical shaft travel is 72 deg. against 90 deg. in the horizontal shaft, thus:

$$\omega_h = 1.25 \cdot \omega_v \tag{1}$$

Relation of Control-Operating Shaft to Horizontal Shaft. The relation between these two shafts is more

complicated. The coefficient $D = \frac{a}{b}$ gives the ratio

of the angular velocities:

$$\omega_c = D \cdot \omega_h \tag{2}$$

It is evident that D changes with each position.

The coefficient D is also essential for the determination of the torque relation in the various shafts. If a torque is available at the control shaft, the corresponding torque around the horizontal shaft follows from:

$$T_h = D \cdot T_c \tag{3}$$

Finally, assuming distribution to be equal among the three shafts, the torque appearing at a single vertical shaft is:

$$T_{1v} = D \cdot T_c \cdot \frac{1}{3} \cdot 1.25 = 0.42 \cdot D \cdot T_c \tag{4}$$

Forces Acting upon the System. The following external forces, listed in order of their importance, have to be considered: Spring pressures of control; friction

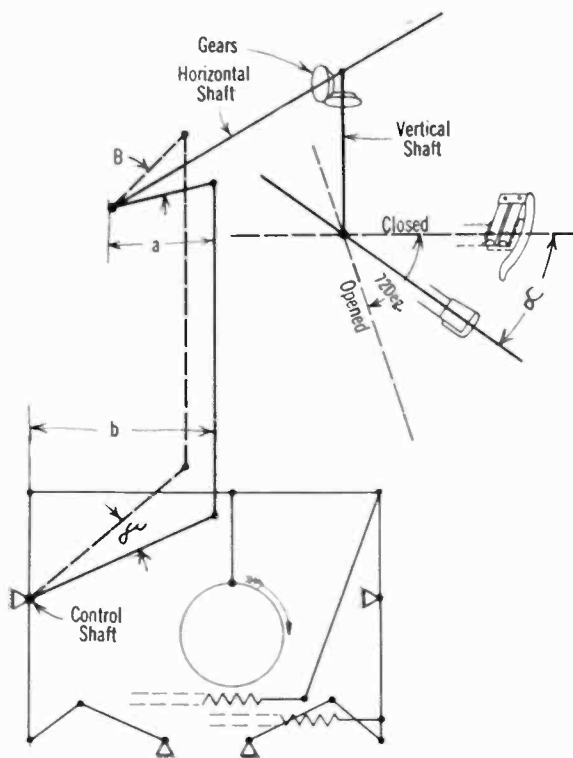

FIG. 3—SINGLE-LINE DIAGRAM OF CONTROL AND BREAKER

between stationary contacts and blades while in contact; friction between rotating units and oil; friction of bearings; and gravity.

The resultant of all these forces, for each position of the stroke, will produce a certain torque which when referred to the vertical shafts will be denoted T_α . This is the torque available for acceleration; its variation is shown in Fig. 5 Curve A. (For a more complete analysis of T_α see Appendix in the complete paper).

DYNAMICS OF THE SYSTEM

Applying the energy equation, and denoting by E_α the potential energy which has been transformed into kinetic energy in the moving parts of the breaker, and

control at the position α of the vertical shaft, it follows that, by integrating

$$E_\alpha = \frac{I_c \omega_v^2}{2g} + \frac{I_h \omega_h^2}{2g} + \frac{3I_v \omega_v^2}{2g} \quad (5) \quad dt = \frac{d\alpha}{\omega_\alpha} \quad (12)$$

where E_α can be expressed as:

$$E_\alpha = \int_0^\alpha T_\alpha d\alpha \quad (6) \quad t_\alpha = \int_0^\alpha \frac{d\alpha}{\sqrt{\frac{1.28g}{I_{ocB} + D^2 I_c} \cdot \int_0^\alpha T_\alpha d\alpha}} \quad (13)$$

From Equations (1), (2), (3), (4), and the definition,

$$I_{ocB} = 3 \cdot 1.25^2 I_v + I_h \quad (7)$$

is obtained,

$$\int_0^\alpha T_\alpha d\alpha = \frac{1.25^2}{2g} \omega_v^2 (I_{ocB} + D^2 I_c) \quad (8)$$

Thus

$$\omega_v^2 = \frac{2g}{1.25^2} \frac{\int_0^\alpha T_\alpha d\alpha}{I_{ocB} + D^2 I_c} \quad (9)$$

ω_v varies with the position α ; the index v in the future is

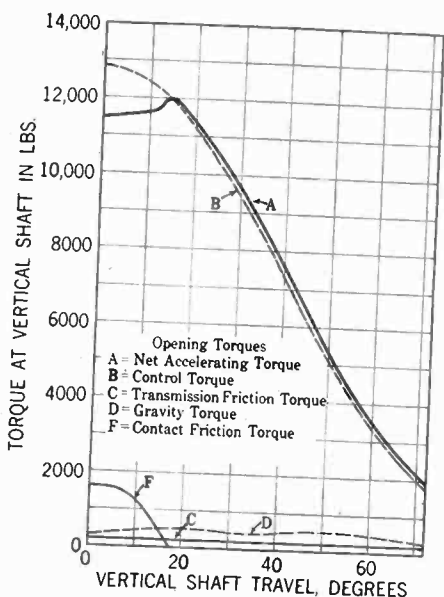

FIG. 5—TORQUES DUE TO FORCES ACTING UPON CIRCUIT BREAKER REFERRED TO VERTICAL SHAFT

replaced by α , it being always understood that it refers to the vertical shaft.

The final formula for the angular velocity at the position α is,

$$\omega_\alpha = \sqrt{\frac{1.28g}{I_{ocB} + D^2 I_c} \cdot \int_0^\alpha T_\alpha d\alpha} \quad (10)$$

This is the equation for the travel-velocity curve.

The formula for the time required to reach position α is obtained from

$$\omega_\alpha = \frac{d\alpha}{dt} \quad (11)$$

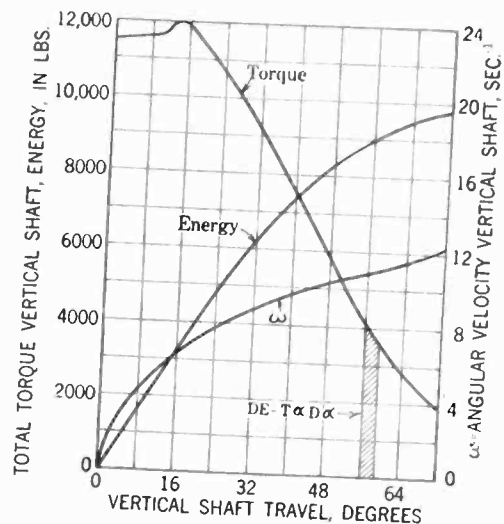

FIG. 6—VERTICAL SHAFT TORQUE, RESULTING ENERGY AND ANGULAR VELOCITY CURVES

This is the equation for the travel-time curve.

Method of Computation of ω and t . In Equation (10) two quantities vary with α

$$\int_0^\alpha T_\alpha d\alpha \text{ and } D^2(\alpha)$$

The procedure is to compute each one separately as a

function of α : $\int_0^\alpha T_\alpha d\alpha$, representing the energy used

up for acceleration up to position α , is obtained as the area below the torque curve.

Fig. 6 shows torque T_α , the resulting energy and angular velocity curves for a given opening spring combination of the breaker under consideration.

The area under the curve $\frac{1}{\omega}$ represents the time

required to reach position α . (See Fig. 7)

The time obtained from Fig. 7 is measured from the instant the breaker starts to move; to this time has to be added the time delay in the electrical trip system. This time delay, for a certain control is known by tests. It is not the intention of this paper to deal with the electrical part of the tripping problem.

Referring to Fig. 6, the velocity attains its maximum

value at the end of the stroke. To bring the breaker to rest, the kinetic energy of all the moving parts would have to be absorbed instantly, causing excessive shock, vibration, and possible destruction of parts. It is thus essential that to bring the rotating masses smoothly to a complete stop a dashpot be applied in the last part of the stroke. To impose the smallest possible stresses to the parts, this has to be so designed as to give a constant dashpot force.

When considering the simplified arrangement shown in Fig. 11, the requirements of a constant dashpot force, are a constant pressure, a constant retardation, and a linear decrease in velocity.

A constant pressure in the dashpot cylinder causes the oil to leave at a constant velocity independent of the size of the aperture, and determines its area, to

in the following, the curves calculated will be compared with charts obtained from tests on an actual breaker: Curve A in Fig. 14 is the test curve for the opening stroke. Choosing the instant of relay contact closing as the origin of time, we note that a certain time delay becomes apparent before the breaker starts to move. This time delay is caused by the electrical tripping mechanism.

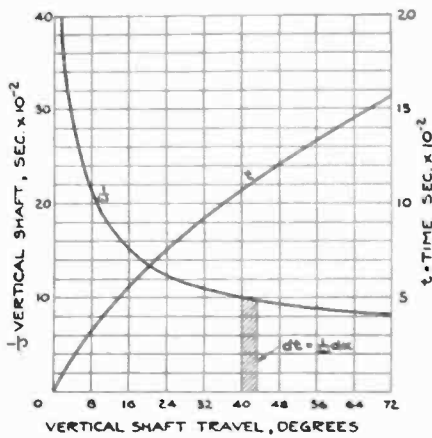

FIG. 7—TIME—TRAVEL CURVE

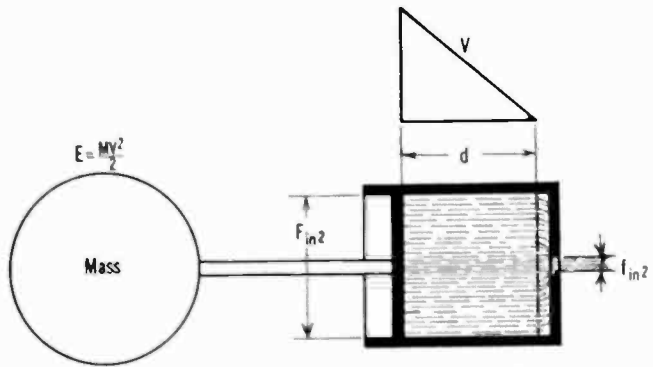

FIG. 11—SCHEMATIC ARRANGEMENT OF DASHPOT

In the calculation this has not been included and the calculated charts thus start at the ordinate T .

Curve B is the calculated curve of the breaker tested above. It is seen that the two curves show a very close agreement both in the accelerating as well as in the retardation period which latter is controlled by the dashpot action.

In conclusion, it follows that the method of speed

decrease proportionately with the velocity. Denoting with,

$$E = \frac{M v^2}{2} = \text{Total kinetic energy to be absorbed}$$

F = Area of dashpot piston

d = Stroke of piston

f_o = Cross-section of aperture for $t = 0$

v_o = Velocity of piston for $t = 0$

v_x = Velocity of oil through aperture

p = Pressure of liquid

K = Conversion constant.

one gets,

$$E = p \cdot F \cdot d \tag{14}$$

And with

$$v_x = \sqrt{2 g K p}$$

and condition of incompressibility, $f_o v_x = F \cdot v_o$, one arrives at the following formula for the initial area of the aperture;

$$f_o = v_o \sqrt{\frac{F^3 d}{2 g K E}} \tag{15}$$

COMPARISON BETWEEN CALCULATION AND TEST

In the foregoing analysis, the calculation of the time-travel chart for an oil circuit breaker has been outlined;

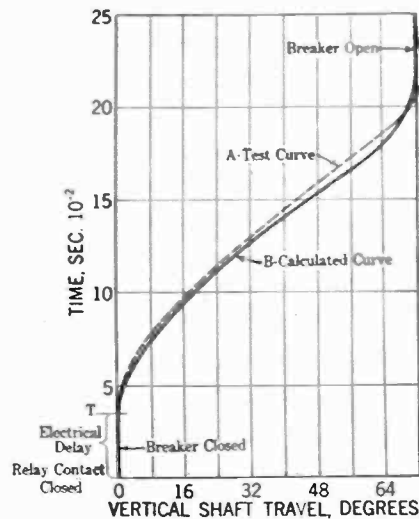

FIG. 14—TRAVEL-TIME CURVES. COMPARISON BETWEEN CALCULATION AND TEST

and time determination developed makes possible the design of equipment to perform within technical accuracy of specified requirements.

A thorough investigation of the formulas reveals the importance of each quantity involved, and enables the selection of the kinematic arrangement in such a manner that the design can be carried out with the greatest possible economy.

Abridgment of Steam Power Development of the Pacific Gas & Electric Company

BY RICHARD C. POWELL

Associate, A. I. E. E.

Synopsis.—Improvements in steam power generation, and economic changes in the fuel supply, have caused increasing interest in steam power on the Pacific Coast.

After a brief history of the development of steam power on the system of the Pacific Gas & Electric Company, the author discusses

some of the fundamental factors entering into the problem of providing additional steam plant capacity for this company in accord with the changed economic conditions.

The author describes recent work completed and under construction and gives some of the economic results obtained and expected.

INTRODUCTION

As a result of recent progress in the art of electric generation by steam power, most of the utilities on the Pacific Coast are either engaged on or planning power developments in which steam is predominant or occupies a very prominent position. Consequently, the economics and design of steam plants formerly of little interest to most Pacific Coast utility executives and engineers, are now of increasing importance.

In this paper will be discussed some of the fundamentals entering into the problem of increasing the steam-electric generating capacity on the system of the Pacific Gas & Electric Company and a brief description will be given of work recently completed and under construction.

HISTORY

The electric system of the Pacific Gas & Electric Company and its subsidiaries, as it now stands, is essentially an interconnected system supplying service to almost the whole of Northern and Central California, an area roughly 425 mi. long and 150 mi. wide, with a peak demand of about 850,000 kw. and an annual generation of about 4,500,000,000 kw-hr. Fig. 1 is a map of the generating and transmission system. Out of a total of 1,100,000 kw. in generating capacity, 300,000 kw., or roughly 30 per cent, is in steam. It has reached its present size by consolidation and extension covering a period of over 40 years. The nuclei for this growth were the independent systems which had been started in San Francisco, Oakland, Sacramento, and San Jose, all supplied from generators driven by steam engines.

About 1900 the development of high-voltage transmission permitted water-power to be brought to these and other cities at a much lower cost than steam power, which was then unable to hold its position and was rapidly shoved into the background. Steam power would undoubtedly have been almost entirely supplanted but for two factors; viz., the unreliability of those early lines, and the entire lack of sites for, or pro-

hibitive cost of, reservoirs to provide the necessary storage to enable the water-power plants to carry the load during the dry seasons when the stream flows fell greatly below normal.

Up to about 1924, the ratio of total steam-plant

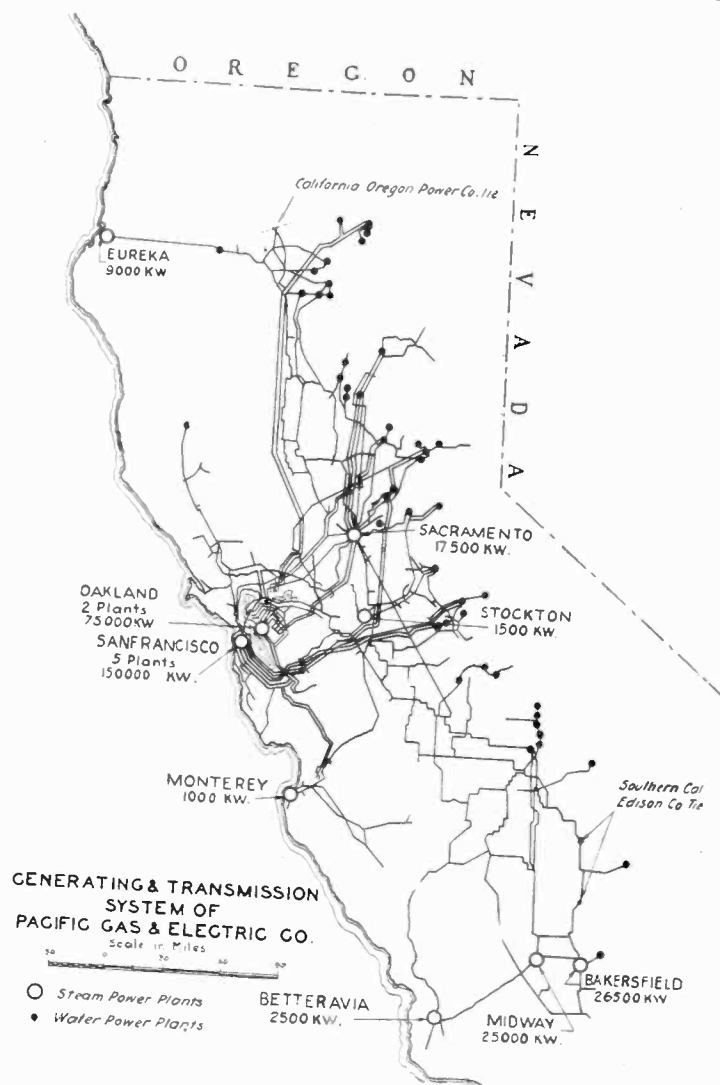

FIG. 1

capacity to system peak demand, for the Pacific Gas & Electric Company System, varied rather consistently from about 40 to 60 per cent, and the ratio of kw-hr. generated by steam to the total ranged from about 15 to 30 per cent. For the years 1924-1929, inclusive, these data are shown by the curves in Fig. 2.

1. Pacific Gas & Electric Co., San Francisco, Calif.
Presented at the Pacific Coast Convention of the A. I. E. E., Portland, Oregon, Sept. 2-5, 1930. Complete copy upon request.

The requirements for the steam plants during the period under review were: (1) low investment cost, since the load factor on steam over a period of years was not high; (2) high reliability, since steam was always the pinch hitter during seasons of low water and at times of sudden failure of a line, flume, or some other part of the water-power and transmission system; and (3) the ability to pick up full load quickly from a very light load condition. On the whole, these plants met the above requirements very satisfactorily. They have never seriously failed to meet the service demands made upon them by way of picking up load in the event of line or other failures on the water-power system,

PLANS FOR STEAM POWER DEVELOPMENT

About four years ago it became apparent that the economic relation between steam and water-power had become reversed. The reasons for this change were:

1. The generally increasing cost of additional water-power due to the best sites having been developed and for sites already developed, the rather prolonged series of years of subnormal water supply which indicated that the supply was not so great as formerly supposed.
2. The rather pronounced lowering of steam-power costs due to improved efficiency, lowering of investment, operating, and maintenance costs, and, for California at least, the oversupply of oil with consequent reduction in price; and finally, the tremendous production of natural gas and its supply to Northern California.

A comprehensive plan was developed which would provide not only for the immediate needs, but also for at least 15 years hence in the matter of the acquisition of steam plant sites and transmission line rights of way for lines necessary to connect such sites with the general system. In working up this plan, consideration was given to all the elements involved which included:

1. Sizes of units and when and where to be installed.
 2. Costs for investment, maintenance, operation, and fuel.
 3. Obsolescence.
 4. Operating reliability and flexibility.
- A careful study was made of all the factors entering into the above elements, these factors including such items as:
- a. New plants *versus* the rebuilding of old plants.
 - b. Sizes of turbine and boiler units.
 - c. Steam pressure and temperature.
 - d. Extraction heaters, economizers, air heaters, and furnace water walls.

Most, if not all, large systems have need for two types of generating units,—the first highly efficient for so-called base-load operation, and the second for peak-load service and reserve. The Pacific Gas & Electric Company also requires a third type necessitated only by excessively dry years, which are infrequent and of uncertain occurrence. That any given year will be very dry is not known until about February. It is very difficult, it not impossible, to provide against such deficiency of water unless such abnormal deficiencies are recognized as liable to occur, and are provided for at all times. Examples of where failure to provide for this contingency have resulted in power shortage are well known; on the Pacific Coast such cases occurred in California in 1924, and in the Northwest in 1929. The Pacific Gas & Electric Company has never found it necessary to cut off load on account of a dry year except during the war, when it was obliged to curtail new construction because of war conditions.

In view of the conditions of space available at Station "C," and the nearer location of Oakland to the water-power supply, it was determined that increased capacity at Station "C," (at least to the extent of 75,000

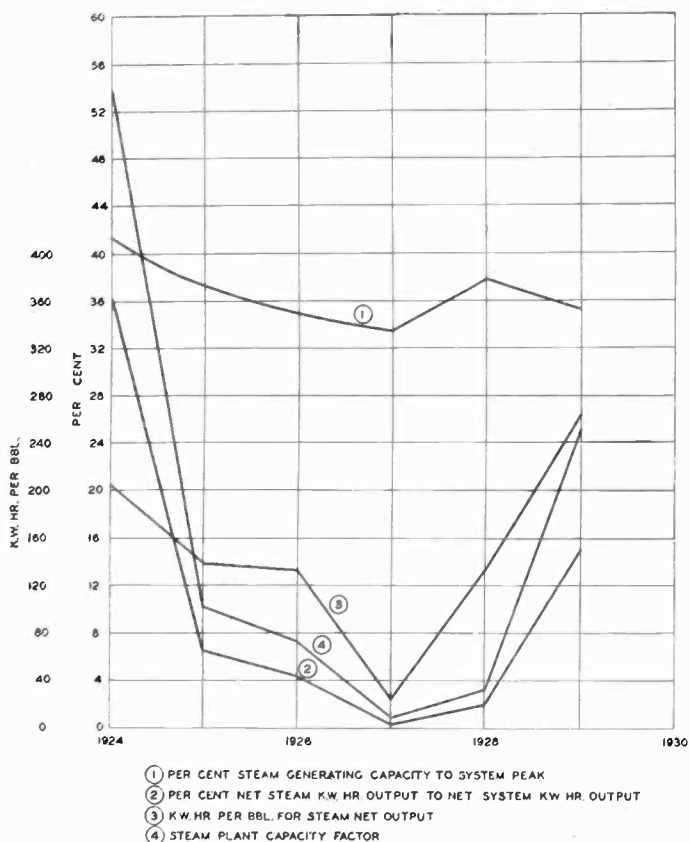

FIG. 2

although no especial features of design were employed to enable the equipment to respond rapidly to a sudden increase of load. Dependence was placed entirely upon keeping sufficient turbine capacity on the line at very light load—that is, from just floating to 5 per cent of rating with corresponding boiler capacity either steaming or with pressure at or near that of the line,—and the ability with oil firing, to get boilers to full steaming capacity in a very short time. Experience has proved that under the conditions just outlined, full load could be picked up with little or no disturbance to service.

At the beginning of 1928, the investment per kw. varied among the plants from about \$60 to \$80; the steam pressures and temperatures were low, and the design was simple, with no economizers, fans, or automatic devices worth mentioning.

kw.,) would conform to the second type of plant just mentioned, and that Station "A" would supply the first type. To provide for the third type of capacity, it was decided to retain the North Beach Plant in San Francisco and the Station "B" plant in Sacramento, with a combined capacity of 35,000 kw. During normal years, these would probably be shut down.

As is evidenced by the discussions which appear from time to time, the problem of how best to provide peak and reserve capacity is not always clear and includes proposals such as steam plants with accumulators and pumped storage for water plants. It is believed that the most practicable way to obtain such capacity in steam is to provide overload capacity for each unit. The rating of both turbines and boilers is entirely arbitrary. The maximum output of a turbine is determined by the maximum steam flow for a unit built to a given frame. A boiler can be forced to a very high output. The ratings may be set according to the efficiencies desired for both turbines and boilers, and the maintenance cost for boilers, which will increase at high outputs.

Cost studies showed that it would be more economical to rebuild and enlarge Station "A" in San Francisco, and Station "C" in Oakland, than to provide the same additional capacity at new sites.

The size of turbine and boiler units has a marked effect upon costs. This is particularly true of large boiler units. For large units, investment per kilowatt is lower, efficiencies higher, and operating costs much lower; and for automatic control and instruments, the investment is decidedly lower. Large units, especially boiler units, are more flexible as regards load fluctuations; and there is no reason to believe that they are not just as reliable as small units. Costs for maintenance and periodic inspection are less for large turbine units than for small ones and should be no higher for large boiler units; maintenance costs for automatic-control equipment is much less, since the cost and amount of such equipment is almost entirely dependent upon the number of units and not upon the size.

In the matter of pressure and temperature, it was recognized that the trend was very definitely to higher pressures and temperatures. Careful estimates made in 1926 showed that a plant operating at 450-lb. pressure should cost no more than one operating at 250 lb. although the use of 650 lb. with reheating would cost more. No very careful estimates at that time were made for 1250 lb., since that pressure was then regarded as still in the development stage. The use of pressures and temperatures as high as consistent with reliable operation will of course have a favorable influence upon obsolescence.

Extraction heaters, economizers, and air heaters, although adding complication as compared with the old plants, did not seem to affect reliability adversely, and their use was considered entirely a matter of economics. With reference to furnace water walls, an installation

made in 1925 in one boiler as a trial had definitely showed that their use would not only reduce furnace maintenance—one of the largest items of boiler room maintenance—but would greatly improve reliability. If boilers were to be operated at high rating with mechanical, atomizing oil burners, they were necessary since with such burners, furnace temperatures of the order of 3200 deg. fahr. are encountered.

To obtain increased steam-power capacity, the first installation was to be made at Station "C," to be followed with the next increase at Station "A," San Francisco. From studies made in 1926, it was concluded that design for Station "C" should be based upon a 450-lb. drum pressure, approximately 750 deg. fahr. total steam temperature, and large boilers with water walls, the question of extraction heaters, economizers, and air heaters to be a matter of economics and layout in the space available.

INSTALLATION AT STATION "C," OAKLAND

The installation for a 37,500-kw. unit at Station "C" was started in 1927 and put into operation in October 1928. The size of turbine was determined by the then existing turbine room which, with a small extension, permitted the erection of two 37,500-kw. turbines in the space occupied by two vertical units, one for 9000 kw. and the other for 12,000 kw. In line with the type of capacity desired,—*viz.*, the second type mentioned above,—and on account of space limitations, a 37,500-kw., 9-stage impulse multi-valve turbine with guaranteed overload capacity of 42,000 kw. was selected. This was quite a departure from established practise. As compared with the conventional unit of this size, it has better efficiency up to about 30,000 kw.; and by extracting heavily, its efficiency was not much less for higher loads, and the cost for the unit, foundation, and building, was about \$1.50 per kw. less. For the load conditions it will have to meet during its life, it should be considerably more efficient.

Straight tube sectional header boilers were decided upon because experience on the whole had been better with this type than with the bent tube type. The size was selected by making the width the maximum that could be obtained for a riveted drum, and the number of tubes high was gaged so that without an economizer the preheated air temperature would not exceed 500 deg. fahr. With 24-ft. tubes this resulted in a very economical unit of 35,453 sq. ft., with a maximum, guaranteed output of 425,000 lb. per hr., having about 84 per cent efficiency at maximum output with an air heater of 51,232 sq. ft. Two such units were installed, one to serve as a spare for the first and future turbines. A maximum steam temperature of 730 deg. fahr. was selected as the highest then considered desirable without the use of alloy tubes.

Automatic equipment was provided for combustion control, condenser hot well level, feed water pressure, and drum water level.

Auxiliary power is supplied from two three-phase transformers connected to the main station busses. Most of the motors, including one 500-hp. synchronous motor, are started on full voltage.

This brief description will give an idea of the type of design and character of the equipment. The over-all cost of the plant, including land, building, etc., after the installation of this unit and increase to 68,000 kw. capacity, was very closely the same per kw. as for the original 33,500-kw. plants, although the efficiency was about doubled and the operating and maintenance costs reduced to about half on a kw. basis. The turbine has a maximum output of 43,750 kw., and the boilers have put out 435,000 lb. per hour. The boiler room installation is quite compact and occupies 7.7 sq. ft. of ground area and 586 cu. ft. of building volume per 1000 lb. per hour output. This includes the boilers, air heaters, fans, and fuel oil pumps and heaters.

The new unit was put into service on October 1928 and shortly thereafter, on account of very cold weather in the mountains with consequent reduction of water supply, was required to carry practically a continuous load of 43,750 kw. until some time in February. It was therefore not until the spring of 1929 that the turbine or a boiler could be taken out of service for the necessary adjustments of automatics, etc., incident to the starting up of a new unit. Leaving out of account the time when equipment could have been operated but was out for adjustment of automatic equipment, the turbine was available during 1928 over 99 per cent of the year, and both boilers, about 96 per cent. The turbine output was on a 65 per cent capacity factor, and the net output was just at the rate of 14,000 B. t. u. per kw-hr.; the auxiliary power was 3 per cent. It is to be noted that the unit was loaded very unfavorably, since for practically all of the time, its load was either very light, 500 to 1000 kw.; or a heavy overload at 43,750 kw.; and for very little or none of the time was it at the most efficient point of about 30,000 kw.

Curve 3, Fig. 2, shows the average kw-hr. per bbl. of oil for all the plants for the years 1924-1929 inclusive. The effect of the Station "C" installation is easily seen by referring to Curve 4; in 1924, operating on 54 per cent capacity factor for the total system steam capacity, the net output was at the rate of 205 kw-hr. per bbl., but in 1929, although the capacity factor was only 25 per cent, the net kw-hr. per bbl. was raised to 260. Had the capacity factor been 54 per cent, the kw-hr. per bbl. would have been about 280, which represents a saving of 36 per cent in fuel.

INSTALLATION AT STATION "A," SAN FRANCISCO

In 1928 studies were made for the rebuilding of Station "A" and included plans and estimates for 450, 750 and 1350 lb., drum pressures. The use of any pressure between 450 and 1350 lb. was shown to be uneconomical and it appeared that 1350 lb. might cost \$3.00 per kw.

more than 450 lb. However, there was a very pronounced trend toward lowering costs for 1350-lb. equipment and an increase in the size of boilers which manufacturers were willing to build. All items considered, it was decided that the use of 1250 lb., throttle pressure and 750 deg. fahr. total temperature would be the most economical and that the plant could be rebuilt for 1350 lb. cheaper than for some lower pressure. It was believed that the cost of 1350-lb. equipment would go down as production increased, and that within a few years it would be possible to build a plant for this pressure as cheap as for some lower pressure. This view has proved correct for it is now definitely known that the costs for 1350 lb. are no greater than for 450 lb.

The installation now under construction consists of two turbine and three boiler units. The turbine units are each compound-rated at 50,000 kw. with maximum output of 65,000 kw. at unity power factor. At a sacrifice of 10 B. t. u. per kw-hr. chargeable to the turbine room at the most efficient load point, the maximum turbine output for the same frame was increased from 58,000 kw. to 65,000 kw.

For the type of boiler unit which has been used in most of the 1250-lb. plants, the cost on a kilowatt basis is very little more than for a 400-lb. plant. Although the so-called boiler part—that is, drum, headers, and tubes—is costly, it is relatively small, and most of the complete boiler unit surface is in other elements; namely, superheater, resuperheater, economizer, and air heater. Table I gives the percentages for the various surfaces.

TABLE I

	Per cent of heating surface			
	Reheat boilers		Standard boiler	
	Steam and water absorbing surface	Steam, water, and air absorbing surface	Steam and water absorbing surface	Steam, water, and air absorbing surface
Boiler.....	24.1	11.2	26.5	12.3
Water walls.....	3.6	1.7	4.0	1.9
Superheater.....	14.2	6.6	17.6	8.2
Reheater.....	18.0	8.3		
Economizer.....	40.1	18.5	51.9	24.0
Air heater.....		53.7		53.6

The area and space occupied by the boiler and fan rooms are, per 1000 lb. per hr. output, 9.35 sq. ft. and 865 cu. ft., respectively. In comparison with similar figures for Station "C" on a kilowatt basis, the area for Station "A" is 90 per cent and the volume 1.09 per cent of those for Station "C." At Station "A" the space is that of an existing building with height increased to provide for the fans, and for a new plant the cubic space could be reduced. It appears that on the whole a high-pressure plant will require at least no greater space than a plant for lower pressure.

The remainder of the equipment, such as fans, feed

water heaters, pumps, etc., are similar to that for lower pressure plants and requires no detailed description here.

The reconstruction of Station "A" is an example of the recent progress in the art of generating electricity by steam power, and shows how the great improvement in fuel economy has been effected without increase in capital; in fact for Station "A," there will be a marked reduction in investment. With the completion of the present construction, the capacity will have been increased from 64,000 kw. to about 160,000 kw.; and it is expected that the over-all investment per kw. will be reduced by about \$15.00 per kw. and the fuel, and operating and maintenance costs per kw., reduced to one-half. With the completion to the ultimate capacity of about

260,000 kw., a further reduction of \$5.00 per kw. is expected, or a total of \$20.00 per kw. The cost of the new Station "A" will be comparable with steam plant costs in Great Britain and Europe. The fuel consumption for the 1250-lb. units should be at the rate of 12,000 B. t. u. or better per net kw-hr.

Since plants for operation at 1250 lb. pressure cost no more than for some of lower pressure, undoubtedly there will be in the near future a number of plants in operation on the Pacific Coast at this pressure. In time, higher pressures and temperatures are to be expected but with the present fuel situation, particularly in California, it is not anticipated that pressures higher than 1250 lb. and temperatures above 800 to 850 deg. Fahr. will prove profitable for some years.

Abridgment of New Trends in Mercury Arc Rectifier Developments

BY OTHMAR K. MARTI¹

Member, A. I. E. E.

Synopsis.—Research investigations conducted by engineers as well as physicists during the last few years have resulted in notable improvements in the mercury arc rectifier, in particular with reference to backfire protection and voltage regulation as well as improved manufacturing methods. These improvements have made it possible to build rectifiers of very large current capacities as well as for very high voltages. In order to explain the results obtained with the aid

of these improvements the basic principle of rectification is briefly reviewed. Methods of testing rectifiers have also been improved upon and new ones developed. Standard parts are now used for different rectifiers up to the largest capacities. An account is given of notable recent rectifier installations for city subway service, for a portable street-railway substation, radio transmission, electrolytic zinc refining, and for Edison systems.

WHEN the steel-enclosed mercury arc rectifier became available to users of direct current, it entered into keen competition with rotary converters and motor-generators, and presents over the latter a number of advantages which are now well-known to operating engineers. In the last few years, the use of rectifiers has been extended to fields which may be designated as their own, in that they comprise applications for which rotary converters or motor-generators are either costly and inefficient or not obtainable.

Very little has so far been published about the work done by physicists on the mercury arc, and comparatively scant literature is available to power engineers, traction engineers, and chemical engineers, in spite of the fact that during recent years they have been using rectifiers in increasing numbers in all parts of the world. It is not intended to give here a complete account of the theory of rectification, but in order to explain some of the latest developments, a brief explanation of the valve action of the rectifiers will be given.

1. Chief Engineer, American Brown Boveri Company, Inc., Camden, N. J.

Presented at the Pacific Coast Convention of the A. I. E. E., Portland, Oregon, September 2-5, 1930. Complete copy upon request.

THEORY AND DESIGN

In order to explain simply the principle of the rectifier, a single-phase two-anode rectifier set is usually considered. Such a rectifier is shown schematically in Fig. 1. Each anode carries the whole current for the half cycle during which it is positive with respect to the cathode, whereas for the other half of the cycle it carries no current. During this operation, the voltage between the two anodes is equal to the whole voltage of the transformer secondary whose peak value is over twice the d-c. voltage. Therefore, in the case of a 13,000-volt radio transmission rectifier described below, the mercury vapor between the two anodes must be able to withstand over 26,000 volts without breaking down.

The passage of current is due to the motion of positive ions and negative electrons traveling freely between the cathode and whichever anode is at a positive potential. The other anode, which is at that time negative with respect to the cathode, is at too low a temperature for the emitting of electrons. Since it is charged negatively, it continually repels the free electrons moving about inside the cylinder and at the same time attracts the positively charged mercury ions which therefore concentrate around the anode and form all around it what

is called a positive space charge which will insulate it for considerable voltages. The actual thickness of this layer, represented by plus signs in Fig. 1, varies in proportion to the voltage. The voltage diagram below Fig. 1 shows how it localizes the voltage drop between the anodes with a very high gradient in the immediate neighborhood of the negative anode, while outside of the space charge, the electrons and positive ions move as if there were no potential difference present between the two anodes.

If for any reason the space charge surrounding the negative anode is broken down, the ions and electrons will circulate between the two anodes, impelled by a potential difference, which is no longer 25 volts but 26,000 volts. The secondary of the transformer is actually short-circuited by the arc and a heavy short-circuit current circulates between the anodes. This phenomenon is called an arc-back or back-fire. The protective equipment with which the rectifier is provided will disconnect it from the a-c. line, the valve action will be immediately restored in less time than the breaker requires for reclosing, and the rectifier will again be ready to take load.

ENGINEERING DEVELOPMENTS

The danger of breakdown of the space charge increases with the capacity of the rectifier so that special means had to be devised for insuring continuity of the valve action of the rectifier. The most important improvement along this line was obtained by means of screens introduced into the arc path in the vicinity of the anodes. These screens may be made of iron or graphite in the shape of concentric rings or wire meshes, and may be solidly connected to the anode shields or insulated from them; or they may be energized by an outside source of electric potential. When designing such screens, care must be taken that they do not increase the voltage drop in the arc. Following is a brief explanation of the action of these screens:

When an anode is carrying current, its screen takes its potential from the arc and is therefore at a lower potential than the anode. When the anodes cease to carry current, the screen retains its potential for a short time, during which it is negative with respect to the anode. It therefore attracts the positive ions and maintains the space charge at the instant when the anode ceases to be positive, at which time the tendency to back-fire is most pronounced.

Since the introduction of these screens, it has become possible to build rectifiers for very high current capacities per anode at medium high voltage and also rectifiers for very high voltages, while keeping their dimensions within reasonable limits. The progress made in this respect is evident when one considers that rectifiers for traction purposes now in operation are rated as high as 3000 kw. nominal rating at 600-650 volts and 2000 kw. at 3000 volts; cylinders used for electrochemical purposes range from 7200 kw. at 500 volts to

2000 kw. at 8000 volts; for radio transmission, only 400 kw. at 13,000 volts has so far been required.

One problem which gave some concern to operating engineers a few years ago is the problem of interference with commutation circuits due to the ripple in the direct current delivered by the rectifier. This problem was carefully studied at the outset and may now be said to be completely solved.

In order to reduce the effect of back-fires on the rectifier circuit, large capacity rectifiers are equipped not only with quick-acting d-c. breakers but also with high-speed a-c. breakers. Oscillographic records taken in service show that with modern a-c. breakers back-fire can be interrupted in less than eight cycles after the trip coil of the breaker is energized. The rectifier is put back into service immediately after the interruption.

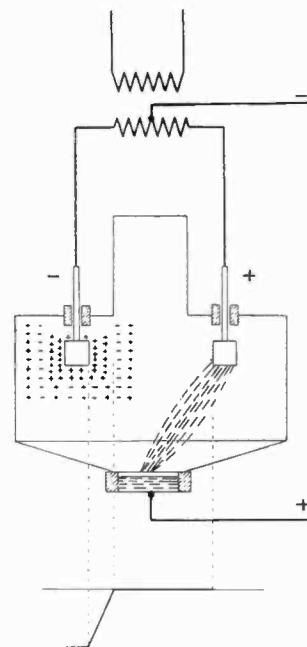

FIG. 1—SINGLE-PHASE TWO-ANODE RECTIFIER SET AND DIAGRAM OF VOLTAGE BETWEEN ANODES

Another recent development of great value is the regulation of the d-c. voltage of the rectifier by controlling the electric field inside the rectifier. This is obtained by controlling the point of the cycle at which the anodes pick up current in rotation.² This control is obtained by means of the energized screens mentioned above. This will be made the subject of a later paper.

In the case of rectifiers provided with interphase transformers, it is also often desirable to eliminate the abrupt rise of the voltage curve at no-load. This voltage rise is present because when the load decreases below a certain value, the third-harmonic flux in the interphase transformer decreases below its saturation value, thereby making the interphase transformer ineffective. This is easily remedied by providing the interphase transformer with an exciting winding permanently connected to a bank of very small auxiliary

2. Mercury Arc Power Rectifiers, by Marti and Winograd, McGraw-Hill, Chapter XII.

transformers connected so as to give a voltage which is a third harmonic of the fundamental wave.

Not only in the design of rectifiers has considerable progress been made, but also in the measuring methods used with them. This was made necessary by the increased capacities of rectifier cylinders. Since in a rectifier the losses are independent of the output voltage, at very low voltages they become large compared to the output and it is possible to measure them accurately by means of the input-output method. The output is easily determined by means of d-c. instruments, while the input is determined by the following novel method:

Each wattmeter current coil is connected to a current transformer having two primaries inserted in opposition into the leads of two anodes working half a cycle apart. The wattmeter voltage coil is connected to one of these anodes and ground; thus the wattmeter measures the output of two opposite phases of the transformer, and the current transformer, alternately receiving positive and negative current impulses, is no longer sat-

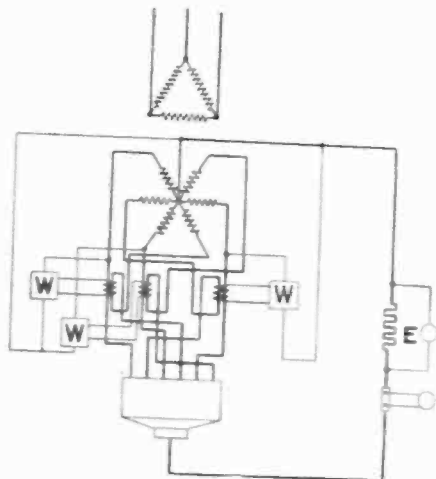

FIG. 2—MEASUREMENT OF RECTIFIER LOSSES—DIAGRAM OF CONNECTIONS

urated, so that accurate measurements can be made. For diagram of connections see Fig. 2. By this method, half of the secondary copper losses of the transformer are included in the measurement, but the readings can be corrected accordingly.

For a load test at normal voltage and normal output, the rectifier is fed by a transformer having the same rating. The capacity of the required transformers, however, can be reduced almost one-half by the following ingenious method:

As shown in Fig. 3, half of the anodes of the rectifier are fed at normal voltage and normal current by a transformer which must therefore have only half the capacity of the rectifier. The d-c. output is fed back into the a-c. line by a motor-generator also having half the rating of the rectifier. The remaining anodes of the rectifier are fed at a fraction of the normal voltage and at normal current by another transformer which has only a very small rating and an output usually dissipated in a water rheostat. This method is made possible by the fact that the voltage drop in the rectifier

is independent of the voltage on the load, so that both groups of anodes can work in parallel without difficulty. All anodes are fully loaded and with half of them receiving the full voltage, the operating conditions are practically the same as when all anodes are fed at normal voltage. When the test has run for one-half of the

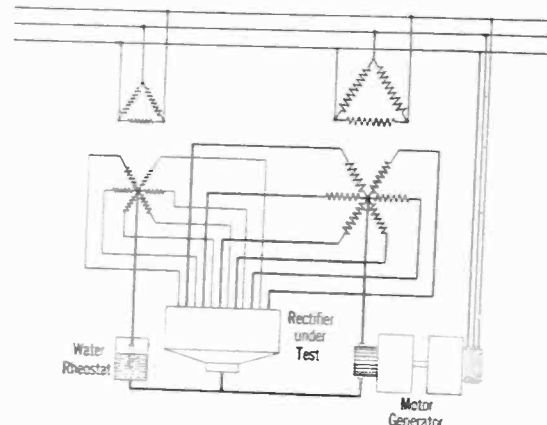

FIG. 3—LOAD TEST OF RECTIFIER—DIAGRAM OF CONNECTIONS

required time, the connections between the groups of anodes and the two transformers are interchanged so that each group of anodes will have received full voltage during one-half of the run.

STANDARDIZATION OF RECTIFIERS

Fig. 4 shows schematic cross-sections on a comparative scale of one series of rectifiers of the Brown Boveri design having respectively, 6, 12, 18, and 24 anodes.

The types of rectifiers shown are standard and in their design care was taken to use as many identical parts as possible so as to reduce the number of spare parts necessary for different sizes. Among those parts

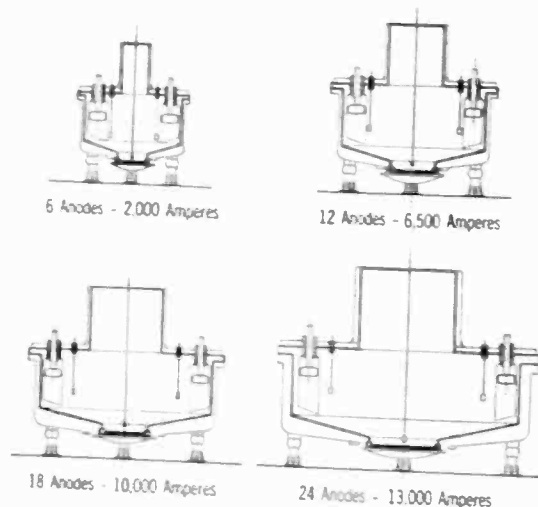

FIG. 4—COMPARATIVE CROSS-SECTIONS OF A SERIES OF BROWN BOVERI RECTIFIERS

are the anodes, the anode insulators, ignition anodes, excitation anodes, cathode plates, and the component parts of the seals for their various joints.

The evacuating equipment, which consists of a rotary pump and a high-vacuum pump, is the same for all types of rectifiers, two sets of pumps in parallel being used for the larger types of cylinders. In order to

simplify erection and reduce the space required for the rectifier, the pumps are now mounted directly on the cylinder.

The excitation and ignition transformers are combined in one compact unit which is the same for all sizes of rectifiers.

EXPANSION OF FIELDS OF APPLICATION OF MERCURY ARC RECTIFIERS

Early in 1930 a new field of application for large-capacity mercury arc rectifiers was opened by putting into operation in a substation supplying power to the

Philadelphia City Transit subways, two 2500-kw. 650-volt nominally rated rectifiers.

readily to very compact layouts. The cylinders are covered by sheet metal housings, and are directly connected to their transformers. Rectifiers and transformers can be rolled into position on a car running on adjacent track siding. The d-c. feeders can be brought out overhead or through cables from the switchhouse located in the center of the substation. The a-c. feeder layout is in accordance with standard practise, and requires no further explanation.

A very interesting application of high-voltage rectifiers was found in radio transmitting stations where voltages ranging from 10,000 to 30,000 are required. For such stations of considerable power, the mercury arc rectifier is especially well adapted as it can be put into service instantly, resists short-circuits which are disastrous to other types of converters, and has a high efficiency which will effect a considerable saving as compared with thermionic tubes. In addition, the life of the rectifier is indefinite whereas the tubes have a limited life.

Considerable interest was aroused by the installation by the Consolidated Mining & Smelting Company, Trail, B. C., of six rectifiers for 5000 amperes each at 460-560 volts as shown in Fig. 10. These rectifiers are used for electrolytically refining zinc and are the largest installed on the American continent.

In hydrogen plants, one advantage of the rectifier is that it is not subject to reversals of polarity, which are a source of disastrous explosions. Moreover, in the

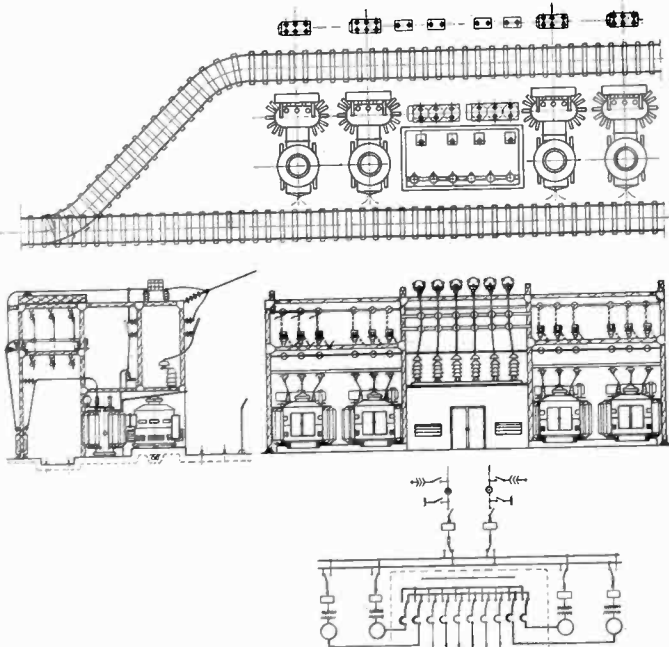

FIG. 8—PROJECT OF LAYOUT OF OUTDOOR RECTIFIER SUBSTATION

Philadelphia City Transit subways, two 2500-kw. 650-volt nominally rated rectifiers.

The mercury arc rectifier has another very promising application in railway portable substations. Portable substations being mounted on springs, the capacity of rotating equipment which could be installed in them is very limited, as machines of large capacity would produce excessive vibration in a car of standard design. On the other hand, the mercury arc rectifier being a static piece of apparatus, the only limitations to its use will be the weight and the size of the transformer. It is comparatively easy to install a complete rectifier substation for 3000 kw., at a d-c. voltage of 600, 1500 or 3000, on a standard flat car, which is far beyond the present requirements for portable substations. In view of the ease with which it can be remotely controlled or made fully automatic, the mercury arc rectifier is especially desirable for this application.

For installations with very large d-c. outputs, it may be economical to install the rectifiers outdoors, and, as may be seen from Fig. 8, rectifiers lend themselves

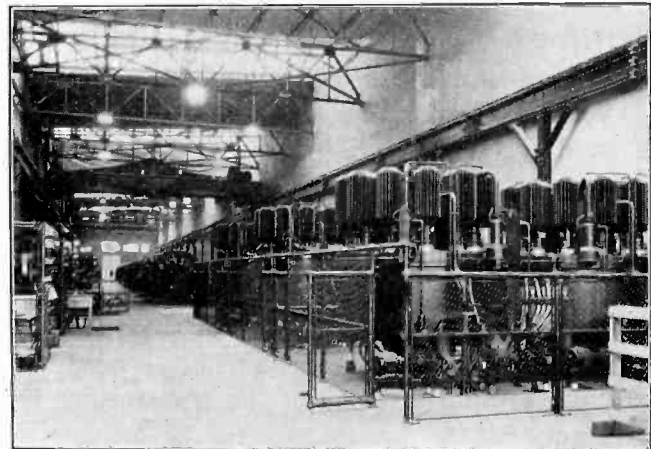

FIG. 10—RECTIFIER INSTALLATION OF SIX, 5000-AMPERES, 460/560-VOLT RECTIFIERS FOR CONSOLIDATED MINING & SMELTING Co., TRAIL, B. C., CANADA

case of large electrochemical installations operating continuously 24 hr. a day, the absence of brush wear alone constitutes an appreciable advantage for the steel-enclosed mercury arc rectifiers.

Very recently a number of rectifiers have been installed for supplying power alternately to a 250-volt, three-wire d-c. Edison system and a 600-volt railway system. As the mercury arc rectifiers work at any com-

mercial voltage, these abnormal operating conditions are being taken care of by merely changing the transformer connections.

CONCLUSION

This brief study of recent rectifier developments shows that the rectifier can be used to advantage for any power application requiring conversion from alternating to direct current. It has made available for existing applications reliable units of higher capacity

and has permitted the development of applications hitherto retarded by the lack of a suitable converter. Due to the ease of its generation and conversion, alternating current has taken a long lead over direct current, and is being used for applications where direct current would be preferable. Since the advent of the rectifier, however, the use of direct current has received a considerable impetus and it will no doubt in the near future gain additional momentum.

Abridgment of Grounding Banks of Transformers with Neutral Impedances and the Resultant Transient Conditions in the Windings

BY F. J. VOGEL*

Associate, A. I. E. E.

and

J. K. HODNETTE*

Associate, A. I. E. E.

Synopsis.—The question of grounding transformer bank neutrals through different impedances has recently arisen due to the desire to limit system single-phase and two-phase short-circuit currents. It was found that the use of resistance, only, may be undesirable on account of the high voltage at the neutral in limiting the short-circuit current. The use of inductance, only, may result in high voltages within the transformer and at the neutral due to lightning transients, which necessitates the transformer being fully insulated

throughout. Methods using parallel paths with the inductance, (these parallel paths being designed primarily to reduce the lightning transients at the neutral), have been studied and found to limit the transients within the transformers to values approximating those for solidly-grounded neutral which permit the grading of the transformer insulation. The method to be selected depends upon the individual case; but generally, the use of the valve type lightning arrester is the simplest to apply.

I. INTRODUCTION

MODERN methods of power transmission involve the transformation of energy with large high-voltage transformers, which usually have one or more windings connected in star and until recently solidly grounded at the neutral. With the increase in size of transformers and generating equipment, trouble has developed due to excessive currents under single- and two-phase short circuits. To relieve these conditions and to improve the stability of the system generally, the practise of inserting impedance between the neutral and ground of some of the transformer banks has been adopted.

Either a resistance or an inductance can be used for the impedance. It is the purpose of this paper to study the characteristics of neutral impedances under lightning surge conditions and suggest means for improving their performance.

II. FACTORS INFLUENCING THE LIGHTNING TRANSIENT

It has been shown that the worst stresses within the transformer windings were those due to steep-front short waves and steep-front long waves. The former,

*Insulation Engineer, Westinghouse Elec. & Mfg. Co., Sharon, Pa.

Presented at the Pacific Coast Convention of the A. I. E. E., Portland, Oregon, Sept. 2-5, 1930. Complete copy upon request.

by virtue of its greater magnitude, imposes the greater stress upon the winding near the entrance terminal. With steep-front long waves, the initial distribution is essentially the same except for absolute magnitude, but due to oscillations within the winding, the amplitude of voltage at internal points is greater. The magnitude of lightning voltages which can be propagated on transmission lines is limited by the line insulation and is lower for long waves than short waves. Oscillographic records of lightning waves taken in the field indicate that the greatest duration of voltage probably would not exceed 60 microseconds to one-half value, and the most rapid rate of rise was of the order of one microsecond to maximum value.

Waves having the characteristics of the two above described would impose the most severe stresses upon transformers grounded through neutral impedance. It has been previously pointed out that with short surges, only a small amount of energy penetrates the winding as far as the neutral and consequently the increase in voltage at the grounding impedance will be very small. From the standpoint of stress at the neutral impedance and the interior of the transformer winding, it will be necessary to consider only the 60-microsecond surge.

Another important factor influencing the amplitude of voltage in the transformers and at the neutral is the magnitude of voltage occurring simultaneously on the

three separate phases. If simultaneous waves of equal amplitude are impressed on each of the three phases, the voltage at the neutral would rise to three times the amplitude that it would if the wave were impressed upon one phase only. In making this investigation, the worst condition of three equal surges is assumed.

III. TEST CIRCUITS AND METHOD OF TESTING

Impulses were generated by discharging banks of condensers through a resistance and impressing the

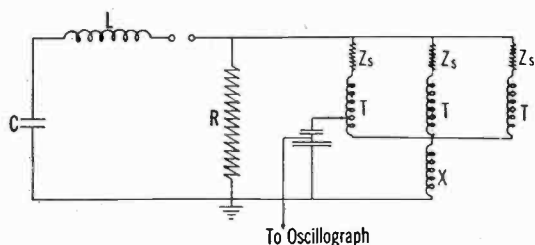

FIG. 2—SCHEMATIC DIAGRAM OF TESTING CIRCUIT

voltage drop upon the transformer terminals. The windings of the transformers under test were connected together at the neutral and grounded through the impedance under consideration. The connections from the surge generator to the high-voltage terminals of these windings were made as short as practicable and terminated in lumped surge impedances of approxi-

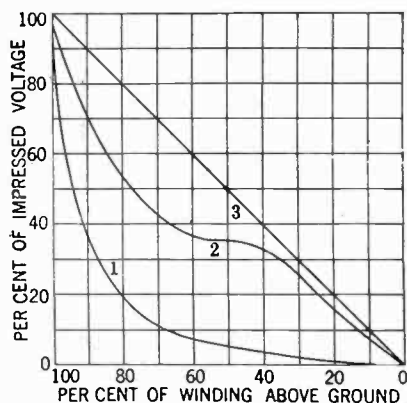

FIG. 3—VOLTAGE-TO-GROUND PRODUCED IN A TRANSFORMER WINDING WITH NEUTRAL SOLIDLY GROUNDED BY A 60-MICRO-SECOND SURGE

1. Initial voltage distribution
2. Maximum voltage by oscillation
3. Final or steady state distribution

mately 450 ohms. The remaining windings of the transformers were connected to ground through similar surge impedances (Fig. 2).

The transformers used in making this study were 25,000-kv-a. 220-kv. power transformers of shell type construction, and of recent design.

The neutral reactors were air core, and the neutral resistors were practically non-inductive.

IV. TRANSFORMERS WITH SOLIDLY-GROUNDED NEUTRAL

The initial distribution of voltage with the steep-front wave is shown as Curve 1, Fig. 3. The maximum voltage-to-ground occurring at internal points in the winding by oscillation is represented by Curve 2 of the same figure. These two boundary curves define the envelope of oscillation of the internal-voltage transient. It is to be noted that the maximum voltage does not exceed the uniform distribution curve.

V. TRANSFORMER WITH NEUTRAL INSULATED

The initial distribution, (Fig. 4) is practically the same, irrespective of whether the transformer is solidly grounded, grounded through an impedance, or completely isolated.

The final distribution is quite different from that with the neutral grounded. When the neutral is isolated and a surge is impressed, the winding tends to assume the

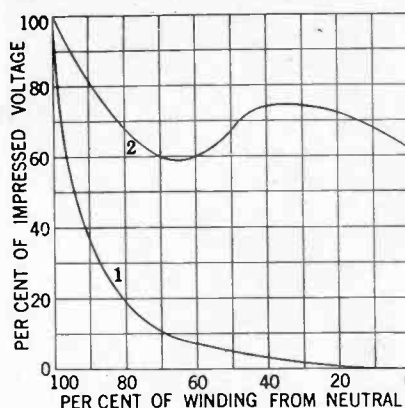

FIG. 4—VOLTAGE TO GROUND IN A TRANSFORMER WINDING WITH ISOLATED NEUTRAL

1. Initial voltage distribution
2. Maximum voltage by oscillation
3. Final distribution or axis of oscillation

same potential throughout. In reaching this potential, it oscillates about the potential on the line terminal. The amplitude of the oscillation at the neutral depends upon the magnitude of the terminal voltage and the relation of the length of the surge to the natural period of oscillation. Under lightning surges, the voltage rises to relatively high values. In the experimental case, the maximum amplitude in per cent of the impressed voltages is given in Curve 2, Fig. 4.

It is to be noted that the voltage does not attain values in excess of the applied voltage; this is explained, as above mentioned, by the fact that Curve 3, representing the initial axis of oscillation, decreases as the voltage on the transformer decreases. Since the rate of decrease of the latter is rapid as compared with the period of oscillation of the transformer, the oscillations do not develop to the extent that they would if limited only by inherent damping, as would be the case with an infinitely long wave.

VI. TRANSFORMER WITH NEUTRAL GROUNDED THROUGH RESISTANCE

When the transformer neutral is grounded through a non-inductive resistance, the axis about which the winding tends to oscillate is a straight line extending from the line to the neutral end of the winding. The voltage at the neutral will be raised to a value depending

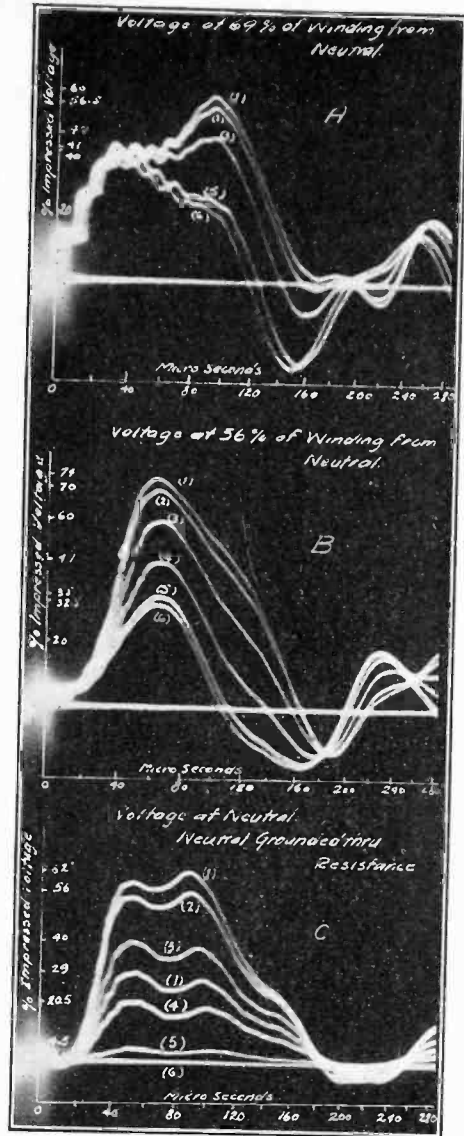

FIG. 5—OSCILLOGRAMS SHOWING THE VARIATION OF INTERNAL OSCILLATIONS IN TRANSFORMER WINDINGS WITH DIFFERENT VALUES OF NEUTRAL RESISTANCE

- A—69 per cent of winding from neutral
- B—36 per cent of winding from neutral
- C—Neutral
- 1 - $R = \infty$ (neutral isolated)
- 2 - $R = 100,000$ ohms
- 3 - $R = 25,000$ ohms
- 4 - $R = 5,000$ ohms
- 5 - $R = 450$ ohms
- 6 - $R = 0$ (neutral solidly grounded)

upon the value of neutral resistance, the relative effective impedance of the transformer winding, and the length of the traveling wave. In the limiting cases of zero resistance and infinite resistance, the axes coincide with those for a solidly-grounded transformer and for an isolated-neutral transformer (Curves 3, Figs. 3 and 4). For finite resistances, the axis lies between these limits.

With the 60-microsecond test wave, the voltage at the neutral and points in the winding 36 per cent and 69 per cent from the neutral are shown in the oscillograms of Fig. 5, for various values of resistance between the two limiting conditions. With the transformers grounded through 450-ohm resistance, the rise in voltage at the neutral was approximately 4.5 per cent. The increase in voltage at the two points in the winding mentioned above, over that for a solidly-grounded neutral was small—only about 2 or 3 per cent.

VII. TRANSFORMER NEUTRAL GROUNDED THROUGH INDUCTANCE

In the case of the neutral grounded through inductance as in the previous cases, the initial distribution is the same as for solidly-grounded neutral. The oscillatory voltage occurring across the reactor is a function of the relative inductance of the transformer and reactor and the relative length of the traveling wave. The higher the ratio of reactor inductance to transformer inductance, the greater will be the rise of voltage at the neutral. During the transient existing in the trans-

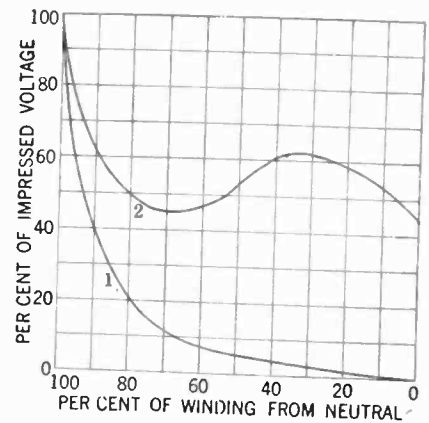

FIG. 6—VOLTAGE-TO-GROUND IN 25,000-KV-A. 220-KV. SHELL TYPE TRANSFORMER WINDINGS WITH NEUTRAL GROUNDED THROUGH A 315-MILLIHENRY REACTOR

- 1. Initial distribution of voltage
- 2. Maximum voltage by oscillation

former winding, the reactor enters into oscillation with the transformer winding. This results in an increase in voltage stress at the neutral and throughout the winding, as illustrated by the curves given in Figs. 6 and 3.

A reactor is a desirable means for grounding the neutral, since its reactive drop adds directly to the impedance voltage of the transformer, reduces the shock of short circuit on generating equipment, has less watts loss, and can generally be designed more economically than a resistor. A method of reducing the excessive transient voltage at the neutral is therefore highly desirable. Several ways of improving this feature are described below.

A. *Reactor Shunted with Resistance.* If the neutral reactor is shunted by resistance, a part of the energy is conducted directly to ground and a damping effect

imposed upon the oscillations in the reactor circuit. Obviously, the lower the resistance used, the lower will be the voltage across the reactor.

B. Reactor Shunted by Spark-Gap. The second method of preventing excessive voltage at the neutral is to shunt the reactor with a spark-gap. This method permits the voltage to rise to some safe, predetermined value and then reduces it to zero. The voltage at which the gap would be set is determined by the insulation of the reactor. The superimposed transient accompanying the gap discharge has no damaging effect upon circuits of as long a time constant as that of the transformer winding. The effect of this transient is shown by the oscillograms in Fig. 8, where the resulting voltages at 36 or 69 per cent from neutral are compared with those with the neutral solidly grounded. The increase in voltage is 7 to 9 per cent over that with solidly-grounded neutral or about 3 per cent of the impressed voltage.

C. Reactor Shunted by Lightning Arrester. Proceeding as in the case of the shunting spark-gap, the proper lightning arrester for protecting the insulation of the reactor was selected. For this application an arrester of the valve type is ideal. In applying the arrester it is necessary only to fix the cut off voltage slightly in excess of the dynamic rise of voltage. By so doing, the maximum discharge voltage can be limited to

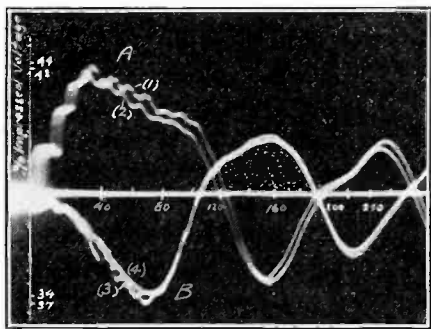

FIG. 8—OSCILLOGRAM SHOWING THE EFFECT UPON THE INTERNAL TRANSFORMER WINDING TRANSIENT SHUNTING NEUTRAL REACTOR WITH SAFETY GAP

- A —Voltage at 69 per cent of winding from neutral
- B —Voltage at 36 per cent of winding from neutral
- 1,3—Neutral grounded through reactor shunted with safety gap
- 2,4—Neutral solidly grounded

approximately 2.5 times the dynamic voltage, even when discharging large currents.

This method of reducing the neutral voltage has other advantages in addition to those mentioned. It employs a standard protective device which requires no special consideration or calculation for its application.

D. Reactor Shunted with Resonant Circuit. A series capacitance and inductance circuit was connected in parallel with the neutral reactor and the constants proportioned so as to be in resonance at the frequency of the transient voltage existing at the reactor terminal. This circuit offers a very low impedance path to the surge current and shunts it directly to ground; but at normal operating frequencies it has a very high impedance.

With the surge current determined largely by the impedance of the transformer winding, the two elements are proportioned so as to give a minimum rise in voltage at the neutral and keep the drop across each within safe limits.

In the experimental application, the circuit was proportioned so that the rise in voltage at the neutral due to lightning would not exceed twice the dynamic voltage under the most severe conditions. Fig. 10 shows oscillograms of the voltage at two internal points in the winding and at the neutral. In oscillogram A the voltages resulting from the reactor being shunted with the resonant circuit are compared with the voltages with the neutral solidly grounded. The maximum

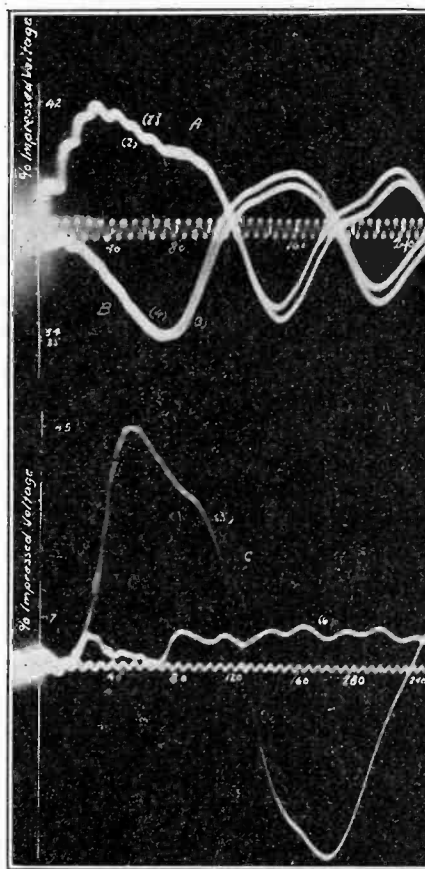

FIG. 10—OSCILLOGRAMS SHOWING THE EFFECT UPON THE INTERNAL TRANSFORMER WINDING TRANSIENT OF SHUNTING NEUTRAL REACTOR WITH AUXILIARY RESONANT CIRCUIT

- A —Voltage at 69 per cent of winding from neutral
- B —Voltage at 36 per cent of winding from neutral
- C —Voltage at neutral
- 1, 3 & 6—Neutral grounded through reactor shunted with resonant circuit
- 2, 4—Neutral solidly grounded
- 5—Neutral grounded through reactor only

amplitudes of the voltage at each point are practically equal for the two conditions, and the shape of the voltage-time curves are practically identical except that with the reactor shunted by the resonant circuit, the axis of oscillation is shifted upwards on account of the drop through the circuit. In oscillogram C are compared the voltage at the neutral with the reactor alone and with it shunted with the resonant circuit. The amplitude of the voltage in the latter case is reduced to approximately one-sixth of that when the neutral is grounded through the inductance only.

Abridgment of
The East River Generating Station
of the New York Edison Company

BY C. B. GRADY,¹ W. H. LAWRENCE,² and R. H. TAPSCOTT³
Non-member Member, A. I. E. E. Fellow, A. I. E. E.

THE New York Edison Company and affiliated companies operate two 25-cycle stations aggregating 402,000 kw., four combined 25- and 60-cycle stations aggregating 1,110,000 kw., and two 60-cycle stations aggregating 405,000 kw., a total generating capacity of 1,917,000 kw. with a 1929 peak load of 1,225,200 kw.

All stations are interconnected by means of tie feeders which in each instance approximate the capacity of the largest unit. Five frequency changers with a total capacity of 190,000 kw. tie the 25- and 60-cycle systems.

At the time East River Station was designed, Manhattan Island was served almost exclusively from the 25-cycle system, with conversion to direct current. The policy of the company at the present time, however, is to curtail the d-c. load in favor of the 60-cycle network. This paper deals with the development of the East River Station as originally planned under a proposed growth of the 25-cycle system. Under the present policy of the company, no additional 25-cycle units will be installed, and the future development of the station will be devoted exclusively to 60 cycles. It is estimated that in ten years the 60-cycle load of the New York Edison System will be at least four times the 25-cycle load.

SITE

The site chosen has the following advantages: It is near the center of the Manhattan load; it provides a continuous area for future expansion both as to buildings and high-voltage feeder outlets; favorable waterfront conditions provide ample water depth, (some 30 feet), for docking ocean-going colliers and for extensive disposal of ashes.

COAL HANDLING AND PREPARATION

The coal is brought to the station in 1000-ton barges and unloaded by two 350-tons per hr., electric-traveling, coal towers, in which it is crushed and discharged by belt conveyers to bins in the coal preparation house.

The pulverizing equipment consists of two 15-ton and four 25-ton Raymond air-swept mills, each operating

1. Mechanical Engineer, The New York Edison Company, New York, N. Y.

2. Chief Operating Engineer, The New York Edison Company, New York, N. Y.

3. Electrical Engineer, The New York Edison Company, New York, N. Y.

Presented at the Summer Convention of the A. I. E. E., Toronto, Ont., Canada, June 23-27, 1930. Complete copy upon request.

in a closed system with a fan and cyclone separator. Air for drying is preheated in two steam-air preheaters operating at 15-lb. and 400-lb. gage, respectively. From the cyclone separators, the coal flows by gravity into the transport system which conveys it to the boiler bins.

The average fineness of the coal is approximately 96 per cent through a 60-mesh, 90 per cent through a 100-mesh, and 70 per cent through a 200-mesh sieve.

BOILERS AND FULL BURNING SYSTEM

The initial boiler installation consisted of six Springfield horizontal cross-drums boilers, each containing 14,809 sq. ft. of boiler heating surface, 4134 sq. ft. of water wall surface on all four sides of the furnace and in the slag screen, 3430 sq. ft. of hairpin type superheater and 28,900 sq. ft. of effective plate type air preheater surface. The Lopulco system of vertical firing, with ten main and ten auxiliary burners, is used. Table I gives data from a test made on Boiler No. 4.

The new installation consists of three 800,000-lb. per hr. boilers of the Ladd type, fired from both ends as shown in Fig. 1. Each boiler contains 60,706 sq. ft. of boiler heating surface, 7345 sq. ft. of water wall surface on all four sides of the furnace and in the slag screen, 13,900 sq. ft. of hairpin type superheater, and 82,721 sq. ft. of effective plate type air preheater surface. The Lopulco system of vertical firing with 20 main and 20 auxiliary burners, (10 of each on each end), is used.

The steam conditions for the new boilers are 425-lb. gage and 725-deg. fahr. total temperature at 800,000 lb. per hr. evaporation. At this rating the feed water temperature is 360 deg. fahr. and the air temperature from the air preheater, 450 deg. fahr.

Table II gives heat balance data of a test recently run on one of these new boilers at an output of 1,000,000 lb. of steam per hr. This output, which is 25 per cent greater than the maximum guaranteed capacity of 800,000 lb. per hr., was maintained continuously for 12 hr. with entirely stable furnace and water level conditions and with no signs of distress in any part of the equipment. Further, an efficiency of 86.5 per cent is indicated. An output of 1,250,000 lb. per hr. has also been maintained on one of these boilers for 15 min., but was accompanied by a considerable drop in efficiency.

Stable firing conditions are maintained in these boilers at all ratings by the use of small auxiliary burners, set at right angles to the vertical burners, so that their

TABLE I

		April 23, 1929	May 7, 1929	May 14, 1929
		108,630	169,100	239,720
Actual evaporation per hour	lb.	86.1	87.1	84.1
Heat absorbed by steam	per cent	2.0	0.5	1.0
Heat absorbed by air preheater and returned to other boilers	per cent	0.2	0.3	0.2
Heat loss due to moisture in coal	per cent	3.2	3.2	3.1
Heat loss due to moisture in burning hydrogen	per cent	6.0	7.3	6.1
Heat loss due to dry chimney gases	per cent	0.8	0.8	2.5
Heat loss due to combustible in refuse	per cent	1.7	0.8	3.0
Heat loss due to radiation and unaccounted for	per cent			
Total	per cent	100.0	100.0	100.0

TABLE II
HEAT BALANCE OF NO. 7 BOILER—OUTPUT 1,000,000
LB. PER HR.

	B. t. u.	Per cent
Loss due to moisture in coal	11	0.1
Hydrogen	453	3.0
Dry chimney gases	1,137	7.7
Combustible in refuse	73	0.5
Moisture in air	30	0.2
Radiation and unaccounted for	294	2.0
Total losses	1,998	13.5
Efficiency and heat to boiler	12,772	86.5
Total	14,770	100.0

flames impinge on the streams of fuel leaving the vertical burners, at a point slightly below their entrance into the furnace. This method accelerates combustion to a point where the heat radiated from the flame to the water cooled walls does not reduce the flame temperature to a point where combustion is retarded. In addition, unburned carbon losses have been reduced, slag troubles eliminated, and furnace capacity increased.

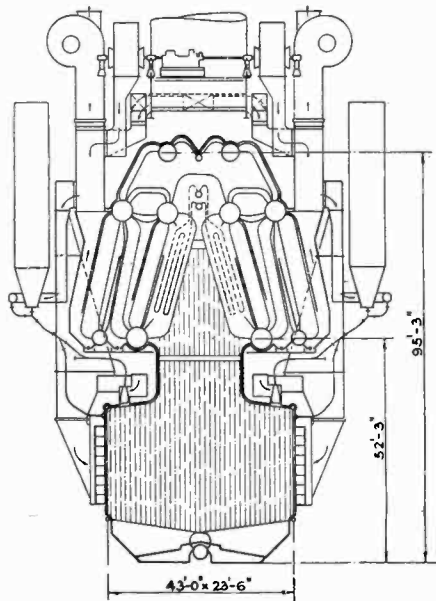

FIG. 1—CROSS-SECTION NEW BOILER UNITS

Two types of cinder catchers are in use; Davidson Cyclone Separators on the first six boilers and Cottrell Precipitators, on the three new boilers. The efficiency of this apparatus is such that we have been unable to locate any deposits of flue dust in the surrounding neighborhood.

GENERATING EQUIPMENT

The generating building will have accommodations for

nine steam turbo-generators of large capacity, three of which are already in operation. Fig. 2 shows the new 160,000-kw. unit.

The generated potential is 11,400-volt, three-phase, 25-cycle. All 25-cycle energy is transmitted at this voltage except for two 33-kv. feeders which tie through Lorimer Street Substation with the Brooklyn Edison Company's Gold Street Generating Station, serving as both a supply to the Long Island Railroad and a

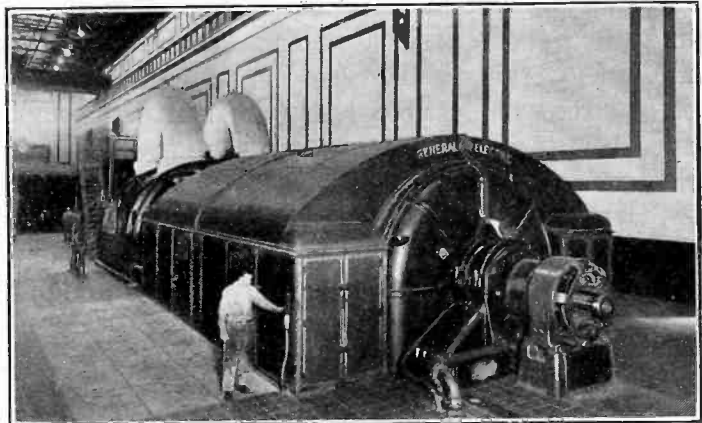

FIG. 2—160,000-Kw. GENERATOR

means of interchanging power between the generating stations. Three 15,000-kv-a. transformers step up the energy from the 60-cycle end of the frequency changer to 27,600 volts.

EXCITATION SUPPLY

Excitation for the main units is furnished exclusively by direct-connected exciters, each exciter being connected solidly to the main field through the main field rheostat. The exciter field circuit is equipped with remote-control air circuit breakers which are automatic in operation when actuated by the over-all differential relay of the main unit.

FREQUENCY CHANGER

A 40,000-kw. frequency changer, designated as Unit No. 3, is of the synchronous induction type. The 60-cycle induction generator excited by means of an 18,500-kw. transformer from the 25-cycle system provides a transformer tie as well as a power tie, (Fig. 3).

The frequency changer was installed for a twofold purpose; first, to make possible the pooling of the spare capacity on the 60-cycle and 25-cycle systems; and second, to maintain the two systems in synchronism.

At the time the frequency changer was installed, the rotary converters supplying the d-c. network were all 25-cycle machines; but it was thought that in view of the pronounced trend toward 60 cycles as a standard frequency, it might become desirable in future installations to use 60-cycle converters. In order to obtain satisfactory operation of the two types of rotary converters, it was realized that it would be essential to

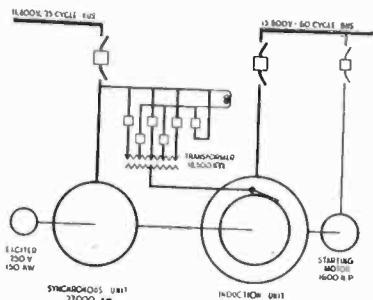

FIG. 3—FREQUENCY CHANGER CONNECTIONS

keep the two systems in synchronism and, furthermore, that to prevent possible damage to the commutation equipment, the tie between the two systems should be as strong as possible. It was with this thought in mind that the synchronous induction type of frequency changer was chosen. Although the anticipated use of the 60-cycle rotary converters has not developed, due to the expansion of the a-c. network system in Manhattan it is felt that the use of the synchronous induction type of frequency changer has been of advantage in increasing the stability of operation between the two systems.

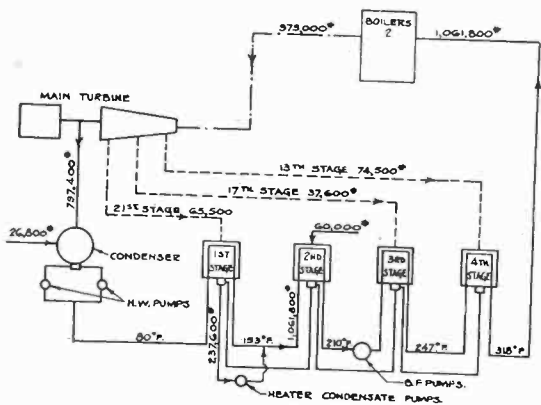

FIG. 4—HEAT BALANCE—UNIT No. 4

By taking advantage of this it is possible to keep on the system only such frequency changer capacity as may be required for load interchange without operating additional machines for the sole purpose of maintaining synchronism. In view of the magnitude of the two systems it is felt that the performance from this point of view has been very gratifying.

CONDENSERS

The condensers for the three units are of the single-pass surface type, those for Units Nos. 1 and 2 having 47,500 sq. ft. of surface and the Unit No. 4 condenser, 90,000 sq. ft. of surface.

AUXILIARIES

Steam turbines are used to drive the main auxiliaries, thus providing a very even acceleration or retardation of speed. The non-essential auxiliaries, or those which may be shut down for short periods of time without affecting service, are motor driven and supplied from the 2300-volt or 440-volt, 25-cycle busses energized from the house transformers on the main bus.

The exhaust steam from the steam-driven auxiliaries is used for feedwater heating, the practise at the East River Station being four stages of heating; three by steam bled from the main units and one by the exhaust steam. This is shown by the typical heat balance diagram for Unit No. 4, Fig. 4. Units Nos. 1 and 2 are bled from the 11th, 14th, and 18th stages, and Unit No. 4 from the 13th, 17th, and 21st stages.

ELECTRICAL EQUIPMENT OF 160,000-KW. UNIT

The main and emergency busses for the first two

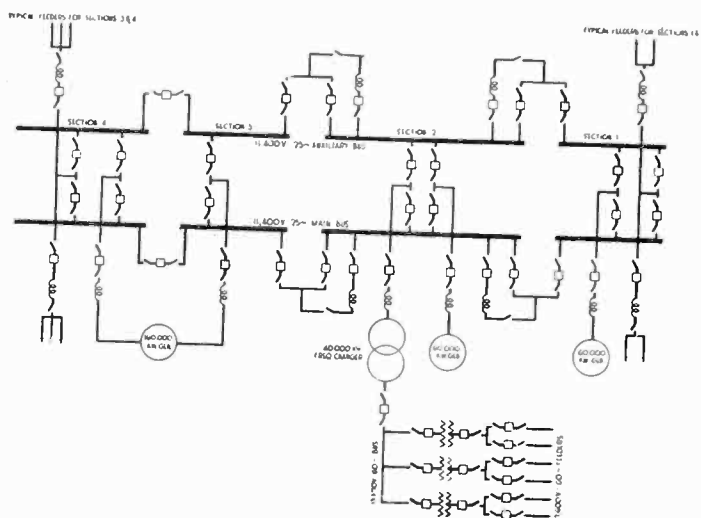

FIG. 5—STATION BUS ARRANGEMENT

60,000-kw. units were sectionalized,—one section for each generator with its complement of feeders, the sections being connected through 10 per cent reactors based on the full load of a generator.

In the latest edition, the one 160,000-kw. unit is of the single-shaft type and due to the high current of a unit of this size, it was impossible to procure single generator switches of sufficient carrying capacity. It was therefore necessary to consider two switches in parallel. The use of a double-winding generator, however, provided a very simple means of assuring satisfactory load division between the output circuits, and at the same time reduced the current capacity and interrupting duty on the switches, (see Fig. 5). In this unit the windings in alternate slots are connected to separate circuits, and the circuits alternated under adjacent pole faces, thus distributing the circuits and producing balanced magnetic forces. This method of winding results in an added number of end connections and leads, but is otherwise identical with a standard single-winding unit.

It may be interesting at this point to digress for a

moment and consider the application of such a unit to the general layout of a system. The increase in capacity of units, stations, and systems in recent years with the consequent requirements of greater interrupting capacity of circuit breakers and other costly problems resulting from excessive currents and high magnetic forces has brought to the art entirely new conceptions of station bus layouts, all tending toward the splitting up of stations into small sections which may in themselves be considered as separate generating stations.

Through its transformer action, the double-winding generator creates a very high reactance between windings (equivalent to generator bus sections) but due to the linkage of a common field, the stability is not decreased by this increase in reactance. In large sized generators it seems feasible to increase the number of windings which may be brought out of a unit and by use of multiple windings in conjunction with the scheme of synchronizing at the load to still further reduce the magnitude and extent of short-circuit disturbances and at the same time to improve system stability.

For the one 160,000-kw. unit at East River, however, it was possible to use only the high-reactance sectionalizing due to double windings as the 25-cycle system is not operated as a parallel system at the substations. While there were no immediate economies over the previous layout of one generator to a section with 10 per cent sectionalizing reactance, the adoption of the double-winding design looked forward to future economy due to the elimination of bus tie switches and reactors. The decrease in maximum instantaneous short-circuit duty from approximately 2,500,000 kv-a. to 1,500,000 kv-a. was one of the outstanding advantages of the new design.

FEEDER ARRANGEMENT

In order to still further reduce the number of switches required, outgoing feeders were grouped together. The H arrangement was used in this station with two selector and two feeder switches per group. The standard feeder is 350,000 cir. mils and supplies one 4200-kw. converter in a substation.

ELECTRICAL GALLERIES

The electrical galleries are of the vertical isolated-phase type; there are few special features incorporated which are not common to all modern isolated phase galleries. The long narrow formation of the building permits economical grouping of compartments and easy physical separation of generator sections; the busses, (main and emergency,) are mounted on two sides of the room with about 30 ft. separation, but this separation cannot be maintained in the selector switches. All busses and bus connections are bar copper mounted on 25,000-volt insulators: but in addition, all copper is wrapped with varnished cambric to a thickness equivalent to 15,000-volt insulation in order to minimize possible short circuits due to gases which might be present as the result of minor disturbances. All feeder cables are

single-conductor lead, both in the station and in the adjacent streets and no cable joints are made within the station.

GENERAL DESIGN FEATURES OF 1929 EXTENSION

When it was decided to go ahead with the first extension of this station, it was found that turbine builders were prepared to supply single turbo-generators, having a capacity of 160,000 kw. each, at a considerably lower cost per kw. than for the 60,000-kw. units in the original installation. It was then decided that in the extension of this station the same number of units as originally planned would be installed but that these units would have nearly three times the capacity of the original units. The manner in which this has been accomplished is demonstrated by the following:

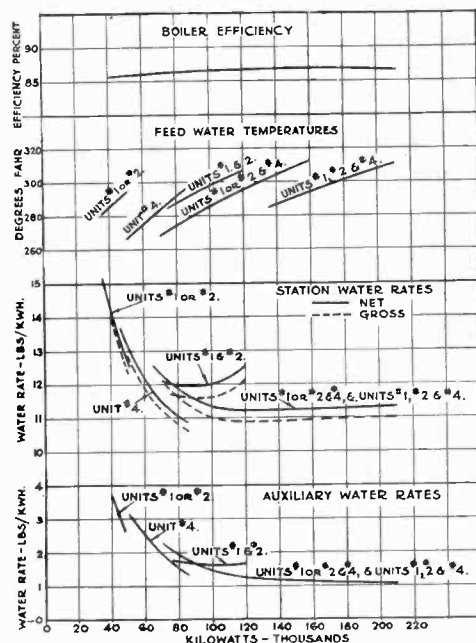

FIG. 6—STATION PERFORMANCE DATA

Turbo-generators Nos. 1 and 2 (60,000-kw. capacity each) occupy 0.083 sq. ft. per kw. capacity, while turbo-generator No. 4 (of 160,000-kw. capacity) occupies 0.0452 sq. ft. per kw. capacity. Boilers 1 to 6 (of 250,000-lb. capacity each) occupy 9.2 sq. ft. and 1140 cu. ft. per 1000 lb. steam capacity, while boilers 7, 8, and 9 (of 1,000,000-lb. capacity each) occupy 4.5 sq. ft. and 625 cu. ft. per 1000 lb. steam capacity. Similarly the electrical galleries for generators Nos. 1 and 2 require 0.48 sq. ft. of floor area and 7.39 cu. ft. per kw. capacity, whereas similar equipment for generator No. 4 occupies 0.215 sq. ft. of floor area and 3.92 cu. ft. per kw. capacity.

STATION OPERATING DATA

Fig. 6 shows in graphic form boiler efficiency, feed-water temperature, total station and auxiliary water rates of this station when carrying loads from 35,000 to 210,000 kw. These curves are based on the station performance for the months of February and March 1930. The station heat rate is 15,000 B. t. u. per net kw. hr.

Abridgment of High-Speed Protective Relays

BY L. N. CRICHTON¹

Member, A. I. E. E.

Synopsis.—During the past year or so, studies of stability have been made to determine methods of preventing loss of synchronism upon the occurrence of faults. Of the several methods found, the most obvious and effective is the high-speed isolation of the faulty section of the line; and this of course means high-speed relays and high-speed breakers. Investigation so far has indicated that the time required depends upon the type of fault. Since a three-phase short circuit prevents the flow of synchronizing power, it is the most serious type and must be cleared in from six to ten cycles. This demands the use of relays which will operate “instantaneously.”

Recent suggestions have been numerous, and these are discussed, this discussion covering relays operating at normal frequency and those which have been operated or suggested for higher superimposed frequencies.

While there is a number of difficulties attendant on the design of high-speed relays—these troubles depending on the type and con-

struction of the relay—still high-speed relays may be made to operate on any of the present well-known principles, such as impedance principle, current balance principle, etc. They may employ either a mechanical structure or may make use of thermionic or gas-filled tubes.

Attention is given to a mechanical relay of the impedance type operating with a speed of one cycle or less. Some discussion is also given of the reactance type relay with mention of its limitations, particularly that of the extra time required for its initiating element to operate.

The effect of resistance at the point of fault (arc resistance) is discussed and the conclusion drawn that, for extremely high-speed operation, it does not interfere with satisfactory relay performance. This is because of the time required for the arc resistance to increase to an appreciable value.

* * * * *

DURING the past year or so, studies of system stability have been made with the view of determining the conditions under which large amounts of power can be transmitted without danger of the equipment falling out of step under fault conditions.

With high-speed relay and breaker operation, more power can be sent over a transmission line without losing synchronism on faults; insulator damage due to flashovers will be negligible; the damage to conductors will be practically eliminated, and interference with communication circuits reduced.

NORMAL FREQUENCY SYSTEMS

Since high-speed breakers require from four to eight cycles to open the circuit, high-speed relays, in order to keep the total clearing time within the required limits, must operate in one cycle or less on a 60-cycle system. Many relay operations will be less than one cycle,—possibly even below $\frac{1}{4}$ cycle.

High-speed relays may be constructed to operate on any of the present well-known principles, such as the impedance principle, the current balance principle, etc., and may employ either a mechanical structure or may make use of thermionic or gas filled tubes.

A difficulty is that the transient values of short-circuit current may vary through a wide range depending upon the point on the voltage wave at which the trouble occurs.

A simple overcurrent relay may be compensated by means of a “transient shunt,” shown in Fig. 1, so that its performance will be uniform no matter at what point of the voltage wave the short circuit occurs.

1. Meter Engg. Dept., Westinghouse E. & M. Co., Newark, N. J.

Presented at the Summer Convention of the A. I. E. E., Toronto, Ontario, Canada, June 23-27, 1930. Complete copy upon request.

This shunt is made up of resistance and reactance and is so proportioned that it carries the d-c. component of the unsymmetrical current and allows the normal symmetrical current to flow through the relay.

It is necessary to make sure that a directional relay integrates the conditions existing in the power circuit over a considerable period of time. Except at unity power factor, the flow of power is always alternating so that the direction of trouble cannot be instantaneously determined. The oscillograms in Fig. 12 show some

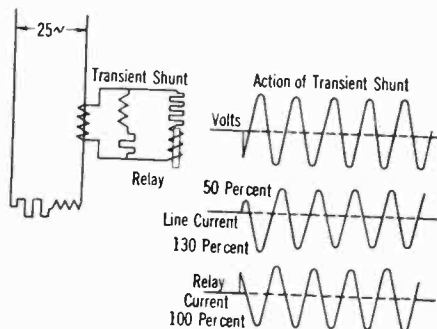

FIG. 1—TRANSIENT SHUNT AND LABORATORY TEST RESULTS

Showing that the shunt diverts the d-c. component from the overcurrent relay so that the first half cycle of current is the same value as the sustained current

of the conditions which exist when the current is suddenly reversed in a transmission line.

DIFFERENTIAL RELAYS

On parallel lines, differential relays might be used and can easily clear the majority of troubles by opening the breakers simultaneously at each end of the line. It is well recognized, however, that when trouble is close to one bus (X Fig. 2), the relays at the other bus cannot tell which is the bad line and must wait until the closer relay has operated before they can act. This is what has been called “sequential” operation.

IMPEDANCE RELAYS

The impedance relay will not eliminate sequential operation because (referring to Fig. 2) the two impedance relays at substation A cannot distinguish trouble at X any better than can differential relays. Furthermore, a relay at substation A cannot distinguish between a short circuit at X and one at Y if these two

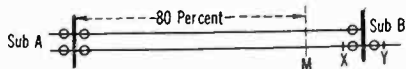

FIG. 2—ILLUSTRATING THE DIFFICULTY THAT THE RELAYS AT SUB A WILL HAVE IN DISTINGUISHING BETWEEN TROUBLE AT X AND Y AND IN DETERMINING WHETHER THE POINT X IS ON THE TOP OR BOTTOM LINE

points are both close to the bus bars. It is therefore necessary to limit the operation of relays at substation A to a zone extending from the relay to M. This zone will be approximately 80 per cent of the length of the line section but it will vary depending upon the nature of the fault and the accuracy of the relay.

The fundamental design of this type of relay, (Fig. 3),

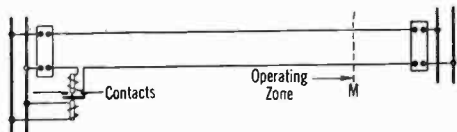

FIG. 3—THE SIMPLE, HIGH-SPEED, IMPEDANCE RELAY

is simple. A current coil attempts to close the contacts but is restrained by the voltage coil. The two coils are so proportioned that they balance each other when a short circuit occurs at the point M. If the trouble is closer than that point, the relay will operate; if it is farther away, the relay will not operate. This device is instantaneous in the usual meaning of the term but of course it will operate faster when the trouble is close to it. Fig. 4 shows a characteristic time curve of the high-speed element as it is at present developed.

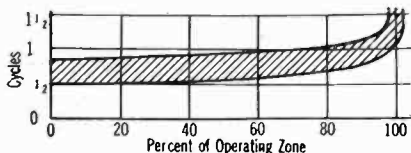

FIG. 4—A CHARACTERISTIC TIME CURVE OF AN IMPEDANCE RELAY ADJUSTED FOR OPERATION ON A LINE OF MODERATE LENGTH.

When used on a short section the time may be slightly greater

In order to care for the section of the line beyond the instantaneous zone, it has been proposed to use a definite time relay whose operation is initiated by a second impedance relay set to operate over a longer zone. This should be sufficient protection but to satisfy a frequent requirement, a second longer time relay, operated by a third impedance element, has been added for back-up protection to operate in case the breaker at the next station should fail to open as

expected. Several sections of transmission line representing part of a network are shown in Fig. 5 with the relay time steps superimposed on top of the line.

DIRECTIONAL ELEMENT

Conventional induction type directional elements would be too slow for high-speed relays, but a modification has been made which will do fairly well if the voltage can always be kept above 20 per cent of normal.



FIG. 5—A SECTION OF TRANSMISSION LINE HAVING SEVERAL SUBSTATIONS

Showing the method of adjusting the instantaneous and time element impedance relay

For unbalanced short circuits this is satisfactory if the customary connection is used which permits at least one relay of a set to obtain its voltage from an unaffected phase. For three-phase faults, this type of directional element will not be satisfactory, particularly because three-phase faults are most serious and must be cleared with the highest possible speed. One of several methods which has been suggested for overcoming this

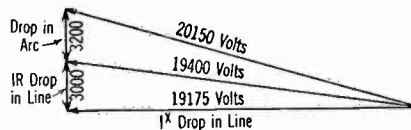

FIG. 6—EFFECT OF RESISTANCE OF AN 8-FT. ARC ON THE IMPEDANCE OF 50 MI. OF SHORT-CIRCUIED 220-KV. LINE

Insulators on all three phases assumed to have flashed over simultaneously

trouble is to drive continuously a small synchronous motor having a sufficient flywheel effect so that it can keep its proper phase position during the line disturbance. (Fig. 8) Of course this motor will not stay in step for any great length of time but we are concerned with only the first few cycles.

REACTANCE RELAYS

The effect of resistance at the point of fault in shortening the operating zone is frequently mentioned, but

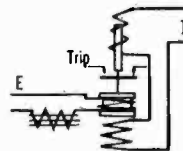

FIG. 7—SIMPLE REACTANCE RELAY

The balance point is where $I^2 = E I \sin \phi$ which, simplified, is $I = E \sin \phi$

a number of years' experience with relays of the impedance type indicates that this is not serious; at least for short circuits. In a short circuit, as distinguished from a ground, the only resistance can be that of an arc. A remarkable set of tests made by Mr. P. Ackerman several years ago showed that long arcs of heavy-current values have a potential across them of

Normal frequency relays of the distance type are recommended.

The shortcomings of these relays lie in the frequent troubles which can only be cleared by them sequentially.

High-frequency protection must be used to overcome sequential operation on long lines where pilot wires are out of the question.

The use of high frequency is largely an economic problem. If the lines have sufficient capacity, if the breakers are fast enough, and if the excitation response is quick enough, simultaneous breaker operation will

not be necessary. But where all these factors, or a sufficient weight of them, cannot be economically attained, then high-frequency methods should be used.

ACKNOWLEDGMENT

In addition to the acknowledgments made in the text, the writer is indebted to the following members of the Westinghouse organization whose work has been studied in the preparation of this paper: Messrs. R. C. Bergvall, R. C. Curtis, S. L. Goldsborough, R. D. Evans, and H. A. McLaughlin, who is now with the Central Hudson Gas & Electric Company.

Abridgment of Arcing Grounds and Effect of Neutral Grounding Impedance

BY J. E. CLEM*

Associate, A. I. E. E.

Synopsis.—This paper was written to review and extend the theory of overvoltages due to the arcing grounds because of the increasing tendency to use impedances between the neutral point and the ground, thereby losing the advantage of the solidly grounded neutral. The "third-class conductor" theory of Steinmetz is touched upon very briefly and is considered as not applying to transmission line conditions. The theory when the phenomenon is controlled by normal frequency arc extinction, as presented by Peters and Slepian, is reviewed, and the maximum voltage for this analysis is found to be $3 \frac{1}{2} E$, where E is the normal line to neutral voltage. The theory

when the phenomenon is controlled by oscillatory frequency arc extinction as originated by Doctor Petersen is given in detail but in a modified and extended form. The maximum voltage for a single-phase circuit when no damping is considered is found to be $6 E$.

The analysis for the three-phase circuit is newly developed for the case in which there is an impedance between the neutral and ground

and the maximum voltage is found to be $7.5 E$ when the effect of the damping factors and capacitance between lines is neglected. The method of determining the various reductions or damping factors is outlined.

The effect of a neutral grounding resistor is discussed and it is pointed out that a surprisingly high value of resistance can be used without incurring the possibility of dangerous overvoltages. It is shown that the use of reactance is more liable to result in overvoltages than resistance but that relatively large values of reactance can be used in conjunction with resistance.

The Petersen Coil is usually considered as causing the arc to go out by giving a balance of lagging and leading currents in the arc. It is brought out in this paper that there will be no voltages built up when the Petersen Coil is used, whether or not the arc goes out.

The relation of the overvoltages on a non-grounded and an effectively grounded system is outlined, and a criterion for determining whether or not a system is effectively grounded is proposed.

* * * * *

IN the early days of the industry most of the power systems were operating with an isolated neutral.

Overvoltage troubles due to the accidental grounding of one line were prevalent. Frequently the accidental grounding of a line in one place would cause flash over of the insulation in many other widely separated points on the system. This trouble was practically eliminated by the adoption of the practise of solidly grounding the neutral.

The operation of systems with solidly grounded neutrals was very satisfactory until the systems grew so large that the power concentration in the fault became a serious matter. As a result it was proposed to

*Central Station Engg. Dept., General Electric Company, Schenectady, N. Y.

1. For references see Bibliography.

Presented at the North Eastern District Meeting of the A. I. E. E., Springfield, Mass., May 7-10, 1930. Complete copy upon request.

cut down the current which would flow in the fault by the introduction of impedance in the neutral ground connection, which raised the question of the possibility for overvoltages to be developed on the system as a result of arcing grounds. This analysis was made to find out whether or not such overvoltages might result, and if so to determine what the magnitudes might be.

There are three methods of explaining the overvoltages which might result from an arcing ground: One was put forth by Dr. Steinmetz, but probably does not apply to conditions as found in the transmission line; in another, the extinguishing and restriking of the arc is assumed to be controlled by the normal frequency conditions; while in still another, the extinguishing of the arc is assumed to be controlled by oscillatory arc conditions and the arc is assumed to restrike at the instant the normal frequency voltage next reaches its crest value.

With an isolated neutral, the oscillatory frequency arc

extinction is the most probable one, while if the neutral is grounded through an impedance, the normal frequency arc extinction appears to be most probable. However, two recent incidents indicate that occasionally even with the neutral grounded through impedance the phenomenon may be controlled by oscillatory frequency arc extinction. One case involved a cable circuit for which the ground connection was made through a grounding transformer. Trouble occurred in the joints and insulators at each end of the cable flashover. The voltage required to flashover the insulators could not be accounted for by an analysis made on the assumption of normal frequency control. The disconnecting switches on which the flashovers occurred had recently been installed so that dirt on the insulators could not be held accountable. In another case, the neutral was grounded through a reactance coil; one conductor broke and fell down with the result that an oil circuit breaker flashed over and a transformer broke down at another point on the system; the voltage required to flash over the oil circuit breaker was higher than that indicated by normal frequency arc control. These two instances indicate that for the present at least it is best to take a pessimistic view of the situation and base the analysis in regard to possible arcing ground voltages on the assumption that will give the highest voltages, which is that the phenomenon is controlled by oscillatory frequency arc extinction.

In making the analysis it is assumed that the arc on the faulty line strikes at the crest of the voltage wave and is extinguished the first time the oscillatory frequency current passes through zero. At this instant, the sound lines have their maximum voltage to ground, and to establish this voltage over the capacitance of the two sound lines to ground there is a charge necessary on these lines. Since the arc is extinguished, these charges are trapped on the sound lines and cannot escape to ground; accordingly, this charge distributes itself over the system and establishes an average potential of the system to ground. This redistribution of the trapped or bound charge is assumed to take place rather quickly and any oscillations incident to it are neglected in the analysis. The arc is assumed to restrike the next time the faulted line reaches a maximum potential to ground; and since the neutral is displaced, the voltage to ground increases in steps, as does also the voltage to which the sound lines oscillate, these steps becoming smaller and smaller as they approach a limit. This is a brief outline of the theory when the neutral is isolated and was originally proposed, the author believes, by Doctor Petersen.

The theory as modified to take into account the grounding of the neutral through an impedance is based on the same assumptions. When the neutral is grounded through an impedance, however, there is a path to ground over which the bound charge can escape. If the impedance of this path is sufficiently low, the bound charge will all be gone before the arc restrikes

and of course there will be no overvoltages built up. If the impedance between the neutral and ground is high, there will be a portion of the bound charge still on the sound lines when the arc restrikes, and it will be possible to build up a certain overvoltage by the arcing ground phenomenon. Ordinarily, however, the flow of the dynamic short-circuit current will be sufficient to prevent the control of the phenomenon by the oscillatory frequency current. In view of the fact that high voltages have occasionally been developed on supposedly grounded systems, it appears desirable,—for the time being at least,—to base analysis on the assumption that the control is by oscillatory frequency arc current. When the system is isolated and one line grounded, the dynamic neutral shift is equal to the leg voltage; but when the neutral is grounded, the dynamic shift is less than the leg voltage. This factor has been taken into consideration in the determination of voltages when the neutral is grounded.

The maximum possible voltage on a three-phase system that can be developed from an arcing ground is 7.5 times normal line-to-neutral voltage. In an actual system there are various reduction factors present which bring the maximum voltage to be expected on an isolated system down to approximately 5.5 times normal. When the neutral is grounded through an impedance, the calculated voltage may be anything up to 5.5 times normal, depending upon the value of the neutral grounding impedance.

The insulation of certain apparatus depends upon whether or not the circuit may be classified as a grounded circuit. In the past it has generally been the practise to classify a circuit as isolated neutral when any impedance at all is placed in the neutral. This analysis indicates that rather high values of either resistance or reactance may be placed in the neutral without incurring the possibility of dangerous overvoltages due to arcing grounds. However, it seems wise to go slowly in this matter and base the limitations as to an effectively grounded circuit on the assumption that the arcing ground phenomenon is controlled by oscillatory frequency arc extinction. This will give conservative results and later, if experience warrants, the requirements may be modified.

This analysis shows that successful operation of the Petersen coil, in which in this country increasing interest is being shown, does not require that the arc be extinguished. When the Petersen coil is exactly tuned, the arc will be extinguished and no overvoltages will result; and even if the coil is not tuned exactly, the arc may not be extinguished but over a considerable range of inductance on either side of the resonant value, serious arcing ground voltages will not be built up.

OSCILLATORY FREQUENCY ARC EXTINCTION

Single-Phase Circuit. To illustrate the method of analysis the analysis for the single-phase circuit will be given complete and in detail. In Fig. 7 are repre-

sented the two wires of a single-phase circuit together with the respective capacitances. The effective value of these capacitances at any instant depends upon the potentials of Lines 1 and 2. In Fig. 2 is shown the voltage wave of the two wires in respect to ground. The maximum voltage to ground of either line wire is E and the voltage between wires is $(E_2 - E_1)$ or $(E_1 - E_2)$ with a maximum of $2E$.

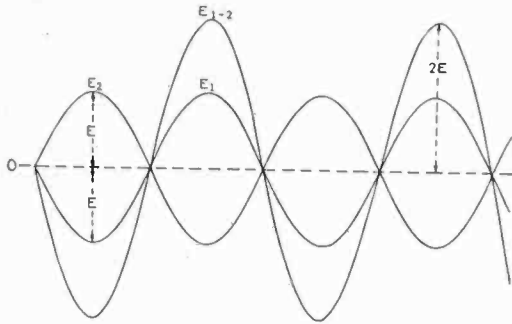

FIG. 2

The arc is assumed to strike from Line 2 to ground, thereby reducing the potential of this line to zero and short-circuiting the capacitance between it and ground. The initial arc is considered to occur when Line 2 is at its maximum potential to ground ($E_2 = +E$). At this instant for steady-state conditions the zero potential of Line 2 requires a potential of $(-2E)$ on Line 1, which is equivalent to impressing a voltage of $(-2E)$ on Line 1. At the instant the arc strikes, the potential of Line 1 is $(-E)$ and the transition from $(-E)$ to $(-2E)$ takes place as an oscillation (see Fig. 14A). It is assumed that the arc goes out the first time the oscillatory arc current passes through

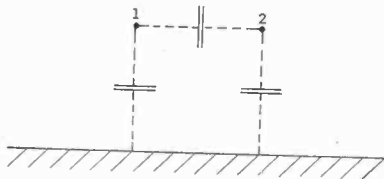

FIG. 7

zero, which is practically simultaneous with the instant of maximum potential of Line 1.

In Fig. 8 are shown the conditions immediately after the arc has struck and the conditions at the instant the arc has gone out. At the instant the arc goes out, the voltage to ground on Line 1 is $(-3E)$, which necessitates a corresponding charge $(-Q)$ on the sound line. After the arc goes out, this charge distributes itself over the system, passing through the apparatus at the end of the line, and establishes the average potential to ground

of the system as $(-1 \frac{1}{2} E)$, corresponding to a

charge of $(-\frac{Q}{2})$ on each of the two lines. This re-

distribution of charge takes place through an oscillation which is not shown in the diagrams.

After steady state conditions are attained, conditions are as indicated on the right of Fig. 8. However, this steady state cannot be maintained, as the faulty Line 2

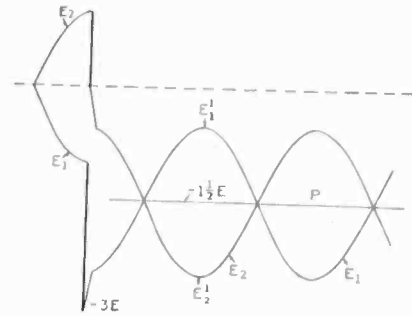

FIG. 8

will again arc to ground and it is assumed that this will occur when its potential to ground becomes a maximum. This is shown in Fig. 9 in which the second arc is given as striking when the voltage of the faulty Line 2 has

reached a value of $(-2 \frac{1}{2} E)$. At this instant the potential of Line 2 immediately goes to zero. For re-

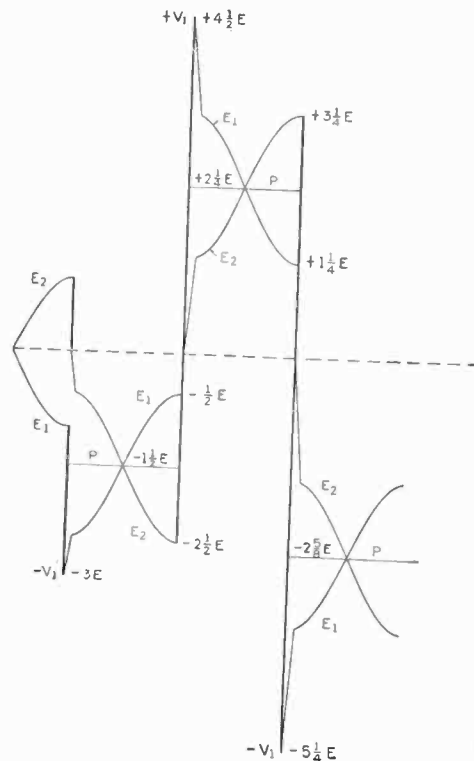

FIG. 9

sulting oscillation, the initial potential of Line 1 is $(-\frac{1}{2} E)$ and the impressed voltage is $(+2E)$, as required by the condition of zero potential on Line 2.

The transition from a potential of $(-\frac{1}{2} E)$ to $(+2E)$

takes place through an oscillation which has an applied voltage of $\left\{ + 2 E - \left(- \frac{1}{2} E \right) \right\}$ or $\left(+ 2 \frac{1}{2} E \right)$. The maximum potential to which Line 1 oscillates during the oscillation is $\left(2 \frac{1}{2} E + 2 E \right)$ or $\left(+ 4 \frac{1}{2} E \right)$, at which instant the arc goes out, leaving a charge corresponding to a potential $\left(+ 4 \frac{1}{2} E \right)$ on Line 1. This charge then diffuses itself through the entire system establishing an average potential of $\left(+ 2 \frac{1}{4} E \right)$ through the system.

As before, the potentials of Line 1 and Line 2 vary about this average potential, and when the potential of Line 2 reaches its maximum value of $\left(+ 3 \frac{1}{4} E \right)$, the arc strikes again. At this instant the potential of Line 1 is $\left(+ 1 \frac{1}{4} E \right)$ so that the resulting oscillation has an impressed voltage of $(- 2 E)$ and an applied voltage and amplitude of $\left(- 2 E - 1 \frac{1}{4} E \right) = \left(- 3 \frac{1}{4} E \right)$. The potential of Line 1 goes to a maximum of $\left(- 5 \frac{1}{4} E \right)$, at which instant the arc goes out. A charge corresponding to a potential of $\left(- 5 \frac{1}{4} E \right)$ is left on Line 1 and this charge diffuses as before throughout the entire system, establishing an average potential of $\left(- 2 \frac{5}{8} E \right)$ over the two lines. This process repeats itself until the maximum voltage is attained or something happens to remove the system voltage.

The maximum possible voltage can be determined from the following considerations and by reference to Table II. Let the maximum potential of a negative oscillation be denoted by $(- V_1)$, (see Fig. 9). Immediately following the extinction of the arc, the charge associated with the voltage $(- V_1)$ will distribute itself throughout the system and establish a potential P . To determine P it is necessary to know the relationship existing between the various capacitances involved. When Line 2 arcs to ground, it goes to zero potential, and the potential $(- V_1)$ to which Line 1 oscillates is established over the capacitance C_o , requiring a charge

$$Q_1 = - V_1 C_o \tag{11}$$

The capacitance C_o is defined as the capacitance of one

line wire to ground when the other line wire is grounded; *i. e.*, at zero potential.

The arc goes out when the oscillatory arc current passes through zero, and this charge Q_1 now diffuses throughout the system and establishes the average potential P over the capacitance of the two line wires in parallel. If C_a be defined as the capacitance of one of

TABLE II
DERIVATION OF MAXIMUM VOLTAGE

Arc No.		1	2	3	4	5	N	N + 1	N + 2
Line 2	E_2	+1	$-\frac{1}{2}$	$+\frac{1}{4}$	$-\frac{5}{8}$	$+\frac{13}{16}$		-4	+4
Line 1	E_1	-1	$-\frac{1}{2}$	$+\frac{1}{4}$	$-\frac{5}{8}$	$+\frac{13}{16}$		-2	+2
Line V_1	E_1	-1	$-\frac{1}{2}$	$+\frac{1}{4}$	$-\frac{5}{8}$	$+\frac{13}{16}$		-2	+2
Impressed V.	E_o	-2	+2	-2	+2	-2		+2	-2
Amplitude	A	-1	$+\frac{1}{2}$	$-\frac{3}{4}$	$+\frac{5}{8}$	$-\frac{13}{16}$		+4	-4
Max. V.	V_1'	-3	$+\frac{1}{2}$	$-\frac{5}{4}$	$+\frac{5}{8}$	$-\frac{13}{16}$	-6	+6	-6
Average V.	P	$-\frac{1}{2}$	$+\frac{1}{4}$	$+\frac{5}{8}$	$+\frac{13}{16}$	$-\frac{29}{32}$	-3	+3	-3
Line 1	E_1'	$-\frac{1}{2}$	$+\frac{1}{4}$	$-\frac{5}{8}$	$+\frac{13}{16}$	$-\frac{29}{32}$	-2	+2	-2
Line 2	E_2'	$-\frac{1}{2}$	$+\frac{1}{4}$	$-\frac{5}{8}$	$+\frac{13}{16}$	$-\frac{29}{32}$	-4	+4	-4

Voltages given in the table are in terms of the line voltage E . All reducing factors have been neglected.

Since Line 2 is assumed to arc to ground the impressed voltage is $2 E$ with the sign taken as opposite to that of E_2 and the initial voltage is the voltage of Line 1.

$$A = E_o - E_1 \text{ taking proper sign of } E_o \text{ from sign of } E_2$$

$$V_1' = E_a + A \quad E_1' = P - E$$

$$P = \frac{V_1'}{2} \quad E_2' = P + E$$

The values for the first three arcs can be taken from or checked against Fig. 9 and the rest of the values follow obviously

two wires to ground when both are at the same potential, the capacitance of the two wires together will be $2 C_a$ and we can write

$$P = - \frac{1}{2} V_1 \frac{C_o}{C_a} (1 - a) \tag{12}$$

The factor $(1 - a)$ is added to make allowance for any charge that may leak off and for the charge that may be taken up by the terminal apparatus. It should be noted that the resistance in the circuit has no effect upon the final average voltage P except to influence the time required to reach the steady state conditions.

After a half cycle, the voltages are

$$E_1 = - \frac{1}{2} V_1 \frac{C_o}{C_a} (1 - a) + E \tag{13}$$

$$E_2 = - \frac{1}{2} V_1 \frac{C_o}{C_a} (1 - a) - E \tag{14}$$

and when the faulty Line 2 reaches this potential the arc will strike again. These expressions for E_1 and E_2

have been obtained directly from (12) by adding or subtracting E .

When the arc strikes, the potential of Line 2 drops to zero, losing its charge, and the charge Q_1' which is associated with the voltage E_1 must now establish another voltage E_1' over the capacitances C_o of Line 1 to ground when Line 2 is at ground potential. This involves a change in the electrostatic field only and takes place very rapidly.

The charge associated with the potential E_1 is

$$Q_1' = C \frac{E_1 - E_2 \frac{C}{C_m}}{1 - \frac{C^2}{C_m^2}} \quad (15)$$

and upon substituting the values of E_1 and E_2 from (13) and (14) there results

$$Q_1' = C_o \left\{ E \left(1 + \frac{C}{C_m} \right) - \frac{1}{2} V_1 (1 - a) \right\} \quad (16)$$

the potential established by this charge being

$$E_1' = E \left(1 + \frac{C}{C_m} \right) - \frac{1}{2} V_1 (1 - a) \quad (17)$$

The fact that Line 2 is at zero or ground potential requires that Line 1 be at a potential $(+2E)$, but instead, it has the potential E_1' , and this difference between impressed and initial potential produces an oscillation having an amplitude of

$$A = \{ 2E - E_1' \} (1 - d) \quad (18)$$

and giving a maximum voltage of

$$V_1' = 2E + A \quad (19)$$

The limiting value will occur when the maximum potential of any oscillation is the same as that of the immediately preceding oscillation; that is, when $V_1' = V_1$; and then

$$V_1 = 2E \frac{2 + \left(1 - \frac{C}{C_m} \right) (1 - d)}{2 - (1 - a) (1 - d)} \quad (20)$$

This expression gives the maximum voltage that can be set up by an arcing ground on a single-phase circuit, with the analysis based on the extinction of the arc when the oscillatory current first passes through zero.

The maximum possible value is six times normal line-to-neutral voltage as compared with four times, as obtained from the preceding analysis. Table II further illustrates the building up of the voltage on the sound line and also fixes six times as the limit. By inspection of Table II and Fig. 9 it can be seen that the values of V_1 and V_1' have the following relation between any two consecutive values,

$$V_1' = V_1 + \frac{1}{2} (6 - V_1)$$

which indicates that V_1 can never be greater than 6. Writing in the values 6 for V_1 in the column for the n th arc it is seen that the $(N + 1)$ th and $(N + 2)$ th arcs give no higher values, thereby establishing the

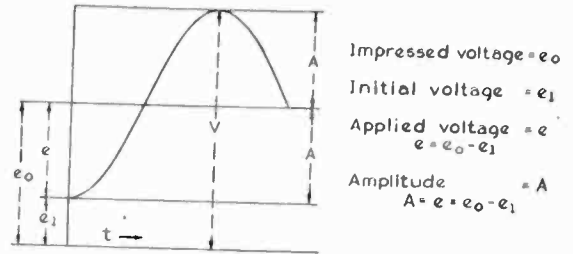

FIG. 14A

limit as 6 times line to neutral voltage, for the voltage produced by an arcing ground in a single-phase system.

Bibliography

1. *Voltages Induced by Arcing Grounds*, by Peters and Slepian, A. I. E. E. TRANS., 1923, Vol. 42, p. 478.
2. *Frequency Conversion by Third Class Conductor and Mechanism of the Arcing Ground and Other Cumulative Surges*, by C. P. Steinmetz, A. I. E. E. TRANS., 1923, Vol. 42, p. 470.
3. "The Intermittent Grounding Effect," by W. Petersen, *Elektrotech. Zeitsch.*, Nov. 22 and 29, 1917.
4. "Grounding the Neutral through Resistance or Reactance," by W. W. Lewis, *General Electric Rev.*, June 1929.
5. "Inductive Interference Report," Railroad Commission of California, April 1, 1919. Also Reference 2.

DROPPING A DAM INTO PLACE

The Alcoa Power Company, Limited has under construction a large hydroelectric power development at Chute-a-Caron on the Saguenay River which has a flow varying from 35,000 to 225,000 cu. ft. per sec. The site selected was a gorge located in a rocky section of the river. To complete the large masonry dam across this gorge it was necessary to divert the river, at low flow, through a new channel.

Due to the extreme depth and high velocity of this water it was suggested that a large, reinforced-concrete tower, or "obelisk," of the proper length, curved on one side to fit as nearly as possible the bottom of the river, be built on a concrete pier at a convenient place upstream from the power dam; then by blasting away a small portion of the pier, tip the obelisk over into the river to form a dam. So carefully was the whole scheme worked out by the engineering staff and construction engineers on the ground that when this block of masonry, 92 by 45 by 45 ft., containing 5500 cu. yds. of concrete, was dropped into the river, it landed almost perfectly into the place for which it was computed.

The entire scheme was a bold one but was carried through successfully and accomplished complete, satisfactory cofferdamming of a most dangerous and difficult stream.—*Research Narratives*.

Abridgment of The Calculation of Cable Temperatures in Subway Ducts

BY WALLACE B. KIRKE¹

Associate, A. I. E. E.

Synopsis.—Underground transmission and distribution circuits are being continually extended, and large amounts of new capital invested each year in the conduit and cable systems which this extension requires. More and more frequently the cable engineer is called upon for accurate information as to the maximum loads that may safely be impressed on underground cables without exceeding the temperature limits recognized in present day practise.

The importance of the study of cable temperatures has long been recognized, and much excellent material has been published concerning its several phases. In particular, the copper temperature rise of loaded cables above the surrounding air has been fully analyzed. Less thorough treatment, however, has been given the determination of the temperatures existing in loaded duct structures, and to the behavior of cables carrying cyclic loads.

It is the purpose of this paper to present a comprehensive survey of the whole problem of cable temperatures by consolidating information on cable temperature characteristics with the equally important problem of the characteristics of duct structure when the cable circuits are subjected to the cyclic loads usually found in practise.

The information herein presented on the subject of duct bank temperatures is the result of an investigation in the metropolitan district of New York, carried on for several years under widely varying conditions. The constants given for certain types of duct structures may not be universally applicable to other localities, but it is believed that the method of attack will be helpful to other engineers in analyzing test data obtained upon their systems and in separating the various factors involved.

* * * * *

CABLE TEMPERATURE RISE ABOVE AIR IN ADJACENT IDLE DUCT

Temperature Rise of Copper above Sheath. In general this temperature difference can be expressed as:

$$T_1 = W H_1 \quad (1)$$

where

T_1 = Temperature rise of copper above sheath in deg. cent.

W = Total watts per ft. of cable for all cables occupying the same duct.

H_1 = Heating factor or thermal resistance per foot length of cable.

This factor depends upon the geometry of the cable and on the thermal resistivity of the insulation and can be expressed as $H_1 = R \times$ form factor, where R is the thermal resistivity of the insulation expressed in deg. cent. per watt per in. cube.

The charts shown in Figs. 1 to 4 (complete paper) give form factors for several types of cables. The nearest equivalent mathematical expressions for these form factors are as follows:

1. Single-conductor cables

$$\text{Form factor} = \frac{0.0305}{n} \log_{10} \frac{d_2}{d_1} \quad (\text{Fig. 1}) \quad (2)$$

where

d_1 = conductor diameter

d_2 = inner sheath diameter

n = number of cables in same duct

2. Concentric cables

$$\text{Form factor} = 0.0305 [0.5 \log (d_3/d_1) + \log (d_2/d_4)] \quad (3)$$

1. Outside Plant Engineer, Brooklyn Edison Company, Inc., Brooklyn, N. Y.

2. A. I. E. E. TRANS., 1923, p. 600.

Presented at the North Eastern District Meeting of the A. I. E. E., Springfield, Mass., May 7-10, 1930. Complete copy upon request.

where

d_1 = diameter of inner conductor

d_2 = inner diameter of sheath

d_3 = inner diameter of outer conductor

d_4 = outer diameter of outer conductor

3. Three-conductor cables, round conductors. (Fig. 2)
Form factor (three conductors to sheath)

$$= 0.0102 \text{ Log}_{10} \left[3 \frac{(8c + b)(c + b)}{4d_1c} + 1 \right] (\text{Simons})^2 \quad (4)$$

where

c = thickness of conductor insulation

b = thickness of belt insulation

d_1 = diameter of conductor

In the case of sector conductors d_1 should be taken as the diameter of the equivalent round conductor and the form factor as calculated should be multiplied by 0.9.

4. Shielded conductor cables (type "H")

In the case of shield-conductor cable, the form factor was derived by averaging the form factors for three-conductor belted cables and three single-conductor cables. This method has been found to check with the results of comparative tests between the belted type and the shield-conductor type of cables manufactured under similar conditions.

Values of R , the thermal resistivity for impregnated paper insulation, have been found as follows:

R		Type of cable	Remarks
Deg. cent/ watt/in. ³	Deg. cent/ watt/cm. ³		
350	(900)	600 volt	Old, dry, operated at high temperatures
300	(760)	15,000 "	Old, fairly dry
270	(685)	" "	Well impregnated but several years in service
200	(510)	33,000 "	New cable

Temperature Rise of Sheath above the Surrounding Duct Wall.

$$T_2 = W H_2 \tag{5}$$

Where T_2 = temperature rise of sheath above the surrounding duct wall.

And H_2 = heating factor or thermal surface resistance of the sheath in deg. cent. per watt per ft. length.

It is impracticable to measure the rise of the sheath above the air in the same duct except by soldering thermocouples along the cable sheath at intervals before pulling it into the duct, and by comparing the sheath temperatures thus obtained with the temperature of the air in an adjacent idle duct at corresponding locations. The rise of sheath above air should be independently determined by testing the cable in still air in a laboratory. The difference between the values thus obtained by testing in air and by testing in the duct, when the adjacent empty duct temperature is referred to as the ambient, will give the temperature drop in the duct wall, as discussed in Section C. At low temperature differences, the temperature rise of the sheath above surrounding air approximates 185 deg. cent. per watt per in.² or 1200 deg. cent. per watt per cm.²; but at higher temperature differences, there is a strict proportionality between temperature rise and the four-fifths power of the watts per unit area.

The four-fifths power relation can be readily approximated by the following expression:

$$H_2 = \frac{4.9}{D(1 + 0.013 W)} \tag{6}$$

Where D = sheath diameter in inches
 W = watts per ft.

In the case of several single-conductor cables in the same duct the effective sheath area can be taken as the "envelope" surface. If n is the number of cables in the duct:

$$H_2 = \frac{15.4}{(n + \pi) D (1 + 0.013 W)} \tag{7}$$

Temperature Rise of Loaded Duct Wall Above Air in Adjacent Idle Duct. The table below gives the temperature rise of the sheath of a cable having a diameter of 2.52 in. when tested in air and also when tested in a concrete duct structure.

Watts/foot	Temp. rise sheath above air	Temp. rise sheath above adjacent duct air temp.	Difference in temp. rise in the two tests	Temperature difference per watt per foot
10	17.1	25.1	8.0	0.80
20	30.6	46.2	15.6	0.78
30	42.0	64.5	22.5	0.75
40	53.3	81.6	28.3	0.71

The temperature differences through the duct wall obtained in this way were found to give a heating constant of 0.75.

Therefore $T_3 = W H_3 = 0.75 W \tag{8}$

It is usually desirable to associate this heating constant with that of the cable insulation and sheath since being a function of the loss of the individual cable, it refers the temperature rise of the cable to a point where temperature surveys can most easily be made; *i. e.*, in an adjacent empty duct.

Summary of Cable Rise Above Air in Adjacent Duct.
 $T_a = T_1 + T_2 + T_3$ = temperature difference between copper and air in an adjacent idle duct.

$$T_a = W (H_1 + H_2 + H_3) = W \left(R \times \text{form factor} + \frac{4.9}{D(1 + 0.013 W)} + 0.75 \right) \tag{9}$$

Load Temperature Chart. It has been found very advantageous to prepare a chart as shown in Fig. 7.

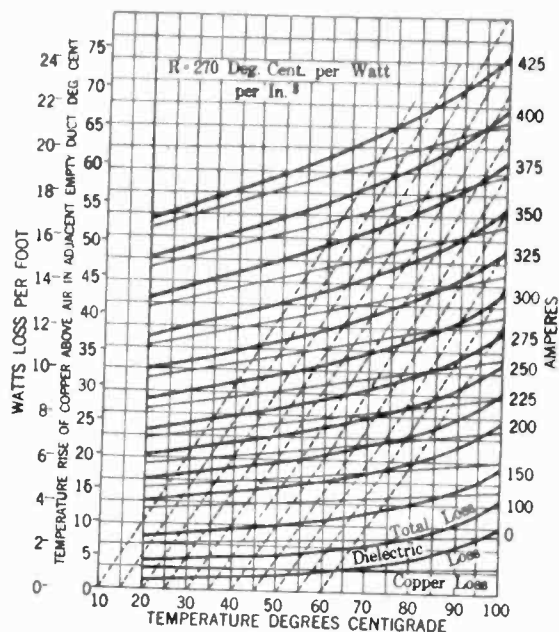

FIG. 7—CHART OF 350,000-CIR. MIL THREE-CONDUCTOR CABLES

27,000-volt 60-cycle 2-1/64-in. insulation
 Shielded type—sector conductor
 Outside diameter 3.0 in.

To obtain copper temperature for a continuous load from air temperature in adjacent empty duct start at bottom scale at the duct temperature and follow dotted line until it intersects full heavy line for current value used. Drop vertically down and read copper temperature on bottom scale

for each type of cable used by the operating company. These charts show the relation between ampere loading and temperature for any duct air temperature and can be used as a ready reference for almost any sort of operating condition. Curves of temperature *vs.* watts lost are plotted as a series of dotted lines slanting upward to the right and from 5 to 10 deg. apart.

Next, the copper loss per foot length of cable is calculated for various ampere loads and for the two temperatures that mark the extremes of the horizontal scale. These values are plotted on the chart and a straight line drawn between each pair of points. One then has a second group of curves representing copper losses as a function of current and temperature.

The dielectric loss as estimated or determined for the cable under consideration should be plotted on the chart as a no-load curve and should also be added

directly to the line representing copper losses for each value of ampere loading. In Fig. 7, the lighter, straight nearly horizontal lines represent the condition when no dielectric loss is present, but for operation at 27,000 volts, for which this cable is designed, the heavier, more curved lines should be used. It is assumed for simplicity that the entire dielectric loss for three-conductor cables occurs at the conductor surface. This assumption, while not strictly true, is on the side of safety.

To obtain the continuous rating for the cable whose

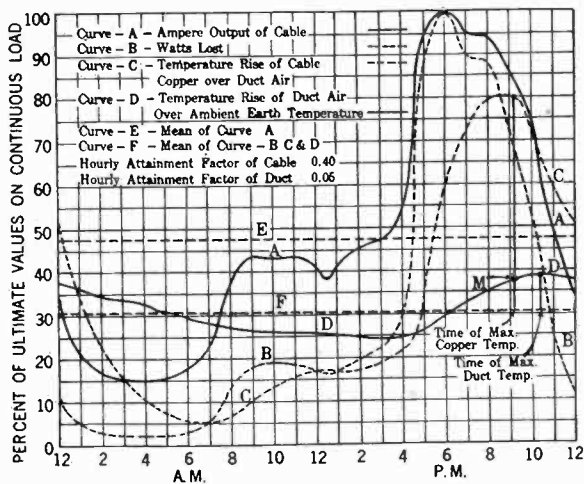

FIG. 10—CHARACTERISTIC TEMPERATURE CURVES

thermal and total loss characteristics are shown in Fig. 7, start at the duct temperature on the horizontal and follow the dotted curve of temperature rise vs. watts lost until it intersects a vertical line representing the limiting copper temperature. By interpolation, the nearest ampere reading is obtained on the total loss curve.

CALCULATION OF CABLE TEMPERATURES UNDER VARIABLE LOADS

It is frequently desirable to have two ratings for each cable; one for continuous loads, and one for the actual 24-hr. load cycle that the cable is operating under.

It has been found that the most practical method of calculation for variable loads is a "step-by-step" method which is described in detail in the complete paper.

TEMPERATURE RISE OF DUCT BANKS ABOVE AMBIENT EARTH TEMPERATURES

The temperature rise of the air in the idle duct of a loaded-duct bank will vary with respect to the ambient earth temperature; (1) throughout the day as a function of the heat generated by the cables in the duct bank; (2) throughout the length of the run from manhole to manhole as depending on the condition of the soil surrounding the duct bank; and (3) throughout the cross-section of the duct bank as a function of the shape, dimensions, and material composing the structure.

1. The duct bank and surrounding earth acts as such a large heat reservoir that the duct temperatures require a long time to reach sustained values. Starting

cold, about 24 hr. are required to reach two-thirds of their ultimate temperature rise and with the usual cyclic loading, about three days are required to reach maximum temperatures. Due to the falling off of load in metropolitan districts over week-ends, duct temperatures are much lower on Mondays than on following days and the maximum temperatures usually occur on Wednesdays, Thursdays, and Fridays. There is a certain amount of daily variation in temperature rise, as illustrated in curve D of Fig. 10, this fluctuation being about plus or minus 25 per cent for load factors of 40 per cent to 60 per cent, the maximum duct temperatures occurring several hours after the maximum load. The constants used in this paper are selected to give the duct temperature at the time of maximum copper temperature, and as such, represent values approximately 20 per cent greater than would be expected for strictly 24-hr. continuous loading as indicated by point M on curve D. In all cases, duct temperature calculations are based upon the losses over a 24-hr. period.

2. The temperature rise of the air in the empty duct is likely to vary plus or minus 25 per cent along the length from manhole to manhole, principally on account of the type of soil, moisture content, etc. Variations greater than this may indicate the proximity of steam pipes or other sources of heat.

3. The temperature rise throughout the cross-section of the duct bank varies with the shape, dimensions, and material composing the structure. Each layer of ducts from the outer surface towards the center has an increment of temperature rise over the next outer layer which is proportional to the heat generated within the layer. If one assumes that the losses are evenly distributed throughout the bank, (a condition only approximated

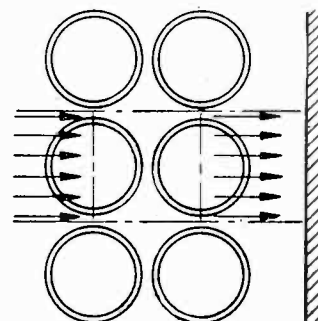

FIG. 11—PATH OF HEAT FLOW FROM ONE DUCT TO NEXT OUTER DUCT

in practise) the temperature rise of each layer can be expressed as a function of the total watts lost per foot in the entire bank. Each layer of ducts will then have its own heating constant which if multiplied by the average watts per foot over 24 hr. for the entire bank will give the temperature rise of that particular layer of ducts. In the case of deep narrow duct banks the end ducts will have more than the average amount of radiating surface, and will run cooler, since the constants used in this paper refer to the more centrally located ducts.

The temperature rise of the air in the idle duct above the ambient earth temperature is divided into two parts as follows:

The Temperature Rise of Air in the Idle Duct above the Surface of the Duct Bank. Let the temperature rise of the air in any duct over the outer surface of the duct bank be T_4 , then

$$T_4 = W_m H_4 \quad (13)$$

where H_4 represents the heating constant of a particular layer of ducts above the outside surface of the duct bank and W_m is the mean watts per ft. of all cables in the duct bank, over 24 hr.

Let K_1 be the thermal resistance of a single duct in deg. cent. per watt per ft. length. This, in Fig. 11, is the temperature rise of the center of one duct above the center of the next outer duct with a heat transfer of one watt per ft. Fig. 12 shows a duct bank M ducts wide and N ducts in depth. An assumption can be made that the temperature of the air in an idle duct is approximately half way between the temperature of the air in loaded ducts in the same layer and the temperature of the next outer layer. The heating constants of the different

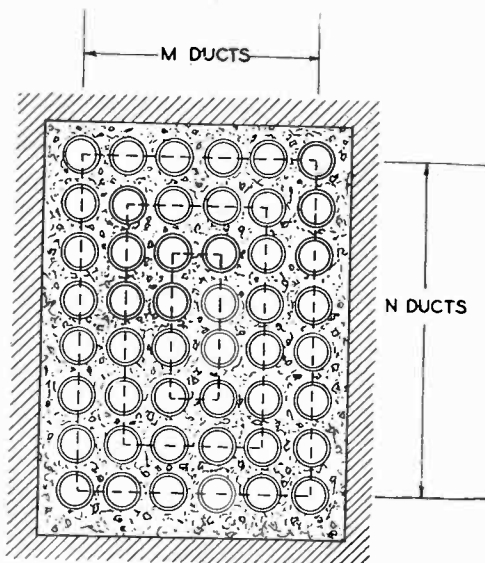

FIG. 12—DUCT BANK SHOWING ASSUMED ISOTHERMAL SURFACES

layers of duct over the outer surface of the bank can be represented by,

Outer Duct

$$H_4 = \frac{K_1}{4(M+N)} \quad (14)$$

Next Inner Duct

$$H_4' = \frac{K_1}{2(M+N)} + \frac{K_1(M-2)(N-2)}{4MN(M+N-4)} \quad (15)$$

Inner Ducts

$$H_4'' = \frac{K_1}{2(M+N)} + \frac{K_1(M-2)(N-2)}{2MN(M+N-4)} + \frac{K_1(M-4)(N-4)}{4MN(M+N-8)} \quad (16)$$

In analyzing a great many temperature survey tests made in the New York district, it was found that the increment of temperature rise between various layers was best checked when K_1 was 4.

The Temperature Rise of the Outer Duct Bank Surface above Ambient Earth. Most of the temperature drop from the surface of the duct bank to ambient earth occurs close to the duct bank, partly on account of the more restricted path of heat flow and partly because the soil has a tendency to become dried out next to the duct bank and has therefore a higher thermal resistance. For the range of ordinary shapes and sizes of duct banks the heating constant is inversely proportional to the perimeter of the bank and we may write

$$T_5 = W_m H_5 \quad (17)$$

where H_5 represents the heating constant from the surface of the bank to the ambient earth temperature

and is equal to $\frac{K_2}{2(M+N)}$.

For average soil conditions in the metropolitan New York District, K_2 was found to be 10. The highest temperature rises were checked when K_2 was assumed equal to 13 and the lowest, when K_2 was assumed equal to 8. No allowance was found to be necessary to correct for depth of bank although it would have some small influence.

The combined temperature rise of the air in an idle duct above the ambient earth temperature is $T_4 + T_5$ and is equal to $W_m(H_4 + H_5)$. Table I shows the combined heating constants ($H_4 + H_5$) for various sizes and shapes of single-duct banks as found in the metropolitan district.

AMBIENT EARTH TEMPERATURE MEASUREMENTS

The base temperature for all duct temperature calculations is the ambient earth temperature. This temperature varies with the depth below the surface, the season of the year, and geographical location.

Earth temperature curves such as the one in Fig. 14

TABLE I
EFFECTIVE HEATING CONSTANTS IN METROPOLITAN NEW YORK DISTRICT
For various shapes of duct banks and daily load factors between 40 and 60 per cent. average soil conditions

Number of ducts high	Number of ducts wide					Location		
	2	3	4	5	6	$H_4 + H_5 =$ Outer	$H_4 + H_5 =$ Next inner	$H_4 + H_5 =$ Innermost
2	1.50	1.20	1.00	0.86	0.75	$H_4 + H_5$		
3	1.20	1.22	1.06	0.92	0.82	$H_4 + H_5$	$H_4 + H_5$	
4	1.00	1.06	0.94	0.84	0.76	$H_4 + H_5$	$H_4 + H_5$	
5	0.86	0.92	0.84	0.76	0.69	$H_4 + H_5$	$H_4 + H_5$	$H_4 + H_5$
6	0.75	0.82	0.76	0.69	0.64	$H_4 + H_5$	$H_4 + H_5$	$H_4 + H_5$
		0.67	0.60	0.54	0.50			$H_4 + H_5$

for the New York metropolitan district can be approximated for each depth from test readings.

The methods given above for calculating empty duct temperatures have been checked by a large number of

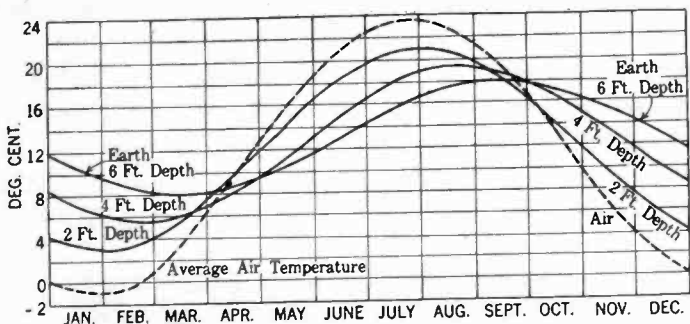

FIG. 14—AMBIENT TEMPERATURES IN METROPOLITAN NEW YORK DISTRICT

duct temperature surveys in the field. Comparisons of calculated and test results for a few typical cases are given in Table V.

TABLE V
TYPICAL DUCT TEMPERATURE SURVEYS
In Single Banks Compared with Calculated Values

Cross-section of duct bank x-surveyed duct	Type of bank	Bank constant from tables	Mean watts per trench foot over 24 hrs.	Calculated temp. surveyed duct deg. cent.	Measured temp. surveyed duct deg. cent.
	3x2	1.20	12.0	31.4	33.5
	4x3	1.06	36.7	47.4	41.0
	4x3	0.86	17.9	20.9	18.0
	4x6	0.60	99	70.4	67.0
	6x4	0.76	66.8	55.9	56.0

Abridgment of

The Influence of Polarity on High-Voltage Discharges

BY F. O. McMILLAN¹

Member, A. I. E. E.

and

E. C. STARR²

Member, A. I. E. E.

Synopsis.—An experimental investigation of the influence of polarity on high-voltage discharges is reported in this paper. Particular attention is given to those discharges used in high-voltage measurements.

A theory of the formation of Lichtenberg figures is given together with experimental evidence upon which it is based. A polarity indicator utilizing visual Lichtenberg figures is described.

Results of 60-cycle and impulse tests on various types of gaps are given. It is shown that polarity has a distinct effect upon the sparking voltages of all types of gaps. Impulse measurements with grounded sphere-gaps are shown to be subject to serious error unless the polarity effects are taken into consideration.

An explanation of the influence of polarity on spark-over is proposed.

INTRODUCTION

HIGH-VOLTAGE discharges in two principal forms are very extensively employed in the measurement of high electrical potentials. For a number of years spark-gaps of different types have been in general use, and recently, extensive use has been made of photographic Lichtenberg figures in high-voltage studies. This paper covers a study of the characteristics of the discharges involved in spark-gaps and Lichtenberg figures as affected by electrode polarity.

A THEORY OF THE FORMATION OF LICHTENBERG FIGURES

The Negative Figure. The negative Lichtenberg figure is characterized by fine, straight-line striations

1. Research Professor of Electrical Engineering, Oregon State College, Corvallis, Oregon.

2. Assistant Professor of Electrical Engineering, Oregon State College, Corvallis, Oregon.

Presented at the Pacific Coast Convention of the A. I. E. E., Portland, Oregon, September 2-5, 1930. Complete copy upon request.

projecting radially from the recording electrode, (Fig. 1A). This figure is formed by the repelling action of the negatively charged recording electrode on the free electrons in the surrounding dielectric field and on those extracted from the electrode. These electrons are driven radially outward because of the shape of the electric field and bombard the air molecules at the surface of the film as well as the silver salts in the emulsion, producing ionization by collision. Other electrons thus produced also move outward under the influence of the electric field leaving the heavy and relatively immobile positive ions behind. The figure increases in size in this manner until the positive-ion space-charge reaches a value sufficiently large to reduce the negative field of the electrode below the ionizing potential at the edge of the figure. This condition of equilibrium will be reached quite quickly, resulting in a comparatively small figure, because the free electrons are swept out of the field, (reducing the loss of positive ions by re-combination to a relatively small

number) and because the space position of the positive ions formed is such that a comparatively small space charge will neutralize, at the outer border of the figure the effect of a large negative electrode potential.

When the electrode potential is decreased, the mass of electrons forming a negative space charge at the outer border of the figure is released and drawn back toward the electrode by the positive ions, usually forming a very small positive figure superimposed on the original negative. (Fig. 1A.) The higher the rate of removal of potential on the electrode, the more pronounced this effect becomes. (Fig. 1B.)

The Positive Figure. Coarse striations that branch repeatedly at acute angles with the main striation much like the tributaries of a stream characterize the positive Lichtenberg figures, especially those formed by impulse voltages of comparatively short duration. (Fig. 1A.) This figure is formed by the attraction of the free electrons in the field of the positively charged electrode. The electrons move radially inward toward the positive recording electrode bombarding the air molecules at the surface of the film and the silver salts on the photographic surface producing ionization by collision. As the electrons are swept from the field, a positive space charge composed of the relatively immobile positive ions produced by ionization by collision is left. This space charge is positive and adds its field to the positive field of the recording electrode causing the figure to grow outward. This growth of the figure continues until the positive voltage gradient at the edge of the figure, due to the combined effect of the potential on the electrode and the positive space charge, is less than the ionizing gradient. The positive figure is therefore always larger than the negative figure for a given voltage because the positive space charge subtracts from the field of the negative electrode and adds to the field of the positive electrode.

As in the case of the negative figure, the positive-figure space charge also forms a small figure of negative polarity when the electrode potential is suddenly removed, but in a different manner. The positive space charge holds the area surrounding the electrode at a positive potential while the electrode voltage drops below the space value causing the electrode to become negative with respect to the space, and hence electrons flow out along the striations superimposing a small negative figure on the positive. (Figs. 1A and B.)

Investigation of Lichtenberg Figure Space Charges. To establish definitely the existence of a persistent space charge during and immediately after the formation of Lichtenberg figures, a circuit was devised for quickly reversing the potential during the formation of the figures. This circuit and the type of wave produced are shown in Fig. 2. A series of four Lichtenberg figures taken with this circuit is shown in Fig. 1, parts B to E, inclusive.

In all of the Lichtenberg figure records, the initial negative figure was formed on the left, the initial posi-

tive figure on the right and figures of the reverse polarity were superimposed on these. All of the superimposed figures showed a very definite change due to the space charge formed by the original figure. For values of reversed potential up to 50 per cent, the superimposed positive figures are confined entirely to the area ionized by the previous negative figure. For values of reversed potential of 50 per cent and greater, the positive ionization breaks over the boundary of the previous negative figure. The negative figures superimposed on the positive grow progressively larger as the reversed

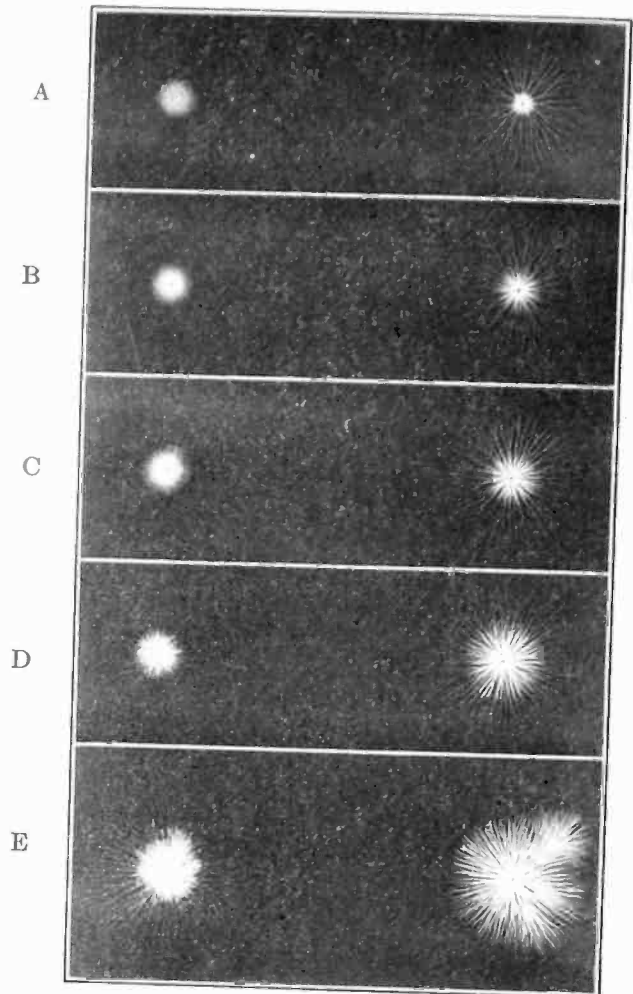

FIG. 1—LICHTENBERG FIGURES

- A. 14.5-kv. unidirectional impulse
- B. 14.5-kv. quickly forced to 0
- C. 14.5-kv. quickly reversed to 7.25 kv.
- D. 14.5-kv. quickly reversed to 14.5 kv.
- E. 14.5-kv. quickly reversed to 21.8 kv.

potential is increased, and follow the ionized paths previously formed by the positive striations. Both the positive and negative figures are altered in size and character by previous ionization. The positive figures are reduced in size until well beyond the boundary of the previous ionization. The negative figures are very much larger than normal.

THE INFLUENCE OF POLARITY ON SPARK-OVER PHENOMENA

Polarity Indicator. The polarity indicator consists essentially of two pairs of oppositely connected electrodes enclosed in a light-proof viewing hood. Both

the positive and negative Lichtenberg figures are seen simultaneously by the observer and hence the polarity of the discharge is definitely established. The observer is therefore able to make polarity determinations in very rapid succession and a large number of observa-

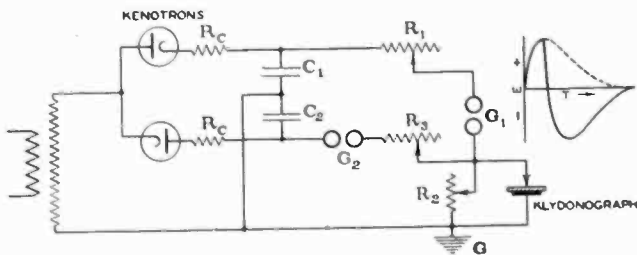

FIG. 2—CIRCUIT FOR QUICKLY REVERSING THE IMPULSE POTENTIAL DURING THE FORMATION OF LICHTENBERG FIGURES

tions can be made in a short time. Each of the curves in this paper was determined from a thousand or more individual sparkover observations and the time element was of considerable importance.

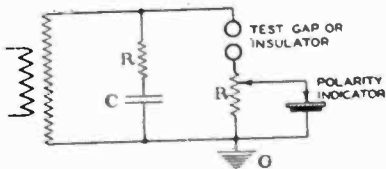

FIG. 3—CIRCUIT FOR DETERMINING THE POLARITY OF INITIAL A-C. SPARK-OVER

For polarity determinations during 60-cycle tests the instrument was connected as shown in Fig. 3.

During the impulse tests the polarity indicator was connected as shown in Fig. 4.

GROUNDING SPHERE-GAPS

6.25-cm. Spheres. Spark-over tests at 60 cycles were made on a 6.25-cm. sphere-gap spaced from 0.5 to 12.5 cm. The results are shown in Fig. 5. Between

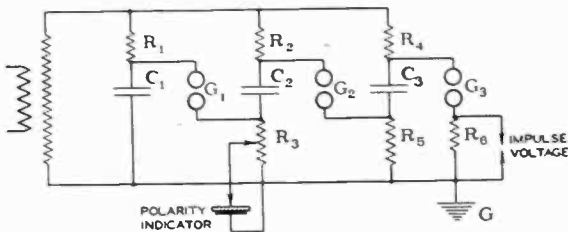

FIG. 4—IMPULSE GENERATOR CIRCUIT

0.5 and 1.5 cm., approximately 10 per cent of the spark-overs were positive. There is a very rapid change in the percentages of positive spark-overs between 1.5 and 3 cm. reaching a maximum of 76 per cent positive at 2.25 cm. Between 3.0 and 9.0-cm. spacing no positive spark-overs could be obtained. A rapid transition from 100 per cent negative to 100 per cent positive occurs between 9.0 and 11.0 cm. Above 11.0 cm., all spark-overs obtained were positive.

Impulse tests on the 6.25-cm. sphere-gap gave the results shown in Fig. 6. Up to 1.75-cm. spacing the spark-overs for both polarities occur at practically the same voltages. Between 1.75 and 8.4 cm., spark-over occurs at a lower voltage when the upper sphere is negative than when positive. The percentage difference is maximum at 4.0-cm. spacing at which point the positive voltage is 11.5 per cent greater than

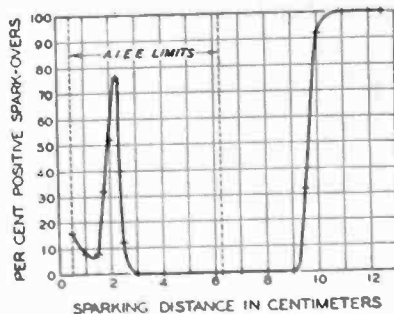

FIG. 5—POLARITY DISTRIBUTION OF 60-CYCLE SPARK-OVERS FOR A 6.25-CENTIMETER SPHERE-GAP

Lower sphere grounded

the negative. At 8.4 cm., the positive and negative become equal and from this spacing to the upper limit of the tests the positive spark-over voltage becomes rapidly less than the negative. It is interesting that the negative spark-over curve follows the A. I. E. E. standard sphere-gap data throughout the recommended range.

25-cm. Spheres. Fig. 7 gives the results of 60-

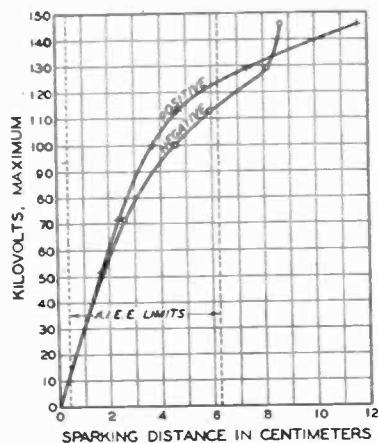

FIG. 6—6.25-CM. SPHERE-GAP IMPULSE SPARK-OVER

Lower sphere grounded

cycle tests on a 25-cm. gap. These tests were limited to a maximum spacing of 10 cm. because the upper limit of the available transformer voltage was 235 kv. maximum. Both positive and negative spark-overs, with the negative predominating, were obtained between 1.0- and 8.0-cm. spacing. At 9.0 and 10.0 cm., no positive spark-overs were obtained.

Impulse spark-over data were taken on the 25-cm. gap up to 38.0-cm. spacing. These data are shown in Fig. 8. It is interesting that as was found in the case of

the 6.25-cm. sphere-gap, the average negative spark-over data conforms with the A. I. E. E. standard over the recommended range of sparking distances. The positive curve coincides with the negative up to approximately 5 cm. From this point the percentage difference becomes increasingly higher up to 25 cm., at which spacing it is a maximum and the positive spark-over voltage is 35 per cent greater than the negative.

The wave form of the impulse voltage impressed upon the test gap probably has a pronounced effect upon the

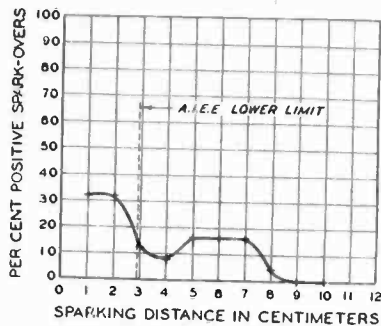

FIG. 7—POLARITY DISTRIBUTION OF 60-CYCLE SPARK-OVERS FOR A 25-CM. SPHERE-GAP

Lower sphere grounded
(Incomplete)

spread of the positive and negative spark-over curves. However, it is believed that the wave form of the impulse generator used in this investigation is quite similar to that of the impulse generators used in other laboratories. Calculation shows that the voltage wave rises to a maximum very abruptly and then decreases to half value in approximately five microseconds. The impulse ratio obtained on a 25-cm. needle-gap was 1.78 positive and 1.78 negative and on a 66-kv. pin type insulator was 1.36 positive and 1.55 negative.

AN EXPLANATION OF THE POLARITY EFFECT IN SPARK-OVER

When a sphere-gap has a voltage impressed upon it, the positive sphere attracts the free electrons in the surrounding space and when the potential is increased to the proper value accelerates them to the ionizing velocity. The free electrons and those liberated by collision, except the ones lost by recombination, are conducted away by the sphere leaving a relatively immobile positive space charge in the surrounding ionized space. This space charge adds to the positive-sphere potential and extends the critical ionizing potential gradient, as well as the effective radius of the sphere. The negative sphere repels the free electrons in the surrounding space and when the critical voltage gradient is reached produces ionization by collision adjacent to the negative electrode. This action results in the formation of both a positive and a negative space charge. The positive space charge is composed of the relatively immobile positive ions left close to the sphere. Part of the electrons expelled from this region are carried entirely across the gap and the remainder, forming the

major part of the negative space charge, is bound near the outer edge of the positive space charge.

At close sparking distances this negative space charge is attracted by the positive sphere and carried away leaving the negative-electrode positive space charge in the combined field of three charges. These charges are the potential on the positive sphere, the positive space charge of the positive sphere and the potential on the negative sphere. This resultant field forces the negative-sphere positive space charge back on the negative electrode producing heavy ionization and extracting large numbers of electrons resulting in local breakdown and removal of the positive space charge in the immediate vicinity. The conducting streamer thus formed extends the negative-sphere potential beyond the positive space charge and the breakdown progresses to the positive sphere. At these close spacings the dielectric flux distribution in the sphere-gap between sparking surfaces is practically unaffected by usual ground proximity. Because of this symmetrical flux distribution on the spheres, spark-over takes place from either the grounded or ungrounded sphere at practically the same voltage and there is no appreciable polarity effect. (Figs. 5, 6, 7, and 8).

For sphere spacings greater than approximately $1.6\sqrt{R}$ the influence of ground on the flux distribution causes higher voltage gradients to exist on the ungrounded sphere than exist on the grounded sphere at the sparking surfaces. Therefore ionization starts at a lower voltage on the ungrounded sphere. As shown above when the field is symmetrical, local breakdown occurs at the surface of the negative sphere at lower voltage than at the surface of the positive sphere when the spacing is sufficiently close for the removal of the

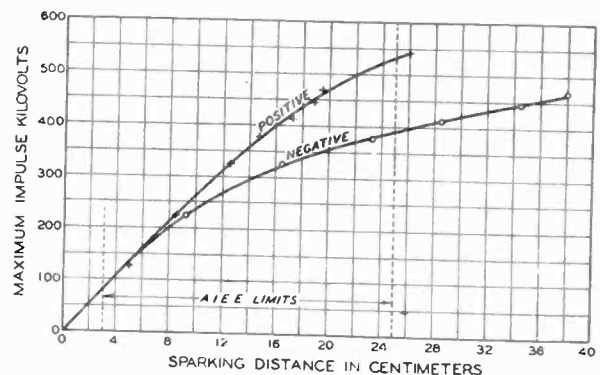

FIG. 8—25-CM. SPHERE-GAP IMPULSE SPARK-OVER

Lower sphere grounded

negative space charge. When the field becomes unsymmetrical under the influence of ground, local breakdown and spark-over occur at a lower voltage when the sphere having the more intense field is negative. This condition obtains until the spacing is increased to the point at which the negative space charge neutralizes the negative-sphere positive space charge sufficiently to reduce the gradient near the surface of the sphere, when negative, to that value obtaining at an equal posi-

tive voltage. At this spacing, which for the gaps and conditions investigated was considerably over diameter separation, the positive and negative spark-over voltages again become equal. For greater spacings, spark-over occurs at a lower voltage when the ungrounded sphere is positive.

SUMMARY

1. Lichtenberg figures are produced by ionization phenomena at the surface of the recording medium and are visible in a darkened instrument.

2. The positive figure is extended in size by the positive space charge surrounding the recording electrode. The negative figure is held to a relatively small size by the positive space charge adjacent to the electrode. The existence of these space charges is clearly demonstrated when figures of opposite polarity are quickly superimposed.

3. Tests with different types of gaps show that polarity has a pronounced effect upon spark-over.

4. The grounded sphere-gap sparks over at the same voltage with ungrounded sphere positive or negative up to spacings of approximately $1.6\sqrt{R}$.

5. For the conditions investigated the grounded sphere-gap sparks over at a lower voltage negative than positive at spacings ranging between approximately $1.6\sqrt{R}$ and well over diameter separation. This characteristic is due to high local negative gradients caused by the negative-electrode positive space charge.

6. At wide spacings the grounded sphere-gap sparks over at lower voltages positive than negative.

7. Near diameter spacing, the grounded sphere-gaps investigated spark over at much lower impulse voltages negative than positive. The shape and duration of the impulse wave probably have a pronounced effect upon this difference.

Abridgment of

Transmission System Relay Protection—III*

BY WILLIAM W. EDSON¹

Member, A. I. E. E.

INTRODUCTION

IN 1919 a paper² was presented before the A. I. E. E. giving a very interesting résumé of the relay protective systems up to that date. Part II, which appeared in 1922, is still a reliable and instructive guide for the protection engineer.³

Since the publication of the last paper, several important developments have been made, and it is now felt that the recent improvements warrant a third paper on this subject.

Probably the greatest change in the design of a protective system has been the realization of the importance of shortening the time for removing a fault. With the large quantities of power involved in the present generating and transmission systems and in order to preserve the system stability, insure continuity of service through other circuits, prevent synchronous apparatus from dropping out of step, minimize the

spread of the disturbance to adjacent phases or lines and to remove the fault before much material damage has occurred it is very important to disconnect faulty equipment as soon as possible.

PHASE-TO-PHASE PROTECTION OF TRANSMISSION LINES

Selective Timing Between Stations. Probably three-quarters of the present relay applications include an inverse definite time relay whose time of operation decreases as the current increases until the adjusted minimum time setting is reached. This insures selectivity between stations, rapid tripping on heavy faults, and improved discrimination between feeders on one bus.

Although the above relay has given and is giving a very good account of itself, it is often too slow for present day systems, as the relay next to the generating station must be set longer than is desirable.

One of the most interesting developments in recent years has been the production of the so-called "distance" relay. The impedance type consists of an inverse definite timing element similar to the above, with an added feature which automatically decreases the time setting as the line voltage decreases. Such a design permits the relays at the successive stations to be set for the same minimum time, the discrimination between adjacent stations being obtained by this feature.

A new impedance relay is being developed which will have a constant minimum time setting approaching a very few cycles.

* (Paper prepared in conjunction with H. P. Sleeper, Chairman, O. C. Traver, R. Cordray, L. N. Crichton, E. A. Childerhose, and H. A. McLaughlin, all members of the Relay Subcommittee of the Committee on Protective Devices.)

1. Station Engg. Dept., Edison Electric Illuminating Co. of Boston, Boston, Mass.

2. *Transmission Line Relay Protection*, by H. R. Woodrow, D. W. Roper, O. C. Traver, and P. MacGahan, A. I. E. E. TRANS., Vol. XXXVIII, 1919, p. 795.

3. *Transmission Lines Relay Protection—II*, by E. A. Hester, O. C. Traver, R. N. Conwell, and L. N. Crichton, A. I. E. E. TRANS., Vol. XLI, 1922, p. 670.

Presented at the Summer Convention of the A. I. E. E., Toronto, Ontario, Canada, June 23-27, 1930. Complete copy upon request.

Directional Relays. Faults beyond a substation produce currents and voltage conditions for the incoming line the same as for the outgoing feeder in trouble. This would tend to operate both relays; therefore it is necessary to add a device which will prevent the relay on the incoming line from operating. This directional feature should be included on all incoming feeders which have a source of power, these elements being connected to operate only when the fault current is away from the substation bus.

The directional feature may be used in conjunction with any of the overcurrent or impedance relays men-

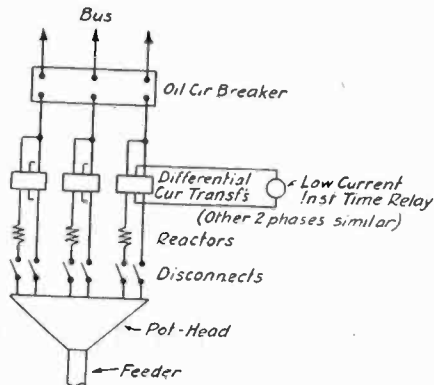

FIG. 1—SPLIT CONDUCTOR

tioned above, the individual considerations being the same as described.

BALANCED OR DIFFERENTIAL SCHEMES

Split-Conductor Method. Each phase lead is composed of two conductors operating in parallel and normally carrying approximately equal currents. Most faults will initiate on one of the wires, thereby causing an unbalance in the pair. The differential relays can safely be set very fast and for quite small current. (Fig. 1.)

Pilot Wires. Schemes using pilot wires to balance conditions at one end of a line section against the other end are very much in use in Europe but due to the high cost and the technical difficulties involved in the use of pilot wires over the long distances common to our lines, they have not received much favor in America.

There are many types of pilot wire schemes, some using current and other voltage balancing. In some installations, current is circulated through the pilot wires; but the tendency is towards the zero or opposed voltage methods. (Fig. 2.)

Carrier Current. A very ingenious system has been devised to balance the instantaneous polarity of the current waves at the two ends of a line section by means of carrier current superimposed on the line itself.

PARALLEL LINES

Due to the increased reliability of service and relative ease of obtaining selectivity and high speed in relay protective systems the growth of the use of parallel lines (usually in pairs) has been rapid.

Individual Lines. Each line may be treated individually and equipped with directional overcurrent or impedance relays; but there are some limitations which should be considered.

Balanced Current Schemes. The various balanced current schemes have several important advantages, such as fast operation, simplicity of connections, omission of potential transformers, etc., but their application is also limited.

One of these schemes uses the mechanical balancing relay described in the previous paper. A recent modification of this relay includes a potential restraining coil, which automatically reduces the required operating differential current if the fault is near by and the line voltage is affected. This relay is being discussed in a companion paper.

A second type has two induction elements, each having an operating and a restraining coil. The action is similar to the above mechanical or plunger type.

In another type, the currents from the two lines are balanced magnetically. The relay is provided with double-throw contacts and an unbalance causes the relay disk to operate to trip the breaker carrying the greater current.

Cross-Connected Directional Schemes. The simplest and most general arrangement consists of two sets of directional overcurrent relays with their current coils connected in series across the cross-connected current transformers of the two lines. The potential connections to the relays are reversed so that only the trip cir-

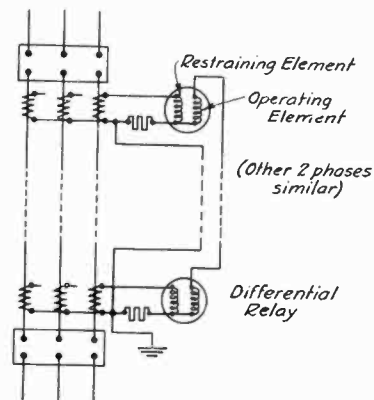

FIG. 2—PILOT WIRES

cuit of the breaker carrying the greater current will be closed by the unbalanced current.

A second method sometimes known as the short and long time schemes uses two sets of directional relays, but the overcurrent and directional contacts are interconnected so that each directional contact is associated with an individual line, while the overcurrent contacts are common. One of these current elements has a short time setting and the other a long time setting. The first is arranged to be cut out by auxiliary switches on the circuit breakers when either line is open, thus leaving the long time setting in service for single-line operation. (Fig. 3.)

A scheme which gives short time protection for double-line operation, and long time protection for single-line operation, and which also offers protection against simultaneous line and through faults has recently been developed and appears to meet most situations. (Fig. 4.)

The current transformers of the two lines are cross-connected through an auto-current transformer, across which is an overcurrent relay. The directional relay is

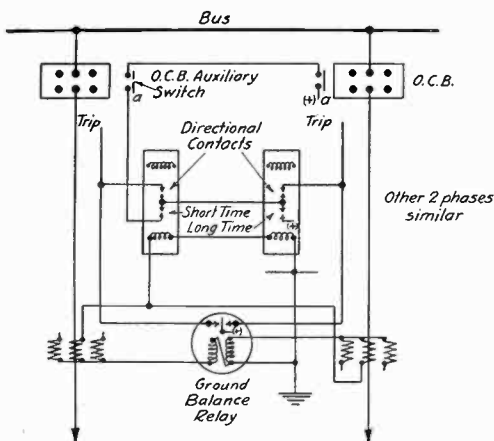

FIG. 3—PARALLEL LINES—CROSS-CONNECTED DIRECTIONAL RELAYS

connected to the midpoint of this auto-transformer. The "back-up" protection for through faults has the same pick-up, whether one line or both lines are in service.

In all these balance schemes, careful thought and study should be given to the matter of back-up pro-

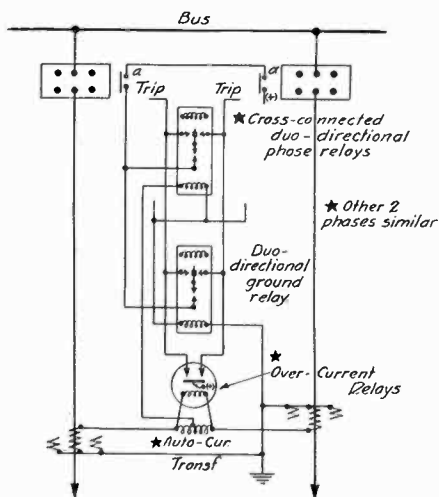

FIG. 4—PARALLEL LINES—CROSS-CONNECTED RELAYS WITH AUTO-CURRENT-TRANSFORMER

tection, for simultaneous faults on both lines and for bus faults.

These schemes should be carefully studied as to the effect of switching in or out the second of a pair of balanced lines, since it is impossible to close or open both ends simultaneously.

GROUND PROTECTION

Present-day transmission systems are generally grounded at one or more points. Experience has shown that most faults on these systems start as a flashover or failure to ground; therefore, the flow of ground current is a positive sign of trouble.

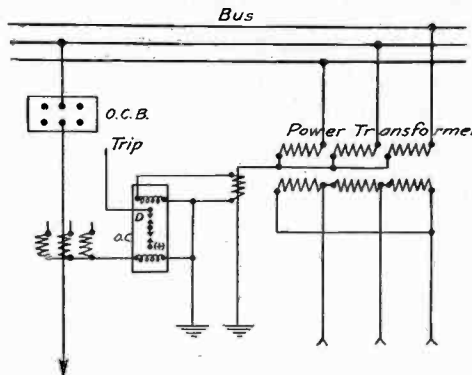

FIG. 5—DIRECTIONAL GROUND RELAY

Solidly Grounded Systems. Frequently the ground fault currents exceed the load values, and the line phase-to-phase relays will also give ground protection.

Residual Current Protection. Overcurrent relays used as ground relays may be installed in the residual circuits of current transformers.

Current Differential Protection. Current differential relays may be connected in the residual circuits of the current transformers on parallel feeders. (Fig. 3.)

Directional Residual Current. Directional ground protection may be obtained with directional overcurrent relays the potential element being connected in one corner of the secondary delta of three star-delta connected potential transformers.

Directional overcurrent ground protection may also

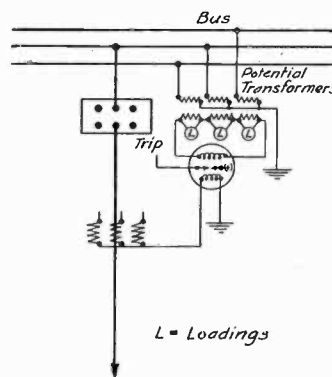

FIG. 6—POWER DIRECTIONAL GROUND RELAYS

be obtained by use of a relay whose directional element is polarized by a current transformer in the neutral of the main power transformers. (Fig. 5.)

Power Type Residual Relays. Protection against ground faults may be obtained by using a power type relay with its potential element connected in the sec-

dary delta of star-delta potential transformers and the current coil in the residual circuit of the current transformers. (Fig. 6.)

A power relay with its current coil operated by the residual current of the current transformers and its other coil in the ground connection of the power transformer, is directional, quite sensitive, and has the desired inverse time characteristics.

Balanced Directional Residual Current Relays. Directional overcurrent relays may be balanced to give protection against ground faults in manners similar to those for protection against phase-to-phase faults, except that potential must be supplied as described above. (Fig. 4.)

Distance Relays. Various types of distance relays used for phase-to-phase protection may be connected to the current transformer residuals and star-star connected potential transformers. Three relays are required per line for complete ground protection. The wiring is complicated and operation is sluggish for small fault currents.

Pilot Wire Protection. Any of the split-conductor or pilot wire schemes inherently give ground protection, though for small ground fault currents it may be preferable to add a sensitive relay in the current transformer neutral circuit.

Isolated-Neutral or Delta-Connected Systems. A ground on one phase is not followed by a power current, and in itself is not particularly dangerous; however it increases the potential strain on the two ungrounded phases on all parts of the system and unless removed, may develop into a phase-to-phase short circuit. An arcing ground may set up surges which cause dangerous voltages to appear.

Voltage Relay. Overvoltage relays connected in the corner of the delta of three star-delta-connected potential transformers may be used to indicate these unbalanced voltage conditions. Under normal operating conditions there is no current flowing in the delta, and the relay potential is zero. In case of a ground on the line, this voltage becomes large.

Charging Currents. When one phase of the system is grounded, there immediately appears on all conductors a charging current to ground. On a large system, this charging current is of sufficient magnitude to operate relays. It increases in magnitude as the point of fault is approached. It appears in the residual circuit of three star-connected current transformers, and may be used to operate directional overcurrent relays.

High-Impedance Grounded Systems. The ground protection of high-voltage systems using a relatively high-impedance ground presents a difficult relay problem. It is particularly pertinent that such faults be relieved, since dynamic current actually flows to ground. Moreover, high voltages may appear on the

system during such a ground fault, and simultaneous faults may be avoided if the ground fault is relieved quickly.

The ground relay system must obviously operate on a small amount of current to ground, thus requiring sensitive relays.

If the ground current is sufficient to produce a difference in voltage drop between stations, impedance ground relays which are introduced by fault detector relays during a disturbance may be used. These fault detectors are usually a combination of overcurrent and undervoltage relays.

APPARATUS PROTECTION

Bus Sections. In recent years, there has been a tendency to install some type of protection due to the large amounts of connected kv-a. capacity, especially since most of the protective schemes for the rest of the system exclude the bus.

Balanced protection of each phase where all the

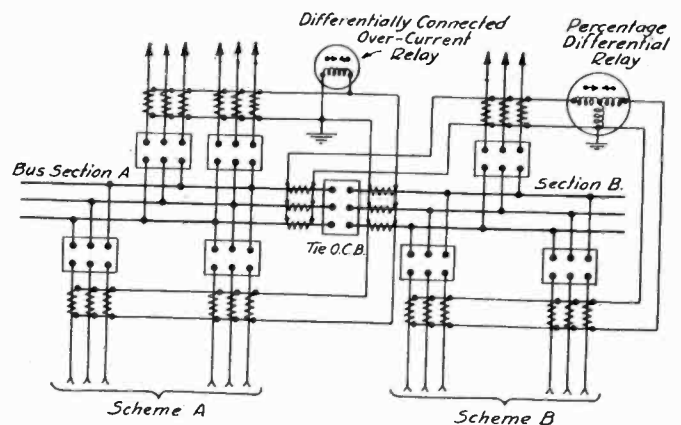

FIG. 7—GROUND PROTECTION NEUTRAL DIFFERENTIAL

current transformers (using auto-balance-transformers if of unequal ratio) are connected together to an overcurrent or differential relay, is commonly used and offers accurate and fast protection.

A modification of the above connects only the secondary neutrals together. This is safer in many ways, but it gives protection against ground faults only. (Fig. 7.)

Overcurrent protection, especially if combined with undervoltage relays, may sometimes be applied. The impedance relay may safely be used for bus installations having feeder reactors.

Several installations have been made using sections of ground bus connected to insulator bases, circuit breaker tanks, supports, etc., with relays inserted in the ground connections from these busses. The action is rapid and satisfactory as long as the ground bus and structure are well insulated from the building steel. (Fig. 8.)

Power Transformers. Since the input and output of

the transformers are very nearly equal, it is a relatively simple matter to balance one against the other and consider any unbalance to be due to a fault within the transformer.

There are now available current differential relays which operate on the percentage of the unbalanced current with respect to the load current instead of on a

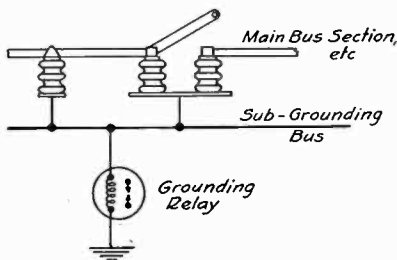

FIG. 8—GROUND PROTECTION

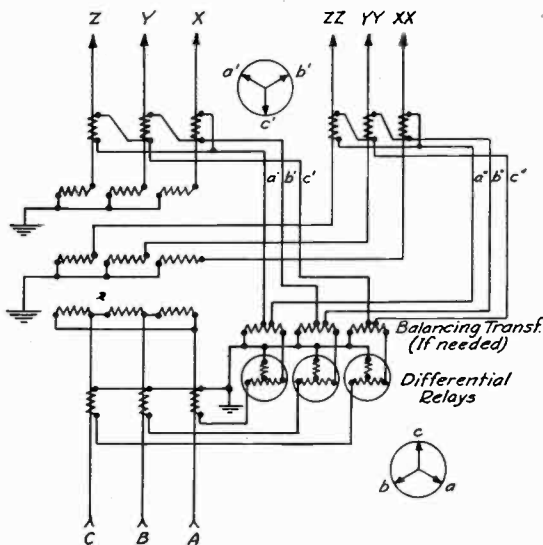

FIG. 9—THREE-WINDING TRANSFORMER

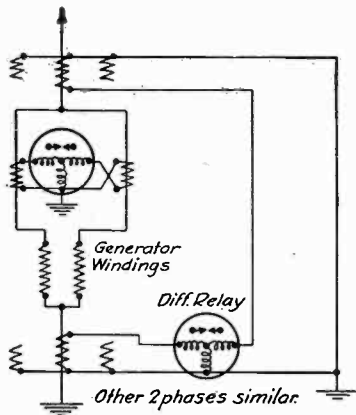

FIG. 10—PARALLEL-WINDING GENERATOR DIFFERENTIAL RELAYS

fixed value of unbalance. Such relays will detect a minor fault at normal loads, yet will not operate improperly during an external short circuit.

Two-Winding Transformers. Single-phase or three-phase transformers which are delta-delta or star-star

connected offer no complexity as the corresponding phase leads are balanced together. A delta-star combination, however, requires the current transformer on one of the phases of the delta side to be balanced with the two current transformers of the star winding.

Three-Winding Transformers. Here the same principles as above apply, with the added requirement that the primary winding be balanced against the two secondary windings. (Fig. 9.) If the system connections require it, it may be necessary to balance the two secondary windings against each other.

Regulating Transformer. Protection is obtained by balancing the current of the exciting or voltage winding against that of the series or current winding when the equipment is on either the maximum buck or boost position.

Generators. Generators are normally unprotected against overload, as it is desirable to maintain service as long as possible and to permit the fault to be isolated by the circuit breakers of the line in trouble. On the other hand, the value and importance of the generator necessitates its removal immediately in case of internal trouble. This is best met by providing some type of balanced or differential protection.

Parallel-winding generators in addition to the overall differential protection, may have balanced protection between the windings. (Fig. 10.) Another scheme uses a current transformer and relay connected between the midpoints of the two windings.

CONCLUSIONS

We have endeavored in this paper to point out that at this time the trend of the relay art is toward the use of those which operate in much shorter times than heretofore practised.

One of the greatest needs of the protection engineer at this time is that of improved types of ground relay protection. Ground relays are needed that are instantaneous in operation and inherently selective. The fundamental advantages of ground relaying are detection of the fault in the incipient stage, reduction in voltage disturbance to the system, minimizing of damage at fault, and reduced stress on circuit breakers. The increased spacing of high-voltage open wire lines and the use of type H cable should greatly increase the preponderance on ground faults and consequently the protective relays should be able to recognize such faults and remove them before phase-to-phase action results.

Another factor which demonstrates the necessity for improved ground relay protection is the advent of current limiting devices in system neutrals.

The purpose of this paper has been to present standard practise in relay protection at the moment, and to endeavor to point out what appeared to be the necessities of the immediate future. It is the hope of this committee that the practise of presenting such a paper every few years will be continued.

Abridgment of The Effect of Transient Voltages on Dielectrics—IV

Law of Impulse Spark-over and Time Lag

*Relative Effects of Different Wave Shapes—Comparison of Lightning Waves
and Laboratory Waves—Coordination of Line Insulation*

F. W. PEEK, JR.*

Fellow, A. I. E. E.

I. INTRODUCTION

IT is the object of this paper to discuss the relative effects of different forms of voltage transients on insulators, gaps, and insulation; to show how the effects and breakdown voltages of various types of transients are related; and to compare natural lightning waves with those used in the laboratory. Such knowledge is necessary in making a comparison of insulators, insulation, and in coordination. The law of impulse sparkover has been determined and formulas have been developed to predetermine time lag and breakdown voltage for the various types of transients.

II. TYPES OF IMPULSE TESTS

There are three general types of impulse tests, as follows:

1. *Rectangular Wave.* The rectangular wave method is illustrated in Fig. 1. A theoretical rectangular wave would rise instantly to a given value and remain constant until breakdown occurred. However, such a wave can generally only be approximated.

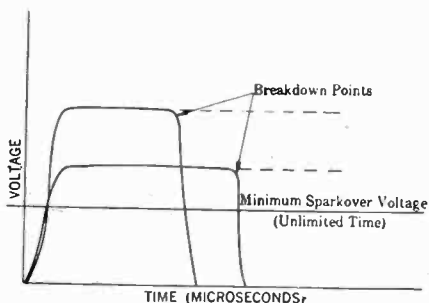

FIG. 1—RECTANGULAR FORM OF IMPULSE WAVE

2. *Uniformly Rising Voltage.* Sparkover for a uniformly rising voltage is illustrated in Fig. 2. The time and voltage are indicated at sparkover. Note that when the minimum sparkover voltage is reached breakdown does not occur immediately because con-

*Consulting Engineer, General Electric Company, Pittsfield, Massachusetts.

Presented at the Summer Convention of the A. I. E. E., Toronto, Ontario, Canada, June 23-27, 1930. Complete copy upon request.

siderable time is required at that voltage. The wave accordingly rises above this value. The more rapidly the voltage is applied, the higher the breakdown voltage and the less the lag.

3. *Standard Wave of Fixed Shape.* In this method a fixed or standard wave of the form shown in Fig. 3 is used, and there are several ways in which the test may be made. By the proper application of this method

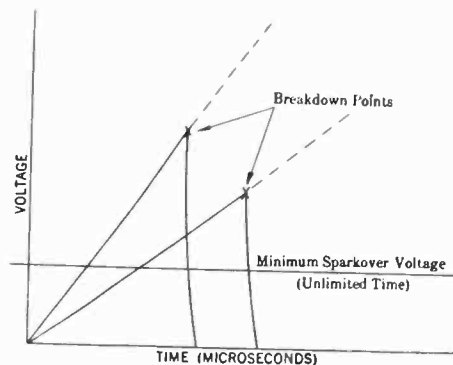

FIG. 2—SPARKOVER ON FRONT OF WAVES OF VARIOUS SLOPES

the whole range of breakdown effects caused by the rectangular wave, the uniformly rising voltage or any other wave can be obtained. The two general methods are:

a. *Full-Wave Method.* The given wave is applied and the voltage is gradually increased until sparkover occurs on 50 per cent of the applications. Breakdown is then taking place on the tail as shown in (a) Fig. 3.

b. *Overvoltage Method.* This is the same as the above except that an overvoltage is applied which may be any given percentage in excess of the full-wave value.

III. THE EFFECTS AND RELATIVE BREAKDOWN VALUES OF VARIOUS TYPES OF WAVES—LAW OF IMPULSE SPARKOVER AND TIME LAG

The effects and relative breakdown values of the various types of waves will now be discussed in more detail.

The results of insulator sparkover voltages are given with impulse ratio in Fig. 5 for rectangular waves. It is seen that the values for the various lengths of insulator

strings fall well on this curve. This impulse ratio-time curve has particular interest because it seems to offer a means of correlating the sparkover values of different waves. This follows because these curves follow the equation

$$\beta = \left(1 + \frac{a}{\sqrt{t}} \right) \tag{1}$$

$$\beta = \text{impulse ratio} = \frac{e}{e_0}$$

t = time lag in microseconds

a = a constant (under certain conditions a may vary; it may be necessary to add a factor depending upon the spacing)

when β and a are known, the lag can be calculated:

$$t = \left(\frac{a}{\beta - 1} \right)^2 \tag{2}$$

The impulse sparkover voltage is

$$e = e_0 \left(1 + \frac{a}{\sqrt{t}} \right) \tag{3}$$

where e_0 is the continuously applied breakdown value.

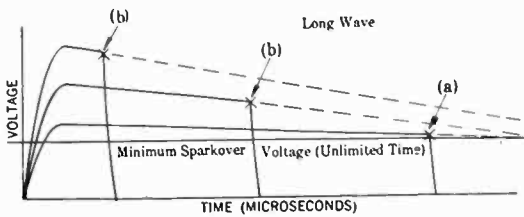

FIG. 3—SPARKOVERS ON TAILS OF WAVES

For convenience in practical application, the 60-cycle crest sparkover value has been taken as e_0 . If the impulse ratio is known, the impulse sparkover value is then found by multiplying β by e_0 . For certain dissymmetrical electrode arrangements the sparkover voltage may be materially lower when the non-grounded electrode (or the one in the denser field) is positive.

This equation is of further interest because it appears to be rational. In the original paper on this subject it was pointed out that energy, and therefore voltage and time, were necessary to rupture insulation.*

It may be assumed that a given amount of energy is necessary to break a given gap. This requires a definite ionization apparent as corona and corona loss. Corona loss, according to the quadratic law, is:

$$p = (e - e_0)^2 k$$

For the rectangular wave the energy may be expressed

*The Effect of Transient Voltages on Dielectrics, F. W. Peek, Jr., A. I. E. E. TRANSACTIONS, Vol. 34, 1915, p. 1857.

$$w = (e - e_0)^2 k t$$

or

$$\sqrt{w} = (e - e_0) \sqrt{k t}$$

$$e - e_0 = \sqrt{\frac{w}{k t}}$$

$$e = e_0 + \sqrt{\frac{w}{k t}}$$

$$e = e_0 \left(1 + \sqrt{\frac{w}{e_0^2 k t}} \right)$$

$$e = e_0 \left(1 + \frac{a}{\sqrt{t}} \right)$$

where

$$a^2 = \frac{w}{k e_0^2} = \frac{w}{k_1 l^2}$$

l = length of gap

When the impulse ratio is constant, a is constant; and it then follows that w varies as the square of the e_0 voltage or approximately as the square of the gap

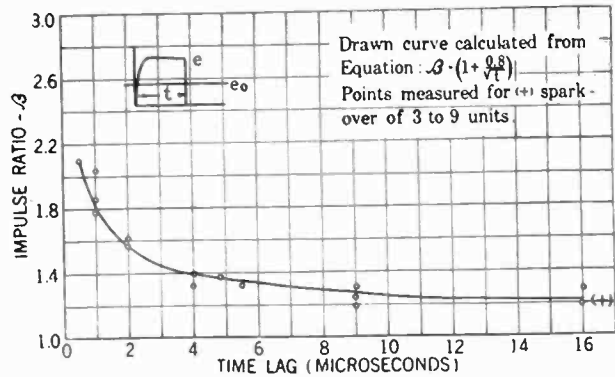

FIG. 5—IMPULSE RATIO-TIME LAG CURVE OF INSULATOR SPARKOVER WITH RECTANGULAR WAVE OF 1/2-MICROSECOND FRONT

(Standard 5 3/4-in. spacing—10-in. diameter insulators)

length. This also follows when β is constant with varying gap length in the case of the fixed wave.

Thus

$$\frac{e}{e_0} = \left(1 + \frac{a}{\sqrt{t}} \right) = \beta$$

The drawn curve in Fig. 5 was plotted from the equation

$$\beta = \left(1 + \frac{0.8}{\sqrt{t}} \right)$$

The difference between (+) and (-) for insulators (Fig. 7) represents a range rather than a definite division, with (-) maximum high and (+) minimum low. Individual (+) values of β may be approximately 5 per cent higher than the calculated and (-) values 5 per cent lower.

The same general laws apply for sparkover on the rising front and for standard waves. From these laws,

voltage-time relations can be calculated for any given condition. Values of a can be obtained from Table I. in the unabridged paper. For convenience, the time for sparkover on the rising front is measured from zero to breakdown.

For full-wave sparkover it was found that with constant front the impulse ratio decreases with increasing length of tail and that with constant tail the impulse ratio decreases with increasing length of front.

Values of impulse ratio β are given for various waves in Table II in the unabridged paper. The impulse sparkover can be found for a given wave and gap by multiplying the 60-cycle crest sparkover by β .

Full-wave sparkover curves are given in Fig. 12. Full-line curves represent values for transmission line conditions. The crosses give natural lightning sparkover voltages measured on transmission lines. Note that the effects are closely approximated by the standard $1/2/5$ - and $1/2/20$ -microsecond waves. These

as illustrated in Fig. 2. If the waves were not chopped the voltages would go much higher. Fig. 7 shows how the impulse ratio varies with time on typical gap and line insulator arrangement.

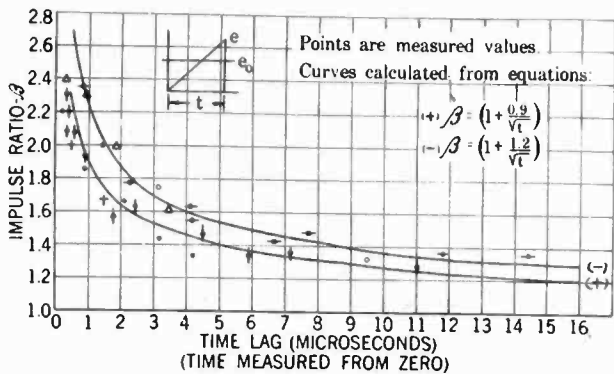

FIG. 7—IMPULSE RATIO-TIME LAG CURVE OF INSULATOR SPARKOVER ON FRONT OF WAVE
(Standard $5\frac{3}{4}$ in. spacing—10 in. diameter insulators)

curves are the average of (+) and (-) sparkover values. Fig. 14 records the results of tests of insulators and point-gaps in parallel. The gaps were adjusted for equal sparking on points and insulators. The waves used cover an impulse ratio range of 2 to 1.2 and unity at 60 cycles. Practically the same relation between insulators and points holds throughout the range.

4. Law of Impulse Sparkover for Oil and Solid Insulation. Equation (1) above applies for oil insulation and also seems to apply for solid insulation. However, the factor a must be properly evaluated.

IV. COMPARISON OF LABORATORY AND OBSERVED NATURAL LIGHTNING WAVES—A STATISTICAL STUDY OF LIGHTNING EFFECTS

Data from natural lightning waves measured by the cathode ray oscillograph are given in Fig. 22. Typical measured natural lightning waves are shown in Fig. 23 with the laboratory waves. These waves, in general, produce the same effects on lines and apparatus as the laboratory waves. It is probable that insulator sparkovers frequently occur on the rising front of the wave

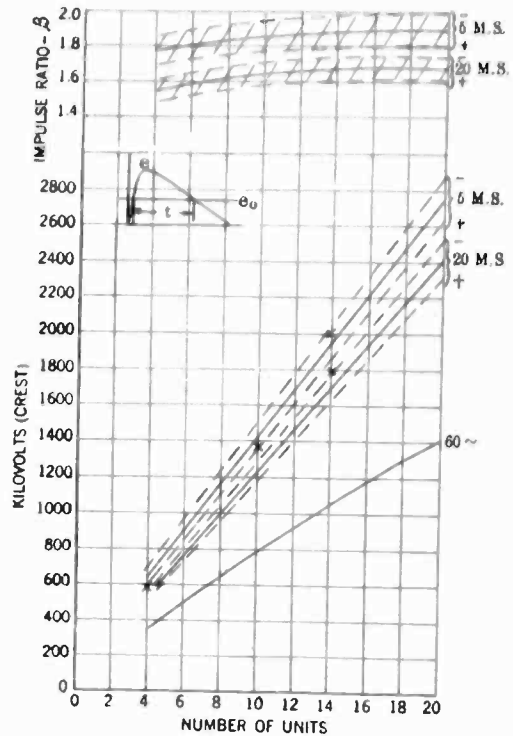

FIG. 12—SPARKOVER VOLTAGES OF SUSPENSION INSULATORS WITH "STANDARD" WAVE—50 PER CENT SPARKING
(Standard $5\frac{3}{4}$ -in. spacing, 10-in. diameter insulators). The full curves should be used for transmission line conditions

An examination of Fig. 22 shows that for the measured traveling waves 50 per cent reach crest voltage V_1 in less than three microseconds and 90 per cent in less than eight microseconds. However, the rise in voltage

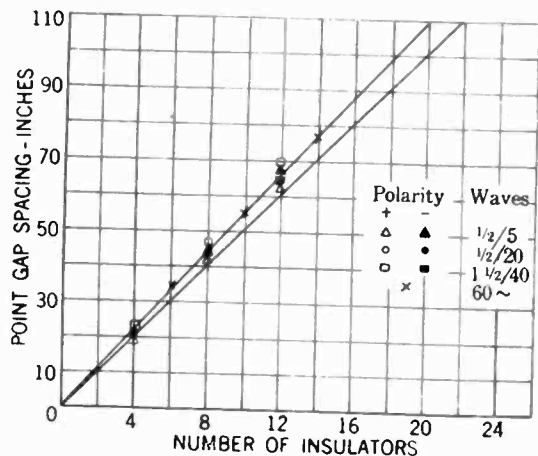

FIG. 14—CURVES SHOWING RESULTS OF PARALLEL TESTS ON STANDARD SUSPENSION INSULATORS
($5\frac{3}{4}$ -in. spacing—10-in. diameter) and point-gaps, made to determine equivalent sparkover values. Curves represent range between β 0-cycle and $1/2/5$ -microsecond waves

V at the origin should be at least twice as steep as V_1 the impulse ratio at the origin should thus correspond very approximately to the dotted curve in Fig. 22. This shows that 50 per cent reach crest in less than one and

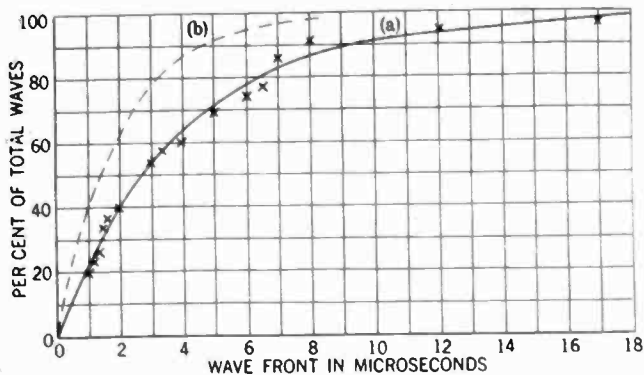

FIG. 22—PERCENTAGE OF LIGHTNING WAVES OF VARIOUS FRONTS MEASURED ON TRANSMISSION LINES

(a) Curve showing fronts of 35 highest natural lightning waves (voltage V_1) measured on Wallenpaupack-Siegfried Lino in 1929
 (b) Estimated equivalent fronts (voltage V) at points of origin of corresponding waves on curve a

one-half microseconds and 90 per cent reach crest in less than four microseconds. On Fig. 7 are plotted impulse ratio curves for sparkover on the rising front of a wave with time. This shows that for the waves measured the impulse ratio for V should be higher than the average 1.55 for 90 per cent of the waves and over 1.9 for 50 per cent. These measurements thus seem to check the former impulse ratios obtained by surge voltage recorders of natural lightning in Fig. 12 and also justify the laboratory values of lightning voltage given in these figures. Of course, occasionally conditions may be right for breakdown to occur on the tail of the wave at a lower impulse ratio.

From the statistical study plotted in Fig. 25 it is possible to estimate the probable outages on a given line with varying insulators and ground wire arrangement.

VI. CONCLUSIONS

1. The law of breakdown and time lag has been derived from experimental data.
 2. The three general types of waves, which are rectangular, uniformly rising front, and standard logarithmic, are discussed and their characteristics given.

3. Data are tabulated from which the impulse spark-over voltage for a wide condition of waves can be calculated. These data will be added to and corrected for greater accuracy as quickly as laboratory work permits.

4. The field investigation of lightning indicates that: The average lightning wave, even with maximum voltages sufficient to cause sparkover on a 220-kv. line, can be accounted for by induction, with reasonable assumptions as to size of cloud and rate of discharge.

Sparkovers may be caused by either induced voltages or direct strokes. Direct strokes become of proportionally increasing importance as causes of outages when line insulation is increased.

Waves giving impulse ratios of the order of 1.8 cause a large percentage of the sparkovers on high-voltage lines.

5. Waves giving low impulse ratios are not representative of average field conditions on high-voltage lines, and do not give sufficiently severe effects for impulse testing.

6. Statistics compiled from lightning records gathered from widely scattered power systems serve as a valuable basis for considering economically the line insulation necessary under different conditions.

7. It seems desirable to select two preferred waves for insulator testing and coordination. The $1/2/5$ giving the steep wave effects and the $1 1/2/40$ giving the moderate wave effects are recommended.

8. Coordination of system insulation on transmission lines has been used on important systems and its value is now recognized. The law of time lag given above permits the proper coordination under all conditions.

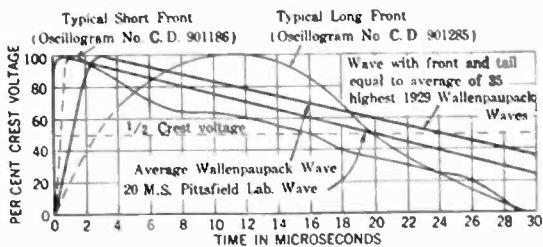

FIG. 23—TYPICAL NATURAL LIGHTNING WAVES OF LONG AND SHORT FRONTS, AND AVERAGE SHAPE AS RECORDED AT WALLENPAUPACK IN 1929

Pittsfield Standard 20-microsecond wave included for comparison

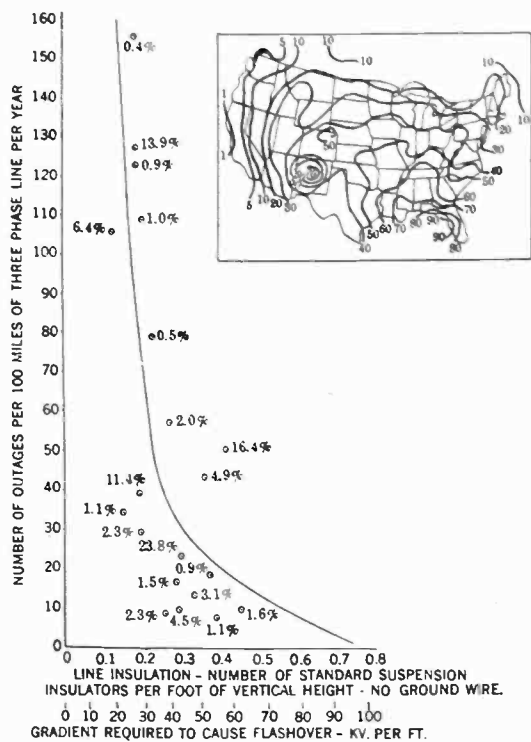

FIG. 25—ESTIMATE OF PROBABLE OUTAGES ON TRANSMISSION LINES FROM A STATISTICAL STUDY

(Reduced to standard basis by dividing insulators by height of conductor, correcting for ground wire effects, and reducing to 100 storms per year. Figures on points indicate percentage of total year-miles used in estimate)
 This curve refers to a location having 100 thunderstorm days per year. For other locations take values from curve and apply to section under consideration by multiplying by percentage of 100 thunderstorm days per year as shown on the above map

Abridgment of
The M. I. T. Network Analyzer
Design and Application to Power System Problems

BY H. L. HAZEN,* O. R. SCHURIG,† and M. F. GARDNER*

Synopsis.—Previous network computing devices with their uses and limitations are reviewed briefly, following which is a statement of the requisites for an effective a-c. calculating table. The M. I. T. Network Analyzer, a static miniature a-c. power system designed and constructed jointly by the Massachusetts Institute of Technology and the General Electric Company for the computation of actual power

networks is described in detail and its operation outlined. The fields of its application are enumerated and include the study of normal operating conditions, stability, and short circuits. An example illustrating its application to the solution of a normal-operation problem is given.

* * * * *

INTRODUCTION

TO determine the behavior of a power system under various conditions of operation necessitates numerous solutions for the distribution of current, voltage, and real and reactive power in its network. The advantages of experimental methods over lengthy and usually impracticable mathematical calculations for the determination of these quantities have long been recognized and several types of experimental computing devices or miniature systems for network analysis have been developed and have proved their usefulness.

The following paper deals with an improved form of network computing device designed and built jointly by the Massachusetts Institute of Technology and the General Electric Company. The network analyzer, as this device is called, is installed in the Electrical Engineering Research Laboratory of the Massachusetts Institute of Technology at Cambridge, Mass.

Most of the network computing devices developed have been in the form of miniature systems. These are imitations on a small scale of those features of the real system considered significant or indispensable for solution of the class of problem for which the model was developed. One of the earliest developed was the d-c. short-circuit calculating table.¹ Due to the use of direct current, it is limited in its application to those problems in which phase angles can be neglected, as, for example, in short-circuit studies involving only questions of current magnitudes. Its simplicity has made it almost indispensable for this purpose.

The first miniature to employ alternating current was a three-phase representation of one particular system.² Like the d-c. table it was a static duplication, containing no rotating elements. Although the phase angles at generating points were not adjustable, it afforded an ingenious means of investigating relay performance

with unbalanced short circuits at a date when the usefulness of symmetrical component analysis was as yet unappreciated.

The necessity for representing angle differences between synchronous machines led to the use of a-c. miniature systems with three-phase generators, motors, static loads, and lumped three-phase artificial lines. One such system³ used synchronous machines of 3.75-kv-a. rating and normal system currents of 10 amperes at 440 volts. This scale was considered the minimum which would permit the use of the usual types of portable indicating ammeters, voltmeters, and wattmeters for measuring quantities in the circuits without the necessity of correcting for their presence.

Similar systems⁴ of larger ratings, having machines ranging from 200 to 600 kv-a. and employing line voltages of 2300 volts, have been used in the study of stability. Questions of stability involve mechanical momentum and electrical damping, and the normal relationships between these cannot be retained with the customary type of rotating machine as the model scale is indefinitely reduced.

Because of their cost, space and power requirements, and their instability when an attempt is made to employ more than three or four units, rotating machines in general are not adapted to use in network computing devices of laboratory convenience and accuracy.

The limitations of the foregoing schemes for network representation led to the experimental development at M. I. T. of a static type of miniature system⁵ incorporating features which could be applied to the solution of normal operation problems in extensive systems on laboratory scale. It was demonstrated that generating stations are adequately represented by static phase-shifting transformers, thereby eliminating the difficulties associated with rotating machines.

The network analyzer described in this paper is a comprehensive a-c. calculating table incorporating these ideas. While it has been built primarily for educational and research purposes, careful consideration has been given in its design to make it suitable for commercial engineering service.

*Massachusetts Institute of Technology, Cambridge, Mass.

†General Electric Company, Schenectady, N. Y.

1. For references see Bibliography in complete paper.

Presented at the North Eastern District Meeting of the A. I. E. E., Springfield, Mass., May 7-10, 1930. Complete copy upon request.

GENERAL DESIGN CONSIDERATIONS

For a network computing device to adequately achieve its purpose it must embody such complete representation of significant electrical constants and terminal conditions that such errors in method as are inherent in the d-c. table are eliminated. Furthermore, for practical usefulness, it must be sufficiently extensive and flexible to represent numerous actual systems, it must yield results of suitable accuracy with a reasonable expenditure of time, its operation should be simple, its space and weight requirements must be reasonable, and its cost should be of a minimum consistent with these requirements.

The principal features of the design follow:

1. Representation of one phase line-to-neutral.
2. Representation of the lumped impedance and admittance equivalents of lines, transformers, cables,

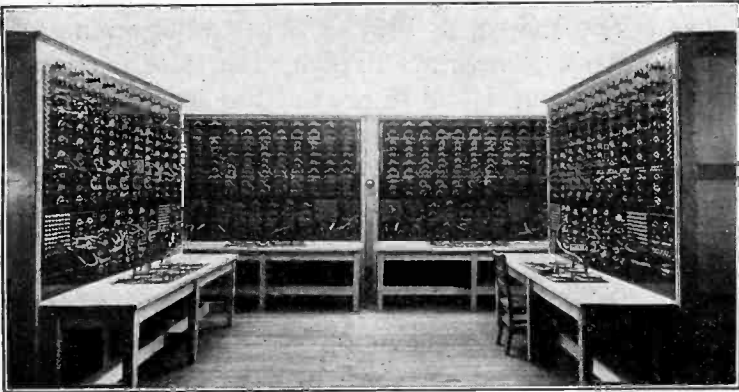

FIG. 1—THE NETWORK ANALYZER

General view of analyzer plugged for a problem showing the layout of the four sections and the accompanying instrument tables

and loads by adjustable resistors, reactors, and capacitors.

3. Representation of either the terminal or excitation voltage of a synchronous machine by the single-phase terminal voltage of a phase-shifting transformer, this voltage being adjustable in magnitude and phase.

4. Use of minimum electrical scale consistent with direct measurements by portable indicating instruments.

5. Use of such portable indicating instruments—ammeters, voltmeters, and wattmeters—that they can be plugged into or removed from the network without materially altering the voltage drop and current distribution.

6. Provision for interconnecting the units to represent complete power transmission networks.

The selection of the relative sizes and ranges of line and load units required an analysis of the constants of modern transmission systems. (See Table I).

A high operating voltage for the analyzer appears desirable of course to reduce the effects of series-connected instruments on line impedances at a given operating current. An operating voltage of 200 volts

was chosen because it was not desired to subject the operators to the hazards of a higher voltage.

The voltage scale having been fixed, the nominal operating current was chosen at a value which would give relatively small errors due to the insertion of instruments. This nominal current was set at 0.5 ampere.

For current measurements, thermocouple type ammeters were chosen because of their relatively low series resistance in the lower current ranges when compared with other portable ammeters. Likewise, thermocouple type voltmeters were chosen because of their low current requirements. Suspended armature type of wattmeters were chosen because their current and voltage elements could be made to meet these requirements.

DESCRIPTION OF NETWORK ANALYZER AND ITS OPERATION

The equipment in the present installation includes a sufficient number of units to represent in its electrical essentials a system consisting of as many as eight generating stations, 60 lines and cables or other connecting elements, 40 loads, four ratio-changing transformers for closing loops, and any desirable number of synchronous condensers. In general, it may be assumed that any network whose number of elements falls within the above limits can be represented on the analyzer with a completeness adequate for the engineering study of the problems for which it was designed.

The six principal phase-shifting transformers used to represent an equal number of generating stations are rated at 0-500 volts, six amperes with 0.5-volt steps.

A manual angular adjustment of the rotor provides the time-phase adjustment of the secondary voltage, and by means of the tap switches and the angle control, the vector representing this voltage can be made to terminate at any point within a circle of 500 volts radius. This secondary voltage can be used to represent either the terminal or the excitation voltage of a synchronous machine under transient as well as steady-state conditions.

In Table I the number, range, and principal constants of the various units are given.

In Table II the instruments used for making all measurements on the analyzer are listed, together with their use and approximate energy demands. These are all of the portable direct-reading type.

The resistor units, adjustable by means of dial switches, are of assembled resistor tubes, each consisting of high-resistivity, low-temperature coefficient wire wound on a porcelain tube covered by vitreous enamel. The reactors have nickle-iron alloy cores with air-gaps and are adjustable by taps connected to dial switches. Because of the small R/X ratio, the constancy of inductance with current, and the space limitations, the design of suitable reactors was a difficult problem. This, together with the design of

TABLE I
NETWORK ANALYZER UNITS

Type	No.	Max. rating	Max. setting	Steps
Line units	60			
Resistors	25	4 amperes	10 ohms	0.1 ohm
	35	2	100	1 ohm
Reactors	20	4	20	1% of setting
	40	2	120	1% of setting
Load units	40			
Resistors	30	1 ampere or 200 volts	4,000	4 ohms
	10	200 volts	20,000	200 ohms
Reactors	30	1 ampere or 200 volts	4,000	1% of setting
	10	200 volts	20,000	1% of setting
Generators	8	6 amperes	500 volts	0.5 volt
Generator reactors	6	500 volts or 6 amperes	500 ohms	1% of setting
Capacitors	32	350 volts	12 μf	0.1 μf
Auto-transformers	4	2 amperes	$\pm 10\%$	0.5%

TABLE II
LIST OF INSTRUMENTS

	No.	Type	Full scale range	Requirement for full scale	Where used
Voltmeter	6	Standard			
Ammeter	6	Portable	300/600 v.	Normal	Generators
Wattmeter	6	Portable	2/6 a.	Normal	Generators
Ammeter	6	Portable	400 to 2400 w.	Normal	Generators
Ammeter	4		0.1 to 5.0 a.	0.12 v.	General
Voltmeter	2	Thermocouple	5 to 250 v	0.002 a.	General
Wattmeter	6	Special	40 to 800 w.	0.003 a.-0.1 v.	General

certain of the necessary instruments constituted the major difficulties of the development.

FIELDS OF APPLICATION OF THE NETWORK ANALYZER

The chief function of the network analyzer is to serve as an experimental substitute for the lengthy and generally impractical calculations of normal-frequency current, voltage, power and phase relations in electric power networks for which the resistance, inductance, and capacitance constants of lines, generators, transformers, and loads are known. Before considering its fields of application it is well to point out that it will *not* serve for the determination of circuit constants of lines, generators, transformers, or of other system apparatus, but rather requires for its use a knowledge of these electrical circuit constants. Moreover, since it has lumped line units and phase shifters to represent synchronous machines, it is not applicable to the study of high-frequency transient phenomena, corona problems, arcing grounds, lightning induction, synchronous machine characteristics, harmonics due to transformers or generators, etc.

Studies of Normal System Operation. One of the important problems requiring solution by means of a miniature system is the determination of load division among the various branches and stations of a power network. This is frequently desirable for the best design of new systems as well as for the study of additions or changes and the best operation of existing systems.

Two problems closely related to the foregoing are (1) voltage regulation in power networks and (2) power-factor correction, which requires a study of the effect

of certain classes of terminal apparatus, such as synchronous condensers, when added at different points of a system.

Studies of System Stability. Problems of static stability can be studied with the network analyzer even beyond the stable point of the power system because synchronous machines are represented by stationary phase shifters. Although it will not serve actually to reproduce the transient swings of generating and receiving machinery, problems of this class can be studied by the point-by-point method⁸ with its aid. In this method, the rotor-position changes together with field-current and prime-mover torque changes, are computed for successive arbitrary short intervals of time, the progress of the transient thus being developed by small steps. Since a change in field current and the angular position of the rotor changes the armature current and power in every machine, it is necessary to determine the values of these armature currents and powers as they exist at the beginning of each interval. These are fixed by the rotor positions and field currents found to exist at the end of the previous interval. In other words a normal steady-state electrical solution of the network with the known terminal conditions must be made for the end of each interval, and the result used to compute the changes which will occur in the following interval. The calculation of these numerous steady-state conditions is the most laborious part of the point-by-point method and is the type of calculation for which the analyzer was developed.

Short-Circuit Studies. Since the short-circuit calculating table ordinarily serves adequately for the more common short-circuit studies of systems, the analyzer will not supplant this simple and effective d-c. device. The errors⁸ of the latter are commonly below 10 per cent and rarely in excess of 20 per cent. The errors of the network analyzer will, in general, be less than 3 per cent.

The solution of unbalanced short circuits on the analyzer may be accomplished either by successive single-phase set-ups with the aid of symmetrical-coordinate analysis, or in an approximate manner by a three-phase set-up with a three-phase power supply with or without the use of the phase shifters.

Educational Uses. Perhaps the application of the analyzer most far reaching in its effect is its educational use, not only in the solution of sample problems by classes but as a computation tool which opens fields of research to graduate students otherwise closed by excessive labor requirements.

SUMMARY AND CONCLUSIONS

1. An improved a-c. network computing device, called the network analyzer, is described in this paper, its purpose being to determine by direct measurements in the laboratory the voltage, current, power, reactive power, and phase angle at any point of a network. Its scope of representation in its present form is eight

generating stations, 60 lines and cables with their capacitance, 40 loads, four ratio-changing transformers, and the usual number of synchronous condensers.

2. The analyzer uses phase-shifting transformers rather than rotating machines to represent synchronous machines and generating stations. Its operation is thus greatly simplified and speeded up in comparison with previous miniature systems.

3. A voltage scale of 200 volts at 60 cycles is used, the nominal current scale being 0.5 ampere.

4. Portable indicating instruments are used throughout, including thermocouple voltmeters and ammeters and suspended-armature wattmeters, by means of which current, voltage, and power are read directly at any point of the system without materially disturbing current distribution and voltage drops in the network and without necessitating corrections or adjustments for the presence of the instruments. The accuracy of the instruments is 1 per cent of full scale.

5. The accuracy with which a given set of circuit constants can be reproduced is approximately 1 per cent. The accuracy with which the instrument readings represent the quantities which are uniquely determined by a given set of circuit constants and terminal conditions is one per cent or better in the case of voltages, approximately 2 per cent in the case of currents, and 3 per cent—with a maximum of 5 per cent for small magnitudes—in the case of power and reactive kv-a. This accuracy has been attained by providing (a) steps as low as 1 per cent or smaller for the adjustment of the impedance units and in the settings of the phase-shifting transformers, (b) a value of effective resistance in the reactors of the order of 4 per cent of the reactance, (c) a design of magnetic circuit in the reactors such as to give not over 1 per cent change of inductance due to change of current throughout the entire operating range.

6. The network analyzer is intended to be used:

(a) For purposes of teaching and research by students and research staff of the Massachusetts Institute of Technology, and

(b) For commercial engineering service in the solution of network problems for engineers in operating and designing work.

In its design major consideration was given to the requirements for the use by students. As a tool for engineers, it is adapted to the solution of system problems arising in normal operation, growth, and interconnection; to the point-by-point computation of stability problems including the effects of symmetrical or unsymmetrical short circuits and sudden circuit changes; to the determination of steady-state load limits and to short-circuit studies in the relatively few cases where the d-c. calculating table will not yield adequate results.

7. The ability of the analyzer to accomplish the purpose for which it was designed has been demonstrated by the solution of actual network problems which it has been called upon to solve.

ORIGIN OF THE WORD ELECTRON

A recent publication in a contemporary radio journal gives the date 1891 as that at which the word "electron" was coined. The authority quoted is G. Johnstone Stoney.

In view of the fact that the electron in modern times is fairly well understood and that its migrations in evacuated tubes account for many astounding and useful applications of electricity to industry, it is of interest to attempt to trace the origin of the word.

Although it was not until 1896 that the electron as we know it today was identified and determinations made relative to its physical characteristics, it is history that the ancient Greek poets called the sun $\eta\lambda\epsilon\chi\tau\omicron\varsigma$ and Homer repeatedly so terms it (*Illiad*. Z/513; T./398). "Electron" was used indefinitely by the Greek classic writers. In the minds of the Greeks, gold and the gold alloys were all children of the sun "elector," and, in common with these, amber, in Hellenic speech, came to be called "electron."

During the past century and a half the unending excursions of investigators into the realm of physics brought to light all of the now known and understood properties of electricity and magnetism. In many of the new discoveries need arose for the coining of new words and terms by means of which particular effects or applications might be identified. Variations of the word electricity were convenient and suggestive. Such words as electro, electrostatic, electrolytic, electroscope, electrolyze, electrotonic, electrol, electrograph, electrolysis, electross, electrolyte, dielectric, etc., were coined from time to time to meet the needs of invention.

It is hardly probable that the word electron would escape the notice of workers in electricity until so late as the year 1891.

A thorough search of historical electrical records might disclose that the word has been used long after the Greeks used it to refer to amber. That the term was current and had some significance in scientific circles is evident from the fact that in the electrical journal, *The Telegrapher*, of December 26, 1864, the word electron appears on page 36, at the bottom of the first column.—Donald McNicol, in *Radio Engineering*, New York.

WAYS AND MEANS TO TRAFFIC SAFETY

The Department of Commerce has recently released a booklet entitled "Ways and Means to Traffic Safety" which is a summary of all recommendations of the National Conference on Street and Highway Safety. This pamphlet may be secured by addressing Honorable Robert P. Lamont, Secretary of Commerce, Washington, D. C.

American Engineering Council participated in the National Conference on Street and Highway Safety and made as its chief contribution the cooperative study on Street Traffic Signs, Signals and Markings.

INSTITUTE AND RELATED ACTIVITIES

Middle Eastern District Meeting at Philadelphia, October 13-15

Plans have been completed for a meeting of the Middle Eastern District to be held in Philadelphia, October 13-15 with headquarters at the Benjamin Franklin Hotel. An excellent program has been arranged,—engineering sessions and a number of interesting inspection trips; facilities for sports at the various country clubs; several social events, including an informal reception and dance, a meeting banquet, and many entertaining features especially provided for the ladies who will be in attendance.

Three luncheon meetings are scheduled as follows: 12:30 p. m. Monday, October 13, Joint Luncheon Meeting for Branch Counselors and Branch Chairmen; on the following day, Tuesday, October 14, at the same hour, Luncheon Meeting of Branch Counselors and another Luncheon Meeting of Branch Chairmen. And in addition to these three luncheon meetings, a conference of Branch Counselors and Branch Chairmen will be held at 2:00 p. m. on Monday, October 13. Those who are interested

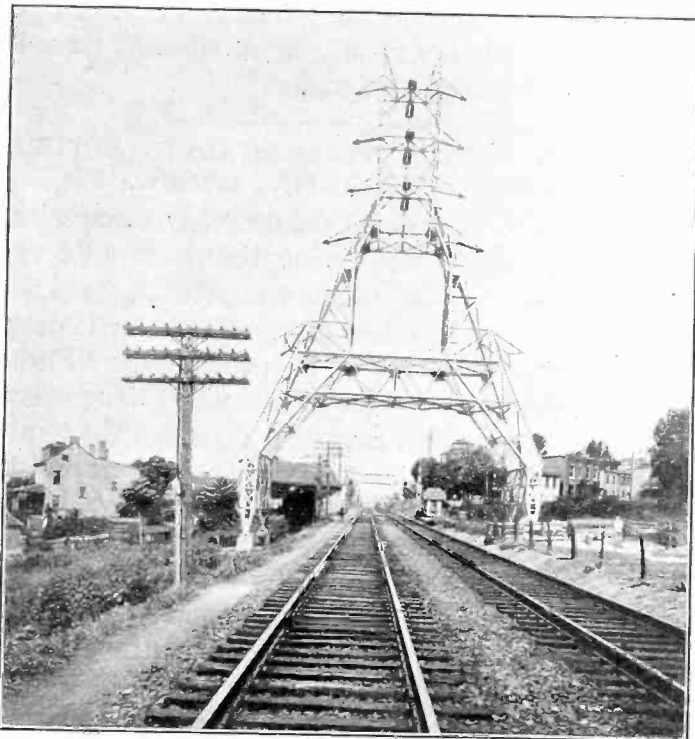

TRANSMISSION LINE TOWERS OVER READING RAILROAD TRACKS

in the names of speakers, their subjects, and further detailed description of these events, should consult the mailed announcement.

On Monday evening, October 13, at 8:30 p. m., an Informal Reception and Dance will be held in the ball room of the Benjamin Franklin Hotel. On the following evening at 7:00 p. m., there will be a banquet followed by entertainment and dancing in the Benjamin Franklin Hotel ball room.

REGISTRATION

All who plan to attend the meeting should register in advance by mail. A fee of \$1.00 will be asked of members, and for students there will be a fee of 50 cents.

Those intending to participate in the inspection trips should make application at the Registration Desk as far in advance as possible.

INSPECTION TRIPS

Numerous inspection trips have been coordinated with technical sessions and include widely different kinds of installations to

appeal to the varied engineering interests. The bus trips will start from the Benjamin Franklin Hotel. A trip to the Conowingo Generating Station has been scheduled for Thursday, October 16; those taking this trip will leave about 10:00 a. m. and arrive back at 5:00 p. m., while at Conowingo lunch will be provided without extra cost.

Tickets for all trips may be purchased at the Registration Desk, where rates and any additional information may also be obtained. In order to allow the committee ample time to complete arrangements, registrations for all trips should be made as early as possible.

Following is a list and schedule of the various inspection trips offered by the local committee:

Monday, October 13, 1:30 p. m.

R. C. A. Victor Corporation.
Bell Telephone Company—Radeliff Station.
Plymouth Meeting and Westmoreland Substations, Philadelphia Electric Co.

Tuesday, October 14, 9:00 a. m.

Atwater Kent Manufacturing Company.
Philadelphia Storage Battery Company.
Philadelphia Rapid Transit and City Transit Substations.

Tuesday, October 14, 1:30 p. m.

Pennsylvania Railroad—West Philadelphia Terminal and Lamokin Substation.

Wednesday, October 15, 9:00 a. m.

General Electric Company.
Westinghouse Electric and Manufacturing Company.

Wednesday, October 15, 2:00 p. m.

Reading Railroad Electrification.
American Brown-Boveri Company, and New York Shipbuilding Corporation.
Deepwater Station.

Thursday, October 16, 10:00 a. m.

Conowingo Hydro-Electric Station.

(For a detailed description of the various features which may be seen on each of the above trips, see paragraphs under the heading "Inspection Trips" in the program).

A complete list of the titles of the technical papers, together with the names of their authors and the companies with which they are affiliated, also the technical session at which these papers are to be presented, was published in the September issue of the JOURNAL pages 800-801 inclusive.

COMMITTEES

The officers of the General Committee are as follows: E. C. Stone, Vice-President, Middle Eastern District, No. 2, Chairman; J. A. Cadwallader, Secretary, Middle Eastern District, No. 2, Secretary; L. F. Deming, Vice-Chairman. The chairmen of the local subcommittees making the immediate arrangements for the meeting are as follows: H. C. Albrecht, Entertainment Committee; P. H. Chase, Committee on Inspection Trips; L. J. Costa, Headquarters-Hotels and Publicity; E. C. Drew, Finance Committee; C. D. Fawcett, Students' Activities; D. H. Kelly, Committee on Registration and Arrangements; I. M. Stein, Meetings and Papers Committee; G. I. Wright, Transportation Committee; Mrs. P. H. Chase, Ladies' Committee; and the following additional members: T. H. Clegg, J. V. B. Duer, I. C. Forshee, C. N. Johnson, J. L. MacBurney, E. E. Merriam, J. H. Tracy, E. B. Tuttle.

**Southern District Meeting at Louisville, Ky.
November 19-22**

The Southern District will hold a four day meeting at Louisville, Ky., November 19-22, with headquarters at the Brown Hotel. A variety of subject matter comprises the technical program and will prove interesting and valuable to all who will attend. The social features of the program consist of an informal Smoker on Wednesday evening and a formal Dinner-Dance on Thursday evening. In addition, numerous attractive activities have been arranged for the ladies during their stay at the meeting.

TECHNICAL SESSIONS

Many interesting engineering features are to be presented in five technical sessions, arranged as follows: Industrial Applications; Electric Railways; Transmission and Distribution; Protective Devices; and Selected Subjects. In the latter session engineering papers describing local hydroelectric stations, a modern steam station, the progress and design of single-phase series railway motors, and arc welding in the electrical industry, will be presented. In the following part of this announcement is published a list of the titles of the papers, together with the names of their respective authors and the companies with which they are affiliated.

ENTERTAINMENT

There will be an informal Smoker on Wednesday evening at which Mr. E. L. Manning of the General Electric Research Laboratories will present interesting developments in the electrical sciences.

On Thursday evening there will be a formal Dinner-Dance in the ballroom of the Brown Hotel. Following the dinner there will be various entertainment features, which will be announced later, and dancing.

Golf will be arranged for any time to suit the convenience of the player.

Ladies' Entertainment

Wednesday Morning —Welcome and announcements of activities.

Wednesday Afternoon—Sightseeing tour of residential section of city and parks.

Wednesday Evening —Ladies are invited to attend the informal Smoker and lecture.

Thursday Morning —Bridge Luncheon at the Louisville Country Club.

Thursday Afternoon —Tea at the French Village.

Thursday Evening —Dinner Dance.

Friday Morning —Shopping Tour of the business section of Louisville.

Friday Afternoon —Matinee.

PROGRAM

Wednesday, November 19

10:00 a. m. Meeting called to order by General Chairman, J. P. Barnes.

Welcome by the Mayor of Louisville, with Professor Rodman, Presiding.

Remarks: Mr. W. S. Lee, President, A. I. E. E. Professor Rodman, Vice-President of the Southern District.

TENTATIVE TECHNICAL PROGRAM

Wednesday, November 19

INDUSTRIAL POWER APPLICATIONS

10:30 a. m. *Electric Power in the Cement Industry*, R. H. Rogers, General Electric Co.

Electric Power in the Lumber Industry, A. H. Onstad, Weyerhaeuser Timber Company.

A Modern Rubber Mill, N. A. Nigosin, Goodyear Tire & Rubber Co.

TRANSPORTATION AND ELECTROLYSIS

2:00 p. m. *Electric Railways*, Mr. Gordon.

Lackawanna Electrification, E. L. Moreland, Jackson & Moreland, Engineers.

A Cooperative Electrolysis Survey in Louisville, Ky., W. C. White, Southern Bell Telephone & Telegraph Co.

Thursday, November 20

10:00 a. m. Technical Student Session, D. C. Jackson, Jr., Presiding.

TRANSMISSION AND DISTRIBUTION

2:00 p. m. *Lightning Investigation at Aloc, Tenn.*, J. E. Housley, Knoxville Power Company.



THE BROWN HOTEL, HEADQUARTERS OF THE A. I. E. E. SOUTHERN DISTRICT MEETING

Operating Experience with Reactance Type Distance Relays, E. E. George, The Tennessee Electric Power Co.

Trailer Mounted Substations for Emergency Use, F. L. Moses & H. B. Wolf, Duke Power Co.

Lighting Airway Beacons Direct from High Voltage Transmission Lines, F. W. Cartland, Westinghouse Elec. & Mfg. Co.

Friday, November 21

PROTECTIVE DEVICES

10:00 a. m. *Grounded Neutral Y-Connected Potential Transformers*, C. T. Weller, General Electric Co.

Physical Nature of Neutral Instability, A. Boyajian & O. P. McCarty, General Electric Co.

Theory of Abnormal Line to Neutral Transformer Voltages, C. W. La Pierre, General Electric Co.

Protection of Three-Winding Power Transformers, R. E. Cordray, General Electric Co.

Power Transformer Noise—Its Characteristics and Reduction, R. B. George, Westinghouse Electric & Mfg. Co.

SELECTED SUBJECTS

- 2:00 p. m. *Governor Characteristics under Varying Load Conditions*, R. C. Buell, R. J. Coughery, E. M. Hunter, General Electric Co. and V. M. Marquis, American Gas & Electric Co.
- The Ohio Falls Hydro-Electric Station at Louisville, Ky.*, R. M. Stanley, Byllesby Engineering & Management Corp. and E. D. Wood, Louisville Gas & Electric Co.
- Modern Steam Stations of the Duke Power Company*, M. E. Lake, Duke Power Co.
- Progress in the Design of Single-Phase Series Railway Motors*, H. G. Jungk, Westinghouse Elec. & Mfg. Co.
- Automatic Arc Welding in the Electrical Industry*, G. H. Koch, Westinghouse Electric & Mfg. Co.

INSPECTION TRIPS

The local committee in charge of the inspection trips has provided numerous interesting and instructive trips to points of engineering interest as well as points of historical interest. Hydroelectric stations, automatic substations, distribution networks, railway switching and signaling, and applications of electric power to manufacturing processes, together with high power radio broadcasting, offers a varied and interesting opportunity to engineers attending this meeting to see a number of local developments.

Following is a list of the available inspection trips that may be taken daily:

- Ohio Falls Hydro-Electric Station.
- Waterside Steam-Electric Station.
- Automatic Substation.
- Low-voltage distribution network.
- Electric signaling and switching display.
- Application of electric signals to steam and electric railroads.
- Industrial application of electric power to manufacturing processes.
- A modern high power broadcasting station.

Saturday has been reserved for trips by bus to points of scenic and historic interest in Kentucky, among which the following are included:

Mammoth Cave—An all day trip to one of the wonders of the world.

Dix River and Lock 7 Hydroelectric Developments—A trip of unusual interest through some of the most beautiful scenery in this part of the country. These two plants include many features that are unique in hydroelectric plant design.

Historic Tour—A visit to the original Old Kentucky Home at Bardstown, where Stephen Collins Foster was inspired to write many of his immortal songs, and to the memorial erected at the Lincoln birthplace near Hodgenville.

COMMITTEES

The personnel of the General Meeting Committee consists of the following: W. S. Rodman, Vice-President, Southern District, No. 4, Honorary Chairman; James P. Barnes, Chairman; E. D. Wood, Vice-Chairman; A. S. Hoefflin, Secretary; Philip P. Ash, James Clark, Jr., G. W. Hubley, D. C. Jackson, Jr., F. H. Miller, L. S. Streng, Stanley Warth, H. W. Wischmeyer; and the following who are chairmen of the various sub-committees: F. H. Miller, Technical Program; Philip P. Ash, Hotels and Registration; H. W. Wischmeyer, Transportation and Inspection; Stanley Warth, Entertainment; D. C. Jackson, Jr., Student Activities; E. D. Wood, Attendance and Publicity; James Clark, Jr., Finance.

Pacific Coast Convention

AT PORTLAND, OREGON, SEPTEMBER 2-5, 1930

With an attendance of more than three hundred, an excellent technical program, and attractive entertainment and recreation features, the nineteenth annual Pacific Coast Convention held in Portland, Oregon, September 2-5, 1930, was counted a very successful one. There were many expressions of appreciation of the excellent preparations made by the committees in charge and of the promptness and effectiveness exhibited in the conduct of all parts of the convention.

TECHNICAL SESSIONS

Seventeen technical papers presented at five sessions constituted a program of great variety and interest. A summarized report of the discussions on these papers will be published in the November issue of the JOURNAL.

STUDENT ACTIVITIES

Ten papers by engineering students in the Pacific and North West Districts were presented at the Thursday morning and Friday afternoon sessions, which were devoted entirely to student papers. A joint Conference on Student Activities of the two Districts were held on Wednesday evening. A more complete report on all student sessions is given in the Student Activities Department of this issue.

ENTERTAINMENT

The President's Reception and informal dance held on Tuesday evening constituted a very enjoyable opening of the social activities. The banquet held Thursday evening was the principal social event, and was attended by nearly all present at the convention. As toastmaster, L. T. Merwin, Vice-President and General Manager of the Northwestern Electric Company, Portland, contributed much to the success of the program. C. P. Osborne presented two prizes for the ladies' bridge contest held on Wednesday afternoon, two for the ladies putting contest held on Thursday afternoon, and three for ladies who held the winning numbers, determined by a drawing from numbers distributed to all ladies at the banquet. President Lee expressed his deep appreciation of the excellent convention, and gave a brief address, very much interesting all present. He then presented the certificates and checks to the authors who had won prizes for the presentation of papers in the Pacific District during 1929, as follows:

District First Prize. N. B. Hinson for his paper *Population as an Index to Electrical Development*, presented at the Pacific Coast Convention at Santa Monica, California, September 3-6, 1929.

District Prize for Initial Paper. Mabel Macferran for her paper *Parallel Operation of Transformers Whose Ratios of Transformation are Unequal*, presented at the Pacific Coast Convention at Santa Monica, California, September 3-6, 1929.

District Prize for Branch Paper. H. R. Lubeke for his paper *Design Equations for Vacuum Tube Voltmeters*, presented at the joint meeting of the San Francisco Section, University of California Branch, University of Santa Clara Branch, and Stanford University Branch on April 10, 1929. Each prize consisted of \$25.00 paid from the Institute treasury and a certificate issued by the District officers.

C. P. Osborne presented many attractive and useful prizes to the winners in the golf tournament. W. F. Hynes of Portland won the Fischen cup and first prize—a gladstone. Many features of entertainment interspersed the events of the evening. Dancing followed the dinner and the program outlined above.

Other events for the ladies included teas, a luncheon, and a motor trip on the Columbia River Highway.

TRIPS

During the convention, inspection trips were made to many points of interest in and near Portland, and several longer trips were planned for Saturday, including those to the Crown-Zellerbach Paper Mill, Camas, Wash.; the Oak Grove Hydroelectric Plant on the Clackamas River; the Ariel Hydroelectric Development on the Lewis River; and Oregon State College, Corvallis, Ore.

FUTURE CONVENTIONS

At a luncheon meeting held on Wednesday and attended by several Institute officers, officers or representatives of all Pacific Coast Sections, and others, it was decided to recommend that the Sections named below be hosts for the next three Pacific Coast Conventions:

1931—San Francisco
1932—Vancouver
1933—Utah

CONVENTION COMMITTEE

The members of the General Convention Committee and the various subcommittees received just praise for the effectiveness with which the plans were made and carried out. The chairmen were:

H. H. Schoolfield, General Convention Committee; H. H. Cake, Program; C. W. Fick, Entertainment; R. J. Cobban, Golf; A. K. Morehouse, Hotel; E. F. Pearson, Local Trips; Berkeley Snow, Publicity; A. S. Moody, Finance; C. P. Osborne, Transportation; J. E. Yates, Reception; A. H. Kreul, Registration; Mrs. A. S. Moody, Ladies' Entertainment.

New York Section to Hold Three October Meetings

The New York Section will open the administrative year for 1930-31 with a series of three meetings during October: A Power Group meeting will be held on October 8th, the Communication Group will get together on October 14th, and a general Section meeting will be held on October 24th. A detailed statement follows.

Power Group—October 8, 1930

The first meeting of the Power Group for 1930-31 will be held at 7:30 p. m. on Wednesday, October 8, 1930 in Room 1, Fifth Floor, Engineering Societies Bldg., 33 West 39th St., New York. The speaker for the evening will be D. K. Blake of the Central Station Engineering Department, General Electric Company. Mr. Blake will give a talk on "A-c. Network Systems." He will cover the history and economics of the present low-voltage a-c. network system and the medium-voltage network of the future. In his conclusion, Mr. Blake will claim that the network principle is ideal for electrical distribution because it permits the ready connection of loads at any point and easy reinforcements by connecting new sources of supply at heavily loaded centers. It is believed that the application of the network principle to 4000-volt overhead distribution in residential and industrial areas will greatly simplify system planning and operation.

In accordance with the policy established for Group meetings an open discussion will follow, the meeting adjourning promptly at 9:30 p. m. to permit commuters to catch early trains.

Communication Group—October 14, 1930

The Communication Group will hold its first meeting in the Auditorium of the Bell Telephone Laboratories, 55 Bethune St., New York, N. Y., on the evening of Tuesday, October 14, 1930 at 7:30 p. m.

In order to give those attending the meeting a chance to get together with their friends, arrangements have been made

through the courtesy of the Bell Laboratories for the opening of their cafeteria to A. I. E. E. members and guests. A supper will be served at 75 cents per plate beginning at 6 p. m. A sound picture and musical program will be given in the auditorium from 7 to 7:30 p. m. Promptly at 7:30 p. m. Chairman A. F. Dixon will open the meeting which covers the general subject "Use of Communication Facilities in Aviation." There will be five short talks on various phases of this subject, as follows:

"Application of Communications to Air Transport Operation," by A. K. Bohman, Pan-American Airways, Inc.

The problem confronting air transport operators, with specific references to its international aspects.

"Supplying Weather Information and Navigational Aids to Planes by Radio," by V. J. Clarke, General Electric Company.

The dispatching of reports on weather and emergency landing-field conditions, supplying directional aids in the form of radio range service, and direction finding from the ground.

"Two-Way Telephone Communication with Aircraft," by H. E. Young, Western Electric Company.

The necessity for traffic control of planes by ground forces, and a general description of apparatus and methods for direct conversation with pilots.

"Sources of Power for Aircraft Radio," by F. C. Doughman, Westinghouse E. & M. Co.

A description of generators used as power sources for transmitters and receivers, with a discussion of the design problems involved.

"Landline Handling of Aviation Traffic," by C. M. Brentlinger, Western Union Telegraph Co.

Facilities and methods employed in furnishing weather reports, plane dispatching information, and commercial telegraph service to planes and airports.

General Section Meeting—October 24, 1930

Believing that the first general meeting of the New York Section should be one of particular interest to all engineers, the officers of the Section have arranged as the subject for the evening of Friday, October 24, 1930, "The Electron Tube—A New Tool for the Electrical Engineer." A list of only a small fraction of the amazing number of the present day applications of the vacuum tube throughout industry, in the arts and sciences, far exceeds the compass of this notice. Just a bird's-eye view from what has now become a commonplace application: the broadcasting and reception of entertainment and cultural programs, through train and traffic control, lighting, navigation, measurements, communication, power transmission, and many others, will make it evident that the introduction of the vacuum tube presents almost inconceivable potentialities in the electrical future. To quote a prediction—"There will be nothing that the average man sees, hears or buys, but what will be controlled, regulated or affected in some important respect by an electronic tube."

This amazing picture—the result of fundamental research and development work with which every engineer should be thoroughly familiar—will be presented in outline by the first speaker of the evening, O. H. Caldwell, editor of *Electronics* and former Federal Radio Commissioner. The exact details of the rest of the program, it is not possible to give at the present time, but other speakers from the staffs of the large manufacturers of tubes will follow Mr. Caldwell, detailing some of the more interesting and most recent developments. There will also be an extensive exhibit of apparatus arranged in conjunction with the meeting with spectacular demonstrations.

The meeting will start at 8:00 p. m. sharp in the Engineering Auditorium, 33 West 39th Street, New York, N. Y.

Nomination of Officers of the A. I. E. E.

The actions specified in the Institute's Constitution and By-laws relative to the organization of a National Nominating Committee are being taken, and the meeting of the National Nominating Committee for the nomination of officers to be voted upon at the election in the Spring of 1931 will be held between November 15 and December 15. All suggestions for the consideration of the National Nominating Committee must be received by the Secretary of the Committee at Institute Headquarters, New York, not later than November 15.

The sections of the Constitution and By-laws governing these matters are quoted below:

CONSTITUTION

28. There shall be constituted each year a National Nominating Committee consisting of one representative of each geographical district, elected by its Executive Committee, and other members chosen by and from the Board of Directors not exceeding in number the number of geographical districts; all to be selected when and as provided in the By-laws; The National Secretary of the INSTITUTE shall be the Secretary of the National Nominating Committee, without voting power.

29. The executive committee of each geographical district shall act as a nominating committee of the candidate for election as vice-president of that district, or for filling a vacancy in such office for an unexpired term, whenever a vacancy occurs.

30. The National Nominating Committee shall receive such suggestions and proposals as any member or group of members may desire to offer, such suggestions being sent to the secretary of the committee.

The National Nominating Committee shall name on or before December 15 of each year, one or more candidates for president, national treasurer and the proper number of directors and shall include in its ticket such candidates for vice-presidents as have been named by the nominating committees of the respective geographical districts, if received by the National Nominating Committee when and as provided in the By-laws; otherwise the National Nominating Committee shall nominate one or more candidates for vice-president(s) from the district(s) concerned.

BY-LAWS

SEC. 22. During September of each year, the Secretary of the National Nominating Committee shall notify the chairman of the Executive Committee of each geographical district that by November 1st of that year the executive committee of each district must select a member of that district to serve as a member of the National Nominating Committee and shall, by November 1st, notify the Secretary of the National Nominating Committee of the name of the member selected.

During September of each year, the Secretary of the National Nominating Committee shall notify the Chairman of the Executive Committee of each geographical district in which there is or will be during the year a vacancy in the office of vice-president, that by November 15th of that year a nomination for a vice-president from that district, made by the district executive committee, must be in the hands of the Secretary of the National Nominating Committee.

Between October 1st and November 15th of each year, the Board of Directors shall choose five of its members to serve on the National Nominating Committee and shall notify the secretary of that committee of the names so selected, and shall also notify the five members selected.

The Secretary of the National Nominating Committee shall give the fifteen members so selected not less than ten days' notice of the first meeting of the committee, which shall be held not later than December 15th. At this meeting, the committee

shall elect a chairman and shall proceed to make up a ticket of nominees for the offices to be filled at the next election. All suggestions to be considered by the National Nominating Committee must be received by the secretary of the committee by November 15th. The nominations as made by the National Nominating Committee shall be published in the January issue of the A. I. E. E. JOURNAL, or otherwise mailed to the INSTITUTE membership during the month of January.

October 1, 1930

F. L. HUTCHINSON,
National Secretary

New Laboratory to be Dedicated at Lehigh, October 15-17, Inclusive

At Lehigh University there will be dedicated by exercises to be held October 15-17, inclusive, the new James Ward Packard Laboratory of Electrical and Mechanical Engineering, probably one of the finest buildings of its kind in existence and a memorial to James Ward Packard, an alumnus of the University.

The morning of the first day will be given over to registrations; the dedicatory exercises will take place in the afternoon in the auditorium of the Laboratory, Doctor Charles Russ Richards, President of the University, delivering the introductory address. The keys of the building will then be presented formally to Doctor Eugene Gifford Grace, President of the Board of Trustees, by the architect, Theodore Cuyler Visscher. The dedicatory address, to be delivered by Charles M. Schwab, will follow, with the reading of greetings from sister institutions and an inspection of the building itself completing the program. In the evening, a demonstration lecture by S. M. Kintner, Assistant Vice-President in Charge of Research at the Westinghouse Electric & Manufacturing Company will be given in the new auditorium.

Among those to speak at the Tuesday morning session on the subject "What Industry Expects of the Technical Schools," will be F. A. Merrick, President of the Westinghouse Electric & Manufacturing Company; William Butterworth, President of the United States Chamber of Commerce; L. W. Baldwin, President of the Missouri Pacific Railway; A. R. Glancy, President of the Oakland Motor Car Company; M. S. Sloan, President of the Brooklyn Edison Company and Baneroff Gherardi, Vice-President and Chief Engineer of the American Telephone and Telegraph Company; and also President of the Institute 1927-1928.

"What the Technical Schools Expect of Industry" will be the keynote of addresses by Dexter S. Kimball, Dean of the College of Engineering, Cornell University, Dugald C. Jackson, Head of the Department of Electrical Engineering, Massachusetts Institute of Technology (another Past-President of the Institute); David Ross, President of the Ross Gear Company and member of the Board of Trustees of Purdue University, and W. W. Wickenden, President of the Case School of Applied Science.

In the evening, a formal dinner will be tendered at the Hotel Bethlehem to the representatives of institutions and associations.

Starting at 9:00 a. m. on Friday a conference on the future of American industry will be held in the auditorium of the new Laboratory, Magnus W. Alexander, President of the National Industrial Conference Board, opening the session with an address on "The Future of Industry, Its Problems and Needs," will be followed by Edward A. Filene, President, and Chairman of the Board, of William Filene's Sons' Co., Boston, Massachusetts, who will offer a discourse on the subject of "Distribution and its Effect on Industry." Doctor John Johnson, Director of Research of the United States Steel Corporation, will be the third speaker, on "The Effects of Research on the Future of Industry," S. L. Andrew, Chief Statistician of the American Telephone and Telegraph Company, closing the session with a discussion of "The Methods of Industrial and Business Broadcasting."

New Graduate Courses at the Polytechnic Institute of Brooklyn

Dean Erich Hausmann, in charge of Graduate Study at the *Polytechnic Institute of Brooklyn*, has announced the appointment of Doctor Vladimir Karapetoff, Professor of Electrical Engineering, Cornell University as Visiting Professor at the Institute. Doctor Karapetoff will conduct a seminar in "Contemporary Advances in Electrical Engineering", including a review of the theory, construction and application of various groups of electrical machinery, the modern trend of development and the principal problems in the design, manufacture and operation of major types of electrical apparatus, as well as the analysis of recent literature on controversial points in electrical engineering and the prediction of probable paths of future development. He will also give a course in "Electric Waves", a study of the physical characteristics of waves traveling along parallel conductors, and the transmission and reflection of energy at junctions and line terminals. This course includes a study of the propagation, reflection and refraction of waves in free spaces, variation of the electromagnetic energy and the characteristics of transmission media.

Mr. T. K. Kvale of the New York and Queens Electric Power and Light Co. will conduct a course in "Power Distribution Theory" studying the application of symmetrical coordinates in polyphase theory, the theory of faults on power systems, protective devices, phase converters and operating characteristics of interlinked systems.

"Advanced Circuit Theory and Electromagnetic Theory", given last year by Doctor Bernard Hague, visiting professor from the University of Glasgow, will be given this year by Doctor Ernst Weber, visiting professor from the Technical Institute of Charlottenberg, Germany, an eminent engineer-scientist.

Ninth National Power Show

Pursuant to notice which appeared on page 802 of the September issue of the Institute's *JOURNAL*,—a notable feature of this year's Power Show seems to be a determination to exhibit heavier and larger units than ever before,—in many cases in actual operation. In fact, one nationally known manufacturer has arranged to display one of the largest units to go into the operation of a power plant (with reference to fueling equipment) and exhibit it under practical, operating conditions.

The exposition is under the management of the International Exposition Company, Grand Central Palace, New York, of which Mr. Charles F. Roth is Manager. Annual Meetings of The American Society of Mechanical Engineers and the American Society of Refrigerating Engineers will parallel the Power Show dates, December 1-6 inclusive, and for these meetings, the programs are now being arranged.

NATIONAL RESEARCH COUNCIL

COMMITTEE ON ELECTRICAL INSULATION

The regular annual two-day meeting and conference of the Committee on Electrical Insulation of the Council's Division of Engineering and Industrial Research will be held November 7-8, 1930 at the Bureau of Standards, Washington, D. C. The meeting will include three technical sessions at which 18 informal papers reporting current progress in dielectric and insulation research will be presented. On Friday evening, the 7th, there will be a subscription dinner followed by an illustrated lecture by a prominent physicist, on recent advances in dielectric theory. A statement of the complete program will be published shortly. Doctor J. B. Whitehead is Chairman of the Committee.

INDUSTRIAL RESEARCH LABORATORIES

The Research Information Service of the National Research Council is preparing a revision of its "Industrial Research Laboratories of the United States, including Consulting Research Laboratories," the third edition of which was published in 1927.

This Bulletin is the only list of Research Laboratories known to the compilers and is undoubtedly used by many people, not only as a source of information concerning such laboratories but also as a mailing list for important announcements concerning new apparatus and processes, and for compilations of interest to research workers in industrial fields.

In securing additional names of firms to which questionnaires should be mailed for the revision, the membership lists of all of the National Societies interested in chemistry, physics and engineering were searched for names of men who listed themselves as research or development chemists, physicists or engineers; the personnel notes of the important technical journals were read for similar information; and, finally, the names of laboratories publishing research papers were secured from the pages of these same journals. In this way were secured the names of 1250 firms, all of which are believed to maintain research or development laboratories.

In spite of this rather extensive search, however, it is felt that many firms maintaining research laboratories have been overlooked. Since the value of such a compilation is in direct proportion to its completeness, it is hoped that every one interested will cooperate in this undertaking.

If, therefore, your firm is not one of the 2250 to which a questionnaire has been sent (1000 in the third edition and the 1250 additional names secured as above), will you not please write immediately to the RESEARCH INFORMATION SERVICE, NATIONAL RESEARCH COUNCIL, Washington, D. C., requesting that a questionnaire be mailed to your firm, in order that proper information may be secured regarding the research personnel and work carried on in your laboratory. This listing involves no financial obligation on the part of any firm and may be of considerable value at some time in the future.

International Electrotechnical Commission

The Seventh Plenary Meeting of the International Electrotechnical Commission took place from June 27th to July 9th, 1930. The opening plenary meeting was held in Copenhagen, the meetings of the Advisory (working) Committees were held in Stockholm, and the final plenary meeting to approve the work done was held in Oslo.

The Scandinavian Governments and the Scandinavian National Committees contributed greatly toward making the meeting most successful, both from the standpoint of organization and technical results accomplished.

Professor Enström of Sweden was elected President in Succession to Professor Feldman, the Retiring President. It was decided to hold the next plenary meeting in Czechoslovakia in 1934.

About 300 delegates representing twenty-two countries took part in the meetings. Thirty-two delegates represented the United States National Committee. A chief delegate was designated for each committee who acted as spokesman and voted for the U. S. A. Meetings on the various subjects which were held in parallel. The following subjects were dealt with:

Nomenclature.

There is under preparation a comprehensive vocabulary of technical definitions in French and English. Parts dealing with fundamental and general definitions, also telegraphy, telephony, and signaling are practically completed. The former group contains, among others, definitions of fundamental importance such as relate to the Constitution and Properties of Matter, Electricity and Magnetism, Electrochemistry, and Units and Systems of Measurement.

A particularly important action was the official adoption by the I. E. C. of the following names for the magnetic C. G. S. units: magnetic flux, maxwell; flux density, gauss; magnetic field intensity, oersted; magnetomotive force, gilbert.

Rating of Electrical Machinery.

Agreement was reached, subject to ratification by the various National Committees, to a revised standard specification for rating. This will contain new material relating to tolerances and revised values of temperature rise.

Symbols.

Symbols for Radio Communication and a revision of Publication 35 dealing with heavy-current systems, were approved. Graphical symbols for telephones and telegraph, electric traction and other automatic devices were studied with a view to adoption at a later date.

Steam Turbines.

A document was completed and approved. It will be published in two parts comprising:

Part I—Specifications for Condensing Steam Turbines.

Part II—Rules for Acceptance Tests of Condensing Steam Turbines.

Lamp Caps and Sockets.

Agreement was reached concerning most of the essential dimensions of the bayonet cap and the medium flashlight and Goliath Edison screw caps. Certain outstanding questions which will probably be settled in the near future will, in case an agreement is reached, be submitted for approval to the International Commission on Illumination at its meeting in England in 1931. If such approval is received, these additional standards will be printed by the I. E. C. and finally considered at the next Plenary Meeting in 1934. This arrangement is proposed for the purpose of obviating a delay of three years.

Aluminum.

The adoption of international standard for hard drawn aluminum was postponed on account of failure to agree upon a standard value for the resistivity, regarding which American and European practices are different.

Investigations are being made preparatory to the establishment of standards for annealed aluminum wire.

Standard Voltages and High-Voltage Insulations.

It was decided not to add 132 kv. to the list of standard voltages published by the I. E. C. in Publication 36 but to adopt provisionally 400 kv.

As regards insulators agreement was reached relative to the duration and methods of applying the test voltage, the position of the insulator during tests, and the angle of incidence, intensity and resistivity of the water spray. Other points remain to be settled.

The meeting asked the National Committees to approve under the six months' rule, taps of plus and minus four per cent for distribution transformers with primary voltages less than 60-kv.

Electric Traction Equipment.

Considerable progress was made towards completing standards for traction motors. The various national committees were asked to submit proposals regarding other apparatus used in traction systems, including mercury arc rectifiers; also data regarding overvoltages of the power supply.

Insulating Oils.

Certain principles for making tests were agreed upon and a subcommittee was appointed to devise a test method in accordance therewith. Comparative tests will then be carried out by the various national committees, mainly with the object of determining the accuracy with which results may be obtained by the various laboratories. Methods of sampling proposed by the United States National Committees were accepted for adoption under the six months' rule.

For international purposes viscosity will be expressed in kinematic centipoises.

Rules and Regulations for Overhead Lines.

Study and comparison of the rules in force in various countries was continued. A proposal relating to the calculation of the mechanical stability of conductors was discussed at length but no final conclusion was reached. Replies from the National Committees relative to principles underlying the program for future work were read and discussed. These views will be collated and distributed to the national committees.

Radio Communication.

Agreement was reached as regards certain dimensions of tubes and bases, and connections and other requirements for bases. Tentative recommendations were made regarding standard directions of switches and other controls. Proposed safety regulations were reviewed concerning which further discussion will take place. The advisability of establishing a committee to study non-radio electrical interference with radio reception was referred to the National Committees. A comparison was made of the letter symbols in use by various countries for amplification, slope and internal resistance with a view to standardization later. The committee considered that the time is ripe to undertake to define the general lines of acceptance specifications for radio valves.

Measuring Instruments.

Specifications for two classes of a-c. watt-hour meters and two classes of current and voltage transformers more especially intended for use with watt-hour meters were adopted.

Rating of Rivers.

Bases for computing and units for expressing waterpower resources for statistical use and for the purpose of making comparisons between different rivers, river basins, regions and countries were adopted.

Shellac.

It was agreed to enlarge the scope of the committee to cover Lac for insulating purposes. Various tests, including tests to determine rosin and ash content were considered. Further proposals for research and methods of tests are solicited from the National Committees.

Terminal Markings.

Agreement on a system of marking is delayed because of three radically different schemes in use in different countries. Enlargement of the scope of the committee to include a definition of the direction of rotation, indications of transformer diagrams and colors for polarity of batteries and for conductors was requested.

Oil Switches and Circuit Breakers.

Definitions or rules for the following items were agreed upon. Operating Duty, Series of Operations, Standard Series of Interrupting Operations, Standard Series of Circuit making tests, Recovery Voltage, Making and Breaking Current (for determining the performance of the circuit breakers), Short Time Current, Power Factor, and Breaking Power and Breaking Capacity.

Internal Combustion Engines.

This being the first meeting on this subject, the attention of the committee was given to reviewing the proposals of the various countries and to reaching agreement as to what subjects would first be given consideration.

Of the subjects under consideration by the I. E. C. five are in charge of the United States National Committee to which is entrusted the duties of the Secretariat as follows: Nomenclature, which by a vote of the Committee of Action includes Letter Symbols for Scientific and Engineering Quantities,

Steam Turbines, Hydraulic Turbines, Internal Combustion Engines and Rating of Rivers.

The Scandinavian meeting was a noteworthy one with respect to the amount of work which reached a stage of final adoption. Incidental to the meetings, opportunities were given for visiting some of the noteworthy power installations and manufacturing plants of Sweden and Norway. A dramatic touch was given by the homage paid to Oersted in Copenhagen. Following a brief address by President Pedersen, President of the Danish National Committee, in the presence of all delegates, a wreath was deposited at the foot of the Oersted Statue. The delegates and ladies were entertained by official banquets offered by the cities of Copenhagen, Stockholm and Oslo, as well as by the National Committees of each country.

New Test Method for Thermal Conductivities Issued by A. S. T. M.

Designed to provide a simple and convenient means for determining the thermal conductivity of electrical insulating materials, as well as for use in testing laboratories which are now specially equipped for heat transfer work, a new Method of Test for Comparing the Thermal Conductivities of Solid Electrical Insulating Materials has been issued by the American Society for Testing Materials. The method is the thermal analogy of the potentiometer method of comparing electrical resistances. A specimen of unknown conductivity is placed in series with a standard specimen of known conductivity between plates which are maintained at different temperatures. The respective temperature differences across the standard and the test specimens when a steady state of heat flow is attained are inversely proportional to their relative conductivities. The conductivity of the standard specimens must, of course, be measured by an absolute method. Sets of thermal conductivity standards covering the usual range of electrical insulating materials may be prepared by incorporating suitable proportions of graphite in rubber. Such sets may be calibrated in laboratories equipped to make absolute measurements of thermal conductivity.

This tentative A. S. T. M. method is designed for an accuracy of ± 5 per cent which is sufficient for all present practical purposes. However, the method is inherently capable of as great an accuracy as the calibration of the standard specimens will warrant.

Luncheon in Honor of Baron Shiba

Baron Chuzaburo Shiba, Member of the House of Peers, Director of the Aeronautical Research Institute of Japan, Tokyo Imperial University, and Vice-President of the World Engineering Congress, was guest of honor at a luncheon held at The Engineers' Club, New York, on September 23, 1930, and attended by eighty-five officers, past officers, and members of the national societies of Civil, Mining, Mechanical, and Electrical Engineers, and other engineering organizations.

Robert Ridgway, Chairman of the Reception Committee, welcomed Baron Shiba and paid high tribute to his ability and energy, to which the great success of the World Engineering Congress was in large measure due. Francis Lee Stuart, toastmaster, and George Otis Smith and John R. Freeman, both of whom gave brief addresses, all spoke in high terms of the contributions of Baron Shiba to the success of the Congress, which has done much toward bringing engineers in various countries into a common understanding of their problems.

Baron Shiba responded with an expression of deepest gratitude for the reception with which he had met, and the hope that the development of international understanding among those in the same profession, which was one of the principal purposes of the

World Engineering Congress, will continue in order that engineers and scientists of all countries may cooperate more closely for the benefit of all.

A Memorial to George Westinghouse

At the head of the ravine in Schenley Park, Pittsburgh, there will be dedicated October 6 to the memory of George Westinghouse, great inventor and founder of the vast industries which bear his name, a bronze group of heroic proportions, created by Daniel Chester French, America's foremost sculptor, and hailed by sculptors and art critics as the masterpiece of his brilliant career. The main unit rises twenty feet from a Norwegian granite base. It includes a dominating figure of Mr. Westinghouse in the prime of life, and flanking him are two figures—a skilled workman and an engineer typical of the thousands of artisans who have assisted the master in his work. Facing this group on a separate pedestal is a figure of American youth in an inspired attitude as he studies the monument of achievement. This statue has been lauded as the only figure ever created truly interpretative of the typical American boy.

Airport Drainage and Surfacing Committee Program

The program of the Committee on Airport Drainage and Surfacing, representing the American Engineering Council, the American Road Builders Association and the Aeronautics Branch of the Department of Commerce, has developed the most extensive series of cooperative studies that has ever been undertaken by American engineers on a nationwide basis, as announced by Harry H. Blee, Director of Aeronautic Development of the Aeronautics Branch and chairman of the committee.

"Eighty-seven local engineering committees, representing a total of about 450 engineers located throughout the United States, have been organized to work in cooperation, and some thirty additional local committees are in process of organization. Each local committee is composed of outstanding engineers in the community, including a highway engineer, drainage engineer, soil technologist and an engineer identified with the establishment and development of the local airport."

New Member of Journal Staff

In October 1930, Mr. G. Ross Henninger of San Francisco will join the Institute headquarters staff in New York as Associate Editor of the Institute's JOURNAL. This appointment is one step in the development of the recently adopted Institute publication policy announced in the August 1930 issue of the JOURNAL.

Mr. Henninger was born in Ohio in 1898, was graduated from the University of Southern California with the degree of B. S. in E. E. in 1921, and while attending the University, was affiliated with the Southern California Edison Company, Ltd. During 1922-23 he was with the Westinghouse Electric & Manufacturing Company at East Pittsburgh, after which he was again with the Edison Company until December, 1924. From the latter date until the present he has been Engineering Editor of *Electrical West*, published in San Francisco by the McGraw-Hill Company of California.

Mr. Henninger is well known to the Institute membership on the Pacific Coast, having joined the Institute in 1922, and having been an active member of the San Francisco Section. He has served on various Section and convention committees, and a year as Secretary of the San Francisco Section. He leaves the post of Vice-Chairman of that Section to come to New York.

PERSONAL MENTION

W. HERBERT SNIDER has moved from the Chicago office of the Curtis Lighting Company to the New York City office, and is now in charge of house sales there.

R. S. MASSON, Consulting Engineer, announces change of address from the National Bank Building to 430 South Berendo Street, Los Angeles, California.

HOMER O. BLAIR, Consulting Engineer, announces the removal of his office from the Pacific Savings Building, Tacoma, to the Puget Sound Bank Building that city.

GEORGE C. CROM, formerly Research Engineer for the American Transformer Co., Newark N. J., is now with Bludworth, Inc., makers of high-grade sound reproducing apparatus.

J. ANDREW DOUGLAS, upon completion of a year of graduate study at the State University of Iowa, has accepted a position as Instructor in Electrical Engineering at Stevens Institute.

A. L. O'BANION has resigned as Professor of Electrical Engineering at Clemson Agricultural College, S. C., to join the Design Division of Stone & Webster Engineering Corp., Boston, Mass.

R. J. S. PIGOTT resigned as consulting engineer for Stevens & Wood, Inc., (now Allied Engineers) and has become Staff Engineer at the Gulf Research Laboratory, in charge of engineering research.

WEYBURN H. DRESSER, who was formerly Power Engineer for the Universal Wireless Communication Co., on February 1 became Electrical Engineer with Harza Engineering Co., Hydroelectric Consulting Engineers.

C. E. CHATFIELD, formerly Sales Engineer of the W. D. Hamer Company and Chief Engineer Transelectric Company, Indianapolis, Ind., has become associated with the Lapp Insulator Company as Chicago Manager.

J. S. MOULTON, formerly Executive Engineer of the Great Western Power Company, now is in the Pacific Gas and Electric Company's executive offices as Assistant to the Vice-President and Assistant General Manager.

MARSHALL G. HOUGHTON, for the past three and one-half years Electrical Engineer with Allied Engineers, Inc., Jackson, Michigan, has been appointed Supervisor of Electrical Engineering at the Detroit Institute of Technology, in Detroit.

RUDOLPHO ORTENBLAD has recently been named as Chief Engineer for Pirelli S/A—Companhia Nacional de Conductores Electricos, Rio de Janeiro, Brazil. Mr. Ortenblad's previous affiliation has been the International General Electric, in Brazil.

R. C. FRYER, who for the past twelve years has held the position of Superintendent at the Meter, Laboratory and Test Department of the Union Gas & Electric Company has recently become associated with The Thos. J. Corcoran Lamp Co. of Cincinnati, Ohio, in charge of its new Electric Engg. Division.

HENRY L. THOLSTRUP who has been engaged by the Westinghouse Elec. & Mfg. Co., since April 1928, as Radio Engineer on Development of Special Radio Apparatus, on July 15 became associated with the General Motors Radio Corp. as Radio Engineer in charge of the Measurements Department.

JAMES B. MACLEAN, after being for five years with the J. G. White Engineering Corporation as an engineer in their electrical division, has just transferred to the Electrical Department of the Central Railroad Company of New Jersey, Jersey City, N. J., to be Assistant Engineer.

JAMES W. OWENS, an international authority on welding, and formerly Welding Aide for the Bureau of Construction of the U. S. Navy, has resigned as Director of Welding at the Newport News Shipyard to become associated with the Welding Engineer-

ing and Research Corporation, New York, N. Y., as its Secretary and Director of Engineering.

WALTER KRAUSNICK, who was previously Assistant Professor of Electrical Engineering at Texas A. & M. and Associate Professor of Electrical Engineering at the College of Engineering, Newark, N. J., this year received his Ph. D. from the University of Michigan and has now been appointed Professor of Electrical Engineering at the Ohio Northern University, Ada, Ohio.

H. C. LEONARD, formerly of the Virginia Electric & Power Company, Richmond, Va., has been transferred to the El Paso Electric Company as General Superintendent of Light & Power. In this capacity, Mr. Leonard will be directly in charge of the Light & Power Department, including sales of the El Paso Electric Company and the Mesilla Valley Electric Company.

CLAUDE G. MATTHEWS, after 14 years of service with Graybar and its predecessor the Western Electric Company in Texas, first as a territorial salesman, then city salesman in San Antonio, supply and line material sales specialist, and for the past six years District Sales Manager, received effective August 1st, the appointment of Manager of the Graybar Electric Co., Milwaukee house.

O. F. BITZER has resigned from the Acme Wire Company of New Haven, Connecticut, where for the past four years he has been General Superintendent. Entering the employ of this company in 1908, his has been an unusually comprehensive experience in development and manufacture of magnet wire. Before assuming general supervision he had charge in all the manufacturing departments of the plant successively. After a period of travel and recreation Mr. Bitzer expects to make an announcement which he believes will be of interest to industry.

Obituary

Frank Richards Ford, designer of the Philadelphia Rapid Transit and for thirty years a leader in industrial and public utilities engineering, died at the Medical Center, Philadelphia, September 17th. He was a director of numerous large corporations and a member and one of the organizers of Ford, Bacon & Davis, Inc., New York City.

Philadelphia was his birthplace; after attending the public schools, he entered the University of Pennsylvania, from which in 1890, he obtained his Bachelor of Science degree. Realizing something of the importance and magnitude of electricity as applied to industry and the transit situation, Mr. Davis concentrated on public utility and industrial engineering. He served his apprenticeship, and in 1894 became a partner in the company that bears his name. From 1894 to 1906, his work included design, supervision, construction and reconstruction of, electrical equipment of the Orleans Railroad; electrical plant and motor equipment of a new building for the American Lithographic Company; electric motor equipment for printing machinery of Kaufmann & Strauss Co.'s factory (New York City); general supervision of design and construction of the Siegel-Cooper store; equipment of lines of the Bergen County Traction Company of Edgewater, N. J., and others; he also compiled statistical reports for many large and representative organizations such as the Northern Railroad Company of New Jersey, the Electric Illuminating & Power Company of Long Island City, the Annapolis, Washington & Baltimore Railroad Company, and the Chicago City Railway Company. As a member of the firm of Ford, Bacon & Davis, Mr. Ford had general supervision of the firm's engineering work of reconstruction, equipment and extension on the specific operations of the Canal & Claiborne Railroad Company of New Orleans; the Washington Traction & Electric Co., Washington, D. C.; the Metropolitan Street Railway Company, and Consolidated Electric Light & Power Company of Kansas City, as well as that on the Memphis Street Railway Company and the United Railroads of San Francisco. He was a member

of the New Jersey Port & Harbor Development Commission from 1917 to 1921 and from 1921 to 1923, a member of the Port of New York Authority. Among his achievements were his work in bringing about the unification of electric street railways in Chicago and the drafting of plans for the Philadelphia Rapid Transit. He became an Associate of the Institute in 1896 and in 1907 was transferred to the grade of Member.

Theodore Inslee Jones, of the engineering firm of T. I. Jones, Inc., also Vice-President and General Manager of the Radford Company, the Pneum-electric Corporation, and the American Flexible Shaft Manufacturing Company, died suddenly September 12 from heart attack. For sixteen years Mr. Jones had served as General Sales Agent of the Brooklyn Edison Company, and in every undertaking proved his rare ability as an executive and organizer. As a recognized authority on electrical subjects, he was engaged by the Department of Education of the City of New York to give a series of lectures to be delivered during the year 1913. He was born in Ilion, New York, March 3, 1873 and was graduated with the class of 1896 from the Massachusetts Institute of Technology. He engaged with the American Telephone and Telegraph Company in its New York Office, identifying himself with the Inspection and Traffic Departments and originating and equipping, in collaboration with Assistant General Superintendent Brooks, the first school of instruction for employes engaged in telephone traffic, which has since become an important adjunct of all telephone companies' work. After four years' experience with the American company, he took up similar duties with the New York and New Jersey Telephone Company, in its New Jersey Division. Leaving the telephone field, the early part of 1907 he became Illuminating Engineer for the Nernst Lamp Company of New York, and while still there, he received his call to organize the sales department of the United Electric Light & Power Company of New York, of which he was the first Sales Manager. He was elected to Associate membership in the Institute in 1904 and transferred to the grade of Member in 1913. He was also a member of the Illuminating Engineering Society and other engineering bodies before which he has delivered numerous papers.

Elwood Wesley Beck, of Reading, Pennsylvania, an Associate of the Institute since 1923, died at his home on September 5th. He was born in Reading July 6, 1891 and his general and technical education was obtained from International Correspondence School courses on Electric Lighting, and Railways, and Electrical Construction and Installation, Carnegie Institute of Technology. He was a veteran of the World War, in which he was completely disabled, the extent of his recovery being restricted to ability to sit up in a wheel chair. For a week or so prior to his death he was confined to his bed.

Fenton L. Osgerby, an electrical engineer with The Detroit Edison Co., was killed in a glider accident at Marysville, Michigan, on August 17, 1930.

He was born at Fenton, Michigan, February 12, 1898. His was a varied career; after his course at the University of Michigan was interrupted by an enlistment in the Navy, he continued his studies in 1920 at Cornell. During the 1921 and 1922 summer periods, he worked with The Detroit Edison Co. and the Westinghouse Electric and Manufacturing Company. He then left college to spend a year with the Deep Springs Trust Company (California), but in 1925 returned to Cornell to receive his M. E. degree. While at College, he was elected a member of the honorary society $\phi \kappa \phi$. After graduation, he associated in turn with the Lincoln Electric Company of Canada, the Ohio Power Company at Canton, and The Detroit Edison Company. In his last position, he was active in calculations and field work on lightning, and also in overhead line calculations. During the past year, he became interested in gliding. He studied with Professor Franklin of the University of Michigan, readily learned to glide, made over 200 trips, and was giving a demonstration at the Marysville airport when he was killed.

Mr. Osgerby was a member of the National Glider Association,

the A.B.C. Glider Club of Detroit, the Intercollegiate Club of Detroit, and an Associate of the Institute.

William F. Willman, Assistant Purchasing Agent for the Edison Electric Illuminating Co. of Boston and member of the Institute (1921), died at Boston August 24, 1930. He had been in the employ of the company for 25 years, in standardizing and testing work, Station Engineering Department, and still later in the Electrical Division of this Department. He came to the Purchasing Department about six years ago as Assistant Superintendent, his appointment to his last position taking place last year. Under his supervision many of the extensions to the main generating station of the Boston Edison Co., as well as many of its substations, were satisfactorily designed and executed.

Charles Donaldson Knight, Manager of the General Electric's Bloomfield Plant, died September 4th at his home in East Orange. While in Bad-Nauheim, Germany several months ago, he suffered a serious attack of the heart, and a second one recently upon his return to East Orange.

Mr. Knight was born in Philadelphia in 1870 on the 25th of December. He attended the public schools there, but received his technical education in Paris. He was also a student in London under Hiram S. Maxim. For three years he was at the Watervliet Arsenal, New York, and for the next four years, in the Engineering Department of the General Electric Company. He subsequently spent two and a half years with the National Electric Company and six months with the Cutler Hammer Company in Milwaukee in its Engineering Department. His connection with the General Electric Company at Bloomfield was formed thirty-five years ago.

Mr. Knight was a Director of the Young Men's Christian Association of the Oranges; also of the Bloomfield Bank and Trust Company and of the Watsessing Bank. He has resided in East Orange for eleven years and during that time has proved his worth in an active citizenship. He joined the Institute in 1905 as an Associate but in 1913 advanced to the grade of Fellow.

Addresses Wanted

A list of members whose mail has been returned by the postal authorities is given below, together with the addresses as they now appear on the Institute records. Any member knowing the present address of any of these members is requested to communicate with the Secretary at 33 West 39th St., New York.

All members are urged to notify Institute Headquarters promptly of any changes in mailing or business address, thus relieving the member of needless annoyance and assuring the prompt delivery of Institute mail through the accuracy of our mailing records, and the elimination of unnecessary expense for postage and clerical work:

Birdsall, W. T., 6 Vincent Place, Montclair, N. J.
 Blackwedel, Geo. H., 1 Rose St., Cedarhurst, L. I.
 Cole, C. M., 1814 Grove St., Berkeley, Calif.
 Ellenwood, Warren E., 1100 E. 177th St., New York, N. Y.
 Gailun, Ben, P. O. Box 257, Angola, Ind.
 Ghous, Shah G., P. O. Box 733, Schenectady, N. Y.
 Goldschmidt, A. L., 416 Washington Bldg., Tacoma, Wash.
 Gorrissen, Chas., Hermannstrasse 38, Hamburg, Germany
 Grybek, John, 1575 Alice St., Oakland, Calif.
 Holroyd, H. B., Dept. of Mech. Eng., Calif. Inst. of Tech., Pasadena, Calif.
 Jones, D. Brainerd, 4306 45th St., Sunnyside, L. I.
 Keegan, W. G., 767 Maple Ave., Los Angeles, Calif.
 King, R. P., 43 W. 71st St., New York, N. Y.
 Lakos, Alexander, 3347 Cross Island Blvd., Bayside, L. I.
 McDougall, D. J., 1501 W. Pierce St., Phoenix, Ariz.
 McLaughlin, R. A., 203 Oley St., Reading, Pa.
 Pearson, Ernest, c/o Brewster, Marley Rd., Hartsdale, N. Y.
 Schnake, H. C., 7 E. 42nd St., New York, N. Y.
 Syed, Mustafa, 93-30 86 Road, Woodhaven, L. I.
 Trainer, Geo. T., Electrical Research Prod. Inc., Grand Rapids Nat'l. Bank Bldg., Grand Rapids, Mich.

PERSONAL MENTION

W. HERBERT SNIDER has moved from the Chicago office of the Curtis Lighting Company to the New York City office, and is now in charge of house sales there.

R. S. MASSON, Consulting Engineer, announces change of address from the National Bank Building to 430 South Berendo Street, Los Angeles, California.

HOMER O. BLAIR, Consulting Engineer, announces the removal of his office from the Pacific Savings Building, Tacoma, to the Puget Sound Bank Building that city.

GEORGE C. CROM, formerly Research Engineer for the American Transformer Co., Newark N. J., is now with Bludworth, Inc., makers of high-grade sound reproducing apparatus.

J. ANDREW DOUGLAS, upon completion of a year of graduate study at the State University of Iowa, has accepted a position as Instructor in Electrical Engineering at Stevens Institute.

A. L. O'BANION has resigned as Professor of Electrical Engineering at Clemson Agricultural College, S. C., to join the Design Division of Stone & Webster Engineering Corp., Boston, Mass.

R. J. S. PIGOTT resigned as consulting engineer for Stevens & Wood, Inc., (now Allied Engineers) and has become Staff Engineer at the Gulf Research Laboratory, in charge of engineering research.

WEYBURN H. DRESSER, who was formerly Power Engineer for the Universal Wireless Communication Co., on February 1 became Electrical Engineer with Harza Engineering Co., Hydroelectric Consulting Engineers.

C. E. CHATFIELD, formerly Sales Engineer of the W. D. Hamer Company and Chief Engineer Transelectric Company, Indianapolis, Ind., has become associated with the Lapp Insulator Company as Chicago Manager.

J. S. MOULTON, formerly Executive Engineer of the Great Western Power Company, now is in the Pacific Gas and Electric Company's executive offices as Assistant to the Vice-President and Assistant General Manager.

MARSHALL G. HOUGHTON, for the past three and one-half years Electrical Engineer with Allied Engineers, Inc., Jackson, Michigan, has been appointed Supervisor of Electrical Engineering at the Detroit Institute of Technology, in Detroit.

RUDOLPHO ORTENBLAD has recently been named as Chief Engineer for Pirelli S/A—Companhia Nacional de Conductores Electricos, Rio de Janeiro, Brazil. Mr. Ortenblad's previous affiliation has been the International General Electric, in Brazil.

R. C. FRYER, who for the past twelve years has held the position of Superintendent at the Meter, Laboratory and Test Department of the Union Gas & Electric Company has recently become associated with The Thos. J. Corcoran Lamp Co. of Cincinnati, Ohio, in charge of its new Electric Engg. Division.

HENRY L. THOLSTRUP who has been engaged by the Westinghouse Elec. & Mfg. Co., since April 1928, as Radio Engineer on Development of Special Radio Apparatus, on July 15 became associated with the General Motors Radio Corp. as Radio Engineer in charge of the Measurements Department.

JAMES B. MACLEAN, after being for five years with the J. G. White Engineering Corporation as an engineer in their electrical division, has just transferred to the Electrical Department of the Central Railroad Company of New Jersey, Jersey City, N. J., to be Assistant Engineer.

JAMES W. OWENS, an international authority on welding, and formerly Welding Aide for the Bureau of Construction of the U. S. Navy, has resigned as Director of Welding at the Newport News Shipyard to become associated with the Welding Engineer-

ing and Research Corporation, New York, N. Y., as its Secretary and Director of Engineering.

WALTER KRAUSNICK, who was previously Assistant Professor of Electrical Engineering at Texas A. & M. and Associate Professor of Electrical Engineering at the College of Engineering, Newark, N. J., this year received his Ph. D. from the University of Michigan and has now been appointed Professor of Electrical Engineering at the Ohio Northern University, Ada, Ohio.

H. C. LEONARD, formerly of the Virginia Electric & Power Company, Richmond, Va., has been transferred to the El Paso Electric Company as General Superintendent of Light & Power. In this capacity, Mr. Leonard will be directly in charge of the Light & Power Department, including sales of the El Paso Electric Company and the Mesilla Valley Electric Company.

CLAUDE G. MATTHEWS, after 14 years of service with Graybar and its predecessor the Western Electric Company in Texas, first as a territorial salesman, then city salesman in San Antonio, supply and line material sales specialist, and for the past six years District Sales Manager, received effective August 1st, the appointment of Manager of the Graybar Electric Co., Milwaukee house.

O. F. BITZER has resigned from the Acme Wire Company of New Haven, Connecticut, where for the past four years he has been General Superintendent. Entering the employ of this company in 1908, he has been an unusually comprehensive experience in development and manufacture of magnet wire. Before assuming general supervision he had charge in all the manufacturing departments of the plant successively. After a period of travel and recreation Mr. Bitzer expects to make an announcement which he believes will be of interest to industry.

Obituary

Frank Richards Ford, designer of the Philadelphia Rapid Transit and for thirty years a leader in industrial and public utilities engineering, died at the Medical Center, Philadelphia, September 17th. He was a director of numerous large corporations and a member and one of the organizers of Ford, Bacon & Davis, Inc., New York City.

Philadelphia was his birthplace; after attending the public schools, he entered the University of Pennsylvania, from which in 1890, he obtained his Bachelor of Science degree. Realizing something of the importance and magnitude of electricity as applied to industry and the transit situation, Mr. Davis concentrated on public utility and industrial engineering. He served his apprenticeship, and in 1894 became a partner in the company that bears his name. From 1894 to 1906, his work included design, supervision, construction and reconstruction of, electrical equipment of the Orleans Railroad; electrical plant and motor equipment of a new building for the American Lithographic Company; electric motor equipment for printing machinery of Kaufmann & Strauss Co.'s factory (New York City); general supervision of design and construction of the Siegel-Cooper store; equipment of lines of the Bergen County Traction Company of Edgewater, N. J., and others; he also compiled statistical reports for many large and representative organizations such as the Northern Railroad Company of New Jersey, the Electric Illuminating & Power Company of Long Island City, the Annapolis, Washington & Baltimore Railroad Company, and the Chicago City Railway Company. As a member of the firm of Ford, Bacon & Davis, Mr. Ford had general supervision of the firm's engineering work of reconstruction, equipment and extension on the specific operations of the Canal & Claiborne Railroad Company of New Orleans; the Washington Traction & Electric Co., Washington, D. C.; the Metropolitan Street Railway Company, and Consolidated Electric Light & Power Company of Kansas City, as well as that on the Memphis Street Railway Company and the United Railroads of San Francisco. He was a member

of the New Jersey Port & Harbor Development Commission from 1917 to 1921 and from 1921 to 1923, a member of the Port of New York Authority. Among his achievements were his work in bringing about the unification of electric street railways in Chicago and the drafting of plans for the Philadelphia Rapid Transit. He became an Associate of the Institute in 1896 and in 1907 was transferred to the grade of Member.

Theodore Inslee Jones, of the engineering firm of T. I. Jones, Inc., also Vice-President and General Manager of the Radford Company, the Pneum-electric Corporation, and the American Flexible Shaft Manufacturing Company, died suddenly September 12 from heart attack. For sixteen years Mr. Jones had served as General Sales Agent of the Brooklyn Edison Company, and in every undertaking proved his rare ability as an executive and organizer. As a recognized authority on electrical subjects, he was engaged by the Department of Education of the City of New York to give a series of lectures to be delivered during the year 1913. He was born in Iliou, New York, March 3, 1873 and was graduated with the class of 1896 from the Massachusetts Institute of Technology. He engaged with the American Telephone and Telegraph Company in its New York Office, identifying himself with the Inspection and Traffic Departments and originating and equipping, in collaboration with Assistant General Superintendent Brooks, the first school of instruction for employes engaged in telephone traffic, which has since become an important adjunct of all telephone companies' work. After four years' experience with the American company, he took up similar duties with the New York and New Jersey Telephone Company, in its New Jersey Division. Leaving the telephone field, the early part of 1907 he became Illuminating Engineer for the Nernst Lamp Company of New York, and while still there, he received his call to organize the sales department of the United Electric Light & Power Company of New York, of which he was the first Sales Manager. He was elected to Associate membership in the Institute in 1904 and transferred to the grade of Member in 1913. He was also a member of the Illuminating Engineering Society and other engineering bodies before which he has delivered numerous papers.

Elwood Wesley Beck, of Reading, Pennsylvania, an Associate of the Institute since 1923, died at his home on September 5th. He was born in Reading July 6, 1891 and his general and technical education was obtained from International Correspondence School courses on Electric Lighting, and Railways, and Electrical Construction and Installation, Carnegie Institute of Technology. He was a veteran of the World War, in which he was completely disabled, the extent of his recovery being restricted to ability to sit up in a wheel chair. For a week or so prior to his death he was confined to his bed.

Fenton L. Osgerby, an electrical engineer with The Detroit Edison Co., was killed in a glider accident at Marysville, Michigan, on August 17, 1930.

He was born at Fenton, Michigan, February 12, 1898. His was a varied career; after his course at the University of Michigan was interrupted by an enlistment in the Navy, he continued his studies in 1920 at Cornell. During the 1921 and 1922 summer periods, he worked with The Detroit Edison Co. and the Westinghouse Electric and Manufacturing Company. He then left college to spend a year with the Deep Springs Trust Company (California), but in 1925 returned to Cornell to receive his M. E. degree. While at College, he was elected a member of the honorary society $\phi \kappa \phi$. After graduation, he associated in turn with the Lincoln Electric Company of Canada, the Ohio Power Company at Canton, and The Detroit Edison Company. In his last position, he was active in calculations and field work on lightning, and also in overhead line calculations. During the past year, he became interested in gliding. He studied with Professor Franklin of the University of Michigan, readily learned to glide, made over 200 trips, and was giving a demonstration at the Marysville airport when he was killed.

Mr. Osgerby was a member of the National Glider Association,

the A.B.C. Glider Club of Detroit, the Intercollegiate Club of Detroit, and an Associate of the Institute.

William F. Willman, Assistant Purchasing Agent for the Edison Electric Illuminating Co. of Boston and member of the Institute (1921), died at Boston August 24, 1930. He had been in the employ of the company for 25 years, in standardizing and testing work, Station Engineering Department, and still later in the Electrical Division of this Department. He came to the Purchasing Department about six years ago as Assistant Superintendent, his appointment to his last position taking place last year. Under his supervision many of the extensions to the main generating station of the Boston Edison Co., as well as many of its substations, were satisfactorily designed and executed.

Charles Donaldson Knight, Manager of the General Electric's Bloomfield Plant, died September 4th at his home in East Orange. While in Bad-Nauheim, Germany several months ago, he suffered a serious attack of the heart, and a second one recently upon his return to East Orange.

Mr. Knight was born in Philadelphia in 1870 on the 25th of December. He attended the public schools there, but received his technical education in Paris. He was also a student in London under Hiram S. Maxim. For three years he was at the Watervliet Arsenal, New York, and for the next four years, in the Engineering Department of the General Electric Company. He subsequently spent two and a half years with the National Electric Company and six months with the Cutler Hammer Company in Milwaukee in its Engineering Department. His connection with the General Electric Company at Bloomfield was formed thirty-five years ago.

Mr. Knight was a Director of the Young Men's Christian Association of the Oranges; also of the Bloomfield Bank and Trust Company and of the Watsessing Bank. He has resided in East Orange for eleven years and during that time has proved his worth in an active citizenship. He joined the Institute in 1905 as an Associate but in 1913 advanced to the grade of Fellow.

Addresses Wanted

A list of members whose mail has been returned by the postal authorities is given below, together with the addresses as they now appear on the Institute records. Any member knowing the present address of any of these members is requested to communicate with the Secretary at 33 West 39th St., New York.

All members are urged to notify Institute Headquarters promptly of any changes in mailing or business address, thus relieving the member of needless annoyance and assuring the prompt delivery of Institute mail through the accuracy of our mailing records, and the elimination of unnecessary expense for postage and clerical work:

- Birdsall, W. T., 6 Vincent Place, Montclair, N. J.
 Blackwedel, Geo. H., 1 Rose St., Cedarhurst, L. I.
 Cole, C. M., 1814 Grove St., Berkeley, Calif.
 Ellenwood, Warren E., 1100 E. 177th St., New York, N. Y.
 Gailun, Ben, P. O. Box 257, Angola, Ind.
 Ghous, Shah G., P. O. Box 733, Schenectady, N. Y.
 Goldschmidt, A. L., 416 Washington Bldg., Tacoma, Wash.
 Gorrissen, Chas., Hermannstrasse 38, Hamburg, Germany
 Grybek, John, 1575 Alice St., Oakland, Calif.
 Holroyd, H. B., Dept. of Mech. Eng., Calif. Inst. of Tech., Pasadena, Calif.
 Jones, D. Brainerd, 4306 45th St., Sunnyside, L. I.
 Keegan, W. G., 767 Maple Ave., Los Angeles, Calif.
 King, R. P., 43 W. 71st St., New York, N. Y.
 Lakos, Alexander, 3347 Cross Island Blvd., Bayside, L. I.
 McDougall, D. J., 1501 W. Pierce St., Phoenix, Ariz.
 McLaughlin, R. A., 203 Oley St., Reading, Pa.
 Pearson, Ernest, c/o Brewster, Marley Rd., Hartsdale, N. Y.
 Schnake, H. C., 7 E. 42nd St., New York, N. Y.
 Syed, Mustafa, 93-30 86 Road, Woodhaven, L. I.
 Trainer, Geo. T., Electrical Research Prod. Inc., Grand Rapids Nat'l. Bank Bldg., Grand Rapids, Mich.

A. I. E. E. SECTION ACTIVITIES

PAST SECTION MEETINGS

Los Angeles

Coordinating Design, Construction, and Operation, by W. S. Lee, President of the Institute. Following this talk, Mr. Lee answered questions concerning engineering practise and Institute affairs, and also outlined the changes which will be made in the publication of the JOURNAL. The 1929 Initial Paper Prize in the 8th District was presented by Mr. Lee to Miss Mabel Macferran of the Southern California Edison Co., Ltd., for her paper entitled, *Parallel Operation of Transformers Whose Ratios of Transformation are Unequal*. A report of the Pacific Coast Convention held in Portland, Oregon, was given by Dean P. S. Biegler who was the representative of the Section. Dinner preceded the meeting at the Engineers Club. September 10. Attendance 75.

Louisville

Dinner in honor of Professor D. C. Jackson, Jr., prior to his departure from Louisville to assume duties at the University of Kansas. E. D. Wood, representing the Section, presented Professor Jackson with a cigar lighter on which the A. I. E. E. emblem was inscribed. Professor Jackson, after thanking the Section members for the token, related some of his experiences while affiliated with the Section. August 29. Attendance 18.

Annual recreational meeting devoted to sports, followed by a business meeting in the evening. E. D. Wood reported on the plans being made for the District Meeting to be held in November, and Philip Ash, Section Secretary, gave an outline of the Convention held in Toronto last June. September 9. Attendance 40.

Memphis

Electricity as Applied to the Paper and Pulp Industry, by W. F. Bowld, Procter & Gamble Company. Following this talk a motion picture entitled "Paper and Pulp Industries" was presented. August 12. Attendance 33.

Niagara Frontier

Executive Committee meeting. August 25. Attendance 6.

Vancouver

Coordinating Design, Construction, and Operation, by W. S. Lee, President of the Institute. A discussion on Institute affairs preceded the presentation of this paper. In the afternoon, there was an inspection trip to the B. C. Electric Railway Company's generating station under construction at Ruskin. Dinner at the Georgia Hotel. September 1. Attendance 18.

A. I. E. E. STUDENT ACTIVITIES

STUDENT SESSIONS AT PACIFIC COAST CONVENTION

TECHNICAL PAPERS

The Thursday morning and Friday afternoon sessions of the Pacific Coast Convention, held at the Multnomah Hotel, Portland, Oregon, September 2-5, 1930, were devoted to the presentation and discussion of ten technical papers written by engineering students in the Pacific and North West Districts.

At the Thursday morning session, Victor Siegfried, Chairman of the Stanford University Branch, presided, and the papers named below were presented:

- A *Visual Lichtenberg Figure Voltmeter*, Lowell Hollingsworth, Oregon State College. (Presented by H. D. Moreland.)
- A *New Synchronous Switch and Transient Visualizer*, Leon Oldberg, University of Washington. (Presented by Karl Ellerbeck.)
- The Development of an Oscillation Transformer or Tesla Coil*, L. E. Steele and H. R. Garrison, University of Washington. (Presented by Karl Ellerbeck.)
- A *Study of Transients on Disconnecting Short Circuited Induction Motors and Air Core Inductances at Low Power Factors*, C. L. Black and E. C. McCarter, University of Southern California. (Presented by R. C. Lewis.)

Measurement of Heat Flow from Underground Electric Power Cables, W. Warren, T. Selna, and G. Vokota, University of Santa Clara. (Presented by W. Warren.)

Lenard R. Engvall, Chairman of the State College of Washington Branch, presided on Friday afternoon during the presentation of the following technical program:

A *Vacuum Tube Wattmeter*, George W. Barnes, Oregon State College. (Presented by Glen Barnett.)

Application of the 24 Vacuum Tube to Radio Frequency Amplification, Elmer P. Gertsch, University of Utah. (Presented by F. C. Lundberg.)

Characteristics of Transformer Coupled Audio Frequency Amplifiers, Wayne L. Shaw and Owen E. DeLange, University of Utah. (Presented by F. C. Lundberg.)

A *Rapid Method of Measuring Loudspeaker Response*, C. R. Skinner, Stanford University.

Linear Conductors as Radio Directors and Reflectors, Leonard J. Black, University of California.

The papers were well presented, and the authors received many compliments upon the importance of the results secured by their work. The attendance at each session was about 50, many of whom were practising engineers. There was a considerable amount of discussion.

CONFERENCE ON STUDENT ACTIVITIES

In accordance with the plan which has been in effect for several years, a joint Conference on Student Activities of the Pacific and North West Districts was held on Wednesday evening, September 3. All Branches in the two Districts were represented by their chairmen, and nearly all Counselors were present. Professor R. D. Sloan, Chairman, Committee on Student Activities of the North West District, presided. President Lee and Assistant National Secretary Henline were called upon for brief remarks. Chairman Sloan reported upon the discussions at the Summer Convention concerning Institute publications and student affairs.

In a brief address on the subject, *The Graduate Student's Place in the Branch*, Professor T. H. Morgan, Chairman of the Committee on Student Activities of the Pacific District, emphasized strongly the desirability of conducting Branch activities on such a basis that graduate students may be active participants and contribute the benefits of their interest and maturity. He said the recent changes in the provisions regarding enrolment have entirely cleared up the aspects which were unsatisfactory from the standpoint of graduate students, and that the contemplated plan of offering national and District prizes for papers by graduate students is desirable.

During a rather extended discussion of the provisions for Student enrolment and for admission to the Associate grade upon the expiration of Student enrolment, the new plan was considered very satisfactory.

There was a general discussion of each of the three following subjects:

Methods of Maintaining Student Interest in the Branch.

Summer and Permanent Employment in the Student Branch.

The Institute and the High School Student.

In the discussion on employment, President Lee, speaking as an employer and for success in engineering strongly emphasized the necessity of some experience in doing work with the hands, advocating summer experience as very helpful.

A motion was adopted requesting the Chairmen of the two District Committees on Student Activities to ask the Vice-Presidents of the Districts to call meetings of employers and representatives of the schools to discuss the entire subject of employment.

At meetings held separately after the close of the Joint Conference, the Counselors elected chairmen of their respective District Committees on Student Activities as follows: Pacific District (No. 8), Professor S. G. Palmer, University of Nevada; North West District (No. 9), Professor G. L. Hoard, University of Washington.

Engineering Societies Library

The Library is a cooperative activity of the American Institute of Electrical Engineers, the American Society of Civil Engineers, the American Institute of Mining and Metallurgical Engineers and the American Society of Mechanical Engineers. It is administered for these founder societies by the United Engineering Society, as a public reference library of engineering and the allied sciences. It contains 150,000 volumes and pamphlets and receives currently most of the important periodicals in its field. It is housed in the Engineering Societies Building, 29 West Thirty-ninth St., New York.

In order to place the resources of the Library at the disposal of those unable to visit it in person, the Library is prepared to furnish lists of references to engineering subjects, copies or translations of articles, and similar assistance. Charges sufficient to cover the cost of this work are made.

The Library maintains a collection of modern technical books which may be rented by members residing in North America. A rental of five cents a day, plus transportation, is charged.

The Director of the Library will gladly give information concerning charges for the various kinds of service to those interested. In asking for information, letters should be made as definite as possible, so that the investigator may understand clearly what is desired.

The library is open from 9 a. m. to 10 p. m. on all week days except holidays throughout the year except during July and August, when the hours are 9 a. m. to 5 p. m.

BOOK NOTICES, AUGUST 1-31, 1930

Unless otherwise specified, books in this list have been presented by the publishers. The Institute does not assume responsibility for any statement made; these are taken from the preface or the text of the book.

All books listed may be consulted in the Engineering Societies Library.

BEITRAG ZUR FRAGE DER ERMITTLUNG DER MECHANISCHEN VERLUSTE BEI SCHACHTFORDERANLAGEN.

By Albert Vierling. (Forschungsarbeiten, no. 328) Berlin, V. D. I. Verlag, 1930. 35 pp., illus., diags., tables, 12 x 9 in., paper 6-r. m.

Reviews the methods that have been used to determine the mechanical losses in mine hoists and compares their accuracy. Two new methods applicable to hoists driven by three-phase induction motors are then developed and the results obtained with them at German mines are given. The use of the methods is described in detail.

BERECHNUNG UND KONSTRUKTION DER DAMPFERBINEN.

By C. Zietemann. Berlin, Julius Springer, 1930. 452 pp., illus., diags., 9 x 6 in., bound. 33-r. m.

Aims to give a comprehensive, connected exposition of the principles, design and construction of steam turbines, with examples selected from current practise. Chapters are devoted to the thermodynamic principles, turbine design, the design and construction of single parts, governing, turbine types, and turbines for special purposes. The use of methods is illustrated by many solved problems. The book is an excellent introduction to the subject.

GESTEHUNGSKOSTEN UND VERKAUFSPREISE ELEKTRISCHER ARBEIT.

By Fr. Brock. Wien u. Berlin, Julius Springer, 1930. 48 pp., diags., 9 x 6 in., paper, 4.80 r. m.

A discussion of the cost of electrical energy, intended to present the principles that underly rate making in a form easily understood by consumers and producers. The cost of production is first discussed and the influence of various factors shown. Rate making is then explained and various forms of tariffs are described. The influence of the power factor is given special attention.

LEGAL ELEMENTS OF BOUNDARIES AND ADJACENT PROPERTIES.

By Ray Hamilton Skelton. Indianapolis, Bobbs-Merrill Co., 1930. 580 pp., illus., 8 x 6 in., fabrikoid. \$5.00.

The legal principles of surveying, although as important as mathematical precision, are usually less well understood by engineers. The deficiency is met by this book, which discusses the questions of law and fact that may arise, and illustrates, by numerous cases, the principles upon which courts have adjudicated them.

MEASUREMENT OF HYDROGEN ION CONCENTRATION.

By Julius Grant. N. Y., Longmans, Green & Co., 1930. 159 pp., illus., diags., 9 x 6 in., cloth. \$3.75.

The widespread importance of this subject has made a knowledge of it essential to many persons who are unversed in electro-chemistry. This volume is planned to meet their needs. A simple, yet adequate account of the theoretical side of the sub-

ject is given, with detailed descriptions of the methods used both in general and in particular cases. A collection of data and numerous references are included.

OPTICAL ACTIVITY AND HIGH TEMPERATURE MEASUREMENTS.

By F. M. Jaeger. N. Y. McGraw-Hill Book Co., 1930. (George Fisher Baker Non-resident lectureship in chemistry at Cornell University), 450 pp., illus., diags., port., tables, 9 x 6 in., cloth. \$4.00.

Contains three series of lectures delivered at Cornell University during 1928-29 by Professor Jaeger of Groningen University. The first series surveys modern views concerning relations between certain geometrical and physico-chemical properties of atomic systems, as they appear in the molecules of certain substances. The second reviews the methods for measuring high temperatures which have been developed at Groningen University, the results obtained, and the problems awaiting solution. The third series is concerned with the problem of the constitution of ultra-marines.

PERSONENKRAFTWAGEN, KRAFTOMNIBUS UND LASTKRAFTWAGEN IN DEN VEREINIGTEN STAATEN VON AMERIKA.

By Emil Merkert. Berlin, Julius Springer, 1930. 356 pp., illus., 9 x 6 in., cloth. 29,50 r. m.

An examination of automobile passenger and freight transportation in the United States, with particular reference to the economic problems involved and to its effect upon the railroads. The development of motor transport, the economics of motor trucking, the economic limits of railway competition, regulation of motor traffic, motor-bus lines, highway financing, and the social, cultural and economic effects of the automobile are considered.

PHOTOCELLS AND THEIR APPLICATION.

By V. K. Zworykin and E. D. Wilson. N. Y., John Wiley & Sons, 1930. 209 pp., illus., diags., 8 x 5 in., cloth. \$2.50.

This book is intended to give an accurate account of the origin and rise of the photoelectric cell, of its behavior and functions, and of its applications for picture transmission, television, sound projection, etc. The authors have endeavored to be comprehensible to the untrained man, as well as useful to the specialist. The book is a welcome addition to the scanty literature of a subject that is rapidly growing in importance.

PREDPISY; ELEKTROTECHNICKÉHO SVAZU CESKOSLOVENSKEHO, 1930. Also a German translation; VORSCHRIFTEN DES E S C, 1930.

[Prague, Czechoslovak Electrical Assoc.] 1930. 269 pp., 8 x 6 in. bound. \$3.50. German trans. \$4.70.

The Czechoslovak equivalent of the National Electrical Code. Rules are given governing the installation and operation of transmission lines, radio equipment, telephones and telegraphs, and medical apparatus, with approved symbols, units, laws, etc. The rules have been prepared by the Czechoslovak Electrical Association and approved by the government.

SELLING TRANSPORTATION.

Edited by Albert S. Richey. N. Y. American Electric Railway Association, 1930. 214 pp., illus., 9 x 6 in., cloth. \$2.00.

This volume records the outstanding accomplishments of seven electric railway companies, as shown by their records submitted in competition for the Coffin award of 1928 and 1929. The work

describes methods of increasing patronage and revenue, winning public cooperation, lowering costs, increasing reliability and safety, and improving management and labor relations.

STAHLBAU.

Edited by Otto Bondy. (Schweisskonstruktionen, bd. 1) Berlin, V. D. I. Verlag, 1930. 16 pp. text and 100 plates. 12 x 9 in., cloth. 12-r. m.

One hundred photographs illustrating the use of welding in the erection of bridges and buildings. The photographs are taken from various American and European structures and illustrate the wide variety of ways in which welds can be substituted for riveted joints. Brief descriptions accompany the plates, and references are given to fuller published accounts. The book is sponsored by the Welding Division of The Verein Deutscher Ingenieure.

STATIK, bd. 1, Die Grundlagen der statik starrer Körper.

By Ferd. Schleicher. Ber. u. Lpz., Walter de Gruyter & Co., 1930. 143 pp., diags., 6 x 4 in., bound. 1,80 r. m.

A condensed presentation of the principles of statics intended for beginners.

TECHNICAL ARTS AND SCIENCES OF THE ANCIENTS.

By Albert Neuberger. Trans. by Henry L. Brose. N. Y. Macmillan Co., 1930. 518 pp., illus., 10 x 7 in., cloth. \$10.00.

A translation of Neuberger's "Die Technik des Altertums" which has for over a decade been widely read in Germany. The book brings together much information that is widely scattered, and presents it in understandable, interesting fashion. Numerous photographs and drawings illustrate the text. The whole field of mining, metallurgy, agriculture, ceramics, engineering, dyeing, etc., is treated.

Engineering Societies Employment Service

Under joint management of the national societies of Civil, Mining, Mechanical and Electrical Engineers cooperating with the Western Society of Engineers. The service is available only to their membership, and is maintained as a cooperative bureau by contribution from the societies and their individual members who are directly benefited.

Offices:—31 West 39th St., New York, N. Y.—W. V. Brown, Manager.
1216 Engineering Bldg., 205 W. Wacker Drive, Chicago, Ill., A. K. Krauser, Manager.
57 Post St., San Francisco, Calif., N. D. Cook, Manager.

MEN AVAILABLE—Brief announcements will be published without charge but will not be repeated except upon requests received after an interval of one month. Names and records will remain in the active files of the bureau for a period of three months and are renewable upon request. Notices for this Department should be addressed to **EMPLOYMENT SERVICE, 31 West 39th Street, New York City**, and should be received prior to the 15th day of the month.

OPPORTUNITIES.—A Bulletin of engineering positions available is published weekly and is available to members of the Societies concerned at a subscription of \$3 per quarter, or \$10 per annum, payable in advance. Positions not filled promptly as a result of publication in the Bulletin may be announced herein, as formerly.

VOLUNTARY CONTRIBUTIONS.—Members obtaining positions through the medium of this service are invited to cooperate with the Societies in the financing of the work by contributions made within thirty days after placement, on the basis of one and one-half per cent of the first year's salary; temporary positions (of one month or less) three per cent of total salary received. The income contributed by the members, together with the finances appropriated by the four societies named above will it is hoped, be sufficient not only to maintain, but to increase and extend the service.

REPLIES TO ANNOUNCEMENTS.—Replies to announcements published herein or in the Bulletin, should be addressed to the key number indicated in each case, with a two cent stamp attached for reforwarding, and forwarded to the Employment Service as above. Replies received by the bureau after the positions to which they refer have been filled will not be forwarded.

POSITIONS OPEN

DRAFTSMAN, possessing a sound technical education and considerable experience in the design of air circuit breakers. Air circuit breaker experience essential. Salary about \$50 a week. Apply by letter. Location, Pennsylvania. W-1649.

ELECTRICAL ENGINEER, with ten or more years' experience in the design and application of small fractional horsepower motors. Apply by letter, stating full details as to education and experience. Location, Middle West. W-1689-C.

ELECTRICAL ENGINEER, familiar with design of small capacity air circuit breakers. Apply by letter. Location, Middle West. W-261-C.

ASSISTANT TO CHIEF ENGINEER, electrical designer on a-c. motors up to 200-hp. Apply by letter. Salary \$300 a month. Location, New Jersey. W-519.

SALES ENGINEER, with experience in automatic motors starting equipment for industrial plants and machinery manufacturers. Apply only by letter stating age, education, experience and compensation expected. Location, Middle West. W-1714-C.

ELECTRICAL ENGINEER, must be able to speak the Swedish, Danish and Norwegian languages and able to take charge of the department for calculation and construction of starters, controllers, automatic switches and special apparatus for traction purposes (direct current). Apply by letter. Location, Foreign. X-8731.

MEN AVAILABLE

GRADUATE ELECTRICAL ENGINEER, also trained in electrochemistry, desires to improve his position. Has experience acquired in estimating and designing electrical layouts, con-

ducting and upkeeping large light and power plants, and research work carried out in the metallurgical field for a number of years. B-9034.

GRADUATE ELECTRICAL ENGINEER, 26, single, 10 years' experience in motion picture projection, one year radio. Desires connection with concern interested in production end of motion pictures or television. Location immaterial. Future behind position controlling factor. C-7934.

ELECTRICAL, STEAM AND MECHANICAL SUPERVISOR, 33, married, 12 years' experience in industrial and power plants. For the past four years has had charge of all steam and electrical power and maintenance of large industrial plant consuming 4000 kw. electric and 1200 hp. steam. Efficient consumption of power a specialty. B-7004.

ENGINEER, wide sales and executive experience. Electrical training at Worcester Polytechnic Institute. Capable of developing or managing sales. C-5431.

ELECTRICAL ENGINEER, 22, single. Recent graduate from the college of Electrical Engineering University of Dayton, Dayton, Ohio. Seeking position in any electrical line with opportunity for advancement. Available now. C-7456.

RECENT GRADUATE, 23 years, single, 1930 graduate in electrical engineering. Has had 2½ years' experience in radio production work, two years' cooperative training in the manufacture of electric motors and generators. Desires a position in production work along any electrical line. Location preferred, New York or New Jersey. C-7918.

ELECTRICAL ENGINEER, 20, single. Graduate Pratt Institute 1930. Has worked in boiler shop. Desires job along electrical construc-

tion lines. Languages; Lithuanian. Location, immaterial, interested in foreign countries. Best of references, and available soon. C-7938.

ELECTRICAL ENGINEERING GRADUATE, age 26, single. Five years' practical experience in service of electrical machinery, a-c. and d-c. Will consider any position in E. E. where advancement is possible. Available on a week's notice. C-7822.

ELECTRICAL CONDENSER ENGINEER, with thorough knowledge of, and extensive experience in, the design and application of impregnated paper, mica, and air dielectric condensers. Has proven ability by producing highest grade products at extremely low costs. Will present convincing details on receipt of correspondence. C-7970.

COLLEGE GRADUATE, B. S. Degree, Wesleyan University 1924, in electricity, physics, mathematics. One year electrical test, meters. Six years' electrician, power and light, manager, estimating. Desires position as junior engineer in laboratory. Would consider position as chief electrician in manufacturing plant. Location, East. Available immediately. C-4294.

RECENT GRADUATE, electrical engineer; married, age 24. Location preferred, Northern United States. Available December 1st. C-7975.

ELECTRICAL DESIGNER, 36, married, 15 years' experience on design of generating stations, substations and industrial plants. Technical school graduate. C-7979.

ELECTRICAL GRADUATE, B. S. Degree, 30; married; 2 years' public utility experience. Experience covers organization, teaching line-men's school, design of construction equipment, testing construction materials, construction estimates, various cost account reports, cable layouts,

standard construction drawings. Executive ability. Desires permanent position with growing organization. C-7867.

GRADUATE ELECTRICAL ENGINEER, 30, wishes employment with large utility company. Has had 3 years' experience with large industrial concern in power department and 4 years' experience with large contracting projects on maintenance and electrical work. Well qualified as a junior executive for large industrial or public utility corporation. B-8606.

INSTRUCTOR, to teach d-c. and a-c. classes and laboratory. Position desired by University graduate, 5 years' practical experience, 3 years' graduate work in engineering and business administration, but congenial personality is greatest asset. Linguistic qualifications: German and French. Special aptitude for teaching. C-930.

GRADUATE ENGINEER, 31, married. Two years Graybar Electric, 3½ years' sales engineer followed by 3½ years manager and officer of large electrical shop-construction company. Conversant with electrical and other machinery, its installation and maintenance. Available immediately. Location immaterial, West Coast preferred. C-7987.

SALES ENGINEER, single, 38, distinctly electrical background, factory representative, likes contact work immensely. About 15 years' selling experience New England proved ability. Desires permanent connection. Future. Specialized knowledge of electrical conductors. Substantial working knowledge, physics, chemistry electrical instruments and apparatus. Definite interest in standards, standards projects. Location, East except New York City. C-7897.

ELECTRICAL ENGINEER, married, three years power and substation construction and maintenance, five years electric distribution construction, five years system planning and voltage regulations and load control. Available on two weeks' notice. Eastern U. S. or Canada preferred. C-7992.

ELECTRICIAN, age 40, single, technical and practical instruction, foreman, wireman, repairs, maintenance radio, etc. Twenty-five years' experience. Speak Spanish and French. No job too large. Now under Civil Service wants to make a change. C-7993-308-C-3.

DISTRIBUTION ENGINEER, age 30, single, with four years' experience in South America in distribution and maintenance. At present employed as superintendent of cables in large South American city. Desires position as salesman or distribution engineer. Location, immaterial, but South America preferred. Available on three months' notice. C-1222.

EXPERIENCED SALES ENGINEER, wants additional lines. Now located at Denver and calls on the utilities from Omaha to Salt Lake City. C-8014.

EXECUTIVE, 38, married, technically trained. Connections with large public utility, manufacturers and industrial consultants on work of administrative and commercial nature. Especially qualified as assistant to busy executive needing man with management ability. Well endorsed. Prefers East. B-9122.

METER ENGINEER, 26, single. Desires position in research or testing laboratory. Ten years' experience with electrical measuring instruments including the potentiometer, oscillograph and special laboratory instruments. Also extensive experience with relays. Capable of taking charge of meter laboratory. C-7961.

GRADUATE ENGINEER, 22, single, protestant, B. S. in electrical engineering. One year's experience teaching. Desires position in communication on power development work. Would consider South American position. Available now. C-8021.

GRADUATE, 1920, with B. S. in electrical engineering. Desires position in technical department of public utility. One year Westing-

house graduate Student Course. Location preferred in or near New England States. C-8020.

EXECUTIVE, SALES MANAGER, DISTRICT MANAGER, 36, married. Diversified experience power system construction and operation. Fifteen years engineering application and sales electrical apparatus. Last ten years District Manager, General Sales Manager, special representative for large transformer manufacturer. Broad experience dealing with executives, engineers and operating personnel of public utilities companies. Location, immaterial. C-8012.

ELECTRICAL ENGINEER, experienced in estimate, design, negotiation and construction for railroad electrification and grade crossing elimination, responsible project management, etc. Desires position as budget or designing engineer. C-7096.

PUBLIC UTILITY RATE ENGINEER, graduate M. I. T. Six years' experience large public utility and management companies, includes preparation of gas, electric, and steam rates; economic studies and cost allocations; electrical engineering and design of power plants, substations, industrial installations. Will also accept commercial executive or sales position in utility. B-9077.

ELECTRICAL ENGINEER, 28, five years' general legal, banking, industrial experience. Two years assistant sales manager, purchase and sales engineer, large N. Y. mfr. telegraph equipment. Extensively familiar important manufacturers and jobbers. Excellent qualified to relieve busy executive and build sales and service. Also experienced in appraisals and specification wiring. C-8032.

1929 GRADUATE ELECTRICAL ENGINEER, single, 22, 15 months on General Electric Test Course. Desires location with utility or manufacturing company or with concern doing consulting or construction engineering. Available immediately. Location preferred, New England. C-8028.

1930 GRADUATE ELECTRICAL ENGINEER, single, 24. Desires position in steel mill or with some utility company that sells power to large industrial concerns. Will accept other work. Location, immaterial. C-7880.

GRADUATE ELECTRICAL ENGINEER, Columbia University 1906, age 45, with 25 years' experience with design and general engineering problems of steam-electric, generating stations and distribution substations. Desires position as electrical engineer with public utility company or engineering firm. A-5466.

1930 GRADUATE ELECTRICAL ENGINEER, one of the best engineering schools in the country, 25, single. Desires position. Especially interested in municipal work, editorial work, however, anything will be considered. Experience one year radio concern also various business experience, and college training in business and law. Can furnish best of references. C-8039.

ESTIMATOR AND APPRAISER, 15 years' experience with largest concerns. Graduate electrical and mechanical engineer, M. A. degree. Age 40, executive ability, now employed. Would consider new connections. C-3260.

GRADUATE ELECTRICAL ENGINEER, 35, married. Three years' experience design, construction, operation, distribution system, power plant light, power utility. Three years' electrical design, construction, operation street railway, one year assistant to chief engineer same property. Four years assistant electrical engineer head office large public utilities operating in foreign countries. Desires position with public utility, United States. C-5091.

FELLOW A. I. E. E. long experienced in the manufacture of coils, transformers, high-frequency apparatus, and so forth, and the fussy details inherent thereto. Familiar with winding machine patent situation. B-6008.

1929 GRADUATE ELECTRICAL ENGINEER, 24, single, 14 months on General Electric

Test Course. Desires location with utility or engineering work with manufacturing company in the south. Also interested in instructorship in a southern college. Hard worker. C-7881.

MECHANICAL AND ELECTRICAL ENGINEER, married. Degrees here, and Doctor, Germany for research. Fifteen years connected and in charge purchasing, sales and export office handling materials every possible description in large amounts. Available because company closed. Wide business experience. Linguist. Adaptable to any position outside those mentioned. C-7823.

GRADUATE ELECTRICAL ENGINEER (1909.) Native of India, with considerable experience in America, Europe and India, including teaching. Desires connections with electrical firm doing business with India. Will also consider an educational appointment with an engineering institution offering scope for research in railway electrifications. C-8072.

ELECTRICAL ENGINEER, age 27, M. S., Iowa State College, 1930, B. S., Pennsylvania State College, 1925. Experience in calculation of a-c. distribution, testing, and as Graduate Assistant in Electrical Engineering. Desires position in testing of miscellaneous electrical machinery, or other technical work. Experimental work will be considered if it seems suitable. C-3202.

ELECTRICAL ENGINEER, with 15 years' experience in design, construction, reports and editorial work. Now engaged on special publishing job; will be available November 1st for publicity or editorial work on trade publications. References with leading engineering and publishing firms can be furnished. B-4022.

ELECTRICAL ENGINEER, (E. E. and Ch. E.), 34 years old, married, with ten years of diversified experience in construction and public utility practices, is available for new engagement at short notice. For the past three years employed in administrative position with large eastern utility company. C-658.

DEVELOPMENT ENGINEER, graduate of Case School, also has completed several graduate courses. Two years' experience in laboratory and research work. Familiar with vacuum tube amplifiers, relays and signal apparatus. Desires position in Middlewest in development of signal or control apparatus. Age 24, single. Available on two weeks' notice. C-8002.

MECHANICAL ENGINEER, college graduate, age thirty, married, protestant. Six years' talking picture and allied fields, research, design, quantity production. Has handled large crews in factories, small groups in laboratories. Experienced executive and organizer, dealing with important men and problems. Early background in automotive industry. Location partly determinessalary. C-6872.

EXECUTIVE, ELECTRICAL ENGINEER, graduate. Extensive Latin American experience. Capable taking complete field managerial charge operating, construction, preparing reports on properties public relations, new business and development work along acquisition lines. Desires connection public utility or holding company either domestic or foreign. Acquainted Latin American requirements for obtaining concessions, etc. Speaks Spanish fluently. Married. C-761.

ELECTRICAL ENGINEER, technical graduate, 40, experienced in design and construction for industrial plants, including power-houses, substations, duct lines, distribution systems, lighting. Seeks position as designer or superintendent of maintenance and construction. East preferred, but will go anywhere. C-8001.

GRADUATE ELECTRICAL ENGINEER, 35, experienced transformer engineer. Twelve years General Electrical Company, Schenectady, Pittsfield test course, sales, engineering depts. Transformer quotation, design, development, factory engineering supervision, technical reports, investigating materials, power factor distribution systems. Technical school instructor. Desires

position design, sales, consulting engineer or instructor. Location preferred, East, South. C-7321.

ENGINEER, EXECUTIVE, B. S. degree. Twenty years' experience in engineering contract-

ing, and purchasing. Desires permanent connection with large industrial company or as a local representative. Location, New York City. B-5050.

ELECTRICAL ENGINEER, B. Sc., 42 single. Twenty years of diversified experience in

public utility practice with largest Utilities in the country. Broadly traveled here and abroad. Speaks English and French equally well and some German. Location immaterial. Desires position of responsibility. Available now. C-8105.

MEMBERSHIP—Applications, Elections, Transfers, Etc.

RECOMMENDED FOR TRANSFER

The Board of Examiners, at its meeting of September 24, 1930, recommended the following members for transfer to the grade of membership indicated. Any objection to these transfers should be filed at once with the National Secretary.

To Grade of Fellow

BASCOM, HENRY M., Local Central Office Development Engr., American Tel. & Tel. Co., New York, N. Y.
BEARDSLEY, CLIFFORD R., Electrical Construction Engr., Brooklyn Edison Co., Brooklyn, N. Y.
CLARK, ALVA B., American Tel. & Tel. Co., New York, N. Y.
HOLBROOK, HENRY S., Chief of Power Transformer Engg. Dept., British Thomson Houston Co., Ltd., Rugby, England.
LEE, EVERETT S., Assistant Engineer, General Electric Co., Schenectady, N. Y.

To Grade of Member

ARLAND, FREDERICK L., Engineer of Special Studies, N. Y. Telephone Co., New York, N. Y.
BARTEK, JOSEPH T., Asst. Elec. Engr., Stone & Webster Engg. Corp., Seattle, Wash.
BOSSARD, GIBBERT L., President and Director of Engg. Research, General Kontrolar Co., Inc., Dayton, Ohio.
BOWEN, WILLIAM C., Substation Design Engr., West Penn Power Co., Pittsburgh, Pa.
BRETTE, ARTHUR C., Switchgear Specialist, General Electric Co., Buffalo, N. Y.
BROOKS, GUY W., Elec. Engr., General Elec. Co., Buffalo, N. Y.
BROWER, R. FRANK, Asst. Engr., N. Y. Edison Co., New York, N. Y.
CLARKE, JOHN L., Transmission Engr., Bell Telephone Co. of Canada, Montreal, Que., Canada.
CRITZAS, D. J., Designer, N. Y. Edison Co., New York, N. Y.
DALY, CHARLES J., Transmission and Protection Engr., Southern New England Telephone Co., New Haven, Conn.
DAVIS, J. CLARK, Engineer, Kansas City Pr. & I. Co., Kansas City, Mo.
FORBES, HARLAND C., Research Engr., N. Y. Edison Co., New York, N. Y.
FROST, LAURANCE E., Asst. Inside Plant Engr., Brooklyn Edison Co., Brooklyn, N. Y.
GABAY, Henry R., General Commercial Engr., N. Y. Telephone Co., New York, N. Y.
GAULT, JAMES S., Asst. Professor of Elec. Engg., University of Michigan, Ann Arbor, Mich.
HAGGERTY, DAVIS H., Asst. General Foreman, N. Y. Edison Co., New York, N. Y.
HARRIS, HARVEY L., Vice-President, Theodore Gary & Co., Chicago, Ill.
HOLLAND, MAURICE, Director, National Research Council, New York, N. Y.
HOOVEN, MORRIS D., Engr., Transmission, Public Service Gas & Elec. Co., Newark, N. J.
HOPPER, FRANCIS L., Acoustical Engr., Electrical Research Products, Inc., Hollywood, Calif.
HUGHES, RUSSELL H., Asst. Vice-President, N. Y. Telephone Co., New York, N. Y.
JOHNSON, J. RALPH, Manager, Cali Office, Int. General Electric S. A., Colombia, S. A.

KOENIG, HERMAN C., Engr.-in-charge, Electrical Testing Labs., New York, N. Y.
KOERNER, C. A., Elec. Engr., Delta-Star Elec. Co., Chicago, Ill.
LAKIN, C. E., Elec. Engr., Electrical Mgt. & Engg. Corp., New York, N. Y.
LAURIE, R. M., Chief Load Supervisor, Hydro-Electric Power Comm., Niagara Falls, Ont. Canada.
MACFADDEN, SAMUEL P., Vice-President, Puget Sound Pr. & Lt. Co., Seattle, Wash.
MACLEAN, JAMES B., Engr., J. G. White Engg. Corp., New York, N. Y.
McCARTY, GEORGE M., Telephone Engr., American Tel. & Tel. Co., New York, N. Y.
MEDBERY, STEPHEN C., Engr. of Maintenance Practises, N. Y. Telephone Co., New York, N. Y.
NILSSON, NILS J. E., Designer, Pacific Gas & Elec. Co., San Francisco, Calif.
OLSON, MARTIN C., Elec. Engr., General Elec. Co., Schenectady, N. Y.
OSCARSON, G. L., District Mgr., Electric Machinery Mfg. Co., St. Louis, Mo.
PASSAGE, DAVID H., Designing Engr., Edison Elec. Ill. Co., Boston, Mass.
POWERS, PHILIP H., Vice-President, West Penn Power Co., Pittsburgh, Pa.
READ, GEORGE J., Division Engr., Brooklyn Edison Co., Brooklyn, N. Y.
ROACH, CHARLES L., Toll and Transmission Engr., Bell Telephone Co. of Canada, Montreal, Que., Canada.
ROBINSON, LYMAN W., Elec. Engg. Dept., Allied Engineers, Inc., Jackson, Michigan.
RODGERS, WM. H., Central Station Engr., Westinghouse Elec. & Mfg. Co., E. Pittsburgh, Pa.
ROOSEVELT, JOHN K., Vice-President, All America Cables, Inc., New York, N. Y.
RUTHERFORD, PAUL H., Supervisor of Motor Design, Delco Products Corp., Dayton, Ohio.
TANZ, ISADORE, Engr. of Toll Plant Extension and Transmission, N. Y. Telephone Co., New York, N. Y.
TARANIK, JAMES S., Senior Designer, Pacific Gas & Elec. Co., San Francisco, Calif.
THOMAS, AHERTON, Asst. Engr., N. Y. Edison Co., New York, N. Y.
THORP, I. JAY, Supplies Engr., N. Y. Telephone Co., New York, N. Y.
TRURAN, WALTER W., General Toll Engr., N. Y. Telephone Co., New York, N. Y.
VON DANNENBERG, CARL O., Asst. Elec. Engr., Elec. Mgt. & Engg. Corp., New York, N. Y.
WARNER, SEWARD A., Asst. Outside Plant Engr., Brooklyn Edison Co., Brooklyn, N. Y.

APPLICATIONS FOR ELECTION

Applications have been received by the Secretary from the following candidates for election to membership in the Institute. Unless otherwise indicated, the applicant has applied for admission as an Associate. If the applicant has applied for direct admission to a grade higher than Associate, the grade follows immediately after the name. Any member objecting to the election of any of these candidates should so inform the Secretary before October 31, 1930.

Barnes, F. C., Canadian General Electric Co., Toronto, Ont., Can.
Boger, K., General Electric Co., Fort Wayne, Ind.
Bower, M. M., American Tel. & Tel. Co., New York, N. Y.

Calhoun, M., 555 Smithson Ave., Erie, Pa.
Case, B. A., General Electric Co., Fort Wayne, Ind.
Collins, H. S., Stromberg Carlson Tel. Mfg. Co., Rochester, N. Y.
Cozzens, R. I., Philadelphia Rapid Transit Co., Philadelphia, Pa.
Creekmore, F. B., Jr., Oklahoma Gas & Electric Co., Oklahoma City, Okla.
Dalglish, R. H., Jr., Westinghouse Elec. & Mfg. Co., Toledo, Ohio
Deck, F. W., (Member), Philadelphia Electric Co., Philadelphia, Pa.
Diehl, E. E., 999 West Delaware Ave., Toledo, Ohio
Dodge, E. J., Pacific Tel. & Tel. Co., San Francisco, Calif.
Douey, J., Saskatchewan Power Commission, Regina, Sask., Can.
Dyer, H. C., Poindexter Electric Co., Denver, Colo.
Elton, M. B., Puget Sound Pr. & Lt. Co., Bremerton, Wash.
Emory, C. R., 300 West Chesapeake Ave., Towson, Md.
EoYang, T. T., Stromberg Carlson Tel. Mfg. Co., Rochester, N. Y.
Foster, C. V., Tonawanda Power Co., North Tonawanda, N. Y.
Fuller, T., (Member), Westinghouse Elec. & Mfg. Co., Atlanta, Ga.
Gallagher, L. C., American Tel. & Tel. Co., Oklahoma City, Okla.
Gardner, M. E., Pomona College, Claremont, Calif.
Giesinger, P. E., Thomas A. Edison Inc., West Orange, N. J.
Gutzwiller, W. E., American Brown Boveri Co., Inc., Camden, N. J.
Haase, H. W., T. M. E. R. & L. Co., Milwaukee, Wis.
Hepp, J. A., (Member), Union Elec. Lt. & Pr. Co., St. Louis, Mo.
Howell, E. H., General Electric Co., Toledo, Ohio (Applicant for re-election.)
Humble, C. E., Burke Electric Co., Pittsburgh, Pa.
Iseminger, C. R., Westinghouse Elec. & Mfg. Co., East Pittsburgh, Pa.
Judson, W. G., Ward Leonard Electric Co., Mt. Vernon, N. Y.
Kun, E., (Member), 120 Liberty St., Rm. 1100, New York, N. Y.
LaBell, F. H., Northeastern University, Boston, Mass.
Landers, L. J., Ohmer Fare Register Co., Atlanta, Ga.
MacMahon, A. E., The Pacific Telephone & Telegraph Co., San Francisco, Calif.
Macomber, S. L., Jackson & Moreland, Pullman Car & Mfg. Co., Chicago, Ill.
Mathews, H. M., (Member), Messrs. Merz & Partners, Montreal, Que., Can.
McGoldrick, J. J., Dept. Water Supply Gas & Electric, New York, N. Y.
Mearls, W. J., New York & Queens Elec. Lt. & Pr. Co., Flushing, N. Y.
Meier, O., Jr., University of Pennsylvania, Philadelphia, Pa.
Mengel, W. R., Allis-Chalmers Mfg. Co., Toledo, Ohio
Morris, B. G., General Electric Co., Buffalo, N. Y.
Nicholl, H. I., Canadian Westinghouse Co., Regina, Sask., Can.
Nicolson, E. L., General Electric Co., Chicago, Ill.

Parker, L. H., Turlock Irrigation District, Turlock, Calif.	Sussenberg, C. G., 1261 Broadway, New York, N. Y.	Bakhsh, K., Indian Telephones & Telegraphs, Simla, India
Patterson, J. C., Pennsylvania Railroad, West Philadelphia, Pa.	Tanner, F. R., The C. & S. B. T. Co., Cincinnati, Ohio	Fourmarior, P., 140 Avenue de l'Oleservatoire, Liege, Belgium
Peterson, E. F., University of Santa Clara, Santa Clara, Calif.	Van Wie, W. A., Westinghouse Elec. & Mfg. Co., Toledo, Ohio	Kuriyan, K. T., 11 George Square, Edinburgh, Scotland
Poppino, C. A., International General Electric Co., New York, N. Y.	Wales, J., 23 Washington St., Beverly, Mass.	Lenners, G. J., Berliner Stadtische Elektrizitatswerke A. G., Berlin, Germany
Ritland, H. O., General Delivery, Menlo Park, Calif.	Walters, L. G., (Member), Jobbers Supply Co., Portland, Ore.	Narayanaswamy, N. V., Indian Institute of Science, Bangalore, India
Ross, J. J., (Member), Welded Products Corp., Kansas City, Mo.	Woods, H. E., National Aniline & Chemical Co., Inc., Buffalo, N. Y.	Potts, L. A., Poverty Bay Electric Power Board, Gisborne, N. Z.
Ross, W. H., Dominion Electric Power, Regina, Sask., Can.	Woolaver, G. I., Jr., Metropolitan Edison Co., Easton, Pa.	Seshasayee, R., "Servindia House," Tennur, Trichinopoly, India (Applicant for re-election.)
Sadler, F. M., Clarksburg Water Board, Clarksburg, W. Va.	Wright, J. L., Toledo Edison Co., Toledo, Ohio	Short, C. M., Jr., Anglo-Chilean Consolidated Nitrate Corp., Chile, South America
Saracino, F. E., Lincol-Boyle Ice Co., Chicago, Ill.	Youngs, H. E., Sears, Roebuck & Co., Buffalo, N. Y.	Total 9
Sturtevant, G. R., General Electric Co., West Lynn, Mass.	Total 61	

Foreign

OFFICERS A. I. E. E. 1930-1931

President	
WILLIAM S. LEE	
Junior Past Presidents	
R. F. SCHUCHARDT	HAROLD B. SMITH
Vice-Presidents	
HERBERT S. EVANS	H. V. CARPENTER
W. S. RODMAN	G. C. SHAAD
C. E. FLEAGER	I. E. MOULTROP
E. C. STONE	H. P. CHARLESWORTH
C. E. SISSON	T. N. LACY
Directors	
F. C. HANKER	J. E. KEARNS
E. B. MEYER	C. E. STEPHENS
H. P. LIVERSIDGE	A. B. COOPER
J. ALLEN JOHNSON	A. E. KNOWLTON
A. M. MACCUTCHEON	R. H. TAPSCOTT
A. E. BETTIS	(Vacancy)
National Treasurer	
GEORGE A. HAMILTON	
National Secretary	
F. L. HUTCHINSON	
General Counsel:	
PARKER & AARON, 30 Broad Street, New York	

LOCAL HONORARY SECRETARIES

- T. J. Fleming, Calle B. Mitre 519, Buenos Aires, Argentina, S. A.
- H. W. Flashman, Aus. Westinghouse Elec. Co. Ltd., Catcart House, 11 Castlereagh St., Sydney, N. S. W., Australia.
- F. M. Servos, Rio de Janeiro Tramways, Light & Power Co., Rio de Janeiro, Brazil.
- A. P. M. Fleming, Metropolitan Vickers Elec. Co., Trafford Park, Manchester, England.
- A. S. Garfield, 45 Bd. Beausejour, Paris 16 E., France.
- F. W. Willis, Tata Power Company, Bombay House, Bombay, India.
- Renzo Norsa, Via Caravaggio 1, Milano 25, Italy.
- P. H. Powell, Canterbury College, Christchurch, New Zealand.
- M. Chatelain, Lesnoi Polytechnic Institute, Apt. 27, Leningrad, U. S. S. R.
- Axel F. Enstrom, 24a Ingeniorsvetenskapsakademien, Stockholm, 5 Sweden.
- W. Eldson-Dew, P. O. Box 4563 Johannesburg, Transvaal, Africa.

A. I. E. E. COMMITTEES

(A list of the personnel of Institute committees may be found in the September issue of the JOURNAL.)

GENERAL STANDING COMMITTEES AND CHAIRMEN

- EXECUTIVE, W. S. Lee
- FINANCE, C. E. Stephens
- MEETINGS AND PAPERS, A. E. Knowlton
- PUBLICATION, W. S. Gorsuch
- COORDINATION OF INSTITUTE ACTIVITIES, H. P. Charlesworth
- BOARD OF EXAMINERS, H. W. Drake
- SECTIONS, Everett S. Lee
- STUDENT BRANCHES, W. H. Timbie
- MEMBERSHIP, J. Allen Johnson
- HEADQUARTERS, R. H. Tapscott
- LAW, E. B. Meyer
- PUBLIC POLICY, Bancroft Gherardi
- STANDARDS, F. D. Newbury
- EDISON MEDAL, D. C. Jackson

- LAMME MEDAL, Charles F. Scott
- CODE OF PRINCIPLES OF PROFESSIONAL CONDUCT, F. B. Jewett
- AWARD OF INSTITUTE PRIZES, A. E. Knowlton
- SAFETY CODES, A. W. Berresford
- ENGINEERING PROFESSION, H. A. Kidder
- COLUMBIA UNIVERSITY SCHOLARSHIPS, W. I. Slichter
- POPULAR SCIENCE AWARD, A. E. Knowlton
- ADVISORY COMMITTEE TO THE MUSEUM OF THE PEACEFUL ARTS, J. P. Jackson

TECHNICAL COMMITTEES AND CHAIRMEN

- AUTOMATIC STATIONS, F. Zogbaum
- COMMUNICATION, G. A. Kositzky
- EDUCATION, W. R. Work
- ELECTRICAL MACHINERY, Philip L. Alger
- ELECTRIC WELDING, P. P. Alexander
- ELECTROCHEMISTRY AND ELECTROMETALLURGY, P. H. Brace
- ELECTROPHYSICS, O. E. Buckley
- GENERAL POWER APPLICATIONS, C. W. Drake
- INSTRUMENTS AND MEASUREMENTS, E. J. Rutan
- APPLICATIONS TO IRON AND STEEL PRODUCTION, A. C. Cummins
- PRODUCTION AND APPLICATION OF LIGHT, George S. Merrill
- APPLICATIONS TO MARINE WORK, R. A. Beekman
- APPLICATIONS TO MINING WORK, Carl Lee
- POWER GENERATION, F. A. Allner
- POWER TRANSMISSION AND DISTRIBUTION, P. H. Chase
- PROTECTIVE DEVICES, Raymond Bailey
- RESEARCH, L. W. Chubb
- TRANSPORTATION, Sidney Withington

A. I. E. E. REPRESENTATION

(The Institute is represented on the following bodies; the names of the representatives may be found in the September issue of the JOURNAL.)

- ALFRED NOBLE PRIZE COMMITTEE, A. S. C. E.
- AMERICAN ASSOCIATION FOR THE ADVANCEMENT OF SCIENCE, COUNCIL
- AMERICAN BUREAU OF WELDING
- AMERICAN COMMITTEE ON ELECTROLYSIS
- AMERICAN ENGINEERING COUNCIL ASSEMBLY
- AMERICAN MARINE STANDARDS COMMITTEE
- AMERICAN STANDARDS ASSOCIATION
- AMERICAN YEAR BOOK, ADVISORY BOARD
- CHARLES A. COFFIN FELLOWSHIP AND RESEARCH FUND COMMITTEE
- COMMITTEE OF APPARATUS MAKERS AND USERS, NATIONAL RESEARCH COUNCIL
- COMMITTEE ON ELIMINATION OF FATIGUE, SOCIETY OF INDUSTRIAL ENGINEERS
- COMMITTEE ON HEAT TRANSMISSION, NATIONAL RESEARCH COUNCIL
- ENGINEERING FOUNDATION, INC.
- ENGINEERING SOCIETIES RESEARCH BOARD
- HOOVER MEDAL COMMITTEE
- JOHN FRITZ MEDAL BOARD OF AWARDS
- JOINT COMMITTEE ON WELDED RAIL JOINTS
- JOINT CONFERENCE COMMITTEE OF FOUR FOUNDER SOCIETIES
- LIBRARY BOARD, ENGINEERING FOUNDATION, INC.
- NATIONAL FIRE PROTECTION ASSOCIATION, ELECTRICAL COMMITTEE
- NATIONAL FIRE WASTE COUNCIL
- NATIONAL RESEARCH COUNCIL, ENGINEERING DIVISION
- NATIONAL SAFETY COUNCIL, ELECTRICAL COMMITTEE OF A. S. S. E.—ENGINEERING SECTION
- RADIO ADVISORY COMMITTEE, BUREAU OF STANDARDS
- U. S. NATIONAL COMMITTEE OF THE INTERNATIONAL COMMISSION ON ILLUMINATION
- U. S. NATIONAL COMMITTEE OF THE INTERNATIONAL ELECTROTECHNICAL COMMISSION
- WASHINGTON AWARD, COUNCIL OF

GEOGRAPHICAL DISTRICT EXECUTIVE COMMITTEES

District	Chairman (Vice-President, A. I. E. E.)	Secretary (District Secretary)
No. 1—North Eastern	I. E. Moulthrop, Edison Elec. Illum. Co. of Boston, 39 Boylston St., Boston, Mass.	A. E. Stevens, General Electric Co., Schenectady, N. Y.
No. 2—Middle Eastern	E. C. Stone, Duquesne Light Co., 435 Sixth Ave., Pittsburgh, Pa.	J. A. Cadwallader, Bell Tel. Co. of Penna., 416 Seventh Ave., Pittsburgh, Pa.
No. 3—New York City	H. P. Charlesworth, 463 West St., New York, N. Y.	C. R. Jones, Westinghouse Elec. & Mfg. Co., 150 Broadway, New York, N. Y.
No. 4—Southern	W. S. Rodman, Box 675, University, Va.	J. S. Miller, Jr., Box 12, University, Va.
No. 5—Great Lakes	T. N. Lacy, Michigan Bell Tel. Co., 1365 Cass Ave., Detroit, Mich.	A. G. Dewars, Northern States Power Co., 15 S. 15th St., Minneapolis, Minn.
No. 6—North Central	Herbert S. Evans, University of Colorado, Boulder, Colo.	M. S. Coover, University of Colorado, Boulder, Colo.
No. 7—South West	G. C. Shaad, University of Kansas, Lawrence, Kans.	Robert W. Warner, University of Kansas, Lawrence, Kans.
No. 8—Pacific	C. E. Fleager, Pacific Tel. & Tel. Co., 140 New Montgomery St., San Francisco, Calif.	H. W. Hitchcock, 1050 Telephone Building, 740 South Olive St., Los Angeles, Calif.
No. 9—North West	H. V. Carpenter, State College of Washington, Pullman, Wash.	R. D. Sloane, State College of Washington, Pullman, Wash.
No. 10—Canada	C. E. Sisson, Canadian General Electric Co., 1025 Lansdowne Ave., Toronto, Ont.	W. L. Amos, Hydro-Elec. Power Commission, 190 University Ave., Toronto, Ont.

Note: Each District Executive Committee includes the chairmen and secretaries of all Sections within the District and the chairman of the District Committee on Student Activities.

LIST OF SECTIONS

Name	District	Chairman	Secretary	Name	District	Chairman	Secretary
Akron	(2)	H. C. Paiste	Alvin P. Regal, Phila. Rubber Works Co., Akron, Ohio	New York	(3)	J. B. Bassett	C. R. Jones, Westinghouse Elec. & Mfg. Co., 150 Broadway, New York, N. Y.
Atlanta	(4)	H. C. Uhl	O. O. Rac, Westinghouse Elec. & Mfg. Co., Atlanta, Ga.	Niagara Frontier	(1)	E. S. Bundy	G. W. Eighmy, General Elec. Co., 1100 Elec. Bldg., Buffalo, N. Y.
Baltimore	(2)	W. B. Kouwenhoven	J. Wells, Western Electric Co., 25 Broening Rd., Baltimore, Md.	North Carolina	(4)	E. P. Coles	Marshall E. Lake, Duke Power Co., Power Bldg., Charlotte, N. Car.
Birmingham	(4)	W. E. Bare	O. E. Charlton, Alabama Power Co., Birmingham, Ala.	Oklahoma City	(7)	F. J. Meyer	C. E. Bathe, Oklahoma Gas & Elec. Co., Oklahoma City, Okla.
Boston	(1)	J. P. Kobrock	G. J. Crowdes, Simplex Wire & Cable Co., Sidney St., Cambridge, Mass.	Philadelphia	(2)	D. H. Kelly	J. L. MacBurney, Electric Storage Battery Co., 1955 Hunting Park Ave., Philadelphia, Pa.
Chicago	(5)	F. H. Lane	L. R. Mapes, Illinois Bell Telephone Co., 212 W. Washington St., Chicago, Ill.	Pittsburgh	(2)	C. T. Sinclair	F. A. Connor, General Elec. Co., 1309 Oliver Bldg., Pittsburgh, Pa.
Cincinnati	(2)	T. C. Reed	L. L. Bosch, Columbia Engg. & Mgt. Corp., 314 West 4th St., Cincinnati, Ohio	Pittsfield	(1)	C. H. Kline	L. H. Burnham, General Electric Co., Pittsfield, Mass.
Cleveland	(2)	F. W. Braund	John M. Smith, Nela Park, Cleveland, Ohio	Portland, Ore.	(9)	A. H. Kreul	C. W. Fick, General Electric Co., Portland, Oregon
Columbus	(2)	C. D. Price	K. Y. Tang, Ohio State University, Columbus, Ohio	Providence	(1)	J. W. Young	O. W. Briden, Blackstone Valley Gas & Elec. Co., 231 Main St., Pawtucket, R. I.
Connecticut	(1)	Samuel Ferguson	R. G. Warner, Yale University, 10 Hillhouse Ave., New Haven, Conn.	Rochester	(1)	Harvey J. Klumb	F. C. Young, Stromberg-Carlson Tel. Mfg. Co., 100 Carlson Rd., Rochester, N. Y.
Dallas	(7)	L. T. Blaisdell	G. A. Dyer, Southwestern Bell Telephone Co., Dallas, Texas	St. Louis	(7)	C. B. Fall	E. A. Forkner, Wagner Elec. Corp., 6400 Plymouth Ave., St. Louis, Mo.
Denver	(6)	R. B. Bonney	N. R. Love, 807 Tramway Bldg., Denver, Colo.	San Antonio	(7)	D. W. Flowers	Eugene Bissett, San Antonio Pub. Serv. Co., 201 N. St. Mary's St., San Antonio, Texas
Detroit-Ann Arbor	(5)	LeRoy Braisted	J. J. Shoemaker, Detroit Edison Co., 2000-2nd Ave., Detroit, Mich.	San Francisco	(8)	P. B. Garrett	E. A. Crellin, Pacific Gas & Elec. Co., 245 Market St., San Francisco, Calif.
Erie	(2)	G. R. McDonald	G. I. LeBaron, General Elec. Co., Erie, Pa.	Saskatchewan	(10)	W. T. Hunt	A. B. Coward, Light and Power Dept., Regina, Sask. Canada
Fort Wayne	(5)	W. J. Morrill	C. M. Summers, General Elec. Co., Fort Wayne, Indiana	Schenectady	(1)	E. S. Henningsen	E. P. Nelson, D. C. Engg. Dept., General Electric Co., Schenectady, N. Y.
Houston	(7)	C. D. Farman	Hezzie Clark, 2012 Melrose St., Houston, Texas	Seattle	(9)	C. E. Carey	Philip D. Jennings, Puget Sound Pr. & Lt. Co., 7th and Olive Sts., Seattle, Wash.
Indianapolis-Laf.	(5)	E. G. Ralston	C. E. Dutton, American Tel. & Tel. Co., 256 N. Meridian St., Indianapolis, Ind.	Sharon	(2)	S. S. Cook	R. M. Field, Westinghouse Elec. & Mfg. Co., Sharon, Pa.
Iowa	(5)	J. K. McNeely	H. B. Hoffhaus, Des Moines Elec. Lt. Co., 312-6th Ave., Des Moines, Iowa	Southern Virginia	(4)	J. H. Berry	Cecil Gray, Westinghouse Elec. & Mfg. Co., 912 Electric Bldg., Richmond, Va.
Ithaca	(1)	W. C. Ballard, Jr.	W. E. Meserve, 614 E. Buffalo St., Ithaca, N. Y.	Spokane	(9)	Loren A. Traub	C. F. Norberg, Washington Water Power Co., Spokane, Wash.
Kansas City	(7)	J. S. Palmer	Bruce E. Dolch, 736 Board of Trade Bldg., Kansas City, Mo.	Springfield, Mass.	(1)	J. N. Alberti	L. C. Packer, Westinghouse Elec. & Mfg. Co., Page Blvd., Springfield, Mass.
Lehigh Valley	(2)	W. M. Harbaugh	J. H. Diefenderfer, Pennsylvania Pr. & Lt. Co., Hazleton, Pa.	Syracuse	(1)	F. E. Verdin	Charles W. Henderson, 504 University Pl., Syracuse, N. Y.
Los Angeles	(8)	W. H. Hitchcock	Philip S. Biegler, 3551 University Ave., Los Angeles, Calif.	Toledo	(2)	F. H. Dubs	Max Neuber, 1257 Fernwood Ave., Toledo, Ohio
Louisville	(4)	James Clark, Jr.	Philip P. Ash, Louisville & Nashville Rd. Bldg., 9th and Broadway Ave., Louisville, Ky.	Toronto	(10)	D. A. McKenzie	G. D. Floyd, Hydro Electric Pr. Comm., 190 University Ave., Toronto, Ont., Canada
Lynn	(1)	A. L. Ellis	W. K. Dickinson, General Elec. Co., West Lynn Works, Lynn, Mass.	Urbana	(5)	C. E. Skroder	W. J. Putnam, 123 Mat. Test. Lab., University of Illinois, Urbana, Ill.
Madison	(5)	L. C. Larson	G. F. Tracy, Elec. Lab. Bldg., University of Wisconsin, Madison, Wis.	Utah	(9)	L. B. Fuller	Paul Ranson, Utah Apex Mining Co., Bingham Canyon, Utah
Memphis	(4)	M. Eldredge	W. A. Gentry, Memphis Pr. & Lt. Co., Memphis, Tenn.	Vancouver	(10)	H. Vickers	C. Arnott, B. C. Electric Railway Co., Ltd., 425 Carrall St., Vancouver, B. C. Canada
Mexico	(3)	G. Solis-Payan	E. Leonarz, Jr., Apartado 2601, Mexico City, Mexico	Washington	(2)	George W. Vinal	J. L. Carr, General Elec. Co., 800-15th St. N. W., Washington, D. C.
Milwaukee	(5)	F. A. Kartak	I. L. Illing, Milwaukee Elec. Ry. & Lt. Co., 380 Public Serv. Bldg., Milwaukee, Wis.	Worcester	(1)	J. K. Oldham	R. P. Bullen, c/o General Elec. Co., Worcester, Mass.
Minnesota	(5)	D. K. Lewis	H. J. Pierce, Northwestern Bell Telephone Co., Minneapolis, Minn.				
Nebraska	(6)	W. O. Jacobi	A. L. Turner, 1112 Telephone Bldg., Omaha, Nebraska				
							Total 58

LIST OF BRANCHES

Name and Location	District	Chairman	Secretary	Counselor (Member of Faculty)
Akron, Municipal Univ. of, Akron, Ohio	(2)	Harmon Shively	T. W. Brewster	J. T. Walther
Alabama Polytechnic Inst., Auburn, Ala.	(4)	J. A. Willman	C. A. Brock	W. W. Hill
Alabama, Univ. of, University, Ala.	(4)	Walter H. Croft	Harold B. Hendrix	F. R. Maxwell, Jr.
Arizona, Univ. of, Tucson, Ariz.	(8)	W. T. Brinton	Carl Ludy	J. C. Clark
Arkansas, Univ. of, Fayetteville, Ark.	(7)	Ned S. Muse	E. Wylie Head	W. B. Stelzner
Armour Inst. of Tech., 3300 Federal St., Chicago, Ill.	(5)	K. A. Knittel	E. Squires	D. E. Richardson
Brooklyn Poly. Inst., 99 Livingston St., Brooklyn, N. Y.	(3)	George Morton		C. C. Whipple
Bucknell University, Lewisburg, Pa.	(2)	O. R. Sterling	P. Hort	W. K. Rhodes
Calif. Inst. of Tech., Pasadena, Calif.	(8)	Edson C. Lee	J. L. Hall	R. W. Sorensen
Calif. Univ. of, Berkeley, Calif.	(8)	Frank R. Norton	A. G. Forster	L. E. Reukema
Carnegie Inst. of Tech., Pittsburgh, Pa.	(2)	M. W. Smedberg	G. H. Ikola	G. Porter
Case School of Applied Science, Cleveland, Ohio	(2)	G. A. Sanow	Irwin J. Rand	H. B. Dates
Catholic University of America, Washington, D. C.	(2)	T. J. Dunn	E. C. McCleery	
Cincinnati, Univ. of, Cincinnati, Ohio	(2)		Henry Suter	A. M. Wilson
Clarkson College of Tech., Potsdam, N. Y.	(1)		C. L. Brown	A. R. Powers
Clemson Agri. College, Clemson College, S. C.	(4)		G. A. Douglass	S. R. Rhodes
Colorado State Agri. College, Ft. Collins, Colo.	(6)		L. Haubrich	F. L. Poole
Colorado, University of, Boulder, Colo.	(3)		John Buffo	W. C. DuVall
Cooper Union, New York, N. Y.	(6)		H. Grissler	A. J. B. Fairburn
Cornell University, Ithaca, N. Y.	(1)		John D. McCurdy	
Denver, Univ. of, Denver, Colo.	(5)		Fay Olmsted	R. E. Nyswander
Detroit, Univ. of, Detroit, Michigan	(2)		L. F. Ross	H. O. Warner
Drexel Institute, Philadelphia, Pa.	(4)		G. R. Bowers	E. O. Lange
Duke University, Durham, N. C.	(4)		H. M. Shepard	W. J. Seeley
Florida, Univ. of, Gainesville, Fla.	(4)		E. Menendez	Joseph Weil
Georgia School of Tech., Atlanta, Ga.	(4)		H. A. List	T. W. Fitzgerald
Idaho, University of, Moscow, Idaho	(9)			J. H. Johnson
Iowa State College, Ames, Iowa	(5)			F. A. Fish
Iowa, State University of, Iowa City, Iowa	(7)			E. B. Kurtz
Kansas State College, Manhattan, Kansas	(7)			R. G. Kloeffler
Kansas, Univ. of, Lawrence, Kansas	(4)			
Kentucky, Univ. of, Lexington, Ky.	(2)			
Kentucky, Univ. of, Lexington, Ky.	(2)			
Lafayette College, Easton, Pa.	(2)			
Lehigh University, Bethlehem, Pa.	(2)	P. W. Seal	Wm. F. Titus L. R. Wanner	W. E. Freeman Morland King J. L. Beaver

LIST OF BRANCHES—Continued

Name and Location	District	Chairman	Secretary	Counselor (Member of Faculty)
Lewis Institute, Chicago, Ill.	(5)	G. W. Malstrom	E. R. Borden	F. A. Rogers
Louisiana State Univ., Baton Rouge, La.	(4)	Fred H. Fenn	R. A. Crain	M. B. Voorhies
Louisville, Univ. of, Louisville, Ky.	(4)	John G. Lips	Wm. E. Bailey	S. T. Fife
Maine, University of, Orono, Maine	(1)	A. E. Crockett	H. R. Mayers	W. E. Barrows, Jr.
Marquette University, 1200 Michigan St., Milwaukee, Wis.	(5)	David Becker	Edward Halback	Edward Kane
Massachusetts Institute of Technology, Cambridge, Mass.	(1)	G. S. Brown		W. H. Timbie
Michigan College of Mining and Technology, Houghton, Mich.	(5)	C. F. Sawyer	B. G. Swart	G. W. Swenson
Michigan State College, East Lansing, Mich.	(5)		G. R. Severance	W. A. Murray
Michigan, Univ. of, Ann Arbor, Michigan	(5)	C. W. Doane		B. F. Bailey
Milwaukee, School of Engineering of, 163 East Wells St., Milwaukee, Wis.	(5)	William P. Gainer	H. F. Volkmann	Oscar Werwath
Minnesota, Univ. of, Minneapolis, Minn.	(5)	Wesley D. Taylor	R. C. Cady	J. H. Kuhlmann
Mississippi Agricultural & Mechanical College, A. & M. College, Miss.	(4)	J. M. Leigh	A. H. Peale	L. L. Patterson
Missouri School of Mines & Metallurgy, Rolla, Mo.	(7)	G. W. Douglas	J. D. Shelton	I. H. Lovett
Missouri, University of, Columbia, Mo.	(7)	R. L. Young	Walter Sevchuk	M. P. Weinbach
Montana State College, Bozeman, Mont.	(9)	Bruce Mull	Wm. McKay	J. A. Thaler
Nebraska, Univ. of, Lincoln, Nebraska	(6)	V. L. Bollman	W. E. Stewart	F. W. Norris
Nevada, University of, Reno, Nevada	(8)	Francis Headley	Eugene Tucker	S. G. Palmer
Newark College of Engineering, 367 High St., Newark, N. J.	(3)	H. Harrison	A. L. Davis	J. C. Peet
New Hampshire, Univ. of, Durham, N. H.	(1)	A. K. Whitcomb	Carl B. Evans	L. W. Hitchcock
New Mexico, Univ. of, Albuquerque, New Mexico	(7)	C. E. Henderson	S. M. Pelatowski	F. M. Denton
New York, College of the City of, 139th St. & Convent Ave., New York, N. Y.	(3)	Joseph Preuss	Howard Klein	Harry Baum
New York University, University Heights, New York, N. Y.	(3)	N. G. Shutt	T. S. Humphrey	J. L. Arnold
North Carolina State College, Raleigh, N. C.	(4)	R. C. Kirk	J. H. Mauney	R. S. Frazier
North Carolina, Univ. of, Chapel Hill, N. C.	(4)		Charles Hayes	J. E. Lear
North Dakota Agricultural College, State College Station, Fargo, N. D.	(6)	R. Stockstad	R. Carlson	H. S. Rush
North Dakota, Univ. of, University Station, Grand Forks, N. D.	(6)	C. J. Breitwieser	R. C. McConnell	H. F. Rice
Northeastern University, 316 Huntington Ave., Boston 17, Mass.	(1)	A. K. Wright	P. H. Townsend	W. L. Smith
Notre Dame, Univ. of, Notre Dame, Indiana	(5)	Earl Brieger	H. J. Perry	J. A. Caparo
Ohio Northern University, Ada, Ohio	(2)	D. Pringle	H. L. Hartman	
Ohio State University, Columbus, Ohio	(2)	G. F. Leydorf	R. W. Steenrod	F. C. Caldwell
Ohio University, Athens, Ohio	(2)	T. A. Elder	Jess W. Best, Jr.	
Oklahoma A. & M. College, Stillwater, Okla.	(7)	Paul H. Foster	Merle C. Brady	A. Naeter
Oklahoma, Univ. of, Norman, Okla.	(7)	G. S. Hammonds		F. G. Tappan
Oregon State College, Corvallis, Oregon	(9)	H. Glen Barnett	Gordon N. Smith	F. O. McMillan
Pennsylvania State College, State College, Pa.	(2)	W. C. Mason	W. J. Wood	
Pennsylvania, Univ. of, Philadelphia, Pa.	(2)	R. R. Creighton	N. Smith	
Pittsburgh, Univ. of, Pittsburgh, Pa.	(2)	W. A. Aeberlie	G. L. Bolender	H. E. Dyche
Pratt Institute, Brooklyn, N. Y.	(3)	J. E. Cook	J. A. Hoag	C. C. Carr
Princeton University, Princeton, N. J.	(2)	C. F. Nesslage	N. T. Humphrey	M. MacLaren
Purdue University, Lafayette, Indiana	(5)	A. Simon	C. B. Bruse	A. N. Topping
Rensselaer Polytechnic Inst., Troy, N. Y.	(1)	C. E. Keeler	E. M. Lockie	F. M. Sebast
Rhode Island State College, Kingston, R. I.	(1)			Wm. Anderson
Rose Polytechnic Institute, Terre Haute, Indiana	(5)	D. E. Henderson	J. H. Corp	C. C. Knipmeyer
Rutgers University, New Brunswick, N. J.	(3)	G. E. Weglener	E. R. Crawford	P. S. Creager
Santa Clara, Univ. of, Santa Clara, Calif.	(8)	T. L. Selna	J. D. Gillis	
South Carolina, Univ. of, Columbia, S. C.	(4)	H. L. Stokes	Anderson Riley	T. O. Kammerman
South Dakota State School of Mines, Rapid City, S. D.	(6)	C. Laws	C. Spilker	B. B. Brackett
South Dakota, Univ. of, Vermillion, S. D.	(6)	Myron Cole	Carl Bauman	Wm. G. Angermann
Southern California, Univ. of, Los Angeles, Calif.	(8)	Rodney Lewis	J. G. Ellis	H. F. Huffman
Southern Methodist University, Dallas, Texas	(7)	B. J. Beard	D. J. Tucker	T. H. Morgan
Stanford University, Stanford University, Calif.	(8)	V. Siegfried	G. E. J. Jamart	F. C. Stockwell
Stevens Institute of Technology, Hoboken, N. J.	(3)	G. M. Border	G. J. Costello	L. Fussell
Swarthmore College, Swarthmore, Pa.	(2)	Lewis Fussell, Jr.	Robert H. Lamey	C. W. Henderson
Syracuse University, Syracuse, N. Y.	(1)	D. A. MacGregor	M. J. Wright	J. G. Tarboux
Tennessee, Univ. of, Knoxville, Tenn.	(4)	A. M. Howery		H. C. Dillingham
Texas, A. & M. College of, College Station, Tex.	(7)	T. M. Sowell		Wm. J. Miller
Texas Technological College, Lubbock, Texas	(7)	E. W. Street	W. L. Pearson	J. A. Correll
Texas, University of, Austin, Texas	(7)	W. E. Toepperwein	Wm. Webber	J. H. Hamilton
Utah, University of, Salt Lake City, Utah	(9)	Fred Lundberg	Ray Bohne	L. P. Dickinson
Vermont, University of, Burlington, Vt.	(1)	R. F. Bigwood	P. H. Thomas	S. W. Anderson
Virginia Military Institute, Lexington, Va.	(4)	W. T. Saunders	A. S. Britt, Jr.	Claudius Lee
Virginia Polytechnic Institute, Blacksburg, Va.	(4)	C. V. West		W. S. Rodman
Virginia, University of, University, Va.	(4)	H. R. Holt	C. H. Dickinson	O. E. Osburn
Washington, State College of, Pullman, Wash.	(9)	L. Engvall	E. W. Graf	H. G. Hake
Washington University, St. Louis, Mo.	(7)		P. Grivet	G. L. Hoard
Washington, University of, Seattle, Wash.	(9)	K. H. Ellerbeck	F. Buckman	A. H. Forman
West Virginia University, Morgantown, W. Va.	(2)	C. E. Moyers	G. H. Hollis	C. M. Jansky
Wisconsin, University of, Madison, Wis.	(5)	G. H. Brown	A. Norman O'Neill	J. O. Phelon
Worcester Polytechnic Inst., Worcester, Mass.	(1)	Albert M. Demont	William Sinclair	G. H. Sechrist
Wyoming, University of, Laramie, Wyoming	(6)	J. Earl Mowry		W. B. Hall
Yale University, New Haven, Conn.	(1)	E. R. Eberle	R. S. Newhall, 2nd	
Total 106				

AFFILIATED STUDENT SOCIETY

Brown Engineering Society, Brown University, Providence, R. I.

ORDER FORM FOR REPRINTS OF PAPERS ABRIDGED IN THIS ISSUE OF THE JOURNAL*

(October 1930)

Number	Author	Title
<input type="checkbox"/> 28-77	J. E. Clem	Arcing Grounds and Effect of Neutral Grounding Impedance
<input type="checkbox"/> 30-70	W. B. Kirke	The Calculation of Cable Temperatures
<input type="checkbox"/> 30-76	H. L. Hazen, O. R. Schurig and M. F. Gardner	The M. I. T. Network Analyzer
<input type="checkbox"/> 30-90	H. F. Brown	Railbonding Practise and Experience on Electrified Steam Railroads
<input type="checkbox"/> 30-102	F. W. Peek, Jr.	The Effect of Transient Voltages on Dielectrics—IV
<input type="checkbox"/> 30-116	C. B. Grady, W. H. Lawrence and R. H. Tapscott	The East River Generating Station
<input type="checkbox"/> 30-133	W. W. Edson	Transmission System Relay Protection—III
<input type="checkbox"/> 30-140	L. N. Crichton	High-Speed Protective Relays
<input type="checkbox"/> 30-146	F. J. Vogel and J. K. Hodnette	Grounding Banks of Transformers with Neutral Impedances
<input type="checkbox"/> 30-147	R. C. Powell	Steam Power Development
<input type="checkbox"/> 30-149	A. C. Schwager	Calculation of Mechanical Performance of Oil Circuit Breakers
<input type="checkbox"/> 30-151	O. K. Marti	New Trends in Mercury Arc Rectifier Developments
<input type="checkbox"/> 30-154	R. J. Corfield	Electricity's Part in Open Cut Copper Mining
<input type="checkbox"/> 30-155	F. O. McMillan and E. C. Starr	The Influence of Polarity on High-Voltage Discharges

*Members, Enrolled Students and subscribers are entitled to one complete copy of any paper abridged if it is requested within one year from date of its JOURNAL publication. Thereafter a charge of twenty-five cents per complete copy will obtain.

Name

Address

Please order reprints by number. Address Order Department, A. I. E. E., 33 West 39th Street, New York, N. Y.

DIGEST OF CURRENT INDUSTRIAL NEWS

NEW CATALOGUES AND OTHER PUBLICATIONS

Mailed to interested readers by issuing companies

Traffic Signals.—Bulletin GEA-566B, 20 pp. Describes "Novalux" electric traffic signals. General Electric Company, Schenectady, N. Y.

Floodlighting Projectors.—Bulletin GEA-161F, 28 pp., describes "Novalux" floodlighting projectors and their applications. General Electric Company, Schenectady, N. Y.

Electric Equipment for Cranes.—Bulletin GEA-1210, 32 pp. Describes electric equipment for cranes and illustrates typical applications. General Electric Co., Schenectady, N. Y.

Switchboard Instruments.—Catalog AE-48, describes the entire line of Roller-Smith switchboard type instruments; direct-current, alternating-current, thermocouple and instrument transformers. Roller-Smith Company, 12 Park Place, New York.

Die-Castings.—Bulletin, 24 pp. Describes and illustrates the use of aluminum alloys in die-castings for a wide range of applications. The properties of the metal and factors in die-casting are also defined. Aluminum Company of America, Oliver Building, Pittsburgh, Penna.

Temperature Control Gauges.—Bulletin TB-18, 8 pp., describes Trent automatic temperature control gauges for stabilizing industrial heat processes at any point up to 1000 deg. Fahr. Harold E. Trent Company, 439 North 12th Street, Philadelphia, Penna.

Terminal Electrification.—Bulletin GEA-1228, 12 pp., entitled "Cleveland Union Terminal Electrification." This preliminary bulletin describes the locomotives, substation apparatus, control, signal and protective equipment for this project. General Electric Co., Schenectady, N. Y.

Automatic Control.—Bulletin, 32 pp., entitled "The Era of Automatic Control." Illustrates the applications of Brown instruments in many industries in the automatic control of temperatures, pressures, flows, liquid levels and speeds. The Brown Instrument Company, Philadelphia, Penna.

Carrier-Current Telephony.—Bulletin GEA-546A, 12 pp. An elementary explanation of the operation of single-frequency, duplex, carrier-current telephone equipment as applied to high-voltage transmission lines. General Electric Co., Schenectady, N. Y.

Enclosed Motors.—Bulletin 2124, 4 pp., describes a new line of Allis-Chalmers totally enclosed, fan-cooled induction motors, squirrel cage type "ARZ," particularly adapted for use in locations where dust, fumes or moisture tend to shorten the life of motor windings. Allis-Chalmers Manufacturing Company, Milwaukee, Wis.

Air Operated Control Equipment.—Catalog 4000, 20 pp. Describes the new line of Bristol's air operated control equipment, applicable in many industries. In power plants, it may be used in stack temperature control, steam pressure regulation and for draft and damper control. The Bristol Company, Waterbury, Conn.

Pyrometers.—Catalog 15A, 104 pp. Describes Brown indicating, recording and automatic control pyrometers; profusely illustrated. A comprehensive resume of the theory and practise of applied pyrometry is presented, together with descriptions and illustrations of all instruments, thermocouples, protecting tubes and other required equipment. Brown Instrument Company, Philadelphia, Penna.

Sag Meter.—Bulletin, 8 pp., describes a new instrument, manufactured by the Askania Werke, A. G., in Germany, for measuring the definite amount of sag of individual spans and other distances that have to be determined on transmission lines, as distances of cables from railways, roads, rivers and wires of crossing lines, etc. American Askania Corporation, 622 Marine Bank Building, Houston, Texas.

Arc Welding of Structural Steel.—Bulletin 1879, 32 pp. The subjects covered include the strength of welded joints,

design data, test and inspection data, building code, estimating costs and bridge specifications. There are, in addition, numerous illustrations, a review of the progress made in structural arc welding and a discussion of future and possible developments. Westinghouse Electric & Manufacturing Company, East Pittsburgh, Penna.

Oil Circuit Breakers.—Bulletin 35, 16 pp. Describes Pacific Electric floor mounted oil circuit breakers for use on systems operating at voltages from 69 kv. to 230 kv. Interrupting capacities of these breakers range up to 2,500,000 kv-a. They are the first circuit breakers to be equipped with roller-bearings on the control shaft. Pacific Electric Manufacturing Corporation, 5815 Third Street, San Francisco, Calif.

Time Switch.—Folder, 8 pp. Describes the new Sangamo time switch, recently placed upon the market, which combines the experience of the Sangamo Electric Company, manufacturers of Sangamo watt-hour meters, and Hamilton, long-known as makers of precision watches. These time switches are available for any commercial voltage or frequency, alternating or direct current. The Sangamo time switch is the first step in the company's plan for a complete line of these instruments. It is also planned to include astronomical control in the development program. Sangamo Electric Company, Springfield, Ill.

NOTES OF THE INDUSTRY

General Cable Now One Unit.—Effective October 1, 1930 the sales, manufacturing and accounting operations of the following companies, which have operated as separate divisions, will be combined into a single organization—General Cable Corporation. These companies were the A-A Wire, American Insulated Wire & Cable, Detroit Insulated Wire, Dudlo Manufacturing, Peerless Insulated Wire & Cable, Phillips Wire, Rome Electrical, Rome Wire, Safety Cable, Standard Underground Cable, and Southern States Cable. A complete electrical wire and cable sales and engineering service is now available through 22 General Cable offices.

Cable Connector.—The Burndy Engineering Company, Inc., 230 East 45th Street, New York, has announced a cable connector for wires, cables and rod that, when once installed, can be locked. It is made of two parts and constructed of forged copper so that it will not corrode when exposed outdoors. It is also so designed that it will not nick the cable and invite accelerated breakage, since many installations are outdoors where they sway in the wind.

A Dry Electrolytic Condenser.—A new, self-healing, high-voltage electrolytic condenser has been placed upon the market by the Concourse Electric Co., 294 East 137th Street, New York. The condenser is made in several types and is absolutely dry, and its makers claim that it has a better power factor efficiency than the old type condenser. It is recommended especially for operation under peak loads of 500 or more volts. Capacities range from 1 MFD or less to 200 MFD or more.

Westinghouse Orders.—Recent orders placed with the Westinghouse Electric & Manufacturing Company include two 196/230 kv. oil circuit breakers with a published interrupting capacity of 2,500,000 kv-a., for the Southern California Edison Company. The shipping weight, including the oil, will be 246,000 pounds per breaker, and the quantity of oil used will be 16,200 gallons for each breaker. The Pacific Gas & Electric Company has placed an order for two oil circuit breakers, rated at 1200 amperes and 196/230 kv., with a published interrupting capacity of 1,500,000 kv-a., at 230 kv.

The New Kanawha Power Company, a subsidiary of the Union Carbide & Carbon Corporation, has awarded a contract to the Westinghouse Company for four 30,000 kv-a., 3-phase, 6900-volt, 25-cycle, 150 r. p. m., vertical water wheel generators with direct connected and pilot exciters. The generators will be installed on the New River, West Virginia.

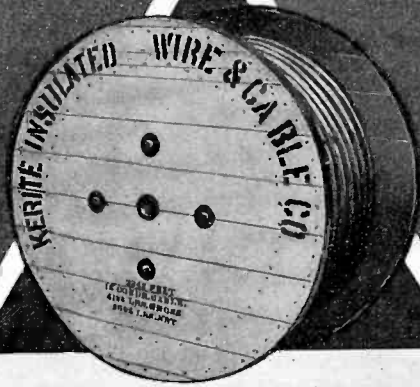

The careful investor judges a security by the history of its performance.

KERITE

in three-quarters of a century of continuous production, has established a record of performance that is unequalled in the history of insulated wires and cables.

Kerite is a seasoned security.

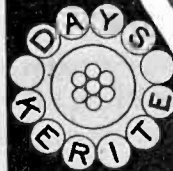

THE KERITE INSULATED WIRE & CABLE COMPANY INC
 NEW YORK CHICAGO SAN FRANCISCO

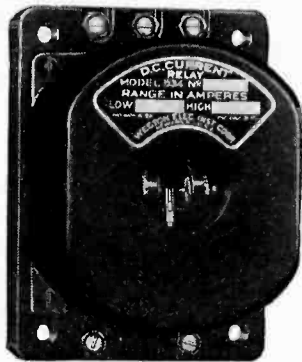

Model 534
Surface Type



Model 30

Model 534
Flush Type



The BRAIN of the ROBOT

WITHIN recent years, the inventive genius of Industry has given to machines fingers that feel, eyes that see, ears that hear, noses that smell, tongues that taste. Yet when it came to the brain, the means to intercept, translate and direct the stimuli to produce the desired reactions, Industry turned to Weston. This time it was for special adaptations of the Weston Direct Current Relays.

As in the past 42 years, during which time Industry has laid thousands of electrical measuring and testing problems on Weston's doorstep, the Weston laboratories again provided the necessary instruments; built in the typical Weston manner — not only to meet specification requirements, but to be dependable and faithful in service.

Weston direct current relays have proven extremely flexible in their application, having been made for hundreds of different uses and in thousands of ranges. They have been employed in regulating currents or voltages within definite narrow limits, in operating signals and alarms, automatic control apparatus of many types and in conjunction with light-sensitive cells.

The Weston Engineering Department will be glad to apply its accumulated knowledge and experience to any particular relay problem you may have.

WESTON ELECTRICAL INSTRUMENT CORP.

584 Frelinghuysen Avenue

Newark, New Jersey



Please mention the JOURNAL of the A. I. E. E. when writing to advertisers.

the New
SANGAMO
TIME-SWITCH

IS DESIGNED BY ENGINEERS TO MEET
 ENGINEERING IDEAS OF PERFORMANCE

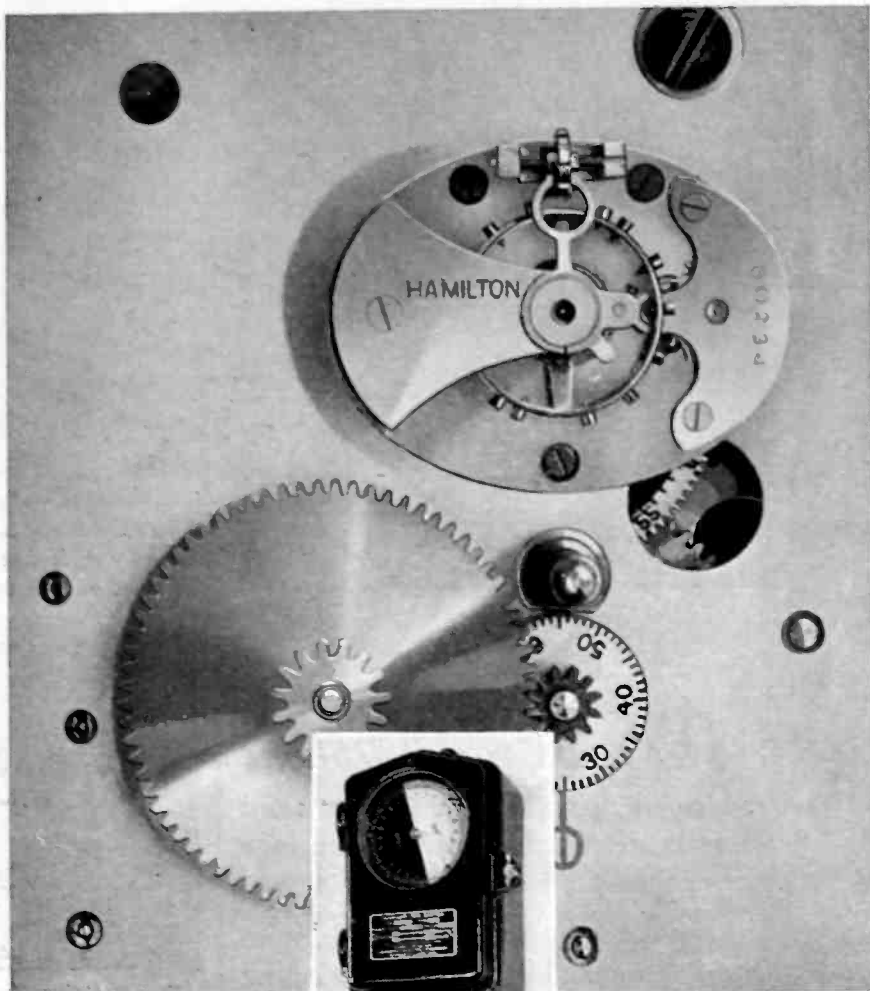

Close-up of the escapement of the Sangamo Time-switch with cover open, with dial off and with dust cap for escapement removed. Precision of design and construction is evident throughout. Accurate adjustment of clock movement is assured by micrometer adjustment provided on escapement.

Precise synchronization of switching operation with clock movement is effected by dial located below the escapement. Inset: Sangamo Time-switch with meter terminal base.

THE Sangamo Time-switch has been designed and constructed to measure up fully to every engineering requirement of performance: accurate time-keeping, operation through current interruptions, independence of frequency and voltage variations, suitability for a. c. or d. c. operation.

The Sangamo Time-switch embodies the high-grade construction of the Hamilton-Sangamo clock. The clock mechanism is a standard Hamilton-Sangamo movement with a jeweled Hamilton escapement, temperature compensated, and equipped with a micrometer adjustment, providing perfect regulation without removing the protecting dust cap.

The switch mechanism is actuated by the mainspring through a differential gear. It is not affected by current interruptions, because the mainspring is kept at a constant tension by a noiseless Sangamo Motor.

The 24-hour dial is arranged to provide one "open" or "close" operation, as frequently as every fifteen minutes through a 24-hour cycle.

All working parts are readily accessible, removable as units and interchangeable. This results in low cost operation and maintenance.

Sangamo Time-switches are available with H C Meter terminal chamber or conduit-connected base.

Send for literature.

SANGAMO ELECTRIC COMPANY, SPRINGFIELD, ILLINOIS

Backing up your Telephone—



The Man in the Iron Mask—electro-welding a switchboard frame—is one of many skilled workers who see that every part is made right.



Wire Enough in a Single Telephone Exchange to span the United States three and a quarter times!

To make your telephone and back it up with all the apparatus and supplies needed for your service is a work of infinite variety.

Buying rubber from Singapore, mica from India, conduit from Ohio—Making each year a million telephones, 15,000 miles of cable, switchboards by the trainload—Distributing supplies to 32 warehouses, holding them ready for the nation's telephone companies—Installing the equipment in all the telephone exchanges—

All this is the responsibility of Western Electric—whose dependable service of supply helps make possible dependable telephone service.



From Pencils to Telephone Poles everything the Bell Telephone System uses is found in Western Electric's market basket.

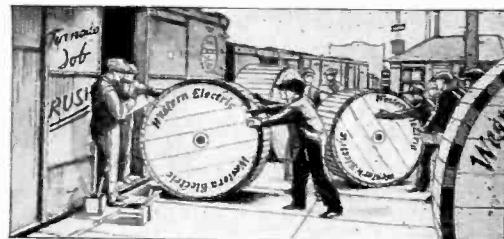

Meeting Emergencies is the real test of a service. Western Electric's system of supply distribution is always ready!

Western Electric



MAKERS
OF YOUR
TELEPHONE

Please mention the JOURNAL of the A. I. E. E. when writing to advertisers.

Let JEWELL Solve « « « Your Instrument Problems!



*Some details of this sound
picture analyzer built
by Jewell*

- 1 Provides filament, control grid, screen grid, and plate readings.
- 2 Provides complete tube test under operating conditions through change of grid bias potential.
- 3 Provides output measurement for checking both volume and quality. (Used in conjunction with a record having variable pitch, constant frequency notes.)
- 4 Provides means for measuring photo electric cell current and grid current on microammeter with ranges of 15 and 150 microamperes.
- 5 Measures continuity and resistances.
- 6 Provides means for phasing dynamic speakers.
- 7 Binding posts make all ranges available for special testing.
- 8 Operation is simple and rapid.

WHY worry about correct testing facilities for either production, installation or service testing?

Many of the most prominent radio manufacturers have formed the profitable habit of turning their special instrument problems over to Jewell, where they are solved better, quicker, and for less actual cost by skilled instrument engineers.

The Sound Picture Installation Analyzer illustrated is a typical example of special instruments designed and built by Jewell to meet the exacting requirements of some of the foremost manufacturers and users.

Hundreds of similar cases can be shown. It's interesting to note that when a manufacturer once learns how economically and effectively Jewell can solve such problems for him that he keeps coming back with new ones.

The next time you are confronted with a special instrument requirement, no matter how simple or how difficult, call in the nearest Jewell Representative and let him show you what we can do for you.

JEWELL ELECTRICAL INSTRUMENT COMPANY
1650 Walnut St., Chicago, Illinois, U. S. A.

30 YEARS MAKING GOOD INSTRUMENTS
JEWELL



There's More Information In ONE Chart Record than a week's batch of ordinary reports . . .

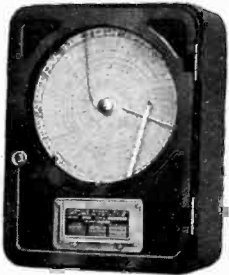

Round Chart Instrument furnished with choice of 24-hour or 7-day clock movement—to give complete daily or weekly records.

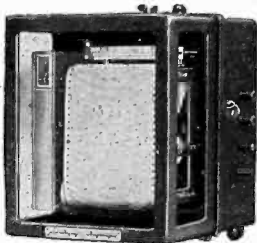

Strip Chart Recording Instruments; suitable for test work where it is desired to obtain continuous operating records over a period of several days or weeks.

To meet present day demands for greater operating economy and at the same time anticipate future production conditions, calls for careful, accurate analysis of existing operating methods and equipment.

This analysis must be based upon FACTS . . . such as those provided automatically by BRISTOL'S Recording instruments . . . concise accurate chart records of daily or weekly operating conditions that leave no room for doubt.

Whether it be temperature, pressure, speed, humidity, electrical condition, power consumption or some other condition of operation . . . Bristol's Recording Gauges, Thermometers, Pyrometers, Voltmeters, Ammeters, Wattmeters, etc., give the complete story.

Bristol's field service engineers will gladly suggest the instruments that will give best results. Write or wire for consultation. No obligation.

THE BRISTOL CO., Waterbury, Conn.

BRANCH OFFICES:

Akron
Boston
St. Louis

Philadelphia
Denver
Chicago

Pittsburgh
Los Angeles
Detroit

New York
Birmingham
San Francisco

BRISTOL'S Recording Instruments

Uninterrupted Service <<<

results from regular testing

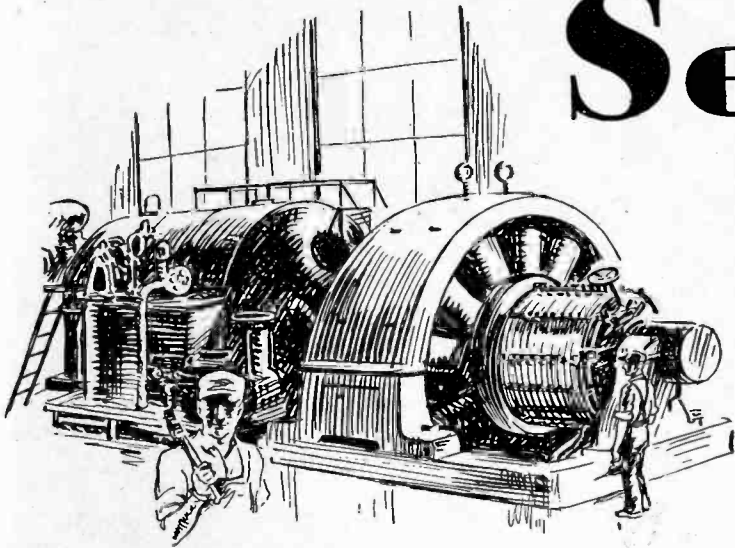

In order to maintain standard maximum performance, constant testing of materials is required of power companies and manufacturers and users of cable, insulation, and other electrical apparatus carrying high voltages.

The American Transformer Company builds several types of High Voltage Testing Transformers designed for various testing applications. These can be supplied in sizes from 5 to 500 KVA, voltages up to 300,000 volts.

The illustration shows a 50 KVA, 150,000 volts, 60 cycle, testing transformer, oil-immersed, self-cooled, with one end permanently grounded. It has an oil-filled, porcelain type high tension bushing on one end of the secondary winding, the other end being brought to a low tension terminal to be grounded through a meter. By this means it is possible to measure the high tension current in the secondary. This set is equipped with standard voltmeter coil, and separate regulating apparatus can be supplied.

Whatever may be your need in transformers, we can supply it. Many large companies* call upon our engineering staff for special transformers to meet unusual requirements. For descriptions of several of our regular line of high voltage transformers, write for Bulletins, 1035 and 1130.

AMERICAN TRANSFORMER COMPANY

180 Emmet Street

Newark, N. J.

*Names on request.

Representatives

Atlanta, Ga.—H. Douglas Stier, 101 Marietta Street	Montreal, Canada—W. O. Taylor & Co., Ltd., 415 Canada Cement Bldg.
Boston, Mass.—Electrical Apparatus Sales Co., 10 High Street	Philadelphia, Pa.—L. D. Joralemon, 112 South 16th Street
Chicago, Ill.—Westburg Engineering Co., 53 W. Jackson Blvd.	San Francisco, Calif.—James H. Southard, 682 Mission Street
Knoxville, Tenn.—Arthur L. Pollard	St. Louis, Mo.—J. W. Jones, 432 Pennant Building
Minneapolis, Minn.—Elliott Equipment Co., 708 Sixth Avenue, South	



50 KVA—150,000 Volt
Testing Transformer

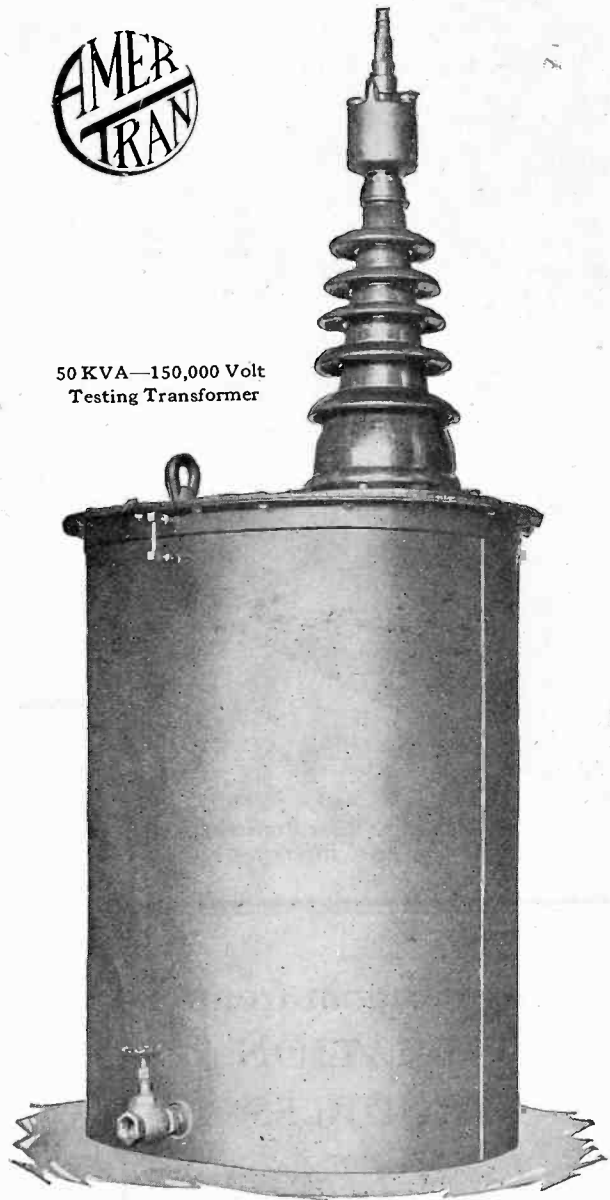

AMERICAN TRANSFORMERS

Please mention the JOURNAL of the A. I. E. E. when writing to advertisers.

ANACONDA

from mine to consumer

REG. U.S. PAT. OFF.

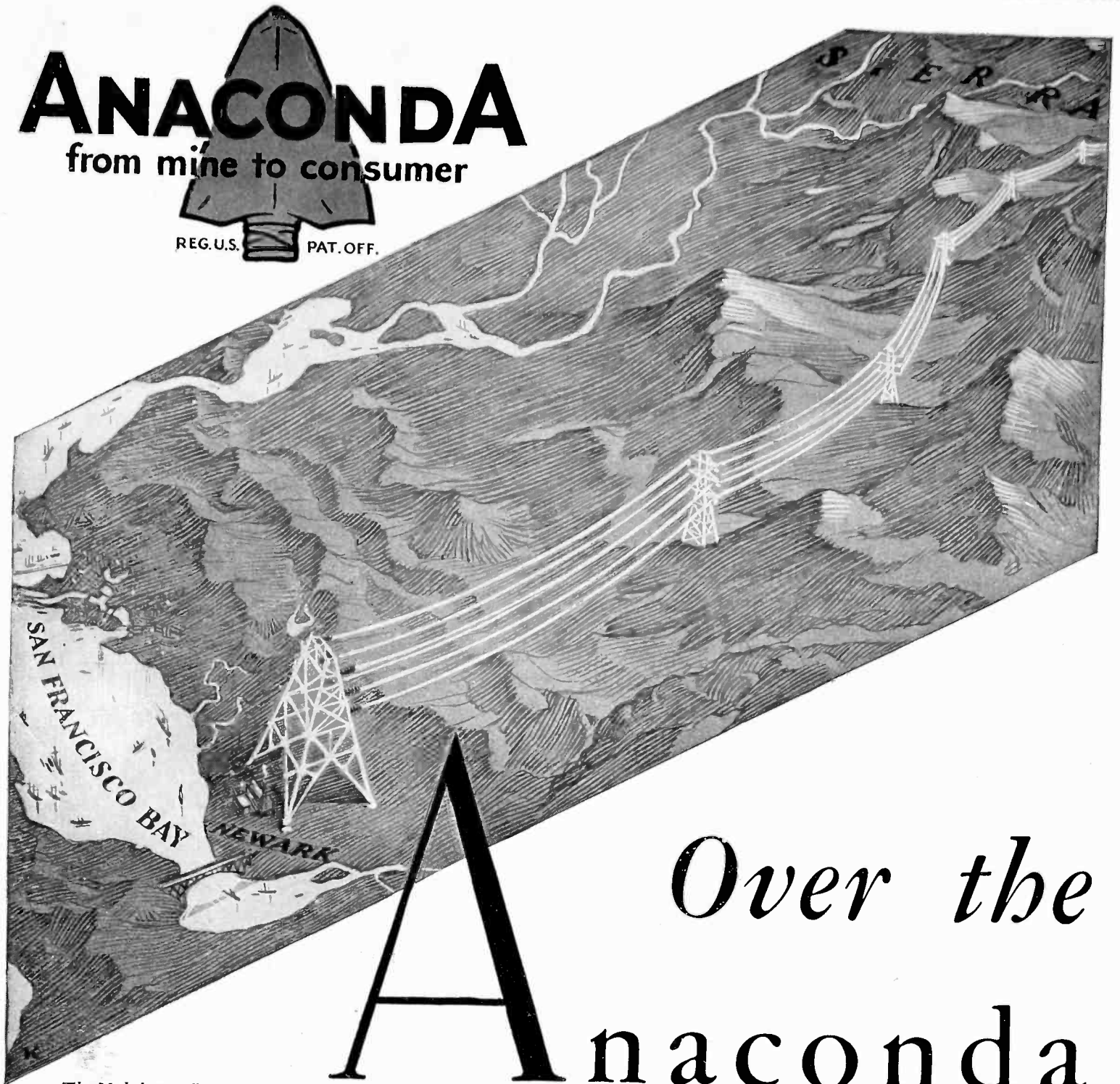

The Mokelumne River Project of Pacific Gas and Electric Co.

A Over the Anaconda

For Freedom from
VIBRATION
TROUBLES
Use Non-Ferrous
Non-Corrosive
ANACONDA
Wire and Cable
Conductors

From Tiger Creek in the Sierra Nevada mountains to Newark on San Francisco bay, Pacific Gas and Electric Company will erect a 220 kv transmission line in connection with their Mokelumne River project. For this construction Anaconda will supply 4,250,000 lbs. of its Hollow Conductor, the largest individual order ever released for this type of copper cable.

Pacific Gas and Electric Company chose Anaconda Hollow Conductor only after the most exhaustive studies by P. G. & E. and Anaconda engineers, in collaboration with the staff of the Ryan High Voltage Laboratory of Leland Stanford University. Tests conclusively showed this cable ideally adapted for use in the mountainous terrain over which the line will run. Its ruggedness withstands the necessary

ANACONDA WIRE

General Offices: 25 Broadway, New York City

Please mention the JOURNAL of the A. I. E. E. when writing to advertisers.

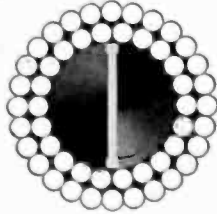
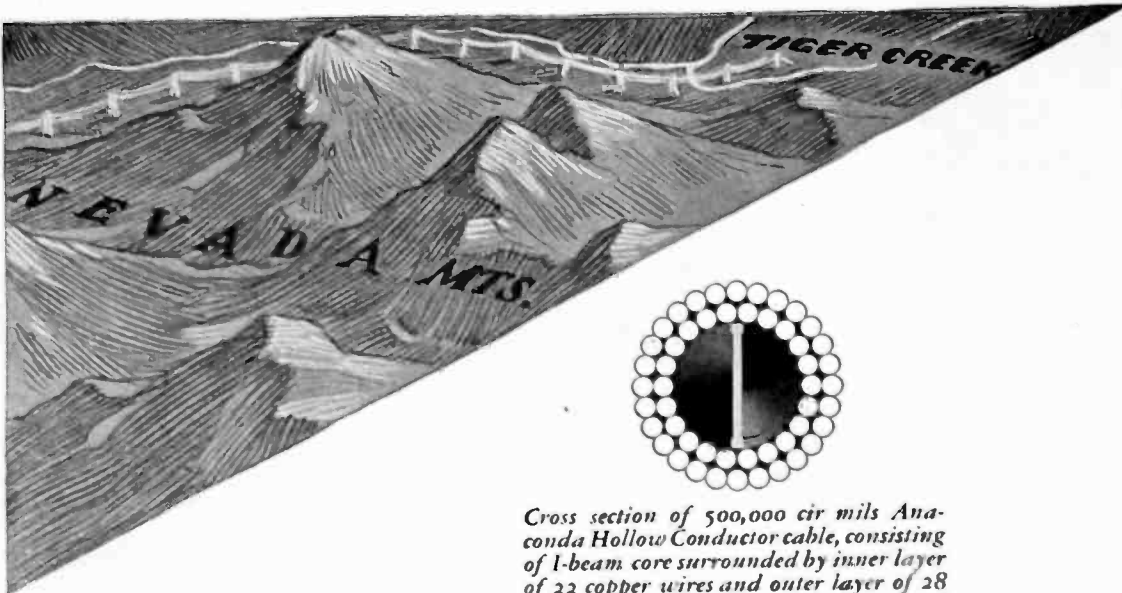

Cross section of 500,000 cir mils Anaconda Hollow Conductor cable, consisting of 1-beam core surrounded by inner layer of 22 copper wires and outer layer of 28 copper wires, both layers of medium hard drawn temper to meet P. G. & E. specifications; outside diameter, 1 inch; minimum breaking strength, 19,350 lbs.

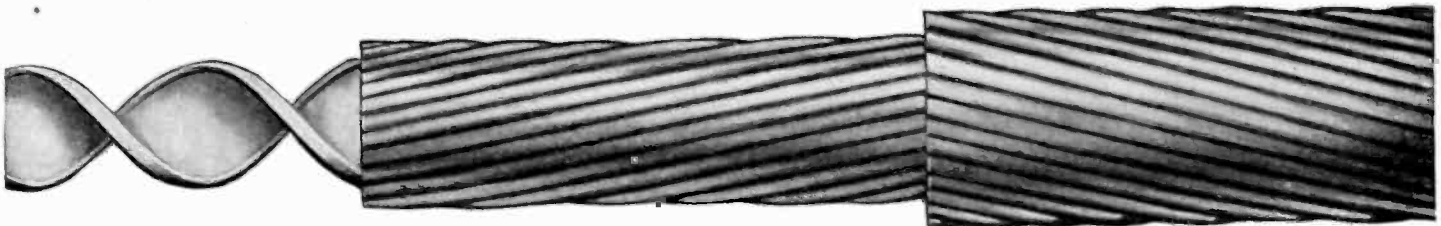

Longitudinal section of Anaconda Hollow Conductor cable.

mountains to the sea

Hollow Conductors

mechanical abuse, and yet it can be handled as easily as an ordinary stranded cable. It makes possible the reduction of corona and the elimination of skin effect losses.

Anaconda engineers perfected the connectors that will be used with the cable, each length being furnished with half sections of Anaconda seamless connectors to be joined later in the field by Bronze coupling nuts . . . Complete details of the cable as well as of the connectors will be furnished on request.

Again Anaconda demonstrates its ability to supply the industry with *wires and cables for every electrical requirement* . . . again invites engineers and purchasing agents to avail themselves of the technical knowledge and the vast manufacturing facilities of the Anaconda organization.

& CABLE COMPANY

Chicago Office: 20 North Wacker Drive Building

There is an
ANACONDA
CABLE
for every
Transmission
and
Distribution
Requirement



(Left) The Type PM-12 oscillograph with film holder in place for photographing recurrent phenomena

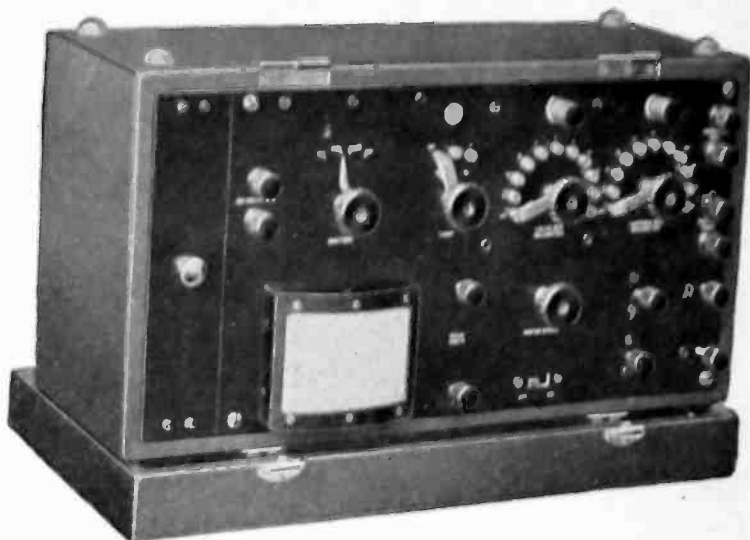

(Right) The Type PM-12 oscillograph, with viewing screen, as ordinarily used in classroom demonstration

This new two-element OSCILLOGRAPH *is a simple, portable instrument*

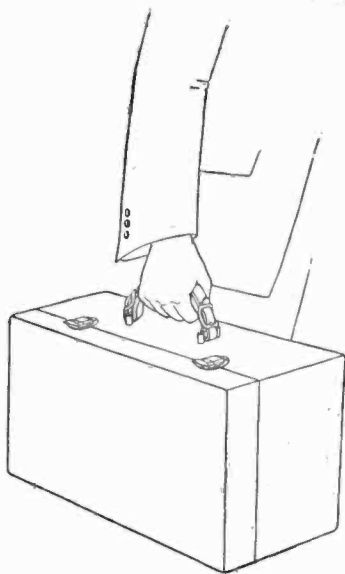

JOIN US IN THE GENERAL
ELECTRIC PROGRAM, BROAD-
CAST EVERY SATURDAY EVE-
NING ON A NATION-WIDE
N.B.C. NETWORK

THIS portable oscillograph is self-contained, and weighs only 30 lb., including the accessories in a built-in compartment.

It is an entirely new design for observing and photographing the *wave shapes* of the circuit current and voltage, just as an ammeter and a voltmeter indicate the *effective value* of current and voltage.

For use in the field, in the laboratory, or in the classroom, this oscillograph is truly portable, shows wave forms in proper phase relation, and is so simple that anyone can operate it.

The case is of high-grade walnut.

Described in Bulletin GEA-1209A.

GENERAL ELECTRIC 610-52
SALES AND ENGINEERING SERVICE IN PRINCIPAL CITIES

Please mention the JOURNAL of the A. I. E. E. when writing to advertisers.

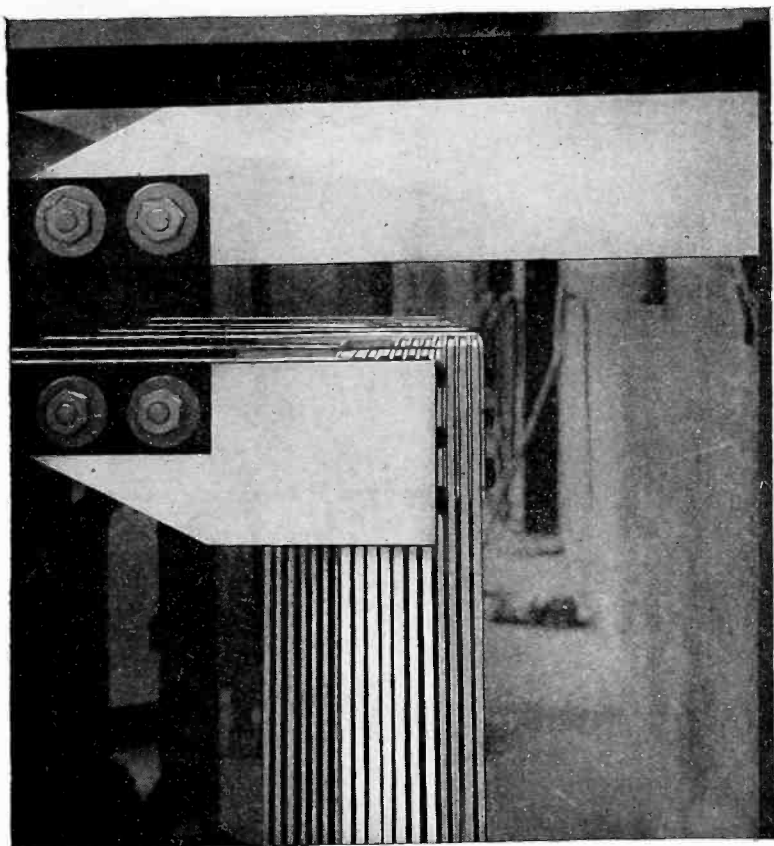

The 48

1/4" x 10" Aluminum Bars in this big job were easily formed

Light in weight—over 50% lighter than any other busses—Alcoa Aluminum Bus Bars are worked with surprising ease. Use them—bending, assembling and erection are speeded up—labor costs are saved.

Because of these advantages Alcoa Aluminum Bus Bars were used to connect the world's largest circuit breaker. The picture is a view of the rear of the panel board showing the connection of eight 1/4 in. x 10 in. Alcoa Aluminum Bus Bars per group. There are six groups per terminal. The upper terminal leads directly to the load. The lower terminal connects to a vertical riser from the common bus under the main floor of the station.

Unit for unit, for large or small jobs, Alcoa Aluminum Bus Bars are cheaper to use because for the same conductance the required weight is only half that of other metals commonly used. Another unique advantage of Alcoa Aluminum Bus Bars is that they have a much lower operating temperature.

A representative will be glad to call and discuss the advantages of Alcoa Aluminum Bus Bars for any installation you may have in mind. Let us send you the booklet, "Alcoa Aluminum Bus Bars", showing tables of weights, carrying capacities and other technical data. Address ALUMINUM COMPANY of AMERICA, 2448 Oliver Building, PITTSBURGH, PA.



TRADE MARK BUS BARS MADE OF

ALCOA ALUMINUM

Please mention the JOURNAL of the A. I. E. E. when writing to advertisers.

OB
Watt-hour Meters

Overall Accuracy



Single-Phase



Detachable

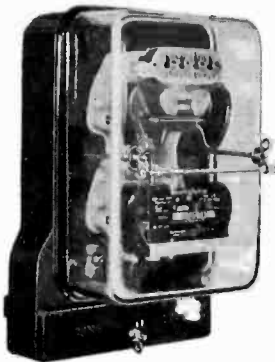

Polyphase

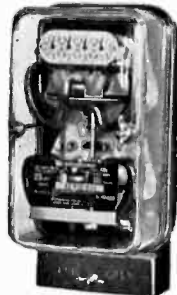

Network

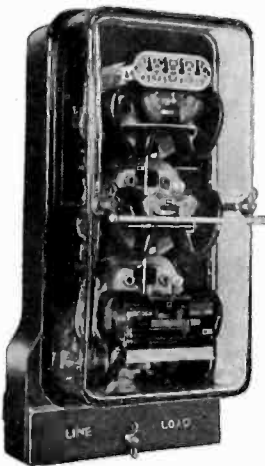

Three-Element

PROTECTS
your income

THE superior overall accuracy of Westinghouse Type OB Watt-hour Meters protects your income; lays the foundation for a proper return on your investment in the central station system; and assures justness to both the central station and the consumer.

Other advantages of type OB meters are: ability to register accurately under all load conditions and to maintain this accuracy during long periods with minimum attention and expense; reliability; low internal losses; independence of normal variations of temperature, voltage, power factor, wave form, and frequency; ability to start at very light loads and capacity for overloads. They are compact and of strong mechanical construction, easy to install and to test.

An indicating demand attachment or contacts for use with demand devices can be supplied with all OB meters. The polyphase meters can be supplied, if desired, with open potential lamp indicators, at a small extra charge.

The meter specialist in our sales office near you is at your service.

Service, prompt and efficient, by a coast-to-coast chain of well-equipped shops

Westinghouse

T 31243-A

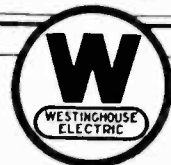

TUNE IN THE WESTINGHOUSE SALUTE OVER THE N. B. C. NATION-WIDE NETWORK EVERY TUESDAY EVENING.

Please mention the JOURNAL of the A. I. E. E. when writing to advertisers.

U-Re-Lite All-Steel Distribution Groups

The Multumite Type

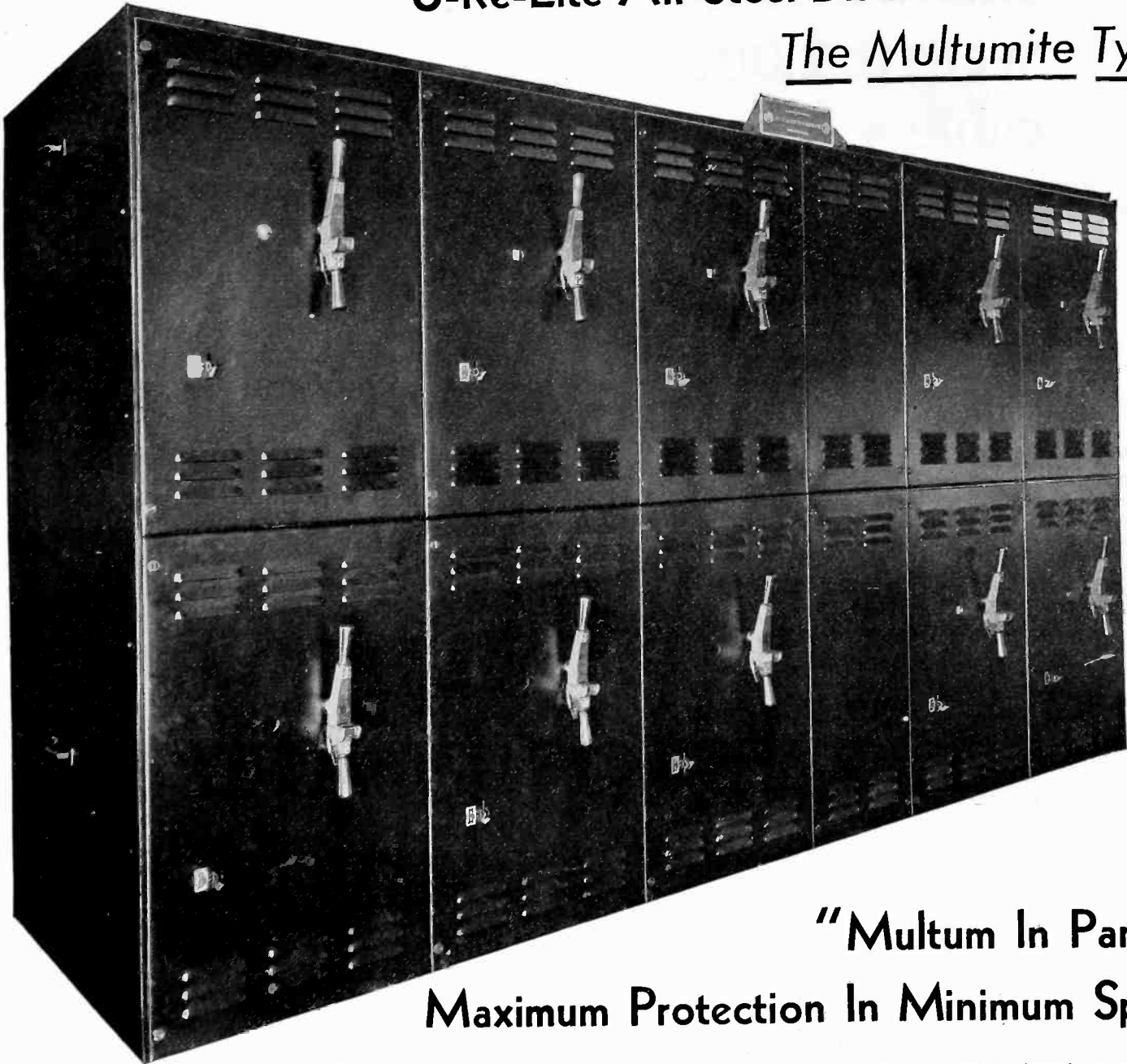

"Multum In Parvo"

Maximum Protection In Minimum Space

This Multumite Group is 13'-4" wide, 7'-10" high, and 3'-9" deep. Occupying only 50 square feet of floor space, it offers the following advantages:

1. Positive overload and short circuit protection of ten 1250 ampere circuits at 550 volts, 3 phase, 60 cycles.
2. Rupturing capacity of 40,000 amperes.
3. Absolute safety to operators—every live part enclosed in steel.
4. Remote solenoid control with hand control for emergency.
5. Disconnects on the line and load side of each breaker.
6. Disconnects for control circuit.
7. Easy inspection of breakers by opening doors.
8. Custom built—from standard parts—to exactly fit your requirements.

Get in touch with our nearest representative for data on a Multumite Group to protect and control your circuits.

I-T-E CIRCUIT BREAKER COMPANY, 19th and HAMILTON STS., PHILADELPHIA

Birmingham, Crawford Bldg.; Boston, 201 Devonshire; Buffalo, Ellicott Sq. Bldg.; Chicago, 333 N. Michigan Ave.; Cincinnati, Union Trust Bldg.; Cleveland, Terminal Tower Bldg.; Denver, Tramway Bldg.; Detroit, Penobscot Bldg.; Duluth, Providence Bldg.; Kansas City, Midland Bldg.; Los Angeles, 106 W. 3rd; Minneapolis, Plymouth Bldg.; Montreal, 151 LaGauchetiere St. West; New Orleans, 708 Girod St.; New York, 12 E. 41st; Omaha, Electric Bldg.; Philadelphia, 1505 Race; Pittsburgh, Grant Bldg.; St. Louis, Bank of Commerce Bldg.; San Francisco, Call Bldg.; Seattle, 802 33rd Ave.; Toronto, 149 Adelaide St. E.; Vancouver, 500 Beatty Street; Winnipeg, National Carriage Office Building.

I-T-E PROTECTION

U-RE-LITES ~ I-T-E CIRCUIT BREAKERS

Please mention the JOURNAL of the A. I. E. E. when writing to advertisers.

—and when their work
went to 2,000,000-c.m.
cable

—they still used
the **DOSSERT**
principle

The photo shows a Dossert Terminal for connecting with 2,000,000-c.m. cable.

Without change in the basic Dossert principle, **SPECIAL** connectors may be supplied to meet any engineer's need in connecting cables, stranded or solid wires, rods or tubing.

The Dossert book showing the complete standard line and also giving valuable data on wires and cables will be sent upon request.

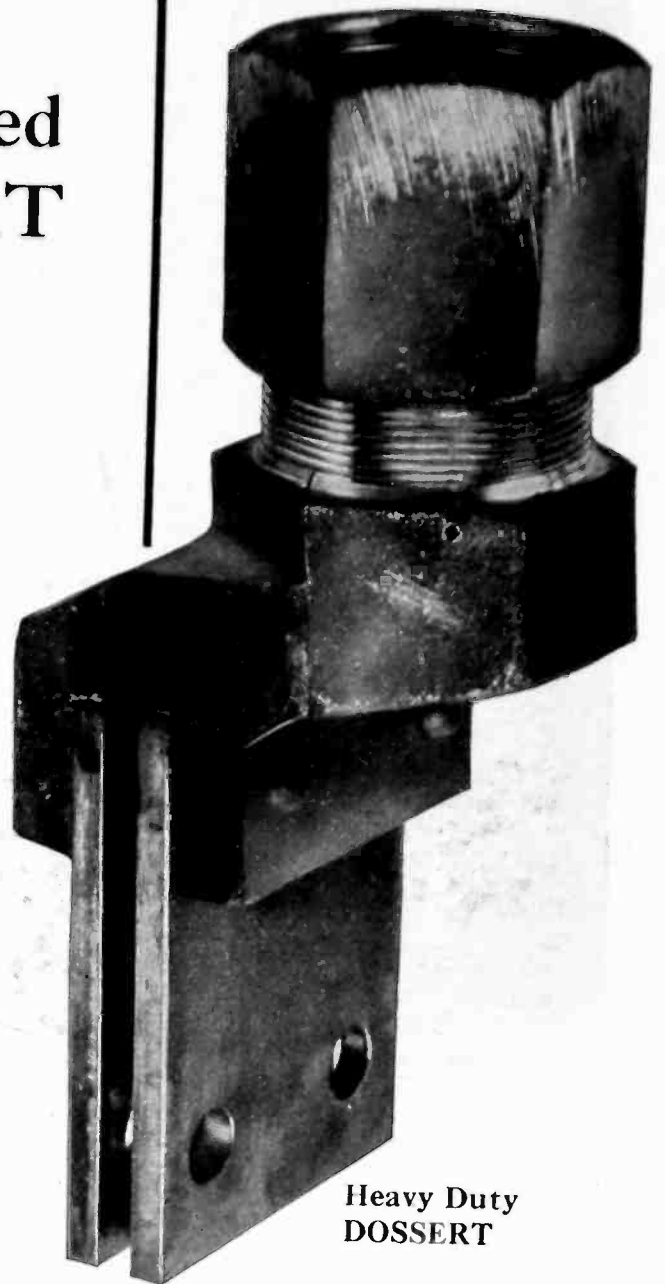

Heavy Duty
DOSSERT

DOSSERT & COMPANY

H. B. LOGAN, President

242 West 41st St., New York, N. Y.

Connect with
DOSSERTS

Please mention the JOURNAL of the A. I. E. E. when writing to advertisers.

Cables of Quality... as Measured by Service

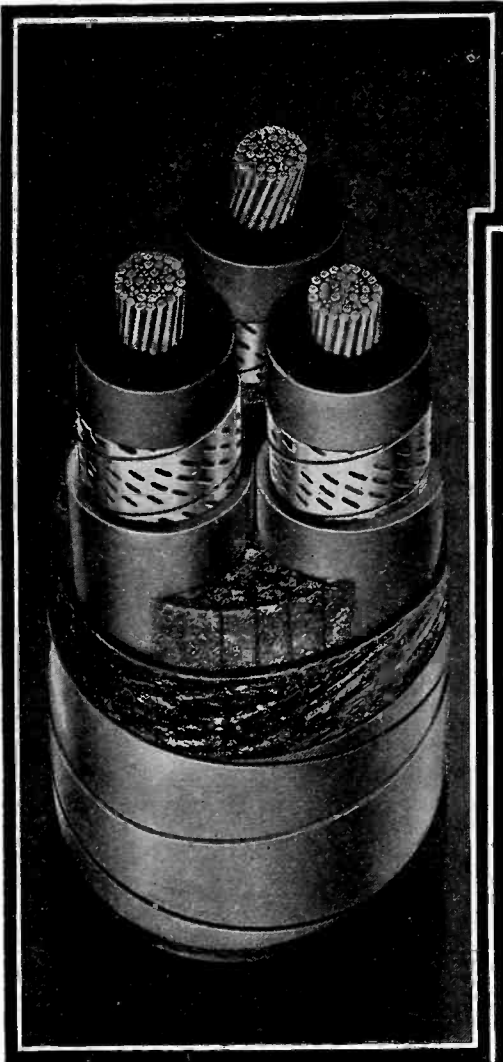

TRIPLE SHEATHED
44KV Buried Cable
Highest Voltage Multiple Conductor Buried Cable in this Country.

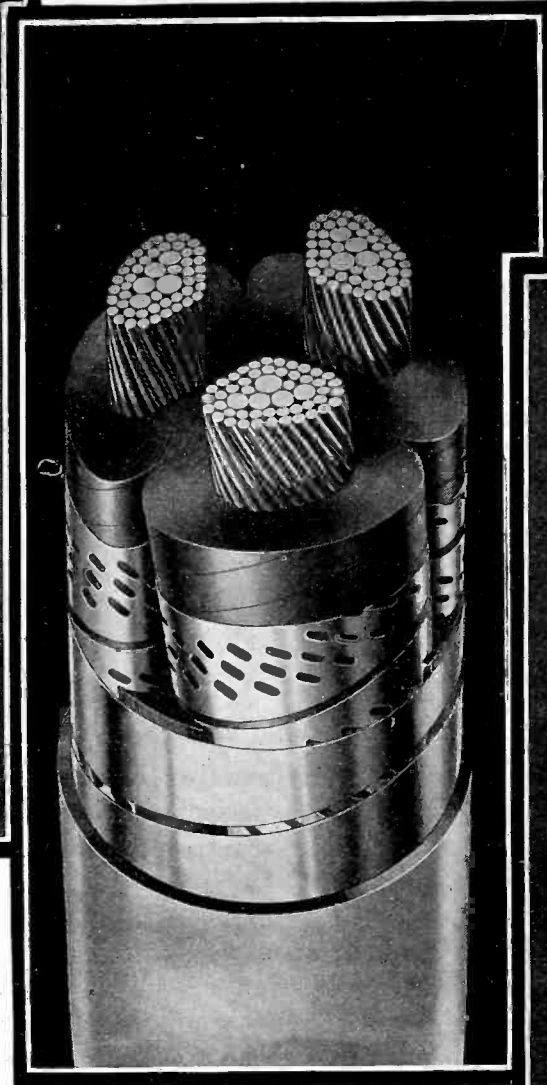

TYPE "H"
For Aerial and Duct Installation.
Hundreds of "Mile Years" of Operation Without a Failure.

TRIPLE "L"

Lead Less Laid

Submarine Cable

Hundreds of installations—some 9 miles in length, some 750 feet deep, some at 27.6KV, some 25 years old—all giving perfect service.

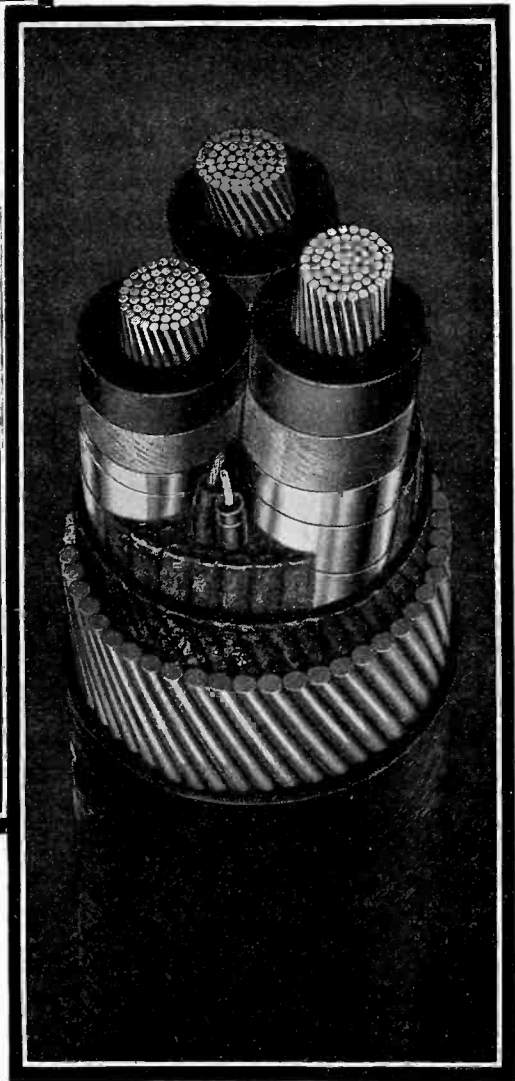

AMERICAN STEEL & WIRE COMPANY

SUBSIDIARY UNITED STATES STEEL CORPORATION

208 S. La Salle Street, Chicago
Other Sales Offices: Atlanta Baltimore Birmingham
Denver Detroit Kansas City Memphis Milwaukee
Pittsburgh Salt Lake City St. Louis
Pacific Coast Distributors: Columbia Steel Company,
San Francisco Los Angeles Portland Seattle Honolulu



30 Church Street, New York
Boston Buffalo Cincinnati Cleveland Dallas
Minneapolis-St. Paul Oklahoma City Philadelphia
Wilkes-Barre Worcester
Export Distributors: United States Steel Products Co.,
30 Church St., New York City

1930

1930

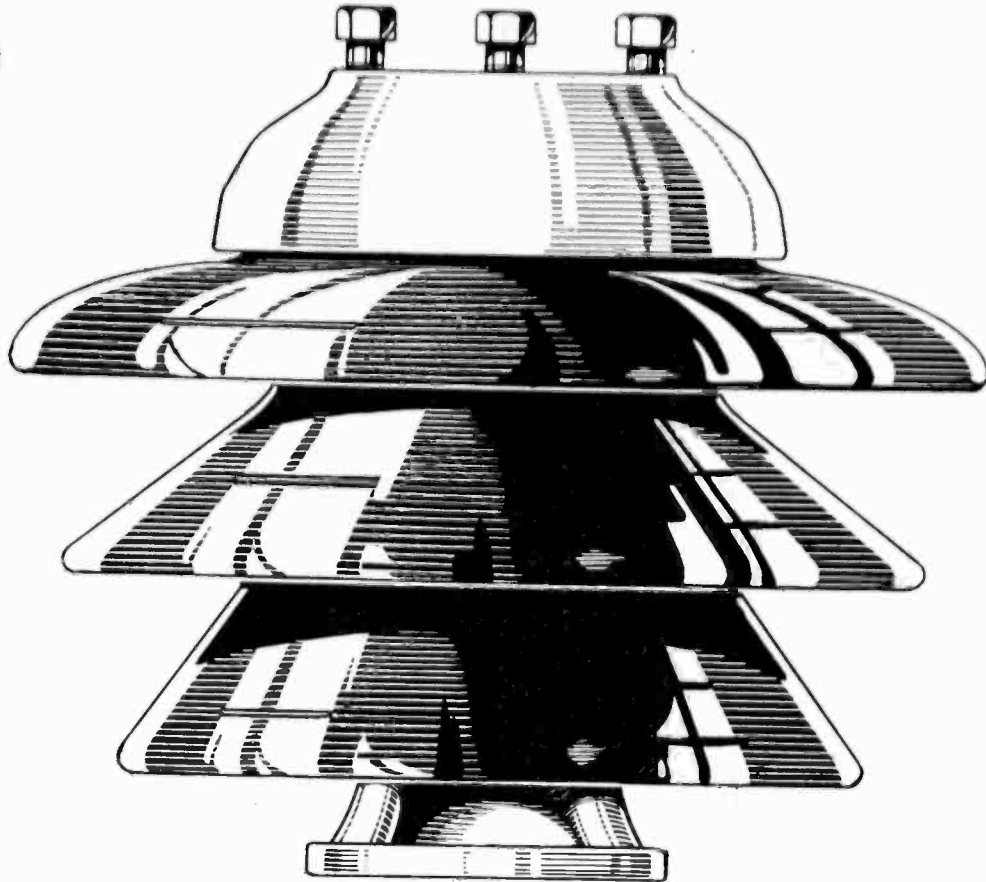

PERFORMANCE IS THE ONLY MEASURE OF QUALITY

Only a very few of the features that are responsible for the performance of an insulator are visible features. Assembly, however, is one vital factor you can to a certain extent check for yourself.

When you look at an assembled insulator be sure that the cement joints are narrow and that the cement is obviously dense: See that all exposed joints are waterproofed: Be certain that all metal parts are clear of the porcelain: Or, simpler still, specify Locke Insulators—insulators whose performance records have endorsed every step of their design and manufacture.

LOCKE

PORCELAIN INSULATORS

LOCKE INSULATOR CORPORATION • • BALTIMORE, MARYLAND

Please mention the JOURNAL of the A. I. E. E. when writing to advertisers.

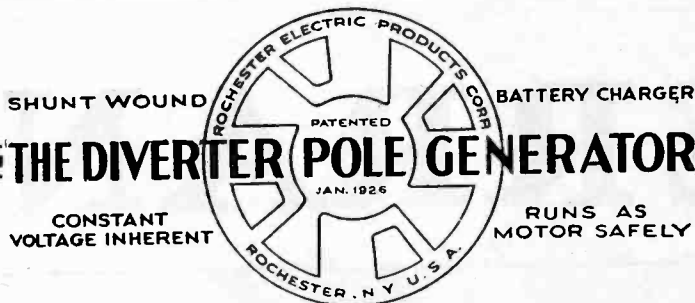

FOR ALL KINDS OF BATTERY CHARGING—WITH SAFETY & ECONOMY

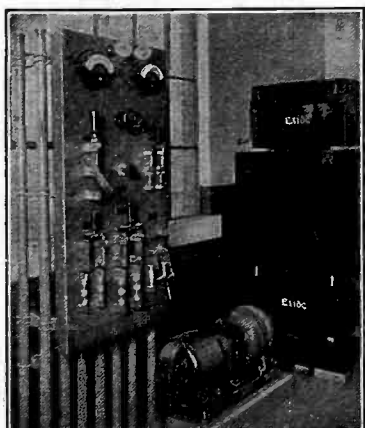

A Diverter Pole Generator set floating with a bus control battery in an automatic substation. The trickle charge is regulated by the counter E. M. F. of the battery. The generator voltage drops rapidly when load on battery exceeds the generator rating. Generators as small as 250-watt and as large as 50-kw. are now in this class of service.

A Diverter Pole Generator set floating with an automatic telephone exchange battery. The generator carries the normal exchange load and maintains the battery in a fully charged condition ready to furnish power in any emergency.

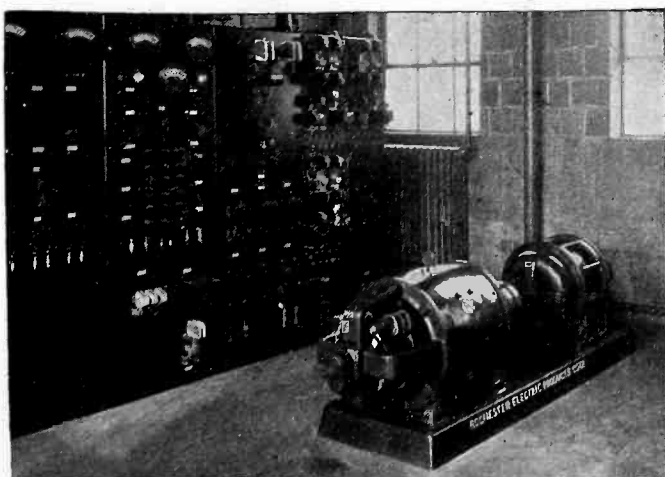
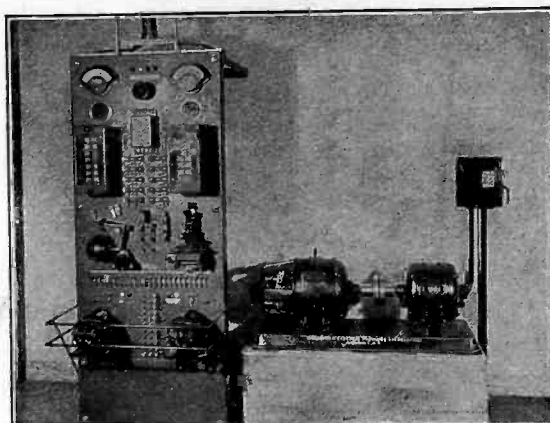

A Diverter Pole Generator driven by a synchronous motor floating [with a standby battery in a railroad classification yard. The generator normally carries the d-c. switching load, etc. In case of failure of commercial power, the generator takes energy from the battery and the synchronous motor acts as a generator and furnishes a-c. power for signal operation, etc.

ELECTRIC PRODUCTS COMPANY, 1725 Clarkstone Road, CLEVELAND, OHIO

Successors to

ROCHESTER ELECTRIC PRODUCTS CORP.

FERRANTI

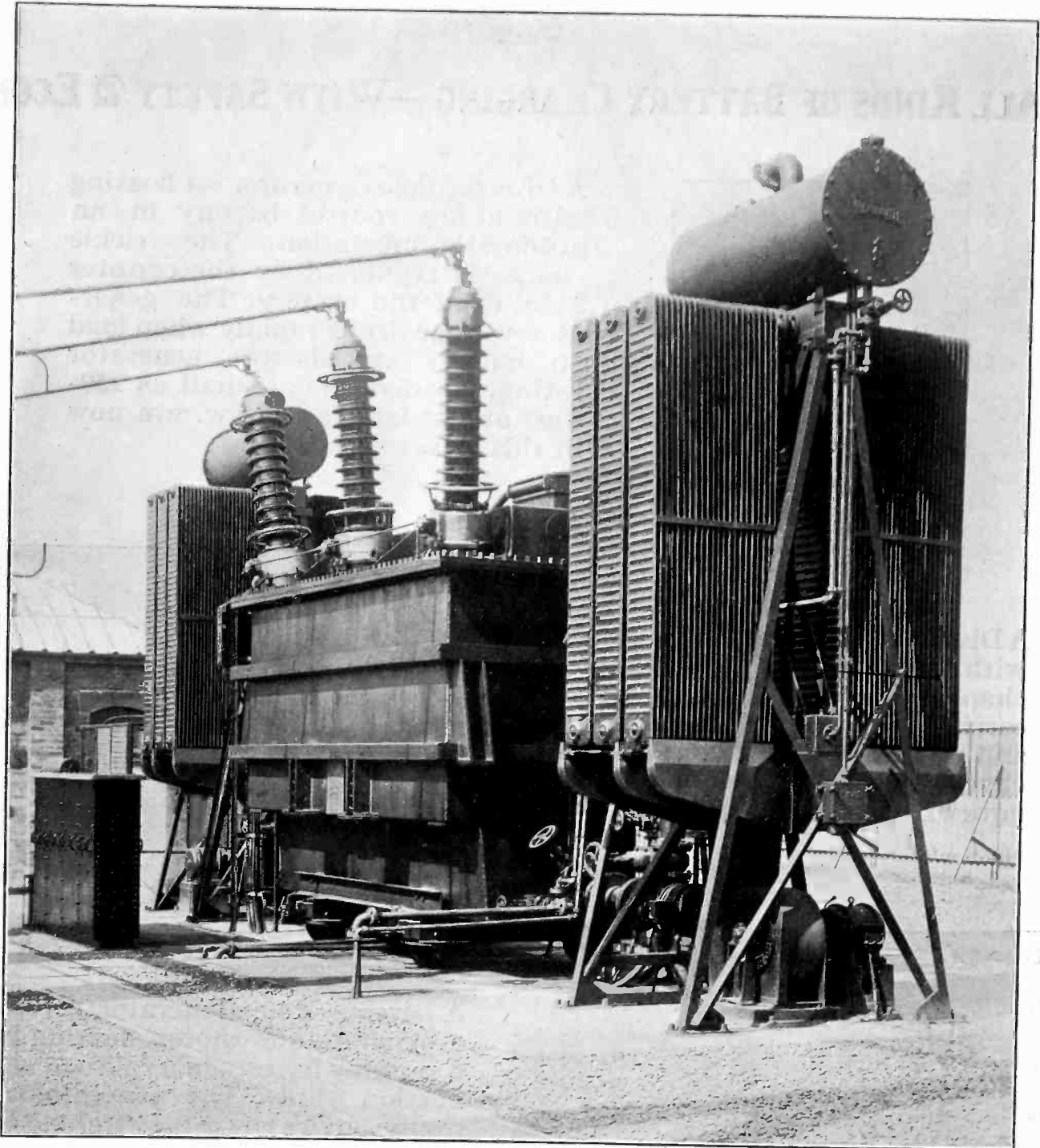

20,000 KV-A., 132 KV., Three-Phase Transformer
at Bonnybridge, Scotland

FERRANTI, LTD.
Hollinwood
England

FERRANTI, INC.
130 West 42nd Street
New York, N. Y.

FERRANTI ELECTRIC, LTD.
26 Noble Street
Toronto, Canada

MINERALLAC STATISCOPES

Safety Devices for the Protection of the Electrical Worker

STATION TYPE

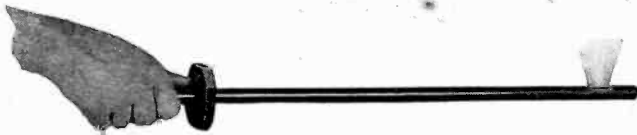

Recommended for use in Stations and Substations.

Made from hard rubber rod, 24 inches long. Gives positive indication on 2000 volts and up.

Direct contact is not necessary as the instrument will indicate at a distance.

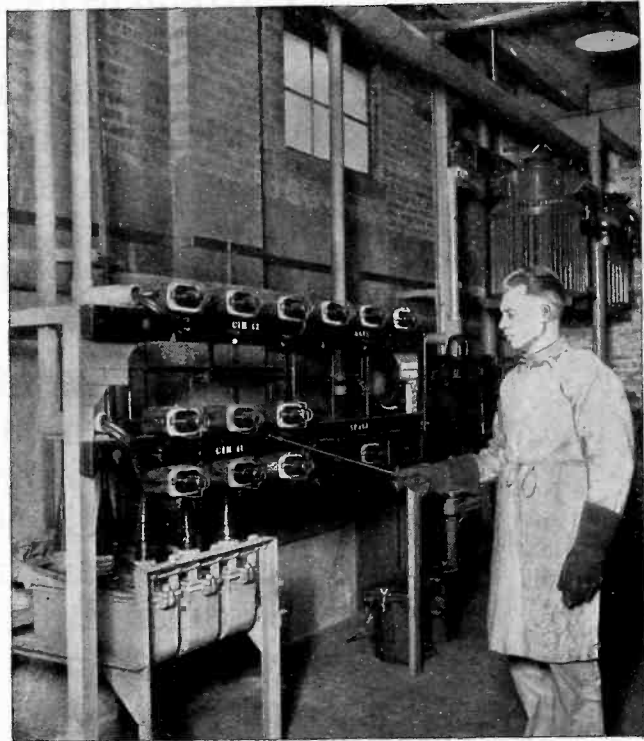

STATION TYPE—indicating on outside of 2300 volt rubber-covered insulated wire. Direct contact is made with the outside of insulation.

Pocket, Station and Overhead Statiscopes

MINERALLAC ELECTRIC COMPANY

25 No. Peoria St.

Chicago, Ill.

Send the coupon for details



Pocket Type

MINERALLAC ELECTRIC COMPANY
 25 North Peoria Street
 Chicago, Ill.

Gentlemen: Please send me complete details of your Minerallac Statiscopes.

Name

Address

Position

Company



Standards **TODAY** That Give Reliability to the Suspension Insulator

— THE ONE-PIECE SUSPENSION UNIT —

THE high-efficiency, one-piece, petti-coat type suspension insulator unit—first used in the insulation of the 110,000 volt Niagara Falls-Toronto line of the Hydro Electric Power Commission of Ontario, Canada—differed radically from the designs prevalent at that time.

But this type of insulator proved so superior, both in initial tests and subsequent performance in actual service that today this O-B design of insulator—improved and refined it is true—sets the standard for practically all high-voltage transmission line insulation.

O-B

GAVE IT TO THE INDUSTRY IN

1909

Ohio Brass Company, Mansfield, Ohio
Canadian Ohio Brass Co., Limited
Niagara Falls, Canada
1198H

Ohio Brass Co.

NEW YORK PITTSBURGH PHILADELPHIA BOSTON

CHICAGO CLEVELAND ST. LOUIS ATLANTA SAN FRANCISCO LOS ANGELES DALLAS

PORCELAIN INSULATORS
LINE MATERIALS
RAIL BONDS
CAR EQUIPMENT
MINING MATERIALS
VALVES



Please mention the JOURNAL of the A. I. E. E. when writing to advertisers.

ABC TRANSMISSION TOWERS



TOWERS shown carry 4-circuits of 66,000 volts, in addition to 4-ground wires, for Beach Thorofare Crossing, Atlantic City Electric Company.

Height to Bottom Conductors 135 ft. Provision made for future extension to 6-circuits.

Designed, fabricated
and galvanized by
AMERICAN BRIDGE COMPANY



AMERICAN BRIDGE COMPANY

Subsidiary of United States Steel Corporation

General Offices **71 Broadway, New York City**
Tower Department, Frick Building, Pittsburgh, Pa.

Please mention the JOURNAL of the A. I. E. E. when writing to advertisers.

PAPER »»» CAMBRIC »»» RUBBER

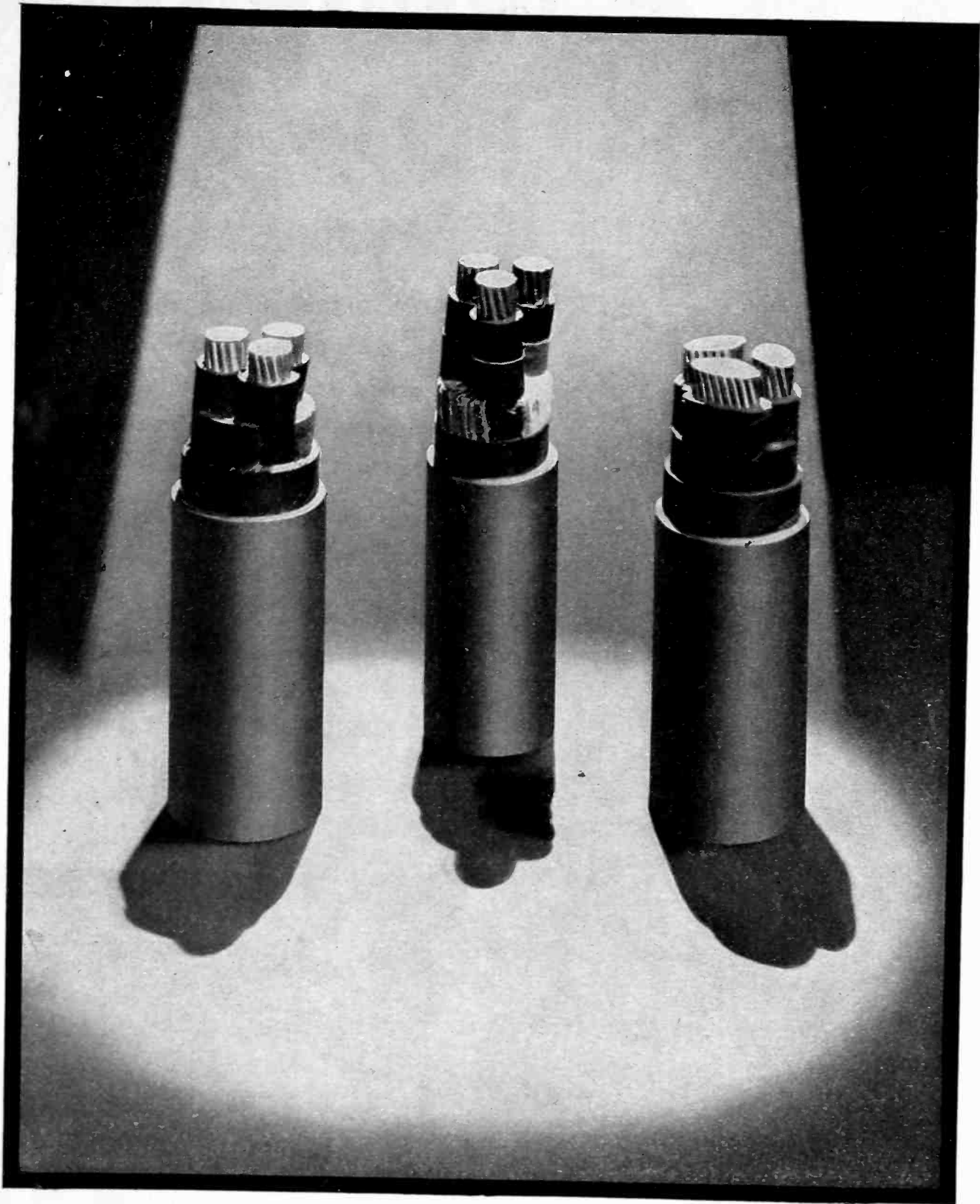

Long-lived performance is evidence that Safety Power Cables are outstanding achievements in cable manufacture. Underground, aerial, submarine—for transmission or distribution circuits—with paper, cambric or rubber insulation.

GENERAL CABLE CORPORATION

EXECUTIVE OFFICES: 420 LEXINGTON AVENUE, NEW YORK • OFFICES IN PRINCIPAL CITIES

Please mention the JOURNAL of the A. I. E. E. when writing to advertisers.



BURNDY SERVIT

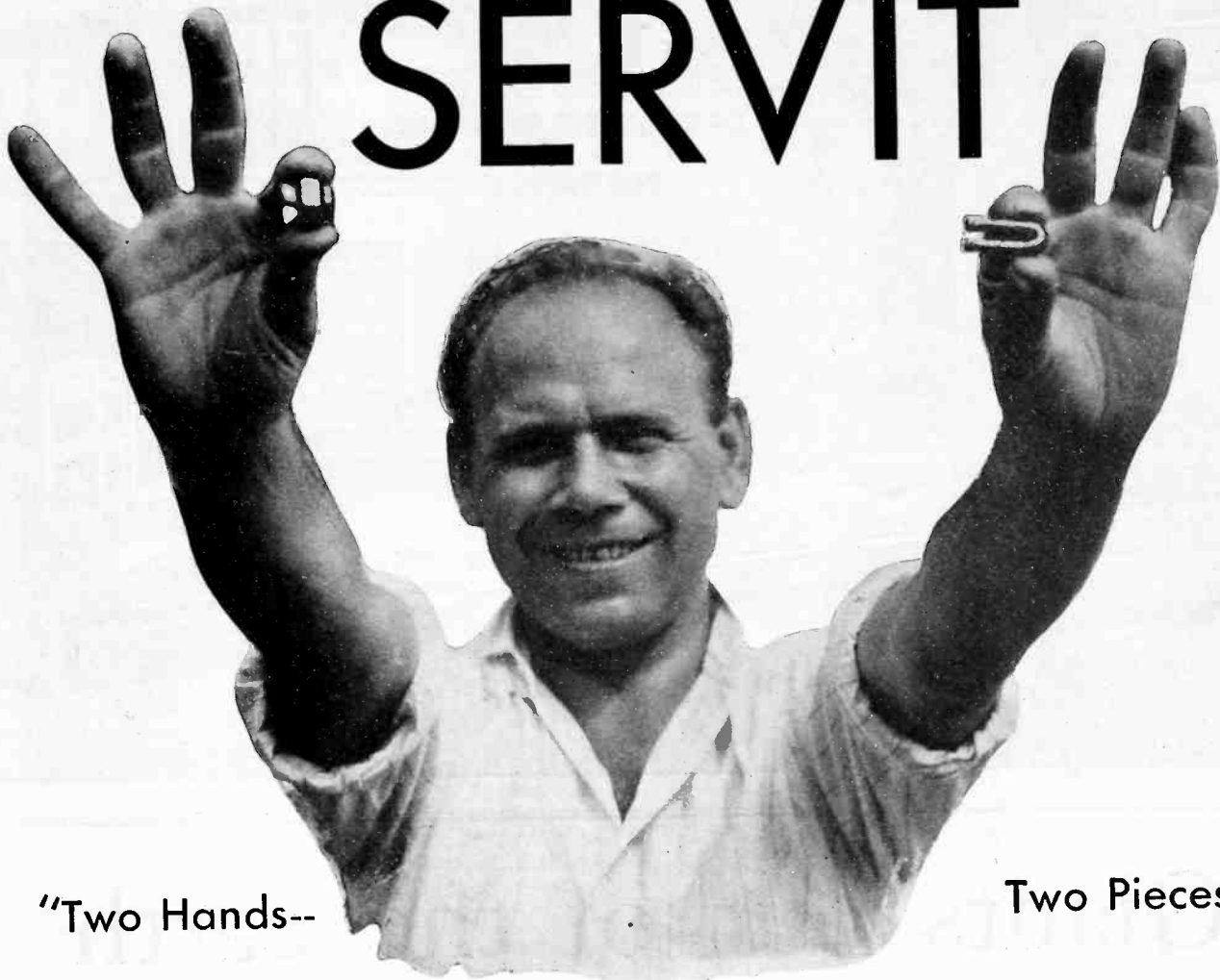

"Two Hands--

Two Pieces"

A TWO-PIECE, ALL-COPPER SERVICE CONNECTOR

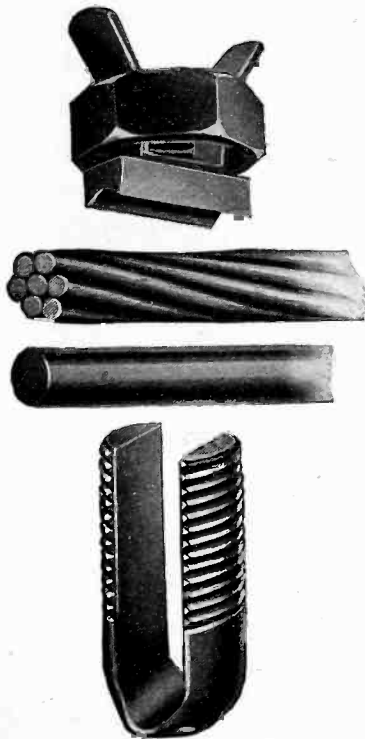

which when locked, cannot open under any vibration. The SERVIT is welcome to the lineman who has only two pieces to handle. It is made of forged copper with no brass parts to corrosion crack. All contact edges are extended and rounded and will not nick the cables. Prices will interest you because SERVITS are made by the most modern methods of production. There are seven sizes to choose from.

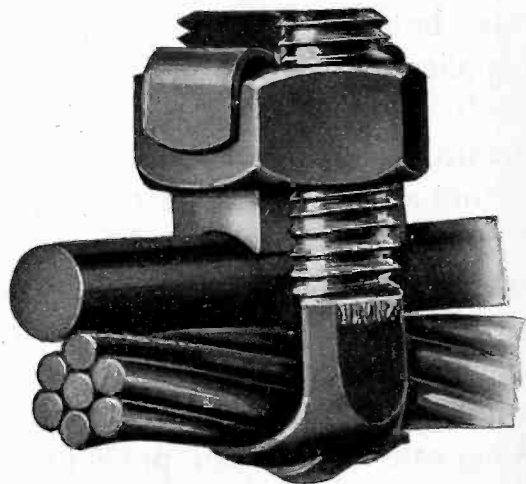

BURNDY
ENGINEERING CO. INC
230 EAST 45TH STREET, NEW YORK

Ask for Samples

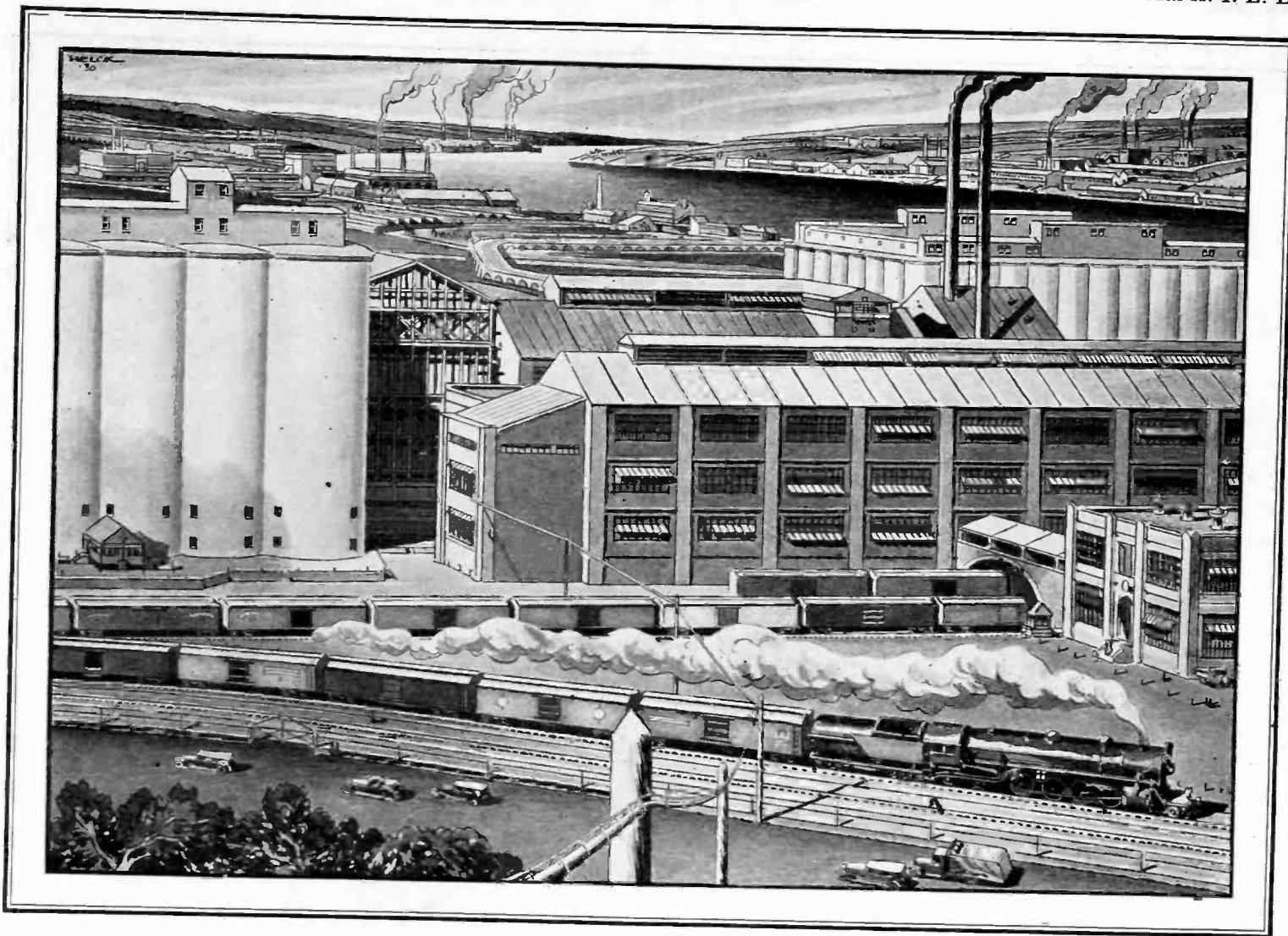

Giants out of the earth

An Advertisement of the American Telephone and Telegraph Company

No AGE but ours has seen so swift and complete an application of natural forces to the doing of daily tasks. Man's leaping knowledge . . . embodied in industrial plants and laboratories, airplanes and electric locomotives . . . has won new power and freedom. Machines are the symbols of a new relationship with nature. They are the servants of this civilization . . . helping men to extend the limits of their opportunities, to change the character of their life.

Americans have been pre-eminent in this change, for in whatever they do they seek to utilize nature to the utmost. They have taken the power out of the earth and from the running streams. They have made it turn the wheels of their industry and move their products by rail and road. They have made color and variety out of chemistry. They have spun

metal in slim wires to carry their voices anywhere with the speed of light . . . and make neighbors of the scattered millions of America.

Joining homes and work places, towns and distant cities, the Bell Telephone System has furnished a new communication for this new age. Forwarding the growth of the nation, giving better and more complete service in advance of the demand, its function has become the indispensable one of furnishing the means of social and business contacts in crowded cities and scattered villages over the length and breadth of a continent.

The Bell System is constantly improving the scope, speed and accuracy of its service.

Its work of contributing to the welfare and prosperity of American life goes on with increasing purpose and pace.



Please mention the JOURNAL of the A. I. E. E. when writing to advertisers.

This close-up shows the Lapp Cotter Key in place. Forward contractions lock key in place when withdrawn.

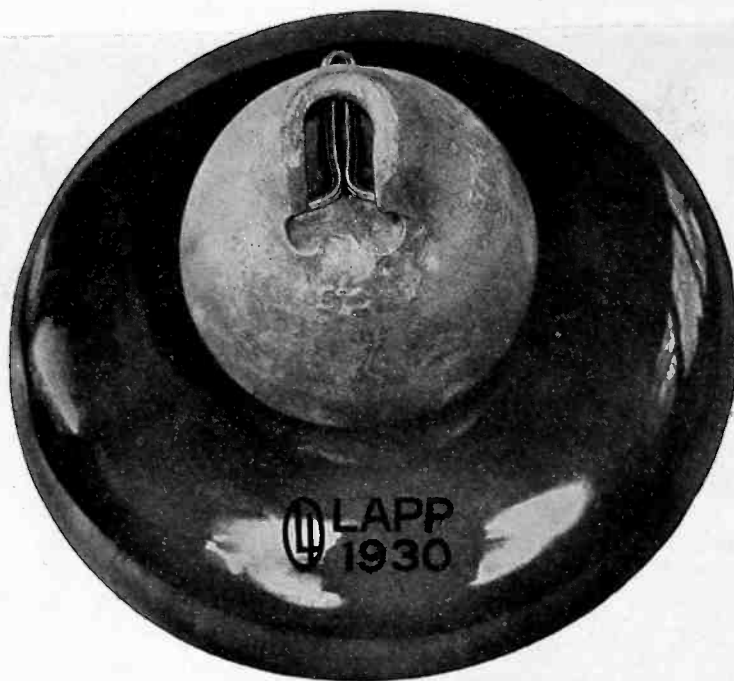

Another Reason Why LAPP INSULATORS COST MORE TO MAKE

CONSIDER this ball socket insulator's cotter key—eliminating much petty annoyance.

IT locks definitely in two positions—within the insulator or drawn back for insertion of the ball. Withdrawn at the base of the tower, it remains in place, without possibility of jamming, until your lineman up above drives it in. How much time such a cotter will save him may surprise you.

BOTH ends are to be bent. That avoids turning, prevents jamming while inserting the ball and permits easy removal.

OF heavier stock than usual, it requires special forming, special assembly at the factory—adding a few pennies to our cost, but cutting your installation cost by dollars.

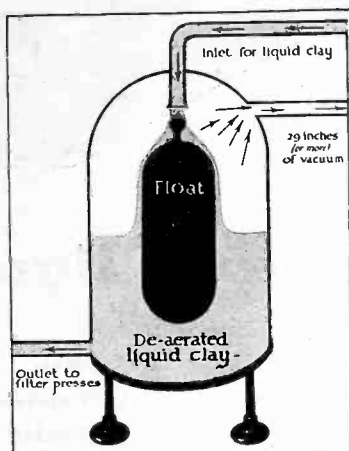

Mechanical and Dielectric faults in porcelain are usually due to air previously occluded in the liquid clay. The Vacuum Process removes the air and (naturally) the troubles due to occluded air.

LAPP
INSULATORS

LAPP INSULATOR CO. INC. LEROY, N.Y. U.S.A.

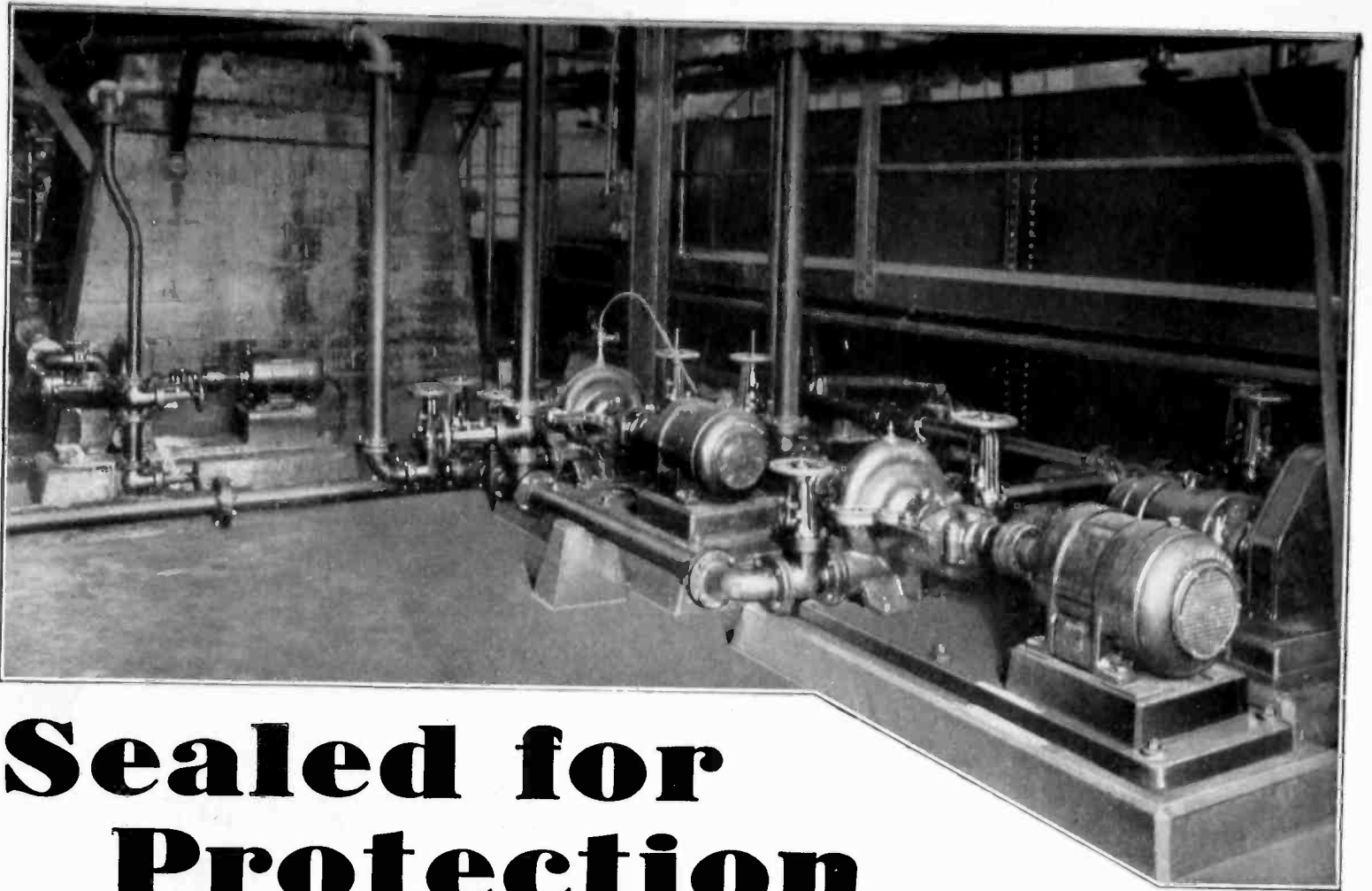

Sealed for Protection

against corrosive gases and liquids



One 5 h.p. and two 15 h.p. (1730 r.p.m.) Type ARZ Motors operating Allis-Chalmers centrifugal pumps, handling brine in an Electro-Chemical plant.

Corrosive moisture and gases, often present in chemical plants, cannot harm Allis-Chalmers totally enclosed fan-cooled motors because the windings of these motors are thoroughly sealed from contact with the outside air.

Because of this protection against harmful corrosives, dust and dirt, the motors may be installed in out-of-the-way places with very little attention except periodic greasing—thus eliminating frequent and expensive inspection, cleaning and repairs.

And this protection is accomplished by a simplified design that includes no rubbing or revolving seals and that provides accessibility equal to that of the standard open type motor.

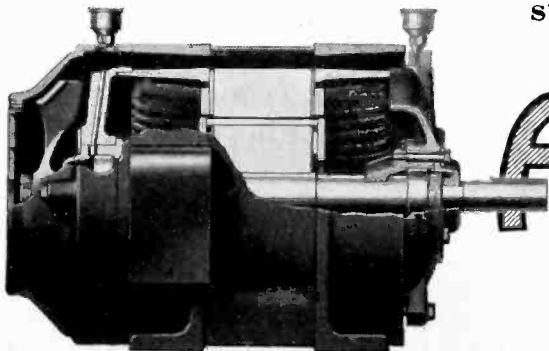

ALLIS-CHALMERS
Totally Enclosed
Fan-cooled **MOTORS**

Allis-Chalmers Manufacturing Company, Milwaukee, Wisconsin

Please mention the JOURNAL of the A. I. E. E. when writing to advertisers.

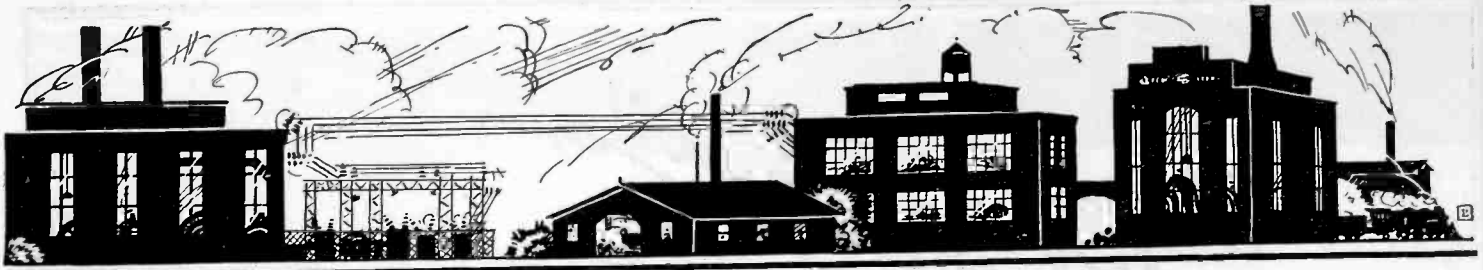

SHARPLES CLEANS OIL FOR 20,000 K. W. TURBINE AT OHIO EDISON COMPANY

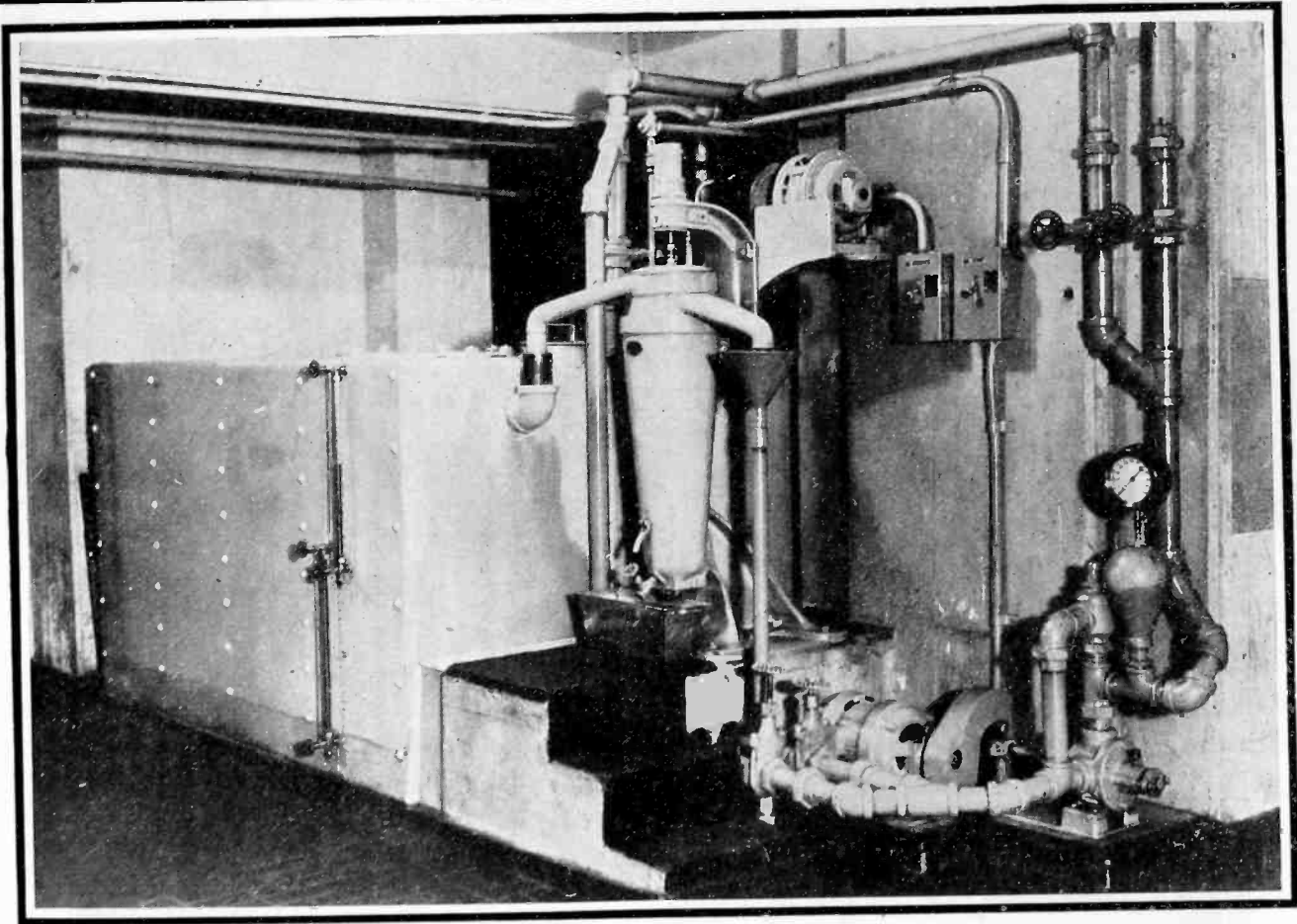

This Sharples installation—at the Ohio Edison Co., Springfield, Ohio—does an important job in protecting the bearings of a 20,000 K.W. Turbine against the effects of dirty “lube” oil. Sharples Super Centrifugal Force keeps the oil clean and sweet, thus insuring maximum lubricating efficiency at all times.

Sharples Super Centrifugals are effecting great

savings in power plants throughout the world. They have supplanted older and more costly methods of clarifying, purifying and dehydrating. There is no substitute for Sharples Super Centrifugal Force for reconditioning switch and transformer oil, Diesel and turbine “lube” oil, and Diesel fuel. Detailed technical bulletins will be mailed free on request.

THE SHARPLES SPECIALTY COMPANY, 2324 WESTMORELAND STREET, PHILADELPHIA. Boston, New York, Pittsburgh, Chicago, Detroit, Tulsa, San Francisco, Los Angeles, Toronto. Factories in England and France.

SHARPLES

CENTRIFUGAL ENGINEERS ♦ ♦ PHILADELPHIA

Please mention the JOURNAL of the A. I. E. E. when writing to advertisers.

Chandeysson

Generators
25 to 25,000 Amperes

Direct Connected to



Motors

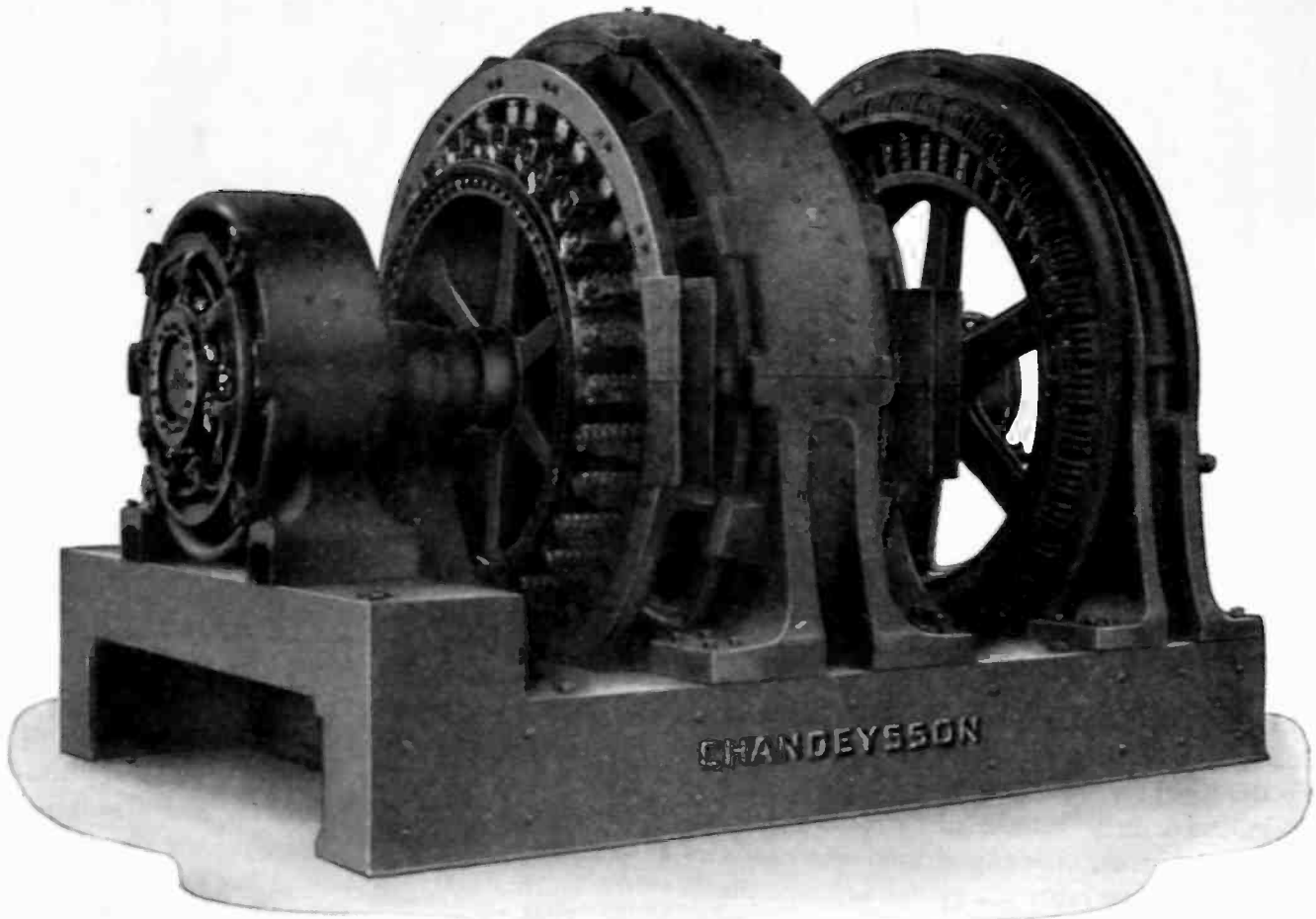

20,000 AMPERES 12 VOLTS UNIT

WEIGHT 85,600 POUNDS
FABRICATED STEEL SUB-BASE

CHANDEYSSON ELECTRIC CO., St. Louis, U. S. A.



Can be Mounted Out-of-the-way —because they require infrequent attention

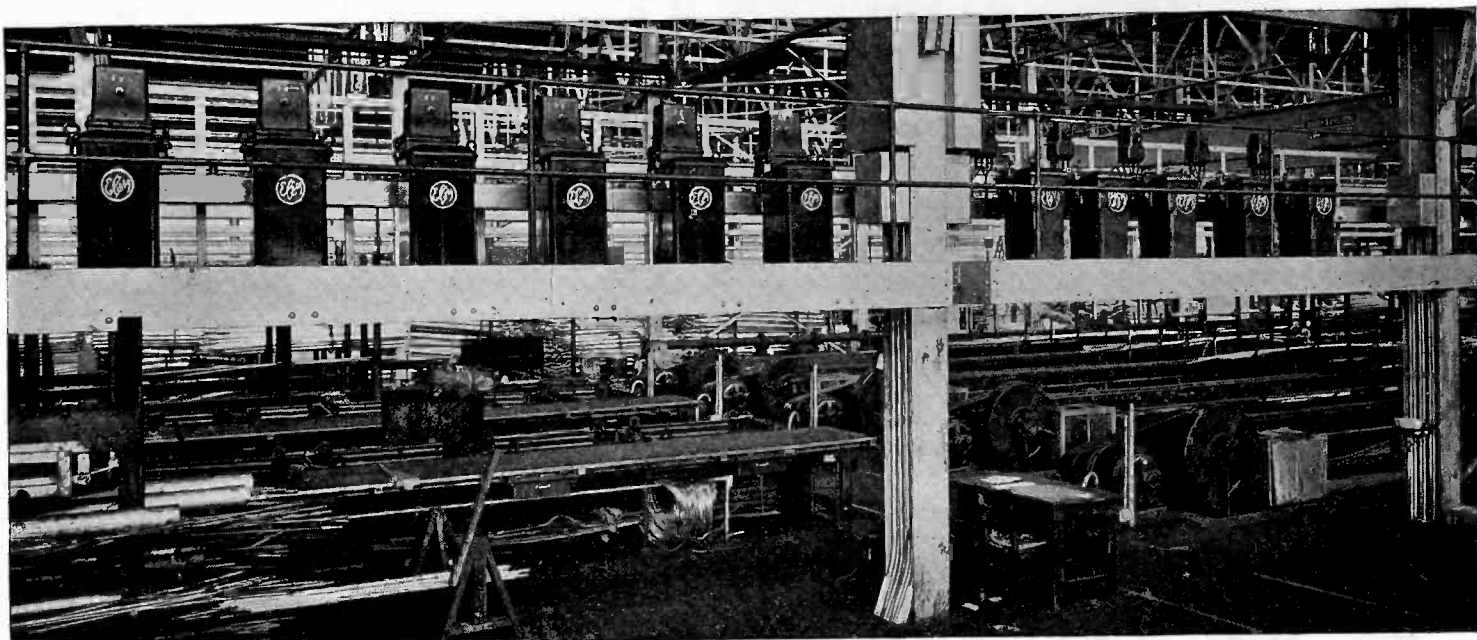

EC&M Automatic Low Voltage Compensators can be mounted overhead out of the way and thus save valuable floor-space, because they require infrequent attention—inspection twice a year proving ample in the majority of cases. This is due to simple design, accurate machine work and totally oil-immersed construction.

The oil-immersed construction, likewise protects the operating mechanism against dusty or corrosive atmospheres at all times. All working parts are always well lubricated and the starter is ready for operation at any time whether it is out of service for a few minutes or for several months.

This is only one of the many advantages of EC&M Oil-Immersed Compensators. Other outstanding advantages are: elimination of fire hazards, low maintenance, few working parts, and a large volume of oil insuring an abundance of cooling area.

Over one thousand industrial plants use these Automatic Low Voltage Compensators. Actual operating experience has proven to them that the slightly higher initial cost of this equipment is repaid many times over in freedom from trouble, reduced maintenance, increased production and safety.

Write for Bulletin 1042-G, just off the press



THE ELECTRIC CONTROLLER & MFG. CO. CLEVELAND, OHIO

NEW YORK-50 CHURCH ST.
CHICAGO-CONWAY BLDG.
DETROIT-DIME BANK BLDG.
BIRMINGHAM-BROWN-MARK BLDG.
CINCINNATI-127 NATIONAL BANK BLDG.
ST. LOUIS-4221 A CASTLEMAN AVE.

LOS ANGELES-912 E. THIRD ST.
HOUSTON-P.O. BOX 4182
TORONTO-REFORD BLDG.

PHILADELPHIA-WITHERSPOON BLDG.
PITTSBURGH-OLIVER BLDG.
SAN FRANCISCO-CALL BUILDING
MONTREAL-CASTLE BLDG.
TULSA-217 E. ARCHER ST.
SEATTLE-ALASKA BLDG.



Please mention the JOURNAL of the A. I. E. E. when writing to advertisers.

Gasoline industrial locomotive built by Atlas Machinery & Supply Company, Birmingham, Ala.

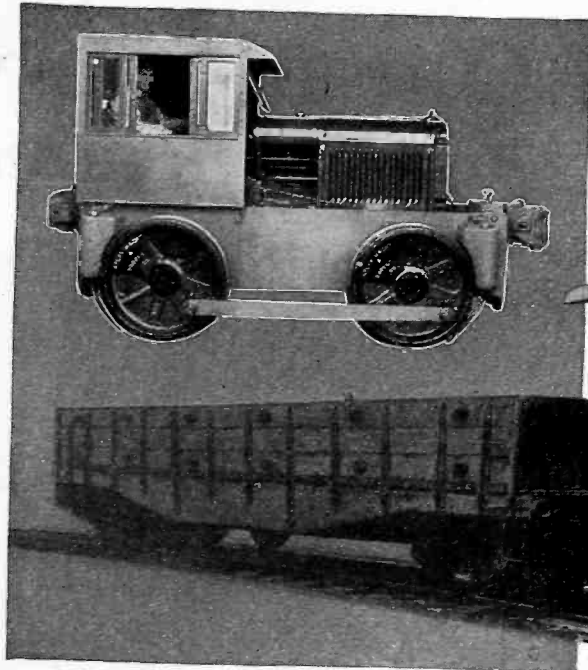

The "Plymouth" gasoline locomotive built by Fate-Root-Heath Company, Plymouth, Ohio.

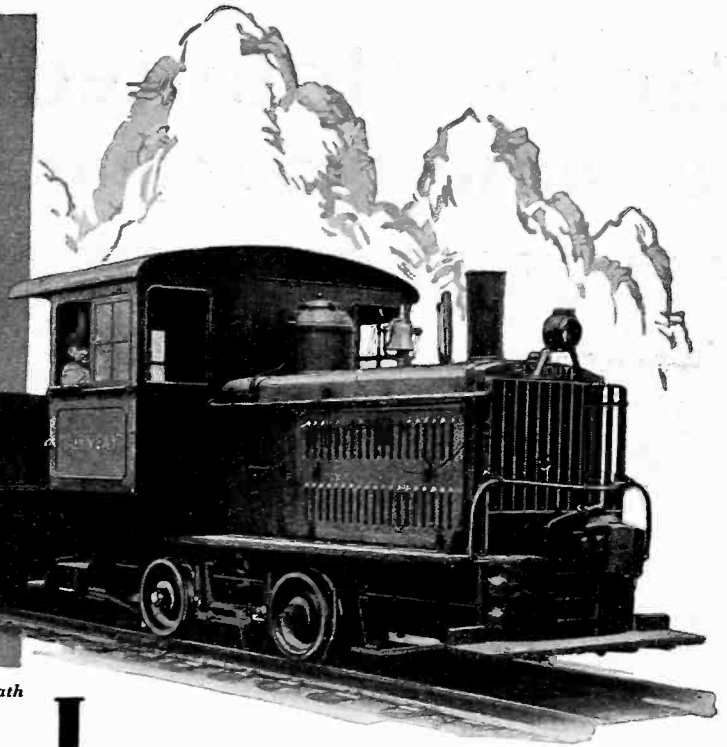

LOAD-ABILITY!

that's what counts ~ ~ ~
in **BEARINGS** as well as **LOCOMOTIVES**

THE two manufacturers whose products are here pictured, design and build their locomotives with the idea of maximum haulage capacity at minimum cost for fuel and upkeep. They must handle their loads with economy and dispatch.

NORMA-HOFFMANN Precision Bearings are used by both these locomotive builders—because they have the load-ability which haulage service demands and which contributes so largely to uninterrupted operation at least cost for bearing upkeep.

Wherever loads are heaviest, or speeds highest, or duty hardest, there is the place where PRECISION, as a commercially valuable quality, reveals its true worth.

Let our engineers work with you, on your bearing problems. And ask for the Catalogs.

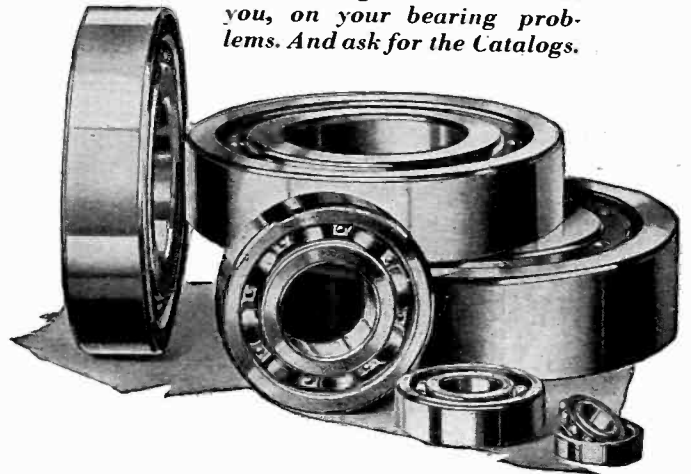

"NORMA-HOFFMANN"

PRECISION BEARINGS

NORMA-HOFFMANN BEARINGS CORPORATION STAMFORD, CONN., U.S.A.

Please mention the JOURNAL of the A. I. E. E. when writing to advertisers.

THEY KEEP A-RUNNING

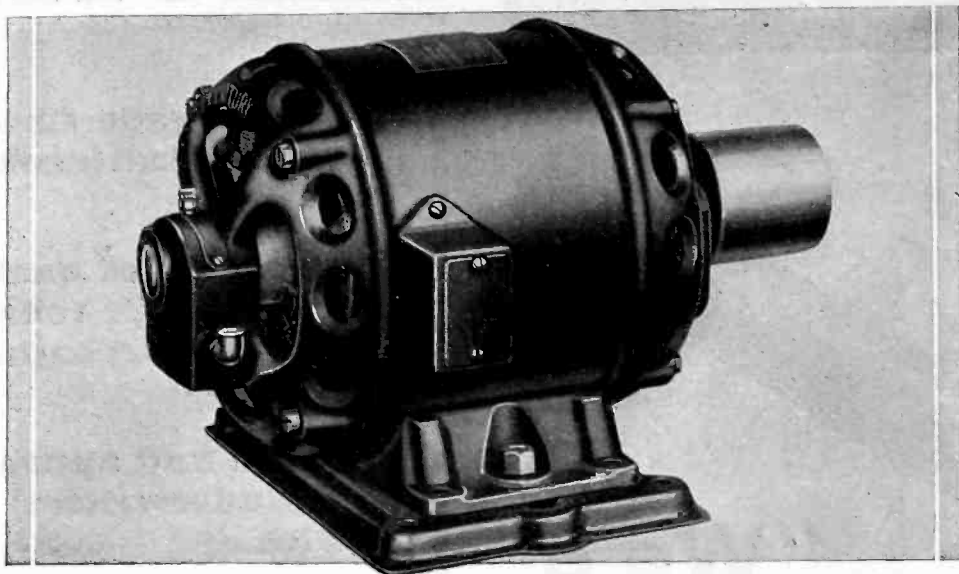

¼ Horse Power Century Type RS Repulsion Start Induction Single Phase Motor

Exclude Dust and Dirt Protect Bearings Against Abrasive Wear

The bearing housings of Century Sleeve Bearing Motors are protected against the entrance of dust, dirt, and abrasive particles by brass dust caps and collars, which make the housings as nearly dust-tight as it is possible to build them.

Additional protection is afforded by the Century Wool Yarn System of Lubrication—which is standard equipment on all 1 horse power and smaller size sleeve bearing motors. The use of continuous unbroken strands of pure yarn assures complete filtering of the oil before delivery to the bearing surfaces, and permits at least one year's 24 hour per day operation without re-oiling.

Type RS motors are built in all standard sizes from $\frac{1}{8}$ to 40 horse power.

CENTURY ELECTRIC COMPANY
1806 PINE ST. • ST. LOUIS, MO.

40 U. S. and Canadian Stock Points and More Than 75 Outside Thereof

SINGLE PHASE,
THREE PHASE,
AND DIRECT
CURRENT MOTORS

Century
MOTORS

MOTOR GENERA-
TOR SETS, ROTARY
CONVERTORS, FANS
AND VENTILATORS

FOR MORE THAN 26 YEARS AT ST. LOUIS

Please mention the JOURNAL of the A. I. E. E. when writing to advertisers.

VITROHM **WL** RESISTORS

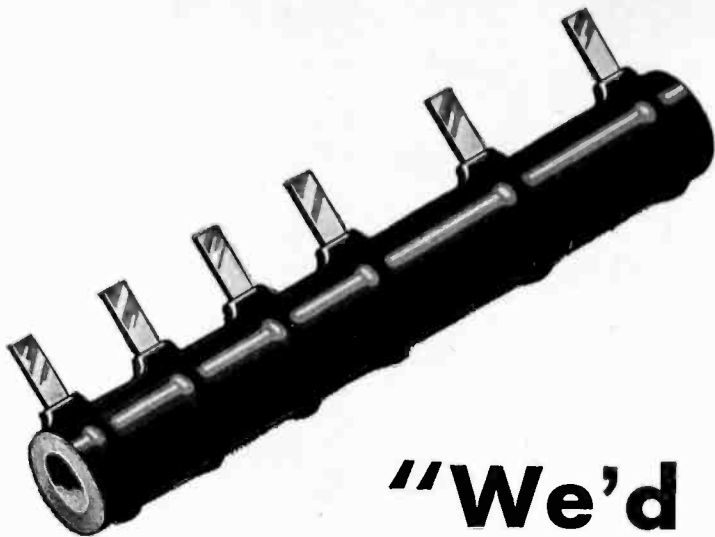

"We'd Like to Get—"

OUR Sales Department doesn't answer people who want an especially difficult resistor job with, "so do we." It isn't polite and, frequently, today's NO is tomorrow's YES, for our Engineering and Research Departments are always busy at the job of making possible the impossible with all types of resistor designs.

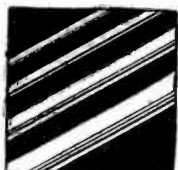

There are many sizes and kinds of resistance wire



Each lot of wire is carefully tested for tensile strength

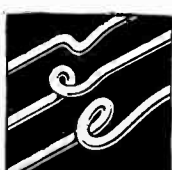

An ingenious machine rejects all kinked or distorted wire.

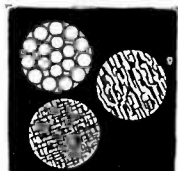

One wire cannot be used for all applications. The duty dictates the choice

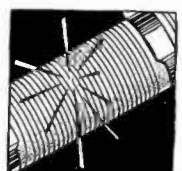

Neglect of any detail means trouble later



Wire specifications drawn by Ward Leonard are rigid. It protects you.

During the past few months **VITROHM** **WL** RESISTORS have become available in many new types and sizes. If you have a resistor problem, tell us; the chances are excellent that we have what you want.

WARD LEONARD ELECTRIC CO.
Mount Vernon, New York
resistor specialists for more than 39 years

ELECTRITE

A high grade fibre board for electrical insulation.

A material of quality possessing high tensile and dielectric strength.

Tested and approved by the Underwriters' Laboratories.

Pulp Products Department

WEST VIRGINIA PULP & PAPER COMPANY

230 Park Avenue
New York, N. Y.

35 East Wacker Drive
Chicago, Ill.

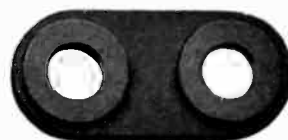

BLOCKS
made of
LAVA
the Superior Insulation



Appliances insulated with Lava denote careful thought on the part of the manufacturer.

AMERICAN LAVA CORP.
27-67 Williams St.
CHATTANOOGA, TENNESSEE
Manufacturers of Heat Resistant Insulators

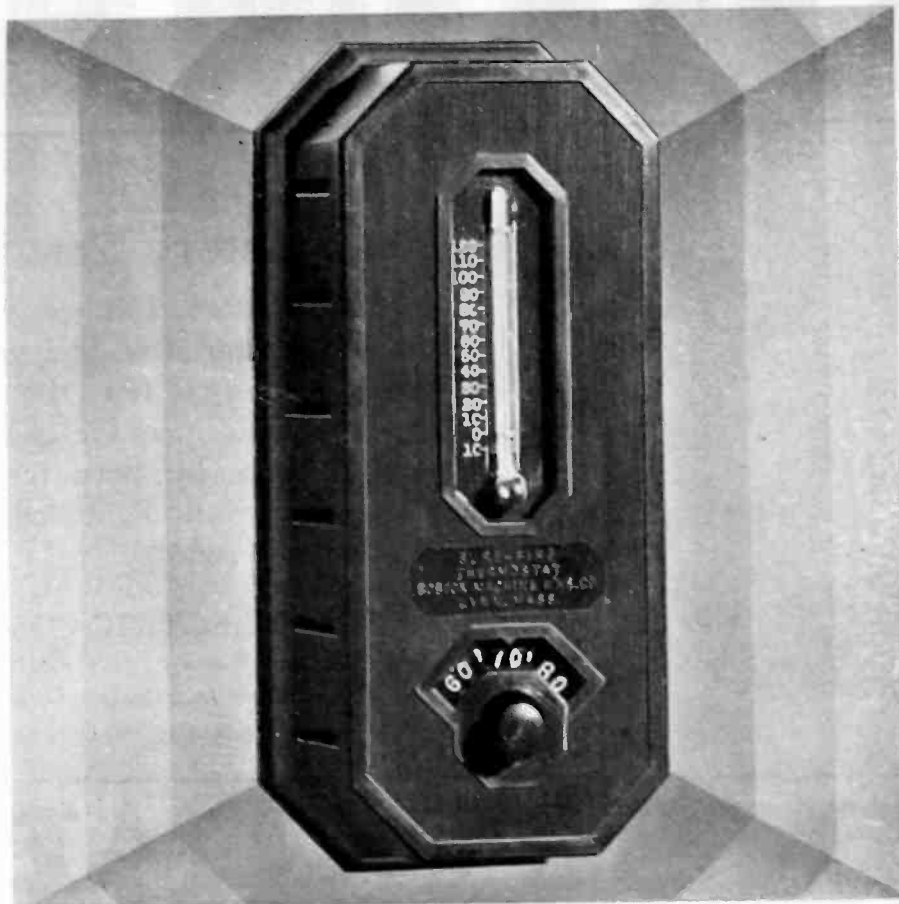

Sure-Fire Electric Thermostat with case of Bakelite Molded. Made by Boston Machine Works Co., Lynn, Mass.

PRODUCING THIS ATTRACTIVE CASE REQUIRES ONLY ONE PRESS OPERATION

Notwithstanding the refinement of design, and fine detail of this thermostat case, and the fact that it is a shell 1½ inches deep, it is successfully formed of Bakelite Molded in one press operation. It comes from the mold, octo-rectangular in shape, with a ribbed face and smooth lustrous sides, openings for the thermometer and temperature setting, and clear relief lettering. In the mold, too,

the case is given a beautiful mahogany finish which is a valuable selling point, since it harmonizes with the usual fittings of a modern house. Bakelite Molded is responsible not only for the attractive appearance and simple production of this case, but also for high insulating value, desirable in an electrical instrument of this kind. Write for Booklet 3-M, "Bakelite Molded."

Bakelite Engineering Service—We manufacture a wide variety of phenol resinoid molding materials, varnishes, lacquers, enamels, cements, and other products. Twenty years experience in the development of these materials for electrical and other uses, provides a valuable background for the cooperation offered by our engineers and laboratories.

BAKELITE CORPORATION, 247 Park Avenue, New York. CHICAGO OFFICE, 635 West 22nd Street
BAKELITE CORPORATION OF CANADA, LIMITED, 163 Dufferin Street, Toronto, Ontario

BAKELITE

REGISTERED U. S. PAT. OFF.



The registered Trade Mark and Symbol shown may be used only on products made from materials manufactured by Bakelite Corporation. Under the copyright "B" is the numerical sign to identify or determine quantity. It symbolizes the relative number of present and future uses of Bakelite Corporation's products.

THE MATERIAL OF A THOUSAND USES

Please mention the JOURNAL of the A. I. E. E. when writing to advertisers.

MOLONEY

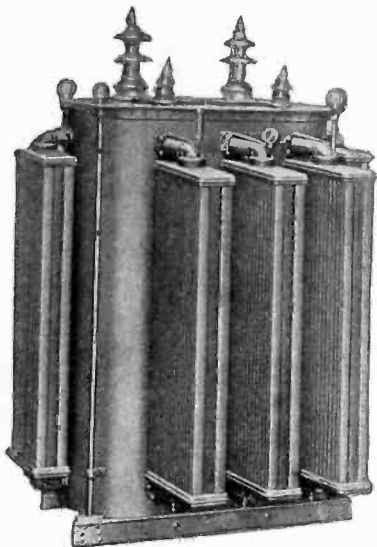

Satisfactory Service

Under all conditions and in any service —that's the guarantee you get with Moloney Quality—it's the reason Moloney Transformers are being used more and more by both large and small power and light companies throughout the country.

MOLONEY ELECTRIC COMPANY

Main Office and Factories: ST. LOUIS, MO.

Sales Offices in Principal Cities

TRANSFORMERS

Metal-Clad Switchgear

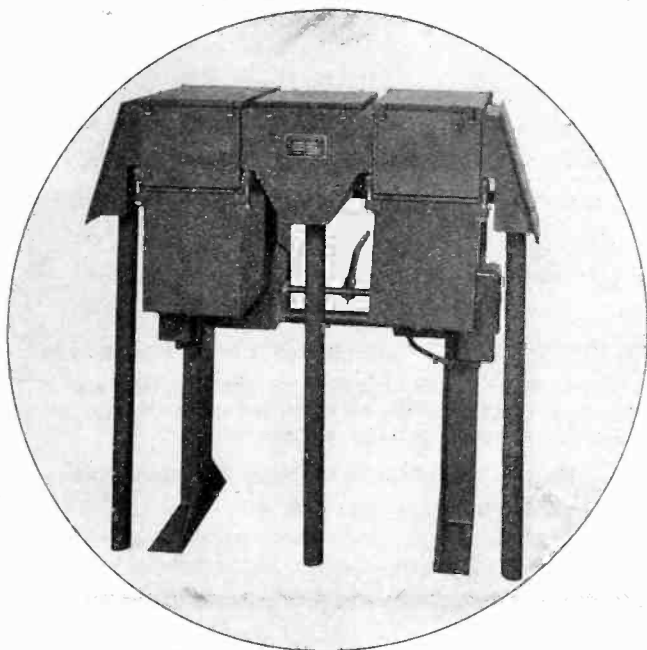

SIMPLE—SAFE—LOW COST. CATALOGS?

Delta-Star  **Electric Co.**

2400 BLOCK, FULTON ST., CHICAGO

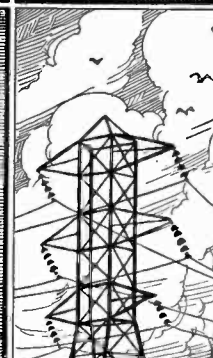

Thomas Quality
 PORCELAIN INSULATORS
 LINE HARDWARE
 WIRING PORCELAINS
and
 Porcelain Specialties
An American Standard since '73

THE R. THOMAS & SONS CO.
 New York Boston Lisbon, Ohio Chicago London

HEMINGRAY

GLASS INSULATORS

The transparency of Hemingray Glass Insulators makes line inspection very simple. The lineman can tell at a glance whether the insulator is intact or not. Hemingray insulators are mechanically and dielectrically dependable, non-porous and uniform in structure. They defy moisture and age.

Send for Bulletin No. 1.

HEMINGRAY GLASS COMPANY
 Muncie, Indiana

Please mention the JOURNAL of the A. I. E. E. when writing to advertisers.

one pothead—three uses

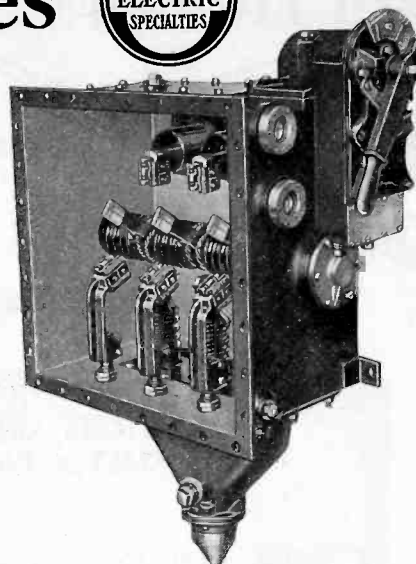
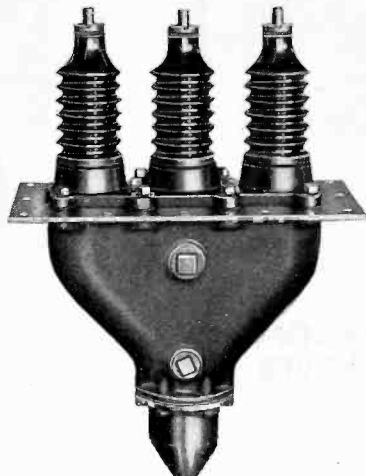
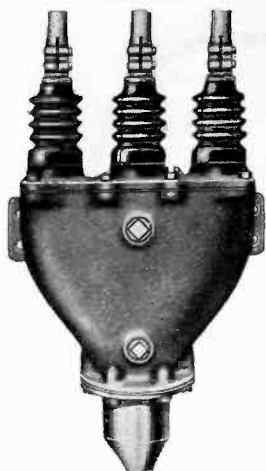

G & W type "NT" three conductor indoor pothead. A definite cable seal even at the lowest end of the cable. Interchangeability of parts enables us to carry in stock a variety of assemblies to fit your own installation conditions.

The "TT" pothead has a mounting plate inserted between the lid and body of the standard "NT" pothead. Type "TT" is properly gasketed and an ideal pothead, price considered, for use with transformers, boxes, switches and other devices.

Type "TT" pothead is also used in the G & W Disconnecting and Grounding Oil Switch. This switch disconnects and grounds the three phase primary cable. It is electrically interlocked for safety. Furnished for voltages up to 25,000.

Potheads / Subway Boxes / Cable Terminal Devices / Automatic Transfer Switches
G & W Electric Specialty Co.
 7780 Dante Avenue, Chicago / / / / Representatives in Principal Cities

TYPE H - POWER CABLE

For High Voltage Installations

Type H Cable is especially suited to high voltage systems. The outstanding characteristic of Type H Cables is a thin layer of conducting material which surrounds the insulation and acts as an electro-static shield. In single conductor cable of this type a thin layer of metal is usually applied over the insulation, immediately under the lead sheath whereas in multi-conductor cables, the metal is applied around each conductor and the metal sheathed conductors are then twisted together and rounded out with filler material. The assembled conductors are surrounded by a strong metallic binder directly under the lead sheath.

The conducting layer is usually a metal tape. Possible induced losses in the tape may be minimized by properly designed perforations which also facilitate the thorough impregnation of the cable.

Type H Cable features are: Control of temperature, Avoidance of tangential insulation stresses, Elimination of voids, and Removal of stress from cable fillers.

Further information on request.

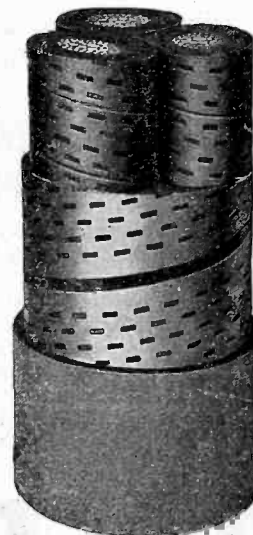

TYPE H - POWER CABLE

- Other SIMPLEX Cables
- TIREX Cables
- FIBREX Tree Wire
- PAPER Insulated Cables
- VARNISHED Cambric Cables

SIMPLEX WIRE & CABLE CO

MANUFACTURERS

201 DEVONSHIRE ST., BOSTON

BRANCH SALES OFFICES

CHICAGO, 564 W. Monroe St. SAN FRANCISCO, 390 Fourth St.
 NEW YORK, 1328 B'way CLEVELAND, 2019 Union Trust Bldg.
 PHILADELPHIA, 1227 Fidelity-Philadelphia Trust Building
 JACKSONVILLE, 1010 Barnett National Bank Building

Please mention the JOURNAL of the A. I. E. E. when writing to advertisers.

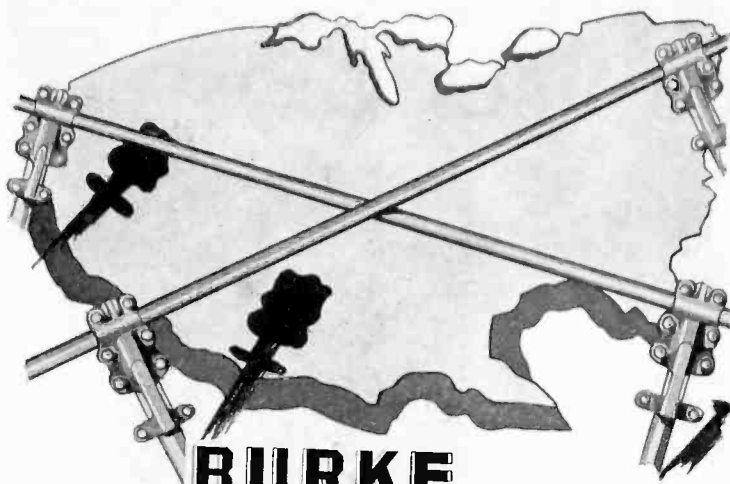

BURKE
CONNECTORS ARE USED FROM
COAST TO COAST and BORDER TO BORDER

FROM coast to coast and border to border BURKE High Tension Equipment is giving satisfactory performance for Central Station users.

Designed by engineers with experience in Central Station Operation BURKE High Tension Equipment is built to meet the actual day to day needs of Public Service Companies.

Quite naturally BURKE ENGINEERS—in their nation wide contacts with transmission and distribution problems—have become proficient in the various problems involved in the transmission and distribution of electricity. These experiences are available to Central Stations.

Why not let us send you the catalog of High Tension Equipment?



CLAMP TYPE CONNECTORS

and the tap may be assembled on the ground and can be elevated to the run as a unit. The connector is held firmly in position on the tap by means of the auxiliary clamp. This leaves the operator with both hands free to place the hinge clamp over the run and insert the bolts—a wrench is all you need. Tighten the bolts and you have a positive grip on both the run and tap.

BURKE

ELECTRIC COMPANY

main office and works: ERIE, PA.

SALES AND SERVICE OFFICES IN PRINCIPAL CITIES

HIGH TENSION EQUIPMENT

BUS BAR CLAMPS, CABLE CLAMPS, TERMINAL LUGS, LEAF TERMINALS, END CONNECTORS, BRACING CLAMPS, CONNECTORS, JUNCTION BOXES, EXPANSION JOINTS, MOULDED INSULATION, CONTROLEAD TERMINAL BLOCKS.

**"COPPERWELD"
LINE WIRE**



Long spans are practical with Copperweld telephone line wire. This high strength wire is non-rusting.

When designing a new line, make an estimate of its cost and safety, using the pole spacings obtainable with Copperweld. You may be able to decrease pole costs 40%.

Copperweld Steel Company

General Offices and Mills

Glassport, Penna.

MEMCO

- Insulator Clamps
- Copper Fittings
- Splicing Sleeves
- Disconnects
- Choke Coils
- Fuse Mountings
- Substation Combinations
- Air Break Switches
- Bus Supports

Memco builds this equipment in all standard and special sizes—ask for bulletins of interest to you.

Memco Engineering & Manufacturing Company, Inc.
381 Hamilton Street, Long Island City, N. Y.

INSULATORS

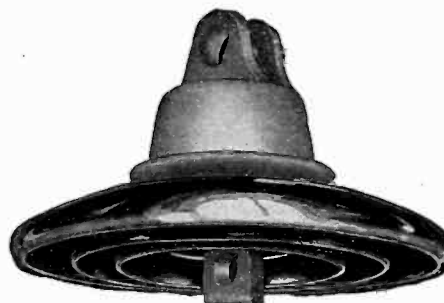

CANADIAN PORCELAIN CO., Ltd.

Hamilton—Ontario—Canada

Quebec District Office
612 Transportation Bldg.
Montreal, Qu.

London Office
343 Abbey House, 4 Victoria Street
London, S. W. 1.

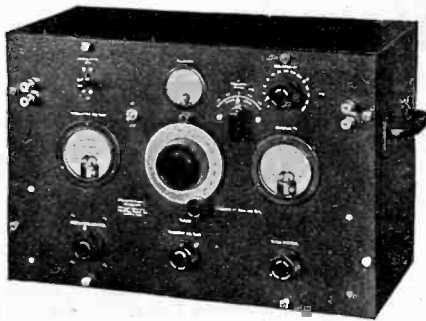

Standard-Signal Generator

The Type 403-B Standard-Signal Generator is a calibrated oscillator for delivering known radio-frequency voltages which are localized between two terminals. Its principal use is in measuring radio field intensity (field strength) and in taking sensitivity, selectivity, and fidelity characteristics on radio receivers. It may be used either with or without modulation; a 400-cycle modulating oscillator is contained in the instrument and there is provision for supplying modulating voltages from an external oscillator.

Its range is from 500 to 1500 kilocycles, but others can be built to cover other bands on special order.

GENERAL RADIO COMPANY

Manufacturers of Electrical and Radio Laboratory Apparatus
30 State Street CAMBRIDGE, MASSACHUSETTS

Roebing

Electrical Wires & Cables

High in
Conductivity
and Reliability

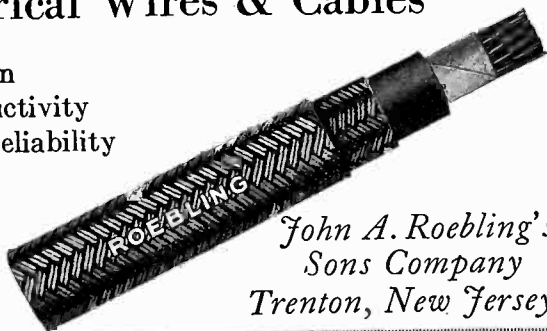

John A. Roebing's
Sons Company
Trenton, New Jersey

KEARNEY

DOUBLE DUTY CUTOUTS

OTHER KEARNEY PRODUCTS

Screw Anchors—4 in 1 Expansion Anchors—
Solderless Connectors—One and Two Fuse
Insulator Fuse-Switches—Fuse Choke Coil
Combinations—Sleeve Twisters—Guy Wire
Clips—Live Line Tools and Accessories.



Complete Catalog Sent On Request

JAMES R. KEARNEY CORPORATION
4220 CLAYTON AVE. ST. LOUIS, MO.

ROLLER-SMITH

Announces

New Catalog No. AE-48 On Switchboard Type Instruments

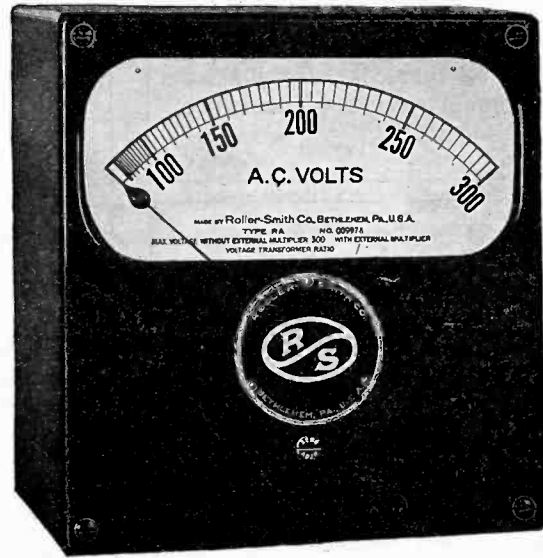

THE New Roller-Smith Catalog No. AE-48 covers the entire line of Roller-Smith Switchboard Type Instruments.

Direct Current
Alternating Current
Thermo Couple
Instrument Transformers

All sizes of instruments from the small 3½" up to the Illuminated Dial are included.

This Catalog is in compact and convenient form. A copy should be in the hands of every man who is interested in any way in electrical measuring instruments.

Send for your copy of New Catalog No. AE-48.

*Over thirty-five years' instrument experience
is back of*

ROLLER-SMITH COMPANY
Electrical Measuring and Protective Apparatus

MAIN OFFICE:
12 Park Place, NEW YORK



WORKS:
Bethlehem, Penna.

Offices in Principal Cities in U. S. A. and Canada

PROFESSIONAL ENGINEERING DIRECTORY

For Consultants in the Fields of Engineering, and Related Arts and Sciences

ALLIED ENGINEERS, Inc.

Engineers and Constructors

120 WALL STREET, NEW YORK

Birmingham, Ala. Jackson, Mich.

EDWARD E. CLEMENT

Fellow A. I. E. E.

Attorney and Expert
in Patent Causes

Soliciting, Consultation, Reports,
Opinions

McLachlen Bldg. Washington, D. C.
700 10th St., N. W.

ROBERT S. KRUSE

Consultant for Radio
Stations and Manufacturers

103 Meadowbrook Road Telephone
West Hartford, Conn. Hartford 4-5327

AMBURSEN DAMS

Hydroelectric Developments

Water Supply and Irrigation Dams
DAMS ON DIFFICULT FOUNDATIONS

AMBURSEN CONSTRUCTION CO.

Incorporated
Grand Central Terminal, New York
Kansas City, Mo. Atlanta, Ga.

DAVID V. FENNESSY

Consulting Power Engineer

1108 Bassett Tower EL PASO, TEXAS

N. J. NEALL

Consulting Engineer

for
Electrical and Industrial Properties

12 Pearl Street 41 Broad Street
BOSTON, MASS. NEW YORK CITY

W. S. BARSTOW & COMPANY

Incorporated

Engineering Design
Construction

50 Pine Street, New York
412 Washington St., Reading, Pa.

FORD, BACON & DAVIS

Incorporated

ENGINEERS

39 Broadway, New York
Philadelphia Chicago San Francisco
New Orleans Chattanooga

NEILER, RICH & CO.

Electrical and Mechanical
Engineers

Consulting, Designing and
Supervising

431 So. Dearborn St. — — — Chicago

BATTEY & KIPP

Incorporated

ENGINEERS

Complete Industrial Plants
Power Plants & Electrical Installations
Engineering Reports, Analyses & Appraisals
231 South LaSalle Street CHICAGO

FRANK F. FOWLE & CO.

Electrical and Mechanical
Engineers

221 No. La Salle Street CHICAGO

FARLEY OSGOOD

Consultant

Design, Construction, Operation
Inter-Connection

of
PUBLIC UTILITIES

National Bank of Commerce Building
31 Nassau Street, New York, N. Y.
Tel.: Rector 7878 Cable Address: Fargood

BLACK & VEATCH

Consulting Engineers

Water, Steam and Electric Power Investiga-
tions, Design, Supervision of Construction,
Valuation and Tests.

Mutual Building KANSAS CITY, MO.

FREYN ENGINEERING COMPANY

Industrial Electric Power
Generation—Application—Purchase

Combustion Engineering
Electric Furnace Installations

310 South Michigan Ave. CHICAGO

To appear in the following
issue, cards must be re-
ceived not later than the
20th day of the month.

ROBERT C. BURT, E. E., Ph. D.
DONALD H. LOUGHRIDGE, Ph.D.

Consulting Physicists
Designers and Makers of
Scientific Instruments

327 So. Michigan Ave. PASADENA
California

HOOSIER ENGINEERING COMPANY

Erecting Engineers

Transmission Lines, Substations

100 W. Monroe St., Chicago, Ill.
225 Broadway, New York
Smith Tower, Seattle, Wash.

SANDERSON & PORTER ENGINEERS

for the

FINANCING—REORGANIZATION—
DESIGN—CONSTRUCTION

of

INDUSTRIALS and PUBLIC UTILITIES

Chicago New York San Francisco

BYLLESBY

ENGINEERING AND MANAGEMENT
CORPORATION

231 S. La Salle Street
CHICAGO

New York San Francisco

JACKSON & MORELAND

CONSULTING ENGINEERS

Park Square Building Boston, Mass.

SARGENT & LUNDY

Incorporated

ENGINEERS

20 NORTH WACKER DRIVE
CHICAGO, ILLINOIS

When you require technical advice —
Or a solution to an engineering problem —

CONSULT THIS DIRECTORY

PROFESSIONAL ENGINEERING DIRECTORY

For Consultants in the Fields of Engineering, and Related Arts and Sciences

SCOFIELD ENGINEERING CO.
CONSULTING ENGINEERS
 Utility and Industrial Plants
 Design, Construction, Operation
 Valuations and Appraisals
PHILADELPHIA

STOCKBRIDGE & BORST

Patent Law

41 PARK ROW NEW YORK CITY

THE J. G. WHITE
ENGINEERING CORPORATION
 Engineers—Constructors
 Oil Refineries and Pipe Lines,
 Steam and Water Power Plants
 Transmission Systems, Hotels, Apartments,
 Offices and Industrial Buildings, Railroads
 43 EXCHANGE PLACE NEW YORK

JOHN A. STEVENS, INC.
 Established 1909

CONSULTING ENGINEERS
 Power Plants Paper Mills
 Dye Houses Surveys
LOWELL, MASSACHUSETTS

STONE & WEBSTER
 Incorporated

DESIGN AND CONSTRUCTION
 EXAMINATIONS REPORTS
 APPRAISALS
 INDUSTRIAL AND PUBLIC SERVICE
 PROPERTIES
 New York Boston Chicago

J. G. WRAY & CO.
 Engineers

J. G. Wray, Fellow A. I. E. E. Cyrus G. Hill
 Utilities and Industrial Properties
 Appraisals Construction Rate Surveys
 Plans Organizations Estimates
 Financial Investigations Management
 2130 Bankers Bldg., Chicago

Your card in each issue of this publication—12 times a year, will keep your name and specialized service constantly before the electrical industry.

ELECTRICAL TESTING LABORATORIES

80th Street and East End Ave.
NEW YORK

Inspections — Tests — Research

Tests may be used by the purchaser for the following purposes:

- (1) To determine the quality of competing samples. This enables the purchase of the best quality for the money.
- (2) To make sure that shipments comply with specifications. This makes possible the assurance to the customer that shipments match buying samples.
- (3) To furnish an impartial decision in case of disputes between purchaser and manufacturer.

Testing places the whole buying problem on a sound basis.

To Engineers
 Manufacturers ✦ Inventors

We possess exceptional facilities for doing your experimental work . . . models, dies, tools, instruments, light machinery . . . general manufacturing . . . inventions developed. Customer's supervision in machine shop permitted. Over thirty years' specialized experience. Clients include Bell Telephone Laboratories, All-America Cables, Inc., and other well known organizations.

MANUFACTURERS' & INVENTORS' ELECTRIC CO.

Incorporated 1897

228 West Broadway, New York

(Smith Building at Franklin St.)

Tel. Walker 8687-8688

Cable Address "MANDIELECO"

Trade "ESCO" Mark

ELECTRIC SPECIALTY CO.

Engineers and Manufacturers



TYPE NA AIRPLANE GENERATOR

DESIGN —
 DEVELOP —
 PRODUCE —

Small Motors, Generators, Dynamotors,
 Motor Generators, Rotary Converters, Etc.

FOR SPECIAL PURPOSES—Send Us Your Problems

222 South Street, STAMFORD, CONN., U.S.A.

If You Are Looking For Outstanding Performance By

TRANSFORMERS

make your selection from our stock of over 5000. Every transformer guaranteed either brand new or re-built and tested to A. I. E. E. Standard. We can save you 30 to 60 per cent on the purchase price.



The **ELECTRIC SERVICE CO. Inc.**
 America's Used Transformer Clearing House
 212 Walnut Street Cincinnati, Ohio



We buy modern type transformers—any size—any quantity.
 Wanted especially—high voltage large capacity transformers in carload shipments.

Please mention the JOURNAL of the A. I. E. E. when writing to advertisers.

Classified Advertiser's Index for Buyers

Manufacturers and agents for machinery and supplies used in the electrical and allied industries.

Note: For reference to the advertisements see the Alphabetical List of Advertisers on page 46.

- AIR COMPRESSORS**
Allis-Chalmers Mfg. Co., Milwaukee
General Electric Co., Schenectady
Western Electric Co., All Principal Cities
- AMMETER COMPENSATING COILS**
Minerallac Electric Co., Chicago
- AMMETER, VOLTMETERS**
(See INSTRUMENTS, ELECTRICAL)
- ANCHORS, GUY**
Copperweld Steel Co., Glassport, Pa.
Kearney Corp., Jas. R., St. Louis
Matthews Corp., W. N., St. Louis
- BATTERY CHARGING APPARATUS**
Electric Specialty Co., Stamford, Conn.
General Electric Co., Schenectady
Rochester Electric Products Corp., Rochester, N. Y.
Wagner Electric Corp., St. Louis
Ward Leonard Electric Co., Mt. Vernon, N. Y.
Western Electric Co., All Principal Cities
Westinghouse Elec. & Mfg. Co., E. Pittsburgh
- BEARINGS, BALL**
Norma-Hoffman Bearings Corp., Stamford, Conn.
- BOXES, FUSE**
Bull Dog Electric Products Co., Detroit
General Electric Co., Schenectady
Kearney Corp., Jas. R., St. Louis
Metropolitan Device Corp., Brooklyn, N. Y.
Western Electric Co., All Principal Cities
Westinghouse Elec. & Mfg. Co., E. Pittsburgh
- BOXES, JUNCTION**
Burke Electric Co., Erie, Pa.
G & W Elec. Specialty Co., Chicago
General Cable Corporation, New York
Metropolitan Device Corp., Brooklyn, N. Y.
- BRUSHES, COMMUTATOR**
Carbon
Morganite Brush Co., Inc., L. I. City, N. Y.
National Carbon Co., Inc., Cleveland
Westinghouse Elec. & Mfg. Co., E. Pittsburgh
Copper Graphite
Morganite Brush Co., Inc., L. I. City, N. Y.
National Carbon Co., Inc., Cleveland
Westinghouse Elec. & Mfg. Co., E. Pittsburgh
- BUS BARS, ALUMINUM**
Aluminum Co. of America, Pittsburgh
- BUS BAR FITTINGS**
Burke Electric Co., Erie, Pa.
Burndy Engineering Co., Inc., New York
Champion Switch Co., Kenova, West Va.
Delta-Star Electric Co., Chicago
General Electric Co., Schenectady
Memco Engg. & Mfg. Co., L. I. City, N. Y.
Ohio Brass Co., Mansfield, O.
Westinghouse Elec. & Mfg. Co., E. Pittsburgh
- BUSHINGS, PORCELAIN**
Ohio Brass Co., Mansfield, O.
- CABLE ACCESSORIES**
Burke Electric Co., Erie, Pa.
Champion Switch Co., Kenova, West Va.
Delta-Star Electric Co., Chicago
Dossert & Co., New York
G & W Electric Specialty Co., Chicago
General Cable Corporation, New York
General Electric Co., Schenectady
Minerallac Electric Co., Chicago
Western Electric Co., All Principal Cities
- CABLE RACKS**
Metropolitan Device Corp., Brooklyn, N. Y.
- CABLES**
SEE WIRES AND CABLES
- CABLEWAYS**
American Steel & Wire Co., Chicago
Roebbling's Sons Co., John A., Trenton, N. J.
- CASTINGS, ALUMINUM**
Aluminum Co. of America, Pittsburgh
- CIRCUIT BREAKERS**
Air-Enclosed
Condit Elec. Mfg. Corp., Boston
I-T-E Circuit Breaker Co., The, Philadelphia
Roller-Smith Co., New York
Ward Leonard Electric Co., Mt. Vernon, N. Y.
Western Electric Co., All Principal Cities
Oil
Condit Electrical Mfg. Corp., Boston
General Electric Co., Schenectady
Pacific Electric Mfg. Corp., San Francisco
Roller-Smith Co., New York
Westinghouse Elec. & Mfg. Co., E. Pittsburgh
- CLAMPS, GUY & CABLE**
Burke Electric Co., Erie, Pa.
Burndy Engineering Co., Inc., New York
Kearney Corp., Jas. R., St. Louis
Matthews Corp., W. N., St. Louis
- CLAMPS, INSULATOR**
Champion Switch Co., Kenova, West Va.
Memco Engg. & Mfg. Co., L. I. City, N. Y.
- COILS, CHOKE**
Burke Electric Co., Erie, Pa.
General Electric Co., Schenectady
Kearney Corp., Jas. R., St. Louis
Memco Engg. & Mfg. Co., L. I. City, N. Y.
Westinghouse Elec. & Mfg. Co., E. Pittsburgh
- COILS, MAGNET**
Belden Mfg. Co., Chicago
General Cable Corporation, New York
General Electric Co., Schenectady
Westinghouse Elec. & Mfg. Co., E. Pittsburgh
- COMMUTATOR SEGMENTS AND RINGS**
Mica Insulator Co., New York
- CONDENSATION PRODUCTS**
Bakelite Corporation, New York
- CONDENSERS, RADIO**
General Radio Co., Cambridge, Mass.
Sangamo Electric Co., Springfield, Ill.
- CONDENSERS, STEAM**
Allis-Chalmers Mfg. Co., Milwaukee
General Electric Co., Schenectady
Westinghouse Elec. & Mfg. Co., E. Pittsburgh
- CONDUIT, UNDERGROUND FIBRE**
Western Electric Co., All Principal Cities
- CONNECTORS, SOLDERLESS**
Burke Electric Co., Erie, Pa.
Dossert & Co., New York
Kearney Corp., Jas. R., St. Louis
Westinghouse Elec. & Mfg. Co., E. Pittsburgh
- CONNECTORS AND TERMINALS**
Belden Mfg. Co., Chicago
Burke Electric Co., Erie, Pa.
Burndy Engineering Co., Inc., New York
Champion Switch Co., Kenova, West Va.
Dossert & Co., New York
G & W Electric Specialty Co., Chicago
Western Electric Co., All Principal Cities
Westinghouse Elec. & Mfg. Co., E. Pittsburgh
- CONTACTS, TUNGSTEN**
General Electric Co., Schenectady
- CONTROL SYSTEMS**
Ward Leonard Electric Co., Mt. Vernon, N. Y.
- CONTROLLERS**
Electric Controller & Mfg. Co., Cleveland
General Electric Co., Schenectady
Rowan Controller Co., Baltimore, Md.
Ward Leonard Electric Co., Mt. Vernon, N. Y.
Westinghouse Elec. & Mfg. Co., E. Pittsburgh
- CONVERTERS—SYNCHRONOUS**
Allis-Chalmers Mfg. Co., Milwaukee
Electric Specialty Co., Stamford, Conn.
Wagner Electric Corp., St. Louis
Westinghouse Elec. & Mfg. Co., E. Pittsburgh
- COPPER CLAD WIRE**
Belden Mfg. Co., Chicago
Western Electric Co., All Principal Cities
- COPPERWELD WIRE**
Copperweld Steel Co., Glassport, Pa.
General Cable Corporation, New York
- CUT-OUTS**
Bull Dog Electric Products Co., Detroit
Condit Electrical Mfg. Corp., S. Boston
General Electric Co., Schenectady
G & W Electric Specialty Co., Chicago
Kearney Corp., Jas. R., St. Louis
Metropolitan Device Corp., Brooklyn, N. Y.
Wagner Electric Corp., St. Louis
Westinghouse Elec. & Mfg. Co., E. Pittsburgh
- DIMMERS, THEATRE**
Ward Leonard Electric Co., Mt. Vernon, N. Y.
- DIVERTER POLE GENERATORS**
Rochester Electric Products Corp., Rochester, N. Y.
- DYNAMOS**
(See GENERATORS AND MOTORS)
- DYNAMOTORS**
Burke Electric Co., Erie, Pa.
Electric Specialty Co., Stamford, Conn.
Rochester Electric Products Corp., Rochester, N. Y.
- ELECTRIFICATION SUPPLIES, STEAM ROAD**
General Electric Co., Schenectady
Ohio Brass Co., Mansfield, Ohio
Westinghouse Elec. & Mfg. Co., E. Pittsburgh
- ENGINEERS, CONSULTING AND CONTRACTING**
(See PROFESSIONAL ENGINEERING DIRECTORY)
- ENGINES**
Gas & Gasoline
Allis-Chalmers Mfg. Co., Milwaukee
Oil
Allis-Chalmers Mfg. Co., Milwaukee
Steam
Allis-Chalmers Mfg. Co., Milwaukee
- EXPERIMENTAL WORK**
Manufacturers' and Inventors' Electric Co., New York
- FANS, MOTORS**
Century Electric Co., St. Louis
General Electric Co., Schenectady
Wagner Electric Corp., St. Louis
Westinghouse Elec. & Mfg. Co., E. Pittsburgh
- FLOW METERS**
General Electric Co., Schenectady
- FURNACES, ELECTRIC**
General Electric Co., Schenectady
Westinghouse Elec. & Mfg. Co., E. Pittsburgh
- FUSES**
Enclosed Refillable
General Electric Co., Schenectady
Westinghouse Elec. & Mfg. Co., E. Pittsburgh
Enclosed Non-Refillable
General Electric Co., Schenectady
Open Link
General Electric Co., Schenectady
Metropolitan Device Corp., Brooklyn, N. Y.
High-Tension
Metropolitan Device Corp., Brooklyn, N. Y.
- FUSE MOUNTINGS**
Memco Engg. & Mfg. Co., L. I. City, N. Y.
- FUSE PULLERS**
Kearney Corp., Jas. R., St. Louis

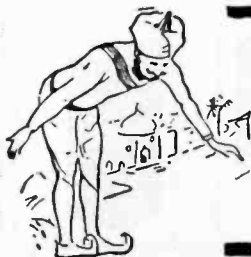

Is your name on our mailing list for bulletins and catalog?

Morganite Brushes

Morganite Brush Co., Inc.
3302-3320 Anable Ave.,
Long Island City,
N. Y.

Please mention the JOURNAL of the A. I. E. E. when writing to advertisers.

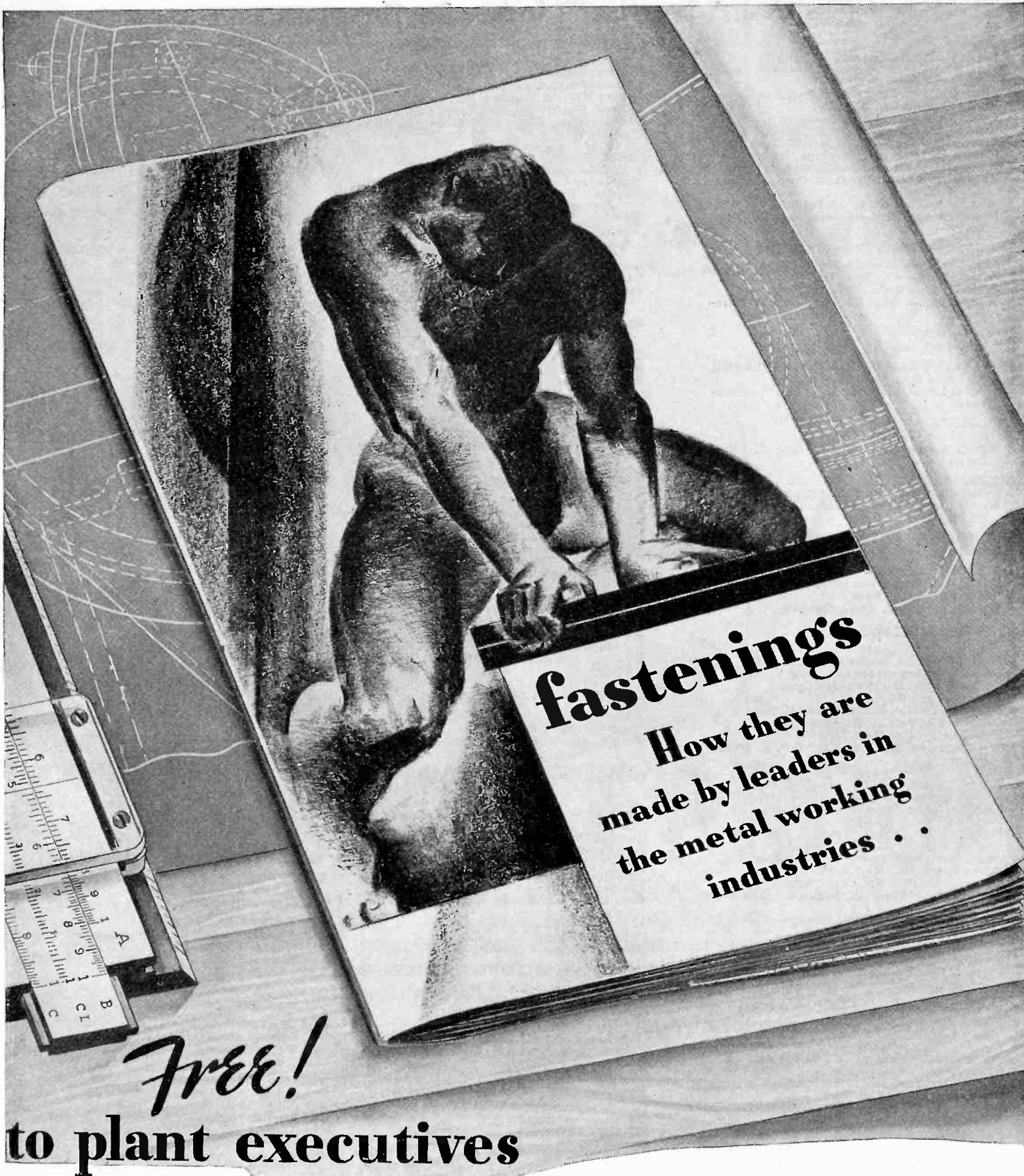

fastenings
 How they are
 made by leaders in
 the metal working
 industries . . .

Free!

to plant executives

This book was prepared for you with the cooperation of fourteen of the most prominent manufacturers in their respective fields, who permitted a nationally known firm of engineers to enter their plants and make studies of fastening methods which have proved particularly advantageous.

Every plant executive who is interested in the production of a product made wholly or partly of metal will find "Fastenings" interesting and helpful. Distribution of the book must be limited to those concerned with production, who may obtain it free.

CLIP COUPON TO YOUR LETTERHEAD

PARKER-KALON CORPORATION
 198 Varick Street, New York, N. Y.

Send a free copy of "Fastenings" marked for the personal attention of:

Name and Title.....

Company

Street and City.....

Please mention the JOURNAL of the A. I. E. E. when writing to advertisers.

Classified Advertiser's Index for Buyers—Continued

GEARS, FIBRE

General Electric Co., Schenectady

GENERATORS AND MOTORS

Allis-Chalmers Mfg. Co., Milwaukee
 Burke Electric Co., Erie, Pa.
 Century Electric Co., St. Louis
 Chandeysson Electric Co., St. Louis
 Electric Specialty Co., Stamford, Conn.
 Electro-Dynamic Co., Bayonne, N. J.
 General Electric Co., Schenectady
 Rochester Electric Products Corp., Rochester, N. Y.
 Wagner Electric Corp., St. Louis
 Westinghouse Elec. & Mfg. Co., E. Pittsburgh

GENERATING STATION EQUIPMENT

Allis-Chalmers Mfg. Co., Milwaukee
 Burke Electric Co., Erie, Pa.
 General Electric Co., Schenectady
 Westinghouse Elec. & Mfg. Co., E. Pittsburgh

GROUND RODS

Copperweld Steel Co., Glassport, Pa.

HARDWARE, POLE LINE AND INSULATOR

Ohio Brass Co., Mansfield, O.
 Westinghouse Elec. & Mfg. Co., E. Pittsburgh

HEADLIGHTS

Ohio Brass Co., Mansfield, O.
 Westinghouse Elec. & Mfg. Co., E. Pittsburgh

HEATERS, INDUSTRIAL

General Electric Co., Schenectady
 Westinghouse Elec. & Mfg. Co., E. Pittsburgh

INDICATORS, REMOTE, WATER LEVEL

Bristol Co., The, Waterbury, Conn.

INDICATORS, SPEED

Bristol Co., The, Waterbury, Conn.
 Roller-Smith Co., New York
 Weston Elec. Inst. Corp., Newark, N. J.

INSTRUMENTS, ELECTRICAL

Graphic

Bristol Co., The, Waterbury, Conn.
 Cambridge Instrument Co., New York
 Ferranti, Ltd., Hollinwood, England
 Ferranti, Inc., New York
 Ferranti Electric, Ltd., Toronto, Ont.
 General Electric Co., Schenectady
 Roller-Smith Co., New York
 Westinghouse Elec. & Mfg. Co., E. Pittsburgh

Indicating

Bristol Co., The, Waterbury, Conn.
 Cambridge Instrument Co., New York
 Ferranti, Ltd., Hollinwood, England
 Ferranti, Inc., New York
 Ferranti Electric, Ltd., Toronto, Ont.
 General Electric Co., Schenectady
 Jewell Elec. Instrument Co., Chicago
 Roller-Smith Co., New York
 Sangamo Electric Co., Springfield, Ill.
 Westinghouse Elec. & Mfg. Co., E. Pittsburgh
 Weston Elec. Inst. Corp., Newark, N. J.

Integrating

Ferranti, Ltd., Hollinwood, England
 Ferranti, Inc., New York
 Ferranti Electric, Ltd., Toronto, Ont.
 General Electric Co., Schenectady
 Sangamo Electric Co., Springfield, Ill.
 Western Electric Co., All Principal Cities
 Westinghouse Elec. & Mfg. Co., E. Pittsburgh

Radio

Cambridge Instrument Co., New York
 General Radio Co., Cambridge, Mass.
 Jewell Elec. Instrument Co., Chicago
 Roller-Smith Co., New York
 Weston Elec. Inst. Corp., Newark, N. J.

Repairing and Testing

Cambridge Instrument Co., New York
 Electrical Testing Laboratories, New York
 Jewell Elec. Instrument Co., Chicago
 Roller-Smith Co., New York
 Weston Elec. Inst. Corp., Newark, N. J.

Scientific Laboratory, Testing

Cambridge Instrument Co., New York
 General Electric Co., Schenectady
 Jewell Elec. Instrument Co., Chicago
 Metropolitan Device Corp., Brooklyn, N. Y.
 Roller-Smith Co., New York
 Western Electric Co., All Principal Cities
 Westinghouse Elec. & Mfg. Co., E. Pittsburgh
 Weston Elec. Inst. Corp., Newark, N. J.

INSULATING MATERIALS

Board

General Electric Co., Bridgeport, Conn.
 West Va. Pulp & Paper Co., New York

Cloth

General Electric Co., Bridgeport, Conn.
 Mica Insulator Co., New York
 Minerallac Electric Co., Chicago
 Westinghouse Elec. & Mfg. Co., E. Pittsburgh

INSULATING MATERIALS—Continued

Composition

American Lava Corp., Chattanooga
 Bakelite Corporation, New York
 Belden Mfg. Co., Chicago
 General Electric Co., Bridgeport, Conn.
 Westinghouse Elec. & Mfg. Co., E. Pittsburgh

Compounds

General Electric Co., Bridgeport, Conn.
 Mica Insulator Co., New York
 Minerallac Electric Co., Chicago
 Standard Underground Cable Co., Perth Amboy, N. J.
 Western Electric Co., All Principal Cities
 Westinghouse Elec. & Mfg. Co., E. Pittsburgh

Fibre

Belden Mfg. Co., Chicago
 General Electric Co., Bridgeport, Conn.
 West Va. Pulp & Paper Co., New York

Lava

American Lava Corp., Chattanooga, Tenn.

Mica

Chicago Mica Co., Valparaiso, Ind.
 Mica Insulator Co., New York
 Westinghouse Elec. & Mfg. Co., E. Pittsburgh

Paper

General Electric Co., Bridgeport, Conn.
 Mica Insulator Co., New York
 Westinghouse Elec. & Mfg. Co., E. Pittsburgh

Silk

General Electric Co., Bridgeport, Conn.

Tape

Belden Mfg. Co., Chicago
 General Electric Co., Bridgeport, Conn.
 Mica Insulator Co., New York
 Minerallac Electric Co., Chicago
 Okonite Co., The, Passaic, N. J.
 Western Electric Co., All Principal Cities
 Westinghouse Elec. & Mfg. Co., E. Pittsburgh

Varnishes

General Electric Co., Bridgeport, Conn.
 Mica Insulator Co., New York
 Minerallac Electric Co., Chicago
 Westinghouse Elec. & Mfg. Co., E. Pittsburgh

INSULATORS, HIGH TENSION

Composition

Burke Electric Co., Erie, Pa.
 General Electric Co., Schenectady

Glass

Hemingray Glass Co., Muncie, Ind.

Porcelain

Canadian Porcelain Co., Ltd., Hamilton, Ont.
 Champion Switch Co., Kenova, West Va.
 General Electric Co., Schenectady
 Lapp Insulator Co., Inc., LeRoy, N. Y.
 Locke Insulator Corp., Baltimore
 Ohio Brass Co., Mansfield, O.
 Thomas & Sons Co., R., Lisbon, O.
 Westinghouse Elec. & Mfg. Co., E. Pittsburgh

Post Type

Delta-Star Electric Co., Chicago
 Ohio Brass Co., Mansfield, O.

INSULATORS, TELEPHONE & TELEGRAPH

Hemingray Glass Co., Muncie, Ind.
 Ohio Brass Co., Mansfield, O.

INSULATOR PINS

Ohio Brass Co., Mansfield, O.
 Thomas & Sons Co., R., Lisbon, O.

LAMP GUARDS

Mathews Corp., W. N., St. Louis

LAVA

American Lava Corp., Chattanooga

LIGHTNING ARRESTERS

Delta-Star Electric Co., Chicago
 General Electric Co., Schenectady
 Western Electric Co., All Principal Cities
 Westinghouse Elec. & Mfg. Co., E. Pittsburgh

LOCOMOTIVES, ELECTRIC

General Electric Co., Schenectady
 Westinghouse Elec. & Mfg. Co., E. Pittsburgh

MAGNETIC SEPARATORS

Electric Controller & Mfg. Co., Cleveland

METERS, ELECTRICAL

(See INSTRUMENTS ELECTRICAL)

METER SEALS

Metropolitan Device Corp., Brooklyn, N. Y.

MICA PRODUCTS

Mica Insulator Co., New York
 Westinghouse Elec. & Mfg. Co., E. Pittsburgh

MOLDED INSULATION

Bakelite Corporation, New York
 Belden Mfg. Co., Chicago
 Burke Electric Co., Erie, Pa.
 Westinghouse Elec. & Mfg. Co., E. Pittsburgh

MOTORS

(See GENERATORS AND MOTORS)

OHMMETERS

Jewell Elec. Instrument Co., Chicago
 Roller-Smith Co., New York
 Weston Elec. Instr. Corp., Newark, N. J.

OIL SEPARATORS & PURIFIERS

Sharples Specialty Co., The, Philadelphia
 Westinghouse Elec. & Mfg. Co., E. Pittsburgh

PANEL BOARDS

(See SWITCHBOARDS)

PATENT ATTORNEYS

(See PROFESSIONAL ENGINEERING DIRECTORY)

PLATING GENERATORS

Burke Electric Co., Erie, Pa.
 Chandeysson Elec. Co., St. Louis
 Electric Specialty Co., Stamford, Conn.
 Rochester Electric Products Corp., Rochester, N. Y.

PLUGS

Delta-Star Electric Co., Chicago
 General Electric Co., Schenectady
 Westinghouse Elec. & Mfg. Co., E. Pittsburgh

POLE LINE HARDWARE

Ohio Brass Co., Mansfield, O.

POTHEADS

G & W Electric Specialty Co., Chicago
 General Cable Corporation, New York
 Ohio Brass Co., Mansfield, O.

PUBLIC ADDRESS SYSTEMS

Western Electric Co., All Principal Cities

PULLERS, SLACK

Mathews Corp., W. N., St. Louis

PUMPS

Allis-Chalmers Mfg. Co., Milwaukee

RADIO LABORATORY APPARATUS

General Radio Co., Cambridge, Mass.
 Western Electric Co., All Principal Cities
 Westinghouse Elec. & Mfg. Co., E. Pittsburgh

RAILWAY SUPPLIES, ELECTRIC

General Electric Co., Schenectady
 Ohio Brass Co., Mansfield, O.
 Westinghouse Elec. & Mfg. Co., E. Pittsburgh

REACTORS

General Electric Co., Schenectady
 Metropolitan Device Corp., Brooklyn, N. Y.

RECTIFIERS

General Electric Co., Schenectady
 Wagner Electric Corp., St. Louis
 Westinghouse Elec. & Mfg. Co., E. Pittsburgh

REELS, PAYOUT AND TAKEUP

Mathews Corp., W. N., St. Louis

REGULATORS, VOLTAGE

General Electric Co., Schenectady
 Westinghouse Elec. & Mfg. Co., E. Pittsburgh

RELAYS

Automatic Electric, Inc., Chicago
 Condit Elec. Mfg. Corp., Boston
 Electric Controller & Mfg. Co., Cleveland
 General Electric Co., Schenectady
 Roller-Smith Co., New York
 Westinghouse Elec. & Mfg. Co., E. Pittsburgh

RESISTORS, VITREOUS

Electrad, Inc., New York
 International Resistance Co., Philadelphia
 Ward Leonard Electric Co., Mt. Vernon, N. Y.

RESISTOR UNITS

Electrad, Inc., New York
 General Electric Co., Schenectady
 International Resistance Co., Philadelphia
 Ward Leonard Electric Co., Mt. Vernon, N. Y.
 Westinghouse Elec. & Mfg. Co., E. Pittsburgh

RHEOSTATS

General Electric Co., Schenectady
 Ward Leonard Electric Co., Mt. Vernon, N. Y.
 Western Electric Co., All Principal Cities
 Westinghouse Elec. & Mfg. Co., E. Pittsburgh

ROPE, WIRE

American Steel & Wire Co., Chicago
 Roebling's Sons Co., John A., Trenton, N. J.

Turn Your Locking Problems Over to



SHAKEPROOF

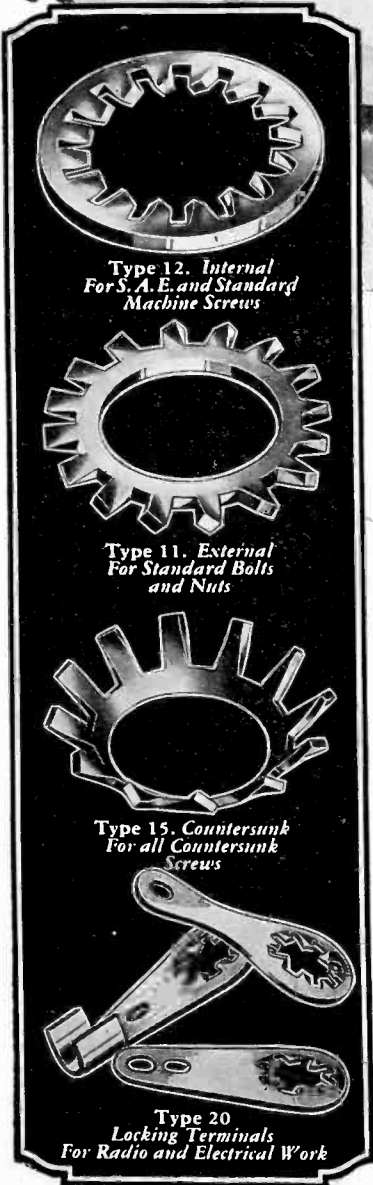

Type 12. Internal For S. A. E. and Standard Machine Screws

Type 11. External For Standard Bolts and Nuts

Type 15. Countersunk For all Countersunk Screws

Type 20 Locking Terminals For Radio and Electrical Work

LEADING manufacturers in hundreds of industries have solved their locking problems by using Shakeproof on their products. Better performance, fewer customer complaints and reduced service costs have proved that Shakeproof Lock Washers are a real contribution to industrial progress.

The fact that the Shakeproof multiple-locking principle can also be incorporated in other parts means that a substantial saving is made possible by eliminating the purchase of separate lock washers and also in reducing the number of assembly operations. Our Shakeproof engineers are at your service and will gladly consult with you regarding your locking problems without cost or obligation to you.

Decide now to test Shakeproof on your product. Free samples of any type or size will be sent on request and, if you desire, a Shakeproof engineer will call and personally study your problems.

Write for your free samples today!

SHAKEPROOF Lock Washer Company

U. S. Patents: 1,419,564
1,604,122—1,697,954
Other patents pending.
Foreign patents.

{Division of Illinois Tool Works}

2517 North Keeler Avenue, Chicago, Illinois



"It's the Twisted Teeth that LOCK"

Please mention the JOURNAL of the A. I. E. E. when writing to advertisers.

Classified Advertiser's Index for Buyers—Continued

SCREWS

Drive Hardened Metallic
Parker-Kalon Corp., New York
Sdf-Tapping Hardened
Parker-Kalon Corp., New York
Sheet Metal, Hardened Sdf-Tapping:
Parker-Kalon Corp., New York

SEARCHLIGHTS

General Electric Co., Schenectady
Westinghouse Elec. & Mfg. Co., E. Pittsburgh

SLEEVE TWISTERS

Kearney Corp., Jas. R., St. Louis

SLEEVES, SPlicing

Memco Engg. & Mfg. Co., L. I. City, N. Y.

SOCKETS AND RECEPTACLES

General Electric Co., Schenectady
Westinghouse Elec. & Mfg. Co., E. Pittsburgh

SOLENOIDS

Belden Mfg. Co., Chicago
Electric Controller & Mfg. Co., Cleveland
General Electric Co., Schenectady
Roebbling's Sons Co., John A., Trenton, N. J.
Ward Leonard Electric Co., Mt. Vernon, N. Y.
Westinghouse Elec. & Mfg. Co., E. Pittsburgh

SPRINGS

American Steel & Wire Co., Chicago

STARTERS, MOTORS

Condit Electrical Mfg. Corp., Boston
Electric Controller & Mfg. Co., Cleveland
General Electric Co., Schenectady
Roller-Smith Co., New York
Rowan Controller Co., Baltimore, Md.
Ward Leonard Electric Co., Mt. Vernon, N. Y.
Westinghouse Elec. & Mfg. Co., E. Pittsburgh

STOKERS, MECHANICAL

Westinghouse Elec. & Mfg. Co., E. Pittsburgh

SUB-STATIONS

American Bridge Co., New York
Champion Switch Co., Kenova, West Va.
General Electric Co., Schenectady
Memco Engg. & Mfg. Co., L. I. City, N. Y.
Westinghouse Elec. & Mfg. Co., E. Pittsburgh

SWITCHBOARDS

Allis-Chalmers Mfg. Co., Milwaukee
Ball Dog Electric Products Co., Detroit
Condit Electrical Mfg. Corp., Boston
General Electric Co., Schenectady
Metropolitan Device Corp., Brooklyn, N. Y.
Westinghouse Elec. & Mfg. Co., E. Pittsburgh

SWITCHES

Automatic Times
General Electric Co., Schenectady
Mineralogic Electric Co., Chicago
Sangamo Electric Co., Springfield, Ill.
Westinghouse Elec. & Mfg. Co., E. Pittsburgh

Disconnecting
Ball Dog Electric Products Co., Detroit
Burke Electric Co., Erie, Pa.
Champion Switch Co., Kenova, West Va.
Condit Electrical Mfg. Corp., Boston
Delta-Star Electric Co., Chicago
General Electric Co., Schenectady
Kearney Corp., Jas. R., St. Louis
Matthews Corp., W. N., St. Louis
Memco Engg. & Mfg. Co., L. I. City, N. Y.
Pacific Elec. Mfg. Corp., San Francisco
Roller-Smith Co., New York
Westinghouse Elec. & Mfg. Co., E. Pittsburgh

Pan
Ball Dog Electric Products Co., Detroit
General Electric Co., Schenectady
Kearney Corp., Jas. R., St. Louis
Matthews Corp., W. N., St. Louis
Metropolitan Device Corp., Brooklyn, N. Y.

Knife
Electric Controller & Mfg. Co., Cleveland
General Electric Co., Schenectady
Matthews Corp., W. N., St. Louis
Westinghouse Elec. & Mfg. Co., E. Pittsburgh

Magnets
Electric Controller & Mfg. Co., Cleveland
Ward Leonard Electric Co., Mt. Vernon, N. Y.

Oil
Condit Electrical Mfg. Corp., Boston
General Electric Co., Schenectady
Pacific Elec. Mfg. Corp., San Francisco
Roller-Smith Co., New York
Westinghouse Elec. & Mfg. Co., E. Pittsburgh

Remote Control
Automatic Electric, Inc., Chicago
Condit Electrical Mfg. Corp., Boston
General Electric Co., Schenectady
Roller-Smith Co., New York
Rowan Controller Co., Baltimore, Md.
Westinghouse Elec. & Mfg. Co., E. Pittsburgh

TELEPHONE CONNECTORS

Kearney Corp., Jas. R., St. Louis

TELEPHONE & SIGNALING SYSTEMS

Automatic Electric, Inc., Chicago

TERMINAL BLOCKS

Burke Electric Co., Erie, Pa.

TESTING LABORATORIES

Electrical Testing Labs., New York

TOWERS, TRANSMISSION

American Bridge Co., New York

TRANSFORMERS

Allis-Chalmers Mfg. Co., Milwaukee
American Transformer Co., Newark, N. J.
Electric Service Co., Cincinnati
Ferranti, Ltd., Hollinwood, England
Ferranti, Inc., New York
Ferranti Electric, Ltd., Toronto, Ont.
General Electric Co., Schenectady
Kuhlman Electric Co., Bay City, Mich.
Moloney Electric Co., St. Louis
Sangamo Electric Co., Springfield, Ill.
Wagner Electric Corp., St. Louis
Westinghouse Elec. & Mfg. Co., E. Pittsburgh

Factory

American Transformer Co., Newark, N. J.
Kuhlman Electric Co., Bay City, Mich.
Moloney Electric Co., St. Louis, Mo.
Wagner Electric Corp., St. Louis

Furnace

Allis-Chalmers Mfg. Co., Milwaukee
American Transformer Co., Newark, N. J.
Moloney Electric Co., St. Louis
Westinghouse Elec. & Mfg. Co., E. Pittsburgh

Metering

American Transformer Co., Newark, N. J.
Ferranti, Ltd., Hollinwood, England
Ferranti, Inc., New York
Ferranti Electric, Ltd., Toronto, Ont.
Roller-Smith Co., New York
Sangamo Electric Co., Springfield, Ill.
Weston Elec. Inst. Corp., Newark, N. J.

Radio

American Transformer Co., Newark, N. J.
Ferranti, Ltd., Hollinwood, England
Ferranti, Inc., New York
Ferranti Electric, Ltd., Toronto, Ont.
Sangamo Electric Co., Springfield, Ill.

Street Lighting

Kuhlman Electric Co., Bay City, Mich.

TRANSFORMERS, USED

Electric Service Co., Cincinnati

TROLLEY LINE MATERIALS

General Electric Co., Schenectady
Ohio Brass Co., Mansfield, O.
Westinghouse Elec. & Mfg. Co., E. Pittsburgh

TURBINES, HYDRAULIC

Allis-Chalmers Mfg. Co., Milwaukee

TURBINES, STEAM

Allis-Chalmers Mfg. Co., Milwaukee
General Electric Co., Schenectady
Westinghouse Elec. & Mfg. Co., E. Pittsburgh

TURBO-GENERATORS

Allis-Chalmers Mfg. Co., Milwaukee
Westinghouse Elec. & Mfg. Co., E. Pittsburgh

VALVE CONTROL, ELECTRIC

Bristol Company, The, Waterbury, Conn.

VALVES, BRASS

Gas, Water, Steam
Ohio Brass Co., Mansfield, O.

VARNISHES, INSULATING

General Electric Co., Bridgeport, Conn.
Mica Insulator Co., New York
Mineralogic Electric Co., Chicago
Westinghouse Elec. & Mfg. Co., E. Pittsburgh

WASHERS, LOCK

Shaluproof Lock Washer Co., Chicago

WELDING MACHINES, ELECTRIC

Burke Electric Co., Erie, Pa.
General Electric Co., Schenectady
Ohio Brass Co., Mansfield, O.
Westinghouse Elec. & Mfg. Co., E. Pittsburgh

WELDING WIRES & RODS

Aluminum Co. of America, Pittsburgh
American Steel & Wire Co., Chicago
Ohio Brass Co., Mansfield, O.

WIRES AND CABLES and A. C. S. R.

Aluminum
Aluminum Co. of America, Pittsburgh

Armored Cable
American Steel & Wire Co., Chicago
Belden Mfg. Co., Chicago
General Cable Corporation, New York
General Electric Co., Schenectady
Kerite Ins. Wire & Cable Co., New York
Okonite Company, The, Passaic, N. J.
Roebbling's Sons Co., John A., Trenton, N. J.
Simplex Wire & Cable Co., Boston
Western Electric Co., All Principal Cities

Asbestos Covered
American Steel & Wire Co., Chicago
Belden Mfg. Co., Chicago
General Electric Co., Schenectady
Rockbestos Products Corp., New Haven, Conn.

Asbestos, Varnished Cambric
Rockbestos Products Corp., New Haven, Conn.

WIRES AND CABLES—Continued

Automotive

American Steel & Wire Co., Chicago
Belden Mfg. Co., Chicago
General Cable Corporation, New York
General Electric Co., Schenectady
Kerite Ins. Wire & Cable Co., New York
Roebbling's Sons Co., John A., Trenton, N. J.
Simplex Wire & Cable Co., Boston
Western Electric Co., All Principal Cities

Bare Copper

American Steel & Wire Co., Chicago
Anaconda Wire & Cable Co., New York
Belden Mfg. Co., Chicago
General Cable Corporation, New York
Roebbling's Sons Co., John A., Trenton, N. J.
Western Electric Co., All Principal Cities

Copper Lead

Belden Mfg. Co., Chicago
Western Electric Co., All Principal Cities

Copperweld

Copperweld Steel Co., Glassport, Pa.
General Cable Corporation, New York

Flexible Cord

American Steel & Wire Co., Chicago
Belden Mfg. Co., Chicago
General Cable Corporation, New York
General Electric Co., Schenectady
Okonite Company, The, Passaic, N. J.
Roebbling's Sons Co., John A., Trenton, N. J.
Simplex Wire & Cable Co., Boston

Flexible Cord, (Heater) Asbestos Insulated

Rockbestos Products Corp., New Haven, Conn.

Heavy Duty Cord

American Steel & Wire Co., Chicago
Belden Mfg. Co., Chicago
General Cable Corporation, New York
Okonite Company, The, Passaic, N. J.
Simplex Wire & Cable Co., Boston

Fuse

Aluminum Co. of America, Pittsburgh
American Steel & Wire Co., Chicago
General Electric Co., Schenectady
Roebbling's Sons Co., John A., Trenton, N. J.

Lead Covered (Paper and Varnished Cambric Insulated)

American Steel & Wire Co., Chicago
Anaconda Wire & Cable Co., New York
General Cable Corporation, New York
General Electric Co., Schenectady
Kerite Ins. Wire & Cable Co., New York
Okonite Company, The, Passaic, N. J.
Okonite-Callender Cable Co., The, Inc., Passaic, N. J.

Roebbling's Sons Co., John A., Trenton, N. J.
Simplex Wire & Cable Co., Boston
Western Electric Co., All Principal Cities

Leads, Asbestos Insulated

Rockbestos Products Corp., New Haven, Conn.

Magnet

Aluminum Co. of America, Pittsburgh
American Steel & Wire Co., Chicago
Anaconda Wire & Cable Co., New York
Belden Mfg. Co., Chicago
General Cable Corporation, New York
General Electric Co., Schenectady
Roebbling's Sons Co., John A., Trenton, N. J.
Western Electric Co., All Principal Cities

Magnet, Asbestos Insulated

Rockbestos Products Corp., New Haven, Conn.

Rubber Insulated

American Steel & Wire Co., Chicago
Belden Mfg. Co., Chicago
General Cable Corporation, New York
General Electric Co., Schenectady
Kerite Ins. Wire & Cable Co., New York
Okonite Company, The, Passaic, N. J.
Roebbling's Sons Co., John A., Trenton, N. J.
Simplex Wire & Cable Co., Boston
Western Electric Co., All Principal Cities

Switchboard, Asbestos Insulated

Rockbestos Products Corp., New Haven, Conn.

Tree Wire

General Cable Corporation, New York
Okonite Company, The, Passaic, N. J.
Roebbling's Sons Co., John A., Trenton, N. J.
Simplex Wire & Cable Co., Boston

Trolley

American Steel & Wire Co., Chicago
Anaconda Wire & Cable Co., New York
Copperweld Steel Co., Glassport, Pa.
General Cable Corporation, New York
Roebbling's Sons Co., John A., Trenton, N. J.
Western Electric Co., All Principal Cities

Weather proof

American Steel & Wire Co., Chicago
Anaconda Wire & Cable Co., New York
Copperweld Steel Co., Glassport, Pa.
General Cable Corporation, New York
General Electric Co., Schenectady
Kerite Ins. Wire & Cable Co., New York
Okonite Company, The, Passaic, N. J.
Roebbling's Sons Co., John A., Trenton, N. J.
Simplex Wire & Cable Co., Boston
Western Electric Co., All Principal Cities

WOOD RESIN

Hercules Powder Co., Wilmington, Del.

OFFICES

- Asheville, N. C.
Electric Supply Co.
Commerce Street
- Atlanta, Georgia
Roy Young
405 Bona Allen Bldg.
- Baltimore, Md.
Industrial Power Equip. Co.
421 W. Camden St.
- Boston, Mass.
Geo. H. Wahn Co.
69-71 High Street
- Buffalo, N. Y.
John E. Hoffman
280 Carolina St.
- Chicago, Ill.
John R. Smith
844 Rush St.
- Cincinnati, Ohio
S. L. Currier
833 Union Trust Bldg.
- Cleveland, Ohio
Public Service Supply Co.
627 Union Trust Bldg.
- Dallas, Texas
F. T. Morrissey & Co.
1408 Allen Bldg.
- Denver, Colo.
Joy & Cox, Inc.
314 Tramway Bldg.
- Detroit, Michigan
Richard P. Johnson
10-230 General Motors Bldg.
- Indianapolis, Indiana
Scott Jacqua Co., Inc.
202 Indiana Terminal Whse.
- Lincoln, Neb.
Enterprise Electric Co.
1425-35 M. St.
- Los Angeles, Cal.
Thomas Machinery Co.
912 E. 3rd St.
- Milwaukee, Wis.
Wm. H. Fernholz
1031 Clybourn St.
- Minneapolis, Minn.
Joseph L. Barnard
2101 Blaisdell Ave.
- Montreal, Quebec
W. O. Taylor & Co.
415 Canada Cement Bldg.
- New Orleans, La.
Lyman C. Reed
1230 Hibernia Bank Bldg.
- New York, N. Y.
D. F. Potter, Jr.
Graybar Bldg.
- New York (Export)
Parr Electric Export Corp.
77 Warren St.
- Omaha, Neb.
J. H. Nicholson
6315 N. 33rd St.
- Philadelphia, Pa.
J. Edward Bolich
1015 Chestnut St.
- Phoenix, Arizona
Frank C. Fassett
15 East Jackson St.
- Pittsburgh, Pa.
Continental Sales & Eng. Co.
839 Oliver Bldg.
- Richmond, Va.
Edwin Wortham, Engineers
Box 910.
- San Francisco, Cal.
C. F. Henderson
Call Building
- Seattle, Wash.
Equipment Sales Co.
514 Lloyd Bldg.
- Toledo, Ohio
Howard J. Wittman
319 Spitzer Bldg.
- York, Pa.
Harry W. Motter
25 N. Duke St.

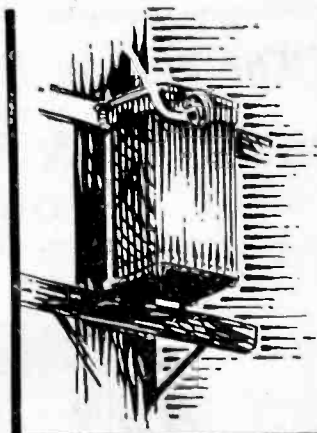

EVIDENCE OF LONG LIFE

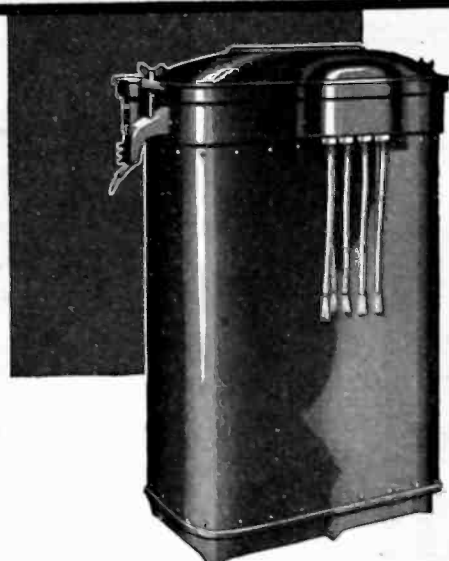

1906

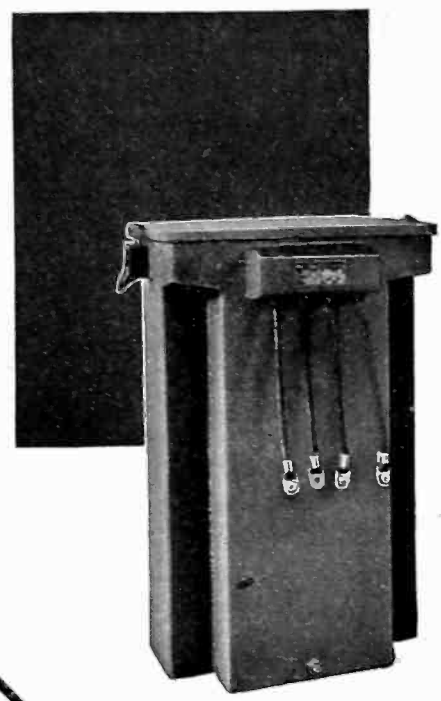

1930

A WESTERN light and power company* recently requested prices upon primary and secondary bushings for two Kuhlman distribution transformers. The serial numbers indicated that one unit was shipped in November 1906 and the other in June 1908. Since the customer desires new bushings, it is evident that the transformers are still serviceable.

Many improvements have been made in Kuhlman Transformers since these units were placed in service — improvements that have added to the Kuhlman reputation for long life . . . and low losses.

KUHLMAN ELECTRIC COMPANY
BAY CITY MICH.

* Name on Request.

KUHLMAN TRANSFORMERS

LONG LIFE

LOW LOSSES

Please mention the JOURNAL of the A. I. E. E. when writing to advertisers.



OIL IMMERSED
for long life in constant service

ROWAN Oil Immersed equipment is selected by a large and constantly growing number of engineers because of its long life in constant service under the most extreme conditions. Rowan Oil Immersed Control is dust-tight, vapor-proof, weather-tight, positive in contact, constantly lubricated and built to withstand extraordinarily rough usage. Bulletins and descriptive literature sent upon request.



ROWAN CONTROL
THE ROWAN CONTROLLER CO., BALTIMORE, MD.

The Pioneer Manufacturer
— of —
Interpole & Ball Bearing Motors

½ to 1000 H. P. D. C. and A. C.

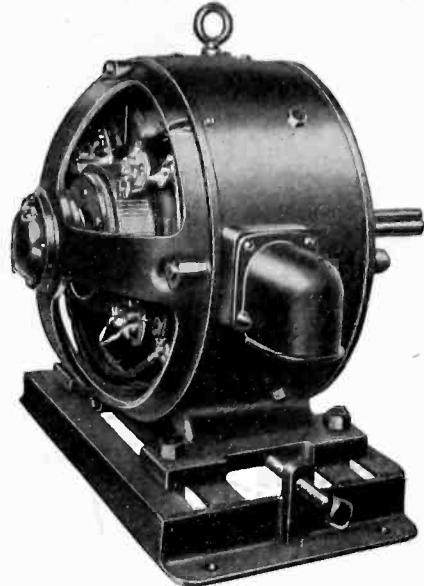

Type "S"
Ball
Bearing
Motor

ELECTRO DYNAMIC COMPANY

Manufacturers of Ball Bearing Motors Since 1904

BAYONNE, N. J.

Sales Offices in Principal Cities

"Quality for Half a Century"

ALPHABETICAL LIST OF ADVERTISERS

PAGE		PAGE		PAGE	
Allied Engineers, Inc.	38	Electro Dynamic Company	46	Neill, N. J.	38
Allis-Chalmers Manufacturing Company	26	Engineering Directory	38, 39	Neiler, Rich & Company	38
Aluminum Company of America	11	Fennessy, David V.	38	Norma-Hoffman Bearings Corporation	30
Ambursen Construction Company, Inc.	38	Ferranti, Incorporated	18	Ohio Brass Company	20
American Bridge Company	21	Ford, Bacon & Davis, Inc.	38	Okonite Company, The	Third Cover
American Lava Corporation	32	Fowle & Company, Frank F.	38	Okonite-Callender Cable Co., Inc.	Third Cover
American Steel & Wire Company	15	Frey Engineering Company	38	Osgood, Farley	38
American Telephone & Telegraph Co.	24	G & W Electric Specialty Company	35	Parker-Kalon Corporation	41
American Transformer Company	7	General Cable Corporation	22	Rochester Electric Products Corporation	17
Anaconda Wire & Cable Company	8, 9	General Electric Company	10	Roebing's Sons Company, John A.	37
Bakelite Corporation	33	General Radio Company	37	Roller-Smith Company	37
Barstow & Company, Inc., W. S.	38	Hemingray Glass Company	34	Rowan Controller Company, The	46
Battery & Kipp, Inc.	38	Hoosier Engineering Company	38	Sanderson & Porter	38
Belden Manufacturing Company	Fourth Cover	International Resistance Company	47	Sangamo Electric Company	3
Black & Veatch	38	I-T-E Circuit Breaker Company	13	Sargent & Lundy, Inc.	38
Bristol Company, The	6	Jackson & Moreland	38	Scofield Engineering Company	39
Burke Electric Company	36	Jewell Electrical Instrument Company	5	Shakeproof Lock Washer Company	43
Burndy Engineering Company, Inc.	23	Kearney Corporation, James R.	37	Sharples Specialty Company	27
Burt, Dr. Robert C.	38	Kerite Insulated Wire & Cable Co., Inc.	1	Simplex Wire & Cable Company	35
Byllesby Engineering & Management Corp.	38	Kruse, Robert S.	38	Stevens, Inc., John A.	39
Canadian Porcelain Company, Ltd.	36	Kuhlman Electric Company	45	Stockbridge & Borst	39
Century Electric Company	31	Lapp Insulator Company, Inc.	25	Stone & Webster, Inc.	39
Chandeysson Electric Company	28	Locke Insulator Corporation	16	Thomas & Sons Company, The R.	34
Clement, Edward E.	38	Manufacturers' & Inventors' Elec. Co.	39	Ward Leonard Electric Company	32
Copperweld Steel Company	36	Memco Engineering & Mfg. Co., Inc.	36	West Va. Pulp & Paper Company	32
Delta-Star Electric Company	34	Metropolitan Device Corporation	48	Western Electric Company	4
Dossert & Company	14	Minerallac Electric Company	19	Westinghouse Elec. & Mfg. Company	12
Electric Controller & Mfg. Co., The	29	Moloney Electric Company	34	Weston Electrical Instrument Corp.	2
Electric Service Company, Inc., The	39	Morganite Brush Company, Inc., The	40	White Engineering Corp., The J. G.	39
Electric Specialty Company	39			Wray & Company, J. G.	39
Electrical Testing Laboratories	39				

(For classified list of Advertisers see pages 40, 42 and 44)

Please mention the JOURNAL of the A. I. E. E. when writing to advertisers.

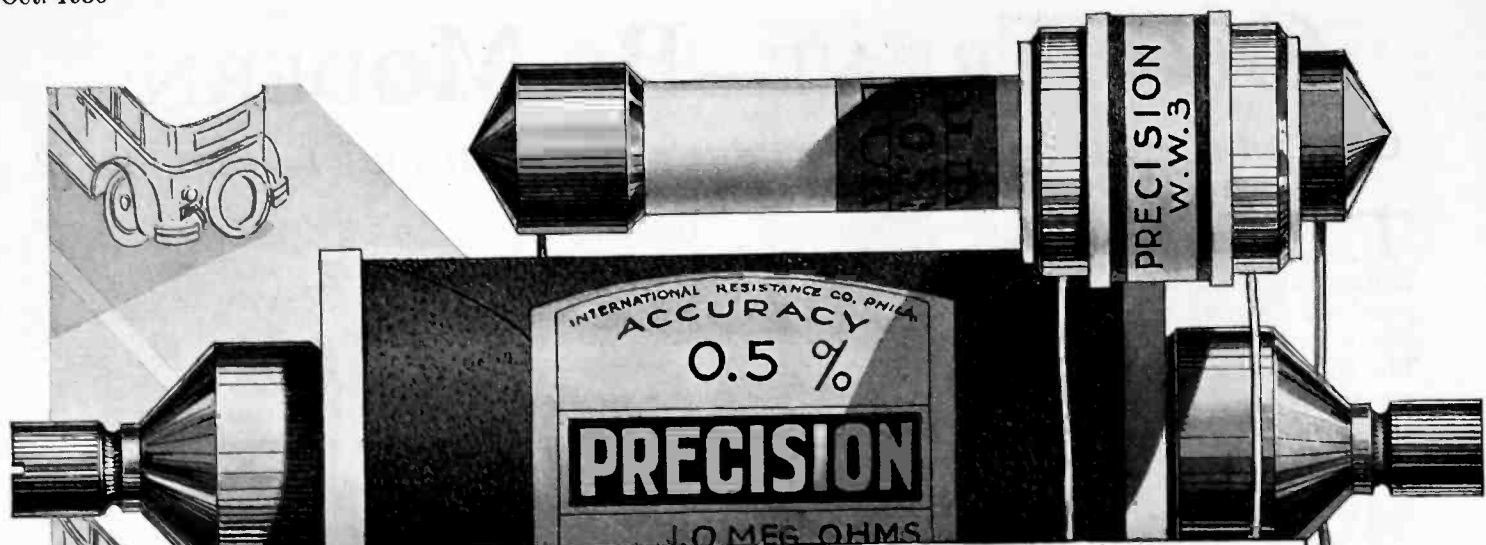

Precision Wire Wound Resistors Find Many Industrial Uses . . .

In the Holland Tunnel, resistors are used in connection with an automatic counting device operated by the light rays from each car passing through. This is but one of the many interesting industrial requirements for Precision Wound Resistors.

Other uses for our Precision Wire Wound Resistors are: — radio, sorting devices, photo-electric cells, lightning arrestors, control and signal apparatus, voltage dividers, all electron tube circuits, sound pictures, broadcasting, carrier systems, amplifiers, measurements, therapeutics, all kinds of meter circuits, traffic control, aviation, metallurgy, telephony, etc.

Engineers have found that for accurate, high-value, non-inductive, low-distributed capacity resistors, our New Precision Wire Wound Resistors answer their most exacting requirements. Among the features of these new resistors are moulded ends, new insulating methods and exclusive winding process. The wire is wound in the form of "pies"; for instance on a form 2" x 1/2" it is possible to obtain resistance values up to 500,000 ohms.

For higher values, we use a slightly larger diameter. From 1 ohm to 200 megohms you will find what you need in our wide range of quality resistors. All are minutely tested and accurately rated. Whatever your resistor problem may be, we can help you just as we have cooperated with leading engineers throughout the country.

MADE BY THE MAKERS OF
DURHAM

Metallized
RESISTORS

**INTERNATIONAL RESISTANCE
COMPANY**

2006 CHESTNUT ST.

PHILADELPHIA, PA.

**COUNTING
DEVICE
AT
HOLLAND
TUNNEL**

Please mention the JOURNAL of the A. I. E. E. when writing to advertisers.

OUR TREAT—BE MODERN

Ground resistance variations due to drought may be regulated

TO TREAT the soil so as to regulate ground resistance to values suitable or desirable to certain operating conditions is readily accomplished by pouring a copper sulphate, saline or calcium chloride solution into a Murray Copper Tube Ground Rod. The copper tube which is a non-corrosive long-life ground, is made with holes through which the solution dissipates into the surrounding soil.

Obtaining 15 ohms or less resistance is possible by using the easily treated Murray Copper Tube Ground Rod—a success wherever installed.

Test rod on application. Also chart showing effect of soil treatment on ground resistance.

METROPOLITAN DEVICE CORPORATION
1250 Atlantic Avenue, Brooklyn, N. Y.

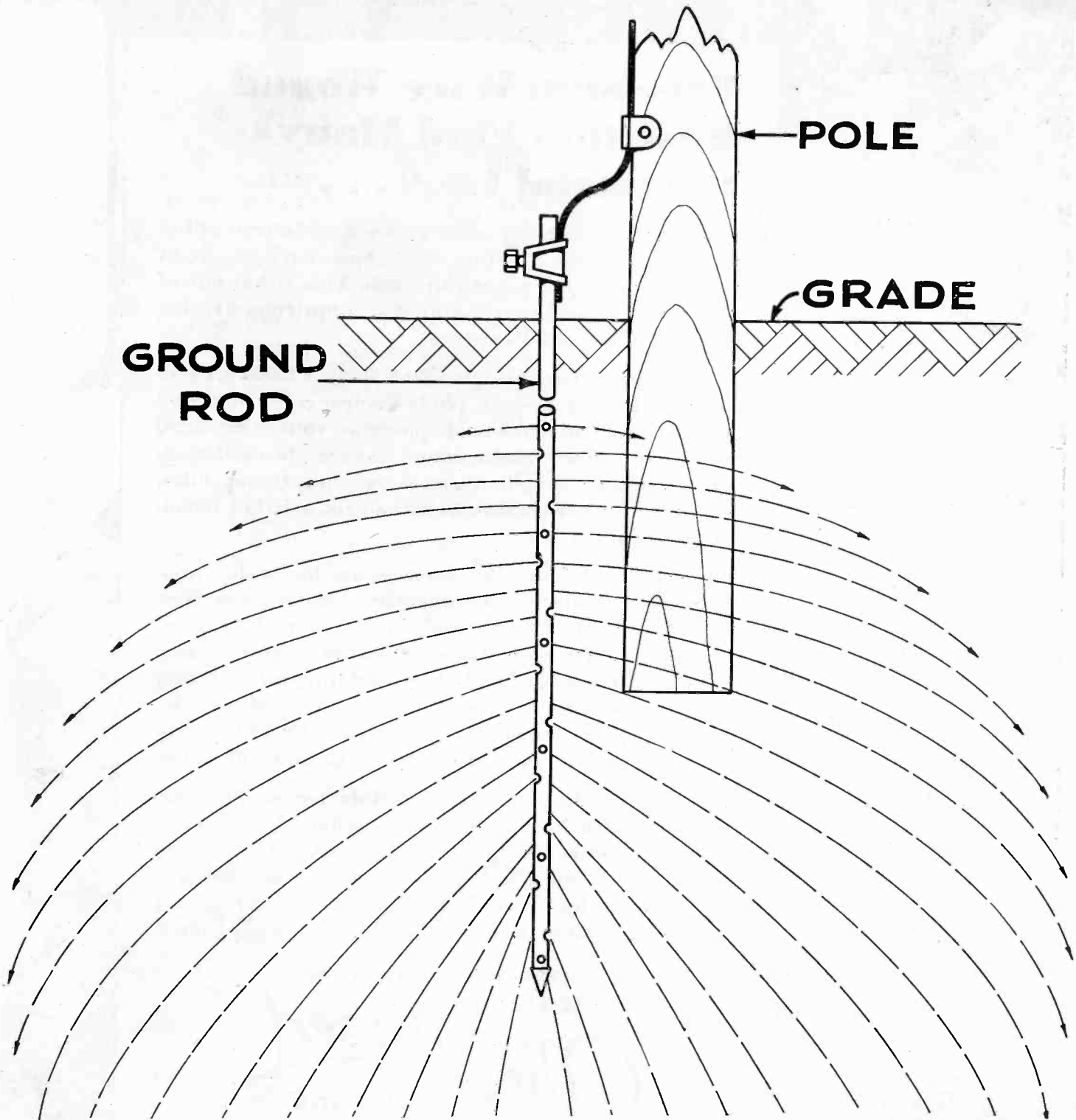

MURRAY COPPER TUBE GROUND ROD

Please mention the JOURNAL of the A. I. E. E. when writing to advertisers.

THE OTHER QUALITY TWIN- OKONITE

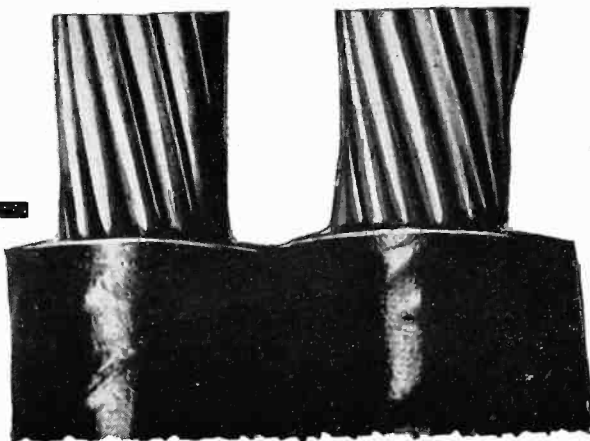

VARNISHED CAMBRIC INSULATION

FIFTY years of service have established the reputation of Okonite rubber insulation for absolute quality.

Okonite Varnished Cambric Insulated Cables have been installed in enormous numbers and for every kind of work, and their performance has been comparable to that of their twin product, Okonite Rubber Insulated Cables.

Okonite Varnished Cambric Cables exemplify the way that The Okonite Company progresses with the Electrical Industry, perfecting and producing the kinds of insulated wires and cables needed to meet the expanding requirements of plant construction and operation.

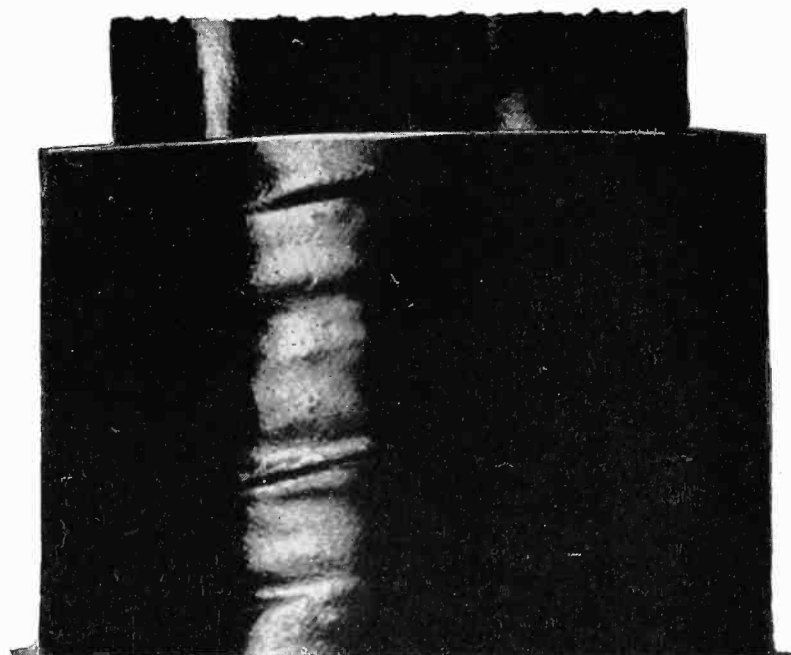

OKONITE PRODUCTS

Okonite Insulated Wires and Cables	Varnished Cambric Cables
Okonite Insulating Tape	Manson & Dundee
Okocord	Friction Tapes
	Okoloom

OKONITE-CALLENDER PRODUCTS

Impregnated Paper Cables	Super-tension Cables
Splicing Materials	

THE OKONITE COMPANY
Founded 1878

THE OKONITE-CALLENDER CABLE COMPANY, INC.

Factories: Passaic, N. J. Paterson, N. J.

 NEW YORK	CHICAGO	PITTSBURGH	 ST. LOUIS
BOSTON	ATLANTA	BIRMINGHAM	SAN FRANCISCO
LOS ANGELES	SEATTLE	DALLAS	

Novelty Electric Co. Philadelphia, Pa.	F. D. Lawrence Electric Co. Cincinnati, O.
Canadian Representatives: Engineering Materials, Limited, Montreal	
Cuban Representatives: Victor G. Mendoza Co., Havana	

OKONITE QUALITY CANNOT BE WRITTEN INTO A SPECIFICATION



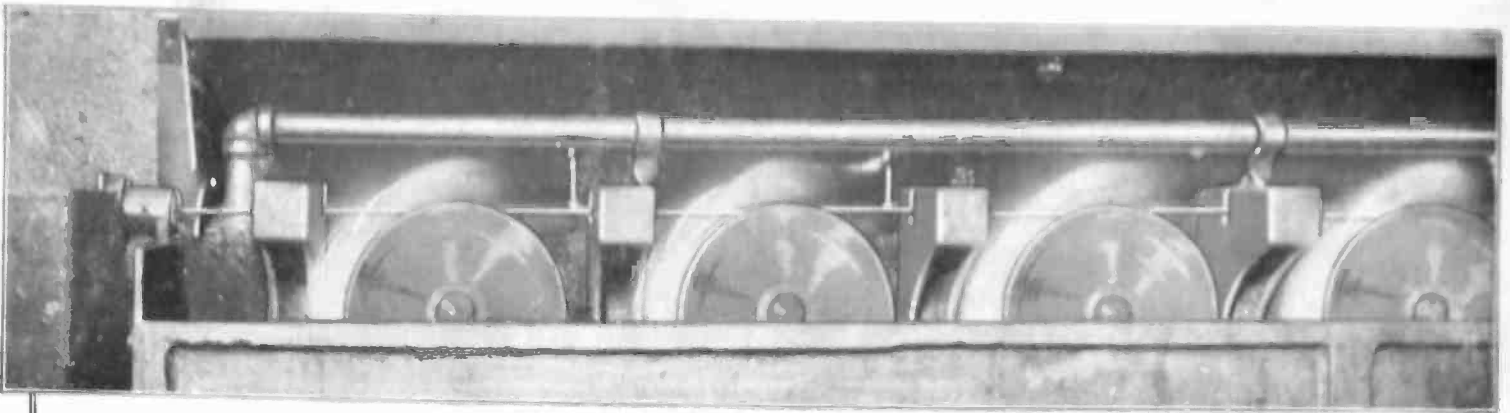

From Copper Rod to Magnet Wire on Spools

THE remarkable uniformity of Belden Magnet Wire, from spool to spool or from carload to carload, is universally recognized by large wire users.

In footage, the annual output of Belden Magnet Wire runs into billions of feet. Yet this tremendous output is maintained within such close tolerances, at each step, that every foot of finished wire is of accurate gauge, "dead soft," and perfectly insulated throughout the entire spool.

Such excellence is the result of long experience. Furthermore, every operation from wire drawing, annealing, enameling, insulating, spooling, to final inspection is done under one management. Such Belden facilities provide a source of supply which is dependable for quality and delivery.



Beldenamel Department

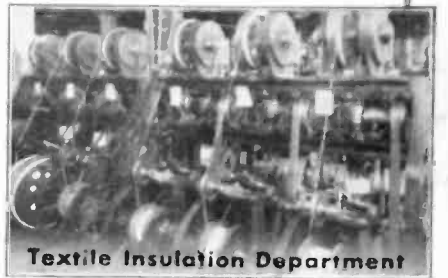

Textile Insulation Department

*Specify Belden on your
next magnet wire order*

Belden Manufacturing Company
4631 W. Van Buren Street
Chicago, Ill.



Inspection Department

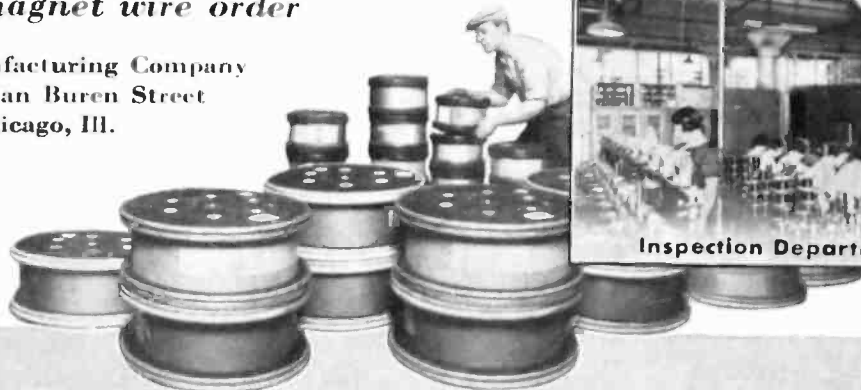
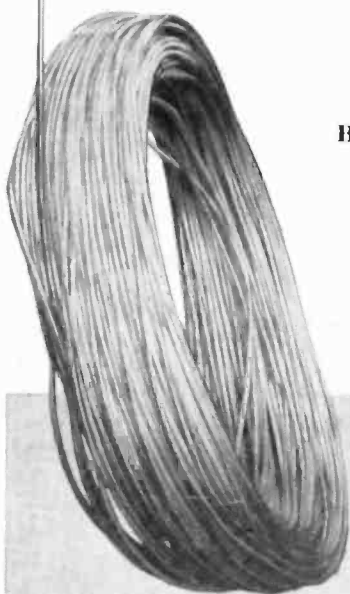

Belden Products

Belden

Beldenamel and Textile Magnet Wire • Beldenmold Parts • Coil Windings • Automotive Wires and Cables
• Airplane Assemblies • Radio Wires, Leads and Cables • Rubber Covered Wires • Armored Cables •
Flexible Armature Wires • Motor Lead Wires • Braided and Stranded Copper Cables • Cotton Sleaving