

Registered at the G.P.O., Melbourne, for
Transmission by Post as a Periodical.

MODERN THERMIST

MONTHLY

OCT

1933



The Cossor One Valver

PRICE 9^D

E 444

GOLDEN DIODE and SCREEN GRID

(SIX-PIN)

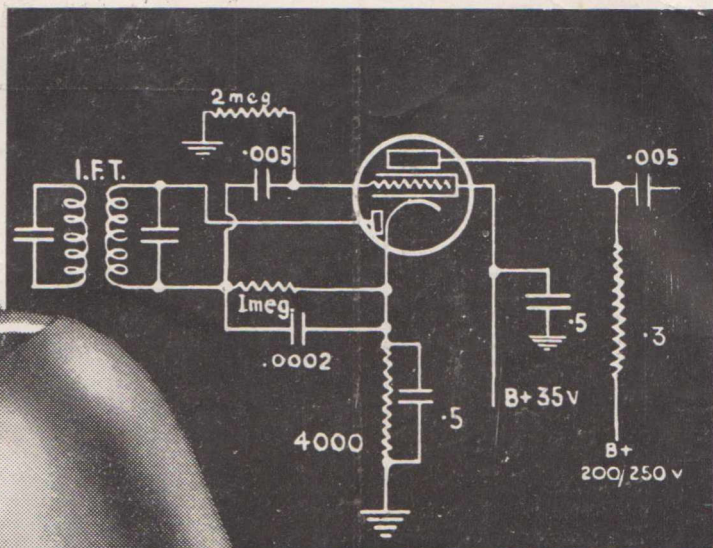

A typical circuit arrangement incorporating the E444 Diode Screen Grid as a combined second detector and first audio stage in a conventional superheterodyne.

THE E444 Diode Screen Grid renders possible the economical incorporation of the DIODE principle in modern set production, offering at the same time the high gain of the screen grid audio amplifier, which was lacking in the triode types.

It is capable of delivering 30 volts to the grid of the power valve with an input of only two volts, and consequently can be used successfully for gramophone as well as radio reproduction. In addition, automatic volume control is available if desired.

The Golden Range, of which the E444 is an outstanding type, offers performance of unequalled efficiency, a fact which manufacturers have quickly appreciated.

"THE GOLDEN RANGE"

TYPE	PRICE
E452T	18/6
E445	18/6
E444	19/6
E455	18/6
E443H	18/6
E443N	22/-
1561	15/-

FOR BETTER RADIO

PHILIPS

GOLDEN RANGE



EDITORIAL

“THE best intentions of mice and men often go astray.”

When we reorganised “Modern Sets,” we published our first edition in August, dating it August. We, furthermore, promised our readers that we would keep dates in future—be, in fact, a model of regularity. Well, we had to break our word. We have to admit it, but we plead circumstances beyond our control. Our chief technical man, just when the whole stage was set for early production, went down with the prevailing Melbourne ‘flu. Sets were left half built, and so personal is the construction and conception of a new radio set or circuit that it was impossible to get his work carried on by anyone else. Further, another radio journalist who does a great deal of work for us went sick also. Wireless magazines such as “Modern Sets” differ radically from other journals. With the ordinary magazine it is possible to have stop-gap matter so that in an emergency an issue can be produced. With radio, however, our readers would immediately smell a rat if we attempted to foist on them out of date or useless information. The success of this magazine has been largely due to the fact THAT WE BUILD UP AND TEST EVERYTHING OURSELVES BEFORE PEN IS PUT TO PAPER. We apologise again, and trust our readers will understand why this number has to be the October issue.

**WHY NOT
become a
Regular
Subscriber
to
Modern Sets
?**

**for 9/-
we will send it
POST FREE
to you
for 12 months**

THE MANAGER, “MODERN SETS,”
48a Queen Street, Melbourne.

*Please enrol me as a subscriber to “Modern Sets”
for 12 months, post free, for which I enclose 9/-
(postal notes).*

Name.....

Address.....

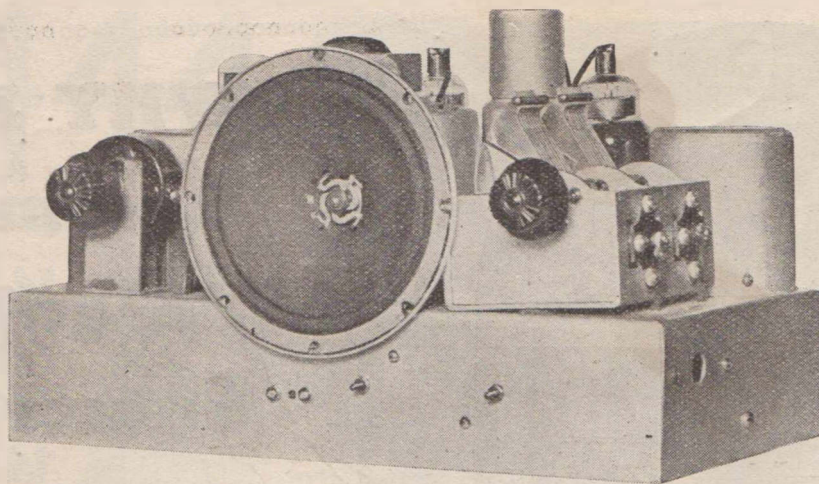

Actual size of set, 12 inches wide by 7½ inches high.

Build Your Own Midget

A MIDGET SUPER for the Home Constructor

By C. A. CULLINAN.

WHILST many midget radio receivers have recently appeared on the commercial market, very little has been done to cater for the home set builder. Therefore, it is our aim in this article to describe a most successful commercial midget, a five valve superheterodyne, which can be obtained in kit form for home assembly. It is manufactured by the Essanay organisation, and is probably the smallest midget yet produced in Australia.

In order to keep down the size of a full electric receiver, careful attention must be paid in respect to placing of components. The photographs clearly show the position of the various parts, and, although the bottom view shows that the set appears to be somewhat cramped, it is quite easy to wire if all the sockets are wired first.

Many may perhaps wonder at the direct dial drive, but in actual practice no difficulty is experienced in tuning in even weak stations. As remarked before, the placing of the parts is important if the size is to be kept down: part of the variable condenser mounts behind the speaker, while the volume control is located on a bracket to bring its shaft into line with that of the variable condenser. The latter, by the way, should be mounted on rubber washers to give it a slight flexibility.

The top view clearly shows the position of the oscillator coil can and the second 1F transformer assembly. Only one valve is shielded, this being the 58 1F tube. Looking at the back of the chassis, the valves, from left to right,

are: First detector 57; 1F tube 58, second detector 57, audio tube 2A5, and rectifier 280.

Underneath the chassis can be seen the R.F. coil, the two electrolytics, bot-

BUILD YOUR OWN MIDGET.

A Midget Super for the Home Constructor.

- 1 Essanay 2 gang condenser, .0005 mfd. per section, C1, C2.
- 1 Essanay padder condenser, C3.
- 1 0.002 mfd. condenser, C4.
- 2 0.5 mfd. paper non-inductive condensers, 400 volt working, C5, C7.
- 3 0.1 mfd. paper non-inductive condensers, 400 volt working, C6, C10, C11.
- 2 0.01 mfd. mica condensers, C9, C14.
- 1 0.001 mfd mica condenser, C3.
- 2 8 mfd. 450 volt electrolytic condensers, C12, C13 (Concourse).
- 1 5000 ohm resistor, R1.
- 1 400 ohm resistor, R2.
- 1 10,000 ohms pot. volume control, R3.
- 1 10,000 ohm 1 watt carbon resistor, R4.
- 1 10,000 ohm 1 watt carbon resistor, R5.
- 1 15,000 ohm 1 watt carbon resistor, R6.
- 1 250,000 ohm 1 watt carbon resistor, R7.

- 1 100,000 ohm 1 watt carbon resistor, R8.
- 1 250,000 ohm 1 watt carbon resistor, R9.
- 1 400 ohm wire wound resistor, R11.
- 1 Essanay aerial coil, L1, L2, and can.
- 1 Essanay oscillator coil, L3, L4, and can.
- 2 Essanay 1F transformers with condensers, L5, L6 (1 can).
- 1 Rola Midget, 1300 ohm dynamic speaker, F.C. (to match 2A5 valve).
- 1 Essanay power transformer, P.T.
- 4 Essanay 6 pin sockets.
- 1 Essanay 4 pin socket.
- 2 57 valves, either Ken-rad or Radio-trons.
- 1 58 valve, either Ken-rad or Radio-tron.
- 1 2A5 valve, either Ken-rad or Radio-tron.
- 1 280 valve, either Ken-rad or Radio-tron.
- 1 Chassis, 12 in. x 6½ in. x 2½ in. Essanay.
- 1 Volume control bracket.
- 1 Essanay R.F. choke.
- 1 Essanay 6 pin valve shield and top.
- 1 Essanay midget cabinet.

tom of power transformer, the padder on one corner, and the first 1F transformer assembly, which is mounted without a shield.

When mounting and wiring the coils care must be taken not to damage them, as they are wound on celluloid formers and need only a touch from a soldering iron to burn them. Even when soldering to the lugs care must be exercised or the celluloid will soften and allow the lug to drop out. With all the components mounted, the wiring can be commenced according to the circuit diagram.

The coil wiring is as follows:—

R.F. Coil: Top of grid (large) winding to stator of variable condenser. Bottom of grid winding and top of aerial (small) winding to chassis. Bottom of aerial winding to aerial terminal.

Oscillator Coil: Top of tuned (large) winding to stator of padder condenser. Bottom of tuned winding to B plus maximum. Top of cathode winding (small) to cathode of first detector socket. Bottom of cathode winding to .002 by-pass condenser.

Both of the 1F transformers are wired in the same way, and are so connected that the coils are in opposition to prevent self-oscillation of the 1F system.

Both windings are of the same size, so that either can be used as primary.

Primary Coil: Outside to plate of tube. Inside to B plus.

Secondary Coil: Outside to grid of tube. Inside to chassis.

Adjustments.

If a voltmeter is available the voltages should be checked when the set is ready for trial.

Filter input, rectifier socket to chassis, 310 volts.

Filter output, 2A5 screen to chassis, 200 volts.

2A5 bias, HT centre top to chassis, -16 volts.

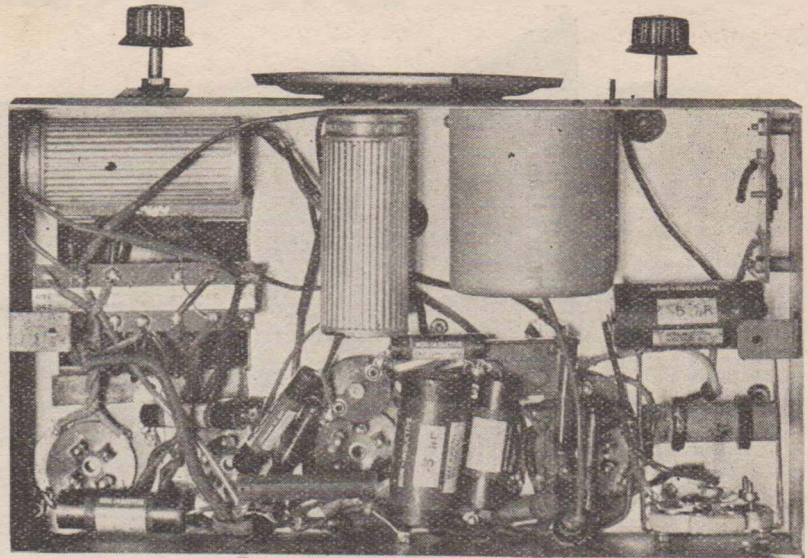

This under-chassis view of the finished set shows the arrangement of the components underneath.

First detector plate V, plate to chassis, 220 volts.

1F plate, plate to chassis, 220 volts.

Second detector plate, plate to chassis, 100 volts approx.

First detector screen, screen to chassis, 100 volts approx.

1F tube screen, screen to chassis, 100 volts.

Second detector screen, screen to chassis, 100 volts.

1F bias cathode to screen, 3 volts.

Volume control, cathode 53 to chassis, 3-50 volts.

2A5 plate current 30 M.A.

It must be understood that these voltages are approximate only, and are determined to a great extent by the available line voltage and the condition of the various valves, as well as the accuracy of the speaker field.

Tuning Up.

When all voltages have been found to be correct, the volume control should be turned to the full-on position, and the condenser turned to see if a station can be heard. Failing this, set the condenser about one-third on, hand temporarily connect a .1 condenser across the .002 oscillator by-pass condenser. A loud whistle should be heard, the pitch of which will vary as the variable condenser is turned should the oscillator be functioning. It is presumed that the set is above, up to the oscillator section.

Failure to oscillate can be traced to a faulty tube, incorrectly wired oscillator coil, or open by-pass condenser across the B plus maximum. When signals have been received, adjust the

(Continued on page 31.)

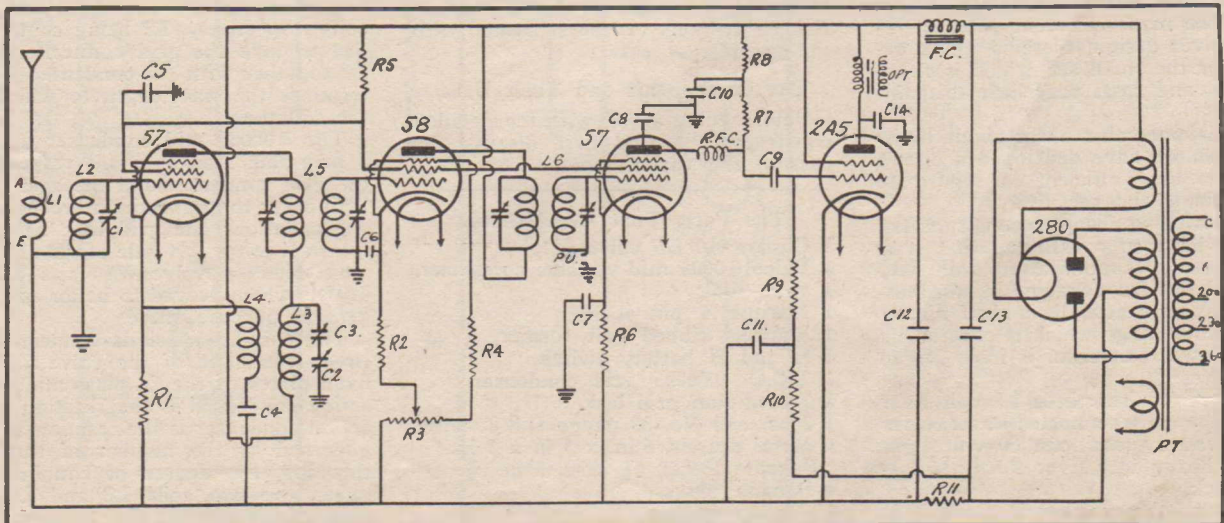

Schematic Diagram of the Midget Super, showing circuit arrangements.

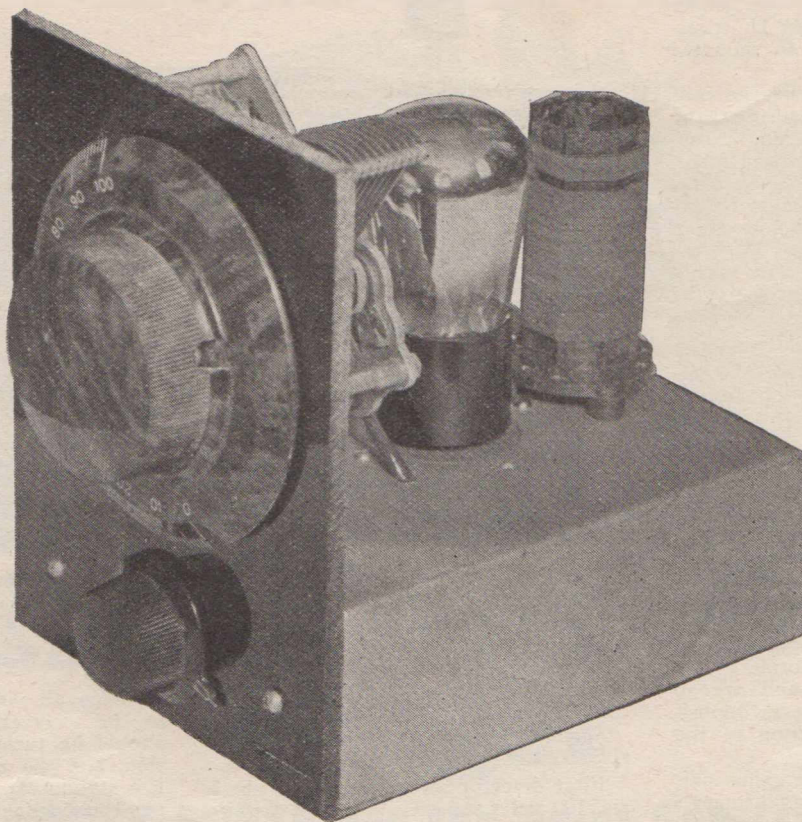

THE COSSOR ONE VALVER

A Cheap and Efficient Local Set

By C. M. SCOTT.

ALTHOUGH rapid strides have been made in recent years in receiver design, there is still a demand for the small set, which is cheap to build, and costs very little to maintain.

In this one-valve outfit about to be described, we have developed a circuit which is very efficient in regard to both volume and selectivity.

Besides being cheap to construct, the set has been so constituted that it is exceptionally economical in both "A" and "B" battery consumption, the batteries having practically a shelf life.

The wave range which is covered by a 0.0005 mfd condenser is from 200 to 550 metres.

The set requires three 1.5 volt Ever Ready dry cells connected in series for the A battery, and one 60 volt light duty or heavy duty Ever Ready B battery block.

Although the receiver is small it is capable of picking up all the A and B class stations, as well as the local amateurs, at excellent phone strength.

Within nine miles of the city all the B class stations can be separated with the greatest of ease.

The Components and Their Uses.

Before going ahead with the detailed construction let us first discuss the uses of the various components.

The Parts That Are Needed.

- 1 Cossor 410 LF valve, V1.
- 1 Velco 0.0005 mfd variable condenser.
- 1 4 in. dial.
- 1 Marquis 4 pin socket.
- 1 Marquis ribbed coil former.
- 1 H and H battery switch.
- 1 T.C.C. 0.00025 grid condenser.
- 1 2 meg-ohm grid leak.
- 1 2 oz. reel No. 32 gauge D.S.C. wire.
- 1 Metal chassis, 6 in. x 5 in x 2 in.
- 1 Bakelite Panel, 6½ in. x 5 in.
- 4 Banana plugs.
- 4 Banana sockets.
- 1 Doz. 1/8 in. nuts and bolts.
- 1 Radiokes 23 plate midget.
- 1 Radiokes radio frequency choke.

L1 and L2 are the aerial and grid coils respectively, L2 being centre-tapped to take the grid connection. Coil L2 together with the condenser C1 determines the wavelength to which the set will tune.

The 0.00025 mfd condenser and the 2 meg-ohm resistance are respectively the grid condenser and the grid leak.

In order to get maximum response to weak stations the grid leak has been returned to the AX side of the filament. The detector valve V1 is a Cossor 410LF which proved to be an excellent general purpose valve.

The coil L3 which is connected between the plate of the valve and the fixed plates of the 23 plate midget reaction condenser is the reaction will be governed by the number of turns on this coil, the degree of coupling between the two coils L2 and L3, the plate potential and the reaction condenser. SW is the on-off "A" battery switch, which is connected in the A-lead.

R.F.C. is an ordinary radio frequency choke connected in the head-phone leads on the plate side. The purpose of this choke is to force the radio frequency currents back to the filament through the reaction coil.

Now for the actual construction.

The receiver is built up on a 16-gauge metal chassis, measuring only 6 in. x 5 in. x 2 in., to which is fixed a 5 in. by 6½ in bakelite panel.

In the rear side of the chassis cut a rectangular slot half an inch deep by two and a half inches long. Over this slot mount a piece of bakelite to carry the aerial, earth and phones, banana sockets, and drill a three-eighth hole in the centre of the bakelite to take the battery switch SW.

The battery cable can come out through a three-eighth hole drilled in the top of chassis.

After mounting the various components, reaction condenser under the main tuning condensers, valve socket, coil, condensers, etc., we are now ready to go ahead with the actual wiring of the set.

Point-to-Point Wiring.

From the aerial socket, a wire is connected to one end of the aerial coil L1, the end nearest the top of the coil. The other end of L1 is now connected to the second banana socket, which is earthed, and to a holding-down bolt on the chassis.

The A+ lead is brought in to one nearest the aerial coil is joined to the fixed plates of the tuning condenser C1 only. The other end of L2 is then connected straight to the earth, and the moving plates of C1. The centre tap on L2 now connects to one side of

the 0.00025 mfd grid condenser, the remaining lug on the condenser being connected to the lug on the valve socket V1 and one end of the grid leak.

The AX lead is brought in to one side of the battery switch SW and to the F+ lug on the valve socket V1, also to the free end of the grid lead. The other filament lug on the socket V1, which is F- can now be earthed directly, and both the A-

and B- leads can be brought in and earthed to the chassis.

From the P plug on the socket V1 run a short lead to the end of coil L3, farthest away from L2, and to one side of the radio frequency choke RFC. The remaining side of RFC is now joined to one side of the phones PH, the other sides of the two phones being taken directly to the B+ lead (60 volts).

The remaining free end of L3 is connected across to the fixed plates of the 23 plate midget, and its moving plates earthed.

This completes the actual wiring of the set.

Coil Construction.

The coil which consists of three windings is wound on a Marquis ribbed former, and No. 32 gauge double silk covered wire has been used for all the windings, L1, L2, and L3.

L1, the aerial or primary coil, is commenced about 1/16 inch from the top of the former, and consists of 18 turns of No. 32 d.s.c. This then completes L1.

Now 3/16 inch away start winding the grid or secondary coil L2, which must consist of 118 turns of No. 32 gauge D.S.C. wound in the same direction as L1. L2 must be centre-tapper at the 59th turn.

Now the third and last coil is the reaction coil L3, and it consists of 27 turns of No. 32 gauge D.S.C. wound in the same direction as L2, and the first turn starts right up against L2, that is, there is no spacing between L2 and L3.

Each coil is close wound, and is held to the former in places with a little coil dope, celluloid cement being one of the best. Wind the wire tight-

(Continued on page 34.)

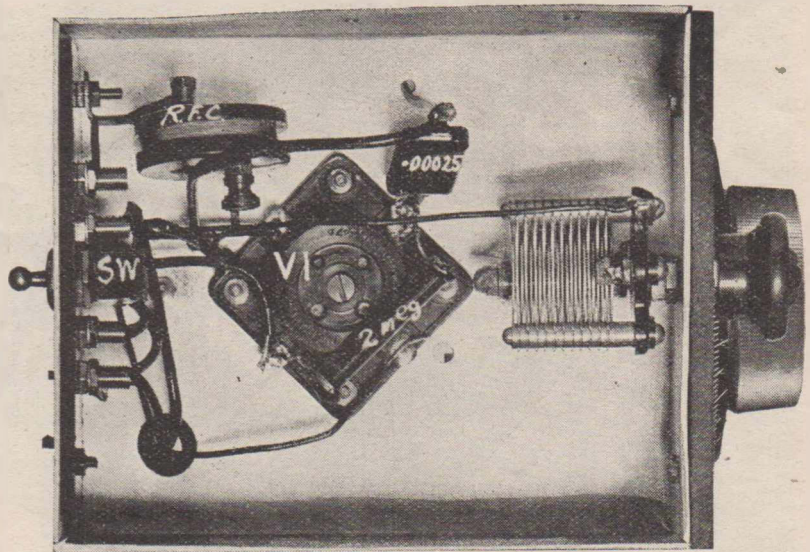

Looking at the One Valver from underneath. Note the simplicity in the wiring and layout.

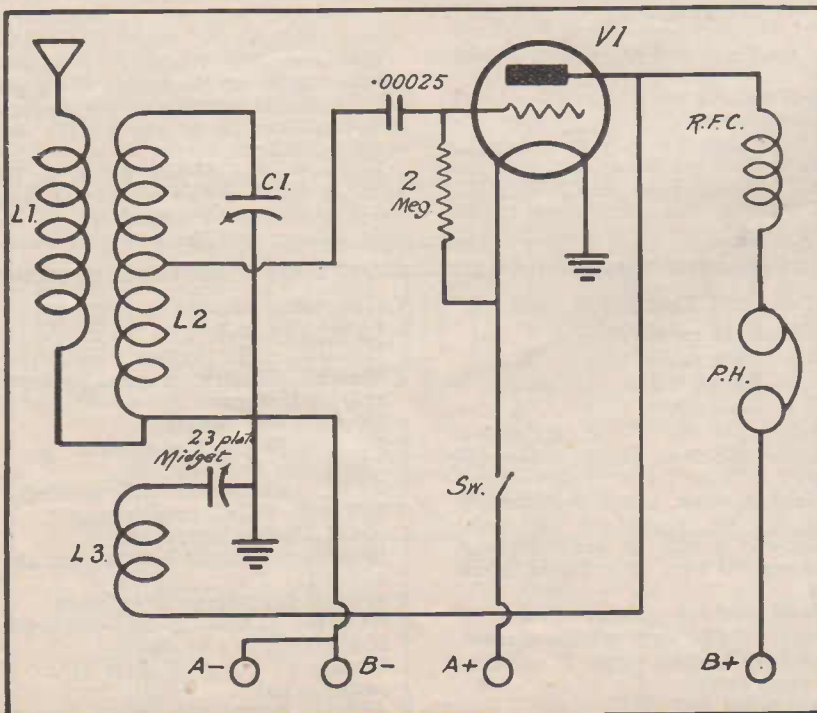

The circuit diagram of the Cossor One Valver.

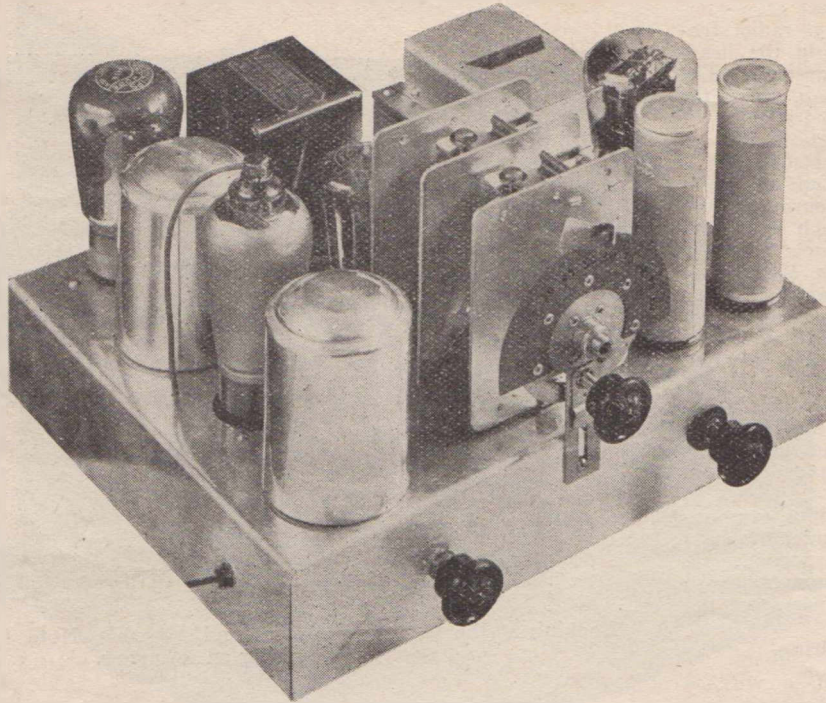

The PHILIPS FOUR

An Efficient Local and Inter-State Set with an Extremely Low Hum Level

By X.Y.Z.

ALTHOUGH rapid strides have been made in the development of the super-het, there is still a certain demand for the smaller type of T.R.F. receiver.

After all, every set has its advantages and disadvantages, whether it be a super or a T.R.F.

The chief advantages of the receiver described here are—namely, its comparatively low cost, excellent tone and volume, inter-State reception under good atmospheric conditions, low hum level, and easy to construct.

A glance at the circuit diagram will indicate that the job is a three valve and rectifier outfit employing a Philips E455 screen grid, an E424 high gain detector, followed by an E443N pentode. The rectifier is a 1561 which also belongs to the new Golden series.

With reaction on the detector the overall gain of the three valves is extremely high, this high gain being also due to the efficiency of the Velco coils and the Wendel input push-pull transformer. When connected as an ordinary audio transformer, we found that the Wendel input push-pull job gave excellent results.

The application of reaction to the detector more than doubled the signal strength without the slightest introduction of distortion into the output.

The increase in signal strength gained by the use of reaction on the detector is easily equivalent to an additional stage of radio frequency amplification.

Provided that reaction is applied within reason no noticeable distortion will result. Of course, if the detector is forced too much, the quality will certainly suffer.

In the Velco Coil Kit, which, by the way, was used in this set, the reaction coil has been so arranged that it has little influence on the grid coil, conse-

The Parts That Are Needed.

- 1 Philips E455 valve.
- 1 Philips E424 valve.
- 1 Philips E443N valve.
- 1 Philips 1561 valve.
- 2 T.C.C. 7 mfd electrolytic condensers.
- 1 Wendel Electric Filter choke (30 henry).
- 1 Wendel Electric power transformer, high tension secondary 350 volts aside, one 4 volt 3 amp filament winding, and two four 2 amp windings.
- 1 Wendel Electric voltage divider.
- 1 Marquis 10,000 ohm volume control.
- 1 Stromberg-Carlson type D condenser (two gang).
- 1 Velco aerial coil.
- 1 Velco R.F. coil with reaction.

- 3 5 pin valve sockets.
- 1 4 pin valve socket.
- 1 Radiokes radio frequency choke.
- 1 Wendel Electric input push-pull audio transformer.
- 1 400 ohm bias resistor.
- 1 700 ohm 50 mill bias resistor.
- 1 2 megohm grid leak.
- 1 0.5 fd. condenser 250 volt working.
- 2 0.01 mfd. T.C.C. condensers.
- 1 1 mfd Chanex condenser.
- 1 10 mfd. electrolytic bias by-pass condenser.
- 2 30 ohm C.T. filament resistors.
- 1 Radiokes 23 plate midget condenser.
- 1 Full vision vernier dial.
- 1 Chass's 12 in. x 10 in. x 2½ in, 16 gauge metal.
- 1 Ambion permanent magnet dynamic speaker, to match E443N valve.

quently the ganging of the two tuning circuits is not affected in any way.

The Volume Control.

Once again the volume control question arises; well, what is the best volume control and where is the best place to connect it up? As for the best position, the argument is still going on, and it looks as though it will continue to do so.

However, in the meantime, we have to be satisfied with the variable bias method which is so common at the present time.

A good control can be made by connecting one side of a 10,000 ohm potentiometer to the aerial and the other side to earth, the moving arm being connected to one side of the 400 ohm limiting resistor, which is inserted in the cathode lead of the E455. The 400 ohm limiting resistor is by-passed to earth by a 0.5 mfd. condenser.

General Discussion of the Components.

The screen of the E455 valve, which is by-passed to earth by a 0.01 mfd. condenser, is connected to a tapping on the voltage divider, giving approximately 70 volts.

The high tension supply for the plate of this tube comes from a tap at the high voltage end of the divider. This lead is also by-passed to earth by a 0.01 mfd. condenser, for preference near the high tension or B+ end of the primary winding.

In the detector circuit the E424 is used as a leaky grid power detector, using a 0.00025 mfd. grid condenser and a 2 megohm grid leak.

Reaction in this circuit is obtained by the coil L5 and controlled by the 23 plate midget reaction condenser.

The plate supply for the E424 comes from a tap on the divider via the primary of the audio transformer A.F.T., and the radio frequency choke, R.F.C. The B+ side of the transformer primary is by-passed to earth by a 1mfd. condenser.

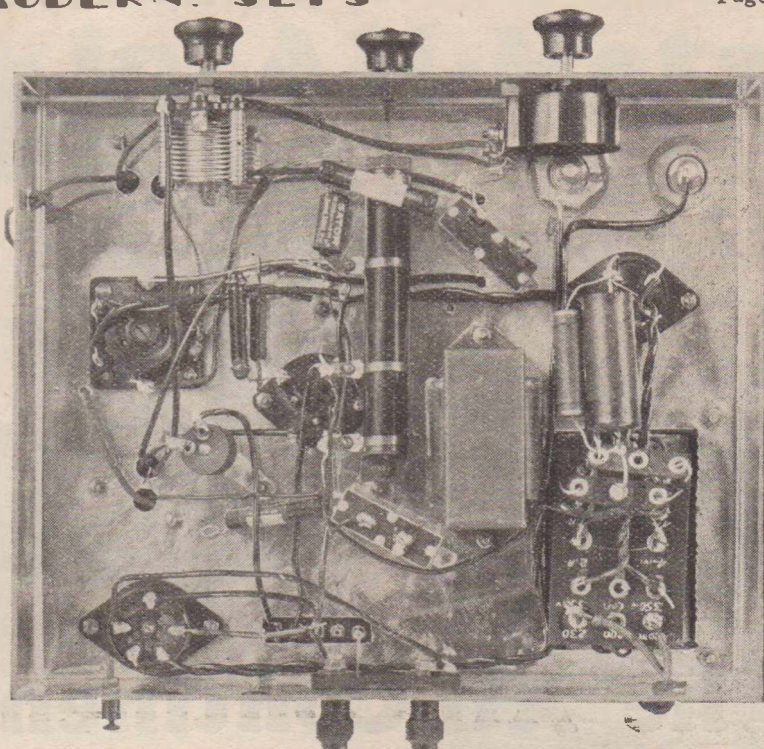

Sub. Chassis, view showing wiring details.

Bias for the E443N is obtained by means of a 700 ohm bias resistor inserted between the centre tap of the filament resistor and the earth. This bias resistor must be rated at 50 milliamps and by-passed by a 10 mfd. electrolytic bias condenser. The auxiliary grid and the plate are both connected to the B+ maximum tap on the divider.

In the filter circuit we have departed from the usual practice of using the speaker field as a filter choke, which has become so generally accepted as a means of smoothing rectified A.C.

An ordinary Wendel filter choke has been used in place of the speaker field.

The reason for this is that no speaker field was ever designed to be a choke,

and simply acts more or less as a resistance in the filter circuit; thus its smoothing effect is very limited.

By introducing an amply permanent magnet dynamic speaker, not only is the hum reduced, but the actual range and overall efficiency of the receiver is raised considerably.

As the speaker field is obtained from a permanent magnet, no power is drawn for magnetising purposes.

In the power pack the standard 1561 rectifier has been used in full wave rectification, the output from which is smoothed by the aid of two 7 mfd. electrolytic condensers, one on each side of the filter choke.

When connecting up the electrolytics, make sure that you have the polarity correct—that is, the positive terminals connected to the choke and the negative earthed.

Each filament winding is shunted by a 30 ohm resistor, the centre tap of which is earthed.

The power transformer has a secondary voltage of 350 volts each side of the centre tap, one 4 volt 2 amp filament winding for the rectifier, one 4 volt 2 amp winding for the filament of the E443N, and one 4 volt 3 amp winding for the filaments of the E455 and the E424.

Adjustment and Operation.

Set the variable condenser at about 10 on the dial, turn up volume controls to about half on, and you should be able to hear 3AW. Now adjust the trimmers on the variable condensers, C1 and C2, until you can get the loudest volume without altering the setting of the volume controls. However, if signal input (or volume) is too loud, turn volume down and adjust trimmers to the most sensitive and

(Continued on page 31.)

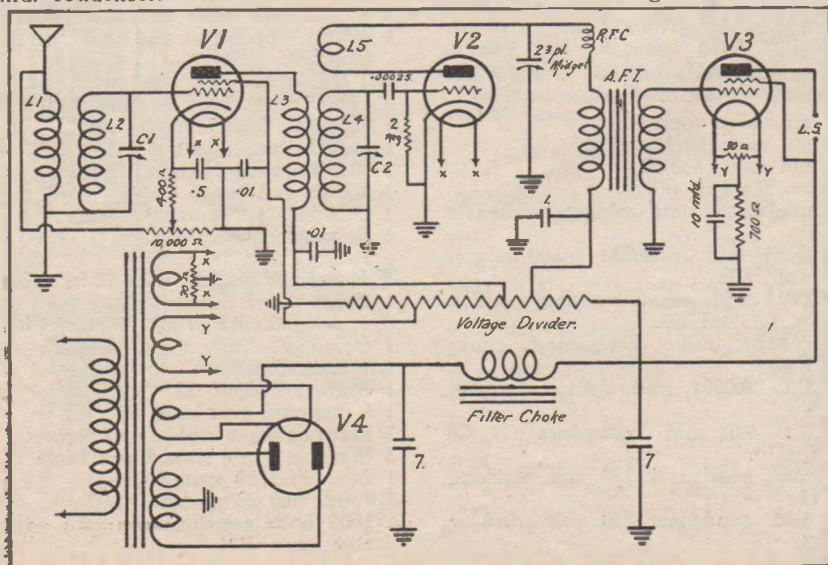

The schematic diagram of the Philips Four, showing circuit arrangements.

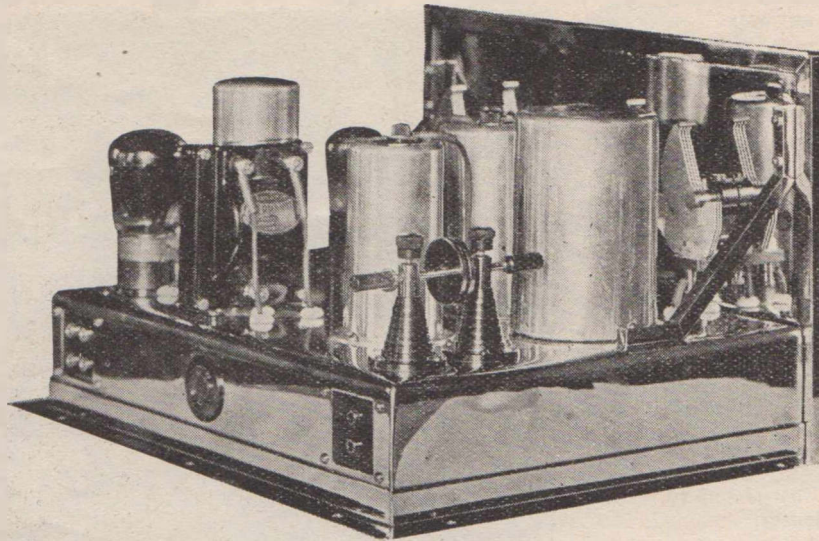

General view of the completed Receiver, with Detector Coil Can removed.

The All-Continents Battery Five

An Easily Built 5-Valve "De Luxe" Short-Wave Receiver of Great Range

Constructed by E. T. SVENSSON and Described by C. M. SCOTT.

WITH the summer season in view, most radio enthusiasts will be improving and reconstructing their short-wave receivers, so as to be ready for the good conditions which, strangely enough, exist during the hot season of the year.

Conditions at night have been very poor during the winter months, but within the next month or so a big improvement will take place in the general reception of stations from Europe and the East.

In any short-wave receiver it is absolutely essential that the best components available should be used throughout. In the past we have found that some radio parts which behave well on the broadcast band are practically useless when used in a receiver handling the higher frequencies.

Every part must be strong and rigid; this is particularly true of the chassis and front panel, which are often overlooked.

When the hands are working the dials, there should be no relative movement between the chassis and the panel. This can be prevented by the use of two large strong brackets, one at each end of the panel.

Again, we have departed from the usual box shielding common in short

wave receivers, and have adopted the orthodox method of mounting the components as in the ordinary broadcast receiver.

The receiver is capable of giving good speaker strength on the best short wave stations.

(Continued on page 29.)

The Parts That are Needed.

- | | |
|---|--|
| 1 Philips B443 valve, V5. | 1 T.C.C. 0.001 mfd. condenser, C16. |
| 2 Philips A442 valve, V1 and V2. | 1 T.C.C. .006 mfd. condenser, C15. |
| 2 Philips A415 valve, V3 and V4. | 1 4 mfd. condenser 250 volt working, C14. |
| 1 Ferranti AF5 audio transformer, A.F.T. | 1 T.C.C. 0.02 mfd. condenser, C12. |
| 5 4 pin valve sockets. | 2 15,000 ohms 1 watt resistors, R3, R4. |
| 2 6 pin valve sockets. | 1 500,000 ohm 1 watt resistor, R6. |
| 1 5 pin valve socket. | 1 50,000 ohm 1 watt resistor, R5. |
| 1 6 pin Marquis plug. | 1 3000 ohm wire wound resistor. |
| 1 Radiokes 3 plate midget condenser, C4. | 2 3 inch coil cans. |
| 1 0.00025 mfd. variable reaction condenser, C6. | 3 Ordinary valve cans. |
| 2 0.00015 mfd. variable tuning condensers, C2 and C3. | 6 Banana sockets. |
| 1 Screened radio frequency choke, R.F.C. | 6 Banana plugs. |
| 1 T.C.C. 0.0001 mfd. grid condenser, C5. | 1 Brass chassis, 13½ in. x 12 in. x 3¼ in. |
| 4 T.C.C. 0.01 mfd condensers, C7, C8, C9, C10. | 1 Brass panel shield. |
| 1 1 mfd. condenser 250 volt working, C11. | 1 Black bakelite panel, 14 in. x 9 in. |
| 1 2 mfd. condenser 250 volt working, C13. | 2 Ormond vernier dials. |
| | 1 4 inch d'al. |
| | 1 Battery switch, S1. |
| | 1 5 megohm grid leak, R2. |
| | 3 Marquis 5 pin ribbed coil formers. |
| | 3 Marquis 6 pin ribbed coil formers. |
| | 1 2 oz. reel 30 gauge D.S.C. |
| | 1 2 oz. reel 24 gauge D.S.C. |
| | 1 1000 ohm resistor with two adjustable clips, R7. |

The Catkin All-Metal Valve

A RADICAL DEPARTURE IN VALVE DESIGN

VALVE design is never at a standstill. The steadily increasing figure for mutual conductance is, perhaps, to be expected, and the addition of an extra grid or so no longer creates surprise. Now we are to experience what is undoubtedly a most radical development in valve technique since the inception of the triode. The familiar form of valve with its glass bulb is soon to disappear. Its place will be taken by one of greatly reduced dimensions where the glass envelope is replaced by a metal cylinder which is actually the anode.

Valves in which the glass envelope has been replaced by a copper container represent, of course, well-proved practice in transmitting valves where water-cooling is directly applied to the anodes. Such valves are designated C.A.T. (cooled anode transmitters), promptly designated "cats" in laboratory slang. From this abbreviation is derived the name "Catkin" as indicating the genealogy of the valve better than kitten; so Catkin was adopted as the name for the new miniature air-cooled version now to be available for reception.

An examination of the Catkin valve

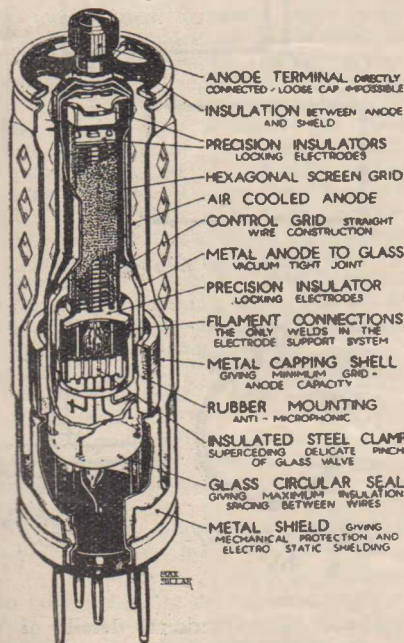

The internal construction of the All-Metal Valve.

manufactured by Marconi and Osram supports the claims put forward.

Smaller Valve Losses.

The spacing between the elements of a valve governs characteristic. If uniformity between one valve and another of corresponding type is to be maintained, accuracies of less than a thousandth of an inch are required in the disposition of the electrodes. Such precision is undoubtedly difficult to maintain when the only support afforded to the elements depends upon the critical setting up of wires embedded in glass. The Catkin has no such arrangements. First of all a robust steel clamp surrounding a mica insulator firmly holds the supporting wires. These wires are, moreover, straight, for it will be appreciated that where bent wires are used accuracy cannot so well be maintained. Next, the entire electrode system is located with precision within the anode envelope by mica spacing pieces. Thus the entire system forms a single and absolutely rigid unit as distinct from the comparatively meagre support which it is possible to provide for the electrodes in the glass type. This is the primary merit of the Catkin, accruing from which we may expect uniformity of set performance, and there will be no such thing as a "picked" valve. To the set manufacturer valve uniformity permits of standardisation of receiver performance, and the correct working conditions will be maintained without the need for special testing of the initial set of valves. The rigidity of the electrodes and accuracy of spacing are claimed to be immeasurably greater than is possible in the valve of conventional design.

It cannot be denied that the flattened glass portion giving support to the electrodes is a source of losses. Glass is by no means one of the best dielectrics, and the time has come when attention must be drawn to the magnitude of the dielectric losses arising in the valve itself. The advent of tuning coils of very high efficiency has served to emphasise that the losses arising from the conventional type of valve are of sufficient magnitude to mar the superior merits of a modern tuned circuit. Bearing this in mind, in the design of the Catkin it was decided to abandon the glass "pinch" and substitute mica as the insulator. It is true that the outgoing leads pass through

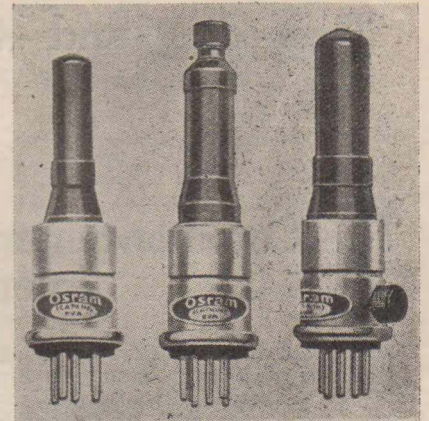

Three different types of unshielded "Catkin Valves."

a glass ring at the base of this new valve, but here they are set around the circumference. The resulting capacity between the leads is exceedingly small where we have glass as the dielectric.

Screen-grid and detector valves are, nowadays, usually metallised. There is thus an earth potential spread over the insulating glass, preventing it from acquiring an electric charge. Metallising has the effect of reducing interelectrode capacity, and, moreover, it prevents the setting up of stray electric fields which would otherwise arise between the charged globe and the surrounding leads, a condition which, if permitted, is a prodigious source of hum in mains receivers and a common cause of spurious back-coupling.

The electric field within the anode of the Catkin valve is entirely uninfluenced by any surrounding charges, and the electrons cannot build up unwanted potentials which might interfere with the field within the electrodes.

Better Screening.

Should circumstances demand it the signal potential on the anode of the Catkin may be prevented from creating stray coupling by the provision of a tubular metal screening cover shown in the photograph. The inclusion of this outer screen is optional. It extends over the valve from top to bottom, and, like metallising, is connected

Continued on page 20.)

There's Money in Talkies

PART I.

By W. GREEN.

Recording and Reproduction on Film Present No Difficulties This Way

The Commencement of a New Series which will Prove of Deep Interest and Profit to Our Readers

EARLY in 1925 the first talking picture made its appearance in America, a crude attempt when compared with the talkie of to-day, but nevertheless the start of a new and wonderful industry which completely revolutionised motion picture production.

Technicians worked feverishly to overcome difficulties which first seemed insurmountable, and slowly emerging from something comparable with the old-time gramophone came the talkie of the excellence which we enjoy to-day. And now as with radio, with all the "bugs" taken out of it, there comes the talkie apparatus which the amateur can build and operate and get results equal to the finest theatre apparatus obtainable.

It is interesting to note that apart from talking pictures, records have been made in America using the sound on film method, and these should be available any time now. Apart from the superior recording, these films have the advantage of being in such lengths as to make it unnecessary to change them more frequently than every 40 minutes. There are no needles to change, no records to be interrupted by having to turn them over; a complete opera or a complete dance programme is available just as it comes to you in the theatre or dance hall. Such films are available in both 16 mm. and 35 mm., and it is proposed to deal with both sizes in this article.

There are two methods of sound on film recording generally used, namely, Fox Case Movietone and R.C.A. Photophone. The latter method, although being the better, is far too complicated and costly for the amateur, so we will confine our efforts to the former system, which gives excellent reproduction and combines simplicity with efficiency.

In these series of articles we propose to work backwards, for the very good reason that the last or final amplifier can always be used and improved while we are waiting for the remainder of the gear to be completed. There are many uses to which such an amplifier could be put—namely, radio, pick-up, or public address work.

Analysing the Final Amplifier.

Here a new departure has been made in that direct coupling between stages has been adopted; however, in such a manner that all previous drawbacks to this system have been removed in regard to both tone and reliability. The method employed has not, to the writer's knowledge, ever been used before, and will be presented in such a manner that even the mere novice can build and use the amplifier without the slightest trouble. The reason for departure from orthodoxy will be explained in non-technical language, making it easy for the builder to follow intelligently the whole process of building and operating from start to finish.

The circuit employs one 256 driver valve and one Philips F410, the plate of the 256 being coupled directly to the grid of the F410, but between the two valves is an auto transformer having a step-up ratio of $3\frac{1}{2}$ to 1. This transformer can be one of the ordinary audio type with the F or C—terminal joined to the B plus terminal.

The purpose of this transformer is to give a step-up effect to the signal which is to be impressed on the grid of the last valve, it being obvious that a three element tube having a moderate amplification factor could not possibly load up the last valve satisfactorily.

Even if we were to use a screen grid driver valve the output valve would not be fully loaded, and you will see that we have deliberately avoided the

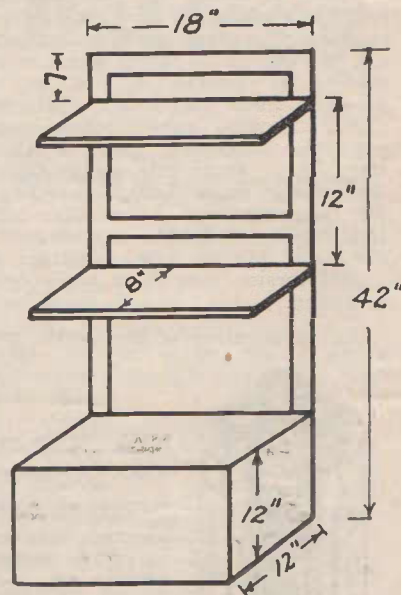

Rack & Panel



Clamp of Cutting Tool.



Block of Cutting Tool

Above: Constructional details of the Rack and Panel. Below: Diagrammatic sketch of the clamp and block of cutting tool.

use of the screen grid valve because of the distortion it introduces.

One may at first think that the introduction of an audio transformer would reintroduce distortion, but a careful study of the circuit will soon dispel this idea. As no current is flowing in the transformer circuit, saturation of the core, the real enemy of transformer coupling, cannot take place. Another advantage is that the transformer will act in much the same way as a resistance in the grid circuit of a valve that has become slightly soft, that is, it prevents self-oscillation of the valve. The apparent effect, apart from stepping up the signal, is to lift the whole of the reproduction out cleanly—in other words, it puts the third dimension, so much sought after, but rarely achieved, in reproduction. With a good speaker, this should be most apparent.

The Power Pack.

The power pack is quite conventional, and consists of a half-wave transformer delivering 900 volts A.C. at 60 milliamps on the high tension side, and having three filament windings.—five volts at three amps for the 5Z3 rectifying valve, one 2½ volt winding at 3 amps for either a 227 or the 256 valve, and one 4 volt winding at 2 amps for the F410.

Extreme care should be taken with the selection of a power transformer, cheap mass produced jobs should be avoided. You will note in the filter circuit that only two four microfarad condensers and one two microfarad condenser are used. Higher capacities than these are unnecessary; but they must be a first-class job, not less than 2000 volt test. The filter choke which connects to the centre tap of the rectifier filament winding must be at least an inductance of 50 henries at 60 milliamps, and must also be centre-tapped and well designed, as this is the main part of the filter system. One may wonder why a choke has been used in place of the speaker field, which has become so generally accepted as a means of smoothing rectified A.C. The reason is that no speaker field was ever designed to be a choke and simply acts more or less as a resistance in the circuit. It certainly does have some smoothing effect, but not to the extent it is credited with; hence hum being so pronounced in most receivers or alternatively their lack of true bass response, which is another scheme used to overcome hum.

If the constructor has only a D.C. speaker on hand, it would be best to build a small power pack for it. The pack can be used with other parts of this equipment, and made to do a double job without the least trouble.

The coupling choke must be designed to have primarily a D.C. or direct current resistance of 300 ohms, and secondly to have an inductance of 100 henries at 50 cycles at 5 milliamps. Chokes having other D.C. resistances can be used, but the whole of the cal-

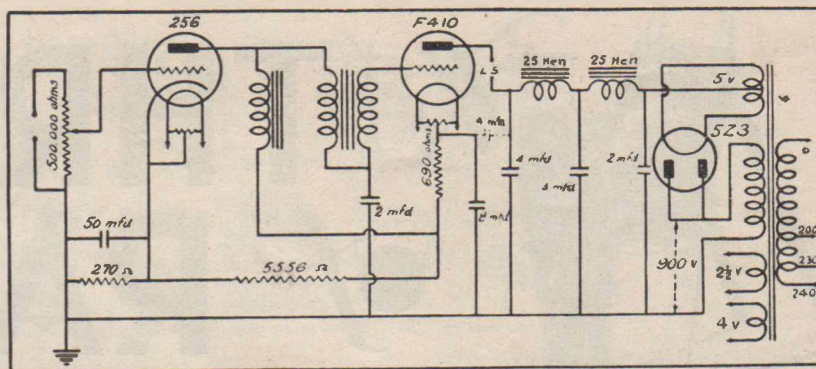

The circuit diagram of the final amplifier. Note that the 4 mfd. condenser shown dotted between the filament of the F 410 and the high tension is optional.

culations of resistance values will have to be gone over and altered to suit the new conditions.

The voltage divider should have a total resistance of 7500 ohms, although the actual resistance required is only 6516 ohms, to allow for adjustable clips, which take up and waste some of the resistance, and should be capable of carrying 75 milliamps.

Care should be taken to get clips carefully adjusted before inserting in the circuit, this is done by the aid of a battery and milliamp meter. After adjusting the clips to their approximate positions by sight, connect a 2 volt battery and an 0 to 10 milliamp-meter in series with each section in turn. In each case adjust the clip, starting from one end first until, as in the first case, a current of 2.9 milliamps is registered by the meter, the resistance corresponding to this amount reading will be 690 ohms. Similarly the clips on the other sections are moved until current readings of 0.36 and 7.4 milliamps are recorded.

The table of resistance values thus obtained is shown hereunder:—

- Grid bias section for the F410.
- Resistance required 690 ohms. Meter reading 2.90 milliamps.
- Plate voltage for 256.

LIST OF PARTS.

- 1 Power trans., 900 v. at 60 M.A.
- 1 Power choke, 50 henries centre-tapped 60 M.A.
- 1 Audio choke D.C. resistance, 300 ohms. 100 henries at 50 cycles 5 M.A.
- 1 Voltage divider, 7500 ohms.
- 2 2 mfd. fixed condensers.
- 2 4 mfd. fixed condensers.
- 1 8 mfd. fixed condenser.
- 2 25 mfd. fixed condensers (paralleled 5.0 mfd.
- 1 Audio transformer.
- 1 Volume control 500,000 potentiometer.
- 2 Porcelain UX sockets.
- 1 UY socket.
- 5 Terminals.
- Engraver's zinc as per text.
- 2 Centre tap resistors.
- 1 UX 256 valve (Kenrad).
- 1 F410 valve (Philips).
- 1 5Z3 Valve (Kenrad).

Resistance required 5556 ohms. Meter reading 1.36 milliamps.

Bias for 256.

Resistance required 270 ohms. Meter reading 7.40 milliamps.

These readings are as reasonably accurate as it is possible for an amateur to get, and can be regarded as right until the final check up with the milliammeter in the plate circuits of the valves has been made when the whole apparatus is working. Voltage readings across resistances cannot be regarded as accurate unless taken with an electrostatic voltmeter, as all other types of voltmeters draw current. This being so, an ordinary voltmeter cannot be used where a precision amplifier is being adjusted.

The only other resistances in the circuit are the two centre tapped 25 and 50 ohms respectively, and a 500,000 ohm potentiometer. These resistances should be well made and capable of standing long use. A thing that is liable to be overlooked or passed over is the valve socket. It has been the experience of the writer to have trouble in this regard, which has taken considerable time to locate, not to mention the worry and annoyance. The nature of the trouble was that an abnormally high bias was found to be on the last valve, and on being traced out was found to be due to leakage of the material of which the last valve socket was made. Since then it has been invariably my practice to use porcelain sockets for the rectifier and final valve.

Construction.

As this is to be a recording as well as a reproducing amplifier, extreme care has to be taken to see that in the first place the reproduction is the best that can be obtained, with a minimum of expense and labour, and that hum is kept as low as reasonably possible. It must be remembered that the same amplifier is being used to record and reproduce, and that any distortion in recording will be doubly emphasised in reproducing, and the same thing applies to hum. We have to consider first of all the layout.

Most amplifiers of this type are built on the rack and panel idea, and this is the one we will adopt. First of all,

(Continued on page 25.)

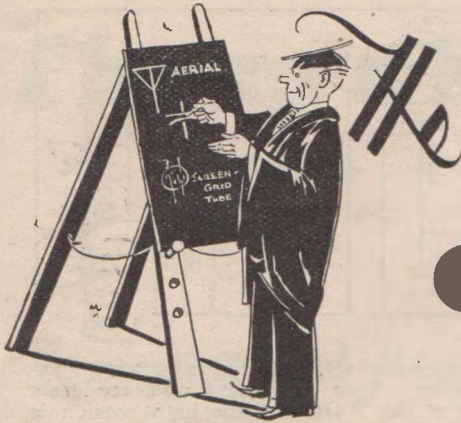

THREE "R'S" OF RADIO

(Continued from last issue.)

ONE of the most important characteristics of a series tuned circuit is that for a given combination of inductance L_4 and capacity C_4 , the reactance (opposition to current flow) of the inductance current of a certain frequency is equal and opposite to the reactance of the condenser for currents of this same frequency. Therefore, since these two balance each other out, the total impedance or opposition to the flow of current of this frequency is merely equal to the natural resistance R of the tuned circuit. This is called the resonant frequency of the tuned circuit.

$$f = \frac{1}{2\pi\sqrt{LC}}$$

Since under this condition we find by solving this equation that

$$2\pi fL = \frac{1}{2\pi fC}$$

Where f = frequency in cycles per second at resonance.

L = inductance in henries at resonance.

C = Capacity in farads at resonance.

This can be expressed in terms of the wavelength if we remember that

$$\text{Wavelength} = \frac{300,000,000}{f}$$

$$\text{or } f = \frac{300,000,000}{\text{Wavelength}}$$

Substituting this value of f in the equation above we obtain 300,000,000.

$$\frac{300,000,000}{\text{Wavelength}} = \frac{1}{2\pi\sqrt{LC}}$$

$$\text{or Wavelength} = \frac{300,000,000}{2\pi\sqrt{LC}}$$

If L is expressed in microhenries and C is expressed in microfarads, as is usually the case, this equation becomes where $W. L. =$ Wavelength in metres.

$$W.L. = 1885\sqrt{LC}$$

This formula makes it possible to compute the combination of inductance L and capacity C necessary to tune a series circuit to resonance at a particular wavelength.

Now, getting back to our discussion of resonance, it is evident that these induced voltages of various frequencies existing in coil L_4 , will attempt to send currents around the closed tuned circuit $L_4 C_4$. However, the current set up by any alternating voltage is equal to the voltage divided by the total impedance of the circuit. Therefore, if the circuit is tuned, say, to 600 kilocycles (500 metres) an induced voltage in L_4 having a frequency of 600 kilocycles is able to send a comparatively large current through the tuned circuit. The strength of this current is determined by Ohm's law and is therefore equal to the impressed voltage coil L_4 divided by the total

resistance of the tuned circuit or — R_4

This resistance consists of the sum of the resistances of the coil, connecting wires, and condensers.

These resistances are the A. C. resistances measured at the frequencies considered. The resistance of a coil is much greater on high frequency A. C. than it is on direct current. A voltage having 610 or 590 kilocycles frequency sets up a smaller current in this circuit, because it must not only overcome the natural resistance of the circuit, but the impedance offered by

the coil and condenser to currents of this frequency as well. As we go further from this resonant frequency down to 580, and up to 620 kc., etc., the impedance becomes greater and greater and the current is diminished. This is shown graphically by the turning curve A of Fig. 94. Notice the large current set up by the voltage of resonant frequency. This current, circulating through the inductance L_4 , builds up a larger voltage E_4 across $L_4 C_4$ circuit. This is the A. C. grid potential applied to the tube, and is amplified by the tube. Notice that E_4 is much larger than e_4 , depending on the size of the inductance L_4 and its resistance. It would seem to be advisable to make L_4 large in order to make E_4 as large as possible. However, the resistance of a solenoid tuning coil increases almost in the same proportion as the inductance is increased by adding more turns on the end of the coil.

Resistance and Selectivity.

What we desire in the secondary coil L_4 is inductance and nothing else. Actually it is impossible to obtain this alone, since the coil, being made of wire, has resistance also. This A. C. resistance should be kept as low as possible by proper design, since the current flow at resonance is limited only by this resistance. The currents flowing at frequencies are also reduced by resistance as shown by curves B and C of Fig. 94. "B" is the resonance curve when a medium amount of resistance has been included in the tuned circuit, C is for a greater amount of resistance. Notice that these curves are flattened somewhat, showing that for a tuned circuit containing appreciable resistance the increase of current at resonance is not as great proportionately as is the case in a circuit of low resistance. This means that the selectivity is greatly decreased since

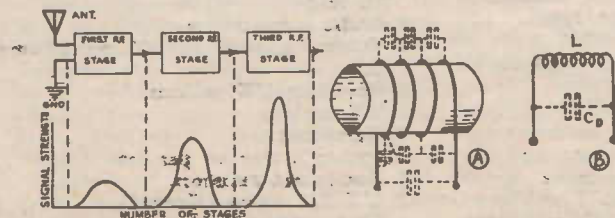

Figs. 97 (left) and 98 (right).

the signal current of the wanted station is only slightly stronger than that of the unwanted stations, so they all come in with nearly the same volume.

The curves of Fig. 94 can be plotted in another way, in order to bring out another important point regarding selectivity. In Fig. 95, the curves have been re-plotted to show the relation between frequency in kilocycles and per cent. of the response at resonance. Curve A is for the circuit of very low resistance, B is for a circuit having higher resistance, and C is for one having still higher resistance. At resonance the response for all curves is 100 per cent. The response at any other frequency is plotted in terms of the percentage of the response at resonance. Notice that the curves having resistance and broad tuning are wider, showing that the response for a signal slightly off the resonant frequency is not much less than that of the resonant signal.

The A. C. resistance of a good isolated tuned circuit is around 12 ohms at a frequency of 1500 kilocycles (200 metres). However, its behaviour when placed in a receiver depends largely on what circuits are brought into electrical association with it, and what mechanical things are brought near its field. The associated circuits consist of coupled primaries and the input circuits of vacuum tubes which are connected directly across the tuned circuits. From the standpoint of signal strength and selectivity alone, all these factors should be controlled so that a low resistance results in the tuned circuits. However, the resistance can be so low, and the tuned circuits made to tune so sharp, that an undesirable effect is produced. This is known as cutting sidebands. Curve A of Fig. 95 has purposely been drawn to illustrate this condition.

Consider that a musical selection is being received from a station transmitting at 600 kilocycles (500 metres), through the tuned circuit A. It will be remembered from a discussion in an earlier lesson that the complete range of musical frequencies broadcast lies between about 30 and 5000 cycles. Therefore at the broadcasting station the 600,000-cycle carrier current wave is modulated by the audio frequency currents ranging from 30 to 5000 cycles. Consider first that only a 5000-cycle note is being played by the orchestra. This 5000-cycle audio current then combines with the 600,000-cycle carrier current producing two currents, one having a frequency equal to the sum of these two (605,000 cycles), and one having a frequency equal to the difference of the two (595,000 cycles). Therefore, to receive this note, the R.F. amplifier must pass these two currents through it with equal strength. You will notice that they differ in frequency by 10,000 cycles, or 10 kilocycles. Now, if a 3000-cycle note is played, the carrier wave will contain a 603,000-cycle note,

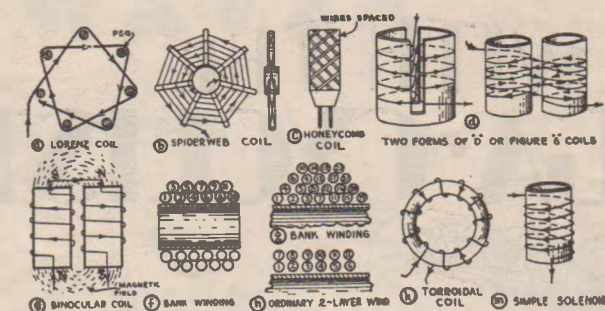

Fig. 99.

and a 597,000-cycle note, and the amplifier will have to amplify these equally. It can be seen that if the entire range of musical frequencies is being covered at once by the orchestra, there will be present a carrier wave covering a band of frequencies from 605,000 cycles to 595,000 cycles, and in order to secure faithful reproduction at the receiver, every one of these frequencies must be passed through the R. F. amplifier and amplified equally. If any frequency is lost or suppressed in the amplifier, then that note will not be reproduced in the loud speaker, and the music will not be a true reproduction of that played in the broadcast studio. This condition would occur if the frequency response of any one tuned circuit or of the entire R. F. amplifier were as shown by curve A, Fig. 95. The 5 kilocycles above the carrier and the 5 kilocycles below the carrier (10 kc. altogether) constitute what are known as the "sidebands."

It is evident that the response for the 595 and 605 kc. sidebands (5000-cycle audio note) is only 20 per cent. as large as the response of sidebands near resonance (low note). Therefore this high 5000-cycle note would hardly be heard in the loud speaker.

Tuning characteristics represented by curve B would be more nearly ideal since the response at 545 kc. is per cent. of the response at resonance. Curve C is obviously a further improvement in this respect. However, curves B and C indicate broad tuning with poor selectivity and consequent danger of station interference. It can be seen that with this type of tuned circuit some compromise must be effected. Some compensation for the loss of the high frequency notes due to cutting the sidebands by over-selective tuning circuits can be secured in the audio amplifier and reproduced by designing these to have a rising characteristic at the high frequencies. This means selecting the audio and reproducer units to match the operating characteristics of the R.F. amplifying system.

Obviously the ideal response curve would be that shown at D, Fig. 95. The curve has straight vertical sides and a flat top, and is 10 kc. wide. Since the peak of the wave is no greater at the carrier than at 5 kc. above or below the carrier, equal transmission is obtained on all frequencies within the 10 kc. side band range. A frequency

curve approaching this can be secured by a tuning system known as the Vreeland band selection system.

Selectivity and Multiple Stages.

The selectivity of an R. F. amplifier depends on the number of stages, tightness of coupling in the R. F. transformers, amount of regeneration, etc. Fig. 96 explains the first factor. Let curve A represent the response curve of a single R. F. stage. For a frequency 5 kc. off resonance, the circuit gives about 90 per cent. of the amplification at resonance; at 10 kc. off resonance the amplification has dropped to 81 per cent. Now if another stage with characteristics exactly identical to the first is added to it the selective action shown by curve B is obtained. This can be understood from the fact that if at a certain frequency off resonance the first stage reduced the amplification to 90 per cent., then the second stage would reduce the amplification to 90 per cent. of what came through the first stage, i.e., 90 per cent. \times 90 per cent. or 81 per cent. A third stage would reduce it to 81 per cent. \times 90 per cent. or 73 per cent. A fourth stage would make it 73 per cent. \times 90 per cent. or 66 per cent., etc. Reference to the curves at a point 5 kc. off resonance shows the selective action referred to above. Under these conditions of selectivity, since a sideband of 5 kc. resonance is reduced to 66 per cent. strength, considerable sideband suppression would result, with consequent signal distortion.

Fig. 97 shows in a pictorial way how the signal strength is increased and the width of the frequency band passed through is decreased as the number of tuned R. F. stages is increased. It is obvious that the tuning of each stage must be designed to be broader than that desired from the amplifier as a whole. By proper design of the

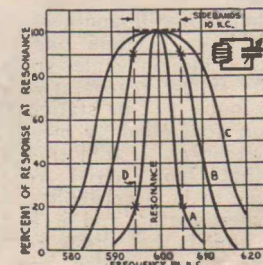
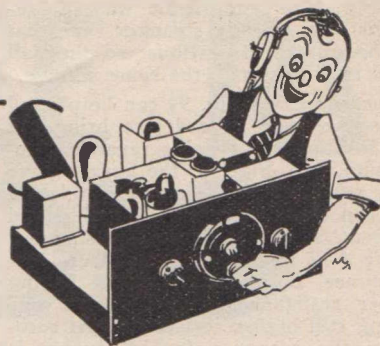

Fig. 95.

(Continued on page 21).

WITH THE MEGA-CYCLISTS



Conducted by

CHARLES M. SCOTT (VK3CS).

Short-Wave "Loop" Reception

By HUGO GERNSBACK.

IT is curious to note how custom and usage sometimes prevent worthwhile developments. In short-waves, experimenters have become accustomed to aerial and ground when, as a matter of fact, it is now believed that there is something better. By this I refer to loop reception.

The loop aerial, of course, is nothing new. It has been used since the early days of radio. In the past, however, its use lay chiefly in the broadcast and ship bands, although during a trip through Continental Europe last summer I observed much more widespread usage of the loop than in this country.

Obviously, many advantageous characteristics of loop aeriels have been overlooked during the past few years, particularly in the development of high gain tuned radio frequency, superheterodyne and regenerative receivers.

There is no question that the loop offers great advantages. Here is an almost virgin field that awaits development by the short-wave experimenter. The advantages of the short-wave loop as compared to the broadcast loop lie particularly in its size, because the short-wave loop may be only a fraction of the size employed for broadcast reception. As yet, no standard short-wave loop has been designed. The editors recently experimented not only with the customary loop, but also with spiral loops and other designs.

Then, there is still another variety, the double loop, wherein one of the sections is made movable so as to produce the fullest regenerative effect, or the two loops may be stationary and regeneration controlled by means of a variable condenser. From this it will be seen that loop aerial reception should prove to be a veritable paradise for the experimenter, and it is to be sincerely hoped that loop reception will become more popular from now on.

Of course, existing present-day circuits require some modification for loop reception. This refers particularly to the input circuit of the first tube.

Another important point is that the receiver must be shielded thoroughly in relation to the loop. The reason is that excessive capacity between the loop and the receiver usually destroys the loop's directional effect. This directional property is very important. Most experimenters already know that a loop works best when turned in the direction from which the signals come—that is, facing the transmitter edgewise. The directional effect of the loop is valuable in eliminating interference from other radio transmitters. It often happens that a local short-wave station or one only a short distance away sends out such a broad and powerful signal that a distant station several thousand miles away on a nearby frequency cannot be brought in with the usual aerial and ground combination. The directional qualities of the loop help to relieve this condition, unless, of course, the two stations are in exactly the same direction, which is unusual.

While we are considering the problem of interference, it has been noted that a small loop will cut out man-made static to a considerable degree. This man-made static is always a bug-aboo, and while the new types of transposed aerial lead-ins help a great deal, and are indeed a forward step, loop reception, in many cases, is even better.

Experimenters should try centre-tapped loops with balanced input tuning circuits, which hold some excellent promises.

We also have the so-called shielded loop. Such loops have been widely used for ship direction finders, army field sets, directional reception and

transmission, etc. By a shielded loop is meant one having the wires entirely encased in metal, with only a small section at the top left open. Such loops greatly enhance the directional effect, and also tend to eliminate interference between the loop itself and the receiving set.

One of the reasons that loop reception is not more popular with experimenters is that most of them seem to think that different loops for different wavelengths are required. Of course, that is the best arrangement, but it is not absolutely necessary. It should be possible to build a loop for all wavelengths, and by using a multiple switch, the same as is now in use in the modern short-wave sets, to switch from one wave band to another merely by turning a switch knob. Of course, when trying out tapped loops, it is necessary to have shielded connections, but this problem offers no unusual obstacles.

Those experimenters who already own short-wave sets can try loop reception simply by fitting the upright support of the loop to the usual coil form so as to fit into the coil socket. For experimental supports, ordinary broomsticks or dowel sticks work very well. The wire to be used may be the ordinary No. 16 or 18 flexible. The wire is held in place by means of tacks, brass brads, or diagonally cut saw slots.

Loop aeriels are excellent, and offer many points of advantage both for receivers and transmitters, particularly those of the portable short-wave types. It eliminates the problem of the long wire and ground, with their uncertain characteristics. Short wave sets with loop aeriels can be logged and tuned very accurately.

It is certain that during the next few years loop reception will become very popular, and perhaps standard.

SHORT WAVES

Notes and News

NEW STATIONS REPORTED ON THE AIR.

THE SIAMESE PHONES.

THE Chief Engineer of the Government Post and Telegraph of Bangkok, Siam, announces that station HSP, on 6.9 metres, is working Berlin nearly every day from 7.30 p.m. to 9.30 p.m. HSJ, on 37.6 metres is used irregularly when HSP does not get through to Berlin. Another station, H.S.G., is also mentioned as being used irregularly.

NEW WAVELENGTH FOR RABAT.

STATION CNR at Rabat, Morocco, announce that they are now on 37.33 metres, and broadcast each Monday from 5.30 a.m. to 8.00 a.m.

They also broadcast on 23.38 metres from 10.30 p.m. to midnight each Sunday.

MORE STATIONS FOR SWITZERLAND.

IN addition to HBL on 31.27, and HBP on 38.47 metres, which broadcast a special programme from 8.00 a.m. to 8.45 a.m. each Monday morning, the League of Nations have the following stations operating on speech, HBF on 15.78, HBH on 16.25, HBJ on 20.60, and one on 20.74 whose call is not known.

INDIA AGAIN.

A REPORT has come to hand that station VUC at Calcutta is now on 49.10 metres. The schedule seems to be daily, excepting Sundays, from 5.36 p.m. to 3.00 a.m., and Sundays from 1.36 p.m. to 3.54 p.m.

WOO OR WOY

IT has been announced that station WOO, at Ocean Gate, New Jersey, has been granted permission to work on 70.22 metres, and a WOY, at Ocean Gate, is granted permission to operate on 70.22 metres, 63.13, 35.05, 23.36, and 17.52 metres. These waves are now used by WOO.

LOOK FOR THESE STATIONS.

A STATION believed to be RAU Tachkent, Turkestan, has been heard fairly regularly on 19.85 metres, 15.10 megacycles, between 8.00 p.m. and 11.00 p.m., working a Rus-

sian Station which can also be heard a little higher up about 22 metres.

All times used in these pages are Eastern Australian standard time.

AMATEUR PHONE BANDS EXTENDED BY COMMISSION.

WITH a general announcement of new amateur regulations to go into effect on October 1, the Federal Radio Commission authorised one immediate change in the existing regulations, at the request of the American Radio Relay League, national amateur body. This change, which is now in effect, provides for extending the territory in the radio spectrum authorised for the use of amateur radio-telephone stations.

This increase is made in two of the frequency bands reserved for amateur use, and provides for the operation of 'phone in the region from 1800 to 2000 kc. near the broadcast band, as well as from 28,000 to 28,500 kc, and from 400,000 to 401,000 kc in the ultra high frequency band. This territory has previously been available only for code transmission.

WIRELESS ON SMALL SHIPS.

A MOST interesting demonstration of apparatus for use on board small ships for the purpose of sending out wireless messages from a ship in distress was given recently by the chief engineer of Amalgamated Wireless (A/asia) Ltd. (Mr. A. S. McDonald), during a lecture in St. John's Hall, Wahroonga, N.S.W.

He explained that this apparatus is quite automatic in its action, and can be set in motion by the ship's personnel by the closing of the switch. The apparatus automatically transmits the distress signal, "S.O.S.," followed by the name of the ship, and by an ingenious device the latitude and longitude can be set by the navigating officers in an extremely short space of time, representing seconds only. Mr. McDonald also demonstrated an automatic receiver with an alarm bell, which comes into operation only when the international distress signal is transmitted. The alarm can be fitted on the bridge of any ship or in the quarters of the ship's personnel. By the use of these two pieces of automatic wireless equipment, a very great measure of safety can be ensured, particularly in regard to small ships of

which there have been a number lost during the past few years.

Mr. McDonald also described the function of the Australian Coastal Radio Service, both in relation to safety of life at sea and general business, and quoted some very interesting figures. He stated that the average number of words handled per annum during the past few years approximated five millions, of which 1½ millions of words were transmitted free of all charges. Included in this 1½ millions of words were messages relating to weather conditions and navigation warnings, which were transmitted from time to time by the various stations. He also stated that the coast stations at Perth, Adelaide, Melbourne and Sydney, transmit time signals daily, without charge, so that navigators at sea and surveyors on land can correct their chronometers, exact time being so necessary for this work.

IONISED ATMOSPHERE LAYERS MEASURED BY AUTOMATIC DEVICE, GIVING TIME AND FREQUENCY.

THE Institute of Radio Engineers, at its convention, heard new information on the series or ionised layers formerly named for Kennelly and Heavyside, but now known as the ionosphere. A means of accurate measurement of the layer heights and effects was described by T. R. Gilliland, of the Bureau of Standards, U.S. Department of Commerce, while D. M. Stuart and L. V. Berkner, also of the bureau, spoke on the same general subject.

The Bureau's "measuring rod" gives a height-frequency curve and comprises transmitter and receiver, automatically varied from 2500 kc. to 4400 kc. cycles at a uniform rate of 200 kc. cycles every minute. The virtual height is recorded photographically by an oscillographic recorder as used for fixed frequency work.

Three Layers Measured.

"In the daytime," Mr. Gilliland said, "three different strata were usually indicated. As a rule the E layer, with a virtual height of about 120 kilometres, is found to return energy for frequencies below 3,000,000 cycles. Between 3,000,000 and 3,600,000 cycles reflections are likely to come from the F-1 region, with a virtual height of about 200 to 240 kilometres, while above 3,600,000 cycles, the F-2 region, at 280 kilometres and higher, returns energy. These values vary considerably from day to day.

"Of particular interest is the character of the change observed when passing from one stratum to another as the frequency is increased. Although, at times, when passing from E to F-1, reflections may drop out completely for a short interval, frequently the curve is continuous and the time retardation will reach a high value just before the appearance of the F-1 reflection.

(Continued on page 23.)

Making Your Own Records

A New Series of Articles which will tell you about this Fascinating Hobby

PART VIII.

Commercial radio loud speakers vary from 2 to 18 ohms, and if the cutter impedance is off a few ohms, the impedance match is way off in percentage. For consistently good results and for the prevention of needless expense, only the high impedance cutters should be used.

If the set has the output transformer mounted on the speaker, then the output terminals on the chassis are high impedance and the cutter is connected directly to them. Also, if the set has "phono" terminals the input connections are as shown.

Some radio sets use a power detector into two power tubes, and the high gain of this power stage is not sufficient for recording, necessitating the use of a pre-amplifier such as shown in Fig. 58.

The booster one stage amplifier, shown in Fig. 59 is manufactured by the Pacent Electric Co. of New York, and can be used for recording by the addition of a microphone transformer as shown. This adapter is provided with a toggle switch so that when it is in the "radio position" records can be made from the radio. When it is in the "record" position the microphone is in use.

The booster is connected to the radio set in the following manner: The detector tube is removed from the set and inserted into the adapter at the end of the cable supplied as part of the "Booster Unit." The adapter with the tube in it is then placed in the detector tube socket of the set.

RECORDING STUDIOS.

Commercial studios for instantaneous recording can be divided into two separate types—first, studios devoted exclusively to voice recordings and individual instrument playing, and, second, studios that have facilities for recording complete orchestras and bands.

In the first type of studio only one microphone is used, and the recording machine, amplifier, etc., are all located in the same room with the microphone. This room usually contains about 42 square feet of floor space, and the over-all frequency characteristic of the system is not made very flat, since it is rarely necessary to record any frequency above 4000 cycles. A moderately priced two-button carbon microphone, used in conjunction with a suitable amplifier whose gain is about 70 DB, and a made-over pickup is all that is necessary as equipment. For the recording machine an ordinary phonograph turntable is all that is necessary if pre-grooved records are to be

used, but if blank uncut records are desired for recording, then it is absolutely essential that an excellent feed-screw device be used in order to insure a good, even groove. As has been pointed out, if the recording machine makes a periodic groove—that is, the lines are unevenly spaced, when the record is played back, the results will be poor, and if steps are not taken to prevent this, the finished product will only serve to cast reflection on the studio, with a consequent loss of business.

A piano should be provided for accompaniment, and it is usually a good policy to have a person who is a pianist run the studio. This will cut down labour costs and at the same time attract the singers who usually are very reticent about singing if accompaniment is not easily provided. For playback, the acoustic phonograph is best. The reason why this type of machine is recommended is that if the finished record plays back satisfactorily on it, the customer is assured of success in his own home. Too many of these small studios that are rapidly springing up all over the country use inefficient apparatus and naturally their results are poor. To compensate for these poor results on playback, electrical reproduction is used and the record then sounds quite satisfactory in the studio, but when it is reproduced in the home on the old style phonograph (of which there are still many in existence), the results are very poor. The reproducer may be too heavy or the groove may not be deep enough, with the result that there is double tracking. The

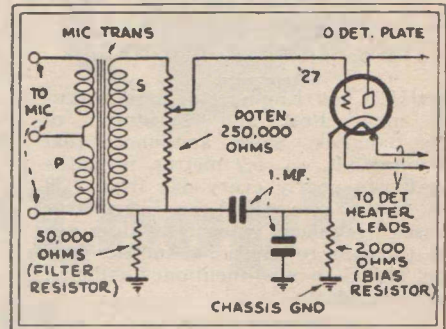

Fig. 58. Circuit of a one stage pre-amplifier for use with radio receiver.

customer is dissatisfied, and therefore any future business from him is lost. Instead of becoming a supporter, he turns "knocker." In the writer's opinion, the acid test for any instantaneous record is the acoustic phonograph. If the record sounds well on this, then it will sound much better on any other type of machine.

Acoustical Treatment of Studios.

In most of the studios that the writer has had occasion to come in contact with the acoustic treatment of the studio has been simply to cover the walls and ceilings with heavy drapes and the floor with a heavy carpet. A studio that is so treated will prove unsatisfactory for recording from the standpoint of fidelity. The record will sound "tubby" and very unnatural. This is due to the absorption of all the high frequencies by the heavy drapes. For proper acoustics the studio should be so constructed that there is a certain amount of resonance present so that the high frequencies may be properly recorded. In the proper treatment of recording rooms two objects must be kept in view; first, the exclusion of all unwanted external noises, and second, the production of the right acoustic conditions for good recording.

The excluding of extraneous noises is accomplished by building the room of double walls (see Fig. 60) with a dead air space between them. The dead air space is an excellent insulating medium against sound, and is very effective in keeping out external noises. Great care must be taken to see that the walls and ceiling are all absolutely air tight. If this construction is carefully followed out, it will be observed that no sound originating in the studio will be heard outside; and, vice versa, no sound originating on the outside will be heard inside the studio. As an added insurance against external noises the outside of the outer wall is covered

(Continued on page 23.)

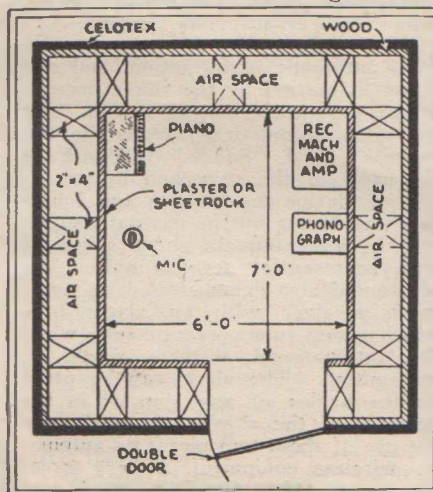

Fig. 60. Interior layout of a sound recording studio.

VOLTAGE DOUBLING

Alternate Charging of Condensers Builds Up Potential

Why the 25Z5 Doubles Voltage

THE voltage doubler has lain dormant in radio books for over a decade. It is just emerging from its slumber. Just what is a voltage doubler? Many have asked that question. How does it double? Many have asked that, even after they have just read about it. Perhaps just a little bit more writing will help to answer the questions.

Refer to Fig. 1, A. Let R1 and R2 be two equal rectifiers of any type, and let them be connected so that they will conduct in the direction of the arrows. Connect two equal condensers C1 and C2 in series across the two rectifiers. Between the junction of the two rectifiers and the junction of the two condensers, connect a source of alternating e. m. f. Let the maximum value of this voltage be E.

First assume that the voltage is acting in the direction of the arrow a. Condenser C1 charges up to a voltage E because R1 conducts in the direction that permits the condenser to charge up. Let the voltage subside to zero. The charge on the condenser remains because there is no way in which it can escape. It cannot discharge through R1 because it will not conduct in the proper direction. Therefore, after the voltage has subsided there is a potential difference E across C1.

Charging Second Condenser.

Now let the voltage act in the opposite direction, as shown by arrow b in Fig. 1, B. R2 now conducts in the direction that permits condenser C2

to charge up. When the voltage has again subsided to zero the charge remains on that condenser because it cannot escape through R2. It is trapped. Hence there is a potential difference E across that condenser. The polarities of the charges are indicated by appropriate signs.

When the supply is rapidly alternating in direction, both condensers are charged to the potential E, as indicated in Fig. 1 C. The potentials across the two condensers are in the same direction so that they add up, and therefore the voltage across the two condensers is 2E, or twice the value of the amplitude of the supply voltage. That is why the device is called a voltage doubler.

Effect of Leakage.

It was assumed that the charges will remain on the condensers. This is not strictly true because of leakage, so if the supply voltage were turned off the potential would gradually drop to zero. But when the voltage is alternating rapidly, as in the case of 60-cycle supply, the leakage between charges is inappreciable. It is the potential that has the value 2E, and in order to test the theory it would be necessary to use a static voltmeter or a vacuum tube voltmeter. Any current-drawing voltmeter would read less than twice the peak of the supply voltage.

The voltage doubler would be of little value in a radio receiver unless it could sustain a considerable leakage. The current required for the plates, screens, and the speaker field in a

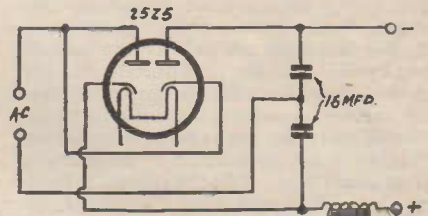

Fig. 2: This illustrates how the principle of voltage doubling can be applied with a 25Z5 rectifier tube. Large capacity condensers are essential for good voltage regulation.

radio set constitutes a heavy leakage. In order that the voltage shall be maintained when a heavy current is drawn, it is necessary that the two condensers C1 and C2 be of large capacity. In rectifiers using the voltage doubler it has been recommended that the capacity of each condenser be at least 16 mfd. if the circuit is to deliver a current of 40 milliamperes.

Another object of using such large condensers is to reduce the ripple to as low a value as possible. The frequency of the ripple is twice that of the supply voltage, as is the case for all full-wave rectifiers. The amplitude of the ripple is approximately inversely proportional to the capacity of each condenser. As a means of further reducing the ripple a choke can be used in series with the load line, as is done in other B supply circuits.

(Continued on page 21.)

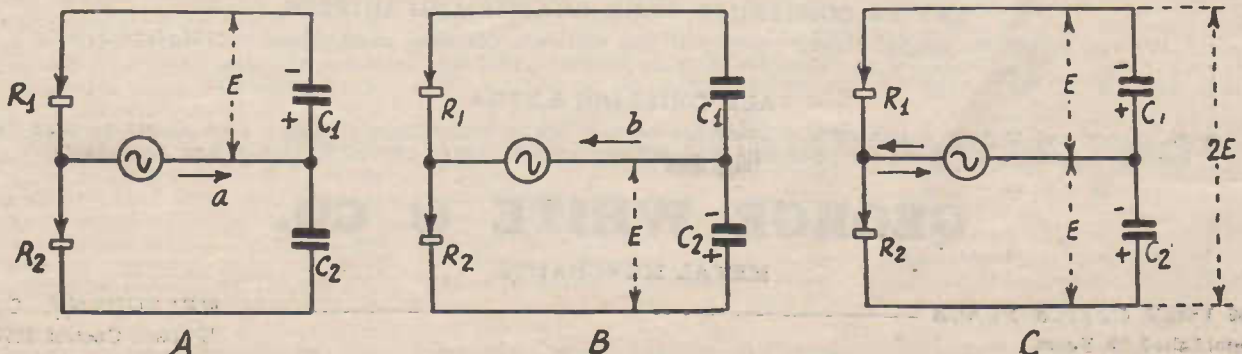

Fig. 1: These circuits show the principle involved in voltage doubling by means of two rectifiers. The input is a-c, and the doubled output voltage is about twice the peak value of the input.

THE CATKIN VALVE.

(Continued from page 11.)

to the cathode in the case of mains valves, but has the additional advantage that it embraces the outgoing leads at the base. This outer screen is perforated to afford ready dissipation of heat and its octagonally flattened faces prevent it rolling. Being parallel sided, quantities of valves occupy much less space than hitherto.

In the exposed anode type a coating of black enamel is applied giving sufficient insulation to prevent shock should one accidentally touch the high-voltage anode. It will be appreciated that the generous heat dissipation afforded by the Catkin design gives cooling for the grid as well as the anode. Conditions are very different in the glass type, where the large surrounding vacuum presents the difficult problem of getting the heat away where dissipation by convection or conduction is non-existent. Effectiveness of cooling does, of course, to a very large extent, govern the rating of output valves.

Present-day sets with enormous overall gain are very prone to what is commonly called "howling," which arises from the sound vibrations causing movement of the electrodes, usually in the case of the detector valve. By virtue of its rigidity the Catkin is not likely to be influenced in this way. As a further precaution, however, the valve is secured to its base ring by a rubber clamp, and the sound conduction path is limited to the thin conducting wires joined to the valve pins. It is well known that rubber is the only sound insulating material which will provide a non-microphonic mounting, and we now have, for the first time, an effectively sprung clamp, and this is independent of the valve holder. A non-microphonic mounting is of vast importance when the set, as is now commonly the case, takes up a

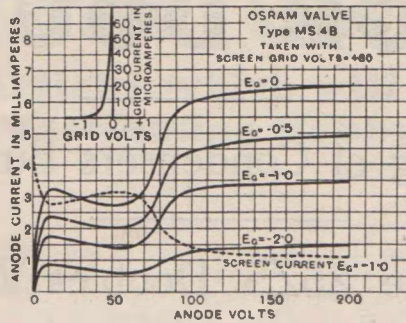

Characteristic curves of the Osram MS4B Valve.

position immediately behind a single or perhaps dual loud speakers, into which the output valve delivers several watts.

Wireless is now finding its place as part of the equipment of the car, and the Catkin valve, being uninfluenced by vibration, whilst being robust and compact, has attractive possibilities for car radio. In this connection, in addition to durability, it should be noted that a new form of filament-cathode design has been adopted, which permits of a 10 per cent. fluctuation of heater potential, thus allowing for the voltage variation of the car battery. Compactness is another important advantage in this application. The much reduced size of the metal envelope as compared with the glass counterpart is an important feature in the prevention of direct coupling with the sound-output of the loud speaker.

Some valve users have experienced trouble due to the glass bulb breaking away from its bakelite base. Fracturing of the cement in this way is a weakness of present valves, and it is interesting to note that no form of cementing is employed, and a loose cap becomes an impossibility.

Copper-to-glass Union.

The Catkin valve is practically unbreakable, and may be dropped from a height of several feet on to a concrete floor with but little risk of damage either by fracture, or by derangement of the critical spacing of the electrodes.

The copper-to-glass union is an interesting feature of the new valve, and it is a creditable achievement to produce a gas-tight seal under mass production methods. In order that the vacuum may be well maintained in a valve, excessive temperature rise for any prolonged period must be avoided. All metal parts within the valve are, of course, gas-fired at a high temperature, but in the course of manufacture the glass bulb in a conventional valve is a prolific source of gas and necessitates prolonged de-gassing.

Catkin equivalents of the MS4B, VMS4, MH4, and MPT4 will make (Continued on page 23.)



The All-Metal Screen Grid Catkin, showing external screen attached.

ALUMINIUM SHEETS

FOR CHASSIS AND SHIELDING WORK.

We stock a wide variety in Metals as required in Wireless Set building, and also for model engineering construction.

LET US CONSTRUCT YOUR CHASSIS AND SHIELDS.

We can supply the special chassis used in all the receivers described in this issue of "Modern Sets." "The Philips Four" Chassis, 7/-, plus freight. All prices inclusive of Sales Tax.

ALL DRILLING EXTRA.

All work carried out to your specification. Phosphor bronze, brass, and copper sheets. Zinc sheets as used for battery manufacture. Send for price list of aluminium, copper, brass, phosphor bronze, and zinc sheets.

GEORGE WHITE & CO.

METAL MERCHANTS.

280 POST OFFICE PLACE
Established 79 Years.

MELBOURNE, C.1.
'Phone: Central 1100.

Practical Hints and Tips

AN ARTIFICIAL CENTRE-TAP.

WHEN the usual remedies for mains hum in an A.C. set have been tried and found to be ineffective it may be remembered that a misplaced centre-tap on one of the L.T. windings of a power transformer is not unknown, and may be largely responsible for the trouble. To unwind the transformer, and then to experiment with another position for the tapping, is a laborious task, not to be recommended to the amateur, but, fortunately, the use of an adjustable potentiometer, whereby an artificial centre point may be located accurately, provides a solution of the difficulty.

The connection of a potentiometer in place of the existing centre-tapping is quite simple, and, indeed, is only the work of a moment. The ends of the resistance winding are joined across the transformer winding, and the wire which was originally connected to the centre point is transferred to the potentiometer slider terminal.

A suitable value of resistance is about 20 ohms, and is by no means critical. Ready-made potentiometers, specially intended for this purpose, and which occupy very little space, are available commercially.

WHERE TO PUT VOLUME CONTROL.

THE type of volume control and its placement will depend considerably on receiver design. Thus, if the detector (or second detector in superheterodynes) is fully protected from danger of overload, it is permissible to put the control in the audio channel, although this should be done in a manner not to constitute change in volume a control of tone as well. One advantage of such location is the avoidance of detuning effects, otherwise inevitably present. However, in a superheterodyne these would not be serious in the intermediate amplifier. Grid bias variants have shown detuning to as much as 20 kc. for the controlled circuit near the high frequency end of the broadcast band. Theoretically at least, the volume control should be a gain control and an input control, because the amount of gain should be cut down to reduce the noise, and the amount of signal input cut down to prevent cross-modulation and overloads of other types. So compound controls are sometimes used. There is no altogether satisfactory volume control, so far as we know, and most engineers must feel mildly stumped when they come to the control feature. Perhaps the day will come when constant output tubes will be developed, so that

one may make a permanent setting, and the volume will come up to that in nearly all instances, at least will not exceed the predetermined value. A close approximation to this could be made with the present duo-diode tubes, using the rectifier for auxiliary biasing of each tube (automatic volume control), and the amplifier section (whether triode, quadrode, or pentode) for gain. However, the circuit would be awkward, and no doubt the constant output tube will see the light of day some time.

OHM'S LAW.

OHM'S law relates current, voltage and resistance. The current in amperes is equal to the voltage in volts divided by the resistance in ohms. The voltage in volts equals the resistance in ohms multiplied by the current in amperes. The resistance in ohms equals the voltage in volts divided by the current in amperes. Where fractional values are treated it is usual to express them in their decimal forms—that is, one-tenth ampere would be 0.1 ampere, and one one-thousandth of an ampere as 0.0001 ampere. One of the first things one should learn about electricity is Ohm's law for direct currents. If you will work out a few examples you will soon become familiar with the three forms of the law and then will need no printed reminder.

PUSH-PULL RESISTANCE AUDIO.

WHAT is the trouble with what seems to be a likely audio circuit, push-pull resistance coupling? This is a common question at the present time.

As yet push-pull resistance coupling is in the experimental stage, so designers of kits and sets do not want to include a circuit that is not more or less foolproof. Tests of such circuits made in our laboratories showed varying results, but even the best results did not produce enough sensitivity. The method, so far, seems to concern simply coupling from one stage to the output without much distortion, but that could be done with less adjustment trouble by the single-sided coupling from detector to output. New possibilities are offered by the 53 tube, and no doubt experiments will be carried on, but the adjustment must be expected to be beyond the capabilities of the general run of constructors, who have not the dynamic instruments for effectuating proper balance. An unbalanced attempted push-pull audio circuit is a sorry thing indeed.

VOLTAGE DOUBLING. (Continued from page 19.)

A B Supply Doubler.

The 25Z5 rectifier tube has been so designed that it can be used as a voltage doubler. The reason why it may be so used is that it is two independent cathodes and two independent anodes. That is, it is two independent rectifiers contained in the same glass envelope. The connections for a voltage doubler with this tube are shown in Fig. 2. It will be noticed that the cathode of one element is connected to the anode of the other. To this lead is connected the a-c supply, just as in Fig. 1. The other side of the a-c line is connected to the junction of the two condensers. The positive side of the output line is that which is connected to the cathode not previously used, and the negative of the output is the anode not previously used. A choke coil is connected in the positive lead to the load.

Rating of 25Z5.

One advantage of a circuit like this is that it is often possible to dispense with the power transformer, for if a 110 volt line is connected directly to the rectifier the output voltage will be about 220 volts. Indeed, if the drain is not great the voltage may be higher, because the limiting value is twice the peak of the line voltage. Assuming that the line voltage is sinusoidal, the limit is 331 volts. If the set does not require a great deal of current the voltage will be at least 220 volts, and that is sufficient for most purposes.

The 25Z5 tube is rated at 125 volts R.M.S. maximum per anode and a maximum current of 100 milliamperes. Thus it can be used safely in a set using two 48 tubes provided that the 48s are slightly overbiased and the other tubes do not take a great deal of current. However, with combination there would be nothing with which to actuate the field of a magnetic speaker, unless some of the available voltage were dropped in the field, that is, if the field coil were connected as a choke.

A rectifier of this kind is particularly useful in midget sets. If this rectifier is used on a 230 volt circuit a resistor must be placed in series with the input voltage to the rectifier so that the voltage is reduced to 110 volts.

THE THREE R'S OF RADIO.

(Continued from page 15.)

individual tuning circuits it is possible to secure an overall response curve approaching the flat topped curve of Fig. 95.

Although extreme selectivity is undesirable from the point of view of sideband suppression, it is usually advantageous to keep the resistance of the tuned circuits as low as possible in order to secure maximum amplification, and secure the right amount of

(Continued on page 24.)

“SERVICE PLEASE”



A DEPARTMENT TO HELP SOLVE THE VARIOUS TECHNICAL PROBLEMS WHICH ARE ENCOUNTERED BY THE RADIO SET BUILDER AND EXPERIMENTER.

Will you please explain the method of impregnating power transformers, and other such transformers, and state the advantages gained by doing so? “Stalloy,” Geelong, Victoria.

When the transformer is built it is put in a vacuum tank, and after a certain degree of evacuation molten wax or similar compound is poured into the vat and thus fills the transformer pores or openings, as well as covering the surface. The transformer thus treated becomes relatively free from the deleterious effects of moisture, and should have a longer life and give better performance. It also tightens up the core if this is dipped also, and prevents vibration of the laminations. After the impregnation the transformer is cased in iron.

* * *

After constructing a receiver, using the 2B7 as detector, a, v, c, tube and audio amplifier, coupled to the 2A5, I find that there is a high-pitched note if there is a bypass condenser across the 2A5 biasing resistor. If I leave out the condenser the set seems to work all right. Would you please explain the cause of this? R.K.S., Ringwood, Victoria.

The omission of the condenser under such circumstances is not only good practice, but necessary. However, if you desire to include the condenser, which would be of large capacity, then you could get rid of the interfering note by putting a 0.002 condenser from the plate of the 2B7 to earth.

* * *

I am rebuilding my receiver to bring it up to date, and am intending using the 5Z3 rectifier instead of the present 280. Would you give me your advice on this move? L.R.J., Bendigo, Victoria.

You do not give particulars about your set, but if there is a little hum in it at present, even a barely discernible note when no station is tuned in, you can reduce the hum materially by doubling the amount of capacity next to the rectifier, and using the 5Z3 instead of the 280.

The 5Z3 hasn't anything particular to do with the hum, but it does stand about twice as much current drain as the 280, and the extra condenser will put a high current starting drain on the rectifier tube, besides raising the B voltage a little, the latter a continu-

ous contribution. It may be that the amplification in the set also will be noticeably increased in consequence. A present set using a 280, with up to 8 mfd. next to the rectifier (filament to B minus), may have the capacity doubled, and if the newer tube is substituted it will stand the drain nicely, which the 280 might not, because of the high demand on it at turning on the set.

* * *

Would you give me details of both coils in the “Music Master Battery Four”? Also is it satisfactory to work the set from a D.C. mains eliminator, and what are the B and C voltages when using 150 volts as maximum? B.R., Brunswick, Victoria.

For both coils we refer you to the Messrs. A. J. Veall, 247 Swanston-street. The high tension supply could be obtained from a D.C. eliminator, but it would be advisable to use a battery for the filament lighting. Do not earth the set.

The voltages will be as follows: B plus max. 150 volts, B plus S.G. 75 volts, C — 2, 15 volts, and C — 1, 3 volts.

* * *

I am anxious to build a battery-operated receiver, using electron coupling in the mixer of the superhetrodyne, but would desire to confine this work to one tube, so will you suggest the proper tube? S.T., Footscray, Victoria.

Since the receipt of your inquiry a battery type pentagrid tube has been announced, and you will find the details in this issue. Also, the circuit is given. This tube fills a need, as you intimate, particularly as the a-c and 6-volt equivalents, the 2A7 and the 6A7,

This Free Technical Information Service is Open to All “Modern Sets” Readers. When Forwarding Your Question Be Sure to Give Every Detail Possible Regarding the Type of Receiver, Make and Type of Valves and Speaker, and All Details Which You Consider May Help Us to Solve Your Trouble. Only in Special Circumstances Can We Answer Enquiries by Post.

have proved so successful in actual operation. It isn't always true that a tube representing a departure from previous methods proves readily useful in actual circuits, since experience has to dictate the best way to operate the tube. But in this instance, as is true in regard to nearly all the tubes announced during the past year, considerable experience preceded the announcement of the tube, and results were superb. An exception is the 2B7, which requires careful choice of load constants and voltages and experimenters are finding that slight departure from what the tube manufacturers recommended improves results, e.g., use of a 100,000-ohm plate load, instead of 250,000 ohms, and of a low screen voltage in audio amplification, around 20 to 25 volts.

In using my newly-purchased short-wave set I hear what I assume to be commercial stations, although the set is tuned to some frequency or frequencies in the amateur band. Is it a fact that there are commercial stations in the amateur bands, and is it permissible? I thought the amateur bands were for amateurs. A.R.C., Bondi, N.S.W.

Yes, there are commercial stations operating in the amateur bands, particularly the 40-metre band, where their location is of doubtful legality. The question is likely to come to a head when the Madrid conference recommendations are considered by the Senate. Although the topic is not directly in line with the Madrid report, confinement of amateur privileges to continental use is one of the direct considerations, and no doubt the other subject will be broached, along with other problems netting amateurs. There is too much congestion in the principal amateur bands by amateurs themselves (though unavoidable at present), without interference added by commercial stations.

Recently I substituted a pair of 2A3 tubes for 2A5's in push-pull, and was surprised to find that the volume dropped to about one-third of its former strength. As the 2A3's are rated at 15 watts undistorted output, how is it that the high-mu output tubes gave better results?—F. McR. (Kew, Victoria).

Using a pair of 2A3's in push-pull, the output may be 15 watts without as much distortion as is obtained from 2A5 push-pull at least less than half that power output. To be able to use 2A3 tubes instead of 2A5 tubes it is necessary to have sufficient driving voltage ahead of the output stage, which your receiver evidently hasn't, for the working mu of the newer tubes is only a small fraction of that of the pentodes. You might try a 56 driver stage. Then, of course, the output impedance is quite different, being about half as great for the 2A3's as for the 2A5's. Either you should get a proper speaker or install a proper matching transformer in your present speaker. When these precautions are taken you

should be in a position to side with those who realise the superior quality attained from the low-mu output tubes, and, moreover, you should not confuse sensitivity with power-handling capability. Sensitivity relates to the amount of voltage input required for adequate quantity of sound output. Power-handling capability relates to the amount of voltage that can be put in without distorting the output.

IONISED ATMOSPHERE LAYERS.

(Continued from page 17.)

Effect of Darkness.

"When passing from F-1 to F-2, the virtual height frequently reaches 800 or 900 kilometers, about 550 miles.

"As evening approaches, reflections no longer come from the E layer and the long retardation between F-1 and F-2 becomes less pronounced. By sunset the curve is almost straight and there is little change of height with frequency. Later at night the highest frequencies cease to be returned and long retardations again occur. The phenomenon of double refraction is in evidence at this time.

"The curves contain many important details which would be impossible to record by present methods of manual operation."

Magnetic Waves.

Dr. Karl A. Jansky, of the Bell Telephone Laboratories, discussed electromagnetic waves:

"Electro-magnetic waves of an unknown origin were detected during a series of experiments on atmospheric waves at high frequencies. Directional records have been taken of these waves for a period of over a year. The data obtained from these records show that the horizontal component of the direction of arrival changes 300 degrees in about twenty-four hours in a manner that is accounted for in the daily rotation of the earth.

"Furthermore, the time at which these waves are at a maximum, and the direction from which they come at that time, changes gradually throughout the year in a way that is accounted for by the rotation of the earth about the sun.

Direction Is Fixed Above.

"These facts lead to the conclusion that the direction of arrival of these waves is fixed in space: that is, that the waves come from some other source outside of the solar system. By noting the right ascension and the declination when their intensity is greatest, the source is indicated to be either the centre of the Milky Way galaxy or from the direction of the movement of the solar system with respect to the naked-eye stars. The Milky Way is the more likely source of the two."

THE CATKIN VALVE.

(Continued from page 20.)

their appearance on the market almost immediately. These are the types which

are in most general use, and it is the intention of the manufacturers to add to this range shortly. The characteristics of the Catkin valves follow those of the glass equivalents, and for which they serve as replacements. The four types issued are those adopted in the more popular sets, so that in many cases immediate advantage can be taken of their use.

At a later date we hope to give a report of our own experiences with these valves.

MAKING YOUR OWN RECORDS.

(Continued from page 18.)

with an insulating material such as Celotex. The inside walls and ceiling should be partly covered with heavy drapes so as to lower the reverberation constant. The amount of drapery is best determined by experiment. The room should have a slight amount of resonance so that the faithful recording of the high notes is possible. By a slight amount of resonance is meant that the conditions must be such that a person talking at the microphone will sound the same as a person talking in an average dining room. It must be borne in mind that in commercial work the proper acoustical treatment of the recording room is just as important an item as the apparatus itself, and no effort should be spared to achieve these results. Good records mean "repeat business."

BLIND WORKER'S COURAGE.

WHEN a man is up against it and yet still struggles on, fighting the misfortunes that beset him, we admire him for his courage, don't we? How much more then must we admire the courage, and fortitude, too, of the craftsmen of the Victorian Blind Institute, who, despite their tremendous physical handicap, are trying to earn a living for themselves and their families.

These craftsmen are producing coir mats and matting which is of equal, if not superior, quality to that manufactured by native sighted labour in other countries. When you need mats, give a thought to these brave people who are keeping themselves, assisted by the compassionate allowance which generous citizens subscribe to the Institute to encourage them in their work. The products of these blind craftsmen are on sale throughout Victoria. You can recognise them by the brand, "Blind Institute."

Other skilled Blind Institute workmen are engaged in producing basketware and brushware. Piano tuning, too, is among their activities.

Can You Tie a Knot—Blindfolded?

It is not easy to do even simple manual tasks without the use of your eyes. Therefore, all credit is due to the craftsmen of the Victorian Blind Institute, who, facing a tremendous physical handicap, produce coir mats and matting that are equal, if not superior, to that produced by native sighted labour in foreign countries.

THE THREE R'S OF RADIO.

(Continued from page 21.)

selectivity by proper coupling of the primary and secondary coils. The sum total of all the losses in a tuning coil are usually lumped and expressed as the A. C. resistance of the coil. While this is not technically correct, it has become the accepted practice, since the final effect of these losses is to reduce the current in the tuned circuit, just exactly as if the tuned circuit had no resistance and we inserted resistance in it by means of a rheostat.

One source of loss, known as the skin effect, is due to the fact that at the high frequencies the currents travel only over the surface or "skin" of the wire, thus making only a small proportion of the total cross-sectional area of the wire effective in carrying the current, increasing the resistance.

Another is that due to the eddy currents set up in the wires of the coil by the varying magnetic field. This increases as the diameter of the wire used is increased. The total resistance of the R. F. coil increases greatly as the frequency is increased. The amount of resistance increase depends on the shape of the coil and size of wire. For instance, a single layer solenoid coil of 300 microhenries inductance, consisting of about 58 turns of No. 28 D. C. C. (double cotton covered) wire wound on a 3-inch diameter tube, was measured and found to have a resistance of 3.15 ohms on direct current, 6 ohms at 500 kilocycles (600 metres), 10 ohms at 1000 kilocycles (300 metres), and 14 ohms at 1500 kilocycles (200 metres).

Distributed Capacity.

Another undesirable coil characteristic is known as the distributed capacity. Since the various turns of a coil are conducting surfaces separated by insulating materials, they form tiny condensers. The adjacent turns are at different voltages, so that at high frequencies, small alternating currents exist in these distributed condensers (Fig. 98A). By imagining all the little distributed capacities of these condensers lumped into one condenser, the coil may be considered as a pure inductance with a condenser Cd in parallel. At low frequencies the condenser effect is negligible and all the current flows through the wire. However, if the frequency is progressively increased, the reactance of the inductive part of the coil increases and that of the distributed capacity decreases, until a point is reached where practically all of the current passes through the distributed capacity, and the coil behaves like a condenser. The working frequency range of a tuning coil must be necessarily small if it is to have constant inductance. Since there are losses in these small condensers due to the solid insulating material, the apparent resistance of the coil is increased by their presence.

It is for this reason that tuning coils should not be coated with shellac and other "dope" preparations which in-

crease the distributed capacity effect and also the losses. Distributed capacity in a tuning coil is also a disadvantage since it lowers the frequency range over which a coil can be tuned by an external condenser; for even when the external condenser is at its minimum value, the full distributed capacity is shunting the coil. If high inductance values, necessitating the use of multi-layer coils, are necessary, the windings should be bank-wound (Fig. 99F) to reduce the distributed capacity.

Just as the capacity of a condenser may be decreased by decreasing the size of the plates or increasing the distance between them, the distributed capacity of a coil can be reduced by using a smaller wire or by leaving a space between the adjacent turns of a coil. The size of the wire cannot be decreased too much, for the resistance will then increase, and the distance between turns cannot be made too large, for the inductance will then be decreased, necessitating more turns for a given value with consequent increased resistance and added capacity.

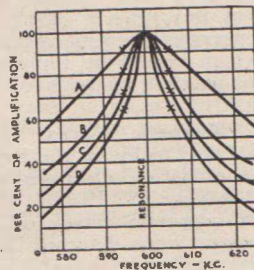

Fig. 96.

A solenoid, cotton covered wire around No. 24 B and S gauge wound tight, already has enough spacing between the conductors due to the double thickness of the insulation. When enamelled wire is used a spacing equal to half the diameter of the wire may be employed. The wire is usually wound in a spiral groove, machine cut lightly into the coil form. This gives accurate spacing. It is obvious that the distributed capacity increases with the diameter of the coil, since this increases the effective surface area.

Lorenz developed a coil having a low distributed capacity; by winding the wire on a series of pegs arranged in a circle, he was able to zigzag it as shown in Fig. 99a. No two wires are parallel to each other for any distance at close proximity.

Another way of reducing capacity is by winding the coils on flat strips mounted radially like the spokes of a wheel as in Fig. 99b, and zigzagging the wire. This is known as the spider web coil.

The honeycomb coil, Fig. 99c, is used when large values of inductance are required. It is mounted on a base having two contact pins for plugging in a receptacle. The turns of each adjacent layer are made to cross each

other at different angles. They may be purchased in a wide variety of sizes.

Fig. 99D shows a D or "figure 8" coil, so called because each of its two halves form the letter D, and the whole coils forms the figure 8.

It is wound by slotting a tube or may consist of two separate interconnected coils. The magnetic fields of the two aid each other inside the tube, and oppose each other outside, so that a very small external field is produced.

This reduces stray magnetic coupling with other coils in the receiver.

Fig. 99E shows a binocular coil. This consists of two separate coils connected in series, and having magnetic fields as shown. This also has a very restricted external magnetic field, is easier to construct, and is more efficient than the D coil.

Fig. 99 F shows a two layer bank wound coil, and Fig. 99g shows one of four layers. This type of winding is used where a large inductance is required with a small distributed capacity. Fig. 99K shows a torroidal coil. This has practically no external field.

While these and many other forms of coils have been developed for special purposes, the fact remains that for a given amount of inductance (within the broadcast frequency range) the most efficient coil is one of a simple solenoid form, Fig. 99M having a ratio of diameter to length of about 2.5. This ratio can be reduced to about 1 without seriously affecting the efficiency of the coil. On broadcast wavelengths it makes little difference whether the coil is self supporting or whether it is wound on a thin insulated form. The latter is preferable for its mechanical rigidity. It is not necessary to use wire larger than about 24 B and S gauge. No. 26 or 28 can be used satisfactorily. The design of a tuning coil of this type will be considered.

Now it is evident that for practical reasons coils must be made of a definite size and of proper rigidity. Since the position of nearby metallic objects causes losses due to absorption of energy due to the setting up of eddy currents, and interstage coupling is undesirable, the sizes and shapes of coils vary. Some coils are 3 inches in diameter, some 2 inches, and lately coils as small as 1 inch in diameter have come into extended use on account of their limited external field.

9/-
BRINGS YOU
"Modern Sets"
FOR
TWELVE MONTHS,
POST FREE.

THERE'S MONEY IN TALKIES.

(Continued from page 13.)

we require a wooden frame-work 42 inches high, 18 inches wide, and having built on to the bottom, a box 12 inches wide and 12 inches high. The frame-work will have a strengthening strip across the middle, so that the frame will be rigid. The timber used is 3 x 1 inch, white pine, for the frame, and 1 inch white pine for the box.

The panel is of 16 gauge engraver's zinc, and is screwed to the front of the frame work with semi-round headed wood screws. The panel is left its natural colour, and can be covered with clear lacquer to preserve its polish. Two brackets are screwed to the back of the framework, 7 inches from the top, and can be ordinary iron shelf brackets or wooden ones 8 inches wide. The actual shelf which is screwed to these brackets is another piece of 16 gauge zinc 18 inches x 8 inches, on which is mounted the gain amplifier. Another shelf is placed on the framework identical with the one above, except that it is reinforced with 3/8 inch pine, 19 inches from the top of the panel or 12 inches below the other shelf. This shelf houses the main amplifier. The whole of the interior of the box is lined with 16 gauge zinc including the top and bottom. Where the sides of the zinc lining join, with the exception of the lid, thin strips of copper, bent to the shape of the corners, should be soldered in order that shielding is as complete as possible, as this portion houses the power supply. The lid of the box is then taken, and two holes 3 inches in diameter are cut, both in the zinc and lid, and soldered to the zinc over these holes is either copper or zinc gauze. This is the only flaw in an otherwise perfect shield and must be done for ventilation purposes. Six holes 3/8 inches in diameter are drilled 1 inch apart both in the wood and zinc of the lid near the front panel to take filament and D.C. output wires from the power packs to their respective amplifiers.

These holes can be drilled with an ordinary wood bit, as zinc is quite soft and workable. As regards cutting the larger holes, a gadget can be constructed in accordance with the following: Take a piece of wood or a tin lid 3 inches round and drill a hole in the centre of it 3/16 inches in diameter, and pass a 2 inch bolt through it; locking it on the other side with two nuts. Make a clamp to fit round the lid or block of thin iron, bending at right angles the two ends and drilling holes to take a bolt (in accordance with diagram). Now carefully bend a hack-saw blade or portion of one round the lid or block, and secure it on to the lid or block with the clamp, leaving about half the width of the blade projecting below the lid or block. Place the bolt in the brace as you would a drill, and "drill" out the hole. This method can be applied to all sizes of holes either for aluminium or zinc even down to as

small as 1 inch in diameter. It has the added advantage that filing after cutting is unnecessary.

You are now ready to mount your components. Commence by putting the power pack into one end of the box, the power transformer nearest the panel choke next to power transformer, and the three filter condensers next to the choke, with the rectifying valve immediately in front of the power transformer. All the components can be secured with wood screws to the wood forming the floor of the box, through holes drilled in the zinc. Wire up the pack, with the exception of 2½ and 4 volt filaments, in accordance with the circuit, taking care to take one end of the high voltage winding and solder it to the base. This forms your "B" negative, and is also earthed, an earth terminal being fitted to the metal lining of this box.

On the middle shelf the main amplifier components are mounted. Four inches from either end of the shelf and directly equidistant from either side mount the sockets for the valves, the socket for the F410 at the end above the power pack, and in between the two valve sockets the choke and transformer. These should be placed at right angles to each other in order to prevent inter-coupling. (The choke should be parallel to the front panel.) The voltage divider is mounted along the back of the shelf, taking care to insulate the end that goes to the centre-tap of the 4 volt filament winding from the metal portion of the shelf. The by-pass condenser for the auto transformer can be soldered to the zinc shelf directly beneath the transformer itself. The volume control is mounted in the centre of the panel, in between the two shelves, taking care that the centre shaft is insulated by means of fibre washers, from the front panel. The remaining by-pass condensers can be soldered to the bottom of the shelf as near as possible to their respective points of duty. The

centre tap resistors are floated across their respective sockets.

Wiring.

All wiring is carried out in shielded and earthed 2 and gauge bell wire, with the exception of filament and high-voltage leads, for which purpose 16 gauge twin lead-covered copper wire is used; the lead covering to be earthed and all wires made as short as possible. The panel and shelves as well as the box lining should be joined together with heavy gauge copper wire to ensure good earthing.

Testing and Operation.

Having wired up and checked over wiring with the circuit, we now commence our testing. With the rectifier omitted, carefully measure voltages of the filaments at the valve sockets. These should read 2½ and 4 volts respectively with the valves burning.

Close the grid circuit of the 256 valve with a pick-up or piece of wire, and the plate circuit of the F410 with the speaker. Replace the 5Z3 valve and switch on the current. After allowing for the 256 to warm up, usually about ten seconds, listen at the speaker and note the hum level. It should be practically non-existent, and if pronounced indicates that something is wrong.

Observe the rectifier and see that it is not blue glowing. This is an indication of a broken-down filter condenser. If there is any apparent trouble switch off and check over wiring again. If everything seems in order, open the plate circuits of both 256 and F410, and measure plate current with a milli-ampmeter. These valves should read 5 and 45 milliamps respectively. Slightly higher readings on both valves indicate an excess of plate voltage and vice versa; but, so long as the ratio is the same and the reading not more than 2 or 3 milliamps high on the F410, there is nothing to worry about. Check over bias and plate voltages of the tubes with an electro-static voltmeter, and see

(Continued on page 26.)

Amplifiers Built to Order
or For Hire

SOUND INSTALLATIONS _____
_____TALKIE AND PUBLIC ADDRESS SYSTEMS

Microphones. _____ Precision Measuring Instruments.

_____ Consulting Radio and Sound Engineers.

F. S. GREGORY

30 Davis Street _____ South Yarra, S.E.1.



A SECOND RADIO-MILANO.

IN putting into service the new Milan transmitter, situated at Siziano, the old station at Vigentino has not been pulled down, but has been allowed to remain intact. The management of the Italian broadcasting company have now conceived the project of operating the old station by the side of the new one on a different wavelength. Now that the music cable connection between Rome and Milan has been established, it is intended to have the programmes of the Rome-Naples group of transmitters broadcast by the old station, whilst the 50-kilowatt transmitter at Siziano will as usual give the programmes of the northern group. In this way listeners at Milan and Lombardy will have the choice between two different programmes. The old transmitter at Vigentino will operate on the international joint wave of 453.2 metres (622 kc/sec), and the power will be so great that good reception is ensured throughout the entire region. Experimental transmissions have already taken place, and it is now a question of waiting for the consent of the Ministry of Communication. Should such consent be refused, the old station will be dismantled.

Roumania.

If the rumours in circulation are to be believed, negotiations are at present going on between the Roumanian Government and a group of foreign financiers with a view to building in Roumania a super-power transmitter that will pass on advertising programmes. This station is to be erected in the neighbourhood of Tamasvar, at the Roumanian-Hungarian frontier; the transmissions will be effected in all the languages spoken in the Balkans and also in French and German.

Licences in England.

The time when England and Germany vied with each other in a sportsmanlike manner to produce the greatest number of radio listeners is long since past. As a matter of fact, the number of listeners in England has increased during the last few years with such

amazing rapidity that Germany has been left far behind, and still the number of registrations in England is increasing more rapidly than in any other country. In August last year the B.B.C. were able to welcome their five millionth listener, and at the beginning of this year another quarter of a million had already been added. According to the latest official statistics, England can now show the formidable figure of 5,262,953 radio listeners.

State Broadcasting in Norway.

The Norwegian National Assembly recently carried by 91 votes to 48 a resolution to the effect that in future the control of broadcasting in Norway shall be placed entirely in the hands of the State. Although no particulars are known as yet, it is fairly certain that the compiling of programmes will be entrusted to a committee that will be responsible to the Ministry of Institution and Education. The technical management will fall within the province of the telegraph department, which belongs to the Board of Trade. Listeners' licences will, as at present, be issued by the post and telegraph offices. It is stated that efforts will be made to keep the new programme service immune from departmental influences.

Radio-Agen on the Air Again.

In March, 1930, the French private station Radio-Agen ceased operating as a result of floods. It is now stated that this transmitter has for some weeks past been heard again on a wavelength of 453 metres. The transmitting times are from 1.30 to 2.30 a.m. and from 8.30 to 9.30 p.m. daily.

Exemptions from Broadcasting Licence.

We understand that a proposal has been submitted to the Belgian National Assembly to exempt unemployed radio listeners from payment of the broadcasting licence, which for valve sets is 60 Belgian francs per year. Such exemption has already been granted in Germany and other countries.

Microphone Prohibition.

It appears that the regular cabaret performances given in English broadcast programmes are having a detrimental effect on the frequenting of "real" cabarets. At any rate, we understand that the managements of several big English cabarets have decided to forbid their artists to perform before the microphone. At first attempts were made to arrive at an arrangement with the B.B.C. by which the latter would have to pay a substantial annual amount. But the parties could not agree, and a microphone prohibition ensued.

THERE'S MONEY IN TALKIES.

(Continued from page 25.)

that they correspond with the chart shown with this article, and make adjustments of the clips until they do.

No difficulty should be experienced in either making or operating this amplifier, and if any trouble should be experienced, a note to the writer, care of this office, will give you all the information you require.

Our next article on this subject will deal with the building of the gain amplifier and some further developments of the valve amplifier, including "The Perfect Push-Pull Amplifier."

Voltage Readings.

From plate of F410 to centre tap of filament = 550 volts. Centre tap of F410 filament to the end of choke 34.5 volts. End of choke to cathode of 256, 251.5 volts. Cathode of 256 to ground, 13.5 volts. Across coupling choke, 1.5 volts.

Car, Cycle or Radio

BATTERIES ON TERMS

Payments at the rate of 1/- in the £1 per week. Delivery guaranteed the same day as order is placed. Every Battery is fully covered by the Manufacturer's Guarantee. Each inquiry receives the personal and confidential attention of one of the principals. Remember! We do not ask you to purchase any particular make of battery. You have the whole range to select from at current List Prices.

For Further Particulars, cut out and mail this advertisement to—

MORGAN & WRIGHT

35-39 Little Latrobe St., Melbourne, C.1.

If unable to write or call, 'phone F 6441.

M.S., Oct. '33.

Melbourne's Leading Radio and Electrical Stores

THE PHILIPS FOUR DESCRIBED IN THIS ISSUE.

THE PARTS THAT ARE NEEDED.

1 Philips E455 valve	18/6 ea.
1 Philips E424 valve	16/6 ea.
1 Philips E443N valve	22/- ea.
1 Philips 1561 valve	15/- ea.
2 T.C.C. 7 mfd. electrolytic condensers . .	6/- ea.
1 Filter choke (30 henry)	10/9 ea.
1 Power transformer, high tension secondary, 350 volts aside, one 4 volt 3 amp filament winding, 2 four volt 2 amp windings	18/3
1 Voltage divider (remade)	4/6 ea.
1 Marquis 10 000 ohms volume control . .	5/9 ea.
1 Stromberg-Carlson Type D condenser (two gang)	16/9 ea.
1 Velco aerial coil	4/6 ea.
1 Velco R.F. coil, with reaction	4/6 ea.
3 5-pin valve sockets	10d. ea.
1 4-pin socket	10d. ea.
1 Radiokes radio frequency choke	2/- ea.
1 Wendel electric input push-pull audio transformer	25/-
1 400 ohm bias resistor	1/3 ea.
1 700 ohm 50 mill bias resistor	1/6 ea.
1 2 megohm grid leak	1/5 ea.
1 0.5 mfd. condenser, 250 volt working . .	2/6 ea.
2 0.01 T.C.C. condensers	2/9 ea.
1 1 mfd. Chanex condenser	3/- ea.
1 10 mfd. electrolytic bias by-pass condenser	3/- ea.
2 30 ohm. C.T. filament resistors	1/3 ea.
1 Radiokes 23-plate midget condenser . .	4/9 ea.
1 Radiokes full vision Vernier dial	8/11 ea.
1 Chassis, 12 in. x 10 in. x 2 1/2 in., 16 gauge metal	10/6
1 Amplion Permanent Magnet dynamic speaker	77/6

Vealls have a radio set or a range of parts to suit every purse and purpose—that is why you are assured of satisfaction when you deal with Vealls, Melbourne, Leading Radio and Electrical Stores. Huge stocks, an efficient, courteous staff; a prompt, expert Mail Order Department—everything necessary to back our Guarantee of Utmost Satisfaction.

BIG ILLUSTRATED CATALOGUE FREE

For the benefit of those who cannot call, Vealls have prepared a big catalogue of 74 pages, with hundreds of illustrations. Write for your copy—it's free. Merely enclose a 2d. stamp to defray actual postage cost.

FOR COUNTRY LISTENERS

Vealls have a complete range of Radio Sets designed for Country Reception, or you can build your own. Here are the parts to build the—

The All Continents Battery Five

FULL CONSTRUCTIONAL DETAILS ELSEWHERE IN THIS ISSUE.

PARTS REQUIRED:

1 Philips B443 valve	21/- ea.	1 2 mfd. condenser, 250 volt working . .	4/- ea.
2 Philips A442 valves	21/- ea.	1 T.C.C. 0.001 mfd. condenser	2/- ea.
2 Philips A415 valves	15/- ea.	1 T.C.C. 0.006 mfd. condenser	2/3 ea.
1 Ferranti AF5 audio transformer	75/6 ea.	1 4 mfd. condenser, 250 volt working . .	6/3 ea.
5 4-pin valve sockets	10d. ea.	1 T.C.C. 0.02 mfd. condenser	4/- ea.
2 6-pin valve sockets	10d. ea.	2 15,000 ohm 1 watt carbon resistors . . .	1/3 ea.
1 5-pin valve socket	10d. ea.	1 500,000 ohm 1 watt carbon resistor . .	1/3 ea.
1 6-pin Marquis plug	10d. ea.	1 50,000 ohm 1 watt carbon resistor . . .	1/3 ea.
1 Radiokes three-plate midget condenser . .	2/3 ea.	1 3000 ohm wire-wound resistor (Velco) .	1/3 ea.
1 0.00025 mfd. variable reaction condenser . .	2/9 ea.	2 3 inch coil cans	1/6 ea.
2 0.00015 mfd. variable tuning condensers .	2/6 ea.	3 Ordinary valve cans	1/4 ea.
1 Screened radio frequency choke	2/- ea.	6 Banana sockets	2d. ea.
1 T.C.C. 0.0001 mfd. grid condenser	1/6 ea.	6 Banana plugs	3d. ea.
4 T.C.C. 0.01 mfd. condensers	2/9 ea.	1 Black panel	10/6 ea.
1 1 mfd. condenser, 250 volt working	3/- ea.	2 Ormond Vernier dials	11/3 ea.
		1 4 inch dial	5d. ea.
		1 Battery switch	2/3 ea.

VEALLS

243-249 SWANSTON STREET, MELBOURNE.
163-172 SWANSTON STREET, MELBOURNE.
299-301 CHAPEL STREET, PRAHRAN.
3-5 RIVERSDALE ROAD, CAMBERWELL.
Cent. 2058 (5 lines), 10524 (2 lines); Wind. 1605 and C5160.

Ken-Rad

The Fine
Valves
of Radio



ALL CONTINENTS FIVE.
(Continued from page 10.)

On actual test no hand capacity or fringe howl was experienced throughout the tuning range, and stations, when once tuned in, remained steady while the headphone or speaker cords were held in the hand.

The fringe howl worries have been overcome by the use of a resistance coupled unit. Take particular notice of the layout of the components, and when wiring see that all battery and earth wires are as near to the chassis as possible, while those carrying high frequency currents should be kept at least half an inch above the metal. Where wires come through the chassis, drill rather larger holes, so as to reduce capacity losses, and prevent short circuits to the metal chassis.

Another point that requires stressing is that eighteen gauge tinned copper wire with spaghetti sleeving has been used throughout to ensure absolute rigidity which is necessary when the detector is on the verge of oscillation.

Porcelain bushings have been used everywhere where a wire comes through the chassis.

To insure short, good and definite earth connections a brass chassis and panel shield have been used.

The panel, which comprises a brass shield and a piece of bakelite, is edged with a brass channel and held firmly to the chassis by brass brackets. The whole job is nickel-plated, which gives a very imposing appearance and lasting finish.

Technical Details.

Briefly the receiver comprises one stage of untuned radio frequency amplification, followed by one tuned stage of R.F., which is transformer-coupled to the detector.

The detector is followed by a resistance-coupled first audio, which is transformer-coupled to the output pentode.

The valves used are as follows: V1 and V2 are Philips A442 screen grid valves, V3 and V4 are A415's, and the output pentode V5 is a B443.

The output valve and the first audio are provided with automatic bias, which dispenses with the C battery.

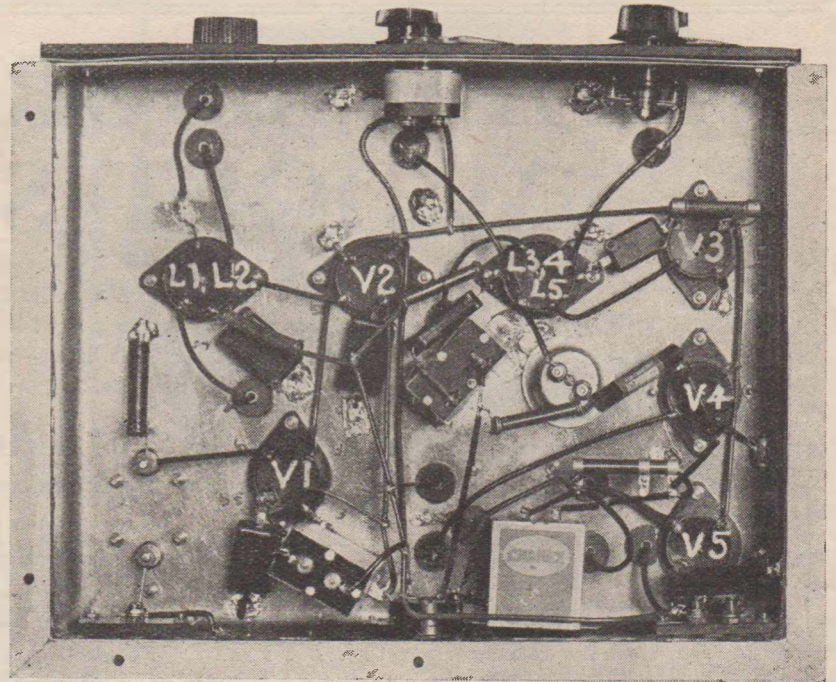

In this sub-chassis view, note how carefully the components have been laid out to permit the shortest leads possible.

The bias voltages are obtained from the 1000 ohm wire wound resistor R7. The C— end of R6 should be tapped on near the earthed end of R7.

The wave range is approximately from 19 to 85 metres, covered by three six-pin plug-in coils for the detector, and three five-pin plug-in coils for the R.F. stage.

Looking at the top view of the chassis, we have nearest to us the tuning condenser C2 of the R.F. stage, which is fitted with a 4 inch dial. Next to this in the centre of the panel is the reaction condenser C6, which is fitted with a vernier dial. The furthest condenser at the other end of the panel is the detector tuning condenser C3, which is also controlled by a vernier dial. Directly below this is mounted the two-plate midget trimmer or note splitter condenser, C4. The battery

switch S1 is mounted on the panel directly below the reaction condenser.

The layout of the valves and the coils can be clearly seen from the sub-chassis view. Note that C4 is used as an additional vernier when tuning in weak stations.

At the back of the chassis we have two square windows about one and a half inches by one and a half inches, and behind these are mounted pieces of ebonite to carry the banana sockets for the aerial, earth and two sets of headphones and speaker.

Looking down underneath the chassis the aerial and earth leads are brought in at the left end, and the phones at the extreme right end.

The battery leads are connected to a six-pin Marquis plug, which plugs into a six-pin socket mounted centrally in the back of the chassis.

The aerial coupling condenser C1 which adjusts the selectivity and signal strength, is constructed in the usual way from two copper or brass discs about the size of pennies mounted on cats' whisker arms.

These arms move through two double terminals mounted on stand off insulators, and when the correct distance between the plates is found they are clamped by means of the thumb screw on top.

The coils L1 and L2 are wound on 5-pin formers, so that they cannot get mixed up with the six-pin detector coils.

Note that the grid leak return is connected to the A+, this-connection

(Continued on page 33.)

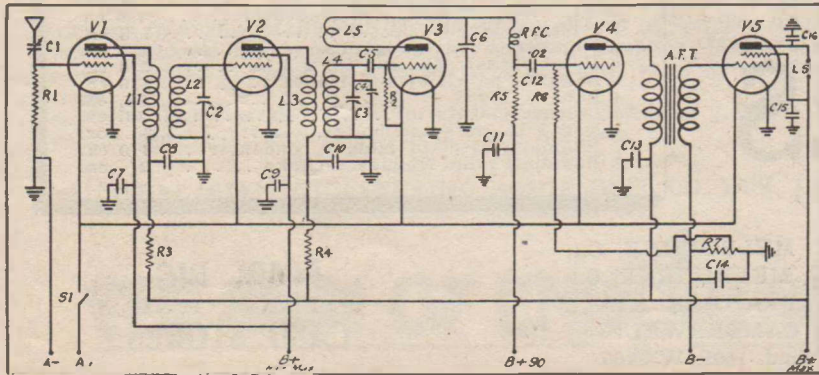

The schematic diagram of the "All-Continents Battery Five," which is key-lettered to agree with other constructional details provided.

BUILD YOUR OWN MIDGET SET!

To-day is the day of the "midget" set—a radio that can be carried from room to room, home to home, when you visit your friends. . . . See the Midget Receiver described in this issue—build one for your own convenience.

PARTS REQUIRED :

A MIDGET SUPER. FOR THE HOME CONSTRUCTOR.

1 Stromberg-Carlson 2-gang condenser, .0005 mfd. per section	16/9 ea.	1 100,000 ohm 1 watt carbon resistor	1/3 ea.
1 Velco padder condenser	4/3 ea.	1 250,000 ohm 1 watt carbon resistor	1/3 ea.
1 T.C.C. 0.002 mfd. condenser	2/- ea.	1 100,000 ohm 1 watt carbon resistor	1/3 ea.
2 0.5 mfd. paper non-inductive condensers, 400 volt working	4/8 ea.	1 400 ohm wire-wound resistor	1/- ea.
3 0.1 mfd. paper non-inductive condensers, 400 volt working	1/2 ea.	1 Velco Aerial Coil and can	4/6 ea.
2 0.01 mfd. mica condensers, C14	2/9 ea.	1 Velco Oscillator Coil and can	4/6 ea.
1 0.001 mfd. mica condenser	2/- ea.	2 Velco I.F. transformers with condensers, L5, L6 (can)	27/- ea.
2 8 mfd., 450 volt electrolytic condensers (Concourse)	6/6 ea.	1 Jensen Midget 1300 ohm dynamic speaker FC (To match 2A5 valve)	26/6 ea.
1 5000 ohm resistor (carb.)	1/3 ea.	1 Power Transformer	22/6 ea.
1 400 ohm resistor (Velco)	1/- ea.	4 Velco 6-pin sockets	10d. ea.
1 10,000 ohms pot. volume control	4/9 ea.	1 Velco 4-pin socket	10d. ea.
1 10,000 ohm 1 watt carbon resistor	1/3 ea.	2 57 valves, either Ken-Rad or Radiotrons	17/- ea.
1 10,000 ohm 1 watt carbon resistor	1/3 ea.	1 58 valve, either Ken-Rad or Radiotron	17/- ea.
1 15,000 ohm 1 watt carbon resistor	1/3 ea.	1 2A5 valve, either Ken-Rad or Radiotron	17/6 ea.
1 250,000 ohm 1 watt carbon resistor	1/3 ea.	1 280 valve, either Ken-Rad or Radiotron	14/- ea.
		1 Chassis, 12 in. x 6 3/4 in. x 2 1/2 in.	9/6 ea.
		1 Rad. R.F. choke	2/- ea.
		1 Essanay 6-pin valve shield and top	1/9 ea.

Here are the Parts Required for the COSSOR One Valver

VISIT VEALLS

Every one of Vealls Four Big Stores is packed with thousands of Radio and Electrical items of interest. Visit Vealls—inspect the enormous range that awaits your choice—all brand new, up-to-date stock, bought by experts to suit your most exacting needs.

Call at your convenience. You will not be pressed to buy.

VEALLS

(ARTHUR J. VEALL PTY. LTD.)

243-249 SWANSTON STREET, MELBOURNE, C.1.
 168-172 SWANSTON STREET, MELBOURNE, C.1.
 299-301 CHAPEL STREET, PRAHRAN, S.1.
 3-5 RIVERSDALE ROAD, CAMBERWELL.
 'Phones: Cent. 2058, 10524; Wind. 1605, W 5160.

THE COSSOR ONE VALVER

THE PARTS THAT ARE NEEDED.

1 Cossor 410 L.F. valve, V1	15/- ea.
1 Velco 0.0005 mfd. condenser	6/11 ea.
1 4 inch dial	5d. ea.
1 Marquis 4-pin socket	1/- ea.
1 Marquis ribbed coil former	1/3 ea.
1 H. & H. battery switch	2/3 ea.
1 T.C.C. 0.00025 mfd. grid condenser	1/6 ea.
1 2 megohm grid leak	1/5 ea.
1 2 oz. reel No. 32 gauge d.s.c.	2/2 ea.
1 Metal chassis, 6in. x 5 in. x 2 in.	6/6 ea.
1 Bakelite panel, 6 1/2 x 5 inches	1/9 ea.
4 Banana plugs	3d. ea.
4 Banana sockets	2d. ea.
1 Doz. 1/4 in. nuts and bolts	6d. doz.
1 Radiokes 23-plate midget condenser	4/9 ea.
1 Radiokes radio frequency choke	2/- ea.

FOUR BIG CASH STORES

BUILD YOUR OWN MIDGET.

(Continued from page 5.)

condenser to about 15 degrees in, and then adjust the oscillator trimmer to bring in 3AW, following up with adjustment of the R.F. trimmer for best results. Now turn to the top of the condenser and adjust the padder for best reception of 2CO, rocking the condenser while adjusting the padder. Finally, return to 3AW and reconnect the oscillator trimmer if necessary. For those who have an oscillator, it may be mentioned that the 1F frequency is 460 k.c.

For more complete specifications of the components specified, write to the Essanay Manufacturers at 54-60 Buckhurst-street, South Melbourne.

Since any set is not really completed until fitted into a cabinet, the builder can obtain a very neat Essanay cabinet to finish the job.

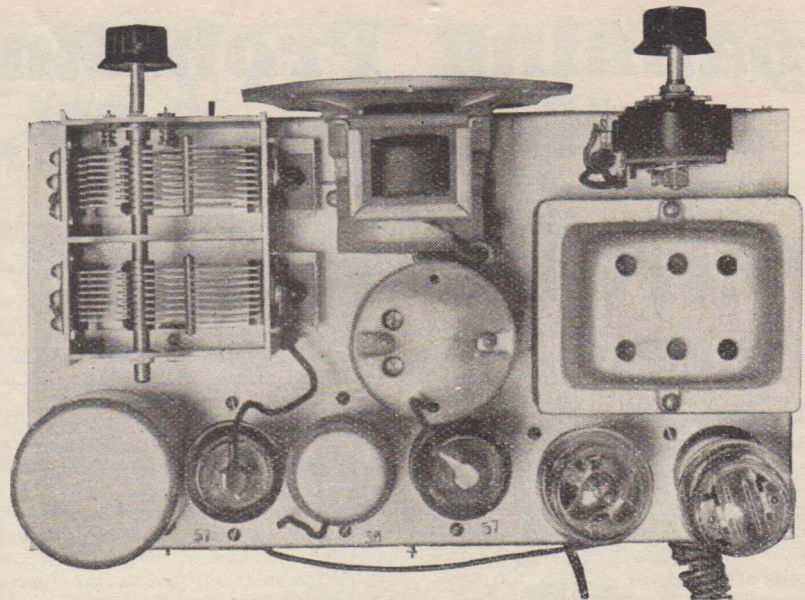

Looking down on the completed mid get. Note how compact and neat the components are.

THE PHILIPS FOUR.

(Continued from page 9.)

loudest volume. Now turn to 3AR or 2CO, at about 90 on the dial, and adjust the volume control until you can hear station quite comfortably. Re-adjust trimmers for maximum signals. Next turn back to 3AW and again adjust trimers on the condensers, C1 and C2. Do one at a time, and be sure you get same adjusted correctly, the

result of which should be to tune stations at full volume to any position on the dial.

Operated in the suburbs and near country districts, this outfit will separate and bring in all the local broadcasters at full speaker strength. The

best of the inter-State stations can also be heard at good speaker strength.

If located in the country, the set will definitely receive all A class stations at good speaker strength if an efficient aerial is used.

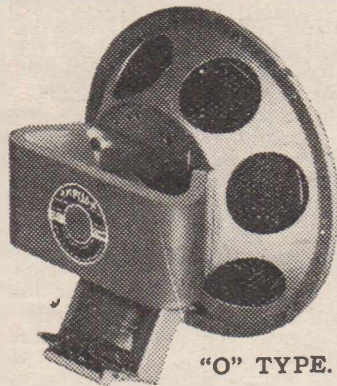

"O" TYPE.

PRICE:

Type "O", £3/17/6

Type "L", £5/0/0

Write for free copy of Bulletin No. 12, giving details of Amplion Permanent Magnet Dynamic Speakers; also chart showing Amplion Matching Transformers required to match up with any type of output valve on the Australian market.

Descriptive Bulletins also gladly forwarded, giving details of Amplion Electro Dynamic Speakers, Giant Exponential Horn Speakers, etc.

VICTORIAN DISTRIBUTORS:

AUSTRALASIAN ENGINEERING EQUIPMENT CO. PTY. LTD.,
415 Bourke Street, Melbourne, C.1.

AMPLION

"O" and "L" type Permanent-Magnet Dynamic Speakers
For use with all types of Battery-Operated and All-Electric Receivers

Thousands already Sold are giving Reproduction from SMALL BATTERY SETS comparable in Volume and Quality to Powerful A.C. Sets. Modernise your set by fitting this Speaker and obtaining perfect dynamic reproduction. The fitting of Amplion "O" or "L" Speakers definitely and permanently eliminates the hum problem.

MAGNET BY

Darwin

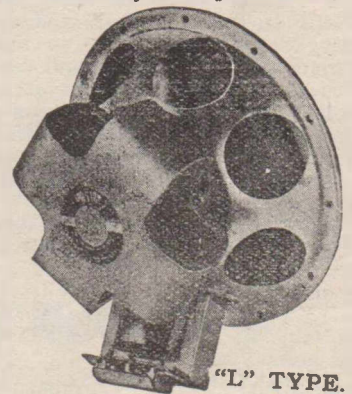

"L" TYPE.

THE SIGN OF ENDORING QUALITY

ADVERTISEMENT OF SPEAKERS (A/sia) LTD., 70 CLARENCE ST., SYDNEY.

Spanning Problem As Affecting S.W. Receivers

An Article Which Should be of Interest to All Short-Wave Listeners

By WILLIAM H. EASTLAKE.

THE diverse spans of frequencies in short-wave tuning have been given considerable attention by amateurs, who build or buy band-spreading sets, so that the particular bands they are interested in may be tuned in more conveniently, because being spread over a large part of the dial.

In short-wave sets generally, where four coils are used for each circuit, and the condenser is around 0.00014 mfd., the frequency ratio is the same for all bands, usually about 2.2. Thus the frequency span for the lowest-frequency spectrum is 1500 to 3300 kc, a difference of 1800 kc, whereas in the highest-frequency band, same ratio of frequency, the absolute extremes are 15,972 and 35,138 kc, a difference of 19,166 kc, or the frequencies covered are nearly 10.7 times as great as in the first instance.

As the handiest aid to helping to atone for this a dial of large reduction ratio may be used, say 30-to-1, instead of the usual 5-to-1. Parallel condensers may be inserted, usually the adjustable type, to reduce the capacity ratio, hence frequency ratio, but if calibration is of any importance this method is not so good, because you can't have a satisfactory calibration of an unknown, can you?

Padding on Two Bands.

If the setting of any band-spreading effect capacity is determined by a scale position, then it would be necessary, for exactitude, to have a built-in single frequency separate oscillator, so that any variation from the scale point may be compensated by trimmer setting.

The local oscillator of a short-wave superheterodyne would have to be padded for the first or lowest-frequency band, perhaps also for the next, but not for the succeeding ones, if popular intermediate frequencies lower than the lowest broadcast frequency are to be used.

The situation with the four-coil system may be visualised from the following table for the fixed ratio frequency, normally 2.2:

Extreme Signal Frequencies	Frequency Difference
1,500 to 3,300 kc	1,800 kc
3,300 to 7,260 kc	3,960 kc
7,260 to 15,972 kc	8,712 kc
15,972 to 35,138 kc	19,166 kc

The frequency span is equal to the low-frequency setting multiplied by the

frequency ratio, and as the low-frequency extreme is always a higher frequency as smaller coils are used, the difference mounts rapidly.

Use of 10 Coils per Circuit.

Certainly it would be advisable to have a better spread than that denoted by the tabulation, which is close to what exists in actual practice.

One limitation is the number of coils, whether plug-in coils or switching is used.

Instead of having a fixed frequency ratio, the difference between maximum and minimum frequencies may be fixed. This is equivalent to bandspread on all bands. A computed instance indicates that ten coils would be needed for each circuit, and, of course, at such a handicap the circuits would be limited to two.

Since the frequency span is fixed, say, at 3000 kc., the ratios will have to differ. Let us see from a table what the change would be:

Extreme Signal Frequencies.	Ratio
1,500 to 4,500 kc	3.
4,500 to 7,500 kc	1.67
7,500 to 10,500 kc	1.43
10,500 to 13,500 kc	1.29
13,500 to 16,500 kc	1.222
16,500 to 19,500 kc	1.18
19,500 to 22,500 kc	1.154
22,500 to 25,500 kc	1.133
25,500 to 28,500 kc	1.118
28,500 to 31,500 kc	1.1

Series and Parallel Capacities.

The ratio as between the first and second examples of the variable-ratio table is practically halved, but thereafter the ratio reduction is gradual. The situation suggests that a regular broadcast capacity, 0.00035 mfd. or so, be used for the lowest-frequency band, reduced by series capacity for the next step, to reduce the ratio, and thereafter that the ratio reduction be attained by a parallel capacity, be manually operated, and to make a frequency-calibrated dial effective, the built-in extra oscillator would be virtually imperative, to check up each time on the correct extra parallel capacity.

Instead of the awkward capacity jump from the first to the second bands, the even distribution of spans by 3,000 kc could be disregarded in the one instance, and the low-frequency band split into two bands, which is entirely

contrary to the principle of equal frequency difference, and gives most spreadout where least is needed, but does permit parallel capacity padding throughout, and the use of the physically small tuning condensers now so popular for short waves.

Single Calibration of Dial.

If frequency calibration is to be adhered to, naturally the problem becomes a little more difficult, but a built-in oscillator would facilitate this. It would oscillate at one frequency and be used on its fundamental and harmonics for setting the parallel or spanning condenser to the accurate position, which would be somewhere close to a marker position. Even the markers could be worked out to a fair degree of accuracy, without the extra oscillator.

If the even-frequency-span method is adhered to, the signal frequency and oscillator frequency dials may be calibrated with a single scale, say the lowest frequency, with a reference table giving the multiplication factor. This would be true even in the case of ganging. Thus for the 1500 to 4500 kc band the factor would be 1, for the 4500 to 7500 kc band it would be 3, for the 7500 to 10,500 kc band it would be 5, for the 10,500 to 13,500 kc band it would be 7, etc., and for the last or highest frequency band it would be 19. Any splitting up of the low-frequency band as compared to the table would upset this handy calibration for two bands.

Low Fixed Ratios.

Another way out would be to use a fixed ratio of frequency, but have it a low ratio, so as to effectuate a compromise. Thus, the numerical average of the ratios of the preceding table of frequencies (the sum of the ratios divided by the number of bands) is very nearly 1.3. This would dispense with the complication of series of parallel padding, but would not be a band-spread approximation. Also, there would have to be a separate calibration for each coil, as the difference in frequency will increase as the frequencies of the bands increase.

The frequency ratio of 1.3 would require a capacity ratio the square thereof, or 1.69, or, assuming a minimum capacity of 30 mmfd., the maximum would have to be 0.0000507 mfd., or approximately 50 mmfd. Thus, the tabulation would show that the lowest band would be 1500 to 2900 kc,

THE ALL CONTINENTS BATTERY FIVE.

(Continued from page 29.)

gives greater signal strength than a direct earth.

R1 is a 3000 ohm resistor connected between the grid of V1 and earth. This arrangement makes a non-resonant aerial circuit which greatly improves the general stability near the verge of oscillation.

R3 and R4 are 15,000 ohm decoupling resistors connected in the high tension plate leads of V1 and V2.

A value of approximately 50,000 ohms was found best for the plate resistor R5, and 500,000 ohms for the grid leak R6.

It is interesting to note that when the primary of the Ferranti transformer was connected as specified by the manufacturers, severe motor boating resulted, but on reversing the connections everything worked well, and no feed-back was apparent.

Screening the Coils.

A few other points which will be of assistance to those who intend to construct a similar receiver are:

The chassis measures 13½ inches in length, 12 inches in width, and 3¼ inches in depth. The coil screens are made of aluminium, and are three inches in diameter and 4½ inches in height.

It might be thought that these screens would not be necessary on a short wave receiver. However, they help in the general stability quite a lot, and also prevent induced low frequency R.F. (power line interference) from getting into the grid circuits, should the set be used near an AC line.

The two R.F. valves and the first audio valve are provided with shields also.

The shield on the first audio valve was necessary to prevent interaction between it and the detector. If the detector is screened a loss in signal strength is noted.

Coil Data.

All coils are wound on Marquis ribbed formers, five pins being used for the R.F. coils, L1, L2, and six pins for the detector coils, L3, L4, L5.

Windings L2 and L4 consist of 24 gauge double silk covered wire, while L1, L3, and L5 are wound with 30 gauge d.s.c. wire. Spacing between the windings L4 and L5 is 1/8 inch.

The coupling primary L1 is wound alongside L2, about 1/32 inch away.

The coupling primary L3 is wound one half alongside the grid coil L4, and the other half between the end turns of the grid coil, forming a tight coupling.

Wave Band	Number of turns.				
	L1	L2	L3	L4	L5
45 to 48 metres	12	16	12	16	9
26 to 45 metres	8	10	8	9½	7
18 to 30 metres	5	5½	5	5	5

Operation.

Tuning is done on the condensers C2 and C3, the most critical being C3. Both condensers are turned together (Continued on page 34.)

THE NEW

SUPER-PHONIC RADIOTRONS

BRING 266 TONES OF RADIO TO LIFE!

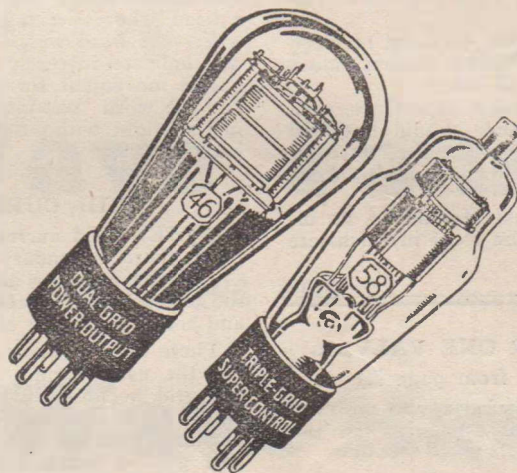

To-day—hear at last what you have missed—hear REAL MUSIC on the Radio! Hear the amazing difference! 266 tones of the orchestra, formerly "lost in the air," bring their added richness, mellowness, thrills and glamour to stirring music produced by the latest audio circuits made possible by the complete line of new SUPER-PHONIC RADIOTRONS.

THESE 266 "SILENT TONES" BROUGHT TO LIFE BY THE NEW SUPER-PHONIC RADIOTRONS.

- 29 "Silent Tones" of the Piano.
- 35 "Silent Tones" of the Trombones.
- 29 "Silent Tones" of the Harp.
- 19 "Silent Tones" of the Saxophones.
- 8 "Silent Tones" of the Cello.
- 30 "Silent Tones" of the Bassoons.
- 7 "Silent Tones" of the Piccolo.
- 30 "Silent Tones" of the Tubas.
- 7 "Silent Tones" of the Kettle Drums.
- 17 "Silent Tones" of the Bass Viol—and 55 "Silent Tones" of other musical instruments.

EQUIP YOUR RECEIVER WITH THE AMAZING NEW SUPER-PHONIC RADIOTRONS.

RADIOTRONS

ASSOCIATED GENERAL ELECTRIC SUPPLIES CO. LTD.,
 93-95 Clarence Street, Sydney.
 Corner Queen and Little Collins Streets, Melbourne, C.I.
 AMALGAMATED WIRELESS (A/SIA) LTD.,
 47 York Street, Sydney.
 167-9 Queen Street, Melbourne.

(Advertisement of Amalgamated Wireless Valve Company Ltd.)

ALL CONTINENTS FIVE.

(Continued from page 33.)

so that the two tuning circuits are kept in resonance. Tuning on C2, however, is broad and not at all critical, so that it becomes more of a volume control.

When looking for stations turn the reaction condenser C6 until the detector just begins to oscillate. After the station is located, reduce the amount of regeneration until the reception becomes clear, then centre up the carrier by means of the two plate trimmer.

For our tests we used 120 volts of Ever-Ready B batteries, the full voltage being applied to the B max. terminal.

The B+ half max. terminal received 60 volts and the detector various values between 60 and 90 volts.

After a few weeks' experience with this receiver, listeners should have no difficulty in bringing in the powerful overseas stations during their maximum periods.

Operated at East Melbourne, no interference from the local broadcasters was experienced.

THE COSSOR ONE VALVER.

(Continued from page 7.)

ly and neatly, otherwise you will not be able to get all the turns on the former.

Operating the Set.

After connecting up the 60 volt "B" battery and the 4½ volt "A" battery, the aerial, earth and 'phones are plugged in, and the filament switch turned on. Now turn the reaction condenser until the detector valve is oscillating. Then turn the tuning dial until a whistle is heard. Turn the reaction condenser back until the whistle disappears, and the station will come in clearly with a slight alteration of the setting of the tuning condenser.

To avoid interfering with neighbouring receivers, do not let the set howl; it is a good plan to bring the valve out of oscillation when you just start to tune the station in.

TUNING METER "BACKWARDS.

IN a set that I built I have put a tuning meter, but it reads the wrong way. There is a direction printed on the meter scale saying, "Tune for maximum deflection," and the arrow points one way, but I have the meter in the plate circuit of a 55, and the meter should be tuned for minimum deflection. I cannot reverse the meter, as it would not read (goes from 0 to less than 0). What shall I do?

You may remove the rim of the meter and slide the "works" out of the case, get some Chinese white and effectively hide the head and tail of the arrow, and with a sharp pencil draw in a head where the tail was, and a tail where the head was. Then the arrow will indicate correctly the direction of needle movement for greatest volume, and the word "maximum" may be read in that light without slight tax on the imagination.

GRID CURRENT.

WHEN grid current is flowing, is there secondary emission in a tube from its plate circuit, or is the grid supplied directly from cathode and acting as anode of a rectifier?

There may be some of both actions, but the usual condition meant is that the grid becomes like the anode in a rectifier, the positively-charged element during the rectification cycle. When that grid is negative and the cathode positive no current flows and no rectification takes place.

* * *

55 AS V.T.V.M.

IS it possible to use a 55 in connection with a vacuum tube voltmeter, so that I can use the device for a-c measurements, and if so should the triode unit be used or not?

It is quite practical to use the 55, as the diode units provide linear rectification. This takes place not in the entire region, but over a good part of it, say, from 5 to 20 volts, which would be sufficient for calibration for a-c within those ranges. For the higher voltage parts of this scale the load

resistor current alone may be read, and the calibration run that way, whereas for lower voltages the triode may be cut in, due to its amplification, and a plate circuit meter used. It does not make much difference whether the diode is used alone or in connection with the triode, so long as the coupling is direct (non-reactive). The triode is not linear, of course, but even that is not so important, because the calibration would take into account the non- or to put it differently, the average voltages read would be calibrated in terms of r-m-s input values, and these would be the values even though the curve when plotted will not be a straight line.

WE
SHALL
BE
PLEASED
TO
WRITE
PERSONALLY
TO
THOSE OF OUR
READERS
WHO
REQUIRE
A WORTHY, LENGTHY
ANSWER TO THEIR
PROBLEMS
THAN SPACE
ALLOWS IN THESE
COLUMNS.
SEND 1/-
IN POSTAL NOTES
OR STAMPS
TO COVER NECESSARY
EXPENSES.

Vertical or Horizontal Mountings.

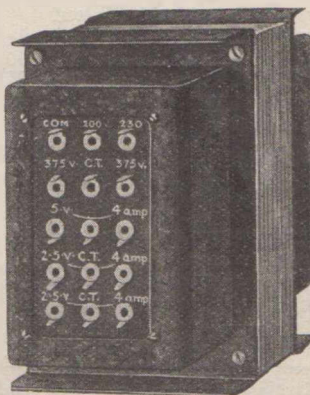

BUILT FOR RELIABILITY AND PERFORMANCE.

"WENDEL TRANSFORMERS"
QUALITY PRODUCTS.

Power, B Class, O.P., and I.P.P.P. Transformers. Filter and Coupling Chokes. Power Laminations and Press Work.

Consult us for special windings of all kinds, including Resistances.



The I.P.P.P. Transformer.

WENDEL ELEC. CO. Pty. Ltd.

14 St. Francis St., Melbourne. F 6917.

Opp. Myer's, Lonsdale St.

DO YOU WANT

DISTANCE?

WELL, YOU

Short Wave Fans

SEND YOUR SHILLINGS ALONG FOR

**The Short Wave Hand
Book**

1/- Post Free

100 Pages Brimful of the Latest A.C. and D.C. Sets — Call Signs — Overseas Programmes — All the Short Wave Information.

Published by

MODERN SETS

48a Queen Street,
Melbourne

MODERN SETS,
48a Queen Street, Melbourne.

Please send me.....copies of the Short Wave Handbook, for which I enclose.....in Postal Notes or Stamps.

Name.....

Address.....

"The stumps scores were won by 'Dainty Girl' at 10 to 1"



It probably happens to you. Just as you are listening to some piece of interesting news another station, which you have not quite succeeded in tuning right out, suddenly increases in volume and "drowns" what you want to hear.

When that occurs it's time you changed your valves. Worn out or inefficient valves are generally the cause of "cross modulation" in a receiver, and it is this "cross modulation" which results in overlapping stations and difficult tuning.

Replace those inefficient valves with Cossors — the modern valves designed for modern broadcasting conditions. Cossors will restore your set's efficiency and end your wireless worries.

...one more reason why you should **CHANGE TO COSSORS**



For the "COSSOR ONE VALVER" described in this issue of "Modern Sets" the following Cossor Valve is specified.
THE COSSOR 410LF 15/-

Wholesale Distributors:
W. G. WATSON & CO., LIMITED
 398-400 POST OFFICE PLACE,
 MELBOURNE, C.I.

14. Rep. for A. C. Cossor Ltd., London
 C. L. MacLurean 26 Jamieson Street, Sydney

COSSOR
 100% BRITISH
VALVES