

THE RADIO CONSTRUCTORS' GUIDE

*Trumble
Hend
p 26*



HERE'S WHY THE NEW DIAMOND

Tripledynne

is To-day's Most

Sensational "B" Battery

★ Same size and price as other older types, but with greater capacity, Diamond Tripledynes offer **TWICE** the power and **TWICE** the punch!

★ Sealed both inside and out, and sold by the thousand, every Diamond Tripledynne reaches you **FRESH**, ready to give you the fullest measure of service no matter where you live.

Diamond engineers and chemists spent years perfecting this sensational new Radio Battery—but only a test in your own radio can show you exactly how much better the Diamond Tripledynne Radio Battery is over other older types. Built according to a new and exclusive formula, it is capable of a much longer period of useful service, cutting down the cost of running your set enormously. In addition, you will find that Diamond Tripledynes pep up the volume and range of your set, making your radio twice as good as it is now. Sold everywhere.



T3

AND FOR A BRIGHTER WHITER LIGHT—
Reload your Torch with
DIAMOND TORCH REFILLS



D7T



C5 with desk stand



D9T



A.G. with desk stand

"AMERICAN" Microphones Of Quality

AS USED IN THE ASSEMBLY HALL
OF THE LEAGUE OF NATIONS

Standard equipment with the majority of
leading American amplifier manufacturers.

Select your Microphone requirements from the range of American
Models as listed below. Technical information on request.

PRICES AT HEALINGS

Model	Type	Impedance (ohms.)	Output (D.B.)	Directivity	Retail Price	Model	Type	Impedance (ohms.)	Output (D.B.)	Directivity	Retail Price
D5T	Dynamic	500	-55	Semi-Dir.	£8/17/6	A.G.	Crystal	125,000	-52	Semi-Dir.	£7/7/6
D9T	Dynamic	10,000	-56	Uni-Dir.	£10/5/-	B9	Crystal	125,000	-54	Semi-Dir.	£6/10/6
D7T	Dynamic	10,000	-56	Semi-Dir.	£6/5/-	B7	Crystal	125,000	-54	Non-Dir.	£6/10/6
D7T	Dynamic	500	-56	Semi-Dir.	£6/5/-	A1	D.B. Carbon	400	-38	Semi-Dir.	£12/10/-
C5	Crystal	65,000	-54	Non-Dir.	£7/7/6	CD4	D.B. Carbon	400	-35	Semi-Dir.	£4/17/6
						EL4	D.B. Carbon	400	-32	Semi-Dir.	£2/12/6

COMPLETE RANGE OF FLOOR AND DESK STANDS AVAILABLE

PAILLARD GRAMO MOTORS

Why not completely electrify that radio-gramophone receiver of yours by installing a Paillard Gramo-motor. Silent in operation and designed to give a strong, even driving torque at 78 r.p.m. Paillard Electric Gramo motors are available in two models.

PAILLARD MODEL 4004. — Single speed A.C. induction motor complete with 12in. turntable and speed regulator. Price **£4/10/**
PAILLARD MODEL 6004. — Single speed A.C.-D.C. commutator motor, complete with 12in. turntable and speed regulator. Price **£5/10/**

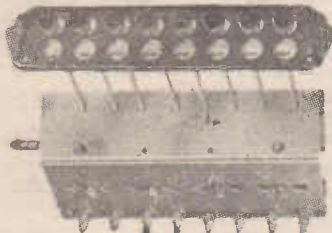

The "CROWN"
PERMATUNE
Press Button Tuning Unit
Usually 79/6 each
HEALINGS PRICE . 69/6
(T)

Tuning Unit. Easily fitted — only five wires to connect. Simplifies tuning—just "Press a Button, there's your Station." Dial tuning is in no way affected.

A recent census of radio listeners revealed the remarkable fact that the majority of listeners spend about 90% of the time listening to the one station — due probably to the trouble required to tune the average receiver, simple as it is. This, in itself, is sufficient indication of the value of "Press Button" Tuning. To be able to just press a button and receive a desired programme must be many a listener's idea of the "perfect radio."

"Press Button" Tuning may be regarded as the lazy man's method, but there are many more features, than just ease of tuning, for the average listener, although probably capable of correctly tuning-in a receiver 99 times out of 100, fails to do so. Therefore, being incorrectly tuned it is impossible to obtain the best results from the receiver. This is especially so with the high fidelity receivers which require very accurate tuning. By using "Press Button" Tuning it is possible to obtain absolutely perfect tuning on ANY station to which it is adjusted. In difficult locations, a "CROWN" PB8/ST Tuning Unit provides better selectivity and sensitivity than the original receiver, as each station is individually aligned for best results.

WRITE OF FREE INSTRUCTION CHART for Fitting to Standard Receivers.

Healings
261 SWANSTON STREET,
MELBOURNE

Phone Cent. 2064. Mail Order Specialists
Wholesale Distributors: A. G. Healing Ltd., 167 Franklin St., Melbourne.

CROWN RADIO FD6 "G" DIALS

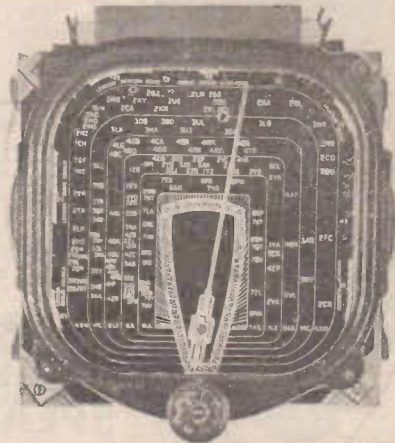

FD6G—"Acid-etched" D/W
Price at Healing's, each **27/6**
(T)

This magnificent dial is ideal for the amateur or serviceman for use in modernising sets which have an old type of dial. Fitted with easy friction drive, providing a 180 degree movement, thus allowing simple gang mounting without the necessity for gang-mounting brackets. The Glass Scale is beautifully acid etched in four colors, resulting in a brilliantly illuminated "Sunrise Effect," whilst the escutcheon design provides protection for the cabinet front from finger nail scratches when tuning in.

Values to Prove
HARTLEYS
 Leadership in
ELECTRICAL GOODS
 Radio Parts and Accessories



Cosmocord Gramo-Motor

Model A7/MP — latest type motor with high constancy of speed. Special anti-microphonic suspension on steel base plate, with fully automatic stop, speed control, and 12in. turntable. Voltage adjustments are easily made from top of base plate. For A.C. operation. 100/250 volts, 50 c/s.

67/6

COSMOCORD Crystal Pick-Up

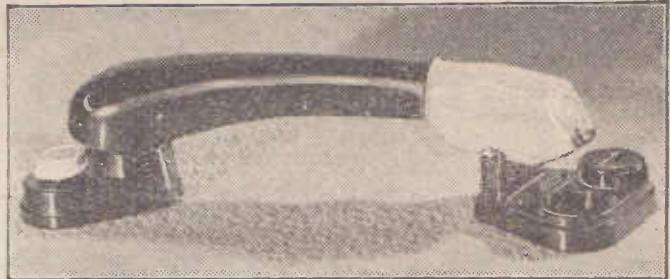

A high quality Crystal Pick-up of sterling English make. Swivel type head which simplifies the fitting of needles.

67/6

Now Distributors of the world-famed
AMPLION SPEAKERS

Hartleys are proud to present an entirely new range of Electrically Welded Amplion Speakers, which fully maintain the high standard of efficiency and quality synonymous with the name Amplion. The five new "V" Series give performance which is positively amazing yet are offered at popular prices. Call at Hartleys and inspect these remarkable instruments.

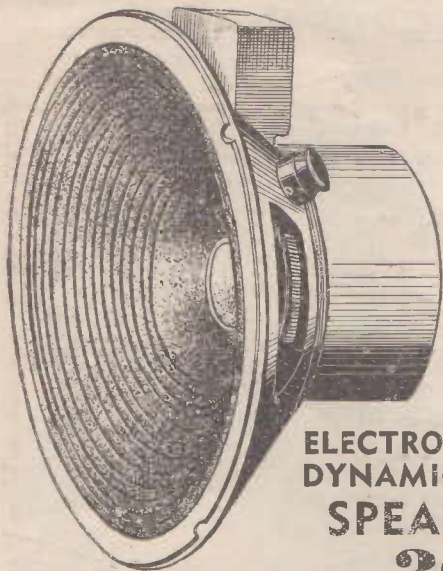

12in.

ELECTRO-DYNAMIC SPEAKER
36/-

Model	Electro Magnet Types			Price
	Usual Dia.	Undistorted Output	Max. Output	
V	12 1/2 in.	10	15	£1 15 0
VL	12 3/4 in.	13	20	£2 7 6

Model	Permanent Magnet Types			Price
	Usual Dia.	Undistorted Output	Max. Output	
VP1	12 1/2 in.	8	12	£2 7 6
VP2	12 3/4 in.	12	18	£2 18 6
VP3	12 3/4 in.	20	30	£5 10 0

Bulgin Panel Bracket Fitting



Soundly made fitting; suitable for Amplifiers, Transmitters, etc. Type D7 Red, D35 Green, D36 Blue.

2/6

Silvatone Special Voltage Dividers

Dividers of first quality wound on heavy boiler glass tubes, wound with Eureka wire.

15,000 Ohms **2/9** 25,000 Ohms **3/9**

ELECTRON NOISELESS AERIAL

A fine Aerial Kit made by one of the leading English houses. Results are amazing. This Aerial eliminates those troublesome noises and crackles which spoil broadcast or short wave reception.

27/6

Bulgin Section Wound H.F. Choke

A highly efficient Choke for modern sets. Special low loss construction on "Ceramide" former. 8W68, 2100 M.A., 167 M.A.

4/6

Bulgin Knobs & Indicator Plates

I.P.8 Indicator Plate K.18 Knob with White Pin Line

1/-

1/3

HARTLEYS

Flinders St. (Opp. Station) and 148 Swanston St.

INDEX

	Page		Page
"A," "B" and "C" BATTERIES	56	I.F. ALIGNMENT	49
Aerials	24	I.F. Transformers	22
Alignment	48	LAY-OUT, CHASSIS	10
Assembly Hints	9	Loudspeakers	50
A.V.C.	59	MAINS AERIALS	24
BATTERY SET FAULTS	28	Mileage Chart	58
Battery-less Set Wiring	62	NOISE REDUCING AERIALS	24
By-pass Condensers	19	OSCILLATION	27
CHASSIS CONSTRUCTION	8	Oscillator Coils	21
Chokes, Filter	14	PADDING CONDENSERS	18
Circuit section	29	Pick-Ups	53
Coils	20	RECEIVER ALIGNMENT	48
Condensers	18	Resistor Load Ratings	16
DIRECTIONAL AERIALS	25	Resistors	15
Distortion	27	SHORT-WAVE COILS	20
Dynamic speakers	50	Short-Wave Convertors	54
ECONOMISER CIRCUIT	23	Socket Connections	69
Electrolytic condensers	19	TRANSFORMERS, POWER	12
FAULT LOCATION	26	Trouble Location	26
Fields, Loudspeaker	13	Tuning Indicators	61
Filter Circuits	12	VALVE CHARACTERISTICS	65
GRAMO-PICK-UPS	53	Valve Socket Connections	69
Grid Bias	57	Vibrator Filament Wiring	62
HEADPHONE ATTACHMENT	50	WAVELENGTH-FREQUENCY TABLE	64
Howls, Crackles, Whistles	27	World Mileage Chart	58

Make a Receiving Set of Your Pass-Book!

YOUR RECEIVING SET spreads the world at your feet. It regales you with the Witchery of Art in a hundred forms, and lifts you out of yourself.

Your Pass-book may do the same! Build it up by prudent spending and patient thrift and it will repay you a hundredfold in pleasures that will forever remain beyond your reach—unless you save!

Save Systematically—Bank Regularly

STATE SAVINGS BANK OF VICTORIA

THE BEST PLACE FOR YOUR SAVINGS

HEAD OFFICE: 139-153 ELIZABETH STREET, MELBOURNE, C.I.

214 Branches — 375 Agencies

J. THORNTON JONES, General Manager.

HOMECRAFTS

CONCESSION PRICES on MATCHED Kitsets

Fidelity Super Five

Complete Kit of matched parts, including Radiotron Valves and Rola Speaker. **CONCESSION PRICE £9/19/6**

The A/C Three/Four

Matched parts with Radiotron Valves and Rola Speaker. **CONCESSION PRICE £6/15/-**

The D.C. Two/Three

Matched parts, complete with Radiotron Valves and Rola Speaker. **CONCESSION PRICE £6/5/-**

4½-Watts A.C. Amplifier

Complete parts, with Rola Speaker. **CONCESSION PRICE £5/10/-**

One-Valve Battery Kit

Complete parts, with Valve. **CONCESSION PRICE £1/12/6**

The A/C One-Valver

Complete with Radiotron Valve, Rectifier and Phones. **CONCESSION PRICE £3/9/6**

Push-Pull Melodious 3

Complete parts, with Radiotron Valves and Rola Speaker. **CONCESSION PRICE £7/15/6**

2-Valve Battery Set

Complete parts, with Valves only. **CONCESSION PRICE £2/15/6**
Speaker Extra, 27/6.

5-Valve AC/DC Superhet.

Complete Kit of matched parts, including Radiotron Valves and Rola 8 in. Speaker. **CONCESSION PRICE £10/5/**

The 40 Super 4

Matched parts, complete with Radiotron Valves and Rola Speaker. **CONCESSION PRICE £8/2/6**

FREE Radio-aid

The advice and guidance of our Radio-aid experts is available FREE to ensure your success in assembling any of these Kit Sets.

Your Complete Set checked up and accurately aligned by our experts for the nominal charge of 7/6.

The Melodious 1.4

4 Valve Battery Kit Set absolutely complete with Radiotron Valves, Batteries and Speaker. **CONCESSION PRICE £10/10/**

Band-Spread Converter

Matched parts, complete with Radiotron Valves. **CONCESSION PRICE £6/15/-**

Battery or Air Cell D.W. 5V.

Complete Kit, matched parts, including Radiotron Valves and Rola 8 in. Speaker. **CONCESSION PRICE £8/5/**

5-Watt AC/DC Amplifier

Kit of matched parts, including Radiotron Valves and Rola-Permagnetic Speaker. **CONCESSION PRICE £7/10/**

The AC/DC Dual Wave

Six-Valve Super Matched parts, complete with Radiotron Valves and Rola 8in. Speaker. **CONCESSION PRICE £13/5/-**

Melodious Super 3 Kit

Absolutely complete with Radiotron Valves. B. batteries and Rola Speaker. **CONCESSION PRICE £9/15/**

30-Watt Amplifier

Complete matched parts, with Radiotron Valves and two High Fidelity Speakers. **CONCESSION PRICE £22/10/**

Push-Pull Battery 4

Complete matched parts, with Radiotron Valves, Batteries and Speaker. **CONCESSION PRICE £11/11/**

The 1.4V. 5-Valve Super

Complete parts, with Radiotron Valves and 8 in. Speaker. **CONCESSION PRICE £8/-/-**

The AC. Two/Three

Complete matched parts, with Radiotron Valves and Rola Speaker. **CONCESSION PRICE £5/5/-**

Professional Set Constructors find Palec Test Equipment an invaluable aid. Write for latest catalogue.

Homecrafts PTY. LTD. **Kit Specialists**

211 Swanston St.—MELB.—290 Lonsdale St.

Phone: Cent. 8200 — Country Calls: TL202.

The

RADIO CONSTRUCTOR'S GUIDE

THE LISTENER IN
HANDBOOK No. 14

It is always a good policy to start at the beginning, so before dealing with the various phases of radio set construction, we shall discuss the tool kit which is necessary for the job.

The essential tools for the radio builder who is prepared to purchase the chassis already formed and drilled are few. They comprise screw-drivers, pliers, socket wrenches, and spanners, a soldering iron and a set of alignment tools.

Where the experimenter proposes to undertake the construction of the chassis himself, this kit must be added to by a hammer, a brace and a set of drills, some files, a steel rule, a scribe, a centre punch, a carpenter's square, and a wood chisel. Other desirable tools include a counter sinking bit, a small plane, an expanding bit, a set of taps, and a reamer. A vice is almost a necessity.

Let us run briefly through this list and describe the desirable features of each of the tools.

Look for these Features

Two screw-drivers will be needed. Preferably they should be about nine or ten inches in length, for it is seldom that a very short driver is required, and the longer ones permit the work to be handled more readily.

One of the drivers should have a quarter-inch blade, whilst the other should have a narrower blade, so that it may be used to align the trimmers of condensers and i.f. transformers. It may be necessary to grind the blades down to the correct widths and thickness. This can easily be done on an oil stone.

Two pairs of pliers, or, if you feel extravagant, three, should be purchased. The first will be an ordinary pair of electrician's pliers with parallel flat jaws.

The second should be what are known as "side-cutting" pliers, whilst the third should be a pair of long-nosed pliers for holding nuts, wires, or small components whilst they are being placed in position.

It is essential to buy the best quality

pliers and screw-drivers. Although quality is desirable in any tools, it is particularly so with radio pliers and screw-drivers.

Be particularly careful to avoid cheap side-cutting pliers. A good pair of side-cutters should be able to snip even the thinnest sheet of paper, and yet to permit wire to be pulled from its braided covering without cutting it.

Select your pliers to suit the size of your hands. Pliers which are too large for one's hands are both tiring and awkward to use. The wrenches necessary for most radio work are of two types, the flat spanner and the socket wrench. The spanners can be obtained in "nests," and should be capable of handling the 1/8th, 5-32nd and 3-16th inch nuts usually met with on radio parts. Two sizes of socket wrenches, 1/8th and 5-32nd inch will suffice.

Whichever is used, be sure it is small, because the few times that the heat of a large iron is required does not offset the difficulty met in getting it to the job in the usually cramped confines of a radio chassis. An electric iron of 60 watt rating will usually suffice.

It usually is fitted with a bit only 3/16in. in diameter, a size which permits the iron to be "wangled" into almost any part of the set.

If you can get an electric iron which takes a round copper rod for the "bit" do so, because, by purchasing similar diameter rod and suitably bending it you can make "right-angle bits" which can be inserted in the iron when some particularly awkward position must be reached.

For an ordinary type of soldering iron select one having a bit measuring about 2in. in length and half an inch square in cross section. It certainly will require frequent re-heating, but its small size will permit any job to be reached.

Metal Working Tools

We come next to the tools required for chassis construction. For this class of work we require a six-inch steel square, a 12-inch steel rule graduated in one-eighths of an inch, a steel scribe, a centre punch, a brace capable of taking metal drills, the necessary drills, a wood plane, a wood chisel, and some files.

The brace should be capable of taking drill shanks up to half an inch and yet be well enough made to ensure that the smaller drills

down to 1-16th inch will be securely held in the chuck.

The essential drills are the 1-16th, 1-8th, 3-16th, and quarter inch sizes. Intermediate sizes will also be required if metal taps are purchased. Two standard Whitworth taps, one for 1-8th and one for 5-32nd inch threads, will be needed.

The expanding bit should be the ordinary carpenter's type capable of being opened to cut 1/16in. diameter holes for valve sockets. The wood plane is used

FOREWORD

ALTHOUGH the theoretical side of radio has been covered extensively by engineering and popular writers, the average experimenter experiences great difficulty in obtaining the practical information which is so necessary for him to achieve successful results from his hobby.

The Radio Constructor's Guide has been published with the idea of overcoming this deficiency. Wherever possible the theoretical side of radio design has been passed over and the writers have concentrated upon the subject from the practical side.

Each section of the receiver, from the Aerial to the Loudspeaker, has been concisely covered and further aids, in the form of valuable reference tables, have been included. The result, we believe, is a new type radio handbook which will prove invaluable to all who are interested in the design and building of radio receivers.

THE EDITOR.

These spanners and wrenches should be designed to handle the hexagon nuts which are usually fitted to components.

Small Soldering Iron Best

The soldering iron may be an ordinary copper bit, which can be purchased for 1/ or so, or may be an electrically heated one. The latter is to be preferred because one does not have to waste time waiting for the iron to heat up.

to trim aluminium, clean up the edges of insulating strips, and dress any wooden brackets used for chassis support. A six or seven-inch plane will suffice.

The wood chisel is to be used for cutting out ports for power transformers or chokes, or for aerial-earth, or pick-up strips. It should have a half-inch wide blade.

Three files will do most of the cleaning up jobs likely to be encountered. One should be a 12-inch half-round, one a 12-inch flat, and one an 8-inch rat-tail. The flat file should have what is known as a "guard edge" on it, i.e., a perfectly flat edge without cutting teeth. All three should be of medium cut.

The alignment tool will consist of a special screw driver which has its blade formed of only a tiny fragment of clock spring riveted into a bakelite or fibre handle.

The only other essential tool is the vyce. This should be of robust construction and of sufficient size for its jaws to open about 4½ inches. A smaller vyce will be cheaper but will soon have to be scrapped because it will not hold the gear for chassis bending.

It should be fitted with guards made by bending pieces of 16-gauge copper sheet so that they fit over the serrated jaws of the vyce and prevent them marking the soft aluminium used for chassis construction.

Chassis Construction

Having collected the tool kit, let us start making our first chassis.

First, we will gather the components required for the particular set we have in mind. We shall set these out on a piece of paper and arrange them in accordance with our ideas of correct layout.

Suppose they take up a space 12 inches in length and 10 inches in width. Now, depending upon what is to go underneath the chassis we have to estimate the depth of its walls.

Except in cases where the receiver is to be a dual-wave one, we will find that a 2½ inch depth is ample. For a dual-wave receiver, where the wave changing switch has to be accommodated underneath the chassis, the depth of the walls must be increased to 3, or even 3½, inches. Where dual-wave coil boxes are used, the depth must be still further increased.

Having settled the depth problem, we can either make a drawing of the chassis area and plot the position of each socket hole, the transformer port, condenser mounting holes, i.f. transformer and tuning coil mounting holes, etc., on this drawing, or mark these holes directly on the aluminium sheet from which we are going to fashion the chassis.

Provided that some means is available to clamp the paper template firmly to the aluminium sheet whilst the position of the holes is being marked on the latter the first method is the best, because it avoids the presence of unsightly marks which are always liable to result because of the temporarily wrong placement of components.

Drilling and Bending

Before we proceed with the description of the actual procedure, let us digress to deal with the actual method to be followed in making the chassis.

For reasons of rigidity, the chassis must have four supporting walls. The only way in which these can be made is

The first stage of chassis construction—the bending and folding of the metal sheet.

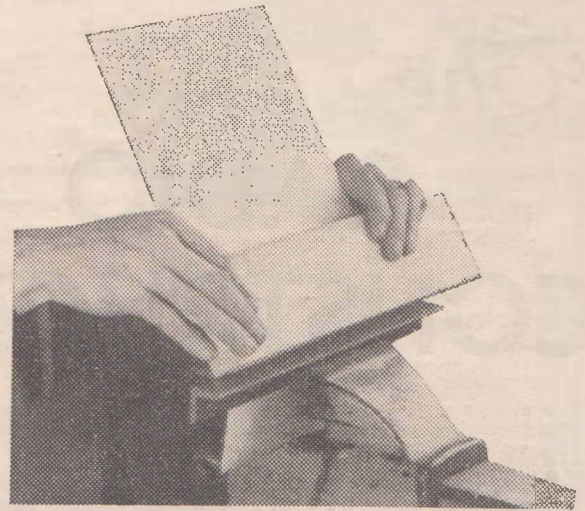

by bending the metal sheet. The manner in which it is bent is as follows:

Two pieces of smooth 1½ inch angle iron are placed in the jaws of the vyce so that their faces meet. Before the vyce is finally screwed up, the aluminium sheet is placed between the two pieces of angle iron, and arranged so that the line along which it is to be bent is exactly parallel to the face of the iron. Then the vyce is tightened.

After inspecting the assembly to see that everything is square, take a piece of soft wood, such as kauri, which has been planed perfectly square, and, placing it on the side of the aluminium sheet which is farthest from you, pull it towards you so as to bend the aluminium sheet down flat.

Remember that the bulk of the aluminium sheet should project from the vyce. The piece of wood should overlap the sheet sufficiently far for the pressure to be applied on it by one hand at each end.

When the sheet has bent as far as it will go, take another piece of flat wood, lay it on top of the aluminium where it projects from the clamping pieces of angle iron, and, working along the sheet from one end to another, gently tap it with a hammer. When this is done properly, it will be found that the sheet of metal has a perfectly square bend. This procedure is followed with the other side of the sheet to form the second wall.

Now if we are to make four metal walls we must first bend the two long ones and then endeavor to juggle things to bend the short walls. This will be found fairly difficult, so to get over, it we suggest that the end walls be formed of wood, to which the top and the front and back walls of the chassis are screwed.

This method of chassis construction is extremely simple, and provided the wooden end blocks are painted or lacquered the appearance of the chassis is every bit as attractive as if aluminium ends were used. To mount such a chassis a hole capable of taking a long quarter-inch coach bolt is drilled through the top of the chassis and through each end block.

Setting Out the Work

We shall assume then that we intend to construct a chassis on the principle described above. Its dimension, we al-

ready have discovered, will be 12 inches by 10 inches by 2½ inches when finished.

First we shall draw out a paper template on which is set out the position of every socket hole, the transformer port, the holes for the electrolytic condensers and the gang condenser mounting bolt holes.

We shall check the dial mounting carefully and, if necessary, arrange for a port to be cut out of the front of the chassis to let the dial fit flush against the front wall.

In the centre of the position marked for the i.f. transformers and the aerial and oscillator coils (assuming the set to be a super-het) we shall mark for a quarter inch hole to carry the leads from these components. On the front wall of the chassis we shall set out the mounting holes for the volume and tone controls, whilst on the rear of the chassis we shall mark the holes for the aerial and earth terminals, the loud speaker socket and the hole through which the power flex is to be brought.

At this juncture we shall drill all holes up to quarter of an inch in diameter. The holes for the valve sockets, the power transformer and the electrolytics can best be left until we have bent the chassis because these comparatively large holes will weaken the chassis and cause it to distort when it is being bent.

However, they should be clearly marked whilst the aluminium sheet is still in the "flat."

The template may be held over the aluminium by clamping it in some way or simply by sticking it to the metal sheet with glue. The sheet can be washed off afterwards.

Cutting the Socket Holes

After the chassis is bent we can start to cut out the valve socket holes. Circles drawn around the centre of each of the valve socket positions (always work from a centre to mark the two socket mounting holes) should be of sufficient size to clear the valve sockets.

If no expanding bit is available to cut these holes they may be drilled out with an ¼th or 5/32nd inch drill. Assuming an ¼th inch drill is to be used, draw an inner circle 3/16th of an inch from the true marking for the socket. Around this drill a series of ¼th inch holes as closely together as possible. When the circle has been completed take the wood chisel

and, with someone holding the chassis squarely on a piece of hardwood (cut into the end grain of the wood), break away the remaining aluminium with a wood chisel.

Tap the chisel lightly with the hammer to avoid buckling the chassis around the socket holes. Finally, remove the remaining metal up to the originally scribed socket hole circle by means of a half round file. Any burrs which result may be removed by using the side, not the edge, of the wood chisel as a scraper. This method of drilling holes larger than those for which you have bits may be used for the electrolytic condenser mountings.

For the power transformer port it is necessary to drill four holes, one in each corner of the rectangle which is to be cut out. Starting from these and again cutting on to the end grain of a piece of hardwood, cut this port out with the chisel. Another method is to clamp the chassis between the jaws of the vice in such a manner that the previously mentioned angle iron brackets are in line with the marked line on the chassis.

Start the chisel at one of the corner holes and cut along the edge of the chassis held in the vice. Hit the chisel lightly but frequently and keep its blade always at an angle of about 45 degrees to the line of cut. The final trimming of the cut out can be done with a file.

Incidentally, when bending the chassis by the method suggested earlier it should be remembered that the bend is extremely sharp so that the overall dimensions of the sheet to be bent should be the finished size plus only the thickness of the material. That is to say, with a twelve-inch wide chassis, 2½ inches in depth would normally require a piece of metal 17 inches wide.

To allow for the bends add the thickness of the material for each bend. Thus if two bends to be made in 16 gauge aluminium sheet (approximately 1-16th of an inch in thickness) the unbent sheet should measure 17½ inches to finish at the specified dimensions.

Dipping Makes Attractive Finish

The next thing to consider is the finishing of the chassis. When all the bending has been completed and all holes and cut-outs have been drilled, the chassis may be cleaned and coated with lacquer. This may be of the glossy variety or one of the crackle finishes which are readily obtained.

If a crackle finish is to be used it is desirable to bake the chassis after the lacquer has been applied.

With aluminium chassis an excellent finish may be had by dipping in a caustic soda solution made by boiling one gallon of water to which has been added one pound of caustic soda. The chassis should be immersed in the solution from 3 to 5 minutes, but should not be left in too long because a form of oxidation which produces black patches on the aluminium will take place.

On removal from the dipping solution the chassis should be washed in cold water, rubbed over with a weak acid solution, and dried.

A solution of 1½ gallons of nitric acid to 10 gallons of water will neutralise the alkali of the caustic soda solution. Dilute 1½ ounces of acid with a pint of water, adding the acid to the water and mixing it in an earthenware vessel.

With a piece of soft rag or a swab

With the aid of a flat piece of wood and a carpenter's mallet the chassis bends are finished off to form true right angles.

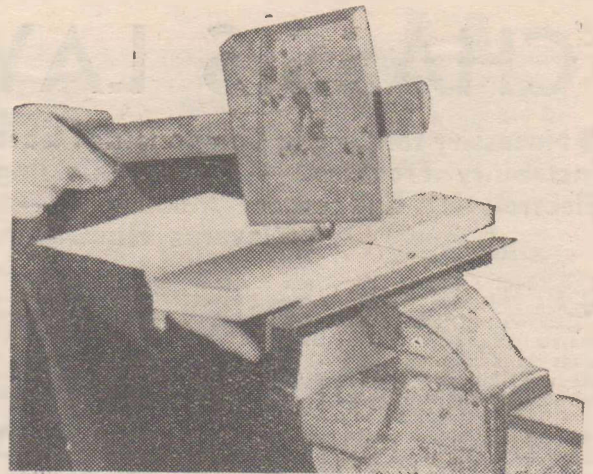

of cotton wool wash the chassis with the acid and then rinse it in water. The resultant finish on the chassis is a dull silver sheen which harmonises perfectly with the dipped or sandblasted cans of the coils and the sprayed or nickelled finishes on the gang condenser, electrolytics and power transformer cover.

Assembly Hints

Assembly of the various components can be carried out with ordinary machine screws and nuts, with self-tapping screws, or with eyelets.

The former method will appeal to most constructors, particularly those of

an experimental turn of mind, because the nuts and bolts can be used time and again. The most useful size are ½th. inch machine screws, which should be half and one inch in length.

Most of them should be nickelled round heads, but a few countersunk screws will be of use for some assembly jobs.

Self-tapping screws, although more expensive, are easiest to use and providing they do not have to be unscrewed frequently provide an almost shake-free method of assembly. Eyelets and similar forms of rivets are unpopular with the home builder, although widely used in factory production.

SHUNT-FED A.F. TRANSFORMERS

DESPITE the many opinions expressed to the contrary, it can be accepted that the audio transformer still represents the best method of coupling a single stage driver valve to a push-pull output stage. Phase inversion and similar methods of resistance coupled push-pull amplifiers have only one real advantage over the transformer coupled type—they are cheaper to build.

This construction economy is offset by effective inductance decreases with an increase of the direct current flowing the difficulty of obtaining a true balance with the result that so-called resistance coupled push-pull amplifiers are far from being distortionless.

High quality audio transformers are capable of responding faithfully to a

frequency range extending from below 30 to above 12,000 cycles per second, but such components, because of the amount of iron in their cores and wire in their windings, are rather expensive for ordinary receiver applications.

The chief requirement of a transformer, if the low note reproduction of the amplifier with which it is associated is to be good, is high inductance in the primary winding. Now the transformer's effective inductance decreases with an increase of the direct current flowing through its windings.

Consequently the working inductance of low priced transformers is exceptionally low, and the frequency response characteristic is poor.

A practical method of maintaining the primary inductance at the highest possible level is the complete elimination of direct current flow through the windings. In the accompanying circuit a "shunt fed" transformer coupled arrangement is shown. It is intended only for use with medium impedance valves of the triode class. R1 is the load resistor, which may range from 25,000 to 100,000 ohms, depending upon the individual valve. C1 is the coupling condenser. Its capacity may range from .006 mfd. to .1 mfd. The lower values of capacity will restrict the amplifier's low frequency response.

Resistor R2 is a de-coupling condenser necessary to eliminate hum from the plate circuit of the driver valve. It will range from 15,000 to 25,000 ohms in resistance. Condenser C2 may have a capacity from .5 mfd. to 8 mfd., and in combination with R2, acts as a de-coupling system.

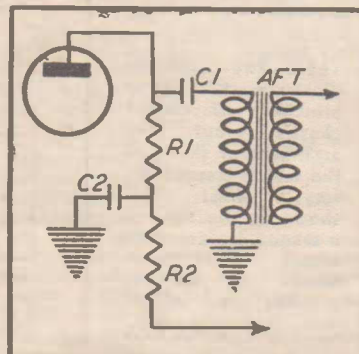

A Shunt-fed a.f. transformer

CHASSIS LAY-OUT

● **Necessity for Care in Components Placement — Avoiding Instability Troubles — Where Shielding is Required — Electrolytic Condenser Mounting — Choke Position Governs Hum.**

ONE of the most important features of radio set design is the correct layout of the components on the chassis. Many minor variations may be made to individual designs, but unless the chief rules of good layout are followed the resultant receiver will suffer from instability at r.f. or i.f. levels, hum in the audio stages, restriction of tuning range, and liability to filter system breakdowns.

The old rule that the designer should "keep the grid leads short and keep the plate leads well away from the grid circuits" still holds good. It does not matter whether the receiver is a simple single valve short waver or the most elaborate multi-tube superhet., this basic rule must be adhered to and the chassis layout planned accordingly.

In fact, with the high gain r.f. and i.f. circuits employed in the modern super, the necessity for careful placement of the components is even greater than before.

RESULTS OF POOR LAYOUT

Glance at Fig. 1, which illustrates a possible components layout for a standard six-valve superheterodyne which employs one r.f. and one i.f. stage. This is a layout method frequently used by the novice. Let us analyse it and see exactly what effect it is likely to have on the set's ultimate performance.

On the input side we find that the aerial coil and r.f. valve have been mounted side by side and in line with the section of the gang which is to tune the aerial coil.

Unfortunately, however, the designer has neglected to consider the length of grid lead which is necessary to join G3 to V1 and AER. If the grid lead to V1 is taken from the top of AER it is in proximity to the grid of V3 and is likely to cause r.f. feedback into the i.f. stage. The result will be partial oscillation of both the r.f. and i.f. amplifier stages.

Similarly, there is likelihood of r.f. instability being caused by pick-up between the grid leads of V1 and V2.

The oscillator coil and oscillator section of the gang are nearest the front of the receiver and so, particularly in short waves, are likely to be subject to hand capacity effects when tuning.

Another bad effect is caused by the long arid lead which must be run from 1F1 to V3. This layout is particularly bad from the stability viewpoint and will also give trouble in frequency coverage because of the long grid leads.

Similar poor design is shown in the power section. The two electrolytic condensers, E1 and E2, are mounted near the rectified tube V6, the radiated heat from which causes the speedy evaporation of the electrolyte in the condenser. The effect of this is to reduce the capacity of the condensers, and to cause them to set up a chemical action which results in the appearance of a white crystallised deposit at the top of the cans.

The combined effect of these two things is to introduce filter circuit hum into the set and to hasten the condenser breakdown with its consequent destruction of the rectifier tube and the filter choke or l.s. field.

"FEED" SHOULD BE PROGRESSIVE

Now glance at the second diagram, which shows how a standard six valve chassis should be laid out. Here we have the aerial, r.f. and oscillator coils mounted right alongside the tuning gang. The gang leads to the coil are taken into the cans underneath the chassis and are only a couple of inches in length.

The grid leads to V1 and V2 are brought from the tops of the AER and

RF coil cans and similarly are short. The "feed" of the receiver is progressive and there is no turning back of r.f. carrying lines such as existed in the first lay-out design.

The electrolytics have been safeguarded from the effects of heat by mounting them well away from the rectifier and by placing the power transformer between them and the output and rectifier tubes.

Another point worthy of note in arranging the layout of a receiver is the placement of the volume control. Very

Even in compact mantel type receivers such as this the cardinal rule of "progressive feed" should be followed in planning the components layout.

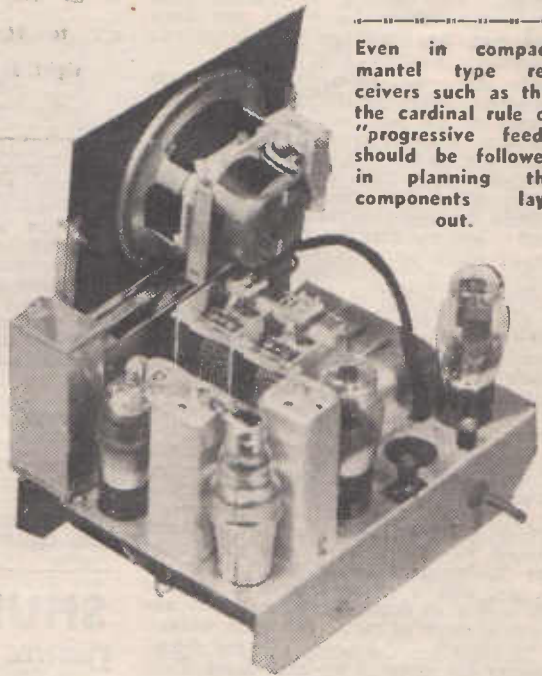

often we find midget receivers so planned that the volume control, usually consisting of a potentiometer in the grid circuit of the audio amplifier, is jammed right against the power transformer where powerful a.c. fields exist. This results in a bad audio hum being generated. The logical thing to do is to move the volume control well away from the a.c. part of the receiver. Even if this necessitates the use of long leads it is still desirable. The shielding of these leads will prevent any hum pick-up or audio instability yet will not affect the set's tonal quality or audio sensitivity.

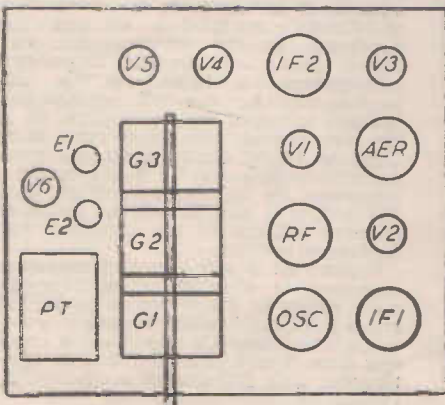

These two diagrams illustrate the basic principles of correct chassis lay-out. The arrangement shown at the left is unsatisfactory, whilst that shown at the right is a standard plan which meets all requirements so far as stability and efficiency are concerned.

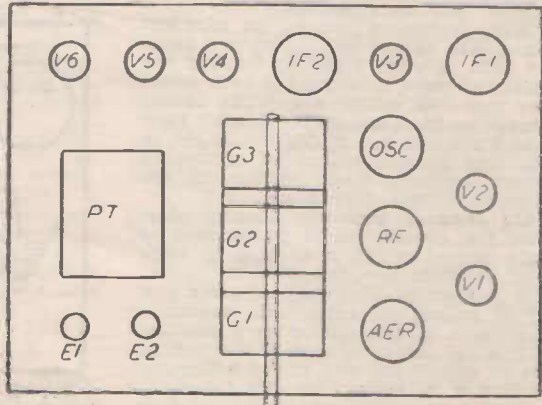

With standard receivers it is desirable to mount the volume control immediately below the main-tuning control. If a tone control is used then mount that on the power transformer side of the chassis and place the volume control potentiometer on the opposite side.

In dual wave designs the volume control may be centrally mounted and the wave change switch placed at the right of the tuning gang in line with the coil units.

SHIELDING POINTERS

We come next to a consideration of the shielding necessary or desirable in a receiver. Proper lay-out and careful wiring will eliminate the necessity for most shielding, bearing in mind, of course, that the tuning coils, i.f., transformers, and the r.f. and i.f. valves are individually shielded.

However, if the r.f. gain is very high it may be necessary to cut this stage off from the mixer stage by running a small shield across the top of the chassis from the gang condenser. This shield should be shut off the aerial coil and the r.f. amplifier tube from the mixer stage.

Its placement is shown in Fig. 2. Care should be taken in the use of braided wire for shielding purposes. Ordinary Belden type braided wire is unsuitable for shielding r.f., carrying leads such as those to the plate and grid circuits.

The reason for this is that a comparatively high capacity exists between the outer shield or braid and the inner conductor. When the braid is earthed this capacity is directly across the r.f. line and by-passes a considerable amount of r.f. The circuit so shielded may be very stable, but this will be because its sensitivity has been greatly reduced by the by-passing of the r.f. current.

Don't use shielding on the grid leads. Don't use it on the aerial leads if you can possibly avoid it, and on no account use it on the aerial leads to a short-wave coil. If you DO you'll wonder where all the short-wave sensitivity has disappeared because the capacity effect of the braid is particularly serious at the higher frequencies.

Standard braid may be used for 'B' plus leads and for shielding a.v.c. lines. The shielding of a.v.c. lines, however, should be confined to those on the series resistor side of the diode. Avoid connecting braided wire leads directly to the a.v.c. diode for the capacity effect so introduced still further damps a heavily damped circuit and adds to its lack of selectivity.

The presence of a series resistor between the diode and the line (such a resistor normally is used for filtration purposes) reduces the effect of the braid capacity so that shielding may be used between this resistor and each of the grid circuits to be controlled.

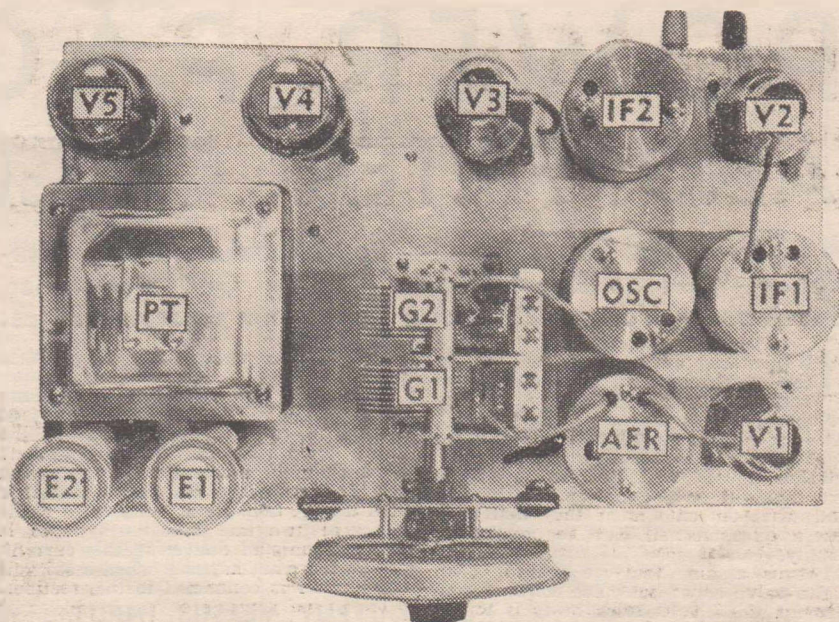

A typical five valve super-heterodyne chassis laid out in accordance with the principles described here.

Where it is essential for braid to be used on grid or plate circuits the only way out of the difficulty is to get quarter or half inch diameter braid and keep this as far away from the inner conductor as possible.

Grid leads to audio tubes may be braided without serious effect and in fact this braiding often is necessary to avoid trouble from hum pick-up.

With a volume control potentiometer connected between the diode return and the high side of the cathode all three of its leads should be braided. Remember, though, that unless the braid is earthed to the chassis it has no effect so far as shielding is concerned.

Coming back to the question of inter-stage shields we find that these often are necessary in dual wave receivers. In some circuits individual short wave coils are used and are mounted near the gangs of the wave changing switch.

In order to avoid coupling between them it then is necessary to fashion small aluminium shields which are attached to the supporting pillars of the wave change switch and to the chassis floor.

These shields should be wide enough completely to cut off the fields of each coil and might extend two inches on each side of the wave change switch. Suitable extension pieces can be purchased to provide sufficient space between each switch gang.

Another form of shielding, one which is seldom used but which has very important attributes, consists of a metal sheet fitting right over the bottom of the chassis and a fine mesh copper gauze cover which completely encloses the top of the chassis. This rather elaborate form of screen has been proved to have particular advantages in cutting down all but the aerial pick-up, and so is of special value in areas where intense electrical interference is present.

Furthermore, by reducing pick-up other than that introduced by the aerial

system it is valuable in circumstances where the receiver must be operated close to a broadcasting station.

CHOKE AND TRANSFORMER PLACEMENT

When shielding coils remember that the effect of the shielding is to reduce the inductance of the coil. The closer the shield is to the coil the greater the eddy current effect the greater the lowering of the coil's inductance and the greater the losses introduced.

No coil shield should be nearer than one inch to the coil. This is particularly important at the higher frequencies. Short wave coils always should be mounted clear of the aluminium chassis and so wired that their high potential ends are farthest from the metal floor.

Allied to the shielding question so far as hum suppression is concerned is the orientation of filter chokes and audio frequency transformers. Often it will be found that a marked reduction in hum will be obtained by suitable pivoting of the filter choke or transformer so that its field cuts that of other components in the receiver.

Assuming the choke or transformer to be held by four bolts remove three of them and, with the receiver running, slowly move the component until the smallest amount of hum is heard in the loud speaker. The choke, or transformer, then should be bolted down in its new position.

Later we shall deal with other hum suppression methods, but those already mentioned are closely allied to the layout plan followed in the original chassis design.

In planning shields it should always be remembered that whilst copper, brass, or aluminium, provide excellent shielding against radio frequency current, they are useless for audio frequency current. The only satisfactory shielding metals for a.f., are iron and steel.

POWER PACKS AND FILTER CIRCUITS

● Planning the Power Pack — Loud Speaker Field Excitation — Voltage Regulation — Using Odd Resistance Speakers — Voltage Drop and Regulation Characteristics.

IN planning an a.c. receiver one of the most important questions to be answered by the designer is "What voltage power transformer do I need? At what current must it deliver this voltage? What field resistance will the loud speaker have? What filament windings are required on the power transformer and what currents must they deliver?" These questions all can be answered simply.

Let us assume that we are to build a five-valve super-het. The conventional line-up of 6.3 volt series tubes is to be used. We shall have a mixer tube, an i.f. amplifier tube, a combined second detector, a.v.c., and first stage audio amplifier, and an output tube. We shall select the rectifier in accordance with the requirements of these valves.

We start off by assuming the current which these tubes will draw under their rated working condition of 250 volts. Looking at the operating characteristics of the mixer tube, we find it will draw a cathode current of around 11 m.a. The i.f. amplifier tube will draw 10 m.a. Under resistance coupled amplifier conditions, the pentode section of our diode pentode will draw about 1 m.a. The output pentode will draw about 40 m.a. This totals up to 62 m.a.

This is a little over the rating of a 60 m.a. transformer, so let us concentrate on an 80 m.a. one. To provide for easy selection of intermediate voltages without the use of series resistors and to permit the set to be extended later, we might have a matter of 13 m.a. of current dissipated.

VOLTAGE DIVIDER CALCULATIONS

If we are to add to the drain of the receiver we must place some additional load on the power pack. The voltage divider offers the simplest way out of the difficulty. The question now is "What resistance voltage divider do we want?" Before we can answer this we must know what voltage is to be delivered from the set side of the filter circuit.

Studying our output tube requirements we find that a plate voltage of 250 and a bias voltage of 16 is required. No matter how we get this voltage from our power pack it means that the output from the filter must be 250, plus 16 or 266 volts. We require a current of 13 m.a. to flow through the voltage divider so, from Ohm's Law, that R equals E divided by C when R is the resistance in ohms, C the current in amperes, and E the potential in volts, we arrive at the following equation: $\frac{266}{13}$

18

which must be multiplied by 1000 as the current, C, is in milliamperes. The answer is 14,777 ohms, or 15,000 ohms,

which is near enough for all practical purposes.

So far we have arranged for the use of a voltage of 266 at a current of 80 m.a. to be used at the output of the filter. What type of rectifier is needed? What shall the power transformer rating be? What resistance will the loud speaker field have? Looking at our lists of rectifier tubes we find that the type 80 is easily capable of delivering this current. Let us see what happens when a 385 volt transformer is connected to this rectifier.

OUTPUT VERSUS INPUT VOLTAGES

It should be realized at this juncture that the output voltage for a given a.c. input to the rectifier depends upon the current drawn from the rectifier. The higher the current drain the lower the d.c. potential available for a given a.c. input. From a study of the operating curves of the 80 we find that a 385 volt input will result in a d.c. output of about 430 volts at a current of 80 m.a.

This means then that we have to drop the 430 volts to 266 volts — a reduction of 164 volts. Before we decide on the d.c. resistance of the field winding let us check the wattage of this voltage and current. Watts equal current by voltage

$$80 \times 164$$

or in this case —

$$13000$$

because the current is in milliamperes.

The answer is 13.12 watts. This is too high for the average loud speaker field and will cause it to over-heat. With this knowledge in mind and the appreciation of the fact that a maximum excitation of from 8 to 10 watts is desirable we can proceed with our calculations.

FIELD EXCITATION POWER

Our 164 volts drop at 80 m.a. necessitates a resistance of $\frac{164}{80} \times 1000$, or

approximately 2000 ohms. Now we have discovered that we require approximately 9 watts excitation for our speaker field. The resistance of the field then will be 9 divided by $13\frac{1}{2}$ (nearest approximation of the 13.12 watts, which is to be dissipated in the filter circuit) multiplied by 2000 to give the speaker field resistance in ohms. The answer is 1333 ohms. To keep as nearly as possible to standard field resistances we shall employ a 1300 ohm field winding and make up the difference, 700 ohms by connecting a resistance of this value between the output of the rectifier tube and the input to the filter.

Note, however, that our calculations of d.c. output from the rectifier are based on good quality transformers. If the transformer is only of ordinary design it is unlikely that the d.c. potential from the rectifier will exceed 400 volts under the conditions mentioned.

In this case we might take a chance with a 1500 ohm loud speaker field which would increase the excitation to around 11 watts and, by the natural process of balance between power drain and voltage output, would raise the plate voltage on the tubes by only about 10 or 15 volts.

This method favors a good deal of compromise and should not be adopted where it is possible accurately to work out the combination of plate voltage and field resistance.

We come next to a problem which the home set builder often encounters. He has a loud speaker field of incorrect resistance for the circuit in which he proposes to use the loud speaker.

We already have explained that if the field resistance is too low and sufficient voltage is not dropped across it he can

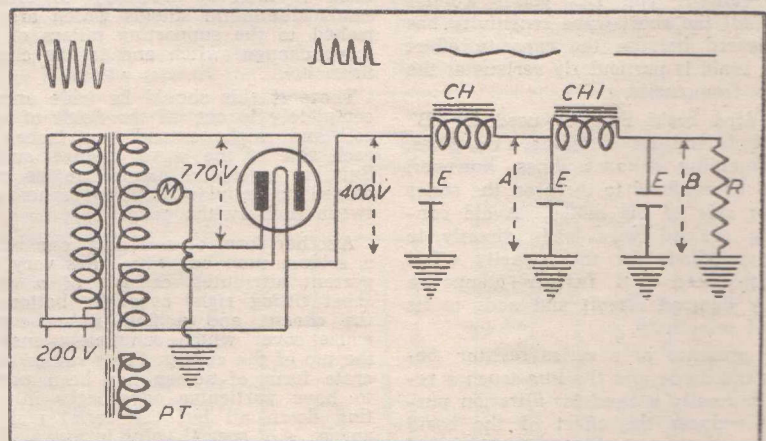

Fig. 1.—A typical power unit showing (above) the wave form changes undergone by the input potential as it passes through the filter circuit.

connect a series resistor of suitable value between the speaker field and the output of the rectifier tube. If the resultant voltage drop across the speaker field is not sufficient to provide adequate excitation of its windings then, having regard to the current delivering capabilities of the power transformer and rectifier tube, he can reduce the value of the bleeder resistor or voltage divider in order to make a heavier current pass through the speaker field.

USING STANDARD FIELDS

For example, we might have a 1000 ohm loud speaker field operating under a condition where a current of 60 m.a. was being drawn by the receiver and voltage divider with which it was associated. This would mean that the voltage drop across the loud speaker field was 60 volts.

Now, because wattage is a product of the current and voltage, we would find that the speaker field was being energised to the tune of 60 (volts) by 60 (m.a.) divided by 100 because the current is rated in m.a. instead of amperes. This 3.6 watts excitation is far too low for the majority of dynamic loud speakers.

Furthermore, it is likely that with the average receiver whose power transformer and rectifier is capable of delivering 400 volts d.c. at a current of 80 m.a. that there would be 340 instead of 260 volts available at the set end of the filter.

The problem first is to boost the drain of the receiver as high as practicable to get the best excitation of the loud speaker field.

Say that instead of the customary 100 m.a. drain imposed by a 25,000 ohm voltage divider connected across a d.c. output of 250 volts, we lowered the voltage divider resistance to 8000 ohms.

This would immediately increase the total drain of the divider to 31 m.a., or an increase of 20 m.a. through the speaker field. A current of 80 m.a. through the 1000 ohm speaker field will produce a voltage drop of 80 volts, so that the resultant field excitation has been boosted to 6.4 watts, a big increase on the first figure.

However, the fact that the output voltage from the rectifier was 400 and the speaker field drop was only 80 volts, makes it necessary for us to insert a series dropping resistor capable of bringing the remaining 320 volts down to the 250 or 260 volts required for the receiver.

This resistor may be inserted at any point in the d.c. supply circuit, but is best included between the rectifier output and the input to the filter circuit.

Calculation of the actual value can easily be worked out for individual receivers.

The next problem is a more serious one for the average constructor. Here we have a loud speaker whose field resistance is too high for the receiver with which we wish to use it.

ADJUSTMENTS FOR HIGH RESISTANCE FIELDS

Take a case in point. With a receiver whose power requirements are 250 volts at 80 m.a., we have a power pack capable of delivering to the filter input a d.c. voltage of 400 at a current of 80 m.a. We have only a 2500 ohm loud speaker on hand. A few calculations will show that the current of 80 m.a. through the loud speaker field winding will produce a voltage

drop of 200 volts since E equals $C \times R$. Furthermore, the field excitation of the loud speaker will be far too high because 80 m.a. x 200 volts equals 16 watts.

How can this loud speaker be used with the receiver without the necessity for re-winding its field?

First we decide on the voltage which must be available at the receiver end of the filter. This is to be 250 volts in the present case, so we require a drop of 150 volts across the loud speaker field. Now, 150 volts by 80 m.a. represents a field excitation of 12 watts, which is still too high.

After reference to the loud speaker's operating characteristics we decide to keep the field excitation wattage down to eight watts.

This leaves us with a power of four watts to be dissipated. We have proposed to have a drop of 150 volts across the loud speaker field winding. Therefore, the remaining four watts of power which we wish to dissipate must be produced at this voltage.

Since power, W , equals the product of current, C , and voltage E , we can divide the voltage into the power and multiply the result by 1000 to determine the current in milliamperes which must flow through the resistance which we are to use in parallel with the loud speaker to dissipate the unwanted power and to reduce the voltage drop from the 200 volts existing when a 2500 ohm field is used.

This results in the following:—

$$4 \times 1000$$

$$\frac{150}{}$$

Or 26.6 milliamperes.

Let us even this to 27 m.a. for ease of calculation.

Using Ohm's Law again, we find that the resistance required is:—

R equals E divided by C and multiplied by 1000,

$$\frac{150 \times 1000}{}$$

$$\text{or } \frac{150}{27}$$

which means that a 5555 ohms resistance must be placed in parallel with the 2500 ohm field winding to produce the desired result.

Let us check this back and see exactly what voltage drop will take place across the combination of the field winding and the parallel resistance.

From the formula for parallel resistances

$$\frac{R1 \times R2}{}$$

$$\frac{R1 \quad R2}{}$$

we get

$$\frac{5555 \times 2500}{}$$

$$\frac{8055}{}$$

or 1724 ohms (app.)..

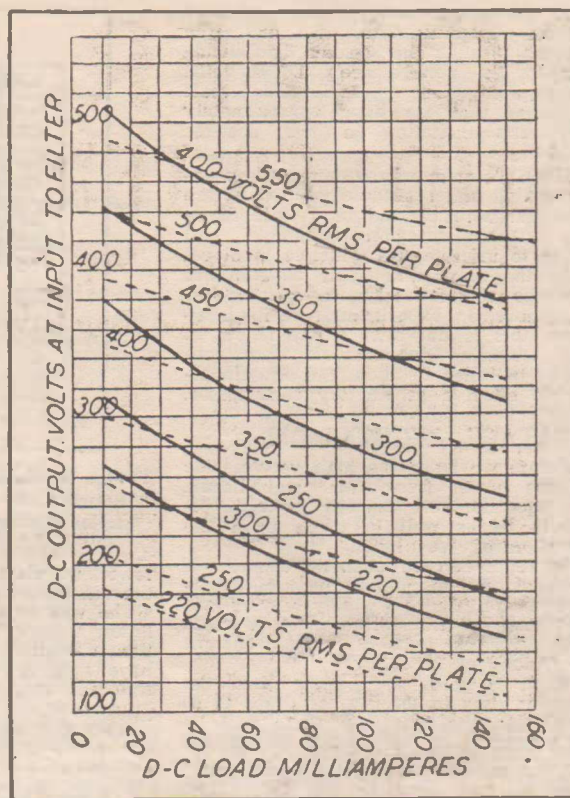

Fig. 2 illustrates the relationship between voltage output against voltage input for various current loads. The curves refer to a type 80 rectifier.

This is the product of the combined resistances and is the equivalent resistance in series between the output of the rectifier and the input to the receiver proper.

Now at a current of 80 m.a., the voltage drop across the filter circuit will be

$$E \text{ equals } C \times R \text{ divided by } 1000 \text{ or } 80 \times 1724$$

$$1000 = 137.92 \text{ volts.}$$

Subtracted from our available d.c. input of 400 volts this drop leaves us with 262.08 volts, which is near enough for practical purposes and proves that we have achieved our aim.

POWER DISSIPATION IN PARALLEL CIRCUITS

Now let us look into the question of field excitation from another angle. The current flowing through each leg of a parallel resistance network is proportional to the ratio existing between the product of the combined resistances and the resistance of each section of the network.

The current which flows through the loud speaker field winding is

$$\frac{1724}{}$$

$$\frac{2500}{}$$

of the total current (80 m.a.) or 55.1 m.a. whilst the current flowing through the parallel resistance is

$$\frac{1724}{}$$

$$\frac{5555}{} \times 80$$

or 24.6 m.a.

From this we can calculate the ac-

RESISTORS

● Watt Ratings — Current Carrying Capacity — R.F. and A.F. Volume Controls — Suppressors in Oscillator and A.F. Circuits — Simple Chart for Calculations.

RESISTORS, as the most widely used of all radio components, are worthy of special attention by the set designer and builder. Two general types, solid carbon resistances, and wire wound resistances, are generally employed.

The carbon types include both fixed and variable resistances, the latter usually being employed as volume controls. Wire-wound resistors are used for bias resistance, volume controls, and voltage dividers!

Now, any resistance used in an electrical circuit is employed as a power dissipator. That is to say, a given voltage flows through it at a given current. The voltage drop taking place across the resistor is a product of the current flowing through it and the combination of the two produce the power which is dissipated by the resistor.

If we applied a potential of 200 volts to a 10,000 ohm resistor and arranged for a current of, say, 1 milliampere to be drawn from this power supply source then, by Ohm's Law that E equals $C \times R$ we find that a potential of 100 volts is dropped across the resistor and only 100 volts remains for the load to which the power supply, in series with the resistor, was connected.

WATTAGE RATINGS

Now 100 volts at a current of 1 m.a. equals a power of .1 Watt. This is the power which the resistor has to dissipate.

Which brings us to the watt ratings of resistors. All the carbon resistors used in radio, ranging from 100 ohms to up to 10 megohms, are rated according to the power they are able to carry without overheating.

The table included in this section shows the maximum current which may be permitted to flow through typical 1 watt resistors of various ratings. These currents produce sufficient voltage drop in each case to run the resistor at the maximum rating. Where the current is to be exceeded the constructor must use resistors capable of carrying heavier currents.

As a general guide it may be taken that 1 watt rating resistors are suitable for all general plate and screen dropping in radio receivers.

Lower powered resistors such as the half, one-third, and quarter watt types will suffice for audio grid resistors, grid resistors for mixer tubes, series audio "stoppers" and tone control resistors.

The main requirement of the carbon or metallized resistor is noiseless operation. Faulty or overloaded resistors will produce a background of crackling. Incidentally, when wiring resistors into circuit be sure not to smear them with soldering flux because the high resistance leakage path so formed across the body of the resistor will almost certainly cause a noise background in the receiver or amplifier.

Audio volume controls and tone controls usually employ carbon type resis-

tors either arranged as straight variable resistors or as potentiometers. Don't attempt to use the carbon type resistors in circuits in which direct current is present. They are not designed for such work and soon become noisy.

WIRE-WOUND RESISTOR USES

For circuits where appreciable current is flowing the wire-wound resistors are to be preferred. These circuits include the cathode bias circuits for amplifier tubes. Variable type wire-wound resistors and potentiometer are used for volume control in circuits where comparatively large direct currents are flowing. They also are used for regeneration control in regenerative sets in which the control is effected by means of adjustment of the screen voltage on the detector tube.

Another use of wire-wound resistors is for voltage dividers. Here, as in other

resistor applications, it is wise to err on the safe side so far as current carrying capabilities are concerned. Wire-wound resistors usually are intended to carry fairly heavy currents, but overload is likely to produce both a variation in resistance caused by overheating, and noise due to the stretching of the wires so that adjacent turns touch.

Coming to the application of resistors in volume control circuits, let us first glance at Fig. 1. Here is shown one of the simplest forms of volume control applied to an audio amplifier which is coupled by means of transformers.

The audio transformer, T, has connected across it a high resistance potentiometer, R1. The arm of this potentiometer is taken to the grid of the following amplifier tube, which is biased in the ordinary way by means of the cathode resistor, R2. R1 must have a high resistance in order that its effect will not upset the coupling properties of the audio transformer.

From 250,000 ohms to 1 megohm would be a desirable value for such a volume control. Normally, we find that a 500,000 ohm resistance will work nicely in this position. It should be realized, however, that such a volume control arrangement cannot be used in amplifiers such as the AB2 and B types, which draw grid current.

In Fig. 2 we have shown a similar method of control applied to a resistance

RESISTANCE CHART

THE accompanying chart shows the relations between resistance, applied voltage, watts load, and milliamps for the usual values of resistance.

To find —
Watts Load for specified voltage and resistance —

follow the resistance line vertically until it intersects the diagonal line corresponding to the applied voltage. Read the watts load horizontally to the left of this intersection.

For instance 10,000 ohms and 50 volts give ¼ watt load.

Current for specified voltage and resistance —

follow the resistance line vertically until it intersects the diagonal line corresponding to the applied voltage.

Read the current on the system of diagonal lines at right angles to the voltage lines.

For instance 10,000 ohms and 50 volts give 5 mils current.

Voltage for specified load and resistance — follow the specified watts load line horizontally until it intersects the vertical resistance line. Read the required voltage on the diagonal line through this intersection.

For instance, 1 watt load on a 2500 ohm resistor requires 50 volts.

Resistance for specified load and voltage — follow the specified watts load line horizontally until it intersects the diagonal voltage line. Read the resistance at the bottom directly under the intersection.

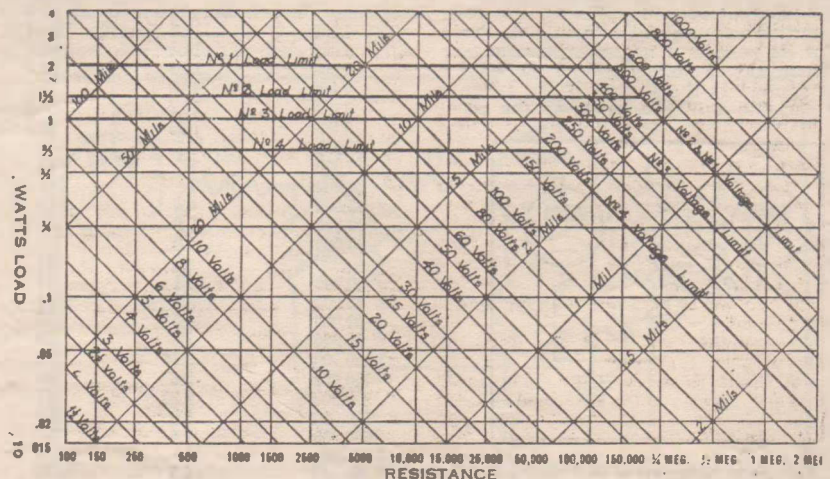

Resistance, voltage and current relationships for common carbon type resistors can be determined from this chart.

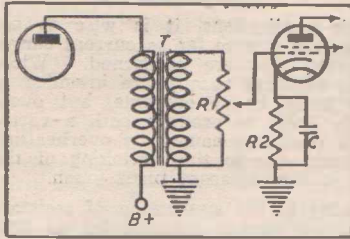

Fig. 1.—Audio volume control in a transformer coupled amplifier.

coupled amplifier. Here R is the normal plate resistor and R2 the cathode bias resistor for a succeeding tube. R1 is a potentiometer of between 250,000 and 500,000 ohms which serves as a grid resistor for the controlled valve. C is the normal coupling condenser.

This circuit may be applied to any resistance coupled amplifier providing that the resistance of R1 is that specified by the valve manufacturers for the grid resistance of the valve with which it is used.

Carbon resistors are used in both Fig. 1 and Fig. 2.

CONTROL AT R.F. LEVELS

Now this control of an audio amplifier is all very well, but if a sensitive receiver is connected ahead of the amplifier it may be found that the detector tube or one of the r.f. amplifier tubes in the tuner unit is overloaded on strong signals. In this circumstance, although it is possible to reduce the output volume to the desired level, undesirable distortion will be present because of the overload taking place in the r.f. section of the set.

This difficulty is overcome by controlling the r.f. stages. Fig. 3 and Fig. 4 show methods used for this control. In Fig. 3 R is the customary cathode bias resistor for the type of amplifier tube being used.

Instead of being connected between cathode and earth, as is normal in such bias arrangements, the lower end of the cathode resistor is joined to the selector arm of a wire-wound potentiometer R1. One end of this potentiometer is connected to the "B" plus line at some intermediate point between 25 and 40 volts, whilst the other end of the potentiometer is grounded.

The grid circuit of the amplifier tube is grounded through the tuning coil in the normal way. Adjustment of the arm of R1 permits a negative bias ranging from, say, 3 volts to 25 or 40 volts to be applied to the valve. If the latter is a variable-mu type, such as the 5B,

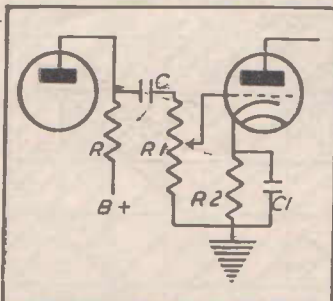

Fig. 2.—Application of volume control, to resistance coupled amplifiers.

6D6 or 6K7, this control of bias will permit the amplification factor of the tube to be varied from maximum to minimum, and so will control the r.f. output from the receiver.

Note that R fixes the minimum bias which may be applied to the valve. As R is selected for the correct bias voltage for the particular valve, it is impossible for it to be operated without bias when the arm of R1 is at the earth end. R1 will have a resistance of 5000 in most applications and should be of the wire-wound type.

AUDIO VOLUME CONTROL

Another control system is shown in Fig. 4, where control is effected on the screening grid of the amplifier tube. The screening grid of the amplifier tube is returned to the arm of a 50,000 ohm potentiometer. R1, connected in series with earth and the 100 volt tap of

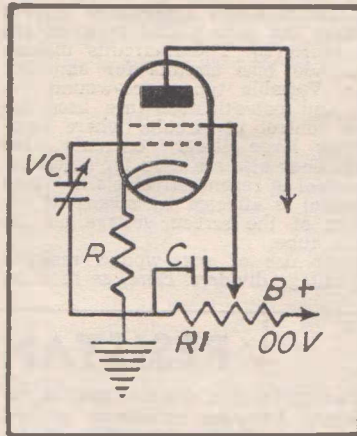

Fig. 4.—Screen control of volume.

the voltage divided. Reduction of the screen voltage from the rated 100 volts maximum reduces the amplification of the valve accordingly.

We come in Fig. 5 to another form of audio volume control used widely in the super-heterodyne circuit.

It will be remembered that we remarked that audio volume control was

LOAD CHARACTERISTICS

One Watt Metallised Resistors

Resistance Ohms.	Current m/A.	Volts.
4,000	15.8	63.4
5,000	14.2	71.0
6,000	12.9	77.5
7,000	12.0	84
8,000	11.2	89.5
9,000	10.5	95.0
10,000	10	100
15,000	8.1	122
20,000	7	141
25,000	6.3	158
30,000	5.8	173
40,000	5.0	200
50,000	4.5	224
60,000	4.1	245
70,000	3.8	264
80,000	3.5	283
90,000	3.3	300
100,000	3.16	316
150,000	2.6	388
200,000	2.23	447
250,000	2.0	500
500,000	1.4	707
1,000,000	1	1000
2,000,000	0.7	1410
4,000,000	0.5	2000

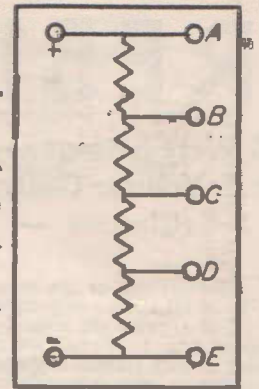

Fig. 6. — A typical voltage divider set-up.

usually unsatisfactory because it made no provision for control of r.f. overload. However, in the modern super-heterodyne this is looked after by the automatic volume control applied to the r.f., mixer and i.f. stages.

In the second detector stage R and R1 in Fig. 5 constitute the diode load resistor across which the audio voltage is developed after rectification of the r.f. signal by the diode. C is the customary diode condenser. R1 is a 500,000 ohm potentiometer, the arm of which is connected to the audio amplifier stage of the combined diode triode or diode pentode valve, through the coupling condenser, C1.

By adjustment of the arm of R1 a greater or smaller proportion of the audio voltage is tapped off for injection into the control grid of the audio amplifier tube. R3 is the grid resistor necessary so that the amplifier tube will receive the bias developed across cathode resistor, R2.

The auxiliary resistor, R, is not always used, and in this case R1 is connected between cathode and the return of the i.f. transformer secondary. However, with modern high gain audio amplifiers it has been found practicable to reduce the amount of audio voltage available across the diode load without seriously affecting the sensitivity of the receiver.

The idea of splitting the audio voltage divider, for that is what R and R1 really constitute, is that a much larger signal than normally can be applied to the diode from the r.f. section of the receiver.

Diode detectors operate best when called on to rectify comparatively high

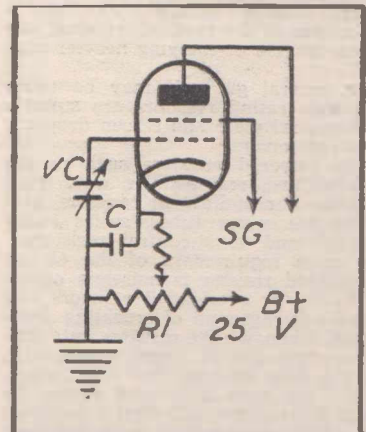

Fig. 3.—Control of volume by means of variable cathode bias.

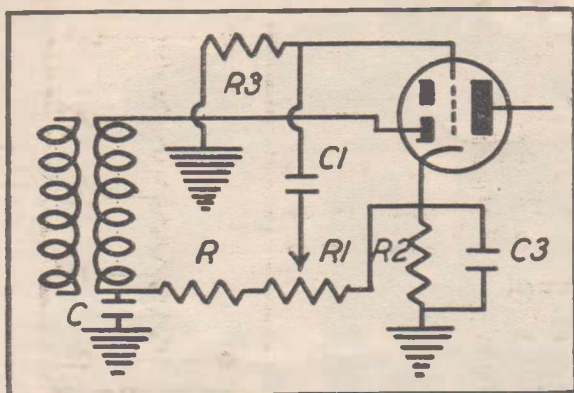

Fig. 5 shows a typical volume control circuit for a diode detector.

voltages and for this reason the proportion of R to R1 usually ranges from 1 to 5 or 1 to 2. R may be 100,000 or 250,000 and R1 500,000 ohms.

With R1 at 500,000 ohms the greater we make the resistance of R the smaller the proportion of the signal voltage developed across the diode will be available for the audio amplifier. If R was made equal to R1, then we should be able to take off only half the available rectified signal.

However, the sensitivity of the modern super-het. tuner unit and the gain of modern audio amplifiers is such that adequate signal sensitivity still exists in spite of such apparent wastage.

R.F. AND A.F. CHOKES

Other applications of fixed resistors to modern receivers include their use as r.f. chokes, audio chokes, and harmonic suppressors.

Resistance ranging from 100 to 250 ohms sometimes are connected in the oscillator grid circuits of super-heterodynes to prevent the generation of spurious signals which result in whistles in the receiver. The resistors are connected in series between the oscillator grid and the oscillator grid condenser.

However, they are likely to affect the short wave operation of the oscillator.

For r.f. choke purposes the resistor is particularly effective because it does not exhibit the frequency discrimination of inductive chokes of the ordinary type.

Values of from 10,000 to 100,000 ohms may be connected in series between the plate circuit of a detector tube and the following audio stage.

For audio choking purposes suppressor resistors ranging in size from 100,000 ohms to one half megohm are connected in series with the control grids of critical type pentode tubes to prevent the generation of super-oscillation.

It should be realised, however, that the latter method is wasteful of audio power and should be avoided if possible. Furthermore, such stoppers cannot be connected in the grid circuits of amplifiers which draw grid current during their operation.

VOLTAGE DIVIDERS

Finally we come to the question of voltage dividers. Although in most cases the set builder simply purchases a voltage divider of suitable resistance for the particular circuit he is employing, a knowledge of the basic design principles of these components is desirable.

In Fig. 6 is diagrammed a standard divider network connected across a

voltage source. Taps are taken off at the points A, B, C, D, and E for connection to various points.

The voltage divider serves two purposes. First, it is a means by which different potentials may easily be tapped off a main supply and secondly it

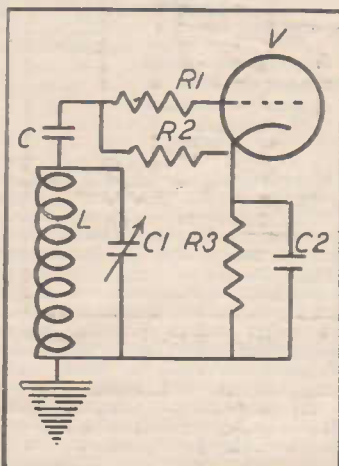

Fig. 7.—How a resistor is connected to suppress oscillator harmonics.

serves as a limiting load on the power supply and thus reduces the fluctuation of voltage under varying conditions of current drain.

We already have explained how the "bleed" current is taken into the consideration of power pack design. With

our present voltage divider we shall assume that the potential delivered between the points A and E is to be 250 volts. Consideration of the current power drain of the receiver and the output power of the pack indicate that we can permit a bleeder current of 10 m.a.

The voltage divider is to be made up from four separate resistances. At point B 20 m.a. is to be drawn, at point C 15 m.a., and at point D 10 m.a. How much current will flow through the various sections of the divider?

Remembering that we have a bleeder current of 10 m.a., we find that at the point D we have 10 plus 10 m.a., or 20 m.a., flowing. This flows through resistor CD. At the point C we have 15 m.a. flowing to the circuit. This plus the 20 m.a. drawn at D means that 35 m.a. flows through resistor BC.

At the point B we have 20 m.a. flowing, which, in addition to the current flowing through the preceding sections of the network, brings our total current through AB to 55 m.a.

Now we require the following potentials at the different points: B 200 volts, C 100 volts, and D 50 volts. What will the individual resistance values be?

The potential at point A is 250 volts. We want 200 volts at B. Therefore the voltage drop will be 50 volts at a current of 55 m.a. R equals E divided by C, so our answer is that resistor AB must be a 909 ohm one capable of carrying 55 m.a.

The potential at point B is 200 volts, and we want 100 volts at C. The current drain at C is 35 m.a., so, using the previous formula, we find that a resistance of 2857.1 ohms capable of carrying a current of 35 m.a. is required for resistor BC.

At point D we want 50 m.a. and the current flowing through the network at this point is 20 m.a., therefore the resistance CD must have a value of 2500 ohms and be able to carry a current of 20 m.a.

A 50 volt drop is required across resistor DE, and the current flow through this resistor is only the bleed current of 10 m.a. Consequently DE must have a resistance of 5000 ohms.

The total resistances, then, are 909 ohms, 2857 ohms, 2500 ohms and 5000 ohms, making a total of 11,268 ohms in parallel with the supply line. Provided that it was capable of carrying the 55 m.a. of current at its maximum end, a 12,000 ohm voltage divider could be purchased. Otherwise the unit would need to be made up from separate resistors of the correct value.

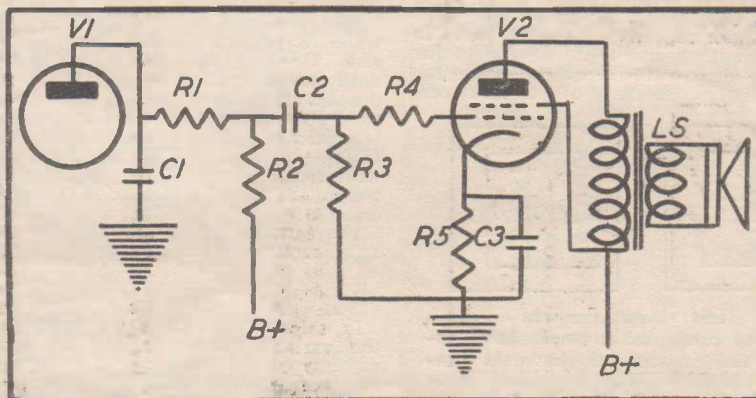

Fig. 8 illustrates the placement of resistors for r.f. and a.f. blocking.

CONDENSERS

● Fixed and Variable Capacitors — Band Spread Tuning — Reduction of Capacity by Series Connection — Padding Condensers. — Electrolytic Condenser Leakage.

WITH resistors, condensers comprise the bulk of the components in the radio receiver. And like resistors, condensers are made in both fixed and variable types.

The fixed types employ either paper, mica or an electrolyte as the dielectric whilst the variable types are insulated either by air, in the case of the true variables, or by mica in the pre-set compression type condensers.

One of the most puzzling things to the radio novice is the determination of the capacity of a variable condenser. Forgetting that the capacity of any condenser depends on the area and number of the plates, the dielectric separating them, and the thickness of this dielectric he thinks that two condensers having the same number of plates must necessarily have the same capacity. This is completely wrong, although, for general guidance, we may assume that the following number of plates in standard sized variable condensers result in the given capacities.

43 plate .001 mfd., 23 plates .0005 mfd., 13 plates .00025 mfd., 5 plates .0001 mfd. In the midget variables we can assume that a 23 plate has a capacity of .0001 mfd., a 17 plate .000075 mfd., a 13 plate .00005 mfd., a 7 plate .000025 mfd. and a 5 plate .000005 mfd.

Incidentally, the application of the micro-farad rating to condensers is rapidly passing out in favor of the handier micro-micro-farad because the latter permits the elimination of the decimal and the capacity of a .000385 mfd. condenser, for example, may be given as 385 mmfd. or a .000005 mfd. condenser as 5 mmfd.

The usual capacity of a gang condenser used for broadcast band tuning is from 385 to 410 mmfd. depending upon the particular make of condenser. Of equal importance to the set designer is the minimum capacity of the condenser. If this is high the tuning range of the set is unduly restricted.

Most standard gang condensers have a minimum capacity of around 18 to 20 mmfd., but special types developed for use in dual-wave receivers have the surprisingly wide range of 9 to 410 mmfd.

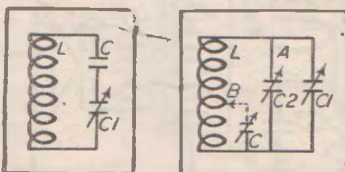
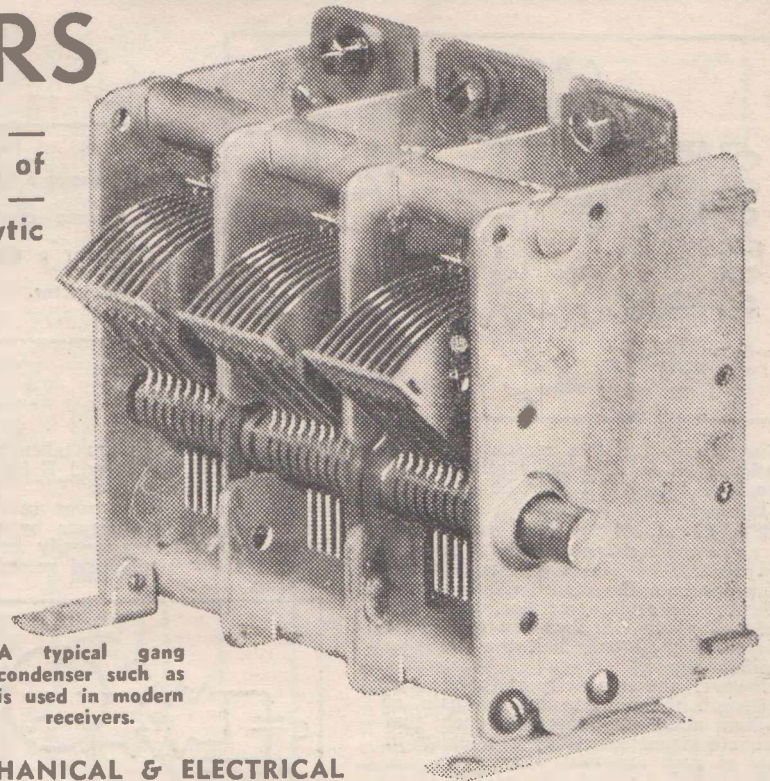

Fig. 1 (left) shows the way in which a series condenser is employed to reduce the capacity of the main tuning condenser. Fig. 2 (right) illustrates a band spread tuning system.



A typical gang condenser such as is used in modern receivers.

MECHANICAL & ELECTRICAL EFFICIENCY

IN selecting a gang condenser the main thing to see is that it is robust in mechanical design. Heavy plates which are unlikely to vibrate when struck by the sound waves from the loud speaker, good bearings which provide smooth mechanical movement, and the provision of wiper contacts to ensure good electrical contact, are features to be looked for in a gang condenser.

So far as midget condensers are concerned, particularly if they are to be used for short-wave work, it is desirable carefully to inspect the method used to maintain the spacing between rotor and stator. If at all possible, avoid those condensers which rely on a spring contact. It also is advisable to select condensers which use isolantite or similar plastics for the insulated end plates.

The capacities most useful for short-wave condensers are from 100 mmfd. down. The smaller the capacity the greater the band-spread, but the greater the number of tuning coils required to cover a given range.

Unfortunately, it is difficult in Australia to get low capacity gang condensers. One way over this is to use standard gangs and to connect fixed condensers in series to reduce the capacity to the desired value. This arrangement is shown in Fig. 1, where C1 is the variable condenser and C2 the fixed condenser. Note that C is connected between the fixed plates of C1 and the coil L.

The formula for determining the capacity required for condenser C is

$$C1 \times C2$$

$$C1 + C2$$

In this formula C1 is the capacity of the variable condenser and C2 is the capacity of the condenser it is proposed to place in series with it.

Assume we have a 400 mmfd. gang

condenser and want to use it in a short wave receiver where the capacity must be around 100 mmfd. Then, because the resultant capacity of series condensers is slightly below that of the smallest one of the two we can start off with the assumption that a 125 mmfd. fixed condenser will be necessary.

Thus

$$400 \times 125$$

$$525$$

which equals approximately 95 mmfd., which is near enough for our purposes.

Naturally if more than one series condenser is to be used as would be the case if the large variable was a two or three gang one it is essential that the fixed condensers should be fairly close to one another in capacity.

One advantage of this method of reducing the capacity of a condenser is that the reduction also takes place at the minimum capacity end of the scale so that the overall tuning range of the combination is improved.

BAND SPREAD TUNING

NEXT we come to the question of band spread tuning in short wave receivers. Although by judicious reduction of the capacity of the main tuning gang we can spread the stations fairly widely over the dial it will be found that this spreading is insufficient on crowded short-wave broadcasting and amateur bands. It then becomes necessary to connect an auxiliary condenser across the tuning coil. Fig. 2 shows how this is done. The main condenser, C1, may or may not have a fixed condenser in series with it.

However, the maximum capacity of C1 should be around 100 mmfd. Condenser C2 is a 25 mmfd. variable. It may be connected right across the coil as shown at A, or may be tapped across portion of it as in B. The band-spread effect

will be greater at B although less frequency coverage will be possible than with A.

The idea is that condenser C1 shall provide the rough adjustment, i.e. the "band set." The main tuning condenser will be C2. With this arrangement it is possible by correct proportioning of the tuning coil to spread even the 20 metre amateur band right across the tuning dial.

PADDERS & TRIMMERS

WE come next to the semi-fixed condensers. These include the trimmers on the tuning gangs, the trimmers on the i.f. transformers, and the padding condenser. The first two usually have capacities ranging from 2 to 50 or 100 mmfd. The condenser trimmer's range is from 2 to 30 mmfd. They are compression type condensers whose plates are separated by thin strips of mica. It is essential in handling these trimmers to take care not to fracture the mica. On condenser trimmers it is sometimes found that a complete short circuit of the tuned stage has been caused by the burred edge of the compression plate puncturing the mica and making contact with the grounded plate.

It should be noted that in receivers employing plug or switched in coils, it is undesirable to have trimmers on the tuning gang. Each coil should be individually trimmed, otherwise it is impossible to make them track. The compression type padding condensers have capacities around 400 mmfd. for a 465 k.c. i.f. or around 750 mmfd. for 175 k.c.

Sometimes in 175 k.c. receivers a fixed condenser of suitable capacity is connected across a small capacity semi-fixed padder. On short-waves fixed capacities are used for padding or, with carefully built coils, no padding is used at all.

The point in the oscillator grid circuit at which the padding condenser is connected is not important so long as it is in series with the tuning condenser and the oscillator grid winding.

In Fig. 3 is shown a method often used by commercial set manufacturers. Here the padding condenser is connected at the "hot" side of the grid winding and

used as an oscillator grid condenser as well as a padding condenser. In Fig. 4 a separate oscillator grid condenser, C, is employed, and the padder is connected between the "cold" end of the oscillator grid winding and earth.

This latter scheme is to be preferred if the receiver is to operate on short-waves as well as on the broadcast band.

FIXED CONDENSERS

IN the fixed condenser class we have paper dielectric condensers, mica condensers, and electrolytic condensers. Each has its range of applications. Paper condensers from .05 to .5 mfd are used for by-passes and sometimes for audio coupling condensers.

The most usual by-pass capacity on cathode, screen and "B" return circuits is .1 mfd, although occasionally a .25 or .5 mfd condenser may be needed where r.f. feedback is prevalent.

The voltage ratings of any condensers used on high voltage d.c. always should be watched. It is of no use placing a condenser having a working voltage rating of 400 on a circuit in which 500 volts is flowing. The test voltage of a condenser has little bearing on its application. It is the working voltage which must be considered.

It always is wise to connect a .1 or .5 mfd. paper condenser from the set side of the power filter to earth. The electrolytic condensers in the filter can handle the low frequency component of power rectification, but they do not behave well so far as radio frequency currents are concerned. In some cases the special non-inductive type paper condensers which are provided with braided wire connecting leads will be found helpful in clearing up r.f. instability.

Wherever possible, use mica condensers, both for their reliability and their freedom from r.f. losses. This applies particularly to the grid condensers and to the a.v.c. coupling condensers and diode load filters.

Small capacity mica condensers, from 50 to 200 mfd. will be found useful as filters in the plate and grid leads of the first audio tube. Incidentally, connection of condensers ranging from 500 mfd. to .005 mfd. between the plate or the grid of an audio tube and earth will be found useful in limiting the high frequency response of a receiver or in cutting out the background hiss and rattle often heard on the short waves.

CATHODE BY-PASSES

THE question of cathode resistor by-pass capacities is one which often puzzles the novice. Broadly, the capacity of the cathode by-pass should be high enough to present a negligible opposition to the flow of alternating currents in the frequency range to be handled.

For r.f. currents such as encountered in the mixer and i.f. stages of a superhet, a capacity of .1 mfd. is adequate. However, in the second detector stage, where the diode triode or diode pentode handles audio as well as r.f. currents, a high capacity condenser is required.

For this and other audio cathode by-passes a 25 mfd. electrolytic condenser is usually employed. It is essential in using any electrolytic condenser to see that it is connected in the right polarity. If the chassis is at negative potential, then the negative lead of the electrolytic and the "outside foil" leads of all paper condensers must be earthed.

If the receiver utilises a "back bias" system in which bias for the output tube

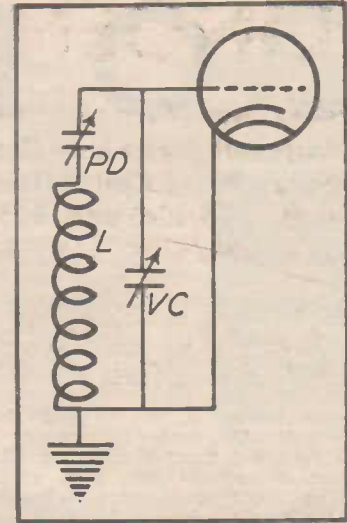

Fig. 3 illustrates one method of connecting the padding condenser in the oscillator grid circuit.

is derived from a resistor connected between the high voltage centre tap of the power transformer and earth then the negative lead of the by-passing electrolytic must join to the transformer centre-tap.

It should be stressed that in the case of the cathode by-pass for the second detector tube the electrolytic condenser should have a .1 mfd paper condenser connected in parallel with it to provide adequate r.f. by-passing.

Refer now to Fig. 4, where we find a condenser, C2, connected between the plate supply to the oscillator section of the mixer and earth. If the receiver is to operate on short as well as broadcast wave lengths this condenser should consist of 8 or 10 mfd. electrolytic and .1 mfd. paper condensers.

The purpose of this is to remove any irregularities in the power supply and so to overcome the "flutter" effect often heard when the set is tuned to a short wave station.

ELECTROLYTICS

FINALLY we come to the electrolytic condensers used in the filter circuit. These ordinarily are 8 mfd. capacity condensers, although sometimes 16 mfd. condensers are used.

These condensers should be rated for at least 25 per cent. higher working voltage than will be delivered from the power pack and rectifier. For example, if the power transformer is rated at 385 volts it will deliver some 420 volts to the input of the filter. The first electrolytic condenser, then, should have a working voltage of 500, or, better still, 600. The second electrolytic may be a 450 volt type.

Take particular care in laying out the chassis to keep the electrolytic condensers away from the heat generated by the rectifier and output tubes and the power pack. If you have any doubt about the efficiency of the electrolytics connect a milliammeter in series with them whilst the working potential is applied. The leakage current of a good electrolytic should be about .2 m.a. per microfarad or 1.6 m.a. for an 8 mfd. unit.

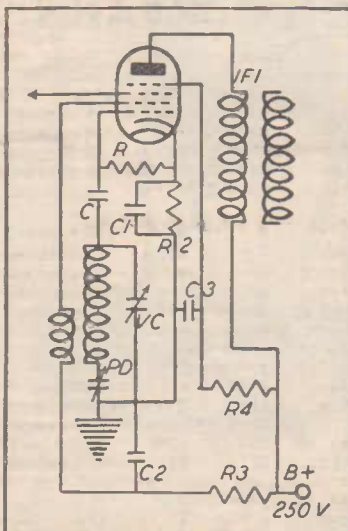

Fig. 4.—A standard oscillator circuit in which the padding condenser, PD, is connected at the low potential end of the grid coil.

COILS

● Advantages of Iron Cores — High Input Gain Desirable — Short Wave Coil Details — Band Spread S.W. Coils — 175 k.c. and 465 k.c. Oscillator Details

THE efficiency of the tuning coils used in a receiver has a very important bearing on the operation of the receiver. Unless the coils are properly designed the receiver will lack sensitivity, selectivity and wide coverage of the frequency band over which it is expected to tune.

Today, except in the field of short wave coils the home construction of radio coils is a thing of the past. Mass production methods have been applied with particular advantage to radio coils and the machinery used for their construction is extremely intricate. Most modern coils are wound honeycomb fashion and the home builder finds it well nigh impossible to duplicate this type of construction.

Recognising this we shall deal only with the construction of basic types of coils so far as the broadcast band is concerned. The types we propose to deal with can be accepted only as compromises and are not to be compared with the better quality commercial coils.

For short wave reception the home constructor still may wind his own coils secure in the knowledge that if he winds them in accordance with the general principles we shall set out they will be every bit as effective as the average commercial types.

IRON OR AIR CORED

Now existing commercial coils fall into two types. We have the iron cored and air cored coils. The former are to be preferred because they are considerably more efficient and in addition to providing higher gain have greater selectivity than the air cored varieties. The same thing applies in the case of i.f. transformers.

The general trend today is to use what is known as high impedance coupling coils. Instead of relying upon primary windings consisting of a few turns of wire more or less loosely coupled to the secondary winding for the best transfer of signal energy, the practice today is to employ a large number of primary turns mounted so that small inductive coupling exists between primary and secondary.

The real coupling is provided by means of a capacity. In some types of coil this capacity effect is obtained by running a link of wire from the "hot" end of the primary coil and winding this closely around the hot end of the secondary winding.

Actually, the link wire does not usually make a complete turn around the secondary winding, being terminated about three-quarters of the way around the secondary coil. No actual connection is made to the secondary coil.

FLEXIBLE COUPLING

The second method, and one largely used by manufacturers of the highest grade coils is to use condenser coupling

between the primary and secondary coils. A small condenser, having a capacity variable from some 2 to 30 micro-microfarads, is connected between the "hot" ends of primary and secondary windings.

The capacity of this condenser to a large extent governs the operation characteristics of the coil, and is used in conjunction with the primary winding to control the amplification of the coil throughout its tuning range.

The high impedance primary winding is so constituted as to resonate at a low frequency outside the highest wavelength to which the coil tunes. This resonance point is usually set about 530 k.c. The effect then is to bring the primary more and more into tune with the secondary as the receiver is tuned from 1500 to 545 k.c. so that at the high wavelength end of the dial the sensitivity of the receiver is boosted.

Now, because the capacity of the coupling condenser is small its value as a coupling medium is very small at the low frequencies but is quite useful at the higher frequencies. Thus we have a coil whose coupling characteristics can be made quite even or "flat" over the whole frequency range.

The greater the capacity of the coupling condenser the less will be the selectivity of the coil at the high frequencies, but the greater the gain will be from 1500 to around 1000 k.c.

HIGH INPUT GAIN

In designing any receiver it is essential that the gain between the aerial and the grid of the first stage amplifier be as high as possible. This is necessary to reduce the effect of valve noise in the receiver itself. It will be realised that apart from their actual effect on the receiver's overall sensitivity the use of high gain aerial coils is very desirable.

Standard iron-cored aerial coils have gains ranging from 4 to 25 between the aerial and grid windings. Air-cored coils will range from less than unity to perhaps 6 or 8 with high quality coils.

The yardstick by which a coil's "goodness" is measured is its "Q Factor." The higher the Q Factor the better the coil. The "Q" of a very good broadcast band air-cored coil of commercial dimensions may reach 120, but an iron-cored coil can be as high as 360, although more normal "Qs" would range from 200 to 250.

Incidentally the "Q" Factor for two coils must be taken at the same frequencies in order that the relative efficiencies of the two can be compared.

The best types of coils are those high impedance types which have their secondaries wound with Litz wire and are fitted with iron cores. Coils of this type have a really high performance characteristic both from the selectivity viewpoint and from the viewpoint of aerial to grid gain.

SHORT WAVE COILS

When we come to short wave coils we find the "Q" is still the yardstick by which performance is measured. Broadly, though, we can assume that short wave coils wound with heavy gauge wire on formers ranging from 1/2 inch to 1 1/2 inches in diameter will give as good results as any. The main thing to watch in making short wave coils is that they are wound on good quality dielectric formers. Actually the less solid dielectric there is in the fields of the coils the better the Q Factor.

This is one reason for the popularity

SHORT WAVE COIL DETAILS

Wave Range.	Aerial Coil		R.F. Coil		Reaction.	Wire Gauge.
	Primary.	Secdry.	Primary.	Secdry.		
150 mmfd. Capacity.						
12 to 21 metres	2	3	2	3	2 1/2	16 enamel
19 to 32 Metres	3 1/2	6	3 1/2	6	4	18 enamel
30 to 52 metres	8	15	8	15	8	22 enamel
48 to 83 metres	10	26	10	26	9	24 enamel
75 to 115 metres	12	33	13	33	11	24 enamel
100mmfd. Capacity.						
12 to 18 metres	2	3	2	3	2 1/2	16 enamel
17.5 to 25.5 metres	3 3/4	7	3 3/4	7	4 1/2	18 enamel
25 to 37 metres	5	10	5	10	6	18 enamel
36 to 54 metres	7	16	7	16	8	22 enamel
53 to 82 metres	10	25	10	25	10	24 enamel
80 to 110 metres	12	34	12	34	11	24 enamel
75 mmfd. Capacity.						
12 to 16.5 metres	2	3	2	3	2 1/2	16 enamel
16 to 23 metres	3 1/2	7	3 1/2	7	4 1/2	18 enamel
23.5 to 33 metres	4 1/2	11	4 1/2	11	6	18 enamel
32.5 to 49 metres	6	17	6	17	8	22 enamel
49 to 74 metres	8	25	8	25	10 1/2	24 enamel
72 to 95 metres	10	35	10	35	12	24 enamel
50 mmfd. Capacity.						
12 to 16 metres	2	3	2	3	2 1/2	16 enamel
15.9 to 21 metres	3 1/2	6	3 1/2	6	4	18 enamel
20.5 to 31.5 metres	5	10	5	10	5	18 enamel
30 to 42 metres	7	16	7	16	7	22 enamel
41 to 62 metres	8	23	8	23	10	24 enamel
61 to 90 metres	9	36	9	36	12	24 enamel

of ribbed formers. Probably the best dielectric of all those easily obtainable is a ceramic. Other compounds such as those manufactured under various trade names, including Isolantite, Steatite, and Mycalex, also are excellent dielectrics and are favored by overseas coil manufacturers. The difficulty is to obtain the fabricated coil formers in Australia.

Next to them comes good quality bakelite. Some of the better quality bakelites give excellent results, although the same cannot be said of the moulded powders.

WIRE GAUGE SELECTION

Next to the coil formers we come to the question of winding wires. Wherever possible enamel insulated wire should be used. From a loss viewpoint silver-plated wire is best of all, but few experimenters will care to go to the trouble or expense of silver plating the wire.

Most effective results, judged by the Q Factor of the coil, are obtained when the length of the winding is approximately half the diameter of the coil former. From this it can be seen that it does not pay to use heavy gauge wires for coils which employ a large number of turns. On the smaller coils for very high frequency reception the use of heavy gauge wire suitably spaced will enable the "form factor"—length to diameter ratio—to be retained.

Shielding of short wave coils should be handled with care and no metal should be brought nearer than 1 inch from the coil. Incidentally, the "hot" end of the coils should be kept as far away from the metal chassis as practicable.

In referring to the "hot" end of a coil we refer to the end of greatest r.f. potential. In secondary windings this is the end of the coil normally con-

nected to the grid circuits. In primary windings it is the aerial or plate end of the coil.

Now there are one thousand and one different coil combinations for short wave receivers because only small changes in the capacity of the tuning condenser will have a marked effect on the frequency range of a given coil.

For this reason we shall content ourselves with giving a list of the coil windings necessary to cover the 12 to 100 metre wave range with four standard capacity tuning condensers.

These coils are intended for use with tuned radio frequency receivers. The coils should be wound on 1 1/4 inch diameter formers with the various gauge wires specified. The gauges listed are for the Aerial and Detector grid coils. The other windings should be laid on with 32 gauge double silk covered wire.

S.W. COIL DATA

Modern practice is to interwind the Aerial and plate windings between the grooves formed between the turns of the respective grid coils. The aerial and plate windings are laid on in the same direction as the grid windings, but start from the "cold" or low potential end of the respective coils.

The reaction windings will, as usual, need to be experimented with because correct spacing and number of turns for the reaction windings will vary with individual valves and detector circuits.

These reaction windings are for the old style of regenerative detector in which control is effected by means of a reaction condenser connected between the plate coil and ground. We may be old-fashioned, but we still believe this type of regenerative detector gives better results than the new-fangled electron-coupled types.

If this coil winding data is to be used in conjunction with the design of a short-wave superheterodyne some trimming of the windings will be necessary. The oscillator grid winding, assuming that the superhet. is to operate on a 465 k.c. intermediate frequency, will have a slightly lower inductance than the mixer and r.f. grid windings, and, except at the very high frequencies where the feedback winding may have 75 per cent. of the number of turns on the grid winding, the plate coil will have from 40 to 25 per cent. of the number of turns on each grid coil.

In the short wave coil table the aerial coil is the one connected between aerial and the grid of the r.f. valve. The primary is the aerial coil proper, whilst the secondary is the r.f. grid winding. The R.F. coil is the one connected between the plate of the r.f. valve and the grid of the detector. The primary is the plate coil and the secondary the detector grid coil.

All windings should be laid on in the same direction. The wire gauges shown refer only to the grid windings. The two primaries and the reaction winding are wound with 32 or 34 gauge d.s.c. wire.

These coils may be either the plug-in variety or those wound on plain formers and joined to a wave-changing switch so that they can be cut in or out of circuit as desired.

COIL CONNECTIONS

Looking at an aerial coil from the bottom or "cold" end the connections are as follow: Bottom of primary to the earth. Top of primary to the aerial. Bottom of secondary to earth. Top of secondary to the grid. Similarly the

A typical high gain i.f. transformer in which isolantite is used as the insulating material supporting the trimmers. Note the separation between the primary and secondary windings.



connections of the r.f. coil are as follow: Bottom of primary to "B" plus. Top of primary to plate of r.f. valve. Bottom of primary to earth. Bottom of secondary to earth. Top of secondary to grid of detector valve. Bottom of reaction winding to plate of detector valve. Top of reaction winding to fixed plates of reaction condenser.

The reaction winding should be spaced 1/8th to 1/4 of an inch from the cold end of the grid winding. The coil details have been provided for a 23 plate midget condenser as reaction control. If it is desired to reverse wind the reaction coil to obviate tuning effects caused by inter-action between the r.f. and detector valves also reverse the connections to the reaction winding.

Coil-winding information is provided for a set of band spread coils to be used with a 465 k.c. short-wave superheterodyne in the table in page 22.

The aerial, R.F. and oscillator primaries are wound with 34 gauge d.s.c. wire interwound between the turns at the "cold" end of the respective secondaries.

The secondaries of the coils for the 9 to 21 metres and 11.5 to 27.5 metre band coils are wound with 18 gauge s.w.g. enamelled copper wire spaced 6 turns to the inch. The coils for the 26.5 to 58 metre band are wound with 20 gauge enamelled copper wire spaced 10 turns to the inch. The 56.5 to 130 metre coils are wound with 28 gauge enamelled copper wire spaced 32 turns to the inch.

All windings are laid on in the same direction on 1 1/4 inch diameter ribber formers. The coils are tuned by a three gang 180 mmfd. (.00018 mfd.) condenser as the band setting condenser and a three gang 35 mmfd. (.00035 mfd.) condenser as the band spreading condenser.

No padding condensers are used because each of the oscillator coils has been designed to track properly without the necessity for padding the oscillator tuning condenser.

Coming back to the design of broadcast coils, we provide the following winding data for standard super-het coils:—

For 175 k.c.—
Aerial Primary.—25 turns of 36 gauge d.s.c. S.W.G. wire.

R.F. Primary.—35 turns of 36 gauge d.s.c. S.W.G. wire.

Aerial and R.F. Secondaries.—130 turns of 30 gauge enamel S.W.G. wire.

Oscillator Primary.—25 turns of 30 gauge enamel S.W.G. wire.

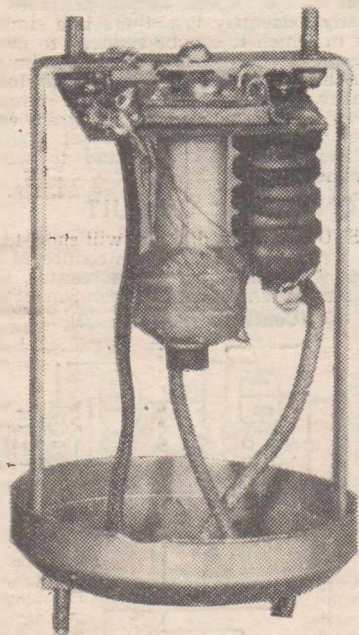

One form of high gain iron cored r.f. coil. The "pi wound" primary inductance can be seen at the top right. Above it is the smaller variable capacity used to transfer energy from the primary to the secondary winding.

Oscillator Secondary.—100 turns of 30 gauge enamel S.W.G. wire.

The aerial and r.f. primaries are wound over the cold ends of the aerial and r.f. secondaries. The oscillator primary is wound over the cold end of the oscillator secondary and is insulated from it by a single thickness of Empire cloth or writing paper. All coils are wound in the same direction on 1¼ inch diameter coil formers. The tuning condenser should have a capacity range from 18 to 35 mmfd. (.000385 mfd. maximum).

For 465 k.c.—

The same coil specifications are used for 465 k.c. super heterodyne, except that the oscillator secondary is wound with only 62 turns of 30 gauge enamel S.W.G. wire.

It would be absurd to claim that these home made coils could be as efficient as the modern commercial types, but the information on broadcast coils has been provided to help out those who may be in trouble with old type receivers.

One final word of warning in coil winding is that when soldering the coil leads to the connecting lugs — and they should be soldered to avoid trouble from high resistance contacts — endeavor always to use resin as a soldering flux and to avoid spreading paste type fluxes all over the coil former, where they will form high resistance leakage paths, which will destroy the efficiency of the coils and introduce noise into the receiver.

I.F. TRANSFORMERS

It is equally important that the i.f. transformers be efficiently designed for the type of receiver with which they are to be used.

As with r.f. coils, we have air cored and iron cored i.f. transformers. Some of the latter are what are known as the permeability tuned type in which the customary compression type trimmer is replaced by an adjustable metal plug which can be screwed in or out of the iron core. The secondary windings are set roughly to the frequency on which the i.f. transformers are to work by connecting a fixed condenser of suitable capacity across them. Fine adjustments are made with the aid of the iron core plug.

This type of i.f. transformer is particularly effective because it is not subject to the frequency variations which take place in the compression condenser tuned type due to aging of the condenser metal.

In some forms of condenser tuned i.f. transformers the compression type condenser is replaced with a midget air condenser. These air tuned i.f. transformers also are very free from unwanted frequency shift.

Apart from the methods used to tune them, there are other considerations involved in the selection of i.f. transformers.

Broadly, there are three main types, the high gain type, the high selectivity type, and the variable selectivity type.

The high gain type is normally employed in battery receivers, while the high selectivity type finds its greatest application in a.c. sets.

Where really high fidelity reproduction is desired, variable selectivity i.f. transformers are used.

These can be adjusted to pass a wide frequency band for high-fidelity reception or a narrow one for reception under

S.W. Super-Het. Coil Design

Wave Range	Aerial		R.F.		Oscillator	
	Pri.	Sec.	Pri.	Sec.	Pri.	Sec.
9 to 21 metres	1¾	2¾	1¾	2¾	2¾	3¾
11.5 to 27.5	2½	5¾	4½	5½	4	6
26.5 to 58 metres	5½	15¼	11	15	7	15½
56.5 to 130 metres	9	33	25	33	9½	36

conditions where inter-station interference is likely to be experienced.

The i.f. transformers should be selected for the particular type of service which the receiver is expected to give.

The exact intermediate frequency on which the receiver will work is another subject for consideration. Today we find that most sets, particularly the dual wave types, operate on a comparatively high intermediate frequency of around 460 k.c.

The other generally used i.f. is 175 k.c. but with recent advances in i.f. transformer design the 175 k.c. i.f. is rapidly going out of favor. Its image selectivity is poor compared with the 460 k.c. i.f.

and if no r.f. stage is used ahead of the mixer tube the receiver must be fitted with a pre-selector tuner.

There is little if anything to choose between the high and the low i.f. so far as stage gain is concerned.

For short wave super-heterodynes a still higher i.f. is sometimes used. This may be anything from 1000 to 2000 k.c. The idea is to eliminate the image interference at the higher frequencies. However, the gain of these very high i.f. amplifiers is low, and a two-stage amplifier will usually be necessary to provide the same gain on 1500 k.c. as is obtainable from a single stage amplifier working on 460 175 k.c.

Application of 1.4 Volt Valves

THE development of the 1.4 volt series of valves has opened up a new era of economy operation for battery set users. The new valves require only a single cell for their filaments and a maximum plate voltage of 90 volts. It must be admitted this economy is achieved at some sacrifice of performance, and although in average circumstances receivers built around the 1.4 volt types of valves will prove perfectly satisfactory, such receivers will not be nearly so sensitive as similar type sets employing the two-volt valves.

Nevertheless, the 1.4 volt valve will gain popularity with country set users chiefly because it is possible almost entirely to overcome the "A" battery problem in receivers in which they are used. A single dry cell will give over 200 hours' service on a four-valve receiver, while one of the special 1.5 volt "A" batteries developed by Diamond and Ever-Ready will give over 1000 hours' service without attention.

Another precaution which must be taken is that to prevent the application of too high a filament voltage when the "A" battery is switched on for the first time. This point is dealt with more fully in the section devoted to "A," "B," and "C" batteries.

Some of the valves, notably the diode triode 1H5G, are inclined to be microphonic. If this trouble is encountered, it can be overcome by mounting the 1H5G socket on sponge rubber supports.

Although the plate consumption of either of the 1.4 volt output pentodes is already extremely low, there is a simple way in which it can be reduced to even a lower level provided that maximum volume is not required from the loud speaker. The "Economiser" circuit shown in the accompanying diagram was developed by an American set manufacturer and has been found to work extremely well.

ECONOMISER CIRCUIT

A STUDY of this diagram will show that a resistor, RL, has been connected in series with the existing bias resistor, R9, and the condenser, C9, has been connected

(Continued on Page 53)

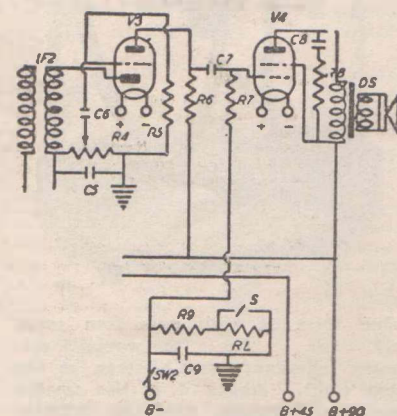

Circuit modifications necessary for economy operation.

MOUNT VERTICALLY

THERE are one or two points about the application of the 1.4 volt valves which should be thoroughly understood before any attempt is made to use them. First the valves cannot be satisfactorily used when mounted in any but a strictly vertical position. For mechanical reasons the valve filaments are placed extremely close to the other elements, and if any horizontal sag should take place the result would be a short circuit which would destroy not only the valve with the sagging filament, but all the other valves in the receiver.

Again, the extremely small current, .05 to .1 ampere, drawn by the 1.4 volt valve filaments, means that these filaments must be extremely fine and so they will not stand any severe overload. The best safeguard against filament burn-outs due to "B" battery short circuits is to use automatic bias in the receiver.

The resistance of the bias resistor usually is high enough to prevent the passage of sufficient "B" battery current to burn out the valve filaments should a short circuit take place.

THE 1.4 VOLT VALVE -

the Newest thing IN COUNTRY RADIO..



● Hailed as the greatest single step forward in the development of country radio, the new 1.4 volt valve is destined to make all other types of sets designed for use in non-powered districts obsolete and out of date! Operating on a filament current equivalent to that of a torch bulb, it makes accumulators and costly substitutes unnecessary. Ask your dealer when he will have a 1.4 volt receiver available.

1.4 volt receivers use dry batteries—the smoothest and most reliable source of power for outback radio . . .

But their current consumption is so low that the Ever Ready "A" battery illustrated gives over 950 hours of service!

The 1.4 volt valve eliminates the need for accumulators, recharging and costly substitutes. It means CHEAPER radio for you!

Field tests have PROVED the value of the 1.4 volt radio. "It has a great future," says the "Radio Retailer," mouthpiece of the industry in Australia.

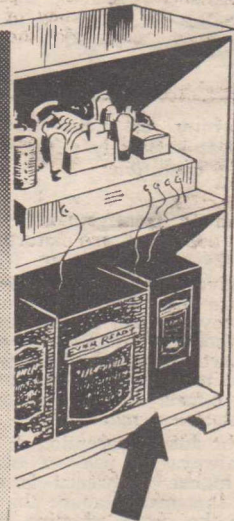

Compact and convenient, the Ever Ready 1.5 volt dry battery specially designed for use with the 1.4 volt valve gives you over 950 hours of service for 15/-! This means that you need no replacements, no recharging costs, no further outlay for NEARLY A YEAR!

● Many Australian radio manufacturers have already produced 1.4 volt radio receivers because they know that, for value and better service to the country listener, they have no equal. Ask YOUR local dealer when he will have 1.4 volt models available for delivery.

THE EVER READY CO. (AUST.) PTY. LTD.
Harcourt Parade, Rosebery Sydney
A4.

EVER READY
RADIO BATTERIES

AERIALS

● Design Details — Indoor and Mains Aerials — Short Wave Doublets — Directional Effects — Impedance Matching of Transmission Lines — Noise Reducing Aerials.

EXCEPT in cases where reception of short wave stations is desired the average experimenter gives little thought to the aerial system with which his receiver is to be used. Quite fre-

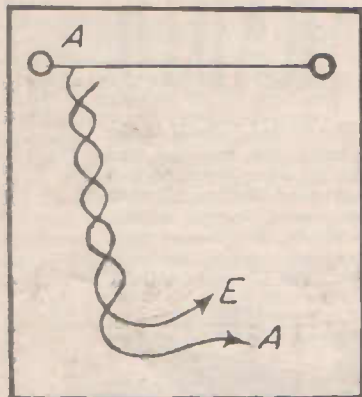

A simple form of noise-reducing aerial which is extremely effective in operation.

quently it consists merely of a few feet of wire draped around the picture railing.

This may give apparently good results simply because the receiver is sensitive enough to provide good signal strength with even the most inefficient aerial. However, apart from its efficiency the modern aerial must be so designed as to mitigate the effects of the interference created by electrical machinery.

Even for broadcast reception it is a good rule always to use an outdoor aerial. The higher the aerial is above ground—and that means above the level of buildings—the more effective is the signal pick-up and the less likelihood of trouble from electrical interference.

Indoor aerials are usually right in the fields of the household electric wiring and so pick up every disturbance circulating through the supply cables. The outdoor aerial need not necessarily be a long one. Modern technique is to use quite short aerials and to connect them to the receiver through what are known as transmission lines.

For all normal broadcast reception an aerial fifteen to twenty feet in length will be adequate. It should be erected as high as possible above ground and in cases where interference is experienced from overhead electric light lines, or electric train or tram supply lines, an effort should be made to get the aerial above these sources of noise.

Then, by connecting the aerial to the receiver through a transmission line which itself is incapable of picking up either a signal or the electrical interference through which it passes the

outside pick-up of the set, is confined to that of signals and natural static.

PRACTICAL POINTS

In all aerial construction use heavy gauge hard drawn copper wire, or stranded wire. The longer the span of the aerial the heavier should be the wire gauge. For the ordinary 20 metre half wave doublets in use today 16 gauge copper or 7/22 stranded wire may be used.

For most applications it is desirable that the wire be insulated either by means of an enamel coating or by being covered with rubber and braid. This is particularly important in the cities and near the sea, where smoke and the effect of the salt soon corrode the aerial wire and causes it to lose its electrical efficiency.

The insulators should be either glazed porcelain or one of the Pyrex or other forms of glass. They should be of the strain type, and large enough to provide a long leakage path in addition to being strong enough to withstand the stress of the aerial itself. Standard 2½ to 3 inch porcelain insulators or 3½ inch corrugated glass insulators are best.

Now let us review some of the simpler forms of aerials. For broadcast work we may use a single horizontal wire to which is attached one wire of the pair of a length of lighting flex. The wire is soldered to one end of the aerial. The other wire of the pair is folded back at the aerial end and taped down securely.

At the set end the wire which was soldered to the aerial joins to the aerial terminal. The other one of the pair is earthed. This form of aerial is quite effective as a noise reducer and does not seriously affect the set's sensitivity.

The other form of broadcast aerial we shall deal with is the so-called "mains"

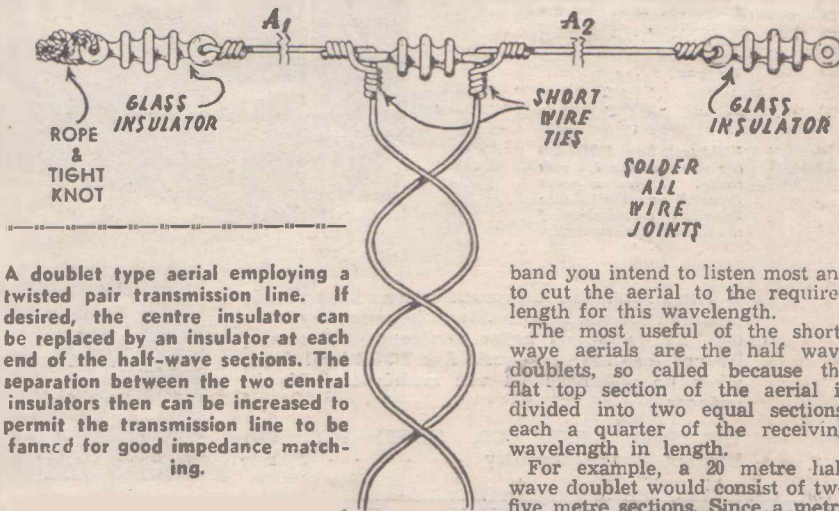

A doublet type aerial employing a twisted pair transmission line. If desired, the centre insulator can be replaced by an insulator at each end of the half-wave sections. The separation between the two central insulators then can be increased to permit the transmission line to be fanned for good impedance matching.

aerial. Although this is not to be recommended, because it is even more subject to electrical interference troubles than the indoor aerial, there are cases where it simply must be used.

In the "mains" aerial the aerial terminal of the set is joined to one side of the a.c. power line through two high quality mica condensers. The first may have a capacity of .01 mfd. and be connected to the primary of the power transformer.

It is used to provide an adequate safeguard against electric shock. The second one will need to be a much smaller capacity because of the loading of the mains on the set's input circuit. Capacities from .0001 to .00025 mfd. will be found suitable. The small condenser is connected between the set's aerial terminal and the large condenser.

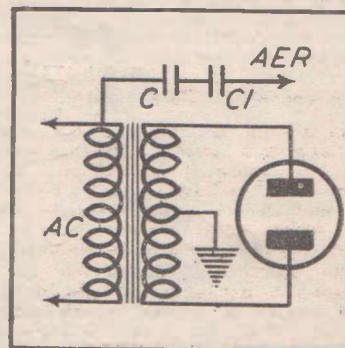

How the condensers are connected to the power lines for a "Mains Aerial."

SHORT WAVE AERIALS

When we come to short-wave reception we find that the choice lies between the aerial which is tuned to a definite wavelength and the so-called "all-wave aerial." Unless the latter has been specially designed for the receiver with which it is to be used it will not be efficient. Even if it is specially designed, the all-wave aerial is merely a compromise and will be easily out-performed by an aerial which has been definitely tuned for reception on a given wavelength.

The moral, then, in short-wave reception is to decide on which wave-

band you intend to listen most and to cut the aerial to the required length for this wavelength.

The most useful of the short-wave aerials are the half wave doublets, so called because the flat top section of the aerial is divided into two equal sections, each a quarter of the receiving wavelength in length.

For example, a 20 metre half wave doublet would consist of two five metre sections. Since a metre

is equal to 39.37 inches this means that each section would be 16.4 feet in length.

Each section of the flat top should be provided with an insulator at each end. When the two sections are joined together the transmission line, which consists of the already mentioned twisted flex, is attached to the centre of the aerial.

One of the pair of transmission line leads is attached to the A1 quarter wave section of the doublet, whilst the other is attached to the A2 section. This is shown in the diagram which assumes that the aerial and transmission line are all in one piece. Such a procedure is hardly ever likely to be followed.

Now, if we have two insulators in the middle of the aerial it follows that we can alter the distance between each quarter wave section. The advantage of this is that we can obtain a better impedance match between the transmission line and the aerial.

"FANNING" THE LINE

By spacing the two flat top sections anything up to a metre apart and spreading the twisted pair line so that it begins to "fan" at a point about two metres from the aerial it will be found that better signal strength, due to the better impedance match, is obtained.

The transmission line should be cut similarly to the aerial. It should be an odd number of quarter wavelengths in length. If the aerial is a 20 metre one then the transmission line may be 5, 15, 25, 35 or 45 metres in length, but must not be 10, 20, 30 or 40 metres in length. The line should be cut to the nearest usable length and coiled up if too long.

The transmission line should not be connected between the aerial and earth terminals of the receiver. It is necessary that it shall operate above ground, so to do this it is essential for it to join to the ends of the aerial coupling coil. The end of this coil, which normally would be earthed, must be taken to a separate insulated terminal. The normal earth lead is taken to the conventional earth terminal on the chassis.

DIRECTIONAL EFFECTS

Now, nearly all aerials have directional properties, that is, they receive better from some directions than from others. This is rather fortunate, for the aerial can then be designed to give most efficient response from desired directions and exclude noise and interference from other directions. The problem confronting the average short-wave enthusiast is what kind of aerial to install for efficient reception from a given direction.

Let us suppose that we wish to receive signals from an ultra shortwave station which lies due south of us and that the frequency of transmission is 46.5 megacycles (6.45 metres, or 21.15 feet). If we lay the doublet east and west, as shown in Fig. 1, efficient reception will be obtained from the N-S direction, as shown by the lobes; the lobes merely show the direction from which the most efficient reception takes place. We may run into a practical difficulty here — the construction of our roof may be such that an E-W aerial is out of the question.

The way to solve the problem with the doublet in this case is to make the aerial longer than one-half wavelength, for the directional properties of a doublet

change when its length is changed. But we must be careful to increase its length by half wave lengths, thus, we may increase it to one wave length, one and one-half wave lengths, two wave lengths and so on.

LENGTH AFFECTS DIRECTION

Fig. 2 shows how the directional properties of the doublet change as its length is changed. It should be noted, although it is not shown in the figure, that as the length is increased, the length of the lobes increases, and a greater signal is picked up.

Suppose that we consider doublet (b.). Here we see four lobes, each one making an angle of 54 degrees with respect to the aerial wire. Hence, if the condition of our roof is such as to permit the erection of an aerial one wave length long (6.45 metres or 21.15 feet) and at an angle of 54 degrees toward the east from the horizontal direction, we will receive the station due south of us with good strength — in fact, 20 per cent stronger than with the conventional E-W half-wave doublet. In addition, we will receive signals from three other directions with equal efficiency.

The doublet one and one-half wave lengths long has six lobes (see C), each giving 40 per cent more signal than the conventional half-wave doublet. Four of these lobes make angles of 42 degrees with respect to the wire and two make angles of 90 degrees with respect to the wire. With an aerial of this length, therefore, we have quite a bit of leeway with regard to direction, although the space requirements are getting harder to satisfy — one and one-half wave lengths correspond to 31.75 feet.

The doublet, which is two wave lengths long (see D), has four large lobes, each making an angle of 36 degrees with respect to the wire, and two short lobes. The short lobes show that some, although poor, reception is obtained from the directions corresponding to those of the short lobes.

Of course, in the directions where lobes are not shown no reception is obtained.

"V" AERIAL SELDOM USED

The V aerial is one that has marked directional properties, although it has not been in general use among amateurs for 10 years or so. The V aerial is simply a doublet, bent around as shown in Fig. 3. If the length of each leg

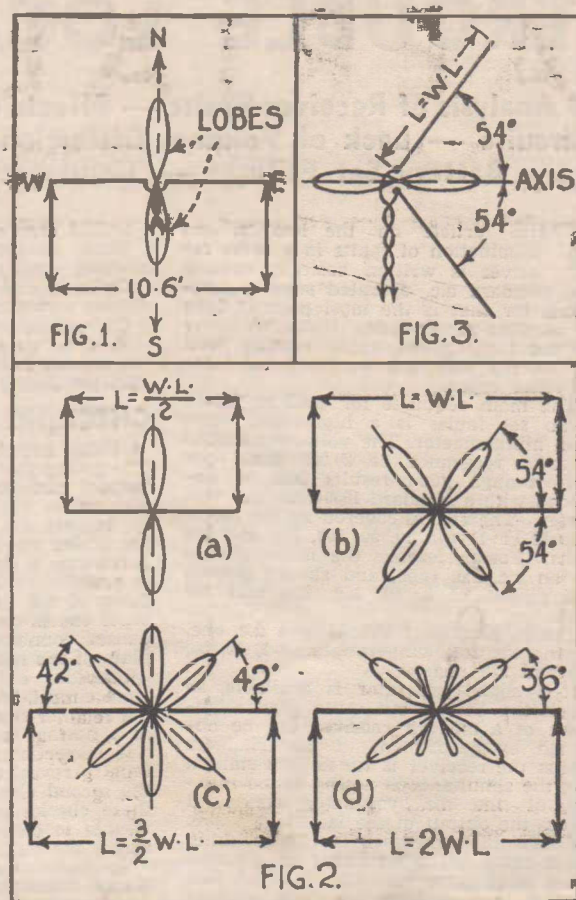

A series of explanatory diagrams showing the pick-up characteristics of different types of aerials.

(L) is made one wave length, the aerial will be very directional along its axis, provided each leg makes an angle with the axis of 54 degrees.

If each leg is made two wave lengths long, and if each makes an angle of 36 degrees with respect to the axis, the directional properties will be as shown in Fig. 3, but the signals will be correspondingly stronger. In other words, the longer each leg, the greater the signal strength.

The foregoing facts lead to a very interesting conclusion. Suppose that we erect a 49-metre half-wave doublet (actual aerial length is 24.5 metres); the directional properties are then as shown at (a) of Fig. 2. Now, should we tune to a signal of 24.5 metres, the aerial then corresponds to one wave length long and signals will be received from the directions indicated by the lobes of (b) Fig. 2. And should we desire a signal of 12.25 metres, the aerial is really two wave lengths long, and its directional properties will be as shown by (d) of Fig. 2.

Of course, all these results are modified somewhat by the presence of the earth, but if the aerial is at least one wave length high they are pretty close to being correct.

TROUBLE LOCATION

● Analysis of Receiver Faults — Effects of Short and Open Circuits — Lack of Volume, Distortion and Whistles — Battery Set Failures — Condenser Leakages.

THIS article on the location and elimination of faults in a radio receiver is written basically around the standard a.c. operated super-heterodyne, for that is the most popular type of receiver in use today. However, many of the hints given apply equally well to battery and a.c. operated receivers of other types.

The main requisite for tracking down radio set faults is a high-grade volt-ohm milliammeter. The voltmeter should have a resistance of 20,000 ohms per volt, though good results will be obtained with a standard 1000-ohm per volt meter. The ranges covered by the meter should be 1 volt, 10, 50, 100, 250, and 500 volts. For preference the meter should be an a.c.-d.c. type, and should possess a.c. ranges of 5, 50, 100, 250, and 500 volts.

The milliammeter should be a d.c. one, having the following ranges:—0-1, 10, 50, 100 and 250 m.a.

If a signal generator is available, so much the better; but quite good alignment of a modern receiver can be obtained by adjustment of the trimmers whilst the receiver is tuned to a station, and the simultaneous noting of the reading of the a.c. voltmeter connected across the output of the last stage valve.

Above all, remember that in tracking down radio faults an ounce of common sense is of more use than a bench full of test instruments. Carefully analyse the symptoms of any receiver before attempting to track down the trouble.

Incidentally, these trouble-hunting tips cover only the procedure to be followed in endeavoring to make a properly designed set function. Other faults caused by incorrect lay-out and similar constructional weaknesses already have been covered in other sections of this manual, and should not be present in the properly designed receiver.

We can summarise the faults likely to be encountered in any radio receiver under four general headings. These are:—

- (1) Complete lack of signals.
- (2) Lack of volume.
- (3) Distortion.
- (4) Crackles and whistles.

COMPLETE LACK OF SIGNALS

IF the receiver fails to give any indication of being "alive"—this can be determined by touching the grid cap of an audio valve whilst the grid clip is removed, or by touching the aerial terminal of the set—any one of the following faults may be present:—

- Burnt-out rectifier valve.
- Broken-down filter condensers.
- Open-circuited field winding or filter choke.
- Short circuit in the "B" plus bypass condensers.
- Open circuit in the "B" supply line to the r.f. or a.f. valves.
- Faulty valves (especially the mixer tube).
- Open-circuited cathode resistors.
- Open circuits in the r.f. or i.f. windings.

Shield cans shorting to the grid clips. Short circuits between the braid of braided leads and the inner conductor.

Open-circuited loud speaker transformer secondary.

Open-circuited voice coil winding.

Now let us assume that we are looking for the fault which has rendered the receiver inoperative.

CHECKING FOR TROUBLE

AFTER switching on the power and giving the valves time to warm up, inspect each to see that the heater or filament is alight. Assuming this to be so, inspect the rectifier tube to note if the plates are becoming red-hot. If such is the case, a short circuit is taking place. It probably will be caused by a breakdown of the first electrolytic condenser, or, if one is used, the hum-bucking condenser connected between filament and plate of the rectifier.

Unsolder either of these components from circuit, and note if the overload on the rectifier ceases and the plates operate at a normal temperature.

If inspection of the input to the filter fails to reveal anything wrong, unsolder the second electrolytic condenser. Whilst these checks are taking place it is advisable to connect a high-voltage meter across the output of the "B" supply.

Complete absence of signals is almost always characterised by a heavy drop in the supply voltage. Assuming the voltage still to be down, replace the leads to the second electrolytic, and then progressively unsolder the bypass condensers from the "B" plus line.

If the fault still persists and the supply voltage remains abnormally low, then it will be necessary to look for short circuits between the various feed resistors and chassis. Excessive heat on any of these resistors will immediately give a clue to the "short."

Should a voltmeter check show that voltage is present on the rectifier side of the filter and not on the set side of the filter, the fault will lie in the filter choke or loud speaker field winding.

Perhaps there is a supply voltage available at the output of the filter, yet there is no voltage being applied to one or more valves. The remedy then is to track down the various "B" supply lines until the cause of the open circuit is discovered.

Besides checking the "B" supply line voltage also check the potentials at the plate and screen lugs of each tube. Remember, though, that apparently low voltage will be read by the average meter when connected to the plate lugs of resistance coupled tubes. This is caused by the voltage drop across the resistor brought about by the current drain of the measuring instrument.

If plate voltage is available at each tube, then measure the potentials from plate to cathode to make sure that no cathode resistor has open circuited.

Check all the sockets and the connections to them to make sure the fault does not lie here. Watch also for breakdowns between the primary and second-

ary windings of r.f. coils or between the plates of the midget coupling trimmers used in modern iron cored coils.

OPEN SPEAKER TRANSFORMER

A FAULT which is not usually recognised speedily by the average experimenter is that caused by an open circuited winding on the speaker input transformer. If a pentode output tube is used in the set, this fault will show up in the form of a red hot screening grid in the output tube. If the secondary of the output transformer or the speaker voice coil winding is open circuited a faint rattle of the output transformer laminations will be heard when the set is tuned to a station.

We have left till last the most obvious—and therefore the least looked for—cause of no signals.

This is the earthing of the amplifier or mixer tubes by the contact between the screening cans and the control grid cap.

In a similar category comes the short-circuiting of audio or r.f. circuits in which braided wire is used. The braid frays and comes into contact with the inner conductor.

It may be found that all voltages are correct, and that no breakdowns exist anywhere in the circuit. In this case it is logical to suspect the mixer tube. The oscillator section may not be functioning. A rough check of this can be obtained by touching the oscillator grid lug on the socket with a screwdriver blade.

A slight click should be heard in the speaker as the blade makes contact with the socket lug.

A more positive check is to connect an 0-1 m.a. meter in series between the oscillator grid leak and earth. The meter should read from .1 to .4 m.a. as the tuning condenser is swung throughout its range. Should the grid current drop to zero at any point it will indicate that the oscillator section has ceased oscillating.

Finally, it is desirable to check all the valves in the receiver to make sure that none of them is so low in emission as to prevent the set from functioning nor has any internal shorts between its elements.

LACK OF VOLUME

THIS condition often is encountered even in comparatively new receivers. Broadly, we can assume it to be caused by one or more of the following:—

- Weak valves.
- Low "B" supply voltage.
- Low filament supply voltage.
- Mis-alignment of the tuning circuits.
- Open-circuited r.f. or i.f. windings.
- After checking the plate voltage and discovering whether or not it is normal, check over the filament voltage with an a.c. meter. Often it is found that the short-circuiting of the dial light leads either at the socket or inside the socket itself reduces the potential at the valve sockets.

The cause of low "B" supply voltage already has been covered. Heating of the dial light leads or dimming of the lights will give a speedy indication of a short.

Next check over the r.f. and m.f. windings with a continuity meter to make sure that no open circuit has occurred.

Should these tests fail to show where the trouble lies align both the r.f. and

i.f. circuits. If the set is still insensitive, then the valves, probably the audio ones, are at fault.

CRACKLES AND WHISTLES

ONE of the most generally encountered troubles in a super-het is crackling. This is usually caused by:

- Faulty resistors.
- Faulty Condensers.
- Loose contacts at the valve sockets.
- Leaky audio or output transformer windings.
- Fault in the power transformer.
- Outside electrical interference.
- Interference coming through the power line.

Start by looking for this fault by assuming that the noise is coming in from the outside. Remove the aerial from the receiver and if the noise stops or diminishes greatly you can be sure that it is caused by nearby electrical machinery. The remedy then is a noise suppression type of aerial.

If the noise is reduced greatly, but still is present in a noticeable degree, short circuit the mixer tube by bridging the control grid to chassis. If the noise still persists short circuit the i.f. amplifier tube and progress similarly to the first stage audio tube.

Should the noise cease at any point in this progressive elimination test it will pay to examine the resistors and condensers associated with the circuit immediately preceding the valve concerned. Valves themselves can give rise to considerable noise, and it is well to check the operation of the set with a set of valves known to be free from this trouble.

Persistent crackling in resistors is caused by overloads, poor pigtail connections and poor connections between the

metal end caps and the resistance element.

Power transformer faults are primarily due to overload, and if the windings have their insulation burned away then trouble will most certainly occur. In some of the cheaper types of power transformers it is not uncommon to find that one of the two leads which constitute the high voltage secondary winding has corroded and open circuited. This fault is responsible for low voltage and the presence of hum in the set with which the transformer is associated.

In checking audio transformers or output transformers it is desirable to replace these with units known to be o.k., although, if the noise is particularly bad, a sensitive ohm-meter connected across their windings will usually show up the trouble. It should be understood, though, that during the tests of the audio section the r.f. portion of the receiver should be cut out of circuit.

It may be found that the noise is getting into the set through the power lines despite the fact that the power transformer is electrostatically shielded. Connection of .1 to .5 mfd. condensers between each side of the line and earth usually will overcome this difficulty.

STATION INTERFERENCE

WHISTLING in a super-heterodyne can be caused by:

- Incorrect alignment of the i.f. and r.f. stages.
- Instability caused by lack of shielding and poor wiring arrangement.
- Unstable valves.

The most potent source of whistles in a super-heterodyne receiver is incorrect alignment of the i.f. amplifier.

Most of the existing supers work on an intermediate frequency ranging between 450 and 465 k.c., depending upon the whims of each manufacturer. In Melbourne we have a broadcasting station, 3UZ, working on 930 k.c. It follows, then, that if we align a super-het's i.f. amplifier to 465 k.c., i.e., half the frequency of the broadcasting station mentioned, and the receiver is not sufficiently selective in its signal circuits, a beat will take place between the 930 k.c. signal and the i.f. amplifier frequency.

The beat will be noticeable on 3UZ's wave-length, where it will be present in the form of a tone ranging from a low rumble to a very high-pitched whistle, depending upon how close to the 930 k.c. frequency the 465 k.c. amplifier is tuned.

The best thing to do, then, is to use a calibrated signal generator and so set the i.f. amplifier's frequency that no beat will take place between it and the local broadcaster. It is necessary, though, to exercise care in altering the i.f. channel of sets equipped with station calibrated dials. Too large a shift of the i.f. amplifier's frequency will prevent the r.f. circuits being adjusted for accurate tracking of the dial.

If a signal generator is not available then adjust each of the i.f. trimmers by hand, moving each only a fraction of a turn, and all in the same direction. Start with the trimmer connected to the diode plate and work back through the i.f. primary to the grid winding of the first transformer and finally to the plate winding for the mixer stage. It will then be necessary to re-align the oscillator circuit and to re-pad the receiver.

Other causes of whistles are instability in the r.f. stage. Here we find

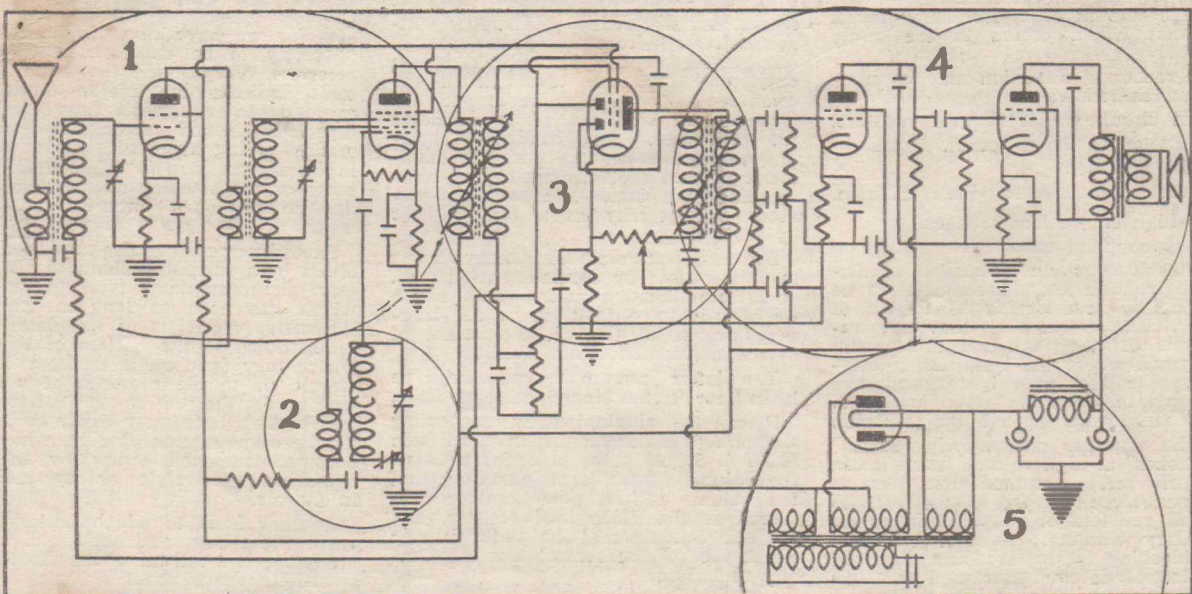

For all practical purposes, a radio receiver may be divided into sections. Some of these, as shown in the above diagram, are inter-related because of the widespread use of multi-purpose valves. The five general sections are:—(1) The signal selecting circuits; (2) The oscillator section; (3) The i.f. amplifier and second detector; (4) The audio amplifier and output stage, and (5) The power supply and filter system.

that long plate leads often give rise to oscillation troubles. A simple remedy, and one which often gets over the trouble at small expense, is the connection of stopping resistors, in series with the "B" supply lines to the r.f. mixer and i.f. tubes.

The resistors should be of the carbon type ranging in value from 1000 to 3000 ohms. They should not be by-passed. Their use will reduce the set's sensitivity somewhat, but if the trouble is due to r.f. oscillation, the sensitivity usually can be lowered without impairing the set's pick-up capabilities materially.

Another type of instability is that encountered where the turning up of the volume control is the signal for a succession of howls and whistles.

Here the trouble is due to poor layout, and too high gain in the mixer and i.f. stages. Suppression resistors in the plate circuits of the mixer and i.f. tubes and in the grid circuits of the audio tubes often will eliminate the whistles. The grid resistors should range from 100,000 ohms to 250,000 ohms.

Occasionally it is found that a valve will work satisfactorily in a given set while it is new, but after it has been in use for a few months will become unstable. The remedy in this case is to replace the valve or to interchange it with another of similar type, which may be used in some less critical part of the circuit.

CAUSES OF DISTORTION

DISTORTION in a radio receiver may be divided into two classes — that which occurs at radio frequency levels and that which occurs in the audio amplifier.

The causes of distortion may be summarised as follow:—

- Open circuited bias or grid resistors.
- Oscillation in the r.f. or i.f. stages.
- Audio feedback.
- Valves which have lost their emission.
- Too high or too low voltages.
- Leaky coupling condensers.

We shall start our discussion of distortion troubles and the remedies to be applied by considering distortion at audio levels. Assuming that any receiver is distorting and that no idea can be formed where the distortion is originating the best plan is to connect a pick-up into the audio amplifier and to run a test record through the amplifier.

If the amplifier momentarily "blocks" or "chokes" at high volume levels it can be fairly safely assumed that there is an open circuit either in the cathode or grid resistors or in the transformer secondary winding. Another cause of this blocking is the breaking down of the electrolytic condenser used as a by-pass on the audio tubes bias resistors.

In some audio amplifiers, notably those employing beam type tetrodes, a form of distortion, caused by ultra high frequency oscillation within the tubes, takes place at the higher audible fre-

quencies. One remedy for this form of oscillation is to connect stopping resistors in series with each of the grid circuits.

It should be remembered, though, that in amplifiers which draw grid current, those of the Class AB1 and AB2 types, it is undesirable to increase the resistance of the grid circuit by introducing such resistors.

The next form of distortion is that caused by tubes having low emission. In this case, both the volume and the tonal quality will suffer. Another trouble encountered by many users of receivers using single ended pentode amplifiers is that in which the set "blocks" when a light switch is switched on or when any particularly loud burst of static — man-made or otherwise — reaches the output stage.

This trouble is caused by the combination of a low emission tube and a high value grid resistor.

The 2A5 and 42 type pentodes are particularly bad offenders. The remedy is to reduce the value of the customary 1 megohm or 500,000 ohm grid resistor associated with the output tube to something around 250,000. Naturally, though, this does not aid the emission of the tube. It merely stops it blocking. The valve will need replacement in the near future.

The problems of too high or too low voltage already have been covered so need not be enlarged on here except to say that the presence of too high a voltage usually indicates that the valves are low in emission and are not drawing their normal plate currents.

LEAKY CONDENSERS

ONE other form of audio distortion is that caused by leaky coupling condensers. Even mica condensers are prone to this fault. What happens is that the plate voltage leaks through the condenser and positively biases the following tube. If this is the output tube the resultant plate current increase also will reduce the supply voltage delivered from the power pack.

In some cases this leakage takes place only at high audio levels when the combined effects of the audio and d.c. voltages are sufficient to break down the condenser. Any condenser showing below 500,000 ohms on the ohmmeter should be discarded for audio coupling purposes, although it may serve satisfactorily as a bias resistor by-pass.

Distortion at radio frequency levels may be caused by oscillation in the r.f. or i.f. amplifiers, a matter with which we already have dealt, or by the leaking through of the r.f. component of detection into the audio circuits.

The latter can most commonly be looked for in the second detector stage.

It can be eliminated by connecting a stopping resistor ranging in value from 50,000 to 500,000 ohms in series between the volume control arm, assuming that the volume control potentiometer also serves as the diode load resistor, and the grid condenser of the audio tube to which the volume control arm is normally connected.

It also is wise in receivers employing diode triodes or diode pentodes as combined second detector and first stage audio amplifiers to connect a resistor of from 50,000 to 100,000 ohms in series with the plate of the valve and the

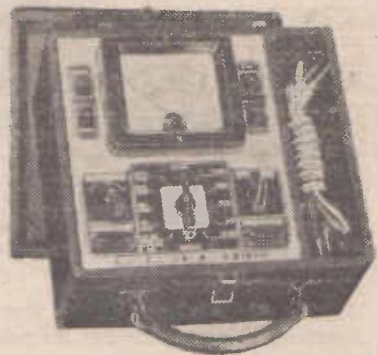

A modern volt-ohm-milliammeter designed for a.c. as well as d.c. voltage measurements is of inestimable value in tracking down faults in radio receivers.

coupling condenser for the next tube. Both these stopping resistors should be by-passed by means of small capacity condensers. Capacities ranging from .00005 mfd. to .00025 mfd. will prove satisfactory.

The foregoing more or less summarises the service of the receiver itself. Speaker troubles usually can be confined to the rattles caused by imperfect centring of the voice coil, to the breakdown of the speaker transformer, or to the open-circuiting of the voice coil itself. Although the average experimenter can attempt the re-centering of the voice coil by slackening off the centre adjustment bolt and inserting three or four thin strips of card between the coil and the centre pole piece, he will usually find it best to entrust all speaker adjustments to the manufacturers.

BATTERY SET FAULTS

SO far we have covered the troubles likely to be experienced with a.c. receivers. Very much the same symptoms indicate the major faults encountered in battery sets. Loss of volume, especially when accompanied by a gradual dying away of signals, usually indicates run down "A" or "B" batteries or the blocking of an audio valve due to an open circuited "C" bias lead.

Excessive crackling also may be caused either by a partially exhausted "B" battery, an accumulator type "A" battery which has been so long in use that the active materials of its plates have fallen down to the bottom of the cell, where they form an intermittent short-circuit, or to the presence of a leaky path across the "A" or "B" battery terminals. This latter may easily be caused by the accumulation of dust, which has become dampened either by the accumulator electrolyte or by moisture in the air.

Another fault to which battery dual wave super-hets. and some a.c. supers are prone is a fall off of the short wave sensitivity above about 35 metres. This will usually be found to be due to the fact that the oscillator section of the mixer tube has ceased to function. The remedy is to replace the tube with one whose emission is sufficiently high to ensure oscillation.

CIRCUIT SECTION

● In this Section are Contained Representative Circuits of All Types of Receivers ranging from the Simple Crystal to the most elaborate Dual-Wave Super-heterodyne... Each circuit has been Thoroughly tried Out and can be Guaranteed

CRYSTAL CIRCUITS and WAVE TRAPS

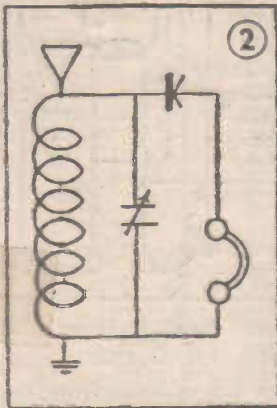

The Direct Coupled Crystal Receiver.

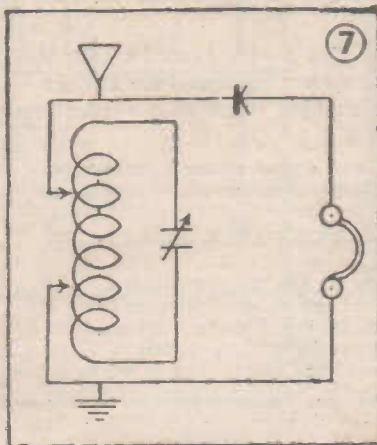

The Famous "Hart" Circuit.

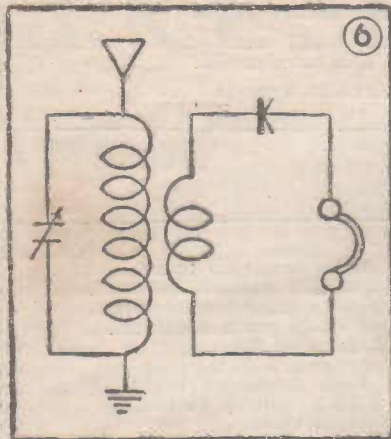

A Trap-tuned Circuit.

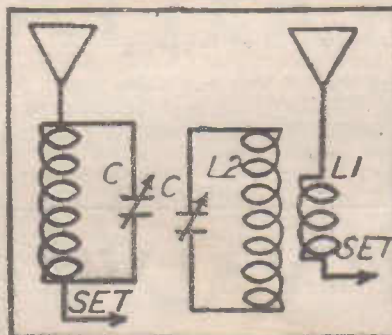

Direct (left) and Loosely Coupled (right) Wave Trap circuits.

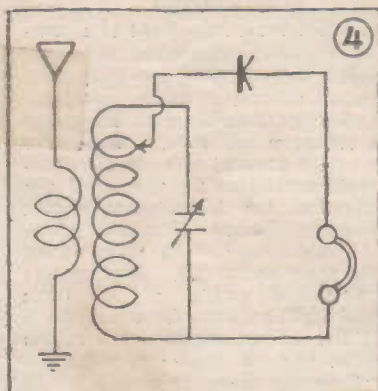

The Un-damped Crystal Circuit.

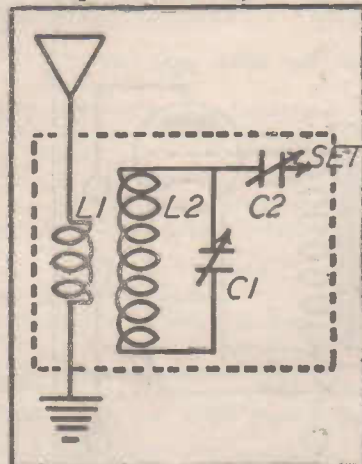

An Ultra-selective Wave Trap circuit.

BECAUSE they are both cheap and simple to construct the radio novice invariably makes a start by building crystal receivers. His flair for experimenting is catered for by an almost infinite variety of circuits, and his only costs are extra coil formers and winding wire.

The cardinal points to bear in mind in making crystal sets are (1) that the crystal itself does not amplify so that the efficiency of the tuning circuits must be kept as high as possible and (2) that selectivity can be obtained only at the expense of sensitivity.

So far as the size of the coil former and the gauge of the winding wire are concerned the crystal set builder is advised to stick to 2 3/8 inch diameter formers and either 24 or 26 gauge d.c.c. wire. The circuit values given below refer to the use of formers and wires of these sizes.

Reviewing the circuits on this page we find that the direct coupled one is the best for use at points distant from broadcasting stations. Where more selectivity is needed the trap tuned or the tapped type circuit will be needed. For all round selectivity and sensitivity the "Hart" circuit is outstanding. The wave trap circuits shown range from the simple direct coupled to the elaborate inductance-capacity type shown in the lower right hand diagram. The latter is the most selective but is likely to reduce signal strength considerably and should not be used with a crystal receiver.

Here are the coil specifications for all the circuits. The tuned circuit winding should consist of 50 turns of 24 or 26 gauge wire on a 2 3/8 inch diameter former and should be tuned with a 500 mmfd. (.0005 mfd.) variable condenser. The small windings of the trap tuned circuit, the un-damped circuit, and the loosely coupled wave trap circuits may consist of 15 turns of the same gauge wire wound over the centre of the 50 turn winding and in the same direction as it.

The tap point on the un-damped circuit should be from 5 to 15 turns from the aerial end of the tuned circuit coil. The taps on the "Hart" circuit are at the 17th and 34th turns from the start of the winding. The coupling condenser, C2, of the ultra selective trap circuit should have a capacity of 100 mmfd. (.0001 mfd.)

BATTERY RECEIVERS

ONE of the most important points in the design of battery receivers is the plate current consumption of the set. It is of little use building a receiver which, although sensitive and capable of great output volume, requires frequent "B" battery replacements. This danger can be guarded against by careful selection of the valves.

For general battery set applications valves of the two volt type will prove best but where extreme "A" and "B" battery economy is required the 1.4 volt series valves should be used.

The next important requirement is sensitivity. The average two valve battery set will provide good night-time reception at headphone strength from stations 500 miles or more distant, but if loud speaker strength reception is needed a three valve set is desirable to cover this range.

Daylight reception is a more difficult matter and a very efficient three valve tuned radio frequency type set can be expected reliably to cover only distances up to 300 miles. The foregoing figure pre-supposes the use of a good outdoor aerial, erected from 25 to 50 feet above the ground and consisting of a 50 to 100 feet long flat top section.

Possibly more important even than sensitivity is the set's selectivity. So many broadcasting stations are now on the air that the country set user finds it difficult to separate one from the other unless his set be of modern design. For reasons of selectivity as well as sensitivity the super-heterodyne circuit is to be preferred before the regenerative or tuned radio frequency types. Use of the latest type valves permits a sensitive super-heterodyne to be evolved around only three valves, although, of course, four or more will give considerably better results.

These little three valve super-hets., such as The Melodious Three and the Push Pull Melodious Three, are not only sensitive and selective but require very low "B" battery currents.

This type of battery receiver requires an accumulator or an Air-Cell for "A" battery supply. Where battery re-charging is inconvenient the 1.4 volt series valves such as are used in the Melodious 1.4 and the 1.4 Volt Five Valve Super should be used. With these valves a dry cell "A" battery can be expected to provide from 900 to 1000 hours service before needing replacement.

One Valver

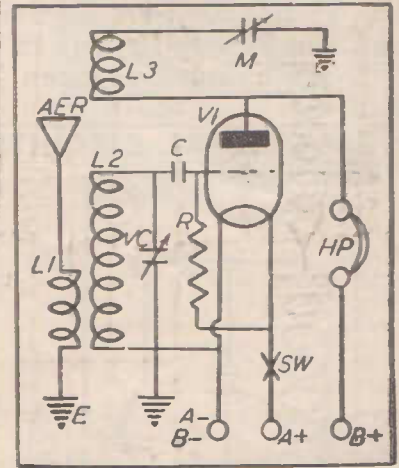

COILS: See Battery "2" Valve for Details.

- C:** 0.00025 mfd. fixed mica condenser.
- M:** 23 plate midget condenser.
- R:** 2 megohm carbon resistor.
- SW:** Battery switch.
- VC:** 0.0005 mfd. variable condenser with vernier dial.
- VALVE:** Type 30.

BATTERY "2" VALVE

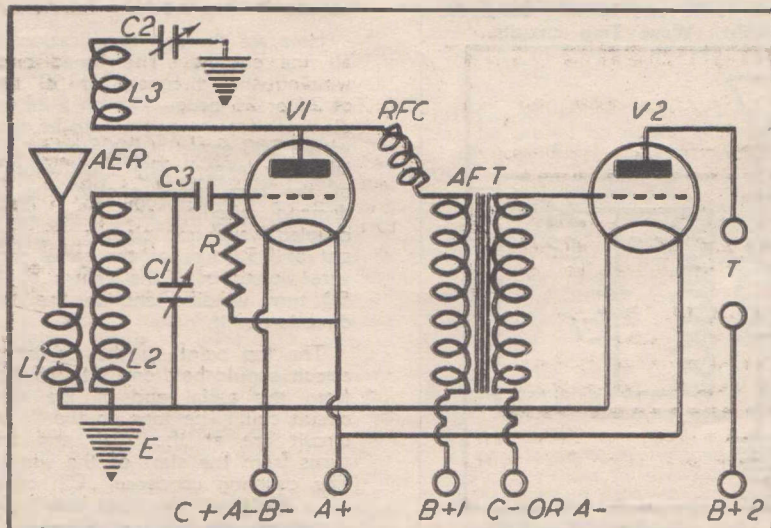

- AFT:** Audio frequency transformer.
- C1:** Variable condenser .0005 mfd.
- C2:** 23 plate midget condenser.
- C3:** .00025 mfd. mica condenser.
- L1, L2, L3:** Coil Kit.
- R:** 2 megohm resistor.
- RFC:** Radio frequency choke.
- SW:** S.P.S.T. battery switch.
- V1:** Detector valve.
- V2:** Audio valve.

COIL DETAILS

ALTHOUGH the employment of a commercially made iron cored aerial coil is desirable the following dimensions for home made air-core coils are provided.

All windings should be of 26 gauge double cotton or silk covered wire. For double cotton covered wire the L2 winding should consist of 50 turns. If silk covered wire, the L2 winding should be reduced to 45 turns. The aerial winding, L1, may consist of 15 turns wound over the earth end of L2. The reaction winding should consist of 25 turns separated half an inch from the earth end of the L2 winding. All windings should be laid on the same direction. The coil former diameter should be 2 3/4 inches.

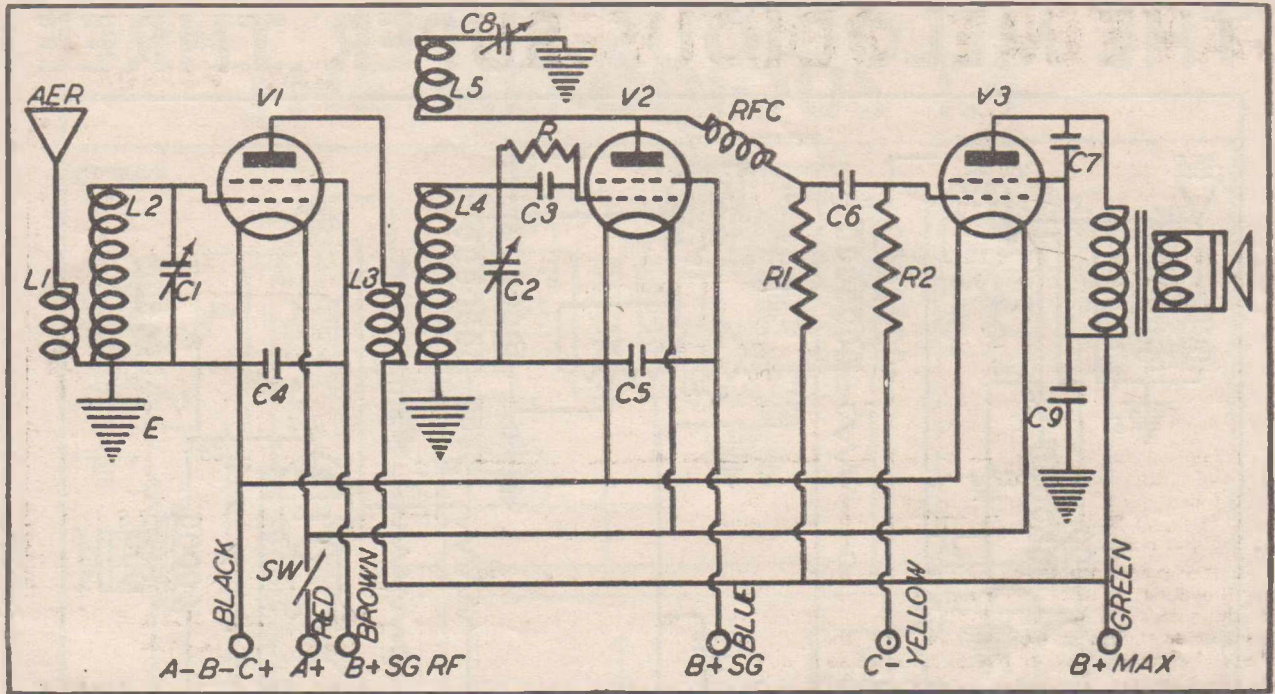

T.R.F. BATTERY THREE

ALTHOUGH it is quite practical for the home builder to wind suitable coils for ordinary regenerative type receivers, it is a more difficult task for him to undertake if the receiver employs an r.f. stage ahead of the detector and is to be tuned with a gang condenser.

The secondary windings of the coils must be matched so that the condenser will track properly throughout its tuning range. Next the primary windings have to be carefully proportioned in order that the maximum gain and selectivity will be obtainable. Finally, the two coil units (L1-L2, and L3, L4-, L5) will need to be encased in shield cans so that no r.f. feedback will take place.

Even if the coils do not have iron cores the commercial types are far superior to anything the home builder can produce. Where the very best selectivity and sensitivity is required it is advisable to use iron cored coils. Remember, though, that unsatisfactory results will be obtained if the iron cored r.f. coil is worked into a triode detector. The detector impedance is so low that it damps the coils and lowers its gain as well as spoils its selectivity.

In laying out a tuned r.f. receiver, particularly if it is fitted with a regenerative detector, be careful to ensure that the plate and grid leads are kept well apart and that the plate circuit lead from the r.f. coil does not come closely in contact with the detector grid lead.

Sometimes it may be found that the detector regeneration control produces the customary oscillating whistle only when the condenser plates are fully out of mesh. This condition indicates that the r.f. valve is oscillating and is only damped when the detector regeneration control is fully advanced.

Such a condition is unsatisfactory for reception and steps must be taken, by

re-arranging the plate and grid leads, and shielding the valves and coils, to make the r.f. valve function stably.

Sometimes with a regenerative t.r.f. set it will be found advantageous in maintaining ganging of the tuning circuits, even when the regeneration control is advanced, to arrange for the detector plate winding to be wound in the reverse direction to the grid winding. Naturally, the connections to this winding also will be the reverse from the normal ones.

The following rules can be followed for connection of the plate coil of any regenerative detector:—

When the plate and grid windings are laid on in the same direction and the plate coil is at the earth end of the grid winding the plate coil lead nearest to the grid winding is joined to the condenser controlling reaction, whilst the other lead of the plate winding goes to the plate of the regenerative detector valve.

On the other hand, if the two coils are wound in the same direction but the reaction winding is placed at the grid end of the grid coil the end of the reaction coil nearest to the grid winding joins to the plate of the detector valve.

If the reaction coil is wound in the reverse direction to the grid coil then the above connections are reversed in each case.

Components List

- C1, C2: Two gang .000385 mfd. Variable Condenser.
- C3: .00025 mfd. Mica Condenser.
- C4, C5, C9: .1 mfd Tubular Condensers.
- C6: .02 mfd. Mica Condenser.
- C7: .005 mfd. Mica Condenser.
- C8: 23 Plate Midget Variable Condenser.
- L1, L2, L3, L4, L5: Aerial, and R.F. Coils with reaction.
- R: 2 megohm Carbon Resistor.
- R1: .25 megohm Carbon Resistor.
- R2: .5 megohm Carbon Resistor.
- RFC: Radio Frequency Choke Coil.
- SW: Single pole single throw battery switch.
- VALVES: One each 1C4 (V1), 1K4 (V2), and 1D4 (V3).

THE MELODIOUS SUPER THREE

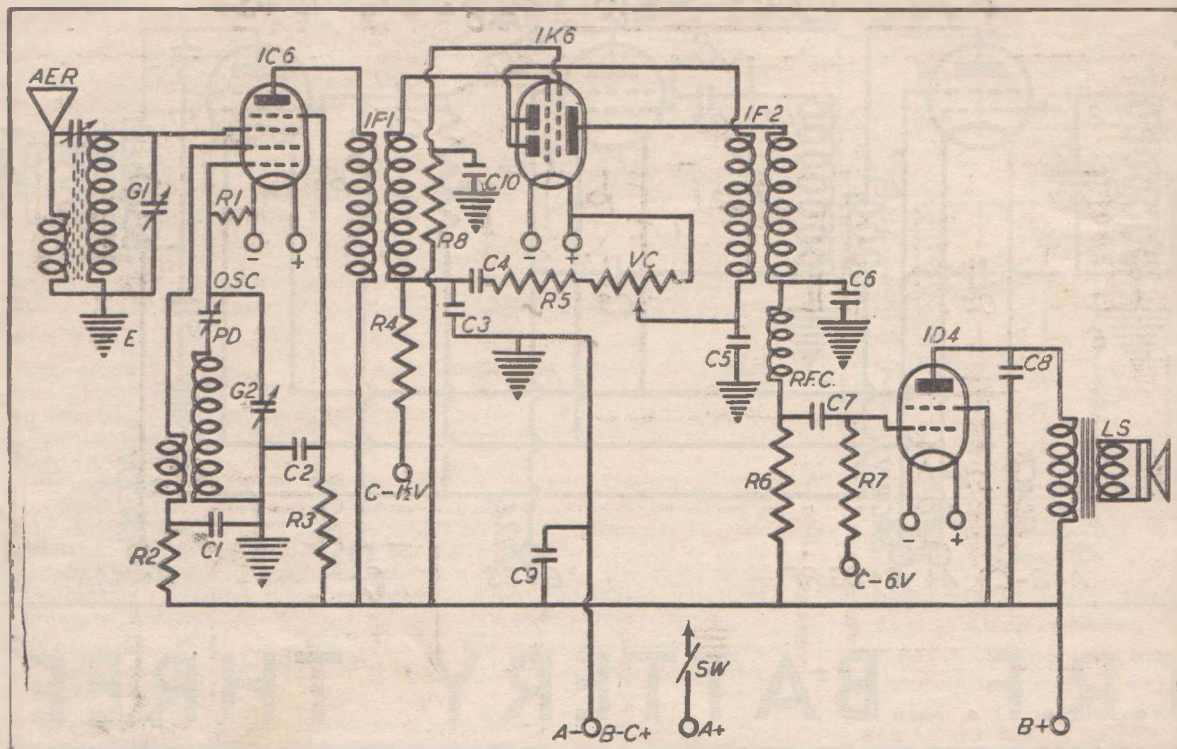

CHASSIS: Measuring 9 inches by 7 1/2 inches by 2 3/4 inches.
COIL KIT: Consisting of iron core aerial and oscillator coil with built-in padder condenser.
C1, C2, C10: 1 mfd. tubular condensers.
C3, C6: .0001 mfd. mica condensers.
C4, C7: .02 mfd. tubular condensers.

C5: .00025 mfd. mica condensers.
C8: .006 mfd. tubular condenser.
C9: .5 mfd. tubular shielded type.
Dial: To suit gang condenser.
G1, G2: Two gang condenser.
IF1, IF2: Air core battery IF's.
LS: Permagnetic speaker to suit ID4.
R1: 50,000 ohms 1/2 watt resistor.
R2: 50,000 ohm 1 watt resistor.

R3: 60,000 ohm 1 watt resistor.
R4: 1 megohm 1/2 watt resistor.
R5: 100,000 ohm 1/2 watt.
R6: 100,000 ohm 1 watt resistor.
R7, R8: 500,000 ohm 1/2 watt resistor.
RFC: Radio frequency choke.
VC: 500,000 ohm Potentiometer with switch.

PUSH-PULL MELODIOUS THREE

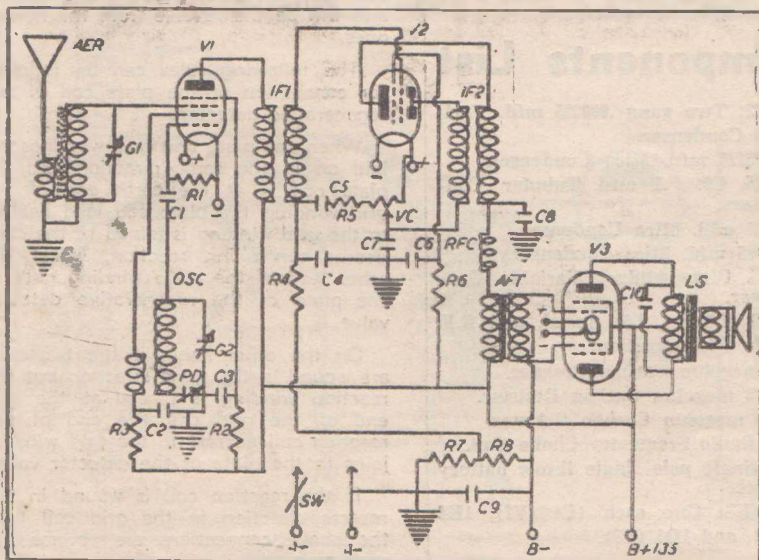

AFT: Special audio frequency transformer.

CHASSIS: Aluminium measuring 11 inches by 8 inches by 2 1/2 inches.

COIL KIT: Consisting of Aerial and Oscillator coils and two 465 k.c. intermediate frequency transformers (AER, OSC, IF1 and IF2).

C1, C4: .0001 mfd. mica condensers.
C2, C3, C6: .1 mfd. tubular condensers.
C5, C10: .02 mfd. tubular condensers.
C7, C8: .0002 mfd. mica condensers.
C9: 25 mfd. 25 volt electrolytic condenser.

DIAL: Midget straight line type.
DS: Permagnetic speaker to suit output valve.

G1, G2: Two gang type G condenser.
R1, R3: 50,000 ohm resistors.
R2: 60,000 ohm resistor.
R4: 1 megohm resistor.
R5, R6: 100,000 ohm resistors.
R7: 100 ohm wire wound resistor.
R8: 650 ohm wire wound resistor.
RFC: Radio frequency choke.
R7: 100 ohm wire wound resistor.
R8: 650 ohm wire wound resistor.
SW: Single pole single throw filament switch.

VALVES: One each 1C7G, 1F7GV and 1E7G.

THE MELODIOUS 1.4

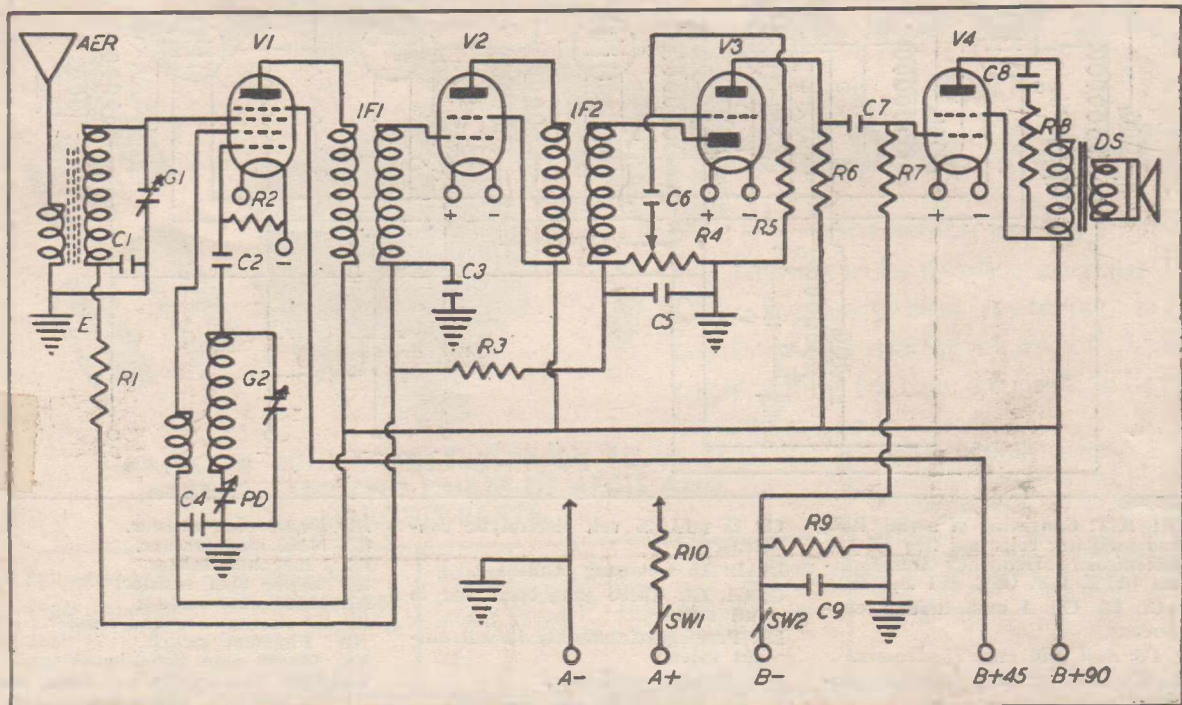

CHASSIS: Aluminium measuring 9 inches by 7 inches by 2 1/4 inches.
COIL KIT: Consisting of aerial and oscillator coils and two 465 k.c. intermediate frequency transformers. (Aer, OSC, IF1, and IF2). (Parco).
C1, C3, C4: 1 mfd tubular condensers.
C2: .0001 mfd. mica condenser.
C5: .00025 mfd. mica condenser.

C6, C7, C8: .02 mfd. tubular condenser.
DIAL: To suit gang condenser.
DS: Permagnetic speaker to suit output valve.
G1, G2: Two gang condenser to suit coil kit.
R1, R3: 100,000 ohm resistors.
R2: 200,000 ohm resistor.
R4: 500,000 ohm potentiometer.

R5: 1.75 megohm resistor.
R6: 250,00 ohm resistor.
R7: 500,000 ohm resistor.
R8: 10,000 ohm resistor.
R9: 800 ohm wire wound resistor.
R10: .2 ohm wire wound resistor to carry .5 ampere.
VALVES: One each 1A7G, 1N5G, 1H5G and 1C5G.

CHASSIS: Aluminium, measuring 12 inches by 9 inches by 2 1/2 inches.
AFT: Pushpull audio transformer. Ratio 1 to 3 1/2 (ea. Sec.).
AER, OSC: Iron Cored Aerial and 465 k.c. oscillator coils.
C1, C2, C3: .1 mfd tubular condensers.
C4: .05 mfd. tubular condenser.
C5, C6, C8: .0001 mfd. mica condensers.
C7, C9, C10: .02 mfd. mica condensers.
C11: .5 mfd. tubular condenser.
DS: Dynamic speaker. Permanent magnet type. Load resistance 24,000 ohms plate to plate.
G1, G2: Two-gang tuning condenser to suit coil kit. Dial to suit.
IF1, IF2: 465 k.c. iron-cored I.F. transformers.
R1: 250,000 ohm carbon resistor.
R2, R3, R4: 50,000 ohm carbon resistors.
R5, R6: 500,000 ohm carbon resistors.
R7: 1.75 megohm carbon resistor.
R8, R9: 10,000 ohm carbon resistors.
RX: Wire-wound resistor to carry 480 m.a. .81 ohms, including resistance of battery leads.
SW: Switch built into VC.
VC: 500,000 ohm potentiometer with switch.
VALVES: One each 1C7G, 1D5G, 1H5G, 1E7G.

PUSH-PULL BATTERY FOUR

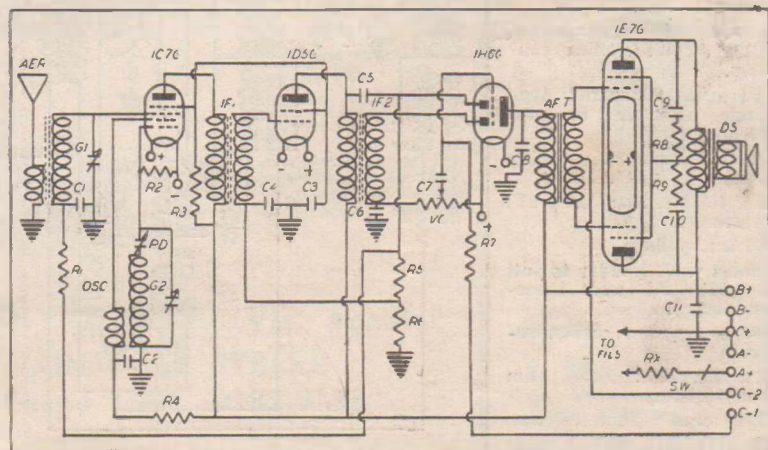

Note:—Resistor Rx is needed only for Air Cell Operation.

FIVE VALVE 1.4 VOLT SUPER

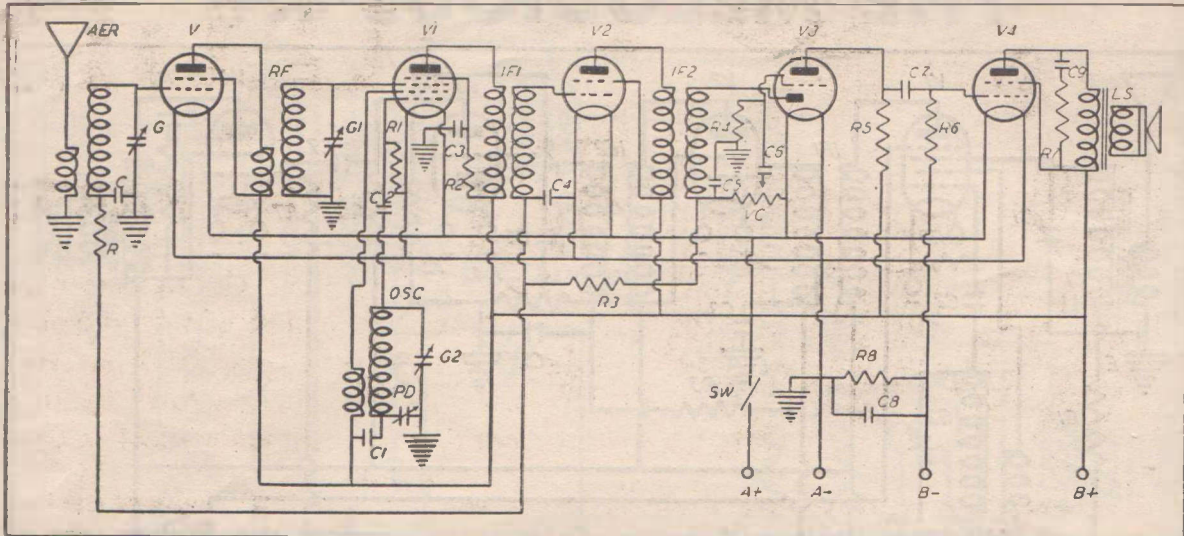

COIL KIT: Consisting of aerial, R.F., and oscillator coils and two 465 k.c. intermediate frequency transformers (AER, R.F. OSC, IF1 and IF2).
C, C1, C3, C4: .1 mfd. tubular condensers.
C2, C5: .0001 mfd mica condensers.
C6, C7, C9: .02 mfd. tubular condensers.

C8: 25 mfd. 25 volt electrolytic condenser.
DIAL: To suit gang condenser.
G, G1, G2: Three gang condenser to suit coils.
LS: Permagnetic speaker to suit output valve.
PD: Padder condenser.
R, R3, R5: 250,000 ohm resistors.

R1: 200,000 ohm resistor.
R2: 70,000 ohm resistor.
R4: 1 megohm resistor.
R6: 500,000 ohm resistor.
R7: 10,000 ohm resistor.
R8: 450 ohm wire wound resistor.
SW: Filament switch.
VC: 500,000 ohm potentiometer.
VALVES: Two 1N5G's, one 1H5G, one 1A7G and one 1A5G.

AIR-CELL OR BATTERY D.W. FIVE

CHASSIS: Aluminium measuring 15 inches by 9 inches by 2 1/4 inches.

COIL KIT: Dual-wave iron-cored aerial, R.F. and 465 k.c. oscillator coils.

C1, C2, C5, C7: .05 mfd. tubular condensers.

C3, C9, C10, C11: .0001 mfd. mica condensers.

C4, C8, C14: .1 mfd. tubular condensers.

C6: .5 mfd. tubular condenser.
C12, C13: .02 mfd. mica condensers.

DS: Permanent magnet type dynamic speaker to suit 15,000 ohm load.

G1, G2, G3: Three gang tuning condenser to suit coil kit.

IF1, IF2: 465 k.c. iron cored I.F. transformers.

PD: 465 k.c. padder.

PD1: Short wave padder to suit coils (.004 mfd. with home-wound type).

R1, R8: .1 megohm carbon resistor.

R2, R3, R5, R15: 50,000 ohm carbon resistors.

EA: 20,000 ohm carbon resistor.

R6, R9, R10, R11, R13: 1 megohm carbon resistors.

R7: 75,000 ohm carbon resistor.
R12: 250,000 ohm carbon resistor.
R14: 200,000 ohm carbon resistor.
RX: .52 ohm 120 m.a. w.w. resistor.
S: Single pole double throw pick-up switch.

S1: Battery switch built into VC.
VALVES: Two 1C4's, one each 1C6, 1K6, and 1D4 (or IF4 for air-cell use).
VC: 500,000 ohm potentiometer with switch.

NOTE.—Resistor RX is needed only for air-cell operation.

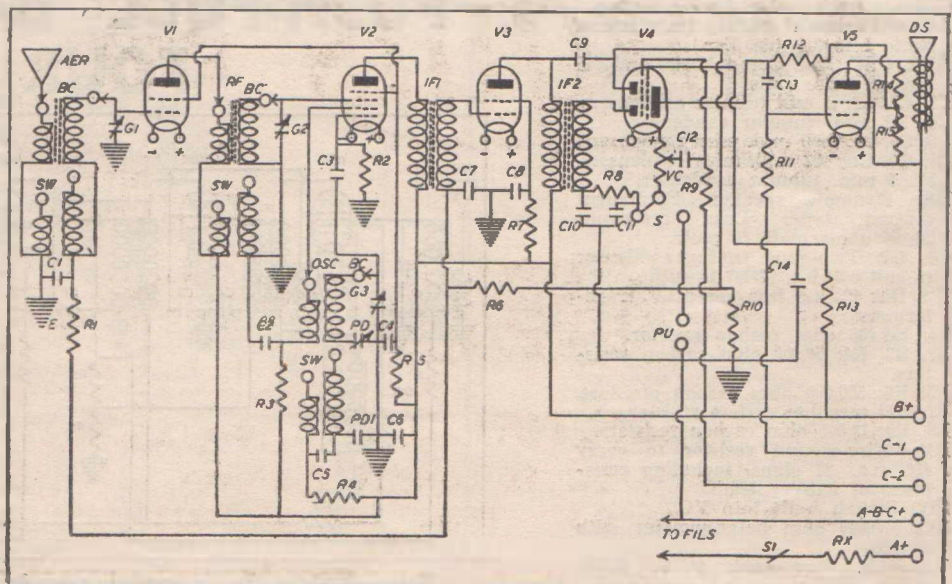

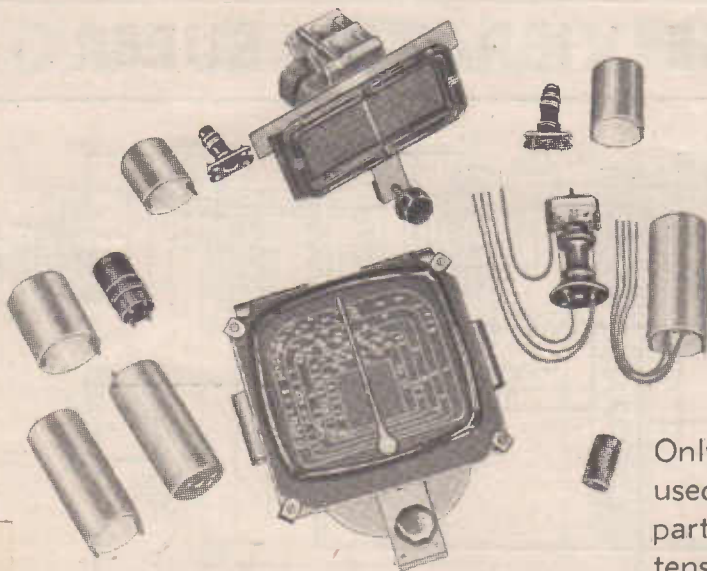

AEGIS

(REG.)

RADIO PARTS

The motif which stands for protection in both price and quality. Only the very best materials are used in the manufacture of AEGIS parts, which further are backed by extensive research.

WRITE TO YOUR WHOLESALE OR TO US FOR PARTICULARS AND PRICES OF AEGIS AND MARQUIS PARTS.

AEGIS COMPONENTS include an extensive range of COILS, a range of attractive DIALS, as well as R.F. CHOKES, drilled CHASSIS and almost everything required to make a radio receiver.

PERMEABILITY (Iron-core) Coils. Types available—Aerial, R.F. Osc. (Pentagrid and Octode) fitted to round can $1\frac{7}{8} \times 2\frac{1}{2}$.

Solenoid Coils, Types — Aerial (High gain, optional), R.F., Osc. (Pentagrid or Octode). Highest quality wire and formers fitted to round can $2 \times 2\frac{1}{2}$.

PERMEABILITY (Iron-core) Intermediates. Type — 465 k.c. using the ingenious self-locking device. Size of can, $1\frac{7}{8} \times 4\frac{1}{2}$

Air-core Intermediates — 465 k.c. and 175 k.c. Moisture proof-dust proof. Top tuning — round can. $1\frac{7}{8} \times 4\frac{1}{2}$.

SHORT WAVE COILS — Solenoid type — space wound — guaranteed to improve any hook-up.

DIALS R.F. CHOKES PADDING, CONS. DRILLED CHASSIS POWER TRANS. ETC.

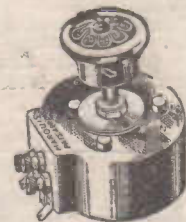

Marquis Volume Controls Type MPP8, 400 to 20,000 ohms. The standard replacement control as used by leading set manufacturers. Retail price, 4/6.

Marquis

TRADE MARK (REG.)



Type MVS2, 4, 5, 6, 7, pin reversible valve sockets. Retail price, 1/3 ea.

Type M LA1 — Lightning Arrestor — Retail price, 2/.



Marquis components in an extensive range are manufactured by the Commonwealth Moulding Co. of Arncliffe, Sydney, N.S.W.



Marquis MCF/4,5,6,7 Pin ribbed bakelite. Formers ensuring stability of winding. Only 7% of periphery is touched by winding wires, virtually making for air wound low loss coils. Retail price 2/-.

G. P. EMBELTON & CO. (Vic. Agents)

208-212 LITTLE LONSDALE STREET
MELBOURNE, C.I. Phone Cent. 9132-9133

FOUR VALVE VIBRATOR SUPER

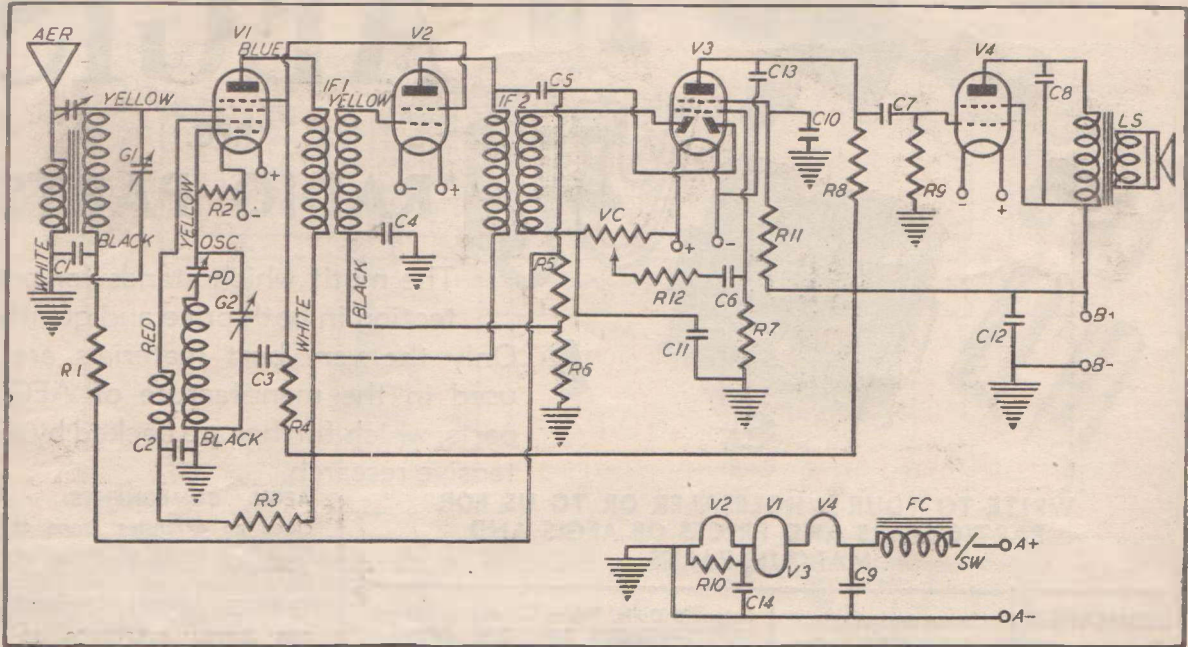

CHASSIS: Aluminium. 12½ inches by 7½ inches by 2½ inches.
COIL KIT: Iron Cored Aerial, 465 k.c. Oscillator, and two Air Cored i.f. transformers.
C1, C2, C3, C14: .1 mfd. Tubular Condensers.
C4: .05 mfd. Tubular Condenser.
C5, C11, C13: .0001 mfd. Mica Condensers.
C6, C7: .02 mfd. Mica Condensers.

C8: .006 mfd. Mica Condenser.
C9: 500 mfd. 12 Volt Electrolytic Condenser.
C10, C12: .5 mfd. Tubular Condensers.
FC: ¼ ohm 25 Henry Filter Choke.
G1, G2: Two Gang Condenser to suit Coil Kit.
IF1, IF2: 465 k.c. Air Cored i.f. Transformers.
R1, R8: .25 megohm Carbon Resistor.
R2: 50,000 ohm Carbon Resistor.

R3: 20,000 ohm Carbon Resistor.
R4: 30,000 ohm Carbon Resistor.
R5, R6, R9: .5 megohm Carbon Resistors.
R7, R11: 1 megohm Carbon Resistors.
R10: 16 ohm 300 m.a. W.W. Resistor.
R12: 100,000 ohm Carbon Resistor.
VC: 500,000 ohm potentiometer with switch.
VALVES: One each 1C6, 1C4, 1K6, and 1D4.

BATTERY S.W. CONVERTER

CHASSIS: Aluminium. 8 inches by 8 inches by 2½ inches.
COILS: See below.
C1, C2, C4: .1 mfd. Tubular Condensers.
C3: .0001 mfd. Mica Condenser.
C5: .007 mfd. Mica Condenser.
G1, G2, G3: Three Gang 385 mfd. Condenser.

IFT: Special 550 k.c. Converter type I.F. Transformer.
PD: 7 plate Padding Condenser.
R1: 30,000 ohm Carbon Resistor.
R2: 20,000 ohm Carbon Resistor.
R3: 50,000 ohm Carbon Resistor.
R4: 250 ohm Carbon Resistor.
VALVES: One each 1C4 and 1C6.

COIL DETAILS

THE coils are wound on ¾ inch diameter bakelite formers. The secondaries are wound with 22 gauge enamel wire. The aerial and R.F. coil secondaries consist of 11 turns of wire spaced the diameter of the wire. The oscillator secondary winding, L6, has only 10½ turns. The aerial winding, L1, and the R.F. plate winding, L3, each consist of four turns of the 26 gauge silk covered wire wound in the space between the turns of the secondary windings. These windings are wound in the same direction as the secondary windings and are wound at the grid end of these windings. The primary of the oscillator coil, L5, is wound with 34-gauge silk covered wire, and consists of six turns wound in the reverse direction to the secondary winding, L6.

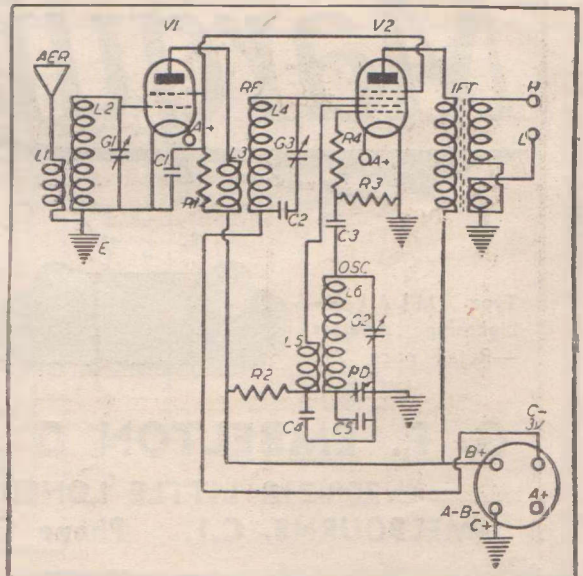

D.W. BATTERYLESS SUPER 5

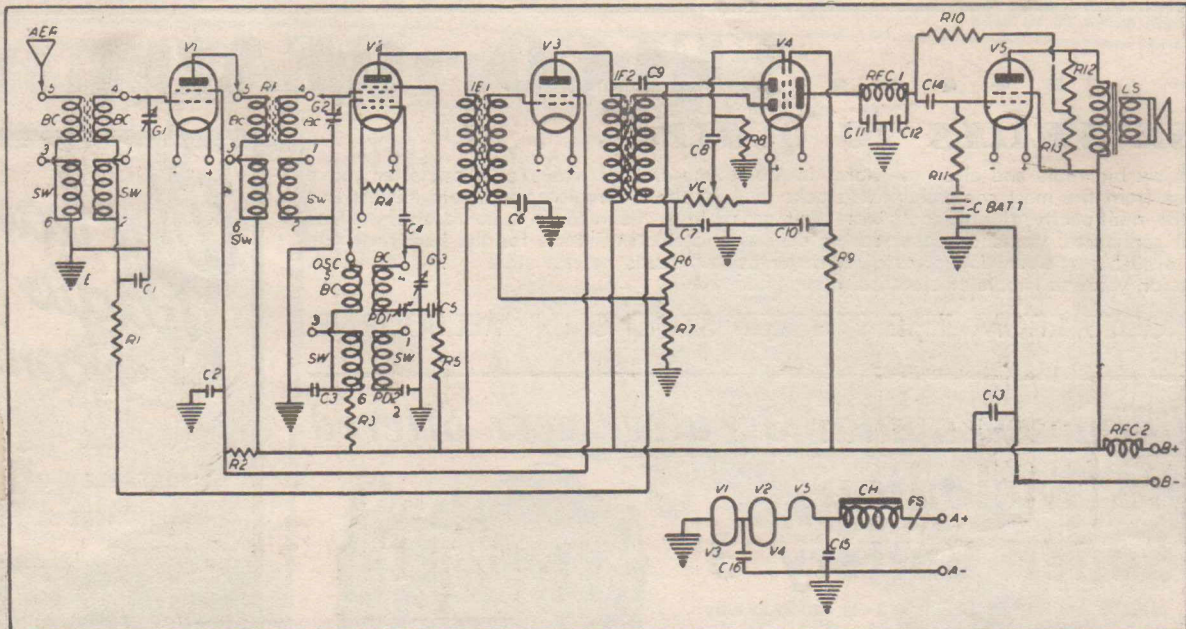

CHASSIS: Aluminium, 13 inches by 8½ inches by 2¾ inches.
 COIL KIT: Dual Wave Aerial, R.F., and 465 k.c. Oscillator Coils.
 "C" BATTERY: Two 1½ volt Cells.
 C1, C2, C3, C5, C10, C16: .1 mfd.
 C4, C7, C9, C11, C12: .0001 mfd. Mica
 C6: .05 mfd. Tubular Condenser.
 C8, C14: .02 mfd. Mica Condensers.

C13: .5 mfd. Tubular Condenser.
 C15: 500 mfd. 12 volt Electrolytic.
 CH: 25 Henry ¼ ohm Filter Choke.
 G1, G2, G3: Three Gang Condenser.
 IF1, IF2: 465 k.c. Iron Cored I.F.'s.
 L.S.: P.M. Type Speaker to match 1D4.
 PD: 465 k.c. Padding Condenser.
 RFC1, RFC2: Radio Frequency Chokes.

R1, R10: .25 megohm Carbon Resistors.
 R2, R3, R4, R5: 50,000 ohm Carbon.
 R6, R7: 500,000 ohm Resistors.
 R8, R9, R11: 1 megohm Carbon.
 R12: .1 megohm Carbon Resistor.
 R13: 10,000 ohm Carbon Resistor.
 VC: 500,000 ohm volume control.
 VALVES: Two 1C4, and one each 1C6, 1K6, and 1D4.

P.P. BATTERY AMPLIFIER

BT: Class B audio transformer to suit 1J6G.
 C1, C2: .02 mfd. mica condensers.
 C3, C4: .004 mfd. mica condensers.
 C5: .1 mfd. tubular condenser.

LS: Permagentic type speaker to match output valve.
 R1: 500,000 ohm resistor.
 R2: 100,000 ohm resistor.
 R3: 250,000 ohm resistor.
 VALVES: Two type 1H4G and one type 1J6G.

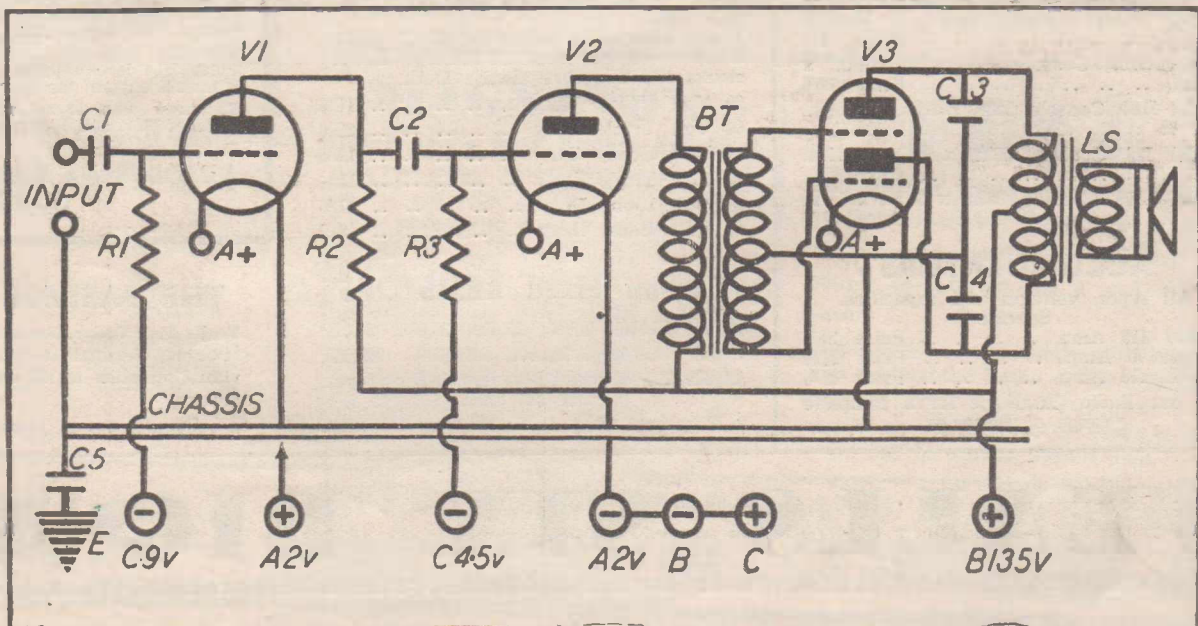

TESTED AND PROVED ... VELCO READY TO

ASK VALLS TO QUOTE

With six big radio and electrical stores in Melbourne and suburbs, Vealls can offer you a choice from the most comprehensive stocks in Australia. Complete radio sets, kitsets and all the multiplicity of bits and pieces that go to form the modern radio receiver. Electrical appliances, household labor-saving devices and electrical tools for the handyman are also available at keen, low prices. Write or call at Vealls nearest store . . . let Vealls quote on your next radio or electrical requirements.

CHOOSE FROM THE BIGGEST STOCKS IN MELBOURNE

The most popular 3-Valver ever offered The Melodious Super Battery 3



The Melodious Super Battery 3 is undoubtedly the best 3 Valve set ever described in The Listener In, yet for only £9/5/ Veall's will supply the complete kit—everything, including Valves, H.D. Batteries and Magnavox Speaker, being included in the price. Hundreds of these kits are giving satisfactory reception throughout Australia. Order a kit today.

For those who desire to build the Dual Wave Version of the Melodious Super 3, Vealls will supply the Complete Kit for £9-15-0.

PARTS FOR SET BUILDERS

RADIO CABINETS

- A complete Range of well-finished Cabinets.
- Major Mantel, 18in. x 16½in. x 12in. Price 32/6
 - Model G180, Console, 37½in. x 19½in. x 12in. Price 39/6
 - Model J100, Console, 38in. x 21in. x 12½in. Price 50/-
 - Model J20, Console, 36in. x 30in. x 15in. Price 35/-
 - Model E190, Console, 36in. x 36in. x 13in. Price 70/-

ACCUMULATORS

All types, voltages and capacities.
Special

- 2 Volt 110 Amp. Price 19/-
 - 6 Volt 90 Amp. Price 27/6
 - 6 Volt 110 Amp. Price 32/6
- See our Radio Catalogue for a complete range of Batteries.

DIAMOND and EVERREADY "B" BATTERIES

Vealls have daily deliveries of all leading Batteries—direct from the factory. Battery stocks are therefore always fresh.

- 60 Volt Heavy Duty 17/6
- 60 Volt Triple Duty 22/6
- 45 Volt Heavy Duty 12/6
- 45 Volt Triple Duty 15/-
- 60 Volt Light Duty 11/6
- 45 Volt Light Duty 8/9

Carbon Fixed RESISTORS

- 10,000, 15,000, 20,000, 25,000, 30,000, 50,000, 75,000, 150,000, 200,000, 250,000, 300,000, 500,000, 750,000 and 1 Megohm, 1 Watt types. Price 9d. each.
- 2 Meg. or 3 Meg. 1 Watt types, 1/9 each.

*Why leave your
Radio at
Home?*

YOU CAN TAKE A VELCO
PORTABLE 4 WITH YOU
ANYWHERE . . . ANY TIME

The Velco
PORTABLE 4

OR THE
COMPLETE KIT **11**
—EVERYTHING
FULL CONSTRUCTIONAL DE

The Velco Outdoor Portable 4 is an c worth all over Australia. Weight consumption only 8 ma. For only necessary to build the complete Portable accum., "B" batts. and speaker, together Assemble it in one evening — failure Portable 4 is equally at home . . . in it for 365 days in the year.

For those who do not wish to assemble Outdoor Portable 4 completely assembled —ready for operation.

**A MODERN 4 VALVE BATT
OUTSTANDIN**

THE FASTEST MAIL

Vealls Mail Order Department offers its same-day despatch that will surprise and vidual attention to all orders—big or always.

A reputation for 25 years' fair and sq

VEALLS SIX BIG STO

BY HUNDREDS OF USERS

BUILD KIT-SETS



14
Gns.
Gns.
AL DETAILS—FREE

is an outstanding performer and has proved its
light with standard size batteries, 28 lbs. "B"
only 11 Guineas Vealls will supply everything
Portable including ready-made cabinet, valves,
together with full instructions.
failure impossible — and remember, the Velco
indoor or outdoor. Order a kit today—use
assemble this kit Vealls will supply the Velco
assembled, wired and tested for only 14 Guineas
BATTERY OPERATED RECEIVER OF
DIN PERFORMANCE

MAIL ORDER IN AUSTRALIA
offers the fastest service in Australia. A prompt,
price and delight you. Careful, expert and indi-
ing or . . . Get the habit—try Vealls first and
and square desling protects you.

The Ideal
COUNTRY
KIT

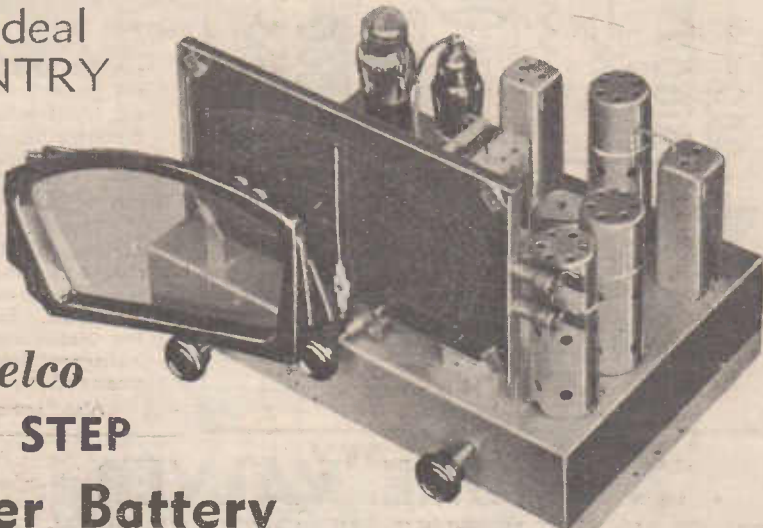

The Velco
EASY STEP
Master Battery
FIVE

£11/17/6

The Velco Master Battery 5 features Automatic Volume Control, Automatic Bias and Inverse Feedback, thereby eliminating distortion and increasing the overall gain of the receiver. Priced at only £11/17/6 the complete kit comprises everything necessary, including 8 inch, Magnavox Speaker, 1-1C6, 1-1D4, 1-1K6 and 2-1C4 Radiotron or Kenrad Valves, 3-45V Heavy Duty Diamond or Everready Batteries and 2 Volt 100 amp. Velco Accumulator.

WRITE FOR FULL CONSTRUCTIONAL DETAILS—FREE

Remember, when you buy this complete kit the price, £11/17/6, includes everything necessary—there's nothing else to buy. For those who wish to purchase the Master 5 as a complete set in cabinet—ready for reception—Vealls can supply it for only £17/9/6.

MAGNAVOX

The World's Best Known Speaker

For years these world-famous speakers have only been available to high-class set manufacturers — now Vealls can supply YOU.

PERMANENT MAGNET TYPES.

Type 382PM, 12in. Cone, 37½oz. Magnet	65/
Type 380L, 10in. Cone, 37½oz. Magnet	55/
Type 380H, 10in. Cone, 26½oz. Magnet	46/
Type 380M, 10in. Cone, 21oz. Magnet	41/6
Type 388M, 8in. Cone, 21½oz. Magnet	38/
Type 388S, 8in. Cone, 13½oz. Magnet	35/
Type 886S, 6in. Cone, 13½oz. Magnet	32/

DYNAMIC FIELD TYPES.

Any Field or Transformer.	
6½in. Cone	24/
8½in. Cone	30/
12½in. Cone	44/
8in. Cone, not dustproof	27/6
8in. Cone	24/6
10½in. Cone	35/
All Dustproof.	

FREE

Every home requires a copy of Vealls Radio or Electrical Catalogue . . . every radio fan or handyman will find it a source of interest and a real money-saver. Send for your copy today—state whether you require the Radio or Electrical section—or both. Merely enclose a 2d. stamp to defray cost of postage—your copy will be sent by return mail.

EVERYTHING RADIO AND ELECTRICAL

ADDRESS ALL LETTERS TO BOX 2135 G.P.O., MELBOURNE, C.1.
490 Elizabeth Street, Melbourne. F3145. | 243-249 Swanston Street, Melbourne. C3059.
168 Swanston Street, Melbourne. C10524. | 299-301 Chapel Street, Prahran. Wind. 1605.
3-5 Riversdale Road, Camberwell. W1188. | 97-99 Puckle Street, Moonee Ponds. FU7822.

TORES

A.C. RECEIVERS

THE experimenter should always remember that the voltages employed in modern all-electric receivers are sufficiently high to give serious or even fatal electric shocks. Consequently the wiring of the receiver should not be tampered with whilst the set is switched on.

Whilst the maximum plate potential normally associated with battery receivers is only 135 volts, the a.c. receiver will have a mains voltage of from 200 to 250 volts applied to it and will develop from 750 to 1000 volts across the outers of the power transformers high voltage secondary winding. The a.c. input voltage itself is sufficient to give a fatal shock and adequate voltage exists in the power supply circuits to give a serious shock and one which the experimenter will find hard to break loose from when once the circuit has been completed through his body.

Sometimes, of course, it is essential to have the receiver running whilst adjustments are being made and voltages checked. However, play safe and use test instrument leads which are provided with long bakelite insulating handles and test prods. Even then it is wise to earth the negative lead to the chassis and to bring only the positive lead from the test instrument into contact with the section of the circuit to be measured.

Also, remember that condensers store up current and if the receiver is not provided with some form of voltage dissipating device such as a voltage divider or bleeder resistance it will be necessary to short-circuit the filter condensers after the set has been switched off and before any attempt is made to explore the wiring.

Provided that reasonable precautions are taken the a.c. receiver is as safe to handle as a crystal set but woe betide the set builder who is careless during his tinkering with the high voltage circuits of the modern receiver.

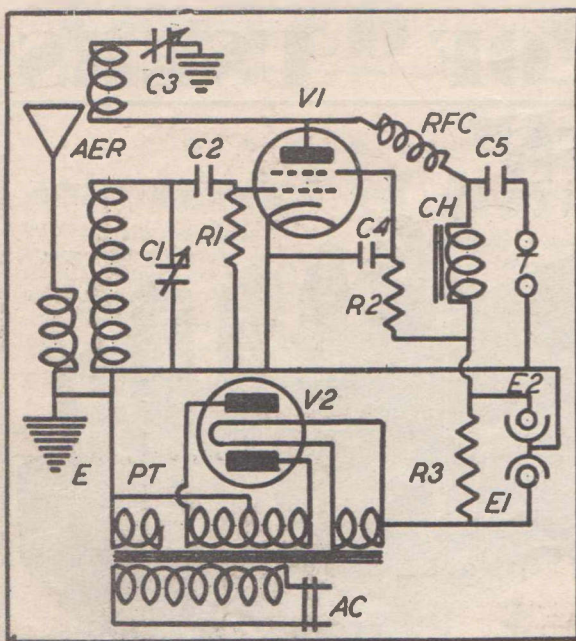

A.C. ONE VALVER

- CHASSIS: Aluminium. Measuring 12 inches by 9 inches by 2½ inches.
- AER: Three coil tuner.
- CH: Audio frequency choke coil.
- C1: .0005 mfd. variable condenser.
- C2: .00025 mfd. mica condenser.
- C3: 23 plate midget variable condenser.
- C4: .1 mfd. tubular condenser.
- C5: .02 mfd. mica condenser.

- E1: 600 volt 8 mfd. electrolytic condenser.
- E2: 500 volt 8 mfd. electrolytic condenser.
- PT: Power transformer, 385-0-385 v. at 60 m.a., 5 v. at 2 a., 6.3 v. at 2 a.
- RFC: Radio frequency choke coil.
- R1: 2 megohm carbon resistor.
- R2, R3: 500,000 ohm carbon resistors.
- T: 2000 ohm headphones.
- VALVES: One each 6C6 and 80.

A.C. 2/3

- C1: Variable condenser .0005 mfd.
- C2: Midget condenser 23 plate.
- C3: .00025 mfd. mica condenser.
- C4: .1 mfd. tubular condenser.
- C5: .02 mfd. mica condenser.
- C6: .004 mfd. mica condenser.
- E1, E2: 8 mfd. 500 volt electrolytics.
- E3: 25 mfd. 25 volt electrolytic condenser.
- L1, L2, L3: Coil kit.
- PT: Power transformer.
- R: 2 megohm resistor.
- R1: 1 megohm resistor.
- R2: .25 megohm resistor.
- R3: .5 megohm resistor.
- R4: Bias resistor to suit valve.
- RFC: Radio frequency choke.
- SPEAKER: 2500 ohm field input to match output valve.
- V1: R.F. pentode valve.
- V2: Output pentode valve.
- V3: Rectifier valve.

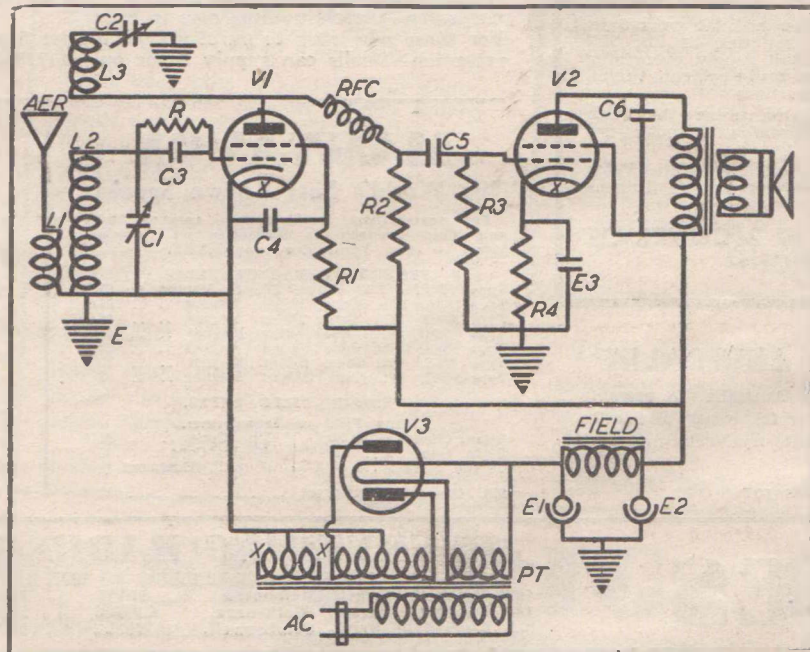

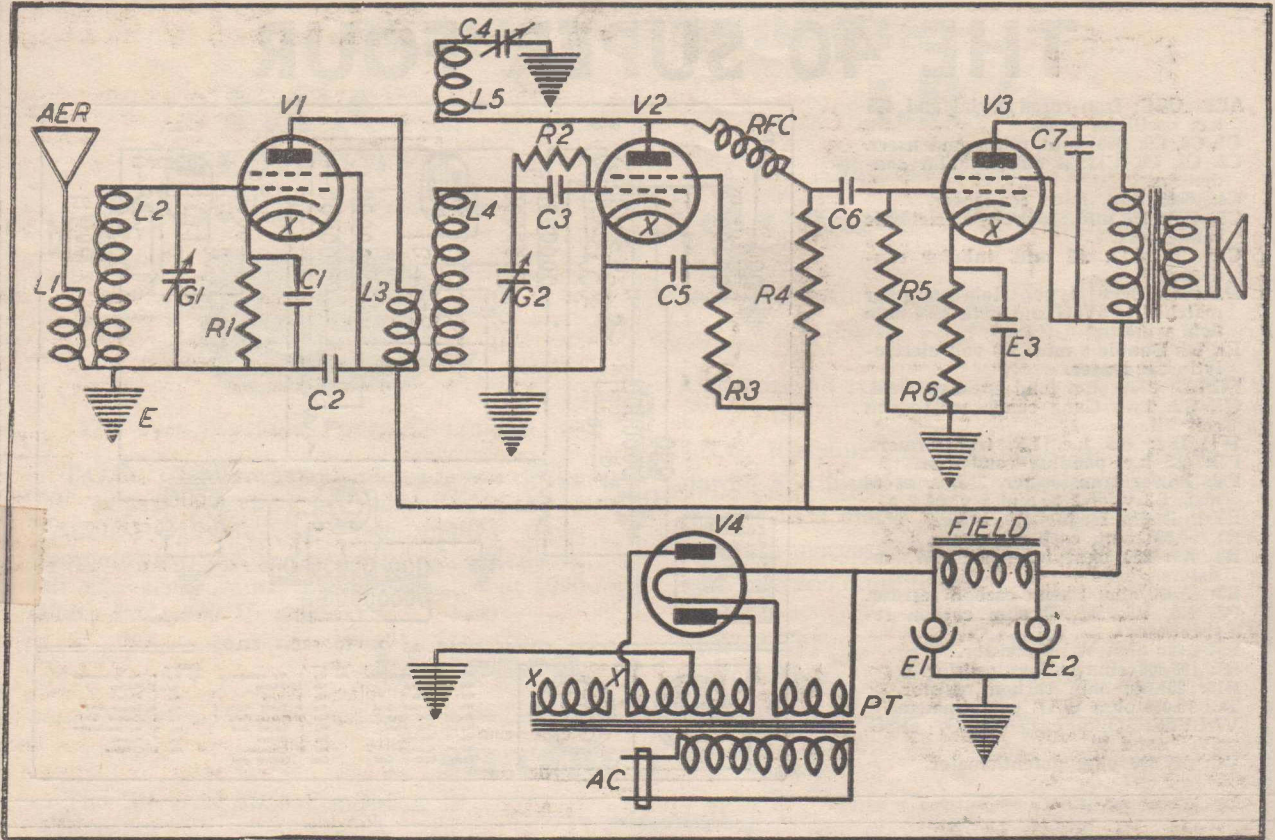

T.R.F. THREE VALVER

SO far as the general lay-out requirements are concerned the a.c. operated tuned r.f. receiver is the same as the battery type. In addition, though, care must be taken to ensure that the power transformer, rectifier, valve, and filter choke, if any, are not too close to the filter condensers, and are not so placed as to introduce hum into the audio circuits.

The remarks already made on coils in the battery circuit section apply equally to the a.c. t.r.f. receiver. For best results commercial coils should be used and for preference these should be of the high gain iron cored type.

One thing which must be given consideration with t.r.f. receivers, and in fact with all a.c. operated receivers, is the voltage of the supply lines. Most power transformers are provided with one or more taps so that compensation can be made for a rise or fall in the mains supply voltage.

Unfortunately, all too few set builders and users take advantage of this provision for they do not realise how variation of the input voltage affects the terminal voltages in the receiver itself.

PARTS LIST

- C1, C2, C5: 0.1 mfd. tubular condensers.
- C3: 0.00025 mfd. mica condenser.
- C4: 23 plate, midget condenser.
- C6: 0.92 mfd. mica condensers.
- C7: 0.004 mica condensers.
- E1, E2: 8 mfd. electrolytic condensers.
- E3: 25 mfd. 35 volt electrolytic condenser.
- G1, G2: Two gang condenser, .000385 mfd.
- L1, L2, L3, L4, L5: Aerial and R.F. coils.
- PT: Power transformer.
- R1: Bias resistor for V1.
- R2: 2 megohm resistor.
- R3: 1 megohm resistor.
- R4: 25 megohm resistor.
- R5: .5 megohm resistor.
- R6: Bias resistor for V3.
- RFC: R.F. choke.
- SPEAKER: Field 2500 ohms. Transformer to match V3.
- V1: R.F. pentode (variable mu) and socket.
- V2: R.F. pentode and socket.
- V3: Pentode output valve and socket.
- V4: Rectifier valve and socket.

Take the case of a receiver fitted with a power transformer tapped for use on either 200 or 250 volts. Assume the mains to be 250 volts and further assume that they are connected between the "Common" and 200 volt lugs of the power transformer. The voltage of the 6.3 volt windings then will increase to 250/200 of 6.3 volts or nearly 8 volts.

Meantime the 400 volt output from the rectifier will have increased to 500 volts with subsequent increase in current drain by the valves in the set and overloading of them and the power transformer.

Conversely, if the receiver is operating on the 200 volt mains which are connected between the "Common" and 250 volt taps the plate and filament voltages will be only four fifths of what they should be normally.

In each case the set is operating under abnormal conditions and the life of the valves, and possibly their associated components will be shortened. The moral is obvious. Always connect the power mains to those lugs of the power transformer primary which most nearly meet the mains voltage requirement.

THE 40 SUPER FOUR

- AER, OSC:** Iron-cored aerial and 465 k.c. oscillator coils.
C1, C8, C9: .0001 mfd. mica condensers.
C2, C3, C6, C13: .1 mfd. tubular condensers.
C4: .0005 mfd. mica condenser.
C5, C11: 25 mfd. 25 volt electrolytic condensers.
C7, C10, C12: .02 mfd. tubular condensers.
D.S.: Midget type Rola speaker matched to 6V6G and with 2500 ohm field winding.
E1, E2: Double 8 mfd. 500 volt electrolytic condenser.
FIELD: 2500 ohm loud speaker, field.
G1, G2: Two Gang condenser to suit coil kit.
IF1, IF2: 465 k.c. I.F. transformers.
PD: 465 k.c. padding condenser.
PT: Power transformer, 385 v. at 60 m.a., 6.3 v. at 2 a. and 5 v. at 2 a.
RFC: Radio frequency choke.
R1: 50,000 ohm carbon resistor.
R2, R9: 250 ohm 100 m.a. W.W. resistors.
R3: 15,000 ohm 1 watt carbon resistor.
R4, R6, R8: 500,000 ohm carbon resistors.
R5: 2,000 ohm W.W. resistor.
R7: 100,000 ohm carbon resistor.
R10: 250,000 ohm carbon resistor.
TC: 10,000 ohm W.W. potentiometer.
VALVES: One each 6K8G, 6B8G, 6V6G, and 80.
VC: 500,000 ohm potentiometer.

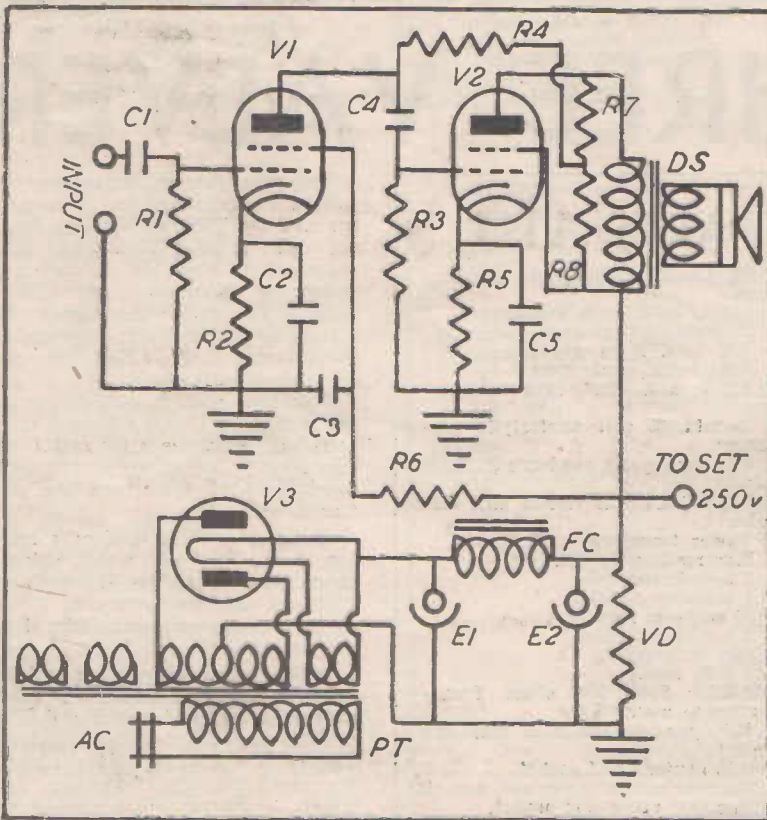
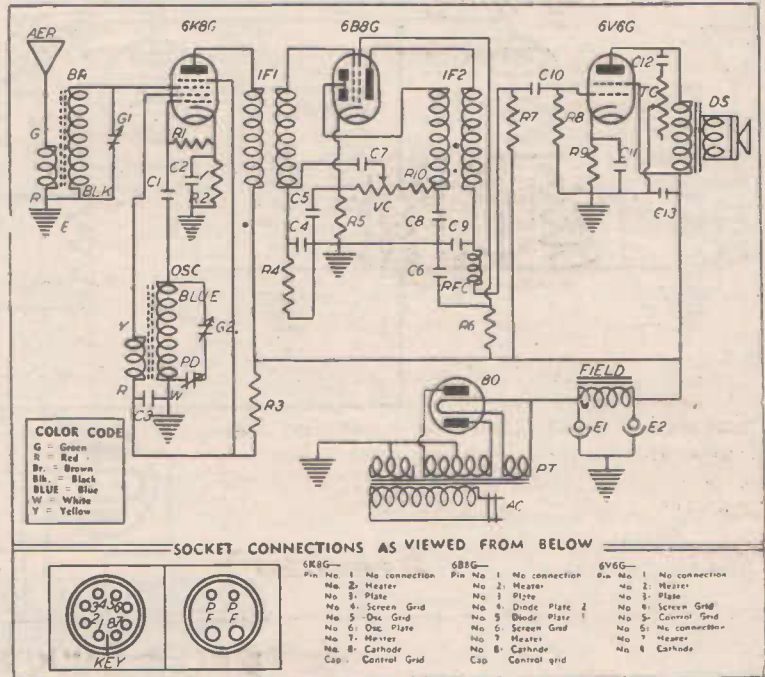

A 4 1/2 WATT A.C. AMPLIFIER

- CHASSIS:** Aluminium 6 inches by 6 inches by 2 inches.
C1: .02 mfd. tubular condenser.
C2, C5: 25 mfd. 25 volt electrolytic condensers.
C3: .25 mfd. tubular condenser.
C4: .05 mfd. tubular condenser.
DS: 1500 ohm field dynamic speaker to match 5000 ohm load.
E1, E2: 16 mfd. 500 volt electrolytic condensers.
FC: 1500 ohm loud speaker field winding.
PT: Power transformer, 385-0-385 v. 6.3 v. 2 a. and 5 v. 2 a. windings. 100 m.a. type.
R1: 1 megohm carbon resistor.
R2: 2000 ohm 10 m.a. w.w. resistor.
R3: 500,000 ohm carbon resistor.
R4: 250,000 ohm carbon resistor.
R5: 210 ohm 50 m.a. w.w. resistor.
R6: 1.75 megohm carbon resistor.
R7: 100,000 ohm carbon resistor.
R8: 20,000 ohm carbon resistor.
VALVES: One each 6C6, 6V6G, and 80.

QUALITY PRODUCTS

T.C.C. STEDIPOWER

Moulded Paper Condensers



The only Moulded Paper Condenser

T.C.C. "Stedipower" Condensers are of the "3" paper type and are surrounded by a Seamless Bakelite Case—this makes them temperature and moisture proof. Made in all sizes from .01mf. to .1mf. Tested at 1000 Volts D.C., 400 V. working.

Capacity
0.1 to .1mf.

1/- each

I.R.C.

RESISTORS

CAR RADIO SUPPRESSORS

Built for lasting service, long life. Special Types for Ford and Buick.

List Price all types **2/6**

I.R.C. Resistors are also made in the Standard 1 and 2 watt types. Their construction insures low noise level and dependability, and are necessary components in all high gain sets and amplifiers.

.5 Watt Types .. 1/- 2 Watt Types .. 2/-
1 Watt Types .. 1/3 **LIST PRICE**

SILVERED MICAS

The Silvered Mica Condenser is something new in Australia and was designed to eliminate the rapid change in capacity with temperature that is the fault with ordinary mica condensers.

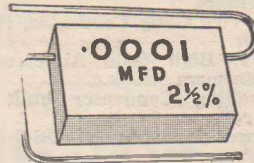

This Condenser is housed in a non-Hygroscopic Ceramic Case and is ideal for all coupling and Osc. Circuits where change of capacity is detrimental. Manufacturers quoted any quantity.

ELECTROLYTIC

C O N D E N S E R S

AQUEOUS TYPE

T.C.C. 8 mf. Electrolytics type 805 and 806 are surge proof. Their leakage factor being very low, i.e. 1 M/A at full Rated Voltage.

Type—606 **4/6**
460v. w.

Type-805 **5/-**
500v. w.

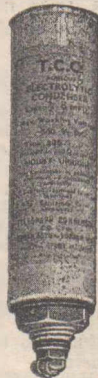

F.W. Electrolytic Condenser

Is ideal for service men and manufacturers.

8 mf 500 Volt Working **3/6**

DRY PIGTAIL TYPE

T.C.C. F.W. 10 mf. and 25 mf Electrolytics are of the "Dry" type and are guaranteed within 10 per cent. of their rated capacity.

25 mf 25 Volt **2/6**

25 mf 75 Volt **3/6**

10 mf 50 Volt **2/6**

AUSTRALASIAN ENGINEERING EQUIPMENT CO. PTY. LTD.

370 LIT. COLLINS ST. and 476 LATROBE ST., CITY. Phone F5585

THE FIDELITY SUPER FIVE

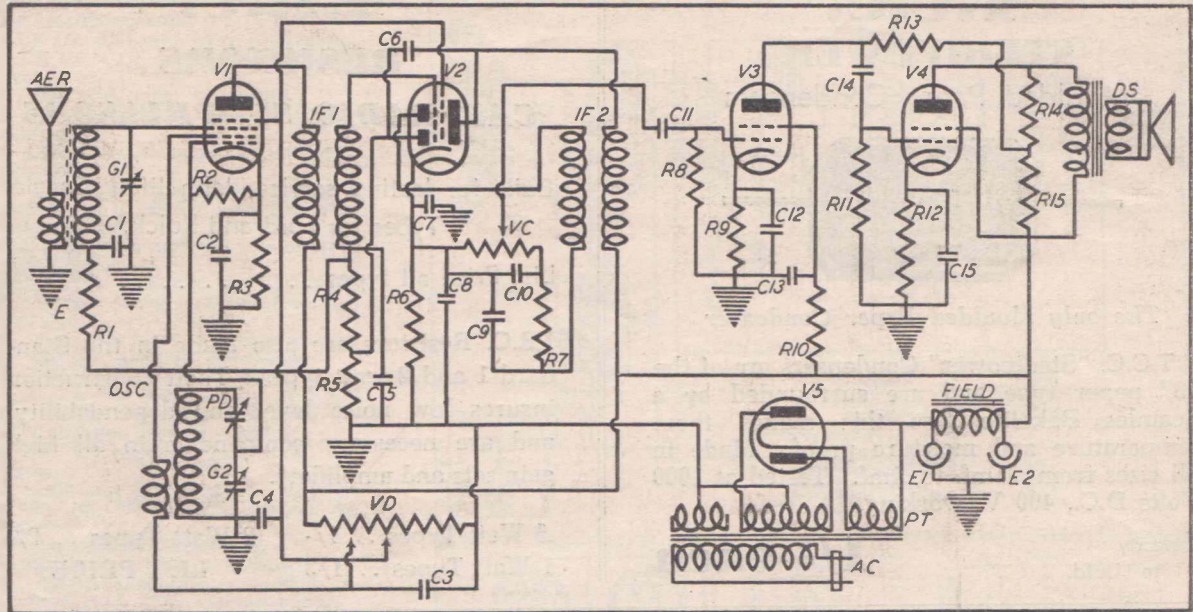

AER, OSC: Aerial and 465 k.c. Oscillator coils. Iron-Cored.

CHASSIS: Aluminium, measuring 13½ inches by 8 inches by 2¾ inches.

C1, C5: .05 mfd. Tubular Condensers. C2, C3, C7, C13: .1 mfd. Tubular Condensers.

C4: .5 mfd. Tubular Capacitor.

C6, C9, C10: .0001 mfd. Mica Condensers.

C8, C12, C15: 25 mfd. 25 volt Electrolytic Condensers.

C11, C14: .02 mfd. Mica Condensers.

DS: 2000 ohm field type Dynamic Speaker, matched to 7000 ohm load. E1, E2: 8 mfd. 500 volt Electrolytic Condensers.

G1, G2: Two Gang Condenser, to suit coil kit.

IF1, IF2: High Gain Air-cored i.f. Transformers, 465 k.c.

PD: Padding Capacitor built into OSC coil.

PT: Power Transformer:—385-0-385 v. at 60 m.a., 6.3 v. at 2 a., and 5v. at 2 a.

R1, R7, R14: .1 megohm 1 watt Resistors.

R2: 50,000 ohm ½ watt Resistor.

R3: 300 ohm 25 m.a. w.w. resistor.

R4, R5, R8, R11: 1 Megohm ½ watt resistors.

R6: 250 ohm 25 m.a. w.w. resistor.

R9: 2000 ohm 25 m.a. w.w. resistor.

R10: 1.5 megohm 1 watt resistor.

R12: 400 ohm 100 m.a. w.m. resistor.

R13: 250,000 ohm 1 watt resistor.

R15: 11,000 ohm 1 watt resistor.

VALVES: One each types 6A7, 6B7's, 6C6, 42, and 80.

VC: 500,000 ohm potentiometer.

30 WATT P.A. AMPLIFIER

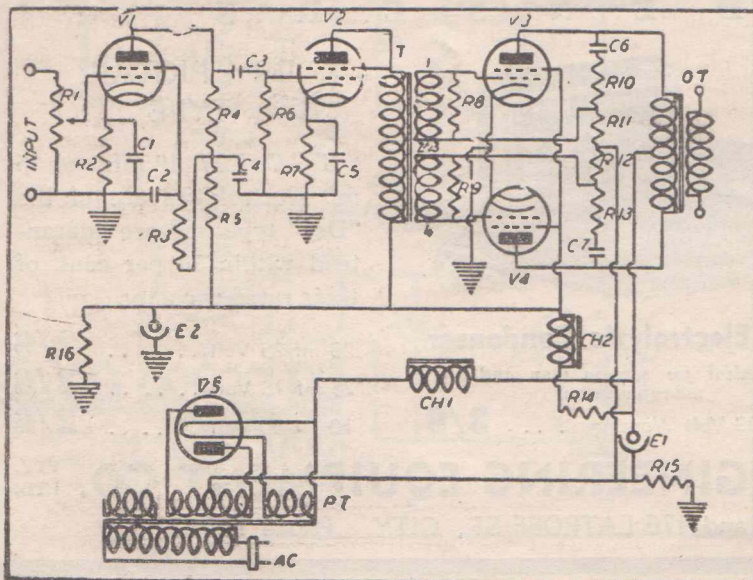

C1, C5: 25 mfd. 25 volt electrolytic condensers.

C2: .5 mfd. tubular capacitor.

C3: .02 mfd. mica capacitor.

C4: 8 mfd. 600 volt electrolytic.

C6, C7: .25 mfd. fixed condensers.

CH1: 10 henries (Min) at 200 m.a. filter choke.

CH2: 30 henry choke to total 1600 ohms with R14.

E1: 24 mfd. electrolytic capacitor.

E2: 8 mfd. 600 volt electrolytic.

OT: 30 watt output transformer

PT: Power transformer 475-0-475 250 m.a.; 5 volt and 6.3 volt filament

R1: 500,000 ohm potentiometer.

R2: 2000 ohm w.w. 10 m.a. resistor.

R3: 1.5 megohm carbon resistor.

R4: 250,000 ohm carbon resistor.

R5: 50,000 ohm carbon resistor.

R6: 1 megohm carbon resistor.

R7: 1600 ohm 10 m.a. w.w. resistor.

R8, R9, R10, R13: 100,000 ohm carbon resistors.

R11, R12: 20,000 ohm carbon resistors.

R14: See CH2.

R15: 120 ohm 250 m.a. w.w. resistor.

R16: 4800 ohm w.w. resistor.

T: Audio transformer to match 6C6, to 6L6G's.

VALVES: Two 6C6's, two 6L6G's and one 83.

DUAL WAVE A.C. 5/6

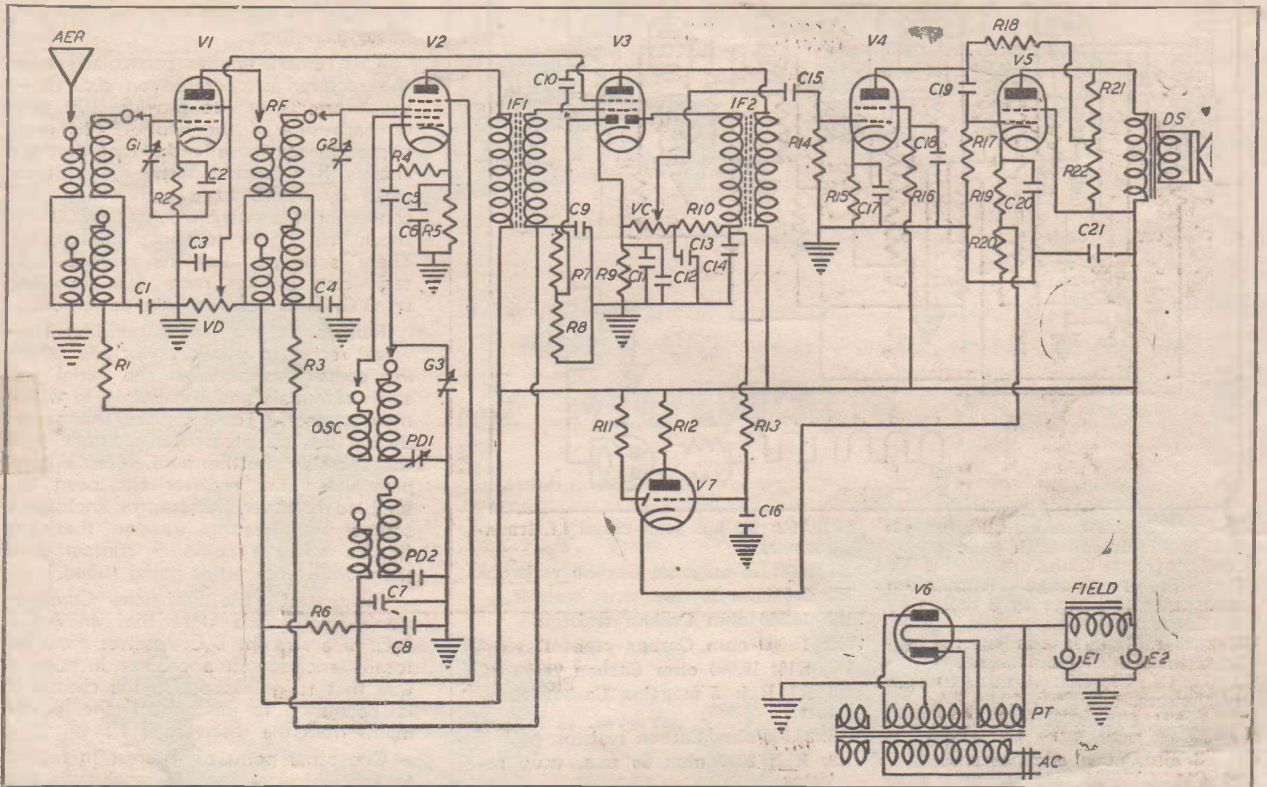

COMPONENTS LIST and DESIGN HINTS

AER, R.F., OSC.: Coil Kit (dual-wave) to suit tuning condenser.

CHASSIS: Aluminium 16 gauge. Measuring 16 inches by 10 inches by 3 inches.

C1, C4, C7, C9, C16, C19: .05 mfd. tubular condensers.

C2, C6, C11: .1 mfd. tubular condensers.

C3, C18, C21: .5 mfd. tubular condensers.

C5, C10, C13, C14: .0001 mfd. mica condensers.

C8: 8 mfd. 350 volt electrolytic condenser.

C12, C17, C20: 25 mfd. 25 volt electrolytic condensers.

DS: Dynamic speaker, 5,000 ohm. load, 1,600 ohm. field.

E1: 8 mfd. 500 volt electrolytic condenser.

E2: 16 mfd. 350 volt electrolytic condenser.

FIELD: 1,600 ohm loud speaker field winding.

G1, G2, G3: Three gang condenser to suit coil kit.

IF1, IF2: 465 k.c. iron-cored I.F. transformers.

THE two most important things in the design of dual-wave receivers are the wave range covered and the design of the mixer tube.

Unless it is desired to go into the matter elaborately the usual type of dual wave coils which cover the 16 to 50 metre band will suffice. These may be home made or of standard commercial type. The coils are easily wound but their matching is a thing a little beyond the average experimenter. For that reason standard commercial coils, which can be purchased fairly cheaply, are advised.

The type of mixer tube used has an important bearing on the satisfactory operation of the receiver. In the standard 6.3 volt valve class probably the best available tube is the 6K8G. With this type of tube it is possible to a.v.c. the mixer on short waves without getting into frequency drift trouble.

To overcome "flutter" difficulties by-pass the oscillator "B" plus lead with a .1 mfd. paper condenser and an 8 or 16 mfd. electrolytic.

PD1, PD2: Broadcast and S.W. padding condensers.

PT: Power transformer, 385 v. at 100 m.a.; 5 v. at 3 a. and two 6.3 v. at 2 a. windings.

R1, R3, R10: .1 megohm carbon resistors.

R2: 300 ohm. 50 m.a. w.w. resistor.

R4: 50,000 ohm. carbon resistor.

R5, R9: 250 ohm. 50 m.a. w.w. resistor.

R6: 15,000 ohm. carbon resistor.

R7, R8, R12, R14: 1 megohm carbon resistor.

R11, R22: 20,000 ohm. carbon resistors.

R13: 2 megohm carbon resistor.

R15: 2000 ohm. 50 m.a. w.w. resistor.

R16: 1.5 megohm carbon resistor.

R17: .5 megohm carbon resistor.

R18: .25 megohm carbon resistor.

R19: 150 ohm. 100 m.a. w.w. resistor.

R20: 60 ohm. 100 m.a. w.w. resistor.

R21: .1 megohm resistor.

VC: 500,000 ohm. carbon potentiometer.

VD 25,000 ohm. voltage divider.

VALVES: One each 6U7G, 6K8G, 6G8G, 6J7G, 6V6G, 6U5 and 5Y3G.

D.W. UNIVERSAL 4/5

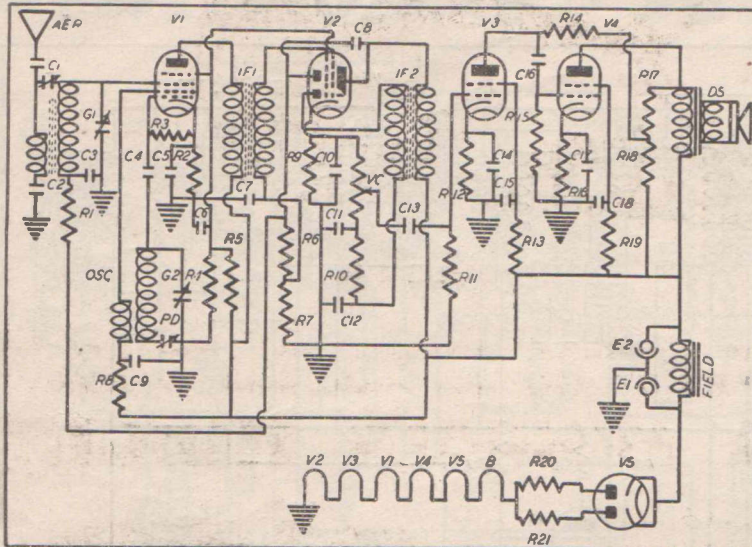

- AER, OSC: Iron-cored aerial and 465 k.c. oscillator coil with padder.
- B: 302 Barretter Tube.
- CHASSIS: 16 gauge Aluminium measuring 12 inches by 8 inches by 2 1/2 inches.
- C1: .0005 mfd. mica condenser.
- C2: .01 mfd. mica condenser.
- C3, C5, C6, C9, C15: .1 mfd. tubular condensers.
- C4, C8, C11, C12: .0001 mfd. mica condensers.
- C7: .05 mfd. mica condenser.
- C10, C14, C17: 25 mfd. 25 volt electrolytic condensers.
- C13, C16: .02 mfd. mica condensers.
- C18: 8 mfd. 300 volt dry electrolytic condenser.
- DS: Dynamic speaker to suit 43 valve. Field 1,000 ohms.
- E1, E2: 16 mfd. 400 volt electrolytic condensers.
- G1, G2: Two gang tuning condenser to suit coil kit.

- IF1, IF2: 465 k.c. Iron-cored i.f. transformers.
- R1, R14: .25 megohm Carbon resistors.
- R2: 300 ohm 50 m.a. w.w. resistor.
- R3: 50,000 ohm Carbon resistor.
- R4: 15,000 ohm Carbon resistor.
- R5, R18: 10,000 ohm Carbon resistors.
- R6, R7, R15: .5 megohm Carbon resistors.
- R8: 20,000 ohm Carbon resistor.
- R9, R12: 2000 ohm 50 m.a. w.w. resistor.
- R10, R17: .1 megohm Carbon resistors.
- R11: 1 megohm Carbon resistor.
- R13: 1.5 megohm Carbon resistor.
- R16: 450 ohm 100 m.a. w.o. resistor.
- R19: 6,000 ohm 50 m.a. w.w. resistor.
- R20, R21: Centre tapped 200 ohm 100 m.a. w.w. resistor.
- VALVES: One each 6A7, 6B7s, 6C6, 43, and 25Z5.
- VC: .5 megohm potentiometer.

A.C./D.C. Circuits

THE Universal receiver, designed for operation on either direct or alternating current mains is even more dangerous than the a.c. set when handled in a "live" condition.

This remark applies particularly when the receiver is operated on d.c. mains which are "split" to provide 200 volts on each side of the neutral. In these circumstances, despite the fact that the chassis is insulated from the external earth by means of a high grade mica condenser it is possible to get a 200 volt shock merely by touching the chassis. There is no job that the average radio technician dislikes more than handling an A.C./D.C. set with the power on.

Remember, too, when building Universal receivers always to include isolating condensers between the aerial and earth terminals and the points to which they connect. The terminals themselves should be insulated from contact with the chassis. Furthermore, it is a good plan when the receiver has been assembled to cover the control knob grub screws with sealing wax so that the fingers will not come in contact with them whilst the set is being tuned.

Incidentally, the Electricity Commission's Regulations state that an A.C./D.C. or a straight D.C. receiver must be totally enclosed in a cabinet in such a way that to get access to the chassis it is necessary to disconnect the power mains from the receiver.

One other point of interest in regard to the Universal type of receiver is the possibility of rectifier breakdown due to momentary voltage surges. To overcome this resistors of approximately 100 ohms each are connected in series with each plate of the rectifier tube. Such an arrangement overcomes the surge difficulty and enables long service life to be obtained from the rectifier tube.

5 Watt A.C./D.C. Amplifier

- CH: 30 Henry 100 m.a. Filter Choke.
- C1, C2, C9: .02 mfd. mica condensers.
- C3, C7, C8: 25 mfd. 25 volt electrolytic condenser.
- C5: .05 mfd. tubular condenser.
- C6: 8 mfd. 350 volt electrolytic.
- DS: Dynamic speaker, P.M. type, 8,000 ohm load.
- E1: 16 mfd. 350 volt electrolytic.
- E2: 8 mfd. 350 volt electrolytic.
- R1: R6: .5 megohm carbon.
- R2: 2,000 ohm. 10 m.a. w.w.
- R3: 1.5 megohm carbon resistor.
- R4: .25 megohm carbon resistor.
- R5: 50,000 ohm. carbon resistor.
- R7: 2,700 ohm. 50 m.a. w.w.
- R8: 225 ohm. 150 m.a. w.w.
- R9: 15,000 ohm. carbon resistor.
- R10, R11: 100 ohm. 150 m.a. w.w.
- R12: 3,000 ohm 25 m.a. w.w.
- T: Class A. coupling transformer ratio (Pri. to Sec.), 1 to 3.
- VALVES: One 6C6, one 76, two 43's and one 25Z5.

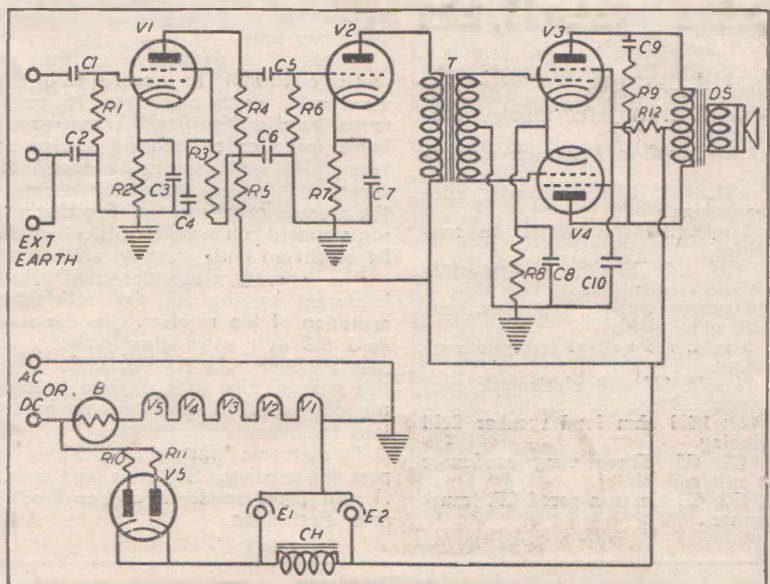

ONLY
£5



OFFER

*The cheapest, easiest, and most useful
RADIO SET you could wish to build*

A MODERN MIDGET



Everything necessary to complete the job including:—

**KIT OF NEW PARTS,
HANDSOME WALNUT
CABINET, RADIOTRON
VALVES, ROLA
SPEAKER.**

£10
WORTH
FOR
ONLY **£5**

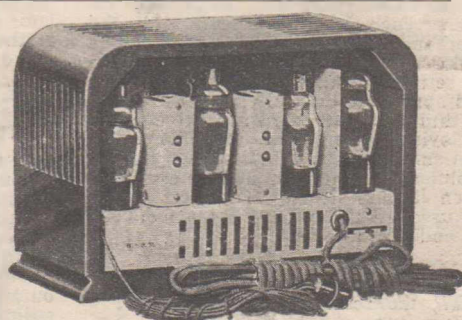

Back View —
Note the Finished Appearance

FREE

Full wiring instructions with every kit.
Also Final Checking, Testing and Lining.

SET BUILDERS . . .

It will pay you to inspect our Stock of Used Chassis mostly complete with Power Supply, Condenser Assemblies, Tuning Coils, Resistors, Condensers, etc. Prices from . . . **5/-**

Our Used Department is the largest in Australia, and carries a comprehensive range of quality-tested parts at ridiculously low prices. Valves from 2/-; Trans. from 2/6; Cabinets from 3/6; etc.

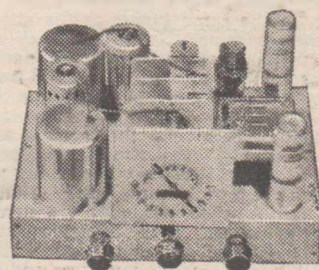

We are noted for our Prompt Efficient Repair Service. Low Prices on Replacements. Amplifiers built to Specification. Hire Service on Sets. Quotes willingly, given — Every Part Guaranteed. Ring, call or write.

MARCO'S

*The
Radio Store*

**230-232 SWANSTON ST.
(Corner Little Bourke Street)
CENT. 2579 — MX1993**

ALIGNMENT

● Application of Generator and Output Meter . . . Stage by Stage Alignment . . . Simple Padding Procedure . . . Aligning T.R.F. Receivers . . . Meterless Adjustment

ONE of the most serious problems for the uninitiated set builder is the alignment of a super-het. This fear of the multiplicity of tuned circuits encountered in such receivers is probably responsible for the home builder's unwillingness to build super-het. receivers in spite of the fact that he realises their advantages.

Yet when it is all boiled down the alignment of any receiver is a matter merely of patience and an understanding of what is to be done. Even without instruments it is possible quite accurately to align a standard super. and make it perform as it should.

There are three major stages of super-heterodyne alignment, the i.f. amplifier, the oscillator, and the aerial and r.f. tuners. Each is inter-related with the other and so the alignment of any one of the three sections has a bearing on the settings of the others.

To appreciate this fully, let us examine the tuning of a standard five valve super. employing a single i.f. amplifier stage. Most modern super-hets. have an i.f. amplifier operating on a frequency between 450 and 470 k.c. The most generally used frequency band is that between 455 and 465 k.c.

CONDENSER TRACKING

NOW the receiver is to tune over a frequency range of 1500 to 550 k.c., 200 to 545 metres. The aerial coil and its associate tuning condenser are proportioned to cover this wave band. The oscillator tuning has to keep progressively in step with the aerial tuning, although separated from it by a frequency equal to the i.f. amplifier frequency.

Suppose this to be 460 k.c. Then the oscillator must tune from 1960 k.c. to 1010 k.c. in the same sweep as the aerial tuner swings from 1500 to 550 k.c. At any particular dial setting the frequency of the oscillator tuner should differ from the frequency of the aerial tuner by 460 k.c.

In modern receivers the aerial and oscillator tuning condensers are equal in capacity and are mounted on the same shaft. In order that the oscillator tuner shall tune to a higher frequency (lower wavelength) it is necessary, since the condenser capacity is the same, that the oscillator coil shall have less inductance (fewer turns) than the aerial coil. Note that in referring to the aerial and oscillator coils we are considering only the grid windings and not the primary windings of each coil.

The minimum number of turns on the oscillator grid coil will depend on the lumped or fixed capacity in the circuit when the tuning condenser is set at minimum capacity. This will probably be quite small, with the result that when the oscillator tuning condenser is swung to maximum capacity the oscillator frequency will be lower (wavelength higher) than that necessary to maintain the tracking or frequency separation between it and the aerial tuner.

To balance up this discrepancy we introduce what is known as a padding condenser in series with the oscillator tuning condenser. Condensers in series reduce the effective capacity of the combination so that the padding condenser alters the maximum capacity of the oscillator section of the gang to a marked extent, although changing the minimum capacity only microscopically.

Here then we have the set-up for alignment of a super-heterodyne.

First we must adjust the tuned circuits of the i.f. amplifier to the desired frequency. Next we adjust the oscillator and aerial tuners to cover the maximum frequency (lowest wavelength) to which it is desired to tune. Finally we adjust the padding condenser to make the oscillator tuner track with the aerial tuner at the low frequency (high wavelength) end of the latter's sweep.

VALUE of SIGNAL GENERATOR

THE very best way in which the super-heterodyne can be aligned is with the aid of a signal generator and an output meter. The signal generator is calibrated to emit a signal of known frequency at a strength controllable by the operator. The output meter is connected in the output stage of the receiver and indicates the rise or fall of output level as the tuning circuits are adjusted for each setting of the signal generator.

Let us start the practical description of alignment procedure by assuming the use of a signal generator and output meter. Later we shall explain how a super may be aligned without their aid.

First switch the set on and, removing the grid clip from the mixer valve, attach another clip to which has been soldered one lead of a .02 mfd. condenser and one lead of a 100,000 ohm resistor. The remaining lead of the resistor joins to earth whilst the "hot" side of the signal generator is wired to the vacant lug on the condenser. The other lead from the generator is earthed.

Switch on the generator and turn the receiver volume control to the full on

position. The output meter should be connected in series with a 4 mfd. condenser to the plate of the output valve. The other connection on the meter should be earthed to the chassis.

Tune the generator to the desired i.f., say 460 k.c. and with a tiny screwdriver, or better still a tool made by fastening a small piece of clock spring in a piece of quarter inch bakelite tube, start the alignment by adjusting the trimmer of the secondary (diode) winding on the second i.f. transformer.

During this and subsequent tuning adjustments the signal generator should be cut back to the lowest level at which an indication can be observed on the output meter. This is necessary to avoid complications due to the effect of the automatic volume control which might take charge at high signal levels and prevent accurate indication of the correct tuning adjustment.

When the i.f. secondary has been adjusted move on to the primary of this transformer and adjust it similarly for a peak signal. Next adjust the trimmer on the secondary of the first i.f. transformer and finally adjust the primary trimmer on this component. It is a good plan to short-circuit the tuning gang of the oscillator stage by connecting a piece of wire from the fixed plates to earth.

AERIAL & OSCILLATOR ALIGNMENT

WHEN the i.f. amplifier has been aligned remove the generator grid clip from the mixer tube and the short from the tuning gang. Replace the grid lead from the grid coil and connect the generator to the aerial and earth terminals of the set through the former's "dummy aerial" if one is included. Now tune the receiver to a frequency around 1450 k.c. and, if the tuning dial is calibrated in frequencies, also swing it to this point.

Temporarily increase the output of the signal generator to facilitate a rapid rough adjustment of the trimmers on the oscillator and aerial stages of the tuning gang. Adjust the oscillator trimmer first so that the signal is indicated on the output meter.

Next, after reducing the output of the generator, adjust the aerial trimmer for peak results. When this has been done swing the generator to a frequency around 600 k.c. and tune the receiver up towards this end of the dial.

Again for a start it may be necessary to increase the output level to facilitate the speedy determination of the

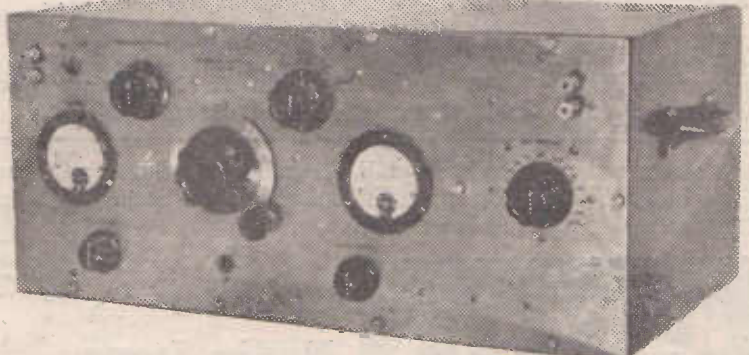

For precision alignment, and for definite checks on the sensitivity and selectivity of a receiver, high grade equipment, such as this laboratory type signal generator, is needed.

signal. Now adjust the padder condenser for peak output. After each adjustment of the padder remove the screwdriver from the slot of the adjusting screw and turn the tuning condenser control slightly. Continue to move the dial either forward or back after each adjustment of the padder until the peak output is read on the output meter.

The correct method is to increase the dial reading slightly each time the padder capacity is reduced by slackening the tension on its plates.

The reverse procedure is followed if the capacity of the padder is increased by increasing the plate tension by screwing up the adjustment screw. Eventually a stage will be reached where these adjustments, which have been showing a progressive increase in output, begin to produce a fall off. The correct setting is the peak output adjustment.

Finally return to the lower end of the dial and retune both the generator and the set to 1450 k.c. Adjust the aerial trimmer again for peak out-put.

Providing the tuning and oscillator coils have been correctly proportioned and the i.f. amplifier is set to the correct frequency, the receiver now should be in perfect alignment.

R.F. STAGE ADJUSTMENTS

THE above procedure has been outlined for a receiver which does not possess an r.f. stage. However, when an r.f. stage is included the secondary phase of the alignment, the adjustment of the aerial and oscillator circuits at 1450 k.c., remains the same except that it may be necessary still further to increase the signal generator's output to get the initial adjustment.

Once the oscillator trimmer has been fixed, adjust the r.f. trimmer and then the aerial trimmer. Again, after padding the receiver attempt readjustments to the r.f. and the aerial trimmers.

If the set is badly out of alignment, or the signal generator has not sufficient output, the adjustment of the aerial tuning of a set employing the r.f. stage may be tackled in the following way:—

After the i.f. amplifier has been aligned shift the grid clip to which the resistor and the .02 mfd. condenser was attached to the control grid of the r.f. valve. Set the generator to 1450 k.c. and adjust the r.f. trimmer. Then attach the generator leads to the aerial and earth terminals and adjust the aerial trimmer.

Incidentally, the alignment frequencies given are merely approximate. If a local broadcasting station is working on or sufficiently near these frequencies to cause interference, by all means shift away from it before commencing alignment.

OUTPUT INDICATORS

ONE final point on meter alignment is that of the output indicator. This may be any sensitive a.c. meter or a d.c. milliammeter provided with a rectifier. It should be capable of reading from 5 to up to 150 volts, although the low voltage meter may have a potentiometer connected across it so that only sufficient voltage to ensure adequate deflection reaches the instrument.

Another useful means of alignment check is that furnished by the "magic eye" tuning indicator. If the a.v.c. system is cut out during alignment the output level of the generator can be raised to a point sufficient to give a visual indication on the eye when the adjustments reach peak. Maximum closure movement of the eye indicates

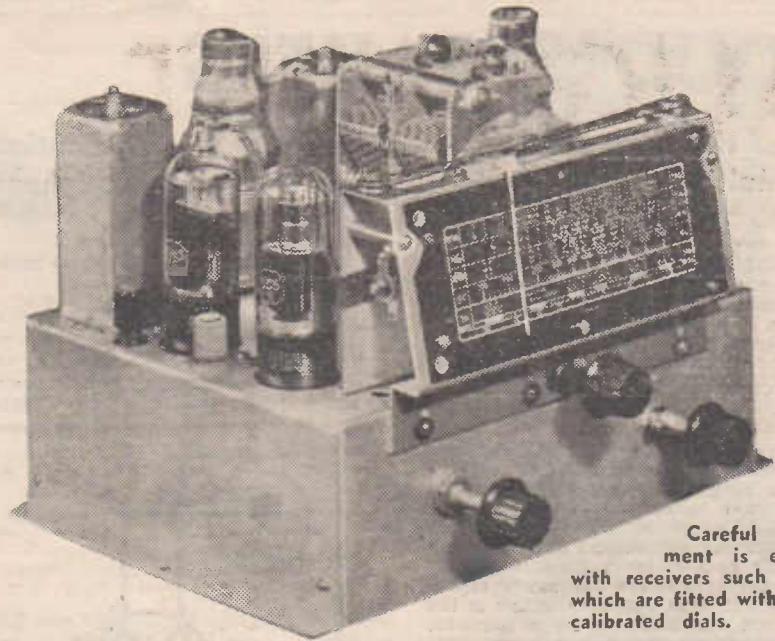

Careful alignment is essential with receivers such as this, which are fitted with station calibrated dials.

the peak setting. However, remember it is essential to cut out the a.v.c. system.

ALIGNMENT WITHOUT INSTRUMENTS

THOSE who have not access to a signal generator must rely upon the various broadcasting stations for alignment. Provided that a little care is exercised this method can be quite satisfactory.

The first thing to do is to align the i.f. amplifier and this is the most difficult job of all. Providing that the set is used near enough to a station operating on the 900 to 930 k.c. band the aerial outdoor can be attached to a .02 mfd. condenser whose other lug and one lead of a 100,000 ohm resistor is joined to the control grid lug of the mixer tube, and the other end of the resistor earthed and the station then is tuned in on the i.f. amplifier.

The trimmers on the i.f. amplifier transformers are adjusted in exactly the same manner as outlined for signal generator alignment. The frequency at which the i.f. amplifier is then set will be half that of the broadcasting station's frequency, details of which can readily be obtained from a station list.

Failing the use of an output meter or the inclusion of a magic eye in the receiver aural means can be used to determine the peak setting. For any adjustments such as these, it is desirable to remove the a.v.c. system and to set the volume control at the minimum level at which variations can be noticed in signal strength.

Probably a more satisfactory method is to assume that the i.f. transformers are set fairly accurately by the manufacturer and to proceed with the alignment of the aerial and oscillator tuning. Start by tuning the receiver to a station operating around 1450 k.c. and proceed as outlined for the signal generator alignment. Either visual or aural means of determining the peak setting may be used. Next, tune to a station around the 600 k.c. mark and pad the receiver in the same manner as previously explained but using the station as the source of a signal.

Assuming that it was decided to leave

the adjustment of the i.f. amplifier until after the aerial and oscillator circuits had been tracked, the next move is to tune the receiver to a station operating around 1000 k.c. and, starting from the secondary of the second i.f. transformer and working back in the order outlined for generator alignment, adjust each tuned circuit in turn. However, don't adjust the plate circuit trimmer on the first i.f. transformer, i.e., the one nearest the mixer tube.

T.R.F. RECEIVERS

THE alignment of a tuned r.f. receiver is simpler than that of a super-het. Here, the major adjustments are made by setting the trimmers for peak reception when the set is tuned to a high frequency around 1450 k.c. Again, either a generator or a station may be used as the signal source and either visual or aural means employed to determine the peak setting.

If the coils and the tuning gang are accurately matched then the receiver will track throughout its range. However, if it should be suspected that the set is out of track then, for most of the old model t.r.f. sets are fitted with slotted end plate gang condensers, it will be necessary to adjust each of these end plate sections.

To do this start at the high frequency end of the dial and adjust the trimmers for peak results. Turn the condenser till a station comes in at about the end of the first split plate section. With a wooden or bakelite skewer lightly press in or bend out this split plate section on each section of the gang. If the signal strength increases as this test is made it will be necessary permanently to bend each section in the direction indicated by the signal strength rise.

Then move on to a station falling in the middle of the next split plate section and repeat the procedure. Subsequent tests and, if necessary, re-adjustments of successive sections will result in the receiver being correctly aligned. Remember, though, to start at the high frequency end of the dial and to work progressively up towards the low frequency (high wave-length) end. Don't reverse the procedure.

LOUD SPEAKERS

Power Handling Capacity — Baffling — Field Excitation — Multi-Speaker Installations — Alternative Headphone Connections

THE loud speaker is the final link in the electronic chain between the broadcasting station and the listener, and as such demands at least as much attention from the set builder as other portions of the complete receiver.

The essentials of a loud speaker are its tonal fidelity, its power handling capacity, and its sensitivity.

Most of the lower-priced loud speakers are capable of covering only the frequency range extending from 90 cycles per second to around 5000 cycles per second. The better quality auditorium type speakers will extend this frequency coverage so that tones from 50 to 7500 cycles per second are adequately reproduced. For most applications this is the maximum frequency coverage required, although, where true high fidelity reproduction is desired, special "tweeter" type auxiliary loud speakers may be used in conjunction with the main speaker to boost the upper frequency range to 12,000 or 15,000 cycles.

The selection of the loud speaker will depend largely on the application for which it is intended, but, broadly, we can assume that good low note and reasonable high note reproduction is desirable.

BAFFLE-BOARD DESIGN

The former will be aided by the use of baffle boards of one kind or another. The size of the baffle board to permit the loud speaker (assuming that it is designed to cover the particular frequency) to reproduce tones of various frequencies without appreciable loss can be computed from the following simple formula:—

$$\text{Baffle size in feet equals } \frac{1130}{2f}$$

where $2f$ is equal to twice the frequency in cycles per second of the lowest note it is desired to reproduce.

This dimension, when applied to square flat baffles, is the size of each side of the square since the loud speaker is to be mounted centrally in the baffle. The board itself should be not less than 1 inch in thickness and may be of wood,

masonite or celotex. The latter is probably the most effective of all.

POWER-HANDLING CAPABILITY

The next consideration is the amount of audio power which a given type

watts of power continuously or 25 watts on peaks.

The sensitivity of a loud speaker is governed both by its construction and by the amount of field excitation which can practically be applied. The calculation of field wattages was dealt with fully in the section devoted to power supply equipment, so will not need further consideration here.

The figures listed in the Loud Speaker Characteristics Table are optimum figures. It is not desirable to increase these because of the danger of burning out the field windings. Reduction of the field excitation power, however, will reduce the sensitivity of the loud speaker. In the P.M. type loud speakers the sensitivity is governed by the size of the permanent magnet.

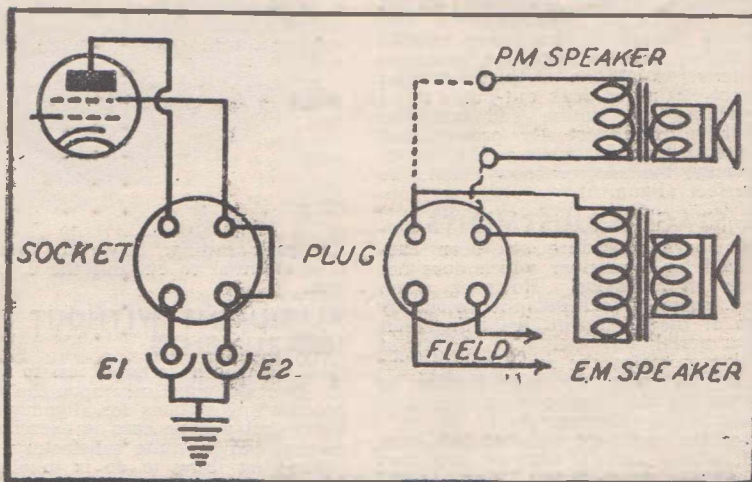

Fig. 1.—Methods of attaching external loud speakers to A.C. receivers.

of loud speaker will handle. Whether this power is to be handled continuously or only during momentary peaks also has a bearing on the matter.

The table of loud speaker operating characteristics shows that for continuous handling the output capability of the majority of low priced speakers ranges from 5 to 7 watts. This is a continuous rating and probably can be increased by 33 per cent. for most applications. From this it can be seen that practically any of the low priced speakers can be used as single units on amplifiers having power outputs up to nine or even 10 watts. For larger amplifiers it will be necessary to use more than one loud speaker or one of the auditorium type units which is capable of handling 15

The larger and more powerful this magnet the more sensitive the loud speaker will be, and the more audible output will be obtained for a given signal input. This point is of particular importance in battery receivers where audio power can be obtained only at relatively high expense.

A point which has an important bearing both on the apparent efficiency of the loud speaker and its tonal fidelity is the impedance match between the speaker and the source of audio power, i.e., the output of the audio amplifier.

The speaker voice coil has a low impedance, ranging from 2 to 8 ohms, whilst the output impedance of the audio amplifier tube may vary from 1500 ohms to as high as 24,000 ohms, depending upon the particular valves or valves used.

To match this impedance the output transformer connecting the speaker to the amplifier has a step-down transformation ratio to reduce the plate impedance to the voice coil impedance.

Theoretically, the match between impedances should be complete, but practical tests show that mis-matches having ratios as high as 4-1 can be tolerated by the ear. This, of course, does not take into consideration the power loss attendant on ill matched impedances, because fidelity is seriously affected only when the impedance mis-match is such that the "sink"—in this case the speaker impedance—is higher than that of the impedance matching winding to which it is being connected.

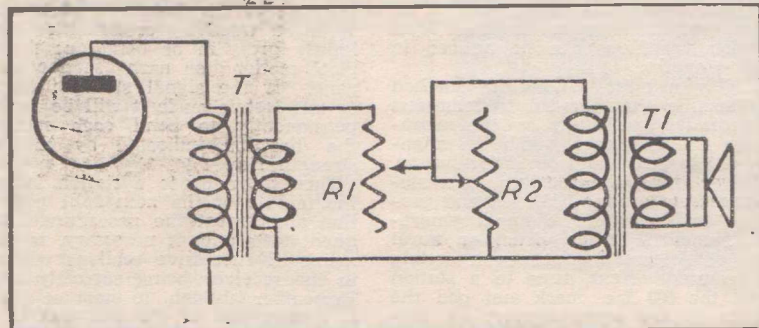

Fig. 2 illustrates the method of volume control employed in multi-speaker installations.

Rola

The World's Finest Sound Reproducers

To Radio Builders . . .

You have thought out your design with infinite care. You have selected the most suitable components for the job! Long hours of building and experiment will be put in before your job is "right."

Now . . . give your set that final finish of true craftsmanship. . . .

Select the Rola reproducer that is designed to give you maximum results.

Years of experience, skilled design and painstaking manufacture combine to make Rola the finest sound reproducer in the world. From the specifically selected raw materials to the final testing Rola incorporates just that little extra "something" that makes the final product superior. The exclusive Isocore transformer, combining electrical and mechanical principles new to transformer manufacture, is not subject to electrolysis. The new dustproof acoustic filter is one of the most important improvements ever introduced into dynamic loud-speaker manufacture. But these are two only of the many features that made for Rola clear cut superiority.



K8 is a quality 8in. electro-dynamic speaker used as a standard with most types of console receivers and frequently in Public Address and other special applications.

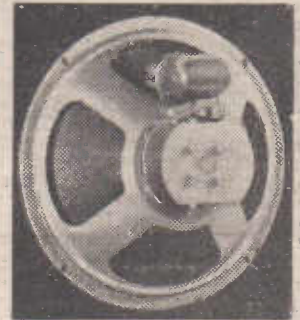

12-42 is the finest standard 12in. permanent magnet reproducer available anywhere. This series of 42oz. magnet speakers covering 8in., 10in., and 12in. will improve any set or amplifier.

Abridged Specifications and Retail Price List of Rola Reproducers

Type No.	Overall diameter	Voicecoil Diameter	Voicecoil impedance	Normal field excitation	Maximum weight of field coil	PRICES		
						Internal spider	External spider	Dustproof
Electro-Dynamic								
G-12	12 1/2 in.	1 3/4 in.	8 ohms	18 watts	3 1/2 lbs.	—	£8	—
K-12*	12 1/2 in.	1 in.	2.3 "	9 "	2 "	—	—	44/-
F-12*	12 1/2 in.	1 in.	2.3 "	8 "	1 1/2 "	—	—	35/-
K-10*	9 3/4 in.	1 in.	2.3 "	9 "	2 "	—	35/-	—
F-10*	9 3/4 in.	1 in.	2.3 "	8 "	1 1/2 "	32/6	—	—
K-8*	8 in.	1 in.	2.3 "	8 "	1 1/2 "	27/6	28/6	30/-
F-8	8 in.	3/4 in.	3 "	6 "	3/4 "	—	—	24/6
F5B	6 3/4 in.	3/4 in.	3 "	6 "	3/4 "	—	—	24/-
F-4	5 in.	3/4 in.	3 "	6 "	3/4 "	—	—	23/-
Permanent Magnet								
G-12	12 1/2 in.	1 3/4 in.	8 "	—	—	—	—	£11
12-42*	12 1/2 in.	1 in.	2.3 "	—	—	—	—	72/-
12-21*	12 1/2 in.	1 in.	2.3 "	—	—	—	—	50/-
12-20*	12 1/2 in.	1 in.	2.3 "	—	—	—	—	44/-
10-42*	9 3/4 in.	1 in.	2.3 "	—	—	—	—	65/-
10-21*	9 3/4 in.	1 in.	2.3 "	—	—	—	—	46/-
10-20*	9 3/4 in.	1 in.	2.3 "	—	—	—	—	41/6
8-42*	8 in.	1 in.	2.3 "	—	—	—	—	61/-
8-21*	8 in.	1 in.	2.3 "	—	—	—	—	42/6
8-20*	8 in.	1 in.	2.3 "	—	—	—	—	38/-
8-14*	8 in.	1 in.	2.3 "	—	—	—	—	35/-
6-14*	6 3/4 in.	3/4 in.	3 "	—	—	—	—	34/-
6-6	6 3/4 in.	3/4 in.	3 "	—	—	—	—	27/-
5-6	5 in.	3/4 in.	3 "	—	—	—	—	26/-

All speakers except G12 fitted with leads and plug as standard equipment.

*Fitted with Rola Isocore transformer to prevent electrolysis.

Write for further technical particulars.

When ordering state field coil resistance (in the case of electrodynamic speakers) and impedance of matching transformer.



K12. — A 12in. electro-dynamic reproducer designed to give the best possible results from high quality radio receivers and amplifiers with single or push pull output valves.



8-20, a moderately priced but highly efficient 8in. permanent magnet reproducer for battery receivers, auto radios, extension speakers and public address work.

Rola Co. (Aust.) Pty. Ltd.

THE BOULEVARD, PARK AVENUE, RICHMOND, VIC. J5351
116 Clarence Street, Sydney. B5867.

To obtain the turns ratio of a given output transformer we first determine the impedance ratio between the "source" to "sink."

The square root of this, 30, is the ratio between number of the primary and secondary turns of the output transformer and, supposing the primary to consist of 3000 turns, the secondary will need 100 turns to match the output valve to the speaker voice coil.

MULTI-SPEAKER INSTALLATIONS

SOMETIMES it is desired to operate more than one loud speaker from a single audio amplifier. The speakers may be operated simultaneously or not, but it is desirable that they be fitted with some form of individual volume control.

The circuit of Fig. 2 shows how this best can be done. We can assume at the start that the line connecting the loud speakers with the receiver is to have an impedance of 500 ohms. Consequently, the impedance step down of the output transformer, T, in the receiver itself, will be from the valve impedance, say 7000 ohms, to the 500 ohm line. Each of the loud speakers will be fitted with its own input transformer.

The impedance of the primaries of these transformers must be matched to the 500 ohm line. The impedance of each primary will equal the line impedance by the number of speakers to be used. Suppose ten are to be used. Then each speaker should be fitted with a 5000 ohm (500 x 10) input transformer.

It should be noted that in Fig. 2 transformer T is the output transformer matching the output valve to the 500 ohm line. Transformer T2 is the input transformer to be connected to each of the additional speakers.

VOLUME CONTROL

INCORPORATED with this input transformer are the ganged potentiometers R1-R2, which serve as a volume control for each speaker. A ganged unit is needed for each of the speakers.

Potentiometer R2 should have a resistance some five times that of the impedance of the speaker, into which it is to work. R1 should be approximately a quarter of the resistance of R2.

In the case of the 10 speaker set-up, previously mentioned, where each

LOUDSPEAKER OPERATING CHARACTERISTICS

BELOW are tabulated the essential operating characteristics of the Rola series of electro-magnetic and permanent magnet types of loud speakers.

Model	Voice Coil Impedance	Field Watts	Output Watts
Electro-magnet Types—			
K12 . . .	2.3	9	7
F12 . . .	2.3	8	7
K10 . . .	2.3	9	6
F10 . . .	2.3	8	6
G12 . . .	8.0	18	15
K8 . . .	2.3	8	6
F8 . . .	3.0	6	5
F5B . . .	3.0	6	5
F4 . . .	3.0	6	5
Permanent Magnet Types—			
10-20 . .	2.3	—	7
10-21 . .	2.3	—	7
10-42 . .	2.3	—	7
12-20 . .	2.3	—	7
12-21 . .	2.3	—	7
12-42 . .	2.3	—	7
8-42 . .	2.3	—	7
8-21 . .	2.3	—	7
8-20 . .	2.3	—	7
8-14 . .	2.3	—	7
6-6 . .	3.0	—	5
5-6 . .	3.0	—	5

speaker is fitted with a 500-ohm transformer, R2 should be 25,000 ohms and R1 approximately 6000 ohms. If it is desired to take the speaker and its volume control completely out of circuit the balance of the whole network can be maintained simply by switching a 6000-ohm fixed resistance across the line in place of the speaker-volume control unit.

HEADPHONE CONNECTION

NEXT we come to applications where it is desired to cut in a pair of headphones to the output stage of a powerful receiver. To do this and yet permit either the head-set or the speaker to be operated independently, a switching system such as that shown in Fig. 3 should be used. The coupling condenser C should be a high-grade mica one, in order to prevent the possibility of dangerous shocks.

The condenser and control switch for the head-set are wired in series with one phone terminal and the plate of the output valve. The other head-set terminal is earthed. To "mute" the loud speaker the secondary of the output transformer is broken with a switch.

The capacity of C may range from .02 mfd. to .002 mfd. The higher values will give good fidelity, whilst the lower ones will mitigate the hum effect produced by poor filtering in the receiver itself.

ADDING A P.M. SPEAKER

In Fig. 1 we have considered an application where the existing loud speaker is an electro magnet type, but where it is desired to rig a permanent magnet type speaker for remote listening. At the left is shown a typically wired four-pin loud speaker socket.

It is the practice of most manufacturers to wire the field leads to the large (filament) pins on the socket and the input transformer leads to the other pins on the socket. However, this point should be checked before embarking on any alterations to the set because some manufacturers depart from standard.

To cut in the external speaker we arrange matters so that the field connections of the built-in speaker are left in circuit. The input transformer connections to this speaker are removed and are replaced by the input transformer connections to the P.M. speaker.

If it is so desired, though, it is practicable merely to parallel the input transformer connections of the two loud speakers and to operate them simultaneously.

Such an arrangement will upset the impedance match existing between the output valve and the loud speaker, and should be avoided if possible.

POINTS TO WATCH

There are two or three important things to bear in mind when attempting any alteration or extension to the speaker arrangements of the existing set. If the set is fitted with a field type dynamic speaker do not make any changes which will result in the speaker field winding being taken out of circuit unless you are able to replace this field winding with a choke coil or combination of choke and resistance the total resistance of which equals that of the field winding.

Wherever possible avoid running direct current carrying leads to an external speaker. Use a P.M. type speaker and connect it so that the d.c. does not flow in circuits away from the receiver.

Don't attempt to improvise by using standard audio transformers as coupling chokes. If the transformer is of the output type its primary winding will be robust enough to carry the heavy plate current drawn by modern valves, but to expect an audio transformer rated to carry, say, 5 m.a. to handle currents in the vicinity of 40 to 50 m.a. is simply looking for trouble.

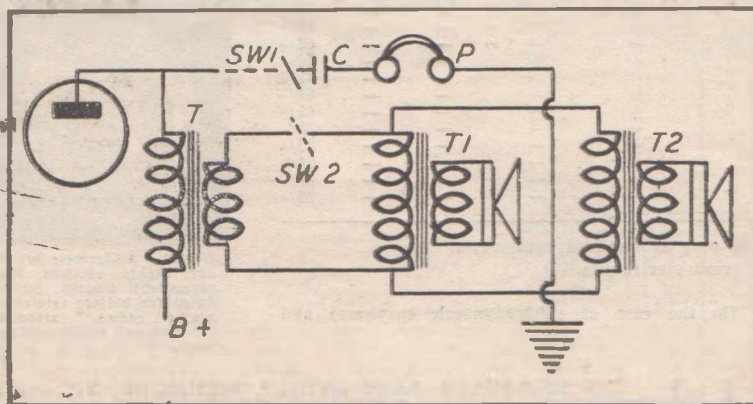

Fig. 3.—A simple arrangement for selection of multiple loud speakers or sets of headphones as desired.

GRAMO. PICK-UPS

Advantages of Magnetic and Crystal Types — Tracking Methods — Scratch Filters — Needle Selection.

WHEN faced with the selection of a gramophone pick-up, the average home set builder is likely to feel somewhat puzzled as to which type to purchase. Essentially, there are only two types in general use — the electro-magnetic and the electro-static, or crystal.

The chief advantage of the electro-magnetic type is that it is robust in design. Its frequency response is not nearly so good as the crystal type of pick-up, but even this disadvantage is more apparent than real when we come down to practical applications.

One point on which the crystal pick-up scores is that it has a higher output than the magnetic type, and so does not require so much amplification to produce full output in the amplifier's final stage.

Where fidelity of reproduction is desired, and good quality recordings are being used, a scratch filter should not be used. However, for those who wish to eliminate surface noise — and with it most of the higher audible frequencies — series resistors between the pick-up and the grid of the amplifying valve may be used for crystal pick-ups and parallel resistors across the pick-up terminals for magnetic types. Suitable values are 500,000 ohms for crystal pick-ups, and from 2000 to 4000 ohms for magnetic types. The resistors should be of the carbon variety.

PICK-UP CONNECTIONS

We come next to a consideration of the methods to be followed in connecting a pick-up into an amplifier circuit. Fig. 1 shows the basic circuit — irrespective of the fact that the valve may be a triode, a pentode, or one of the more complicated diode-pentodes. The pick-up should have its volume control connected across its terminals, notwithstanding that series of parallel scratch filter resistors may be employed.

As a general rule, use a volume control potentiometer having a resistance of 5 to 1 megohm.

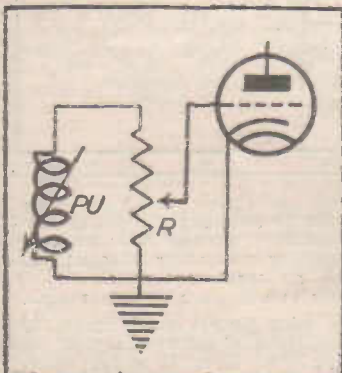

The fundamental circuit for pick-up connection to an amplifier stage.

The arm of the potentiometer connects to the grid of the amplifying tube, while one of its outside terminals joins to earth as well as to one side of the pick-up. It is essential, of course, that the amplifier valve receive its bias in the normal manner.

However, with crystal pick-ups it is undesirable to permit any polarising voltage to flow through the reproducer unit, so it will be necessary to isolate the pick-up from direct current by means of a .02 to .1 mfd. condenser connected in series between it and the grid of the valve.

The bias return for the valve is provided by means of a quarter megohm resistance joined between the grid and earth if the valve is a cathode biased type or the negative of the "C" battery if it is a directly heated type of tube.

Another essential to good quality reproduction is the speed at which the record is played. Today the general standard is 78 or 33 r.p.m. Not many of the slower speed recordings will come the average pick-up user's way, but the same provision for accurate running must be observed with them as with the 78 r.p.m. discs.

SELECTION OF NEEDLES

Needles require just as much care in their selection as was given to the purchasing of the pick-up itself. Most pick-up manufacturers specify a particular type of needle for their units. Stick to these. Use a new needle with each record, and don't try to economise by turning a needle after it has been played once. Full tone needles should always be used.

With magnetic pick-ups hold the needle in such a way as to take up the torque imposed on it during tightening, otherwise the pick-up armature will be forced against the pole-piece. Any attempt

Pick-up tracking method.

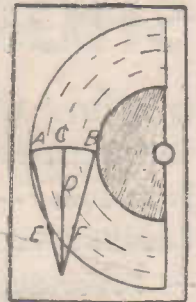

to fit new rubbers to a pick-up will usually be fraught with disappointment.

It is worthy of note, too, that with magnetic pick-ups it is essential that pains be taken to keep them away from metallic dust.

With high gain audio amplifiers it is desirable that the pick-up connecting leads be run in braided cable, the braid of which should be earthed to the motor frame and the main earth point.

These braided leads, however, should not be so stiff as to impose drag on the movement of the pick-up arm.

MOUNTING THE PICK-UP

Considerable care must be taken in mounting the pick-up on the motor board, because if any inaccuracy exists here, both the reproduction and the record wear will be affected.

Two general types of pick-up arms, the bent and the straight, are available. The bent arm generally will be found to provide more correct tracking.

In any case, follow this procedure in mounting a pick-up. Taking the centre spindle of the motor shaft, draw a line at right angles out towards the edge of the turntable. Now, taking the inner and outer circles of the start and finish of the record, describe an arc A to B, on this line.

Next bisect this arc at its midpoint, and project a line from the bisection at right angles. Project two more lines from the inner and outer terminations of the arc to form an isosceles triangle, and at the apex of this mount the pick-up.

Application of 1.4 Volt Valves

(Continued from Page 27)

across the two. A short circuiting switch is wired across RL.

The "Economiser" circuit works in the following way:—

When the receiver is operating normally most of the power is consumed in the final amplifier stage. As the output pentode is operated under Class "A" conditions it follows that no matter what the input signal is the plate and screen consumption will remain practically constant.

Control of volume is effected by means of the potentiometer, R4. With the "Economiser" arrangement the bias on the output tube is raised when it is desired to reduce signal strength. Consequently the plate current is reduced and the output of the tube also falls off.

The resistor, RL, should have a value

of between 1000 and 1500 ohms for use with the 1C5G, and between 1200 and 2000 ohms for use with the 1A5G. Checks with the former tube showed that the total plate consumption for an output of 200 milliwatts was 10 m.a. This was reduced to 6 m.a. for an output around 120 milliwatts.

One other point requiring comment is that the present stage of 1.4 volt valve development has not reached a level where good short wave performance can be expected from the mixer tube type 1C7G.

This valve refuses to oscillate well on wave lengths below 100 metres, unless the coil and condenser constants are carefully proportioned. For this reason it is unwise to attempt to incorporate dual wave tuning in a 1.4 volt valve superhet.

SHORT-WAVE CONVERTERS

● **Desired Wave Range — Coil Constants and Winding Procedure — Method of Coupling to Broadcast Set — Power Supply.**

THE converter unit offers the simplest and most practical means of adapting a standard broadcast receiver for overseas short wave listening. Furthermore, it is much easier to provide efficient tuning arrangements in a converter unit than it is in a broadcast receiver, because the latter is usually laid out in a manner which prevents the tuned circuit leads being kept as short as desirable in S.W. receivers.

The first matter for consideration by the prospective S.W. converter builder is the tuning range of the receiver. Most International short-wave broadcasting is conducted on wave-lengths between 13 and 50 metres. The average single coil converter can be expected to cover a wave range of from 16 to 50 metres, or, alternatively, from 13 to around 40 metres. All things considered, the second range will give most satisfactory general reception throughout the year, because in Australia the 49-metre band reception usually is weak and is subject to bad interference from static.

BAND SPREAD TUNERS

However, the true short-wave enthusiast will not be content with a single band converter. He will aim to cover the whole frequency spectrum from 10 to 100 metres, and, to avoid trouble from the station interference likely to be experienced on the 19, 20, 25, 31 and 49 metre bands will endeavor to incorporate band spread tuning in the set.

This can be done with the aid of two tuning condensers for each tuned circuit. The first or "band set" condenser may have a capacity of 180 mmfd. per section, whilst the "band spread" tuner will have a maximum capacity of 35 mmfd.

In practice the band set condenser is tuned to pre-determined points on the scale.

For example, it might be tuned to the lower edge of the 19 metre band when the band spread condenser plates were in the full out position. Fine tuning then is carried out with the band spread condenser—the capacity of this condenser and the inductance of the coils being so proportioned that the 19 metre band would be spread over almost the whole dial of the band spread condenser.

INDEPENDENT POWER SUPPLY

On this page we have given design details of an a.c. operated s.w. converter designed for band spread tuning. Coil details also are provided. It will be noticed that this converter unit employs an r.f. stage and is equipped with its own power supply system.

AN A.C. SHORT-WAVE CONVERTER Parts List and Circuit

CHASSIS: Aluminium.
AER, RF, OSC: Tuning coils. See below.
CH: 30 henry 50 m.a. filter choke.
C1, C3, C5: Three-gang 35 m.mfd. tuning condenser.
C2, C4, C6: Three-gang 180 m.mfd. tuning condenser.
C7, C8, C11: .1 mfd. tubular condensers.
C9: .0001 mfd. mica condenser.
C10: .02 mfd. mica condenser and 10 mfd. 250 volt electrolytic condenser.
C12: .001 mfd. mica condenser.

E1, E2: 8 mfd. 500 volt electrolytic condensers.
PT: Power transformer 385-0-385 v. at 60 m.a., 6.3 v. at 2 a. and 5 v. at 2 a.
RFC: Radio frequency choke.
R1: 300 ohm 50 m.a. w.w. resistor.
R2: 70,000 ohm 1 watt carbon resistor.
R3: 50,000 ohm 1 watt carbon resistor.
R4: 15,000 ohm 2 watt carbon resistor.
R5: 250 ohm 50 m.a. w.w. resistor.
R6: 100 m.a. w.w. resistor.
VD: 15,000 ohm voltage divider.
VALVES: One each 6K7G, 6K8G and 80.

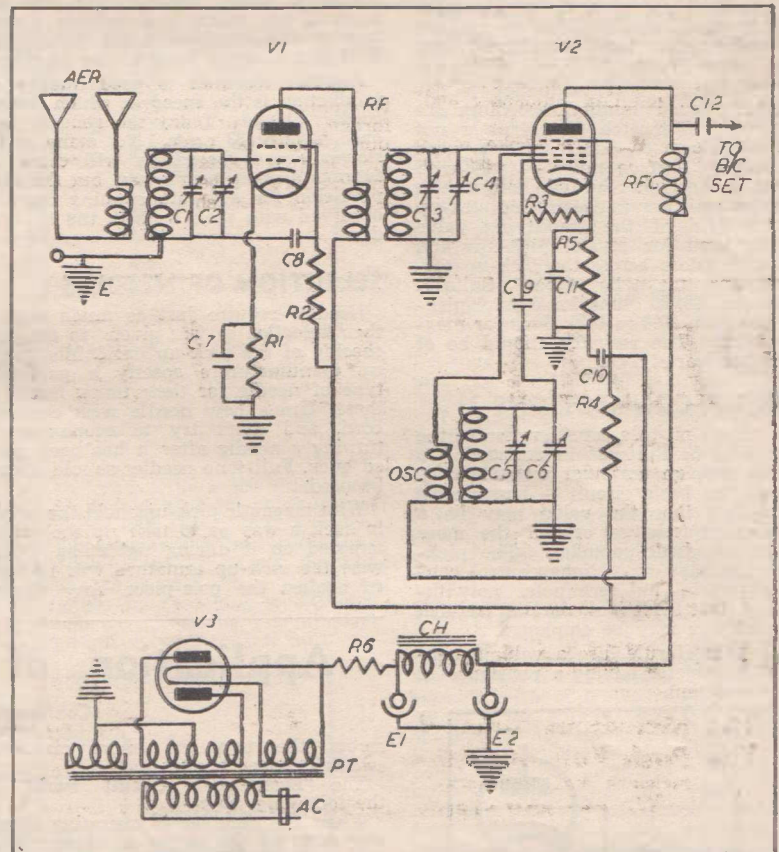

The r.f. stage is a definite advantage and in our opinion no converter unit which does not incorporate such a stage is worth while.

Provision of the self-contained power pack overcomes any possibility of damage to the broadcast receiver which might result from the imposition of the converter plate and filament drains on a power system which already was running at maximum capacity.

So far as coils are concerned the converter either can be built to use plug in types or a number of coils can be wound on separate formers and wired directly to the wave change switch.

The wire gauges used for secondary windings should be as heavy as possible ranging from 16 or 18 gauge enamel on the lowest wave ranges to 26 or 28 gauge on the highest. The primary windings should consist of 30 or 32 d.s.c. wire.

The aerial and r.f. primaries should be interwound between the grid ends of the secondaries.

A fair idea of the proportion of primary to secondary turns can be obtained from a study of the coil data for the a.c. converter. The oscillator primary (plate winding) should be wound at the earth end of the secondary. It should consist only of enough turns to enable the oscillator tube to function through the tuning range of the grid coil.

The best method of checking the oscillator performance is to connect an 0-1 milliammeter in series between the 50,000 ohm oscillator grid resistor and earth. Currents of from 100 to 250 micro amperes should be registered over each tuning range.

COUPLING SYSTEMS

Finally, we come to the method of connecting the converter to the broadcast receiver. The receiver is to be tuned to some frequency around 550 k.c., and we have to transfer the converter signal to the receiver proper. In the a.c. short wave converter circuit on the preceding page, this has been done by means of a coupling condenser and an r.f. choke coil.

The trouble is that the choke must be a very efficient one if r.f. energy is not to leak away through the "B" supply circuit.

S.W. Super Het. Coil Details

Band.	AER.		Pri.	R.F.	Sec.	O.S.C.	
	Pri.	Sec.				Pri.	Sec.
1	9	33	25	33	9	35½	
2	5½	15¼	11	15	4½	15½	
3	2½	5¼	4½	5½	1¼	5¼	

Wavelength Range.—Band 1: 170 to 57 metres Band 2: 59 to 25 metres. Band 3: 27.5 to 11.5 metres.

THE coils are wound on ¼-inch diameter ribbed bakelite formers. Standard Marquis four-pin types will be suitable. However, on reviewing the coil-winding specifications, it will be seen that secondary windings are spaced. The best way to do this, of course, is to have a thread cut on the former, but, failing this, the windings may be spaced with wire or string, which is removed when the coil has been completed. Before placing the coils into use, dip them in clear lacquer and allow this to dry. This will prevent trouble from slipping turns.

All primary windings are laid on with 30-gauge d.s.c. wire inter-wound between the turns of the secondary windings in the same direction as the latter, and starting from the earth end of the grid windings.

Use 28-gauge enamelled wire spaced to 32 turns per inch (slightly greater distance between turns than the actual wire diameter) for the secondaries of Band 1 coils. For Band 2 coil secondaries use 20-gauge tinned copper wire spaced to 10 turns to the inch (nearly three wire diameters between turns).

For Band 3 secondaries use 18 gauge tinned copper wire spaced to 6 turns per inch (nearly three wire diameters between turns).

A better and more efficient method is to employ a special type of i.f. transformer. The primary winding of this unit should be peaked to around 550 k.c., and connected to the output of the converter tube. The secondary of the transformer should have a special

impedance matching winding designed to match the impedance of the aerial coil in the broadcast receiver.

If this winding is correctly proportioned, such a coupler will have higher gain and better selectivity than the straight choke-capacity coupler.

PLAY SAFE!

PARCO Coils, I.F. Transformers, and Audio Transformers have been specified EXCLUSIVELY by The Listener In Technical Staff for use in such outstanding receivers as The Melodious Super Three, the Push Pull Melodious Three, the Melodious 1.4, and many other A.C. and Battery Receivers and Amplifiers.

Take their advice and use only the Best Coils and Transformers — PARCO.

KIT PRICES:

- The Melodious Super 3 . . . 32/-
 - The Melodious 1.4 30/-
 - The Push Pull Melodious 3 . . . 45/-
 - The Fidelity Super 5 32/-
- Including P.P. Transformer
- We can also supply special High Efficiency Short Wave Coils at 2/6 each

DISTRIBUTED BY:

- MELBOURNE: Arthur J. Veall Pty. Ltd. Homecrafts Pty. Ltd. Hartleys Ltd.
- ADELAIDE: A. G. Healing Ltd. Oliver J. Nilsen & Co. Newton, McLaren Ltd.
- PERTH: Atkins (W.A) Ltd. Carlyle & Co.
- TASMANIA: W. & G. Genders Pty. Ltd.



J. G. PARR, 90-98 CHAPEL ST., ST. KILDA
 TELEPHONE: WINDSOR 7280 **S.2.**

"A", "B", AND "C" BATTERIES

●Large Capacity Batteries Most Economical — "Shelf Life" Important — Care of Accumulators — Dry "A" and Air Cell Batteries — Automatic "C" Bias — Working Life Table.

HOW long should a radio "B" Battery last? Put this question to half a dozen radio technicians and you will get half a dozen different answers, all of them vague and most of them very wide of the mark.

Every answer will be qualified by the remark that the life will depend on the type of battery, the amount of use it is given, and the amount of current it is required to deliver.

This qualification is correct, but the radio technician's estimate of working life is incorrect, because he has only a vague idea of the ampere hour capacity of any particular type of battery.

With the object of clarifying the position and indicating to the average non-technical user exactly what service he can expect from a set of "B" batteries, the accompanying general table has been prepared with the assistance of the Widdis Diamond Dry Cell Co.

The table has been arranged to cover the current drains likely to be imposed on the batteries from any one of five general classes of radio receiver. The working life has been estimated for three different types of battery under any one of five different daily usage periods.

So far as the current drain is concerned we can assume that a two valve receiver using a small triode output tube will draw a current around the five milliampere mark. Modern three and four valve battery super-heterodynes usually draw currents ranging from 7½ to 10 m.a. A standard five valve receiver may draw from 10 to 15 m.a., although some of the older types will draw currents up to 20 m.a.

If the receiver is fitted with a class "B" output stage we can expect peak plate currents ranging from 20 to 25 m.a. to be drawn. The daily use of the receiver will depend upon individual needs, but the average can usually be set down at four hours. However, other periods are covered so that the individual can estimate the battery life under his particular set of conditions.

TRIPLE CAPACITY TYPE BEST

WE come next to the three types of battery — the Light Duty type, the Heavy Duty type, and the Triple Capacity type.

On reviewing the table we find that the light duty type of battery is useful only for current drains up to 5 m.a. Even then it is incapable of providing any long service when used for extended daily periods.

For example, when used for three hours daily a Light Duty battery will stand up to a 5 m.a. current drain for approximately 135 days, but will last for only 45 days if the daily hours of usage are increased to eight.

The Heavy Duty battery will give good service on current drains up to

12 milliamperes. As shown in the table it will deliver a 10 m.a. current three hours daily for 180 days, but will stand up for only 60 days if this drain is imposed for eight hours each day.

A survey of the figures in the right-hand column of the table cannot fail to impress on the battery user the advantages of the Triple Capacity battery. Although this unit is designed for drains around the 20 m.a. mark, it is particularly economical on lower drains. For example, the Heavy Duty battery will give 180 days' service when used for three hours daily under a 10 m.a. drain condition.

Under similar conditions the Triple Capacity battery will give 300 days' service. In view of the small price difference between the Heavy Duty and the Triple Capacity types, there is no doubt that the latter type is the more economical for the set user.

Incidentally, the figures for the triple capacity battery are based on an average of a large number of tests with the new Diamond Tripledyne.

UNEQUAL CURRENT DRAINS

HERE are a few more points on battery operation, points which are not generally appreciated by the average battery user. A dry battery is every bit as much a delicate piece of apparatus as a radio valve, and should be handled just as carefully as the valve.

Don't drop the battery or subject it to heavy knocks. If you do there is a likelihood of it developing an open circuit. This may be determined by measuring the voltage between each of the taps with a high resistance voltmeter.

If approximately correct readings are obtainable between some tappings and no reading is obtainable between others, then an open circuit has developed in the battery.

In some receivers it will be found that after a period of use one section of the battery may be exhausted, whilst another section is still o.k. Examination of the circuit of the receiver will probably show that intermediate currents and voltages are being drawn from the battery. For example, we might take the case of a receiver using four standard valves. Two of them, the mixer and the output tube, operate at 135 volts, and draw a total current of, say, 7 m.a. The remaining two draw a plate current of 2 m.a. at 135 volts, but also require a screen potential of 67½ volts at a current of, perhaps, 2 m.a.

This screen voltage is obtained by tapping the 135 volt battery at the 67½ volt point. This is what happens:—The first battery of the three will have a total current of 11 m.a. drawn from it. The first 22½ volt section of the second battery will have a similar cur-

rent drain. The second 22½ volt section of this battery, and the third 45 volt unit will be called on only to supply the plate currents which, in this case, are 2 m.a. less than the combined plate and screen potentials.

There are two ways of overcoming this. The first is to supply the screen potentials through a dropping resistance of suitable value. This method suffers from the weakness that the current drain of the second section of the battery will be increased by the screen current—2 m.a. in this case — and its life reduced to that of the first section.

A compromise which will result in the set user getting a more even performance can be made by changing over the first and third batteries when the half-way mark is reached in their estimated useful life.

One other point which should be watched by the battery user who wishes to obtain the best service from his dry batteries is to prevent dust, moisture or accumulator acid from collecting on the top of the batteries.

When there is a layer of dust on the top of the battery, the presence of moisture in the air is responsible for the creation of a high resistance leakage path across the battery terminals. Consequently, the battery is continually discharging, and rapidly becomes exhausted.

Faulty condensers, resistors and coils or transformers in a radio receiver also can impose a continual load on the "B" battery, even when the valve filaments are switched off. Some forms of volume control also impose a similar drain on the battery. To eliminate these wasteful leakages, it always is desirable so to switch the receiver that the "B" battery circuit is broken at the same time as the filament circuit.

"SHELF LIFE"

ANOTHER point which interests the dry battery user is the "Shelf Life" of the battery, i.e., the length of time it can stand unused without deterioration. It has been found that the average Light Duty battery can be left unused for a period of four months before it shows any signs of deterioration. With the Heavy Duty and Triple Capacity types of battery the shelf life is from 9 to 12 months. The same shelf life exists for the new 1.5 volt batteries developed for use with the 1.4 volt valves.

In Australia normal atmospheric conditions do not affect the performance of dry batteries except in some of the far northern areas where excessive heat tends to dry out the electrolyte and so reduce their life.

"A" BATTERIES

SO far as the "A" battery supply is concerned, the country set user has the choice of accumulator batteries, dry batteries or semi-dry batteries, such as the Air Cells.

The accumulator battery is still probably the most widely used of all. Whether it be a two volt type for parallel lighting of 2 volt filaments or a six volt unit for series-parallel operation of vibrator powered receivers, the accumulator type of "A" battery requires care-

ful maintenance and regular re-chargings if it is to give anything like a long service.

The average accumulator cannot be expected to last more than two years. At the end of this time it must either be re-plated or replaced by a new battery. So far as re-charging is concerned it is wise to have this attended to at least every two months, despite the fact that the battery may not be fully run down at the end of this period.

With the average vibrator powered receiver it will be found that the battery is completely discharged at the end of three weeks.

HYDROMETER TEST

THE best test of a battery's condition is that furnished by a reliable hydrometer. The battery originally should be filled with sulphuric acid and distilled water in the proportions necessary to produce the specific gravity listed by the manufacturer. Always add the acid to the water and not the water to the acid. The acid and water should be mixed in a bakelite, glass, porcelain or wooden container, never in a metal one.

The electrolyte in a fully charged battery has a specific gravity of about 1.250, whilst the complete discharged battery has a specific gravity of 1.100. On no account permit the s.g. to fall below this level or the battery will be seriously damaged.

So far as the charging of the batteries is concerned, it is best to rely on the manufacturer's suggestion as to the current rate. However, if this is unknown a fairly safe rule is to adjust the charging rate to a maximum of 1-10th the ampere hour capacity of the battery. Old batteries should be charged at a lesser rate. Thus a new 100 ampere hour battery might be charged at a maximum rate of 10 amperes but 5 to 6 amperes charge would be safer for an old battery.

Incidentally, so long as it is higher than the voltage of the battery the exact charging voltage does not matter. A two volt cell might be charged from a 3 volt, or higher, source, but could not be charged from a 2 volt source.

Besides the specific gravity reading, other indications of complete charge are the gassing of the cells, the rise of the cell voltage whilst charging is taking place to from 2.3 to 2.6 volts, and the color of the battery plates.

When fully charged the positive plates are a deep chocolate color and the negative plates a slaty grey.

Don't bring naked lights near the vents of the cells for the hydrogen and oxygen gases given off by the battery are highly explosive.

Other hints on battery maintenance are:

Always keep the top of the battery container clean and free from electrolyte.

Cover all terminals and connecting lugs with a coating of vaseline to prevent corrosion.

Always keep the vent plugs screwed tightly into place.

Add distilled water (rain water caught in an earthenware container will do in an emergency) to a level half an inch above the top of the battery plates. The water is best added just before the battery is to be recharged.

DRY "A" BATTERIES

THE next types of "A" battery are the dry and semi-dry types. For most types of valves the standard dry battery is uneconomic although for portable sets this failing must be overlooked. However, with the new 1.4 volt valves standard dry cells and the specially designed 1.5 volt batteries which consists of a number of small cells connected in parallel are ideal.

The standard dry cell can be expected to give between 150 and 200 hours' service from a four-valve 1.4-volt valve receiver. The special type of dry "A" battery can give upwards of 1000 hours' service with a four-valve and about 900 hours with a 5-valve set.

Other than the fact that care must be taken to protect the valves from overload during the initial period of its life, the dry battery needs no attention except that of keeping the top free from dust or moisture. For convenience and freedom from recharging worries it would seem that the combination of the 1.4 volt valves and the dry "A" battery is ideal.

The remaining type of "A" battery is the "Air Cell." This is a Leclanche type cell, although vastly improved over this form of primary cell.

The Air Cell, as developed by "Ever-Ready" and others, consists of two cells in a single container. These are provided with the necessary electrically active materials which remain completely inert until the cells are filled with water. Ordinary drinking water is quite suitable for this purpose and the cells are ready for use a quarter of an hour after the water has been added.

One advantage of the Air Cell is that it delivers over two volts, and so, when suitable voltage reducing resistors are employed, can be used in conjunction with the highly efficient 2-volt type battery valves. The Air Cell requires no attention after initial filling and will continue to function for approximately 1000 hours. At the end of this time it is exhausted and must be replaced.

"C" BATTERIES

WITH modern amplifying valves the application of a negative bias to their grids is essential if long valve life and good performance is to be expected. This bias usually was derived from a small dry battery capable of delivering potentials ranging from 1½ up to as high as 22½ volts, depending on the various types of valves used.

So far as its initial performance was concerned, the "C" battery functioned excellently, but as the set continued in use over a period, the dry "C" battery became something of a drag on its performance. The reason for this was that as no current was drawn from the "C" battery it did not deteriorate nearly so rapidly as the "B" battery and consequently its voltage remained fairly constant. Over the same period a 90-volt "B" battery from which the plate and screen currents were being drawn might show a voltage drop to 67½ volts.

It can be appreciated that if a given valve requires a 6-volts negative bias at 90 volts plate potential it needs only 4½ volts bias at 67½ volts plate potential. Yet the "C" battery continued to deliver 6 volts when the "B" had fallen to 90 volts.

Naturally there would be a noticeable deterioration in the set's performance when the plate voltage had been reduced 25 per cent, even if the "C" voltage was correspondingly reduced. When the "C" voltage remained at its original level, however, the deterioration was more marked, for, in addition to having sub-normal plate voltage, the valves were overbiased.

AUTOMATIC "C" BIAS

THE general trend today is to use what is known as Automatic Bias, so called because it is obtained by means of the drop across a resistance connected in the negative side of the "B" supply system. This resistance is so proportioned that the correct bias will be obtained when the valves are new and the "B" battery is delivering its rated voltage.

As the "B" battery ages and fails to deliver its normal voltage, so the plate current drawn by the valves is reduced. As the voltage across the bias resistor is governed by the current flowing through it, the bias is correspondingly reduced and the balance between "B" and "C" voltages maintained.

The same condition applies when the valves age and start to lose their emission. As they draw less plate current, so less bias is applied to them. The practical advantage of automatic "C" bias is that from 15 to 20 per cent. longer useful life can be obtained from the "B" batteries when automatic instead of battery bias is used.

Study of the various diagrams of battery receivers will illustrate the application of automatic bias. It should be noted, however, that battery bias is the only practical system when Class "B" audio amplification is included in the receiver.

BATTERY LIFE TABLE

Approx. Service in Days

Drain of Set.	Hours per Day	Light Duty	Heavy Duty	Triple Capacity
5 milliamperes—	3	135	400	600
	4	100	300	450
	5	80	220	340
	6	65	170	280
10 milliamperes—	8	45	120	200
	3	65	180	300
	4	45	130	220
	5	30	100	170
15 milliamperes—	6	25	80	140
	8	—	60	100
	3	30	110	200
	4	20	80	140
20 milliamperes—	5	—	60	110
	6	—	50	90
	8	—	35	65
	3	20	80	140
25 milliamperes—	4	—	60	100
	5	—	45	80
	6	—	35	65
	8	—	—	45
	3	—	60	110
	4	—	45	80
	5	—	—	60
	6	—	—	50
	8	—	—	35

A.V.C.

● Necessity for Automatic Volume Control . . . Practical Circuits . . . Need for Filters . . . Delayed and Amplified A.V.C. . . . Distortion in Controlled Receivers . . . Application of Tuning Eye.

BEFORE we can attempt to discuss the workings of Automatic Volume Control systems we MUST know exactly how such control is applied to a radio receiver, and why it is considered desirable or even necessary in modern designs.

First we must accept the fact that the propagation of a radio signal from a transmitting aerial is not subject to any human control after it leaves the aerial. Drawing on the old analogy of the radio signal disturbing the ether in the same way as a stone thrown into a pond will produce a series of ever-widening ripples, we might think that a signal radiated from an aerial system would spread out equally around the aerial system, only gradually dying away in strength as the distance from the transmitting station was increased.

Given an ideal topography in which large buildings, trees or metallic deposits do not exist, this theoretical transmission characteristic will be present up to moderate distances from the transmitter.

The signals from a given station travel via two paths—what are known as the Ground Ray path and the Sky Ray path.

Now the Ground Ray dies out first. The exact distance from the transmitter at which it dies out has little bearing on this discussion, for the Ground Ray does not usually fade. The Sky Ray, however, travels upwards towards the Heaviside and other layers in a manner analogous to the focussing of a beam of light from an electric torch on to a mirror attached to the ceiling of a room.

EFFECTS OF UPPER LAYER

HOWEVER, our radio mirror, "The Heaviside Layer," is not steady. It is continually increasing or decreasing its height above earth. The result is that the reflected signal, which does not hit the layer in a concentrated beam, "spatters" down to earth at varying angles.

So long as all components of the "spatter" are within range of the distant receiver so the signal strength will be constant. As the variation of the angle of reflection takes place, so a proportion of the available signal strength passes outside the range of the receiver, and the signal is said to fade.

This fading, or waxing and waning of signal strength, is present to a more or less marked degree on all distant signals. The primary fading area of medium wave broadcasting stations lies within the 60-100 miles radius of the transmitter. Secondary fading characteristics are exhibited on short, medium, and long waves at greater distances.

It will readily be appreciated that the only way in which this fading bugbear can be overcome is to hold the output volume of the receiver at a constant level for any range of input signal strengths.

This is precisely the aim of Automatic Volume Control.

Automatic Volume Control, or A.V.C.

to give it its technical abbreviation, makes use of the characteristic of the so called super-control type of amplifying valve which is so designed that increased negative bias has the effect of reducing the amplification capabilities of the valve.

The A.V.C. system is so arranged that large signal inputs produce a large negative potential which, when applied to the grids of the amplifying valves cuts down their gain and so maintains the set's output at a fixed level for the maximum large signal input. When the signal level drops less negative bias is applied to the valves so that they in turn are able to amplify the weak signal to a greater degree than they were permitted to amplify the strong signal.

DIFFICULTIES OF CONTROL

THE A.V.C. system is so proportioned that this see-saw action can follow rapid changes in signal strength such as encountered with fading signals. Theoretically such a system is ideal, but in practice there are a number of snags to be guarded against.

First, it should be realised that the A.V.C. action must take place on the "mean" carrier strength, and not on the variations produced by the rapid changes in intensity which take place

when the carrier is being modulated by an audible tone.

It can be appreciated that if the automatic volume control were permitted to function at audible frequencies the result would be a complete distortion of the intelligible characteristics of the signal.

For this reason the a.v.c. action has to be faster than the frequency of the lowest tone it is desired to reproduce. For example, an audible tone of 50 cycles per second will occupy only .02 seconds for one cycle to register in the reproducing system of the receiver. A 10,000 cycle tone will require only .0001 seconds to register a single cycle.

This brings us to the question of the Time Constant of an a.v.c. system. It should be so worked out that the rapidity with which the a.v.c. system functions is greater than that of the lowest frequency which it is desired to receive.

PRACTICAL CIRCUITS

NOW for some practical information on control methods. First, let us take the case of a standard super-heterodyne which employs an r.f. stage, a mixer stage, an i.f. stage, and a second detector stage plus the usual audio and power stages.

Here it is usual to find the second detector consisting of a diode, diode-triode, or diode-pentode valve. One of the diodes is used for demodulation of "second detection" of the signal from the i.f. amplifier. It is this demodulated signal that we look to for our a.v.c. voltage. Most a.c. super-hets. and a good number of the battery types are equipped with valves possessing a pair of diode plates. Conventional practice is to use one of these plates for signal rectification and one to rectify the a.v.c. voltage.

Glance now at Figs. 1 and 2 whilst we explain the basic a.v.c. systems. In Fig. 1 we see a conventionally circuited i.f. amplifier valve, V4, transformer coupled to the diode second detector or de-modulator valve V5. This valve is a double-diode valve and the two diodes are connected through the medium of a coupling condenser, CC. This condenser may have a capacity from .006 mfd. to .0001 mfd., the lower value being best when the frequency of the i.f. amplifier is high, say around 460 k.c.

Now, the r.f. voltage induced in the secondary winding of the i.f. transformer is fed to the D1 diode by means of which it is rectified through the cathode return circuit provided by the i.f. transformer secondary, and the load resistor, RL. R1 and the condenser CF can be considered in exactly the same way as the filter circuit in a power pack. Their job is to remove the r.f. component from the rectified signal and to leave only the audio signal, which is passed on to the set's audio amplifier.

Now diode D2, being coupled to D1 through a condenser capable of passing a fair amount of r.f. current also receives its quota of the r.f. voltage fed to the second detector from the i.f. amplifier. This potential is rectified in a similar manner to the signal voltage, but by means of the return path provided by R1 and R2.

R1 and R2 also serve as a voltage divider and so may be used to distribute percentages of the a.v.c. voltage as desired. Connected to this resistor network are the feed lines to the control grids of the various valves in the receiver.

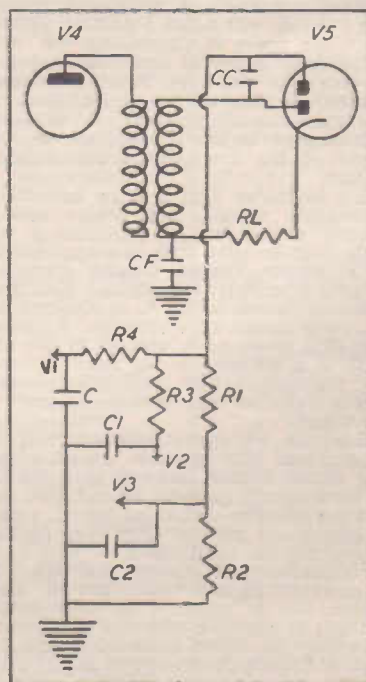

Fig. 1 illustrates a simple but practical form of Automatic Volume Control.

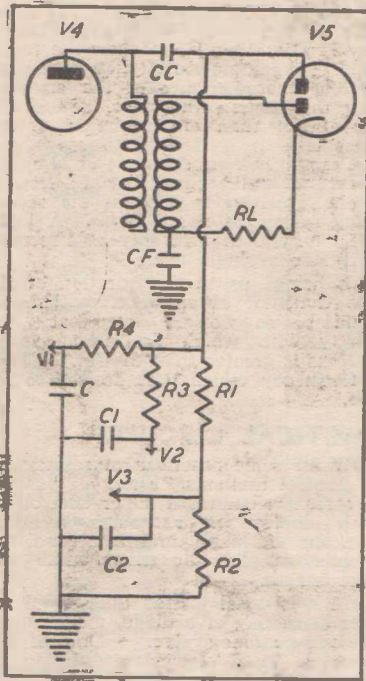

Fig. 2.—Although a similar type of control circuit to Fig. 1, this method possesses the advantage that less diode circuit loading is produced.

FILTER NECESSARY

WE have assumed that three valves are to be controlled. The r.f. amplifier valve V1 and the Mixer tube V2 are to get the full control voltage. Consequently, their supply lines are tapped off from the diode side of the R1-R2 network where the potential is greatest. We already have explained the undesirability of attempting any a.v.c. at audio frequencies.

Yet the rectified component from D1 and D2 consists largely of an audio frequency signal. To prevent the flutter effect which would result if this varying potential was applied to the control grids of the amplifier valves we insert a series of filters designed to suppress all irregularities of potential and to translate the controlling voltage into what essentially is direct current.

A filter is provided for each stage. It is made up of resistor R4 and condenser C for the first stage valve, V1, and of resistor R3 and condenser C1 for the second stage valve, V2. Because resistor R1 in the voltage divider network also will serve as a filter for audio voltages only condenser C2 is necessary to complete the filtration for the third stage valve, V3.

This type of a.v.c. system works all right except for one thing. The capacity of diode D2 and the resistance of R1-R2 are introduced across the secondary winding of the i.f. transformer, with the result that this is heavily damped, loses selectivity, and has a lower gain than if a.v.c. were not applied.

SECOND CIRCUIT BETTER

EXCEPT for the variation of the method of obtaining the control voltage the a.v.c. system of Fig. 2 is identical with that of Fig. 1. Here, however, an effort has been made to overcome the damping. The coupling condenser, CC, is connected between the plate of the i.f. amplifier valve, V4, and the a.v.c. diode, D2. The damping still exists, but it has been transferred to the primary winding of the i.f. transformer, where it does not have nearly so serious an effect as it has on the secondary.

Condenser CC should have a capacity of from .0005 to .0001 mfd. for 460 k.c. i.f. operation. Another valuable feature of this method is that a higher control voltage is available from the plate of V4 because the average i.f. transformer has a step-down characteristic.

This brings us to another question, the desirability of using what is known as delayed a.v.c. In our brief reference to a Time Constant we dealt with some form of delay, but this is not the type we refer to now.

In order that the receiver shall not be made insensitive to weak signals it is desirable that the a.v.c. system does not come into operation until some predetermined amount of audio output is available to the loud speaker.

DELAYED A.V.C.

TO achieve this the A.V.C. circuit is so arranged that a negative bias is placed on the A.V.C. diode. This has been used in both Fig. 1 and Fig. 2. To make it clear though, refer to Fig. 3, which shows the A.V.C. resistor returning from the diode to either of the points X or Y on the cathode resistor of the diode-triode or diode-pentode tube usually used in the demodulator stage. Now, because point Y is usually at a negative potential, it stands to reason that point X will be at a positive potential. But point X, neglecting the fact of the small potential drop due to cathode emission currents, is at a neutral potential so far as the diode plate is concerned, whilst point Y is negative with respect to the diode plate to the extent of the drop across the cathode resistor.

The circuit of Fig. 2 is an eminently practicable circuit, but before giving general details of its functioning we shall deal broadly with the application of Automatic Volume Control circuits.

First, it should be realised that the maximum effect of a.v.c. is obtained in the early stages of a receiver. Application of a given a.v.c. voltage to the r.f. stage of a set will do far more to control the output than will the application of a similar voltage to the i.f. amplifier stage.

This can be appreciated when it is remembered that between the r.f. input and mixer output there is quite likely to be a signal gain of around 2000, so that the effective control on the r.f. valve is 2000 times greater than that of the control on the third valve.

Furthermore, to ensure that the r.f. valve functions as a "sharp cut-off" amplifier, i.e., is sensitive to only small changes in negative grid bias it is desirable that its screen potential should be derived from a potentiometer rather than from a series voltage dropping resistor.

Next, if the receiver is to be used on short as well as broadcast wavelengths do not attempt to apply A.V.C. to the mixer on the short wave bands. This

proviso does not need so much consideration if the mixer valve is a separate oscillator type, such as the 6L7G, or one of the new triode-hexodes, such as the 6K8G. Other type valves, however, will develop a bad frequency drift if any attempt is made to A.V.C. them on short waves.

PREVENTING DISTORTION

ALTHOUGH it is possible so to "over control" a receiver that its sensitivity is badly marred, up to three controlled stages can be used to advantage. For this reason it is desirable to split the controlling voltage, and apply less to the i.f. amplifier tube than to those preceding it. This serves two purposes. It eliminates the distortion which is likely if a strong signal is applied to the i.f. tube, whilst it is in an over-biased condition, and it prevents any serious restriction of the receiver's overall gain.

In normally designed receivers utilising an output pentode sufficient A.V.C. delay is obtained by returning the A.V.C. divider to earth and utilising the voltage across the cathode resistor to provide the delay voltage. In battery receivers it is sometimes found necessary to return the A.V.C. resistor to earth through a 1.5 volt "C" battery in order to provide sufficient delay, but usually the direct earth return will suffice.

"TIME CONSTANT"

WE come next to the question of the time constant of the A.V.C. system. For most applications it is desirable that this shall not exceed 2 of a second and in some short wave receivers the time constant can be reduced to .008 of a second.

Calculation of the Time Constant is effected by adding the values of all resistors in the A.V.C. system and multiplying them by the total capacity of the filter condensers.

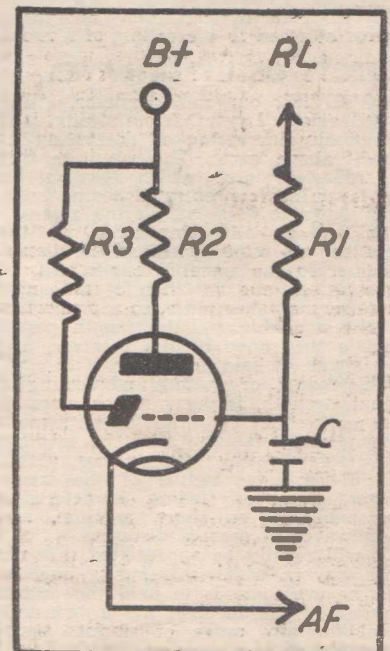

Fig. 4 shows the simple circuit requirements of the cathode-ray tuning indicator valve.

For example, in Fig. 2 we might assume that R1 and R2 each are .5 megohm resistors, whilst R3 and R4 are .1 megohm resistors. The total resistance then is $R1+R2+R3+R4$ or 1.2 megohms. C and C1 each have a capacity of .1 mfd. and C2 has a capacity of .05 mfd. The total capacity then is .25 mfd. Multiplication of R by C when R is in megohms and C is microfarads gives the Time Constant in seconds — in this case .3 seconds. This is a little too slow, so we must see what we can do to speed it up.

Suppose we reduce the capacity of C2 to .005 mfd. Then we would find that the Time Constant had been reduced to .245 of a second. This is still hardly fast enough, so we shall reduce the capacities of C and C1 to .05 mfd. Here we have a capacity total of .05 mfd. + .05 mfd. + .005 mfd., which produces a Constant of .168 of a second, a figure which is quite satisfactory for general purposes.

If only two controlled stages, mixer and i.f. amplifier, were used then with the same capacities, .05 mfd. and .005 mfd. for the mixer and i.f. tube respectively and the same resistances for R1, R2 and R3 the time constant would work out at .05 mfd. (C1) .005 mfd. (C2) multiplied by .5 megohm (R1) .5 megohm (R2) .1 megohm (R3) or $1.1 \times .055$ equalling .06 of a second.

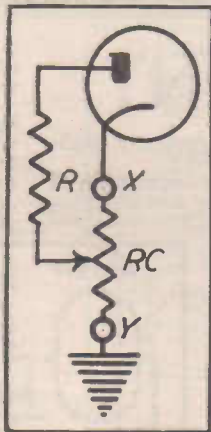

Fig. 3 illustrates the principle of delayed A.V.C.

TUNING RANGE RESTRICTION

IT must be realised, though, that it is impracticable to use too small filter capacities for C and C1 because these are effectively connected in series with the tuning coils and gang condenser. If they are too small in capacity they will restrict the tuning range of the condenser. A capacity of .05 mfd. is about the lower limit for broadcast band tuning.

To sum up we find that the A.V.C. system is desirable in all modern receivers. It cannot effectively be applied without considerable circuit modification in tuned r.f. receivers, but is easy to include in standard super-heterodyne receivers which use diode-triode or diode-pentode second detector tubes. Separate A.V.C. obtained from an independent control tube and amplified A.V.C. in which the control voltage is boosted before being applied also are practical A.V.C. applications, but their use does not come within the scope of the average home experimenter.

The A.V.C. system should work as rapidly as possible and yet should be so delayed that it does not come into action before a fair volume of sound is emitted by the loud speaker.

Every effort should be made to reduce the damping of the tuned circuits by the A.V.C. system and to overcome the feedback of audio frequency potentials into the controlled stages. The circuit shown in Fig 2 will meet these two requirements.

TUNING INDICATORS

A SUBJECT allied with the application of a.v.c. is the use of the so-called "Magic Eye" tuning indicator. Briefly, this is a form of cathode ray tube in which the fluorescent screen is so designed that its angle of closure varies almost proportionately to the amount of negative potential applied to its control grid.

When a strong signal is received the rectified voltage is large, with the result that the "eye" closes up. When no signal or only a small signal is available the "eye" remains open.

The circuit of Fig. 4 shows the most practical way of applying a "Magic Eye" to a receiver. With this application of the "eye" it will be found that definite closure takes place on even the weakest signals.

The plate of the "eye" is fed from a 250 volt supply through the 1 megohm resistor, R2, whilst the target derives its supply from the 250 volt line through the 20,000 ohm resistor, R3. Condenser C, which has a capacity of .05 mfd., and resistor R1, which has a resistance of 2 megohms, constitute an audio frequency filter circuit.

The far side of R1 is connected to the diode load resistor, RL, at the point where this resistor joins to the i.f. transformer secondary. The cathode of the "eye" tube is joined to a point of negative potential. Some 2½ to 3 volts negative will prove adequate. This potential may be obtained by tapping the bias resistor for the final audio tube in the receiver or by arranging some other form of voltage divider.

**ACCLAIMED
THROUGHOUT
THE WORLD
AS THE MOST
REMARKABLE
RADIO VALVES
YET
PRODUCED -**



**CLEARER TONE -
LONGER LIFE -
WIDER RANGE**

BRIMAR
[BRITISH MADE]
and **RAYTHEON
VALVES**

Set builders and listeners will find a revolutionary advance in the Brimar — British Made Valves. Made by the world-famous S.T.C. Company of England, they combine the features of the best American Valves with the added advantage of longer life. Brimar Valves are available in all American types.

- ★ The Queen Mary relies on Brimar Valves. Brimar Are Ten Times Tested.
- ★ The New 1.4 Volt Brimar Battery Valves are designed to operate from a single dry cell with only 90 Volts "B" Battery.
- ★ The New Brimar 6AG6-G high slope pentode has been especially designed for the Australian market. With an input of only 2 volts R.M.S., the valve is fully loaded, thus enabling the initial audio frequency stage to be done away with, and giving the results of a 5 valve Receiver with only 4 valves.
- ★ Brimar "80's" Indirectly Heated Rectifier Obviates strain on the valves by delaying the application of the high tension voltage. It also affords complete protection to the electrolytic condensers and replaces the standard "80"
- ★ Raytheon Valves have four pillar construction.

Sole Victorian Distributors

NOYES BROS (Melbourne) LTD.

597-603 LONSDALE STREET — MELBOURNE, C.1

Phone Central 10104 (6 lines)

Dealers Throughout City, Suburbs and Country Centres

VIBRATOR FILAMENT WIRING

● Series - Parallel Wiring — Necessity for Current Balance — Hum and Hash Elimination — Typical Valve Combinations.

SINCE the first "batteryless" or vibrator operated receivers were developed during 1936 considerable progress has been made. To the original features of the vibrator set — freedom from "B" and "C" battery replacements, and higher gain and better tonal quality due to the employments of voltages higher than those normally available, designers now have brought increased operating economy.

There are two general types of vibrator units. The first and most generally used is the Synchronous type. With this type a double set of contacts is employed. The first set, on the primary side, make and break to produce the pulsating direct current which is stepped up in the conventional manner by a power transformer, and is rectified by the second set of contacts. In the Non-synchronous type rectification is carried out by a valve or similar type rectifier.

There is a good deal to be said for the Non-synchronous type of vibrator unit, but the economy and generally satisfactory operation of the Synchronous type has been responsible for its use in at least 90 per cent. of batteryless receivers.

SPECIAL TRANSFORMER

One thing which should be made perfectly clear at this juncture is that the wave form of the vibrator output is far from being a pure sine wave, so that conventional power transformers and filter chokes cannot be satisfactorily employed in vibrator power packs.

Unless you have sufficient knowledge to design suitable power and filter equipment, it is best to buy the complete unit. Furthermore, in modern vibrator power packs considerable research has been expended on the suppression of hash and other interfering r.f. currents. a six-volt source of direct current supply for the vibrator and the set filaments.

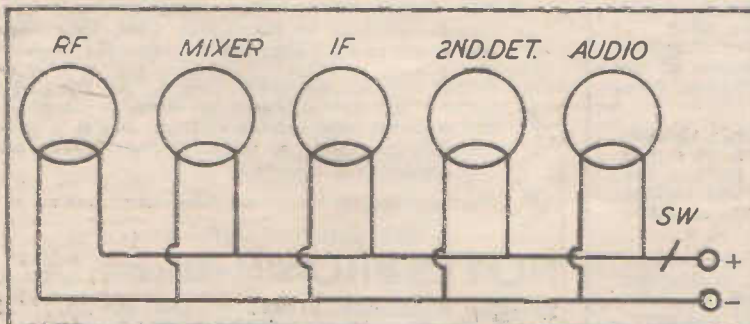
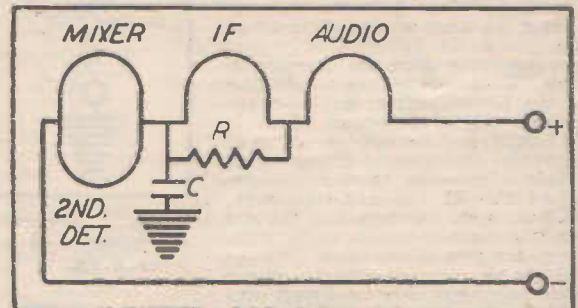

Fig. 1.—In contrast to the series wired filament circuit of the vibrator set, the standard parallel wired system is shown here.

This information is not generally available for the home builder.

In order to employ a vibrator form of power supply, we require a power pack of suitable electrical characteristics and

Fig. 3.—Where it is impossible, by judicious valve selections, to balance the current drains on each section suitable parallel resistors must be employed.



This six-volt supply is essential, whether the set be fitted with 1.4, 2, 4, or 6.3 volt valves.

In passing it may be mentioned that although the standard type of vibrator pack is capable of delivering a 140-volt supply at a current of 16 m.a., it is possible to get units which produce potentials of from 250 to 500 volts at currents as high as 100 m.a. Such units, of course, have much higher drains than the receiver types.

FILAMENT WIRING ARRANGEMENT

In Figure 1 we have the schematic circuit diagram of the filament wiring of a standard five-valve receiver. All filaments are wired in parallel because all take the same VOLTAGE. The fact that some require greater filament CURRENTS than others does not matter. We assume these valves are of the two-volt type. Let us assume that they are the standard American series.

Then the R.F. and I.F. tubes will be 1C4's, the Mixer a 1C6, the second detector a 1K6, and the audio a 1D4. Study of the operating characteristics of these valves will show that all except the 1D4 require a filament current of .12 amperes. The 1D4 draws .24 amperes.

With this as a basis let us examine Fig. 2, in which is shown the filament circuit of a vibrator powered receiver. Here, again, our two volt series of valves is employed. However, as we are operating two volt valves from a SIX volt source of "A" battery supply,

In the case of our five valve receiver we wire the filaments in SERIES-

PARALLEL, so that whilst the six volts is dropped across the whole filament circuit each section of it receives two volts and at the same time the current in each section is the same.

PARALLEL, so that whilst the six volts is dropped across the whole filament circuit each section of it receives two volts and at the same time the current in each section is the same.

The factor governing the current drain is the valve with the highest filament consumption. In the present example this is the 1D4, which requires .24 amperes filament current. Assuming that the total drain of the filament circuit is to be .24 amperes it becomes necessary to wire the remaining four valves in SERIES-PARALLEL so that the combination of the Mixer and the Second Detector draws .24 amperes, and the combination of the R.F. and I.F. tubes draws a similar current. The three groups, Mixer-Second Detector, R.F.-I.F., and Audio, then are wired in series to provide the required six-volt drop across the filament circuit.

This is the key to the whole method of filament wiring for vibrator circuits.

PARALLEL, so that whilst the six volts is dropped across the whole filament circuit each section of it receives two volts and at the same time the current in each section is the same.

PARALLEL, so that whilst the six volts is dropped across the whole filament circuit each section of it receives two volts and at the same time the current in each section is the same.

PARALLEL, so that whilst the six volts is dropped across the whole filament circuit each section of it receives two volts and at the same time the current in each section is the same.

PARALLEL, so that whilst the six volts is dropped across the whole filament circuit each section of it receives two volts and at the same time the current in each section is the same.

PARALLEL, so that whilst the six volts is dropped across the whole filament circuit each section of it receives two volts and at the same time the current in each section is the same.

PARALLEL, so that whilst the six volts is dropped across the whole filament circuit each section of it receives two volts and at the same time the current in each section is the same.

VALVE PLACEMENT IMPORTANT

It should be particularly noted that in order to eliminate trouble from hum and hash the CRITICAL valves such as the Mixer and Second Detector tubes should be at the low potential or earth end of the filament circuit.

Next should be the R.F. and I.F. tubes. The final Audio tube, which is not critical as far as hum is concerned, may be at the high end of the filament circuit.

Referring again to Fig. 2, we find that a condenser, C, is shown connected between earth and the junction of the Mixer and R.F. filaments.

This condenser should have a capacity of .1 mfd., and is intended to eliminate hum from the second detector circuit. In the positive filament line will be seen a filter circuit consisting of an iron cored choke, CH, and a pair of electrolytic condensers, E1 and E2.

CH is a very low resistance choke, having a d.c. resistance of not more than a quarter of an ohm. E1 and E2 are 12-volt type 500 microfarad condensers. This filter system is intended to suppress all hum from the filament circuit. In the "B" plus line of the vibrator a radio frequency choke coil, RFC, and a .5 mfd. condenser, C1, are employed to eliminate r.f. "hash." C1 should be one of the special r.f. type condensers provided with heavy braided pigtail connections.

In most modern vibrators, these components are included inside the power unit, so do not need to be wired into the receiver circuit.

CIRCUIT BALANCING

Now glance at Fig. 3, whilst we continue our discussion of the balancing of the filament wiring. In this circuit we find that only four valves are used. The Mixer and Second Detector tubes are 1C6 and 1K6 types, the I.F. tube is 1C4, and the Audio tube is a 1D4.

As before the 1D4 governs the filament drain—24 amperes in this case. The two .12 ampere filaments of the Mixer and Second Detector tubes can be paralleled for one section of the filament, but as the 1C4 I.F. tube only takes .12 amperes, it is necessary to increase the drain across this portion of the filament circuit by an additional .12 amperes to bring it up to the same value of current flowing through other parts of the circuit.

This is done by connecting a resistor in PARALLEL across the filament lugs of that valve which is not drawing the requisite current.

To calculate the value of this resistor we use Ohm's Law. First subtract the filament current flowing through the unbalanced portion of the circuit (through the I.F. tube in this case) from the filament current flowing through the other portions.

Thus in our example we subtract the 1C4's filament current (.12 amperes) from the .24 ampere current fixed by the Audio tube to get a result of .12 amperes.

Then from Ohm's Law we get:—
R equals E divided by C.

Where

R is the value of the resistance which must be connected across the unbalanced section of the filament circuit.

E is the potential drop across this portion of the filament circuit.

C is the current in amperes.

From this we get R equals 2 divided by .12 or 16.6 ohms. It should be remembered that this resistor must be capable of carrying the current it is supposed to dissipate. In the present case this is .12 amperes or 120 m.a. The condenser C shown in Fig. 3 is the .1 mfd. one previously referred to in Fig. 2 and can be omitted with a modern type vibrator.

MORE COMPLEX COMBINATIONS

EARLIER, when discussing the arrangement of the filament wiring we mentioned that the current drain of this was usually set by the filament

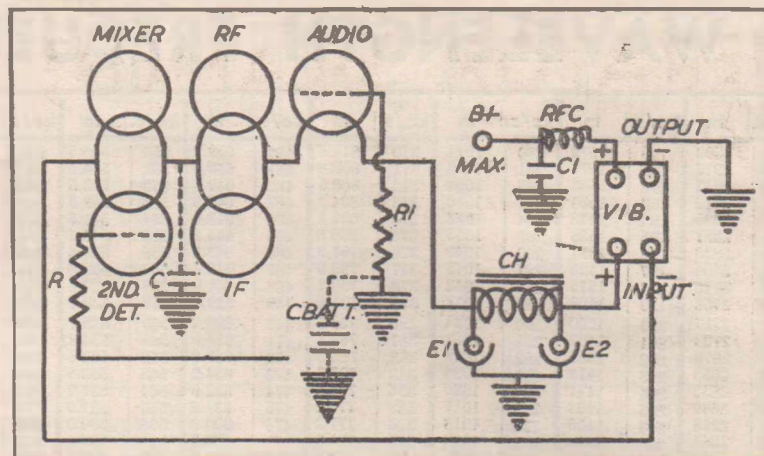

Fig. 4 shows the methods adopted to apply negative grid bias to the output tube of a vibrator power receiver.

current consumption of the output tube. This is not always the case. With the English or Continental series valves we can get into quite a lot of trouble unless we pay strict attention to our figuring.

Take the case of a 5-valve receiver employing KF3's in the R.F. and I.F. stages, a KK2 in the Mixer stage, a KBC1 in the Second Detector Stage, and a KL4 in the output stage.

The KF3's draw .05 amperes filament current, the KK2 .13 amperes, the KBC1 .1 ampere, and the KL4 .14 amperes. The arrangement of these tubes for vibrator operation provides a particularly good example of filament circuit balancing.

We desire to keep the Mixer and Second detector tubes at the low potential end of the filament circuit. Let us parallel them then so that the pair of them will draw a total filament current of .23 amperes. The next pair shall be the KC3's, but their total filament drain is only .1 amperes. Finally, we have the KL4 drawing .14 amperes.

In this line-up the controlling factor of the filament circuit drain is the .23 ampere consumption of the Mixer and Second Detector tubes. Calculating similarly to the previous example we find from Ohm's Law that a resistance of 154 ohms must be connected in Paral-

lel with the already paralleled KF3 filaments and that the KL4 filaments must be Paralleled with a 22.5 ohm resistor.

Both these resistors must be able to carry the difference between the filament current of the valves to which they are connected, and the total current flowing through the circuit. Thus, the one across the KF3 filament must carry 130 m.a., whilst that across the KL4 filament must carry 90 m.a.

From the examples provided the values of resistors for use with other tube combinations may easily be calculated. All that must be remembered is that the tubes must be so arranged that a total drop of six volts takes place between the positive and negative sides of the filament line and that the same current flows through each portion of the circuit.

In using vibrator power units it is essential to remember that the "A" battery cable must be heavy enough to carry the .9 to 1 ampere current required for the vibrator and filament supplies, and MUST BE SHIELDED. Ordinary shielded Belden wire will do. The shielded wire should be run right to the filament switch if the set be fitted with one.

The final point to be dealt with in vibrator receivers is the application of suitable bias to the various valves. With most of the American series two-volt valves no bias is required on the R.F., I.F., and Mixer tubes. However, both the Second Detector and Audio tubes must be biased. It is possible in some cases to obtain sufficient bias by returning the grid circuits of these tubes to some point on the filament supply line.

If we refer to Fig. 4, it will be seen that if the Audio tube's grid resistor, R1, is returned to earth this valve will be biased to the extent of four volts, for the earth end of the filament circuit is four volts negative (due to the drop across the Mixer and R.F. pairs of tubes) in respect to the filament of the audio valve.

However, this may not be enough bias for the audio tube, and instead of returning the grid resistor direct to ground it should be taken there via a "C" battery. The positive side of the battery is the grounded side. The voltage of this battery should be sufficient in conjunction with the voltage drop already mentioned, to provide the necessary bias.

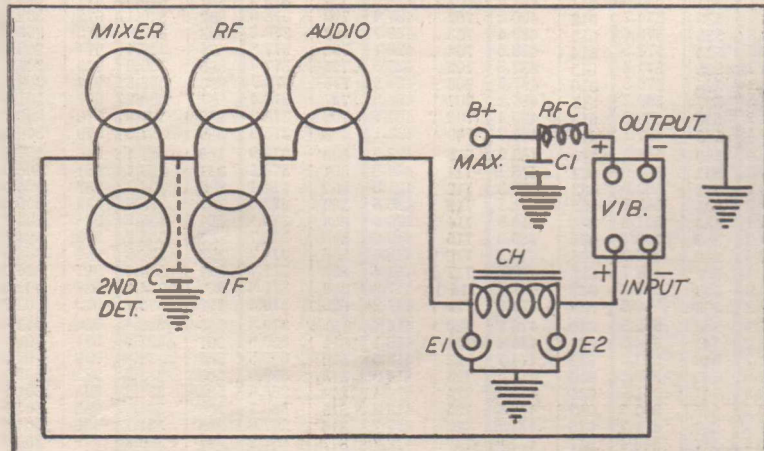

Fig. 2.—The schematic circuit diagram of a conventionally wired vibrator set filament circuit.

VALVE CHARACTERISTICS

1.4 VOLT BATTERY VALVES

AMERICAN TYPES

Type.	Filament Volts.	Filament Amps.	Purpose	Plate Volts.	Plate Current m.a.	Grid Volts.	Screen Volts.	Screen Current.	Plate Impedance	Mutual Cond. mmhos.	Ampl. Factor.	Load Resist. ohms.	Power Output. (m/watts)
1A5G	1.4	0.05	Class A Amplifier	90	4	4.5	90	0.8	.3 Meg.	850	255	25,000	115
1A7G	1.4	0.05	Converter	90	0.55	0	45	0.6	.6 Meg.	Osc. Plate 90V., 1.2 m.a. Osc. Grid Resistor 20,000 ohms. Conversion Conductance 250 mmhos.	—	—	—
1C5G	1.4	0.10	Class A Amplifier	90	7.5	7.5	90	1.6	.115 Meg.	1,550	180	8,000	240
1H5G	1.4	0.05	Resist. Coup. Triode	90	0.14	0	—	—	.24 Meg.	275	65	—	—
1N5G	1.4	0.05	R.F. Amplifier	90	1.2	0	90	0.3	1.5 Meg.	750	1,160	—	—

Note 1.—Screen voltage to be obtained by means of 70,000 ohm dropping resistor in series with 90 volts.

2 VOLT BATTERY VALVES

CONTINENTAL TYPES

Type.	Filament Volts.	Filament Amps.	Purpose	Plate Volts.	Plate Current	Grid Volts.	Screen Volts.	Screen Current.	Plate Impedance	Mutual Cond. mmhos.	Ampl. Factor.	Load Resist.	Resist. Output. (m/watts)
KK2	2.0	0.13	Converter	135	0.7	0	45	700	2.5 Meg.	Osc. Plate (No. 2) 135V. Oscillator Grid (No. 1) Resistor, 50,000 ohms. Conversion Conductance, 270 mmhos.	—	—	—
KF3	2.0	0.05	R.F. Amplifier	135	2.0	0	135	600	1.3 Meg.	650	850	—	—
KB2	2.0	0.095	Detector and A.V.C.	—	—	—	—	—	—	Maximum Diode Voltage 125V (peak); Maximum Diode Current 0.5 m.a.	—	—	—
KBC1	2.0	0.1	Triode as Class A Ampli.	135	2.5	4.5	—	—	16,000	1,000	16	—	—
KCB	2.0	0.21	Class A Ampli. (Driver)	135	3.0	2.8	—	—	12,000	2,500	30	—	—
—	—	—	R.F. Amplifier	135	2.6	0	135	1.0	1.0 Meg.	800	800	—	—
KF4	2.0	0.065	Bias Detector	135	—	5.0	135	—	—	Plate coupling resistor, 250,000 ohms.	—	—	—
KL4	2.0	0.14	Class A Amplifier	135	7.0	5.0	135	1.0	0.15 Meg.	2,100	—	19,000	440
KDD1	2.0	0.22	Class B Amplifier	135	3.0	0	—	—	Power output is for one valve at stated load plate to plate.	—	—	10,000	2,000

2 VOLT BATTERY VALVES (Vibrator Ratings)

Type.	Filament Volts.	Filament Amps.	Purpose	Plate Volts.	Plate Current	Grid Volts.	Screen Volts.	Screen Current.	Current Impedance	Mutual Cond. mmhos.	Ampl. Factor.	Load Resist.	Power Output. (m/watts)
1C4	2.0	0.12	R. F. Amplifier	150	2.5	0 Min.	Note 1	0.9	900,000	1,000	900	—	—
1M5G	2.0	0.12	R. F. Amplifier	150	1.25	0 Min.	Note 2	0.5	1.6 Meg.	780	1,250	—	—
1C6	2.0	0.12	Converter (All Wave Operation)	150	2.5	0 Min.	Note 1	0.9	1.22 Meg.	1,000	1,220	—	—
1C7G	2.0	0.12	—	150	1.25	0 Min.	Note 2	0.5	1.92 Meg.	780	1,500	—	—
1D4	2.0	0.12	—	150	1.9	0 Min.	Note 3	1.5	—	—	—	—	—
1L5G	2.0	0.24	Class A Amplifier	150	9.5	—	150	2.3	—	—	—	15,000	0.45

Osc. Plate 150V. through 20,000 ohms. 2.2 m.a. Osc. Grid resist. 50,000 ohms. Conversion Cond. 550 mmhos.

VALVE CHARACTERISTICS (Contd.)

2 VOLT BATTERY VALVES (VIBRATOR RATINGS) Contd.

1K6	Resistance Coup. Triode	150	0.8	—	Note 4	—	—	—	—	100,000	—
1K7G	Resistance Coup. Pentode	150	0.33	—	Note 5	0.12	—	—	—	250,000	—

Note 1.—Dropping resistor 100,000 ohms. from B+. 2.—Dropping resistor 200,000 ohms from B+. 3.—Dropping resistor 60,000 ohms from B+. 4.—Screen tied to Plate. 5.—Dropping resistor 750,000 ohms from B+.

4 VOLT A.C. VALVES

CONTINENTAL TYPES

Type.	Filament Volts.	Amps.	Purpose	Plate Volts.	Plate Current m.a.	Grid Volts.	Screen Volts.	Screen Grid Current.	Screen Impedance	Mutual Cond. mmhos.	Ampl. Factor.	Load Resist. ohms.	Power Output. (m/watts)
AK2	4	0.65	Converter	250	1.6	1.5 Min.	70	3.8	1.6 Meg.	Osc. Plate 90 V., 2 m.a. Oscillator Grid Resistor, 50,000 Ohms. Conversion Conductance, 600 mmhos.	—	—	—
AB2	4	0.65	R.F. Amplifier	250	8.0	3.0 Min.	100	2.6	1.2 Meg.	1,800	2,200	—	—
AB4	4	0.65	Detector and A.V.C.	Maximum Diode Voltage 200V. (peak); Maximum Diode Current 0.8 m.a.									
ABC1	4	0.65	Triode as Class A Ampli.	250	4.0	7.0	—	—	13,500	2,000	27	—	—
AC2	4	0.65	Class A Amplifier	250	6.0	5.5	—	—	12,000	2,500	30	—	—
AF7	4	0.65	R.F. Amplifier	250	3.0	2.0	100	1.1	2.0 Meg.	2,100	4,200	—	—
AL2	4	1.0	Bias Detector	250	—	—	100	—	Plate Coup. Resist. 0.25 Meg.; Cath. Resist. 10,000 ohms.	—	—	—	—
AL3	4	1.75	Class A Amplifier	250	36	25.0	250	5.0	60,000	2,600	—	7,000	4,500
E406N	4	1.0	Class A Amplifier	250	36	6.0	250	5.0	50,000	9,500	—	7,000	4,500
AZ3	4	1.85	Class A Amplifier	250	48	22.0	—	—	1,700	3,500	6	3,500	1,600

Maximum A.C. Volts per plate 385 (R.M.S.) — Maximum D.C. Output Current 120 m.a.

200 M.A. A.C./D.C. VALVES

CONTINENTAL TYPES

Type.	Filament Volts.	Amps.	Purpose	Plate Volts.	Plate Current	Grid Volts.	Screen Volts.	Screen Current.	Plate Impedance	Mutual Cond. mmhos.	Ampl. Factor.	Load Resist. ohms.	Power Output. (m/watts)
CK1	13	0.2	Converter	200	1.6	1.5 Min.	70	3.8	1.5 Meg.	Osc. Plate 90V., 2.0 m.a. Oscillator Grid Resistor, 50,000 ohms. Conversion Conductance, 600 mmhos.	—	—	—
CF2	13	0.2	Class A Amplifier	200	4.5	2-22	100	1.4	1.4 Meg.	2,200	3,000	—	—
CB1	13	0.2	Detector and A.V.C.	Maximum Diode Voltage 200V. — Maximum Diode Current 0.8 m.a.									
GC1	13	0.2	Triode as Class A Ampli.	200	4.0	5.0	—	—	13,500	2,000	27	—	—
CC1	13	0.2	Class A Amplifier	200	4.6	3.7	—	—	18,000	3,000	50	—	—
CF1	13	0.2	Class A Amplifier	200	3.0	2.0	100	0.9	1.7 Meg.	2,300	4,000	—	—
CL2	24	0.2	Bias Detector	200	—	—	100	—	—	Plate Coupling Resistor, 250,000 ohms. Cathode Resistor, 10,000 ohms.	—	—	—
CL4	33	0.2	Class A Amplifier	200	40	19	100	5.0	23,000	3,100	—	5,000	3,000
CY2	30	0.2	Class A Amplifier	200	45	8.5	200	6.0	45,000	8,000	—	4,500	4,000
C1	—	0.2	Resistance Lamp	Maximum A.C. Volts per plate 250 (R.M.S.) — D.C. Output Current 120 m.a. Regulating Range 80—200 Volts.									

Valve Characteristics (Contd.) **6.3 VOLT VALVES (Battery Types)**

Type.	Filament Volts.	Filament Amps.	Purpose	Plate Volts.	Plate Current	Grid Volts.	Screen Volts.	Screen Current.	Plate Impedance	Mutual Cond. mmhos.	Ampl. Factor.	Load Resist. (m/watts)	Power Output. (m/watts)	AMERICAN TYPES	
														Power Output. (m/watts)	Power Output. (m/watts)
6D8G	6.3	0.15	Converter	135	—	—3 Min.	67.5	—	400,000	Osc. Plate 135V. through 20,000 ohms. Osc. Grid resistor 50,000 ohms. Conversion Conductance 325 mmhos.	—	—	—	—	—
6L5G	6.3	0.15	Class A1 Amplifier	135	3.5	—5	—	—	11,300	1,500	17	—	—	—	—
6N5	6.3	0.15	Tuning Indicator	135	0.5	0 Min.	—	Target 135V. Grid C.O.—12V.	—	—	—	—	—	—	.25 Meg
6S7G	6.3	0.15	R.F. Amplifier	135	3.7	—3 Min.	67.5	0.9	680,000	1,250	850	—	—	—	—
6T7G	6.3	0.15	Class A1 Amplifier	135	0.9	—1.5	—	—	65,000	1,000	65	—	—	—	—

6.3 VOLT A.C. VALVES

Type.	Filament Volts.	Filament Amps.	Purpose	Plate Volts.	Plate Current	Grid Volts.	Screen Volts.	Screen Current.	Plate Impedance	Mutual Cond. mmhos.	Ampl. Factor.	Power (m/watts)	Power Output. (m/watts)	AMERICAN TYPES	
														Power (m/watts)	Power Output. (m/watts)
2A3	2.5	2.5	Class A1 Amplifier Push-Pull Class AB1 Push-Pull Class AB1	250 300 300	60 80-140 80-110	—45 —62	— — —	— — —	800 (Fixed Bias Operation.) (Self Bias Operation.)	5250	4.2	2,500 3,000 5,000	3.5 15 10	—	—
6A7	6.3	0.3	Converter	250 300 300	3.5 3.3 3.3	—3 Min. —3 —3	100' 100 100	2.2 3.2 3.2	360,000 Osc. Plate 250V. through 20,000 ohms. 4 m.a. Osc. Grid resist. 50,000 ohms. Conv. Cond. 520 mmhos. 360,000 Osc. Plate 250V. through 20,000 ohms. 4 m.a. Osc. Grid resist. 50,000 ohms. Conv. Cond. 500 mmhos.	— — —	— — —	— — —	— — —	—	—
6A8G	6.3	0.3	Converter	250	2.5	—3	100	6.0	.6 Meg.	—	—	—	—	—	—
6B7S	6.3	0.3	R.F. Amplifier	250	6.5	—3 Min.	100	1.5	850,000	1,100	900	—	—	—	—
6G8G	6.3	0.3	Resistance Coup. Amplif. Audio A.V.C.	250 250	— —	— Note 1	Note 2 Note 2	— —	— —	— —	— —	— —	— —	250,000 250,000	— —
6C6	6.3	0.3	R.F. Amplifier	250	2.0	—3.0	100	0.5	2.7 Meg.	1,225	3,300	—	—	—	—
6J7G	6.3	0.3	Resistance Coup. Amplif. Class A Triode	250 250	5.5	—9.0	Note 3	—	Screen dropping resistor 1.5 Meg. from 250 Volts 10,500	1,800	19	250,000 29,000	— 0.25	— —	
6D6	6.3	0.3	R.F. Amplifier	250	8.2	—3 Min.	100	2.0	800,000	1,600	1,280	—	—	—	—
6U7G	6.3	0.3	Class A Amplifier	250	34.0	—16.5	250	6.5	80,000	2,500	200	7,000	3.0	—	—
42	6.3	0.7	Class A Amplifier	315	42.0	—22	315	8.0	75,000	2,650	200	7,000	5.0	—	—
6F6G	6.3	0.7	Push-Pull Class A Class A Triode	315 250	84.0 31.0	—22 —20	315 Note 4	16.0	— 2,600	— 2,700	— 7	10,000 4,000	13.0 0.85	—	—
6V6G	6.3	0.45	Class A1 Amplifier Push-Pull Class AB1	250 250	45-47 70-79	—12.5 —15	250 250	4.5-6.5 5-12	52,000	4,100	218	5,000	4.25	—	—
6U5	6.3	0.3	Push-Pull Class AB1 Tuning Indicator	300 250	78-90 0.24	—20 0,-22	300 —	5-13.5	— Target 250V. 4.5 m.a.	— —	— 100	8,000 1 Meg.	13	—	—
75	6.3	0.3	Class A Triode	250	0.8	—2	—	—	91,000	1,100	100	—	—	—	—
6B6G	6.3	0.3	Resistance Coup. Amplif.	250	0.35	—1.6	—	—	—	—	—	—	—	—	—
80	5.0	2.0	Full Wave Rectifier	400 R.M.S.	—	—	110	(Total D.C. Current)	—	—	—	—	—	—	—
5Y3G	5.0	2.0	Full Wave Rectifier	550 R.M.S.	—	—	135	(Total D.C. Current)	—	—	—	—	—	—	—

Note 1.—Fraction of A.V.C. voltage to be applied in addition to self bias. 2.—Screen supply from voltage divider consisting of 1 megohm and .25 megohm resistors. 3.—Screen tied to Plate and suppressor tied to Cathode. 4.—Screen tied to Plate.

RADIO BOOKS FOR 1939

Radio Amateur Handbook (ARRL), 1939		Amplification and Distribution of Sound,	
Postage (10d.)	8 0	Greenlees	(6d.) 16 0
Jones Radio Handbook, 1939	9 0	Foundation of Wireless, by Sowerby . .	(5d.) 6 9
Admiralty Handbook of Wireless Tele-		Wireless Transmission for Amateurs,	
graphy, 2 vols.	(2/-) 17 0	by Camm	(4d.) 3 9
Radio Manual, by Sterling	(9d.) 39 6	Radio Trouble Shooters' Handbook, by	
Radio Engineering, by Terman	(1/-) 36 0	Ghirardi	(1/-) 21 0
Keen's Direction Finding	(1/-) 39 6	The Radio and Telecommunications	
Laboratory Handbook, by Scroggie . . .	(6d.) 13 9	Engineers' Design Manual	(6d.) 22 0
Testing Television Sets, by Reyner . . .	(6d.) 14 6		

NEW ADDITIONS TO RADIO CRAFT LIBRARY

- 16 Practical Radio Circuits
- 17 Servicing Set Analyzers
- 18 Point to Point Resistance Analysis
- 20 Cathode Ray Oscilloscope
- 21 Breaking Into Radio Servicing

3/6 and 3d. postage

FOR ALL MODERN TECHNICAL BOOKS

McGILLS AGENCY

SUBSCRIPTION AGENTS

ALL MAGAZINES

183-185 ELIZABETH STREET, MELBOURNE

G.P.O. is Opposite

Telephones Cent. 8113-8114

"YOU CAN GET IT AT MCGILL'S"

!! STOP — COMPARE THESE PRICES — LOOK !!

From **EASTERN RADIO COMPANY** EASTERN MARKET BOURKE ST., MELB., C.1 Phone J4807

COMPLETE KITS FOR SETS & AMPS.

Everything to Build excepting Valves & Spkrs.
 Crystal Set Kit, 10/. Headphones, 3/6 to 7/6
 1 Valve Battery, 10/; 2v., 20/; 3v., 25/
 Modern Bat. Supers. etc., with Aero Dials,
 etc. 4 Valve Kit, 25/ to 40/; 5v., 30/ to 40/
 Electric, 4v., 25/ to 40/; 5v., 30/ to 23
AMPLIFIERS—Kits, Battery, 2 to 4 valve, 22
 Electric Kits, high grade parts, 3 to 5 watt,
 20/ to 23; 7 watt, 70/; 10w., 25; etc., etc.
 Complete Amps, 5v. PP 45's, 70/; 5v. P.P.P.,
 25; 6 valve 50's, P.P., heavy duty with
 valves, 25; D.C. Comp., 15 Watt . . . 212
 Others complete, A.C. or D.C., from 23
 Specials built from 210 to 2100
COILS, KITS, GANGS, Coils . . 1/ to 2/6
 Iron Cored, 2/6 to 6/. I.F.S., 1/6 to 5/6
 I.C., I.F.S., 7/6. Odd Coils, I.F.S., 6d., 2/6
 Car Radio Kits, 3 coils, 2 Hfs. and Gang, 20/
 Crystal & Battery Set & odd coils, 3d. to 1/6
 Gangs, 2g, 3/6 to 8/6; 3g, 2/6 to 12/6; 1g, 2/6
 Aero Dials, 3/6 to 20/. Full Vision, etc., 2/6
SHORT WAVE Coils, 1/. Pilot, 2/6. Con-
 densers, Midgets, 3 to 11p., 1/ to 1/6;
 23p., 2/6; .00015 Tuning Cond. . . . 2/6
 Cans, Aluminium, 2/6 to 10/. Dials, 1/ to 7/6

MANUFACTURER'S PARTS & KITS

Saxon, .01, .02, .03. Platalt Condensers, 6d.
 100 New Chassis Plates . . 1/, 2/6, 3/6
 Press Button Tuning Switch, 8-way, 2/6 & 5/
 Amplifier, 5v. Emmco, 45's, P.P. Comp., 23
 Amplifier & Transmitting Gear & Racks.
 Variable Condensers, .0005 1/ & 2/
 Resistors, Leaks, Sockets, Rheos., etc. . 3d.
 Fixed Condensers, .0001 to 4mid., 3d. to 2/6
 Transformers, Audio, best makes, 2/ to 7/6
 Ferranti, A.F.3, 8/6, 10/; 3C, 20/; A.F.5, 25/
 5C, 40/. Other Push P. Trans. 5/ to 20/
 Power Trans. Replacements . . 5/ to 10/
 2.5 Type, 80M., 7/6; 150, 200M., 500-0-500,
 2.5, 6.3, etc., 25/. Also Trans for Trains.
 Projectors, Welding, Chargers, etc.
CHOKES—30 hrv. 60-80M. . . . 2/6 to 5/6
 100-200M., 10/ to 15/. Impedance, etc., 5/
SETS & CHASSIS—Battery Sets, from 10/
 Complete Batt. Spkr., etc. . . . 70/ to 210
 Electric Sets, 25/ to 26; D.C. Sets, 40/ to 25
 Chassis, less Valves, 4 & 5v., T.R.F. &
 Supers., 25/ to 50/. With Valves, etc.,
 guaranteed perfect order from 50/ to 25
 Special Experimenters' Sets & Part Sets,
 Chassis, etc. 2/6 to 20/
 Eliminators, Philips, B & C, 15/, 20/;
 A.B.C., 25/; A Elims., giving 2-4-6
 volts, 2A 30/
 Valves, 100's. Write for list . . 2/6 to 10/

SPEAKERS, MIKES, METERS, GRAMO MOTORS, PICK-UPS, CABINETS

Crystal Microphones, D104 hand type, 25
 American Desk Type, 70/. Floor Type, 28
 Analyzer, Weston Jewell, 5 Meters . . 90/
 Microphones, complete with Transformer,
 Latest Type. Guar. Worth 25, at 25/
 Genemotors, Pioneer, 6-volt-to 180, new, 60/
 Carter, 12v. output, 500v/100 M/A . . 29
 Gramo. Motors, double spring, 12/6 to 20/
 Pick Ups, all types, from . . 12/6 to 25/
 Amplion D.B. Microphone, complete with 100
 ft. 4-way shielded cable, etc. . . . 50/
 P.A. Spkr. Units, 6v., M.O. Cost 210 ea., 50/
 Dynamic Speakers, 2/6, 5/, 7/6, 10/, 15/
 High Fidelity, 50/ to 25. Permag. Rola,
 15/ to 25/. 10in. Magnavox, Rola Amplion,
 etc., 17/6 to 25/
 Cones & Horns, 2/6 to 15/. Units, 1/ to 7/6
 Electric Gramo. Motor, U.S.A., G.E., 22
 Television Signal Recorders, comp. . . 35/
 Console Cabinets, cut and uncut, 8/, 7/6;
 Low Boy, 35/; Combination Mantel, 25/
 Mantel Cabinets, bakelite, slightly damaged,
 2/6; good, 7/6; wooden 12/6
 Meters, full range, 5/ to 25. Write for list.
 Signal Generators & Test Kits ditto.

We invite any enquiry. Watch "Listener In" for Special List. We advise to order early.

WE HAVE THE MOST COMPREHENSIVE STOCK OF NEW AND USED PARTS AND REPLACEMENTS IN VICTORIA

FOR SETS AND EXPERT SERVICE TRY OUR SUBURBAN BRANCH

at 688 GLENHUNTLY RD., GLENHUNTLY (R. Smart, Radiotrician). Est. 1921. Phone UL2802

Radios, 4v. Table Models, complete Valves, etc. . . . 20/ to 30/
 3 & 4 Valve Consoles, 35/ to 50/. 4v. T.R.F. Consoles, 50/ to 24
 5v. Superhets., 25 to 28. 4 & 5 Valve Super. Chassis, comp., 23 to 28

11 Valve Dual Wave Latest Super Gramo-Radio, Rola Power Spkr.,
 P.P. Amplifier. Worth 100 Gns. for 50 Gns.
 4 & 5 Valve Beautiful Midget Super., guar. 1 yr., 6 Gns. to 9 Gns.

FULL STOCKS OF ALL RADIO PARTS—AMPLIFIERS, MIKES, VALVES, IRONS, TOASTERS AND ELECTRICAL GOODS. WE INVITE ENQUIRIES AND WILL HELP WITH ANY RADIO PROBLEM. MAIL ORDER, ETC., PLEASE INCLUDE POSTAGE.

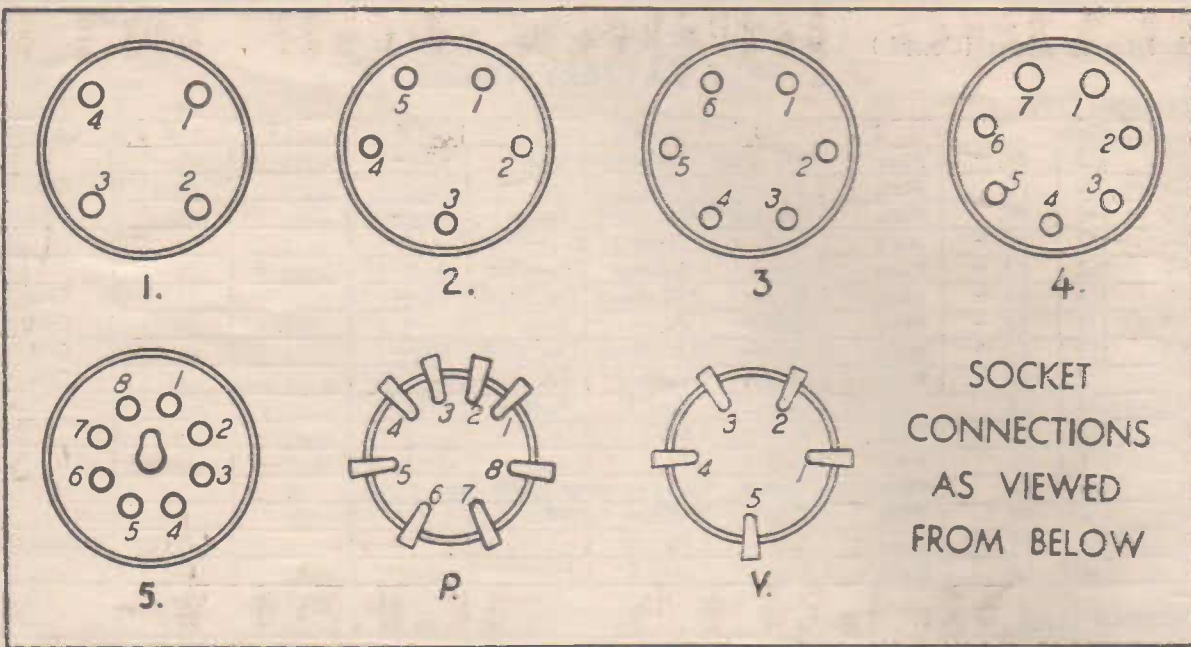

VALVE SOCKET CONNECTIONS

All socket connections are as viewed from the underside of the sockets. The bases are numbered to agree with the diagrams above.

1.4 VOLT BATTERY VALVES

AMERICAN TYPES

Type.	Base.	1	2	3	4	5	6	7	8	Cap.
1A5G	5	—	Fil. +	Plate	Screen	Grid		Fil.—	—	
1A7G	5	—	Fil. +	Plate	Screen	Osc. grid	Osc. plate	Fil.—	—	Grid
1C5G	5	—	Fil. +	Plate	Screen	Grid		Fil.—	—	
1H5G	5	—	Fil. +	Plate	—	Diode plate		Fil.—	—	Grid
1N5G	5	—	Fil. +	Plate	Screen	—		Fil.—	—	Grid

2 VOLT BATTERY VALVES

AMERICAN TYPES

1C7G	5	—	Fil. +	Plate	Screen	Osc. grid	Osc. plate	Fil.—	—	Grid
1D5G	5	—	Fil. +	Plate	Screen	—		Fil.—	—	Grid
1D7G	5	—	Fil. +	Plate	Screen	Osc. grid	Osc. plate	Fil.—	—	Grid
1E5G	5	—	Fil. +	Plate	Screen	—		Fil.—	—	Grid
1E7G	5	—	Fil. +	Plate 2	Grid 2	Grid 1	Plate 1	Fil.—	Screen	
1F5G	5	—	Fil. +	Plate	Screen	Grid		Fil.—	—	
1F7GV	5	—	Fil. +	Plate	AVC diode	Det. diode	Screen	Fil.—	—	Grid
1G5G	5	—	Fil. +	Plate	Screen	Grid		Fil.—	—	
1H4G	5	—	Fil. +	Plate	—	Grid		Fil.—	—	
1H6G	5	—	Fil. +	Plate	AVC diode	Det. diode	Grid	Fil.—	—	
1J6G	5	—	Fil. +	Plate 2	Grid 2	Grid 1	Plate 1	Fil.—	—	
1K5G	5	—	Fil. +	Plate	Screen	—		Fil.—	—	Grid
1K7G	5	—	Fil. +	Plate	AVC diode	Det. diode	Screen	Fil.—	—	Grid
1L5G	5	—	Fil. +	Plate	Screen	Grid		Fil.—	—	
1M5G	5	—	Fil. +	Plate	Screen	—		Fil.—	—	Grid
1A4	1	Fil. +	Plate	Screen	Fil.—					Grid
1A6	3	Fil. +	Plate	Osc. plate	Osc. grid	Screen	Fil.—			Grid
1B4	1	Fil. +	Plate	Screen	Fil.—, Sup.					Grid

Socket Connections (Contd.)

2 VOLT BATTERY (Contd.)

AMERICAN TYPES

Type.	Base.	1	2	3	4	5	6	7	8	Cap.
1B5	3	Fil. +	Plate	AVC diode	Det. diode	Grid	Fil.—			
1C4	1	Fil.	Plate	Screen	Fil.					Grid
1C6	3	Fil. +	Plate	Osc. plate	Osc. grid	Screen	Fil.—			Grid
1D4	2	Fil. +	Plate	Grid	Screen	Fil.—, Sup.				
1F4	2	Fil. +	Plate	Grid	Screen	Fil.—, Sup.				
1F6	3	Fil. +	Plate	Screen	AVC diode	Det. diode	Fil.—			Grid
1K4	1	Fil. +	Plate	Screen	Fil.—					Grid
1K6	3	Fil. +	Plate	Screen	AVC diode	Det. diode	Fil.—			Grid
1S	2	Fil.	Plate	Screen	Cath.	Fil.				Grid
19	3	Fil.	Plate 2	Grid 2	Grid 1	Plate 1	Fil.			
30	1	Fil.	Plate	Grid	Fil.					
31	1	Fil.	Plate	Grid	Fil.					
32	1	Fil.	Plate	Screen	Fil.					Grid
33	2	Fil.	Plate	Grid	Screen	Fil.				
34	1	Fil.	Plate	Screen	Fil.					Grid
49	2	Fil.	Plate	Grid 1	Grid 2	Fil.				

EUROPEAN TYPES

A209	1	Fil.	Plate	Grid	Fil.					
B217	1	Fil.	Plate	Grid	Fil.					
B240	3	Fil.	Plate 2	Grid 2	Grid 1	Plate 1	Fil.			
B242	1	Fil.	Screen	Grid	Fil.					Plate
B255	1	Fil.	Screen	Grid	Fil.					Plate
B262	1	Fil.	Screen	Grid	Fil.					Plate
C243N	2	Fil.	Plate	Grid	Screen	Fil.				
KB2	V	Diode 2	Fil.	Fil.	Cath.	Diode 1				
KBC1	P	Met.	Fil.—	Fil. +	—	AVC diode	Det. diode	—	Plate	Grid
KC3	P	—	Fil.	Fil.	—	—	Grid	—	Plate	
KDD1	P	—	Fil.	Fil.	—	Plate 1	Grid 2	Grid 1	Plate 2	
KF1	3	Fil.	Screen	Met.	Grid	Sup.	Fil.			Plate
KF2	3	Fil.	Screen	Met.	Grid	Sup.	Fil.			Plate
KF3	P	Met.	Fil.	Fil.	—	Sup.	—	Screen	Plate	Grid
KF4	P	Met.	Fil.	Fil.	—	Sup.	—	Screen	Plate	Grid
KK2	P	Met.	Fil.—Sup.	Fil. +	—	Osc. plate	Osc. grid	Screen	Plate	Grid
KL4	P	—	Fil., Sup.	Fil.	—	—	Grid	Screen	Plate	
PM1H1	1	Fil.	Plate	Grid	Fil.					
PM2A	1	Fil.	Plate	Grid	Fil.					
PM2B	3	Fil.	Plate 2	Grid 2	Grid 1	Plate 1	Fil.			
PM2BA	3	Fil.	Plate 2	Grid 2	Grid 1	Plate 1	Fil.			
PM2DX	1	Fil.	Plate	Grid	Fil.					
PM12A	1	Fil.	Screen	Grid	Fil.					Plate
PM12M	1	Fil.	Screen	Grid	Fil.					Plate
PM22	2	Fil.	Plate	Grid	Screen	Fil.				
PM22A	2	Fil.	Plate	Grid	Screen	Fil.				
PM202	1	Fil.	Plate	Grid	Fil.					
PM252	1	Fil.	Plate	Grid	Fil.					
SP2	3	Fil.	Screen	Met.	Grid	Sup.	Fil.			Plate
TDD2	3	Fil. +	Plate	Det. diode	AVC diode	Met.	Fil.—			Grid
VP2	3	Fil.	Screen	Met.	Grid.	Sup.	Fil.			Plate

2.5 VOLT A.C VALVES

AMERICAN TYPES

2A3	1	Fil.	Plate	Grid.	Fil.					
2A5	3	Fil.	Plate	Screen	Grid	Cath.	Fil.			
2A6	3	Fil.	Plate	Diode 1	Diode 2	Cath.	Fil.			Grid
2A7	4	Fil.	Plate	Screen	Osc. Plate	Osc. grid	Cath.	Fil.		Grid

Socket Connections (Contd.)

AMERICAN TYPES

2.5 VOLT A.C. VALVES (Contd.)

Type.	Base.	1	2	3	4	5	6	7	8	Cap.
2B7	4	Fil.	Plate	Screen	Diode 1	Diode 2	Cath.	Fil.		Grid
24A	2	Fil.	Plate	Screen	Cath.	Fil.				Grid
27	2	Fil.	Plate	Grid*	Cath.	Fil.				
35	2	Fil.	Plate	Screen	Cath.	Fil.				Grid
45	1	Fil.	Plate	Grid	Fil.					
46	2	Fil.	Plate	Grid 1	Grid 2	Fil.				
47	2	Fil.	Plate	Grid	Screen	Fil.				
53	4	Fil.	Plate 2	Grid 2	Cath.	Grid 1	Plate 1	Fil.		
55	3	Fil.	Plate	Diode 1	Diode 2	Cath.	Fil.			Grid
56	2	Fil.	Plate	Grid	Cath.	Fil.				
57	3	Fil.	Plate	Screen	Sup.	Cath.	Fil.			Grid
58	3	Fil.	Plate	Screen	Sup.	Cath.	Fil.			Grid
59	4	Fil.	Plate	Screen	Grid	Sup.	Cath.	Fil.		

4 VOLT BATTERY VALVES

EUROPEAN TYPES

A409	1	Fil.	Plate	Grid	Fil.					
A415	1	Fil.	Plate	Grid	Fil.					
A425	1	Fil.	Plate	Grid	Fil.					
A442	1	Fil.	Screen	Grid	Fil.					Plate
B403	1	Fil.	Plate	Grid	Fil.					
B405	1	Fil.	Plate	Grid	Fil.					
B409	1	Fil.	Plate	Grid	Fil.					
B443	2	Fil.	Plate	Grid	Screen	Fil.				
C443	2	Fil.	Plate	Grid	Screen	Fil.				
PM3	1	Fil.	Plate	Grid	Fil.					
PM4	1	Fil.	Plate	Grid	Fil.					
PM4DX	1	Fil.	Plate	Grid	Fil.					
PM14	1	Fil.	Screen	Grid	Fil.					Plate
PM24	2	Fil.	Plate	Grid	Screen	Fil.				
PM254	1	Fil.	Plate	Grid	Fil.					

4 VOLT A.C. VALVES

EUROPEAN TYPES

AB2	V	Diode 2	Fil.	Fil.	Cath.	Diode 1				
ABC1	P	Met.	Fil.	Fil.	Cath.	Diode 2	Diode 1	—	Plate	Grid
AF2	4	Fil.	Cath.	Screen	Met.	Grid	—	Fil.		Plate
AF3	P	Met.	Fil.	Fil.	Cath.	Sup.	—	Screen	Plate	Grid
AF7	P	Met.	Fil.	Fil.	Cath.	Sup.	—	Screen	Plate	Grid
AK1	4	Fil.	Cath.	Plate	Osc. plate	Osc. grid	Screen	Fil.		Grid
AK2	P	Met.	Fil.	Fil.	Cath.	Osc. plate	Osc. grid	Screen	Plate	Grid
AL2	P	—	Fil.	Fil.	Cath.	—	—	Screen	Plate	Grid
AL3	P	—	Fil.	Fil.	Cath.	—	Grid	Screen	Plate	
AZ3	P	—	Fil.	Fil.	Cath.	Plate 2	—	—	Plate 1	
C443	2	Fil.	Plate	Grid	Screen	Fil.				
E406N	1	Fil.	Plate	Grid	Fil.					
E409	2	Fil.	Plate	Grid	Cath.	Fil.				
E424	2	Fil.	Plate	Grid	Cath.	Fil.				
E442	2	Fil.	Screen	Grid	Cath.	Fil.				Plate
E443H	2	Fil.	Plate	Grid	Screen	Fil.				
E444	3	Fil.	Screen	Diode	Grid	Cath.	Fil.			Plate
E445	2	Fil.	Screen	Grid	Cath.	Fil.				Plate
E446	4	Fil.	Cath.	Screen	Met.	Grid		Fil.		Plate
E447	4	Fil.	Cath.	Screen	Met.	Grid		Fil.		Plate
E452T	2	Fil.	Screen	Grid	Cath.	Fil.				Plate
E454	4	Fil.	Cath.	Plate	Diode 1	Met.	Diode 2			Grid

Socket Connections (Contd.)

4 VOLT A.C. VALVES (Contd.)

EUROPEAN TYPES

Type.	Base.	1	2	3	4	5	6	7	8	Cap.
E455	2	Fil.	Screen	Grid	Cath.	Fil.				Plate
E463	4	Fil.	Cath.	Plate		Grid	Screen			
F443	2	Fil.	Plate	Grid	Screen	Fil.				
Pen4VA	4	Fil.	Cath.	Plate	—	Grid.	Screen	Fil.		
PM24A	2	Fil.	Plate	Grid	Screen	Fil.				
PM24B	2	Fil.	Plate	Grid	Screen	Fil.				
PM24M	2	Fil.	Plate	Grid	Screen	Fil.				
SP4	4	Fil.	Cath.	Screen	Met.	Grid	—	Fil.		Plate
S4VA	2	Fil.	Screen	Grid	Cath.	Fil.				Plate
S4VB	2	Fil.	Screen	Grid	Cath.	Fil.				Plate
TDD4	4	Fil.	Cath.	Plate	Diode 1	Met.	Diode 2	Fil.		Grid
VP4	4	Fil.	Cath.	Screen	Met.	Grid	—	Fil.		Plate
164V	4	Fil.	Plate	Grid	Cath.	Fil.				
354V	2	Fil.	Plate	Grid	Cath.	Fil.				
1561	1	Fil.	Plate	Plate	Fil.					
1867	1	Fil.	Plate	Plate	Fil.					

5 VOLT A.C. VALVES

AMERICAN TYPES

5T4	5	Shell	Fil.		Plate		Plate		Fil.	
5U4G	5		Fil.		Plate		Plate		Fil.	
5V4G	5		Fil.		Plate		Plate		Fil.	
5W4	5	Shell	Fil.		Plate		Plate		Fil.	
5X4G	5			Plate		Plate		Fil.	Fil.	
5Y3G	5		Fil.		Plate		Plate		Fil.	
5Y4G	5			Plate		Plate		Fil.	Fil.	
5Z3	1	Fil.	Plate	Plate	Fil.					
5Z4	5	Shell	Fil.		Plate		Plate		Fil.	
00A	1	Fil.	Plate	Grid						
O1A	1	Fil.	Plate	Grid						
40	1	Fil.	Plate	Grid	Fil.					
71A	1	Fil.	Plate	Grid	Fil.					
80	1	Fil.	Plate 1	Plate 2	Fil.					
82	1	Fil.	Plate 1	Plate 2	Fil.					
83	1	Fil.	Plate 1	Plate 2	Fil.					
83V	1	Fil.	Plate 1	Plate 2	Fil.					
112A	1	Fil.	Plate	Grid	Fil.					

6 VOLT BATTERY VALVES

EUROPEAN TYPES

A615	1	Fil.	Plate	Grid	Fil.					
A609	1	Fil.	Plate	Grid	Fil.					
A635	1	Fil.	Plate	Grid	Fil.					
A642	1	Fil.	Screen	Grid	Fil.					Plate
B605	1	Fil.	Plate	Grid	Fil.					
C603	1	Fil.	Plate	Grid	Fil.					
PM5X	1	Fil.	Plate	Grid	Fil.					
PM6	1	Fil.	Plate	Grid	Fil.					
PM16	1	Fil.	Screen	Grid	Fil.					Plate
PM26	2	Fil.	Plate	Grid	Screen	Fil.				

Socket Connections (Contd.)

6.3 VOLT A.C./D.C. VALVES

AMERICAN TYPES

Type.	Base.	1	2	3	4	5	6	7	8	Cap
6A8G	5	—	Fil.	Plate	Screen	Osc. grid	Osc. plate	Fil.	Cath.	Grid
6AC5G	5	—	Fil.	Plate		Grid		Fil.	Cath.	
6AF6G	5	—	Fil.	Ray Con. 1	Ray Con. 2	Target		Fil.	Cath.	
6B6G	5	—	Fil.	Plate	Diode 2	Diode 1		Fil.	Cath.	Grid
6B8G	5	—	Fil.	Plate	Diode 2	Diode 1	Screen	Fil.	Cath.	Grid
6C5G	5	Shield	Fil.	Plate		Grid		Fil.	Cath.	
6C8G	5	—	Fil.	Plate 2	Cath. 2	Grid 1	Plate 1	Fil.	Cath. 1	Grid 2
6D8G	5	—	Fil.	Plate	Screen	Osc. grid	Osc. plate	Fil.	Cath.	Grid
6F5G	5	Shield	Fil.	Plate				Fil.	Cath.	Grid
6F6G	5	—	Fil.	Plate	Screen	Grid		Fil.	Cath.	
6F8G	5	—	Fil.	Plate 2	Cath. 2	Grid 1	Plate 1	Fil.	Cath. 1	Grid 2
6G6G	5	—	Fil.	Plate	Screen	Grid		Fil.	Cath.	
6H6G	5	Shield	Fil.	Diode 2	Cath. 2	Diode 1		Fil.	Cath. 1	
6J5G	5	—	Fil.	Plate		Grid		Fil.	Cath.	
6J7G	5	Shield	Fil.	Plate	Screen	Suppr.		Fil.	Cath.	Grid
6J8G	5	—	Fil.	Plate	Screen	Osc. grid	Osc. plate	Fil.	Cath.	Grid
6K5G	5	—	Fil.	Plate	—	—		Fil.	Cath.	Grid
6K6G	5	—	Fil.	Plate	Screen	Grid		Fil.	Cath. Sup.	
6K7G	5	—	Fil.	Plate	Screen	Suppr.		Fil.	Cath.	Grid
6K8G	5	—	Fil.	Plate	Screen	Osc. grid	Osc. plate	Fil.	Cath.	Grid
6L5G	5	—	Fil.	Plate		Grid		Fil.	Cath.	
6L6G	5	—	Fil.	Plate	Screen	Grid		Fil.	Cath.	
6L7G	5	—	Fil.	Plate	Screen	Osc. grid		Fil.	Cath. Sup.	Signal grid
6N7G	5	—	Fil.	Plate 2	Grid 2	Grid 1	Plate 1	Fil.	Cath.	
6Q7G	5	—	Fil.	Plate	Diode 2	Diode 1		Fil.	Cath.	Grid
6R7G	5	—	Fil.	Plate	Diode 2	Diode 1		Fil.	Cath.	Grid
6S7G	5	—	Fil.	Plate	Screen	Suppr.		Fil.	Cath.	Grid
6SF5	5	Shell	Cath.	Grid		Plate		Fil.	Fil.	
6SJ7	5	Shell	Fil.	Sup.	Grid	Cath.	Screen	Fil.	Plate	
6SK7	5	Shell	Fil.	Sup.	Grid	Cath.	Screen	Fil.	Plate	
6SQ7	5	Shell	Grid	Cath.	Diode 1	Diode 2	Plate	Fil.	Fil.	
6T7G	5	—	Fil.	Plate	Diode 2	Diode 1		Fil.	Cath.	Grid
6U7G	5	—	Fil.	Plate	Screen	Suppr.		Fil.	Cath.	Grid
6V6G	5	—	Fil.	Plate	Screen	Grid		Fil.	Cath.	
6X5G	5	—	Fil.	Plate 2		Plate 1		Fil.	Cath.	
6Y6G	5	—	Fil.	Plate	Screen	Grid		Fil.	Cath.	
6Z7G	5	—	Fil.	Plate 2	Grid 2	Grid 1	Plate 1	Fil.	Cath.	
6Z57G	5	—	Fil.	Plate 2		Plate 1		Fil.	Cath.	

Connections to all-metal valves are as above, except that Pin 1 is the shell and should be earthed.

1V	1	Fil.	Plate	Cath.	Fil.					
6A4	2	Fil. +	Plate	Grid	Screen	Fil. —, Sup.				
6A6	4	Fil.	Plate 2	Grid 2	Cath.	Grid 1	Plate 1	Fil.		
6A7	4	Fil.	Plate	Screen	Osc. plate	Osc. grid	Cath.	Fil.		Grid
6B7	4	Fil.	Plate	Screen	Diode 1	Diode 2	Cath.	Fil.		Grid
6B7S	4	Fil.	Plate	Screen	Diode 1	Diode 2	Cath.	Fil.		Grid
6C6	3	Fil.	Plate	Screen	Sup.	Cath.	Fil.			Grid
6D6	3	Fil.	Plate	Screen	Sup.	Cath.	Fil.			Grid
6E5	3	Fil.	Plate	Grid	Target	Cath.	Fil.			
6F7	4	Fil.	Pent. plate	Pent. sc'n	Trio. plate	Triode grid	Cath.	Fil.		Pent. grid
6G5	3	Fil.	Plate	Grid	Target	Cath.	Fil.			
6N5	3	Fil.	Plate	Grid	Target	Cath.	Fil.			
6U5	3	Fil.	Plate	Grid	Target	Cath.	Fil.			
36	2	Fil.	Plate	Screen	Cath.	Fil.				Grid
37	2	Fil.	Plate	Grid	Cath.	Fil.				
38	2	Fil.	Plate	Screen	Cath.	Fil.				Grid
39/44	2	Fil.	Plate	Screen	Cath.	Fil.				Grid

Socket Connections (Contd.)

6.3 VOLT A.C. OR D.C. VALVES (Contd.)

AMERICAN TYPES

Type.	Base.	1	2	3	4	5	6	7	8	Cap.
41	3	Fil.	Plate	Screen	Grid	Cath.	Fil.			
42	3	Fil.	Plate	Screen	Grid	Cath.	Fil.			
75	3	Fil.	Plate	Diode 1	Diode 2	Cath.	Fil.			Grid
76	2	Fil.	Plate	Grid	Cath.	Fil.				
77	3	Fil.	Plate	Screen	Sup.	Cath.	Fil.			Grid
78	3	Fil.	Plate	Screen	Sup.	Cath.	Fil.			Grid
79	3	Fil.	Plate 2	Grid 2	Cath.	Plate 1	Fil.			Grid 1
84/6Z4	2	Fil.	Plate 1	Plate 2	Cath.	Fil.				
85	3	Fil.	Plate	Diode 2	Diode 1	Cath.	Fil.			Grid
89	3	Fil.	Plate	Screen	Sup.	Cath.	Fil.			Grid

EUROPEAN TYPES

EB4	P	Met.	Fil.	Fil.	Cath. 1	Diode 1	Shield	Diode 2	Cath. 2	
EBC3	P	Met.	Fil.	Fil.	Cath.	Diode 2	Diode 1	—	Plate	Grid
EBF1	P	Met.	Fil.	Fil.	Cath., Sup.	Diode 2	Diode 1	Screen	Plate	Grid
EBL1	P	—	Fil.	Fil.	Cath., Sup.	Diode 2	Diode 1	Screen	Plate	Grid
EF5	P	Met.	Fil.	Fil.	Cath.	Sup.	—	Screen	Plate	Grid
EF6	P	Met.	Fil.	Fil.	Cath.	Sup.	—	Screen	Plate	Grid
EK1	P	Met.	Fil.	Fil.	Cath. Sup.	Osc. anode	Osc. grid	Screen	Plate	Grid
EK2	P	Met.	Fil.	Fil.	Cath. Sup.	Osc. anode	Osc. grid	Screen	Plate	Grid
EL2	P	—	Fil.	Fil.	Cath. Sup.	—	—	Screen	Plate	Grid
EL3	P	—	Fil.	Fil.	Cath. Sup.	—	Grid	Screen	Plate	
EL5	P	—	Fil.	Fil.	Cath. Sup.	—	Grid	Screen	Plate	
EM1	P	—	Fil.	Fil.	Cath.	—	Grid	Target	Plate	
EZ2	P	—	Fil.	Fil.	Cath.	Plate 2	—	—	Plate 1	
EZ3	P	—	Fil.	Fil.	Cath.	Plate 2	—	—	Plate 1	
EZ4	P	—	Fil.	Fil.	Cath.	Plate 2	—	—	Plate 1	

12 TO 13 VOLT A.C./D.C. VALVES

AMERICAN AND CONTINENTAL TYPES

12Z3	1	Fil.	Plate	Cath.	Fil.					
C1	P	—	—	—	—	Fil.	—	—	Fil.	
CB1	V	Met.	Fil.	Fil.	Cath.	Diode 1				Diode 2
CBC1	P	Met.	Fil.	Fil.	Cath.	Diode 2	Diode 1	—	Plate	Grid
CC1	P	Met.	Fil.	Fil.	Cath.	—	—	—	Plate	Grid
CF1	P	Met.	Fil.	Fil.	Cath.	Sup.	—	Screen	Plate	Grid
CF2	P	Met.	Fil.	Fil.	Cath.	Sup.	—	Screen	Plate	Grid
CK1	P	Met.	Fil.	Fil.	Cath.	Osc. plate	Osc. grid	Screen	Plate	Grid

20 TO 30 VOLT A.C./D.C. VALVES

AMERICAN AND CONTINENTAL TYPES

25A6G	5		Fil.	Plate	Screen	Grid		Fil.	Cath.	
25A7G	5	Rect. Cath.	Fil.	Plate	Screen	Grid	Rect. Plate	Fil.	Cath.	
25B6G	5		Fil.	Plate	Screen	Grid		Fil.	Cath.	
25L6G	5		Fil.	Plate	Screen	Grid		Fil.	Cath.	
25Z5	3	Fil.	Plate 2	Cath. 2	Cath. 1	Plate 1	Fil.			
25Z6G	5		Fil.	Plate 2	Cath. 2	Plate 1		Fil.	Cath. 1	
43	3	Fil.	Plate	Screen	Grid	Cath.	Fil.			
48	3	Fil.	Plate	Screen	Grid	Cath.	Fil.			
CL2	P		Fil.	Fil.	Cath.			Screen	Plate	Grid
CL4	P		Fil.	Fil.	Cath.			Screen	Plate	Grid
CY2	P	Cath. 2	Fil.	Fil.	Cath. 1	Plate 2			Plate 1	

Abbreviations: Fil., Heater of Filament; Cath., Cathode; Sup., Suppressor Grid; Met., Metallised coating on Continental type valves. Screen, Screening grid on pentodes.



The most comprehensive Selection of Technical Books in Australia!

SEND FOR OUR LATEST CATALOGUE

- 1 RADIO ENGINEERING. By F. E. Terman, Sc.D., Professor of Electrical Engineering, Stanford University. Second Edition, second impression. 813 pages, 474 diagrams. A comprehensive treatment, covering all phases of radio communication. 36/- (post 1/-).
- 2 THE "RADIO" HANDBOOK 1939. By Frank C. Jones and the Technical Staff of "Radio." An entirely revised edition, rewritten to include all new developments in the radio field. 9/- (post 6d.).
- 3 HOW TO PASS RADIO LICENCE EXAMINATIONS. (Commercial Radiotelegraph and Radiotelephone). By Charles E. Drew, Member I.R.E. 201 pages, 73 illustrations. 16/- (post 6d.).
- 4 THE RADIO AMATEUR'S HANDBOOK, 1939. Latest Edition. Published by the American Radio Relay League. More than 500 pages, hundreds of illustrations. 8/- (post 9d.).
- 5 AUTOMATIC FREQUENCY CONTROL SYSTEMS. By John F. Rider, author of "The Cathode-Ray Tube at Work," "Servicing Superheterodynes," etc. 142 pages, 97 diagrams. 6/6 (post 4d.).
- 6 FUNDAMENTALS OF RADIO. By F. E. Terman, with the Collaboration of Lt. F. W. Macdonald, U.S.N. An elementary version of the author's well-known "Radio Engineering." First Edition. 458 pages, 277 illustrations. 24/6 (post 1/-).
- 7 ADMIRALTY HANDBOOK OF WIRELESS TELEGRAPHY. 1938. Vol. 1. Magnetism and Electricity. Vol. 2. Wireless Telegraphy Theory. 2 Vols. 16/6 (post 2/-).
- 8 RADIO LABORATORY HANDBOOK. By M. G. Scroggie, B.Sc., A.M.I.E.E., Consulting Radio Engineer. 384 pages, 211 diagrams. 14/- (post 8d.).
- 9 PRACTICAL WIRELESS SERVICE MANUAL. A complete work on the testing of all types of wireless receivers, and the remedying of faults in them. Edited by F. J. Camm, Fellow, Royal Society of Arts, etc. 295 pages, 221 diagrams. 8/3 (post 7d.).
- 10 THE WIRELESS CONSTRUCTOR'S ENCYCLOPAEDIA. A complete guide in alphabetical order, to the construction, operation, repair, and overhaul of all types of wireless receivers and components. By F. J. Camm. Sixth Edition, fully revised. 394 pages, with over 500 illustrations. 8/3 (post 9d.).
- 11 AUTO-RADIO POCKET TROUBLE SHOOTER. By A. A. Ghirardi. Consists of a set of pocket size wear-resisting cards printed in two contrasting colors and eyeleted together to cover all these troubles. 3/6 (post 3d.).
- 12 HOME RADIO POCKET TROUBLE SHOOTER. By A. A. Ghirardi. Consists of a set of pocket size wear-resisting cards printed in two contrasting colors and eyeleted together to cover all these troubles. 3/6 (post 3d.).
- 13 WIRELESS DIRECTION FINDING. By R. Keen, B.Eng. With a Foreword by T. L. Eckersley, F.R.S. Third and Enlarged Edition. 803 pages, 549 illustrations. 42/- (post 1/2).
- 14 SIXTY TESTED WIRELESS CIRCUITS. Including circuits for battery and mains-operated receivers, adaptors, units, portables, short-wave receivers, all-wave receivers, and amplifiers. By F. J. Camm. 168 pages, 113 illustrations. 4/3 (post 4d.).
- 15 SERVICING SUPERHETERODYNES. By John F. Rider. Revised edition. 223 pages, illustrated. 6/6 (post 6d.).
- 16 WIRELESS SERVICING MANUAL. By W. T. Cocking. Fourth Revised Edition. 278 pages, diagrams. 7/6 (post 6d.).
- 17 THE RADIO ENGINEERING HANDBOOK. Prepared by a Staff of Twenty-Eight Specialists. Keith Henney, Editor-in-Chief, Member, the Institute of Radio Engineers. Second Edition, 850 pages. 1935. 32/6 (post 9d.).
- 18 MODERN RADIO SERVICING. A practical text on the theory, construction and use of modern radio service equipment, and the rapid and systematic methods of radio servicing in all its branches. By Alfred A. Ghirardi, E.E. 1302 pages, 706 illustrations, diagrams, etc. 1935, corrected 1936. 27/6 (post 1/3).
- 19 RADIO PHYSICS COURSE. An elementary textbook on electricity and radio. By Alfred A. Ghirardi, E.E. A book no technical student set builder, experimenter or serviceman can afford to be without. 974 pages, 508 illustrations; second revised and enlarged edition, 1933. Eighth impression June, 1937. 30/- (post 1/-).
- 20 PRACTICAL RADIO COMMUNICATION. Principles—Systems—Equipment—Operations. Including Short-wave and Ultra Short Wave. By Arthur E. Nilson, Member of Institute of Radio Engineers, and J. L. Hornung, Member of Institute of Radio Engineers, etc. 758 pages, illus. 1935. 32/6 (post 1/-).
- 21 HANDBOOK OF TECHNICAL INSTRUCTION FOR WIRELESS TELEGRAPHISTS. By H. M. Dowsett, M.I.E.E., F. Inst. P., M. Inst. R.E. New and thoroughly revised edition, 1938. 644 pages, including comprehensive index and 578 illustrations. 34/- (post 1/-).
- 22 THE RADIO MANUAL. By George E. Sterling, Assistant Chief, Field Section, Engineering Department, Federal Communications Commission Member, Institute of Radio Engineers. New third Edition, 1938. Completely revised and rewritten. 1,120 pages, 443 illustrations and figures. 42/- (post 1/3).
- 23 RADIO TROUBLE - SHOOTERS' HANDBOOK. By A. A. Ghirardi, author of "Modern Radio Servicing." This takes the place of the author's former data book "Radio Field Service Data." It contains 518 pages (8 1/2 in. x 11 in.) and 134 illustrations (1939) and is described as a "monumental new compilation of compact reference material to aid service men in speeding up their trouble-shooting and repair work" 22/6 (post 1/-).
- 24 RADIO INTERFERENCE AND ITS SUPPRESSION. By J. H. Reyner, B.S., A.C.G.I., D.I.C., A.M.I.E.E. and M. Inst. R.E. Consulting Engineer, 138 pages, 55 illus. 1936 15/6 (post 6d.).

POST TODAY!

ON APPROVAL ORDER FORM

ANGUS & ROBERTSON LTD.,
89 Castlereagh Street, Sydney, N.S.W.

Please send me the book(s) numbered below for seven days' free examination. For any not returned at the end of that period I agree to forward the price quoted (including postage) on receipt of your statement. State if terms desired.

NAME _____

ADDRESS _____

BUSINESS ADDRESS _____

OCCUPATION _____

L.I./R.C./39.

A Successful Australian Valve Industry



NEW
MICRO-SENSITIVE

RADIOTRONS

AUSTRALIAN
GENERAL ELECTRIC
LIMITED

Sydney, Melbourne, Brisbane
Adelaide, Hobart

AMALGAMATED
WIRELESS (A/SIA) LTD.

47 York Street, Sydney
167-169 Queen St., Melbourne

NATIONAL ELECTRICAL
& ENGINEERING CO. LTD.

Wellington
New Zealand

(Advertisement of Amalgamated Wireless Valve Co. Pty. Ltd.)