

ALL WAVE RECEIVERS



SHORT WAVE SETS:
(BATTERY, ALL-ELECTRIC, ADAPTORS)

ALL WAVE RECEIVER:
(FOR RECEPTION 15-30 METRES)

BROADCAST RECEIVERS:
(2, 3 and 4-VALVE A.C. and BATTERY OPERATED)

**SHORT WAVE STATIONS
OF THE WORLD**
Etc., Etc., Etc.

EVERY-THING IN RADIO



**AT VEALLS^{PTY.}
LTD.**

3 BIG STORES

No matter your Radio or Electrical Requirement Vealls can supply. Three Huge Stores packed with goods—all class, new stock, bought by experts to fill the most exacting radio conditions.

Over twenty years of fair and square dealing has earned Vealls a reputation that equals behind EVERY transaction. Veall's aim is to give YOU the maximum service, the highest quality goods—at the LOWEST possible price. Our cash with order policy allows us to offer high-class radio and electrical lines at a big saving to you.

FREE

At frequent and regular intervals Vealls publishes Radio and Electrical Price Lists containing valuable information for those interested. Send us your name and address. We will gladly place your name on our mailing list and post copies of this literature to you.

**VEALLS PRICE LISTS
WILL KEEP YOU UP-
TO-DATE IN RADIO**

Country Clerks are offered a unique service in Veall's Mail Order Dept. Expert individual and careful attention to every order—no matter how small. EVERY order despatched within an hour or two of receipt—positively never longer than 12 hours. Try Vealls with your next order.

VEALLS 3 BIG STORES

225-240 SWANSTON ST., MELB., C.I.
205 CHAPEL ST., PERTH, S.I.

105-111 SWANSTON ST., MELB., C.I.

RADIO TIME GAUGE

Showing Principal Short Wave Stations of the World



To determine the time for any city indicated, revolve the clock face until the hour of the day and the city from which the calculation is to be made coincide. The corresponding time for any other city can then be readily seen. To determine the corresponding date, traverse the chart by the shortest distance unless it involves passing the "stop mark," in which case the

chart must be traversed in the opposite direction. If midnight is passed when traversing in a clockwise direction, the corresponding date will be the following day; if the opposite direction has to be taken, and midnight is passed, the corresponding date will be the previous day. Otherwise if midnight is not passed in either direction the date will be the same in both cities.

Come
to
HARTLEY'S
for
your
Radio
goods

HARTLEY'S
"Where Sportsmen
Congregate"

HOME SET BUILDERS AND DEALERS

Write for Price List!

To Purchase once is to Become a Regular Customer. It is in Your Own Interests to Give Us a Trial

MAIL ORDERS RECEIVE SAME DAY SERVICE

Mail Orders Over 20/- in Victoria forwarded
FREIGHT FREE (Except Batteries and
Accumulators).

Send for Catalogue . . . Lists Everything for Radio
and all Leading Makes.

Build the Set of the Year, Using Stromberg-Carlson Super Het. Kit

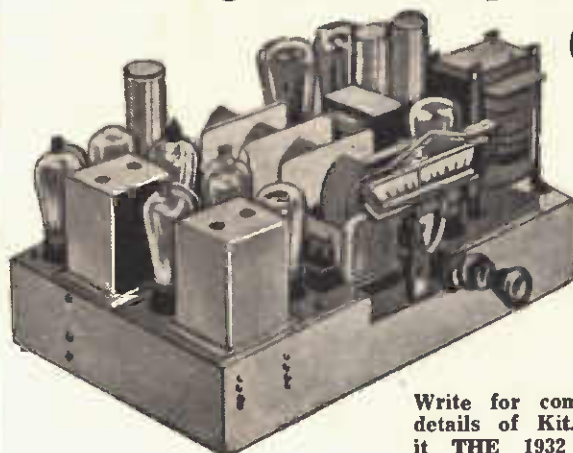

Complete, £9

KIT COMPRISES

- 1 Set of 4 Coils
- 1 4 Gang Condenser.
- 2 Intermediate Transformers.
- 1 Padder Condenser.

Designed by
Mr Ross Hull
the famous
Sydney expert.
Write for details.

Write for complete quote and
details of Kit. Results prove
it THE 1932 ACHIEVEMENT

HARTLEYS are AGENTS and DISTRIBUTORS
(Wholesale and Retail)

SILVATONE

and

RADIOLA

Demonstrations Daily.

270 FLINDERS ST. (opp. Station), MELBOURNE
Branches: 148 Swanston St. (Nr. Town Hall), 407 Bourke St., (Next
Danks').

NEW DIAMONDS

Chosen by

WIRELESS EXPERTS

RADIO SET MANUFACTURERS

The knowledge, experience and requirements of Wireless Experts and Radio Set Manufacturers, should be a guide to you whether you are making your own set, or are renewing batteries in your present set.

Wireless Experts

Those in charge of our leading Broadcasting Stations pay remarkable tributes to New "Diamonds" Longer Life. Working under hardest and most exacting conditions New "Diamonds" give greater service than any other batteries manufactured today. Original Testimonials may be seen if desired.

Set Manufacturers

No manufacturer of Radio Sets can afford to take a chance with his reputation as a manufacturer—the good name of a set might easily be spoiled by a poor battery.

These Manufacturers realise that New "Diamonds" make a good set better, and instal and recommend them.

LET Experience Be YOUR Guide

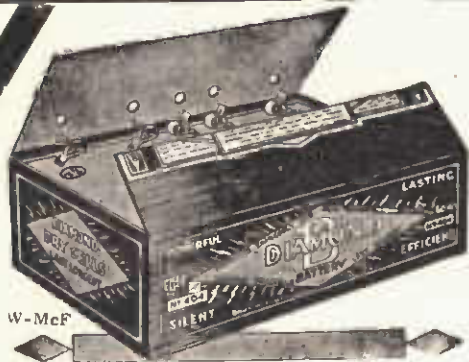

W-McF

New Diamond "B" Batteries

TRIPLE CAPACITY
HEAVY DUTY
LIGHT DUTY TYPES

NEW DIAMOND "C" BATTERIES
NEW DIAMOND "BUZZER" BATTERIES
NEW DIAMOND TORCH UNITS

Catalogue and Complete Price List Free.

(W.-McF.)

Direct Factory Distributors: THE HENDON ELECTRICAL CO.

Ground Floor—"Whitehall"—Bank Place, Melbourne, C.I.
Phone F4952.

Interstate Representatives:

N.S.W.—REG. ROSE & COMPANY	SYDNEY.
S.A.—NEWTON McLAREN LTD.	ADELAIDE.
A. G. HEALING LTD.	ADELAIDE.
Q'LAND.—J. B. CHANDLER	BRISBANE.
W.A.—CARLYLE & COMPANY	PERTH.
TAS.—W. & G. GENDERS PTY. LTD.	LAUNCESTON AND HOBART.
OLIVER & OLIVER PTY. LTD.	HOBART AND LAUNCESTON.
A. MEDHURST & SONS PTY. LTD.	HOBART.

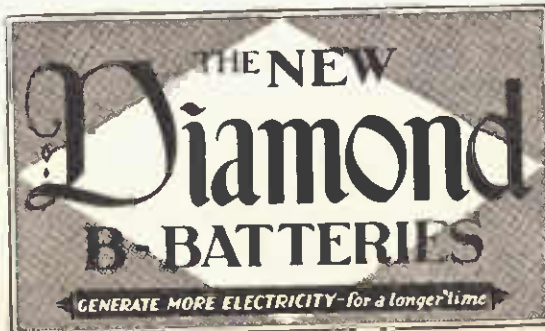

CONTENTS:

	Page
A Modern Short-Wave Receiver	27
"All-Wave Receiver" Trouble Chart	43
A.C. Gramophone Amplifiers	48
A.C. Short-Wave Two	11
An Efficient Baffle-board	54
A Simple Power Pack	68
An Efficient Four Valve Receiver	60
Baffle-board—An Efficient	54
Battery Problem	74
Changing Kilocycles to Metres	75
Efficient Baffle-board	54
Efficient Four-Valve Receiver	60
Fine Tuning with Short Wave Sets	46
Gramophone Amplifiers—A.C.	48
Logging Chart	82
"My Own" All-Wave A.C. Receiver	15
Plate and Grid Detection	72
"Q" Signs	76
Reception on the Short-Waves	30
Short-Wave Aerial Systems	25
Short-Wave Aerial Couplings	40
Systems of Tone Control	41
Short-Wave Four Valve	44
Self-Contained Screen Grid Two	52
Soldering—How to Do It	66
Simple Power Pack	68
Two Short-Wave Aerial Systems	25
The Ultra-Selective A.C. Three	78
Trouble Chart	43
Unwanted Oscillation	42
The World Short-Wave Adaptor	22
Table Model Four Valve Receiver	56
The Battery Problem	74
Ultra-Selective A.C. Three	78
Various Forms of Reaction	71
World Short-Wave Adaptor	22
What Is Being Done on the Short-Waves	7
World Short-Wave Chart	32



RADIO!

You'll buy fewer and better Batteries if you insist on **EVER-READY**, which are backed by 30 years of scientific research.

LIGHT!

The instant your finger presses the switch of an **EVER-READY** Torch or Hand Lamp, you are provided with a bright, clear beam of penetrating light. Be sure your Refills are **EVER-READY** too!

POWER!

Stipulate **EVER-READY** Batteries for doorbells, buzzers, telephones, etc. World-famous for consistently perfect service.

Manufactured by
THE EVER-READY CO. (GT. BRITAIN) LTD.
SYDNEY and LONDON

AUSTRALIA'S BEST BATTERIES



EVER READY
REGD. TRADE MARK.

TORCHES, REFILLS AND RADIO BATTERIES

WHAT IS NOW BEING DONE

On the SHORT-WAVES

A general review of the work which is being carried out on the higher frequencies

By "SHORT-WAVE"

UNTIL recently the short-wave receiver was usually constructed by experimenters from obsolete apparatus contained in the "junk" box, provided that the apparatus was still in workable order. In the hands of expert workers it was quite capable of producing signals of good volume and of reasonable stability.

The quality of the reproduction was a secondary consideration. Reception was obtained mainly from head-phones, and the gist of the transmission could be readily recognised just as one is able to recognise what is being reproduced from the receiver of a telephone, although the audible range of frequencies handled by the telephone is strictly limited.

Indeed, the quality of the transmission was not above suspicion, the main consideration being that of transmitting intelligible speech or music signals over long distances, and the discovery of some of the phenomena associated therewith.

The consequence has been that the average person whose contact with radio does not extend beyond the range of the broadcast receiver, who has been invited to "listen in" on a short-wave receiver, has experienced much of gurgles and squeaks and groans, but little that could be distinguished as pleasant musical reception.

With a better understanding of the possibilities and limitations of short-wave reception, coincident with an improvement in the transmitting apparatus to ensure faithful transmission of the musical frequencies, attention has been directed toward perfecting the quality of the reproduction of the receiver and has resulted in almost complete elimination of unpleasant noises.

Reception of interstate or distant stations operating on the 200 to 500-metre broadcast band is not always possible without static and other interference on all occasions, notwithstanding the employment of multi-valve broadcasting receivers capable of enormous amplification. The time must be right and the conditions suitable.

For effective short-wave broadcast reception the position is exactly similar. Static and electrical interference is more or less beyond human control, and if conditions are very bad may render the receiver useless for short periods. Short-waves, however, have one decided advantage over the longer waves, in that there is so much "territory" contained within the band of wave lengths between 15 and 100 metres that one or

Time enters into the problem very seriously, because one may hear stations on short waves from all parts of the world, each with a different local time which is not always convenient to Australian time or receiving conditions.

From our observations of the transmissions of these foreign stations, we are able to deduce fairly approximately for the season when maximum signals can be expected for a given wave length and distance, and thus effect the necessary compromise between our local and foreign times.

The construction of a short-wave receiver is no more difficult than that of a broadcast receiver. Nevertheless, there are a number of pitfalls into which the inexperienced constructor may stumble, and it is with the object of consolidating custom and standard laboratory practice in the building of suitable receivers, and to produce, in a handy form, a reference of as much as possible of all the available information in connection with the overseas broadcasting stations, that this booklet is presented.

Historical Development

In the early days of radio reception—pre-war period—wave lengths were to a certain extent accidental, depending primarily on the facilities

available, including finance, and to the resources at the command of the transmitting station for the erection of an aerial as high and as long as possible.

Transmitting practice at that time seemed to indicate that enormously high power and a long wave length, in the vicinity of 20,000 metres, was essential for reliable communication over a long distance.

With the development of the three electrode valve both for transmitting and receiving, it became possible to employ shorter wave lengths and to obtain a more efficient radiation than with the earlier spark systems.

In the post war period of rapid advancement the time soon came when there was not enough "territory" between 2000 and 30,000 metres (the upper limit) to contain all the stations wishing to begin transmission.

The introduction of commercial broadcasting added further trouble from this source, and as each new service came on the air in congested districts it was forced to exploit a shorter and shorter wave length.

In the scramble, privately-owned experimental stations (amateurs) played a very

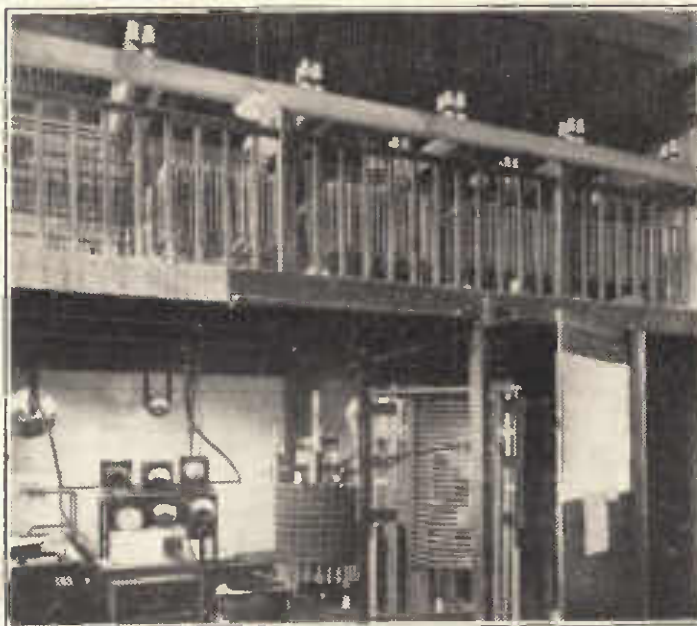

Portion of the transmitter of P.C.J., the popular Holland short-wave station

more parts of the band will be less affected than another. Unless the disturbance is purely local, some band for general listening can always be found which is not subject to the interference experienced at the same time on another band.

In severe cases of fading there does not seem to be any remedy in sight at present, although the attention of investigators everywhere is directed upon it. Minor cases can be minimised by means of fading "compensators" which can be fitted to the more elaborate receivers, but they are usually beyond the reach of the average listener. It appears to be dependent on very many different conditions.

Static and electrical interference is heard as a "background" of crackles on certain wave lengths, which will vary in strength (or level) during different times and seasons. The stronger the signal is the less will be the interference experienced with a programme from this source, and it is often possible to reduce the sensitivity of the detector valve in the receiver until it only operates on the signal, the necessary amplification being applied from this point to produce speaker strength.

(Continued overleaf)

important part in the investigatory work. These stations were always to be found on the low end of the "spectrum," and as each shorter wave length was proved to be useful, were pushed lower and lower in the race for commercial exploitation.

In 1921 and 1922, amateur transmissions were relegated to 200 metres and below—the current, although unexpressed, technical opinion being that as wave lengths below 200 metres were useless for commercial activities, amateur transmissions could be undertaken here without very much chance of interference.

The stations themselves were loth to be relegated to obscurity, but immediately began investigations to ascertain whether reliable communication could be established with fellow experimenters in other countries.

The tests, which included transmission and reception across both sides of the Atlantic and Pacific, were crowned with success although the actual feat, viewed from our present knowledge of the limitations of transmission on 200 metres, was stupendous.

The success, however, stimulated investigation of still lower and lower wave lengths and directed attention to the possibilities of utilising wave lengths below 100 metres and it was quickly realised by the commercial stations that utilisation of the very short wave lengths would enable the number of permissible stations operating at the one time, to be increased enormously without interference with each other. Still further investigation indicated that long distances could also be efficiently covered on the shorter wave lengths for a relatively lower consumption of power and a consequential saving on capital costs for equipment.

In the meantime, commercial broadcasting had become well established between 1000 and 2000 metres. The utilisation of wave lengths about 200 metres enabled these stations to extend their reception areas over considerably greater distances, because of the better carrying properties for a given power. Thus increasing the potential "audiences" upon which they were dependent for revenue, and there was a general exodus to our present broadcast bands of 200 to 500 metres.

About 1926, commercial stations found it possible to modulate the extremely low wave lengths with speech and music, thus pointing the way to broadcasting below 100 metres. Late in the year Australian experimenters were thrilled to hear a transmission of speech and music from a studio in Pittsburgh, U.S.A., through station KDKA (now W8XK) working on a wave length of about 60 metres.

In March, 1927, the first transmission from Holland was heard locally from station PCJ on a wave length of about 30 metres. The number of stations steadily increased, and as the work progressed many new avenues of useful service were found for these "telephony" stations besides the providing of merely interesting entertainments.

Short-wave stations are now being used for the exchange of international programmes of important events and in recent months we have been privileged to listen to the voice of His Majesty the King, His Holiness the Pope, international sporting, fixtures, air races, addresses by Arctic and Antarctic explorers, and probably most thrilling of all, the description by an eye-witness of the appalling scenes which followed on the disastrous New Zealand earthquake within a few hours of the actual event.

What of the Future?

From a purely utilitarian aspect, the greatest benefit conferred on mankind by the success of these shorter wave lengths has probably been the development of the short-wave link as a medium connecting the various telephone networks of nearly all the settled countries of the world. From a local telephone set installed in a suburban residence it is now possible to obtain connection with more than 25 million other telephone subscribers living in Great Britain (2 million subscribers), United States of America (19½ million subscribers), 22 European countries, Canada, South America, New Zealand and the Pacific Islands. East and West Indies.

The success of the telephone services, of relays of broadcasts of important events, and the increase in the number of short-wave stations engaged in broadcasting which are audible in Australia (about 70 at present), have placed short-wave reception beyond the stage of an "interesting experiment," and it will be apparent that there are many new experiences which unfold themselves to the possessor of a suitable receiver.

The successful broadcasts mentioned earlier have all been in the nature of "descriptive" speech, although among the slightly less successful we have been profoundly stirred to hear the funeral strains of the magnificent and stately organ at Westminster Abbey mourning the gallant men who lost their lives when the British airship R101 crashed in France. We have been thrilled at being able to hear Italian opera from Rome, and lightly entertained on more than a few occasions by the lilting strains of some famous jazz orchestra from America.

Every night, if one listens, it is possible to hear the music of half a dozen nationalities from Orient and Occident, which are reproduced with fair fidelity.

Developmental work is progressing all the time, and with the advent of regular international services undertaken by such organisations as the British Broadcasting Corporation to provide a truly Empire service, the French authorities and their colonial service, the World Service of Amalgamated Wireless from Sydney and Melbourne during the week-ends, and the host of Americans, etc., these opportunities are becoming more and more frequent.

The future will therefore see a rapid expansion of these international services operated by foreign government or semi-government bodies devoted entirely to broadcasting festivals and events of international interest with, perhaps, many minor services operated by public or private corporations, and thus adding one further link in world communications.

Fundamentals—Wave Length

Thoroughly to understand the short-wave receiver and to obtain the maximum efficiency, it is desirable to be familiar with certain fundamentals, including that of wave length, international time, and other factors which affect the reception.

When a broadcast station radiates its transmission from the aerial, the energy is dissipated in the form of electrical and magnetical strains in the surrounding ether which permeate all matter and space. These electro-magnetical strains impinge on the receiving aerial.

If the receiving aerial is in "tune" with the transmitting aerial, small currents are set up therein, by the ether strains, which are exactly similar to

the currents circulating backwards and forwards (oscillating) in the transmitting aerial. These etheric strains radiate from the transmitter aerial in the form of waves, travelling with a velocity of the speed of light (approximately 300,000 kilometres per second). The circulating currents in the transmitting aerial form one complete wave as the current surges from end to end, beginning at zero, rising to maximum value, and falling back to zero at each oscillation.

A complete wave is formed when the circulating currents go through a regular "cycle," i.e., the current surges from end to end of the aerial, beginning at zero, rising to a maximum value in one direction, falling back to zero, surging to a maximum in the opposite direction and again dying away to zero, or returning to a condition of stability. A thousand of these cycles is known as one "kilocycle."

The distance between the beginning of each successive wave can be measured in metres and depends on the frequency in seconds of oscillation of the currents setting up the wave strains. The velocity at which the wave strains travel through the ether remains constant, so that the wave length is actually the distance measured in metres through which the head of one wave has passed before the succeeding wave strain is started. The frequency with which the waves are formed can be very accurately controlled in the constants of the aerial and transmitting circuits.

There is a very definite relation between wave length, frequency of their formation, and velocity of propagation through space of these etheric strains, and we deduce the formulae: wave length (in metres) is equal to the dividend of the velocity (in kilometres) divided by the frequency (in kilocycles). Conversely the frequency is equal to the velocity divided by the wave length.

We have been in the habit of visualising the transmission of a station by the length of the wave that it sends out into the surrounding ether and differentiating between two stations by saying that one transmits on a certain wave length, and the other on a different wave length, thus enabling us to determine a suitable combination of coils and condensers to tune our receiver into resonance with each transmitting aerial.

Unfortunately whilst being quite suitable for classifying stations on the normal medium broadcast band, the wave length measurement leaves a very hazy idea, when used below 100 metres, which is only approximate without using a large number of meaningless decimals. A reference to the Frequency/Conversion Table, number 5, on page 75 will make this clear.

For instance, on the normal broadcast band it is possible to accommodate 25 broadcast stations between 200 and 300 metres (a difference of 100 metres) without undue interference to each other in properly designed receivers. This position is actually surpassed in congested areas such as Europe and America.

On short-waves, however, it is possible to accommodate 250 stations between 20 and 30 metres (a difference of only 10 metres). The wave length separation required between two stations on the 200,300 metre band averages 4 metres, but varies between 2.7 metres for the lower end and 5.9 metres for the upper end.

On the shorter 20/30 metre waveband the separation required only amounts to approximately .4 metre, again varying between .27 for the lower, and .59 for the upper extremities.

When we turn our attention to other and more difficult bands for calculation we get hopelessly lost in the tangle of ever differing variations.

We find, therefore, that a classification based on the frequency with which the wave-trains are sent into the ether, is much more useful and that, unlike wave length measurements, its relative value does not vary throughout the whole useful "spectrum" from the extremely low to the ultra high. Thus we find from the formulæ referred to in the foregoing, that at 200 metres a station separation of 2.7 metres is equivalent to 20 kilo-cycles, and that at 300 metres a 5.9 metre separation is also equivalent to 20 kilo-cycles. On the shorter wave lengths—27 metre at 20 metres and .59 at 30 metres, are again equivalent to the same 20 k.c. separation.

Sometimes it is more convenient further to divide our kilocycles by a thousand (then calling it a "megacycle") and expressing the last three figures as a decimal. 15,285 k.c. then becomes 15.285 m.c. This is usually the case when dealing with the very high frequencies which are met with below about 13 metres and occasionally above.

In technical circles, the frequency standard has long since superseded the wave length classification, but the latter is so deeply rooted in the mind of the layman that it has been considered advisable to retain the wave length terms to indicate an approximation. Where greater accuracy is desirable the frequency classification will also be used. It will be apparent, from the examples quoted, that, as the wave length is lowered, the frequency rises.

Experienced short-wave listeners know that practically all the short-wave broadcasting stations (apart from commercial telephone stations, which occasionally indulge in broadcasting records for test purposes) are located at definite points in the wave-length spectrum, between 13 and 100 metres, which have been fixed by an international convention. New-comers, however, until this fact is learnt, often miss them by not searching on the correct wave-length.

All the useful wave-lengths have been allocated between the various services who use them. The different services are classified as:—"Point to Point" stations, such as beam telegraph and telephone circuits, where communication is between two fixed points; "Fixed" services, which are stations used for communication with other stations in all directions, such as shore stations in marine communication systems; "Mobile" stations, which include ships, commercial aircraft, etc.; "Army, Navy and Air Force" stations; "Amateur and Experimental" and "Radio Diffusion" services,

which are broadcast stations as we know them.

Below 100 metres there are six channels set aside for these broadcast services, and they fall as follows:—50 to 48.8 metres (6000 to 6150 k.c.); 31.6 to 31.2 m. (9500 to 9600 k.c.); 25.6 to 25.2m. (11700 to 11900 k.c.); 19.85 to 19.55m. (15100 to 15350 k.c.); 16.9 to 16.85m. (17750 to 17800 k.c.); and 14 metres to 13.92 m. (or 21450 to 21550 k.c.). The two lower bands are not used, at present, to any large extent, but should be of importance for the new Empire Service when the station is completed.

International Time

Eastern Australian time is based on observations made at Sydney Observatory, and, for convenience, all districts in the eastern States situated east or west of an imaginary line (meridian)

The circle which the equator makes is divided into 360 degrees, through each of which a meridian passes. The meridians are numbered east and west of Greenwich from 1 to 180, and, as the earth revolves on its axis once in every 24 hours, 15 of these meridians would pass a fixed point in space in every hour.

If one were to begin at Greenwich with a clock set to Greenwich time, and travel in a westerly direction to America, across the Pacific Ocean to New Zealand, Australia, Africa and back to Greenwich, midday or midnight would vary from G.M.T. by one hour for every 15 meridians through which one passed. Deviation north or south of the general direction would not affect the time.

On the outward journey "local" time would gradually drop behind Greenwich time until we found that, on reaching the east coast of New Zealand, local time there would be 12 hours behind G.M.T. On the homeward journey the lost time would be recovered, and on reaching Greenwich our clock would be correct again, but if we watched our calendar we would find that we were a day behind the English calendar from which we started.

If we began the journey in an easterly direction the reverse effect would be noticed. Our clock would drop behind local time until the 180th meridian, then gradually recover, but at the end of the journey we would be a day ahead of the English calendar.

Therefore, in common with mariners, when we wish to make calculations of international time, we have to add one hour to G.M.T. for every fifteen degrees east of Greenwich, or subtract one hour for every fifteen degrees west, and drop one day of our calendar whenever we cross the 180th meridian going east,

or add one day when we cross it going west.

The importance of having an "International Time" will be apparent from the following example:—The use of local time for indicating a transmission period for a short-wave station would lead to considerable confusion and an elaborate calculation. If an Australian short-wave station announced that it was to be heard from 8 a.m. to 9 a.m. every Wednesday, it would be difficult for an American listener to decide whether he would hear the transmission on Tuesday, Wednesday or Thursday in his country, although his local time to correspond with Sydney time could be easily ascertained by counting the degrees of longitude (meridians) between the two places.

By adopting an International Time based on Greenwich time, however, the Sydney station, knowing that its local

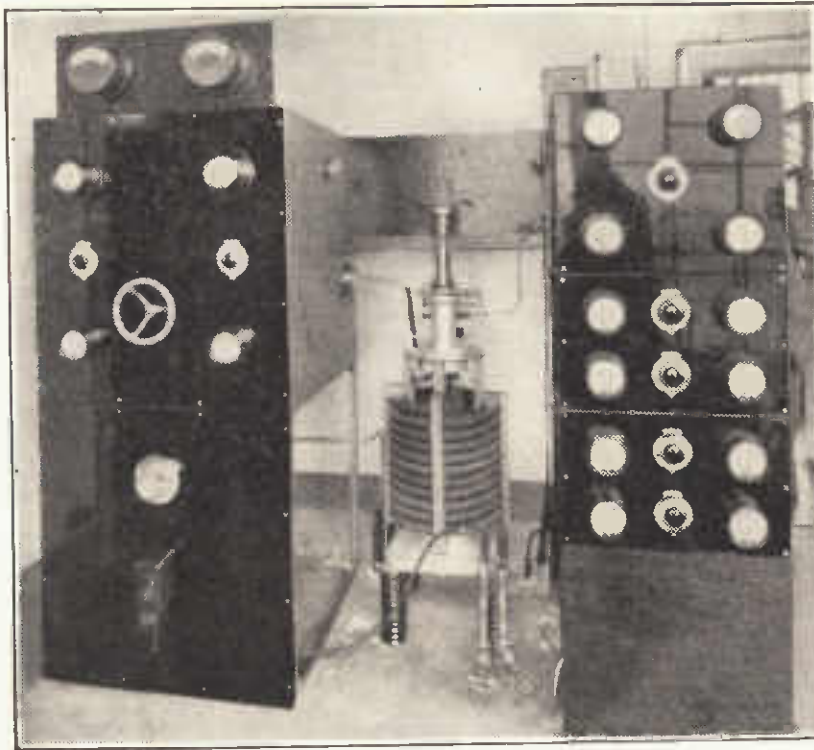

A section of the transmitter of W8XAL, America, which station is very familiar to Australian listeners.

running north and south of this point adopt this standard as their "zone" time which is that indicated by our clocks.

"Time" all over the world is "zoned" in the same way, but there are no definite limits indicating how much of a district or country will observe a certain zone time other than convenience and physical contour. The Dutch East Indies, for instance, consist of a series of elongated islands running more or less parallel with the equator and through which several meridians pass necessitating more than one zone time for convenience.

The Malay Peninsula, on the other hand, runs approximately north and south, and only requires one zone time.

International time is based on the same observations made at Greenwich Observatory, in England, and is known as "Greenwich Mean Time" (G.M.T.). The meridian which passes through Greenwich is numbered, for convenience, "zero" (or O).

(Continued overleaf)

time was 10 hours ahead of G.M.T., would announce the time of the transmission to commence at "10.00 p.m. G.M.T. Tuesday." The American listener, knowing that his local time was five hours behind G.M.T. again (assuming that he lived on the east coast of North America), would realise immediately that the transmission would commence at 5 p.m. of the same day in his locality.

The International Time Chart, which is supplied as a supplement to this handbook, will enable the local time for all parts of the world to be quickly ascertained.

The use of a.m. and p.m. for an international time also causes a certain amount of confusion. G.M.T. is therefore indicated by four figures, of which the first two indicate the hour of the day, and the last two the minutes past the hour.

The hours of the day are numbered up to 24, beginning after midnight, similar to the system employed in several European countries. The hours from after midnight to midday are numbered from 1 to 12 (or 01 to 12), and from midday to midnight, from 13 to 24. The minutes are numbered from 1 to 60, as usual. Thus 25 minutes after 12 o'clock midday would be indicated as 12.25 (p.m. being unnecessary); 25 minutes past 1 p.m. becomes 13.25; 25 minutes after midnight is 00.25; and 1.25 a.m. is correctly written as 01.25 in G.M. time.

Choice of Suitable Equipment.

Having learnt something of the factors which control our best periods for the reception of international broadcasting stations — fading and static, wave-length allocations, and international time variations — we may turn our attention towards technical considerations in the design and operation of suitable receivers.

Of what must the receiver be capable? Reproducing signals at headphone strength or from a loudspeaker? Is it to be battery operated or "all electric"? If we wish to listen also to local broadcasting, are we to employ two receivers — or a converter to change the existing broadcast receiver into a modified super het. for shortwaves — an adapter, to plug into the audio stages of the existing receiver, and only employed to "tune" in the short-wave stations — or one receiver (an "all waves") to tune all the short-wave stations and the local broadcasters? And, finally, how many valves are to be employed for amplification?

Fortunately, all these questions are a matter of convenience, and can best be solved by the reader. Examples of suitable receivers covering all these considerations will be found within the following pages with enough constructional data to enable them to be put into successful operation.

From the writer's personal experience, the "all waver" has been found to be most convenient, giving a choice of programmes, etc., for entertainment, which on the score of economy, can not be bettered. Where an existing receiver is available the converter will give satisfaction for all electric receivers employing radio frequency amplifying stages.

Broadcasting immediately implies fidelity of reproduction, which is obtainable from a speaker of the dynamic or moving coil type. Nevertheless, for speech work, headphones are quite satisfactory, if one does not mind the inconvenience of wearing them.

Loud speaker reception necessitates a receiver of three or four stages of valve amplification, preferably consisting of at least one stage of radio frequency, power detector and one or two stages of audio with, in the last socket, either a pentode or power valve capable of de-

livering the necessary energy to operate the speaker.

A three valve combination of this description fills the bill admirably on loud signals and the addition of the fourth stage, without much extra cost, gives just that little extra which is desirable on the weaker stations.

For headphones, a receiver consisting of a detector, and pentode or two stages of audio has been found excellent by a number of regular contributors of The Listener In.

Short-wave superheterodyne receivers, with which are bracketed "converters," are very popular overseas, and in this type of receiver the number of valves employed may be as high as seven or nine.

The "straight" type of receiver, outlined in the foregoing, depends for its sensitivity on a regenerative detector which is the gateway for a certain amount of distortion, and other undesirable features, to creep in. They can be minimised, however, if the reaction is very carefully designed and adjusted.

The relative sensitivity of the super het, compared with the high powered "straight" receiver, will be found about equal, and the disadvantages of the latter are balanced by an increase in the parasitic noises, due to valves principally, brought about by the extra stages of amplification in the super het.

All electric operation, wherever available, is strongly recommended for the new receiver. Apart from the convenience of having no batteries to worry over, modern A.C. valves give an increased amplification many times greater than that of any of the older types.

Building an all electric short-wave receiver is no more difficult than a battery set. Indeed, with the exception of the power supply, the fundamentals of the two receivers are identical. A word of warning is necessary, however — never change the component values, or arrangement, unless the effect of the change is thoroughly understood.

"Chassis" construction in which all the components are mounted on a metal tray (usually of aluminium, copper, brass or other non-magnetic metal for short-wave work), with the smaller condensers, resistances, etc., below, is now standard practice for both all electric and battery receivers, and results in simplified "shielding," and consequential saving of space, short wiring, elimination of hand capacity, interlocking between r.f. stages, and a very workmanlike appearance and finish.

"Shielding," to confine the radio and other frequency fields within certain clearly defined paths, is a subject about which an enormous amount of detail could be written. In the receivers described, this and other considerations detailed have all received considerable attention and are presented in their final determination.

Briefly, the object of the metal shielding, which is more important than even on the ordinary broadcast receiver, is to isolate separate stages of radio frequency amplification in order that their respective fields (electro-magnetic strains in the surrounding ether) may not interact and cause uncontrollable self oscillation and general instability. A secondary effect is to prevent the coils and r.f. circuits from picking up stray interference from nearby high frequency generating apparatus.

Broadly speaking, each "stage" (consisting of coils, condensers, valves and coupling devices) should be contained within separate "boxes" with even the spindles of the condensers (if ganged),

"split" or isolated from each other, and the shielding effectively earthed.

Coils (and r.f. chokes, when possible) should not be placed closer to the metal walls than one half of their diameters. Power supply leads must be adequately "choked" and "by-passed" before leaving the compartment.

Individual receivers always require special consideration, and a certain amount of compromise, which is discussed in the proper place, is usually possible, and necessary, to accommodate the "layout."

"Wiring" requires very little mention, the necessity for short leads and rigidity being apparent on perusal of the constructional articles.

"Reaction," by which means the detector sensitivity is increased, being both the "heart" of the receiver and the most vulnerable part through which distortion and general instability may enter, requires more attention than any other portion.

Examples of the more popular systems — "resistance," "throttle" or condenser, and "screen grid" control — are to be found in the receivers described. It is not possible to specify, accurately, the number of turns necessary for each receiver, but the constructor should adjust the finished coils by:—1. Adding or removing turns, one or two (or even a half), at a time. 2. Separating, further, the reaction and grid coils on the "former." 3. Spacing out the last turn of the reaction coil. 4. Or, by a combination of all three methods until rotation of the control employed results in the detector valve going into or out of oscillation very gradually and almost imperceptibly, and absolutely without either a "plop," "squeal," or "howl."

This point is very important, both from the operator's viewpoint in ensuring quality reception, and that of nearby listeners.

A badly controlled reaction, on a set in which the detector valve is coupled immediately after the aerial, will definitely "radiate" energy therefrom and cause interference in nearby, and even distant, receivers tuned to approximately the same wave length. Since the popularity of short-wave reception reached such large proportions this nuisance has increased enormously, and is none the less annoying when one realises that, besides one's own and other people's reception being spoilt, the selfish operator himself is probably ignorant or careless of the devastation caused.

A simple but effective way of detecting whether the trouble is likely to arise from one's own receiver is to enlist the co-operation of a "neighbor," arranging to tune both receivers to the one station, and for the receiver being tested to vary the tuning at predetermined moments. The use of a stage of r.f. amplification, or a "coupling" valve, will eliminate the whole trouble.

And now we leave the reader to peruse the constructional articles and decide upon the type of equipment which will best suit the purpose.

The technical staff will be pleased to assist in unravelling "mysteries" and the current notes which appear weekly in the pages of The Listener In, together with the "List of Audible Stations" on page 32 of this booklet will enable the constructor to get the maximum of enjoyment and pleasure out of this new branch of broadcast entertainment.

THE A.C. SHORT WAVE TWO

THE object of this article is to explain to set builders some of the difficulties they are likely to encounter in short wave receiver construction, and to illustrate by practical example how a really good receiver may be built without undue trouble. All kinds of difficulties beset the path of the newcomer to short-wave radio. The short wave receiver, although tamed considerably during the last three or four years, is by no means the docile animal which non-technical writers would like us to believe.

Even a really good receiver requires a certain amount of skill to operate, and in the hands of an expert the mediocre short wave receiver can be made to give better results than the novice will get from a first-class set. Pages and pages have been written about short-wave receivers of various types, and in many cases the optimistic "blah" which has been hashed up has led unsuspecting newcomers into a field in which their inexperience absolutely prevents any possibility of success.

Before we come down to any practical details regarding the receiver, we are to describe it would be as well, in view of the foregoing remarks, to outline briefly the position of the modern short waver; to show what the newcomer to short waves can expect; and to put him wise to at least some of the things which spoil his chances of satisfactory reception.

Let us get this clear from the start. Short wave reception is not the cure all and end all of radio problems. The short waves are eminently suitable for communication under certain definite circumstances, but let these be departed from to any marked degree, and we have the proverbial celluloid dog's chance of hearing a distant station.

Such things as the hour of the day, the wave length employed at the transmitter, the type of aerial used, and the general electro-atmospheric conditions all exert tremendous influences on results.

Because a given station can be heard at loud speaker strength today it does not necessarily follow that it will come in at the same strength at the same time tomorrow. It may not be heard again for weeks. On the other hand, unskilful operation of the receiver may prevent reception of good strong stations, and of course in these circumstances the weak ones will not be heard either.

An All-Electric Short Wave Receiver which is easy to construct and operate

By A.K.

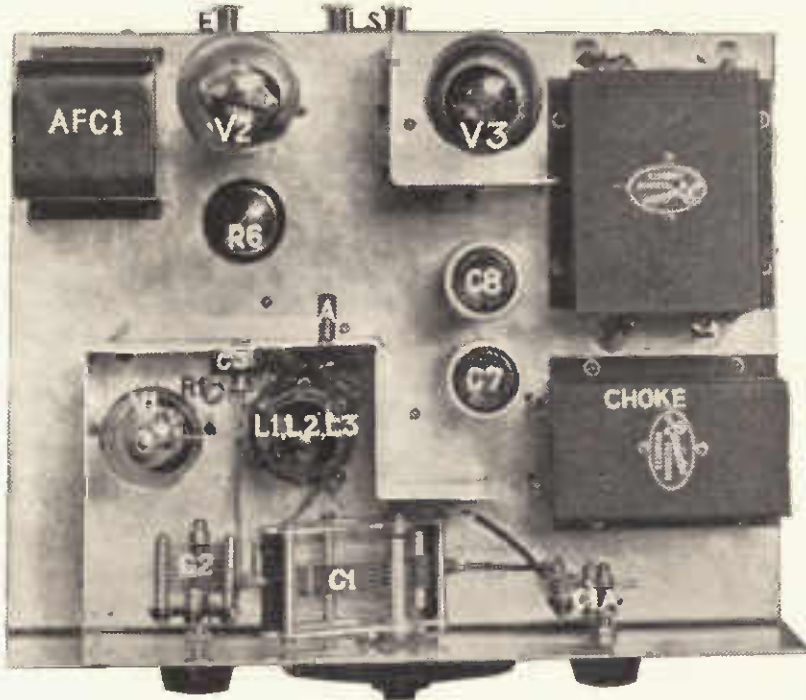

An idea of the layout of the components will be obtained from this photograph.

Details Which Spell Success

Point number two in this discussion of short wave reception is that the design of the receiver will influence results to a marked degree. Whether the receiver be a single valver or a multi stage r.f. job, it is essential that an exceptionally smooth reaction control be provided. The usual plop in—plop out type of reaction which serves its purpose on the average broadcast receiver will not do. We cannot tolerate any audible "bump" in the change from a non-regenerative to a regenerative condition in our short wave receiver.

This smooth control of reaction can be obtained only by experiment with the individual receiver. The spacing of the reaction coil from the grid coil, the number of turns on the former, the plate voltage on the detector valve, and the capacity and resistance of the grid condenser and leak all help in this matter, and between them all enable the experimenter to get the desired control of the detector valve.

Just as is the case with broadcast reception, we cannot expect to get first class results from an insensitive receiver. Unless we are prepared to employ a very sensitive detector and a high gain audio stage as has been done with the present receiver, it is imperative to precede the detector with a stage of radio frequency amplification. The idea of using an untuned r.f. stage ahead of the detector now appears definitely to be washed out. Why it ever achieved any prominence will always remain a mys-

tery because, as far as amplification of signals was concerned, the untuned valve was a passerger.

In passing it is interesting to note that as far back as four years ago technical writers in *The Listener* were advocating the use of tuned stages in the short wave receivers. The Americans started off with the untuned idea, but in the last twelve or eighteen months appeared to have scrapped it entirely in favor of the tuned stage.

As far as types of receivers are concerned, there is no doubt at all that the only real receiver for use in the reception of short wave broadcasting is the specially designed super-heterodyne. Unfortunately for the majority of us, this type of receiver costs a good deal to build. Furthermore, it is an extremely ticklish job for the average radio set builder, and in fact gives many experienced engineers headaches before it is "moting" properly.

Next to the super-het comes the one or two stages r.f. set with a regenerative detector and one or two audio stages. This type of set is ideal for the average short wave enthusiast because it gives an excellent overall amplification, is easy and reasonably cheap to build, and does not require any special skill to operate.

A word of warning at this stage. Do not attempt to build a two stage r.f. short waver if you have the idea of tuning each stage. Three fairly critical tuning dials and a reaction control are a little more than even the expert tuner can handle on short waves. If you decide to build a two stage job make the first stage aperiodic.

Next down the scale we come to the detector audio combination. Ordinarily speaking, this combination is not looked on with great favor by those who have had experience with it in the reception of short wave broadcasting. With the standard three element detector the sensitivity is not of the best and the two stage audio amplifier necessary to bring the signal level up to a reasonable point also has the unhappy knack of bringing up the noise level. However, the modern four element screen grid tube is noted for its sensitivity as a detector, and when combined with a single audio stage employing a pentode tube, is capable of exceptionally good results. The sensitivity is good, and because of the single lift audio system the noise level is not brought up disproportionately to the signal.

Converters and All Wavers

This summary of the different types of short wave receivers would not be complete without reference to two recent developments, the all wave receiver and the short wave converter.

The all wave receiver, as its name implies, is intended to cover both the broadcast and the short wave bands. Provided that the set is properly engineered, and not fitted up with a multitude of inefficient switching systems.

The short wave converter is a kind of adaptor which is intended to convert a broadcast receiver into a short wave super-het. The converter should not be confused with the adaptor which operates only into the audio stages of the set. The converter can be used only with receivers which have two or more tuned r.f. stages. These stages are set at a fixed point by means of the usual broadcast tuning controls and the converter then acts as the oscillator and first detector of a super-het, transforming the high frequency incoming signal into a lower radio frequency (equal to the frequency to which the broadcast set is tuned), which then is rectified and amplified in the usual way.

Having dealt as briefly as possible with the various types of short wave receivers, we now shall come to the equally important question of tuning them. Any properly built short wave receiver has

its tuning coils and condensers so proportioned that the stations are spread fairly widely over the dial. Even so the tuning can be sharper than the average broadcast set user will like.

It is worth while remembering that in any short wave receiver the greatest "spreading" of stations is obtained by the use of a given coil paralleled by a fixed condenser and tuned by a very small midget condenser. Short wave experimenters who are interested in amateur Morse code communication employ this system, but for the reception of short wave broadcasting over a wide range, say, from 15 to 100 metres, the scheme is impracticable, for, to be of any use, we would require about 20 coils for each tuned stage.

A far better system is to employ a reasonable capacity condenser, about 100 or 125 mfd (.0001 to .000125 mfd) and to parallel the detector tuning condenser with a three-plate double spaced midget. This little "note trimmer" condenser will give exceptionally smooth control of tuning, a fact which is of extreme value in the reception of a weak phone station when "zero beat" tuning has to be used.

Another important matter in the selection of parts for our short waver is that of the tuning dial. We do not require a very slow moving dial, for this will mean that it will take us too long to

cover the tuning range. What we do want, though, is a dial which is free from back-lash and which will not be electrically noisy in operation.

Although they are very difficult to obtain, the best type of dial is one in which the primary drive is of metal and the secondary drive of some non-metallic substance. If this type of dial cannot be obtained, the next best thing to do is to get a metal to metal drive type, and if any noise should develop to put a spot of oil on the drive.

The same thing applies with tuning condensers. Some condensers, notably those with pig-tail connections, are noisy in operation. Avoid the pig-tail type condenser and keep to one which has good solid bearings. Any electro-metallic noise in these bearings can also be overcome by the use of a little oil. As to the remainder of the components the guiding rule in their selection is to purchase only the best obtainable. Do not go in for shock absorber sockets, but buy those which give a firm, positive contact to the valve legs.

Value of Electrolytic Condensers

When building a.c. short wavers it is as well to use only the electrolytic type of filter condensers. Paper condensers may be satisfactory in some cases, but the rectifying action peculiar to the electrolytic type of condenser gives them

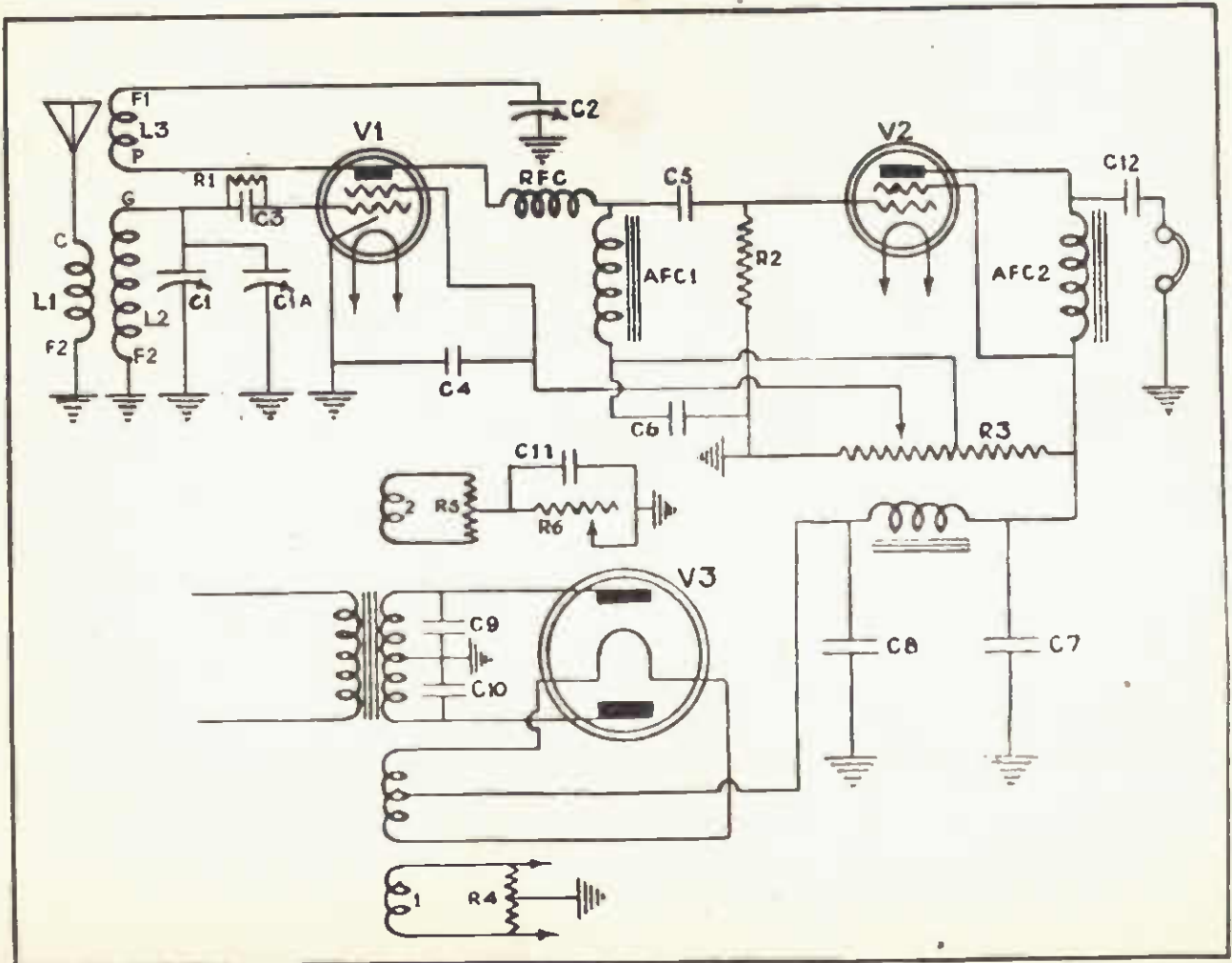

Schematical diagram of the Short Wave Two.

an undoubted advantage in the s.w. set's filter system. Another point which does not appear to have been given much attention even by expert short wave set builders is the desirability of avoiding aluminium shielding when it is to be brought in contact with brass.

Some sort of electrolytic action sets up between these metals, with the result that the set always has a noisy background, even when not connected to the aerial. It is best to stick to copper or brass shielding, although shields made of these metals cost more than the commonly used aluminium shields. In any case, remember to use fairly substantial metal sheet for the shields, nothing less than 18 to 20 gauge is of much use in eliminating unwanted r.f. transfer.

Really we could go on almost indefinitely dealing with the do's and don't's of short wave receiver design and operation, but space does not permit us enlarging upon the subject now.

Technical High Lights

Technical high lights of the receiver we propose to describe can be summed up fairly briefly. The receiver is a standard detector audio combination, but the use of a screen grid detector and a high gain American pentode lifts the set above the ordinary level of two-valve short wave receivers.

The screen grid detector is coupled to the pentode by means of a high impedance choke, AFC1, which permits us to get the maximum signal amplification from the high impedance tube. The combination of this choke, a coupling condenser, C5, and a fixed resistance, R2, forms an impedance coupling unit which, whilst giving excellent signal amplification, possesses the advantage of providing excellent tone quality.

The pentode is coupled to the headphones by means of an output filter made up on a second high impedance choke (although not as high impedance as the first), AFC2, and a 2 mfd. condenser, C12. This allows us to connect the headphones in the plate circuit of V2 without any possibility of obtaining a dangerous shock. The whole receiver is carefully by-passed with condensers which are used to obtain stability and tone quality.

A further safeguard against hum troubles is the provision of separate filament windings for the detector and audio valve filaments.

Take a glance at the pictures of the finished set while we describe some of the constructional details. The whole receiver is built on a metal chassis, measuring 15 inches in length, 10 inches in width and 2 inches in depth. The front panel measures 15 inches by 8 inches. A dividing shield encloses the coil, detector valve, main tuning condenser and reaction condenser. The grid leak and grid condenser also are mounted on the side of this shield while an

insulating strip in the side carries the aerial terminal A.

A second metal shield surrounds the rectifier valve (V3), and prevents any modulation hum from getting into the audio stage. The power pack, filter choke and the two electrolytic filter condensers, are mounted at the right hand end of the chassis, while the audio valve (V2), the audio coupling choke (AFC1), and the bias resistor control (R6) are mounted at the left hand end.

Note that in the original receiver the output choke (AFC2) and the filter condenser (C12) have not been mounted. The original receiver was an experimental one, and the loud speaker output was taken to a special step down transformer. The correct place to mount the choke is between AFC1 and the front panel, while C12 can conveniently be mounted underneath the chassis in the left hand front corner.

The front panel carries three controls. From left to right they are the 23 plate

which are to take the bolts to secure it to the chassis. Further holes will need to be drilled for the two dividing screens.

When these holes have been drilled and the various components mounted on chassis and front panel, turn to the mounting of the condensers, resistors and terminals underneath the chassis. Note that inside the detector valve compartment the UY socket used for the plug-in tuning coils is kept from the metal chassis by means of two insulating extension pieces.

Point to Point Wiring

When the assembly of the receiver has been finished, start the wiring of the set by connecting the aerial terminal to the C terminal on the coil socket, and the F2 terminal on this socket to earth. The G terminal on the socket is wired to the fixed plate terminals on C1 and C1a, and to one terminal on the grid leak and grid condenser. The remaining terminals on these last components are joined together and connected to the top (grid) connection on the screen grid valve. (Note that this set employs American type 2.5 valves, so that the grid terminal for V1 is the metal "pip" on the top of the tube.)

The fixed plate terminal on the reaction condenser (C2) is connected to the F1 terminal on the coil socket. This completes the top panel wiring, and all our other wiring will be carried out underneath the chassis.

The next job is to run a lead from the P terminal on the socket of V1 to the P terminal on the coil socket, and to one terminal on the radio frequency choke (RFC). The other terminal on this choke is wired to one of the leads on the coupling choke (AFC1) and to one terminal on the .006 mfd. fixed condenser (C5). The other terminal on this condenser is connected to one terminal on the mount for the resistor (R2), and to the G terminal on the socket of V2. The P terminal on this socket is connected to one terminal on the output choke (AFC2), and to one terminal on the condenser (C12).

The remaining terminal on C12 is connected to the insulated loud speaker terminal.

Now for a few earth connections. Connect the C terminal on V1, one lead on the 2mfd. condenser (C4), one terminal on the 2 mfd. condenser (C6), one terminal on the 4 mfd. condenser (C11), one end of the voltage divider (R3), the vacant terminal on the mount for R2, and the arm terminal on the variable bias resistor (R6) to earth.

The vacant terminal on AFC2 is wired to the free end of the voltage divider, to the positive terminal on the 8 mfd. electrolytic condenser C7, and to one terminal on the filter choke. About 1½ inches from the positive end of the divider R3 a lead is taken to the C

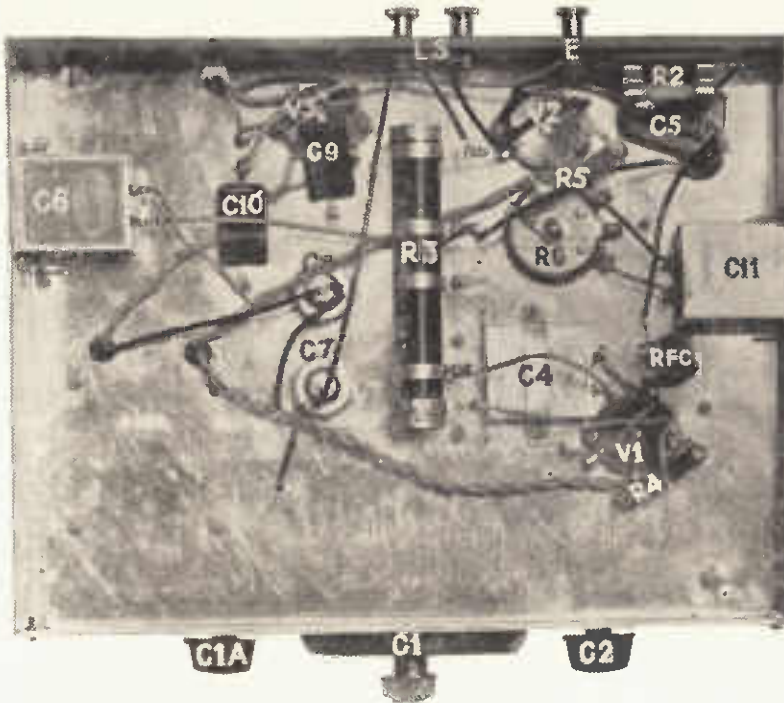

Showing the underneath wiring and components.

midget reaction condenser (C2), the main .00015 mfd. tuning condenser (C1), and the three plate "note splitter" condenser (C1a). Along the back edge of the chassis are the two loud speaker terminals and the earth terminals. One of the former is insulated from the chassis, whilst the remaining two are connected direct to it. Underneath the chassis are mounted the various filter and by-pass condensers, the voltage divider, the bias and centre tap resistors, and the grid coupling resistor. Practically all the wiring is carried out underneath the chassis.

When the various components, as set out in the list, have been obtained, the construction of the set should be started by drilling the chassis to take the sockets for the three tubes, the electrolytic condensers, the bias resistor, and the filter, outlet and coupling chokes, and the power transformer. The front panel should be drilled for the three variable condensers, and for the holes

terminal on the socket of V2. About half an inch from this tap on the divider a second tap carries a lead to the vacant terminal on C6 and the free lead on AFC1. Half an inch from the negative end of the divider a clip carries a lead going to the vacant terminal on C4 and the G terminal on the socket of V1.

This completes all except the power pack wiring of the receiver.

Start wiring the power pack by connecting one of the 350 volt secondary (outside) leads to the G terminal on V3 and to one lug on the .01 mfd. condenser C9. The other outside high voltage lead connects to the P terminal on V3 and to one lug on the second .01 mfd. condenser C10. The centre tap on this winding is connected to the vacant lug on C9 and C10 and to earth. One of the outside leads on the five volt filament winding is connected to one F terminal on the socket of V1, whilst the other outside filament lead is wired to the remaining terminal on this socket.

The centre tap on this winding is connected to the positive terminal on the electrolytic condenser C8 and to the vacant terminal on the filter choke. One of the 2.5 volt filament windings which we shall call No. 1, is connected to the filament terminals on the socket of V1. Across these terminals is connected the extremities of a 20 ohm filament centre tap. The centre connection of this tap (R4) is wired to earth.

The second 2.5 volt filament winding (No. 2) is connected to the F terminals on V2. Across its terminals is connected a second filament centre tap R5. The centre connection of this resistor is wired to the vacant terminal on the 4 mfd. condenser C11 and to the remaining terminal on the variable bias resistor R3. When once the primary of the power transformer has been connected to the line we have completed the building of the receiver except for the winding of the various coils which now will be dealt with.

Coil Details

In order to cover the wave band between 20 and 100 metres we shall need three sets of coils. To go beyond 20 metres an additional coil will be needed, but because it is rather difficult to get the screen grid detector to oscillate easily below this wave length we have not included coil data. The coils are wound on the Pilot type of short wave coil former. These are made by an Australian concern now, and can be obtained from any big radio dealer at a reasonable price.

The coil formers are provided with five pins and are intended to plug into a UY socket. Note in the diagram of the former and its base that the filament terminals have been lettered F1 and F2 so that we shall have no difficulty in following the connection of the windings to the pins.

All windings consist of 28 gauge d.s.c. wire, and in the case of the wave lengths below 60 metres it is possible to space wind the grid coil, L2, and thus further improve the efficiency of the coil.

Following are details of the windings:

Turns.	L1	L2	L3	Wave Range
7	23	9		100 to 60 metres
10	13	8		31 to 62 metres
12	7	6		20 to 34 metres

Details of the windings can be seen from the diagrams of the coil former and the plug in base.

Further information is:—L1 is started at the top of the former, the top end of the winding connecting to the F2 pin on the former (earth). The end of the

The Parts You Will Need

- 1 Metal Chassis, Panel, and Dividing Screens.
- 2 UY Sub-Panel Sockets for V1 and V2.
- 1 UX Sub-Panel Socket for V3.
- 1 UY Baseboard Socket.
- 1 .00015 mfd. Variable Condenser (C.1).
- 1 Three plate Midget Condenser (C1a).
- 1 23 Plate Midget Condenser (C2).
- 2 8 mfd. Electrolytic Condensers (C7, C8).
- 1 4 mfd. Paper Condenser (C11).
- 3 2 mfd. Condensers (C4, C6, C12).
- 1 5 meg. Grid Leak (R1).
- 1 .0001 mfd. Fixed Condenser (C3).
- 2 .01 mfd. Fixed Condensers (C9, C10).
- 1 .006 mfd. Fixed Condenser (C5).
- 3 Pilot type Short Wave Coil Formers.
- 1 UY 224 Valve (V1).
- 1 UY 247 Valve (V2).
- 1 UX 280 Valve (V3).
- 2 20 Ohm Centre Tap Resistors (R4, R5).
- 1 500 Ohm Bias Resistor (R6).
- 1 Filter Choke (30 Henries).
- 1 High Impedance Coupling Choke (AFC1).
- 1 Medium Impedance Output Choke (AFC2).
- 1 5 meg Grid Leak and Mount (R2).
- 1 Radio Frequency Choke (RFC).
- 1 12,000 Ohm Voltage Divider (R3).
- 4 Terminals.
- 1 Power Transformer, having one 350-0-350 volt, one 5 volt, and two .5 volt windings.

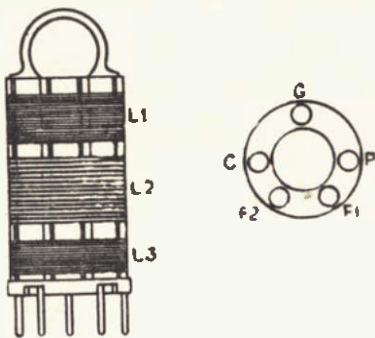

A diagram of the coil and socket.

winding nearest to L2 is connected to the C (aerial) pin. The top end of L2, nearest to L1, is the grid end of the winding and goes to the G pin on the former. The other end of L2 goes to the F2 pin (earth).

The top end of the reaction winding (L3) is connected to the F1 pin on the former, whilst the bottom end (nearest the base of the former) is connected to the P pin on the socket.

Note that the values of these windings will vary slightly with different valves, plate potentials, and tuning condensers so that the experimenter probably will need to readjust the number of turns on L2 and L3 to suit his particular conditions.

Note that no specific dimensions are given for the two screens because the sizes of these will need to be adjusted to suit constructional details. Each of them, however, should be 5½ inches high.

Tests and Adjustments

This completes the construction of the receiver, and all is ready for the initial tests. Be prepared to spend some little time making the set function, for any work put in at this juncture will be well repaid when we settle down to the business of tuning in overseas broadcasters.

Plug in the three valves in their sockets, attach the aerial and phones, and turn on the a.c. After a few seconds when the set has warmed up we can gain some idea of how things are "perk-ing." For this initial test it will be as well to use the middle coil (31 to 62 metres) because on this wave band most of the traffic will be heard.

Don't expect to hear an overseas broadcaster the first time you try the set, but busy yourself adjusting the reaction so that the set can be brought in and out of oscillation with the gentlest of "swishes." This desirable state of affairs can be obtained by the correct adjustment of screen and plate potentials on the detector valve, by the use of a suitable value grid leak, and by altering the number of turns on L3 and its separation from L2. Even when this has been fixed up properly it will be necessary to tune very slowly if you are to hear the weaker phone stations.

To search for a broadcasting station throw the set into weak oscillation by means of the reaction condenser C2 and tune around the dial until you strike the continuous whistle which indicates a steadily radiating transmitter. At this point bring the set out of oscillation by reducing the capacity of C2 and then re-adjust the main tuning by means of the "note splitter" condenser C1a.

If you have hooked a phone station the transmission should then be heard, but if it is only one of the straight commercial transmitters which send out an r.f. signal for test purposes it will be necessary to try again. The best test as to the receiver's efficiency, for the newcomer at least, is the number of Morse stations which can be heard. If you can tune in code transmitters nearly all round the dial when the middle coil is being used you can be sure that the set is working properly and that it will need only a little patience and a study of "Short Wave's" first class information of short wave station schedules to ensure success.



A Time Conversion Table

A necessity for short-wave users.

INTERNATIONAL broadcasting stations working on the short waves have for the most part adopted the principle of announcing test and schedule times in Greenwich mean time to obviate confusion and simplify conversion by foreign listeners into local time.

The possession by short wave enthusiasts of a time conversion table thus becomes a necessity. Conversion tables can be arranged in a number of different ways, and it is thought that the one reproduced will prove of particular use because on it are marked most of the stations heard regularly in Australia.

Every 15 degrees of longitude corresponds to one hour time difference, and local standard time for any particular district is usually reckoned to the nearest meridian of longitude. The "zero" meridian passes through Greenwich (England) Observatory, longitude being measured east or west from this point.

Greenwich mean time (G.M.T.) is usually expressed in four figures, the first two representing hours and the last two minutes after the hour. For convenience the hours of the day are numbered from 1 to 24 (midnight to midnight). Numbers 1 to 12 represent a.m. and 13 to 24 (or 0) p.m. Thus 00.01 would be one minute after midnight, 12.01 one minute after noon, 18.45, 6.45 p.m.

"MY OWN" ALL-WAVE A.C.

RECEIVER

An all-electric receiver which is the "last word" in short-wave design, which will tune all broadcast bands, and which may be duplicated by any experienced constructor

By "SHORT-WAVE"

THE all-wave receiver has been proved the most economical broadcast receiver if one is desirous of listening to the local stations in addition to overseas broadcasts when available. It obviates the necessity of a converter or an adaptor, and some means of coupling them which, in practice, is not found very convenient.

In early examples the short-wave receiver was "made to do" for broadcast reception by means of suitable coils which, with the small tuning condensers necessary for short-wave work, means at least two pairs to cover the broadcast band of 200-500 metres—obviously a nuisance—and which lacked selectivity.

In this receiver the problem has been solved by special condensers and an ingenious system of switching, which is entirely automatic, whenever a suitable coil is plugged in.

Sallent Features

Tuning of the local broadcasters is exactly the same as for normal receivers, and is effected by means of .0005 mfd. condensers (CX), and coils (L1, L3, etc.), which are plugged into the same sockets as the short-wave coils. These, however, are tuned by smaller condensers of .0001 mfd., approximately, the maximum capacity which can satisfactorily be used for short waves.

The condensers will be described in detail later.

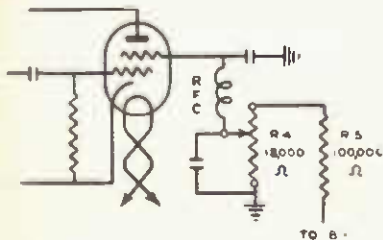

Fig. 2.—Indicating the screen grid resistance control.

The receiver will tune from 16-100 metres, and from 185-500 metres, and is built upon a chassis, thus facilitating the layout and shielding of components.

A glance at the diagram (which is identical for both bands) will show that the receiver consists of a tuned radio frequency stage of amplification, loose coupled (for selectivity) to a screen grid detector valve, to which regeneration is, however, applied on the short waves only.

Audio frequency energy for the demodulated signal is applied by means of resistance coupling to the first audio, which, in turn, is transformer-coupled to a power valve of the E406 type, feeding a dynamic or moving coil speaker.

Reaction control is effected by a new variation of "screen grid" control, in which the voltage applied to the screening grid is variable within narrow limits. The system consists essentially of a potentiometer network from which the variable voltage may be picked off.

In previous examples of this method (which is excellent), difficulty was experienced in getting the necessary fine control, because, as the rotating arm of an

average potentiometer can only move through a complete circle (360 degrees), the small variations of voltage (about 15 to 30) required to bring the valve in and out of oscillation were cramped into about 5 degrees.

In this variation the major voltage drop (approximately 170 volts) is taken up by a 100,000 ohms fixed resistor (R5) and the variable member (R4), therefore,

List of Components.	No. Required.
Condensers—	
CX.—See letterpress	2
C1 and C2.—See letterpress	2
C4 .01 ("M" type)	5
C5 .0002 ("M" type)	1
C6 .0001 ("M" type)	1
C11 .006 ("M" type)	1
C7 2 mfd. (1500 v.d.c.)	8
C8 8 mfd. Electrolytic 435 p.v.	2
C9 4 mfd. (1500 v.d.c.)	1
C10 1/1 (1500 v.a.c.)	1
Resistances—	
R1 350 ohms or 400 ohms L.D.	1
R2 1000 ohms, light duty	1
R3 500 ohms (50 mlls.)	1
R4 Special (See letterpress)	1
R5 1 meg. Carborundum	2
R6 Voltage Divider (see letterpress)	—
R8 30 ohm centre tapped	2
R9 .5 meg volume control	1
R10 2 meg. leak (pigtail type)	1
R11 10,000 ohm Carborundum	1
Miscellaneous—	
Audio Transformer	1
30 Henry Choke, 80 mlls.	2
Power Transformer, 275 275 v. at 120 mlls.; 4 v.-3 amps., 4 v.-2 amps., 5 v.-2 amps.	1
Dynamic Speaker, 7500 ohm Field	1
Back Panel Dial and Pilot Light	1
R.F. Chokes	4
Valve Sockets, UY (manufacturer's type)	5
Valve Sockets, UX (Manufacturer's type)	3
Coil Shields (1/2 x 3)	2
Valve Shield	1
Valves—	
R.F. (S4Vb type)	1
Det. (E442 type)	1
Audio. (E415 type)	1
Output. (E406 type)	1
Rect. (280 type)	1

has a voltage drop of only approximately 50 to 60 volts. The reaction control is thus "opened out" considerably, enabling very fine, smooth, and stable control to be obtained.

This method of a fixed and variable resistor in series has been found to be more effective (because of the "decoupling" and "choking" action) than the alternative of tapping the variable resistance across the voltage divider. Suitable resistors will be described later.

It will be noticed that the tuning condensers are "ganged" for simplicity of control, and that each is paralleled by a midget condenser ("trimmer") (C1, C2), consisting of three plates for the aerial and two plates for the detector stage. The object of these small balancing condensers is to enable fine tuning to be accomplished, and, in the case of the aerial stage, to compensate for variations in the "tracking" of ganged condensers due to the load imposed by the aerial itself. This is standard practice in broadcast receivers and is easily adjusted.

This accounts for three of the control knobs shown in the photograph. The others are: On the right, a volume control (R9), and on the left, the reaction control (R4). The switch shown between them is to enable the high tension to be switched off for safety whilst changing coils.

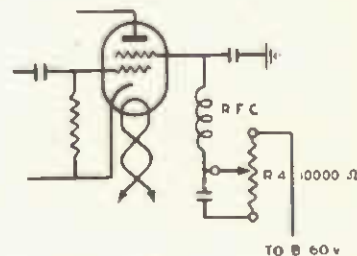
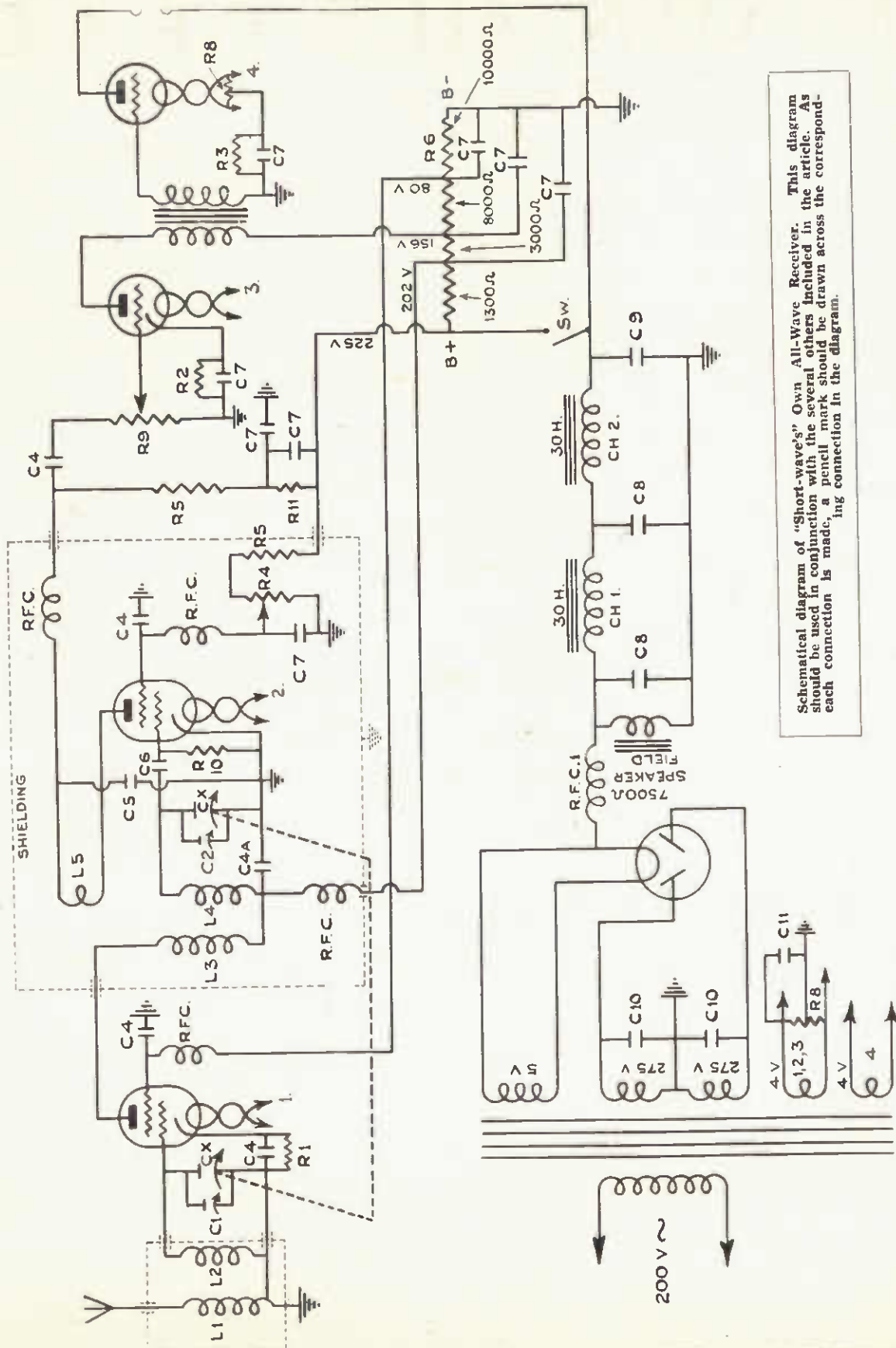

Fig. 3.—An alternative method if suitable units are not obtainable.

The interesting wiring of this switch, indicated in the schematic diagram, has been devised to keep a heavy load on the pack (via the output valve, no live parts of which are exposed above the chassis), to protect the smoothing condensers (C8&9) against overload. The switch, therefore, only has to break a small current of from 15 to 20 milliamps at about 225 volts, and all exposed parts above the chassis are rendered "safe."

The remaining components indicated on the schematic diagram which need mention are as follows:—The condensers marked C4 are simply R.F. by-pass units, with the exception of the plate coupling condenser between R5 and R9, but are all of the same value (.01 mfd.) and similar type—bakelite moulded.

Condensers C7 are smoothing or audio frequency by-passes, of 2 mfd. capacity. That one shown across R11 is important, as without it the receiver will "motorboat" badly and fringe howl becomes apparent even before the valve approaches the regenerative point. The



Schematic diagram of "Short-wave's" Own All-Wave Receiver. This diagram should be used in conjunction with the several others included in the article. As each connection is made, a pencil mark should be drawn across the corresponding connection in the diagram.

condenser (C7), shown across the variable portion of the reaction control (R4) keeps the unit silent when the contact is rotated.

Resistances R1, R2 and R3 are bias resistors, and the latter must be capable of passing 50 mils without heating unduly (5 watt type for preference). R5 is the plate coupling resistance from the detector valve to the first audio unit.

R11, with its associated condenser, C7, is an audio feedback, decoupling unit, and plays an important part in attaining the excellent smooth and silent operation which is such a pleasant feature of the receiver. The remainder of the components, which have not been mentioned are standard, and their function is apparent from their position on the schematic diagram.

Shielding

Effective shielding has been incorporated, thus materially increasing the efficiency and enabling a very compact and economical layout to be adopted.

The tuning condensers are shielded from each other by an aluminium partition six inches square, mounted on the chassis between them, and through which the rotating shafts pass. As part of the shielding system, both shafts are "broken" with standard gang couplers. This is necessary on short waves and

adds greater flexibility to the controls, than would be the case if solid shafting were used.

Each coil is enclosed in a shield can, and is plainly visible on the photo-

velope when using European type valves.

Reference to the underneath side of the chassis will disclose a compartment, on the right-hand front corner, built from a strip of aluminium and bolted to the side walls. In fitting, the edge of this strip (and any other long edge which is not bolted securely to the chassis) should be kept about 1-8th of an inch off the floor of the chassis to prevent intermittent contacts and "chattering," or mechanical vibration by the loud speaker, on loud passages of music.

Within this compartment, the whole of the components associated with the detector valve are mounted and thus shielded from the rest of the apparatus. The shielding outlined conforms to the specifications mentioned earlier in this booklet, and is so effective that there is no trace whatever of "locking" between the R.F. and det. controls; and the selectivity and sharpness of tuning is improved substantially over previous models.

The only other feature which needs mention at this stage is the power pack consisting of transformer, chokes and filter condensers (C8 and C9) which are contained within the metal box (aluminium, or mild steel for preference—because of its magnetic shielding—although the former is quite satisfactory) as a "protective" cover. No hum trouble

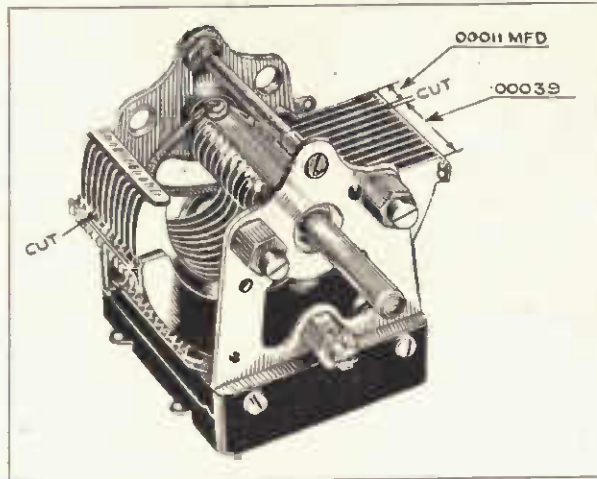
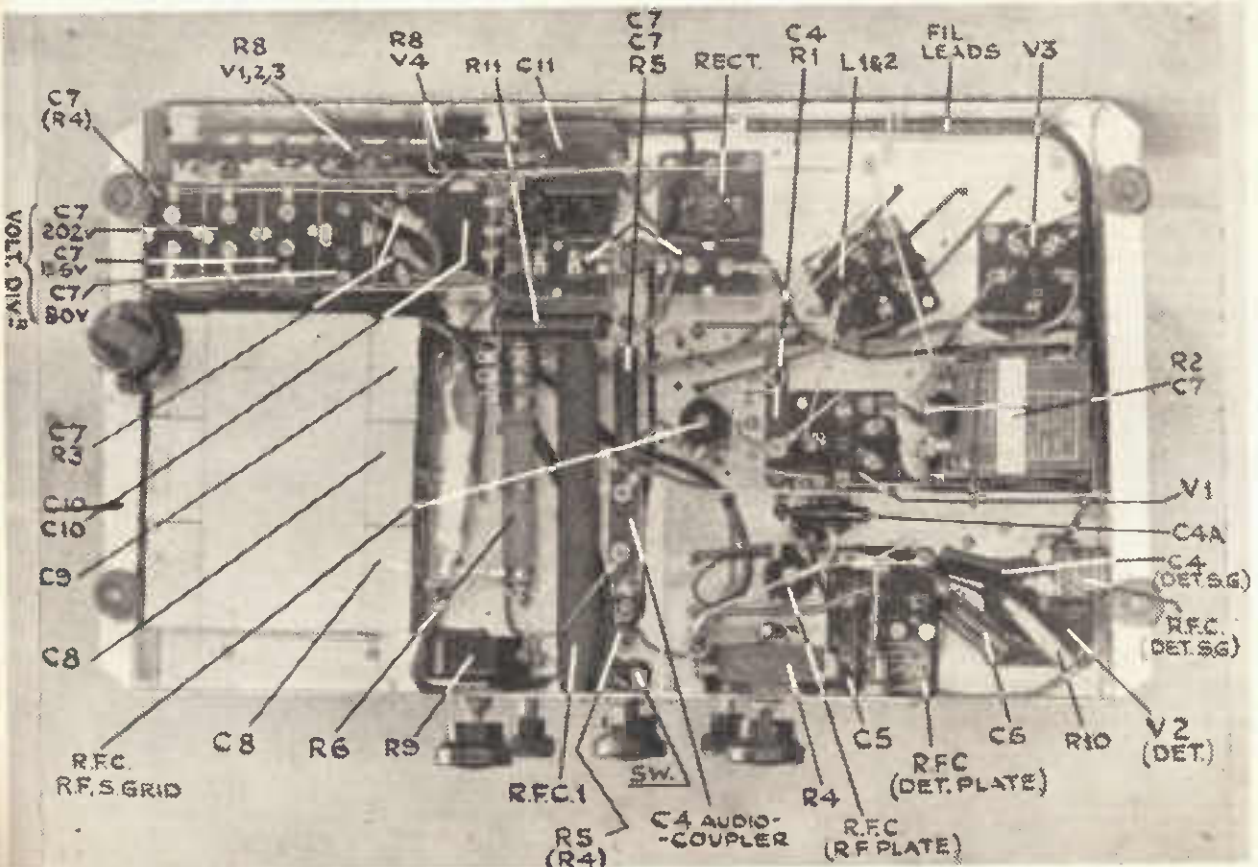
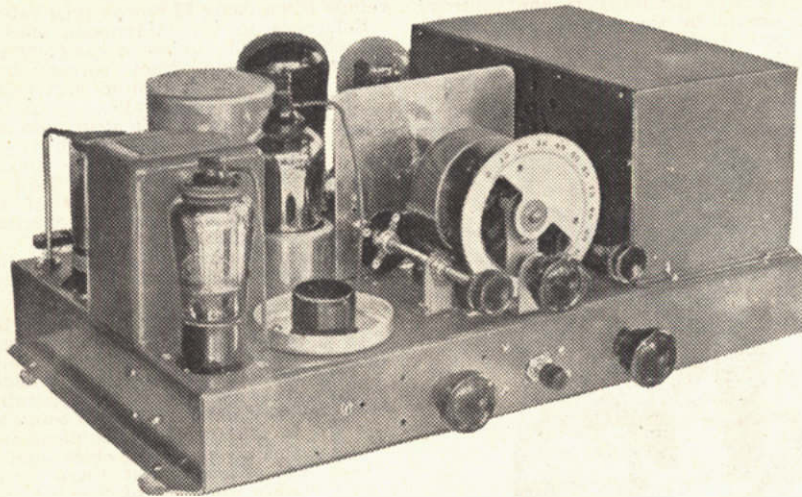

Fig. 4.—Condenser showing separation of fixed plates.

graphs. The R.F. valve (V2) has its grid end shielded from the plate end by an ordinary valve "can" cut down to fit, with the top level with the internal shielding within the glass envelope. This is much more effective than placing a shield over the whole of the valve en-



The above photograph shows how the receiver will look when finished. The components are lettered to correspond with the letterpress.



Front view of the finished chassis.

of any description was experienced in the construction of the receiver.

The electrolytic filter condensers (C3) can be mounted, with advantage, outside of this compartment for cooler operation and appearance. Electrolytic condensers, which are quite satisfactory, however, were not used actually, because the condensers illustrated (which are expensive) were on hand. Electrolytic condensers are cheaper and more economical of space and weight, have better voltage regulation, are self healing after breakdown due to overload, etc., and have many superlative features.

A UX valve socket (not illustrated) can be mounted on the back wall of the chassis to accommodate the speaker leads to which a suitable connector is sometimes fitted by local manufacturers. If not, a burnt-out valve base can be used. The thick pins are connected to the field coil and the thin pins to the voice coil.

The arrangement and mounting of the smaller components are illustrated in the photographs.

Constructional Details

It will be as well first to prepare the components which require workshop attention.

The tuning condensers are of special design. In this model they consisted of Emuco "Stratelyne" condensers of .0005 mfd. capacity in which the stators (fixed plates) have been split into two sections (fig. 4), resulting in a maximum capacity of about .0001 mfd. for the smaller section (used on the short-wave bands) and about .0004 mfd. for the larger section, which, linked together, make up the full capacity for tuning the local broadcasters.

An examination of the condensers will show that the fixed plates are in one piece, secured by means on four bolts through the bakelite base and that on removing these, the plates can be taken out. Four metal strips are soldered to the edges of the plates to keep them accurately spaced and solid, and it is only necessary to cut through each between the third and fourth plates from the back, with a fine hacksaw or jeweler's saw to complete the severance.

In remounting, fit additional solder lugs under each bolt for making connections and secure with ordinary hexagon nuts, taking care to see that the spacing of the fixed and movable plates is right. The whole operation is so simple, and is quite efficient for short-wave tuning, that it should not take

more than 30 minutes. The proximity of the larger section, which is "dead" when not in circuit, does not affect the tuning range or operation materially. The moving plates (which are "grounded" by means of the wiring) are not altered in any way.



Remove shaded portion of fixed plate.

If the constructor does not feel confident enough to carry out the "cutting" operation, any operative jeweller will undertake the job at a very small cost. Failing this also, an alternative is offered, but it is doubtful whether anything easier can be suggested.

The alternative is to use two separate condensers, consisting of one of .00035

mfd., and the other of .00015 mfd. in each stage, in the some connections, but great difficulty will be experienced if any attempt is made to gang the whole four of them in "line." If this method is used, it will be better to dispense with the single dial control and tune each stage separately.

The two balancing condensers are fitted as close as possible to the tuning condensers which they serve, to reduce the wiring (a very necessary precaution on short wave). The three plate midget (C1) is mounted directly on the shield panel between the two condensers, and an extension rod of 1/4 inch brass tube or rod coupled by means of the standard "gang" coupler, so that it may be operated from the front panel of the cabinet.

The forward end of the extension rod needs supporting, which is effected by means of a bushing and bracket mounted at the end of the chassis. The bracket and bushing portion of an old "jack" or the bushing from an old rheostat, etc., is ideal for the purpose.

The two plate midget condenser, C2 (trimmer) across the detector stage (on the right of the tuning dial) is simply supported by an aluminium bracket close to the edge of the panel.

Midget condensers, unfortunately, have semi-circular plates, which cause the balancing action to be congested if it falls at the minimum end, in the same way as semi-circular plates, in a variable condenser, affect the tuning. If the constructor is at all fastidious, the fixed plates can be dismantled and the shape modified (this was actually done for this receiver) as shown in Fig. 5, which may be used as a template. If this is done it will be an advantage to increase the size of C1 to 5 plates, to compensate for the reduced capacity maximum.

The modification results in "straight line tuning," and it is such a simple modification that it is a wonder such condensers are not available on the local market. The cutting will, however, prove difficult without the necessary tools, and is only a refinement which may be dispensed with if necessary.

The variable resistance (R4) for reaction control must be wire-wound for stability, and any sturdy potentiometer

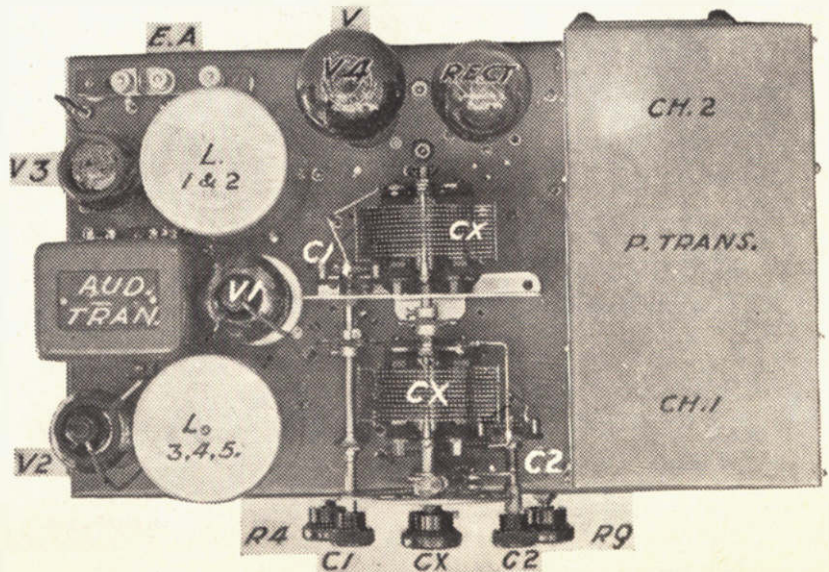

A top view showing the layout required.

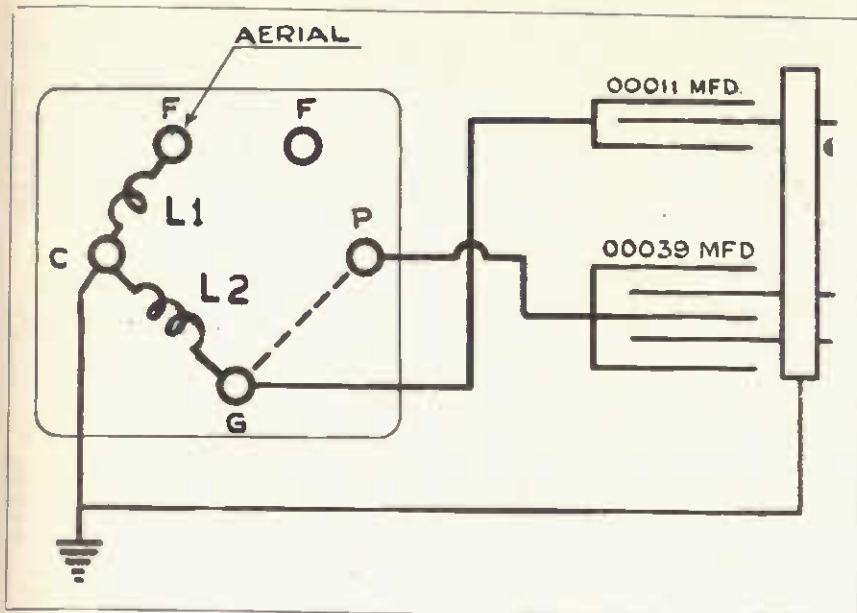

Fig. 6.—The R.F. coil connections looking at the bottom of the valve base pins.

of 18,000 or 20,000 ohms. is suitable. If any difficulty is experienced in procuring suitable values, an old potentiometer can usually be rewound at a cost of a few shillings. Many of the old rheostats of the better type, which were used on battery receivers, are suitable for re-winding, and conversion to potentiometers, provided the strip is large enough to accommodate the wire (about 5 inches by 5-8ths by 1-16th). The efficiency of this new control is such as to warrant any extra trouble.

The unit actually employed in this receiver was a broken-down "Chanex" 100,000 ohm wire-wound job, which was rewound for the writer, and, because of the mechanical features of this particular unit (the movable arm does not engage directly with the resistance wire) is eminently suitable.

The alternative method of tapping off the screen grid control (in case of difficulty in procuring a value of 18,000 to 20,000 ohms) is indicated in diagram Fig. 3. It consists of a 10,000 ohm potentiometer of which there are several varieties available, tapped on the voltage divider at 60V., but will upset the voltages of the other taps across the same divider.

Still another alternative is suggested (devised to make the duplication of this receiver possible under almost any conditions), where no suitable voltmeter is available to the constructor for determining the correct voltage points. It is suggested to substitute a 10,000 ohm potentiometer for R4 and a 50,000 ohm, 5-watt carbon resistor for R5. Both alternatives indicated will increase the drain on the power pack slightly (not a very serious consideration), but the potentiometer network should be such that the temperature does not rise appreciably, otherwise it will tend to make the control unstable.

Coil Mounting

Interest will have been aroused by this time in the method of selecting the right condenser combination whenever a coil is plugged in. The coils, including those for the broadcast band, are wound on five pin formers or valve bases which are plugged into UY sockets. The connections are shown in Figs. 6 and 7.

These are illustrated as when looking at the bottoms of the pins of the formers and, as the coil sockets are all wired from the underneath side of the chassis, this will facilitate the wiring connections without having to turn the diagram upside down. The lettering of the pins corresponds with the standard "Filament," "Plate," "Grid," and "Cathode" connections, when viewed from the same angle. The dotted line indicates a "jumper" wire, which is fitted only to the broadcast coils and therefore switches in the larger sections of the condensers whenever these coils are plugged in. On Fig. 7 the second "jumper" between "C" and "F" takes the place of the reaction coil.

It will be noticed that the detector coil former and socket needs a sixth connection fitted. The valve base former, for the broadcast coil only, is fitted with an extra valve pin, tapped or screwed into the centre, and the socket (manufacturers' type) already has an "eyelet" in place, rivetting a spacing washer (to keep the contacts in position), which only needs a length of wire soldered to it

on the underneath side for making the connection.

Care should be taken to see that the pin and eyelet make good contact, and that the connecting wire does not short-circuit any of the other contacts in the restricted space.

The Chassis

Having completed the preparation of the components, the chassis may be prepared. It is of 16 gauge aluminium, and in this model consists of a "tray" 16 inches long, 9½ inches wide and 2½ inches deep. If cabinet space permits, a couple of inches added to the length will be an advantage.

The bending and the cutting of the round holes (1½ inches diameter) for the valve sockets (5UY and 3UX manufacturers' type) was done in the workshop with simple home-made tools, but unless one is used to working this sort of metal it will prove cheaper to have the work done by one of the firms who specialise in this work.

The corners of the chassis where the side edges meet should be "eased in" slightly so that they do not chatter or set up intermittent or noisy contacts; or may be strengthened with corner pieces cut from "motor car footboard angle strip" securely bolted in place.

Lay out the components, which are mounted on the upper side of the chassis, on a sheet of paper, and accurately mark the position each component will occupy, including that of the speaker socket at the back, before attempting to cut out the holes.

The power-pack cover, which can be purchased ready built if desired, should also be fixed temporarily in place, and the whole given several coats of "Duco" finish.

The components may now be mounted on the chassis, completing the upper side before commencing the lower. The reaction and volume controls require insulated bushings to prevent short circuit, and comfortable sized holes should be drilled where any wiring has to pass through the chassis.

The variable condensers with the dial should be mounted first, and a good deal of care taken to see that each is in line, and that the dial will operate them smoothly and easily at all settings. Nothing is more annoying on short waves than a condenser unit which is "stiff" and liable to "jump" when the dial is rotated.

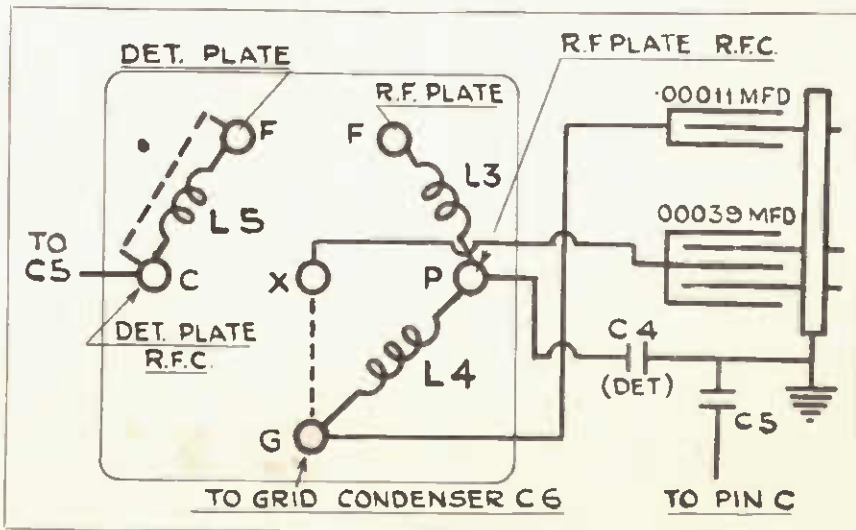

Fig. 7.—The detector coil connections looking at the valve base pins.

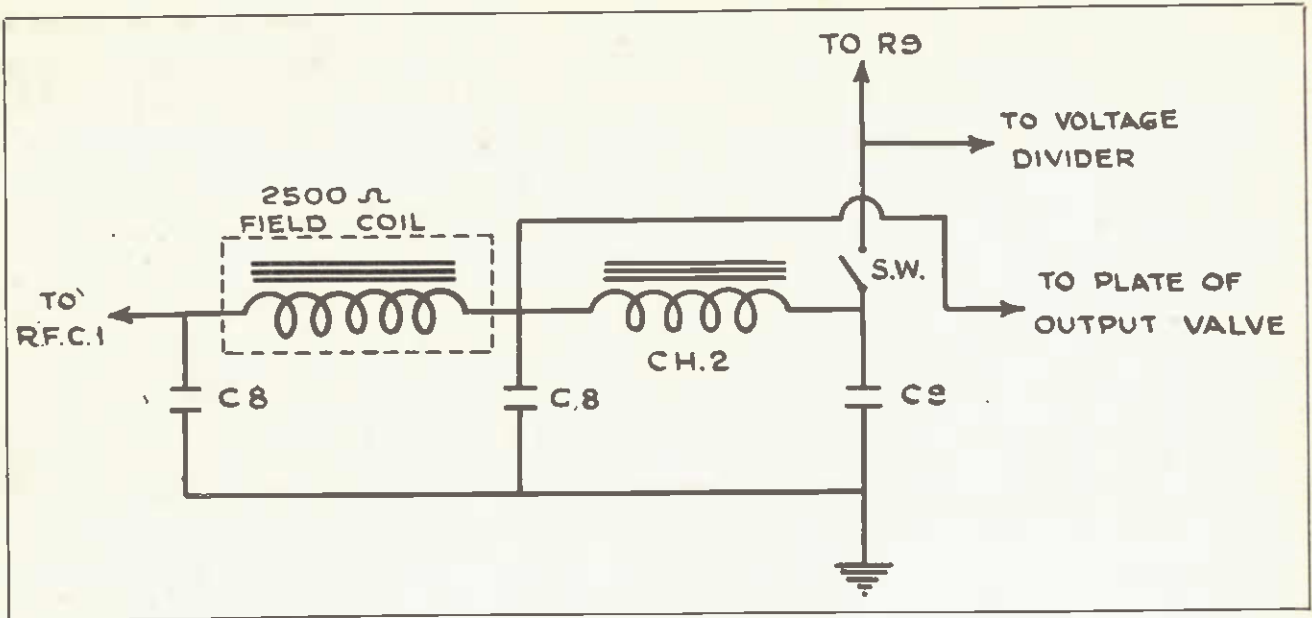

Fig. 8.—Alternative connections for incorporating 2500 ohm speaker (see letterpress).

Back-panel dials vary greatly in size and method of securing to the chassis, and the best means will be suggested by a study of the design chosen. If it is necessary to raise the condenser off the chassis to fit in the dial, a block of wood, etc., can be cut and "duco" finished with the chassis.

The mounting of the valve and coil sockets, coil shields, valve shield, and other components, either above or below the chassis, will not occasion any difficulty. Because so many components have to be mounted close to the detector coil socket, a little congestion is experienced within this compartment.

The R.F. chokes (3 of them) have been located, one on the underneath side of the chassis floor, one on the front edge, and one on the side edge, thus placing the field of each at right angles to the others, and eliminating any danger of "coupling" or interaction.

The false wall of this compartment has no leads passing through it and need not be bolted in position until the wiring is completed, which will facilitate soldering, etc.

Rigid (round or busbar) wire is used for wiring the R.F. and detector stages, but all power leads, being adequately choked, and by-passed at the necessary points, together with the simple wiring of the audio stages, can be made with flex. Insulation of the bare wire, wherever it passes through or close to the metal chassis or grounded components, must be of a double thickness of spaghetti sleeving, because of the high voltages carried. The "layout" controls the length and arrangement of the wiring of each component and there is no need to detail it "point to point."

The arrangement of the "earthing" of the R.F. and detector components, shown in the schematic diagram, should be adhered to, i.e., grounded at one point only. This may be effected by connection to the chassis direct, but a much better way, preventing eddy currents being set up in the chassis itself, is to run a separate earth lead bolted to the front and back of the chassis (to ground the chassis) at convenient points and to which all indicated grounded leads may be securely soldered. In addition, this

prevents parasitic noises being set up by electrolytic action between aluminium and copper by the passage of small currents. This system was used in the receiver and can be followed in the photograph.

For convenience, a strip of bakelite has been mounted on the back wall of the chassis to carry several solder lugs and the centre tapped resistors (R8), to facilitate the connections of the filament and transformer leads, which are usually difficult to handle neatly. Each filament lead is of 18 gauge bell wire, well twisted and encased in spaghetti sleeving for neatness.

Details of the Power Equipment

The special R.F. choke marked R.F.C.1 is home-made, and consists of about 200 turns of 22 gauge d.c.c. wire wound as a single layer on a piece of 5-8 inch bakelite tube or rod, or even wood which has been thoroughly dried and "ducoed."

The power transformer has a primary winding suitable for the mains voltage and four secondaries consisting of high tension, 275 volts either side of centre at 120 milliamps; a 5 v. 2 amp. winding for the filament of the rectifier valve (UX280 type); one 4 v. 3 amp. winding for the filaments of valves 1, 2, 3; and an additional 4 v. 2 amp. winding for the last valve or output valve. The pilot light for illuminating the dial, if necessary, and as an indication that the power to the set is "on" or "off," is also taken from this winding. A transformer having an astatic shield between the primary and secondary windings should be chosen if available.

The combination of R.F.C.1 and the buffer condensers (C10) helps to reduce any radio frequency interference which might be fed to the set from the supply lines, and to reduce the noises which are sometimes set up by the rectifier valve itself. The centre-tap connection from between the two condensers C10, to be effective, should be made as short and direct as possible to the earth terminal on the receiver.

The two filter chokes, Ch.1 and Ch.2, are both rated at 30 henries at not less than 80 milliamps, otherwise their effec-

tiveness will be reduced and the voltage available for the plate of the last valve lowered. The total drain on the filter, it might be mentioned in passing, is approximately 70 mills., two-thirds of which is accounted for by the power valve.

The speaker field (7500 ohms resistance) is not part of the filter system. If the constructor already has a speaker with a 2500-ohm field which it is desired to use, it could be incorporated in place of Ch. 1 at a slightly lowered efficiency.

The voltage of the high tension secondary will then have to be raised to 375 v. either side of centre, and the connections of the plate lead for the output valve altered as shown in the alternative diagram, Fig. 8. The filtering will not be so complete as in the original connection, and the voltage available for the last valve considerably lowered, although it will still operate satisfactorily.

Because of the necessity of switching off the high tension to change coils, it is impossible to arrange the connections to better advantage (because of poor current and voltage regulation, etc.), and the alternative is only offered as a measure of economy.

The voltage divider will be the same in either case, although calculated for the original method. It consists of a 22,300-ohm resistance, tapped at 10,000 ohms (80 volts), 18,000 ohms (156 v.); and 21,000 ohms (202 v.). The respective points which they feed can be traced off on the schematic diagram. The voltages are, of course, measured to "ground," and therefore include the voltage drop across each bias resistor.

The divider in the receiver illustrated consists of an "Electrad" type D250, on which has been mounted three additional clips, but any suitable resistance of the same value will be suitable. It may also consist of separate sections of light duty resistors, which are readily obtainable, wired in series and supported by the terminals of the respective smoothing condensers, C7, which by-pass each section to "ground." The resist-

ance value of each section is shown on the schematic diagram.

So much detail with regard to a regular unit like the power pack, has been included to assist constructors who do not possess suitable measuring instruments, although a high resistance volt meter if available makes the determination of the tapping points a simple matter. Otherwise it will be well to adhere strictly to the specified units.

Coils

The coils are wound on valve bases or other suitable 5-pin formers, and a table of turns for each is given. The aerial coils (L1) are all spaced about 3-in. from the top end of the grid coils (L2), with the exception of the broadcast coils in which the spacing had to be reduced to "fit."

The plate coils (L3) of the R.F. transformers (primaries) are close wound over, or in between, the last few turns of the lower end of L4 with one turn taken up and round the grid end to improve the transference of energy while keeping the damping (and therefore the selectivity) at the optimum point.

The reaction coils on the short-wave coils (L5) are spaced about 1/4 in. away from the grid end of L4. All coils are

a knob of dial on the rear end of the shaft of the R.F. tuning condenser, so that each stage may be tuned separately, or independently, whilst the adjustment and lining up is being done. Before finally adjusting the reaction, tune in a station on the lower end of the scale, and preferably on one of the short wave broadcast bands, with the balancing condenser C1 just engaged, in order that the condensers may be lined up to tune together in gang control.

Leave the detector stage alone and adjust the R.F. coil (L2) by 1. Spacing out the last turn or two; 2. Removing half a turn at a time, until both condensers read alike. Re-couple the condensers and tune in a station at the top end of the scale and the balancing condenser C1 should then be able to compensate for any slight irregularity in the capacity of the two tuning condensers.

If the selectivity needs any correction adjust by removing a turn or two from the bottom of L1 and/or L3. At a slight sacrifice of signal strength it can be made as sharp as a "hairline."

All coils may be finally treated with a thin coating of "Duco" to protect and hold the windings in place during handling, but if the formers are fitted with knobs, etc., it will be better to leave

COIL DATA

Covering.	L1.	L2.	L3.	L4.	L5.	S.W.G.
500/185 metres	8	70	6	67	—	40 enamelled
100/70 metres	4	25	3½	24	20	30 D.S.C.
70.40 metres	4	16	3½	14½	12	26 D.S.C.
40/30 metres	3	9	3	8	7	26 D.S.C.
30/22 metres	3	5	3	5	5	24 D.S.C.
22/16 metres	2½	3	2½	3	3	(Spaced diam. of wire) 24 D.S.C.
						(Spaced diam. of wire)

wound in the same direction, and the connections for obtaining reaction will then be: Top of L5 to detector "B" plus; bottom of L5 to detector anode; top of L4 to detector grid; bottom of L4 to R.F. "B" plus; top of L3 to R.F. anode, and bottom of L3 to R.F. "B" plus.

This unusual method, which is caused by the necessity of having plug-in coils, of connecting together the bottom ends of both L3 and L4 (they are effectively grounded through C4a, which also acts as an isolating condenser to keep the power pack from shorting to ground) functions quite normally.

Adjustment and Operation

It is impossible accurately to specify the correct number of turns for each coil because of the number of varying factors which affect it, but the table is to be used as a guide. The number of turns for each grid coil will be found very nearly right, but the reaction coils will need some adjustment.

The broadcast coils, not having any reaction, should be lined up first, and adjusted for selectivity in the manner described below. This will ensure that the receiver is functioning correctly before any time is wasted on the lower wave coils.

For the short waves adjust the reaction coils first by:—1. Removing half a turn or a turn at a time; 2. Increasing the spacing between L4 and L5; 3. Spacing out the last turn or two until the receiver glides smoothly and silently into mild oscillation over the whole band.

For the purpose it will be necessary to uncouple the ganged condensers and fit

them uncovered. So much depends on the coils that a little extra time taken up in making careful adjustments will be well spent.

Probable Faults

Most of the probable faults have been dealt with already. The field set up by the power-pack might possibly happen to inter-act with the audio transformer, causing an uncontrollable low frequency howl. The internal connections of the audio transformer usually have a lot to do with it, and if the external connections are reversed, it will usually cure this trouble.

Weak signals, failure to make the valve oscillate, very little control over the output by the volume control, and a general sense of "deadness" in the receiver indicates either incorrect voltage on the plates or screen grids of the valves, a wrong connection, or a faulty piece of apparatus.

Tuning

Tuning a local broadcast station is done on the main dial, and balanced with C1 only.

A short-wave station is tuned in with the main dial, and the reaction slightly advanced. When a station has been heard, the reaction control is cut back as far as possible, whilst the "peak" of the carrier is found with the two balancing condensers C1 and C2, which act as verniers.

This is extremely simple, and a little practice in tuning will delight and surprise the constructor with the potentialities of this receiver for broadcast entertainment.

Short-Wave Coil Construction

A brief article on the winding of coils suitable for use on the lower wave belts.

By W.G.S.

UY tube base formers are generally specified for winding short-wave coils, because they simplify the coil construction, and mounting, considerably, and are fitted with the requisite number of pins to suit. The "Emmco" make of coil formers are made to fit UY sockets, and are an excellent medium for construction.

UX valve bases can also be easily modified by mounting a fifth pin in the centre of the base, and arranging an extra contact on the UX socket. For this additional contact, a piece of springy brass can be bent to suit, and fitted between any convenient pair of the existing contacts.

English pattern, four-pin valve bases also suggest themselves for adaptation, also with an additional pin mounted in the centre of the base. English valve holders are even easier to mount the additional pin socket on.

Of course, there is no necessity to confine the coils to valve bases and holders, and several other methods of mounting are in vogue. If the coils are wound on ordinary bakelite tubing, the plug-in pins can be arranged in a straight line along one side. Suitable sockets to receive them can be attached to a strip of bakelite, which is fixed to the baseboard. Five, six or seven pins, if necessary, can then be arranged without difficulty.

Coil Diameters

There seems to be a certain amount of confusion also about the correct diameter to which short-wave coils should be wound. In 1921, when experimenters were first investigating wave lengths below one hundred metres, it was considered standard practice to use coils of a diameter of three inches, space wound on "air," i.e., self supporting. The underlying idea was that it was essential to reduce the distributed capacity of the coil to the lowest possible minimum.

About three years ago, valves were first manufactured with caps made of bakelite and similar composition, and it was not long before experimenters adopted the ready-made formers so thoughtfully provided.

Valve base coil formers, or similar factory-made formers, are practically standard practice in America, and at the writer's station are invariably employed nowadays. No noticeable difference in signal strength has been apparent between these handy little units and coils constructed on more correct scientific principles. Many readers have probably had the same experience, but, nevertheless, there is quite a lot to be said in favor of the slightly larger space wound coils in which the amount of insulating substance is kept at a minimum.

Some experimenters favor 2in. diameter coils, space-wound for the shorter wave lengths, and mounted on their sides on sawn-off valve bases. Many of the stations heard are received on commercially-built kits, such as "Radiokes," which are also 2in. in diameter, and space wound on a skeleton former; so that it seems to be a matter of individual preference.

THE WORLD SHORT-WAVE ADAPTOR

OWING to the excellent broadcasts that are transmitted from short-wave stations in all parts of the world, and the number of these stations that are operating, a stage has been reached which warrants the use of a short-wave adaptor which can be connected at will to an all-electric broadcast receiver, so that these broadcasts can be received and enjoyed.

No one can deny the thrill and satisfaction on tuning in some foreign station and waiting for the call sign to be announced. In a number of cases the announcement will be made in a language which the listener has never heard, and, although he will not understand what is meant, he can appreciate the vocal and instrumental items which follow.

Naturally, the time that these foreign stations are on the air does not always coincide with the time that the local stations are broadcasting, and there is a specified time when to listen for these stations.

The quality of the reception varies according to the time of the year, atmospheric conditions, and the time that the station is broadcasting; but, for all this, the number of successful receptions definitely compensates for the number of bad receptions.

If one short-wave station comes in poorly it is only a matter of changing the coils and trying on another wave band, as on some bands at certain times of the year there is less static than on others. As the times for which to listen for the different short-wave broadcasting stations and the number that can successfully be received here, appear in the Short-Wave Page of The Listener in each week, the listener need not needlessly twirl the knobs of the adaptor and trust to luck to bring in the stations. It is just as easy to tune in a short-wave station situated in England as it is to receive a Sydney short-wave station, providing conditions are favorable. There may be a difference in the volume of these two stations, but the tuning is no more difficult.

The programmes broadcast from the main short-wave stations are of excellent quality and compare more than favorably with those transmitted from stations operating on the broadcast band. Some of the most interesting pro-

grammes are those put over by the foreign stations, and may be heard at about a quarter to ten, Melbourne time. Listeners who have not heard Chinese music will be astonished on hearing notes issuing from the loud speaker

By F. OLSEN

grammes are those put over by the foreign stations, and may be heard at about a quarter to ten, Melbourne time. Listeners who have not heard Chinese music will be astonished on hearing notes issuing from the loud speaker

List of Parts

- Aluminium chassis 10½in. by 6½in. by 1in., of 18 gauge material.
- Aluminium panel 10½ by 6½ of 18 gauge material.
- Aluminium partition 5½ by 6½. 20 gauge material.
- 3 Midget condensers, consisting of 23 plates. (Radiokes type.)
- 400 ohm resistance R1.
- 5 meg. grid leak, R3.
- 50,000 ohm variable resistance, R4.
- 100,000 ohm resistance, R2 (grid leak type).
- 2 .01 mfd. condenser, C5, C4.
- 1 mfd. condenser C6.
- .0001 mfd. condenser, C7.
- 2 UX valve sockets.
- 2 UY valve sockets.
- 8 length of fibre tubing having an outside diameter of 1½in., 2in. long.
- 8 UX valve bases.
- 1 UY valve base.
- Miscellaneous flex, wire, spaghetti, ¼lb., 28 gauge D.S.C. wire, metal thread screws and nuts, etc.
- 2 Vernier dials.

when one of the Javanese short-wave stations is received.

Having shown what may be expected

on the short waves, the next thing to consider is the requirements of an adaptor which will enable the listener to tune in these stations by connecting it to an all-electric broadcast receiver. At this stage it may be well to point out that only the audio stages of the broadcast set are brought into action other than to obtain the various voltages necessary for the valves in the adaptor. The audio stages of the set with which the adaptor is used in conjunction must not be directly coupled, as in the Loftin White or any similar system, as the adaptor will not work if it is. Only A.C. receivers using transformer, resistance coupling, etc., between the audio valves will be suitable for use with this adaptor.

Briefly, the most important point is that the adaptor should give good results. Next, it should be simple to construct so that any reader who is at all interested in the greatest of hobbies should have no difficulty in assembling and wiring the components.

Another factor of vital importance is that of hum. There should be no hum coming from the adaptor, and it should be silent when the reaction condenser is out of oscillation, or, in other words, no noise such as crackling, frying, spluttering, etc., should originate from the adaptor due to faulty design, which will mar the reproduction.

The circuit and the design of the adaptor which we present here was the outcome of a considerable amount of experimenting, and was found to be the most suitable for the average all electric receiver using resistance or transformer coupling for the audio stages. It does not matter how many stages of R.F. amplification a set may have, as only the audio side of the set is used.

On test, this adaptor, when connected to the detector socket of a three valve electric set, gave excellent results, and delivered enough volume from the dynamic speaker on the main S.W. stations to comfortably fill a large size room.

The Circuit.

On looking at the circuit it will be seen that fundamentally it is an old favorite, being commercially used in broadcast receivers as far back as 1924, only that D.C. three electrode valves were then employed.

The advantage of this circuit over that of the tuned anode, which is rapidly

Showing the adaptor connected to an all electric receiver ready for operation.

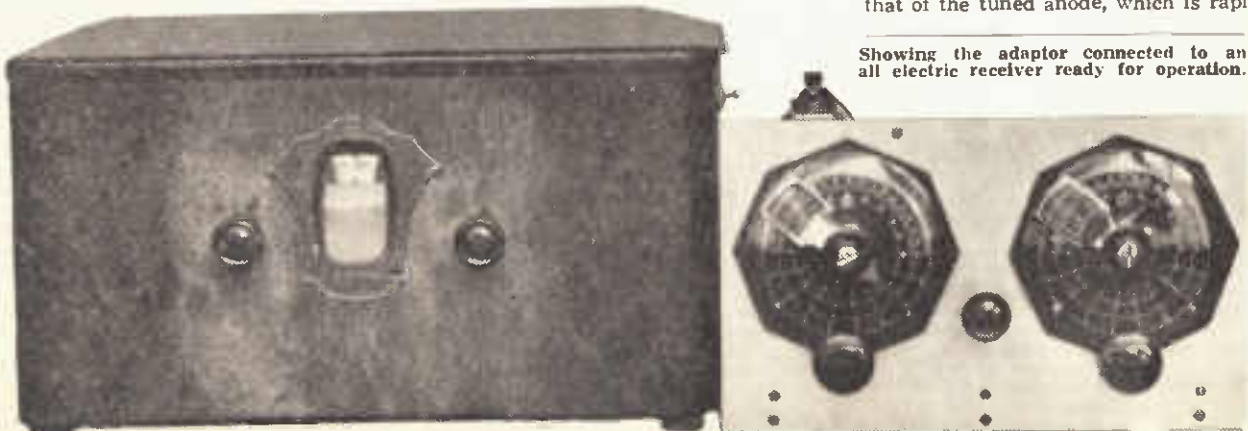

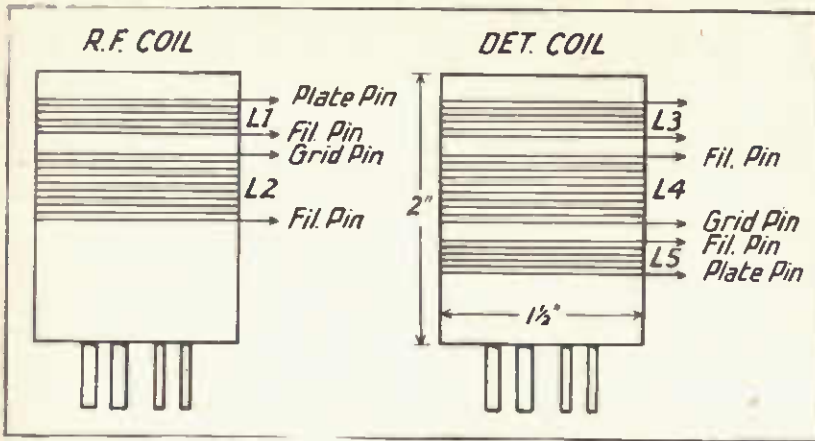

A diagram of the coils giving the size, positions of the windings, and the connections.

being discarded (where experimenters and amateurs are concerned) is that hum is entirely eliminated. Even when parallel feed was used, a slight hum could be heard coming from the adaptor, and on changing to the radio frequency transformer system this hum disappeared.

It will be noticed that the aerial coil, L1, is inductively coupled to the grid coil L2. This coil is tuned by a variable condenser, C1. The grid of the screen grid radio frequency amplifier is biased by connecting a resistance in the cathode lead of this valve.

The plate of the screen grid valve is coupled through the coil L3 to one side of a 1 mfd. condenser and to B positive. A variable condenser C2, tunes the grid coil L4, while a grid leak and condenser is used to enable the detector to rectify. Reaction condenser, C3, controls the oscillation of the detector valve.

Owing to the high voltages which are impressed on the plate of the detector valve in some commercial receivers, it was found necessary to incorporate a variable resistance, R4, in series with the primary of the transformer in order to reduce this voltage, so that the smoothest oscillation could be obtained. This resistance, R4, is shown in the circuit as one side going to the P terminal of the UY plug and the other side to the fixed plates of the reaction condenser and one side of the reaction coil.

Due to the fact that the voltage applied to a detector valve is seldom higher than 100 volts in the majority of sets, the B positive lead which comes from the screen grid valve connects to a terminal which can be brought out at the back of the broadcast set.

A tapping on the voltage divider or a series resistance, at which should be about 150 volts, should be taken to the terminal, which is on the back of the set. In this way the performance of the adaptor is increased out of all recognition compared with obtaining all the voltages from the detector valve socket of the set by means of the adaptor plug. The filament voltage and the cathode lead for both valves and the plate voltage for the detector valve is derived from the detector valve socket of the set.

Components Reviewed

VALVES.—These must be of the same filament voltage as the detector valve, used in the broadcast receiver. Those used in this adaptor were E442 for the R.F. stage and an E424 for the detector stage, although any particular make of valves can be used, providing their characteristics are similar to those mentioned here. This, however, is exclusive of the filament voltage. In a number of

cases hum in S.W. adaptors and S.W. receivers have been traced to the valves themselves, so, in order to assure that the valves which are to be used in the adaptor are immune from this defect, it would be advisable to have them tested for hum before inserting them in the valve sockets of the adaptor.

CONDENSERS.—Both tuning and reaction condensers are of the same capacity about .0001 mfd., and for preference should all be midgets having roughly 23 plates. A smaller capacity reaction

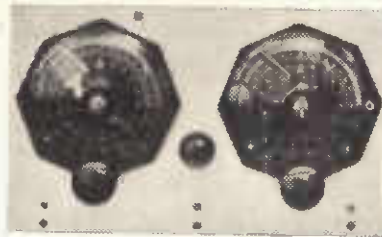

A front view of the panel.

condenser may be used if one is on hand, but this will necessitate more turns on the reaction coil. There must be no side-play in the spindles of the condensers; by this is meant that on exerting a pressure on one side of the spindle and then the other the spacing between the fixed and moving plates should not vary.

FIXED CONDENSERS.—The by-pass condenser, C5, on the screen grid lead

should not be of the paper type, but should have mica as a dielectric. This also applies to C4. Although theoretically the condenser C6 should be of the mica type, a paper one was found to be just as satisfactory. It is not important what type condenser C7 is so long as it is of the correct capacity, namely .0001 mfd.

VALVE SOCKETS.—In a broadcast receiver, providing the contacts of the valve sockets are fair, everything will be all right, but with a S.W. receiver this matter is entirely different. If there is a high resistance leakage between one of the contacts and the earth, an annoying crackle will set in which it is difficult to trace if a socket is not suspected. Besides this, spluttering can also be traced to sockets which have loose contacts or make bad contact with the prongs of either the legs of the valves or the legs of the UX valve base which holds the coil windings. From this it can be seen that only the best of sockets should be selected. Two U.X. baseboard mounting sockets are required for use as coil holders, and two U.Y. baseboard mounting sockets are needed to hold the valves.

DIALS.—These should have a smooth movement and no backlash, otherwise tuning in of the short wave stations will be difficult, and stations may be quite easily missed. The ones used with this adaptor are not only smooth in movement, but are attractive in appearance and make the view of the panel very pleasing. No cheap or inefficient dials should be used, as only the best should be selected.

Construction of the Chassis

The chassis, which consists of 18-gauge aluminium, is 10 1/2 in. long by 6 1/2 in. wide by 1 in. deep.

Before starting on the construction of the chassis it would be a good plan to obtain all the components and stand them on a sheet of paper in the same positions as shown in the photographs, so that the size of the chassis may be obtained. This is due to the fact that the size of the valve sockets, dials, valves, etc., may be slightly larger than those used in this receiver, with the result that the size of the chassis may have to be bigger than the sizes of the one given here.

The chassis may be bent by the local tinsmith or may be bent by the constructor. Having bent the chassis, cut the

(Continued overleaf)

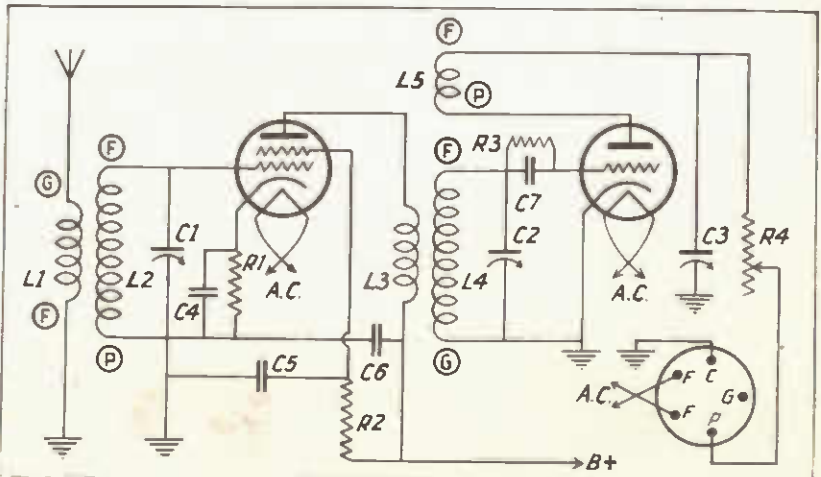

Circuit of the World short-wave adaptor.

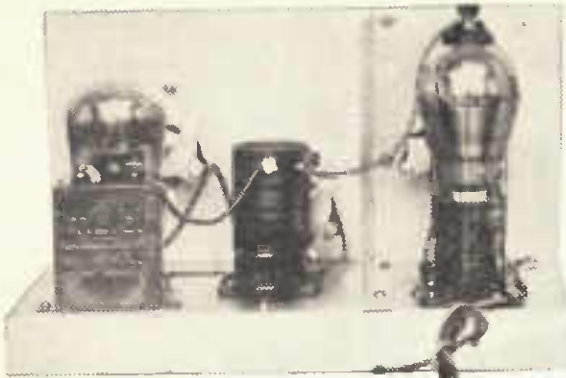

A photograph showing the back of the adaptor.

panel to size. The one used with this set was 10½ in. by 6½ in., and was of the same gauge material as that of the chassis. Next, the aluminium partition which shields the R.F. side of the adaptor from the detector stage, may be cut to size. This is 6½ in. wide by 5½ in. high, and has a flange of half an inch on two sides, so that it can be fastened to the chassis and to the front panel which it helps to support.

If a dull finish on the aluminium is desired, this may be obtained by the use of emery paper and oil. Care should be taken in doing this in that the rubbing should all be in the one direction.

The panel and the chassis may be now drilled for the screws to pass through to hold the panel to the chassis, and then the partition can be drilled to support the chassis and the panel.

Now screw the partition to the sub-panel and drill the holes for all the components which are on the face of the chassis, except the hole for the variable resistance. The positions for the components can be obtained by studying the photographs of the finished adaptor. Mount the components whose holes have just been drilled, care being taken to see that there is plenty of space for the variable condensers so that they do not foul any of the components.

The resistances and condensers which are underneath the chassis may now be placed in position and the holes drilled. Regarding the variable resistance, R4, the hole in chassis through which this passes should be of ample size, as if this spindle or any part of the resistance touches the aluminium, a short-circuit will take place.

The holes for the condensers on the panel should be drilled and the condensers mounted. All the spindles must make good contact with the panel, as the movable plates are connected to these, and should not be insulated. Fasten the panel with the condensers and dials mounted, to the chassis, with metal thread screws and nuts, and screw the partition to the panel. The construction of the chassis is now completed.

Point to Point Wiring

It is not generally realised that in a short wave receiver or adaptor the wiring has a considerable effect on its performance. By this is meant that the grid and plate wires should be as short as pos-

sible, and all A.C. filament leads should be well away from the above wires. In this set the plate and grid wires are on one side of the chassis and the A.C. and H.T. leads on the other. In this way, hum is reduced to a minimum and feed-backs in the form of whistles and squeals are entirely eliminated. The wiring of the filament circuit should be carried out in twisted flex, the rest of the wiring being done with 20 gauge bare or tinned copper wire covered with spaghetti.

In the case where a contact should be connected to the chassis, there is no need to insulate the wire unless there is a chance of its touching a component which should not be earthed, and it can be connected to the nearest screw in the chassis.

There is no need to solder the wires to terminals if a good contact is made, as this will in no way increase the efficiency

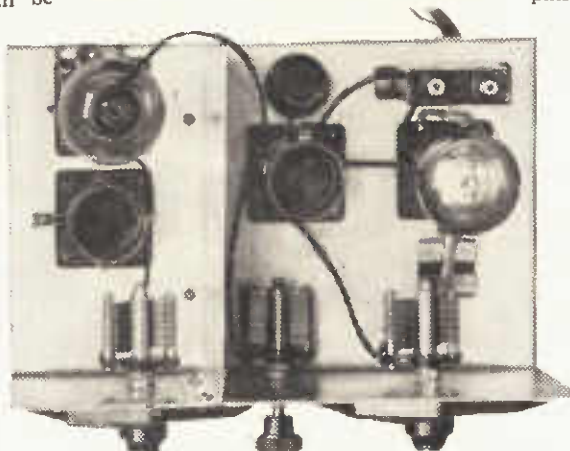

From the top of the adaptor with the valves and coils inserted, the small number of connecting wires which is a feature of this adaptor will be noticed.

of the joint, and is only extra work done for nothing.

By studying the photographs an idea of the position of the wiring may be obtained, and the holes in the chassis through which the voltage wires go. These may be drilled when the constructor comes to that portion of the wiring.

Start the wiring by taking a lead from the F terminal nearest the P terminal of the R.F. UX valve socket which holds the R.F. coil to the fixed plates of the midget condenser C1 and to the grid terminal of the S.G. valve socket.

The P terminal of the R.F. coil holder goes to the chassis, likewise the remaining F terminal. A terminal is soldered to the G contact of this socket, so that the aerial wire may be connected.

Run a wire from the cathode terminal of the S.G. valve through a hole in the chassis to one side of R1 and one side of

C4. The vacant sides of R1 and C4 are connected to the chassis. From the P terminal of the S.G. valve socket a wire is taken through a hole in the aluminium to one side of R2, and one side of C5, as the P terminal in the case of Contentential type valves becomes the screen grid terminal while the plate is taken to a contact on the top of the valve.

Earth one side of condenser C6 to the chassis.

Take a lead from the G terminal of the detector coil holder to the aluminium. The F terminal of this socket nearest the P contact goes to one side of the grid leak and condenser R3, C7. From the P terminal of the same socket run a wire to the P terminal of the detector U.Y. valve socket. The remaining F terminal of the coil socket goes to one side of the variable resistance R4.

Next, the vacant side of the grid leak and condenser C7, R3 connects to the grid contact of the detector U.Y. valve socket. All that remains to be wired now is the leads to the U.Y. valve base, which plugs into the detector socket of the broadcast receiver.

A defective valve having a U.Y. base should be obtained, and the glass removed. Hold a soldering iron to the pins of the socket, and with a needle push the wire which originally connected to the elements of the valve out of the hollow legs.

Note that if the broadcast set, to which the reader intends to connect the adaptor has a different type of socket to the one used with this adaptor, the connections are the same but the position of the pins will naturally be different.

For the wires connecting the adaptor to the socket 23/36 rubber covered flex may be used; this will fit in the socket legs.

From the vacant terminal on the voltage varying resistance R4 a wire is taken through the hollow P leg of the UY valve base and soldered in position. A flex lead is soldered to the cathode leg of the U.Y. valve base and connects to the aluminium chassis. Run a pair of twisted flex leads from the filament connections of the screen grid U.Y. valve socket to the filament connections of the detector valve socket, and from here continue the twisted flex leads to the two F legs on the U.Y. valve base.

This completes the wiring except the B + lead for the S.G. G of the

(Continued on page 26)

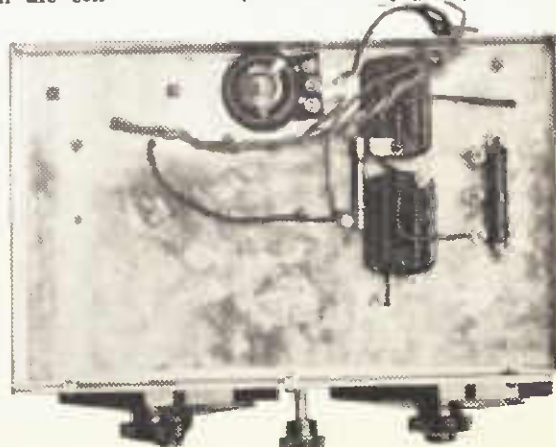

An underneath view of the chassis showing the placement of components and the remainder of the wiring.

TWO SHORT-WAVE AERIAL SYSTEMS

There are a good number of short wave enthusiasts who are not familiar with the Zeppelin antenna, while among the ranks of the transmitters there are a number who have not yet adapted this form of aerial to the reception portion of their stations. In the following article, the writer will attempt to describe some of the forms

Forms of the "Doublet" and "Zeppelin" types improve reception and decrease interference

By H. R. CARTER, VK2HC

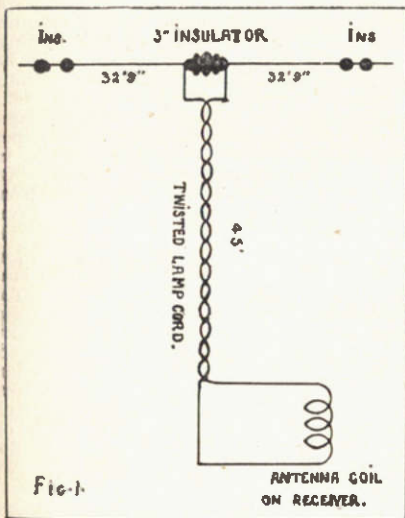

The "Doublet" antenna.

tried at his own station, and proved in every way to be very satisfactory, and superior to the common "untuned" aerial.

The erection of a suitable "Zepp" antenna at most stations does not present any great mechanical difficulties for wave lengths of forty metres or less, while those having a greater amount of space available, can satisfactorily build them to suit wave lengths up to eighty or a hundred metres.

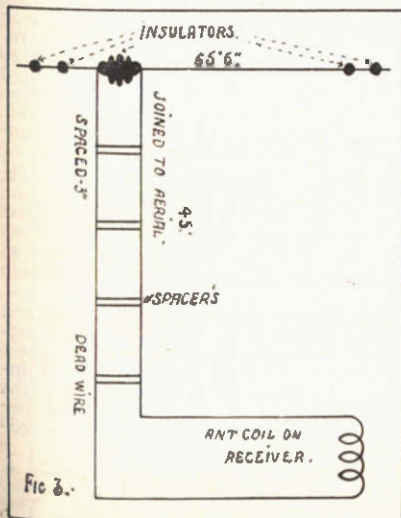

The "Zeppelin" aerial.

Owing to the fact that this type of receiving antenna will probably be most popular amongst those who desire to listen on the amateur wave lengths, the whole of the following constructional details will be based on that point.

The length of the straight wire should

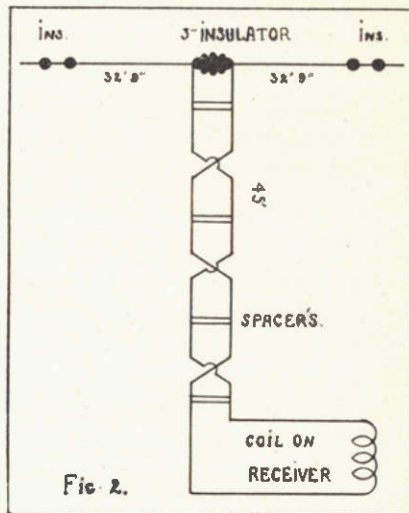

Fig 2.

Illustrating a two-wire feeder arrangement.

The "Zepp" really consists of two portions, the antenna itself, and the two feeder lines, one of which is connected to the antenna, while the other is brought to a "dead end" near the antenna. The straight antenna wire is measured and cut to the desired wave length, or at a number of half lengths, for example, $\frac{1}{2}$, $\frac{2}{2}$ etc. The feeder lines should be any odd number of quarter wave lengths, or bearing a definite relation to the antenna length, for example, $\frac{1}{4}$, $\frac{3}{4}$, $\frac{5}{4}$, and so on.

The feeder system is so arranged that the currents in the feeders are exactly out of phase, and, therefore, the induction from them is practically zero, and if correctly constructed, should absorb practically nil of the desired signals, or undesired interference, the actual reception taking place in the antenna itself, and conveyed to the receiving apparatus by the feeders.

This arrangement, therefore, reduces induction from neighboring power leaks, mains, etc., or other troubles that are experienced, with the ordinary type of single wire arrangement. The receiving antenna, being sharply tuned, and having low losses near ground, gives a considerable increase in signal strength, and a decrease in background noises. From actual experience here, signals which were previously R6 are now R7/8.

At VK2HC, the power supply is from 32 volts D.C., this current being obtained from an engine direct-coupled to a generator. The mains from the generator and battery room are overhead, and the segments of the commutator on the generator are rather widely spaced and large, the result being severe interference.

Before erecting the antennae about to be described, reception of all the short wave lengths, or higher frequencies, with the engine in operation, was practically impossible, while now it cannot be heard on the ten metre band, R2/3 on twenty, and operation on the forty and eighty metre bands is quite good; any signals over R4 are easily readable, and the increased antenna coupling improves the sharpness of the oscillation fringe for radiophone reception.

It must be understood, however, that the antenna when constructed for the amateur wave lengths is not flexible. For instance, a station operating on 32 metres will in all probability be received at slightly less strength than with the common one wire arrangement. However, this point can be avoided by stations, which desire to listen to a station on a special wave length, building the antenna to suit it.

be either $\frac{1}{4}$ or $\frac{2}{2}$ for the 42 metres or 7MC band. By a series of experiments in the U.S.A. the following formula was obtained:

$L = \text{wave length} \times 1.56$
where L equals length of the antenna in feet ($\frac{1}{2}$ wave).

This is disputed on the grounds that it varies in whichever country the antenna is situated. In U.S.A. it may

(Continued overleaf)

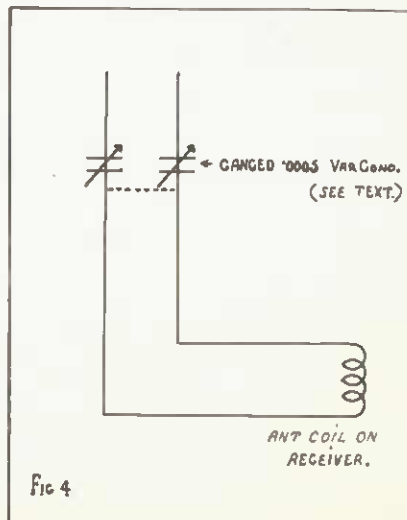

Fig 4

Showing how the antenna "feeders" are tuned.

TWO SHORT-WAVE AERIAL SYSTEMS—(Continued from previous page)

be 1.56, while in Great Britain it will probably be less; in other countries where there are fewer buildings and conducting structures in the vicinity of the station, the factor is likely to be as high as 2.

For a full-wave antenna the figures obtained by the 1.56 method are simply doubled. We take then, for example, an antenna suitable as a half wave on 42 metres; we obtain the result as follows: $42 \times 1.56 = 65$ feet 6 inches, which, of course, is the half wave.

With regard to the feeders, if the antenna is to be used on all the amateur bands, it is obvious that one cannot build a quarter wave feeder, for the 42 metre band as this would come out at half wave on 21 metres.

The length has therefore been taken as 45 feet. This has a relation to most of the bands, being a combination of the correct quarter or number of quarter wave lengths, for ten, twenty and forty metres.

The "Doublet"

The first type of antenna tried was the "Doublet." This consisted of two main antenna wires, 32 feet 9 inches long, fed by the ordinary twisted lamp cord used for house wiring purposes, 45 feet long. The two lengths of antenna wire are erected as per Figure 1, with the insulator of about 3 inches of length inserted in the centre, the two feeder wires connecting at this point.

Most people have noticed the arrange-

ment used by the P.M.G.'s Department to minimise induction in telephone and telegraph wires, a cross over of the lines at various points. This is called transposition, and is the basis for an erection of a different feeder line. This consisted of the same two wire feeder arrangement set up as per Figure 2. The wires are spaced at 3 inches and at every nine feet are transposed. Special insulators are made but were not available in Australia, so that small 4×4 inch bakelite sheets had to be used, with a small bolt and nut holding a button insulator in place, to which the wires are attached, and the point where the wires cross should not be under 1 inch.

It is important that these wires should be kept taut, and not allowed to vibrate against themselves, the whole feeder, however, can swing as one without affecting reception, to any serious extent.

This feeder arrangement is connected in the same manner as the twisted cord type.

The "Zeppelin"

The arrangement of the "Doublet" just described, will doubtless prove rather inconvenient to most stations who have another antenna for transmitting. That was the case here and I immediately set about the erection of a suitable receiving "Zepp." Unlike the "Doublet" the plain "Zepp" has only the one antenna wire, $\frac{1}{2}$ $2\frac{1}{2}$ wave length long, and the feeders arranged similar to the common inverted "I" type, with two "lead-ins"; one of course is a dead end. This arrangement is similar to the usual amateur transmitting antenna, and can best be followed as per Figure 3. The antenna in this case is 65 feet 6 inches long with 45 feet feeders. The wires are spaced 3 inches apart, and must be well constructed, to prevent swinging in the

wind. The spacers in the feeders can easily be made from scrap bakelite or some such material.

The type of feeder illustrated in Fig. 2 may also be substituted, but in this case no improvement could be noticed. The plain "Zepp" arrangement shown on Figure 3 gave the best results at this station, being easier to erect and a very slight increase in signal strength over the "Doublet," although the twisted feeders may be slightly less subject to interference.

Tuning Feeders and Coupling to the Receiver

The 45-foot feeders, not exactly corresponding to any actual frequency or wave length with regard to the antenna, are only slightly affected by tuning, whereas a 32 feet 9 inch feeder would be considerably affected. However, tuning extends slightly to increase the efficiency, and two .0005 mfd. variable condensers, ganged and connected as per Figure 4, are well worth the trouble, in any of the pre-described systems. Of course, the ganging must be made from some insulating material, such as ebonite rod.

These types of antennae are most satisfactorily applied to receivers employing a stage of screen-grid radio frequency before the detector, as a dead spot would tend to put the receiver out of oscillation somewhere in the band. This, however, using a 45 feet feeder, will be most noticeable on 10 metres. The number of turns for a coupling coil for an S G set is about eight turns on a valve socket, while for receivers not possessing a screen grid stage only two or three turns are ample.

It is advisable to mount the valve socket well away from the aluminium or screening material, otherwise there may be considerable loss of energy directly on to the frame of the receiver.

THE WORLD SHORT-WAVE ADAPTOR—(Continued from page 24)

U.Y. valve base is not connected to anything.

The Coils

The coils are wound on tubing having an outside diameter of $1\frac{1}{2}$ inches and glued in position over a U.X. valve base. The diagrams of the coils shown here speak for themselves, with the result that very little explanation is needed. All coils are wound with the same gauge wire, namely 28 D.S.C., and cover a wave length range from roughly 18 to 80 metres. If any other coils are required to cover the higher wave lengths above 80 metres, it is merely a matter of adding extra turns to the coil below it. All windings are in the same direction. In the case of the plate coil two terminals are mounted so that the beginning and end of L3 can connect to these terminals.

Filament plate pin, grid pin, etc., in the diagrams refer to the pins of the U.X. valve bases which the coil formers fit over. For example, the beginning of coil L1 goes through a small hole drilled in the former and through the hollow plate pin where it is soldered in position.

The following is the number of turns

for the various coils. The wave length ranges are only approximate.

R.F. Coil		Detector Coil			Wave Length
L1	L2	L3	L4	L5	in Meters.
3	4	$3\frac{1}{2}$	$3\frac{1}{2}$	2	12 to 16
4	5	$4\frac{1}{2}$	$4\frac{1}{2}$	2	16 to 25
7	10	6	9	3	25 to 45
12	15	10	14	4	45 to 90

It will be necessary to experiment with the number of turns on the reaction coil L5 if a different capacity reaction condenser to the one specified is used.

Operation

Plug the socket from the adaptor in the detector socket of the broadcast receiver after the detector valve has been taken out. Now insert the detector valve in the adaptor and also the screen grid valve. The R.F. and detector coils for the highest wave band should now be inserted, and a lead taken from the plate terminal at the top of the S.G. valve to one of the L3 terminals of the detector coil. From the remaining terminal of coil L3 take a wire to the vacant terminal on the 1 mfd. condenser C6. From this side also run another wire to the vacant side of R2 and from here to the B positive terminal which is fastened at the back of the set.

The current at the power point should then be switched on. When the valves have heated up rotate the reaction con-

denser, C3. A hissing sound should be heard in the speaker at a certain position of this condenser which will vary as the tuning condensers are altered. The variable resistance, R4, should now be adjusted to give the maximum hissing sound without squealing. If the detector valve will not oscillate increase the number of turns on the reaction coil until it does.

In some receivers, the reaction coil may affect the working of the adaptor as it is connected in series with the reaction coil of the adaptor. If this is so a switch may have to be incorporated in the broadcast by which the reaction coil may be short circuit when required. This also applies to the reaction condenser of the broadcast set.

If the receiver has a poor power pack, and there is a hum in the reproduction of the set on stations on the broadcast band, there will be a louder hum when the adaptor is connected. This is not so noticeable, however, when a S.W. station is received.

The various coils should be tested and should all oscillate. When on the shortest wave length coils the hum, if there was any on the 80 metre coil, will increase. This is only natural and the voltage applied to the plate of the detector valve should be decreased by adjusting the resistance, R4.

The set with which this adaptor is used does not hum except for a few peaks on the shortest wave coil. This is in no way annoying, and the results that are being obtained are excellent.

A MODERN SHORT-WAVE RECEIVER

DEPARTURES from conventional receiver designs are usually regarded as freaks to be avoided. Generally, the possibility of greater efficiency in the new design is overlooked by the prospective set builder.

Chassis-type construction of the short wave receiver has, in most circuit arrangements employing one or more r.f. stages, improved efficiency through better shielding and design.

Selectivity has become a big consideration in the modern short wave receiver, and, without it, numerous phone transmissions will be found to be interfered with by Morse code stations. The new circuit possesses a greater degree of selectivity, is easier to tune, and is very simple to put into operation compared with the average short wave receiver using a single r.f. stage in the common tuned anode circuit.

On consulting the circuit, it might be argued by some that series feeding of the r.f. valve plate would be more efficient than the parallel feed used in this new circuit on the grounds that energy will be lost through the r.f. plate choke. This argument would be in order if the r.f. stage plate choke were inefficient, but otherwise it is groundless, parallel feed permitting the coupling between r.f. and detector stages to be adjusted, which is a decided advantage when it is difficult to get the detector circuit to oscillate, as well as improving selectivity, according to the coupling condenser capacity.

Throughout the construction of this receiver, efforts have been made to keep wiring and design as simple as possible. The placement of parts in this compact

Of table type and unusual design, the set described in this article is compact and highly efficient. The circuit used is something new, and will be found simple to put into operation.

By VK3GT

receiver enables shortest connections to be obtained.

Trap tuning possesses more than one advantage. The direct application of the aerial and earth connections to the grid circuit of the r.f. valve will effectively suppress any tendency towards oscillation in the r.f. stage besides giving a higher degree of selectivity.

The receiver, including valves, is built into an aluminium chassis built from gauge 16 or 18 material.

Review of Parts

The ALUMINIUM CHASSIS can usually be bent to specification by metal suppliers. See advertisers in this journal for details. In order to obtain a dull finish the metal of the original receiver chassis was rubbed down with emery paper and oil or water. This type of finish wears well, and although it may become dirty, it still looks well, and is far superior in appearance to the original glossy finish.

The TUNING CONDENSERS and 17 plate reaction condenser should be examined for any play in the movable plates shaft when purchasing. Any components with such play should be rejected, since they would be worthless if used for tuning in a short wave re-

ceiver. By the absence of play is meant that, on pressing the movable plates shaft in any sideways direction, holding the fixed plates, no change in the spacing between fixed and movable plates is noticeable.

THE AUDIO TRANSFORMER must be a completely shielded type. The ratio is not particularly important.

The R.F. CHOKES should both be made

according to the following specifications: Each choke is wound in four sections. The containing former for the wire is made by cutting five discs of thin sheet fibre each 1in. in diameter. The five discs for each choke are bolted together with a 1-8in. brass bolt, each disc being spaced about 3-32in. from its neighbor by means of fibre washers 1/2in. in diameter. The bolt through the centres of the discs is also used for mounting purposes, and should not be cut short. The connections from the choke winding are taken to two solder lugs riveted or bolted, through either of the end cheeks of the former. To complete each choke all that is necessary is to fill the former with wire of about gauge 38 double silk covered. Care should be taken to wind each section of each choke in the same direction. No breaks should be made in the wire until all sections have been filled. The number of turns will be unimportant if the foregoing details and measurements are followed with any degree of accuracy.

The U.X. TYPE VALVE SOCKETS should be carefully selected. It might be advisable when purchasing the sockets to take along an old U.X. valve or base, trying each socket in turn to

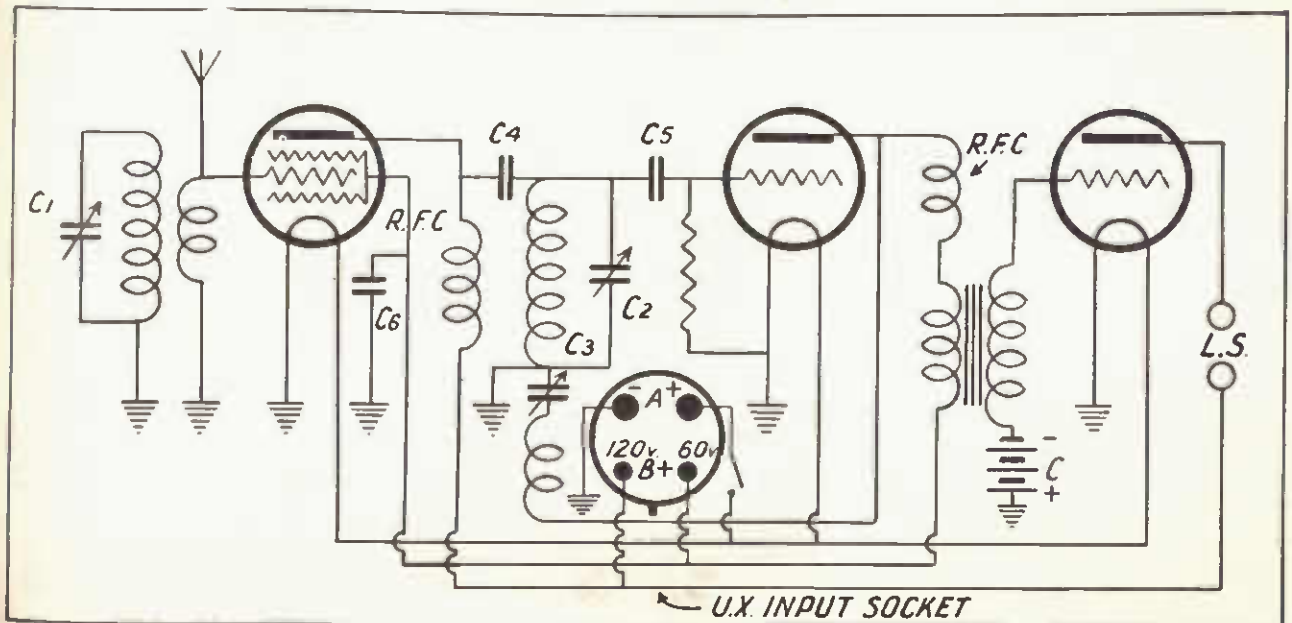

Schematic diagram of the modern short-wave receiver.

discover whether it can be easily plugged in or removed, as well as maintaining positive contact. Poor valve sockets are responsible for much noise in the average short-wave receiver, and faulty components could prevent a receiver from ever working satisfactorily.

The FILAMENT SWITCH also should be one having good contacts and positive connection. Bad noises can arise from use of a poor type of switch.

The GRID LEAK should be a metalised filament type. Carborundum and similar types will be found noisy when used in short wave receivers. A manufacturer's type of grid leak, with wire at either end, should be obtained since the use of this form of leak will save the space which would be occupied by a grid leak holder.

The GRID FIXED CONDENSER (C5), as with each other fixed condenser used in this circuit, should be non-inductive and preferably of a type which is completely sealed and uses copper plates and mica dielectric in its construction.

The R.F. COUPLING CONDENSER value will be around .00025 mfd. capacity. Several values from this capacity up to .001 mfd. may be tried, however.

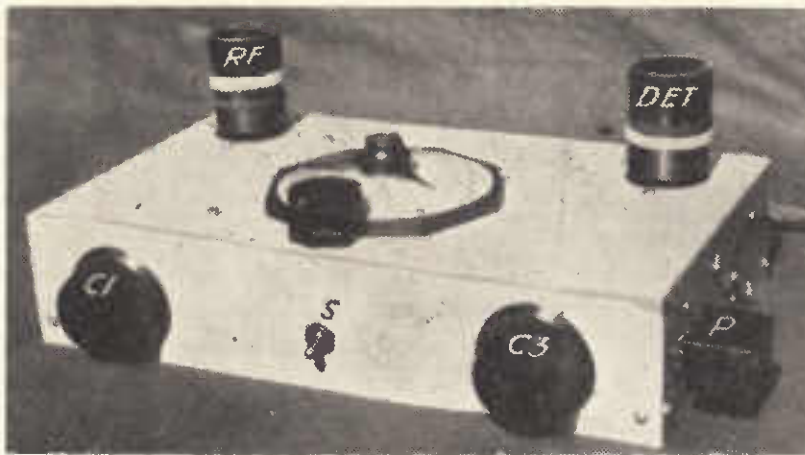

A front view of the actual receiver.

respective holders, and then placing the rest of the components. This will ensure that no component will foul a valve or

fastened to the back of the chassis. The use of the socket will prevent accidental burning out of valves and will be generally more satisfactory than terminals. The head-phone connections in the original receiver were available through the medium of a two-pin plug and socket. Terminals may be used here, however, although the socket method is safer, since the possibility of "shorting" either side of the head-phones to chassis with possible damage to the "B" supply, is eliminated. The circuit wiring is such that the "shorting" to frame of either of the "B" positive wires will short out the "B" supply, but will not harm the filaments of the valves.

The earth terminal is mounted directly to the chassis. The aerial terminal should be bushed (insulated) from the metal chassis. This can be done easily by cutting two washers from the fibre used in making the choke coil formers and mounting the terminal through a hole sufficiently large in the chassis to prevent the metal of the terminal from touching the chassis after it has been centred within the hole and tightened up with one of the washers on either side of the chassis. The terminal must be carefully centred, and must be tightened up to the fullest extent, otherwise there will be a possibility of shorting to frame (chassis).

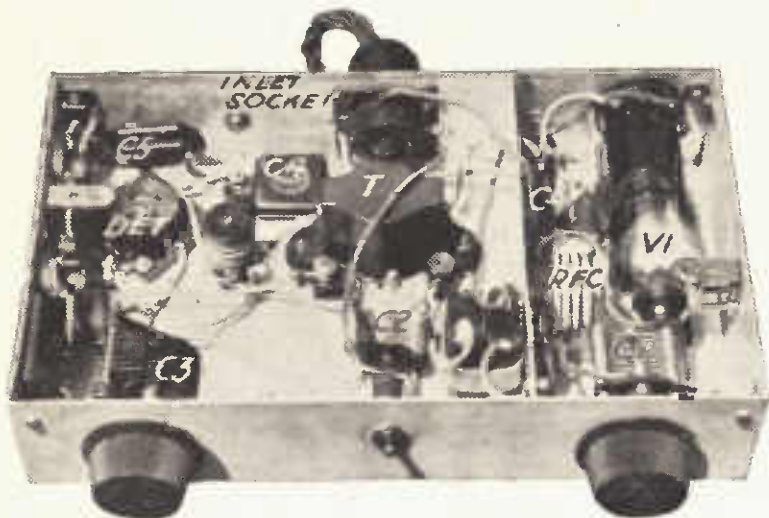

An underneath view of the receiver showing the layout of the components.

The smaller the condenser the better will be selectivity, so that the .00025 mfd. capacity value would generally be the most suitable.

The VERNIER DIAL, as with other components, should be selected with care. Its action should be absolutely smooth, and it should have no back-lash. By backlash is meant that the response of the indicating scale, on turning the dial knob, should be immediate. If the knob must be turned a fraction of an inch in either direction before the indicating scale or pointer moves, then the dial should be rejected, since it will definitely prevent satisfactory tuning.

Mounting the Parts

Positions should be carefully measured before any single component is mounted. If parts are mounted haphazardly, it will probably be found, on finishing the receiver, that one or more of the valves cannot be plugged into its socket because of the intervention of some component. The positions in the photographs of the original receiver should be approximated as nearly as possible.

Probably the best method of mounting would be to fix the three valve sockets into position, plugging valves into their

prevent its being plugged in or removed.

The power input, both A and B, to the receiver is available via the four connections of the U.X. power inlet socket

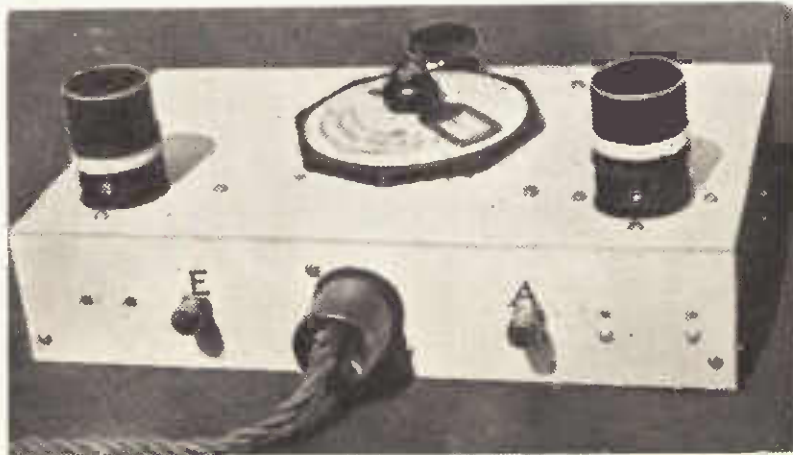

In the rear of the photograph the aerial and earth terminals can be seen with the battery cable in the centre.

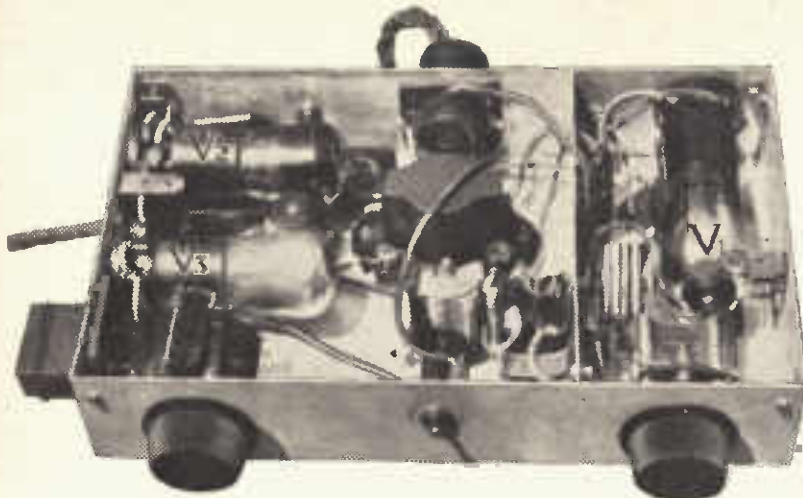

An underneath view with the valves mounted in their sockets.

- The Necessary Parts**
- Aluminium chassis, gauge 16 or 18 material, 12in. x 7in. x 2 3/4in. deep.
 - Aluminium 12in. x 7in., to fit into base of chassis.
 - Aluminium shield, 7in. x 2 3/4in., to separate r.f. stage.
 - Two 23-plate Radiokes type midget tuning condensers.
 - One 17-plate, do.
 - One 3 or 5-1 ratio audio frequency transformer.
 - Two r.f. chokes to be made by set builder.
 - 6 U.X. type valve sockets.
 - One filament switch.
 - Two terminals for aerial and earth connections.
 - Grid leak, 3 megohms.
 - Grid fixed condenser, .00015 mfd. capacity.
 - R.F. detector coupling condenser, about .00025 mfd. capacity screened grid by-pass condenser, .006 mfd. capacity.
 - Two large type knobs for r.f. and reaction condensers.
 - One vernier dial.

The Circuit Symbols

In order that the builder of this receiver can follow the order of the placement of parts when mounting, the symbols used in the circuit are placed beside the component they represent.

- C1 r.f. stage 23 plate midget tuning condenser.
- C2 detector stage 23 plate midget tuning condenser.
- C3 17 plate midget reaction condenser.
- C4 r.f.-detector coupling condenser .00025-.001 mfd. capacity.
- C5 detector grid fixed condenser .00015 mfd. capacity.
- C6 screened grid .006 mfd. capacity by-pass fixed condenser.
- R.F.C. r.f. plate and detector plate chokes.
- C is the C battery of 6 volts and mounted under the chassis in the original receiver.

Wiring

Connections in this receiver are made using rubber-covered flex wire. The wiring will make or mar the performance of the finished receiver, and the following details should be followed carefully.

Start by connecting the A positive terminal of the U.X. input socket to one side of the filament switch.

Other side of the filament switch to one filament terminal of each of the three U.X. valve sockets.

The A negative terminal of U.X. input socket to chassis.

Grid terminal of r.f. valve socket to G terminal of r.f. coil socket.

Plate and right filament terminal of r.f. coil socket to chassis.

Movable plates of r.f. tuning condenser C1 to left filament terminal of r.f. coil socket.

Plate terminal of r.f. valve socket to one side of the screened grid by-pass condenser C6 and to the B positive 60 volts terminal of the U.X. input socket.

One side of r.f. stage plate choke to one side of coupling condenser, C4, and short flex lead to connect to terminal at top of the r.f. screened grid valve.

Other side of condenser, C4, to grid terminal of detector coil socket, movable plates of tuning condenser, C2, and one side of grid condenser, C5.

Plate terminal of detector coil socket to chassis.

Left F terminal of detector coil socket to movable plates of reaction condenser, C3.

Right F terminal of detector coil socket to plate terminal of detector valve socket and one side of the detector plate r.f. choke.

Other side of grid condenser C5 to grid terminal of detector valve socket and one side of grid leak.

Other side of grid leak to chassis.

Other side of r.f. stage plate choke to B positive 120 volts input terminal of inlet socket.

Other side of by-pass condenser C6 to chassis.

Other side of detector plate choke to P terminal of primary of the a.f. transformer. B terminal of this transformer to the B positive 60 volts terminal of input socket.

G terminal of a.f. transformer secondary to grid terminal of amplified valve socket. F terminal of a.f. transformer secondary to negative side of C battery.

Positive side of B battery to chassis. Plate terminal of amplifier valve socket to one phone terminal. Other

phone terminal to maximum positive terminal of U.X. input socket.

Remaining filament terminal of each of the three valve sockets to chassis.

Aerial terminal to grid terminal of r.f. valve socket.

All tuning condenser connections should be made so that the flex leads cannot move when the chassis is jarred. If all r.f. and detector stage plate and grid connections are made as short as possible, so that they cannot move about, the receiver will be very stable in operation.

Wherever possible, solder connections. Components with nickel-plated soldering lugs attached should be fitted with tinned lugs, since it is difficult to solder to plated metal, the result usually being a dry joint and poor connections.

Wherever the flex wiring is to be fastened under a terminal or machine screw, twist a loop of the necessary size into the wire and then apply a hot soldering iron so that solder runs right

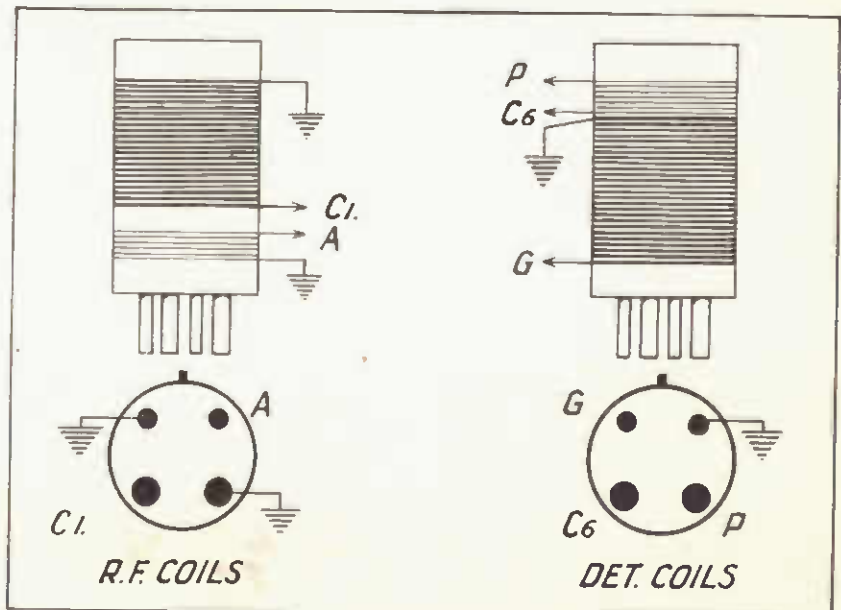

Diagrammatical drawing of the coil details.

through the flex loop. This will prevent the possibility of stray strands causing damage through shorting to frame.

The coil details are available from the accompanying diagram, which shows the placement of r.f. stage grid and tuning coils, and detector grid and reaction coils.

Looking at the diagram, it will be noticed that the grid pin of the r.f. coil socket connects to chassis. This is opposite to the instructions given in the wiring, but the connections to the r.f. grid or aerial coil can be either way round without affecting the operation of the receiver.

In the coil diagram the connections for the two U.X. coil sockets are given looking down into the sockets, and not looking up from underneath.

A space of about a quarter of an inch is left between r.f. tuning and grid coils; no space is left between detector grid and reaction coils.

The coils are wound on formers which fit tightly over the standard diameter U.X. valve base. The gauge of wire must be adhered to, otherwise coil sizes will not be correct for the above wave bands. It will be seen that the size of the reaction coil varies within wide limits. The size of this coil will be affected by the exact value of the grid leak, capacity of the grid condenser, and the r.f. detector coupling condenser, and the efficiency of the detector plate choke as well as the characteristics of the a.f. transformer primary. For this reason, the exact numbers of turns as used in the coils for the original receiver have not been given.

Each detector stage coil should be adjusted separately. The ideal point is reached when, with the fewest reaction coil turns, control of regeneration can be obtained over the whole tuning range of any particular coil. This value is not difficult to arrive at, and a little experiment will soon reveal the exact turns to be used for each detector coil.

The valves used in the original receiver were Philips, type A442 in the r.f. stage, A415 in the detector stage, and type A409 in the amplifier stage.

In the original receiver, a type A425 high impedance valve was used with a great improvement in the amplification available in the audio frequency stage. Use of this valve gave a large increase in signal strength when using a bias of 3 volts with a plate voltage of 150. Use of this valve will not give quite the same quality of reproduction available with an amplifier type of valve, but the extra gain, and the lower plate current consumption would recommend its use, particularly by those who are restricted to the use of B batteries. Two light-duty 60-volt B batteries are sufficient for satisfactory operation of the receiver. Using the type A425 valve in the amplifier stage, plate current consumption should be no more than 7 milliamperes, an ideal condition for the battery user.

Filament supply can best be obtained from a 4-volt accumulator. Accumulators and battery chargers can now be obtained very cheaply, and the low filament consumption by the three valves of this receiver requires that the average 30-ampere-hour battery be charged every three or four months with average use.

The "A" battery and two "B" positive connections between receiver and batteries are made through flex leads and a valve base to plug into the inlet socket. The "B" negative terminal is con-

nected at the battery end of the four-wire cable to "A" negative.

With a pair of coils in position, batteries, phones, aerial and earth connections made and filament switch in the on position, on turning the knob of the reaction condenser a position will be found where the receiver will go into oscillation, this condition being indicated by a rushing sound and whistles whenever a station is tuned in. For phone transmissions the best condition for reception is at a point of the reaction condenser just before oscillation commences. Transmissions are first found with the detector valve oscillating. Pure continuous wave Morse transmissions are received with the detector valve oscillating the whole time during reception. Modulated continuous wave transmissions can be received with the detector in an oscillating condition or in the position as explained for the reception of phone transmissions.

The r.f. tuning condenser knob is a sensitivity control. After tuning in a

station with detector tuning and reaction condensers, the r.f. tuning condenser is adjusted until a distinct increase in signal strength is noticeable. The point where this increase is found is marked, and cannot be missed if connections are all correct.

Angle brackets, to the back of which have been soldered a nut, are fastened into position so that the aluminium baseplate can be easily fitted and screwed up. To the bottom of the baseplate in the original receiver have been fastened six pieces of quarter-inch sponge rubber.

Whilst the receiver is in operation it should be possible to lift the chassis (provided the hands are not brought within about two inches of tuning coils) without affecting reception of any particular station. A carrier wave should not wobble when the chassis is jarred. If it does, this is a sign of loose components or wiring.

W.L.	R.F. COILS		DETECTOR COILS		
	Tuning	Grid	Grid	Reaction	
14-21 m.	3	3	3	4-7	gauge 22 d.c.c.
20-31 m.	5	4	4	5-7	gauge 22 d.c.c.
30-52 m.	10	5	9	6-10	gauge 24 d.c.c.
49-81 m.	20	8	19	8-15	gauge 24 d.c.c.
80-152 m.	38	10	36	10-20	gauge 26 d.c.c.

RECEPTION ON THE SHORT WAVES

By W.G.S.

STATIC noises and other interference brought in from outside by the aerial are fairly high at any time, and for reception of short wave phone stations noises in the receiver itself must be eliminated as much as possible.

The usual adjustments for stable operation—silent batteries and smooth reaction, with quiet control—are the essentials. In addition the slight adjustments outlined later will often bring about just that little extra which makes the weak signal stand out from the accompanying background of noise.

Earthing the "A" negative and "B" negative is useful in totally shielded sets or in receivers where a metal panel and baseboard are used for partial shielding. Where the grid returns are all to the "A" minus lead and the shield, being earthed, is also the "A" minus return, this adjustment means nothing more than connecting the "A" minus and "B" minus leads together instead of the more usual "A" plus and "B" minus.

It has the effect, where cabling or long leads are used to connect the batteries to the receiver, of eliminating the resistance of the long leads (from "B" minus to terminal strip, thence to "A" battery plus and through the "A" battery and "A" minus lead to earth) for the return path of the radio frequency currents.

Bypassing the "A" battery with 1 or 2 mfd. condensers would probably have the same effect, but the alteration outlined also takes the "A" battery and its high current capacity (storage) out of the "B" plus to earth circuit and greatly minimises the chance of an unpleasant shock through touching the metal panel when wearing head-phones.

Most detector valves will work best when the grid has a slightly positive potential impressed on it. Where all the grid returns are to the "A" minus,

the grid itself can be given a positive potential by connecting the leak between the valve grid and "A" plus leg of the tube socket, making a series connection with the grid condenser instead of a parallel connection across it. This is usually the easiest way of making an extremely short connection, because grid leak clips can be mounted under the terminals of the valve socket marked "G," and the nearest "F" and the leak slipped between them.

A slightly higher value of the leak will be required when the return is made direct to the valve leg than if a rheostat is employed between the socket and battery to obtain the same positive potential. Adjustment of the positive grid potential for detection in a short wave receiver is always rather critical, so that rheostats are best kept out of the grid return circuit by this means, or else inserted in the other filament lead.

In the process of noise elimination it is often an advantage to couple the reaction coil to the filament end of the grid coil rather than to the grid end. This results in an easier control and smaller effect on tuning as the reaction is varied. There is a simple rule to follow in connecting up the ends of the coils in this manner, which will result in being certain that the phase is correct, and that the coils will oscillate if the number of turns is correct. Assuming that the coils have been wound in the same direction, the top and bottom connections will be Grid and Plate respectively, and the two middle ends Filament and "B" plus respectively. If the coils are wound on tube bases the reaction coil will, of course, be wound at the bottom of the base and be mechanically less liable to shift when inserting or removing from the set.

"CHANEX" LEADERSHIP

Test Voltage	Safe Working Voltage
500 V.D.C.	150 V.D.C.
700 V.D.C.	200 V.D.C.
1500 V.D.C.	400 V.D.C.
2000 V.D.C.	600 V.D.C.
3000 V.D.C.	750 V.D.C.

EVERY "CHANEX" CONDENSER
CARRIES THE MAKER'S
GUARANTEE

DON'T RUN
ANY RISK !!



SPECIFY AND INSIST ON

"CHANEX"

The Condenser with a

WORLD REPUTATION

We specially wish to draw your attention to the NEW "CHANEX" for use in Receivers and Amplifiers of exacting specifications (Loftin-White and similar circuits). They are double tested on 2000 Volts D.C. and have a guaranteed WORKING VOLTAGE of 600 Volts D.C.

Stocked by Leading Radio Firms.

Sole Factory Representatives:

H. HECHT & CO.

Melbourne and Sydney

Interstate Distributors:

Queensland: J. C. PRICE, Brisbane; TRACKSON BROS. LTD., Brisbane.

West Australia: CARLYLE & CO., Perth.

South Australia: WM. T. MATTHEW, Adelaide.

Tasmania: W. & G. GENDERS PTY. LTD., Hobart and Launceston.

WORLD SHORT-WAVE CHART

LEADING INTERNATIONAL STATIONS

Call and Power.	Location and Address.	Wavelength or Freq.	Operating Schedule		Remarks.
			Melbourne Time	Station Time	
PK2AG	Samarang, Java. Radio Society of Mid., Java.	105 Metres.	M., T., W., F., Sa.—9.40-11.40 p.m. S., 12.40 a.m. to 2.40 p.m., and 9.40 to 11.40 p.m.	Same Days.—6.40 to 8.40 p.m. Sun.—9.40 a.m. to 11.40 a.m., and 6.40 to 8.40 p.m. (Subtract 3 hours.)	Seldom reported.
Radio Roma	Rome, Italy.	80 m. 3750 k.c.	Not known definitely.	Not known definitely. (9 hours behind Melbourne time.)	Audible occasionally after midnight and early morning, but not recently.
PK1AA 300 watts	Batavia, Java. Radio Society of Batavia, Hotel des Indies, Weltevreden, Java.	77.5 m.	M. to Sat.—9.40 p.m. to 12.40 a.m. Sun.—1.40 p.m. to 4.10 p.m., and 9.40 p.m. to 12.40 a.m.	Same Days.—6.40 p.m. to 9.40 p.m. Sun.—10.40 a.m. to 1.10 p.m., and 6.40 to 9.40 a.m. (Subtract 3 hours.)	Seldom reported.
RV15	Khaboravsk, Siberia. Radio R.V.15. Khaboravsk, Far East, Siberia, U.S.S.R.	70.2 m.	Daily.—7 p.m. to midnight.	Daily.—6 p.m. to 11 p.m. (Subtract 1 hour.)	Full speaker strength from about 8 p.m. or 9 p.m. usually.
PMY 250 watts	Bandoeng, Java. Wireless service of the Govt. Post and Telegraph service. Bandoeng, Java, D.E.I.	58.3 m. 5145 k.c.	M. to Sat.—3.30 p.m. to 5.30 p.m., and 9.30 p.m. to 12.30 a.m. Sun.—1.30 p.m. to 4.30 p.m., and 9.30 p.m. to 12.30 a.m.	M. to Sa.—Midday to 2.30 p.m., and 6.30 p.m. to 9.30 p.m. Sun.—10.30 a.m. to 1.30 p.m., and 6.30 p.m. to 9.30 p.m. (Subtract 3 hours.)	Fair station, operated by amateur society. Second session only audible.
HVJ 2-15 k.w.	Vatican City, Italy. Stazi-one Radio Vaticana, Citta Del Vaticano.	50.26 m. 5968 k.c.	Daily.—5 a.m. to 5.30 a.m.	Daily.—8 p.m. to 8.30 p.m. (Subtract 9 hours.)	Powerful station, used for various Papal services. Audible in early mornings at present.
ZL3ZC 45 watts	Christchurch, N.Z. 3ZC Broadcasting Service, 230 T u a m Street, Christchurch, N.Z.	50 m. 6000 k.c.	W.—4.30 to 6 p.m. F.—8.30 to 10 p.m. S.—8.30 to 9.30 p.m.	W.—6 to 7.30 p.m. F.—10 to 11.30 p.m. S.—10 to 11 p.m. (Add 1½ hours.)	Very low power. N.Z. time is advanced by one hour between October and April.
XEW	Mexico City.	49.8 m. 6000 k.c.	Not known definitely.	Not known definitely. (Subtract 16 hours.)	Heard on Sunday afternoon irregularly between 4 and 5.30 p.m.
Moscow 100 K.W.	Moscow, U.S.S.R. All Unions Central Council of Trades Unions Palace of Labor, Follanka 12, Moscow, U.S.S.R.	50 m. 6000 k.c.	Daily.—2.30 a.m. to 8 a.m.	Daily.—7.30 p.m. to 1 a.m. (Subtract 7 hours.)	Very strong station up till 7 a.m. and later.
W9XF (W.E.N.R.) 5 K.W.	Chicago, U.S.A. Great Lakes Broadcasting Coy., 30 Nth. Wacker Drive, Chicago, Ill.	49.83 m. 6020 k.c.	M.—Midnight to 3.30 a.m. T., W., Th., F., Sa., S.—1.15 to 2.45 a.m. Daily.—6.30 to 10 a.m. (M., close 9 a.m.). Mon. to Sat.—11 a.m. to 4 p.m. Sun.—3 p.m. to 5 p.m., 11 p.m. to midnight.	Sun.—8 a.m. to 11.30 a.m. M., T., W., Th., F., Sa.—9.15 to 10.45 a.m. Daily.—2.30 p.m. to 6 p.m. (S. close 5 p.m.) S. to F.—7 p.m. to midnight. Sat.—11 p.m. to 1 a.m. Sun. (Subtract 16 hours.)	Local afternoon sessions heard best here.
PK3AN 250 watts	Sourabaya, Java. Radio Society of Sourabaya. Sourabaya, Java, D.E.I.	49.7 m. 6035 k.c. 49.56 m.	Daily.—9.40 p.m. to 12.40 a.m. Sun.—10.40 a.m. to 11.40 a.m., 12.40 p.m. to 2.40 p.m. additional.	Daily.—6.40 p.m. to 9.40 p.m. Sun.—7.40 a.m. to 8.30 a.m., 9.40 to 11.40 a.m. additional. (Subtract 3 hours.)	Heard occasionally after 9.30 p.m. at fair strength.
W8XAL (WLW WSAI) 10 K.W.	Cincinnati, U.S.A. Crossley Radio Corporation, Cincinnati, Ohio, U.S.A.	6060 k/c.	Daily.—9.30 p.m. to 1.30 a.m. 4.30 to 6.30 a.m. 9.30 a.m. to 4.30 p.m.	Daily.—5.30 a.m. to 9.30 a.m. 12.30 a.m. to 2.30 p.m. and 5.30 p.m. to 12.30 a.m. (Subtract 16 hours.)	Heard best during late afternoon or early evening. 24-hour transmission on last and first day of month. Reception varies with seasons, but regularly reported.
ZL2ZX (2ZW) 400 watts	Wellington N.Z. Western Electric Co., N.Z., Ltd., Hope G l b o n s Bldgs., Courtenay Place, Wellington, N.Z.	49.51 m. 6059 K.C.	Mon. and Thurs.—5.30 p.m. to 9.30 p.m.	M. and Th.—7 p.m. to 11 p.m. (Add 1½ hours.)	Excellent station after 5 or 6 p.m. Operates irregular schedules in addition.

WORLD SHORT-WAVE CHART

Call and Power	Location and Address	W'length or Freq.	Operating Schedule		Remarks
			Melbourne Time	Station Time	
VQ7LO 2½ K.W.	Nairobi, Kenya Col. Brit. East Africa Broadcasting Coy., Nairobi, Kenya Colony, B.E.A.	49.15? 6100 K.C.	T., Th., Sa.—1.30 a.m. to 5 a.m. W., F., Sun.—2 a.m. to 5 a.m. T.—5.30 p.m. to 6.30 p.m. Th.—10.30 p.m. to 11.30 p.m.	M., W., F. — 5.30 p.m. to 9 p.m. T., Th., Sa. —6 p.m. to 9 p.m. M.—9.30 a.m. to 10.30 a.m. W.—2.30 p.m. to 3.30 p.m. (Subtract 8 hours)	Weak station heard in the early morning.
W9XAA 500 Watts	Chicago, Ill. U.S.A., Chicago Federation of Labor, 623-633 South Wabash Av., Chicago, Ill., U.S.A.	49.34 m. 6080 k.c.	First Sun. in every month. Midday to 8 p.m., corresponding with	First Sat. in every month, 8 p.m. to 4 a.m. (Subtract 16 hours.)	Low powered station heard at good strength occasionally.
D.E.I. B'casting Coy. 1 K.W.	Batavia, Java, N.V. Nederlandsch Indische Radio Omroep Maatschappij Tandjong Priok, Zuiderweg, Batavia.	49.3 m.	M.—9.30 a.m. to 10 a.m. 1 p.m. to 2 p.m. 3.15 p.m. to 4.15 p.m. 9.45 p.m. to 10.45 p.m. 11.15 p.m. to 12.15 a.m.	Mon.—6.30 a.m. to 7 a.m. 10 a.m. to 11 a.m. 12.15 p.m. to 1.15 p.m. 6.45 p.m. to 7.45 p.m. 8.15 p.m. to 9.15 (Subtract 3 hours)	Station heard regularly at quite good strength, but extremely difficult to identify.
W3XAL 12 K.W.	Boundbrook, N.J., N.B. Coy. Inc. (Operators), 711 Fifth Av., New York.	49.18 m. 6100 k.c.	Tues to Sun.—7 a.m. to 8 a.m. 1 p.m. to 3 p.m.	Mon. to Sat.—4 p.m. to 5 p.m. 10 p.m. to midnight. (Subtract 15 hours)	Excellent station being heard afternoons, relays N.B.C. programmes.
Radio Saigon 12 K.W.	Saigon, F.I.C., Campagne Franco-Indo-Chinoise de Radio-Phonie, 106 Boulevard Charner Saigon Fr.I.C.7	49.05 m. 6114 k.c.	Daily, except Wed.—10 p.m. to 1.45 a.m. Wed.—9.30 p.m. to 1.30 a.m.	Daily, except Wed.—7 p.m. to 10.45 p.m. Wed.—6.30 p.m. to 10.30 p.m. (Subtract 3 hours.)	Excellent strength. European session commences about 11 p.m.
W2XE (WABC)	New York, U.S.A. Columbia B'cast System, 485 Madison Av., New York.	49.02 m. 6120 k.c.	Daily.—10.30 p.m. to 4 p.m. next day.	Daily.—7.30 a.m. to 1.30 a.m. next day. (Subtract 15 hours.)	Irregular station not often reported. Relays Colombia B. Chain.
W8XK (KDKA) 40 K.W.	Pittsburg, Westinghouse Electric and Manfg. Co., Pittsburg, Penn.	48.85 m. 6140 k.c.	Thurs. and Sun.—7 a.m. to Midnight.	Wed. to Sat.—4 p.m. to 9 p.m. (Subtract 15 hours.)	Alternative wave length, occasionally reported.
VE9CL (CJRM) 2 K.W.	Winnipeg, Can. James Richardson and Sons, 1018 Grain Exchange Bldg., Winnipeg, Can.	48.8 m.	Daily. — 9.30 a.m. to 3 p.m.	Daily. — 5.30 p.m. to 11 p.m. (Subtract 16 hours.)	Good station, but not heard regularly. Afternoon reception best.
W2XL	Boundbrook, N.J. N.B. Coy. Inc. (operators), 711 Fifth Av., New York.	46.7 m. 6425 k.c.	Sat.—4.30 p.m. to 9.45 p.m. Sun.—2 p.m. to 11 p.m.	Sat.—1.30 a.m. to 6.45 a.m., and 11 p.m. to 8 a.m. Sun. (Subtract 15 hours)	Relays N.B.C. to Pacific Islands. Afternoon reception best.
Ren	Moscow, U.S.S.R.	46.6 m. 6414 k.c.	Daily.—Midnight to 7 a.m.	Daily—5 p.m. to midnight. (Subtract 7 hours.)	Weak station heard irreg. off broadcast band.
PLV (20 k. w.)	Bandoeng, Java (Eng. Mgr., Internationale Telephone Service, Bandoeng, Java).	31.86 m.	Daily, 5.45 p.m. to 6.30 p.m. Broadcast Session, 11.40 p.m. to 1.40 a.m. on Tuesdays.	Daily, 8.45 p.m. to 9.30 p.m. T., 8.40 p.m. to 11.40 p.m. (Subtract 3 hours.)	Aust.-Javanese Phone Service, and with Holland. Broadcasts heard regularly. Excellent station.
Radio Maroc 8 k.w.	Morocco, Rabat, Morocco, Post, Telegraph and Telephone Dept.	32.26 m.	Mon.—5.30 a.m. to 8.30 a.m.	Sun.—7.30 p.m. to 10.30 p.m. (Subtract 10 hours.)	Irregular reception. Operates telephone and telegraph with Paris normally.
VK3ME 5 k.w.	Melbourne, A.W. (Aust.) Ltd., Wireless House, Queen St., Melbourne.	31.55 m. 9507 k.c.	Wed. and Sat.—8 p.m. to 9.30 or 10 p.m.	Local time.	Operated by A.W.A.

WORLD SHORT-WAVE CHART

Call and Power	Location and Address	Wavelength or Freq.	Operating Schedule		Remarks
			Melbourne Time	Station Time	
W2XAF (WGY) 30 k.w.	Schenectady, N.Y. International General Electric Co. Inc., Schenectady, N.Y.	31.48 m. 9530 k.c.	Daily.—7 a.m. to 1 p.m.	Daily.—4 p.m. to 10 p.m. (Subtract 15 hours.)	Only fair when heard at 8 a.m. but excellent when on irreg. schedule at 9 or 10 p.m.
Zeeson 8 k.w.	Germany. Reichspost- zentralamt, Berlin- Tempelhof of Schöneberger Strasse 11-15.	31.38 m. 9560 k.c.	Daily.—11 p.m. to mid- night, 1.30 to 4.30 a.m., 5 to 9.30 a.m., and in special cases to 10.30 a.m.	Daily.—2 p.m. to 3 p.m. 4.30 p.m. to 7.30 p.m. 8 p.m. to midnight. In special cases to 1.30 a.m. (Subtract 9 hours)	Heard at best strength at about shortly after midnight. Diffi- cult to identify. Transmission in German.
W1XAZ (WBZ) (WBZA) 5 k.w.	Springfield, Mass. Westinghouse Electric and Manfg. Co., Boston, Mass.	31.35 m. 9570 k.c.	Daily.—9.30 p.m. to 2 p.m. next day. Special for Australia—Sat., 8 a.m. to 2 p.m. Sun.	Daily.—6.30 a.m. to 11 p.m. Friday. — 5 p.m. to 11 p.m. (Subtract 15 hours.)	Weak station at present — heard fairly regularly.
D.E.I. B'cast Co. 1 k.w.	Batavia, Java. N.V. Neder- landsch- Indische Radio Omroep Moatschalpij, Priok Zuiderweg, Batavia.	31.3 m.	Tues.—9.30 a.m. to 10 a.m. 1 p.m. to 2 p.m. 3.15 p.m. to 4.15 p.m. 9.45 p.m. to 10.45 p.m. 11.15 p.m. to 12.15 a.m.	Tues.—6.30 a.m. to 7 a.m. 10 a.m. to 11 a.m. 12.15 p.m. to 1.15 p.m. 6.45 p.m. to 7.45 p.m. 8.15 p.m. to 9.15 p.m. (Subtract 3 hours.)	Changes pending in this sche- dule. Good reception usu- ally.
VK2ME 20 k.w.	Sydney, N.S.W. A.W. (Aust.) Ltd., 47 York St., Sydney N.S.W.	31.28 m. 9590 k.c.	Sun.—4-6 p.m., 8 p.m.- 12 mid. Mon. — 12.30 a.m.-2.30 a.m.	Local time.	Only afternoon and morning sessions audible in Mel- bourne.
PCJ	Eindhoven, Holland. Philips Laboratories, Eindhoven, Holland.	31.28 m. 9590 k.c.	Th. — 2 a.m. to 6 a.m. Fri. — Midnight to 2 a.m. 9 a.m. to 1 p.m. Sat.—4 a.m. to 6 a.m., and 10 a.m. to 4 p.m., or Sun.—Midn. to 3 a.m.	Wed.—4 p.m. to 8 p.m. Thurs.—2 p.m. to 4 p.m. 11 p.m. to midnight. Frid. — Midnight to 3 a.m. 6 p.m. to 8 p.m. Sat. — Midnight to 6 a.m. or 2 p.m. to 5. (Subtract 10 hours)	Patchy reception lately, al- though a very old timer. Station closed till May, 1932.
Radio Goldberg 200 watts	Sourabaya. Java. R. H. Gold- berg, Sourabaya. D.E.I.	26.5 m.	Mon., Wed., Frid.—8.30 p.m. to 10.30 p.m.	Mon., Wed. & Frid. — 6.30 p.m. to 8.30 p.m. (Subtract 2 hours.)	Only recently in operation.
Radio Coloniale (Paris) 14 K.W.	France. Radio Poste Coloniale, Ministere des Postes, Telegraphes et telephone Service de la radio diffusion, 103 Rue de Grenelle, Paris.	25.2 m.	Daily.—4.30 a.m. to 6.30 a.m.	Daily.—6.30 p.m. to 8.30 p.m. (Subtract 10 hours.)	Very strong station under suit- able conditions.
Radio Coloniale (Paris) 14 k.w.	France. Radio Poste Coloniale, Ministere des Postes, Tele- graphes et telephone ser- vice de la radio diffu- sion, 103 Rue de Grenelle Paris.	25.63 m.	Daily.—7 a.m. to 9 a.m.	Daily.—9 p.m. to 11 p.m.	This schedule is now seldom suitable for reception, but is excellent during winter.
G5SW 9.5 k.w.? 16 k.w.?	Chelmsford, Eng. B.B.C., Savoy Hill, London. W.C.2.	25.53 m. 11.750 k.c.	Mon. to Fri.—10.30 p.m. to 11.30 p.m. Tues. to Sat.—5 a.m. to 10 a.m.	Mon. to Fri.—Midday to 1 p.m. Mon. to Fri.— 7 p.m. to midnight. (Subtract 10 hours)	Best reception at night for the present. Excellent transmis- sion. Varies considerably.
Radio Roma	Rome, Italy. Italiana Audi- zioni Radio- foniche sta- zione de Roma via Maria Christina, 5. Rome, Italy.	25.4 m.	Daily.—6.30 to 8.10 a.m.	Daily.—9.30 p.m. to 11.10 p.m. (Subtract 9 hours.)	Signal strength drops to zero by 7 a.m., but should improve in a month or so. Excellent transmission.
W9XAA 500 watts	Chicago, Ill. Chicago Feder- ation of Labor. 623- 633 South Wabash Av., Chicago.	25.34 m. 11.840 k.c.	Sun.—2 p.m. to Mon. 2 p.m.	Sat.—10 p.m. to Sun. 10 p.m. (Subtract 16 hours.)	Schedule not confirmed. (See 49.34 m.)

Smooth Power Flow Gives Better Tone

Use **RADIOKES** Power Equipment

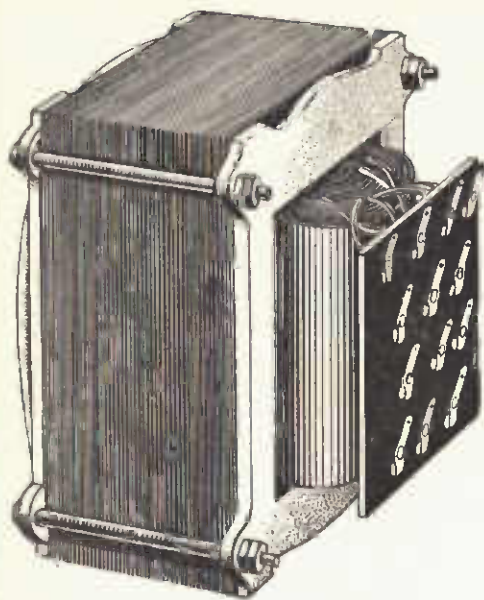

Radiokes Power Transformers

Specially heavy gauge wire and large cores used in the Power Transformer give a minimum of voltage drop on load, and ample safety factor against burning out.

The full area of core is effective because the clamping screws are outside instead of through the core.

A special terminal panel is provided with double soldering lugs which gives greater rigidity and simplifies soldering.

The transformer is easily mounted on the chassis, all wiring coming from beneath.

Pure aluminium castings are specially made to hold the laminations absolutely firmly, eliminating vibration hum.

Overall dimensions are 4in. x 4 $\frac{3}{4}$ in. x 3 $\frac{1}{2}$ in.



RADIOKES POWER CHOKES

Compactness and high efficiency are coupled features of the Radiokes power chokes.

The clamping casting is of pure aluminium, avoiding the magnetic loss which always occurs when iron is used. Magnetic saturation is avoided by using a correct air gap, kept constant with brass plates tightly clamped into the laminated core.

Soldering lugs are provided for easy connection. The choke is so compact that it can easily be placed on a sub-panel below the chassis. Overall dimensions are 2in. x 3in. x 2 $\frac{1}{2}$ in.

Transformers and Chokes by Radiokes use the finest quality stalloy cores and aluminium clamping castings. Compare the prices of Radiokes products, bearing in mind the quality of production. Remember, all Radiokes products carry a 12 months' guarantee.

Transformers

Finished with Aluminium Castings and Terminal Panel

Type Numbers.	Primary	Secondary	Output	Primary	Secondary	Notes	Price
M712	275/275	75MA.	5V.	2A.	280 type rectifier		32/6 ea.
			5V.	1A.	2-171A type		
			2 $\frac{1}{2}$ V.	6A.	3-224 or 235 types		
M714	275/275	75MA.	5V.	2A.	280 type rectifier		32/6 ea.
			5V.	1A.	2-171A type		
			4V.	5A.	5-4 volt types		
M455A	300/300	75MA.	5V.	2A.	280 type rectifier		32/6 ea.
			2 $\frac{1}{2}$ V.	5A.	3-Screen Grid tubes		
			2 $\frac{1}{2}$ V.	2A.	1-245 or 247 types		
M6043	325/325	50MA.	5V.	2A.	280 type rectifier		32/6 ea.
			4V.	1A.	C443 or E406 types		
			2 $\frac{1}{2}$ V.	5A.	3-224 or 235 types		
H455	350/350	100MA.	5V.	2A.	C.T. 280 type rectifier		39/6 ea.
			2 $\frac{1}{2}$ V.	3A.	2-245 or 247 types		
			2 $\frac{1}{2}$ V.	8A.	5-224 or 235 types		
F250	—	—	7 $\frac{1}{2}$ V.	2 $\frac{1}{2}$ A.	C.T. 2-281 types		32/6 ea.
			7 $\frac{1}{2}$ V.	2 $\frac{1}{2}$ A.	C.T. 2-250 types		
			2 $\frac{1}{2}$ V.	8A.	5-224 or 235 types		
H250	650/650	150MA.	—	—	—		39/6 ea.
M4345	330/330	50MA.	4V.	1A.	506 type rectifier		32/6 ea.
			4V.	5A.	5-4 volt tubes		
			4V.	1A.	C443 or E406		
M452	450V.	50MA.	5V.	2A.	280 type rectifier		32/6 ea.
			2 $\frac{1}{2}$ V.	2A.	1-224 or 235 types		
			2 $\frac{1}{2}$ V.	2A.	1-245 or 247 types		
M455D	475V.	50MA.	5V.	2A.	280 type rectifier		32/6 ea.
			2 $\frac{1}{2}$ V.	3.5A.	2-224 or 235 types		
			2 $\frac{1}{2}$ V.	2A.	1-245 or 247 types		
M2475	500V.	70MA.	5V.	2A.	1-280 type rectifier		39/6 ea.
			2 $\frac{1}{2}$ V.	5A.	3-224 or 235 types		
			2 $\frac{1}{2}$ V.	2A.	1-247 type		
M4347	650V.	50MA.	7 $\frac{1}{2}$ V.	1 $\frac{1}{2}$ A.	1-281 type rectifier		39/6 ea.
			4V.	2A.	1-F443 type		
			2 $\frac{1}{2}$ V.	6A.	3-224 or 235 types		
H4554	350/350	110MA.	5V.	2A.	280 type rectifier		39/6 ea.
			2 $\frac{1}{2}$ V.	3A.	2-245 or 247 types		
			2 $\frac{1}{2}$ V.	10A.	5-224 or 235 types		
			4V.	2A.	2-4 volt types		

Chokes

C30M.S.—Power Chokes, 50 M.A.	30 Henries	12/6 ea.
C50M.S.—Power Chokes, 50 M.A.	50 Henries	16/3 ea.
C30M.S.—Power Chokes, C.T., 50 M.A.	30 Henries	15/ ea.
C50M.S.—Power Chokes, C.T. 50 M.A.	50 Henries	17/6 ea.
C30 H.—Power Chokes, 100 M.A.	30 Henries	19/6 ea.
C30M.S.—Power Chokes, 70 M.A.	30 Henries	17/6 ea.

RADIOKES PRECISION PRODUCTS

Australian Made and Guaranteed by

METROPOLITAN ELECTRIC CO. LTD.

Cleveland and George Streets Redfern, Sydney, N.S.W.

AND SOLD BY ALL GOOD RADIO DEALERS

WORLD SHORT-WAVE CHART

Call and Power	Location and Address	W'length or Freq.	Operating Schedule		Remarks
			Melbourne Time	Station Time	
W8XK (KDKA) 40 k.w.	Pittsburgh, Westinghouse Electric and Manfg. Coy., Pittsburgh, Penn.	25.25 m. 11.880 k.c.	Daily. — 4 a.m. to mid- day.	Daily.—1 p.m. to 9 p.m. (Subtract 15 hours.)	Fair reception round about 7 to 8 a.m. An old-timer.
PK6KZ	Makassar. D.E.I.	25. m.	Wed. and Fri.—10.10 p.m. to 11.40 p.m.	Wed to Fri.—8.10 p.m. to 9.40 p.m. (Subtract 2 hours.)	Being reported fairly consist- ently lately. Often mistaken for a German.
HVJ 12-15kw.	Vatican City, Stazione Radio Vaticana, Citta Del Vaticano.	19.84 m. 15.120 k.c.	Daily. — 8 p.m. to 8.30 p.m.	Daily.—11 p.m. to 11.30 a.m. (Subtract 9 hours.)	Time generally unsuitable for good reception. HVJ stations used for Papal communica- tions, etc.
W8XK (KDKA) 40 k.w.	Pittsburgh, Westinghouse Electric and Manfg. Coy., Pittsburgh, U.S.A.	19.7 m. 15.210 k.c.	Th. and Sat.—4 a.m. to 7 a.m.	Wed. and Fri.—1 p.m. to 4 p.m.	No data. Should be heard dur- ing summer months.
Radio Paris Coloniale 14 k.w.	France. Radio Poste Coloniale, Ministere des Postes Tele- graphes et Telephone, Service de la radio diffu- sion, 103 Rue de Grenelle, Paris.	19.68 m.	Daily.—Midnight to 3.30 a.m.	Daily.—2 p.m. to 5.30 p.m. (Subtract 10 hours.)	Very often duplex transmission is undertaken with 25.2 m. transmitter. Excellent recep- tion at midnight.
W2XAD (WGY)	Schenectady, New York. International General Coy. Electric Coy. Inc., Sche- nectady, N.Y.	19.56 m. 15.340 k.c.	Mon. only.—3 a.m. to 5 a.m. Daily.—5 to 8 a.m.	Sun. only.—Midday to 2 p.m. Daily.—2 p.m. to 5 p.m.	Very seldom reported.
Batavia 1 k.w.	D.E.I. N.V. Neder- landsch, Indische Radio Omroep, Moatschappij Tandjong Priok Zuiderweg, Batavia.	19.55 m.	Wed.—9.30 a.m. to 10.30 a.m. 1 p.m. to 2 p.m. 3.15 p.m. to 4.15 p.m. 9.45 p.m. to 10.45 p.m. 11.15 p.m. to 12.15 a.m.	Wed.—6.30 a.m. to 7.30 a.m. 10 a.m. to 11 a.m. 12.15 p.m. to 1.15 p.m. 6.45 p.m. to 7.45 p.m. 8.15 p.m. to 9.15 p.m.	Same station as on 31.3 m. and 49.3 m.
P.L.F.	Bandoeng, Java, Eng. Mgr., Internationale telephone ser- vice, Govern- ment post Telegraaf-en- telefoon dienst in Neder- landsch Indie Bureau Inter- nationale, Telefonie Bandoeng, Java.	16.8 m.	Daily.—10 p.m. to 2 a.m.	Daily.—7 p.m. (Subtract 3 hours.)	Phone station commences traf- fic occasionally with records.
W9XAA 500 watts	Chicago, Ill. Chicago Feder- ation of Labor, 623-633 South Wabash Av., Chicago.	16.57 m. 17.780 k.c.	No reg. schedule.	(Subtract 16 hours.)	No data. Should be audible during summer.
PLE 15-20 kw.	Bandoeng, Java. Eng. Mgr., Internationale telephone ser- vice, Govern- ments post Telegraaf-en- telefoon dienst in Neder- landsch Indie, Bureau Inter- nationale, Telefonie, Bandoeng, Java.	15.93 m.	Tues.—11.40 p.m. to 1.40 a.m.	Tues.—8.40 p.m. to 10.40 p.m. (Subtract 3 hours.)	Otherwise used for phone to Holland. Good reception dur- ing summer.

MINOR SHORT-WAVE STATIONS

Call and Power	Location and Address	W'length or Freq.	Operating Schedule		Remarks
			Melbourne Time	Station Time	
PK1BR (1 k w)	Bandoeng, Java. (C/o Ego. A. Crygsman, Boela-Baal, Ceram, Moluccas, D.E.1)	58 m.	M., T., W., Th., F., 9.40 p.m. to 12.40 a.m. Sa., 9.40 a.m. to 1.40 a.m. S., 1.40 p.m. to 4.40 p.m.; 9.40 p.m. to 12.40 a.m.	M., T., W., Th., F., 6.40 p.m. to 9.40 p.m. Sa., 6.40 p.m. to 10.40 p.m. S., 10.40 a.m. to 1.40 p.m.; 6.40 p.m. to 9.40 p.m. (Subtract 3 hours.)	This station is probably identical with PMY, although the particulars supplied are dissimilar.
ZL4ZO (20 watts)	Dunedin, N.Z. (Barnett Radio Supplies, The Octagon, Dunedin)	49.2 m. (6100 k.c.)	M. to Sa., 1.30 p.m. to 2.30 p.m.; 6 p.m. to 7.30 p.m. F., also 8.30 p.m. to 1.30 a.m.	M. to Sa., 3 p.m. to 4 p.m.; 7.30 p.m. to 9 p.m. F., also 10 p.m. to 3 a.m. (Add 1½ hours.)	No reports.
PK3CH	Sourabaya, Java (Radio Shop, Sourabaya, Java, D.E.1)	45 m.	M. & W., 10.40 p.m. to 12.40 a.m.	M. & W., 7.40 p.m. to 9.40 p.m. (Subtract 3 hours.)	No reports.
PK3BQ	Sourabaya, Java (Radio Shop, Radio Nova, Sourabaya, D.E.1)	43 m.	None available.	(Subtract 3 hours.)	No reports.
XGO (20-40 k.w.)	Shanghai, China (Chinese Govt. Radio Administration, International Service, Sasson House, Jinkee Road, Shanghai, China).	39.58 m. (7580 k.c.)	No regular schedule.	(Subtract 2 hours.)	Heard between 11 p.m. and 1.15 a.m.
J1AA (3-5 k.w.)	Tokio, Japan (Kemikawoa- cho, Chiba-Ken, Japan)	38.07 m. (7800 k.c.)	None available.	(Subtract 1 hour.)	Heard between 6 p.m. and midnight.
PK6KZ	Makassar, Celebes (Rusch, Makassar, Celebes, D.E.1)	38 m.	M., W., F., 10.10 p.m. to 12.10 a.m. S., 12.10 a.m. to 2.10 a.m.	M., W., F., 8.10 p.m. to 10.10 p.m. S., 10.10 p.m. to 12.10 a.m. (Subtract 2 hours.)	No reports.
HSP2	Bangkok, Siam. Engineer Ser- vice, Royal Siamese P. & T. Dept., Bangkok, Siam.	41 m. 7312 k.c.	Mon.—11 p.m. to 2 a.m.	Mon.—7.30 p.m. to 10.30 p.m. (Subtract 3½ hours.)	Experimental broadcaster heard at excellent strength when in operation.
PKP (3 k.w.)	Medan, Sumatra (Address same as PLV. See above)	28.84 m.	Daily, 7 to 9.30 p.m.	Daily 4 to 6.30 p.m. (Subtract 3 hours.)	New phone service between Sumatra and Java. Heard reg- ularly.
PLR	Bandoeng, Java (Address same as PLV. See above)	28.2 m.	Daily, 10 p.m. to 2 a.m. When necessary.	Daily, 7 p.m. to 11 p.m. (Subtract 3 hours.)	Phone to Holland.
GBP	Hilmorton, Rugby, England. (Engineer in Chief, Radio Section, G.P.O., London)	28 m.	Daily.	(Subtract 10 hours.)	Anglo-Aust. phone terminal Heard regularly.
ZLW	Wellington, N.Z. (Post & Tele- graph Dept., Wellington, N.Z.)	27.3 m. (11000 k.c.)	Daily when necessary.	(Add 1½ hours.)	Anglo-Aust.-N.Z. phone service.
Radio Saigon (12 k.w.)	Saigon, F.I.C. (Compagnie Franco-Indo- Chinoise de Radiophonie, 106 Boule- varde Charner Saigon, Fr. I.C.)	25.465 m.	Irregular tests.	(Subtract 3 hours.)	Occasionally on Friday even- ings about 8 p.m.

WORLD SHORT-WAVE CHART

Call and Power	Location and Address	Wavelength or Freq.	Operating Schedule		Remarks
			Melbourne Time	Station Time	
CJA (10 k.w.)	Montreal, Canada. (Canadian Marconi Co., Marconi Building, 211 St. Sacramento St., Montreal, Canada).	24.793 m. (12000 k.c.)	Irregular tests.	(Subtract 15 hours.)	Aust.-Canadian phone occasionally. Telegraph communication with VIY Melb. by Beam.
PLM	Bandoeng, Java (Eng. Mgr. Internationale Telephone Service, Govts. Post Telegraaf-en-Telefoondienst in Nederlandsch-Indie, Bureau Internationale Telefonie, Bandoeng, Java).	24.46 m.	Irregular tests.	(Subtract 3 hours.)	Java-Aust. phone service, and duplex with Holland.
ZLW	Wellington, N.Z. (Post & Telegraph Dept., Wellington N.Z.)	24.46 m.	Daily when necessary.	(Add 1½ hours.)	Anglo-Aust.-New Zealand phone service.
JIAA (3-5 k.w.)	Tokio, Japan. (Radio Dept. of the Japanese Govt., Kemikawoa-Cho-Chiba-Ken, Japan).	19.036 m. (15760 k.c.)	Irregular tests.	(Subtract 1 hour.)	Experimental telephone service.
PMC	Bandoeng, Java. (Eng. Mgr. Internationale Telephone Service, Govts. Post Telegraaf-en-Telefoondienst in Nederlandsch-Indie, Bureau Internationale Telefonie, Bandoeng, Java).	16.33 m.	Daily 6.10 p.m. to 7.40 p.m. 11 p.m. to 12.20 a.m., except Sundays and holidays.	Daily 3.10 p.m. to 4.40 p.m. 8 p.m. to 9.20 p.m., except Sundays and holidays. (Subtract 3 hours.)	Duplex phone with Holland.
PCK	Kootwick, Holland (Parkstraat 29, The Hague Holland).	16.3 m	None available.	(Subtract 10 hours.)	Duplex with Java.

TO publish a complete list of all the stations in the world which are known to transmit speech or music would be to publish the official list issued by the Berne International Bureau, but it would contain many low-powered stations which can never hope to be heard in Australia except under extraordinarily favorable conditions.

The stations contained in the list on the preceding pages have nearly all been heard in recent months, or should be audible, and the operating schedules have been checked by correspondence. However, in a number of cases, there may be discrepancies of an hour or so due to difficulties encountered in converting to local time. The original schedules were quoted in standard time, daylight saving time (for the countries in question), G.M.T., G.S.T. and G.C.T., and in two particular instances both in G.M.T. and D.S.T., which did not agree, although G.M.T., as being standard throughout the world, was requested.

Irregular Phone Services.—CJA, 24.793 metres, Canadian end of beam circuit; HZA, 24.91 metres, Saigon end of Paris-Saigon phone circuit; PLM, 24.46 metres, Java end of Australia-D.E.I. service (alternative wave length); ZLW, 24.4 metres, Wellington end of Australia-New Zealand phone; FIN, 24.4 metres, Paris end of colonial service; JIAA, 20.5 metres, Japanese experimental phone; JIAA, 19.1 metres, Japanese experimental phone; FFQ, 19 metres, Paris end of Saigon service; FZR, 18.5 metres, Saigon end of same service; PMC, 16.33 metres, Bandoeng terminal of Holland-Java service; PCK, 16.3 metres, Hague end of same service.

Anglo-Australian Service, etc.—GBP, 28 metres, Rugby (England) end (alternative wave lengths are available);

VLK, 28.5 metres, Sydney end (alternative wave lengths are available); ZLW, Wellington; PLV, 31.86 metres, Bandoeng, and VLP, Sydney, on a number of wave lengths, make up the terminals for extending the service to Java and New Zealand.

Trans-Pacific Telephone (American).—KEL, Bolinas, Cal., heard on 43.46 metres mainly; KEE, Bolinas, Cal., heard on approximately 29 metres or 38.62 principally; KBK, Manila, P.I., heard on 31.25, and 45 metres approximately; HQH, Kunuku, Hawaii Islands, heard on about 40 metres.

Trans-Atlantic Telephones.—WND, 16.36 metres, 22.4 metres, 32.7 metres, 44.4 metres, to GBS, Rugby (Eng.); WLO, 14.01 metres, 18.44 metres, 28.44 metres; WMI, 15.14 metres, 20.05 metres, 30.9 metres, to GBU, Rugby; WNC, 15.61 metres, 20.73 metres, 30.77 metres, to GBW, Rugby; GBU, 16.11 metres, 24.41 metres, 30.15 metres, to WMI, Deal, New Jersey; GBS, 16.38 metres, 24.16 metres, 42.9 metres, to WND, Deal, New Jersey; GBW, 16.54 metres, 20.7 metres, 30.6 metres, to WNC, Deal, New Jersey.

Atlantic Ship Phones.—GFVV, s.s. Majestic, on one or other of 17.1 metres, 22.5 metres, 34.1 metres, or 72.7 metres; WSB, s.s. Leviathan, on 7.1 metres, 33.5 metres, 34.1 metres, 35.5 metres, 65.1 metres, or 72.7 metres; DDDX, s.s. Bremen, 130 metres; GLSQ, s.s. Olympic, 23.5 metres, 35 metres, 13 metres; OCW, 36 metres, is the English terminal; WOO, 17.52 metres, 23.36 metres, 34.76 metres, 73.13 metres, 96.03 metres, and 46.1 metres, is the American terminal; GZA, 62.7 metres, is at Drummondville, and works with s.s. Homeric.

Harrington's Announce . . .

The "DUFFY" SHORT WAVE TRANSPOSER

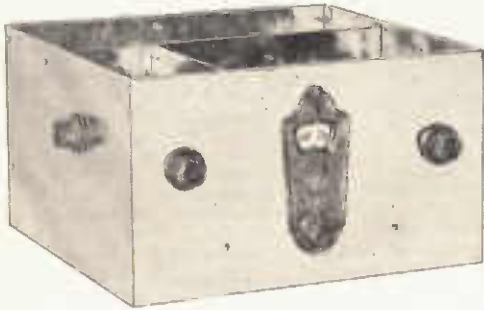

Model DSW 50

HAVE YOU EXPERIENCED THE
FASCINATION OF RECEIVING
THE PROGRAMMES FROM, SAY:
STATION G5SW, LONDON?

APPRECIATING the extraordinary significance of the progress made in Short Wave Broadcasting, extensive experimental and constructional activities are continuously in progress at our Radio Research Laboratories, VK2HR Waverley, Sydney.

THE "DUFFY SHORT WAVE TRANSPOSER"

Represents the latest proven developments in Short Wave Receivers.

All old theories have been rejected, entirely new principles incorporated.

It operates in conjunction with your present All-Electric Radio Set. You can hear on your own loud speaker, the programmes from the world's most famous short wave stations.

Call or write for descriptive information—gladly supplied.

And also the . . .

Pilot A.C. Super Wasp With Screen Grid Detector



THE WORLD'S MOST FAMOUS ALL-WAVE RECEIVER

Further proof of leadership! This famous Short and Long Wave Receiver now comes equipped with the new P224 Pilotron, giving four times the signal strength on short waves and three times on the broadcast band. Reaction is made smoother, and an additional control gives a vernier adjustment to the reaction, controlling same without affecting the tuning.

Price: Assembled Chassis (A.C.), less power pack . . . £25

Complete in Table Model Cabinet £42/10/-

Special service to all owners of Pilot A.C. Super Wasp Sets. We will completely overhaul your set.

- | | |
|--|--|
| 1. Cleaning and testing Condensers. | 5. Testing and marking all valves on our new Weston Testing Panel. |
| 2. Resoldering and electrically testing all joints. | 6. Installing the new Screen Grid method of Detection, which gives the advantages described above. |
| 3. Balancing and adjusting Coils on Oversea Signals. | |
| 4. Logging Signals and marking dials. | |

All work carried out at the Experimental Station—VK2HR, Waverley—under the personal supervision of our Short Wave Research Engineer, Mr J. Duffy, who has perfected this Screen Grid Detector invention.

Complete Cost of Converting — £5

266 COLLINS STREET
MELBOURNE
Phone Cent. 4070

Harringtons
PHOTO-RADIO-CINE-MERCHANTS

386 GEORGE STREET
SYDNEY

Wholesale:
213 Clarence Street, Sydney
Branches in all States and N.Z.

SHORT-WAVE AERIAL COUPLINGS

THERE are three standard methods of coupling a short-wave receiver to the aerial, and the diagrams reproduced show two of them. Both have a considerable number of adherents, although for both there are a number of disadvantages which can be enumerated.

The first diagram illustrates inductive coupling, and consists of a coil of about seven or eight turns of wire on a 1½-in. diameter former, placed in close proximity to the tuning coil. Small current oscillations induced in the aerial circuit set up an electro-magnetic field which links with the secondary or tuned coil, setting up similar oscillations in this circuit when it is tuned to the frequency of the incoming signals.

The tuning of the secondary has a tuning effect on the aerial coil if the two are closely coupled, and the aerial coil also has an undesirable influence on the secondary under the same conditions. The aerial circuit "pulls" a certain amount of energy from the secondary, resulting in an increased resistance and a lowered selectivity. At the same time the transfer of energy from the aerial to the tuned circuit, and therefore the signal strength, is more or less dependent on the closeness of coupling, so that a compromise must be effected.

The aerial coil must be arranged in some way in which the coupling, or the distance between the two coils, can be varied, and a position determined where the selectivity and transference (signal strength) are at a maximum, with neither maximum selectivity and poor transference, nor maximum transference and poor selectivity.

It will be found by experiment that considerably looser coupling will be required on the lower bands than on the higher wave length of about 100 metres, so provision should be made whereby the coupling can be varied within set limits for each band of wave lengths covered by any one coil.

Another effect which will be noticed with inductive coupling is that, when searching for stations at certain points on the dial, the receiver goes out of oscillation completely. This is due to the aerial getting into tune with the fundamental or some harmonic frequency (fundamental multiplied by 1, 2, 3, or 4, etc.) of the tuned secondary circuit.

A receiving aerial consists of a length of wire having inductance, due to its length and capacitance to earth (the suspended wire and the earth about it, each forming one side of a condenser with the air in between as the dielectric).

Having inductance and capacitance, the combination forms a closed circuit

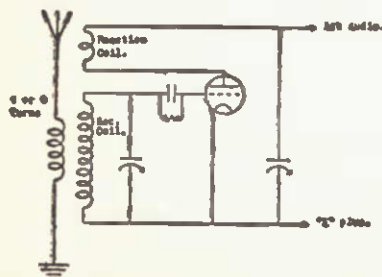

Fig. 1. Showing inductive coupling by means of an aerial coil.

A discussion on the merits of inductance and capacitive coupling

By W.G.S.

(Fig. 3), which will have a fundamental or natural frequency, or some harmonic thereof, to which it will tune. The natural period is bound to fall within the range of the closed secondary circuit, and we get these "dead spots."

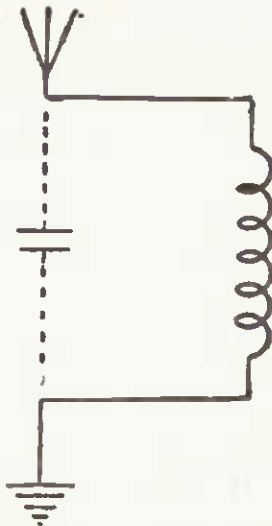

Fig. 3. The inductance of the coil and the capacity of the aerial-earth system form a closed contact.

Fortunately, the degree of coupling between the circuits also has a bearing on the natural period of the aerial, and to shift the dead spot all that is necessary is a further variation of the coupling coil.

Capacitive coupling (Fig. 2) is one method of minimising dead spots, and at the same time eliminating the mechanical difficulties of a variable coupling coil.

The diagram has been drawn slightly from the conventional to illustrate more clearly that this method also includes inductive coupling — the tuned secondary coil acting as an "auto-transformer" INCLUDED IN THE AERIAL CIRCUIT.

The insertion of the small coupling condenser (C1) in series with the aerial lead in has the effect of reducing the total capacity of the aerial system to a very low value (the total capacity of condensers in series is less than the capacity of any one of them), and the natural period to which it will tune, to a value outside of the band of wave lengths covered by any particular coil. The selectivity/transference ratio mentioned above can also be varied by means of the coupling condenser, but is not as difficult as with inductive coupling, and the adjustments outlined below will prove quite sufficient.

The series condenser must be of a very low capacity, and may consist of a small sized two plate midget in which the plates are well spaced. It

is an advantage to have the coupler continuously variable, although, after being fixed for one of the lower bands, it will require little or no attention for the others. Having the coupler continuously variable enables the operator to adjust each coil quickly, not only for dead spots, but also for selectivity and signal transference.

A substitute can be made with two pieces of brass or copper strip bent to the shape of a letter "L" with the opposing faces about half an inch square and mounted on a piece of bakelite about one-eighth of an inch to half an inch apart. The separation can be roughly fixed for maximum signal strength, and selectivity before being finally screwed down and the final adjustment made by opening out the faces with the fingers, etc., when a dead spot is encountered.

More elaborate couplers of this sort may suggest themselves to individual readers. Several which have been effectively used by the writer consisted of two farthings, or brass discs of similar dimensions, mounted on pieces of busbar wire twisted at one end like a toasting fork. The "handle" end was left rather long and just sufficiently wide to screw down under a couple of binding posts mounted on bakelite. Couplings up to 1½ inches were possible with this small condenser, and with another consisting of similar discs mounted on a screwed brass rod, which in turn was tapped into old-fashioned telephone terminals again mounted on bakelite, and thus provided a micrometer adjustment.

Such extremely minute adjustment, however, is not necessary for every-day purposes, but whatever means are employed, care should be taken, when mounting the coupler, to ensure that it does not offer too great a capacity to earth via the metal shielding, panel or baseboard. This would provide a high frequency short circuit to earth for the aerial currents, and can be obviated by keeping it away from the metal by about 1½ inches.

If a midget condenser is used for the coupler and mounted on a metal panel, it will be necessary to insulate both plates therefrom, otherwise the aerial will be directly short-circuited. Some readers may prefer to mount the midget behind the panel, as would be done in the case of the home-made couplers.

The third method, "tube coupling," requires the use of an extra valve (screen grid type), working on a radically different principle.

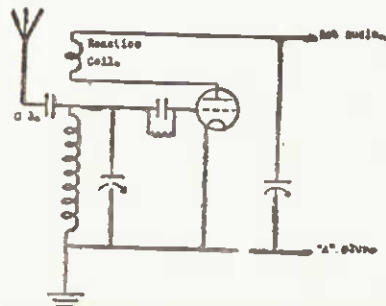

Fig. 2. A series condenser in the aerial lead provides capacitive coupling.

SYSTEMS of TONE CONTROL

By VK3FO

THE subject of tone control has recently been brought to the attention of listeners through the advertisements of radio firms.

For the benefit of the home constructor, a review of the many methods of controlling the tone of a valve receiver is given.

Tone control means changing the relative strength of various audible frequencies, while other frequencies remain unchanged. The distinctive quality or "timbre" of an audible sound can

vastly improve the reception. Also, local "static" interference may be minimised by judicious use of the tone control; naturally, there will be less "brilliance" of reproduction, but it is more enjoyable to listen to this than to the naturally reproduced programme interspersed with an equal volume of static.

Quality of Interstate Stations

Interstate stations come through with a quality differing to that of a high-powered local; this is not so noticeable with a modern receiver as with an older set. By the use of a tone control the older set is greatly improved in this respect.

Some broadcasters talk into the microphone with a normally heavy voice and sound to listeners as though they "were talking into a barrel." Here, again, a slight modification of the audio amplification characteristic of the receiver will entirely alter the reproduction.

It is essential to insert the tone control in the audio side of the set in order to control not only the reproduction of transmitted signals, but also the reproduction of gramophone records when using a pick-up. In the latter case, the needle scratch can be controlled as the owner deems necessary.

Among radio engineers it is a well-known fact that there are many listeners who rarely hear notes above a certain frequency, considerably below the average limits of audible reception. As a tone control properly designed can bring the high notes to a lower volume level, it is of great value to listeners who are unable to hear high notes or frequencies.

There are many radio sets which reproduce programmes with a fidelity which varies to a certain extent with the position of the volume control. At low volume there is generally a loss of base notes. If a tone control is fitted then this defect can be remedied.

As can be seen, the advantages of a tone control are considerable, and no wireless enthusiast or listener should hesitate to incorporate one in his present receiver.

Examples of Tone Controls

In Fig. 1 the tone control consists of a number of fixed condensers ranging in capacity from 175 mmf. to 1450 mmf., connected to a switch with 4 contacts, the moving arm of which is earthed.

By moving the switch arm to C4 contact the tone of the reproduction is deepened; bringing the arm back to C3 contact the tone is a shade less deep. In this manner four shades of tone are obtainable.

This system of controlling the tone was one of the first adopted by set manufacturers, but was soon dispensed with in favor of the type shown in Fig. 2, which is operated by means of a single switch.

The condenser, C, has a capacity of .004 mfd. and resistance, R, has a value of 650,000 ohms, the tone being varied by closing the switch.

The limitation of this system is that only one variation of tone is available. This could be overcome, however, by using a variable resistance of roughly

one megohm in place of R, and different capacity condensers.

Another system of control is shown in Fig. 3, the action of which is gradually to change the value of the coupling condenser.

A .001 fixed condenser connected in parallel with a one megohm variable resistance is inserted between the grid of the last audio valve and the coupling condenser, in order to control the tone.

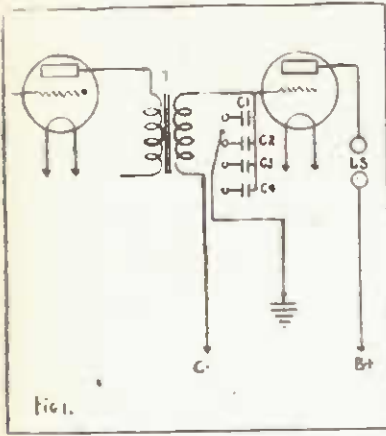

One of the first tone controls adopted by set manufacturers.

be modified to such an extent as entirely to mislead the listener as to the true origin of the sound. For example, a violin can be made to sound like a cello; or, a baritone like a bass, and a soprano voice can be made to sound like an alto. In each of these examples the effect is obtained by reducing or removing a portion of the high notes. The opposite effect is obtained when the low notes are removed or reduced, while the high notes are not affected.

All valve receivers should have tone control fitted in order to compensate for various deficiencies in the broadcasting stations. For instance, a slight distortion may creep into one of the transmitting circuits and may go uncorrected for the rest of the programme. Modification of the received signal will

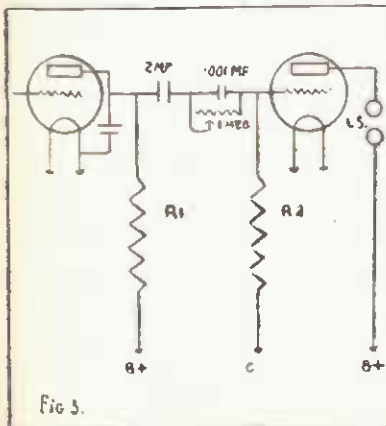

A tone control for a resistance coupled amplifier.

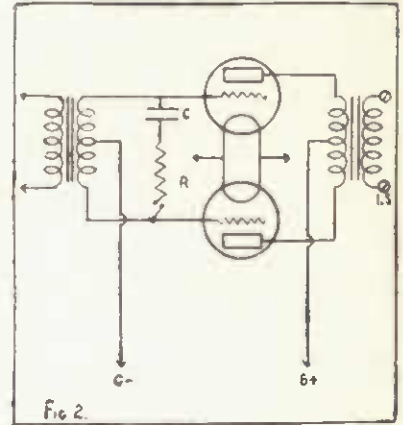

By means of a switch the tone of this push-pull amplifier is altered.

The advantage of this combination is that, although the volume is reduced, there is a greater reduction of low notes than of high; an opposite effect to that obtained when condensers are used to by-pass high frequencies around transformer windings.

If this tone control system is used, care must be taken to make the leads of this unit as short as possible, in order to eliminate the hum which would otherwise be picked up by the grid wire.

Figure 4 shows a tone control connected across the secondary of an output transformer. The value of the variable is 50,000 ohms and the capacity of the fixed condenser is .006 mfd. This system is effective and is very simple to install in any receiver. Another feature in its favor is that a gradual variation of tone is obtainable.

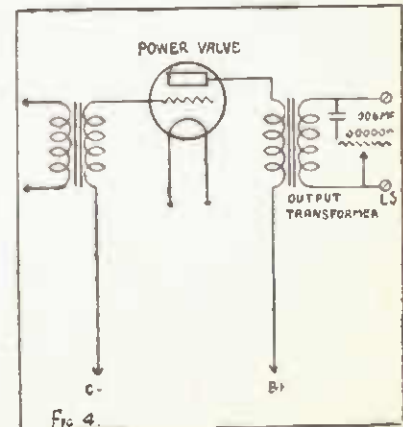

This tone control is simple and effective.

ELIMINATING UNWANTED OSCILLATION

ONE of the difficulties that the set builder has to contend with in designing a valve receiver is to prevent uncontrollable oscillation.

Were it not for the electrical oscillation which valves produce, broadcasting would not be possible. But, although valves are deliberately made to oscillate in transmitters by adjusting various circuits, valves in receivers should only oscillate when required to.

If valves did not oscillate, but merely amplify, as they are generally intended to in a multi-valve receiver, it would be a simple matter to build a set that would be able to receive the overseas stations by using a sufficient number of

OSCILLATION

How to overcome and control oscillation due to feedback

By VK3FO

is tuned to the higher frequencies than to the lower ones, but incorporated in the set there is generally a means for controlling these oscillations.

This feedback is caused by a portion of the signal strength in the plate circuit of the R.F. valve being sent back to the grid circuit, which increases the signal strength fed into the grid and the amplification. This process of feeding back is called regeneration.

Enough of the output power can be fed back to the grid side to overcome the resistance in the grid circuit. When the output power overcomes the grid resistance the maximum point of regeneration has been passed and the point of oscillation is reached.

Although regeneration vastly increases the receiving signal, no distortion is caused if used in moderation. But if oscillation takes place in a valve it is almost impossible to hear music or speech, or if they are heard they will be badly distorted.

The difference between regeneration and oscillation will be seen.

Causes of Oscillation and Prevention

In Fig. 1 the manner in which the energy in the plate circuit feeds back to the grid circuit is shown.

Oscillation may be prevented by arranging the couplings through which the energy can feed back between the output and input circuits in such a manner as to eliminate feedback. These couplings may be capacitive, such as a coupling between two wires, or inductive, an example of which is the coupling between two coils. Coupling may also take place through resistance, such as that of power units, connected to more than one stage.

Another method of preventing oscillation is to neutralise or balance our feedbacks by allowing an undesired feedback to take place, and adding another feedback which sends energy in the opposite direction into the grid circuit in the same amount as that of the undesired feedback, so that the two balance each other. An example of this is the neutrodyne receiver.

In Fig. 2, a system of controlling the oscillation of a radio frequency valve is shown, and was used to a large extent in the earlier types of receivers. By moving the arm of the potentiometer to either the positive or negative side of the resistance, the bias applied to the grid of the valve is altered, and results in increased or decreased plate current.

One of the simplest ways of stopping oscillation in a R.F. valve is to insert a resistance in the grid circuit, as shown in Fig. 3. The value of the resistance may be as high as 1200 ohms, but it is advisable to keep the value as low as possible, or lack of sensitivity and poor selectivity results.

Reducing the plate voltage applied to the anode of a valve by means of a

variable resistance stops the valve from oscillating. This method of controlling oscillation is more satisfactory than that of altering the bias.

A sketch of the connections is shown in Fig. 4. It will be noticed that a by-pass condenser is shown connected across the resistance, the action of which is to by-pass radio frequency currents. The capacity of the fixed condenser is .01 mfd., and the value of the variable resistance is 50,000 ohms.

An annoying howl is often caused by feedbacks from audio frequency stages to preceding amplifying stages. This trouble may be eliminated by using short wiring connections in the audio amplifier and by shielding the audio

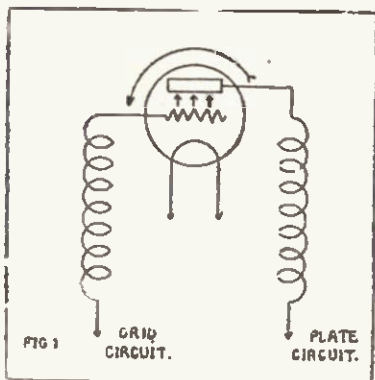

Showing the feedback between the plate and grid circuits of a valve.

valves. Naturally the static would be terrific, but the stations would be heard.

The greater the number of radio frequency amplifying valves that are used the greater is the tendency for the valves to oscillate due to feedback between the R.F. circuits.

It will be noticed, when operating a receiver which has at least one stage of R.F. amplification, using three electrode valves, that the receiver tends to oscillate when tuning in the lower wave-length stations, unless it is perfectly balanced, which is very seldom the case.

The reason for this is that, owing to the design of the set, a greater feedback occurs between the grid and plate circuits of the R.F. valve when the set

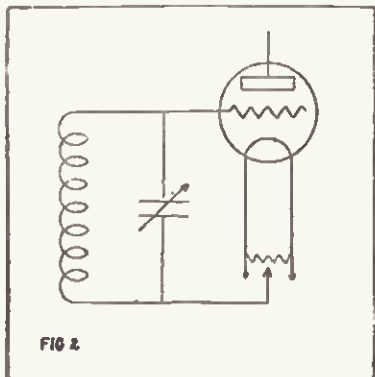

Potentiometer method of controlling oscillation in an R.F. valve.

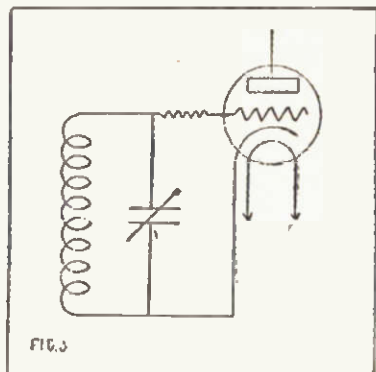

Resistance method of eliminating oscillation.

side from the remaining portion of the set.

If a loud speaker cord is placed near the aerial terminal of a set employing radio frequency valves, a feedback will occur, resulting in a howl.

Capacity feedbacks are generally the most troublesome, as they are the most difficult to locate and the hardest to remedy.

A common offender in this respect is a feedback due to plate and grid wires of an audio amplifier running parallel. This can be eliminated by keeping the plate and grid wires as far away as possible. When it is necessary that they should come near each other, run them at right angles.

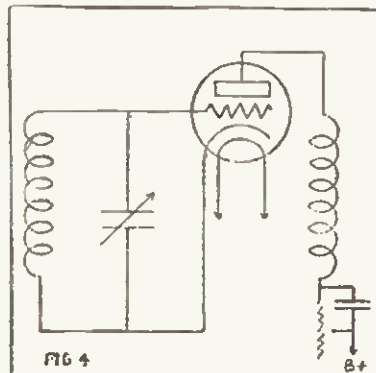

By varying the plate voltage of a valve oscillation is controlled.

All-Wave Receivers Trouble Chart

POSSIBLE SOURCE OF TROUBLE	NO RECEPTION	VOLUME WEAK	IRREGULAR RECEPTION	DISTORTION	NOISY RECEPTION	HUMS & WHISTLES
"A" BATTERY	Battery exhausted. No water in storage battery. Battery terminals corroded.	Battery exhausted. Poor connection at corroded terminals. Charger not equal to demand on battery. Trickle charger not functioning.	Loose connection.	Battery exhausted.	Battery sulphated. Connected charger operating.	Hum from charger operating. Whistles from depleted battery.
"B" BATTERY	Battery exhausted. Battery not properly connected.	Battery exhausted. Volume starts off well but quickly diminishes while set is played.	Defective cell. Loose connection.	Battery exhausted.	Erratic noises — battery exhausted. Fluttering, motor-boating high resistance of run-down battery.	Whistles from run-down battery.
POWER PACK	Not connected to power socket. Rectifier valve not operating. Filter coils burned out. Resistor burned out. Fuses in power supply burned out. Plate of rectifier valve red-hot — condenser broken down or short circuit in filter. Electric light line power off—or fuse blown.	Eliminator overloaded. Rectifier valve worn out. Transformer short-circuited. Buffer condensers punctured. Filter condensers punctured. Improper resistor values in voltage divider. Electric light line voltage too low.	Interrupted current supply from power lines. Poor voltage regulation of power line.	Plate voltage too low. C bias resistors not properly adjusted. Too high resistance in choke coils. Insufficient capacity of filter condensers.	Defective resistor in voltage divider. Sparking over punctured condenser. Motor-boating — insufficient capacity of last filter condenser. Improper value of resistors in voltage divider. Rectifier valve wearing out.	Transformer not balanced on centre tap return. Eliminator overloaded. Insufficient inductance in chokes; cores too small; resistance too high. Insufficient capacity in condensers. Choke coil short circuited. No grounded shield between primary and secondary of power transformer. Eliminator not shielded. Coupling between A.F. amplifier stages and eliminator, placed too close to set.
AERIAL AND EARTH	Aerial earthed. Aerial disconnected. Earth connection open. Defective lightning arrester.	Aerial disconnected. Aerial poorly insulated. grounded or wire corroded. Aerial too short. Aerial too long; insert midgeet condenser. Coupling between aerial coil and secondary too loose. Loose or corroded ground connection.	Swinging aerial becoming grounded at times. Loose or corroded ground connection.	Parallels, or too close to aerial of near-by oscillating receiver.	Aerial too close, or parallel, to power lines. Aerial too long, picks up too much stray noise. Loose or corroded ground connection. Aerial runs too near interfering electrical devices.	A.C. hum or commutator ripple picked up from near-by power lines. Negative side of filter circuit not grounded. (B—)
VALVES	Valve burned out. Valve paralysed. Valve prongs not making contact.	Valves exhausted. Wrong type of valve used. Power detector not warmed up. Too much grid bias. Corroded valve contacts.	Imperfect prong contacts. Detector valve paralysed. Improper value of grid leak.	Valves worn out. Valves getting insufficient current. Improper C bias on grids. Detector valve overloaded. Wrong type of valve in last stage.	Microphonic valves; require cushioned sockets. Gaseous rectifier valve aging. Hissing, due to power detector valve starting characteristic, or worn-out valve.	Valve deteriorating. Too high voltage on detector valve. Wrong type of A.C. valve in detector stage. No centre tap on detector valve filament circuit.
CIRCUIT	Switch open. Open circuit in set. Burned out A.F. transformer winding	Insufficient regeneration (S.W. set). Aerial too long (S.W. set). Grid leak improper value. Imperfect contacts. Defective piece of apparatus. Neutralisation system out of adjustment. Insufficient plate voltage. Burned out A.F. transformer winding.	Loose connection somewhere in set, eliminator, power supply or speaker connection. Sharply moving wires or set while in operation will accentuate trouble.	Over regeneration. Near-by oscillator. Poorly designed transformers. Coupling condensers too small. Circuit too sharply tuned. Last stage inadequate. No biasing on valves.	Squeals, bleeps—set not neutralised. Neutralising condensers not properly adjusted. Defective grid leak. Motor-boating — lower the value of resistors in resistance coupled amplifiers. Broken wire or imperfect contacts. Burned out audio transformer.	Oscillation from over-regeneration. Set not properly neutralised. Magnetic feed back between stages. Open grid circuit. Centre tap of transformer not balanced. Grid return to centre point of potentiometer across A.C. valves not properly adjusted.
SPEAKER	Speaker disconnected. Open circuit in speaker unit, jack, plug or cord. Speaker short circuited. Coil in speaker unit burned out.	Speaker out of adjustment. Loose contact. Leak across speaker cord. Choke coil in output circuit has too high resistance or insufficient impedance.	Defective cord, jack or plug.	Speaker overloaded; eliminate direct coupling by using output transformer or choke condenser coupling. Not matched to valve in last stage. Poorly designed speaker.	Sound vibrations communicated from speaker to valves in set. Electrical feed back from speaker cord to amplifying circuits.	Buzz or rattle in dynamic speaker due to moving coil rubbing against pole pieces. Hum due to worn out rectifier. Feedback from speaker circuit to amplifying stages due to sound vibrations communicated from speaker to valves in set.
GENERAL	Incorrectly wired set. Shielded location of dead spot. S.O.S. on air. Set not turned on. Breakdown at broadcasting station — try another station.	Set inadequate. Spot poor for reception. Fading.	Breakdown at broadcasting — try another station.	Improper tuning. Fading. Weather condition. Un satisfactory transmission from station — try another station.	Static—try disconnecting aerial and earth. Eliminator too close to set. Near-by regenerative set. Sparking electrical machinery.	Two stations on nearly same wave-length cause heterodyne whistle. Interference from near-by oscillator. Near-by regenerative or oscillating receiver.

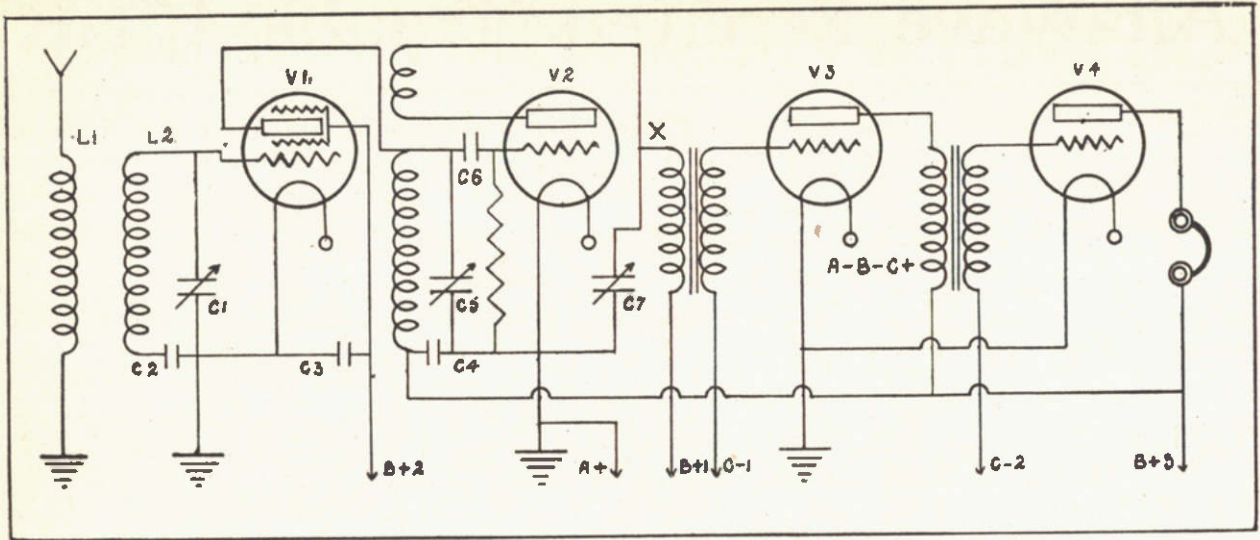

Schematic diagram of the Short-wave Four Valve Receiver.

THE SHORT-WAVE FOUR VALVE

THERE are many listeners who wish to build a short wave receiver, but hesitate to do so owing to the difficulties encountered in the construction of a set of this type.

The set which is described in this article has been designed so that the novice will have no difficulty in the construction and operation, providing instructions are carefully followed.

After experimenting with various circuits, the one shown below was finally adopted owing to its simplicity and straight-forwardness.

On glancing at the circuit it will be seen that it consists of a tuned radio frequency stage employing a screen-grid detector valve followed by a three electrode detector valve using a variable condenser to control the oscillation, and two stages of transformer-coupled audio frequency amplification.

Using this method of oscillation the detector valve is extremely sensitive and has the advantage over the resistance system as the voltage applied to its plate is constant.

It will be noticed that no rheostats are employed for altering the filament voltage of the valves. None are needed as the valves used in this receiver function best at their rated voltage.

After testing various types of coils it was finally decided that the valve base coils would be used.

It was found that no radio frequency choke was required in the plate circuit of the detector valve. This was due to the audio transformers having a very sharp cut-off at the high frequency end of the amplification curve.

The set is built on an aluminium chassis, the components being mounted in such a manner as to enable short grid and plate leads. All filament and battery leads are taken underneath the sub-panel to their respective connections.

A Simple battery operated four valve receiver capable of receiving the overseas stations at speaker strength

By F. OLSEN

otherwise noise may result when the movable plates of the condensers are rotated. Midget condensers may be used provided they are of the correct capacity.

SOCKETS.—These are of the UX type, and should be baseboard mounted. Sub-panel sockets may be used for the coil sockets, as they are held above the sub-panel of the set by means of fibre bushings, but should not be used for the valve sockets.

AUDIO TRANSFORMERS.—Only high grade transformers should be used having a ratio of approximately 3 to 1, as the quality of the reproduction depends on these. If transformers having a high ratio are used, it would be advisable to connect a 500,000-ohm variable resistance across the secondary of the first transformer in order to prevent overloading of the power valve when using the broadcast band coils.

VERNIER DIALS.—These should have a high gear ratio, and should be free from backlash, otherwise tuning will be rather difficult on the high frequencies. Although no vernier dial was used to rotate the reaction condenser the builder may use one if he wishes to balance the appearance of the panel.

TERMINALS.—Eleven terminals are required, two for the speaker, two for the aerial and earth, and the rest for the batteries.

Any particular type of terminals may be used, as they are fastened to an ebonite strip. Banana sockets may be used in the place of terminals.

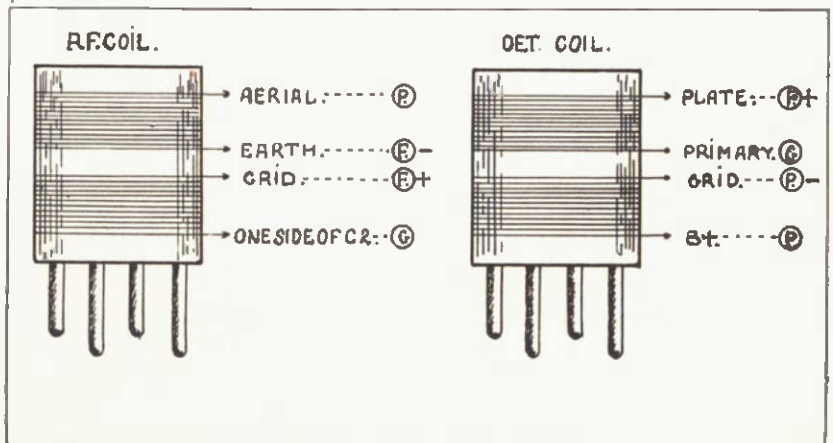

Showing the coil details.

Review of the Components

VARIABLE CONDENSERS.— It is essential that the variable condensers be of good make and solid construction,

VALVES.—Those used in the set described here are Philips type A 442 for the radio frequency stage, A 415 for the detector socket, B 406 for the first audio stage, and B 405 in the last audio stage. Any reliable make of valves may be used providing they are of similar characteristics to that of the valves just mentioned.

Coil Details

All coils are wound on UX bases, and cover a wave length of from 12 to 100 metres. Also a wave length range of 200 to 500 metres is covered, using different gauged wire to that of the short wave coils, and wound on a celluloid former covering the valve bases.

The diagram of the connections for the coils is shown in the accompanying illustration.

To wind a coil, first hold a soldering iron to each pin of the valve socket, and draw the wire which originally was connected to the elements of the valve, and at the same time blow the molten solder out of the hollow legs by blowing from the top of the valve base with the mouth.

Now drill a 1-16 inch hole about 1-8th of an inch from the top rim of the valve base directly in line with the valve pin to which the wire has to be soldered.

Remaining coils, which cover from 350 to 500 metres, are wound with 32 gauge wire, except the reaction coil, which is wound with 36 gauge enamel wire.

In the case of the broadcast band coils, it was found that the reaction coil worked just as well jumble wound as in the ordinary fashion. These coils are wound on the celluloid extensions fitted over the valve bases, as the length of the valve base is insufficient to allow for these windings.

The following is the number of turns for the various coils for the different wave bands:—

W.L. in Metres	R.F. Aerial	R.F. Grid	Detector Grid	Detector
10-15	2½	2½	2½	2½
15-30	5½	6½	5½	5½
30-50	6½	9½	8½	10½
50-100	12½	17½	15½	14½
200-350	15	95	95	30
350-500	15	190	190	35

Construction

The sub-panel consists of a sheet of 18 gauge aluminium 15 inches long by 8 inches wide. This is fastened to three strips of ebonite by means of brackets, the length of the longest strip which holds the sockets for the battery connections being 15 inches. The other two

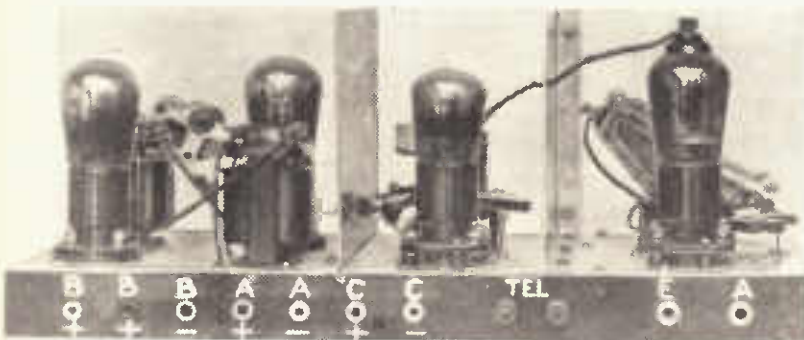

A rear view of the finished receiver.

Run a wire through the hole in the valve base, and then through the hollow pin. Next solder the wire to the end of the pin and wind on the necessary number of turns.

Drill another hole at the finish of the winding in line with the pin to which it has to be connected.

Pass the finish of the winding through this hole and then through the hollow valve pin, where it is soldered in place.

It will be noticed that the coil will have half a turn, as well as a number of full turns, as the finish of the coil is opposite the starting point.

About one-eighth of an inch below the finish of the first winding drill a 1-16 inch hole, in line with the valve pin, to which the beginning of the second winding is to be connected. Wind the correct number of turns after soldering the beginning of this winding to the valve pin, and drill another hole at the finish of the winding in line with its respective pin. Run the end of the winding through the hole and the hollow valve pin, and solder it in place.

The aerial, R.F. grid and detector grid coils are wound with 26 gauge enamel or d.s.c. wire, while the reaction coils are wound with 30 gauge enamel wire. This only applies to coils ranging from 10 to 100 metres. For the 200 to 350 metre coils the aerial, R.F. grid and detector coils are wound with 28 gauge wire, the reaction coil being wound with 36 gauge enamel.

side strips are 7½ in. long, a ¼ of an inch being allowed for the thickness of the long strip. The width of these strips is 1½ inches.

Having fastened the strips to the sub-panel, the next operation is to fasten the panel, which is 15 inches long by 6½ inches wide, in position to the sub-panel. This is done by means of small right-angular brackets, as can be seen in the photographs.

The two partitions are now cut to size and screwed in position. The space between the partitions depends upon the size of the audio transformers and the variable condensers. There is no need to space the partitions the same distance apart, as shown in the photograph, although the components should be spaced as near as possible to the original positions.

All the holes for the components should now be marked on the aluminium, also the holes for the battery and filament leads, which are to be taken through the sub-panel and then drilled by means of a brace and bit or, better still, a hand drill.

Remove the burred edges of the holes with a countersunk drill, and start mounting the components. The variable condensers should be mounted first, followed by the valve sockets which hold the coils, and the valve sockets. The position of the audio transformers can be seen from the photograph, the

Parts Schedule

- The following is a list of the components required to construct this receiver:
- 6 U.X. valve sockets.
 - 3 .00015 mfd. variable condensers, C1, C2, C7.
 - 2 High grade 3 to 1 ratio audio transformers.
 - 1 filament switch.
 - 2 vernier dials.
 - 2 .006 mfd. fixed condensers, C2 and C4.
 - 1 .01 mfd. fixed condenser, C3.
 - 1 .0001 mfd. fixed condenser, C6.
 - 1 5 meg. grid leak.
 - 12 U.X. valve bases.
 - 1 aluminium panel, 15 x 8.
 - 1 aluminium sub-panel, 15 x 8.
 - 2 aluminium partitions, 6 by 8.
 - 11 terminals or banana sockets.
 - Miscellaneous wire, screws, etc.

first audio transformer being mounted nearest the panel.

It is essential to mount the coil sockets at least one inch above the sub-panel by means of a fibre tube with a bolt running through it. If this is not done, oscillation will be fierce, with the result that it will be difficult to receive the overseas stations.

Although no shield is shown separating the plate of the screen grid valve from the connections at the base of the socket, it may be necessary, if using a different type of screen grid valve to that used in the set described, to shield the valve. This could be done by obtaining a cylindrical shield from any radio shop and slipping it over the valve.

Wiring

Take a lead from the P terminal of the R.F. coil socket to the aerial terminal. Connect a wire from the F negative of this socket to the chassis. Run a wire from the F positive terminal of the same socket to the fixed plates of the variable condenser C1, and to the grid terminal of the R.F. valve socket. From the grid terminal of the R.F. coil socket take a wire to one side of the fixed condenser C2. The other side of C2 is connected to the chassis.

The wiring of the R.F. coil socket is now completed.

Connect the A positive terminal of the screen grid valve socket to the chassis. Run a lead from the S.G. terminal of this socket to one side of the fixed condenser, C3, and to the B positive, S.G., terminal. The remaining side of condenser C3 is taken to the chassis.

Run a wire from one side of grid condenser, C6, to the fixed plates of the variable condenser, C5. From the fixed plates take a lead to the F negative terminal of the detector coil socket. Take a lead from the F negative terminal of this coil socket through the hole in the aluminium partition which shields the R.F. stage from the detector stage to the plate terminal of the screen grid valve.

The grid terminal of the detector valve socket is connected to the vacant side of the condenser C6. One side of the grid leak is taken to the grid terminal of the detector valve. The remaining side of the grid leak is connected to the chassis.

Take a lead from the P terminal of the detector coil socket to one side of the fixed condenser, C4, and to the B positive maximum terminal. The A positive terminal of the detector valve socket and the remaining side of condenser C4 are connected to the chassis.

From the fixed plates of the reaction condenser, C7, run a wire through the hole in the partition to the G terminal of the detector coil socket. The F positive terminal of this socket is connected to the plate of the detector valve socket. Take a lead from the P terminal of the first audio transformer to the fixed plates of the condenser, C7.

Connect the B positive terminal of the first transformer to the B positive detector terminal, the G terminal of this transformer being taken to the G terminal of the first audio valve socket. The remaining terminal of this transformer, C negative, is connected to the C negative terminal on the terminal strip. Run a wire from the F positive terminal of the first audio valve socket to the chassis.

Run a lead from the plate terminal of the first audio valve socket to the P terminal of the second audio transformer. The B terminal of this transformer connects to the B positive maximum terminal. From the G terminal of the same transformer connect a wire to the G terminal of the power valve socket. The remaining terminal, C negative of the second transformer, goes to C negative terminal on the ebonite strip.

The plate terminal of the last valve socket is connected to the speaker terminal on the ebonite strip. From the other speaker terminal run a wire to the B positive maximum terminal. The F positive terminal of the power valve socket connects to the chassis.

Connect the remaining F negative terminals of four valve sockets together, and take a lead from any one of the terminals to the A negative terminal on the ebonite strip. The A positive terminal connects to the chassis. This completes the wiring of the set.

Operation

Connect the batteries to the set by means of flexible wire. A voltage of about 40 should be applied to the detector, the maximum voltage being applied to the B positive max. terminal. The voltage delivered to the screen grid should be approximately half that of the plate voltage.

Having connected the batteries, insert the broadcast coils in their sockets and then the valves.

Next connect the aerial to the aerial terminal, and rotate the reaction condenser. If a pop or rushing noise is heard in the speaker when the condenser is rotated, oscillation is denoted. The other two dials should be turned and a station tuned in. The oscillation may be a little fierce on the broadcast band coils, but this should not interfere with the reproduction, if used in moderation.

If the set works all right on the broadcast coils, insert the short wave coils and tune in a Morse or telephone station if there is one operating on that particular band.

The set is rather broadly tuned when using the broadcast coils, but this can be overcome to a fair extent by using a piece of wire about eight feet long for the aerial.

FINE TUNING with S.W. SETS

By "S.W."

MANY radio enthusiasts are disappointed when first "breaking in" to short wave phone at not being able to tune in stations as expected. The set is probably well constructed, the reaction properly adjusted and easily controlled, yet, because of the extremely fine tuning necessary in handling a sensitive piece of apparatus. the weak stations are passed over.

Tuning the average short-wave receiver is sometimes a "hair-line" business, and quite a little practice is needed before one becomes proficient.

There are a number of methods of broadening the tuning or "opening out the dial," whereby the same 100 degrees of the tuning dial will space out the stations or cover a smaller territory of frequencies (or wave lengths). Most of them depend on cutting down the size of the tuning condensers, but there is a very definite limit to this for short-wave phone work.

The Amateur Band.

When the set is designed to cover only a narrow band of frequencies, as, for instance, the amateur bands of 20, 40 or 80 metres, where the widest band is only 500 kilocycles wide (10 metres at the 80 band or only .7 of a metre at the 20 band), the scheme works fairly satisfactorily; but where it is desired to cover from about 15 to 100 metres (approx. 20,000 k.c.), cutting the size of the tuning condenser raises a very strong objection in necessitating too many coils to change to cover the territory, as well as introducing difficulty in building and adjusting the reaction coil for each. A stage of tuned radio frequency entails double the trouble.

In passing, it might be as well to add that there is also an upper limit to the size of the tuning condenser employed, and that, if it is too high, difficulty will

be experienced in getting the set to tune down to the lower bands (because of the high minimum capacity); as well as reducing the desirable inductance to capacity, relationship resulting in a lowered efficiency for the tuner.

The usual condenser value specified for short-wave phone receivers is, therefore, about .00015 mfd. maximum capacity, and a vernier arrangement is employed to make the tuning easier.

In addition to the usual vernier dial there is also a modern variation of the one-time popular vernier condenser, which may be incorporated with advantage in almost any receiver. Known nowadays as a "trimmer," it consists of a very small two-plate midget condenser, connected in parallel with the main tuner. The connections are indicated in the diagram reproduced herewith. The "trimmer" can be mounted very close to the main condenser, in order that the leads can be kept as short as possible.

Tuning.

Tuning in a station should be first done with the main condenser and the trimmer used to get right on to the peak of the station's carrier. It should not be larger in capacity than will just tune across the carrier without much overlap.

Due to its very small maximum capacity, the trimmer will not materially affect the coverage of the coils employed in the set previously, but readers who try it out will be astonished at the difference in signal strength resulting from being able to tune right on to the peak of the carrier.

Enthusiasts interested in the reception of code stations as well will find it useful for varying the "pitch" of the best note produced in heterodyning c.w. signals, the beat frequency being easily adjustable to a pleasant audible frequency of round about 1000 cycles.

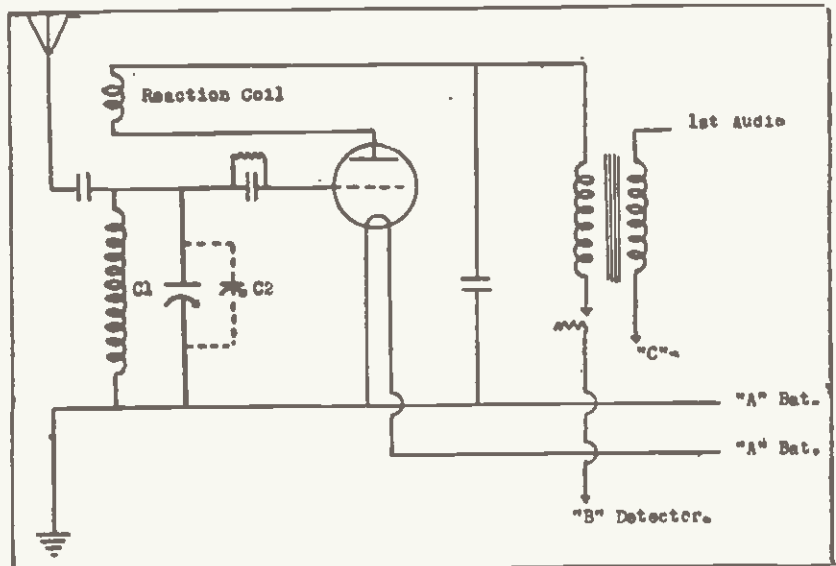

Showing how to add a "trimmer" condenser to the tuning condenser to improve the tuning.

SET-BUILDERS

Let Us Help You!

.....
The oldest and largest Repair
Specialists in Victoria--Est. 1924
.....

We can build any set described in "All Wave Receivers," be it Short-Wave, Broadcast or of the All-Wave variety.

Or, if you experience any difficulty, let us advise you. Perhaps some of your components are faulty? Let us test them for you.

Speakers, Transformers, Power Packs, or Phones can be quickly and efficiently repaired. We can save you quite a lot of money, and, in addition, give you much valuable advice.

We can give your set a professional appearance by bending the chassis and punching the socket holes. Aluminium supplied.

WRITE — PHONE — CALL

P. & L. Wireless Supplies
Proprietary Limited

Note New Address:

11 HARDWARE ST., MELBOURNE

Telephone F4323

A. C. GRAMOPHONE AMPLIFIERS

Descriptions of two simple Amplifiers which will be suitable for Home or for Public Address Work

By A. K. BOX

DESPITE the increasing demand by gramophone owners for straight out radio receivers, there still is a great deal of interest taken in amplifiers which can be connected either to simple radio detector units or to an electro-magnetic pick-up for the rendition of gramophone records.

Irrespective of circuits and components the basic principle underlying all amplifier design is the amount of power it is desired to deliver to the loud speaker. This in turn is governed by the amount of "coverage" desired. "Power" in an amplifier is discussed in terms of "undistorted watts output." "Coverage" means the area over which speech or music is to be heard properly, and takes into consideration all acoustical conditions.

Thus, we are able to set out a definite power requirement for any particular job. To boil this down to cold facts we may say:—

- (1) Home use calls for an amplifier having an output of at least 1 watt.
- (2) For use in small halls (up to 500 seating capacity) an output of at least 2 watts is required.
- (3) Larger halls, having a seating capacity of up to 1500, require an output of from 10 to 12 watts.
- (4) For an outside demonstration over a radius of 400 yards an output of around 12 watts is necessary, although the absorption of trees, hills, etc., will need to be overcome by using greater power.
- (5) Almost any reasonable amplifier job can be covered by the use of an output power of around 25 watts, although for special work, really outside the scope of this article, output powers of up to 250 watts will be necessary.

Now for the examination of the equipment necessary to provide the output powers required for the various jobs.

There are two distinct types of audio amplifier:—

- (1) The straight amplifier, which employs cascaded valves and either a single valve or two in parallel in the last stage.
- (2) A push-pull amplifier, which employs two or more valves in push-pull or parallel push-pull.

Note that we are disregarding the various forms of inter-valve coupling which can be employed. Either transformer, resistance-capacity or impedance coupling can be used in any amplifier but the push-pull type. This form of amplifier can be used only with transformer coupling, or in some cases with

a specially adapted form of impedance coupling.

It is wise wherever possible to keep the number of amplifying stages before the last valve down to a minimum. However, this should not be done by employing two or more very high gain stages before the power valve. One high gain stage before this valve is all that we can permit, because tone quality and amplifier stability will suffer with the inclusion of more than one high gain tube. By high gain tubes we mean valves which have a theoretical amplification factor of more than 10. This includes the screen grid valve, which, of course, can be used with great satisfaction in audio frequency amplifiers.

Now for the question of power output. Note that in setting out tubes which can be employed we are giving examples merely for the guidance of the novice. The experienced set-builder will be able to select tubes of similar or perhaps better characteristics which will give the desired results.

We will draw our examples from the four volt range of tubes. For case No. 1, where we require a power output of 1 watt, we may use either a single D404 or a pair of B 405's in push-pull. The advantage of using the lower powered B405's is that they require a plate potential of only 150 volts at a current of 16 m.a., against the 200 volts, and 30 m.a. of the single tube.

For case No. 2, where a two watt output is necessary, a single E406, or a pair of D404's may be employed. Although the power output of the 406 would be quite large enough, better re-

sults, from the viewpoint of reproduction, would be obtained from a push-pull pair of D404's.

For case No. 3, which calls for an output of from 10 to 12 watts, a pair of E408N's in push-pull, or a single F410 will be required. These tubes, of course, require high voltages and heavy plate currents, but this disability must be endured in such a high powered amplifier.

For cases (4) and (5), we will have to employ a pair of F410's in push-pull.

Note that where high powers are required, it is much more economical to use valves in push-pull rather than to attempt to obtain the required output from a single tube, when the question of power supply is to be considered. However, in most cases, more than one preceding stage will be required to load up the push-pull valves, as against the single stage usually required for the straight power tube. This, though, is no real disadvantage to the set builder, who, after all, is chasing the best quality of reproduction which modern equipment will permit.

One thing which does not receive great attention from the technical writer for papers intended for the average experimenter is the methods used to calculate valve requirements for a given amplifier set-up. It is proposed here to deal briefly with these calculations, and to show how easy it is for the set builder who is provided with reliable valve data charts to figure out a given valve combination for an amplifier.

The first thing which must be decided, of course, is the required power output. When this has been fixed it will be necessary to calculate from details provided in the characteristics of various types of valves the particular tube

which will give best results. The standard formula for undistorted output is $Eg^2 \times Mu^2 \times 1000$

8rp
(Eg squared x Mu squared x 1000.)

Where Eg equals the rated "C" bias voltage.

Mu equals the rated amplification factor.

Rp equals the plate impedance in ohms.

The answer then is in milliwatts or one thousandths of a watt. For valves bigger than the B405 type the "1000" may be dropped out of the equation when the answer will be expressed in watts. Remember that the greater the rated output of a tube as worked out on this formula the greater the audio frequency power it can handle without overloading.

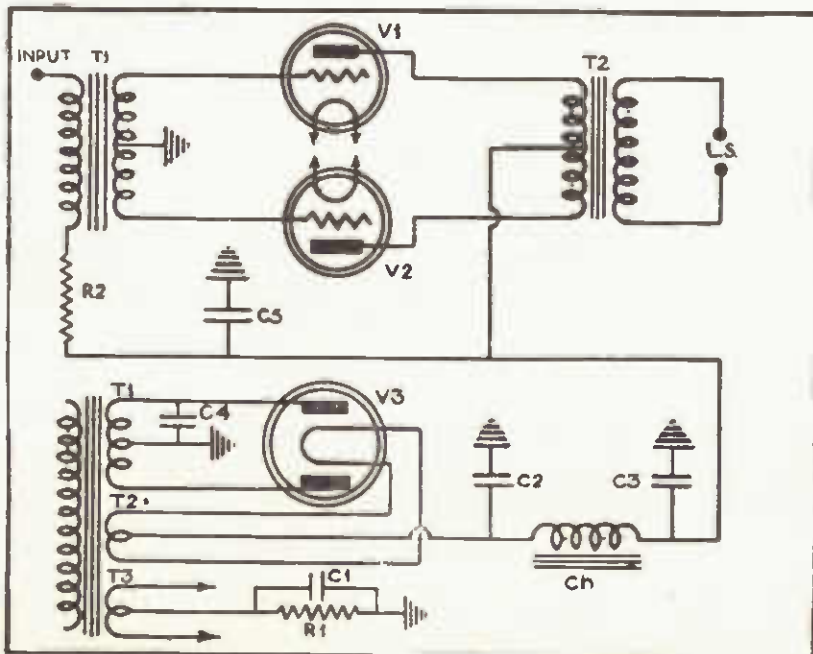

Circuit of a Push-Pull amplifier.

One method of calculating the valve requirements of a given amplifier is to work back from the last stage tube. As an example, we shall take the case of the E406 which requires a negative bias of 24 volts. This is the "peak" signal voltage which can be placed on the grid of the last stage valve before it starts to overload. For purposes of calculation we take what is known as the Root Mean Square voltage which is roughly 7-10ths of the peak voltage. The r.m.s. voltage on the grid of the E406, when it is fully loaded, thus will be 16.8 volts. Now assuming that we couple this tube to the first audio tube by means of a 3:1 transformer we will need to get 16.8 divided by 3 (or 5.6) volts output from the plate of the audio tube. Supposing that this tube is an E409 having an amplification factor of 9, we will assume that 2/3rds of the theoretical amplification factor works out in practice. This means that the input to this tube will need to be 5.6 (the output voltage required) divided by 6 or about .9 of a volt. The average pick-up will just about load up this audio amplifier combination, but if we connected a 2/1 step up transformer between the pick-up we should then require an output of only .9 divided by 1/2 or .45 of a volt from the pick-up in order to load up the last stage valve to maximum output.

The same system of figuring is used in the case of a push-pull amplifier, except that the push-pull valves require exactly twice the signal input to load them right up than does the single valve. Thus the calculations for two E406's in push-pull would start off with the assumption that the r.m.s. input voltage to the last stage tubes would be twice 16.8 or 33.6 volts. The difficulty of loading this combination up with a single audio stage preceding it is at once apparent.

The solution lies in the addition of a second stage, preferably resistance or impedance coupled, rather than in an attempt to avoid the difficulty by using a single high-gain valve. From the foregoing explanation of the method of calculation it should be easy for the builder to figure out suitable valve combinations.

Having dealt with the general aspect of amplifier design we now shall progress to a brief, but fairly complete description of two practical amplifiers which can be used for various purposes by the home experimenters.

The Two Stage Amplifier

The first amplifier is a simple two stage, one employing a high gain E438

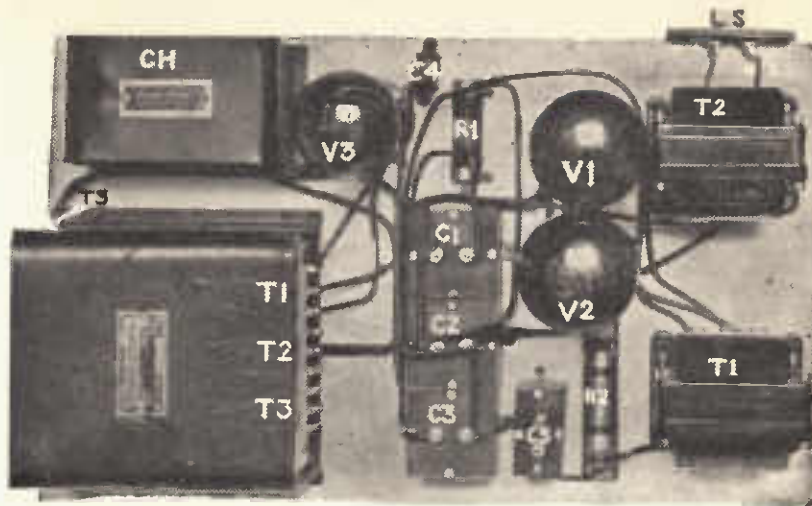

Photograph of the push-pull amplifier showing the layout required.

type tube in the first stage, and a power tube of the E406 class in the second stage. It is entirely a.c. operated, and, as built up by the writer, is self-contained and ready for connection to any existing detector. The power output of this amplifier is in the vicinity of three watts, which, to the writer's way of thinking, is an ideal value for a good home amplifier.

It is not so much the volume of output which can be obtained from this combination as the reserve of power it offers in the reproduction of bass passages. To the writer's mind, at least, any reasonably good dynamic loud speaker demands an amplifier of these proportions. This, by the way, is not intended to, and does not conflict with statements made earlier in this article.

To continue with our story of the technicalities of this amplifier. The fact that the amplifier is self-contained, i.e., has a built-in power pack, permits us to obtain the necessary filament, plate, and bias potentials without any difficulty. Despite the fact that the amplifier is designed, when used in conjunction with a high-grade dynamic speaker, to reproduce frequencies as low as 50 cycles, no trouble from hum is likely to be experienced. This is because the lay-out is such that all grid leads are short and are entirely separated from the A.C. carrying filament leads. The use of resistance coupling between the two tubes also aids in hum suppression.

The list of materials required to build the amplifier is given elsewhere in this article, and, presupposing that these have been obtained, we may start the building of the unit. All the components have been assembled on a wooden baseboard measuring 15 inches by 10 inches. If desired, they could be contained on a metal chassis 12in. x 10in. x 2in. deep. In this case the filter condensers, the bias resistors, the voltage dropping resistor and the various bypass condensers all could be mounted underneath the chassis.

Assuming that the various components have been assembled in the same relative positions as has been done in the original amplifier, the wiring may be started.

Connect one of the input terminals to the P terminal on the 2-1 ratio audio transformer AFT. The other input terminal is connected to the B plus terminal on this component. The G terminal on the transformer connects to the G terminal on the UY socket of V1, whilst the plate terminal on V1 is wired to the P terminal on the resistance capacity coupling unit. The G terminal on this unit is connected to the G terminal on the UX socket of V2, the P terminal on this socket going to one of the L.S. terminals. The other one of these terminals connects to one terminal on the mount for the decoupling resistance R4, to one terminal on the filter choke CH, and to one terminal on the 4mfd. filter condenser C2. The other terminal on the choke is connected to one terminal on the second 4 mfd. filter condenser C1 and to the centre tap on the five volt filament winding T2. One of the outside leads on this winding is connected to one F terminal on the UX rectifier valve socket V3, whilst the other F terminal on this socket connects to the remaining outside 5 volt filament winding lead. One of the outside leads on the 4 volt filament winding is connected to one F terminal on the sockets of V1 and V2. The remaining F terminal on each of these sockets is wired to the remaining outside lead on T3.

The centre tap on T3 connected to one terminal on the 500 ohm resistor R5 and to one terminal on the 4 mfd fixed condenser C3. A lead is taken from the C terminal on the socket of V1 to one terminal on the 1200 ohm bias resistor R1. The vacant terminal on the mount for R4 is connected to one terminal on

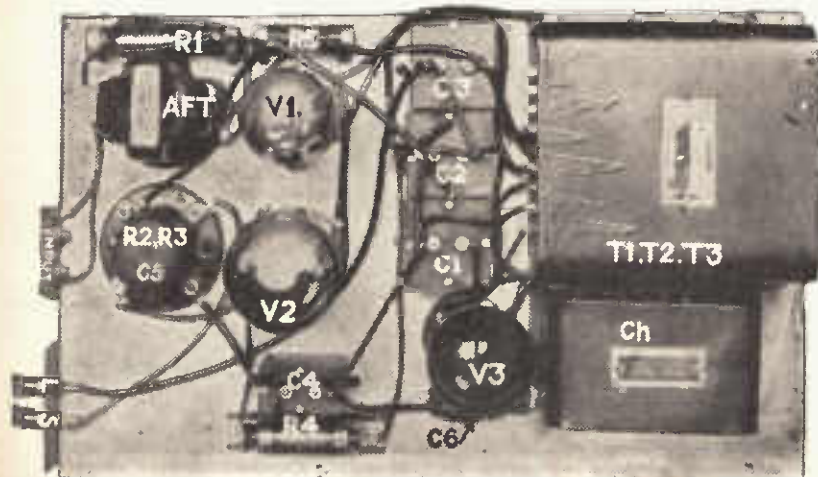

Above is a photograph of a resistance coupled amplifier.

the 2 mfd. condenser C4 and to the B plus terminal on the resistance capacity coupling unit. Now the F minus terminal on AFT, the corresponding terminal on the resistance capacity coupling unit, the vacant terminals on C4, C2, C1, C3 the vacant terminals on R1 and R5, and the centre tap of the high voltage winding T1, all are connected to earth. This conveniently can be arranged by placing a separate earth terminal on the amplifier, although it may be found unnecessary in operation to earth the amplifier directly. One of the outside leads on the high voltage winding is connected to the P terminal on the UX socket of V3 whilst the G terminal on this socket is connected to the remaining outside high-voltage lead.

The little "humming" condenser C6 should be connected between the centre tap of T1 and one of the outside terminals. The correct one will be found only when the set is being operated. The object of this condenser is to prevent that harsh undercurrent of "rattle" which sometimes makes its appearance even in well-designed power packs. In operation the loud speaker is connected to the terminals marked L.S., and the pick-up or detector output to the terminals marked input.

For the benefit of those who wish to make up their own resistance coupling unit, the following values are given. R2 is a 100,000 ohm wire wound resistor, R3 and .5 meg. grid leak type resistor, and C5 a .009 mfd. mica dielectric type, fixed condenser. The end of R2, which is connected to C5 corresponds to the P terminal on the commercial unit whilst the end of R3, which connects to the other terminal on C5, corresponds to the G terminal on the commercial unit.

This amplifier will be found to give wonderful output and to provide ample volume for any ordinary room. The use of such a low impedance valve as the E406 also will improve the bass register tremendously.

The Push Pull Stage

The second amplifier is a straight out push pull stage which can be used for

connection to any existing voltage amplifier. For good pick-up results it will need to be preceded by one straight-out audio stage and a detector valve fed by means of a resistance or impedance coupling system into this first audio tube. The detector, of course, would operate as an audio amplifier when the pick-up was being used.

The list of parts for the push-pull stage is small, the most expensive item probably being the input and output transformers. However, provided that the dynamic speaker which is to be used with this amplifier already is fitted with a push-pull input transformer, it will not be necessary to employ T2.

The wiring is started by connecting the P terminal on the input transformer T1 to the input terminal on the amplifier. One of the outside grid terminals on T1 is connected to the G terminal on the UX socket of V1, while the other Grid terminal on T1 is connected to the G terminal on the socket of V2. The P terminal on V1 is connected to one P terminal on T2 or to one of the outside terminals on the input transformer on the dynamic speaker. The P terminal on V2 is connected to the second P terminal on T2 or to the second outside terminal on the dynamic speaker input transformer. The B plus terminal on T2 or the centre terminal on the input transformer on the speaker is connected to one terminal on the mount of the resistance R2, to one terminal on the 2 mfd. condenser C5, to one terminal on the 4 mfd. filter condenser, C3, and to one terminal on the filter choke Ch. The other terminal on the mount of R2 is connected to the B plus terminal on T1.

If T2 is built on to the same board as the rest of the push pull amplifier a lead is taken from the output terminals to the L.S. terminals on the board.

The vacant lead on the choke CH is connected to one terminal on the second 4mfd. filter condenser C2, and to the centre tap on the five volt filament winding T2 (on the power transformer). One of the outside leads on this winding is

Parts for the Push-Pull Amplifier

- 1 Power Transformer, delivering 300-0-300 v., 5 v., and 4 v. (T1, T2, T3).
- 1 30 Henry Filter Choke (Ch.).
- 3 UX Valve Sockets, for V1, V2 and V3.
- 3 4 mfd. 1000 volt Test Fixed Condensers (C1, C2, C3).
- 1 2 mfd. Fixed Condenser (C5).
- 1 .009 mfd. Mica Condenser (C4).
- 1 Voltage Dropping Resistor (R2).
- 2 Power Valves (V1 and V2).
- 1 280 Type Rectifier Valve (V3).
- 1 250 ohm. Bias Resistor (R1).
- 1 Push-pull Input Transformer (T1).
- 1 Push-pull Output Transformer (T2).
- 2 Loud Speaker Tip Jacks.
- Wire, Spaghetti Sleeving, Screws and Wooden Baseboard.

Parts for the Two Stage Amplifier

- 1 Power Transformer, delivering 300-0-300 V., 5 v., and 4 v. (T1, T2, T3).
- 1 30 Henry Filter Choke (Ch.).
- 1 UY Socket for V1.
- 2 UX Sockets for V2 and V3.
- 3 4 mfd. 1000 Volt Test Fixed Condensers (C1, C2, C3).
- 1 2 mfd. Fixed Condenser (C4).
- 1 .009 mfd. Mica Condenser (C6).
- 1 Resistance Capacity Coupling Unit, or Components (R2, R3 and C5).
- 1 15,000 ohm. Resistor (R4).
- 1 1200 ohm. Bias Resistor (R1).
- 1 500 ohm. Bias Resistor (R5).
- 1 2:1 Ratio Audio Transformer (AFT).
- 1 280 Type Rectifier Valve (V3).
- 1 Power Valve (V2).
- 1 High Impedance Valve (V1).
- 2 Pick-up Tip Jacks.
- 2 Loud Speaker Terminals.
- 1 Baseboard, Wire, Spaghetti, and Wood Screws.

connected to one F terminal on the socket of V3, the other F terminal on this socket being wired to the remaining outside lead on the 5 volt filament transformer T2.

One of the outside leads on the high voltage winding T1 is connected to the G terminal on V3 whilst the other outside lead is wired to the P terminal on the same socket. The centre tap on this winding is connected to earth. The "humming" condenser C4 is connected after the amplifier has been placed into operation. The C minus terminal on T1, the vacant terminals on C5, C2, C3, and one terminal on C1 and R1, all are connected to earth. The remaining lead on R1 and the vacant terminal on C1 are connected together, and to the centre tap on the four volt filament winding T3. One of the outside leads on this winding is connected to one F terminal on the sockets of V1 and V2. The remaining F terminal on each socket is connected to the remaining outside lead on T3. This completes the wiring of the amplifier.

The original amplifier employed a pair of E406's in push pull and was capable of delivering something like 9 watt output. Thus it was more than sufficiently powerful for any small public address jobs, although the quality of output was of such a high order that even "flat out" the reproduction from this amplifier would not offend truly musical ears.

A final word on the question of bias resistances. These, of course, will vary with any departure from the particular types of valves which happened to be used in the amplifiers just described. In this case it is a simple matter for the set builder to calculate the correct values for his special purpose.

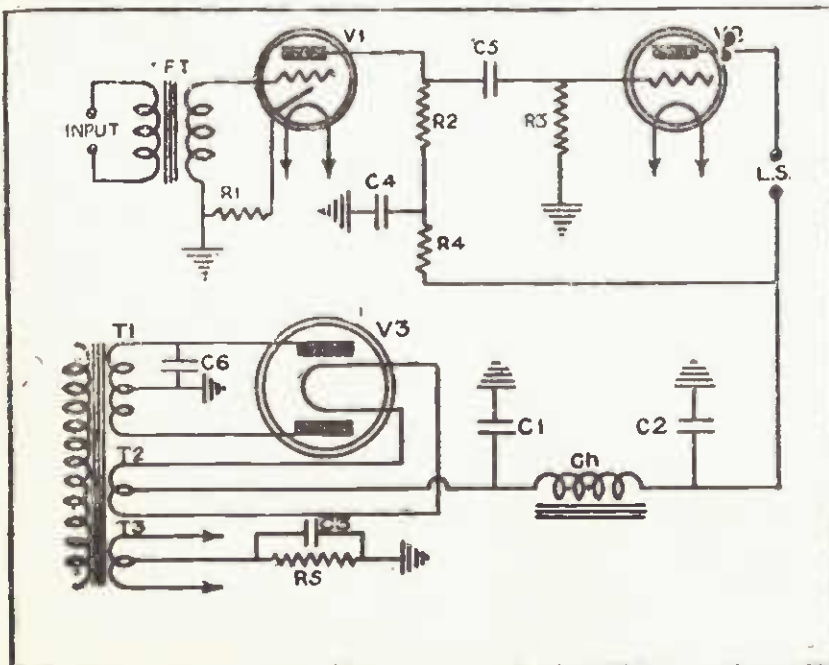

A circuit of a resistance coupled amplifier.

Announcement

To RADIO DEALERS

We have just released the most comprehensive Radio Catalogue issued in Australia, and dealers without a copy are invited to write for one.

We claim to carry in stock the most complete list of parts, and no matter what the circuit is we are in a position to supply all the parts required.

FOX & MACGILLYCUDDY LTD.

MERINO HOUSE
57 YORK ST., SYDNEY

WHOLESALE
ONLY

All Wage Receivers

CAN BUILD

ALL-WAVE RECEIVERS

From Materials Supplied by a Thrift Account !

Build up your Radio or Hobbies' Fund by regular deposits every pay-day in the State Savings Bank of Victoria, and you will always have the means to build better Radio Sets, and extend your hobbies.

FOR NINETY YEARS the PEOPLE'S BANK
STATE SAVINGS BANK OF VICTORIA

Head Office: 139-153 Elizabeth Street, Melbourne, C.1.

ALEX COOCH, General Manager.

THE SELF-CONTAINED SCREEN GRID TWO

THE early employment of valves in radio sets was marked by the large number which were necessary to obtain anything like satisfactory results. This has given birth to the idea that volume and quality could only be obtained in that way. Certainly those results were achieved, but it meant heavy initial cost of the set, and a high cost of maintenance. Then, when anything went out of order, there was a wider field to explore to locate the source of the trouble.

During the intervening years, however, continuous experiments have been made to obtain satisfactory results from sets employing fewer valves with a consequent decrease in cost.

Some time ago no one would think of building or purchasing a receiver unless it had at least four valves, whereas today there are a remarkable number of two-valve sets which can be built and purchased at a very modest figure. Naturally, all these two-valve receivers do not give the same even results, owing to the different designs and types of valves employed.

Following modern experiments closely, we are able to present a design of a two-valve electric speaker which will reproduce faithfully, have good selectivity, and be of low cost. Not only is this receiver capable of first-class performance, but it has the added advantage of being so compact when installed in a suitable cabinet that it can be set up on any small shelf in the room without upsetting the room's arrangement.

Modern cabinets are of artistic design, and the choosing of a cabinet for the receiver illustrated can safely be left to the constructor's own taste.

A magnetic type of speaker was used in conjunction with the set described in this article. Some readers may desire to instal a moving-coil speaker, and this can be done without any alteration to the receiver, providing the speaker does not require direct current to excite its field.

The tuning of this receiver is extremely simple. The centre knob connected to the dial tunes in the stations, and the left-hand knob controls the volume. The knob on the right hand of the receiver is connected to a push-pull type switch which brings a tone filter inserted across the speaker terminals into or out of circuit, thus altering the tone of the reproduction. While this filter is not absolutely necessary, it is advisable to incorporate one in the set as penthode valves, when used as audio amplifiers, tend slightly to over-emphasise the high notes. The opera-

A simple A.C. receiver capable of a good performance

By VK3FO

tion of the filter, which consists of a capacity and resistance joined in series, is to by-pass the high audible frequencies and emphasise the low notes.

The Circuit

An examination of the circuit will show that the Reinartz method of controlling oscillation is used; this necessitates a fairly low voltage applied to the plate of the screen grid valve as an audio transformer is employed for coupling purposes. A full-wave rectifier

midget condenser consists of 15 plates—8 fixed and 7, moving. If the constructor already has a midget condenser of a slightly larger capacity there will be no need to obtain a new one with the same number of plates as specified in the foregoing.

Power Transformer.—This may be purchased ready made, but, if the constructor wishes to build his own, he will have to design one to deliver 220 volts each side of the centre-tap and a four-volt winding for the plates and filament respectively of the rectifier, also two four-volt centre-tap windings for the detector and amplifier filaments.

Audio Transformer.—It is essential that a first-class audio transformer having a fairly low ratio in the vicinity of 3 to 1 be used. If a high ratio transformer be employed there is a big risk of overloading the grid of the penthode.

S M O O T H I N G C H O K E .—At the present time there are many chokes on the market suitable for the filter circuit. One having an inductance of about 30 Henries and capable of passing 40 milliamps should be chosen.

R E S I S T A N C E S .—The resistance R2 can be of the carbon type, as the amount of current it has to carry is only slight, its value being 200,000 ohms. Both R3 and R4 should be wire-wound types, having values of 75,000 and 10,000 ohms respectively. The amount of current that R4 is called upon to carry is approximately 12 milliamperes, while R3 is only required to carry about 1 M.A. The bias resistance R5 has a resistance of 1250 ohms.

S M O O T H I N G C O N D E N S E R S .—

These condensers are very important, as they have to withstand a continuous voltage of about 250 when the receiver is in operation. Purchase only the best; the working voltage should be rated at least 500. Have these voltages tested on high voltage before inserting them in the receiver, as a great amount of damage can be caused by a broken-down condenser.

VALVES.—An E442S medium impedance screen grid valve was used in the detector socket, with an anode voltage of roughly 55 and a screen grid voltage of 30.

A B443 penthode taking 150 volts on the plate and screen grid was employed as the power valve. This valve requires a bias of 15 volts. The 506 rectifier is used as its characteristics coincide with those of the power transformer.

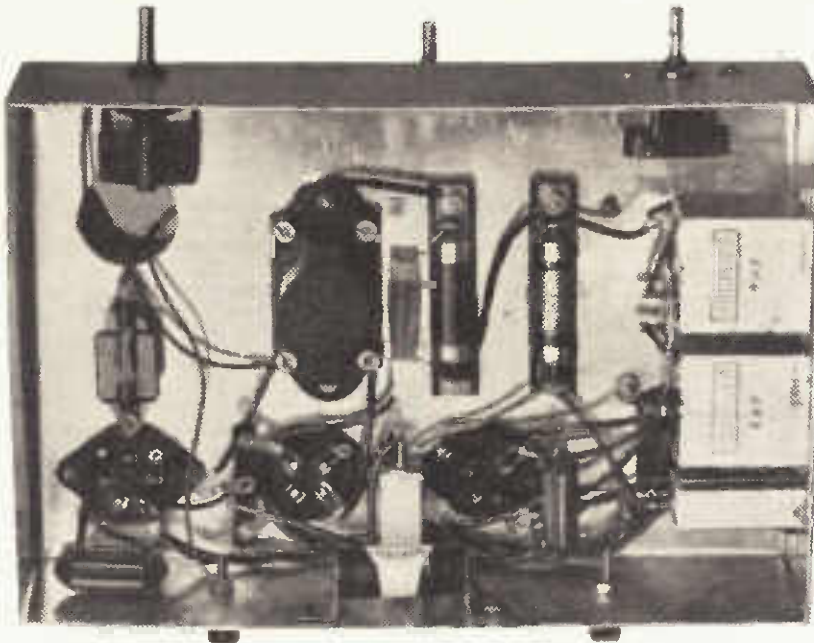

From the underneath view of the chassis a general knowledge of the wiring and spacing of the rest of the components will be obtained.

converts the alternating to direct current, which is smoothed by means of a 30-Henry centre-tapped choke coil and a simple system of fixed condensers.

The high-tension voltages are broken down by fixed resistances to the various voltages required, and the grid bias for the penthode is obtained by inserting a resistance between the centre-tap of its filament winding and earth.

It will be noticed that no output transformer is included in the circuit. This is because it was found that there was little difference in volume and quality when such was used, and it was therefore considered unnecessary.

Variable Condensers.—C1 has a capacity of .00035 mfd. and should be of good make. If a .0005 mfd. is used the number of turns on the grid coil, L2, will be decreased by about 10. The

Construction

The next step is to mount the components on the chassis, which is 12in. long, 8in. wide, and 3in. deep. It is advisable to obtain the chassis, which is of 18 gauge aluminium, from a tinsmith's as it is rather a difficult job to bend the aluminium without the necessary appliances.

The various positions of the components can be gained by studying the photographs. Now drill the chassis to take the valve sockets, which are of the sub-panel mounting type and clean the edges of these holes with a round file. Then drill the holes for the rest of the parts and securely mount them on the chassis.

The Coil

The winding of the coil is extremely easy. Proceed as follows: On the 2-inch former wind 15 turns, starting 3-8 from one end of the former. The next coil consists of 65 turns wound half an inch below the finish of the first coil. On the diagram these two coils are marked L1 and L2 respectively. The third coil, L3, is wound a quarter of an inch away from the end of coil L2, the number of turns being 30.



Looking from the rear of the set, showing the speaker in the cabinet.

All these windings are wound with the same gauge wire, namely, 28 D.S.C. A small right-angled bracket is now bolted to the coil, as shown in the sketch, to enable it to be mounted in an upright position on the face of the chassis.

The Wiring

Starting with the pack, connect the two leads from the rectifier filament winding to the filament contacts of the rectifier socket, and join the two plate contacts of the same socket to the two outside leads of the main secondary.

Connect one side of the humming condenser, C5, to one of the filaments contacts of the rectifier socket and the other side of the condenser to either of the plate contacts of this socket. The correct connections of this condenser can only be determined by experiment when the receiver is functioning.

The centre tap of the high-voltage secondary is earthed to the chassis. Run a lead from one filament contact of the rectifier to one side of the condenser C6 and the smoothing choke. The other side of C6 is earthed to the chassis, also one side of C7 and C8. The other side of C7 goes to the centre point of choke, and the remaining side of C8 to end of this coil.

Run a pair of twisted leads from the four-volt winding of the transformer whose centre-tap is earthed to the filament contacts on the detector valve socket. Connect the resistance, R5, between

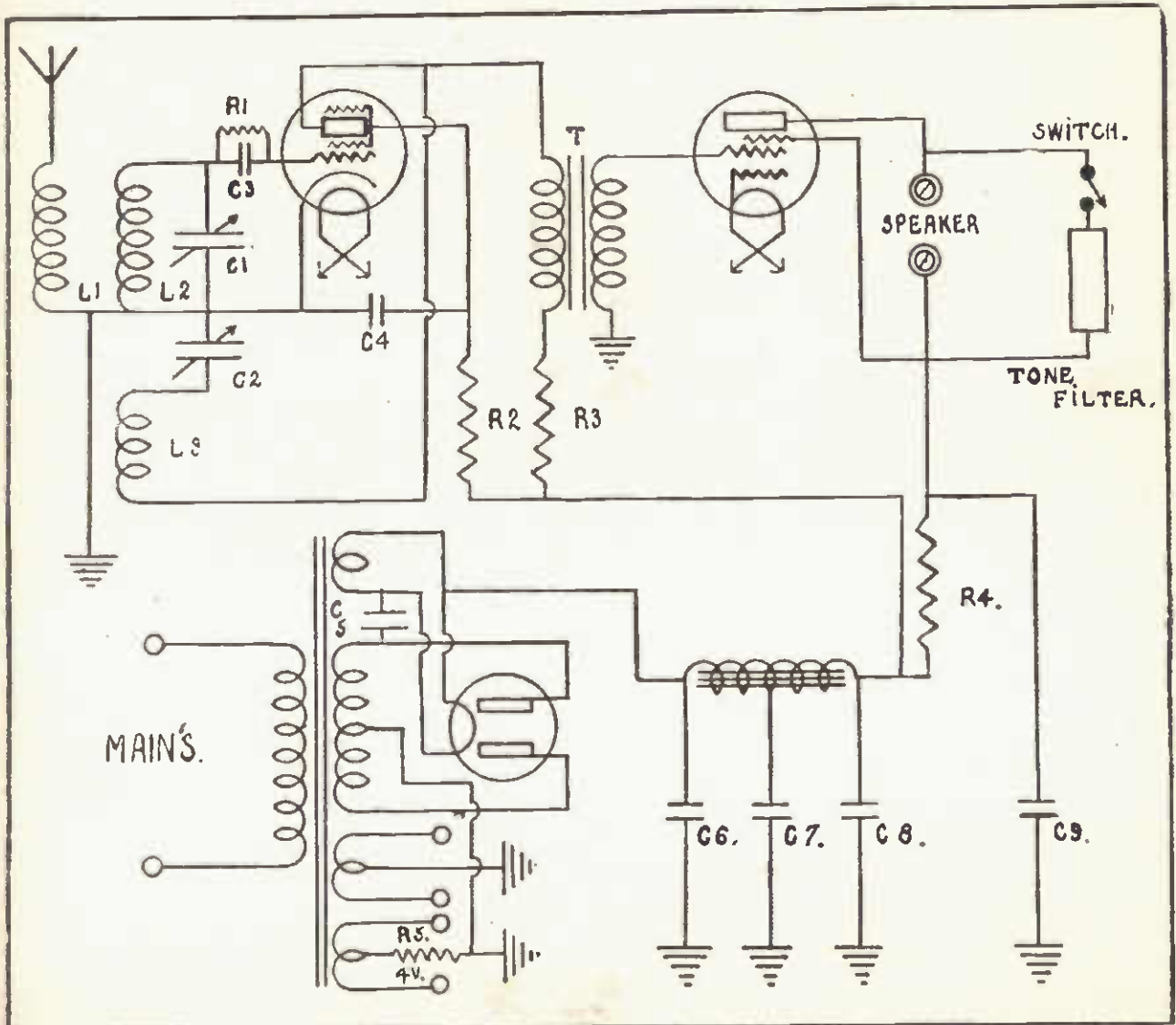

Circuit diagram of the Screen Grid Two.

the centre-tap of the remaining four-volt filament and the chassis.

From the two outer ends of this winding run a pair of twisted leads to the filament terminals of the penthode valve socket.



A front view of the finished receiver.

Continuing the wiring of the high tension supply, connect one end of resistance, R4, to the output end of the choke. The other end of this resistance goes to the screen grid terminal of the penthode valve, also to one of the speaker leads, one side of the tone filter and one side of condenser, C9. The other side of C9 goes to the chassis.

The remaining speaker lead connects to the plate of the penthode and to one side of the switch.

Connect a wire from the vacant terminal of the switch to the remaining side of the tone filter. Now connect the "C" negative terminal of the audio transformer to the chassis, and the "G" terminal to the grid contact of the penthode socket. One side of resistance, R3, goes to "B" positive of the audio transformer, the other side going to the output end of the choke.

The screen grid contact of the detector socket connects to one side of C4 and one end of R2. From the output end of the choke run a wire to the other end of Resistance R2. Earth the remaining side of C4 to the chassis. Connect the "P" terminal of the audio transformer to the plate of the screen grid valve and to the beginning of coil L3.

The end of the reaction coil winding goes to the fixed plates of the midget condenser, C2. The moving plates of this condenser are already connected to the chassis. Run a wire from the cathode contact of the detector socket and fasten it to the chassis, and connect the G contact of this socket to one side of R1, C3. The other side of R1, C3 goes to the fixed plates of the tuning condenser, C1, and the beginning of coil L2; the vacant terminal of C1 and the end of L2 are connected to the chassis, also the end of coil L1. From the aerial terminal run a wire to the remaining end of L1.

Operation

Having thoroughly checked over the wiring, connect the primary of the transformer to the mains by means of a length of flex.

On plugging into the power point, insert the rectifier to the socket; a voltage should be found at the output terminals of the power pack. If by chance,

List of Components

- 3 sub-panel valve sockets, IUX, IUX, 1 English.
- 1 .00035 mfd. variable condenser, C1.
- 1 15-plate midget condenser, C2.
- 1 3 meg. grid leak, R1.
- 1 .0001 mfd. fixed condenser, C3.
- 2 .006 mfd. fixed condenser, C4, C5.
- 1 Audio transformer, 3 to 1 ratio.
- 1 push-pull type switch.
- 1 tone filter.
- 1 1/2 meg. resistance, R2.
- 1 100,000 ohm resistor, R3.
- 1 10,000 ohm resistor, R4.
- 2 1 mfd. condensers, C7, C9.
- 2 4 mfd. condensers, C6, C8.
- 1 Power transformer.
- A length of 2in. former, 3 1/2in. long.
- 2 oz. 28 gauge D.S.C. wire.
- 1 Aluminium chassis, 18 gauge, 12in. by 8in. by 3in.
- 1 30 Henry centre-tapped choke.

when switching on the receiver with the rectifier inserted a blue haze is seen in the interior of the rectifier, immediately switch off the current at the power point, as this denotes that there is a short circuit.

Test the various components and wiring of the receiver for short circuits. Having found and remedied the trouble, insert all the valves, connect up the aerial and power lead, and switch on the current. If the signals are weak and the

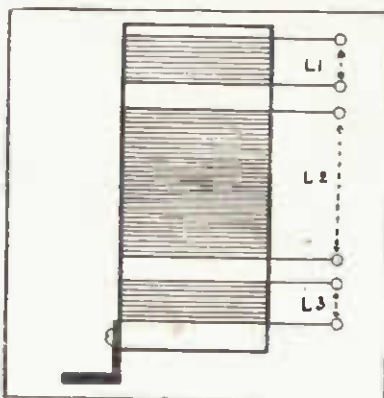

A diagram showing the spacing between the various coils.

reaction condenser has no effect on the volume, reverse the leads going to the reaction coil. The set should then oscillate and receive whatever station the set is tuned to.

If the variable condenser tunes broadly, resulting in interference between stations on adjacent wave lengths, the number of turns on the aerial coil L1 should be decreased until the tuning is considerably sharpened, and no interference between the stations is heard. On the other hand, if the condenser tunes too sharp, causing loss of volume and sensitivity, by increasing the turns on coil L1 this state of affairs will be altered, as the condenser will not tune so sharp and the volume and sensitivity will be increased.

A point worth trying will be to experiment with the resistances R2, and R3 if the results are not all that are desired. The function of these resistances is to break down the voltage from the pack to those required by the screen grid valve. Unfortunately, an accurate reading of the voltage at the plate and screen of the screen grid valve cannot be obtained by a 1000 ohm per volt voltmeter owing to the small amount of plate and screen current taken by the tube,

and due to the fact that the resistance of the voltmeter affects the value of the series resistances as it is connected in parallel.

In order to find the value of resistances for different voltages the following formula can be made use of. The value of R equals the voltage from the pack at the output side of the choke minus the voltage required at the plate or screen of the tube over the plate or screen current in decimal points of an ampere. It will be necessary to obtain a leaflet showing the characteristics of the valve in order to find the plate and screen currents at any particular voltage. In this way the voltage applied to the plate and screen may be determined.



An Efficient Baffle-board

To Improve the Tone of a Loud Speaker

AT what frequency does the dynamic speaker in a baffle board "cut off"? In other words, what is the lowest audible note it will respond to with any degree of efficiency?

To answer this question it is necessary to consider the diagram. A sound wave originates at the rear of the baffle board as well as at the front. If these two waves come together at the correct phase they will interfere and the resultant sound will be less than if one of the sound waves was suppressed. The object of the baffle board is to increase the path through which the air waves must travel from front to back before they can interfere.

The distance from front to back via the shortest mechanical path must be at least one quarter the wave length of the lowest tone desired. Sound travels in air at a velocity of 1110 feet per second. A frequency of 110 cycles then has a wave length of 10 feet from the familiar formula that wave length is equal to the velocity divided by the frequency. Thus if the shortest mechanical path is to be one quarter the wave length of the 110 cycle note it must be 2 1/2 feet. This is the distance from the centre of the hole in the front of the baffle round to the corresponding position at the back. Another way to understand it is that if the baffle is in the centre of the board it must be 2 1/2 feet square.

A 5ft. square board would be needed for reproduction of 55 cycle notes and so on. For general reception of broadcast music a baffle board three feet square will prove satisfactory.

As shown in the diagram, a simple formula for the computation of baffle board sizes is: 275 divided by the frequency of the desired musical note to which the speaker must respond. The answer from this formula is directly in feet square. For example, if we wished

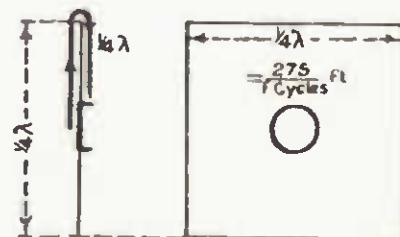

Details of the Baffle-board.

to make the speaker reproduce a 25 cycle note the answer to our problem would be 275 plus 25 equals 11 feet, which means that the baffle board for this job must be 11 feet square.

ALUMINIUM SHEETS

For Chassis and Shielding Work

We stock a wide variety in Metals as required in Wireless Set building, and also for model engineering construction

Let Us Construct your Chassis and Shields

All work carried out to your specification. We have always on hand aluminium tubes and wires, also aluminium in flat, half-round, angle and round sections.

Brass and copper rods and tubes in all sizes and sections, as used in model engines.

Phosphor bronze, brass and copper sheets.

Zinc sheets as used for battery manufacture.

Send for price list of aluminium, copper, brass, phosphor bronze. and zinc sheets.

GEORGE WHITE & CO.

METAL MERCHANTS

280 POST OFFICE PLACE

Established 78 Years.

MELBOURNE, C.1.

Phone Central 1100.

T.C.C.

MICA (Type M)

CONDENSERS



Tested to 1000 Volts

Now made in Australia and available in full range of sizes:—

.00005 to .0009	1/9
.001 to .009	2/6
.01	3/6

Every Radio need fully met by T.C.C. Condensers — the acknowledged leaders in the Quality field.



T.C.C. MANUFACTURERS TYPE CONDENSERS

All Capacities from .02 mf. to 10 m.f.

300 A.C. Working.

T.C.C. TRANSMITTING CONDENSERS

800, 1500 and 5000 Volt Working.

T.C.C. HIGH VOLTAGE SMOOTHING CONDENSERS

All Capacities up to 12,000 Volt Working.

All Radio Dealers

The Australasian Engineering Equipment Co. Pty. Ltd.,
2nd Floor, Evans House,
415-419 Bourke Street, Melbourne, C.1.

The New



Inverted Type

AQUEOUS ELECTROLYTIC CONDENSERS

8/-

Capacity — 8 mfd.

Maximum Working Voltage, 440 D.C.

Every Condenser is tested and re-formed in our Melbourne laboratory before being sent out.

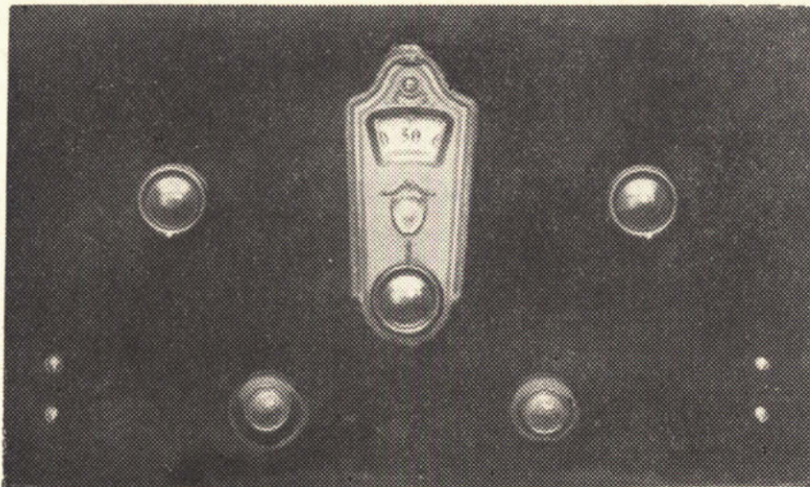

A view of the front panel showing the neat finish the receiver has when completed.

TABLE MODEL FOUR-VALVE RECEIVER

RADIO commerce in the last few years has grown so rapidly, that it has made many a set-builder decide not to construct his own receiver, but rely on a commercially made receiver.

But, on the other hand, it will be found that there are numerous radio enthusiasts who still prefer to build their own receivers.

For the benefit of these builders the following article should prove very helpful.

The receiver employs one stage of tuned radio frequency amplification, a detector, and two stages of audio frequency amplification. It will be seen by the schematical diagram that the first stage of audio consists of a resistance coupler while the second is transformer coupled.

By use of these two coupling devices in the audio stage, a high degree of quality can be expected, provided the specifications given are closely followed.

The tuned radio stage and the detector are more or less straightforward.

The original receiver obtained its supply from a "B" eliminator and an accumulator. Many set builders hesitate to build an All-Electric set, and to these this receiver should particularly appeal.

With an accumulator supplying the filament current it will be found that excellent reproduction may be obtained, and with the addition of a simple trickle charger installed in the receiver the accumulator may be kept fully charged without any trouble.

Constructing the Chassis

A piece of aluminium, 16½ by 13 inches, may be used for the chassis. Cut a 2½-inch square out of each of the corners. Having done this, the aluminium should be placed in a right angular metal edge and the side bent over. Fasten the corners of the chassis with the pieces of aluminium cut from them by simply putting them in a vice and bending them at right angles.

Another piece of aluminium, of approximately 12 by 8 inches, should be used for the front panel.

RECEIVER

An excellent Four-Valve Receiver employing a stage of tuned radio frequency, detector and two stages of audio amplification

By P.R.D.

In order to shield the radio frequency coil from the other coil it is essential to place a piece of aluminium across the bottom of the chassis as shown in the underneath view photograph of the actual receiver. This piece may either be secured by use of two small brass brackets or by placing the metal in a vice and turning about one half inch of one of the sides at right angles to the rest of it.

Mounting the Components

We will begin by mounting the parts on the front panel. These consist of the condenser tuning the radio frequency stage, the pilot illuminated dial, reaction condenser, volume control and battery switch.

The pilot illuminated dial will require letting into the chassis, as it will be found that it fouls it when screwing the panel on the chassis. Turning next to the components above the chassis, it will be seen that three valve sockets are evenly spaced, with the audio transformer mounted after the third valve socket. The remaining valve is so arranged that it will fall between the mid-gear reaction condenser and the audio transformer.

In mounting the components great care must be taken in so arranging that the builder will get as short leads as possible.

This can be obtained by placing the valve sockets so that the grid terminal of the first socket is opposite the G terminal of the coupler, and so on.

Two terminals, bushed from the chassis on the left-hand side of the receiver, serve as the output terminals. On the right-hand side one terminal is arranged for the aerial terminal. Like the output terminals this also requires bushing from the chassis.

At the rear of the chassis a terminal strip is mounted. If the builder is going to use the ordinary terminals it will be necessary for him to bush them all from the chassis.

Two valve shields, as shown in the photograph, are mounted over the radio frequency valve and the detector.

Next come the parts to be mounted underneath the chassis.

Begin by mounting the two coils as shown in the photograph, having the shield so that it is between the coils.

The resistance coupler, which consists of two resistances and a condenser, is mounted in such a way that all the leads are short.

The grid-leak and holder should be placed between the detector grid coil and the detector valve socket. The by-pass condenser will not be mounted until the wiring is started as it is only wired into the circuit.

The radio frequency choke is mounted near the terminal strip.

This completes the mounting of the parts.

Reviewing the Parts

The Vault type TUNING CONDENSER is not absolutely essential, any condenser having the same capacity and which is shielded from the radio frequency tuning condenser will do.

The RESISTANCE COUPLER may be bought as a complete unit or it may be built by the constructor. The values of the resistances required are: the plate resistor, 100,000 ohms; the grid resistor, .5 of a megohm; and the coupling condenser of approximately .006 mfd. capacity.

The mid-gear or REACTION CONDENSER in the original receiver consists of an 11-plate type. The type of condenser used is not important provided the right number of turns is applied to the reaction coil to suit it.

The **VOLUME CONTROL** is an 0-500,000 ohms.; one having a resistance of 50,000 will serve the purpose excellently.

AUDIO TRANSFORMER. It is advisable to get a good make of audio transformer, as it will be found in the cheaper makes distortion will be apparent on some of the note frequencies.

VALVE SOCKETS. The type of valve sockets may be either of the sub-panel type or of the ordinary kind.

Winding the Coils

In winding the coils a piece of former 2 in. in diameter and approximately 2½ in. long will be needed for the radio frequency coil. Begin by winding 55 turns on it. This serves as the grid coil of the radio frequency stage. Next comes the aerial coil, of 15 turns.

The detector coil is wound on a piece of former corresponding to the size given for the other coil. The grid coil of the detector stage will be of 55 turns with a reaction coil of approximately 30 turns. The reaction coil will be found to differ considerably in different receivers owing to the different capacities set up in each receiver.

Wiring in Words

We now come to the wiring of the actual receiver. Flexible wire is the most suitable to use.

Connect the ends of the aerial coil to their respective terminals as shown in the diagram. Having done this, wire the grid coil of the radio frequency valve circuit, the beginning of this coil being connected to the cap on top of the screen grid valve. If the builder is going to use the UX222, he will need to connect the grid coil to the top of the valve. If he is using the Philips screen grid valve, he will need to connect the screen grid lead on to the plate terminal of the valve socket, while the plate of the valve is brought out at the top of the valve.

The G terminal of the radio frequency valve socket is taken direct to a terminal on the terminal strip. This lead is by-passed by a .01 mfd. condenser to earth. The other end of this coil is connected to the chassis.

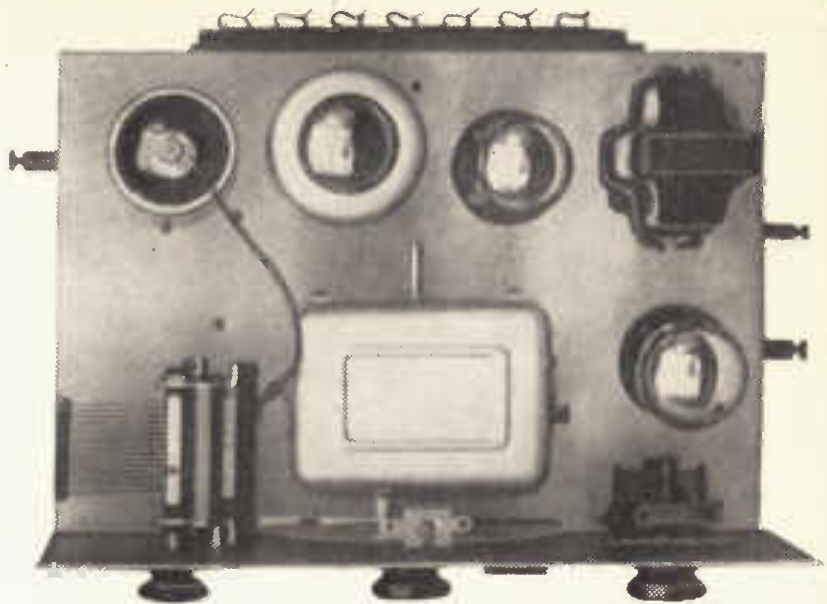

Looking down on the chassis; a good idea of the layout of the components mounted on top will be obtained.

The .0005 mfd. condenser, which is used for tuning this coil, is connected directly across the coil.

The P terminal on the R.F. valve socket is wired to the beginning of the 55-turn detector grid coil, and to the fixed plates of the Vault-type tuning condenser, and from this to the grid condenser. The other side of the grid condenser is taken to the G terminal of the detector valve socket.

The grid leak is connected to the G terminal of the detector valve socket, the other side going to the chassis.

The movable plates of the tuning condenser are connected to earth through the medium of the front panel.

The end of the detector grid coil is taken to one side of the radio frequency choke, the other side of this choke being connected to another terminal on the strip.

The beginning of the reaction coil is connected to the fixed plates of the midget condenser, while the other side of this condenser is taken to earth through the chassis.

The end of the reaction coil connects to the P terminal of the detector valve socket and to the P terminal on the resistance coupler.

The B terminal on the resistance coupler is soldered to a terminal on the terminal strip. The G terminal of the resistance coupler is taken to the G terminal of the first audio frequency valve socket, the F terminal of the resistance coupler being connected to the terminal strip.

The P terminal of the first audio valve is wired to the P terminal of the transformer, while the B terminal on the transformer is taken to the terminal strip. The G terminal on the transformer is connected to the G terminal of the output valve socket. The P terminal of this valve socket is taken to one of the terminals serving the place of one of the loud speaker terminals.

The outer speaker terminal is taken to the terminal strip.

The volume control is connected across the secondary of the audio transformer.

A condenser having the capacity of .01 should be wired between the end of the grid detector coil and earth.

Wiring the Filament Circuit

Now comes the wiring of the filament circuit.

This is very simple owing to the fact that one of the F terminals of all the valve sockets is connected to the chassis. The remaining F terminals are connected up in parallel, the last filament terminal being continued to a terminal on the strip.

This completes the wiring of the receiver.

In the case where a UX222 is going to be used it will be necessary for the builder to insert a resistance of 8 ohms in the filament lead, and take it direct to the terminal on the strip, the reason being that this valve only requires three volts on the filament.



A rear corner view of the finished receiver.

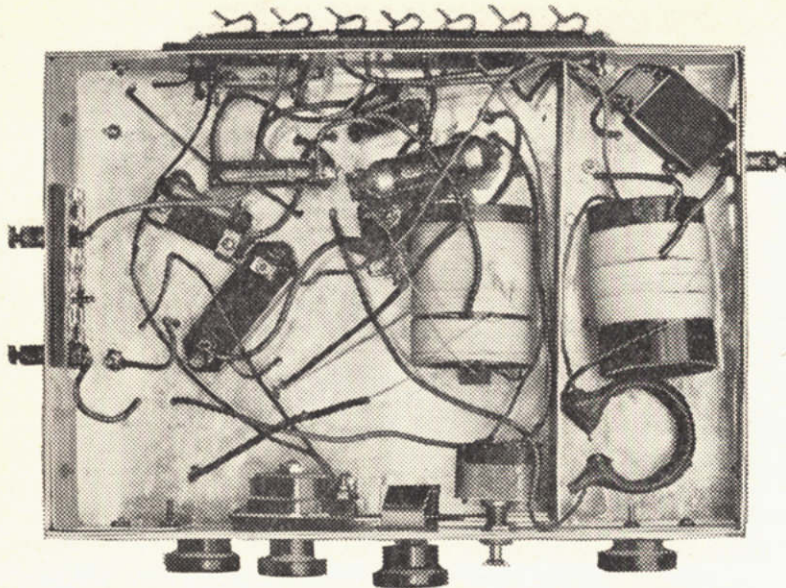

An underneath photograph of the chassis showing how the wiring is done, thus leaving a clean appearance on top of the chassis.

Operation of Receiver

The A-, B- and C+ leads of the battery supply will be connected direct to the chassis. The lead coming from the screen of the screen grid valve will require maximum voltage applied to it. The lead from the grid coil of the detector valve socket will also require maximum voltage.

The lead from the B terminal on the resistance coupler will require about 45 to 60 volts, while the other lead coming from the B terminal of the audio transformer will need about 100 volts, the remaining B+ lead which comes from one side of the loud speaker terminals is connected to the highest voltage.

The value of the two C- bias voltages will depend on the particular types of valve employed in the receiver.

Interstate reception on this receiver is exceptionally good, and, provided the receiver is built on the lines as described, the builder should receive a considerable amount of satisfaction from it.

Components Required

- The following is the list of parts quired to construct this receiver:
- 1 Vault-type tuning condenser having a capacity of .000375.
 - 1 ordinary tuning condenser with a capacity of .0005 mfd.
 - 1 11-plate midjet condenser for reaction.
 - 1 0-500,000 volume control.
 - 1 filament switch.
 - 4 UX valve sockets.
 - 1 audio transformer of a ratio of 3 to 1.
 - 1 radio frequency choke.
 - 1 resistance coupler.
 - Some flex for wiring.
 - 2 pieces of former 2 1/2 inches long and of a diameter of 2 inches.
 - Reel of gauge 30 wire.
 - Some terminals.
 - 1 pilot illuminated dial.
 - Some machine screws, a piece of bakelite for bushing.
 - 1 grid-leak and holder, and 1 condenser of a capacity of .00025 mfd. for the grid condenser.
 - 2 condensers having a capacity of .01 mfd. for by-passing.
 - 2 valve shields.

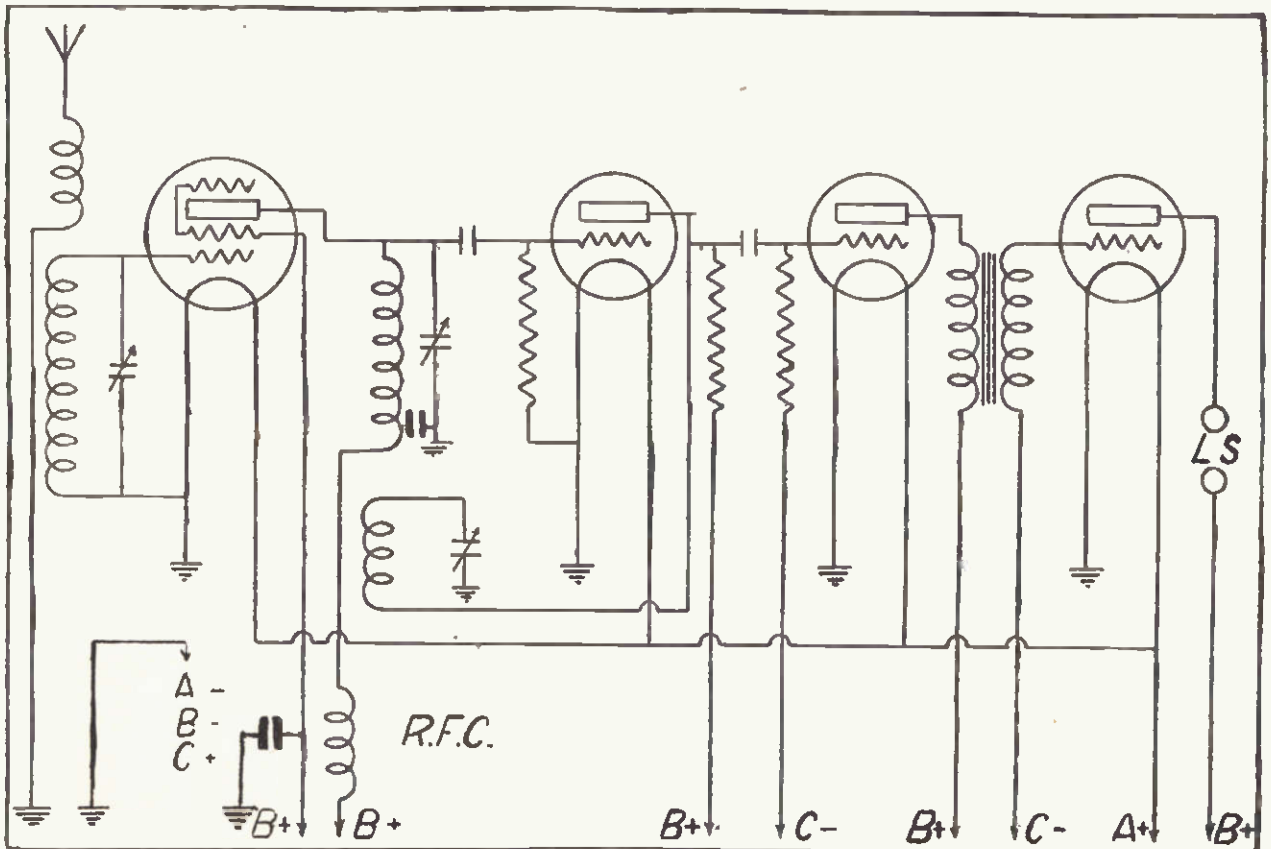

Schematic diagram of the Table Model Four Valve receiver.

A NAME THAT IS DEPENDABLE !

SINCE 1924 the name WETLESS on a condenser has marked a product of outstanding quality and has been the user's assurance of dependable service and long-lasting satisfaction.

Whether you are a radio experimenter buying a single part from a dealer, or a radio manufacturer buying thousands of parts direct from the factory, you are assured of the same high quality of material and workmanship.

HERE is a new (Tubular type) condenser, made by Wetless. They are bakelite encased, and provided with handy "Pigtails" of heavy gauge tinned copper wire for quick assembly.

Being very compact, these condensers require only a minimum of space.

.01 M.F. 2/8	.1 M.F. 3/-
.02 M.F. 2/10	.25 M.F. 3/-
.03 M.F. 3/-	.3 M.F. 3/3
.04 M.F. 3/-	.5 M.F. 3/9
.05 M.F. 3/-	



HERE is illustrated a Wetless (Canister type) condenser. Made to a very rigid standard, in the capacities listed, they are conservatively rated to work at 500v. D.C., and the dielectric resistance is 1000 megohms per microfarad.

.01 M.F. to .25 M.F. 3/-	4 M.F. 11/9
.5 M.F. 4/-	2 x .25 M.F. . . . 5/6
1 M.F. 5/-	2 x .5 M.F. . . . 6/-
2 M.F. 7/6	3 x .5 M.F. . . . 7/9
	4 x .5 M.F. . . . 9/6



WETLESS CONDENSERS

Obtainable from:—

FOX & MacGILLYCUDDY LTD., & BLOCK & GERBER LTD. Sydney
 NATIONAL RADIO, TRACKSON BROS. LTD., & J. B. CHANDLER & CO. . . Brisbane
 A. G. HEALING LTD. & NEWTON McLAREN LTD. Adelaide
 Representatives: ALAN S. DUKE PTY. LTD., Melbourne — T. W. EGAN, 45 King St., Perth

AN EFFICIENT 4-VALVE RECEIVER

A feature of this Receiver is the ease with which it may be put into operation

By VK3GT

THIS receiver can be expected to give good quality reproduction of station programmes with all the volume that will be required for ordinary purposes.

The circuit is selective and employs a screened grid r.f. stage, and a regenerative detector, followed by two transformer coupled audio frequency amplifying stages.

Those who have had no experience in building receivers using a stage of radio frequency amplification will find this circuit an excellent one to use because of the simplicity with which it may be put into operation. Once built, a receiver using this circuit requires no neutralising or critical coil adjustment.

Trap tuning of the radio frequency stage grid circuit enables tuned anode coupling to be used between r.f. and detector stages without spoiling the selectivity of the circuit. Parallel feed of the plate voltage to the r.f. valve through an r.f. choke keeps the plate voltage off the detector stage tuning condenser. In the normal tuned anode circuit one side of this tuning condenser would be about 180 volts positive, and touching or almost touching condenser plates would result in shorting of plate supply with possible damage to the power pack equipment.

Cheapsness of construction was a feature of the original receiver. By the use of manufacturers' equipment, which is available at much lower prices, the

complete outfit, including the power pack, was built at very low cost.

From the photographs it will be noticed that no panel is used, the tuning and reaction condensers and the volume

control being mounted to the wooden panel of the containing cabinet. A panel may be fitted to the chassis if it is not intended that the receiver be fitted into a console or table type cabinet.

Several points in installing any modern all-electric receiver with its accompanying speaker in the same cabinet must be watched, otherwise trouble from mechanical feed-backs will prevent satisfactory operation of the finished receiver.

Vibration of the plates of a reaction or tuning condenser when circuits are tuned to resonance and the set is near its most sensitive condition for reception will set up a howl if speaker and components have not been mounted to prevent this trouble occurring. This trouble can only be cured by mounting the speaker so that it is insulated from the cabinet work by use of thick felt, or, better still, by sponge rubber. Mounting of the tuning and reaction condensers through extra large holes, using rubber bushings and rubber washers, will help to prevent them vibrating at frequencies which would be audible in the speaker. The bushings can be made of thick walled rubber tubing which just fits over the shafts of the various components.

Most home set-builders have had this trouble when they have attempted to mount speaker and receiver in the same cabinet, and have usually blamed vibration of a microphone detector valve

Parts Required

- Steel chassis.
- 3 UY type valve sockets.
- 1 UX type valve socket.
- 2 3-1 a.f. transformers.
- Grid leak (R2).
- Grid condenser (C4).
- Coupling condenser (C5).
- Screen grid by-pass condenser (C7).
- Bias by-pass condenser (C6).
- Bias by-pass condenser (C8).
- Bias by-pass condenser (C9).
- Plate Voltage by-pass condensers (C10, C11, C12).
- R.F. tuning condenser (C1).
- Detector tuning condenser (C2).
- Reaction condenser (C3).
- One r.f. choke.
- R.F. stage bias resistor (R1).
- First Amplifier bias resistor (R4).
- Power amplifier bias resistor (R5).
- Volume controlling resistance (R3).
- Voltage dividing resistance (R6).
- Two pieces of 2in. dia. former 3in. long.
- 7 terminals.

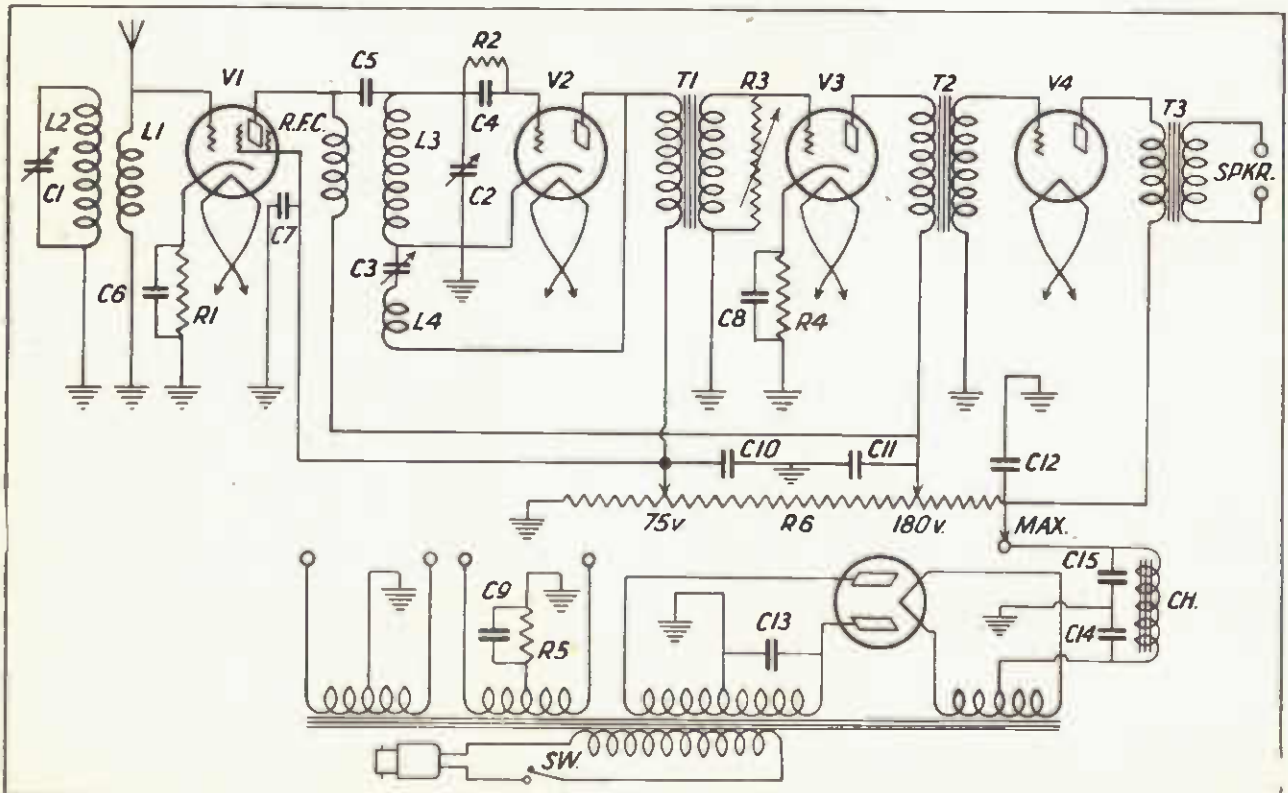

Schematic diagram of the circuit.

Use OSRAMS for every socket in any circuit

English-made Osram Valves are the eventual choice of every set owner who wants long life, power, and freedom from interference and "hum." Osram Valves in any circuit immediately improve the standard of radio reception, and retain that standard consistently and reliably throughout an exceptionally long life.

Another all-important reason for buying Osram Valves is that the new British Tariff has opened up an enormous additional market for Australian goods. Every pound spent in Australia for English-made products makes available to England more money to be spent on Australian goods, to the greater benefit of Australia.

As your old valves wear out, replace them with Osram; and if you are buying or building a new set, trust only to Osram Valves to give you the full benefit of the circuit.



MY224

is a Screen-Grid A.C. Detector or R.F. Amplifying Valve with indirectly heated Cathode. Non-microphonic.

MY247

is an A.C. Pentode recommended for the power output stage of A.C. operated receivers designed for it. Capable of delivering a large amount of power for a relatively small input.

Osram Valves

BRITISH GENERAL ELECTRIC CO. LTD.
104-114 CLARENCE STREET, SYDNEY. 590 BOURKE ST., MELBOURNE.

Victorian Distributors

Oliver J. Nilsen & Co. Pty. Ltd.,
45 Bourke Street,
Melbourne.

A. J. VEALL,
172 and 243 Swanston St., Melb.
Also 302 Chapel St., Prahran.



MY235

A super-control Screen Grid Radio-Frequency Amplifier which has been designed especially with a view to reducing cross-modulation. Osram MY 235 is destined to become the most favorably known of the Variable Mu types.

MX280

is a full-wave Rectifying Valve specially designed to withstand overloading and fluctuations in line voltage.

Made in
England

Absolutely
Non-Microphonic

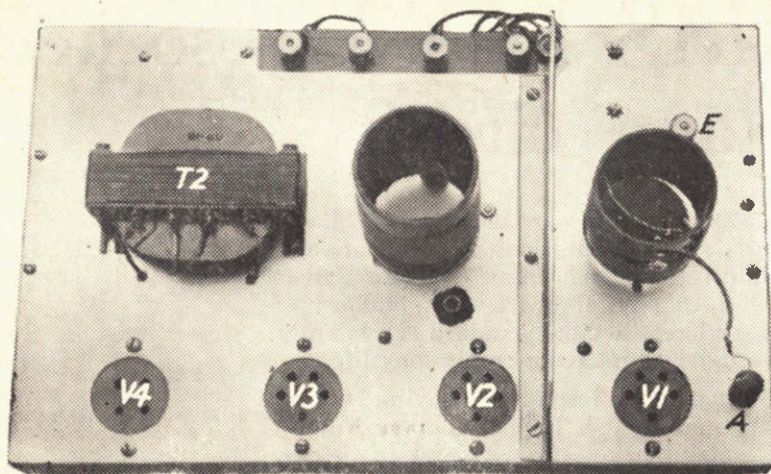

A top view of the receiver from which an idea of the layout of the components will be obtained.

for the trouble. The modern indirectly heated A.C. detector valve is not very microphonic, and tuning and reaction condensers should be suspected before the detector valve, and its treatment by use of lead weights and shock absorbing valve sockets should seldom if ever be necessary.

Before proceeding with the receiver description it might be advisable to mention that if the receiver is to be a musical instrument, good solid cabinet work will be necessary. Three-ply wood cabinets are seldom satisfactory, since they vibrate at various frequencies, and besides introducing unpleasant rattles will introduce distortion. Excepting for the panel, which should also be as thick as possible, the cabinet work should be of material no less than five-eighths of an inch in thickness.

Review of Components

In describing this receiver we are not recommending any particular make or type of valve to use, since the circuit is one in which any standard valve combination may be used. There is no reason why a four-volt indirectly heated valve should not be used in the r.f. stage in conjunction with 2.5 volt valves in the remainder of the stages. In other words, valves of any filament and heater voltage may be used in the receiver provided the power pack is equipped to supply the various heating voltages. All that must be remembered is that the directly heated final stage power valve must be heated by a filament secondary of its own. In the original receiver an American type 24 valve was used in the r.f. stage, a type 27 in the detector stage, another type 27 in the first amplifier stage, and an Osram type LS6A in the final stage.

It will be seen from this that the maximum voltage required from the power pack will depend entirely upon the valve used in the power stage. If, for instance, a pack is available to deliver 400 volts, then a power valve to operate at this voltage may be used in the final stage, the voltages for the plates of the r.f. and amplifier valve, and the r.f. valve, screen and detector valve plate being adjusted along the voltage dividing resistor, no matter how high the maximum plate voltage from the power pack be. There would be nothing to prevent the use of the ordinary 200 volt B eliminator, provided the power valve used was small enough to operate at this maximum plate voltage.

THE STEEL CHASSIS is a standard manufacturer's three valve and rectifier type, ready drilled to take four valve sockets. Most of the holes in the chassis can be utilized in mounting the components. Such a chassis can be obtained for about 2/6 at any radio dealers. For the benefit of those who wish to make the chassis themselves out of steel, copper or aluminium, the measurements are 13in. long, 8in. wide, and 2in. in depth. The positions for valve sockets and components can be easily approximated after looking at the photographs of the finished receiver.

The three U.Y. and U.X. VALVE SOCKETS are of the manufacturer's type, and can be obtained for about tenpence each.

The A.F. TRANSFORMERS should both be of 3-1 ratio preferably. It will be noticed that an unshielded transformer has been used in the original receiver. Although unshielded and an old type, this transformer has excellent characteristics. It is preferable to have the first transformer shielded and mounted under the chassis, the unshielded type, if one is used, being mounted on the top of chassis, where interaction which might cause feedback, cannot occur. It is not essential that the transformers be both of the same make.

It will be found that a high gain is available in the r.f. amplifier stage, and this would very easily overload the de-

detector valve if the GRID LEAK value is too high. One having a resistance of one megohm was used in the original receiver.

The GRID CONDENSER, C4, is of .00025 mfd. capacity.

The COUPLING CONDENSER, C5, will control selectivity to a large extent. If situated close to an interfering station the value should be between .0001 and .0005 mfd. capacity. Higher capacities up to .006 mfd. capacity may be used to obtain greater gain from the r.f. stage. The higher the capacity here the less selective will be the tuning of the circuit. A capacity of .001 mfd. capacity was used in the original set, and was found satisfactory in the suburbs.

The SCREEN GRID BY-PASS CONDENSER, C7, should be of .01 mfd. This value is not critical, however, and can be between .001 and .1 mfd. capacity.

The BIAS BY-PASS CONDENSERS, C6 and C8, should both be of .01 to .1 mfd. capacity.

The BIAS BY-PASS CONDENSER, C9, is considered unnecessary by many set-builders, but if the best is to be obtained from the amplifier stages, one of no less than 1 mfd. capacity should be used. It will be found that if this condenser is omitted as recommended in most of the American circuits loss of the lower range of frequencies will prevent anything like best reproduction and volume being obtained.

The PLATE VOLTAGE BY-PASS CONDENSERS should be of between .5 and 2 mfd. The higher the capacity here the better.

The R.F. TUNING CONDENSER, C1, should be of .0005 mfd. capacity. The control of this condenser is not critical, and for this reason it is fitted with a knob and not a vernier control.

The DETECTOR TUNING CONDENSER, C2, is also of .0005 mfd. capacity, and should be fitted with a smooth control illuminated dial.

The REACTION CONDENSER, C3, should be a 13-plate midget, although the number of plates is not absolutely critical. The number of turns given for the reaction coil is for a 13-plate condenser.

The R.F. CHOKE should have no less than 500 turns on a half-inch bobbin. A good commercially made choke may be used. A poor choke will prevent maximum sensitivity being obtained. A good choke may be made at home by bolting together four inch discs of thin fibre

(Continued on page 64)

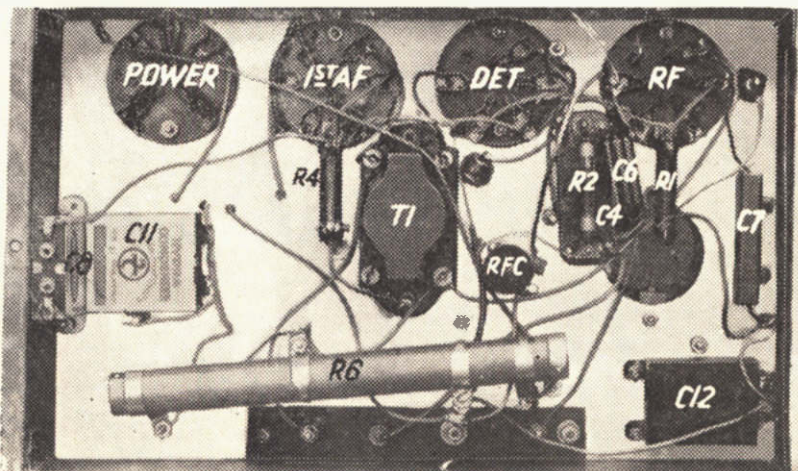

Showing the underneath components and wiring.

Opportunities in RADIO

Answer This Ad!

Take up "Radio Engineering as a Career." Be educated in the latest developments of Wireless Technology. It costs no more. We supply radio parts for the

Most Thorough Practical Radio Course in Australia



CARVE YOUR DESTINY

AROUND THE VALVE

TELEVISION

All there is to learn about it is included in our "A" Course without extra cost. Get ready for this forthcoming gigantic industry, by mastering its early principles FREE. It enables anyone to keep up with the progress of this new industry. We teach you the very latest information.

SOUND PROJECTION

Learn all about it. How recorded and re-recorded. Read over the syllabus of 50 specialised lessons. Find out how little it costs you to qualify. Become a specialist — a qualified one.

NINE COURSES

Nine home-study individual instruction methods are placed at your disposal. If you think you have advanced to a certain point in Radio Knowledge, well, read the Syllabus of our Courses. Start where you wish. Advance where you will. If you wish an Independent career. If you wish an Amateur Operator's Certificate. If you wish to become a Service Engineer. If you wish to obtain your BRITISH DEGREES, such as M.I.W.T., A.M.I.W.T., Assoc. I.W.T. or Student I.W.T., send for particulars by filling in the coupon below.

Your age, amount of education, or experience makes no difference. If you are interested and ambitious, you can succeed. You can learn at home in your spare time.

Answer This Ad!

YES, by all means answer this advertisement, if you wish to share in the profits of the World's fastest growing industry. Learn ALL about it first. Get to know it as you do your A.B.C. Master of this knowledge, the entire World is your field of endeavor. While you sit at home and read this advertisement—while you listen to your own receiver at home—let your imagination go back a few years to the introduction of Radio, then pause and look ahead. It needs little imagination to visualise the future, it is too replete with possibilities, possibilities that are beyond comprehension. You have to carve out your own destiny. Carve it around the thermionic radio valve. Look ahead. Investigate the facts. Let the A.S. of R.E. show you how to master this all-absorbing subject. Show you how to turn your knowledge into earnings. How to advance your present position. Insure your future. Never mind about the other people in the business; your chance is as good as theirs—in fact, better.

SUITABLE TERMS

If our terms are not suitable, quote your own, and we shall give them our earnest consideration. We have no BINDING CONTRACTS TO SIGN. You pay for what you want. Nothing More!

Send for FREE BOOK

Without obligation, please post a copy of your FREE Booklet.

AUSTRALIAN SCHOOL OF RADIO ENGINEERING

Keene's Chambers, 12 Oxford St., Sydney.

NAME

ADDRESS

CITY

STATE

CLIP and MAIL To day THE COUPON

SET BUILDERS NOTE!!

The following RADIO EXPERTS Contribute

to

The Listener In

F. OLSEN, VK3FO

MAXWELL HOWDEN, VK3BQ

G. G. THOMPSON, VK3GT

J. L. BAIN ("Radex")

H. K. LOVE, VK3BM

W. G. SONES ("Shortwave")

As a consequence The Listener In publishes the
BEST AND MOST UP-TO-DATE TECHNICAL ARTICLES

Secure a Copy Each Week—Price Threepence.

sheet, using 1-8in. fibre spacing washers $\frac{1}{16}$ in. in diameter, and filling the resultant grooved former with gauge 38 or finer covered wire. Lugs should be fitted to the end cheek of the former for soldered connections. A brass machine screw should be used to bolt the cheeks of the former together.

The values of the BIAS RESISTORS, R4 and R5, will depend entirely upon the valves to be used in the first and power stages. The values can be obtained from the dealer from whom the valves are obtained, or from the recently published *Listener In Set Constructor Handbook*. The resistors, particularly the resistor for the final amplifier valve, must be able to pass the total plate current drawn by the particular valve it is to bias.

The Volume Controlling Resistance, R3, comprises an 0-500,000 ohms variable resistance.

The Voltage Dividing Resistance Value, R6, will depend upon the maximum plate voltage available from the power pack or B eliminator. For voltages up to 200, a resistance having a total value of 12,000 ohms may be used. For voltages above this and up to 450, the resistance should be one of 25,000 ohms. Smaller values than this at high voltages will draw too much "bleeder" current from the power pack.

Making the Coils

Using the two pieces of 2in. diameter former and some gauge 28 and 34 wire, the coils should be made according to the following specifications.

The r.f. stage coils L1 and L2 are of 15 and 50 turns respectively. The 50 turns are wound in the centre of one of the formers using the gauge 28 covered wire. The 15 turns using the same wire gauge are wound over the centre of the 50 turns.

The detector stage coils, L3 and L4, are of 55 and 30 turns respectively, the 55 turns being wound at the top of the former, using the gauge 28 covered wire, the 30 turns being wound in the same direction and at the bottom end of the 55 turn coil, using the gauge 34 covered wire.

Double cotton covered wire should be used for the above sizes. Different types of insulation as enamel and silk will alter the coil sizes given.

The formers are mounted by use of small brass right angle brackets so that the ends are an inch from the top of the chassis.

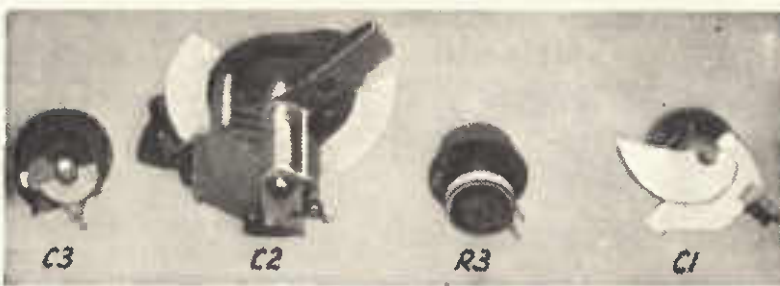

The positions of the panel components can be seen from this photograph.

In place of the metal shield mounted between the r.f. and detector stages, a coil shield may be fastened over the r.f. stage coils. This will require that an additional 10 turns be used on the r.f. stage tuning coil L2. Aluminium or copper shielding should be used.

No difficulties should be encountered in mounting the components. Valve sockets should be mounted with the grid connection of each socket nearest the back edge of the chassis.

All parts should be mounted so that grid and plate leads will be short and a.c. heater leads well separated from the rest of the wiring.

Here in brief, is the order in which the components will be mounted.

First the r.f. U.Y. valve socket. The bias resistor R1 and by-pass condenser C6 should be mounted as close to the cathode terminal of this valve socket as possible.

Next the detector valve socket. The grid leak and condenser should be mounted as close to the grid terminal of the detector socket as possible. Next the first amplifier valve socket. The first stage amplifier bias resistor and accompanying by-pass condenser should be mounted close up to the cathode terminal.

Cathode terminal of r.f. valve socket to one side of the bias resistor R1 and by-pass condenser C6. Other side of resistor and by-pass condenser to chassis. Other side of coupling condenser C5 to one side of grid leak and condenser, beginning of 50 turns coil L3, and to second terminal on strip to connect to the fixed plates of the detector tuning condenser on panel.

Cathode terminal of detector valve socket to chassis.

Other side of 50 turns coil L3 to chassis.

Other side of grid leak and condenser to grid terminal of detector valve socket.

Beginning of reaction coil L4 to third terminal on strip to connect to the fixed plates of the reaction condenser.

Other side of reaction coil L4 to plate terminal of detector valve socket, and P terminal of primary of the first a.f. transformer. Grid terminal of first a.f. transformer to grid of first amplifier valve socket, and fourth terminal on strip to connect to one side of the volume controlling resistance.

Remaining connection of each of the four panel components to terminal mounted on chassis metal.

F terminal of secondary of first a.f. transformer to chassis.

Cathode terminal of first amplifier valve socket to one side of bias resistor R4 and by-pass condenser C8. Other side of this bias resistor and condenser to chassis. Plate terminal of first amplifier valve socket to P terminal of primary of second a.f. transformer. B terminal of this transformer to other side of r.f. choke and B positive 180 volts clip on voltage dividing resistor and to one side of by-pass condenser C11.

G terminal secondary of second a.f. transformer to G terminal of power valve socket. Plate terminal of this socket to one speaker lead.

Other speaker lead to positive end of voltage dividing resistor and one side of by-pass condenser C12.

Other side of by-pass condensers C10, C11, C7 and C12 to chassis.

The bias resistor for the final stage valve is connected between the centre tap of the filament secondary supplying this valve and the chassis. The by-pass condenser C9 is connected across this resistance.

The negative end of the voltage dividing resistor is connected to chassis.

If the first three valves of the circuit are operated from the same secondary voltage, the heater terminals may be connected in parallel and connected to the power pack by means of a pair of flex leads. A second pair of flex leads connect the filament of the power valve to the corresponding filament secondary of the pack. Two more flex leads connect the negative of the pack to the receiver chassis and the positive of the pack to the extreme end of the voltage dividing resistor.

The earth connection to the receiver is made to a terminal mounted at any part of the receiver chassis and in contact with the metal of the chassis.

This completes the wiring.

In taking coil leads through the metal of the chassis, sleeve them in spaghetti.

In taking A.C. filament and B positive leads through the metal of the chassis, drill extra large holes through the metal and force short pieces of ebonite tube, or, failing this, short sections of thick

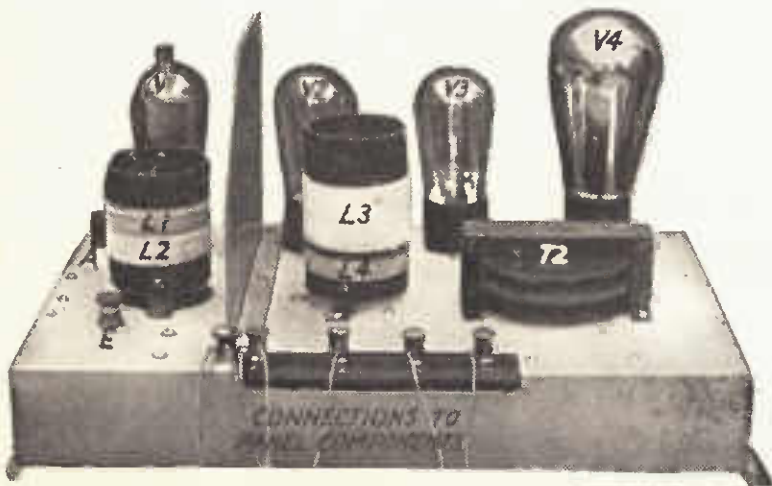

A back view of the receiver showing the valves in position.

(Continued on page 66)

When the talk
turns to Radio —

it will be found that those getting
the best reception are utilising
Radiotron Valves in their receivers.



RADIOTRONS

THE WORLD'S STANDARD
OF PERFORMANCE !



For over ten years they have been
recognised throughout the world as
the standard valves of the entire Radio
Industry.

For long life, consistent performance,
distance and durability, Radiotrons are
unequalled.

Take home a set of Radiotrons to-night,
and mark the difference in reception.

Obtainable at all Radio Dealers

AMALGAMATED WIRELESS (A/SIA) LTD

SOLDERING—HOW TO DO IT

AN EFFICIENT 4-VALVE RECEIVER—

(Continued from page 64)

This article is intended to make clear the fundamentals of successful soldering, and the set constructor who follows the hints given will find no difficulty in mastering this much over-rated art

ONE of the most important factors of successful soldering is the proper cleaning and preparation of the iron and the work. When metals such as copper, brass, lead and iron are exposed to the air for any length of time a thin layer of the oxide of the metal forms on their surfaces.

If they are heated in air the oxide forms very rapidly. This oxide layer is a poor conductor of heat, and when it is present on metals to be soldered it prevents the solder from flowing into the pores of the metal.

Dirt of any kind has the same effect. Thick accumulations of dirt and oxide can first be removed by cleaning the metal with sandpaper, emery cloth, steel wool or a file until the metal is bright and shiny.

However, it will be found that on heating the clean piece of metal preparatory to soldering a new layer of oxide has been formed. This can be removed by introducing what is known as "flux."

Having secured an iron suited to the work in hand, the first job is to "tin" the faces in order to allow the heat to be easily transmitted from the iron to the work. If there is a layer of dirt or oxide on the surface of the iron the flow of heat from iron to work is impeded, and it may be impossible to get enough heat to the work to melt the solder. This is why it takes so long for the solder to melt when you are using a dirty iron.

Tinuing An Iron

To tin an iron, heat it to the "soldering temperature" and remove all the oxide by filing the hot working faces with a fine file until they are clean and bright. The temperature can be easily tested by touching the end of the strip of solder to the face of the iron. If it melts instantly, the iron is ready to tin, but if it takes a few seconds before the heat of the iron causes the solder to run, then the iron must be heated still more.

To tin the iron using soldering paste, the tinning may be continued as follows: After the iron has been heated to the correct temperature dip the end of the strip solder into the tin of soldering paste and apply the solder to the faces of the iron. Do not dip the iron into the soldering paste because the heat of it will melt and disintegrate the paste. With resin-cored solder the tinning process resolves itself into the application of the solder to the faces of the heated iron.

After the solder has been made to run on each face of the iron the latter should be wiped quickly with a piece of cloth to ensure an even distribution of solder over each of the four working faces. If the iron becomes dirty or over-heated after use, so that the coating of solder is destroyed or oxidised, it should be retinned before being used for another job.

Never try to use a dirty iron, and always keep it well tinned. You will find that it pays in the long run. Now that the iron is tinned, we are ready to begin

the actual soldering. First we must apply the iron to the work to heat it. To heat the work as quickly as possible, the maximum surface of the iron must be applied in order that its stored heat may be quickly transmitted to the object to be soldered. By keeping the working face flat, much more heat is delivered than where only the point is in contact.

If the work to be soldered is made of brass, or is nickel-plated, or covered with enamel, or other foreign substance, clean it by scraping or rubbing it with sand-paper or emery cloth. If it is reasonably clean, or is tinned, it need not be scraped. Apply the iron flat on the work, so as to pre-heat it, then raise the iron a trifle from the work, and introduce the resin-cored solder, if this is being used. Then press the iron against the work, and hold it there until you notice the solder flowing smoothly and freely around the contact. Then, and not before, lift the iron and allow the work to cool, when you will find you have a perfect joint.

Using Soldering Paste

To solder with soldering paste first be sure that the iron is clean and well tinned. Then if there is any accumulation of dirt on the metals to be soldered clean them with sand or emery paper until they are bright and shiny. Take a little of the soldering paste on a small brush or stick—a match is the most convenient—and rub it on both parts to be soldered.

Now if it can be done hold the soldering iron under the two parts to be soldered. As the heat rises it melts the soldering paste, which flows to all parts of the joint. Apply the solder to the joint, and hold the iron in contact with the work until the solder flows round and distributes itself uniformly. Take the iron away and hold the parts rigidly until you see the bright molten metal shimmer a bit, whiten, and finally harden. Where it is impossible to apply the heat from below, good work can be done by keeping the iron on top, provided you are careful to keep it there long enough to heat the parts sufficiently.

It will be found that the region immediately surrounding the joint is smeared with the molten paste, which has run off from the joint whilst heated. As this contains some acid it will eventually corrode the metal parts if left there. It will also cause electrical leakage if it bridges the space between two conductors, and in any case it will serve to collect dust and other foreign material, with the result that the finished work soon gains a sloppy appearance.

It is the simplest thing in the world to remove this residue of the soldering paste by wiping the joint with a cloth dipped in petrol or alcohol.

When making joints or splices in bus-bar or even in soft copper wire, it is important to remember that the purpose of the soldering is not so much to provide a conducting path for the r.f. current as it is to exclude the atmosphere and moisture from the joint.

walled rubber tubing through the holes taking the flex lead through the tubes. This will guard against shorting to chassis with possible damage to the power pack.

Since the receiver and power pack have been built into separate units, there is absolutely no hum in the output of the original receiver. The receiver is as silent in its operation as a battery one. Headphones can be connected to the output of the power valve, and with the volume sufficiently reduced reception is quite comfortable and hum-free.

The receiver may be used to operate a dynamic speaker or an ordinary cone. The use of an output transformer is absolutely necessary with the first type of speaker and is to be recommended for use with any type of cone speaker to protect its windings from the heavy plate current which must inevitably flow when using a power valve and a fairly high plate voltage.

If it is found that the dynamic type of speaker produces a hum with the receiver disconnected, extra filter of the field supply current will be needed. What form this filter will take will depend upon the type of field supply. If this comprises a metal rectifier and transformer, the addition of an electrolytic type of filter condenser connected across the field leads will help to minimise if it does not completely eliminate the hum.

If the supply is from a 280 type of rectifier, the inclusion of a 30 henry filter choke and another 4 mfd. capacity filter condenser may eliminate the speaker hum completely. If the field is connected in series with the filter choke in the power pack, a 4 mfd. capacity condenser connected across the field leads to the power pack should prevent the hum.

If a combination of no less than 10 mfd. in conjunction with a 60 henry choke and the 1 mfd. capacity by-pass condensers in the receiver chassis is used, no hum, unless caused by poor design, will be experienced by anyone who may build the receiver from the foregoing description.

Tuning the Receiver

Tuning is quite a simple operation with this circuit. With the volume control in about the half position, the reaction condenser is adjusted until a slight rushing sound denoting oscillation is heard, when on turning the knob of the detector tuning condenser, station carrier waves will be heard in the form of whistles. When a whistle is heard, the knob of the r.f. tuning condenser is turned until a point is found where there is a big increase in strength of the whistle, when on turning the plates of the reaction condenser out of mesh, the whistle will resolve itself into clear music and speech, volume being controlled by adjustment to the knob of the variable resistance. On loud signals it is advisable to slightly detune the r.f. stage to prevent possible overloading of the detector valve.

In adjusting the plate and screened grid voltages, a voltmeter should be borrowed, and the first clip adjusted until the meter, when connected with its positive terminal to the clip and its negative terminal to the chassis, reads between 60 and 75 voltages. The second clip should then be adjusted to read between 150 and 180 volts. The speaker must be covered and all valves must be plugged in when adjusting the clips.

FOR YOUR PROTECTION



EVERY VALVE
IS TESTED

Philips Valves are designed to improve your radio. Into each valve is built the knowledge and experience of the World's most famous radio engineers.

But again—and for your protection—each valve is critically examined and tested in Australia prior to release.

Look for the seal on the carton—it is your guarantee of trouble-free radio—long service and outstanding performance.

If you would revitalize your receiver and enjoy the new brilliance of modern radio, see that your set is equipped with PHILIPS 1932 A.C. VALVES.

PH 2.5 v.

PE 4 v.

EVERY CARTON
SEALED

PHILIPS 1932 AC VALVES



A SIMPLE POWER PACK

Building the Power Unit
for the efficient four
valve receiver

By VK3GT



Looking at the power pack from the front, showing the rectifier inserted in its socket.

THE following notes deal generally with power supply packs for the obtaining of filament, heater and plate voltages from the mains.

The first consideration, when building a power-pack, is that of the final stage valve to be used in the receiver or amplifier, whichever it may be. This valve will be the one to require the highest plate voltage.

The voltage delivered by the power-pack should be just a little in excess of the maximum voltage required for the final stage power valve.

Once the voltage and current requirements of the power-pack are known, the rectifier may be selected. For voltages up to 400, the type 280 rectifier will be found ideal, since a maximum of 125 milliamperes may be safely taken from a pack using this type of tube.

Next comes the filament and heater supply question in the design of a power pack. The type 226 directly-heated valve is now seldom used, which means that, excepting for the power stage, indirectly-heated valves are used as r.f. amplifiers, detectors and intermediate stage amplifiers, which makes for absolute freedom of hum in the final speaker output.

There would be nothing to prevent the use of a different valve requiring a different A.C. filament or heater voltage, in each stage of a receiver, provided there were sufficient low voltage

secondaries on the power transformer core to supply the various voltages.

Indirectly-heated valves of the same heater voltage may be operated from the same secondary winding provided it can handle the current taken by the paralleled heaters. Always will the final stage directly-heated valve, or valves in push-pull, be supplied by a separate filament secondary winding.

The power-pack for the original four valve receiver was made from apparatus which has been around the workshop for years.

The equipment of the pack includes a transformer having a single centre-tapped secondary winding delivering 300 volts either side of the tap, a separate transformer delivering 5 volts for the 280 type rectifier filament, 2.5 volts for the type 224 and 227 valves used in the r.f. detector, and first a.f. amplifier stages - 6 volt winding for the power valve and several other voltages which were not required in the original set. A manufacturer's type 60-henry filter choke in conjunction with 1000 volt test filter complete the pack.

No voltage divider is used in the pack since this is incorporated in the receiver chassis. This method of construction requires that only two leads be connected to the plate power supply of the pack, to the chassis of the pack and to the positive, this connection being made to the filter choke to the terminal farthest away from the rectifier side of the choke.

The circuit of the pack shows a fuse and switch incorporated in the primary circuit of the power transformer. The fuse should be a 1 amp. type or smaller, depending on the power taken from the pack. This fuse will be sure to blow out should a breakdown occur in the transformer windings. A torch globe inserted in the lead from the centre-tap of the high voltage secondary will protect the rectifier by burning out should one of the filter condensers break down. This can very often happen and the inclusion of the torch globe fuse in this position is of more importance than the primary fuse. The primary switch may be fitted into the side of the cabinet. Generally, this switch is seldom mounted on the front of the cabinet where it could very easily spoil the appearance of the layout.

If the switch is mounted where it cannot be seen, it can comprise an ordinary tumbler lighting switch which can be obtained for about two shillings or less.

It will be found much cheaper to purchase power transformers and chokes than to make them, and the voltages delivered by commercially built types can usually be relied upon which makes for a greater degree of safety when the home construction of this equipment without the aid of reliable meters is attempted.

Eliminating Noise

A noise which appears in an apparently well designed power pack may be caused by "modulation," which is an interference which is not eliminated by the filter circuit, and which occurs in the operation of the half or full wave thermionic valve. This interference may be by-passed out by use of .001 mica condensers connected one between the high voltage centre tap and each outer connection of the high voltage secondary winding. Generally, one condenser may be sufficient, but which half of the secondary it should be connected across will be decided by experiment. The noise may be heard on some stations and not on others, and will usually be very strong when the detector valve is brought into oscillation. The "modulation" eliminating condenser is C13 in the circuit of the pack.

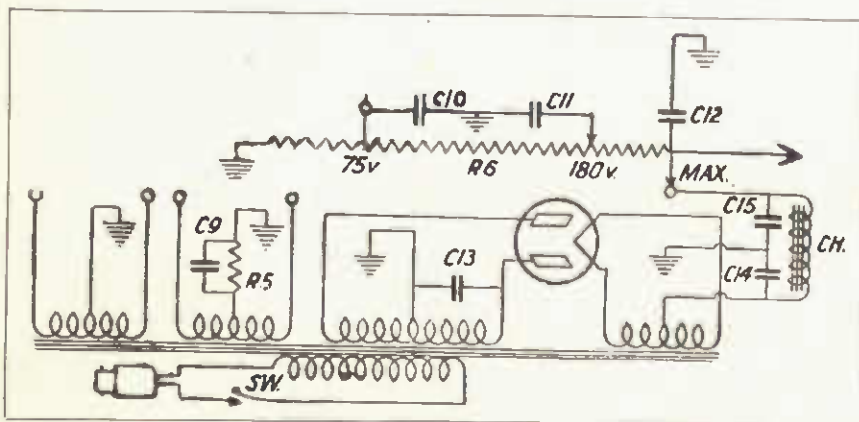

Schematic diagram of the circuit.

(Continued on page 70)

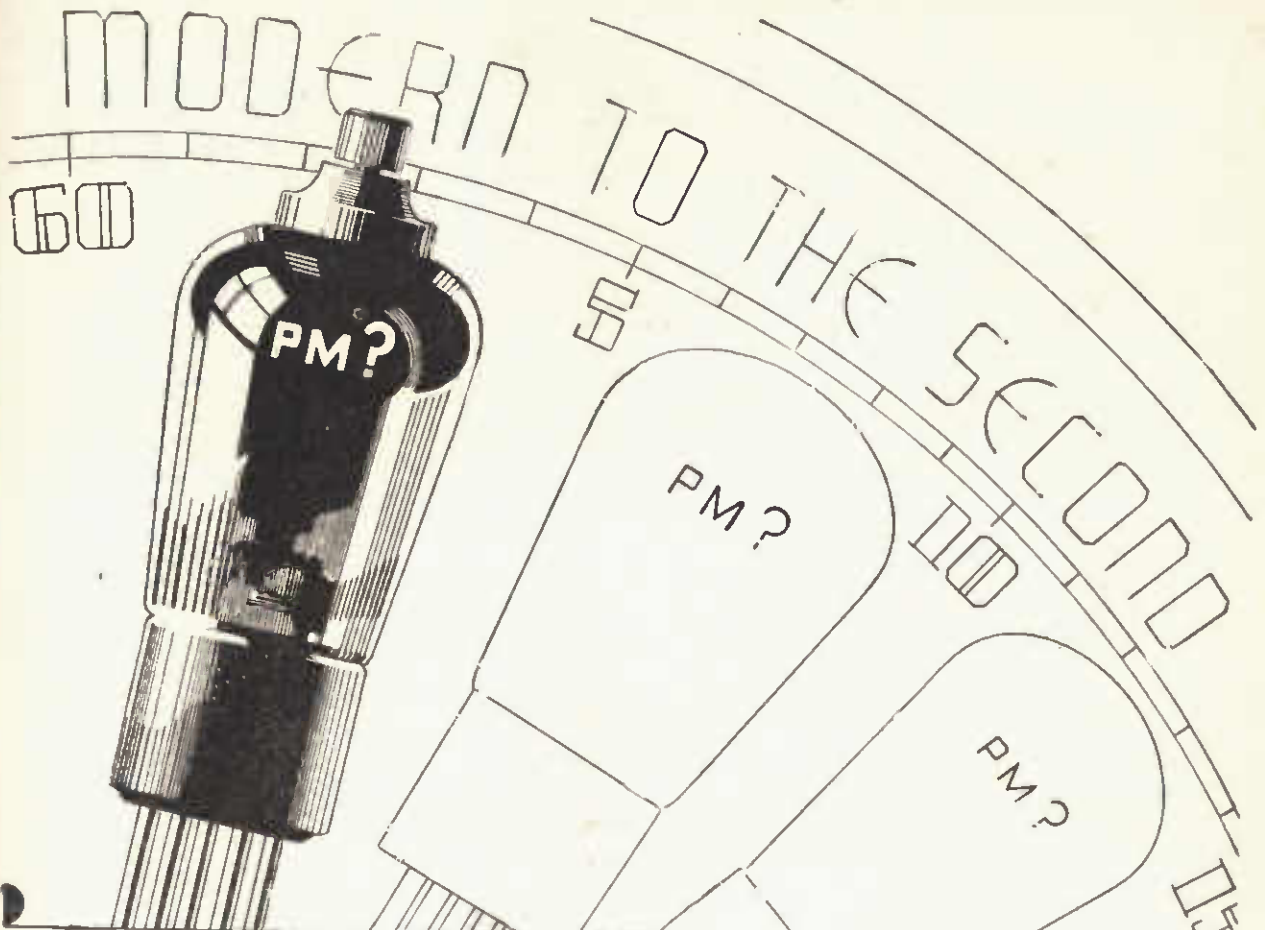

**... Keeping pace
and often ahead**

A better Multi-mu :: an indirectly heated pentode :: a power-grid detector with a gain of 85 :: a combined oscillator and detector for super-heterodynes and amazing new battery radiovalves — provide definite proof of leadership for 1932.

Mullard
RADIOVALVES

PRODUCT OF ENGLAND

ADVERTISEMENT OF THE MULLARD RADIO COMPANY (AUSTRALIA) LIMITED. HEAD OFFICE: 35 CLARENCE STREET, SYDNEY.

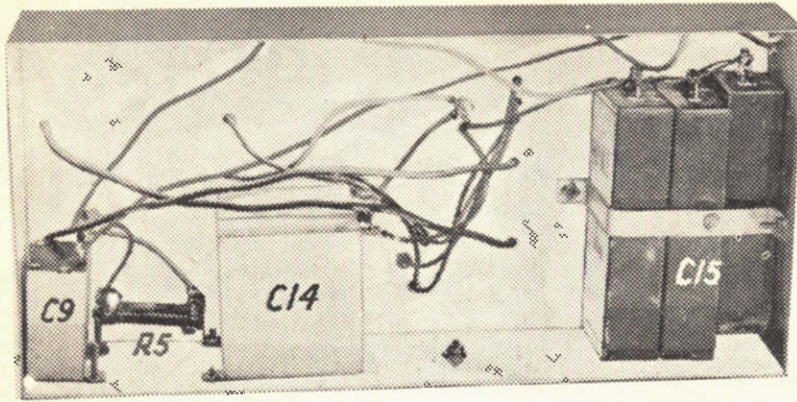

An underneath view showing the wiring.

A SIMPLE POWER PACK—(Continued from page 68)

Looking at the circuit of the power-pack we have the bias resistor R5 and its by-pass condenser, C9. This condenser does not require to be a high voltage type, and one which is satisfactory at 200 volt may be used. On the other hand, the modulation condenser, C13, should be one which will withstand an operating voltage of no less than 1000 volts d.c.

The value of the bias resistor, R5, should be selected according to the power valve used. The value given by the valve makers is only correct when the prescribed plate voltage is applied the power valve. A voltmeter should be borrowed to ascertain whether voltages delivered by the divider resistance tapings have been adjusted correctly.

The condensers, C14 and C15, are filter condensers. Filter condensers which have not a high breakdown voltage are a source of danger and could be the possible cause of breakdown of the rectifier or power transformer, so that a few shillings extra in their purchase may prove to have been well spent. There is no reason why a power-pack built from reliable equipment, and with the replacement of rectifiers every two years or so, should not give good service for ten years or longer. The writer has had a power-pack in constant operation for six years, during which time the rectifier has had to be replaced only once.

CH is the filter choke, a vital part of plate power supply circuits. Insufficient inductance in the filter choke will prevent all a.c. modulation from being filtered from the supply, the result being a bad hum and sometimes distortion if the hum is particularly bad. It is in the end the cheapest proposition to invest in a filter choke which has a value of 60 henries and no less, and will pass the maximum current drawn by the receiver and voltage dividing resistor, adequately. A choke or too low a value of inductance will require more filter capacity to clean up hum, a costly business. Normally, the values of the filter condensers, C14 and C15, can be 4 microfarads each, this being sufficient in conjunction with the 60 henry choke to eliminate all hum.

It would be wise to discuss the connection of the dynamic speaker while dealing with the filter system of the power-pack.

The connecting of a dynamic speaker to the four valve receiver will depend upon the type of speaker. If the

speaker has its own power supply, only two connections to the speaker terminals of the receiver need to be made. A 6-volt type of field without a supply is useless as far as this power-pack is concerned. To operate with this receiver when using a power valve to operate at or around 300 volts, the dynamic speaker should have a field resistance of several thousand ohms which will permit its being connected in series with the filter choke of the pack for its excitation current. A 4 mfd. capacity filter condenser should be connected across the two field supply leads if this is done. The primary of the step-down transformer, usually mounted in the speaker itself, will connect to the normal speaker leads from the receiver.

If the filament and heater supply secondaries of a power transformer are not centre-tapped, the connecting to chassis of all indirectly heating secondaries will be satisfactory while the secondary supplying the power valve filament may be centre-tapped by the use of a centre-tapping resistance of the order of 20 ohms connected across the secondary terminals. It is not essential that the rectifier filament secondary be centre-tapped, although longer life from the rectifier may be expected if the positive connection to the filter is from the secondary of this winding and not from either end.

Chassis Method of Construction

Use of the chassis method of construction will give neatest results, and since all negative connections may be made to the chassis metal, whether it be made of aluminium, copper or iron, by means of the nearest mounting screws, wiring is simplified considerably. All that must be watched is the passing of mains wires and high voltage positive wires through the chassis. It is advisable to bush all holes through the chassis through which wires of any voltage must pass, by using small sections of ebonite tubing pushed through the metal after holes of suitable size have been drilled.

No particular order in the mounting of the power-pack equipment must be observed. Before the chassis is made the parts should be arranged to occupy as little space as possible and the measurements for the chassis may then be taken. The filter condensers are mounted underneath the chassis. A sub-panel type of UK socket is used. The socket is mounted underneath the chassis, a large hole being removed above it to permit the rectifier to be plugged into its socket.

Most rectifiers are equipped with the standard U.X. base. The filament connections to the thermionic type of rectifiers are to the F terminals of the socket, the plate of the rectifier connecting to the plate terminal of the socket in the case of a half wave rectifier, and to the grid and plate terminals of the socket in the case of a full wave rectifier such as the 280 type.

Ordinary house lighting flex wire is the best to use in wiring up the components of the power-pack. The only terminal in the pack need be one mounted through the metal of the chassis for the negative connection to ground and to the receiver. The ground connection to the receiver chassis is through the B negative connection, the pack chassis being earthed direct.

In the standard console type of cabinet, the pack should be fitted into the bottom near the speaker, and well away from the receiver chassis. Twin flex wires for the negative and maximum positive of the pack, and each heater and filament secondary, can be easily taken, and the pack connected to the receiver within a few minutes.

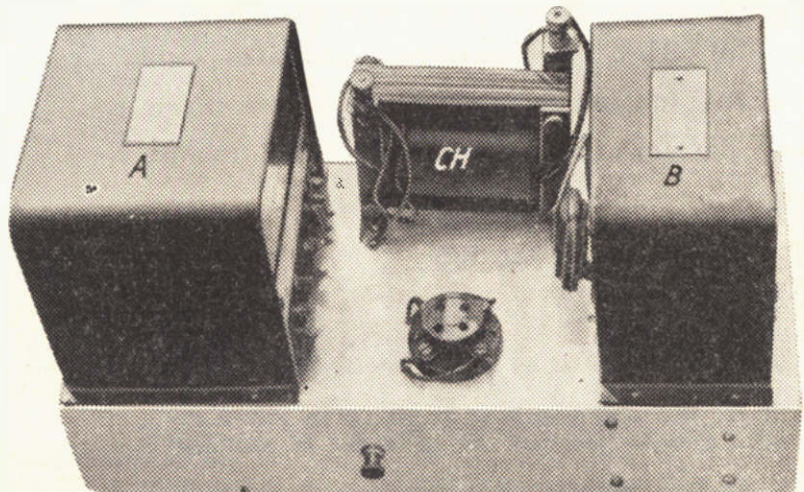

This photograph will give the builder a good idea of the layout required.

VARIOUS FORMS of REACTION

An interesting article dealing with different systems used to obtain oscillation in the detector

By W.G.S.

PROBABLY the most important, and usually the least understood part of any short-wave receiver is the reaction or regenerative feedback. Reaction does not add range, or signal strength to the set, but it will, if correctly handled, very materially increase the sensitivity of the detector valve, causing it to be responsive to the extremely weak signals fed from the aerial.

pendent for the drop across the coupling resistance.

In this new method of controlling reaction the control resistance is inserted in the lead to the screening grid and serves to vary the potential applied thereto thus varying the mutual conductance of the tube and controlling the amount of feedback obtained. The value of the variable resistance used should be at least 200,000 ohms and the normal po-

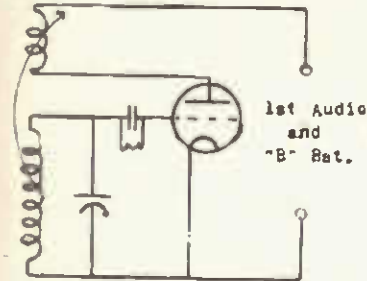

Fig. 1.—Reaction by a moving coil is not satisfactory.

For reception of short wave phone stations, reaction must be very critically adjusted in order that distortion, due to the valve breaking into self-oscillation, shall not be introduced. For the reception of code stations, however, weak oscillation is usually desirable, so that the artificial "note" created by the beat between the incoming and the local frequencies can be adjusted to the most comfortable audio frequency for the head phones.

The movable coil (Fig. 1) is the simplest example of reaction produced by inductive coupling, and reaction occurs when both plate and grid coils are magnetically linked and in phase, the amount of feedback being dependent on the coupling between them. Arrangements are made for varying the coupling by varying the position of the plate coil. It has the strong disadvantage of being mechanically difficult to handle, and every variation causes a serious change in the tuning of the grid coil.

"Throttle" control is probably one of the most common and useful methods employed, and consists of a combination of inductive and capacitive control. It is essentially inductive in nature, the coupling being fixed, and the "throttle" condenser arranged as a variable "by-pass" across the batteries, phones, etc. Being variable, the amount of high

frequency energy by-passed (or short-circuited), from the plate coil can also be varied, and the regenerative field of the plate coil and grid coil adjusted to a very fine degree. Throttle control is a good method, very stable and easy to adjust, but although not so bad as the moving coil method, it also has a serious effect on the tuning. For short wave work the size of the throttle condenser is usually .00025 mfd.

"Resistance" control is a newer and better method. In this case the inductive coupling is again fixed, and the strength of the regenerative field of the plate coil adjusted by variations in the plate potential by means of a variable high resistance (usually about 50,000 ohms), inserted in the lead to the battery. This method, provided the resistance is smooth and silent in action, is the easiest of all to adjust, and has a negligible effect on the tuning. As will be seen from the schematic diagram a fixed "by-pass" (.00025 to .002), is arranged for the high frequency currents to keep the inductive feedback very low, and a large 1 mfd across the resistance to help smooth its action.

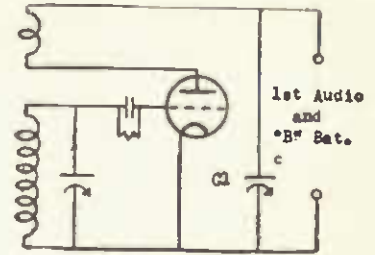

Fig. 2.—Capacity control of regeneration is popular.

tential applied to the battery end of it, should be approximately 2/3rds of the actual voltage applied to the plate, measured from the plate terminal of the valve itself.

Differential reaction employs a condenser specially constructed which is so fashioned as to exert a continuous load across the reaction coil, but which has a variable by-pass to earth. It is inserted in the place of the throttle condenser in the place of the Schnell or Reinartz tuner and serves the same purpose with the added advantage that the reactance load on the valve is always the same, thus improving the performance of the detector. Constructors who desire to try the scheme out will have to construct the special condensers for themselves.

A suitable unit can be made from two 23-plate midget condensers mounted on a piece of bakelite in "tandem" fashion, with the straight edge of both sets of stator plates facing the rotor spindle. The two sets of rotor plates are mounted so that they appear on opposite sides of the main spindle, when it will be seen that a movement of the "ganged" spindle will increase or decrease the capacity of the two condensers simultaneously. Connection is made from the two stators to both ends of the reaction coil and the rotors to earth.

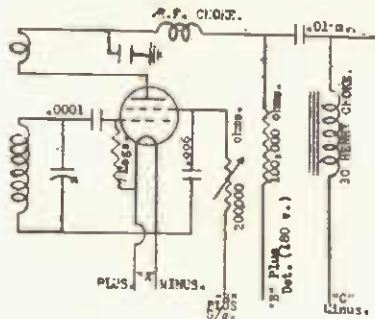

Fig. 4.—Resistance control of the screen grid voltage supplied to a screen grid detector.

Reaction Control

Two variations of the method described are worthy of comment. Resistance control employed in the screen grid lead to screen grid valve used as a detector, is used by a number of Australian experimenters.

Screen grid valves make excellent detectors, providing a high amplification gain when followed by resistance/capacity or resistance/choke coupling, and it requires very little alteration to the existing wiring of the set to incorporate it.

The connection of the reaction coil is the same as for other methods of control for three electrode detector valves, and should be shunted with the usual condenser, which may be variable in the case of throttle control if previously employed, or fixed as in resistance control. The usual variable high resistance must be replaced by a fixed plate coupling resistance of 100,000 ohms (1 meg ohm). High plate voltages are essential to com-

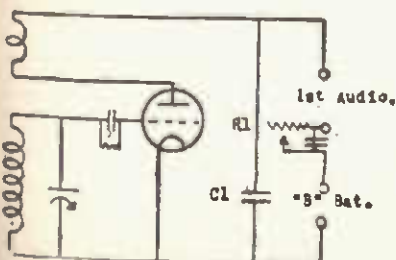

Fig. 3.—Resistance control of regeneration is excellent only if a good resistance is used.

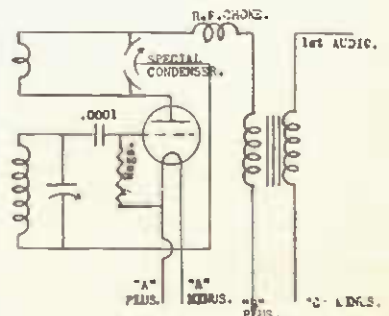

Fig. 5.—The "differential throttle" control of regeneration.

PLATE AND GRID DETECTION

Some information on their relative merits and disadvantages

THE detector is the heart of a receiver. Around it radio frequency amplifiers are built in order to boost the volume, and in the former case, in some instances, to also separate the various stations.

Although it is a simple matter to construct a receiver employing either grid or plate detection, few constructors understand just how the detector functions and its limitations.

Even now radio engineers are still discussing rectification and new data is

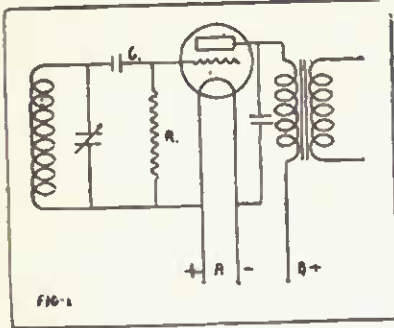

Circuit of a grid leak and condenser detector.

being continually published in highly technical journals.

This article, however, is going to deal with the practical aspect more than the theoretical aspect.

The reason why a detector is used in a receiving set is to rectify and make audible the audio frequency currents impressed on the carrier wave which may be at any radio frequency.

In a plate circuit detector rectification as the name implies takes place in the plate circuit of the valve. A modulated radio frequency signal which is impressed on the grid of the valve is amplified and when it appears in the plate circuit is rectified. As the signal is first amplified and then rectified, the detector is called an amplifier rectifier. All that is necessary to produce plate circuit detection is to apply sufficient bias to the grid of the valve in order to bring the operating point to the curved portion of the characteristic of the valve.

A grid circuit detector functions altogether differently from that of a plate detector. When a modulated R.F. signal is applied to the grid circuit of a valve using this system of detection, it is first rectified and then amplified by the valve.

Since the audio frequency component is rectified first and amplified after, this class of detector is known as rectifier amplifier. This type of detection is possibly the most popular in Australia, although it is doubtful whether it will continue to be so owing to certain disadvantages which will be described later. An illustration of rectified amplified detection is that of a detector using a grid leak and condenser.

Having noted the difference between the two classes of detectors, the advantages and drawbacks of the grid leak and condenser detector will be discussed. In Fig. 1 a circuit of a grid leak and

condenser detector is shown, the capacity of C being .00025 mfd. and the value of the grid leak from 1 megohm to 4 megohms. Values other than these may be used, and in many cases may give better results.

Undoubtedly the popularity of this system is due to its sensitivity, which is greater than that of any other system. With a plate voltage of 45 and the average values of grid leak and condenser, the output of an ordinary detector is, roughly, 3 volts, which is not very great. The only constants that can be altered to increase the output are the values of condenser and leak and the plate voltage which has a big effect.

If contemplating using a higher voltage on the plate of the detector, the increased plate current must be taken into consideration in the case where an audio frequency transformer follows the detector, as the characteristics will be affected. It is an advantage to use as high a plate voltage as the transformer and valve will stand if maximum results are desired.

In the case where oscillation of the valve is desired to be controlled, too high a voltage will result in a loud squeal when bringing the valve into oscillation, so it can be seen that plate voltage must not be too high.

As previously stated, different values of grid leak and condenser have a marked effect on the output, but they also have a greater effect on the quality.

It is not generally realised that, when fairly large radio frequency signals are impressed on the input of the condenser and leak detector, the circuit may tend to block sufficiently to affect the frequency response of the detector, but not

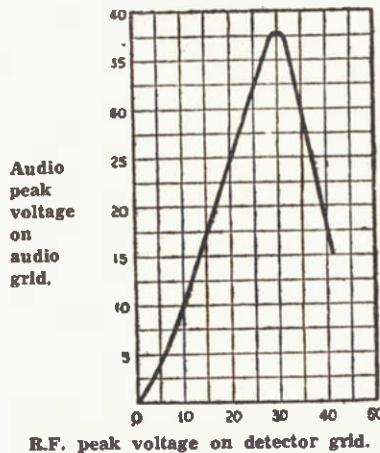

Curve showing relation between R.F. voltage applied to the grid of a UY 227, and the audio voltage across the secondary of an audio transformer.

sufficiently to give out a noise similar to that of "motor boating."

To overcome this trouble the value of the grid condenser and leak should be as low as possible, although the sensitivity will be sacrificed. The reason for keeping these values as low as possible is to make the change in the total im-

pedance of the circuit between the highest and lowest audio frequencies as small as possible in order to give a uniform frequency response. It is best to make a compromise between sensitivity and quality.

A sensitive ear can sometimes notice an improvement in the high frequency response of a receiver using grid leak and condenser detection on changing the values, which are generally in the vicinity of .00025 mfd. and 2megs. to .0001 mfd. and 1/2meg. for the leak.

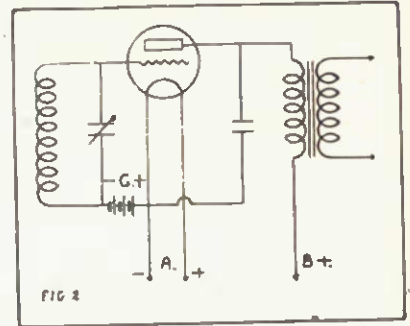

A valve used as a plate circuit detector.

These values are recommended where sensitivity is not the most important factor.

When using a grid leak and condenser detector of the low voltage type preceding a pair of medium power valves in push-pull, which requires a bias of about 15 volts each, it will be found that the output of the detector will not load the grids of the two power valves even if the push-pull transformer has a ratio of 5 to 1, assuming the output of the detector to be 3 volts.

Taken all round, in order to obtain the best quality from a grid leak and condenser detector, it is essential to use a small capacity fixed condenser, a fairly low value of grid leak, and a high plate voltage. Unfortunately this arrangement will not give the maximum sensitivity, but it is better to sacrifice sensitivity than to sacrifice quality.

Turning to plate rectification, the advantage of this system is that comparatively large audio frequency voltages can flow in the plate circuit, with the result that one stage of audio frequency amplification can be used successfully. This means that there is less likelihood of hum in the reproduction and better quality.

The disadvantage of plate rectification is that it lacks sensitivity, resulting in the use of radio frequency amplifiers if the maximum results are to be obtained.

In Fig. 3 is shown a circuit of a plate detector, which is used in commercial receivers. The bias resistance is inserted between the cathode connection of the valve and earth, which is B negative. A bypass condenser of 1 mfd. is connected across the resistance.

A circuit of a plate detector, the filament of which is shown in Fig. 2, is directly heated by a battery. In this case a "C" battery is used to supply the negative voltage to the grid of the

(Continued on page 74)

YES

The answer is . . .



. . . there ARE definite reasons for Cossor's superiority . .

MANY radio set owners are under the impression that all valves are pretty much alike. When someone advises them to change to Cossors they ask: "Why should I? Are Cossors so very different?" The answer is, "YES . . . and there are definite reasons for Cossor's superiority."

A "rapid-heater" filament which, twisted tightly around a central porcelain pillar, is practically unbreakable; carbonised anodes to facilitate heat dissipation and thus increase life; mica-bridge assembly of the elements for absolute rigidity and uniformity—these are a few of many exclusive Cossor features. Your radio dealer will explain their importance and show you why Cossors can, quite definitely, improve the reception of your set.

THE COSSOR 235/C

(illustrated above)

Filament Volt. — 2.5
 Filament Current 1.75 amp.
 Plate Volt. 275
 Screen Volt. 90
 Amp. Factor 450

Price **25/-**

Ask about Cossor Valves at Veall's 3 Big Cash Stores, Harrington's, Hartley's or The Leviathan.

Wholesale Distributors for Australia:

W. G. WATSON & CO. LTD.

200 Queen Street, Melbourne

BRANCHES ALL STATES.

100 PER CENT BRITISH
COSSOR
 New Process VALVES

THE BATTERY PROBLEM

High and Low Tension Batteries and the relation they bear to the various valves used

THERE can be no doubt that the greatest drawback at the present time to the valve receiving sets not worked direct from the AC or DC current is that batteries are required for their operation. Of course, the grid bias battery gives little or no trouble since, owing to the fact that the drain upon it is minute, small dry cells, which will last for a year or more without attention, can be employed. Matters are, however, very different when we consider the plate and filament batteries. The plate, or "B" battery, has to deliver a small high-pressure current, while the filament or "A" battery is called upon to supply a low-pressure comparatively high-amperage current to light the filaments of the receiving valves.

A very large number of owners of such receiving sets use an accumulator for heating the filaments of their valves, and a battery of small, dry cells for furnishing the plate supply. There is a good deal to be said for this combination, though it has certain drawbacks. The accumulator is without doubt the best medium for the supply of filament current if facilities are available for efficient recharging. Those who live at or near large towns have, as a rule, no difficulty in getting their accumulators recharged, though at many charging stations the work is indifferently done, with the result that the battery runs down long before it should, and its working life is considerably shortened.

Primary Batteries for L.T. Work

The advent of the dull emitter valve, types of which use as little as .06 amperes of current for filament lighting at four volts, has made it possible to employ primary batteries instead of accumulators for low-tension purposes. At the present time a large number of receiving sets installed in the country are fitted with dry cell primary batteries, which function satisfactorily up to a point. Apart from the fact that its voltage is continually falling while it is in use, the disadvantages of the dry cell primary battery are two—if it is to heat the filaments of a multi valve receiver for some months the battery must be of large size, which means that it is expensive to install, and once the battery is run down it must be discarded, as it cannot be re-charged.

The dry cell is simply a form of Leclanche cell, similar to those which are often used to work electric bells. This consists of a glass jar within which are zinc rods, the negative pole, and a carbon element, the positive pole. The carbon element is sealed into a porous pot which also contains a depolarising compound, the purpose of which is to prevent the formation of hydrogen bubbles on the carbon rod. The formation of these bubbles, which would collect were it not for the depolariser, would increase the internal resistance of the cell, and reduce its useful life greatly. In the dry cell the zinc element is made into a containing case, and the

electrolyte, instead of being in liquid form, is a paste. The wet Leclanche cell is quite inexpensive, and can be recharged at the cost of a few pence when run down.

Unfortunately the standard type is not suitable for filament heating purposes, since it is designed for giving current only for brief periods separated by long intervals. However, it is possible to obtain specially designed Leclanche cells, three of which will, when wired in series, provide enough current to operate from three to five dull emitter valves of the .06 ampere type for months on one charge.

"Wet" H.T. Battery

The accumulator "B" battery is becoming increasingly popular, and with good reason, for it gives a perfectly steady current, and makes for quiet working. It cannot, however, be installed unless recharging facilities are available, and it is more easily damaged by ill-treatment than the filament accumulator. For multi-valve receivers the dry cell "B" battery is not a very satisfactory component since it is expensive to install, and is apt prematurely to develop certain faults; such a battery, too, is liable to become noisy when it has been in operation for some time.

The Duffy Short Wave Transposer

THE Duffy Short Wave Transposer is announced as a scientific achievement to meet the demand that has been created for a reliable and sensitive short wave radio set. Today, the ever increasing interest in the short wave field is being displayed by every nation in the world. Proof of this lies in the fact that every country has realised the extreme importance of speedy communication, and the latest development in radio has enabled them to erect powerful short wave transmitting stations that are capable of being heard in every portion of the globe.

This means now that in Australia, with the aid of a suitable medium, overseas stations may be tuned in.

"The Duffy Short Wave Transposer" is now introduced as the suitable medium. It is the result of considerable research, and can be used with any suitable audio system or as a separate and independent set. Simplicity and efficiency are the keynote in this new piece of apparatus. The "Transposer" is plugged in to any type of radio set that gives satisfactory results on a gramophone pick-up, and it reproduces the programmes from overseas.

The special output device enables the Transposer to be used as a complete set, capable of operating a small speaker. It also automatically changes the present detector stage in an existing set to an extra audio stage, providing actually three stages of audio frequency and giving distortionless results.

PLATE AND GRID DETECTION—

(Continued from page 72)

valve. In both Fig. 1 and Fig. 2 it will be seen that a condenser is connected between the plate of the valve and B negative, which in turn goes to earth. This condenser is essential in order to bypass the high frequency impulses to earth. It generally has a capacity in the vicinity of .002 mfd., with the result that the reactance of this condenser is very great to the audio frequency impulses, but its reactance to the H.F. impulses in plate current is low.

If the capacity of this condenser is too great, the high notes of audio frequency will be bypassed, but if the value of capacity is too small, H.F. currents will flow in the audio amplifying system, causing poor tonal quality and whistles in the reproduction.

A plate circuit detector is biased at about the centre point of the curved portion of the valve's characteristic in order that when a modulated radio frequency signal is impressed on the input, certain parts of it are amplified more

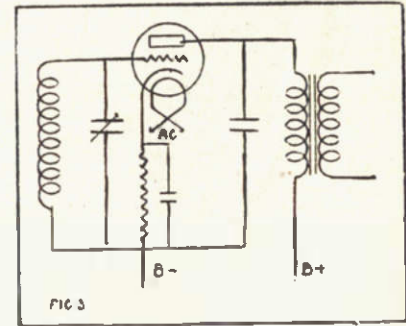

Circuit of an A.C. valve used as a plate circuit detector.

than others, due to the curvature of the characteristic.

In Fig. 4 the curve of a UY227 valve, when used as a plate circuit detector, is shown. The voltage applied to the plate is 180, while the grid bias is negative 25 volts.

The curve shows the relation between the peak value of the radio frequency input to the grid of the valve and the peak value of the audio voltage across the secondary of the transformer following the detector.

It will be seen that the valve begins to overload with a radio frequency input of 30 volts.

This valve should be ideal as a detector when using a power valve in the one audio stage.

One has frequently heard the term power detector used, and merely refers to a plate circuit detector, which is operated at a high voltage in order to amplify and rectify comparatively large radio frequency voltages, and is generally followed by only one stage of audio.

It is due to being able to handle large radio frequency voltages without distortion that the plate rectifier appears to be the rectifier of the future.

For those who desire to use a minimum number of valves, the grid leak and condenser detector will always be popular, while those who want the best possible quality, irrespective of the type or number of valves, plate detection will be used.

**WAVE LENGTH FREQUENCY
CONVERSION TABLE**

Changing Kilocycles into Metres. (Velocity—3,000,000 Km. per second).

Freq.	W/length.	Freq.	W/length.	Freq.	W/length.
50 Metre Broadcast Band					
6000	50.00	6055	49.54	6110	49.10
6005	49.95	6060	49.50	6115	49.06
6010	49.91	6065	49.46	6120	49.02
6015	49.86	6070	49.42	6125	48.98
6020	49.83	6075	49.38	6130	48.94
6025	49.79	6080	49.34	6135	48.90
6030	49.75	6085	49.30	6140	48.86
6035	49.71	6090	49.26	6145	48.82
6040	49.66	6095	49.22	6150	48.78
6045	49.62	6100	49.18	6155	48.74
6050	49.58	6105	49.14	6160	48.70
				6165	48.66
40 Metre Amateur Band					
7000	42.86	7100	42.25	7200	41.67
7010	42.80	7110	42.19	7210	41.61
7020	42.74	7120	42.13	7220	41.55
7030	42.67	7130	42.07	7230	41.49
7040	42.61	7140	42.01	7240	41.44
7050	42.55	7150	41.96	7250	41.38
7060	42.49	7160	41.90	7260	41.32
7070	42.43	7170	41.84	7270	41.26
7080	42.37	7180	41.78	7280	41.21
7090	42.31	7190	41.72	7290	41.15
				7300	41.10
31 Metre Band					
9500	31.58	9535	31.46	9570	31.35
9505	31.56	9540	31.45	9575	31.33
9510	31.54	9545	31.43	9580	31.32
9515	31.53	9550	31.41	9585	31.30
9520	31.51	9555	31.40	9590	31.28
9525	31.50	9560	31.38	9595	31.27
9530	31.48	9565	31.36	9600	31.25
				9605	31.23
25 Metre Band					
11700	25.64	11770	25.49	11840	25.34
11705	25.63	11775	25.48	11845	25.33
11710	25.62	11780	25.47	11850	25.32
11715	25.60	11785	25.46	11855	25.31
11720	25.59	11790	25.45	11860	25.30
11725	25.58	11795	25.43	11865	25.29
11730	25.57	11800	25.42	11870	25.28
11735	25.56	11805	25.41	11875	25.26
11740	25.55	11810	25.40	11880	25.25
11745	25.54	11815	25.39	11885	25.24
11750	25.53	11820	25.38	11890	25.23
11755	25.52	11825	25.37	11895	25.22
11760	25.51	11830	25.36	11900	25.21
11765	25.50	11835	25.35	11905	25.20
20 Metre Band					
14000	21.428	14140	21.216	14280	21.008
14010	21.413	14150	21.201	14290	20.994
14020	21.398	14160	21.186	14300	20.979
14030	21.383	14170	21.171	14310	20.964
14040	21.368	14180	21.157	14320	20.950
14050	21.352	14190	21.142	14330	20.935
14060	21.337	14200	21.127	14340	20.921
14070	21.322	14210	21.112	14350	20.906
14080	21.307	14220	21.097	14360	20.891
14090	21.292	14230	21.082	14370	20.877
14100	21.277	14240	21.067	14380	20.862
14110	21.262	14250	21.053	14390	20.848
14120	21.246	14260	21.038	14400	20.833
14130	21.231	14270	21.023		
19 Metre Band					
15100	19.867	15185	19.756	15275	19.639
15105	19.861	15190	19.749	15280	19.632
15110	19.854	15195	19.743	15285	19.626
15125	19.847	15200	19.736	15290	19.619
15120	19.841	15205	19.730	15295	19.613
15125	19.834	15210	19.723	15300	19.607
15130	19.827	15215	19.716	15305	19.600
15135	19.821	15220	19.710	15310	19.594
15140	19.814	15225	19.704	15315	19.588
15145	19.807	15230	19.698	15320	19.581
15150	19.801	15235	19.691	15325	19.575
15155	19.794	15240	19.685	15330	19.569
15160	19.787	15245	19.678	15335	19.562
15165	19.781	15250	19.672	15340	19.556
15170	19.774	15255	19.666	15345	19.550
15175	19.768	15260	19.659	15350	19.543
15180	19.762	15265	19.652	15355	19.537
		15270	19.646		

The Key to Perfect Reception



Radio Parts

GIVE your Receiver a fair chance by constructing it with the best materials available. Ask for and see you get the world-famous "FERRANTI" PARTS. The reliability of "FERRANTI" equipment is unquestioned, and assures perfect reception at all times.



Audio Push Pull and Output Transformers

These are available in a wide range and are the accepted standard of Transformer quality. For best results you must use "FERRANTI" Transformers.



Ferranti Radio Meters

The use of these reliable instruments has done much to bring Radio to its present state of efficiency. "FERRANTI" Meters are available in a complete range for D.C. and A.C. measurements and types for A.F. supplies as well as types for use in R.F. Circuits.

Sole Agents:

NOYES BROS. (Melb.) Pty. Ltd.

597-603 LONSDALE STREET, MELBOURNE, C.1.
Phone Cent. 10106 (11 lines).

HOBART

LAUNCESTON

ADELAIDE

AMATEUR ABBREVIATIONS

These letters, otherwise known as "Q" signals, are used by amateur transmitters when communicating between themselves

1.—Abbreviations available for all services.

Abbreviation	Question.	Answer or Advice.
QRA	What is the name of your station?	The name of my station is
QRB	How far approximately are you from my station?	The approximate distance between our stations is nautical miles (or kilometres).
QRC	What private enterprise (or Government Administration) settles the accounts for your station?	The accounts for my station are settled by the private enterprise (or by the Government Administration of).
QRD	Where are you bound?	I am bound for
QRE	What is the nationality of your station?	The nationality of my station is
QRF	Where are you coming from?	I am coming from
QRG	Will you tell me my exact wave length in metres (or frequency in kilocycles)?	Your exact wave length is metres (or kilocycles).
QRH	What is your exact wave length in metres (or frequency in kilocycles)?	My exact wave length is metres (or frequency is kilocycles).
QRI	Is my note bad?	Your note is bad.
QRJ	Do you receive me badly? Are my signals weak?	I cannot receive you. Your signals are too weak.
QRK	Do you receive me well? Are my signals good?	I receive you well. Your signals are good.
QRL	Are you busy?	I am busy (or, I am busy with). Please do not interfere.
QRM	Are you being interfered with?	I am being interfered with.
QRN	Are you troubled by atmospherics?	I am troubled by atmospherics.
QRO	Shall I increase power?	Increase power.
QRP	Shall I decrease power?	Decrease power.
QRQ	Shall I send faster?	Send faster (..... words per minute).
QRS	Shall I send more slowly?	Send more slowly (..... words per minute).
QRT	Shall I stop sending?	Stop sending.
QRU	Have you anything for me?	I have nothing for you.
QRV	Shall I send a series of V's?	Send a series of V's.
QRW	Shall I tell that you are calling him?	Please tell that I am calling him.
QRX	Shall I wait? When will you call me again?	Wait until I have finished communicating with I will call you immediately (or at o'clock).
QRY	What is my turn?	Your turn is No. (or according to any other method of arranging it).
QRZ	Who is calling me?	You are being called by
QSA	What is the strength of my signals (1 to 5)?	The strength of your signals is (1 to 5).
QSB	Does the strength of my signals vary?	The strength of your signals varies.
QSC	Do my signals disappear entirely at intervals?	Your signals disappear entirely at intervals.
QSD	Is my keying bad?	Your keying is bad. Your signals are unreadable
QSE	Are my signals distinct?	Your signals are sticking.
QSF	Is my automatic transmission good?	Your automatic transmission disappears.
QSG	Shall I transmit the telegrams in series of 5, 10 (or according to any other indication)?	Transmit the telegrams in series of 5, 10 (or according to any other indication).
QSH	Shall I send one telegram at a time, repeating it twice?	Send one telegram at a time, repeating it twice.
QSI	Shall I send the telegrams in alternate order without repetition?	Send the telegrams in alternate order without repetition.
QSJ	What is the charge per word for including your internal telegraph charge?	The charge per word for is francs, including my internal telegraph charge)
QSK	Shall I suspend traffic? At what time will you call me again?	Suspend traffic. I will call you again at (o'clock).

Abbreviation	Question	Answer or advice
QSL	Can you give me acknowledgment of receipt?	I give you acknowledgment of receipt.
QSM	Have you received my acknowledgment of receipt?	I have not received your acknowledgment of receipt.
QSN	Can you receive me now? Shall I remain on watch?	I cannot receive you now. Remain on watch.
QSO	Can you communicate with direct (or through the medium of)?	I can communicate with direct (or through the medium of).
QSP	Will you retransmit to free of charge?	I will retransmit to free of charge.
QSQ	Shall I send each word or group once only?	Send each word or group once only.
QSR	Has the distress call received from been cleared?	The distress call received from has been cleared by
QSU	Shall I send on metres (or kilocycles) waves of type A1, A2, A3 or B?	Send on metres (or on kilocycles), waves of Type A1, A2, A3 or B. I am listening for you.
QSV	Shall I change to the wave of metres (or of kilocycles), for the rest of our communications and continue after sending a few V's?	Change to the wave of metres (or of kilocycles) for the rest of our communications and continue after sending a few V's.
QSW	Will you send on metres (or on kilocycles) waves of Type A1, A2, A3 or B?	I am going to send on metres (or kilocycles) waves of Type A1, A2, A3 or B. Continue to listen.
QSX	Does my wave length (frequency) vary?	Your wave length (frequency) varies.
QSY	Shall I send on the wave of metres (or kilocycles) without changing the type of wave?	Send on the wave of metres (or kilocycles) without changing the type of wave.
QSZ	Shall I send each word or group twice?	Send each word or group twice.
QTA	Shall I cancel telegram No. as if it had not been sent?	Cancel telegram No. as if it had not been sent.
QTB	Do you agree with my number of words?	I do not agree with your number of words; I will repeat the first letter of each word and the first figure of each number.
QTC	How many telegrams have you to send?	I have telegrams for you or for
QTD	Is the number of words which I am confirming to you accepted?	The number of words which you confirm to me is accepted.
QTE	What is my true bearing? or What is my true bearing in relation to ?	Your true bearing is degrees or Your true bearing in relation to is degrees at (time).
QTF	Will you give me the position of my station according to the bearings taken by the direction-finding stations which you control?	The position of your station according to the bearings taken by the direction-finding stations which I control is latitude longitude.
QTG	Will you send your call sign for one minute on a wave length of metres (or kilocycles) in order that I may take your bearing?	I am sending my call sign for one minute on the wave length of metres (or kilocycles) in order that you may take my bearing.
QTH	What is your position in latitude and longitude (or by any other way of showing it)?	My position is latitude longitude (or by any other way of showing it).
QTI	What is your true course?	My true course is degrees.
QTI	What is your speed?	My speed is knots (or kilometres per hour).
QTK	What is the true bearing of in relation to you?	The true bearing of in relation to me is degrees at (time).
QTL	Send radioelectric signals to enable me to fix my bearing in relation to radiobeacon.	I will send radioelectric signals to enable you to fix your bearing in relation to the radiobeacon.
QTM	Send radioelectric signals and submarine sound signals to enable me to fix my bearing and my distance.	I will send radioelectric signals and submarine sound signals to enable you to fix your bearing and your distance.
QTN	Can you take the bearing of my station (or of) in relation to you?	I cannot take the bearing of your station (or of) in relation to me.
QTP	Are you going to enter dock (or port)?	I am going to enter dock (or port).
QTR	What is the exact time?	The exact time is
QTS	What is the true bearing of your station in relation to me?	The true bearing of my station in relation to you is at (time).
QTU	What are the hours during which your station is open?	My station is open from to

THE ULTRA SELECTIVE A.C.

THREE

A three valve receiver which, owing to its coil construction and the shielding of the components, is extremely sharp in tuning

By F. OLSEN

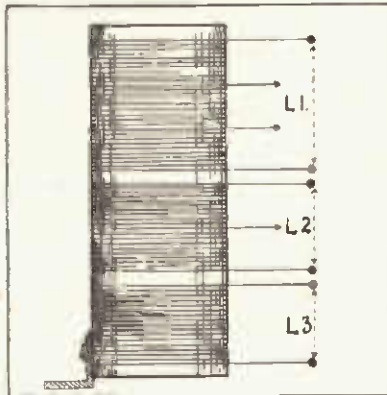

A diagram of the coil.

NOW an increasing number of stations are operating on wave lengths close to each other, separated in some cases by only 10 kilocycles, the average receiver employing a regenerative detector followed by one or more stages of audio amplification is incapable of eliminating the interference caused by a more powerful station on an adjacent wave length to the station the set is tuned to.

Naturally, if the difference in the fields strengths of the stations is excessive—that is, for example, if the interfering station has a field strength of about 25 m.v. per metre, and that the station received has a strength of only 5 m.v. per metre, and the separation between them is only 10 k.c.—it is doubtful whether any straight detector employing one tuned circuit can successfully eliminate the background of the stronger station. Even if it were eliminated the volume of the desired station would be so weak, owing to the lack of sensitivity on the part of the detector due to the extreme selectivity that to all intents and purposes reception of the weaker station would be satisfactory.

From this it can be seen that the capabilities of a single tuned circuit coupled to a detector valve are limited from a viewpoint of selectivity, and that a large factor in the results obtained from a receiver using such a detector depends upon what locality the listener is situated and whether he is near a broadcasting station.

Country Reception

The reason why country residents get such good results from plain detectors is that they are well away from broadcasting stations, with the result that the selectivity problem which the city listener has to contend with is non-existent. The result is that they are able to get more sensitivity from their detectors by increasing the number of turns on the aerial coil and increasing the plate voltage applied to the detector valve.

With the local listener this state of affairs is entirely different. If the number of turns on the aerial coil are increased, interference between stations makes it impossible to obtain satisfactory reception. If the plate voltage on the detector valve is increased, the sensitivity of the detector is increased to such an extent that the background of some unwanted station, which was before hardly noticeable, now becomes louder. In remedying this trouble by taking turns off the aerial coil we come back to where we were previously in that the results are no better.

Having made this point thoroughly clear, that the results obtainable from a regenerative detector using a single-tuned circuit are limited and are dependent to a large extent upon the locality where the listener is situated, the circuit of the three-valve receiver which we present here will be discussed.

The Circuit

On examining the circuit diagram it will be seen that it is more or less standard practice, the only difference, if any, being that the tuned-grid coil is centre-tapped. It was found that centre tapping the grid coil in the manner shown

mfd. variable condenser was selected for the tuning condenser. This condenser, used in conjunction with a 65-turn centre-tapped coil, covers from, roughly, 200 to 520 metres.

The aerial coil, L1, governs the selectivity of the receiver, and to get the maximum results the number of turns should be experimented with. It would be a good plan to tap this coil at, say, every five turns up to 20, as the volume and selectivity can be altered when required.

Regeneration is controlled by the reaction condenser, C,2 which is of the midget type, and to obtain the smoothest oscillation the turns on this coil should also be varied until the detector valve will oscillate over the whole of the broadcast band. The voltages applied will also have a large amount to do with the oscillation, likewise the value of the grid leak.

The output of the screen grid valve is fed by means of the resistance coupling unit to the grid of the first audio valve, which is indirectly heated. The use of an indirectly-heated valve in the first audio stage eliminates any possibility of hum coming from this stage, providing the wiring and components are connected in the correct manner. The tube is biased by inserting a resistance in the cathode lead, and can be by-passed by a fixed condenser if necessary.

From the plate of the first audio valve the audio voltages are transferred to the grid of the power valve by an audio frequency transformer having a fairly low amplification ratio of about 3 to 1.

The power valve used in this receiver is a UX245, and requires a grid bias of about 50 volts. This is obtained by connecting a resistance between the centre-tap of the filament winding which heats the filament of this valve and earth. It is necessary to by-pass this resistance by a 1 mfd. condenser in order to obtain the best quality of reproduction.

At this stage it might be advisable to mention that as the 245 takes 36 M.A. at 250 volts, it will be necessary to use some output device which will stop the plate current from flowing through the speaker coil, as this will in time burn out the coil unless the speaker coil is wound with a fairly heavy gauge wire which will carry the current without overheating. This, however, is seldom the case, and to protect the speaker, and at the same time to obtain the maximum quality, an output transformer or output filter should be incorporated.

Where a dynamic speaker is employed an output transformer will be mounted on the speaker, and the two outside connections of this transformer will go one to the plate of the 245 and the other to a tapping on the voltage divider. Output transformers can also be purchased to suit magnetic cone speakers.

If one does not want to go to the expense of buying an output transformer, an output filter can be made by connecting a choke and a one or two mfd. fixed condenser in the following manner. One side of the choke goes to the plate of the 245 and the other side to the B positive tap on the voltage divider. From the plate of the 245 run a wire

the volume and sensitivity increased slightly without broadening the tuning. In order to space the stations as far apart on the dial as possible, a .00035

List of Components

- .00035 mfd. variable condenser, C1.
- .0001 mfd. Midget condenser, C2.
- .00025 mfd. condenser, C3.
- .01 mfd. condenser, C5.
- .006 mfd. condenser, C8.
- Two 4 mfd. condensers, C10, C11.
- Four 1 mfd. condensers, C6, C9, C12, C13.
- Two meg. grid leak, R1.
- ½ meg. grid leak, R3.
- ¼ meg. or 200,000 ohm grid leak, R2.
- 100,000 ohm variable resistance, R4.
- 1000 ohm resistance, R5.
- 1500 ohm resistance, R6.
- 14,000 ohm voltage divider.
- Two UY sub-panel valve sockets, V1, V2.
- One UX sub-panel valve socket, V3.
- One UX baseboard mounting valve socket.
- Chassis, 11in. by 7in. by 2½in., 18 gauge aluminium.
- Chassis, 10in. by 5½in. by 2½in., 18 gauge aluminium.
- Aluminium panel, 11in. by 6½in., 18 gauge aluminium.
- Seven terminals.
- Miscellaneous wire, spaghettil, metal thread screws, nuts, flex. ¼lb. 28
- D.S.C. wire, length of cardboard former, 2in. diameter.
- One 280 type rectifier.
- One 245 type valve.
- One type E415 valve.
- 1 type E442S valve.

to one side of the fixed condenser and from the remaining side to one of the speaker tips. The other speaker tip goes to the chassis, which is earthed. This arrangement, although not as efficient as the output transformer, does not introduce distortion.

The voltages are delivered from a separate power-pack, as this is far simpler to get working than if the power-pack were built into the chassis of the set, and there is also the advantage that no hum can be caused by induction between components of the power-pack and the wiring of the set.

The Power-Pack

Turning to the circuit of the power-pack, it will be noticed that it consists of a full-wave rectifier and two separate filament windings, one for the 245 and the other for the two indirectly heated valves. A 280 rectifier is used which takes about 350 volts on each plate and has a filament voltage of five. The filter system includes two 4 mfd. and two one mfd. condensers, also a 60-henry choke. A voltage divider is connected across the filter circuit between the output side of the choke and the chassis, which is negative. It is upon the efficiency of the filter circuit that the amount of hum that is heard in the speaker depends; this, of course, is exclusive of the hum that comes from the speaker itself, assuming a dynamic is used.

This concludes the discussion of the circuit, and the capabilities of the set will be given.

In the first place the reproduction is excellent; in fact we will go so far as to say that, for the number and type of

valves employed, it would be difficult to improve upon it. Naturally the volume is not terrific when using a small aerial, but when the set is turned full on when tuned to an A class station the volume is too loud for the average room. It can therefore be seen that it possesses ample volume for ordinary household use.

By terrific volume is meant that one cannot hear oneself speak even when situated at a fair distance from the speaker.

Next, the selectivity of the receiver is as good as can be obtained using this system. When this set was tried out in the suburbs 3KZ could be tuned in when 3AW was working and the background from this latter station was so faint that no objection could be taken. The shielding of the receiver and coil construction has a lot to do with this.

One of the most important points in any all electric receiver, to the writer's way of thinking, is that of hum. In this respect the set to be described here could be classed as humless when using a high grade magnetic speaker. Even when a dynamic was connected the hum from the set, combined with that of the speaker, could just be detected when the set was detuned from a station, and the door of the room in which the set was installed closed. This can be attributed to the careful design of the set and the fact that the power-pack is built up as a separate unit.

From the amateur constructor's viewpoint, this receiver should present no difficulties in either the building or the operating; and another factor which is of great importance these days—namely

the cost—is that this receiver may be built for a very limited sum.

A review of the various components will now be given after which the construction of the receiver will be dealt with and then the construction of the power pack.

Review of the Components

VARIABLE CONDENSERS. — The tuning condenser, C1, has a capacity of .00035 mfd. and should be of a good make, as a poorly designed one or an old-fashioned condenser will not separate the stations evenly, but will bunch them on various portions of the dial. If a .0005 mfd. condenser is used for tuning, the number of turns on the grid coil will have to be decreased by about 10 turns. There is no objection to using a .0005 mfd. if the constructor already has one on hand and does not want to go to the expense of purchasing the specified one. The midget condenser has 11 fixed and 12 moving plates, and a capacity of about .0001 mfd.

RESISTANCE COUPLING UNIT. — This may be constructed by mounting a .006 mfd. and four clips which hold the two resistances, R2 and R3, on a piece of bakelite of a suitable size. The value of R2 is 200,000 ohms, approximately, though a 250,000 ohm may be used. Resistance R3 has a value of 1/2 meg. Standard resistance coupling units may be purchased from any radio shop and, providing the values of the resistances and the condenser are similar to those specified, they will be quite suitable.

AUDIO TRANSFORMER. — A high-
(Continued overleaf)

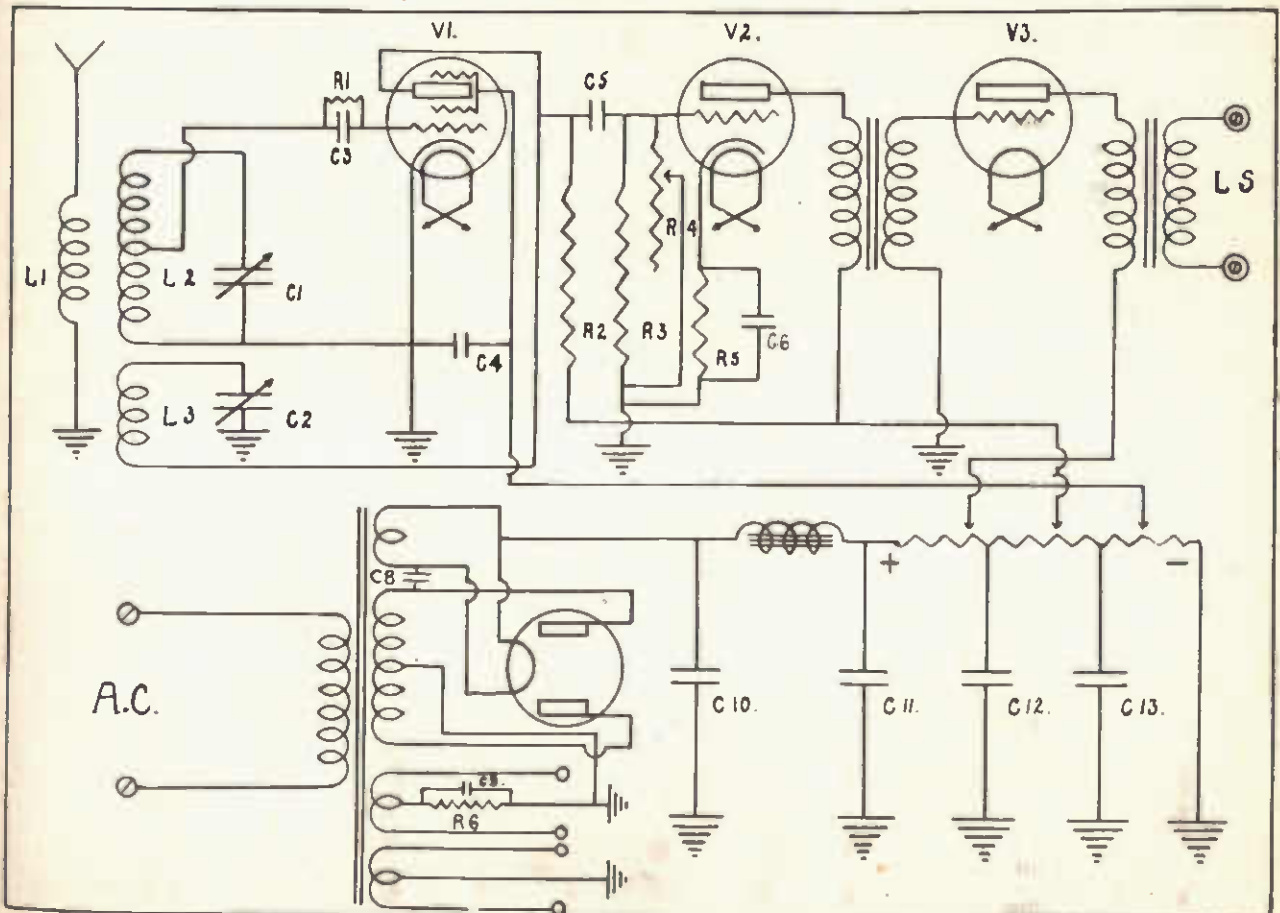

Circuit diagram of the ultra-selective A.C. three-valve receiver.

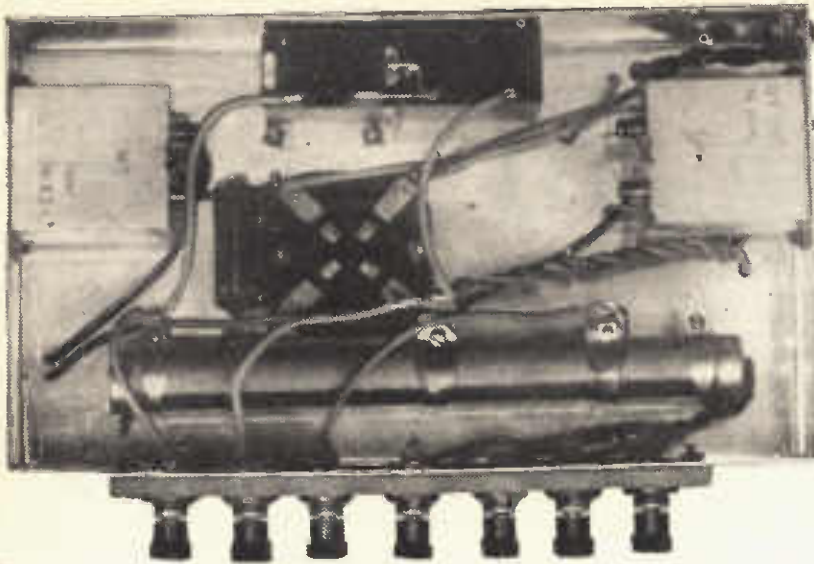

A photograph of the underneath side of the chassis of the power-pack, from which an idea of the spacing of the components will be obtained.

(Continued from previous page)

grade transformer only should be selected as the quality of the reproduction depends largely on this component.

VALVES.—Those used in this receiver were Philips E442S as the detector and E415 type as the first audio amplifier. Both the 280 rectifier and the 245 power valve were of American manufacture. Any make of valve may be used providing the characteristics of the tubes selected are similar to the ones used in this set and are of good make. It is advisable to have any valve that is purchased tested on a reliable valve tester before inserting in a valve socket of the receiver as untold troubles can arise through a slightly weak or defective valve, especially those of the high voltage type.

VALVE SOCKETS—Two UY and one UX subpanel type sockets are required for the receiver, while one UX base-board mounting socket is wanted for the rectifier valve of the power pack.

POWER TRANSFORMER.—It is advisable to purchase this ready made. It should be wound to suit a 280 rectifier. This tube requires a plate voltage of at least 325 and has a filament voltage of five. Two filament heating windings should also be incorporated in the transformer; the voltages of these windings should be 4 for the two indirectly-heated valves and 2.5 for the 245 power valve.

SMOOTHING CONDENSERS.—All the condensers used in the filter circuit should be tested, to be on the safe side, for 1500 volts, as if a condenser short-circuits extensive damage can occur. Two 4 mfd. condensers are connected on each side of the choke; these are C10 and C11. With the exception of C8 and C5 the rest of these condensers have a capacity of 1 mfd.

SMOOTHING CHOKE.—This should have a value of not less than 30 henries, and should, to obtain the best results from the set, be 60 henries. The current that this component will require to pass will be about 50 M.A.

VOLTAGE DIVIDER.—One having a resistance of 12,500 ohms will serve the purpose, although the higher the resistance up to 25,000 ohms the better, in

that it would not heat up as much as the lower resistance one.

The Coil

Obtain a piece of cardboard former having a diameter of 2 inches, and cut a length 3 inches long. At a distance of about half an inch from the end of the former start winding coil L1. This consists of 20 turns tapped every five. A quarter of an inch below the finish of L1, begin winding coil L2, which has 65 turns and is centre-tapped. The remaining coil, L3, is started about a quarter of an inch below the end of coil L2 and consists of 30 turns. All these windings are wound with the same gauge wire, namely, 28 D.S.C. Before winding the coil, glance at the diagram of the coil.

Construction

The size of the chassis of the set is 11 inches long, 7 inches wide and 2½

inches deep, and is of 18-gauge aluminium. This may be purchased from a tinsmith, or the size of the chassis given if one is not on hand and can be bent by them.

For those who wish to bend their own chassis the following instructions may be helpful:—Mark a rectangle on the face of the aluminium 11 inches long by 7 inches wide. Now mark another 2½ inches parallel to the outside of the rectangle. Continue a line from the inner rectangle until it cuts the outer one. Do this to all four corners. There will be four squares of 2½ inches. With a heavy pair of tin-snips cut these four squares out. Then cut the aluminium to size.

Next bend the four sides at right angles to the face of the aluminium by means of either a book-press or a vyce. In the same way the chassis of the power-pack is constructed, although the size of this is 10 inches long by 5½ inches wide by 2½ inches deep. This is made of the same gauge aluminium as that of the receiver chassis.

Placing the Components

Next comes the job of placing the various components on the chassis to determine their positions and to see that no components foul each other. The holes for the valve sockets are now marked.

The rest of the components positions on the underneath side of the chassis and the holes through which the wires to the power pack lead are now marked and then the positions for the coil on the top side are marked. After the holes are drilled the valve sockets may be mounted. One-eighth inch washers should be inserted between the chassis and the valve sockets through which the bolt which holds them in position is passed. This is done in order to eliminate any chance of the contacts on the top of the sockets touching the chassis and thus causing a short circuit.

All the remaining components may be now mounted in position.

The panel which is of heavy gauge aluminium, is the same length as the chassis, and is about 6½ inches high. The size of this can be left to the constructor's own taste.

Mark the holes on the panel which

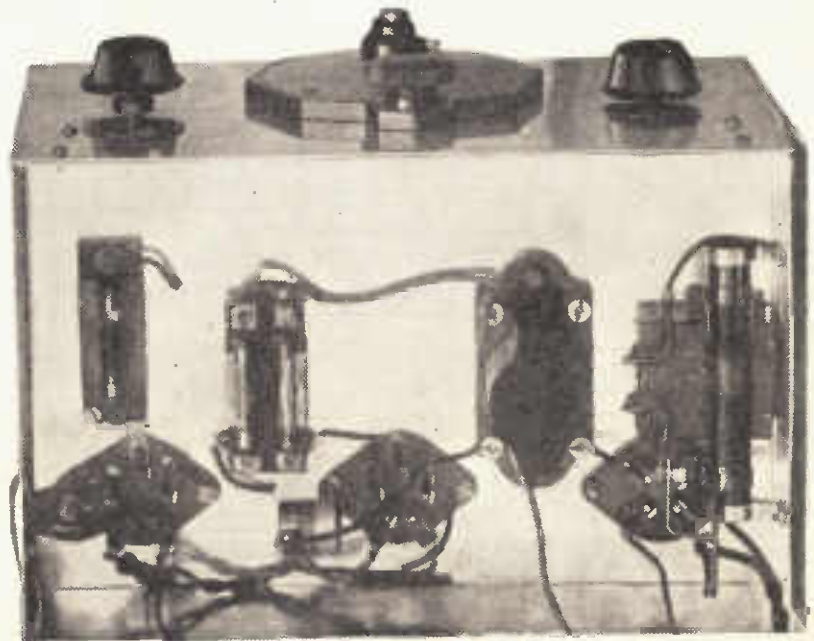

Underneath view of the set showing the placement of components and the wiring.

takes the tuning and reaction condensers and the volume control; also mark about 6 holes through which the screws pass to hold the panel to the chassis and drill these holes. At the same time, the six holes in the side of the chassis may be drilled and the panel fastened in position.

The chassis of the power-pack may now be drilled to take the components. The photographs of the pack will show the position for these. A slot is cut in the chassis to hold the terminal strip, and this should be wide enough so that there is no possibility of the terminals touching the aluminium.

Wiring in Words

The lower end of the aerial coil goes to the chassis. The beginning of this coil can connect to an aerial terminal which could be mounted alongside, although, in the original set, the aerial went direct to the coil. A wire is taken from the centre-tap of coil L2 through a hole in the chassis to one side of the grid leak and condenser. From the other side of the grid leak and condenser solder a wire to the grid terminal of socket V1. The end of the grid coil nearest the aerial coil goes to the fixed plates of the tuning condenser, while the end of this coil connects to the chassis as the movable plates of the variable condenser are also earthed.

Take a lead from the end of the reaction coil to the fixed plates of the midget condenser. The beginning of this coil goes to the plate side of the resistance coupling unit (which is the end of R2, which connects to one side of C5). From this side of the R.C. unit a lead is taken through a hole in the chassis to the top of the E442S. The cathode connection on socket V1 is earthed to the chassis.

Connect the vacant side of C5 and one end of R3 to the grid of socket V2 and to the terminal of the volume control on the right-hand side of the panel, which is not connected to the chassis. The C terminal of this valve socket goes to one side of bias resistance R5 and to one side of C6. The remaining sides of R5 and C6 are connected to the chassis.

From the plate terminal of socket V2 run a wire to the P terminal of the audio transformer. The B positive terminal of this transformer is connected to the vacant side of resistance R2. Take a lead from the G terminal of the transformer to the G terminal of the valve



A back view of the receiver with the valves inserted in their sockets.

socket V3. The remaining terminal on this transformer C negative is connected to the chassis. Run a wire from the P terminal of socket V3 to one side of the output transformer or output filter which is incorporated in the speaker.

Run two leads of rubber-covered flex from the filament terminals of socket V1 to the filament terminals of valve socket V2.

Power Pack Winding

The wiring of the power pack will now be commenced.

Join a length of flex sufficient to reach to whatever power point or light socket the current is to be derived from to the primary connection of the power transformer. The centre-tap of the high voltage secondary is connected to the chassis. The two outside leads from this winding are taken to the plate and grid terminals of the UX valve socket. The two ends of the five volt winding are taken to the two filament terminals of the valve socket. From one of these terminals, it does not matter which, run a wire to the one side of C10 and one side of the choke. Earth the vacant side of C10 to the chassis. From the remaining end of the choke take a lead to one side of C11 and one side of the voltage divider. The other end of the

voltage divider is earthed. Earth one side of C12 and C13.

From the vacant sides of these condensers run two wires to two taps on the voltage divider. These two taps are connected to two terminals on the strip. The centre-tap of the four-volt filament is earthed to the chassis. From the centre tap of the 2.5 volt winding take a wire to one of the terminals. The two outside connections of the four volt winding, and the two outside connections of the 2.5 volt winding are connected to terminals. The humming condenser C8 may be connected between one of the plate and one of the filament terminals of the rectifier socket.

Operation

Take a wire from the B positive terminal of the audio transformer to the terminal that connects to about 140-volt positive tapping on the divider. The vacant side of the output transformer or filter can be connected to the B positive maximum tapping on the divider providing the voltage is not more than 250. Next run two rubber covered flex leads from the filament terminals of either V1 or V2 to the two terminals on the strip which connect to the four volt winding.

From the two filament terminals of the 245 socket run a pair of wires to the two terminals which connect to the 2.5-volt winding. From the terminal which goes to the centre tap of the 245 filament winding run a wire to one side of R6 and C9 which is located near the 245 socket of the set. The remaining sides of R6 and C9 are connected to the chassis.

As the speaker is already connected to the output transformer, the aerial and earth wires may be connected to the aerial coil and to the chassis respectively; also a wire from the chassis of the power pack should be taken to the chassis of the set.

The current should be now switched on and the valve watched for a few minutes to see that it does not flash over, and should then be left; it should be quite hot.

Next the current is again switched off and the three receiving valves inserted in their right sockets and the plate wire leading to the top of the screen grid valve connected. On turning on the current a fair hum will be heard if the speaker is held to one's ear. It may take up to half a minute before the valves are properly heated.

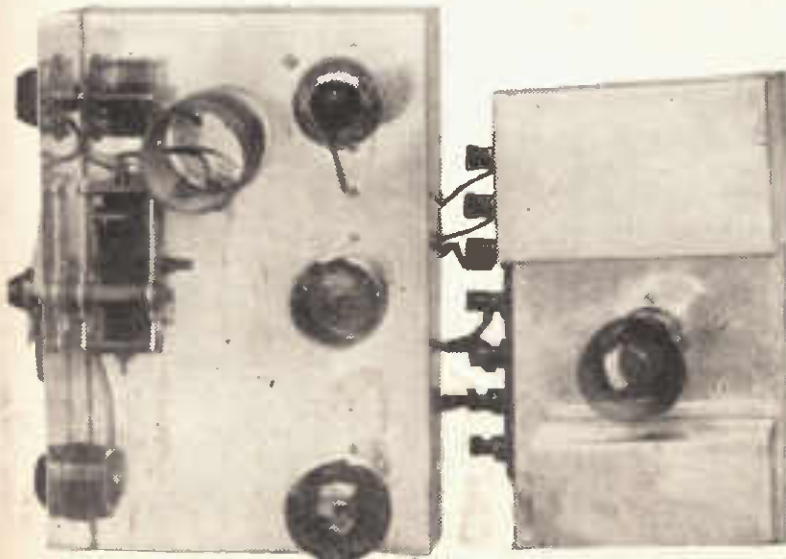

Showing the power pack connected to the receiver.

The Super-Het

Not a Mass Production Receiver
Each an Individual Masterpiece

Selective !!

Three Stations in
one Degree AND
...No Background

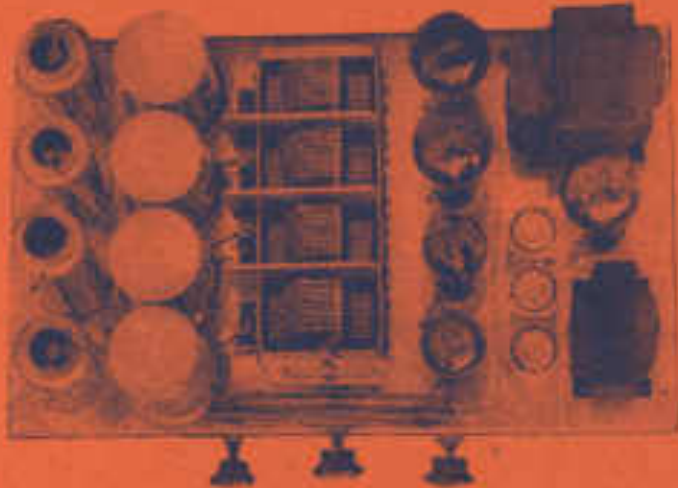

INCORPORATES

Two Type 235 Variable MU
Two Type 224 Screen Grid
Two Type 227 Audions
Two Type 245 Push Pull
Amplifiers
One Type 280 Rectifier

First Quality Material Throughout
Gramophone Pick-up Terminal
Tone Control
Absolutely Hum Free
Guaranteed 12 Months
Full Vision Dial

The "SYLVAN" SUPER - NINE

Hair line Selectivity!

Powerful!!

Tone Perfect!!!

PRICES RADIO SERVICE
5, 6, 7 ANGEL PLACE, SYDNEY
Kindly Mail me Full Particulars
of your X **REPTRE** Superheterodynes

NAME

ADDRESS

X **CHINE CITY**
1934

new

Jensen

DYNAMIC SPEAKERS

Used by Astor Radio and other large manufacturers.

ACHIEVE the hearing of the hitherto unheard in sound reproduction. A high frequency response and reinforced bass tone that have been previously unknown are now realised in the new Jensen Dynamic Speakers. Jensen acoustical superiority is such that set manufacturers everywhere select these dynamic speakers as a definite assurance of the finest possible tone quality. See that the set you buy is Jensen-equipped, for remember Jensen speakers are guaranteed with reproduction true as the original.

The New Jensen Auditorium models in like manner revolutionise reproduction of Talkie and Public speech apparatus, and with the new Radio models represent the culmination of Peter L. Jensen's genius and twenty years of experience. All are available for operation from either A.C or D.C current supply.



Auditorium
Junior



Jensen D 10

JENSEN D10. With 7½ in.
Cone from . . . **£6/5**

Jensen CONCERT D8. With
10in. Cone from **£7/10**

Jensen AUDITORIUM Junr.
with 10in. Cone from **£13**

Jensen AUDITORIUM with
12 in. Cone from **£23**

From All Reputable
Dealers

see that your
new set is
equipped with
a Jensen
DYNAMIC SPEAKER
for
true reproduction.