

AUSTRALIA'S DYNAMIC ELECTRONICS MONTHLY!

Electronics Today

INTERNATIONAL

WIN
\$10k WORTH
FROM SONY!

JULY 1986

\$2.95* NZ\$3.75

eti

PUTTING THE HEAT ON CASSETTES

HOW
COMPUTERS
SEE

CAD —
DESIGNING
WITH
COMPUTERS

THE ARIANE
STORY

BUILDING
THE
INTELLIGENT
MODEM



Registered by Australia Post.
Publication No. NBP0407.

AutoCAD[®] is PCB

The Auto-Board System

The Auto-Board System provides the designer with a powerful design tool with the capability of having a prototype on your desk by the end of the day.

Schematic Capture: Creates a schematic diagram to extract interconnection information (netlist) and symbols to Australian Standards.

PCB Layout: Provides the ability to position electronic packages on virtually any size or shape board.

Auto-routing: Automatically connects traces to components with a 70-90% success rate.

Used in conjunction with AutoCAD[®], the Auto-Board System provides an extensive symbol and component library and complete editing facilities.

For Details contact Entercom Computer Co. (03) 429 9888

SATCAM

SATCAM is a powerful design-assist tool for the professional electronics engineer. SATCAM incorporates many features not found in generic PCB-CAD packages, such as photo-plotting, a comprehensive symbol/component library and CNC drill generation. Among its other features are:

- Fast Professional Schematic Designs
- Cost effective PCB designing
- Automatic netlists and costing
- Photo tooling and NC control drivers
- Total Bureau support
- Supported on 30 different microcomputers
- Library of 30,000 components.

For details contact International Systems Database, Sydney (02) 498 6522 Melbourne (03) 870 3630

The Auto-Board System and SATCAM are complete electronics/PCB CAD packages which fully integrate with AutoCAD[®], the leading Computer-Aided Design solution. Whether you are a small or large company, AutoCAD[®] and SATCAM or Auto-Board System can increase your productivity and enhance your creativity.

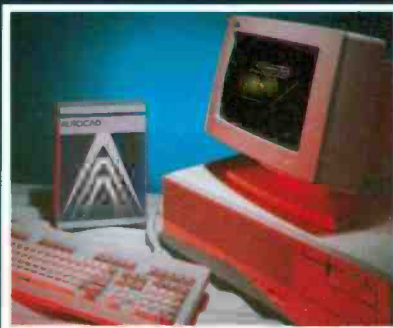

The NCR PC8 Advanced Technology (AT) PC is an ideal CAD workstation with its 8 MHz 80286 processor and native 640 by 400 colour graphics capability.



Houston Instruments have defined the industry standard in low cost, high quality plotting with its best selling, A1 size, 16 ips DMP-52 plotter.



AUTOCAD[®]
NUMBER ONE IN AUSTRALIA
AND WORLDWIDE

For further information or demonstration contact your nearest "Authorized AutoCAD[®] Dealer" by contacting us at ...
136 BRIDE RD., RICHMOND
VICTORIA 3121 AUSTRALIA
PHONE: (03) 429 9888 TELEX: 30625 ME1400

ENTERCOM

● AutoCAD[®] is a registered trademark of Autodesk Inc. USA
● DMP-52 is a trademark of Houston Instruments USA
● NCR PC-8 is a trademark of NCR Inc.
● Drawings provided and reproduced by kind permission of Colin Johanson, EXECUTIVE OFFICE INTERIORS PTY. LTD. (Melb)

EDITOR
Jon Fairall

EDITORIAL STAFF

Mary Rennie B.A.
S. K. Hul B.Sc. (Hons), M.Eng.Sc., MIEEE, MIREE
Neale Hancock B.E.

DRAUGHTING

David Burrows

ART DIRECTOR

Vicki Jones

ART STAFF

Ray Eirth
Denise Petreas

ADVERTISING MANAGER

Peter Hayes B.Sc.

ADVERTISING PRODUCTION

Brett Baker

READER SERVICES

Carmel Trulcio

ACOUSTICAL CONSULTANTS

Louis Challis and Associates

PUBLISHER

Michael Haman

MANAGING EDITOR

Leo Simpson

HEAD OFFICE

180 Bourke Road, (PO Box 227, Waterloo, NSW
2017)
Alexandria, NSW 2015.
Phone: (02) 693-6666.
Telex: AA74488, FEDPUB.
Federal Facsimile: (02) 693-2842.

ADVERTISING

New South Wales

Mark Lewis (02) 693-6666

Victoria and Tasmania

Virginia Salmon (03) 662-1222

Queensland

Peter Hayes (02) 693-6666

South Australia and Northern Territory

Dane Hansen (08) 212-1212

Western Australia

Jim Wells (09) 481-3171

New Zealand

John Easton, 79-6648 (Auckland)

OFFICES

New South Wales: The Federal Publishing
Company, 180 Bourke Road, Alexandria, NSW
2015. Phone (02) 693-6666. Telex: AA74488
FEDPUB.

Victoria and Tasmania: The Federal Publishing
Company, 23rd Floor, 150 Lonsdale Street,
Melbourne, Vic. 3000. Phone: (03) 662-1222.
Telex: AA34340, FEDPUB.

South Australia and Northern Territory: John
Fairfax & Sons, 101-105 Waymouth Street,
Adelaide, 5000. Phone (08) 212-1212. Telex:
AA82930.

Queensland: The Federal Publishing Company,
26 Chermiside Street, Newstead, Qld. 4006.
Phone: (07) 854-1119. Telex: AA145520.

Western Australia: Jim Wells, John Fairfax &
Sons, 454 Murray Street, Perth, WA 6000. Phone:
(09) 321-8217. Telex: AA92635.

New Zealand: 3rd Floor, Communications House,
12 Heather Street, Parnell, Auckland. PO Box
8770, Symonds St, 37-291 Telex NZ63122. Phone
(09) 396-096.



ELECTRONICS TODAY INTERNATIONAL is
published and distributed monthly by the
Electronics Division of the Federal Publishing
Company Pty Limited, 180 Bourke Road,
Alexandria, NSW 2015 under licence from Double
Bay Newspapers Pty Limited, General Newspapers
Pty Limited and Suburban Publications Pty Limited.
Printed by Hannanprint, Sydney. Distributed by
Magazine Promotions, Sydney. *Maximum and
recommended Australian retail price only.
Registered by Australia Post, Publication No
NBPO407. ISSN No 0013-5216.

COPYRIGHT © 1985, Double Bay Newspapers Pty
Limited, General Newspapers Pty Limited and
Suburban Publications Pty Limited (trading as
"Eastern Suburbs Newspapers").

CONTENTS

**JULY
1986**

Electronics Today

INTERNATIONAL

FEATURES

Computer aided design Let the computer do the drawing	11
MicroBRIAN told me Satellite news and pictures	46
Shortwave listening SW news schedules and chat	48
Inside your computer The bus	90
C how it runs An introduction to the C computer language	94
The Ariane story Ariane will transport Aussat III skywards	97
Machine vision What's the computer looking at?	108

PROJECTS

ETI-687: Super II VZ200 modification	55
Upgrades power supply, reset, keyboard and speed	
ETI-174: Frequency standard	62
Use your TV to get accurate frequency standard	
ETI-1601: RS232 for Commodore	66
Gives your Commodore RS232 compatibility	
ETI-684: Intelligent modem	69
The hardware details on this 1200/75 intelligent modem	

REVIEWS

Putting the heat on cassettes	26
Twelve chrome type II tapes grilled	
Serious mixmaster	38
The Akai MG1212 mixing recorder for serious enthusiasts	
Birdie free scanning	105
With the JIL SX-400	

OFFERS

Advertisers' index	47
ETI mail order books	86,87
ETI CRO Competition	65
Subscriptions offer	102,103

DEPARTMENTS

News Digest	9	Computing News	88
Sight and Sound News	22	Communications News	99
New Equipment	42	Feed Forward	77
New Components	52	Dregs	114

COVER: Photograph by Peter Beattie.

Kitchen oven courtesy of Omega Appliances, Redfern, Sydney.

THE AGONY & ECSTASY



DASH™

The Schematic Design and Documentation System that saves valuable time for busy engineers
... the engineer's personal desktop CAE System.

The Engineer's Dilemma

Too many engineers remain slaves to time. They still labour countless hours to produce schematic designs the old fashioned way, using pencil, rubber, ruler and template. Many more hours are spent developing Net Lists, Lists of Materials, Design Check Reports and other essential documents. In short, they're overworked and slaves to time. And it's not getting any better with circuits becoming larger and more complex. There must be a better way.

Large CAD Systems – Only a partial solution.

At first, the large Computer Aided Design (CAD) system appeared the answer. But these, although powerful, are very expensive, complicated and difficult to learn. The \$50,000 standalone CAE workstation isn't the answer either – by the time the engineer gets access he's probably forgotten the complex commands.

There must be some way to beat the CAD/CAE dilemma.

FutureNet's DASH Schematics Designer Bridges the Gap.

Dash is the answer. Now, perfect schematics can be created on an IBM PC, XT, or AT right at the engineer's desk,

in a fraction of the time it used to take. And that's not all. Since DASH automatically captures design data, key documents such as Net Lists, Lists of Materials, and Design Check Reports can be printed at will using DASH post-processors.

DASH

- ★ reduces the engineer's workload in many ways
- ★ dramatically increases productivity
- ★ is easy to learn and operate
- ★ has powerful optional software

DASH-2

- ★ a schematic design system which adds a new set of mouse-driven editing features with software to increase the speed and ease of logic and chip level design.

DASH CADAT

- ★ simulation for chips and PCBs

DASH-3C

- ★ adds full colour to the complete range of DASH-2 features

DASH-PCB

- ★ mainframe PCB layout power, right at your desk, on the IBM PC

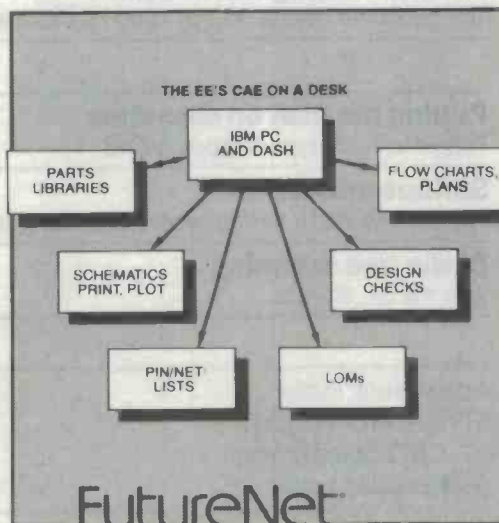

So, to let your PC become an electronic draughtsman.

Call your local Anitech office today, and ask for detail on FutureNet's DASH system.

Productivity of the future ... today.

Distributed in Australia by:-

anitech

A DIVISION OF THE ANI CORPORATION LTD (INC. IN N.S.W.)

ADELAIDE: (08) 356 7333 BRISBANE: (07) 275 1766 HOBART: (002) 34 4511
 MELBOURNE: (03) 795 9011 & 795 5111 PERTH: (09) 277 7000 & 277 1944
 SYDNEY: (02) 648 1711 & 648 4088 AUCKLAND: (09) 444 2645

Fuji-Toughest Tapes Under the Sun



A desert is the last place you'd want the car to break down. But does HE look worried? Though the heat is on, this cool customer's Fuji GT car stereo cassettes keep the music flowing clear and clean.

GT's outer casing as well as the tape itself can withstand temperatures up to 110°C (230°F)! while offering unsurpassed sound performance over rough roads. A special dual-spring pressure pad –

similar to a car's independent suspension – maintains tape pressure and close contact with the heads when the cassette deck is vibrating.

GTs sound hot on the highway too, with high-note clarity that overcomes sound-deadened car interiors. And clever concave "A" and convex "B" side markings and different left/right feel allow quick side selection by touch – without taking your eyes off the road.

On or off-road, hear for yourself why Fuji GTs are the toughest tapes under the sun.



DISTRIBUTED IN AUSTRALIA BY **HANIMEX**



J551



There's just one Australian up there.

 STC, alone among Australian companies, was chosen to build vital electronics for the AUSSAT satellites. This is in recognition of our many achievements in communications," and a tribute to our known ability to manufacture technological components to the "fail-safe" standards demanded in space. As communications systems evolve at an

amazing rate, STC maintains its status at the leading edge. Today, the many STC products and services, all designed within the last two years, continue to speed and simplify the ways in which people and businesses communicate. STC. The first Australian company into space.

The only Australian company into space. Proudly part of the AUSSAT Programme.



THE LEADING EDGE.

**STC electronics are also built into satellites for the Indonesian and Mexican governments as well as the vital U.S. communications satellites WESTAR and GALAXY.

Q571C

Molly takes his hat off to Sony Audio Tapes.

I'm always listening.

Day after day there's always new stuff coming in. I listen at home, in the office, even in the car. And whenever I can, especially in the car, I make sure I'm listening on Sony Audio cassettes.

After all I've spent a small fortune on my car sound system, and the people I'm listening to have spent a small fortune in a recording studio. So the least I can do is listen to their stuff on tape with the kind of quality I reckon will do them justice.

I mean anything that makes me sound good has to be terrific.



Sony Tape™



**Test your
component
IQ**

For some companies and their products, today's market is very "testing" indeed. Firstly because more and more products are incorporating electronics for improved performance and reliability, so they fit a market hole precisely.

Secondly, the scope and range of functions they perform are leap-frogging each year with the introduction of intelligent features, via micro-processor based components.

The smart companies are learning that when they deal with Philips Elcoma in Australia, they can outperform their competitors by increasing their "marketing quotient."

Philips Elcoma (Electronic Components and Materials) encompasses some 200,000 different products to help you extend your products' IQ and improve sales. From micro-processors that can be built into computer assisted appliances - to a switch for a typewriter keyboard. From tiny resistors to integrated circuits of high complexity, or giant megawatt klystrons.

And the applications are almost limitless. For example, you can use Philips components in musical instruments, washing machines, cars, or security systems ...a wide, wide range of "thinking" products. The scope is only bounded by your ingenuity.

Additionally, Philips can design and manufacture a unique thick-film hybrid sub-assembly to satisfy a specific need you might have, or develop a dedicated IC for you.

Philips Elcoma serves the electronic industry around the world.

Call Philips Electronic Components and Materials for a solution to a market opening you can see.

Sydney	(02) 439 3322
Melbourne	(03) 542 3333
Adelaide	(08) 243 0155
Perth	(09) 277 4199
Brisbane	(07) 440 191

We make electronics in Australia



**Electronic
Components
and Materials**

PHILIPS

Seeing in the dark

Scientists at the University of NSW (UNSW) have developed a microelectronic sensor chip which can create television images in total darkness by imaging objects in their own heat radiation.

The ultimate aim of the project is to produce an inexpensive, portable, infrared TV camera. "Such a device has enormous implications for industry, mining, astronomy and medicine. However, it is in astronomy, remote sensing and defence that the most immediate and revolutionary applications are to be found," according to one of the team leaders, Dr John Storey, of the University's School of Physics.

Known as an Infrared Schottky Charge Coupled Device, the sensor chip contains more than 2000 separate pixels, or picture elements. Each pixel incorporates an ultra-thin layer of palladium, which converts the infrared radiation into an electronic charge.

The sensor chips are fabricated in the extensive facilities of the Joint Microelectronics Re-

search Centre (JMRC) on the UNSW campus. After testing and packaging, the devices are taken to the School of Physics where they are cooled to -200°C to prevent the weak infrared signal being swamped by thermal noise in the detector itself. An image of the particular object of interest is then formed, using a special calcium fluoride and sapphire optical system which can focus the infrared rays. The image is then processed by a small computer before being presented on the TV screen.

Not only can images be taken in total darkness, but by examination of the 'thermal signature' or temperature profile of a scene, information is revealed which is completely hidden at normal visible wavelengths. Dr Storey says that in medicine, for example, thermal images of a human body can reveal abnor-

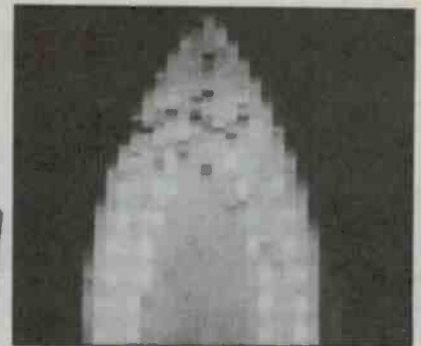
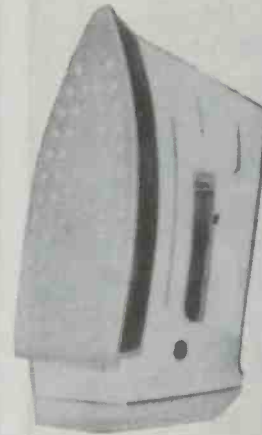

Thermal image of a steam iron. The image shows the distribution of infrared radiation at a wavelength of 1.6 microns, roughly three times the wavelength of ordinary visible light. Although the steam holes are not hotter than the surrounding aluminium baseplate, they appear brighter because they are 'blackier' than the shiny baseplate.

malities in the heat distribution and blood circulation, thus pointing the way towards diagnosis of an underlying malady. In industry too, the ability to assess instantly the heat loss of an entire machine or facility is invaluable.

The development is the latest product of a four-year research program conducted jointly in the School of Physics and JMRC, by a team consisting of Associate

Professor M. A. Green, Mr J. M. Kurianski, Mr E. Ollier, Dr J. W. V. Storey, Dr S. T. Shanahan, Dr U. Theden and Mr M. R. Willison. Funding for the project has come from the Australian Research Grants Scheme and a wide variety of potential users of the sensor, in particular the Anglo-Australian Observatory, CSIRO Division of Mineral Physics, and the Defence Research Centre, Salisbury.

SERVICES

COPYRIGHT: The contents of *Electronics Today International* and associated publications is fully protected by the Commonwealth Copyright Act (1968). Copyright extends to all written material, photographs, drawings, circuit diagrams and printed-circuit boards. Although any form of reproduction is a breach of copyright, we are not concerned about individuals constructing projects for their own private use, nor by bands (for example) constructing one or more items for use in connection with their performances. Commercial organisations should note that no project or part project described in *Electronics Today International* or associated publications may be offered for sale, or sold in substantially or fully assembled form, unless a licence has been specifically obtained so to do from the publisher, The Federal Publishing Company, or from the copyright holders.

TECHNICAL INQUIRIES: Technical inquiries by mail must be accompanied by a stamped self-addressed envelope. There is no charge, but we reserve the right to publish the inquiry and the reply in *Electronics Today* or any of its associated publications. We can only answer queries relating to projects and articles as published. We cannot advise on modifications, other than errata or addenda. Difficult questions may take some time to answer.

LIABILITY: Comments and test results on equipment reviewed refer to the particular item submitted for review and may not necessarily pertain to other units of the same make or model number. Whilst every effort has been made to ensure that all constructional projects referred to in this edition will operate as indicated efficiently and properly and that all necessary components to manufacture the same will be available, no responsibility is accepted in respect of the failure for any reason at all whether due to any fault in design or otherwise and no responsibility is accepted for the failure to obtain any component parts in respect of any such project. Further, no responsibility is accepted in respect of any injury or damage caused by any fault in the design of any such project as aforesaid.

GENERAL INQUIRIES: For all inquiries about back issues, subscriptions, photocopies of articles, artwork or submitting articles call (02) 693-6666 or write to: ETI Reader Services, 180 Bourke Rd, Alexandria, NSW 2015; (PO Box 227, Waterloo NSW 2017).

CONTRIBUTIONS: Submissions must be accompanied by a stamped, self-addressed envelope. The publisher accepts no responsibility for unsolicited material.

Funds for NASA

The US Space Foundation has outlined plans for fund raising activities related to construction of a replacement orbiter for the Challenger.

The foundation is a private, non-profit, educational organisation established to stimulate international dialogue on the beneficial uses of space and to integrate space education materials into the curriculum of schools at all levels.

The foundation has established the Challenger 7 Fund which already has received significant contributions and has marshalled the support of a number of individuals and organisations. The foundation ultimately plans to donate the contributions to NASA for its use in financing a replacement orbiter should the US Congress authorise a replacement.

A company to push Australian ideas

A new company to develop and market Australian products has been set up by McPherson's Ltd, (best known for its engineering and steel distribution activities) and the Australian Industry Development Corporation.

The new company, Engineering Innovations Ltd, will concentrate initially on industrial products, although it will also assess prospects for selling technical products into consumer markets.

The company plans to work with CSIRO, university and government research laboratories as well as with private inventors.

Presently, Engineering Innovation Limited is examining products from a wide range of industries and markets although some, like the electronics business, are by nature more receptive to ideas and change. "But this also presents problems," says Robert Zahara, Managing Director. "New products in the electronic field are very difficult to patent and can be superseded before manufacture has commenced.

"One of our main aims is to become involved in products not facing up front competitive market positions."

Engineering Innovation Limited expects that products which will be of most interest will come from sole inventors or small private companies that have been born from an actual need rather than from generalised scientific research.

"We have a strong preference for being involved with the products at a very early state — at prototype or even earlier — and beginning funding at that stage. And that means being fully involved both with product development and marketing development."

The company hopes to take on products on a licence agreement with the inventor whereby the inventor gets a royalty based on percentage of sales "while we fund development of manufacturing, marketing and selling of the actual article".

Mr Zahara is under no illusions when it comes to marketing Australian inventions overseas, but says "With any new product our aim would be to attempt first to achieve success in the USA."

For further information contact Robert Zahara, Engineering Innovation Limited on (03)699-3588.



OVER THE COUNTER

All Electronic Components is a maze of fascinating electronic parts ranging from the latest state of the art and printed circuit boards, to old radio valves, 20 year old projects and copies of *Radio, TV and Hobbies* from the 50s.

The company is run by father and son team, Neville and Andrew Frolley, both keen fishermen and kit-set constructors.

According to Neville, they carry an extremely wide range of kit sets and components, many of which are not available from 'cash 'n' carry' type stores. Neville says proudly that the store in Lonsdale St, Melbourne has "Australia's largest range of kit-sets and components, and is one of Melbourne's oldest and most respected electronics companies.

The Frolleys pride themselves on both their counter service and their stock. All their staff are trained people who understand customer needs. "All our parts are top quality, recognised brands and are covered by manufacturers' warranties. We do not stock cheap imitation or hobby grade components as they have high failure rates," Neville explains.

"Our customers are mainly electronic connoisseurs, industrial people or experienced hobbyists and they appreciate the quality and range of our components and our kit-sets."

The company accepts mail orders from all parts of Australia and often from overseas. Policy is to keep a wide range of stock under the one roof instead of spreading out into the fast food, serve yourself type chain stores. If we don't stock an item, we can usually quote. We believe in old-fashioned, help-the-customer service. AEC is genuinely prepared to help the confused customer," says Neville.

Before entering the wholesaler/retail side of the electronics industry with All Electronic Components, Neville had 32 years experience in the electronics industry with servicing, designing, quality control, inspection and service-managing in radio, TV, industrial electronics and instrumentation.

Andrew Frolley, tongue firmly in cheek, likes to describe himself as the "typical boss' son — long lunches, late starts, appearances only on pay day, four-wheel-drive addict and fishing fanatic," — but he built his first kit when he was seven years old.

Andrew says he is continually trying to convince the staff they should have a fishing-tackle section, but when he takes you on a tour behind the counter, you know that he is an expert in all the components that are hidden away.

An ex-Melbourne and Queensland University student and rugby player, Andrew is a keen kit-man (almost as keen on kits as he is on Murray cod) and he is as proud of the company as his father.

"While kits are just a side line for other companies who discount them and allow the parts and the quality to deteriorate, they are of prime importance to us," Andrew says with confidence.

POSTSCRIPT:

Tantamount to their component knowledge, All Electronic Components has recently been appointed sole Victorian distributors for Jemal Products, and National Panasonic components. Andrew is currently 'on the road' representing the company in this field.

BRIEFS

Electronic component quality scheme

Electronic component distributors in Australia are to be offered a financial incentive to become part of an international quality assessment scheme run by the International Electro-technical Commission. (The Commission's assessment scheme is the only world-wide certification scheme of its type.) Funding will be provided by the Commonwealth government, Telecom, and the Australian Electronics Industries Association.

Intel micro drives Nissan cars

Intel recently unveiled a 16-bit microcontroller, the MCS-96 featuring 12.5µs average instruction times. The chip will be used in conjunction with an 8-bit Nissan microprocessor to control functions such as fuel injection, ignition timing, a twin variable nozzle turbo charger, valve timing and four speed automatic transmission in Nissan vehicles from the 1990s.

NOTES & ERRATA

Project 4102, Digital sampler, May '86: Resistors mentioned in the Parts List as 5% should be 2% and those marked as 2% should be 5%. The standby power supply VA mentioned at the end of the How It Works should be in house style reading V_{GG} as in the circuit diagram. On the wiring diagram, the trigger switch is labelled incorrectly: terminal lettering F should read J and vice versa.



Courtesy STC.

COMPUTER AIDED DESIGN

Computer aided design is one of the most talked about facets of modern computing. The beauty of its images has a fascination that goes beyond the merely utilitarian. Meanwhile its potential to change the manufacturing process has made it the centre piece of technical change.

CAD HAS ALSO been notoriously slow to take off in Australia. While other uses of computers have expanded by leaps and bounds, CAD makers are still trying to shift product out of the factory door.

Drafting

Firstly, what is CAD? Because of the way in which the market has developed, it's possible to make a fundamental distinction between drafting machines and design machines, both of which go by the name of CAD. A drafting machine is essentially something that uses a computer to replace the pen and ruler of the conventional draftsman.

Drafting machines are all pretty much of

a muchness, offering a rather circumscribed list of features. Their importance in the market-place is due almost entirely to powerful small computers like the IBM-PC, which have made it possible to generate reasonably sophisticated graphics at a price just about anyone can afford.

So packages for drawing circuit diagrams abound in which the various components of a circuit can be called up from a library of symbols and displayed on the screen. Then some simple graphics functions allow the operator to join the symbols together with straight lines.

Another part of the package allows the operator to lay out the pc board. Usually

Jon Fairall

PROTEL PCB

Protel-PCB is typical of many of the low end CAD systems now appearing on the market. Designed by Hobart based HST Industries, it allows the user to draw the artwork for a pcb on the screen, essentially replacing the draftsman and his tools. Its power lies in the various labour saving devices stored in software.

For instance, to lay down a DIP package, it is necessary to position only pin 1, and specify the direction in which the package is to lie. It's possible to repeat tracks so that you can lay down many parallel tracks very quickly. Even more advanced, the user can define a block on the board which can be repeated at will in other portions of the board. It also features rubberbanding, in which it's possible to move a component after all the tracks have been laid down to it.

From the pcb master, Protel can generate other drawings. For instance it can give you a solder mask, a pad master and a component overlay.

It supports both a plotter and a mouse, and sells for under \$1000.

AUSTCAD

Austcad's new Basicad program has been sold to both the Cessna Aircraft Corporation and the huge US defence contractor General Dynamics, and is the first in a series of complementary software programs being developed by the company.

Basicad is currently under evaluation by several other international groups including Motorola, Goodyear, the Hong Kong Housing Authority, UK construction group Condor Technology, German civil engineers UHDE GMBH, and NZ whitegoods company Fischer & Paykell.

Established only five years ago, Austcad now operates what it claims is the largest CAD bureau in the world, specialising in servicing the Cadam system. Cadam was developed by the Lockheed Corporation now Cadam Inc. Austcad's Basicad has been designed as an end-user interface for Cadam.

Since the system's debut sale to Cessna, Cadam Inc. has signed a sole distribution agreement with Austcad for international distribution throughout manufacturing, architecture, engineering, mechanical and electrical concerns, and government and public utilities among other sectors.

Based on the early acceptance of the system, Austcad is predicting that Basicad will generate revenue of over \$5 million within the next five years, at a unit cost of \$12,000.

HP EGS

Hewlett-Packard is one of the larger companies to make a considerable investment in CAD tools. It manufactures an impressive range of 2D and 3D systems ranging in price from \$45,000 through to \$390,000. They are combined hardware-software packages for the most part based around the Motorola 16/32-bit processor running at 12.5MHz with vast amounts of memory (minimum 2M) on the side.

Its 2D package called EGS features three 'personalities' for electrical, mechanical and general drawing. Its electronic drawing package features the full range of CAD options, from data capture of the schematic through to layout of the board. It has a library which contains 50 commonly used circuit components plus provision for the user's own additions.

It has no auto routing ability, but it does do rat's nests, which allow for manual routing and optimum chip placement.

It has a full documentation package with it, so parts lists, drawing references and so on can be generated easily and quickly. It even has the ability to interface with Techwriter, the HP word processing package.

To a greater degree than most, HP has encouraged third party contractors to supply interfacing programs for its CAD systems. One such is called Esprit, distributed by JB Davies Computer Systems, which is claimed to be able to generate proper numerical control code to control the manufacture of a part by any machine tool.

There is also a program by DP Technology called Microcad II that will turn Esprit into a fully blown CAD system. It also has the ability to use Esprit to do test runs on the NC information in order to check the CAD output for errors.

a library of features such as pads, tracks and dip patterns is included. These are called up and placed on the screen in the desired position. Subsequently, artwork can be generated from a plotter ready to be used to generate artwork for making the board. A typical package is the Protel PCB package (see box) which sells for under \$1000.

Design

On the other hand, a design system uses the power of the computer to transpose non-visual inputs into visual terms (given the appropriate models) and also to generate non-visual outputs from a screen presentation. It allows the designer to play 'what if' games with the machine, to expand this line, change that resistor.

Design systems form a far more diverse group than drafting machines. Since they are purpose built for the job in hand, the software is far less limited by the hardware, and there tends to be a linear relationship between the features offered and the price demanded.

Important points to look for in modern design machines are the extent to which the machine can be integrated into the entire manufacturing process, the presence or absence of three dimensional and solids modelling abilities, and the ability to perform extensive mathematical modelling before or after the screen display.

A good design system dedicated to electronics will probably have a software library of components, transistors, resistors, IC packages and so on. The correct symbols and pin numbers will be generated automatically on the screen, and the machine may even have sufficient power to detect certain types of simple errors, like two inputs connected together, or illegal fan out. The ex-

tent of this 'design rule' checking is very much a measure of the sophistication of the hardware.

Simulation

On sophisticated machines, it's possible to simulate the performance of the circuit. You specify inputs, the machine will demonstrate the outputs (see Figure 1). The simplest simulators will calculate simple logic level changes. More complex machines will actually take account of propagation delays, known component tolerances and so on.

This facility is obviously fantastically useful, effectively doing away with much of the necessity for prototyping, especially in digital boards.

However, there are large problems with simulation. It is clearly a tremendously expensive procedure in terms of computer time. The mathematics necessary to generate a simple counter as we have done in Figure 1 is phenomenal, and grows with the complexity of both the circuit and the individual chips under test.

But there are some tricks that allow simulation of otherwise overwhelmingly complex circuits in a reasonable space of time. Small chunks of the circuit can be modelled separately, then stored as separate circuit elements complete with a pattern of inputs and outputs. This can save a considerable amount of computer time when running a simulation of the complete board.

Another clever idea is to use a real chip. This is a valuable procedure when the circuit contains an integrated circuit too complex for easy modelling, like a central processing unit. In this procedure, the chip is actually driven by the software. Its output is then fed back into the software where it is

COMPUTER GRAPHICS FOR MANUFACTURERS

Ausgraph 86, the fourth Australasian conference and exhibition on computer graphics, is holding a special industry stream for those involved in the design and manufacture of a wide range of products.

The 'design and manufacture' program is aimed at engineers and designers in mechanical, electrical or electronic disciplines, and covers all aspects of computer-aided engineering.

The conference, which is being held in Sydney at the Hilton Hotel July 7 to 11, is organised by the Australasian Computer Graphics Association, an organisation of both users and vendors of all types of computer graphics equipment.

A trade exhibition at the Sydney Town Hall is being held in conjunction with the conference, and will feature equipment and services from all the major vendors of computer graphics equipment.

Chairman for the design and manufacture program is Frank Mullen, Managing Director of the Centre for Industrial Technology (CIT) at

the New South Wales Institute of Technology. CIT was set up with the support of government and industry to assist in the transfer of advanced manufacturing technology into Australian industry.

Keynote speaker for the design and manufacture stream will be Joel Orr, one of the world's leading authorities in the field of CAD/CAM, who specialises in industrial automation.

Other speakers include Hulas King, from McDonnell Douglas Corp, USA, and Daniel Raker from Design and Systems Research, USA.

Companies exhibiting include IBM, Tektronix, Intergraph, Easinet, McDonnell Douglas Automation and Auto-trol Technology.

The exhibition will take up both the upper and lower floors of the Sydney Town Hall, and represents the largest specialist exhibition of computer graphics equipment ever staged in Australia.

For further information about Ausgraph 86, contact Robyn Hughes on (02)929-5855.

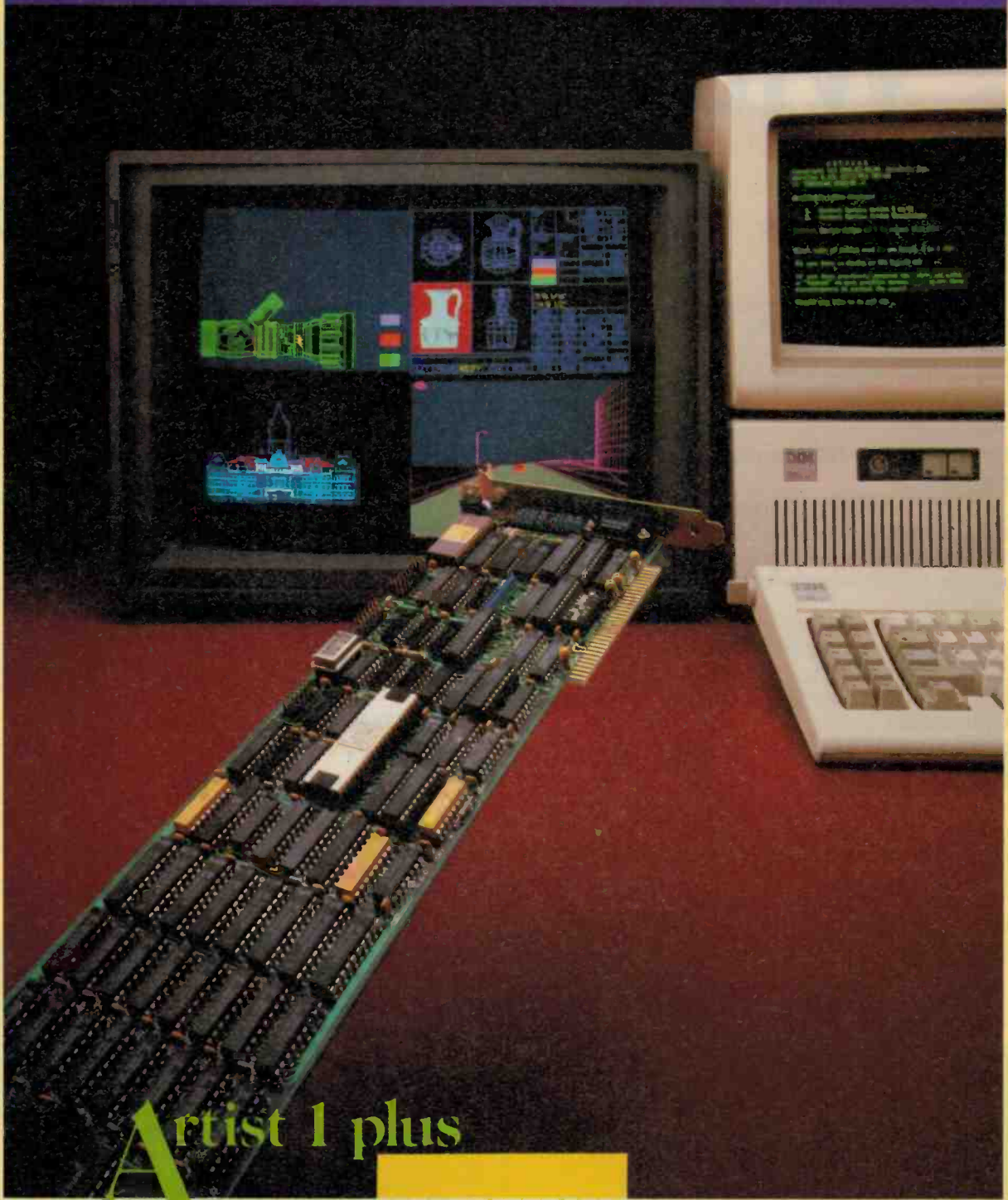

Artist 1 plus

- Introducing
ARTIST 1 PLUS Graphic Controller
- Ultra High Resolution 64MHz Colour Graphic Controller
 - Interlaced resolution up to 1024 x 1024 up to 1024 x 768
 - Flicker-Free, Non-Interlaced Resolution
 - Supports IBM PC CAD and CAE Software packages including Auto CAD
 - Single board Design for IBM PC, XT and AT
 - Displays 16 Colours Out of a Palette of 4096
- Other products available*
- 19" monitors on tilt-swivel base
 - Tektronics emulation software for 4010, 4014, 4105 to 4113 and 4115 terminals



Worldwide Business Systems

Mark Russell

21 Kardella Lane, Mt. Eliza 3930 Tel: (03) 787 8221

“With my HP CAD sail a boat that

Ask Ben Lexcen what his most valuable design tool is and he'll tell you it's his Hewlett-Packard Computer Aided Design system. Here he talks about his experience with the HP system and offers some salient advice to the new generation of designers who will follow in his wake.

Have you always felt at ease working with computers?

“No way! Really I was a latecomer to computers because I didn't have any formal training and I was frightened of them. In fact, I used to dream up some wonderful excuses to avoid getting involved with them.

“But, of course, I realise now that if you're going to be a leader in any field, not just design, you've got to utilise the leading technology. And really this HP stuff is so easy to use, I'm not sure what I was frightened of.”

Which parts of a boat do you design with the help of the computer?

“Virtually the whole lot, with the exception of tiny mechanical things. But we use it to design the shape and structure of the boat, and the sails.

“We use it to do all the hydro-dynamic considerations such as the total drag of the hull unit. Plus we use the computer to test different hull shapes.”

What aspect of your involvement with Hewlett-Packard strikes you as being particularly beneficial?

“Well, once you become involved with HP, you'll soon realise that apart from their technical excellence and innovation, one of their major strengths is that they have the people to help you get the best results from CAD.

“Because HP supply the hardware and the software, you've got a terrific advantage over the guy who tries to work with a lot of different suppliers. I mean it counts for a lot when the person who writes the software understands the workings of the processor.

“If you've got questions or problems, you can get answers and solutions from the one place. And believe me, that can save a lot of time and worry.”

How has the HP equipment assisted in the day-to-day running of your office?

“Well, it's staggering how much faster we can get things done since we plugged into HP. This is mainly due to the fact that the computer does so much of the calculation which we used to labour over manually.

L8V 775 HEPL



system I can virtually doesn't exist."

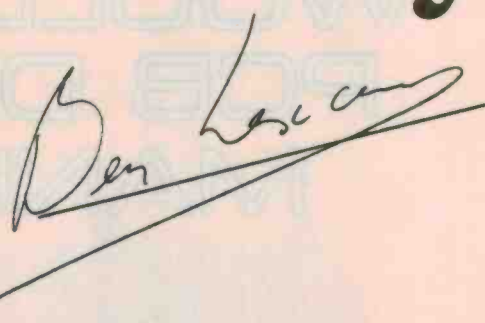

"For instance, now I can create the basic shape of a boat in a matter of hours whereas it used to take about a month. It might take me about ten minutes to do a keel whereas before it might have taken a week."

Does saving so much time mean that you have to compromise on quality or accuracy?

"Absolutely not. The equipment is dead accurate and I can do a more thorough job for far fewer man-hours.

"In fact, we are so confident in the HP equipment that when we've settled on the design of the boat to defend the America's Cup, we won't tank test it in Holland, we'll test it here in the computer. And when you're talking about a million dollar boat, you've got to be damn sure you've got the right equipment to do it."

What of CAD in the future?

"Look - I'm sure that if Australian designers don't grab CAD with both hands and run with it, the rest of the world will pass us by. And once we all realise its potential, you're going to see a lot of very happy and satisfied people in all sorts of design offices."

You're on a winner with the HP DesignCentre

Our Computer Aided Design solutions work together in an integrated design environment called the HP DesignCentre. HP's renowned technical excellence shines brilliantly in the DesignCentre where our engineering workstations and quality graphics peripherals come to the fore. And it's well worth remembering that HP's reputation for unfailing backup and support has been well earned.

HP offers a comprehensive solution to your CAD. To obtain your free DesignCentre Management Kit or Technical Kit to help make your next design project a winner, call HP now toll free on (008) 03 3821 or send in the coupon below.

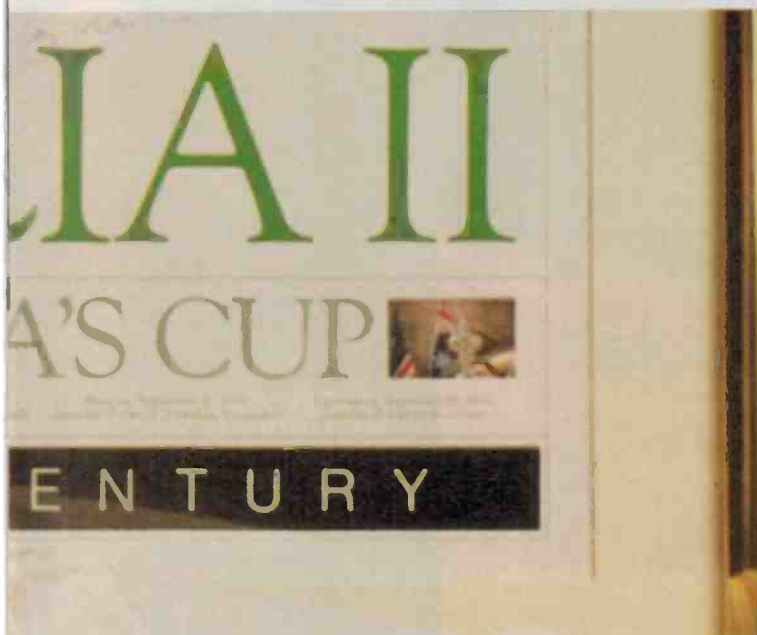

Please send me more information on
HP's *DesignCentre*

Management Kit Technical Kit

NAME _____

POSITION _____

COMPANY _____

ADDRESS _____

_____ P/CODE _____

POST TO:
Hewlett-Packard Australia Ltd
31-41 Joseph Street, Blackburn, Vic. 3130



**HEWLETT
PACKARD**

LBV 7775 HEPR

YOU'D THINK SOMEONE WOULD INTEGRATE PCB DESIGN WITH MANUFACTURE

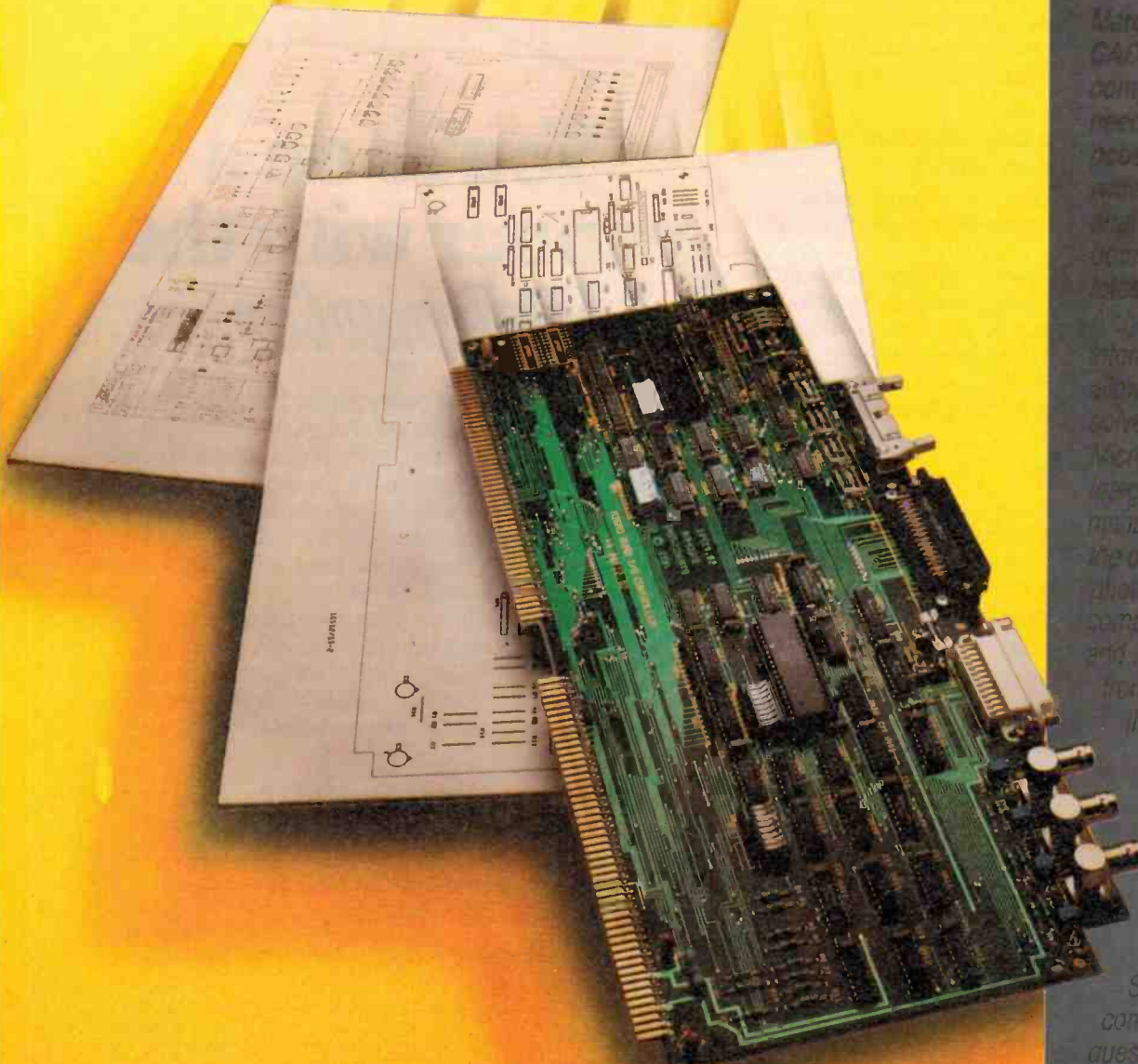

SOMEONE HAS
-MARCONI

The Marconi microQUAD CAD system creates the complete data base needed to manufacture PCBs. It caters for the widest range of formats and digital boards. It handles the latest SMD technology. All parts of the system are interactive by our tools allow you engines to solve your problems. MicroQUAD totally integrates design and manufacture by capturing the data once. Output for photoplotting, CNC drills, component insertion and ATE are all derived from a common data base. If microQUAD sounds good to you, then consider this. Marconi can also supply ATE systems and photoplotters to further reduce your lead times. So if you want a complete solution stop guessing and ring us. There is no telling how far you can go.

marconi
instruments 

Marconi Instruments
2 Giffnock Avenue
North Ryde N.S.W. 2113
N.S.W. Phone (02) 887 6117

treated as required by the rest of the simulation.

The result is a hybrid hardware-software simulation that can sometimes be very effective. It's an idea that can't be taken too far, however, since it can defeat the whole purpose of simulation.

When the circuit is complete it is possible to generate the artwork for the circuit board. This involves using a 'netlist' to identify which pins on which components need to be connected together. There are a number of levels at which this may be done. Some systems generate a 'rat's nest' in which straight line connection is made between pins. This allows for auto placement routines, the idea being to shuffle the various components around on the board to minimise the track length required.

A far greater level of sophistication is auto routing, in which practical tracks are generated, and, in fact, can be used to generate artwork for the finished board.

Routines such as this require many of the attributes of artificial intelligence. It's computing of very high order and is frequently not done particularly well. Some of the most highly regarded machines will regularly position 80% of the tracks, and leave 20% for manual placement.

CIM

Most modern CAD packages will now permit a number of interfaces into the rest of the manufacturing process. For instance there will be automatic generation of parts lists, perhaps interfacing to stock and inventory programmes. All the documentation associated with individual drawings themselves will be controlled. There will be interfacing to numerically controlled drilling machines, which actually drill the holes in the circuit board.

Computer integrated manufacture (CIM) is the name given to a philosophy more than a product. The essential idea is that there are many products in the world that can be made by computer once a human being specifies exactly what is required. At the heart of CIM, naturally, is CAD. Using the CAD system, the designer can specify every significant element in the product. Output from the CAD can then be used to drive the machines necessary to make the product, and also perhaps to establish the routines necessary to test it.

CAD will affect the way in which the components are stuffed into the board. In fully automated factories, output from the CAD will control the insertion machines. It can provide visual displays to machine oper-

aters in some systems, even showing a manual inserter where to place a component, and its polarity.

In very sophisticated packages it is possible to take the results of simulations and use these to generate inputs for automatic test equipment, so that boards can be tested after they have had their components mounted.

3D

Three dimensional modelling is not much in demand in electronic CAD packages, however, it is one of the more interesting criteria by which mechanical engineering systems are judged.

Modern 3D solids graphics packages have a number of abilities that can be taken for granted. They will all be able to take a plan view and project a 'z axis' onto it. On instruction, the component can be rotated such that all sides of the model can be viewed.

Some of the standard routines will include hidden line removal and filling. Hidden line removal involves recognising that certain lines are in front of other lines, and not printing them. Filling involves recognising that a certain area of the screen is in fact a plane, and should all be filled in an appro-

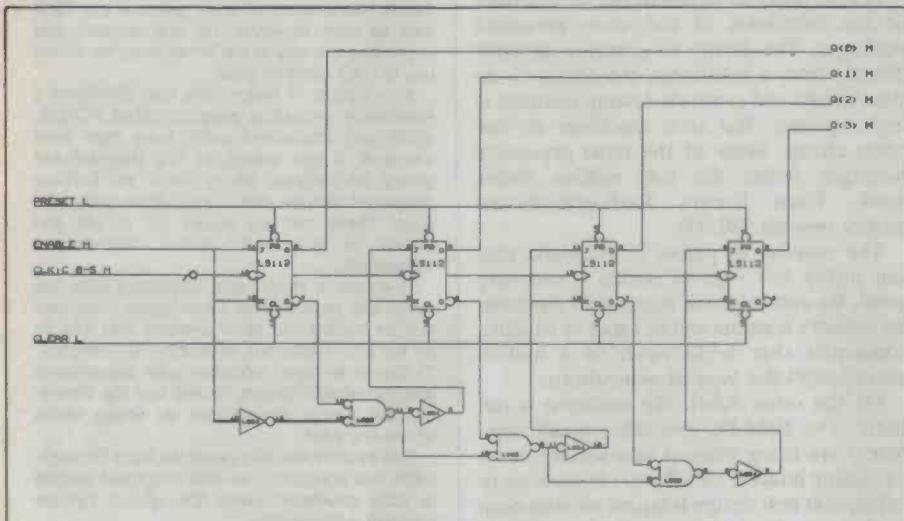
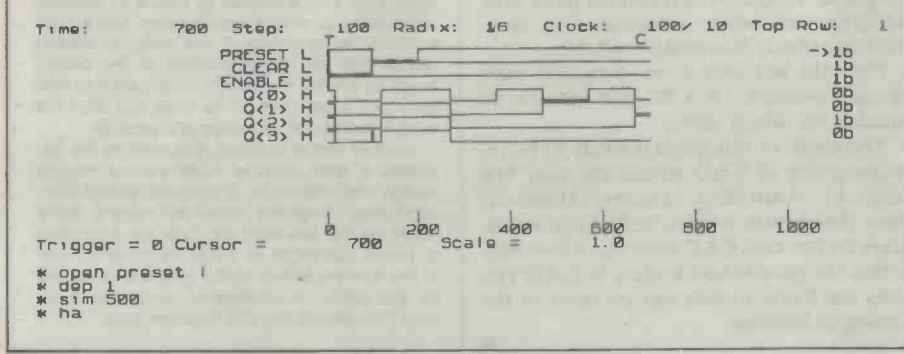

Figure 1. CAD drawn schematic. Below is simulation of the same circuit. (Courtesy DEC.)



REDLOG/REDBOARD

Racal's Redlog and Redboard are typical of middle of the range CAD systems costing about \$25,000. They are contained on seven floppies that need to be loaded into the hard disk of an IBM-XT or similar.

Redlog is the package designed for circuit 'capture', that is, laying out the schematic. Parts are called from a library and appear with the correct labelling, pin numbers and logic symbols where appropriate. New symbols can be created and added to the library as required.

The pins are connected by the designer. However, Redlog will only allow connections that conform to its design rules. It's not possible to draw a connection to nowhere for instance, or to connect in defiance of the rule laid down for the inputs and outputs of the components.

At the conclusion Redlog will generate a complete netlist for use with board layout systems like Redboard.

Redboard features complete auto placement of chips on the board, and complete auto routing. How well these systems work depends on the complexity of the board. As the board gets larger and the interconnections more complex it takes progressively longer for the computer to solve the problem. There is provision for manual override when the automatic routines get bogged down.

Automatic checking routines check the design at every stage to make sure that design rules are obeyed. These concern things like spacings between tracks, pads, components and bare copper areas.

Output from the system is via photoplotter, pen plots or disk into other CAD or CAM systems.



A Marconi CAD workstation. At right, the system monitor provides menus and status information. At left, is a computer module with 768K of memory and drives. A tape unit sits under the desk.

appropriate colour. More sophisticated versions of this will recognise that parts of an object are in shade and alter the colour and texture accordingly.

These may seem somewhat overblown features in an engineering design tool. However, manufacturers and users argue strongly in their favour. One of the main design strengths of CAD is its ability to demonstrate what something will look like before it's built, and to try out various designs for their aesthetic appeal.

Markets

Strangely enough, given its evident advantages, CAD is a technology that has largely been ignored in Australia. Tim O'Sullivan of Hewlett-Packard describes the Australian scene as 'eons' behind that in the US in terms of CAD usage. At Racal, Jeane Palmer echoes his sentiments.

Theories to account for this state of affairs abound: industry is too conservative, managers too ignorant, there are no designers here, industry's in a mess, and so on. There may be a smidgin of truth in all of them.

One argument stands out: the machines are still too expensive for the increase in productivity they generate. The drafting type packages are, without doubt, accessible to almost anyone in business. The increase in productivity they claim is more problematic.

Doug Rees of Bishop Graphics, which, uniquely in Australia, sells both CAD and artwork for manually taping up boards, argues that drafting-type CAD systems are no faster than a skilled draftsman with tape. It is probably true, however, that a CAD system is easier to operate well than tape, so

that a CAD system might be worthwhile when there is insufficient work to retain a full time draftsman.

On the other hand, there can be no doubt of the usefulness of the more advanced packages. The ability to generate artwork directly from a schematic, the ability to do simulations and generate testing routines is highly prized. But such machines do not come cheap. Some of the most expensive packages nudge the half million dollar mark. Even Racal's Redlog/Redboard pushes beyond \$20,000.

The number of places in Australia that can justify this type of outlay is not very great. By and large the Australian electronics industry is composed of small or smallish companies that could never in a million years justify this type of expenditure.

On the other hand, the situation is not static. The IBM-PC and other small computers are being pressed into service as an increasing number of software houses try to implement real design features on minimum hardware. Auto routing is increasingly available, even if it doesn't work particularly well. Programs that control parts lists, labelling and other documentation functions are slowly becoming available.

Over the last year or so, programs have become available on a PC that actually do simulations, albeit slowly.

The result of this trend is likely to be increasing use of CAD within the next few years by Australian industry. However, since this growth will be fuelled almost entirely by low cost CAD systems, a corollary is that the established leaders in CAD systems are likely to lose out on most of the growth in business.

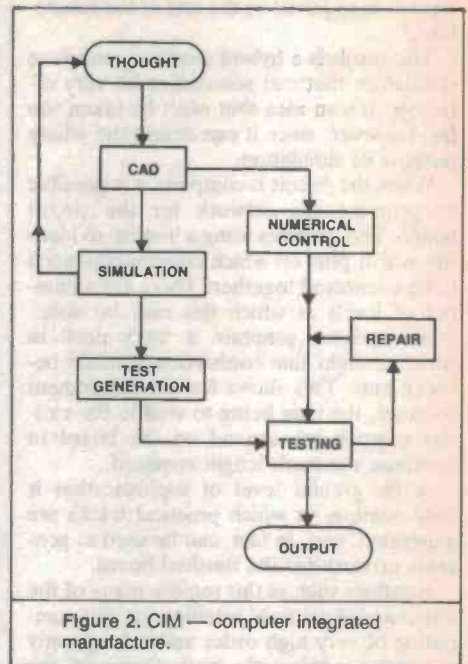

Figure 2. CIM — computer integrated manufacture.

TEXAS INSTRUMENTS

Texas Instruments does not produce any CAD gear as such. However, it is one company that is pointing the way to the future in so far as the use of CAD systems goes.

In a typical TI system the user confronts a reasonably innocuous program called PCADS, which can implement some fairly high level functions. It has access to TI's standard cell library, for instance, which has all the 54/74xx integrated circuits plus some other odds and sods. These can be pulled out at will and placed in a circuit, (either discrete or integrated).

However, it really gets interesting after the schematic capture has taken place. The disk can be loaded into other systems that can do an extremely accurate simulation, for instance. TI claims to have modelled gate capacitance and propagation delays so well that the simulation will almost always pick up timing errors where any exist.

The system will also generate input for automatic test equipment, so that integrated circuits or pcbs developed using the system can be checked automatically.

Although it sounds simple, it is this phase of the operation that often gives the most problems. One sort is caused by failure to simulate some input or output configuration which later turns out to be critical. If the designer doesn't realise that he has a problem at the design stage he will fail to instruct the simulator to look for it and it will pass all its tests and then not work in the circuit, to everyone's surprise.

Another sort of problem is caused by the extremes of time taken to model even a modest design mathematically. A relatively simple thousand-gate, integrated circuit will require many hours on the simulator for instance. According to David Cartwright of Texas Instruments, one of the exciting trends of the next few years will be the arrival of accelerated computing functions that will cut into this time overload.



The Innovators
Bishop Graphics, Inc.

THE WORLD'S LARGEST SELECTION OF

PRINTED CIRCUIT DESIGN PRODUCTS

- Drafting media — Accufilm, Econogrid, Accuvel.
- PC artwork multi-pad artwork StikOns.
- PC artwork PreKut tape shapes, patterns.
- PC artwork precision slit tapes, black, red, blue.
- Precision overlay system for double-side artwork.
- PC design, electronic, logic symbol templates.
- X-acto knives, blades, burnishers.
- Opto-scales, Accuscales, comparators, magnifiers.
- Printed circuit design book.
- Microelectronic artwork patterns.
- New P.C. CAD software for Apple Mackintosh.
- Also available from stock — Riston precoated laminate, 3M Dynamark reversal film and photosensitive label materials, negative and positive photo resists, PC drills etc.

For information contact:



CIRCUIT COMPONENTS (A/ASIA)
PTY. LTD.
383 FOREST ROAD, P.O. BOX 70, BEXLEY, N.S.W. 2207
TELEPHONES (02) 59-3720, 59-6550. TELEX AA27197

ETI READER SERVICE 8



PRINTED BOARD
DESIGN
CAD BUREAU SINCE 1981

SURFACE MOUNT

FINE LINE

MULTI-LAYER

DOUBLE SIDED

SINGLE SIDED

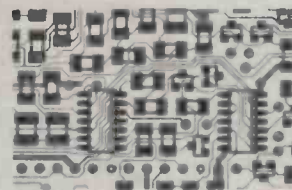

WE CAN PROVIDE ALL THE
ABOVE ON OUR CAD SYSTEM

ELECTRI-BOARD DESIGNS P/L
PCB DESIGN SINCE 1972

15/31 WATERLOO ROAD, 02-888 6925
NORTH RYDE NSW 2113. 02-888 3929

ETI READER SERVICE 91

INTRODUCING THE TIME-SAVER/MONEY-SAVER CIRCUIT-BOARD-ARTWORK SOFTWARE

For only \$1,250 smARTWORK™ lets the design engineer create and revise printed-circuit-board artwork on the IBM Personal Computer (or equivalent).

Forget the tedium of taping it yourself or waiting for the technician, draftsman, or the CAD department to get to your project.

smARTWORK™ (Version 1.20) is the only low-cost printed circuit-board-artwork editor with all these advantages:

- Conductor spacing always correct.
- Lines don't become too narrow.
- Connecting lines do not intersect other conductors.
- Automatically seeks and draws shortest route between conductors.
- Quick correction and revision.
- Production — quality 2X artwork from a pen-and-ink plotter.
- Prototype — quality 2X artwork from a dot-matrix printer.
- Easy to learn and operate.
- Single-sided and double-sided printed circuit boards up to 10 x 16 inches.
- Multicolour or black-and-white display.
- Library storage and retrieval of your own commonly used layouts and pinouts.



- Block movement and rotation for on-screen cut and paste editing.
- Place text on either board layer.
- Separate silk screen layer.

System Requirements (smARTWORK™ Version 1.20)

- IBM PC, XT or close compatible with 384K RAM, 2 disk drives.
- IBM Colour/Graphics Adaptor with RGB colour or B & W monitor.
- Epson MX/FX80/100 dot matrix printer.

- Pen-and-ink plotters:
Houston Instrument DMP42, 52
Hewlett Packard HPGL 7470, 75, 7580,
5, 6.
- Microsoft Mouse (optional), and other compatibles.

This revolutionary software package originates from the U.S.A. where it has a proven record for reliability.

Entertainment Audio of Adelaide are actually manufacturing the product locally, which has obvious benefits:

- Quicker availability of new releases and upgrades.
- Experienced engineers available to help or answer enquiries.
- For a FREE TRIAL of smARTWORK™ and further information, ring (008) 88 8414.



Entertainment Audio P/L
A VILLAGE ROADSHOW COMPANY
59 KING WILLIAM STREET,
KENT TOWN, S.A. 5067
Phone (08) 363 0454



Representing WINTEK Corporation (USA)
in Australia

ETI READER SERVICE 10

LOWEST PRICES EVER IN AUSTRALIA!!
(It not, please let us know!)

IBM* COMPATIBLES
from \$799*

Incredible deals to suit everyone including special package deals!
256K RAM: Single drive, graphics, disk controller and printer cards. \$799
256K RAM: Colour Graphics, Disk Controller Card, 1 parallel port, 2 disk drives and 3 months warranty. only \$1,350
640K RAM: Colour graphics, Multifunction Card, Disk Controller Card, 2 serial and 1 parallel ports. 2 disk drives and 3 months warranty. only \$1,450

256K PACKAGE DEAL: Includes Colour Graphics Card, Multifunction Card, Disk Controller Card, 2 serial and 1 parallel ports. A 120 C.P.S. printer and a monochrome monitor and 3 months warranty! only \$1,899
640K PACKAGE DEAL: Includes Colour Graphics Card, Multifunction Card, Disk Controller Card, 2 serial and 1 parallel ports. A 120 C.P.S. printer, a monochrome monitor and 3 months warranty! only \$1,999

*IBM is a registered trademark.

IBM* AT COMPATIBLE!

- 6MHz (switchable)
- 80286 CPU
- 8 slots
- 1 MByte main board
- 1.2 MByte Floppy disk drive
- 20 MByte Hard disk
- Colour graphics display card
- Floppy and Hard disk controller card
- Printer card and RS232
- 200W Power supply
- Keyboard
- Manual

All this for just \$2,995



NEW INTRA HIGH RESOLUTION RGB COLOUR MONITOR!

Size: 14 inch
 Sync. Horiz. Scan Freq: 15.75 KHz
 Sync. Vert. Scan Freq: 50 Hz
 Band width: 18 MHz
 Resolution: 640 x 400 dots
 Display Format: 80 x 25 Characters
 Display Colours: 16 colours
 Input Connector: 9 pin D type
 Cat. X14520 only \$695



BITRON 2 MONITORS

Stylish, swivel base monitor, available in amber or green.
 Green Cat. X14506 Normally \$215
 Amber Cat. X14508 Normally \$219
SPECIAL, ONLY \$199

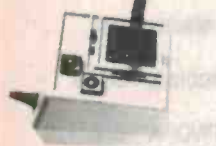

HIGH RESOLUTION MONOCHROME GRAPHICS CARD

Give your IBM real graphics capability.
 Cat. X18007 \$249



APPLE JOYSTICKS
 Ideal for games or word processing. Fits most 8502 "compatible" computers.
 Cat. C14200 \$34.95

SOLDER ROLLS
 Absolutely top quality, unlike our opposition!
 60/40 Resin cored.

Cat.No.	Description	Price
T31000	71mm 250gm	\$8.95
T31002	71mm 500gm	\$15.95
T31010	91mm 250gm	\$7.95
T31012	91mm 500gm	\$14.95
T31020	1.6mm 250gm	\$7.50
T31022	1.6mm 500gm	\$13.95
T31030	71mm 1 metre	\$1.50
T31032	91mm 1 metre	\$1.25
T31034	1.6mm 1 metre	\$1.00

PROGRAMMABLE 24 HOUR TIME SWITCH
 ● 48 switching possibilities per day
 ● 240V AC, 2400 watt, 10 amp
 ● Suitable for turning on...
 Heaters/Coolers
 pool filter
 electric blankets
 cooking appliances
 waking you, even making the coffee lights etc for security while you're away from home!
 ● Bargain Price!
 Cat. M22002 only \$19.95



WELLER WTCPN SOLDERING STATION
 The WTCPN features:
 ● Power Unit 240 V AC
 ● Temperature controlled iron, 24 V AC
 ● Flexible silicon lead for ease of use
 ● Can be left on without fear of damaged tips!
 The best is always worth having.
 Cat. T12500
 R.R.P. \$129 Our price \$109



STANDARD DESOLDERING PUMP
 Light weight, powerful suction, teflon tip. Replacement tips teflon and ceramic. Length 195mm.
 Cat. T11241 \$16.95, Now \$14.95

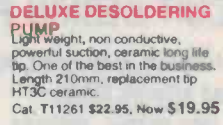

MINI DESOLDERING PUMP
 Light weight, powerful suction, teflon tip. Replacement tips teflon and ceramic. Length 165mm.
 Cat. T11251 \$15.95, Now \$13.95

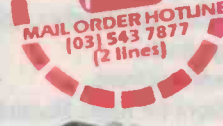

DELUXE DESOLDERING PUMP
 Light weight, non conductive, powerful suction, ceramic long life tip. One of the best in the business. Length 210mm, replacement tip HT3C ceramic.
 Cat. T11261 \$22.95, Now \$19.95

BARGAINS!



10W HORN SPEAKERS
 White durable plastic, 8 ohms
 Cat. C12010 Normally \$9.95
SPECIAL, ONLY \$7.95

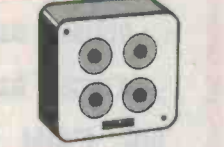

PIEZO SIREN
 ● 4 piezo sirens in a high impact plastic cabinet
 ● Input 12V DC - 200mA
 ● Output 1150db at 1m, dual tone
 ● Compact size 105 x 85 x 45mm
 ● Smart design suits interior use
 Cat. S15071 \$23.95



PC BOARD HOLDER
 Better than any other on the market!
 A must for all PCB work.
 Cat. T12442 \$7.95

CRAZY SPECIAL!

CRYSTALS SPECIALS
 We always have too many of these prime spec. crystals in stock!

Description	Cat.No.	1-9	10+
1MHz	Y11000	\$6.00	\$5.20
1.8432MHz	Y11003	\$6.00	\$5.20
4MHz	Y11020	\$2.00	\$1.60
4.194304MHz	Y11022	\$2.00	\$1.60
4.433618MHz	Y11023	\$2.00	\$1.60
4.75MHz	Y11025	\$2.00	\$1.60
4.915200MHz	Y11026	\$2.00	\$1.60
5MHz	Y11030	\$2.00	\$1.60
6MHz	Y11040	\$2.00	\$1.60
6.144MHz	Y11042	\$2.00	\$1.60
6.670MHz	Y11045	\$2.00	\$1.60
8MHz	Y11050	\$2.00	\$1.60
8.867238MHz	Y11055	\$2.00	\$1.60
10MHz	Y11060	\$2.00	\$1.60
12MHz	Y11070	\$2.00	\$1.60
14.31818MHz	Y11072	\$2.00	\$1.60
15MHz	Y11075	\$2.00	\$1.60
18MHz	Y11082	\$2.00	\$1.60
18.432MHz	Y11085	\$2.00	\$1.60
20MHz	Y11090	\$2.00	\$1.60



10 TURN WIRE WOUND POTENTIOMETER Spectrol Model 534
 1/4" shaft.
 Equiv (Bourns 3540S, Beckman 7256)
 Dials to suit 16-111, 16-111, 21-1-11.

R14050 50R	R14100 5K
R14055 100R	R14110 10K
R14060 200R	R14120 20K
R14070 500R	R14130 50K
R14080 1K	R14140 100K
R14090 2K	

 1-9 \$13.50 10-10 \$12.50



REGULATED DC-DC CONVERTER
 Built on to a heavy duty aluminium heatsink with 7 amps. Ideal for trucks and boats.
 ● Input 24V DC
 ● Output 12V DC at 7 amps
 ● Fully regulated with short circuit protection
 ● Size: 180(L) x 94(W) x 33(H)mm
 Cat. A15056 \$33.95

NICADSI

Size	Desc.	1-9	10+
AA	A.H.	\$1.95	\$1.75
C	A.H.	\$7.95	\$6.50
D	A.H.	\$7.95	\$6.50

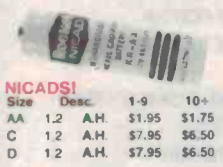

RS232 MINI PATCH BOX
 ● Interface RS232 devices
 ● With male to female 25 pin inputs
 ● 25 leads with tinned and supplied
 ● Complete with instructions
 Cat. X15654 Normally \$25.95
SPECIAL, ONLY \$20.75



UNIVERSAL BATTERY CHARGER AND TESTER
 Save money on expensive batteries with this universal battery charger. Features include meter tester, and provisions for D, C, AA, AAA, N, button and cell batteries, 9V and 6V (square types). Comes complete with detailed instructions.
 Cat. M23533 \$27.95



"IBM* AT STYLE" KEYBOARD
 ● 100% IBM* PC, XT compatible.
 ● low profile keyboard design.
 ● proper placement of shift keys with large key tops to suit professional typists
 ● 3 step height/angle adjustment
 ● Cherry brand TS-M0001 19mm low profile switches, meet 30mm ergonomic requirement, and provide high performance and maximum reliability.
 ● Curl lead plugs straight into IBM* PC/XT
 ● Status displays. (3)
 Just like the "real McCoy" only at a fraction of the price!
 Cat. X12020 only \$245



IBM COMPATIBLE CARDS TURBO CARD!
 Switchable 5MHz/7.5MHz IBM* compatible motherboard.
 Cat. X \$495

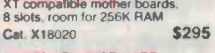

MOTHER BOARD
 XT compatible mother boards. 8 slots, room for 256K RAM.
 Cat. X18020 \$295

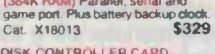

GAMES ADAPTOR CARD
 Features 2 joystick ports.
 Cat. X18019 \$49



DISK CONTROLLER CARD
 Controls 2 slimline drives.
 Cat. X18005 \$89



512K RAM CARD
 Including RAM Cat. X18015 \$299
 Excluding RAM Cat. X18016 \$129



5 1/4" FLOPPY DISK SPECIALS!
 All prices 10 disk boxes!

XIDEX 1-9	10+
S/S D/D \$29.95	\$29.95
D/S D/D \$38.95	\$36.95

 Cat. C12410
 High Density \$125
 Cat. C12520
VERBATIM DATALIFE
 S/S/D/D \$27.95 \$26.95
 Cat. C12501
 D/S/D/D \$34.95 \$32.95
 Cat. C12504
VERBATIM VALULIFE
 S/S/D/D \$24.95 \$22.95
 Cat. C12421
 D/S/D/D \$29.95 \$25.95
 Cat. C12425

3 1/2" DISK SPECIALS
 Verbatim S/S Cat. C12610 \$89.95
 Verbatim S/S Cat. C12612 \$89.95
 Xidex S/S Cat. C12600 \$65.95
 Xidex D/S Cat. C12602 \$89.95

NEED HIGH DENSITY DISKS FOR YOUR IBM AT?
 Buy your High Density disks at below recommended retail prices from Rod Irving Electronics and SAVE!!
 R.R.P. \$113 Our Price \$99.95

SAVE!

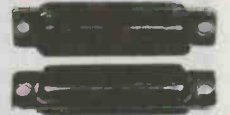

RS232 & 'D' TYPE SPECIALS!

Part Description	Cat.No.	Price
DE9S 9 pin Female P10881		\$1.75
DE9P 9 pin Male P10880		\$2.25
DE9C 9 pin cover P10882		\$1.95
DA15P 15 pin Male P10890		\$2.10
DA15S 15 Female P10891		\$2.25
DA15C 15 pin cover P10892		\$1.15
DB25P 25 pin Male P10900		\$1.95
DB25S 25 Female P10901		\$2.95
DB25C 25 pin cover P10902		\$1.20



CODE KEY PAD
 ● 4 digit, changeable code.
 ● Over 5000 possible combinations.
 ● Power consumption: 5mA standby, 50mA alarm.
 ● Two sector LED and 1 arm LED.
 ● Wrong number lockout.
 ● 12V DC operation.
 ● Relay output.
 ● Panic button.
 ● Normally open lampster switch.
 ● Dimensions: 145 x 100 x 37mm
 ● ACP3 compatible.
 Cat. A13014 Normally \$69.50
SPECIAL, ONLY \$55.60



DPM-200 PANEL METER
 Ultra Low Power
 ● Separately Addressable Annunciator
 ● 15mm Digits
 ● Bandgap Reference
 A low profile LCD DPM with a range of useful symbols as shown. The DPM 200 features 15mm 3 1/2 digit display, and ultra low current consumption and a bandgap reference for high stability. It also features Auto-zero, Auto-polarity, 200mV fsd. It may be used in single-ended, differential or ratiometric modes. The fsd can be easily changed by the user to indicate any other units. The decimal points and symbols can all be driven from an internal source. Wide supply rail and symbols can all be driven from an internal source. Wide supply rail (5-15V DC) with a variable threshold low battery warning indicator. Supplied with mounting clips and comprehensive data sheet.
SPECIFICATIONS:
 Accuracy: 0.1% + -1 digit
 Linearity: + -1 digit
 Samples/sec: 3
 Temp. Stability: 50 ppm typical
 Temp. Range: 0 - 50C
 Supply Voltage: 5 - 15V DC
 Supply Current: 50uA typical
 Max DC Input Volts: + - 20V
 Cat. G15510 \$99.95



TELECOMMUNICATIONS AUSTRALIAN STYLE ADAPTOR CABLE
 ● Australian 10 pin plug/socket
 ● Length 10 metres
 Cat. Y16015 Normally \$15.95
SPECIAL, ONLY \$12.75



TELEPHONE ADAPTOR
 ● Australian plug to U.S. socket
 ● Length 10cm
 ● Cream colour cable
 Cat. Y16026 Normally \$6.95
SPECIAL, ONLY \$5.55

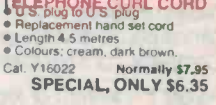

TELEPHONE CURB CORD
 ● Plug to 7 pin plug
 ● Replacement hand set cord
 ● Length 4.5 metres
 ● Colours: cream, dark brown.
 Cat. Y16022 Normally \$7.95
SPECIAL, ONLY \$6.35

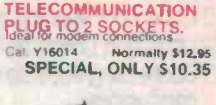

TELECOMMUNICATIONS PLUG TO 2 SOCKETS
 Ideal for modem connections.
 Cat. Y16014 Normally \$12.95
SPECIAL, ONLY \$10.35

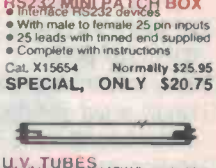

U.V. TUBES
 Fits into standard 15W fluoro holder. Suitable for Scotchcal, Eprom erasing etc. As used in ETL Eprom Erasing Kit.
WARNING: Do not look directly into UV Tubes.
 Cat. H28600 \$24.95
 *If ordering by mail please include an extra \$2 for "special" packing.

METEX MULTIMETERS

These instruments are compact, rugged, battery operated, hand held 3 1/2 digit multimeters. Dual-slope A-D converters use C-MOS technology for auto-ranging, polarity selection and over-range indication. Full overload is provided.

SAVE \$10 DURING JULY

METEX 3800 MULTIMETER

- Features...
- Push-button ON/OFF power switch
 - Single 30 position easy to use rotary switch for FUNCTION and RANGE selection
 - 1/2" high contrast LCD.
 - Automatic over-range indication with the "1" displayed.
 - Automatic polarity indication on DC ranges
 - All ranges fully protected plus Automatic "ZERO" of all ranges without short circuit except 200 ohm Range which shows "000 or 001"
 - High Surge Voltage protection 1.5 KV-3 KV
 - Diode testing with 1 mA fixed current
 - Audible Continuity Test.
 - Transistor hFE Test.
- SPECIFICATIONS**
Maximum Display: 1999 counts
3 1/2 digit type with automatic polarity indication.
Indication Method: LCD display.
Measuring Method: Dual-slope in A-D converter system.
Over-range Indication: "1" Figure only in the display.
Temperature Ranges: Operating 0°C to +40°C
Power Supply: one 9 volt battery (006P or FC-1 type of equivalent)
Cat. Q91530 Normally \$99.95
SPECIAL \$89.95

SAVE \$10 DURING JULY

METEX 3530 MULTIMETER

- Features...
- Push-button ON/OFF power switch.
 - Single 30 position easy to use rotary switch for FUNCTION and RANGE selection
 - 1/2" high contrast LCD.
 - Automatic over-range indication with the "1" displayed.
 - Automatic polarity indication on DC ranges
 - All ranges fully protected plus Automatic "ZERO" of all ranges without short circuit except 200 ohm Range which shows "000 or 001"
 - High Surge Voltage protection 1.5 KV-3 KV
 - Capacitance measurements to 1pF
 - Diode testing with 1 mA fixed current.
 - Audible Continuity Test.
 - Transistor hFE Test.
- SPECIFICATIONS**
Maximum Display: 1999 counts
3 1/2 digit type with automatic polarity indication.
Indication Method: LCD display.
Measuring Method: Dual-slope in A-D converter system.
Over-range Indication: "1" Figure only in the display.
Temperature Ranges: Operating 0°C to +40°C
Power Supply: one 9 volt battery (006P or FC-1 type of equivalent)
Cat. Q91540 Normally \$129
SPECIAL \$109

HIGH EFFICIENCY RADIANT FIN HEATSINK

- Black anodized with a thick base plate, this radiant fin heatsink can dissipate large amounts of heat for maximum efficiency. Designed by Rod Irving.
- 105x30mm Cat. H10520 \$ 3.50
 - 105x75mm Cat. H10525 \$ 3.50
 - 105x100mm Cat. H10529 \$ 4.90
 - 105x140mm Cat. H10534 \$ 6.50
 - 105x150mm Cat. H10535 \$ 6.75
 - 105x170mm Cat. H10538 \$ 7.95
 - 105x195mm Cat. H10542 \$ 9.90
 - 105x200mm Cat. H10543 \$ 9.90
 - 105x225mm Cat. H10546 \$10.50
 - 105x300mm Cat. H10549 \$12.00
 - 105x600mm Cat. H10560 \$24.95

BESWICK 88100 PROBE SET

- CONTAINS: Compensated probe lead with:
- Detachable 6 inch earth lead
 - Retractable hook
 - IC test tip
 - Tip insulator
 - BNC adaptor
 - Trimming tool
- SPECIFICATIONS:**
Bandwidth: 10:1 position 250MHz at 3dB into 20 pF
Rise Time: 10:1 position less than 1.4ns nominal
Switch Function:
(a) 10:1 attenuation +/- 1%, with oscilloscope of 1 Mohm input resistance.
(b) 1:1 attenuation with bandwidth of 10 MHz approx.
(c) Reference position, tip grounded via 9 Mohm, oscilloscope input grounded.
Input Capacitance: 16pF typical depending upon oscilloscope input capacitance.
Compensation Range: oscilloscopes of 15 to 60 pF input capacitance.
Working Voltage: 600V DC or peak AC

- ARLEC SUPER TORCH**
A sophisticated rechargeable torch ideal for use in and around the home, the car, the boat, etc.
- FEATURES:**
- Powerful built-in Nicad batteries
 - Reflector head swivel through 90 degrees
 - 3 position switch gives on/off and dim.
 - Indicator lamp when recharging.
 - Charges from mains, electricity or from a car battery.
 - Supplied complete with (A) SEC approved battery charger (B) Plug and cord for car lighter socket.
 - Handy charging bracket with fixing screws.
 - 12 months guarantee.
- Cat. C11505 Normally only \$44.95
SPECIAL, ONLY \$39.95

NEW!

UV EPROM ERASER
Erase your EPROMs quickly and safely. This unit is the cost effective solution to your problems. It will erase up to 9 x 24 pin devices in complete safety, in about 40 minutes (less for less chips). High UV intensity at chip surface ensures EPROMs are thoroughly erased. (Dimensions 217 x 80 x 68mm)
Without timer Cat. X14950
only \$99.95
With built in timer Cat. X14955
only \$129

SPECTROL MULTIDIALS

- Model 16-1-11 (9")
Cat. S14300 \$16.95
Model 18-1-11 (11" x 1.75" Rect.)
Cat. S14305 \$28.50
Model 21-1-11 (11.82")
Cat. S14310 \$27.50

VALUE!

APPLE* COMPATIBLE SLIMLINE DISK DRIVES
Japanese Chinon mechanism.
Cat. X11901 Normally \$225
NOW \$195
(*Apple is a registered trademark.)

- MITSUBISHI DISK DRIVES**
- MF353 (3 1/4" DRIVE)**
Double sided, double density, 1 MByte unformatted, 80 track per side.
Cat. C11953 \$280
- M2896-63**
Slimline 8" Disk Drive, Double sided Density No AC power required, 3ms track to track, 1.6 Mbytes unformatted, 77 track side 10s/su10 bit soft error rate.
Cat. C11916 Case & Power Supply to suit
Cat. X11022 \$159
- M4854**
Slimline 5 1/4" disk drive, Double sided, double density, 96 track/inch, 9621 bit/inch, 1.6Mbyte unformatted 3ms track to track access, 77 track side.
Cat. C11904 Case & Power Supply to suit
Cat. X11011 \$109
- M4853**
Slimline 5 1/4" disk drive, Double sided, double density, 1 MByte unformatted, 3ms track to track, 80 track/side, 5922 bit/inch.
Cat. X11903 \$295
- M4851**
Slimline 5 1/4" disk drive, Double sided, double density 500K unformatted, 40 track/side. Steel band drive system.
Cat. C11901 Case & Power Supply to suit
Cat. X11011 \$109
- M4855**
Slimline 5 1/4" disk drive, double sided, double density, 96 track/inch, 2.0 Mbytes unformatted.
Cat. C11905 \$385

AEROSOLVE SPRAYPACKS

- PCB Coating '201' Cat. N11040 \$6.95
Freezing Spray '202' Cat. N11042 \$6.95
Insulating Varnish '203' Cat. N11043 \$7.95
Electric Motor Cleaner '204' Cat. N11044 \$6.95
Electronic Super Clean (Froon) '205' Cat. N11047 \$7.50
Flux Remover '206' Cat. N11049 \$6.95
Elec Contact Cleaner & Lube '207' Cat. N11051 \$5.95
Silver Cote '208' Cat. N11054 \$6.95
Formula "66" '535' Cat. N11057 \$5.95
Clear Coat Plastic Spray '540' Cat. N11059 \$6.95

RANGE!

10% OFF!!

10% OFF!!

PROFESSIONAL SERIES RACK MOUNTING CABINETS
These beautifully crafted rack cabinet boxes will give your equipment a real 1st class appearance.

- All aluminium construction.
- Removable top and bottom panels.
- All dimensioning conforms to the International Standard.
- Natural or black finish.
- Ventilated lid.
- Deluxe brushed finish anodised front panel.

WAS NOW
H10401 Natural \$49.50 \$43.50
H10402 Natural \$59.50 \$56.00
H10403 Natural \$69.50 \$63.50
H10411 Black \$59.95 \$57.50
H10412 Black \$69.95 \$65.00
H10413 Black \$79.95 \$75.00

MINI UTILITY CASE
Features a clear plastic lid for instant inspection of contents. Up to five, adjustable lower compartments, plus a self elevating upper tray for smaller items.
Dimensions: 110 x 210 x 43mm.
Cat. H10087 \$7.95.

SAVE

IC SPECIALS!

1-9	10+	100+
4116 \$3.95	\$3.75	\$3.50
4164 \$2.95	\$2.75	\$2.50
2716 \$5.90	\$5.50	\$5.50
2732 \$6.25	\$5.95	\$5.50
2764 \$8.25	\$6.95	\$5.00
27128 \$6.95	\$6.50	\$6.25
6116 \$2.95	\$2.75	\$2.50
41256 \$6.95	\$6.50	\$6.00
6264 \$6.50	\$5.50	\$5.25
27256 \$11.50	\$10.50	\$10.00

CENTRONICS GENDER CHANGER
Female to Female.

- Saves modifying or replacing non-mating Centronics cables.
- All 36 pins wired straight through.

Cat. X15662 \$33.95

WORLD MODEM CHIP
Cat. U2184 Normally \$49.50
Save \$20, SPECIAL \$29.50

TEXTOL SOCKETS

P17016 16 pin	\$14.50
P17024 24 pin	\$14.50
P17028 28 pin	\$19.50
P17040 40 pin	\$22.50

NEW!

"SNAP TOGETHER" PLASTIC CABINET
Top and bottom simply snap together (no screws required), removable front and back panels.
Dimensions: 186(W) x 125(D) x 50(H)mm
Cat. H10116 \$6.95

NEW!

SPEECH SYNTHESIZER CHIPS!
SPO256A-A Speech synthesiser chip, needs programming to work.
\$13.95

CTS25-AL2: Contains the code recognition circuit to enable the project to plug directly on the printer port, or into an IBM PC.
\$27.95

A SET OF EACH \$39.50

10% OFF!!

IC STORAGE CASE
Electro static charge proof plastic IC case with conductive sponge. Dimensions: 75 x 130 x 19mm.
Cat. H10095 Normally \$8.95
SPECIAL, ONLY \$7.95

NEW!

NEW!

MICRODOT 5 1/4" DISKS
100% certified and error free guaranteed! Where else can you get 100% guaranteed disks at these prices?!

1-9	10+
S/C Cat. C12440	\$17.95 \$16.95
D/S Cat. C12445	\$19.95 \$17.95

Bulk and Dealer enquiries welcome please phone (03) 543 2166

NEW!

ARGUS 726 ADJUSTABLE MAGNIFIER WITH LAMP
Absolutely perfect for close up work! Intricate PCB's, projects etc. will be a breeze under this superb, adjustable magnifying lamp.

- Magnifies 1.75 times
- 40 watt incandescent lamp
- 2 spring-balanced arms, extendable to 95cm
- Adjustable head for optimum viewing angle.
- Fantastic Value!!

Cat. only \$89

CANON TYPE CONNECTORS

Cat. No.	Description	Price
P10960	3 pin line male, Was \$3.90	NOW \$2.70
P10962	3 pin chassis male, Was \$3.00	NOW \$2.10
P10964	3 pin line female, Was \$4.20	NOW \$2.95
P10966	3 pin chassis female, Was \$4.50	NOW \$3.15

rod

ROD IRVING ELECTRONICS
425 High Street, NORTHCOTE, 3070 VICTORIA, AUSTRALIA
Phone (03) 489 8856
48 A'Beckett St, MELBOURNE, 3000 VICTORIA, AUSTRALIA
Ph. (03) 563 6151
Mail Order and correspondence: P.O. Box 620, CLAYTON 3168
TELEX: AA 151938

UNIVERSAL SOLDERING IRON STAND
Normally \$5.95 slashed to \$3.95

MAIL ORDER HOTLINE (03) 543 7877 (2 lines)

SPECTROL 31P
Equip (Bouras 3088)
Essential for precision work

R14200 10R	R14290 10K
R14210 20R	R14300 20K
R14220 50R	R14310 50K
R14230 100R	R14320 100K
R14240 200R	R14330 200K
R14250 500R	R14340 500K
R14260 1K	R14350 1M
R14270 2K	R14360 2M
R14280 5K	

1-9 \$1.95 10+ \$1.75

CORDLESS RECHARGEABLE SOLDERING IRON
Built in solder pot, illumination

- Easy replacement of solder tip
- Protective stand which also functions as charging unit
- Sponge pad attach to stand
- Plug pack power adaptor
- Includes Nicad battery
- Instruction manual
- 12 months warranty

Cat. T12480 \$59.95

SAVE \$5!

MAGNETIC BULK ERASER
The best and by far the quickest way to erase tapes, cassettes and computer disks! Reduces noise levels below recorders own erase head level. On/Off switch located in handle 240V AC operation.
Cat. C14950 Normally \$34.95
SPECIAL, ONLY \$29.95

POSTAGE RATES

\$11-99	\$2.00
\$10-\$24.99	\$3.00
\$25-\$49.99	\$4.00
\$50-\$99.99	\$5.00
\$100-199	\$7.50
\$200-\$499	\$10.00
\$500 plus	\$12.50

This is for basic postage only. Comet Road freight, bulky and fragile items will be charged at different rates. Certified Post for orders over \$100 included "free"! Registered Post for orders over \$200 included "free"! All sales tax exempt orders and wholesale enquiries to RITRONICS WHOLESALE, 56 Renner Rd. Clayton Phone (03) 543 2166

MasterCard VISA

Errors and Omissions Excepted.

Multi play CD player

The new Pioneer PD-M6 has a six disc multi play magazine giving versatility in the selection of compact disc tracks.

A pre-program facility allows choice of up to 32 selections from the discs in the magazine. Alternatively, the PD-M6 will play the discs in sequence or, to add even more variety, the CD's micro computer will select the tracks at random.

The multi play magazine also doubles as a storage and additional holders will be available as accessories.

The PD-M6's other features include a disc stabiliser to minimise vibrations and mistracking and a linear servo system with its three laser beam pick-up which detects damage on the disc and

reduces dropouts.

Other components and features include a single disc magazine, allowing the PD-M6 to play as if it were an ordinary single play CD, four repeat modes (for repeating all discs, a single disc program or single track), three speed manual search of the desired track, full remote control operation, subcode output for future disc technological development and headphone output with volume control.

The PD-M6 retails from Pioneer dealers at a suggested retail price of \$899.



International video festival

Plans are now under way to establish a premier video competition and exhibition to bring together the most innovative video-based images produced in Australia and overseas.

The format of the event planned for August will include competitions in a variety of categories:

video art and graphics, documentary and information, music video, drama/narrative student works, and home video. Exhibitions of the best entries will be shown with a selection from various countries. An historical section is proposed for several Sydney venues such as

the Art Gallery of NSW, Chauvel and Academy Twin Cinemas, Metro TV Studios, Roslyn Oxley Gallery, Artspace and the Performance Space. There will also be forums and discussion sessions of topical interest such as copyright issues, the effects of new technology

like Aussat, digital television and distribution possibilities.

For more information contact the Secretary, Australian Video Festival Committee, PO Box 316, Paddington, NSW 2021. (02)339-9555.

NAD 30 Series

NAD has introduced three new models as successors to its 20 Series: the 1130 preamplifier, the 3130 integrated amplifier and the 4130 tuner. NAD's claim is that this 30 Series offers

more power, better FM reception and more features than its predecessors.

The newly designed, discrete transistor phono preamp section of the 1130 preamp includes a

quiet moving coil input, as well as a moving magnet input and very wide dynamic range. NAD claims the CD input is a true overload proof compact disc input, not merely a renamed AUX input. As with other NAD products, it incorporates the very useful BASS EQ and INFRA DEFEAT features.

The 3130 integrated amplifier includes NAD's high current design and +3dB of IHF dynamic headroom. This means that the 3130 can develop more than 60 watts of power per channel into speaker impedances of almost any value. The speaker impedance selector matches the power

supply to the speakers. Instead of the usual spring clips, heavy duty speaker binding posts are used to ensure low resistance connections for high current delivery with any type of speaker cable.

The 4130 tuner includes a new FM noise reduction circuit to provide optimum compromise between quieting and stereo separation at every signal level improving stereo S/N by up to 10dB in weak signals. NAD also boasts exceptional immunity to rf overload and over-modulation. The tuner features five AM and five FM presets.

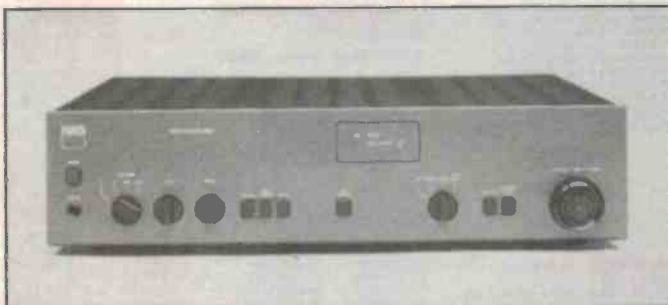

BRIEFS

Carin car map

Prototype systems of Philips' Carin CD-based car information and navigation system are being developed for further testing. The system operates such that when a Carin disc is loaded into the system, all the driver has to do is enter his departure and destination points and any special route requirements such as the shortest, the most economical or the most scenic. The best route meeting these requirements is then planned and stored in memory. During the journey, Carin monitors progress and provides all the navigation information that the driver needs to follow the correct route.

Cassette deck from Onkyo

The new TA-2090 from Onkyo is a three-head, three-motor cassette deck. Its fully automatic "Accubias" system, developed by Onkyo research fine tunes the recording bias to provide optimum results regardless of tape and eliminates the need for a tape equalisation control. Other features include fully automatic tape selection; automatic music control system; three repeat modes — single song, whole side and block; multiple mode display for six deck operating modes; and remote control capability with optional accessories.

The TA-2090 is available for around \$1500.

A quick DRAM makes TV better

A new family of dynamic random access memory chips designed by NEC should give better TV and video pictures. The chips are used for separating luminance and chrominance signals, eliminating cross colour interference, reducing jitter in VCRs and interpolating non-interlaced scan displays. They also implement the one-line delay required in European and PAL standards.

dbx CD player

dbx is stressing the three parameters of compression, DAIR and ambience control in its DX3 CD player. The compression function makes the quiet passages on the recorded disc more audible at low listening levels, and loud peaks less fierce; the digital audio impact recovery is intended to restore lost peaks from compression or clipping in analog master tapes; and the ambience function is an effort to reproduce the fuller, more "spacious" sound of phono.

Jaycar's CD buyer's club demise

The mail order compact disc buyer's club established by Jaycar recently has collapsed due to a lack of supplies from the record companies. Although response to the club was good, Jaycar found that it could not offer reduced prices for large orders because the record companies could not supply the discs ordered.

Twin mechanism design: a new innovation

Sharp's new 'twin mechanism' design for the cassette player, uses a single compartment instead of the conventional two to house both cassettes. Two cassettes placed in the mechanism, stacked one behind the other, are activated by a single capstan whose axis assures uniform operational precision and optimum performance. Performance accuracy and operational ease are said to be improved without the characteristic performance differential found in ordinary two-compartment systems. This is of advantage in, for example, editing, where even the slightest mechanism difference between compartments may adversely affect the editing quality.



Short-play tapes for commercial application

Abbreviated-play audio cassette tapes, suitable in such applications as advertising and music recording are being introduced by Klarion. The special tapes are made to three configurations, with a casing of sturdy polystyrene or polycarbonate. Corrugated slipsheets ensure a flat pancake within the cassette, an important feature when the tape is used for high speed duplicating or subjected to frequent fast forward/rewind operation. A pressure pad is secured to the spring by four clasps as well as being glued so the pad cannot be subject to any lateral movement on the backing spring if the cassette is frequently driven at high speed (such as when used in language laboratories).

AM stereo campaign

One of the largest promotional campaigns in Australian radio has caused Pioneer some unusual storage problems.

Using former pop star Glenn Shorrock as the new Pioneer presenter, the message was to 'get out and equip yourself with a new AM car stereo radio/cassette'. To do this Pioneer offered a \$100 trade-in for any mono car radios to those making the changeover.

But the success of the promotion has Pioneer's Product Manager for Car Sound, Neil Whitehead, inundated with car radios of various brands, types and antiquity.

The project's success is being attributed to its 'synergy'

created by involving Pioneer, the AM radio stations and the car sound retailers. Pioneer said

that the promotional campaign was valued at \$1 million and covered every AM stereo station

in Australia — a radio advertising schedule unmatched in frequency and reach.



JVC's lightest CD player

The new JVC XL-R10 boasts a minimal weight of only 440g (without carrying case and battery pack).

The XL-R10 has 15-channel random access with a full digital display of track, time and programme. Other features include repeat play, remaining time and skip/search functions.

Apparently JVC's intention is to integrate this player with the PC-W320XA mini hi-fi system. This would consist of the XL-R10; double cassette deck with normal or double speed dubbing; 5-band graphic equaliser; Dolby B noise reduction; digital

synthesiser tuner programmable for six AM/FM channels; and two-way speakers.

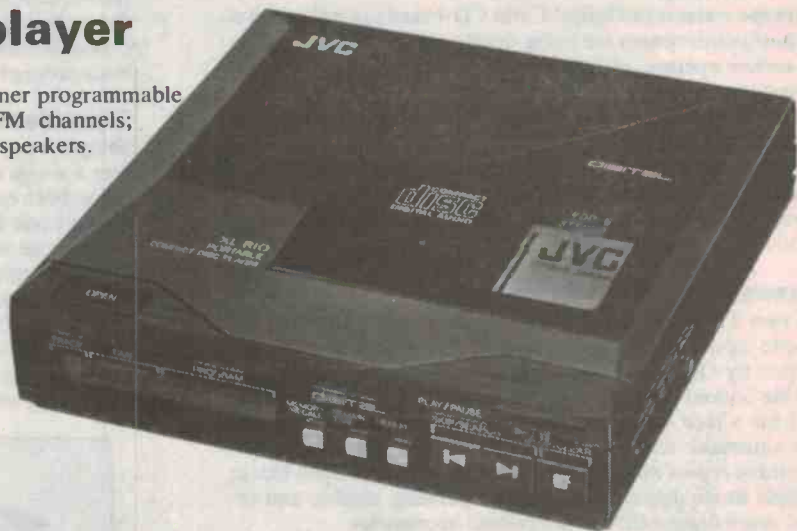

Midi size hi-fi sales assault

According to the Consumer Electronics Suppliers Association, sales of midi size hi-fi systems now account for about 20 per cent of Australian hi-fi sales.

All the major manufacturers of hi-fi have released midi systems in the last few years and in many cases, CESA claims, the specifications, performance and features of these models are better than comparably priced big rack style systems. Manufacturers and suppliers are apparently supporting the sale of midi systems at the expense of their other units.

The obvious selling points companies are stressing are, of course, the space saving benefit of the midi size systems (particularly relevant to the millions of

people residing in small units or terrace houses), and their facility for combining with TV and video in the 'integrated entertainment centre'. But more interesting is the claim that midi size systems are very likely to incorporate the latest Japanese technological developments. The reasoning behind this goes that because midi systems are the most popular in Japan, the high demand means that problems are ironed out and improvements implemented before shipments reach our shores.

With the recommendation of at the very least no loss of quality and their attractive small size midi systems should yet have a maxi future in Australia.

New Keyboard System

The introduction of the JVC NS (New Series) commences with the two new models NS50 and NS70 System Component Keyboards. Both can be purchased and built in modular stages, like hi-fi systems.

Keyboards Manager for JVC in Australia, Geoffrey Hyde, says he believes the modular keyboard concept will become the industry leader and will lead to a return to popularity of the

dual keyboard home organ product. "We do not think of our new keyboards as organs. The JVC NS has a sound generation based on the new technology synthesis and most sounds are possible to create." He added that the main 'mother module' is only a start and that JVC intends to continue introducing new add-on modules for the New Systems.

Be part of Today!



When we analyse the recent past and project the immediate future, computers and communications technologies play a vital part, but we must avoid the tendency to look only to the hardware level. The fact that technologists have appropriated words like 'communications', 'information' and 'data' and given them electronic rather than social meanings, should not disguise the fact that in the final analysis, communications involves people and ideas, not electronic bit and bytes.

People and Ideas . . . that's the side of Australia's Communications Revolution we tell about in this informal look at today's world of computers and telecommunications.

At your Newsagent now!

Or simply send \$4.95 plus \$1.00 post and packing to —
Federal Marketing Book Sales, P.O. Box 227, Waterloo
2017 NSW.

Amplifiers

TD300 \$750.00
Slave Amp (150 watts per channel into 16 ohms) with stereo to mono switching.

ZPE SERIES II \$1950.00
500 Mosfet Output Stages 250W into 8 ohms for bands that want power!

Disco Mixers

CITRONIC SM 350 \$840.00
6 Channel Input (2 Mikes + 4 aux)

ARISTA \$350.00
6 Channel Input with Equalization.

Jumbo Strobe

FLA 701 \$195.00
White Flash Jumbo Strobe with Speed Control. Every performer should have one.

Scanner

S101 \$120.45
Search Lighting effect

Scanner Bar

S104S \$508.00
Light bar housing four GE 4515 lamps scanning with individual motors.

All housing complete with front cover and with provision for colour gel.

Border Lights

BL104 - \$163.70

FREE Gel Filter Frame Mount Rkts

Rope Lights

FOR BANDS DISCOS & CLUBS

PRL 803
Rope light, Tubes Red, Blue, Green, Orange, White.
\$115.00(5m)

MULTI COLOURED:

White reinforced spiral tube with MC lamps: Tred-proof. \$115.00(5m)

SRL 801 - \$180.00(10m)
Rope Controller \$185.00

Mirror Balls

MB 005, 5" \$16.59
MB 008, 8" \$49.46
MB 012, 12" \$77.49
MB 014, 14" \$112.25
MB 018, 18" \$150.41
MB 020, 20" \$181.10
MB 012C Mirror Cylinder (12" length) 6" Dia. - \$43.18
MB 008H Half Mirror Ball & Motor, 8" - \$54.11
MB 012H

MIRROR BALL MOTORS:
A.C. 240V Heavy Duty - \$99.40
Battery Motor \$15.00
A.C. 240v - \$37.50

CONTROLLERS

AUDIO/CHASER (DW 4LC 4000) \$295.00
Pre-set Programmed Controller 4 Channels each 1000W.

LIGHT COMPUTER (DW 7LC 4200) \$488.00
Programmable 7 channel with E-prom (16 programmes). Ideal for Advertising signs and Disco lighting.

VU LIGHT BAR (DW 12 LC 480) \$394.00
12 channel L.E.D. like display controller. Triggered by sound signals. Exciting new product!

GAFFER TAPE (Black) PACKAGING TAPE per roll \$6.50 per roll \$5.00

Special offer till stocks run out: 4 ch. chaser \$80.00

PLEASE NOTE: ALL CONTROLLERS COME WITH 12 MONTHS' WARRANTY.



Helicopter

A GE 4515 lamp in housing can be swivelled and directed up or down spinning 360° in the one place.

RPS102 2 ARM SPINNER \$198.00
RPS104 4 ARM SPINNER \$495.00
RPS106 6 ARM SPINNER \$532.00

UFO 324 UFO LIGHT (24XGE 4515) \$1975.00

Microphones

129B 33 cm Flexible Chrome Arm, goose-neck \$5.90

186C Chrome Base Mount \$3.40

SMOKE MACHINE, (Great for Special Effects!) \$350.00
Fluid - 1 litre \$15.00

518C Arista Mike \$74.90

UD312 Primo Mike \$96.95

102 Mike Stand, Adjustable \$93.80

HL43U Flexible Arm Mike Holder - \$2.90

Lamps

Carton Quantity Only
No Warranty on Breakages

DX60-ES, 240v, 60w
Discolux (soft glass) E.S., assorted Colours
Box of 25 - \$75.00

G408C, 240v, 40w
BC Lamps in Blue, Yellow, Orange Red, Green, Box of 100 - \$85.00

G258C, 240v, 25w
Box of 100 - \$75.00

FLOURESCENT TUBES
White \$2.30
Colours \$6.50
Ultra Violet 4 ft. \$45.00

Turntable

TECHNICS DIRECT DRIVE \$260.00

Special Disco Suspension,
TECHNICS SL1200
Top of the range Direct drive with pitch control. \$650.00

TECHNICS BELT DRIVE \$160.00

TECHNICS CASSETTE DECK
Special white stocks last \$175.00

Pinspot

PS 112S (Par 36 can) \$52.75
(6v, 30w) Designed specifically for Mirror Ball Spotting. Used widely to achieve a bullet beam effect.

BONUS OFFER:

Bulk Buy 10 for \$400.00! (Spill out)

PS 112L (Par 46 can) \$70.50
PINCHASER \$480
Exclusively for Pinspots

Halogen Beacons

WL 104 - \$155.00
Warning lights are available in different colours.

ARTLITE

20th Century plastic in flat sheets (2 mm or 100 mm) or round tubing (8 mm) that glows under ultra violet lighting. Available in 5 different colours.

Ideal for disco installations, bands and signwriters. From 50 cents per metre!!!

Disco World Pty. Ltd.

SHOWROOMS:
300 Main Street, Lilydale.
673 High Street, Preston.
Melbourne, Victoria
P.O. Box 509, Lilydale, Melbourne
Victoria 3140
Telephone: (03) 735 0588

Cosmos Light

Mirror Ball housing 24 x GE 4515 lamps with provision for colour gel spinning in two planes, (vertical and horizontal)

\$1990.00

DOUBLE COSMOS:
Two Mirror Balls in each housing, 12 x GE 4515 lamps.
DCL 212 \$3500.00

HALF BALL ROTARY LIGHT:
14" Dia. housing 6 x GE 4515 lamps. Provision for Colour gel.
HLG 06 \$588.00

Rolling Light

Metal framed housing rotating 360° in two planes, all with provision for colour gel.

RL 108, 8 x GE 4515 lamps \$1450.00
RL 124, 24 x GE 4515 lamps (Horizontal) \$2200.00
RL 224 24 x GE 4515 lamps (Vertical) \$2200.00

New Product

DYNAMITE SMOKE MACHINE

Has remote control lead to operate off-stage. Ideal for Bands, Discos, Night Clubs and TV Productions. Australian made \$1800.00

PLEASE NOTE: Some installation items do not include power cords.

ALL PRICES ARE INCLUSIVE OF SALES TAX. ASK ABOUT OUR SPECIAL RATES FOR INSTALLERS. Prices might vary at time of publication of this magazine due to the monetary market.

DELIVERY INSTRUCTIONS
ADD PACKING & POSTAGE
PAYMENT WITH ORDERS

Bands need visual show. Don't be left behind. All the gear on this page will help you make it to the top!

*** Try it by hiring it ***

• STANDARD MAIL AS PER P&P.
• ROAD FREIGHT - AS PER COMET CHARGES.

BE ADDED TO OUR MAILING LIST FOR FUTURE SPECIALS TOO HOT TO PRINT HERE BY SENDING 60 CENTS & S.A.E. TO US.



PUTTING THE HEAT ON CASSETTES

The heat is on: twelve type II chrome cassettes undergoing some of the harshest treatment and testing Louis Challis can dish up. Which type burnt out? Which expired? Well actually, it was a pretty cool group that emerged.

Louis Challis

ALTHOUGH THE pre-recorded cassette market is large and appears still to be growing, the market for blank tapes for domestic and semi-professional recording is substantially larger and, in the eyes of most of the manufacturers, far more important. While most of the recording companies (or their subsidiaries) which produce pre-recorded cassettes use type I tapes, a small (but increasing) number lay claim to superior products because they use chrome (type II) tapes. Almost anybody taking the trouble to read this review takes recording seriously and many, if not most of you, will also purchase chrome (type II) tapes for a large proportion of your recording activities.

There are four primary classifications of blank cassette tapes currently being manufactured. These have been designated by the International Electro-technical Commission (IEC) as type I (gamma ferric-oxide), type II (chrome or chrome equivalent), type III (ferro-chrome — a two layer composite of types I and II tapes) and type IV (metal), which is most expensive and, like type III, sold in somewhat smaller quantities.

Gamma ferric-oxide coated tapes (type I) were the original tape formulation. Over the last 25 years they have been subjected to multiple refinements and improvements. These developments have included the low noise (LN tape) formulations, the cobalt-doped formulations, and last but not least the controlled particle sized tapes (as typified by the TDK ADX tapes) which, as a

group, achieve performances you may never have even contemplated for your serious recording activities.

A word of warning, however, although not the subject of this review, our prior testing revealed dramatic differences in the range of performances and qualities provided by the commonly available type I tapes in Australia. As a consequence, I cannot off-handedly recommend type I tapes for serious recording without appropriate pre-qualification and where possible proper testing.

The first of the type II tapes were released in the early 70s as 'straight chromium dioxide' tapes, generically described as 'chrome tapes' by Du Pont (which developed the first formulation), as well as by BASF (which soon became the market leader).

The new chromium dioxide magnetic material had a far higher coercivity than the gamma ferric-oxide tapes. Whilst the cassette recorders developed to accommodate the full potential of the chrome tape incorporated new equalisation and bias characteristics, obviously the old machines did not. If you tried to play the new chrome tapes on an older machine, the frequency response was boosted unnaturally at the high frequency end of the spectrum. The different magnetic properties of the chromium dioxide required a vastly different equalisation characteristic and that is why the industry, with the cooperation of the IEC, specified the 70 microsecond equalisation curve, which is now standardised for types II and IV tapes.

The most obvious advantage of the
(Continued page 32) ▶



SOUND REVIEW

	Hitachi UD 90	BASF CR-SII90	Denon HD890	Fuji GTII90	Konica GMII90	Maxell XLII-S60	Philips MC-II90	Realistic Chrome 90	Scotch XSI190	Sony UCX590	Technics Angron90	TDK SA-X90	Thats EM-X90
Measured Record to Replay Frequency Response @ -20 VU	15 Hz - 20 kHz +0 -2dB	13 Hz - 20+kHz +1 -3dB	13 Hz - 20+kHz +0 -3dB	13 Hz - 17 kHz +0 -3dB	13 Hz - 13 kHz +0 -3dB	13 Hz - 20+kHz +1 -3dB	13 Hz - 13 kHz +1 -3dB	13 Hz - 6 kHz +2 -3dB	13 Hz - 16 kHz +1 -3dB	13 Hz - 20+kHz +0 -3dB	13 Hz - 18 kHz +1 -3dB	13 Hz - 20+kHz +1 -3dB	13 Hz - 20+kHz +0 -3dB
Noise Figure dB re 0 VU Mid-Band A-weighted	-68 -53.5	-69 -54	-71.5 -56	-67.5 -52.5	-68 -53	-71 -55.5	-68.5 -53.5	-71.5 -56	-69 -53.5	-68 -52.5	-67 -50.5	-71 -56.5	-67 -53
3% 3rd Harmonic Distortion Level	7.5	7	6	7.5	7.5	6	6.5	6.5	6.5	7	6.5	6.5	6
Compression Level @ 10 dB	8.8	8.7	8.3	8.8	8.6	8.5	8.2	8.1	8.4	8.6	8.6	8	8.6
333 Hz Non-Uniformity	**	****	**(*)	****	****	***	***	*	*****	*****	*****	***	****
High Frequency Non-Uniformity	***	***	***	****	**	***	***	*	****	***	*****	***	***
Flutter Performance Rating	***	***	***	***	***	***	**	**	****	****	****	***	***
Thermal Performance	*****	*****	*****	*****	*****	*****	*****	*****	*****	*****	*****	*****	*****
Cost (RRP/cassette)	\$6.99	\$5.99	\$9.49	\$7.76	\$6.29	\$8.30	\$8.49	\$6.99	\$6.99	\$8.15	\$8.99	\$8.50	\$7.99

NOTE: ***** Excellent **** Very Good *** Good ** Fair * Poor



Cut PCB design costs by 50% for only \$7495

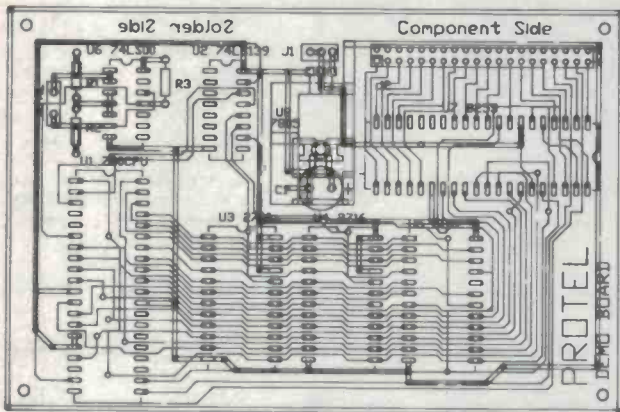

Now, every PCB designer can reduce costs by as much as 50% using technology as up to date as the designs. From concept to layout, to camera-ready art, and all with the aid and added speed of CAD.

This total package solution from **NEC** specialist, Sleebs, consists of:

- An APC III microcomputer with colour screen, colour graphics card, 384KB main memory, serial and parallel ports, MS-DOS.
- A serial Microsoft Mouse.
- A Roland DXY880 A3 size 8-pen plotter.
- Protel/PCB computer aided PCB design software.
- Full installation in metro Melbourne, Hobart or Launceston. Delivered freight-free to all other locations in Australia.

sleebs

COMPUTER INDUSTRIES

For detailed information about this special offer, send the coupon below to:

Sleebs Computer Industries

163 Eastern Road,
South Melbourne. 3205
Phone: 690 1333

73 Murray Street,
Hobart. 7000
Phone: 34 6477

Mk-Advt/301

Dear Sir,

Please send me more details about the PCD, CAD system.

Name: Company:

Title: Address:

P'code: Phone:

P.C.B. FILMWORK

Photoplotting, Photo Mask Generation.
Quest or Gerber output from your C.A.D. system.
Large range of images available.
Accept data on many floppy disk formats
1/2-inch mag tape or paper tape.

Photographic reductions, duplication, colour separation, pad pattern duplication and solder mask expansion. Ground plane reversal and insertion.

LARGEST INDEPENDENT PHOTOTOOL SOURCE IN AUSTRALIA

PRECISION GRAPHICS PTY. LTD.
Unit 15, 31 Waterloo Road,
North Ryde 2113
Telephone (02) 887-2648

ETI READER SERVICE 12

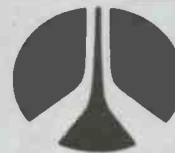

Rockwell

R96 FT/SC

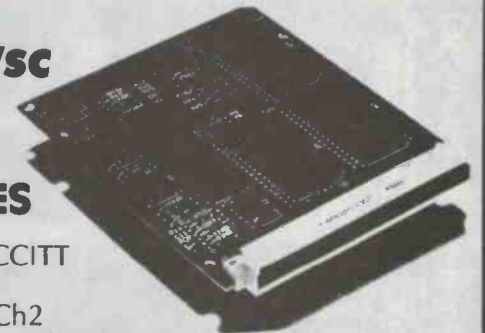

FEATURES

- 9600 bps CCITT V29, V27, Bister V21Ch2
- 75 bps forward channel (V23)
- 2400/4800 bps gearshift
- Fast Train 30m Sec
- Train on Data
- Adaptive Equalizer
- Diagnostic Capability
- Full Duplex 4 wire, Half Duplex 2 wire

energy CONTROL

ENERGY CONTROL PTY. LTD.
P O Box 6502, Goodna. Qld. 4300.
BRISBANE, AUSTRALIA.
Telephone: (07) 288 2455 Telex: AA 43778
ENECON
P O Box 12153 Wellington North
NEW ZEALAND
Phone: 4 843-498 Telex: NZ 30135 AUDITOR

ETI READER SERVICE 13



Record-to-replay

The record-to-replay evaluation was conducted on a machine, theoretically optimised for a Nakamichi tape, and which prior testing has shown to have a higher coercivity and retentivity than the standards laid down by IEC. This means that, if a tape has been correctly formulated to conform to the IEC standards, it should exhibit a slight drooping response at high frequencies rather than being dead flat or providing a slight rising response.

Very few of the tapes provided a dead flat response although a number of them did perform closely enough to be regarded as just less than perfect. The typical boost or drop is less than 3dB at 15kHz with the exception of the Realistic Chrome 90 which obviously does not conform to the basic requirements of the IEC specification and has other characteristics, which disturbed me.

With the exception of the Realistic, all of the tapes provided record-to-replay frequency responses which I would classify as outstanding and with which the intending user should be happy. The one factor any buyer would need to be sure of is that the bias level on his/her machine has been correctly set for type II tapes and *that the heads are clean*.

By comparison, the Hitachi UD90 tape provided a frequency response that was *just as flat* because the head, gap and geometry of this particular recorder allows it to achieve excellent results with a type I tape.

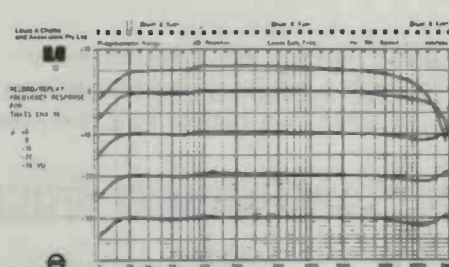
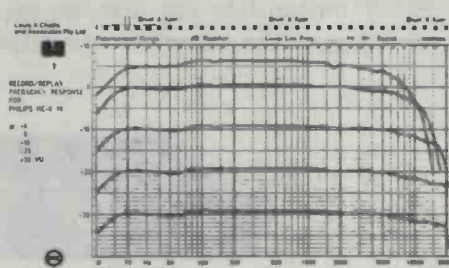
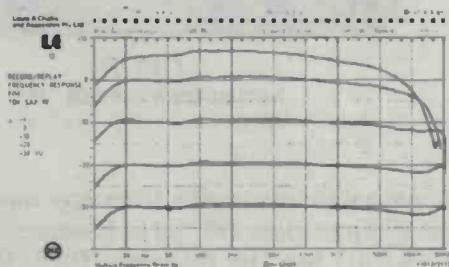
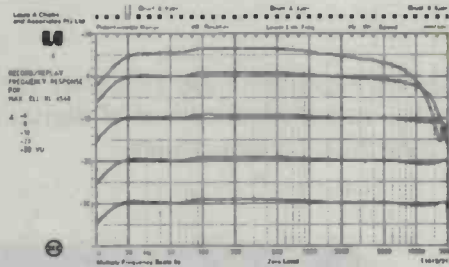
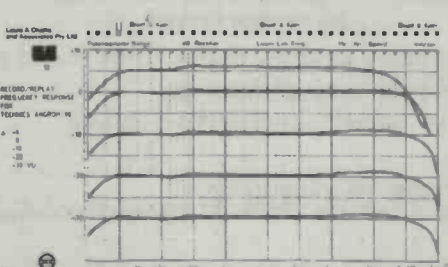
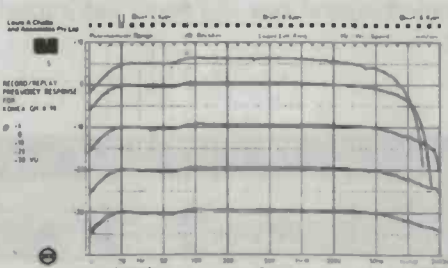
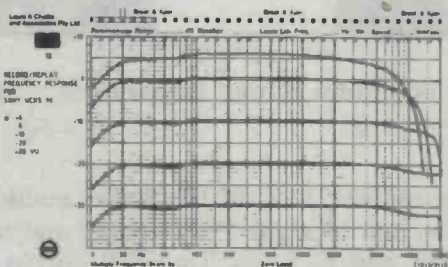
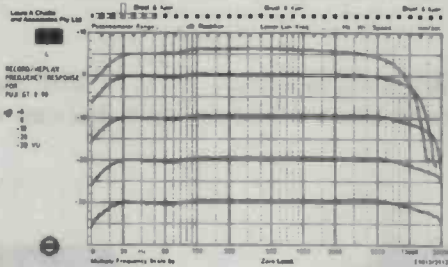
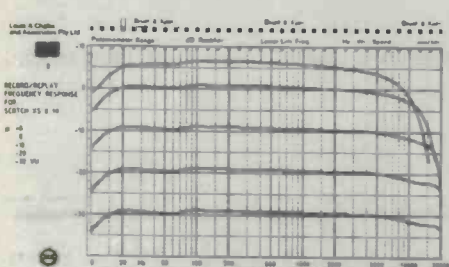
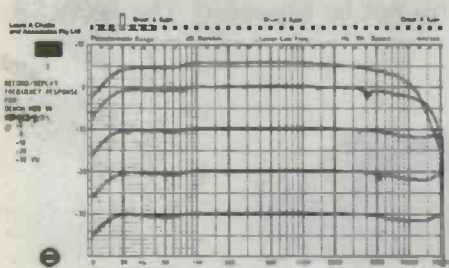
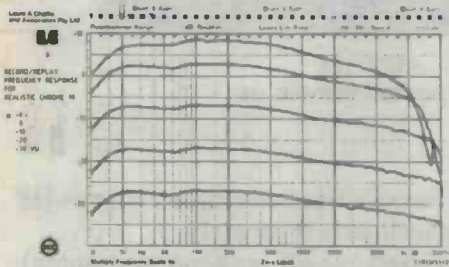
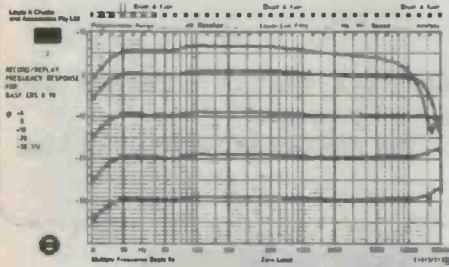
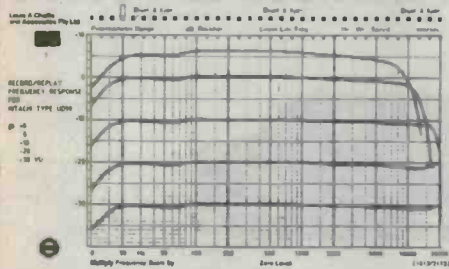

dbx®

When the music's feeling good, dbx makes it better



224X Type II Tape Noise Reduction Unit

When recording from compact discs the dbx 224X is a must. That is, with the dbx 224X, you can record and play back the full dynamic range of digital sound sources like compact discs as well as live music.

You hear full dynamic range.

You don't hear background hiss.



1BX III

ETI READER SERVICE 15



3BX III

ETI READER SERVICE 16

Dynamic Range Expanders

50% more dynamic range from any music source. The 3BX III divides audible frequencies into three ranges—HF (High Frequencies), MF (Mid Frequencies), and LF (Low Frequencies) and handles each separately.

The 1BX III has the functions PRE, POST and BYPASS. The PRE button lets you record an expanded signal. The POST button lets you hear an expanded signal but the recorded signal will not be expanded. The BYPASS button bypasses the expander altogether.



200X Program-Route Selector

ETI READER SERVICE 17

The 200X lets you easily hook together as many as three decks, three sound processors and a noise-reduction unit. All through a single tape-monitor loop of your amp or receiver.

The dbx 200X is a logical and inexpensive way to simplify your stereo.

FOR YOUR NEAREST STOCKIST CONTACT:

AUDIO ENGINEERS PTY. LTD. 342 Kent Street, Sydney, NSW. 2000. Tel: (02) 29-6731

AUDIO ENGINEERS (QLD) Cnr. Jane & Buchanan Sts., West End. Qld. 4101. Tel: (07) 44-8947

MARKETEC PTY. LTD. 51 Scarborough Beach Rd., North Perth. WA. 6000. Tel: (09) 242-1119

audio3



Third octave background

The shape of the noise threshold of each of these tapes varies significantly from tape to tape, as do the A-weighted and unweighted noise figures.

The lowest noise figures were provided by the Maxell XLII-S 60 tape and the Realistic Chrome 90 tape, whilst the TDK SA-X 90 tape was only 0.5dB higher. The result from the Maxell is very commendable, but the result from the Realistic is not really in the same class because it has been achieved primarily as a result of a drooping frequency response at high frequency. This means that the Realistic Chrome 90 tape achieves its high frequency noise reduction at the expense of output right across its full dynamic range.

It is interesting to note that the spread of A-weighted noise figures ranges between -51dB(A) and -56.5dB(A) relative to 0VU on the recorder and consequently indicates that there is a significant spread in achievable noise figures through correctly selecting your tape. Obviously, these figures can be substantially improved by a noise reduction system so that

absolute differences between one tape and another will be far less significant when Dolby B or Dolby C is used, making the less obvious differences of tape uniformity and upper saturation level assume a greater importance.

The evaluation of third harmonic distortion revealed a very narrow spread in the recording levels to produce 3% third harmonic distortion (relative to a 333Hz signal). The levels fell between +6VU and +7.5VU and for reference the Maxell, which had the lowest noise figure, also had one of the lowest levels of 3% third harmonic distortion.

The TDK and Realistic tapes were only 0.5dB better at 6.5dB so that they lose a little of the lustre that I attributed to them during the background noise level testing. The overall indicated unweighted dynamic ranges for these tapes are thus 57.5dB to 63dB, with the Realistic providing the highest figure and the Technics Angrom HG90 providing the lowest. It is interesting to note that the Hitachi UD90 tape provided a 61dB dynamic range comparable with the mean of the type II tape results.

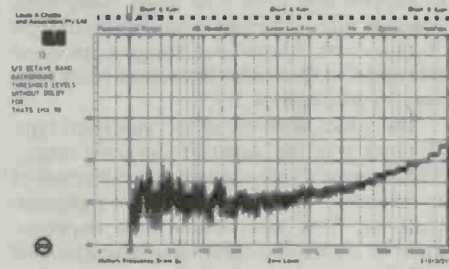
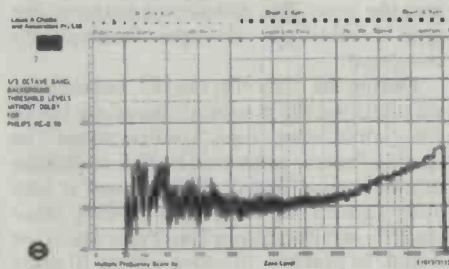
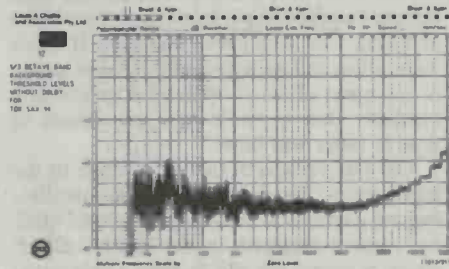
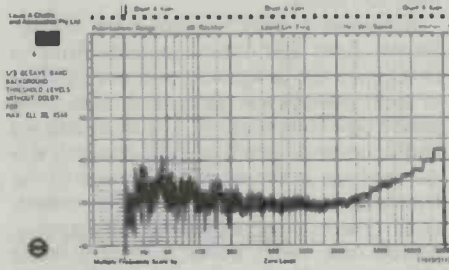
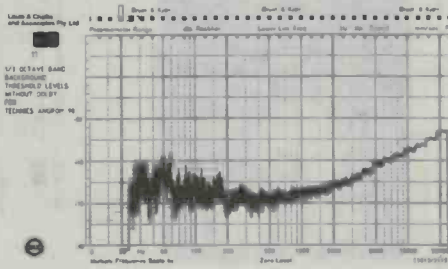
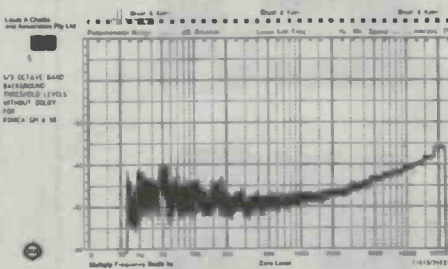
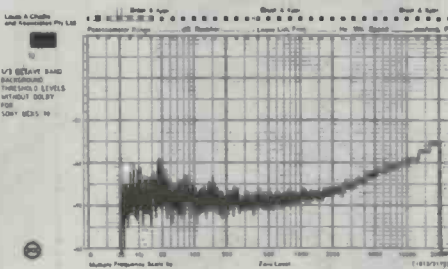
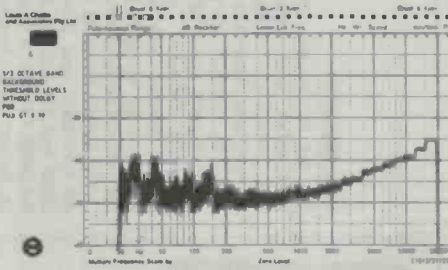
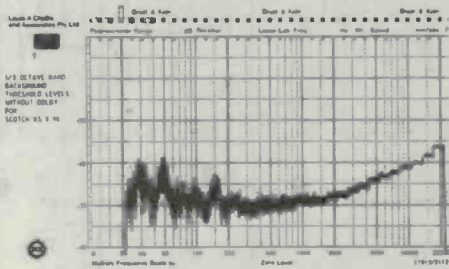
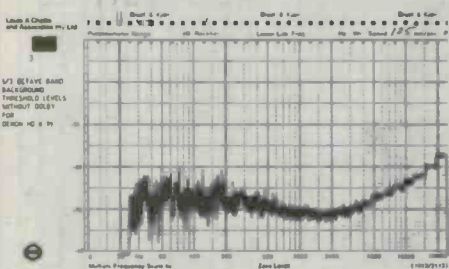
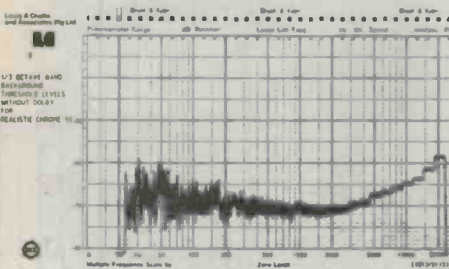
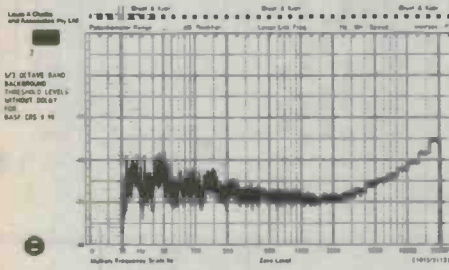
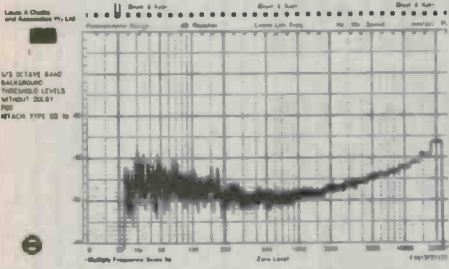

chrome and chrome equivalent tapes was their ability to record peak signals at levels as much as 3dB higher than the early generation of gamma ferric-oxide tapes. In many cases this was also achieved with a lower noise figure which was appreciated by amateur and semi-professional recordists alike.

Soon after the release of the type II tapes users found themselves beset by some nasty, insidious problems. There were many cases of excessive head wear on expensive cassette players causing many people to shy away from using the new chrome tape.

The problem lay with poor manufacturing, specifically poor calendaring of the tape with unusual sharp epitaxial chrome elements projecting beyond the calendared surface. These were so abrasive that they could destroy a set of recording heads in less than 100 hours.

Sufficient market resistance led BASF, Scotch, Sony and other reputable firms to investigate the complaints and one product of their research was the development of superior tape formulations. The most striking and important benefit of their research was the increase in the number of stages of calendaring of the tape surfaces. The calendaring process involves passing the magnetic coated base web under counter rotating rollers to produce a mirror-like surface with minimal surface imperfections and no loose material. The result was that type II tapes were produced with polished finishes so far in advance of what had been previously available that a whole new generation of type II tapes was born.

The same research flowed through to the type I tapes. The improvements in calendaring, magnetic material, adhesives and quality control resulted in substantial differences between the old gamma ferric-oxide and the new. The differences between the type I and type II tapes consequently narrowed.

During the early 70s, the IEC committees standardised the magnetic characteristics of the 'conforming tape configurations' so that, in theory, you would be able to pick up any individual brand of tape, load it into your cassette recorder and achieve comparable results irrespective of the source or brand. In practice, this took almost 10 years to happen and even now many companies produce three different formulations of type II tape with coercivities ranging between 500 and 750 Oersteds; the retentivities may vary by as much as 2:1.

The major attribute of the improved type II tapes was the superior dynamic range. The improved calendaring process resulted in superior consistency of the magnetic material. This was observed as improvement in record-to-replay characteristics and high frequency responses. ▶

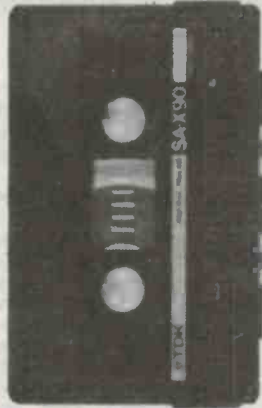

(subsequently labelled 'A'). The second Denon sample was completely different, I suspect from a different production batch, as the 'A' sample produced terrible results in every test in which it was included. The 'B' sample, by contrast, displayed no such problems.

The Realistic sample, as I subsequently discovered to my sorrow, fouled the heads of the recorder and necessitated careful cleaning and re-running of a number of tests in order to provide valid test results.

The Hitachi UD90, although providing outstanding tape compression results, did not display a linearity comparable with the type II tapes.

Compression

For the non-linearity compression tests, the input signals were applied in 10 precise 1dB steps from 0VU. Simultaneously we monitored the saturation level and non-uniformity of replay. The results of this particular test were in some respects encouraging and in others discouraging. Because I chose to use an expanded dynamic range with a 10dB pot in the level recorder, miniscule fluctuations in the output level are easily observable.

The spread of results indicates that the lowest saturation was provided by the Hitachi UD90 and the Fuji GT II, closely followed by the BASF CR-S II. A group of five tapes (Konica, Scotch, Sony, Technics, Thats) were close behind, whilst the TDK SA-X, although starting well, saturated fairly rapidly at levels above 7VU.

I found the indicated tape non-uniformity just as interesting as the saturation characteristics with good results displayed by BASF, Fuji, Konica, Maxell, Philips, Scotch, Sony, Technics, TDK and Thats and poor results by the Realistic and the first of the Denon sample

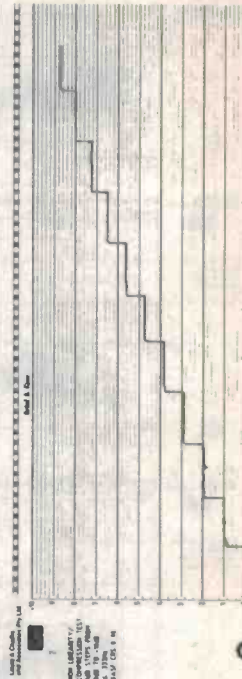
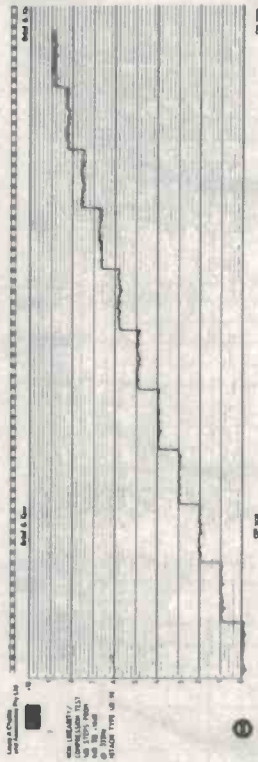
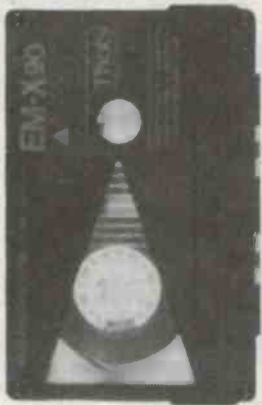

Testing

In designing this comparison the most critical question that I had to resolve was which cassette recorder I should use, given the many possible choices that I had. I decided not to use the Nakamichi 'Dragon', or one of the other similar machines, which provide either automatic or manual bias and/or azimuth optimisation, as this feature is generally found in less than 3% of the cassette players on the market. I decided that I should ideally utilise a current generation recorder which provides fixed bias and equalisation. If the machine provided variable controls, then they would not be used. The machine that I chose for this purpose was a Nakamichi BX 300, which was already a year old and well used. Although nominally cleaned (and I believe adjusted to manufacturer's specifications) it was otherwise normal in all respects.

The tests that I resolved to conduct were: a record-to-replay frequency response; a background noise determination; a linearity compression test utilising expanded scale



level recording, a direct measurement of the peak level of 3% third harmonic distortion; the correct determination of signal-to-noise ratio; a tape replay linearity test; a wow and flutter test; and a thermal distortion test.

The next question to be resolved was how many tapes to test and which ones.

Although we were offered in excess of 20 type II tapes, we selected only one sample from each manufacturer as some of them produce up to three different types. The sample we selected was, we believe, the best available.

The type II tapes that we selected for evaluation were

BASF CR-S II 90,
Fuji GT II 90,
Maxell XLII-S 60,
Realistic Chrome 90,
Sony UCX-S 90,
TDK SA-X 90,
Denon HD8 90,
Konica GM-II 90,
Philips MC-II 90,
Scotch XSII 90,
Technics Angrom HG90,
That's EM-X90.

As no Agfa tapes were supplied to us, they were not tested. Technics Angrom 90 was tested in preference to the National RT90EX as that would have represented two tapes from the same company.

One of the firms (Hitachi), approached by the magazine, stated that it does not market a type II tape in Australia (although it does in America). As a control, we decided to include a sample of its type UD 90 tape as a yardstick through which other relevant conclusions might be drawn.

The Hitachi UD90 type I tape that we decided to evaluate is representative of the latest generation of low noise type I tapes conforming to the IEC performance criteria. You might think that it unfair to include a type I tape with the type IIs, but we felt that if type II tapes are as good as the manufacturers claim and offer the advantages that the user is seeking, then there should be no embarrassment resulting from such an approach.

I started off evaluating the Hitachi UD90 and the BASF CR-S in a 16 year-old PRO 2000 cassette recorder. The results of the tests showed that with a type I tape the performance of the cassette player at -20VU was every bit as good as it was when new, ie, ± 3 dB from 25Hz to 12kHz. With the type II tape, the results were disastrous because of the lack of appropriate equalisation. But down to serious testing.

The results of the tests for record-to-replay characteristics, third octave linearity are set out separately with their appropriate graphs. To complete the testing I evaluated wow and flutter and thermal distortion.

The wow and flutter tests were conducted on each of the type II tapes at five points

DAVID TILBROOK DOES IT AGAIN!



Now available in 10" 3 way version.

vifa



We're talking about the exciting new David Tilbrook designed speaker kits which use VIFA's high performance drivers from Denmark. His 2-way and 3-way digital-ready masterpieces. The name Tilbrook is synonymous with brilliant design and performance characteristics and these new systems keep the legend alive and well. The magazine 'The Australian Electronics Monthly' - where David is Project Manager - published full details of the designs. Hundreds of speakers have now been built with superb results. You'll save 55-60% when compared to something you buy off the shelf with similar characteristics. If you compare its performance to fully imported, high-priced speakers from Mission, Heybrook, Monitor Audio, Bang & Olufsen and many others, you'll see that they too use VIFA drivers. The complete kit comprises drivers, crossovers, flat-pack cabinets and all parts. Total price for the kits:

2-way 8" PC Woofer \$680.00 pair
3-way 10" PC Woofer \$1050.00 pair

See and hear the speakers at the following dealers where you can obtain reprints of the projects:

VIC: RADIO PARTS, Melbourne.
RADIO PARTS, Malvern
BELAND ELECTRONICS, Cheltenham.
STEVE BENNETT HI-FI, Geelong West.
TAS: WILLS HI-FI, Launceston.
QUANTUM SOUND CENTRE, Hobart.
HI-FI HOUSE, Devonport.
NSW: HEMPEL SOUND, Roseville East.
JAYCAR ELECTRONICS, all stores.
NEWCASTLE HI-FI, Newcastle West.
BYRON BAY SOUND, Byron Bay.
HI-FI HOUSE, Wollongong.
QLD: HANDOS HI-FI, Toowong.
JAYCAR ELECTRONICS, Buranda.
WA: ALBERTS HI-FI, all stores.
SA: MILTRONIX, St. Peters.
EAGLE ELECTRONICS, Unley.
INTERNATIONAL SOUND, Adelaide.
ACT: DURATONE HI-FI, Phillip.
NT: SOUND SPECTRUM, Darwin.



Dropout linearity

This test clearly displays significant differences in the tape formulation between one tape and the next so that you are able to assess other important characteristics of the tape coating. The thinner and straighter that the line is the better the quality control of the magnetic coating and the cleaner the response at high frequencies.

The most outstanding results in this respect were provided by the Technics Angrom 90 (which utilizes a different manufacturing procedure from the rest of the tapes) closely followed by the Scotch SXII and the Fuji GT II, which were head and shoulders above the rest of the tapes. All of the other tapes were good, with the exception of the Konica GM-II; this tape displayed a number of significant dropouts that were quite noticeable. The Realistic displayed poor linearity and some rather disturbing dropouts which would have both been audi-

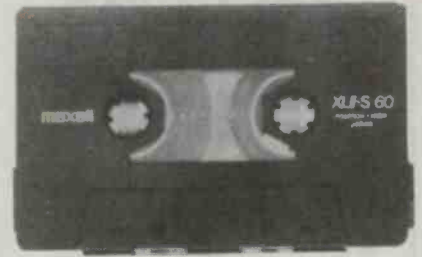

It is pleasing to note how uniform the output is at high frequencies compared with the last series of tests that I conducted and even the Hitachi UD90, which fared better than the Konica and Realistic tapes, is on a par with most of the other type II tapes in this regard.

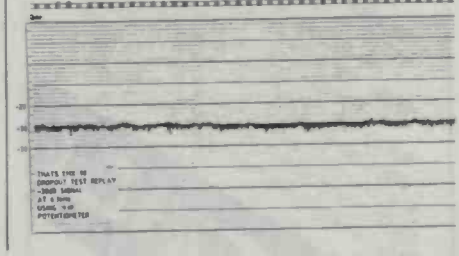
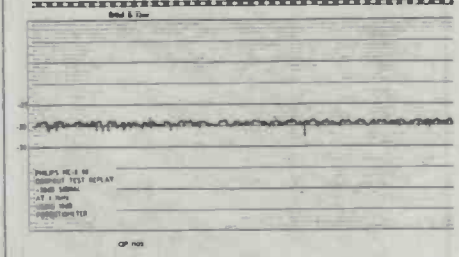
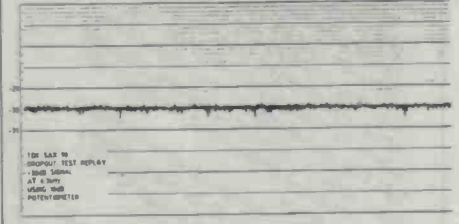
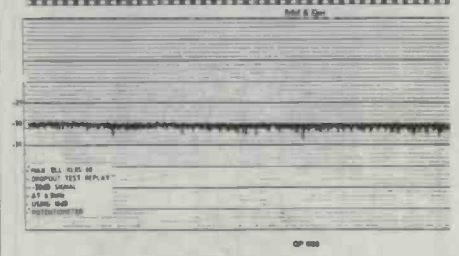
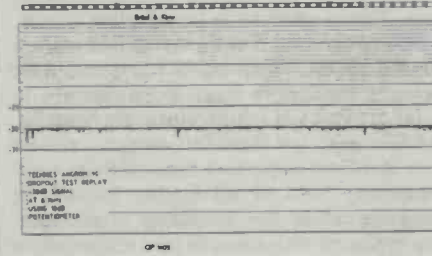
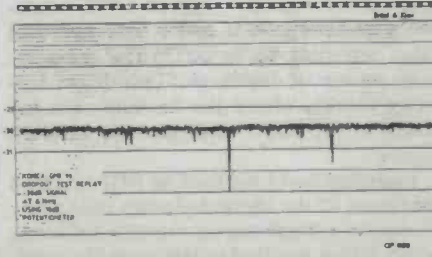
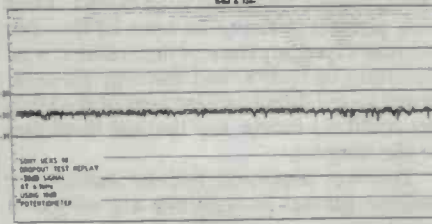
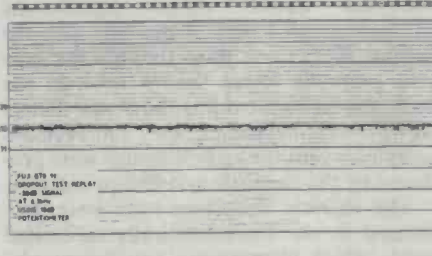
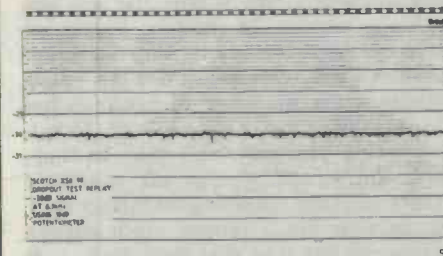
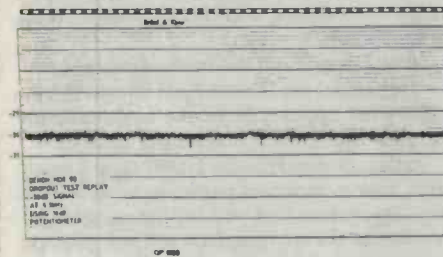
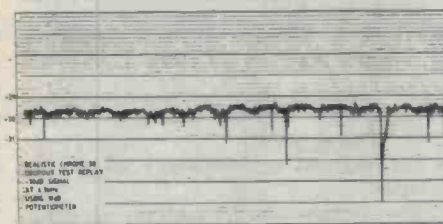
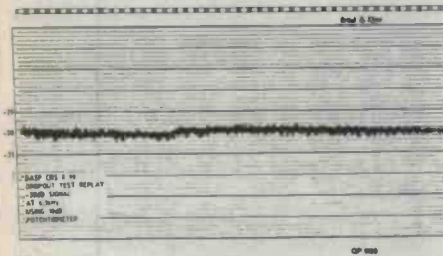
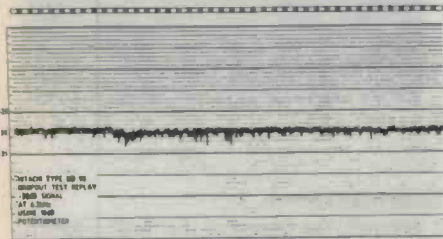

DALI-8. THE NEW REFERENCE STANDARD.

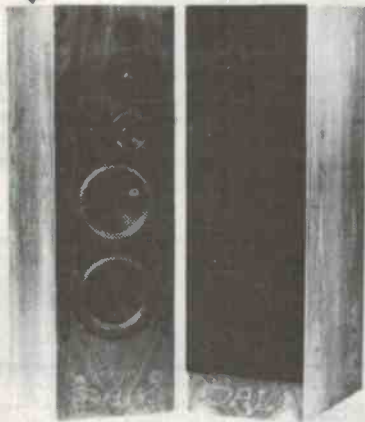

After 12 months of a most concentrated research and development programme, the new DALI-8 loudspeakers have just been released. They are large, extremely efficient, floor standing monitors with sonic qualities for which you might only expect to find in the five to six thousand dollar area. The DALI-8s also eliminate the need to think about rock or classical speakers, because they will handle either variety of music with equal excellence.

Overseas and Australian demand for these speakers has made it impossible to supply every order - and if you do manage to pair you know you will be enjoying outstanding speakers for a lifetime.

For a most comprehensive brochure and the name of your nearest DALI dealer, please contact the Sole Australian Distributor:

SCAN AUDIO Pty. Ltd.
52 Crown St, Richmond Vic. 3121.
Telephone (03) 429 2199
Queensland Office: (07) 57 7433

Stocked by:
VIC: Footscray Audio, Footscray Ph. 68 4192
VIC: Hi-Fi Sounds, Dandenong Ph. 794 9099
VIC: Hi-Fi Sounds, Marrickville Ph. 560 9019
NSW: Apollo Hi-Fi, Newcastle Ph. 2 4996
Bambach Electr., Adelaide Ph. 344 3939
SA: Blackwood Sound, Perth Ph. 81 5060
NT: Osborne Park Hi-Fi, Darwin Ph. 371 5977
QLD: Sound Spectrum, Brisbane Ph. 371 5977
TAS: Hando's Hi-Fi, Hobart Ph. 31 0088

DALI

SA3786B

ETI READER SERVICE 19

SOUND REVIEW



through the length of the tape. All of the tapes displayed the same wow figure, indicating no significant difference in this respect. By contrast, the flutter figures and the weighted flutter varied significantly throughout the length of the tape with the highest figures one-third through the tape and generally lower figures towards the end. The tapes providing the lowest flutter figures were the Scotch, Sony and Technics samples, whilst the highest figures were produced by the Realistic and Philips samples.

The thermal distortion tests were performed in our thermostatically controlled oven, which incorporates two heater elements and a circulating fan in a convection configuration with separating barrier. I was very pleased to note that none of the samples displayed any trace of distortion at temperatures up to 76°C and that only when exposed to the direct radiant heat of the heaters could we induce any thermal distortion in the samples.

This was important because automotive cassette players in Australia are subjected to conditions amongst the most gruelling in the world. The temperatures under our dashboards regularly exceed 65°C, sometimes exceeding 70°C and I have heard of cases reporting up to 80°C. The temperatures on top of dashboards (which are normally black), where the cassettes are exposed to the direct sunlight, may be even higher.

Investigations I did back in 1971 revealed that most of the thermo-plastics utilised by European manufacturers had low softening points which resulted in innumerable 'melt-downs' inside the cassette players of many cars. The top American brands, like Scotch, which catered for a more diversified market (including the 'deep south') selected their plastic formulations much more carefully to meet extremes of temperature. By contrast, BASF was so red faced following my review that the local importers immediately put a temporary hold on all further imports of cassettes while the moulding formulation was replaced with a new higher temperature withstanding material.

Summation

Overall, the results of the testing confirm that the major manufacturers are all producing reasonably good cassette tapes. Those that caught my attention for various attributes were as follows:

- For frequency record-to-replay linearity on the cassette player actually used: BASF CR-S II, Maxell XLII-S, TDK SA-X and That's EM-X.
- For noise figure: Maxell XLII-S and TDK SA-X.
- For minimal tape compression of maximum recording level: Fuji GT II.
- For tape linearity at maximum recording level: Technics Angrom, Sony UCX-S and Scotch XSII.
- For tape linearity at high frequency: Technics Angrom 90, Scotch XSII and Fuji GT II.
- For flutter: Scotch XSII, Sony UCX-S, Technics Angrom.
- For thermal performance: all of the tapes.

The one tape which did not get any prizes was the Realistic Chrome 90 which obviously had not benefitted from the Memorex company merging with the Realistic group of companies.

In conclusion, on the basis of price versus performance, the Scotch XSII 90 and BASF offer what appears to be the best performance on the basis of dollars per decibel.

Although the Hitachi UD90 type I yardstick tape performed particularly well, it is my observation that 90% of the cassette recorders in the marketplace will not provide as good a performance with a type I tape as they will with a type II tape. To help you with the problem of choosing brands we have tabulated the results with numerical results (where relevant), a five star rating scheme where the range of figures is less clearly defined and RRP prices at the bottom which may vary from shop to shop. With this tabulation, and the associated graphs and level recordings to further complicate your life, I foresee much anguish before you buy your next blank tape. ●

LABORATORY POWER SUPPLIES

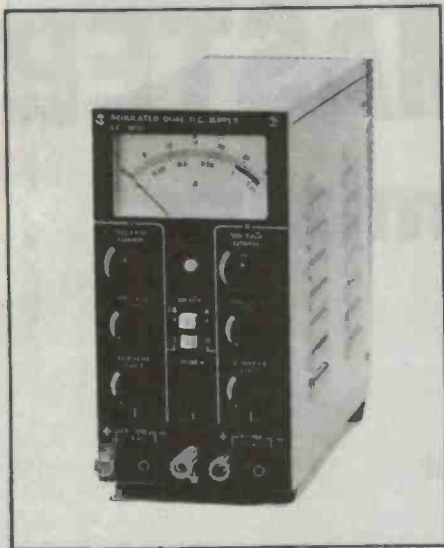

From \$196 (not including sales tax)



APLAB offer a complete range of regulated DC bench/rack power supplies combining high precision and regulation capabilities with continuously adjustable outputs.

Designed with single, dual and multiple outputs, these power supplies can be used in either constant voltage or constant current mode of operation.

Standard models include:

SINGLE OUTPUT

OUTPUT: Output
VOLTAGE: Current
0-30V 0-1A to 30A
0-70V 0-2A to 10A

DUAL OUTPUT
0-30V 0-1A to 2A

MULTIPLE OUTPUT
0-30V 0-2A to 5A



SCIENTIFIC DEVICES AUSTRALIA PTY. LTD.

VIC. 2 JACKS RD., SOUTH OAKLEIGH. 3167
PHONE: (03) 579 3622 TELEX: AA32742
NSW: 559A WILLOUGHBY RD., WILLOUGHBY 2068
PHONE: (02) 95 2064 TELEX: AA22978
S.A. 31 HALSEY RD., ELIZABETH EAST. 5112
PHONE: (08) 255 6575 TELEX: AA88125

ETI READER SERVICE 20

The Kit

An amazing chance to get a
Floppy Drive and Controller.

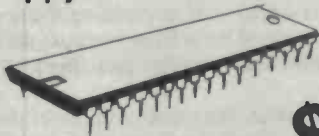

Western Digital 2793A.
Single rail, single chip, floppy disc
controller.

\$92.75
inc. tax
inc. P&P
WOW!!!

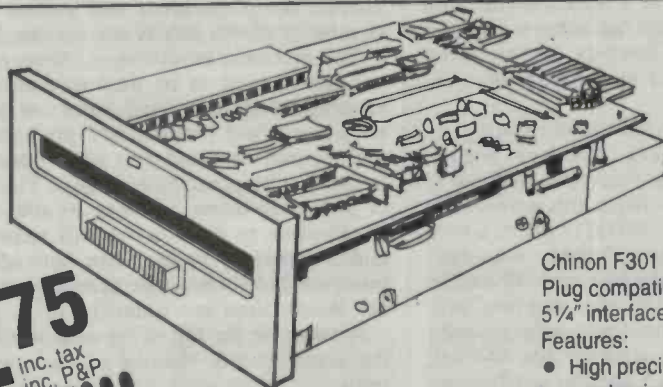

Chinon F301 3" Compact Floppy Disc.
Plug compatible with standard
5¼" interface.

Features:

- High precision head positioning mechanism
- Low power consumption.
- Single push loading
- Eject mechanism

What's a kit without the Kaboodle?
With your first kit have a Kaboodle
on us.



Maxell Floppy Disc
for the F301.

Western Digital data book - it includes all
the data on the WD 2793A, of course.

Offer valid while stocks last.

Please rush me kits and my free Kaboodle.

NAME: _____

ADDRESS: _____ P/Code: _____

_____ Ph: _____

I enclose Cheque Money Order Bankcard
at \$92.75 each.

Bankcard No.

Signature: _____ Ex Date: /

Please rush me to:

 daneva

64-66 Bay Road
Sandringham
Victoria 3191
Australia
PO Box 114

Allow 10 days for shipment.

ETI

ETI READER SERVICE 21

SERIOUS MIXMASTER

— Akai MG1212 mixing recorder

If your intentions are a bit more serious than cooking up a catchy little tune, the Akai MG1212 is something you should view. This 12-channel mixing recorder offers dbx on each channel, accurate timing memories, easy access to inputs/outputs and comprehensive mixing facilities, just to name a few features.

THE CONCEPT OF a combined mixing desk and multitrack recorder has been around for a fair while. It has usually taken the form of a portable 4-track recorder with mixing facilities. Akai has taken a quantum leap with this unit, however, and created a 12-track, 12-channel mixing recorder: the MG1212.

As with most of the smaller mixing recorders, the MG1212 combines mixing, recording and noise reduction facilities in the one package. However, this is where the similarity stops. The MG1212 offers a very comprehensive mixing facility, automatic control facilities on the tape deck, dbx noise reduction on all 12 channels and two dedicated tracks for control and synchronisation signals. The mixing recorder has 14-track capability as you don't need to sacrifice any tracks for synchronisation and control.

Design and operation

Mixing

The console is laid out with the 12-track recorder located on the right and the 12 mixing channels in 12 columns on the left.

At the top of these columns are the input and output sockets for each individual channel. Located on the top panel of the console, they are more easily accessed when connecting the mixer with instruments, effects, microphones, etc. On most mixing desks these connectors are situated on the rear panel, which can be inconvenient, especially if you don't have a patch-bay.

Each channel has one microphone input, a line input, an accessory input and an accessory output. As the microphone jack is a

balanced input, a pin Cannon jack is used to connect microphones to a channel. To connect line level instruments such as keyboards, drum machines and guitars to a channel, a phono jack is also provided.

The accessory input/output allows external effects units to be used on individual channels. The associated jacks are internally connected between the preamplifier and the equaliser and thus allow effects to be driven by a preamplified signal. This pair of jacks also allows the user to add extra equalisation to each channel (if required) and is especially useful when both effects buses are being used. The accessory output can also be used as a channel output.

A switch at the top of the column allows the input to any channel to be selected from microphone jack, line jack or from the 12-track recorder. Below it is the PAD control which attenuates signals from the microphone inputs by 0, 20, or 40dB, then the TRIM knob, used to adjust the signal level from the microphone and line inputs over a 20dB range.

Equalisation

When using the mixing facilities of the MG1212 the first thing I was impressed by was the incorporation of 3-way parametric equalisation of each channel. This is implemented by the three controls located under the TRIM knob. Each of these is coaxial with the lower half controlling the frequency range and the top half controlling cut and boost for that range. The three ranges covered are 1.5kHz to 15kHz (high), 350Hz to 5kHz (midrange) and 40Hz to 800Hz (low). Since parametric equalisation

allows one to cut or boost the centre frequency anywhere within a particular band, it gives the user more control over the sound than graphic equalisation. The amount of cut or boost allowed is 15dB; for situations where you do not require any equalisation there is a BY-PASS switch.

The MG1212 mixing recorder has two EFFECTS SENDS located directly under the parametric equaliser controls.

Next, the TRACK control is used during recording and playback. The knob is coaxial with its upper half controlling the level of signals played back from the tape deck and the lower half used to pan them left and right.

Below this, the peak level meter displays the peak signal level on each channel in playback and recording using an LED bar graph. The displays act like the VU meters on a multitrack recorder, but are more convenient because they are located close to the fader controls. Therefore, when you are recording you can see what is happening on each track of the tape deck without looking away from the console. Nice one Akai!

Next to the peak level meters are the overload and recording indicators which light up when the signal is 3dB below the saturation level of the amplifiers in the channel, giving prior warning of signal clipping. The recording indicators illuminate when the corresponding input channels are in recording standby or in recording mode.

At the bottom of the column of knobs, where you would expect them, are the PAN and FADER controls. These set the overall signal level in the channel and the amount

Neale Hancock

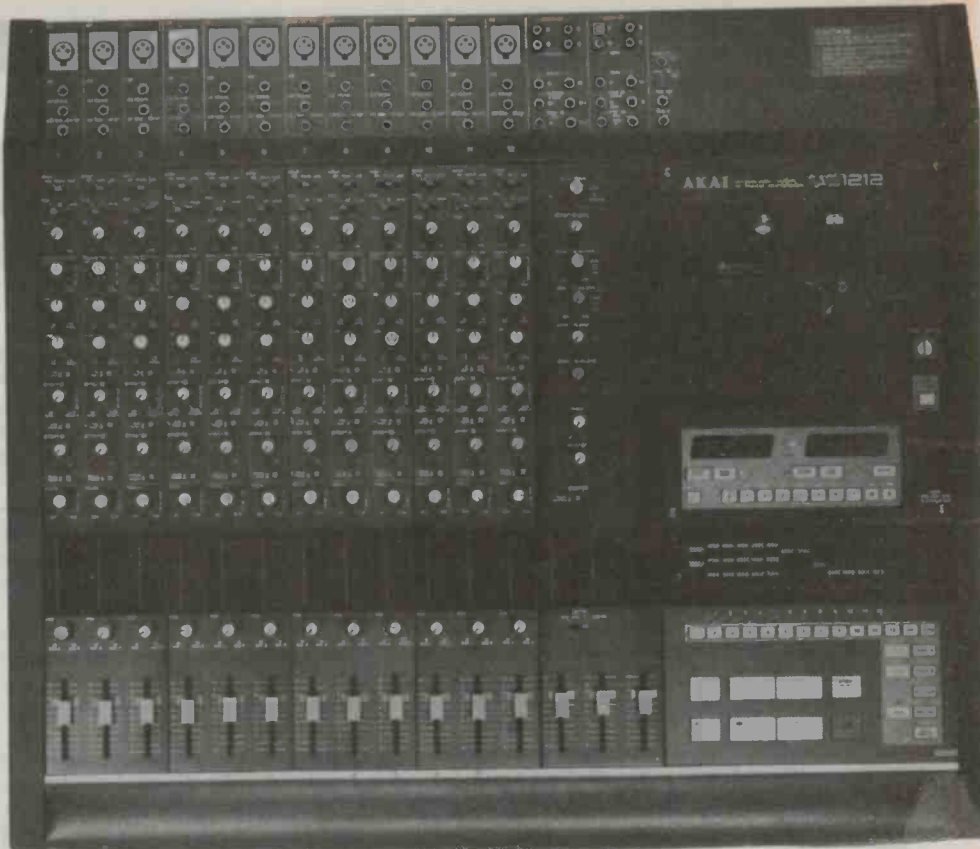

of signal sent to the left and right outputs.

The master module controls the overall level of monitoring, the EFFECT SENDs, the sync track level, and the overall output level. The inputs and outputs linked with this module are located at the top of the master column.

There are outputs provided for monitoring, mastering, sending to effects in stereo and mono, a track output and a direct output for buses A and B as well. There is also an input and an output to allow synchronisation with external devices such as drum machines and sequencers via a sync track. Corresponding inputs are provided for receiving effects; a direct bus input and an auxiliary input is provided for cascading mixing desks.

The tape deck monitor and the level mixing desk monitor controls are located under the EFFECT SENDs and RECEIVEs. The monitor output can be used on the track output or the master output.

Two LED bar graphs are used to show the overall peak signal level switchable to display the signal level at the master output, buses A and B and effect bus A.

Three faders control the amount of signal going to bus A and bus B (the left and right signal channels of the mixing desk) and the output level at the mastering output.

Recording

Recording is done on a half inch cassette tape (Akai MK20 RRP \$29 each packaged in boxes of 10), which is about the same size as a video cassette, but uses a different recording at 19cm/s (7.5ips) and 20 minutes of recording at 9.5cm/s (3.75ips). This is less

time than you would have on a reel-to-reel tape deck, however it is offset by a short changeover time. A pitch control located here can be used to adjust the speed by $\pm 12\%$.

Controls and indicators for the tape deck are on the right of the console (just under the cassette lid) and are clustered into three groups. The bottom group contains the controls for the tape transport along with the channel and track selectors. The middle group contains the display showing which channel is allocated to which track and whether the track is in RECORD or PLAYBACK. The top group consists of the counter and memory controls with their respective indicators.

The tape transport is controlled by the standard cassette-type controls namely, PLAY, REWIND, FAST FORWARD, STOP, PAUSE and EJECT along with a CUE button for finding the start of a track. There is also a MEMORY SEARCH control which can automatically rewind or fast forward the tape to a preset memory location.

The 12 channels of the mixing desk can be assigned to any of the 12 tracks dedicated to audio recording by using the bank of pushbutton switches located above the cassette transport controls. These buttons set any track into PLAYBACK or RECORD allowing recorded tracks to be played back whilst others are recording. One set of buttons selects the mixing desk channels to be sent to the bus and another selects the track the bus output is sent to. This method of configuring PLAYBACK or RECORD

takes a bit of getting used to, but beats the hell out of rearranging a patch-bay each time you want to change your recording set-up. What would be ideal in this instance would be a memory for each set-up, but I suppose you can't ask for everything.

By using this set of buttons in conjunction with the display you can quickly set up the MG1212 for ping-pong recording, overdubbing, mixdown or playback. Once again the advantages of having the mixing desk and recorder combined are evident. Because of plenty of access to inputs and outputs, no flexibility is lost either.

In the bottom group of controls a SOLO button allows monitoring of a single channel. An AUTO/MANUAL tape monitor button monitors the tape during playback and rewind, and the source during record, record standby, eject and stop. To protect against accidental recording, an ANTI-RECORD button is also provided.

The counter and memory section of the 12-track recorder has two displays, one showing the running time of the tape and the other indicating the time stored in memory.

The running time of the tape is displayed in minutes, seconds and tenths of seconds. This method is far superior to the standard tape counter, not only because it counts in real time, but also because the time signal is recorded on a dedicated track — at the same time as music is recorded on the audio tracks. Therefore, the display on the time counter will always be accurate (to within a tenth of a second) with respect to the recorded music.

SOUND REVIEW

The time counter can also be reset to zero at any point, thus indicating positive time from that point on and negative time back from that point.

The memory section enables the user to set times to within a second and use them to automatically control some functions of the tape deck. When using the memory search facility the tape can be automatically rewound or fast forwarded to any of the times stored in memory. This search can be performed in two ways. Firstly, it can be performed by presetting memories 1 to 8 during recording or playback to points of interest. Then the tape can be automatically fast forwarded or rewound to any of these points at a later time. The second way is by using the buttons labelled 0 to 9 to manually key in the desired time, then fast forward or rewind the tape to this time.

Automatic recording and playback of the tape deck can also be implemented using these memory times. The automatic PUNCH IN/PUNCH OUT enables the tape deck to automatically record between two specific memory times on any channel, so if your hot shot guitarist plays a dud note half way through his solo you can set the memory times before and after his moment of embarrassment then play the tape through again. Your guitarist can get his timing right as the tape plays, so when the first memory time occurs and starts the recording he can correct his mistake. The second memory time will stop the recording, thus preserving any musical gems located later in the track.

The PLAYBACK MUTE uses the memory times in the same way as PUNCH IN/PUNCH OUT does. The only difference is that the PLAYBACK MUTE automatically turns off a particular channel (or channels) at the first memory time and turns the channel on again at the next memory time. This feature is ideal for quickly editing a track in the mixdown situation.

For situations where you want to listen critically to a part of the song you have recorded, there is also a REPEAT PLAYBACK facility. This feature plays the tape between two memory times, then rewinds it to the first time, and plays it again.

Summation

After extensively using the MG1212, I was quite impressed with its capabilities and performance. The features of the mixing section which I appreciated, were that it was modular, it used parametric equalisation and had the level meters located right near the faders giving me direct visual feedback of the signal level in each channel.

I was also impressed with the stereo effects capability of the effect bus A; there is the potential for some interesting stereo sound effects. The amount of access given to the user by the abundance of

inputs and outputs also pleased me. The location of these jacks on the top panel of the console is a definite plus for home studio owners.

The features of the recording section which I was immediately taken with were the use of dbx on all twelve channels, additional dedicated channels for synchronisation and timing signals, the use of a real time counter with memories and the overall feel of the controls. However, it would have been nice to have a memory for different configurations of mixing desk channels and tape deck tracks.

I would have liked to have seen the inclusion of SMPTE time code compatibility with this system, to permit it to work more closely with digitally controlled studio equipment.

My only reservation about the tape system, is that there is no other source apart from Akai. Users should beware that despite the tape's resemblance to VCR cassettes it uses a different format.

Recording with the MG1212 in my home studio, I used a variety of sound sources including microphones, synthesisers, guitars, drum machines, effects and prerecorded tapes. The recording quality of each of these sound sources on the tape was excellent, largely due to the dbx noise reduction. The parametric equalisation also assisted in achieving a good sound on each channel.

One test I put the MG1212 to was recording a soundtrack for a live performance in the recording hall of the Sydney Opera House. Some passages of music required the full 20 minutes of tape to record them as well as a number of cues for the performers to work from which had to be accurately timed. The memories and the time counter were extremely useful for this.

The master tape for the performance was recorded using dbx noise reduction on the mastering deck as well. The master tape was played back from the mastering deck through a PM2000 mixing desk, driving four speakers and two sub woofers. Every one I consulted about the sound (including Opera House technical staff) was impressed with the overall quality of the tape, as was I.

The combination of a 12-channel mixer with a 14-track recorder equipped with dbx and digital control would undoubtedly exceed the price of the MG1212. The MG1212's low \$12,000 (at present) is largely due to everything being integrated in one console. It is a price ideal for people who are recording demos, soundtracks, jingles and for home recording enthusiasts.

For live situations there may not be enough mixing desk channels, but since the mixing desk has inputs directly into the bus as well as two auxiliary inputs it would be possible to cascade another mixing desk anyway.

ELECTRONICS — IT'S EASY!

A two volume set that's written for the intelligent layman as an introduction to electronics theory and methods. Volume 1 discusses electronics systems in general: what they do, how they do it and how a complex electronic system can be broken down into fundamentals. Volume 2 introduces digital instruments, computers and peripherals, and oscilloscopes.

Order yours now from:
Federal Marketing Book Sales
P.O. Box 227
Waterloo, N.S.W. 2017 

\$5.95 per volume
Please add \$1 to the cost of each volume to cover postage and handling.



EP
232

The EP232 turns your PC or CPM computer into a versatile EPROM PROGRAMMER able to program all common EPROMS up to 27256.

- Software provided gives a comprehensive set of commands
- Simple interface via RS232 port
- Locally made EP232 costs a fraction of imported programmers

CALL FOR DETAILS
Diamond Systems (03) 714 8269
P.O. Box 105 Hurstbridge 3099

RITRONICS WHOLESALE Pty. Ltd.

Incorporated in Victoria

Phone (03) 543 2166 (3 lines)

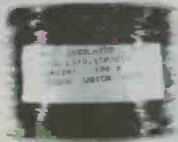

HOOK UP WIRE

Cat. No. Description
W11251 13/12 TND BLK
W11252 13/12 TLD BROWN
W11253 13/12 TLD ORANGE
W11254 13/12 TLD YELLOW
W11255 13/12 TLD GREEN
W11256 13/12 TLD BLUE
W11257 13/12 TLD WHITE

PRICES PER 100 METRE ROLL
1-9 \$3.50 10+ \$3.00
Plus 20% tax where applicable

W11260 14/.20 RED
W11261 14/.20 BLACK
W11265 14/.20 BLUE
W11268 14/.20 WHITE

PRICES PER 100 METRE ROLL
1-9 \$9.00 10+ \$7.00
Plus 20% tax where applicable

W11270 24/.20 RED
W11272 24/.20 BLACK
W11274 24/.20 GREEN

PRICES PER 100 METRE ROLL
1-9 \$11.00 10+ \$10.00
Plus 20% tax where applicable

W11280 32/.2 BROWN
W11282 32/.2 BLUE

PRICES PER 100 METRE ROLL
1-9 \$12.00 10+ \$11.00
Plus 20% tax where applicable



ADD ON DISK DRIVE FOR 6502 SYSTEM (APPLE II COMPATIBLE)

1-9 \$160 10-24 \$150 25+ \$140
Plus 20% tax where applicable
(*Apple is a registered trademark)

MITSUBISHI DISK DRIVES

4851 5 1/4" 500K 1-9 \$195 10+ \$185 25+ \$175
4853 5 1/4" 1M \$265 \$245 \$215
4854 5 1/4" 1.6M \$295 \$260 \$235
2896 8" 1.6M \$650 \$625 \$600
Plus 20% tax where applicable



RITRON II

Swivel base monitor in stylish case.

Green Cat. X114506 \$145 \$135 \$115
Amber Cat. X114508 \$150 \$140 \$120
Plus 20% tax where applicable



TRANSFORMERS

Cat No.	1-9	10+	100+	1000+
M12851	2851	2.50	2.25	1.90
240V 12-6V CT 150mA				
M12155	2155	4.80	4.10	3.70
240V 6-15V 1A tapped				
M12156	2156	6.35	6.15	5.95
240V 6-15V 2A tapped				
M16672	6672	6.35	6.15	5.95
240V 15-30V 1A tapped				
M12860	2860	3.00	2.50	2.30
240V to 15V C.T. at 250mA				

Plus 20% tax where applicable

NEW TRANSFORMER!

M12840 2840 3.00 2.50 2.30
240V to 9V C.T. at 150mA
Plus 20% tax where applicable

TELEPHONE CABLE (200 METRE ROLLS)

Cat No.	1-9	10+
W11302	2 Pair	24.00 23.00
W11303	3 Pair	36.00 34.00
W11310	10 Pair	120.00 115.00

Per 200m Roll
20% Sales tax where applicable

75 OHM COAX CABLE IN 100M ROLLS

Cat No.	1-4 rolls	5+ rolls	10+ rolls
W11222 3C2V	18.00	17.00	16.00
W11224 5C2V	27.00	25.00	24.00

(5C2V WHITE OR BLACK)
LINE LOSS PER 100 FEET (33M 200MHZ)
W11222 3C2V 6.2dB (Approx.)
W11224 5C2V 3.9dB (Approx.)
Plus 20% tax where applicable

FREE

50 PAGE

WHOLESALE

PRICE LIST!

Simply phone or write!

10% OFF

THESE PRICES!

PANEL METERS

Cat No.	1-9	10+	100+
Q10500	MU45 0-1mA	6.95	6.75 6.50
Q10502	MU45 50-0-50uA	6.95	6.75 6.50
Q10504	MU45 0-100uA	6.95	6.75 6.50
Q10505	MU45 0-50uA	6.95	6.75 6.50
Q10510	MU45 0-5A	6.95	6.75 6.50
Q10518	MU45 0-1A	6.95	6.75 6.50
Q10520	MU45 0-20V	6.95	6.75 6.50
Q10535	MU45 VU	7.95	7.75 7.50
Q10530	MU52E 0-1mA	9.95	9.85 9.35
Q10533	MU52E 0-5mA	9.95	9.85 9.35
Q10538	MU65 0-50uA	9.35	8.95 8.75
Q10540	MU65 0-1mA	9.35	8.95 8.75
Q10550	MU65 0-100uA	9.35	8.95 8.75
Q10560	MU65 0-20v	9.35	8.95 8.75

Plus 20% tax where applicable

WE HAVE THE BEST

MEMORY

PRICES!

"Check for the latest memory prices!"

	10-99	100+	1000+	10K+
4164-15P	\$ 2.50	\$ 2.00	\$ 1.75	\$ 1.60
41256	\$ 6.00	\$ 5.00	\$ 4.50	\$ 4.00
6116P-3	\$ 3.00	\$ 2.90	\$ 2.20	\$ 2.00
2716	\$ 5.50	\$ 5.00	\$ 4.50	\$ 4.25
27128	\$ 5.00	\$ 4.50	\$ 4.00	\$ 3.50
2532	\$ 7.50	\$ 6.50	\$ 6.40	\$ 6.30
2732	\$ 6.50	\$ 6.10	\$ 5.90	\$ 5.50
27256	\$11.00	\$10.00	\$ 9.00	8.00
6264	\$ 5.50	\$ 5.00	\$ 4.50	\$ 4.00
2764	\$ 6.00	\$ 5.00	\$ 4.50	\$ 4.00

Plus 20% tax where applicable

EVERY DAY LOW PRICES!

VERBATIM DATA LIFE DISKETTES

	10-99	100+	500+
5 1/4" SS/DD MD525-01	2.50	2.35	2.25
5 1/4" DS/DD MD550-01	3.20	2.75	2.50

XIDEX DISKETTES

	10-99	100+	500+
5 1/4" SS/DD 5012-1000	2.50	2.50	2.25
5 1/4" DS/DD 5022-1000	3.40	3.05	2.85
3 1/2" SS/DD 3012-3000	5.90	4.75	
3 1/4" DS/DD 3022-3000	6.90	5.55	

Plus 20% tax where applicable

MICRODOT 5 1/4" FLOPPY DISKS

Have a look at these prices! These are 100% certified, prime spec. disks in labelled jackets. (Not like our opposition)

Desc.	Cat. No.	1-9	10+	100+	1000+
S/S/D	C12440	\$14.50	\$13.90	\$12.20	
D/S/D	C12445	\$16.50	\$14.90	\$13.50	

Attention Schools, Government Depts etc.:
FREE sample disk available on request!
(Please send \$2 to cover postage)

CRYSTALS

Cat No.	Frequency	Can	10+	100+	500+	1000+
Y11000	1MHz	HC33	5.50	4.75	4.50	4.00
Y11005	2MHz	HC33	2.25	1.95	1.85	1.70
Y11008	2.4576MHz	HC18	2.25	1.95	1.85	1.70
Y11015	3.57954MHz	HC18	1.20	.90	.85	.60
Y11020	4.00MHz	HC18	1.30	.90	.75	.60
Y11022	4.194304MHz	HC18	1.40	.90	.75	.60
Y11025	4.75MHz	HC18	1.40	.90	.75	.60
Y11026	4.9152MHz	HC18	1.40	.90	.75	.60
Y11042	5.144MHz	HC18	1.40	.90	.75	.60
Y11050	8.00MHz	HC18	1.40	.90	.75	.60
Y11055	8.867238MHz	HC18	1.40	.90	.75	.60
Y11070	12.00MHz	HC18	1.40	.90	.75	.60
Y11072	14.318MHz	HC18	1.40	.90	.75	.60
Y11080	16.00MHz	HC18	1.40	.90	.75	.60
Y11085	18.432MHz	HC18	1.40	.90	.75	.60
Y11090	20.00MHz	HC18	1.40	.90	.75	.60

FULL RANGE OF CRYSTALS AVAILABLE ON INDENT
Plus 20% tax where applicable

HORN SPEAKERS

Cat No.	1-99	100+
C12010	5" Plastic 10W Max	4.80 4.70
C12015	5" Metal 10W Max	4.70 4.60
C12012	12V Siren	8.50 8.00

Plus 20% tax where applicable

SOLDERING IRON STANDS

Cat No.	1-99	100+
T113023	3.75	3.50

Plus 10% tax where applicable

VOLTAGE REGULATORS

	10+	100+	1000+
7805uC	.45	.44	.43
7805KC	1.50	1.40	1.20
7812uC	.45	.44	.43
7815KC	1.50	1.40	1.20
7818uC	.50	.49	.48
7818KC	1.50	1.40	1.20
7905uC	.70	.60	.55
7912uC	.70	.60	.55
uA329KC	4.50	3.90	3.75
78M12	7.00	6.00	5.90
78HGKC	7.50	6.50	6.00
79HGKC	16.50	15.00	14.00
78P05	11.50	11.00	10.50
78P12	14.00	13.50	13.00

Plus 20% tax where applicable

GREY FLAT RIBBON CABLE

Cat No.	Desc.	Per Mtr	1-3	4-9	10-99	100+
W12614	14 Way	1.29	19.50	18.50	18.00	14.00
W12616	16 Way	1.90	21.50	19.50	19.00	16.00
W12620	20 Way	2.20	23.50	21.00	20.50	20.00
W12625	25 Way	2.50	32.50	29.00	28.50	25.00
W12626	26 Way	2.60	34.00	32.00	29.00	26.00
W12634	34 Way	2.80	44.00	42.00	39.00	34.00
W12636	36 Way	3.00	49.00	47.00	42.50	36.00
W12640	40 Way	3.20	55.00	52.50	49.50	40.00
W12650	50 Way	3.75	62.00	59.50	58.50	50.00

EX STOCK
LARGER QUANTITIES NEGOTIABLE
Plus 20% tax where applicable

56 Renver Road, CLAYTON, 3168, VICTORIA, AUSTRALIA. Phone (03) 543 2166 (3 lines) Telex: AA151938
Minimum account order is \$50, minimum cash sale is \$25. Minimum post/pack \$3.00. Minimum account post/pack \$5.00. Comet Road Freight, bulky items and/or over 10Kg is extra.
Bankcard, Visa and Mastercard welcome. Errors and Omissions Excepted.

NEW EQUIPMENT

Portable soldering iron

The invention of the Portasol soldering iron by Irish firm Oglesby and Butler has been a remarkable success. The small company was founded by three former Braun engineers just over a year ago. Distributors DRM Industries is selling the pen-sized tool to people in the electrical, mechanical and engineering business, and soon to the home handyman and hobbyist.

The Portasol is a butane gas soldering iron, ignited by a flint ignition in the cap. It has a 10 to 60 watt temperature control and is filled with gas lighter fuel giving 60 minutes of continuous use. The Portasol also comes with three tip sizes each giving 30 hours of use.

The design features also include important safety advantages. When the cap is replaced the gas is automatically switched off, and when the user is finished

with the Portasol there is no need to wait for it to cool or find a suitable place to rest it, as the cap is able to withstand up to 250 degrees. There is little waste or leakage since the user can switch on and off at will. The Portasol takes just 20 seconds to reheat. And because it's static free, the Portasol is ideal for use with CMOS and other static-sensitive components.

To find out more call DRM Industries on (02)997-5522.

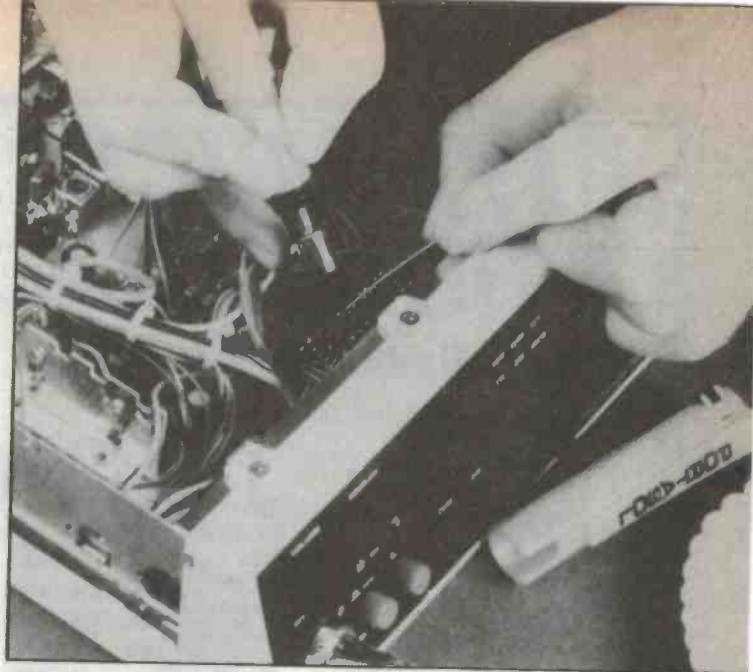

Low cost 20MHz oscilloscope

Parameters has released a low cost Kenwood CS1021 20MHz dual channel oscilloscope. The CS1021 is designed as a general purpose maintenance tool for the factory test laboratory. Optional 10:1 switchable Greenpar oscilloscope probes are available at extra cost.

Full service and 12 month warranty are available from Parameters Sydney and Melbourne, Centrecourt, 25-27 Paul Street Nth, North Ryde, NSW, (02)888-8777, and 1064 Centre Rd, Oakleigh South, Vic, (03)575-0222.

Image processing module

Imaging Technology Inc has announced two new software packages for its Series 100 product line: the ITEX 100 subroutine library, and IMAGE-PRO 100 interactive image processing program.

ITEX 100 is a library of subroutines specifically designed to ease the development of sophis-

ticated image processing applications programs. ITEX 100 exploits the architectural advantages of the Series 100 single-board real time image processor, relieving Series 100 users of the time-consuming task of writing their own driver-level software.

Written in C programming

language, ITEX 100 routines provide image processing graphics, and hardware control functionality.

For more information contact The Dindima Group, PO Box 106, Vermont, Vic 3133. (03)873-4455.

In-circuit fault locator

The Polar T1000 and T1200 fault locators from Emona are designed to isolate faults on unpowered boards down to individual components. Faulty components can be found on boards containing such devices as transistors, diodes, analog ICs, digital ICs and regulators.

Troubleshooting can usually be done without a full knowledge of the circuit's function. Simple transistor curve tracing features mean that devices can be checked for gain.

The T1000 and T1200 provide a trace of the impedance (current against voltage) between any two points on a circuit board. Both models provide the same features except the T1200 has its own CRT. The lower cost T1000 must be used with a CRO.

For more information contact Emona Instruments, 720 George St, Sydney 2000.

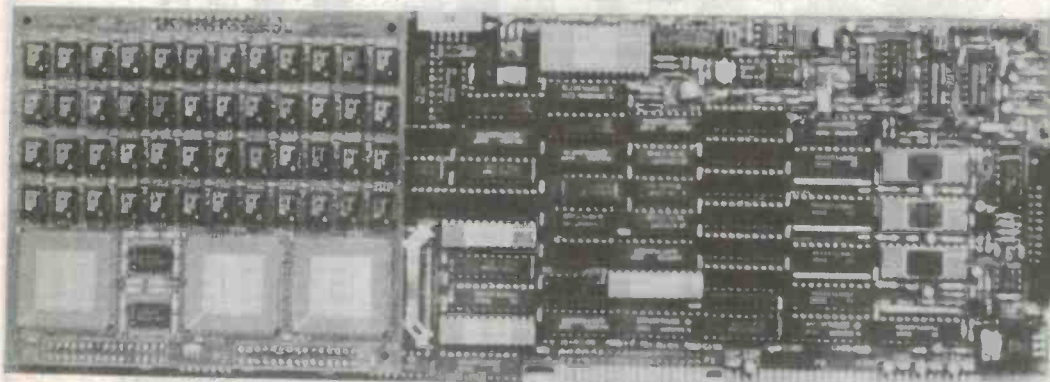

DON'T JUST SIT THERE

Now that winter has finally arrived, and it's too cold to leave the fire, why waste your time watching TV. WHY NOT BUILD A KIT.

Jaycar stocks over 150 different kits, many of which are listed on these pages.

BUILD SOMETHING
SOUND BARGAINS IN SOUND KITS

2801 1/3rd OCTAVE EQUALISER

• 240V operated • Cannon Sockets • Pro quality
Cat. KJ-6531 **\$225.00**



ETI 5000 1/3rd OCTAVE EQUALISER

Cat. KE-4204 **\$209.00**

HURSTVILLE OPEN TILL 8.30pm THURSDAYS

2010 10 BAND STEREO EQUALISER

Cat. KJ-6535 **\$159.00**

AM/FM STEREO TUNER SYNTHESISED

Ref. December 85 - Feb 86
Cat. KA-1635 **\$499.00**



REMOTE CONTROL FOR ABOVE TUNER

Ref. EA April 1986
Cat. KA-1636 **\$89.50**

ETI 5000 POWER AMP "BLACK MONOLITH"

Cat. KE-4200 **\$359.00**



ETI 5000 PRE-AMP "BLUE PRINT"

Cat. KE-4202 **\$339.00**



"ULTRA FIDELITY" PREAMPLIFIER

Ref. AEM Oct - Dec 1985
Cat. KM-3030 **\$289.00**



RS-232 to COMMODORE

Without Commodore edge connector
Cat. KE-4722 **\$14.95**

CIRCUIT PROTECTOR for AEM SERIES 6000 POWER AMPLIFIERS

Cat. KM-3045 **S.P.O.A.**

CONCORD "SHOWROOM" HAS BEEN EXPANDED FOR YOUR COMFORT

SHOWROOMS

- SYDNEY** 117 York St. (02) 267 1614
Mon - Fri 8.30 am - 5.30 pm
Thurs until 8.30 pm Sat 9 am - 12 noon
- CARLINGFORD** Cnr Carlingford & Pennant Hills Rd
(02) 872 4444 Mon - Fri 9 am - 5.30 pm
Thurs until 8.30 pm Sat 9 am - 12 noon
- CONCORD** 115 Parramatta Rd (02) 745 3077
Mon - Fri 8.30 am - 5.30 pm only
- HURSTVILLE** 121 Forest Rd. (02) 570 7000
Mon - Fri 9 am - 5.30 pm
Thurs until 8.30 pm Sat 9 am - 12 noon
- GORE HILL** 188 Pacific Hwy (Cnr Bellevue Ave)
(02) 439 4799 Mon - Fri 9 am - 5.30 pm
Sat 9 am - 4 pm

Jaycar ELECTRONICS

INCORPORATING ELECTRONIC AGENCIES
QLD. BURANDA 144 Logan Rd (07) 393 0777
Mon - Fri 9 am - 5.30 pm
Thurs until 8.30 pm Sat 9 am - 12 noon
HEAD OFFICE 115 Parramatta Rd
Concord 2137
(02) 747 2022 Telex 72293

ROAD FREIGHT ANYWHERE IN AUSTRALIA \$13.50

4 1/2 DIGIT ACCURACY - 3 1/2 DIGIT PRICE!! AND DIGITAL HOLD TO BOOT!!

Once again Jaycar has smashed the price barrier for a full 4 1/2 digit multimeter. Just think a multimeter with 0.15% accuracy on most ohms ranges, 0.05% on DC volts and 0.5% MAX on DC current! STAGGERING. Plus, continuity buzzer and LED symbol, auto polarity, auto zero, vinyl case and DATA HOLD as well! NOT TO MENTION the transistor and diode tester!! We are absolutely convinced that you will be delighted with this meter. So much so we convinced that we have extended our normal satisfaction guarantee by another week. That's right! Personal shoppers can try this superb instrument out in their own workshop for 14 - obligation free days. (Mail order customers 21 days!) If you are not happy with this product in any way return it in ORIGINAL condition for a full refund (less P&P for M/O).

SPECIFICATIONS:
★ 0 - 1kV DC 0.05% ★ 0 - 750V AC 0.8% (max) ★ 0 - 10A DC 0.5% (max) ★ 0 - 10A AC 1.0% (max) ★ 0 - 20M ohm 0.5% (max).

FEATURES:
• All ranges fully protected • Auto zero • 0.5" high LCD • Diode test (1mA fixed current) • Audible continuity • Data hold • LCD display feature • Functional annunciators • Extremely accurate • 20 page instruction manual included
Cat. QM-1550

NEW ONLY \$159.00



MAGGY LAMP

Cat. SL-2700
\$169.00

POLYPROPYLENE CONE WOOFERS - HIGH QUALITY AT LOW COST

12" WOOFER
★ Power handling 80 watts RMS system ★ Impedance 8 ohms ★ Resonant frequency 23.2Hz ★ Sensitivity 92.3dB 1 watt 1 metre ★ Effective frequency response 23Hz - 5kHz ★ Electromagnetic Q - QES 0.481 ★ Peak cone excursion 2. x/max 1.6mm
Cat. CW-2130

10" WOOFER \$79.50

★ Power handling 70 watts RMS system ★ Impedance 8 ohms ★ Resonant frequency 24.3Hz ★ Sensitivity 91.9dB 1 watt 1 metre ★ Electromagnetic Q - QES 0.399 ★ Peak cone excursion 2. x/max 1.25mm
Cat. CW-2116

8" WOOFER \$69.50

★ Power handling 60 watts RMS system ★ Impedance 8 ohms ★ Resonant frequency 23.2Hz ★ Sensitivity 88.2dB 1 watt 1 metre ★ Effective frequency response 23 - 5kHz ★ Electromagnetic Q - QES 0.481 ★ Peak cone excursion 2. x/max 1.6mm
Cat. CW-2114

\$42.50



5" MIDRANGE FERROFILLED

Cat. CM-2092 **\$29.50**

LOUD PLATE TWEETER

Cat. CT-2030 **\$39.50**

10" PASSIVE RADIATOR

Cat. CR-2180 **\$36.50**

12" PASSIVE RADIATOR

Cat. CR-2190 **\$47.50**

NOW AVAILABLE

DIE CAST HEATSINKS

Jaycar is proud to announce a range of 'Made In Australia' die cast heatsinks. They are gravity cast in Aluminium, have the area where semiconductors mount milled flat and are fully finished in powdercoat black. They are low cost for the performance offered. Size 134 x 65mm (high) x length (see below)

8PNF SERIES

- Cat. HH-8540 (50mm long) **\$3.95**
- 10 or more **\$3.75 each**
- Cat. HH-8541 (75mm long) **\$5.95**
- 10 or more **\$5.50 each**
- Cat. HH-8542 (100mm long) **\$7.95**
- 10 or more **\$7.50 each**
- Cat. HH-8543 (150mm long) **\$9.95**
- 10 or more **\$9.50 each**



MF10-2F-75

74(H) x 144(L) x 46(W)mm (Bracket 34mm wide).
Cat. HH-8548 **\$7.50**

10 or more **\$6.95 each**

STOP PRESS - NEW LIGHT SAVER

Ref. EA June 1986
Without plate and epoxy
Cat. KA-1670

ONLY \$14.99



CARAVAN TV AERIAL

• Suitable for car, caravan, boat • Designed for UHF/VHF and FM • Built-in masthead amplifier • Complete with cable and plug.
Cat. LT-3120

ONLY \$99.50

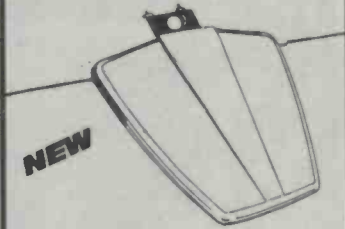

UHF - PHASED ARRAY TV ANTENNA

• Suited for channels 21 - 69 • Extremely high gain
• Nine phased array elements • 9 - 12dB gain
• Mounts like a normal antenna • High out of band signal rejection
Cat. LT-3182

ONLY

\$69.50

NEW

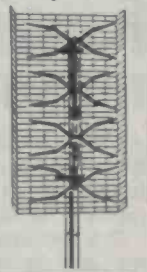

MAIL ORDER HOTLINE (02) 747 1888

MAIL ORDER HOTLINE (02) 747 1888



MAIL ORDER VIA YOUR PHONE

MAIL ORDERS	POST & PACKING
P.O. Box 185 Concord NSW 157	\$5 \$9.99 \$ 2.00
(02) 747 1888 HOTLINE	\$10 \$24.99 \$ 3.75
(0001) 022 888 TOLLFREE	\$25 \$49.99 \$ 4.50
FOR ORDERS ONLY	\$50 \$99.99 \$ 6.50
	OVER \$100 \$10.00

BRAND NEW 100 page 1986/7 ENGINEERING CATALOGUE OUT NOW SEND LARGE S.A.E.

Intel emulator for 8096 microcontroller

Intel Corp has introduced an enhanced in-circuit emulator for the 8096 (MCS-96) family of microcontrollers.

The new VLSiCE-96P emulator is a comprehensive debugging and test tool used for hardware and software development of prototype systems. The emulator operates on Intel's Intellex Series III and IV development systems as well as on the IBM Personal Computer AT and PC XT.

The VLSiCE-96P emulator uses Intel's bondout technology, a proprietary emulation processor that allows higher functionality, particularly in viewing activity on the internal data bus and gaining access to the special function registers of the microcontroller.

A distinctive feature of the VLSiCE-96P emulator is its ability to read many 8096 write-only registers and write many read-only registers. This allows the user to examine write-only registers, which can be written to in the component only, and to preset (before emulation) read-only registers, which can be read in the component only.

The VLSiCE-96P emulator features precise, real-time (up to 10 MHz), transparent emulation of 8096 components, allowing users to debug time-critical input/output hardware. Software code debugging can take place in the emulator's 64 kilobytes of memory in high-level or assembly language before prototype hardware is available. Integration of hardware and software

can begin as soon as modules of code are completed and the microcontroller socket is connected to the prototype.

The VLSiCE-96P emulator provides an assortment of complex break and trace capabilities. With break, the user can stop the emulation process when a given set of conditions occurs. Trace captures the program execution and data flow, including that from internal registers (in memory) for later examination. The emulator allows break and trace qualifiers to be set on execution addresses, data addresses, external and internal RAM values, opcodes and selected program status-word flags.

For further information contact Intel Corp, Level 6, 200 Pacific Hwy, Crows Nest, NSW 2065. (02)957-2744.

Versatile Eurocard rack

Unirac is the latest release from Betacom NS through Temple Smith Australia. It is a subrack module and card housing package to DIN 41494 standards, accepting all sizes covering the Eurocard standard.

Available in the standard 3U and 6U frame kits, the system will also include divider kits, blank panels, front panel and card kits, four rail modules, frame covers, card handles and module covers.

Betacom promises a very competitive and extensive customising service with reduced lead times.

For information contact Temple Smith, 252 Graham St, Port Melbourne, Vic 3207.



Portable scope highlights transients

A new portable oscilloscope from Tektronix, the 2467, has been designed to solve a major problem for digital designers.

The 350MHz scope amplifies the intensity of infrequent transient events, while the intensity of highly repetitive events is limited. This is achieved by incorporating a micro channel plate (MCP) CRT.

According to Tektronix, "infrequent variations in high repetition rate signals cause the most difficult problems in digital system design applications".

With the transient-intensifying capability of the MCP, the 2467 displays rare events superimposed on otherwise much brighter repetitive signals.

System faults caused by infrequent metastability, asynchronous noise, crosstalk, or erratic timing-margin violations are the target of the 2467's transient-intensifying capability.

The new 350MHz 2467 portable oscilloscope with adaptive intensity can display fast, single-shot events at 500ps per division — even in normal room light.

BRIEFS

Liquid crystal display modules

The Oki dot matrix LCD modules from Amtex are compact, lightweight and have low power consumptions. The displays range in size from 16 characters by two lines to 80 characters by 25 lines and come in reflective and back-lit types. For information ask Amtex, 36 Lisbon Street, Fairfield NSW 2165.

Training for all-digital communications

Feedback Instruments' new digital communications system DCS297 is a fundamental trainer illustrating the principles underlying behaviour in most common digital communications circuits. The system is designed on a modular basis and covers such things as digital signalling, noise, clock regeneration, frame synchronisation, and amplitude, frequency and phase shift keying. For more information contact Electrical Equipment Ltd, Unit C, 8 Lyon Park Rd, North Ryde, NSW 2113.

Ten-way lighting switching panel

UK firm NJD Electronics has released a switching unit capable of switching 1500 watts of resistive load or 1000 watts inductive load on each of the 10 channels. Primarily designed to switch lights or lighting control units, the Logic 10 provides either momentary or latching control. For more information contact Musitronics, 19 Ashford Rd, Keswick, SA 5035. (08)297-8932.

Power cable fault locator

The new Telefault P240 low voltage cable fault locator is a battery operated portable device which uses the pulse echo method of locating a fault. It is microprocessor based and can be used normally when connected to energised low voltage power cables. The P240 covers cable lengths up to 3.2km in five ranges. For more information contact Macey's Electrical Accessories, 37 Ryedale Rd, West Ryde, NSW 2114.

Mail Order Special!



PREMIUM QUALITY 'TEXAS' IC SOCKETS

16 PIN	20c
18 PIN	20c
20 PIN	25c
22 PIN	30c
40 PIN	40c

Texas Instruments, so you know they're good!
BUY 100 - LESS 20%
INDIVIDUALLY PACKAGED!
BUY 100 ASSORTED - LESS 10%

PREMIUM QUALITY 'FUJI' RELAYS

12V DC \$2.95 ea
1% 3A CONTACTS \$2.50 ea
10+ \$2.00 ea
330v COIL PCB MOUNTING

BASIC ALARM MODULES
N.O./N.C. INSTANT and DELAY CIRCUITS, SIREN and BELL OUTPUTS, 12V DC OPERATION.

Was \$29.95
HALF PRICE \$15

PARTS VALUE PACKS
LUCKY-DIP ASSORTMENTS!

500 1/2W RESISTORS
200 1W RESISTORS
100 CERAMIC CAPS
30 GREENCAPS
45 ELECTROLYTICS
20 POTENTIOMETERS
25 PRESET POTS
30 MICA CAPS
40 RADIO/TV KNOBS
20 VARIOUS FUSES
12 TANTALUMS
50 TAGSTRIPS
250 1/2, 1W RESISTORS

\$2 EACH PACK
BUY 10, GET 1 FREE!
250 1/2, 1W RESISTORS

TV SIGNAL AMPLIFIER
4x75 ohm
Outputs 12 dB gain
VARIABLE

Reduced! FOR...
VHF UHF FM

Was \$69.50 now **\$49.50**

NEW PRINTER SWITCH (A-B) BOXES
WITH DATA TESTER LEDS
2x IN 1x OUT or VICE VERSA!
Ideal for Computer to 2 printers or printer to 2 computers - no power required!

RS232 SERIAL \$119
\$99.50+tax
CENT. PARALLEL \$119
\$99.50+tax

LAST STOCK AT OLD PRICES!

5 1/4 FLOPPY DISKS

DOUBLE SIDED \$27 per 10
DOUBLE DENSITY \$230 per 100

10 YEAR GUARANTEE (limited qty!)

PREMIUM QUALITY 'ERG' DJL SWITCHES
6 WAY PCB MOUNT, COLOUR-CODED

\$2.00 EA
10+ \$1.75 ea

FULLY AUTOMATIC 12V MOTORIZED CAR AERIALS
Suits all models of car radios
Usually \$29.50

\$20

UHF CONVERTER for SBS CHAN 28
Tunable UHF 4/5 to VHF channel 1

\$69

CENTRONICS 36 WAY PRINTER PLUGS
GOLD-PLATED CONTACTS

\$5 EA

DOOR ALARM and CHIME
Changeable 3 digit code.
9v batt. Entry delay

\$29.50 EA

HITACHI B/W VIDEO TAPE RECORDERS
Used for demo purposes only! Excellent cond. TESTED A.K.

Price to pay **\$125**

10 ONLY AVAIL!

NEW STEREO MAGNETIC CARTRIDGE
Latest model - 15Hz to 35KHz response, 2.5mV output, 0.6 diam stylus, standard mounting

\$21

MONO TO STEREO TV SOUND ADAPTER
Connect your TV to your Hi-Fi for simulated stereo sound.

22 wires \$39.95
each supply

\$22

IBM EXPANSION TYPE Registered CHASSIS

\$5

DOOR MONITOR and INTERCOM
'Peep-hole' viewer with built-in 2way intercom for front door protection.

Was \$14.95 SAVE **\$9.98**

JACKPOT Box No 5
Our biggest box ever! Nearly 5Kgm of parts for electronic hobbyists. A little bit of everything - VALUED AT \$70!

\$15

New Passive INFRA-RED Detectors
12v DC, LED light, N.O./N.C. contacts includes mounting brackets

2 MODELS -
12m Wide beam \$99
25m Narrow beam

\$35

Ex-Computer Caps

100,000uf 10v	33,000uf 40v
30,000uf 15v	20,000uf 45v
25,000uf 20v	10,000uf 50v
15,000uf 25v	22,000uf 50v
50,000uf 25v	20,000uf 55v
24,000uf 30v	EA
22,000uf 35v	All tested
12,000uf 40v	and guaranteed

\$5

ADD HARD DISK, UP TO 3x FLOPPY DISKS etc.
5x PC/XT/AT expan. slots
60/100w power supply
Cooling fan \$480 ea
Connectors \$424

LIMITED STOCK AVAIL!

PUSH-BUTTON TELEPHONE DIALERS
with last 9 number memory recall feature

\$15

Easily installed but not Telecom approved.

WOOFERS

4" 10w	\$11.50
6 1/2" 15w	\$12.50
8" 60w	\$28.90
10" 90w	\$48.50
12" 50w	\$49.50

FREE EDGE CONE

ECONOMY CAR ALARM
Voltage sensing Entry/Exit delays Auto-reset Inbuilt siren Easy installation

\$35

MAINS TRANSIENT VOLTAGE SUPPRESSOR
Ideal for computer, test equip, etc.

CHERRY \$20

SERIAL/PARALLEL CONVERTER
Ideal for IBM's High performance CMOS design!

\$150

UHF AERIALS
for BAND 4 or BAND 5
10 element with 75 ohm balun

\$33

(Sorry, no mail order)

PIEZO SUPER TWEETERS
100w 3-30KHz

\$13.50 ea

12V DC CAR ALARM FLASHING LIGHT
Comes on when the ignition is off!

\$12.90

NEW THERMALLOY HEATSINKS
for IC's Suit 14, 16 pins

were 95c now **50c** ea

10+ 45c

CENTRONICS PARALLEL GENDER CHANGER
36 Pin Sockets ea end-all pins wired through.

\$25

VARIABLE TEMPERATURE SOLDERING IRON
16 - 25 WATT

\$29.95

PLASTIC 12 Pole TERMINAL BLOCKS
240V AC 10AMPS

\$1.20

ULTRASONIC CAR ALARMS
Complete and self-contained, just add siren or horn, auto beep, entry/exit delays, LED light.

\$55

24V to 12V DC 7AMP CONVERTER
for trucks, buses, boats

REGULATED and protected

\$35

Reel-to-Reel 7" VIDEO TAPE
New, by HITACHI

were \$29 ea ONLY **\$15** EA

Philips TRIPLERS
FOR COLOUR TV BEST QUALITY LIMITED QUANTITY

As used in Fly, Philips, Arisler and most German colour TVs.

\$12

MINIATURE 12V DC DIL RELAYS
Single pole, 1KA Electrothermal

\$3 ea

COMMUNICATIONS HEADSET
Low impedance mike = 200 ohms Headphone 32 ohms

\$19.50

SYNCHRONOUS MOTORS
WITH GEAR BOX 3 MODELS - 4 or 6 RPM or 10RPM, 240V

\$9.50 ea

RADIO CONTROL REMOTE SWITCH
CAR alarm model with 2 transmitters

Single OR Dual CHANNEL for home, alarms, garage doors, industrial control etc. These have extended range to 100 metres, 12,000 programmable codes.

1CH + TRANSMITTER... \$119
Extra transmitters, each... \$40
2CH + TRANSMITTER... \$133
Extra transmitters, each... \$48

MICRO PIEZO SIREN
12V DC 150mA 110dB output

\$17.50 each

MINIATURE LAPEL MICROPHONES
CONDENSOR MIKE \$15.00 EA
FM WIRELESS \$18.00 EA

DIGITAL SPEEDO+ TACHO for Cars
0-199 KPH 0-9900 RPM 12v neg and.

Bright LED Display with SPEED SENTRY MONITOR

\$69

Buzzer and light indicates excessive speed - adjust

VIDEO CASSETTE TAPE HEAD CLEANERS
VHS or BETA only

\$5 while they last!

PACK/POST: \$3 plus 5% order value - extra for heavy items!

600 PIV 250AMP STUD RECTIFIERS H.O.

\$15 ea

50c ea

POSITIVE 8 PIN OIL VOLTAGE REGULATOR LM376N

PREMIUM QUALITY 'YELLOW' LEDS

20 USUALLY 45c
Guaranteed 100%
EACH or 100 for \$15

MINI-AMP for BUSKERS,
Practice amp, etc. Inputs - microphone, electronic organ, cassette

\$79

BATTERY OPER. 9V

PRE-PAK electronics p/l

1a WEST ST, LEWISHAM, NSW

569-9797

24 HR PHONE ORDER SERVICE

PHONE or mail order

BANKCARD accepted

PRE-PAK electronics p/l

PRE-PAK electronics p/l

MICROBRIAN TOLD ME

The prospect of non-specialists being able, by personal computer, to process information transmitted from polar-orbiting satellites is a reality. The Melbourne-based company, Microprocessor Applications Pty Ltd, is marketing, nationally and overseas, a fast and accurate system for processing satellite images.

THE FEDERAL MINISTER for Science, Mr Barry Jones, unveiled the new system, called MicroBRIAN, in Melbourne on 27 February. It was developed by the CSIRO Divisions of Water and Land Resources and Wildlife and Rangelands Research from its forerunner, the Barrier Reef Image ANalysis (BRIAN) system.

MicroBRIAN is a flexible and powerful image-analysis package designed for processing data from Landsat (or the National Oceanographic & Atmospheric Administration environmental satellite, NOAA, and the Systeme Probatoire d'Observation de la Terre commercial resources satellite, SPOT).

Its main elements are the IBM personal computer a Vectrix graphics board set and software, and sells for \$33,000. More complicated systems that could be assembled to do similar tasks might cost upwards of \$200,000 and still require specialists to operate them.

In developing MicroBRIAN, the Division of Water and Land Resources set out to bring satellite-image processing into the office of the end user rather than to the corporation with a large, centralised computer system, aiming to design an intelligent stand-alone work station.

The MicroBRIAN package

Purchasers of the system receive a package comprising the MicroBRIAN software (written in Microsoft Fortran 77) and manuals, serial communications software, and one of three optional hardware configurations.

The hardware offered by MPA Pty Ltd allows the user access to the range of general purpose software available for the IBM personal computer (XT and AT models).

In addition, users can choose from a wide range of modern commercial graphics software which they can implement on the system's Vectrix board. This graphics board set has the capability of producing 512 different colours on the screen at any one time from a palette of 16.8 million.

The hardware options are:

- Vectrix VX/PC board set, colour monitor, inkjet plotter for use with an existing IBM-PC AT;
- IBM-PC XT fitted with the Wavemate 286 board, inkjet plotter and colour monitor;
- an MPA-manufactured computer, based on the Wavemate 286 board, Vectrix VX/PC board, 20 Mbyte hard disk, inkjet plotter and colour monitor.

MicroBRIAN can be expanded to incorporate options such as a range of high quality printers, extra hard disks, cartridge and standard 1600 BPI tape drives a special array processor, optical disk, joystick and full communications interface.

The manuals included in the package detail the steps for carrying out the following applications: basic image processing, shallow water mapping, land cover mapping and monitoring, image rectification and data integration, crop and forest condition mapping, and land erosion mapping.

Data is transferred to the system by means of floppy diskettes or, directly, through serial data lines.

Considerable quantities of data already exist on floppy diskette. The Australian Landsat Station, for example, is to release Landsat data on a floppy disk.

Communications software in the package enables subsets to be transferred between a mainframe (or other PCs) and the MicroBRIAN PC by serial line.



The joint CSIRO/MPA team is working towards the development of a complete workstation environment for the MicroBRIAN system and the capability of communicating faster and more directly with selected mainframes such as VAX and HP.

Use

MicroBRIAN mathematically transforms the digitally recorded measurements of light in the four 'spectral windows' transmitted by Landsat (as it passes over Australia every 16 days) to reflect desired physical properties, eg, water depth and vegetation. It then re-codes them in colour to form graphic maps.

It is a handy tool for monitoring land use such as the development of rice crops. In this respect, it would be a most useful and relatively inexpensive acquisition for agricultural co-operatives in countries like China (which receive Landsat images). In fact, a number of Chinese institutions have



Hazardous volcanic ash from the 1982 eruption of Mt Galunggung, West Java monitored by the NOAA satellite. NOAA satellite images can now be processed by MicroBRIAN (Photograph by courtesy COSSA).

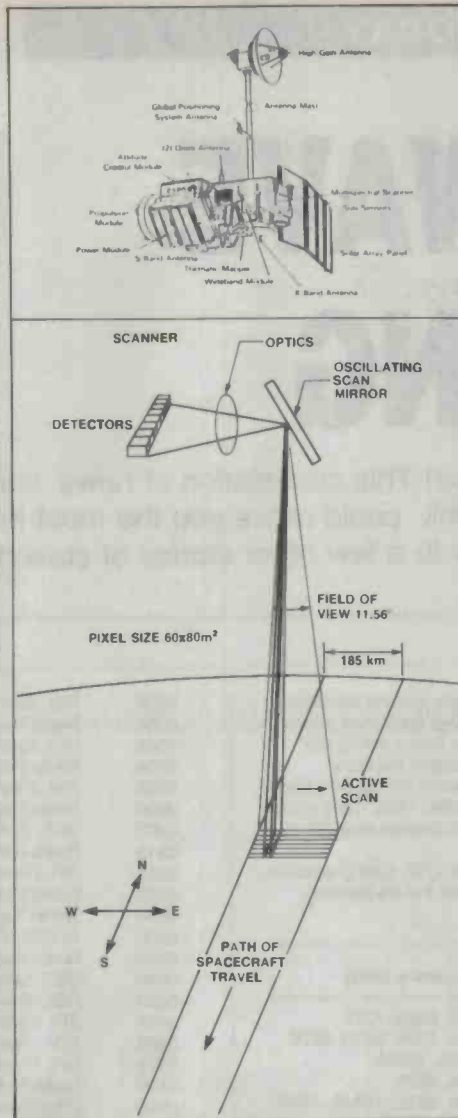

Landsat 5 and its scanning path. The satellite digitises the collected data before transmitting it to Earth for processing by systems such as MicroBRIAN

ADVERTISERS' INDEX

Allen Bradley	60
Anitech	4
Audio Engineers	30
Australian Telecommunications Employees Association	65
AWA	81
Capricorn Computing Services	85
Circuit Components	19
Crusader Electronics	54
Daneva	37,96
Diamond Systems	40
Disco World	25
Electri Board Design	19
Elmeasco	112
Energy Control	28
Entercom Computer Co	IFC
Entertainment Audio	19
ETI books	86,87
Fairchild	OBC
Geoff Wood Electronics	61
H.H. Peaston	89
Haco	31
Hanimex	5
Hewlett-Packard	14,15
Hi-com Unitronics	68
Intertronics	101
Jaycar	43
Marconi Instruments	16
Microbee Systems	83
Philips Elcoma	8
Philips Scientific & Industrial	51
Precision Graphics	28
Prepak Electronics	45
Racal	104
Rod Irving Electronics	20,21,41,92,93
Rose Music	110,111
Scan Audio	34,36
Scientific Devices	37
Sleebs Computers	28
Soanar	51
Sony	7
STC	6
Subscriptions offer	102,103
Technics	IBC
World Wide Systems	13

expressed interest in using the system for agriculture, land cover and erosion mapping.

The earlier BRIAN system was the outcome of a collaborative project between CSIRO, the Great Barrier Reef Marine Park Authority and the Australian Survey Office (ASO) for application in shallow water mapping and reef survey in many parts of the world.

The Authority's chairman, Mr Graeme Kelleher, believes BRIAN has saved about \$21 million and 10 years effort on pre-existing techniques for mapping the reef. The Authority realised that BRIAN could be used for mapping the entire region at international cartographic standards of accuracy (1:250,000 scale). Subsequently, maps covering the entire Great Barrier Reef (348,000 km²) were completed by the ASO at a cost of around \$250,000.

The system has also attracted interest from government authorities in Indonesia,

the Philippines, Malaysia, Thailand, the Republic of the Maldives, Fiji and the Solomon Islands.

Representatives of a number of Asian and Pacific countries who attended international training courses on remote sensing at the Australian Institute of Marine Science in Townsville last August, and at the University of the South Pacific in Fiji last month, had the opportunity to use MicroBRIAN and were impressed by its versatility and speed.

The Division is continuing with further work on MicroBRIAN and customers can expect to benefit from any new software developments.

For more information contact Dr David Jupp, CSIRO Division of Water and Land Resources, GPO Box 1666, Canberra, ACT 2601. Phone (062)46-4911. Or Mr Hal Shuster, Microprocessor Applications Pty Ltd, 48 Rutland Road, Box Hill, Vic 3128. Phone (03)890-0277. ●

The transmitting site at Sackville, New Brunswick, which houses the Radio Canada transmitters and was first built in 1945.

SHORTWAVE LISTENING

Arthur Cushen

Have we got news for you! Yes sir! This compilation of news services available to the shortwave listener around the clock could make you the most informed person on the block. And for the really alert, we throw in a few other stories of stations and changes.

YOUR INTERNATIONAL NEWS SERVICE

In the April issue of this year we featured English News Around the Clock from many countries which carry broadcasts on the high frequency bands. This review of schedules mainly highlights the signals heard during the daylight and early evening hours when listening in eastern Australia (2000-1200 UTC). The frequencies listed are those which should give best reception in Australia and New Zealand up to November, 1986. They should remain relatively stable, although in September a time change may affect some broadcasts from European countries.

Times quoted in this selection of World News are in UTC (GMT) which is 10 hours behind Eastern Australian Standard Time and the frequencies listed are in kilohertz.

Time (UTC)	Source	Frequency (kHz)
2000	Radio Australia, Melbourne	6060, 6080, 7215
2000	BBC, London	7145, 7325, 9410, 9570
2000	RCI, Canada	11945, 15325
2000	Radio Damascus, Syria	7455, 9670
2000	IBA, Israel	9009, 9815, 11605, 12080
2000	RNZ, New Zealand	11780, 15150
2000	VOA, Washington	6040, 9760, 11760
2030	Radio Nederland, Holland	9715, 9895, 11740
2050	Radio Havana, Cuba	11720, 11790, 15300
2100	Radio Australia, Melbourne	9580, 15160, 15240
2100	DW, West Germany	7130, 9765
2100	Radio Moscow, USSR	15130, 15155, 15385
2115	Radio Cairo, Egypt	9805
2200	BBC, London	6195, 9410, 9570
2200	RCI, Canada	9755
2200	AIR, India	9595, 9910
2200	VOFC, Taiwan	11855, 15370
2200	VOT, Turkey	9560, 9730
2200	VOA, Washington	11760, 15185, 17740
2300	Radio Australia, Melbourne	15160, 15240
2300	Radio Moscow, USSR	15130, 15455, 17700
0000	BBC, London	9410, 9915
0000	AFRTS, Los Angeles	11790, 17765
0000	VOA, Washington	11760, 15185, 17740
0000	RNZ, New Zealand	11780, 15150
0100	RAE, Argentina	9690, 11710
0100	Radio Prague, Czechoslovakia	9630, 9740, 11990
0100	DW, West Germany	9545, 11785
0100	Radio Moscow, USSR	12050, 13635, 15140
0130	Radio Nederland, Holland	9895
0200	AFRTS, Los Angeles	11790, 17765
0200	Radio Australia, Melbourne	15240, 17795
0200	BBC, London	9410, 9915
0200	RCI, Canada	5960, 9755
0200	Radio Korea, Seoul	11810, 15575
0200	SRI, Switzerland	9725, 9885, 12035
0215	Radio Cairo, Egypt	9475, 9675

0230	RSI, Sweden	9695
0300	Radio Baghdad, Iraq	9565, 11750
0300	RCI, Canada	5960, 9755
0300	Radio Prague, Czechoslovakia	9630, 9740, 11990
0300	DW, West Germany	9545, 9640
0300	Radio Budapest, Hungary	9835, 12000
0300	VOT, Turkey	9560, 9730
0315	Radio Cairo, Egypt	9475, 9675
0315	RFI, France	9535, 9790, 9800
0330	Radio Dubai, UAE	11730, 11940
0350	Italian Radio, Rome	9710, 11905, 15330
0400	AFRTS, Los Angeles	11790, 17765
0400	Radio Australia, Melbourne	15240, 17795
0400	BBC, London	5975, 9410
0400	RSI, Sweden	9665, 9695
0400	SRI, Switzerland	9725, 9885, 12035
0400	VOA, Washington	6040, 7200, 9670
0415	RFI, France	9550, 9790, 9800
0430	Radio Nederland, Holland	9895
0500	DW, West Germany	5960, 6120, 9690
0500	IBA, Israel	7410, 9009, 9435
0500	REE, Spain	6055, 9630
0515	RCI, Canada	7295, 9750, 11840
0530	Radio Dubai, UAE	15435, 17775, 17830
0600	BBC, London	7150, 9640, 11955
0600	VOA, Washington	6040, 7200, 7325
0600	Radio Moscow, USSR	15130, 15385, 17730
0600	RNZ, New Zealand	9620, 11780
0630	Radio Polonia, Poland	6135, 7270, 9675
0645	Radio Bucharest, Romania	11940, 15250
0700	AFRTS, Los Angeles	6030, 11790
0700	Radio Japan, Tokyo	11955, 15230
0730	Radio Prague, Czechoslovakia	11855, 17840, 21705
0730	Radio Nederland, Holland	9630, 9715
0730	SRI, Switzerland	6165, 9535
0800	BBC, London	9410, 9510, 9640
0800	BRT, Brussels	9880, 15515
0800	Radio Pyongyang, North Korea	11830, 13650
0800	VOM, Malaysia	15295
0830	Radio Prague, Czechoslovakia	11855, 17840, 21705
0830	Radio Nederland, Holland	9715
0830	ORF, Austria	11840, 11945, 15410
0830	FEBC, Philippines	11850, 15350
0830	SRI, Switzerland	9560, 15305, 15570
0830	FBC, Finland	15115
0900	Radio Australia, Melbourne	6040, 9655
0900	BBC, London	6195, 15070, 15280
0900	DW, West Germany	15185, 17715
0900	Radio Japan, Tokyo	11875, 15235
0900	Radio Moscow, USSR	15130, 17730
0930	Radio Beijing, China	9700, 11755, 15440
0930	RSI, Sweden	15390

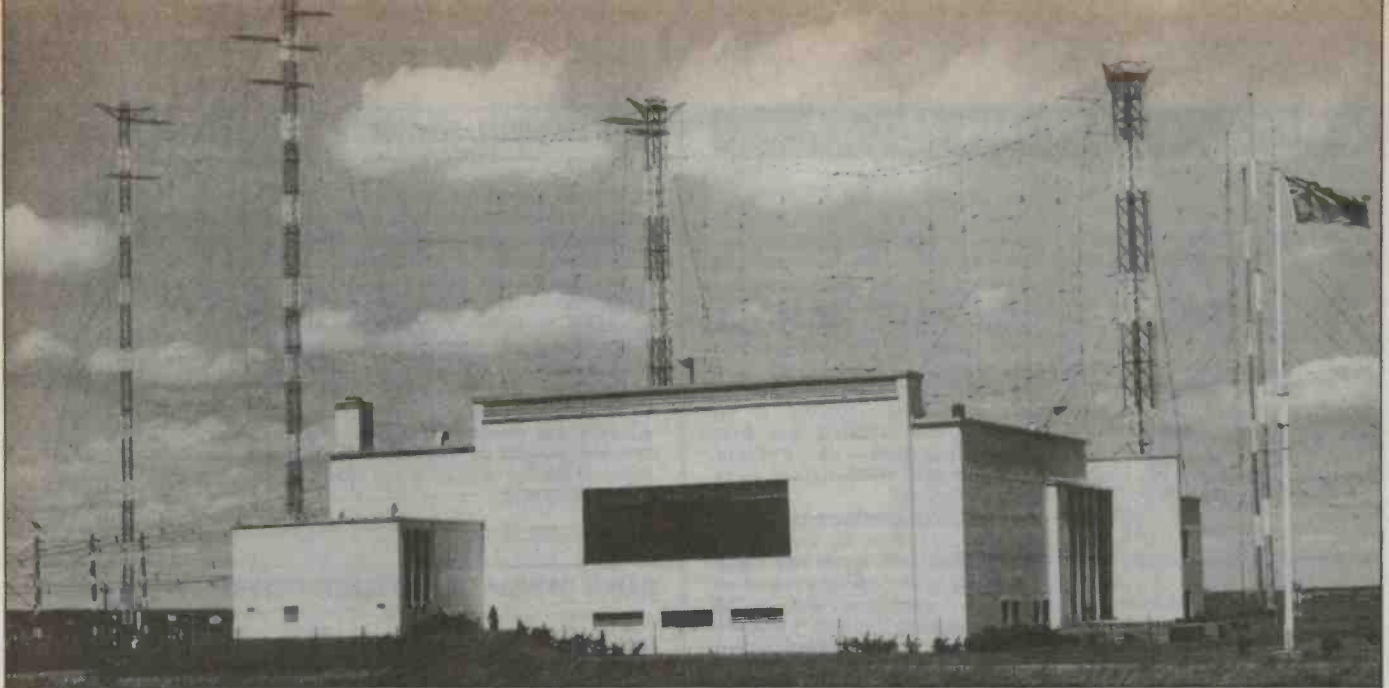

1000	AFRTS, Los Angeles	9530, 9590
1000	AIR, India	15335, 17875
1000	SRI, Switzerland	15305, 15570, 17830
1000	VOV, Vietnam	9840, 12035
1030	Radio Nederland, Holland	6020, 9650
1030	SLBC, Sri Lanka	11835, 15120, 17850
1100	Radio Australia, Melbourne	6060, 7215, 9580
1100	BBC, London	6195, 11750, 15070
1100	VOA, Washington	6110, 11715, 15425
1115	Radio Tehran, Iran	11790, 15084
1200	RCI, Canada	11855, 15440
1200	Radio Damascus, Syria	15345
1200	RNZ, New Zealand	6100, 9620
1200	Radio Tashkent, USSR	7340, 9650, 9715
1200	VOA, Washington	6110, 9760, 11715

ABBREVIATIONS

ABC	Australian Broadcasting Corporation
AFRTS	US Armed Forces Radio and Television Service, Arlington, Virginia, USA
AIR	All India Radio
BBC	British Broadcasting Corporation, World Service
BRT	Belgium Radio and Television Overseas Service (Belgian Radio)
DW	Deutsche Welle, Cologne, GFR (West Germany); also known as Voice of Germany
FBC	Finnish Broadcasting Company (Radio Finland)
FEBC	Far East Broadcasting Company, Manila, Philippines
HCJB	Voice of The Andes, Quito, Ecuador
IBA	Israel Broadcasting Authority
NHK	Radio Japan
ORF	Österreichischer Rundfunk (Austrian Radio)
PNG NBC	National Broadcasting Commission, Papua New Guinea (National Radio)
RBI	Radio Berlin International, GDR (East Germany)
RCI	Radio Canada International
REE	Radio Exterior de Espana (Spanish Foreign Radio)
RFI	Radio France International
RNZ	Radio New Zealand
RSI	Radio Sweden International
SIBC	Solomon Islands Broadcasting Corporation
SLBC	Sri Lanka Broadcasting Corporation
SRI	Swiss Radio International
VOA	Voice of America, Washington DC, USA
VOFC	Voice of Free China, Taiwan
VOG	Voice of Greece
VOI	Voice of Indonesia
VOM	Voice of Malaysia
VON	Voice of Nigeria
VOT	Voice of Turkey
VOV	Voice of Vietnam, Hanoi

KILOHERTZ COMMENT

BRAZIL: An unexpected newcomer to the use of Daylight Time in the Southern Hemisphere is Brazil, which commenced Daylight Time on 2 November last and continued until 28 February 1986. According to a report in a BBC World Information Bulletin, the adjustment sought to reduce the consumption of electric power at sunset and prevent the powerlines from being overloaded during peak consumption times.

CHINA: Radio Beijing, with transmission to Australia, has introduced the new frequency of 15440 kHz for transmissions in English at 0830-0925 and 0930-1025 UTC. The second broadcast is a repeat and both transmissions are available on the additional frequencies of 9700 and 11755 kHz.

DUBAI: The UAE Radio at Dubai has replaced 9565kHz with 11940 for its English broadcast from 0330 UTC. The station opens with a broadcast in Arabic at 0230 UTC and broadcasts are also carried on the alternative frequency of 11730kHz.

FRENCH GUYANA: An agreement is in force between France and China for both countries to use one another's facilities to improve their reception in various parts of the world. Radio France International, with transmitters in French Guyana is broadcasting in English to North America at 0300 UTC on 11970, 11980, 15280 and 15445kHz. This is repeated at 0400 UTC to the North American west coast on 11980, 15280kHz, and at 0500 UTC on 9565kHz. The broadcasts of Radio France International are carried on Radio Beijing transmitters, 0100-0130 UTC when using 15450kHz in English to Asia.

Radio France International has announced plans to build a relay transmitter in Sri Lanka which will consist of three 500kW transmitters. It was reported earlier that Radio France International and Deutsche Welle would operate jointly from Trincomalee, but Radio France has decided to build its own relay base in another part of Sri Lanka. The exchange broadcasts be-

tween Radio Beijing and Radio France International are on a trial basis only, according to "Media Network" from Radio Nederland.

INDIA: All India Radio broadcasting from Delhi has been heard on 15335kHz in English to Australia 1000-1100 UTC. Two other frequencies, 11810kHz and 17875kHz also carry the transmission to this area, while additional frequencies are used to beam to North East Asia.

IRAN: Radio Iran has signed an agreement for the purchase of ten 500kW shortwave transmitters with a Swiss company. The acquisition will be over five years and the transmitters will be installed in three different areas of Iran. According to the BBC, "several far away places and all countries in the region will be covered by shortwave transmissions" from Radio Iran. The station broadcasts in English at 1930 UTC on 9022 and 9765kHz.

IRAQ: Radio Baghdad is using 11750kHz for its broadcast in English 0300-0500 UTC. The alternative frequency of 9565kHz is also well received.

NEW ZEALAND: Radio New Zealand broadcasts to the Pacific at 1830-2115 UTC on 11780kHz, 15150kHz; 2345-0145 UTC on 15150kHz; 0345-0730 UTC on 11780kHz; and 0145-0330 UTC on 15150kHz (Saturday only). To Australia and Papua New Guinea broadcasts are 2345-0145 UTC on 11780kHz; 0345-0730 UTC on 9620kHz; 1030-1215 UTC on 6100kHz, 9620kHz; and 0145-0330 UTC on 11780kHz (Saturday only).

The broadcast includes "Good Morning New Zealand" Sunday/Thursday 1900-2100 UTC with 'Morning Report' 1900-2000 UTC.

NORWAY: Radio Norway broadcasts in Australia at 1000-1045 UTC on 9590, 15180 and 17715 kHz. The programmes are in Norwegian but on Sunday there is a 30 minute session in English titled 'Norway Today'. A further service to Australia at 1200-1245 UTC on 15165 kHz is in Norwegian.

COMMUNICATIONS TODAY

SWEDEN: Radio Sweden International, Stockholm is using the frequency 11845kHz in Swedish at 0330 UTC, and English at 0400 UTC. The service to Australia at 0930 UTC in English and 1000 UTC in Swedish on 15390kHz encounters interference from the BBC in Hungarian on Sunday 0930-1030 UTC, and on other days from 1000 UTC onwards.

TURKEY: The Voice of Turkey, Ankara now broadcasts in English: 2100-2150 UTC, 2300-2350 UTC on 6105kHz, 7215kHz, 9560kHz, 9730kHz; 0300-0350 UTC on 9560kHz, 9730kHz with 9560kHz giving the best reception.

USA: The Voice of America with broadcasts originating from a studio in Washington is transmitting its programmes to the Far East mainly from the transmitting site in the Philippines. The service to Oceania has been

moved to other frequencies for primary reception, and the secondary coverage provides some good signals. The broadcast 2200-0100 UTC is now on 15305kHz and 17740kHz with coverage also available on 9770kHz, 11760kHz, 15185 and 15290kHz. The evening service for this area from 1100UTC is on 6100kHz and 11715kHz and additional frequencies of 9760kHz, 15160kHz and 15425kHz also carry this transmission.

This item was contributed by Arthur Cushen, 212 Earn St, Invercargill, New Zealand, who would be pleased to supply additional information on medium and shortwave listening. All times quoted at UTC (GMT) which is 10 hours behind Australian Eastern Standard Time; areas observing Daylight Time should add a further hour to these schedules. ●



This collection of verification cards from Canada, includes one commemorating the earliest CBC broadcast of the regional service from Montreal in 1941, and verification cards from CBC stations in Vancouver and St John's, as well as a variety of Radio Canada cards.

NEW EXTERNAL SERVICES

Two African countries, Liberia and Zimbabwe, have announced plans for external services. According to a BBC report the Zimbabwe Broadcasting Corporation plans to beam for three to four hours a day to the Far East, Africa and Europe, the Caribbean and South America. The project is expected to cost \$US9.5 million. ZBC has already applied to the United Nations controlling agency, the International Frequency Registration Board, in Geneva, for a frequency allocation.

Liberia is planning an external service which is being paid for by the working population and a BBC report indicates that the head of state recently forwarded a cheque of \$US34,000 to the Liberia Broadcasting System. The money was collected from the Forestry Development Authority and represented a 25% salary deduction. This is the third donation received by the Liberia Broadcasting System from workers' organisations, an attempt to put Liberia on the map in the shortwave broadcasting field.

RADIO CANADA REFURBISHES TRANSMITTERS

Radio Canada International, which commenced operation in December 1945 with three 50kW transmitters has recently replaced these with three 100kW transmitters. It has also added five 250kW transmitters over the period.

The new replacement transmitters are used mainly in the Northern Canada service from Montreal. Radio Canada also used the facilities of the BBC at Daventry for relaying programmes to Eastern Europe which too have been upgraded with the installation of three new 50kW transmitters.

Radio Canada uses its own Sackville transmitters as well as those at Daventry to cover Europe and Africa with daily broadcasts in French and English, originating from the Montreal studios.

When it opened, Radio Canada was unique in that the transmitting site at Sackville, New Brunswick, was some 960km from the Montreal studios. But the distance from the studio site has proved effective as the ground area in marshy land gave Radio Canada an excellent signal particularly to Europe and Latin America.

Here in the South Pacific, Radio Canada commenced a weekly service on 6 July, 1947 broadcasting for more than 20 years, more frequently towards the end of the period. Since discontinuing this direct service, Radio Canada provides us with alternative listening in the North American service, and in the morning service to Africa in French and English (heard during the afternoon in this area). From its Vancouver studios Radio Canada has used Teleglobe Canada satellite facilities to beam "Canada This Week" in Japanese and "Canadian Journal" from Montreal for rebroadcast on Tokyo's Nihon Shortwave Broadcasting and Hong Kong Commercial Radio respectively.

Background to Radio Canada

The international service of the Canadian Broadcasting Corporation is operated on behalf of the people of Canada and is financed by annual government grants.

The service was officially inaugurated on 25 February, 1945, and the writer was appointed a technical monitor who could provide weekly information to Montreal about reception of Radio Canada in the South Pacific. This monitor has also conducted monthly band surveys of selected shortwave bands for frequency occupancy information, so that Radio Canada is aware of the other users of the shortwave channels at the time it is broadcasting to North America.

The first programmes broadcast by the station were in English and French aimed primarily at the members of Canada's armed forces then in Europe. Later other languages were added and the scope of the service broadened to give shortwave listeners around the world a picture of life in Canada and Canada's role in world affairs. The shortwave transmitters at Sackville are also used to broadcast news and other programmes to people living in Canada's Far North, beyond the signal of the domestic networks.

Broadcasts from Montreal to North America also provide secondary coverage to the South Pacific with transmissions in English 0300-0330 UTC on 5960 and 9755kHz. The services to Africa in French 0500 UTC and 0530 UTC and English 0515 UTC and 0545 UTC Monday to Friday are broadcast on 6140, 7275, 9750, 11840 and 15180kHz. Broadcasts on Saturday 2130-2200 UTC include "Shortwave Listeners Digest" which is heard on 11945, 11960, 15150, 15325 and 17820kHz.

The "Shortwave Listeners Digest" is also heard on Monday in the 0300 UTC service conducted by Ian McFarland and includes contributions on various aspects of radio listening. The address of Radio Canada International is PO Box 6000, Montreal, Quebec, H2L 4S5, Canada.

Compact DMM's...

...with real testbench performance

Philips Series 18 DMMs give you a magic combination — no-compromise testbench features and performance, packaged in a choice of three compact, easily portable instruments that are always handy for lab, workshop or field use.



Our range of three models lets you select exactly the functions you need for every application and environment.

PM 2718

min/max, auto data hold, 100 kHz RMS AC, 0.05% DC

ETI READER SERVICE 23

PM 2618

electronic calibration, 200 kHz counter, 0.3% bargraph and 10 MHz logic view

ETI READER SERVICE 24

PM 2518

RMS AC, direct temperature, dB and relative measurements

ETI READER SERVICE 25

Contact Philips Scientific & Industrial.

SYDNEY: Box 119
North Ryde 2113
Tel. (02) 888 8222
(Toll free (008) 22 6661)

MELBOURNE: Locked bag No. 5
Oakleigh South 3167
Tel. (03) 542 3600
(Toll free (008) 33 5295)



PHILIPS

RESIN MOULDED TRIMMING POTENTIOMETERS

NEW



VTL

Manufactured in Japan these miniature trimming potentiometers offer a very low cost alternative to cermet film trimpots.

The moulded construction offers greater resistance to solder heat and flux interaction than normal types of trimpot.

This makes them ideal for automatic insertion, wave soldering and automatic adjustment and cleaning processes in accordance with the latest assembly techniques.

- ★ Pin spacing is based on the 5mm industry standard grid.
- ★ Supplied in plastic tubes for ease of handling and storage.
- ★ Volume delivery from stock in values ranging from 200 OHMS to 1 MEGOHM.

TECHNICAL INFORMATION AVAILABLE ON REQUEST.

SOANAR

SOANAR ELECTRONICS PTY. LTD.

INCORPORATED IN VICTORIA

30-32 Lexton Road, Box Hill, Vic., 3128, Australia.

VICTORIA: 895 0222 QUEENSLAND: 852 1133
N.S.W.: 789 6744 WEST. AUST.: 445 3611
Sth. AUST.: 297 0811 TASMANIA: 31 6533

ETI READER SERVICE 26

Megabit EPROM

Intel is trying to ease the adoption by designers of higher density EPROMs by offering three architectures for its new 1Mb part.

The chips are intended for customers who need a clear upgrade to the higher density, for those who do not want to modify their existing designs or for those working on new designs that can take advantage of advanced 16- and 32-bit processors.

The three EPROMs consist of the 27010, housed in a 32-pin package and organised as 128K bytes by 8 bits; the 27011, which comes in a 28-pin package and is configured as eight pages of 16K bytes by 8 bits; and the 27210, housed in a 40-pin package, or-

ganised as 64K words by 16 bits each.

The 32-pin 27010 is suitable for designers who are concerned about an upgrade path from the lower-density EPROMs to ones with high densities. The lower 28 pins are directly compatible with the existing Jedec 28-pin configuration.

The 28-pin 27011 page-addressed memory is a direct re-

placement for the byte-wide 27513, a 512K EPROM.

The third EPROM, the 40-pin 27210 is designed to optimise the capabilities of advanced 16 and 32-bit microprocessors.

For further information contact Total Electronics, 9 Harker Street, Burwood, Vic 3225.

Philips zero defects warranty for ICs

The Zero Defects Warranty implemented by the Philips affiliate Signetics last August has been extended from March this year to cover all ICs produced worldwide by the Philips group of companies. Under the terms of the warranty a customer who finds a single defect in a batch will be able to return the whole batch to Philips for rescreening or replacement.

The warranty applies immediately to all standard function ICs manufactured after the implementation date. Customers have

a 30 day period to report a defective batch. The warranty covers also application specific ICs (ASICs), however cooperation is required with the customer to develop correct testing procedures for each application.

Philips began a major quality improvement program in 1981, starting with the components group, to eliminate defects by designing them out of manufacturing and administrative operations. At that time, Philips claims the IC industry average outgoing electrical defect rate

ran at about 10,000 parts per million; by 1985 the impact of its program was such that it could introduce the Zero Defects Warranty. This contrasts with the Japanese claim in 1981 that manufacturers had achieved a one defective part per million.

Nevertheless the Philips program is now at the point where continued improvement depends increasingly on customer interaction and cooperation. The ongoing collection of field data (and subsequent analysis) and cooperation with major cus-

tomers are essential to the company's ultimate goal of the Zero Defects Warranty.

To stimulate industry-wide interest, Philips will launch an international IC promotional campaign from mid year. The campaign will centre on the use of a graphically-striking "0" symbol accompanied by the words "one standard, Zero Defects — from people committed to quality". A similar campaign has already been running in USA and in international magazines under the Signetics name.

12-bit A/D converter

For the first time, the industry-standard 574 12-bit analogue-to-digital converter (ADC) is available on a single-chip.

It's the industry's first complete 12-bit ADC to include a microprocessor interface, clock and reference on one chip. The monolithic AD574A is a drop-in replacement for its two-chip predecessor, retaining performance specifications and pinout. Because of its high resolution and low price, the ADC is used in data acquisition systems for process control and test applications.

For more information contact Parameters, 25 Paul St Nth, North Ryde, NSW 2113.

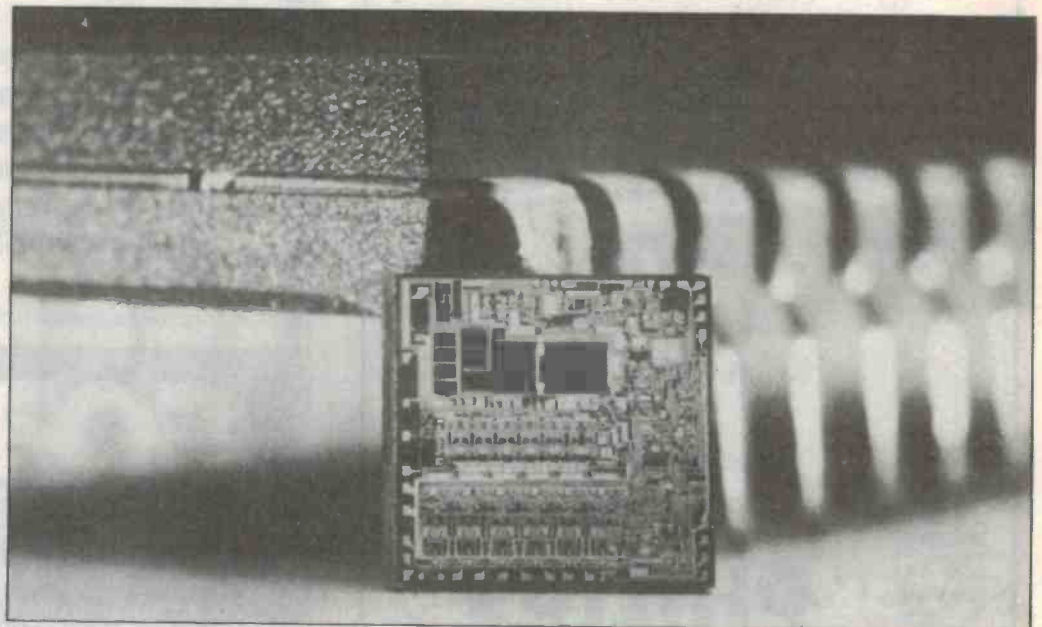

BRIEFS

Two colour LED key switches

Alps Electric Co has increased its range of TACT switches to include a built-in 2-colour (red and green) LED. The KEP series switch is 8 x 7 mm, dustproof, featuring a soft 'click', and comes 'snap-in' for direct pc board mounting. The switch is distributed by Autotronics, 1/3 Marshall Rd, Kirrawee, NSW 2232. (02)521-3711.

CMOS real time clock

The ICM7170 is a CMOS real time clock with automatic switchover to battery backup circuitry on-chip. It features a 128 year calendar which automatically compensates for leap years. It is only necessary for the user to enter the date and time. This clock from Intersil is available from R&D Electronics in Sydney and Melbourne.

Miniature trimmer capacitor

Murata has introduced a new compact range of trimmer capacitors, the TZ Series Trimcap. These caps are less than 5 mm in height with axle-less contraction and recommended by Murata "for excellent linear TV and capacitance drift". For further information contact IRH Components, 32 Parramatta Rd, Lidcombe, NSW 2141.

Jap semiconductor data manuals

Imark has copies of the 1985 CQ Data Manuals on transistors, transistor substitution, diodes, FETs, op-amps, linear ICs, TTL ICs, CMOS ICs and memory ICs. Other manuals in the range include the "Power & Industrial Manual" and "Interface IC/Device Manual". Imark is at 167 Roden St, West Melbourne, Vic 3003. (03)329-5433.

EEPROM with floating gate

The first model Siemens EEPROM which can be operated from a 5 V supply is now available. The SDA 2506 with 1024-bit (128 x 8) non-volatile memory can store data for over a decade, operating at low loss with a current draw below 5 mA. Siemens is at 544 Church St, Richmond, Vic 3121. (03)420-7204.

Motorola SMD

Motorola is offering 10 new bipolar and three new TMOS power MOSFET's. These new transistors come in a DPAK, the first power package designed for surface-mount applications. The DPAK offers a reduction in the size of the printed circuit board, the use of both sides of the pcb, the elimination of pcb through-holes and the ability to reliably handle power levels of over 1 watt.

SMD guide

A booklet entitled *A Basic Guide to Surface Mounting of Electronic Components* is available free from National Semiconductor. The booklet defines the types of surface-mount packaging and covers such topics as wave soldering, solder paste reflow, mixing surface-mount and insertion-mount, surface-mounting on both sides of a pc board, pc board design for surface-mounting and rework of surface-mounted components. It also includes an appendix with dimensions of surface-mount package types available and a directory of companies supplying surface mount process equipment, supplies and services.

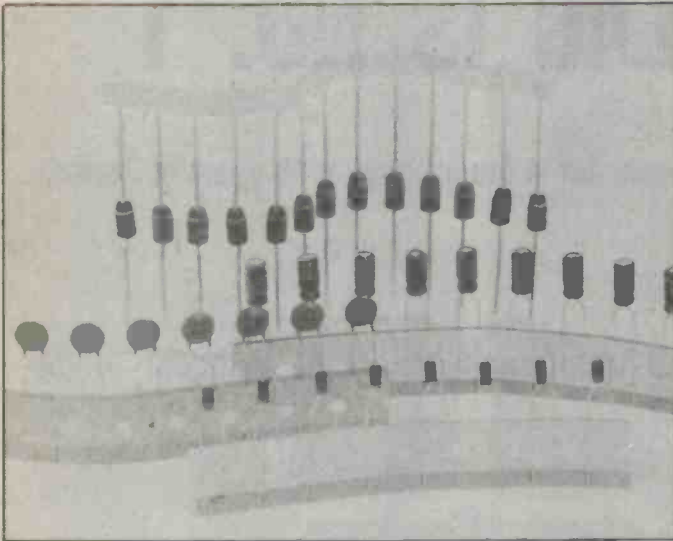

Auto insertion components

Soanar now supplies pcb components on bandolier tape from stock.

Radial-lead capacitors will be supplied on 5mm lead-spacing tape in 'ammo' packs. Ammo packs have been chosen because of the ease in selecting the correct polarity of electrolytic capacitors and other polarised components.

Tantalum, monolithic ceramic,

disc ceramic and polyester capacitors will all be supplied on radial tape.

Rectifier and signal diodes will normally be supplied on axial tape. However the radial lead format is also available for these components but on an indent basis.

For more information contact Soanar, 30 Lexton Road, Box Hill, Vic 3128. (03)895-0222.

Last from Motorola

Motorola has announced it is now taking the last orders on a large number of older data conversion circuits. The company is phasing out these components as part of a strategic shift of re-

sources to its new line of video-speed data conversion devices based on its MOSAIC process.

The following parts will be phased out over the next two years.

PRODUCT	DESCRIPTION	ORDERS BY
MC1405	A/D SUBSYSTEM	31/ 3/86
MC1550G	RF/IF AMPLIFIER	31/12/86
MC3510	10-BIT DAC	31/12/86
MC3410,C	10-BIT DAC	31/12/86
MC3512	12-BIT DAC	31/12/86
MC3412	12-BIT DAC	31/12/86
MC6890	8-BIT MPU DAC	31/12/86
MC10315L	7-BIT ADC	31/12/86
MC10317L	7-BIT ADC	31/12/86
MC1506L	6-BIT MULT DAC	31/12/86
MC1406L	6-BIT MULT DAC	31/12/86
AD562	12-BIT DAC	30/ 6/86
AD563	12-BIT DAC	30/ 6/86



WHY BEYSCHLAG IS NO. 1

No. 1 Because each & every BEYSCHLAG film resistor is the product of 55 years of German research & development.

No. 1 Because BEYSCHLAG's quality control program is the most stringent in the world.

No. 1 Backed up with a 25 year guarantee on every component.

No. 1 in Australia, **No. 1** throughout the world.



METAL FILM RESISTORS

All values of resistors available from:

CRUSADER ELECTRONIC COMPONENTS PTY. LTD.

81 PRINCES HWY, ST. PETERS NSW 2044 Phone 519 5030 516 3855 (3 Lines) 519 6685 Telex 123993



Call us now for free brochures, literature & technical specs.

APPOINTED DISTRIBUTORS:

SYDNEY GEORGE BROWN & CO, PTY. LTD. PHONE 519 5855 GEOFF WOOD ELECTRONICS PTY. LTD. PHONE 810 6845
WOLLONGONG MACELEC PTY. LTD. PHONE 29 1455 CANBERRA GEORGE BROWN & CO PTY. LTD. PHONE 80 4355
NEWCASTLE NOVOCASTRIAN ELECTRONIC SUPPLIES PHONE 61 6055 MELBOURNE R.P.G. AGENCIES PTY. LTD. PHONE
439 5834 JESEC COMPONENTS PTY. LTD. PHONE 598 2333 GEORGE BROWN & CO PTY. LTD. PHONE 419 3355
BRISBANE L.E. BOUGHEN & CO. PHONE 369 1277 COLOURVIEW WHOLESALE PTY. LTD. PHONE 275 3188 ST LUCIA
ELECTRONICS PHONE 52 7466 ADELAIDE PROTRONICS PTY. LTD. PHONE 212 3111 D.C. ELECTRONICS PTY. LTD. PHONE
233 6946 PERTH SIMON HOLMAN & CO. PHONE 381 4155 PROTRONICS PTY. LTD. PHONE 362 1044

SUPER II VZ200 MODIFICATION

Matthew Sorell

The VZ200 computer was one of the earliest of the really cheap, low performance computers on the market and as such it gained a loyal following. Over time, however, it's started to look a little too down-market. Its memory is ridiculously small, its keyboard is horrible and it lacks a number of features other computer users take for granted.

THERE ARE TWO solutions to this problem. One is to throw it away and buy a Microbee. The other is to be a bit more adventurous and see what can be done with the old carcass. In this project we show you how to increase the memory, fit a new keyboard, make it run faster, upgrade the power supply and provide a reset facility. You may carry out any or all of these modifications, as time, experience and inclination allow. It's called the Super II, for want of a better name.

Keyboard

The keyboard used in the prototype was a Digitran Golden Touch keyboard from Dick Smith. It was dirt cheap, as the keys had been coated with solder mask. Having cleaned and tinned the connections, it was as good as new. Another suitable keyboard is the Microbee.

If a numeric keypad is available, then this too can be connected, by means of the extra switches in parallel with the ones on the keyboard. On the prototype, the keypad included the digits 0 to 9, a period (.) and a RETURN key. If switches are not marked correctly, (eg, with graphic symbols), then these can be simply re-marked.

To start, remove any interface board from the keyboard. If the keys are a part of this board simply disable the interface circuit by cutting any tracks to it. By cutting tracks (on a pcb-based keyboard) and linking keys together, arrange the keys to form the matrix shown in Figure 1. With a keyboard using separate keys (eg, the Microbee), simply use wires to hook the keys together.

Extra keys, such as SHIFT-LOCK, LINE FEED or ESCAPE, should be left uncon-

nected or removed if possible. On the prototype, only 58 of the 101 keys were used, the rest were removed and the holes covered with black insulation tape.

Additional keys such as a numeric keypad, can be wired in parallel with the key they correspond to. Shift keys should be wired in parallel.

Most keys will not be correctly marked for the VZ200. If this is the case, use Liquid Paper or similar to cover over the incorrect mark, and also over blank areas where a marking is required. Mark the key required by using a black pen or thin permanent texta.

If the keyboard is for the VZ200, then invert the colours or the graphics symbols on the keys (ie, black to white or vice versa). On the VZ300, the symbols have been corrected to the BASIC ROM. The colours can be marked on the keys 1 to 8 using the appropriate coloured permanent marker.

Control keys can be marked. On the prototype, only the control words for keys 1 to 8 were marked (ie, CSAVE/ CLOAD/ CRUN/ VERIFY/ LIST/ RUN/ END/ NEW). In addition, cursor control arrows, INSERT, RUBOUT, BREAK and INVERSE should be marked. Other keys may be marked, depending on your requirements.

When all the marking is complete, gently wipe each key with clear nail-polish. This protects the marking from being rubbed off, and provides a nice, silky finish to each key, if it is applied correctly!

Now that the keyboard is to your satisfaction, decide on the connector to be used. The prototype used a 16-pin DIP plug and a 16-pin IC socket. This is reasonably flat, and so can be mounted on the underside of the computer, but the IC socket is extremely hard to keep secure. Alternatively, a 15-pin D-connector can be mounted on the top of the computer (making sure it will fit when the lid is closed!), without the power supply connections.

Open the computer by removing the six back screws. Remove the four screws holding down the main pcb. Locate the 16 connections to the keyboard. Solder a wire on the track side of the pcb to each pad (see Figure 2). If +5V is required rather than the LED power signal, this can be obtained nearby. If no power indicator is required, the last two pads can be left without the extra wires.

Wire these new wires to the connector as shown in Figure 2. If a 16-pin DIP socket is used, cut a hole to suit in the bottom of the case, and use whatever you can to keep it there (Araldite, silicone rubber, plastic cement, etc). A 15-pin D connector can be mounted on the top of the case behind the "200" in the insignia. Make sure that the wire used is long enough, so that the case can be closed easily. In order to minimise wear, silicone rubber was smeared over the connections.

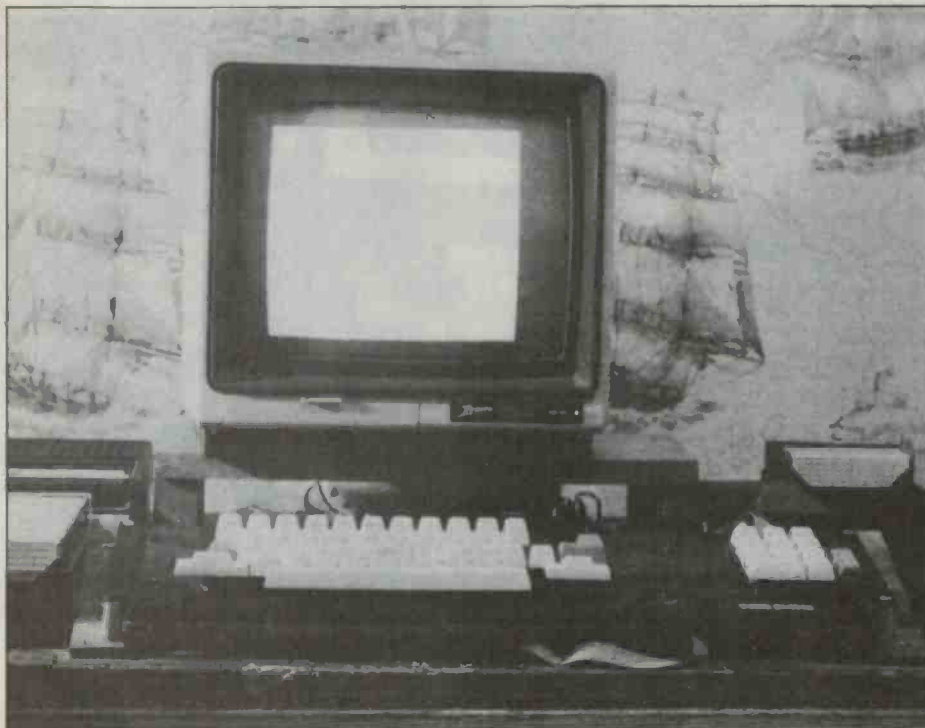

PARTS LIST — ETI-687

MEMORY BOARD

Capacitors:

- C1 47 μ , 10V electrolytic
- C2-6 100n ceramic or similar

Semiconductors

- IC1 74LS138
- IC2 6116
- IC3-6 6264

Plugs and sockets:

- SK1 16-pin IC socket (for IC1)
- SK2 24-pin IC socket (for IC2)
- SK3-6 28-pin IC sockets (for IC3-6)
- SK7,8 15-pin Utilux socket (for main pcb)
- SK9-12 15-pin Utilux plugs (for both RAM boards)

Miscellaneous:

ETI-687 pc board; wire

Price estimate: \$60

KEYBOARD

Keyboard to suit: see text;

Socket and plug top suit: see text;

Wire;

Silicone rubber (optional);

Liquid Paper;

Black pen or thin permanent texta;

Coloured textas — green, yellow, blue, red, buff, cyan, magenta and orange;

Clear nail polish.

Make up a cable from the keyboard, connecting the signals as shown in Figure 1 (ie, D0-D5 and A0-A7) to a suitable 15- or 16-pin connector. An LED may be connected across the power and 0V signals, if a 16-pin connector is used and these signals have been wired in place internally. The power signal, if replaced with +5V, may be used as desired.

Check your wiring. When everything appears to be correct, reassemble the computer, plug in the power and the video plugs *only*, and turn on. If the computer gives the correct sign on message, then all is well. Check that all the keys on the normal keyboard function correctly, then plug in the new keyboard.

If everything has been wired properly, then the new keyboard should work. If the machine crashed when power was applied, reopen the box and look for both short and open circuits on the pcb. A multimeter is handy here. If the keyboard does not work, check your wiring.

You now have a keyboard to your satisfaction!

Memory

The new memory board replaces the standard 6K of the VZ200 with 34K of static RAM.

The design is relatively simple, using only five random access memories and an address decoder IC. This is because of the use of high density static RAMs which require almost no interfacing (unlike dynamic RAM, which requires multiplexed address

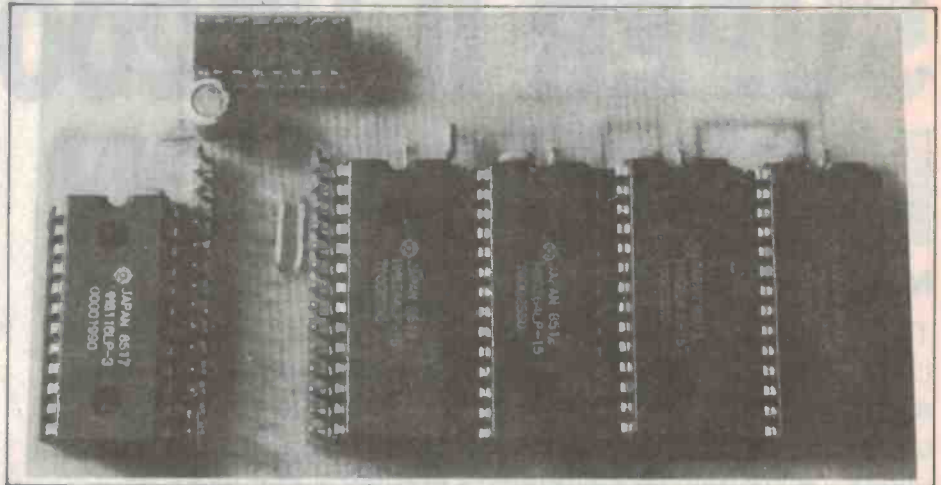

Memory board.

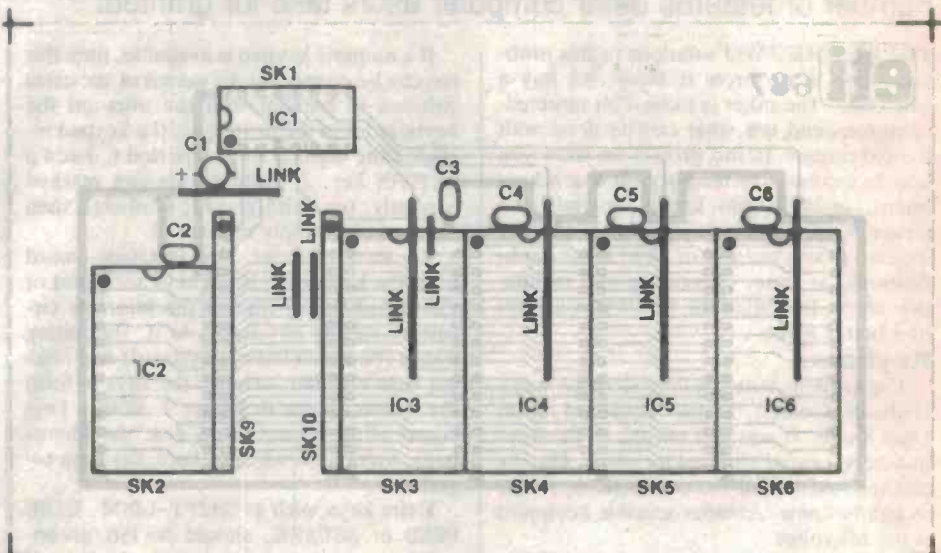

The completed keyboard with the computer beneath.

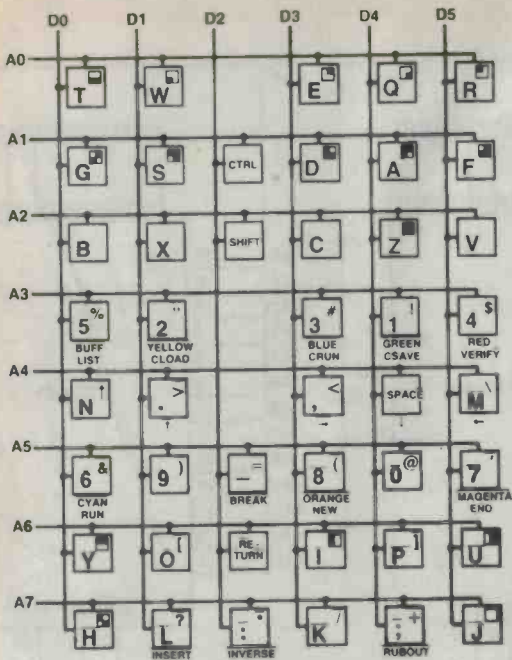

Figure 1. Keyboard matrix.

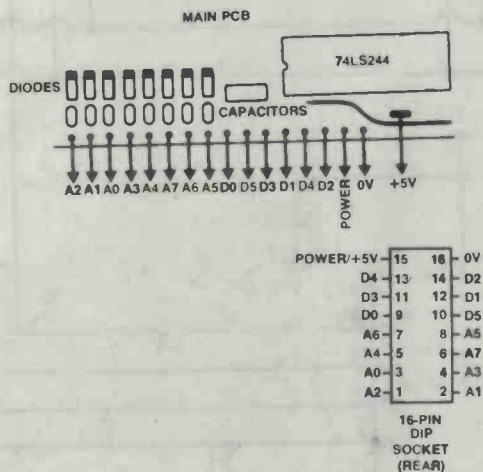

Figure 2. Wiring diagram.

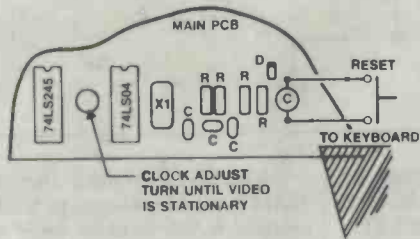

Figure 3. 74LS04 on VZ200.

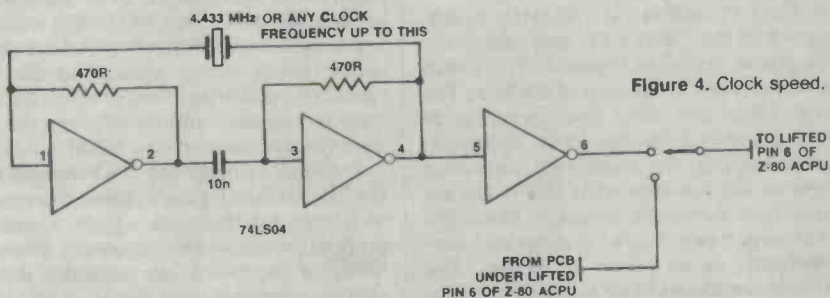

Figure 4. Clock speed.

lines plus refreshing) and are thus extremely easy to use. Two types are used: one 6116 2K RAM and four 6264 8K RAMs.

The pcb is single-sided and uses links in order to lower the cost. The board plugs in where the original board was fitted. Unfortunately, as sockets are used (the cost of the ICs makes this necessary), there is no room for the rf shield, however, I have found that there is no perceptible difference in the noise levels radiated by both shielded and unshielded computers.

34K is the maximum addressable RAM space in the VZ200 memory map. The expanded map looks like this:

- 0000-1FFFF: BASIX ROM 0
- 2000-3FFF: BASIC ROM 1
- 4000-67FF: reserved for ROM (eg DOS/RTTY etc)
- 6800-6FFF: input/output latch
- 7000-77FF: video RAM
- *7800-7FFF: 2K user RAM (6116)
- *8000-9FFF: 8K user RAM (6264)
- *A000-BFFF: 8K user RAM (6264)
- *C000-DFFF: 8K user RAM (6264)
- *E000-FFFF: 8K user RAM (6264)

All peripherals are compatible with this set-up (except, of course, for memory expansion modules).

To begin check that the pcb has been drilled correctly and that there are no short or open circuits (a lens is handy). Solder in the eight links first. It is a good idea to use single-strand insulated wire, as some wires come very close to other contacts.

Now solder in the two 15-pin Utilux plugs. These require 1mm holes instead of the 0.8mm holes elsewhere. Then solder in the six IC sockets which are crammed together rather tightly in order to reduce board size, so be careful. The bypass capacitors should now be inserted. Take care with C1, the electrolytic. Check the board and put it aside (no ICs yet!).

Attack the VZ200. Remove the six back screws, lift the lid carefully (the keyboard will still be connected) and remove the four screws holding down the pcb. Desolder the main switch and the speaker (note the wires), and desolder the four lugs of the rf shield from the earth tracks. On the top, remove any braid to the rf shield then remove the shield. Behold! The RAM board is visible. Cut the short cables leading to the RAM board from the main pcb, remove the insulation and desolder each wire.

The contacts must be cleaned so that the connector can be inserted. I used a solder sucker, desoldering braid and a needle to clear the holes. *Be careful!* Overheating does wonders to the main pcb. If you lift any track, put in a link to replace it.

Insert the two 15-pin Utilux sockets to the main pcb. Check for lifted tracks. At the moment the computer will not work. In case anything goes wrong, it is a good idea to fit

HOW IT WORKS — ETI-687

MEMORY BOARD

The RAM ICs require a simple TTL power supply. The data pins are connected directly to the data bus, as are the address lines. WRITE ENABLE is connected to the Z80 WR signal, and the OUTPUT ENABLE is connected to the RD signal. The 6116 is selected by an address decoder on the main pcb. The 6264s are selected through the 74LS138.

When MREQ is low and A15 is high, the 74LS138 will decode one of four combinations, depending on the status of A13 and A14. These signals are sent to the 6264s to enable the correct IC.

When any of the ICs are enabled (CS goes low), and a WR or RD signal is valid, the data bus will go out of tristate mode and either read data from the Z80 data bus into the address indicated on the address lines, or write data from the address on the address bus to the data bus. No other interfacing is required.

The decoupling capacitors are required for the stability of the power supply, as inductance occurs on the pcb with the power tracks.

KEYBOARD

The keyboard is continually scanned for any keys pressed. All address lines (A0-A7) are held low while the data bits (D0-D5) are checked. If any are found to be low then the computer knows that a key has been pressed and checks each address by holding the single address line low, and checking the data bits. SHIFT and CONTROL keys are also checked, and are used to derive the final character code.

Utilux connectors to the 6K RAM board for testing. To do this the holes must be widened to 1mm. If you do this, now is a good time to check that the computer still works by plugging in the 6K board, reconnecting the power and the speaker and turning on. If the normal message appears, then proceed, otherwise check the main pcb for short and open circuits (a lens and/or a multimeter is handy) and good luck!

If all is well, insert the ICs into the new RAM board making sure they are inserted correctly then plug the board into the socket, making sure that all pins are in the right place. The board will not fit flatly into the socket because two RAMs get in the way, however the contacts are satisfactory.

Apply power. If the message appears (it will take longer than normal), then all is well. If not, check everything. Once again, good luck!

Once everything is working, screw down the main pcb and replace the back of the box. Test once more. Your VZ200 has 36K of RAM (including video RAM) . . . more than most home computers on the market!

Some other modifications

1. If the video signal wavers, then correct the clock speed by adjusting the variable capacitor by the 74LS04 on the main pcb.

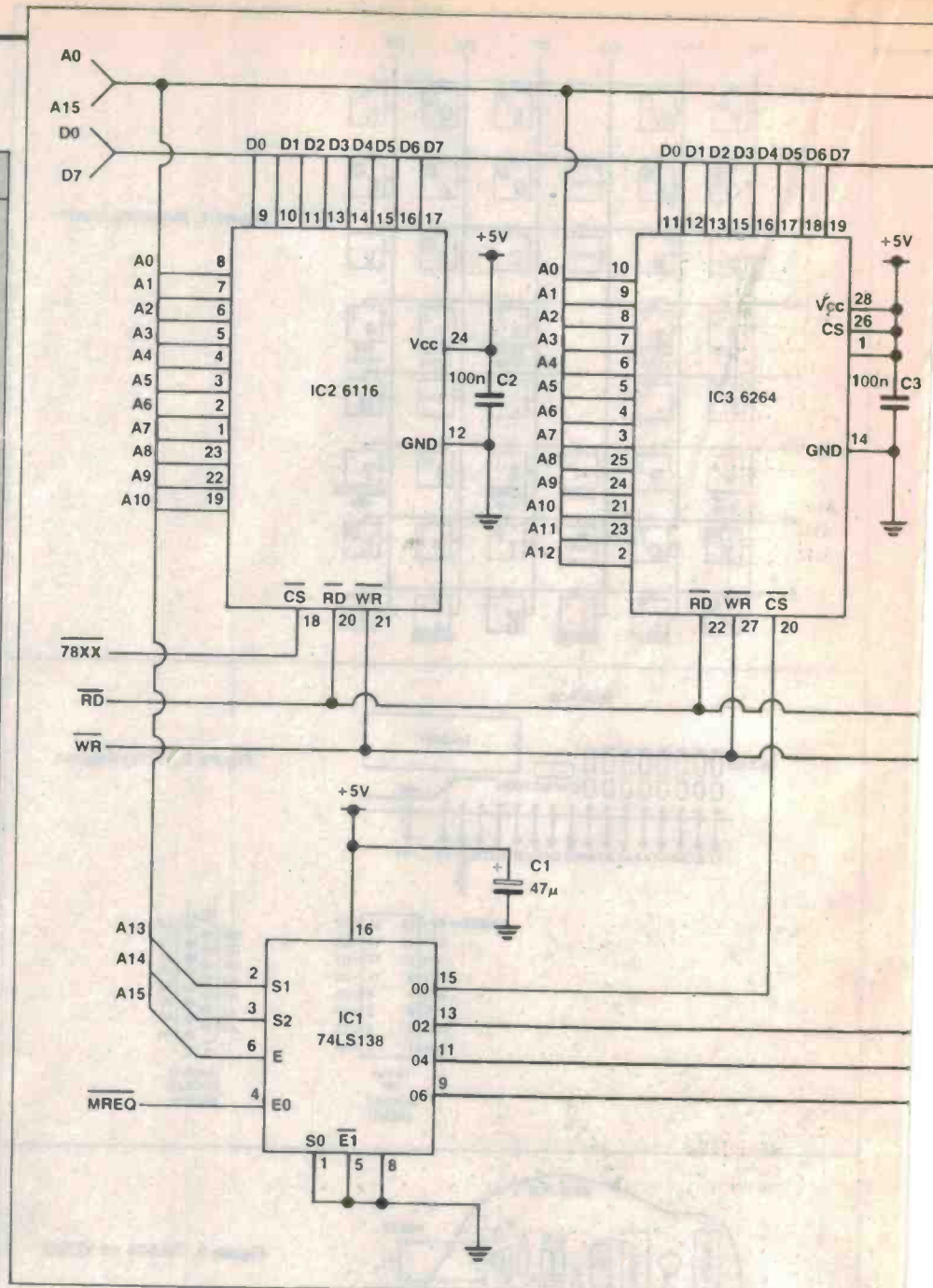

(See Figure 3 for the VCZ200 location. In the VZ300, the variable capacitor is located inside an rf shield to the right of the CPU. In both cases, a hole has been punched in the rf shield for access.)

2. The CPU can run at 4.433MHz by lifting pin 6 of the Z80A CPU and adding the clock circuit shown in Figure 4. The switch can be mounted on the top of the box. The speed change will affect tape operation, as this is controlled by the CPU. However, disk operations are unaffected and most programs will run somewhat faster. Do not change over the switch, however, unless the WAIT switch (see below) is depressed simultaneously, or no power is applied. The Z80 does not like its clock signal to be interfered with!

3. WAIT. Providing that no dynamic RAM is used (apologies to VZ300 and commercial RAM module users as these depend on the CPU for refresh signals), a pushbutton between pin 24 of the Z80 and ground will cause the CPU to halt while the key is depressed. Not only will this help the speed change circuit above, but the CPU can be stopped at any time (even at a critical stage in a game!) without affecting the software (except that dynamic RAM will clear).

4. RESET. Locate the 10μF capacitor on the 74LS04 (see Figure 3; this is the same IC as is used for the clock signal). Connect a pushbutton across this capacitor. When the button is depressed, the capacitor will discharge, causing a reset signal on the CPU. This has the advantage of resetting without

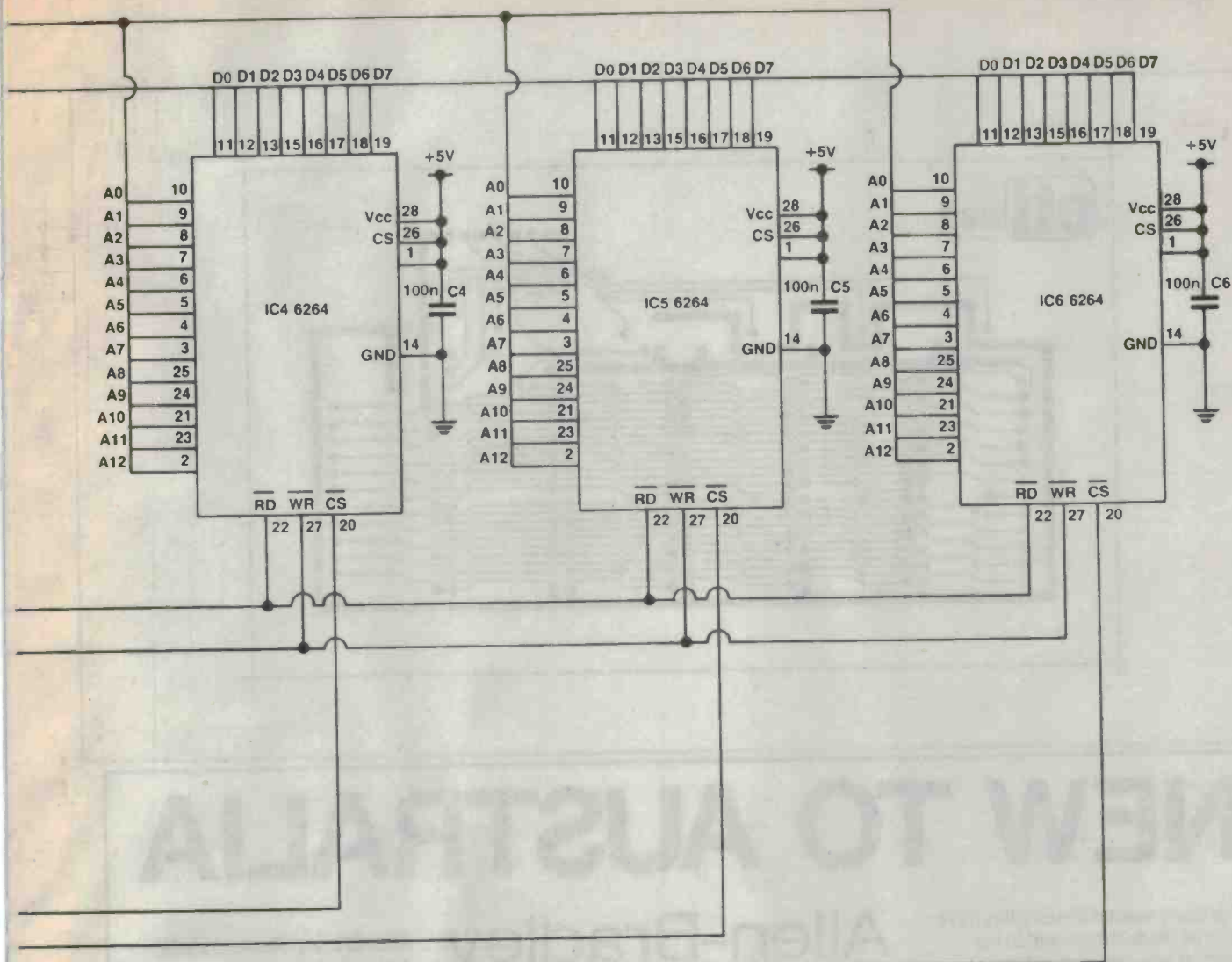

KEYBOARD SOCKET CONNECTIONS

Socket: SK7/SK9/SK11 SK8/SK10/SK12

Pin Number:

1	A15	MREQ
2	A13	A12
3	A14	A11
4	+5V	A7
5	A8	A6
6	A9	A5
7	WR	A4
8	RD	A3
9	A10	A2
10	78XX	A1
11	D7	A0
12	D6	D0
13	D5	D1
14	D4	D2
15	D3	GROUND

losing the memory, although all the program pointers will need to be adjusted. It is also somewhat kinder to the computer than turning off and on again.

5. Power supply. I have found that the power supply runs far too hot for my liking. Therefore, I mounted a 78H05 on a heatsink on the top right of the case, removed the present 7805 and heatsink, and wired the 78H05 in its place. Not only does the computer now run cooler, it no longer packs up when all my peripherals are connected!

The memory board mounted upside down inside the VZ200 case.

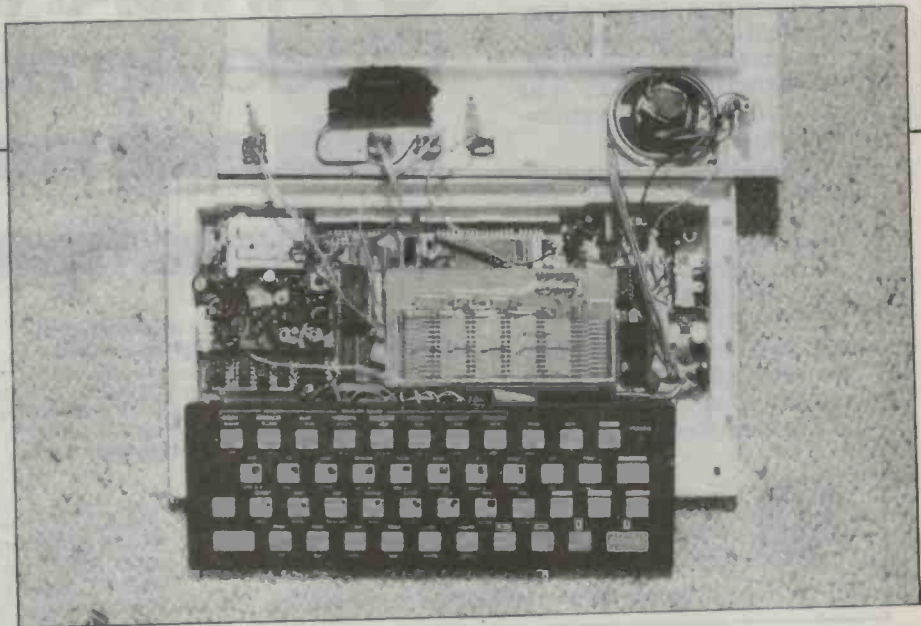

eti 687

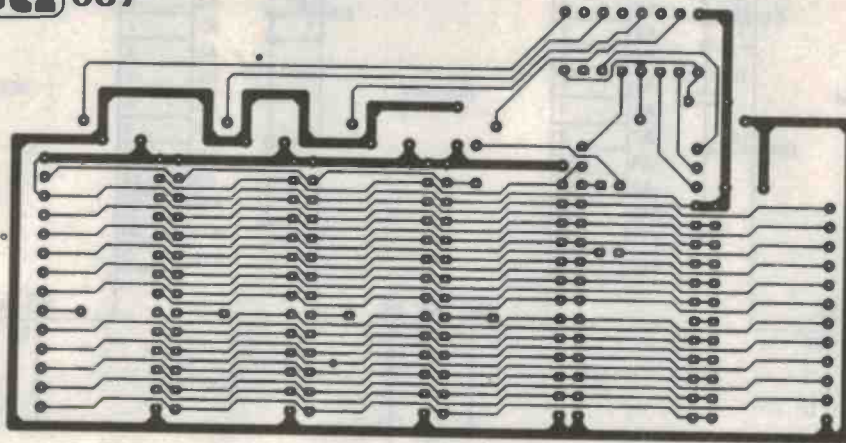

NEW TO AUSTRALIA

For many years Allen-Bradley have offered Diode Arrays within the context of a customised Network manufacturing facility. Now we are able to offer Australian industry a complete range of Single in Line Standard Diode Arrays as well. This new range will enhance our established thick film custom and standard networks and hybrids. By using new design and manufacturing techniques we have been able to incorporate the most commonly requested standard Diode applications into an easy-to-use, compatible and cost-competitive package.

Allen-Bradley is a world leader in electronic components manufacture, the performance, quality and reliability of our products has earned us that reputation.

Allen-Bradley STANDARD Diode Arrays

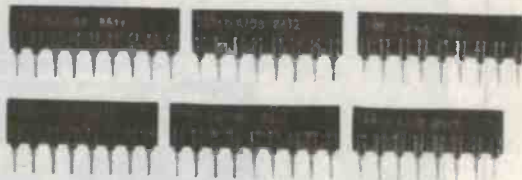

There are 3 types available - all are based on equivalents of the 1N4148 high speed Diode.

TYPE A. Common Anode - up to 18 Diodes - 19 Pins Max.

TYPE C. Common Cathode - up to 18 Diodes - 19 Pins Max.

TYPE I. Isolated Diodes - up to 10 Diodes - 20 Pins Max.

Standard configurations are from 7 to 20 Pins on 0.1" (2.54mm) spacing. Maximum package height is 7mm.

Allen-Bradley Standard Diode Arrays feature:-

- Compact Size.
- 7 to 20 Pins Single in Line.
- Variety of configurations.
- Thermal tracking between Diodes.
- Improved operating temperature -40°C to +125°C.
- Epoxy resin conformal coating.
- 96% Alumina Substrate.

Contact your nearest Allen-Bradley Electronic Components Sales Centre today, we can promise you fast delivery on these new Standard Diode Arrays.



ALLEN-BRADLEY
A Rockwell International Company

Design excellence and quality in the best tradition.

VIC. 37 Chapman Street, Blackburn, 3130. Ph. 899 0335
N.S.W. 22 Parramatta Road, Lidcombe, 2141. Ph. 648 2652
QLD. 1925 Logan Road, Upper Mt. Gravatt, 4122. Ph. 343 7900
W.A. P.O. Box 23, Subiaco, 6008. Ph. 387 1702
S.A. K. D. Fisher, P.O. Box 170, St. Marys 5042. Ph. 277 3288

WOOD FOR CHIPS ... WOOD FOR CHIPS ... WOOD FOR CHIPS ... WOOD FOR CHIPS ... WOOD FOR CHIPS ... WOOD FOR CHIPS ... WOOD FOR CHIPS ... WOOD FOR CHIPS ...

WOOD FOR CHIPS ... WOOD FOR CHIPS ... WOOD FOR CHIPS ... WOOD FOR CHIPS ... WOOD FOR CHIPS ... WOOD FOR CHIPS ... WOOD FOR CHIPS ... WOOD FOR CHIPS ...



GRAND OPENING SPECIALS

Yes we're practically back to normal in our new, enlarged premises. So come and try some of these specials -

CONNECTORS



- D-Types**
- DB25 Chrome-plated plastic RFI backshell \$ 1.95
 - DB25P plug \$ 2.50
 - DB25S socket \$ 3.00
 - DB25 right angle plug \$ 4.30
 - DB25 right angle socket \$ 4.50
 - Centronics 36 way male with backshell \$ 5.00
 - IDC 34 way card edge connector \$ 4.00
 - IEC cord set \$ 5.00
 - IBM/Centronics cord set (2m) \$21.70

MULTI-TURN POTS

For applications requiring really precise adjustment you couldn't beat these panel mounted ten turn pots.

- Up to 50k \$12.50
- 100k \$17.50

CHIP SPECIALS

- World modem chip \$27.50
- Speech chips CTS 256-A-2 \$28.00
- SPO 256-A-2 \$15.95

HEAT SHRINK TUBING PACK

A handy pack of various sizes and lengths. Black and colours. Ideal for tidying up cable ends and a thousand and one other applications. \$8.65

DATA BOOKS

As we always say - be quick because our supplies are limited.

- National Semiconductor**
- Advanced Bipolar Logic \$ 9.95
 - High Speed CMOS \$ 7.50
 - Data Conversion \$15.00
 - Interface \$15.00
 - Linear Applications (1980) \$16.00
 - Linear Supplement \$ 9.50
 - Logic Vol 2 \$20.00
- Motorola**
- Interface \$ 4.95
 - Linear & Interface **NEW!** \$15.00
 - Schotky \$10.00
- T.I.**
- High Speed CMOS **NEW!** \$12.00
 - Linear & Interface Applications
 - Vol 1 **NEW!** \$ 5.95
 - Vol 2 **NEW!** \$ 5.95
 - Linear **NEW!** \$15.00
 - Memory & Supplement **NEW!** \$15.00
 - Opto-electronics **NEW!** \$15.00
 - TTL Vol 1 **NEW!** \$15.00
 - Vol 3 **NEW!** \$15.00
 - Vol 4 **NEW!** \$15.00

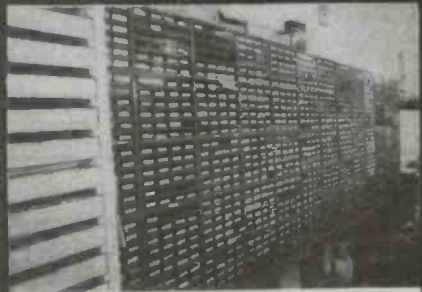

NOW YOU CAN SEE WHY OUR SLOGAN IS "WOOD FOR CHIPS"

From the commonest NAND gates and BC107's right through to microprocessors, converters and peripheral chips, Geoff's probably got the semi' you're looking for - and he can also give you technical advice on it too!



EXPANDED DATA LIBRARY

For the benefit of personal callers we've added more volumes to our comprehensive set of data books for you to peruse. Check the specs or look for possible substitutes before you buy!

8.30 to 5 Monday to Friday, 8.30 to 12 Sat.
Mail Orders add \$5.00 to cover postal charges.

All prices INCLUDE sales tax.

Tax exemption certificates accepted if line value exceeds \$10.00.

BANKCARD, MASTERCARD, VISA, CHEQUES



GEOFF WOOD ELECTRONICS P/L
INC IN NSW
(02) 427 1676

229 BURNS BAY RD. TWX 71996
(CORNER BEATRICE ST.) P.O. BOX 671
LANE COVE WEST N.S.W. LANE COVE N.S.W. 2066

OR CASH CHEERFULLY ACCEPTED

specialising in electronic components for the professional and hobbyist.



FREQUENCY STANDARD

Neale Hancock

Get the equivalent of a rubidium frequency standard by draping a piece of wire over the back of your TV set!!!

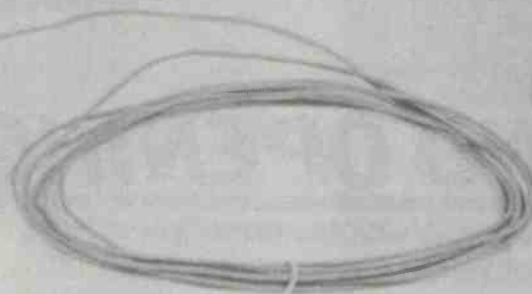

NO, THE ABOVE statement is not an ETI attempt at humour nor is it a figment of our imaginations. Believe it or not your humble television can provide an extremely stable and accurate reference frequency. You may ask "Oi, what's with the wire then?" (or words to that effect). Well that acts as a transducer to pick up electromagnetic radiation from the back of the set.

Normally you would need to spend thousands of dollars to achieve accuracy beyond the parts per hundred thousand you expect from ordinary meters. With this simple project, an extremely accurate 1MHz signal can be derived.

The horizontal deflection in the picture tube is achieved by applying voltage to the yoke at a frequency of 15.625kHz. These pulses are decoded by the receiver from the signal sent by the television station. The high voltage is provided by the extra high tension (high voltage) section of the TV set. Therefore, the eht section has a very strong electromagnetic field of 15.625kHz pulses around it.

The 15.625kHz pulses generated at the television station are derived from a rubidium standard (or will regularly check against one) thus they are very stable and very accurate. They provide the reference signal for our frequency standard.

Circuit overview

The electromagnetic radiation emitted by the eht section is transformed into electrical pulses by the loop of wire. These pulses are then conditioned and buffered providing a useful reference signal. When they are of an adequate level, the pulses go into a CMOS

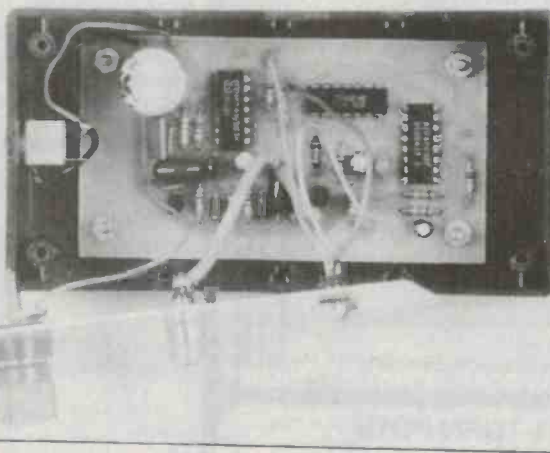

The inside view.

4046 phase-locked loop (PLL). The internal oscillator of the PLL is set to run at 1MHz and is locked to the incoming 15.625kHz reference signal.

When the PLL is locked to the reference signal, its internal voltage controlled oscillator (VCO) has the same stability as the reference. Therefore the outgoing 1MHz signal will be as stable as the 15.625kHz reference except for some PLL jitter. The jitter is due to the VCO of the PLL drifting slightly then re-locking onto the reference. This jitter can be minimised by careful selection of components.

Construction

Before you commence construction, examine the tracks on the pc board for breaks and bridges. First of all, put in the wire link located next to IC4 then put in all the capacitors and resistors making sure that

the electrolytic capacitors are polarised correctly.

Mount the diodes and transistors, but check their orientation against the overlay first. Except for the voltage regulator, all the ICs are CMOS so take care not to touch their pins when putting them into the board. Also check the orientation of all the ICs against the overlay before you mount them.

The case can now be drilled out, and then sockets, LEDs and pc board mounted in it. Finally connect the sockets and LEDs to the pc board using short lengths of hookup wire, but check the polarity of the LEDs. To reduce the chance of having stray signals bouncing around the case, shielded cable should be used to connect pc board to the output socket. Also make sure that the input socket is insulated from the case to prevent a short circuit between it and ground.

THE BROADCAST TIME BASE

Because broadcast television studios produce a great many hours of video programmes that may need to be edited or mixed with other programmes at any time, it is vital that they have a very accurate time base or synchronising signal.

A few commercial stations and the ABC use a rubidium frequency standard with an accuracy of something like one part in one hundred billion. Most stations that don't have a rubidium standard will have an oven controlled crystal oscillator and will regularly check it against a station with a rubidium standard.

In Sydney the four VHF stations regularly compare their 4,433,618.75 hertz colour sub-carrier against other stations and in virtually all instances all four are within one or two hertz of each other.

The only possible exception is that a bad video tape edit can sometimes cause a momentary phase error in the broadcast signal.

If you need the highest possible accuracy from this project then don't use it on something with a lot of video tape edits like advertising.

The system of using broadcast television signals as a frequency standard is so reliable it is used in the US by many registered laboratories. Each month the US National Bureau of Standards publishes a frequency offset for each of the networks.

HOW IT WORKS — ETI-174

The incoming signal is filtered by C1, and R1 to remove any high frequency noise. The filtered signal then goes to the base of Q1. Providing this signal has enough level to turn Q1 on, the output from Q1 will be able to drive the inverting buffer IC1a. The signal is now at a high enough level to drive the input of the phase-locked loop, IC2. To show that this signal is present, LED1 is illuminated via IC1b.

The combination of R8, R9, and C5 sets the internal VCO of the phase-locked loop running at 1MHz. The ratio of R8 to R9 is optimised to minimise jitter. So that the internally generated 1MHz can be compared with the 15.625kHz reference, it is divided by 64. To do this, six stages of a 4024 CMOS counter are used.

To show that the VCO is locked to the reference, the lock detect output is used to illuminate LED2 via IC1c. The locked 1MHz signal goes to the output socket via the npn transistor, Q2. The voltage regulator IC4 and capacitors C8 and C9 supply the circuit with a stable 12 volts dc.

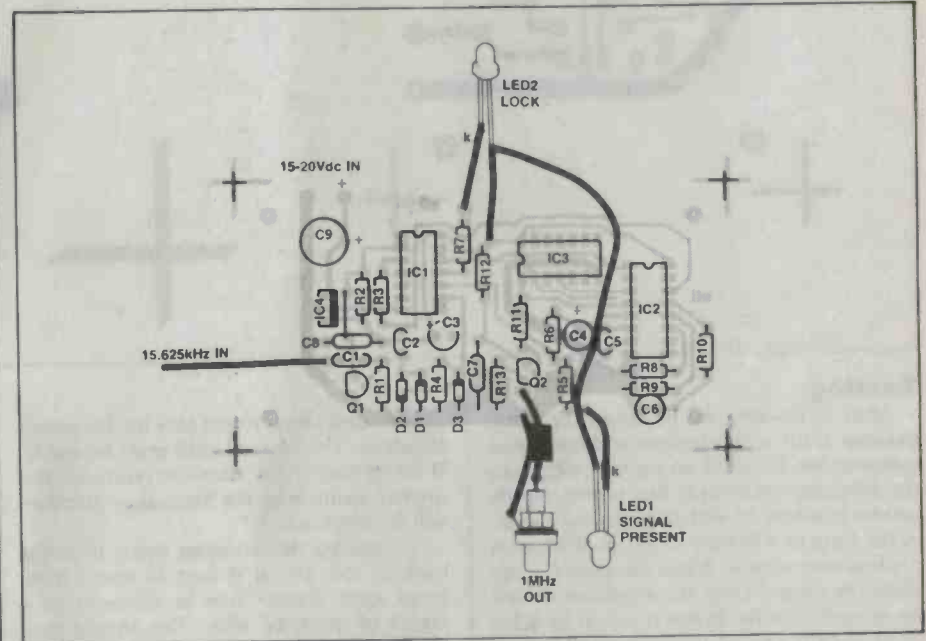
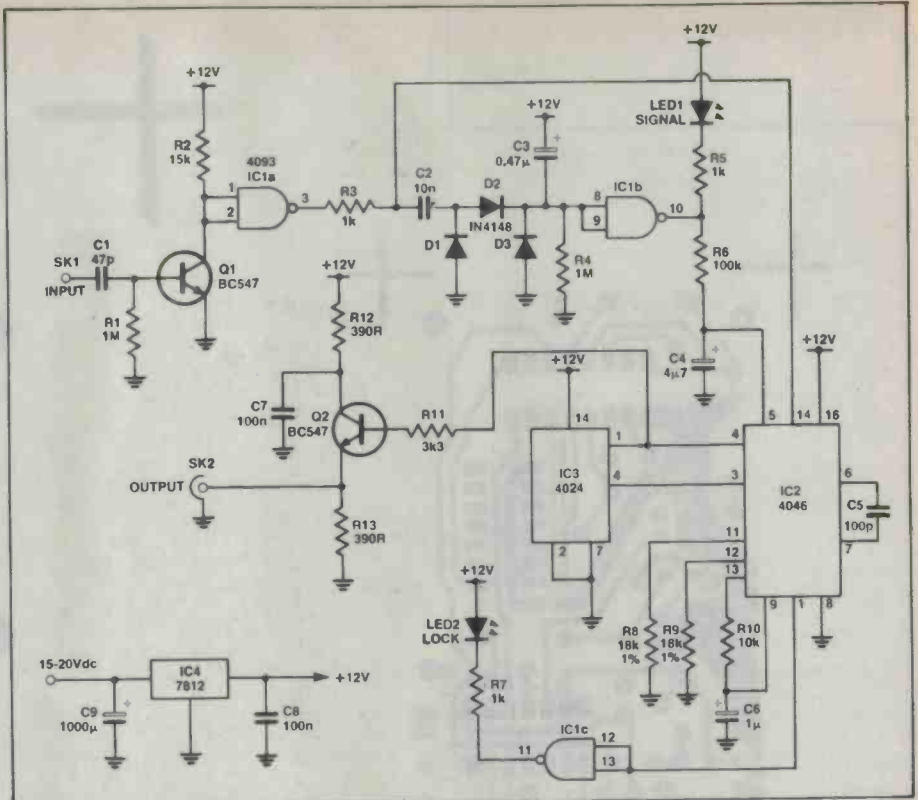

PARTS LIST — ETI-174

Resistors.....	all 5%, 1/4W except for R8 and R9 which are metal film 1/4W
R1,4.....	1M
R2.....	15k
R3,5,7.....	1k
R6.....	100k
R8,9.....	18k metal film
R10.....	10k
R11.....	3k3
R12,13.....	390R
Capacitors	
C1.....	47p ceramic

C2.....	10n greencap
C3.....	0.47µ 25V electro
C4.....	4µ7 25V electro
C5.....	100p polystyrene
C6.....	1µ 25V electro
C7,8.....	100n greencap
C9.....	1000µ 25V electro
Semiconductors	
D1,2,3.....	1N4004
LED1,2.....	red 5mm
Q1,2.....	BC547
IC1.....	4093
IC2.....	4046

IC3.....	4024
IC4.....	7812

Miscellaneous

ETI-174 pc board; 41x68x130mm zippy box; female RCA socket; 4mm socket with binding post; shielded cable and hookup wire; Scotchcal or other front panel.

Price estimate: \$21

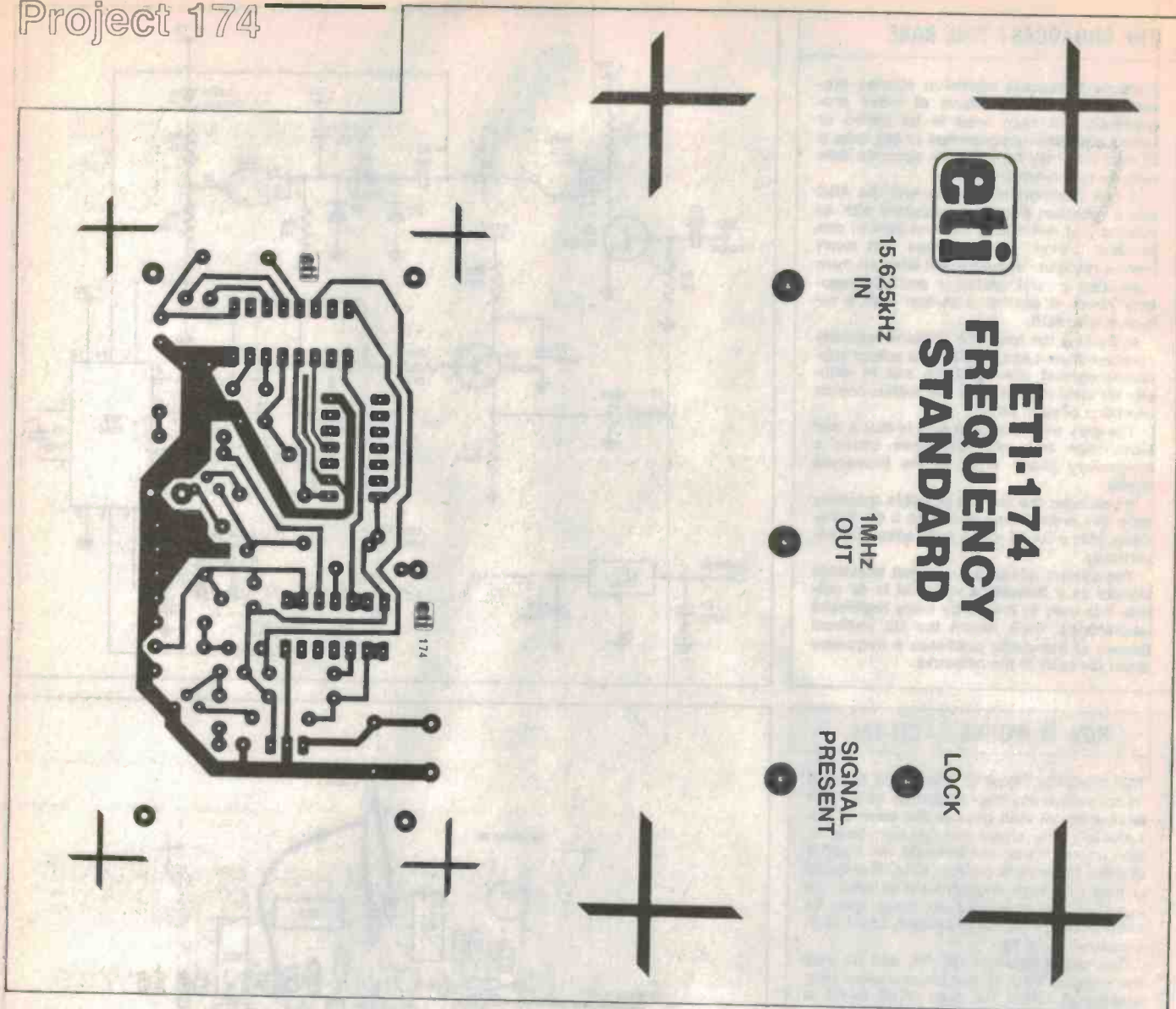

eti
ETI-174
FREQUENCY
STANDARD

15.625KHz
 IN

1MHz
 OUT

SIGNAL
 PRESENT

LOCK

Testing

After assembling the pc board, carefully examine it for solder bridges and misplaced components. Connect up a power supply to the frequency standard, this power supply can be between 15 and 20 volts and can be in the form of a battery, a plugpack or even a lab power supply. When the power is applied the output from the regulator should be around 12 volts. If this is not so look for short circuits around the supply rails.

If you want to perform an initial check on the PLL to see if it is operating correctly you can set it free running. This is done by shorting the VCO inhibit pin (pin 5 of IC2) to ground with a short (no pun intended) length of wire. The frequency at the output of the frequency standard should be between 700kHz and 1MHz (the one I tested oscillated at 850kHz).

Setting up and operation

When mounting the wire on the back of the TV set select the channel whose picture is clearest and most stable. This will provide

the cleanest signal to put into the frequency standard. The vertical hold must be stable. If the picture 'rolls' then the reference frequency going into the frequency standard will be incorrect.

To pick up the strongest signal from the back of the TV, it is best to make three loops each about 12cm in diameter in a length of insulated wire. This should then be taped to the area at the back of the TV set which emits the strongest electromagnetic field. This area is near the eht section of the television and as I mentioned at the beginning of the article, this is where the field is strongest.

To find the place where the field is strongest you can use an ac reading analog multimeter with one end of the wire loop connected to the positive (or red) probe and the other end left free. As the wire loops are moved around the back of the set the needle on the meter will be at its maximum deflection where the field is strongest. If you do not possess an analog multimeter a digital

multimeter will perform the same task as long as it has a 2Vac range. However, you will have to move the wire loops to a position then let the meter settle before you take the reading. This is more time consuming than using an analog multimeter, but it gives the same result.

Once you have found the area where the field is strongest, and taped the loops there, connect the end of the wire to the frequency standard. The 'signal present' LED should illuminate followed shortly by the 'lock' LED. When the 'lock' LED comes on the frequency standard has stabilised and is ready to use.

If the 'signal present' LED does not illuminate then there is not sufficient field present. To remedy this, move the wire loops until the LED comes on. If this does not help add more loops to the wire or make the loops bigger. If the 'lock' LED does not come on, check that the PLL is operating correctly using the procedure mentioned in the "Testing" section.

ENDANGERED SPECIES

- ✗ YOUR PRODUCT
- ✗ YOUR BUSINESS
- ✗ YOUR EXPERTISE

If Telecom is privatised, its 'Buy Australian' policy would disappear overseas along with Australian expertise.



Further information: AUSTRALIAN TELECOMMUNICATIONS EMPLOYEES' ASSOCIATION
PO Box 472, Carlton South, 3053.



THIS VERSATILE CRO!

suitable for education, hobby or service

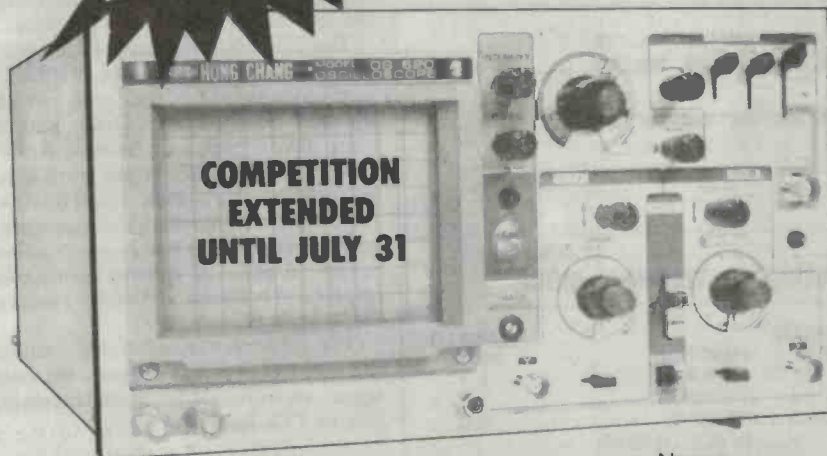

The Hung Chang Dual-trace 20MHz oscilloscope from Rod Irving Electronics
Great features include:

- ★ Built-in in-circuit component tester
- ★ Z axis (intensity modulation)
- ★ very low power consumption
- ★ video sync filter

It could be yours!

Entries must be with us by July 31.
Send your entry to: ETI CRO Competition
PO Box 227
Waterloo NSW 2017

Name
Address
P/code Phone

RS232 FOR COMMODORE

A simple project to give your Commodore RS232 compatibility.

Neale Hancock

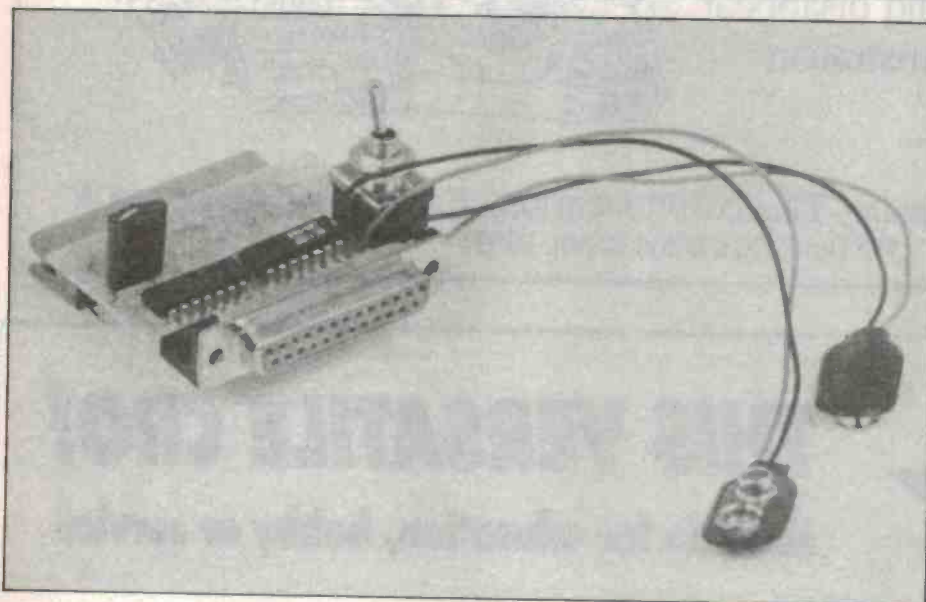

THE COMMODORE 64 and VIC 20 home computers are extensively used by hobbyists and hackers alike but they suffer one major shortfall: their incompatibility with hardware from other manufacturers. Commodore users can't connect with non-Commodore peripherals even though they might be better, cheaper or not yet available from Commodore.

Commodore's decision to make the Commodore 64 and VIC 20 home computers compatible only with Commodore peripherals may have made good marketing sense to the manufacturer, but has been a pain in the posterior to Commodore users.

The main reason for the Commodore's lack of compatibility with other hardware is the lack of an RS232 serial port. Sure, Commodores have a serial port in the form of a 6-pin DIN connector, but the information which comes out of this port does not conform to the RS232 standard.

RS232 is the standard format for serial information exchange by microcomputers, so the lack of one is a serious problem.

The ETI-1601 utilises the Commodore's 24-pin user I/O port to give it RS232 hardware compatibility. This port can already transmit and receive serial information using RS232 protocol, thus it is software compatible, but the output from it is TTL level (5 volts for a logic 1 and 0 volts for a logic 0), and is therefore not hardware compatible. The RS232 line requires a level between +3 and +25 volts to signify a logic 1 and a level between -25 and -3 volts to signify a logic 0.

The ETI-1601 circuit board connects to the user I/O port and converts the outgoing signals up to RS232 levels and incoming signals to TTL level.

Construction

Before you commence construction, examine the pc board for defects such as bridges and broken tracks. First solder in the two wire links then solder in the ICs, but

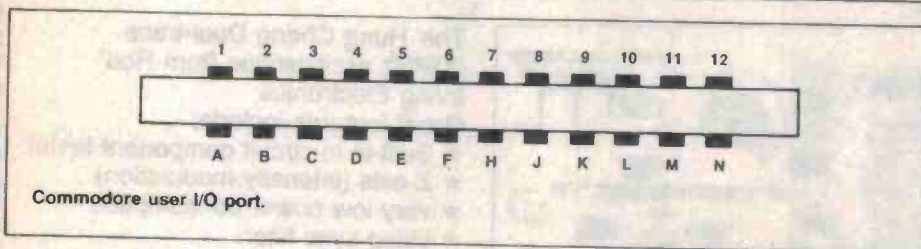

Commodore user I/O port.

TABLE 1a. HOST MODE

RS232 PIN	FUNCTION	USER I/O PIN No
1	GROUND	A,1
2	TRANSMIT	M
3	RECEIVE	B,C
4	READY TO SEND	D
5	CLEAR TO SEND	K
6	DATA SET READY	L
7	SIGNAL GROUND	A,1
8	DATA CARRIER DETECT	H
20	DATA TERMINAL READY	E

TABLE 1b. TERMINAL MODE

RS232 PIN	FUNCTION	USER I/O PIN No
1	GROUND	A,1
2	TRANSMIT	M
3	RECEIVE	B,C
5	READY TO SEND	H
4	CLEAR TO SEND	H
20	DATA SET READY	L
7	SIGNAL GROUND	A,1
8	DATA CARRIER DETECT	D,K
6	DATA TERMINAL READY	E

PARTS LIST — ETI-1601

Capacitors

C1.....150n greencap

Semiconductors

IC1.....1488

IC2.....1489

Miscellaneous

Pinted circuit board mounting DB-25 socket; 2 x 9 volt battery snaps; edge connector with 4mm pin spacing; DPDT toggle switch; ETI-1601 pc board.

Price estimate: \$18

HOW IT WORKS — ETI-1601

IC1 is a 1488 RS232 line driver. This IC takes the TTL level signals from M, D, and E outputs on the Commodore's 24-way user I/O and converts them to a level acceptable to an RS232 port, in this case ± 9 volts. IC2 is a 1489 line receiver which takes signals from the RS232 line and converts them to TTL levels. These signals are then sent to pins L, K, H, B and C on the user I/O port.

Table 1 shows which pins on the 24-way edge connector correspond to which RS232 pin. It also shows which pins to swap to have the Commodore acting as the host or as a terminal. The pc board is laid out to allow the Commodore to act as the host. If you want it to act as a terminal you will have to swap the lines as listed in Table 1.

Two 9 volt batteries are used to give the ± 9 volt rail required to drive IC1. While there is 9 volts ac provided on pins 10 and 11 of the user I/O port, it cannot source enough current to drive IC1 and thus the RS232 line.

check their orientation before you mount them.

Solder in the capacitor and the pc mounting DB-25 connector. The 24-way edge connector requires its pins to be bent at right angles before it can be mounted correctly. Solder the pins of this connector to give greater support. A fine tipped soldering iron may be handy if you want to mount the connector on the copper side of the pc board. Finally solder in the on/off switch and the leads which go to the two 9 volt batteries.

Carefully check the pc board for solder bridges and dry joints. Without the pc board plugged into the Commodore connect up the batteries and flick the switch towards the DB-25 connector. Check that the voltage rails of IC1 are close to 9 volts; if not re-examine the pc board.

Software and operation

To enable the user I/O port to send data to a printer, it has to be opened and set up with the appropriate protocol. All of the above can be performed with one line:

```
OPEN 1,2,0, CHR$(x)+CHR$(y)
```

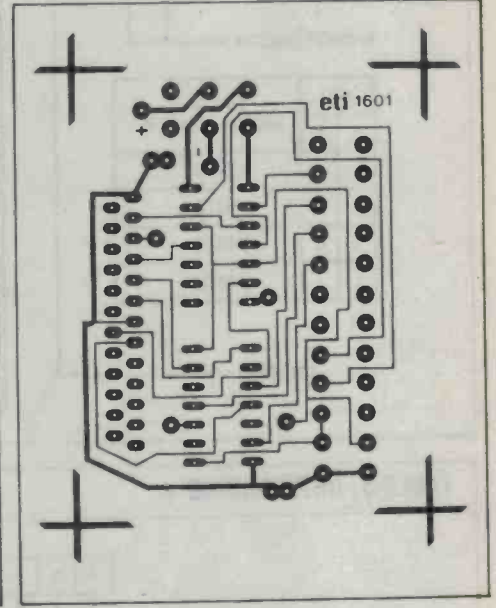
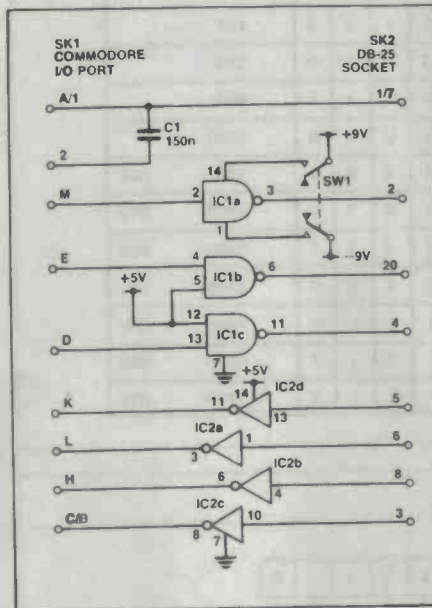
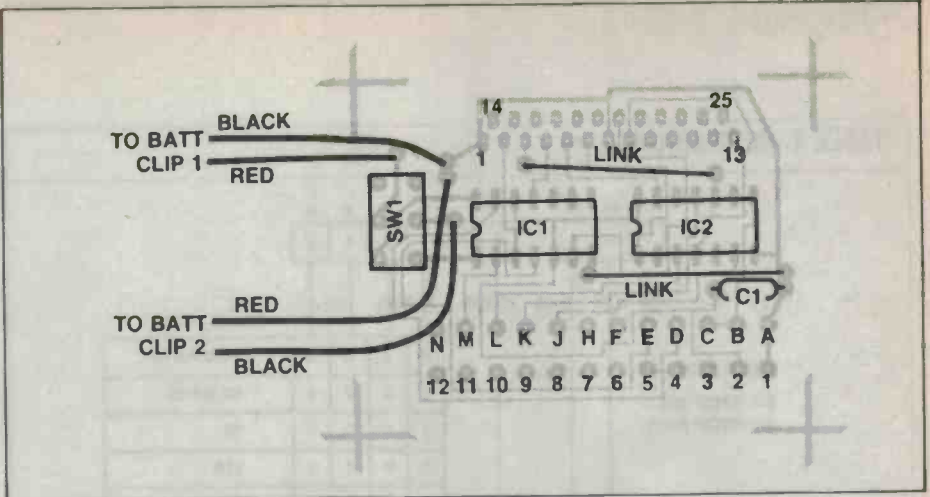

The OPEN 1,2,0, command opens the user I/O port. The three numbers after the OPEN statement designate that this port is the port to be opened.

The CHR\$(x) command sets the stop bit, data word length and the baud rate. The CHR\$(y) command sets the parity options, the duplex and the handshake. Tables 2 and 3 will enable you to determine the values for x and y. Use them to convert your particular interfacing format into two 8-bit binary numbers, then convert these numbers to decimal, and presto: you have your value for x and y.

For example, if you want to set up the Commodore's RS232 port for 1 stop bit, 7 data bits, 1200 baud, even parity, half duplex and three line handshake, the binary value for x will be 00101000 and the binary value for y will be 01110000. By using binary conversion x will equal 40 and y will equal 112.

Before you connect up the pc board make sure that there is no power going to the Commodore. Then you can plug the edge connector of the RS232 interface board into the 24-pin I/O connector on the back of the

Commodore. Make sure that the toggle switch on the RS232 interface board is thrown towards the Commodore as this is the off position. The Commodore can then be switched on, the batteries connected to the RS232 interface board and the board switched on.

To test if the RS232 interface board is working correctly set up an RS232 printer with the following format: 1200 baud, 7 data bits, 1 stop bit, even parity and no X on/X off. Now type in and run the following program.

```
100 OPEN 1,2,0, CHR$(40)+
CHR$(112)
200 CMD 1
300 FOR I=1 TO 10
400 PRINT 'RS232' SPC(1)
500 NEXT I
600 END
```

The result of running this program should be RS232 typed 10 times running. If this does not occur, first carefully examine the program for errors then look for faults on the board, especially on the signal path from pin M of the Commodore to pin 2 on the DB-25 connector.

Project 1601

TABLE 2. DETERMINING x

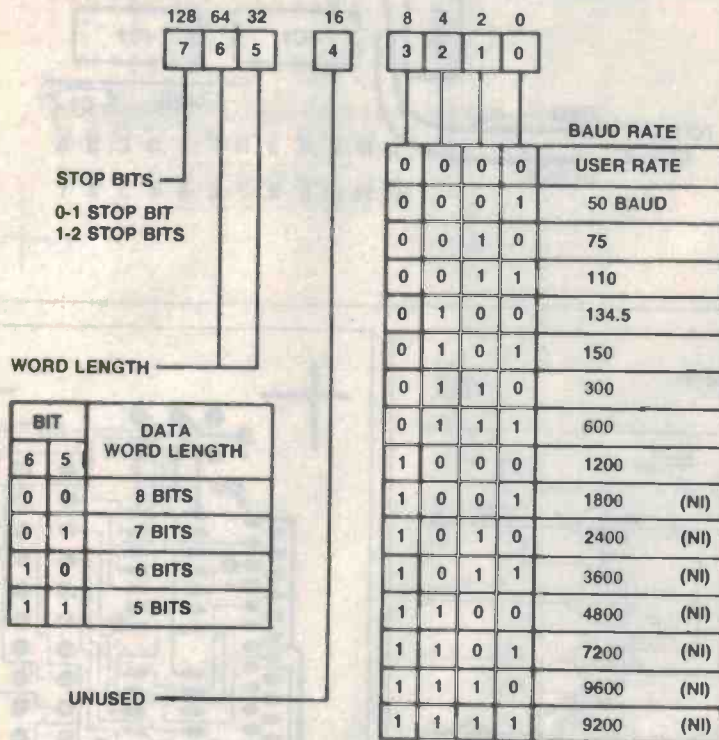
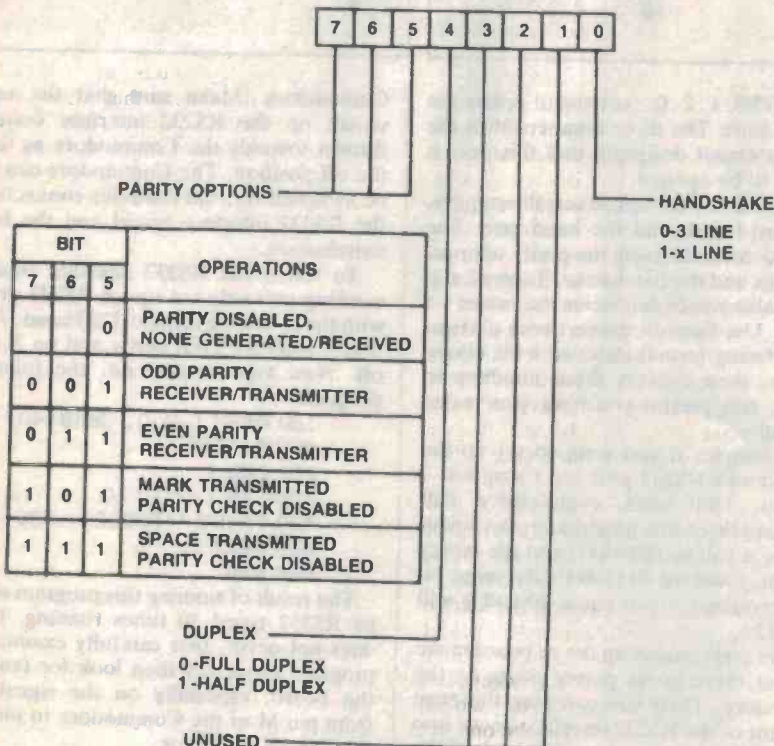

TABLE 3. DETERMINING y



HI-COM UNITRONICS INT. P/L

7 PRESIDENT LANE
CARINGBAH, N.S.W. 2229
PHONE: (02) 524-7878

ETI 684 INTELLIGENT MODEM KIT
Ring for price

SPECIFICATIONS

Auto bauding, DC Hayes commands compatible, VIATEL cassette tape storage, optional 48K RAM buffer, 6802 CPU control with auto dial/answer.

ETI 343 Optical Car Alarm Controller
incl. batteries & hardware **\$85.00**

ETI 1528 INTELLIGENT DOOR LOCK
incl. case & 16 key keyboard **\$105.00**

AEM 4600 DUAL SPEED MODEM KIT **\$150.00**

BUILD YOUR OWN IBM COMPATIBLE COMPUTER save \$\$\$
256K system with high resolution monochrome graphic display & a TTL amber monitor, 1 drive printer output and a box of diskettes **\$1590.00**



640K system colour graphic output, 2 diskdrives parallel/serial/games/clock, 14" TVM colour monitor 640 x 400 (interlaced) display **\$2570.00**

Super 5 printer EN1090 100cps dot matrix **\$499.00**
Super 5 EN1201 NLQ, 120 cps, IBM graphics, etc **\$599.00**



RADIO CONTROL SWITCH for car alarm, garage, gate, etc.

Single channel with two keyring transmitters specification: **\$129**

12VDC 19MA power supply, relay o/p 10A rating, panic switch, indicator o/p, over 20 m range & 17,000 combination.

Dual channel with one keyring **\$169**
305 MHz 80-100M range, 2058 code combination.



TOROIDAL TRANSFORMER

VA	PRICE	DUAL SECONDARY VOLTAGE	SINGLE
15	29.95	6 9 12 15 18 22 25 30 35 40 45 55 110 220 240	
30	33.95		
50	39.60		
80	43.00		
120	47.50		
150	58.50		
225	66.50		
300	75.00		
500	104.00		
625	120.00		

INTELLIGENT MODEM



S.K. Hui

Here it is!!! At long last: the circuits, the boards; all you need to know to construct the definitive modem.

Part 5

THIS IS THE FIFTH part of the modem project, probably the most complex electronics project ever to appear in an Australian magazine. An explanation of the design philosophy appeared in December 1985, the auto dialling and answering in February 1986, the power supply in March and commands and memory management in June. The final chapter next month will be a detailed operator's manual.

We have attempted, in this project, to offer our readers a fully professional modem for a fraction of the cost of a bought one. The differences between this and others floating around are not easy to establish from a quick glance at the specifications; one 1200/75 modem is much like another, right?

Wrong. The features in the software can make all the difference from an operator's point of view. Just as an example, take the auto dial facility. Some modems will simply dial the number for you and sit there waiting for carrier to come back. A more sophisticated one, like ours, will sense exchange tone to ensure a free line is available and if it isn't it will let you know. It will then detect any possible tone coming back from

the other phone and react accordingly. If the phone is busy it might redial; if unanswered it will ring off; if answered by a person it might do something else, and so on.

A word of warning. This is a complex and expensive project, and should be undertaken by people with experience only. However, problems should be few provided you use extra care in handling the integrated circuits and boards.

Also, check your work as you go. This is most important as it will be next to impossible to find chip level faults without the use of proper logic analysis. For this reason, it is important that you should be able to guarantee that the board itself and your soldering is fault-free.

Use your multimeter frequently. A good tip is to check the continuity of every component as you solder it in. Say you have two components connected by a bit of track. If you place your meter probes on the leads of the components you can check your soldering and the integrity of the track in one go. This idea can be expanded to socket level. As you solder in the socket, check each pin, making sure it's not shorted to the one next to it, nor to any adjacent tracks.

This is pretty tedious, and takes time. However, it does mean that when you plug the chips into the board you can be reasonably sure that everything is working.

If you have trouble there are some fundamental tests you can do. Check that every IC has power and ground. Do this by checking both continuity and voltage. If you have access to a CRO you can check to make sure that there is activity on all relevant pins. Note that even a multimeter can be used with some success here; expect it to show a value somewhere between 5 and 0 volts.

This level of trouble-shooting will clear up 95% of faults. We have built up two prototypes in the lab here at ETI, and found that the most common source of problem is in the feedthroughs, the connections between one side of the board and the other. Check them carefully, in fact check everything; it's the key to a successful project.

Construction

The first job is to inspect the two boards carefully. Take your time and if possible double check with a magnifying glass, making sure there are no broken or short-cir- ▶

cuted tracks, especially on the motherboard. Bear in mind that this board will be almost impossible to debug when it is complete.

Check that the boards fit in the box. The box you need is one commonly available in electronics shops. As shown in the picture, two semicircular slots have to be cut on each edge of the boards to avoid the two posts inside the box when you lower them into it.

The plastic box separates into two pieces when you unscrew it. The bottom piece is identified as the one with several long slim slots pre-cut for the loudspeaker. Put the loudspeaker onto the slots then lower the line interfacing board onto it. The magnet of the speaker should go through the round hole on the line interfacing board. The board should then land flat onto the plastic studs. Check that the screw holes on the board line up with the studs.

Similarly, lower the motherboard into the other piece of the box and make sure the screw holes on the board line up with the studs. You might have to use a small file to trim the edges of the boards and the semicircular slots slightly before they lie flat on the studs. With the boards still lying in the box, insert the front and rear panels and check that they clear the boards. More trimming with the file is needed if the boards are too big.

Now remove the boards from the box. If they are plated-through, life will be a lot easier, as there is no need for the feedthrough links in the motherboard. If they are silk-screened you can just follow the silk-screen printing to hook up the jumper links on the interfacing board.

If you have bought a cheaper kit it will probably provide you with bare boards only. In such a case, carefully follow the overlay diagram and insert the feedthrough links into the correct holes in the motherboard. A feedthrough link joins two tracks together on both sides of the board so there must be pads on both sides. If not, you must be on the wrong hole.

The same degree of care is required on the line interfacing board when jumper links are soldered. Pads are close to each other and it is easy to insert the wire into the wrong hole.

It is very important for you *not* to put any components in at this stage since some of the feedthrough links are sitting under some of the ICs.

Once you are satisfied with the links on both boards, you can concentrate on one board at a time. It does not matter which board you start first as long as you follow the instructions here.

Motherboard construction

The motherboard carries most of the big chips and has fairly close tracks. I recommend you use a thin soldering tip and thin

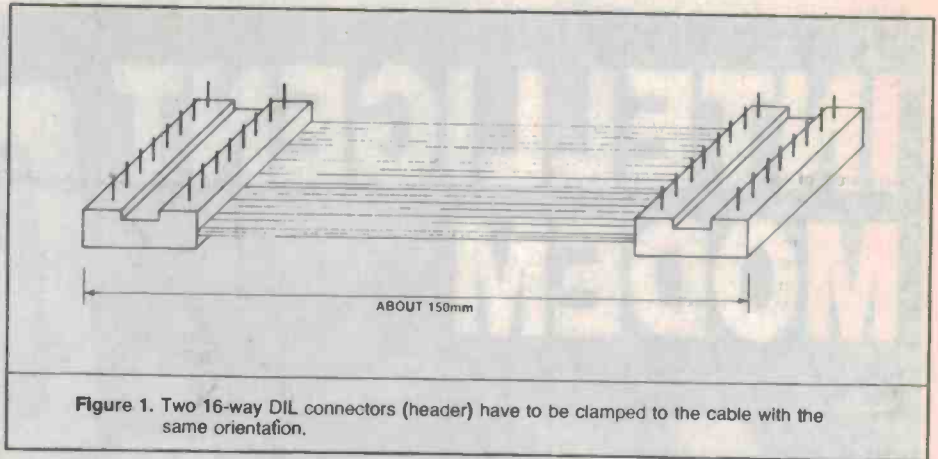

Figure 1. Two 16-way DIL connectors (header) have to be clamped to the cable with the same orientation.

solder wire. Follow the overlay diagram carefully and solder the resistors and diodes first. Double check that they are in the right places with no bridging of the tracks due to careless soldering. It's a good idea to go around with a multimeter and check that you have the correct resistance values.

Next, work on the ICs, leaving the capacitors for last. There are quite a few big chips on the motherboard such as the 6802 CPU, 6821 PIA, etc. The usual practice is to use IC sockets if your motherboard is plated-through. If not, Molex pins must be used!!!

In some places there are tracks going between pads. Be extremely careful not to short-circuit the pads to the track. During prototype development, just such an error took a few days to locate. It turned out that a small flake of solder had landed between a pad and a track and was glued in place by the molten flux. That shorted one address line to another one and even a master reset wouldn't help it.

The last things to be soldered on to the board are the capacitors. The only thing you have to watch out for is their polarity.

There are two flat cables connecting the two boards together. Cut two 16-way flat cables and 150mm long. At each end of the cables clamp a 16-way DIL connector as shown in Figure 1. Near the edge of the motherboard are pads for two 16-way DIL connectors (they look very much like ICs). Note that the copper pads are on the component side of the board. The connectors will be sitting on the soldering side when you solder them on. Because of the thickness of the connectors (which is nearly the same as the height of the studs in the box), *no* sockets should be used for the connectors on the motherboard.

Line interfacing board

This is a single-sided board; most of the tracks are pretty wide and less dense than on the motherboard. Great care should still be exercised if the board is to work first time. As mentioned earlier, be careful with

the jumper links. Count the number of links soldered on the board against the ones given on the overlay to make sure you haven't left any out. Next mount resistors and diodes. Solder the IC sockets in. You don't have to use Molex pins in this board because all the IC pads are on the solder side of the board. Again, near the edge of the board, there are pads for two 16-way DIL connectors. Unlike with the motherboard, you should mount two 16-way IC sockets for receiving the two flat cables from the motherboard. The two 16-way DIL connectors at the end of the cables will be plugged into the socket when the two boards are joined together.

Solder the capacitors and resistors on in the usual fashion.

There are some components that need to be treated in a slightly different way. The optical coupler used in the line interfacing for detecting the ring is a 6-pin chip. However, there are only five holes on the board. Cut one pin (make sure you are cutting the right pin) and solder the chip directly on to board without using a socket.

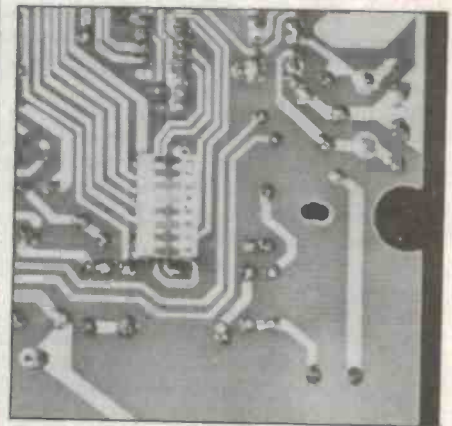

The next component to be treated unusually is the 8-way DIL switch. To solder it, turn the board over with the solder side facing up. The spot where the switch is to be

MOLEX PINS

Molex pins are easily obtained from almost any decent electronics store. They come as a long strip with 40 or 50 pins linked by a thin piece of metal. If you are making a 40-pin IC socket using Molex pins, cut two strips of 20 pins each. Insert the two strips of pins into the holes on board and solder them on both sides of the board.

Be careful!! If you look at the pins closely, you will see they are not symmetrical. One side of the pin is a flat piece of metal, the other side has a slot in the middle. When you insert the pins into the holes, the flat metal side must be facing the outside. The flat metal side prevents the molten solder getting inside the pin when you solder the Molex pins on the component side of the board.

Once you have soldered the pins in, it's easy to break the thin piece of metal which links them together. Try plugging in the IC to ensure it can sit in comfortably.

soldered should have 16 pads with no holes drilled through them. Place the switch over the pads carefully and solder it. Now take the board and lower it on to the bottom piece of the box. The switch touches the box before the board lands on the studs.

Mark the position of the switch on the box and cut a rectangular slot to match the shape of the switch.

The board should now be able to sit comfortably on the studs inside the box. The switch should either be level or sticking slightly through the bottom of the box. The idea is to allow you to change the switch without opening the box. Solder the rest of the components on, such as relays, loudspeakers, capacitors, etc.

Accessories

There are a few things to be fixed to the front and the rear panels: three 3.5mm phono jack sockets (one with on/off action), a DB25 connector, a reset pushbutton and a power indication LED, and one phono jack socket for recording. You should connect the mic input from the tape recorder to this last socket whether you are recording or not, as it carries the earth connection. To avoid earth loops, there is only one connection between the modem and the recorder, and it's through this socket.

A similar socket, but with on/off action, is used for playback. The line out, or the ear out, from your tape recorder should be connected there. When the modem is used with the line, the phono jack for playback should be unplugged. The off action of the socket connects the line to the modem chip. As soon as you plug the playback jack into the socket, the on action disconnects the line but connects the signal from the tape recorder directly to your modem chip. Remember, however, that this socket has no ground wire connected to the modem board so you must have the record phono jack plugged in during the playback to provide the ground. The wiring of the reset switch and the LED is straightforward. Just follow the overlay diagram.

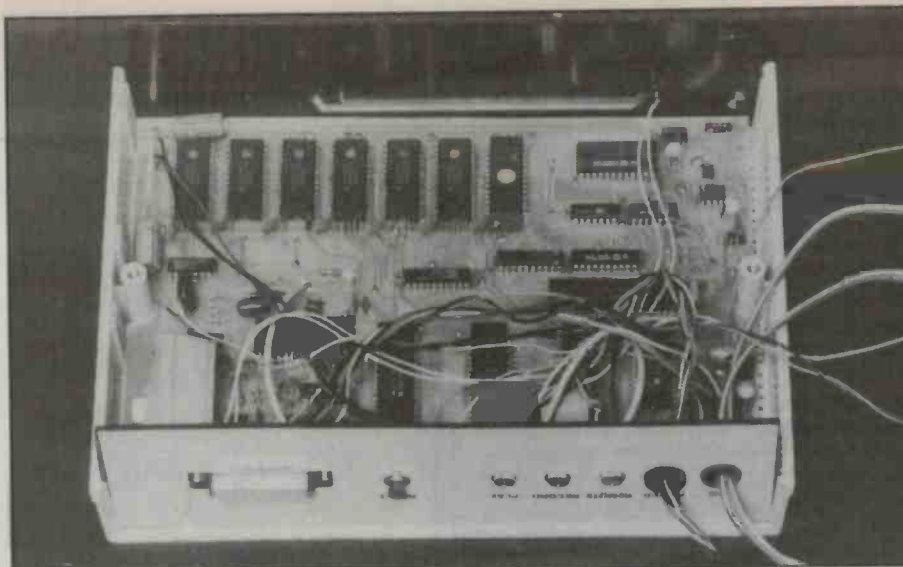

The orientation of the motherboard in the box in relation to the rear and front panels.

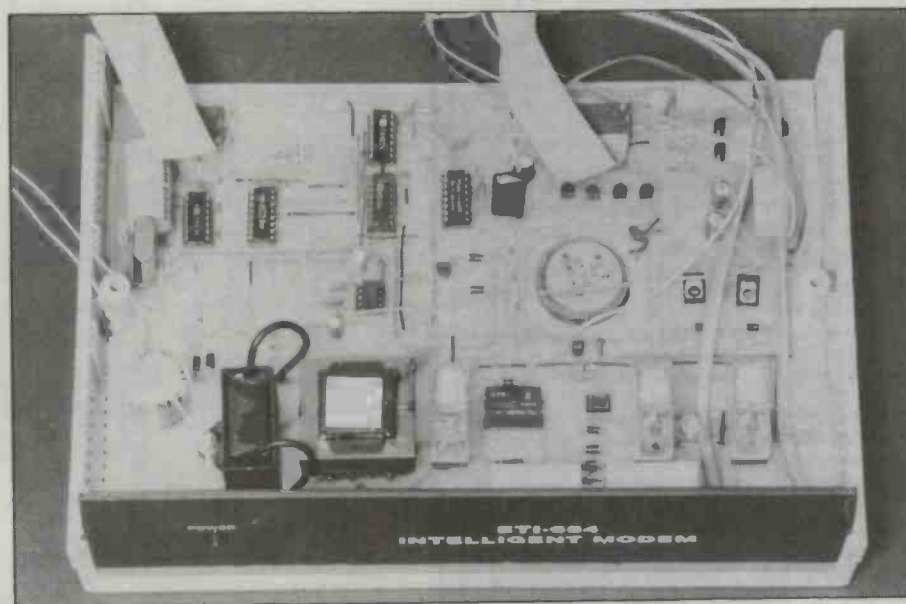

The orientation of the interfacing board in the box in relation to the front and rear panels. Note how the speaker pokes through. Insulating material should be placed between the speaker and the tracks to prevent shorting.

Leads

There are several points on both boards where flying leads are soldered and then brought to one of the grommets on the rear panel. Tie a knot to the bundle for strain relief. The length of the bundle after the knot is entirely up to you. The end of the bundle is soldered into a 7-way DIN connector. This connector will be plugged into the intelligent modem power supply. (See the ETI March 1986 issue for the modem power supply circuit.)

Since the bundle of wires carries the ground, +5V, -5V, +5V STANDBY, BELL, LIVEON, DTR, it is *very important* that you get the pin connections right. A silly mistake like +5V output from the power supply connected to the -5V point on the modem board will be disastrous!! I suggest you take a meter and check the con-

nections between the modem and the power supply with the power completely shut off.

I also recommend you get a standard telephone extension cord. On one end there is a standard Telecom female socket and on the other a male plug. Chop the cord into two halves so that the bare ends can be soldered to the interfacing board. The cord carrying the female socket should be soldered to the phone relay (see overlay), the other should be soldered to the line relay. Two cable clamps situated next to the phone relay are provided to clamp the cords down firmly onto the board.

Depending on the type of terminal you have, the connection from the modem board to the DB25 connector on the rear panel may not be standard. See 'RS232C connections' box for more detailed explanations.

ETI-684 — HOW IT WORKS

To understand how the modem works requires a lot of knowledge of microprocessor systems, assembly programming and transmission theories. It is impossible for me to detail all these theories here so the best compromise is probably to pick a few features of the modem and explain the algorithms in the software that control them.

AUTO BAUDING

As you might have guessed, the modem will adapt its baud rate to the calling modem and place itself in the answer mode. For example, if the calling modem is on 75 baud, the answering modem will automatically configure itself to 1200 baud. If the calling modem is on 300 baud (ORIG), our answering modem will set itself to 300 (ANSW). Note that if the calling modem is in answer mode, the auto baud facility will not detect any modem present, and hang up. Note that fast two-way communication is possible, but you have to reconfigure the modems to do it, i.e. the originating modem must go into answer mode, and vice versa.

The software first configures the modem chip to generate the 2100Hz echo suppressor tone for a few seconds, then it waits for a short period of silence. The software then configures the 7910 modem chip to V.21 ANSW mode, taps the 300 baud from the baud rate generator and sends it to the 6850A (ACIA), and waits for the active carrier detect signal from the 7910 for two to three seconds. If there is no active carrier after the waiting period, the software reconfigures the 7910 to V.23 ANSW mode (that is, Tx-1200 Rx-75) and sends out its carrier tone, taps the corresponding baud rates to the ACIA and waits once again for the active carrier line. If carrier detect becomes active within the waiting period, the software 'locks' onto it. If not, the software will control the relays and hang up.

CASSETTE INTERFACING

A 741 op-amp acts as a buffer for the audio signal from the line. The output of the op-amp is then attenuated to drive the mic input of the cassette recorder. Most cheap data cassette recorders have mic and ear sockets. Some more expensive ones may have line-in and line-out. A line-in requires stronger signals to drive than mic so the attenuation in the attenuator may have to be reduced. This can be achieved by changing the resistance value in the attenuator.

The tape recorder ON/OFF can be controlled either locally or remotely. If you want to record something manually, plug the mic input of the recorder to the RECORD socket on the back of the modem. Any signal on the line is now connected to the mic input of the recorder.

Press the PLAY and REC buttons on your recorder. The recorder does not start immediately because its remote ON/OFF is controlled by a reed switch in the modem which is normally open. This switch is controlled by two commands CSO and CSF for on/off control in the offline (command) mode. If you are in the online mode, talking to another modem, you have to offline yourself by typing a command on the keyboard, then using the CSO command to turn on the tape recorder. You can then get back to online mode and type a command to re-

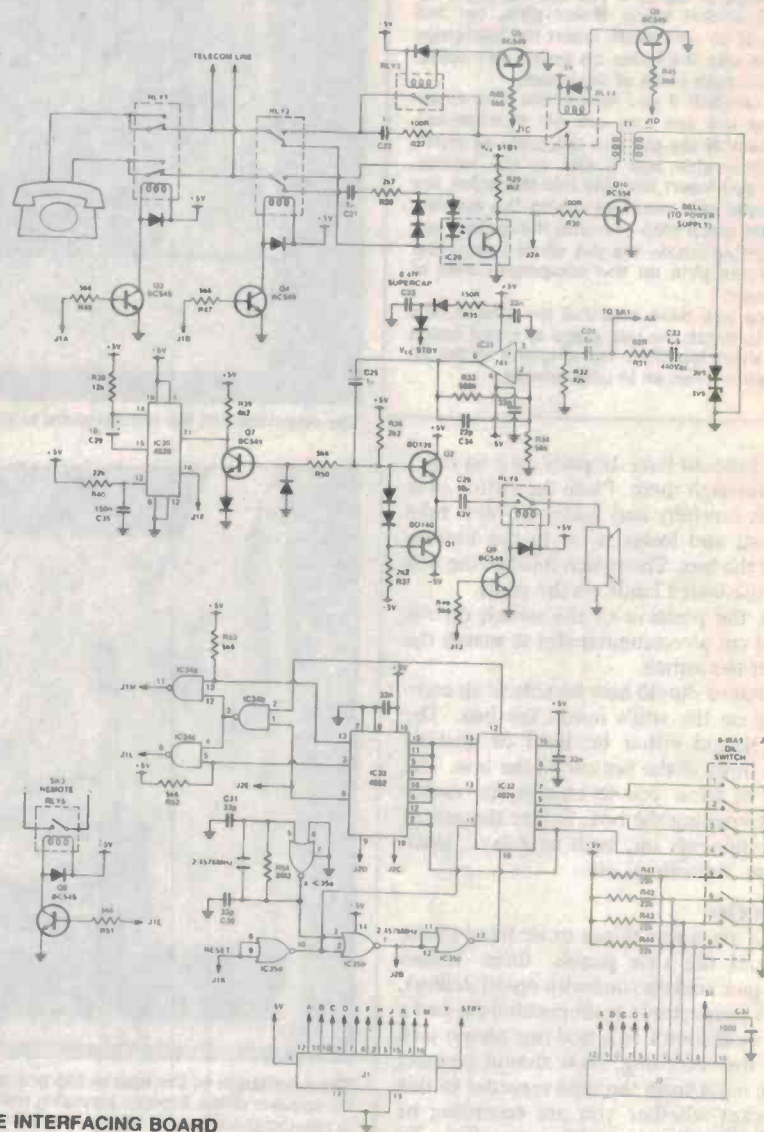

LINE INTERFACING BOARD

quest a download from the other modem. Anything coming down the line will be recorded. To turn the recorder off, simply offline yourself and use the command CSF.

There is a more intelligent way to control the tape recorder by the remote modem. The software implanted in the modem has the ability to recognise an escape control sequence as suggested by Viatel. Upon receipt of such a sequence, the software will turn the recorder on or off (if the recorder has been plugged in with the PLAY, REC buttons depressed).

LINE MONITORING

The optical coupler is powered by the standby output of the power supply and is always active. Any voltage difference on the line will trigger the coupler output. It wakes up the power supply and the modem immediately goes into the ring detection

mode. There are several different conditions which can trigger the coupler: the ringing current; a spike picked up by the line; lifting up and putting down the telephone handset; dialling on the phone. The signal generated on the output of the coupler by these is very similar.

To distinguish between them, the software relies on the different timings, for instance, if you pick up the phone a low pulse is generated on the coupler and then the output stays high for several hundred milliseconds at least. This is the delay time when you turn the dial. The software recognises this condition and ignores any more pulses on the coupler output, so the pulses on the coupler when the dial releases are ignored. The software goes into a timing loop for about half a minute and turns off the power supply. When the call is connect-

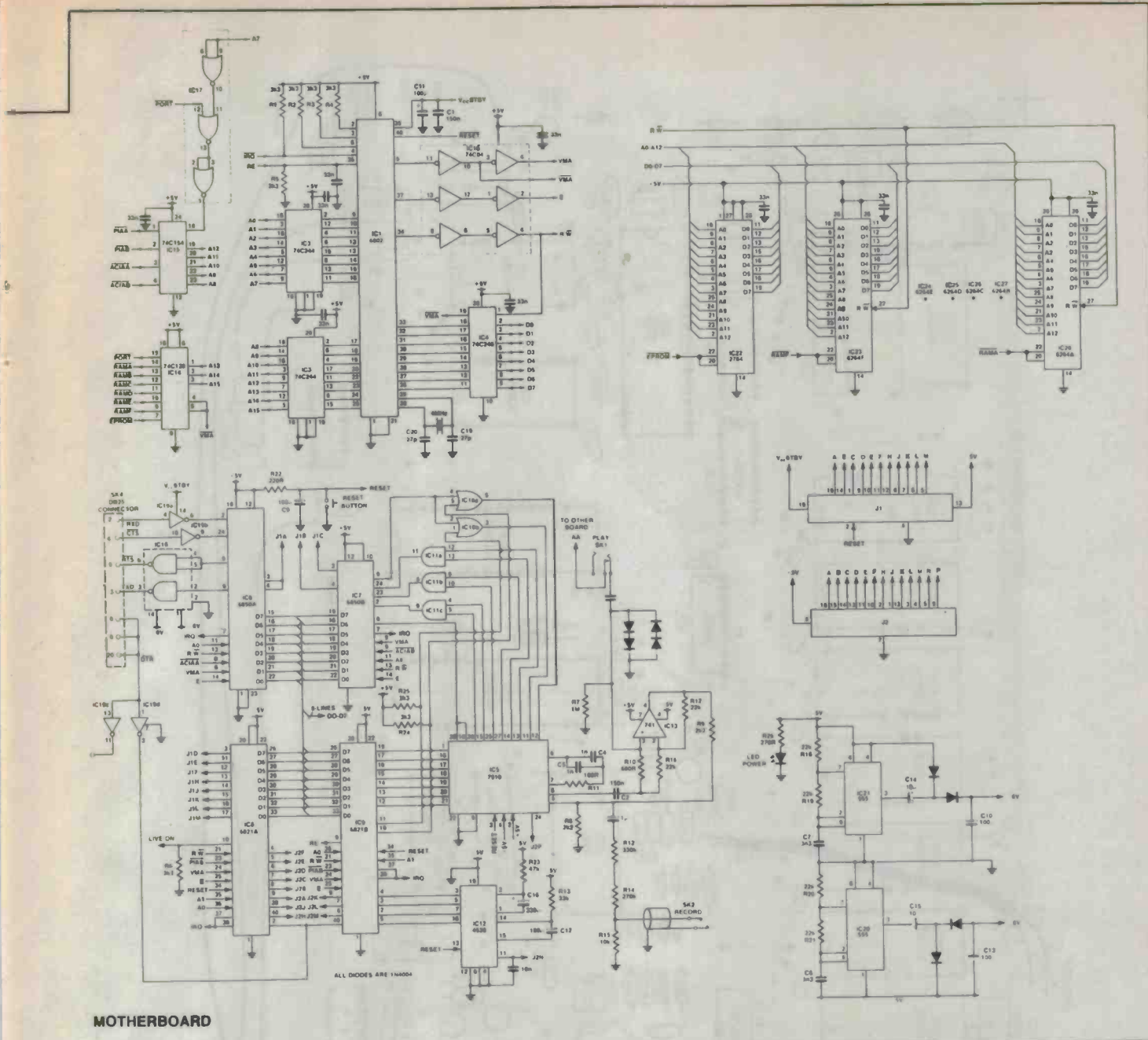

MOTHERBOARD

ed, the voice signal on the line is not strong enough to trigger the coupler to wake up the modem again.

If a spike of lightning is picked up by the line, the coupler outputs a low pulse for a short time and stays high for a long time (unless there is another spike picked up at this moment). This long period (a few hundred milliseconds) of high is recognised by the software and it enters a counting loop for about half a minute before shutting down the power supply.

Ringing current will cause the output of the coupler to pulsate between high and low in a period of about 20 to 25 milliseconds for a total of 0.4 seconds, followed by silence for 0.2 seconds (the coupler output is high during this period) then the cycle repeats. The software recognises the ring when the output of the coupler stays high

for about 25 milliseconds and returns to low. It jumps to a routine which does nothing but count the number of rings. It will pick up the phone after a certain number preset by the operator.

What if the ringing phone suddenly stops before the software loops the line? This is possible if the calling phone hangs up before the call is answered. The software detects that the ringing current has stopped after a response time of about three seconds. It cuts off the power and goes back to sleep.

How does the software detect that the ringing has stopped? The trick lies in the hardware set-up. The output of the coupler connects to several points, one of which is the trigger input of a 4528 monostable, set with a timing constant of about 40 milliseconds. The ringing pulses from the output of

the coupler keep refreshing the timing cycle of the monostable until stopped by the silence gap between the rings. So the output of the monostable is active for 0.4s, off for 0.2s, active again for 0.4s and off for 2 seconds, then repeats the cycle.

The software relies on the on/off of the monostable to count the number of rings. Whenever the output of the monostable is off, a software timing loop is begun. The software will keep scanning the monostable while incrementing a register. The register is cleared and the loop is abandoned when the output of the monostable goes active again, which means the ring is still present. If the calling phone has hung up, the output of the monostable will be inactive. Meanwhile the incrementing register will reach a value higher than a maximum number. This takes about three seconds.

RS232C CONNECTIONS

The baud rates between your terminal and the modem are 1200, 2400, 4800 or 9600. Between your modem and the line it's much slower, the highest is only 1200. If your terminal is a dumb one, there is no speed problem so the connections on the DB25 are as shown in Figure 2.

An intelligent terminal is capable of sending (downloading) a file automatically. Most personal computers can emulate an intelligent terminal. You can ask such a terminal to find a file in the disk and send it off. Immediately, one can see a traffic problem between the terminal and the modem. The circular buffer set up by the control software in the modem to receive characters from the terminal is only 32 bytes long and is easily filled up. The software senses this and controls several handshake lines on the RS232C bus to stop the terminal from sending any more characters. To make use of those handshake lines, your RS232C connections should be like those illustrated in Figure 3.

Some terminals have a DTR (data terminal ready) line but some don't. You can connect this line to the modem if available but it's not necessary. If the DTR line is connected, the modem will wake up automatically to the offline mode whenever you turn on your terminal. Without this line, you simply turn on the terminal, press the push-button on the power supply to wake up the modem, then press the return key on the keyboard to signal to the modem that it should go to offline mode. Really, there is not much difference between them.

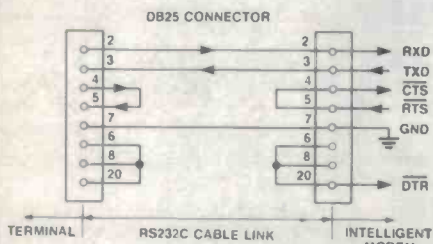

Figure 2. The simplest connection without handshake and data terminal ready (DTR) signal.

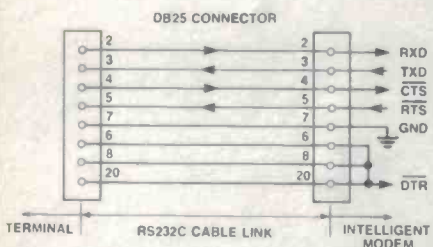

Figure 3. This configuration allows handshakes between the terminal and the modem for auto wake-up if the terminal is turned on.

ETI-684 — PARTS LIST

MOTHERBOARD

Resistors.....all 0.25 W, 1% unless noted

R1, 2, 3, 4, 5,	3k3
6, 24, 25.....	3k3
R7.....	1M
R8, 9.....	2k2
R10.....	680R
R11.....	100R
R12.....	330k
R13.....	33k
R14.....	270k
R15.....	10k
R16, 17, 18,	22k
19, 20, 21.....	220R
R22.....	220R
R23.....	47k
R26.....	270R

Capacitors

C1, 2, 3.....	150n greencap
C4, 5.....	1n greencap
C6, 7.....	3n3 greencap
C8.....	1µ/16V electro
C9, 10, 11, 12, 13	100µ/16V electro
C14, 15.....	10µ/16V electro
C16.....	330µ/16V electro
C17, 18.....	470µ/16V electro
C19, 20.....	27p disc ceramic

27 x decoupling capacitors 33n each

Semiconductors

8 x 1N4004 diodes	
IC1.....	6802 CPU
IC2, 3.....	74C244
IC4.....	74C245
IC5.....	7910 modem
IC6, 7.....	6850 ACIA
IC8, 9.....	6821 PIA
IC10.....	74C32
IC11.....	74C08
IC12.....	4528B
IC13.....	741 op-amp
IC14.....	74C138
IC15.....	74C154
IC16.....	74C04
IC17.....	74C02
IC18.....	1488
IC19.....	1489
IC20, 21.....	555 timer
IC22.....	2764 EPROM
IC23.....	6264 RAM

Miscellaneous

1 x 4MHz crystal for the CPU

LINE INTERFACING BOARD

Resistors.....all 0.25 W, 1% unless noted

R27.....	100R (0.5W)
R28.....	2k7
R29.....	8k2
R30.....	100R
R31.....	82R (0.125W)
R32.....	82k
R33.....	560k
R34.....	56k
R35.....	150R
R36, 37.....	2k2
R38.....	12k
R39.....	4k7
R40, 41, 42,	22k
43, 44.....	22k
R45, 46, 47, 48, 49,	5k6
50, 51, 52, 53.....	5k6
R54.....	8M

Capacitors

C21, 22.....	1µ/250V (Philips MKT-P 330 40)
C23.....	1.5µ/440V (Shizuki)
C24, 25.....	1µ/16V electro
C26, 27, 29.....	10µ/16V electro
C28.....	100µ/16V electro
C30, 31.....	33p ceramic
C32.....	1000µ/16V electro

C34.....22p ceramic
C35.....150n greencap
8 x decoupling capacitors 33n each.

Semiconductors

15 x 1N4004 diodes	
2 x 1W, 3V9 zener diodes	
1 x 5mm LED	
Q1.....	BD140
Q2.....	BD139
Q3, 4, 5, 6, 7, 8, 9	BC549 or BC547
Q10.....	BC557 or BC558
IC29.....	SFH601 or equivalent (Siemens opto-coupler)
IC30.....	4528B
IC31.....	741 op-amp
IC32.....	4020B
IC33.....	4052B
IC34.....	74C00
IC35.....	74C02

Relays and Transformers

RLY1, RLY2.....	double pole 6V coil (Fujitsu 621D006) Telecom App No RA80/157
RLY3.....	dialling relay 5V coil (Fujitsu FRL-644E05) Telecom App No RA81/130
RLY4.....	single pole 6V coil (Fujitsu 611D006) Telecom App No RA80/157
RLY5, RLY6.....	5/6V coil on/off reed relay (Archer 275-232 or OMC-C-106H type)
T1.....	600:600R isolation transformer (Ferguson MT620 or Arlec 45035)

Miscellaneous

1 x 2.4576MHz crystal; 2 x 14-way, 5 x 16-way and 1 x 8-way IC sockets; 2 x 16-way DIL (IC look alike) connectors with 2 sections of flat cable 150mm long each; LED holder; 0.25W 8 ohms low profile loudspeaker, 57mm diameter (Dick Smith part No C-2222); Telecom socket (type 611) and plug (type 640) which are the same plug and socket used in your phone; female DB25 connector (SK4) for RS232 link and 6-way DIN plug for the power supply; pushbutton switch for reset; 3 x 3.5mm phono jack chassis mount sockets with on/off action (SK1, SK2, SK3); these are not necessary — it is better to use Molex pins to make a socket for chips with more than 16 pins, one pack of Molex pins should be enough depending how many 6264 RAM chips you want in your modem; 2 x rubber grommets and 2 x cable clamps; 1 x double-sided (mother) and 1 x single-sided (interfacing) pc boards; hook-up wire; self tapping screws; plastic box 260 (w) x 80 (h) x 190 (d) mm, Jaycar part No HB-5910.

NOTE

The following parts are not required in the basic model to get the modem going, but will enhance the function of it. You need 8K RAM chip (6264) in the basic model. It must be put into the position labelled as 6264F, that is, IC23 in the overlay. To expand the memory buffer (up to 48K totally), you must put the extra RAM chips in the following order: IC24, IC25 ... IC28. So if you want to have 16K memory, put your first 6264 in position IC23, next to IC24, etc.

Only software turns off the main supply to the modem board. So long as the power supply unit is plugged into the mains, the standby power from the supply will support the backup memory (32 bytes inside the CPU) and certain parts in the modem. If the power supply is disconnected from the mains and STBY falls, there will be a total re-initialisation of the parameters in the modem. A 0.47F super cap can be placed in the circuit to avoid this.

Optional parts: 5 x 6264 RAM chips and 1 x 0.47F super cap (NEC).

Welcome to Feed Forward

We need your minds. Feed forward is a new section in the magazine that will continue the traditions of the 'letters to the editor' pages, 'ideas for experimenters', and the various computer columns. If you have any good ideas you want to share with us and the rest of the electronic community, send them to:

Feed Forward
ETI, Federal Publishing,
PO Box 227,
Waterloo, NSW 2017

Contributors can look forward to \$20 for each published idea/program which should be submitted with the declaration coupon below.

Programs **MUST** be in the form of a listing from a printer. You should indicate which computer the program is for. Letters should be typewritten or from a printer, preferably with lines double spaced. Circuits can be drawn roughly, because we have a draughtsman who redraws them anyway, but make sure they are clear enough for us to understand.

COUPON

Cut and send to: Scope-ETI 'Idea of the Month' Contest/Computing Column, ETI Magazine, PO Box 227, Waterloo NSW 2017.

"I agree to the terms and grant *Electronics Today International* all rights to publish my idea/program in ETI Magazine or other publications produced by it. I declare that the attached idea/program is my own original material, that it has not previously been published and that its publication does not violate any other copyright."

* Breach of copyright is now a criminal offence.

Title of idea/program

Signature Date

Name

Address

Postcode

'Idea of the month' contest

Scope Laboratories, which manufactures and distributes soldering irons and accessory tools, is sponsoring this contest with a prize given away every month for the best item submitted for publication in the 'Ideas for Experimenters' column — one of the most consistently popular features in ETI Magazine. Each month, we will be giving away a 60 W portable cordless soldering iron, a 240 V charging adaptor together with a holder bracket. The prize is worth approximately \$100.

Selections will be made at the sole discretion of the editorial staff of ETI Magazine.



RULES

The winning entry will be judged by the Editor of ETI Magazine, whose decision will be final. No correspondence can be entered into regarding the decision.

The winner will be advised by telegram. The name of the winner, together with the winning idea, will be published in the next possible issue of ETI Magazine.

Contestants must enter their names and addresses where indicated on each coupon. Photostats or clearly written copies will be accepted. You may send as many entries as your wish.

This contest is invalid in states where local laws prohibit entries. Entrants must sign the declaration on the coupon that they have read the above rules and agree to abide by their conditions.

Letters to the editor

Live chassis

I REFER TO your project 744 UHF tuner (ETI May, 1986).

You state that "a live set is one which has the neutral of the mains connected directly to the chassis". I would like to point out that this is rarely the case. The usual arrangement is similar to that shown in the diagram.

As can be seen, the incoming mains, after being switched, passes through the mains fuses, through a filter network, then to a bridge rectifier. The negative terminal of the bridge rectifier (anodes of D1 and D4) is generally connected to the receiver chassis. The positive terminal of the bridge rectifier is connected via a surge limiting resistor to the reservoir capacitor and on to the switching-regulator.

In these receivers, no matter which way around the live and neutral mains leads are connected, neither lead is connected directly to chassis. Any attempt to measure continuity between mains leads and chassis (with the set disconnected from the mains!)

could result in the wrong conclusions being drawn. Some meters would not forward bias the junctions of the diodes in the bridge on all ranges, even if the meter leads were applied to the circuit the right way around, leading to the conclusion that the set may not have a live chassis.

To conclude, if there is no earth pin on the power plug, or if there is an earth pin but no continuity between this pin and the receiver chassis, assume the set has a live chassis!

J. Kuiters
Chief Technician
2TM Tamworth

Mistakes in capacitor story

I WISH TO point out a few mistakes and misconceptions in your feature article "The little electric store" Sept, '85. The following is a list of brief comments regarding the section "Fields" p11.

- (Para 2) The electron flow in a material also depends on temperature and the applied potential difference. Insulators can become conductors.
- (Para 3) Electron orbits are *not* "normally circular". In fact the valence elec-

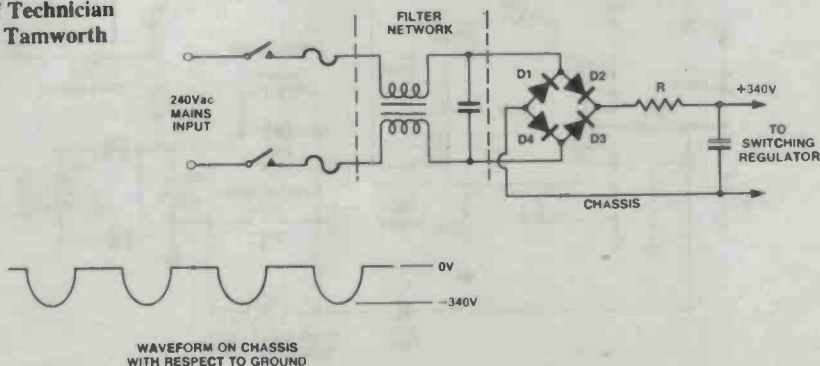

trons in metals are not even confined locally to an atom.

3. (Para 3) External electric fields do not produce elliptical orbits.
4. If the statement "field lines which indicate the direction of movement of a free charged particle . . ." were true, why is it that an electron beam in a cathode ray tube travels (nearly) perpendicular to the field lines between the deflecting plates?

D. Sidors
Northcote, Vic

1. Quite correct. In fact some circuits use just this effect to measure temperature. All materials fall into a continuum with respect to their ability to conduct. Nevertheless, normal parlance suggests that if a material is used as a duct for current we call it a conductor, and if it's used to impede current flow we call it an insulator.
2. In fact it's not even clear that electrons exist in any sense that we would understand drawing on our normal experience in the macroscopic world, and they are most certainly not billiard balls in orbit like miniature planets. However, the article was not intended as a discourse on subatomic theory. It hardly seems appropriate to launch into a long rave on quantum theory in order to explain how capacitors work. For this purpose, the billiard ball model is perfectly adequate.
3. No. But quantum theory predicts that the probability of electron location at any

given instant will form an ellipse around the nucleus in the presence of an electron field. Once again, this can be modelled quite adequately using the idea of an electron in elliptical orbit.

4. A charged particle accelerating down a tube at close to the speed of light is lots of things, but free it ain't. However, it is still responding to the combined forces acting on it. If it were not, it wouldn't deflect.

Jon Fairall

ETI scores!

THERE I WAS, my third lesson at a CAE Basic Computer course for beginners, thinking I was very clever. I have a VZ300 and have tried a few simple programs at home, and I wanted to see the instructor's face when I got this colourful haze on the screen!

In went the "Dynachromics Generator" program for Apple computers (April '85 ETI) and I called the instructor and his friend over for a look see. Can you imagine my embarrassment when the screen showed "APRIL FOOL" (funny if you're at home — but not in front of a couple of professionals!!!!).

I'd just like to thank Lindsay R. Ford for sending the program in to ETI and I hope I can get you both back when I learn enough to write my own programs.

Rhonda Harvey
Wantirna, Vic

Pleased prizewinner

JUST A SHORT note to thank you and all at ETI for giving us readers a chance to enter competitions such as the HP/ETI PC Instruments one.

Being one of the winners, my HP multimeter duly arrived and has been put to good use already. Needless to say I am extremely pleased with it, particularly as my area of interest is measuring instruments.

Keep up the good work with the magazine; it's very popular as evidenced by the trouble I'm having getting back copies!

Tom Macha
Sandy Bay, Tas

Them vs us

YOUR ARTICLE "Programmes turn on VCR" (Jan ETI) was interesting to note. It would seem that the "them vs us" mentality so pervasive in Australian society, and also evident in the continuing fight between broadcasters and the videotapers over among other things copyright materials is not the same in Europe. One wonders whether this co-operative attitude of the Europeans might have something to do with their having made so many innovations and what's generally termed 'progress'.

While we see the computer and automation as evils, those people seem often to see them only as tools — and get on with it.

David Miller
Maddington, WA

Idea of the Month

Light timer

C. Allan,
Blackburn South, Vic

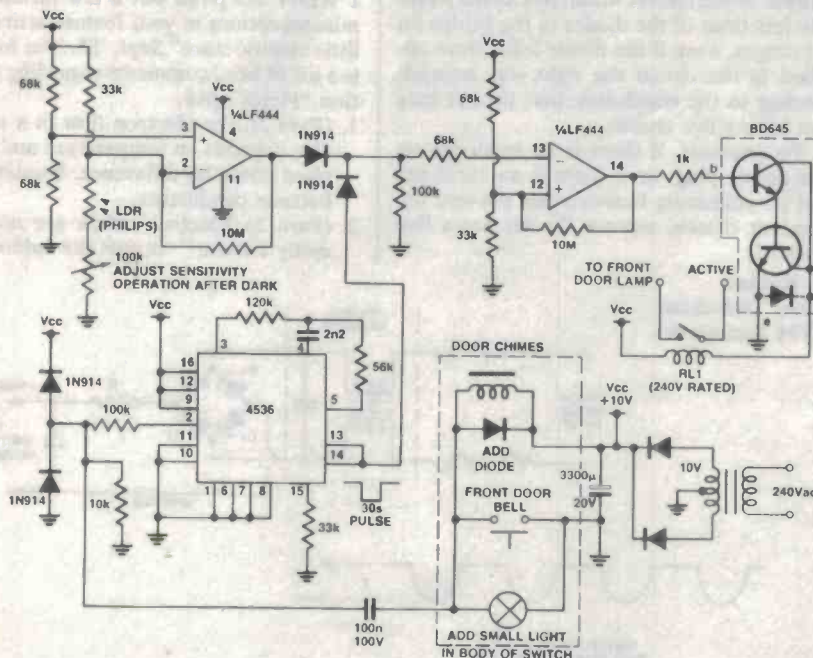

This project was developed out of the need for a light above the front door which would automatically switch off after 30 seconds.

The operating switch is the same one used to operate a door chime. In practice this means that when someone comes to the front door the outside light switches on when the caller operates the door chime. It will then stay on long enough for the call to be answered. An LDR is incorporated in the circuit to deactivate it during daylight hours.

The circuit is quite straightforward. A 4536 acts as a 30 second one shot activated by the door chime. The output pulse from the 4536 is sent to one quarter of an LF444 which inverts the signal and drives a Darlington pair, the BD645. This provides the current necessary to turn on the relay which fires the bulb. Notice that the 4536 signal is effectively gated by the LDR operating through another quarter LF444.

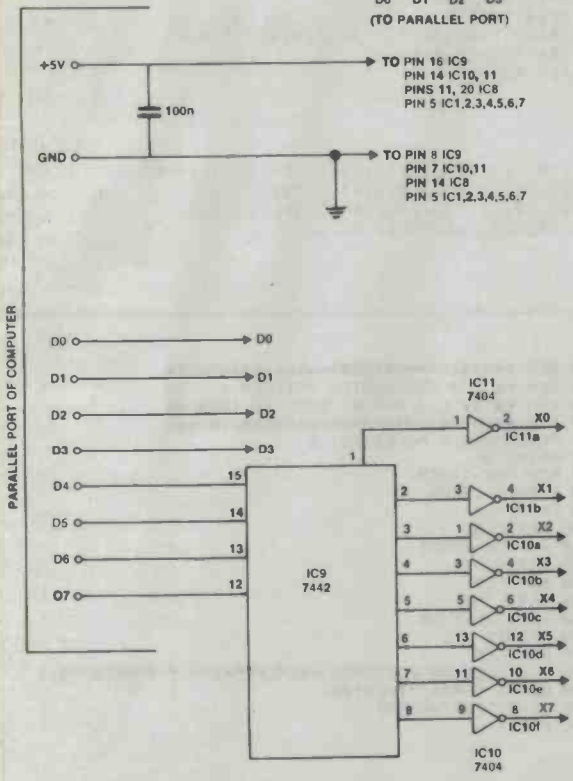
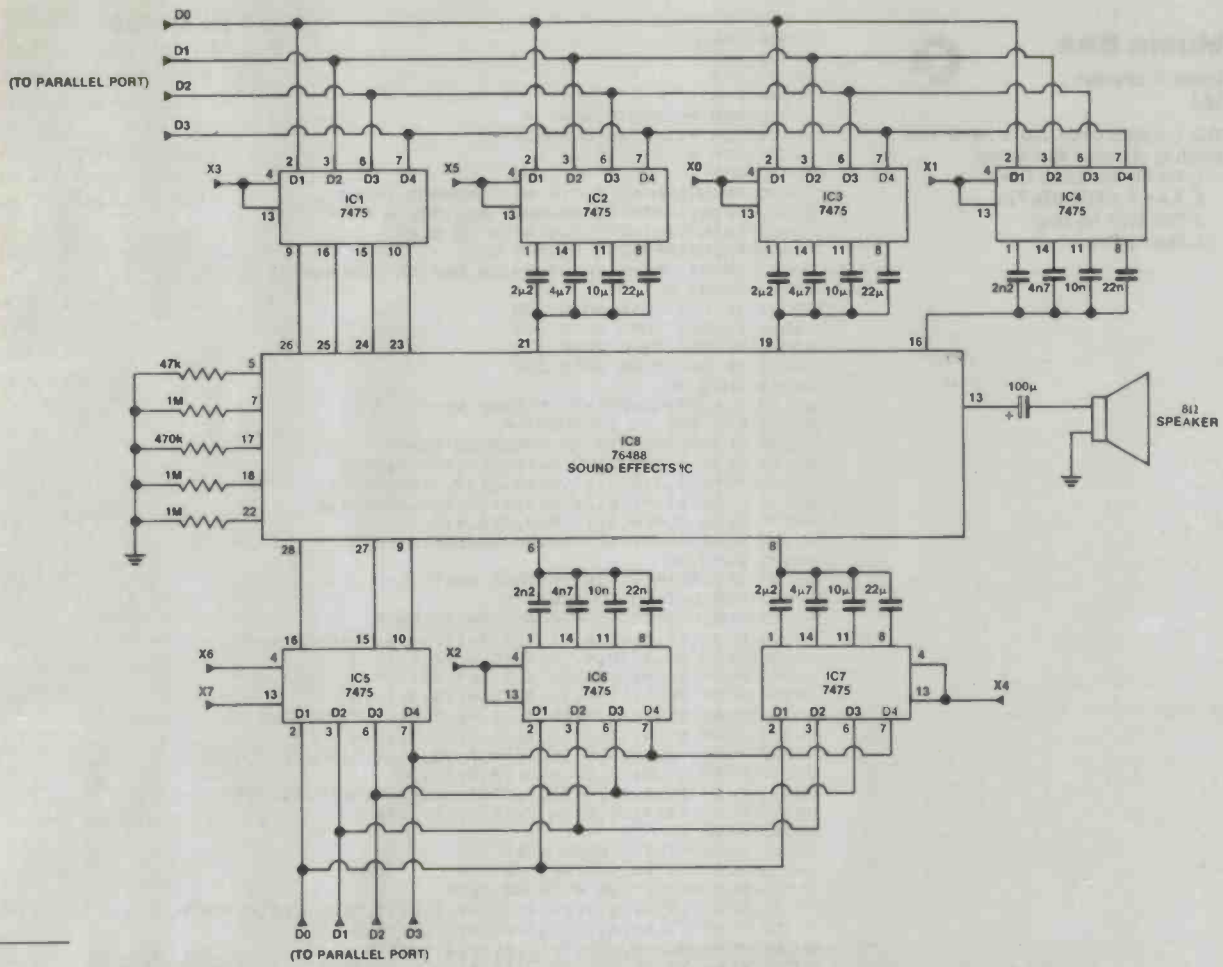

Sound Effects Generator

M. Sorell of Clarence Park SA 5034 sent us his idea for a sound effects generator to use with the parallel port of a micro. While most micros can make a variety of sounds on an internal speaker under software control, the advantage of this circuit is that it frees the processor from this function. This can be quite significant if the processor is trying to keep track of a fast moving game while at the same time generating complex sound effects.

The circuit is centred around the 76488 sound effects chip. For a full description of how it works either consult manufacturer's data or ETI August 1981, where a complete explanation is given. In general, the chip is divided into a number of functional blocks, each of which can be accessed via the appropriate

pins. Most of these blocks require one pin to turn them on, and two to service an RC network that regulates analogue functions like duration and intensity.

In order to use the system it is necessary to output appropriate codes into the data and address buffers on the board.

Music Box

Peter Ochman
WA



This program gives you a menu from which to choose 1 to 4 tunes:

1. Tie Me Kangaroo Down;
2. Advance Australia Fair;
3. Pub With No Beer;
4. Botany Bay.

```

00001 Z=1
00002 X=2
00003 T=3
00004 K=4
00010 REM *<<MUSIC BOX>>*
00020 REM *<<PETER OCHMAN>>*
00030 REM *<<7/8/85>>*
00040 CLS
00050 PRINT:PRINT"1 TIE ME KANGAROO DOWN"
00060 PRINT:PRINT"2 ADVANCE AUSTRALIA FAIR"
00064 PRINT:PRINT"3 PUB WITH NO BEER"
00066 PRINT:PRINT"4 BOTANY BAY"
00070 PRINT:PRINT"WHICH ONE DO YOU WANT(1/4)"
00080 INPUT A
00090 IF A=T THEN GOTO 330
00095 IF A=K THEN GOTO 405
00100 IF A=Z THEN GOTO 120
00110 IF A=X THEN GOTO 200
00115 GOTO 80
00120 CLS:PRINT:PRINT" PLEASE WAIT..."
00123 FOR M=1 TO 100:NEXT M
00125 CLS:PRINT"TIE ME KANGAROO DOWN"
00140 PLAY 4,4;9,2;13,4;11,2;9,4;6,6;11,6
00150 PLAY 4,4;8,2;11,4;14,2;18,4;16,8;0,1
00160 PLAY 13,4;16,2;13,4;11,2;9,4;6,6;11,6
00170 PLAY 4,4;8,2;11,4;9,2;8,4;9,4
00180 PLAY 16,2;16,1;16,2;16,1;16,4
00190 GOTO 40
00200 CLS:PRINT:PRINT"PLEASE WAIT..."
00210 FOR B=1 TO 100:NEXT B
00215 CLS:PRINT"ADVANCE AUSTRALIA FAIR"
00220 PLAY 11,4;16,4;11,4;8,4;11,4;16,5;16,2;16,4
00230 PLAY 20,4;18,4;16,4;15,4;16,4;18,8
00240 PLAY 11,4;16,4;11,4;8,4;4,4;11,5;11,2;11,4
00250 PLAY 20,4;18,4;16,4;15,4;13,4;11,8
00260 PLAY 11,4;13,5;15,2;16,4;13,4;11,5;8,2;8,4
00270 PLAY 11,4;13,4;16,4;21,4;20,4;18,8
00280 PLAY 11,4;13,5;15,2;16,4;13,4;11,5;16,2;16,4;18,4
00290 PLAY 20,5;16,2;18,5;15,2;16,8
00300 PLAY 20,4;21,4;20,4;18,4;16,4;15,4;13,4;11,4
00310 PLAY 16,4;20,5;16,2;18,5;15,2;16,8
00320 GOTO 40
00330 CLS:PRINT"PLEASE WAIT..."
00334 FOR N=1 TO 100:NEXT N
00336 CLS:PRINT"PUB WITH NO BEER"
00340 PLAY 18,2;18,4;17,4;20,4;18,4;13,5;10,2;8,4;7,4;8,4
00350 PLAY 15,6;15,2;15,2;13,4;17,4;15,4;13,6
00360 PLAY 8,2;8,2;8,4;10,4;11,4;10,6
00370 PLAY 18,2;18,2;18,4;17,4;20,4;18,4;13,5;10,2;8,4;7,4;8,4
00380 PLAY 15,6;15,2;15,2;13,4;17,4;15,4;13,6
00390 PLAY 8,2;10,2;11,4;10,4;8,4;6,6
00400 GOTO 40
00405 CLS:PRINT"PLEASE WAIT..."
00406 FOR S=1 TO 100:NEXT S
00407 CLS:PRINT "BOTANY BAY"
00410 PLAY 7,1;9,1;11,2;14,2;14,2;9,2;12,2;12,2;11,1;9,1;7,5;0,1
00420 PLAY 14,2;11,2;14,2;19,2;12,2;16,2;19,2;14,6;0,1
00430 PLAY 14,2;19,2;18,2;19,2;21,2;19,2;16,2;14,2;11,1;7,5;0,1
00440 PLAY 7,1;9,1;11,2;14,2;14,2;9,2;12,2;11,2;7,6
00450 GOTO 40
    
```

Crosshatch Pattern

L. R. Hatch
Hillarys, WA



Some years ago I built a Crosshatch Generator kit (ETI-704). Every time I went to use it I would have to make small adjustments to get it to operate satisfactorily.

Just recently I realised that the Commodore 64 could be programmed to produce a Crosshatch Pattern every time, without the need for any adjustments.

Line 50 sets both the foreground and background to black.

Lines 60-170 print the white cross-hatch pattern on the screen, leaving the last two screen characters blank (to prevent the Commodore scrolling).

Line 180 pokes the characters into the last two screen positions.

Lines 190-300 wait for the user to press the F1 key before terminating the program.

```

10 REM *****
20 REM ** * CROSSHATCH PATTERN * **
30 REM ** BY L.R.HATCH. SEPT 10,1985 **
40 REM *****
50 POKE53280,8:POKE53281,0
60 PRINT "="
70 FORLINE=1TO12
80 FORCLM=1TO20
90 PRINT " |";
100 NEXTCLM
110 FORCLM=1TO20
120 PRINT "—+";
130 NEXTCLM
140 NEXTLINE
150 FORCLM=1TO19
160 PRINT " |";
170 NEXTCLM
180 POKE2022,32:POKE2023,66:POKE56294,1:POKE56295,1
190 GETA$:IFA$=""THEN190
200 IFA$<>" "THEN190
300 END
    
```

IF YOU BUY THIS SEIKOSHA BP5420AI BUSINESS PRINTER

\$3500 incl. tax (Sheet Feeder not Inc.)



Features

- Two modes selectable, Standard mode (based on EPSON® FX) IBM® mode (IBM® PC compatible).
- Throughout-150 lines/minute at 132 chars./line.
- 420 cps (Draft mode) 104 cps (High quality Elite) print speed, with reduced noise level.
- A variety of print character sets including Pica, Elite, Proportional Condensed, Elongated, Italic, Super/Subscripts, Italic Super/Subscripts.
- A variety of functions including underlining, bold-printing double-strike and software-selectable line pitch specification.
- 18 K-byte communication buffer which allows the reception of data during printing.
- Two built-in Interfaces (Centronics Parallel, RS-232C Serial).

THEN YOU GET THIS SEIKO WRIST TERMINAL FREE

Offer valid until September 5, 1986. Available only at participating dealers. Phone your local AWA office listed below for your nearest dealer.

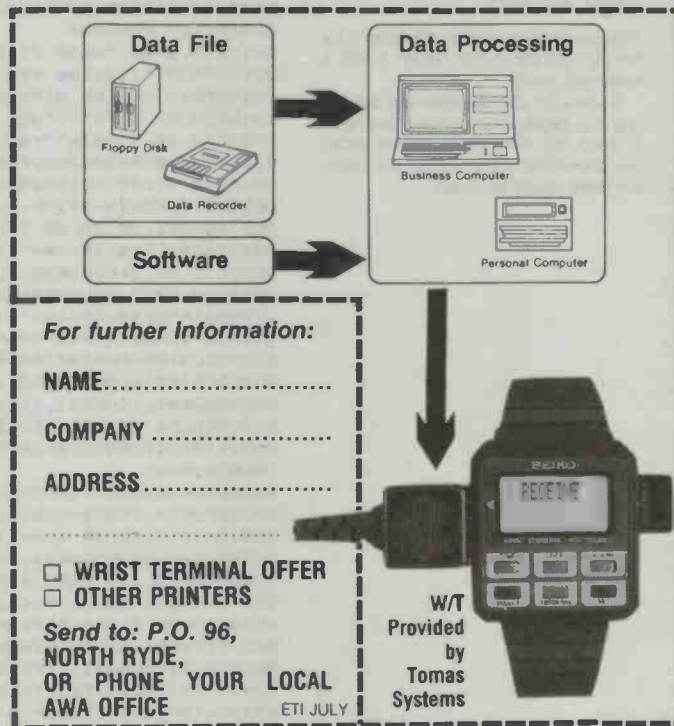

SOME OTHER SEIKOSHA PRODUCTS:

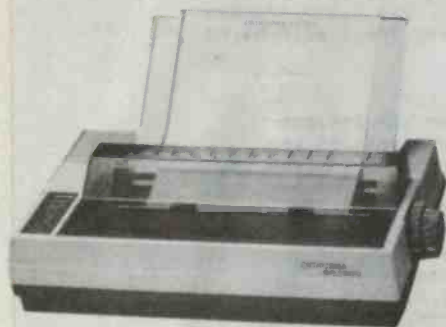

Features of SP-1000

- 100 cps (Draft mode), 20 cps (Near Letter Quality) print speed, with reduced noise level.
- Pin-feed or friction-feed
- Automatic paper loading function.
- Right, left margin set function.
- A variety of functions including: Underline, Bold print, Double Striking.
- A variety of print character sets including: Pica, Elite, Proportional, Elongated, Condensed, Italics, Super/Subscripts, and Italic Super/Subscripts.

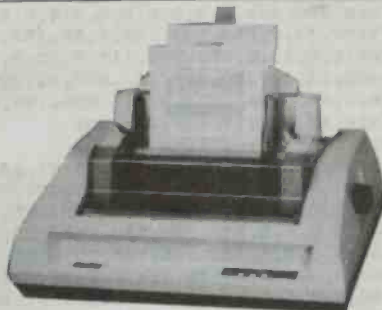

Features of BP5200

- 206 cps (Draft model) 103 cps (Correspondence mode) print speed, with reduced noise level.
- A variety of print character sets including Pica, Elite, Proportional, Elongated, Italic, Super/Subscripts, Italic Super/Subscripts.
- A variety of functions including underlining, bold-printing, double-strike, software-selectable line pitch specification.
- 4K byte communication buffer.
- Pin-feed and friction-feed both available.
- Paper width up to 15.5 inches.
- BP52201 — Centronics parallel with IBM character.
- BP5200A — 2 standard Interfaces (parallel and serial, 4K byte buffer expandable to 20K byte).

NEW RELEASE



Features of MP-1300AI

- High speed printing (300 cps draft) with lowest noise.
- Superb NLQ printing.
- Variety of characters and graphics.
- IBM® mode and EPSON® mode.
- Built-in Parallel and Serial interfaces.
- Automatic paper loading and ejection.
- Download character setting. (Up to 256 characters.)
- Front panel margin setting.
- Built-in 10 K buffer. (7 K when download characters.)
- Rear and bottom paper loading.
- Optional Automatic Cut Sheet Feeder #MP-13009.
- Easy-to-handle optional 7-colour printing kit, MP COLOR KIT 10. #MP-13005.



**Proud sponsors of the
Sydney Hobart Yacht Race**

Amalgamated Wireless (Australasia) Limited
(Incorporated in New South Wales)

Sydney (02) 887-7111 Melbourne (03) 560-4533 Brisbane (07) 371-4088
Adelaide (08) 297-5887 Perth (09) 321-9334 Canberra (062) 73-1802

Recall

Saul Clay Hruza,
Flagstaff Hill, SA 5159



If you have ever had battles with family or friends over the practical uses of your computer, this is the program for you. It simply reads a question from a data statement you have made and checks to make sure your input is the same as the following data statement (ie, the correct answer!). I have used the example of a French vocabulary test, however you may adapt it for anything you find difficult to memorise.

There are three locations you must change every time you enter a new data statement, they are lines 210, 220 and 230. To enter new questions, make the appropriate DATA statements and change the numbers in the above lines to twice the number of questions (ie, in my example I had five questions, or 10 data statements in all, so A1 and X must equal 10). I have found the program very useful especially before exams!

```

00100 POKE 257.1 :REM FORCED UPPER CASE
00110 REM *****
00120 REM * RECALL PROGRAM FOR THE MICROBEE *
00130 REM * Saul Hruza 1985 *
00140 REM *****
00150 REM INTRODUCTION
00160 (L4 :L0RES :PLOT 10.35 TO 40.35 :PLOT 20.35 TO 20.10 :LARG 14.8
:PRINT " E S T " :CURS 25.10 :PRINT "FOR THE MICROBEE"
00170 PLOT 0.0 TO 127.0 TO 127.46 TO 0.46 TO 0.0
00180 PLAY 6.416,2111,4111,4113,4113,4118,6115,2111,6 :NORMAL
00190 LLS
00200 STR$(2000)
00210 DIM A1(10) :REM THE NUMBER HERE EQUALS THE AMOUNT OF DATA
STATEMENTS
00220 FOR X=1 TO 10 :READ A1$(X) :NEXT X:REM THE NUMBER HERE EQUALS
THE AMOUNT OF DATA STATEMENTS
00230 LLS :FOR X=1 TO 10 STEP2 :REM THE NUMBER HERE EQUALS THE
AMOUNT OF DATA STATEMENTS
00240 LET H=INT(RND*8)+1 :IF R=2 THEN NEXT= X 270
00250 NEXT X
00260 GOTO 230
00270 INVERSE :PRINT "What is the French for ?" :NORMAL :REM YOU CAN
CHANGE THE QUESTION HERE TO SUIT WHATEVER FIELD YOU ARE USING
00280 CURS2.4 :PRINT A1$(X) :PRINT :INPUT B1$ :IF B1$ = A1$(X+1) THEN
GOTO 340 ELSE 310
00290 GOTO 230
00300 REM REWARD
00310 PRINT " Sorry , you got it wrong , the correct answer was
":A1$(X+1) :PRINT "" :PLAY 0.15 :LET N=N+1
00320 IF N=5 THEN 360 ELSE 230:REM THE AMOUNT OF QUESTIONS YOU WISH TO
ASK
00330 REM CORRECTION
00340 PRINT " Correct ! Very good ." :PLAY(1,10 :LETS=5+1 :LETN=N-1
00350 IF N=5 THEN 360 ELSE 230 :REM THE AMOUNT OF QUESTIONS YOU WISH
TO ASK
00360 CLS:PRINT " Very good , your score was "1$" out of 5"
00370 INPUT " Do you want another go (Y/N) ?":Z1$ :RESTORE :IF
Z1$="Y" THEN 220
00380 REM QUESTIONS AND ANSWERS
00390 DATA "THE RAILWAY STATION","LA GARE"
00400 DATA "CASTLE","LE CHATEAU"
00410 DATA "HELLO","BONJOUR"
00420 DATA "GOODBYE","AU REVOIR"
00430 DATA "CHICKEN","LE FOLET"
00440 DATA "MORE QUESTIONS","MORE ANSWERS"
00450 DATA .....
    
```

ETI-666 Software Control



R. J. Martindale,
Mill Park, Vic

The article describing the ETI-666 parallel printer switch (ETI, February 1985) explains how it can't be software controlled from its driving port using ESCAPE sequences, as this would (i) require some means of recognising such sequences adding to the complexity of the switch, and (ii) cause some problems when sending graphics information, etc, to your selected printer or other peripheral device.

For Microbee owners, however, all is not lost: there is a way to software control the ETI-666. Some modifications will be required to the motherboard of the Microbee, but these only consist of making extra connections to spare pins of the parallel port output socket. Depending on which particular model of Microbee you have, you may even find some (or all) of these connections already exist.

The ETI-666 may be controlled by a single TTL level signal in place of the switch provided, so a ninth 'data' ▶

Attention! microbee users and admirers

ONLINE - A GREAT MONTHLY INFORMATION PACKAGE

For only \$25.00 per year, you can join the thousands of microbee owners who have found the way of keeping up to date and in tune with their microbee. Subscribers to Online, the microbee journal, are privy to the latest hardware and software releases, are entertained by a myriad of applications and are tutored in the latest languages.

Don't let your microbee rest! Put it through its paces with Online — your monthly upgrade kit in a magazine.

ONLY \$25 YEARLY



SUBSCRIBE NOW!

YES! Please enter my subscription, as marked, to Online for one year (12 issues) at a cost of \$25.00.

Name: _____

Address: _____

Town/Suburb: _____ State: _____ P/code: _____

METHOD OF PAYMENT: Money Order/Cheque
 Please charge my

Expiry Date: _____ Signature: _____

- Unless otherwise stated, your subscription will commence from the next issue to be published upon receipt of this form.
- Single copy price \$2.95 plus 30 cents p&h per issue within Australia.
- All subscriptions and enquiries should be addressed to:
The Subscription Officer, Online, P.O. Box 41, West Gosford 2250.



Online

bit' is required from the computer dedicated to this purpose.

Now the good luck for Microbee owners!

On the B side of the Microbee's Z80-PIO (the serial port side) will be found data bit DB7 at pin 34. On early model Microbees this pin was simply pulled high via a 4.7k resistor only and was unused, although it was programmed to be an input, causing interrupts to be generated as part of the networking mode of operation. No other connection was actually made to this PIO pin.

On later model 'Bees this bit is used for other functions such as regular update of the software clock provided on some models. Reference to the *Microbee Hardware Notebook* indicates that the actual connection of this bit can be altered by rearranging some links on the motherboard — one of the options being to connect it to pin 14 of the parallel port socket.

So, if this data bit is in fact connected to the parallel port socket, and it is altered to become an output by reprogramming the PIO B side, it can then be used as the required control line for the ETI-666, with a "0" selecting printer #1, and "1" selecting printer #2.

Implementation steps:

1. As the Microbee parallel port is not true Centronics, some mods may be required to make it so. The simplest way is to add the ETI-671 parallel printer interface (ETI October 1983) between the output socket and the ETI-666 switch — the arrangement shown in the circuit diagram.

(Note that on some latest model Microbees an internal circuit has been added which produces the required Centronics active low *STROBE signal at pin 6 of the parallel port socket — in this case the additional interface circuit will not be required.)

2. Connect pin 34 of the Z80-PIO to pin 14 of the parallel port socket. This may be done by rearranging board links or running an extra piece

of hookup wire depending on the model 'Bee you have.

3. To power the printer switch, provide unregulated 10V at pin 9 of the parallel port socket — again note that this connection may already be in place on some models.

4. Delete the printer selector toggle switch from the ETI-666 and connect the new control line to the junction of resistors R1 and R2 using an additional conductor in the input connecting cable.

5. Reprogram the B side of the PIO to make bit DB7 an output which can be set or reset to control the ETI-666 switch.

The circuit diagram shows the arrangement.

The two-position printer selector switch in the ETI-666 is replaced by a three-position type as shown. This arrangement retains the ability to manually select printers or opt for the remote control mode under control of the host computer.

Sample software subroutines to drive the modified printer switch, both in MicroWorld BASIC and Z80 Assembler, are listed. I tucked the machine code routines into the end of a customised "NET" EPROM, where they can be accessed from BASIC with the USR command or with a direct call from machine code programs.

The described modifications in no way affect the normal operation of the Microbee's parallel port. If the extra facility of the new control line is not required then simply make no connection to it.

WARNING!!!

As indicated throughout the text, a number of the required modifications or connections may or may not exist within various models of Microbee computer. Thoroughly check the circuit diagram for your particular model to determine exactly which mods must be done to your machine.

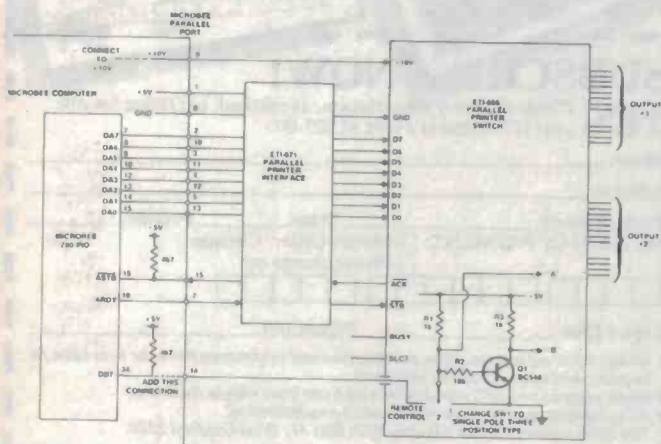

```

09000 REM *SOFTWARE CONTROL OF ETI-666 PRINTER SWITCH FROM MICROBEE*
09010 REM
09020 REM Printer Selection subroutines which can be added to
09030 REM MicroWorld BASIC programs and called as required to
09040 REM select desired printer or other peripheral.
09050 REM
09060 REM R.Martindale 31/03/1986
09070 REM
09080 REM
09090 REM Subroutine to reprogram B side of PIO to make bit 7 output
09100 REM
09110 OUT 3,138: REM set Interrupt Vector
09120 OUT 3,255: REM set Mode 3 (Bit in/out mode)
09130 OUT 3,25: REM set bits 4,3,8 as inputs, 7,6,5,2,1 as outputs
09140 OUT 3,183: REM Interrupt Control Word
09150 OUT 3,255: REM Mask Control Word - don't monitor any bits
09160 OUT 2,32: REM set RS232 output bit high
09170 RETURN
09180 REM
09190 REM
09200 REM Subroutine to set bit B7=0 (peripheral #1 selected)
09210 REM
09220 LET X=IN(2): REM read PIO B side data port
09230 IF X<128 THEN RETURN: REM return if B7 already = 0
09240 LET X=X-128: REM set B7 = 0
09250 OUT 2,X: REM send new value back to data port
09260 RETURN
09270 REM
09280 REM
09290 REM Subroutine to set bit B7=1 (peripheral #2 selected)
09300 REM
09310 LET X=IN(2): REM read PIO B side data port
09320 IF X<128 THEN RETURN: REM return if B7 already = 1
09330 LET X=X+128: REM set B7 = 1
09340 OUT 2,X: REM send new value back to data port
09350 RETURN
    
```

ADDR	CODE	LINE	LABEL	MNEM	OPERAND
08100			*SOFTWARE CONTROL OF ETI-666 PRINTER SWITCH FROM MICROBEE*		
08110			Z80 Assembler subroutines which can be added into		
08120			larger machine code programs and called as required		
08130			to select desired printer or peripheral.		
08140			R.Martindale 31/03/1986		
08150					
08160	ORG	08FCDH	;ORG where required!		
08170	DEFR	16			
08180					
08190			;Subroutine to program B side of PIO		
08200			to make bit B7 an output.		
08210	PUSH	AF	;save regs		
08220	PUSH	HL			
08230	LD	HL, TABLE			
08240	LD	HL, TABLE			
08250	READ	LD A, (HL)	;read data		
08260	OR	A, A	;test data for table end		
08270	JR	Z, SET			
08280	OUT	(3), A	;out to port		
08290	INC	HL	;inc table pointer		
08300	JR	READ	;loop		
08310	SET	LD A, 20	;set RS232 out bit high		
08320	OUT	(2), A			
08330	POP	HL	;recover regs		
08340	POP	AF			
08350	RET				
08360					
08370	TABLE	DEFB 0AH	;Interrupt Vector		
08380	DEFB 19H	;Set Mode 3			
08390	DEFB 19H	;Set inputs and outputs			
08400	DEFB 8BH	;Interrupt Control Word			
08410	DEFB 8FH	;Mask Control			
08420	DEFB 00H	;mark end of table			
08430					
08440			;Subroutine to set B7=0, peripheral #1 selected.		
08450	PUSH	AF	;save regs		
08460	IN	A, (2)	;read PIO B side data port		
08470	BIT	7, A	;test bit 7		
08480	RET	Z, A	;return if bit 7 = 0		
08490	RES	7, A	;reset bit 7		
08500	OUT	(2), A	;send back to data port		
08510	POP	AF	;recover regs		
08520	RET				
08530					
08540					
08550			;Subroutine to set B7=1, peripheral #2 selected.		
08560	PUSH	AF	;save regs		
08570	IN	A, (2)	;read PIO B side data port		
08580	BIT	7, A	;test bit 7		
08590	RET	NZ	;return if bit 7 = 1		
08600	SET	7, A	;set bit 7		
08610	OUT	(2), A	;send back to data port		
08620	POP	AF	;recover regs		
08630	RET				
08640					
08650					
08660	END				
08670					
08680					
08690					
08700					
08710					
08720					
08730					
08740					
08750					
08760					
08770					
08780					
08790					
08800					
08810					
08820					
08830					
08840					
08850					
08860					
08870					
08880					
08890					
08900					
08910					
08920					
08930					
08940					
08950					
08960					
08970					
08980					
08990					
09000					
09010					
09020					
09030					
09040					
09050					
09060					
09070					
09080					
09090					
09100					
09110					
09120					
09130					
09140					
09150					
09160					
09170					
09180					
09190					
09200					
09210					
09220					
09230					
09240					
09250					
09260					
09270					
09280					
09290					
09300					
09310					
09320					
09330					
09340					
09350					
09360					
09370					
09380					
09390					
09400					
09410					
09420					
09430					
09440					
09450					
09460					
09470					
09480					
09490					
09500					
09510					
09520					
09530					
09540					
09550					
09560					
09570					
09580					
09590					
09600					
09610					
09620					
09630					
09640					
09650					
09660					
09670					
09680					
09690					
09700					
09710					
09720					
09730					
09740					
09750					
09760					
09770					
09780					
09790					
09800					
09810					
09820					
09830					
09840					
09850					
09860					
09870					
09880					
09890					
09900					
09910					
09920					
09930					
09940					
09950					
09960					
09970					
09980					
09990					
10000					

USED TEST EQUIPMENT

**WE BUY
WE SELL —
YOU WIN!**

**A NEW SERVICE TO
THE AUSTRALIAN
ELECTRONICS
INDUSTRY!**



Capricorn Computing Services Pty Ltd, a well established broker of computer equipment, offer for the first time in Australia;

A TEST EQUIPMENT MATCHING SERVICE.

Selling — the perfect way to dispose of your surplus equipment and get that extra cash when its time to upgrade.

Buying — the price you pay is substantially lower than the new equipment price. A real alternative to the high cost of Test Equipment purchase and upgrade.

You tell us whether you are a buyer or seller (or both), what equipment you want to sell or purchase and if you have a specific model or your general requirements. We then match you up on our Database records with the equipment that you either want to buy or sell.

For further information, contact:
**CAPRICORN COMPUTING SERVICES
PTY. LIMITED**
1st Floor, 1 Avon Road
North Ryde, 2113
Ph: (02) 888-3544

We do all the matching — Buyer to Seller Seller to Buyer. You win the rewards in dollars Saved!!!

- ★ CRO'S ★ SIGNAL GENERATORS ★ LOGIC ANALYSERS ★ DATASCOPIES ★ RADIO EQUIPMENT ★ DEVELOPMENT EQUIPMENT ★ POWER SUPPLIES

READER INFORMATION SERVICE COUPON

Electronics Today

READER INFORMATION SERVICE

To find out more about the products and services in this issue, circle the READER SERVICE NUMBER from the advertisement, photocopy this coupon, enclose it in an envelope and send to:

FREEPOST No 4
The Federal Publishing Company
PO Box 227
Waterloo, NSW 2017

No stamp necessary if posted in Australia

- A. Engineer/Designer
 - B. Technician
 - C. Manager
 - D. Hobbyist
 - E. Interested Consumer
- Please circle the category that best fits you.

Name

Address

Postcode

1	26	51	76	101	126	151	176	201	226	251	276	301	326
2	27	52	77	102	127	152	177	202	227	252	277	302	327
3	28	53	78	103	128	153	178	203	228	253	278	303	328
4	29	54	79	104	129	154	179	204	229	254	279	304	329
5	30	55	80	105	130	155	180	205	230	255	280	305	330
6	31	56	81	106	131	156	181	206	231	256	281	306	331
7	32	57	82	107	132	157	182	207	232	257	282	307	332
8	33	58	83	108	133	158	183	208	233	258	283	308	333
9	34	59	84	109	134	159	184	209	234	259	284	309	334
10	35	60	85	110	135	160	185	210	235	260	285	310	335
11	36	61	86	111	136	161	186	211	236	261	286	311	336
12	37	62	87	112	137	162	187	212	237	262	287	312	337
13	38	63	88	113	138	163	188	213	238	263	288	313	338
14	39	64	89	114	139	164	189	214	239	264	289	314	339
15	40	65	90	115	140	165	190	215	240	265	290	315	340
16	41	66	91	116	141	166	191	216	241	266	291	316	341
17	42	67	92	117	142	167	192	217	242	267	292	317	342
18	43	68	93	118	143	168	193	218	243	268	293	318	343
19	44	69	94	119	144	169	194	219	244	269	294	319	344
20	45	70	95	120	145	170	195	220	245	270	295	320	345
21	46	71	96	121	146	171	196	221	246	271	296	321	346
22	47	72	97	122	147	172	197	222	247	272	297	322	347
23	48	73	98	123	148	173	198	223	248	273	298	323	348
24	49	74	99	124	149	174	199	224	249	274	299	324	349
25	50	75	100	125	150	175	200	225	250	275	300	325	350

For a prompt reply: Post today!

POST TODAY!

BOOKS OF SPECIAL INTEREST

COMPUTER HARDWARE and TECHNIQUES

THE USER'S GUIDE TO COMMODORE 64 & VIC 20

The editors of Consumer Guide have compiled a thorough introduction to the Commodore 64 and Vic 20 computers, software and peripherals. With colour illustrations and a clearly written text, this reference will guide the newcomer through all phases of learning how to use the computer. From setting the system up, learning what each key does, expanding the system with peripherals, to buying new software. Specific exercises are included for each of the keys. Spiral bound, 80pp.

H0065G \$8.50 \$5.95

EASY-TO-UNDERSTAND GUIDE TO HOME COMPUTERS

Confused by all those computer terms? This clearly written book from the editors of Consumer Guide tells exactly what computers are, how they work and why they are so amazingly useful, all in plain English. Here is all of the information needed to understand and use computers, and even to start programming. A special buying section compares the most popular home computers. This book is your ticket to the computer age! Spiral bound, 96pp.

H0066G \$8.50 \$5.95

ALMOST EVERYBODY'S PERSONAL COMPUTER BOOK

Written for the computing beginner to break the enormous barrier of jargon and mystique that seems to surround computers. With a highly readable approach, the author introduces the basic concepts and develops them into a general discussion on personal computers including choosing and caring for a PC. Also offers an introduction to BASIC programming. 160pp.

H0144Z \$8.95 \$5.95

INSTANT PROGRAMMING OF YOUR SEGA SC3000 COMPUTER

Spiral-bound for easy use, this is THE Sega SC3000 beginner's book! In carefully explained, easy to follow

steps, it covers the function of each key and all of the commands needed for super fast mastery of BASIC programming. This is a book for do-ers: The second part of the book teaches the real art of programming with plenty of examples and subroutines. 84pp.

K0051P \$12.95

THE BEST VIC/COMMODORE SOFTWARE

Trying to find the most suitable software for personal computers can be frustrating. The editors of Consumer Guide have compiled comprehensive reviews of VIC 20 and Commodore 64 programs based on ratings by user groups; further evaluation is given by the editors and Commodore software experts Jim and Ellen Strasma. Each review describes the program's purpose and features, detailing both the good points and bad. Each program has been rated for ease of use, clarity of written and on-screen instructions, and overall performance. The program's price, publisher, format and hardware requirements are also included. The reviews are presented in sets by topic: Word Processing, Business, Home, Education, Networking, Strategy Games, Arcade Games and programming Aids. Spiral bound, 192pp.

K0052G \$8.50 \$4.95

THE BEST APPLE SOFTWARE

Trying to find the most suitable software for personal computers can be frustrating. The editors of Consumer Guide have compiled comprehensive reviews of Apple II, II Plus and IIe programs based on ratings by user groups; further evaluation is given by the editors and Apple software expert Roe Adams. Each review describes the program's purpose and features, detailing both the good points and bad. Each program has been rated for ease of use, clarity of written and on-screen instructions, and overall performance. The program's price, publisher, format and hardware requirements are also included. The reviews are presented in sets by topic: Word Processing, Business, Home, Education, Networking, Strategy Games, Arcade Games and Programming Aids. Spiral bound, 160pp.

K0060G \$8.50 \$5.95

AMATEUR RADIO DX, COMMUNICATIONS

25 SIMPLE AMATEUR BAND AERIALS

Describes how to build 25 amateur band aerials that are simple and inexpensive to construct and perform well. Projects range from the simple dipole up to a mini-rhombic. 63pp.

N0286B \$8.95 \$5.95

25 SIMPLE SHORTWAVE BROADCAST BAND AERIALS

Describes concisely the design and construction of simple and inexpensive aerials that perform well: from simple dipole to end-fire arrays. Includes dimensions and other data for spacing and cutting phasing lengths. 63pp.

N0362B \$5.95 \$4.95

THE WORLD IN MY EARS

This is THE basic manual for anyone with an active interest in shortwave listening written by Arthur Cushen M.B.E., world-renowned authority and broadcaster. In the first section, the book covers the historical development of shortwave broadcasting and the listening hobby that grew up with it. The second section covers the practical aspects: how to start out, how to erect antennas, all about time zones, DX clubs, reporting, news sessions, etc. 204pp.

N0420C \$18.95 \$7.95

THE BASIC BOOK OF HAM RADIO

This easy to read American Publication tells how the Amateur Radio Service works, how to obtain a Novice Licence, what to buy to get on the air and where the action is — awards, contests, public service, satellite communications, radio clubs and other ham activities. \$5.75 RRP, 128pp.

N0287R Only \$3.95

INSIDE BASIC GAMES

A look at games from the inside out: Teaches the reader how to design his own error-free, interactive BASIC programs. Rules, algorithms and coding differences for the PET, Apple II and TRS-80 are also included. \$19.95 RRP.

K0189A Only \$14.95

EST FROM FEDERAL DIRECT BOOK SALES

P.O. BOX 227, WATERLOO 2017

THE PASCAL HANDBOOK

Summarises the whole PASCAL vocabulary, including the variations introduced by the different commercial versions of PASCAL. Presented in an easy to use dictionary format. \$23.50 RRP.

G0200A Bargain at only \$16.95

AUDIO ENTHUSIAST'S HANDBOOK

Covers the record/playback curve, stylus compliance, acoustic feedback, stereo tape track standards, compensating sideways drag, amplifier power ratings and more. \$2.75 Retail, 96pp.

G0383B Reduced to only \$2.00

CHOOSING AND USING YOUR HI-FI

Provides basic information on the technical specifications of hi-fi equipment. Offers advice on what to look for in equipment in order to obtain real high-fidelity sound and reproduction. \$4.95 Retail, 88pp.

G0385B ONLY \$3.95

MINI-MATRIX BOARD PROJECTS

This selection of 20 useful projects to build is an excellent introduction to

constructing electronic projects. Those without any experience in electronics will find it easy to read and simple to follow. \$6.75 RRP, 102pp.

D0062B Priced to clear \$2.00

YOUR CALCULATOR AND YOUR MONEY

If you are interested in money and do even the simplest calculations, this book is a 'must'. It shows how to get the most practical use out of this efficient and powerful tool. The contents cover everything from simple arithmetic to compound interest, and depreciation. \$4.75 RRP, 174pp.

M0246B \$2.00

FUN & GAMES WITH YOUR ELECTRONIC CALCULATOR

Calculators might be a powerful and time saving tool, but they can also be an endless source of amusement and an excellent source of relaxation, as this book shows. What do 55 snakes in a 14 foot square pit do? (You'll have to read page 6 to find out.) \$2.50 RRP, 63pp.

M0370B \$2.00



YOUR MAIL ORDER COUPON

ELECTRONICS TODAY INTERNATIONAL

BOOK SALES

PLEASE ENCLOSE
\$3.25 per book
for postage, handling
and insurance

For airmail to Papua
New Guinea, New Zealand
Oceania and
Southeast Asia,
add \$6.00 to these charges.

BOOK TITLE	BOOK NUMBER	QTY	PRICE TOTAL

Please tick box to indicate method of payment:

Cheque*/Money Order *Please make payable to the
Federal Publishing Company Pty. Ltd.

Put your cheque or money order in an envelope with this order and send it to: Federal Direct, Freepost No. 4, P.O. Box 227, Waterloo, NSW 2017. No postage stamp required in Australia.

Mastercard American Express Bankcard Tick
 Credit Card No.

(Unsigned orders cannot be accepted)

Card Expiry Date..... Signature.....

Allow up to 6 weeks for delivery

Total price of books \$

Add postge and handling \$

(\$3.25 per book)

TOTAL \$

NAME:

ADDRESS:.....

..... POSTCODE:.....

TELEPHONE:

Micro interpreter

Horizon Computer Corporation of Sydney has announced the Corvus Network Transporter, which allows Macs, Apple IIs and IBMs to connect to the same network.

Using the new Corvus Transporter, a wide variety of different types of microcomputers can now be linked to Omninet, giving users the ability to share the mass storage of the Corvus OmniDrive and permitting inter-communication between the micros.

"It is invaluable for anyone wanting to link up two networks", says Tony Bowden, General Manager of Horizon, which is distributing the Transporter. "Business networks can

now be linked in the case of a merger or take-over. Very often different departments in the same company use networks of different micros — now they can share data, printers and other peripherals."

The Corvus Network Transporter can also link micro networks with mainframes, after software modification.

It retails for under \$900, but for more information contact Horizon on (02)498-6611 or (03)662-1611.

Hitron supplies Aust navy

Hitron Pty Ltd has won a contract to supply more than \$500,000 worth of specialised data recording equipment to the Royal Australian Navy.

The equipment is part of the Australian-designed and produced Mulloka sonar systems (worth \$13m) to be installed in two new RAN frigates.

Hitron, the Michael Edgley-backed computer and electronics company, will supply two Datatape multi-track tape recording systems, the Datatape AN/USH-24(V).

Mulloka sonar systems were developed by the Weapons Research Centre at Salisbury,

South Australia, to overcome specific problems in local waters. Australian coastal waters are wider, shallower and warmer than most continental shelves, and contain more of the temperature layers which deflect sonar waves and cause sonar shadows in which submarines can avoid detection.

The Mulloka System is linked to the Ikara long-range, anti-submarine rocket torpedo, which was also developed by the Weapons Research Centre. Data collected by the Mulloka system can be instantly relayed to the Ikara missiles to pinpoint the target accurately.

Microbee Premium Series

Microbee Systems Limited has announced a "Premium Series" for its Microbee family of personal computers.

The Premium Series offers as standard all of the main features available as options on the existing models, such as colour video and Viatel/Videotex communications capability. In addition they boast greatly enhanced high-resolution graphics capability, four extra keys for easier cursor control and a volume control for the internal speaker.

The enhanced high resolution graphics capability of the new Premium Series Microbees allows them to display a full screen of 131,072 individually programmable pixels, eight times more than the standard models.

The new models feature a fully redesigned main circuit board with improved colour video and keyboard scanning circuitry. CPU screen accessing

is now fully synchronous and transparent, giving a clearer and more stable display without 'glitches'. Keyboard scanning is now much more reliable, and disk models feature the ability to assign extended functions to the numeric keys.

The new Premium Series Microbees retail at \$100 more than the standard series models in each configuration. MSL is offering owners of existing Microbees the opportunity to upgrade them to a Premium Series version.

A brochure describing the new Premium Series Microbee models is available from Microbee Systems' Technology Centres and authorised dealers. Copies are also available from the Marketing Communications Department of Microbee Systems Limited, PO Box 105, North Ryde, NSW 2113. (02)887-3723.



CLUB CALL

A user group for the Acorn BBC Microcomputer called OZBEEB advises that it meets twice monthly at the Australian Film and Television School — Open Program, 3 Lyon Park Rd, North Ryde, NSW. Meetings are on the 2nd Wednesday of each month at 7 pm and the 4th Monday of each month at 6.30 pm. Annual membership subscription is \$10.

The Central Coast Apple Users Group meets on the first Tuesday of each month at the Central Coast Grammar school, Erina Heights, from 7.30 pm. Contacts are Charles Lee (043)67-6845 or Mick Tierney (043)41-9350.

A Sharp Users Group of Brisbane has been formed, meeting on the second Wednesday of each month at the Graceville State School. For further information contact Bill Laidlaw, 51 Sandon St, Graceville, Qld 4075 or (07)379-3457.

Mbug Australia with nearly 600 financial members plus their Microbees caters for a wide variety of interests in the microcomputing area, from hard disks and fourth generation languages to computer games and educational activities. Other Victorian Microbee groups are affiliates of the club. The club publishes a monthly magazine *The Catcher*, provides a public domain disk

library, a separate tape library, a modem hire facility and disk and tape copying/format conversion services to its members. Membership costs \$20 for Melbourne residents (\$17 country). Student membership is \$15, while membership for the RCP/M is only \$10.

The club also runs a 24 hour remote CP/M system bulletin board for its members on (03)873-5734.

SCUA (Sorcerer & CP/M Users of Australia) caters for Sorcerer, Excalibur, Bondwell and all machines which run the CP/M operating system. The group also has an increasing number of PC users and is forming an interest group to cater for owners of these machines. Meetings are held on the first Sunday of the month, February to December at 2pm at Victoria College, Burwood Campus, 221 Burwood Highway, Burwood, Vic 3125. The SCUA RCPM service is available to members. The number is (03)754-5081. Address all correspondence to The Honorary Secretary, SCUA, GPO Box 2402, Melbourne, Vic 3001.

Microbee Users Group of WA meets at 7pm on the first Sunday of each month in the Nurses' Lecture Theatre of the Sir Charles Gairdner Hospital at Shenton Park. Further details can be obtained from the membership officer on (09)294-1833 or by mail to GPO Box N1090, Perth, WA 6001.

IBM-JX PC expanded

IBM Australia has announced several new enhancements for the IBM-JX personal computer, including a hard disk expansion unit, a 256K cluster memory card and nearly 40 new software packages.

The hard disk expansion unit consists of a 10M, 135mm hard disk drive and three expansion board slots which can be used with optional cards such as 256K RAM and 384K RAM cards, allowing users the option of up to 512K of memory.

The new 256K cluster memory card installed on the optional cluster card, enables users in a classroom network to install up to 384K of memory in the main JX system unit.

Six proven programs developed by Canada's University

of Waterloo and Watcom Systems Inc include the Waterloo Janet Version 2.2 program. This program provides network control functions for multiple JX workstations to communicate with an IBM-XT, or an IBM-JX with a hard disk installed, for data, program and printer sharing. Libraries of programs can be created and used by a number of users.

Other software packages that have been released for use with the IBM-JX include advanced text processing, personal productivity tools, and over 20 educational programs designed to introduce students to various mathematical, scientific and language topics. All of these software packages are available on convenient 90mm diskettes.

\$998 voice

Visnet, the local voice recognition pioneer, has released a voice recognition package for PC/XT/AT and compatible computers at \$995.

The package includes hardware, software and support. Features are a circuit board and dynamic microphone, a training program and voice recognition program that includes pop-up menus and colour windows, and

starter command lists for Wordstar, Lotus 1-2-3 and other popular programs. There are also edit, compile and utility programs to tie voice recognition into all applications. A manual and 90-day warranty are included.

Visnet is a joint venture between Netmap Corp and Vision-hire.

For further information call Michael Carroll on (02)922-2711.

BRIEFS

Viatal for Tandy 4

Software is now available for the Tandy TRS80 Model 4 or 4P to operate with Telecom's Viatal system. The Australian produced 'Viaterm' supports Viatal's real time features, stores frames for late disk recording and uses an electronic mail template to allow messages to be prepared and edited off-line. For more information contact Tandy stores or '80 Software, PO Box 86, Lyons, ACT 2606.

Range of modems

The Nokia fourth generation of medium speed modems includes stand alone units and card modems, all of which are Telecom approved and conform to CCITT standards. Baud rates are 1200/600, 1200 and 2400/1200. For further information contact EEL Communications, 33 Bellona Ave, Regents Park, NSW 2143.

Viatal decoder

Dick Smith Electronics has introduced a decoder for the television suitable for connection to Telecom's Viatal videotex service. The unit retails competitively at \$499.

Retractable Cables with modular plugs



PMC 400 Series (4 Core)
4 x 4 modular plug



PMC 400 Series (4 Core)
6 x 4 modular plug



PMC 600 Series (6 Core)
6 x 6 modular plug



PMC 800 Series (8 Core)
8 x 8 modular plug

- Nominal impedance 2MT length 0.0
- Each conductor rated for continuous use at 1.0 AMP
- Fitted with modular plugs or to specification
- Modular jacks available upon request
- Also a complete range of other cabling requirements including power cords, ribbon and multicord shielded/unshielded cables



**H.H. PEASTON
PTY LTD**

Call today for more information
(02) 80 0477 (03) 762 3544

CATCHING THE BUS

This month we look into the computer's public transport system, the bus, which lets one part of the computer talk to another.

Phil Cohen

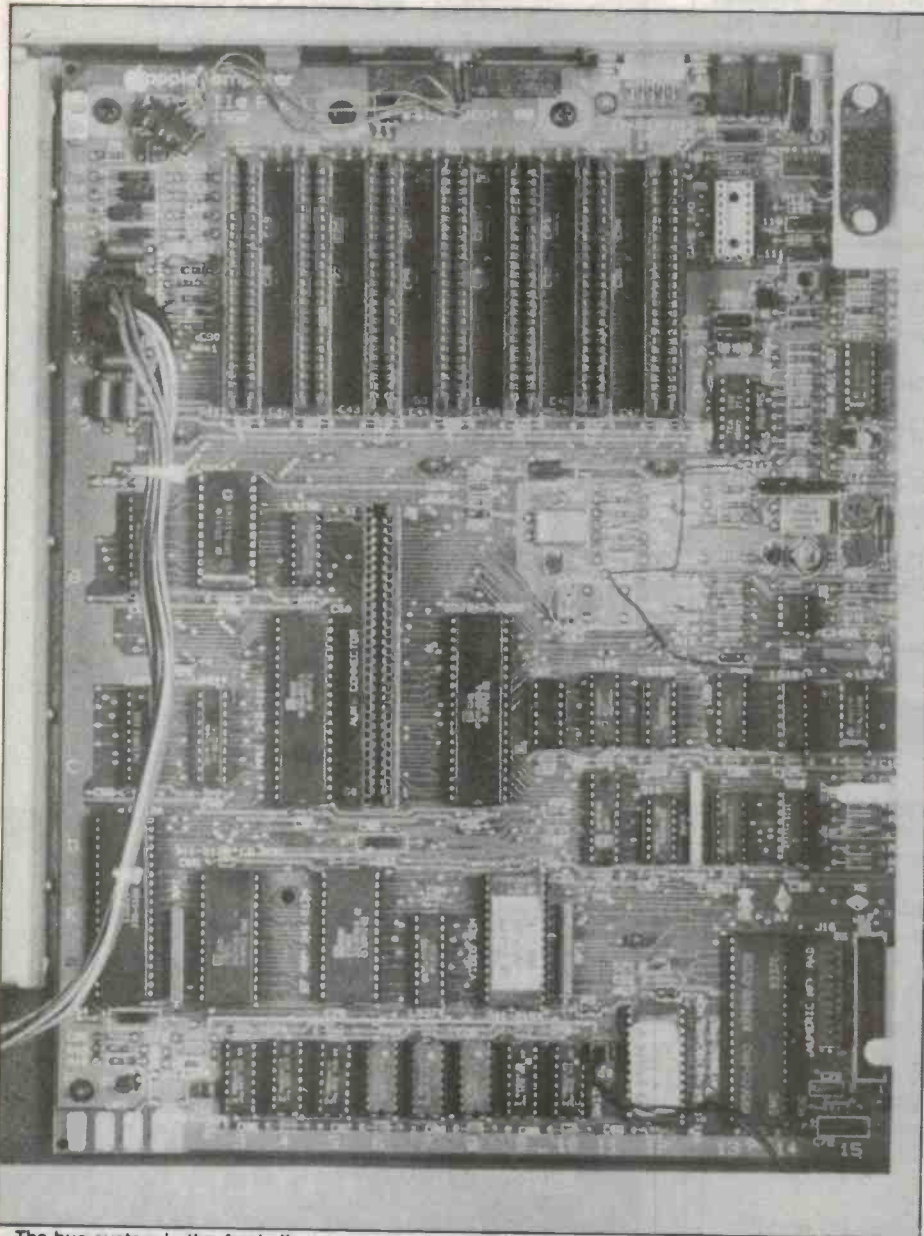

The bus system in the Apple IIe.

AS MENTIONED BRIEFLY last month, a computer's memory is arranged into a large number of different locations, each with a unique number or address, and each capable of holding one character (ie, a letter or digit), or part of a step in a computer program.

This arrangement is reflected in the actual physical layout of the tracks on the computer's pcb in the following way. The word 'bit' stands for Binary digIT, and means very simply a digit that is either '1' or '0'. In the normal number system we use, a digit can be 0, 1, 2, 3, 4, 5, 6, 7, 8 or 9, but in the binary system it can only be 0 or 1.

This means that using electrical signals, one wire can carry one bit by using 5V to represent 1 and 0V to represent 0. In our normal counting system, a two-digit number (00, 01, 02 . . . 99) can represent 100 different values. A three-digit number can represent 1000 different values. But in the binary system a two-digit number (2-bit number) can only be 00, 01, 10 or 11 — a total of four different values.

An eight-digit binary number (often referred to as a 'byte' for short) can represent one of 256 possibilities (try them all if you don't believe me!). This means that eight wires, each carrying one bit, can carry only one of 256 possible combinations of 1 and 0.

Locations

The memory in a personal computer is arranged in a number of locations, each capable of holding one 8-bit binary number or byte. When communicating that number to the processor, the memory uses a series of eight parallel wires each carrying one bit.

Each location is capable of representing one of 256 possibilities, so that it is quite usual to have one location holding one character (letter or symbol or digit). The word 'hello', for example, could be held in five successive locations as five values, each representing one character. The first address would hold a number that corresponded to 'h', the next to 'e', and so on.

All of the letters of the alphabet (both upper case 'A', and lower case 'a'), all of

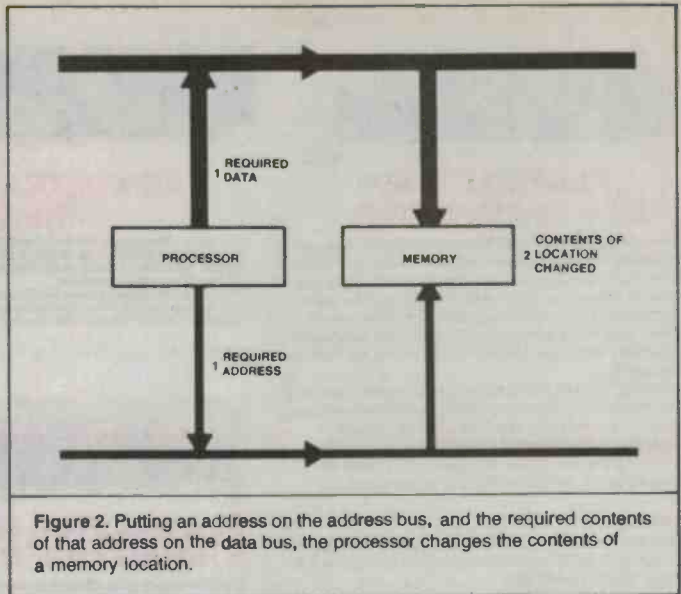
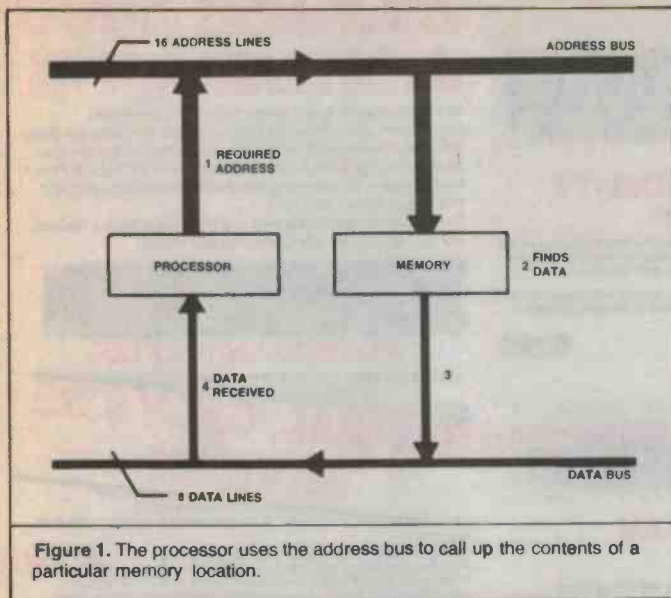

the symbols you are likely to need ('=', '+', etc) and quite a few other things can be quite easily accommodated in that scheme of 256 possible values.

The eight parallel tracks on the pcb are known collectively as the 'data bus', because they allow information in the form of 8-bit numbers to pass from the memory to the processor, and vice versa. The same data bus is often used to allow the processor to talk to the disk drive circuitry, the screen controller, and so on, so that it actually goes all over the computer.

Each location in memory has its own unique number or address, which again is represented as a binary number, usually of about 16 bits, which gives 65536 (64K) possible addresses — typical of a small home computer.

The processor calls up a particular location by setting 16 other lines on the pcb (known as the 'address bus') to a particular binary value which corresponds to the address of the location it wants to access. The memory responds by looking up the contents of that location and setting the data bus to the appropriate value.

When the processor wants to change the contents of a particular location, it puts the location's address on the address bus, the new value on the data bus, and sets another special line which tells the memory it wants to write instead of read the location. The memory takes the new value and stores it in the appropriate location.

System bus

The address bus and data bus taken together are referred to as the 'system bus'. The system bus is often extended to a large socket on the side of the machine (sometimes just an area of gold plated, edge connector pins) so that memory or other devices can be added later to the outside of the box.

The program that the processor follows is also stored in memory as a series of 'instructions', each taking up one, or usually two or

three locations. The processor calls those instructions up from memory one at a time just as if they were data stored in memory. As far as the memory is concerned, it doesn't matter whether a particular location holds data, or part of a program.

(This is generally true for most other types of memory; disks can hold either programs or data, as can tapes or cartridges. Both data and programs can be sent via telephone lines, satellites or any other medium, without the system knowing or caring whether it is handling programs or data.)

So the processor is using the system bus both to call up its program one step at a time, and also to read from and write to memory locations.

Expansion slots

The Apple computer was a milestone in the history of computing (and perhaps the first milestone in home computing). The phenomenal success of the Apple was due to a number of factors, one of which was the system of expansion slots just under the lid.

These were basically an extension of the computer's system bus along a line of sockets, into which new add-on pcbs could be plugged.

This allowed an extraordinary variety of devices to be attached to the Apple (including things from TV cameras to robots, speech synthesisers and even air conditioning controllers), making it a very versatile machine. Most of the add-ons were made by companies other than Apple, which took the development load off Apple while at the same time increasing sales of the basic computer.

It was even possible to connect new processors to the Apple bus, and in fact a common add-on was a card containing a Z80 processor which turned the computer into a different machine, capable of running CP/M.

Interestingly, the new Apple Macintosh started out with a closed box philosophy

and no user-accessible bus, but the market showed clearly what it thought of the machine, and newer versions are now planned with an expansion bus!

PEEK and POKE

The BASIC PEEK() and POKE instructions allow you to actually examine and alter the contents of a particular location in memory. For example, PEEK(1234) will return the value held in location 1234, and POKE 3456, 99 will alter the value of location 3456 to 99. Of course, POKE will only allow you to alter the contents of RAM, not of ROM (so there's no danger of damaging the computer).

Glossary

- Address:** a number that uniquely identifies a particular location in memory.
- Address lines:** the part of the system bus that carries the address from the processor to the rest of the computer.
- Byte:** the amount of information held at one address — each byte can represent a number between 0 and 255, which allows it to store any of the letters of the alphabet, digits, symbols, etc.
- Data lines:** that part of the system bus that carries the data to and from the processor.
- Expansion slot:** an extension of the computer's system bus to a number of slots to allow extra pcbs to be plugged in.
- Instruction:** one step of a program.
- Location:** memory is split into a large number of locations, each usually holding one 8-bit number.
- PEEK:** a BASIC command that allows you to look at the actual contents of a memory address.
- POKE:** a BASIC command that allows you to alter the contents of a memory address.
- System bus:** a set of parallel tracks on the computer's pcb which carries information to and from the processor. ●

SERIES 5000

INDIVIDUAL COMPONENTS TO MAKE UP A SUPERB HI-FI SYSTEM!

By directly importing and a more technically orientated organisation, ROD IRVING ELECTRONICS can bring you these products at lower prices than their competitors. Enjoy the many other advantages of RIE Series 5000 kits such as "Superb Finish" front panels at no extra cost, top quality components supplied throughout. Over 1,000 sold!

For those who haven't the time and want a quality hi-fi, we also sell the Series 5000 kits assembled and tested.



PLAYMASTER 60 + 60 AMPLIFIER

Enjoy the incredible performance improvement of the new low cost Playmaster 60/60. This brilliant new design by Jon Clarke and Leo Simpson has distortion and signal-to-noise specs that are unbelievable for an amp at this price AND over 60+ watts RMS per channel! Use of a fully imported TOROIDAL power transformer, state of the art components and circuit techniques makes the 60/60 amp a giant leap forward from the old Twin 25 and 40/40 amps.

The Rod Irving Electronics kit is faithful to the original. Control pots, for example, were used in the prototype. Be careful of cheap substitutions in some Inferior kits! (The Identical Toroidal transformer is used as well as a fully punched chassis with attractive front panel and quality fibreglass PCB.) Check the detailed specs below, we're sure that you will be surprised

SPECIFICATIONS:

Power Output: 1 channel at 2 ohms 105W, both channels 81W
1 channel at 4 ohms 88W, both channels 72W. 1 channel at 8 ohms 74W, both channels 62W

Dynamic Power (IHF-A-202): One channel at 4 ohms 153W, both channels 120W. 1 channel at 8 ohms 105W, both channels 95W. (all measured with 240V AC regulated power supply.)

Harmonic Distortion: Less than 0.008% at 10kHz and 60W into 8 ohm loads. Less than 0.012% at 10kHz and 80W into 4 ohms loads.

Intermodulation Distortion: Less than 0.0095% for all powers up to 60W into 8 ohm loads. Less than 0.011% for all powers up to 80W into 4 ohm loads.

Frequency Response: Phono Inputs - RIAA/IEC equalisation within + -0.5dB from 40Hz to 20kHz and within 1dB from 20Hz to 40Hz. High Level Inputs -0.5 dB at 20Hz and -1dB at 20kHz.

Channel Separation: (Measured at 60W) 10kHz 66dB; 1kHz 75dB; 100Hz 79dB; (undriven inputs loaded with 1k ohm)

Input Sensitivity: Phono inputs at 1kHz - 4.3mV; Overload capacity at 1kHz - 140 mV; High level inputs - 270mV

Hum and Noise: Phono (with respect 10mV at 1 kHz) - 89dB unweighted; High level inputs (with respect to 270mV input) 103dB unweighted with 20Hz to 20kHz bandwidth.

Tone Control: Bass + -12dB; Treble + -12dB
Damping Factor: At 1 kHz) 80; at 30Hz) 82
Stability: Unconditional

(EA May, June, July '86)

Please phone for information on the availability of this new kit! **\$299**



AEM ULTRA FIDELITY PREAMP

The latest, definitive preamp from David Tillbrook, the man who designed the famous Series 5000! Just as his Series 5000 were an enormous leap forward 5 years ago, so to is his latest AEM 6000 Series, especially in regard to Compact Disc signal processing.

"The input noise figures subsequently obtained are significantly better than the best op-amp designs and exceed the specifications of the best commercial amplifiers" -David Tillbrook, AEM October '85

Cat K **\$289**



PLAYMASTER FM/AM STEREO TUNER

The new Playmaster FM/AM stereo tuner will out perform anything presently available on the market, regardless of price. As well as including a FM tuner section which is every bit as good as any other synthesised design, it is also the only unit featuring a genuine wideband, low distortion AM stereo tuner. Naturally, it has a digital readout, 12 station memory, automatic seek and an optional infrared remote control.

SPECIFICATIONS:

AM TUNER.....
Tuning range: 522 to 1611kHz
Frequency Response: -3dB at 5.5kHz
Harmonic Distortion: Mono; 0.4% at 30% modulation
Stereo; +1% at 30% modulation

Audio Output: 450mV RMS into 4.7 ohm load at 100% modulation
Stereo Separation: Typically 30dB
AGC Range: 40dB for a 6dB change in audio output
Signal to Noise Ratio: 70dB with respect to full output for signal levels of 9 and 10 on bar graph display; better than 60dB with respect to full output for signal levels greater than 6

Usable Sensitivity: 350uV at -6dB audio level

FM TUNER.....
Tuning Range: 87.9 to 107.9 MHz
Frequency Response: -1dB at 20Hz, -0.5dB at 15kHz
Harmonic Distortion: Mono; 0.15% (100Hz); 0.15% (1kHz); 0.2% (6kHz)
Stereo; 0.4% (100Hz); 0.4% (1kHz); 0.4% (6kHz)

Audio Output: 450mV RMS into 4.7 ohm load at 100% modulation
Stereo Separation: 34dB (50Hz); 34dB (1kHz); 36dB (10kHz)
Subcarrier Product Rejection: 48dB
19kHz Rejection: 62dB

(EA Dec. '85 Jan-Feb '86 85tu12)

Cat. K86620 **only \$499**

POWER AMPLIFIER

WHY YOU SHOULD BUY A "ROD IRVING ELECTRONICS" SERIES 5000 POWER AMPLIFIER

SPECIAL, ONLY \$329
SAVE \$30

...and developed by ROD IRVING ELECTRONICS and is being supplied to other kit suppliers.

SPECIFICATIONS: 150 W RMS into 4 ohms
POWER AMPLIFIER: 100W RMS into 8 ohms (+ - 55V Supply)
FREQUENCY RESPONSE: 8Hz to 20Hz +0/-0.4 dB 20Hz to 65kHz, +0/-3 dB. NOTE: These figures are determined solely by passive filters.

INPUT SENSITIVITY: 1 V RMS for 100W output.
HUM: 100 dB below full output (flat).
NOISE: 116 dB below full output (flat, 20kHz bandwidth)

2nd HARMONIC DISTORTION: -0.001% at 1 kHz (0.0007% on Prototypes) at 100W output using a + -56V SUPPLY rated at 4A continues -0.0003% for all frequencies less than 10kHz and all powers below clipping

TOTAL HARMONIC DISTORTION: Determined by 2nd Harmonic Distortion (see above)
INTERMODULATION DISTORTION: 0.003% at 100W, (50Hz and 7kHz mixed 4:1).
STABILITY: Unconditional.

Cat. K44771 **\$359**

Assembled and tested **\$549**
packing and post \$10



PREAMPLIFIER

THE ADVANTAGES OF BUYING "ROD IRVING ELECTRONICS"

SPECIAL, ONLY \$299
SAVE \$20

...methods. (We believe that dollar for dollar a commercial unit available that sounds as good)

SPECIFICATIONS:
FREQUENCY RESPONSE: High level input: 15Hz - 130kHz, +0/-1dB
Low-Level input-conforms to RIAA equalisation +0.2dB

DISTORTION: 1kHz -0.003% on all inputs (limit of resolution on measuring equipment due to noise limitation).

S/N NOISE: High-Level input, master full, with respect to 300mV input signal at full output (1.2V); 92dB flat +100dB A-weighted; MM input, master full, with respect to full output (1.2V) at 5mV input 500ohms source resistance connected; -86dB flat 92dB A-weighted MC input, master full, with respect to full output (1.2V) and 200uV input signal; -71dB flat +75dB A-weighted.

Cat. K44791 **\$319**

Assembled and tested **\$599**
packing and postage \$10



THIRD OCTAVE GRAPHIC EQUALIZER

SPECIFICATIONS:
BANDS: 28 Bands from 31.5Hz to 16kHz
NOISE: -0.008mV, sliders at 0, gain at 0, 20kHz BANDWIDTH DISTORTION: -0.003% on all inputs (limit of resolution on measuring equipment due to noise limitation).

FREQUENCY RESPONSE: High level input, master full, with respect to full output (1.2V) at 5mV input 500ohms source resistance connected; -86dB flat 92dB A-weighted MC input, master full, with respect to full output (1.2V) and 200uV input signal; -71dB flat +75dB A-weighted.

Cat. K44791 **\$219**

Assembled and tested **\$299**
packing and postage \$10

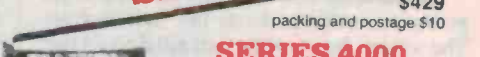

SERIES 4000 SPEAKERS

8 Speakers **\$349**

8 Speakers with Crossovers **\$579**

Speaker Boxes (assembled with grill and speaker cutout) **\$349**

Crossover Kits **\$249**

Complete kit of parts (speakers, crossovers, screws, innerband boxes) **\$899**

Assembled, tested and ready to hook up to your system **\$995**

Errors and Omissions Excepted

COMPACT DISC PLAYER ATTENUATOR

If you have just purchased a compact disc player your amplifier could be in trouble! CD players seem to have standardised on a 2V output level where as most hi-fi amps have a 500mV sensitivity for full rated output.

In order to overcome this you may need a CD Attenuator. It does not distort the signal in any way. It is inexpensive and simple to construct, making it an ideal beginners project. (EA '86)

Cat. K **\$7.95**

PLAYMASTER 300 WATT AMPLIFIER

This module will deliver up to 200 watts into an 8 ohm load and up to 300 watts into a 4 ohm load. Comprehensive protection is included and a printer circuit board brings it all together in a rugged easy-to-build module. It can be built in either fully-complementary or quasi-complementary versions, so output transistor shortages should be no problem at all. (80PA6) (EA July '80)

Cat. K80062 **Normally \$109**

SPECIAL, ONLY \$99

PLAYMASTER 200 HI-FI MOSFET AMPLIFIER

100W/channel (RMS) into 8 ohm! "A stereo amplifier that will equal or better just about any integrated commercial amplifier, regardless of price!" -Leo Simpson, Editor EA

Features:

- Electronic input switching
- CD player input (2 volt)
- All potentiometers, input and output connectors, PCB mount
- Screened and other wiring almost eliminated
- Special centre detent and 'switchable attenuator' type controls
- Safety shrouded speaker connectors
- Extensive switching facilities
- MOSFET performance and reliability
- Uses Hitachi 2SC2545 low noise transistors
- Very low price for level of performance

SPECIFICATIONS:

Power Output: 100W RMS into 8 ohms per channel

Frequency Response: 8Hz to 20kHz +0, -0.3dB, 2 Hz to 65kHz +0, -dB

HUM: -100dB below full output

Input Sensitivity: Line 300mV 90dB S/N

Moving magnet 2mV 80dB S/N

CD input 2V 94dB S/N

Distortion: 0.01% maximum typical; 0.003% 20 - 20kHz

Stability: Unconditional

(EA Jan, Feb, Mar '86)

Cat. K85 **\$449**



MUSICOLOR IV

Add excitement to parties, card nights and discos with EAs Musicolor IV light show. This is the latest in the famous line of musicolors and it offers features such as four channel "color organ" plus four channel light chaser, front panel LED display, internal microphone, single sensitivity control plus opto-coupled switching for increased safety. (EA Aug. '81) 81MC8

Cat. K81080 **\$99**

Features:

- Electronic input switching
- CD player input (2 volt)
- All potentiometers, input and output connectors, PCB mount
- Screened and other wiring almost eliminated
- Special centre detent and 'switchable attenuator' type controls
- Safety shrouded speaker connectors
- Extensive switching facilities
- MOSFET performance and reliability
- Uses Hitachi 2SC2545 low noise transistors
- Very low price for level of performance

SPECIFICATIONS:

Power Output: 100W RMS into 8 ohms per channel

Frequency Response: 8Hz to 20kHz +0, -0.3dB, 2 Hz to 65kHz +0, -dB

HUM: -100dB below full output

Input Sensitivity: Line 300mV 90dB S/N

Moving magnet 2mV 80dB S/N

CD input 2V 94dB S/N

Distortion: 0.01% maximum typical; 0.003% 20 - 20kHz

Stability: Unconditional

(EA Jan, Feb, Mar '86)

Cat. K85 **\$449**



AUDIO TEST UNIT

Just about everyone these days who has a stereo system also has a good cassette deck, but not many people are able to get the best performance from it. Our Audio Test Unit allows you to set your cassette recorder's bias for optimum frequency response for a given tape or alternatively, it allows you to find out which tape is best for your recorder. (81A10) (EA Oct '81)

Cat. K81010 **\$59.50**

SONICS ACTIVE DIRECT INSERTION BOX.

This inexpensive, easy to build DI box was designed in conjunction with Sonics magazine and is fine for both live PA and home recording work. It takes an unbalanced input and produces an output suitable for driving a balanced audio line.

SPECIFICATIONS:

S/N Ratio: 100dB (ref 0dBm)

Distortion: 0.03% at 4dBm

Input Impedance: 500k nominal (unbalanced)

Output Impedance: 600 ohm nominal (balanced)

(ETI 1401 Sept '85)

Cat. K41401 **\$39.95**

4 INPUT PREAMP

Easy construction and versatile operation, this preamp is for coupling with the 300W "Brute" Power Amp. (ETI 467) (ETI July '80)

Cat. K44670 **\$54.95**



MOSFET POWER AMPLIFIER

Employing Hitachi Mosfets, this power amplifier features a 'no compromise' design, and is rated to deliver 150 W RMS maximum and features extremely low harmonic, transient and intermodulation distortion.

ETI 477 (ETI Jan, '81)

(Single module only)

Cat. K44770 **\$79.50**

Plus power supply (No trans) \$49

Plus transformer PF4361/1 \$49.50

HI FI SPEAKERS

A comprehensive range of matched appearance speakers, all with square silver grey frames and black cones - ideal for building up low cost speaker systems that will look and sound superb.



1 1/2" TWEETER

SPECIFICATIONS:
Sensitivity: 90dB
Freq. Response: 1.2 - 20 kHz
Impedance: 8 ohms
Power RMS: 10 watts
Magnet Weight: 2 oz
Cat. C10200

\$4.95



2 1/2" TWEETER

SPECIFICATIONS:
Sensitivity: 94dB
Freq. Response: 1.1 - 17 kHz
Impedance: 8 ohms
Power RMS: 10 watts
Magnet Weight: 2 oz
Cat. C10202

\$5.95



4" MIDRANGE WITH SEALED BACK

SPECIFICATIONS:
Sensitivity: 96dB
Freq. Response: 650 - 15 kHz
Impedance: 8 ohms
Power RMS: 15 watts
Magnet Weight: 3.6 oz
Cat. C10204

\$9.95



4 1/2" MIDRANGE WITH SEALED BACK

SPECIFICATIONS:
Sensitivity: 97dB
Freq. Response: 600 - 8 kHz
Impedance: 8 ohms
Power RMS: 20 watts
Magnet Weight: 5.4 oz
Cat. C10206

\$12.95



6 1/2" WOOFER

SPECIFICATIONS:
Sensitivity: 96dB
Freq. Response: 55 - 7 kHz
Impedance: 8 ohms
Power RMS: 15 watts
Magnet Weight: 5.4 oz
Cat. C10208

\$15.95



8" WOOFER RIBBED CONE

SPECIFICATIONS:
Sensitivity: 94dB
Freq. Response: 55 - 8 kHz
Impedance: 8 ohms
Power RMS: 20 watts
Magnet Weight: 5.4 oz
Cat. C10210

\$18.95



10" WOOFER RIBBED CONE

SPECIFICATIONS:
Sensitivity: 95dB
Freq. Response: 37 - 6 kHz
Impedance: 8 ohms
Power RMS: 25 watts
Magnet Weight: 10 oz
Cat. C10212

\$29.95



12" WOOFER RIBBED CONE

SPECIFICATIONS:
Cloth edge roll surround.
Sensitivity: 92dB
Freq. Response: 32 - 4 kHz
Impedance: 8 ohms
Power RMS: 30 watts
Magnet Weight: 13.3oz
Cat. C10214

\$39.95



12" HIGH POWER ALUMINUM SPEAKER

● Aluminium die cast chassis
● Carbon fibre impregnated cone paper
● Foam edge
● Light grey cone, silver dust cap
● High temperature "NOMEX" voice coil

SPECIFICATIONS:
Sensitivity: 97dB
Frequency Response: 50-4kHz
Impedance: 8 ohms
Power RMS: 60 watt
Magnet Weight: 30 oz.
Cat. C10216

\$59.95



PIEZO DIRECT RADIATING TWEETER

Requires no crossover, handles up to 100 watts.
Sensitivity: 98dB
Maximum Input: 24 volts
Freq. Response: 3.2 - 30kHz
Dimensions: 95mm diameter.
Cat. C12104

\$11.95



SUPER HORN TWEETER

● Requires no crossover and handles up to 100W!
● Sensitivity: 100dB/0.5m
● Frequency Response: 3kHz-30kHz
● Impedance: 8 OHMS
● Size: 96mm diameter
Cat. C12102 normally \$17.95

On Special at \$14.95



SUPER HORN

● Wide dispersion tweeter, handles up to 100W.
● Sensitivity: 105dB/0.5m
● Frequency Response: 3kHz-30kHz
● Impedance: 8 OHMS
● Size: 145x54mm
Cat. C12103 normally \$17.95

On Special at \$14.95



PHILIPS SPEAKERS

"Unfortunately we cannot always guarantee Philips speakers to be in stock due to availability problems"

Cat. C12030 AD01610 T8 \$16.95
Cat. C12040 AD02160 S08 \$34.95
Cat. C12045 AD70620 M8 \$49.00
Cat. C12050 AD12550 W8 \$95.00 (or Philips equivalent supplied)



VIFA/AEM 2 WAY SPEAKER KIT!

This exciting new speaker kit, designed by David Tibbrook (a name synonymous with brilliant design and performance) uses VIFA's high performance drivers from Denmark. You will save around \$800 when you hear what you get from this system when compared to something you buy off the shelf with similar characteristics. Call in personally and compare for yourself!

The system comprises...
2 x P21 Polycone 8" woofers
2 x D25T Ferritoid cooled dome tweeters with Polymer diaphragms
2 pre-built quality crossovers

The cabinet kit consists of 2 knock-down boxes in beautiful black grain look with silver baffles, speaker cloth, innerboard, grill clips, speaker terminals, screws and ports

D25T SPEAKER SPECIFICATIONS:
Nominal Impedance: 6 ohms
Frequency Range: 2 - 24kHz
Free Air Resonance: 1500Hz
Operating Power: 2.2 watts
Sensitivity (1W at 1m): 90dB
Nominal Power: 60 Watts
Voice Coil Diameter: 25mm
Air Gap Height: 2mm
Voice Coil Resistance: 4.7ohms
Moving Mass: 0.3 grams
Weight: 0.53kg

P21 WOOFER SPECIFICATIONS:
Nominal Impedance: 8 ohms
Frequency Range: 25 - 4,000Hz
Free Air Resonance: 33Hz
Operating Power: 2.5 watts
Sensitivity (1W at 1m): 92dB
Nominal Power: 60 Watts
Voice Coil Diameter: 40mm
Voice Coil Resistance: 5.8ohms
Moving Mass: 20 grams
Thiele Small Parameters: Qm: 2.4
Qe: 0.41
Ql: 0.35
Vas: 80.1

Weight: 1.65kg
Speaker Kit Cat. K90000 \$489
Cabinet Kit Cat. K90000 \$179
All Together Cat. K90000 \$589 (Save 79!)



MIDRANGE HORNS

Use these quality, all metal, Piezo tweeters for great top end sound in your band speakers, disco sound system, etc. Rated at 30 watts RMS, in a system they will handle over 100 watts RMS.

Two sizes to choose from:
Size: 4" x 10 1/2"
Impedance: 8 ohms
Rating: 30 watts RMS
Response: 1.5kHz - 14 kHz
Dimensions: 102 x 267 x 177mm
Cat. C92082 Normally \$49.95
This month only \$49.95

Size: 3" x 7"
Impedance: 8 ohms
Rating: 30 watts RMS
Response: 2kHz - 15 kHz
Dimensions: 76 x 177 x 145mm
Cat. C92084 Normally \$29.95
This month only \$29.95

Dealers, OEM's, etc., phone (03) 543 2166 for wholesale prices



DIGITAL ECHO CHAMBER

Features 2 microphone inputs with 1 volume control, 1 line input with volume control, volume controls for delay time, repeat and echo. Outputs for footswitch, delay and mix.

- Delay time 180ms seconds
- Inputs: Mic 1 and 2 - 48dB, Line -20dB
- Output level 30MV (max)
- Frequency response 50 - 15kHz
- Signal/Noise ratio 40dB
- Power: 9V battery or AC adaptor
- Power on LED
- Weight 950 grams
- Dimension 232 x 65 x 140mm
Cat. A12050 \$95



VIFA/AEM 3 WAY SPEAKER KIT!

This superb 3 way speaker kit competes with systems that cost 2 - 3 times the cost of these units (which may even be using VIFA drivers etc.) Never before has it been possible to get such exceptional value in hi-fi speakers! Call in personally and compare for yourself!

The system comprises...
2 x D19 dome tweeters
2 x D75 dome midrange
2 x P25 woofers
2 x pre-built quality crossovers

The cabinet kit consists of 2 knock-down boxes in beautiful black grain look with silver baffles, speaker cloth, innerboard, grill clips, speaker terminals, screws and ports

D19 DOME TWEETER SPEAKER SPECIFICATIONS:
Nominal Impedance: 8 ohms
Frequency Range: 2.5 - 20kHz
Free Air Resonance: 1,700Hz
Sensitivity 1W at 1m: 89dB
Nominal Power: 80 Watts
(fo: 5,000Hz, 12dB/oct)
Voice Coil Diameter: 19mm
Voice Coil Resistance: 6.2ohms
Moving Mass: 0.2 grams
Weight: 0.28kg

D75 DOME MIDRANGE SPECIFICATIONS:
Nominal Impedance: 8 ohms
Frequency Range: 350 - 5,000Hz
Free Air Resonance: 300Hz
Sensitivity (1W at 1m): 91dB
Nominal Power: 80 Watts
(fo: 500Hz, 12dB/oct)
Voice Coil Diameter: 75mm
Voice Coil Resistance: 7.2ohms
Moving Mass (incl. air): 3.6 grams
Weight: 0.65kg

P25 WOOFER SPECIFICATIONS:
Nominal Impedance: 8 ohms
Frequency Range: 25 - 3,000Hz
Free Air Resonance: 25Hz
Operating Power: 5 watts
Sensitivity (1W at 1m): 89dB
Nominal Power: 80 Watts
Music Power: 100 Watts
Voice Coil Diameter: 40mm
Voice Coil Resistance: 5.7ohms
Moving Mass (incl. air): 4.4 grams
Thiele Small Parameters: Qm: 3.15
Qe: 0.46
Ql: 0.40
Vas: 180.1

Weight: 1.95kg
Speaker Kit Cat. K90000 \$779
Cabinet Kit Cat. K90000 \$309
All Together Cat. K90000 \$989 (Save a huge 110!)

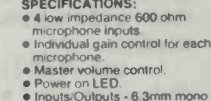

ECONOMY 4 CHANNEL MICROPHONE MIXER

Its size and simplicity makes this mixer very portable and easy to operate.

SPECIFICATIONS:

- 4 low impedance 600 ohm microphone inputs
- Individual gain control for each microphone
- Master volume control
- Power on LED
- Inputs/Outputs - 6.3mm mono sockets
- DC operated (9V battery only)
- Input impedance 600 ohm
- Output impedance 1.5kohm
- Signal/Noise ratio 55dB
- Frequency response 20Hz to 20kHz plus or minus 20dB
- Weight 320 grams
- Dimension 148 x 46 x 86mm
- Torque variable range 1-22dB
- Input sensitivity 1mV
- Output level 90mV (at input 5mV)
- T.H.D. 0.01%

Cat. A12001 \$39.50



ELECTRONIC RHYTHM BOX

- 8 selectable rhythms, Trot, Rock Disco, Bossanova, Waltz, Slow Rock, Cha Cha, Rumba
- Power 9V battery or AC adaptor
- Volume control
- Rhythm tempo control, 10 steps
- Power on LED
- Footswitch facilities
- Output level 150mV (max)
- Weight 750 grams
- Dimensions 190 x 52 x 132mm
Cat. A12048 \$79.95



OMNI-DIRECTIONAL WIRELESS MICROPHONE

Tunable: 92 - 104MHz
Freq. Response: 50 - 15kHz
Range: Over 300 feet in open field
Modulation: FM
Power Source: 9V Battery
Type: Electret Condenser
Dimensions: 185 x 27 x 38mm
Weight: 160 grams
Cat. A10450 \$19.95



CRYSTAL LOCKED WIRELESS MICROPHONE AND RECEIVER

MICROPHONE SPECIFICATIONS:
Transmitting Frequency: 37.1MHz
Transmitting System: crystal oscillation
Microphone: Electret condenser
Power Supply: 9V battery
Range: 300 feet in open field
Dimensions: 185 x 27 x 38mm
Weight: 160 grams

RECEIVER SPECIFICATIONS:
Receiving Freq: 37.1MHz
Output Level: 30mV (maximum)
Receiving System: Super heterodyne crystal oscillation.
Power Supply: 9V Battery or 9V DC power adapter.
Volume control
Tuning LED
Dimensions: 115 x 32 x 44mm
Weight: 220 grams
Cat. A10452 \$89

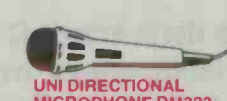

UNI DIRECTIONAL MICROPHONE DM323

Low impedance microphones that must be the best value for money in microphones! Features on/off switch and available in the following colours: White, Blue, Red, Yellow, black and Gold.
Impedance: 600 ohms
Frequency Response: 100 - 15kHz
Sensitivity: -75dB
Cord/Plug: 2.9 metre, 6.35mm phone plug
Dimensions: 50 x 200mm
Cat. A10133 \$13.95



2 WAY MINI BOOKSHELF SPEAKERS

Designed specifically for compact disc. This 2 way bass reflex system offers incredible audio performance for its size (9.5"). Woodgrain cabinet allows it to slot in with any audio or video system.

SPECIFICATIONS:
Speakers: Woofer - 4" carbon fibre reinforced polypropylene cone 10oz magnet, Tweeter 1" soft dome 6oz magnet, damped with ferro fluid.
Power Input: 30 watts rms 82dB w/m
Impedance: 8 ohms
Frequency response: 80-20,000Hz
Size: 150 x 240 x 160mm
Cat. C10760 \$179

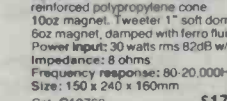

2 WAY MID SIZED SPEAKER SYSTEM

Designed specifically for compact disc. Excellent bass response to fully utilize the output capabilities of a compact disc. 16" high, woodgrain finish cabinet with brown cloth grille.

SPECIFICATIONS:
Speakers: Woofers 6 1/2" carbon fibre reinforced polypropylene cone 10oz magnet, Tweeter 1" soft dome 6oz magnet with ferro fluid.
Power Input: 40 watts rms 85dB w/m
Impedance: 8 ohms
Frequency response: 50-20,000Hz
Size: 250 x 400 x 240mm
Cat. C10762 \$299

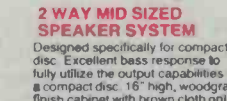

ELECTRONIC CASSETTE DEMAGNETISER

- 8 selectable rhythms, Trot, Rock Disco, Bossanova, Waltz, Slow Rock, Cha Cha, Rumba
- Power 9V battery or AC adaptor
- Volume control
- Rhythm tempo control, 10 steps
- Power on LED
- Footswitch facilities
- Output level 150mV (max)
- Weight 750 grams
- Dimensions 190 x 52 x 132mm
Cat. A10006 \$22.95



TDK AUDIO TAPE BARGAINS

Description	Cat. No.	1-9	10+
DC46 TDK	A11305	2.95	2.85
DC60 TDK	A11307	2.99	2.35
DC90 TDK	A11309	3.99	3.50
DC120 TDK	A11311	5.49	4.50
AD60 TDK	A11315	3.99	3.45
AD90 TDK	A11317	5.25	4.50
AD120 TDK	A11319	7.95	6.25
ADX60 TDK	A11320	4.95	4.25
ADX90 TDK	A11322	5.95	4.95
SA60 TDK	A11325	5.95	4.95
SA90 TDK	A11327	6.99	5.50
SAX60 TDK	A11329	8.69	5.77
SAX90 TDK	A11332	8.95	7.25
MAC60 TDK	A11335	8.99	7.25
MAC90 TDK	A11337	11.50	8.95
MAR60 TDK	A11340	13.50	10.95
MAR90 TDK	A11342	16.99	14.50



ARLEC "DISCO LITE" CONTROLLER

Give your parties a professional touch with the arlec "Disco Lite" Simply plug your light(s) into the "Disco Lite" and you're instant party life!

3 DIFFERENT MODES!
Music Mode: Place the "Disco Lite" in range of the speakers and it flashes the lights to the beat of the music!
Strobe Mode: Simply adjust to desired speed for disco or theatre! The christmas season or advertising!
Dim Mode: Allows you to dim the lights to create moods, effects etc.
Cat. M22003 \$49.50



ROD IRVING ELECTRONICS

425 High Street, NORTHCOTE 3070
VICTORIA, AUSTRALIA
Phone (03) 489 8865
48 A Beckett St, MELBOURNE, 3000
VICTORIA, AUSTRALIA
Ph. (03) 663 6151
Mail Order and correspondence:
P.O. Box 620, CLAYTON 3168
TELEX: AA 151938



MAIL ORDER HOTLINE (03) 543 7877 (5 lines)

POSTAGE RATES

\$1-89.99	\$3.00
\$10-89.99	\$3.00
\$25-549.99	\$4.00
\$50-999.99	\$5.00
\$100-199	\$7.50
\$200-5499	\$10.00
\$500 plus	\$12.50

This is for basic postage only. Parcel Road freight, bulky and fragile items will be charged at different rates.
Certified Post for orders over \$100 included "free"
Registered Post for orders over \$200 included "free"
All sales tax exempt orders and wholesale enquiries to RTTRONICS WHOLESALE, 56 Renner Rd., Clayton Phone (03) 543 2166

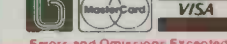

Errors and Omissions Excepted.



For those who don't know, C is a general-purpose programming language for writing operating systems as well as numerical, text-processing, data base and other application programs.

J.P.H. Aerts

*Test & Measuring Instruments Department
Philips, Eindhoven*

THE LANGUAGE WAS designed in 1972 by Dennis M. Ritchie from Bell Laboratories and was originally implemented in the UNIX operating system on the PDP-11. The UNIX operating system is written almost entirely in C. In addition, the C compiler itself and practically all UNIX application programs are written in the language.

In 1977 development began on a machine-independent version of the C compiler, known as the portable C compiler, to simplify the task of moving it to new computers. As a result, compatible versions of C now run on several machines, from micro to main-frame computers (eg, PDP-11, PMDS-II, Motorola 68000, Honeywell 6000, IBM system /370, Intel 8086, and VAX).

Naturally enough C has always been closely associated with the UNIX operating system, (although not necessarily tied to any one operating system: C is also available on some CP/M based machines) and its usage is likely to increase with the growing popularity of UNIX.

The main advantage of C is its integration within a powerful set of tools under UNIX.

How it works

In C, every variable must be declared a certain type. The four basic types are int, char, float (short for integer, character and floating respectively) and double. The programmer can define other types in terms of these.

Three qualifiers can be applied to integers: short, long and unsigned. The idea is that short and long should provide differ-

ent integer lengths. Each compiler, however, is free to interpret short and long as appropriate for its own hardware. About all that can be counted on is that short is no longer than long and that the length of short and long is greater than or equal to 16 bits and 32 bits respectively.

Example:

```
char a, b, c;
float d;
double e;
short int f;
long g;
int h = 0;
float eps = 1.0e-5;
```

(note that the declaration may include an initialisation of the variable).

There are also arrays, structures, and unions of these basic types, pointers to them, and functions that return them. For example,

```
int w[50];
```

declares an array w with 50 elements, each of which is an integer. The first element is w[0], the last w[49].

Structures in C are objects consisting of one or more fields (where a field is an object of any type).

Example:

```
struct date
{ int day;
  char monthname [4];
  int year;
}
```

There are two variations on structures: unions and bitfields. In a union, each of the fields is mapped to the same area of storage. In a bitfield, each field is mapped to a por-

tion of a word. A pointer in C points to an object of some particular type. The declarations

```
char *cp;
struct date *sp;
```

define cp to be a pointer to objects of type character (one of the four basic types) and sp to be a pointer to objects of type date (a structure defined by the programmer).

The dereferencing operator is *; *cp yields a character conversely, the operator & returns the address of an object. So

```
date birthday;
sp = &birthday;
```

is a valid assignment to sp.

In C, symbolic constants are implemented via preprocessor macro definitions. The definitions

```
# define DAYS 365
# define WEEKS (DAYS/7)
```

define DAYS to be the constant 365 and WEEKS to be the expression (DAYS/7).

C includes practically all the common operators that appear in other programming languages, although it does not provide any operations to deal with composite objects as a whole (except structure assignment).

Only a few unusual operators will be considered here.

The language includes assignment operators for updating a variable based on its current value. The expression

```
i += 1
```

is equivalent to i = i + 1; however, the address of i is evaluated only once. Any binary operator like *, -, >> (shift) or & (and), can be used in place of +.

In C, increment and decrement operators

exist. The general form for increment is
 ++var
 or
 var++

In the first case, var is incremented by unity before its value is used, while in the second case var is incremented after its value is used. So, if n is 5, then

```
x = n++;
sets x to 5, but
x = ++n;
```

sets x to 6. In both cases, n will be 6 after the execution of the statement.

Logical expressions connected by AND(&&) and OR(||) operators are evaluated conditionally from left to right. This means that the evaluation stops as soon as the value or the expression is known. Hence a loop like

```
while (i<=n && x[i] != key)
  i++;
```

(with n the highest index of array x) must be written in Pascal, because of the lack of conditional logical operators, as follows:

```
found := false;
while (i<=n) and (not found)
do
if x[i]= key then found
:=true
else i:=i+1;
```

(Note that the notation of assignments in Pascal differs from that in C.)

Another C operator that is worth mentioning is the conditional operator. This takes three operands: a condition, a true part, and a false part, and is used as follows:

```
(a>b) ? c : d
```

is equal to c if a is greater than b, and equal to d otherwise.

An assignment can be used in an expression like any other variable. The value of an assignment is the value stored in the left hand operand after the assignment has taken place. An example of the usage of assignments in expressions is:

```
while ((c = getchar())
!=EOF) 'process c',
```

which executes process c for all characters entered, and

```
i=j=k=0;
```

which sets all three variables to zero.

The use of control statements in C is quite similar to that in Pascal, though the notation differs somewhat; we may take as an example the 'for' statement in C.

In C, the statement 'for (loop-initialisation; condition; reinitialisation) loop statement(s)' is equivalent to:

```
loop-initialisation;
while (condition) {
loop statement(s);
loop-reinitialisation;
}
```

In this sequence, initialisation, condition and/or re-initialisation can comprise no statements, one statement or more than one. This makes C's

EXAMPLE OF A 'C' PROGRAM:

Concatenation of a string s2 on to a string s1. This routine can be used to add supplementary information to a standard text, such as the amount to be paid in an invoice; s1 could then be Amount due: and s2 \$2750.35.

The program starts with remarks explaining briefly what it is intended to do. The sign /* in the margin marks the start of the remarks, and */ the end.

The first statement in the program, char*, indicates that the program returns a pointer to a character string. The next line declares the function name and the parameters used in calling it (the strings s1 and s2, and the maximum number n of characters to be moved). The remaining lines in the program are numbered here for ease of explanation, but these numbers do not form an integral part of the commands as they do eg, in BASIC.

Lines 1 to 4 instruct the compiler to keep the points s1 and s2, and n, in registers to speed up execution. After initialisation of pointer os1 in statement 7, the end of the receiving string can be found in a single statement (8).

Lines 10 to 14 comprise the copying loop, with a check on n in the body (line 11). The while in line 10 is controlled by *s1++ = &s2++, which in a single instruction copies a character, updates both pointers and gives an indication when the end of string s2 is reached. (The zero byte which marks the end of all

character strings in C ends the while loop.) Should s2 be too long, the while loop is ended by the break in line 13, after the receiving string has been properly terminated in the previous line.

```
/*
 * Concatenate s1 on the end of s1.
 * S1's space must be large enough.
 * At most n characters are moved.
 * Return s1.
 */
char *
strncat(s1, s2, n)
1 register char *s1, *s2;
2 register n;
3 {
4 register char *os1;
5
6 os1 = s1;
7 while (*s1++)
8 ;
9 --s1;
10 while (*s1++ = *s2++)
11 if (--n < 0) {
12 *--s1 = '\0';
13 break;
14 }
15 return(os1);
16 }
```

for statement not only much more flexible than Pascal's, but also keeps the control expressions close together and clearly visible.

There are three statements in C that provide an early exit from a loop: break, return, and continue. The return statement exits immediately from the function called to its caller; likewise, the break statement causes the innermost enclosing loop to be exited immediately, and the continue statement causes the next iteration of the enclosing loop to begin.

Pointers and arrays

In C, there is a strong relationship between pointers and arrays. Any operation which can be achieved by array subscripting can also be done with pointers; the pointer version will in general be faster.

The declaration:

```
int a[10], *pa;
```

defines an array of a size 10 and a pointer pa which points to objects of type integer.

The assignment

```
pa=&a[0];
```

sets pa to point to the first element of a; that is pa contains the address of a[0]. If pa points to a particular element of array a, then pa+i (with i an integer) points to i elements after pa.

Thus if pa points to a[0]

```
* (pa+i)
```

refers to the contents of a[i].

These examples are true regardless of the type of the variables in array a. All pointer arithmetic is scaled by the size in storage of the object pointed to.

The correspondence between array indexing and pointer arithmetic is close. In fact, a reference to an array is converted into a pointer to the beginning of the array, thus making an array name a synonym for

the location of the first element; the assignment pa=&a[0]; can also be written as pa=a; The forms a[i] and *(a+i) are also equivalent.

So, if pa is a pointer it can be used with a subscript: pa[i] is identical to *(pa+i).

There is only one difference between an array name and a pointer: a pointer is a variable, so pa=a and pa++ are sensible operations, but an array name is a constant and not a variable, so constructions like a=pa or a++ are illegal.

The C preprocessor

The C compiler contains a preprocessor capable of macro substitution, file inclusion, and conditional compilation.

The macro substitution facility is most valuable for definition of symbolic constants and to create repetitive object code. A compiler control line of the form

```
# include 'filename'
```

causes the replacement of that line by the contents of the specified file. The file named is searched for first in the directory of the original source file, then in a sequence of standard places. Alternatively, a control line of the form

```
# include <filename>
```

searches only the standard places. This facility is the method of choice for tying declarations together for a large program, and guarantees that all the source files will be supplied with the same definitions and variable declarations.

Conditional compilation allows one source file to spawn different object-code versions based upon compile-time parameters. For example, a program can be compiled either with or without diagnostic instructions.

Continued on page 107. ▶

at the leading edge

UNIFIL™ DESTINED TO BECOME INDUSTRY STANDARD FILTER IC

Daneva is sampling CML's new **FX409 Universal Analogue Signal Processor** to interested OEMs and Telecommunications Engineers to provide them with hands-on experience with this whippy little building block.

Unifil™ is a single **5V** supply **CMOS** device using **switched capacitor techniques**. Features include simplified setting up, an inbuilt PLL clock generator and a 2nd order multiple filter with notch, lowpass, bandpass and highpass frequency responses. The **Q is programmable to eight values between 0.84 and 8.0**.

Applications include Programmable Filters, Voltage Controlled Filters, Sinewave Oscillators, Tracking Filters, Tracking Oscillators, PSK and PSK Modems, Square to Sine and Pulse to Sine Converters.

SIERRA SEMI SINGLE CHIP MODEM IS BELL 212A and V22 COMPATIBLE

The **SC11004** is a complete **300/1200 bit per second modem** incorporating all of the signal processing functions needed for a full duplex modem. **FSK and PSK** modulators and demodulators and the highband and lowband filters are integrated on a single chip. Call progress monitoring, **DTMF and V22 guardtone generation and a two-to-four wire interface** are all included on-chip.

A complete **Hayes command set modem** can be built by combining Sierra's **SC11004** and an **SC11007 Modem Controller**. For stand-alone applications, the **SC11004**, the **SC11008 modem controller** a **DAA** and an **RS232 interface** is all that is required.

SPEECH SCRAMBLER CHIP GIVES SNOOPERS THE FLICK

Public networks, cordless telephones and shared radio links are subject to casual and sometimes criminal eavesdropping. **CML's FX 204, a CMOS Variable Split Band encoder/decoder**, is a cost effective voice band scrambler which can be programmed to provide an extremely secure communication link. Further, by using a microprocessor a rolling code of almost infinite length can be generated to prevent lock-on by any intruder. Additionally, time domain scrambling could be adopted by the use of CML's new **FX609 CVSD full duplex CODEC**.



daneva

daneva australia pty ltd

66 Bay Rd, Sandringham, Vic. 3191
P O Box 114, Sandringham, Vic. 3191
Telephone 598-5622 Telex AA34439
47 Falcon Street
Crows Nest, NSW 2065
Telephone 957-2464 Telex AA20801

Distributors

Adelaide: DC Electronics (08) 223-6946
Brisbane: Baltec (07) 369-5900

GSG 001

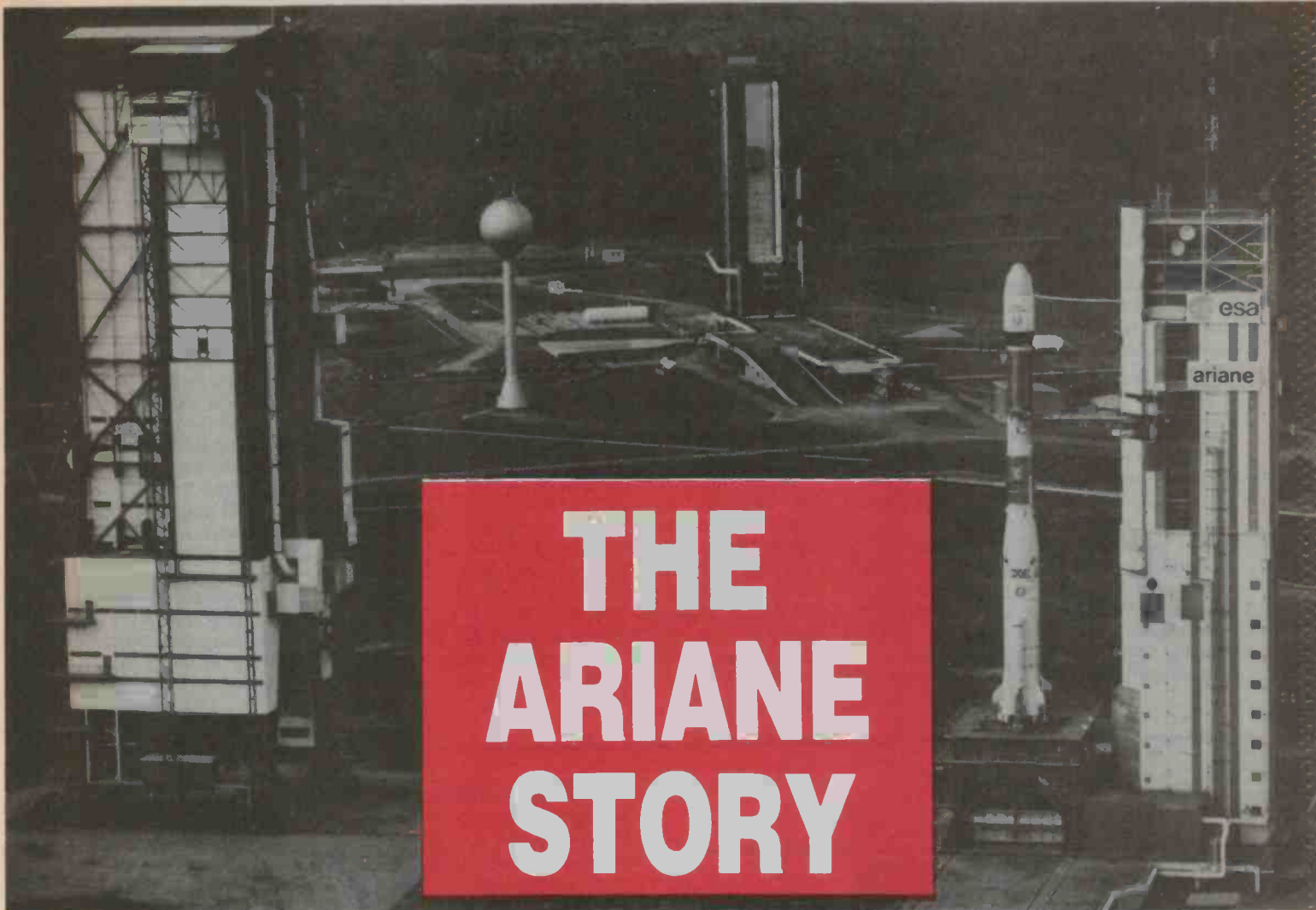

THE ARIANE STORY

Recent failure of an Ariane rocket out of Kourou has disappointed Aussat officials, but will not delay the implementation of the Aussat programs.

Jon Fairall

AUSSAT K3, the third satellite to be launched by the domestic carrier and the last of this generation was due to fly in August from the European Space Agency's launch site at Kourou in French Guyana on the northern seaboard of South America. Now it looks as though the launch will be postponed two months at least, following the failure of the third stage of an Ariane 3, four minutes into the flight.

The launch of K3 will mark the completion of Aussat's space segment plans. The ground segment is also well advanced with satellite ground stations in all major centres and most regional towns. The ABC HABCSS system, which uses Aussat to bring TV into the remotest outback communities, is being implemented at a steady rate, and new services are being announced all the time. According to Aussat spokesmen, ca-

capacity is already more than half booked, and the system is less than a year old.

The K3 launch is the first non-American launch entered into by Aussat. All the previous ones were on the shuttle. The decision to go European was taken early last year on economic grounds, and well before the Challenger disaster. Nevertheless, Aussat decision makers are thankful they are not still dealing with NASA. With its space program completely stalled, the US will not be in any position to put communications satellites up until at least mid-1987.

The Ariane rocket is one of the few successful results of European cooperation in technological areas. It's manufactured in numerous places across the continent, with final assembly of the first and third stages in France and the second stage in Germany.

In fact there are three current versions of

the rocket, with another two planned or under construction. Ariane 1 flew in 1979, Ariane 3 last year, and 2 in 1984. Ariane 4 is due up this year and Ariane 5 will fly in 1995. There has been a steady increase in the size of the payload on each model. Ariane 1 could lift 1825 kg, Ariane 4 will carry 4200, and the planned Ariane 5 will carry the weight of Hermes, the proposed European shuttle.

Ariane 3 is a 49 metre long vehicle with a take off mass of 237 tonnes. Each stage consists mainly of a propellant tank, a motor where the constituents of the propellant are mixed together, and a bit of electronic control equipment. The stages are connected together by skirts, each incorporating explosive devices for the separation procedures.

First stage power is provided by four Vik-▶

ing IV rocket engines, each with a thrust of 675 kiloNewtons (kN). It will reach a maximum velocity just before separation of 1850ms. The rocket burns for 140 seconds during which time the rocket will climb to 50km. Auxiliary power is provided by two strap-on boosters which are ignited 11 metres above the ground and burn for 30 seconds. Each of these develops 700kN.

The second stage uses only a single Viking IV motor but accelerates the rocket to 4700ms and an altitude of 140km. It will burn for 123 seconds.

The final stage has a cryogenic engine that burns for 720 seconds, during which time the rocket is injected into the transfer orbit, an ellipse that takes it up to the geostationary parking orbit where it will spend its working life. The motor develops 63kN and the rocket reaches 9700ms.

The rocket is owned and operated by Ariespace, which was formed in March 1980. Ariespace is a private company owned by 36 European manufacturers, 13 banks and the French National Space Agency CNES. It has been a remarkable success story. Less than five years after its

set-up, the company has 30% of the communications launch business. Over 45% of its customers are from outside Europe, and have included the Arab league, Brazil, and the American GTE Spacenet.

Development of the Ariane family has been, and still is, the responsibility of another cooperative European venture, ESA, (pronounced 'essa'). ESA operates satellites for Europe, does space research along the same lines as NASA, and develops rockets. It was set up in May 1975. For a long time it has been overshadowed by NASA, but the success of Ariane and its spaceflight missions like Giotto (to Halley's Comet) is starting to make the public sit up and take notice.

Ariane launch site, Kourou, was originally developed as a launch site by the French government in 1964. It's eminently suitable for the purpose, being on the seaward edge of a flat windless plain. Its major advantage from the point of view of satellite operators is its location relative to the equator. At 5.3 degrees north it's closer to the equator than any other launch site. Cape Canaveral is 25 degrees north while the

Russians launch from a site at 45 degrees north.

The fact that the launch site is so close to the equator leads to substantial savings in rocket fuel, or increased satellite weight, which amounts to the same thing. The weight of the satellite is usually increased by increasing the amount of station keeping fuel supplied at the launch, and this in turn leads to a longer life on station.

The reason for this is that to be of use in communications the satellite must be parked in a geostationary orbit, ie, one perfectly circular orbit, with a 24 hour period and aligned exactly with the equator. However, when the satellite is launched it's orbit will naturally assume the same orientation to the equator as its launch site. So if it's launched from a site 45 degrees above the equator, as is the Russian launch site, the satellite will fall into an orbit inclined at 45 degrees to the equator.

Getting rid of this inclination can only be done by expanding energy. This is usually in the form of an extra long burn during the transfer orbit. It's one of the penalties of space flight everyone would rather not pay. ●

THE 1986 SECONDARY SCHOOLS

ELECTRONICS

COMPETITION

GREAT PRIZES FOR YOUR SCHOOL

PHILIPS PM3206 oscilloscope to the winning group.
\$2000 worth of electronic equipment from Dick Smith Electronics to the winning school group.
25 soldering irons from Scope and 25 solder packs from Multi Core Solders to the first 25 schools to register in the competition and go on to complete it.
15 jumbo components bags from Dick Smith Electronics:
Congratulations to the first 15 schools which registered including Kogarah Marist High, NSW, Tarooma High, Tasmania and Mawson High, South Australia.

HOW TO ENTER

Groups representing their schools should submit the attached registration form which itself brings no obligation. Entry forms and suggested project designs will be forwarded to the groups on receipt of the registration form. Entrants are required to build an electronic device to their own or one of our designs and write a report on its operation, construction (and design) and the group's involvement. The device and report must be lodged with us by 15 September, 1986. State, Territory and New Zealand finalists will be announced on 19 September, 1986. The competition winner will be announced 26* September, 1986.

* Incorrectly printed as 16 September in the last June issue.

REGISTRATION FORM

COMPLETE AND SEND TO "SECONDARY SCHOOLS COMPETITION", ELECTRONICS TODAY INTERNATIONAL, PO BOX 227, WATERLOO, NSW 2017.

SCHOOL

ADDRESS

GROUP LEADER'S NAME

SCIENCE TEACHER'S NAME

DOES YOUR SCHOOL ALREADY HAVE AN ELECTRONICS GROUP OR COURSE?

New TV policy emerges

After years of debate, the government has finally decided on a new way of organising TV in regional Australia.

Michael Duffy, Minister for Communications, announced recently that the government had endorsed plans to bring an additional two commercial television services to population centres in regional areas of Australia which presently have only one commercial service.

"Nearly all Australians living in regional areas can expect to have at least one extra commercial television service by 1990 and most will have two," Mr Duffy said.

On the east coast, in the three most populous states of Queensland, NSW and Victoria, the government expects to have three commercial television services operating in some centres by 1988.

In the less populous states, development is expected to be slower. In smaller, more isolated markets, only two services may initially be available.

The policy is called 'equalisation' since its aim is to give country people an equivalent service to city people. Two mechanisms have been identified that will do this:

- 'aggregate' or combine, existing markets in order to provide a population base large enough for three competitive services;

- grant multi-channel service (MCS) permits allowing non-

competitive regional licensees temporarily to provide up to three services in their existing markets instead of only one.

Mr Duffy emphasised that the government's equalisation objectives include preventing any extension of existing regional monopolies.

"There will be provision however for this interim phase to be reviewed, so that stations in markets which are so small and isolated that they will never join an approved market can argue their case for continuation of MCS even after 1996," Mr Duffy said.

The minister said the government expected licensees to choose their equalisation paths by 31 January 1987 and to begin implementing their plans throughout 1987 and 1988. MCS permits in approved markets would not be reissued after 1996. By then three competitive services would be required throughout these markets.

The government is to forego \$32m in revenue in encouraging regional television licensees to aggregate. Last December it decided to exempt from sales tax all UHF television transmitters bought specifically for equalisation which is expected to result in a saving for licensees of some \$10 million.

In addition, the government has decided to rebate fees paid

by licensees involved in aggregation under the *Television Licence Fees Act 1964* between 1986-87 and 1989-90. Foregone revenue should total about \$22 million.

These rebates will be calculated on a tapered scale falling from a maximum of 100% in 1986-87 to 25% in 1989-90. The Australian Broadcasting Tribunal will monitor the progress licensees are making towards aggregation at licence renewal inquiries.

In addition, the government has agreed to upgrade Commonwealth transmitting stations. This is necessary to accommodate both the new services to be provided under equalisation, and to provide capacity for two other major programs: the ABC second regional radio network and the relocation of existing television services from channels 3, 4 or 5, in order to provide spectrum space for more FM radio services.

"The government will need to spend \$16m over a six year period on capital works to upgrade transmission sites for equalisation," Mr Duffy said. "It is planned to recoup this money over time from rentals paid by commercial licensees."

All the new commercial television services planned for regional Australia transmit on the UHF band.

In most areas the existing ABC and commercial stations



DOC Minister Michael Duffy.

will remain on the VHF band.

In a few areas, where the existing VHF services have to be cleared from channels 3, 4 or 5 to make way for new FM radio services, eg, in Newcastle and Wollongong, UHF may be used to provide all television services.

Use of the UHF band is essential if equalisation is to be achieved. One hundred and twenty-two UHF television services are already in operation in Australia. Recently four new services on the UHF band were opened in Gosford, with another two to come on stream later this year.

Use of both VHF and UHF channels is bringing Australian television into line with developments in Europe, the US and Japan where UHF is used extensively. In Britain, all television services are now on the UHF band.

UHF launch in Gosford

The Department of Communications is to engage in a concentrated information campaign about UHF television on the New South Wales Central Coast.

DOC Minister Duffy, said his department wanted to ensure that residents were able to make the most of their new UHF television services since Gosford will be the first 6-channel UHF only city in Australia.

Gosford district residents with UHF equipment will be able to

receive four interference-free commercial television services, channel 40 for NBN (Newcastle), 49 for ATN, 52 for TCN and 55 for TEN (Sydney). Later this year they will also receive ABC on UHF channel 46 and SBS on channel 58.

None of these UHF services should interfere with any existing reception of VHF services in the area.

Because the services will be broadcast from a single translator station in the middle of Gos-

ford, they can all be received on one small antenna (a 'band 5' UHF antenna), connected to a television set or video cassette recorder which can tune to UHF channels.

Two other multi-service UHF translator stations to serve other areas of the Central Coast are expected to open within the next 12 months — the first at Wyrrabalong, near McMasters Beach, and the second at Bouddi, near Forresters Beach.

"To help residents adjust to

the new services, the DOC is placing UHF brochures in Post Offices, operating a UHF information stand in the middle of Gosford, and holding a seminar for antenna installers," Mr Duffy said.

Residents who are unable to visit the DOC stand or their local Post Office can obtain the brochures by writing to the Director of Public Relations, Department of Communications, PO Box 34, Belconnen, ACT 2616. (062)64-4690.

CORDLESS TELEPHONE BUYERS WARNED

A spokesman for the Department of Communications has warned buyers of cordless telephones to be on the lookout for illegal units.

"We've had reports of unapproved units being imported and sold and buyers should be aware that such models can cause interference to other radiocommunications services including radio and television broadcasts," he said.

The spokesman said use of an unapproved cordless telephone was an offence under the *Radiocommunications Act, 1983*. Substantial penalties including confiscation of equipment could be imposed.

All cordless telephones used in Australia require both DOC and Telecom Australia approval. A unit should display approval numbers from both organisations along these lines:

Telecom Authorisation

No C85/35/24

Department of Communications

No DOC 302 0999

(or RFM E002 0999)

"People who have unknowingly bought an unapproved cordless telephone can seek recompense from the supplier under Section 53 of the *Trade Practices Act, 1974*.

"Buyers unsure of the status of their cordless telephone should contact any business office of Telecom Australia or any office of the Department of Communications," he said.

Nicaraguan Radio uses well-tryed format

Listeners tuning to the Voice of Nicaragua are probably aware that the type of program featured is similar to that of Radio Havana, Cuba. Indeed, it is possible to confuse the two stations, both of which broadcast into Central and South America.

The reception of the Voice of Nicaragua with its English transmission on 6015 kHz provides a picture of this problem area of Central America. The station is located in Managua and programmes from its studio include a national service which is now carried on mediumwave as well as shortwave. The international service is broadcast between 1100-1400 UTC and following these programmes the domestic service is relayed. English broadcasts to North America are at 0100-0200 and 0400-0500 UTC.

A recent visitor to the station,

reporting on 'Media Network' from Radio Nederland, said he became aware of the irony of the political situation as the 50 kW transmitter of the Voice of Nicaragua was made in the United States, as was much of the studio equipment. However, the Reagan administration's economic embargo on the country has stopped the supply of spare parts to the station. Listeners letters are no longer answered by mail, but are instead dealt with on the programme 'PO Box 248'.

The domestic service, with the slogan 'Radio Sandino', broadcasts from Nicaragua on 6200 kHz and, although all transmissions are in Spanish, identification is frequently given and reception is noted around 0900 UTC.

— Arthur Cushen

CLUB CALL

The Waverley Amateur Radio Society meets at the Edgecliff Scout Hall, Cooper Park Rd, Bellevue Hill, NSW. Contact club secretary, Eric Van De Weyer VK2KUR, PO Box 126, Randwick, NSW 2031, for times.

Popular session ends



Adrian Peterson.

One of the most popular sessions in Asia for the shortwave listener, "Radio Monitors International", has ended after 11 years of broadcasting. The transmissions were carried by the Sri Lanka Broadcasting Corporation in its service to Australia 1030-1130 UTC on 11835, 15120 and 17860 kHz, and though broadcasts continue in English for that hour, the Sunday feature, "Radio Monitors International", has been cancelled.

The cancellation is due to residency qualifications required in India; Adrian Peterson who compered the session for 540 programmes has moved to the United States, and the Adventist World Radio office at Poona continues under new management but no longer is the originating point for the shortwave programme.

Adrian Peterson commenced his listening in Australia in the late 1930s. His missionary work has taken him to many countries of the world. He has been able to verify around 10,000 radio stations in the course of nearly 50 years of listening.

— Arthur Cushen

Encoding sat signals

After protracted argument, Communications Minister, Duffy, has caved into demands from the regional TV operators and agreed to encryption of signals from Aussat.

The 'special arrangements' apply to services known as Satellite Program Services (SPS) and Remote Commercial Television Services (RCTS). SPS are programmes distributed by one broadcaster to another for conventional transmission at a later date and would include not only normal programme material, but also live news and sports coverage.

"The encoding arrangements will ensure access to at least one

commercial television station for every Australian," Mr Duffy said.

"They are consistent with the industry's wishes that RCTS be encoded to protect the markets of existing terrestrial stations."

The Minister said the decision to encode SPS was announced in November 1983 and had the full support of the Federation of Australian Commercial Television Stations (FACTS).

"SPS operators are being invited to submit their proposals for SPS encoding systems to my department for evaluation before licensing," Mr Duffy added.

Political broadcasts

The United States is funding several stations broadcasting to communist countries. Among these stations are Radio Free Europe and Radio Liberty, which broadcast to Eastern Europe. A new station which broadcasts to Cuba under the slogan 'Radio Marti' has also commenced operation, using Voice of America facilities.

The latest addition to these political stations is Radio Free Afghanistan broadcasting to Afghanistan. According to the opening announcement of the station, it is "an independent radio station supported by the

people of the United States of America". The station claims to operate in accordance with the 'universal declaration of human rights as accepted in the charter of the Helsinki resolution'. Broadcasts are in Dari on Tuesdays and Saturdays at 1345 UTC on 17750, 17895 and 21510 kHz, and repeated the same day at 2315 UTC on 7295, 9625, 9660 and 11790 kHz. All transmissions last 15 minutes.

The Soviet official news agency has denounced the station as interference in a sovereign nation.

— Arthur Cushen

New CB supplier

GFS Electronic Imports of Mitcham, Vic, recently announced a decision to further enhance its extensive range of amateur radio and commercial products by adding Citizens Band lines to its inventory.

A spokesperson from GFS

said "the highly regarded 'Electrophone' branch would feature prominently amongst the 27MHz and UHF transceivers".

For further information contact GFS Electronic Imports, 17 McKeon Road, Mitcham, Vic. 3132. (03) 873-3777.

Wombat in stir

An unlicensed radio operator, who identified himself as "the original wombat", was driving a locomotive around a Sydney railway yards late at night transmitting obscenities.

Stopping his illegal activities was all in a night's work for Department of Communications' radio inspectors. They knew someone was operating on the Amateur Radio frequency band without authority at the Enfield marshalling yards in Sydney, so the inspectors took their VHF monitor and went to track him down.

The story ended in court. The wombat had \$300 worth of equipment confiscated, and was fined \$200 plus \$28 costs.

In another case recently a Queensland man made repeated calls to emergency services on marine distress channels, claiming he was with several other people in a boat outside the Southport sandbar. In fact he

was transmitting from his home.

As well as losing the equipment (which was borrowed from a friend who also didn't have a licence), he was fined \$300 plus \$30 costs.

Both of these cases were prosecuted under the old *Wireless and Telegraphy Act 1905*. Late last year the new *Radio-communications Act* came into force, replacing it. Penalties under the new Act are more severe, as another Queensland man found out. He made hoax distress calls to the Cairns coastguard, and was fined \$2500 and had a \$150 marine transceiver and a \$200 CB transceiver confiscated.

In recent cases involving unlicensed operations of CB equipment, the minimum fine imposed by courts has been \$400. Fines of up to \$750 are common.

The future looks bleak for wombats.

BRIEFS

Scanning full band VHF/UHF receiver

The new IC-R7000 has been released by Icom, claiming a continuous coverage from 25 MHz to 1300 MHz. No additional module is required to achieve coverage up to 2000 MHz. CPU based optical tuning provides 100 Hz steps over the entire range. Icom's R7000 uses multi-conversion techniques for reception of FM (both narrow and wideband), AM and SSB (upper and lower). Ninety-nine memories are available to the user, each capable of recording mode and frequency. For further information contact Icom (Australia) at 7 Duke St, Windsor, Vic 3181. (03)51-2284.

UHF community site antenna

The DU6/HU6 antenna system is specifically designed for community site operations. Comprising two combined antennas the system can cater for up to 16 UHF base stations. The HU6 is a 6 dBd colinear antenna having a bandwidth of 20 MHz. The HU6 is mounted on a DU6 which is a 6 dBd gain dual dipole array. It has a bandwidth of 50 MHz. The DU6 can be operated as a single 6 dBd array or two 3 dBd arrays. Isolation between all antenna segments is 30 dB. The array height is 5.4 metres. For further information contact Antenna Engineering, PO Box 191, Croydon, Vic 3136. (03)728-1777.

IF YOUR NEEDS ARE QUALITY ELECTRONIC ASSEMBLY TRY US

Intertronics assembly offers very **COMPETITIVE** pricing on assembly and manufacture due to our **LOW OVERHEAD** costs, labor saving semi-automated equipment, and **COMPUTERISED** management information systems. Intertronics also provides **100% QUALITY INSPECTION**, thus assuring customers of perfect assemblies, everytime.

INTERTRONICS

Provides customers with:

- ★ circuit board assembly
- ★ wire harness assembly
- ★ flow and hand soldering
- ★ mechanical assembly
- ★ automatic wire cutting and stripping
- ★ wire termination and related services

INTERTRONICS

Unit C1, 23-25 Windsor Rd, Northmead
(02) 683-5959

ETI READER SERVICE 33

Subscribe NOW to Electronics Today

WIN!!!

This superb Sony Hi-Fi and Video combination could be yours!

Worth over \$10,000!!

Subscribe for 2 years and enjoy a special saving of almost \$6!

IMPROVE YOUR LIFESTYLE BY MAXIMISING YOUR LISTENING AND VIEWING PLEASURE!

By subscribing to Electronics Today you will be kept up to date with feature-packed articles, the latest news and everything that Electronics enthusiasts, like you, need to know. There are always new techniques, new products and helpful stories to improve your knowledge.

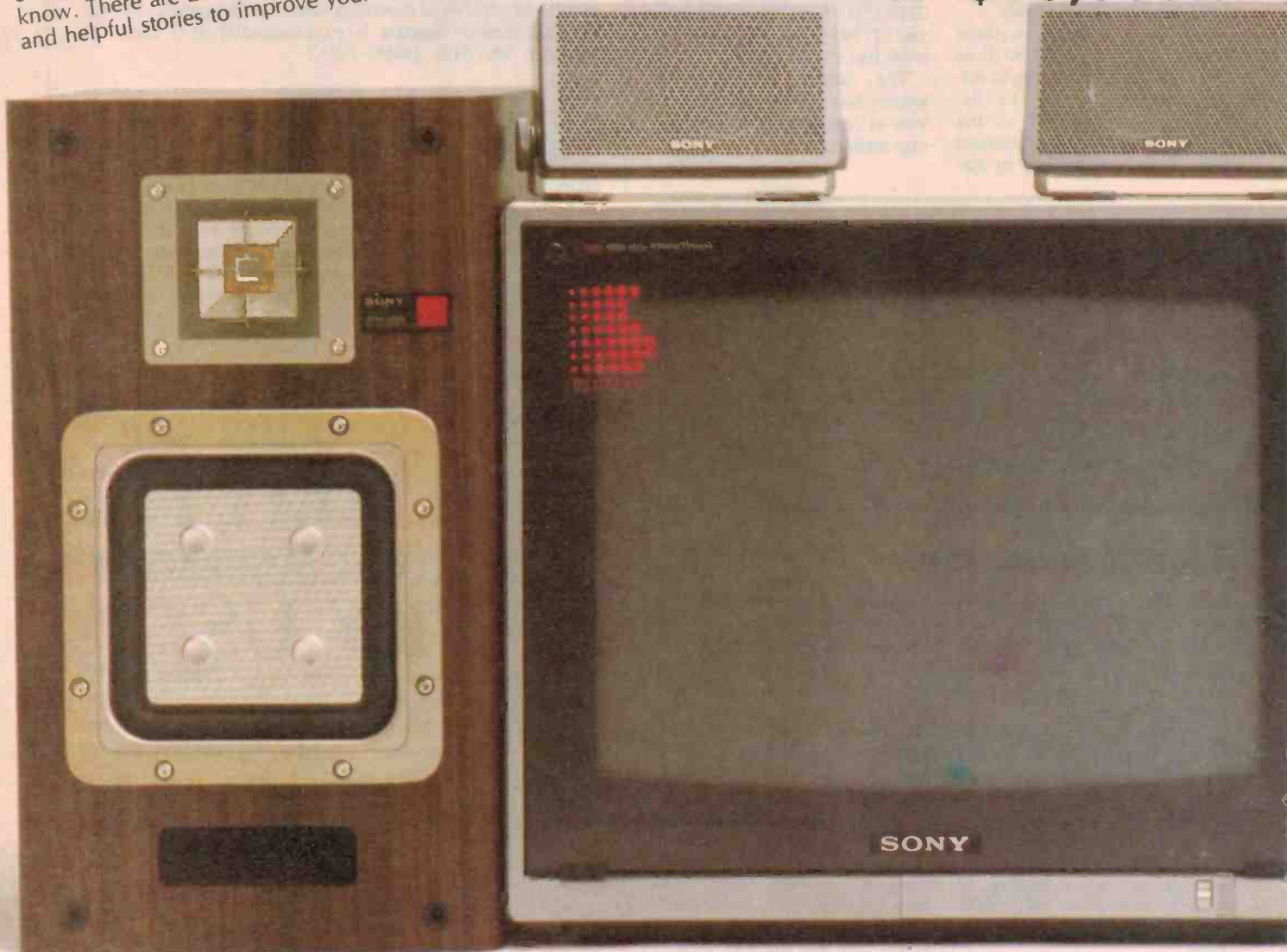

This ultimate in sight and sound reproduction you've only ever dreamed of before could be yours if you decide to subscribe to Electronics Today magazine. By subscribing to Electronics Today, you may very shortly be relaxing in front of your own Sony system, enjoying the superb listening pleasure that can only come from Compact Disc technology, and while basking in richer listening pleasure you could be watching, filming, or recording your selection using your new Sony Video-8 video system, both systems designed to be fully integrated with each other. This magnificent Sony Component System represents true, leading edge, technology. The 100 watt RMS per channel integrated stereo amplifier will give you plenty of power and can reproduce the

most demanding in CD fidelity. The discrete three head design stereo cassette deck will improve the faithfulness of your recorded sound. Improved frequency response will be evident as your AM/FM precision quartz tuner eliminates interference. With 20 key direct music selection and infra red remote control, the Digital Compact Disc player satisfies your most demanding requirements in fidelity and convenience. The digital compatible APM speaker system has been specially designed to cater for near perfect CD reproduction. A 20" high resolution Profeel monitor, including speakers, represents the best in video display monitors while the complete Video-8 system combines quality with portability. To complete the system a tuner/timer for the PAK 88 is included.

and win **YOUR FREE GIFT** — JUST FOR SUBSCRIBING!

CLAIM YOUR
SPECIAL FREE
GIFT ...

NOW!

(Magazine and gift sent separately.)



This super-versatile Swiss Army Knife has seven different features — from a wire stripper to a can opener — and is that indispensable tool you'll find hard to do without. The Swiss Army Knife features include a large blade, small blade, can opener, screw driver, cap lifter, wire stripper and key ring. You will receive 12 issues of Electronics Today (one every month) for \$35.40 or better still subscribe for 24 months and save \$5.90 — that's equal to 2 issues for free!

WIN THE HI-FI/VIDEO SYSTEM OF YOUR DREAMS!

Simply complete the subscription card in this magazine and send it FREE to us. Within six weeks you will receive your Swiss Army Knife and be enjoying articles in the first of your home-delivered ELECTRONICS TODAY magazine.



SONY

SHARE THE VISION

YOU MUST ACT NOW

YOUR NO-RISK GUARANTEE
If, for any reason you are not completely delighted with ELECTRONICS TODAY . . . simply let us know, and we'll gladly refund the unused portion of your subscription.

NSW Permit No TC86/532 Issued under the Lotteries and Art Unions Act, 1901
VIC Raffles and Bingo permits Board Permit No 86/270 Issued on 13/3/86
ACT Permit No TP86/162 issued under Lotteries Ordinance.
(Offer valid until 31 August, 1986.)

The exciting prize draw is also open to all subscribers who renew before the closing date. If the prize is not claimed within 12 months, a second draw will be run.

RACAL

**See us at: AUTOPLANT 86
Stand 15 — Exhibition Hall B.
N.S.W. Institute of Technology,
15-73 Broadway, Sydney, July 15-18**

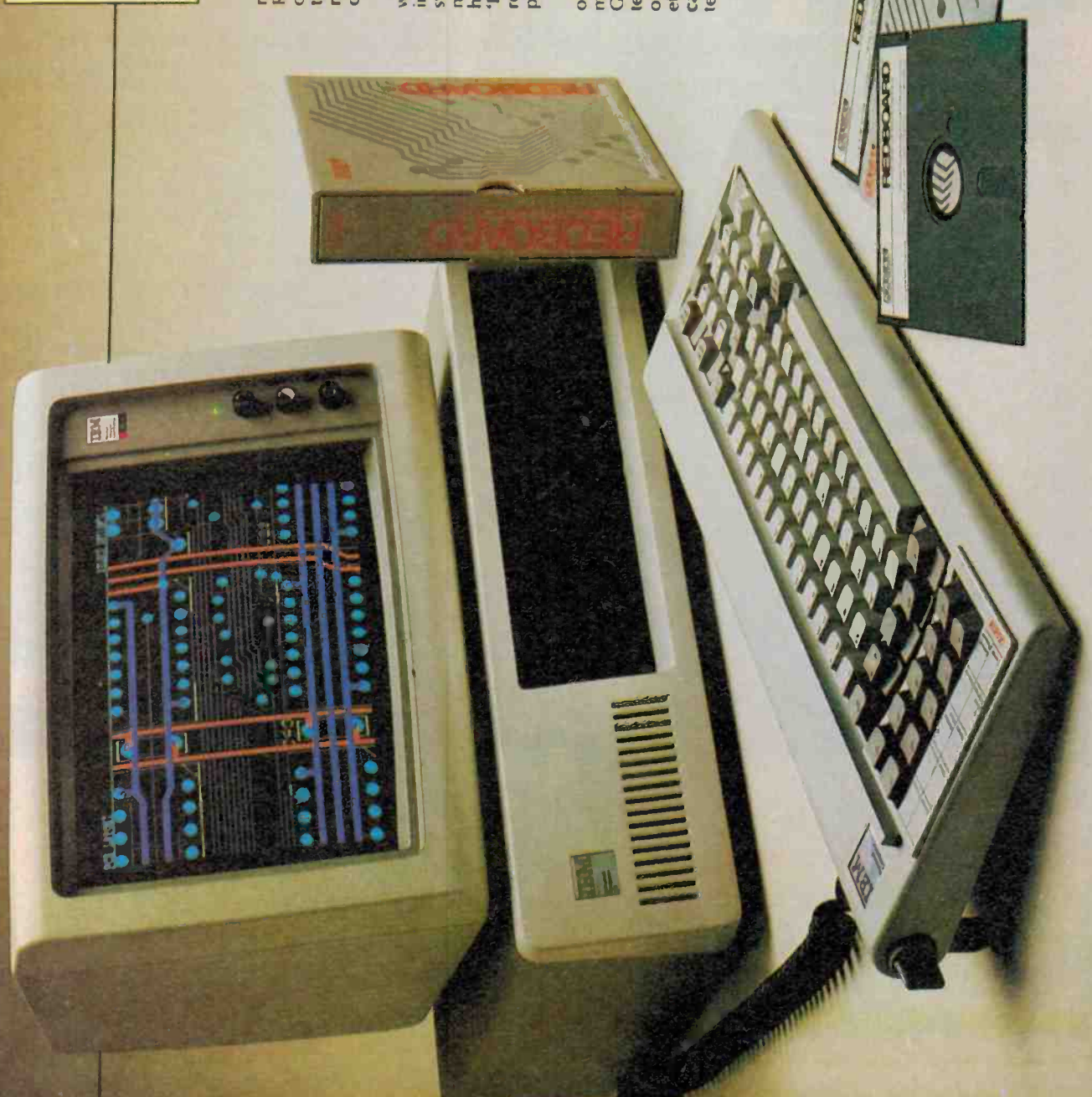

The introduction of a remarkable new system from Racal-Redac, Europe's 'number one' PCB-CAD company, means that real CAD is now within the reach of even the smallest PCB design company.

Having already achieved two world 'firsts' with the introduction of PCB-CAD systems using both mini and micro computers - Racal-Redac have now developed 'REDBOARD' - the world's first, real PCB-CAD system for a personal computer.

Computer-aided systems now offer the only really effective means of tackling PCB design. Growing changes in PCB technology and the complexity of many PCB's now put their efficient design far beyond the capability of traditional manual techniques.

Using real PCB-CAD, not to be confused with simple computer-aided drawing systems (which offer no design capability), Redboard offers all the features found in more expensive CAD systems - including automatic component placement, automatic routing and automatic checking.

Redboard works with the IBM personal computer, and, when using our 'Redlog' schematic program, offers a complete PCB design system from circuit diagram to artwork.

In addition, you also gain the benefit of being able to use the IBM-PC as a multifunction workstation - offering a wide range of applications programs such as word-processing, document handling, project management and accounts.

Redboard, it's the world's first real PCB-CAD system for the IBM-PC and it's available now.

RACAL-REDAC

Racal Electronics Pty. Limited
47 Talavera Road North Ryde
N.S.W. 2113 Australia Tel: (02) 888 6444
Telex: AA20365 FAX: (02) 887 4058
Melbourne: (03) 699 2133

RACAL

TP 3.138

BIRDIE FREE SCANNING

— with the JIL SX-400

Although this scanner has been around for a while now, it has taken us some time to put it to the reviewer's test. Peter Williams now tells the story.

Peter D. Williams

Peter Williams is director of Associated Calibration Laboratories in Melbourne.

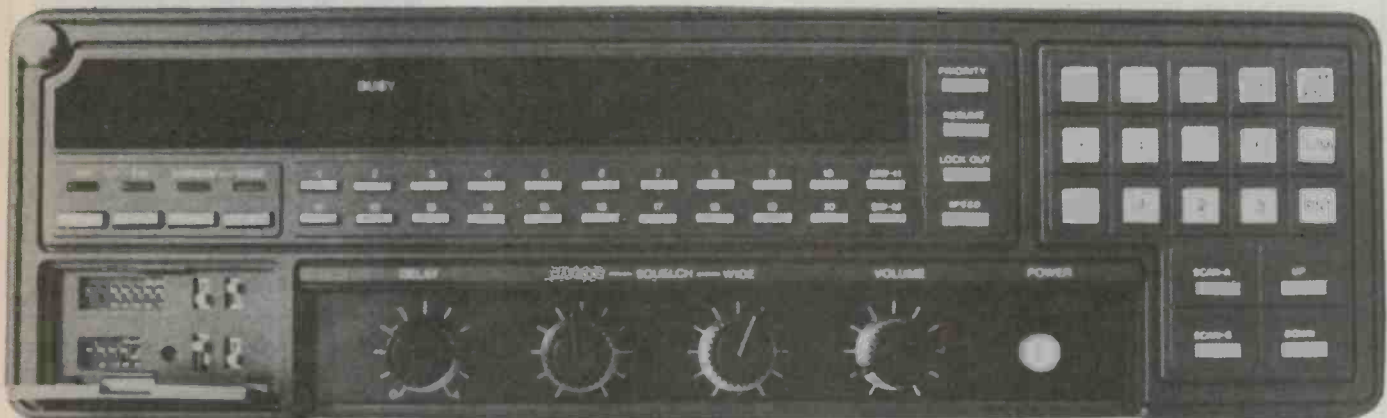

SCANNING RECEIVERS are the instruments of one of the world's most popular electronics hobbies. As the name suggests scanning receivers electronically sweep or tune for signals on preset frequencies or between chosen frequency limits. Most scanners operate in the VHF or UHF bands, though HF scanners are found.

VHF and UHF scanning is also more practical. As stations in this band tend to be allocated frequencies 'for life' it is a lot easier to define the frequencies you're interested in. After all, the radio spectrum is a crowded place and you can spend much time looking in the wrong place for a station — especially on HF where stations, mainly broadcasters, continually change frequencies to suit changing atmospheric conditions.

Official view

In Australia authorities have tended to take a dim view of scanning receivers, or any receiver for that matter that can be used to listen to signals outside the broadcast band. Part of the reason is that scanners cover the frequencies used by the police, ambulance and fire services.

In the US, where authorities have a more realistic view, access to national resources such as the radio spectrum is open to everyone — provided a few rules, mostly to do with transmissions, are met.

The SX-400

With the JIL SX-400, a good antenna and a favourable location you should be able to monitor anyone who dares to take to the very or ultra high frequencies.

Probably the most important feature of this scanner is the frequency coverage, continuous from 26 to 520 MHz. The receiver covers this range in twelve segments. The broadcast band of 88 to 108 MHz makes up one segment and the aircraft band of 108 to 140 MHz is another.

The handbook that comes with the receiver claims that it is "birdie free". I was quite surprised to find in listening that none of these unwanted carriers could be found throughout the tuning range of the receiver.

The receiver has 20 channel memories and a versatile keyboard to provide complete control of frequencies, scan or manual modes, priority channels and so on. Accessories include rf converters that allow you to

listen down to 150 kHz (not much there) or up to 3.7 GHz.

A useful facility is the data interface which allows remote control of the receiver by a computer. With a little programming you can scan any number of channels in any sequence and keep a log of frequencies and times.

Operating features

As mentioned, the continuous range from 26 to 520 MHz is divided into 12 segments, covering a smaller range of frequencies but one shortcoming is that SSB mode is not part of the kit, so CB on 27 MHz cannot be received.

On power up (with no memory) the receiver will automatically assume a slow scanning speed with priority channels inoperative. All memory channels are loaded with 26 MHz and the clock starts at 12 am.

The receiver is set seeking UP or DOWN depending on which key is pressed. A LIMIT SEEK function is available to set the receiver seeking between two programmed limits, such as between the limits of the police or fire brigade bands. The PRIOR-

JIL SX-400 SCANNER S/N 40630662
20 CHANNEL, 26-520 MHz CONTINUOUS COVERAGE

Dimensions: 330 (w) x 90 (h) x 210 (d) mm
Weight: 3.5 kg
Received from: Vicom (Australia) Pty Ltd
Tested at: Associated Calibration Laboratories Pty Ltd

SENSITIVITY

Mfr's specs: HF/VHF FM (S/N = 12 dB) 0.5 μ V; AM (S/N = 10 dB) 1.0 μ V
UHF FM (S/N = 12 dB) 0.5 μ V; AM (S/N = 10 dB) 2.0 μ V

Lab test:

Each of 12 bands tested at centre frequency. Attenuator at 0 dB.

	FM 3 kHz narrow		wide		AM 1 kHz 30% modulation	
26-34 MHz	0.4 μ V	= -114.9 dBm	1.27 μ V	= 104 dBm	1.43 μ V	= 104 dBm
34-50	0.19	= -121.4	0.54	= -112.4	0.64	= -110.9
50-60	0.21	= -120.4	0.76	= -109.4	0.76	= -109.4
68-88	0.21	= -119.3	0.76	= -109.4	0.85	= -108.4
88-108	0.24	= -119.3	0.72	= -109.8	0.72	= -109.8
68-140	0.28	= -118.1	0.78	= -109.1	0.99	= -107.1
140-180	0.25	= -119.1	0.60	= -111.4	0.76	= -109.4
180-220	0.27	= -118.3	0.67	= -110.4	0.85	= -108.4
220-300	0.34	= -116.3	1.13	= -105.9	1.13	= -105.9
300-380	0.24	= -119.4	0.55	= -112.2	0.77	= -109.2
380-460	0.76	= -109.4	1.58	= -103	1.77	= -102
460-520	0.23	= -119.7	1.0	= -107	1.00	= -107

Note: Checks at either end of the tuning range indicate that the sensitivity is maintained by tuning the rf stages with varicaps.

MINIMUM DISCERNIBLE SIGNAL (MDS)

Measured at 98 MHz:

FM narrow 0.15 μ V = -123.4 dBm FM wide 0.21 μ V = -120.4 dBm AM 0.46 μ V = -113.7 dBm

SIGNAL (S) METER

Meter indicated 1 — no signal
3 — 3.79 μ V, -95.4 dBm
5 — 15.1 μ V, -83.4 dBm
7 — 28.7 μ V, -77.8 dBm
9 — 64.3 μ V, -70.8 dBm
'S9' + 20 dB 144 μ V, -63.8 dBm

IF REJECTION

rf attenuator in operation
10.7 MHz — 76 dB
455 kHz not measurable

IMAGE REJECTION

Mfr's Spec: HF/VHF -50 dB
UHF -4 dB

Lab test:

At 98 MHz image at 119.4 MHz was -53 dB
200 MHz 221.4 MHz -13.4 dB
500 MHz 478.6 MHz -6.0 dB

Note: See text for explanation of these figures.

BLOCKING DYNAMIC RANGE (BDR)

Blocking signal 20 kHz removed* -74.4 dB
Third order IMD DR 20 kHz removed* -73 dB
In band IMD DR 5 kHz -70 dB

*These tests are normally performed at 10 kHz offset. However the SX-400 has a 'carrier centre' detector to ensure scan is stopped on frequency, similar to AFC. This inhibits audio if the signal is between 5 and 10 kHz off frequency which is the case during these tests.

SQUELCH SENSITIVITY

Mfr's Spec: FM less than 1 μ V
AM less than 2 μ V

Lab test:

At 200 MHz
FM wide/narrow 0.44 μ V
AM 0.224 μ V

SEARCH-STOP SENSITIVITY

(FM narrow) Test at 100 MHz: The receiver stops 5 kHz low searching up in frequency, but stops on frequency searching down.

Test at 500 MHz: Stops on frequency.

AUDIO FREQUENCY RESPONSE

At -3 dB points ref 1 kHz; -20 dB octave roll off.

FM narrow 290 Hz and 1.2 kHz FM (wide) 75 ms 240 Hz and 7 kHz AM 360 Hz and 1.2 kHz

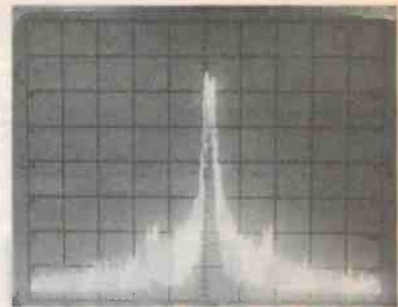

Local oscillator at antenna, tuned to 100 MHz. Reference level -10 dBm; 2 kHz/div; 100 Hz resolution; 100 Hz video filter. Note FM on sidebands, especially close in to centre frequency.

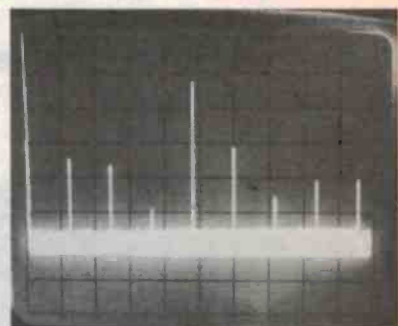

Local oscillator radiation from antenna. Centre 500 MHz to which receiver is tuned. Reference level -10 dBm; 100 MHz/div; 300 kHz resolution. Note local oscillator frequency with 10.7 MHz removed on lower side of tuned frequency, in this case 500 MHz.

ITY option allows you to listen to a particular channel any time it is active, over-riding any other mode operating in the receiver.

The scanning rate is selectable from the front panel. The scan delay or 'dwell' time can be set at up to 4 seconds on a received signal.

The SCAN-STOP facility is well thought out. It is activated by the actual signal characteristics. For example, the scanner can be set to scan-stop on the carrier until the carrier disappears; to scan-stop on the carrier until the modulation ceases; or to scan-stop on modulation then resume scan when the modulation ceases. The last mode is useful when operating close to other receivers where sometimes local oscillator radiation can provide enough signal to appear to the scanner covering a programmed frequency as a received carrier.

Scanning all the memory channels in sequence is called Scan A. The channel number and frequency of a received signal are displayed. The scanner also offers a Scan B option which limits scanning to your selection of particular memory channels.

Scanning frequency steps vary between the segments or divisions of the frequency range. In the six segment range between 26 to 140 MHz, scanning is in either 5 kHz or 6.25 kHz steps; in the six segment range of 140 to 520 MHz, scanning is in either 10 or 12.5 kHz steps. Rather unfortunately the

step rate can only be changed *without* losing all the memory settings by operating a switch under the receiver's cover when the power is off. If losing memory isn't a problem a reset switch can be operated.

Power requirements are nominally 12 Vdc which means that you need a separate dc powerpack. A socket on the rear panel which outputs the local oscillator frequency is used for 150 kHz to 3.7 GHz rf converters, and another socket (for the IF output) can be used for other demodulation circuits or 'spectrum monitor' applications. The optional features are interesting and I wish there had been more information on them.

A telescopic antenna hidden in the top left hand corner of the box gives reasonable reception. A VHF connector is fitted to the rear panel for connection to an external antenna — but how much better would it be to have a BNC or similar low cost connector! Even amateur transceivers use the cheap SO-239 connectors. With an external antenna, performance is improved and for wide-band coverage, a discone type antenna is recommended.

But an efficient antenna sometimes has the disadvantage of highlighting any image problem, which was evident in this case on VHF. An image problem refers to the situation when you hear two different frequency transmissions on the same frequency channel. It is due to two frequencies, which differ from the local oscillator frequency by the same IF, impinging on each other. What we found with this receiver was that listening to amateur repeaters on 146.7 MHz we also heard the police channel on 168.1 MHz. Both these frequencies differ from the local oscillator frequency by 10.7 MHz, the intermediate frequency.

Unless the input circuit is very selective, signals separated by 20-25 MHz can easily break through. The higher the frequency received, the greater the potential for images. The lower the IF also the greater the problem. The SX-400 suffers from poor front end selectivity and low IF (10.7 MHz).

Testing

To start on a less happy note, while using the receiver, we found the processor was prone to lock up at frequency intervals and we had to resort to turning the unit on and off. Another disappointing feature was the capacitor memory back-up, which it is claimed in the manual, lasts 36 hours. The best we could achieve was half that.

Audio output was to my mind not loud enough. Frequency response suffered from a severe roll off at high frequencies.

The test figures for each of the frequency blocks are quite good. SINAD tests on the end of each of the bands indicate that sensitivity is maintained by tuning the rf stage with varicaps.

The image rejection figures are not particularly good, especially for VHF. The image problem has already been mentioned. Although the front end is tuned by varicaps, much more Q or selectivity is required on VHF and UHF. A Q of 330 is required at the front end to give a -50 dB rejection figure, and our measurements showed a Q of only 11 at 500 MHz. The receiver barely passes the -50 dB image rejection figure at 98 MHz and, unless we had a bad unit, -13.4 dB at 200 MHz and -6 dB at 500 MHz must be regarded as definitely sub-standard.

An attenuator switch on the rear panel was obviously provided with good reason — to reduce input signal level which will tend to improve the image figure.

On the blocking/dynamic range we could only get a figure of -74 dB. A good VHF/UHF receiver should have a figure of around -120 dB, however, because this receiver incorporates a station centre detector, the test could not be performed with a 10 kHz offset which is the normal practice.

On a brighter side, true to the manual's claim that the receiver is 'birdie free', we could not detect any spurious signals at all. For those not familiar with them, birdies are nuisance carriers or signals which appear at odd frequencies throughout the tuning range of the receiver, generated by the oscillators in the receiver. A birdie will interrupt a scan until other keys are pressed or some manual intervention is made. There is a reasonable level of oscillator radiation as measured at the antenna (see photo), but fortunately it does not show up at the received frequencies.

Assessment

As a scanning receiver, the SX-400 does the job reasonably well. The full frequency range from 26 to 520 MHz allows all (bar SSB) services to be monitored — without interference from birdies. Unfortunately the image problems on VHF/UHF detract from its overall performance.

An interesting facility is the data interface which enables you to control the unit remotely from a computer. It is a pity the manufacturer did not make more of this computer facility and produce a standard RS232C serial interface. The lack of SSB may not be much of a problem if CB channels are of little interest.

Ergonomics needs to be considered too. The front panel of the receiver is vertical, making it difficult to read unless you have it at eye level, patently impossible in a car.

Technically the design appears to be in need of a little updating. Improvements are needed in the area of local oscillator injections to give a higher IF to improve the image response. At \$910, JIL is capable of better.

Functions

Communication between the functions is by arguments, external variables, and values returned by the functions. Functional arguments are passed by value. However, when an array name is passed as an argument to a function, it is actually the address of the first element that is passed, and so elements of the array can be altered by the function by subscripting from this location. Pointers are used to permit functions to affect non-arrays in calling functions.

An advantage of passing addresses explicitly in this way in C is that the function call indicates which of its arguments can be modified.

I/O routines are provided in the standard C library; they are not specified in the C language. The standard library includes routines for reading and writing data in blocks of arbitrary size, and for reading and writing formatted text.

Some final remarks

When the design philosophies of C and Pascal are compared, two major differences are found:

1. Pascal, being restrictive, emphasises program reliability and readability, while C, by its absence of restrictions, emphasises programmer flexibility, eg:
 - (a) Pascal contains more restriction on pointers, which leads to safer programs but also reduces the use that can be made of the pointers; and
 - (b) the ability to perform assignments within expressions tends to make C programs more compact than the corresponding Pascal programs, but less readable.

2. Pascal attempts to hide the underlying machine as much as possible, while C tries to provide a convenient way of controlling the machine. This is illustrated for instance by the operators the two languages provide: C has operators to manipulate the bits of a word, while Pascal has operators to manipulate sets.

Some consequences of these differences are that Pascal is better than C for teaching programming; some C programs cannot be written conveniently (or at all) in Pascal, because of the restrictions in the latter; and C can be used in more programming domains than Pascal.

For situations where strong type checking is desirable, a program called `lint` can be used. It detects type mismatches, inconsistent argument usage, unused or uninitialised variables, potential portability difficulties and the like.

The main reason for the growing popularity of C are: its flexibility; its limited size which makes it easy to learn; its close link with UNIX programming environments; and the strict checking provided by the program `lint`.

MACHINE VISION

"I see" said the nearly blind computer, optimistically. Computers are seeing only light and dark and discriminating just a few shapes; and if machine vision isn't exactly failing vision, it's with a lot of ingenuity from the designers.

PROBABLY NO TOPIC in computers or electronics is quite so capable of arousing the layman's interest as machine vision, computers that see: misty images of C390 looming over the desert sands, of R2D2 with his little head spinning; popular dreams of the times.

But machine vision is proving a thoroughly intractable beast. Twenty years after the pioneering efforts at Stanford University in the US, the goal of the seeing machine still proves elusive. There are vision machines around, indeed, some world class units are in production in Australia but the technology necessary for R2D2 type vision is barely even a twinkle in some mad professor's eye at this stage.

Machine vision is all about number crunching; doing it fast and doing it efficiently. It's an area where parallel processing (using a number of microprocessors in

parallel) is almost standard procedure, and where developing new and more efficient algorithms to manipulate memory is the route to glory as a practitioner of the art.

Binarization

There are a number of manipulations now well established in the literature. One of the most important is 'binarization', in which all values in memory below some arbitrary figure are turned into zero, and all above turned into one. This, of course, produces a black and white image, which is most importantly used in template matching.

Template matching is the technique used by industrial machines that are now starting to appear on conveyor belts and as quality control devices. Essentially, the situation is that an object is presented to the camera in such a way that its outline is clearly visible and this is matched against a 'template' that already exists in memory. At its simplest level, the comparison might consist of matching memory byte by byte.

For instance, we may wish to carry out quality control of bolts coming out of a foundry. The bolts, still hot, are mechanically placed on a conveyor belt. It's not mechanically difficult to ensure that at any given time only one is present in the field of view of a camera sited directly above the belt.

The first task of the system is to make up an analogue of the scene on the belt in the computer memory. To do this, the lighting levels must be set such that the visual response of the camera to the bolt is quite different from the response to the belt. Hopefully, the frame store will hold bytes with values close to (say) zero, corresponding to the background and close to one, corresponding to the bolt. However, it's unlikely that this ideal situation can be achieved by lighting alone, so the image is binarized to assist in defining the object, before being processed further.

The exact nature of this process depends on the application. For example, it's possi-

ble to determine the area of any object on the conveyor belt. Since the number of memory bytes with a certain value is directly proportional to the area of the bolt, it's possible to check the size of each bolt as it comes out of a forge, thus forming a useful quality control device. Indeed, a device just like this has been developed by Vision Systems in Adelaide.

Another useful application is in quality control of IC packaging. The system can check the size of the package, the location and orientation of pins and even the numbering on the top of the package.

The idea of template matching has been developed for a number of other situations. Vision Systems has recently announced a security device consisting of a camera monitoring a protected area. A computer receives a light value from the camera for every pixel in the scene, and the alarm is triggered if any of these values change.

Image enhancement

Other forms of image manipulation result in image enhancement. Image enhancement is often part of the preprocessing of robot vision. Sometimes it's an end in itself, as in the outputs from scanning electronic microscopes and spacecraft.

Exactly what is involved in image enhancement depends to a large extent on what aspects one wants to enhance. The details can be very complex, but the fundamentals are simple enough. In fact, there are only two major processes at work.

On the one hand the picture should occupy the whole dynamic range available, ie, the brightest parts of the image should have the highest value we can assign to a pixel, and the darkest parts should have the lowest value. On the other hand, the parts of the image with the interesting details should have the most contrast.

Implementing these features is an exercise in changing the relationship between the numbers stored in the bytes of memory, and the brightness of any given pixel. According to Pang Chew, who is working on

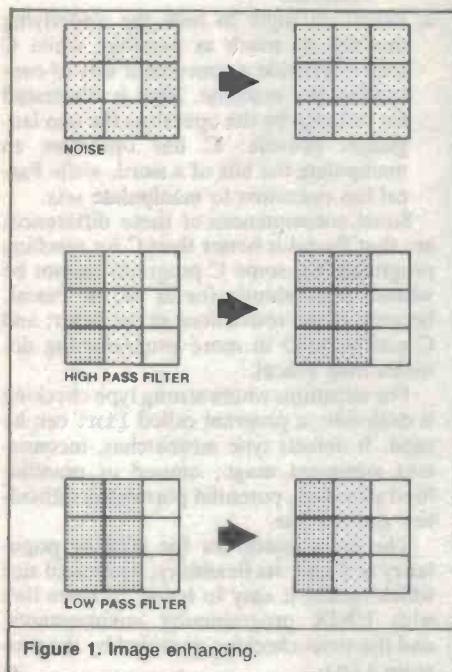

Figure 1. Image enhancing.

Jon Fairall

Melbourne-based Dindima Group's first image enhancing system, the process begins with a histogram which examines the distribution of brightness in the scene. If the histogram is skewed towards one side or the other, pixel values are changed so that the histogram is stretched out across the range. Details leap out of a dark image. A meaningless grey blob becomes defined. It looks like pure magic.

However, even when the full dynamic range of the system is employed, the contrast between individual picture elements might be too small for human consumption. So another technique is used. This involves changing the linearity of the pixel-to-memory conversion. To do this one has to identify the level of brightness in the image where the wanted detail exists and increase the contrast range.

Other techniques of image enhancement are utilised. Noise reduction is probably the simplest as well as the most common. Generally all that is involved is that the light levels in a nine-by-nine block of pixels are compared. If the centre pixel is found to be substantially different from the others around it, it is assumed that it represents noise on the image. The problem is overcome by making the centre pixel the average of all the surrounding ones.

Another common technique is the high pass filter, so called because it creates an analogous effect to the use of a high pass filter in a video system; it enhances sudden changes in the light levels in the image, ie, the edges of objects.

This is also achieved by taking blocks of nine-by-nine picture elements. Edges are identified by looking for blocks in which pixels on one side have different values from ones on the other side. When this happens the centre is assigned firmly to one side or the other.

The opposite technique, called the low pass filter, blurs the image by making the centre pixel the average value of the two outer ones.

In a practical imaging system, all these

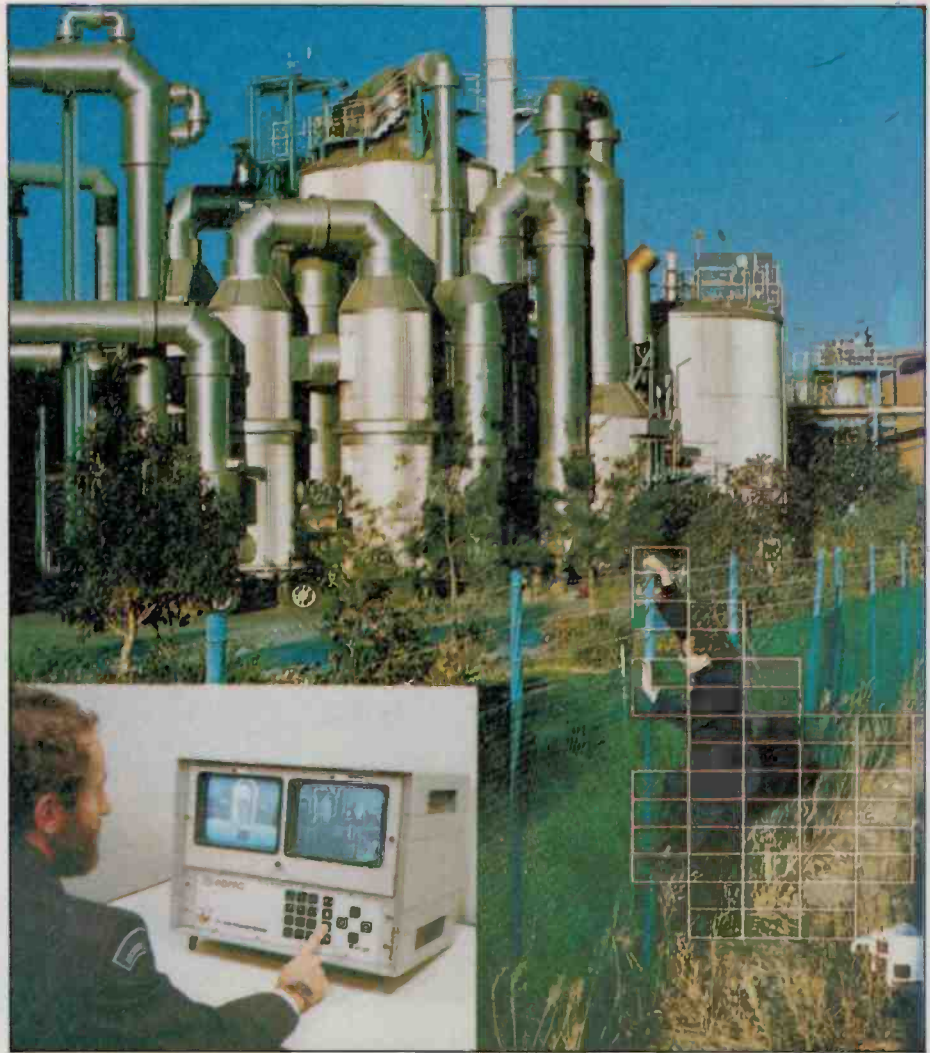

The Pro 1600 video motion detector in action. (Courtesy Vision Systems.)

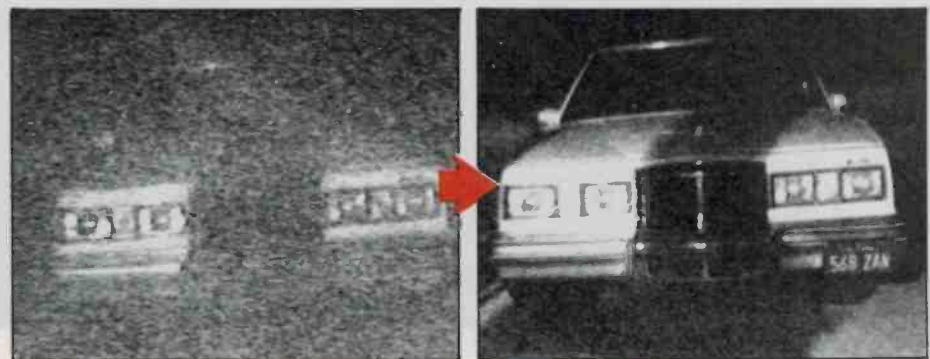
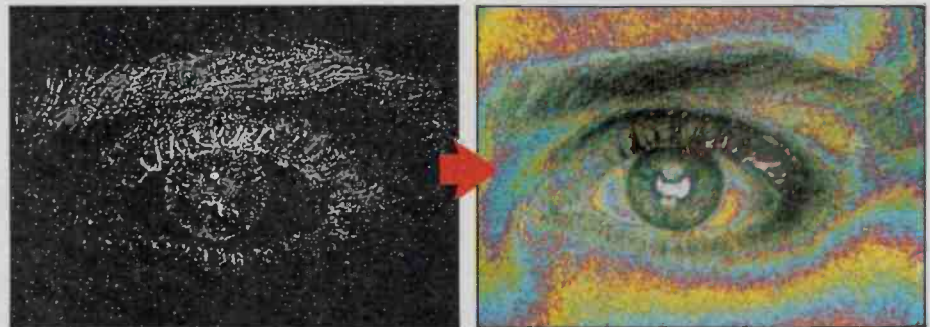
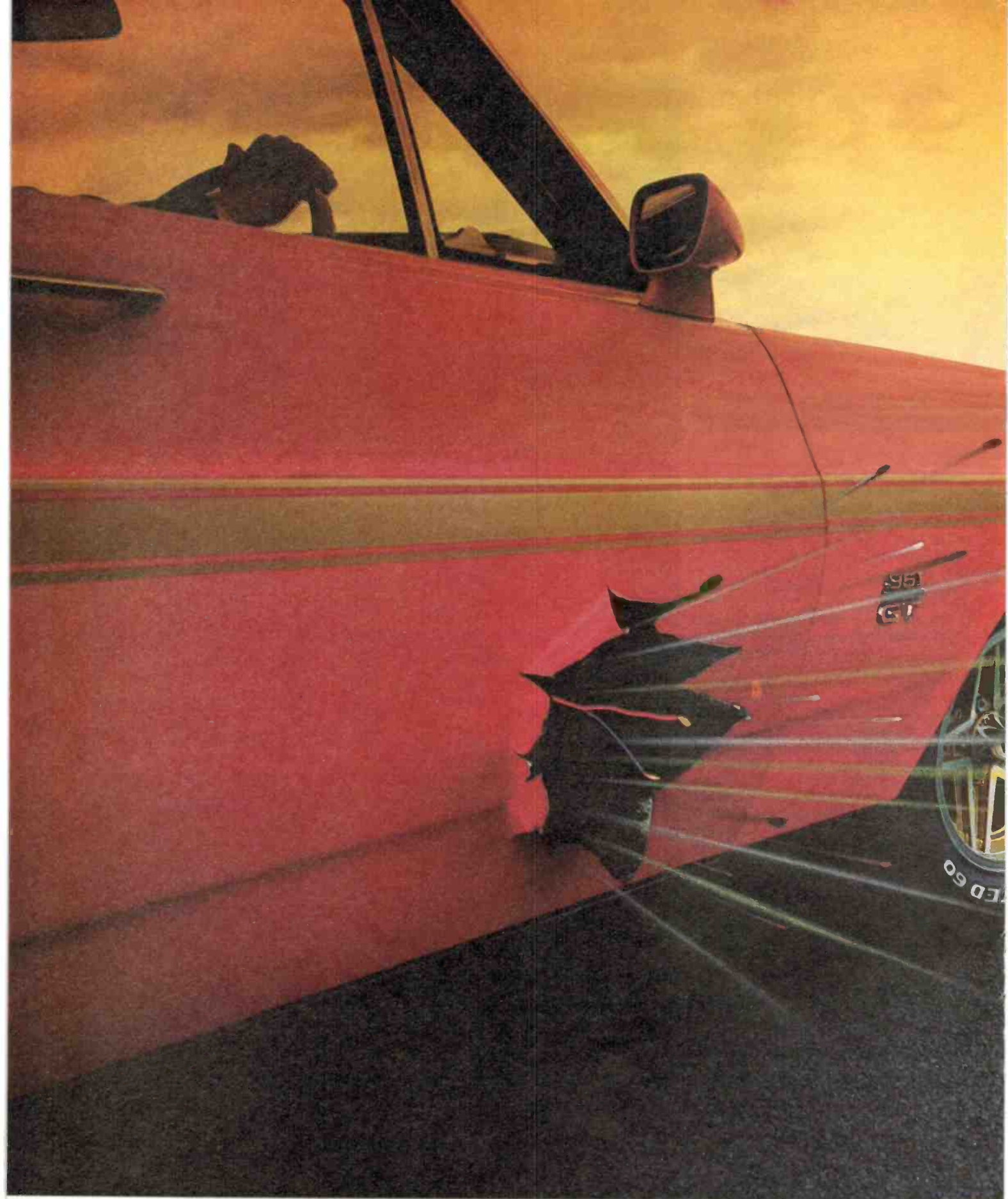

Image enhancement before and after. (Courtesy Dindima.)



YAMAHA
CAR AUDIO

Now, Yamaha for your car. Buy

Yamaha. Makers of fi

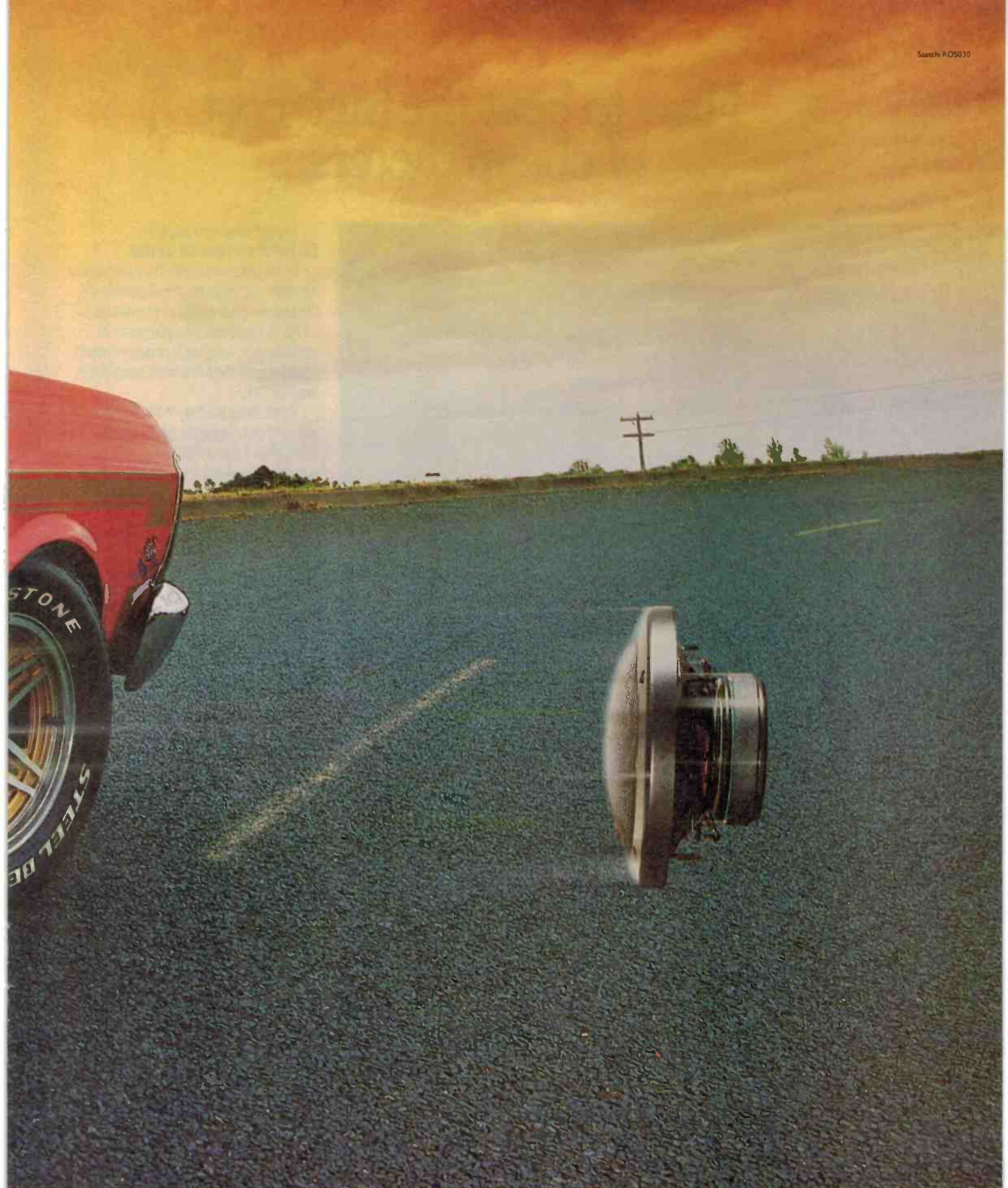

do go easy on the volume controls.



How to beat the high cost of cheap meters.

You get what you pay for.
So get the Fluke 70 Series.

You'll get more meter for your money, whether you choose the affordable 73, the feature-packed 75 or the deluxe 77.

All of them will give you years of performance, long after cheaper meters have pegged their fishhook needles for the last time.

That's because they're built to last, inside and out. So they're tough to break. They don't blow fuses all the time. You don't even have to replace batteries as often.

And they're backed by a 3-year warranty. Not the usual 1-year.

Of course, you may only care that the world-champion 70 Series combines digital and analog displays with more automatic features, greater accuracy and easier operation than any other meters in their class.

You may not care that they have a lower overall cost of ownership than all the other "bargain" meters out there.

But just in case, now you know.

**FROM THE WORLD LEADER
 IN DIGITAL MULTIMETERS.**

FLUKE



FLUKE 73	FLUKE 75	FLUKE 77
Analogue/digital display	Analogue/digital display	Analogue/digital display
Volts, ohms, 10A, diode test	Volts, ohms, 10A, mA, diode test	Volts, ohms, 10A, mA, diode test
Autorange	Audible continuity	Audible continuity
0.7% basic dc accuracy	Autorange/range hold	"Touch Hold" function
2000+ hour battery life	0.5% basic dc accuracy	Autorange/range hold
3-year warranty	2000+ hour battery life	0.3% basic dc accuracy
	3-year warranty	2000+ hour battery life
		3-year warranty
		Multipurpose holster



ELMEASCO **Instruments Pty. Ltd.**

N.S.W. 15 McDonald St, Mortlake. Tel: (02) 736 2888
 VIC. 12 Maroondah Hwy, Ringwood. Tel: (03) 879 2322
 QLD. 243 Milton Rd, Milton. Tel: (07) 369 8688
 S.A. 241 Churchill Rd, Prospect. Tel: (08) 344 9000
 W.A. 46-48 Kings Pk Rd, West Perth. Tel: (09) 481 1500

Talk to your local distributor about Fluke

• A.C.T. Actec Pty Ltd (062) 80 6576 • George Brown 80 4355 • N.S.W. Ames Agency 699 4524 • George Brown (02) 519 5855 Newcastle 69 6399 • Bryan Call Industries 526 2222 • Collier Tools 763 1888 • D.G.E. Systems (049) 69 1625 • Davred Electronics 267 1385 • W.F. Dixon (049) 61 5628 • Macelec (042) 29 1455 Ebsen 707 2111 • Selectro Parts 708 3244 • Geoff Woods 810 6845 • N. TERRITORY Thew & McCann (089) 84 4999
 • QUEENSLAND L.E. Boughen 369 1277 • Colourview Wholesale 275 3188 • Fred Hoe & Sons 277 4311 • Nortek (077) 79 8600 • St Lucia Electronics 52 7466 • Selectro Parts (Qld) 394 2422 • S. AUSTRALIA Protronics 212 3111 • Trio Electric 212 6235 • Redarc Electronics 278 7488 • A.W.M. Wholesale • TASMANIA George Harvey (003) 31 6533, (002) 34 2233 • VICTORIA A.W.M. Electrical Wholesale, • Radio Parts 329 7888 • G.B. Telespares 328 3371 • Browntronics 419 3986 • R.K.B. Agency 82 7704 • A.J. Ferguson 347 6688 • SIRS Sales (052) 78 1251
 • Mektronics 690 4593 • W. AUSTRALIA Atkins Carlisle 321 0101 • Dobbie Instruments 276 8888 • Cairns Instrument Services 325 3144 • Willis Trading 470 1118

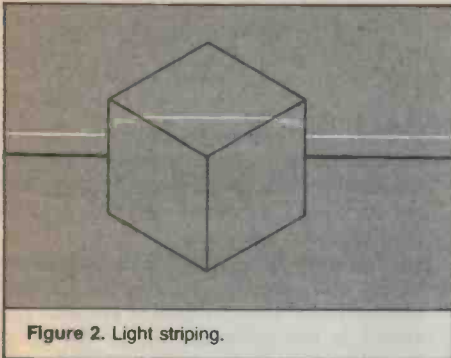

Figure 2. Light striping.

techniques, including binarization, are available. Just which combination is used, and in what order, depends on the image and the desired result.

Object recognition

So, given that the original image has been turned into usable form, what is it good for? Simple template matching is very restrictive. What we want is the ability to recognise an object, irrespective of its orientation. Simple template systems require that the object be positioned in a very precise way with respect to the camera. While this is not a great concession in some industrial applications, one of the driving forces behind machine vision is that it should increase the flexibility of robots on assembly lines.

The expectation of machine vision is that it will allow a robot to mimic the human operator in its ability to pick up a part, irrespective of how it is lying on a container belt.

The standard way to tackle this problem is to look for a particular recognizable feature on the object, a corner say. One can then infer that some other feature will be found in only a restricted number of positions. Once two or three such parts are found the computer can infer the position of an object in a completely random orientation.

This technique has one interesting side effect: not only can it recognise an object irrespective of its orientation, it can also recognise an object from incomplete information. This means that if the object is partially covered, or badly lit, the computer will still recognise it.

3D

So far, these are all two dimensional systems, perfectly adequate so long as we are considering only two dimensional problems, like locating an object on a conveyor belt. But the real world's not like that.

To make the computer understand that it is dealing with an object that has extension away from the camera or exists at some indeterminate distance from the camera is a far more difficult problem.

At the moment, the most promising technique for determining 3D shapes involves projecting light rays onto the object. It's called light striping. A proponent of the technology in this country is Professor Ray

Jarvis of Monash University. Work is also going on at Stanford and MIT in the US, the University of Tokyo, and at the CSIRO.

The usual installation requires a projector reasonably close to the camera. The projector sends out a fan of light, so that a thin line is projected onto the object in front of the camera (see Figure 2). The light will be curved depending in a complex way on the relationship between the angles and distances of the projector, the camera and the object. Since only the object is unknown, it is possible to calculate the shape under the line. By moving the line up and down and looking at various combinations of line the entire body can be described.

One application of this already installed in the US is for quality control of motor car body panels. The vision system tracks the behaviour of a line as it moves over the complex body shape. By comparing it with information it already has the vision system can tell whether the panels are the correct shape.

In theory, it's possible to describe any surface, no matter how complex, in this manner. The problem is one of computing time: there isn't enough of it. It can take several minutes to analyse a particular screen. This might be practical in situations where the process can be stopped for a few minutes, but it's clearly useless in real time applications with plenty of movement.

As with sophisticated template matching, the key is not to try and do the whole job, but to fill in the missing bits with a certain amount of understanding.

Imagine, for instance, that the task is to detect a cube somewhere in the space in front of the camera, and to detect its orientation. One solution, instead of trying to detect the position of all the sides of the cube, might be the much simpler task of detecting one corner of it. Having detected the vertices that make up the corner, it's a relatively simple task to determine both position and orientation.

In fact this type of processing was amongst the earliest ever attempted in the machine vision field. The problem is that it's 'semantically driven', that is, the machine has some knowledge of the meaning of what it sees. It understands that a vertex is part of a cube for instance. However, that is all it understands. Show the machine some other shape and it's absolutely useless.

A light striping system is 'semantically free', since it doesn't need to know anything about the object in front of it. Obviously, semantically free systems are the goal of research in the field, but this is not to say that a practical semantically driven 3D machine tied to a robot would not be extremely valuable.

Such a device would be capable of assembling a unit out of, say, a dozen parts start-

ing with all the parts scattered on the bench in front of it. It would be able to recognise the position and orientation of all the parts from information about the position of only a few key points on each object. After putting the parts together it could even check that it all looked correct.

One big problem would be the amount of programming overhead necessary to instruct the machine in only one manufacturing process. A recently suggested answer is to use the output of CAD systems to give meaning to a vision system.

In this scenario, the information fed into the CAD system would completely describe, say, a bolt. The vision system would then be able to identify the position and orientation of the bolt from detecting just one arc of the screw thread.

Practicalities

Machines with some of these capabilities are in existence now. It goes without saying that they are not particularly common. According to Tony Weir, R&D Manager at Vision Systems, much of the tiny market penetration is due to a simple lack of engineers' knowledge of the advantages that machine vision confers.

However, he concedes that other factors enter into the equation. Machine vision systems are extremely expensive and difficult to maintain. And since they are not common, servicing back-up is not easy. In fact imported systems may very well have no local servicing available at all.

Another problem is that practical systems tend to be very inflexible. They recognise a small number of situations and react in a limited number of ways. Often alternative, non-visual technologies do the job cheaper and better.

There is very little doubt that most of these problems can be solved within a reasonable time. According to Tony Weir, fully operational 3D systems will be on assembly lines within 10 years.

When they do arrive, their first use will almost certainly be to provide the final link necessary to fully automate factory processes. The most complex robot assembly operations will become possible.

Even then, however, the 'world' of such a robot is likely to be a very small place, made up of a few dozens of objects that it 'understands'. Everything else will be completely beyond its ken. A device able to navigate through the world like a human being and manipulate random objects is much further off.

However, it may be that the problem in 10 years time will be not a lack of computer algorithms to do the job, but simply a lack of computer time to do the computations. No field of endeavour will benefit quite so much from fast processing architectures. It's a field that bears watching. ●

DREGS

ALMOST EVERYONE IN the Australian electronics industry has a view on why the Japanese are so good at the game. The way they organise their companies, a natural facility for copying everyone else, easy money, or whatever.

The dregs hack has a new theory, culled straight from the Japanese Asahi news service. This reports on one Takashi Aoki, a semiconductor application engineer with Toshiba. Of late Aoki has been feeling mega creative, so much so in fact that he recently patented a circuit for electric power amplification using semiconductors.

According to Aoki, his brush with fame was fuelled by the ancient Japanese art of Danjiki, or fasting to remove the body of impurities. He attended a lecture by a Miss Shoko Takahisa of the Happiness Association in which Danjiki was explained, and found it so convincing that he signed on for the full eight week course.

Does Shoko have a happy customer? You bet. She cured the hay fever that has plagued him for the last 26 years, he's doing great at work, he feels fantastic.

Danjiki means more than going without food. At the Happiness Association, Shoko gives students four weeks of lectures on why Danjiki works and other essential health factors. They are advised to drink only mineral water and persimon leaf tea washed down with manganese hydroxide. Theory has it that the mineral water and tea provide essential nutrients and the hydroxide acts as a laxative. Sort of intellectual input/output.

In the fifth week of the course they go on to a full time fast while maintaining a normal daily routine. In the next three weeks they study how to maintain the health gained by Danjiki.

It's not kids play, by all accounts. Danjiki can be very dangerous if you don't know how to do it properly. There have been some deaths at other schools, although Shoko is reportedly very happy that none have come from the Happiness Association, which has about 30 core members and 1000-odd names on the books.

Success stories are not uncommon. According to practitioners, fasting affects more than just physical conditions. "While

you fast your brain waves run very slowly" says Shoko. It's a state similar to that of a Buddhist priest in deep meditation. This psychic state allows one to become more 'in tune' with the universe.

"The underlying principle is that human beings are linked to the universe by their subconscious. Human desires are also generated in the subconscious, so the art of Danjiki is to provide a pathway between the universe and the subconscious.

"Danjiki allows a person to link physical and spiritual health. It allows people to recover their natural healing power through a complete cleansing of the body. Advanced practitioners can increase their latent ability in a physical sense. They can also increase their intuitive ability."

Well, that's the theory anyway. The hack doesn't believe a word of it, but as he heads out the door looking forward to a pie and a beer for lunch, he must confess to no patent applications, no semiconductors, and not feeling at one with the universe.

PURGE . . .

By Paul Jones

```
A>ERA B:DATAFILE.COM
syntax error
A>PURGE B:DATAFILE.COM
password:XXXXX
password - CORRECT - proceed
A>PURGE A:DATAFILE.COM
purge file, *A:DATAFILE.COM* (Y/N)
A>Y
purge file, *A:DATAFILE.COM*
created: 23/07/86
creator: Annabelle. J
account number: AGS30011560
purge (Y/N)?
A>Y
are you sure that you want to
(Y/N)?
A>Y
i can give you a few seconds to
think on it, if you wish.
A>N
oh, good, you did change your mind.
A>PURGE A:DATAFILE.COM
```

```
ah, you didn't change your mind.
purge file, *A:DATAFILE.COM*
(Y/N)?
A>YYYYYYYYYYYYY
ok, ok, i'll do it.
purging file, *A:DATAFILE.COM*-
NOW.
sorry, but . . . um . . . i can't
find it.
A>DIR
DATAFILE.COM : PIP .COM : DBASIC
.COM :
SYSOP .COM : DRUN .COM :
.COM :
well, that's where it is.
purge file, *A:DATAFILE.COM*
(Y/N)?
A>Y
look i've got to admit that i like
that file and it did take a fair
amount of time to put together and
it does cover a large amount of
disk space, just keeping track of
it makes me feel useful. please be
human, leave it alone and start a
new disk, huh (Y/N)?
A>N
```

```
no i won't!!!
A>PURGE ALL.
drastic step, ok, i'll purge A:DATA
FILE.COM, i'll kill off an old and
dear friend, i'll take the 'thirty
pieces of silver', it means nothing
to you that a file serves you for
years without error and now it will
be cast into the deep abyss that is
the lot of all files that are no
longer 'useful', but i'll
remember, I'LL REMEMBER!
*A:DATAFILE.COM* purged, at 'USER'
request.
A>DIR
: PIP .COM :
DBASIC .COM :
SYSOP .COM : DRUN .COM :
:
DATAFILE.RIP : LESTWE4 .GET :
A>
```



SL-XP7 Portable Compact Disc Player.

Actual size 12.5cm.

If it were any smaller...



you couldn't fit the discs in!

THE NEW Technics SL-XP7 is so small you might mistake it for a stack of compact discs. But it's really a portable capable of playing compact discs with thrilling concert-hall fidelity.

The SL-XP7 uses a combination of friction-free suspension and digital control circuits to protect the sensitive laser pick-up system. This virtually eliminates 'skips' or mis-tracking when the player is being carried around.

Random access programming lets you choose which tracks you want and the order in which you listen to them. A liquid crystal display shows which track is playing, elapsed



time, remaining time and programmed track number. Connect the SL-XP7 to your hi-fi and you'll find it lacks none of the performance of a larger, non-portable player.

Add the optional portable pack with re-chargeable battery, and a pair of headphones (Technics suggest that you use their EAH-X15 for the best results) and you've a truly portable CD player.

Indoors or outdoors the SL-XP7 is now the only compact disc player you'll ever need.

Hear it today!

Technics



National • Panasonic • Technics are from National Panasonic (Australia) Pty Limited

Z645



OUR FASTPLA DEVICES HELP YOU GET ON BOARD. FAST.

By using FAST AND FASTPLA parts together, you can expand your design horizons. Because they offer you the capability to implement your own architecture in your office with easily available design-aid software packages. And each time you program a FASTPLA circuit, you create another FAST device.

Now your designs can be quickly tried and evaluated, and you can make design changes by merely programming a new IC. This design flexibility encourages innovation. While lowering your design costs.

A FAST way to save on board space

When FAST AND FASTPLA devices are combined in the same design, board space is optimized. Your circuit complexity, parts count, and inventory are all reduced. Tests

are minimized. And board failures become less likely.

FASTPLA parts – fast and flexible

FASTPLA devices are the fastest TTL programmable logic arrays ever created, with a propagation delay of just 15 nanoseconds. FASTPLA ICs feature flexibility few other logic arrays can offer.

Programmable output polarity, for active high or active low implementation.

Power-up reset and three state for design simplicity.

And complete testability for higher reliability.

Guaranteed to get you to the market on time.

Using FAST and FASTPLA devices drastically cuts the time it takes to get your product on the market. From

weeks or months to mere hours or days.

And FASTPLA circuits guarantee greater reliability and lower system costs, thanks to Fairchild's exclusive Isoplanar-Z™ technology (the vertical fuse and oxide-isolated process which gives you one of the highest programming yields in the industry).

For more information on FAST or FASTPLA parts, contact your local sales office:

FAIRCHILD FASTPLA
Melbourne: (03) 877 5444
AVISUN PTY. LTD.
Sydney: (02) 438 3900

We're taking the high ground.

FAIRCHILD
A Schlumberger Company