

AUSTRALIA'S DYNAMIC ELECTRONICS MONTHLY!

\$2.75*
NZ \$3.50

Electronics Today

INTERNATIONAL

eti

JUNE 1985

**WRISTWATCH COMPUTER!
WALL-HANGING HI-FI
— TWO REVIEWS
RADIO VIA SATELLITE
ARE YOU A COMPUTER ADDICT?**

**AUSTRALIA QUICK TO
DESIGN ITS OWN ICs**



Registered by Australia Post, Publication No. NBP0407.



PROJECTS:

**UHF LINEAR AMPLIFIER
CASSETTE TAPE
AUTO-SEARCH
SIMPLE JOYSTICK
ADAPTOR**

The one you can't afford not to own!

AQUARIUS™

The REAL computer that starts from under \$100! You'd love to learn about computers? But thought all you could buy for your money were a few boring games. Now, we are the EXCLUSIVE Australian distributors of the new Aquarius. Not the "Claytons" computer but the perfect beginner's computer which gives you the opportunity to see what a real computer does.

Learn how to RUN YOUR OWN PROGRAMS in the Basic language! PLAY GAMES! Organise your HOUSEHOLD FILES! And much much more!

Simply connect the Aquarius to any colour TV and it's ready to teach and entertain the whole family. There's something for everyone. And what's more, you won't outgrow the Aquarius! As you need to

learn more, the Aquarius offers a huge range of add-ons that will take you into the world of electronic wizardry once offered only by the BIG ones.

With a full moving-key keyboard Aquarius is truly EASY to USE. Microsoft BASIC computer language is built right in! The easy-to-read manual and simplified instruction cards make learning a snap.

CREATE your own VISUAL EFFECTS with 16 colours and 256 built-in characters or design your own sound effects! Once you start to expand your Aquarius with the huge software and hardware range you'll find endless uses and possibilities for your system. With its own mini expander, data recorder, memory expansion cartridges and thermal printer you'll soon wonder what the Great

Computer Secret was all about!

FANTASTIC SOFTWARE RANGE

With more than two dozen fantastic games and educational programs available now and many being developed to add to the range shortly, there's just no end to the versatility of Aquarius. Software cartridges just plug into your Aquarius and you're ready for work or play. All software programs are available separately so you can purchase only those which interest you.

AQUARIUS with built in 2K memory (expandable to 34K) and its long list of expansion units and software is the REAL computer for the price of a TOY!

1. MINI EXPANDER

Adds versatility to your AQUARIUS. Game playing is easier and more exciting with 2 detachable hand controllers and additional sound channels. Also has 2 cartridge ports so you can plug in your expanded memory cartridge into one even while you're using software in the other.

Cat X-6005 \$69

2. DATA RECORDER

Save your own program or utilise one of the many great software programs available on cassette with this great value unit.

Cat X-6010 \$49

3. MEMORY EXPANSION CARTRIDGES

16K or 32K memory cartridges give you far greater flexibility by giving your computer a much larger memory. For more advanced programming.

16K Cartridge Cat X-6015 \$69

32K Cartridge Cat X-6020 \$129

4. THERMAL PRINTER

Ideal for documenting programs, keeping records or printing charts and records. You'll probably never again see one at this price!

Cat X-6025 \$129

Paper roll to suit. Cat X-6026 \$350

Aquarius Colour Computer

Cat X-6000

Fantastic
Value
ONLY

\$99

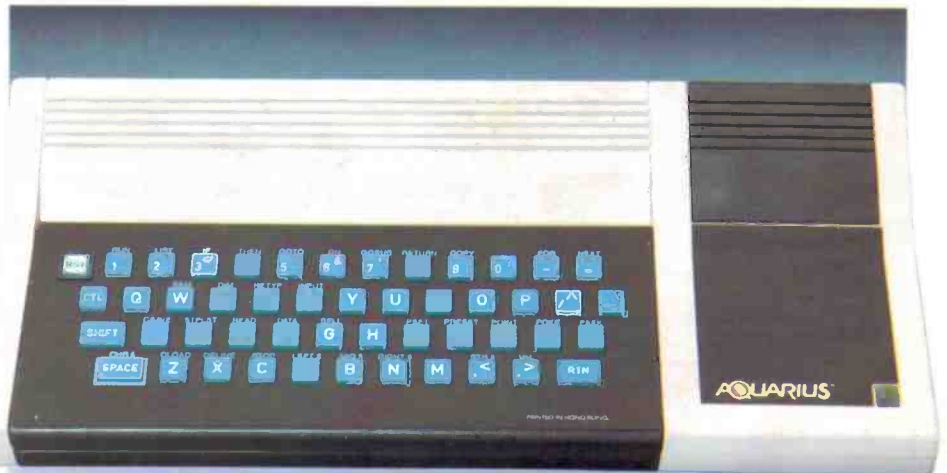

Dick Smith Electronics Pty Ltd

COMPUTERSTOP



Your one stop computer shop at your nearest Dick Smith Electronics centre.

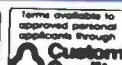
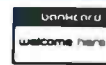

A-923

Electronics Today

INTERNATIONAL

EDITOR
David Kelly

EDITORIAL STAFF
Mary Rennie
Jon Fairall B.A.
Geoff Nicholls B.Sc./B.E.
Robert Irwin B.E.
S. K. Hui B.Sc. (Hons)

DRAUGHTING
David Burrows

ART DIRECTOR
Vicki Jones

ART STAFF
Sharon Hill

ADVERTISING PRODUCTION
Danny Hooper

ADVERTISING SALES
Arthur Whall
Kate Stuart

READER SERVICES
Elizabeth Barnett
Felicity Skinner

ACOUSTICAL CONSULTANTS
Louis Challis and Associates

MANAGING EDITOR
Jamieson Rowe

PUBLISHER
Michael Hannan

HEAD OFFICE
140 Joynton Avenue, (PO Box 227)
Waterloo, NSW 2017.
Phone: (02) 663-9999 Sydney.
Telex: 74488, FEDPUB.

**ADVERTISING OFFICES
AND AGENTS:**

Victoria and Tasmania: Virginia Salmon
The Federal Publishing Company, 23rd
Floor, 150 Lonsdale Street, Melbourne, Vic.
3000. Phone: (03) 662-1222 Melbourne.
Telex: 34340, FEDPUB.

South Australia and Northern Territory:
The Admedia Group, 24 Kensington Road,
Rose Park, SA 5067. Phone: (08) 332-8144
Adelaide. Telex: 82182, ADMEDIA.

Queensland: Geoff Horne, C/- The Federal
Publishing Company, 25 Balaclava Street,
Woolloongabba, Qld. 4102. Phone: (07)
391-4041, (07) 391-8003. Telex: AA145520.

Western Australia: Cliff R. Thomas, Adrep
Advertising Representative, 62 Wickham
Street, East Perth, WA 6000. Phone: (09)
325-6395 Perth.

New Zealand: Chris Horsley, 4A Symonds
Court, Symonds Street, Auckland. Telex:
NZ60753, TEXTURE. Phone: 39-6096.
Auckland.

Britain: Peter Holloway, John Fairfax and
Sons (Australia) Ltd, Associated Press
House, 12 Norwich Street, London EC4A
1BH. Phone: (01) 353-9321 London. Telex:
262836, SMHLDN.

Japan: Genzo Uchida, Bancho Media
Services, 5th Floor, Dai-ichi Nisawa
Building, 3-1 Kanda Tacho 2-chome,
Chiyoda-ku, Tokyo 101. Phone: (03)
252-2721 Tokyo. Telex: 25472, BMSINC.



ELECTRONICS TODAY INTERNATIONAL
is published monthly by the Electronics
Division of the Federal Publishing Company
Pty Limited, 140 Joynton Avenue, Waterloo,
NSW 2017. Typeset and printed by
ESN-The Litho Centre, Sydney. Distributed
by Gordon and Gotch Limited, Sydney.
Cover price \$2.75 (maximum and
recommended Australian retail price only;
recommended New Zealand price, \$3.50).
Registered by Australia Post, Publication No
NBP0407. ISSN No 0013-5216.

COPYRIGHT © 1985, THE FEDERAL
PUBLISHING COMPANY

FEATURES

The next generation of custom chips ICs make the takeover bid	12
Starting electronics 5 Making your own pc boards	48
Energy saving car air-conditioning Air-conditioning with attention to power consumption	96
Keyboard encoder A simple design for any keyboard	107
Compulsive programmers Are you addicted to your computer?	124

PROJECTS

ETI-743: 25 watt UHF power amplifier	58
ETI-679: Microbee joystick adaptor	68
ETI-693: Tape auto-search	74
ETI 1527: Home burglar alarm module Part 2	84

REVIEWS

'Stereo nouveau' The wall-hanging SA-R100 stereo radio/cassette	18
More tricks from Technics Compact, versatile SB-R100 speakers	26
Seiko's TUC-2000 wristwatch computer Ultra-portability not the only consideration	102

OFFERS

Hewlett Packard offer	45
Subscriptions offer	51
Nashua offer	100
ETI mail order books	72, 73, 82, 83 & 116

DEPARTMENTS

News Digest	6	Ideas for Experimenters	93
Sight & Sound News	32	MicroBee Column	110
New Components	38	Commodore Column	114
New Equipment	42	Shoparound	127
Computing News	98	MiniMart	127
Communications News	119	Perspective	129
Letters	9	Dregs	130
Idea of the Month	92		

COVER: Photograph courtesy of Plessey Australia.

Gasp!



Nothing we can say will prepare you for your first sensational audition of the Sony D-50 Compact Disc Player.

We could compare it with turntables that cost as much as a family car. But the turntables don't measure up.

We could compare it with other full-size Compact Disc Players. But its suggested retail price of \$429 defies description.

We could exhaust our supply of superlatives just talking about its specifications. But the D-50 is so superior to what you're used to, the exercise would be academic.

We could shake our heads in amazement at the fact that this extraordinary piece of digital audio equipment will improve almost any hi-fi system.

Yet it is so completely portable you can carry it, and its optional battery pack, around with you.

But nothing will prepare you for the experience of hearing it play.

When you hear it, you'll respond like everyone else has responded on first hearing the Sony D-50.

Gasp!

SONY®

AUD0606/R

ADVERTISERS' INDEX

A. Hankin & Co	56
Active Electronics	80,81
All Electronic Components	128
Altronics	46,47
Applied Technology	90,101
Associated Calibration Sales	35
Audio Engineers	23
Australia School of Electronics	89
Australian Electronic Components	123
Autotron Australia	57
Daneva Australia	IBC
Delsound Pty Ltd	127
Dick Smith Electronics	IFC,40,41, 45,50,117
Disco World	116
Electronic World	123
Emona Instruments	56
Energy Control	70
Epson Australia	65
ETI Books	116,123
ETI Offers	51,91,100
Federal Publishing Co	72,73,82,83
Geoff Wood Electronics	16
Hewlett Packard	17
Ian Huntley Pty Ltd	109
I.E.I. Australia	55
Jaycar Electronics	36,37,96 97,112,113
Leisure Imports	44
Marantz Australia	24,25
Microtrix	126
Plessey	66,67
Positronic Computers	56
Prepak Electronics	122
Robert Ford	22
Rod Irving Electronics	30,31,71 94,95,118
Rose Music Pty Ltd	10,11
Scan Audio Pty Ltd	44
Scientific Devices	44
Siemens Ltd	OBC,106
SME Systems	105
Sony Australia	4
Union Carbide	122
Wireless Institute	123

This index is provided as an additional service. The publisher does not assume any liability for errors or omissions.

IN ABOUT THIRTY SECONDS the groans will be heard around Australia, emanating mainly from the top floors of electronics and other so called high technology companies. That's because I am about to pontificate on that most sacred of holy cows, high-technology manufacturing.

In the 1940s many Australians were impressed by the power that the ability to manufacture motor vehicles and other machinery apparently gave a country. As a result of these emotive rather than economic reasons we now have a heavily subsidized car industry.

We pay more than \$25,000 per year per worker to keep the industry going. But that is only half the cost; we all pay \$4000 to \$6000 more than we need to when we buy a new car, leaving us less money to spend with other Australian manufacturers.

Tariffs and other barriers to imports serve more to protect other countries from Australian competition than they do any good for the Australian industry.

We cannot apply tariffs to protect industry and not expect any adverse side-effects. The very fact that these measures limit imports means the value of the Australian dollar will be artificially high.

Any manufacturer that might have had a chance to export now has a barrier that prevents him from doing so. What's worse is he now has to compete for resources, like skilled personnel, with operations that could not have survived otherwise.

We are so used to having a piddling level of exports that we don't consider the export market important. Our local market is so small it makes the world market look infinite by comparison. We only need a few products to be really competitive on the world market to have a huge electronics industry.

It would also be a much more interesting industry to work in, because we would be running a complete research, manufacturing, testing and marketing operation instead of the hand assembly shops we seem to be lumbered with under tariffs.

The major part of the Australian electronics industry has developed ad hoc with particular manufacturing operations to suit particular local needs. Most don't get any tariff protection now and would only be helped by the reduction or abolition of tariffs.

Ironically it is precisely those who most profess the need for free enterprise that are the first to ask for government intervention. Is it that our pillars of industry are just closet socialists?

It is never easy to argue against the widely held beliefs of your peers, but for the Australian electronics industry the argument is vitally important.

I look forward to the comment of industry in these pages.

David Kelly
Editor

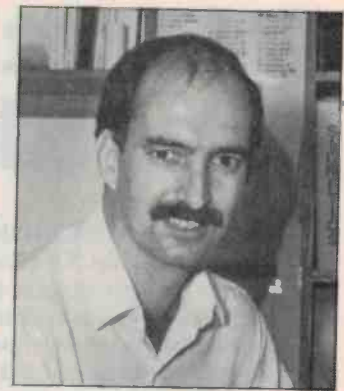

SERVICES

TECHNICAL INQUIRIES: Technical inquiries by mail must be accompanied by a stamped self-addressed envelope. There is no charge, but we reserve the right to publish the inquiry and the reply in *Electronics Today* or any of its associated publications. We can only answer queries relating to projects and articles as published. We cannot advise on modifications, other than errata or addenda. Difficult questions may take some time to answer.

GENERAL INQUIRIES: For all inquiries about back issues, subscriptions, photocopies of articles, artwork or submitting articles, call (02) 663-9999 or write to: ETI Reader Services, 140 Joynton Avenue (PO Box 227), Waterloo, NSW 2017.

CONTRIBUTIONS: Submissions must be accompanied by a stamped, self-addressed envelope. The publisher accepts no responsibility for unsolicited material.

COPYRIGHT: The contents of *Electronics Today International* and associated publications is fully protected by the Commonwealth Copyright Act (1968). Copyright extends to all written material, photographs, drawings, circuit diagrams and printed-circuit boards. Although any form of reproduction is a breach of copyright, we are not concerned about individuals construct-

ing projects for their own private use, nor by bands (for example) constructing one or more items for use in connection with their performances. Commercial organisations should note that no project or part project described in *Electronics Today International* or associated publications may be offered for sale, or sold in substantially or fully assembled form, unless a licence has been specifically obtained so to do from the publisher, The Federal Publishing Company, or from the copyright holders.

LIABILITY: Comments and test results on equipment reviewed refer to the particular item submitted for review and may not necessarily pertain to other units of the same make or model number. Whilst every effort has been made to ensure that all constructional projects referred to in this edition will operate as indicated efficiently and properly and that all necessary components to manufacture the same will be available, no responsibility is accepted in respect of the failure for any reason at all of the project to operate effectively or at all whether due to any fault in design or otherwise and no responsibility is accepted for the failure to obtain any component parts in respect of any such project. Further, no responsibility is accepted in respect of any injury or damage caused by any fault in the design of any such project as aforesaid.

Aussat countdown

As the dust slowly settles on the controversy surrounding the technical standards for TV broadcasting from Aussat, the fight over how the satellite is going to be used is hotting up. Essentially there are three contestants: the big city networks, the regional broadcasters and the rest of us. Piggy in the middle is the government, represented by the Department of Communications, and the Australian Broadcasting Tribunal.

The big three city stations want it all for themselves. They would like to be able to network to terrestrial ground stations and do direct broadcasting to remote receivers. Advantage: more money for them, and the same service all over the country. Disadvantages: the end of the regional broadcasters and an increase in the already incredible monopoly situation of broadcasting in this country.

Regional broadcasters would prefer it if Aussat became geostationary on the bottom of the South Pacific ocean very soon after launch. Since this is unlikely to happen they would prefer it if there was no direct broadcasting via the satellite at all. That is politically untenable, since Malcolm Fraser used direct broadcasting as the carrot to spur the electoral donkey into paying for it all those years ago. Option three: preserve the regional broadcaster's monopoly

by using the addressing capabilities of the BMAC transmission system, and make it illegal for people inside their reception zones to receive signals outside.

Option three was Communications Minister Duffy's favourite compromise until his secretary Bob Lansdowne told an industry seminar he foresaw policing the policy as a "nightmare". He regaled the conference with stories of the Canadian experience, which had mounties clambering through the backyards of rural Canada looking for dishes pointing in the wrong direction.

After dithering around for years the government decided that the best way to do things would be to form separate commercial broadcasters out of consortiums of the rural broadcasters and let them run the satellite channels. However, it now appears that the rurals' response has been to form themselves

The areas covered by the four spot beams from the satellites plus another spot beam for Papua New Guinea.

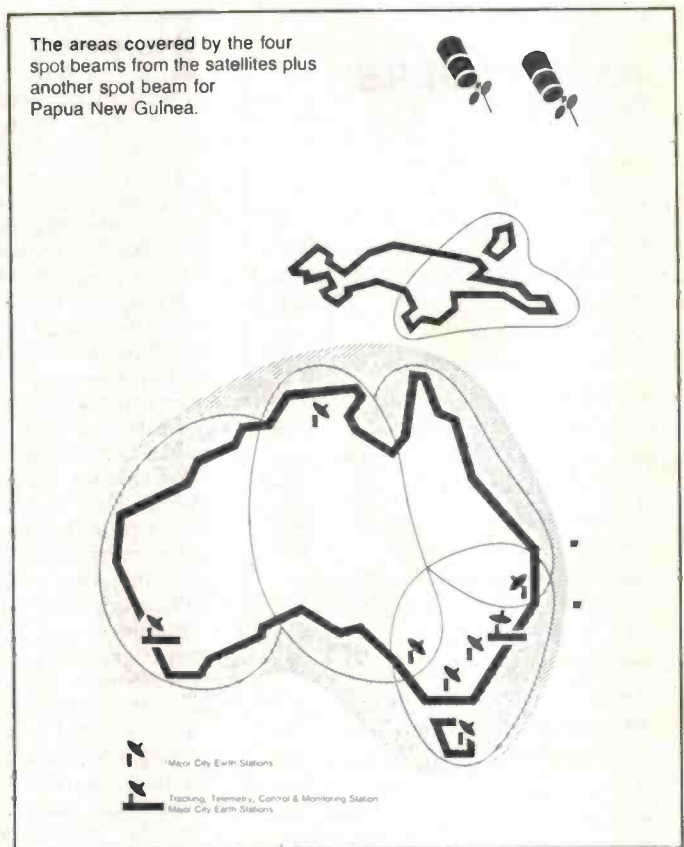

into one large network. And it seems that the government has accepted that that is the best deal it can get from the broadcasters.

The idea is that the regional commercial network will apply for all the regional licences that have been granted, and presumably with government blessing, get them all. Advantages: they

will be able to compete with the big city networks, and they won't lose their monopolies. Disadvantages: the country cousins get only one commercial channel plus the ABC.

And the people? Well the people pay for it all, and get as few channels as the networks can get away with.

Plans for new telescope

Work begins next year on a new generation optical telescope. It is the most significant leap in size for almost a generation, when the two hundred-inch Hale telescope atop Palomar mountain was unveiled. Since then only one bigger instrument has been built, by the Russians. But it used conventional technologies and came up against the same engineering problems that constrained the Palomar designers. The new instrument will

be ten metres across.

The problem has always been to support such a huge weight of glass to tolerances within a few wavelengths of light. As the telescope is shifted about its axis the stress on it changes. When the wind blows, or the temperature changes, all the dimensions of the lens alter.

The proposal that has led to megascopes has been to build not bigger, but smaller lenses. These can all be controlled sepa-

retely and integrated into one huge lens.

The American project has been made possible by a \$70 m bequest from the W. M. Keck foundation of Los Angeles. The telescope will consist of 36 hexagonal mirrors designed by Jerry Nelson, an astronomer. Each segment will be 1.8 m across, and positioned relative to its neighbours to a tolerance of less than 3.75 nanometres. The segments are repositioned 300

times a second.

The Keck telescope will be the perfect complement for the space telescope to be launched next year. The space telescope will have 10 times the resolving power, because it will be above the atmosphere. But the Keck telescope will have much greater light gathering power, so important when looking at exceptionally faint objects.

Ballistic transistors

The world's electronic press has been abuzz this month with an announcement from Cornell University in the United States that Gallium Arsenide transistors have been developed with a switching time of about 1.5 ps (1.5×10^{-12}).

This is so fast that it would require a major rethink of computer architecture; it is expected that the biggest computers in existence today could be shrunk to the size of a lap top. Other immediate applications would be in satellite technology, where it would be possible to transmit in the 94 GHz band, where atmospheric attenuation is at a minimum.

The technology is based on

the ballistic electron effect. Electrons in such devices travel about six times faster than they do in conventional transistors. The increase stems partly from the inherently faster transit time of GaAs material, but mostly from the travel paths, which are so small that collisions with other subatomic particles become insignificant. As a result, the electrons begin to speed up as they travel. The electric equivalent is that of feeding current into zero resistance.

Fundamental work on the idea of ballistic transistors was done at Cornell. Important advances have also been made by Bell and CNET in Grenoble, France.

Charon exists

In the old legends Charon is the ferryman who takes the souls of the damned across the river Styx to Hades, ruled by the implacable Pluto. Modern astronomers have it that the Greeks got it all wrong. Pluto rules a hell that is not hot, but frigid cold, and Charon, far from being the ferryman, is a companion engaged in frenetic dance, pirouetting about Pluto every eight hours.

Pluto, furthestmost planet from the sun was discovered by Percival Lovell in 1930. It is so small and so far away that no pictures exist of its surface, and astronomers have only a hazy idea of its size. However, watching the intensity of light coming from the planet, scientists have been convinced for quite a while that there was something distinctly odd about it. The suspicion has been growing for quite a while that the planet was either strongly marked, or strongly deformed, or maybe not one, but two distinct bodies.

Supporters of the latter school christened the new body Charon, but have been unable to get official recognition of the name, since no visual proof of its existence could be produced.

Now a series of eclipses has been observed, and the existence of a moon directly con-

firmed for the first time.

The reason that proof has been so long in coming is that Charon orbits in a curious manner, such that it actually only eclipses Pluto for five years in every 124. The initial work on the orbit of Charon was done in 1978 by Jim Christie at the US Naval Observatory. He argued from the pattern of light intensity coming in from Pluto that if Charon existed, it would have this peculiar orbit. He predicted that eclipses would start in 1982.

In line with his predictions, a team of US astronomers began a joint effort to detect the eclipses in early 1983. After early errors and inaccuracies caused by calibration problems in the telescope and other uncertainties, the team has now announced the definite existence of an orbiting body.

Scientists are excited, not only because of the discovery of another major object in the solar system, but also because the existence of a moon will allow accurate determination of the mass of both bodies, their size and thus density, and from that, some idea of their composition.

But whatever is determined, Pluto and Charon are certainly small, and cold, and a long way away.

Hands on custom chips

The Centre for Industrial Microelectronic Applications, (CIMA) is offering hands on experience to people wishing to use custom chip technologies in their circuits. Appropriate CAD workstation development tools are available for use under the guidance of technical staff. Charges are minimal owing to inputs from both Federal and Victorian governments. For more information contact CIMA on (03)660-2991.

3 x 3 LSI

Mitsubishi Electrical Corporation has reported the development of a three dimensional, large scale integrated device. A new process has been applied to three devices, one of which has three layers. This makes it the first time a three layer, three dimensional LSI device has ever been constructed. The work is part of a ten year development program for future industry.

Scholarships to Eindhoven

Philips International Institute of Technological Studies is offering places for study towards a Masters Degree at Eindhoven in the Netherlands. Since its foundation in 1957 thirteen Australians have been awarded scholarships. Prerequisites include a good electronics degree and competency in English.

Recycling silicon

Europe's first purpose-built plant for the recovery of old silicon wafers has come on-line in Riddings, UK. According to the principal of the company running the operation, significant cost savings result from stripping and repolishing silicon wafers.

Data services directory

Telecom is updating its directory of computer based data services accessible through AUSPAC. The directory was first issued last year and covered most of the data bases available. If you missed out then contact Graham Martin on (03)606-7772.

Asian computer market conference

Hundreds of the world's leading information and communications suppliers and experts will converge on the World Trade Centre in Singapore to compete for a share of the Asian market worth a reported \$6.5 billion. The conference will run from September 3 to 6. Full details for exhibitors can be obtained from BPI exhibitions, (02)266-9799.

Electronics exhibition in Melbourne

The 20th International Electronics Exhibition and Convention begins Monday 30 September in the Royal Exhibition Buildings, Melbourne. According to organizers only 9% of space is left for exhibitors. Alan Stoops, chairman of IRECON '85, expressed satisfaction with the way things were going and with the direction of the papers to be presented at the convention. He said it all reflected the fact that IRECON '85 will be the largest exhibition in the Southern Hemisphere this year.

Prizes, prizes

Mr David Josling has won the DSE "everybody's a winner" contest. His prize includes a CAT personal computer and a trip for two to the UK.

COMPANY NEWS

Cybernex of Canada has selected Datatel as the Australian distributor for its range of Hi-tek visual display terminals. Cybernex manufactures terminals compatible with IBM, Honeywell, etc. Datatel is at 19 Raglan St, South Melbourne, on (03)690-4000.

Allen Bradley Ltd, supplier of resistive components has announced the appointment of K. D. Fischer Ltd as its SA distributor. Included in the range are fixed and variable resistors, resistor networks and trimpots. It also sells the Australian assembled Mod Pot range of potentiometers.

Arista Electronics has moved its offices to 57 Vore Street, Silverwater, Sydney. The new phone is (02)648-3488.

Telecom has appointed Mr Harry Wragg as director of research to replace Ed Sandbach who resigned recently. Mr Wragg has been assistant director of business development since 1983.

Philips announces that its data systems, electronic systems and radio departments have been combined into Philips Communications, based in Carroll Road, Oakleigh South, Vic 3167. Sales is on (03)542-3600 and service on (03)542-3650.

Telecorp, the Australian communications manufacturer, has announced the appointment of a national dealer network. To find out who your local dealer is call Telecorp in Sydney on (02)450-2522.

Arlec Ltd has appointed Jewel Distributors as its agent in the Northern Territory. Arlec manufactures a range of electrical and electronic goods. To contact it call at Unit 2, Lot 1737 Albatross St, Winnellie, NT 5794 or phone (089)84-4227.

NOTES & ERRATA

Project 662B, April '84. The circuit diagram for this project, page 74, contained an error. The pushbuttons are labelled incorrectly. The correct positioning is detailed below. The pc board artwork shown in the original article is correct.

Other minor corrections are: Pin 20 of the 24 pin DIL plug is the PA7 connection. PB4 is on pin 9, not pin 15 as shown. IC1, pin 1 should be pulled down to ground.

Project 677, January '85: On page 76 the input connection attached to pin 6 of IC2c should be labelled STROBE-bar. The corresponding Centronics connector pin number should also be 1, not 10, while the Centronics pin number for the BSY output line should be 11 not 1.

If the Catterbox is to be used with a VZ200 computer, capacitor C1 should be reduced to 100p to allow the circuit to trigger reliably from the narrower strobe pulse. Note also that the BASIC Interpreter normally sends a CR-LF combination to the printer when returning to READY after running a program. This causes the Chatterbox to produce a continuous sound, even if your program leaves it silent. The solution is to end your program with a dead loop line (e.g. 1000 GOTO 1000), and break it using the CTRL + BREAK keys.

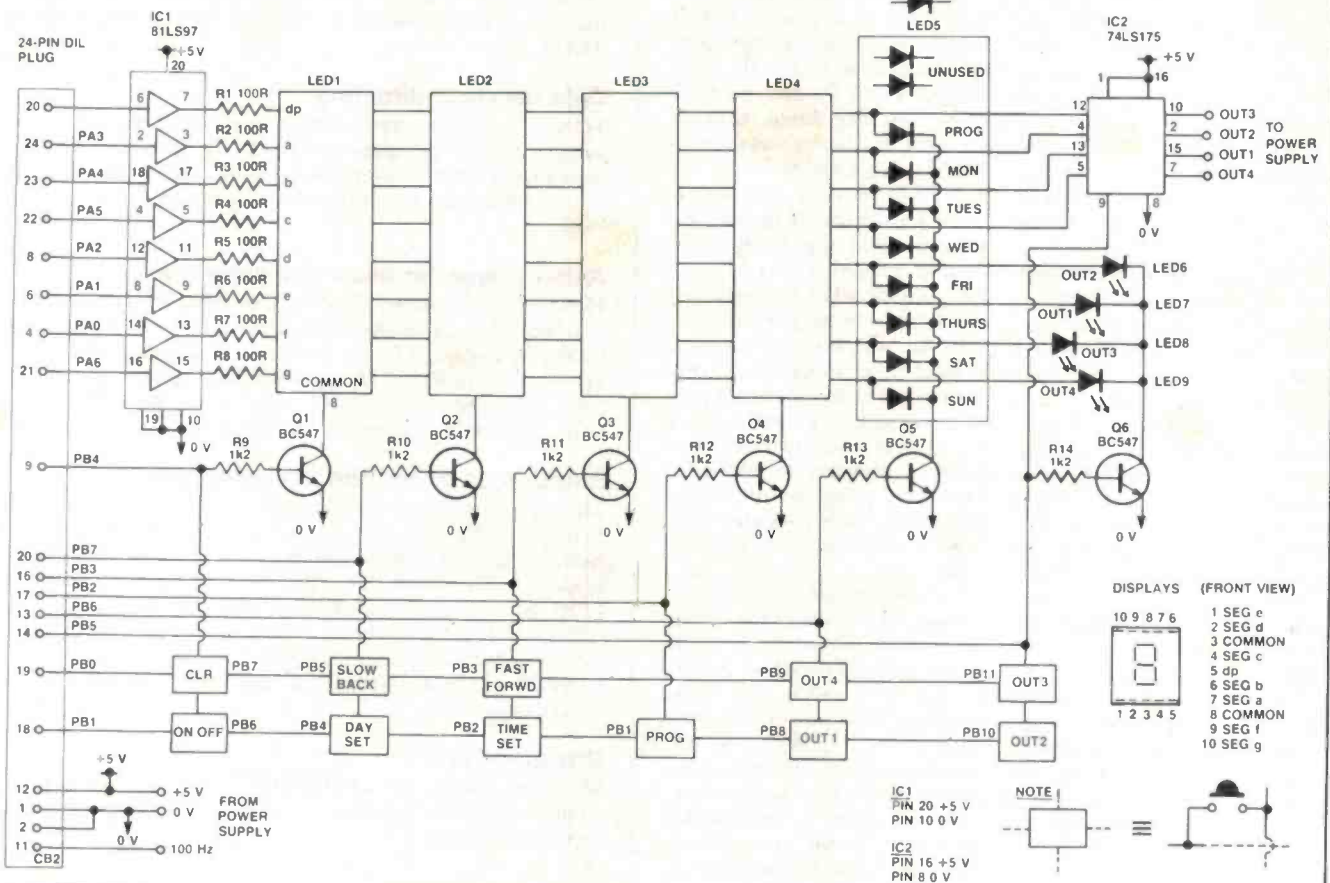

Letters to the Editor

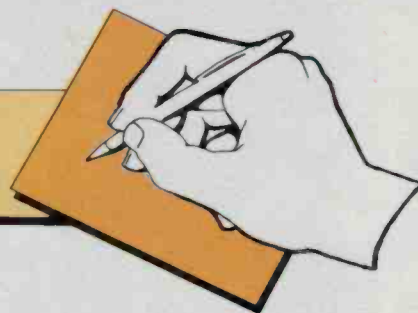

BMAC, be careful

JON FAIRALL is to be congratulated for his article "BMAC — We'll be the first to use it," March 1985. The article was informative and covered the areas of the introduction of satellite broadcasting into Australia very well.

The BMAC decision was brave, hopefully it doesn't prove to be foolish. Now that the Americans' plans for DBS have been shelved, Australia is going BMAC alone, Europe is debating the issue of broadcasting standards via satellite and the only other 12 GHz systems are based on NTSC primarily using Japanese technology.

It appears that the most advanced Japanese manufacturers are more interested in the step beyond MAC, high definition TV, rather than entering the ever confusing debate on the different forms of MAC.

It is to be expected that the confusion over universal standards may be cleared later this year at the CCIR conference — with results that may well see Australia either on its own with BMAC or being the first with a widely accepted system.

Experience from the Japanese though, was not heeded by our governing authority. In Japan the manufacturers preferred to put in an interim system (readily available to Australians if necessary) and change to the very high tech HDTV when available, rather than go one way and take the risk of either isolation, or backtracking.

The new issue of this debate is that of 'equalization', a just recently announced policy of the DOC which may result in the MAC system being used only for HACBSS, with all other broadcasting using lower cost Japanese systems.

The decision to be first to use the BMAC system will raise the cost to all users. Before the BMAC alternative was decided upon, we put a proposal to the Department of Communications outlining the basic Japanese developed system which would cost the end user approximately \$1700 not including government duty and tax charges but including transport and retail charges.

The BMAC Baseband Processor, on the other hand, will have a basic factory cost of around \$500-\$600 which will end up costing the end user an additional \$1000 by the time transport, re-handling and retail charges are added because of the small quantities involved to supply the Australian market, and the hi-tech nature of BMAC with the devel-

opers of the system having to recoup their R&D expenditure.

For the same \$1000, an interested consumer could purchase a larger 2.5 m antenna and servo control unit to redirect it and be able, if the government allows equalization to follow its course, to pick up all three national broadcasters (if Aussat and the networks can agree on prices for transponders, all using the basic Japanese system adapted to PAL). Then in a few years when the CCIR has released its policy guidelines, all Australians can enjoy the benefits of an internationally accepted system at very low cost which will keep us well satisfied until the HD and digital TV systems are introduced in 1990.

Jeff Lillis
Product Development Specialist,
Toshiba, Australia

I HAVE recently returned from a two-year period abroad and brought back a Sony Trinitron Colour TV receiver, KV-2024E and Sony Beta videocassette recorder SL-C7E, which I bought in Singapore one and a half years ago.

Though both TV and VCR work and I can pick up CTC-7 and SBS-28 here in Canberra, I cannot pick up ABC-3. I have no trouble with an older TV which I have. All I can get of ABC-3 on the Sony is a vague picture and the sound. Also the picture on CTC-7 and SBS-28 has a greenish hue.

When I bought the sets I was assured that they were alright for Australia but I now suspect that was not entirely true.

I am almost totally ignorant about the mysteries of electronics. I have been informed by a Sony agent here that I need a kit which would cost about \$180.

I would be most grateful if you could advise me on what, if anything, is wrong with the equipment and what I need to put it right to suit Australian conditions and what I might reasonably expect to have to pay.

M. R. Freeman,
Curtin, ACT

It's of considerable embarrassment to the Department of Communications that we are the only country in the world to have allocated part of the international FM radio broadcasting band to television (channels 3, 4 and 5). To prevent visible interference to television channels around 7, 8, 9 and 10, overseas video recorders and receivers have

a filter (between the aerial socket and the tuner) for the FM broadcasting band (88 to 108 MHz). These recorders won't work in Australia for television channels 3, 4 and 5 unless the filter is removed. — Ed.

And the answer lan . . .

ON PAGE 66 of the article on CDIs in the February '85 issue, Ian Thomas asks "If this type of inverter has all these advantages then why hasn't it been used before?" The answer is that it has. See the RCA application note AN-6288E published December 1974. As you can see it is very similar in principle (although less refined) than the design published in the February '85 ETI edition.

G. J. Shepherd,
Newtown, Tas

With some suggestions

I HAVE read Part 1 of the "Improved CDI" with interest. On page 66, the question, "Why hasn't this system been used before?" is answered by "It has. See AWA 'Radiotronics' August 1969, page 45".

I have been using this circuit, with small mods, since early 1970, along with several colleagues. My original unit is still in use, but now with a Hall effect device. There has never been any hint of cross-firing.

The two main differences between it and your new circuit are the use of an easily wound transformer using EI laminations and the use of the points to stop the inverter whilst the plugs are fired.

An unmentioned advantage of this type of circuit is the low current drain under stalled engine conditions. TAI systems need to turn themselves off if not fired within a reasonable time; a circuit in *Elektor* several years ago, did make this safety provision.

A short-coming in your circuit as published: although OK in the points version, the mods to R13,14 for using a Hall effect device would preclude the use of three other now essential circuits: tachometer; air-conditioner low speed clutch release; and cruise-control (manual transmission).

I am presently using a BD139, switched by the Hall effect device, to switch my equivalent of R13, with the connection brought out for use.

G. A. Tidy,
Murrumbidgee, Vic



They sound even better

Forget the price, a digital disc player is only as good as it sounds.

And how well it sounds depends on how well it converts the digital signal to an analog signal.

It's as simple as that. (Providing you understand it!)

Both the Yamaha CD-X2 and CD-3 digital disc players feature Yamaha's superbly engineered and much praised LSI (Large Scale Integrated Chip).

This LSI converts the digital sound to an analog signal at twice



\$499



\$699

with these attachments.

the rate of its competitors. This over-sampling virtually eliminates phase distortion, greatly improving playback resolution.

It also eliminates the need to pay any more than between \$499* and \$699* for a digital disc player.

For more information, please send the coupon to: Rose Music, 17 Market St., Sth. Melbourne, 3205.

Name _____

Address _____

Postcode _____

YAMAHA
Saatchi/RM 6138(a)

* Recommended retail price. * Silver model available.

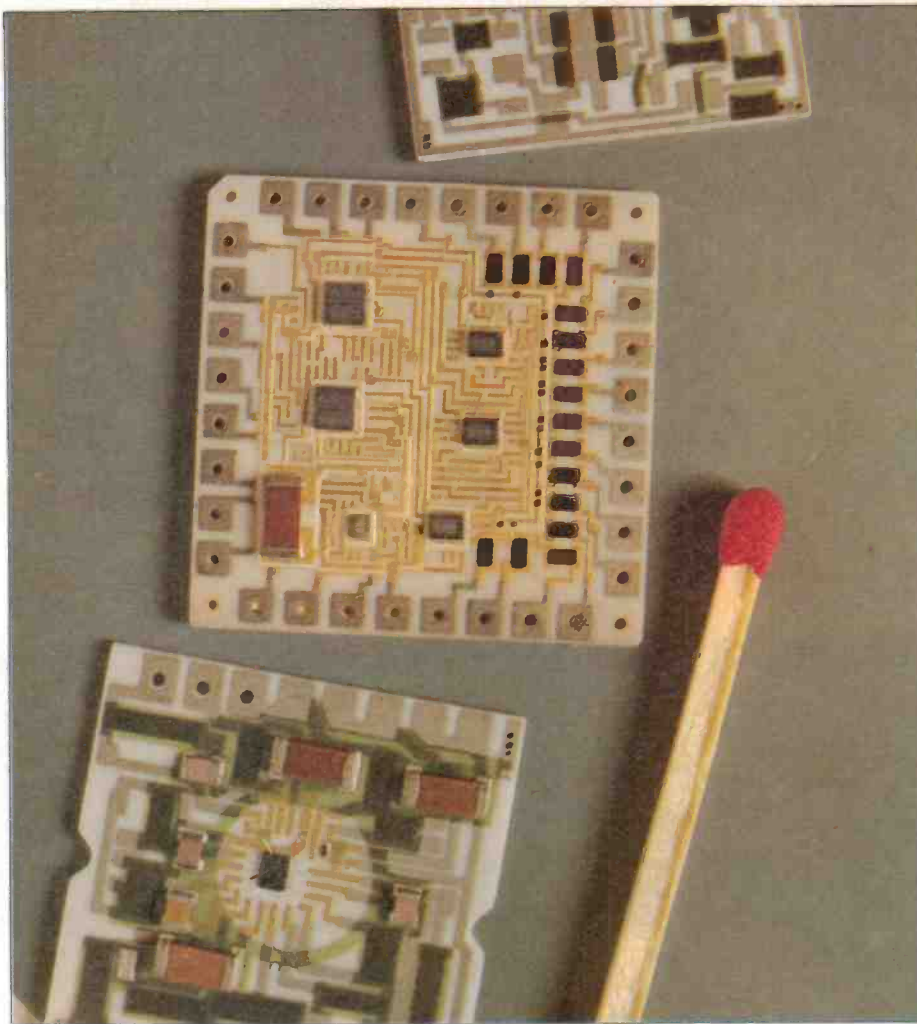

New technologies are changing the face of electronic manufacturing. During the next few years the humble 'board stuffer' will become an endangered species as automation and miniaturization take their toll.

SO, YOU'VE finished it. You have your prototype. It's full of ad-hoc resistors but a thing of beauty nevertheless. And you have your manufacturer.

Many a brash young man finds out at this stage of his designing career that the fun is only just beginning. Choice and compromise is the name of the game.

What services can a manufacturer offer you? What questions will he ask? How much will it cost?

On the way to answering these questions ETI discovered a world in flux. A revolution in the way circuits are integrated and constructed is occurring in electronic manufacturing. Over time it's becoming cheaper and easier to put part or all of a design on silicon.

Traditional assumptions that integration is always too expensive to be considered are eroding. The humble pc board is under threat.

A sign of the times: in February the giant National Semiconductor Corp predicted that custom designed chips would account for 25% of the total market for ICs this year. That's a quarter of \$US34 billion, the kind of money that makes people sit up and take notice.

The changes are not the result of great scientific breakthrough. By and large they depend on well understood technologies. What is happening in electronic manufacturing today is the application of novel techniques to old problems.

It's a development that Australia has been quick to capitalize on. In fact some pundits see the new technology as the saviour of the Australian electronics industry, the great equalizer in fact. Enthusiasts predict that using new developments in micro technology will allow us to compete with overseas countries without the dead weight of small markets and high labour costs.

Whether that is so remains to be seen. What is for sure however, is that integrated circuit technology is entering a revolution. And in any revolution there are winners and losers.

New techniques

It's possible to categorize the new technologies in order of the number of units required to make them economical. There are

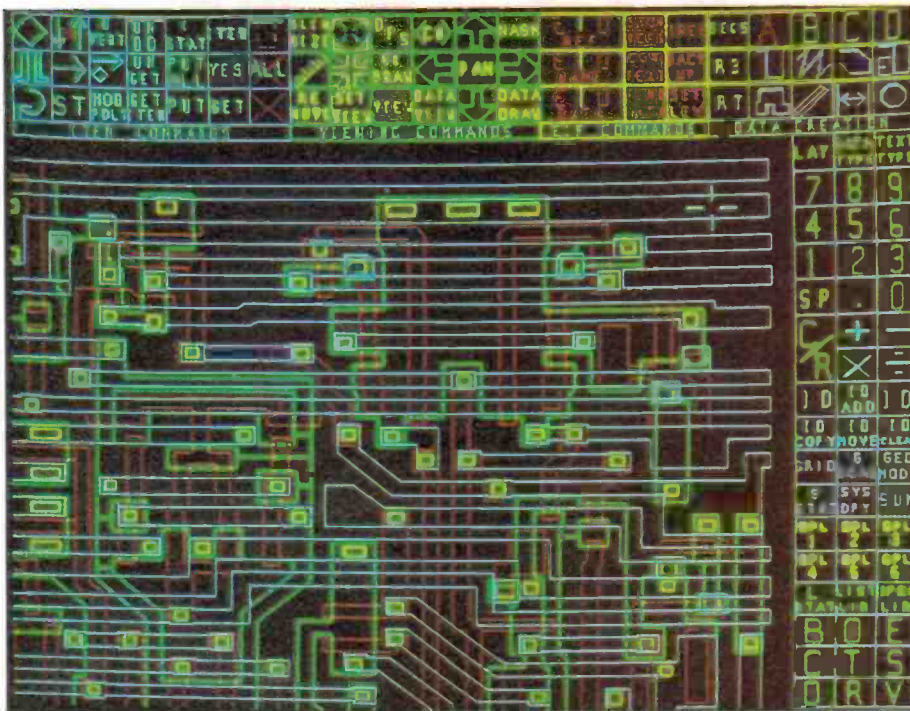

Above. Some typical hybrid circuits, with a match for comparison.
Below. Screen output of a CAD system used in designing integrated circuits. (Courtesy Plessey)

The next generation of CUSTOM CHIPS

Jon Fairall

two factors at work here: on the one hand a development gradient, in which it gets more and more expensive to develop a particular design, and a price per item gradient, which slopes the other way. It gets cheaper and cheaper to produce the end unit.

Predictably, the two extreme positions are held by the two tried and tested technologies. On the one hand is a mixture of ICs and discrete components plugged into a circuit board. Set up cost: essentially nil. Price per unit: depends on the size of the board and the number of components, but high by comparison.

On the other hand is a fully integrated design, in which you put your entire idea on silicon, encapsulated in a single plastic package. Set up cost: well . . . think of a very large number and double it. Quotes seen by ETI have varied from \$40 000 up to \$100 000. However the cost per item is likely to be very small.

The new technologies: a new generation of hybrids, semi-custom chips known as gate arrays and standard cells, and multi project chips (MPC).

Hybrids

Conventionally, a hybrid circuit is one that includes both integrated and discrete components. A hybrid, however, is a device that consists of surface mounted devices or bare chips and some small number of discrete components mounted on a special miniaturized board.

Superficially, the board looks a lot like a conventional pc board, only smaller. However, it's produced by technology more akin to an integrated device. Tracks are laid down by silk screening layers of aluminium or gold alloys onto a substrate. It is possible to have multiple layers by depositing a dielectric on top of each layer. In this way the tracks can be made extremely dense.

SMDs, or surface mounted devices are a new way of encasing integrated circuits. Instead of pins that go through a board they have gull shaped leads that are soldered directly onto the track. In manufacture, the case of the SMD is glued to the circuit board, and then the leads are soldered in a wave soldering machine.

Bare chips have been around longer than SMDs, and represent the favoured way of

constructing hybrids at the moment in Australia. These are naked blocks of silicon on which an integrated circuit has been etched. Typically, the silicon is glued onto the circuit board and then connections made by attaching microscopically fine wires between the silicon and the conductors on the board.

Bare chip manufacturing technology is quite sophisticated. It must be, since it involves working to extremely small tolerances. However, it is also quite labour intensive, since each chip must be fitted to each board, one at a time, under the control of a skilled operator using micro-manipulator equipment and a microscope.

Surface mounting, however, is a totally automatic process, in which the chip is precisely positioned on the board by a robot assembler and then wave soldered. For this reason, and because parts are more readily available and cheaper, surface mounting is rapidly gaining in popularity.

The discrete components on the board may be a number of different types. Surface mount transistors, diodes and capacitors are now commonplace. In many instances they measure less than a millimetre square. Resistors are usually made by depositing a resistive 'paint' on the board between two

conductors, and then laser trimming. (See box.)

Typically a hybrid comes encased in plastic of some kind. It can be treated as a separate component, to be plugged into a motherboard and serviced by replacement only.

Gate arrays

The GA consists of thousands upon thousands of transistors etched onto the silicon. These are joined together to form logic gates that perform NAND, NOR, OR, etc type functions. The task of the designer is then reduced to working out the interconnections between these gates.

Over the last few years this technology has become very sophisticated. Recently, Toshiba engineers announced the creation of a 6000-gate array with 3-port static RAMs. This is packed in a chip less than a centimetre square. These gates use two-micron technology and propagation delays of 1.5 μ s. Toshiba's biggest GA contains 10 000 gates.

There are other versions of the gate array that work with linear rather than logic components. These arrays consist of cells of individual transistors and various passive

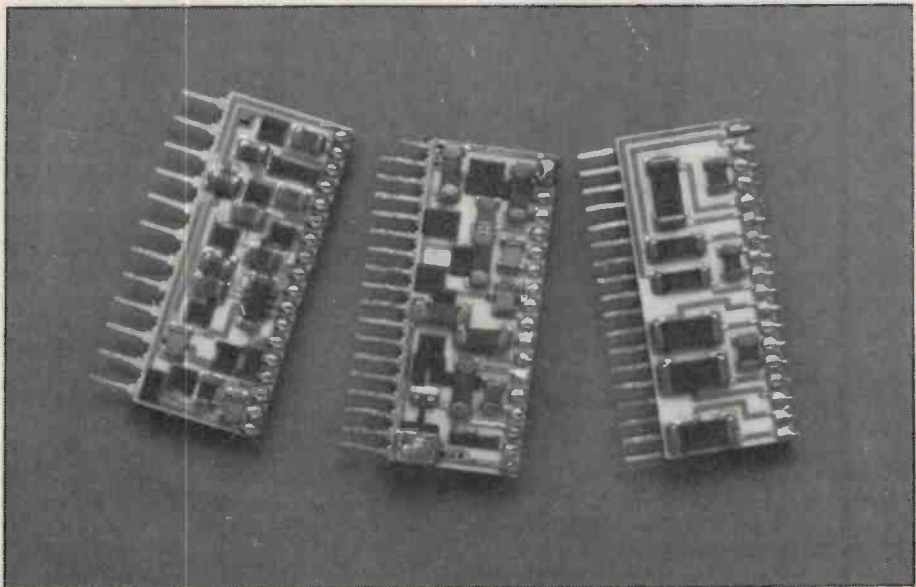

Hybrid circuit. This configuration allows ICs to be mounted on a pc board and treated just like any other discrete component.

Hybrids — laser trimming

When boards get small, real estate gets valuable, too valuable to waste on discrete resistors. This line of thinking has led to a technology producing extremely small and very accurate resistors.

After the tracks have been laid on the board as described in the main text, a block of resistor paint is screen-printed onto the board between two tracks. Since resistance is related to length and cross sectional area, the resistance can be predetermined.

Unfortunately it's not particularly accurate. In fact the resistance between the conductors cannot be guaranteed to better than 25%. Since this could be quite a design problem steps need to be taken to increase accuracy. The method is known as laser trimming.

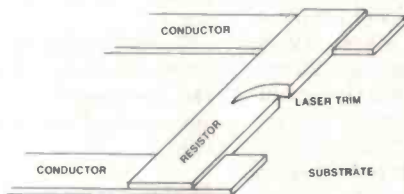

In a laser trimming process the original blob of paint is made bigger than it should be, so that resistance is definitely lower than required. Two probes are attached to the conductors so that resistance can be accurately determined. Then a laser is used to cut a wedge in the paint.

As the laser cuts the paint away the total resistance of the pad increases. As the resistance approaches the required value the laser power is reduced and the groove is bent around in a longitudinal direction so that the process may be controlled more precisely.

Using these techniques it is possible to control the value of the resistance to better than 1%. It's almost totally automatic and can be done in about five seconds. Ain't science wonderful?

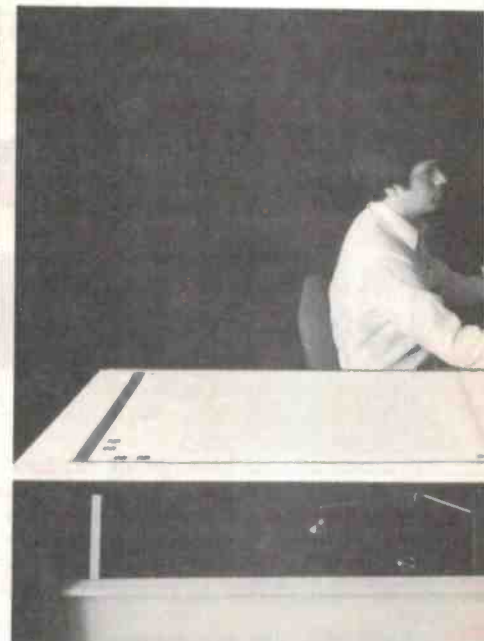

A typical work station for the design of integrated circuits. Such CAD systems make much modern integrated technology possible.

components. Once again the idea is that the designer can implement any function simply by connecting together sufficient cells.

GAs can certainly get your circuit design onto silicon at a fraction of the cost of a fully customized chip, but they suffer from a building block character. In any particular design unused space is likely to abound. Propagation is likely to be long compared with a custom design because of the number of gates. A more elegant solution is the standard cell.

Standard cells

Manufacturers have been offering standard cell facilities overseas for the last few years, and they have recently become available in Australia. It's a technique which tries to implement many of the features of the GA while preserving the efficiency of the custom IC.

A standard cell can be thought of as a simple functional block, a logic gate, a flip flop, counter or whatever. The designer selects these from a standard cell library, and puts them together the same way as a normal circuit is put together.

The circuit is given to the manufacturer who then arranges the standard cells on the silicon to create the semi-customized chip. In fact, to all intents and purposes it is a customized chip. The main difference is in the design process. Instead of man-years of labour designing in silicon the same job can now be done in weeks. The savings are astronomical.

MPC

Another new option is the multi project chip. These have been made possible by vary large scale integration and essentially consist of a number of completely separate designs on one chip. The silicon is divided up into a number of areas, each functionally

independent of the other, down to separate input/output arrangements.

The function of the chip is then decided only at the bonding stage. Bonding is the process of connecting the silicon to the outside world by microscopic wires running between the silicon and the pins.

The idea of the MPC was first proposed by Lynn Conway and Carver Mead in the USA, and imported into Australia by Dr Craig Mudge. Mudge spent a number of years with the CSIRO developing the Conway-Mead idea before spinning off a separate company, Austec, to exploit his experience in custom chips.

CAD

The key element in all these technologies is the computer aided design system. From the point of view of the user, this consists mainly of a monitor and touchpad. The operator is usually presented with a menu from which logic or linear symbols may be selected and positioned on the screen. It's then a simple matter to draw in the interconnections between them.

Whatever the details of the particular CAD system, the philosophy is always the same: to reduce the time and cost necessary to turn an idea into silicon.

In the nature of the game, not all systems are equally good at achieving these goals. It's an area that is red hot in research circles as academics hunt for kudos and the elusive silicon compiler.

A silicon compiler would be just that: a device that would take your design and compile it on silicon. It's an area that has particularly interested Australian researchers, both in industry and the universities.

For instance JMRC, the Joint Microelectronic Research Establishment, set up by the University of New South Wales and the

Melbourne Institute of Technology, has had a large research team working on the development of a new CAD system for about a year, according to UNSW Professor Graham Rigby.

Current expertise at JMRC is the ability to compile about 1000 transistors on a wafer. "It won't be optimum", says Rigby, "but it will be error free". This is not quite the best ever achieved, but in terms of international experience, it puts JMRC into world class.

The problem with obtaining a silicon compiler is just one of complexity, that is, it's not difficult to see how it should be done, just difficult to do it. Difficult because there are so many design options.

In fact, the computer is being asked to simulate the partially intuitive function of a human designer. Thus, according to Rigby, the final solution to really large scale designs will probably have to await the arrival of artificial intelligence.

The industry

Australian industry can offer all these technologies to a designer with prototype burning a hole in his pocket.

Plessey Pacific is one of four manufacturers of hybrids. Staff there are in the middle of an extensive upgrading of the facilities of the plant.

According to Clyde Witcombe, design engineer in the Hybrid Unit, current plans call for the introduction of Calma CAD equipment to ease the task of designing hybrids, as well as the introduction of SMD techniques.

Another producer of hybrids is Hybrid Electronics in Melbourne. According to manager Wally Berryman, the company produces about 5000 hybrids a week. The smallest production run is about 100. He

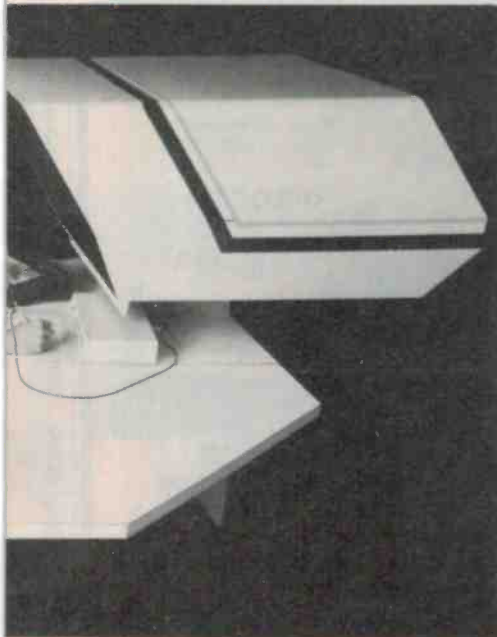

of the processes used by TI, such as access time and propagation delay. As a result very accurate emulation of the outputs is possible.

The effect of the new technologies is being felt by smaller manufacturers as well. Increasing automation of assembly lines is making the process cheaper, by doing away with labour. At the same time increasing integration and SMD are making for smaller and less costly boards.

At General Power Controls, located in Penrith, west of Sydney, managing director Fred Morris has just finished evaluating an SMD addition to his flourishing board 'stuffing' operation.

According to Morris SMD is currently 20% more expensive than conventional DIP assembly. Thus one would expect it to be used only where the application would justify the additional expense. He predicts SMD and DIP procedures will continue in parallel for a long time.

In fact, it appears that there is quite a role emerging for SMD devices in ordinary circuit board assembly. They are particularly amenable to mounting on the underside of the board, with the possibility of tremendous space savings in board real estate.

Costs

The exact amount that a circuit will cost to manufacture depends on a whole host of imponderables, such as the complexity of the circuit and how well the designer does his homework. But it is possible to get some ball park figures that illustrate trends.

For instance, a TI spokesman said that assuming a requirement for 10,000 units,

which might be the production run for a typical Australian manufacturer. GAs with 200 gates would cost about \$1.40 each. Up that to 700 gates and the price increases to about \$4. Development costs for such a GA would probably be of the order of \$10,000.

To do the same job on standard cells would cost about \$15,000. Price would depend strongly on the number of units ordered, but they would be cheaper than GAs in quantities above 1000.

At Plessey, John Nicol wasn't prepared to commit himself to dollars and cents, but expressed the same problem in an equally useful way. According to Nichols, if you have a production run of between 1000 and 10,000 units, gate arrays are relevant. Up that to less than 100,000 units and custom cell technologies apply. Over 100,000 and fully customized chips are worth looking at.

Depending on the application the MPC can also be a very attractive choice. It costs as much to do as a fully customized chip, but its cost is spread among the various users. So the implication is that if you can count on 100,000 units between, say, five or six users, that is 20,000 each, the MPC can be economically attractive.

Hybrids don't fit neatly into this picture because they are sometimes preferable on non-economic grounds. For instance, inductors can't be integrated, and thus demand a hybrid. Another problem can be power. The typical hybrid can dissipate more than an IC.

They start to become economic in units of a few hundred, and for large scale production, say in the order of tens of thousands, they are rapidly becoming indispensable. ●

strongly supports the use of chip and wire technology, claiming it represents a better blend of reliability and economy than SMD techniques.

A few manufacturers have the capacity to manufacture complete custom chips. AWA for instance is engaged in the manufacture of custom chips for the BARRA Sonabuoy Project for the RAN.

In Adelaide, Austec offers full custom VLSI facilities. So far applications have included signal processing, computer graphics and disk controllers. Many other applications are reportedly in the pipeline following an aggressive marketing strategy by the company. The MPC technology pioneered in Australia by Austec's director, Craig Mudge, is now done by AWA.

Texas Instruments and Philips have joined together to offer semi-custom services. TI recently introduced its custom cell library to Australia. This is a CAD system especially designed to run on the IBM-PC. It comes in the form of 5¼-inch floppy disks which give the designer access to all the building blocks in the TI/Signetics cell library. (Signetics is the Philips US subsidiary.)

The CAD system has been designed for a person who knows how to put a circuit together, without knowing anything about how to design an IC. Everything is expressed in ordinary TTL circuit terms with which an engineer or technician would be familiar. In fact, the cells have standard 74xx numbers.

One interesting feature of the CAD system is that it allows complete circuit emulation. According to TI spokesman, Ron Jukov, it is possible to specify the inputs (either static or dynamic), and then observe the outputs. The software is especially detailed so that it knows all the parameters



Through the looking glass. The silicon chip is connected to the substrate via fine wire lines. These are held, positioned and glued by the micro-manipulators she is controlling.

A TRUE RMS DIGITAL MULTIMETER FOR ONLY \$225.00

• 4½ digits • 8 functions Vdc, Vac, Adc, Aac, Ohms, Audible Continuity, Diode test, Data Hold • 0.05% basic dc accuracy



DC Voltage	
Range	• 200mV, 2V, 20V, 200V, 1000V
Resolution	• 10µV, 100µV, 1mV, 10mV, 100mV
Accuracy	• 200mV - 1000V ± (0.05%rdg + 3dgt)
AC Voltage: (True RMS, AC coupled 10% to 100% of range)	
Range	• 200mV, 2V, 20V, 200V, 750V
Resolution	• 10µV, 100µV, 1mV, 10mV, 100mV
Accuracy	• 200mV - 20V @45Hz-1KHz ± (0.5%rdg + 20dgt) @1KHz-2KHz ± (1.2%rdg + 30dgt) @2KHz-5KHz ± (5.0%rdg + 40dgt) (200V @2KHz - 5KHz not specified!) 750V @45Hz-1KHz ± (1.0%rdg + 20dgt)

DC Current	
Range	• 2mA, 20mA, 200mA, 2A, 10A
Resolution	• 100nA, 1µA, 10µA, 100µA, 1mA
Accuracy	• 2mA - 200mA ± (0.3%rdg + 3dgt) 2A-10A ± (0.75%rdg + 3dgt)
AC Current: (True RMS, AC coupled 10% to 100% of range)	
Range	• 2mA, 20mA, 200mA, 2A, 10A
Resolution	• 100nA, 1µA, 10µA, 100µA, 1mA
Accuracy	• 2mA @45Hz-400Hz ± (2.5%rdg + 20dgt) 20mA - 200mA @45Hz-400Hz ± (0.75%rdg + 20dgt) @400Hz-1KHz ± (0.75%rdg + 30dgt) 2A-10A @45Hz-500Hz ± (1.2%rdg + 20dgt)

Resistance	
Range	• 200Ω, 2KΩ, 20KΩ, 200KΩ, 2MΩ, 20MΩ
Resolution	• 0.01Ω, 0.1Ω, 1Ω, 10Ω, 100Ω, 1KΩ
Accuracy	• 200Ω ± (0.2%rdg + 5dgt + 0.04Ω) 2KΩ ± (0.15%rdg + 3dgt) 2MΩ ± (0.15%rdg + 3dgt) 20MΩ ± (0.5%rdg + 3dgt)

EDM1346 only

\$225.00 ex tax
\$258.75 inc. tax.

AND A 3½ DIGIT SIX FUNCTION DMM FOR ONLY \$75.00

• 3½ digit • 6 functions Vdc, Vac, Adc, Ohms, Diode test • 0.8% basic dc accuracy



EDM1105 only

\$75.00 ex tax
\$86.25 inc. tax.

DC Voltage	
Range	• 200mV, 2V, 20V, 200V, 1000V
Resolution	• 100µV, 1mV, 10mV, 100mV, 1V
Accuracy	• 200mV - 1000V ± (0.8%rdg + 1dgt)
AC Voltage	
Range	• 200mV, 2V, 20V, 200V, 750V
Resolution	• 100µV, 1mV, 10mV, 100mV, 1V
Accuracy	• 200mV - 750V @45Hz - 500Hz ± (1.5%rdg + 4dgt)
DC Current	
Range	• 2mA, 20mA, 200mA, 2A, 10A
Resolution	• 1µA, 10µA, 100µA, 1mA, 10mA
Accuracy	• 2mA - 200mA ± (1.25%rdg + 1dgt) 2A-10A ± (2.5%rdg + 3dgt)
AC Current	
Range	• 2mA, 20mA, 200mA, 2A, 10A
Resolution	• 1µA, 10µA, 100µA, 1mA, 10mA
Accuracy	• 2mA @45Hz-400Hz ± (4.0%rdg + 2dgt) 20mA - 200mA @45Hz-400Hz ± (2.0%rdg + 3dgt) 2A - 10A @45Hz-400Hz ± (3.0%rdg + 4dgt)

Resistance	
Range	• 200Ω, 2KΩ, 20KΩ, 200KΩ, 2MΩ, 20MΩ
Resolution	• 0.1Ω, 1Ω, 10Ω, 100Ω, 1KΩ, 10KΩ
Accuracy	• 200Ω ± (1.0%rdg + 4dgt) 2KΩ - 2MΩ ± (1.0%rdg + 1dgt) 20MΩ ± (3.0%rdg + 5dgt)

WHY PAY MORE FOR CENTRONICS CONNECTORS?

Gold plated contact. 36 way. Solder eyelet. Metal shell. Save, our plugs are **ONLY \$8.50**, Sockets \$7.75!!



MODULAR P.C. EDGE CONNECTORS & PLUGS

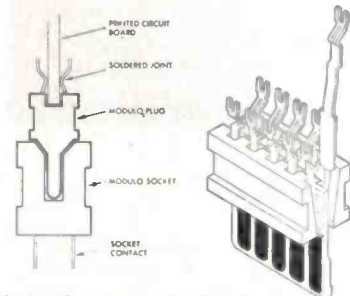

We are now stocking the double sided Modulo 100 Plug which is ideal for adding an edge connector plug to pcbs. Saves cost of gold plated fingers on pcbs. We supply cut to size with 10+10 to 85+85 contacts. Moulded in glass-filled DAP with gold plated solder contacts. Fits standard double sided pcb. 0.1" pitch. 500V, 5A rating.

Matching modular edge connectors on 0.1" pitch. Double sided. Choice of terminations - mini-wrap, Dip solder, solder eyelet. Contact us for prices.

LORLIN SWITCHES

Inexpensive single wafer rotary switches of moulded construction. Adjustable stop. Av available in 1 pole/12 way, 2 pole/6 way, 3 pole/4 way, 4 pole/3 way. **ALL \$2.20.**



HIGH CAPACITANCE ELECTROLYTICS EYF Electrolytics, Polarized, switchproof, radial version

2200uF	63V	25mm(D)	27mm(H)	\$3.70
3300	50	30	30	\$3.85
4700	50	35	30	\$5.54
6800	25	30	30	\$3.85
6800	35	35	30	\$5.54
10000	25	35	30	\$5.54
15000	16	35	30	\$5.54

WOOD FOR CHIPS ... WOOD FOR CHIPS ... WOOD FOR CHIPS ... WOOD FOR CHIPS ... WOOD FOR CHIPS ... WOOD FOR CHIPS ... WOOD FOR CHIPS ... WOOD FOR CHIPS ...

WOOD FOR CHIPS ... WOOD FOR CHIPS ... WOOD FOR CHIPS ... WOOD FOR CHIPS ... WOOD FOR CHIPS ... WOOD FOR CHIPS ... WOOD FOR CHIPS ... WOOD FOR CHIPS ...

8.30 to 5 Monday to Friday, 8.30 to 12 Sat.
Mail Orders add \$3.00 to cover postal charges.
Next day delivery in Sydney add \$5.00.

Tax exemption certificates accepted if line value exceeds \$10.00.



GEOFF WOOD ELECTRONICS PTY LTD

Incorporated in N.S.W.
656A Darling St, Rozelle 2039
(One door from National Street)

Tel: **810 6845**



\$10.00 minimum

specialising in electronic components for the professional and hobbyist.

50,000 hr MTBF

One style: fully loaded
One price: \$1665*
One source: Hewlett-Packard

If putting a big dent in your instrumentation budget is not for you, the HP 3478A should prove ideal for your bench or system automatic measurements. For only \$1665* you get a fully loaded six function DMM with HP-IB—not just a starter unit you have to pay later to upgrade.



All the right features plus HP-IB.

You can measure dc volts, RMS ac volts, dc current, RMS ac current, and 2- and 4-wire ohms. Plus, the HP 3478A is a fully programmable HP-IB system instrument. You have the convenience of switchable front/rear terminals, scanner advance, and external trigger input. You can even automate the HP 3478A's built-in electronic "no pots" calibration.

Costs less to own.

When it comes to reliability, the HP 3478A is one of the best. Our field-proven reliability figures indicate over 50,000 hr MTBF (equal to 25 operational years).** So intensive is our attention to quality, from design right through production, that once you install your HP 3478A chances are you won't have to repair it or worry about it for the life of your system.

Call HP today.

For full details on the cost-cutting reliability leader HP 3478A DMM, ring your nearest HP office listed: Melbourne: 895 2895; Adelaide: 272 5911; Perth: 383 2188; Brisbane: 30 4133; Canberra: 80 4244; Sydney: 888 4444; Auckland: 68 7159. **For 2,000-hour years, based on warranty data and other statistical projections. *List price subject to change.

System DMMs...HP's the right decision



HP-IB: Not just IEEE-488, but the hardware, documentation and support that delivers the shortest path to a measurement system.



**HEWLETT
PACKARD**

Leo Burnett 7123 HEP 90455

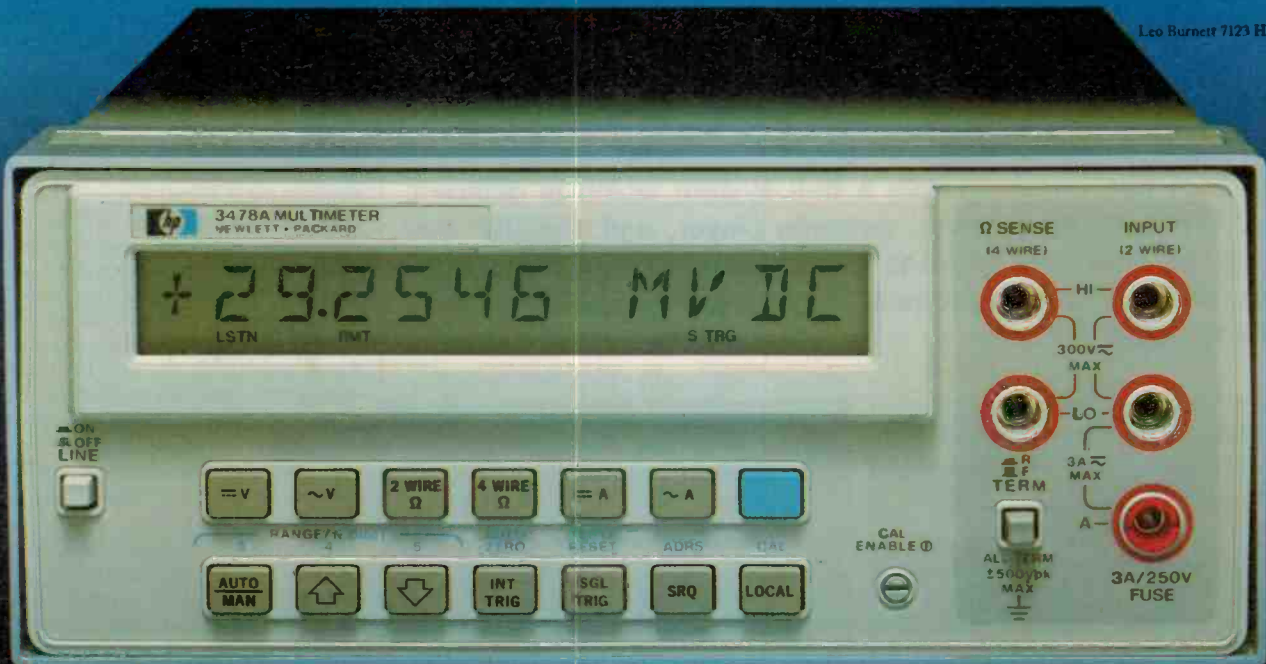

'STEREO NOUVEAU' TO HANG AMONG YOUR NOLANS

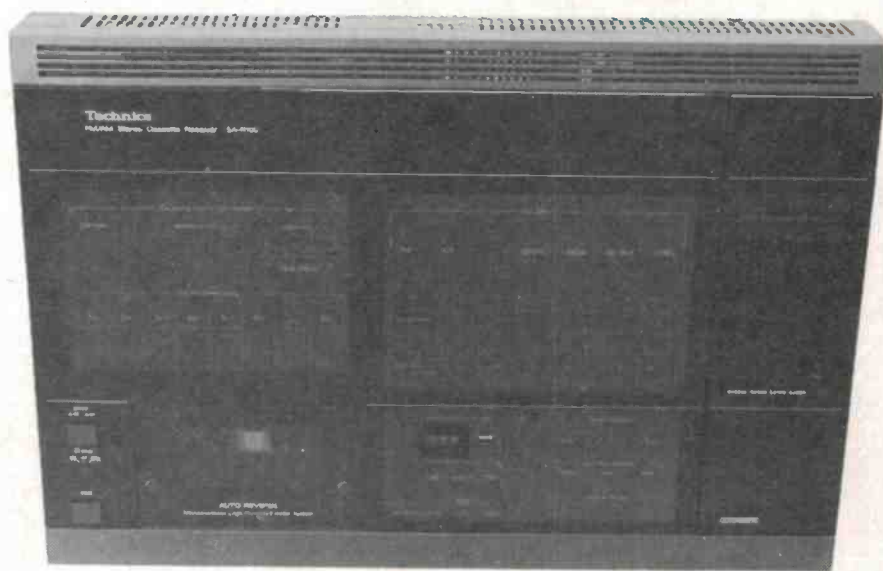

Technics has come up with a hi-fi system which is different: an AM/FM stereo receiver, cassette player, and amplifier that hangs on your wall and has inputs for your other equipment! The SA-R100 is not only neat, it gives quality performance at an accessible price.

TECHNICS SA-R100 RADIO/CASSETTE

Dimensions: 460 mm (wide) x 315 mm (high) x 65 mm (deep)
Weight: 7.1 kg
Manufacturer: Matsushita Electric Trading Co. Ltd, Osaka Japan
RRP: \$1,350 (excluding speakers)

Absolute copyright in this review and accompanying measurements is owned by Electronics Today International. Under no circumstances may any review or part thereof be reprinted or incorporated in any reprint or used in any advertising or promotion without the express written agreement of the Managing Editor.

FOR ALMOST 50 years consumers have been forced to accept the shapes, sizes and often unacceptable concepts forced on them by the electronics industry. Nowhere has this been more evident than in the field of wooden boxes, silver boxes and more recently black boxes which contain the individual pieces of high fidelity equipment you will find in your local hi-fi shop. If you are satisfied with stacks of equipment, racks of equipment or other configurations and layouts on the tops of your sideboards which I generally find equally restrictive, then the contents of this review will not prove to be as exciting as I found it to be.

Spurning convention!

The trouble with all these 'conventional' systems is that they presume that you have the space, the furniture and the layout which is appropriate for hi-fidelity but standard sized equipment. However, in most houses in which I have been consulted, or in which I have been a private guest, the existing room layout normally conflicts with the optimum layout for hi-fi equipment.

Technics has seen a way to overcome this problem with an extremely natty and ingenious concept that I guess everybody else will start copying next year. That is to attach the whole hi-fi system (console and speakers) to a wall (preferably the most convenient wall) without the need of any furniture. To make the system more 'user friendly' the package contains an integral infrared remote control unit which provides the most important controls from any chair within the room or even from your bed.

To make the system really work, Technics has supplemented this design concept with an exciting new set of speakers which are only 65 mm deep and which provide an unbelievably good performance for their

Louis Challis



In the ETI workplace. The SA-R100 radio/cassette can be either hung on the wall like the speakers or placed elsewhere using its supporting stand.

miniscule size.

The SA-R100 incorporates an AM/FM stereo receiver, a bi-directional cassette recorder, a power amplifier and inputs for record player, video, CD player and auxiliary inputs all within one neat and attractive flat package. Although capable of using all of these other inputs, the unit will achieve its greatest potential when these other inputs are not used.

The appearance of the unit is remarkably attractive, with the front panel divided into six primary areas. At the top left hand corner is the quartz controlled receiver section which indicates whether FM or AM has been selected, as well as the frequency (to a five digit resolution), the signal strength and whether the quartz phase-locked loop circuit is activated. It also indicates which of the eight FM or eight AM preset channels has been selected. Immediately below this display are the power ON/OFF switch, the external timer input and the eject button for the auto reverse cassette recorder, which is located immediately to the right.

The cassette recorder incorporates two motors and a bi-directional capstan drive system. All controls, other than the selection of recording levels and Dolby noise reduction, are provided by means of the remote control transmitter (either when inserted in its internal well, or when located remote from the unit).

In the upper central section of the front panel is the input selection display, which provides six amber light emitting diodes to indicate whether FM, AM, PHONO, TAPE, CD/AUX or VIDEO has been selected. Immediately below this is a ten level amber display to indicate the setting of the digitally controlled externally selected volume control level. This particular display

is very important particularly when you are switching from one input to another, as I subsequently discovered.

The third level of the input selector display is the digital peak level indicator covering the range -30 to $+8$ dB, which neatly displays the incoming signal level (irrespective of the source) and with sufficient number of diodes in each section to be readily visible from almost any point within a room.

In the lower central section of the front panel is a three digit tape counter with reset button and a Tape Programme Selector red indicator light. Immediately below these displays are green arrows to indicate forward and reverse direction of tape travel, a green PLAY display light, a red RECORD light and an amber PAUSE light. The TPS function provides a convenient means of searching the next number by pressing the FAST FORWARD button when in the PLAY mode so that the recorder automatically searches for the next recorded track.

On the right hand side of the lower section of the central display are the indicator lights for Dolby B or Dolby C and the auto tape selector, which indicates whether normal gamma ferric oxide, chromium dioxide or metal tapes have been automatically selected and correctly detected by the internal electronics. Below this is the display which indicates whether normal single direction play has been selected, single pass reverse play, or multiple continuous reverse play.

On the extreme right hand side of the front panel is a vertically hinged cover behind which all of the infrequently used controls are located. At the top are the eight AM/FM tuning controls. Immediately below these is the photo diode detector which receives the remote control signal when either used remotely, or when the remote control is tucked into its normal stor-

age 'cubby hole' immediately below. The remote control provides buttons for the six input selector modes, eight station frequency pre-sets and full function controls for the cassette recorder. These controls also include a RECORD MUTE button and a REVERSE mode button by means of which the three separate modes are achieved by sequential pressing.

The volume (loudness) is controlled by two separate up/down switches and last but not least the remote control transmitter has an indispensable BATTERY CHECK light. With the remote control transmitter removed from its cubby hole, an additional group of supplementary controls is revealed on the panel immediately behind. These controls include a LOUDNESS on/off switch at the top, a set of BASS and TREBLE slider controls, a MICROPHONE mixing input control on the left, a BALANCE control on the right and a LEFT/RIGHT channel VOLUME control slider switch below.

At the very bottom right hand corner is a three position selectivity switch for the AM receiver, a pair of up/down tuning controls for setting the station frequencies, a Dolby Out, Dolby B or Dolby C switch. Next is a memory activation button, an FM mono or auto position and an FM frequency shift selector which provides 25 kHz steps to facilitate selection of FM stations which do not lie at the normal 50 kHz step frequency provided by the digital synthesizer.

On the left hand side of the unit are aerial terminals, behind a neat access cover. This is normally intended to be used with the internal FM dipole antenna provided, as well as with the ferrite loop-stick antenna which neatly clips onto the top of the unit and plugs into a miniature socket on the rear panel. ▶

AMPLIFIER DATA SHEET

MEASURED PERFORMANCE OF: TECHNICS FM/AM CASSETTE RECEIVER
SA-R100

SERIAL NO.: FA4L25B006

FREQUENCY RESPONSE (-3dB re 1 watt):

Tone Controls Centred

Left 16.0 Hz to 27 kHz
Right 16.0 Hz to 29 kHz

SENSITIVITY (for 1 watt in 8 Ohms):

	Left	Right
CD Auxiliary	23.2 mV	22.8 mV
Video	24.2 mV	22.5 mV
Microphone	0.3 mV	0.3 mV
Phono m/m	0.4 mV	0.4 mV
OVERLOAD Phono m/m	115 mV	112 mV

INPUT IMPEDANCE (@ 1kHz):

	Left	Right
CD Auxiliary	33 k ohms	33 k ohms
Video	33 k ohms	33 k ohms
Microphone	10 k ohms	10 k ohms
Phono m/m	47 k ohms	47 k ohms

OUTPUT IMPEDANCE (@ 1kHz): 185 milliohms

NOISE & HUM LEVELS (re 1 watt in 8 ohms):

Input 0.5 V	CD Auxiliary	77.5 dB(Lin)	77.0 dB(A)
Input 5 mV	Phono m/m	71.5 dB(Lin)	76.0 dB(A)

HARMONIC DISTORTION:

AT RATED POWER OF 1.0 WATTS INTO 8 OHMS

	100Hz	1kHz	6.3kHz
2nd	-84.1	-87.3	-79.3
3rd	-82.1	-93.1	-83.2
4th	-103.1	-90.0	-86.3
5th	-99.4	-94.2	-
T.H.D. = dB	0.01%	0.006%	0.014%
	-79.9	-84.3	-77.2

AT RATED POWER OF 28.0 WATTS INTO 8.0 OHMS

	100Hz	1kHz	6.3kHz
2nd	-79.3	-83.9	-74.1
3rd	-73.3	-83.1	-72.4
4th	-113.3	-96.1	-76.4
5th	-93.1	-96.2	-
T.H.D. = dB	0.024%	0.009%	0.034%
	-72.3	-81.0	-69.2

IEC HIGH FREQUENCY TOTAL DIFFERENCE FREQUENCY DISTORTION

8 kHz and 11.95 kHz mixed 1:1

At rated power 0.0072%
At 1 watt 0.013%

MAXIMUM OUTPUT POWER AT CLIPPING POINT (IHF-A-202):

(20 mS burst repeated at 500 mS intervals) = 50.2 V p-p
= 39.4 watts
∴ Dynamic Headroom re 28 watts = 1.5 dB

Date: 13th April 1985

Characteristics of the SA-R100 AM/FM stereo cassette receiver.

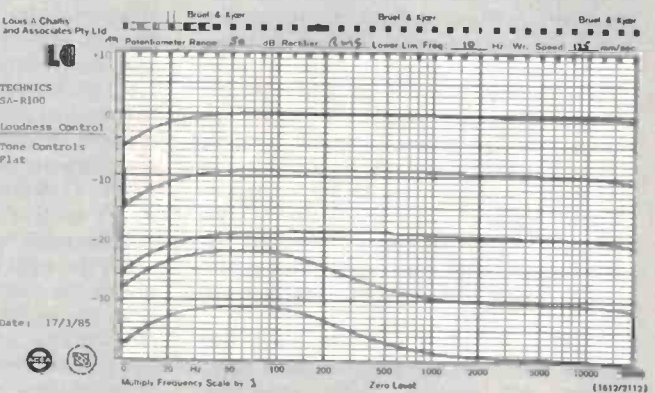
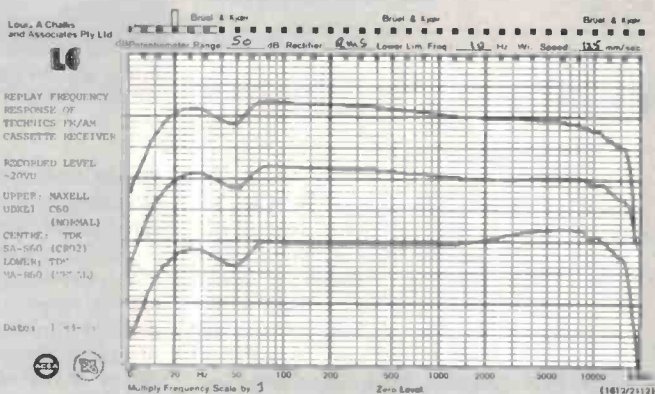
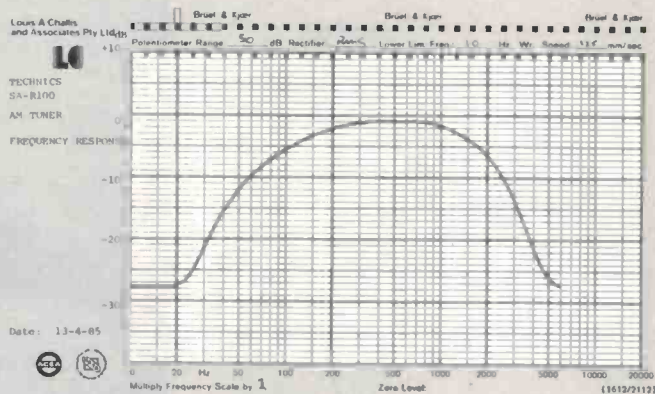

On the right hand side of the unit is a hinged panel with a HEADPHONE socket, MICROPHONE socket, PHONO synchronization cable intended to be used for automatic recording with Technics turntables, and RCA sockets for recorder out, CD or AUXILIARY, VIDEO, PHONO, and last but not least, a screwed ground terminal.

On the back of the unit are two pairs of colour coded speaker lead sockets for one set of speakers into which bared leads are

inserted and the terminals rotated to retain the wire. The unit also comes with a detached pair of chrome plated tubular steel, rear mounted supporting brackets (legs) for positioning the unit with its front sloping on top of desk or shelf or sideboard. It also comes with complete hardware for screwing the unit on the wall.

Specs

All of this is provided in what is an un-

sually small package with a pair of power amplifiers rated at 28 watts per channel into 8 ohms.

The unit is designed for vertical mounting with a very effectively designed thermal dissipation circuit which places the power output stage at the very top of the panel. The power output stage is a vapour phase-finned heat tube system. All of the other electronics is neatly mounted on well interconnected and wired printed circuit boards.

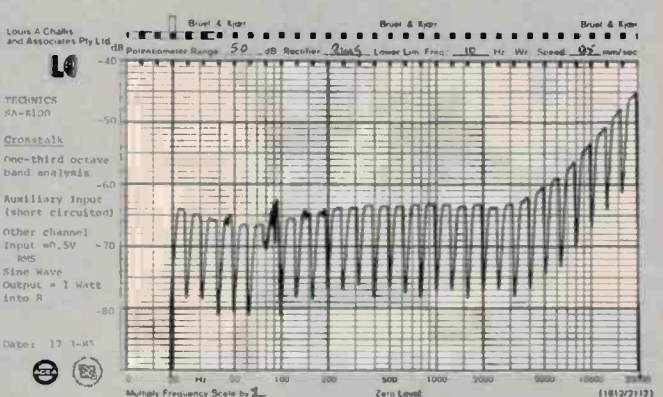
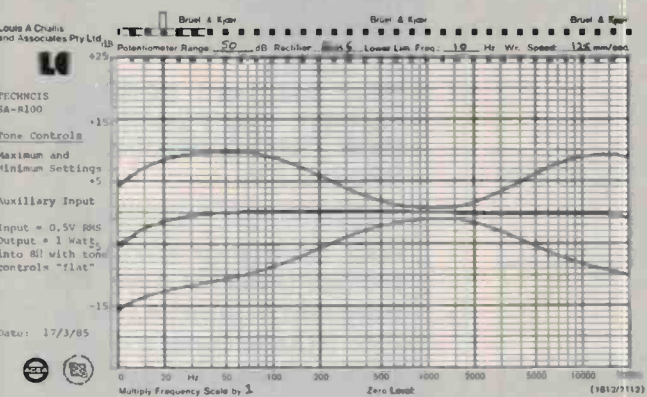
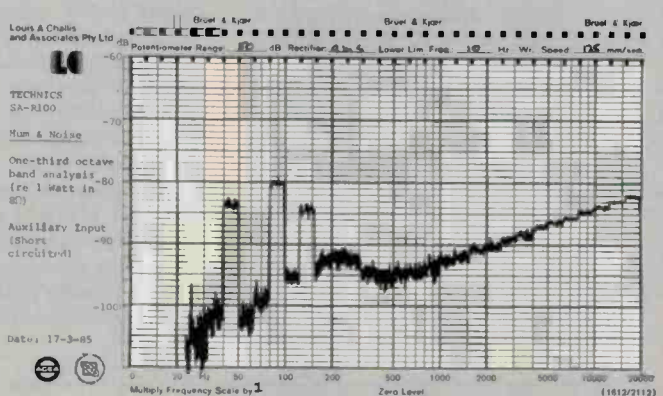
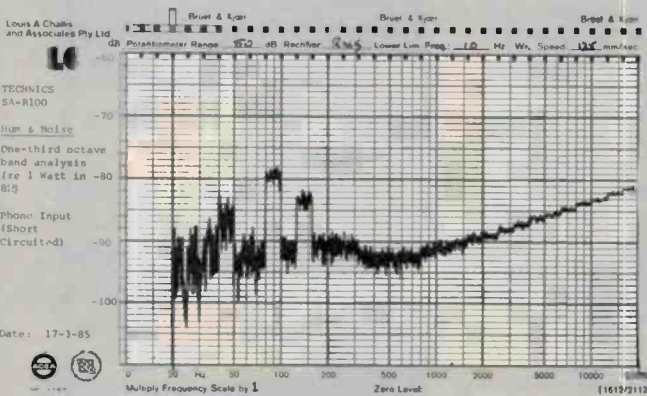
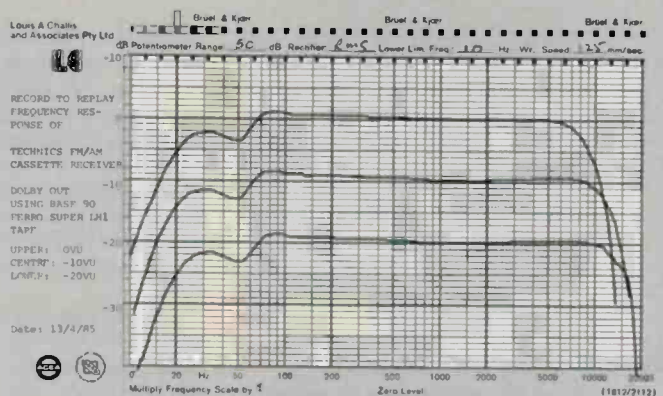
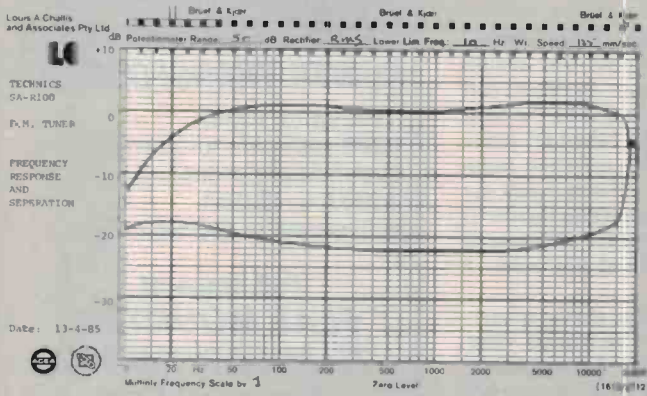

The objective performance of the unit was surprising considering the section of the market for which this unit has been designed. The amplifier produces a frequency response of 16 Hz to 27 kHz at the -3 dB points and a power output of 28 watts with both channels driven for distortion levels of less than 0.4%. The IEC total difference frequency distortion measurements reveal that the distortion at maximum output is only 0.0072%, which is really excellent.

The tone controls provide 10 dB of boost and cut at 50 Hz, and 9 dB of boost and 8 dB of cut at 10 kHz.

The phono input signal-to-noise performance is an excellent 80 dB(A) relative to 0 VU, the auxiliary signal-to-noise input is 77 dB(A) relative to 0 VU. The interchannel crosstalk is better than 63 dB at frequencies up to 3.5 kHz, drooping to a figure of 45 dB at 20 kHz. The loudness controls really do work and provide a reasonable

duplication of the equal loudness contours of the human ear.

Overall, the amplifier's performance is particularly good and more than good enough for the above average hi-fi enthusiast.

The tuner response is particularly good with only 0.9 micro volts of signal required for 26 dB signal-to-noise ratio the frequency response is flat from 20 Hz to 15 kHz within ± 1.5 dB. The AM tuner, al-

SOUND REVIEW

though offering adequate sensitivity and reasonable selectivity, still provides only a 2 kHz bandwidth at the 6 dB point, which is neither high fidelity, nor really adequate for mono reception let alone stereo AM reception which is now received in Australia.

The cassette player performance on replay is particularly good with an effective +2 to 4 dB frequency response from 18 Hz to 16 kHz with gamma ferric oxide tape and 22 Hz to 16 kHz record to replay response on gamma ferric oxide tape.

Subjective performance

To evaluate the subjective performance, I interconnected the unit with the pair of SB-R100 speakers which were provided with it (also reviewed in this issue), at the time of testing. I initially set up the total system on a bedroom wall (with a volume of 30 m³).

The most important initial response was the clarity of the audible signal with both the intended speakers and subsequently with alternative speakers. The cassette player in particular provides a quality of signal with power outputs which are unexpectedly loud in a small bedroom. Repeating the exercise in a larger room (with a volume of more than 250 m³) did not really change my subjective impression.

The basic unit has the capacity to deliver considerable low frequency power even

though the intended speakers are not specifically designed for that purpose. The quality of the stereo FM signal is excellent and nearly as good as that provided by the Sansui model TX tuner, which I used for inter-comparison. The frequency selection capabilities with eight station pre-sets meets my current FM and AM station requirements to a 'T' and I believe would prove adequate in any Australian capital city at this point of time.

The AM reception, while almost acceptable, exhibited the time honoured complaint of inadequate bandwidth even though the sensitivity and selectivity were quite adequate for local listening purposes.

I connected the unit up to an external CD player and an external record player and the overall audible quality was maintained without any significant criticism whatsoever.

The unit offers so many attractive ergonomic design features that it seems hard to believe that Technics could provide so many desirable features and with such excellent performance in one neat, compact and attractive package. This unit has just so much going for it that it ought to out-sell all its competitors almost irrespective of its price. That price however is still sufficiently attractive to make it one of the most desirable hi-fi systems that I have evaluated in the last few years. ●

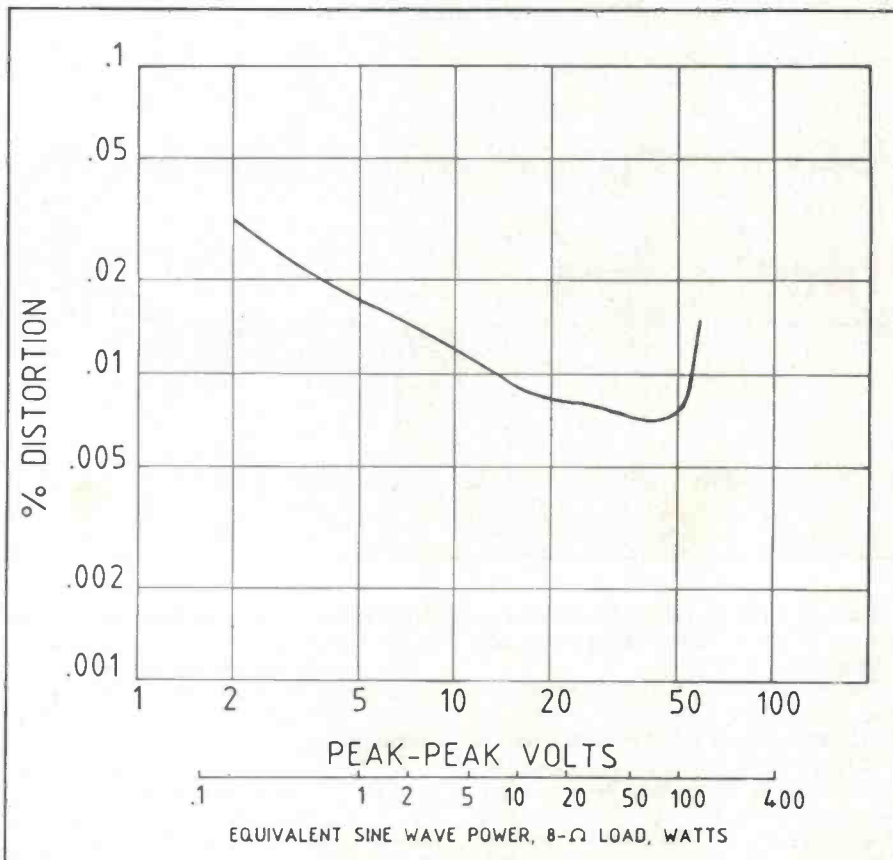

TELECTRAN

TRANSFORMER MANUFACTURERS

POWER TRANSFORMERS

1VA up to 100VA
fitted with pins for printed
circuit board mounting.
150VA to 250VA
with screw or QC terminals.

Full range of FLAT MOUNTED TRANSFORMERS

from as small as
5VA up to 500VA.

AUDIO MATCHING TRANSFORMERS

100V line to low
impedance.

Printed Board Mounting also
Screw or Tag Terminals

TOROID WINDINGS for
Filters or Switching Applications.
High Production of Custom
Designs.

Production Capacity:

always available for winding of
POT CORES
RM CORES
EP CORES
EE, E and U or L CORES
FERRITE AND POWDERED
IRON TOROID WINDINGS A
SPECIALITY.

FULL RANGE OF STOCK
TRANSFORMERS AVAILABLE
MANUFACTURING FACILITIES
FOR TRANSFORMERS UP TO
35KVA SINGLE OR 3 PHASE.

PLEASE WRITE FOR DETAILS

TELECTRAN

59c MYOORA RD.,
TERREY HILLS. 2034 N.S.W.

OR PHONE (02) 450-2868
(02) 450-2395

Robert Ford & Co. Pty Ltd

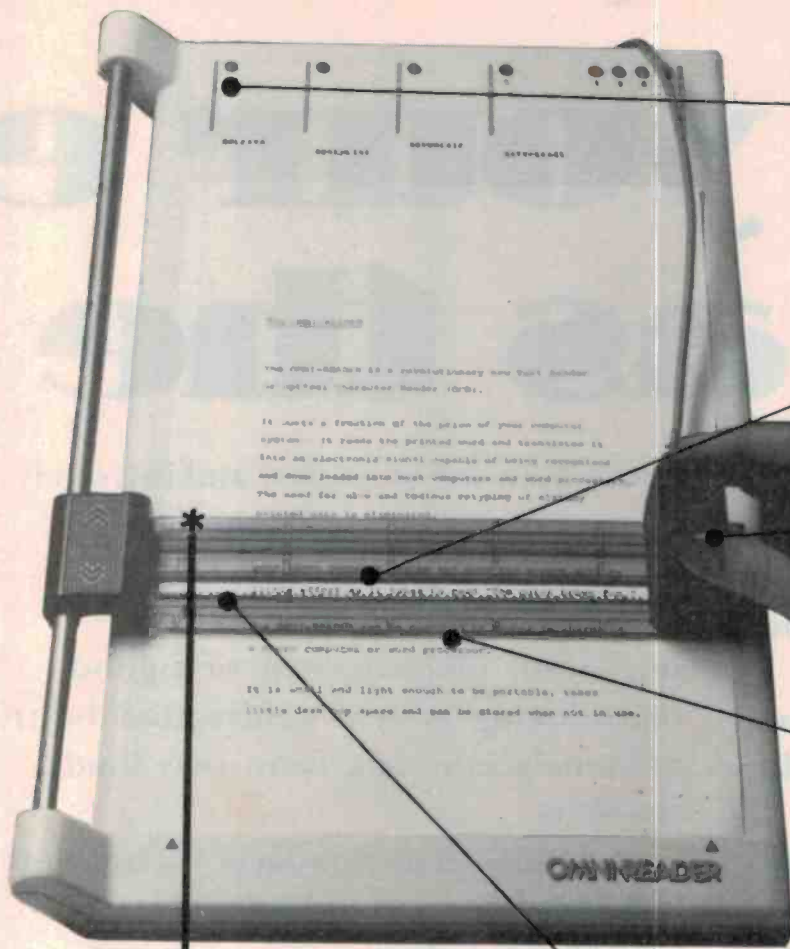

● **TYPEFACE LEARNING MODE:**
Extra typefaces maybe read by the OMNI-READER either by downloading from the computer or by scanning a new typeface in a pre-set format.

● **TYPEFACE RECOGNITION:**
The OMNI-READER comes pre-programmed to recognise the most common typefaces.

● **MANUAL OPERATION:**
Alpha or numeric print is scanned line by line by moving the reading head along the text. Capable of scanning forward or backward — the reading head can be used to input all or just selections from the text.

● **GUIDE RULE:**
A specially engineered guide rule makes text-alignment easy. Because of the unique clock-track, the reading head can be moved at varying speeds and still read the text.

OMNI-READER

* reads the printed word and translates it into an electronic signal capable of being recognised and down-loaded into most computers or word processors.

Audio Engineers announce a revolution in taking words from page to your computer

Speed-reading & input of printed materials for:

- Word Processor Input
- Entering Electronic-Mail Text
- Storing/Editing documents for Electronic Filing.
- Transferring text between incompatible computers or WP's without re-typing.
- Input datatables or new data into Spreadsheet/dataBase programs.

OMNI-READER

attaches through a Serial RS232 interface as easily as a modem.

EXCLUSIVE TO

Audio Engineers

342 Kent St., Sydney 2000

Call (02) 29-6731 to arrange a demonstration or in W.A. call (09) 361-5954

Are your ears as the

"The CD-44 is most probably the 'sharpest' and most marketable CD player introduced by the Marantz company. Its major attributes extend beyond the realm of price as the designers have aimed at providing a sophisticated performance which does not appear to be limited by price.

The frequency accuracy of the player proved to be outstanding. The consequent frequency deviation was only a paltry 0.1Hz for the 20kHz reference signal. The frequency linearity was 20Hz to 20kHz \pm 2dB. That sort of accuracy is not likely to be improved upon by any other player.

This sort of performance would be raved about by other manufacturers and their P.R. personnel as state of the art performance."

Louis Challis. "Electronics Today International". May 1985.

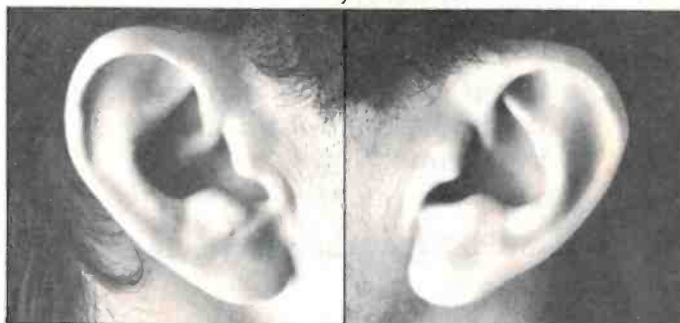

STAN CURTIS' RIGHT EAR.

STAN CURTIS' LEFT EAR.

"By contrast, the Marantz player produced a sound which was smoother,

not so forward or bright, and infinitely more musically convincing.

Many recordings played on the Marantz exhibited that very important characteristic of a good reproducing system – the sound didn't obviously emanate from two loudspeakers.

Obviously at this level we are not talking about a standard of reproduction that was poor, but of a difference in absolute performance which made the Marantz preferable."

Stan Curtis. "Hi-Fi for Pleasure."

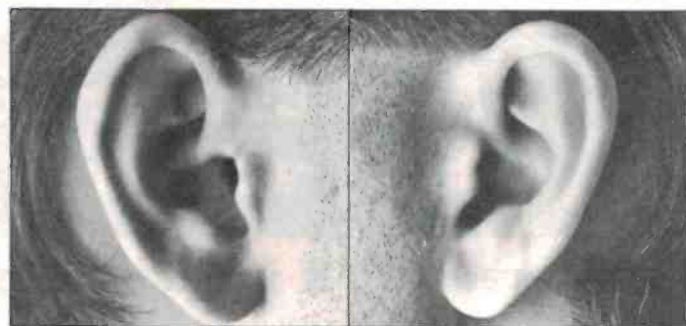

DAVID PRAKEL'S RIGHT EAR.

DAVID PRAKEL'S LEFT EAR.

"I have been surprised by the quite audible difference between CD players and have already stated a preference for the sound of the Marantz machine in terms of its handling of "ambience" and its sheer unfatiguing listenability.

Other players I've heard in direct comparisons have shown a bright veiling effect with more up-front presentation and a fatiguing quality.

ars as good experts?

How much of this is down to the quality of the analogue audio circuitry in the players in question, and how much to the 14 versus 16 bit systems, I'd hate to guess."

David Praker. "Hi-Fi Answers," U.K.

"Ironically, after all the opulent lavish and wholly enjoyable CD launches of the past four years, it was in these very low key surroundings that I can truly say I first heard the potential of this system.

To my ears and those of our Technical Editor, Dave Berriman, it was the most convincing and encouraging demonstration to date.

But why should little Marantz get it right where the others have failed? It certainly encouraged many who had come to despair of CD ever attaining the heights claimed for it."

David Praker. "Practical Hi-Fi," U.K.

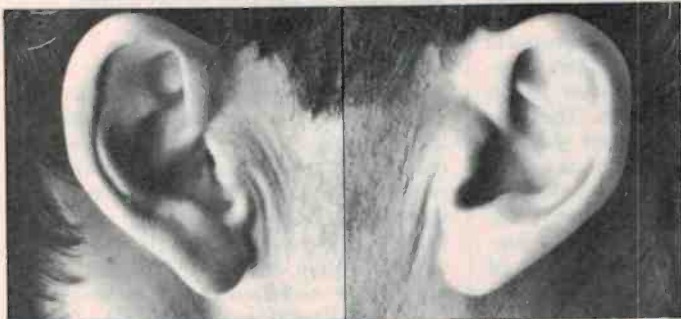

MARTIN COLLOMS' RIGHT EAR.

MARTIN COLLOMS' LEFT EAR.

"Marantz U.K. managed to lend me a CD player for just a few hours.

To my ears and in my system the CD player provided a standard of home replay as good as I have ever used.

It was found that during the sessions the sound level was very high, in fact to the limit of the system, and yet the sound itself did not appear loud.

This is a very good sign, a feature familiar to me from my collection of copy master tapes. Moreover, in certain respects, the sample programme bettered my master tapes.

Judging from the advance sample, the Marantz CD has a very bright future."

Martin Colloms. "Hi-Fi for Pleasure," U.K.

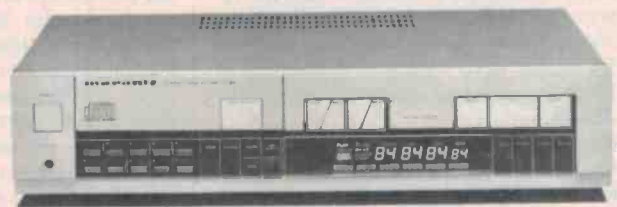

For further information contact: Marantz (Australia) Pty. Limited. Incorporated in NSW. 19 Chard Road, Brookvale, NSW, 2100.

Telephone (02) 939 1900 or your nearest Marantz dealer.

marantz

MORE TRICKS FROM TECHNICS

— wall-mounting speakers

A speaker system to go with the compact SA-R100 radio/cassette unit, the Technics SB-R100s perform remarkably. Hanging on the wall they permit a flexibility in positioning and saving of space that could even do away with the notorious stereo enhancer!

Louis Challis

THE SB-R100 COAXIAL HONEYCOMB disc speaker system is one of the smallest, if not flattest, speaker systems available in the world. The reason (raison d'être) underlying its design was to provide a wall-mounted speaker which would match the characteristics of the SA-R100 AM/FM stereo cassette recorder system. What resulted from the development was considerably better than the marketing personnel and design engineers originally envisaged.

I have been aware of the SB-R100s since I first read their description in a *Newsweek* 'new product' technical release late in 1983. In the long period that followed, I unsuccessfully attempted to obtain a pair for review purposes. During that period however, I reviewed other Technics speakers, like the SB5s, which gave excellent performances and only increased my desire to evaluate the SB-R100s.

When these speakers finally arrived, they were accompanied by the SA-R100 system which was equally interesting and so a double review resulted.

A unique speaker

The SB-F.100 has been based on a 'tried and true' concept of a dual concentric loudspeaker system. Thereafter any similarity between this speaker system and any other speaker system with which you may desire to compare it becomes highly questionable.

The central tweeter in this system uses a honeycomb element with a diameter of 30 mm. This has a protective diaphragm that looks for all the world like a diaphragm

from a Bruel & Kjaer laboratory microphone. The reasons for this are not too hard to find, as the Technics speaker development laboratory in Osaka is well equipped with Bruel & Kjaer microphones which form the backbone of their measurement systems.

This choice of configuration is well conceived as it does provide maximum sound dispersion at high frequencies. Around the outside of the tweeter is a concentric annular woofer with inner and outer rolled flexible terminations. This provides a remarkably flexible diaphragm system, with generally low resonance characteristics in the normal operating range. It is supported on an annular basket structure which is shown more clearly in the attached cross section (Figure 1). Surrounding the woofer is yet another annular diaphragm with its own flexible surround. This incorporates the passive radiator structure which boosts the low frequency performance of the basic two-way speaker system.

The total coaxial structure is supported in a remarkably rigid ribbed diecast box structure which contains integral screw fixings supported on the stiffening ribs. The edge structure is designed to support the perforated black finished front cover as well as contain all the optional fixings for the supporting brackets and wall brackets. This unit also incorporates a self-powered protection circuit to prevent the destruction of speakers.

The diameter of the woofer is a modest 160 mm which is not much bigger than most mid-range speakers, while the diameter of

the tweeter diaphragm is only 35 mm. The passive radiator has an external diameter of 230 mm and this leaves considerable space beyond its surround for the speaker cabinet damping material, which forms an integral part of the total speaker system design.

The tweeter has a voice coil diameter of only 19 mm. The woofer voice coil diameter is a massive 100 mm. With a voice coil diameter as large as this and a very rigid structure provided by the honeycomb speaker diaphragm, low-frequency resonance problems ought to be minimal. This is exactly what happens. The cabinet stiffness derived from this unusual configuration as well as the small dimensions provide the opportunity to achieve technical performance characteristics which are not only unusual but also impressively good.

The speakers are supplied with an unusual flat ribbon cable which is brown on one side and light fawn on the other. This is suitable to fix to the wall or lay behind your furniture.

Objective performance

The performance evaluation of this speaker system in our anechoic room was done without a backing wall. This revealed that the frequency performance over the range of 100 Hz to 20 kHz is positively outstanding: a frequency variation with less than ± 5 dB from 100 Hz to 20 kHz on axis and still within ± 6 dB at 30° to the main axis. These measured responses would be better with a backing wall behind the speakers; the wall would then extend the lower end of the frequency response down to a fig-

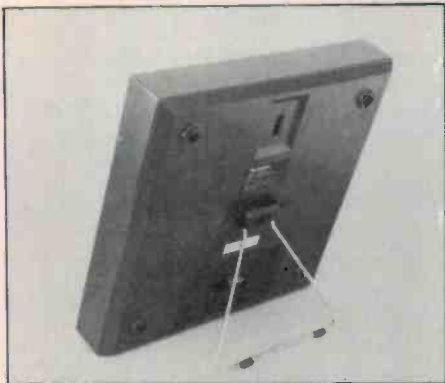

TECHNICS SB-R100 SPEAKER SYSTEM

Dimensions: 315 mm (wide) x 315 mm (high) x 65 mm (deep)
Weight: 4.5 kg (each)
Manufacturer: Matsushita Electric Trading Co. Ltd., Osaka Japan
RRP: \$440 (per pair)



These speakers can either be propped up somewhere convenient, or hung on the wall with brackets which fit into the space provided.

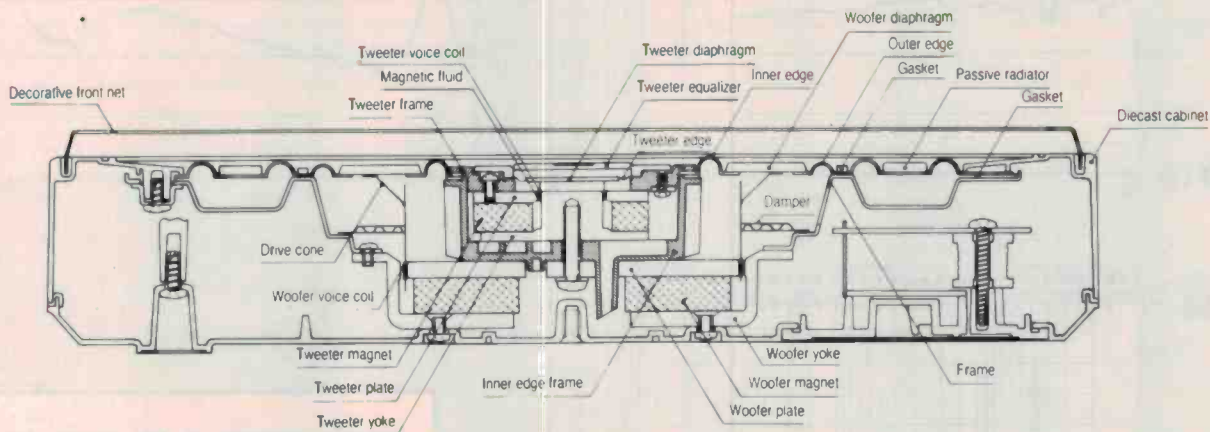

Figure 1. Cross-sectional view of the SB-R100 speaker system.

ure of approximately 80 Hz.

One inexplicable characteristic observed on the level recordings was the sharp change in response observable at 500 Hz. I presumed that this was the result of some form of interaction between the woofer and the tweeter but couldn't actually confirm this as the cross-over is supposedly 2 kHz. Both speakers exhibited the same problem and this also showed up in the decay response spectra.

The impact of the design configuration on the impedance curve is rather interesting and the unit displays two prominent fundamental resonances at 48 Hz and 110 Hz respectively. These have relative sharp 'Qs' and particularly high impedances. The lowest impedance of the SB-R100 is only 8 ohms and consequently it is possible to parallel two pairs of the same type or a pair of these with other speakers without necessarily introducing serious impedance problems.

The phase response of the speakers

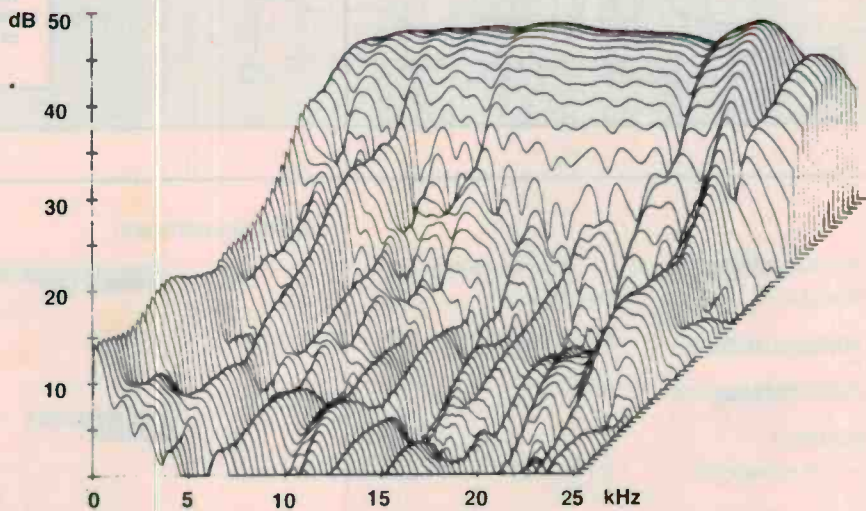

Decay response. Smooth for such a small system.

Characteristics of the SB-R100 speakers as measured.

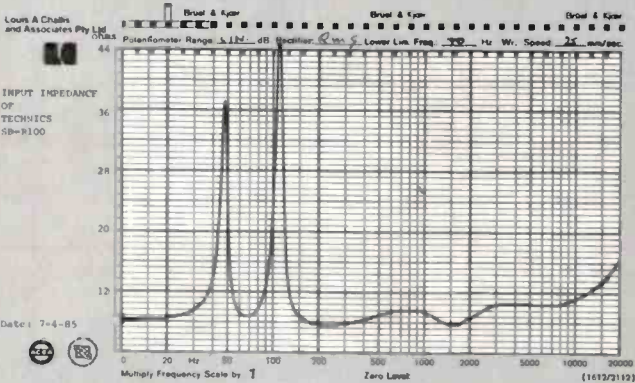
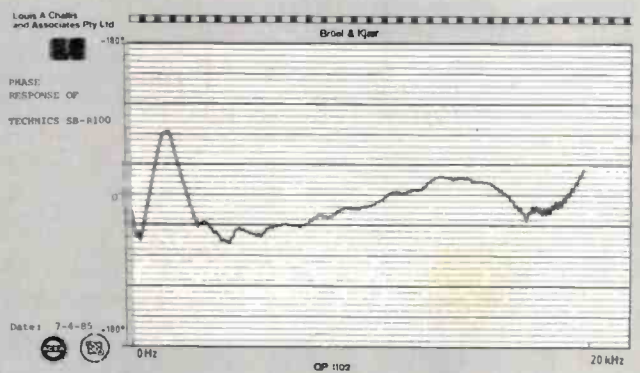
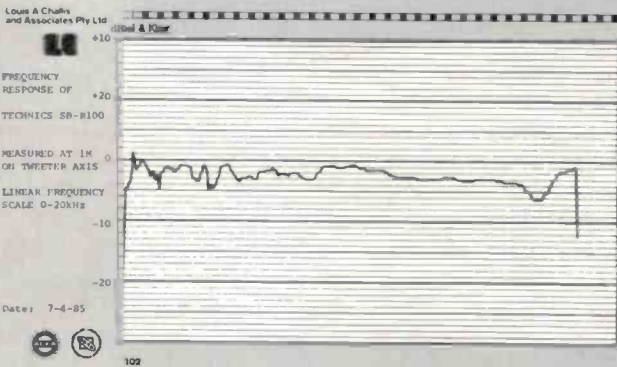
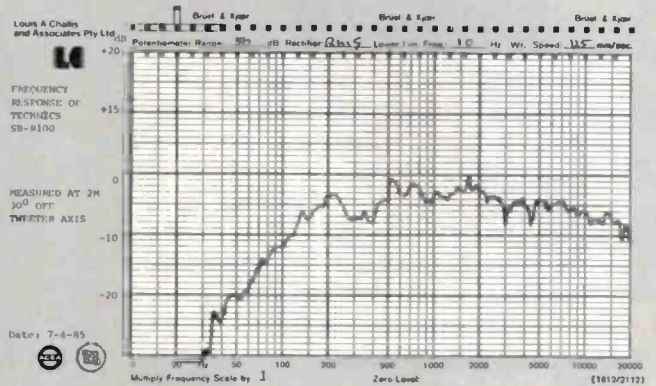
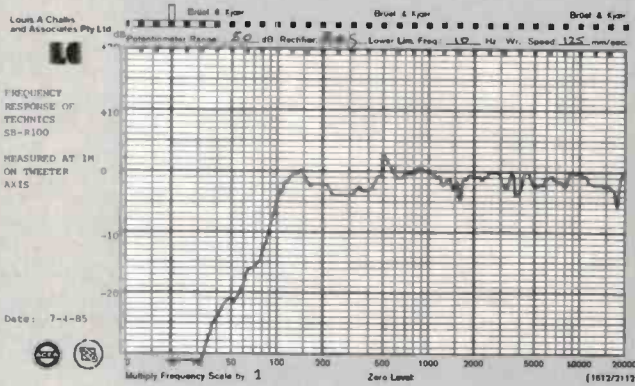

Absolute copyright in this review and accompanying measurements is owned by Electronics Today International. Under no circumstances may any review or part thereof be reprinted or incorporated in any reprint or used in any advertising or promotion without the express written agreement of the Managing Editor.

LOUDSPEAKER DATA SHEET

MEASURED PERFORMANCE OF: TECHNICS SB-R100

SERIAL NO: BB4817A163

FREQUENCY RESPONSE: 90 Hz to 20 kHz +

CROSSOVER FREQUENCY: 2 kHz

SENSITIVITY:
(for 96 dB average at 1m) 10.1 V r.m.s. = 12.75 Watts (nominal into 8 Ohms)

Date: 7th April 1985

HARMONIC DISTORTION : (for 96 dB at 1m)	100Hz	1kHz	6.3kHz	
2nd	-32.9	-49.7	-58.0	dB
3rd	-35.3	-43.4	-56.3	dB
4th	-	-65.3	-69.8	dB
5th	-54.3	-64.1	-	dB
THD	2.8	0.75	0.20	%

INPUT IMPEDANCE ONE TEST:	100Hz/7kHz 4 : 1	
100Hz	24.0	ohms
1kHz	9.4	ohms
6.3kHz	10.4	ohms
Minimum at 250 Hz	7.6	ohms
Maximum at 120 Hz	4.6	ohms

Polar response plots. An outstanding performance is marred by asymmetry at low frequencies.

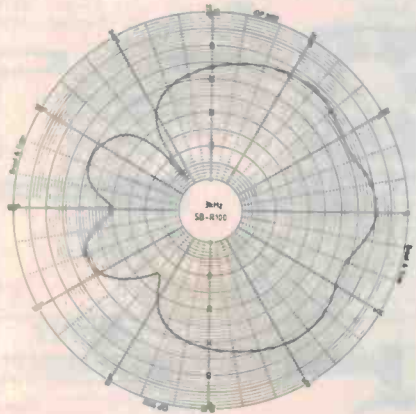
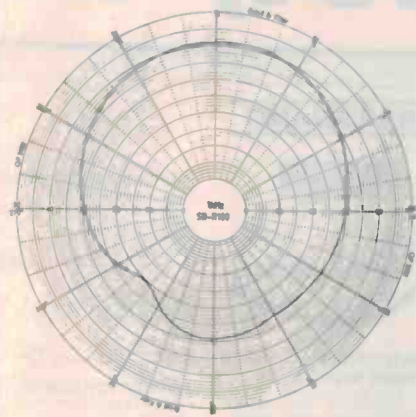

Tone burst response of the Technics SB-R100 for 90 dB steady state SPL at 1 m on axis. Upper trace is electrical input; lower trace is loudspeaker output.

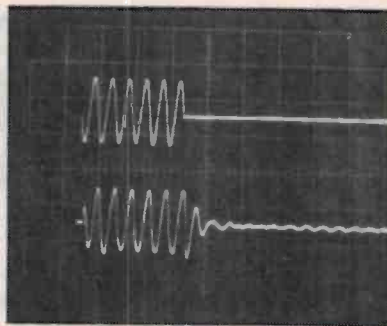

100 Hz (20 ms/div)

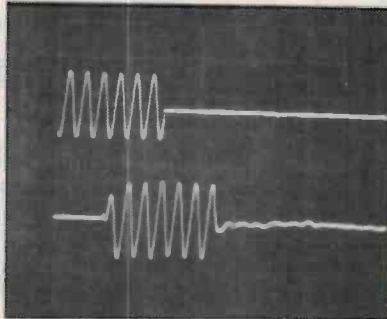

1 kHz (2 ms/div)

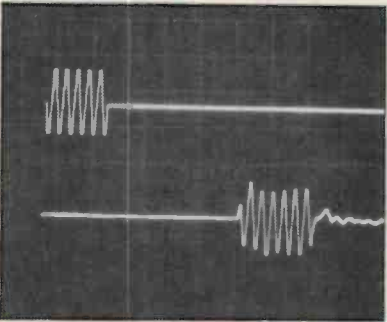

6.3 kHz (0.5 ms/div)

proved to be remarkably smooth and indicative of the extremely stable performance and almost complete lack of interaction between the tweeter diaphragm and the woofer diaphragm. The tone burst spectra reveal a reasonably stable performance at 100 Hz, excellent performance at 1 kHz and some traces of carryover in the tail of the response at 6.3 kHz.

Surprisingly, the polar plots reveal an unexpected minor degree of asymmetry at all frequencies, with a low asymmetry at 1 kHz, a slightly greater degree at 3 kHz and a most significant asymmetry at 6.3 kHz. The bandwidth at 6.3 kHz and 10 kHz is remarkably smooth all the way out to $\pm 30^\circ$ to the main axis. The response band is within 3 decibels of 90° at 6.3 kHz and more than 60° at 10 kHz. This is quite an outstanding performance and is considerably better than that provided by many

speakers costing four times the price.

The distortion characteristics of the speaker are good to excellent at all frequencies above 110 Hz. Only when frequencies come close to 100 Hz and particularly at lower frequencies does the distortion characteristic become significant. This is a result of the interaction of the high impedances, speaker diaphragm resonances and extremely small volume of the cabinet. With an output of 96 dB at 1 m, this distortion is still only 2.8% which is still just acceptable. At lower frequencies the distortion is much higher and generally unacceptable. The droop in output is so great however, that these distortion products are almost inaudible in the most 'real' signal content.

The decay response spectra reveal that, with the exception of a very measurable resonance at 3 kHz, and a further significant resonance at 20 kHz, the overall characteristics are reasonably smooth and far better than one could reasonably expect from a loudspeaker system which is so small (although admittedly not inexpensive).

Subjective performance

The subjective impressions I acquired listening to these speakers was that they are good, and in many respects memorable. With classical music, the performance is a little crisp, generally clean and normally uncoloured. When listening to the spoken voice or singing, the fidelity is particularly good. However, when listening to most popular music with significant low frequency output, the low frequency response is particularly modest and not unlike that provided by the original Quad Electrostatics speaker system against which I performed a direct A/B type comparison.

On rock music with considerable low frequency content, the performance was less than satisfactory particularly at a listening level in excess of 96 dB where frequency doubling and significant second and nasty third order distortion soon become very evident.

The SB-R100s are not everybody's 'cup of tea'. They are designed for people who have no space, no floor and maybe even no furniture. They are unquestionably the perfect bedroom speaker system, the perfect 'waiting room' speaker system and if they had a better low frequency response, they would almost be a perfect monitor system.

I like these speakers because of the things that they do better than other speakers, rather than being put off by those aspects of their performance in which they do not excel. As a matching system to the SA-R100 they are almost perfect and as a remote speaker system for an existing hi-fi, a kitchen speaker system, bathroom speaker system, patio speaker system or even child's room speaker system — they are almost unbeatable. ●

We've got the lot, at

COMPONENTS!



SIP RESISTORS
Standard values

1-9	10+
6 Pin 50c	40c
8 Pin 60c	50c
10 Pin 65c	60c



RELAYS
Massive 3A connectors.
1-9 100+
S.P.D.T. S14060
\$1.20 \$1.10 \$0.90
D.P.D.T. S14061
\$1.50 \$1.40 \$1.20



50 K LOG POT
Shaft as illustrated
1-9 10-
\$0.60 \$0.55



QUALITY MOMENTARY (RED BODY)
SPDT Cat. S11050 \$1.40
DPDT Cat. S11052 \$1.75
\$1.95

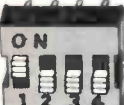

DIP SWITCHES

1-9	10-
2 Way \$1.50	\$1.10
4 Way \$1.60	\$1.20
5 Way \$1.70	\$1.30
7 Way \$1.80	\$1.40
8 Way \$1.90	\$1.50



RELAY AND BASE
Can carry 10A at 28V DC or 5A at 240V AC. Supplies with Chassis Mounting Socket with screw terminals. Great for school projects and demonstrations. switching DC power supplies, central circuits and with contacts parallel up to 20A can be switched.
Normally \$8.95
Cat. S14074 **NOW \$6.95**



NEW JOINABLE PCB MOUNTING SCREW TERMINALS
Less than half the price of the old ones!
2 Way 1-9 10+
Cat. P10542 \$0.50 \$0.40
3 Way
Cat. P10543 \$0.75 \$0.65
(please note these are the new blue ones)



ENCLOSED ROTARY SWITCHES AT SPECIAL PRICES!!

1-9	10+
\$1.20	\$1.00



CRYSTALS SPECIALS
Prime Spec's. We just have too many in stock!

3.5795 MHz	14.318 MHz
4.00 MHz	18.00 MHz
4.1934 MHz	20.0 MHz

All \$2.50 each!
10 or more \$2 each!

CONNECTORS!



SOLDER CENTRONICS PLUGS
Unreal price for absolute top quality. Normally \$14.95 (Our opposition charge up to \$19.95).
1-9 10+ 100+
\$6.50 \$5.95 \$4.95



36 WAY CENTRONICS CRIMP PLUG
Cat. P12200
1-9 10-99 100+
\$7.95 \$7.50 \$7.25



CANNON TYPE AUDIO CONNECTIONS
We've sold 1000's because of their great value!!

3 Pin line male	1-9	10-	
Cat. P10960	\$1.90	\$1.80	
3 Pin chassis male	Cat. P10962	\$1.90	\$1.80
3 Pin line female	Cat. P10964	\$2.50	\$2.10
3 Pin chassis female	Cat. P10966	\$2.90	\$2.20



RS232 & 'D' TYPE CONNECTORS

PART DESCRIPTION	CAT. No.	1-9	40+
DE 9P 9 Pin Female	P10880	\$1.75	\$1.60
DE 9S 9 Pin Male	P10881	\$2.25	\$2.45
DE 9C 9 Pin Cover	P10992	\$2.55	\$2.45
DA 15P 15 Pin Male	P10894	\$2.10	\$1.95
DA 15S 15 Pin Female	P10895	\$2.25	\$2.10
DA 15C 15 Pin Cover	P10892	\$1.15	\$1.05
DB 25P 25 Pin Male	P10900	\$2.95	\$2.80
DB 25S 25 Pin Female	P10901	\$3.45	\$3.30
DB 25C 25 Pin Cover	P10902	\$1.20	\$1.10

CASES!



PROFESSIONAL SERIES RACK MOUNTING CABINETS
These beautifully crafted rack cabinet boxes will give your equipment a real 1st class appearance.

- All aluminum construction
- Removeable top and bottom panels
- All dimensioning conforms to the International Standard.
- Natural or black finish
- Ventilated lid
- Deluxe brushed finish anodized front panel.

H10401 Natural	1-4	5+	\$49.50	\$43.50
H10402 Natural			\$55.50	\$49.50
H10403 Natural			\$62.50	\$55.50
H10411 Black			\$49.50	\$43.50
H10412 Black			\$55.50	\$49.50
H10413 Black			\$62.50	\$55.50

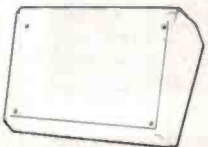

NEW SLOPING CASES
Plastic with metal front panel, available in two sizes.
Cat. H10450 190x120mm \$9.95
Cat. H10455 256x185mm \$17.95
(measurements are approx. only)



ECONOMY 19" RACK CASE
Tremendous Value! Dimensions W 480 x H 134 x D 250mm.
Cat. H10400 1-9 10+
\$34.95 \$29.50

TOOLS OF TRADE!



DIGITAL MULTIMETER YFE YF1100 FEATURES

- Large easy to read 3 1/2 digit display
- Facilities for transistor and diode testing
- Clearly laid out front panel
- 10A DC AC range
- Priced to undersell the others

Cat. Q16025 \$69.50



LOGIC PROBE 3800A
Features 20MHz memory, TTL/CMOS operation. Normally \$29.50
Cat. Q11272 1-9 10+
\$23.50 \$19.50



UNIVERSAL SOLDERING IRON STAND
Cat. T11302 \$5.95 slashed to \$3.95

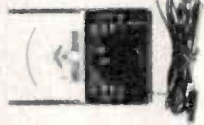

2K OHM MULTI METER
11 Ranges, pocket size. SPECIFICATIONS:
11 RANGES
DC VOLTAGE: 0-10-50-250-1000 volts 2000 ohms/volt
AC VOLTAGE: 0-10-50-250-1000 volts 2000 ohms/volt
DECIBELS: -10 to +22dB in four ranges
OHMETER: 0-10 kohms 0-1 mega-ohms
DC CURRENT: 1-100mA
Normally \$14.95 **NOW \$9.95**

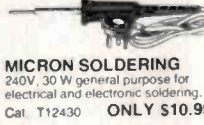

MICRON SOLDERING
240V, 30 W general purpose for electrical and electronic soldering.
Cat. T12430 **ONLY \$10.95**



WE HAVE DONE IT AGAIN!
New millimeter at unbeatable value for under \$45! The new YU-FONG YFE-1030C features:

- Large 3 1/2 digit display (1/2 inch high)
- Autopolarity, "-" display for negative input.
- High over-load protection for all ranges.
- Over-load display highest figure "1" or "-1" alone glows.
- Power consumption 20mW approx.

Cat. \$49.95

IC'S GALORE!

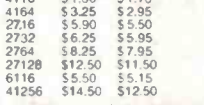

IC SPECIALS!

4116	1-9	10+
4164	\$3.25	\$2.95
2716	\$5.90	\$5.50
2732	\$6.25	\$5.95
2764	\$8.25	\$7.95
27128	\$12.50	\$11.50
6116	\$5.50	\$5.15
41256	\$14.50	\$12.50

BATTERIES!

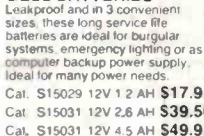

RECHARGEABLE 12V GELL BATTERIES
Leakproof and in 3 convenient sizes, these long service life batteries are ideal for burglar systems, emergency lighting or as a computer backup power supply. Ideal for many power needs.
Cat. S15029 12V 1.2 AH \$17.95
Cat. S15031 12V 2.6 AH \$39.50
Cat. S15031 12V 4.5 AH \$49.95

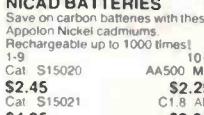

NICAID BATTERIES
Save on carbon batteries with these Apollon Nickel cadmiums. Rechargeable up to 1000 times!
1-9 10+
Cat. S15020 AA500 MA \$2.45
Cat. S15021 C1.8 AH \$2.25
Cat. S15022 D4 AH \$3.95
Cat. S15022 D4 AH \$3.95
Cat. S15022 D4 AH \$6.95

HARDWARE!

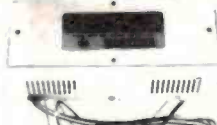

UHF/VHF/FM ANTENNA
Frequency: VHF 48-216 MHz (Ch 1-12)
UHF 536-764 MHz (Ch 25-62)
Impedance: 75 300 1200 Ohm
Element: VHF 4 UHF 9
Gain (dB): VHF 4-6 UHF 4-8
Cat. L11014 \$39.50



SWITCH MODE POWER SUPPLY
DC+5V at 3A +12V at 1A
DC -5V at 200mA -12V at 500mA
Dimensions: L250 x W90 x H55mm
Cat. M16680 \$89



BRAND NEW FANS
Not noisy pullouts! Stacks of uses in power amps, computers, hotspot cooling etc. Anywhere you need plenty of air.
240V 4 5/8" Cat. T12461 \$10.95
115V 4 5/8" Cat. T12463 \$10.95
240V 3 1/2" Cat. T12465 \$10.95
115V 3 1/2" Cat. T12467 \$10.95
10 Fans (mixed) less 10%

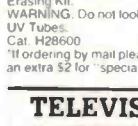

KEY SWITCHES

1-9	10-
Cat. S12500	\$4.95 \$3.95



TELEVISION ACCESSORIES!

HYBRID SPLITTERS

2 Way	\$3.95
4 Way	\$5.95



METAL CO-AXIAL CONNECTORS
Plug Cat. P10402 \$0.95
Socket Cat. \$0.95



CONNECTOR CORDS
For TV/VTR (using cord 3C-2V) 2.5m long.
Male to Female \$2.95
Male to Male \$2.95



MATCHING BALUN TRANSFORMER
Female Type 75-300 Ohm
Cat. L11010 \$2.95



MATCHING BALUN TRANSFORMER
75-300 Ohm Type
Cat. L11038 \$6.95

CIRCUIT EQUIPMENT!



S100 PROTOCOL CARDS SAVE \$20

Horizontal Buss	Cat. H19125	\$19.50
Vertical Buss	Cat. H19130	\$19.50
Pad Per Hole	Cat. H19135	\$19.50



NEGATIVE & POSITIVE CIRCUIT RESIST
Make your own presensitized PC Boards POSITIVE PHOT RESIST using 1 1/2 tapes and pads on clear film for one off or prototypes. Resist: 50mi bottle for approx. 1500 sq cm of pcb.
Cat. P85500 \$6.95



DEVELOPER: 70gms of crystals to mix with 2lit of water, enough to complement 50ml of resist.
Cat. P85504 \$3.25

NEGATIVE PHOTO RESIST for using normal negative PCB images. Resist: 50mi bottle for approx. 1500 sq cm of pcb.
Cat. P85508 \$5.45



ETCHANT: 400gms of crystals to mix with 1 to 1 1/2 lts of HOT water.
Cat. P85512 \$3.25

FULL STRENGTH FERRIC CHLORIDE

1-9	10-	
250ml	\$1.95	1.75
500ml	\$2.95	\$2.50
1 litre	\$4.95	4.50

Rod Irving Electronics!

"If not, then very nearly!"

SECURITY EQUIPMENT!



LOCAL BURGULAR ALARM CONTROL PANEL

The odds against you are climbing and prevention is better than cure!

- Adjustable exit/entry time delay and alarm time (avoids unnecessary noise pollution)
- 12V D.C. 1.5Amp
- Provision for battery back-up.
- Tamper switch
- Optional outputs: Sirens, bells, floodlights, automatic diallers, tape recordings, closed circuit TV, etc.
- Accepts N.C. and N.O. detectors such as infrared, microwave, ultrasonic, wireless, vibration sensor, magnetic switch, door mat, smoke detector, glass breakage sensor panic button etc.

Cat. S15051 **\$99.95**



ULTRASONIC BURGULAR ALARM

- Easy to install
- Connect with magnetic switch, infrared detector, etc.
- Equip with homspeaker, lockswitch, flashlight, closed circuit TV, etc.
- Rechargeable battery circuit with recharge indicator L.E.D.
- N.O. and N.C. circuit breakdown indicator
- Low dry battery indicator.

Cat. S15052 **\$89.95**



GLASS BREAKAGE DETECTOR

Adjustable for closed circuit or open circuit type glass. Instructions supplied.

Cat. S15060 **\$3.95**



HORN SIREN

12V D.C. 8W
Cat. C12012 **\$14.95** **\$13.95**



ULTRASONIC MOTION DETECTOR

A compact design that can be used with virtually any alarm system which has an input for N.C. or N.O. external sensor. Coverage is approximately 110 degree angle and up to 8 metres. Comes with detailed instructions.

Cat. S15033 **\$39.95**



MOUNTING BRACKET

For above Ultrasonic Alarm and features ball pivot for horizontal and vertical adjustment.

Cat. S15042 **\$11.95**

VIDEO ACCESSORIES!



TDK VIDEO TAPES AT BARGAIN PRICES!

VHS:	E60	\$12.50
	E120	\$12.50
	E180	\$11.80
	E240	\$22.40
BETA:	L250	\$13.50
	L500	\$14.40
	L750	\$17.50



VDK1 VIDEO DUBBING KIT

For European and Japanese machines.

- Contains:
- Audio/Video: 6 pin DIN plug to 6 pin DIN plug 1.5 metres.
 - Audio/Video: 6 pin DIN socket to (a) Video: RCA plug (b) Audio: 5 pin DIN plug. (Both 16cm in length)
 - Video: 1 each plug adaptor (PA21) RCA socket to PL259 plug. (PA23) RCA socket to BNC plug.
 - Audio: 5 pin DIN socket to 2 RCA plugs 16cm length 2 plug adaptors (PA60) RCA socket to 3.5mm phone plug.

Cat. **\$16.95**

AUDIO PRODUCTS!



P.A. SPEAKERS

Low dual cone, wide range, 200mm (Bin.). Ideal for public address, background music, etc. Tremendous Value at these prices!

Cat. C12000 **\$5.95** **\$4.95**



Would you like a quality sound system in your car? ...at an affordable price?!!

Rod Irving Electronics now sell quality Ferris sound systems (A brand everyone knows and trusts.) Prices start from a very affordable \$55.95. Feel free to call in for a personal demonstration at either of our two stores.

FERRIS 1600: AM/FM Manual Car Radio, Integrated Circuit, Automatic Dual Polarity

FERRIS JM 700: AM/FM/MPX Radio/Auto Reverse Cassette Stereo with Lock-in F Forward and LOC/IX Switch, Output 7 Watts per Channel, Balance and Tone Controls, Overall Dimensions 162(W)x114(D)x44mm(H)

FERRIS JMPA 600B: Auto Reverse Stereo Cassette Player with AM/FM/MPX Electronic Scanning, Digital Radio and Digital 12 Hour Clock, 12 Station Memory, Metal/Normal Tape Switch, 8W/8W Max. Local/IX Switch, FM Interference Absorption Circuit, Base and Treble Control

FERRIS FA 1004: 10 Level Graphic Equaliser Amplifier with LED read out on L & R Channels, Fader Control, 20W/20W 4 speaker Wiring

FERRIS FA 104: High Power Module, up to 10x times your volume, suits all Ferris Normal Power Sets, and most other Car Stereo Units with Normal IC Output.

FERRIS F7 55X: Flush Mount 4 & 4 Ohm, Soz. Dual Cone, 5 Watts NOM. 10 Watts Max, Mesh Grille

FERRIS TRI-510: "Super Power Deluxe" Flush Mount, 4 Ohm, 10 oz., Triaxial Three Way, 6 1/2 inch Diameter, Mesh Grille 40 Watts Max



SUPER HORN

- Wide dispersion tweeter, handles up to 100W.
- Sensitivity: 105dB/0.5m
- Frequency Response: 3kHz-30kHz
- Impedance: 8 OHMS
- Size: 145x54mm
- Cat. C12102 **\$12.95**



PHILIPS SPEAKERS

You don't have to "imagine" Philips quality at these prices!

Cat. C12030 AD01610 T8 **\$12.95**

Cat. C12040 AD02160 S08 **\$34.95**

Cat. C12045 AD70620 M8 **\$49.00**

Cat. C12050 AD12550 W8 **\$79.00**

JOYSTICKS!



CENTRE RETURN JOYSTICK

Features 2x150k pots, long shaft 40mm with 25mm centre travel. Bonus adjustable offset feature on pots.

Cat. X15637 1-9 **\$9.95** **\$8.95**



JOYSTICK FOR APPLE

Ideal for games or word processing. Fits most 6502 compatible computers.

Cat. C14200 **\$27.95**

COMPUTER ACCESSORIES!

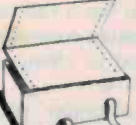

COMPUTER PAPER

Top quality at a very affordable price! Blank 11 x 8 1/2", 2,000 sheet, quality 60 gsm bond paper

Cat. C21001 **\$29.50**



RITRON (ZETA) DATASETTE

For data loading and saving, this Micron DATasette suits most home computers and features tags, counter, monitor function for audio verification and slide volume control for output level.

Cat. C14900 **\$29.95**



RITRON 2

Stylish swivel base monitor, available in amber or green.

1-9 **\$215** **\$205**

Green Cat. X14500 **\$215** **\$205**



RITRON MULTI PURPOSE MODEM

Our New RITRON Multi Purpose Modem has arrived and has all the standards you require.

- Just check the RITRON's features:
- CCITT V21 300 Buad Full duplex
- CCITT V23 1200/75
- Bell 103 300 Full duplex
- Bell 202 1200 Half duplex
- Auto answer, auto disconnect.
- Telecom Approval No. C84/37/1134 **\$399**



RITEMAN INFO RUNNER

An exciting new printer from the experts "Riteman". This compact stylish printer performs like printers twice its price and size, 120 C.P.S., dot resolution graphics, tractor/ribbon feed, 10" paper.

Cat. C11901 **\$199**

Case & Power Supply to suit **\$89**

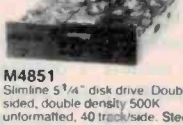

M4851

Slimline 5 1/4" disk drive. Double sided, double density 500K unformatted, 40 tracks/track. Steel band drive system.

Cat. C11901 **\$199**

Case & Power Supply to suit **\$89**



TELECOMMUNICATION PLUG TO 2 SOCKETS.

Ideal for modem connections

Cat. Y16014 **\$12.95**



READY MADE CABLES

Serial to Serial **\$18.95**

Parallel centronics to centronics **\$23.95**



IBM* COMPATIBLE COMPUTER

\$2,450
Including Tax!

*IBM is a registered trademark.

CHEAP DISKS!



DISKS GALORE!!

All prices for boxes of 10 Single disks 10% extra.

SPECIALS!

MD525-01 S/S D/D Cat. C12501 **\$29.50**
MD550-01 D/S D/D Cat. C12504 **\$39.50**

Head Cleaners

C12551 S Head Cleaner **\$10.50**
C12851 B Head Cleaner **\$11.50**

VALUELIFE

C12421 S/S D/D **\$22.95**
C12425 D/S D/D **\$29.95**

8" Verbatim

C12800 FD32-1000 S/S D/D **\$39.50**
C12801 FD32-8000 S/S D/D **\$49.50**
C12802 FD32-8000 S/S D/D **\$49.50**
C12803 FD34-1000 S/S D/D **\$49.50**
C12804 FD34-8000 S/S D/D **\$55.50**
C12805 FD10-4008 D/S D/D **\$59.50**
C12806 FD10-4015 D/S D/D **\$64.50**
C12807 FD10-4026 D/S D/D **\$64.50**
C12808 FF32-2000 S/D D/D **\$69.00**
C12809 FF34-2000 S/D D/D **\$69.00**
C12810 DD32-4000 D/S D/D **\$52.50**
C12811 DD34-4001 D/S D/D **\$52.50**
C12812 DD34-4008 D/S D/D **\$54.50**
C12813 DD34-4015 D/S D/D **\$54.50**
C12814 DD34-4026 D/S D/D **\$54.50**

5 1/4" Verbatim Disks

5 year DataLife guarantee

MD525-01 (S/S D/D) **\$29.50**
C12501 **\$29.50**
MD525-10 (S/S D/D 10 Sect. 40 Track) **\$39.50**
C12502 **\$39.50**
MD525-16 (S/S D/D 16 Sect. 40 Track) **\$39.50**
C12503 **\$39.50**
MD550-01 (D/S D/D) **\$49.50**
C12504 **\$49.50**
MD550-01 (D/S D/D 10 Sect. 40 Track) **\$49.50**
C12505 **\$49.50**
MD550-16 (D/S D/D 16 Sect. 40 Track) **\$49.50**
C12506 **\$49.50**
MD577-01 (S/S D/D Soft Sect 80 Track) **\$49.50**
C12507 **\$49.50**
MD577-10 (S/S D/D 10 Sect 80 Track) **\$49.50**
C12508 **\$49.50**
MD577-16 (S/S D/D 16 Sect 80 Track) **\$49.50**
C12509 **\$49.50**
MD557-01 (D/S D/D Soft Sect 80 Track) **\$59.50**
C12510 **\$59.50**
MD557-16 (D/S D/D 16 Sect 80 Track) **\$59.50**
C12511 **\$59.50**



BLANK DATA CASSETTES

Brings out the best in any micro!
Cat. D11141 1-9 **\$1.50** **\$1.40** **\$1.20**



SWIVEL BASE

Makes life easier, normally \$29.50

Cat. D11100 **\$27.50**

PUBLICATIONS!

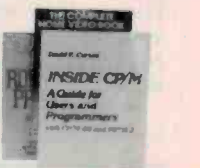

Inside CP/M

by David E. Cortesi **\$41.95**

The Complete Home Video Book Vol. 2

\$25.95

The Robotics Primer by Robert A. Ulirsch **\$17.95**

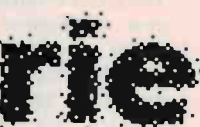

ROD IRVING ELECTRONICS

425 High Street, NORTHCOTE, 3070 VICTORIA, AUSTRALIA

Phone (03) 489 8866

TELEX: AA 38897

48-50 A Beckett Street, MELBOURNE, 3000 VICTORIA, AUSTRALIA

Ph. (03) 663 6151

Mall Order and correspondence: P.O. BOX 235 NORTHCOTE 3070

MAIL ORDER HOT LINE



(03) 481 1436

POSTAGE TABLE

\$1 - \$9.99	\$2.00
\$10 - \$24.99	\$3.00
\$25 - \$49.99	\$4.00
\$50 - \$99.99	\$5.00
\$100 - \$199	\$7.50
\$200 - \$499	\$10.00
\$500 plus	\$12.50

This is for basic postage only, Comet Road freight, bulky and fragile items will be charged at different rates.



Errors and omissions excepted

All in one video-audio disc player

Pioneer in Japan has recently issued a formidable challenge to Philips with the release of an optical videodisc player which can also play digital audio discs.

Philips' Laservision discs are 30 cm in diameter while the audio discs are only 12 cm, and the two are played at different speeds. Pioneer's new player has two motors and the player switches between them so that both video and audio discs can be played.

Pioneer also had to come up with a system to modify the laser

focus for the different discs, since the set standard for video was a double-sided disc slightly over 2.5 mm and for audio, a single sided disc of 1.2 mm thickness. The company solved the problem by using a servo control system that refocuses the optics according to the type of disc being played.

New VHS video system

The latest offering from JVC is a new component video system which provides both portable recording facilities and at-home broadcast reception. A 'mix-n-match' system, it may well provide a solution to choosing between a home deck VCR and a portable.

The new system consists of a HR-S10EA video cassette recorder and matching TU-S10EA tuner adapter. Used together, these matching components give complete broadcast reception and time-shift viewing capability. To record live action, it's simply a case of removing the tuner and adding a video camera (all JVC models are compatible!).

Weighing only 2.4 kg and just 8 cm high, the HR-S10EA recorder is one of the lightest and smallest VHS models on the market for full-sized cassettes. It allows 4 hours of recording on a single E-240 cassette

The TU-S10EA voltage synthesizer tuner can be preset to 16 channels and has a built-in 14-day/8-event timer. A protective flap conceals the keyboard, giving a sleeker appearance.

There are no unsightly cables connecting the recorder and tuner. These components simply slide out of their cordless, direct contact electrical connection in one smooth motion.

Other features of the component system include a dubbing connector, earphone and microphone jacks, audio dubbing facilities, automatic backspace editing, direct playback, three-way power supply, two-way shuttle search, full function wireless remote control, electronic tuning (both manual and automatic) and still frame, frame advance and even reverse-normal speed playback. Advanced post production editing and audio dub features which allow the user to give the recording a professional touch are also incorporated. A full range of accessories is available.

The recommended retail price for this new video system is \$1,899 which includes a carry bag and two batteries.

For further information, contact **Anthony Toope, Hagemeyer (Australasia) B.V., 5-7 Garema Circuit, Kingsgrove NSW 2208. (02)750-3777.**



Latest Teac amp

Teac's latest amplifier is labelled the A-919. Rated output power is 110 watts per channel using "phase inverted drive" circuitry to amplify left and right channels, out of phase. The theory behind this is to provide a more stable power supply and maintain transient response.

The amplifier has facilities for nine audio inputs (naturally in-

cluding CD) and (in the interests of limited lifespan) permits you to record from one source while listening to another. As an extra it also has a built in MC cartridge amplifier.

For further information contact **Teac, 115 Whiteman St, Sth Melbourne, Vic 3205. (03)699-6000.**

AKAI VCR



AKAI Australia has incorporated a number of important design changes in its latest VS-303 video cassette recorder, which replaces the VS-3EA model.

Following current market trends, this new VCR is a slimline model, 99 mm high, and is compatible with all AKAI's current hi-fi range and therefore suited to a visual integration unit. It has a full function infrared remote control that can even be used to change channels on the TV set.

In common with all other Akai VCRs, the VS-303 features an exclusive on-screen instruction system which displays all operating instructions. The interactive monitor system is slightly changed from those of previous models and now incorporates an am/pm clock. Another change is the incorporation of a 16-channel preset tuner, which is easy to operate and error free.

The VS-303 is built on a new chassis designed for simpler service and incorporates a silent mechanism so that loading and unloading a tape is no longer accompanied by the usual mechanical groans.

Another innovation is a tape view system that allows the user to actually see the tape inside the machine, thus eliminating the frustrating guesswork as to how much recording time is left.

This new model also features improved picture quality in normal playback and in noiseless still picture functions, a quick finder with fixed noise bars, sharpness control located on front panel, auto '0' stop and auto-rewind, auto-editing, a 4-programme, 28-day timer, and sleep timer.

The VS-303 is covered by Akai's three-year warranty and sells for a recommended retail price of \$729.

Light compact video

At only 720 g the Konica CV is light and easy to use. It has a minimum of controls to leave hands and concentration free for more important things like aiming, focusing and shooting.

The camera features zoom control, automatic iris system to set exposure, high sensitivity 1/2-inch new Cosvicon pickup tube with f 1.5 Konica Hexanon lens. The colour temperature compensation control combines several settings into a single operation to avoid worrying about white balance and other adjustments.

As well as these features the Konica includes a unidirectional microphone, and an electronic viewfinder on a 1-inch (diagonal) black and white picture tube.



Sleek video

Following successful sales of the NV-600A VTR, National has introduced a slimmer, sleeker version with the feature packed NV-450A.

Its three-video-head System provides special playback functions such as playback with reduced noise and jitter, and still advance. A slow motion effect is obtainable also (1/6 normal playback speed) by keeping the Still Advance button depressed.

For the opposite effect, cue and review operate at five times normal playback speed.

The NV-450A is equipped with a 27-mode infrared remote control and has a large fluorescent multi-function display panel which gives instantaneous confirmation of every activated function at a quick glance.

Other features include a 14-day programmable timer; one-touch timer recording with stand-by function for deferred OTR start; auto-rewind and memory function.

For more information contact National Panasonic, 99 Epping Rd, North Ryde NSW 2113.

BRIEFS

Hi-tech decks

Latest additions to the TEAC Australia lineup are the R-555 and R-666X Auto Reverse Stereo Cassette Decks, retailing at around \$449 and \$549 respectively. The makers claim the auto-reverse mechanism of these models is near perfect and music loss is imperceptible when the tape reverses direction.

Korean VCRs for US

The first Korean VCRs have just hit the United States. Three companies are involved — the Gold Star Company, the Samsung Electronics Corporation and the Dae Woo Company — and orders could total 300,000 units this year. The Korean VCRs are aimed at the low end of the market and priced at approximately 5-10% below comparable Japanese models — a point of interest as this new market initiative follows the recent termination of licensing agreements with Japanese manufacturers which had prohibited the Koreans from export sales.

New AKAI colour TV

AKAI's move into colour TV gains force with the release of the new CTK-201 48 cm model. Featuring VCR stereo compatibility and automatic fine tuning, it joins the CTK-141 34 cm model in the range.

Hi-fi VCR

The latest in hi-fi VCRs comes from NEC, with the release of the N895EA model which incorporates a host of advanced hi-tech electronic features. Product manager John Hurley promises "audio sound quality similar to a CD player".

Audiosound stereo simulator

Audiosound Laboratories of Curl Curl, NSW offer "an excellent spatial stereo effect" with its SS-2 Linear Frequency Stereo Simulator. It has none of the problems associated with either comb-filter types or highly complicated units.

International video contest

Entries are now being received for the 8th annual Tokyo Video Festival contest, which runs until September 10. Competition details are available from any office of this year's festival sponsor, JVC, or by writing to Anthony Toope, Hagemeyer (Australasia), B.V., 5-7 Garema Circuit, Kingsgrove, NSW 2208.

Audio tapes

New to the audio tape market comes the Goldring UD (ultra dynamic) cassette range from Goldring Audio Industries. The range includes three different types of tape: the UDC 10 and UDC 20 for home computer use; the UDC 30, 45, 60, 90 and 120 for hi-fi recording; and a head cleaning tape. Prices are moderate — RRP for the UDC 90 is \$2.95.

LaserVision for China

Philips has received a \$A148 LaserVision order from the Municipal Government of Shenzhen in the People's Republic of China. A basic contract has been signed for the supply of both LaserVision players and equipment to enable them to be assembled in China.

Compact cassette

A new direction for features in portable equipment? Sony's CFD-5 radio-cassette player, just released on the Japanese market, comes complete with a compact digital audio disk player — the small D-50 introduced at the Japan Electronics Show last October. An export version will be ready for the United States later this year.

SIGHT AND SOUND

J-Compo 51 jacket size stereo component system

The Teac J-Comp 51 stereo component system features the following discrete systems:

The A-J51 dc integrated stereo amplifier with 30 W/Ch rated output power; electrically controlled volume buttons; tone control mode select with a visual display; and mic mixing capability.

The T-J51 AM/FM stereo tuner with microcomputer controlled quartz PLL (phase locked loop) tuning; random preset station memory (up to 16 AM/FM stations); and two colour fluorescent preset channel and frequency display.

The W-J51 stereo double cassette deck featuring dolby B-C noise reduction; high speed dubbing function; continuous double-deck playback; line/mic and tape mixing recording capability; and two dc servo motors.

The P-J51 fully automatic turntable with linear tracking tone arm; non-contact optoelectronics tracking error detec-

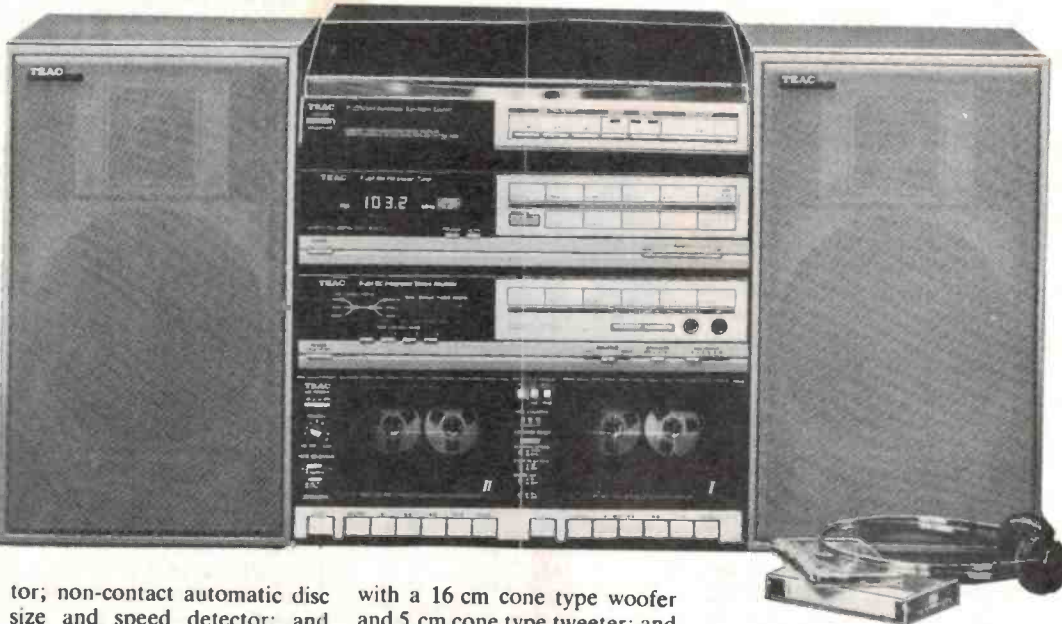

tor; non-contact automatic disc size and speed detector; and program repeat function.

The S-J51 two-way speaker system which comes in a bass-reflex bookshelf type enclosure

with a 16 cm cone type woofer and 5 cm cone type tweeter; and crossover frequency of 8500 Hz. Its input power is 30 W (nominal), 60 W (maximum music signal peak).

For further information contact Teac Corp, 115 Whiteman St, South Melbourne, Vic 3205. (03)699-6000.

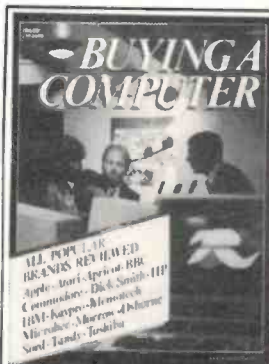

Buying a computer?

Here's a magazine that's sure to help you!

We aim to provide you with the information you'll need to compare, evaluate — and make the right decision on which computer is right for you.

We've collected a wealth of articles, written by rank beginners as well as those deeply experienced in the computer industry. All of them have gone through the drama of buying a personal computer... and they'll share their experiences with you.

**Available at your newsagent now
only \$4.50**

The soft look KP2950



Pioneer has released a new 'soft face' design technology car stereo with the KP2950 AM/FM stereo radio cassette combination.

At its recommended retail price of \$179, the KP2950 has a front-DIN or 'soft-face' car system which uses buttons and flush controls instead of shafts.

The unit also features five preset tuning buttons for the tuner section, while the tape player alerts the user at tape end with

an LED indicator.

Radio reception is protected from pulse noise interference by the inclusion of Pioneer's own PNS synthesizer circuit.

The KP2950 has been designed for easy-fitting into all popular modern cars and will play through a wide range of Pioneer speakers.

For further information, please contact Pioneer on (03)580-9911.

Sharp video camera

Sharp's new XC-78 is designed to appeal to those who produce professional videotapes. A switch operation allows titles or dates to be imposed (up to 48 characters in length), while it features half-inch Newvicon pickup tube and the f 1.2 lens allows pictures to be taken in as little as 10 lux.

The camera also includes auto focus, switches to adjust white balance and a tint control knob.



Easy operation video from National

The new National VTR NV-250A is designed with a three video head system offering still/still advance and still playback functions to stop the picture. It is noiseless and jitter free. Slow motion effects are obtainable by holding down the still advance.

Other features include 16-sta-

tion quartz synthesizer tuning, picture sharpness control, auto rewind and memory function and cue/review at five times normal speed.

For further information contact National Panasonic, 99 Epping Rd, North Ryde, NSW 2113. (02)887-5315.

Perreaux Tone Control

For those people with Perreaux pre-amps and power amps who want a tone control, Perreaux has released the T2 dual channel tone control unit. Specs for this unit include 20 Hz to 20 kHz distortion at maximum output with centred tone controls; THD 0.002% at 1 kHz rising to 0.009% at 20 Hz to 20 kHz; less

than 100 dB noise; and 60 dB channel separation at 20 Hz to 20 kHz.

The unit comes with a class A mosfet headphone amplifier.

For further information contact Eurovox, 70 Princes Highway, Arncliffe, NSW 2205. (02) 597-6611.

Perth Electronics show

The Perth Electronics show starts at the end of next month. The organizer's expectations have it that there will be as many as \$100,000 visitors this year.

As this major Australian consumer electronics show closely

follows the major Chicago Consumer Electronics Show, visitors can expect a few first time Australian releases.

For travel arrangements contact Jepsens Travel (02) 922-4300.

ACOUSTIC CALIBRATION LABORATORIES

WE HAVE MOVED!!!

New laboratory at
27 ROSELLA STREET, DONCASTER EAST

An Independent Laboratory

SPECIALISING IN TESTING OF—

Microphones, sound level meters, filters, acoustic calibrators, measuring amplifiers.

ENTERTAINMENT EQUIPMENT

Tape recorders, turntables, pickups, amplifiers, loudspeakers.

SOUND SURVEYS

Environmental and Industrial

Contact our qualified engineering staff for details

Sound reasoning for sound analysis

ACOUSTIC CAL LABS—A Division of Associated Calibration Lab. Pty. Ltd.



Phone: (03) 842 8822
Telex AA35011



Registered by National Association of Testing Authorities

JAYCAR - YOUR No. 1 STORE FOR GREAT

Because of the devalued Australian Dollar we have sourced some Aussie manufactured items that are outstanding value for money! Check the "Aussie Made" logo in our ads for locally made goods at great prices! Remember! Aussie made goods means your precious dollar stays here!

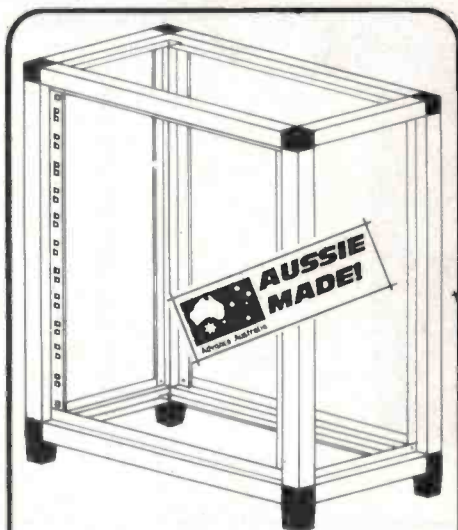

AT LAST! An Economical RACK CABINET MOUNTING SYSTEM!!

This fully Australian-made product we believe will become one of our hottest selling items!

It has taken an Aussie manufacturer to come up with the world's first low cost rack mounting system especially for the budget-conscious home constructor!

The rack mounting system basically consists of specially designed aluminium-extruded frames. Moulded plastic corner and feet pieces connect the extrusions together to form a rigid frame. No spanners, screwdrivers are needed but the use of a rubber or wooden mallet is advised to securely fit together the self-aligning pieces. When assembled the frame can be further strengthened with pop rivets. The system is supplied in knocked-down (kit) form to keep costs and freight down. Assembly takes around 20 minutes and instructions are supplied. In keeping with the low-cost philosophy, side and top panels are not included. Any reasonably competent reader should be able to fashion wooden or metal panels to suit. (Edge finish is not necessary as the panels recess into the frame). Jaycar will have special side panel sets available shortly however. Please watch our ads for further details.

THE RACK IS AVAILABLE IN 3 SIZES
6, 12 and 18 rack unit
 (One rack unit is 44.5mm or 1 3/4")

Each kit comprises: ★ 12 frame pieces, including 2 pieces with pre-punched holes for front panel mounting. Natural anodised finish. (You can use the rack back-to-front to mount non-standard racks) ★ 4 top corners (black) ★ 4 bottom corners (black) ★ 4 x clip-in M-6 nuts (for mounting your equipment) ★ 4 x M-6 Phillips head mounting screws ★ easy to follow instructions. But the best part about this exciting concept is **THE PRICE!**

ONLY

Cat. HR-5310 **6 RACK FRAME \$ 99**
 Cat. HR-5320 **12 RACK FRAME \$119**
 Cat. HR-5330 **18 RACK FRAME \$139**

Extra M-6 captive nuts (Pack of 12)

Cat. HP-0640 **\$4.95**

Extra M-6 x 16mm plated Phillips head mounting screws (pack of 12)

Cat. HP-0645 **\$2.95**

AVTEK MULTIMODEMS

State-of-the-art multimodem - has the following data standards CCITT V.21 & V.23, BELL 103 & 202 - Data rates 300, 600 & 1200 BPS - Backward channel 75 BPS in conjunction with 1200 BPS - Computer Interface CCITT V.24 (RS232C) - Power requirements 240V AC 3 watts. Talk to the world with this fine Multimodem.
 Cat. XC-4820

INCLUDES PHONE

\$349.00

MiniModem

★ 300 Baud full duplex ★ Answer/originate ★ Plugs straight in hardware phone ★ Superior VLSI chip performance (identical to Multimodem) ★ Telecom approval CB4/37/1173.
 Cat. XC-4825

ONLY \$199.00
INCLUDES PHONE

FREE CATALOGUE

Ask for a FREE COPY of our 1985 Engineering Catalogue or send large SAE with 50¢ stamp.

JAYCAR JVE-1 VIDEO DETAIL ENHANCER

(For technical details see page 15 of our catalogue or send SAE). This is made in Australia exclusively for Jaycar. It was designed at a well-known Australian University. It was designed with Australian standard video systems in mind and beats the pants off some expensive imports!

(Power adaptor Cat. MP-3020 only \$9.95 extra)

Cat. AV-6501 **ONLY \$69.95**



1/4" (6mm) BRASS Clearance Spacers

Bulk packs - from as low as 6¢ each!

We are pleased to announce that we are having these MADE IN AUSTRALIA. They are high quality, natural brass finish and will allow a 4BA screw to pass through with clearance. They are 1/4" dia. as well.

YOU CAN BUY THEM FROM US IN PACKS OF:

8 Cat. HP-0860 **\$ 0.95**

100 Cat. HP-0870 **\$ 8.50**

500 Cat. HP-0871 **\$30.00**

MAIL ORDER HOTLINE

To save you time (and therefore money) we have installed a special HOTLINE direct to the inner workings of our mail order dept. This saves you from going through our Head Office switchboard! If you wish to place an order, enquire about an order or simply check for more information, call:

(02) 646 1300

GREAT NEW PRODUCTS!!!

Our ongoing product development brings you unique new products every month!

RCA Plugs - Yellow and white covers. They match red and black for identification of stereo input/output leads.



Cat. PP-0240 RED	\$0.45	1-9	10+
Cat. PP-0242 BLACK	\$0.45		
Cat. PP-0243 YELLOW	\$0.45		
Cat. PP-0244 WHITE	\$0.45		

5 pin DIN plug 270° spread of pins. These plugs are used in computer and some video applications. Shielded backshell.



Cat. PP-0305	\$0.90	1-9	10+
--------------	---------------	-----	-----

Electricity Authority Approved Fuseholder! At Last! A 3AG 240V 10A fuseholder that is approved but at a reasonable price! (Approval No. CS2929). Ideal for manufacturers.
 Cat. SZ-2025 **ONLY \$3.95**



Blue Strobe Flasher 12V This unit has a magnetic base and is fitted with 4 metres of cable terminating in a cigarette lighter plug. Ideal for car alarms or fitted to a stereo cover to bring visual attention to a theft.



Cat. LA-5105
ONLY \$32.50

NEW! Longer TV plug-to-socket Fly leads (75 ohm)

Cat. AV-6580 1.8 metre Plug-to-Plug	\$3.20
Cat. AV-6582 1.8 metre Plug-to-Socket	\$3.45
Cat. AV-6584 4.5 metre Plug-to-Plug	\$4.95
NEW! Cat. AV-6585 4.5 metre Plug-to-Socket	\$5.95
Cat. AV-6586 10 metre Plug-to-Plug	\$9.75
NEW! Cat. AV-6587 10 metre Plug-to-Socket	\$10.95



Coaxial Cable Joiner Now you can join 3C2V, RG59, RG58, 5C2V coaxial cables together WITHOUT SOLDER with this nifty cable joiner!

Cat. PS-0618 **ONLY \$1.50**



Solderless BNC line plug This enables you to terminate coax in the field without a soldering iron! Reliable screw connection withstands flexing.

Cat. PP-0652 **ONLY \$2.75**



At Last! A car 12V cigarette lighter SOCKET! A panel mount source of 12V for cars, boats, planes. You even can plug a cigarette lighter into it!

Cat. PS-2002 **ONLY \$4.50**

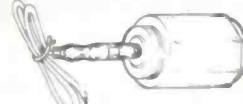

NEW! Gel-cell Battery Charger Specifically for charging Gel-cells with 1/4" quick connect tabs on them. 240V AC to 12V DC @ 300mA ensures fast charge!

Cat. MB-3506 **ONLY \$10.95**

MOTOROLA PIEZO TWEETER BARGAIN!

Quite frankly we were staggered when an Importer came to us with his dilemma. We couldn't believe our ears when we were told the price of the genuine US-made Motorola brand KSN-1071 high performance tweeter. "With such a strong US dollar," they said the price we offer to you is far below our current replacement cost. This HI-FI high power tweeter is a surface mount, controlled dispersion line source unit that is fitted with its own grille panels. The use of high temperature materials in its construction enables it to be used in automotive applications. Two piezo elements provide a wide (90°) dispersion horizontally with a narrow 30° dispersion vertically. Sensitivity is 98dB @ 2.8V @ 1/2m. Frequency response easily goes out to 40kHz but this can be limited with external passive components if necessary. A comprehensive data sheet is supplied, which includes frequency response graph, specs, mounting details etc. The KSN-1071 normally sells for a very reasonable \$24.00 each (pre devaluation). While stocks last, this unit is available from Jaycar for the ridiculously low price of **\$12.95 each!** That's right! A high quality, high power HI FI tweeter for a pittance! HURRY!

Cat. CT-1918
ONLY \$12.95 each

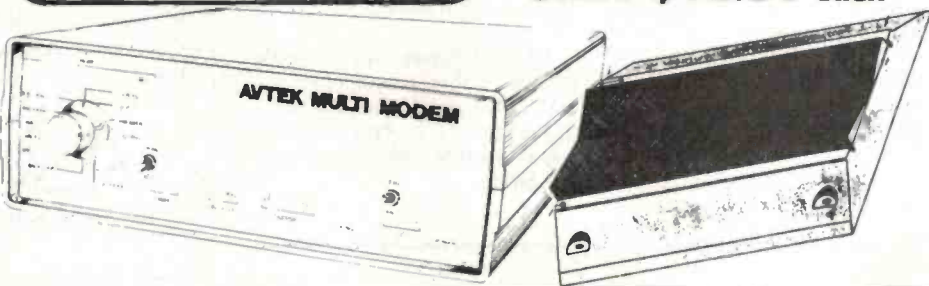

PRODUCTS AT GREAT PRICES!!

SCOOP PURCHASE! GENUINE SIEMENS

Universal voltage tester with LED indicator
The Siemens "UNISPANN" voltage probe has been around for some time now. You can determine the presence of AC or DC voltages safely anywhere with this quality probe. It will even tell you which AC mains conductor is active and works from 6-500V AC or DC. It also shows DC polarity.
Normally these units are very expensive but a Jaycar SCOOP PURCHASE brings them to you at a great price!
WHILE STOCKS LAST - AN INCREDIBLE BARGAIN
Cat. QT-2220

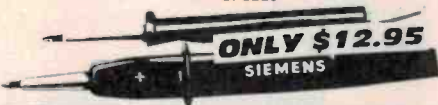

ONLY \$12.95
SIEMENS

TELEPHONE EXTENSION LEADS

Our purchasing guys a "bunny" and now we've got them coming out of our ears! SAVE HEAPS while we are in this dilemma!

- YT-6010 5m Ext. lead **\$9.95 SAVE \$5**
- YT-6012 10m Ext. lead **\$12.95 SAVE \$7**
- YT-6013 15m wind up reel **\$12.95 SAVE \$7**
- YT-6014 20m wind up reel **\$14.95 SAVE \$8**

☆ SAVE HEAPS ☆



BLANK PCB - BARGAIN OF THE CENTURY

We have secured massive stocks of high quality copper-clad PCB material in both single and double sided versions. Jaycar has NEVER had the opportunity to sell material at anything NEAR this price before. We suggest that you stock up NOW as we doubt that we will EVER be able to repeat this bargain again.

OFFER 1

Blank, single sided board. Phenolic base. Dimensions approximately 350mm (14") x 330mm (13").
Limit 2 sheets per customer
Cat. HP-9508

May Only \$3.95
(Normally \$6.95) - SAVE \$3.00

OFFER 2

Blank, single sided board. Fibreglass base. Dimensions 350 x 330mm
Cat. HP-9510

May Only \$4.95
(Normally \$8.95) - SAVE \$4.00

OFFER 3

Blank, double sided board. Fibreglass base. Dimensions 300mm (12") x 300mm (12")
Limit 4 sheets/customer
Cat. HP-9520

May Only \$6.95
(Normally \$12.95) - SAVE \$6.00

Note that the normal price is based on 300mm square sheets and not this larger size - an even greater saving!

FM TRANSMITTER MODULE

FEATURES
★ Ultra low noise output (-60dB or better attainable with suitable tuner)
★ Excellent frequency stability
★ NOT a kit - ready for immediate use
★ Connections required: (A) Power supply or battery (B) Antenna (C) Audio Input
★ Full instructions supplied
★ Suits any application where a stable low noise FM link is required

SPECIFICATIONS.
● Frequency 88 - 108MHz
● Useable range - 50 metres
● Supply - 6 to 9V @ 20mA
● Input sensitivity - adjustable - max 30mV
● Pre-emphasis - 50µs standard
● Dimensions 90 x 22 x 15mm (approx)
Cat. DT-5450



ONLY \$59.95

NEW! BY POPULAR DEMAND! Verminex Transonic V Commercial Ultrasonic Pest Repeller

Everything that we have said about the Verminex domestic unit except that it is for commercial applications!

- ★ Sturdy metal cabinet
- ★ 3 selectable pitch and loudness settings to optimise for particular problems
- ★ Low power consumption
- ★ 14 day satisfaction guarantee
- ★ Includes AC mains adaptor
Cat. YS-5510

ONLY \$159.00



ULTRASONIC PEST REPELLER

Which of these do you need to get rid of? Mice, blowflies, birds, spiders, bats, rats, cockroaches, flies, moths or fleas? The Verminex ultrasonic insect/pest repeller creates a sonic environment which is totally hostile to the creatures mentioned.

HOW DOES IT WORK?

The environment is relatively devoid of ultrasonic sounds. Evolution has not had a compelling reason to protect non-acoustic sensory mechanisms from ultrasonic stimulation. By subjecting an insect or rodent to a high level ultrasonic soundwave of a particular pattern the creature begins to behave in a typical fashion. The pest becomes disoriented, lethargic and bewildered. The natural reaction is to escape from the sound affected area. The sonic pattern is the secret and this pattern is a combination of scores of frequencies mixed together. The pattern was developed by Professor J.L. Stewart - the man who invented the Bionic ear. It works!

Like us, you would be skeptical at first that this would work. Our first reaction was, "If they are so good why haven't we heard about them before?" or "Surely a product like this - if it was any good - would have been around years ago!" There have been ultrasonic repellents around but none of them are from patented soundwave pattern of the Verminex. We have on our file, many letters of testimony to the fact that the Verminex is effective. The letters are from Australian Universities, Animal Husbandry research institutions, commercial Piggeries, restaurants etc. Many of them had several pest problems! Your pest problems may not be as bad but it may still be a nuisance, which is why the domestic Verminex was developed. We are so confident of the Verminex units' effectiveness, we make the following offer.

Buy the Verminex from us and use it for up to 14 days (21 days for mail order customers). If you are not happy with the product after using it as directed, return it to us in a clean, original condition and we will refund your money in full! (Less post/packing). What have you got to lose? The Verminex covers an area of 2000 sq. ft (uninterrupted) and is not cheap. But if the idea of dangerous chemicals, sprays, baits etc worries you it's a great solution. It is supplied with a 240V plug pack but can be battery powered.
Cat. YS-5500

WHAT HAVE YOU GOT TO LOSE EXCEPT THE BUGS! \$79.00

INFRA RED MOVEMENT DETECTOR

- Built-in test lamp
- Tamper switch included
- Alarm output SPST 30V DC @ 1A

- 12V DC powered
- Small 4 1/2" x 2" x 1 1/2"
- Double sensor
- Computerised OC to lower failure rate

MULTIMETER "PIN PLUGS" to

EZ HOOKS - Great multimeter probes that will fit the 2mm diameter pin tip sockets of your multimeter. (NOT "banana" type sockets).
Cat. WT-5314

Normally \$3.95/set
this month \$1.50
WHACKO! Only 430 available. Hurry!



\$99.00

UV EPROM ERASER

Erase your EPROMs quickly and safely. This unit is the cost-effective solution to your problems. It will erase up to 9 x 24 pin devices in complete safety. In about 40 minutes for 9 chips (less for less chips).

- Erases up to 9 chips at a time
- Chip drawer has conductive foam pad
- Mains powered
- High UV intensity at chip surface ensures thorough erase
- Engineered to prevent UV exposure
- Long life UV tube
- Dimensions 217 x 80 x 68mm
- Weight 670 grams

Cat. XE-4950

ONLY \$89.50

Jaycar ELECTRONICS

Incorporating ELECTRONIC AGENCIES

NUMBER 1 FOR KITS

MAIL ORDER HOTLINE (02) 646 1300

N.S.W. SHOWROOMS

- SYDNEY: 117 York Street Tel: (02) 267 1614
- CARLINGFORD: Cnr. Carlingford & Penment Hills Road Tel: (02) 872 4444
- CONCORD: 115/117 Parramatta Road, Tel: (02) 745 3077
- HURSTVILLE: 121 Forest Road Tel: (02) 570 7000
- GORE HILL: 188/192 Pacific Highway (Cnr Bellevue Avenue) 439 4799

QUEENSLAND

BURANDA: 144 Logan Road Tel: (07) 393 0777

MAIL ORDERS:

P.O. Box 480, AUBURN 2144 Tel: (02) 643 2000

HEAD OFFICE:

7/9 Rawson Street, AUBURN 2144.

Tel: (02) 643 2000 Telex: 72293

SHOP HOURS

- Carlingford: Hurstville & Gore Hill
- Mon-Fri: 9am - 5:30pm, Thurs 8:30pm, Sat 12pm
- Sydney
- Mon-Fri: 8:30am - 5:30pm, Thurs 8:30pm, Sat 4pm
- Concord
- Mon-Fri: 9am - 5:30pm, Sat 4pm

POST & PACKING

- \$5 - \$9.99 \$1.50
- \$10 - \$24.99 \$3.20
- \$25 - \$49.99 \$4.50
- \$50 - \$99.99 \$6.50
- \$100 - \$198 \$8.00
- Over \$199 \$10.00

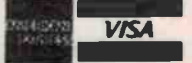

MAIL ORDER VIA YOUR PHONE

COMET ROAD FREIGHT ANYWHERE IN AUSTRALIA ONLY \$12

32-bit CPU chip addresses 4G bytes

The George Brown Electronics Group has announced the availability of Zilog's Z80,000 CPU.

The Z80,000 is an advanced, 32-bit microprocessor that is said to integrate the architecture of a mainframe computer into a single chip. It is fully compatible with Z8000 software and hardware, yet it provides far greater power and flexibility in both

architecture and interface capabilities.

Designers can easily develop operating systems and compilers in the Z80,000 CPU environment. The hardware interface allows simple connection to a wide variety of system

configurations.

Features include: virtual memory management integrated with the CPU; on-chip cache memory; general-purpose register file with sixteen 32-bit registers; sophisticated interrupt and trap handling; software that is a

binary-compatible extension of Z8000 software; ability to support both 16 and 32-bit buses.

Further information is available from the George Brown Electronics Group, 174 Parramatta Road, Camperdown, NSW 2050.

256K EPROM

The M27256 is a 262 144-bit ultraviolet erasable and electrically programmable read only memory. It is organized as 32,768 words by 8 bits and manufactured using the SGS NMOS-E3 process. The EPROM has a single +5 V supply and an access time of 200 ns.

An important feature is separate output control. Output enable (OE) is separate from the chip enable control (CE). The OE control eliminates bus contention in multiple bus microprocessor systems.

The M27256 also features a standby mode which reduces the power dissipation without increasing access time. The active current is 100 mA while the maximum standby current is

only 40 mA. The standby mode is achieved by applying a TTL high signal to the CE input.

The combination of the M27256's high density, and new advanced microprocessors with megabit addressing capability provides designers with opportunity to engineer high-performance systems.

The large storage capability allows it to function as a high density software carrier. Entire operating systems, diagnostics, high-level language programs and specialized applications software can reside in an M27256 directly on a system's memory bus.

Data is available from Ellistronics, 797 Springvale Road, Mulgrave, Vic 3170.

Fiberoptic connectors

The new Optalign metal shell fiberoptic connectors feature a four-rod glass element for inherent fibre self-aligning characteristics, cleanliness and chemical inertness. Used for coupling single-mode/multimode optic fibres. The connectors are immune to shock and vibration and have the ability to match fibre diameters which might be at opposite tolerance limits. The fibre alignment element does not demand precision tolerances and dimensions of its connector envelope to achieve low dB losses, resulting in lower connection costs.

Optalign Model MM connector is suitable for 230 micrometres,

140 micrometres and 125 micrometres multimode fibres and offers 0.2 dB index-matched connections with 500 cycle durability. Model SM is designed for use with 125 micrometres, 110 micrometres and 70 micrometres single-mode fibres, offering less than 1 dB losses. Both models operate from -55 to +80°C.

The connectors are easy to assemble (in as little as 10 minutes) and the connectors do not require epoxies or fibre polishing tools.

For further information contact Total Electronics, 9 Harker Street, Burwood, Vic 3125. (03)288-4044.

Optocouplers with greater isolation

To lengthen the voltage breakdown paths between the pads on pc boards, Siemens has designed its optocoupler SFH 601 with a greater pin centre-to-centre distance.

On the new SFH 601 G the pins are 4/10 inch apart instead of 3/10 inch as in earlier versions. This increased spacing enables these optocouplers to be safely used in office equipment where, in compliance with IEC

380 an isolation distance of at least 8 mm is called for. The test voltage of 5.3 kV remains unchanged.

Another option from Siemens are optocouplers with the ends of the pins bent out at right angles. This design permits surface mounting and automated assembly.

For more details contact Siemens, 544 Church Street, Richmond, Vic 3121.

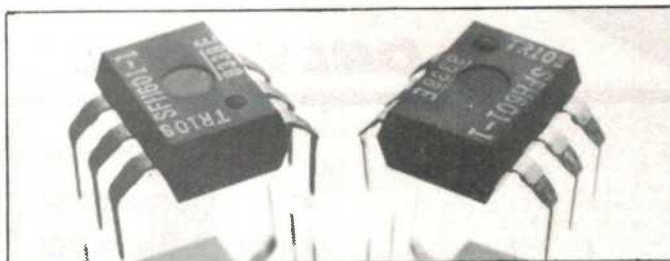

Microswitches are very small

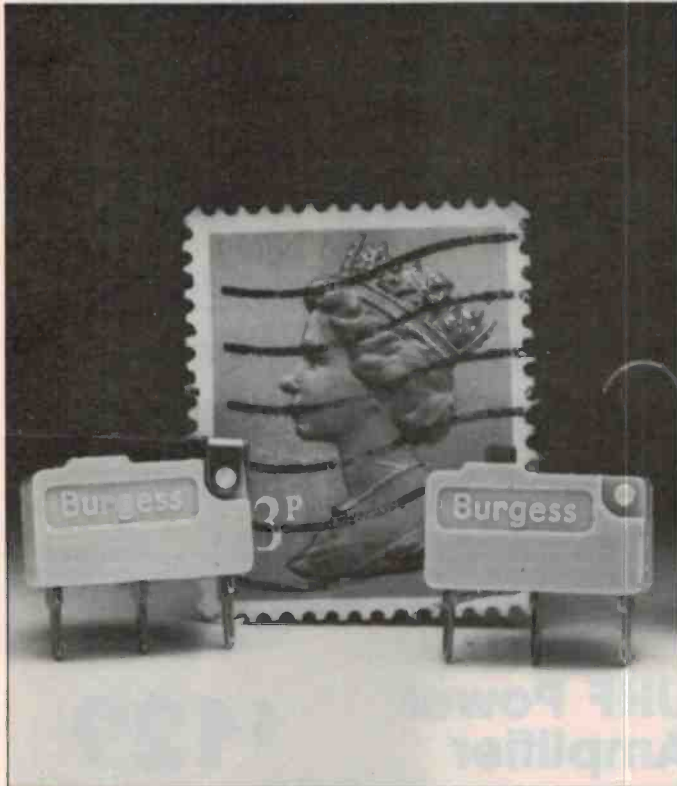

Burgess Micro Switch Company has developed an ultra-miniature microswitch capable of switching 7 amps at 250 Vac.

The F5 ultra-miniature microswitches have an overall body

size of 12.8 x 8.3 x 5.1 mm and weigh only 1 gram.

Burgess switches are available from Email Relays/Bellco Controls, 15 Hume St, Huntingdale, Vic 3166.

High performance voltage suppressors

Zener diodes have a certain amount of surge capability but in most instances the surge handling capability is not a specified parameter. TransZorbs are silicon p-n junction devices which have been designed and tested as transient voltage suppressors. TransZorbs are characterized by their high surge handling capability, fast response time, and low clamping voltage compared to their small physical size.

Different zener diode manufacturers use different manufac-

turing techniques in the formation of the junction. As both the process and the junction size are directly related to the surge performance, a standard JEDEC device purchased from one manufacturer may not have the same surge performance as the original prototype.

The surge performance of TransZorbs can be specified and test results and other data are available from Electronics and Semiconductor Distributors, Barrie Road and Adina Court, Tullamarine, Vic 3043.

BRIEFS

Fast CMOS 8086

Intel Australia reports that the 8086 and 8088 family of processors and peripherals will be made available in high performance, low power versions using Intel's CHMOS process. Processor power consumptions are of the order of 10 milliamperes per megahertz. For details contact Intel Australia, Level 6, 200 Pacific Highway, Crows Nest, NSW 2065.

High power IR diodes

Output powers of 900 mW/sr are possible at 1.5 A peak current from a new series of GaAlAs infrared LEDs manufactured by Telefunken Electronics. The LEDs will be available from Promark Electronics, Suite 208, 6 Clarke Street, Crows Nest, NSW 2065.

Cables, connectors and such

Looking for cables, connectors, switches or accessories, then Acme Electronics has a new catalogue. The booklet covers components for audio to ultra high frequencies and is available from Acme, 205 Middleborough Road, Box Hill, Vic 3125.

Standard cell library

Total Electronics will be able to offer access to an expanded CMOS standard cell library following a joint second sourcing and development agreement in the US by Standard Microsystems and NCR. Information on the library, which includes analogue and digital cells, is available from Total, 9 Harker Street, Burwood, Vic 3125.

Reflective display components

Data on the Ferranti-Packard range of light reflecting electromagnetic display components is available from STC-Cannon Components. The products include seven segment and 5 x 7 matrix components up to 660 mm high. For details contact STC-Cannon Components, 248 Wickham Road, Moorabbin, Vic 3189.

Wideband op-amps

The Harris HA-2542 operational amplifiers have high slew rate and high output currents. Designed for pulse and video applications the devices have a power bandwidth of 5.5 MHz. For information contact VSI, 16 Dickson Avenue, Artarmon, NSW 2064.

CMOS 64K static RAM

Fairchild has made its CMOS memory debut with a 64K x 1 static RAM. Access speeds as low as 45 ns and a maximum standby power of 9 mA are quoted. Further information is available from Fairchild Australia, 366 Whitehorse Road, Nunawading, Vic 3131.

Pc board mount DIN sockets

Preh has introduced a line of pc mounting DIN sockets that comply with FCC rfi rules by providing a reliable connection between the socket and the cord plug. Available in three to eight pin versions, the sockets are distributed by Mayer Krieg, 246 Angus Street, Adelaide, SA 5001.

You'll save a fortune with

DSE KITS



FANTASTIC! \$439

Playmaster series 200 Hi fi Mosfet Amplifier

This is the one you've been waiting for. The all-new Playmaster Series 200 Integrated Amplifier is almost certainly the best build-it-yourself design to be published anywhere in the world! Feature for feature, dollar for dollar, it more than stacks up against the 'big names' in hi fi - with the big price tags to match.

And it has features that aren't even found on many of the 'names'. Features like electronic input switching. Circuitry to handle just about every input imaginable: moving magnet, moving coil, CD player, hi fi VCR, cassette, tuner, etc etc etc. Plus, of course, incredible 'headroom' with 100 watts per channel output power. And much, much more!

And don't forget the exclusive Dick Smith Electronics kit features: *Solder-masked and silk-screened PCB to help eliminate errors. *Power transformer with factory-wound low voltage winding (why wind by hand?). *Special step-by-step construction manual *complete with our 'Sorry Dick, it doesn't work' repair service. *PLUS our exclusive satisfaction guarantee: you can return the kit within 7 days if you think construction is beyond you!

Cat K-3516

4 Sector Home Alarm

Once upon a time, we had a kit for a simple alarm. Then everyone started asking for an all bells and whistles kit. So we brought out the EA 8 sector alarm kit. Now it seems everyone wants a simpler kit again!!!

Here it is: designed by Dick Smith Electronics Research and Development division to suit the requirements of the majority of users.

- Features instant or delayed inputs
- Wire-out-proof system - suitable for all types of sensors
- LED sector and control state indication
- Adjustable entry, exit and alarm periods

Short form kit - suits 'building in' to whatever you like!

Easy to build - and could save your property!
Cat K-3254

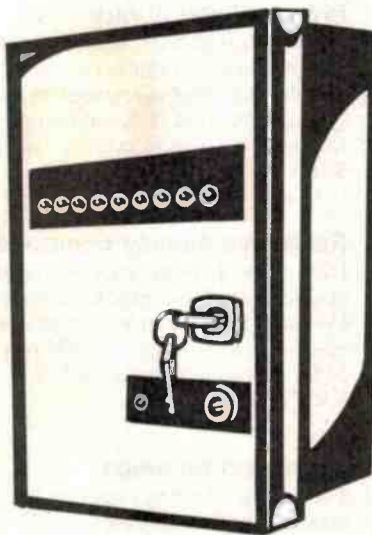

\$49

Short form kit
Does not include case

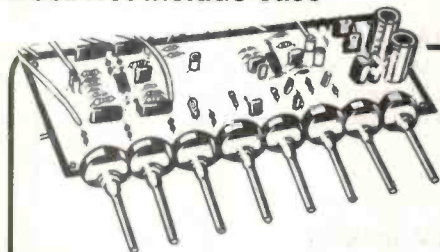

Mixer Preamp

Designed to suit the 300W amp kit, this mixer preamp has 4 inputs with an impedance of 100K - suitable for most microphones, guitars, etc. Ideal also for use with 50W (K-3400) and 100W (K-342) power amp modules. This unit provides bass, treble and presence control. Instructions supplied.

Short form kit: no case, transformer or power supply.
Cat K-3035

\$32⁹⁵

VCR Theft Alarm

WAS \$54.95



Don't let your VCR become the most talked about item behind the pub! Build this neat little kit and it will scream its head off if anyone tries to make off with your pride and joy! Cat K-3423

NOW ONLY **\$29⁹⁵**

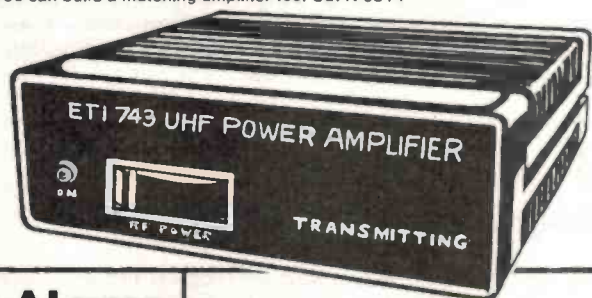

UHF Power Amplifier

\$129

Now a power amplifier for UHF AMATEUR AND CB radio. A very healthy 25 watts output from virtually any UHF input (from around 300mW or so.) And that could make the difference between being heard and...

The amplifier kit is complete to the last nut and bolt - including the same deluxe case used in our UHF amateur transceiver, and its matching power supply. So now you can build a matching amplifier too! Cat K-6314

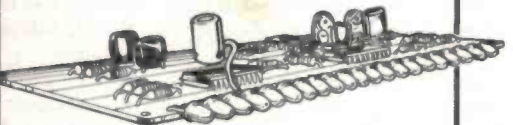

LED TACHO

Don't spend a fortune buying a tachometer - build your own and save! Displays engine speed in an analogue form in an illuminated row of LED's. Instructions included - a great kit!
Cat K-3240

\$24⁵⁰

en you build it yourself!

Earn a Fortune!
(or a few cents)

Build the Busker Amp

Easy-to-build general purpose microphone/guitar preamp & power amplifier, ready to build into a speaker case for a go-anywhere mini pal

Ideal for the budding buskers in the family. Also fantastic for displays, fetes, rallies, etc.

Includes components, speaker but we leave the case to you (if you want to use away from power point you'll also need a 12V gell cell.
Cat S-3320



Cat K-3446

\$79⁹⁵

Short form kit
Does not include case

Stereo Enhancer

Here's a great kit for those on a space budget! If your listening area is not exactly stereo quality, the stereo enhancer will 'widen' the sound to make it sound like it's almost designed that way!

Complete kit, including special abs case together with instructions make this one a beauty to put together - and even more of a delight to use.

As described in ETI, March 1985.
Cat K-3419



\$79⁹⁵

VCR Sound Processor



Unless you're lucky enough to have one of the new hi fi videos, the sound from your VCR is probably pretty pedestrian! Now you can give it a lift with this VCR Sound Processor!

It includes an effective stereo simulator circuit, a 5 band graphic equaliser to make up for the crook audio and your (probably!) equally crook listening room plus noise filtering to get rid of tape hiss and other unwanted high frequency noise. Cat K-3422

\$49⁹⁵



Speed Controller

A completely new circuit offering unbelievable smooth control and torque - even at very low rpm. Yes, it's even better than the previous model! New design includes 'in line' plugs and sockets for extra convenience. Suits virtually all 'universal' (brush type) motors.
Cat K-3084

\$21⁹⁵

Ultrasonic Movement Detector

The problem with 99% of car alarms is that they cannot prevent the thief who breaks a window and reaches in for the goodies. While this kit won't prevent the window being broken, it will protect your property inside the car. Silent ultrasonic rays detect any movement and trigger the main alarm systems. Cat K-3251

\$19⁹⁵

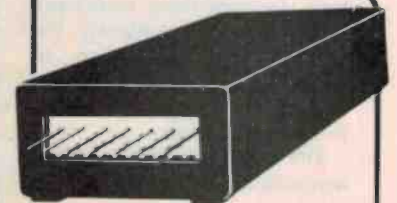

Negative Ion Generator

You've heard all about Negative Ion Generators and their benefits, now buy the kit and find out what it's all about. Many commercial units run from the mains, but our kit is safe - it runs on 12V DC, which also means that you can put one in your car! Kit includes exclusive Dick Smith emitter head, power pack and tough moulded plastic case.
Cat K-3335

\$42⁵⁰

Stereo TV Decoder

TV sound can be very high quality - especially now it's being transmitted in stereo. But 99.9% of TV sets can't take advantage of this because they're only equipped for mono sound. And 99.9% of people aren't willing to get rid of a perfectly good colour telly just to get stereo sound! Especially when a new stereo colour TV can set you back the best part of a tidy bit! Here's the Dick Smith Electronics-low-cost-solution.
Cat K-6325



\$249

DICK SMITH ELECTRONICS

PTY LTD

See page 117
for store addresses

Arbitrary waveform generator

A new arbitrary waveform generator developed by Wavetek of San Diego, USA, has the ability to link a number of waveforms in either series or parallel.

Each waveform has a vertical resolution of 4096 points and a horizontal resolution that is adjustable from two to 8192 points. The waveform memory is broken up into four blocks of 2048 points, so four different waveforms of up to 2048 points can be in memory at any one time. Each of these waveforms can be used independently. Or, adjacent waveforms can be linked. Memory is battery backed, allowing user waveforms to be stored.

The sample period is crystal controlled and adjustable from

500 ns to 50 s, allowing waveform periods of 1 μ s to 113.8 hours. The sample period can also be controlled by an external clock with a period of 500 ns or longer. Waveforms can be stopped and started at any point in the waveform either with an external signal, front panel push-button or pre-programmed triggerpoints.

It contains the unusual (and important) feature of 'rubberband editing', similar to stretching an ordinary rubber band between thumbtacks. On the screen, an electronic drawing pin



is placed at each end of a waveform with the cursor being placed between them. The cursor can be moved either horizontally or vertically, with the waveform following in real time. Thus, with rubberbanding, it is very easy to stretch or compress custom waveforms. Also one cycle of standard waveforms such as sine, havesine, or triangles can be placed between thumbtacks and then modified in amplitude, offset and phase. This powerful editing allows the user to quickly create any waveform directly from the front

panel using only an oscilloscope.

An optional RS-232C or GPIB port is available for entering waveform data from an external computer. Because Synch Out is adjustable, more than one unit can be linked in parallel producing waveforms with controllable phase relationships. An additional feature includes a burst counter that allows the counting of from one to 1,000,000 waveforms, which eliminates the need for an additional counter when the Model 75 is used for structural and fatigue testing.

Intelligent LED

Intelligent LED displays that are able to generate complete characters from simple signals have now been diversified to perform additional functions. The new PD 2816 from Siemens

(eight 18-segment elements, 4.1 mm) allows the user to have the characters flash or underlined and to adjust the display intensity. A CMOS circuit stores the program.

The PD 2816's programmable features extend an LED display's vocabulary beyond alphanumeric characters without calling for additional components.

Intensity of emission can be reduced by 50 or 75% so as to downgrade the significance of the information displayed or adapt the brightness to the ambient light conditions. When the display flashes, the memory contents remain intact. The characters only need to be input once and not in the rhythm at which the LEDs light up.

The electronics in the PD 2816 comprises the character generator (ROM), multiplex, timer logic and driver logic, and also the CMOS circuit for the supplementary programmable functions. The 4.1 mm-high characters are enlarged by lenses. Any number of eight-element displays can be cascaded to form long lines of text.

For more information contact Measurement & Control Division, Electrical Equipment Limited, Unit C, 8 Lyon Park Road, North Ryde, NSW 2113.

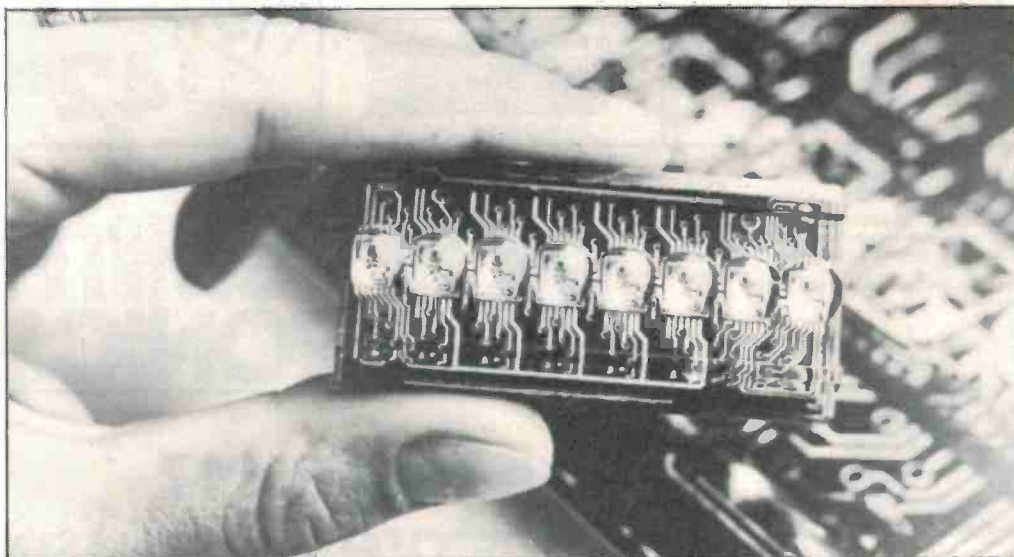

Personal development with MacroDynamics

MacroDynamics has just released the fully integrated Microtek Personal Development System.

With in-circuit emulators (MICE II), cross-assemblers and advanced software, it serves as a high-level design tool for hardware development. MPDS supports debug and testing for products based on 8- or 16-bit microprocessors from Intel,

Motorola, Zilog, etc. An extensive software base is provided to simplify and speed product development. This multi-purpose portable tool supports users in the lab, the factory and the field.

For further information contact the Australian distributor **Macro Dynamics, Bayswater, Vic. 3153.**

STD motherboards

Pro-Log's new 711X Series are four layer motherboards with +5 V and ground planes occupying the centre layers. This virtually eliminates IR drop along the length of the bus with interleaved signal and ground traces and reduces cross-talk. These

features provide a motherboard less susceptible to noise and therefore ideal for higher performance CPU cards.

For further information contact **Pro-Log (Australia), PO Box 1, Canterbury, Vic 3126.**

New electronic time switch

Energy Measurements has released its newest Time Switch — The EM 28. It has a capacity for 123 separate switching functions or 861 events.

The program base is a yearly function which allows for the programming of specific dates up to one year ahead. This is of advantage in building management where air conditioning plants, lighting and other services are not needed on public holidays etc. The four channel unit has a programmable adjustment for automatic daylight saving time changeover.

Programming is by cursor and all instructions can be recalled, changed or erased individually. There is a manual override switch on all four channels and a battery reserve keeps the EM 28 fully operational during power failures.

Each channel has an inbuilt hour meter and switching functions are on-off and impulse (1 second).

For more information contact **Energy Measurement, PO Box 90, Pymble, NSW 2073. (02)449-9910.**



BRIEFS

Static solution

Static can be one of the most annoying and disruptive elements in our hot and dry environment when we are dealing with computer work and electronic instruments. It can cause problems ranging from a small "hiccup" in the system, to a complete loss of your program, and even jamming or destruction of components in your system. ZAP! Just like that! Bill Sharpe and Ray Freer, both of Trio Electrix, are fully conversant and exuberant about STATICIDE and its potential for eliminating static problems. To get in touch call at Trio Electrix Pty Ltd, 177 Gilbert Street, Adelaide SA 5000. (08)212-6235.

Breakpoint control

Microtek International has announced a comprehensive breakpoint control unit for all MICE II in-circuit emulators. Its optional single card pcb, that features sophisticated breakpoint logic. It includes up to 120 new breakpoint structures for more flexibility in target system debug and development. The BPP also includes external hardware triggering and an execution activity timer. This powerful triggering system helps you to quickly solve the most difficult software and hardware bugs.

Test accessories

Tecnico Electronics has announced its appointment as Australian distributor of instrument test leads, probes and accessories from H.C.K. of West Germany. For further information contact Tecnico Electronics, 11 Waltham Street, Artarmon NSW 2064. (02)439-2200 or Vic (03)542-3260.

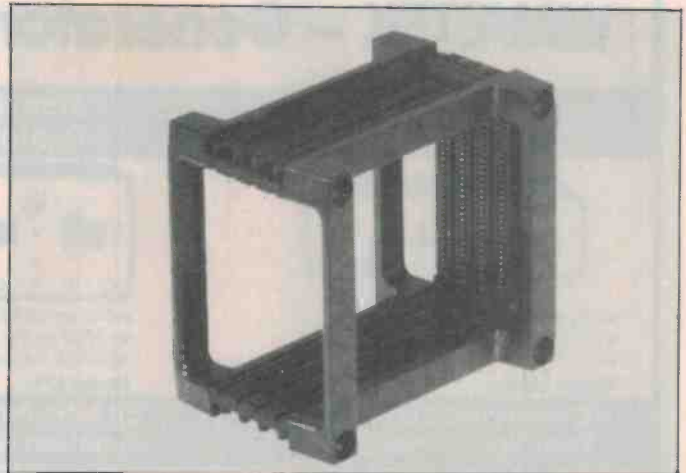

Pulsar racks

Build-A-Rack, from Pulsar Electronics, is a modular bus and card guide system designed for use by research laboratories, specialist electronic engineers and OEM manufacturers.

The systems can be used for any combination from two to 32 slots in each unit. The motherboard contains combinations of 56 pin STD bus slots suitable for

S-100, STD and multibus applications.

A typical four card system including bus, eight card guides and locking pins is priced at \$106.

For further product information contact **Pulsar Electronics, Lot 2, Melrose Drive, Tullamarine, Vic 3043. Phone (03)330-2555.**

JPW

A NEW GENERATION OF BRITISH LOUDSPEAKERS.

The sound from the new JPW speakers is nothing short of a revelation.

Every detail in design and construction is meticulous; from the solid wood cabinets to the immaculately engineered components.

Two of the three JPW models offer the choice of an active or passive crossover system.

For more information:
LEISURE IMPORTS,
233 Military Road,
Cremorne, 2090.
(02) 908 3944



BUILD YOUR OWN SPEAKERS

The superb DYNAUDIO and SCAN-SPEAK drivers from Denmark are now available in Australia. These loudspeaker drivers are used by many superior brand named speakers, some of which sell for up to \$13,000 per pair.

Here is your chance to design and build your own top speakers. If you prefer, you can use the designs and crossover networks we have available. All specifications are available on request, including 'Thiele & Small' parameters for design of bassreflex cabinets.



TRADE AND OEM INQUIRIES WELCOME.

Sole Australian Distributor:

SCAN AUDIO Pty. Ltd.

P.O. Box 242, Hawthorn, 3122. Ph. (03) 819 5352

Wholesalers:

Perth: Sampson Agencies (09) 364 9516

Cairns: Island Agencies (070) 93 7462

Brisbane: Qld. Stereo/Visual Supply (07) 265 7945

WAVETEK – Generators for every application

Low Cost with Trigger & Gate

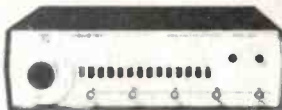

- 20V p-p output
- 0.004 Hz to 4 MHz frequency range
- DC offset with calibrated zero

Model 182A:

Stabilized with Digital Readout

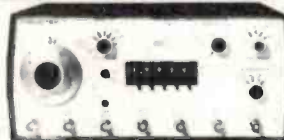

- 4 1/2 digit or 1000:1 dial control
- -70dB spurious
- 0.005% frequency accuracy

Model 171:

50 MHz Pulse Generator



- 100 μ Hz to 11 MHz
- Crystal stabilized to 0.09%
- Trigger, gate and sweep (Model 22)

Model 21:

Model 22:

Combined Synthesizer/Function Generator

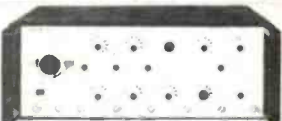

- Lin/Log Sweep plus AM/FM
- Pulse width and transition time control
- Independent pulse width and rate

Model 166:

50 MHz Pulse/Function Generator

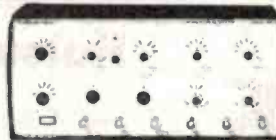

- Variable rise and fall times
- Single, double and pulse burst
- 20V output

Model 801:

20 MHz Sweep/Modulation Generator

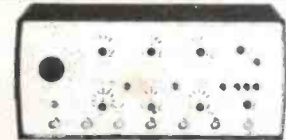

- Two generators in one for AM/FM/sweep
- Easy setup of modulation
- 30V p-p output

Model 193:



SCIENTIFIC DEVICES AUSTRALIA PTY LTD

2 JACKS ROAD, SOUTH OAKLEIGH, VICTORIA, 3167. PHONE: 579 3622
31 HALSEY ROAD, ELIZABETH EAST, S.A. 5112. PHONE: 255 6575
559A WILLOUGHBY RD, WILLOUGHBY 2068. PHONE: 95 2064

NOW MOHAMMED NEED NOT GO TO THE MOUNTAIN...

Imagine! A computer that's powerful enough to run your business . . . yet small enough to take home with you. That's the Bondwell 14 Portable. It has all you need to run a business - yet costs a fraction of the price of other computers. That's why it's the success story of 1985!



In just a few short months, the Bondwell 14 portable has become our largest selling business computer. It offers performance and reliability far exceeding its low price tag. Even first glance will tell you that the Bondwell 14 portable is no ordinary computer!

You'll see:

- 128K RAM on board!
- Twin 360K disk drives!
- 220mm amber-screen monitor!
- Twin RS-232 serial ports!
- Centronics parallel port!
- External video monitor port!
- Ergonomically designed adjustable keyboard!
- PLUS a package of famous Micropro 'Star' series software valued at over \$1200: Wordstar word processing, Calcstar spreadsheet, Datastar information handling and Reportstar report preparation. AND if that's not enough, a host of CP/M utilities including a speech synthesiser! Yes, this is all included FREE with your Bondwell 14 portable.

And just in case your business needs other specialised software, you have one of the biggest 'libraries' in the world at your disposal: the Bondwell 14 portable operates under the world-standard CP/M system. (And it's the latest, most powerful version - Vs 3.0.)

With the huge number of programs written for this system, you'll find the one you require. And the Bondwell 14 portable will read disk files from many other computers - including the IBM PC (& compatibles), Osborne, Kaypro and Spectravideo!

Weighing in at just 12kg and measuring just a little larger than an electric typewriter, the Bondwell 14 is truly portable. Take your Bondwell 14 to where the job is: Mohammed need no longer go to the mountain.

Your business survival depends on your making the correct decisions. Decide on the Bondwell 14 portable. And survive!

Want to know more? Call in to your nearest Dick Smith Electronics Computerstop for a test drive. Ask for a copy of the Bondwell 14 brochure. And then get your own Bondwell 14!

Bondwell Computers: exclusive to Dick Smith Electronics.

ALL THIS FOR ONLY

\$2495

Or \$247 deposit and \$19.85 weekly over 48 months to approved purchasers.

Dick Smith Electronics Pty Ltd

COMPUTERSTOP



Your one stop computer shop at your nearest Dick Smith Electronics centre.

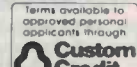

A964/A966RT585

ALTRONICS COMPONENTS

★ ★ ★ ★ ★ ★ ★ ★ ★ ★ Stereo Mixers at Low Import Price

ATTENTION—Social Clubs, Schools, Churches, Disco Operators, Entertainers, Hotels, Night Clubs and sporting Bodies. With Altronics low prices—here is your opportunity to install one of these outstanding sound control mixers. Both models include microphone "Soundover" facility—making either ideal for live entertainment use.

Stereo Audio Mixer



A 2550
\$125.00

240V Mains
Operated

This brilliant little mixing console is absolutely packed with features. Allows blending of Microphone, two Phono inputs and either two Tape or Turner inputs • Right and left VU meters • Separate Bass and Treble controls • 5 slide level controls • Fader control between Phono pickups for professional cueing • Headphone monitor switch • Talkover facility.

SPECIFICATIONS:

- Input Mic 0.5mV 600 Ohms Phono 3mV 50K Ohms Tape/Tuner 150mV 100K Ohms • Output 250mV • Frequency Response 20Hz to 20KHz (plus or minus 1db) • Tone Control (Treble) 10KHz (plus or minus 12db) • Tone Control (Bass) 100Hz (plus or minus 12db) • Distortion Less than 0.07% • S/N Ratio More than 60db • Headphone Impedance 4—6 Ohms • Dimensions 318 (L) x 217 (W) x 85 (H)

Pro-Quality Stereo Mixing Console

240V Mains
Operated



AMAZING VALUE

A 2570 **\$399.00**

Our sophisticated 'NEW' Audio Mixing Console is ideal for 'live' recording • PA mixing • Fantastic Tape recordings • Even Stereo/Mono VCR recording. A truly professional deck that features separate R/L 5 band graphic equalisers • Echo and Peak LED level indicators • Talkover facility • Separate H/Phono level control • Patch switch bank • Individual microphone, Phono 1, Phono 2, Aux/Line 1, Aux/Line 2, and Master slide level controls. — Blend up to two magnetic or crystal turntables, two tape decks or tuners and two microphones all at once!!

SPECIFICATIONS:

- Input Mic 1—0.5mV 600 Ohms Mic 2—0.5mV 600 Ohms Mic 2—0.5mV 600 Ohms (low imp.) 2.5mV 10K Ohms (low imp.) Phono 1 & 2 (Mag) 3mV 50K Ohms Phono 1 & 2 (Cry) 150mV 100K Ohms Tape/Tuner 1 & 2 150mV 100K Ohms • Equaliser 5 frequency bands—60Hz, 250Hz, 1KHz, 4KHz, 12KHz—Boost Cut range—plus or minus 12db @ Centre frequency. • Output 1.5V/0.775V (Selectable) • Frequency Response 20Hz to 20KHz plus or minus 1db • Distortion Less than 0.05% • S/N Ratio More than 50db • Headphone Impedance 4—16 Ohms • Echo B.B.D. System • Delay Time 30—200mS • Echo Repeat Control • Delay Time Control • Dimensions 480 (L) x 240 (W) x 110 (H)



Build These Great EA Projects

Save a bundle on the price you would otherwise pay for a commercial equivalent.

FREQUENCY COUNTER

Measures to 50MHz (to 500MHz with optional Prescaler).

Why Pay up to \$500 For Commercial Units?



UNBELIEVABLE 0.005% ACCURACY

- Frequency and Period measurement to 500MHz (with optional prescaler)
- High input sensitivity. Professional unit at a fraction of the cost of built up units.
- IC sockets provided throughout • Low age rate 10.000MHz XTAL • Quality ABS plastic case with deluxe front panel • Specified LSI.

- K 2500 **\$129.50**
- K 2501 **PRESCALER** **\$29.50**
- K 2502 **DECIMAL POINT** **\$9.50**

FUNCTION GENERATOR

With Digital Display sine, triangle and square wave outputs 15Hz—250KHz.



K 2505 **\$89.50**

The most essential piece of test gear (second only to a good multimeter) on any hobbyist's bench is some kind of audio signal generator.

A truly versatile unit at a bargain price.

- 4 digit frequency readout (eliminates tiresome dial calibration) — typical accuracy +2% • 3 overlapping ranges x1, x10, x100 • 600 Ohm Nominal Output — continuously variable 3MV — 2.5V P-P • Distortion—sinewave : less than 0.7% @ 1KHz • Linearly—triangle wave : better than 1% • 1KHz • Squarewave rise time— 6V/uS maximum output • Amplitude stability— better than 0.1db on all ranges.

With the exception of the display all components mount on a single PCB making this kit suitable for all constructors.

DIGITAL

CAPACITANCE METER

Measures 1 pf to 99.99 uf in 3 ranges



K 2521 **\$59.00**

This superb Test Instrument Kit now compliments our top selling Digital Frequency Counter and Function Generator Project Kit. Electronics Australia Project. Measures capacitance of both polarized and non-polarized capacitors from 1 picofarad to 99.99 microfarads in 3 ranges. Check values of unmarked capacitors, especially those little trimmers that are never coded. Select precise values for filters and timing networks with ease.

EXCLUSIVE TO ALTRONICS

Each Kit includes precision measured capacitors for accurate calibration of each range.

BANKCARD HOLDERS—PHONE ALTRONICS TOLL FREE 008 • 999 • 007 FOR NEXT DAY JETSERVICE DELIVERY

BANKCARD HOLDERS—PHONE ALTRONICS TOLL FREE 008 • 999 • 007 FOR NEXT DAY JETSERVICE DELIVERY

STATE OF THE ART

The Avtek MultiModem

a breakthrough in low cost modem design Using state-of-the-art VLSI integrated circuitry, the Avtek MultiModem provides the highest standards of reliability for data communications on public phone lines. Digital signal processing is used to achieve functions normally requiring analogue filters.



MULTIMODEM NEVER REQUIRES ADJUSTMENT

MULTIMODEM WORKS RELIABLY ON LINES WHERE OTHER MODEMS CAN'T FUNCTION Its digital filters are much sharper than on conventional modems. Line interference is screened out. You get error free data transfer, even on very noisy lines.

MULTISTANDARD OPERATION CCITT and Bell Duplex and Half Duplex.

AUTO ANSWER OPTION (MODEL D 1205) Autoanswer is the ability of your computer/modem to receive when the phone rings. Some computer/software combinations do this. MultiModem offers the alternative for computers without this facility—hardware autoanswer. Leave your computer waiting for information.

TEST FUNCTIONS

DIG: This function enables the user to test the modem's operation over a line, testing both modem and line.

ANL: Provides testing of computer, software, cabling and modem.

SPECIFICATIONS

Data Standards: CCITT V.21 & V.23 Bell 103 & 22
Data Rates: 300, 600 & 1200 BPS
Backward Channel: 75 BPS in conjunction with 1200 BPS
Computer Interface: CCITT V.24 (RS232C)
Power Requirements: 240 VAC Power drain—3 watts

TWO MODELS

D 1200 (Standard) \$349.00
D 1205 with auto answer \$389.00

BLOOD PRESSURE & HEART RATE MONITOR

Why Risk Unnecessary Heart Attack?

A simple (take the reading yourself) periodic check of your blood pressure and pulse provides an "inward look" into a vital aspect of your bodily health. Heart disease strikes down many people in their early 40's (or even 30's). The tragedy remains that had such victims been alerted, remedial medical, physical and dietary action could have been prescribed to avoid illness and in many cases restore full bodily health.

A Superb Gift for the dedicated fitness enthusiast Absolutely essential for those over 40 and concerned with their health, or on Fitness Therapy. Use this easy to operate Monitor to measure your pulse (or heart rate) and Blood Pressure.

DON'T PAY \$150 X 3055

Now Only \$89

Remember high blood pressure is in itself symptomless and the usual forerunner to future chronic heart disease. Features include "error" display warning of incorrect use. Handbook supplied will enable anyone in your family to be fully conversant with this monitor in minutes. Easy to read display of Systolic and Diastolic Blood Pressure and Pulse Rate.

PROFESSIONAL SERIES RACK CABINETS

NOW YOUR PREAMPS, AMPS, CONTROL MODULES MONITOR PANELS ETC. CAN LOOK EVERY BIT AS GOOD AS TECHNICS, NAKAMICHI AND OTHER TOP MANUFACTURERS

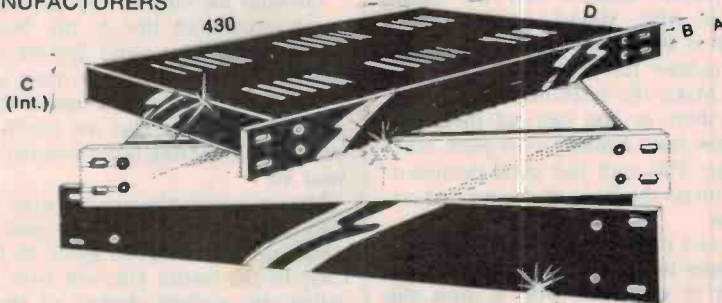

FEATURES:—• These beautifully crafted rack cabinet boxes will give your equipment a real 1st class appearance • Aluminium construction with removable top and bottom steel cover panels • All dimensioning conforms to the International Standard • Natural or Black finish • Ventilated lid • Deluxe finish front panel • Individually cartoned • Supplied in Flat Pack Form—Easily assembled in minutes—**Side Elevations:**—• D= 254mm C (Internal Chassis Height) • B (Mounting Bolt Centres).

SIX NATURAL AND BLACK FINISH MODELS

The Black or Natural finish cabinets are each available in 44mm, 88mm or 132mm high models. Mounting hole centres conform exactly to International Racking Specifications both vertically and horizontally.

Cat. No.	Finish	A	B	C	ea.	5+
H 0401	Natural	44	34	38	\$49.50	\$47.50
H 0402	Natural	88	57	82	\$59.50	\$56.00
H 0403	Natural	132	89	126	\$64.75	\$61.50
H 0411	Black	44	34	38	\$49.50	\$47.50
H 0412	Black	88	57	82	\$59.50	\$56.00
H 0413	Black	132	89	126	\$64.75	\$61.50

ALTRONICS COMPONENTS

105 STIRLING STREET, PERTH FOR INSTANT SERVICE PHONE ORDER TOLL FREE 008 999 007

PERTH METRO AND A/HRS ORDERING SERVICE (09) 328 1599

ALL MAIL ORDERS

Box 8280, Stirling St. Perth WA 6000

PACKING AND DELIVERY CHARGE \$3.00 DELIVERY AUSTRALIA WIDE

-We process your order the day received and despatch via Australia Post. Allow approx. 7 days from day you post order to when you receive goods. Weight limited 10Kgs.

\$5.00 OVERNIGHT JETSERVICE - We process your order the day received and despatch via overnight jetservice Courier for delivery next day Country areas please allow additional 24-48 hours. Weight limit 3Kgs.

\$10.00 HEAVY HEAVY SERVICE - All orders of 10kgs. or more must travel Express Road - Please allow 7 days for delivery.

INSURANCE — As with virtually every other Australian supplier, we send goods at consignees risk. Should you require comprehensive insurance cover against loss or damage please add 1% to order value (minimum charge \$1). When phone ordering please request "Insurance".

TOLL FREE PHONE ORDER - Bankcard Holders can phone order toll free up to 6pm Eastern Standard Time. Remember with our **Overnight Jetservice** we deliver next day.

ALTRONICS RESELLERS

Wanted in all Areas of Australia—Phone Steve Wroblewski on (09) 381 7233 for Details

NSW	QUEENSLAND	VICTORIA
CITY David Reid Electronics 267 1385 Jaycar 267 1614	CITY DeSound P/L 2296155 Jaycar 393 0777	CITY Active Electronics 602 3499 All Electronic Components 662 3505 MaGraths Electronics 347 1122
08SUBURBAN CARLINGFORD Jaycar 872 4444	FORTITUDE VALLEY McGraths Electronics 832 3944 SilLuca 832 3944	SUBURBAN BENTLEIGH Electronics 557 3971 Absolute Electronics 557 3971
GORE HILL Jaycar 439 4799	PADDINGTON Jacques Electronics 369 8594	BOX HILL SOUTH Eastern Communications 288 3107
HURSTVILLE Jaycar 570 7000	SALISBURY Colourview Wholesale 2753188	CHELTENHAM Talking Electronics 550 2386
LEWISHAM PrePak Electronics 569 9770	SLACKS CREEK David Hall Electronics 2088808	DONCASTER Clipstone Electronics 84 2868
08COUNTRY ALBURY Webb's Electronics 25 4066	TOOWONG ECO Technics 3710879	FOOTSCRAY Acron Services 689 1911
BATHURST The Electronics Shop 31 4421	COUNTRY CAIRNS Thompson Instrument 512404	SOUTH CROYDEN Truscott Electronics 723 3860
BROKEN HILL Crystal TV 4803	BUNDEBERG PM Electronics 728 272	COUNTRY BENDIGO K.C. Johnson 41 1411
COFFS HARBOUR Colts Harbour Electronics 52 5684	GLADSTONE Purley Electronics 724321	MORWELL Morwell Electronics 34 6133
GOSFORD Tomorrows Electronics 24 7246	NAMBOUR Nambour Electronics 411604	ROBINVALE John Mason Electronics 26 3643
KURRI KURRI Kurri Electronics 37 2141	PALM BEACH The Electronic Centre 341248	SHEPPARTON GV Electronics 21 8866
NEWCASTLE D.G.E. Systems 69 1625	ROCKHAMPTON Purley Electronics 21058	
NOWRA George Brown & Company 69 6399	TOOWOOMBA Hunts Electronics 329677	
ORANGE Southern Communications 21 4011	TOWNSVILLE Sola 722015	
PORT MACQUARIE MW Electronics 628 491		
RAYMOND TERRACE Hall of Electronics 83 7440		
RICHMOND Alback Electronics 87 3419		
TAMWORTH Vector Electronics 78 4277		
TENTERFIELD Nathan Ross 36 2204		
TOLUKEY Landlink Communications 65 4622		
WOLLONGONG TES Electronics 96 4144		
	WINDANG Madjena Electronics 96 5066	
	WINDSOR M & E Electronics Communications 77 5935	
	WYALLA Newtek Electronics 27 1620	
	WYALLA Vincom Electronics 28 4400	
	WYALLA Eye Electronics 45 4784	
	TASMANIA	NT
	HOBART D & I Agencies 34 7877 George Harvey 342233	DARWIN Electronics 81 3491
	LAUNCESTON George Harvey 31 6533	ALICE SPRINGS Ascom Electronics 52 1713
	LEGANA Frank Beach Electronics 301379	FARMER Farmer Electronics 52 2967
ACT		
CITY Electronic Components 80 4654 SciElectronics 54 8334		

BANKCARD HOLDERS—PHONE ALTRONICS TOLL FREE 008 • 999 • 007 FOR NEXT DAY JETSERVICE DELIVERY

FOR NEXT DAY JETSERVICE DELIVERY PHONE ALTRONICS TOLL FREE 008 • 999 • 007 BANKCARD HOLDERS

MAKING YOUR OWN PRINTED CIRCUIT BOARDS

Ian Thomas

The cheapest and most simple printed circuit board is the one you buy with or for your ETI project — ready made. With this procedure and a little practice you will find it easy to make boards for your own circuits.

IT'S ONE THING to read about all those 'you beaut' projects but quite another to actually build one up. Or perhaps you have ideas about what seems an excellent project but never find anything like it in the magazines (we do our best but . . .). The clever thing to do is to make it yourself. Making a complete printed circuit right from the original idea to the final unit isn't as complicated as it seems and all the necessary ingredients are readily available.

Breadboards

The place to start the whole business is the original diagram. If you haven't got a complete and detailed circuit diagram you aren't really ready to start making hardware and more development is needed. If you're starting from a magazine article then no problem, but if you're designing your own circuit then you must first try out your circuit design with what is politely called a "breadboard" (for reasons I've never really understood) or, less politely but more descriptively, a rat's nest.

Plug-in type breadboards can be bought from almost any supply house and vary considerably in both price and quality. A good hint if you're going to buy one is first to try all different component lead sizes in the breadboard holes to make sure they're held firmly by the sockets. The cheap and nasty ones tend to not hold the finer leads and will drive you crazy by falling out while you use them.

Once you've got your circuit working,

draw the circuit from the breadboard, tracing out each component as you draw it. You'd be amazed how often things aren't exactly as you think they are! Even at this stage it may be desirable to do a little more work in refining the design.

When you're tinkering to get things working you may inadvertently do things that are inelegant (or downright wrong — you'd be amazed how easy it is to get things working only to raise a fierce blister on a transistor because you didn't notice it was dissipating a watt or so!).

After you're satisfied that the circuit diagram is what you've got and what you've got is what you want the next thing to do is redraw the diagram as neatly as possible. Make the lines between components as short as you can get them and have as few lines crossing over each other as possible. This isn't just good documentation; it forms the basis of the printed circuit layout.

If you start the board layout following a neat diagram the layout tends to go pretty easily but if you start with a mess the board will turn out worse! It's a lot easier to have lines crossing each other on paper than copper tracks on fibreglass.

The next step is to decide exactly where you want to mount the board so that you can see how much space you have. Now that you've got the circuit diagram you can make a list of all components and tally up the board area necessary to fit them. This list will normally consist of so many resistors (value doesn't matter), so many

transistors, so many capacitors this size, so many that size and so on. Every component must be used including the power supply bypass capacitors you left out. That must be one of the most common sources of trouble in getting circuits to work. The final list will have every component in sections according to size.

How big a pc board?

Next you have to work out how much board area is needed for each type of component. A good rule of thumb is to allow 0.05 to 0.1 inch greater than the maximum size of the component. For example, your ordinary common or garden resistor has a body about 0.1" in diameter and mounts on 0.4" centre holes. The board area to allow for is therefore 0.15 x 0.5 or 0.075 square inches.

It isn't the object at this stage to allow for the space needed for interconnection but only to find the absolute minimum board area needed.

On your list tally up the areas of all the components and this is the board area you'll need if you could achieve a perfect layout. At this stage you must also consider how you intend to mount the board as mounting holes also use board area — make the mounting holes another item on your list.

Next compare the needed area with the area you have available in your box or whatever. A very good guide to the difficulty of the layout you will have to do is called the packing density of the board. The packing density is the ratio of the board area needed to the total available area usually given as a percentage. For example if your list says you need 4.82 square inches and the total available area is 3" x 2" then the packing density needed is

$$\frac{4.82}{3 \times 2} = 0.803 \text{ or } 80\%$$

This packing density could be done but would be rather difficult. As a general

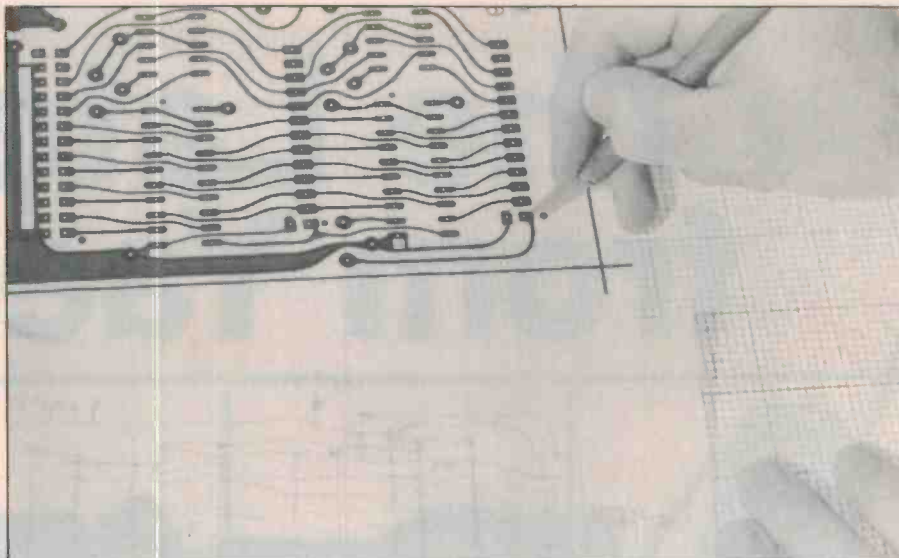

Twice full size artwork being prepared. Note the tenth-inch grid and pencil rough.

rule less than 50% is pretty easy, less than 75% needs a little care, less than 90% needs a *lot* of fiddling and rearranging and greater than 90% means good luck!! (forget it).

If the packing density works out then you're in a position to start blocking out the board layout. Buy some tenth-inch grid graph paper (I know we've all supposed to have gone metric but *all* pin spacing is given in tenths of an inch and $0.1" = 2.54$ mm and the .04 mm can add up horribly) and draw in the outline of the final board you want.

If you're only going to make one board for yourself and you don't have too high a packing density the outline can be the same size as the final board. However if you want a really neat job then the outline should be exactly twice the size of the final board.

Artwork size

Doing the layout at twice full size means that any inaccuracies in the layout and the printed circuit artwork that comes from the layout are reduced to half size when the twice full size artwork is photographically reduced to normal size. This doesn't excuse rough work; it just makes finer detail work possible. Almost all commercial artworks are taped at at least two to one and sometimes four to one if special accuracy is required.

For the hobbyist there are two disadvantages in generating artwork at twice full size. The first is that the artwork has to be photographically reduced to final size after taping is completed. This means you have to take your artwork around to an industrial photographer (there are plenty around) who will photograph your masterpiece so the negative out of the camera is exactly the right final size.

If you're going to use precoated printed board material (more of this later) then this is all you need but if you want to put your own resist on the board then you

must ask him to make a contact positive of the reduced negative.

Both these cost money but not as much as you may think. To give an example, the electronic scales that appeared in June and July ETI last year cost me \$18 for reduction *and* positives. There was no way the artwork could have been done at full size so I had no choice. Even if they could have I would probably still have gone to twice full size originals.

Probably the greatest disadvantage to using twice full size is that you have to find time to go out and have the photography done. If you're beaver away building your technological masterpiece at 2 am on Sunday morning you probably won't want to stop for the weekend to get reductions done. If the artwork is full size you can carry on and the whole process can be done at home.

A second disadvantage with twice full size artwork is that you can't actually place the components on the layout to see if they'll fit. But if you haven't done a lot of artwork then single size is an invaluable way to make sure you aren't asking the impossible. Stencils can be bought with the outlines of most components twice full size on them to act as layout aids (Bishop Graphics Cat # EZ3367 & EZ3368) but it's not quite the same as the actual IC or transistor.

Whatever size you decide to use there are a few essential purchases you must make before you start. The first is the plastic draughting film that is used to make the artwork and the other is the artwork stick-on pads and tape to actually generate the artwork.

If you intend to use single size artwork then you'll need some 0.1" diameter pads, a few 0.2" pads for terminations, some 16 pin IC pads (get the 16 pin ones only and cut them down for 14 or 8 pin IC's) and a few different thickness tapes; say .040" and 0.075" for starters. The tape is specially made for artwork generation and is

completely opaque to light. It can also be bent (it's sort of like black masking tape) to form curved tracks on the artwork but more of this later.

Get yourself a pencil, rubber (a good one as you'll be making a lot of changes) and all the components you intend to finally use and you're ready to start on the real layout. Even if you're doing twice full size artwork it's still essential to hold components on the graph paper to see how they fit sometimes.

Start by drawing in the terminal pads so all the leads come off the board in a nice neat group. Then start drawing in the components in more or less the same pattern as they appear in your neat circuit diagram. This means the components that connect to terminal pads lie near them.

In order to make things look neat and professional there are a few golden rules in placing components. They are:

- All ICs must be oriented the same way with pin 1 pointing to the same corner of the board. If you turn some of the ICs 180° then it's a cert you (or someone else) will put the IC in back to front and destroy it! Never ever put ICs in at random 'convenient' angles — it looks like a mess and writes across your layout in words of fire "this was done by an *amateur*".
- Resistors should also be put in only parallel to the sides of the board for much the same reasons as above. Also if you orient them at odd angles then you're bound to waste space on the board. The same applies to capacitors and diodes.
- Transistors and vertically mounted capacitors can be oriented any way so long as their pins fall on the 0.1" grid of the graph paper.

A way of getting things started is to mentally divide the circuit up into small blocks and then proceed to lay out the circuit block by block so the interconnections between the blocks fall next to each other. ►

The Latest from Yaesu!



Economy 70cm

Value & reliability - with the latest in features! That's the new FT-703 hand held. Tiny size: but what a performer: even has VOX with optional headset! Cat D-3508

\$479



New 2m mobiles, Too!

Want economy? Try the new FT207R. Want power? Try the new FT207RH. You get the choice - up to an amazing 45W output (Yaesu's new duct-flow cooling makes it all possible!) Both have 10 memories, dual VFO's plus all the new goodies that make 2 metres fun again!

FT207R (25/3W) **\$699**
Cat D-3515

FT207RH (45/5W) **\$649**
Cat D-3517



Push-Button 70cm

Real performance in a hand-held. Push-button keypad gives you real control; add the battery pack you want for the output you want!

Cat D-3509
10.8V Battery Pack Cat D-3506 **\$79**
12V Battery Pack Cat D-3507 **\$89**

Mobile 70cm

Full 10 watts output on 70: two 4-bit microprocessors make everything so easy!

And it's small enough to go anywhere. Features a brilliant display for extra road safety - and with fast/slow band scanning, it's great, mate!

Cat D-3505

\$449

\$499

Battery Not Inc.



FRV-8800 VHF Frequency Conv

Fits right inside case - complete with its own telescopic antenna. Frequency range 118-174MHz
Cat D-2823 **\$149**

FRA-7700 Active Antenna

Great for flat dwellers! No need for an outside antenna and preamp will pull in stations you didn't think possible!
Cat D-2845 **\$89.50**

FRT-770 Antenna Coupler

Ensures best performance from all types of antennas. A must if your antenna is not low impedance.
Cat D-2843 **\$95**

FRG-8800 DC Kit

Allows operation of your FRG-8800 on 12V DC. Great for field operation, monitoring, etc.
Cat D-2822 **\$2.50**

FRG-8800:

All band all mode

And all slinging, all dancing. Amazing performance in Yaesu's new masterpiece, the FRG-8800 receiver. Choice of two models, both featuring the very latest in receiver technology.

- 150kHz-30MHz coverage (FRG-8800)
- Fully CAT compatible (computer aided transceiver)
- Provision for VHF converter inside the receiver!
- 10 memory channels inbuilt (nothing more to buy!)

And much, much more. Ask for a free FRG-8800 brochure at your nearest Dick Smith Electronics store.

FRG-8800 (150kHz-30MHz)
Cat D-2820 **\$799**

FRG-8800SW (2MHz-30MHz)
Cat D-2821 **\$749**

VHF converter to suit (118-174MHz)
Cat D-2823 **\$149**



2M/70cm FT2700RH

Versatility: both hands in a set so small you wouldn't believe it! Full duplexing, twin VFO's, ten memories ...whatever you want, the 2700 has got!

It features dual independent front ends, dual local synthesisers, dual IF's and transmitter rf stages to make sure you really do get the best of both worlds.

And it even speaks to you: add the optional voice synthesiser and it actually tells you which frequency you're on. Hows that!!!

- 25 watts continuous on both bands
- two 4 bit CPU's for complete control
- Amazingly tiny size: just 150 X 168 X 50!!!

Cat D-3515 **\$945**

The best from

DICK SMITH ELECTRONICS

PTY LTD

All these items available from your nearest Dick Smith Store.



Subscribe to Electronics Today now, and receive a 20-watt soldering iron worth \$9.95

ABSOLUTELY FREE!

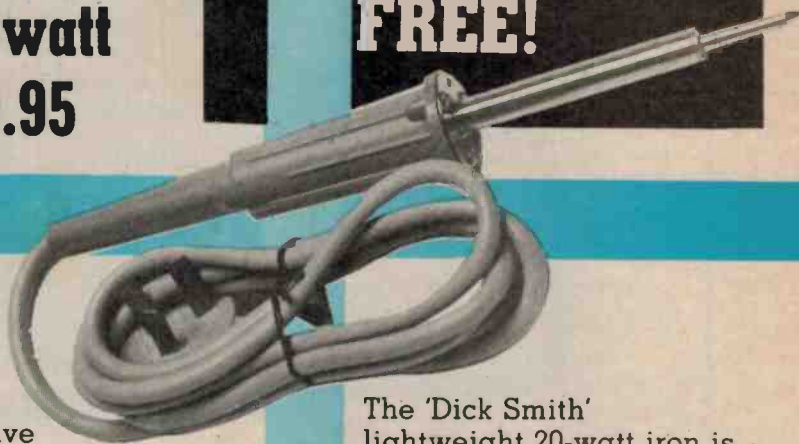

Right now is certainly the best time to take out a 12-month subscription to Electronics Today. You'll not only be ensuring that you receive each copy regularly each month, delivered direct to you, but you'll also receive a bonus gift: a free 'Dick Smith' soldering iron suitable for the electronics hobbyist, home handyman or technician. But don't delay — this offer is limited.

The 'Dick Smith' lightweight 20-watt iron is ideal for most general soldering work. It features interchangeable screw-in tips, a two-metre mains cord with moulded-on plug for safety and durability, and is fully S.E.C. tested and approved. It comes fitted with a plated conical tip, suitable for most general soldering. Normally this quality iron sells for \$9.95 — but currently we're offering it to you FREE with each 12-month subscription to Electronics Today!

Australia's dynamic electronics monthly!

Electronics Today is your key to the exciting world of modern electronics — whether you're a professional, an enthusiast or an interested consumer. Electronics Today provides you with news and analysis of the latest developments, authoritative test reports and reviews of new equipment, down-to-earth information on electronics in theory and practice, and well-engineered construction projects.

Electronics Today is also written right here in Australia, so you know that it really does cover the local electronics scene.

Electronics Today Subscription Offer

YES!

Please send me one full year (12 issues) of Electronics Today, delivered to my home, PLUS my free Dick Smith soldering iron at the special offer price of just **\$27.00**

**FREE
SOLDERING
IRON**

NAME: JOB/TITLE:

ADDRESS:

POSTCODE: ORGANISATION:

Please tick box to indicate method of payment:

Cheque* / Money Order* American Express Bankcard Mastercard

*Please make cheques and money orders payable to the Federal Publishing Company Pty Ltd. Credit Card No.

Card Expiry Date: Signature:

Allow 4-6 weeks for delivery of first issue and soldering iron.

(Unsigned orders cannot be accepted)

Just
\$27.00

That's a \$3 saving on our regular 12-month subscription rate!

**So don't
delay —
subscribe
now in
this issue!**

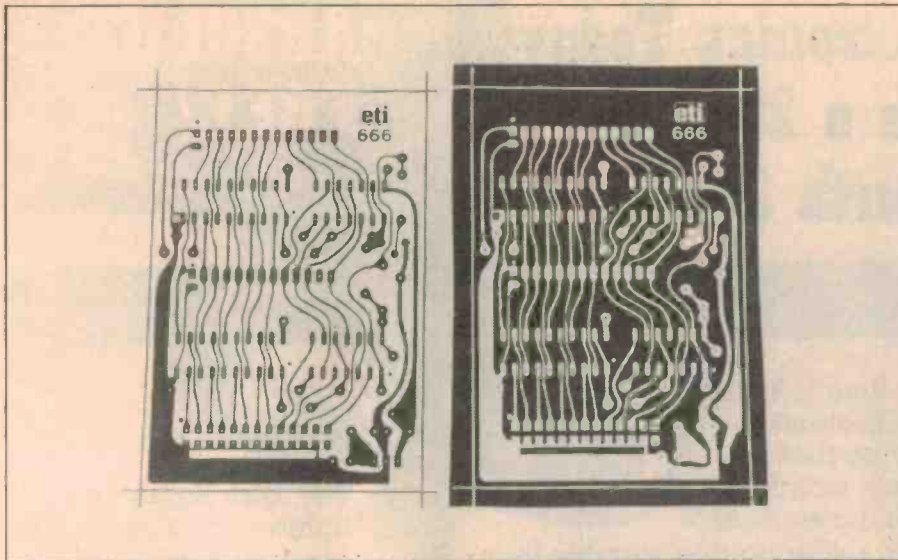

Positive or negative? You can tell that the one on the left is positive because the black on the film looks like the copper tracks on the board.

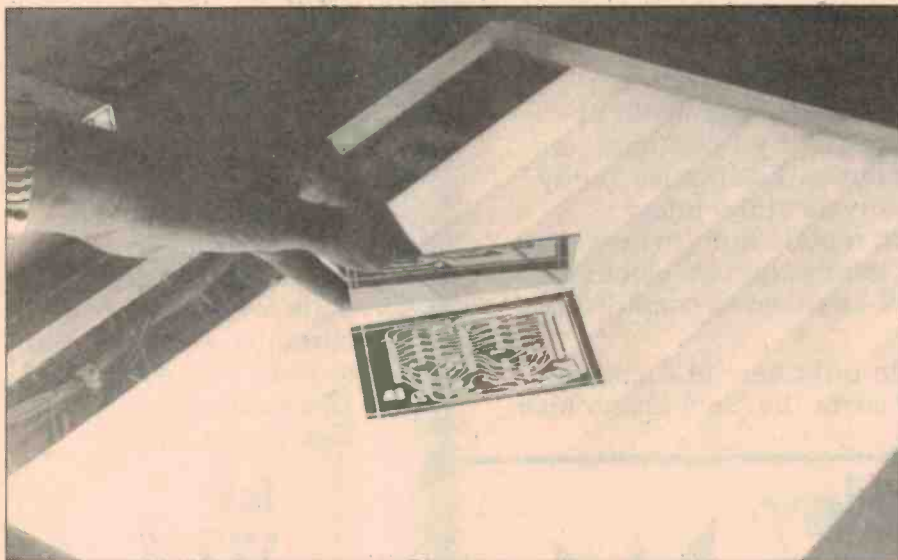

Exposing the resist. With precoated board, simply unwrap in dimly lit artificial light to prepare the surface for exposure.

When a block contains say four or five resistors it's often easy to draw them in side by side with the minimum 0.15" spacing between them then connect them together. Usually the whole group can be connected without moving any component at all or at most the spacing between two resistors may have to be increased to 0.2" to allow two tracks between the pads. The 0.15" spacing only allows clearance for one track between the pads.

The transistor or IC that's associated with the group of resistors can be placed right next to them and connected easily. A strong word of warning must be given — always draw in the power supply lines as you go along and make sure that power supply bypass capacitors go in next to the ICs or transistors that need them. It's no good to try and bypass an IC supply line from half way across the board. A good rule is to put a 10 nF capacitor right next

to every IC on the board or at the very least every three ICs. This probably adds a dollar or so to the cost of the board but is *much* cheaper than spending hours trying to get things to work when you have half a dozen little oscillators whirring away.

Another most important point is to make your earth track *big and short*. Even if your circuit is audio or only dc the transistors and ICs don't know this. They still have gain up to many megahertz and if your earthing and/or bypassing is no good they may oscillate.

In your neat circuit diagram you probably have one earth line drawn along the bottom of the page. Try and preserve this as one earth about 0.2" wide on the board with all parts of the circuit that need it tied back to this track. All bypass capacitors should also connect directly to this track without long straggly connecting

tracks. If you've sufficient space it's a good idea to have a border of earth about 1/2" wide all around the board but that's often a luxury physical constraints won't allow.

Signal lines can be allowed to wander around a bit and power supply lines, so long as they're properly bypassed, can wander even more but the earth must not. Keep on adding in blocks of your circuit diagram until you've got it all in including the mandatory large electrolytic capacitor across the supply terminals.

Then, when you reckon it's all done have a look and see if you can reroute tracks to tidy things up. Once you've actually got the whole thing down on paper it's usually pretty easy to see changes that will improve it a lot.

If you want a really pukka job you'll almost certainly have to work the layout down a bit. Even the pros who do this sort of thing for a living still have to rework part of their layouts (apart from one bloke I know but he's a genius with a mental flair for visualising these things!).

Finally when you're really happy that every component on the board is connected up correctly and all the components are drawn in so they don't touch each other (or worse cross over each other!) you're ready to start making the actual artwork that will be turned into copper on fibreglass. This is where you really start to make the board and this is where you find the worst errors in your layout.

Making the artwork

The artwork is taped up on plastic draughting film that can be bought from the same place you bought the artwork aids. There are two sorts available; one is just plain translucent film and the other has very faint tenth-inch grid lines printed on it.

If you get the plain film then you'll have to stick it down on some tenth-inch graph paper. Use small pieces of masking tape on all four corners and make sure you can see through the film to the grid. If you use the film with a grid on it already then it can be worked on over a plain white sheet of paper and it isn't necessary to stick it down. Either way you should have a sheet of film with a grid easily visible on it.

Start by sticking down all the pads of your layout. Taping is done using a small penknife or, more usually, an exacto knife. Exacto knives can be bought from the same place as all the other artwork aids and have many other uses as well (such as modifying copper tracks on the final board). I personally use surgical scalpels which have long, easily held handles but anything with a small blade will do.

To lay down pads slip the tip of the blade under the edge of the pad and peel it off the backing sheet. The knife is normally held in three fingers of one hand leaving the forefinger and thumb free. When the tip of the blade is just under the pad the forefinger is placed over the tip of the blade and the pad to hold it firmly while the pad is peeled off.

The pad is then carefully aligned over the grid on the plastic film and the pad firmly pressed down on the film so the crossed lines on the grid are still visible in the hole in the pad. If you're putting down IC pads you must line up all 14 or 16 pads correctly. It looks terrible to have an IC drawing to see where they should go. You'll have to count off grid lines to locate the position of some pads but others simply lie side by side.

Keep on making checks to make sure you haven't slipped a grid line or so by holding the artwork being taped and your original layout together up to the light so both are visible over each other. Any errors will be immediately obvious. Also when you're laying down pads you'll probably find the occasional place where the layout shows a track going between two pads and there isn't enough space. Not to worry; this can be fixed later.

Once all the pads are down you're ready to start connecting them up. The golden rule here is to try and make the tracks and the spaces between them of equal width. When you finally use the artwork to make a printed circuit you'll discover that tracks less than about 0.020" tend to be etched right through and similarly spaces between tracks less than 0.020" tend to not separate so these are the absolute minimum spacings to be used. To make things easier until you're familiar with the process I strongly recommend that you use minimum dimensions of 0.040" both for tracks and spaces. These rules (like any) can be bent if you know what you're doing but if not it saves rework to stick to them.

To connect between pads first trim the end of the tape square. Hold the end of the tape over the first pad and press it down firmly. Run the tape carefully in the path you want to follow until it reaches the second pad. Press it down firmly onto the second pad. Cut it off by pressing the blade of your knife onto the tape *not hard enough to cut it* then pull the tape up to cut it off. If you try and cut the tape while it's stuck on the pad you'll cut both tape and pad.

When you're laying down tape you must try not to put it down under tension. If the tape is stretched as it's stuck down it tends to creep back after it's cut off and open up spaces. This particularly applies to taping around corners.

It's inevitable that the layout will in-

clude some curved tracks. When you tape them *the tape must have no tension; better to be slightly in compression.*

To do this you must, as you're laying down the tape, continually push it back on itself slightly with the tip of the knife blade. It's something of a knack to do it correctly.

After every piece of tape is placed and cut off press it down *hard*. Pounding on it with a closed fist is quite acceptable — you can't press it down too hard.

During all this you *must* keep all grease or oil away from the artwork. Contact adhesives simply will not stick to oil and all your work will fall off if the film is dirty.

If you find that you must run tape between two pads that are too close and you can't maintain clearance then as a last resort it's permissible to carefully cut away a bit of the pad. There must be at least 0.030" of pad left around the centre hole or when you drill the hole in the board you'll break through the side of the pad. Then you won't get a good solder joint. This method should always be thought of as an act of desperation — not a standard technique.

When you're taping up the artwork it helps a lot to always refer back to the original diagram to keep track of what you're doing. You'll probably find a mistake or two.

Once the taping is completed and checked, all that remains to be done is to mark the mounting holes with large diameter pads. Mark the corners of the board so you know where to trim after the board's been etched. You can put tape all around the edge of the board if you want but it's more usual only to mark the corners. The tape for the corner marks goes

outside the actual edge of the board so when the board's trimmed the corner marks are cut off. When you think it's really finished check it again. This is the last chance you'll get to have an error free layout.

Etching

The next step is to ensure that the artwork is the correct polarity for the photo-etching process you intend to use. If you are using dry resist pre-coated board material then you must obtain a reversal, or negative, of the taped artwork you've generated. If the original artwork was twice full size this comes naturally, as the photography gives a negative.

If you worked 'one to one' then you must get some "Scotchcal" exposure film. This stuff is like photographic film except that it's only sensitive to ultraviolet light and you only need one chemical to develop it.

To expose the film place the sensitive surface under the UV source and lay the mask over it. Make sure the mask is the right way up so the pattern that will finally appear is not mirror imaged. Place a sheet of good, heavy glass over the mask. I use a piece 6 mm thick which is enough to press the mask flat against the UV sensitive surface. For the suntan lamp UV source it's necessary to cover the whole assembly with something opaque (say a book) for about sixty seconds until the lamp warms up. After that the mask and sensitive material can be uncovered to commence the actual exposure.

If you've bought pre-coated board all you have to do to prepare the surface for exposure is to unwrap it *in dimly lit artificial light*. If you want to do the whole

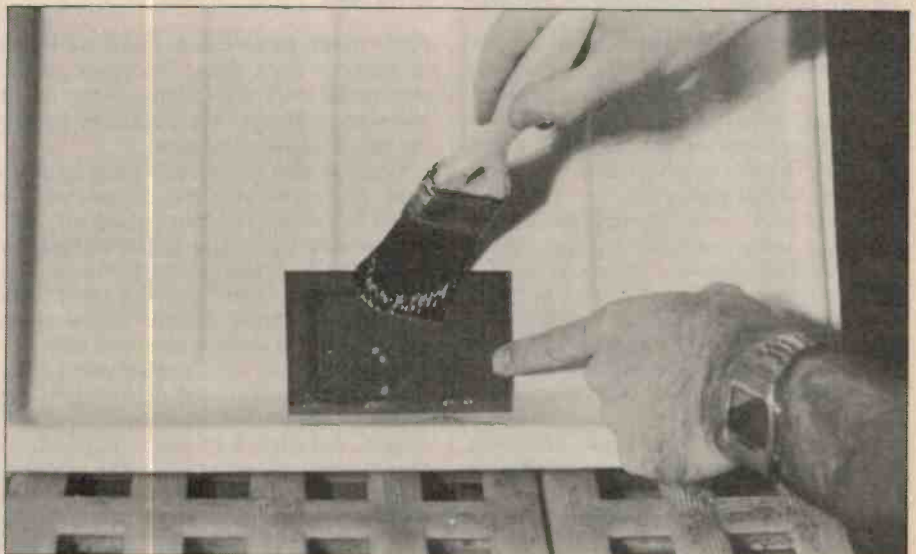

Developing the resist. The developer comes in powder form and has to be dissolved in water to make up a solution. Treat this solution with care as it is poisonous.



The etching process. Place packing under the tray to tilt it at a slight angle and three-quarters cover the bottom with etchant. Drop the board into the high end of the tray, copper side up.



Turn the board over and use a fine (25 mm) brush to get fine detail.

thing yourself then you'll have to buy some photoresist and it's appropriate developer. Circuit Components in Bexley, NSW, sell all the necessary materials for all stages of making printed boards and are quite happy to give advice if you're not certain what you need.

The correct resist to directly expose taped up artwork is CPR Positive Resist. The developer for this resist comes as a powder that has to be dissolved in water to make up a solution. Have a thought for the neighbourhood kids though and *don't keep the developer in a soft drink bottle*. It's a poison and doesn't do rug-rats any good at all to drink.

To coat the board with resist, first clean the copper thoroughly with an abrasive cleanser such as "Gumption" using clean paper towels. Grease or fingerprints on the copper is a disaster for the coating process so don't touch the surface at all. After scrubbing the copper dry it with

paper towels (cloth towels may have traces of grease). Then tip a small pool of the photoresist onto the centre of the board and work it all over the surface by tipping the board this way and that.

You may also use a small paint brush to work the resist into the corners of the board but make sure it's a good one that doesn't shed hairs. Use plenty of resist to make sure the board is completely covered then stand the board on edge on a thick wad of newspaper. All the excess resist will drain off to leave a nice even film.

Next stoke up the kitchen oven (this isn't called "kitchen sink technology" for nothing) and set the thermostat for 175°F or 80°C and allow it to warm up. Place the board in the oven — resist side up on a piece of paper towel or newspaper and cook it for 15 minutes. This serves to drive off all the solvent in the resist and leave a hard dry film.

If you leave it in too long the resist

Exposing the film

The photo etching process used with circuit boards works with ultraviolet light. This has the advantage that it does not require a darkroom. All the equipment can be handled in normal ambient light, with the proviso that you need to avoid any strong sources of UV. Since this includes the sun, it's probably a good idea to work at night if at all possible. If not, then make sure you are well away from windows, etc.

For the actual exposure, you can use either a sunlamp or a purpose built UV light. The recommended UV source for both Scotchcal and photoresist is a Philips UV mercury discharge tube. This will fit into a 20 W fluoro batten.

A quite effective exposure box can be made by nailing together a box with one side open. The internal surfaces should be painted white, and the lamp mounted in its batten opposite the opening. The opening should be filled with a sheet of glass. The distance from the top of the glass to the tube should be about 50 mm.

For exposure the box should be positioned with the glass side up, the artwork placed on the glass and held down with another piece of glass.

Note that when UV tubes have been unused for a while, or are being operated in very cold ambient temperatures, they take a while to reach their normal operating output. Leave them burning for at least fifteen minutes before you start work with them.

If you don't want to go to all that trouble, a simple, but less accurate way to do things is to use an ordinary old sunlamp. Position this about 350 mm above the artwork. But be careful. If you expose your hands to the rays for too long you'll get sunburnt.

won't develop properly; too short and the developer takes off the lot so time it carefully. This process is called the prebake and is vital to good resist processing.

But note that some resists have special requirements you should be aware of. Circuit-components insist that "gas ovens, fan-forced electric ovens and sealed electric ovens are not suitable. Beware of stove ovens with grease deposits." They also warn against direct exposure to infrared from the elements of an electric oven.

After the 15 minutes are up take the board out. Lay the artwork over the board and cover the lot with a piece of glass as described. If you use the suntan lamp as a UV source the CPR film needs between 3 minutes 30 seconds and 4 minutes for correct exposure with the lamp 350 mm from the resist.

For the 20 W UV tube advice on exposure is given with the resist. After exposure lay the board face up in a glass dish and cover it with developer. *Don't* use aluminium or iron dishes as the developer will attack them as well.

Gently agitate the dish by rocking it. The resist will dissolve away where it's been exposed to light.

For the precoated boards you will have exposed it through a Scotchcal reversing film mask and the resist will dissolve where the mask protected it.

The developing process should only take a few minutes and when it's complete

there should be absolutely no trace of resist where it should be dissolved. Even the minutest trace of resist will prevent proper etching and ruin the board so carefully examine the board to make sure the coloured resist has been completely dissolved.

To stabilize the resist film after development turn the oven up to 200°F or 95°C and postbake the board for 20 minutes. This bake isn't quite as critical as the pre-bake (once I forgot and left it in for 3 hours with no ill effects!). Finally take the board out and let it cool and stabilize for about half an hour and it's ready to etch.

The easiest etchant to use is ferric chloride and you can buy bottles of ready made solution. Be warned though, this stuff is the most foul staining corrosive gunk imaginable and the tiniest drop will leave a totally unremovable yellow mark on clothes or anything else.

Good housekeeping is essential. It will also etch stainless steel just fine (like kitchen sinks!!!) so don't spill it. If a few drops are spilt on a stainless steel sink and it's rinsed down the faint traces left will corrode the sink in a few hours and leave rust marks that are hard to get off. It's best to use the etchant in a tray placed on

several thicknesses of newspaper.

As well as the etchant and tray you'll need a very cheap 25 mm paint brush with the bristles trimmed off about 10 mm. Place some packing under one end of the tray so it's tilted at a slight angle and tip enough etchant into the tray to three-quarters cover the bottom. Drop the board into the high end of the tray, coperside up, and brush the etchant over the copper.

You'll see a black powdery deposit form on the bare copper then dissolve and wash away. Keep on brushing, concentrating on the areas that have no tracks and have large bare areas to be etched. For some reason the etching process seems to favour areas that have lots of tracks. In five to ten minutes, depending on solution age and temperature, all the areas not covered by resist will completely dissolve.

It's possible to use ammonium persulphate instead of ferric chloride if you like. This is not as easy to use, but it doesn't stain and it's not as corrosive.

The process is essentially the same. However you need to heat it to 50°-60°C. It won't work at room temperature. Also, it can't be stored. It slowly releases gas and decomposes. If you attempt to seal it

in a bottle, the bottle will explode.

As soon as all the copper is etched away remove the board from the tray and rinse it using megalitres of water. Examine the board carefully to make sure that all the copper is really dissolved then put the solution back in its bottle to be used again.

Rinse out the tray and brush once again using vast quantities of water and make sure you haven't spilled a drop of etchant anywhere. If you have you'll find out soon enough from the tirade of abuse from wife and/or mother.

Finally, remove the resist with solvent acetone and a paper towel. It comes off easily unless you forgot and postbaked it for hours. Trim the board to size with a hacksaw and clean up the edges with a file so you just remove the corner marks. Then drill all the holes with a small hand drill. The drill size should be about 0.8 mm for most components but some need a larger size, say 1.2 mm.

At this stage you should have a nice neat printed circuit board of your own design ready to assemble and try. For the first time the process seems long and messy but after a few tries you'll find it easy, quick and most satisfying. ●



Sealed lead acid & nickel cadmium rechargeable batteries

MAINTENANCE FREE

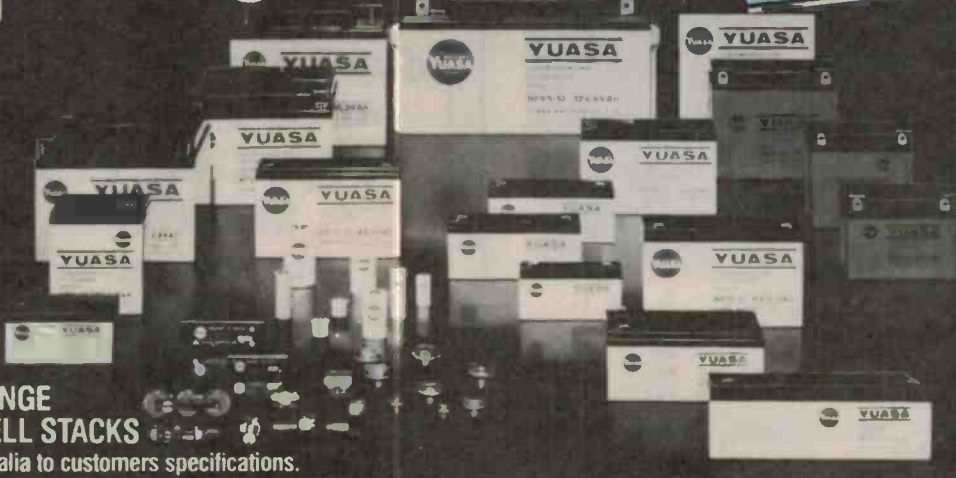

COMPLETE RANGE OF BUTTON CELL STACKS
assembled in Australia to customers specifications.

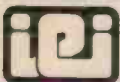

I.E.I. (AUST.) PTY. LTD.

15-17 Normanby Road, Clayton, Vic. 3149 Phone (03) 544 8411
31 Phillips Street, Thebarton, S.A. 5031 Phone (08) 352 2066
248 Johnston Street, Annandale, N.S.W. 2038 Phone (02) 692 096

KIKUSUI

WE'RE NOT RIDING
ON A REPUTATION.
WE'RE MAKING ONE!

COS **5041** 40MHz

DELAY
with
DUAL TIME BASE

2 YEAR
WARRANTY



KIKUSUI COS 5041

- LOW COST
- 2 Channel 40MHz band width
- 1mV/Div • 20nS MAX sweep speed
- Built-in DELAY-LINE • Trigger LEVEL LOCK • Variable HOLD-OFF

Other quality KIKUSUI oscilloscopes —
• COS-5020 20 MHz (on NSW Govt. contract)

- COS-5042 40 MHz 3CH, delay.
- COS-5060A 60 MHz 3CH, delay.
- COS-5100 100 MHz 3CH, delay.
- DSS-5020 20 MHz + Digital Storage

The most economical 40MHz CRO that has more than just a trigger delay BUT a full DUAL TIME BASE that allows ANY portion of a displayed wave-form to be MAGNIFIED.

★ ALWAYS INCLUDED:
2 PROBES 10:1/1:1
2 TERMINAL ADAPTORS

CHECK OUR
LATEST, BEST
PRICE!

GW INSTRUMENTS • PROVEN
• RELIABLE

GW FUNCTION GENERATORS **GFG-Series**



GFG-8016D

- 0.2 Hz ~ 2 MHz
- Sine, Triangle & Square (TTL, CMOS)
- Variable: DUTYCYCLE DC OFF SET
- 1 Year Warranty
- 3 Models Available:

GFG-8015F function generator.
GFG-8016S sweep generator.
GFG-8016D with built in frequency counter.

GW BENCH-TOP DC SUPPLIES



GPS-3020

- ECONOMICAL & ROBUST
- Variable voltage and short circuit current
- Overload/short circuit PROTECTED
- Auto constant voltage, constant current cross-over
- Over 20 MODELS in SINGLE and DUAL tracking available
- FULL 1-YEAR WARRANTY

Some of our popular models include:

- GPS-1830 1 x 18V,3A
- GPS-1820H 1 x 18V,20A
- GPS-3020 1 x 30V,2A
- GPS-3010H 1 x 30V,10A
- GPC-3020 2 x 30V,2A and



EMONA INSTRUMENTS

A division of Emona Enterprises Pty Ltd

1st Floor
720 George St
Sydney, 2000.
Phone: (02) 212-4599

NOW
OPEN
SATURDAY
MORNINGS

ALSO AVAILABLE FROM:

- NSW Davred Electronics Sydney. Phone 267 1385
- Geoff Wood Electronics Pty Ltd. Rozelle. Phone 810 6845
- Emtronics Sydney City 2110531
- Martin De Launay (Newcastle) Pty Ltd. Phone 52 8056
- ACT Electronic Components Pty Ltd. Fyshwick. Phone 80 4654
- QLD Batec Systems Pty Ltd. Brisbane. Phone 369 5900
- Norlec Townsville. Phone 79 8600

- VIC Radio Parts Group. Melbourne. Phone 329-7888
- WA Hince Engineering Pty Ltd. Perth. Phone 381 4477
- SA Int'l Communication Systems Pty Ltd. Port Adelaide. Phone 47 3688
- TAS George Harvey Electronics. Hobart. Phone 34 2233
- George Harvey Electronics. Launceston. Phone 31 6533

R -186 80186 SINGLE BOARD COMPUTER

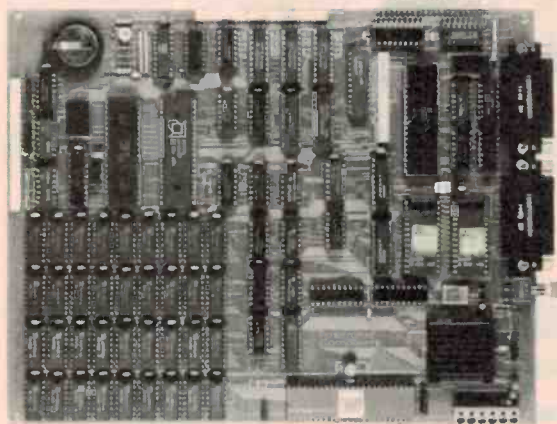

Features

- 8MHz 80186-3 (10MHz optional)
- Up to 1Mbyte parity checked memory
- Two serial ports to 38400 baud
- Centronics printer interface
- Double density 8" or 5 1/4" floppy disc interface
- SASI hard disc interface
- Boot ROMs
- CMOS battery backed calendar clock
- TurboDOS operating system available

Prices

- Kit 995.00
- A&T 1250.00
- Mini Kit 250.00
- TurboDOS 395.00
- Manual 25.00

All + 20% Sales Tax

DESIGNED AND MANUFACTURED IN AUSTRALIA
POSITRONIC COMPUTERS

1 STRATHAIRD CLOSE, DIAMOND CREEK, VIC. 3089 (03) 438 2713

RAM/EPROM SALE

- 4164-12 Ram \$3 plus Tax
- 27128 Eprom \$12 plus Tax
- 2764 Eprom \$7 plus Tax

SWITCHMODE POWER SUPPLIES

- HITRON \$85.00 incl. +12, -12, -5, +5 @ 8A
- VEP \$45.00 incl. +12, -5, +5V @ 8A

BRAND NEW 20inch X Y MONITORS \$100

100's of USED 2732 EPROMS

& VIDEO GAME PCB'S GOING CHEAP

A. HANKIN & CO

SYD (02)5691733,

22-24 Cook Road, Marrickville

MELB (03)4192466,

13 Hood Street, Collingwood

AT LAST!

A BUDGET PRICED 19 INCH RACK SYSTEM

ZIP-RACK 19A is the basic rack system for your 19 inch rack mounting equipment, kits & PCB sub-racks.

ATTRACTIVE
ANODISED
ALUMINIUM
FINISH

STANDARD
FRONT FACE
MOUNTING
FORMAT

FAST
EASY
KIT
ASSEMBLY

THREE
STANDARD
RACK SIZES

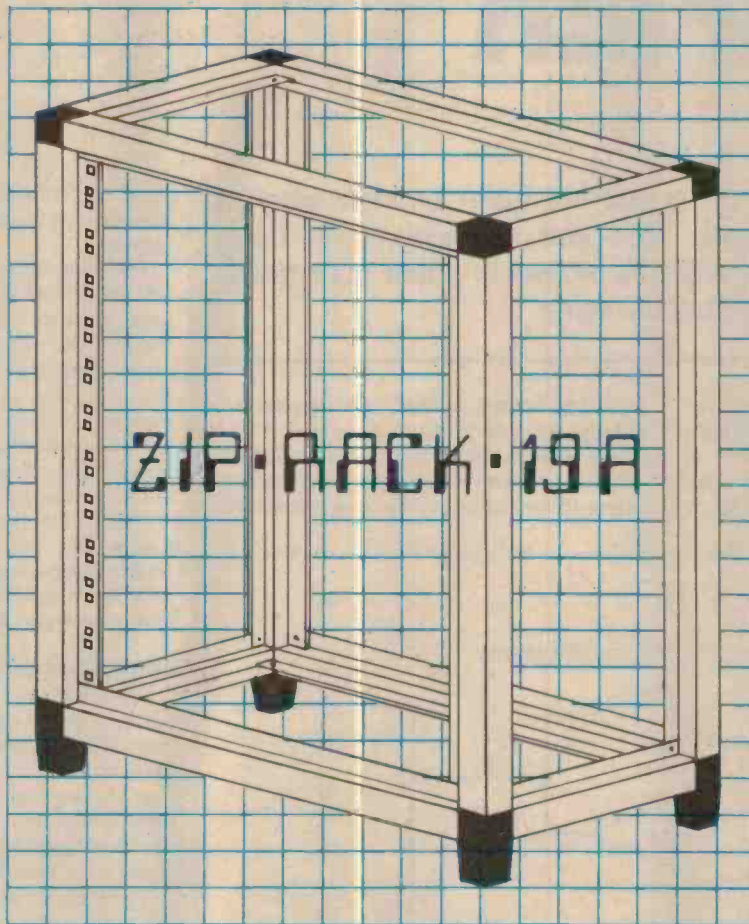

SIZE	KIT No.
6 RU	19-111
12 RU	19-112
18 RU	19-113

1 Rack Unit (RU) Panel
is 44.5 mm high (1 $\frac{3}{4}$ in.)
ALL RACKS ARE
358 mm DEEP.

KIT CONTENTS

- ★ 12 Frame Sections
- ★ 4 Top Corners
- ★ 4 Lower Corners
- ★ 12 Clip-in M6 Nuts*
- ★ 12 M6 Screws*
- ★ 1 Pack of 'Pop'
Rivets
- ★ 1 P&N Drill
- ★ Simple, easy to
follow instructions

* For equipment mounting



Advance Australia

ZIP-RACK 19 IS
DESIGNED AND
MANUFACTURED
IN AUSTRALIA

BY

AUTOTRON AUSTRALIA

PO Box 202,
Glen Waverley, 3150,
Victoria, Australia.
Telex 38433
Telephone (03) 763 6423

ASSEMBLY

Tools required: Small rubber mallet; electric hand drill; hand rivet tool.
Twelve lengths of hollow extrusion are interlocked using eight plastic corner pieces. The plastic corners are inserted into the hollow sections using a small rubber mallet. This assembly is then made permanent by drilling and pop riveting each corner with drill (3.2 dia.) & pop rivets supplied with kit. No spanners, screws, nuts or washers. Just a clean fast fit.

NSW: CONTACT YOUR LOCAL JAYCAR STORE
FOR THEIR CUSTOMISED ZIP-RACK 19J

VIC: ACTIVE ELECTRONICS: MELBOURNE (03) 602-3282
SPRINGVALE (03) 547-1046

W.A.: ATKINS CARLYLE: (09) 321-0101

LOCAL & OVERSEAS DISTRIBUTORS ENQUIRIES WELCOME

25 WATT UHF POWER AMPLIFIER

S. K. Hui

The powers that be are often just not quite enough when it comes to radio transceivers. "Are you receiving me?" Loud and clear with the help of this ETI project to boost your transmitting signal to a very audible 25 watts.

HOW DO YOU feel about your transceiver radio not being able to deliver the full legal output power? Have you ever wanted to stretch your transceiver power to its legal limit? I guess you might think the idea is

great but sounds a little too complicated. Having to modify your expensive transceiver radio is always difficult — and risky! What if you can't put everything back to where it was, after pulling your transceiver

apart? Of course if it blows up, you can always buy a new one with higher output power.

For those of you who are radio communications enthusiasts, the following could be great news for you. Without changing anything in the transceiver, you can boost the output power to 25 watts! All you need is the ETI 743 — UHF amplifier to simply plug the antenna and your transceiver output into. And the cost in building this project is minimal when compared to buying another transceiver set.

Credit for the design is due to Gary Crapp and Gill MacPherson from Dick Smith Electronics. The project is available in a kit form, with parts from Dick Smith Electronics and others.

Amplifier circuit principle

The idea of the ETI-743 UHF amplifier is quite simple. As soon as you start transmitting, the amplifier senses the signal and boosts it up to 25 watts! In the absence of a transmitting signal (receiving mode), the amplifying circuit is bypassed, thus allowing the transceiver to directly see the received signal from the antenna.

The ETI-743 amplifier should be used for amateur radio transmissions. Although technically it could be used in UHF CB band operation in that same frequency range, you must check the conditions of your licence to make sure that it does not exceed the power level stipulated.

The amplifier can be divided roughly into three parts: attenuator, amplifying circuit and signal level detection circuit (see Figure 1). The signal level detection circuit senses the strength of the transceiver output signal. Depending on how strong the signal is the circuit will turn the LED and the relays (RLY1, RLY2) on or off. As soon as the ETI-743 circuit is turned on, a signal path is set up, linking the antenna directly to the output of your transceiver. This allows you to listen to the air as usual.

Pushing the "talk" button on your transceiver radio will activate the signal level detection circuit. As a result both relays and

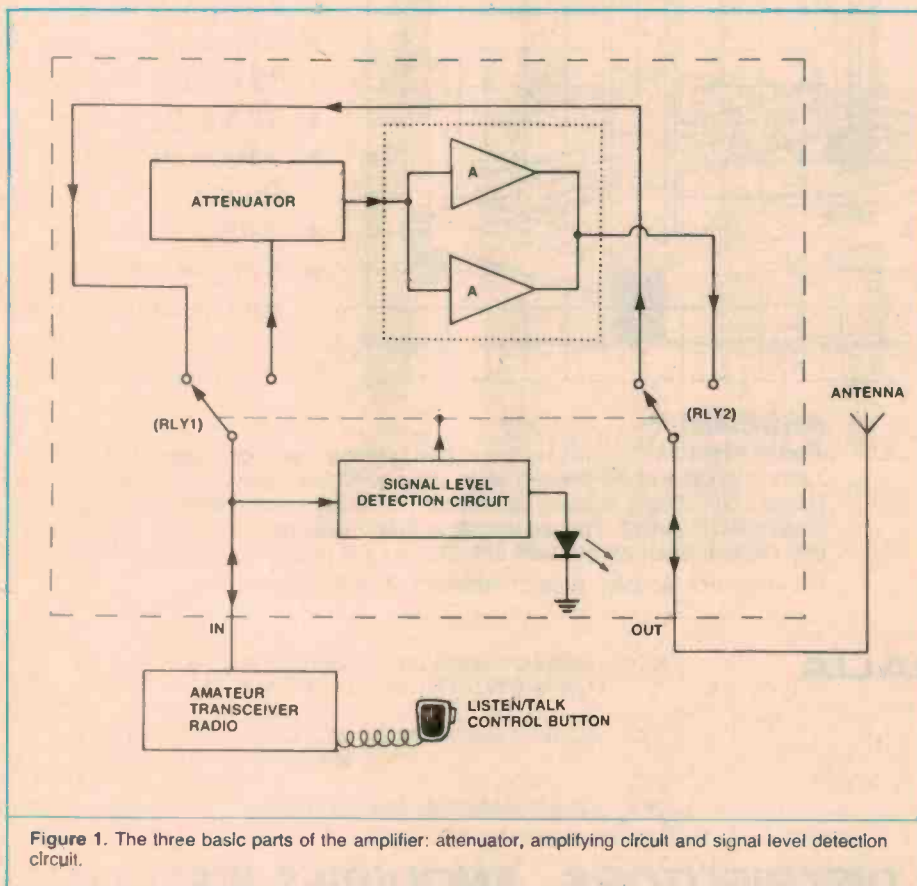

Figure 1. The three basic parts of the amplifier: attenuator, amplifying circuit and signal level detection circuit.



the transmitting LED will be turned on to indicate that amplification is activated. The output signal from the transceiver will be connected to the attenuator by RLY1. The output of the attenuator feeds IC1 and IC2, the hybrids, and output of these hybrids is fed to the antenna by RLY2.

These Motorola MHW710-2 hybrid rf amplifiers (IC1 and IC2) are connected in parallel using four matching transmission lines. These minimize the reflection of signal due to impedance mismatching. Each amplifier by itself can deliver a maximum of 12.5 watts. Two combined will give an exciting 25 watts output. These amplifiers are capable of operating over a frequency range from 440 MHz to 470 MHz.

At first sight, the attenuator network looks rather redundant, however it is important. It attenuates the transmitting signal to a power level that won't saturate the hybrid amplifiers. A 300 mW signal is required by the two rf hybrid amplifiers (each takes 150 mW), to obtain maximum output power.

Most amateur transceiver radios are 5 W output. If yours isn't you must carefully choose the right attenuation to suit your particular transceiver. The selected resistance values shown in the Parts List for R1 to R7 are suitable for 4 to 5 W transceiver radios only. If you happen to be one of the unlucky few who have a 1 or 2 W output transceiver radio, some fiddling of the resistance values is unavoidable (see "attenuator" box).

Construction

The construction work involved in this project is more mechanical than electrical. Instead of the usual method of assembling the board first and somehow mounting it later, you will have to sort out mounting problems first.

You must first make the cut-outs on the main pc board as shown on the pc board artwork. Cut the front and rear panels from a single sided pc board. Rectangular holes and slots have to be cut out in the front and

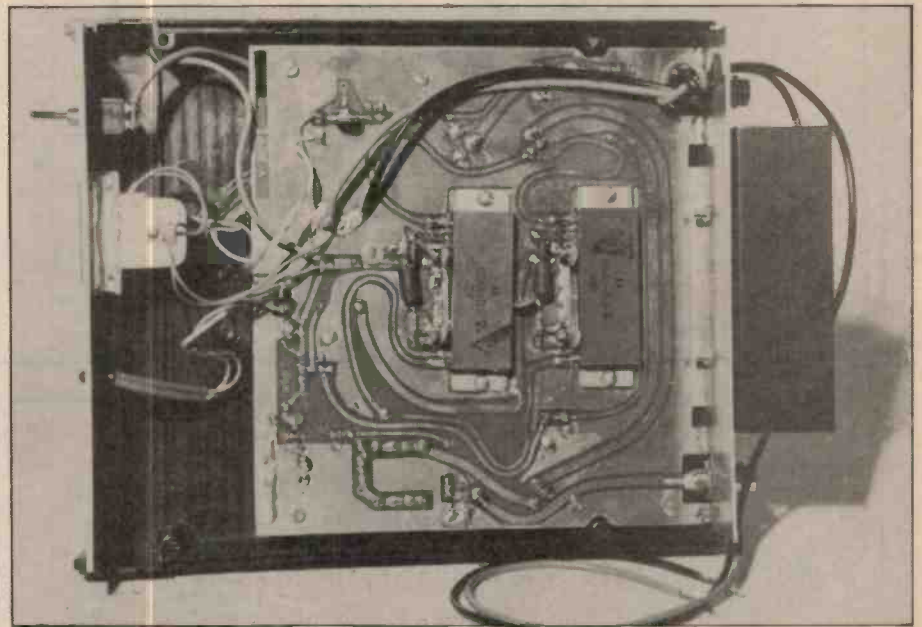

Side A ▲

▼ Side B

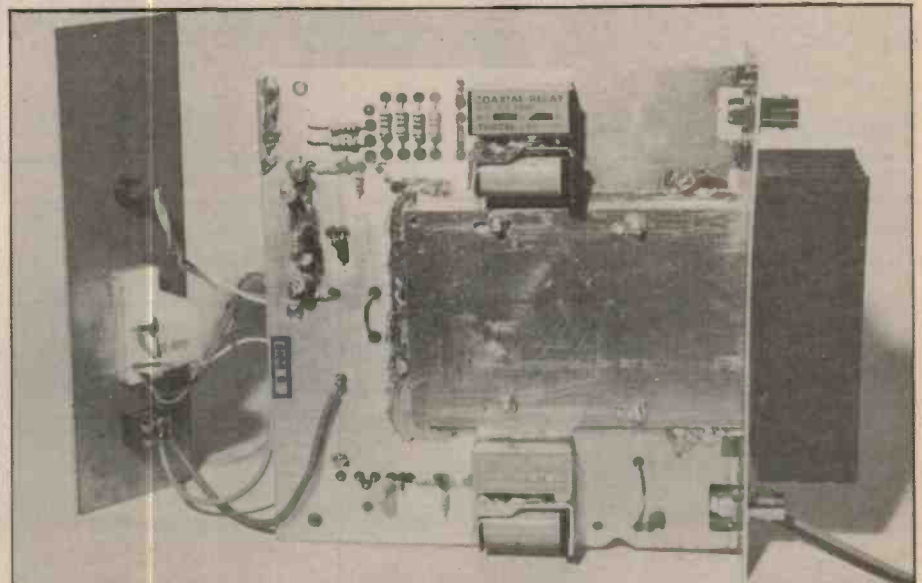

Project 743

rear panel as well as the main board. This can be done by first drilling a hole somewhere inside the area you want to cut out, inserting a saw blade through the hole and cutting out the area.

Next drill and cut all the holes on the main board and the panels. In order to reduce the ground plane impedance, the grounded tracks on both sides of the board have to be joined together electrically by means of copper foil. Three pieces of foil need to be soldered in the positions shown in Figure 2. The 28G copper foil is cut to about 23 mm wide, 12 mm long, soldered on the ground track, bent round the edge of

the board and soldered onto the other side of the board. Now get a bigger piece of copper foil (about 108 x 81 mm) of 24G and solder it onto side B of the pc board as shown in Figure 2, to cover the rectangular holes. I know how anxious you are to solder the components on board but wait a little longer, you will find it worth the time.

The next thing you have to do is to mount the main pc board into the case. If you have the right plastic case, there will be four plastic mounting studs standing out on the floor. Put four 12 mm spacers on the mounting studs. Land the main pc board with side A facing up gently on the spacers without

knocking them down. If the mounting holes on the pc board were drilled correctly, they should align with the spacers. Fasten the board with 20 mm long, 1/8" screws and insert the rear panel. The kinky edge of the main board should now touch the rear panel to form a right angle. With the copper side of the rear panel facing the kinky edge, the main board is soldered onto the rear panel to make this right angle structure rigid and sitting comfortably in the case.

The trickiest part is the mounting of the heatsink and the two hybrid amplifiers. An aluminium angle about the size shown in Figure 3a is inserted into the slot on the rear panel. It goes all the way in until the shorter arm of the aluminium angle is pressing against the rear panel. The longer arm of the aluminium should be forced to press tightly against the large copper foil you just soldered on the main board. You should put something between the longer arm of the aluminium and the floor of the case to provide the support for the aluminium while you drill it.

Now put the two hybrid amplifiers into the rectangular holes on the main board, and align the pins of the amplifiers with their corresponding tracks on side A of the board. Carefully mark out the mounting holes for the amplifiers on the copper foil using a sharp needle. Remove the hybrids and drill the four holes on the copper foil according to your marking. The holes should go right through the aluminium as well. You should mount the hybrid amplifiers onto the copper foil using a heat transfer compound on the bottom sides of the amplifiers. Screw the amplifiers down firmly and solder their pins onto the pc board.

Take a heatsink with dimensions as shown in Figure 3b. Drill two holes in it (for 1/8" screws) about 50 mm apart between two vanes, at about half its height. The heatsink is then placed against the shorter arm of the aluminium angle. On the surface of the shorter aluminium arm mark two corresponding holes and drill them right through to the rear panel. Evenly spread the heat transfer (silicon) compound on the aluminium surface. This sandwich structure (heatsink-aluminium-rear panel) is then fixed by using two 1/4" screws. Holes B and C as shown in rear panel drilling details are for mounting two BNC connectors on the rear panel. When you do so make sure their pins are lying flat on the corresponding tracks on the main board; they are soldered directly onto the tracks. Make sure the connectors are firmly tightened.

The rear panel, heatsink, main board and the aluminium should now form one single rigid structure. Remove this structure from the case and you can start putting components on the main board. You will find some of them are sitting on side A of the

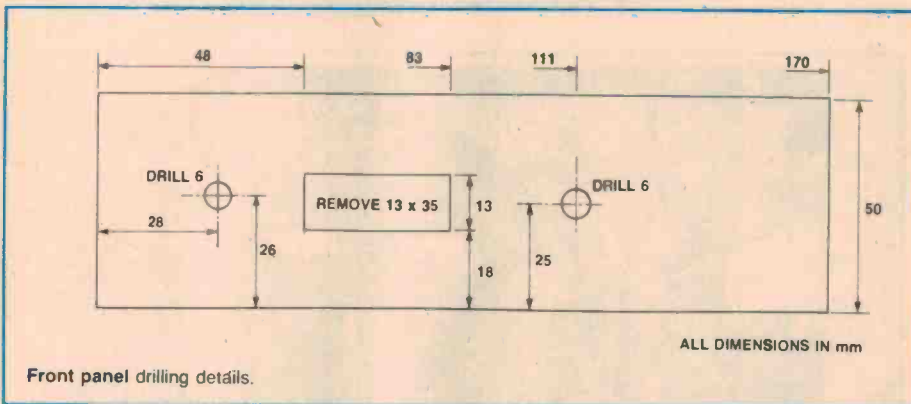

Front panel drilling details.

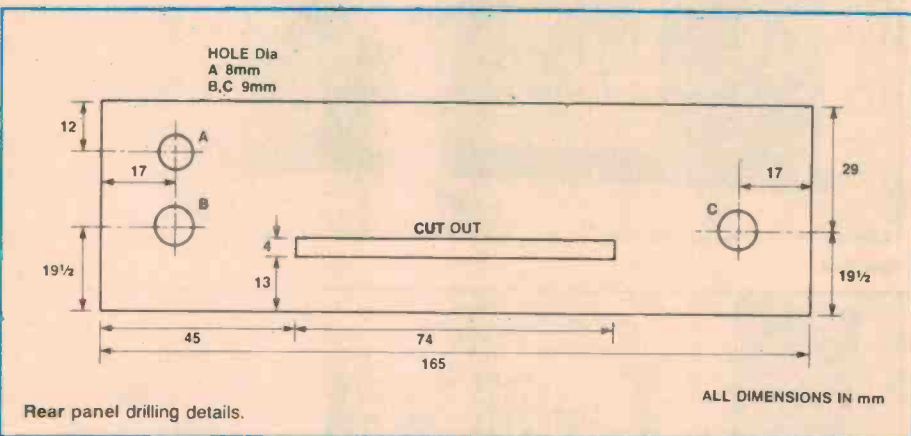

Rear panel drilling details.

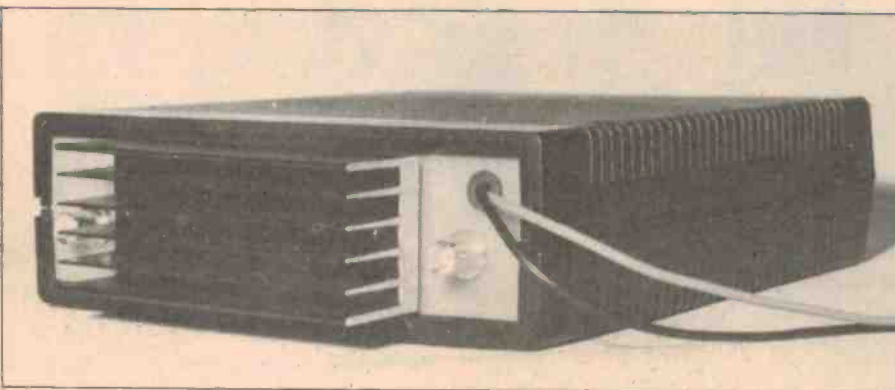

HOW IT WORKS — ETI-743

The rf signal at the BNC input (see Figure 2) is sensed by capacitor C1, and rectified by diodes D1 and D2 before driving the base of transistor Q1. In the receiving mode, the signal from the antenna is not strong enough to turn on Q1. Under this condition, the LED is off, relays are not energized and the amplifying circuit is idle.

As soon as you start transmitting, the much stronger signal from your transceiver radio output will turn on Q1, thus short-circuiting capacitor C3, and forcing R14 and R10 to form a potential divider generating roughly 5.3 V to the base of transistor Q2. This voltage is enough to saturate Q2 (that is, turn it on). The emitter junction of the turned-on Q2 starts to conduct like a forward biased diode and this diode, in shunt with the D3 and R14, effectively brings the 5.3 V back to about 11.3 V. The base current is then limited by R10 to around 11.3 mA.

Both relays RLY1, RLY2 and the LED are connected in parallel. The saturated Q2 will give rise to about 12 V across all three turning them on. Current through the LED is limited to about 12 mA by R11; current through the relays is limited by their resistances. Diode D4 and capacitor C8 are there to protect the transistor Q2 from the damaging inductive effect of the relays' coils during switching.

The amplifying circuit consists of two hybrid amplifiers (IC1 and IC2) each of which has a gain of 19.2 dB. A 150 mW signal injected into one will give an output power of $0.15 \times 10^{1.92} = 12.5$ watts. Two in parallel gives 25 watts but requires a 300 mW input signal.

Connecting both amplifiers together is not an easy job at all. Impedance matching has to be allowed for or signal reflection may occur. Most transceivers have an output impedance of 50 ohms. The input impedance of each hybrid amplifier is also 50 ohms. Connecting two hybrids in parallel obviously won't give 50 ohms anymore. The idea is to connect each amplifier input with a transmission line before they join together. The characteristic impedance of both transmission lines is 75 ohms and they are a quarter wavelength long.

The impedance looking into each amplifier with a quarter wavelength long transmission line connected becomes 112 ohms. Since there are two in parallel, the input impedance looking into the whole amplifying circuit becomes $112/2 = 56$ ohms, which is pretty well matched to your 50 ohm radio. A similar arrangement connects the amplifiers' outputs together to match your 50 ohm antenna. These four transmission lines are printed as normal copper tracks on a pc board with their lengths carefully calculated.

As you may have noticed from the circuit diagram or the mask of the layout, diode D5 connects to the ground through a short piece of copper track. It acts like a little antenna picking up the rf signal from the circuit, rectified by D5. The output drives the M1 meter. Hence the meter provides the indication of the strength of the rf signal.

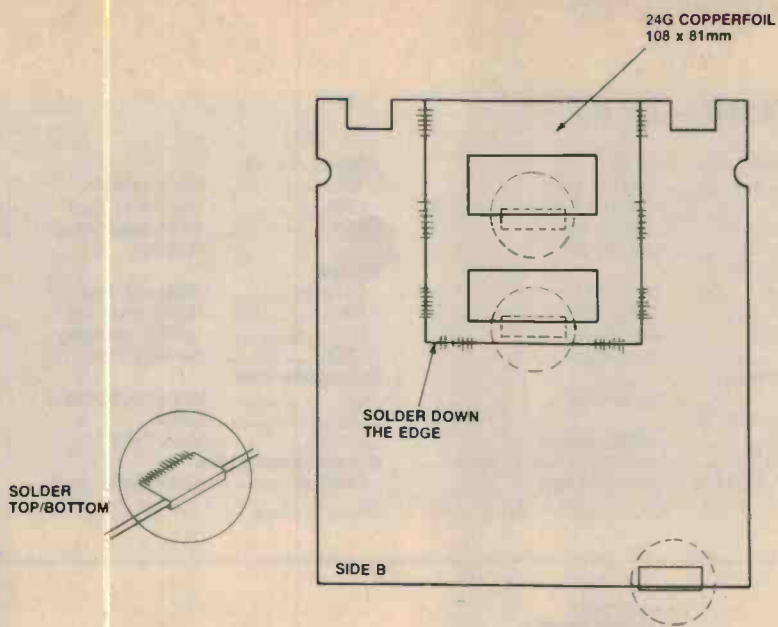

Figure 2. Copper foil soldering positions. Three pieces of foil should be soldered into position. The larger square piece of foil is soldered on to cover two of the small pieces.

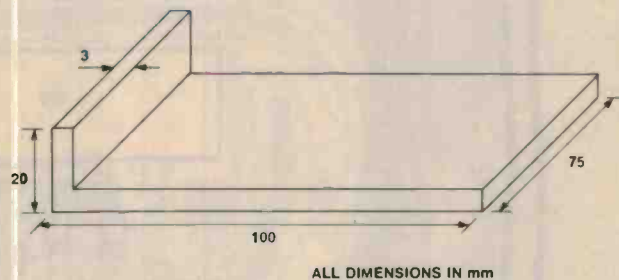

Figure 3a. Dimensions of aluminium angle.

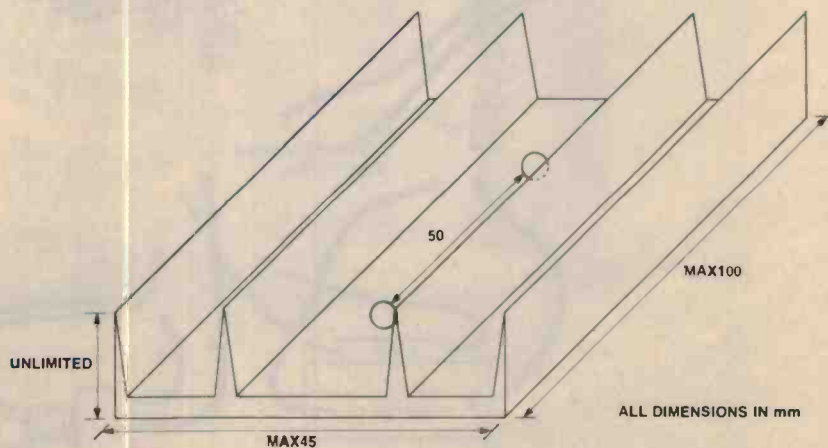

Figure 3b. Heatsink dimensions and drilling details.

Project 743

PARTS LIST — ETI-743

Resistorsall 5%

- R1, 2, 3, 4 180R (1 W)
- R5, 6 12R (1 W)
- R7 39R (1/4 W)
- R8 10k (1/4 W)
- R9, 10, 11, 14, 16 1k (1/4 W)
- R15 2k2 (1/4 W)
- R12, 13 4R7 (1/4 W)
- VR1 10k trimpot

Capacitors

- C1 1p ceramic
- C2, 4, 6, 8, 13, 15, 19 1000p ceramic
- C3, 12 10 μ (16 V) tant. or elect.
- C5, 7, 14, 16 1 μ (35 V) tant.

- C9, 10, 11, 17, 18 0.01 μ ceramic
- C20 10 μ (16 V) elect.
- C21 1000p feedthrough ceramic

Diodes

- D1, 2, 5 1N60 high freq.
- D3 1N914 small sig.
- D4 1N4002 rectifying
- LED1 red LED 5 mm

Semiconductors

- Q1 BC107 or BC548
- Q2 BD140
- IC1, 2 MHW 710-2

rf choke accessories

- CHK1, 2 6-hole ferrite bead

- CHK3, 4 single hole ferrite bead

Miscellaneous

- SW1 DPDT toggle switch
 - BNC1, 2 BNC connectors
 - M1 200 μ A meter
 - RLY1, 2 coaxial relays
- One 24G copper foil (108 x 81 mm); one 28G copper foil (23 x 36 mm); LED holder; four spacers; 100 mm heatsink for IC1, IC2; a right angle aluminium section; one plastic case (210 x 175 x 55 mm); front and rear panels; one double sided pc board; 500 mm red/black wire, a short length of 25BNS insulated wire for making the rf chokes; 10 nuts and screws (1/8") for mounting the hybrid amplifiers.

Price estimate: from \$129

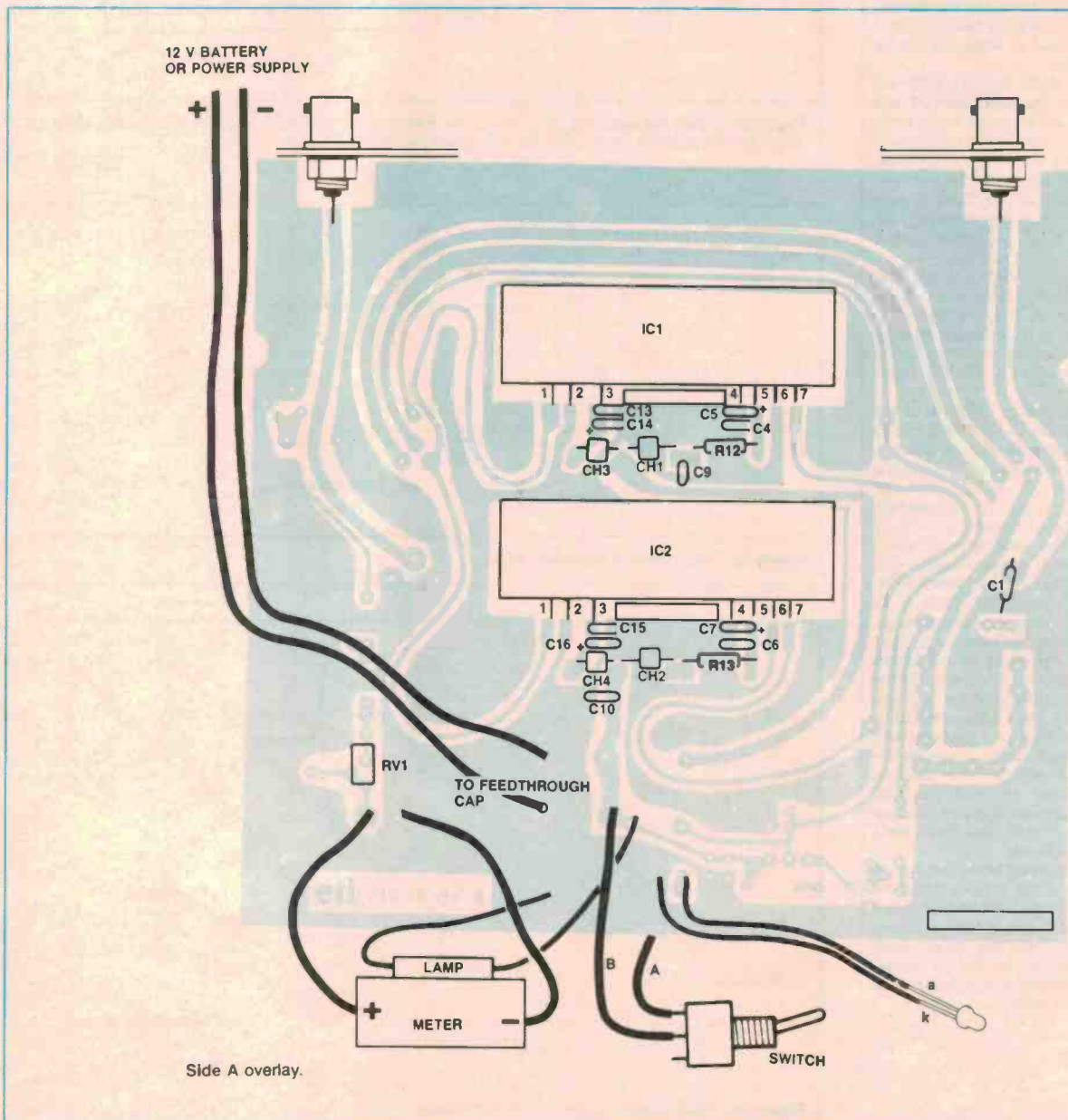

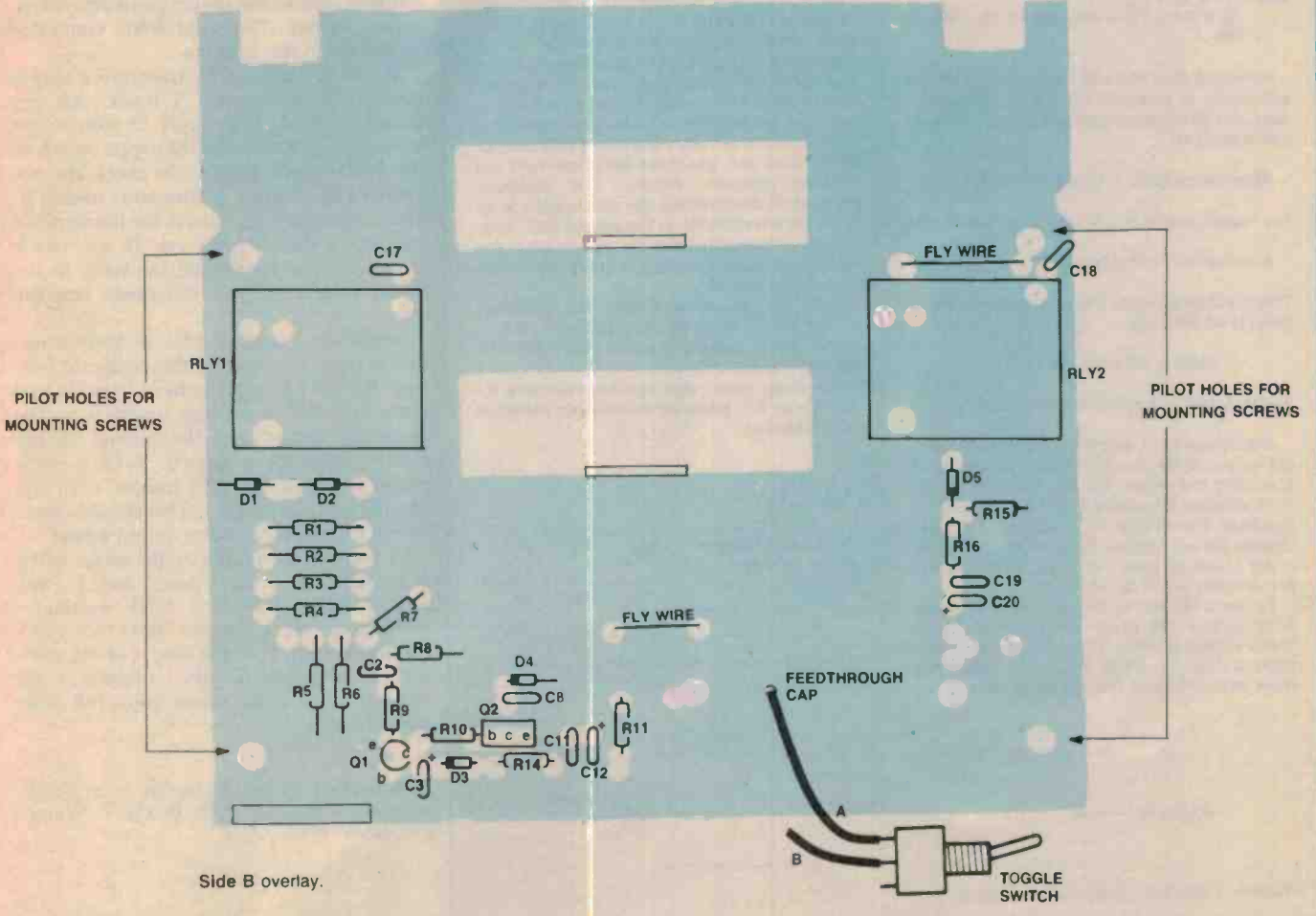
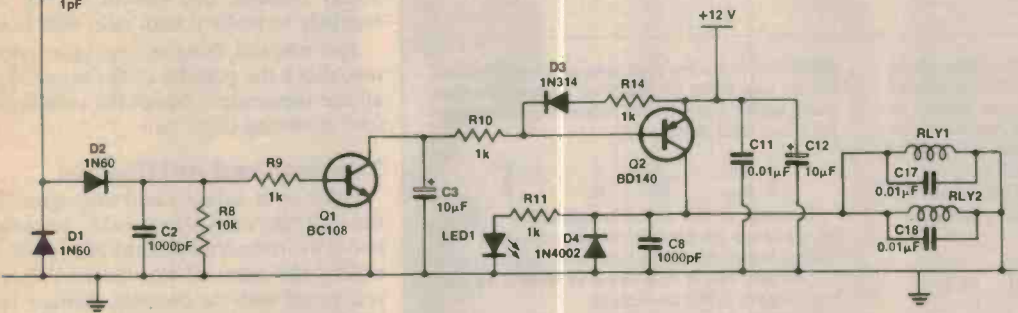
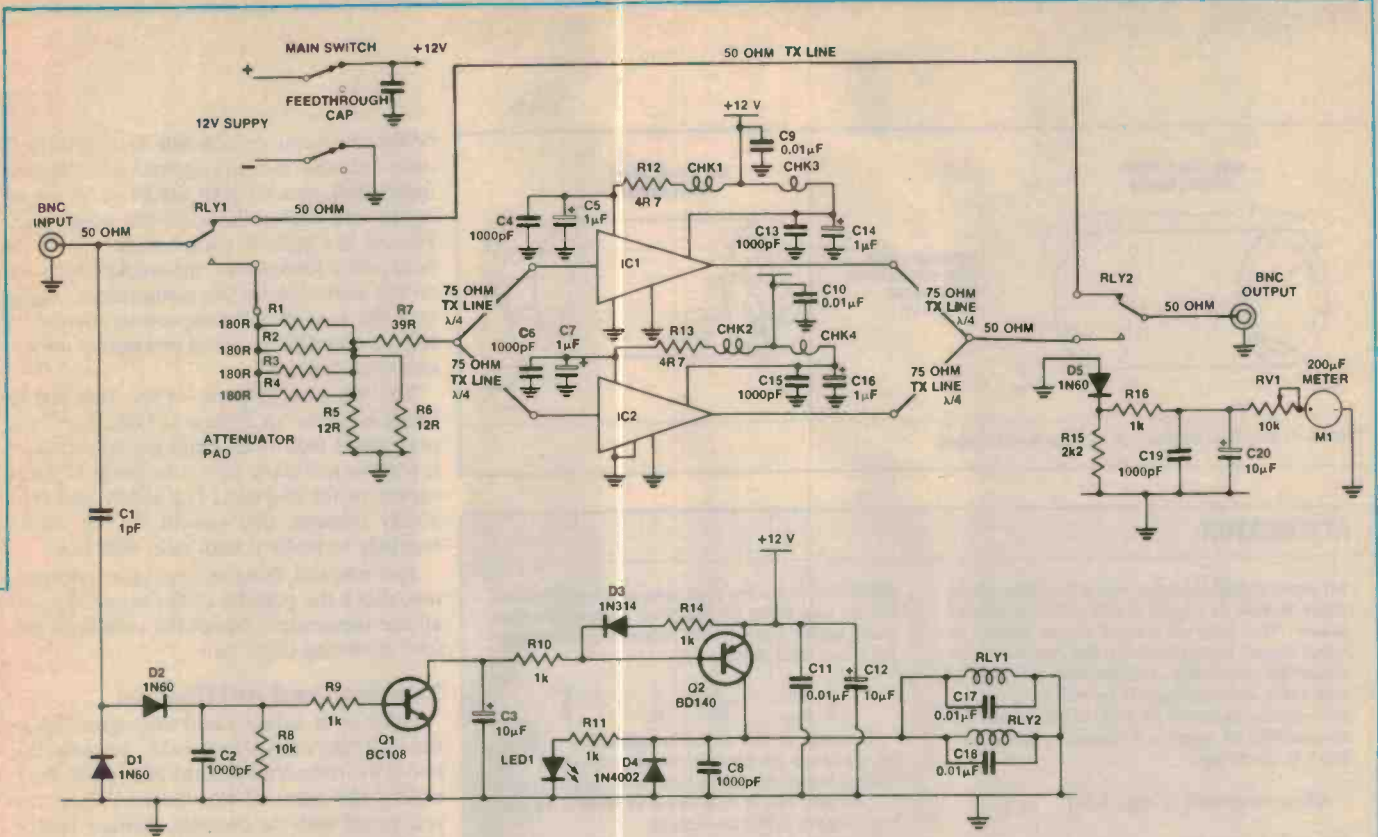

Side B overlay.

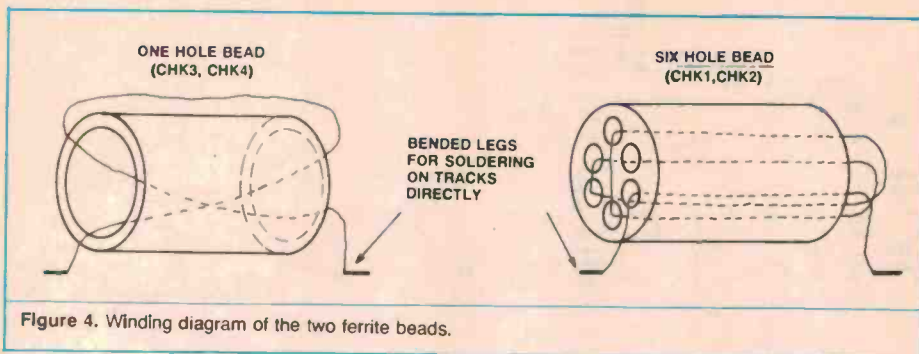

Figure 4. Winding diagram of the two ferrite beads.

ATTENUATOR

An input signal injected into a T-shape attenuator shown in Figure 5 will suffer a loss of power. The ratio of output signal power to input signal power defines the degree of attenuation. Normally, people take the log of this ratio and multiply it by ten to give the attenuation in terms of dBs. In our case, the attenuation of such a T-shape resistor network is given by:

$$\text{Attenuation (dB)} = \log [A/B] \dots (1)$$

where $A = 56 \times R_c$

$$B = R_a \times (R_c + R_b + 56) + R_c \times (R_b + 56).$$

Recalling that 300 mW in the output of the attenuator is required for the hybrid amplifiers, the attenuation you need for an 'M' watt transceiver is:

$$\text{Attenuation (dB)} = 10 \times \log (0.3/M) \dots (2)$$

For instance, if $M = 1$ W, using equation (2):

$$\text{Attenuation} = 10 \times \log (0.3/1) = -5.23 \text{ dB}$$

This must be equal to the expression in equation (1) so we have:

$$-5.23 \text{ dB} = 20 \times \log [A/B]$$

where A and B are defined previously.

The values for A and B are dependent upon the values of R_a , R_b , R_c . It is only a matter of choosing the values for R_a , R_b , R_c to make both sides of the above equation as equal as possible. For this 'M = 1' watt case, I have chosen $R_a = 15$ ohms, $R_b = 18$ ohms and $R_c = 82$ ohms to give -5.25 dB, which is approximately equal to -5.23 dB.

To make life easier for you, a set of resistance values are given for different transceiver output powers. These figures are tabulated below for quick reference. You may have realized from the actual pc board art-

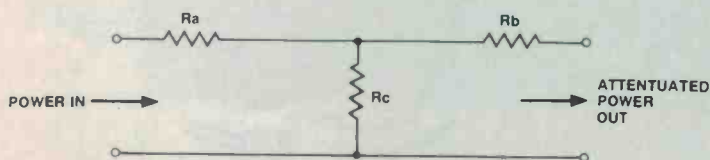

Figure 5. Signal into T-attenuation network.

work that there are four sets of resistor holes for R_a and three for R_b . This means you can build up R_a and R_b with more than one resistor in parallel using:

$$\left(\frac{1}{R_{com}} = \frac{1}{R_1} + \frac{1}{R_2} + \dots \right)$$

Because of the power requirement, parallel resistors R_a and R_b must be at least 1 W rating. If you prefer to have a single resistor for R_a and R_b , it has to be at least 4 W rating — for a 5 W transceiver.

After all these calculations, you probably think this is the end of the story. Unfortunately, it is not! We found the theoretical values don't work in practice. The numbers you have just calculated or borrowed from the table assumed pure resistance. The ones we use in practice are slightly inductive. A factor of 2 was recorded between the calculated attenuation value and the value obtained from the working resistor values. The quickest method of determining the attenuation is to hook up a wattmeter to the output BNC connector of the unit. Take the values from the table (or calculate them) and solder the resistors on the board.

Turn on the unit and note the indication of the power level on the wattmeter. If it is not 25 watts, you will have to fiddle with the resistor values until it is.

Warning: Never use variable resistors for R_a , R_b or R_c , because all variable resistors are inductive.

TABLE 1

Transceiver output power in watts	R_a	R_b	R_c
1	15	18	82
2	110	22	47
3	27	27	33
7	33	33	22

board and some are on side B. The side B ones are soldered in a normal way, that is, insert their pins through the holes on the pc board and solder them on the other side. Pins of the side A components should be bent and soldered onto the tracks which are on the same side as the components. Make sure the pins of the components are cut as short as possible to avoid picking up unnecessary rf signal.

The winding diagram of the two ferrite beads is shown in Figure 4. Hole A on the rear panel (see rear panel drilling details) is for the red/black cables to bring 12 volts supply in for the unit. For safety and reliability reasons, you should tie the cables together to make a knot near that hole.

Just one last thing in case you've forgotten, check the polarity of the meter M1 and all the capacitors (except the ceramics) before soldering them on.

Testing and setting up

Hook your antenna and transceiver up to the unit. Be very very careful, because the two BNC connectors on the rear panel look exactly the same. If you are looking at the rear panel with the heatsink facing you, the left BNC connector should go to your transceiver output. The right BNC connector should go to the antenna.

If you are lucky your transceiver output power will be around 5 watts. All you then have to do is to apply 12 volts to the unit and turn it on using the toggle switch on the front panel. Please, do check the polarity of the battery before you connect it. Once connected, the lamp for illuminating the meter should come on. If not, check that the wires connecting the lamp to the board have a 12 volt difference between them.

Press the "talk" button in your transceiver radio and several things should happen: the red LED on the front panel should come on with a clicking sound from the switching relays, and the pointer in the meter should be deflected. Take a screw driver to adjust the RV1 trimpot until you get full scale deflection. This should correspond to around 25 watts output power.

A better way to calibrate the meter in the front panel is to use a power meter. Dick Smith Electronics has a UHF wattmeter which connects to the unit. With the "talk" button pressed, read the output of the wattmeter and adjust the RV1 trimpot at the same time until the meter gives full scale deflection.

Artwork: pc board layout is available on request to ETI, P.O. Box 227, Waterloo, NSW 2017.

Businessmen & Hackers finally see eye to eye on printers.

Business people will welcome it as a new price break-through in near letter-quality printers. Hackers will welcome it as a whole new standard in low-cost printers.

On appearances, you'd never suspect it was a low-cost printer. And when you see its superb, near letter-quality printing, you'll find it hard to believe that the recommended retail price (excluding sales tax) is around \$410!

The Epson® "NLQ Special" gives you so much more than you've learned to expect from a printer in this price range.

It offers superb, near letter-quality printing in a variety of type styles and sizes.

It has a variety of word processing functions built in so you can produce professional-looking documents even without word processing software.

It prints up to 100 characters per second, and includes a 1024 byte input buffer which reduces the amount of time your computer is tied up during printing.

It produces charts and graphics with a crispness and definition that's seldom been seen on a printer in this price range. It comes with standard friction feed, optional tractor and cut sheet feeders, and uses standard interfaces.

There is so much more to the Epson LX-80 that you won't find on other low-cost printers. Call in to your nearest Epson dealer and see what's so special about the "NLQ Special."

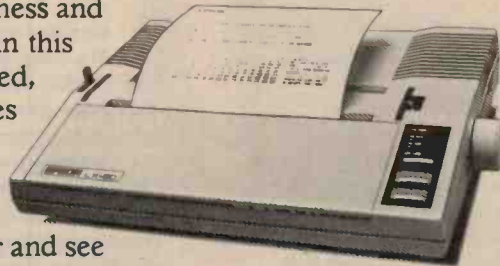

The "NLQ SPECIAL" by **EPSON**
AUSTRALIA

Epson Australia Pty Ltd, 3/17 Rodborough Road, Frenchs Forest, Sydney (02) 452 5222. Melbourne (03) 543 6455. Brisbane (07) 832 5400.

*Registered Trademark of Epson Corporation EPS0051

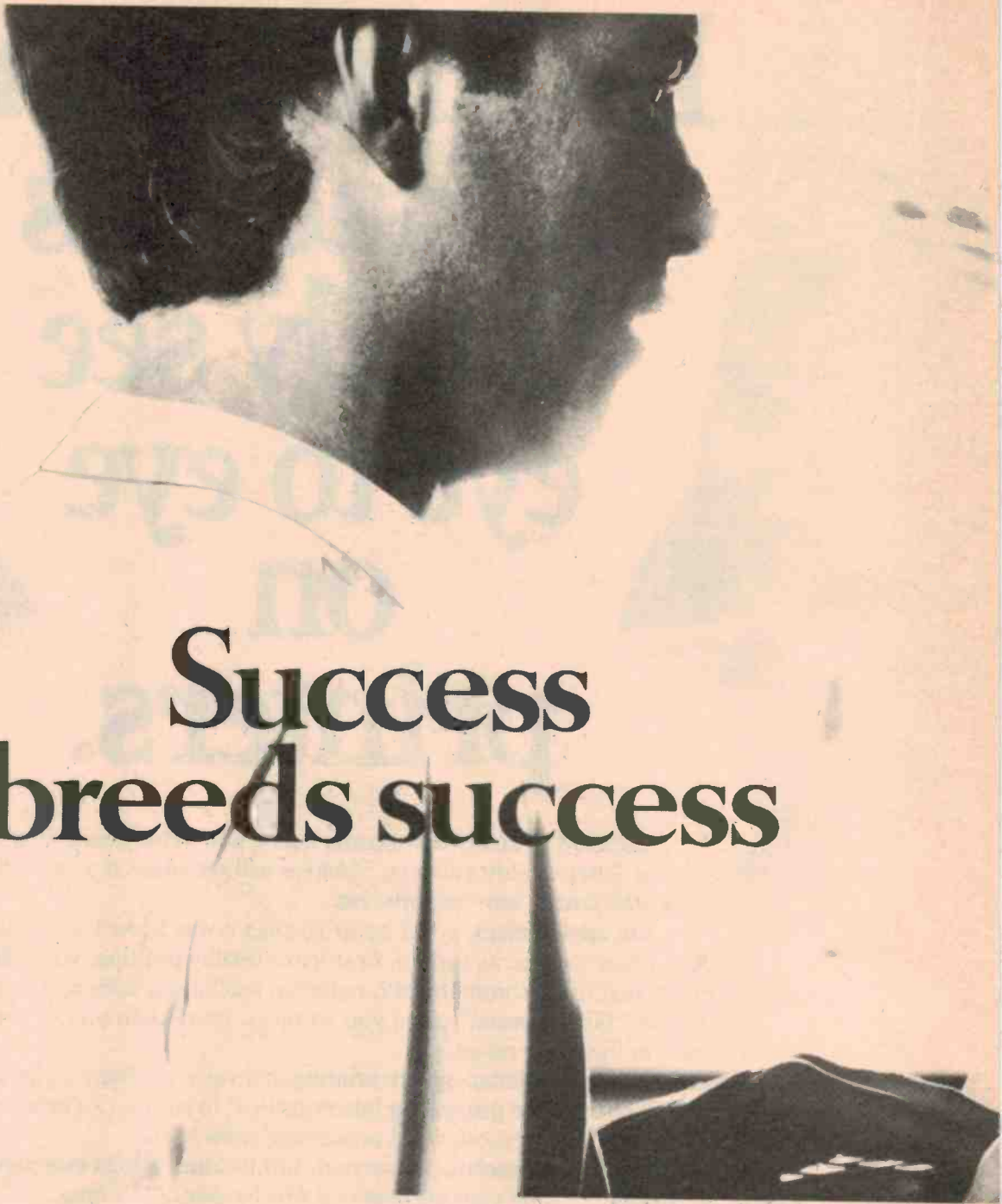

Success breeds success

It seems that every IC company in the world offers a semi-custom service.

So why choose Plessey?

Well, as a major supplier of semi-custom ICs, we can offer a track record of success and experience few others can match. In every area of application, including telecoms, robotics, business computers and data processing, we've consistently achieved a high first-time success rate. In fact, the chances of you not getting it right first time with Plessey are exceptionally low.

How do we do it?

In a word, accessibility. We offer a range of options that gives you maximum access to our semi-custom programs from day one.

A simple low-cost terminal is all you need to key into one of our software suites: proven interactive simulation programs for you to run in your own time, on your own premises. And of course you can call in on our Design Rooms any time you need help or product testing.

But, if you prefer to use our facilities, we have Design Rooms in

At a glance Plessey semi-custom

- Choice of cell-based or gate array techniques.
- High first-time success rate.
- Comprehensive low-cost software support for interactive simulation.
- Full bureau service.
- Total manufacturing capability.
- More performance from a given chip.



England, Germany, California and now in Sydney.

This includes access to the best test unit in the business, the Teradyne J941. (At a cost of nearly \$1 million it should be.)

Our semi-custom routine means that we'll supply you with an end result that's testable, workable and manufacturable, in just a few working weeks.

With all the options to choose from we'll never force you into a

non-optimum solution.

So, whichever semi-custom option you choose, whether cell-based or gate array, the end product will be every bit as advanced as the design techniques.

If you feel the semi-custom service you're using now is only giving you half the story, send for the Plessey Semi-Custom Portfolio.

If you're ready for success so young, that is.



Plessey Semiconductors Pty Ltd.
122 Arthur St, North Sydney
NSW 2060.

For information call: Joy Thorne
(02) 72 0133. Telex 20384.



In a word, success

MICROBEE JOYSTICK ADAPTOR



Geoff Nicholls

This simple project neatly connects a standard joystick to the Microbee's parallel port. You don't have to butcher the joystick cable, it will plug into the adaptor which in turn plugs into the Microbee. And it meets the 'Official Standard For Joysticks On The Microbee' according to Applied Technology.

THE PROJECT IMPLEMENTS the circuit described in the *Microbee Engineering Notebook*, which was reprinted in the *Microbee Hackers' Handbook* on pages 55 and 56. NOTE: There is a mistake in the Connection Table on page 55. The DB9 Table has LEFT and RIGHT interchanged; the correct connections are:

JOYSTICK PINOUT	FUNCTION
1	UP
2	DOWN
3	LEFT
4	RIGHT
5	not used
6	FIRE
7	not used
8	COMMON
9	not used

The Table showing the DB15 connections is also wrong; LEFT should go to pin 12 and RIGHT should go to pin 4.

Construction

Check the printed circuit board for shorts, especially where the tracks pass between the pads of the DB-15P.

Solder the link in first, then the seven resistors. Next, insert the right angle plugs and push them right down flat against the pc board before carefully soldering the pins.

The board comes without pre-drilled mounting holes for the plugs to allow all types to be used, so you will have to run a drill through the pc board. I used 6BA screws to secure the plugs.

NOTE — If you want to do the project on the cheap you can solder the joystick wires straight to the pc board and save the cost of the DB-9P connector.

Programming for the joystick

Two test programs are reproduced to test the joystick. The shorter one was written by Applied Technology and prints out "up",

"left", "fire" etc as appropriate.

I wrote the other program to do simple screen drawing.

There are a few points to watch when writing software to use the joystick. You should include the line "OUT 1,255" in the initialization section of your programs to make sure the PIO is set up for input.

The switches produce a '0' when close and a '1' when open, so the numbers obtained directly from the port may seem a little strange at first. Lines 120 to 190 of the short program show one technique for identifying which switch (or switches) are closed.

If you simply input directly from the port (that is A=IN(0)) then you will get the following numbers; note the centre number is for the stick in the central position.

250	254	246	122	126	118
251	255	247	123	127	119
249	253	245	121	125	117

(fire button off)

(fire button on)

Converting games for joystick control

It is possible to change programs that use the keyboard for game control over to the joystick. The general idea is to list the program and look for the lines that include keywords like "INPUT", "KEY" or "KEYS" and modify the program to use an "IN(0)" instead. Consider the changes made to the following lines of a games program:

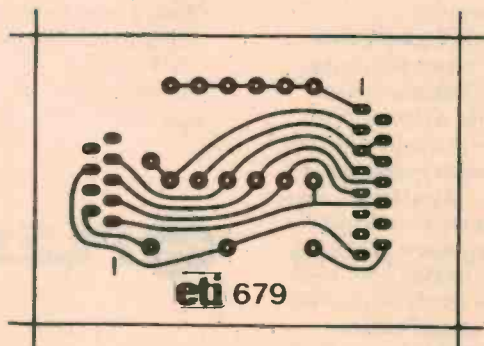

HOW IT WORKS — ETI-679

There is really nothing to it!

The joystick itself consists of four switches arranged so that moving the stick closes one or two of the normally open switches. The switches are arranged like the points of the compass, so that moving the stick in the north-east direction will close both the north and the east switches. A fifth switch is used for the fire button, some joysticks have two parallel fire buttons.

The adaptor provides pull up resistors for the data lines to the port to guarantee a binary '1' when the switches are open. The unused data lines (D4, D5 and D6) are pulled high by R5.

The ASTROBE input to the Microbee's Z-80 PIO is tied low by R7 to allow input operations without handshaking.

PARTS LIST — ETI-679

Resistors

R1-R6.....10k
R7.....1k2

Miscellaneous

ETI-679 pc board; 1 x DB-9P and 1 x DB-15P connectors; 2 x right angle plugs; screws.

Price estimate: \$7

```
00070 F=A:CURS(E+M):PRINTCHR(129);CHR(130);:I=ASC(KEY)
:IF I=44 THEN LET F=B
00080 IF I=46 THEN LET F=P
```

Unmodified keyboard control.

```
00070 F=A:CURS(E+M):PRINTCHR(129);CHR(130);
00075 I=IN(0)
00076 IF I=251 THEN LET F=B
00080 IF I=247 THEN LET F=P
```

Modified for joystick control.

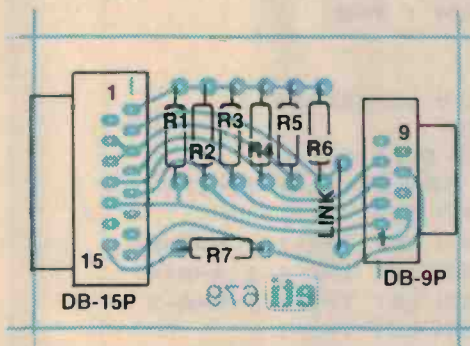
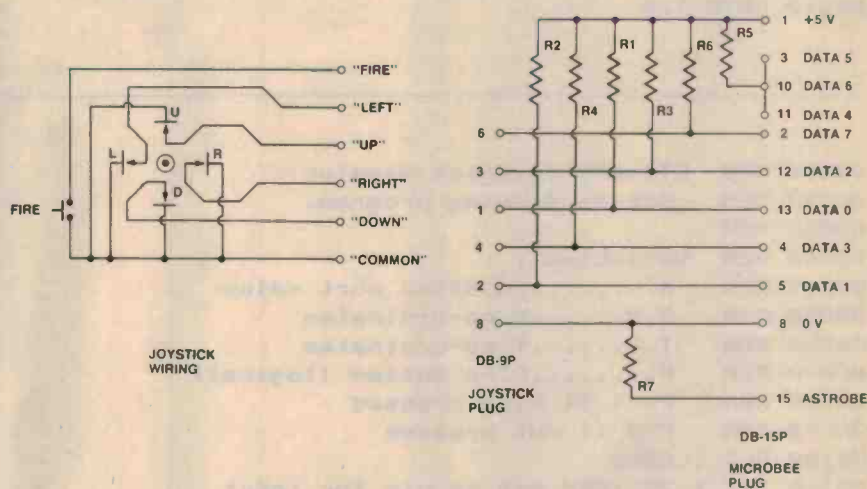
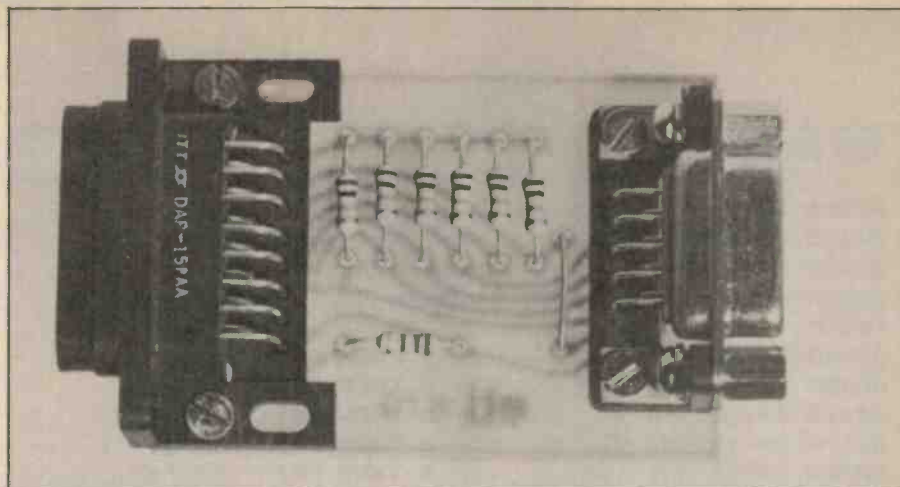

The first two lines use the two arrow keys " \leftarrow " and " \rightarrow " to move the object around. I removed the "I=ASC(KEY)" statement and replaced it with "I=IN(0)" on a new line. All that was left to do was to change the numbers that the "I" variable is compared to, to suit the joystick. In the example the " \leftarrow " key (44) is for left motion and corresponds to 251 on the joystick port. The " \rightarrow " key is replaced by 247. There were no other places in the program where the motion keys were used, so the joystick conversion was complete! ▶

TEST PROGRAMMES

```

00100 REM joystick test program for Microbee
00110 OUT 1,255 :REM initialise port
00120 A=IN(0) :REM read joystick port
00130 A=143-(A AND 143) :REM convert to positive
logic
00140 B=-(A AND 1) :IF B THEN PRINT "up",
00150 B=-(A AND 2) :IF B THEN PRINT "down",
00160 B=-(A AND 4) :IF B THEN PRINT "left",
00170 B=-(A AND 8) :IF B THEN PRINT "right",
00180 B=-(A AND 128) :IF B THEN PRINT "fire",
00190 IF A=0 THEN PRINT "nothing",A ELSE PRINT A
00200 FOR T=1 TO 100 : NEXT T :REM short delay
00210 GOTO 120
    
```

```

00010 REM ETI-679 Joystick Adaptor
00020 REM Screen drawing program.
00030 REM
00040 REM Variables ;
00045 REM A.....joystick port value
00050 REM Z,X.....X co-ordinates
00060 REM T,Y.....Y co-ordinates
00070 REM F.....Fire Button (logical)
00080 REM F=-1 if Fire pressed
00090 REM F=0 if not pressed
00100 CLS :LORES
00110 OUT 1,79 :REM set up pio for input
00120 Z=63 : T=24 : F=0
00130 GOTO 230
00135 REM
00136 REM Update variables
00140 A=255-IN(0)
00145 REM Check Fire Button
00160 IF A>127 THEN LET A=A-128:F=-1
00170 IF A=0 THEN 140
00180 IF A>7 THEN LET Z=X+1 : A=A-8
00190 IF A>3 THEN LET Z=X-1 : A=A-4
00200 IF A>1 THEN LET T=Y-1 : A=A-2
00210 IF A>0 THEN LET T=Y+1
00215 REM Erase last point if Fire Button pressed.
00220 IF NOT F THEN RESET X,Y
00225 REM Set new graphics point.
00226 REM First wrap around to stay within screen
00230 X=Z: Y=T
00240 IF X>127 THEN LET X=0
00250 IF X<0 THEN LET X=127
00260 IF Y>47 THEN LET Y=0
00270 IF Y<0 THEN LET Y=47
00280 SET X,Y
00290 F=0
00300 GOTO 140
    
```



Rockwell

QUALITY SEMICONDUCTOR PRODUCTS 68000-6500

		exempt*
R68000C6	CPU Ceramic DIL	\$55.79
R68000U6	CPU Plastic Compact QUIP	\$36.76
		8, 10 MHz available 12 MHz available soon
R6502P	CPU, 40 pin	\$8.29
R6503P	CPU, 28 pin	\$7.24
R6504P	CPU, 28 pin	\$7.24
R6507P	CPU, 28 pin	\$7.24
R65110	Single chip microcomputer, 64 pin CPU, RAM ACIA I/O, Timers, 64K Address	\$20.93
R6520P	PIA 40 pin	\$5.13
R6522P	VIA 40 pin, 20 I/O, 2 x Timer/Ctr S. Reg.	\$7.37
R6532P	COMBO 40 pin, 128 byte RAM, 20 I/O, Timer	\$9.21
R65410	Slave Processor, 64 x 8 RAM, 23 I/O, host slave I/F, timers 4 K, external address	\$15.01
R6545-1P	Video controller	\$12.51
R6551P	ACIA Integral Baud rate gener.	\$8.82
R6592P	Single chip printer controller for Epson Low cost printer	\$15.14

CMOS

R65C02P1	CPU, 50 pin plastic, enhanced instruction set	\$10.00
R65C21P1	PIA 40 pin	\$7.90
R65C24P1	PIAT, I/O x Timer 40 pin 6821/6521 compatible	\$9.48
R65C51P1	ACIA 28 pin	\$10.00
R2424	MOEM CHIP SETS	\$495.43

PRINTERS

CPA-80	Centronics and Serial versions available, 100 cps, 2K expandable to 8K buffer	Ex Tax \$281.68 Incl Tax \$321.23
	Centronics	Ex Tax \$304.30 Incl Tax \$346.19
	Serial	
DWX-305	Letter quality daisywheel printer, 18 cps	Ex Tax \$519.75 Incl Tax \$595.16
	Cut Sheet Feeder	Ex Tax \$332.73 Incl Tax \$372.66
	Tractor Feeder	Ex Tax \$111.12 Incl Tax \$123.78
SHINKO 1310	300 cps, Dot Matrix, near Letter quality	Ex Tax \$1035.51 Incl Tax \$1188.17
TATUNG TVT600A TERMINAL		Ex Tax \$803.22

DISC DRIVES

F-051APC	5.25" slimline SSDD 40 track, Taut band, direct drive, 250 KB, low noise	Ex Tax \$228.13
CF82AP2	Slimline disc drive	Ex Tax \$187.31

HIGH PERFORMANCE DEVELOPMENT TOOLS FOR 6502 FAMILY

EC-EP	EPROM Programmer	Ex Tax \$77.44
EC-TTLT	Tester	Ex Tax \$138.00
EC-MEMT	Memory Tester With Fast Programmer	Ex Tax \$256.00
EC-PALP	PAL Programmer Incl Software	Ex Tax \$426.52
EC-LOG	Logic Analyser 10 MHz	Ex Tax \$3554.80
EC-64	Apple (TM) compatible, variety of packages available	
MPF-PC	IBM (TM) compatible, variety of packages available	

A variety of Instrumentation tools available for laboratory instrumentation. CONTACT THE OFFICE FOR PRICES AND AVAILABILITY

*All prices subject to sales tax if applicable
Please allow \$5.00 Post and Package with all orders

SUBSTANTIAL OEM QUALITY DISCOUNTS AVAILABLE
PLEASE CONTACT THE OFFICE FOR PARTICULARS

energy CONTROL

73 Eric Street, Goodna, Qld. Aust.
P.O. Box 6502, Goodna, Qld. 4300
Telephone (07) 288-2455.
Telex AA 43778 ENECON

* ALL PRICES ARE SUBJECT TO CHANGE WITHOUT NOTIFICATION *
BANKCARD AND MASTERCARD ACCEPTED

ICL7106	19.50	74H106	2.50	74LS160	1.00	MM53174	19.50	SC1520	6.90	MRF455	37.00	VN8BAF	3.95	74148	2.00	FD1771	19.00	79L05	1.20	
ICL7116	19.50	74H108	1.50	74LS161	1.00	MM53175	19.50	SC1530	6.90	MRF457	37.00	VN8C372	1.95	74150	1.50	FD1791	(8876)	79L12	1.20	
ICL7117	19.50	74H111	1.10	74LS162	1.50	MM53180	14.50	C103B	90	MRF463	19.50	25C495	2.95	74151	1.20	39.00	79L18	1.20	79L24	1.20
ICL7161	6.95	74H114	1.10	74LS163	1.10	MM5369	4.95	C106B	90	MRF464	49.00	25C710	1.95	74154	1.75	FD1793	(8877)	LM332K	1.20	
ICL7660	5.90	74C100	4.00	74LS164	90	LH0007	9.50	C122D	2.50	MRF465	50.00	25C712	1.95	74155	1.20	79L05	1.20	LM333K	2.50	
ICL7661	4.90	74C101	4.00	74LS165	90	LH0262	9.50	C122E	2.50	MRF466	50.00	25C713	1.95	74156	1.20	LM334K	1.20	LM335K	2.50	
ICL7662	4.90	74C102	4.00	74LS166	2.50	LH0071	9.50	C260D	6.50	MRF467	50.00	25C945A	1.95	74157	1.00	FD1795	30.00	LM337K	2.50	
ICM7211	12.50	74C200	60	74LS173	90	TL081	1.50	C260E	9.50	MRF468	50.00	25C1014	2.50	74158	1.00	FD1797	30.00	LM338K	10.50	
ICM7216	48.50	74C201	60	74LS174	2.90	2N2446	1.20	AD162	2.90	MRF469	50.00	25C1017	4.95	74160	1.50	WD1691	29.50	LM339K	10.50	
ICM7216B	44.50	74C10	80	74LS175	80	TL064	4.90	AD162	2.90	MRF470	50.00	25C1018	4.95	74161	1.20	WD1931	22.50	LM340K	10.50	
ICM7217A	16.50	74C10	80	74LS176	80	TL071	2.90	M26027	90	MRF471	50.00	25C1061	2.95	74162	1.20	WD1933	34.00	LM350K	10.50	
ICM7218A	16.50	74C32	80	74LS177	80	TL072	2.90	TRANS.		MRF472	50.00	25C1062	2.95	74163	1.20	WD1983	47.00	LM358K	10.50	
ICM7224A	18.50	74C42	1.90	74LS178	80	TL073	2.90	AD125	1.20	MRF473	50.00	25C1063	2.95	74164	1.20	WD1993	55.00	LM359K	10.50	
ICM7226A	48.50	74C74	1.70	74LS179	1.75	TL082	2.50	AD126	1.20	MRF474	50.00	25C1064	2.95	74165	1.20	WD2129	36.50	LM360K	10.50	
ICM7227A	48.50	74C76	1.90	74LS181	1.75	TL084	3.45	AD127	1.20	MRF475	50.00	25C1065	2.95	74166	1.20	WD2150	16.50	LM365K	22.50	
ICM7231A	19.95	74C85	2.30	74LS182	1.50	TL084	3.45	AD128	1.20	MRF476	50.00	25C1066	2.95	74167	1.20	WD2151	16.50	LM366K	19.50	
ICM7400	15.50	74C89	8.90	74LS183	1.50	TL084	3.45	AD129	1.20	MRF477	50.00	25C1067	2.95	74168	1.20	WD2152	16.50	LM367K	19.50	
ICM7401	15.50	74C90	8.90	74LS184	1.50	TL084	3.45	AD130	1.20	MRF478	50.00	25C1068	2.95	74169	1.20	WD2153	16.50	LM368K	19.50	
ICM7402	15.50	74C91	8.90	74LS185	1.50	TL084	3.45	AD131	1.20	MRF479	50.00	25C1069	2.95	74170	1.20	WD2154	16.50	LM369K	19.50	
ICM7403	15.50	74C92	8.90	74LS186	1.50	TL084	3.45	AD132	1.20	MRF480	50.00	25C1070	2.95	74171	1.20	WD2155	16.50	LM370K	19.50	
ICM7404	15.50	74C93	8.90	74LS187	1.50	TL084	3.45	AD133	1.20	MRF481	50.00	25C1071	2.95	74172	1.20	WD2156	16.50	LM371K	19.50	
ICM7405	15.50	74C94	8.90	74LS188	1.50	TL084	3.45	AD134	1.20	MRF482	50.00	25C1072	2.95	74173	1.20	WD2157	16.50	LM372K	19.50	
ICM7406	15.50	74C95	8.90	74LS189	1.50	TL084	3.45	AD135	1.20	MRF483	50.00	25C1073	2.95	74174	1.20	WD2158	16.50	LM373K	19.50	
ICM7407	15.50	74C96	8.90	74LS190	1.50	TL084	3.45	AD136	1.20	MRF484	50.00	25C1074	2.95	74175	1.20	WD2159	16.50	LM374K	19.50	
ICM7408	15.50	74C97	8.90	74LS191	1.50	TL084	3.45	AD137	1.20	MRF485	50.00	25C1075	2.95	74176	1.20	WD2160	16.50	LM375K	19.50	
ICM7409	15.50	74C98	8.90	74LS192	1.50	TL084	3.45	AD138	1.20	MRF486	50.00	25C1076	2.95	74177	1.20	WD2161	16.50	LM376K	19.50	
ICM7410	15.50	74C99	8.90	74LS193	1.50	TL084	3.45	AD139	1.20	MRF487	50.00	25C1077	2.95	74178	1.20	WD2162	16.50	LM377K	19.50	
ICM7411	15.50	74C100	8.90	74LS194	1.50	TL084	3.45	AD140	1.20	MRF488	50.00	25C1078	2.95	74179	1.20	WD2163	16.50	LM378K	19.50	
ICM7412	15.50	74C101	8.90	74LS195	1.50	TL084	3.45	AD141	1.20	MRF489	50.00	25C1079	2.95	74180	1.20	WD2164	16.50	LM379K	19.50	
ICM7413	15.50	74C102	8.90	74LS196	1.50	TL084	3.45	AD142	1.20	MRF490	50.00	25C1080	2.95	74181	1.20	WD2165	16.50	LM380K	19.50	
ICM7414	15.50	74C103	8.90	74LS197	1.50	TL084	3.45	AD143	1.20	MRF491	50.00	25C1081	2.95	74182	1.20	WD2166	16.50	LM381K	19.50	
ICM7415	15.50	74C104	8.90	74LS198	1.50	TL084	3.45	AD144	1.20	MRF492	50.00	25C1082	2.95	74183	1.20	WD2167	16.50	LM382K	19.50	
ICM7416	15.50	74C105	8.90	74LS199	1.50	TL084	3.45	AD145	1.20	MRF493	50.00	25C1083	2.95	74184	1.20	WD2168	16.50	LM383K	19.50	
ICM7417	15.50	74C106	8.90	74LS200	1.50	TL084	3.45	AD146	1.20	MRF494	50.00	25C1084	2.95	74185	1.20	WD2169	16.50	LM384K	19.50	
ICM7418	15.50	74C107	8.90	74LS201	1.50	TL084	3.45	AD147	1.20	MRF495	50.00	25C1085	2.95	74186	1.20	WD2170	16.50	LM385K	19.50	
ICM7419	15.50	74C108	8.90	74LS202	1.50	TL084	3.45	AD148	1.20	MRF496	50.00	25C1086	2.95	74187	1.20	WD2171	16.50	LM386K	19.50	
ICM7420	15.50	74C109	8.90	74LS203	1.50	TL084	3.45	AD149	1.20	MRF497	50.00	25C1087	2.95	74188	1.20	WD2172	16.50	LM387K	19.50	
ICM7421	15.50	74C110	8.90	74LS204	1.50	TL084	3.45	AD150	1.20	MRF498	50.00	25C1088	2.95	74189	1.20	WD2173	16.50	LM388K	19.50	
ICM7422	15.50	74C111	8.90	74LS205	1.50	TL084	3.45	AD151	1.20	MRF499	50.00	25C1089	2.95	74190	1.20	WD2174	16.50	LM389K	19.50	
ICM7423	15.50	74C112	8.90	74LS206	1.50	TL084	3.45	AD152	1.20	MRF500	50.00	25C1090	2.95	74191	1.20	WD2175	16.50	LM390K	19.50	
ICM7424	15.50	74C113	8.90	74LS207	1.50	TL084	3.45	AD153	1.20	MRF501	50.00	25C1091	2.95	74192	1.20	WD2176	16.50	LM391K	19.50	
ICM7425	15.50	74C114	8.90	74LS208	1.50	TL084	3.45	AD154	1.20	MRF502	50.00	25C1092	2.95	74193	1.20	WD2177	16.50	LM392K	19.50	
ICM7426	15.50	74C115	8.90	74LS209	1.50	TL084	3.45	AD155	1.20	MRF503	50.00	25C1093	2.95	74194	1.20	WD2178	16.50	LM393K	19.50	
ICM7427	15.50	74C116	8.90	74LS210	1.50	TL084	3.45	AD156	1.20	MRF504	50.00	25C1094	2.95	74195	1.20	WD2179	16.50	LM394K	19.50	
ICM7428	15.50	74C117	8.90	74LS211	1.50	TL084	3.45	AD157	1.20	MRF505	50.00	25C1095	2.95	74196	1.20	WD2180	16.50	LM395K	19.50	
ICM7429	15.50	74C118	8.90	74LS212	1.50	TL084	3.45	AD158	1.20	MRF506	50.00	25C1096	2.95	74197	1.20	WD2181	16.50	LM396K	19.50	
ICM7430	15.50	74C119	8.90	74LS213	1.50	TL084	3.45	AD159	1.20	MRF507	50.00	25C1097	2.95	74198	1.20	WD2182	16.50	LM397K	19.50	
ICM7431	15.50	74C120	8.90	74LS214	1.50	TL084	3.45	AD160	1.20	MRF508	50.00	25C1098	2.95	74199	1.20	WD2183	16.50	LM398K	19.50	
ICM7432	15.50	74C121	8.90	74LS215	1.50	TL084	3.45	AD161	1.20	MRF509	50.00	25C1099	2.95	74200	1.20	WD2184	16.50	LM399K	19.50	
ICM7433	15.50	74C122	8.90	74LS216	1.50	TL084	3.45	AD162	1.20	MRF510	50.00	25C1100	2.95	74201	1.20	WD2185	16.50	LM400K	19.50	
ICM7434	15.50	74C123	8.90	74LS217	1.50	TL084	3.45	AD163	1.20	MRF511	50.00	25C1101	2.95	74202	1.20	WD2186	16.50	LM401K	19.50	
ICM7435	15.50	74C124	8.90	74LS218	1.50	TL084	3.45	AD164	1.20	MRF512	50.00	25C1102	2.95	74203	1.20	WD2187	16.50	LM402K	19.50	
ICM7436	15.50	74C125	8.90	74LS219	1.50	TL084	3.45	AD165	1.20	MRF513	50.00	25C1103	2.95	74204	1.20	WD2188	16.50	LM403K	19.50	
ICM7437	15.50	74C126	8.90	74LS220	1.50	TL084	3.45	AD166	1.20	MRF514	50.00	25C1104	2.95	74205	1.20	WD2189	16.50	LM404K	19.50	
ICM7438	15.50	74C127	8.90	74LS221	1.50	TL084	3.45	AD167	1.20	MRF515	50.00	25C1105	2.95	74206	1.20	WD2190	16.50	LM405K	19.50	
ICM7439	15.50	74C128	8.90	74LS222	1.50	TL084	3.45	AD168	1.20	MRF516	50.00	25C1106	2.95	74207	1.20	WD2191	16.50	LM406K	19.50	
ICM7440	15.50	74C129	8.90	74LS223	1.50	TL084	3.45	AD169	1.20	MRF517	50.00	25C1107	2.95	74208	1.20	WD2192	16.50	LM407K	19.50	
ICM7441	15.50	74C130	8.90	74LS224	1.50	TL084	3.45	AD170	1.20	MRF518	50.00	25C1108	2.95	74209	1.20	WD2193	16.50	LM408K	19.50	
ICM7442	15.50	74C131	8.90	74LS225	1.50	TL084	3.45	AD171	1.20	MRF519	50.00	25C1109	2.95	74210	1.20	WD2194	16.50	LM409K	19.50	
ICM7443	15.50	74C132	8.90	74LS226	1.50	TL084	3.45	AD172	1.20	MRF520	50.00	25C1110	2.95	74211	1.20	WD2195	16.50	LM410K	19.50	
ICM7444	15.50	74C133	8.90	74LS227	1.50	TL084	3.45	AD173	1.20	MRF521	50.00	25C1111	2.95	74212	1.					

BOOKS OF SPECIAL INTEREST

electronics textbooks

ELECTRONICS: IT'S EASY — VOL 1

A0001E \$5.95
Meters, resistance, capacitance and inductance, emitter followers, op-amps, power supplies, electronic filters.

ELECTRONICS: IT'S EASY — VOL 2

A0002E \$5.95
Digital sub-systems, counters and shift registers, A-D and D-A conversion, digital instruments and test equipment, computers, transmission links, oscilloscopes.

ELEMENTS OF ELECTRONICS — BOOK 1

A0003B \$9.95
This five-book series is an Introduction to modern electronics. All the maths is taught as the reader progresses. The course concentrates on the understanding of concepts central to electronics, rather than digressing over the whole field. The author anticipates where difficulties lie and guides the reader. Book 1 covers all fundamental theory necessary to full understanding of simple electronic circuits and components.

ELEMENTS OF ELECTRONICS — BOOK 2

A0004B \$9.95
Alternating current theory — see Book 1.

ELEMENTS OF ELECTRONICS — BOOK 3

A0005B \$9.95
Semiconductors technology leading to transistors and ICs — see Book 1.

BASIC ELECTRICITY/ELECTRONICS — VOL 1

A0008H \$15.95
Thorough theoretical and practical background to the overall subject of electricity and electronics.

BASIC ELECTRICITY/ELECTRONICS — VOL 2

A0009H \$15.95
Builds on the basic information in Volume 1 by giving detailed information on AC and DC circuits — covering series and parallel circuits, electro-magnetism, resistance, capacitors and inductance plus associated calculations.

BASIC ELECTRICITY/ELECTRONICS — VOL 4

A0011H \$15.95
Construction, operation and usage of electronic test instruments. Included are analogue and digital multimeters, vacuum-tube voltmeters, oscilloscopes, tube testers, bridge instruments and signal generators.

REFERENCE DATA FOR RADIO ENGINEERS

B0023B \$54.50
Largest and most comprehensive collection of equations, graphs, tables, and other reference data needed in radio engineering and design.

amateur radio

LONG-DISTANCE TELEVISION RECEPTION (TV-DX)

N0250B \$6.95
Written by the British authority, the book includes many units and devices made by active enthusiasts. A practical and authoritative introduction to this unusual aspect of electronics.

HANDBOOK OF RADIO, TELEVISION, INDUSTRIAL AND TRANSMITTING TUBE AND VALVE EQUIVALENTS

N0251B \$3.95
The equivalents books for amateurs and servicemen. More than 18,000 old and new valves from United States, Britain, Europe, Japan. CV (military) listings with commercial equivalents included.

AN INTRODUCTION TO RADIO DXING

N0253B \$6.75
One section is devoted to amateur band reception and the other section covers broadcast band reception, with advice on suitable equipment and the techniques employed when using that equipment. The construction of a number of useful accessories is described.

25 SIMPLE AMATEUR BAND AERIALS

N0286B \$6.75
How to build 25 amateur-band aerials that are simple and inexpensive to construct and perform well. From the simple dipole up to a mini-rhombic.

HOW TO BUILD ADVANCED SHORTWAVE RECEIVERS

N0340B \$6.95
Contains full practical construction details of a number of receivers.

THE WORLD IN MY EARS

N0420C \$9.95
This book would represent the 'basic manual' for anyone interested, or active in, shortwave listening. Written by world-renowned authority and broadcaster, Arthur Cushen, M.B.E., the book is divided into two parts. The first covers the historical development of shortwave broadcasting and the listening hobby that grew up with it. The second part covers the practical aspects: how to start out, how to erect antennas, all about time and time zones, DX clubs, reporting, news sessions, etc.

electronic music and audio/video

CHEAP VIDEO COOKBOOK

G0123P \$12.90
Complete discussion of a new, low-cost way to get words, pictures and opcode out of your computer and onto any ordinary television screen, using a seven-IC easy-to-build circuit which you can build for \$20.

ELECTRONIC MUSIC CIRCUITS

G0126P \$26.95
How to build a custom electronic music synthesiser, outlines numerous other circuit designs and then shows you how to modify them to achieve particular responses. Many of the circuits can be used as special-effects boxes for guitars and other musical instruments.

INTRODUCTION TO ELECTRO-ACOUSTIC MUSIC

G0127N \$24.95
This book assumes no previous technical knowledge. It discusses the relationship between the technology and the composition of electro-acoustic music.

SOUND-SYSTEM ENGINEERING

G0129P \$35.50
Dealing with audio systems as a whole, it includes installing and equalising the sound system and interfacing the electrical and acoustic systems, instrumentation, the acoustic environment and designing for acoustic gain.

TUBE SUBSTITUTION HANDBOOK

G0130P \$8.75
Complete, accurate, up-to-date guide to direct substitutes for receiving and picture tubes. Contains more than 6000 receiving tube substitutes, 4000 monochrome and colour picture tube substitutes, and 600 communications substitutes. Also includes pinouts for quick operational checks.

HOW TO BUILD SPEAKER ENCLOSURES

G0131P \$9.95
A guide to the 'whys' and 'hows' of constructing top-performance loudspeaker enclosures.

SON OF CHEAP VIDEO

G0345P \$17.95
Don Lancaster's sequel to *The Cheap Video Cookbook* (ETI Book Sales No. G0123P) includes new and improved circuits to get alphanumeric and graphics video out of a microcomputer and on to an ordinary television.

SINGLE-CAMERA VIDEO PRODUCTION

G0379H \$25.75
Step-by-step diagrams and illustrations show you how to produce low-budget, high-quality video programs. Chapters on audio, lighting, shooting, editing, graphics and set design.

All prices of publications in this catalogue listing are subject to change without notice.

More **BOOKS** of Special Interest on page 82

ORDER TODAY — Simply return the Freepost reply card to:

TO OUR READERS . . .

best sellers

STARTING FORTH

K0177H \$25.00
A clear and complete guide to Forth, this book covers fundamental principles and then a full set of high-level Forth commands. It concludes with advanced techniques and style.

WALL CHART — RADIO, ELECTRONICS, SEMI-CONDUCTORS AND LOGIC SYMBOLS

B0020B \$2.95
Identify those symbols at a glance. A must for beginners and advanced enthusiasts alike. Professionals can always hide it in their desks!

COIL DESIGN AND CONSTRUCTION MANUAL

B0413B \$6.85
How to make RF, IF, audio and power coils, chokes and transformers. Covers AM and FM radio, and TV. An essential addition to the library of all interested in electronics.

INTERNATIONAL DIODE EQUIVALENTS GUIDE

B0339B \$6.95
Includes zener diodes, LEDs, diacs, triacs, thyristors, OCIs, photo diodes, display diodes and simple rectifier diodes.

ELECTRONICS SECURITY DEVICES

D0059B \$6.95
Besides including both simple and more sophisticated burglar alarm circuits using light, infra-red and ultra-sonics, this book also gives circuits for gas and smoke detectors, flood alarms, fire alarms, doorphones, etc.

50 PROJECTS USING RELAYS, SCRs AND TRIACS

E0068B \$6.95
Practical working circuits using silicon controlled rectifiers, relays and bi-directional triodes. With a minimum of difficulty you can use them in motor control, dimming and heating control, timing and light sensitive circuits, warning devices and many others.

G0135B

ELECTRONIC MUSIC PROJECTS

\$5.95
Provides constructors with practical circuits for the less complex music equipment including fuzz box, waa-waa pedal, sustain unit, reverb and phaser, tremolo generator, etc. Text covers guitar effects, general effects, sound generators, accessories.

HOW TO BUILD YOUR OWN SOLID-STATE OSCILLOSCOPE

F0282B \$6.95
This book comprises a project divided into sections for builder to individually construct and test — then assemble into complete instrument. Includes short section on scope usage.

MODERN RECORDING TECHNIQUES

G0128P \$22.95
Explains the equipment controls and techniques found in a modern recording studio and how to use them creatively and correctly to produce a desired result. Numerous photographs, diagrams and charts.

THE 68000: PRINCIPLES AND PROGRAMMING

K0176P \$19.95
An easy-to-read, systematic approach to the 68000 advanced 16-bit microprocessor. The book guides you through the complex architecture, instruction set, pinouts and interfacing techniques. Written for design engineers, programmers and students.

ELECTRONIC TROUBLESHOOTING HANDBOOK

F0257H \$13.95
This workbench guide shows you how to pinpoint transistor troubles in minutes, how to test almost everything electronic and how to get the most out of low-cost test equipment.

EFFECTIVELY USING THE OSCILLOSCOPE

F0258P \$16.95
Describes the potential uses of the scope, ranging from audio and television tests and measurements to performance tests.

ELECTRONIC SYNTHESIZER PROJECTS

G0133B \$5.95
For the electronic music enthusiast, an invaluable reference. This book is full of circuits and information on how to build analogue delay lines, sequencers, VCOs, envelope shapers, etc. The author takes a clear and logical approach to the subject that should enable the average enthusiast to understand and build up what appears to be a quite complex instrument.

HOW TO GET YOUR ELECTRONIC PROJECTS WORKING

F0114B \$6.95
Helps you to overcome the problems of a circuit that doesn't work by indicating how and where to start looking for many of the common faults that can occur when building up a project.

WORKING IN THE MUSIC BUSINESS

G0279A \$11.95
Gives realistic insights into the work and lifestyles found in the music business, and would be of interest to anyone considering work in recording studios, record companies, music publishing, etc.

THE MUSICIAN AND THE MICRO

G0280A \$9.95
A straightforward and practical guide for musicians, teachers and those who work in the music industry, covering the exciting world of microprocessors and computerised musical instruments.

PRACTICAL ELECTRONIC CALCULATIONS AND FORMULAE

B0027B \$9.95
For the practical person's workbench. Bridges the gap between technical theory and cut-and-dried methods which work but leave the experimenter unfulfilled. There's a strong practical bias. High maths avoided where possible.

HANDBOOK OF ICs EQUIVALENTS AND SUBSTITUTES

B0281B \$6.95
Contains full interchangeability data on more than 9500 ICs with possible alternatives and equivalents shown. Covers many types of digital and linear ICs. Recently reprinted.

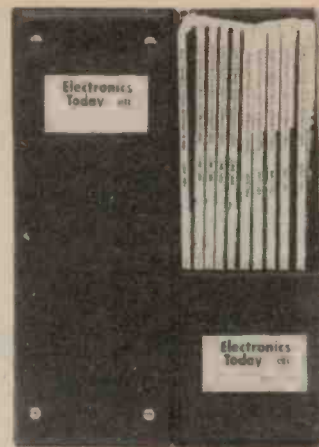

magazine holders/binders

now available

MAGAZINE BINDERS

\$7.50

Ready to use binders with easy, clip-in fastener, covered in soft, decorator brown vinyl. Holds 12 issues of Electronics Today.

MAGAZINE HOLDERS

\$7.00

Big, easy to assemble holders, covered in soft, decorator brown vinyl. Holds 12 issues (at least) of Electronics Today.

Postage and packing additional:
Please refer to reply card for charges.



— SAVE WITH SIX —

6 Holders — only \$37.50
6 Binders — only \$39.95

FEDERAL MARKETING BOOK SALES

PO Box 227, Waterloo 2017, NSW

TAPE AUTO- SEARCH



THE CASSETTE is probably the most cost effective means of information storage in use today. Capable of storing whole symphonies, dozens of computer programs, or anything that can be converted to an electrical signal, the cassette is surely the most widely used form of data storage.

However, the major difficulty with the cassette is accessing information on it. It usually seems to happen that the section you want is somewhere at the end, and it can often take longer to find the selection than to play it out.

Many tape recorders come equipped with search facilities, which will fast forward to the desired track, stop, and then enter the play mode. Marvellous, if you have one, even better if you can commandeer it for your exclusive use to help find the computer program you know is somewhere about half-way along the cassette.

The ETI-693 is a simple add-on device that can be plugged into a suitable portable cassette player, and which can then be used to find any one of 10 selections in a very short time. It uses a player that can cue in search mode, like the National RQ-2133, or other players with modifications.

The principle of operation is to count the gaps between each track, and to then stop when the right number of gaps have been passed. This means that the play head must be in contact with the tape when the tape player is in its fast forward (or even rewind) modes. One difficulty, of course, occurs when the information on the cassette is analogue such as music or speech, and when quiet sections (or pauses in speech) occur. The search system registers these pauses as a gap, and you end up in confusion. However, with judicious selection of components and time periods between each selection on the cassette, even this problem can be overcome. In general, the unit will work best with digital data, but I have used it for both purposes with great success.

The 'hardware'

Before discussing the auto-search unit, it is better to first attend to the requirements of the cassette player. Depending on the brand of player some modifications, either electrical or mechanical, may be required. I have successfully integrated the unit with two totally different types of players, and have checked various others for their suitability.

The main mechanical requirement is that, when the player is in its fast forward mode, the play head be in light contact with the cassette tape. As it happens, some cassette players have this facility already, actuated by pressing both the PLAY and FAST FORWARD (sometimes called the CUE) keys. The idea is to listen to the sound as it passes rapidly past the play head, and to mentally count the gaps.

Many National brand cassette players have this feature, in particular the National Model RQ-2133. This particular unit is ideal for the auto-search, as only very minor electrical modifications are required to adapt it for use. These modifications are described later in this article, so if you own one of these tape players, or intend buying one, then you can proceed happily to building the electronics.

If you decide to try to adapt another type of tape recorder, like the one the kids used to use until they took over the hi-fi, first determine if it can be suitably modified. Many Sony tape recorders cannot be modified, but other types, particularly those with a single rotary switch arrangement can be. It is impossible to describe a general technique, due to the differing arrangements employed. I can only give general requirements, the best will be up to your mechanical ability.

In general, the tape head should advance towards the tape, when in fast forward mode, slightly less than it does when in the play mode. If it is too far forward it will slow

the tape transport system, and if not enough, it will not allow a signal to be generated by the head. An easy method of determining if the head position is correct is to listen to the result through the player's speaker.

The correct position is when the loudest sound occurs, without the transport slowing down. Naturally, the erase head, often just a permanent magnet, should not be allowed near the tape, as you'll lose everything. Often, just bending a lug here and there is sufficient, so don't be surprised if the modifications turn out to be easier than you thought.

Electrical modifications

In order to make the auto-search unit as simple as possible, I decided to make the tape recorder supply the power to the unit. The power requirements are very low, around 10 to 20 mA, because of CMOS and diode logic. This means, however, that the circuit has to be able to cope with either polarity of earth associated with the tape player.

The pc board layout accommodates both types of polarity, with very minor differences occurring between the two. The circuit can operate with differing voltages, with 6 V being the most typical voltage available from the player. The National RQ-2133 uses a negative earth at 6 V but if you are adapting another player, determine the polarity first.

In order that the auto-search can integrate with the player, use is made of the phono sockets generally present somewhere on the side of the player. The sockets used are the so called MONITOR (or earphone) socket, and the REMOTE socket. The REMOTE socket is generally next to the MIC socket. The principle of the auto-search is to replace this switch with a transistor that is in turn operated on by the electronics within the auto-search.

This project requires some electrical modifications to the tape recorder. If you don't feel confident about these we advise you not to try this one.

Now you can load several programs on a single cassette and find a particular one quickly and easily. The ETI-693 auto-search will also find a track on an audio cassette.

Peter Phillips

As already mentioned, it may also be necessary to modify the tape recorder electronically. Because the auto-search not only derives its power from the tape recorder, but also controls the power to the tape recorder, the electrical relationship between the player's power supply, remote socket, and the player's electronics and motor must be as shown in Figure 1b. The differences between Figure 1a and 1b are that in 1a, the remote socket is wired between the motor/electronics and earth, while in 1b, the remote socket has been moved between the supply rail and the motor/electronics. Figure 1 shows how to modify the National RQ-2133 tape recorder.

The procedure for the RQ-2133 is fairly simple. Firstly, remove the five screws holding the back cover, including the one in the battery housing. Remove the single red screw holding the tone/volume control assembly, and lift this assembly clear. Remove the three screws holding the pc board in place to gain access to the track side. Cut the tracks as shown in Figure 1b, and connect the two links. Finally, relocate the wire that originally connected S2 to the point shown in Figure 1b. This completes the modifications, and allows the player to work normally, as well as allowing it to now interface with the auto-search.

Other tape players may already be electrically correct, but this point needs to be determined, and, if necessary, corrected.

Electronic modifications

With the tape player now ready, construction of the auto-search electronics can proceed. Start by mounting all the passive components, then mount the transistors and ICs. Note the wire link to the left of IC1. Also note that all diodes, except D1, are placed the same way, with the cathode towards the bottom of the pc board.

All the ICs are also orientated the same way, with pin 1 facing the top of the pc

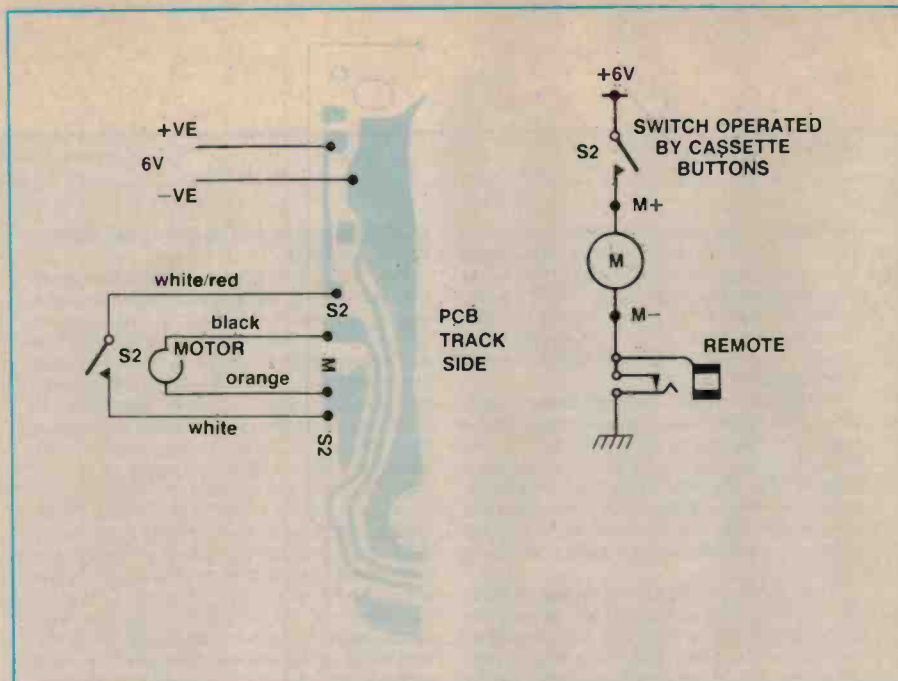

Figure 1a. Circuit diagram of the National RQ-2133 before alterations.

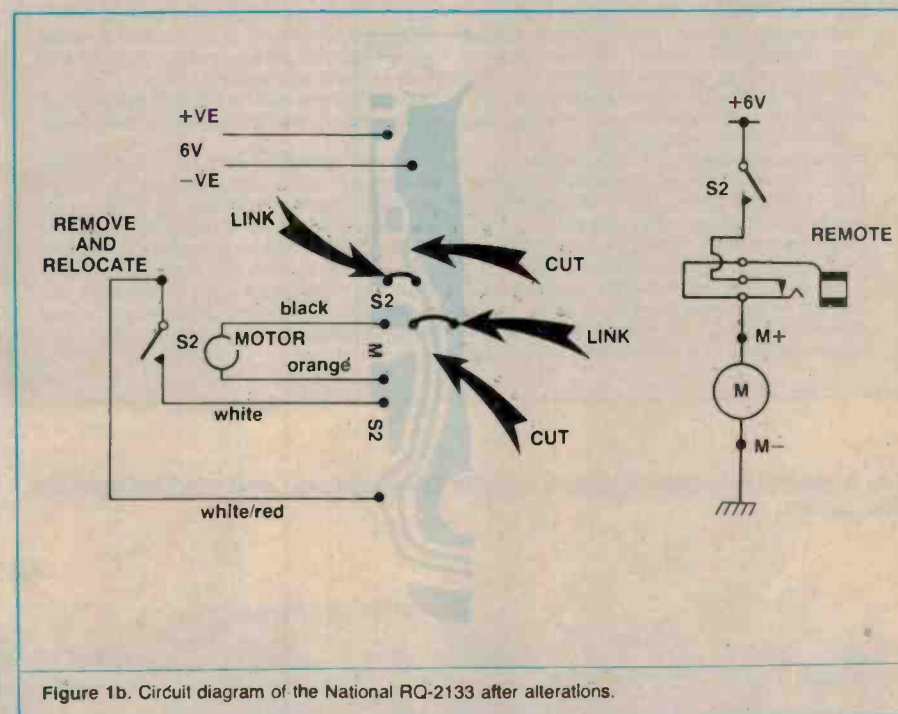

Figure 1b. Circuit diagram of the National RQ-2133 after alterations.

board. When you come to mount transistors Q4 and Q5, follow the layout for the particular polarity of tape recorder. The overlay diagram shows the layout for a negative earth system, such as the RQ-2133 with the necessary modifications for positive earth separately detailed. The differences are the orientation of Q4, the type of transistor for Q5, (NPN for positive earth) and the position of the two links in between these two transistors.

With the pc board completed, connect

the LEDs, and switches SW1 and PB1, allowing about 140 mm lead length. When wiring SW1, note that pin 1 of the switch is not connected. The layout shows the view for SW1 with the connecting terminals facing towards you. The use of rainbow cable is recommended, to facilitate correct connection of SW1 to the pc board.

Normally, a 2.5 mm phono plug is required for the remote socket, and a 3 mm plug for the monitor socket. In the prototype, I squeezed four wires into an 800 mm ▶

HOW IT WORKS

To consider the operation of the circuit, assume selection 6 on a cassette is required. SW1 is set to position 6 and RESET (PB1) has been pressed. Operation of the RESET push-button will cause IC3, a dual decade counter, to be set to 0, which in turn causes Q2 to be turned off, allowing Q3 to be turned on and lighting LED 2.

The position of SW1 (at 6) will cause diodes D6 and D7 to be forward biased, presenting a logic 0 at the inputs of inverters IC1a and IC1c. SW1, diodes D4 to D14 and inverters IC1a to IC1d together form a decimal to binary converter, using diode logic. Inverter IC1a is the LSB, and IC1d the MSB, and the range of output numbers from the inverters is from 0 to 9.

Thus, position 1 causes an output of 0000, and position 10 an output of 1001. At position 6, the output will be binary 5. The outputs of the counter, and the decimal to binary converter are fed, in bit parallel fashion, to the EXOR gates, IC4a to IC4d.

An EXOR gate will have a logic 1 at its output if its inputs differ, so in the case under discussion, gates IC4a and IC4c have differing inputs, and hence produce a logic 1 at their outputs. This will cause Q4 to be turned on, via diodes D15 and D17, which will drive Q5 on. If the tape recorder is now set into motion, current to the tape recorder will flow through Q5, and the search will commence.

Signal from the tape recorder is applied to the half-wave voltage doubler comprising C1, C2, D1 and D2. RV1 is a sensitivity control, and D3 isolates C3 from C2. If the signal level is sufficient from the tape recorder, the dc voltage produced across C2 will forward bias Q1, causing its collector voltage to drop.

Inverters IC1e and IC1f are connected as a Schmitt trigger, and the output of IC1e will now become a logic 1. This allows IC2, a '555 timer connected as a monostable, to time out,

and then to set its output (pin 3) low, lighting LED 1 (SIGNAL).

The '555 timer is present to allow small bursts of signal that may be present during a gap to go unnoticed, and to thus prevent false counting. The delay of the timer must be sufficiently short however, to allow intended short sections of data (such as a small program) to be recognized when tape speed is maximum, towards the end of the tape. Altering either R7 or C4 to a lower value may be necessary under these circumstances.

When a gap on the cassette appears, Q1 will turn off when C3 has discharged. C3 allows small gaps in the signal to be ignored, such as may occur in analogue information. Thus, the output of IC1e goes low, setting the output of the '555 high. The signal LED goes out, and the counter will increment one count, extinguishing the reset LED. Thus, the first block of data on the cassette has been passed, and the sequence continues until five blocks of data have passed. When the gap before the selected block is reached, that is, after the fifth block of data, the counter will increment to binary 5. As this equals the output of the decimal to binary converter, all the EXOR gates (IC4a) to (IC4d) produce a logic 0 at their outputs. As there is no drive for Q4, both Q4 and Q5 are turned off, and the tape recorder stops, cued ready at the desired selection.

As mentioned in the article, the circuit can be adapted for use with either polarity of tape recorder. Because CMOS logic has been used, typical cassette voltages of 6 V and 9 V can be used. It may be necessary to alter the value of R17, to allow adequate saturation of Q5. In the prototype a value of 330 ohms was found suitable, for either polarity, with a tape recorder voltage of 6 V.

PARTS LIST — ETI-693

Resistors	all ¼ W, 5%
R1.....	470R
R2, 14.....	10k
R3.....	100k
R4.....	2k2
R5.....	22k
R6.....	47k
R7.....	82k
R8, 13.....	560R
R9, 10, 11, 12.....	100k
R15, 16.....	4k7
R17.....	330R* see text
RV1.....	25k trimpot (large vertical)

Capacitors	all 16 V tantalum
C1.....	6.8µ
C2, 3.....	22µ
C4.....	15µ
C5.....	33µ

Semiconductors	
D1, 2.....	0A90
D3-D22.....	1N914
LED1.....	5 mm red
LED2.....	5 mm green
Q1, 2, 3, 4.....	BC548 or equiv.
Q5.....	2N3641 or equiv. (for +ve earth tape recorder) 2N3645 or equiv. (for -ve earth tape recorder)
IC1.....	4049 or equiv.
IC2.....	'555
IC3.....	4518
IC4.....	4070 or equiv.

Miscellaneous	
SW1.....	single pole, 10 (or 12) position
PB1.....	SPDT ultra miniature push button

ETI-693 pc board; Scotchlok front panel; knob; mounting bezels for LEDs; zippy box (50 x 90 x 150 mm); 2 phono plugs 2.5 mm and 3.5 mm (or plugs to suit tape recorder); 150 mm length of rainbow cable; 800 mm length of suitable plastic sleeving to house 4 connecting wires between unit and tape recorder.

Price estimate: \$30-\$35
(not including tape recorder)

For a guide to components and kits for projects, see SHOPAROUND this issue.

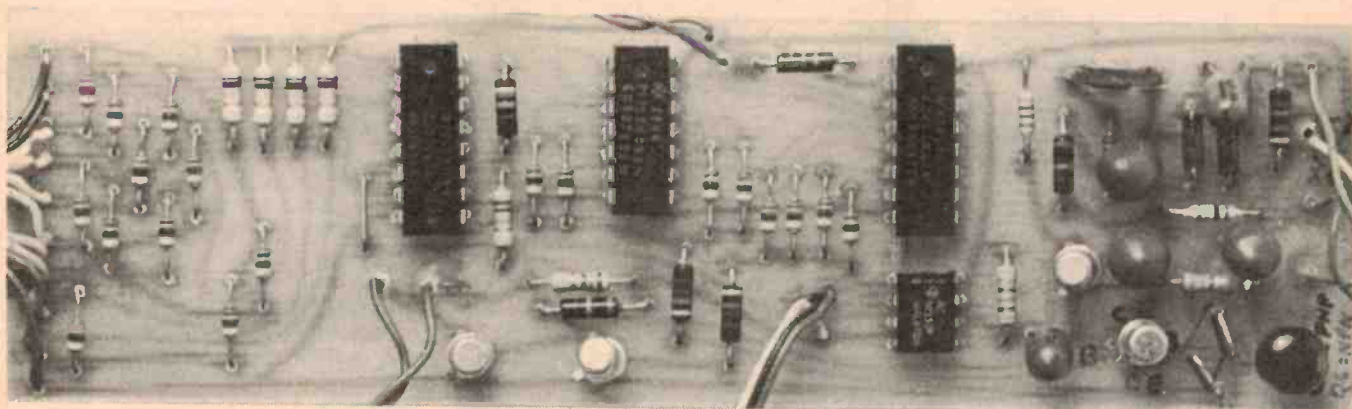

The pc board. Check the polarity of the tape recorder before mounting transistors.

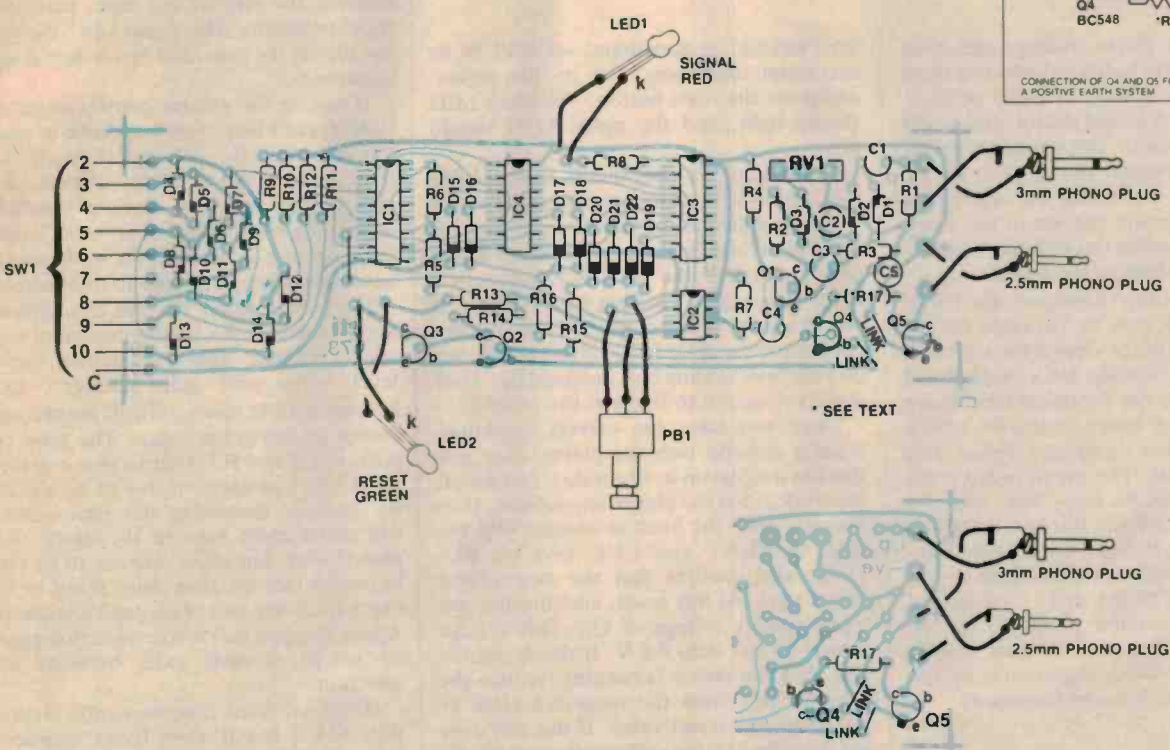
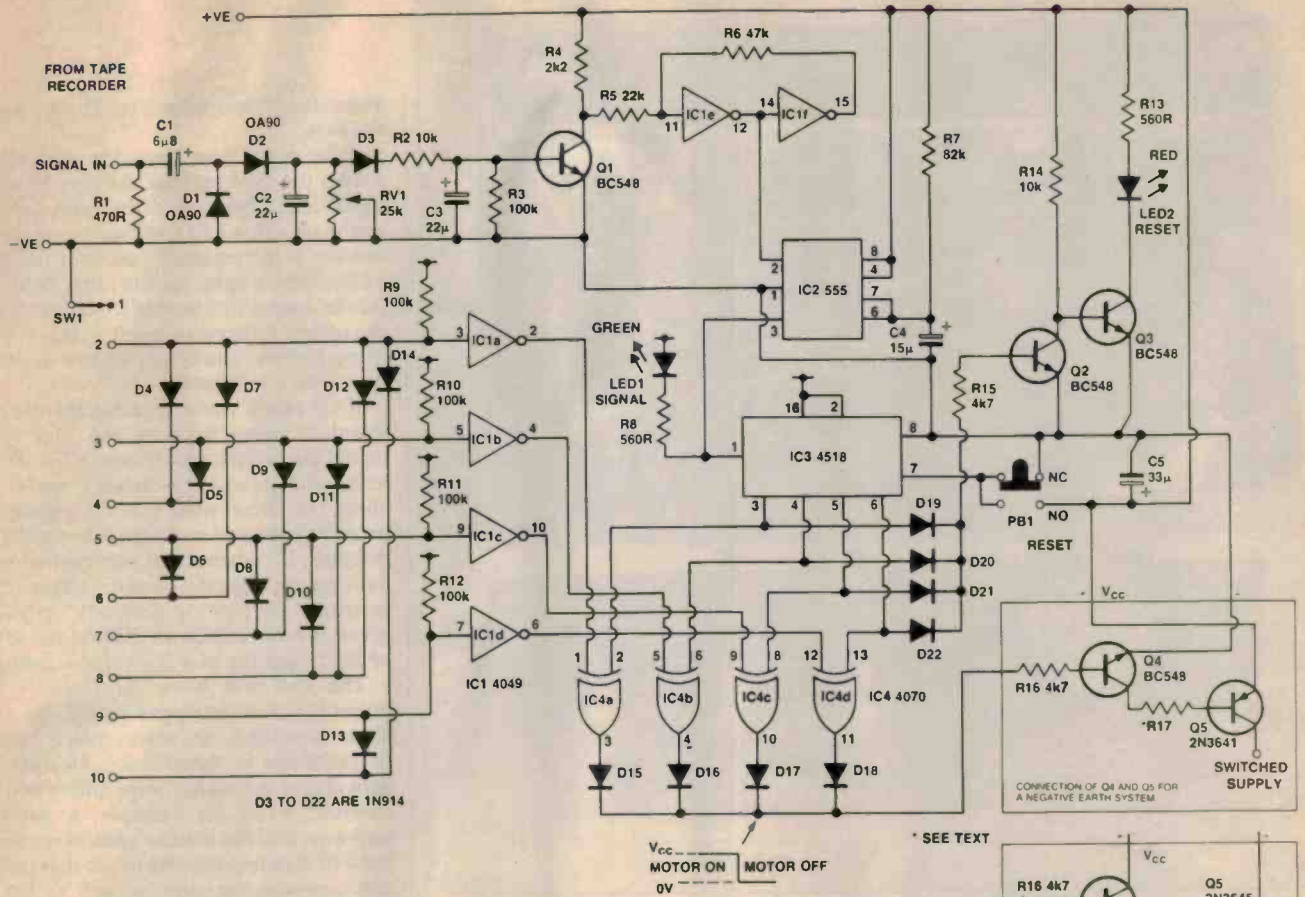

Overlay and wiring diagram for negative earth tape recorders with a positive earth insert. All diodes except D1 are oriented the same way.

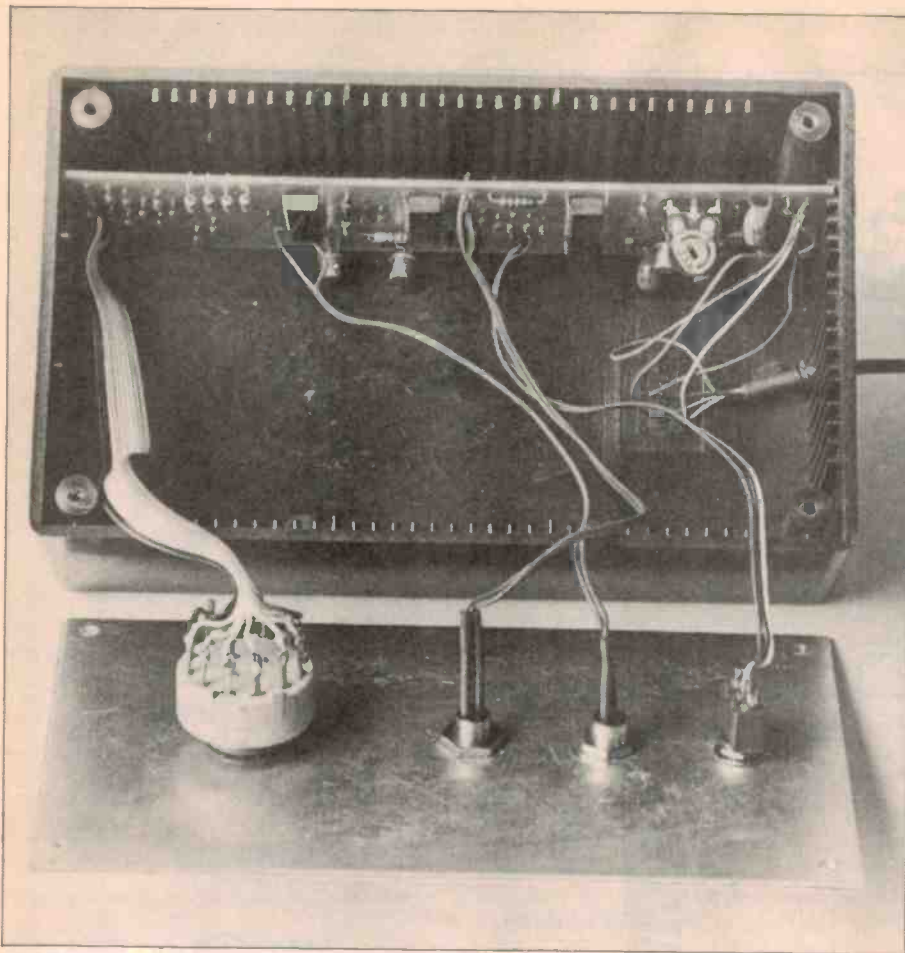

The board in the box. The wires should be passed through the hole in the zippy box before connecting them to the board.

length of 3 mm plastic tubing, and then separated the wires to fan out into two short lengths of 2 mm tubing. A piece of heat-shrink tubing then joined the lot, and a neat looking lead resulted. The important thing, however, is to connect the plugs to the pc board correctly. Note that the wires pass through a hole in the bottom of the zippy box, so pass the wires through this hole before connecting them to the board.

With all the wiring completed, the LEDs and switches can now be mounted on the front panel. Use of the design for a Scotchcal front panel will make for a professional looking unit, with the Scotchcal label being placed on the top cover of the 50 x 90 x 150 mm zippy box, and the holes duly drilled in the cover. The circuit board is designed to slot into the zippy box, with the lead to the plugs exiting the box through a hole drilled in the bottom. Some form of restraint should be attached to the lead to prevent it from being pulled, and exerting pressure on the connection points to the pc board. Finally, check over the job, mainly to confirm the correct orientation of the diodes, capacitors, ICs and transistors.

Testing

When you are convinced that the moment of truth has arrived, plug the unit into the tape recorder, set the volume and tone con-

trols (treble) to maximum, set RV1 to its maximum resistance, turn on the power, and press the reset button. The reset LED should light, and the signal LED should not.

If this is not the case, that is, neither LED is lit, check with a voltmeter to see if power is being applied to the circuit correctly, if at all. This is easily done by looking across pins 1 and 8 of the '555, IC2, with pin 1 being the negative, and pin 8 the positive. If power is present and correct, check the connections of the reset LED. If this is OK, put on your fault finding hat, and read the 'How it works' section to find out the problem.

Once you have the correct condition, place a cassette into the player, (use one that has a signal on it, of course), and select, say track 2. Set the player into motion, (fast forward, with the head in contact with the tape, or PLAY and CUE keys on RQ-2133), and confirm that the tape player motor runs. At this point, measure the collector-emitter voltage of Q5. This voltage should be less than 0.8 V. If this is not the case, but the motor is running, reduce the value of R17 from the suggested value of 330 ohms to a lesser value. If this still does not drop the voltage sufficiently, reduce the value of R16. If the motor isn't running at all, determine why. Check, for example, that the voltage on the diode side of R16 is

about 0.6 V less than Vcc. If not, suspect the logic.

If the motor runs, note that when the signal on the tape reaches the play head, the signal LED lights, and the reset LED remains on. This LED will go out when the counter is incremented past 0. If the signal LED doesn't light, confirm that there is in fact an output by listening to the signal from the player. Otherwise, confirm that RV12 is at maximum, and if so, follow the signal path with a voltmeter.

If Q1 reads Vcc at its collector when the signal is being fed into the auto-search input, the problem is before Q1; if the collector voltage of Q1 is around, say, 0.5 V, check the circuit after Q1. As a guide, the prototype showed a voltage of around 2.5 V dc across C2 when signal was applied to the auto-search from the cassette player. If the system is performing correctly up to this point, it now remains to confirm the setting of RV1, and the player's volume control.

The unit will work satisfactorily with either digital or analogue recordings. Analogue recordings are more critical because of variations in signal level. Dealing first with digital recordings, experiment with the controls, trying for example, to set RV1 half-way, and the volume control about one third of maximum to test to see that the system registers the gaps as well as the recorded sections. Confirm that data registers towards the end of the tape, particularly short programs. The signal LED should go out during the gaps, and be on during signal conditions.

If setting the volume control more critically doesn't help, you may have to reduce the value of either R7 or C15 to allow the timer to reset more quickly. Alternatively, ensure that programs have a reasonable length, made up with a leader tone, if necessary, or that gaps between each program have a duration of around 10 to 20 seconds.

If you wish to use the unit to search analogue tapes, set RV1 to its maximum resistance. Because analogue signals vary in level, often with quiet passages, things become a little more difficult for the auto-search to recognize a gap. The time constant of C3 and R3 is set to give a delay to allow short passages of low or no signal to be ignored. Increasing this time constant will allow short gaps in the signal to be passed over, but some care has to be taken to ensure that the time delay is not so long that gaps at the end of the tape are ignored. Again, the best rule is to ensure that gaps of 10 to 20 seconds exist between each selection.

One final point concerning the National RQ-2133. I found when trying another of these players, that pressing the PLAY and CUE keys to their locked position caused the play head to not be in sufficient contact with the tape to allow adequate output. By

bending or filing a stop lug associated with the mechanism, this problem was fixed. If you are buying one for the purpose of this article, listen to the particular unit with the keys actually locked down, rather than just held down, and buy the one that gives the best output. Otherwise, gently disassemble the mechanism, and modify the stop lug.

This tape recorder also allows for searching in reverse, by pressing the PLAY and REVIEW keys together. Again, you may

have to fiddle with the mechanics if you want this feature.

Pressing the reset button after 10 selections have been passed resets the counter to 0. It is possible to have as many items on the cassette as you wish by repressing reset, and adding 10 each time. If you are adventurous, this simple system can be upgraded to allow modifications to permit, for example, the inclusion of a switch to transfer the signal to the computer, using the cassette

player to play out the program without having to unplug the auto-search. This switch could even be electronic, actuated by the output of diodes D15 to D18, (taking advantage of the fact that this output level is a logic 0 when the cueing has taken place). Other possibilities could include interfacing the cassette to the computer and providing the mechanics can be suitably modified, using the cassette player under software control. ●

ETI 673 TAPE AUTO SEARCH

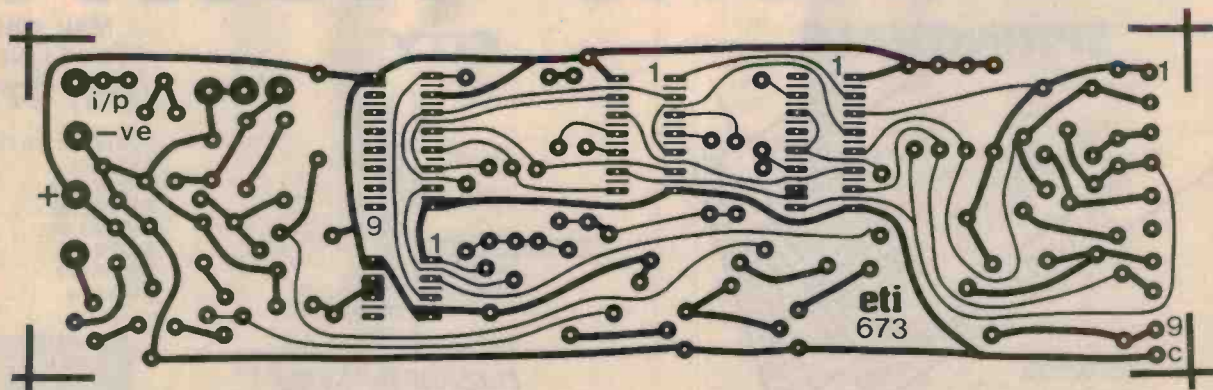
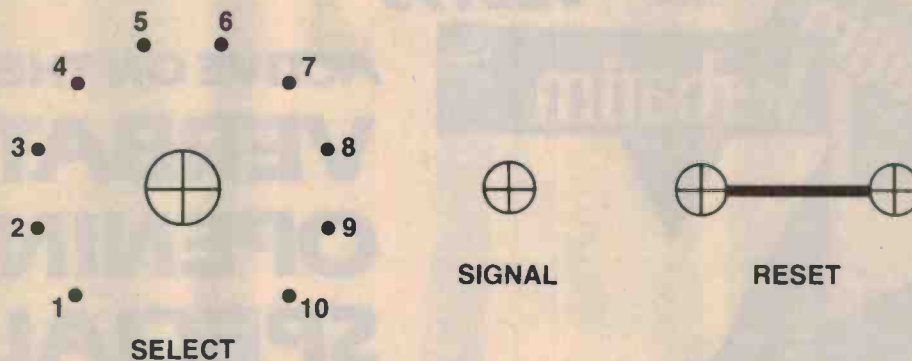



ACTIVE ELECTRONICS

289 LATROBE STREET, MELBOURNE 3000 PH. (03) 602 3499
887 SPRINGVALE ROAD, SPRINGVALE 3171 PH. (03) 547 1046

8.30am-5.30pm MON-THURS; 8.30am-8.00pm FRIDAYS 9am-12noon SATURDAY
ALL YOU HAVE EVER WANTED IN AN ELECTRONIC STORE - AND MORE!

NOW OPEN - NEW SPRINGVALE STORE



SS DD **\$22.95**

ACTIVE ON THE MOVE
**VERBATIM
OPENING
SPECIALS**

DS DD **\$35.50**

ACTIVE'S 2 GREAT LOCATIONS - NOW AT

SPRINGVALE

CITY



MELWAYS
80 A 5

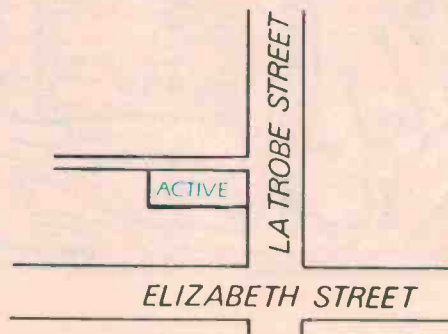

MAIL ORDER
HOT LINE

(03) 671312

POSTAGE RATES

\$1-\$9.99	\$1.50
\$10-\$24.99	\$2.00
\$25-\$49.99	\$3.00
\$50-\$99.99	\$3.50
\$100-\$199	\$5.00
\$200-\$499	\$7.50
\$500 plus	\$10.00



MAIL ORDERS LA TROBE STORE ONLY



ACTIVE ELECTRONICS

289 LATROBE STREET, MELBOURNE 3000 PH. (03) 602 3499
887 SPRINGVALE ROAD, SPRINGVALE 3171 PH. (03) 547 1046

8.30am - 5.30pm MON-THURS 8.30am-8.00pm FRIDAYS 9am-12noon SATURDAY
ALL YOU HAVE EVER WANTED IN AN ELECTRONIC STORE - AND MORE!

AUSTRALIAN MADE DO IT YOURSELF BURGLAR ALARM.

PROTECTS YOUR HOME, OFFICE & FACTORY.









\$399

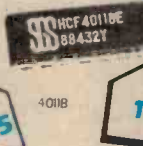

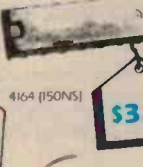
COMES IN CONVENIENT CARRY CASE.

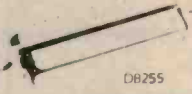
SEMICONDUCTOR OPENING SPECIALS!

 2732 (250NS) \$4.25	 4018 19c	 2764 (250NS) \$5.75
 74LS00 19c	 4164 (150NS) \$3.10	"D" CONNECTORS SPECIAL DB25P \$2.85 ea  DB25S \$2.95 ea 
 7805T REG 55c	 7812K REG 95c	

TOP BRAND MITSUBISHI MONITORS



GREEN
NV1290 x

AMBER
NV1290 x

\$210

\$215

ACTIVE - JUST ABOUT EVERYTHING ELECTRONIC

special offer
\$2 each or ANY 6 for \$10

babani books

Essential Theory for Hobbyists	A0013B
International Transistor	
Equivalents Guide	B0018B
Power Supply Projects	D0047B
Electronic Household Projects	D0048B
Electronic Projects Using	
Solar Cells	D0049B
Digital IC Projects	D0050B
28 Tested Transistor Projects	D0053B
Model Railway Projects	D0054B
Projects in Opto-Electronics	D0057B
Single IC Projects	D0058B
Popular Electronic Circuits	
Book 1	D0060B
Popular Electronic Circuits	
Book 2	D0061B
Mini Matrix Board Projects	D0062B
Multi Circuit Board Projects	D0063B
Aerial Projects	D0064B
Modern Op-Amp Circuits	D0065B
Electronic Projects	
for Cars & Boats	D0067B
Build Your Own Electronic Lab	D0384B
52 Projects Using IC741	D0386B
50 FET Projects	E0069B
How to Use Op-Amps	E0092B
50 Projects Using	
CA 3130 IC's	E0101B
Practical Introduction	
to Digital IC's	E0102B
50 Circuits Using Zener Diodes	E0103B
50 Circuits Using	
7400 Series IC's	E0111B
VMOS Projects	E0112B
Mobile Disco Handbook	G0093B
Introduction to Video	G0124B
Audio Projects	G0134B
Practical Construction of	
Pre-Amps	G0137B
Practical Transistor Novelties	G0382B
Audio Enthusiasts Handbook	G0383B
The 6809 Companion	J0154B
Practical Computer	
Experiments	J0172B
Add-on Projects for Spectrum	
ZX81, Ace	J0285B
Art of Programming 1K ZX81	K0226B
Electronic Calculator Users	
Handbook	M0245B
Your Calculator & Your Money	M0246B
Fun & Games with Your	
Calculator	M0370B
Radio Stations Guide	N0252B

special offer
\$2 each or ANY 6 for \$10

BOOKS OF

computer hardware and techniques

MICROPROCESSOR CIRCUITS

J0157P \$14.75
Presents basic microprocessor concepts in simple language for beginners and teaches you to construct a useful microcontroller system. Offers 30 demo circuits which take you through assembly, operation and programming of a microcontroller.

THE \$100 AND OTHER MICRO BUSES

J0160P \$14.50
The key to successful computer expansion is a complete understanding of the bus system, through which the computer communicates with peripherals. This book will give you that understanding.

MICROCOMPUTER DESIGN AND TROUBLESHOOTING

J0161P \$26.75
Tells you how to design microcomputer systems and make them work without an expensive commercial development system or the need for costly test instrumentation. Includes a complete description of two microprocessors — the 8085 and the 6502.

MICROPROCESSING INTERFACING TECHNIQUES

J0167A \$29.95
Teaches you how to interconnect a complete microprocessor system and interface it to the usual peripherals. The hardware and software skills needed to effectively interface peripheral devices are covered along with various buss standards and A/D conversion. Third edition.

MICROSOFT BASIC

J0406A \$24.50
Presents a complete introduction and tutorial on programming in BASIC using Microsoft BASIC, Release 5.0. Covers branching and loops, strings, editing, arrays and files, and arithmetic in BASIC.

A Z80 WORKSHOP MANUAL

J0283B \$8.95
Intended for those who want to progress beyond BASIC programming to topics such as machine-code and assembly language programming or who need hardware details of the Z80-based computer.

USING THE OSBORNE 1 COMPUTER

J0327H \$21.50
How to get the most out of the Osborne 1 portable computer.

6809 MICROCOMPUTER PROGRAMMING AND INTERFACING, WITH EXPERIMENTS

J0170P \$21.95
Gives a solid understanding of how to program and interface the high-performance 6809 microprocessor. The author completely explores internal structure, addressing modes, data movement instructions, registers, arithmetic logic and test instructions for the 6809.

HOW TO PROGRAM AND INTERFACE THE 6800

J0303P \$22.95
An in-depth introduction to microprocessors and microcomputers in general and the Motorola 6800 microprocessor family in particular. Includes experiments for the Heath ET3400 and Motorola MEK6800D2 learning systems designed to demonstrate 'real world' applications. Limited supplies.

Z8000 CPU USER'S REFERENCE MANUAL

J0337H \$17.95
Though written as a manual for Zilog's Z8000 microprocessor, this text is also applicable to the Z8001 and Z8002 microprocessors. Includes overviews of architecture, addressing spaces, CPU operation and external interfacing.

16-BIT MICROPROCESSORS

J0342P \$22.20
A guide to the most popular of the 16-bit microprocessors, including the Intel 8086, the Zilog Z8001 and 8002 chips, the DEC LSI-11, Texas Instruments 9900, the Motorola 68000 and the National Semiconductor 16000 family.

PET INTERFACING

J0169P \$25.25
Demonstrates how to build numerous interfacing devices for PET hardware. BASIC language programs are used throughout, and the book includes a discussion of the microprocessor's internal architecture and general hardware/software interfacing.

EXPERIMENTS IN ARTIFICIAL INTELLIGENCE FOR SMALL COMPUTERS

J0168P \$14.25
Artificial intelligence is the capability of a device to perform functions normally associated with human intelligence. With this book, a small computer with extended BASIC and some knowledge of BASIC language, you can conduct experiments in artificial intelligence.

STD BUS INTERFACING

J0164P \$21.75
Explains what the STD bus is, in easy-to-understand language.

electronics for beginners

BEGINNER'S GUIDE TO BUILDING ELECTRONIC PROJECTS

C0030B \$6.95
Enables total beginners to tackle electronic projects. Includes component identification, tools, soldering, building methods, cases, legends, etc. etc. Practical basic projects are included.

BEGINNERS GUIDE TO BUILDING ELECTRONIC PROJECTS

C0030B \$6.95
Enables total beginners to tackle electronic projects. Includes component identification, tools, soldering, building methods, cases, legends, etc. etc. Practical basic project are included.

Prices subject to change without notice

ORDER TODAY — Simply return the Freepost reply card to:

SPECIAL INTEREST TO OUR READERS ...

computers for beginners

PROGRAMMING FOR REAL BEGINNERS: BOOK 1

H0344A \$8.95
Written for complete beginners, this book assumes no previous knowledge of computing, and guides you gently through the initial stages of building up simple programs. The text is written to be non-machine-specific, and so can be used with any micro that is programmable in BASIC.

PROGRAMMING FOR REAL BEGINNERS: BOOK 2

H0387A \$13.95
This book introduces you to the stages involved in planning a program, including the use of flow-charts, and explores the wider range of facilities the computer has to offer. You'll also learn to plan your screen displays attractively to make your programs really user friendly.

ATARI PILOT FOR BEGINNERS

H0308H \$21.95
Shows how to make the Atari 400 and 800 home computers play music, display colourful moving pictures and do mathematics. Shows how to use the Pilot computer language.

FOUNDATIONS OF COMPUTER TECHNOLOGY

H0312P \$29.95
A thorough introduction to computer technology for business people, engineers, professionals, students and hobbyists. Assumes no prior knowledge of computers, electronics or mathematics.

MODERN COMPUTER CONCEPTS

H0313P \$29.95
The second volume in this series (following ETI Book Sales No. H0312P) covers subjects such as semiconductor memory devices, central processor units, magnetic memories, datacommunications, computer networks and videotex.

DON'T (OR, HOW TO CARE FOR YOUR COMPUTER)

H0153A \$19.95
A guide to computer and peripheral preservation. Specific advice for the computer, floppy disks, hard disks, the CRT terminal, the printer, tape units, the computer room, software and documentation.

COMPUTERS FOR EVERYBODY

H0270A \$8.95
In this easy-to-understand book it is explained how a computer can be used at home, in the office or at school. Includes a consumer's guide to computer equipment that will help the reader decide what to buy and who to buy it from. Second edition.

YOUR FIRST COMPUTER

H0271A \$15.25
An easy-to-understand beginner's book to small computers. Understanding them, buying them and using them for personal and business applications.

MICROCOMPUTERS: A PARENTS' GUIDE

H0275J \$13.75
In clear, non-technical language, the authors explain what micros are, what they can do and what to expect in the future.

HART'S DICTIONARY OF BASIC

H0276J \$15.75
Contains more than 800 entries which summarise the actions of almost every statement, command or function you are ever likely to meet. Each entry is explained in plain English, not computerese.

COBOL FOR BEGINNERS

H0140H \$33.95
It is a solid text for introductory programming courses in Cobol, using a format that is easy to understand, yet comprehensive enough to make supplementary readings unnecessary.

circuit techniques and design

BUILD YOUR OWN HI-FI AND AUDIO ACCESSORIES

D0052B \$4.95
Essential for keen hi-fi and audio enthusiasts. Projects include stereo decoder, three-channel mixer, FET preamp for ceramic pick-ups, mic preamp with adj. bass, stereo dynamic noise limiter, loud-speaker protector, etc.

RF CIRCUIT DESIGN

E0079P \$36.95
A practical approach to the design of RF amplifiers, impedance-matching networks and filters. Uses a minimum of complex maths.

GUIDE TO CMOS BASICS, CIRCUITS, AND EXPERIMENTS

E0107P \$15.95
If you are already familiar with TTL devices and are ready to examine the benefits of CMOS, this book is your complete source. It tells you what CMOS devices are, their characteristics and design rules. Experiments demonstrate the concepts discussed.

ELECTRONIC DESIGN WITH OFF-THE-SHELF ICs

E0099H \$15.70
It contains virtually all the information you need to design and build electronic circuits, systems and subsystems with readily available ICs. Shows how to interface them into highly complex systems.

MODERN FILTER DESIGN

E0100H \$65.00
This book details the advances in active RC filters, both from a practical standpoint and from a state-of-the-art point of view. Gives detailed analysis and design procedures for switched capacitor filters.

Prices subject to change without notice

computing software

FORTH PROGRAMMING

K0298P \$24.25
Describes both Forth-79 and fig-Forth and shows how to write software using these languages, add new operations (words) and manipulate the stack. Includes more than 50 useful programs.

COMPUTER PROGRAMS IN BASIC

K0192H \$18.25
Fully indexed guide to more than 1600 BASIC computer programs published in personal computer magazines for microcomputers, minicomputers and mainframe computers. Compiled by Paul Friedmann, first published in 1981.

6502 APPLICATIONS BOOK

K0228A \$20.95
Use this book and a few low-cost components to build a complete home alarm system, an electric piano, a motor speed-regulator, a time-of-day clock, a simulated traffic control system and a Morse code generator, etc.

6502 GAMES

K0229A \$21.95
You learn how to play 10 sophisticated games and also learn assembly language programming. Also learn the techniques of algorithm design and data structures.

PROGRAMMING THE Z80

K0231A \$26.95
This book will enable every reader to write complete application programs for Z80-based computer systems. Includes exercises to measure progress and comprehension at each level of programming.

PROGRAMMING THE Z8000

K0232A \$25.95
A complete introduction to programming concepts and techniques for use with the 16-bit, Z8000 microprocessor. Presents detailed descriptions of the architecture and functions of this 'super chip'.

APPLE II ASSEMBLY LANGUAGE

K0195P \$23.45
Teaches assembly-language programming at the beginning level — no prior knowledge of 6502 assembly language is needed. Includes hands-on computer exercises and experiments, with both software and hardware. Provides interfacing circuits and programs that can be used on the Apple II without modification.

QWIKTRAN

K0196A \$19.95
Quick Fortran for micros, minis and mainframes. Starts with the basic concepts of computing and Qwiktran, a fundamental subset of Fortran IV. Lots of examples to increase the reader's proficiency.

THE C PROGRAMMING LANGUAGE

K0272H \$26.95
C is a general purpose 'low-level' programming language. It is not specialised to any particular area of application, but its absence of restrictions make it convenient and effective for many tasks.

TRS-80 ASSEMBLY-LANGUAGE MADE SIMPLE

K0208P \$19.25
If you have an understanding of BASIC programming, this will help you to plan, write and hand-assemble your own assembly-language programs in memory, using the T-bug and Level II BASIC ROM subroutines.

ATARI GAMES AND RECREATIONS

K0224H \$22.25
Beginners and advanced users can use the preprogrammed games in this book to improve their skill. Charts, flash cards, an error dictionary and graph paper designs are among the features.

PROGRAMMING IN BASIC FOR PERSONAL COMPUTERS

K0186H \$18.95
Simple Instructions show how to give BASIC commands and statements a wide range of applications, from programming video games to developing business or scientific programs.

BASIC FOR EVERYONE

K0187H \$22.40
Some 350 pages of BASIC information for all purposes.

FEDERAL MARKETING BOOK SALES

PO Box 227, Waterloo 2017, NSW

More BOOKS of Special Interest on page 72

ETI June 1985 — 83

HOME BURGLAR ALARM MODULE

Part 2

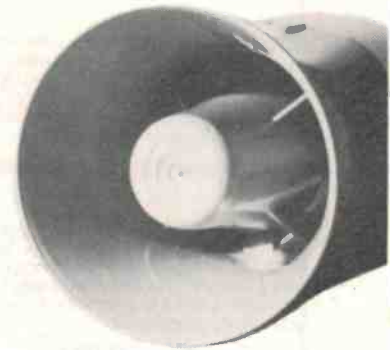
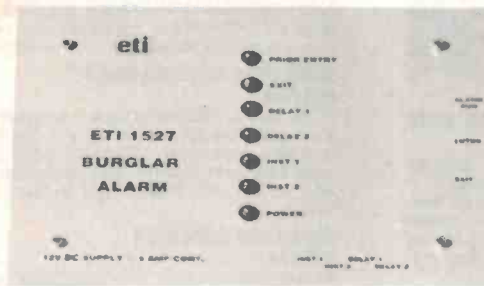

Securing your home takes some careful thought and preparation. Once you've built your ETI-1527 burglar alarm you need to determine your exact needs and use a little camouflaging ingenuity for installation.

Robert Irwin

LAST MONTH I described the design and construction of the ETI-1527 burglar alarm. The following paragraphs are intended as a guide to those hardy adventurers who wish to install their own burglar alarm system. Although primarily intended for use with the ETI-1527 burglar alarm module the comments are mostly general and may help those of you who, perish the thought, are using an alternative control module.

Sensors

Firstly, let's have a look at the types of sensors available. The most commonly used type of sensor is the 'switch' or 'contact' type of detector. The favourite from this

group is the magnet reed switch which uses the proximity of a small magnet to operate a reed relay. These are mainly used to detect the opening of a door or window.

In such cases the relay is mounted on the door or window surround and the magnet is mounted on the moving section in such a way that when the door or window is closed the magnet and reed are in close proximity and the reed switch is kept closed. When the door or window is opened the magnet will be moved away from the reed and the relay will drop out thus breaking the circuit.

The magnet reed switch has the advantages of being cheap and relatively easy to install. If installed correctly and used cor-

rectly the magnetic switch is also reasonably resistant to false alarms.

The one major disadvantage is that it can be fairly easily circumvented by someone who knows how. By clever mounting and disguising, however, this problem can be minimized.

An example of a mechanical contact switch is a plunger or lever operated switch. These switches operate in a similar way to the switch that operates the courtesy light on your car when you open the door. The physical action of opening a door or window actuates a plunger or arm to throw a switch. These types of switches are used in similar applications to that of the magnetic reed switches.

A mercury tilt switch can also be used to detect entry through windows which pivot upwards to open. These switches use a drop of mercury to make electrical contact between points in a sealed glass bulb. The switches have the disadvantage that they can easily be set off if the wind unduly rattles the window and should only be used when this sort of problem could not occur.

Another type of contact switch which is not used on doors or windows is the pressure mat. These are large flat mats with electrical contacts inside. These respond to the pressure of someone walking on them and can be hidden under carpets or rugs and can be placed in hallways or in such a position that someone attempting to take a valuable item, such as your TV, will have to tread on the pressure mat first.

One form of detector which is commonly used where large glass areas need to be protected is metallic foil. This comes in the form of metal foil tape which is stuck on a window or glass door and then connected ▶

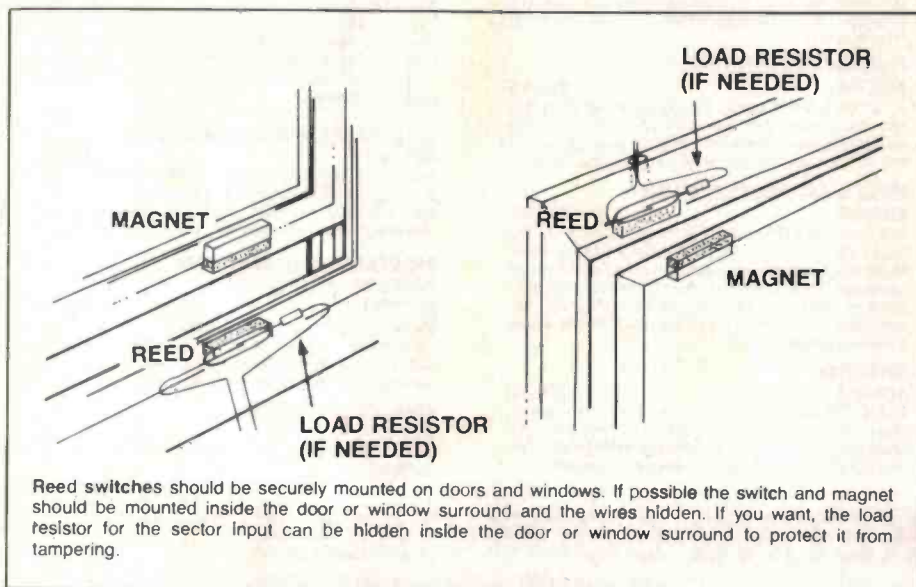

ENTRY THROUGH UNLOCKED DOORS & WINDOWS

FORCE DOOR BY JEMMY OR PRESSURE

ROOF, WALL & FLOOR ENTRY

REMOVE LOUVRES

FORCE WINDOWS BY JEMMY OR PRESSURE

MANIPULATE DOOR LOCKS BY JEMMY OR PRESSURE
OPEN DOORS BY DUPLICATE KEYS

BREAK GLASS IN WINDOW & OPERATE CATCH

Common methods of breaking into a house. Your alarm system should cover each of these entry points.

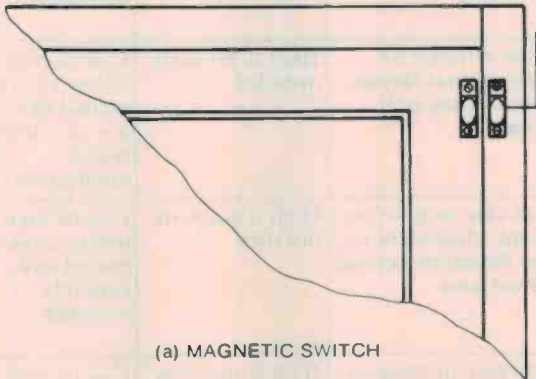

(a) MAGNETIC SWITCH

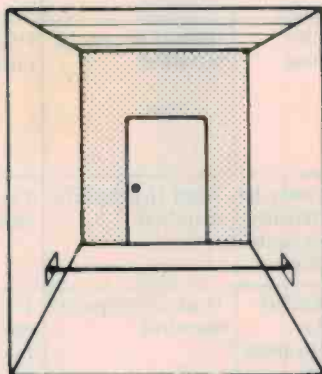

(b) TRIP SWITCH

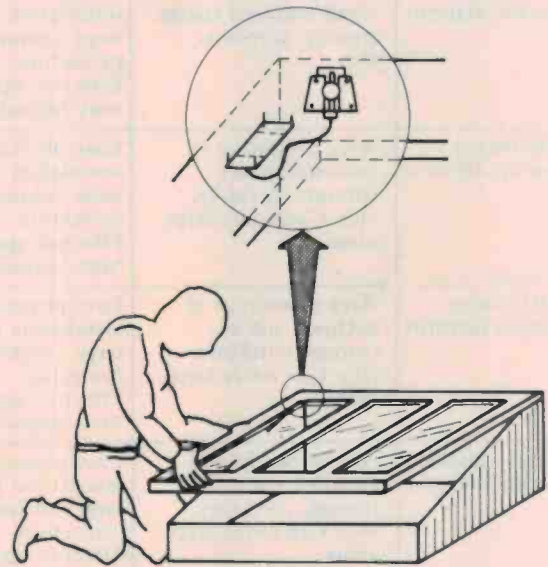

(c) MERCURY SWITCH

Switch detectors have electrical contacts that make or break an electrical circuit in response to a physical movement; they are usually used for perimeter protection.

COMPARISON OF INTRUDER DETECTORS

Detector	Applications	Advantages	Limitations	Resistance to defeat	False alarm susceptibility
Contact mechanical switches	Doors, windows, gates, transoms, hatches, etc. Usually for perimeter protection	Low cost	Low reliability. Low sensitivity. Subject to environmental effects. High installation cost	Low	High if door or window has large amount of play; low if tight
Magnetic switches	Doors, windows, gates, transoms, hatches, etc. Usually for perimeter protection	Relatively resistant to environmental effects. Relatively immune to effects of wear. Low cost	Because of mounting position, may be subject to damage in some applications. High installation cost	Balanced type more resistant to compromise than single magnet types	High if door or window has large amount of play; low if tight
Mercury switches	Same comments as for magnetic switches apply. Application is usually for access points that have covers that open with changing vertical angle thus these switches operate when tilted beyond a certain point				
Metallic foil	Show windows, office windows, glass doors, dry wall board, etc. Usually for perimeter protection	Visibility serves as deterrent	Vulnerable to damage both intentional and through day-to-day use. Must be replaced if damaged	Low	High due to effects of environment
Pressure mats	Small areas, doorways, or under specific objects for point protection	Low cost. Low degree of maintenance. Adaptable to wide variety of shapes and sizes	Subject to wear if in path of heavy foot traffic. Subject to effects of humidity and standing water	Low	Subject to environmental conditions
Acoustic detector	Area protection of enclosed spaces (rooms, vaults, etc), glass breakage detectors	Not affected by air movement	Must be used in stable noise environment where background level is low	High if properly installed	Can be high depending on the type and application
Ultrasonic motion detector	Area protection of small enclosed spaces (rooms, corridors, etc)	Easy physical installation for large volume protection. Effective against 'stay behinds'	Can be affected by environmental factors, air turbulence and motion	High if properly installed	Can be high unless environmental factors are considered before application
Microwave motion detector	Area protection of enclosed spaces (rooms, corridors, etc). Can cover large areas	Easy physical installation for large volume protection. Effective against 'stay behinds'	Needs care in positioning and adjustment to avoid detection beyond required area	High if properly installed	Can be high unless properly placed and carefully adjusted
UHF radio motion detector	Area protection of enclosed spaces (rooms, corridors, etc). Can cover large areas	Easy physical installation for large volume protection. Effective against 'stay behinds'	Needs care in positioning and adjustment to avoid detection beyond required area	High if properly installed	Can be high unless properly placed and carefully adjusted
Passive infrared motion detector	Area protection of enclosed spaces (rooms, corridors, etc). Can cover large areas	Easy physical installation for large volume protection. Effective against 'stay behinds'	Can be affected by changes in thermal environment	High if properly installed	High for receive only sensors
Capacitance detector	Primarily point protection for safes, filing cabinets, valuable objects	Detection field confined to the specific object	Can be applied only to objects not electrically grounded. May require special construction	High if properly installed	Low if properly installed
Vibration detector	Primarily point protection for safes, vaults, show cases, etc. Limited to perimeter protection when installed to protect walls or ceilings, etc	Requires low maintenance. High degree of reliability when properly applied	Detects only forceful attempts at entry. Cannot be used in areas of high vibration (traffic, construction, etc)	High if properly installed	Can be high if environmental factors are not taken into account. May be triggered by minor earth tremors, sonic booms or trains

back to the alarm.

If the window is broken, the foil will break and thus break the electrical contact. The problem with metal foil is that it can easily be damaged by routine cleaning of the window. A protective coating is generally put over the foil after it is attached to the window to get round this problem.

All of these sensors rely on an intruder opening, tilting or in some other way physically disturbing the protected area.

If the intruder gains entry to the premises without setting off these detectors the following group of sensors can be implemented. These consist of several different types of motion detector.

The main types use either microwave,

radio wave, ultrasonic or infrared energy to detect the motion of an intruder in a specific area. Each type of sensor works on different principles and has different properties. Therefore, despite the fact that they all detect the same thing, their individual suitability to a particular situation will vary.

Microwave detectors use a high frequency electromagnetic field to sense motion. They require both a transmitter and a receiver to operate. The shape of the field can be made either directional or omnidirectional and each manufacturer will have different specifications on field pattern and range.

Since microwaves will penetrate most building materials (wood, glass, plastic)

these detectors must be mounted with care to ensure that their range does not exceed the desired area. Otherwise the sensor may pick up motion outside the building and cause a false alarm.

This penetration power of microwaves can, if you are careful, be used to advantage. The sensor can be mounted inside a wall cavity or cupboard and still protect the desired area.

In complete contrast, ultrasonic motion detectors will not penetrate walls and can therefore, be completely contained in a room. Their use, though, still requires much care to be effective as this lack of penetration means that large objects, such as a lounge, can create blank spots in the room where the ultrasonic field will not penetrate.

Any obstructions in the room, such as an intricate chandelier, may distort the field and make it less effective. As with the microwave sensor, the ultrasonic sensor needs a transmitter and receiver.

Radio frequency motion detectors generate a field of UHF radio waves. The generated power changes when a moving object enters the field and thus these detectors do not need a receiver. The field is omnidirectional and has a penetration power better than that of microwave detectors so extra care must be taken.

UHF radio sensors are quite often used to give coverage of two or more rooms at the same time. It should be noted that these waves will not penetrate metal. The power of these detectors is usually variable and coverage areas of up to 20 m diameter are usual. Due to the penetration and reflection off metal surfaces, the actual field shape in a particular application is unpredictable and is usually adjusted by trial and error.

One of the most common motion detectors is the passive infrared sensor. These sensors detect the presence of a moving infrared source. Ambient temperatures or stationary heat sources will not set the detector off but the heat from a human body will at a range of up to 10 m. This type of detector uses the difference between room temperature and body temperature so on very hot days in a hot room the range can be severely limited.

Infrared systems use optical focusing to tailor the coverage of the sensor and so are limited to line of sight. This can sometimes be a problem in odd shaped rooms or areas with large objects in them which may obscure the view. Being passive detectors they do not emit any field of their own and so, unlike all the other motion detectors, they cannot be detected.

Some special types of sensors are available for special applications. Sound and vibration detectors can be used to detect someone trying to break or cut through a wall. These are very prone to false alarms if not mounted in a place where they will not

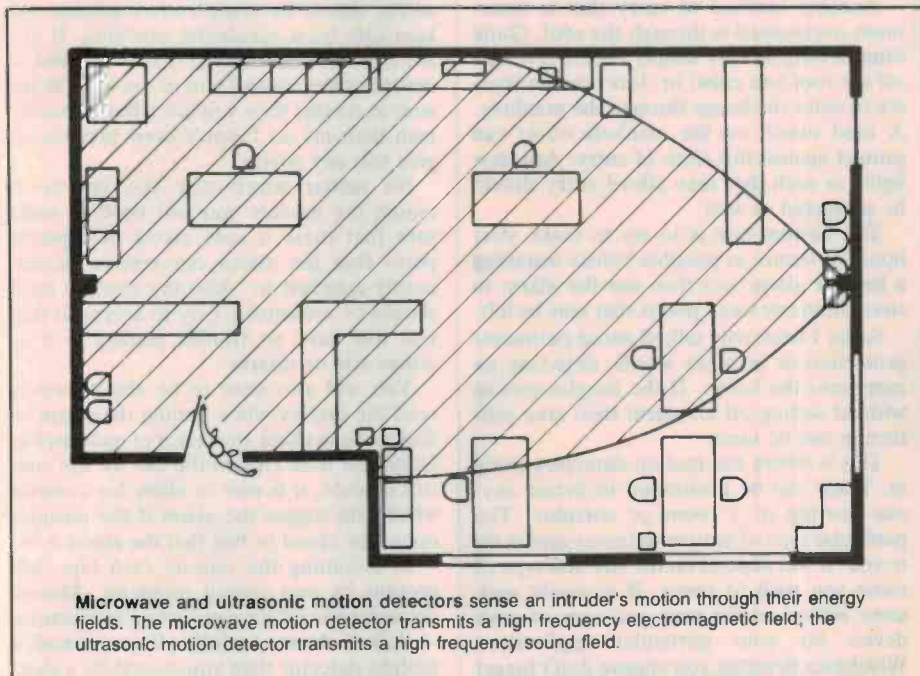

Microwave and ultrasonic motion detectors sense an intruder's motion through their energy fields. The microwave motion detector transmits a high frequency electromagnetic field; the ultrasonic motion detector transmits a high frequency sound field.

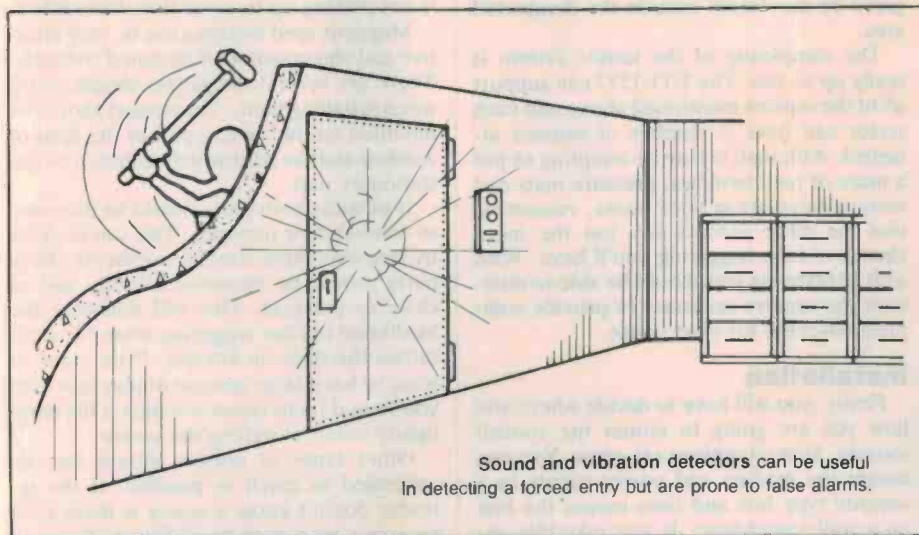

Sound and vibration detectors can be useful in detecting a forced entry but are prone to false alarms.

A capacitance detector detects a change in the electrical field surrounding an object when an intruder enters that field and causes the alarm to operate.

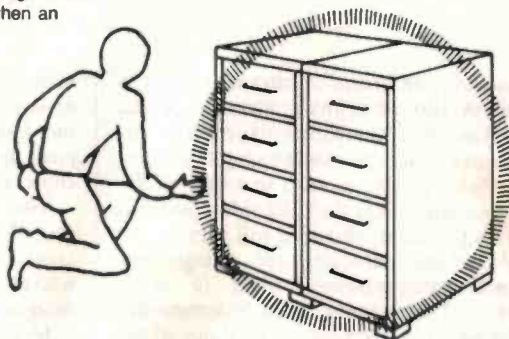

pick up sound or vibration from traffic in the street or other common disturbances.

For protection of safes or filing cabinets a capacitance detector can be used. These sensors will detect the change in capacitance when an intruder approaches a metal object such as a safe.

The above is a summary of the more common types of detectors used. It is wise to check out the manufacturers for information regarding particular products. If you decide to use infrared motion detectors, for instance, do get some information about the different brands as each will have different specifications. One type may be more suited to your application than another.

Defining the security problem

The first thing to do when you are thinking about installing a burglar alarm system is to take a good look at the premises you are trying to protect and to isolate the problem areas.

Start with the doorways. If your front and back doors are solid and well mounted and have a good deadlock correctly installed then there is little need to have advanced security measures on these. A magnetic reed switch correctly mounted should be adequate protection. If the doors contain glass panels then metal foil could be used on these. If the door is not all that secure then perhaps use a pressure mat under the carpet inside the door to give added protection.

The next problem area (and often the most neglected) is windows. Most people spend large sums of money putting expensive deadlocks on their doors but have no adequate locking facilities on the windows. In the majority of break-ins the intruders enter through inadequately secured windows or doors either by simply opening them because they weren't even locked or by jemmying them open because the locking devices (or hinges) weren't secure enough.

The golden rule here, is to make sure your windows can't easily be forced open and to make sure you lock them when you go out. If you are not sure then take a jemmy bar and play criminal (to your own windows not the neighbours!!!). You may be surprised at how easy it is to get in!

As far as electronic security for your win-

dows goes, well installed magnetic reed switches can be used to great effect. If you wish, metal foil can be used to protect against someone breaking the glass.

Another method of entry that is sometimes overlooked is through the roof. Quite often a burglar may simply take a few tiles off the roof and crawl in. It is then no trouble to enter the house through the manhole. A reed switch on the manhole cover can protect against this form of entry. Any skylights or such that may afford entry should be protected as well.

The bottom line is to try to make your house as secure as possible before installing a burglar alarm and then use the alarm to strengthen any weak points that may be left.

So far I have only talked about perimeter protection or in other words, detecting an entry into the house. If the burglar gets in without setting off an alarm then area protection can be used.

This is where the motion detectors come in. These can be positioned to detect anyone moving in a room or corridor. The particular type of motion detector used is up to you. It will depend on the size and type of room you wish to cover. If in doubt seek some advice on the pros and cons of each device for your particular application. Whichever detector you choose don't forget to thoroughly check that it is not being triggered by movement outside the designated area.

The complexity of the sensor system is really up to you. The ETI-1527 can support all of the sensors mentioned above and each sector can have a number of sensors attached. Although it may be tempting to put a maze of reed switches, pressure mats and motion detectors in your house, remember that the more sensors you use the more chance of false triggering you'll have. With a bit of planning you should be able to minimize the sensors necessary to provide complete coverage for your house.

Installation

Firstly, you will have to decide where and how you are going to mount the control module. Several options are open. You can mount the module and power supply in a security type box and then mount the box on a wall somewhere. If you take this ap-

proach then make very sure that it is extremely difficult to break into the box or cut any wire coming from the box. The easiest way to do this is to run any exposed wires in metal conduit which is securely attached to the wall.

Another way is to conceal the control module in a closet or other such place. If you do this then make sure that it is not going to be obviously discovered by a mass of wires emerging from the hiding place. If you are going to hide the module then a security box is not necessary but some form of box should be used to protect the electronics.

The power supply will also have to be mounted in a box for safety as any mains wiring should be completely insulated and kept safe from accidental touching. If you are very adventurous you may even think of mounting the control unit in the wall. If you wish to do this then you are a better handyman than me so I won't even presume to give you any advice.

No matter which way you choose to mount the module you will need to make sure that there is easy access to a power point that the alarm can remain permanently attached to. Also the module itself should be reasonably easy to access so that you will have no trouble getting to it to either arm or disarm.

You will also need to be able to easily read the display when arming the alarm so that you can check the status of each sector. Once you have chosen the site for the control module, it is wise to allow for a sensor which will trigger the alarm if the intruder opens the closet or box that the alarm is in.

In mounting the sensors each type will present its own special problems. Motion detectors should have mounting instructions — follow these carefully. If you install a motion detector then you should do a thorough 'walk' test to ensure that the detector is not picking up in areas that it shouldn't.

Magnetic reed switches can be very effective and cheap sensors if mounted correctly. There are several things you should watch when installing them. The magnet should be mounted on the moving part of the door or window and the reed switch mounted on the stationary part.

If possible both parts should be mounted to conceal their presence. This can be done by recessing them into the woodwork. Both parts should be mounted securely and as close as practical. This will minimize the likelihood of false triggering when the wind rattles the door or window. If the door or window has a large amount of play in it then you should try to repair it so that it fits more tightly before installing the sensor.

Other types of sensors should also be concealed as much as possible. If the intruder doesn't know a sensor is there then he won't take steps to defeat it. Pressure

mats are easily hidden under carpets or rugs and may never be noticed if there are no tell-tale wires running out.

As far as wiring goes the golden rule is conceal the wires and make them as inaccessible as possible. Ideally wires should be run into the sensor via the wall cavities. If this is not possible then concealment under skirting boards and architraves will do. All wiring, as far as possible, should be done with good quality, heavy duty stranded wire to minimize voltage drops and rf pickup.

If it is necessary to run wires in the open (in the roof or under the floor) then the wires should be run in well secured metal conduit to prevent access. All joins in the wires should be securely soldered and insulated and connections should be as secure as possible to prevent them working loose and causing a false alarm. The load resistors needed on the inputs can be put anywhere in the circuit path but if possible they should also be concealed to prevent someone by-passing the sensors.

The alarm siren or bell is something that you should also pay attention to. There are various noise makers on the market and any security company should be able to show

you a few. A siren generator is built into the module so a simple horn speaker can be used.

Whatever you use you should mount on the outside of the building in an out of the way and inaccessible place. It should be mounted securely and if possible with a steel cover to prevent tampering. Any wiring to the siren should be made inaccessible either by running it in conduit or taking it straight through the wall. The alarm will be useless if the intruder can simply disconnect the siren. It is wise to use two separate sirens and mount them in different parts of the building.

Once you have installed your alarm give the whole system an extensive check. This is in both your own interests and your neighbours'. If your alarm system constantly puts out false alarms then the people around you will pretty quickly start ignoring the alarm. They may get upset about the noise so make sure the system is working reliably. If you find you are getting false alarms every time your fridge switches on or every time a taxi uses its radio near your house then you will probably have to add some suppression to the power supply lines and the input lines.

Remember

This article has tried to give a few general guidelines for installing your ETI-1527 module and sensors. If you want some additional information then ring around insurance companies and security agencies. The local police should also be able to put you on to any crime prevention authorities which will be able to advise you on any problems you may have.

It is important to understand that an alarm system is only one part of creating secure premises. You should inform your neighbours to the fact that you have installed an alarm system and organize for them to inform the police in the event of an alarm. You should also familiarize yourself and anyone else who will have access to the alarm of its correct usage. If used correctly and in conjunction with a few good door and window locks this alarm system should minimize your chances of being robbed. Beware, though, as some people who have spent a lot of money on extensive security alarms have found out. "The most sophisticated burglar alarm in the world is totally useless if you don't turn it on."

Master Electronics—Microprocessors—Now! The Practical Way!

- Electronics—Microprocessors—Computer Technology is the career and hobby of the future. We can train you at home in a simple, practical and interesting way.
- Recognise and handle all current electronic components and 'chips'.
- Carry out full programme of experimental work on electronic computer circuits including modern digital technology.
- Build an oscilloscope and master circuit diagram.
- Testing and servicing radio, TV, hi-fi and all types of electronic/computer/industrial equipment.

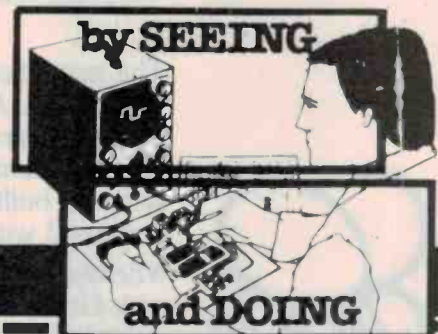

AUSTRALIA SCHOOL OF ELECTRONICS
P.O. Box 108, Glen Iris. 3146 Tel: (03) 523 5622.

FREE

BROCHURE



SEND THIS COUPON NOW.

Please send your brochure without any obligation to:

I am interested in:

ELECTRONICS

MICROPROCESSORS

NAME _____

ADDRESS _____

OR TELEPHONE US
(03) 523 5622
(24 HOUR SERVICE)

ETI 6/85

BLOCK CAPS PLEASE

New Job? New Career? New Hobby?

The microbee PC85 puts advanced computer technology in the hands of Hackers, Hobbyists and Horticulturalists at a cost below any competitors



The new microbee PC85 features a new high level of user friendliness. At the touch of a button you choose from a menu of built-in programs — Wordprocessing, Basic, A Calculator, Telecommunications and more. You can even have your own software built-in! Check out the new microbee PC85. You'll be impressed with the quality and surprised at the price.

Microbee PC85 \$499 incl. Tax
with Green Monitor \$599 incl. Tax
Ask about Printers, Modems and more.

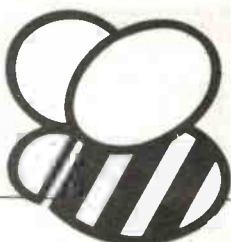

microbee computer

Designed and manufactured
in Australia by
Applied Technology

PHONE ORDERS  ACCEPTED

microbee technology centres

N.S.W.
1 Pattison Ave, Waitara 2077
Phone (02) 487 2711

VIC.
729 Glenferrie Rd, Hawthorn 3122
Phone (03) 819 5288

W.A.
141 Stirling Highway, Nedlands
Phone (09) 386 8289

S.A.
151 Unley Rd, Unley 5061,
Phone (08) 272 1384

QLD
455 Logan Rd, Stones Corner, 4120
Phone (07) 394 3688

FACTORY
Koala Crescent, West Gosford 2250
Phone (043) 24 2711

HP and Electronics Today announce a limited time offer! This snap-in fibre optic kit for just \$33.00.

There's never been a better time than now to try fibre optics for short distance links. Because for a limited time, all you need to get started is \$33.00.

That's all it takes to get HP's HFBR-0500 Snap-In Link Evaluation Kit, including a complete working link with transmitter, receiver, five metres of plastic fibre cable with connectors attached, two spare connectors, polishing tool and technical literature. The connectors simply snap-in to the transmitter and receiver modules. It's easy. And attaching the connectors to cables is simple, too. Data rates up to 5 Mbaud and distances up to 22 metres are guaranteed over a specified temperature range.

The HFBR-0500 Kit normally sells for around \$57.00. But if you want yours for just \$33.00, act now. This special offer expires June 30, 1985.

Fibre optics are rapidly becoming the data link of choice for applications connecting computers to peripherals, and for industrial control applications. Once you see how easy and reliable fibre optics are, you may never go back to traditional wire cable!

Order your kit today! Please complete and send the coupon and your cheque to Federal Marketing, PO Box 227, Waterloo NSW 2017.

HP: The right choice for value in fibre optics.

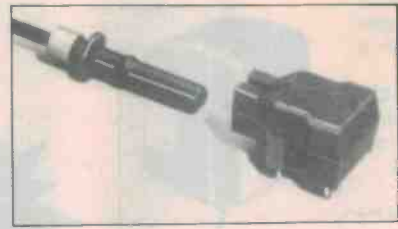

Yes! Send me HP's snap-in fibre optic evaluation kit.

Enclosed is my cheque made payable to Federal Marketing for \$33.00.

Name

Address

..... State

Postcode Phone

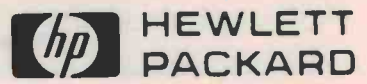

Nicad battery charger

Noel Jackson of Wandin East sent us this Nicad charger. The switch selects a resistor to set the base current of the transistor, and the resulting collector current will charge the battery. Charging current will be reasonably constant irrespective of the number of cells in series being charged; up to 8 cells may be charged at the one time.

Once the circuit has been tested the ammeter could be omitted, or a multimeter switched to an appropriate current range could be plugged in

to the circuit.

The 12 volts dc could be provided by a plugpack, or by a suitable 240 volt transformer and rectifier.

In theory, the collector current will rise as the transistor's temperature increases, but this was not noticeable in the prototype. The transistor could be mounted on a heatsink if desired. Exact values for the resistors will depend on the transistor used and the required charging currents.

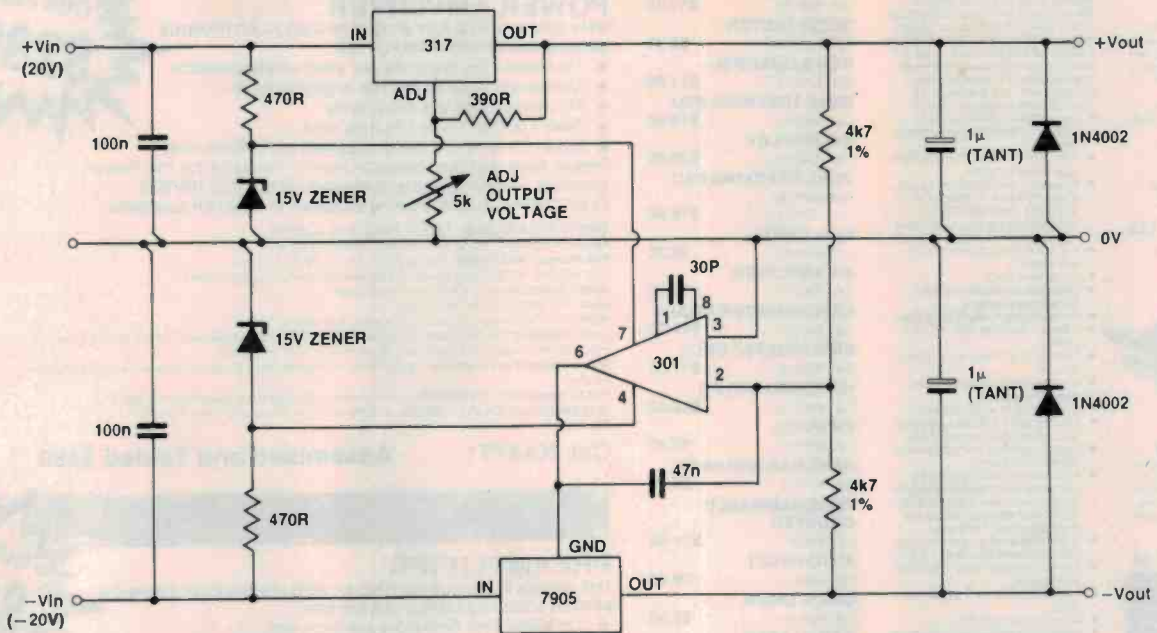
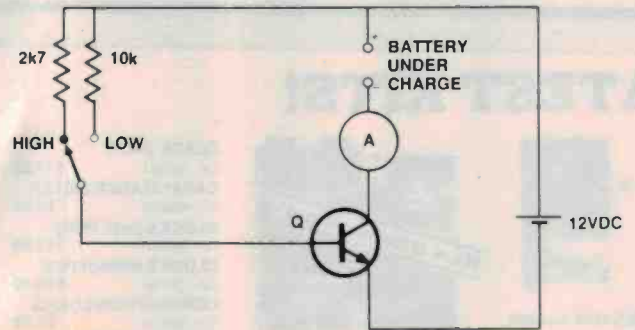

Dual tracking power supply

This circuit from H. Nancovich, Gulgong NSW, is for a dual power supply. It is particularly suitable for powering op-amp circuits which usually require both positive and negative supply voltages. The circuit consists of a positive regulator which gives a positive output voltage variable from 1.2 V to approximately 16.6 V, and a negative regulator which tracks the positive output voltage to give a negative output voltage of equal magnitude. The positive regulator comprises a 317 (μ A317, LM317, etc.) IC which main-

tains a constant 1.2 V between its 'out' and 'adj' terminals. This voltage appears across a 390R resistor which, together with a 5k variable resistor, forms a voltage divider. The positive output voltage is equal to: $1.2 \text{ V} \times (1 + \frac{R}{390})$ where R is the value of the variable resistor in ohms. The negative regulator comprises a 7905 IC regulator and a 301 IC op-amp. The 7905 maintains a fixed -5 V between its 'out' and 'gnd' terminals. Its 'gnd' terminal is connected to the output (pin 6) of the op-amp. The latter compares the

voltage at the junction of two 4k7 resistors across the positive and negative output lines with that at the 0 V line and produces a proportional voltage at its output. The 7905 reflects this voltage (plus -5 V) into the negative output line. By negative feedback action, the voltage at the junction of the two 4k7 resistors is maintained equal to that at the 0 V line. Since these two resistors are equal, the negative output voltage is maintained equal and opposite to the positive output voltage.

The 1 μ tantalum capacitors

across the outputs and the 47n capacitor between pins 2 and 6 of the op-amp ensure stability, while the 1N4002 diodes across the outputs protect the regulators against possible reversal of the output voltages (as may sometimes happen when coupled with other power supplies, for example). Both the positive and negative regulators feature current and thermal limiting, which features are built into the 317 and 7905 ICs.

We've got the kits at

LATEST KITS!



MULTI SECTOR ALARM STATION

Protect your home from intruders with this up-to-the-minute burglar alarm system, its easy to build, costs less than equivalent commercial units, and features eight separate inputs, individual sector control, battery back up and self-test facility.

- Specifications:**
- Eight sectors with LED status indication.
 - Two delayed entry sectors.
 - Variable exit, entry and alarm time settings: entry delay variable between 10 and 75 seconds; exit delay variable between 5 and 45 seconds; alarm time variable between 1 and 15 minutes.
 - Resistive loop sensing: suits both normally open and normally closed alarm sensors.
 - Battery back-up with in-built charger circuit.
 - Built-in siren driver.

Complete kit including deluxe punched metal work and electronics for only...

Cat. K85900 \$119



LOW BATTERY VOLTAGE INDICATOR

Knowing your batteries are about to give up on you could save many an embarrassing situation. This simple low cost project will give you an early warning of power failure, and makes a handy beginner's project.

(ETI 280, March '85)

Cat. K42800 \$7.95



PARALLEL PRINTER SWITCH

Tired of plug swapping when ever you want to change from one printer to another? This low-cost project should suit you down to the ground. It lets you have two Centronics-type printers connected up permanently so that you can select one or the other at the flick of a switch.

(ETI 666, Feb. '85)

Cat. 46660 \$69.95



STEREO ENHANCER

The best thing about stereo is that it sounds good. The greatest stereo hi-fi system loses its magnificence if the effect is so narrow you can't hear it. This project lets you cheat on being cheated and creates an 'enhanced stereo effect' with a small unit which attaches to your amp.

(ETI 1405, ETI, MAR '85)

Cat. K54050 \$79.50



MICROBEE ENHANCER 1

This brand new, totally amazing expansion unit for the Microbee is a must for all Microbee owners/users! Most expansion units up to this time offered at best only one or other features; and this made it impossible to run, say, complex sound effects mingled with speech. The Enhancer 1 will do all this and much more as well. It is quite amazing how much has been shoe-horned into this compact unit. The Enhancer 1's many powerful features include:

- Two ATARI/COMMODORE/COLECO/SEARS type joystick inputs.
- Two TRS COLOR COMPUTER type joystick inputs.
- Allows the connection of Touch Pads, Paddles, Proportional Joysticks, Trackballs, Mice, temperature sensors, lights level sensors, transducers, etc. etc!
- A 4 voice music/sound effects synthesizer.
- A real time clock.
- Unlimited vocabulary speech synthesizer (option).
- Parallel printer interface (option).
- A built-in speaker with volume control.
- Listing of all necessary routines for use.
- An impressive demonstration program package.
- Compatible to all Microbees.
- All units carry a 90 day warranty and servicing is also available.
- Digital recording and playback of speech and sound.
- An 8 channel analog to digital converter with variable voltage or variable resistance type analog inputs and also user selectable resolution from 1 to 9 bits.
- A digital to analog converter with selectable resolution from 1-8 bits.
- Allows automatic data acquisition and logging.
- 5 digital input lines, 4 digital output lines.
- A voice input channel.
- A 40 pin experimenter socket with all 8 analog inputs, 5 digital inputs, 4 digital outputs, 3.58 MHz buffered clock, sound output (so that you can play the sound) effects through your Hi Fi; 3 high resolution voltage comparators, DAC output etc.

The amazing Microbee Enhancer is available exclusively from Rod Irving Electronics.

Cat. \$149

TALKING ELECTRONICS KITS!

- HEADLIGHT REMINDERS Cat. K80022 \$12.90
- IC POCKET RADIOS Cat. K80023 \$10.80
- LED DICE Cat. K80024 \$9.05
- LED ZEPLINS Cat. K80025 \$7.85
- LIGHT THE LED Cat. K80026 \$4.60
- LOGIC DESIGNER (with PC) Cat. K80027 \$20.90
- LOGIC PROBES Cat. K80028 \$11.55
- LOGIC DESIGNER (without PC) Cat. K80029 \$17.60
- LOTTO SELECTORS Cat. K80030 \$16.50

- BLACK JACK Cat. K80001 \$11.00
- CAPACITANCE METER Cat. K80002 \$6.25
- CLOCKS (incl. PCB) Cat. K80003 \$22.80
- CLOCKS without PCB Cat. K80004 \$19.50
- COMBINATION LOCKS Cat. K80005 \$7.50
- COUNTER MODULE Cat. K80006 \$21.70
- 7 SEGMENT DISPLAY Cat. K80007 \$11.40
- CUBE PUZZLE Cat. K80008 \$17.90
- DIGI CHASER Cat. K80009 \$17.40
- DIODE TESTER Cat. K80010 \$3.30
- KEN'S DUAL PSU. Cat. K80011 \$11.80
- DUAL TRACKING PSU. Cat. K80012 \$18.90
- 8x8 DISPLAY Cat. K80013 \$22.80
- DUAL TRACKING PSU. (without PCB) Cat. K80014 \$15.60
- EGG TIMER Cat. K80015 \$8.30
- 8W AMPLIFIER Cat. K80016 \$9.70
- EXPERIMENTER BOARD Cat. K80017 \$14.30
- EXPERIMETER DECK Cat. K80018 \$17.55
- HANGMAN with PC Cat. K80019 \$12.50
- FM BUGS Cat. K80020 \$6.80
- HANGMAN with no PC Cat. K80021 \$9.20
- PROGRAMMABLE COUNTER Cat. K80041 \$11.80
- AUTO RESET Cat. K80042 \$9.70
- QUICK DRAW Cat. K80043 \$3.90
- RAM STACKS Cat. K80044 \$9.70
- RELAY DRIVER BOARD Cat. K80045 \$28.40
- ROULED Cat. K80046 \$8.50
- SQUARE WAVE OSCILLATOR Cat. K80047 \$4.70
- STEREO MINI MIXER Cat. K80048 \$23.10
- STEREO PRE AMPS Cat. K80049 \$13.20
- SIMPLICITY AMPS Cat. K80050 \$6.80
- STEREO VU METERS (no PC) Cat. K80051 \$10.70
- TRAIN SIGNALS Cat. K80052 \$7.70
- STEREO VU METER (with PC) Cat. K80053 \$14.00
- TOUCH PUZZLE Cat. K80054 \$6.25
- TRAIN THROTTLE MK11 Cat. K80055 \$4.30
- TREMOLO Cat. K80056 \$3.80
- TEC 1A Cat. K80057 \$95.00
- STAGE-1 KIT Cat. K80058 \$89.95

SERIES 5000 PRICES SLASHED!

By directly importing and a more technically orientated organisation, ROD IRVING ELECTRONICS can bring you these products at lower prices than their competitors. Enjoy the many other advantages of RIE Series 5000 kits such as "Super Finish" front panels at no extra cost, top quality components supplied throughout. Over 1,000 Sold.

For those who haven't that time and want a quality hi-fi, we also sell the Series 5000 kits Assembled and Tested.



POWER AMPLIFIER

WHY YOU SHOULD BUY A "ROD IRVING ELECTRONICS" SERIES 5000 POWER AMPLIFIER.

- ★ 1% Metal Film resistors are used where possible.
- ★ Aluminium case as per the original article.
- ★ All components are top quality.
- ★ Over 1000 of these kits now sold.
- ★ Super Finish front panel supplied at no extra cost.

Please note that the "Superb Quality" Heatsink for the Power Amplifier was designed and developed by ROD IRVING ELECTRONICS and is being supplied to other kit suppliers.



SPECIFICATIONS: 150 W RMS into 8 ohms (±55 V SUPPLY)
 POWER OUTPUT: 100 W RMS into 8 ohms (±55 V SUPPLY)
 FREQUENCY RESPONSE: 8 Hz to 20 KHz +0/-0.4 dB 2 8 Hz to 65 KHz +0.3 dB NOTE: These figures are determined solely by passive filters.
 INPUT SENSITIVITY: 1 V RMS for 100 W output
 HUM: 100 dB below full output (flat)
 NOISE: 116 dB below full output (flat, 20 KHz bandwidth)
 2nd HARMONIC DISTORTION: <0.001% at 1 KHz (0.0007% on Prototypes) at 100 W output using a ±56 V SUPPLY rated at 4A continues <0.003% at 10 KHz and 100 W
 3rd HARMONIC DISTORTION: <0.003% for all frequencies less than 10 KHz and all powers below clipping
 TOTAL HARMONIC DISTORTION: Determined by 2nd Harmonic Distortion (see above)
 INTERMODULATION DISTORTION: 0.003% at 100 W, 150 Hz and 7 KHz mixed 4 TL
 STABILITY: Unconditional

Cat. K44771 Assembled and Tested \$499



PREAMPLIFIER

THE ADVANTAGES OF BUYING A "ROD IRVING ELECTRONICS" SERIES 5000 PREAMPLIFIER KIT ARE:

- ★ 1% Metal Film Resistors are supplied.
- ★ 14 Metres of Low Capacitance Shielded Cable are supplied (a bit extra in case of mistakes).
- ★ English "Lorlin" switches are supplied (no substitutes here).
- ★ Specially imported black anodised aluminium knobs.

Available Assembled and Tested. (We believe that dollar for dollar there is not a commercial unit available that sounds as good.)



SPECIFICATIONS:
 FREQUENCY RESPONSE: High-level input: 15 Hz-130 KHz +0 -1 dB Low Level input - conforms to RIAA equalisation, ±0.2 dB
 DISTORTION: 1 KHz <0.003% on all inputs (limit of resolution on measuring equipment due to noise limitation)
 S/N NOISE: High-Level input: master full, with respect to 300 mV input signal at full output (1.2V) >92 dB flat >100 dB A-weighted MM input: master full, with respect to full output (1.2V) at 5 mV input 50 ohms source resistance connected >86 dB flat >92 dB A-weighted MC input: master full, with respect to full output (1.2V) and 200 uV input signal >71 dB flat >75 dB A-weighted

Cat. K44791 Assembled and Tested \$599



THIRD OCTAVE GRAPHIC EQUALIZER

SPECIFICATIONS:
 BANDS: 28 Bands from 31.5 Hz to 16 KHz.
 NOISE: <0.008 mV, sliders at 0, gain at 0 (-102 dB0).
 20 KHz BANDWIDTH DISTORTION: 0.007% at 300 mV signal, sliders at 0, gain at 0; maximum 0.01%, sliders at minimum.
 FREQUENCY RESPONSE: 12 Hz-105 KHz, +0, -1 dB, all controls flat.
 BOOST AND CUT: 14 dB.
 Cat. K44590

1 Unit... \$199
 2 Units... \$379

POST & PACKING: \$10 per SERIES 5000 KIT.

Rod Irving Electronics!



HEADPHONE AMPLIFIER
PRACTICE WITHOUT ANNOYING THE FAMILY!
If you play any type of electronic instrument, this headphone amplifier will surely interest you. It will let you practice for hours without upsetting the household, or you can use it to monitor your own instrument in the midst of a rowdy jam session. (EA Feb. '84) 83MA11
Cat. K83011 \$28.00



MICROBEE SERIAL-TO-PARALLEL INTERFACE
Most microcomputers worth owning have an "RS232" connector, or port, through which serial communications (input/output) is conducted. It is a convention that, for listing on a printer, the BASIC LIST or LPRINT command assumes a printer is connected to the RS232 port. Problem is, serial interface printers are more expensive than parallel Centronics' interface printers. Save money by building this interface. (ETI Jan. '84) ETI1675
Cat. K46750 \$59.00



LOW OHMS METER
How many times have you cursed your Multimeter when you had to measure a low-value resistance? Well with the "Low Ohms Meter" you can solve those old problems and in fact measure resistance from 100 Ohms down to 0.005 Ohms. (ETI Nov. '81) ETI 158
Cat. K41580 \$34.50



PHONE MINDER
Dubbed the Phone Minder, this handy gadget functions as both a bell extender and paging unit, or it can perform either function separately. (EA Feb. '84) 84TP2
Cat. K84021 \$24.00



SOUND SIMULATOR FOR MODEL TRAINS
Fancy a diesel sound simulator for your model train layout? This circuit mounts inside the train for added realism and even varies its "speed" according to the throttle setting. (EA Nov. '84)
Cat. K84110 \$18.00



DIRECTIONAL DOOR MINDER
Most electronic door minders function by having a beam of light shining across doorway. Interrupted, but are incapable of detecting whether the light beam is broken by a person entering or leaving the room. This project overcomes that problem with the aid of digital logic. (ETI Nov. '84) ETI 278
Cat. K42780 \$29.95



LAB SUPPLY
Fully variable 0-40V current limited 0-5A supply with both voltage and current metering (two ranges: 0-0.5A/0-5A). This employs a conventional series-pass regulator, not a switchmode type with its attendant problems, but dissipation is reduced by unique relay switching system switching between taps on the transformer secondary. (ETI May '83) ETI 163
Cat. K41630 \$175.00



CAR IGNITION KILLER
Most car burglar alarms are easily circumvented, but not this cunning "Ignition Killer". This sneaky anti-theft device uses a 555 timer to place an intermittent short circuit across the points. Until disabled by its hidden switch the circuit effectively makes the car undrivable — a sure deterrent to thieves! (EA Feb. '84) 84AU1
Cat. K84010 \$16.95
(Our kit includes the box!)



ELECTRIC FENCE
Mains or battery powered, this electric fence controller is both inexpensive and versatile. Based on an automotive ignition coil, it should provide an adequate deterrent to all manner of livestock. Additionally, its operation conforms to the relevant clauses of Australian SIND 3129. (EA Sept. '82) 82EF9
Cat. K82092 \$19.50

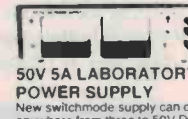

50V 5A LABORATORY POWER SUPPLY
New switchmode supply can deliver anywhere from three to 50V DC and currents of 5A at 35V or lower. Highly efficient design. (EA May/June '83) 83P55
Cat. K83050 \$149



RADIOTELETYPE CONVERTER FOR THE MICROBEE
Have your computer print the latest news from the International shortwave news service. Just hook up this project between your short wave receiver's audio output and the MicroBee parallel port. A simple bit of software does the decoding. Can be hooked up to other computers too. (ETI Apr. '83)
Cat. K82050 \$20.00



ELECTRIC DUMMY LOAD
With this unit you can test power supplies at currents up to 15 Amps and voltage up to 60 Volts. It can "sink" up to 200 Watts on a static test and you can modulate the load to perform dynamic tests. (ETI Oct. '80) ETI 147
Cat. K41470 \$109



VIDEO AMPLIFIER
Bothered by smeary colours, signal beats and RF interference on your computer display? Throw away that cheap and nasty RF modulator and use a direct video connection instead. It's much better! The Video Amplifier features adjustable gain and provides both normal and inverted outputs. Power is derived from a 12V DC plugpack supply. (EA Aug. '83) 83VA8
Cat. K83081 \$15.00



TRANSISTOR TESTER
1000'S SOLD
Have you ever desoldered a suspect transistor, only to find that it checks OK? Trouble-shooting exercises are often hindered by this type of false alarm, but many of them could be avoided with an "in-circuit" component tester, such as the EA Handy Tester. (EA Sept. '83) 83TT8
Cat. K83080 \$15.00

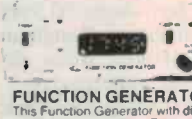

FUNCTION GENERATOR
This Function Generator with digital readout produces Sine, Triangle and Square waves over a frequency range from below 20Hz to above 100KHz with low distortion and good envelope stability. It has an inbuilt four-digit frequency counter for ease and accuracy of frequency setting. (EA April '82, 82AO3A/B)
Cat. K82040 \$87.50
Cat. K82041

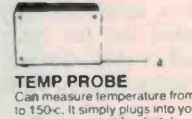

TEMP PROBE
Can measure temperature from -50 to 150°C. It simply plugs into your multimeter - great for digital multimeters. Accuracy of 0.1°C resolution of 0.1°C (ETI June '83) ETI 153
Cat. K41530 \$24.50

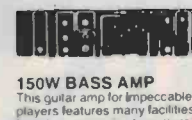

150W BASS AMP
This guitar amp for impeccable bass players features many facilities found on expensive "commercial" ones. It delivers 150 watts into 4-ohms, has a 1-band graphic limiter, line out and bi-amp facilities. (ETI Aug. '84) ETI 1410
Cat. K54100 \$299



40 W INVERTER
This 12 240 V inverter can be used to power up mains appliances rated up to 40 W, or to vary the speed of a turntable. As a bonus, it will also work backwards as a trickle charger to top up the battery when the power is on. (EA May '82) 82IV5
Cat. K82050 \$49.50



ZENER TESTER
A simple low cost add-on for your multimeter. This checks zeners and reads out the zener voltage directly on your multimeter. It can also check LEDs and ordinary diodes. (ETI May '83) ETI 164
Cat. K41640 \$9.50



COMPUTER DRIVEN RADIO-TELETYPE TRANSCIVER
Here's what you've been asking for, a full transmit-receive system for computer driven radio-teletype station. The software provides all the latest "whizz-bangs" like split-screen operation, automatically repeating test message, printer output and more. The hardware uses tried and proven techniques. While designed to team with the popular Microbee, tips are available on interfacing the unit to other computers. (ETI Nov. '84) ETI 755
Cat. K47550 \$139.00



MOTORCYCLE INTERCOM
OVER 300 SOLD!
Motorcycling is fun, but the conversation between rider and passenger is usually just not possible. But build this intercom and you can converse with your passenger at any time while you are on the move. There are no "push-to-talk" buttons, adjustable volume and it's easy to build! (EA Feb. '84) 84MC2
Cat. K84020 \$45.00



EPROM PROGRAMMER EP1
No need for a Micro with EA's great EProm Programmer suitable for 2716/2758 EProms. (EA Jan. '82) 82EP1
Cat. K82013 \$47.50
With Textool Sockets \$59.95



EFFECTS UNIT
An "effects unit" that can create phasing, flanging, echo, reverb and vibrato effects. (EA June '83) 83GA6
Cat. K83060 \$75.00

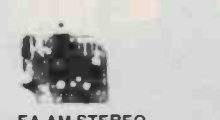

EA AM STEREO DECODER
AM stereo is now broadcast in Australia on an experimental basis. This add-on decoder works with the Motorola C-QUAM system. (EA Oct. '84) 84MS10
Cat. K84101 \$24.95

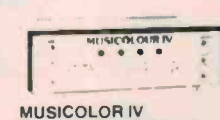

MUSICOLOR IV
Add excitement to parties, card nights and discos with EA's Musicolor IV light show. This is the latest in the famous line of musicolors and it offers features such as four channel "color organ" plus four channel light chaser, front panel LED display, internal microphone, single sensitivity control plus opto-coupled switching for increased safety. (EA Aug. '81) 81MC8
Cat. K81080 \$89.00



ELECTRONIC MOUSETRAP
This clever electronic mousetrap disposes of mice instantly and mercifully, without fail, and resets itself automatically. They'll never get away with the cheese again! (ETI Aug. '84) ETI 1524
Cat. K55240 \$29.95

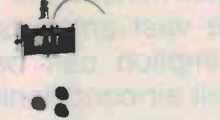

PH METER KIT
Build this pH meter for the swimming pool season is here again! From swimming pools to fish tanks to gardening, this pH meter has many applications around the home. This unit features a large 3 1/2 digit liquid crystal display and resolution to .01 pH units, making it suitable for use in the laboratory as well. (EA Dec. '82) 82PH12
Cat. K82123 \$139



DUAL TRACKING POWER SUPPLY
Built around positive and negative 3-Terminal Regulators, this versatile dual tracking Power Supply can provide voltages up to 2A. In addition the Supply features a fixed +5V 0.9A output and is completely protected against short circuits, overloads and thermal runaway. (EA March '82) 82P52
Cat. K82030 \$87.50

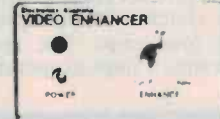

VIDEO ENHANCER
100'S SOLD
Like tone controls in a hi-fi amplifier, touch up the signal with this Video Enhancer. (EA Oct. '83) 83VE10
Cat. K83100 \$35.00

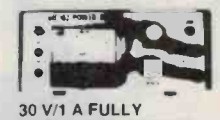

30 V/1 A FULLY PROTECTED POWER SUPPLY
The last power supply we did was the phenomenally popular ETI-131. This low cost supply features full protection, output variation from 0V to 30V and selectable current limit. Both voltage and current metering is provided. (ETI Dec. '83) ETI 162
Cat. K41620 \$52.50



MOSFET POWER AMPLIFIER
Employing Hitachi Mosfets, this power amplifier features a "no compromise" design, and is rated to deliver 150 W RMS maximum and features extremely low harmonic, transient and intermodulation distortion. (ETI Jan. '81) ETI 477
Cat. K44770 \$69.50

Remember... We have over 260 Kits, most of which are in stock!!

WANTED

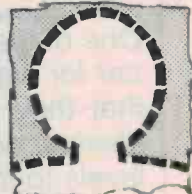

16-18yrs Shop Assistant(s)
If you're an electronics enthusiast and would like to work in electronics retail, we'd like to hear from you.

Phone: Greg Boot (03) 663 6580

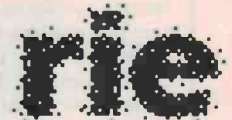

ROD IRVING ELECTRONICS
425 High Street, NORTHCOTE, 3070 VICTORIA, AUSTRALIA
Phone (03) 489 8866
TELEX: AA 38897
48-50 A Beckett Street, MELBOURNE, 3000 VICTORIA, AUSTRALIA
Ph. (03) 663 6151
Mail Order and correspondence: P.O. BOX 235 NORTHCOTE 3070

MAIL ORDER HOT LINE



(03) 481 1436

POSTAGE COST	POSTAGE RATE
\$1-\$9.99	\$2.00
\$10-\$24.99	\$3.00
\$25-\$49.99	\$4.00
\$50-\$99.99	\$5.00
\$100-\$199	\$7.50
\$200-\$499	\$10.00
\$500 plus	\$12.50

This is for basic postage only. Comet Road freight, bulky and fragile items will be charged at different rates.



ENERGY SAVER

For car air-conditioning

Eric Eulenstein

One of the greatest creature comforts that can be installed in a car for summer motoring is the air-conditioner. The problem is that they use vast amounts of power. This idea shows how power consumption can be reduced to acceptable enough levels to install air-conditioning for next summer.

LIKE MOST refrigeration equipment an air-conditioner depends on the latent heat of a refrigerant. The air is used to heat and vaporize the liquid refrigerant in the evaporator and it's cooled in the process. The heated refrigerant is then compressed, a lot more heat being generated in the process, and then passed on to the condenser where it must be cooled substantially before it can reliquify.

Considering that the interior of the car has large amounts of heat entering it via the bodywork, the windows and the engine compartment, it's obvious that the refrigeration plant has an arduous job — far more so than the average home refrigerator. Human bodies also add substantially to the heating problem in such a confined space.

Consider now the electrical system of the unit in question. The high volume fan in the evaporator requires up to six amps to drive it, and the magnetic clutch on the compressor requires about four amps. The condenser fan needs about ten amps to operate.

Hence, when actually operating, the air conditioner load is about twenty amperes.

I discovered these facts after I noticed that the air conditioner cutting in to do a cooling cycle caused the headlights to dim noticeably. The question was: what could I do about it?

On a hot day the condenser needs a large volume of air passing through it. But when on the open road (or, say, above 60 kph) the speed of the car itself forces enough air through the condenser. Under these circumstances the fan is quite unnecessary.

But how to control it? Many electronic means are obvious, but not warranted because of complexity. There is one source of control that will always be available and proportional to need, and that is the wind itself!

With experimentation a wind-controlled flap was designed with a small mercury switch on it that operated the fan relay when the car was stopped or slow moving, but at about 60 kph it reaches the end of its

travel (through about 30 degrees), tilting the mercury switch sufficiently to switch off the fan. A spring in tension across the flap's pivot point causes a small snap action to occur on the flap to prevent midway flutter of the switch.

In the interests of reliability and easy maintenance I transferred the heavy current loads from the evaporator thermostat contacts to relays, i.e: the thermostat now operates a relay, which in turn operates the compressor clutch and the condenser fan relay. The condenser fan relay is then under control of the mercury switch on the wind flap.

The relays used were the small 30 ampere capacity plug-in types with interlocking socket bases now commonly used in automotive electrics. They were mounted together in a row on a length of flat strip at the front of the engine compartment with others that I had installed to control headlights, driving spotlight, and horn. Thus if any relay unit is doubtful in operation it can be replaced very quickly, or various sections of the system can be isolated by relay removal to make fault finding easy.

Also to further improve relay contact life, diodes were connected across the highly inductive circuits such as the clutch and fan to prevent destructive arcing at the relay contacts. Whether this is a significant factor for reliability is probably questionable, but



the infallible electrical operation of the system for seven years seems to indicate that these measures were not entirely superfluous.

The unit I made up used four sheet steel pieces. Dimensions are not critical, and ingenuity (and experimentation) are the order of the day!

The flap is made from a piece of 1.4 mm sheet steel cut into a square about 100 mm across. You must leave two tabs at one end for the flap to hinge around, so they will have to be bent up at 90 degrees.

These tabs must have a hole big enough to take a piece of iron wire or brass rod of about 1/8-inch diameter. This is carried by the flap yoke. This is a strip with ends bent up to carry the brass rod, and mounting holes to allow attachment of the unit to the car.

It is a good idea to burr the ends of the rod to prevent it coming out. Another good idea is to put brass washers between the yoke and the flap to make sure the two pieces move freely.

The mercury switch is carried on its own metal strip. The one I constructed was bent into a U shape to enclose the switch and then pop-riveted onto the flap so that the switch was oriented at 90 degrees to the flap. The bulb and its leads are insulated from the metal parts by a bit of veroboard stuck on with Silastic.

I used a fourth piece of metal for a flap limiter, to prevent the flap from travelling too far and wiggling around in the slipstream. Doubtless with a bit of ingenuity in either cutting the metal or in location this could be omitted.

A small spring placed between the flap and one of the non-moving parts, and running across the axis of the hinge, provides the system with some hysteresis, by attempting to hold the flap open or closed a little longer than the air pressure would allow.

The wind switch should be mounted high in front of the radiator behind the grille so that the flap hinge is about level with the top of the grille opening. Thus it is in direct path of the wind coming through the radiator grille but not entirely open to the weather.

To be sure that it does work, wire a meter or a lamp from the wind switch into the car so that its operation can be observed. If all is well the switch will operate at about 50 kph and a slight hysteresis will be noticed, ie it will switch at plus or minus a few kph depending on whether accelerating or decelerating. If the hysteresis is more than, say, 5 kph, the chances are that the spring tension on the flap is a bit much and a small adjustment is required.

When you are satisfied that the switch is working OK, it can be wired in as per the diagram, and from then on, you may be sure of efficient operation from your air conditioner for summer driving!

Happy motoring!

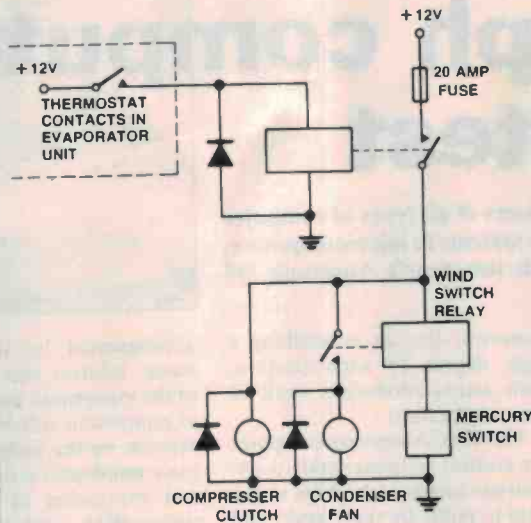

◀ **Wiring it in.** This shows the circuit for connecting the energy saver switch and relay in the air conditioner circuitry. Note the addition of diodes across the various components (see text).

Side view. Showing the flap limiter bracket and mercury switch housing in particular. The tilt of the flap, and consequent spring extension, is shown, too.

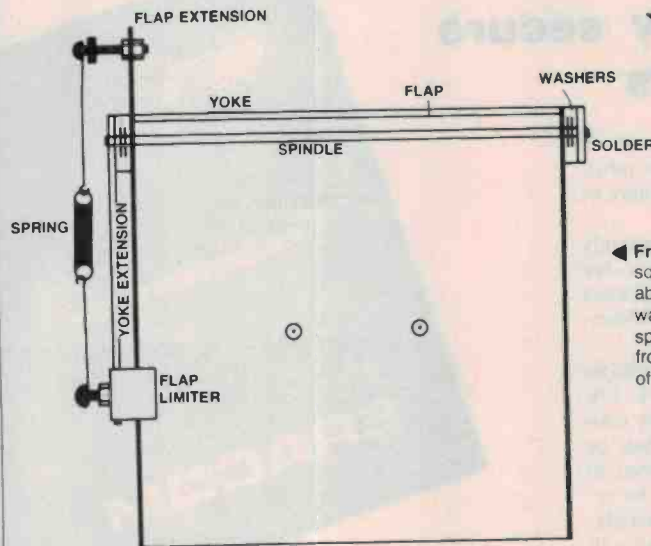
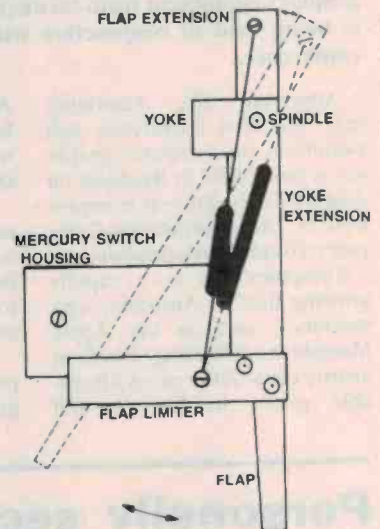

◀ **Front view.** The flap is a square piece of sheet steel about 100 mm a side. Note the washers slipped over the spindle, separating the flap from the yoke. The attachment of the spring is clearly visible.

Top view. Showing the two flap stops on the flap limiter bracket and details of the mercury switch housing.

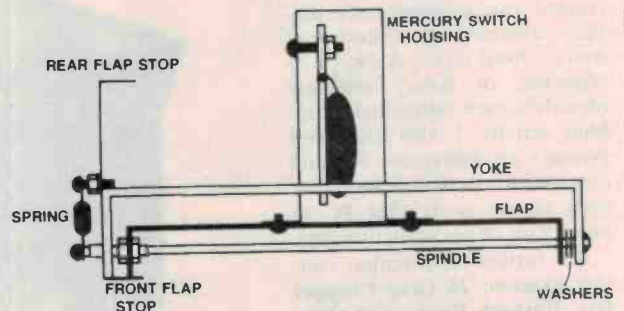

Ausgraph computer art contest

A computer art contest, open to users of all types of computer graphics equipment from turnkey systems to microcomputers, is being held in conjunction with this year's Ausgraph '85 conference.

Ausgraph '85, Australia's only specialist conference and exhibition on computer graphics, is being held in Brisbane on August 12-16, 1985. It is organized by the Australasian Computer Graphics Association.

Computer art is a rapidly growing field in Australia, with machines, such as the Apple Macintosh, providing excellent artistic capabilities at an affordable price. In Europe and

America, the art is reaching a high degree of sophistication, with artists producing work of amazing realism.

The first Ausgraph computer art contest is being held to encourage artists and others in the field to publicize their work, and to further the development of computer art in this country.

Works submitted may be on printout or recorded on photographic media, and should be



accompanied by the entrant's name, address and a statement of the equipment used. The type of equipment will be taken into account by the judges, who will place emphasis on the originality and expression of the overall composition rather than the special effects created by the hardware.

The winning entrant will receive an expenses-paid trip to this year's Ausgraph confer-

ence, although Brisbane entrants may opt for a trip to Ausgraph '86 in Sydney. Other prizes will be awarded at the discretion of the Ausgraph committee, including a \$200 voucher for the best school student entry.

For further information contact the Conference Secretariat, Ausgraph '85, PO Box 29, Parkville, Vic 3052. (03)387-9955.

Personally secure computers

Forget copyright, what about the pilfering of business information with all the nightmare of industrial espionage!

Data security has certainly been a problem in business due to the ease of copying diskettes that could contain any confidential information.

However Eracom Queensland has introduced its new PC Encryptor. The new product consists of an electronic module or 'card' to secure data stored in IBM (or compatible) PCs by activating a set of security installation programs once the card is in place in the computer. The Encryptor can scramble information contained on diskettes as well as fixed disks. A "key" or sequence of binary numbers identifies each individual scrambling activity. It also labels and protects an individual PC and extends to personal keys for each person using that PC to protect his or her particular data.

For further information contact Eracom, 26 Greg Chappel Dve, Burleigh Heads, Qld 4220. (075)56-0911.



Nashua converts computer software

The computer explosion has spawned a multitude of operating systems — all of which work well but cannot talk to one another.

However, the recently-released Australian-designed and manufactured Nashua Data Converter changes that.

This disk-to-disk conversion system emulates the file systems of many of the major computer operating systems including CP/M, CP/M86, PC-DOS, MS-DOS and UNIX.

For example, data files from an NEC APC running on CP/M86 using 8-inch diskettes can be converted to an IBM-PC

using MS-DOS and a 5¼-inch diskette — as a direct transfer without altering the data.

“The Data Converter provides high speed, simultaneous diskette to diskette copies with full verification through the use of specifically written emulation programs. This ensures the destination copy will provide the total reliability that is critical in the distribution of software throughout the user marketplace,” said a Nashua representative.

For further information contact Nashua, PO Box 309, Artarmon, NSW 2064. (02)958-2044.

CLUB CALL

The Melbourne Super-80 Users Group advises that its main group meets at the Heathmont Uniting Church Hall, Canterbury Rd, Heathmont at 7.30 pm on the second Friday of each month; the north-western sub-group at the Broadmeadows High School, Cnr Belfast and Blair Sts, In Room 35 South Wing, at 7.30 pm, fourth Friday each month; the south-eastern sub-group at the Saint Elizabeth School Library, 111 Bakers Road, Dandenong North at 8 pm, first Tuesday of each month.

Artificial intelligence gets closer

Texas Instruments' new Personal Consultant development system enables developers to design programs to help solve problems, by using some of the same techniques used by human experts.

Applications developed with the Personal Consultant package have the capacity to handle uncertain or imprecise data. The use of certainty factors allows the system to determine the state and degree of confidence for a particular conclusion. The TI Personal Consultant system can also explain its line of reasoning; the user can ask why a particular question was asked or how the system reached its conclusions. This allows the user to accept, or have a basis for rejecting the system's recommendations.

Its development tools can be used to prototype and develop applications in diverse areas such as tax and investment counselling, loan analysis and ap-

proval, automotive problem diagnosis, and insurance policy and rate selection.

According to TI Personal Consultant expert systems can co-exist with the MS-DOS compatible business and scientific software products available for the TI desktop and portable professional computers.

The software allows up to 400 production rules on the TI Professional Computer, which specify the actions or steps taken by a program in a particular situation.

TI will be offering the Personal Consultant development package through a specialized direct-sales channel aimed primarily at universities, research organizations, large corporations with internal AI training and development needs, and independent commercial software developers.

For further information contact TI on (02)887-1122.

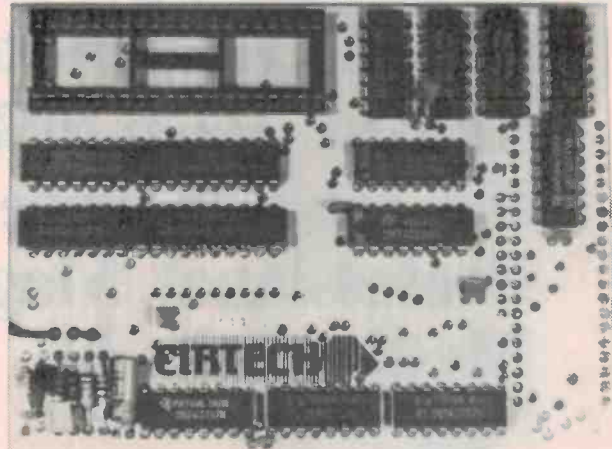

Apple IIc CP/M module

Thinking Systems has announced the national release of its Apple IIc CP/M Module. The dealer-installed CP/M Module fits completely inside the case of the IIc, allowing it to run all standard Apple CP/M software with no modifications, up to 30% faster than most CP/M cards. The module does not affect the normal operation of a IIc as it is only activated when you “boot” a CP/M disk. It operates by “slaving” the Apple to a Z80 microprocessor, thus allowing the direct execution of Z80 or 8080 code. It is also fully compatible with CP/M version 2.23.

Microsoft Cobol

Microsoft has announced the release of Microsoft Cobol (Version 2.0) making it possible for microcomputers to be used in the development of Cobol applications for mainframe computers, and for mainframe computer Cobol applications to be moved to microcomputers. Features of the package include four types of files: sequential, line-sequential, relative, and B+ tree indexed sequential (ISAM); an ISAM file-recovery utility (Rebuild); advanced interactive screen capabilities; file-sharing for multi-user environments; dynamic CALL and CHAIN; and an INSTALL routine, allowing applications to be developed on one type of hardware and run on another.

Graphics Partner for Lotus 1-2-3

A new program distributed by Co-resident Software of Neutral Bay, Sydney, enables a Lotus 1-2-3 user to add symbols, text, special fonts to a graph without exiting Lotus itself. The program is co-resident in memory, having been loaded first. It also has the facility to print the graph without using the normal disk swapping routines. Once the graph is on the screen, pressing a reserved combination of keys activates the Graphics Partner. It is then possible to toggle between the graph and the Graphics Partner menu which has many options such as painting, filling in, drawing circles, loading special fonts and symbols, zooming, printing and saving. It is even possible for a graph to be overlaid by another. For further information contact Co-resident Software, 99 Military Rd, Neutral Bay, 2089 NSW. (02)908-2355.

Commodore management

Introducing the Commodore ‘Manager’, to help organize your cheque book, stamp collection, football team, cricket club or community organisation, investments, Christmas card list, or recipes! An electronic filing cabinet, the Manager does sorting and reorganizing at computer speed with little or no operator intervention.

New 10 megabyte hard disk system makes microbee's 128K Small Business Computer a complete management tool for serious business, scientific and educational applications.



128K SBC single 400K Disk Drive with 10 Megabyte Hard Disk, Monitor and Bundled Software*

\$2995 incl. Tax

128K SBC with dual 400K Disk Drives, Amber Monitor, Bundled Software* and DP100 Dot Matrix Printer (OR DSY120 Daisy Wheel Printer FOR THE SAME PRICE!)

\$2395 incl. Tax

128K SBC with dual 400K Disk Drives, Green Monitor and Bundled Software*

\$1995 incl. Tax

*WOROSTAR/MAILMERGE 3.3 MICROSOFT BASIC AND MULTIPLAN MW BASIC TELCOM COMMUNICATIONS SUPPORT UTILITIES AND MANUALS.



microbee computer

Designed and manufactured
in Australia by
Applied Technology

PHONE ORDERS  ACCEPTED

microbee technology centres

N.S.W.
1 Pattison Ave, Waitara 2077
Phone (02) 487 2711

VIC.
729 Glenferrie Rd, Hawthorn 3122
Phone (03) 819 5288

W.A.
141 Stirling Highway, Nedlands
Phone (09) 386 8289

S.A.
151 Unley Rd, Unley 5061,
Phone (08) 272 1384

QLD
455 Logan Rd, Stones Corner, 4120
Phone (07) 394 3688

FACTORY
Koala Crescent, West Gosford 2250
Phone (043) 24 2711

WRISTWATCH COMPUTER

— the Seiko TUC-2000

The shape of things to come? The central component of this new computer system is a 'wristwatch' which contains a 4-bit microprocessor along with 2K of RAM. It's ultra-portable and smart, but needs more software work to reach full potential.

Jonathan B. Scott

THE TUC-2000 computer seems a touch large on my wrist, but then I am used to a small quartz watch only 6 mm thick, with a white face, hands and Roman numerals. The Seiko is 12 mm thick, 40 mm high and 35 mm wide. Nevertheless, it is the smallest thinking box I have seen.

There are four components available in the series at the moment: the Wrist Module (TUC-2000); the Controller (TUC-2200); a separate Keyboard (TUC-2100); and a ROM Pack which plugs into the controller. The controller provides all the functions of the separate keyboard unit in a larger machine. (It is 3 x 20 x 14 cm, and designed to rest on a desk or be carried in a briefcase.) For this reason I have excluded the keyboard in this review. The only ROM available at the moment is a games ROM which is supplied with the controller.

The controller contains 4K of RAM and 26K of ROM, which expands to 34K when a ROM pack is plugged into it. It also contains a small (20 character) dot matrix thermal printer, a rubber-key QWERTY keyboard, and a flip-up support which is the communication device to connect to the watch module. The watch module itself provides the display, which completes all the requirements for a small computer. Three penlight (AA) cells are expected to give some 300 hours of operation. An ac adapter can also be used, although there is no information indicating what voltage it requires except by implication from the batteries used. Further, the manual has a correction which informs the buyer that the ac adapter is not yet supplied outside America!

The wrist module, as described above, contains 7.5K of ROM (1.5K of character generator) and 2K of RAM. The LCD display has 4 lines of 10 characters, each character being a 7 x 5 dot matrix. Sufficient

alphanumeric and graphics characters are included to allow formation of single, double and quadruple sized numbers, and single and quadruple sized letters and special symbols. The special symbols include aeroplane and telephone ideographs etc, for making concise reminder messages. It also contains the circuitry for non-contact communication with the controller. The front face (it cannot really be called a front panel) is equipped with four press buttons in a row. The wristband is standard.

Like all good inquisitive electronics enthusiasts we opened up the watch module to see what was inside. The single LSI IC is bonded to the pc board and covered with a sealing compound, much like a common digital watch. The battery is a lithium button cell. It is almost the size of my other wristwatch by itself. This accounts for the prediction of 1.5 years of operating life, despite the fact that the watch must transmit to, as well as receive from, the controller. The communication rate is 2K baud, and it is effected by magnetic induction. There is a 3 cm diameter coil in the watch, which forms one half of a transformer (with the counterpart coil in the controller) for data loading and dumping operations. The construction practices are very standard for digital wristwatches.

Operation

The first step in operation is to 'connect' the controller to the watch. This is done by flipping the rest on the controller up, and placing the watch on the rest. Pressing the 'transmit' button on the watch brings about the message "TRANSMIT STAND-BY". Next, turn on the controller and select the operating mode. There are five modes to choose from: Memo A, Memo B, Applications, Basic and Calculator.

Memo modes

The memo mode of the wrist module divides the available RAM up into two areas of 1000 bytes each. These are labelled Memo A and Memo B. When either memo mode is selected on the controller, the watch is programmed for memo operation, and it becomes possible to load the watch with the 1000 bytes of information attached to that memo area. When working with memo A, it is not only possible to enter text into the watch and print it back out onto the printer, but also to back up the memo to the controller or reload a backup to the watch. With Memo B, the backup facility is not available, because RAM is not reserved for that function inside the controller.

The choice of what to do is made menu style. The 'stop' key is the key used to escape to a higher menu level at any time. When in Memo B the menu is only two entries long, offering editing or printing out of the memo. In Memo A, backing up, reloading and a combined backup/print are also offered, giving a five entry menu.

Although the controller's ten function keys are defined for editing (they are never user definable), the editing of the memo space can be quite tedious. For instance, it is not possible to insert a single character early in the memo. Only whole lines can be inserted; this makes correcting minor errors very space wasteful or very tedious. Another way of describing this is that in the memo text area there is no automatic word wrap from one line to another; the only way of eliminating a character is to space over it. This unnecessary crudity could become very annoying after a little while.

When stored in the watch, and with the watch free of the controller, the memo can be viewed using the buttons on the watch. These permit the 100 lines of 10 characters



in each memo to be viewed, though not modified. In effect, the wearer is carrying around 2000 characters of information. This might be phone numbers for example. Because of the formatting constraints this information would be typed in with one line assigned to a name and the next to the number, in order to keep the display sensible. Thus Memo A could hold some 50 names and their associated telephone numbers. Looking through the small book which is crammed in my wallet I find 59 names, some with 2 numbers, but only half of which I probably need with me, so the memory would seem quite adequate for small business use. A further observation: if the data is in a list, such as numbers and names, the line-only editing facilities are most adequate. The neat convenience of this suggests that this is precisely what the original programmer had in mind.

Calculator mode

In the calculator mode the controller operates purely as a four function calculator, with the watch acting as the display. It is a cleverly written routine, as the watch face sets out the problem as one would if doing it longhand:

$$\begin{array}{r} \text{Multiplicand} \\ \times \text{Multiplier} \\ \hline \text{Product} \end{array}$$

Remind you of your schooldays? It looks nice. However, the calculator mode has two very sad omissions. Firstly, there is no way of using the printer at the same time. For accounting functions a printout is very desirable. Secondly, the calculator is four function only. No square roots, no scientific functions. This is very silly, as the routines for doing all that sort of calculation are in-

cluded inside the machine as part of the Basic interpreter ROM. It surely would not have been too hard to incorporate some of those functions that we have come to expect of every calculator costing more than \$10 or so?

Of course, you can execute those sorts of calculations in Basic, as will be seen shortly. You could even write a Basic program that does just what this calculator routine is doing and then include the extra functions that you want. (The Basic is a stripped down version, which would make it tricky, as reading the keyboard for single keystrokes is not supported.) Nevertheless, it cannot help but be noticed that the Seiko man writing the calculator routine was not talking to the rest of the design team effectively — notably the Basic and printer engineers. The result is the beginnings of an elegant facility which is left far short of its potential.

Basic

The Basic mode is 1983 vintage Microsoft, which is pleasing to see. As Basic uses the memory into which Memo A is backed up, the backup must be discarded (not affecting the watch copy of the memo) when entering. In normal mode of operation this gives 1561 bytes free for user use. There is a 'high level' mode, which makes 2922 bytes free, but use of this level means that use of the other functions of the controller, such as memo mode, would destroy the Basic program in memory. It is thus better to make do with the lower limit if possible, so that your memos can be updated and applications run, without losing the Basic program.

The Basic is 8K, and so does not offer much of what the bigger Microsoft Basics do. It is sensibly stripped down, though. It has a command for printing out of Basic

into the Memo B area in the watch, so that you can carry away the results of your sales analysis on your wrist. The editing facility is good (much better than the memo editing!). Multi-dimension arrays are supported, for what that is worth with less than 3K maximum available. Functions may be defined within a program, (DEF FN), but they may not be linked to the 'special' function keys of the keyboard. This is the only machine that I have ever seen which provides *numbered* function keys but does not support them with user definability from within the machine!

The following list of the included commands shows what can be done and what cannot:

Command/Statement	Intrinsic Function
BEEP	ABS
CLEAR	AND
CLS	ASC
CONT	ATN
DATA	CHRS
DEF FN	COS
DIM	CSRLIN
EDIT	EXP
END	FRE
FOR~NEXT	INT
GOSUB~RETURN	LEFT\$
GOTO	LEN
IF~THEN,IF~GOTO	LOG
INPUT	MIDS
LET	NOT
LIST	OR
LLIST	POS
LOCATE	RIGHT\$
LPRINT	RND
MPRINT	SGN
NEW	SIN
ON~GOSUB,ON~GOTO	SPC
PRINT	SQR
READ	STR\$
REM	TAB
RESTORE	TAN
RUN	VAL
STOP	

COMPUTING REVIEW

The important observation that readers familiar with Basic will probably have made by now is that there are no mass storage commands in the list. Unfortunately, this machine does not even allow storage of programs on tape. This is rather disappointing, more so if you have ever had to type in an old 2K long program. So every time you want to do your sales analysis and pump the results out into your watch Memo B area, you get to type the program in first. What you saved on the out, you had to spend on the in! Seiko will have to provide some mass storage facility if they want this machine to go anywhere as a Basic machine.

Application mode

Entering application mode effectively tells the controller to look at the application ROM pack. It responds by presenting the menu, with one entry for each application program found in the 8K of ROM, plus the two intrinsic applications. One of these is the DEMO program, which is basically included for showing off, such as in a shop display. The other is the 'SCHEDULE' program, which will be discussed shortly.

Application programs, with the exception of the DEMO program, seem to be designed to be loaded from the ROM into the wristwatch. (That is to say, there is no mention of ROMs being available for other functions, such as expansion of the Basic to include mass storage, etc.) When a selection is made from the application menu, the corresponding program is loaded into the 2K of RAM in the wristwatch. The ROM pack supplied contains four games which may be played on the wristwatch, once loaded into it.

Neither SCHEDULE nor any of the games from the ROM pack can co-exist in the watch with any memos. Therefore you have to back up Memo A and lose Memo B to get any of the other functions.

The SCHEDULE program allows the watch to contain 20 characters associated with each date for the next month. Thus, instead of scrolling through a memo space,

you have things stored by day, so that you can look up what you are doing on this day or that. There is thus about 620 bytes of data stored, and the rest is program. If this program used the timekeeping facilities of the watch and gave some alarm or daily display of tasks, it would be excellent. Unfortunately, it does not; it is purely data stored in a filing system based on date. At each increment of the date, the program erases that day's message, making the memory available for the day one month ahead. It even does this if the information has not been viewed.

With the clock functions inside the watch, and the large amount of memory, it should have been possible to create a 'SCHEDULE' program which effectively allowed the setting of alarms up to a month ahead, with an alphanumeric label attached to each alarm. Any readers familiar with the operation of the brilliant HP41 Time module will appreciate just how neat and handy such a facility could be on the wrist, instead of in the briefcase. I was most disappointed to see how crude the scheduling program turned out to be.

The games supplied were very amusing, but of course rather limited by the hardware. There are real-time (arcade type) ones, as well as thinking ones. Suffice to say that they are very handy for use on trains and buses to provide some diversion.

Documentation

The controller and watch are supplied with two books, one covering the controller, watch and ROM modes and functions, the other giving a description of the BASIC and a beginners' startup guide to programming. Both of these books are set out just like a set of instructions for using a plain watch, not surprisingly. On the whole the text is readable. I have seen 'instruction' books which were totally undecipherable. This is not at all like that, and provides a neat and complete description of all the facilities available. It tends to be aimed at the sort of person who is practised at reading



concise descriptions, but I observed non-technical friends had no difficulty. Most have had to learn how to drive their new-fangled digital wristwatches, so they were acquainted with the basic style. The Basic book may be inadequate for anyone who has never programmed before, but I have not put this to the test.

Comments and Conclusions

Apart from the shortcomings already mentioned, there is one inadequacy in the controller which will be felt by any computer minded enthusiast: there is *no provision for user-written software to be loaded into the wristwatch*. This means that the great possibilities afforded by 2K of RAM on your wrist cannot be exploited except via the software provided complete by Seiko. As we have already seen, this is rather sparse and unimaginative.

It would not be possible to transfer a Basic program to the watch and have it run, simply because the Basic ROMs are in the controller so the program could not be interpreted. It would be necessary to provide an assembler or similar in a ROM pack.

However, with some simple language or an assembler, a user could write whatever he wanted. I, for instance, would write a program that acted like the watch but with many alarms, all set up to a month or so in advance, and with reminder messages attached to each one. Thus when I make an appointment on Friday for lunch next Tuesday with Tim Brown, to which I must take a certain contract, I enter it with a message. Then next Tuesday at 11.30 when I am in a meeting which has run on, and have forgotten the date, my watch beeps to warn me that I must leave soon, and that I need that contract.

In summary, the TUC-2000 series is a potentially excellent lot of hardware, but has not had its operating system and applications programs as well thought out as it might have. It is already very useful, and it is a gadget of the most avant-garde and eye catching type to boot. If Seiko has some success with the product, they are certain to clean up their software act and issue more useful things in ROM packs. However, whether or not the *current* facilities are worth the few hundreds of dollars required to purchase it is another matter. ●

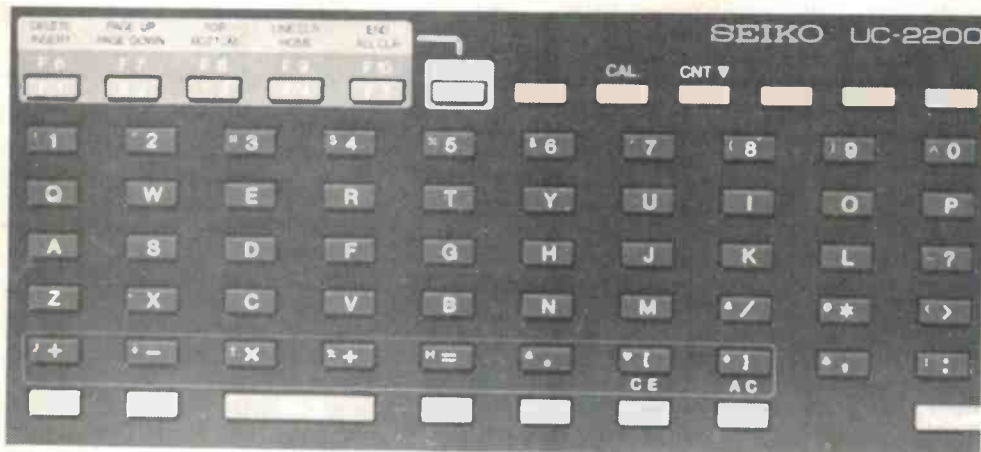

THE MASTER-CARD SYSTEM SOLUTION

THE MASTER-CARD — FEATURES

THE MASTER-CARD is a fully tested and proven Single Board Computer that provides all the necessary requirements for a complete computing system.

THE MASTER-CARD features a 4 Mhz Z80A CPU running CP/M Plus Version 3.0 with 128K of fast dynamic RAM and an 8K Monitor/BIOS Eprom — all standard.

The floppy disk controller handles 3.5", 5.25", 8" and combinations of floppy disk drives. A CRT controller provides an 80 x 24 video display ready for connection to a video monitor.

Parallel keyboards and a Centronics printer are catered for by a Z80 PIO chip while a Z80 SIO provides the two RS232C serial ports.

Other features of **THE MASTER-CARD** include a battery backed real time clock, three spare 28 pin eprom sockets, 16 parallel TTL I/O lines and two expansion slots with Z80 signals.

Using THE MASTER-CARD

THE MASTER-CARD is easy to use. Connect power, drives, keyboard and monitor and the job is done!

Video information from the board is connected via a standard RCA socket while all other signals for peripheral devices are brought out to standard .1 by .1 pitch connectors. Power is connected via a six pin plug on the board.

As with all SME Systems boards and systems, **FULL BIOS SOURCE CODE** is provided on a 5.25" 80 track disk (8" format optional) along with the ready to run CP/M Plus. This allows systems implimentors and hobbyists to tailor their boards to suit a specific task.

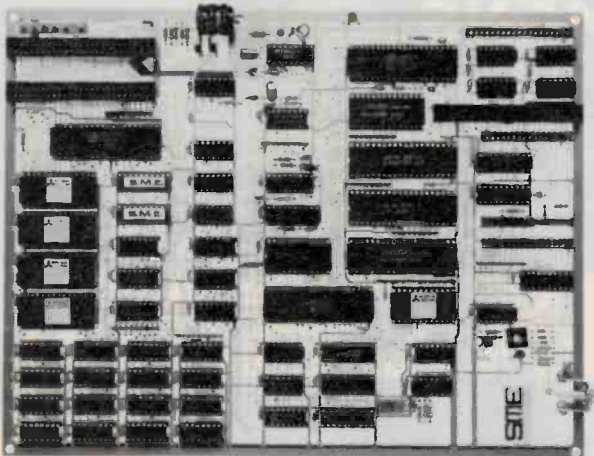

The Master-Card Single Board Computer

The KNIGHT-2002

The **KNIGHT-2002** is a complete ready to use CP/M Plus microcomputer based on the powerful **MASTER-CARD** single board computer.

Features of this machine are its industry standard CP/M Plus, 128K byte memory, dual 1 Mb fast 3 Ms step drives and high quality ergonomic screen and keyboard.

The **KNIGHT** is housed in an attractive grey plastic case with the monitor placed on top and the keyboard located at the front.

KNIGHT-2002 is aimed at the smaller business and advanced hobbyist market where the 1 Mb floppy disks provide enough storage for most normal needs. Software for **KNIGHT** can be chosen from the world wide market since **KNIGHT** uses the industry standard CP/M-80 (Plus) operating system and will run all standard CP/M programs.

Included with **KNIGHT** is the Utilities disk along with a comprehensive operator and technical manual that guides the user through startup, operation and repair of the unit.

The KNIGHT-2026

The **KNIGHT-2026** is an expanded **KNIGHT-2002** with a half height 26 Mb mini Winchester hard disk drive replacing one of the floppy disk drives.

Supplied with this **KNIGHT** are programs to allow backing up data from the hard disk to floppies giving complete data security.

The combination of hard disk and **KNIGHT** features make this computer one of the most powerful and fast computers in its class.

This high capacity unit is primarily designed for the needs of larger businesses where stock, payroll and accounting data far exceed the capabilities of floppy disks.

THE MASTER-CARD

Specifications

CPU.....	Z80 @ 4 Mhz
RAM.....	128 K Dynamic
EPROMS.....	8 K MonBios Eprom
	3 Spare 28 pin sockets
KEYBOARD.....	Parallel Keyboard Port
DISPLAY.....	80 x 24 CRT Display
	Eprom
SERIAL PORTS.....	2 by RS232C Serial
BAUD RATE.....	Software Programmable
PRINTER.....	1 Centronics Printer Port
TTL I/O.....	20 TTL I/O Lines
DISKS.....	8" Floppy Disk Support
	5.25" Floppy Disk Support
	Winchester via add-on card
O.S.....	CP/M Plus version 3.0
CLOCK.....	Real Time, Backed
EXPANSION.....	2 Slots
PCB.....	Resist, Legend, Plated
	Thru Double sided
SIZE.....	215 x 280 (8.5" x 11")
POWER.....	+5v @ 1.2A, +12v - 12v @ 0.1A

KNIGHT-2002 Specifications

* ALL the features of THE MASTER-CARD

KEYBOARD.....	87 keys, Tactile feedback
FUNCTION KEYS.....	Yes, 10 programmable
KEYPAD.....	Numeric + Cursor
ERGONOMIC.....	Yes, low profile with tilt
DISPLAY.....	Separate Green Video Monitor
DISKS.....	2 x 1 Mb DSDD
EXPANSION.....	2 Free slots
SIZE.....	120h x 465w x 430d

KNIGHT-2026 Specifications

* The KNIGHT-2002 plus the following.

DISKS.....	1 x 1 Mb Kb floppy disk 1 x 26 Mb hard disk
EXPANSION.....	1 Free slot

* All disk sizes unformatted

SME
SYSTEMS
THE PROBLEM SOLVERS



SME SYSTEMS PTY. LTD.
Incorporated in Victoria
22 QUEEN STREET, MITCHAM,
VICTORIA, AUSTRALIA 3132
PHONE (03) 874 3666 TELEX AA 37213

	EXEMPT	TAX
MASTER-CARD (with CP/M Plus)	\$ 895.00	\$125.30
KNIGHT-2002 1 + 1 Mb	\$1,995.00	\$279.30
KNIGHT-2026 1 + 26 Mb	\$3,995.00	\$559.30
Video Monitor (Green screen)	\$ 175.00	\$ 24.50
Hard disk interface (#3100)	\$ 175.00	\$ 24.50
Wire wrap card (#3120)	\$ 40.00	\$ 5.60
Utility Disk and manual	\$ 50.00	\$ 7.00

* Prices and Specs. Subject to change without notice.
* Trade Enquiries welcomed.

SIEMENS

64K DRAM IC4164

**NOW
JUST
\$2.99*
EACH!**
While stocks last.



180,000 Components for Peanuts!

Siemens, a world leader in high technology electronic components is even better known for relentless quality control. And now Siemens is offering memory I.C.'s at a lower price.

Both 128 and 256 refresh cycle I.C. memory parts are available immediately.

Each 16 pin dual in line package delivers 180,000 components – mostly transistors and capacitors – in its silicon chip. That's more than 600 components for less than 1 cent!

Siemens Ltd.
544 Church Street, Richmond, Vic. 3121.
Telephone: 420 7318 Sydney 436 8730

Siemens Memory I.C.'s. High quality. New low price.

*Minimum order of 100 + pieces, plus sales tax if applicable.

Cash sales facilities available for non-account customers.

A6/85

CSA 2430/744

KEYBOARD ENCODER

This straightforward design uses common components — no special encoder IC — and features alpha-lock and repeat functions.

Andrew Cousins



THIS KEYBOARD ENCODER uses only seven ICs (six TTLs and one EPROM) and eight transistors. By programming the EPROM with the appropriate data the encoder can be made to match any keyboard, no matter how strange the layout.

When a key is pressed in the matrix, connecting an X and Y line, one of the transistors is turned on, pulling an input to IC4 low. The base current in the transistor is enough to pull an input to IC1 low.

IC1 and IC4 are 8-line to 3-bit binary encoders, i.e.: the output is a 3-bit binary number representing the selected input. The 3-bit output from each encoder is combined into six bits and used as the six low address lines to IC2, the 2716 EPROM. Therefore, each key can select a particular location in a 64-byte block.

To generate the control, shift and alpha-lock characters the address lines A6, A7 and A8 are used to select a particular 64-byte block in IC2. Each block in this EPROM represents a combination of control, shift and alpha-lock. Whatever location is selected, the data appears at the output lines of IC2 and is buffered by IC3.

The shift lock (really an alpha-lock with my PROM) assumes the keyboard has a mechanical lock on this key. However, it should not be difficult to add a flip-flop in a toggle mode for other keyboards.

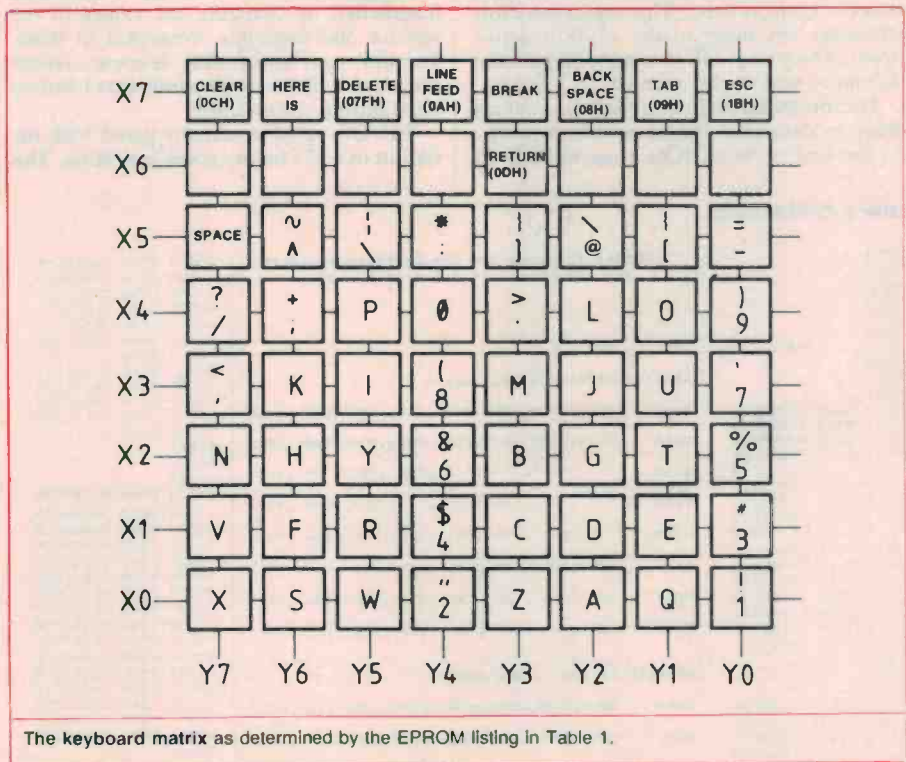

The keyboard matrix as determined by the EPROM listing in Table 1.

```

00043 ;shift=0 ctrl=1 alpha lock=1
00044 :
00045 00C0 0C187F0A byte 00Ch,018h,07Fh,00Ah,018h,008h,009h,018h
00046 00C4 18080918 byte 000h,000h,000h,018h,008h,000h,000h,000h
00047 00C8 00000018 byte * * ,AA* ,\ * ,: * ,] * ,@ * ,[ * ,~
00048 00CC 0B000000 byte /* * ,: ,10h *0* ,* * ,0ch ,0fh ,*9*
00049 00D0 207E7C2A byte * * ,K* ,*I* ,*B* ,*M* ,*J* ,*U* ,*7*
0004A 00D4 7060783D byte *n* ,*h* ,*y* ,*6* ,*b* ,*g* ,*t* ,*5*
0004B 00D8 3F2E5030 byte *v* ,*f* ,*r* ,*4* ,*c* ,*d* ,*e* ,*3*
0004C 00DC 3E4C4F29 byte *x* ,*s* ,*w* ,*2* ,*z* ,*a* ,*o* ,*1*
0004D 00E0 3C484928 byte ;
0004E 00E4 40A5527 ;shift=1 ctrl=0 alpha lock=0
0004F 00E8 4E485926 byte 00Ch,018h,07Fh,00Ah,018h,008h,009h,018h
00050 00EC 42475425 byte 000h,000h,000h,018h,008h,000h,000h,000h
00051 00F0 56465224 byte * * ,AA* ,\ * ,: * ,] * ,@ * ,[ * ,~
00052 00F4 43445223 byte /* * ,: ,10h *0* ,* * ,0ch ,0fh ,*9*
00053 00F8 58535722 byte * * ,K* ,*I* ,*B* ,*M* ,*J* ,*U* ,*7*
00054 00FC 5A415121 byte *n* ,*h* ,*y* ,*6* ,*b* ,*g* ,*t* ,*5*
00055 :
00056 ;shift=1 ctrl=1 alpha lock=1
00057 0100 0C187F0A byte 00Ch,018h,07Fh,00Ah,018h,008h,009h,018h
00058 0104 18080918 byte 000h,000h,000h,018h,008h,000h,000h,000h
00059 0108 00000018 byte * * ,AA* ,\ * ,: * ,] * ,@ * ,[ * ,~
00060 010C 0B000000 byte /* * ,: ,10h *0* ,* * ,0ch ,0fh ,*9*
00061 0110 205E5C3A byte * * ,K* ,*I* ,*B* ,*M* ,*J* ,*U* ,*7*
00062 0114 5D40582D byte *n* ,*h* ,*y* ,*6* ,*b* ,*g* ,*t* ,*5*
00063 0118 2F381030 byte *v* ,*f* ,*r* ,*4* ,*c* ,*d* ,*e* ,*3*
00064 011C 2E0C0F39 byte *x* ,*s* ,*w* ,*2* ,*z* ,*a* ,*o* ,*1*
00065 :
00066 ;shift=1 ctrl=0 alpha lock=1
00067 :
00068 0140 0C187F0A byte 00Ch,018h,07Fh,00Ah,018h,008h,009h,018h
00069 0144 18080918 byte 000h,000h,000h,018h,008h,000h,000h,000h
00070 0148 00000018 byte * * ,AA* ,\ * ,: * ,] * ,@ * ,[ * ,~
00071 014C 0B000000 byte /* * ,: ,10h *0* ,* * ,0ch ,0fh ,*9*
00072 0150 205E5C3A byte * * ,K* ,*I* ,*B* ,*M* ,*J* ,*U* ,*7*
00073 0154 5D40582D byte *n* ,*h* ,*y* ,*6* ,*b* ,*g* ,*t* ,*5*
00074 0158 2F381030 byte *v* ,*f* ,*r* ,*4* ,*c* ,*d* ,*e* ,*3*
00075 015C 2E0C0F39 byte *x* ,*s* ,*w* ,*2* ,*z* ,*a* ,*o* ,*1*
00076 :
00077 ;shift=1 ctrl=1 alpha lock=0
00078 :
00079 ;shift=1 ctrl=1 alpha lock=0
00080 0180 0C187F0A byte 00Ch,018h,07Fh,00Ah,018h,008h,009h,018h
00081 0184 18080918 byte 000h,000h,000h,018h,008h,000h,000h,000h
00082 0188 00000018 byte * * ,AA* ,\ * ,: * ,] * ,@ * ,[ * ,~
00083 018C 0B000000 byte /* * ,: ,10h *0* ,* * ,0ch ,0fh ,*9*
00084 0190 205E5C3A byte * * ,K* ,*I* ,*B* ,*M* ,*J* ,*U* ,*7*
00085 0194 5D40582D byte *n* ,*h* ,*y* ,*6* ,*b* ,*g* ,*t* ,*5*
00086 0198 2F381030 byte *v* ,*f* ,*r* ,*4* ,*c* ,*d* ,*e* ,*3*
00087 019C 2E4C4F39 byte *x* ,*s* ,*w* ,*2* ,*z* ,*a* ,*o* ,*1*
00088 :
00089 ;shift=1 ctrl=1 alpha lock=1
00090 :
00091 01C0 0C187F0A byte 00Ch,018h,07Fh,00Ah,018h,008h,009h,018h
00092 01C4 18080918 byte 000h,000h,000h,018h,008h,000h,000h,000h
00093 01C8 00000018 byte * * ,AA* ,\ * ,: * ,] * ,@ * ,[ * ,~
00094 01CC 0B000000 byte /* * ,: ,10h *0* ,* * ,0ch ,0fh ,*9*
00095 01D0 205E5C3A byte * * ,K* ,*I* ,*B* ,*M* ,*J* ,*U* ,*7*
00096 01D4 5D40582D byte *n* ,*h* ,*y* ,*6* ,*b* ,*g* ,*t* ,*5*
00097 01D8 2F381030 byte *v* ,*f* ,*r* ,*4* ,*c* ,*d* ,*e* ,*3*
00098 01DC 2E4C4F39 byte *x* ,*s* ,*w* ,*2* ,*z* ,*a* ,*o* ,*1*
00099 :
00100 ;shift=1 ctrl=1 alpha lock=0
00101 :
00102 ;shift=1 ctrl=1 alpha lock=0
00103 :
00104 ;shift=1 ctrl=1 alpha lock=0
00105 :
00106 ;shift=1 ctrl=1 alpha lock=0
00107 :
00108 ;shift=1 ctrl=1 alpha lock=0
00109 :
00110 ;shift=1 ctrl=1 alpha lock=0
00111 :
00112 ;shift=1 ctrl=1 alpha lock=0
00113 :
00114 ;shift=1 ctrl=1 alpha lock=0
00115 :
00116 ;shift=1 ctrl=1 alpha lock=0
00117 :
00118 ;shift=1 ctrl=1 alpha lock=0
00119 :
00120 ;shift=1 ctrl=1 alpha lock=0
00121 :
00122 ;shift=1 ctrl=1 alpha lock=0
00123 :
00124 ;shift=1 ctrl=1 alpha lock=0
00125 :
00126 ;shift=1 ctrl=1 alpha lock=0
00127 :
00128 ;shift=1 ctrl=1 alpha lock=0
00129 :
00130 ;shift=1 ctrl=1 alpha lock=0
00131 :
00132 ;shift=1 ctrl=1 alpha lock=0
00133 :
00134 ;shift=1 ctrl=1 alpha lock=0
00135 :
00136 ;shift=1 ctrl=1 alpha lock=0
00137 :
00138 ;shift=1 ctrl=1 alpha lock=0
00139 :
00140 ;shift=1 ctrl=1 alpha lock=0
00141 :
00142 ;shift=1 ctrl=1 alpha lock=0
00143 :
00144 ;shift=1 ctrl=1 alpha lock=0
00145 :
00146 ;shift=1 ctrl=1 alpha lock=0
00147 :
00148 ;shift=1 ctrl=1 alpha lock=0
00149 :
00150 ;shift=1 ctrl=1 alpha lock=0
00151 :
00152 ;shift=1 ctrl=1 alpha lock=0
00153 :
00154 ;shift=1 ctrl=1 alpha lock=0
00155 :
00156 ;shift=1 ctrl=1 alpha lock=0
00157 :
00158 ;shift=1 ctrl=1 alpha lock=0
00159 :
00160 ;shift=1 ctrl=1 alpha lock=0
00161 :
00162 ;shift=1 ctrl=1 alpha lock=0
00163 :
00164 ;shift=1 ctrl=1 alpha lock=0
00165 :
00166 ;shift=1 ctrl=1 alpha lock=0
00167 :
00168 ;shift=1 ctrl=1 alpha lock=0
00169 :
00170 ;shift=1 ctrl=1 alpha lock=0
00171 :
00172 ;shift=1 ctrl=1 alpha lock=0
00173 :
00174 ;shift=1 ctrl=1 alpha lock=0
00175 :
00176 ;shift=1 ctrl=1 alpha lock=0
00177 :
00178 ;shift=1 ctrl=1 alpha lock=0
00179 :
00180 ;shift=1 ctrl=1 alpha lock=0
00181 :
00182 ;shift=1 ctrl=1 alpha lock=0
00183 :
00184 ;shift=1 ctrl=1 alpha lock=0
00185 :
00186 ;shift=1 ctrl=1 alpha lock=0
00187 :
00188 ;shift=1 ctrl=1 alpha lock=0
00189 :
00190 ;shift=1 ctrl=1 alpha lock=0
00191 :
00192 ;shift=1 ctrl=1 alpha lock=0
00193 :
00194 ;shift=1 ctrl=1 alpha lock=0
00195 :
00196 ;shift=1 ctrl=1 alpha lock=0
00197 :
00198 ;shift=1 ctrl=1 alpha lock=0
00199 :
00200 ;shift=1 ctrl=1 alpha lock=0

```

```

00072 0160 2C080938 byte * * ,0bh ,09h ,*8* ,0dh ,0ah ,15h ,*7*
00073 0164 0D0A1537 byte 0eh ,08h ,19h ,*6* ,02h ,07h ,14h ,*5*
00074 0168 0E081936 byte 16h ,06h ,12h ,*4* ,03h ,04h ,05h ,*3*
00075 016C 02071435 byte 18h ,13h ,17h ,*2* ,1ah ,01h ,11h ,*1*
00076 0170 16061234
00077 0174 03040533
00078 0178 16131732
00079 017C 1A011131
00080 :
00081 :
00082 :
00083 :
00084 :
00085 :
00086 :
00087 :
00088 :
00089 :
00090 :
00091 01C0 0C187F0A byte 00Ch,018h,07Fh,00Ah,018h,008h,009h,018h
00092 01C4 18080918 byte 000h,000h,000h,018h,008h,000h,000h,000h
00093 01C8 00000018 byte * * ,AA* ,\ * ,: * ,] * ,@ * ,[ * ,~
00094 01CC 0B000000 byte /* * ,: ,10h *0* ,* * ,0ch ,0fh ,*9*
00095 01D0 205E5C3A byte * * ,K* ,*I* ,*B* ,*M* ,*J* ,*U* ,*7*
00096 01D4 5D40582D byte *n* ,*h* ,*y* ,*6* ,*b* ,*g* ,*t* ,*5*
00097 01D8 2F381030 byte *v* ,*f* ,*r* ,*4* ,*c* ,*d* ,*e* ,*3*
00098 01DC 2E4C4F39 byte *x* ,*s* ,*w* ,*2* ,*z* ,*a* ,*o* ,*1*
00099 :
00100 ;shift=1 ctrl=1 alpha lock=0
00101 :
00102 ;shift=1 ctrl=1 alpha lock=0
00103 :
00104 ;shift=1 ctrl=1 alpha lock=0
00105 :
00106 ;shift=1 ctrl=1 alpha lock=0
00107 :
00108 ;shift=1 ctrl=1 alpha lock=0
00109 :
00110 ;shift=1 ctrl=1 alpha lock=0
00111 :
00112 ;shift=1 ctrl=1 alpha lock=0
00113 :
00114 ;shift=1 ctrl=1 alpha lock=0
00115 :
00116 ;shift=1 ctrl=1 alpha lock=0
00117 :
00118 ;shift=1 ctrl=1 alpha lock=0
00119 :
00120 ;shift=1 ctrl=1 alpha lock=0
00121 :
00122 ;shift=1 ctrl=1 alpha lock=0
00123 :
00124 ;shift=1 ctrl=1 alpha lock=0
00125 :
00126 ;shift=1 ctrl=1 alpha lock=0
00127 :
00128 ;shift=1 ctrl=1 alpha lock=0
00129 :
00130 ;shift=1 ctrl=1 alpha lock=0
00131 :
00132 ;shift=1 ctrl=1 alpha lock=0
00133 :
00134 ;shift=1 ctrl=1 alpha lock=0
00135 :
00136 ;shift=1 ctrl=1 alpha lock=0
00137 :
00138 ;shift=1 ctrl=1 alpha lock=0
00139 :
00140 ;shift=1 ctrl=1 alpha lock=0
00141 :
00142 ;shift=1 ctrl=1 alpha lock=0
00143 :
00144 ;shift=1 ctrl=1 alpha lock=0
00145 :
00146 ;shift=1 ctrl=1 alpha lock=0
00147 :
00148 ;shift=1 ctrl=1 alpha lock=0
00149 :
00150 ;shift=1 ctrl=1 alpha lock=0
00151 :
00152 ;shift=1 ctrl=1 alpha lock=0
00153 :
00154 ;shift=1 ctrl=1 alpha lock=0
00155 :
00156 ;shift=1 ctrl=1 alpha lock=0
00157 :
00158 ;shift=1 ctrl=1 alpha lock=0
00159 :
00160 ;shift=1 ctrl=1 alpha lock=0
00161 :
00162 ;shift=1 ctrl=1 alpha lock=0
00163 :
00164 ;shift=1 ctrl=1 alpha lock=0
00165 :
00166 ;shift=1 ctrl=1 alpha lock=0
00167 :
00168 ;shift=1 ctrl=1 alpha lock=0
00169 :
00170 ;shift=1 ctrl=1 alpha lock=0
00171 :
00172 ;shift=1 ctrl=1 alpha lock=0
00173 :
00174 ;shift=1 ctrl=1 alpha lock=0
00175 :
00176 ;shift=1 ctrl=1 alpha lock=0
00177 :
00178 ;shift=1 ctrl=1 alpha lock=0
00179 :
00180 ;shift=1 ctrl=1 alpha lock=0
00181 :
00182 ;shift=1 ctrl=1 alpha lock=0
00183 :
00184 ;shift=1 ctrl=1 alpha lock=0
00185 :
00186 ;shift=1 ctrl=1 alpha lock=0
00187 :
00188 ;shift=1 ctrl=1 alpha lock=0
00189 :
00190 ;shift=1 ctrl=1 alpha lock=0
00191 :
00192 ;shift=1 ctrl=1 alpha lock=0
00193 :
00194 ;shift=1 ctrl=1 alpha lock=0
00195 :
00196 ;shift=1 ctrl=1 alpha lock=0
00197 :
00198 ;shift=1 ctrl=1 alpha lock=0
00199 :
00200 ;shift=1 ctrl=1 alpha lock=0

```

NOW AVAILABLE IN AUSTRALIA! A LEADING POWERFUL SINGLE BOARD COMPUTER

Slicer—the system that grows with your needs.

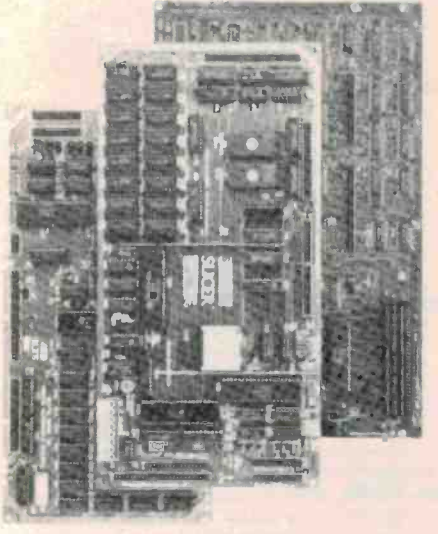

**THE SLICER
Real 16 Bit Power on a Single Board—
Featuring the Intel 80186**

- Complete 8 MHz 16-bit microprocessor on a 6" x 12" board
 - 256K RAM, plus up to 64K EPROM
 - SASI port for hard disk controller
 - Two full function RS232C serial ports with individually programmed transmission rates—50 to 38.4K baud
 - Software compatibility with the 8086 and 8088
 - 8K of EPROM contains drivers for peripherals, commands for hardware checkout and software testing
 - Software supports most types and sizes of disk drives
 - Source for monitor included on disk
 - Bios supports Xebec 1410 and Western Digital WD 1002 SHD controller for hard disks.
- Fully assembled and tested only \$1400. Also available in several kit forms.

**THE SLICER SYSTEM
EXPANSION BOARD
For expanded memory, additional
ports and real time clock**

- Up to 256K additional dynamic RAM
- 2 RS232C asynchronous ports with baud rates to 38.4K for serial communication

- 2 additional serial ports for asynchronous RS232C or synchronous communication (Zilog 8530 SCC)
 - Real Time Clock with battery backup for continuous timekeeping
 - Centronics type parallel printer port.
- Fully assembled and tested only \$1050. Available in several kit forms also.

**THE SLICER PC EXPANSION BOARD
Gives your Slicer high
performance video capability**

- IBM compatible monochrome video
 - Video memory provides 8 pages of text or special graphics capability
 - 2 IBM type card slots for color video, I/O expansion, etc.
 - IBM type keyboard port.
- Fully assembled and tested only \$1200. Available in several kit forms also.

Also available: The Slicer 80188 system. 5 1/4" form factor. Call or write for more information. Operating systems are CP/M 86 by Digital Research, Inc. \$300 and MS DOS by Microsoft Corporation \$300. CCP/M-86 \$450, 8MHz 8087 option \$1600.

Bankcard, MasterCard, Diners Club and American Express. Allow four weeks for delivery. Prices subject to change without notice.

Contact for further details Australian Distributor:

H&H Basicom Systems

221 Eastern Valley Way, Middle Cove, NSW 2068. (P.O. Box 192, Northbridge, NSW 2063) Telex: Y/Money AA71408. Directors: Barrie Hall B.E. (Elec.) Syd. Ian Huntley B.A. Syd. Telephone: (02) 95 3966; (02) 95 4216.

NOTE:
(i) Australian dollar prices quoted as \$1 Aust: 65 cents US exchange rate
(ii) Prices do not include generally applicable 20 per cent sales tax.
(iii) Prices for multiple orders on request.

Turbine

C. Will, Golden Square Vic 3555

Fast moving graphics are generally beyond the capabilities of BASIC. One way of developing real time graphics for the Microbee combines BASIC and Machine Code to obtain fluid motion.

The program appears rather short but it uses about 10K of memory. Most of it is used to store the graphics information. The program creates a turbine in HIRES graphics and stores it in 1K of memory. The turbine is then incremented by 4.4 degrees and stored in the next 1K of memory. This is done nine times. To obtain the illusion of movement, each 1K block is recalled in rapid succession to the screen and PCG RAM.

Four machine code routines are used. The first block moves the first 38 characters from PCG RAM to main memory. The second block moves the centre portion of screen RAM to main memory. The last two routines simply recall this information back to PCG RAM and Screen RAM. The machine code for these routines is stored in the first REM statement so it is vitally important it is typed in exactly as shown in the listing at line No. 1.

Also note that lines 100 to 420 are deleted after the first RUN. The reason for this is that on subsequent RUNS, the memory doesn't need reloading with graphics data so be sure you make a copy to tape before running this program.

PROGRAM DESCRIPTION

Line 0001 : Reserves memory for the machine code
 Lines 0100-0170 : Initialisation page
 Lines 0200-0250 : Pokes machine code into reserved memory
 Lines 0260-0270 : Initialises variables
 Line 0290 : Frame counter
 Line 0300 : Increments next frame by 4.4 degrees
 Lines 0320-0360 : Plots turbine to screen
 Line 0370 : Block moves PCG to main memory
 Line 0380 : Updates memory pointer
 Line 0390 : Block moves screen RAM to main memory
 Line 0400 : Update memory pointer, repeat process for next frame
 Line 0450 : Traps stack overflow. Restarts program
 Lines 0460-0490 : Resets memory pointer, loads PCG & screen RAMs from memory
 Lines 0500-0510 : Determines rotation speed. Detects the ninth frame.

```

00001 REM12345678901234567890123456789012345678901234
00100 REM *** TURBINE - Real Time Graphics Demonstration ***
00110 CLS : CURS 145 : PRINT [A30 42]
00120 CURS 284 : INVERSE : PRINT " TURBINE " : NORMAL
00130 CURS 471 : PRINT "REAL TIME GRAPHICS"
00140 CURS 601 : PRINT "DEMONSTRATION"
00150 CURS 785 : PRINT [A30 42]
00160 CURS 920 : PRINT "By Col Hill 1984"
00170 PLAY 0,50
00180 REM *** INITIALISE ***
00190 HIRES
00200 FOR I=2309 TO 2352 : READ D : POKE I,D : NEXT I
00210 REM *** DATA FOR "USR" ROUTINES ***
00220 DATA 33,0,248,80,89,1,112,2,237,176,201
00230 DATA 17,0,248,96,105,1,112,2,237,176,201
00240 DATA 33,160,241,80,89,1,255,0,237,176,201
00250 DATA 17,160,241,96,105,1,255,0,237,176,201
00260 RESTORE 270 : READ P1,X1,Y1,R1,B1,E1,M
00270 DATA 3.14159,150,110,30,.698,0,4000
00280 REM *** CREATE TURBINE ***
00290 J=J+1 : IF J=10 THEN 410
00300 E1=E1+.08
00310 CURS 327 : PRINT "Loading Frame No. ";J " into memory."
00320 FOR A1=E1 TO 2*M+1 STEP B1
00330 A=INT(.8*R1*COS(A1)+X1) : B=INT(R1*SIN(A1)+Y1)
00340 C=A+30
00350 PLOT A,B TO C,B TO 180,110 TO 150,110 TO A,B
00360 NEXT A1
00370 USR(2309,M)
00380 M=M+700
00390 USR(2331,M)
00400 HIRES : M=M+300 : GOTO 290
00410 CLS : PRINT "Type 'RUN' <CR> for Animation."
00420 DELETE 100,420
00430 CLS : INPUT "Enter speed of rotation (1 - 100) >";S
00440 IF S<1 OR S>100 THEN PLAY 1 : GOTO 430
00450 ON ERROR GOTO 450 : REM Traps Stack Overflow
00460 M=4000 : P=0
00470 CLS : USR(2320,M)
00480 M=M+700
00490 USR(2342,M)
00500 FOR I=1 TO S : NEXT I : M=M+300 : P=P+1
00510 IF P=9 THEN 460 ELSE GOTO 470
    
```

"TURBINE" - Machine Code Routines

USR(2309)- PCG to Memory *Note- Variable M (Memory Pointer) passed into BC.

ADDRESS	OBJECT CODE	MNEMONIC	OPERAND	COMMENTS
0905	2100F8	LD	HL,F800	; Load PCG start address
0908	50	LD	D,B	; (Transfer Memory Pointer
0909	59	LD	E,C	; to DE Register pair)
090A	017002	LD	BC,0270	; No. of bytes to move (38 PCG Chars)
090D	EDB0	LDIR		; Block move
090F	C9	RET		; Return to Basic

USR(2320)- Memory to PCG

ADDRESS	OBJECT CODE	MNEMONIC	OPERAND	COMMENTS
0910	1100F8	LD	DE,F800	; Load PCG start address
0913	60	LD	H,B	; (Transfer Memory Pointer
0914	69	LD	L,C	; to HL Register pair)
0915	017002	LD	BC,0270	; No. of bytes to move
0918	EDB0	LDIR		; Block move
091A	C9	RET		; Return to Basic

USR(2331)- Centre section of Screen RAM to Memory

ADDRESS	OBJECT CODE	MNEMONIC	OPERAND	COMMENTS
091B	21A0F1	LD	HL,F1A0	; Load centre screen start address
091E	50	LD	D,B	; (Transfer Memory Pointer
091F	59	LD	E,C	; to DE Register pair)
0920	01FF00	LD	BC,00FF	; No. of bytes to move
0923	EDB0	LDIR		; Block move
0925	C9	RET		; Return to Basic

USR(2342)- Memory to Centre section of Screen RAM

ADDRESS	OBJECT CODE	MNEMONIC	OPERAND	COMMENTS
0926	11A0F1	LD	DE,F1A0	; Load centre screen start address
0929	60	LD	H,B	; (Transfer Memory Pointer
092A	69	LD	L,C	; to HL Register pair)
092B	01FF00	LD	BC,00FF	; No. of bytes to move
092E	EDB0	LDIR		; Block move
0930	C9	RET		; Return to Basic

Electronic tuning fork

I. B. Crisp, Bayswater Vic. 3153

If you would like to tune up your piano, but you do not have a piano-tuner's ear . . . then a Microbee, CRO and microphone can be the answer. This program not only computes but also generates the necessary frequencies required to tune a piano (or other instrument).

I was prompted to submit this piece of software when I read Tom Moffat's article in the Microbee column in the June '84 issue. I have had this program — in essence — lying around for years, having written and used it to tune my piano. The original however was written entirely in machine code for a different computer. In this re-hash I have used only the waveform generating subroutine as a BASIC USR, and slotted the rest in as an extension to Tom Moffat's BASIC program.

The key is to trigger a CRO timebase with the reference signal from the computer. A microphone placed so that it can "hear" the sound of the strings is connected to the vertical amplifier.

Using this method, a string tuned too high will have its cycles moving to the left on the display, and conversely to the right if low. Tuning is a matter of getting as nearly as possible a stationary pattern.

As shown, the program generates frequencies having perfect fifths and stretched octaves. I have altered the power calculations to slower but more accurate routines. If you would rather have a perfect scale, simply change the value of the number in lines 260 and 270 from 1.059634023 to 1.059463094.

Each frequency is prescaled to the lowest octave of the piano. Thus the trigger frequency always lies approximately within the range 27-55 Hz, and the sweep speed should be set accordingly.

Why prescale to the lowest octave? There are two good reasons: Experience has shown that the CRO display, especially at the high end of the piano is less confusing and therefore less likely to be misinterpreted if the sweep is a low sub-multiple of the piano string frequency. If too high, a near stationary pattern is hard to find as it is moving rapidly even when nearly correct. The other reason is that the accuracy of software generated frequencies is higher the lower we go. The effect of small increments in timing loops increases in direct proportion to the frequency, and while at the low end there is a very fine adjustment, at the top this degrades to a few coarse steps which do not allow accurate setting.

The frequencies as generated are accurate to within .005%, assuming that your computer's crystal is correct. While this may not seem terribly perfect at first glance, it is in fact so close that the worst case error will be about one cycle per minute at A (440 Hz). Prospective piano tuners will find that their own physical accuracy with a tuning key will fall far short of this, no matter how much patience they have!

As for any effect on pitch, rest assured that this has a much smaller error than the wow/flutter variations which we tolerate from even the very best tape and disk players (CD excepted). For comparison, a semitone is about a 6% frequency change.

The octave numbering system has been retained from the original article by Tom Moffat; i.e. the reference A = 440 Hz (the one above middle C) is in octave 0. The other octaves number + and - from this one.

The program as shown will only generate an output for notes within the keyboard range of a normal width piano. It will do the calculations and provide answers over a much wider range — as in the original article. If required the range of frequency generation may be altered by editing values in line 290.

Note also that the value of S1 in line 130 should be made equal to your Z80 clock frequency in MHz. This will make the right correction even if you are using a

```
00100 REM ELECTRONIC TUNING FORK
00110 REM Original calculations by Tom Moffat
00120 REM Frequency generation by Ivan Crisp
00130 S1=2: REM **** S1 is processor speed in MHz. ****
00140 SD10: DIM N1(2,17)
00150 FOR J=1 TO 17
00160 READ N1(1,J),N1*(2,J)
00170 NEXTJ
00180 SD10: INPUT "ENTER A NOTE (C#,Ab,etc.)":A1#
00190 INPUT "WHAT OCTAVE (-1,0,1,etc.)":B1:B1=B1*12
00200 F=0:FOR J=1 TO 17
00210 IF A1#*N1*(2,J) THEN LET B1=B1+N1(1,J):F=1
00220 NEXTJ
00230 IF F=0 THEN PRINT " >>>IMPOSSIBLE NOTE!":GOTO 180
00240 F1=440:IF B1=0 THEN 280
00250 IF B1<0 THEN 270
00260 FOR B2=1 TO B1:F1=F1*1.059634023:NEXTB2:GOTO 280
00270 FOR B2=B1 TO -1:F1=F1/1.059634023:NEXTB2
00280 SDB:PRINT:PRINT " **NOTE FREQUENCY IS":F1;"Hz."
00290 IF F1>3600 OR F1<26 THEN PRINT"Out of range of piano- not being generated."
":PRINT:GOTO 180
00300 DATA -9,"C",-8,"C#",-8,"Db",-7,"D",-6,"D#",-6,"Eb"
00310 DATA -5,"E",-4,"F",-3,"F#",-3,"Gb",-2,"G",-1,"G#"
00320 DATA -1,"Ab",0,"A",1,"A#",1,"BB",2,"B"
00330 IF F1>53 THEN LET F1=F1/2:GOTO 330
00340 T1=1E6/F1*S1/2-99:Z1=T1/21+.1
00350 Z=INT(Z1):Y=INT((Z1-FLT(Z))*5):Z=-Z
00360 DATA 17,0,0,33,238,46,167,237,82,233,0,0,0,0,96,105,30,1,25,210,242,46,219
,2,238,2,211,2,24,226
00370 FOR P=12000 TO 12029:READ M:T=T+M:POKE P,M:NEXTP
00380 IF T+M<>2958 THEN PRINT"DATA ERROR IN LINE 360":END
00390 SD6:PRINT"REFERENCE FREQUENCY":F1;"Hz. NOW BEING OUTPUT"
00400 PRINT"Press RESET to return, then RUN"
00410 POKE 12001,Y:USR(12000,Z)
```

non-standard frequency (such as 4.43 MHz for example).

Output is to the TAPE OUT bit (bit 1) on PIO port B only. It is not audible on the speaker as there is not much point.

Towards the top end of the piano it is possible to get false stationary patterns at incorrect frequencies. This can happen if you get one submultiple higher or lower than the correct pitch. However your ears should then tell you all is not well. If in doubt, first aurally match the string to the octave below and then

start looking for a stationary pattern. With a little practice and awareness this will cease to be a problem.

Use a good solid tuning key and don't be dismayed by the amount of force sometimes required to move tight pegs. If you need to tune the whole piano upwards appreciably, be prepared to replace a broken string or two on the way, and have to repeat the adjustments a few times until the frame settles.

Fine tuning!

CONTRIBUTORS PLEASE NOTE

All contributions to this column should be accompanied by a listing of the program from a printer. Hand written or typed listings are not acceptable.

There are two reasons for this. The first is that a listing from your computer gives us some guarantee that you have got the listing correct.

Secondly, if you present us with a neat final copy of your program we can use photographic techniques to reproduce it in the magazine, without risk of errors.

However, if you present us with a scrawl done on the back of someone's old fag packet it needs to be manually typed twice here, with consequent increase in labour on our part and increase in the probability of errors.

Contributors will be paid \$20 for each item published in this column. Submissions must be original programs which have not been previously published. You may send as many programs as you wish with the accompanying declaration.

"I agree to the above terms and grant *Electronics Today International* all rights to publish my program in ETI Magazine or other publications produced by it. I declare that the attached program is my own original material, that it has not previously been published and that its publication does not violate any other copyright."

* Breach of copyright is now a criminal offence.

Name

Signature Date

Address

Postcode

JAYCAR KITS AUSSIE MADE

PLAYMASTER SERIES II MOSFET AMP KIT

Ref: EA Jan/Feb/March 1985

"...a stereo amplifier that will equal or better just about any integrated commercial amplifier, regardless of price" - Leo Simpson, Editor of EA, February 1985.

MAIN FEATURES OF THE NEW PLAYMASTER

- ★ Switchable phono input for MM and MC cartridges
- ★ Electronic signal switching
- ★ Full facilities for dubbing between two cassette decks
- ★ Monitor loop for either of two cassette decks or a signal processor
- ★ Click action pushbutton switches for selection of sources, dubbing and tape monitor with LED status indicators
- ★ Centre detents on bass, treble and balance controls, multiple detents on volume control
- ★ Heavy duty heatsinks
- ★ Power transformer for low hum and noise
- ★ Easy to build - all parts except power supply mount directly on the two printed circuit boards; wiring has been kept to an absolute minimum
- ★ 100 watts RMS per channel into 8 ohm load
- ★ Less than 0.01% total harmonic distortion

MOTORCYCLE INTERCOM

Ref: EA February 1984

What a great kit! This full duplex unit enables you to talk to your pillion passenger whilst driving with your helmets on! Powered by the bilkes battery - you can both talk at the same time if you wish as there are no switches to activate. The Jaycar kit includes the special headphone inserts and all parts
Cat. KA-1533

ONLY \$39.95



MUSICOLOR IV

Ref: EA August 1981

The ultimate lighting controller. Combines a four channel sound-to-light effect with a four channel chaser.

- Front panel LED display
- 4 different chaser patterns
- Auto and manual reverse chase
- Sound triggered chase
- Inbuilt electret microphone
- Safe, opto-isolated circuitry

ONLY \$99.90

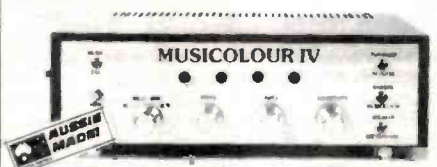

AUSSIE MADE!
NOW IN STOCK
\$399

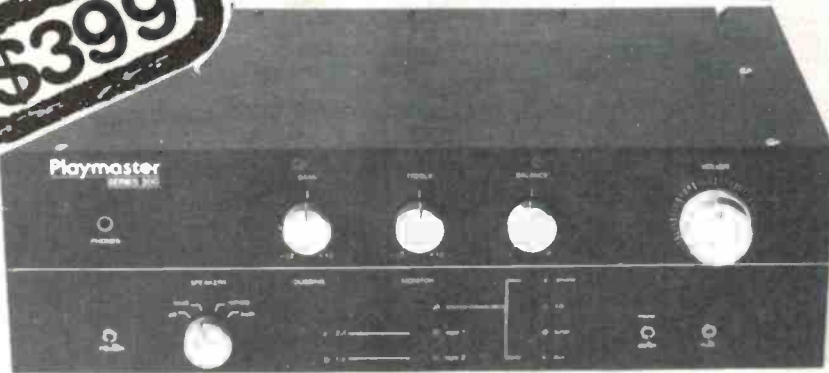

8 SECTOR BURGLAR ALARM

Ref: EA Jan/Feb 1985

Why buy a commercially made up unit for more when you can buy this kit and SAVE money? A unique feature of this kit is the fact that you can wire N/O and N/C alarm sensors ON THE SAME LINE.

★ 8 sectors ★ 2 delayed entry sectors ★ Steel box ★ Includes battery and siren driver in the price ★ Variable exit and entry delays.

Cat. KA-1580

\$139.00

BRAND NEW KIT FROM JAYCAR

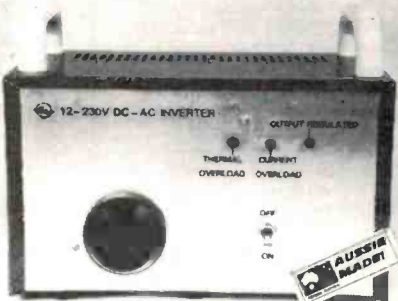

12/230V - 300 WATT INVERTER

This unit provides up to 300VA of power at 235V from an ordinary car battery. It is ideal as a standby AC power supply. The output voltage is regulated and gives a precise 50Hz. The kit also has current limiting with ultimate thermal shutdown.

The Jaycar kit features quality conservatively rated components and is complete down to the case and front panel.

Ref: EA June 1982

Cat. KA 1574

\$195.00



BUSKER AMPLIFIER

Ref: EA February 1985

Fantastic, portable amplifier kit for low-level P.A. Buskers or for practice.

★ Battery or mains operation ★ Full control - bass, treble and volume ★ 2 Inputs (low and high) ★ 17 WATTS RMS output ★ Gel battery automatically recharged when mains used.

★ INTRODUCTORY PRICE ★

All electronics including GEL battery, 8" speaker, metal chassis etc. Cat. KA-1592

ONLY \$125
PRE-CUT WOODEN CABINET to suite Cat. KA-1593

ONLY \$30.00
BUY BOTH AND PAY ONLY
\$149.00
A FURTHER SAVING

EPROM COPIER/PROGRAMMER

Ref: EA December 1984

This unit enables you to program 2716 & 2732 EPROMs and copy 2706, 2716 & 2732 s. It is easy to make and works well. The Jaycar kit includes all PCB components (inc. ZIF sockets) and panel.
Cat. KA-1557



ONLY \$69.00

GREAT NEW KITS FROM ETI Modem Kit

Ref: ETI May 1985

This brilliant new design is a price breakthrough. Never has a modem with such SOPHISTICATED FEATURES been offered at such an incredibly low price. Now you can have no excuse to gain the tremendous benefits that a modem will offer viz:

- ★ Access to huge data banks
- ★ Networking
- ★ Telecommunications
- ★ Electronic shopping
- ★ Software exchange
- ★ And much more

Cat. KE-4695 **ETI 699**

This ETI kit is a full modem with facilities similar to units costing hundreds of dollars more. It even includes a Telecom approved push button telephone. Now is your chance to use your electronic skills in your new hobby and save a fortune over ready built. You can obtain this modem kit (which includes a telephone for us humans) for the incredibly low introductory price of only \$149. That's right! \$149, inc. case, down to the last nut and bolt. But hurry! Stocks of the critical modem chip are very low and will severely limit kit supply.

ONLY \$139

IONISER KITS LESS 20% JUNE ONLY

Complete Kit - High efficiency emitter head - fits completely inside a high quality ABS box (NOT a metal lid) - only 2 core mains flex protrudes from the box.

Cat. KJ-6611 **ONLY \$45**
LESS 20%

Shortform Kit - Runs directly from 240V mains • Low power consumption • Produces high intensity electric field • Output around 7.5kV • Will not necessarily produce Ozone in standard form • Ideal for those who wish to try an ioniser at an economical price.

Cat. KJ-6610 **ONLY \$24.50**
LESS 20%

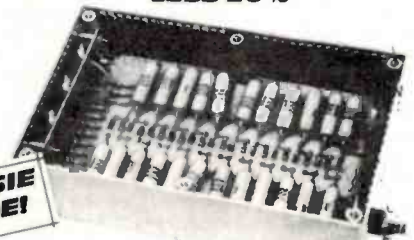

NEW! ETI ECONOMY HOUSE/CAR ALARM MODULE

Ref: ETI May 1985
This low cost full feature module can form the basis of a sophisticated anti theft system!

ETI 1527 Cat. KE-4698 **\$24.95**

- YOU SAVE MONEY! ★ ★ ★

ETI 153 TEMPERATURE PROBE FOR MULTIMETERS - Ref: ETI June 1983

This simple add-on project extends the functions of your multimeter to the measurement of temperature. It is particularly suited to digital multimeters. It can be used to measure temperature over the range from -55°C to +150°C with an accuracy of 0.5°C or better. The Jaycar kit includes the Jiffy case and Scotchpal panel. The AD590 is supplied but not the probe case which is in fact the plastic case of a BIC biro.

Cat. KE-4033 **ONLY \$19.50**

Microwave Leak Detector

Ref: ETI 724 - If you own a microwave oven, your peace of mind is worth the price of this kit. Extremely simple and foolproof to build and use. Gives a positive indication of the security of your oven's seal.

Cat. KE-4013 **ONLY \$14.95**



VOCAL CANCELLER - Ref: EA April 1982

Do you think you can sing? How would you like to be the lead singer in a famous rock (or any) band? You can cancel out the lead singer from almost any stereo record and substitute your own voice or musical instrument. Complete kit including case.

Cat. KA-1430 **ONLY \$19.50**

4164-150ns DRAM 64K x 1 INCREDIBLE SPECIAL SALE

We have made a scoop purchase of National Semiconductor brand-new prime spec 64K DRAM. At the prices shown below we expect many manufacturers to buy so hurry! Quantities naturally are limited. **PLEASE NOTE** that these prices INCLUDE 20% sales tax which the hobbyist MUST PAY so don't be misled by offers that may appear cheaper!

Cat. ZZ-8420

NEW LOWER PRICES

1-9		
\$4.00		
10-24		
\$3.80		
25-99	100-249	250+
\$3.25	\$2.95	\$2.80

3C-2V 75 Ohm COAX - 7 metres??

Seven metres? Well this is a pack of 7 metres of high quality coax cable. Why seven metres is beyond us except that it was thought to be the most asked for length and why not therefore prepack it? The bean counters got their sums wrong because it did not sell! 7 unterminated metres would normally cost \$3.50. Jaycar has a fair quantity of these fairly useful lengths for only \$2.00 which amounts to a substantial saving!



Cat. HP-1360

ONLY \$2.00/7 metres

FREE CATALOGUE

Ask for a FREE COPY of our 1985 Engineering Catalogue or send large SAE with 50¢ stamp.

"RAILMASTER" Pulse-Power Train Controller

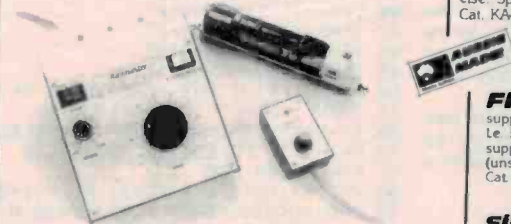

Ref: EA September 1984

"We feel that it is the best controller available, regardless of cost" - John Clarke or Leo Simpson (or both) Sept. '84 This is a state-of-the-art train controller offering tremendous features. • Variable simulated inertia • Full short circuit protection including both audible and visual indicators • Power and track monitor indicators • Adequate power for double and triple heading of locos • Fixed 12V DC and 15V AC power for lighting and accessories • Optional walk-around throttle. The Jaycar kit includes realistic Scotchpal front panel and the special console case only available from us. The large paddle switches have been specially imported just for this kit. We believe that you will be delighted with this unit.

Cat. KA-1560 **ONLY \$79.95**



Optional Walk-around controller

Cat. KA-1559

ONLY \$9.95

Diesel Sound Simulator

Ref: EA November 1984

This project mounts inside a model train (ie goods wagon) and produces a noise similar to a diesel locomotive. The speed varies according to the throttle action for added realism. All parts supplied.

Cat. KA-1561 **ONLY \$19.95**

Steam Sound Simulator

Ref: EA December 1984

Build this realistic steam sound simulator for your model train layout. It features an Infra-Red optical switch to synchronise the 'chuffs' to the wheel rotation. Like the KA-1561 this unit picks up its power from the railway tracks. All specified components supplied including 32 ohm headphone type transducer.

Cat. KA-1562 **ONLY \$15.95**

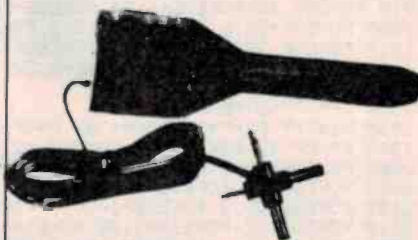

JUNE SPECIAL!! Electronic Crossover Kit

(Ref. EA November 1984)

NEW SHORT FORM KIT!

You can NOW build this desirable project for a lot less! There have been requests for a version of this kit that can be built into other equipment. This is it! The kit contains PCB and all board components etc. The box (inc. front panel) and selector switches are not supplied but everything else! Special price for June only.

Cat. KA-1571

ONLY \$79.00

SQUEAKY CLEAN MAINS

FILTERS - Two fantastic low cost models MS-4010 will supply up to 4 appliances. Each 240V socket is isolated from the other. Le interference from disc drives is decoupled from the CPU power supply etc. It will supply up to 4 outlets with a total load of 6 amps (unswitched).

Cat. MS-4010

ONLY \$125.00

Single 10 amp line socket type Filter (unswitched).

Cat. MS-4012

ONLY \$34.95

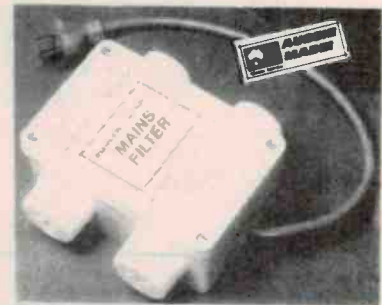

TWO PLUGPACK AND DC CONVERTOR BARGAINS! Plug Pack

This unit will give a DC output of 1 1/2, 3 or 4 1/2 V @ 250mA (max). A switch on the back of the unit changes the voltage. It is also supplied with a 1.6m cord, polarity reversing plug and multiway connecting plug. We have over 500 of them. This voltage range is fairly useless except for small transistor radios, calculators etc. At this price however, it's worth having one or two for the inevitable occasion when such a power source is required.

Cat. MP-3002

ONLY \$2.95

You could pay over \$10 elsewhere!



DC Converter This unit plugs into your car cigarette lighter socket and will provide up to 300mA at 6 and 9V DC. Ideal to power the Ghetto Blaster in your car! We only have just over 200 so hurry!

Cat. MP-3015

Normally sell for around \$10. This month \$4.95 - 1/2 price!!

Jaycar ELECTRONICS

Incorporating ELECTRONIC AGENCIES

NUMBER 1 FOR KITS

MAIL ORDER HOTLINE (02) 646 1300

N.S.W. SHOWROOMS
 SYDNEY 117 York Street Tel: (02) 267 1614
 CARLINGFORD: Cnr. Carlingford & Pennant Hills Road Tel: (02) 872 4444
 CONCORD: 115/117 Parramatta Road Tel: (02) 745 3077
 HURSTVILLE: 121 Forest Road Tel: (02) 570 7000
 GORE HILL: 188/192 Pacific Highway (Cnr Bellevue Avenue) 439 4799

QUEENSLAND BURANDA: 144 Logan Road Tel: (07) 393 0777
MAIL ORDERS: P.O. Box 480, AUBURN 2144. Tel: (02) 643 2000
HEAD OFFICE: 7/9 Rawson Street, AUBURN 2144.
 Tel: (02) 643 2000 Telex: 72293

SHOP HOURS

Carlingford, Hurstville & Gore Hill
 Mon-Fri: 9am - 5:30pm, Thurs 8:30pm, Sat 12pm
 Sydney
 Mon-Fri: 8:30am - 5:30pm, Thurs 8:30pm, Sat 4pm
 Concord
 Mon-Fri: 9am - 5:30pm, Sat 4pm

POST & PACKING

\$5 - \$9.99 \$1.50
 \$10 - \$24.99 \$3.20
 \$25 - \$49.99 \$4.50
 \$50 - \$99.99 \$6.50
 \$100 - \$199 \$8.00
 Over \$199 \$10.00



MAIL ORDER VIA YOUR PHONE



COMET ROAD FREIGHT ANYWHERE IN AUSTRALIA ONLY \$12

COMPUTER DERBY

K. Vonhoff, Toowoomba Qld

The program requires 3K extra memory (Super Expander etc.) and has facilities for betting amounts, number of bets and horse number. Lifelike animated graphics and random movements ensure an exciting and different race each time.

After each race has been run a print-out on the screen displays total betting pool (minus 10% for the house — TAB eat your heart out), the dividend payable for each winning bet and the winning horse number.

While there are only five horses, it is more than enough to empty your piggy bank at a fast rate. So open your tinnies, place your bets and get set for a great day at the track.

VIC-20

CONTRIBUTORS PLEASE NOTE

All contributions to this column should be accompanied by a listing of the program from a printer. Hand written or typed listings are not acceptable.

There are two reasons for this. The first is that a listing from your computer gives us some guarantee that you have got the listing correct.

Secondly, if you present us with a neat final copy of your program we can use photographic techniques to reproduce it in the magazine, without risk of errors.

However, if you present us with a scrawl done on the back of someone's old fag packet it needs to be manually typed twice here, with consequent increase in labour on our part and increase in the probability of errors.

Contributors will be paid \$20 for each item published in this column. Submissions must be original programs which have not been previously published. You may send as many programs as you wish with the accompanying declaration.

"I agree to the above terms and grant *Electronics Today International* all rights to publish my program in ETI Magazine or other publications produced by it. I declare that the attached program is my own original material, that it has not previously been published and that its publication does not violate any other copyright."

* Breach of copyright is now a criminal offence.

Name

Signature Date

Address

Postcode

```

10 PRINT"Q":POKE36879,30:H1=0:H2=0:H3=0:H4=0:H5=0:BS=0
15 PRINT"BETTING VALUE?"
20 INPUT"CENTS";C
25 PRINT:PRINT:PRINT
30 INPUT"NUMBER OF BETS?";BT
35 BS=BS+BT
36 PRINT:PRINT
40 INPUT"HORSE NUMBER?";HS
45 IFHS=1THENH1=H1+BT
46 IFHS=2THENH2=H2+BT
47 IFHS=3THENH3=H3+BT
48 IFHS=4THENH4=H4+BT
49 IFHS=5THENH5=H5+BT
50 PRINT:PRINT"ANY MORE BETS? Y=YES"
55 INPUT YN$
60 IFYN$="Y"THENPRINT"Q":PRINT"BETTING VALUE="C:PRINT:GOTO300
95 PRINT"Q":POKE52,28:POKE56,28
97 POKE36869,255
98 FORI=7168TO7679:POKEI,PEEK(I+25600):NEXT
99 FORI=0TO95:READA:POKEI+7432,A:NEXT
100 DATA0,0,0,0,0,1,2
105 DATA0,0,0,96,224,96,224,224
110 DATA1,63,127,207,28,41,70,32
115 DATA224,252,251,248,56,41,70,32
120 DATA0,0,0,0,1,0,1,10
125 DATA0,0,0,192,192,192,224,224
130 DATA29,63,111,15,28,40,72,132
135 DATA224,252,250,249,56,72,136,68
140 DATA0,0,0,0,255,255,255,255
145 DATA60,60,60,60,60,60,60,60
150 DATA7,7,7,7,7,7,7,7
155 DATA0,0,0,0,0,0,0,0
500 PRINT"Q":POKE36879,121:CO=30720:VC=1
510 SC=7810:SB=7854:SD=7898:SE=7942:SF=7986
520 P=7747
530 FORI=7724TO7745:POKEI,41:NEXT
531 FORI=8032TO8053:POKEI,41:NEXT
535 POKE36878,15:
536 READG:IFG=-1THEN570
537 READG1:READG2
538 POKE36875,0:POKE36876,01
539 FORN=1TO02:NEXTN:POKE36875,0:POKE36876,0
540 FORN=1TO20:NEXTN:GOTO536
570 POKE36875,0:POKE36876,0:GOTO599
575 DATA195,195,3,50,209,209,3,50,225,225,3,50,225,225,3,50,225,225,3,50
576 DATA219,219,3,50,219,219,3,50,219,219,3,50,209,209,3,50
577 DATA219,219,3,50,209,209,3,50,195,195,3,1000
578 DATA-1
599 T1$="000000"
600 POKESC+CO,0:POKESC+1+CO,2:POKESC+22+CO,0:POKESC+23+CO,0
610 POKESC,33:POKESC+1,34:POKESC+22,35:POKESC+23,36
620 POKE36878,VC:NT=INT(RND(1)*20)+130:POKE36877,NT
630 VC=VC+.1
640 IFVC>14THENVC=13
700 POKESB+CO,2:POKESB+1+CO,2:POKESB+22+CO,2:POKESB+23+CO,2
710 POKESB,33:POKESB+1,34:POKESB+22,35:POKESB+23,36
800 POKESD+CO,1:POKESD+1+CO,3:POKESD+22+CO,1:POKESD+23+CO,1
810 POKESD,33:POKESD+1,34:POKESD+22,35:POKESD+23,36
900 POKESE+CO,0:POKESE+1+CO,0:POKESE+22+CO,0:POKESE+23+CO,0
910 POKESE,33:POKESE+1,34:POKESE+22,35:POKESE+23,36
1000 POKESF+CO,2:POKESF+1+CO,2:POKESF+22+CO,2:POKESF+23+CO,2
1010 POKESF,33:POKESF+1,34:POKESF+22,35:POKESF+23,36
1490 POKEP,32:POKEP1,32:POKEP2,32:POKEP3,32:POKEP4,32:POKEP5,32
1520 P=P+1
1530 IFP>7753THENP=7747
1535 P1=P+7:P2=P+14:P3=P+308:P4=P+315:P5=P+322
1540 POKEP,42:POKEP1,42:POKEP2,42:POKEP3,42:POKEP4,42:POKEP5,42
2000 POKESC+CO,0:POKESC+1+CO,2:POKESC+22+CO,0:POKESC+23+CO,0
2010 POKESC,37:POKESC+1,38:POKESC+22,39:POKESC+23,40
2100 POKESB+CO,2:POKESB+1+CO,2:POKESB+22+CO,2:POKESB+23+CO,2
2110 POKESB,37:POKESB+1,38:POKESB+22,39:POKESB+23,40
2200 POKESD+CO,1:POKESD+1+CO,3:POKESD+22+CO,1:POKESD+23+CO,1
2210 POKESD,37:POKESD+1,38:POKESD+22,39:POKESD+23,40
2300 POKESE+CO,0:POKESE+1+CO,0:POKESE+22+CO,0:POKESE+23+CO,0
2310 POKESE,37:POKESE+1,38:POKESE+22,39:POKESE+23,40
2400 POKESF+CO,2:POKESF+1+CO,2:POKESF+22+CO,2:POKESF+23+CO,2
2410 POKESF,37:POKESF+1,38:POKESF+22,39:POKESF+23,40
2500 IFSC=7791THENHW=H1:WH=1:GOTO6000
2510 IFSB=7835THENHW=H2:WH=2:GOTO6000
2520 IFSD=7879THENHW=H3:WH=3:GOTO6000
2530 IFSE=7923THENHW=H4:WH=4:GOTO6000
2540 IFSF=7967THENHW=H5:WH=5:GOTO6000
3000 M=INT(RND(1)*9)
3010 IFM=0THENPOKESC,32:POKESC+1,32:POKESC+22,32:POKESC+23,32:SC=SC-1
    
```



```

3015 IFM=2THENPOKESB,32:POKESB+1,32:POKESB+22,32:POKESB+23,32:SB=SB-1
3020 IFM=4THENPOKESD,32:POKESD+1,32:POKESD+22,32:POKESD+23,32:SD=SD-1
3025 IFM=8THENPOKESE,32:POKESE+1,32:POKESE+22,32:POKESE+23,32:SE=SE-1
3030 IFM=6THENPOKESF,32:POKESF+1,32:POKESF+22,32:POKESF+23,32:SF=SF-1
5000 GOTO600
6000 FORI=7746T08010STEP22:POKEI,43:NEXT:PRINT"5"TIME="T1$
6001 FORI=15T00STEP-.05:POKE36878,I:NEXT
6002 POKE36877,0:POKE36878,0
6020 FORI=1T02000:NEXT
6021 GOSUB6500
6030 GETG$:IFG$<>"Y"ANDIG$<>"N"THEN6030
6040 IFG$="Y"THENPRINT"J":FORI=1T01000:NEXT:RUN10
6050 PRINT"J":END
6500 WN=INT(C*BS-(C*BS)/10)
6501 POKE36869,240
6505 PRINT"J":PRINT:PRINT"PRIZE-POOL="WN
6509 IFHW=0THENPRINT"NO DIVIDEND":GOTO6521
6510 DE=INT(WN/HW)
6520 PRINT:PRINT"DIVIDEND  "DE:PRINT" CENTS"
6521 PRINT:PRINT"WINNER WAS HORSE NO"HW
6522 PRINT:PRINT:PRINT"TO ENTER BETS FOR NEXTRACE PRESS KEY Y"
6525 RETURN

```

DEC-HEX

P. Owen, Busselton, WA 6280

This is a simple program for converting dec to hex. It is useful when you are planning a machine code program on paper and you need to find the memory space 543 spaces past the start of the program (543 was merely the number my internal random number generator picked out). It can work out any number between 0 (0000) and 36565 (FFFF).

```

10 REM DECIMAL TO HEX CONVERSION
20 INPUT "DECIMAL NUMBER";N:N=N+1
30 FORQ=3T00STEP-1
40 FORW=0T015
50 IFN>W*1610THENNEXTW
55 N=N-(W-1)*1610
60 FORE=0TOW-1
70 READX$
80 NEXTE
90 N$=N$+X$
100 RESTORE
110 NEXTQ
120 PRINT"HEX="N$
130 DATA "0","1","2","3","4","5",
"6","7","8","9","A","B","C",
"D","E","F"

```

VIC-20

BUDGET PLAN

Gordon Masters, Pearce, ACT 2607

This program manipulates data in the data statements at lines 70 onwards to present a budget sketch of recurrent household payments. The program fits into an unexpanded Vic with 46 such data statements. Although heavily crunched, a semblance of ordered structure remains in the program.

Line 1 sets the screen, dimensions arrays and sets ND at one less than the number of the data sets to be manipulated.

Lines 3-7 and 16-18 are subroutines.

Lines 10-15 are the main loop displaying a menu.

Lines 20-27 are a subroutine which asks for a month to be selected, prints a heading and the items associated with that month, totals the month's budget and waits for a key-press to return to the menu.

Lines 30-38 do the same for a two-month period, but omit the due day for the second month, so that these items can be distinguished easily.

Lines 40-49 do the same for a quarter, and lines 50-58 give an annual survey. The fortnightly budget figure cheats a little to allow for a spare couple of fortnights for a holiday, a pure extravagance or a calamity. The figure in the carry column shows how much should be in hand at the end of the month to allow for the planned expenditure.

The data statements from line 70 onwards are in the strict format day, month, reason, dollars. I allowed one line per item; it makes for easier amendments.

```

1 POKE36879,25:DIMMO$(11),T(11),C(12):ND=4:GOTO10
3 D$=RIGHT$(" "+STR$(D),4):RETURN
5 PRINT"#####BUDGET PLAN#####":RESTORE:FORI=0T011:READMO$(I):
NEXT:RETURN
7 PRINT"##### ANY KEY TO GO ON":POKE198,0:WAIT198,1:POKE198,
0:RETURN
10 GOSUB5:PRINT"#####MENU#####":SPC(55)"1. THIS MONTH SPC(31)"2. THIS MONTH & NEX
T"
13 PRINT"3. NEXT QUARTER SPC(20)"4. ANNUAL SURVEY"
14 PRINT"#####SELECT NUMBER":GETA$:A=VAL(A$):IFAC(10RA)4THEN14
15 ONAGOSUB20,30,40,50:GOTO10
16 M=INT(M-1):T=0:IFM<0ORM>11THENPRINTSPC(68)"IMPROPER MONTH":GOSUB7:RUN
18 GOSUB5:RETURN
20 GOSUB5:INPUT"WHICH MONTH":M:GOSUB16:PRINT" "M0$(M):PRINT
21 FORE=0TOND:READA,B,C$,D:IFB=1<MTHEN26
24 GOSUB3:PRINTRIGHT$(STR$(A),2)TAB(3)LEFT$(C$,14)TAB(17)D$:T=T+D
26 NEXT
27 D=T:GOSUB5:PRINTTAB(17)"#####":PRINT"TOTAL"TAB(17)D$:GOSUB7:RETURN
30 GOSUB5:INPUT"FIRST MONTH":M:GOSUB16:M2=M+1:IFM=11THENM2=0
32 PRINT" "M0$(M)"&M0$(M2):PRINT:FORE=0TOND:READA,B,C$,D:IFB=1=M2THEN37
34 IFB=1<MTHEN38
36 PRINTRIGHT$(STR$(A),2);
37 GOSUB3:PRINTTAB(3)LEFT$(C$,14)TAB(17)D$:T=T+D
38 NEXT:GOSUB27:RETURN
40 GOSUB5:INPUT"FIRST MONTH":M:GOSUB16:M2=M+1:M3=M+2:IFM=10THENM3=0
42 IFM=11THENM2=0:M3=1
43 PRINT" "M0$(M)"&M0$(M2)"&M0$(M3):PRINT:FORE=0TOND:READA,B,C$,D:IFB=1=
M3THEN47
45 IFB=1=M2THEN47
46 IFB=1<MTHEN49
47 GOSUB5:T=T+D:PRINTM0$(B-1)TAB(4)LEFT$(C$,13)TAB(17)D$
49 NEXT:GOSUB27:RETURN
50 GOSUB5:PRINT"#####ANNUAL SURVEY#####":T=0:FORE=0TOND:READA,B,C$,D:M=B-1:T(N)=T(M
)+D:NEXT
51 PRINT"#####":TAB(8)"CARRY"TAB(18)"PAY"
52 FORM=0T011:T=T+T(M):NEXT:FORM=0T011:MP=M-1:IFM=0THENMP=12
54 C(M)=C(MP)+2*INT(T/24)+2-T(M):IFC(M)<C(12)THENC(12)=C(M)
55 NEXT:FORM=0T011:D=C(M)-C(12):GOSUB3:PRINTM0$(M)TAB(8)D$:
56 D=T(M):GOSUB5:PRINTTAB(17)D$:T(M)=0:NEXT:GOSUB27
58 PRINT"TT":PRINT"FORTNIGHTLY PAY ";INT(T/24)+1:GOSUB7:RETURN
69 DATAJAN,FEB,MAR,APR,MAY,JUN,JUL,AUG,SEP,OCT,NOV,DEC
70 DATA0,1,HOLIDAY EXTRAS,000
73 DATA5,2,GORDON BDAY,30
76 DATA8,5,PHONE BILL,70
100 DATA1,7,NRMA SUBS,25
106 DATA25,12,CHRISTMAS PRESENTS,350

```

VIC-20



Disco World Pty. Ltd.

300 Main Street, Lilydale
P.O. Box 509, Lilydale 3140
(03) 735-0588

AMPLIFIERS

ZPE Series II (500W) \$1300.00

DISCO MIXERS

Citronic SM 330 \$695.00

Arista \$330.00

JUMBO STROBE

FLA 701 \$153.48

Scanner S101 \$99.45

Scanner Bar S104S \$342.86

HELICOPTER

2 ARM Spinner \$198.00

4 ARM Spinner \$289.00

8 ARM Spinner \$497.89

UFO 324 \$1698.55



PINSPOT

PS 112S \$48.94

PS 112L \$58.99

MIRROR BALLS

MB 008-8" \$37.20

MB 012 \$64.58

MB 014 \$93.54

MB 018 \$125.34

MB 020 \$153.79

SMOKE MACHINE

Great for Special Effects
\$328.00

MIRROR BALL MOTORS

AC 240V \$29.99

ROLLING LIGHTS

8 x 4515 lamps \$958.95

24 lamps horizontal \$1985.45

24 lamps vertical \$1985.45



COSMOS LIGHT

24 lamps \$1980.68

Half Ball rotary light

6 lamps \$357.28

LAMPS all colours, soft glass

ES 240V 60W
box of 25 \$75.00

BC 240V 40W
box of 100 \$77.00

BC 240V 25W
box of 100 \$75.00

Bankcard & Mail Orders. Power Cords
not included. Trade Enquiries Welcome.
Send S.A.E. for free price list.

FEDERAL MARKETING BOOK SALES

Special Publications from Electronics Today

Circuits Bookbook #5 E0075E
More than 200 circuit and design ideas covering Alarms, Converters, Electronic Music, Games, Test Equipment and 18 other topics for engineers, technicians, students and hobbyists. \$3.95

Radio Experimenter's Handbook N0418E
Over 130 pages chock-full of circuits, projects to build, antennas to erect, hints and tips. This handbook covers the field from DX listening to building radioteletype gear, from twilight zone DX to VHF power amplifiers, from building a radio FAX picture decoder to designing loaded and trap dipoles. \$7.95

Australian Scanner's World N0283E
There's a whole world beyond 'the shortwaves' — The communications channels. This is an introduction to that world with articles on scanning and scanners, how to build and erect suitable antennas, and a computer-sorted listing of services throughout Australia and NZ; beacons are also listed. Includes a roundup of scanners, antennas and accessories. \$5.95

Electronic Projects for Cars D0216E
Selected projects detail a car alarm, reversing alarm, fuel monitor, thermatic fan controller, twin-range tach, expanded-scale ammeter and many more. Includes ideas for experimenters. \$4.95

Electronics — It's Easy Vol. 1 A0001E
Electronics — It's Easy Vol. 2 A0002E
Written for the intelligent layman as an introduction to electronics theory and methods. Volume 1 discusses electronics systems in general: What they do, how they do it, and how a complex electronic system can be broken down into fundamentals. Volume 2 introduces digital system theory and discusses the practical application to digital instruments, computers and peripherals, and oscilloscopes. \$5.95 ea.

Electronics & Music G0125E
Explains the application of electronics to music reproduction. Articles cover the reinforcing of acoustic instruments, multitrack recording, graphic equalisers and microphone placement techniques plus other topics as well as an effects handbook. Includes seven selected projects. \$5.95

How to Build Gold and Treasure Detectors C0033E
Tells you how metal detectors work and how to construct the different types of detectors: discriminating, BFO, induction-balance and a professional deep-seeking unit. \$3.95

Computer Projects Vol. 1 J0278E
Will let you construct ETI's Little Big Board Computer, an all-year clock for microcomputers, a direct-connect modem, a PPI-based EPROM programmer, a cheap menu-driven expansion for the Microbee and many other projects. \$6.50

Microbee Hacker's Handbook J0291E
Will tell you how to get more from the Bee's graphics capabilities, set up for telecommunications, play music, build a joystick and light pen, get cheap hard copy, expand your 16K Bee to 32K, and more. Also lists contacts for all known Microbee user groups. \$6.50

ETI Circuit Techniques Vol. 1 E0076E
ETI Circuit Techniques Vol. 2 D0077E
The how, what, which, where and how much anthology of electronic components, circuits and techniques. Volume 1 covers op-amps, 555 timer applications, CMOS, VFETs, power MOSFETs, designing with diodes and more. Volume 2 covers remote control systems, experimenting with ultrasonics, transistor arrays, junction FETs and more plus a 16-page circuit source guide. \$4.95 ea.

Lab Notes and Data B0422E
A useful source of circuit design ideas covering transistor arrays, logic troubleshooting, using solar cells, loudspeaker design, electrostatic discharge and 20 other topics. Includes an explanation of the terms and abbreviations used in semiconductor device data sheets plus 26 selected data sheets on op-amps, voltage regulators, npn and pnp semiconductors, LED displays, power transistors, and other devices. \$7.95

Top Projects Vol. 10 D0412E
Twenty-five of the best projects from ETI: Solid state electronic switches, Video enhancer, Low cost dwell meter, Sling psychrometer, Digital exposure meter, Serial/parallel computer interface and 19 others. \$5.95

Order today —

Return the Freepost reply card to

Federal Marketing Book Sales
PO Box 227, Waterloo 2017, NSW
Tel: (02)663-9999 Tlx: AA74488



Two great new services from **DSX** PRESS

1 TOLL-FREE ORDERING

Just because you're out the back of Woop Woop, why should you have to pay exorbitant STD phone charges to place an order?

Now you can order through DSXpress: the original and still the best electronics mail order supplier in Australia (and probably the world!) for the price of a local phone call. Yes, we've installed a special toll-free orderline for our STD customers. To place an order, simply call us on

(008) 22 6610

Sydney customers or enquiries, please call on our normal number - (02) 888 3200

2 ORDER-BY COMPUTER!

The 21st Century is here! Yes, you can now place an order for any Dick Smith Electronics products through the DSE Remote Bulletin Board System.

What is the DSE Bulletin Board? It's an electronic message, file and data handling service which any computer user can use - absolutely free of charge - courtesy of Dick Smith Electronics. All you need is a computer with a suitable communications program, an RS232C (serial) interface and a modem to connect to the telephone line. You can call the DSE RBBS at any time (24 hours per day) and now you can place an order (simply follow the directions on the menu).

Call the DSE RBBS on Sydney

(02) 887 2276

● 300 baud ● 8 data bits ● 1 stop bit ● No parity

STORE LOCATIONS

NSW

Cnr. Swift & Young Sts.
T55 Terrace Level
Shop 1, 85-75 Main St
613 Princess Hwy
Oxford & Adelaide Sts
531 Pittwater Rd
Campbelltown Mall, Queen St
Shop 235, Archer St Entrance
147 Hume Hwy
182 Pacific Hwy
315 Mann St
4 Florence St
Elizabeth Dr & Bathurst St
450 High St
173 Maitland Rd, Tighes Hill
Lane Cove & Waterloo Rds
George & Smith Sts
The Gateway, High & Henry Sts
818 George St
6 Bridge St

Albury
Bankstown Sq.
Blacktown
Blakehurst
Bondi Junction
Brookvale
Campbelltown
Chatswood Chase
Chullora
Gore Hill
Gosford
Hornsby
Liverpool
Maitland
Newcastle
North Ryde
Parramatta
Penrith
Railway Sq
Sydney

21 8399
707 4888
671 7722
546 7744
387 1444
93 0441
27 2199
411 1955
642 8922
439 5311
25 0235
477 6633
600 9888
33 7866
61 1896
88 3855
689 2188
32 3400
211 3777
27 5051

125 York St
Brisbane St & Kable Ave
263 Keira St
ACT
96 Gladstone St
VIC
Creswick Rd & Webster St
145 McCrae St
Shop 46, Box Hill Central, Main St
Cnr Hawthorn Rd & Nepean Hwy
260 Sydney Rd
1150 Mt Alexander Rd
Nepean Hwy & Ross Smith Ave
205 Melbourne Rd
291-293 Elizabeth St
Bridge Rd & The Boulevarde
Springvale & Dandenong Rds
QLD
293 Adelaide St
186 Logan Rd

Sydney
Tamworth
Wollongong
Fyshwick
Ballarat
Bendigo
Box Hill
East Brighton
Coburg
Essendon
Frankston
Geelong
Melbourne
Richmond
Springvale
Brisbane
Bundamba

267 9111
66 1961
28 3800
80 4944
31 5433
43 0388
890 0699
592 2366
383 4455
379 7444
783 9144
78 6766
67 9834
428 1614
547 0522
229 9377
391 6233

Gympie & Hamilton Rds
Cnr Queen Elizabeth Dr & Bernard St
Cnr Gold Coast Hwy & Welch St
Bowen & Ruthven Sts
Ingham Rd & Cowley St, West End
SA
Wright & Market Sts
Main South & Flagstaff Rds
Main North Rd & Darlington St
24 Park Terrace
WA
Wharf St & Albany Hwy
66 Adelaide St
William St & Robinson Ave
Centreway Acde, Hay St
TAS
25 Barrack St
NT
17 Stuart Hwy

Chermside
Rockhampton
Southport
Toowoomba
Townsville
Adelaide
Darlington
Enfield
Salisbury
Cannington
Darlington
North Perth
Perth City
Hobart
Stuart Park

359 6255
27 9644
32 9863
38 4300
72 5722
212 1962
298 8977
260 6088
281 1593
451 8666
335 9733
328 6944
321 4357
31 0800
81 1977

Dear Customers,

Quite often, the products we advertise are so popular they run out within a few days, or unforeseen circumstances might hold up shipments so that advertised lines are not in the stores by the time the advert appears. And very occasionally, an error might slip through our checks and appear in the advert (after all, we're human too!) Please don't blame the store manager or staff: they cannot solve a dock strike on the other side of the world, nor fix an error that's appeared in print. If you're about to drive across town to pick up an advertised line, why not play it safe and give them a call first... just in case! Thanks. Dick Smith Electronics

MAJOR RESELLERS

NSW: • Ballina: A. Cummings & Co. 91-93 River St 86 2284 • Bathurst: Electronic Shop, 74 Bentick Street, 31 4421 • Bowral: Barry Gash Electronics, 370 Bong Bong St 61 2577 • Broken Hill: Hobbies & Electronics, 37 Oxide St 88 4098 • Charlestown: Newtronics 131 Pacific Hwy 43 9600 • Coffs Harbour: Coffs Harbour Electronics, 3 Coffs Plaza, Park Ave. 52 5684 • Deniliquin: Deni Electronics, 220 Cressy St, 81 3672 • East Maitland: East Maitland Electronics, 99 High St, 33 7327 • Gosford: Tomorrows Electronics & HIFI, 68 William St, 24 7246 • Lismore: Decro 3A/6-18 Carrington St, 21 4137 • Port Macquarie: Hall of Electronics, Horton Centre, Horton St, 83 7440 • Orange: Fyfe Electronics 173 Summer St, 62 6491 • Tweed Heads: Stuarts Electronic Sales, Sh 3, 4 Stuart St, • Swansea: Swansea Electronics, 184 High St, 71 1674 • Wagga: Phillips Electronics 82 Forsyth St, 21 6558 • Windsor: M & E Electronics, Sh 7, Mc Ewans Arcade, 206 George St, 77 5935 VIC: • Hamilton: John Thompson & Co, 138-148 Gray St, 72 2000 • Echuca: Webster Electronics, 220 Packeham St 82 2956 • Mildura: McWilliams Electronics 110A Langtree Ave, 23 6410 • Morwell: Morewell Electronics, 95 George St, 34 6133 • Shepparton: GV Electronics Centre 100 High St, 21 8866 QLD: • Atherton: Maatens Music Centre 55 Main St, 91 1208 • Bundaberg: PM Electronics, Takalvan St, 72 8272 • Cairns: Electronic World Shop 27 K-mart Westcourt Plaza, 518 555 • Gladstone: Purely Electronics Shop Cnr Hebert & Auckland Sts 72 4321 • Mackay: Stevens Electronics, 42 Victoria St, 51 1723 • Maryborough: Keller Electronics, 218 Adelaide St, 21 4559 • Rockhampton: Purely Electronics, 15 East St, 21 058 SA: • Mt Gambier: Hutchessons Communications, 5 Elizabeth St, 25 6404 • Whyalla: Eyre Electronics Shop 2 Forsyth St, 45 4764 WA: • Albany: Micro Electronics 133 Lockyer Ave 41 3432 TAS: • Launceston: Advanced Electronics 5A The Quadrant, 34 1399 NT: • Darwin: Ventronics 24-26 Kavanagh St, 81 3491

DSXpress Order Service Order with your Bank-card, Mastercard or Visacard. Just phone 008 22610 toll free for fast 24 hour despatch!
Enquiries: By mail, or phone (02)888 3200.

POST & PACKING CHARGES

Order Value	Charge	Order Value	Charge
\$ 5.00-\$ 9.99	\$2.00	\$50.00-\$99.99	\$6.00
\$10.00-\$24.99	\$3.50	\$100 or more	\$8.00
\$25.00-\$49.99	\$4.50		

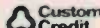
Terms available to approved applicants 

SA Customers: Credit facilities available through C.C.C.
722 King William Street, Adelaide



PTY LTD

P.O. Box 321, North Ryde, N.S.W. 2113. Tel: 888 3200

We've got the lot, at Rod Irving Electronics!*

Monitors, Modems, Printers, Cables, Cheap Disks, Drives, Cheap IC's, Storage Boxes, full range of Connectors, Joysticks, etc etc!

NOW IN STOCK!



RITRON MULTI PURPOSE MODEM
Our New RITRON Multi Purpose Modem has arrived and has all the standards you require. Just check the Ritrón's features:

- CCITT V21 300 Baud Full duplex
- CCITT V23 1200/75
- Bell 103 300 Full duplex
- Bell 202 1200 Half duplex
- Auto answer, auto disconnect.
- Telecom Approval No. CB4/37/1134

\$399



CICADA 300
• 300 baud
• Provides full 12V bipolar output signal
• Direct connect modem
• Full duplex operation (Phone not included)
Cat. X19101

\$180

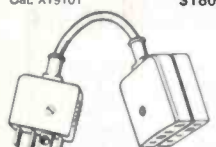

TELECOMMUNICATION PLUG TO 2 SOCKETS.
Ideal for modem connections
Cat: Y16014

\$12.95



ROD IRVING ELECTRONICS
425 High Street,
NORTHCOTE, 3070
VICTORIA, AUSTRALIA
Phone (03) 489 8866
TELEX: AA 38897
48-50 A Beckett Street,
MELBOURNE, 3000
VICTORIA, AUSTRALIA
Ph. (03) 663 6151
Mail Order and correspondence:
P.O. BOX 235
NORTHCOTE 3070

MAIL ORDER HOT LINE



(03) 481 1436

POSTAGE RATES
\$1-\$9.99 \$2.00
\$10-\$24.99 \$3.00
\$25-\$49.99 \$4.00
\$50-\$99.99 \$5.00
\$100-\$199 \$7.50
\$200-\$499 \$10.00
\$500 plus \$12.50

This is for basic postage only. Comet Road freight, bulky and fragile items will be charged at different rates.



New & Sensational!

MICROBEE ENHANCER 1

This brand new, totally amazing expansion unit for the Microbee is a must for all Microbee owners/users! Most expansion units up to this time offered at best only one or two other features; and this made it impossible to run, say, complex sound effects mingled with speech. The Enhancer 1 will do all this and much more as well. It is quite amazing how much has been shoe-horned into this compact unit. The Enhancer 1's many powerful features include:

- Two ATARI/COMMODORE/COLECO/SEARS type joystick inputs.
- Two TRS COLOR COMPUTER type joystick inputs.
- Allows the connection of Touch Pads, Paddies, Proportional Joysticks, Trackballs, Mice, temperature sensors, lights level sensors, transducers, etc, etc!
- A 4 voice music/sound effects synthesizer.
- A real time clock.
- Unlimited vocabulary speech synthesizer (option).
- Parallel printer interface (option).
- A built-in speaker with volume control.
- Listings of all necessary routines for use.
- An impressive demonstration program package.
- Compatible to all Microbees.
- All units carry a 90 day warranty and servicing is also available.
- Digital recording and playback of speech and sound.
- An 8 channel analog to digital converter with variable voltage or variable resistance type analog inputs and also user selectable resolution from 1 to 9 bits.
- A digital to analog converter with selectable resolution from 1-8 bits
- Allows automatic data acquisition and logging.
- 5 digital input lines, 4 digital output lines.
- A voice input channel.
- A 40 pin experimenter socket with all 8 analog inputs, 5 digital inputs, 4 digital outputs, 3.58 MHz buffered clock, sound output (so that you can play the sound effects through your HI FI), 3 high resolution voltage comparators, DAC output etc.

The amazing Microbee Enhancer is available exclusively from Rod Irving Electronics.

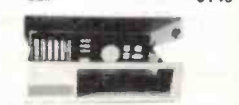

"IBM TYPE" COMPUTER CASING

Give your kit computer a totally professional appearance with one of these "IBM type" casings, includes room for 2 5 1/4 inch disk drives and connection ports. Dimensions 49x39x5cm.
Cat. X11090

\$109

MAINS MUFFLER
Sudden mains disturbances can seriously affect your computer equipment, and stored data. Why risk it, when you can have a Mains Muffler, particularly when the cost of one failure is likely to be greater than the purchase price!

Specification:
Maximum total load:
1000w, 4 AMP 250v 50Hz

First Stage - Single PI Section
Attenuation - 150KHz - 40dB
500 KHz - 65dB
10 KHz - 80dB

Second Stage - Dual T Section
Attenuation - 150KHz - 20dB
500 KHz - 60dB
10 KHz - 70dB

VDR Transient Suppression
Surge capacity 2000 AMP 8x20 uS
Cat. X10090

\$249



GRAPHIC MOUSE SYSTEM

Now everybody can create superb computer graphics in minutes. Think of how much more professional your work could look with the 'Graphic Mouse'! An absolute must for Apple IIe users. Includes software and mouse
Cat. X17037

only \$99



APPLE COMPATIBLE CARDS
Printer Card Cat. X17029 **\$85**
Drive Card Cat. X17019 **\$85**
Speech Card Cat. X17031 **\$75**
80 Column Card Cat. X17025 **\$95**



APPLE JOYSTICKS
Ideal for games or word processing. Fits most 8502 "compatible" computers.
Cat. C14200

\$27.95



APPLE COMPATIBLE SLIMLINE DISK DRIVES
Cat. X19901
1-9 **\$225** 10+ **\$220**
(*Apple is a registered trademark)



REPLACEMENT KEYBOARDS
• For Apple
• 42 single key BASIC command
• One chip custom design encoder
• Made by ALPS, life time.
• 10 million operations
• Dimension: L340xW110xH42mm
Cat. KC2002

\$79.50



• For Apple
• 45 built in function keys, BASIC and CPM commands.
• 45 user defined keys
• Built-in shift lock
• Made by ALPS, life time.
• 10 million operations
• Dimension: L340xW130xH42mm
Cat. KC2002

\$99.00



IBM COMPATIBLE COMPUTER
\$2,450
Including Tax!
*IBM is a registered trademark.



MITSUBISHI DISK DRIVES

M2896-63
Slimline 8" Disk Drive. Double sided Density No AC power required. 3ms track to track, 1.6 Mbytes unformatted, 77 track side 10s/su10 bit soft error rate.

Cat. C11918 **\$550**
Case & Power Supply to suit
Cat. X11022 **\$159**

M2894
Standard size 8" drive. Double sided, double density 500K unformatted, 40 track/side.
Cat. C11914 **\$630**
Case & Power Supply to suit
Cat. X11011 **\$89**

M4854
Slimline 5 1/4" disk drive. Double sided, double density, 96 track/inch, 9621 bit/inch, 1.6Mbyte unformatted 3ms track to track access, 77 track/side.
Cat. C11904 **\$350**
Case & Power Supply to suit.
Cat. X11011 **\$89**

M4853
Slimline 5 1/4" disk drive. Double sided, double density, 1 Mbyte unformatted, 3ms track to track, 80 track/side, 5922 bits/inch.
Cat. C11903 **\$260**

M4851
Slimline 5 1/4" disk drive. Double sided, double density 500K unformatted, 40 track/side. Steel band drive system.
Cat. C11901 **\$199**
Case & Power Supply to suit
Cat. X11011 **\$89**

M4855
Slimline 5 1/4" disk drive, double sided, double density, 96 track/inch, 2.0 Mbytes unformatted.
Cat. C11905 **\$385**

MF351
3 1/2" Standard size disk drive. Single sided, double density.
Cat. C11921 **\$225**

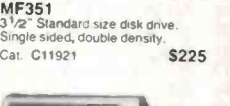

RITRON 2
Stylish swivel base monitor, available in amber or green.
1-9 **\$100+** 10+ **\$100+**
Green Cat. X14500 **\$215**
Amber Cat. X14500 **\$219**



PHOENIX 5
Suits Apple, Commodore, even your VCR!
• Pal and R.G.B.
• Normal Resolution
• 13" CRT Dot Pitch 0.65mm
• Horiz. Resol. 320 TV lines
• Vert. Resol. 560 TV lines
• Display Characters 1,000, Ch (40x25)
• 16 Colours (Pal)
• Green text display
Cat. X14522 **\$499**

PHOENIX 4
• R.G.B. TTL
• High Resolution
• 13" CRT Dot Pitch 0.31mm
• Horiz. Resolution 720 dots
• Vert. Resolution 240 T.V. Lines
• Display Characters 2000
Ch (80 x 25)
• 8 Display colours and intensity
• Green text display
Cat. X14520 **\$849**



	1-9	10+
4116	\$1.80	\$1.70
4164	\$3.25	\$2.95
2716	\$5.90	\$5.50
2732	\$6.25	\$5.95
2764	\$8.25	\$7.95
27128	\$12.50	\$11.50
6116	\$5.50	\$5.15
41256	\$14.50	\$12.50



IBM ADD ON HARD DISK
• 10 Mbyte
• Seagate hard disk
• Hard disk controller by Xebec
Cat. X20010 **\$1,750**



RITEMAN INFO RUNNER
An exciting new printer from the experts "Riteman". This compact stylish printer performs like printers twice its price and size. 120 C.P.S., dot resolution graphics, tractor/ribbon feed, 10" paper.
\$459



MB100S
The next generation of "80" type printers. 100 CPS, internal buffer expandable to 4K, Greek as well as italics. The print quality is the same as its forerunner. Square pins and film ribbon make it unbeatable.
1-4 **\$349** 5+ **\$329**



Juki Printer
Professional daisy wheel printer 18CPS full incremental mode Diablo 630 emulation. Large range of daisy wheels. 8K internal buffer available.
WAS \$790 NOW \$725



FULL RANGE OF ITOH PRINTERS
8510 SP 180 C.P.S. tax exempt \$773 incl. tax \$928
1550 SP 180 C.P.S. tax exempt \$1,000 incl. tax \$1,167
8510 SC (Colour) tax exempt \$906 incl. tax \$1,057
1550 SC (Colour) tax exempt \$1,132 incl. tax \$1,321

READY MADE CABLES
Serial to serial 2 m
Cat. P19011 **\$18.95**
Parallel centronics to centronics, 2m
Cat. P19013 **\$23.95**



DISKS GALORE!!
All prices for boxes of 10. Single disks 10% extra.

SPECIALS!
MD525-01 S/S D/D Cat. C12501 **\$29.50**
MD550-01 S/S D/D Cat. C12504 **\$39.50**
Head Cleaners
C12551 5" Head Cleaner **\$10.50**
C12551 8" Head Cleaner **\$11.50**

VALUELIFE
C12421 S/S D/D **\$22.95**
C12425 D/S D/D **\$29.95**

8" Verbatim
C12800 FD32-1000 S/S/D **\$39.50**
C12801 FD32-8000 S/S/D **\$49.50**
C12802 FD32-9000 S/S/D **\$48.50**
C12803 FD34-1000 S/S/D **\$49.50**
C12804 FD34-8000 S/S/D **\$55.50**
C12805 FD10-4008 D/S/D **\$59.50**
C12806 FD10-4015 D/S/D **\$64.50**
C12807 FD10-4026 D/S/D **\$64.50**
C12808 FF32-2000 S/D/D **\$69.00**
C12809 FF34-2000 S/D/D **\$69.00**
C12810 DD32-4000 D/S/D **\$52.50**
C12811 DD34-4001 D/S/D **\$52.50**
C12812 DD34-4008 D/S/D **\$54.50**
C12813 DD34-4015 D/S/D **\$54.50**
C12814 DD34-4026 D/S/D **\$54.50**

5 1/4" Verbatim Disks
5 year DataLife guarantee
MD525-01 (S/S D/D) **\$29.50** C12501
MD525-10 (S/S D/D 10 Sect 40 Track) **\$39.50** C12502
MD525-16 (S/S D/D 16 Sect 40 Track) **\$39.50** C12503
MD550-01 (D/S D/D) **\$39.50** C12504
MD550-10 (D/S D/D 10 Sect 40 Track) **\$49.50** C12505
MD550-16 (D/S D/D 16 Sect 40 Track) **\$49.50** C12506
MD577-01 (S/S D/D Soft Sect 80 Track) **\$125.07** C12507
MD577-10 (S/S D/D 10 Sect 80 Track) **\$59.50** C12508
MD577-16 (S/S D/D 16 Sect 80 Track) **\$59.50** C12509
MD557-01 (D/S D/D Soft Sect 80 Track) **\$59.50** C12510
MD557-16 (D/S D/D 16 Sect 80 Track) **\$59.50** C12511



XIDEX DISKS
1-9 **\$10+** 10+ **\$10+**
Box of 10 S.S. D.D. Cat. C12401 **\$34.50** **\$29.50**
Box of 10 D.S. D.D. Cat. C12410 **\$44.50** **\$39.50**



DISK STORAGE BOXES
Efficient and practical, these disk storage boxes protect your disks from being damaged or lost.
50's. Features smoked plastic cover with provision for a lock. High impact ABS plastic base
Cat. C16025 **\$26.50**
50's. Features smoked plastic cover Divided into 10 sections, each fan elevates the disks for easy identification and access
Cat. C16050 **\$34.50**
***If not, then very nearly!**
Errors and omissions excepted

Direct sound broadcast satellites

Talk of satellite transmission usually sets us thinking of TV and the telephone, but a conference in Geneva this August hopes to pave the way for direct sound broadcasting with radio transmissions by the 1990s.

On 8 August several hundred delegates will meet for some five and a half weeks in Geneva for a World Administrative Radio Conference (WARC) that will plan what is to become of the world's satellites. If the conference succeeds, a further conference in 1988 may allocate some frequencies for the operation of sound broadcasting in space, from satellites. The plan is to look at the area of 12000 MHz or 12 GHz, and it is expected that the mass production of receivers to cover this band would be no more expensive than those marketed for medium and short-wave.

The low cost direct transmission through satellites would enable many underdeveloped countries, which can now serve only some 20% of the population through standard medium and shortwave broadcasting, to increase coverage through community listening to satellite broadcasting. Three research scientists at the European Space Agency Headquarters in the Netherlands recently published a proposal which they feel should be seriously considered, as planning for direct broadcasting is at a crucial stage.

Direct broadcasting with radio transmissions via satellite would mean that up to 16 or even 20 radio programmes could be distributed by a satellite which can only accommodate one television programme; hence variety is increased and the cost reduced when the satellite is used to relay radio broadcasts.

The West German government is planning direct broadcasts from satellites next year but this would be to a very select audience who would have to have special receivers. The quality of the transmission is comparable to a compact disc and will certainly be appreciated by those who demand excellent reproduction of music. The USSR is using a band below 1 GHz but the European Space Agency scientists believe that this can never reach the quality or the number of programmes which could be sent when using a higher frequency.

The technical aspect of satellite transmission is being investigated, particularly regarding the receiver and aerial, and it could be that the dish would eventually be replaced by a rod aerial on the receiver. The receiver would be very sensitive, which would increase the signal. But on the other hand unwanted noise such as automobile interference would increase, so a development to reject the unwanted noise would have to be part of the new receiver.

Although the German system is planned for introduction next year, scientists feel that this is optimistic and it could be 1987 or 1988 before it comes into operation. In the meantime, pressure will be on manufacturers of receivers and also on researchers to invent new kinds of portable receivers, though these may not be commercially available until the 1990s.

It is obvious that international

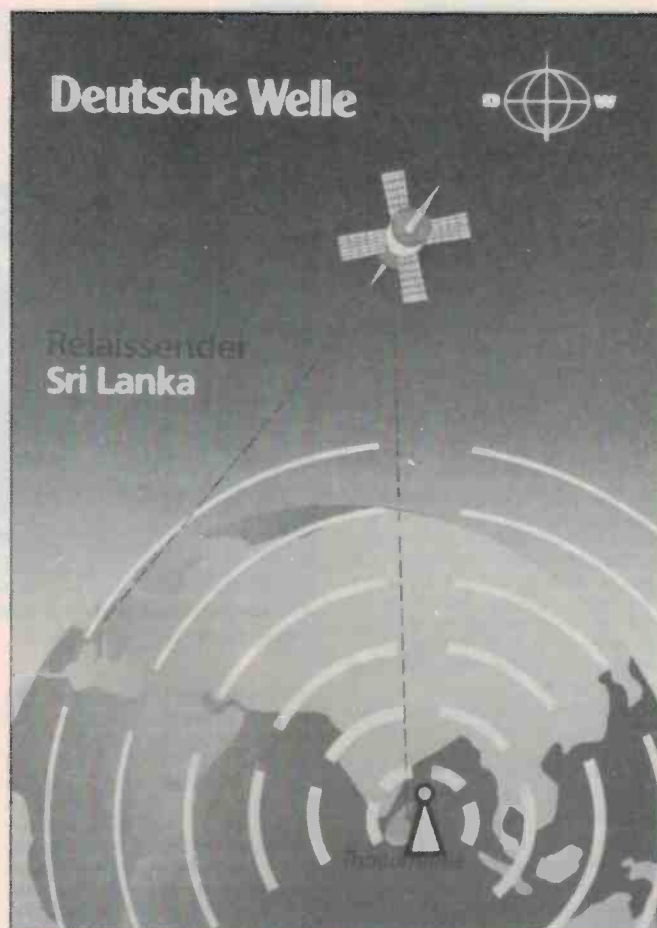

The Deutsche Welle relay station in Trincomalee, Sri Lanka, which receives its programmes by satellite from the studio of Deutsche Welle in Cologne. This verification card shows the link between studio and transmitter.

broadcasters would be interested in direct transmission into the home because of the difficulties of propagation on shortwave. The share of facilities between countries could well overcome the cost factor of satellite transmission. One problem which could occur with joint operation is that programmes covering political matters may be critical of another country using the same satellite, and it is felt that an international body would have to be created to ensure that all programmes carried were not of any controversial nature. However, there seems to be a lack of urgency in this type of operation, mainly because it is felt that the market is not yet

ready for direct broadcasting via satellite.

Nevertheless, in a recent discussion on Media Network broadcast by Radio Netherland, Jonathon Mark interviewed a Professor of Telecommunications at the Eindhoven University of Technology who discussed work on the new type of radio receiver transmission. Officials from Philips and Telefunken have expressed interest in the marketing of these new receivers, and are aware of the high quality reproduction which could be made available to listeners worldwide using this new broadcasting technique.

— Arthur Cushen

KILOHERTZ COMMENT

AUSTRIAN MAIL: Austrian Radio has released figures of its mail count for the M transmission period (March-May 1984) and this shows a considerable number of letters and reports from the South Pacific. Mail from Australia totalled 978, New Zealand 482, Papua New Guinea 13 and Vanuatu 27. The total mail received for the two months was 20,587 from 89 countries. The station also received numerous recordings on cassette from listeners, and commented that a technical evaluation of the recordings gave the station a summary of the receiving conditions in the various target areas and on the different frequencies. The Austrian Radio commented that the receipt of cassette recordings gave the station direct contact with its listeners and that it was able also to return the tape with some Austrian music and confirm the reception. Some 129 listeners sent cassette recordings to Vienna during the two months, and these came from 30 countries. Verifications are issued from DRF and should include:

1. Date, time (UTD), frequency (kHz).
2. Type of receiver, receiving antenna.

Reports should be sent to the Austrian Radio, Technical Department, PO Box 200, A-1043 Vienna, Austria.

LIBYAN REQUEST: In a recent letter the director of Radio Jamaheriya, Mohammed Sweidan, requested



The Austrian Radio transmitter buildings with well known technical director, Herbert Kunhle, in the foreground.

more reports on its radio signal. The station presently transmits two broadcasts on the shortwave band. One is on 11815 kHz between 2230 hours and 2400 hours UTC. The African service of Radio Jamaheriya broadcasts on 15450 kHz between 1800 and 1900 hours UTC. The station would particularly like to receive reports on the 11815 kHz frequency. It is interested in technical informa-

tion, such as the SINPO rating, and remarks about modulations, interference (if any) and signal strength, but would also welcome comments or suggestions on the contents of its programmes. Any reports received will be QSLed. Programme schedules and other information are available on request. The address is Radio Jamaheriya, PO Box 17, Hamrun, Malta, Europe.

VATICAN'S "FOUR VOICES": Vatican Radio's "Four Voices" programme was set up 10 years ago, during the 1975 Holy Year. It was intended as a service for pilgrims to inform them about the daily Jubilee activities, to indicate religious and cultural events in Rome, and to give them brief information on road conditions, the weather and exchange rates, as well as international news.

"Four Voices" was so popular that it was decided to continue it after the closing of the Holy Year as Vatican Radio's general information programme. With the exception of Sundays and other holidays "Four Voices" now goes on the air three times a day (0700, 1130 and 1600 UTC) for a total broadcasting time of two hours in four languages: Italian, French, English and Spanish. The morning transmission consists of 10 minutes of international news in each of the four languages followed by a slot of reports and interviews. The broadcasts at 0700 are heard on 9645 and 11740 kHz. Vatican Radio's daily transmissions to Australia are at 2205-2220 UTC on 6015, 9615 and 11830 kHz, and again at 0200-0215 UTC on 7125, 9650 and 11865 kHz.

This item was contributed by Arthur Cushen, 212 Earn St, Invercargill, New Zealand, who would be pleased to supply additional information on medium and shortwave listening. All items quoted are UTC (GMT) 10 hours behind Sydney time, all frequencies are in kilohertz (kHz).

DOC news

Regional radio and television audiences will have greater access to local programming including news, sporting highlights and advertising for local businesses following Government changes to legislation. In the past individual licencees have been required to broadcast without alteration the same program over their main station and any subsidiary transmitter in their service area. Amendments to the *Broadcasting and Television Act 1942* will enable commercial radio and television licencees to develop more local programming on subsidiary transmitters.

The Minister for Communications, Mr Duffy, said the government was also amending the *B & T Act* to provide for short-term broadcasting permits of up to 28 days. Examples of such temporary services would include ones that had a substantial

connection with a special event, say, a festival or a jamboree, or that would provide information and support services to communities after a disaster or an emergency.

In another change the Government plans to empower the Australian Broadcasting Tribunal to grant permits, initially for up to five years, for broadcasting information services. These services could be operated by commercial enterprises such as leisure resorts and tourist attractions, and cater for the specialized information needs of people enjoying those facilities, Mr Duffy said.

By the end of 1986 Australia's multicultural television network SBS-TV will be operating nationally in all capital cities as well as in the regional centres of Newcastle, Wollongong, Goulburn and Cooma.

The next expansion will be to

Perth and Hobart in January 1986, and Darwin will follow before the end of 1986. Programs will originate from the SBS headquarters in Sydney and be distributed to the three cities via the Aussat satellite system.

In Darwin a temporary mast will be erected in Blake Street to carry UHF transmitting antennas until a replacement tower can be built. SBS-TV will operate on UHF channel 28 in Darwin and later there will be a new commercial station, which will also operate on a UHF channel.

A new satellite receiving earth station on Mt Wellington for Hobart is being tested this winter to check its operating performance in extreme climatic conditions and minor adjustments should be completed before full-time broadcasts begin early next year.

SBS-TV programs in Perth will be received at AUSSAT's Major City Earth Station and

transmitted from Mt Bickley to households in the Perth area.

The Department of Communications has issued a warning that people thinking of buying UHF television antennas should ensure they obtain the correct type for their area. A spokesperson said that to obtain clear reception of stations using UHF Channels 28 to 35 a Band IV UHF antenna was required, while the smaller Band V antenna was suitable for reception of stations operating on Channels 39 to 69.

Most of the main SBS stations will transmit on Channel 28, requiring a Band IV antenna. The Department says to be wary about buying an antenna that is sold merely as a 'UHF antenna', unless a guarantee can be obtained as to whether it is Band IV or Band V.

Pamphlets with UHF reception details are available from DOC local offices.

Modular meter

A new Japanese-manufactured VHF-UHF SWR-power meter has recently become available through GFS Electronic Imports. Called the HS-370S it covers a frequency range of 130 to 450 MHz with extended operation outside this band at reduced accuracy.

The design of the meter incorporates modular construction, with the directional coupler separated from the main meter unit. Each of these sections has its own mounting brackets and the cable that connects them is 1.6 metres long, allowing for wide separation and providing the convenience of not having to bring heavy coax cables up to

the indicator. The indicator is 130 x 62 x 38 mm and the coupler is 70 x 60 x 35 mm.

Power measurement ranges are 0 to 20 watts and 0 to 200 watts, while the SWR range indicates 1:1 through to 3:1. Insertion loss of the directional coupler is less than 0.5 dB. For night-time operation the meter scale can be illuminated by the connection of a 12 volt power source.

The HS-370S is \$90 RRP plus \$6 freight. For further information contact GFS Electronic Imports, 17 McKeon Road, Mitcham Vic 3132. (03)873-3777. Telex 38053 GFS.



Bearcat receiver

Dick Smith Electronics has announced the release of a new communications receiver, the Bearcat DX1000, capable of reception down to 10 kHz.

Featuring microprocessor controlled digital technology, the DX1000 covers 10 kHz to 30 MHz continuously with PLL synthesized accuracy. It has 10 memory channels to allow for instant recall or faster 'band-scanning' during key openings. The digital display measures fre-

quencies to 1 kHz or at the touch of a button doubles as a two time zone, 24 hour digital quartz clock.

The receiver can be programmed to activate peripheral equipment. It can record up to five different broadcasts on any frequency and using any mode, and also includes IF bandwidth selection to help to separate high powered stations on adjacent frequencies.



Albanian broadcaster

Listening to the anti-American, anti-Russian and anti-Chinese broadcasts on Albanian radio, one gains the impression that this country bordering the Adriatic has no friends.

With a population of 2.8 million, Albania has one of the world's biggest shortwave services with 582 hours of programming each week. This figure is twice the weekly broadcasts of Radio Netherland and many of the other well known international broadcasters. But the broadcasts are dull as they come from a country which seems to live in complete isolation. Indeed, many major broadcasters such as the BBC and Radio France International no longer

broadcast in Albanian, although Voice of America, Radio Moscow and Radio Beijing continue with their programmes for Albania, as do many gospel stations.

Since 10 January 1946 when Albania declared itself a communist people's republic, not many foreigners have visited the country. A direct flight from Vienna is one of the few ways of arriving at the capital Tirana, but for men, long hair is not in favour and could be cut by the airport barber, and women should dress in plain clothes.

Radio Netherland recently reviewed a new book written by a West German who visited Albania, mainly to look at Radio Tirana. Photos of the broadcast-

ing building were not allowed, according to an armed guard, though the verification card from Radio Tirana shows a picture of this building. The German visitor had an eventful time trying to meet someone on the staff at Radio Tirana to talk about the broadcasts and found that the studios were far from modern. The foreign language broadcasters on Radio Tirana do not disclose their names; they prefer to remain anonymous to avoid trouble if they decide to return to their own countries some time in the future. Tourists in Tirana can hear the Foreign Service which is broadcast on shortwave and also carried on FM, so that at some time of the

day a programme in English, German and French is available.

Listeners in Australia are aware of the broadcasts of Radio Tirana which has programmes to this area in English at 0700-0730 UTC on 9500 and 11985 kHz, and again at 0930-1000 UTC on 9500 and 11950 kHz, while the third broadcast beamed to Australia is at 1400-1430 UTC on 9500 and 11985 kHz. There are 16 half-hour broadcasts in English each day from Radio Tirana, and as well there is a shortwave relay of the local programmes on 5020 and 5027 kHz. The station confirms reception reports and has the simple address of Radio Tirana, Tirana, Albania.

— Arthur Cushen

TV PIX LOUSY??

FIX IT EASILY: TRY ONE OF OUR NEW PICTURE FIXERS FOR IMPROVED PERFORMANCE ON UHF/VHF/FM BANDS. Specifically designed for Australian Standards and TV channels these superb new signal boosters are just a small part of our huge range of TV and VIDEO ACCESSORIES. SAE for further info!

MASTHEAD AMPLIFIERS

For weak signal, "snowy" picture problems, UHF and VHF antenna inputs, 75 or 300 ohm. Weatherproof, mount underneath antenna, 75 ohm output, use coax cable downward.

2 MODELS: A3 VHF Gain: 24dB UHF Gain: 0dB **\$69**
 A4 VHF Gain: 24dB UHF Gain: 22dB **\$79**

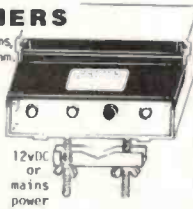

SIGNAL BOOSTER \$39

GAIN: 10dB. Reduces loss from splitters and long cable runs. In-line coaxial amplifier, 5 to 950MHz, 12VDC or mains power.

INDOOR AMPLIFIER \$75

GAIN: VHF 26dB, UHF 24dB, coax 75 ohm in, 75 ohm out. Hi gain indoorsignal amplifier, metal shielded box, 240v mains power.

UHF TO VHF CONVERTOR \$69

Convert UHF signal to VHF, CH1 3,4 selectable. Ideal for UHF VCR'S to use VHF TV set built-in amplifier ensures no signal loss. 12VDC or mains power.

BOOSTER/SPLITTER \$32

GAIN: 6dB, 75 ohm in, 2x75 ohm outputs, for indoor or ceiling aerials, reduce loss from long cables, 12VDC or mains power.

AMPLIFIED SPLITTER \$79

GAIN: 12dB 75 ohm in, 4x75 ohm outputs with new variable gain control, for TV or VCR etc 12V DC or mains power.

ANTENNA ROTATOR \$109

Fully automatic fully approved by Energy Authority, suits VHF and UHF aerials, FM and small HF aerials up to 50kg vertical load. Rotates 360, in 70 secs.

STEREO MAGNETIC CARTRIDGE REPLACEMENT \$21

Cheaper than most styli alone! Latest model moving coil system, 15Hz-35kHz freq response, 2.5mV output, 0.6mm Diamond stylus, tracking force 2 grams, standard 3" mtg with mtg kit.

VARIABLE TV SIGNAL 20dB ATTENUATOR

Cuts out signal overload, variable from 0-20dB. **\$9.99** 75 ohm coax sockets

36 PIN PARALLEL PRINTER PLUGS \$8

GENUINE AMPHENOL ONLY PLUGS from us at this price! 36 way, gold-plated pins, genuine USA made plugs. EACH LIMITED QTY.

Now BELOW COST PHONE DIALERS \$9.95

PUSH-BUTTON WITH MEMORY DIRECT REPLACEMENT FOR STANDARD ROTARY TYPE - EASILY FITTED IN MINS. (Not Telecom approved)

CLEARANCE SALE

STEREO PHONES \$3.99

8 Ohm Not \$19.95 2 PAIRS FOR PARTLY WATER-DAMAGED STOCK - Should be 1 or 2prs working!

SPEAKER BOX SALE

620mm x 350mm x 225mm Deep

LM3900 \$39

EA 1-9 WERE 50c EA 10-29c RCA 3401 EQUIVALENT SUPPLIED!

C106 SCR \$32

50V 4A ea 10-99 ea 29c

EACH **\$6**

Computer \$550
 S100 system 280 CPU 64K Dynamic ram, 2x 8" 5500 disk drives and controller \$550 8" drives only \$300 Used Centonics 703 Printer with spares 160 CPS only...\$450

ULTRASONIC CAR ALARM with radio key \$159

Keyless digital radio control transmitter for arming/disarming, current door sensing AND ultrasonic detectors, panic alarm button, LED status indicator, inbuilt siren, 1 minute exit delay, auto reset, easy installation instructions.

1N5404 4001V 3AMP Rectifiers. 10 for \$2

PRE-PAK electronics p/l

1a WEST ST, LEWISHAM, NSW

569-9797 24 HR PHONE ORDER SERVICE

Phone or mail order BANKCARD accepted

Plug into 'Eveready' rechargeables.

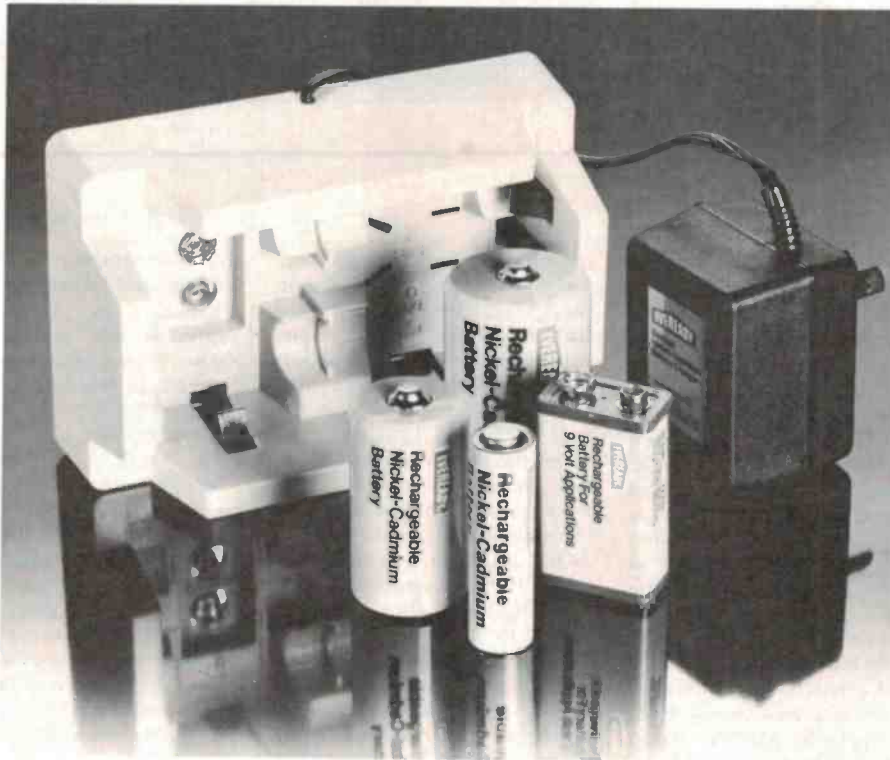

Our rechargeable range, in popular sizes, can be charged up to 1000 times on the new model ACC50E Charger, thus offering an extremely economical power source to the heavy-battery user. Especially ideal for photo-flash, movie cameras, tape recorders, transceivers and electronic games and toys.

Please don't hesitate to call for further information.

EVEREADY Rechargeable Nickel-Cadmium Batteries.

Union Carbide Australia Limited, Battery Products Division, 30/40 Harcourt Pde, Rosebery. Phone 6670444. SALES OFFICES: Sydney: Cnr Hayes Rd & Dunning Ave, Rosebery. Phone 6932666. Brisbane: 47-49 Sherwood Rd, Toowong. Phone 3716877. Adelaide: 121 Greenhill Rd, Unley. Phone 2720611. Melbourne: 14 Queens Rd. Phone 261241, 262332. Perth: 31 Outram St, West Perth. Phone 3212926.



Eveready and Union Carbide are registered trade marks.

WIRELESS INSTITUTE OF AUSTRALIA

FOUNDED 1910

The W.I.A. represents the Radio Amateur at Local, National and International level and offers following services:

- ★ Monthly "AMATEUR RADIO" Magazine, included in membership fee.
- ★ Most REPEATERS have their licence, power and site cost paid by the institute.
- ★ World wide QSL-service.
- ★ Assistance to members in legal problems arising out of the pursuit of their hobby.
- ★ A Weekly Sunday Broadcast to Amateurs and Short Wave Listeners.
- ★ Assistance in dealing with Interference Problems (TVI-RFI etc.)
- ★ Novice and full call courses.
- ★ Trial Novice and AOCIP theory exam papers.
- ★ Advice on Radio Mast approvals
- ★ The ONLY representation of the RADIO AMATEUR in legislative matters.



Join the 8,600 Amateur members in the W.I.A. by forwarding this coupon to:

W.I.A. P.O. BOX 300,
CAULFIELD SOUTH, VIC. 3162

Please forward a membership application form and further details to:

Mr, Mrs, Miss, Ms

Address

Callsign

Postcode

Ian J. Truscott's

ELECTRONIC WORLD MORE & MORE

People are discovering us each week. Both the home enthusiast through to the small manufacturer.

★ ★ ★

COMPONENTS • TOOLS • KITS

In any quantity, buy one, or one thousand, we're happy to oblige

SCHOOLS • CLUBS ETC.

Inquire about our bulk discount deals

Save yourself a trip to the city - come to

30 LACEY STREET CROYDON

OR PHONE

(03) 723 3860/
723 3094

Mail orders welcome.

MAIL ORDER SPECIALS

• PHILIPS

Ultrasonic car alarms
\$129 **\$85**



★ PRO-2

F.M. Lapel mike.
\$25 **\$21**

★ ZN414

One chip radio
\$4.35 **\$2.50**

★ All TEKNIKA

Replacement stylii
15% off

Post & Pack: \$10 or less-\$1.50
\$10 + -\$3.00

AUSTRALIAN ELECTRONIC COMPONENTS

Shop 2, 60-64 Railway Rd.
Blackburn

Phone: (03) 878 9724



NEXT MONTH: SPECIAL BONUS OFFER!

Next month, along with the usual goodies in Electronics Today, we're offering a special extra bonus. With each copy of the July issue, we're going to be giving away a copy of one of our valuable ETI "one shot" publications — absolutely FREE!

Every copy of the magazine will be packaged together with an ETI publication worth more than \$2.50 — giving you not one, but two publications for the price of one.

So don't miss the July issue with its special bonus offer!

How's that for value?

COMPULSIVE PROGRAMMERS

— an alternative view

Just finished fifteen hours in front of the computer? Eyes feel like roadmaps? Well, get yourself a glass of something strong, curl up somewhere quiet, and consider this . . .

DESPITE THE MUCH-LAUDED benefits flowing from computers and information technology there are fears that all is not well for the computer user.

There is growing concern amongst some educationalists and academics that excessive use of computers can create social and psychological problems, especially in the young. It is thought that social development may be inhibited, relationships damaged, and that academic achievement may be adversely affected.

Has society created and encouraged this new compulsion? From every side, via every medium, we are being indoctrinated with the idea that we will have to be able to program computers if we are to survive and cope in our brave new world. Those who are unable will be seen as technological illiterates.

In order to program effectively one must spend vast amounts of time at the keyboard. The concepts involved in writing the simplest program are quite considerable for the naive user. Many never go beyond this stage and confine themselves to using commercial software prepared by those more skilled. Some may never return at all and remain suspicious of this awe-inspiring equipment.

However, others do continue and can become highly involved and skilled; they can also get hooked by the activity and become compulsive programmers. They are more interested in the *process* of programming than in the result of their work.

Who's hooked?

Research currently taking place at Loughborough University, in England by

Margaret Shotton aims to investigate the incidence of this modern phenomenon and determine its causes and effects. After extensive media requests people contacted Margaret about their 'compulsive programming'. The phenomenon was obviously very real for some people.

The initial survey showed that the vast majority (over 97%) of those hooked were male. Many were spending up to 40 hours per week of their spare time at the computer. One could see that there would be little time for other activities in their lives, assuming the human body still needed time for sleep.

Why is this pastime predominantly confined to men? There are many theories that need investigation.

1. Men are generally more obsessive about their hobbies in general; golf and fishing widows are not uncommon.

2. Men are able to devote hours and hours of their spare time to one particular hobby, whereas women have more demands made upon them by their families etc. This argument loses force when one considers that this sex difference in computer 'addicts' occurs in the young and the single.

3. Computer advertising is geared to the business world. But once again there are probably far more women in business and clerical tasks who would benefit from the new technology and should welcome it.

4. Arcade and computer games, often the initial means of contact with new technology, are geared to the male as aggressor and hold little interest for females. There has to be something in this as the computer indus-

try is pouring money into designing games especially for girls, but with very little success.

5. Women are not mechanically-minded and are suspicious of machines (a well-worn adage). Take a look in any woman's kitchen to see this is not so. She probably deals effectively with far more machines each day than most men. True, she may not repair them, but she positively encourages their purchase to ease her day.

6. Women are illogical and disorganized thinkers and cannot cope with the demands of computing. Discussions with the computer industry have revealed that many prefer to employ female programmers, if they can find them, because they tend to be more methodical, practical and efficient.

7. Fewer girls take computer studies courses and are therefore less likely to get into the area. Discussions with teachers have revealed that not only are the majority of computer teachers male and courses geared to male interests, but also that curriculum organization often places computer studies in competition with History, French or even Home Economics, which are all traditionally very popular choices for girls. It is hardly surprising that the computer option is rarely taken up.

In primary schools these sex differences do not seem to occur. Here computers are used mainly as carriers of educational software and usually no bias is observed between the boys' and girls' enthusiasm for computers. In secondary schools, however, computing tends to be taught as a subject in its own right, rather than used as a tool. This is probably a most relevant aspect.

Margaret A. Shotton

8. Women see very little need for a home computer. This statement is supported by the opinions of many women. They cannot see how it will aid their work in the home, and often resent the financial outlay which they feel could be put to better use. The excuse that it can be used for keeping household accounts, when previously the back of an envelope has sufficed, carries little weight with many women.

The damage done

One may wonder how anything so intrinsically fascinating can do any harm. Problems start when an interest becomes an obsession.

A typically obsessed schoolboy will spend every break time in the computer room with little thought for making friends, let alone lunch. At home all his spare time will be spent in his bedroom on the micro. Small boys, not normally renowned for early rising, report waking up at six o'clock in the morning to play games.

Most parents positively encourage their children to use computers initially, as it keeps them occupied and can only be of benefit to their futures. However, when children start refusing to participate in family outings or to come to the meal table, problems can occur. Interactions with their peers may become very limited because of the lack of common interests, and isolation tends to follow. This may drive the child to depend more heavily upon the computer where rewards are fast and fun, and mistakes private, impartial and non-judgmental.

Experience has shown that young hackers

often make poor students, and some university computer departments are now trying to recognize and eliminate them at the interview stage. Others become hooked while at university. Lectures are skipped, course work goes to the wall and many fail their degrees, despite their high levels of intelligence.

Another group which appears to have a great affinity for the computer is married men. Pressures from work or the threat of unemployment convince them that computer literacy is the only way to succeed. There are reports from America that divorces are occurring because of the compulsive behaviour of some husbands: husbands who have changed from lovable, sociable beings into recluses.

Research so far carried out at Loughborough has revealed that there seems to be two different types of men who get hooked by computing. One group may be termed the workaholics. They may either be bringing their office work home with them or they may be writing software in order to sell it. Money, promotion or prestige are their aims and they rarely program for the sake of it. Despite the vast number of hours that they spend, there is always an end product in mind.

The second group appears to be those who in the past have always been obsessive about a hobby to some degree. Computer

programming has become the ultimate pastime.

Do the majority of men, who have at some time had some degree of obsession about a hobby, have *great* difficulty with human relationships? These men usually report that from an early age, they have had great difficulties with human relationships. The computer is refuge.

At last they can interact with something which totally accepts them, offers them continual intellectual challenge and an escape from reality. They report that they prefer this interaction to that with humans.

Still, the computer is not something to fear. Very, very few people get hooked in the way described. To some, with little desire for social interaction, the computer is a boon. It may even increase one's status in the eyes of one's peers, who may see the junky as the computing guru and the fount of all knowledge. Also networking, like CB radio, gives the shy an opportunity to communicate with others without the trauma of face-to-face encounters.

There is much still to be investigated. Margaret would be pleased to hear your opinions and experiences on this subject. (All information will be treated confidentially.)

Please write to: M. A. Shotton, Dept. of Human Sciences, Loughborough University, Leics. LE11 3TU, England. ●



Circuit-Board-Design Without the Tedium

smARTWORK™ lets the design engineer create and revise printed-circuit-board artwork on the IBM Personal Computer.

Forget tape. Forget ruling. Forget waiting for a technician, draftsman, or the CAD department to get to your project. smARTWORK™ software turns your IBM Personal Computer into a professional, high-quality drafting tool. It gives you complete control over your circuit-board artwork—from start to finish.



smARTWORK™ transforms your IBM PC into a CAD system for printed-circuit-board artwork. Display modes include both single-layer black and white and dual-layer color.

What makes smARTWORK™ so smart is that it understands electrical connections. Conductor spacing is always correct, lines don't become too narrow, and connecting lines do not intersect other conductors. smARTWORK™ can automatically find and draw the shortest route between two conductors. Or you can specify the route.

smARTWORK™ is the only low-cost printed-circuit-board artwork editor with all these important advantages:

- Complete interactive control over placement and routing
- Quick correction and revision
- Production-quality 2X artwork from pen-and-ink plotter
- Prototype-quality 2X artwork from dot-matrix printer
- Easy to learn and operate, yet capable of sophisticated layouts
- Single-sided and double-sided printed-circuit boards up to 10 x 16 inches
 - Multicolor or black-and-white display
 - 32 user selectable color combinations; coincident points can be displayed in contrasting colors.
 - Can use optional Micro-soft Mouse as pointing device.

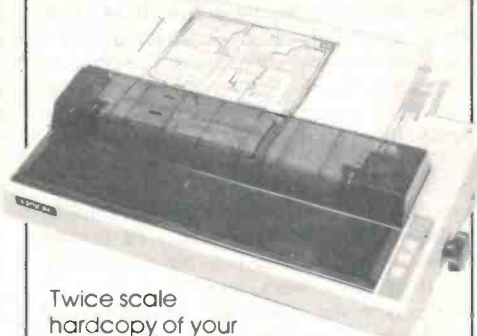

Twice scale hardcopy of your artwork is produced using the Epson dot-matrix printers or the Houston instrument DMP-42 pen-and-ink plotter. Quick 1X check plot is also available from Epson printers.

™smARTWORK™ and "Wintek" are trademarks of Wintek Corporation.

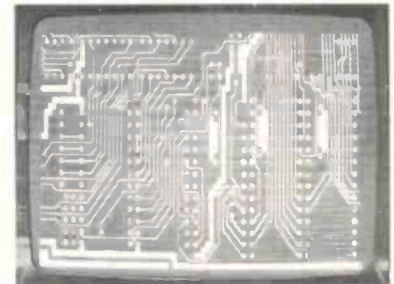

Dual-layer color display of a 2" by 4" section of a 10" by 16" circuit board

The Smart Buy

smARTWORK™ is exceptional value, particularly when compared to conventional engineering workstation costs.

Call or write to us for more information on smARTWORK™. We'll be glad to tell you how smARTWORK™ helps us design our own circuit boards and what it can do for your business.

System Requirements

- IBM PC, XT or close compatible with 192K RAM, 2 disk drives and DOS Version 2.0 or later.
- IBM Color/Graphics Adaptor with RGB color or B&W monitor.
- Epson MX80/MX100 or FX80/FX100 dot matrix printer or compatible with Graffiti.
- Houston Instrument DMP-42 pen-and-ink plotter (preferred). Small Houstons and HP7475A also supported.
- Microsoft Mouse (Optional).



MINI MART

FOR SALE: COLLECTION of antique radios, valves and parts for sale. Prefer to sell the lot. M. Glistinger, 41 Willmington St, Newmarket, 4051.

FOR SALE: BRAND NEW and used semiconductors, ICs — linear and TTL and CMOS logic, resistors, capacitors, electrolytics, power transformers, mixed components etc. Ideal for electronics constructors of all types. Ph. (03)874-2770.

FOR SALE: TRS80M3 COMPATIBLE, 64K DRAM, two SSDD 5¼" drives, sep keyboard, wirewrapped on Eurocards; hi-res amber monitor, DOSs, wordprocessor, BASIC; games, manuals. \$950 ono. Neil (053)67-1480.

FOR SALE: MICROBEE TAPE COPIER. Make back-up copies of M/C programs at 300 or 1200. Allows code modification. \$10 incl. postage. J. Arnold (02)625-8950.

FOR SALE: APPLE SUPER SERIAL CARD. Premium RS232C printer or modem Interface for Apple II, IIe. 50 to 19.2 kilobaud. \$185. Phone (089)52-3692 ah.

FOR SALE: COMMODORE 64. Large variety of software available. For further information contact D. Hamilton, 32 Miro St, Young, NSW 2594.

FOR SALE: SEIMENS 100 teleprinter spare parts, available at low cost. Post anywhere. Send SSAE for details. Frank Rees, 27 King St, Boort, Vic 3537.

FOR SALE: VZ200 and VZ300 software, tape and disk. Educational, games business and ML units. Ext. BASIC with disk commands. SASE J. D'Alton, 39 Agnes St, Toowong, Qld 4066. (07)371-3707.

SHOP AROUND

Of our three projects this week the ETI-679 Microbee joystick adaptor should provide the least trouble. Get the bits at the corner store. If you have any trouble phone engineer Geoff Nicholls and tell him your troubles.

ETI-743: The UHF amplifier was designed from a circuit developed by Dick Smith Electronics. DSE will stock kits for around \$129. You will notice that we have specified a hybrid, the Motorola MHW-710 for this circuit. This is the first time we have used such a device for many years. A nice counterpoint to our article on hybrids *et al* in this issue. Apparently, many of the other hybrid manufacturers are producing equivalent circuits, so if you don't want to deal with DSE, you might like to try them. The cost of an MHW-710 from DSE is about \$20. At the time of going to press all electronic components had advised that it would be making up the kits, also for \$129.

The tape auto search project, **ETI-693**, involves a whole bunch of common as mud components that should be available anywhere. None of the semis are particularly critical; if you can get an equivalent, by all means use it. Most of the common kit suppliers will be supplying it in kit form. Expect to pay in the vicinity of \$30 to \$40.

Artwork

Making your own, here are the prices for this month's projects: **ETI-743** pcb \$7.50 panel \$2.70; **ETI-679** pcb \$1.50; **ETI-693** \$1.85 panel \$2.85. Make cheques or money orders payable to 'ETI Artwork Sales'.

Boards and panels

Front panels and pc boards for our projects may be obtained from the following suppliers:

All Electronic Components
118 Lonsdale St
Melbourne Vic 3000
(03)662-3506

RCS Radio
651 Forest Rd
Bexley NSW 2207
(02)587-3491

Jemal
PO Box 168
Victoria Park WA 6100
(09)451-8726

Mini Tech
PO Box 9194
Auckland NZ

For pc boards produced in recent years, the following suppliers either keep stocks on hand or can supply to order:

Acetronics
112 Robertson Rd
Bass Hill NSW 2197
(02)645-1241

Jaetronics
58 Appian Drive
St Albans Vic 3021

Jaycar
117 York St
Sydney NSW 2000

Rod Irving Electronics
425 High St
Northcote Vic 3070

QUALITY FROM ENGLAND

CLIFF

AUSTRALIAN DISTRIBUTOR

DELSOUND PTY. LTD.

1 WICKHAM TERRACE, BRISBANE 4000.

PH: (07) 229-6155

YOUR ONE-STOP ELECTRONICS SUPPLIER

K9 19 x 20 mm

K9 — Matt black finish available in push-on or screw-fix. Push on caps, available colours red, black, white, blue, yellow, orange, grey or green.



K9PF	1+	100+
(incl. cap)	41c	31c
K9SF	57c	47c
(incl. cap)		

+ tax 20%

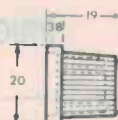

I.C. Test Clip

14-16	—	\$5.00
26-28	—	\$10.00
40	—	\$11.90

+ tax 20%



Quicktest

Ideal for w/shops and test depts.

\$26.00

plus tax 7.5%

S2 Series

S2 range 6.5 mm nylon mono and stereo sockets. High quality brass and Nickel contacts. Colours available.

	1+	100+
S2 BNB Mono	48c	39c
S2 SNB Mono	48c	39c
S2 BBB Stereo	61c	49c
S2 SSS Stereo	48c	36c

Specify colours + 20% tax



ALL ELECTRONIC COMPONENTS

118-122 LONSDALE STREET, MELBOURNE, VIC. 3000, AUSTRALIA. Telephone 662 3506

KIT SPECIALISTS — AND HERE'S MORE POWER TO YOU!!!

"THE BRUTE"—ETI 466—DEVELOPS 300W INTO 4 ohms, 200W INTO 8 ohms

For many audio applications there's no substitute for sheer power. This high power amp affords the full flavour of the dynamic range. This is a "SUPER POWER" module.

PRICE \$107.56 (MODULE ONLY)

ETI 467—FOUR INPUT GUITAR/MIC. PREAMP TO SUIT THE ETI 466 MODULE

Features BASS, PRESENCE, TREBLE and is simple to construct.

ETI JULY 80 \$67.78

ETI 499 (Mar. 82) GENERAL PURPOSE 150 WATT MOSFET POWER AMP MODULE

Here's a high power, general purpose power amp module for guitar and PA applications, employing rugged, reliable MOSFETS in the output.

PRICE \$96.62 (MODULE ONLY)

ETI 498/499 (June 82) VERSATILE PUBLIC ADDRESS AMPLIFIER

Featuring speech filtering and ALC on the mic. inputs to improve intelligibility, an "insert" input and a power MOSFET output stage. 150W RMS MAX. output to 100V, 70V or low impedance lines.

PRICE \$279.90

ETI 477 (Jan. 81) MOSFET POWER AMP

This power amp features a "no compromise" design, is rated to deliver 150W RMS, and features extremely low harmonic, transient and intermodulation distortion.

PRICE \$72.07 (MODULE ONLY)

EA (Dec. 84) VERSATILE EPROM COPIER/ PROGRAMMER

This unit is easy to build and can program 2716 and 2732 Eproms, and copy 2708, 2716 and 2732 devices.

INCLUDES F/P, plugpack, and two gold Z.I.F.'s.

PRICE \$128.00

EA (Jan. 85) MULTISECTOR BURGLAR ALARM

Easy construction, 8 separate inputs, individual sector control, battery backup and a self test facility. INCL. silk screened case, lock, keyswitch, battery, panels, speaker, etc. . . .

PRICE \$211.00

EA (May 85) DELUXE CAR BURGLAR ALARM

New state-of-the-art car burglar alarm features keyswitch operation, delayed entry and exit, automatic reset, and provision for auxiliary battery. INCL. speaker, F/P, case, etc. . . .

PRICE \$89.54

ETI 340 (Apr. 84) VERSATILE VEHICLE SECURITY ALARM — PROVIDES FULL PROTECTION FOR ALMOST ANY VEHICLE

Does not rely on voltage or current sensing to trip alarm but on resonance microphones. Can also protect accessories such as driving lights!

PRICE \$67.47 incl. 2 mics.

EA (Aug. 84) ULTRASONIC MOVEMENT DETECTOR

This kit provides added protection against illegal entry. It will trigger if a window is broken, or there is any movement.

PRICE \$35.86 incl. sensors

Importers ♦ General Sales ♦ Radio Equipment ♦ Microwave Equipment ♦ Radar Equipment ♦ Pulse Techniques ♦ Industrial Electronics ♦ Instrumentation



WE know what's right for you — and you WILL enjoy it!

by Jim Rowe

I LOOK PRETTY BENIGN up there, don't I? Well, you can fake all sorts of things with photography. Right now, as I sit down to write this, I'm hopping mad. I've already given the original June copy for this column to David Kelly a week ago, and it's probably set by now. But never mind, it can wait. I wanted to get this off my chest before it went cold.

You'd think someone my age would be pretty used to the arrogant paternalism of our Aussie bureaucrats by now, wouldn't you? It's hardly something that started last week. Perhaps I'm a particularly slow learner, because it still gets up my nose.

Probably because I've been involved in the electronics industry for 25 odd years, it's the actions of the bureaucrats and technocrats in Telecom and the Department of Communications that most rub me up the wrong way. I guess it's because, like you, I'm more in a position to put their actions into context.

What am I leading up to? I'll tell you. It's a story set in a fairly remote little town called Elliston, in the south-west of South Australia. It was told last night (as I write) on the ABC-TV program "Country Wide".

Apparently the people of Elliston have always wanted to get decent TV reception — not an unreasonable expectation in the 1980s, surely. But as the nearest stations were over 70 km away in any direction, it hasn't been easy. Even putting up elaborate towers and fancy aerial arrays only got them vague, barely recognizable shapes moving through a barrage of snow.

Tests apparently showed that a decent aerial and a VHF-to-UHF translator on a nearby hill would solve the problem. So, for the last seven years or so, they've been trying to get the authorities to provide such a set-up. Without success.

Finally they decided to whip around amongst themselves, and raise the \$25,000 or so needed to put up a translator. They did it all legally — got all the information and a permit from the DOC, used approved equipment, and had an experienced supplier install it all. They were led to believe that if it worked out OK, a proper DOC licence for the set-up would be only a formality.

Soon came the great day to turn it on, and the whole community gathered in the local club hall. The switch was duly thrown, and for the first time they were able to see live TV reception as it should be seen. Fantastic! It had cost them \$25,000, but it was worth it. They were delighted, and also proud of themselves for having had the initiative to 'do it themselves'. As they had every right to be, of course. Australia needs more people like them.

But the smiles didn't last long. A week or two later, they discovered that the DOC was not only inviting applications for *their* translator licence from all and sundry, but also stressing that any translator built would have to be changed for satellite reception as soon as the Aussat satellite becomes operational. When they enquired, they found that such a conversion would cost another \$35,000 or so. Why hadn't DOC mentioned this before they'd blown their money?

"Country Wide" interviewed a rather smarmy DOC engineer, who explained that Elliston was outside the service areas claimed by the nearest licensed stations. Therefore, by definition, they were a remote community, and it was for such communities that the satellite was intended. When operational it would give such communities the best possible reception, and that was why the translator would have to be changed!

Needless to say, the good people of Elliston aren't too impressed with this glaring example of bureaucratic totalitarianism. They're quite happy with the vastly improved reception they're getting now from the existing VHF/UHF translator, thank you very much, and they're going to fight DOC to keep it going. Bravo!

They've got every right right to be cranky with the DOC, of course. In the first place DOC itself should have done something sooner to help the community get better reception — that would have been the best possible way to justify its existence. But then when the Elliston people finally gave up and decided to do it themselves, and asked DOC for advice and permission to set up the translator, why the bloody hell didn't one of these seat-polishing paternalists tell them that supposedly a VHF/UHF transla-

tor could only be given a temporary licence?

Even that's not what is really getting up my nose about this story. It's not the bungling, but the arrogance: the way DOC assumes that it alone knows what is best for the Elliston people, and that it apparently has the authority to force its technocratic will upon them.

Bugger the people of Elliston — what would they know about it? Sure, they might be perfectly happy now with their dramatically improved reception, but WE the experts at DOC know that once the satellite is up, they could get an improved signal-to-noise ratio. Why, our calculations show at least 4.7521 dB theoretical improvement. So they'll just have to change their translator over. Stiff cheese — serves them right for not waiting until we got around to sorting out their problems properly!

What an arrogation of bureaucratic power. Surely the people of Elliston are the best judges of whether their existing VHF/UHF translator is good enough? They had to pay for the bloody thing after all, out of their own pockets. If *they're* quite happy with the reception they're getting, what right does some obviously underworked DOC seat-polisher have to force them to spend more money to upgrade it?

The fact is, of course, that if the reception they're getting now via the VHF/UHF translator is perfectly OK, it won't be one iota less satisfactory when the satellite is operating. It might even be better, if the stations feeding the translator get some of their programs direct from the satellite. So from the technical point of view, there's no earthly reason why the Elliston translator should be changed if the people of Elliston don't want to. No extra-terrestrial reason, either!

It's another example of DOC paternalism run rampant, and I hope ETI readers will join me in condemning it. What'll we have next — DOC stormtroopers blitzkrieging Elliston and forcibly smashing down their verboten translator?

PERIODICALLY, just after April, when everyone realizes that it's time to think of another April fools joke, we get flooded with millions of press releases. Many of them are true. Many are not. People who entered the program for the Dynachromics Generator in our April edition will understand what I mean.

Just for the hell of it, here is something else we received from Moora WA (No, I don't know where it is either). Apparently, the Swedish company Lirpa Luf A.G., well known makers of plastic products has announced the densest recording medium known. It's called the FIK disk, or FD for short.

Apparently, FD technology is very similar to CD technology. However, instead of engraving pits on a mirror surface, it deposits tiny mirrors on an optically clear surface. Twenty of these glass discs can then be stacked together and fused by heating to form a solid lump of material.

The FD is mounted on a Random Access Terminal, and the encoded data read off as the FD spins beneath a laser pickup. A large convergence lens and a high speed servo mechanism focus the beam sequentially on the individual layers as the disc spins. The mirrors reflect the signals back to

the receive head. Here they are decoded in the normal way.

To simplify development and marketing, the system uses the same decoding circuits as CD, with sampling at 44.2 kHz and a brick wall filter slamming down just over 20k. However, the amount of information that can be stored in a given area is much increased.

The marketing department at Lirpa Luf is still trying to work out a name for the device. Front runners at the moment appear to be VLA (very large amounts) or Huge-a-byte.

Meanwhile there are a few software problems to be worked out. It can hold three Sydney Telephone directories, for a start. Why would anyone want three Sydney telephone directories? Not that lack of a use has stopped great developments before. Read the press at the time and it's obvious no one could force the use of telephones, or radio or TV.

In fact if you read *Wireless Weekly* for 2 September, 1927 you will find some very sage words from the editor on the future of television. This worthy notes that some prominence has been given in the non-technical press to the subject of television. Us technical people realize that this should

properly be called radio-vision, since it is simply an application of radio transmissions. True, he notes, there have been some demonstrations of the new art of "looking in", of more or less promising success, but no-one has been able to show how this could be applied with reasonable simplicity and economy. Nor has anyone been able to suggest a practical use for it.

From this view of history we can all see what TV is for. Just consider all the ingenuity that went into the design and construction of the TV system, so you could watch *Perfect Match* and *Blankety Blanks* and have some clown tell you you're mad if you don't "go lotto", whatever that might mean.

Will the same happen to the FD. I hope not. One sees it being applied to all sorts of necessary things. The entire works of Dickens could be held on one side. Two discs would hold your complete Shakespeare. Three discs would tell your optometrist all he needed to know about repairing eyes that had been overstrained by watching computer screens for too long.

Imagination is the only limit to the application of this type of technology. Discuss it with your friends. And don't forget to tell them you read it in the "Dregs" column.●

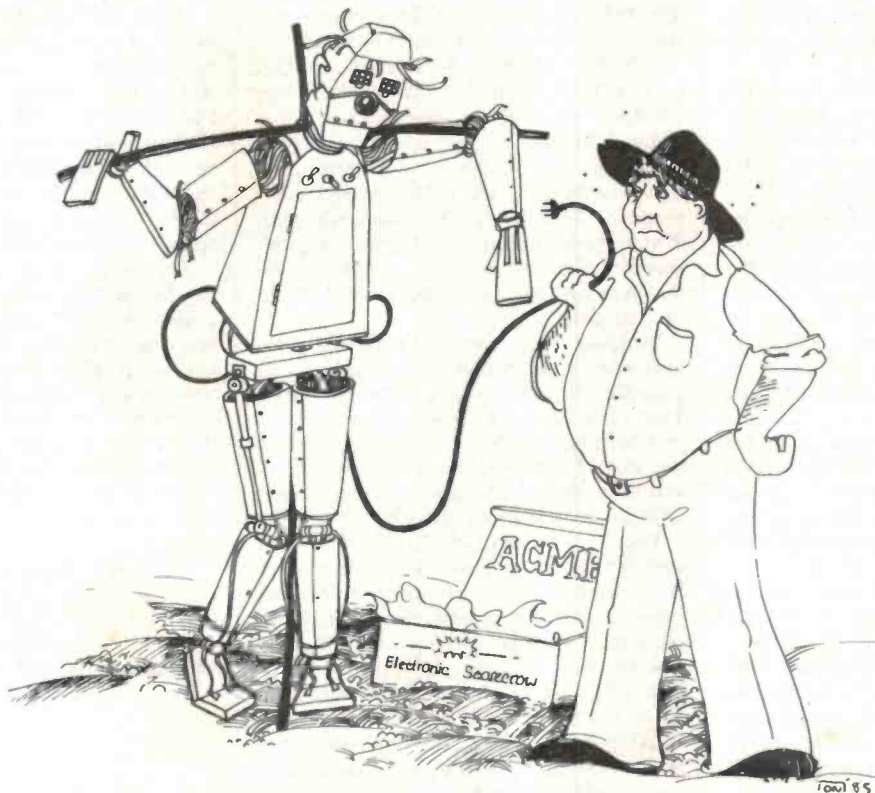

25 LINES OF 80 CHARACTERS!

FLAT PANEL DISPLAYS AVAILABLE NOW!!

This is the actual effective display size of LJ512U05



*** LJ512U05 SPECIFICATIONS ***

- Effective Display Area (mm)
96 (L) × 192 (W)
- Number of Matrix Electrodes
512 Column Electrodes *
256 Row Electrodes
- Number of Picture Elements
131,072 (512 × 256)
- Picture Element Size (mm)
0.225 (L) * 0.275 (W)
- Picture Element Pitch (mm)
0.375 (both lengthwise and
widthwise)
- Display Color
Oranger-yellow
(peak wavelength 5850Å)
- Brightness
25fL (standard)
- Frame Frequency
60Hz (standard)
- Input Signal Level
LS TTL Level
- Outline Dimensions (mm)
148.5 (H) × 228.5 (W) × 35 (D)
- Weight
Approx. 650g

Sharp's full line of EL (Electro Luminescent) Displays are thin (34mm), lightweight (650 grams), low power (15 watts max) and the two latest editions can display 25 lines of 80 characters. These "State of The Art" Displays feature: line by line scrolling, blinking characters, full graphics and a

simple 4 line interface. EL's bright, crisp, easy to read characters will enhance the marketability of any product.

Design the leading edge of display technology into your products today using displays from Sharp, the world's largest manufacturer of EL Displays!

LJ512U01 • Ideal for written characters • Effective display area 44.8mm × 179.2mm • Number of picture elements 512 × 128
• Outline Dimensions (mm): 108.5(H) × 228.5(W) × 34(D)



LJ320U01 • Ideal for fine graphics as well as written characters • Effective display area 90mm × 120mm • Number of picture elements 320 × 240
• Outline Dimensions (mm): 148.5(H) × 178.5(W) × 34(D)



LJ512U05 • Ideal for fine graphics as well as written characters • Effective display area: 96mm × 192mm • Number of picture elements 512 × 256
• Outline Dimensions (mm): 148.5(H) × 228.5(W) × 34(D)

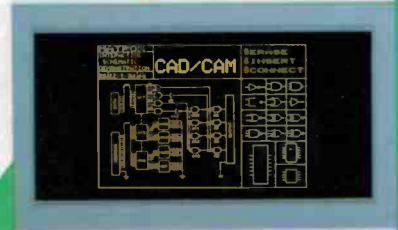

LJ640U01 • Ideal for written characters • Effective display area 60mm × 192mm • Number of picture elements 640 × 200
• Outline Dimensions (mm): 108.5(H) × 228.5(W) × 34(D)

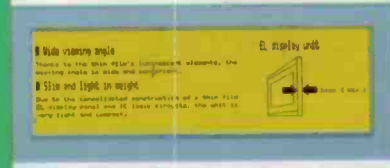

EL DISPLAY

Distributed in Australia by:

daneva australia pty ltd
66 Bay Rd, Sandringham, Vic., 3191.
P.O. Box 114, Sandringham, Vic., 3191.
Telephone: 598-5622. Telex: AA34439.



SIEMENS

The better the drive, the smaller the disc

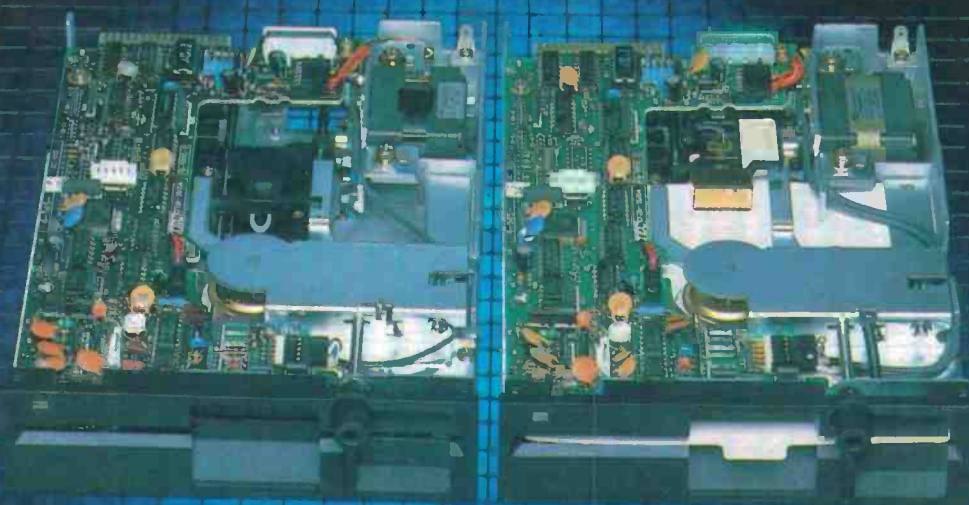

True half height 5 $\frac{1}{4}$ " floppy disc drives competitively priced from Siemens.

Designed for office electronics, business computers and OEM applications, this slim-line FB500 series has four versions with unformatted storage capacities from 250K to 1M bytes. Apart from compactness, these drives offer

fast access time by an advanced stepping motor and steel belt mechanism. The brushless direct drive DC motor is highly reliable and very quiet. The full range is now in stock together with Siemens relentless determination to provide complete service and technical assistance throughout Australia.

Siemens Ltd.

544 Church Street, Richmond, Vic.
Melbourne: 420 7318. Sydney: 436 8730.
Brisbane: 369 9666. Perth: 362 0123.

Distributors:

Auckland: Delphi Industries Limited. 567 258
Adelaide: R.G. Pank Pty. Ltd. 51 2411
Adelaide: Protronics Pty. Ltd. 212 3111
Brisbane: ECQ Electronics. 376 5677
Melbourne: Promark Electronics Pty. Ltd. 878 1255
Perth: Reserve Electronics. 328 9755
Sydney: Promark Electronics Pty. Ltd. 439 6477

Siemens. The discs may be flexible, but never our standards.