

FLYING THE SPACE SHUTTLE

electronics today

MAY 1978

INTERNATIONAL

\$1.25*

NZ \$1.50



UFO DETECTOR
VDU Constructional
details

SWR BRIDGE
Audio Oscillator
Crosshatch Generator

JVC speaker technology has one aim...

Let's face it, the main task of any speaker is to reproduce sound, faithfully, clearly and with low distortion, if any. The way they deliver what we at JVC call 'The Musical Truth'.

The musical truth is something special in sound. It's an indication that your records sound as good in your listening room as they did at the recording studio. These three computer designed JVC SK series speakers do just that, pure hi fi reproduction.

Our engineers have perfected a computer-assisted way of measuring speaker performance that actually translates acoustic response into visible patterns. This is the unique JVC Phase Moire Propagation Pattern technique. With the use of advanced electronic computers we actually see how speaker units and enclosure interact acoustically. This technique was used in the development of these three JVC SK series speakers.

But do yourself a favour. Listen to the reproduction at your JVC dealer.

PHASE MOIRE PROPAGATION METHOD

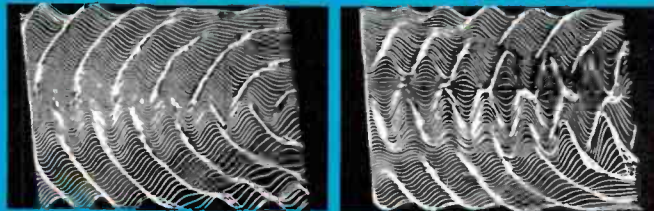

Smooth undulating JVC Series Speaker System Pattern.

Poorly designed Speaker System Pattern.

You'll come to one conclusion. That JVC SK-1000, SK-700 and SK-500 speakers are designed from start to finish by engineers, whose aim is to give you pure hi fi reproduction, or what we at JVC call 'The Musical Truth'.

SPECIFICATIONS

	Type	Speakers	Power Handling Capacity
SK-1000	3-Way, 3-Speaker	Woofer: 30cm (12") Free-Edge Type. Midrange: 12cm (5") Free-Edge Cone Type. Tweeter: 2.5cm (1") Dome Type.	85 watts (RMS)
SK-700	3-Way, 3-Speaker	Woofer: 25cm (10") Free-Edge Type. Midrange: 12cm (5") Free-Edge Type. Tweeter: 2.5cm (1") Dome Type.	60 watts (RMS)
SK-500	2-Way, 2-Speaker	Woofer: 25cm (10") Free-Edge Type. Tweeter: 5cm (2") Free-Edge Type.	35 watts (RMS)

the musical truth!



SK-500

SK-700

SK-1000

For pure Hi Fi entertainment!

JVC

For details on all JVC Hi Fi Equipment, write to: JVC Advisory Service, P.O. Box 49, Kensington, N.S.W. 2033 the right choice

electronics today

INTERNATIONAL

Editorial: Les Bell
 Publisher: Collyn Rivers



By using his photographer's skills, and a little help from our UFO detector project, George Hofsteters was able to produce this shot of a UFO hovering over Sydney's Martin Plaza.

PROJECTS

587: UFO Detector	18
<i>Close Encounters of the ETI kind</i>	
137: Audio Oscillator	35
<i>Incorporates novel digital display</i>	
717: Crosshatch Generator	69
<i>Amazing what a 4040 can do!</i>	
139: Reflectometer	75
<i>For Amateur or CB use</i>	
640: \$100 VDU	89
<i>Constructional details</i>	

FEATURES

The Strange Case of Circinus X1	10
<i>Australian astronomers' latest success</i>	
A Look at the Space Shuttle	12
<i>World's fastest glider</i>	
Sound Section	25
<i>New speakers, arm</i>	
Digital Electronics by Experiment, Part 3	45
<i>Introducing the 7400</i>	
Data Sheet: Intersil 7208	52
<i>7 digit counter/decoder/driver</i>	
Special Offer: TV Game \$19.95	58
<i>Yes, we said \$19.95!</i>	
Print Out	61
<i>A look at the TRS-80</i>	
Propagation: A Closer Look	81
<i>The structure of the ionosphere</i>	
Book Reviews	87
<i>New releases</i>	
Communications Section	101
<i>News for SWL's, hams, CB'ers</i>	

NEWS & INFORMATION

News Digest	4	MiniMart	96
Sound Briefs	31	Ideas for Experimenters	107
Print Out News	61	Reader Services	114
Kits for ETI Projects	86	Index to Advertisers	114

 A Modern Magazines Publication
 * Recommended retail price only.

Registered for posting as a publication — Category B

Interscan Wins Through!

World aviation authorities have adopted a system based on a revolutionary Australian concept as the international requirement for a microwave landing system to be progressively introduced in place of the existing aircraft landing guidance system.

This was announced on 22nd April by the Minister for Transport, Mr. P.J. Nixon, and the Minister for Science, Senator J.J. Webster.

They said the Australian 'Interscan' microwave landing system, developed by the CSIRO and the Department of Transport, and subsequently adopted by the US where it is known as the Time-Reference-Scanning-Beam system (TRSB), was selected in Montreal on Friday, 22nd April by the International Civil Aviation Organization (ICAO) at the Plenary meeting of the ICAO All Weather Operations Division.

The decision meant:

Australian innovative science and technology had proved itself in fierce international competition.

The now internationally accepted system is well suited to Australian future aviation requirements.

Australia is advantageously placed to provide hardware for the new landing system from local resources.

The Ministers said an experimental Interscan system had been undergoing flight trials at Melbourne Airport since 1974.

Microwave landing systems using the TRSB signal format of Interscan should begin appearing at international and major domestic airports across the world during the 1980s. These systems have a key role to play in taking civil aviation through into the 21st century by providing electronic flight paths with a hitherto unobtainable degree of flexibility and accuracy in virtually all weather conditions.

"Australians should feel justly proud of this international recognition of the work of CSIRO and the Department of Transport," the Ministers said.

"ICAO's adoption of the Interscan/TRSB concept, placed before it by the complementary Australian and US submissions, more than vindicates the \$5 million backing the Australian Government has provided for its development.

BACKGROUND:

In 1972 ICAO, the world body of government agencies concerned with civil aviation, launched an international competition to find an all-weather approach and landing guidance system suitable for aviation's developing

requirement into the 21st century. Australia, the US, Britain, France and West Germany decided to develop systems for consideration.

The Australian Interscan system resulted from collaborative research by CSIRO's Division of Radiophysics and the Department of Transport.

The Australian electronics industry has been working with the Commonwealth and built the experimental system used at Melbourne Airport. by 1974 due to the efforts of CSIRO and the Department of Transport, the US Department of Transportation's Federal Aviation Administration elected to adopt the TRSB concept embodied in Australia's Interscan.

Thus the US and Australian submissions to ICAO became complementary. Subsequently the U.S.S.R. indicated its support of TRSB/Interscan system.

In 1977 ICAO's All Weather Operations Panel after lengthy technical and economic evaluations adjudged the TRSB/Interscan concept to be superior to all others. The recommendation of this panel was considered by the world wide meeting of ICAO in Montreal in April 1978.

INTERSCAN:

At present aircraft are guided in to land at airports by means of an instrument landing system (ILS) which indicates to the pilot whether the aircraft is left, right, above, or below a single approach path to the airport runway.

The main disadvantage of the present ILS system is that it can provide only one approach path aligned with the runway centre line and at a fixed angle of descent. The signal may also be perturbed by objects such as buildings or taxiing aircraft.

The Interscan concept will allow air traffic control authorities greater flexibility in choosing the path of aircraft during approach and landing to cater for the needs of a variety of aircraft types and increased traffic, as well as providing more scope for noise abatement over sensitive areas of population.

It comprises several ground antennas which generate scanning microwave beams which are intercepted by an aircraft and define its angular position relative to the runway. The Interscan antennas are completely electronic in operation, having no moving parts.

Information derived from the scanning beam combine with range to a ground beacon determined by distance measuring equipment (DME) in the aircraft pinpoints the aircraft's position in space.

The system is relatively simple, inexpensive and very flexible. It does

away with the single, straight pathway at a fixed angle of descent down which aircraft currently approach and land. Instead it provides dozens of 'highways in the sky' from 50 kilometres out. These may be either straight or curved at a variety of angles of descent.

It can also allow aircraft to approach and land in bad visibility with the same flexibility they have in clear weather.

New Rotary Switch

A unique 12 terminal programmable rotary switch capable of multiple switching has been introduced by Melbourne based Swann Electronics Pty Ltd.

Manufactured in Australia for local and overseas appliance manufacturers, the patented 90 series unit provides versatility in design applications.

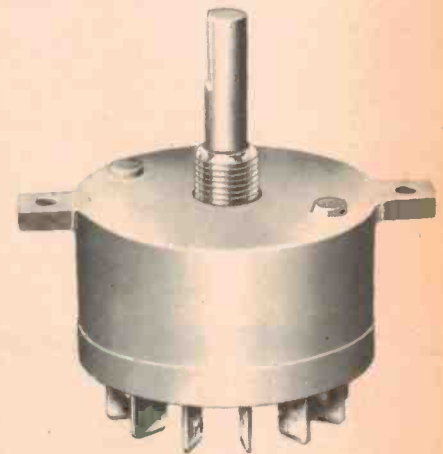

Applications include appliances such as heaters, air conditioners, fan heaters, ranges and washing machines. Rated at 15 amps, 240 volt AC, internal bridging is available to provide additional flexibility in circuit design. Depending on specification, the switch can be barrel or flange mounted, or supplied with a threaded shank for panel mounting. Further information from: Swann Electronics Pty. Ltd., P.O. Box 350, Mt. Waverley, VIC. 3149.

Caller Hung Up

The British Post Office has revealed that it made use of a "special device" to trace the source of indecent and threatening calls to a woman in Lanarkshire, Scotland — after the caller had hung up.

Mr Alistair Duff, in prosecuting, said: "Post Office engineers installed a special device on the telephone. When the woman received her next call from the man, she pressed a button on the device which activated it and held open the line, enabling the Post Office to trace the call back to the man's home".

The man had been making the indecent calls over a period of six months and had threatened to harm the woman's seven year old daughter.



Fibre Optic Microphone

Recent research at University College, London, has developed a microphone which relies on acoustic waves modulating the refractive index of an optical fibre to phase-modulate the light being sent through it. Because of the short wavelengths of light, large phase shifts can be caused by low levels of acoustic power, making microphones possible that are 26 dB better than the human ear, with 180 dB dynamic range.

Midland Charged \$3M

Midland International Corp., an importer of Japanese-manufactured CB radios and TV sets, has been assessed US\$3.4M in 'dumping duties' by the US Customs Service for its TV imports into the US. Said the company's president: 'That's a hell of a lot of money. You don't have that kind of money laying around in petty cash'.

Intel, IBM Trade

Intel and IBM have surprised the industry by signing a royalty-free licencing agreement under which IBM will get rights to the MCS-48 and UPI-41 microcomputer architectures. Intel, in turn, will receive rights on some of IBM's magnetic bubble technology.

DIY Bomb

A recent report in the NY Times describes how a 22 years old former Harvard student with only 1 year of college physics, and without any help, designed a 'highly credible' series of nuclear weapons. As a result, the chairman of the Senate Governmental Affairs Committee's Subcommittee on Nuclear Proliferation has asked President Carter to tighten controls surrounding nuclear materials of use to potential DIY-bombers.

More National CMOS

National Semiconductor Corp. is expanding its family of CMOS devices with the addition of four new digital integrated circuits.

Available now, the new devices include the CD4512, an 8-channel data selector; the CD4514/4515, two 4-bit latch/4 to 16 line decoder (high and low versions); and the CD4543, a BCD to seven segment decoder (LCD). Pin and functionally compatible with similar devices now on the market, the new units are also priced competitively, says Jack Rutherford, Managing Director of N.S. Electronics. In 100-up quantities the CD4512 is \$0.98 each, the CD4514 only \$3.50, the CD4515 is \$3.50 and the CD4543 which is \$1.94.

FRG-7 Owners Guide

Dick Smith has introduced a guide to the Yaesu FRG-7 Short Wave Receiver which, according to Dick, "continues from where the instruction booklet with the set leaves off".

The six-page guide was written specially for Dick Smith by noted short wave correspondent, Arthur Cushen M.B.E.

It describes the step-by-step procedure for tuning stations on known frequencies, provides information on International short wave and amateur bands to listen to, explains the 24 hour clock and G.M.T., lists transmission times and frequencies for broadcasts for the major short wave transmitting countries of the world and concludes with a run-down on short wave listening as a hobby.

Dick Smith is offering this useful guide FREE with each Yaesu FRG-7 receiver sold through his eight electronics stores or by his mail order department.

Dick's April Fools Day Joke

This year Dick pulled off his greatest prank ever — and it had Sydney newspaper, radio and television station's switchboards buzzing all morning.

He towed a 14 metre long "iceberg" into Sydney Harbour at dawn on Saturday April 1st. The "iceberg" was actually a barge covered with framing, white plastic sheet and foam, but in the morning mist it looked surprisingly like the real thing.

The word spread quickly around Sydney and soon the iceberg was besieged by boatloads of newspaper reporters and TV cameramen who didn't take long to realise they had been "had". Dick's secret was out and Sydney's biggest April Fools joke was over.

Electronic Sight

Kurzweil Computer Systems of Cambridge, Mass., have developed an electronic sight system which combines a photodiode array, via a NOVA 312 minicomputer, with a speech synthesizer to form audible signals which represent a visual image of a letter or symbol.

Travelling Clock Radio

Equivalent in size to a pocket calculator, Toshiba's new QR-2000 travelling clock radio can be set to remind the owner of appointments and it can be carried in a suit pocket, brief case or handbag. The small AM/FM radio incorporates a digital clock with backlit LCD display. As well as an alarm, the radio has a 'sleep' button which turns the radio off an hour later.

Further information is available from Toshiba-EMI (Australia) Pty. Limited, 16 Mars Road, Lane Cove, N.S.W. 2066.



News EXTRA



3D Laser Replication

First publication of details concerning a far-reaching scientific and industrial innovation has occurred with the issue of United States Patent 4,078,229 on March 7, 1978.

Arthur C. Clarke, author of "2001: A Space Odyssey," and inventor of the orbiting communications satellite, has recently described the subject of this patent before the Congressional Clearinghouse on the Future:

"the Replicator . . . this is a machine that can make a copy of anything in its three-dimensional form, in all its details. Suppose we could manufacture an object all in one operation. It would put all the mechanics out of work, all the machine tools. I discussed this twenty years ago in a book called "Profiles of the Future," never imagining it would come to pass in my lifetime. Imagine my

astonishment when I learned that the first patent for the replicator had been put out by a company in California called OMTEC . . ."

Commercial development of the complete Replicator system is being negotiated by a group of manufacturing licensees with the co-operation of the Battelle Columbus Laboratory, developers of the first Xerox copying machines.

Late last year Dr. Carl Verber, physicist at Battelle, described at a meeting of the Society of Photo-Optical Instrumentation Engineers work he has carried out toward development of a system of related three-dimensional television. In ordinary television the light and dark areas of a scene are converted by the TV camera to a description or plan in the form of radio waves. On the television screen this plan controls the sweep of an electron beam across the surface of the phosphor-coated tube. The electron

beam "draws" the two-dimensional scene by moving the resulting spot of fluorescence over the screen so rapidly that the eye sees a whole picture.

The three-dimensional television is built around a transparent box containing a gas which fluoresces only when hit by two different colors of laser light. This light is supplied by two fine laser beams which under computer control intersect within the box, and can be scanned together so that they always intersect. Because both colors are required to make visible fluorescence, the result is a spot of light — fluorescence — at the intersection. Just as in the two-dimensional TV, the 3-D TV display makes a three-dimensional picture by rapidly moving this spot inside the box so that the eye sees the whole pictures, but three-dimensional pictures. US Patent 4,041,476 for this 3-D television system was issued to OMTEC Replication in August of 1977.

The Replicator operates on a principle similar to that employed for 3-D television. In this case the computer and laser-control apparatus are adapted to project the intersecting beams into a reaction chamber containing special liquid plastic or a photoactive solution of metal salts. These liquids are unreactive to beams of either red or blue laser light, but they do react to the unique effect of the beams combined at the intersection. Depending on the 3-D plan/description source, the "picture" which forms in three-dimensions (actually a shape or

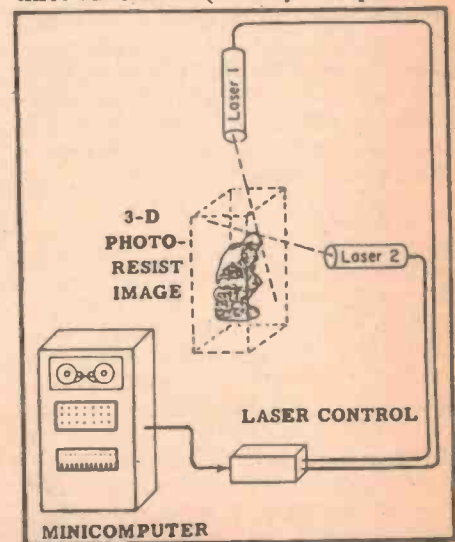

sculpture) can originate in blueprints, a computer-program engineering design, or it can be a reduced or enlarged duplicate made from data transmitted from anywhere in the world.

Wherever the two-beam intersection is moved within the Replicator chamber, a part of the product "crystallizes" out — much like rock candy from a heavy sugar solution — except that in this case the shape is determined by the movement of the laser-beam intersection. The finished articles in photo-resist plastic can be directly used as models or patterns in manufacturing or precision investment casting, or negative images can provide molds for low-temperature casting. Injection molds and dies are obtainable from the model by conventional techniques such as electroforming or plasma-arc deposition of metals. Overall, these methods promise to cut the time involved in making critical industrial components from many months to a few days.

Using the fully developed Replication systems the manufacture of a product will be directly under the control of the design engineer, eliminating stages of drafting, blueprinting, modeling, and many separate steps of machining and assembly. The effect is as though a single machine is capable of making in a single operation complex shapes — carburetors, gears, turbine blades and aircraft parts — without transfer between specialized lathes, milling machines, drills, thread-cutters, or other machine tools. Instead of being stored in the inflexible form of blueprints, design data stored in the computer is instantly adaptable should a design fault later become evident. Tape cassettes containing perfected designs for auto parts or machinery could become international articles of commerce. Use of Replication machines in Third-World countries, combined with modern casting and molding technology, could go a long way toward reducing the need for a building-up of an extensive machine tool infrastructure before industrialization.

In the developed world, further evolution of this technology could lead to plastics materials capable of being recycled repeatedly in new useful Replicated products, created from raw materials obtained by known methods of decomposition of plastic waste. Housewives could select designs for utensils, furniture, or other articles from televised catalogues, with manufacturing instructions for the Replicator being distributed over telephone lines.

"Profipower" Microphone

The new "profipower" dynamic microphone is the top model of Sennheisers' full line of soloist microphones, and has especially been developed to meet the demands of the professional musician. The trade name given this microphone is to indicate that the microphone features certain properties which are described as "power" by professionals: unusually high dynamic range together with the highest possible safety against feedback through an excellent frequency independent directional characteristic.



Since a musician's microphone has to be extremely insensitive to handling noise the "profipower" has been equipped with a temperature-independent damping suspension to protect the transducer system against noise. A built-in low-frequency roll-off filter prevents extremely low-frequency interference reaching the transducer. With this model a microphone is available to the musician featuring excellent low frequency response but at the same time reducing handling and shock noise.

An integrated pop-screen prevents pop-noise and accentuated sibilant sounds.

The "profipower" is delivered with a 3-pin Cannon connector XLR 3. The electrical impedance at 1000 Hz is 200 Ω , the minimal recommended load impedance is 1000 Ω . The microphone is delivered with a 5 m connection cable fitted with a 6.3 mm jack plug for direct connection to musicians' equipment.

Thumbwheels a Problem?

C & K Components Inc. of the USA have released a small booklet entitled "All you should know about thumbwheels . . . and never asked" for free issue to interested customers.

This is a 6-page publication explaining basic fundamentals associated with thumbwheel switches. The approach is light and makes for entertaining reading.

For your free copy contact C & K in Sydney (at P.O. Box 101, Merrylands, 2160) or Interstate Agents.

Walkie-Talkie US Extension

Although the FCC had set a sales cutoff date of September 18th for 27 MHz walkie-talkies, this has now been extended to December 31st. General Electric Co and Fanon/Courier Corp both claimed they needed the extension to sell large inventories of the 27 MHz units. Seems to us that recent publicity over the walkie-talkies in Australia could also be involved in their pleas.

New Office Recorder

Cassette tape recorders have become an essential item of office equipment, especially with secretarial costs rising and the need to economise on labour costs.

However, one problem with many tape recorders on the market is the relatively short life of batteries, which can become a major obstacle in recording long business conferences.

To overcome this problem AIWA have just launched on the market a compact portable cassette recorder which provides 12 hours continuous recording on a single set of batteries. This compares with three to four hours on most other tape recorders.

The new set is ideal for businessmen and secretaries as it also provides a special speed control facility which means that when a businessman is recording he can increase the speed by 10%; and conversely when a secretary is typing back the tape she can slow the speed by 10%.



The AIWA cassette recorder can operate from three power sources (AC, DC and car battery) and has an in-built anti-rolling mechanism which assures stable cassette play from any position or while in motion.

It has a quick cue and review facility which automatically traces the voice back to a particular point of a businessman wishes to correct material he is dictating.

Other features include a digital tape counter; mechanical pause control and auto-stop mechanism; new slide-type ejection for quick cassette removal; and convenient "one push" recording mechanism.

It sells in Australia for \$149.

SWITCH ON

TO THE BIGGEST ELECTRONICS
SHOW EVER SEEN IN AUSTRALIA

3rd CONSUMER ELECTRONICS SHOW July 13 to 16. This year at the Sydney Showgrounds.

MANUFACTURERS & COMMEMORATIVE HALLS RAS, SHOWGROUNDS.

SEE IT FIRST AT CES '78

Everything electronic. Stereo equipment, CB radios, calculators, headphones, tuners, turntables, amplifiers, speaker systems, tape decks and recorders, closed circuit TV, microwave ovens, electronic watches, clocks and games, crossovers, equalizers and new releases you may never have even thought about!

CES '78 WILL MAKE TWICE AS MUCH NOISE AS LAST YEAR!

The response by manufacturers has been so great this year that we needed as much space as we could get. More space than any hotel could offer! This July, then, as the major electronics show of the year, the 3rd Consumer Electronics Show moves into the RAS Showgrounds to occupy more than 80,000 square feet of display area. The advances in technology in the past 12 months have been staggering. It's no wonder that manufacturers have really come out in force to show off their best!

SOUND OUT WHAT'S AVAILABLE

Kriesler, Philips, Pioneer, Pye, Sanyo, Sony, Yamaha . . . those are just a few of the leading manufacturers demonstrating new releases at the Show. See Philips' new 'Sound Project', new front loading cassette, and many other new releases! See Pye's new 'Diotran' range of audio equipment. See Sony's exciting new turntables and cassette deck. All the great names in sound gear from Asia, Europe, U.S.A., the U.K., Scandinavia and Australia will be on hand, all at the same time under one roof! With so much space, it's easy to walk through the CES exhibit halls at the Sydney Showgrounds and meet the manufacturers. Ask questions, compare performance, judge the values and make up your own mind— who's the best at CES '78!

CES '78 WILL SWITCH IT ALL ON FOR YOU

Thursday and Friday, July 13 and 14 from 1 pm to 10 pm.
Saturday and Sunday, July 15 and 16 from 1 pm to 6 pm.



Really worth listening to!

 ANOTHER
RIDDELL
EXHIBITION

RP326



VTR Leader Logic

The engineering supervisor of the Australian Film and Television School, Ernst A. Hadenfeld, has devised a system for electronically generating a leader for video tape recordings in a way that is fully automatic.

A video tape leader must provide accurate aural and visual timing cues both prior to recording and also on replay. It should also be consistent with international recommendations on timing sequences.

In the Hadenfeld system the sequential elements of the leader are switched automatically by digital logic circuitry which is triggered when the RECORD button of the video tape recorder is depressed.

A switch on the front panel of the leader generator module allows the operator to select one of two. The TAPE LEADER sequence, lasting 95 seconds, controls the switching of

separately generated test signals and program identification for the front of each new roll of tape. The second is the shortened TAKE LEADER sequence of 25 seconds providing an accurate countdown and take identification for each take on the roll.

Mr Hadenfeld will give a paper on the system to the Sydney division of the Institute of Radio and Electronics Engineers at the Australian Film and Television School at 6.30 pm on Tuesday, 27 June, 1978. Visitors are welcome to IREE meetings and refreshments will be available from 6.00 pm.

Anyone seeking technical details of the system and who is unable to attend this meeting should write to *The Australian Film and Television School, Box 126, Post Office, North Ryde, 2113.*

Phone-Line TV

Visicom (A/asia) Corp. proudly announces being appointed exclusive Australia/New Zealand/Papua New Guinea distributor of Robot Research Corp. (USA) Phone-Line TV and Professional Slow Scan TV.

Visual information can be transferred in 8½ seconds using a standard TV camera, Robot PLTV units, and TV monitor over regular Telecom or private telephone lines. A permanent record of transmitted data is recorded and stored using an inexpensive cassette recorder and retrieved as required. An extensive range of options and accessories are available. Visual information can be exchanged via almost any two-way radio with little or no modification to the radio equipment using Robot Professional Slow Scan TV (SSTV) equipment. Applications of Robot PLTV and Professional SSTV include military, medical, commerce, scientific, education and security.

Visicom (A/asia) Corp. was recently formed specifically to market Robot equipment and cannot be found in any telephone or other directory as yet.

Inquiries may be directed to: Visicom (A/asia) Corp., Marketing Division, P.O. Box 2058, Cairns, Queensland, 4870.

Antarctic Trip Winner

Mr. A.J. Rothwell, of Chapman, ACT, is pictured drawing the winning entry in the Dick Smith South Pole competition conducted recently.

With Mr. Rothwell is Bob Johnson, Manager of the Dick Smith store at Gore Hill, Sydney.

The lucky winner was Mr. A. Commadeur of Warragul, Victoria. From all reports Mr. Commadeur enjoyed his flight which was conducted in February.



ETI/Unitrex Calculator Contest

You're all getting too smart for us to fool you — hardly anyone got the wrong answer for the March contest. The correct answer is that the tea contains the same amount of coffee as the coffee contains of tea, and the winning entry was submitted by Steve Gagan of East Kew, Victoria, who mathematically proved it to us.

And so to this month's problem. Normally, in our office, to decide who does those particularly boring jobs (like checking the contest entries to see if anyone has enclosed queries or other letters), we toss a coin. Now, this is fair enough, but after I had won the toss six times in a row, young Simon was beginning to wonder if perhaps I wasn't using some kind of mathematical trickery to swing the odds my way. 'O.K.', I said, 'I'll tell you what. You toss two coins and I'll toss one. If you have more heads than I have, you win. If you don't, you lose. How's that?'

'Good', said Simon, 'that sounds better to me'. The question is, was this entirely wise of young Simon?

Seal an empty envelope, write your answer on the back of it, with your name and address, and send it to: Unitrex Calculator Contest (May), ETI Magazine, 15 Boundary Street, Rushcutters Bay, NSW 2011. The closing date is 16th June.

Errata

Linear Capacitance Meter, ETI 136, March 78. Some errors slipped through the system and appeared in this project. In the parts list, R4 is omitted — it should be 120R. On the circuit diagram, R7 should be 1k, R8 should be 10k, and the battery polarity is shown reversed. The orientation of IC2 shown on the component overlay is incorrect — for a 78L12 the flat should face to the right of the drawing, while for a 7812 the flat metal back of the TO-220 pack should face to the left. The markings on the printed circuit board are correct. R7 to R12 and the pilot lamp connect to the point marked '+12V' on the overlay. The common connection to switch S3 should be taken from the point marked 'red terminal' on the overlay.

Dual Power Supply, ETI 581, Jan 77. Some readers have had problems with failure of low powered regulators when using loads connected between the positive and negative outputs. This is caused by one filter capacitor discharging before the other on switch-off and the load pulling the output of the regulator into reverse voltage. This can be prevented by adding diodes (1N4001, 1N914, etc.) across the outputs to limit any such voltage to 0.6V.

The Strange Case of Circinus X1

AN INTENSIVE RESEARCH PROJECT by Australian astronomers using all of the country's major optical and radio telescopes, has the secret of one of the southern sky's most mysterious objects.

THE ENIGMATIC BEHAVIOUR of Circinus X-1, the first cosmic X-ray source to be found in the constellation Circinus, 30,000 light years distant, has defied explanation since it was first detected by NASA satellite-borne X-ray telescopes in 1971-72.

Dr Raymond Haynes, an astronomer with CSIRO's Division of Radiophysics who, with four colleagues, Drs Ian Lerche, David Launcey, Jim Caswell and Paul Murdin, has proposed an explanation for the odd behaviour of Circinus X-1, says it has been found to be not one object but two — a tiny, incredibly dense neutron star in elliptical orbit around a massive supergiant sun.

Approximately every 16 days, after travelling 320 million kilometres, the neutron star hurtles across the face of the supergiant. Tidal forces exerted by the neutron star pull a million billion tonnes of hot, gaseous matter off the supergiant at each pass.

The fiery tide rains down onto the surface of the neutron star, creating a massive three-day outburst of radiation which is detectable by radio and optical telescopes in the southern hemisphere.

Co-operative effort

Circinus X-1 yielded its secrets only after collation of an enormous amount of data from combined observations made with CSIRO's 64-metre Parkes radiotelescope, NASA's 64-metre radiotelescope at Tidbinbilla, Sydney University's Fleurs synthesis and Molonglo radiotelescopes, the Anglo-Australian Observatory's 4-metre optical telescope and the UK Schmidt optical telescope.

Dr Haynes said the co-operative work provided the clues necessary to a detailed understanding of the strange behaviour of Circinus X-1.

Every 16 days and 14 hours, the X-rays are cut off and radio flares are detected at intervals of about 18 hours. The increase in brightness is due to a swelling of the supergiant's size as the tidal attraction of the neutron star grows stronger.

The first radio measurements of a point source near the positional of Circinus X-1 were obtained by CSIRO and Sydney University researchers in 1974-75, using the Parkes and Molonglo radiotelescopes.

About the same time, an Anglo-Australian Observatory team at Siding Spring discovered a massive supergiant with an extremely red spectrum near the same position.

Evidence linking the radio source, X-ray source and visible supergiant was obtained in two ways.

First, a CSIRO-Sydney University team using the Fleurs synthesis radiotelescope confirmed the radio source coincided with the position of the supergiant.

Then CSIRO scientists discovered the radio source flared up in intensity every 16 days, shortly after the X-ray source turned off.

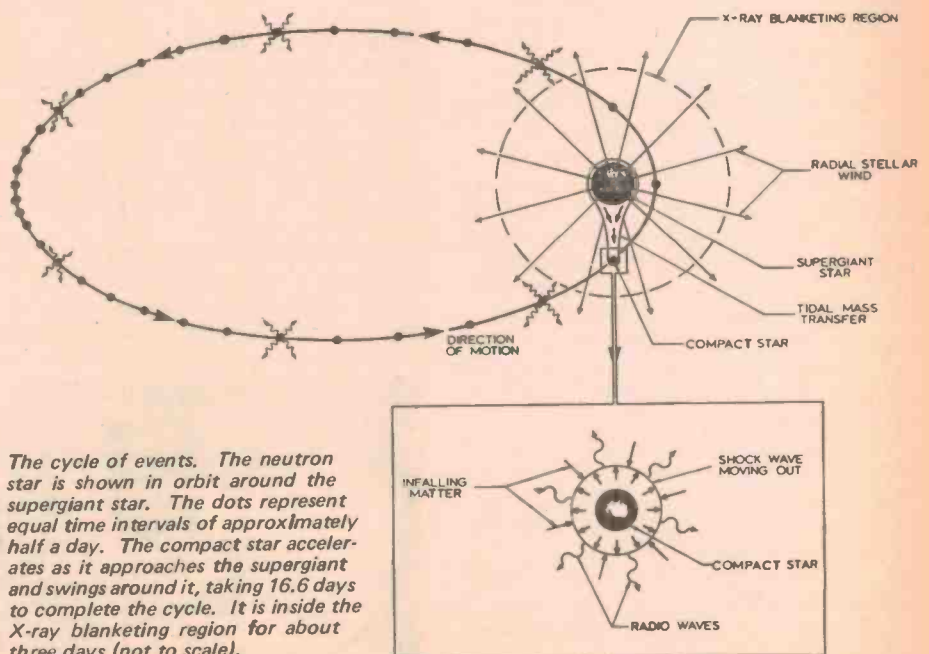

The cycle of events. The neutron star is shown in orbit around the supergiant star. The dots represent equal time intervals of approximately half a day. The compact star accelerates as it approaches the supergiant and swings around it, taking 16.6 days to complete the cycle. It is inside the X-ray blanketing region for about three days (not to scale).

The Strange Case of Circinus X1

Recent radio observations by CSIRO and Sydney University researchers using the Parkes and Tidbinbilla radiotelescopes and the Fleurs synthesis radiotelescope defined the pattern of radio flaring at different frequencies, allowing them to deduce how the radio waves are generated.

Dr Haynes says that during the neutron star's close encounter with the supergiant, the supergiant's stellar wind completely blankets the neutron star's characteristic X-ray emissions.

Only after the compact star has moved away from its supergiant companion does the blanketing effect thin out enough to allow the X-rays to "shine" through and to be detected by X-ray satellites.

Black Hole?

Although the evidence is strongly suggestive that the smaller object is a neutron star, Dr Haynes says there is a possibility that it may be one of the elusive "black holes" predicted by cosmologists.

Such theories predict any star larger than 10 solar masses will undergo complete collapse under its own gravity, so that all matter is crushed to a single point, a "singularity" from which nothing, including light, can escape — a "black hole".

Stars with a mass less than 10 times that of our own sun will eventually collapse under their own gravity into tiny, incredibly dense objects only a few kilometres across in which the spaces within and between atoms no longer exist — neutron stars.

Dr Haynes said astrophysicists were excited by the discovery because their co-operative efforts had not only forced Circinus X-1 to reveal how it "ticks", but had also allowed its future behavior patterns to be predicted.

Two of these predictions had already been verified, adding to the evidence of the supergiant-neutron star pairing.

Dr Haynes said Australian astronomers would now co-operate with the Hartebeesthoek Radio Astronomy Observatory in Pretoria, South Africa, in further investigations of the unique object in efforts to confirm other predictions about Circinus X-1. The discovery also promised to be a major topic for discussion at a high level symposium involving Australian, Russian and American astronomers in Sydney on Monday 17th April.

BLOB BOARD

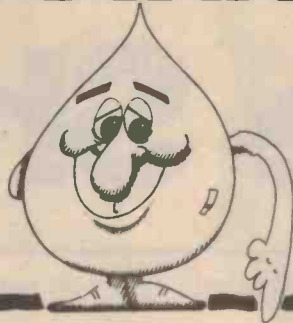

for Digital Electronics by Experiment

Mr. Blob says: "The Technique of inserting components on one side of a board and soldering on the other is done for reasons which are now completely out of date; namely this technique was established originally because heavy and bulky components were used. This no longer applies and has big disadvantages, the circuit is impossible to follow unless the board is continually turned over to inspect each side, its difficult to work on both sides of the board and soldering basically needs three hands. A common fault is to mount both leadout wires on the same track.

Blob — Boards give you the modern, low cost, easy to build circuits. Blob — Boards are roller tinned circuit boards on which each roller tinned copper track is identified by the letter and or number system. Simply tin the end of the component, butt the component lead against the roller tinned track, apply a blob of solder and the component is blobbed into place. All construction is from one side, component location could not be simpler, soldering is much easier, sub-circuits can be tested, then assembled together, the plain side of the Blob-Board is free and so the Blob-Board can be mounted flush on case walls. And they can be re-used. Simply apply a soldering iron to the Blob and remove the component."

Now start Digital Electronics by Experiment.

No need to lose your way round a circuit board that needs a layout drawing — Blob-Boards make construction easy. Blob-Boards have numbered tracks that make layout drawing out of date, the tinning ensures easy soldering, and the tracks don't strip off when you unsolder components. Blobbing components on to the tracks (no holes, no drilling) makes layout easy to follow. Use the 8-IC board for 'Digital Electronics by Experiment' in this issue, but remember that we have "A Blob for every job".

Your nearest dealer?
Write to:

BLOB BOARD ASSOCIATES
P.O. Box 23, Surrey Hills,
Vic. 3127 or ring (03) 89-1019.

AVAILABLE FROM
ELECTRONICS TODAY
INTERNATIONAL

TOP PROJECTS

From Electronics Today \$2.50

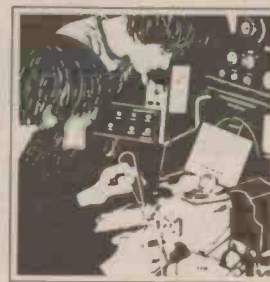

TOP PROJECTS VOL 3

Available from newsagents or directly from ETI. Contains FM tuner, 25 watt amplifier, active crossover, crossover amplifier, booster amplifier, 50 watt power module, 400 speaker system, audio noise generator, cross-hatch/dot generator, ETI utiliboard, linear IC tester, dual beam adaptor, impedance meter, tone burst generator, digital display, digital volt-meter, frequency counter, logic probe, logic pulser, switching regulator supply, nickel cadmium battery charger, radar intruder alarm, intruder alarm, colour organ, car alarm, transistor connections. \$2.50 plus 40 cents postage and packing. Send orders to: - Electronics Today International, 15 Boundary Street, Rushcutters Bay, NSW 2011.

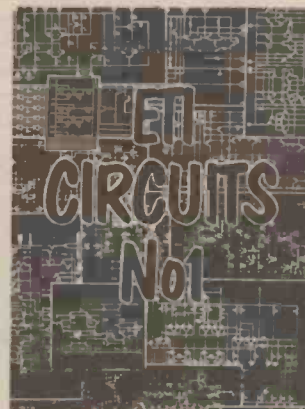

ETI CIRCUITS NO 1

Available from your newsagent or directly from us. ETI Circuits No 1 contains over 200 circuits largely based on the Tech Tips and data sheet sections of ETI. Great care has been taken to index each circuit to enable the reader to locate the item sought. This publication is likely to be regarded as a 'bible' by the experimenter for not only does it contain complete circuits but also ideas and circuit sub-assemblies. \$2.50 plus 40 cents postage and packing. Send orders to: - Electronics Today International, 15 Boundary Street, Rushcutters Bay, NSW 2011.

Flying the Space Shuttle

The Space Shuttle will be the first spacecraft to actually fly on re-entry to Earth's atmosphere.

THE WORLD'S FASTEST glider, which was built by the combined efforts of 50,000 people in 47 States in the US, has now flown five times. On 12th August last year, the Space Shuttle 'Enterprise' was carried, piggyback style, on a specially modified 747, to a height of 8,540 m where the two craft started a descent to 7,350 m, at which point they separated, and Enterprise flew for the first time.

The first free-flight test of the Space Shuttle, watched by 60,000 people marked the commencement of the final phase of months of testing at Edwards Air Force Base in the Mojave Desert of Southern California. At the end of January 1977 the Shuttle was moved from its assembly facility at Palmdale, along 58 km of specially widened roads to Edwards AFB, for the first Approach and Landing Test (ALT).

The Space Shuttle is the first of a new breed of spacecraft which is designed to be reused. Previously, the technology available meant that each spacecraft could be used only once, but for any long-term program of space research this is extremely wasteful. Everything was built to the highest standards and then used only once. The Space Shuttle changes this. The Space Shuttle Orbiter vehicle is designed to land intact in the same manner as an aircraft, and the solid rocket boosters used to provide the enormous thrust at takeoff are also reusable. In fact, a Space Shuttle can be launched as quickly as 160 hours after landing from the previous mission, although a two-week ground turnaround is the goal in actual use.

The Shuttle is launched vertically, attached to an external tank which contains the ascent fuel burnt by the Orbiter's main engines, and two solid rocket boosters. At lift-off all the engines fire in parallel, the SRB's each generating 11,800,000 Newtons of thrust and the three Orbiter engines each generating

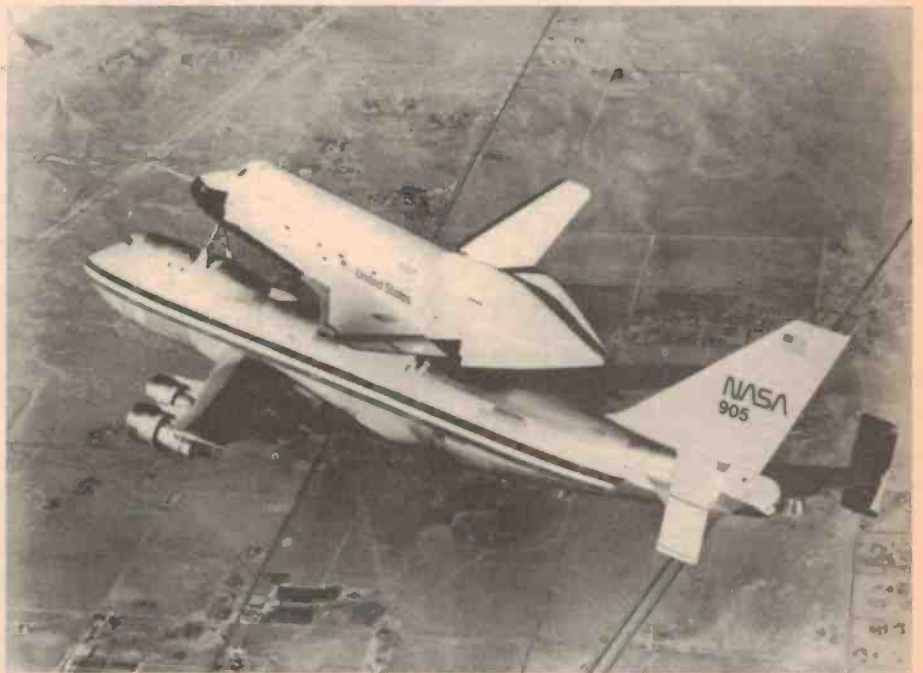

The 747/Shuttle combination fly over California. Note the aerodynamic tail fairing on the Shuttle.

The Shuttle can be used to carry up to five satellites.



2,100,000 N. The two SRB's are jettisoned once they burn out and are recovered after a parachute descent. The external tank is jettisoned before the Orbiter attains orbit.

The orbital maneuvering system is used to make any adjustments to the orbit or any maneuvers that may be required during the mission. The jets for this system are mounted near the nose and in pods on the upper rear of the fuselage. These jets can pitch, roll or yaw the Orbiter.

The Orbiter is designed to carry a crew of seven (early missions call for four), including scientific and technical personnel and a payload up to 18m long and 5m in diameter. Because of the low g forces at launch, only 3g and less than 1.5g on re-entry, space flight is no longer limited to intensively physically trained astronauts - now experienced scientists and technicians can have access to zero g, vacuum conditions.

Payloads up to 29,500 kg can be placed into orbit by the space shuttle. These can range from small satellites to fully equipped scientific laboratories, and not only can the Space Shuttle launch payloads into orbit, it can also retrieve them and return them to earth and service or refurbish satellites in space. The versatility of the Shuttle's cargo bay opens up whole new areas, such as space manufacturing.

Upon completion of the various mission duties, the crew will prepare the Orbiter for re-entry - this is when the Space Shuttle really flies. The Orbiter, since it moves in the two media of air and vacuum, has two separate maneuvering systems. One is the orbital maneuvering system referred to above, and the other is a set of aerodynamic control surfaces that act in much the same way as conventional aircraft.

There are seven aerodynamic control surfaces on the Orbiter. Four of these are on the rear of the wings and are called 'elevons' - they combine the effects of elevators and ailerons. The fifth surface is at the bottom rear of the fuselage between the wings, and assists the elevons in controlling the pitch of the craft. It also protects the rocket engine nozzles from buffeting in the airstream during re-entry. The two remaining panels are on the rear of the vertical tail and can be used as a rudder or spread apart to form a 'speedbrake' by increasing the drag. This is used to limit the airspeed during landing.

At low speeds these surfaces act in a conventional manner. However, at supersonic speeds above Mach 1.5, the effect of some of the control surfaces is reversed, or not the expected one, which makes flying in a conventional manner impossible! To get round this problem, the Space Shuttle, unlike most

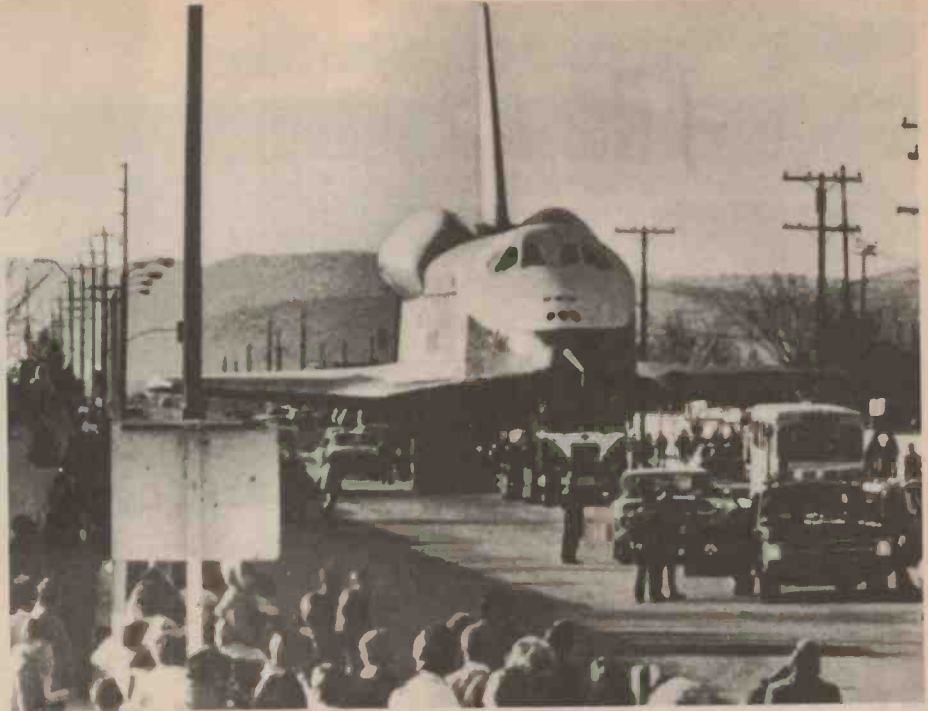

58 km of road was specially widened to move the Space Shuttle.

aircraft, which use mechanical or hydraulic links between pilot and controls, uses a digital 'fly-by-wire' Flight Control System. This is based on three on-board IBM System/4 Pi AP-101 computers which monitor their own operation to provide a measure of fail-safe redundancy.

The Flight Control System (FCS) can be operated in three modes: Direct (DIR), Control Stick Steering (CSS) and AUTO. The mode can be selected separately for pitch, roll/yaw, speedbrake and body flap controls.

In DIR mode, the pilot grips a small stick called the Rotational Hand Controller and ordinary pedals. Movements of these inputs to the FCS produce

movements of the control surfaces in the same way as a conventional aircraft would respond - at subsonic speeds, at least. Above Mach 1.5 things go haywire - the result is like trying to ride a bicycle with your hands crossed, and only with considerable training can the pilot avoid making involuntary, incorrect movements of the RHC stick.

In the AUTO mode, the FCS takes inputs from star sensors, inertial measurements units, rate gyros, accelerometers, and air data sensors, and compares this with the desired trajectory, automatically making corrections to keep on the path. In fact, the Orbiter can land itself from orbit completely automatically, with the only pilot inter-

The Shuttle is dwarfed by its external fuel tank at launch.

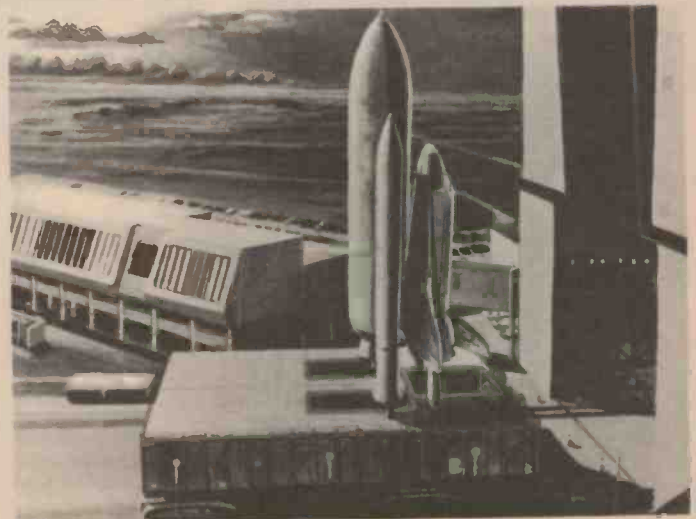

Flying the Space Shuttle

vention required being landing gear extension and operating the brakes on the runway!

In the CSS mode, the Flight Control System interprets between the pilot and the control surfaces. The pilot uses the Rotational Hand Controller and pedals, but the FCS accepts these inputs as rate commands in pitch, roll or yaw - in other words, the way the pilot wants the Orbiter to move. These commands are compared with inputs from the rate gyros and accelerometers, and generates control signals to implement the pilot's commands. In this mode the FCS automatically takes account of the reverse effects produced by the aerodynamic surfaces at high airspeeds.

Re-entry

The Orbiter starts re-entry at a high angle of attack, around 30 to 40 degrees, so that the bottom of the wing and fuselage are exposed to the airstream. The under surface is covered with a high-temperature structure of reinforced carbon-carbon on the leading edges and special silica tiles over most of the other surfaces to maintain the airframe within acceptable temperature limits.

Unfortunately, because of the high angle of attack, moving the RHC to the left in the DIR mode causes the Orbiter to roll to the right. This is because the right elevon is deflected downward, but this causes drag, and turns the vehicle to the right. This increases the lift on the left wing, so it lifts, causing the right roll. In the Control Stick Steering mode, though, this problem is taken care of by the Flight Control System, and the pilot simply moves the stick the way he wants



the vehicle to go and it responds in the correct way.

The angle of attack must be carefully controlled to avoid overheating problems during the descent. To accomplish this, the Shuttle banks at up to 80 degrees, and so flies on a curved path. This would take the Shuttle away from its target and so, several times during the re-entry, the bank angle is reversed, and the vehicle starts turning back towards its target. This maneuver is complicated by the fact that, because of the high angle of attack, the rudder is virtually in a vacuum, and so these turns are executed by rolling the Shuttle.

Approach

Finally, the Orbiter is down to a speed of Mach 1.5, and begins to fly like a conventional aircraft. It is now at a height of 21,000m and about 50km from its landing field. From now on,

things are straightforward as the pilot closes in using conventional electronic navigation equipment like TACAN and Microwave Scanning Beam Landing System. As he turns to the final glide-path, the pilot will use the speedbrake on the tail to lose both speed and height. During this phase of the landing, the speedbrake is normally open at 45°. If the Orbiter is high, the pilot will open the speedbrake and steepen his descent; if low, he will close it and fly a shallower glidepath.

The Orbiter makes final approach at 540km/hr and at an angle as steep as 24°. At 600m, the pilot starts to pull up, or 'flare', and at 300m, the landing gear is dropped. The vehicle touches down at 350km/hour; at this point it is losing 9km/hr of speed every second and stalls at 280km/hr, which is why the land is at such high speed.

The Approach and Landing Test



were designed to check out the performance of the Shuttle during this phase of the mission. They were also designed to check the performance of that now-famous 747/Space Shuttle combination which will continue to fly, delivering Orbiters to the launch site from the production line and landing sites.

First Flight

The first flight of the Space Shuttle took place on 12th August last year. At 8 AM, the 747 Shuttle Carrier Aircraft with its piggyback Orbiter took off on time - the only problem had been a fault in one of the AP101 computers, but that unit was quickly replaced.

At 8.47 the pair were at 8,539m, and the Boeing started a 7° dive. At a speed of 280kts, and a height of 7,346m, the Boeing pilot informed the Shuttle crew that they were ready for separation. The crew, Haise and Fullerton, fired the separation bolts and lifted away, rolling to the left while the 747 dropped to the right. Following a pair of right and left rolls to put some distance between the two craft, Haise tried a practice flare and some banking manoeuvres. This gave the computers at Johnson Space Centre the opportunity to calculate any deviation from the predicted lift/drag ratios, information which would allow a more accurate landing. In fact, the JSC ground controllers muffed it by assuming that the Orbiter was in level flight, whereas it was actually climbing, so they concluded that the lift/drag ratio was lower than predicted.

Fullerton then took the Orbiter into a 90° right turn, with the vehicle responding well, and about 20 seconds later Haise performed the second 90° turn. At this point Haise could see the runway, and noticed that the Orbiter was too high, with excess speed. Opening the speedbrake to 36°, the Shuttle was still accelerating, so Haise opened the speedbrake to 45° and decided to overshoot the original landing point by several hundred metres. By this point, it was becoming painfully apparent that the Shuttle was behaving as originally predicted, and that the calculated excess drag was an error.

Haise could not open the speedbrake beyond 45°; this was a mission constraint to avoid steep glideslope angles. Performing a flare at 270m, Haise touched down 600m beyond the expected touch down point at a speed just over 360km/hr. The overshoot was no problem, as runway 17 at Edwards AFB is 11km long, but with the wheels on the ground, Haise opened the speedbrake to 90° and the nose wheel came down. The flight had lasted just 5 min 23 sec.



Photos clockwise from top left: The Shuttle/SCA assembly lifts off; 1 second after separation; a technician holds a red hot piece of the silica heat insulation in his bare hand; touchdown; the Shuttle approaches, tagged by an observation aircraft; our prize for Mickey Mouse look-alike of the month goes to the Space Shuttle. Pictures courtesy of NASA.

The first three flights were made with a streamlined tail fairing covering the dummy rocket engines at the tail. The fourth flight, on 12th October, was made with the fairing removed, giving a slightly reduced lift/drag ratio. Otherwise, the vehicle did not behave significantly differently.

A final flight on 26th October ended with a clumsy landing, but in every respect the tests were successful. Frankly, the fact that a craft as large and as complex as the Space Shuttle Orbiter can fly at all is a tribute to the advances that have been made since the Orville brothers flew on 17th December, 1903, and the men who made those advances.



SHERIDAN ELECTRONICS PTY. LTD.

THE LEAD NAME FOR ELECTRONIC COMPONENTS IN AUSTRALIA

164-166 REDFERN ST., REDFERN,
P.O. BOX 156 REDFERN, N.S.W. 2016 TEL 699-5922 or 699-6912

FIGHT INFLATION WITH

PLEASE NOTE
NO ORDERS
UNDER \$5
ACCEPTED.
EXCL. OF P&P

Our Cut PRICES

P&P 30c
10 — 75c

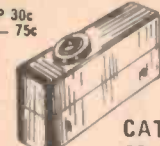

CAT. No:
CP.1.

SUB-MIN. MICRO-SWITCH. Single pole change-over. 250V 5A. Size: 18mm x 9mm x 7mm. U.S.A. manufacture. 5 for \$4.50.

P&P 5 — 40c



CAT. No:
CP.3.

BYF50 Gen. Purpose NPN Silicon transistor in TO-39 case. Vcb 80V 1 amp. 5 for \$2.95.

P&P 5 — 40c



CAT. No:
CP.4.

BD135 NPN silicon Power transistor in TO-126 Flatpak. 8W. 5 for \$3.00.

P&P 10 for 40c



CAT. No:
CP.10.

2N3643 Silicon NPN transistor in TO-105 plastic case. G.P. Amp. and switch. Vcb 60 500mA. Sim. to BC337. 10 for \$2.95.

P&P 10 — 40c



CAT. No:
CP.14.

CMOS Wide-band Amplifier-Discriminator. Type CA3013. In 8 lead TO-5 case. GRAB 'EM WHILE YOU CAN. ONLY LIMITED STOCKS at the silly price of 5 for \$4.75.

P&P 10 — 30c



CAT. No:
CP.15.

BC177 S.S. Amp. transistors in TO-18 metal can. Can say no more about this popular and well tried PNP Silicon semi-conductor. OUR PRICE ONLY 10 for \$1.50.

CAT. No:
CP.16.



P&P 5 — \$1.00

ELECTROLYTIC CAPACITOR. Can type with mounting bracket. Made by DUCON 100mfd 160VW. Tremendous and unrepeatable value at only 5 for \$1.00.

P&P 75c



CAT. No: CP.19.

DISC CERAMICS. High voltage type with axial leads 0.001 12KV. Tremendous value of this hard-to-get Cap. Only limited quantities available. LOOK AT THIS 18c each or 10 for \$1.50.

P&P 50c for 20

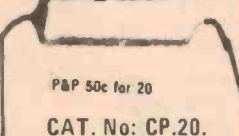

CAT. No: CP.20.

POLYESTER CAPACITOR. Philips tubular foil type 315. 0.01mfd 160VDC Axial leads. WOW! Look at our price. 20 for 75c. Never again like this.

CAT. No:
CP.22.



P&P 75c single

SOLID STATE RELAYS... They'll carry 10 amps and 250V switch and need 3 to 32 volts to operate efficiently. A third of the normal price. ONLY AT S.E. for a paltry \$5.50 each.

P&P 40c for 10



CAT. No: CP.23.

FERRITE BEADS. 6 holes. Size 10mm x 7mm dia. Ready wired. 45c anywhere else but at SHERIDAN'S only 12c each or 10 for \$1.00.

P&P 10 — 40c



CAT. No: CP.24.

FERRITE BEADS... Size 5mm x 5mm dia. 2 holes. Ready wired. Another great BUY from us. Only 10c each or 10 for 90c.

P&P 10 — 40c



CAT. No: CP.28.

MINIATURE CAPACITORS... rotary Vanetype. 2 values available. 12 — 75pf and 9 — 60pf. Only 10mm dia x 15mm deep (overall) 5 of each for only \$2.25. REAL VALUE HERE.

P&P 6 for 30c



CAT. No: CP.29.

MINIATURE TRIMPOTS. Made by PIHER. P.C.B. Mounting. 10mm dia x 15mm long. 2 each of the following values: 50 — 200 — 100K The 6 for 75c.

CAT. No:
CP.34.

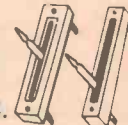

SLIDER POTENTIOMETER... 3 singles in 1K — 10K and 500K and 2 duals in 5K and 50K. Total normal retail approx. \$4.75. but from us only \$1.00.

P&P 60c



CAT. No: CP.35.

WIRE WOUND TRIMMING POTS... Made by EGEN (G.B.) 4 watts. Precision standards complete with integral knob. In the following values: 100 — 220 — 470 — and 1K. The 4 for \$1.75. YOU CAN DO NO BETTER.

CAT. No: CP.36.



FERRITE PDT CORE. Non-adjustable. Supplied complete with formers and clamps as shown. Overall dimensions. 40mm x 40mm x 25mm. Type H74-MB. Ready wound. No data available. \$1ea. or 5 for \$4.50. p&p 40c each.

CAT. No: CP.37.



As CP.36 but size is 30mm x 30mm x 16mm. Type A75-MB. 75c each or 5 for \$3.25. p&p 30c each.

CAT. No: CP.38.



POWER TRANSISTORS IN TO26 'Flatpak' package. The following NPN types are available: BD283, BD281, BD375 & BD377. Hfe between 30 & 200. Fantastic value at only 35c each or the 4 for \$1.30. p & p 30c

CAT. No: CP.39.



As CP.38 to 'The following' PNP types are available: BD284, BD376, BD378, BD282. Hfe between 65 to 200. Same prices as NPN types in CP.38.

CAT. No: CP.40.



4001 C.M.O.S. ONCE IN A LIFETIME OFFER... ONLY 18c each... YES... 18c each or 10 for \$1.50... Where else can you get this kind of 'GIVEAWAY'? p & p 30c

CAT. No: CP.41.



2N3055 Power Transistors. Unmarked but all guaranteed useable. Below specs. 20 for \$3.00. We have now sold 1000's with very little returns. p & p 75c

CAT. No: CP.49.



EDGE CONNECTORS. Top quality brand. 2 types available in 0.15" pitch for 1/16" board. 18-way 75c 12-way 50c. Take 10 percent off for orders of 10 and over.

CAT. No: CP.50.



POWER TRANSFORMER by General Electric. Type MGE03050. Pri: 240VAC. Sec: 117V at 300mA and 20V & 5.7V at 3 amps. ONLY from us at \$7.00 each. p & p \$3.00 all States.

CAT. No: CP.52.



GEL RECHARGEABLE BATTERIES. Use these for your CB. 6 Volt 1.8 Amp Hour. Size: 'A' 75mm x 'B' 52mm x 'C' 50mm. Precision German made. S.E.'s. Price only \$8.75, worth double. p & p \$1.25

CAT. No: CP.56.



'C' CORE TRANSFORMER by General Electric. Type MSC225. Pri: 240 & 254VAC. Sec: 36V & 5.3V at 1amp. Worth treble. ONLY FROM US at \$6.00 each. p & p. \$2.50 all States.

CAT. No: CP.58.



MINIATURE MODEL MOTORS by LENC0. 6-12 VDC. Precision made with inbuilt speed regulation. This kit forms the basis of several electronic games which can be simply devised. The instructions with the kit also explain how the IC's in the kit function and how Binary Coded Decimal works and is used. THE FULL KIT \$8.50 Plus P&P \$1.00.

CAT. No: CP.60.



MINIATURE PRECISION POTENTIOMETERS by COPAL. Screwdriver adjusted. on graduated scale. In 1K vertical mounting or 500Ω horizontal mounting. Dia. 1/2". 45c ea. or 10 for \$4.00. p & p 30c.

CAT. No: CP.67.



A & R POWER TRANSFORMER. Type 6413. Pri: 240VAC. Sec: 32V 2A D.C. Bridge rectifier condenser output. Wt: 4lbs. Ht: 3 1/2". Overall base: 3" x 3 1/2". A KNOCKOUT SPECIAL AT ONLY \$6.00 each. p & p \$2.50.

CAT. No: CP 71



LIGHT OPERATED TRIGGER KIT. (on in darkness). Adjustable sensitivity to light, works from 6 to 9 volts, even 12 volts with a change of bulb and limiting resistor. Bulb lights as darkness falls. Can be attached to SOLID STATE RELAYS (C.P.) 22-\$5.50) to switch 10 amps at 240 mains. Light up your home at night when your out on the town. THE FULL KIT \$3.50. Plus P&P 75c.

CAT. No: CP 72



LIGHT OPERATED TRIGGER KIT. (off in darkness). Adjustable sensitivity to light, works from 6 to 9 volts, even 12 volts with a change of bulb and limiting resistor. Add a SOLID STATE RELAY (C.P.) 22-\$5.50) and place LDR near BULB and you have a self latching, light triggered alarm system. Anyone entering the range of the light trigger with torch, match etc, will set off the alarm. THE FULL KIT \$3.50 Plus P&P 75c.

CAT. No: CP 73

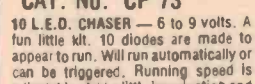

10 L.E.D. CHASER — 6 to 9 volts. A fun little kit. 10 diodes are made to appear to run. Will run automatically or can be triggered. Running speed is adjustable. Add a little imagination and this kit forms the basis of several electronic games which can be simply devised. The instructions with the kit also explain how the IC's in the kit function and how Binary Coded Decimal works and is used. THE FULL KIT \$8.50 Plus P&P \$1.00.

CAT. No: CP 74

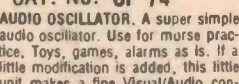

AUDIO OSCILLATOR. A super simple audio oscillator. Use for mouse practice, Toys, games, alarms as is. If a little modification is added, this little unit makes a fine Visual/Audio continuity tester. This is an ideal beginners first kit. Speaker is extra, but any small 8 to 15 speaker will do, and we have one of them around somewhere. Extras for visual continuity tester are 1 resistor, 1 red L.E.D. and probes. THE FULL KIT \$1.75 Plus P&P 50c.

CAT. No: CP 75

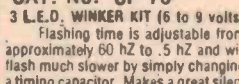

3 L.E.D. WINKER KIT (6 to 9 volts). Flashing time is adjustable from approximately 60 hz to .5 hz and will flash much slower by simply changing a timing capacitor. Makes a great silent door bell when watching T.V. or a silent visual alarm, or even a dummy alarm light in car. Add a SOLID STATE RELAY or TRIAC and switch the mains with this kit, and then use for shop displays, warning lights, parties etc. THE FULL KIT \$3.25 Plus P&P 75c.

CAT. No: CP 76

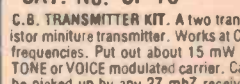

C.B. TRANSMITTER KIT. A two transistor miniature transmitter. Works at CB frequencies. Put out about 15 mW of TONE or VOICE modulated carrier. Can be picked up by any 27 mhz receiver 60 to 100 feet away. Perfect for tuning receive sections of CB units, or remote control of models, T.V. etc. You will have to find your own crystal or input microphone if you use voice modulation. THE FULL KIT \$5.80 Plus P&P 75c.

Sold-out items from previous Adverts: CP6-CP12-CP33-CP63 & CP64.

AMENDMENTS & CORRECTIONS:

CP.19 SHOULD READ: .001 uF & NOT .01 uF;
 CP.25: SHOULD READ: 12 V & NOT 240 V;
 CP.33: SHOULD READ: 5 pos 2 pole & NOT 10 pos 2 pole;
 CP.38/39: SHOULD READ: TO 126 CASE & NOT TO26 CASE;
 CP.53/54: SHOULD READ: NORMALLY OPEN & NOT NORMALLY CLOSED;
 CP.44: SHOULD READ: 2022 SWITCH & NOT 2002,
 CP.46 ONLY WHITE SOCKETS LEFT.

TRADING HOURS

MON-TUES-WED & FRI: 9am-5.30pm THURS: 9am-7pm SAT: 9am-12 noon.
 COD's: Please add \$2.40 to posting fee. NO ORDERS UNDER \$5.00 accepted
 (exclusive of P&P) For replies please send SAE. Post and packing 50c where not
 included in price. PLEASE PRINT YOUR NAME AND ADDRESS ON
 ALL ORDERS AND CORRESPONDENCE. BANKCARD ACCEPTED.

CAT. No. CP 77

7 SEGMENT DISPLAY COUNTER. A three I.C. counting unit incorporating a 555 timer and a 7490. Simple enough for those already into TTL, but an ideal kit for the beginner and completely instructed to cater for the beginner, not to mention a good run down of possible uses for the unit once working and understood by the constructor. Kit is complete with display, 5 volt regulator, veroboard, solder and battery connections. **THE FULL KIT \$8.50 Plus P&P 75c.**

CAT. No. CP 78

SUPER SIMPLE CAPACITANCE TESTER. An ideal project for the beginner trying to get together TEST GEAR for the work bench. A 555 I.C. is used to make two switchable tones, one tone by a fixed resistor and a capacitor, and the second by the unknown capacitor and variable resistor. When the two tones are made to sound the same via the potentiometer the unknown value will then be indicated by the position of the potentiometer. As it is the kit indicates from approximately 100pF to .1 uF **FULL KIT \$5.95 Plus P&P 75c.**

CAT. No. CP 79

MINI TRANSISTOR TESTER. Another I.C. project for the work bench. This kit will test for NPN/PNP, leakage, and junction failure. Also tests diodes too. No meter is used, so unit is very rugged and can be knocked about. A red and green L.E.D represents each leg of the transistor so reading is simple. RED(C) GREEN(B) RED(E) indication means the transistor in test is good and also a PNP, simple as that. Instructions also explain how to interpret the L.E.D's indications. **FULL KIT \$6.00 Plus P&P 75c.**

CAT. No. CP 80

PROBE-LESS CONTINUITY TESTER. Yet another TEST project for the work bench. An interesting and useful kit for YES or NO testing of junctions of silicon transistors and diodes, small capacitors, fuses wiring harnesses, etc. The really useful feature of this kit is that the probes of this tester are your hands. By simply holding the tester in one hand and the item under test in the other, continuity is then tested by touching the item under test to the high impedance input of the tester. **FULL KIT \$3.25. Plus P&P 75c.**

CAT. No. CP 81

SONY A.M. MINIATURE RADIO. 11 C. 3 transistor 2 diode super-het. Freq. coverage 530-1605 kHz. Power output 50 mW 65 mW. Operates on 2.5 V. Size: 35 mm x 25 mm. Complete with speaker, tuning capacitor and full data sheet. (Less Case). Only **\$5.00 P&P 75c. No warranty.**

CAT. No. CP 82



BELLING LEE 50 ohm CO-AXIAL PLUG & SOCKET. Panel mounting socket has insulated body in yellow, green, red and blue. Only 85c a pair, or 4 assorted for \$3.00 P&P 40c.

CAT. No. CP 83



SANYO TAPE RECORDER MOTOR. 12VDC, but ready wired to regulator control and S.C.R. Motor size: 35 mm DIA. x 28 mm. Small brass pulley attached to spindle. Limited quantity only. **\$6.00 each P&P \$1.**

CAT. No. CP 84

S.T.C. MINI-SWITCH (or Unselector) PLUG-IN BOARD. 16 x 16 matrix, giving a total of 256 switching contacts. Operated by 32 switching relays of 48V. Used for cross-bar. Must have cost a fortune, but exclusive to us. Size of board: 285 mm x 220 mm. Only **\$6.00 each P&P \$1.00.**

CAT. No. CP 85



S.T.C. RELAY IN-BOARD. Same size board as CP.84, but contains 32 miniature relays. All double-pole change-over 48 V. Also approx. 100 EM404 diodes, Mylar caps, and 2 percent resistors. Cost around \$250 each. Exclusive to us and only \$20.00 each. A fantastic buy for the experimenter. P&P N.S.W. \$2.00 VIC. QLD & S.A. \$2.50 W.A. TAS \$3.50 N.Z. \$4.00.

CAT. No. CP 86



SONY DIGITAL CLOCK ASSEMBLY. Complete with 120VAC 60 Hz motor. Has sleep, time and alarm facility with neon illumination. Overall size: 155 mm x 65 mm high. Height of numerals 18 mm. Supplied complete with 3 maintenance and data sheets. All new and packed and only from us at **\$5.50 each P&P \$1.00.**

CAT. No. CP 87



100 ASSORTED 1 PERCENT & 2 PERCENT RESISTORS. By Beyschlag, Piher, I.R.C. and Morganite 1/4th to 5 watt. Assorted values in preferred and non preferred range. Normal value of these around \$15.00. Our price **\$5.00 per 100. P&P 50c.**

CAT. No. CP 88



SONY 9 BAND SELECT ROTARY-SLIDE SWITCH. 9 position 12 pole. This was used on the Sony S.W. A.M. radio model CRF 5090. Normal retail \$27.00. This is a fantastic multi-purpose switch and must be seen to be believed. Only from us at **\$10.00 each P&P \$1.00.**

CAT. No. CP 89



TRIMMING CAPACITOR by JACKSON BROS. High grade type with ceramic body. Screwdriver adjustment. Capacity 450 to 2000 pf. Size 23 x 23 mm. 50c each or 5 for \$2.25. P&P 40c for 5.

CAT. No. CP 90



FERRITE POT-CORE H.F. CHOKES, (adjustable). These have been made by Philips to stringent specifications. Fully wound in the following frequencies: 1296, 1698 and 4818 mH. Also a tapped version at 19.5 — 20.7 mH/215 mH. A 'giveaway' at 50c each or 4 assorted for \$1.75. P&P 1 off 30c or 4 for \$1.00.

CAT. No. CP 91

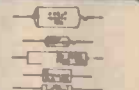

POLYCAP & RESISTOR PAC. 10 each of the following: Philips polycapacitors 0.82 uF and 0.01 uF 160 V tubular foil — Resistors, wire-wound types, 3 and 120 ohm in 10 W, 22 ohm 5 W, 220 ohm and 3.9K ohm in 4 W. A total of 70 resistors and caps. Normal retail value around \$20. Our Crazy 'Giveaway' price **\$6.00 post free.**

CAT. No. CP 92



CLARE MERCURY WETTED RELAY (type HGRX5011). Coil resistance — 1.1 K ohm plus 1.1 K ohm must operate voltage 8.77 V max. Operating voltage 49.8 V (peak efficiency) switches 2 amp 500 VDC (or 100 V) change-over contacts. This is a super-sensitive relay. Cost over \$13.00. S.E.'s price only **\$1.00 each or 5 for \$4.50 P&P 30c each or 5 for \$1.00.**

CAT. No. CP 93



A.E.E. MYLAR 'MINIPRINT' CAPACITORS. Top grade epoxy resin encapsulated, type PHE280. Capacity — 0.1 uF 400 V. These are one of the best capacitors made in Australia. Just 10 for \$1.00. P&P 30c.

CAT. No. CP 94



PYE PLUG-IN-RELAYS. Miniature type 2C/202A. Twin 1 K ohm coils. Will normally operate on 18 VDC. When coils are connected in parallel will operate on 12 VDC. 2 pole change-over with 2amp contacts. Complete with base. Only **\$1.50 each or 4 for \$5.50. P&P 40c each or 4 for \$1.00.**

CAT. No. CP 95



DUAL AIR-SPACED TUNING CAPACITOR. Complete with trimmers. Size: 40 mm x 40 mm x 32 mm deep. Spindle size: 15 mm x 1/4". Extremely well made by Sony Electronics. Only **\$2.25 each P&P 60c.**

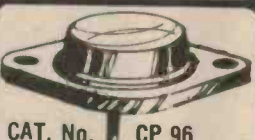

POWER TRANSISTOR. Fairchild type 8149. SIM to 2N3055 except that Vcb is 60 instead of 100. A real nutty price at only 60c each or 10 for \$5.50 P&P 10 for \$1.00.

CAT. No. CP 97



SILICON NPN POWER TRANSISTOR. Fairchild type AX8141B in TO66 case. Used for 12 V auto regulators. Vce 25 Hfe. Min. 15 at 4 amps. 25 V. Icb: 200 uA. 5 for \$2.00, tremendous value P&P 60c.

CAT. No. CP 98



PHILIPS DYNAMIC MICROPHONES. Model 1BB9002/BB. IMP. 500 ohm. Sensitivity 0.3 mV/ubar (-70 dB). Supplied complete with stand and shielded lead. Only **\$5.85 each. P&P 60c.**

CAT. No. CP 99



T.V. GAMES CHIP AY-38550. Complete with 2 joystick controls, 6 games and scoring. Supplied with full data. Value packed at only **\$24.00. P.C. boards to suit \$3.50. P&P \$1.00.**

CAT. No. CP 100



HEAVY DUTY CONTROL KEY SWITCH. On-off-on change-over. Suitable for 250 VAC 10 amp. Supplied with 2 keys. All new at only **\$4.95 P&P 60c.**

CAT. No. CP 101



CAR RADIO FRONT PANEL & KNOB KIT. Will fit most car radio and cassette players. Size of panel 195 mm x 60 mm. Dist. between holes 145 mm. Size of aperture 113 mm x 50 mm. Crazy at only **95c each P&P 40c.**

CAT. No. CP 102



7442 I.C. 16 pin D.I.L. BCD-decimal decoder. Lowest in the country. Only **65c each or 5 for \$3.00 P&P 30c.**

CAT. No. CP 103

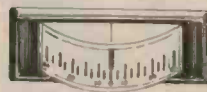

EDGE METER. 50-0-50 mA. (plus/minus 500 uADC). Top brand. Model EW-40. Dimensions: Overall 57 mm x 22 mm. Panel Cut-out: 43 mm x 15 mm. A real knock-out price at only **\$6.50 each P&P 75c.**

CAT. No. CP 104



100 SILICON NPN TRANSISTORS. In metal TO18 can. Unmarked and slightly below spec. Similar to BC107/108/109. Guaranteed all useable. Only **\$2.50 per 100. P&P 50c.**

CAT. No. CP 105

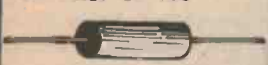

EM SERIES DIODES. 10 each of EM406 (600 V 1A) and EM408 (800 V 1A). Only **\$2.00 for 20.** Outstanding value. P&P 30c.

CAT. No. CP 106



INDICATOR PANELS. With red and green bezel lamps (18-24 V) complete with lamps. Size: 90 mm x 50 mm. Only **50c each or 5 for \$2.25. P&P 30c each or 5 for \$1.00.**

CAT. No. CP 107



4 POLE DOUBLE THROW (ON-ON-ON) TOGGLE SWITCH. Miniature type with paddle handle. Model No: 7411. Only **\$2.00 each or 5 for \$9.25. P&P 30c each or 5 for 75c.**

CAT. No. CP 108



MICRO-SWITCH. Heavy duty type made by Honeywell. Type No: 8E-2R-T4-J. Normally open and normal closed switch. Suitable for 25 A 125 or 250 VAC. Size: 48 mm x 17 mm x 20 mm deep. Pin plunger. Only from us at **\$1.75 each or 10 for \$16.50. P&P 30c each or 10 for \$1.00.**

CAT. No. CP 109



DISC CERAMIC CAPACITORS. 20 0.01 uF 2.5 kV plus 20 0.02 uF 1.6 kV plus 20 470 pF 2.5 kV. All top grade caps. The 60 for only **\$5.00 P&P 60c** worth more than treble.

UFO Detector

Unit detects electromagnetic disturbances often held to be associated with UFO's.

EVERY YEAR MANY thousands of people see objects in the sky which they cannot explain in terms of their previous experience. In this sense the existence of unidentified flying objects (UFO's) is not a matter for debate — people see

flying things they cannot identify, thus, by definition, these things are unidentified flying objects.

The vast majority of sightings' are caused by various objects or phenomena perceived in an unusual manner: cloud

formations, meteors, satellites, planets, an unusually bright star, temperature inversions, etc. There is also a substantial number of hoax devices.

Most people are satisfied if presented with a rational explanation for what they have seen.

But a minority are not — they are 'conspiracy theorists' who deny totally the principle of Occam's Razor. Faced with 99 probable explanations for an unusual happening — and just one explanation which complies with a previously accepted set of concepts — they will inevitably choose the odd one out.

No explanation or proof will convince the dedicated conspiracy theorist to think otherwise — a classic example of this is the oft-repeated story that the results of the USA Department of Air Force UFO Investigation 'Project Blue Book' have been suppressed. This is not really true. The Blue Book Project Files were declassified in 1970, and the USA Department of Air Force Office of Information state that the files are available to *all bona-fide researchers and media representatives*.

The conspiracy theory was well summed up by Salvador Freixedo at the UFO Conference in Acapulco (April 1977). 'The basic appeal of ufology (for the masses) is that it is a belief system rather than a field of scientific investigation'.

A further large number of classic cases quoted by ufologists has been well and truly debunked by Philip Klass (a technical journalist working with Aviation



Fig. 1. The UFO Detector, attached to the solenoid.

Week and Space Technology magazine).

Klass's book ('UFO's Explained') thoroughly demolishes the most classic cases and provides evidence which casts major doubt on those few remaining. Consider for example the often quoted 'UFO landing' in Socorro, New Mexico in 1964. It now turns out that the 'landing' was set up as a publicity stunt by the local mayor, who just happened to own that bit of land where the UFO 'landed'.

It is perhaps significant that no serious challenger has ever taken up the USA's National Enquirer's offer to pay one million US dollars for proof that UFO's are unnatural phenomena emanating from outer space.

A small minority of ufologists should however be taken more seriously. These are dedicated people who investigate reported sightings as thoroughly as they are able. Unfortunately most of their investigations tend to be 'unscientific' in the sense that they lack the rigorous discipline which truly scientific investigation demands. Nevertheless, it is to the movement's great credit that they realise their investigational limitations and are currently doing their best to check out as thoroughly as they can a number of previously accepted classic sightings.

In fact magazines such as the authoritative US publication 'UFO' currently feature exposes of previously 'proven' situations.

In the light of this recent background, Electronics Today International was extremely interested to learn of a UFO magnetic anomaly detector recently developed by one of our contributors.

The basis of this device is that many UFO sightings are claimed to have coincided with major magnetic disturbances. In many reported situations, electrical equipment is claimed to have ceased to operate whilst the UFO was in the vicinity.

Thus, claim some ufologists, it may well be possible to sense the approach of a UFO by detecting abnormal perturbations of the earth's magnetic field.

The unit described here has been designed by Mr. F. C. Gillespie (6 Reginald Ave., Findon, SA), who has considerable expertise in this field.

UFO literature indicates that magnetic disturbances associated with some UFO activity are of such a magnitude that they should be detectable by relatively simple equipment. Naturally the more sensitive the equipment the further away a disturbance could be detected — however an upper practical limit for sensitivity is set in most areas

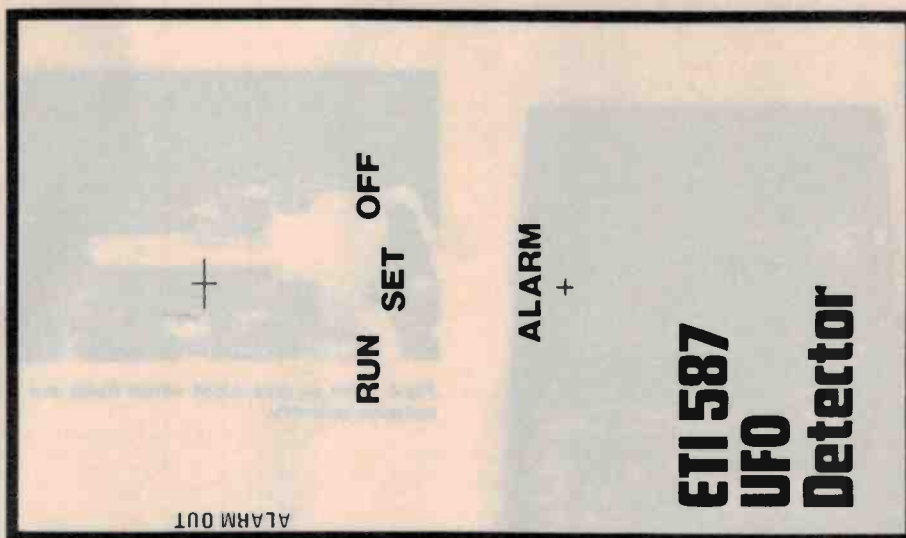
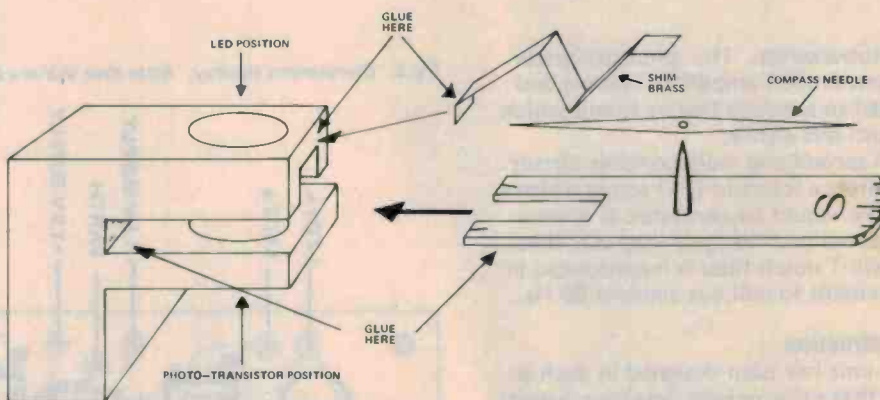

Fig.2.a) Front panel artwork for the UFO Detector (half size). b) Construction of the perspex compass block.



by the generally high level of background noise associated with civilisation — and which, ironically, is often postulated as attracting UFO's to this planet.

It is not at all difficult to detect the magnetic disturbance caused by a light switched on 20 m away — or a car 100 or more metres distant; but one can rarely find a sufficiently magnetic-noise-free environment in which to set up an instrument of such sensitivity.

The detector described here has adjustable sensitivity and in all but the very 'quietest' of areas the sensitivity can be set so that the noise just fails to trigger it. It is only in very rare and remote locations that the detector itself is the limiting factor.

Operating Principles

There is anecdotal evidence that the magnetic disturbances associated with UFO's may be transient in nature or may build up and decay over a period of time or may also be of an oscillatory nature.

For this reason the magnetic anomaly detector has two detecting systems capable of responding to all three types of disturbance.

The simpler of the two systems responds to minor movements of a very sensitive compass. The compass needle is set up so that when undisturbed it blocks the passage of light from a flashing LED, the light output from which would otherwise fall on a sensitive

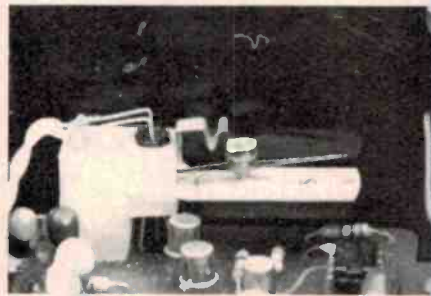
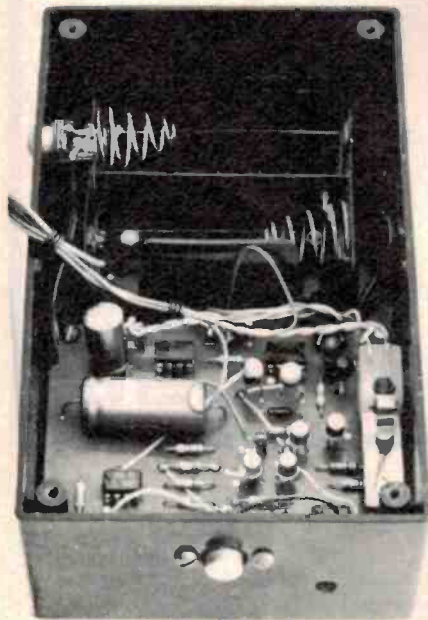

Fig.4. The perspex block which holds the compass assembly.

Fig.3. Internal shot of the UFO Detector.

HOW IT WORKS – ETI 587

Any voltage output resulting from a changing magnetic field around L1 is passed to the two-stage amplifier formed by IC1 and IC2. Fifty Hz background noise is greatly attenuated by the twin-T notch filter formed by the components between L1 and the amplifier. The frequency of the notch is adjustable by RV1.

The gain of the amplifier IC1/IC2 is varied by RV2. Output signals from the amplifier are passed to Q1/Q2/Q3/Q4 which form two latching circuits (each functioning depending on the polarity of the output signal).

The output of the latching circuitry is then passed to IC4. This is a National LM3909 LED flasher. This causes the alarm LED to flash at about 3 Hz.

An external alarm output is also provided.

The compass circuitry is quite straightforward. IC3 is used to extend battery life. Any output from the phototransistor Q5 triggers the latching mechanism thus initiating the alarm sequence.

phototransistor. The phototransistor output is then amplified, latched and passed to a second flasher circuit which in turn sets alarms.

A second and more complex circuit monitors a solenoid (L1) across which a voltage would be generated if it were subjected to a changing magnetic field. A twin-T notch filter is incorporated in this circuit to null out ambient 50 Hz.

Construction

The unit has been designed in such a way that either or both detecting circuits may be used, or indeed, duplicated if required.

Circuit construction is relatively straightforward, especially if the printed circuit board is used. The solenoid is the actuating coil from a Post Office type 3000 relay (5 kohms). Many people will have such a device in their junk boxes – otherwise it can be obtained from disposal stores or other outlets handling Post Office surplus bits and pieces. The solenoid is located external to the unit and connected to it by a screened cable,

The block holding the LED and phototransistor associated with the compass mechanism is a little tricky to make. It may be built up from pieces of wood or plastic – or if you have the facilities it may be milled out of a block of brass or other non-magnetic material. The main requirements are that the

Fig.5. Component overlay. Note that this is a double-sided board.

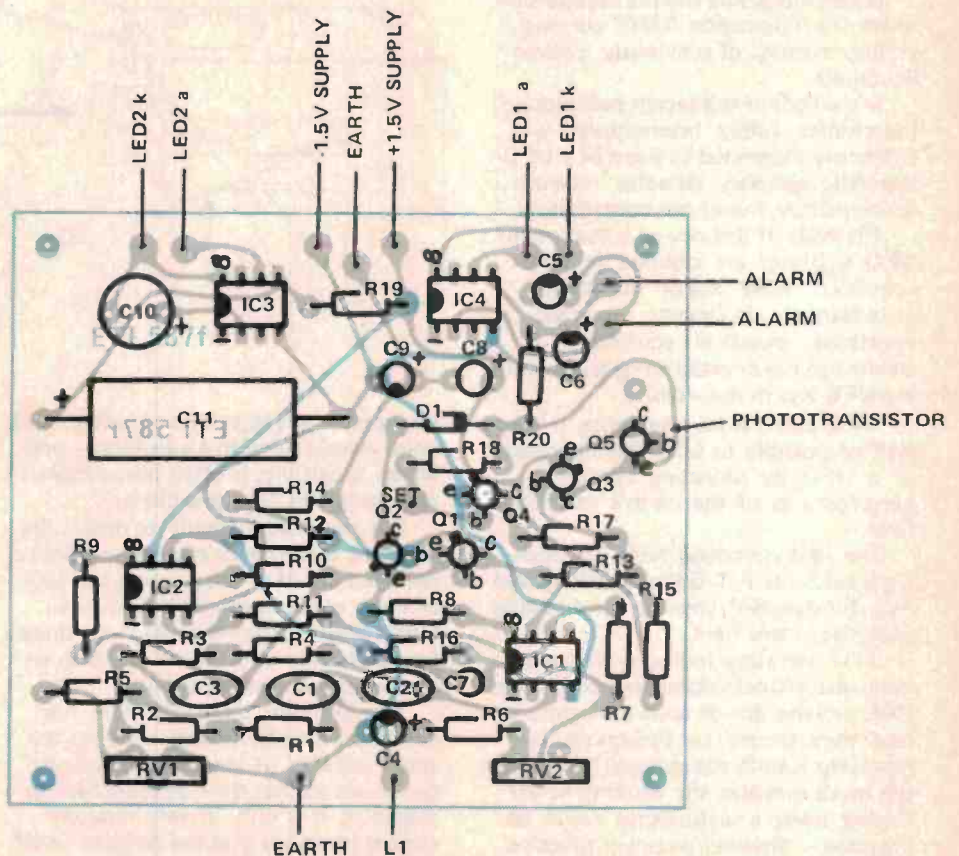

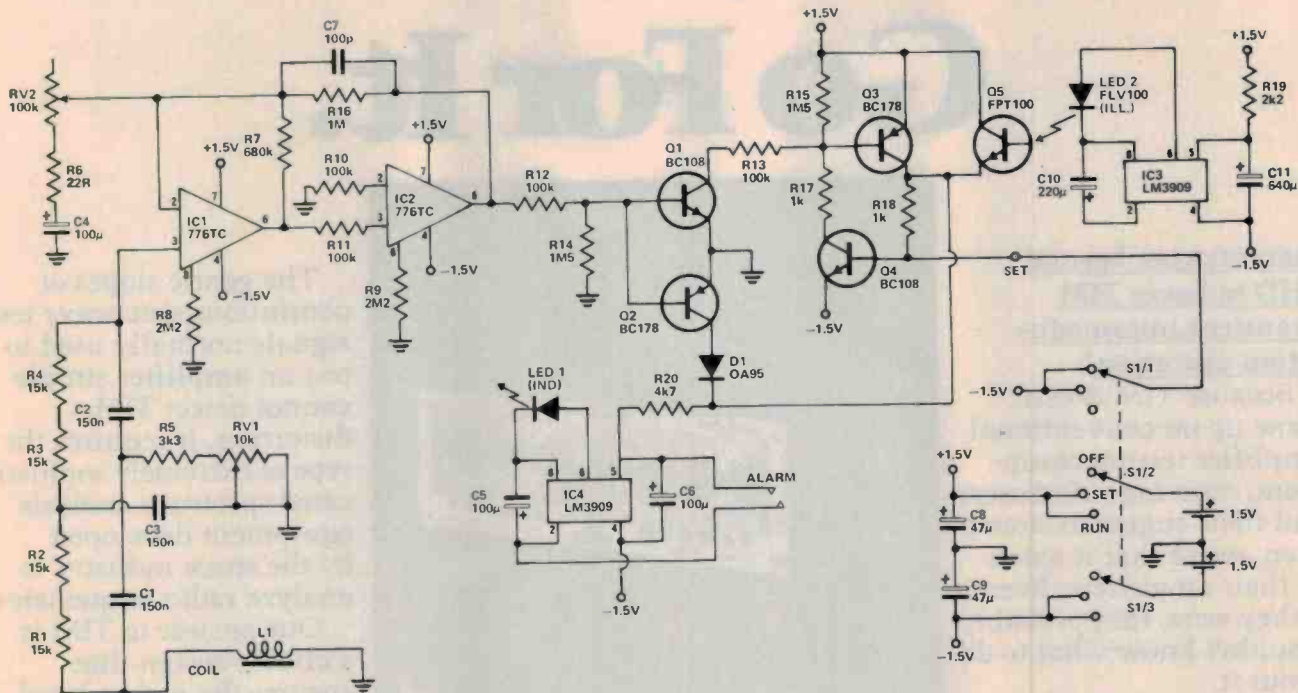

Fig.6. Circuit diagram of the UFO Detector.

LED and phototransistor *must* be very rigidly located and that the compass needle should just — but only just — block the light from the LED. The simplest way to make this section is to rebuild an old compass.

We suggest that you build the unit in sections checking out each section as it is completed.

No matter how you build the device it is absolutely essential to make sure that the compass assembly is mounted very rigidly — if there is any freedom of movement random mechanical disturbances will be registered as alarms.

Setting Up

The compass circuitry is quite straightforward. Provided it has been made correctly the phototransistor should be blocked by the compass needle when the complete detector assembly has been aligned precisely along the magnetic North/South line. Bringing a magnet or iron bar near the assembly should cause the needle to move slightly, thus allowing light to pass from the LED to the phototransistor, triggering Q3 and Q4, actuating the alarm.

The solenoid circuit is slightly more complex in that the twin-T rejection filter must be adjusted to optimise 50 Hz rejection. This may be done by observing the output from IC2 on a CRO while adjusting RV1 for maximum rejection. If a 'scope is not available, then RV1 must be adjusted so that the circuit is

not triggered by 50 Hz — increasing circuit gain via RV2 until the optimum setting is obtained. There is no need to inject 50 Hz into the circuit whilst setting up — in most places there's more around than you'll need!

Once the initial adjustments are made there will be little need to change anything except the sensitivity (gain) control RV2. This should be adjusted so that the unit is just short of triggering under normal conditions.

Local thunderstorms may occasionally trigger the unit but this is inevitable unless you use the unit on low sensitivities.

Well, there it is — the device *will* detect magnetic anomalies. Whether it will consistently detect UFO's is another matter — we were unable to obtain a DIN standard UFO for calibration purposes! Until we do, we refrain from making any claims as to the efficacy of this device!

PARTS LIST — ETI 587

Resistors all ¼ W, 5%

R1-R4 . . . 15k
R5 . . . 3k3
R6 . . . 22R
R7 . . . 680k
R8,9 . . . 2M2
R10-R13 . 100k
R14,15 . . 1M5
R16 . . . 1M
R17,18 . . 1k
R19 . . . 2k2
R20 . . . 4k7

Potentiometers

RV1 . . . 10k trimpot
RV2 . . . 100k trimpot

Capacitors

C1-C3 . . . 150n
C4-C6 . . . 100µ 3.6 V tantalum
C7 . . . 100p
C8,9 . . . 47µ 6.3 V tantalum
C10 . . . 220µ 10 V electrolytic
C11 . . . 640µ 16 V electrolytic

Semiconductors

IC1,2 . . . 776TC op amp (or LM4250CN)
IC3,4 . . . LM3909 flasher (National)
Q1 . . . BC108
Q2,3 . . . BC178
Q4 . . . BC108
D1 . . . OA95, or similar germanium diode
LED1 . . . Red LED with mounting clip
LED2 . . . FLV100 (or NSL100)

Miscellaneous

L1 Solenoid (e.g. the coil from a 5k PO3000 type relay).
S1 3 pole 3 position 'F' switch
Magnetic compass, 40 mm maximum needle length (e.g. 'An Outdoor Must' No. 120).
Input and output plugs and sockets, pc board ETI 587, dual battery holder for two 'C' cells, two 1.5 V 'C' cells, 1 knob, case 155 x 90 x 45 mm (approx) internal, coax cable, shim brass, perspex, glue, black paint, wire.

Ultimately It's Marantz. Go For It.

Marantz goes beyond THD to lower TIM (transient intermodulation distortion).

Because TIM doesn't show up on conventional amplifier testing equipment, most manufacturers and their engineers aren't even aware that it exists in their amplifiers. Even if they were, they probably wouldn't know what to do about it.

But because Marantz builds for the music and not just the specs we know how destructive TIM can be to pure sound reproduction. And we've developed a revolutionary new circuit design to eliminate it.

The reduction of TIM can be the single most important element in making an amplifier sound better. For instance, two amplifiers with identical total harmonic distortion (THD) specifications should sound the same when compared... but the one with low TIM will sound audibly better! That's because TIM adds an unnatural harshness to the music. It's not only detrimental to pure sound reproduction, but it can have an emotional effect that you experience as "listening fatigue!"

TIM is caused by an improper design of "negative feedback circuitry," by other manufacturers. Every modern amplifier uses it to lower THD. But *excessive* negative feedback coupled with an insufficient slew rate* can lead to gross internal overloads under the constantly changing transient and sound levels of music. That distortion is TIM.

*The maximum change of voltage per unit time.



The gentle slopes of continuous sine wave test signals normally used to test an amplifier simply cannot detect TIM distortion. It requires the type of extremely sophisticated spectrum analysis equipment developed by the space industry to analyze radio frequencies.

Our answer to TIM is a circuit design that ensures the widest bandwidth and the lowest obtainable THD *before* negative feedback is applied. The Marantz 170DC Stereo Power Amplifier (the 1152DC

and 1180DC also use this circuitry), for instance, needs only 1/100th (-40 dB) the amount of negative feedback commonly required by other amplifiers to yield the same low THD figures.

Incredibly, Marantz amplifiers with low TIM design can deliver flat frequency response from 0 Hz to 20 kHz *without* the use of negative feedback. And this same circuit design provides the optimum slew rate for minimum TIM and maximum reliability.

Result: Marantz reduces TIM to an inaudible level, which means you get clear, clean sound from all your records and tapes. Think of Marantz with low TIM as a window to the original performance.

If you truly want the best reproduction of musical sound available anywhere—and are willing to spend a little more to get it—then go for it.

Go for Marantz.

marantz®
We sound better.

For further information and literature, please contact:

SUPERSCOPE (AUSTRALASIA) PTY. LIMITED, P.O. Box 604, Brookvale, NSW, 2100. Telephone: (02) 939-1900

SOUND

NEW SPEAKERS FROM TECHNICS

Following the successful introduction of Technics Linear Phase speakers in Australia about a year ago, Haco Distributing Agencies has announced the availability of two new models to augment the range. These are the models SBX1 bookshelf speaker system and the SB-007 a miniature variant of the Technics SB-7000, the original Linear Phase model.

The SBX1 is the first of a range of three Linear Phase models with full timber cabinets to be released this year. It is a two-way two-speaker system and is already available from hi-fi dealers. Two other models in the range are larger three-way speaker models, and they will be released later this year. Recommended retail price of the SBX1 is \$139.

The SB-007 is exactly half the size of its predecessor, the SB-7000, although it has the same features and can handle 50W RMS. Its great advantage is price, which at \$299 recommended retail, is also about half the RRP of the larger model, which is \$599.

NEW Technics

Above: the SB007 Linear Phase model with, in the background an SB7000.

Right: the new SBX1 appears slightly more conventional.



Philips Motional Feedback Speakers. A step closer to sound perfection.

At Philips, striving for perfection is one of our hallmarks. Now, after years of exacting research in our European laboratories, we've come very close to the ultimate in Hi-Fi reproduction. We've developed a very compact way of reproducing low frequencies that's simply known as MOTIONAL FEEDBACK.

A piezo-electric crystal built into the cone of the woofer converts the acceleration of the cone into an electrical signal. The acceleration of the cone is linearly translated back to the original signal driving the loudspeaker. This signal is fed back to the input of the amplifier incorporated in the enclosure and compared with the original signal, thus enabling the loudspeaker to be immediately corrected at the slightest deviation. In this way, the acoustical behaviour of the woofer can be completely controlled.

This has the following advantages:

1. The resonant frequency is registered as a deviation from the original signal and corrected.
2. Unwanted vibrations (distortion) are reduced.

3. The correction signal forces the loudspeaker to produce the extremely low notes clearly.
4. It becomes possible to use smaller loudspeakers and smaller enclosures for reproducing undistorted low notes at a very high sound pressure level.

Specifications — Model 544

Volume: 15 litres; 9 litres acoustic
Total power of amplifiers: 60 Watt, cont. sine wave power
Frequency response: 30-20,000 Hz
Treble filter: continuously variable, 0-18 dB per octave, -3 dB at 7,000 Hz
Cross-over frequencies: electronic cross-over at 500 Hz, passive cross-over at 3,000 Hz
Input sensitivity: continuously variable 1-23V at 100 kohm
Amplifier for woofer: 40 W cont. sine wave power
Amplifier for squawker and tweeter: 20 W cont. sine wave power

Specifications — Model 541

Volume: 8 litres; 4.5 litres acoustic
Power of amplifier: 30 Watt cont. sine wave power
Frequency response: 35-20,000 Hz
Cross-over frequency: 1400 Hz
Input sensitivity: 1 V at 10 kohm, for connection of pre-amplifiers
7.5 V at 100 Ohm, for connection of low power amplifiers
19 V at 100 Ohm, for connection of high power amplifiers

All specifications are subject to alteration without notice.



PHILIPS

367 2077

We want you
to have the best



DV 505 DYNAVECTOR

DYNAVECTOR'S LOW MASS/HIGH MASS ARM

THIS ARM HAS stirred up a great deal of interest since it was first announced by its designer Dr. Tominari of Onlife Corporation, Japan. Unlike most modern arms, it's a heavy beastie, and at first sight looks a most improbable device.

But the weight is for a purpose. Dr. Tominari designed the DV-505 on the understanding that a cartridge should be held in a fixed position relative to the record groove, and the easiest way to ensure this is to use a large mass to hold it in place. This prevents the small motions of the stylus, especially at low frequencies, from shifting the entire system.

The high mass idea is a good one if one works on the assumption that records are perfectly flat. But of course records aren't flat, and the effect of playing a record with a high mass arm, especially with a high-compliance cartridge, is for surface undulations and ripples to cause vertical stylus motion relative to the pickup. This gives rise to substantial sub-audible noise, and at the same time renders the system liable to poor tracking performance, mainly through the inertia of the system.

SOUND

Tominari reasoned therefore that while high mass was definitely desirable in the horizontal plane, as we'll explain in a moment, it definitely isn't desirable in the vertical plane. Thus the problem was to provide high horizontal mass and low vertical mass. This was done by using a very heavy arm, pivoted for horizontal motion only at the pedestal. The vertical pivot was positioned at the end of the main arm and this carries a small offset sub-arm, complete with its own counterweight for balancing and applying tracking force.

Resonances

Bass information on the great majority of stereo records is recorded equally in each channel and in phase, partly because of the nature of bass information itself and partly to avoid certain problems related to cutting and replay. Thus resonances in pickup systems which are related to audible low frequencies should affect only the horizontal plane operation of the arm (at least in theory). Additionally, the problems of surface irregularities are confined to the vertical plane.

The existence of a high mass must obviously have a stabilising effect when these low frequencies are being tracked. Resonances are suppressed entirely at best or at least exhibit reduced Q factor. The fundamental system resonance, which is a complex function of system mass, cartridge compliance and tracking force, tends to be reduced in frequency in the horizontal plane. However, this particular resonance is most troublesome in the vertical plane where it can be excited by record surface ripples. In the Dynavector arm, the use of a very low mass vertical system

Continued on P. 26

Electronics Today International

4600 and 3600 SYNTHESIZERS

Complete plans for the Electronics Today International 4600 Synthesizer are now available in book form. Many hundreds of these remarkable synthesizers have been built since the series of construction articles started in the October 1973 issue of Electronics Today.

Now the articles have been re-printed in a completely corrected and up-dated form.

The International Synthesizers have gained a reputation as being the most flexible and versatile of electronics instruments available.

They have been built by recording studios, professional musicians, university music departments and as hobby projects.

This book is available now as a limited edition of 2000 copies only.

Ensure your copy!

Send \$12.50 to Electronics Today International,
15 Boundary Street, Rushcutters Bay, 2011.

SOUND

helps reduce inertia and consequently the effects of this resonance. These benefits apply at lower sub-audible frequencies as well, the arm operating far more successfully than the majority of conventional arms by riding easily over warps and ripples without causing stylus motion relative to the arm. Should the fundamental system resonance affect horizontal operating modes, the arm has another card up its sleeve — a tuned damper, consisting of a rider weight fitted to a strip of spring steel, is located under the main arm. This can be tuned by moving the weight and is designed to resonate in anti-phase with the main resonance, thus cancelling it.

Further damping of vibration is provided by the accurate strip at the counterbalance end of the main arm. This passes through a magnetic field supplied by a pair of permanent magnets, and any vibration of the strip sets up eddy currents which interact with the fixed field. This expedient also helps reduce the effects of acoustic and mechanical feedback in the player system and in any event, the tremendous mass of the entire device helps reduce structural vibration in the turntable itself.

One of the possible drawbacks of the split pivot system is the substantial change in vertical tracking angle of the stylus when tracking warped and rippled records. Tominari acknowledges this but points out that any distortion due to this is likely to be negligible compared with the distortion produced by a conventional arm, by virtue of its high vertical plane inertia, under the same conditions. Tominari also regards the problem of bias force as negligible with this arm; the force is so small compared with the stabilising mass of the horizontal system that it should have virtually no effect. The bias compensator was added to meet market demands but our tests showed that it probably is superfluous — no audible improvement resulted from its use. In fact, the existence of a bias

force could perhaps be seen as beneficial — helping counteract any tendency there might be for the stylus to be held in contact with the outer groove wall because of the need for so substantial a mass to follow the inward groove spiral to the record centre. But since the force required to move even this large a mass inward is very small indeed, particularly in view of the very low friction of the system, no real problems should arise, and the benefits of the high mass should certainly be far greater than the drawbacks.

Performance

We tried the arm with a range of cartridges, including Onlife's Dynavector 20B, Decca Mk. 6E and Garrott P77 (improved). The 20B has never sounded better, the bass shyness and upper frequency emphasis exhibited with this cartridge in other arms being less pronounced. Stereo performance was greatly improved with better separation, and better perspective, the latter resulting from improved dynamics. So with the Garrott cartridge, which, whilst not exhibiting the excellent definition of very fine detail of the 20B, nevertheless sounded better than we've ever heard it, with a particularly clean and open bass performance.

Our Decca sounded, unfortunately, like a poor sample in this arm — we're not entirely convinced, though, that the arm is incapable of doing justice to the Mk. 6E. We suspect the main problem is the mounting arrangement for the Decca, which is very sloppy and definitely needs attention. Perhaps Decca might see fit to introduce a new body — perhaps like the old C4E — which might help alleviate these problems.

The arm was pleasant to use, despite having no lifting device (one is available as an option). All adjustments were very easy to make and the tracking force calibrations (tracking force is applied by a spiral spring about the vertical pivot) were found to be accurate. Our sample was mounted on a Rega Planar 3 turntable, but that's another story which we hope to tell soon!

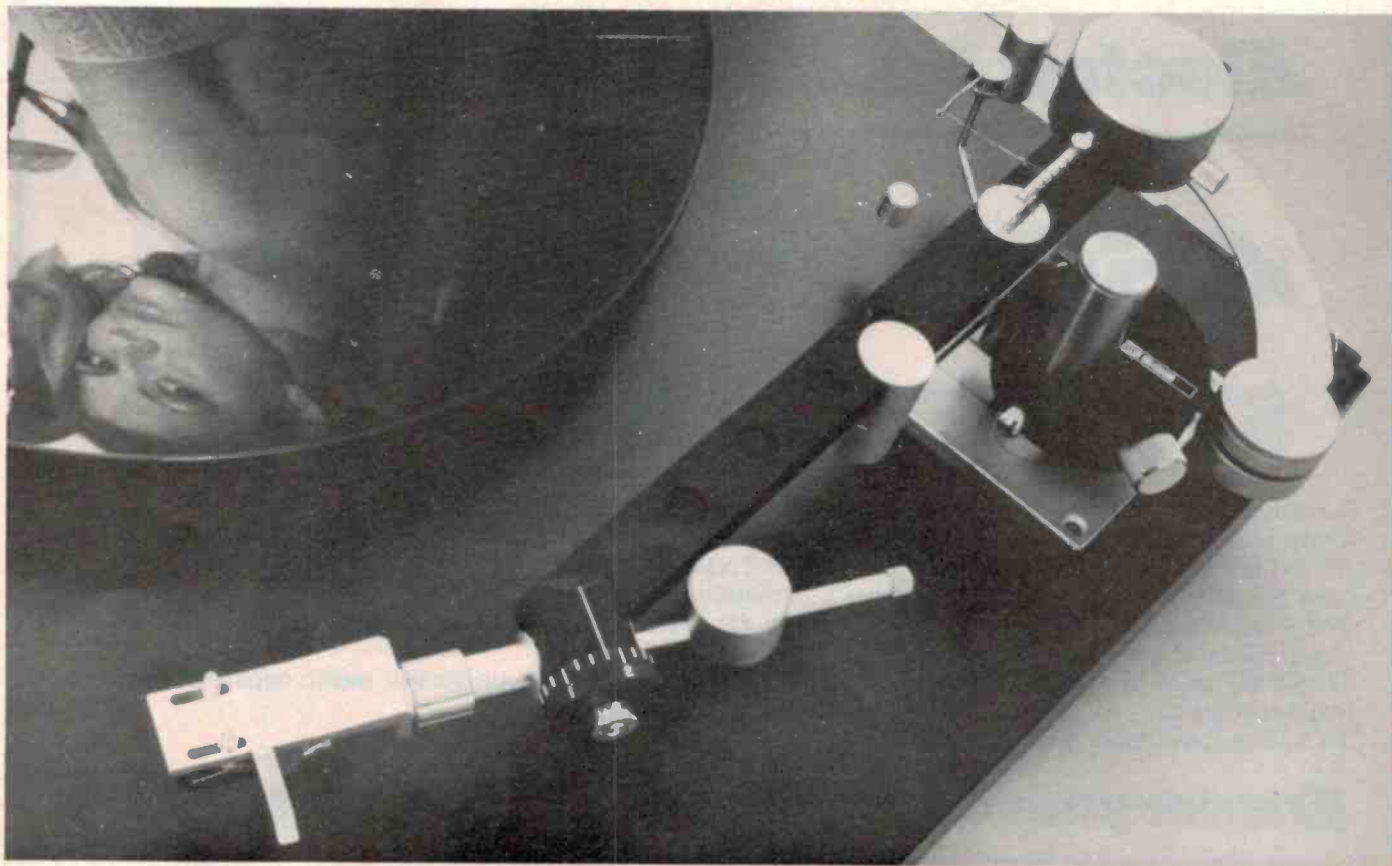



Radiometer BKF 10

Supplier: Foss Electric,
251 Condamine Street,
Balgowlah
Tel. 949.3044

EVERY ENGINEER AND TECHNICIAN at some stage of his career finds himself in the onerous position of having to produce a graph with two or more measured parameters. Most technicians only do this infrequently but for a small number this can be a day-by-day routine which either becomes a "chore" or a "charm" depending on the resources placed at their disposal.

Over the last twenty years a number of enterprising manufacturers have turned that chore into a charm with the development of sophisticated electronic equipment that produce automated graphs from all kinds of electrical, geophysical, physiological and biological data.

The area that interests our readers is acoustical and electro-acoustical data. Whilst many of you may not have realised it, most of the data that we present in our reviews is produced in Bruel & Kjaer equipment. For many years, Bruel & Kjaer of Copenhagen and General Radio of Massachusetts (now renamed Genrad) have dominated the electro-acoustical instrumentation field. More recently, another firm, Radiometer of Copenhagen, has decided to enter this field with a new system which is sufficiently different to warrant evaluation.

Radiometer are a well established firm whose reputation has been firmly founded by their biological equipment and specifically in the area of blood analysis. Over the years they have produced signal generators for AF, RF and voltmeters, all of which have found a receptive market.

Bruel & Kjaer and General Radio equipment is designed principally as building blocks, with which an engineer or technician can perform a wide range of measurements, depending on his ingenuity and which blocks he has at his disposal.

Radiometer carried out a market survey and followed a slightly different approach. They decided to build a series of "stand-alone" instruments which provide the electro-acoustic parameters most often required in one box, with optional chart print-out and other special facilities which are infrequently required being provided by relatively inexpensive stacking systems.

The basic unit, the BKF10 is a 19" unit, capable of being rack mounted, which measures level response (or gain), distortion (or signal to noise ratio), and frequency on three built-in meters, the outputs of these meters can be fed to direct graphs of frequency response or total harmonic distortion. In addition it is a low distortion 20 to 20 kHz signal generator with a 1 mV to 1 volt output capability.

What's so special about that you say — well we suspect that for the first time somebody has built the facilities into one (or two) boxes avoiding many of the complications resulting from at least twenty different controls by providing less than half that number. More important, the key note of the whole

system is simplicity, directed to production testing of almost any electro-acoustic system, including tape recorders which this system measures better than anything else that we've seen.

Inside

The BKF10 is a neat instrument featuring three analogue meters and a minimal number of controls. Inside it contains an audio analyser covering the range 20 Hz to 20 kHz, and capable of measuring low level distortion.

An automatic Level Control Amplifier (ALU) which can control either the output or the input signal of the distortion analyser accurately measures the total distortion of the return signal even if not generated by the BKF10, and last but not least a frequency measuring circuit which can be used to control either the REC6152 servograph or any XY recorder whose Y parameter can be controlled over the range 0 to 3 volts (see figure 1).

The circuitry of the BKF10 has been cleverly conceived with a series of innovative features which will interest the professional and novice alike. The first feature that impressed us was the almost complete absence of controls for the input circuit — provided the level is less than 3 volts, no level or attenuation is necessary. If the level is between 3 and 30 volts a single attenuator switch is provided to reduce the signal to within the 60 dB dynamic range input of the amplifier. Even this is taken care of by the provision of an input out of range indicator light.

Whatever level of signal is fed into the BKF10 input socket, the input frequency and the harmonic distortion are displayed. If the signal being analysed is generated by the BKF10, then the ratio of input to output voltage (i.e. gain or loss) is also displayed directly on the 70 dB linearly scaled central analogue meter.

The other controls on the BKF10 unit are an input filter which provides a flat frequency position and 3 dB high pass or low pass filters at 250 Hertz, a signal to noise button which holds the automatic level control circuit gain fixed, whilst muting the oscillator output. This facilitates instantaneous signal to noise measurements in the "twinkling of an eye".

Control of the output frequency is provided through a switch which either selects a front panel potentiometer or external dc control. (i.e. from servograph if connected). A push button at the top of the panel activates an automatic single sweep when desired.

Back to Front

Unlike all other units with which we are familiar, this unit works back to front and sweeps down from 20 kHz to 20 Hz. The reasons for this are not clear but it was a little disconcerting when first encountered.

Continued on P.29

Modern expertise and computer technology
have created a fine piece of equipment.

The NEW B&W DM 7



The DM7 complements a remarkable range of monitor loudspeakers from B & W.

The B & W DM6 is Britain's first linear phase loudspeaker. A dynamic system that will reproduce sound with transient accuracy usually achieved only by the very best electrostatic designs.



The DM6 is a 3 unit monitor loudspeaker system that produces high quality results from an incredibly small cabinet (20 litres) making it perfect for home or small studio use where space is at a minimum.



Only 28" x 9" x 9". Despite its compact size, DM6 speakers can be rated as a system of very high quality. The design philosophy of John Bowers — "To design loudspeakers that reproduce in your home sound as you would hear in the concert hall!"



DM7 is the first of a new loudspeaker family reflecting our computer-aided research programme. It's a compact 3 unit system employing entirely new drive units in an enclosure engineered to exceptionally high standards. Many advances have been incorporated to reveal new horizons in loudspeaker performance, making possible a standard of musical reproduction unequalled in an enclosure of this size. The DM7 gives almost perfect amplitude linearity throughout the entire audio spectrum, and produces phase-coherent sound within a broad listening area. The drive units are purpose-designed and manufactured entirely in our own factory, employing new technology in order to achieve incredibly low distortion levels — typically less than 1% THD from 30Hz to 200Hz and less than 0.5% above that frequency. Another new feature in the DM7 is a variable energy control giving four frequency weightings — different to those obtainable from the control unit — to accommodate widely varying room acoustics.

Hear the B & W DM7 — you may well agree that this is the finest small speaker in the world today. Guaranteed for 5 years.

NSW: CONVOY SOUND WOOLLOOMOOLOO SHOWROOM 357 2444; INSTROL HI-FI PTY. LTD. 29 7290; PARK ST. HI-FI STEREO CENTRE 26 2798; MILVERSON PTY. LTD. (CHATSWOOD) 412 2122 (PARRAMATTA) 635 3588; RIVERINA HI-FI 938 2663/4; UNITED RADIO DISTRIBUTORS PTY. LTD. 232 3718; ARROW ELECTRONICS 29 8580; RUSSIN HI-FI 799 2421; PITMAN'S RADIO & TV (WAGGA) 25 2155; ALBURY AUDIO CENTRE 25 1712; LEISURE SOUND (CHATSWOOD) 411 4944; WROTH CENTRE HI-FI (BATHURST) 31 2088; BYRON BAY TV & SOUND CENTRE 85 6762; SINGLETON HIGH FIDELITY CONSULTANTS 72 2270; HI-FI JUNCTION 389 4000; ACT: DURATONE 82 1388; VIC: SHEPPARTON HI-FI 21 9006; ENCEL ELECTRONICS PTY. LTD. 42 3761; SOUND SPECTRUM (GEELONG) 9 6616; SOUTHERN SOUND (CITY) 67 7869 (MOORABBIN) 97 7245; TIVOLI HI-FI 81 2872; THE SOUND CRAFTSMAN 509 2444; BUY RITE ELECTRIX 42 6200; NATSOUND 67 8158; INSTROL HI-FI 67 5831; INSTROL HI-FI (FRANKSTON) 783 7535; QLD: JOHN GIPPS SOUND 36 0080; PREMIER SOUND (NTH. ROCKHAMPTON) 27 4004; TARGA ELECTRONICS (CAIRNS) 53 2715; RUSS ADAM (TOWNSVILLE) 71 5618; TAS. BEL CANTO (HOBART) 34 2008; UNITED ELECTRONICS (LAUNCESTON) 31 8528; AUDIO SERVICES (BURNIE) 31 2390; WEST. AUST. TECHNICAL SERVICES PTY. LTD. 31 5455; THE GINZA 61 7444; STH. AUST. BLACKWOOD SOUND CENTRE 278 1281; INSTROL HI-FI 22 3762; SOUND SPECTRUM 22 32181.

Sole Australian agent:

Convoy
INTERNATIONAL

4 Dowling Street, Sydney 2001. Phone: 358 2088.



The back of the unit has a BNC socket which carries the distortion component of the signal being measured which can then be viewed on an oscilloscope. In addition a 25 pin socket allows connection to the external recorder, in our case, the REC 61 Servograph. The Servograph uses this cable to feed back the DC control voltage which it generates on a precision wire wound potentiometer. The distortion signal can be fed to an additional selective measuring unit to provide harmonic data if desired.

The SMU401 provides facilities for the analysis of fundamental, second, third, fourth and fifth harmonics of the signal being measured, and the second, third and fourth harmonics of the mains frequency. What this means is that a distorted signal with superimposed mains components can be further analysed with the SMU401 to determine what is causing the problem and thereby allow a solution to be more readily effected.

Fortunately the SMU401 is a relatively cheap addition to the system, being only \$A1200. This represents only 18% additional expenditure for an extremely powerful facility. No professional worth his salt would fail to appreciate this facility. Most importantly it allows the automatic plotting of selected harmonics on the output distortion graph. By using separate colours, a series of plots can be superimposed providing the user with a neat visual picture of total distortion characteristics. This capability can be further expanded by plotting at different drive levels.

The Servograph, which "neatly stacks on top of the BKF10 or BKF10 + SMU401", is a simple device which seems a little expensive, however, it does its job very well and is accurate and very convenient when compared to a conventional level recorder. Taken all in all it is most probably easier to use and when it comes to producing multiple graphs on the same chart is exceedingly reliable on resetability.

The REA 241 distortion interface provides for the selection of level or distortion plotting on the specially calibrated chart paper. Unlike conventional level recorder charts, this system has two separate areas of the graph for this purpose (see figure 1). The only other controls are Pen Up (Ready), Pen Down, a 12 position chart speed selector and the tracking potentiometer. The 12 position speed selector provides an accurate speed from 1 second/cm to 120 minutes/cm. Additional controls include a coarse and fine pen position and a paper stop, forward and reverse switch.

Loading a graph is extremely simple: because of the flat bed principle utilised nothing could be easier.

Confounding the Sceptics

We are always sceptical of any new system which carries out its functions differently from all others. Fortunately, the Radiometer system caused us to change our minds about its techniques and more importantly, its accuracy. The system provides direct answers using the time honoured black box approach. To evaluate its performance necessitated setting up a series of tests with rationally produced or contrived signals to check out the system accuracy.

The first series of checks were of the distortion read out by means of comparisons with the Hewlett Packard and Bruel & Kjaer laboratory system that we normally use. These units which are fully calibrated, showed that the correlation between the three systems was excellent and that the maximum deviation did not exceed 2 dB, at distortion levels of the order of -74 dB. By reading the 1 kHz signal generated by the BKF10 on the 3 volt position (which clips the output and is intended to be used as a set up signal),

the THD figure was 8.3%. The computed total harmonic distortion (THD) figure from the 2nd, 3rd 4th and 5th harmonics obtained with the use of the SMU401 was 8.26%. An analysis of the same signal by means of our conventional laboratory system resulted in a THD of 7.8%. Our analysis was effected by the method of RMS detection of the distortion component and as it would appear that none of the Radiometer equipment utilises true RMS detection, this is probably the primary reason behind the variation in total or computed distortion figures.

The measured output distortion from the BKF10 unit is quite good for output levels between 10 mV and 1 Volt. Below this range there are hum and noise problems and above it severe assymetry problems in the generated signal (i.e. 10% distortion).

This problem can be overcome on the 3 Volt range if one purchases the BAT10 floating output amplifier which came into our hands late in our evaluation. This unit is particularly useful when evaluating circuits with high gain and or high power output as it can overcome the common earth loop problem when a signal is both generated and measured by the same basic circuit. More important it allows the testing of equipment at distortion levels of less than 0.01% across most of the audible spectrum.

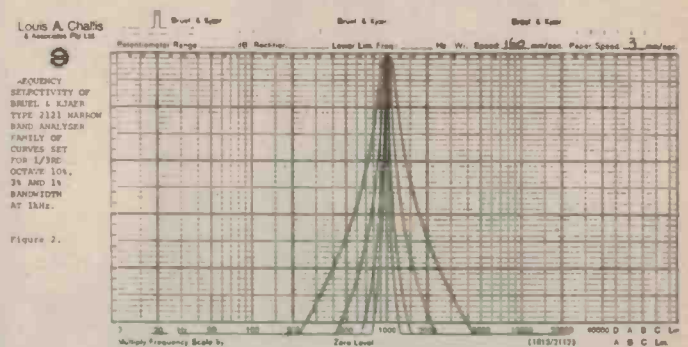

Figure 2.

We measured the accuracy of the frequency meter, for which the manufacturer states a tolerance of $\pm 5\%$. The greatest error that we could find was at one point (1 kHz) on the dial where it was 4.8% high.

The distortion generated by the oscillator varies as a function of level. Whilst the manufacturer states that it is less than 0.01% in one place in his literature, and less than 0.03% in another, we found it to be a function of frequency and level (See table). For most applications the internal distortion will prove to be satisfactory. For the most critical applications we fear the user will face the same problems that we do and be forced to pre-filter the signal to achieve the required low level of signal distortion.

One of the joys of using this machine is when measuring the frequency response and distortion response of Tape Recorders. If the paper is offset by the time lag corresponding to the distance between the record/replay heads and the speed for 3 head machines, or in the case of a single head record and replay machine then without offsetting the paper (but on replay) excellent results can be graphed with great ease.

As the BKF10 automatically determines the fundamental frequency of any signal applied to its input, it can track and accurately analyse (for distortion) any previously recorded signal.

Continued on P. 31

THE LOUDSPEAKER THAT LOOKS AT MUSIC THE WAY YOU DO: JBL'S NEW L110.

You're at a concert. The sound surrounds you. There's a guitar. A piano. Some horns. You hear all of it.

But more than that, you hear each part of it. Each sound. Every sound. All the sound.

Most loudspeakers can't do that. They only meet you half way. Only left and right, all or nothing. JBL's new L110 goes all the way. It looks at music the way you do.

Left. Right. Front. Back.

The L110 has almost perfect stereo imaging—a result of precise, uniform dispersion at every frequency.

Inside the L110, there's a brand new, super-sophisticated crossover network designed specifically to match the new components.

There's a new 10" woofer which utilizes a massive 3" voice coil and 7½ lb. magnetic assembly—normally found in 12" woofers.



Frequency Dispersion of the L110

~~~~~ at 400Hz ~~~~~ at 2kHz ~~~~~ at 10kHz

JBL's new L110 loudspeaker is part of the same research and development breakthrough that created our no-tradeoff, top-of-the-line L212 system.

If this graph looks familiar, it should. The L212 produced an almost identical one.

The result is smooth, accurate bass, plus an amazing level of efficiency and power handling capability throughout the entire system. (One more nice: You get more headroom for your amplifier. Less clipping.)

Now look at the L110. The most acoustically transparent grille JBL has ever created is visually transparent, too. You can see right through to the satin black components inside.

If you'd like a lot more technical information on the L110, write us and we'll send you an engineering staff report. Nothing fancy. Except the specifications.

But you really should come listen to the L110. And ask for it by its first name: JBL. You'll be get-

ting the same craftsmanship, the same components, the same sound heard in the very top recording studios in the world.



Over four hundred of the leading recording studios in the world—from Los Angeles to London to Muscle Shoals to Munich to Tokyo to Tennessee—use our sound to make theirs. Shown here is Capitol Records in Hollywood, California.

HA118/78

Distributed by—  
HARMAN AUSTRALIA PTY. LTD., P.O. Box 6, BROOKVALE, N.S.W. 2100.



GET IT ALL.



One interesting problem occurs with tape drop outs where the distortion analysis responds to the drop-out as a loss of fundamental and artificially boosts the percentage distortion on the chart.

The BKF10 system is equally at home when testing loud speakers, both for linearity, as well as for distortion which it does very nicely. With the SMU401 it really plots out the harmonic components.

#### Conclusion

As a system the BKF10 is very attractive, its only limitation is the REC 61 servograph. This is the only component which limits the speed of analysis because of its need to track slowly if it is to track accurately. The need to provide the BAT10 floating amplifier to achieve 3 Volts output capability is a further limitation. Most oscillators can provide 10 Volts which the typical laboratory would call for in such testing.

Notwithstanding this we are impressed that this system has a lot going for it and will meet most of the requirements that production facilities, maintenance and testing laboratories call for.

*Continued P. 32; Typical frequency response measurement and specifications of BFK 10.*

# AUDAX

Audax speakers are to be imported into Australia by Bill Webb Stereo of Melbourne. Made in France, Audax drivers have been

used for many years by European speaker manufacturers and have recently become popular with a number of well known English manufacturers.

Spendor and Rogers both use Audax drivers and Dudley Harwood, the former B.B.C. design engineer, uses the Audax dome tweeter in his new Harbeth speaker system.

Audax manufacture a comprehensive array of audio components including speaker kits and microphones. Initially the importers intend marketing drivers only and will concentrate on the HF range of which there are over 70 units available ranging from a 355 mm 100 watt base driver to 25 mm soft dome tweeters.

Naturally it is the commercial manufacturer who is expected to show most interest in the range but Bill Webb will be interested in helping and advising all interested parties and will welcome enquiries from enthusiasts generally.

Future plans call for the release of at least a few of the very comprehensive range of speaker kits and these should prove to be of great interest to the home builder. Prices for the kits should be most competitive as they are for the individual drive units.

Further information may be obtained from *Audax Speakers, Bill Webb Stereo, 32 Wilson Street, Oakleigh. Vic. Phone: (03) 579-5196.*

## SOUND BRIEFS

### Otoscan I

This active-line, staggered resonance speaker system has been designed by Colin Wait who was responsible for developing the AMW range. The name? Otos is Greek for ear. Scan is English for scan.

### Armstrong speaker

A new compact reflex speaker system, using dome midrange and high frequency drive units, has been introduced by Armstrong Audio. Designated model 602, the new system should retail at about \$700 per pair according to Concept Audio, 13, Rickard Road, Narrabeen 2101, the local distributors.

### Hadcock Arm

The much-vaunted Hadcock pickup arm should soon be available in Australia. This is the first of a range of top-quality components to be represented by a new distributor, Audio 2000, of Sydney. More details of Hadcock and Audio 2000 will be published as they come to hand.

### Modified Grace

A modification service for Grace G707 arms is available from Riverina Hi-Fi, Brookvale. The mod. consists of decoupling the counterweight and, if a heavy moving-coil cartridge is to be used, addition of a supplementary counterweight.

### Parabolic Decca

Allen Wright of Audiolab and Garrot Brothers in Melbourne have come up with an improved Decca Mk-6 cartridge. Fitted with a Weinz parabolic stylus and hand tuned, the modified Deccas should be in good supply before long. Details of price and availability will be published as soon as they are to hand.

### Win with Boron

Win Laboratories' latest version of the SDT-10 strain-gauge semiconductor cartridge is fitted with a boron cantilever for minimising resonances in the audible spectrum. Details from Megasound, 220 West Street, Crows Nest, NSW.

### Pneumatic Arm Lift

Audio Technica's latest pickup arm, the AT-1009, is fitted with a pneumatic lifter. This is operated by a pump which can be placed at the front of the turntable — good news for owners of soggy suspension decks like Linn Sondek, Thorens etc.

Continued from P. 31.

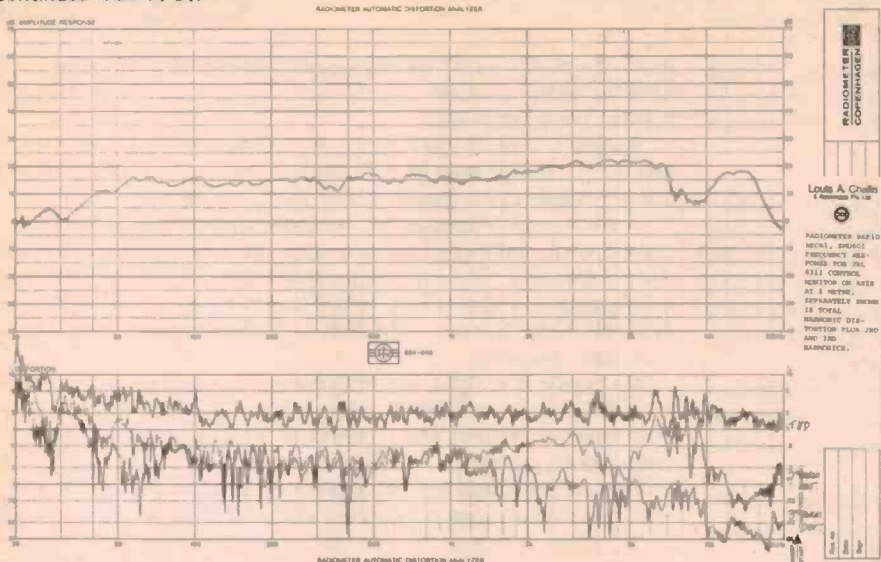

Typical plot produced by BFK 10 from a JBL 4311 speaker.

TABLE 1

**TOTAL HARMONIC DISTORTION GENERATED AND MEASURED ON BKF10**

| Output      | 100Hz  | 1kHz   | 6.3kHz | 10kHz  | 20kHz  |
|-------------|--------|--------|--------|--------|--------|
| 3V          | 8.5%   | 8%     | 8.5%   | 9%     | 8%     |
| 1V          | 0.026% | 0.012% | <0.01% | <0.01% | <0.01% |
| 300mV       | 0.026% | 0.012% | 0.01%  | <0.01% | 0.01%  |
| 100mV       | 0.026% | 0.012% | 0.013% | 0.014% | 0.019% |
| 30mV        | 0.033% | 0.024% | 0.024% | 0.03%  | 0.04%  |
| 10mV        | 0.07%  | 0.07%  | 0.07%  | 0.09%  | 0.13%  |
| 3mV         | 0.18%  | 0.2%   | 0.24%  | 0.28%  | 0.4%   |
| 1mV         | 0.3%   | 0.37%  | 0.45%  | 0.6%   | 0.47%  |
| 3 Volts Via | 0.026% | 0.01%  | <0.01% | <0.01% | <0.01% |

TABLE 2

**ACCURACY OF TOTAL HARMONIC DISTORTION MEASUREMENT**

- (i) Input Frequency : 500Hz  
 Graph Indication : THD = 0.015%  
 BKF10 Meter : THD = less than 0.02%  
 (minimum indication)
- (ii) Input Signal : 3 RMS at 1 kHz (BKF10)

| Frequency (Hz) | Graphed Distortion Components (%) | Distortion Components Measured by External Spectrum Analyser (%) |
|----------------|-----------------------------------|------------------------------------------------------------------|
| 2K             | 6.0                               | 5.6                                                              |
| 3K             | 4.5                               | 4.3                                                              |
| 4K             | 3.0                               | 2.9                                                              |
| 5K             | 1.17                              | 1.5                                                              |
| 6K             | —                                 | 0.5                                                              |
| THD            | 8.3% (Meter)                      | 7.8                                                              |
|                | 8.2% (Sum of Graphed Harmonics)   |                                                                  |

**See & hear The Accutrac 4000 at**

**Sydney City and Metropolitan Area**  
 Douglas Hi Fi.  
 338 George St., SYDNEY 2000  
 Phone 233 3922.

**Russin Hi Fi.**  
 256 Liverpool Rd., ASHFIELD 2131  
 Phone 7992421. John Russin.

**Leisure Sound.**  
 871 Pacific Highway, CHATSWOOD 2067  
 Phone 411 4944. Alex Haindl.  
 387 George St., SYDNEY 2000  
 Phone 29 1364. Andrew Goldfinch.

**Buyers World (NSW) Pty. Ltd.**  
 Shop 7, Lindfield Arcade,  
 Lindfield Ave., LINDFIELD 2070  
 Phone 467 2500. Rob Simpson.

**Warringah Hi Fi.**  
 Shop 5, Bungan St., MONA VALE 2103  
 Phone 997 5313. A. Preston.

**NSW Country**  
**Springwood Hi Fi.**  
 170 Macquarie Rd., SPRINGWOOD 2777  
 Phone (047) 513091. L. Johnston.

**Wroth Hi Fi.**  
 63 George St. (P.O. Box 452),  
 BATHURST 2795  
 Phone 31 6313. Michael Wroth.

**Scotty Wallace Pty. Ltd.**  
 113 Rankin St., FORBES 2871  
 Phone 522300. Scott Wallace.

**Hi Fi Gallery**  
 (C/- P.O.), Tamworth Centrepnt  
 374-388 Peel St., TAMWORTH 2340  
 Phone 662474. L. Taylor.

**John Roworth Television Services.**  
 11 White St., TAMWORTH 2340  
 Phone 664664. J. Roworth.

**Taree Photographics.**  
 Graphic House, 105 Victoria St.  
 (P.O. Box 295), TAREE 2430  
 Phone 52 1488. M. Small.

**Sonarta Hi Fi.**  
 Crown Central, WOLLONGONG 2500  
 Phone 295110.

**Canberra**  
**Duratone Hi Fi Pty. Ltd.**  
 3A Botany St., PHILLIP 2606  
 Phone 821388. M/s. Fay Cull.

**Victoria**  
**Douglas Hi Fi.**  
 202 Bourke St., MELBOURNE 3000  
 Phone 6632211.

**Qld.**  
**Brisbane Agencies Audio Centre.**  
 72 Wickham St., FORTITUDE VALLEY 4006  
 Phone 2683167. G. Eklund.

**Ipswich Hi Fi Centre.**  
 61 Limestone St., IPSWICH 4305  
 Phone 281 5485. Robert Smallwood.

**Sight and Sound Investments**  
 Shop 8, Shaws Arcade,  
 TOWNSVILLE 4810  
 Phone 71 5618. Stephen Shaw.

**SA**  
**Soundynamics Hi Fi Centre.**  
 129 Payneham Rd., ST. PETERS 5069  
 Phone 42 1237. Peter Hazelwood.

**WA**  
**Hub Record & Hi Fi Centre.**  
 Gilmore Ave., CALISTA 6267  
 Phone 99 1256. R. Takes.  
**Audio Distributors Pty. Ltd.**  
 10 Glyde St., MOSMAN PARK 6012  
 Phone 384 1362. P. Craig.

**TAS**  
**Quantam Sound Centre.**  
 194 Liverpool St.  
 (P.O. Box 1788), HOBART 7000  
 Phone 343051. R. MacFie.





# Accutrac. The turntable with eyes.



## Introducing Accutrac.

The only turntable in the world that lets you tell an LP which selections you want to hear, the order you want to hear them in, even how many times you want to hear each one.

Sounds like something out of the 21st century, doesn't it? Well, as a result of Accutrac's electro-optics, computer programming and direct drive capabilities, you can have it today.

Just imagine you want to hear cuts 5, 3 and 7 in that order. Maybe you even want to hear cut 3 twice, because it's an old favorite. Simply press buttons 5, 3, 3 again, then 7. Accutrac's unique infra-red beam, located in the tonearm head, scans the record surface. Over the recorded portion the beam scatters but over the smooth surface between selections the infra-red light is reflected back to the tonearm, directing it to follow your instructions.

What's more, it can do this by cordless remote control, even from across the room.



## The arm your fingers never have to touch.

Since Accutrac's tonearm is electronically directed to the record, you never risk dropping the tonearm accidentally and scratching a record, or damaging a stylus.

And, since it cues electronically, too, you can interrupt your listening and then pick it up again in the same groove, within a fraction of a revolution. Even the best damped cue lever can't provide such accuracy. Or safety.

## What you hear is as incredible as what you see.

Because the Accutrac servo-motor which drives the tonearm is decoupled the instant the stylus goes into play, both horizontal and vertical friction are virtually eliminated. That means you get the most accurate tracking possible and the most faithful reproduction.

You also get wow and flutter at a completely inaudible 0.03% WRMS. Rumble at -70 dB (DIN B). A tracking force of a mere 3/4 gram. And tonearm resonance at the ideal 8-10 Hz.

The Accutrac 4000 system. When you see and hear what it can do, you'll never be satisfied owning anything else.

Its father was a turntable.  
Its mother was a computer.

## The Accutrac 4000



BSR (A'asia) Pty. Ltd. Anne St.,  
St. Mary's. Box 272 St. Mary's  
NSW 2760. Phone 6230375/6.  
Telex 23159. Telegrams "BSR"  
St. Mary's 2760

Audio Dynamics Corporation  
A BSR Company

COMPTON BSR 142



# fact: the IV does more... *much more!*

**new!**

Shure V15 Type IV  
**SUPER TRACK IV™**  
Stereo Dynetic® Phono Cartridge



The creation of the new V15 Type IV is a tour de force in innovative engineering. The challenge was to design a cartridge that would transcend all existing cartridges in musical transparency, technical excellence, and uniformity. The unprecedented research and design disciplines that were brought to bear on this challenge over a period of several years have resulted in an altogether new pickup system that exceeds previous performance levels by a significant degree—not merely in one parameter, but in totality.

In fact, this pickup system has prevailed simultaneously over several extremely difficult music re-creation problems which, until now, have defied practical solutions. Most of all, this is an eminently musical cartridge which is a delight to the critical ear, regardless of program material or the rigorous demands of today's most technically advanced recordings.

## THE V15 TYPE IV OFFERS:

- Demonstrably improved trackability across the entire audible spectrum—especially in the critical mid- and high-frequency areas.

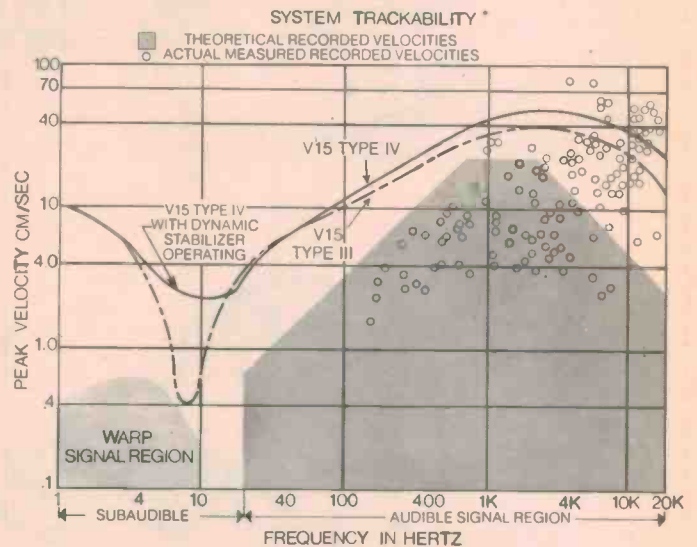

\*Cartridge-tone arm system trackability as mounted in SME 3009 tone arm at 1 gram tracking force.

- Dynamically stabilized tracking overcomes record-warp caused problems, such as fluctuating tracking force, varying tracking angle and wow.
- Electrostatic neutralization of the record surface minimizes three separate problems: static discharge; electrostatic attraction of the cartridge to the record; and attraction of dust to the record.
- An effective dust and lint removal system.
- A Hyperelliptical stylus tip configuration dramatically reduces both harmonic and intermodulation distortion.
- Ultra-flat response—individually tested to within  $\pm 1$  dB.
- Lowered effective mass of moving system results in reduced dynamic mechanical impedance for superb performance at ultra-light tracking forces.

For more information on this remarkable new cartridge, write for the V15 Type IV Product Brochure (ask for AL569), and read for yourself how far Shure research and development has advanced the state of the art.



**AUDIO ENGINEERS P/L**  
342 Kent Street.  
SYDNEY 2000 N.S.W.

**AUDIO ENGINEERS (Vic.)**  
2A Hill Street.  
THORNBURY 3071 Vic.

**AUDIO ENGINEERS (Qld.)**  
51A Castlemaine Street.  
MILTON 4064 Qld.

**ATHOL M. HILL P/L**  
33 Wittenoom Street.  
EAST PERTH 6000 W.A.

# AUDIO OSCILLATOR

Audio oscillator utilises new design in frequency meters, giving good accuracy and fast reading rates.

THE AUDIO OSCILLATOR is an almost essential piece of test equipment in any test lab be it professional or only the home workshop. Only the multimeter would rate more highly. We first published a simple sine-square oscillator way back in 1971 and this design is still very popular and selling well. We decided however to bring the design up to date adding a few improvements, and present it again.

## Design Features

This oscillator started out as a redesign, mainly mechanical, of the earlier design. It then started to evolve as a voltage controlled sweep oscillator but when it became too complex we reverted to a simple Wein bridge oscillator.

One major problem with all home made oscillators is that of scaling the frequency dial. This is not just a problem of positioning the knob but since normally available potentiometers have a tolerance of +/- 20%, the scale length will also vary. In commercial units the use of an expensive wire wound potentiometer solves most of the problems giving reasonably accurate scaling.

We then decided to build in a frequency meter, basing it on the ETI 533 display module. However the high power consumption (we wanted to allow battery operation) and the poor resolution, especially at low frequency, prompted the design of a completely new frequency meter.

This uses what is literally an analogue computer to convert a period measurement into frequency with some digital electronics controlling it and displaying the results. We based this on the Intersil ICL 7106 module which, due to its liquid

*Continued on page 38*



*Front view of the audio oscillator. Note that this is an early prototype and the 3V range has been deleted.*

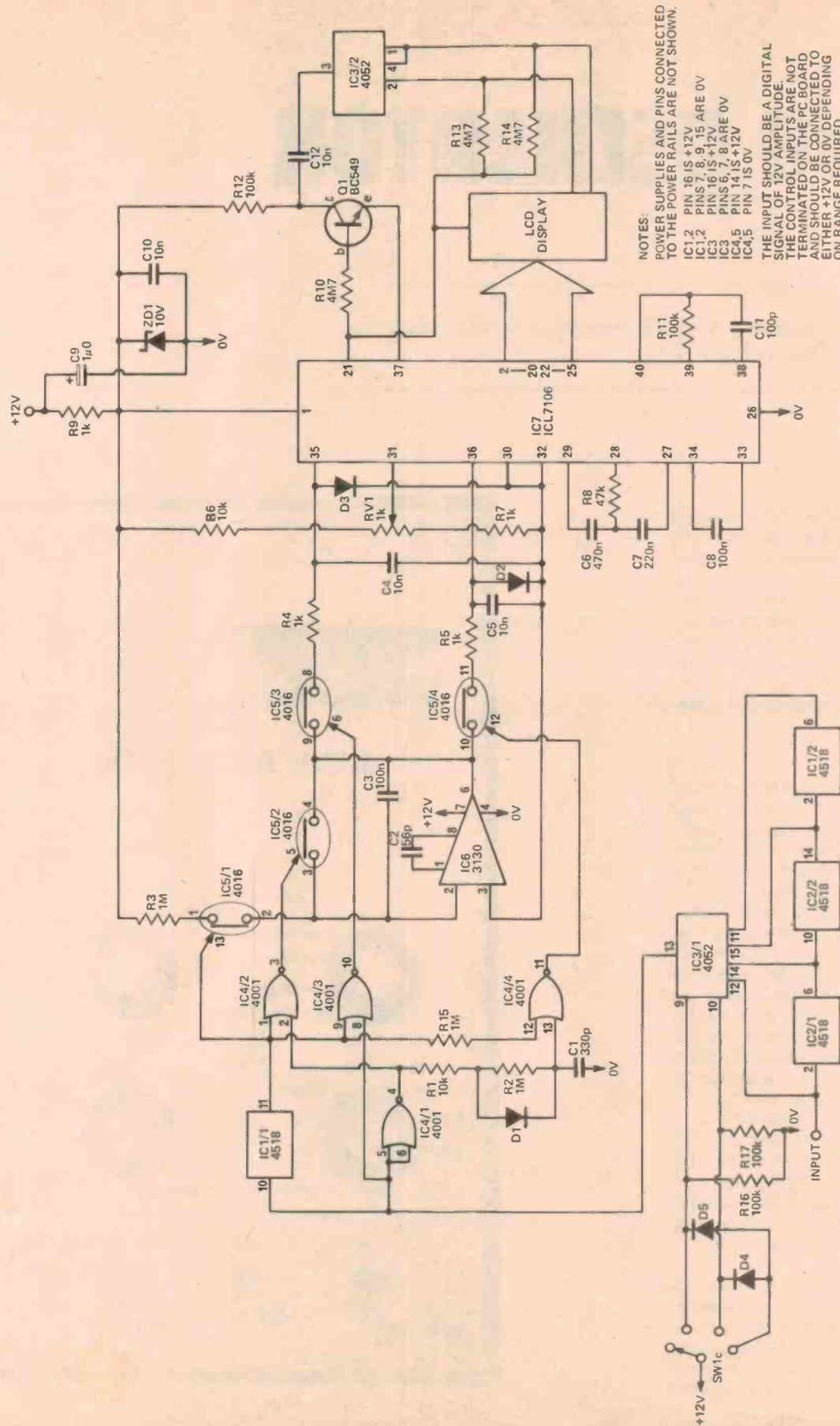

NOTES:  
 POWER SUPPLIES AND PINS CONNECTED TO THE POWER RAILS ARE NOT SHOWN.  
 IC1,2 PIN 16 IS +12V  
 IC1,2 PINS 7, 8, 9, 15 ARE 0V  
 IC3 PINS 6, 7, 8 ARE 0V  
 IC4,5 PIN 14 IS +12V  
 IC4,5 PIN 7 IS 0V  
 THE INPUT SHOULD BE A DIGITAL SIGNAL OF 12V AMPLITUDE. THE CONTROL INPUTS ARE NOT TERMINATED ON THE PC BOARD AND SHOULD BE CONNECTED TO EITHER +12V OR 0V DEPENDING ON RANGE REQUIRED.

Fig. 1. The circuit diagram of the frequency meter section.

Scotchcals of the front panel are available for \$3.50 post paid from Nebula Electronics Pty. Ltd., 15 Boundary St. Rushcutters Bay 2011.

## HOW IT WORKS - ETI 137

### Oscillator

The oscillator is the conventional Wein bridge type by Q1-Q5. Gain stabilization is done by the thermistor TH1. This type of circuit oscillates at the frequency where the impedance of the capacitors equals the resistors in the Wein bridge arms. With this feedback network the attenuation does not vary greatly like that of a twin tee but the phase shift does. The result is a sine wave oscillator with low distortion.

For frequency variation a two gang potentiometer is used to give a 20/1 continuous variation with switched capacitors giving four ranges each a decade apart.

The sine wave output is turned into a square wave by IC1 with the amplitude stabilized by D3-D6.

### Frequency Meter

This section works by generating a voltage proportional to the period of one cycle and using this as the reference voltage for the Intersil voltmeter IC with a fixed voltage on the normal input. This gives the inverse function of normal operation and the display therefore is frequency.

To generate the reference voltage we use an integrator (IC6) which is controlled by IC5. Operation is as follows. Initially C3 is discharged and for one cycle of the

input signal IC5/1 turns on. As the module provides a stable voltage between pin 1 and pin 32 of about 2.8V the output of IC6 will fall linearly with time and as IC5/1 is on for exactly one cycle the voltage change will be proportional to that period.

After IC5/1 turns off the output of IC6 will stay fixed. IC5/3 is then turned on and C4 will charge to that voltage. After half a cycle IC5/3 will turn off leaving C4 at that voltage and IC5/2 will turn on. This discharges C3 to zero volts. After a short delay to allow C3 to discharge IC5/4 is turned on transferring that voltage level onto C5. After a total of two cycles the

process recommences. The voltage difference between the two capacitors is therefore the voltage change, (proportional to frequency) thus eliminating any offset errors in IC6. The pulses which control IC5 are derived from IC1/1 and IC4.

A reference voltage less than half the input voltage will result in the ICL7106 counting past 2000 (over ranging). The two inputs must also lie within the supply rails (less 1.5V). This limits the range of the instrument from 5 Hz to 200 Hz. For the higher frequency ranges, three decade dividers are provided and the necessary output selected by IC3. The correct decimal point is also selected by the other half of this IC.

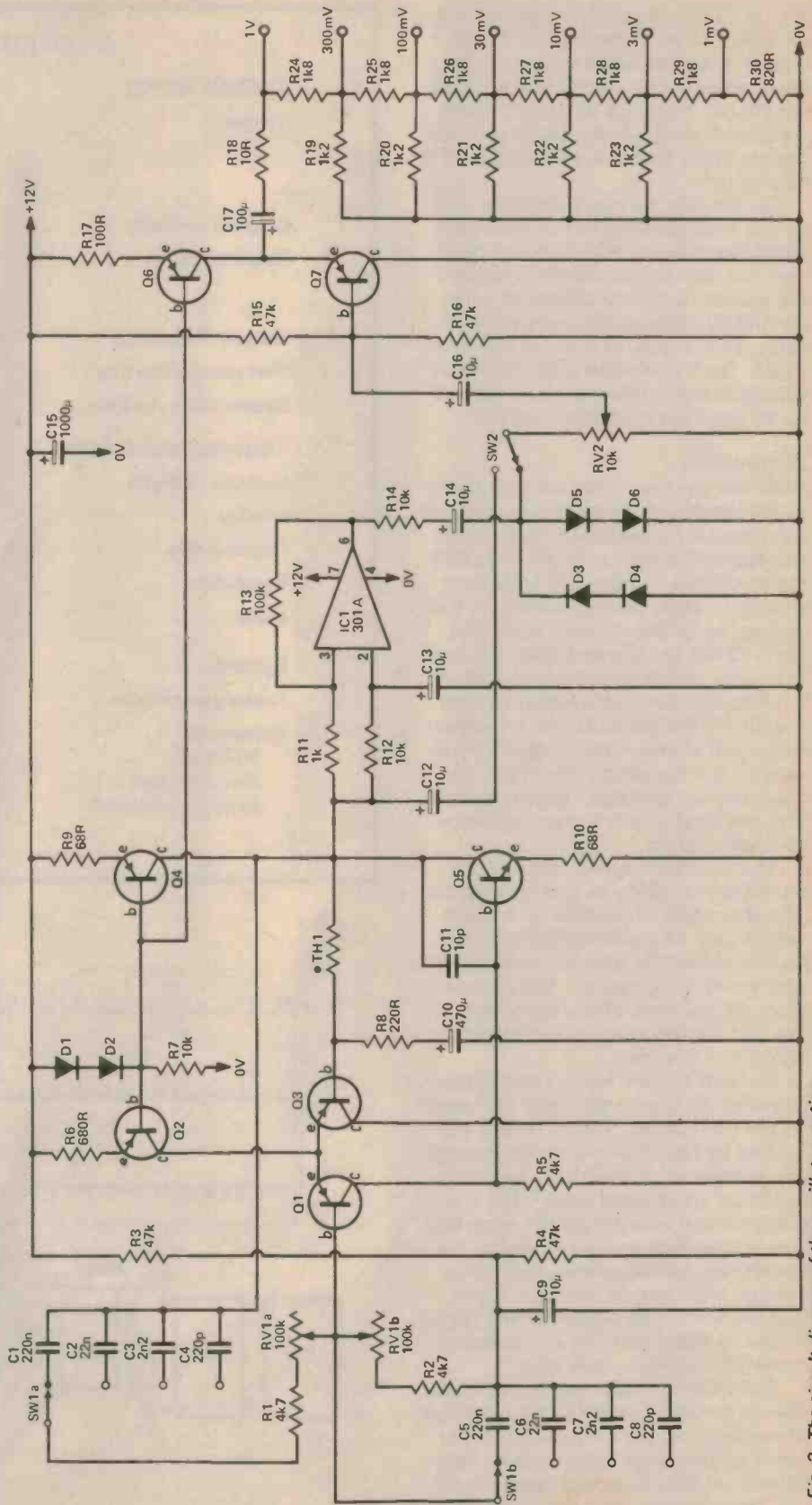

Fig. 2. The circuit diagram of the oscillator section.

# Project 137

crystal display, features low power consumption. Due to the method of conversion from period to frequency the range is limited from about 50 to 1999 counts and therefore automatic range selection is used. As the oscillator itself has less range than this, this limitation is no problem.

To simplify wiring we initially used CMOS analogue switches to select the range changing capacitors in the oscillator but this unfortunately increased the second harmonic distortion when the supply voltage dropped below 12 volts. This is due to the non-linearity of the "on" resistance when the input voltage changes. We therefore reverted to the good old mechanical switch!

## Construction

Assemble the frequency counter board first, following the overlay provided. As this board is mounted very close to the front panel (only the height of the LCD) the capacitors should have leads long enough to allow them to be laid on their side on top of the resistors, etc. Also the CA3130 and the transistor will have to be mounted close to the board. While it is not essential that a socket be used (we didn't) for the LCD, one is recommended and although the Molex pins provided in the evaluation kit are not the best, they are available. Be very careful with the display as it is glass and therefore fairly fragile.

The oscillator board can now be assembled following its overlay diagram. The thermistor should be tied down using a loop of tinned copper wire and pc pins should be used on all external wire terminating points. Cut all leads short on the back of the pc boards as the two are mounted back-back with only 6 mm spacing.

We built the units into a large zippy box with all the components mounted on the front panel. The pc boards are secured by four 6BA c/s screws through the aluminium but hidden by the Scotchcal front panel used. The frequency meter board is spaced using 6BA nuts to give just enough clearance for the display and is held in place using 6.4mm long tapped spacers. Check that the spacers do not touch any tracks on the pc board and if so add pieces of insulation material under them.

The switches and potentiometers can now be mounted on the front panel and the wiring from the frequency counter board to the range switch done. Add wires from the two power connections and the input for later connection to the oscillator board.

*Continued on page 40.*

## SPECIFICATION – ETI 137

### Oscillator section

|                      |                                                                      |
|----------------------|----------------------------------------------------------------------|
| Ranges               | 10.0 – 100.0Hz<br>100 – 1000Hz<br>1.00 – 10.00kHz<br>10.0 – 100.0kHz |
| Outputs available    | sine or square                                                       |
| Output level         | 1V maximum<br>continuously variable plus<br>10dB steps down to 1mV   |
| Output impedance     | nominally 600 ohms                                                   |
| Sine wave distortion | <0.1%                                                                |
| Square wave risetime | 200ns                                                                |

### Frequency meter section

|                  |                                                  |
|------------------|--------------------------------------------------|
| Number of digits | 3½                                               |
| Display          | LCD                                              |
| Reading rate     | 5 per second                                     |
| Resolution       | 0.1Hz on lowest range                            |
| Mode             | Period measurement<br>computed to read frequency |

### General

|                     |               |
|---------------------|---------------|
| Power consumption   | 26mA @ 12V dc |
| Battery life        |               |
| Ni Cads             | 20 hours      |
| Pencells (red)      | 30 hours      |
| Pencells (alkaline) | 50 hours      |

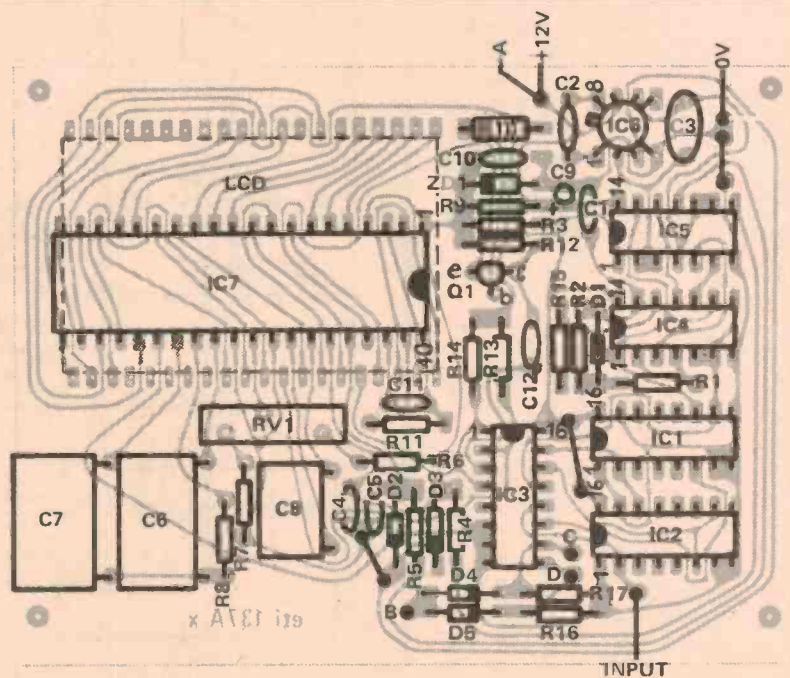

*Fig. 3. Component overlay of the frequency meter board. Insert the LCD such that the +1 digit is on the left.*

## PARTS LIST - ETI 137

### General

- Plastic box UB
- 1 One pole 12 position rotary switch
- 1 Three pole 4 position rotary switch
- 2 STDP toggle switches
- 4 knobs to suit
- 12V battery (8x dry cell or 10x Nicads)
- External power socket
- Scotchcal front panel
- Wire, screws etc.

### Frequency Counter Board - ETI 137A

#### Resistors all 1/4W 5%

- R1 ..... 10k
- R2,3 ..... 1M
- R4,5 ..... 1k
- R6 ..... 10k
- R7 ..... 1k
- \* R8 ..... 47k
- R9 ..... 1k
- R10 ..... 4M7
- \* R11 ..... 100k
- R12 ..... 100k
- R13,14 ..... 4M7
- R15 ..... 1M
- R16,17 ..... 100k

#### Potentiometer

- \* RV1 ..... 1k ten turn trim

#### Capacitors

- C1 ..... 330p ceramic
- C2 ..... 56p ceramic
- C3 ..... 100n polyester
- C4,5 ..... 10n polyester
- \* C6 ..... 470n polyester
- \* C7 ..... 220n polyester
- \* C8 ..... 100n polyester
- C9 ..... 1μ0 35V tantalum
- C10 ..... 10n polyester
- \* C11 ..... 100p ceramic
- C12 ..... 10n polyester

#### Semiconductors

- IC1,2 ..... 4518 (CMOS)
- IC3 ..... 4052 (CMOS)
- IC4 ..... 4001 (CMOS)
- IC5 ..... 4016 (CMOS)
- IC6 ..... CA 3130
- \* IC7 ..... ICL7106
- Q1 ..... BC549
- D1-D5 ..... 1N914
- ZD1 ..... 10V 300mW Zener

#### Miscellaneous

- PCB ETI 137A
- \* LCD display

\* These parts are provided in the Intersil ICL7106 Evaluation Kit.

### Oscillator Board - ETI 137B

#### Resistors all 1/4W 5%

- R1,2 ..... 4k7
- R3,4 ..... 47k
- R5 ..... 4k7
- R6 ..... 680R
- R7 ..... 10k
- R8 ..... 220R
- R9,10 ..... 68R
- R11 ..... 1k
- R12 ..... 10k
- R13 ..... 100k
- R14 ..... 10k
- R15,16 ..... 47k
- R17 ..... 100R
- R18 ..... 10R
- R19-R23 ..... 1k2
- R24-R29 ..... 1k8
- R30 ..... 820R

#### Thermistor

- TH1 ..... type R53

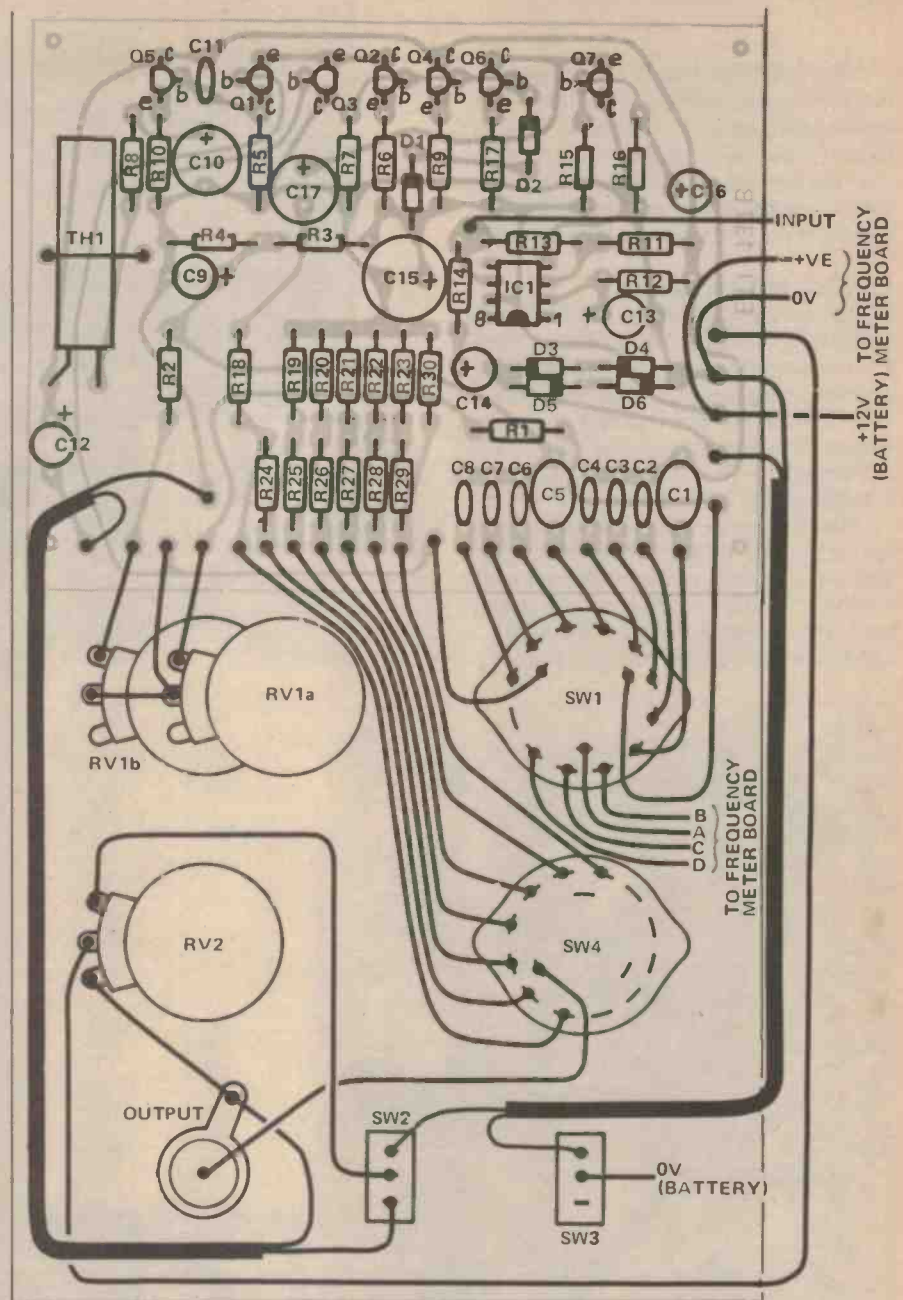

Fig. 4. The component overlay of the oscillator board and the wiring of the front panel.

#### Potentiometers

- \* RV1 ..... 100k dual rotary
- RV2 ..... 10k lin rotary

#### Capacitors

- C1 ..... 220n polyester
- C2 ..... 22n polyester
- C3 ..... 2n2 polyester
- C4 ..... 220p ceramic
- C5 ..... 220n polyester
- C6 ..... 22n polyester
- C7 ..... 2n2 polyester
- C8 ..... 220p ceramic
- C9 ..... 10μ 25V electro
- C10 ..... 470μ 25V Electro
- C11 ..... 10p ceramic
- C12-C14 ..... 10μ 25V electro
- C15 ..... 1000μ 16V electro

- C16 ..... 10μ 25V electro
- C17 ..... 100μ 25V electro

#### Semiconductors

- IC1 ..... 301A
- Q1-Q4 ..... BC559
- Q5 ..... BC549
- Q6,7 ..... BC559
- D1-D6 ..... 1N914

#### Miscellaneous

- PCB ETI 137B

\* RV1 - the preferred curve giving best resolution is antilog. If reverse rotation is acceptable log is as good. Otherwise use a linear curve.

## Project 137

The oscillator board can now be mounted onto the back of the frequency meter board ensuring that no leads short between the two boards. Also check that the spacers do not touch any tracks on the oscillator board. The wiring of the front panel can now be completed.

### Checking and Adjustment

Switch on and check that the frequency meter and oscillator are working. Monitor the output of the oscillator with an accurate frequency counter and adjust the oscillator to the top end of one range. The frequency meter can now be calibrated by means of the 10 turn potentiometer on that board.

Check that the display range changes correctly and that the decimal point also moves. Each range while nominally having a 10-100 variation will be adjustable from about 7 to 150. Check the attenuator has 10 dB between steps.

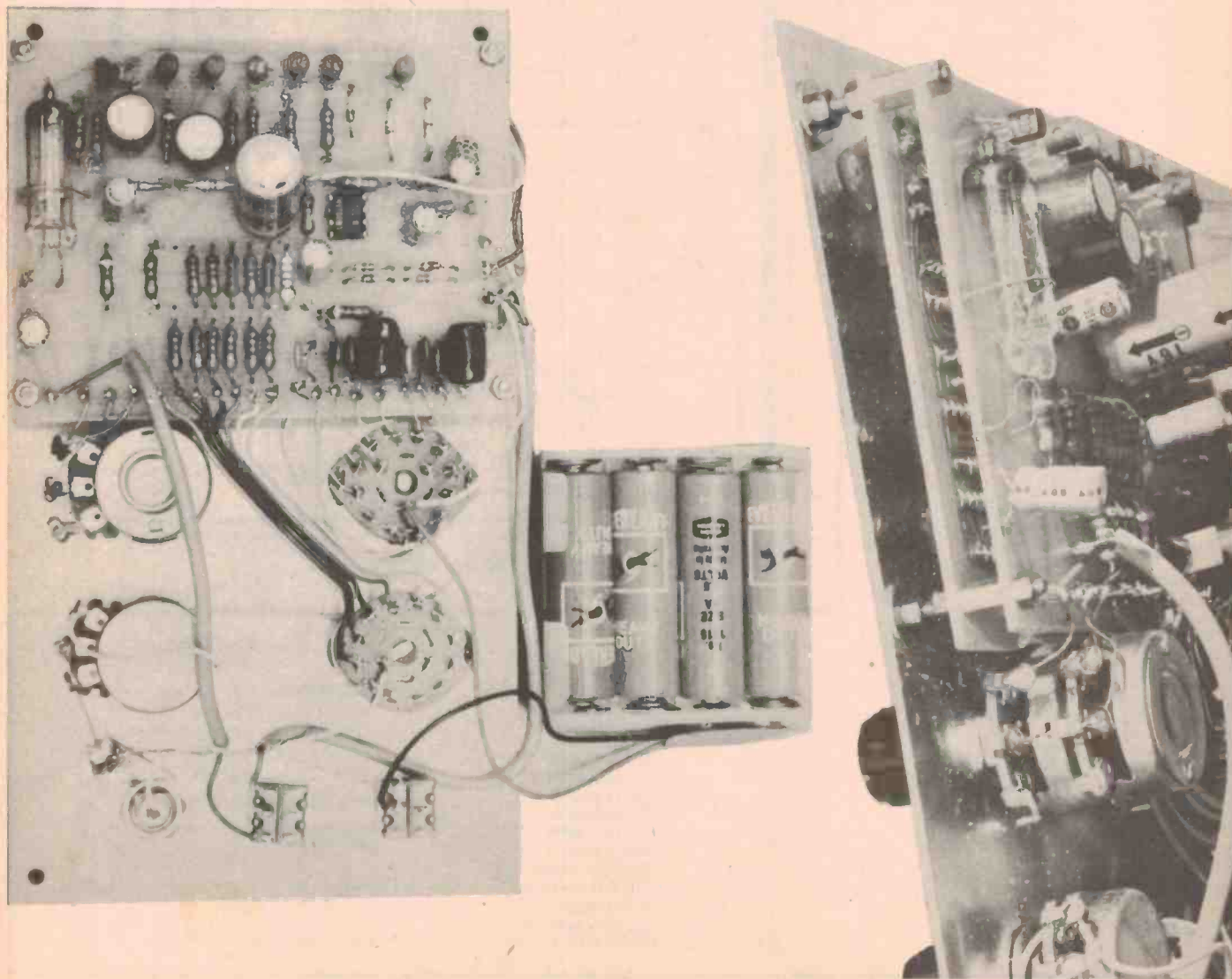
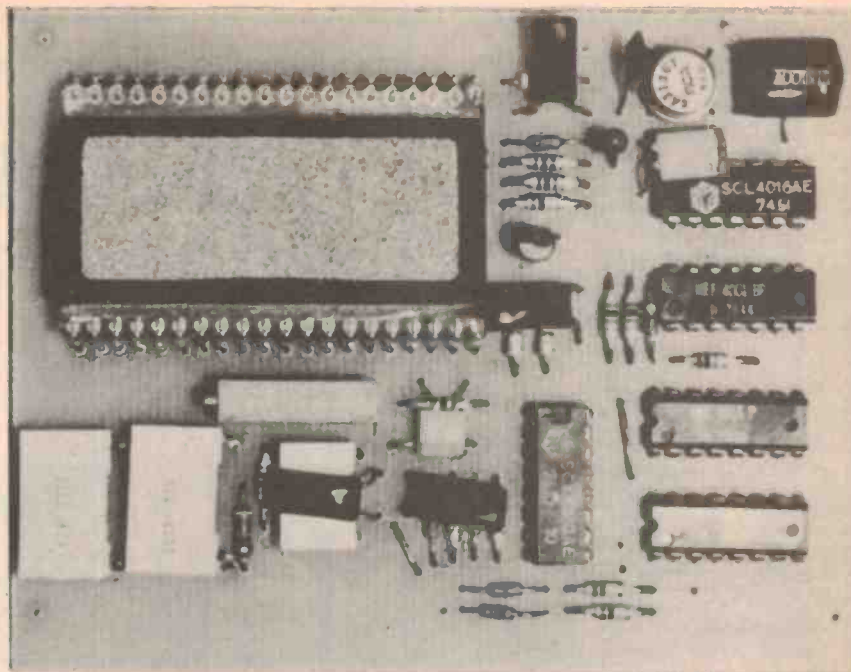



# MAIL ORDERS: PO Box 135, Northcote. 3070.

## SPECIALS FOR THIS MONTH

MJ2955's — \$1.00ea.  
555 TIMERS — 35c ea.

BD139 or BD140 — 50c ea.  
4016 CMOS — 50c ea.

### Pack & Post

50c minimum for Semiconductors.  
\$1.00 minimum for other items.

### 74LS

|         |      |
|---------|------|
| 74LS00  | 40   |
| 74LS01  | 40   |
| 74LS02  | 45   |
| 74LS03  | 40   |
| 74LS04  | 50   |
| 74LS10  | 40   |
| 74LS11  | 40   |
| 74LS14  | 1.40 |
| 74LS20  | 40   |
| 74LS21  | 40   |
| 74LS27  | 40   |
| 74LS30  | 40   |
| 74LS32  | 50   |
| 74LS38  | 50   |
| 74LS47  | 2.50 |
| 74LS73  | 55   |
| 74LS74  | 60   |
| 74LS78  | 65   |
| 74LS90  | 1.60 |
| 74LS92  | 1.60 |
| 74LS93  | 1.40 |
| 74LS109 | 70   |
| 74LS133 | 60   |
| 74LS145 | 2.50 |
| 74LS181 | 3.50 |
| 74LS192 | 2.90 |
| 74LS194 | 2.30 |

### LINEARS

|                   |      |
|-------------------|------|
| LM301             | 55   |
| LM307             | 35   |
| LM308             | 1.90 |
| LM311             | 85   |
| LM317T            | 4.50 |
| LM318             | 4.10 |
| LM3241.30 LM33990 |      |
| LM349             | 2.20 |
| LM380             | 1.30 |
| LM381             | 2.20 |
| LM382 2.20        |      |
| LM386             | 1.75 |
| 555               | 35   |
| 556               | 1.20 |
| 565               | 2.00 |
| 566               | 2.50 |
| 567               | 2.50 |
| 709               | 75   |
| 741               | 40   |
| MA3401            | 90   |
| LM3900            | 95   |
| 3909              | 1.30 |
| CA3130            | 1.95 |
| 9368              | 1.90 |
| RL4136            | 3.90 |

### BLANK CASSETTES

#### HITACHI OR MAXELL

|       |        |        |        |
|-------|--------|--------|--------|
| UDC90 | 1-9    | 10     | 100+   |
|       | \$2.90 | \$2.70 | \$2.60 |

### PCB'S PRECISION DRILLED FIBREGLASS BOARDS

|                             |      |
|-----------------------------|------|
| ETI 134 Volt Meter          | 1.70 |
| ETI 125 Digital Meter       | 1.70 |
| ETI 245                     | 1.40 |
| ETI 445 Stereo Pre-Amp      | 1.40 |
| ETI 446 Limiter             | 1.60 |
| ETI 449 Mic. Amp.           | 1.40 |
| ETI 450A Bucket Brigade     | 1.90 |
| ETI 450B Mixer Filter       | 1.90 |
| ETI 480 100W Power Amp      | 2.00 |
| ETI 480 P/S for above       | 1.90 |
| ETI 480M Mixer Tone Control | 1.80 |
| ETI 481PS 12-40V Inverter   | 2.00 |
| ETI 484 Comp/Expander       | 2.00 |
| ETI 485 Graphic Equalizer   | 2.00 |
| ETI 486                     | 2.00 |
| ETI 581 Dual Power Supply   | 1.60 |
| ETI 583 Gas Alarm           | 1.70 |
| ETI 585R Ultrasonic Switch  | 1.60 |
| ETI 585T Ultrasonic Switch  | 1.40 |
| ETI 586 Shutter Timer       | 2.00 |
| ETI 603 Synthesizer         | 2.30 |
| ETI 604 Metronome           | 1.60 |
| ETI 635 Micro Computer P/S  | 2.50 |
| ETI 713 Add on FM Tuner     | 2.80 |
| ETI 714                     | 1.70 |
| ETI 716 2M Power Amp (RF)   | 2.00 |

Many other project boards in stock.

### KITS

|                                                         |         |
|---------------------------------------------------------|---------|
| ETI 480 100W Module Kit<br>(Includes Heat Sink Bracket) | \$19.75 |
| ETI 480 50W Module Kit<br>(Includes Heat Sink Bracket)  | \$16.00 |

### 12 volt Electronic Siren Kits

|                      |        |
|----------------------|--------|
| 1. "Whip"            | \$8.00 |
| 2. "Wail"            | \$8.00 |
| 3. "Flying Saucer"   | \$8.00 |
| Horn Speaker to suit | \$8.50 |

### SIDEBAND 4 PS353



For CB Radios up to  
15 Watts Rating  
\$38.50

4 Amp peak capability. Automatic overload protection.  
2 Amp continuous output. Size: 140 x 80 x 133mm.

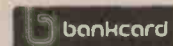

to: Rod Irving Electronics,

Please debit my Bankcard Account

Number .....

Signature .....

Name .....

Address .....

BANKCARD MINIMUM \$10.00

### 74C CMOS

|       |      |
|-------|------|
| 74C00 | 40   |
| 74C02 | 40   |
| 74C04 | 40   |
| 74C08 | 40   |
| 74C10 | 40   |
| 74C14 | 2.35 |
| 74C48 | 2.90 |
| 74C73 | 1.05 |
| 74C75 | 1.05 |
| 74C76 | 1.35 |
| 74C85 | 1.50 |
| 74C90 | 2.90 |

### VOLTAGE REGULATORS

|              |      |
|--------------|------|
| 7805 5V 1A   | 1.40 |
| 7806 6V 1A   | 1.40 |
| 7808 8V 1A   | 1.40 |
| 7812 12V 1A  | 1.40 |
| 7815 15V 1A  | 1.40 |
| 7818 18V 1A  | 1.40 |
| 7824 24V 1A  | 1.40 |
| 7905 -5V 1A  | 2.00 |
| 7912 -12V 1A | 2.00 |
| 7915 -15V 1A | 2.00 |
| 7924 -24V 1A | 2.00 |

### WELLER CORDLESS SOLDERING IRON KIT

Includes 15 watt Iron, Nicad Batteries Battery Charger and 4 Tips. All for only \$29.50.

### ARLEC DIGITAL MULTIMETER

Large display, Multirange. Digital Multimeter. Includes Nicad Batteries, Probes, Battery Charger, Car Adaptor. All for only \$83.50.

**ALSO IN STOCK: Multimeters – Veroboard – Solder – Solderwick - Irons – Transformers.**  
All components brand new by top manufacturers.

# ROD IRVING ELECTRONICS

Phone (03) 489-8131. Hours: Mon-Thurs. 8am to 5.30pm.

Fri. 8am to 7pm. Sat. 9am to 1pm. Send SAE for short-form catalogue

## 443 COMPRESSOR EXPANDER

The 443 Audio Compressor Expander allows the home hi-fi enthusiast to restore much of the dynamic range missing from record tapes. Used during recording and playback the 443 becomes an effective dynamic noise-reduction unit and improves the dynamic capability of a good tape deck by 15-20 dB. KIT PRICE \$98 plus \$2.50 P/P



## 486 FREQUENCY SHIFTER

This circuit as described in ETI Nov. 1977, increases the stability margin of sound reinforcement systems by up to 8 dB. This is achieved by shifting the frequency of signals by 5Hz. Complete kit of 486 module \$25 plus \$1.00 P/P. Suitable power supply No. 581 \$17 plus \$1.00 P/P.



**jaycar** PTY LTD

Tel: 211-5077 P.O. BOX K39, HAYMARKET, N.S.W. AUST.  
2000. 405 Sussex St., Sydney.

Entrance off Little Hay St.

# HI FI DISCOUNT

## TDK

SA C 90 CASSETTES \$47.90 box of 10  
D C 90 CASSETTES \$24.80 box of 10

## DENON

DENON DL 103 CARTRIDGE moving coil type  
freq. resp. 20-45 000 hz .....\$99.00  
DENON DA 307 TONE ARM s shaped, magnetic  
no-contact anti skate system, low mass  
headshell. ....\$179.00  
DENON DA 3500 BROADCAST STANDARD T/T  
w&f less than 0.03 percent, s/n ratio over 60 db  
direct drive, no arm or cartridge. ....\$429.00  
DENON DP 1700 DIRECT DRIVE T/T w&f less  
than 0.03 percent, s/n ratio over 60 db, complete  
with s shaped statically balanced arm .....\$319.00  
DENON SA 3300 AMPLIFIER 30 w per channel,  
distortion less than 0.05 percent has loudness  
muting, bass & treble controls 2 tape inputs. ....\$219.00

## SME

SME NEW SERIES III PICK UP ARM .....\$240.00  
SME 3009 SERIES II PICK UP ARM .....\$115.00

## SHURE

SHURE V15 TYPE IV SPECS: freq resp. 10-2500hz  
channel balance within 2db, separation 25db  
at 1 khz, weight 6.4 grams.....\$145.00

## Technics

TECHNICS SL 2000 DIRECT DRIVE T/T w&f 0.045 percent  
s/n ratio 37 db (din b) stroboscope, tone arm  
and magnetic cartridge, all black .....\$179.00  
TECHNICS RS 615 CASSETTE DECK front loading,  
dolby n.r., 3 position tape switch, w&f .1 percent  
s/n ratio chrome tape dolby on 60 db, dual vu  
meters .....\$249.00

## INTERSOUND

INTERSOUND HI-FI P.O. Box 104 Mawson A.C.T. 2607 Regd. Office 7  
Jelbart St, Mawson A.C.T. 2607. Personal callers only.

All prices include post and packaging to Qld, Vic, SA, NSW,  
freight to WA and NT extra. Insurance extra. Allow at least 2 weeks  
for delivery. All prices subject to change without notice.

# MAD MAL'S BEST BUYS

MAY MADNESS!

ANNOUNCING

**silicon valley**  
SEMICONDUCTOR PRODUCTS are now available at MAD MAL'S electronic

shop OVER 2,000 DIFFERENT SEMICONDUCTORS, INCL. IC's, TRANSISTORS, DIODES, OPTO, etc. AT WHOLESALE PRICES SEND MAL A 9"x4" ENVELOPE FOR PRICE LISTS

**5" TV TUBE**  
150CB4 \$5.95  
NEW! LAST NEW. 2 FOR \$11 OR \$9.95

**3 TRANSISTOR AM RADIO Toner**  
Add-on for Hi-Fi system, for test bench or build your own radio, includes ferrite rod, gang etc, add only 6V AC or DC, 10mA \$9.98

**NT-3102 Eht Trans.**  
Brand new Philips EHT Transformers Popular Model \$6.50

**HI-FI STEREO SYSTEM KIT**  
3W+3W AMPLIFIER  
Volume, Bass, Treble Controls-also h'phone and Spin dia Rec/Play socket-all parts and instructions are supplied-includes teak finish wood base, suit 85R or Gerraud DE-LUXE TURNTABLE \$19

**6" Bass and 3" Tweeter & SPEAKER SYSTEMS** to suit, each reted 10W \$17

**SUPER CARTRIDGES...**  
A MAD MAL'S Bargains \$1.80  
B STEREO CRYSTAL \$1.80  
C MONO CRYSTAL 90¢

**Telescopic Aerial** 2 FOR \$1  
TOP QUALITY CHROME TOTAL LENGTH 5'6"

**6-12V MOTOR** for Cassette \$3.50  
SUITS CAR OR PORTABLE CASSETTE

**2 Gang Condenser** 200pf + 90pf \$25

**U-BEAT POWER TRANSFORMER**  
240V IN, 12V 1A plus 26V 1A OUT BRAND NEW & C'TEED WITH SHIELD. Lots of Uses as: Amplifiers, Power Supplies, Test Equipment etc. Ask our price for quantity-total 800 available. \$3.95 OR 2 for \$7

**Engine Analyzer**  
MEASURE VOLTS 0-16, AMPS 0-60A, RPM 0-12,000/16,000, POINTS TEST ETC with full instructions SO EASY TO USE \$22.50

**MUSICOLOUR MKIII COLOUR ORGAN KIT**  
SAVE \$10 OFF OUR NORMAL PRICE of \$59.90 See E.A. Sept '76 \$49.90

**STEREO PRE-AMP**  
Clearance Sale of SINCLAIR STEREO 60 PRE-AMPS-ideal for building Hi-Fi systems etc. Magnetic or Ceramic input. Volume, Bass, Treble, Balance 18V-27V supply required @ 10mA. PRICE SLASHED! THESE WERE \$21-60 \$12.50

**DIGITAL CLOCK KIT** \$21  
4 DIGIT HRS/MINS/SECS tool Complete in case, with alarm, 240V oper.

**SWITCH BARGAINS!**  
DPDT Toggle \$25, SPDT Toggle \$25, SPST Toggle \$25, DPDT 25-Pole \$55

**ELECTRICAL TERMINAL BLOCKS** IN MULTIPLES OF 12 (12 FOR 50¢) \$50

**FUSE HOLDERS** 15 STD 3AG, 15 1/2 STD FUSE \$15

**ROTARY WAFER SWITCHES** 3 Pole 3 Pos 3 Bank \$1, 6 Pole 2 Pos 1 Bank \$1, 6 Pole 2 Pos 3 Bank \$1

**Hot-Line Filter** SUIT CB or CAR STEREO \$2.50  
Reduces Ignition Noise

**6-5mm STEREO SOCKET** \$50 \$4 FOR 10

**3-5mm PLUGS** 10¢ EA OR 80¢ FOR 10

**3-5mm SOCKETS** 10¢ EA OR 80¢ FOR 10

MAD MAL © 1978

**NEON BEZEL** 40¢  
Std 3/4" Mounting New, top quality 250V AC  
**NE-2 NEONS** 10¢  
**15V 2AMP POWER SUPPLY KIT** \$12.50  
Comprises: Trans, 4x2-5A Sil Rectifiers, 3300uF Electrolytic etc. Plus instructions to build a CB Power Supply etc.

**Push-Button 250V AC Switch** 20¢  
PUSH-ON, PUSH-OFF 1 AMP

**MAL'S VALU-PACKS**  
LUCKY DIP ASSORTMENTS FOR VALUE CONSCIOUS EXPERIMENTERS  
500 1/2W 200 1W 250 MIXED 40 SW RESISTORS RESISTORS RESISTORS RESISTORS \$2 \$2 \$2 \$2

25 NEW PRESET POTS \$2, 12 NEW SLIDER POTS \$2, 40 RADIO TV KNOBS \$2, 20 ASST. POTS \$2

100 CAPS CERAMIC \$2, 45 CAPS ELECTROS \$2, 20 RF IF OSC COILS \$2, 10 PCES PCB REC'D \$2

50 ASST TAGSTRIPS \$2, 20 ASST. LOW VOLTAGE HIGH CLGRES \$2, 30 6' PCES SPAGHETTI TUBING \$2, 20 MINI POTS \$2

BUY 10 PACKS + EXTRA ONE FREE!

**MAD MAL'S BONANZA PAK**  
A VAST ASSORTMENT OF GOODIES FOR ALL YOU ASPIRING HOBBYISTS!  
All new, all high quality parts, samples, specials, end-of-line useful components incl Semiconductors, transformers, resistors, capacitors, pots, IC's, switches, relays etc. etc. WORTH \$88.88! Over 28gm weight, size approx 11"x7"x6" \$9.98

**KRAZY Semiconductor PRICES**

|       |      |         |      |
|-------|------|---------|------|
| 7400  | 38¢  | BF180   | 80¢  |
| 7401  | 37¢  | BF102   | 57¢  |
| 7402  | 38¢  | MPH05   | 51¢  |
| 7403  | 38¢  | 2N2646  | 45¢  |
| 7404  | 43¢  | 2N3055  | 70¢  |
| 7405  | 43¢  | 2N3562  | 29¢  |
| 7406  | 43¢  | 2N3564  | 29¢  |
| 7408  | 43¢  | 2N3555  | 29¢  |
| 7409  | 38¢  | 2N1564  | 29¢  |
| 7410  | 38¢  | 2N3568  | 29¢  |
| 7411  | 46¢  | 2N3569  | 29¢  |
| 7413  | 46¢  | 2N3650A | 29¢  |
| 7420  | 38¢  | 2N3662  | 29¢  |
| 7421  | 40¢  | 2N3664  | 29¢  |
| 7422  | 38¢  | 2N4250  | 32¢  |
| 7440  | 37¢  | TIP255  | 1-53 |
| 7441  | 1-55 | TIP3055 | 97¢  |
| 7466  | 1-67 | LM137A  | 3-73 |
| 7467  | 1-78 | LM137   | 1-93 |
| 7468  | 1-71 | LM130V  | 1-71 |
| 7473  | 63¢  | LM1377N | 1-50 |
| 7474  | 64¢  | LM710   | 80¢  |
| 7476  | 69¢  | LM1310  | 40¢  |
| 7480  | 75¢  | LM135   | 27¢  |
| 7481  | 1-43 | LM1304P | 1-10 |
| 74154 | 2-55 | LM1308  | 3-02 |

**AMPLIFIER BOX!**  
NEW  
SIZE A: 152x75x45mm \$4.90  
SIZE B: 152x100x75mm \$6.90  
BOTH INCLUDE FRONT PANEL

**NEW, DE-LUXE STEREO H'PHONES**  
SAVE 53% NOW ON ALPHA H'PHONES \$15  
Vol, Tone adj

**MASTER/SLAVE INTERCOM SETS**  
Instal Yourself, Complete Kits with all wire, battery, insls, etc. LIMITED QUANTITY  
2 WAY \$12, 3 WAY \$20, 4 WAY \$25

**VORTEX STEREO CASSETTE MECHANISM** \$29.50  
LAST SHIPMENT OF THESE TOP QUALITY DECKS-ideal for computer enthusiasts or build your own cassette recorder, 120V only, 240V-120V TRANSFORMER, also 15V 1A and 6.3V 1A windings \$7.50 EA  
RECORD/PLAYBACK KIT Reduced \$15 EA

**NUTS and BOLTS**  
all packs \$1-20 EA  
Various Sizes JUST BUY 5 PACKS GET ONE FREE!  
60 ASST SELF-TAPPERS \$5.95  
60 ASST HEX. NUTS \$5.95  
100 ASST SCREWS \$5.95  
120 ASST WASHERS \$5.95  
200 ASST HARDWARE PACK \$5.95  
12 POT-NUTS AND WASHERS

**2W+2W STEREO AMPLIFIERS**  
Volume, tone control all parts on PCB \$5.95  
2x LM-380 IC's, 12V-18V supply, add only transformer if required (extra \$4-50), 100mV input, T.H.D. 1% at 1KHz at 1.5W. Ideal mounting under turntable for cheap home stereo!

**12V DC RELAYS**  
10 AMP QTY 1-9 \$2 EA  
3 POLE QTY 10-24 \$1-80 EA  
Contacts Coil: 110V Small Size All new, top grade Popular style.  
QTY 25+ \$1.70 ea. Be early, limited supply available now.

**National DIGITAL CLOCKS**  
MA1002 12 Hr \$12 EA  
MA-1002 12 Hr \$12 EA  
MA-1003 12 Hr \$27.50  
Last few at this low price, transformer is avail, extra \$6.50  
Complete with all switches, black plastic case, 12V auto or portable use GREAT VALUE!

**INSTRUMENT CASE \$3**  
Plastic metal inside cabinet with metal front panel etc. Size 12"x4"x1.5" \$4.95  
**NUMERICAL \* KEYBOARD KIT**  
Ideal for keyless entry lock systems, burglar alarms, microprocessor applications etc. Keys 0-9 and CLR key, top quality low profile, keys are 18mm x 18mm. CUT-OUT AND SEND WITH 9"x4" SAE FOR A \$5.90

Orders To: **MAD MAL** 4% PRE-PAK electronics P.O. Box 43 CROYDON 2132 718 PARRAMATTA RD CROYDON NSW PH 797:6144 OPEN 7 DAYS

# Motorola announces the high-current low cost 35 A bridge

We don't think anybody will admit coming even close to the MDA 3500's high-current, low-cost 35 amp capability.

Like giving 10 extra amps current handling at the 25 amp price. Plus 100 extra amps surge-protection at the 25 amp price, and super-efficient, 70 watt power dissipation at the 25 amp price,

Check these features:—400 ampere surge capability, electrically isolated base, fast recovery availability on request, cost effective in low current applications — and you'll have to admit our point — superior performance at equal cost.

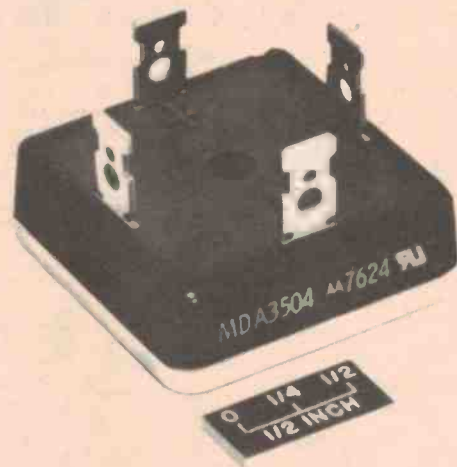

|        |          |        |
|--------|----------|--------|
|        | MDA 3504 |        |
| 1-24   | 25-49    | 50-99  |
| \$2.77 | \$2.46   | \$2.30 |

PLUS TAX

## CEMA ELECTRONICS PTY LTD



|              |                                                                        |
|--------------|------------------------------------------------------------------------|
| SYDNEY:      | 21 CHANDOS STREET,<br>ST. LEONARDS, N.S.W. 2065<br>Phone: 439 4655     |
| MELBOURNE:   | 208 WHITEHORSE ROAD,<br>BLACKBURN, VIC. 3130<br>Phone: 877 5311        |
| ADELAIDE:    | 170 STURT STREET, ADELAIDE,<br>S.A. 3130. Phone: 51 4080               |
| NEW ZEALAND: | CEMA-ELEKON LTD.<br>7-9 KIRK STREET, GREY LYNN,<br>N.Z. Phone: 76 1169 |

BRISBANE: Electronic Components (QLD.) — 371-5677 • CANBERRA: Daicom — 82-3581 • PERTH: Reserve Electronics — 87-1026  
• HOBART: Tasmanian Electronic Supplies — 44-1337 • WOLLONGONG: Macelec — 29-1455.

# DIGITAL ELECTRONICS

## BY EXPERIMENT pt3

A GATE CIRCUIT, in general, is a circuit which will allow a signal to pass for a time defined by another signal, often a rectangular pulse (Figure 1a). In linear circuitry we need linear gates which do not affect the shape of the signal which is gated, but in digital circuitry, all the signals are steady voltage levels, 1 or 0, or fast transitions between these levels, so that speed of operation is important and *no* linear action is needed. Ideally, a perfect switch is also a perfect digital gate.

Logic gates are of two basic types, the AND the OR type. The simplest examples of each have two inputs and one output, though up to 13 inputs are found in some types. Taking the two input AND gate, the output is a

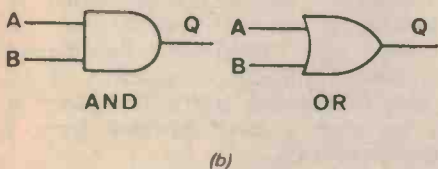
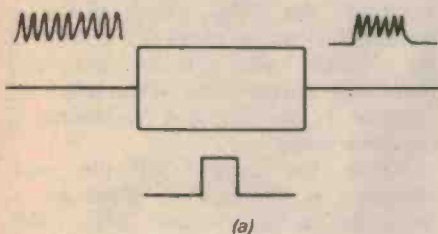

Fig. 1. Gates. (a) General gating action (b) Logic gate symbols.

| AND-GATE |   |   |
|----------|---|---|
| A        | B | Q |
| 1        | 1 | 1 |
| 1        | 0 | 0 |
| 0        | 1 | 0 |
| 0        | 0 | 0 |

| OR-GATE |   |   |
|---------|---|---|
| A       | B | Q |
| 1       | 1 | 1 |
| 1       | 0 | 1 |
| 0       | 1 | 1 |
| 0       | 0 | 0 |

Fig. 2. Truth tables. (a) AND-gate. (b) OR-gate.

logic 1 when, and only when, both inputs are also at logic 1 (A and B are at 1); the output is zero for any other combination of inputs. The two input OR gate gives a logic 1 output when *either* input is logic 1, or when both are at logic 1 (A or B both).

These actions can be summarised in a truth table which shows at a glance what combinations of inputs and outputs are possible. Fig. 2 shows the truth tables for the AND and OR gates. Truth tables, though useful, become rather bulky when the gate has a large number of inputs, so that a better way of memorising the action is to remember that only when all inputs are 1 is the output of the AND gate 1, and only when all inputs are zero is the output of the OR gate zero.

NAND and NOR gates have outputs which are the inverse of the AND or OR gates respectively, as the truth tables of Fig. 3 show; internally these gates are AND/OR gates with inverters at the outputs. Another gate encountered at times is the exclusive-OR (XOR) which has the truth table and symbol shown in Figs. 3c, d. Note that the action is that of the OR gate, except that the output is 0 when both inputs are 1.

### Working over a 7400

The second IC we shall deal with in this series is a 7400 quad NAND gate. This consists of four separate two-input NAND gates, and like all the other ICs used in this series is a TTL circuit. An unconnected input will therefore float to logic 1, and will need a current of 1.6 mA to be sunk to hold it down to logic 0.

Start work on this gate by connecting the power supply leads. Pin 7 is taken to the negative line by a wire connection, and pin 14 is similarly taken to the +5 V line. The connections to the gates are shown in Fig. 4; we shall start by using gate 1.

Connect a 470R resistor between pin 3 and a spare pad, as shown in Fig. 5.

| NAND-GATE |   |   |
|-----------|---|---|
| A         | B | Q |
| 0         | 0 | 1 |
| 0         | 1 | 1 |
| 1         | 0 | 1 |
| 1         | 1 | 0 |

(a)

| NOR-GATE |   |   |
|----------|---|---|
| A        | B | Q |
| 0        | 0 | 1 |
| 0        | 1 | 0 |
| 1        | 0 | 0 |
| 1        | 1 | 0 |

(b)

| X-OR GATE |   |   |
|-----------|---|---|
| A         | B | Q |
| 0         | 0 | 0 |
| 0         | 1 | 1 |
| 1         | 0 | 1 |
| 1         | 1 | 0 |

(c)

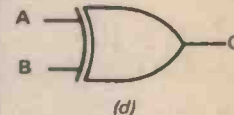

Fig. 3. Truth tables. (a) NAND-gate. (b) NOR-gate. (c) X-OR-gate. (d) Symbol for the X-OR-gate.

Now connect another LED between the spare pad and the zero line to act as an indicator to light when the output is at logic 1.

We could obtain inputs by soldering in wires, but this is rather tedious. Wire up the switches as shown in Fig. 5, wiring the terminals directly to the "0" line and the spare pads. Since these are press-to-make switches, their effect will be to give a logic 0 when pressed, the input to which they are connected will then float to logic 1 when the switch is released. Miniature slide switches were tried, but found to short 1 to 0.

With the switches in place, check the truth table for a NAND gate, using the LED to indicate the state of the output. The truth table should agree with that of Fig. 2a.

Now investigate the effect of adding an inverter, by joining a wire from pin 3 of the 7400 to pin 1 of the 7414, using the LED which is connected to pin 2 of the 7414 as the output indicator (Fig. 6). This connection, using the switches to provide inputs to the 7400, should give the truth table for an AND gate.

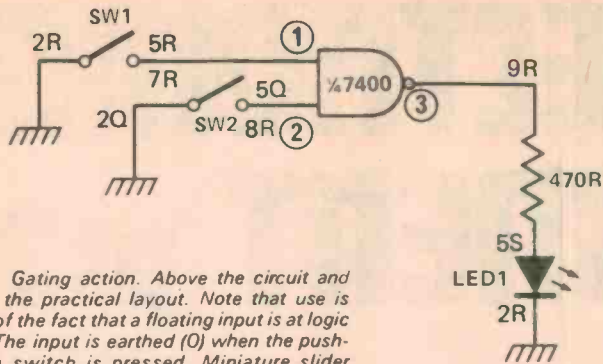

Fig. 5. Gating action. Above the circuit and below the practical layout. Note that use is made of the fact that a floating input is at logic "1". The input is earthed (0) when the push-button switch is pressed. Miniature slider switches were tried, but were found to short momentarily between the 1 and 0 positions.

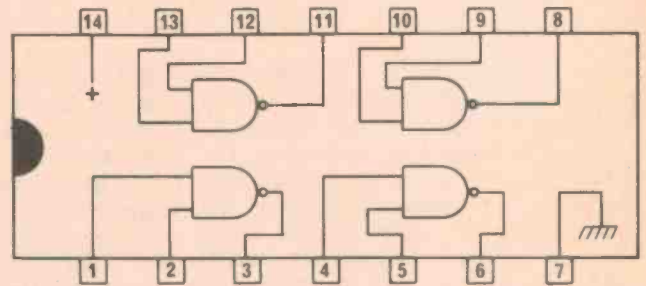
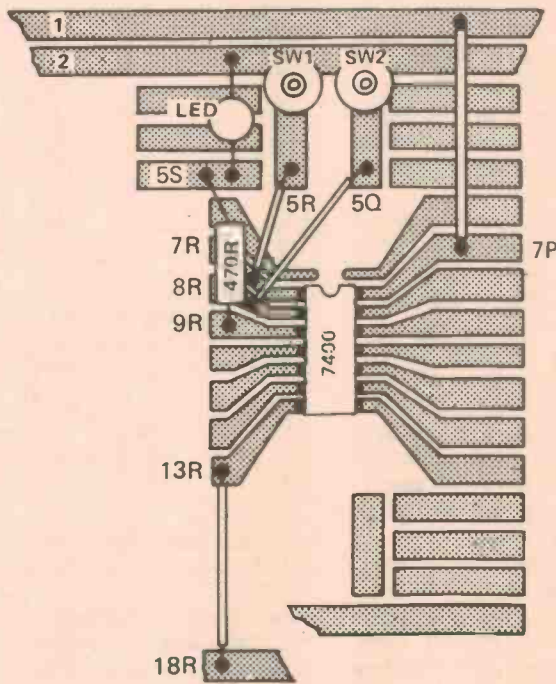

Fig. 4. Pin-out diagram for the 7400.

We find, however, that if we invert each input before applying to the 7400 inputs (Fig. 7) that we do not obtain an AND gate this way. What truth table do we find?

To try it out, connect the switch outputs to the inverter inputs instead of to the 7400, one to pin 1 and the other to pin 3 of the 7414. Join pin 2 of the 7414 to pin 1 of the 7400 and pin 4 of the 7414 to pin 2 of the 7400, using single strand insulated wire. Use the LED which is connected to pin 3 of the 7400 as an indicator.

Having done this, could you design a NOR gate, and construct one? Try out your circuit and draw up a truth table.

The exclusive-OR circuit needs rather more thought. One possible circuit is shown in Fig. 8. Construct this, using the 7400 and 7414 units, and check that the truth table agrees with that of Fig. 3c.

### Combinational Logic

Circuits which contain only logic gates are called combinational logic circuits, because the output can always be predicted from the combination of inputs which is present. As we shall see later in this series, there are circuits in which the previous inputs matter as much as the present ones. Combinational logic circuits obey the rules of Boolean algebra, which will not be dealt with here, but have been previously discussed in ETI.

Because the output can always be predicted from the inputs which are present, logic gates can be used for control circuits. We can, to take a simple example, control the heating of a house by having logic gates control the circulating pump (or fan), by way of a thyristor or triac.

The inputs to the gates will be the signals from room thermostats, perhaps an outside thermostat, a boiler

thermostat, a hot-water tank thermostat, and a timeswitch or two. There will be another output from the gates to control the operation of the boiler.

For such a system, logic gates easily carry out AND and OR actions which would need much more wiring and space to carry out with relays, but the full advantage of using logic gates is obtained when all the thermostats and other signal generating equipment and timing are also electronic.

### Bawdy Work

An application of gating is shown in Fig. 9, using the 7414 and 7400 to make a gated oscillator circuit. Two sections of the 7414 are used as oscillators, one at an audio frequency of about 1 kHz and the other at a much slower rate, and the outputs of the oscillators are taken each to one gate input of the 7400. When the slow oscillator input is high, the output of the NAND gate will be the high frequency square wave, since with one input at 1, the output is the inverse of the other input.

When the output of the slow oscillator is at logic 0, there is no oscillator output from the 7400, because the output is set to logic 1. The output can be detected either by feeding it to an amplifier, or by using high resistance headphones connected through a capacitor, or by using a capacitor and a 1k resistor in series with a small earpiece from a transistor radio.

Could you now design and construct a circuit whose output was a two-tone oscillation (HI-LO-HI-LO-). Remember that the output of the NAND gate in Fig. 9 was a logic 1 when not oscillating. Do NOT be tempted to combine the outputs of two gates by joining output pins; this will BURN OUT YOUR IC, because very large currents will flow if one output is at 1 and the other at 0. One possible scheme uses three of the 7414 inverters as oscillators and one as an inverter, with three NAND gates also used.

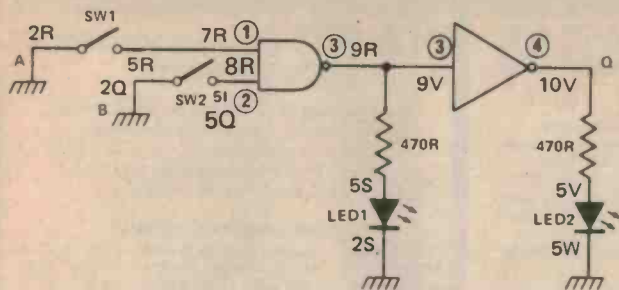

Fig. 6. Using a NAND-gate and an inverter to make an AND-gate.

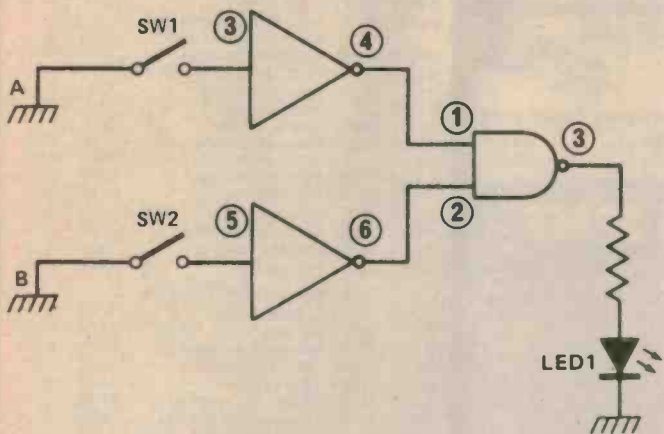

Fig. 7. What is the truth table for this circuit?

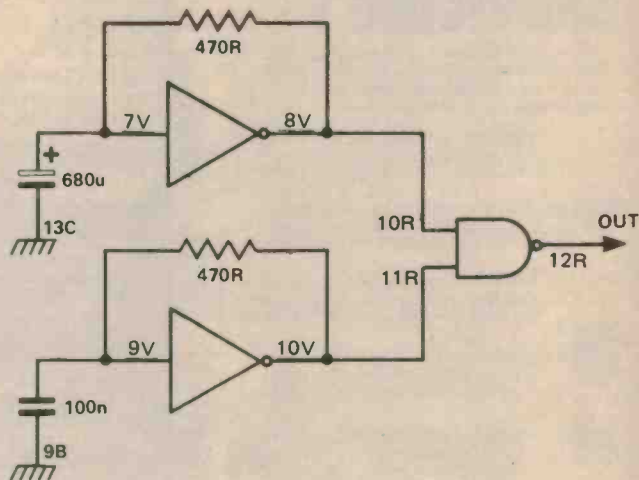

Fig. 9. A gated oscillator. (a) Circuit. (b) using an earphone to detect the note. (c) Connecting the output to an amplifier.

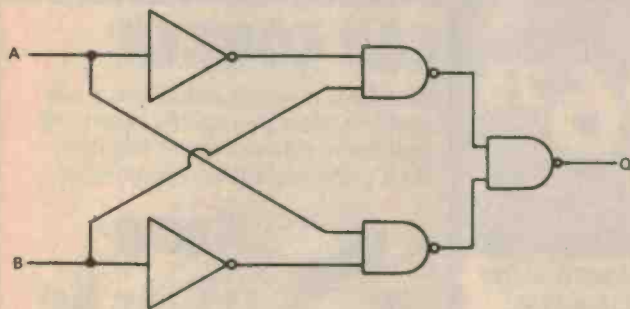
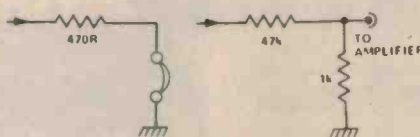

Fig. 8. An exclusive-OR gate built from NOR-gates and inverters.

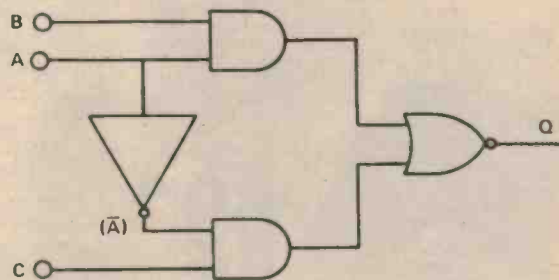

Fig. 10. Race hazards. If we imagine that lines B and C are both at one, then the change from A = 1 to A = 0 should cause no change in the output. Because of the delay in the inverter, however, A goes low just before A-bar goes high so that there is a narrow negative pulse developed at the output. This could cause problems if a counter were being driven from the output.

### Racy Hazards

One problem of combinational logic circuits is the short but measurable time delay (some 30-80 ns) which occurs in a gate, which can cause momentary spikes to appear in the outputs. A circuit which can give such a problem is shown in Fig. 10. Imagine that B and C are both 1 and that A is changing from 1 to 0. With B and C at 1, the output of the circuit is A or A-bar, and since A is obtained from an inverter it will arrive at the OR gate a little later than A. Momentarily, then, A will be at 0, and A-bar will still be at 0, so that the output will dip to 0, and then rise to 1 when A arrives. The pulse will be

IF B=1 AND C=1, THEN A CHANGE OF A FROM 1 TO 0 CAUSES A BRIEF PULSE AT Q



# CLOCK MODULES:



35mm x 78mm  
12.7mm High Digits

The MA-1002 Clock-on-a-chip from National Semiconductor. It's top value - dollars cheaper than most other sources. Huge digits, ideal for building into equipment. All you need to make it work is a transformer! Did someone mention a transformer? We've got the MA1002 module in a special kit consisting of the transformer, setting and on/off switches plus data - all ready to hook together to go! You can make this clock up in just a few minutes (like about 30!) Kit: Cat K-3434 ... \$19.75

**\$12.50** Cat X-1052  
SAVE \$1.00

# DON'T PAY \$11.95

## 3 POSITION ANTENNA LAYOVER

Someone is joking - we've seen these advertised for \$11.95 elsewhere - and we're sure they're not as good as ours at just \$6.95! Ours have a removable stud to allow either end to be used as a male or female connector. Ours have a push button to prevent wind or bumps letting it down. Don't let a carpark or tree eat yours! Use a layover. Cat D-4506

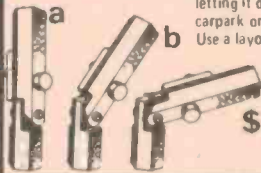

**\$6.95**

# IN A RUT? BUILD YOURSELF AN ELECTRONIC KIT.

Here is a listing of all the printed circuit boards currently stocked. Boards from both major magazines - to help you build the project you want. Don't forget, we've also got the components, just in case you didn't realise ...

## ELECTRONICS AUSTRALIA PROJECTS

|        |        |                                                                 |       |         |
|--------|--------|-----------------------------------------------------------------|-------|---------|
| H-8215 | 75cd7  | Capacitor Discharge Ignition                                    | 7/75  | \$2.00  |
| H-8275 | 75i11  | Playmaster speaker protector                                    | 11/75 | \$1.75  |
| H-8300 | 76a3   | 2 watt audio amplifier                                          | 3/76  | \$1.75  |
| H-8302 | 76a4   | Playmaster 25/25 & 40/40 (inc. f'glass board & printed overlay) | 4/76  | \$5.25  |
| H-8314 | 76r4   | Reverberation unit                                              | 4/76  | \$2.00  |
| H-8315 | 76im5  | LED level meter                                                 | 5/76  | \$2.00  |
| H-8316 | 76s7   | 650MHz counter prescaler                                        | 7/76  | \$2.50  |
| H-8318 | 76pc9  | Musicolor Mk 3                                                  | 9/76  | \$4.50  |
| H-8322 | 77f1   | Digital frequency counter (special fibreglass board)            | 1/77  | \$4.75  |
| H-8324 | 77up5  | Miniscamp computer                                              | 6/77  | \$8.50  |
| H-8325 | 77dit7 | PCB& front panel logic trainer                                  | 7/77  | \$9.75  |
| H-8326 | 77up6  | Miniscamp memory                                                | 6/77  | \$3.75  |
| H-8330 | 77b7   | Radar burglar alarm                                             | 7/77  | \$2.00  |
| H-8331 | 77cc4  | Cassette interface                                              | 3/77  | \$3.75  |
| H-8332 | 78c2   | Stereo cassette deck                                            | 2/78  | \$3.75  |
| H-8336 |        | VOU - double sided f'glass                                      | 2/78  | \$32.50 |
| H-8337 | 76/m5  | VOU video modulator                                             | 4/78  | \$1.20  |
| H-8338 | 78ut4  | VOU ASCII encoder                                               | 4/78  | \$4.50  |
| H-8339 | 78b2   | RCL Bridge                                                      | 3/78  | \$4.75  |
| H-8340 | 78ek3  | Electronic Morse keyer                                          | 3/78  | \$3.75  |
| H-8341 | 78up5  | 2650 Mini computer                                              | 5/78  | \$5.00  |
| H-8342 | 78ps5  | Powermate                                                       | 5/78  | \$2.00  |

## ELECTRONICS TODAY PROJECTS

|        |          |                                 |            |        |        |
|--------|----------|---------------------------------|------------|--------|--------|
| H-8524 | ET1111   | IC Power Supply                 | 11/72      | \$2.00 |        |
| H-8548 | ET1313   | Car alarm                       | Now \$1.00 | 11/74  | \$1.75 |
| H-8552 | ET1413   | 100 watt guitar amplifier       | 12/72      | \$2.50 |        |
| H-8554 | ET1419   | 100 watt pre-amplifier          | 9/73       | \$1.75 |        |
| H-8560 | ET1429   | LM380 amplifier                 | 12/74      | \$2.75 |        |
| H-8578 | ET1701   | TV Masthead amplifier           | 12/74      | \$1.50 |        |
| H-8582 | ET1704   | Crosshatch/Dot generator        | 8/75       | \$2.00 |        |
| H-8591 | ET1480   | 50/100 watt amplifier (f'glass) | 12/76      | \$2.50 |        |
| H-8603 | ET1445   | Stereo preamplifier             | 7/76       | \$1.75 |        |
| H-8604 | ET1602   | Mpi organ                       | 8/76       | \$5.60 |        |
| H-8606 | ET1480PS | Power supply for ET1480         |            |        |        |
|        |          | 50W x 2 or 100W x 1             | 5/77       | \$2.25 |        |
| H-8608 | ET1583   | Gas Alarm                       | 8/77       | \$1.75 |        |
| H-8610 | ET1585R  | Ultrasonic switch - receiver    | 9/77       | \$1.75 |        |
| H-8611 | ET1585T  | Ultrasonic switch - transmitter |            | \$1.50 |        |

# SERVICING?

Whether you're servicing for a living or just a hobby, Dick can make life easy for you. His range of service aids suits the professional and hobbyist alike. Try some of them - you'll be back for more!



**ELECTROLUBE PRECLENE** Highly recommended for cleaning tuners, switches, pots, etc. 340g pressure can. Cat N-1040 ... \$3.90



**DICK SMITH FREON TF** Cleaner, degreaser, moisture removing spray. Non toxic, non explosive, non flammable. Cat N-1051 ... \$2.75



**ACRYLIC CLEAR SPRAY** For protection of screened or lettered panels, also outside weatherproofing for aerials, etc. Cat N-1011 ... \$2.25



**CRC-2-26** Moisture removing spray that leaves a fine film of silicone for continuing protection. Ideal for ignitions! Cat N-1060 ... \$4.75



**FREEZ-IT REFRIGERANT** Intermittent jarrer! Cools components to -50°C instantly. 350g can. Cat N-1056 ... \$3.00



**ELECTROLUBE PCL-2** Printed circuit lacquer can be soldered through, but protects copper and solder against corrosion. Cat N-1045 \$4.60



**MATTE BLACK PAINT** Ideal for touching up scuff marks, etc - or for giving a project a real professional finish. Cat N-1070 ... \$2.20



**INSTANT COLD GALVANISE** Zinc enriched hard coating to stop rust. Many protective uses. 400g. Cat N-1063 ... \$5.00



**ELECTROLUBE 2X LUBE PEN** Handy pocket size spray lubricant. Hard to lose this one - really handy. Cat N-1047 ... \$2.40

# CB OUTPUT TRANSISTORS ARE ALL 6's & 7's!



**YEP! 2SC1306's and 7's - have you got your spares?**  
2SC1306(2SC2166) Cat Z-2501 ... \$4.50  
2SC1307(2SC1969) Cat Z-2502 ... \$6.50

# WATCH THIS SPACE

AND FIND OUT WHAT YOU MISSED!  
Each month, our stores and mail order dept. feature an outstanding **BELOW COST** special. All you have to do is go into any of our stores or buy from mail orders to find out what it is.

**LAST MONTH:**  
**A 'SCOPE' SUPERSPEED IRON FOR \$10.25 - NORMALLY \$16.50**

**SAVING \$6.25**

**WHAT'S THIS MONTH'S SPECIAL? CALL IN AND FIND OUT YOURSELF!**

|                     |              |
|---------------------|--------------|
| 25 ISO Pan Head     | TOTAL 2200pc |
| 25 ISO Oval Head    | TOTAL 5600pc |
| 25 ISO Flat Head    | TOTAL 3800pc |
| 25 ISO Bot Screws   | TOTAL 860pc  |
| 25 ISO Hexagon Nuts | TOTAL 318pc  |
| Washers             | TOTAL 318pc  |
| Spring Washers      | TOTAL 208pc  |
| E Washers           | TOTAL 208pc  |

**FINANCE NOW AVAILABLE:**  
Take the waiting out of wanting! Credit (to approved customers) is available at all Dick Smith stores **NOW** (Minimum item value \$115)



The **ELBEX** time-saver pack will save you money! It contains a huge selection - 2820 pieces - of ISO standard nuts, bolts and washers to help YOU with that tricky service job. This pack is incredible value - the contents are less than 2.5c each PLUS you get the pack! No serviceman can afford NOT to have one of these outstanding packs!

**\$69.00** less than 2.5c each!  
Cat T-5650

# CAR CORNER

In most cars, electrical noise is a real problem. Now you can do something positive to rid your car of this pest: Dick's new noise filter components.



# Noise Filter Kit

**\$22.50**

For the real tough jobs. Heavy duty, with instructions. All cars, etc. Cat A-7950

Also available: Those nearly impossible to get co-ax filter capacitors. 0.5uF, 100 volt, 60 amp. Cat A-7928



**\$3.75**

# WE'VE MOVED! OUR BANKSTOWN STORE IS NOW IN CHULLORA...

Call in today and meet the new manager, Doug Ellis, and his friendly staff. There's parking at the rear of the store, too.





# UPGRADE NOW **STEREO** NEW MODEL!



AM-FM-CASSETTE

Now with fader control. It's new - and it's a beauty! Great sound for your car with stereo cassette, mono stereo fm and broadcast band unit. In dash mounting for top security, four speaker facility available (speakers not supplied). Take the drudgery out of driving - with sound from Dick.

**\$149<sup>00</sup>** Cat. A-6480

# PROJECT ELECTRONIC KITS

THE IDEAL INTRODUCTION TO ELECTRONICS. Yes! Find out about the exciting world of electronics with one of these simple kits. Easy to build, and battery operated so they are completely SAFE! All the details are in the 'Project Electronics' book (see below).

- |                        |            |        |
|------------------------|------------|--------|
| Continuity tester      | Cat K-2041 | \$3.00 |
| Heads and tails        | Cat K-2043 | \$3.50 |
| Two-tone doorbell      | Cat K-2044 | \$4.00 |
| 500 second timer       | Cat K-2045 | \$4.50 |
| Morse practise set     | Cat K-2047 | \$3.50 |
| Buzz board game        | Cat K-2048 | \$3.90 |
| Basic audio amplifier  | Cat K-2061 | \$5.50 |
| Simple AM tuner        | Cat K-2062 | \$6.50 |
| Electronic bongos      | Cat K-2063 | \$5.00 |
| Electronic Siren       | Cat K-2065 | \$5.50 |
| Temperature alarm      | Cat K-2066 | \$4.90 |
| Singing moisture meter | Cat K-2067 | \$4.90 |
| LED dice               | Cat K-2068 | \$5.90 |
| Two octave organ       | Cat K-2072 | \$8.50 |
| Battery Saver          | Cat K-2511 | \$3.90 |

## PROJECT ELECTRONICS HANDBOOK

This book contains all the information you need to build the above projects, plus tips and guides to construction, etc. It's a valuable reference of handy circuits (25 in all) plus the data, 82 pages, fits your magazine binders, too. Cat B-3652



**\$4<sup>75</sup>**

# A CALCULATOR IN A WALLET?

It's got to be the best value going! It's a liquid crystal calculator, with memory, supplied in a wallet, with battery - and it's only \$24.50! The batteries really last - up to 2000 hours - and the whole thing is so thin you can wear it. You'll be able to calculate ad infinitum.



Cat. Q-3020  
**\$24<sup>50</sup>**

# HOME BURGLAR ALARM KIT

Protect your home and property! Complete kit for your security. Easy to install, easy to use, and could save you a lot of heartache. If you can use a screwdriver and read this copy, you can install the alarm. It's that simple!



**\$49<sup>50</sup>**  
Cat L-5105

NOW! 8 page installation booklet - FREE with this alarm system. Written for Dick by an expert, tells you all you need to know. Available separate to system. Cat B-6000 . . . . \$1.50

# EAR & MIC SETS

**\$27<sup>50</sup>**  
don't pay **\$79**



Comfortable, easy to use, fits most CB's - the brilliant Dick Smith headset mic. Safer CBing, at less than half the price of other units on the market (as far as we know!) Cat C-1120

Telephone handset for CB's - ideal for base stations and private operation. Fits most CB sets. Cat D-9007  
**\$29<sup>00</sup>**

# INTERCOMS

2 STATION  
**\$14<sup>00</sup>**



Cat. F-1020

Communicate! You'll do it better with an intercom from Dick Smith! This is ideal from the home (kitchen to garage, etc) or shops, service stations, etc etc. You get a master and slave unit, with connecting lead and battery. Either unit can call the other. Outstanding value.

4 STATION  
**\$29<sup>50</sup>**



Cat. F-1040

For the large house, factory, shop, etc - a four station system. 1 master unit and 3 slaves (any can call master & vice versa) Quality unit features 'hands free' operation for speed and efficiency at slaves. Complete privacy assured.

# KITSBITS

PROJECT AND KIT BUILDERS:  
THIS IS YOUR LIFE!

If you enjoy building electronic project kits, come to Dick Smith. Dick picks the best of the magazine projects and turns them into famous Dickkits. Complete to the last detail, most with detailed instructions, parts as per magazine articles (or the closest possible electrical equivalent if some parts are hard to get) - you can rely on your Dickit.

## AUDIO OSCILLATOR (See June EA)

A great new kit, easy to build. Very handy piece of test gear to have around, too.  
Cat K-3469 . . . . . \$25.00



## ELECTRONIC MORSE CODE KEYS (See March '78 EA)

Complete kit, supplied with paddle, un-drilled case and plain painted panels.  
Kit of parts: Cat K-3470 . . . . . \$37.50  
Paddle only - Cat D-7103 . . \$17.50. PCB only - Cat H-8340 . . \$3.75 9 volt battery Cat S-3200 \$2.00  
R-C-L BRIDGE (See March '78 EA) Complete kit, supplied with printed, but un-punched panel.  
Cat K-3468 . . . . . \$34.50  
PCB only: Cat H-8339 . . . . . \$4.75

## VK POWERMATE (See May '78 EA)

Short form kit includes all electronic components but not metalwork, mains wiring or terminals.  
Short form kit: Cat K-3449 . . . . . \$32.00  
PCB only: Cat H-8342 . . . \$2.00 Special 5600uF/40V electrolytic capacitors: Cat R-4570 . . . \$3.90  
Power transformer: Cat M-2000 . . . . . \$17.32

Special kits for the following projects are not made up, but parts are normally available for these and most other magazine projects, unless special components are required. Ask at our stores for full details.

- White & Pink Noise Generator (see April '78 EA).
- Photo Time (See April '78 EA)
- LED Chaser (See April '78 EA)

# WIN A TRIP FOR TWO TO TOKYO

Every purchaser of Yaesu equipment from Dick Smith or participating dealers receives an entry form in the fabulous 'Win a trip for two to Tokyo' contest, flying Qantas and staying in a luxury hotel. Full details wherever Yaesu/Dick Smith products are sold.

**FLYING QANTAS**  
AUSTRALIA'S AIRLINE TO THE WORLD.

REMEMBER - THE CONTEST CLOSES IN JULY - AND YOU NEED TO THINK ABOUT YOUR ENTRY. SO DON'T DELAY!



# DICK SMITH ELECTRONICS

bankcard welcome here

**SYDNEY** 125 York Street, SYDNEY. Ph. 29-1126  
147 Hume Hwy, CHULLORA. Ph. 642-8922  
162 Pacific Hwy, GORE HILL. Ph. 439-5311  
30 Grose Street, PARRAMATTA Ph. 683-1133

**MELBOURNE** 399 Lonsdale Street, MELBOURNE. Ph. 67-9834  
656 Bridge Road, RICHMOND. Ph. 42-1614  
**BRISBANE** 166 Logan Road, BURANDA. Ph. 391-6233  
**ADELAIDE** 203 Wright Street, ADELAIDE. Ph. 212-1962

MAIL ORDERS P.O. Box 747, Crows Nest, N.S.W. 2065. Post and pack extra. Dealers across Australia.

SHOPS OPEN 9AM to 5.30PM (Saturday 9AM - 12 noon) BRISBANE 1 2 Hour earlier.

Many lines available from the Dick Smith Electronics Centres at **GRACE BROS**  
Broadway - Bondi Junction - Chatswood  
Liverpool - Miranda Fair - Mt Drust - Parramatta - Roselands - Warringah Mall



- Overland Communications 11/53 Wollongong St, Fyshwick ACT. Ph 80-4307
- Trilogy Elec. Supplies 52 Princes Hwy, Wollongong NSW Ph 83-1219
- Sound Components 78 Brisbane St, Tamworth NSW Ph 66-1363
- Hitel Hi Fi 145 Queen St, St Marys, NSW Ph 623-4442
- Don House Electronics 2 Merriwa St, Gordon NSW Ph 498-1398
- DGE Sales 44 Brown St, Newcastle NSW Ph 69-1222
- M&W Electronics 48 McNamara St, Orange NSW Ph 62-6491
- Double Diamond 18 Russet St, Goulburn NSW Ph 215440
- Greg McCartney 99 Fitzmaurice St, Wagga NSW Ph 21-3044
- Rivercom 9 Copeland St, Wagga NSW Ph 21-2125
- GCG Communications 385 Mulgrave Rd, Cairns QLD. Ph 54-1035

- The Elect. Hobby Centre 1168 Gold Coast Hwy, Palm Beach QLD Ph 34-1248
- Premier Sound 239 Musgrave St, Rockhampton QLD. Ph 27-4004
- Summer Electronics 97 Mitchell St, Bendigo VIC. Ph 43-1977
- Aero Electronics 123A Bathurst St, Hobart TAS. Ph 34-8232
- Tasmanian Hi Fi 87A Brisbane St, Launceston TAS. Ph 31-5815
- Devon Electronics 45 Ashburner St, Devonport TAS. Ph 24-4216
- A.E. Cooling Eliz. Town Centre, Peoples St Bldg, Elizabeth SA. Ph 255-9196
- Hutchesson's Communic. 5 Elizabeth St, Mt Gambier SA. Ph 25-6404
- Altronics 105 Stirling St, Perth WA. Ph 328-1599
- BP Electronics 11 Duke St, Albany WA. Ph 41-2681

- 1168 Gold Coast Hwy, Palm Beach QLD Ph 34-1248
- 239 Musgrave St, Rockhampton QLD. Ph 27-4004
- 97 Mitchell St, Bendigo VIC. Ph 43-1977
- 123A Bathurst St, Hobart TAS. Ph 34-8232
- 87A Brisbane St, Launceston TAS. Ph 31-5815
- 45 Ashburner St, Devonport TAS. Ph 24-4216
- Eliz. Town Centre, Peoples St Bldg, Elizabeth SA. Ph 255-9196
- 5 Elizabeth St, Mt Gambier SA. Ph 25-6404
- 105 Stirling St, Perth WA. Ph 328-1599
- 11 Duke St, Albany WA. Ph 41-2681

# Why pay high prices for cermet

The advantages of Cermet are well known. They are small, robust and totally enclosed. They have low thermal coefficients and high power-dissipation characteristics. They are very stable under wide variations in working conditions.

## SOANAR Cermet Trim Potentiometers

Offer you the same advantages but at real down-to-earth prices.

Soanar-Noble VTP/HTP Cermet are available in a range of values from 50Ω to 1 meg and are designed for PCB mounting with vertical or horizontal trim adjustment.

Terminations conform to the standard .1" grid spacing.

Ratings are .5 watts over the temperature Range — 30°C to +80°C

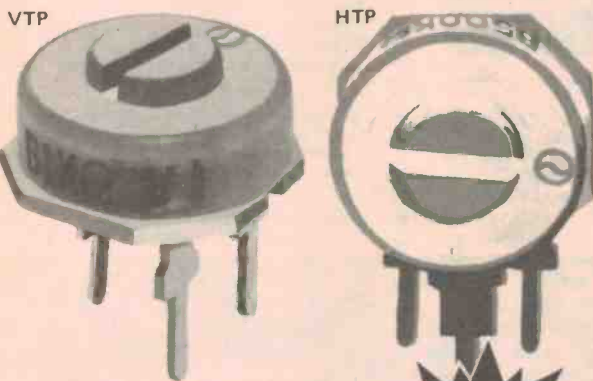

Enclosed, low cost cermet ideal for P.C.B. mounting.

TECHNICAL LITERATURE AVAILABLE ON REQUEST



**SOANAR ELECTRONICS PTY. LTD.**  
A MEMBER OF THE A-R-SOANAR ELECTRONICS GROUP

30 Lexton Road, Box Hill, Vic., 3128  
Australia. Telex: 32286.

SALES OFFICES VICTORIA: 89 0561  
N.S.W.: 78 0281  
S. AUST.: 51 5981  
QUEENSLAND: 52 5421  
W. AUST.: 81 5500



# WHERE IN MELBOURNE CAN YOU BUY



|                                                          |                         |
|----------------------------------------------------------|-------------------------|
| LM340 6v Voltage Regulators .....                        | \$1.00 ea.              |
| 400v 35 amp Bridge Rectifiers .....                      | \$3.50 ea.              |
| Full Spec. 2N3055 .....                                  | 90c ea.                 |
| Full Spec. 2N3054 .....                                  | 60c ea.                 |
| Full Spec. PC208 (plastic 108) .....                     | 15c ea.                 |
| 4001 .....                                               | 25 ea.                  |
| 12v 5 digit Electromechanical<br>Counters .....          | \$2.00 ea.              |
| P/B Micro Switches 250v 3 amp .....                      | 85c ea.                 |
| Permeability Tuners, Broadcast .....                     | 75 ea.                  |
| P.C.I. Project Boxes .....                               | \$4.15 ea.              |
| 240v Prim 115v sec. at 95vA .....                        | \$7.50 ea.              |
| 200v 1.2 amp Diodes .....                                | 10c ea.                 |
| 50v 1 amp Diodes .....                                   | 10c ea.                 |
| 741 Op Amps .....                                        | 40c ea.                 |
| 555 Timers at 10 for .....                               | \$4.00 or 45c ea.       |
| 0A90 Diodes .....                                        | 10c ea.                 |
| BA217 — Similar IN914 Diodes .....                       | 5c ea.                  |
| Project Boxes from only .....                            | 60c ea.                 |
| 21500 UF 35v Electrolytics .....                         | 60c ea.                 |
| Resistors, 1/2 watt, all values .....                    | 3c ea.                  |
| Disc Ceramic Capacitors, 1 pF to .2 uF<br>.....          | 5c ea. (.47 uF 10c ea.) |
| 5 Watt Wirewound Resistors .47 ohm to<br>5.6 K ohm ..... | 20 ea.                  |
| BT100A 300v 4 amp S.C.R. ....                            | 60c ea.                 |
| VU meters .....                                          | \$2.50 ea.              |
| 12v AC 2 c/o 5 amp Contact Miniature<br>Relays .....     | \$1.50 ea.              |
| BC147, BC157, BF198, BF199,<br>PN3694 .....              | 10c ea.                 |
| 500 mW Zener Diodes .....                                | 20c ea.                 |

at

289 Latrobe St, Melbourne and at 297 Lt  
Lonsdale St, Melbourne, 3000. Phone  
602-3282.

# ELLISTRONICS

WHERE JUST ABOUT  
EVERYTHING ELECTRONIC  
COSTS YOU LESS!

# Now. Two 3-way 40 watt speakers with nine tonal choices

## Save about \$50 per hour while you assemble them

Even if you didn't know them by number, you probably heard about the Philips AD12K12 MK11 Speaker Kits.

Because they are now a no.1 best-seller.

And here is the compact AD8K30, 8" 3-way compact system, with fine electronic and acoustic components (1" domed tweeters, 5" mid-range, super 8" bass drivers). Brilliant clean sound, with a frequency response closely following the ideal Bruel & Kjaer curve for hi-fi equipment measured in an actual listening room, using the "Third Octave Pink Noise Method".

Plus 9 combination tonal choices to adjust to the acoustics of your own listening-room.

You can assemble the AD8K30's in about two hours. You will get a professional result and save about \$100 per pair over a comparable system. Phone or send coupon now for full details of this and all our kits.

#### PHILIPS ELECTRONIC COMPONENTS AND MATERIALS

Sydney 427 0888 • Melbourne 699 0300 • Brisbane 277 3332  
• Adelaide 45 0211 • Perth 65 4199



#### ELCOMA

Philips Electronic Components and Materials  
P.O. Box 50, Lane Cove, NSW 2066

Please send me full details and brochures on your loud speaker kits and a list of retailers who stock them.

NAME \_\_\_\_\_

ADDRESS \_\_\_\_\_

STATE \_\_\_\_\_ P/CODE \_\_\_\_\_

ETA



**Electronic  
Components  
and Materials**

# PHILIPS

BA.EL.3

# ETI data sheet

## INTERSIL ICM 7208

### FEATURES:

- Useful for:
  - a. Unit counter
  - b. Frequency counter
  - c. Period counter
- Low operating power dissipation < 10mW
- Low quiescent power dissipation < 5mW
- Counts and displays 7 decades
- Wide operating supply voltage range  
 $2V \leq |V_{DD} - V_{SS}| \leq 6V$
- Drives directly 7 decade multiplexed common cathode LED display
- Internal store capability
- Internal inhibit to counter input
- Test speedup point
- All terminals protected against static discharge

### DESCRIPTION

The ICM 7208 is a fully integrated seven decade counter-decoder-driver and is manufactured using the Intersil low voltage metal gate C-MOS process. As such it has applications as either a unit, frequency or period counter. For unit counter applications the only additional components are a 7 digit common cathode display, 3 resistors and a capacitor to generate the multiplex frequency reference, and the control switches.

Specifically the ICM 7208 provides the following on chip functions: a 7 decade counter, multiplexer, 7 segment decoder, digit & segment drivers, plus additional logic for display blanking reset, input inhibit, and display on/off.

The ICM 7208 is intended to operate over a supply voltage of 2 to 6 volts as a medium speed counter or over a more restricted voltage range for high frequency applications.

As frequency counter it is recommended that the ICM 7208 be used in conjunction with the ICM 7207 Oscillator Controller which provides a stable HF oscillator, and output signal gating.

### TESTING PROCEDURES

The ICM 7208 is provided with three input terminals: 7,23,27 which may be used to accelerate testing. The least two significant decade counters may be tested by applying an input to the 'COUNTER INPUT' terminal 12. 'TEST POINT'

terminal 23 provides an input which bypasses the 2 least significant decade counter. Similarly terminals 7 and 27 permit rapid counter advancing at two points further along the string of decade counters.

### COUNTER INPUT DEFINITION

The internal counters of the ICM 7208 index on the negative edge of the input signal at terminal #12.

### Format of Signal to be Counted

The noise immunity of the Signal Input Terminal is approximately 1/3 the supply voltage. Consequently, the input signal should be at least 50% of the supply in peak to peak amplitude and preferably equal to the supply. NOTE: The amplitude of the input signal should not exceed the supply; otherwise, damage

Fig. 1. Pinout.

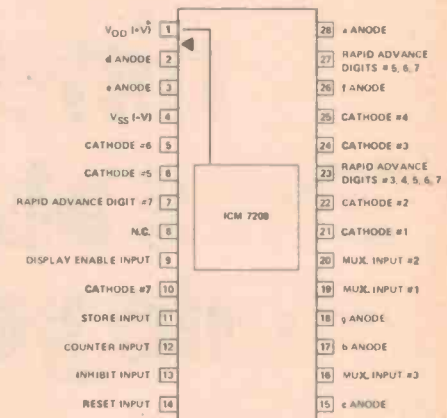

Fig. 2. Absolute maximum ratings.

|                                             |                                  |
|---------------------------------------------|----------------------------------|
| Power Dissipation (Note 1)                  | 1 watt                           |
| Supply voltage $ V_{DD} - V_{SS} $ (Note 2) | 6 V                              |
| Output digit drive current (Note 3)         | 150 mA                           |
| Output segment drive current                | 30 mA                            |
| Input voltage range (any input terminal)    | Not to exceed the supply voltage |
| Operating temperature range                 | -20°C to +70°C                   |
| Storage temperature range                   | -55°C to +125°C                  |

\* Absolute maximum rating define parameter limits that if exceeded may permanently damage the device.

Fig. 3. Typical operating characteristics.

( $V_{DD} - V_{SS} = 5V$ ,  $T_A = 25^\circ C$ , TEST CIRCUIT, display off, unless otherwise specified)

| PARAMETER                                  | SYMBOL    | CONDITIONS                                                                                              | MIN | TYP | MAX | UNITS   |
|--------------------------------------------|-----------|---------------------------------------------------------------------------------------------------------|-----|-----|-----|---------|
| Quiescent Current                          | $I_{DD1}$ | All controls plus terminal 20 connected to $V_{DD}$ . No multiplex oscillator                           |     | 30  | 100 | $\mu A$ |
| Quiescent Current                          | $I_{DD2}$ | All control inputs plus terminal 20 connected to $V_{DD}$ except store which is connected to $V_{SS}$ . |     | 70  | 150 | $\mu A$ |
| Operating Supply Current                   | $I_{DD3}$ | All inputs connected to $V_{DD}$ , RC multiplexer osc operating $f_{in} < 25KHz$                        |     | 210 | 500 | $\mu A$ |
| Operating Supply Current                   |           | $f_{in} = 2MHz$                                                                                         |     |     | 700 | $\mu A$ |
| Supply Voltage Range                       | $V_{DD}$  | $f_{in} = 2MHz$                                                                                         | 3.5 |     | 5.5 | V       |
| Digit Driver On Resistance                 | $R_D$     |                                                                                                         |     | 4   | 12  | ohm     |
| Digit Driver Leakage Current               | $I_D$     |                                                                                                         |     |     | 500 | $\mu A$ |
| Segment Driver On Resistance               | $R_S$     |                                                                                                         |     | 40  |     | ohm     |
| Segment Driver Leakage Current             | $I_S$     |                                                                                                         |     |     | 500 | $\mu A$ |
| Pullup Resistance of Reset or Store Inputs | $R_p$     |                                                                                                         | 100 | 400 |     | Kohms   |
| Counter Input Resistance                   | $R_{IN}$  | Terminal 12 either at $V_{DD}$ or $V_{SS}$ potentials                                                   |     |     | 100 | Kohms   |
| Counter Input Hysteresis Voltage           | $V_{HIN}$ |                                                                                                         |     | 25  | 50  | mV      |

- NOTE 1 This value of power dissipation refers to that of the package and will not be obtained under normal operating conditions.
- NOTE 2 The supply voltage must be applied before or at the same time as any input voltage. This poses no problems with a single power supply system. If a multiple power supply system is used, it is mandatory that the supply for the ICM 7208 is not switched on after the other supplies otherwise the device may be permanently damaged.
- NOTE 3 The output digit drive current must be limited to 150 mA or less under steady state conditions. (Short term transients up to 250 mA will not damage the device.) Therefore, depending upon the LED display and the supply voltage to be used it may be necessary to include additional segment series resistors to limit the digit currents.

may be done to the circuit.

The optimum input signal is a 50% duty cycle square wave equal in amplitude to the supply. However, as long as the rate of change of voltage is not less than approximately  $10^{-4}V/\mu\text{sec}$  at 50% of the power supply voltage, the input waveshape can be inusoidal, triangular, etc.

### Display Considerations

Any common cathode multiplexable LED display may be used. However, if the peak digit currents exceeds 150 mA for any prolonged time, it is recommended that resistors be included in series with the segment outputs (terminals 2, 3, 15, 17, 18, 26, 28) to limit current to 150 mA.

The ICM 7208 is specified with  $500\mu\text{A}$  of possible digit leakage current. With certain new LED displays that are extremely efficient at low currents, it may be necessary to include resistors between the cathode outputs and the positive supply  $V_{DD}$  to bleed off this leakage current.

### Display Multiplex Rate

The multiplex frequency reference is divided by eight to generate an 8 bit sequencer. Thus the display multiplex rate is one eighth of the multiplex frequency reference.

The ICM 7208 has approximately  $0.5\mu\text{s}$  overlap between output drive signals. Therefore, if the multiplex rate is very fast, digit ghosting will occur. The ghosting determines the upper limit for the multiplex frequency reference. At very low multiplex rates flicker becomes visible.

It is recommended that the display multiplex rate be within the range of 50 Hz to 200 Hz which corresponds to 400 Hz to 1600 Hz for the reference frequency.

### CONTROL INPUT DEFINITIONS

| INPUT      | TMNL | VLTG     | FUNCTION                     |
|------------|------|----------|------------------------------|
| 1. Display | 9    | $V_{DD}$ | Display on                   |
|            |      | $V_{SS}$ | Display off                  |
| 2. Store   | 11   | $V_{DD}$ | Counter Inform. Stored       |
|            |      | $V_{SS}$ | Counter Inform. Transferring |
| 3. Inhibit | 13   | $V_{DD}$ | Input to Counter Blocked     |
|            |      | $V_{SS}$ | Normal Opertn.               |
| 4. Reset   | 14   | $V_{DD}$ | Normal Opertn.               |
|            |      | $V_{SS}$ | Counters Reset               |

Fig. 4. Typical performance characteristics.

MAXIMUM COUNTER INPUT FREQUENCY AS A FUNCTION OF SUPPLY VOLTAGE

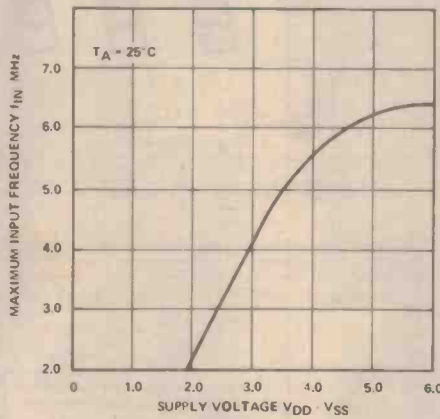

SEGMENT OUTPUT CURRENT AS A FUNCTION OF SUPPLY VOLTAGE

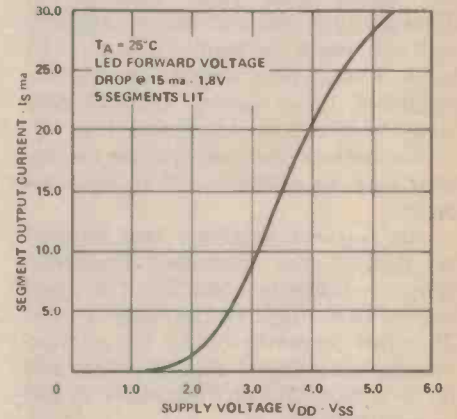

SUPPLY CURRENT AS A FUNCTION OF SUPPLY VOLTAGE

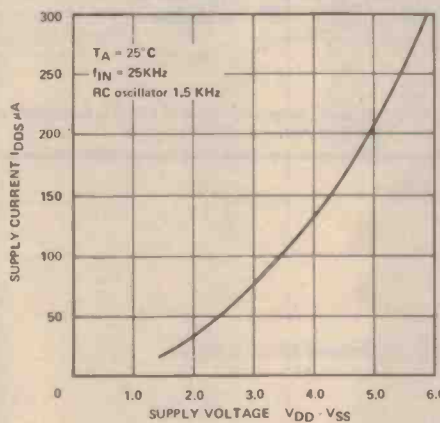

SUPPLY CURRENT AS A FUNCTION OF COUNTER INPUT FREQUENCY

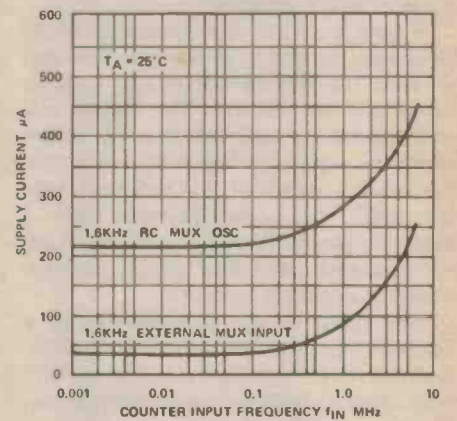
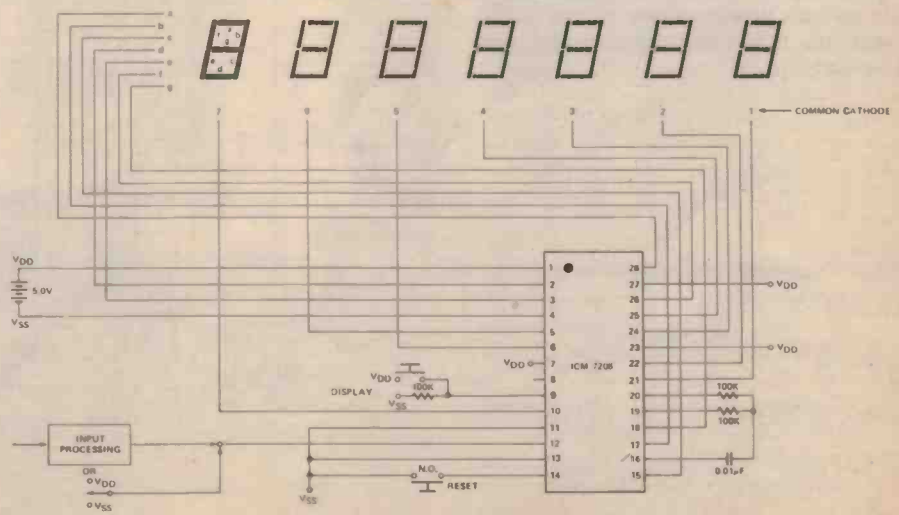

Fig. 5. Unit counter schematic.



# ETI data sheet

## Unit Counter

The unit counter updates the display for each negative transition of the input signal. The information on the display will count after reset from 00 to 9,999,999 and then will reset to 0000000 and will begin to count up again. To blank leading zeros actuate reset at the beginning of a count. Leading zero blanking affects two digits at a time.

For battery operated systems the display may be switched off to conserve power.

An external generator may be used to provide the multiplex frequency reference (input terminal 20). The signal applied to terminal 19 (terminals 16 and 20 open circuit) should be approximately equal to the supply voltage and for minimum power dissipation should be a square wave.

For stand alone systems two inverters are provided so that a simple but stable RC oscillator may be built using only 2 resistors and a capacitor.

Figure 5 shows the schematic of an extremely simple unit counter that can be used for remote traffic counting, to name one application. The power cell stack should consist of 3 or 4 nickel cadmium rechargeable cells (nominal 3.6 or 4.8 volts). If 4 x 1.5 volt cells are used it is recommended that a diode be placed in series with the stack to guarantee that the supply voltage does not exceed 6 volts.

The input switch is shown to be a single pole double throw switch (SPDT). A single pole single throw switch (SPST) could also be used with a pullup resistor. However, anti-bounce circuitry must be included in series with the counter input. In order to avoid all contact bounce problems due to the SPDT switch the ICM 7208 contains an input latch on chip.

Fig. 6. Frequency counter schematic.

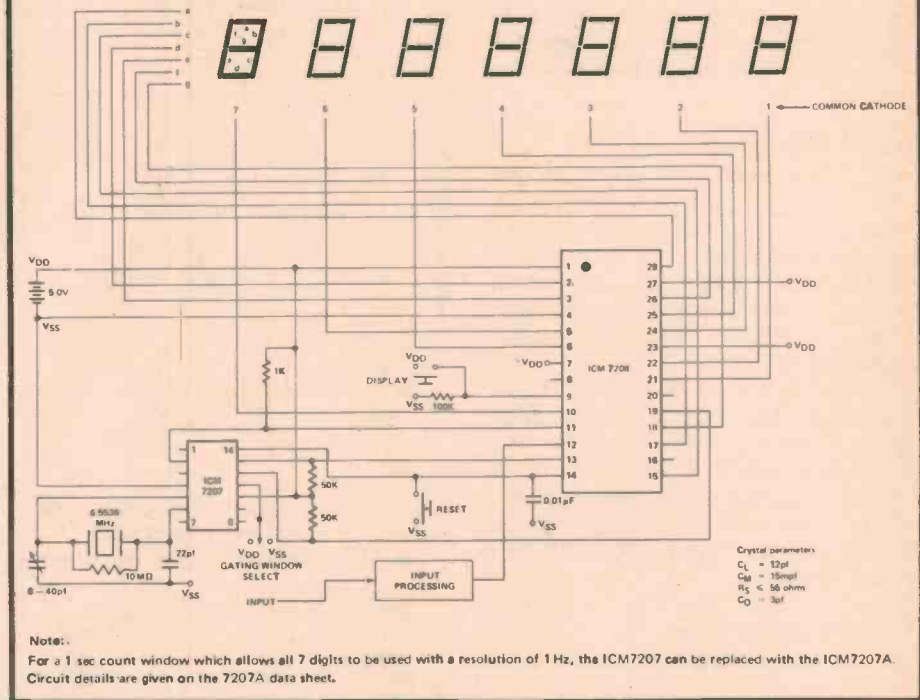

Fig. 7. Internal block diagram.

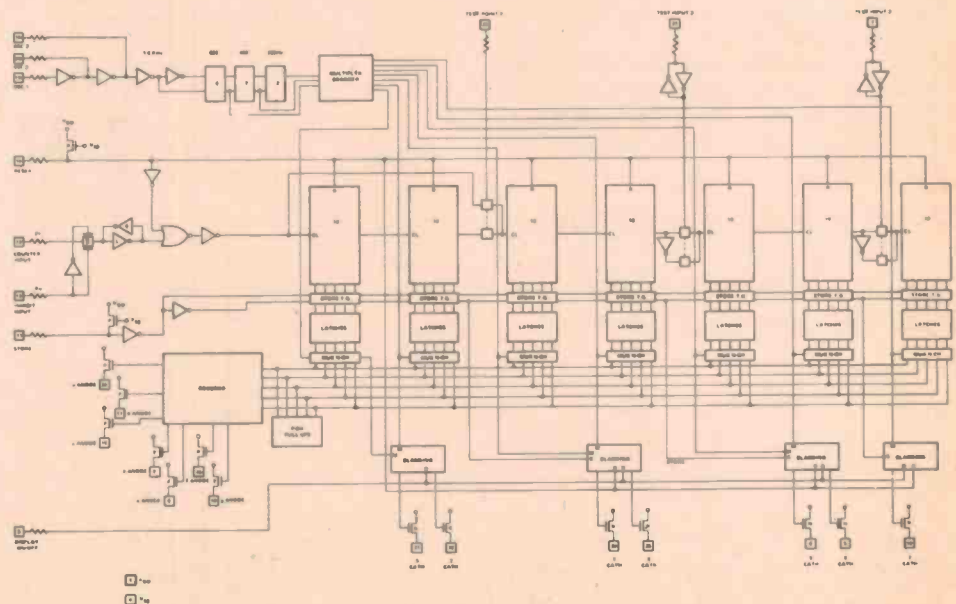
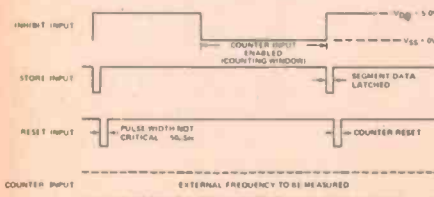

Fig. 8. Frequency counter input waveforms.





**EMONA**  
enterprises

Room 208/661 George Street, Sydney Phone: 212-4815

PO BOX K21, HAYMARKET NSW 2000



**EMONA**  
electronics

## THE NEW NS108

from National Semiconductor Ultrathin (7.5 mm thin) LCD Scientific Calculator!

### NSC 108

#### NS 108 FEATURES

Full 10-digit mantissa or 8-digit mantissa and 2-digit exponent plus sign. Display prompting alpha characters below the mantissa signal the calculator mode: "X10"; "DEG", "RAD", or "GRAD"; "HYP" mode, "and" or "out"; "F" or "2nd" indicates secondary function; Direct access accumulating memory: M, M-, MR, Memory store, Memory-Display exchange; Two levels of parenthesis; Trig and log functions; Inverse trig and log, hyp functions; Algebraic logic; Statistical functions: three accessible, accumulating memories for summations; Sum X, X2, and n; Calculates mean and standard deviation, adding to and subtracting from the summations at will; Separate keys for permutations and combination calculations; Mode selection in degrees, radians, or grads; Rectangular/polar coordinates; Degrees, minutes, seconds; Square, square root and factorial X!; Reciprocals, powers, and roots; Integer/fraction isolation; Degree, radian, grad conversion. Complete with vinyl billfold style carrying case and 3 silver oxide batteries.

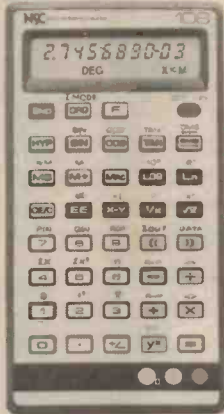

**\$47.00**

#### ALSO:

NS201R, Scientific — \$26.85  
NS202R, Financier — \$29.84  
NS203R, Business — \$22.38

## TEXAS CALCULATORS!

### PROGRAMMABLE:

T1-59 — \$262.00  
T1-58 — \$114.00  
T1-57 — \$74.00

### PROFESSIONAL RANGE:

SR-51-II, Scient./Eng. \$54  
SR-40, Scientific, \$32  
T1-30SP, Student Math Kid, \$20  
MBA-Business, Financial & Programmability, \$76  
T1-MM, Money Manager, \$21  
T1-BA, Business Analyst, \$33  
PC-100A, Thermal Printer, \$222

#### ALSO:

BMC-LCD-8M, Billfold, \$23  
BMC-1212PD, 12 digit display and printer, \$149

WRITE, PHONE OR CALL IN!

## POCKET CALCULATOR WITH LCD CLOCK & ALARM!

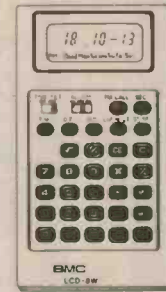

**MICRO QUARTZ LCD-8W**  
6 function LCD watch built-in. Continuous using time — 13,000 hours.

- Day/date/hour/minute/second & 1/10 second.
  - Stop watch, lap time.
  - Alarm time.
  - Automatic return to timepiece mode system.
- Super thin — 6 mm, 8 digits, full memory, 2,200 hours for calculators, operation by mercury battery. **PRICE: \$42**

### ALSO AVAILABLE:

- OLYMPUS — 60 min. Micro Cassette Recorders & Transcribers.
- Full range of National Semiconductors, Fairchild & Unik Time watches & chronographs.
- Digital clocks & digital clock radios.

NOTE: To all calculator prices add 15 percent sales tax if applicable. P & P — NSW \$2.00, INT. \$3.00.

## NEW-NEW **RJX SERIES**

National

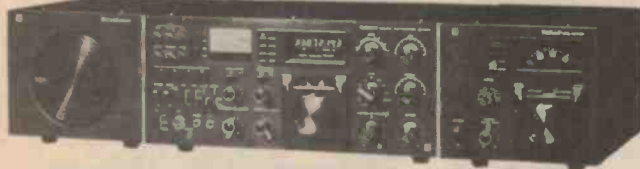

RDX-51011

RDX-1011

RDX-V1011

## A UNIQUE NEW SSB/CW TRANSCEIVER FOR AMATEUR COMMUNICATIONS

There is no substitute for quality, performance, or the satisfaction of owning the very best. Hence, the incomparable National RJX-1011 amateur transceiver. The RJX-1011 covers all amateur bands 1.8-30 MHz (160-10 metres). It utilizes advanced Phase-Lock-Loop circuitry with dual gate MOS FETs at all critical RF amplifier and mixer stages. There's a rotating dial for easy band-scanning and an electronic frequency counter with digital readout and a memory display that remembers frequencies at the flip of a switch. And that's just the beginning. Matching speaker unit RJX-S1011 and complete external VFO RJX-V1011 also available.

- DENTRON MLS-2500 LINEAR AMPLIFIER
- DENTRON ANTENNA TUNERS

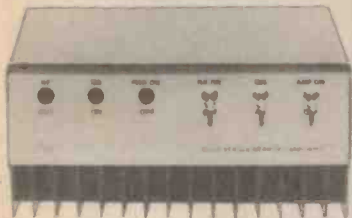

## LINEAR AMPLIFIER!

**100W (AM)  
250W PEP (SSB)  
10-80M**

### HF-10-100L AMPLIFIER

Frequency Range 3-30 MHz  
Input Power 10 W Nom, 5-20 W PEP range  
Output Power 100 W Nom 1/2 dB across band, 200-250W PEP output  
Input Impedance 50 ohm nom, adjustable to match exciter range under 2:1 across band  
Output Impedance 50 ohm nom, up to 3:1 VSWR acceptable with little degradation  
Current Drain: 16 A nom, 20 A supply recommended at 13.6 VDC  
Power supply 13.6 VDC recommended for best results, 11-14 VDC acceptable positive or negative ground  
Pre-amp 18 dB nom gain across entire HF band, 15 dB type at 50 MHz 3-4 dB NF  
Size 19.1 x 16.5 x 8.9 cm wt 1 1/2 kg.

### ANTENNAS:

HUSTLER: 4-BTV — vertical trap antenna.  
HUSTLER: Mobile vertical trap antenna (80-10m).  
HUSTLER: G6-144A, 6 dB gain base colinear.  
HUSTLER: CGT-144, 5.2 dB gain mobile colinear trunk-lit mt.  
HUSTLER: BBLT-144, 5/8 mobile with trunk lip mount/spring.  
CUSHCRAFT: ATB-34, 4 element beam, 10-15-20m.  
CUSHCRAFT: A144-11, 11 element 2M Yagy.  
CUSHCRAFT: A144-20T, 20 element 2M twist antenna.  
CUSHCRAFT: ARX-2 Ringo Ranger, 2M omnidirections.  
WILSON: SY1 5 element, 10, 15, 20m, a DX'ers delight.  
NEW ROBOT 400, SSTV SCAN CONVERTER  
NEW INFO-TECH RTTY EQUIPMENT: Model 150 Keyboard, Model 75 RTTY to video converter.

### AMATEUR BAND TRANSCEIVERS:

NEW — NATIONAL: RJX1011 — Unique SSB/CW 160-10m transceiver with digital readout and matching speaker and external VFO.  
TR10 KENWOOD: TS20S — SSB/CW, 160-10 metres, with optional digital readout.  
TR10 KENWOOD: TS820S, 160-10 metres digital readout.  
TR10 KENWOOD: TS820, 160-10 metres.  
BIGEAR TYPE 1, 2M PLL FM-SSB-CW Transceiver.  
BIGEAR TYPE 2, 2M PLL FM Transceiver.  
TR10 KENWOOD: TR-7400A — 144-148 MHz FM transceiver.  
YAESU MUSEN: FT101E — 160-10 metres, AM, SSB, CW transceiver.  
YAESU MUSEN: FT301 series, 160-10m AM, SSB, CW transceiver.

### RECEIVERS:

DRAKE: SSR-1 Wadley Loop receiver.  
TRIO KENWOOD: R300 general coverage BCL receiver.  
YAESU MUSEN: FRG-7 general coverage Rx, Wadley Loop System.  
NATIONAL: DR48 (RF4800) — general coverage, digital dial, communications and BCL receiver.



### NEW: MEDIUM-SIZED HAM ANTENNA ROTATOR — FU 400.

Constructed for long trouble-free operation. 200 kg vertical weight capacity. Extra heavy duty disc brake that prevents wind-milling.

ALL AMATEUR RADIO EQUIPMENT IS AVAILABLE ON 10 PER CENT DEPOSIT TO APPROVED BUYERS!

CHECK EMONA'S MOST COMPETITIVE PRICES!

## ONE STOP MAIL ORDER SHOPPING AT LOW PRICES

|                                                    |                                            |                                                 |                                            |                                                    |                                            |                                           |                                                   |
|----------------------------------------------------|--------------------------------------------|-------------------------------------------------|--------------------------------------------|----------------------------------------------------|--------------------------------------------|-------------------------------------------|---------------------------------------------------|
| 21 L02 (450 ns)<br>Static Rams<br>100 @ \$1.10 ea. | 1702A<br>E-PROM<br>8 @ \$3.75 ea.          | 6502<br>Microprocessor<br>5 @ \$11.00 ea.       | 2708 (450 ns)<br>E-PROM<br>8 @ \$11.00 ea. | 21 L02 (250 ns)<br>Static Rams<br>100 @ \$1.36 ea. | Z-80A<br>Microprocessor<br>5 @ \$25.00 ea. | 8212<br>8 Bit I/O Port<br>25 @ \$3.00 ea. | 4116 (200 ns)<br>16K Dyn. Ram<br>16 @ \$24.00 ea. |
| Z-80<br>Microprocessor<br>5 @ \$20.00 ea.          | 8224-4<br>Cik.Gen.&Dvr.<br>25 @ \$8.75 ea. | 410D (200 ns)<br>Static Ram<br>100 @ \$8.75 ea. | 4096<br>Dynamic Ram<br>100 @ \$3.50 ea.    | 4200A (200 ns)<br>Static Rams<br>25 @ \$10.00 ea.  | 74LS367<br>Hex Buffer<br>100 @ .70¢ ea.    | 74LS368<br>Hex Inverter<br>100 @ .70¢ ea. | 2513 (5v)<br>Character Gen.<br>5 @ \$9.00 ea.     |

### MICROCOMPUTER COMPONENTS

| MICROPROCESSOR'S | MISC. OTHER COMPONENTS |
|------------------|------------------------|
| F8 16.55         | N8 T20 3.39            |
| Z80 22.00        | N8 T26 2.10            |
| Z80A 28.00       | N8 T55 1.35            |
| CDP1802CD 19.95  | N8 T96 1.35            |
| 2650 24.95       | N8 T97 1.35            |
| AM2901 22.95     | N8 T98 1.35            |
| 6802 11.95       | 81LS93 2.00            |
| 6800 18.95       | 81LS97 2.00            |
| 6802 25.00       | 1488 1.75              |
| 8008-1 9.95      | 1489 1.75              |
| 8035 22.00       | D205 4.00              |
| 8080A 11.95      | D207A 4.85             |
| 8085 27.00       | D220A 14.20            |
| TMS9900TL 75.00  | D3211 10.00            |
|                  | B3222 7.75             |
|                  | B3242 10.15            |
|                  | D3245 6.50             |
|                  | C3404 6.75             |
|                  | P3408A 12.00           |
|                  | PK201A 5.20            |
|                  | MMS320 7.50            |
|                  | MMS369 1.90            |
|                  | TMS501 24.95           |
|                  | DM8130 2.90            |
|                  | DM8131 2.75            |
|                  | DM8133 2.50            |
|                  | DM8135 2.50            |
|                  | DM8137 1.75            |
|                  | MKS0240 20.00          |
|                  | MKS0250 15.00          |

### E-PROM BOARDS

|                                     |          |
|-------------------------------------|----------|
| N8 B 18K (with 2708) KIT            | \$99.50  |
| N8 16T 16K (with 2716) KIT          | \$99.50  |
| N8 16T 16K (with 2716) KIT          | \$99.00  |
| RAM PROM 16K (with 2708) E PROM KIT | \$117.00 |
| JG B18 (with 2708 or 2716)          | \$59.95  |
| BARE BOARD                          | \$30.00  |

### TU-1

Convert T.V. set to Video Monitor.  
KIT ..... \$8.95

### FLOPPY DISC CONTROLLER

|          |        |
|----------|--------|
| 1771B    | \$5.95 |
| 1771B-01 | \$7.95 |

### KEYBOARD CHIPS

|          |       |
|----------|-------|
| AVS-2376 | 13.75 |
| AVS-3800 | 13.75 |

### PROM'S

|           |       |
|-----------|-------|
| 1702A     | 4.00  |
| 2708      | 15.00 |
| 2708      | 12.00 |
| 2716      | 30.00 |
| 2716 Intl | 38.00 |
| 2758      | 26.50 |
| D3601     | 4.50  |
| D3604     | 13.00 |
| S203AQ    | 5.00  |
| S204AQ    | 5.00  |
| 6814      | 17.50 |
| 6814-1    | 14.95 |
| 8252JB    | 4.00  |
| 82529B    | 4.25  |
| 8223B     | 3.50  |

### 8800 SUPPORT

|        |       |
|--------|-------|
| 6810P  | 4.95  |
| 68B10P | 6.00  |
| 6820P  | 7.50  |
| 6821P  | 3.95  |
| 6828P  | 11.25 |
| 6834P  | 16.95 |
| 6850P  | 9.75  |
| 6852P  | 11.75 |
| 6860P  | 10.00 |
| 6862P  | 10.00 |
| 6871P  | 28.00 |
| 6875P  | 8.75  |
| 6880P  | 2.50  |

### Z80 SUPPORT DEVICES

|      |       |
|------|-------|
| 3881 | 12.95 |
| 3882 | 12.95 |

### STATIC RAMS

|              |       |       |      |
|--------------|-------|-------|------|
| 21 L02       | 1.50  | 1.24  | 1.18 |
| 21 L02 (250) | 1.60  | 1.35  | 1.25 |
| 21 L02 (500) | 1.75  | 1.40  | 1.50 |
| 410A         | 10.75 | 10.00 | 9.25 |
| 110A         | 1.00  | .90   | .80  |
| 2101-1       | 2.95  | 2.75  | 2.60 |
| 2102         | 1.25  | 1.15  | 1.00 |
| 2111-1       | 2.95  | 2.50  | 2.25 |
| 2112-1       | 2.95  | 2.80  | 2.69 |
| 2114-3       | 11.00 | 10.00 | 9.25 |
| 2179         | 11.00 | 9.00  | 8.30 |
| 2147         | 37.50 |       |      |
| 31 L01       | 2.50  | 2.25  | 2.00 |
| 3105         | 3.95  | 3.70  | 3.25 |
| 3107         | 3.95  | 3.70  | 3.25 |
| 4200A        | 9.95  | 9.00  | 8.95 |
| TMS-4044     | 11.00 | 10.00 | 9.25 |
| 5101         | 8.30  | 7.40  | 7.25 |
| 74C89        | 3.25  | 3.05  | 2.85 |
| 7489         | 2.25  | 2.10  | 1.90 |
| 74S201       | 4.50  | 4.00  | 3.75 |
| 78191        | 4.20  | 3.40  | 2.80 |
| PH155        | 17.00 | 14.00 |      |
| PH156        | 21.00 | 18.00 |      |
| 8599         | 1.85  | 1.75  | 1.60 |
| 9102BPC      | 1.65  | 1.45  | 1.30 |

### CHARACTER GENERATORS

|               |       |
|---------------|-------|
| 2513          | 6.75  |
| 2513 5v upper | 6.75  |
| 2513 5v lower | 10.95 |
| 2516          | 10.95 |
| MCMS571       | 10.95 |
| MCMS571A      | 10.95 |
| MCMS574       | 13.25 |
| MCMS575       | 13.25 |

### WAVEFORM GENERATOR

|        |      |
|--------|------|
| 8038   | 3.50 |
| MC4024 | 2.25 |
| 566    | 1.50 |

### DYNAMIC RAMS

|           |       |
|-----------|-------|
| 416D4116  | 32.00 |
| 1103      | 1.00  |
| 2104      | 4.00  |
| 2107B     | 4.25  |
| 2107B-4   | 4.00  |
| TMS4050   | 4.00  |
| TMS4060   | 4.50  |
| TMS4070-2 | 32.00 |
| 4096      | 4.00  |
| 4116A160  | 32.00 |
| MMS270    | 4.50  |
| MCMS605   | 5.00  |

### USRT

|       |       |
|-------|-------|
| S2350 | 10.75 |
|-------|-------|

### JART'S

|           |       |
|-----------|-------|
| AVS-1013A | 5.25  |
| AVS-1014A | 8.25  |
| TR1602B   | 2.25  |
| TMS6011   | 5.95  |
| IM6402    | 10.80 |
| IM6403    | 10.80 |

### JADE 8080A KIT

\$100.00 KIT  
BARE BOARD \$30.00

### STATIC RAM BOARDS

| 8K                           |  |          |
|------------------------------|--|----------|
| 250ns ASSEMBLED & TESTED     |  | \$189.95 |
| 450ns ASSEMBLED & TESTED     |  | \$149.75 |
| 250ns KIT                    |  | \$169.95 |
| 450ns KIT                    |  | \$125.00 |
| BARE BOARD                   |  | 25.00    |
| 6800 ADAPTER to S-100 System |  | \$12.95  |
| 16K                          |  |          |
| 250ns ASSEMBLED & TESTED     |  | \$435.00 |
| 450ns ASSEMBLED & TESTED     |  | \$380.00 |
| 450ns KIT                    |  | \$335.00 |
| 32K                          |  |          |
| 250ns ASSEMBLED & TESTED     |  | \$850.00 |
| 450ns ASSEMBLED & TESTED     |  | \$775.00 |
| 450ns KIT                    |  | \$675.00 |

### DYNAMIC RAM BOARDS

On board Refresh power is provided with no wait states or cycle stealing required.

|                |                 |     |                 |
|----------------|-----------------|-----|-----------------|
| *8VDC 400MA DC | *18VDC 400MA DC | and | *18VDC 300MA DC |
|----------------|-----------------|-----|-----------------|

| EXPANDABLE 8K   |  |          |
|-----------------|--|----------|
| 8K (375ns) KIT  |  | \$151.00 |
| 16K (375ns) KIT |  | \$259.00 |
| 24K (375ns) KIT |  | \$367.00 |
| 32K (375ns) KIT |  | \$425.00 |
| EXPANDABLE 64K  |  |          |
| 16K (375ns) KIT |  | \$281.00 |
| 32K (375ns) KIT |  | \$659.00 |
| 48K (375ns) KIT |  | \$757.00 |
| 64K (375ns) KIT |  | \$995.00 |

### MOTHER BOARD'S - S-100 Style

|                              |          |
|------------------------------|----------|
| 13 slot - w/front panel slot |          |
| BARE BOARD                   | \$35.00  |
| KIT                          | \$95.00  |
| 22 slot                      | \$149.95 |
| ASSEMBLED & TESTED           |          |

### THE PROM SETTER

WRITE & READ EPROM  
1702A - 2708 - 2716  
5204 - 6834

- Plugs directly into your ALTAIR/MSAI Computer.
- Includes Main Module Board and External EPROM Socket Unit.
- The EPROM Socket Unit is connected to the Computer through a 25 pin connector.
- Programming is accomplished by the Computer.
- Just load in the Program to be Written on the EPROM into your Processor and let the Computer do the rest.
- Use Socket Unit to Read EPROM's Contents into your Computer.
- Software included.
- No external power supplies. Your computer does it all.
- Doubles as an Eight Bit Parallel I/O.
- Manual included.

KIT ..... \$210.00  
ASSEMBLED ..... \$375.00

### KIM-1

ASSEMBLED & TESTED \$245.00

### MEMORY PLUS

FOR KIM-1  
8K RAM (21L02)  
8K EPROM  
ASSEMBLED & TESTED \$245.00

## JADE Z80 KIT

with PROVISIONS for ONBOARD 2708 and POWER ON JUMP

\$135.00 EA. (2MHZ)  
\$149.95 EA. (4MHZ)

BARE BOARD \$35.00

## JADE Z80 "UPGRADE" KIT

Change your JADE 2MHZ Z80 to a 4MHZ version with this simple kit:

only \$17.95 with trade  
\$49.95 purchase.

To trade, you must give us your 2MHZ Z80 chip and 8224 clock driver.

The "UPGRADE KIT" includes:  
Z80A chip,  
8224 clock driver  
20 pf. capacitor  
38MHz crystal

## COMPU/TIME CT 100

TIME & CALENDAR

Microprocessors need the power that a real-time clock can offer. Date and time becomes instantly available. COMPU/TIME does not have to be initialized every time the system is powered up. It possesses a crystal-controlled time base to obtain superior accuracy and has two settable coincidence counters. Time, date, and counters are set via software.

COMPUTATIONAL FUNCTION  
Microprocessors need to be complemented by hardware arithmetics to free up memory pages dedicated to floating point routines and mathematical software. COMPU/TIME provides a 40 function calculator array so that algebraic, trigonometric, basic arithmetic problems can be solved without the need of developing sophisticated software.

Buy It Your Way

|                  |       |           |       |           |
|------------------|-------|-----------|-------|-----------|
| COMPU/TIME CT100 | \$199 | KIT       | \$245 | Assembled |
| COMPU only       | C101  | \$149     | KIT   | \$189     |
| TIME only        | T101  | \$165     | KIT   | \$205     |
| COMPU/TIME       | PC    | Bare only | \$80  |           |

## JADE VIDEO INTERFACE KIT

FEATURES \$99.95

- S-100 Bus Compatible
- 32 or 64 Characters per line
- 16 lines
- Graphics (128 x 48 matrix)
- Parallel & Composite video
- On board low-power memory

Powerful software included for cursor, home, EOL, Scroll Graphics/Character, etc.  
Upper case, lower case & Greek  
Black-on-white & white-on-black

## full ASCII PROFESSIONAL KEYBOARDS

Full 128 Character ASCII  
Tri-Mode MOS Encoding!  
MOS DTL Compatible Output!  
Two-key Rotator!  
Level and Pulse Strobel!  
Shift and Alpha Lock!  
Selectable Parity!  
Positive or Negative Logic! (56 Keys)

MODEL 756

Model 756 (assembled) \$75.95  
Model 750K (kit) 64.95  
Model 702 Enclosure 29.95  
Model 710 Numeric Pad 9.95  
Model 758M Alg. Frame 8.95

PRICING INFORMATION

## CONNECTORS

|                          |        |
|--------------------------|--------|
| DB - 25P                 | \$3.00 |
| DB - 25S                 | \$4.00 |
| COVER                    | \$1.50 |
| 44 Pin - PC & EYE        | \$1.95 |
| 44 Pin - WW              | \$2.50 |
| 96 Pin - (6800) PC       | \$5.00 |
| 96 Pin - (COSMAC ELF) PC | \$5.00 |
| 100 Pin - (Altair) PC    | \$4.50 |
| 100 Pin - (Imsal) PC     | \$3.75 |
| 100 Pin - (Imsal) WW     | \$4.25 |

## JADE REAL TIME CLOCK FOR S-100 BUS

- 1 MHz Crystal Oscillator
- Two independent interrupts
- One interrupt uses 16 bit counter in 10 USEC steps
- Other interrupt is in decade steps from 100 USEC to 10 sec.
- Both software programmable
- Board can be selected by 128 device code pairs.
- Complete documentation includes software to display time of day.
- Double sided solder mask
- Silk screen parts layout

JG-RT ASSEMBLED & TESTED \$179.95  
JG-RT KIT \$124.95  
BARE BOARD with Manual \$30.00

## TARBELL CASSETTE INTERFACE

- Plugs directly into your IMSAI or ALTAIR
- Fastest transfer rate: 187 (standard) to 540 bytes/second
- Extremely Reliable—Phase encoded (self-clocking)
- 4 Extra Status Lines, 4 Extra Control Lines
- 37-page manual included
- Device Code Selectable by DIP-switch
- Capable of Generating Kansas City tapes also
- No modification required on audio cassette recorder

JADE KIT\* \$99.95 ASSEMBLED \$175.00  
\*6 month warranty from JADE! MANUAL \$4.00

## JADE PARALLEL/SERIAL INTERFACE KIT

S-100 \$124.95 KIT

2 Serial Interfaces with RS232 interfaces or 1 Kansas City cassette interface.  
Serial interfaces are crystal controlled. Selectable baud rates. Cassette works up to 1200 baud. 1 parallel port.

## DATA COMMUNICATIONS ADAPTER

80 103A Serial I/O and FSK modem for professional and hobby communications.

- Completely compatible with your IMSAI, ALTAIR, SOL, or other S-100 microcomputers.
- Trademarks of "MITS," "Processor Technology"
- Designed for use on the dial telephone or TWX networks, or 2-wire dedicated lines, meets all FCC regulations when used with a CBT coupler.
- All digital modulation and demodulation with on board crystal clock and precision filter mean that NO ADJUSTMENTS ARE REQUIRED
- Self test standard frequencies
- Automated dial (manual) answer
- Originate and answer mode
- 110 or 300 BPS speed select
- Complete self test capability
- Character length, stop bit, and parity
- 90 day warranty and full documentation

PRICES: BARE BOARD and Manual \$49.95  
Assembled (48 hr. burn in) \$279.95  
JG-DCA KIT \$159.95

## NUMBER CRUNCHER

The CT200 is a number-oriented microprocessor intended for use in those applications that require fast versatile mathematical solutions. THIS IS NOT A CALCULATOR CHIP. THERE ARE NO KEY DELAYS.

The CT200 has a unique architecture that is designed to be a TASK processing system within a system. This unique architecture will allow the CT200 to work and run with ANY S100 BUS microprocessor system. It is completely compatible with Z80, 8088, 8080, 8080Z microprocessors. A micro encoded instruction set allows programming in a calculator like language. The instruction set includes a full set of test and branch instructions. All decoding of S100 bus signals for select or control functions is performed with strobed latches to eliminate the possibility of glitches.

PRICE: \$249.00  
Includes Manual, ASSEMBLED & TESTED.

## JADE Computer Products

5351 West 144th Street  
LAWDALE, CALIFORNIA 90260  
(213) 679-3313

Discounts available at OEM quantities. All prices above are quoted in USA F.O.B. Lawndale, Calif. USA. To expedite shipments please include international money order or bankers check payable against any USA bank in USA, or affiliated credit cards of Bank America or Master Charge welcome (include card No., expiration date and signature). Add 10% of total order for postage. For orders less than \$10 add \$1.50 service charge.

NEW CATALOG NOW AVAILABLE



# ICS now present another kind of E.L.O.



## Electronic Living Opportunities

The Electric Light Orchestra have a great sound. A sound which has won them numerous gold and platinum records, international acclaim and many thousands of dollars. But without the recording technicians – the electronics experts – ELO's talent would go unheard..

The booming pop music recording industry is just one example of how electronics is the very life source that powers virtually everything in our world today.

Qualifications in electronics are the passport to a whole world of fascinating jobs, opportunities and even life styles.

Now you can take advantage of the amazing "electronic living opportunities" available everywhere today by training with International Correspondence Schools.

Home-tutoring the ICS way allows you to work at your own pace and in your own time. So you can gain qualifications vital to a successful career in electronics without losing valuable income while studying.

Act now. The first step is simple. Fill out the coupon and post it today.

In return you will receive the ICS Electronics Career folder. This gives you all the details of the many courses available – Communications and Broadcasting, Industrial Electronics, Computer Servicing, Audio/Radio Servicing, all of which are endorsed by the Television and Electronics Technicians Institute of Australia.

It will also outline the advantages of in-home study with ICS, plus the many opportunities electronic qualifications will bring you.

Even if you aren't into music or ELO, don't let the "electronic living opportunities" an ICS course offers pass you by for another second. Clip and post this coupon immediately.

### International Correspondence Schools

400 Pacific Highway Crows Nest, NSW. 2065  
18-20 Collins Street, Melbourne. VIC. 3000  
125 Wakefield Street, Wellington. N.Z.

**Please send me, without cost or obligation, the ICS career guidance kit for the course marked below**

Electronics     TV Servicing

Name \_\_\_\_\_

Address \_\_\_\_\_

Postcode \_\_\_\_\_

276700

Age \_\_\_\_\_

Occupation \_\_\_\_\_

# ICS

**ICS courses are not recommended for School students.**

# Videobrain Videogame



Actual size 14.2 cm

# SPECIAL

Although it is over a year since we published the Selecta-game TV game project, there is still a lot of interest in these gadgets. So when Caldor Corporation told us they'd like to offer our readers a TV game for only \$19.95 each, we agreed immediately!

This Videobrain video game is based on the well-known GI chip, type AY-3-8500 and plays four games — tennis, hockey, squash and practice. The circuitry in it is basically the same as in much more expensive games — in fact the cheapest we have ever seen this type of game offered anywhere is \$29.95 and most are discounted at \$39.95 — but this one is much smaller, so shipping and handling costs are less, allowing a lower price.

Although it is so small, this game features selectable bat angle, speed, bat size and auto or manual serve. The two hand controls can be attached to the case or hand-held. The Videobrain game runs on 6 x 1.5 volt pen cells, although an AC adapter is available for \$3.95 plus 50 cents postage, if required. The game, which is warranted by Caldor for 90 days, is black and white — for \$19.95 + \$2.50 p & p, we reckon that's really good value. We also reckon you'll agree.

So to order, complete the coupon below, and send it, with a cheque for the appropriate amount, to: TV Game Offer, Electronics Today International, 15 Boundary Street, Rushcutters Bay, NSW 2011. Cheques should be made payable to 'TV Game Offer'. Please allow 4-6 weeks for delivery.

**\$19**  
plus \$

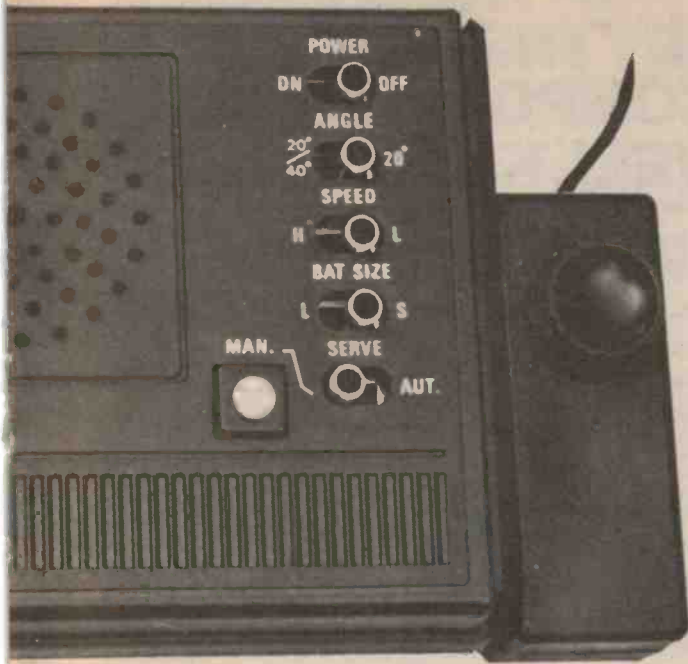

X 9.3 cm (SMALL)!

# OFFER

Send to: TV Game Offer, Electronics Today International, 15 Boundary Street, Rushcutters Bay, NSW 2011.

Please forward . . . . . Videobrain TV games at \$19.95 each plus \$2.50 each postage and packing, and . . . . . AC adapters at \$3.95 each plus 50 cents each postage and packing.

I enclose herewith cheque/postal order total . . . . .  
Please make cheques, etc., payable to 'TV Game Offer'.

Name . . . . .

Address . . . . .

. . . . . Postcode . . . . .

The tradename 'Videobrain' is registered in Australia by the Caldor Corporation. It is not associated with the US VideoBrain Computer Company.

Offer closes July 31st, 1978 and is open to Australian residents only. Apologies to our overseas readers.

**9.95**

\$2.50 P&P

**SEMCON MICROCOMPUTERS PTY. LTD.**

**ATTENTION OWNERS!**

**MOTOROLA D2**  
If you want a functional, expandable system, you need:

**8K BYTE, STATIC MEMORY CARD**

**Australian Designed and Built**

- Fast Access 350 ns Chips (2102LF)
- Low Current - 1.3 Amps
- Motorola Bus Compatible
- Write Protect
- Parity Generation/Checking available
- Professional Finish
- Plated through Holes
- \$275 assembled board
- \$219 in kit form
- 298 Assembled with Parity
- \$110 for 8k kit without rams
- Built Boards Guaranteed 12 months



**CARD CAGE/BACKPLANE:**

- Designed for Motorola Cards
- Anodised Aluminium chassis
- Sturdy Construction
- Tin Plated Backplane
- Accommodates 8 cards

**\$74.00**

**EDGE CONNECTORS —**

43 x 2 x 0.156" \$8.50 each  
Eight for \$59.00

\$100 Connectors \$8.50



**THIS MONTH'S SPECIALS**

**Microprocessors**

6802: The 6800 with a chip clock \$27.00  
8080A ..... \$15.00  
280A 4 MHz version ..... \$38.00  
6820: PIA ..... \$8.50

**Memories**

2708 EPROM ..... \$16.50  
**1 Amp Voltage Regulators**  
7805, 7806, 7812, 7815 ..... all \$1.20  
555 Timer ..... \$0.35

**LOW POWER SCHOTTKY**

|                   |                   |                    |
|-------------------|-------------------|--------------------|
| 74LS00 ..... 33   | 74LS38 ..... 40   | 74LS109 ..... 53   |
| 74LS02 ..... 33   | 74LS40 ..... 37   | 74LS138 ..... 1.20 |
| 74LS04 ..... 34   | 74LS42 ..... 1.30 | 74LS160 ..... 1.20 |
| 74LS05 ..... 37   | 74LS47 ..... 1.30 | 74LS161 ..... 1.20 |
| 74LS08 ..... 33   | 74LS74 ..... 0.55 | 74LS174 ..... 1.00 |
| 74LS09 ..... 33   | 74LS75 ..... 0.70 | 74LS175 ..... 1.00 |
| 74LS10 ..... 33   | 74LS85 ..... 1.58 | 74LS190 ..... 1.20 |
| 74LS11 ..... 33   | 74LS86 ..... 0.60 | 74LS191 ..... 1.20 |
| 74LS13 ..... 80   | 74LS90 ..... 1.20 | 74LS192 ..... 1.20 |
| 74LS14 ..... 1.40 | 74LS91 ..... 1.20 | 74LS193 ..... 1.20 |
| 74LS20 ..... 33   | 74LS92 ..... 1.20 | 74LS367 ..... 80   |
| 74LS30 ..... 33   | 74LS93 ..... 1.20 | 74LS368 ..... 80   |

**I.C. SOCKETS — LOW PROFILE**

| SOLDER      | DIL — TIN   | WIRE WRAP GOLD |
|-------------|-------------|----------------|
| 8 ..... 25  | 22 ..... 35 | 24 ..... 1.40  |
| 14 ..... 28 | 24 ..... 45 | 14 ..... 70    |
| 16 ..... 28 | 28 ..... 50 | 16 ..... 70    |
| 18 ..... 35 | 40 ..... 90 |                |

**SHOWROOM:** 1 Chilvers Road, Thornleigh, NSW 2120.  
**MAIL ORDER:** PO Box 61, Pennant Hills, NSW 2120.  
**PHONE:** 848-0800. Add 15 percent sales tax. P&P \$1.50.

**IF THERE'S A BETTER WAY TO BUY COMPONENTS, IT'S A WELL KEPT SECRET!**

The following is just part of a Telex we received recently:

- QTY 50 STORE UNIT EACH ZENER DIODE BZX70 30 VOLT
- QTY 50 STORE UNIT EACH DIODE BZY96CV8
- QTY 20 STORE UNIT EACH 1N5359B
- QTY 50 STORE UNIT RESISTOR 150 OHM TR8 2 %
- QTY 20 STORE UNIT EACH IC P/NO CA3018
- QTY 20 STORE UNIT EACH CANNON CONNECTOR 3 PIN MALE P/NO XLP-3-12
- QTY 10 STORE UNIT CAN INSTANT FREEZE COMPOUND
- QTY 24 STORE UNIT EACH CAPACITOR 2000MFD 100V
- QTY 100 STORE UNIT EACH CAPACITOR 3.3. MFD 50V TANTALUM
- QTY 50 STORE UNIT EACH CAPACITOR 18 MFD 50 V TANTALUM
- QTY 20 STORE UNIT EACH CAPACITOR 10MFD 50 V TANTALUM
- QTY 20 STORE UNIT EACH MINIBRIDGE PA40 RECTIFIER
- QTY 50 STORE UNIT EACH MINI PLUG 2.1 MM HOLE
- QTY 10 STORE UNIT EACH SILICON DIODE P/NO 55AN31
- QTY 10 STORE UNIT EACH SILICON DIODE P/NO 55AR31
- QTY 10 STORE UNIT EACH DIODE S12AR15
- QTY 10 STORE UNIT EACH DIODE S12AN15
- QTY 3 STORE UNIT EACH DIODE IRC P/NO 30IU120A
- QTY 20 STORE UNIT EACH SCR GR 103 B
- QTY 20 STORE UNIT EACH METAL CAN IC P/NO F7410H 7527
- QTY 10 STORE UNIT EACH 9 CONTACT OCTAL VALVE HOLDER CERAMIC SIMILAR TO PHILIPS 88-700-21

THIS TELEX IS FOR THE ATTENTION OF I. PURDIE

ELDIST AA23343

CLIP THIS OUT YOU NEVER KNOW WHEN YOU'LL BE NEEDING US !!

**CAPACITORS, SEMICONDUCTORS — Fairchild, ITT, National (NS), NEC, Motorola Philips, Plessey, RCA, Signetics, Texas. RELAYS — National (Japan), ITT. ITT/Cannon.**  
**CONNECTORS — Acme /Kings, Philips, Thermalloy. Beyschlag, Phillips, TRANSFORMERS — PLUS MORE**

**HEATSINKS — Delco**  
**RESISTORS — Soanar.**  
**Ferguson ...**



**Orders: (02) 636 6052**

**Office: (02) 636 6222**

**Telex: AA23343**

**Electronic (Distributors)**

2-3 Post Office Arcade, Joyce Street, PENDLE HILL, NSW. 2145.

# ETI's COMPUTER SECTION

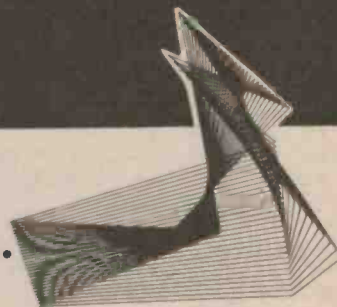

## F8 S100

### F8 S100 CPU

Comptronics, Inc. of 19824 Ventura Blvd., Woodland Hills, CA 91364, has announced an S100 CPU based on the Fairchild F8 3850 MPU and 3853 static memory interface. The board carries sockets for 2 K of EPROM, two processor I/O slots and connections for six I/O ports. The F8 CPU also provides 64 bytes of scratchpad RAM.

Also from Comptronics is an F8-based microcomputer with keyboard and six digit display which has an audio interface and speaker designed to work with a special KD-Bug music routine.

### Timex Calculators?

Timex, suffering problems in the watch market, is now test marketing three calculator models in the US. These are: a basic four-banger at \$19.95; a machine with memory at \$24.95; and a calculator with built-in alarm clock at \$39.95 (all US prices). Timex has reportedly sold one of its watch factories to its chief rival, Texas Instruments.

### Wagga Wagga Activity

Any calculator or computer enthusiasts in the Wagga Wagga area are invited to contact David Aleksic, PO Box 186, Wagga Wagga, NSW 2650, who is trying to organise a club in the district. David is on the phone at (069) 21.4613.

### NZ Micro Clubs

Chris Sullivan, of the New Zealand Microcomputer Club, writes to inform us of several clubs in NZ:

The NZ Microcomputer Club, PO Box 6210, Auckland, New Zealand.  
Paul Campbell, 50 Francis Avenue, Christchurch, New Zealand.

Wellington Microcomputer Club, PO Box 1581, Wellington, New Zealand.

Chris enclosed a copy of 'Comshare', now known as 'Micro', a new microcomputer magazine published in New Zealand. The 28 page magazine is well put together and full of interesting info. Subscriptions are \$10/year from 9 Galsworthy Place, Bucklands Beach, Auckland, New Zealand.

### MM74C911/12

National Semiconductor's new MOS 'intelligent' display controllers interface a microprocessor with an LED or gas discharge display. They replace 5-10 transistors and medium scale ICs.

### Peripheral Drivers

Signetics have released two new addressable peripheral drivers which each incorporate a 1-of-8 decoder and 8 latchable outputs. The 590 is a 16-pin device with open collector outputs which sink current to ground. The 591 has 18 pins with open emitter outputs which source current to the external load from a common collector line. Further details from Philips distributors.

### Octal Reference Card

In our August '77 issue we reviewed George Morrow's front panel, which is the heart of the Equinox range of personal computer gear. In the article we explained the way 8080 machine code naturally works out in byte-oriented octal. Now, most microprocessor programmers work in hex, and Intel give hex machine code on their 8080 reference card, but there are a lot of 8080 users around who prefer to work in octal. To match his front panel, George Morrow has produced an 8080 Octal reference card which gives octal equivalents for the 8080 instruction set, an ASCII-octal table, the 8080 pinout and the S100 bus layout.

For those of you out there who are dedicated octal users, Automation Statham Pty. Ltd., who represent Morrow in Australia, have made available fifty of these cards to be given away to our readers. So, if you send us a stamped self-addressed envelope at least 180mm by 100 mm in size, and if yours is one of the first 50 received, we will send you one of these cards by return, courtesy of Automation Statham. If you get back an empty envelope, tough luck, you weren't one of the first fifty. Just send your SSAE to 'Reference Card', ETI Magazine, 15 Boundary Street, Rushcutters Bay, NSW 2011.

## COMPUTER CLUB DIRECTORY

Sydney: Microcomputer Enthusiasts Group, P.O. Box 3, St. Leonards, 2065. Meets at WIA Hall, 14 Atchison St., St. Leonards on the 1st and 3rd Mondays of the month.

Melbourne: Microcomputer Club of Melbourne, meets at the Model Railways Hall, opposite Glen Iris Railway Station on the third Saturday of the month at 2 p.m.

Canberra: MICSIG, P.O. Box 118, Mawson, ACT 2607 or contact Peter Harris on 72 2237. Meets at Building 9 of CCAE, 2nd Tuesday of month at 7.30 p.m.

Newcastle: contact Peter Moylan, Dept. of Electrical Engineering, University of Newcastle, NSW 2308. (049) 68-5256 (work), (049) 52-3267 (home).

Brisbane: contact Norman Wilson, VK4NP, P.O. Box 81, Albion, Queensland, 4010. Tel. 262 1351.  
New England: New England Computer Club, c/- Union, University of New England, Armidale, NSW 2351. (New club; not restricted to students)  
Auckland: Auckland Computer Club, P.O. Box 27206, Auckland, N.Z.

Computer clubs are an excellent way of meeting people with the same interests and discovering the kind of problems they've encountered in getting systems 'on the air'. In addition, some clubs run hardware and software courses, and may own some equipment for the use of members. Try one - you'll like it!

If your club is not listed here, please drop us a line, and we'll list you. The same applies if you are interested in starting a club in your area. Also, if established clubs know their programme of forthcoming events, we can publicise them.

Get updated . . . keep updated with

# BYTE

the leading magazine in the  
personal computer field



*The personal  
computer  
age is here.*

Join Byte's 110,000 subscribers and catch up on the latest developments in the fast-growing field of microprocessors. Read **BYTE**, The Small Systems Journal that tells you everything you want to know about personal computers, including how to construct and program your own computer (over 30,000 **BYTE** readers have already built, or bought, their own systems and half of these have 8K bytes or more). You'll find our tutorials on hardware and software invaluable reading, also our reports on home applications and evaluative reviews based on experiences with home computer products.

*Home computers  
. . . practical,  
affordable.*

Large scale integration has slashed prices of central processors and other computer components. This has encouraged the development of new, low-cost peripherals resulting in more hardware and software — more applications than you could imagine, more opportunities for you. **BYTE** brings it all to you. Every issue is packed with stimulating and timely articles by professionals, computer scientists and serious amateurs. **BYTE** editorials explore the fun of using and applying computers toward personally interesting problems such as electronic music, video games and control of systems for alarms to private information systems.

Subscribe now to **BYTE** . . . The Small Systems Journal

Please supply me with the following subscriptions

Magazine      1 Year Subscription \*Air Mail

|                           |                                    |                                  |
|---------------------------|------------------------------------|----------------------------------|
| Byte                      | <input type="checkbox"/> 12 Issues | <input type="checkbox"/> \$46.00 |
| Creative Computing        | <input type="checkbox"/> 12 Issues | <input type="checkbox"/> \$46.00 |
| Dr Dobbs                  | <input type="checkbox"/> 10 Issues | <input type="checkbox"/> \$21.00 |
| Interface Age             | <input type="checkbox"/> 12 Issues | <input type="checkbox"/> \$45.00 |
| P.P.C.                    | <input type="checkbox"/> 6 or more | <input type="checkbox"/> \$18.00 |
| Personal Computing        | <input type="checkbox"/> 12 issues | <input type="checkbox"/> \$43.40 |
| ROM                       | <input type="checkbox"/> 12 issues | <input type="checkbox"/> \$46.00 |
| Calculators and Computers | <input type="checkbox"/> 10 issues | <input type="checkbox"/> \$45.00 |

\* Due to constant delays relative to ocean freights, and keeping in mind the fast moving developments in the micro industry we decided to airfreight all magazines to offer you fastest possible service.

Return to **ELECTRONIC CONCEPTS PCY LTD**

55 Clarence Street, Sydney,  
NSW 2000. Phone: 29-3753

CHEQUE    MONEY ORDER ENCLOSED    CHARGE MY BANKCARD

TOTAL REMITTANCE \$ .....

Please send to:

Name .....

Address .....

City ..... State ..... P.C. ....

|                   |
|-------------------|
| <b>BANKCARD</b>   |
| Acc. No. ....     |
| Expiry Date ..... |
| Signature .....   |

**ELECTRONIC CONCEPTS PCY LTD**  
**computer  
land**  
Showroom & Offices  
Ground Floor  
55 Clarence St,  
SYDNEY NSW 2000

# Tandy's TRS-80

Self-contained computer unit is aimed at the first-time user.

AIMED FAIRLY AND SQUARELY at the novice computer user, Tandy's TRS-80 microcomputer has burst forth onto the Australian scene. Designed in the States by Tandy's Radio Shack parent, the TRS-80 is a completely assembled and self-contained microcomputer, based on the Zilog Z-80 microcomputer with 4K bytes of ROM and 4K bytes of dynamic RAM.

The design approach behind the TRS-80 has been to provide a complete, stand-alone system for the non-technical user, and which could be programmed in a simple language (BASIC) with no need to learn about hardware or assembly language. Other design constraints include provision of cassette storage, built in keyboard and video monitor, and, of course, low cost. Several other home computing products have (or will shortly) appeared, based on this philosophy, including the Commodore PET and the F-8-based Videobrain.

The TRS-80 is supplied as a complete package of four separate units. The most important box is the TRS-80 computer itself, which incorporates the keyboard in a moulded plastic case only slightly larger than most keyboard cases. Inside there are two boards, (one is the keyboard) connected by a fragile-looking ribbon cable. The main board carries power supply circuitry (AC power comes from a separately-boxed transformer), the Z-80 CPU, 8 x 4K dynamic RAMs (in sockets), two socketed ROMs containing Level 1 BASIC, VDU circuitry with its own five 2102's, and a cassette interface. Also mounted at the rear of the board are various connectors to other units, including a bus expansion connector, and power and reset switches.

As mentioned above, the second box is the mains transformer for the computer — the unit supplied is manufactured in Australia and meets Australian standards. The video monitor is a separate unit — it appears to be a stripped-down (or rather, not-fully-assembled) mains/portable TV — and the cassette recorder is a standard Realistic model.

All this is yours for \$799. When it first arrives you unpack it all and stand the units on a table — now you are ready to begin. You plug the power supply into the back of the computer, the TV monitor into the back of the computer

and the cassette recorder cable into the cassette recorder and into the back of the computer. Now the three mains cables connect into the wall outlet, the blanking plug connects into the mic. input, the thigh bones connected to de knee bone, now hear de word of de . . . Sorry, got carried away with all these connections!

Apply power, and lo and behold! It says READY on the screen. The first thing most users will do at this stage is

look up how the CLOAD command works so they can load the supplied cassette into the computer and play a game of Blackjack. This soon becomes less exciting, however, so a frantic scuffle amongst the discarded packing reveals the owner's manual. This book is written in a friendly, humorous style which will drive some readers up the wall — especially those with previous BASIC experience, who will find the 'plot development' excruciatingly slow.

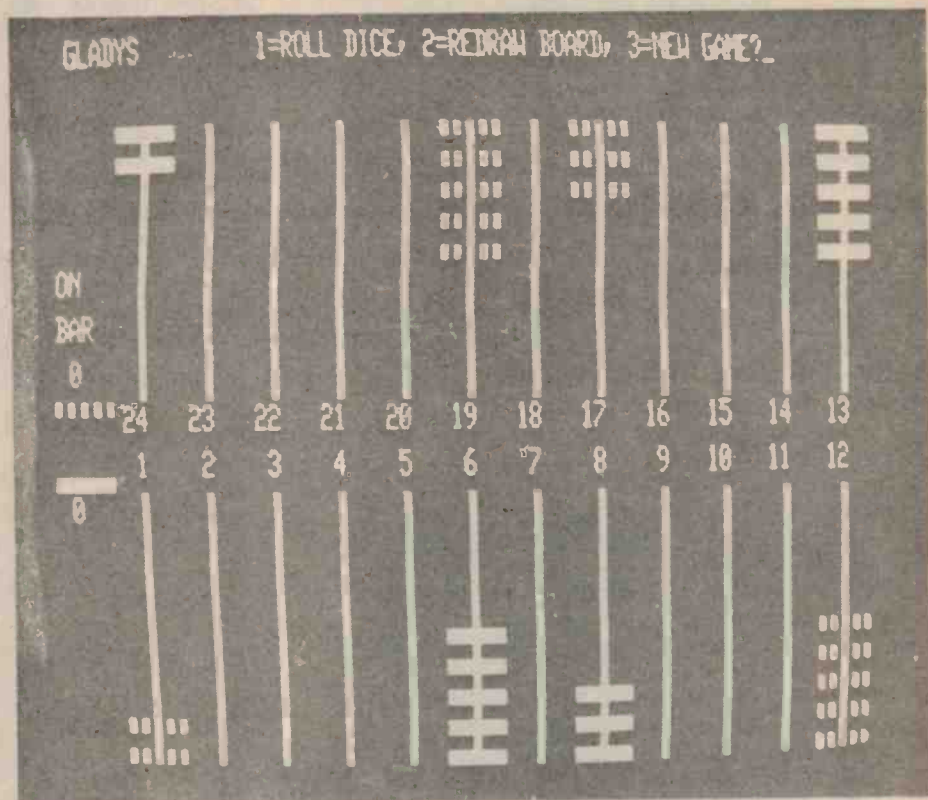

Here's the TRS-80 version of Backgammon.

WITH A BIT OF  
PLAYING ABOUT, WE  
DISCOVERED THESE BIG  
LETTERS, ABOUT TWICE  
REGULAR SIZE.

Wonder where these big letters came from?

# Tandy's TRS-80

Complete neophytes, especially kids, will probably love it; for maximum enjoyment it should probably be read at a local franchised hamburger chain whilst sipping a milk shake.

The manual does however have the redeeming feature of covering the operation of the computer and its BASIC dialect thoroughly, with particular attention paid to graphics operation.

The keyboard itself is fairly typical of those used with hobby-type micros and is of reasonable quality and operation. The construction of the unit is rather frustrating for hardware-oriented enthusiasts, however. There is no room for expansion or modification inside the case — in fact one is hesitant to even open the case, due to that fragile-looking ribbon cable with no connector. There are no I/O ports on the board, which rules out simple add-ons, such as switching devices on and off, hooking up a speaker and other popular experiments.

There is a connector at the back which brings out the address, data and control lines, as well as the keyboard lines, thus facilitating system expansion by an add-on box, or an S100 adapter (soon to be available). The keyboard interface is not implemented with a PIA-type chip as might be expected, but with ordinary buffers and latches, a cheaper, but less

versatile, system.

There are some other bits of hardware in the pipeline, including a floppy desk, printer, and a memory expansion box.

The monitor displays 16 lines of 64 characters, or 128 by 48 dot graphics, on a 30 cm screen. The display is upper case only, but a bit of messing around revealed that double-sized characters can be displayed.

## Expansion

The first expansion of a TRS-80 that is possible is the replacement of the 4K RAM chips with 16K chips (no kidding, it's that easy) and replacement of the 4K ROM, with the Level II BASIC kit contained in 12K ROM \$159.95 — see "LEVEL II"). We have advanced details on a variety of other add-ons as well.

The key to further expansion is the "Expansion interface" unit, which comes in its own TRS-80 style plastic box designed to sit under the monitor. This unit enables you to add more additional RAM (16 or 32K), dual cassettes, four mini floppy disks and a line printer. It includes a clock, and space for an extra PCB. And guess what, it has a separate power supply, but it has a slot in the

back in which to place the power supply, and also the original TRS-80 power supply. The interface requires BASIC Level II.

The Mini Disk unit stores up to 96K bytes, comes with operating system, and gives you an access time for any single byte of less than half a second.

Two printers are to be available. The "Line Printer" is a modified Centronics dot matrix impact printer capable of up to 110 characters per second and 80 or 132 characters per line. Level II and the interface box are required. On the other hand a "Screen Printer" can be obtained for \$899.95, which according to Tandy's literature will at the touch of a button reproduce your screen (including graphics) on 5½" electrostatic paper at a rate of 2,200 characters per second!

## Software

As a home computer system, the TRS-80 is probably the least hardware oriented. There are two points which support this thinking: you can't get at the internal hardware without voiding the warranty and there is no hardware interface capability other than to the display and the cassette recorder.

So how would you go about evaluating a relatively complex product like this? Probably in the same way as you'd evaluate another type of product which enjoys a high profile at Tandy Stores: a home stereo system.

In choosing a computer system, the potential customer will be influenced by what he sees (i.e.: packaging) and by what he can be led to believe about it (by advertising, by friends, by using the system, and even by reading electronics magazines). That customer's attention will be focused on the keyboard and display not on the internals. It won't matter to him that a Z-80 incorporates efficient machine language instructions for data searching and moving or that it's a microprocessor that can run at a 4 MHz clock rate. He will be more interested in what it can do as opposed to how it does it (he's buying capability, fun and perhaps even status, not speed).

## What You Get On The Soft Side

The TRS-80 comes with "Radio Shack Level I BASIC" in 4K ROM; Level I claims to support "standard BASIC statements". But whose standard? It seems to be Radio Shack's since some important capabilities are missing (for example: exponentiation and array dimensioning). All calculations are performed in floating point with 5 or 6



The four units which make up the complete TRS-80 microcomputer.



decimal place accuracy. Twenty-six numeric variables are available (A to Z) along with one numeric array variable. Two 16-character string variables can also be used. Actually, these are more properly called "string things", since they cannot be compared, manipulated, indexed or used in any but the most mundane ways. You can input and output using them, but that's all folks.

Cassettes can be used to handle programs (CSAVE and CLOAD commands) or data (PRINT # and INPUT # statements). Since whatever you have in memory will be wiped out if you cut off the power (intentionally or otherwise), having a cassette recorder to store your information permanently is invaluable. And it makes entering of other people's programs (such as the Backgammon and Blackjack games supplied by Radio Shack) especially convenient.

Speaking of which, the Backgammon game makes extensive use of the TRS-80's rather limited graphics capability: there are virtually no special graphics characters — you've got to construct whatever image you have in mind by turning on some points on the display (48 points vertically by 128 points horizontal). This can be tedious. Mind you, in the low cost home computer system field this is not unusual. To compensate you can write subprograms which draw vertical and horizontal lines, draw patterns, fill them in, etc.

### Programming

Immediately after powering up your display and keyboard, you can:

- 1 do simple calculator type computations (immediate execution)
- 2 bring in a program from tape
- 3 type NEW and enter a program

Program statements are preceded by line numbers to distinguish them from immediate execution statements, and keep them in order. A LIST command is available to display the program. Unfortunately the cursor control keys cannot be used to edit this display, so if you want to change a line in a program, you must retype the entire line.

Output which would otherwise stream by while your program is executing can be frozen by depressing any key. Unfortunately, if you interrupt the program itself, you cannot modify the variables it is using and then return to the point of interruption. So your only alternative is to rerun the program and in many cases, that's a nuisance.

As for error messages, they are confined to: WHAT? HOW? or SORRY (along with an indication of where the problem is). These terse messages are not unexpected when you consider that the interpreter was written to fit into 4K of ROM. In a tradeoff of readability against the amount of program code you can fit into the standard 4K of RAM, Level I has a "shorthand dialect". For example: G.= GO TO, N.= NEXT, and P.= PRINT. However, REA. seems to be a shorthand of dubious value for READ (probably done for consistency).

The overriding philosophy controlling the design of this interpreter seems to have been "make it fit". It's hard to believe that a 4K interpreter is anything but "stripped down" after you've used this one. Radio Shack has dropped a few hints about releasing a Level II BASIC. Until then it is unfair to compare this software package with, say, the 14K monitor/interpreter that comes in Commodore's PET. They're just not in the same leagues.

At the same time, it is somewhat unrealistic (no pun intended) for Radio Shack to claim, as they have in their sales literature, that "applications of the TRS-80 are limited only by the imagination and ability to write programs". Try something quite unimaginative like sorting a list of names. Good luck! You'll need it.

### Level II

Sketchy details are available on Level II BASIC, an interpreter written by Microsoft. From the list of statements and functions to be available, it appears that this version of BASIC is at least as powerful as PET's including many editing features. In fact we would go so far as to say that Level II is the most significant upgrade for the TRS-80. We wonder how logical it is to sell a home computer with such a limited BASIC and then offer the upgrade as an option. Will this turn people off computing, or will most of them jump for BASIC II anyway?

For the average (?) reader of this magazine, who has fairly sophisticated applications in mind for his personal computer, and who is likely to dabble in hardware, the TRS-80 is not the best way to go. For the complete novice, for schools, for people with limited requirements, it offers reasonable value for money. The possibility of expansion of the basic system to 16K Level II BASIC and 16K of RAM simply by replacement of a few IC's is a tempting one, and will appeal to many of our readers. Perhaps the clincher will be the forthcoming \$100 expander board which will allow connection of all kinds of peripherals. With these additions, the TRS-80 looks like being a very powerful and compact computer indeed. Until then . . .



The actual computer, shown here, also incorporates a 53-key keyboard and VDU.

**DIODES/ZENERS**

|         |       |      |     |
|---------|-------|------|-----|
| 1N914   | 100v  | 10mA | .05 |
| 1N4005  | 600v  | 1A   | .08 |
| 1N4007  | 1000v | 1A   | .15 |
| 1N4148  | 75v   | 10mA | .05 |
| 1N753A  | 6.2v  | z    | .25 |
| 1N758A  | 10v   | z    | .25 |
| 1N759A  | 12v   | z    | .25 |
| 1N4733  | 5.1v  | z    | .25 |
| 1N5243  | 13v   | z    | .25 |
| 1N5244B | 14v   | z    | .25 |
| 1N5245B | 15v   | z    | .25 |

**SOCKETS/BRIDGES**

|               |     |              |    |      |
|---------------|-----|--------------|----|------|
| 8-pin         | pcb | .25          | ww | .45  |
| 14-pin        | pcb | .25          | ww | .40  |
| 16-pin        | pcb | .25          | ww | .40  |
| 18-pin        | pcb | .25          | ww | .75  |
| 22-pin        | pcb | .45          | ww | 1.25 |
| 24-pin        | pcb | .35          | ww | 1.10 |
| 28-pin        | pcb | .35          | ww | 1.45 |
| 40-pin        | pcb | .50          | ww | 1.25 |
| Molex pins    | .01 | To-3 Sockets |    | .45  |
| 2 Amp Bridge  |     | 100-prv      |    | 1.20 |
| 25 Amp Bridge |     | 200-prv      |    | 1.95 |

**TRANSISTORS, LEDS, etc.**

|                               |                           |      |
|-------------------------------|---------------------------|------|
| 2N2222A                       | NPN (2N2222 Plastic .10)  | .15  |
| 2N2907A                       | PNP                       | .15  |
| 2N3906                        | PNP (Plastic)             | .10  |
| 2N3904                        | NPN (Plastic)             | .10  |
| 2N3054                        | NPN                       | .35  |
| 2N3055                        | NPN 15A 60v               | .50  |
| T1P125                        | PNP Darlington            | .35  |
| LED Green, Red, Clear, Yellow |                           | .15  |
| D.L.747                       | 7 seg 5/8" High com-anode | 1.95 |
| XAN72                         | 7 seg com-anode (Red)     | 1.25 |
| MAN71                         | 7 seg com-anode (Red)     | 1.25 |
| MAN3610                       | 7 seg com-anode (Orange)  | 1.25 |
| MAN82A                        | 7 seg com-anode (Yellow)  | 1.25 |
| MAN74A                        | 7 seg com-cathode (Red)   | 1.50 |
| FND359                        | 7 seg com-cathode (Red)   | 1.25 |

**C MOS**

|         |       |
|---------|-------|
| 4000    | .15   |
| 4001    | .15   |
| 4002    | .20   |
| 4004    | 3.95  |
| 4006    | .95   |
| 4007    | .35   |
| 4008    | .95   |
| 4009    | .45   |
| 4010    | .45   |
| 4011    | .20   |
| 4012    | .20   |
| 4013    | .40   |
| 4014    | .95   |
| 4015    | .90   |
| 4016    | .35   |
| 4017    | 1.10  |
| 4018    | 1.10  |
| 4019    | .50   |
| 4020    | .85   |
| 4021    | 1.00  |
| 4022    | .85   |
| 4023    | .25   |
| 4024    | .75   |
| 4025    | .30   |
| 4026    | 1.95  |
| 4027    | .50   |
| 4028    | .95   |
| 4030    | .35   |
| 4033    | 1.50  |
| 4034    | 2.45  |
| 4035    | 1.25  |
| 4040    | 1.35  |
| 4041    | .69   |
| 4042    | .95   |
| 4043    | .95   |
| 4044    | .95   |
| 4046    | 1.75  |
| 4049    | .45   |
| 4050    | .45   |
| 4066    | .95   |
| 4069    | .40   |
| 4071    | .35   |
| 4081    | .70   |
| 4082    | .45   |
| MC14409 | 14.50 |
| MC14419 | 4.85  |

|      |      |
|------|------|
| 7400 | .15  |
| 7401 | .15  |
| 7402 | .20  |
| 7403 | .20  |
| 7404 | .15  |
| 7405 | .25  |
| 7406 | .35  |
| 7407 | .55  |
| 7408 | .25  |
| 7409 | .15  |
| 7410 | .10  |
| 7411 | .25  |
| 7412 | .30  |
| 7413 | .35  |
| 7414 | 1.10 |
| 7416 | .25  |
| 7417 | .40  |
| 7420 | .15  |
| 7426 | .30  |
| 7427 | .45  |
| 7430 | .15  |
| 7432 | .30  |
| 7437 | .30  |
| 7438 | .35  |
| 7440 | .25  |
| 7441 | 1.15 |
| 7442 | .45  |
| 7443 | .65  |
| 7444 | .45  |
| 7445 | .65  |
| 7446 | .95  |
| 7447 | .95  |
| 7448 | .65  |
| 7450 | .25  |
| 7451 | .25  |
| 7453 | .20  |
| 7454 | .25  |
| 7460 | .40  |
| 7470 | .45  |
| 7472 | .40  |

|       |      |
|-------|------|
| 7473  | .25  |
| 7474  | .30  |
| 7475  | .35  |
| 7476  | .40  |
| 7480  | .55  |
| 7481  | .75  |
| 7483  | .95  |
| 7485  | .75  |
| 7486  | .25  |
| 7489  | 1.35 |
| 7490  | .55  |
| 7491  | .95  |
| 7492  | .95  |
| 7493  | .35  |
| 7494  | .75  |
| 7495  | .60  |
| 7496  | .80  |
| 74100 | 1.15 |
| 74107 | .35  |
| 74121 | .35  |
| 74122 | .55  |
| 74123 | .55  |
| 74125 | .45  |
| 74126 | .35  |
| 74132 | 1.35 |
| 74141 | .90  |
| 74150 | .85  |
| 74151 | .65  |
| 74153 | .75  |
| 74154 | .95  |
| 74156 | .95  |
| 74157 | .65  |
| 74161 | .85  |
| 74163 | .85  |
| 74164 | .60  |
| 74165 | 1.50 |
| 74166 | 1.35 |
| 74175 | .80  |

**- T T L -**

|        |      |
|--------|------|
| 74176  | 1.25 |
| 74180  | .75  |
| 74181  | 2.25 |
| 74182  | .95  |
| 74190  | 1.75 |
| 74191  | 1.05 |
| 74192  | .75  |
| 74193  | .85  |
| 74194  | 1.25 |
| 74195  | .95  |
| 74196  | 1.25 |
| 74197  | 1.25 |
| 74198  | 2.35 |
| 74221  | 1.00 |
| 74367  | .85  |
| 75108A | .35  |
| 75110  | .35  |
| 75491  | .50  |
| 75492  | .50  |
| 74H00  | .15  |
| 74H01  | .25  |
| 74H04  | .20  |
| 74H05  | .20  |
| 74H08  | .35  |
| 74H10  | .35  |
| 74H11  | .35  |
| 74H15  | .45  |
| 74H20  | .30  |
| 74H21  | .25  |
| 74H22  | .40  |
| 74H30  | .20  |
| 74H40  | .25  |
| 74H50  | .25  |
| 74H51  | .25  |
| 74H52  | .15  |
| 74H53J | .25  |
| 74H55  | .20  |

|        |      |
|--------|------|
| 74H72  | .45  |
| 74H101 | .75  |
| 74H103 | .75  |
| 74H106 | .95  |
| 74L00  | .25  |
| 74L02  | .25  |
| 74L03  | .30  |
| 74L04  | .30  |
| 74L10  | .30  |
| 74L20  | .35  |
| 74L30  | .45  |
| 74L47  | 1.95 |
| 74L51  | .45  |
| 74L55  | .65  |
| 74L72  | .45  |
| 74L73  | .40  |
| 74L74  | .45  |
| 74L75  | .55  |
| 74L93  | .55  |
| 74L123 | .85  |
| 74S00  | .35  |
| 74S02  | .35  |
| 74S03  | .30  |
| 74S04  | .30  |
| 74S05  | .35  |
| 74S08  | .35  |
| 74S10  | .35  |
| 74S11  | .35  |
| 74S20  | .35  |
| 74S40  | .20  |
| 74S50  | .20  |
| 74S51  | .25  |
| 74S64  | .20  |
| 74S74  | .35  |
| 74S112 | .60  |
| 74S114 | .65  |

|               |      |
|---------------|------|
| 74S133        | .40  |
| 74S140        | .55  |
| 74S151        | .30  |
| 74S153        | .35  |
| 74S157        | .75  |
| 74S158        | .30  |
| 74S194        | 1.05 |
| 74S257 (8123) | 1.05 |
| 74LS00        | .25  |
| 74LS01        | .35  |
| 74LS02        | .35  |
| 74LS04        | .30  |
| 74LS05        | .45  |
| 74LS08        | .25  |
| 74LS09        | .35  |
| 74LS10        | .35  |
| 74LS11        | .35  |
| 74LS20        | .25  |
| 74LS21        | .25  |
| 74LS22        | .25  |
| 74LS32        | .40  |
| 74LS37        | .35  |
| 74LS40        | .45  |
| 74LS42        | 1.10 |
| 74LS51        | .50  |
| 74LS74        | .65  |
| 74LS86        | .65  |
| 74LS90        | .95  |
| 74LS93        | .95  |
| 74LS107       | .85  |
| 74LS123       | 1.00 |
| 74LS151       | .95  |
| 74LS153       | 1.20 |
| 74LS157       | .85  |
| 74LS164       | 1.90 |
| 74LS367       | .75  |
| 74LS368       | .75  |
| 74C04         | .25  |
| 74C151        | 2.25 |

|                 |      |
|-----------------|------|
| MCT2            | .95  |
| 8038            | 3.95 |
| LM201           | .75  |
| LM301           | .45  |
| LM308 (Mini)    | .95  |
| LM309H          | .65  |
| LM309K (340K-5) | .85  |
| LM310           | 1.15 |
| LM311D (Mini)   | .75  |
| LM318 (Mini)    | .95  |
| LM320K5(7905)   | 1.65 |
| LM320K12        | 1.65 |

**LINEARS, REGULATORS, etc.**

|                  |      |
|------------------|------|
| LM320T5          | 1.65 |
| LM320T12         | 1.65 |
| LM320T15         | 1.65 |
| LM324N           | .95  |
| LM339            | .95  |
| 7805 (340T5)     | .95  |
| LM340T12         | 1.00 |
| LM340T15         | 1.00 |
| LM340T18         | 1.00 |
| LM340T24         | .95  |
| LM340K12         | 1.65 |
| LM340K15         | 1.25 |
| LM340K18         | 1.25 |
| LM340K24         | .95  |
| 78L05            | .75  |
| 78L12            | .75  |
| 78L15            | .75  |
| 78M05            | .75  |
| LM373            | 2.95 |
| LM380 (8-14 PIN) | .95  |
| LM709 (8,14 PIN) | .25  |
| LM711            | .45  |

|              |      |
|--------------|------|
| LM723        | .50  |
| LM725N       | 2.50 |
| LM739        | 1.50 |
| LM741 (8-14) | .25  |
| LM747        | 1.10 |
| LM1307       | 1.25 |
| LM1458       | .95  |
| LM3900       | .50  |
| LM75451      | .65  |
| NE555        | .50  |
| NE556        | .95  |
| NE565        | .95  |
| NE566        | 1.75 |
| NE567        | 1.35 |

**9000 SERIES**

|      |     |       |      |
|------|-----|-------|------|
| 9301 | .85 | 95H03 | 1.10 |
| 9309 | .35 | 9601  | .45  |
| 9322 | .75 | 9602  | .45  |

**MICRO'S, RAMS, CPU'S, ETC.**

|               |       |
|---------------|-------|
| 74S188        | 3.00  |
| 1702A         | 4.50  |
| MM5314        | 3.00  |
| MM5316        | 3.50  |
| 2102-1        | 1.45  |
| 2102L-1       | 1.75  |
| TR1602B       | 4.50  |
| TMS 4044-45NL | 14.50 |
| 8080AD        | 12.00 |
| 8T13          | 1.50  |
| 8T23          | 1.50  |
| 8T24          | 2.00  |
| 8T97          | 1.00  |
| 2107B-4, A    | 4.00  |
| 2708          | 11.50 |

**INTEGRATED CIRCUITS UNLIMITED**

7889 Clairemont Mesa Blvd., San Diego, CA 92111 U.S.A.  
No Minimum

All prices in U.S. dollars. Please add postage to cover method of shipping. Orders over \$100 (U.S.) will be shipped air no charge. Payment should be submitted with order in U.S. dollars. All IC's Prime/Guaranteed. All orders shipped same day received.

**SPECIAL DISCOUNTS**

| Total Order    | Deduct |
|----------------|--------|
| \$35 - \$99    | 5%     |
| \$100 - \$300  | 10%    |
| \$301 - \$1000 | 15%    |
| \$1000 - Up    | 20%    |

Phone (714) 278-4394

BarclayCard / Access / American Express / BankAmericard / Visa / MasterCard

End noise and cross-talk with our exclusive  
**Noiseguard™ system**

# The WunderBuss™

*A product of Morrow's Micro-Stuff for*

|                 |                                                                                                                                              |
|-----------------|----------------------------------------------------------------------------------------------------------------------------------------------|
| Capacity        | 20 positions for edge connectors                                                                                                             |
| Edge Connectors | S-100 type, 25 spacing<br>Available from Thinker Toys or Masterte                                                                            |
| Shielding       | Every signal fully shielded by both interconnected ground lines                                                                              |
| Termination     | Active termination of each line. Termination network includes LM201 op amp, 2N3904, 2N3906, TIP29 and TIP40 transistors, 2.4 volts, 180 ohms |

**COMPUTER BITS** A DIVISION OF AUTOMATION  
 STATHAM PTY. LTD.  
 47 Birch Street, BANKSTOWN N.S.W. 2200 Phone (02) 709-4144 Telex AA26770

## IMPACT PRESENTS

# T-9900-SS SINGLE-BOARD STAND-ALONE MICROCOMPUTER

### A DUAL-PURPOSE BOARD

The TechnicoT-9900-SS is a masterpiece of design. It is dual purpose: it can operate on its own as a self-contained complete microcomputer, needing only a power supply and a terminal; or it can be interfaced to a complete range of other boards and peripherals, and function as the CPU of a powerful minicomputer system.

Thus this board can be used as a Starter System, an initial stand-alone microcomputer with which a person can learn about microcomputers and programming without spending a fortune. But — unlike some other "beginner's kits" on the market — you never reach the point where you outgrow it and discard it. You just add to it as you want to, without sacrificing a cent of your initial investment. It costs more than the cheaper itty-bitty introductory kits. But then, it gives you 16 bits to work with right from the start, and you will still be using it next year, and for many years after that.

### DESIGN FEATURES

- The T-9900-SS can provide minicomputer performance because its heart is the Texas Instruments TMS9900 microprocessor that was designed to be the CPU of a data-processing system, not to be just a controller or logic replacement device like the 8-bit chips. The TMS9900 looks more like an IBM 360 than it does an 8080 or Z80 or 6800 or 6502. Yet the T-9900-SS costs approximately the same as or only marginally more than systems with equivalent RAM, EPROM, and Monitor that utilize these 8-bit microprocessors.
- The T-9900-SS is fully socketed and fully buffered, and provides hardware multiply and divide, 16 accumulators, 15 index registers, separate 16-bit data and address lines, 8 vectored interrupts, a parallel and serial RS232 and 20 milli-amp current loop. Under the software control of the Monitor, the T-9900-SS automatically adjusts to the baud rate (up to 9600 baud) of the interfaced peripheral.
- The T-9900-SS is NOT S100 bus, but uses the much more flexible and more efficient universal bus system, with ten 16-pin IC sockets along one side of the board for interface plugs: connection to other boards and peripherals is made using 16-conductor cable and 16-pin dual-in-line connectors. Since no backplane or motherboard is needed, a chassis is not required (though one is available) — the unique modular design of the system allows it to operate inside a chassis or without one.
- The ten sockets provide connection for CRU OUT, CRU IN, Ground, Address, Power, Control 1, Control 2, Interrupt, Data, and RS232/TTY. The board provides for connection of either RS232 or 20ma current loop terminals.
- The board has a 1-chip clock (TMS9904) which will operate up to 3.3 MHz.
- One of the most valuable — and unique — features of the board is that it contains an EPROM Programmer for 2708s. These are programmed on the board under the control of the Monitor.
- The T-9900-SS can directly access 64K bytes of memory, and up to 16 megabytes of memory via memory mapping.
- The board can be supplied either as an unassembled kit, or assembled and tested.

We invite you to send for further details to:

**I.M.P.A.C.T. LTD.,**

P.O. Box 177, Petersham, NSW. 2049. (560-7603 AH)

THE WORLD HAS BEGUN TO DISCOVER  
 THE T-9900-SS. HAVE YOU?

Please send me full details and prices for the T-9900-SS. 8

NAME .....

ADDRESS .....

STATE .....

POSTCODE .....

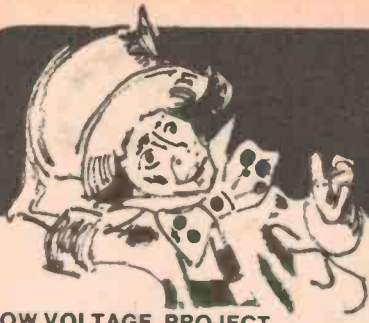

We're gathering nuts in May and have nutty specials just for you!

**LOW VOLTAGE PROJECT TRANSFORMERS**



**XF20**  
200mA, 9-6-0-6-9v DC Mtg.  
holes 54mm, W 35mm, H40mm  
Nuttymay Price - \$4.95

**XF25**  
1.12amp 0-10-20v + 0-10-20v  
RMS Mtg. holes 84mm, W 58mm,  
H80mm

May only \$9.99

**PUSH BUTTON SWITCHES**



All 15 mm spacing between knob centres with standard round push buttons.

- T36 (matches T422)** Mains switch, double pole, push on/push off **\$1.23**
- T357** Mains switch, plus 6 pole push/push change-over module. 2 buttons **\$1.88**
- T358** Mains switch plus 2 only 6 pole change-over interlocked modules. 3 buttons **\$2.48**
- T359** Mains switch plus 3 only 6 pole change-over interlocked modules. 4 buttons **\$3.02**
- T422** This is the one you've asked for. 4 push buttons, each interlocking (one bank on at a time) with DPDT switchbank. Centres spaced at 17.5 mm. As used in ET1422 Amp. **\$3.95**

**Attention** — The above switches come standard with Red or Black round knobs. Spun alum. knobs Alum 1 supplied instead for additional 15c each, or separate 25c each. Also available Alum 2, Black with alum. end, same price as above.

**NOTE** We can make up specials in minimum lots of 10 per order.

**DAVRED TOP 20 REPLACEMENT STYLII AT A NUTTY MAY PRICE.**

- Double Sapphire**
- Two styli for the price of one
- BSR ST3, ST10, ST15, ST16b **\$1.20**
- Sonotone 9TAHCb, KS41b **\$1.20**
- Phillips 3306b **\$1.20**
- Single Diamond**
- BSR TC8S **\$2.00**
- Ronette BF40 **\$2.00**
- Sapphire Diamond**
- Sonotone KS40A, KS41B **\$2.50**
- Double Diamond**
- BSR TS2, ST10a, ST15a, ST17a **\$2.50**
- Sonotone 9TAHCA, KS541Ca **\$2.50**
- Phillips 3306a **\$2.50**
- Piezo Diamond Y995 **\$5.00**
- ADC K8 Magnetic **\$10.50**

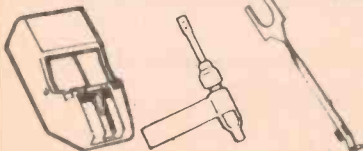

**ZENER DIODES**

| Type          | Volts | Price | Type    | Volts | Price |
|---------------|-------|-------|---------|-------|-------|
| <b>5 Watt</b> |       |       |         |       |       |
| BZX61/C15     | —     | .65   | IS3006A | 6.1   | .65   |
| BZX83C-3V0    | 3     | .30   | IS3007A | 6.8   | .65   |
| BZX83C-3V3    | 3.3   | .30   | IS3008A | 8.2   | .65   |
| BZX83C-3V9    | 3.9   | .30   | IS3009A | 9.1   | .65   |
| BZX83C-4V7    | 4.7   | .30   | IS3010A | 10    | .65   |
| BZX83C-5V1    | 5.1   | .30   | IS3012A | 12    | .65   |
| BZX83C-5V6    | 5.6   | .30   | IS3015A | 15    | .65   |
| BZX83C-6V2    | 6.2   | .30   | IS3016A | 16    | .65   |
| BZX83C-6V8    | 6.8   | .30   | IS3020A | 20    | .65   |
| BZX83C-7V5    | 7.5   | .30   | IS3024A | 24    | .65   |
| BZX83C-8V2    | 8.2   | .30   | IS3027A | 27    | .65   |
| BZX83C-9V1    | 9.1   | .30   | IS3030A | 30    | .65   |
| BZX83C-10     | 10    | .30   | IS3033A | 33    | .65   |
| BZX83C-12     | 12    | .30   | IS3036A | 36    | .65   |
| BZX83C-13     | 13    | .30   | IS3039A | 39    | .65   |
| BZX83C-15     | 15    | .30   | IS3047A | 47    | .65   |
| BZX83C-16     | 16    | .30   | IS3051A | 51    | .65   |
| BZX83C-18     | 18    | .30   | IS3056A | 56    | .65   |
| BZX83C-20     | 20    | .30   | IS3062A | 62    | .65   |
| BZX83C-22     | 22    | .30   | IS3068A | 68    | .65   |
| BZX83C-24     | 24    | .30   | IS3075A | 75    | .65   |
| BZX83C-27     | 27    | .30   | IS3100A | 100   | .65   |
| BZX83C-30     | 30    | .30   | IS3150A | 150   | .65   |
| BZX83C-33     | 33    | .30   | IS3180A | 180   | .65   |
| BZX83C-47     | 47    | .30   | IS3200A | 200   | .65   |

**ADDITIONAL POSTAL CHARGES**

| Mail Order Instructions                             | Order Value   | Charge |
|-----------------------------------------------------|---------------|--------|
| Minimum P+P \$1.00                                  | \$5-\$9.99    | Nil    |
| Orders over \$9.99                                  | \$10-\$24.99  | \$0.50 |
| must include additional postal charges (see right). | \$25-\$49.99  | \$1.50 |
|                                                     | \$50-\$99.99  | \$2.50 |
|                                                     | \$100 or more | \$4.00 |

**UPGRADE YOUR TV RECEPTION**

A Hills TL2 is ideal for Metropolitan areas. Look at this mighty May price. **\$31.40** usually \$39.27

**FRINGE AREAS CHECK OUT HILL TL3**

normally \$49.75 **May price \$41.75**

Plus we have all the accessories that you can also save \$55 on now.

**"STORE IT SAFELY" Boxes from a match box size to a large amp case.**

- PB1** Little Black Box with lid. 40mm x 29mm x 15mm — **18 cents**
- PB2** Plastic box suitable for all mini projects. Aluminium base. Size 100mm x 60mm x 27mm — **\$1.50**
- PB4** Larger version. Tan plastic with aluminium base. 110mm x 184mm x 42mm — **\$1.75**

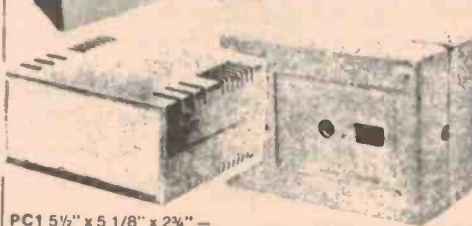

PC1 5 1/2" x 5 1/8" x 2 3/4" — \$4.55

PC2 3 1/2" x 2 1/2" x 1" — \$1.25



**A BEAUTY FOR THE MOTORIST**

K300 12 volt Electric Aerial. 5 sections, 1 metre, complete with Installation list. **Be quick \$19.95** Normally \$25.90

**HEY! GIVE YOURSELF A BOOST. KEEP YOUR BATTERY CHARGED UP WITH A CHARGER 4.**

What a winner for the car, caravan, motorbike or power boat. This charger has a large scale ammeter for monitoring charging rate plus plug selection for 4 or 6 volts.



**TRUE MAY MADNESS. ONLY \$27.50**



**SPEAKER ENCLOSURES FOR THE BUDGET CONSCIOUS**

WOW DA3 speaker enclosures suitable for Kit 50C would normally cost \$130 per pair. **NUTTY MAY ONLY \$115 per pair**



**SPECIAL KIT 50C STEREO AMPLIFIER**

This is a complete 30 watt + 30 watt amplifier using hybrid/modules and including transformer. At this price they'll be coming to take Des away. **Hey Hey MAY ONLY \$99.50**

**LOOK! A NEW SHIPMENT of LU-010 Quartz Car Clocks**

The latest in 4 digital quartz controlled car clocks. Operates off 12V DC supply. Extremely accurate. **Note still at the old price \$19.95**

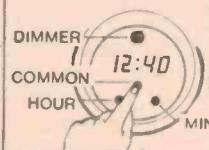

**CUSTOMERS — FOR PROMPT AND EFFICIENT SERVICE CALL INTO OUR CONVENIENT SYDNEY SHOWROOM OR MAIL YOUR ORDER WITH REMITTANCE TO OUR SUPER MAIL ORDER DEPARTMENT. THESE SPECIALS UNTIL 16.6.78.**

**Davred Electronics Pty Ltd.**  
The new breed in electronics service

104-106 KING ST, NEWTOWN, SYDNEY AUSTRALIA. P.O. BOX 317, NEWTOWN NSW 2042. TELEPHONE 516-3544

# CROSSHATCH GENERATOR

New oscillator scheme allows simplified set-up procedure.

THE COLOUR television picture is created in the receiver picture tube by three separate electron guns - one each for red, green and blue. As these guns cannot be in the same physical position they need to be converged into one spot on the screen.

The process of converging at the centre of the screen is called static convergence and is performed by magnets on the yoke assembly.

However, the screen of the picture tube is not everywhere coincident with the deflection plane and this causes errors when the beam is deflected away from centre. These deflection errors are corrected electronically by 12 or more controls and the process is known as dynamic convergence.

An important part of the process is the use of a crosshatch generator to provide horizontal and vertical lines on the screen. Using the generator, the convergence errors are immediately apparent and the controls on the set are usually labelled with the effect each has on a crosshatch pattern.

In addition to setting up convergence the generator pattern may also be used to set up horizontal and vertical linearity and to orientate the deflection yoke coils on both black and white and colour sets.

Most of the inexpensive pattern generators, which are currently available, produce a video waveform, which must be injected into the correct place in the TV, and require a synchronizing signal from the TV set. Such generators are thus fiddly things to use.

*Text continued on page 72.*

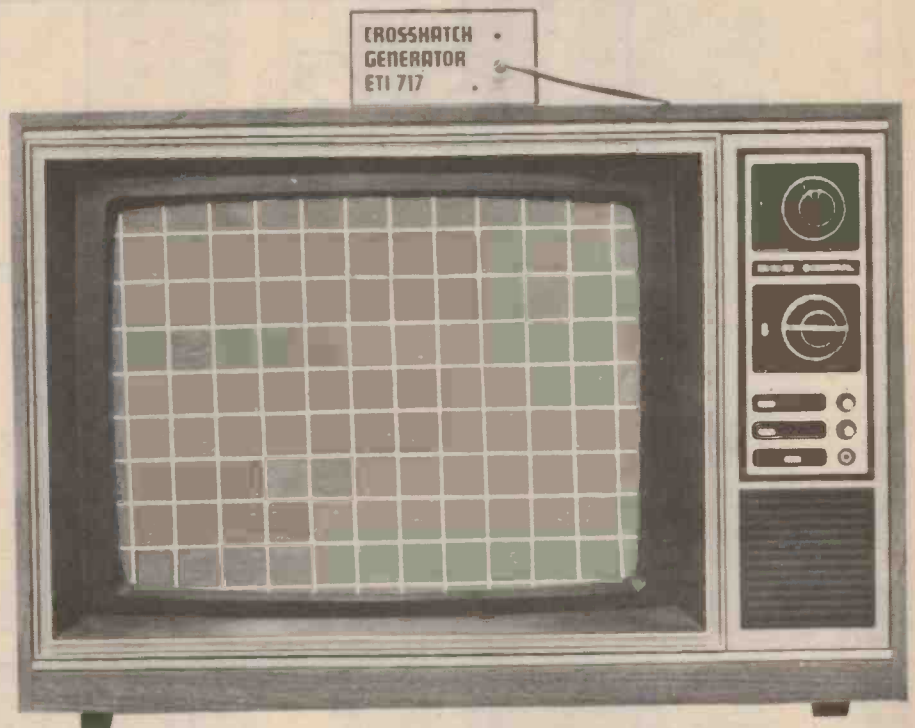

*The new ETI 717 crosshatch generator replaces the earlier ETI 704 and is considerably easier to set up.*

## SPECIFICATION - ETI 717

|                                  |                 |
|----------------------------------|-----------------|
| Line spacing                     |                 |
| Horizontal                       | every 16 lines  |
| Vertical                         | every 4 $\mu$ s |
| Number of Lines normally visible |                 |
| Horizontal                       | 9               |
| Vertical                         | 12              |
| Output impedance                 | 75ohm           |
| Power consumption                | 16mA @ 9V       |
| Battery life (Type 216)          | 10-12 hours     |

# CROSSHATCH GENERATOR

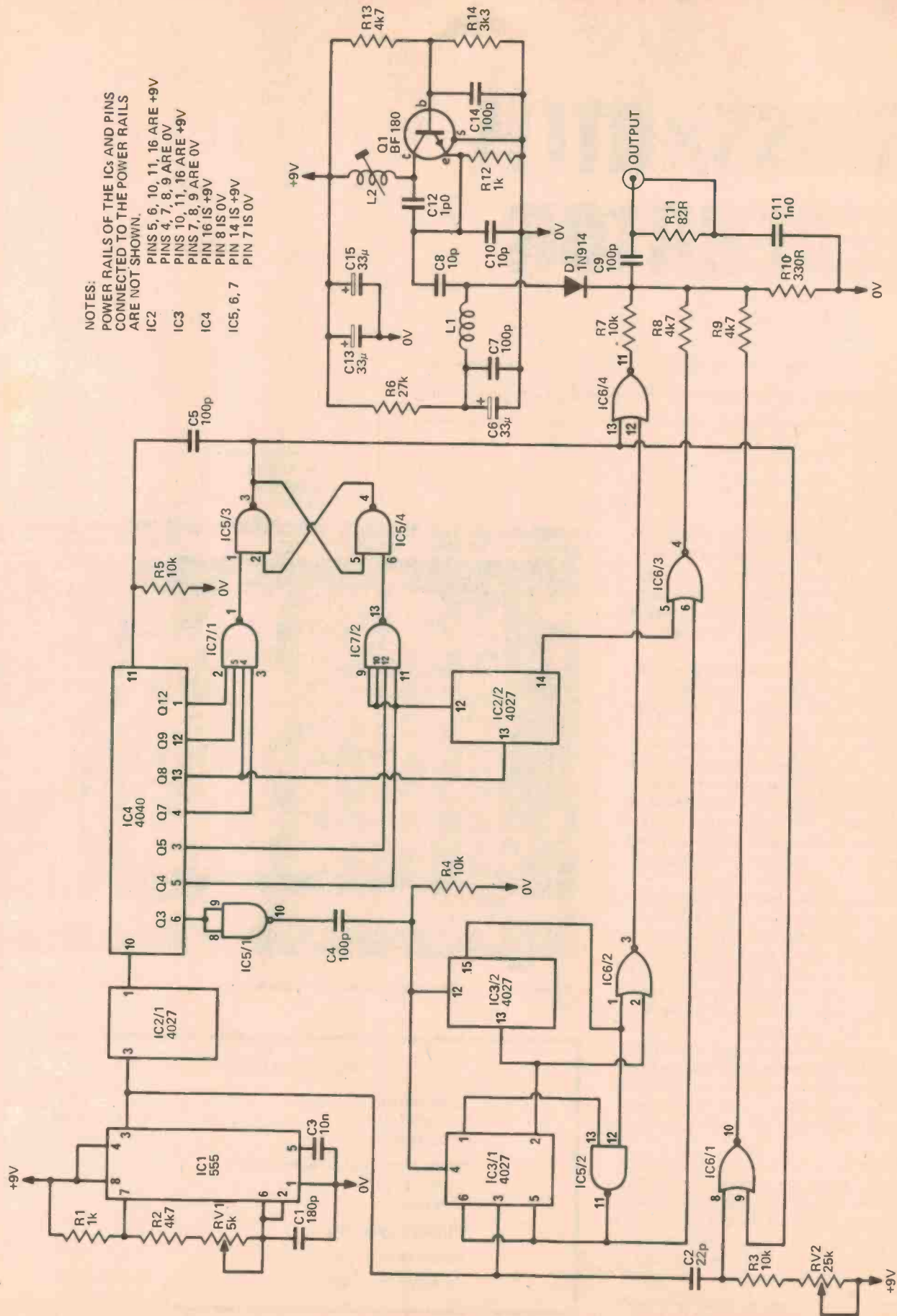

NOTES:  
 POWER RAILS OF THE ICs AND PINS  
 CONNECTED TO THE POWER RAILS  
 ARE NOT SHOWN.  
 IC2 PINS 5, 6, 10, 11, 16 ARE +9V  
 PINS 4, 7, 8, 9 ARE 0V  
 IC3 PINS 10, 11, 16 ARE +9V  
 PINS 7, 8, 9 ARE 0V  
 IC4 PIN 16 IS +9V  
 IC5, 6, 7 PIN 8 IS 0V  
 PIN 14 IS +9V  
 PIN 7 IS 0V

Fig. 1. The circuit diagram of the crosshatch generator.

HOW IT WORKS - ETI 717

A TV picture is made up of a series of horizontal lines equally spaced down the screen with the information transmitted in a serial form along with the necessary synchronization pulses. In Australia there are 625 lines in each complete picture but these are transmitted as two "frames" each of 312½ lines with the second frame interlaced between the first giving a total of 625 lines. This is to reduce flicker of the picture which would otherwise occur.

To simplify our circuit and prevent a double horizontal line we have used 624 lines which eliminates the interlacing. The TV set automatically accepts this change.

To synchronize the TV set we need a 192µs wide pulse every frame (20ms) and a 4µs wide pulse every line (64µs). All pulses, including the information, are derived from a single 249.6 kHz oscillator IC1. This is divided by 2 in IC2/1 and then by 2496 by IC4 giving an output of 50 Hz. This IC is a 12 stage ripple counter which, while normally dividing by 4096, can be forced to divide by 2496 by decoding (IC7) the outputs from the 7th,

8th, 9th and 12th stages and resetting IC4 back to zero. The output of IC7 toggles the RS flip flop IC5/3, IC5/4 which resets IC4 via C5. This flip flop is reset by the decoded output from the 4th and 5th stages of IC4. This occurs 192µs later; thus the output from IC5/3 is the frame sync pulse.

To generate the line sync pulse the output from the 3rd stage of IC4 (15,600 Hz) is used to reset both halves of the dual JK flip flop IC3. This IC is then toggled by the 249.6 kHz clock until, after three pulses, both "Q" outputs are "1" when IC5/2 detects this and disables IC3/1. IC5/2 decodes the second of these clock periods and this becomes the line sync pulse. These pulses are combined in IC6/4 to give a combined sync pulse.

The 249.6 kHz is differentiated by C2/R3 and after being squared up by IC6/1 is used to generate 16 white spots on each line which results in vertical lines. These pulses are deleted during the frame sync period to prevent interference to synchronization. Due to variations in

the CMOS a trim potentiometer is provided to give equal width to the vertical and horizontal lines.

The horizontal line is generated by IC2/2 (JK flip flop) and this IC is toggled by the 8th output (487.5 Hz) of IC4 and is reset by the output of the 4th stage (64µs later). This gives a single white line every 16 lines. To prevent this line interfering with the line sync pulse the output of IC2/2 is combined with that of IC5/2 which is high for a period 4µs before the line sync pulse to 4µs after the pulse. This gives a short black region on both ends of the line (normally off the screen). The outputs of IC6/1, IC6/2 and IC6/3 are combined by R7-R10 to give a composite video signal. Note that the video information gives positive pulses while the synchronization pulses are negative.

The VHF oscillator, Q1, is mixed with this signal and the resulting modulated signal can be tuned in by the TV set. Adjustment of the frequency by the tuning slug allows operation on any desired channel from 7 to 10.

PARTS LIST ETI - 717

- Resistors all ¼W, 5%  
 R1 ..... 1k  
 R2 ..... 4k7  
 R3-R5 ..... 10k  
 R6 ..... 27k  
 R7 ..... 10k  
 R8, 9 ..... 4k7  
 R10 ..... 330R  
 R11 ..... 82R  
 R12 ..... 1k  
 R13 ..... 4k7  
 R14 ..... 3k3

Potentiometers

- PV1 ..... 5k trim  
 RV2 ..... 26k trim

Capacitors

- C1 ..... 180p ceramic  
 C2 ..... 22p ceramic  
 C3 ..... 10n polyester  
 C4, 5 ..... 100p ceramic  
 C6 ..... 33µ 16V tantalum  
 C7 ..... 100p ceramic  
 C8 ..... 10p ceramic  
 C9 ..... 100p ceramic  
 C10 ..... 10p ceramic  
 C11 ..... 1n0 polyester  
 C12 ..... 1p0 ceramic  
 C13 ..... 33µ 16V tantalum  
 C14 ..... 100p ceramic  
 C15 ..... 33µ 16V tantalum

Inductors

- L1 ..... see table 1  
 L2 ..... see table 1

Semiconductors

- IC1 ..... NE555  
 IC2, 3 ..... 4027B (CMOS)  
 IC4 ..... 4040B (CMOS)  
 IC5 ..... 4011B (CMOS)  
 IC6 ..... 4001B (CMOS)  
 IC7 ..... 4012B (CMOS)

Note: all CMOS should be 'B' series

- Q1 ..... BF 180

- D1 ..... 1N914

- Miscellaneous  
 PC board ETI 717  
 Zippy box  
 Output socket  
 Single pole toggle switch  
 9V battery

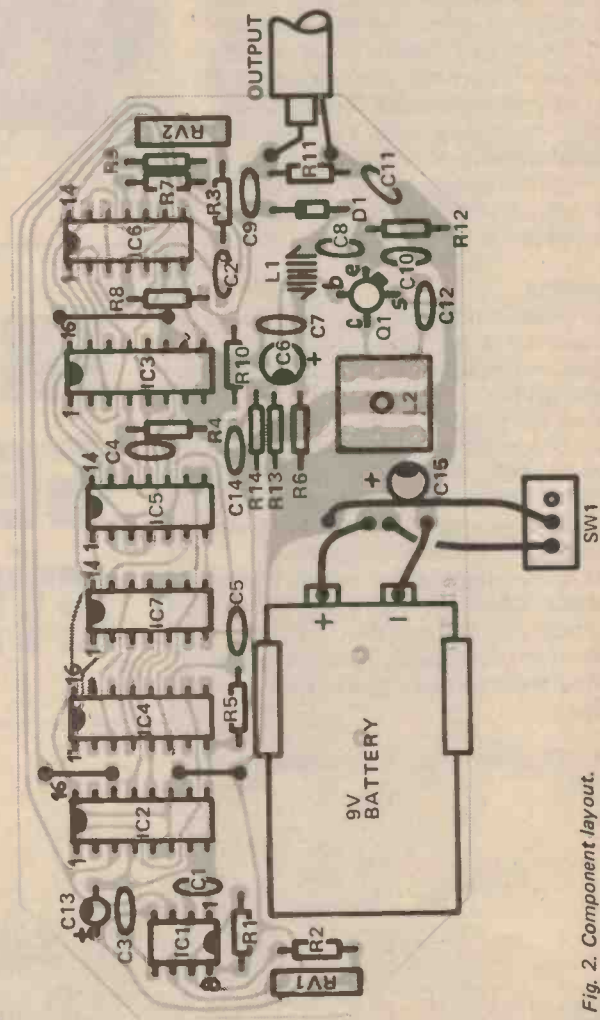

Fig. 2. Component layout.

# Project 717

The ETI 717 generator produces a combined horizontal and vertical sync waveform and this, together with the crosshatch video, is modulated onto a carrier frequency operating in VHF channel 8 (189.25/194.75 MHz). Thus to use the generator one simply attaches it to the antenna terminals and selects channel 8.

## Construction

Assemble the pc board according to the overlay starting with the links, resistors and diodes. The 555 IC, the transistor, capacitors and coils next with the CMOS IC's last. Solder the power supply pins of the CMOS (7 and 14 or 8 and 16) first. This allows the internal protection diodes to protect the inputs of these ICs.

We mounted the unit into a zippy box as it is cheap and available. This does however allow the oscillator to drift due to the presence of hands, etc., as it does not provide good shielding. If the crosshatch generator is going to be used continuously a die cast box is recommended. A teflon or rubber locking strip is necessary on the adjustable coil L2 as slight movement of the slug will put it off frequency.

## Alignment

This is easiest if a frequency counter or oscilloscope is available. Monitor the output on pin 1 of IC4 and adjust RV1 to give 50 Hz.

Connect the unit to the TV set and select channel 8 (or an unused channel from 7 to 10). Switch on and adjust L2 to give a stable picture. RV2 should be adjusted to give vertical lines of about the same width as the horizontal.

If an oscilloscope or counter is not available adjust L2 first to tune channel 8 as best you can and then RV1 to synchronize the picture. Now fine adjust both of these controls to give the best result.

The PCB artwork for the project is on page 94.

**Table 1**  
Coil Winding Data

- L1 6 turns 0.5 mm enamelled wire close wound, 5 mm dia, air core.
- L2 4 turns 0.5 mm enamelled wire close wound onto a miniature Neosid former with VHF slug, 6 pin base and aluminium can.  
Terminate leads on opposite sides of the base. Use teflon locking strip on core.

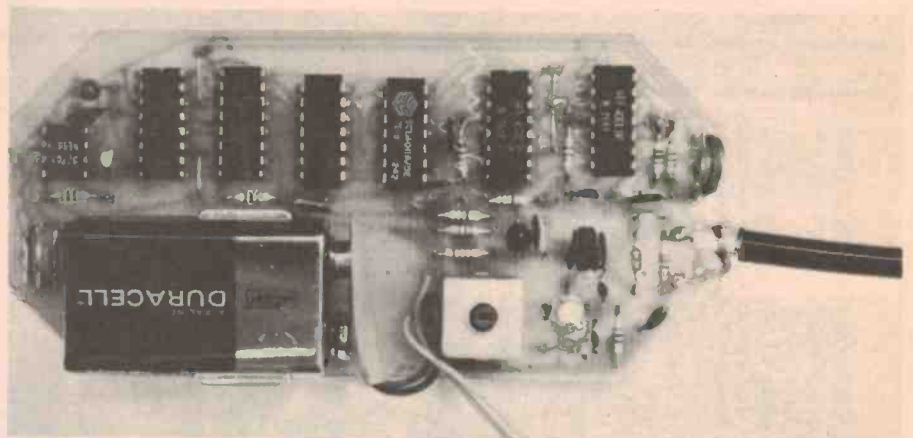

# CROSSHATCH GENERATOR ETI 717

ON



OFF



OUTPUT

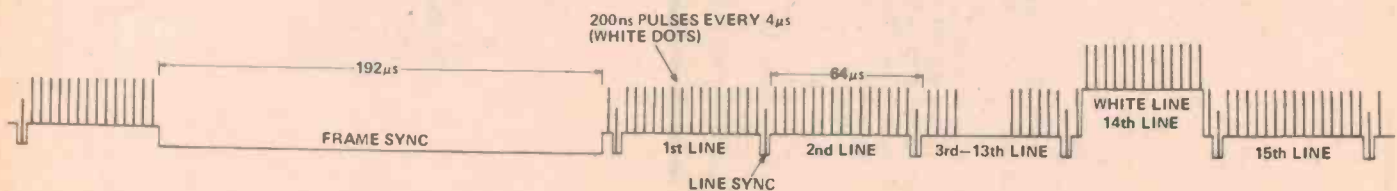

Fig. 3. Diagram showing part of the video waveform across R10. Due to the time scale involved (200ns wide pulses and 20ms between frame sync pulses) it is not possible to show the entire waveform. The first white line is the 14th and is then every 16th line.



DIRECT FROM USA



# MOTOROLA 'PIEZO' SUPER HORN has all the features!

Needs no cross-over network. Frequency response 4.000-30.000 Hz 3 dB patented momentum drive principle. No voice coils or magnets. High internal Impedance. Adapts to any system. High acoustic output. Many can be connected in series to form an array-increased output. Power handling capacity 25 volts RMS.

4 OHMS 100 WATTS

### Trade Enquiries Invited

As used by many major musical equipment manufacturers.  
Available through your local Hi-Fi, Electronic component or Music shop or direct

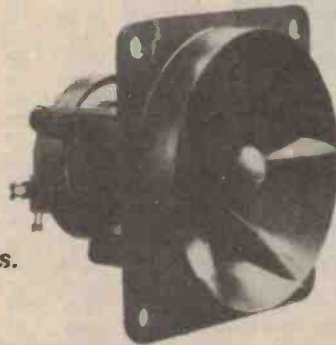

SIZE: 3<sup>3</sup>/<sub>8</sub> x 3<sup>3</sup>/<sub>8</sub> x 2<sup>7</sup>/<sub>8</sub>

Retail price  
\$16.00 \* P&P \$1.00.

Victorian Distributor:  
ZEPHYR PRODUCTS  
70 Batesford Road  
Chadstone VIC 3148  
Tel. 568-2922

Sole Australian Importer

### FREEDMAN ELECTRONICS PTY LTD.

89-91A Liverpool Road, Summer Hill, NSW 2130. Tel: 797-9941 — 797-0986

South Australian Distributor:  
BOB'S SOUND SYSTEMS  
37 Angas Street  
Adelaide, SA  
Tel. 212-3993.

## electronics today

INTERNATIONAL

# BINDERS HOLDS 12 COPIES OF eti



Protect and file your back issues of Electronics Today with these attractive binders. Price: \$4.50 plus postage and packing (80c NSW-\$1.70 other states).

### SUBSCRIPTION DEPARTMENT

ELECTRONICS TODAY INTERNATIONAL  
MODERN MAGAZINES (HOLDINGS) LTD.,  
15 BOUNDARY ST., RUSHCUTTERS BAY, 2011

## INCREDIBLE!



A superbly designed 9 band receiver. Sensitivity, selectivity, (the VEF radios will easily separate the proposed . . . 9 kHz separation) stability, image rejection, and sound quality are all superior to any comparably priced radio.

More than that, VEF reliability is legendary and the construction quality incomparably better — hence our 3 year guarantee.

Normally \$89, this is a special \$69 offer extended to ETI readers.  
(Optional AC unit \$4 extra).

### ELECTROIMPEX AUSTRALIA PTY LTD

• 279-283 Latrobe St, Melbourne, 3000 Ph: 602 3533 • 91 Goulburn St, Sydney 2000. Ph: 212 3676 • 1st Floor, 75 Grenfell St, Adelaide 5000; Ph: 223 6150 • Shops A11 & 12, Local Point Arc. Cnr. Brunswick & Wickham Sts, Fortitude Valley, 4006. Ph: 52 2909

512-30

## International 3600 and 4600 Synthesizers

MODERN MAGAZINES publication

### INTERNATIONAL 3600 AND 4600 SYNTHESIZERS

A totally revised and updated reprint of ETI's phenomenally successful music synthesizer book.

Beautifully printed on heavy art paper with a sturdy cover varnished for protection.

Available only from ETI and some kit suppliers — \$12.50 (including postage and packing).

Send orders to: - Electronics Today International, 15 Boundary Street, Rushcutters Bay, NSW 2011.

## UT UNIK TIME

presents:  
the world's thinnest  
DIGITAL TIMEPIECE



#### Featuring:

- 5 function, 4-digit quartz crystal accuracy Hour, minute, second, month, date
- Super thin styling (6 mm) with 4 elegantly styled faces
- Removable battery hatch for easy customer battery replacement
- Gold or silver toned case with lizard or mesh band options
- High contrast, easy to read liquid crystal display with command backlight
- Full year warranty with worldwide service

An ultra thin slice of time offering accuracy, comfort, elegant jewelry styling and long life. Supported by unexcelled quality and world-wide service. Ask your Unik Time representative about our full line of digital watches and clocks.

### CHRONOGRAPH Electronic LCD Digital Watch

6-digit 11 function chronograph  
Hour/Minute/Second/Month/Date/Day  
/Stop Watch (hour/minute/second/  
1/100 sec.)

Also stocked — large range of  
other Unik time watches & LED  
dig. alarm clocks.

trade enquiries welcome!



Distributed by:  
**EMONA ENTERPRISES**  
CBC Bank Building, Room 208  
661 George Street, Sydney, 2000.  
Phone: Bus. 212-4815, AH 399-9061

# "THE STOCKING EXPORTER"

FREE FREE FREE FREE FREE

WITH EVERY ORDER FOR OVER \$25.00 YOU WILL RECEIVE A  
GRABBAG OF "DO-IT-YOURSELF-TESTING"  
CALCULATOR CHIPS

| TTL  |       |           |
|------|-------|-----------|
| 7400 | \$.12 | 7486 .32  |
| 7401 | .12   | 7490 .36  |
| 7402 | .13   | 7492 .32  |
| 7403 | .13   | 7493 .30  |
| 7404 | .13   | 7495 .45  |
| 7406 | .19   | 74107 .20 |
| 7410 | .12   | 74121 .25 |
| 7413 | .25   | 74123 .42 |
| 7420 | .13   | 74141 .32 |
| 7430 | .15   | 74151 .45 |
| 7438 | .24   | 74153 .50 |
| 7440 | .13   | 74154 .95 |
| 7442 | .50   | 74157 .60 |
| 7445 | .60   | 74161 .60 |
| 7447 | .60   | 74163 .75 |
| 7448 | .55   | 74164 .60 |
| 7450 | .15   | 74174 .80 |
| 7454 | .12   | 74175 .80 |
| 7474 | .21   | 74192 .75 |
| 7475 | .40   | 74193 .60 |
| 7485 | .45   | 74367 .45 |

### LOW POWER SCHOTTKY

|         |       |         |     |
|---------|-------|---------|-----|
| 74LS138 | \$.25 | 74LS00  | .50 |
| 74LS139 | .25   | 74LS02  | .50 |
| 74LS151 | .25   | 74LS04  | .42 |
| 74LS157 | .25   | 74LS08  | .42 |
| 74LS160 | .25   | 74LS20  | .60 |
| 74LS161 | .25   | 74LS30  | .60 |
| 74LS162 | .30   | 74LS32  | .60 |
| 74LS163 | .31   | 74LS38  | .60 |
| 74LS174 | .55   | 74LS42  | .70 |
| 74LS175 | .60   | 74LS47  | .70 |
| 74LS192 | .60   | 74LS48  | .70 |
| 74LS221 | .40   | 74LS74  | .85 |
| 74LS257 | .40   | 74LS75  | .55 |
| 74LS266 | .30   | 74LS86  | .35 |
| 74LS283 | .60   | 74LS90  | .63 |
| 74LS365 | .60   | 74LS94  | .55 |
| 74LS366 | .30   | 74LS109 | .55 |
| 74LS368 | .40   | 74LS126 | .55 |
| 74LS386 | .60   | 74LS132 | .45 |

### C-MOS

|      |       |      |      |
|------|-------|------|------|
| 4001 | \$.22 | 4020 | 1.20 |
| 4002 | .20   | 4021 | .95  |
| 4006 | .90   | 4022 | .80  |
| 4007 | .22   | 4023 | .20  |
| 4008 | .90   | 4024 | .60  |
| 4009 | .50   | 4025 | .18  |
| 4010 | .50   | 4028 | .60  |
| 4011 | .20   | 4030 | .40  |
| 4012 | .20   | 4035 | .95  |
| 4013 | .35   | 4040 | 1.00 |
| 4014 | .80   | 4049 | .50  |
| 4015 | .80   | 4050 | .50  |
| 4016 | .40   | 4071 | .22  |
| 4017 | .80   | 4507 | .28  |
| 4018 | .85   | 4510 | .50  |
| 4019 | .35   |      |      |



### S-100 BUSS KITS

|        |             |        |
|--------|-------------|--------|
| 8K     | RAM         | 179.95 |
| 16K    | RAM         | 449.00 |
| 2K/4K  | 1702A EPROM |        |
|        | less        |        |
|        | PROMS       | 59.95  |
| 8K/16K | 2708 EPROM  |        |
|        | less        |        |
|        | PROMS       | 75.95  |
| 2 + 2  | I/O KIT     | 139.95 |

Write for complete catalog  
of manufacturer and kits.

### Memories and Micros

|                |         |
|----------------|---------|
| 1702A-2K PROM  | \$ 5.49 |
| 2708 - 8K PROM | 15.00   |
| 21L02-1K RAM   | 1.39    |

#### Low Power

|         |              |       |
|---------|--------------|-------|
| 8080A   | CPU          | 15.99 |
| MC6800L | CPU          | 13.50 |
| 7489    | 64BIT<br>ROM | 1.59  |

### LINEAR

|          |        |
|----------|--------|
| LM1458CN | \$ .35 |
| LM3900N  | .42    |
| 75451N   | .30    |
| 75452N   | .30    |
| 75454N   | .30    |
| N8T97N   | 1.30   |
| N8225B   | .65    |

### LINEAR

|                        |        |
|------------------------|--------|
| LM301AH                | \$ .35 |
| LM301AN                | .28    |
| LM304H                 | .75    |
| LM307N                 | .25    |
| LM308AH                | 2.00   |
| LM308H                 | .75    |
| LM308N                 | .75    |
| LM309H                 | .75    |
| 7805KC                 | .95    |
| LM311D                 | 1.90   |
| LM311N-8               | .40    |
| LM312H                 | 1.00   |
| LM317H                 | 1.80   |
| LM317K                 | 3.00   |
| LM318H                 | 1.30   |
| LM318N                 | 1.25   |
| LM320H                 |        |
| 5,6,8,12,15,<br>18,24V | .75    |
| LM320K                 |        |
| 5,6,12,15,18,<br>24V   | 1.00   |
| LM320T                 |        |
| 5,12V                  | 1.00   |
| LM323K                 | 6.50   |
| LM324N                 | .80    |
| LM339N                 | .60    |
| LM340K                 |        |
| 5,12,18,24V            | 1.30   |
| LM340T                 |        |
| 5,6,12,15,18,<br>24    | .95    |
| LM380N                 | .85    |
| LM381N                 | 1.20   |
| LM387N                 | .40    |
| LM555CN                | .40    |
| LM567CN                | 1.25   |
| LM723CH                | .55    |
| LM741CH                | .32    |
| LM741CN                | .30    |
| LM747CH                | .62    |
| LM1458CH               | .50    |

### CLOCK-CHIPS

|         |                    |        |
|---------|--------------------|--------|
| MM5314n | 6-DIGIT CLOCK CHIP | \$3.99 |
| MM5316N | 4-DIGIT CLOCK CHIP | 4.49   |

### OPTO-SPECIAL

|        |    |                                     |       |
|--------|----|-------------------------------------|-------|
| FND503 | .5 | 7 SEGMENT DISPLAY<br>COMMON CATHODE | \$.85 |
| FND510 | .5 | 7 SEGMENT DISPLAY<br>COMMON ANODE   | \$.85 |

### Payment conditions:

Check, International Money order, or Bankdraft (in US Dollars)  
Prices are quoted in Australian Dollars.  
Please incl. Air Parcel Post charges.  
Shipment will be made within 1 week.  
All merchandise guaranteed.

## INTERNATIONAL COMPONENTS SALES

5220 West El Segundo Blvd. • Hawthorne, California 90250 U.S.A.  
Phone: (213) 679-8125 Telex: 673268

# SWR/POWER METER

New design provides wide sensitivity range and wide bandwidth.  
By Roger Harrison VK2ZTB and Phil Wait VK2ZZQ

THIS REFLECTOMETER DESIGN, apart from being simple, elegant and easy to construct, covers three decades — from 100 kHz to 100 MHz, and can be constructed for RF powers as low as 500 mW or up to 500 watts.

The problem with most designs for reflectometers, or "Swar" meters as they tend to be called colloquially these days, is that they generally only cover about one decade in frequency range — usually 3 to 30 MHz or, if further, have discontinuities and drastic sensitivity variations at the extreme ends of their frequency range.

Sensitivity is a problem with the commercially available instruments also. Those with the best sensitivity — 5W full scale usually — are made for the CB market, and while they will work over most of the HF spectrum (some extending beyond that), sensitivity is insufficient if you are working with low power solid state RF circuitry or doing a deal of antenna experimentation.

Performing antenna measurements at powers of 5W or more is discourteous to say the least, especially where sustained or many consecutive measurements need to be made.

The reflectometer/RF power meter described meets the requirements of most people involved in RF measurements requiring such an instrument and where a disparate variety of facilities are required.

This project will be extremely useful to radio amateurs, CBers, servicemen involved in communications, in laboratories etc.

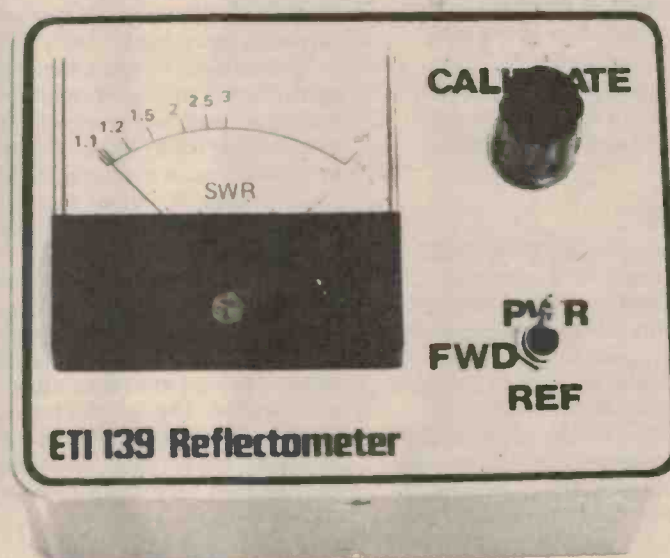

## CONSTRUCTION

Construction is very straightforward. The printed circuit design given is recommended, otherwise variations in layout may affect performance.

All the components are mounted on the *copper side* of the pc board, which is subsequently assembled onto the coax sockets and mounting bolts.

Commence by winding the toroid current transformer secondary turns. Refer to the circuit diagram. Cut a 45 mm length of RG58, stripping back the braid and insulation as illustrated in the component overlay and photographs.

This is not all that critical, but maintain as much braid as you can to reduce problems with errors creeping in at the top end of the frequency range due to discontinuities here.

Slip the toroid over the short length of coax and mount this assembly on the pc board. Position the toroid centrally and fix it in place with a small amount of pliable plastic cement compound such as "Silastic".

Mount all the other components next. Pay particular attention to the orientation of the diodes D1, D2, D3.

The trimmer capacitor, C2 is shown

## Project 139

as a mica compression type. Any suitable trimmer — such as the Philips film trimmers — can be used, however, the mica compression trimmer provides a certain amount of 'vernier' adjustment.

The pc board and major components are assembled into a suitable metal box. We used a Hbrwood type 34/2/D which measures 100 mm by 75 mm by 50 mm. This provides for a compact finished instrument without a crowded layout.

The completed pc board is mounted in the following way:

Once the coax sockets are mounted, and the two mounting bolts are in position, a coax plug (with cable) should be plugged into each of the sockets in order to locate the centre-conductor pins of each socket.

The pc board is then placed into position and the input/output pads soldered to the coax socket pins. make sure that a good fillet of solder secures the pin to the pc board pad.

Two nuts on the mounting bolts, one under the pc board, one on top of the pc board, then secure the board mechanically as well as providing a ground connection. Refer to the pictures and component overlay.

Connections to the meter, pot, and switch — located on the front panel, can then be made with short lengths of hookup wire.

### CALIBRATION

A suitable RF source, a dummy load and an RF voltmeter or a known-accurate RF power meter are required for test and calibration of the instrument.

Suitable low power dummy loads, marketed for Cbers, are readily available or any of the standard amateur texts (ARRL, RSGB handbooks etc) provide excellent construction details of dummy loads to dissipate a variety of powers. The same texts describe suitable RF

voltmeter probes that may be used in conjunction with a multimeter.

### SWR Scale

The instrument is connected between the RF source and the dummy load. Turn the sensitivity control fully anti-clockwise. Switch to read forward power.

Key the RF source and slowly rotate the sensitivity control clockwise. The meter reading should increase. If it doesn't, check wiring. If it goes in reverse, you've got D1 back to front! If all is well, advance the sensitivity control until the meter reads full scale. Switch to read reverse power. Adjust the trimmer C2 to obtain a minimum meter reading. It should go to zero; increase the sensitivity when a very low reading is reached to ensure that C2 is adjusted correctly.

This completes the adjustment of the Reflectometer section. The scale calibration can be obtained from Table 1.

The scale on the meter may be hand-lettered using Letraset or other 'rub-on' lettering. The original lettering may be painted over and the new SWR scale inserted beneath the original scale. Kit suppliers may make a whole new scale available.

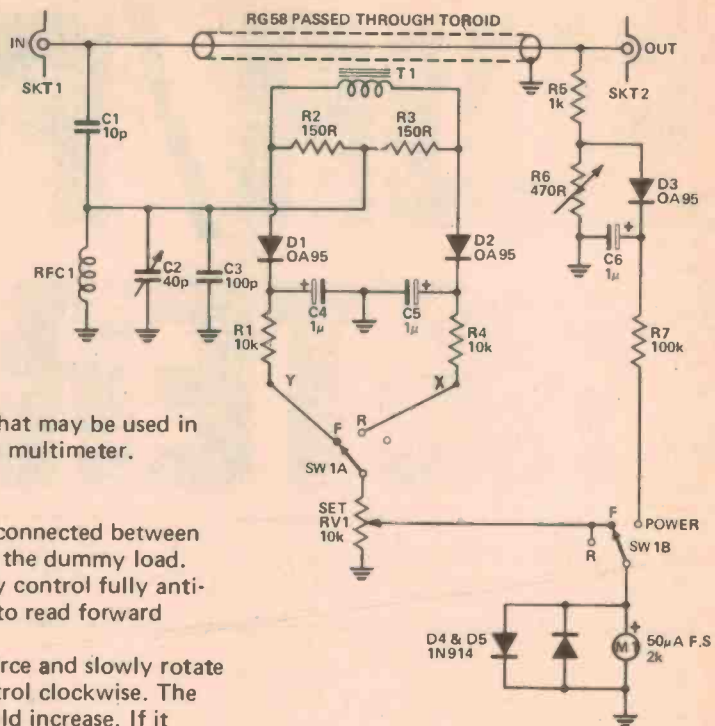

Fig. 1. Circuit diagram of the SWR/Power meter. Note the unusual switch configuration. A special C & K toggle switch was used as it provides the simplest operation. Otherwise, a double-pole, triple-throw switch is necessary.

### Power

The circuit (Figure 1) shows a divider network, consisting of R5 and R6, tapped across the RF on the coax line.

The lower divider resistance R6 is shown as a variable element. A miniature deposited carbon track trimpot was used in the prototype. The low value types seem to perform quite well over a wide frequency range and one was used here for convenience. It was set so that the full-scale reading of M1 corresponded to a particular peak power dissipated by the dummy load (as measured with an RF voltmeter or known-accurate RF power meter).

Fixed resistors may be substituted for a trimpot, necessitating only a check of the accuracy of the full scale peak power reading. Values for particular full-scale power readings are given in Table 2.

The power scale should be calibrated to suit the individual instrument. It will be non-linear, particularly at the bottom end.

### Performance

The inherent impedance of the prototype instrument was measured using a TEK 5 W dummy load and a Hewlett-Packard vector impedance voltmeter. The results are illustrated in Figure 4.

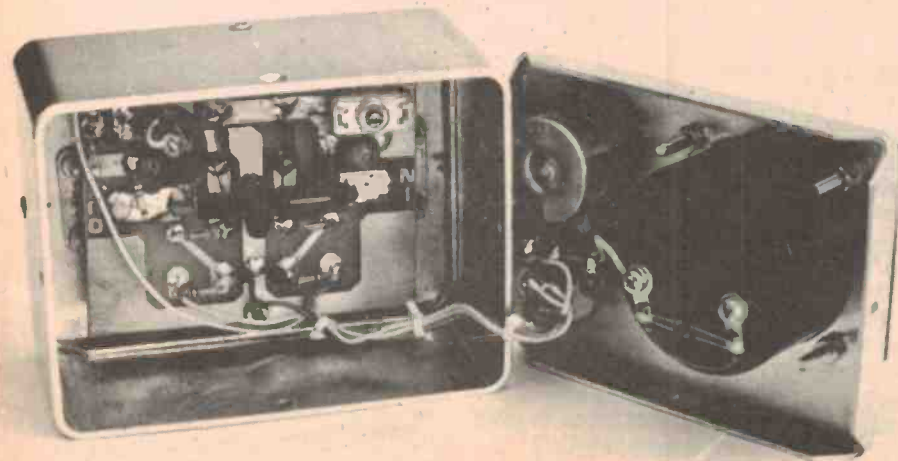

**TABLE 1**

| SWR   | Scale reading   |
|-------|-----------------|
| 3:1   | 0.5 full scale  |
| 2.5:1 | 0.42 full scale |
| 2:1   | 0.34 full scale |
| 1.5:1 | 0.2 full scale  |
| 1.2:1 | 0.1 full scale  |
| 1.1:1 | 0.05 full scale |

**TABLE 2**

| Peak Power, full scale | R2 value              |
|------------------------|-----------------------|
| 500 W                  | 68R                   |
| 200 W                  | 2 x 33R in parallel   |
| 100 W                  | 33R                   |
| 50 W                   | 68R                   |
| 20 W                   | 2 x 330R in parallel  |
| 10 W                   | 330R                  |
| 5 W                    | 680R                  |
| 3 W                    | 1k + 100R in series * |

\*linearity suffers

**PARTS LIST – ETI 139**

**Resistors** all 1/4W, 5%

- R1 . . . . . 10k
- R2,R3 . . . 150R
- R4 . . . . . 10k
- R5 . . . . . 1k
- R6 . . . . . 470R trimpot or fixed  
—see text
- R7 . . . . . 100k

**Potentiometer**

- RV1 . . . . . 10k/C pot

**Capacitors**

- C1 . . . . . 10p ceramic
- C2 . . . . . 40p trimmer
- C3 . . . . . 100p ceramic
- C4 - C6 . . . 1µ solid dipped tantalum

**Semiconductors**

- D1 - D3 . . . OA95
- D4,5 . . . . . 1N914

**Miscellaneous**

- RFC1 . . . . Any moulded RF choke, 1mH or more (value not critical).
- SW1 . . . . . C & K switch type 7211 (see text)
- M1 . . . . . 50 µA meter, T.E.W. type, 2k resistance.
- T1 . . . . . 40 turns of 35 gauge B & S enamelled wire, around circumference of Neosid toroid type 28-511-31, 12.7 mm o.d., 6.35 mm i.d., 3.18 mm thick, F14 material (see text)
- Coax sockets . . . SO239 or other type to suit
- Case . . . . . Horwood type 34/2/D (100 mm x 75 mm x 50 mm).
- PC board . . . ETI 139
- Two 25 mm long bolts with three nuts and two lock washers each; nuts and bolts for coax sockets (if required); length of RG58 coax; 6 mm dia. sleeving; hookup wire, etc.

**How it works – ETI 139**

The reflectometer employs a “current transformer” having an electrostatically-shielded primary with a high-ratio secondary winding driving a low value load resistance.

A short length of coaxial cable, passed through a ferrite toroid, forms the primary with the braid connected so as to form an electrostatic shield.

The secondary of the current transformer consists of a winding around the circumference of the toroid, coupled to the magnetic component of the ‘leakage’ field of the short length of coax cable.

The secondary drives a centre-tapped resistive load (R2/R3) connected to a voltage sampling network (C1-C2/C3) tapped across the RF input such that sum and difference voltages will appear across the ends of the current trans-

former (T1) secondary winding.

Diodes D1 and D2 rectify the sum and difference voltages from the secondary of T1, RF and audio (modulation) bypassing being provided by C4 and C5. The RF choke, RFC1, provides a low-resistance DC return for the signal rectifiers, D1 and D2.

The power measurement facility is obtained by tapping off a portion of the RF voltage on the line via R5 and R6, and rectifying this with D3. Capacitor C6 provides RF and audio (modulation) bypassing.

As the load on the rectifier is so light – R7 being 100 k and the meter being 2 k, peak power is measured.

Diodes D4 and D5 provide protection for the meter.

*Fig. 2. Component overlay for the pc board. Note that, contrary to the usual practice, the components are mounted on the copper side of the board.*

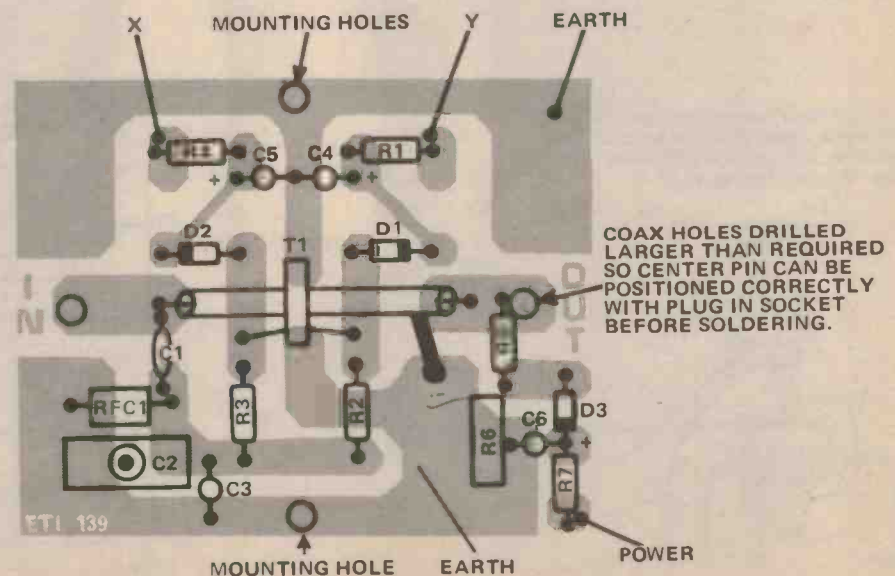

The impedance discontinuities introduced by the prototype are well inside the basic accuracy capability of the meter movement! The real part of the instrument's impedance is within 5% of the nominal 50 ohms — most of this is probably due to connectors and construction discontinuities.

The variation in the real part of the impedance is within +/- one ohm across the frequency range of the instrument, and can be essentially ignored.

The reactive (imaginary) component of the instrument's inherent impedance is negligible up to 20 MHz when it begins to become slightly capacitive.

The overall impedance decreases rapidly above 100 MHz.

Sensitivity and sensitivity bandwidth of the prototype is excellent. The half-power points of the sensitivity bandwidth of the reflectometer are at approximately 350 kHz and 25 MHz.

Full-scale deflection at 27 MHz requires 0.8 watts into 50 ohms. Mid-band sensitivity is under half a watt!

### Modifications

For higher power applications, the basic sensitivity of the reflectometer can be reduced by one of several methods, or a combination.

If you are working with powers around 20 to 50 watts, R2 and R3 can be reduced to 47 ohms. For higher powers, the number of turns on the toroid can be reduced, and R2/R3 further reduced in value. As a guide, reduce the secondary of T1 to 20 turns and R2, 3 to 47 ohms. Everything else remains unchanged. This should suit power levels of 200 watts and higher.

Other types of coax sockets can be used, such as the BNC, type N or the inexpensive Belling-Lee sockets. No modifications to the pc board are necessary, however, mounting details of the sockets and board will need to be altered to suit.

The basic reflectometer construction is so simple and inexpensive that several can be built and installed to provide remote SWR/RF-output monitoring of antenna installations.

The RF portion can be mounted at a convenient place and the reflectometer output leads X and Y taken to remote metering facilities. Power output measurement circuitry is probably superfluous in these circumstances.

Protection circuitry for transceivers and power amplifiers may be simply realised using the basic reflectometer circuit and activating protection devices by comparing the output voltages of D1 and D2.

Swept VSWR measurement can be accomplished using the basic reflectometer circuit. The differential output from D1/D2 can be used to drive the vertical axis of a CRT display (via suitable amplification), the horizontal axis being driven by the sweep voltage of a voltage-controlled signal generator. Voila! - swept VSWR measurements.

Accurate SWR measurements for VSWR values below 2:1 can be made by driving an expanded-scale differential voltmeter circuit that measures the output difference between D1 and D2. This technique is well illustrated in reference 2.

This type of instrument is particularly useful when making VSWR performance plots of antennas over a narrow bandwidth (providing they closely match 50 ohms in the first place).

This reflectometer technique can also be used to measure power. However, the authors opted for the diode RF voltmeter method as it is somewhat more versatile, and is unaffected by the sensitivity bandwidth of the toroidal current transformer. See the two references for more details.

The sensitivity bandwidth may be shifted up in frequency by a decade or more, such that it rolls off around 1 MHz and 50 MHz, by employing a toroid for T1 of the same dimensions but made of F25 material.

### References

Whilst not the 'definitive' texts on this type of reflectometer, these two references provide good practical sources of information.

1. "Frequency Independent Directional Wattmeters"; P.G. Martin, Radio Communication (RSGB journal), July 1972.
2. "Test Equipment for the Radio Amateur", H.C. Gibson G8CGA, published by the RSGB, 1974.

Note: The manufacturers of the toroid, Neosid Limited (Australia), are located at 23/25 Percival Street, Lilyfield NSW. However, components suppliers such as Davred and Dick Smith's may have them in stock — but accept no substitutes!

Fig. 3. The meter, sensitivity pot and switch connections. Leads X and Y go to D2 and D1 respectively, while the lead marked 'POWER' goes to R7. Refer to figure 2.

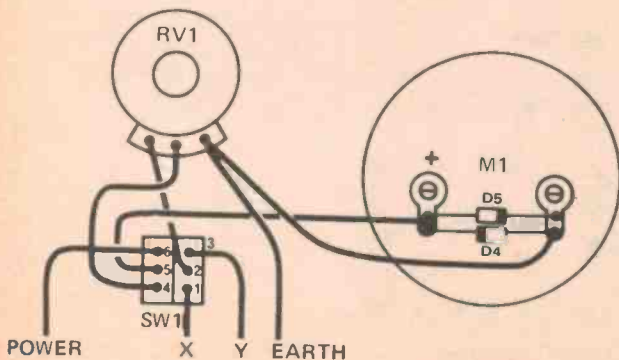
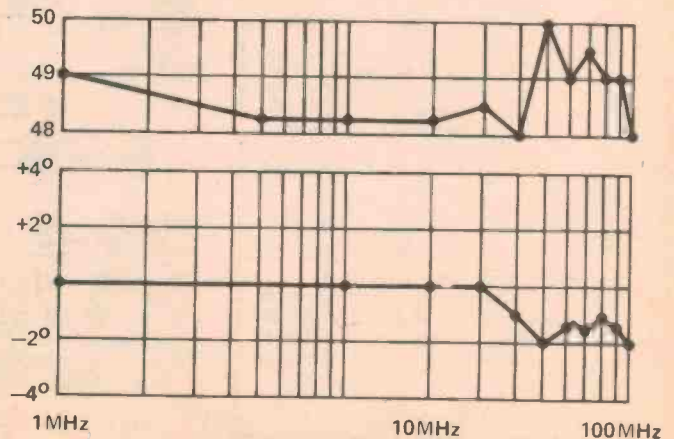

Fig. 4. Top: real or resistive component of the prototype's inherent impedance. Lower: Reactive component.



**DEL SOUND** —PTY LTD—  
BRISBANE

1 Wickham Tce. (Cnr. Warf St.) 229-6155.  
(Park at rear) 35 Logan Rd, Woolloongabba. 391-7048.

**IF WE CAN'T BEAT THE OPPOSITION PRICE,  
WE WILL TRY TO MATCH IT . . . IF WE DON'T STOCK IT,  
WE WILL TRY TO GET IT FOR YOU**

Guess who's now  
a Dick Smith dealer?

● **SPECIALS IN** ●  
**TOP QUALITY COMPONENTS**

|                                          |        |
|------------------------------------------|--------|
| Motorola 2M3055.....                     | 75c    |
| Motorola MJ2955.....                     | 90c    |
| Philips 555 8 P.I.C.....                 | 50c    |
| Philips 741 8 P.I.C.....                 | 45c    |
| 240V 3A.G. Approved<br>Fuse Holders..... | 90c    |
| Neon Bezels.....                         | 25c    |
| 5/8 oz Silicon Grease.....               | \$1.60 |
| Miniature Toggle<br>S.P.S.T.....         | 70c    |

**complete  
electronic  
supplies**

Wholesale, trade and mail orders welcome. Add 10 per cent  
post and pack. Stocks and prices valid at 12.4.78.

**COMMUNICATION  
DEVICES** present

THE

**SABTRONICS**  
**3 1/2 DIGIT DM M**



**SPECIFICATIONS:**

DC volts in 5 ranges: 100uV to 1000V; AC volts in 5  
range: 100uV to 1000V; DC current in 6 ranges: 10n  
A to 2A; AC current in 6 ranges: 10n A to 2A; Resis-  
tance in 6 ranges: 1 to 20M; Input Impedance: 10M;  
Display: 9mm (36") LED; Power requirements: 4.5  
VDC to 6.4 VDC (4 "C" cells — not included); Size: 8  
"W" x 6.5" D x 3.0"H (203W x 165D x 76H mm).

PRICE (KIT) \$97.75 incl. sales tax

PRICE (FACTORY ASSEMBLED AND TESTED) \$129.75  
incl. sales tax

ABOVE PRICES INCLUDE DELIVERY WITHIN AUSTRALIA

AUSTRALIAN AGENTS:

**COMMUNICATION DEVICES**

271 Goulburn St, Darlinghurst, NSW 2010.

Phone: 2113399, 2113652, 2123712.



# ELECTROCRAFT PTY LTD

106A HAMPDEN RD,  
ARTARMON 2064  
PHONE: 411-2989  
411-3772

TELEVISION AERIAL AND DISTRIBUTION EQUIPMENT, CB  
RADIOS, AERIALS & ACCESSORIES, TRADE SUPPLIED

Please enclose postage on all orders.

## TELEVISION

### ELECTROCRAFT DISTRIBUTION AMPLIFIERS AND AMPLIFIER SPLITTERS

**NEW** Medium and high gain distribution amplifiers suitable for all applications with 1, 2, 3 and 4 outputs suitable for small home unit, showroom or household type installations.

TYPE 1.75 DI has one output, 16 db gain with low N/F. \$45.50  
WHILE TYPE 4.75 T19 has 4 outputs 19db of gain with low N/F. \$61.84

## ANTENNAS

A COMPLETE RANGE OF TV & FM AERIALS, HILLS CHANNEL MASTER, MATCHMASTER & H1.Q.

|                                       |        |
|---------------------------------------|--------|
| <b>HILLS</b>                          | \$.... |
| CA16 — High gain phase array          | 45.94  |
| 215.2710 — 8 element yagi             | 25.29  |
| 2010.2710 — Always screened co-linear | 58.26  |
| EFC 1 — 75 for colour low gain        | 36.00  |
| FC2 — 75 for colour medium gain       | 56.96  |
| EFC 3 — 75 for colour high gain       | 75.50  |

|                                |       |
|--------------------------------|-------|
| <b>CHANNEL MASTER</b>          |       |
| 3110 — 2 element coloray       | 27.96 |
| 3111 — 6 element super coloray | 41.98 |

**H1.Q. LOG PERIODICS**  
8 element & 10 elements \$39.00 (Excellent back to front ratio).

**ACCESSORIES:** Outlet plates, Transformer splitters, Attenuators, filters, plugs, sockets for 75 ohm x 300 ohm applications.

**AERIAL HARDWARE:** Wall brackets, chimney mounts, U brackets, guy wire, guy rings, masts from 8ft to 50ft.



**DEGAUSSING COILS** complete with power cord plug and push button switch \$14.00. Ready for use.

## CB EQUIPMENT

### ¼ WAVE SPIRAL TUNED BASE STATION AERIAL.

Omni-directional (top view) radiation pattern with excellent ground wave and sky wave characteristics. Ideal for "Point to Point" & "Skip" communications. Sturdy plated base bracket, 4 telescopic radials and vertical radiator. Spiral tuning stub at base for quick and easy tuning. SWR of 1.1:1 possible. Aerial comes complete with SO 239 socket, U bolt and saddle and detailed instruction sheet. \$37.75\*\*



## BELLING & LEE-HELICAL WHIP MODEL CB 27/GM/T

This CB Whip Antenna is specially designed to provide maximum performance with reduced length. Helically wound on a resilient fibreglass core 76 cm in with length complete base, 3.6 m of cable and connector. \$23.95.

## SWR & POWER METER

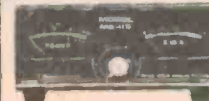

Model ME-11X is SWR & Power Meter with Directional Coupler incorporated. For SWR measurement, it uses the Directional Coupler, com-

paring the power supplied to and reflected from antenna, and this is indicated on the SWR meter. For power measurement, the power meter indicates the travelling wave power detected by Directional Coupler and its frequency range is determined by the figure of Variable Resistor which is for sensitivity adjustment. Specifications: maximum handling power 100W — SWR indication 1:1 to 3:1 — frequency range 3.5 to 150 MHz. \$16.20.

Labgear 29dB High band 9dB Low band 75 ohm mast head amplifier. \$58.90.

Tune your own engine. Analyzers \$16.95. Accuracy +2%

## RADIO CONTROLLED TOYS

"Porsche" racing car. \$16.50.

Army Tank. \$22.00.



# NEW VOLKSMETERS!

With LCD Display —  
Excellent Readability in direct Sunlight!



LM-300 Full three digits  
\$95.00\*



LM-350 3½ digits  
\$105.00\*

## USE THEM ANYWHERE!

### FEATURES:

- Measures DC volts, AC volts, ohms and current.
- Automatic polarity, decimal and overload indication.
- No zero adjustment and no full scale ohms adjust.
- Large LCD display for easy reading without interpolation.
- Size: 1.9" H x 2.7" W x 4.0" D.
- Parts and labor guaranteed for one year.

Standard AA-size batteries provide up to 20 hours of operation. Rechargeable NiCad batteries and charger unit available as optional equipment. \*Batteries not included.



## Non-Linear Systems, (Aust) Pty. Ltd.

61 Lothlan Street, North Melbourne, Victoria, 3051, Australia.  
Telephones: (03) 329-9951 — (03) 329-9377 Telex: 34082.



# propagation a closer look

PART 2

Radio communications beyond the horizon in the high frequency (HF) spectrum between 3 MHz and 30 MHz are carried on as the result of the bending of the radio waves in the ionosphere, that region of our atmosphere extending from about 60 km to about 1000 km above the earth.

## Formation of the ionosphere

As mentioned before, the ionosphere is produced principally by ultraviolet radiation from the sun. The amount of ionisation produced is almost wholly dependent on the strength of the UV radiation and its wavelength. Different wavelengths of the radiation ionise different gases.

The process of ionisation absorbs energy from the UV wave, and as the radiation proceeds down through the atmosphere, it is almost completely absorbed in this way.

This process of creation of ions and free electrons in the ionosphere is offset by recombination which is continually taking place between the two to form neutral atoms once again.

In the lower atmosphere, the molecular density is so great that recombination occurs almost immediately after ionisation the rate of recombination is very rapid. However, in the upper atmosphere, where the number of molecules is very much smaller, the chances of a free electron meeting up with an ion is very much less. Hence, recombination occurs at a much slower rate.

These two opposing mechanisms result in regions in the upper atmosphere where a large amount of ionisation is present, the amount being determined by the balancing forces between the rate of ion production and the recombination rate.

The gases of the upper atmosphere which the solar UV radiation meets first are very rarified, hence little ionisation results and little of the radiation energy is lost. As the radiation penetrates further, the molecular density of the gases increases and hence the ionisation increases.

More and more energy is extracted from the ionising radiation as it penetrates further and at some stage the

amount of ionisation which the radiation can produce begins to decrease. There is thus a certain height at which ionisation is maximised. The region around this height is known as an ionisation layer.

This is how the ionosphere comes to derive its name. It is the region of the upper atmosphere where appreciable ionisation can take place.

The lower limit of the ionosphere is about 50km and it extends to beyond 1000km.

Sydney Chapman, a British scientist, investigated the production of ionisation in the early 1930's and showed that the rate of production of ionisation would vary with height as shown in figure 6. The corresponding layers of electrons have been called Chapman layers.

The height of the 'peak' is determined by the concentration at particular heights of the atmospheric gas and by the ability of the gas to absorb the solar radiation. The less easily absorbed wavelengths of the radiation penetrate lower in the atmosphere before forming a layer of electrons. The height of the layer does *not* depend on the strength of the ionising radiation.

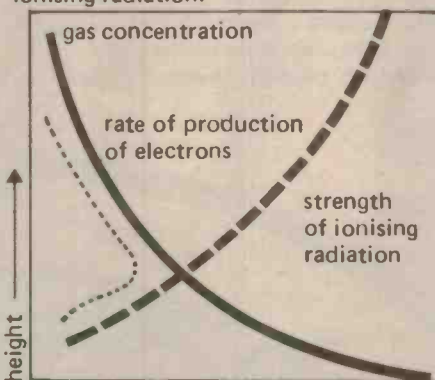
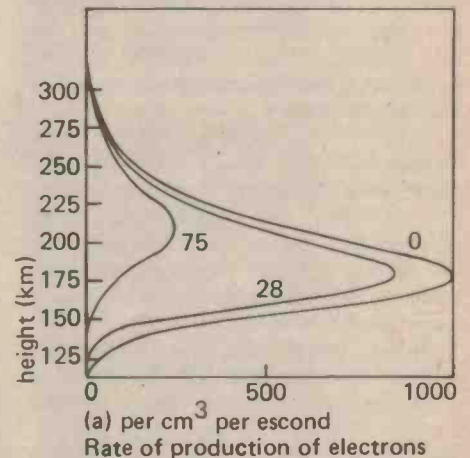

Fig. 6. How a layer of electrons is produced when ionising radiation comes from above the atmosphere. The gas concentration increases with decreasing height while the radiation strength decreases. Peak production of electrons occurs at the height where the curves cross.

The production rate of electrons at the peak of the layer depends on the strength of the ionising radiation and on its direction of arrival. When the radiation is vertically incident on the layer, ionisation is maximum, less when it arrives at an angle.

When curves representing the production rate of electrons of all possible



(a) per cm<sup>3</sup> per escond  
Rate of production of electrons

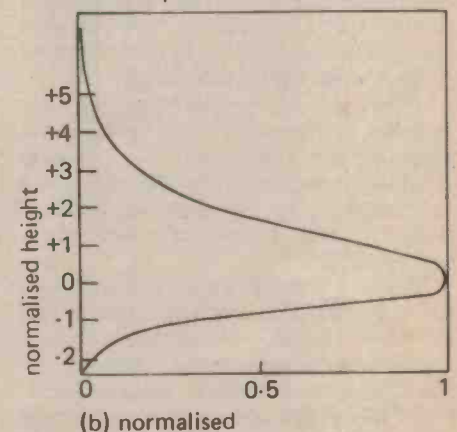

Fig. 7. (a) Theoretical 'Chapman' layers showing how electron production is affected by the angle of the sun's rays — best when sun is overhead (0° zenith angle).

(b) If all curves are 'normalised' about peak height, regardless of the sun's zenith angle, they all have the same shape.

# propagation a closer look

shapes are 'normalised' with respect to the layer peak, they all look the same. See figure 7.

## The three regions

There are three main regions of the ionosphere. They are designated by the symbols 'D', 'E' and 'F'. The F-layer actually divides into two layers, F<sub>1</sub> and F<sub>2</sub>, which I will go into shortly.

The structure of the ionosphere varies widely over the earth's surface as the strength of the sun's radiation will obviously vary with geographical latitude.

## The D-layer

This is a region of low ionisation density which does not show the well-defined 'peak' of maximum ionisation density associated with the other layers.

The D-layer only appears during daylight hours and extends rather diffusely from about 50km to about 90km. The density of electrons in the D region is generally insufficient to cause appreciable bending of radio waves but they do suffer considerable attenuation in passing through this region.

Solar X-ray radiation with wavelengths less than about 20 Angstroms contributes to some of the ionisation in the D-layer. This radiation can ionise all the gases present at these heights in the atmosphere, but this alone does not account for the level of free electrons found in this region.

Nitric oxide (NO) is formed at heights between 60 and 90km by a photochemical process that diffuses atomic nitrogen down from the E-layer above 100km. This nitric oxide is ionised by UV radiation from the sun having a wavelength of 1216 Angstroms — the Lyman-Alpha wavelength.

Hydrogen in the sun radiates very strongly at this wavelength which coincides almost exactly with a 'spectral window' in the atmosphere which allows this radiation to penetrate to very low levels in the atmosphere with little attenuation.

Because it penetrates down to where the nitric oxide is produced there is an abundant supply of electrons which contribute to the general ionisation of the D-layer at a height of around 75km. Solar X-ray and Lyman-Alpha radiation contribute in roughly equal proportions to the ionisation of the D region. However, the strength of the X-rays varies by a large factor both daily and through the solar cycle as well as with solar disturbances. There is no appreciable

change in the strength of the Lyman-Alpha radiation.

Increased X-ray radiation associated with solar flares can increase the ionisation of the D layer thus causing increased absorption of radio waves travelling through the D region. These solar disturbances can be the cause of a complete 'radio blackout' at times.

Ionisation in the very lowest part of the D region is caused by cosmic radiation which consists of high velocity charged particles coming from distant parts of space. They impinge on the earth more or less constantly and can penetrate right to ground level with little loss in energy. The rate at which they produce free electrons and ions is related to the density or concentration of air molecules available to be ionised.

As cosmic rays are deviated by the earth's magnetic field ionisation of the lower D region is greater near the magnetic poles than it is near the equator.

Since the D-layer absorbs radio waves it affects the propagation of radio signals. During the day signals below about 5MHz are almost completely absorbed. Only signals radiated at a very high angle, and above a critical frequency where all signals are absorbed, manage to pass through the layer, being subsequently reflected by the E-layer.

Communication during daylight hours on the lowest frequencies of the HF spectrum from 3MHz to about 5MHz or so is thus limited to short distances, not much beyond ground-wave coverage.

Low angle radiation on these frequencies during the day travels a long way through the D-region and is thus absorbed.

The D-layer of course affects higher frequencies but its attenuation effect lessens as the frequency is increased.

## The E-layer

This occurs during daylight hours, the maximum density or peak of the layer lying between about 100 and 150km. It remains weakly ionised at night.

During daylight hours it stays at

practically a constant height. The height hardly varies from day to day. The electron density of the E-layer is lower in winter than in summer as the oblique angle of the solar radiation reduces the ionising effect.

E-layer ionisation is produced jointly by X-rays having wavelengths less than about 100 Angstroms — this ionising oxygen and nitrogen in the upper atmosphere at heights close to 100km — as well as UV radiation with wavelengths near 100 Angstroms which ionise oxygen.

The atmosphere in the E-region is still dense enough for recombination to take place fairly rapidly. As a consequence, the E-layer can only maintain its signal reflecting ability when it is continuously in sunlight.

Ionisation is generally the best around noon, disappearing rapidly some time after local sunset. (The sun sets on the ionosphere at a height of 100km about half an hour after local sunset.)

From a simple consideration of the geometry of the situation, communications via the E-layer has a maximum distance of about 2000km. See figure 8.

## The F-layer

The F-layer is that region of the ionosphere above about 150km extending up to 800km and beyond.

During daylight hours, two distinct layers appear in the F-region of the ionosphere — the lower is known as the F<sub>1</sub> layer, the upper as the F<sub>2</sub> layer.

The F<sub>1</sub> layer generally occurs around a height of 200km and does not vary greatly in height. Its ionisation density is lower in winter than in summer.

As one would expect, the F<sub>2</sub> layer, being the uppermost has the greatest ionisation and shows considerable variations in density and height.

The height of the base of the F<sub>2</sub> layer during daylight hours is very dependant on solar heating of the upper atmosphere. It varies between about 150km and 300km during winter months.

There is only one layer during the

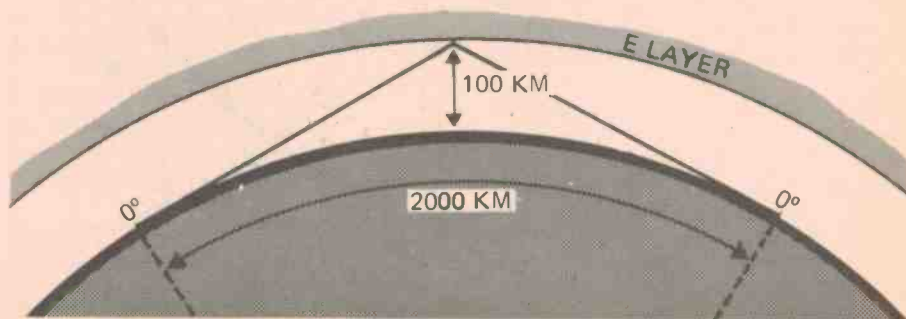

Fig. 8. Geometry of E-layer propagation. As the layer height is about 100 km, low angle radiation from a transmitter will reach distances of about 2000 km maximum.

night in the F-region which is likewise dependant on atmospheric temperature. The height and density of the night-time F-layer is also very variable owing to a number of factors.

Figure 9 illustrates typical variations of the F-layer throughout the day.

The principal ionising agent of the F-layer is the extreme ultra-violet region (EUV). Solar UV with wavelength between about 200 and 800 Angstroms does most of the work in this respect. Radiation at these wavelengths ionises molecular nitrogen and atomic oxygen at heights between about 150 and 180km.

The resulting electron distribution with height does not always show a peak at this level— when there is a peak it is usually that of the F1 layer.

The shape of the F<sub>2</sub> layer electron distribution, and thus the height of the peak, is largely determined by the variation with height of the loss process and by diffusion of the electrons to other regions. Ions and electrons diffuse above the peak of the layer, the production and loss of electrons (by recombination etc) below the peak determine both the position of the peak and the shape of the layer. The peak then occurs at a height where the effects of diffusion and loss of electrons reaches an equilibrium.

The F-layer will provide communications out to a range of 4000km on a single 'hop', multi-hop propagation being used for distances greater than this.

The F<sub>1</sub> layer will provide communications up to about 9 or 10 MHz during the day. The F<sub>2</sub> layer will support propagation beyond 30 MHz under favourable conditions, even higher in frequency and for longer durations at lower frequencies, during a sunspot maximum.

The maximum usable frequency of the F-layer varies seasonally, being greater during summer than during winter.

### Summary so far

The daytime ionosphere consists of an absorbing region — the D-region — with three reflecting ionised layers above that — the E, F<sub>1</sub> and F<sub>2</sub> layers.

The night-time ionosphere consists almost entirely of the F-layer.

It should be noted that the allocation of the letters of these layers was made by Sir Edward Appleton. It was he who did most of the early investigative work on the ionosphere. The F-layer, which he discovered, is also known as the "Appleton Layer". The E-layer was originally named the "Kennelly-Heaviside Layer" (or just the Heaviside Layer) after the two gentlemen who discovered its existence.

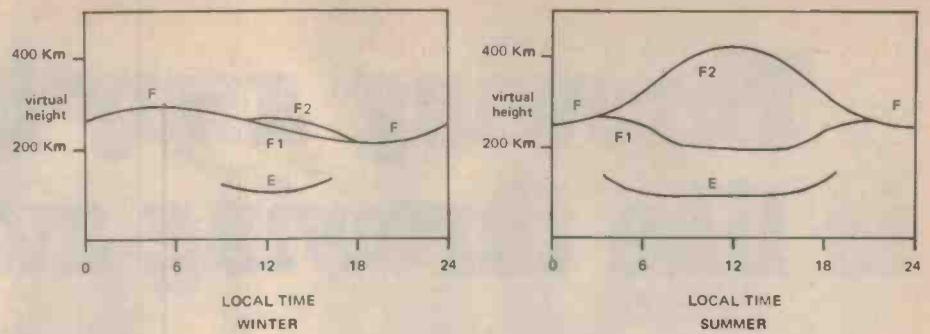

Fig. 9. Typical diurnal (daily) variations of the F-layer and E-layer heights for winter (left) and summer (right), as measured by an ionosonde — an instrument which measures the parameters of the various ionospheric layers.

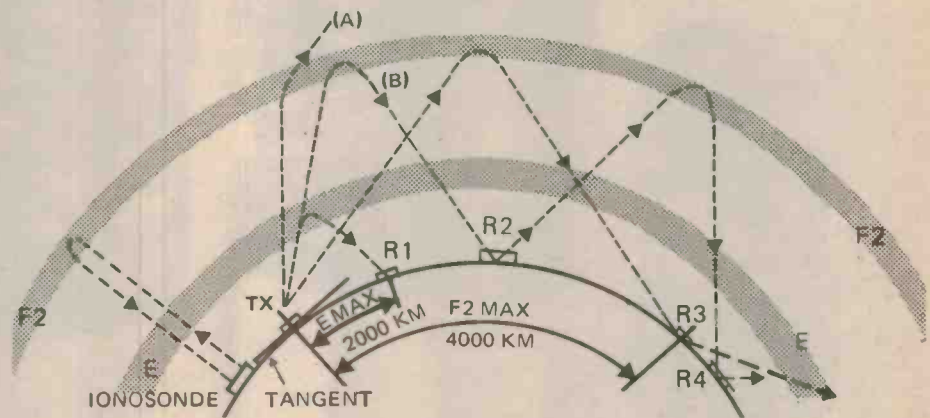

Fig. 10. The transmitter (TX) radiating RF at several different angles illustrates how signals are propagated by the various layers. A wave radiated at a high angle will be deviated by one or both of the layers, but unless the layer is dense enough, will pass through (A). A ray at a lower angle (B) will skip a relatively short distance and may do so several times (R2 - R4 etc.). A low angle ray from TX will skip a maximum of 4000 km from the F2 layer (TX to R3) and subsequently further. The ionosonde measures the heights and critical penetration frequencies of the layers vertically.

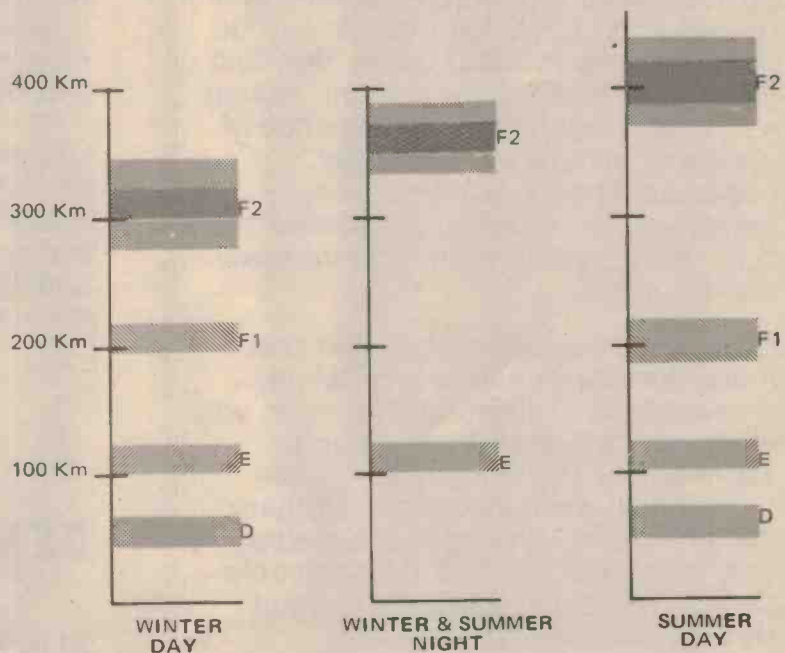

Fig. 11. Illustrating the diurnal and seasonal variations in the various layers.

Figs. 6 & 7 after J.A. Ratcliffe, 'SUN, EARTH AND RADIO', World University Library, 1970. In fact, if you want a good book on the subject, complete with charming historical anecdotes — this is it.

# Throwing away batteries is like throwing away money



The G.E. rechargeable battery system saves you money. Once the carbon zinc or alkaline battery dies they're thrown away. This wastes money and resources. G.E. Nickel Cadmium can be recharged up to 1000 times. They last for years. They are convenient, saving you time, trouble and the expense of replacing ordinary throw away batteries. The more throw away batteries you're using, the sooner the G.E. rechargeable battery system will pay for itself.

G.E. rechargeable batteries do cost more than carbon zinc or alkaline throw aways at first, but they cost you much less when recharging up to 1000 times. The G.E. rechargeable battery will work as well as ordinary batteries, and in most cases, better. The voltage of the G.E. rechargeable battery remains relatively constant throughout their discharge.

G.E. rechargeable batteries will last as well as throw away batteries in most products. The G.E. rechargeable battery system is now available in

Australia and has achieved a high degree of acceptance in industry and government, for use in calculators, photographic and electronic equipment, flash lighting and emergency lighting and all areas where portable power is required.

G.E. rechargeable batteries are available in two types, standard for industrial and domestic use, and heavy duty for use in areas of high ambient temperature and continued discharge overload.

**GENERAL  ELECTRIC**

**AUSTRALIAN GENERAL ELECTRIC LTD.**

Sydney. Telephone 212 3711

Telex 20811

Electronics components section.

# COMPARE OUR **Seif** DIGITAL MULTIMETER WITH 5 SIMILAR UNITS SELLING FOR UP TO \$205 . . .

| MULTIMETER  | PRICE   | READOUT    | DC ACCURACY                                         | RESOLUTION | CURRENT | RESISTANCE  | AC FREQUENCY RESPONSE |
|-------------|---------|------------|-----------------------------------------------------|------------|---------|-------------|-----------------------|
| <b>SEIF</b> | \$145   | 11 mm LED  | $\pm 0.1\% \pm 0.2\% \text{RDG} \pm 1 \text{ dig}$  | 100uV      | AC & DC | 2k to 20M   | 16Hz - 10kHz          |
| Brand A     | \$151   | 7.5 mm LED | $\pm 0.25\% \pm 0.5\% \text{RDG} \pm 1 \text{ dig}$ | 1mV        | AC & DC | 0.2k to 20M | 50Hz - 400Hz          |
| Brand B     | \$81.90 | 7.5 mm LED | $\pm 1\% \pm 1 \text{ digit}$                       | 1mV        | DC      | 1k to 20M   | 40Hz - 5 kHz          |
| Brand C     | \$89.10 | 9.5 mm LED | $\pm 1\% \pm 1 \text{ digit}$                       | 100mV      | DC      | 1k to 1M    | -                     |
| Brand D     | \$80.00 | 8.5 mm LED | $\pm 0.5\% \pm 1 \text{ digit}$                     | 1mV        | AC & DC | 1k to 1M    | 50Hz - 400Hz          |
| Brand E     | \$205   | 11 mm LCD  | $\pm 0.25\% \pm 1 \text{ digit}$                    | 100uV      | AC & DC | 0.2k to 20M | -                     |

**... YOU'LL CHOOSE SEIF!**  
 STOCKS DUE IN JUNE - PLEASE RING STORE BEFORE COMING IN!



Cat Q-1440

*"Just imagine - up to ten times better accuracy . . . more ranges . . . bigger readouts. Yes it certainly pays to pay a little more for Seif performance!"*



**\$145.00**

Or from \$14.50 deposit and easy terms to approved applicants.

**SPECIFICATIONS:**

- DC Volt Ranges: 200mV, 2V, 20V, 200V and 1000V
- AC Volt Ranges: 100mV, 2V, 20V, 200V and 700V
- DC Current: 200uA, 2mA, 20mA, 200mA, 2000mA
- AC Current: 200uA, 2mA, 20mA, 200mA, 2000mA
- Resistance: 2K, 20K, 200K, 2M, 20M ohms.

**GENERAL:**

- Display: 3 1/2 Digit 7 segment red LEDs
- Overload Indication: Flashing Display
- Power Consumption: 800mW
- Weight: 650 grams (without batteries)
- Dimensions: 66(H) x 147(W) x 161(D)
- Accessories include: General purpose test lead set, colour coded (red and black) with banana jacks, and 4-1.5V penlight cells.

## DICK SMITH ELECTRONICS

**SYDNEY** 125 York Street, SYDNEY. Ph 29 1126  
 147 Hume Hwy, CHULLORA. Ph 642-8922  
 162 Pacific Hwy, GORE HILL Ph 439 5311  
 30 Grose Street, PARRAMATTA Ph 683 1133

**MELBOURNE** 399 Lonsdale Street, MELBOURNE. Ph 67-9834  
 656 Bridge Road, RICHMOND. Ph 42-1614  
**BRISBANE** 166 Logan Road, BURANDA. Ph 391-6233  
**ADELAIDE** 203 Wright Street, ADELAIDE. Ph 212-1962



SHOPS OPEN 9AM to 5.30PM  
 (Saturday 9AM - 12 noon)  
 BRISBANE 1/2 Hour earlier.

Many lines available from the  
 Dick Smith Electronics Centres at  
**GRACE BROS**  
 Broadway • Bondi Junction • Chatswood  
 Liverpool • Miranda Fair • Mt Druitt •  
 Parramatta • Roselands • Warringah Mall



**MAIL ORDERS** P.D. Box 747, Crows Nest, N.S.W. 2065. Post and pack extra. Dealers across Australia.

# KITS FOR ETI PROJECTS

We get many enquiries from readers wanting to know where they can get kits for the projects we publish. The list below indicates the suppliers we know about and the kits they do.

Any companies who want to be included in this list should phone LES BELL on 33-4282.

Key to companies:

- A** Applied Technology Pty. Ltd. 109-111 Hunter St, Hornsby. 2077. NSW.
- C** Amateur Communications Advancements, PO Box 57, Rozelle, NSW.
- D** Dick Smith Pty. Ltd. of Crows Nest, NSW. (see Ads. for address).
- E** All Electric Components (formerly ED & E Sales), 118 Lonsdale Street, Melbourne, Victoria, 3000.
- J** Jaycar Pty. Ltd. 405 Sussex St., Sydney 2000.
- L** Delsound Pty. 1 Wickham Terrace. Queensland.
- M** Mode Electronics. PO Box 365, Mascot 2020.
- N** Nebula Electronics Pty. Ltd. 15 - 19 Boundary St., Rushcutters Bay 2011. NSW.
- O** Appollo Video Games of Hornsby, NSW.
- P** Pre-Pac Electronics. 718 Parramatta Rd., Croydon NSW 2132.
- S** BKX Electronics Supply Service. 179 Victoria St., Kings Cross. NSW 2011.
- T** Townsville Electronics Centre. 281E Charters Towers Rd, Rising Sun Arcade, Hermit Park. 4812

## PROJECT ELECTRONICS

|         |                        |       |
|---------|------------------------|-------|
| ETI 041 | Continuity Tester      | DS    |
| ETI 043 | Heads or Tails         | DATSE |
| ETI 044 | Two-Tone Doorbell      | DATSE |
| ETI 045 | 500 Second Timer       | DS    |
| ETI 047 | Morse Practice Set     | DS    |
| ETI 048 | Buzz Board             | DS    |
| ETI 061 | Simple Amplifier       | DATS  |
| ETI 062 | Simple Amplifier Tuner | DSE   |
| ETI 063 | Electronic Bongo's     | DS    |
| ETI 064 | Intercom               | ATS   |
| ETI 065 | Electronic Siren       | DS    |
| ETI 066 | Temperature Alarm      | ADTSE |
| ETI 067 | Singing Moisture Meter | DS    |
| ETI 068 | Led Dice               | ADSE  |
| ETI 072 | 2-Octave Organ         | DS    |
| ETI 081 | Tachometer             | E     |

## TEST EQUIPMENT

|         |                               |      |
|---------|-------------------------------|------|
| ETI 102 | Audio Signal Generator        | E,DS |
| ETI 105 | Lab Power Supply              | E    |
| ETI 107 | Widerange Voltmeter           | E    |
| ETI 108 | Decade Resistance Box         | ES   |
| ETI 109 | Digital Frequency Meter       | E    |
| ETI 111 | IC Power Supply               | ES   |
| ETI 112 | Audio Attenuator              | ES   |
| ETI 113 | 7-Input Thermocouple Meter    | P,E  |
| ETI 116 | Impedance Meter               | ES   |
| ETI 117 | Digital Voltmeter             | E,AS |
| ETI 118 | Simple Frequency Counter      | E,AS |
| ETI 119 | 5V Switching Regulator supply | ETS  |
| ETI 120 | Logic Probe                   | L,ES |
| ETI 121 | Logic Pulser                  | L,ES |
| ETI 122 | Logic Tester                  | ES   |
| ETI 123 | CMOS Tester                   | ES   |
| ETI 124 | Tone Burst Generator          | ES   |
| ETI 128 | Audio Millivoltmeter          | L,ES |
| ETI 129 | RF Signal Generator           | L,ES |
| ETI 130 | Temperature Meter             | E    |
| ETI 131 | General Purpose power supply  | E,N  |
| ETI 132 | Power Supply                  | NSE  |
| ETI 133 | Phase Meter                   | E    |
| ETI 134 | True RMS Voltmeter            | E    |

## SIMPLE PROJECTS

|         |                                |     |
|---------|--------------------------------|-----|
| ETI 206 | Metronome                      | T   |
| ETI 218 | Monophonic Organ               | ET  |
| ETI 219 | Siren                          | ET  |
| ETI 220 | Siren                          | ET  |
| ETI 222 | Transistor Tester              | ETS |
| ETI 234 | Simple Intercom                | T   |
| ETI 236 | Code Practice Oscillator       | E   |
| ETI 239 | Breakdown Beacon               | E   |
| ETI 240 | High Powered Emergency Flasher | E   |

## MOTORISTS' PROJECTS

|         |                              |      |
|---------|------------------------------|------|
| ETI 301 | Vari-Wiper                   | ET   |
| ETI 302 | Tacho Dwell                  | ET   |
| ETI 303 | Brake-light Warning          | E    |
| ETI 305 | Car Alarm                    | E    |
| ETI 309 | Battery Charger              | P,E  |
| ETI 312 | CDI Electronic Ignition      | P,ET |
| ETI 313 | Car Alarm                    | E,DT |
| ETI 316 | Transistor Assisted Ignition | E    |
| ETI 317 | Rev. Monitor                 | E    |

## AUDIO PROJECTS

|          |                            |          |
|----------|----------------------------|----------|
| ETI 401  | Audio Mixer FET Four Input | E        |
| ETI 406  | One Transistor Receiver    | T        |
| ETI 408  | Spring Reverb. Unit        | E        |
| ETI 410  | Super Stereo               | E        |
| ETI 413  | 100 Watt Guitar Amp        | P,L,J,DT |
| ETI 413  | x 200 Watt Bridge Amp      | SE       |
| ETI 414  | Master Mixer               | E,J      |
| ETI 416  | 25 Watt Amplifier          | E        |
| ETI 417  | Amp Overload Indicator     | E        |
| ETI 419  | Guitar Amp Pre-Amp         | P,E,DT   |
| ETI 420  | Four-channel Amplifier     | L,E      |
| ETI 420E | SQ Decoder                 | E        |
| ETI 422  | International Stereo Amp   | S,L,D    |
| ETI 422B | Booster Amp                | E        |
| ETI 422  | 50 Watt Power Module       | E        |
| ETI 423  | Add-on Decoder Amp         | E        |
| ETI 424  | Spring Reverbation Unit    | S,L,E    |
| ETI 425  | Integrated Audio System    | E        |
| ETI 426  | Rumble Filter              | E        |
| ETI 427  | Graphic Equaliser          | S,L,E,J  |
| ETI 429  | Simple Stereo Amplifier    | E        |
| ETI 433  | Active Crossover           | J        |
| ETI 435  | Crossover Amp              | J        |
| ETI 438  | Audio Level Meter          | L,ES     |
| ETI 440  | Simple 25 Watt Amp         | L,E      |
| ETI 441  | Audio Noise Generator      | L,ES     |
| ETI 443  | Compressor-Expander        | E,J      |
| ETI 444  | Five Watt Stereo Preamp    | ES       |
| ETI 445  | Preamp                     | J,E,D    |
| ETI 446  | Audio Limiter              | J        |
| ETI 447  | Phaser                     | E,J      |

|          |                        |      |
|----------|------------------------|------|
| ETI 449  | Balanced Mic Preamp    | JE   |
| ETI 480  | 50 W. 100 W Power Amp  | A    |
| ETI 480P | Power Supply           | DAT  |
| ETI 481  | 12V to 40V DC Inverter | E    |
| ETI 482A | Preamp Module          | AE   |
| ETI 482B | Tone Controller        | AE   |
| ETI 484  | Compressor Expander    | E    |
| ETI 485  | Graphic Equalizer      | JSE  |
| ETI 480  | 50W, 100W Power Amp    | ADBE |

## MISCELLANEOUS

|         |                                 |         |
|---------|---------------------------------|---------|
| ETI 502 | Emergency Flasher               | E       |
| ETI 503 | Burglar Alarm                   | ET      |
| ETI 505 | Strobe                          | L,E,D   |
| ETI 506 | Infra-Red Alarm                 | E       |
| ETI 509 | 50-Day Timer                    | E       |
| ETI 512 | Photographic Timer              | E       |
| ETI 513 | Tape Slide/Synchroniser         | E       |
| ETI 514 | Flash Unit - Sound Operated     | E       |
| ETI 515 | Flash Unit - Light operated     | E       |
| ETI 518 | Light Beam Alarm                | ET      |
| ETI 525 | Drill Speed Controller          | E       |
| ETI 528 | Home Burglar Alarm              | P,ET,MS |
| ETI 529 | Electronic Poker Machine        | E       |
| ETI 532 | Photimer                        | E       |
| ETI 533 | Digital Display                 | L,E,AS  |
| ETI 534 | Calculator Stopwatch            | A,D     |
| ETI 539 | Touch Switch                    | E       |
| ETI 540 | Universal Timer                 | ES      |
| ETI 541 | Train Controller                | ET      |
| ETI 543 | Double Dice                     | A       |
| ETI 544 | Heartrate Monitor               | AE      |
| ETI 546 | GSR Meter                       | E       |
| ETI 547 | Telephone Bell Extender         | E       |
| ETI 548 | Photographic Strobe             | E       |
| ETI 549 | Induction Balance Metal Locator | E       |
| ETI 581 | Dual Power Supply               | E       |
| ETI 582 | House Alarm                     | E       |
| ETI 583 | Gas Alarm                       | ME      |
| ETI 586 | Shutter Speed Timer             | E       |

## ELECTRONIC MUSIC

|         |                            |       |
|---------|----------------------------|-------|
| ETI 601 | 4600 Synthesiser           | J     |
| ETI 601 | 3600 Synthesiser           | J     |
| ETI 602 | Mini Organ                 | E,A,D |
| ETI 604 | Accentuated Beat Metronome | E     |

## COMPUTER PROJECTS

|         |                         |    |
|---------|-------------------------|----|
| ETI 630 | Hex Display             | AE |
| ETI 631 | VDU Keyboard Encoder    | AE |
| ETI 632 | VDU 1 k x 8 Memory Card | AE |
| ETI 633 | VDU Sync Generator      | AE |

## RADIO PROJECTS

|           |                               |          |
|-----------|-------------------------------|----------|
| ETI 701   | TV Masthead Amplifier         | E,D      |
| ETI 702   | Radar Intruder Alarm          | DE       |
| ETI 703   | Antenna Matching Unit         | E        |
| ETI 704   | Crosshatch/Dot Generator      | L,A,D,ES |
| ETI 706   | Marker Generator              | ES       |
| ETI 707   | Modern Solid State Converters | C,E      |
| ETI 708   | Active Antenna                | E        |
| ETI 709   | RF Attenuator                 | E        |
| ETI 710   | 2 metre Booster               | C,E      |
| ETI 711B  | Single Relay Remote Control   | AE       |
| ETI 711C  | Double Relay Remote Control   | AE       |
| ETI 711R  | Receiver                      | AE       |
| ETI 711AR | Remote Control Transmitter    | AE       |
| ETI 711DR | Remote Control Decoder        | AE       |
| ETI 712   | CB Power Supply               | E        |
| ETI 740   | FM Tuner                      | AE       |
| ETI 780   | Novice Transmitter            | E        |

## ELECTRONIC GAMES

|         |              |        |
|---------|--------------|--------|
| ETI 804 | Selecta-Game | O,A,DS |
|---------|--------------|--------|

# BOOK REVIEWS

**World Radio TV Handbook, 32nd Edition, Billboard Publications Inc. \$12.95. Review copy kindly supplied by the Technical Book Co, 295 Swans-ton Street, Melbourne.**

Well, what can we say! This is the standard reference book, the 'bible', if you like, of broadcast band listeners all round the world. Most of the WRTV Handbook is taken up by a listing of the broadcasting stations of every country in the world including frequencies, transmitter power, call signs and station names. For each station, programme information, including times frequencies and beam areas is listed, as well as signature music where appropriate. In order to get all this information in, it is condensed enormously by the use of abbreviations, which means that it is difficult to use at first, but with practice it becomes easy to find one's way around the book.

There is absolutely no way the serious DXer, or even just the interested occasional listener, can get by without this book. It makes sense of what can sometimes seem to be chaos on the broadcast bands, and increases the 'productivity' of hours spent at the receiver.

Apart from the reference material in the book, there are also several articles reviewing new receivers and discussing antennas, frequency counters, clandes-

tine radio stations and log period quad antennas, amongst other things.

For the short wave listener who wants to know where it's at, this is *the* book.

**The Radio Amateur's Handbook, 1978 Edition, American Radio Relay League. \$12.95. Review copy kindly supplied by the Technical Book Co, 295 Swans-ton Street, Melbourne.**

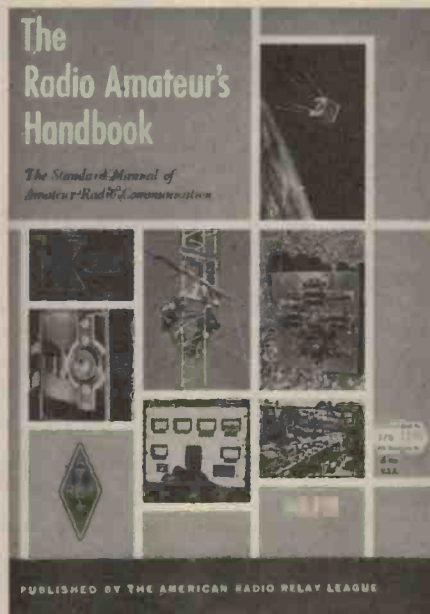

Again, what can we say? Another standard reference, the amateur's 'bible' is on the bookshelf of most shacks already. If you've already got the 1977 edition, it's hardly worth looking at this one - there is a new section on portable AC generators and a new treatment of antenna theory, but for the most part it is the same as the last edition.

But if you only have an old and dog-eared copy of this worthy 700-page (almost) tome, or if - by some sin of omission - you haven't got one at all, then the Radio Amateur's Handbook is a must. It covers just about every facet of amateur radio in a most practical fashion, including principles, HF and VHF/UHF transmitters and receivers, mobile and emergency operation, antennas and feeders, single sideband, FM and repeaters, and so on.

Emphasis throughout the book is on successful construction techniques backed up by solid design - the reader of this book is concerned more with building gear (and getting it to work) rather

than design. Several sophisticated receiver and transmitter projects are described in detail, as well as test equipment and station accessories.

For everyone planning on sitting Novice or other amateur exams, this book will provide a standard text.

**Microelectronics and Reliability Vol 16, No 4, special issue on Semiconductor Technology, 1977, Pergamon Press, \$19.25. Review copy kindly supplied by the publishers.**

This special issue of the professional journal Microelectronics and Reliability contains some of the papers read at the Seminec Seminar held at Imperial College, London in April last year. There are 24 papers on various topics: multiprocessor systems, testing and packaging of hybrids, solar panels, the obsolescence of the microprocessor (?), third generation micros, assemblers, semiconductor processing, A/D conversion, CCD's and bubble memories, LSI CMOS and an industry standard for B-series CMOS.

All the papers are presented by experts in their fields and are well up to date. Probably the papers of most interest to our readers are those concerned with microprocessors which form about one-third of the book, but anyone in industry who is involved with microelectronics would find something of use in its pages.

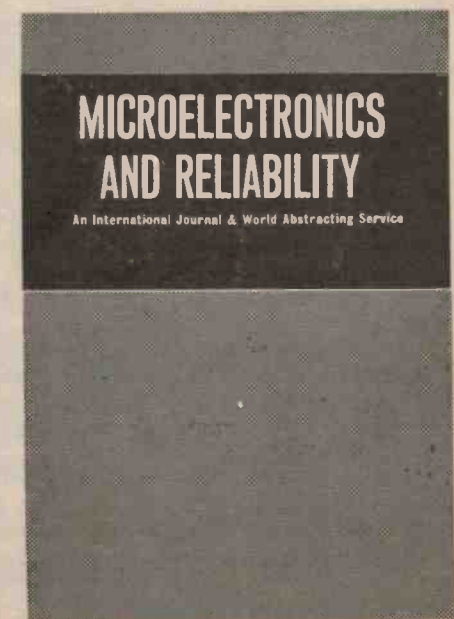
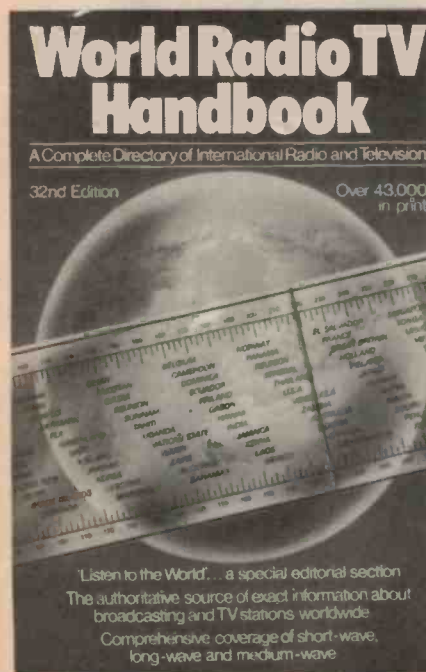

## SCOOP PURCHASE !!!

### Scientific Calculator Module

This incredible module measures only 2" x 1" yet is a complete calculator including 8 digit LED display with full floating decimal system. Application notes are included and addition of a suitable keyboard will produce a full calculator with:

- Reverse Polish Notation
- Common and natural logs/antilogarithms
- Sine, cosine, tangent and inverse trig functions
- Automatic calculation of powers and roots
- Conversion of radians to degrees and vice versa

The SCM100 module can readily be adapted to become a highly accurate stopwatch or even an economy output for a microprocessor. All that is required is to supply a 9V battery and address the relevant points in the 8 x 5 input matrix.

SCM100 MODULE complete with application notes \$14.75

### T.V. MODULATOR I.C. LM1889

I.C. by National Semiconductor can be used to modulate video to any TV aerial socket. Ideal for microprocessor VDU's and TV games. The LM1889 has provision to modulate sound to the TV loudspeaker and can be adapted to produce colour as well. Supplied with full data and application sheets.

LM1889 . . . . . \$3.75

## MICROPROCESSORS

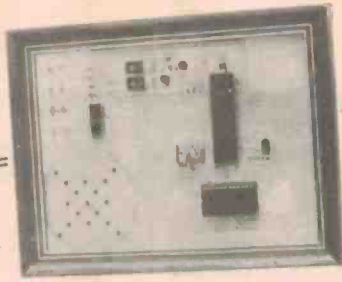

### COMPUTER DOORBELL

A real first, this SC/MP controlled doorbell has been designed and produced in Australia. See ETI March 1978 for full details. This kit comes complete with all components, full instructions for assembly and unique picture frame mount. Can be readily programmed to play any tune although kit is supplied with 8 preprogrammed tunes including:

WALTZING MATILDA TRUMPET VOLUNTARY  
GREENSLEEVES TWINKLE TWINKLE LITTLE STAR  
RULE BRITANNIA COLONEL BOGIE MARCH  
CAN CAN COMPUTER MUSIC

This is an ideal kit for everyone even remotely interested in microprocessors. Picture frame displays finished PCB with all components so you can boast to all your friends and show off the actual computer chips!

ETI 639 kit . . . . . \$39.50

### 2650 COMPUTERS

Baby 2650 as described in E.A. this is an ideal starter kit. We include full instructions for assembly as well as programming manual and sample programs to run. Ideal to use with the new E.A. VDU. . . . \$75.00

KT9500 fully buffered 2650 with 512 bytes RAM, PIPBUG, I/O ports, RS232 and TTY serial I/O. Can be readily expanded using our mother board (see E.A. March 1978) . . . . . \$199.00

Conversion Kit enables you to convert the Baby 2650 to a KT9500 . . . . . \$142.00

### NEW E.A. VIDEO DISPLAY TERMINAL

Described in E.A. Feb/April 1978 this project is an ideal terminal for microprocessor applications. We are pleased to offer this exciting VDU as a package deal or, for those who prefer as a set of individual kits. Naturally we offer our full technical support and backup service (full details with each kit).

VDU Logic Board complete kit with all components, crystal, plated through hole PCB and assembly/troubleshooting manual. . . . . \$99.50

KB04 Top Quality Keyboard Kit with PCB to simplify construction and connection to encoder module . . . . . \$59.50

E.A. 78ut4 Encoder/UART/Power supply module complete with all components including UART and 5740 encoder, power supply and transformers. . . . . \$47.50

VIDEO MODULATOR Complete kit . . . \$4.50

METALWORK: Quality enamel finished console prepunched for KB04 keyboard . . . . . \$24.50

Cost of individual kits purchased separately . . \$235.50  
Complete package deal including assembly manual . . . . . \$214.00

### LOW COST CLOCK MODULES

MA1002b  
LED Alarm Clock \$11.95  
Transformer JT197 \$4.05  
(for MA1002 module)

MA1003  
Crystal controlled 12V gas discharge module. Ideal for cars or boats and can be readily adapted to battery backup applications \$22.50

#### MICROPROCESSORS

|       |       |
|-------|-------|
| 8080A | 16.75 |
| 6800  | 24.50 |
| 2650  | 26.50 |
| SC/MP | 16.75 |

#### SUPPORT DEVICES

|                                   |       |
|-----------------------------------|-------|
| 8212 8 bit I/O                    | 4.95  |
| 8215 bus driver                   | 5.95  |
| 8224 clock generator              | 8.50  |
| 8228 system controller/bus driver | 10.95 |
| 8255 programmable peripheral I/O  | 16.50 |
| 6810 128 byte RAM                 | 6.50  |
| 6820 PIA                          | 13.75 |
| 6850 ACIA                         | 13.75 |
| 6860 0 - 600 BPS modem            | 15.75 |
| 8T26 bus transceiver              | 3.75  |
| 8T97/98 bus drivers               | 1.90  |
| 8T31 8 bit bidirectional I/O port | 5.75  |
| 81LS95/96 octal tristate buffers  | 1.95  |
| 81LS97/98 octal tristate buffers  | 1.95  |
| DP8304 8 bit bidirectional driver | 6.25  |
| DM8131 6 bit address comparator   | 3.50  |
| DM8554 quad switch debouncer      | 2.25  |
| DM8553 8 bit addressable latch    | 4.25  |

#### PROMS

|                            |       |
|----------------------------|-------|
| 2708 E Prom 1K x 8         | 18.25 |
| 5204 E Prom 512 x 8        | 18.25 |
| 82S23 fusible link 32 x 8  | 3.75  |
| 82S123 fusible link 32 x 8 | 3.75  |

#### A/D D/A CONVERTERS

|                              |       |
|------------------------------|-------|
| 5357 8 bit A/D               | 12.75 |
| MC1408-7 8 bit D/A converter | 3.95  |

#### ETC

|                                 |       |
|---------------------------------|-------|
| 2513 character generator        | 11.95 |
| 5303 UART                       | 5.75  |
| 1602 UART                       | 7.50  |
| 5740 keyboard encoder           | 19.75 |
| 57109 number cruncher with data | 19.75 |
| 2101 256 x 4 RAM (static)       | 4.25  |
| 2102 1K x 1 RAM (static)        | 1.95  |
| 2112 1K x 1 RAM (static)        | 3.75  |
| 2114 1K x 4 RAM                 | 14.25 |

LIMITED STOCKS  
AVAILABLE ON SOME  
ITEMS  
POST & PACKAGE \$1.00

#### SOCKETS

|                  |      |
|------------------|------|
| 14 pin wire wrap | .60  |
| 16 pin wire wrap | .65  |
| 8 pin solder     | .35  |
| 14 pin solder    | .40  |
| 16 pin solder    | .45  |
| 18 pin solder    | .50  |
| 22 pin solder    | .85  |
| 24 pin solder    | .90  |
| 28 pin solder    | 1.20 |
| 40 pin solder    | 1.60 |

#### MICROPROCESSOR CRYSTALS

|         |      |
|---------|------|
| 1 MC    | 7.95 |
| 2 MC    | 7.95 |
| 4 MC    | 7.95 |
| 4.43 MC | 4.25 |
| 5 MC    | 7.95 |
| 10 MC   | 7.95 |
| 12 MC   | 7.95 |
| 18 MC   | 7.95 |
| 20 MC   | 7.95 |



**APPLIED  
TECHNOLOGY  
PTY. LTD.**

POST & PACK ON KITS \$2.50

POSTAL ADDRESS P.O. Box 355, Hornsby, 2077

SHOWROOM 109-111 Hunter St., Hornsby 2077

(9-5 Monday to Sat.)

PHONE 476 4758 - 476 3759

PRICES SUBJECT TO CHANGE AFTER MAY 30th, 1978.





# S100 VDU

Constructional details for our advanced VDU. Circuit and board design by David Griffiths and text by Les Bell.

THIS MONTH WE GIVE complete constructional details for the ETI 640 VDU, and give information about several points on the circuit which may require elaboration.

Last month we published the 'How It Works' section, which can now be laid out beside the circuit diagram. Prospective constructors would be well advised to sit down and read through this material checking it against the circuit diagram. A couple of errors in our IC numbering scheme appeared last month - under 'Positioning', the final counter is IC13, not IC14, under 'Graphics', the graphics multiplexer is IC14, not IC15; and under 'Black on White Characters' the 'D' flip flop referred to is IC18. These alterations should be incorporated immediately to avoid later confusion.

In order to minimise both the size and complexity of the circuit diagram, the two blocks of RAM have been represented as one box on the drawing. On the top edge of the box, it can be seen that each DO line goes, via a buffer, to pin 11 of a different 2102 RAM IC, and likewise, each of the DI lines comes from pin 12 of a different IC (right edge). The address lines go to all of the IC's in parallel. Note also that, in S100 parlance, the DO (Data Out) lines are outputs from the CPU (hence inputs to the VDU) and the DI (Data In) lines are CPU inputs, (hence outputs from the VDU). Further information on the S100 bus signals can be found in our September 1977 issue.

MERQ (pin 65) is not a regular S100

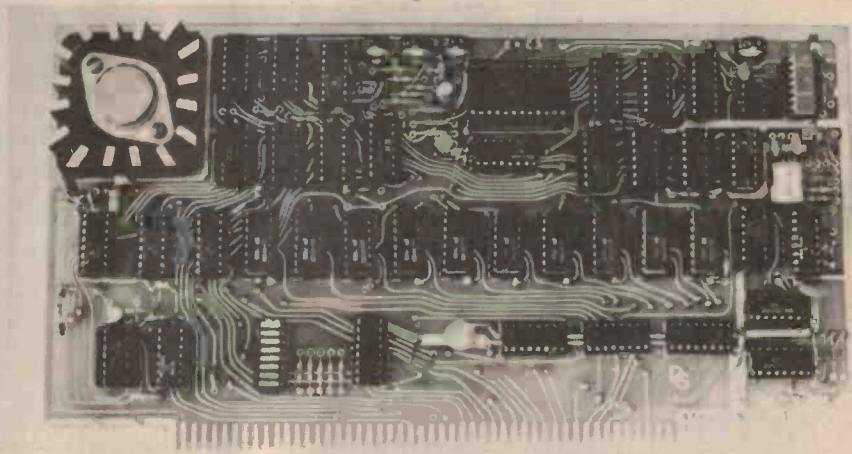

Fig.1. The VDU board prototype.

signal, but was included on the prototype as a means of avoiding some potential problems with the VDU responding to 'mirrored' I/O addresses put out on the upper eight bits of the 8080 address bus. In practice, this is not a problem, and pin 7 of IC34 is normally linked to ground.

Two other links on the board (above IC39 and above IC10) allow 32 character/line operation and operation with a 6 MHz clock. However, the 6 MHz clock modification is not fully implemented, being a 'hangover' from a previous prototype design - nonetheless, we have left it in for the benefit of those incorrigible individuals who must modify their projects.

The data sheet for the MCM6574 reveals that this device requires +5V, +12V and -3V supplies. Where, I hear you ask, does the -3V come from? The answer lies in IC9, a 7404, three gates of which are connected as an oscillator which pumps charge into the D12-D15, C9, 10 and C17 network to produce a negative supply.

## Construction

The ETI 640 is not very difficult to assemble since there is no mechanical construction involved. However, it is a very complex board, and several points should be noted in order to ease construction. Firstly, the board was designed to be through-hole plated to



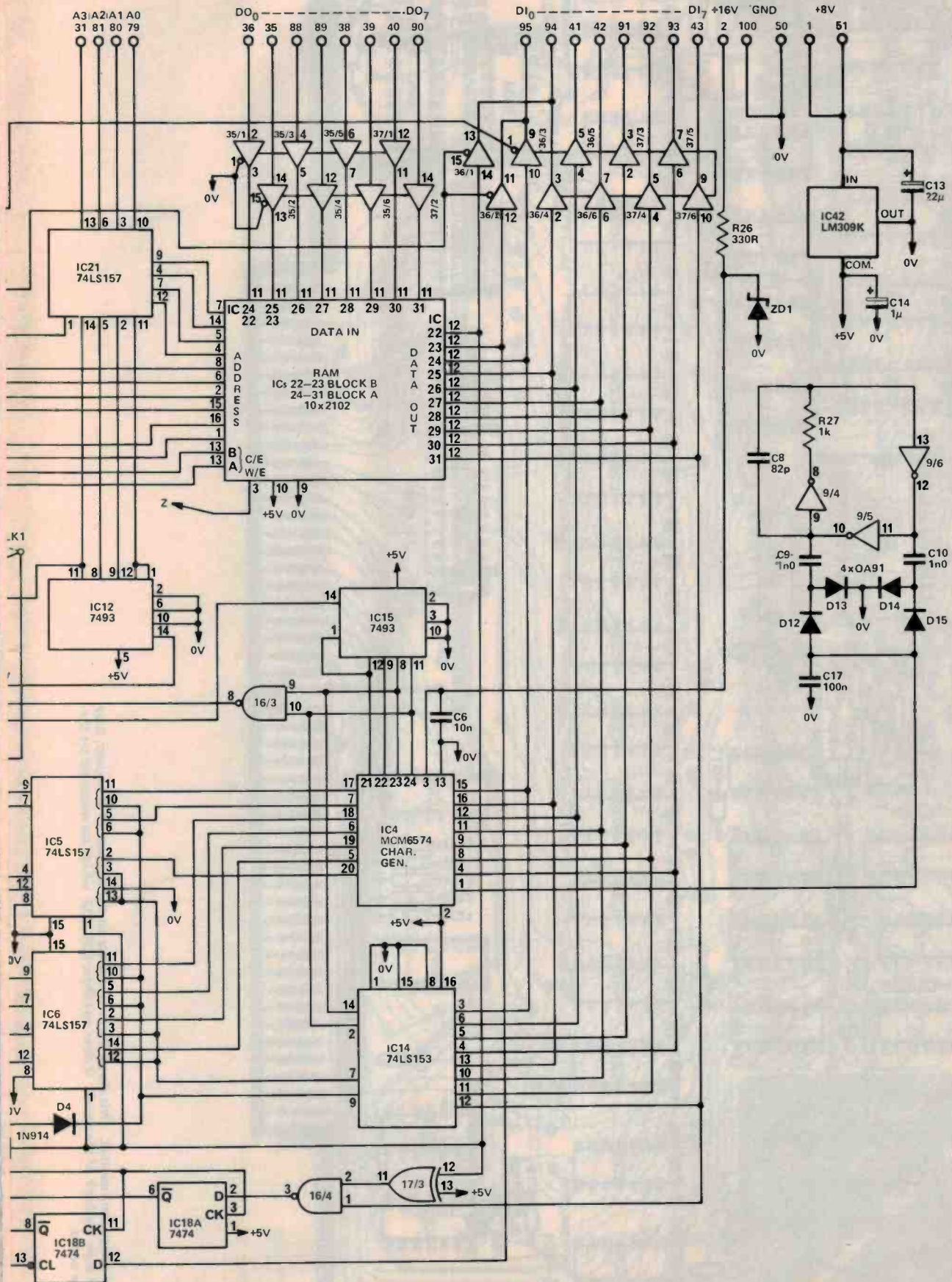

Fig.2. Circuit diagram of the VDU. This should be read in conjunction with the 'How It Works' section published last month.



## Project 640

simplify construction and improve reliability. Although it is possible to build the VDU on a double sided board by soldering links through the board, we strongly recommend use of the through-hole-plated board. Our prototypes were constructed the hard way, by soldering both sides of the board, and believe me, it's no fun! Although the through-hole-plated board is more expensive, we believe the extra money is well worth spending.

The boards will be available shortly from Applied Technology. For all you diehards who are intent on doing it the hard way, although PCB patterns are not printed in the magazine, they are available from us. Send a large stamped self-addressed envelope to 'VDU PCB's', ETI Magazine, 15 Boundary Street, Rushcutters Bay, NSW 2011 and we shall send the patterns back.

If you are using your own printed circuit board, you should start by soldering links through the board in positions which will later be covered by IC's — i.e. IC4, IC11 and IC16. It is virtually impossible to solder the other links in until most of the other components are in place, so these will have to wait until later, when they can be inserted before the IC's.

Construction should commence with the insertion and soldering of all IC sockets (if used), SW1 and the links. Care should be taken with the orientation of sockets, and later, IC's, since they are not all the same way up. All the resistors should be inserted next, followed by capacitors C1-C28, except for C13 which is later mounted on the back of the board. The diodes and transistors can now be soldered in, followed by the potentiometers, and IC42 with its heatsink. Now the board can be flipped over, and C13 soldered onto the back of the board, followed by C29-C39. These 10 nF bypass capacitors mount on the back of the board, across the supply pins of IC's 2, 3, 5, 6, 9, 11, 12, 15, 16, 17 and 18.

At this point, before inserting any other IC's, it is wise to apply power to the board and check for the correct voltage at the regulator output and also on pin 3 of IC4 (which is not yet inserted). If these points are at +5V and +12V respectively, then proceed to either plug in or solder in the remaining IC's, taking care with orientation, and finally solder the crystal in, being careful not to apply excess heat.

This concludes construction of the VDU, and all you have to do now is work up the courage to switch on!

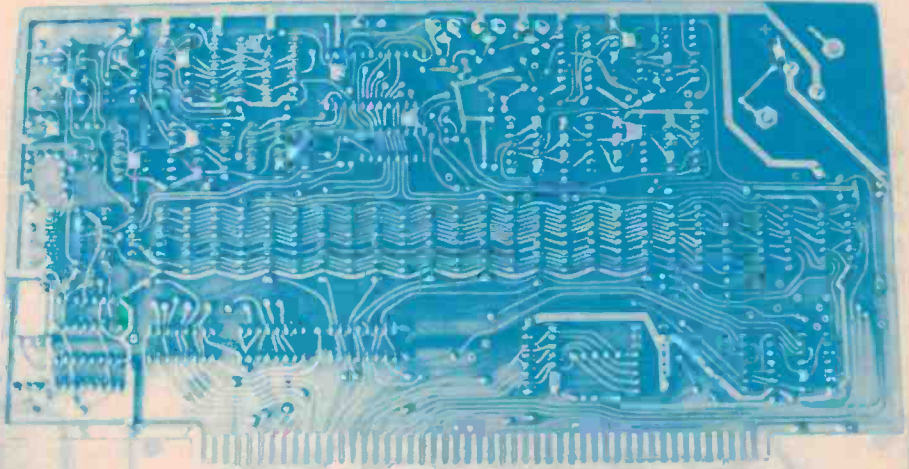

Fig. 4. This photograph shows how the bypass capacitors C29-C39 mount on the back of the board. Since C21-C28, on the front of the board, and C29-C39, on the back, are simply bypass capacitors connected between supply lines and ground, they are omitted from the circuit diagram for clarity.

### PARTS LIST — ETI 640

|                     |                 |                                       |                                 |
|---------------------|-----------------|---------------------------------------|---------------------------------|
| <b>Resistors —</b>  | all ¼W, 5%      | <b>Potentiometers</b>                 |                                 |
| R1 - R4 . . . . .   | 10k             | RV1,2 . . . . .                       | 50k trimpot                     |
| R5,6 . . . . .      | 4k7             | RV3 . . . . .                         | 10k trimpot                     |
| R7 . . . . .        | 22k             | RV4 . . . . .                         | 50k trimpot                     |
| R8 . . . . .        | 330R            |                                       |                                 |
| R9 . . . . .        | 100R            | <b>Semiconductors</b>                 |                                 |
| R10 . . . . .       | 330R            | IC1,2 . . . . .                       | 7473                            |
| R11 . . . . .       | 150R (see note) | IC3 . . . . .                         | 74LS221                         |
| R12 . . . . .       | 120R            | IC4 . . . . .                         | MCM6574                         |
| R13 . . . . .       | 220R            | IC5,6 . . . . .                       | 74LS157                         |
| R14 . . . . .       | 470R            | IC7 . . . . .                         | 74LS165                         |
| R15 . . . . .       | 4k7             | IC8 . . . . .                         | NE555                           |
| R16 . . . . .       | 10k             | IC9 . . . . .                         | 7404                            |
| R17 . . . . .       | 2k7             | IC10 - IC12 . . . . .                 | 7493                            |
| R18 . . . . .       | 150k            | IC13 . . . . .                        | 7490                            |
| R19 . . . . .       | 47k             | IC14 . . . . .                        | 74LS153                         |
| R20 . . . . .       | 150R            | IC15 . . . . .                        | 7493                            |
| R21 - R25 . . . . . | 10k             | IC16 . . . . .                        | 7400                            |
| R26 . . . . .       | 330R            | IC17 . . . . .                        | 7486                            |
| R27 . . . . .       | 1k              | IC18 . . . . .                        | 7474                            |
| R28 . . . . .       | 4k7             | IC19 - IC21 . . . . .                 | 74LS157                         |
|                     |                 | IC22 - IC31 . . . . .                 | 21L02-1                         |
| <b>Capacitors</b>   |                 | IC32 . . . . .                        | 74LS04                          |
| C1 . . . . .        | 10n             | IC33 . . . . .                        | 74LS10                          |
| C2 . . . . .        | 470p            | IC34 . . . . .                        | 8131                            |
| C3 . . . . .        | 220n            | IC35 - IC37 . . . . .                 | 8097                            |
| C4 . . . . .        | 1n0             | IC38,39 . . . . .                     | CD4040                          |
| C5 . . . . .        | 22µ tantalum    | IC40 . . . . .                        | 74LS92                          |
| C6 . . . . .        | 10n             | IC41 . . . . .                        | 74LS221                         |
| C7 . . . . .        | 22µ tantalum    | IC42 . . . . .                        | LM3C9K                          |
| C8 . . . . .        | 82p             |                                       |                                 |
| C9,10 . . . . .     | 1n0             | Q1 . . . . .                          | BC108                           |
| C11,12 . . . . .    | 2n2             | Q2 . . . . .                          | 2N2894 or 2N4258                |
| C13 . . . . .       | 22µ tantalum    | Q3 . . . . .                          | BC108                           |
| C14 . . . . .       | 1µ              |                                       |                                 |
| C15 . . . . .       | 20p             | D1 - D11 . . . . .                    | 1N914                           |
| C16 . . . . .       | 68p             | D12 - D15 . . . . .                   | OA91                            |
| C17 . . . . .       | 100n            | ZD1 . . . . .                         | 12 V, 400 mW zener              |
| C18 . . . . .       | 10p (see note)  |                                       |                                 |
| C19,20 . . . . .    | 22µ tantalum    | <b>Miscellaneous</b>                  |                                 |
| C21 - C28 . . . . . | 10n (see text)  | X1 . . . . .                          | 12 MHz, HC18/U crystal          |
| C29 - C39 . . . . . | 10n (see text)  | SW1 . . . . .                         | 8-way BOSS or Utilux DIL switch |
|                     |                 | PCB . . . . .                         | ETI 640 (see text)              |
|                     |                 | Heatsink for IC42, solder, wire, etc. |                                 |

# PCB's

ONCE AGAIN, there's two pages of blue in the mag, and we've published the PCBs on a page by themselves. We are continuing previous experiments with PCB making directly from the page, and are glad to report that, provisionally at least, the experiment is successful. It

is possible to make PCB negatives in Scotchcal 8007 by exposing it directly through the page to UV light. Actinic blue fluorescent bulbs are ideal for this: around 20 minutes exposure at 3-4" will produce a good negative.

We haven't yet tried this process using direct exposure of a negative

photo resist; this is a matter for further experimentation.

Commercial organisations are reminded that ETI PCB patterns are copyright and reproduction for commercial use is expressly forbidden. Readers are free to make individual copies for their own use.

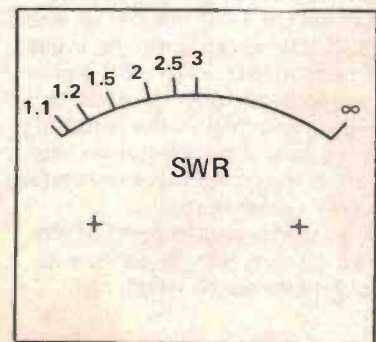
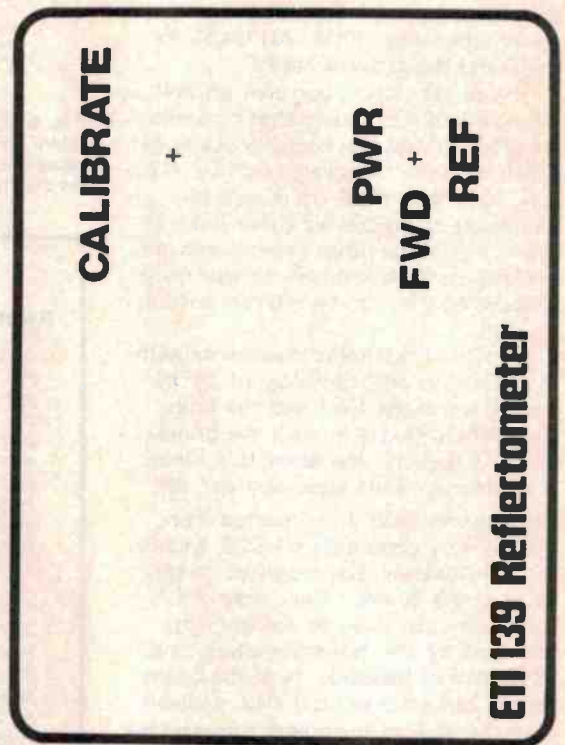
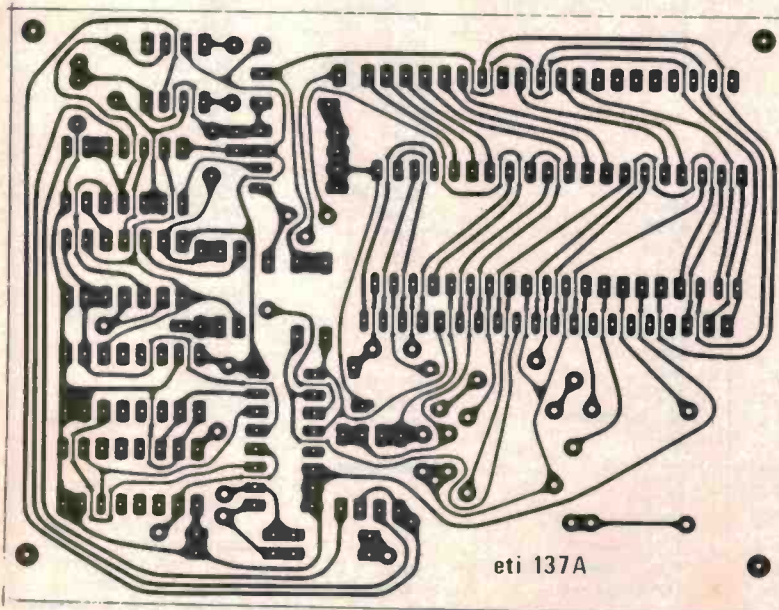
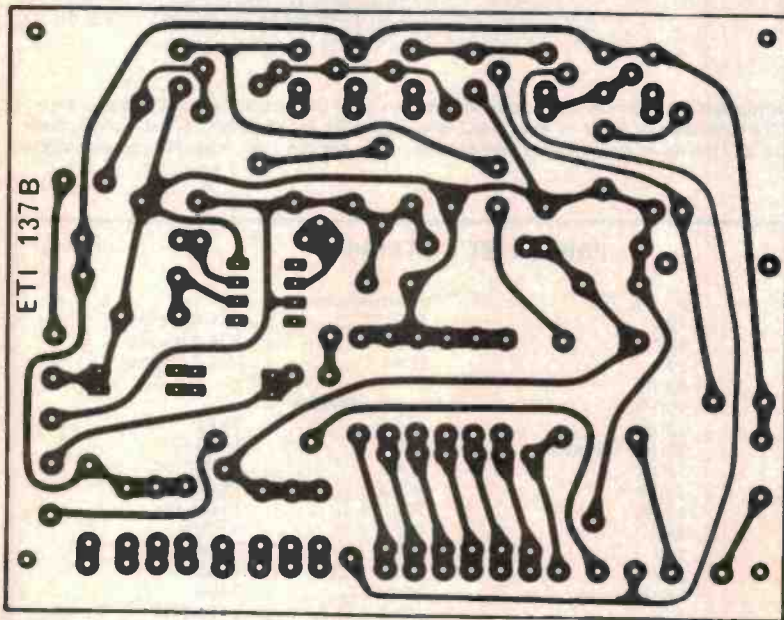

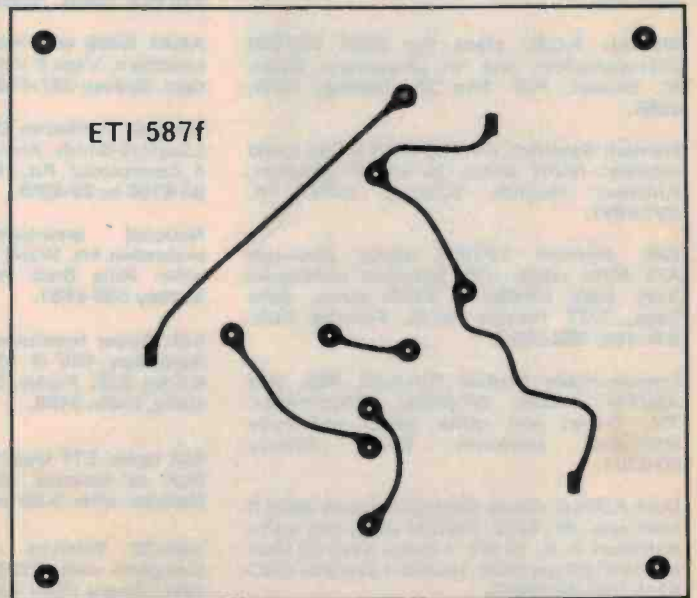
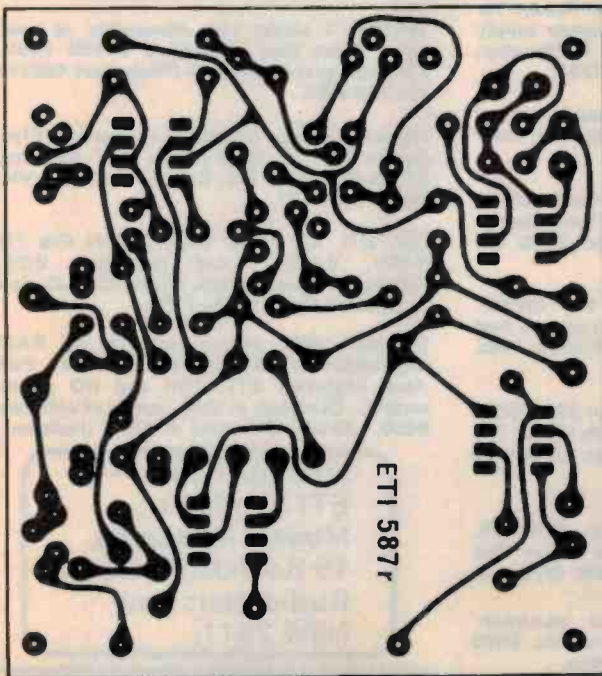
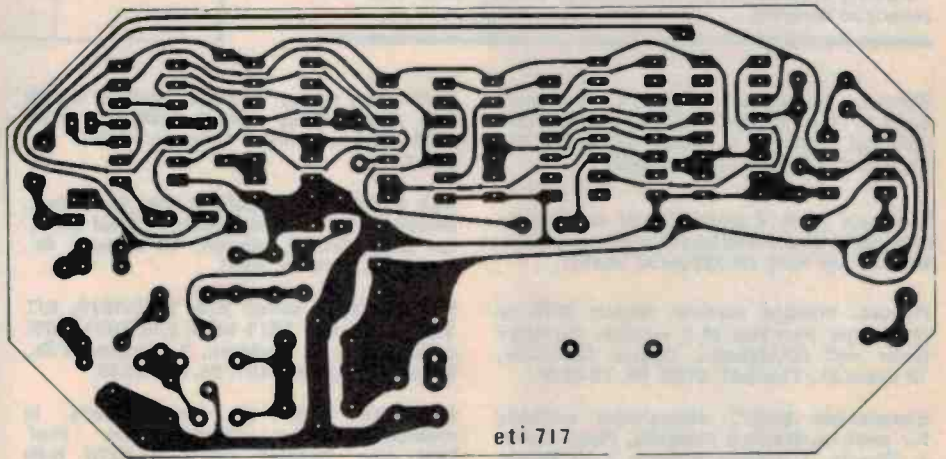
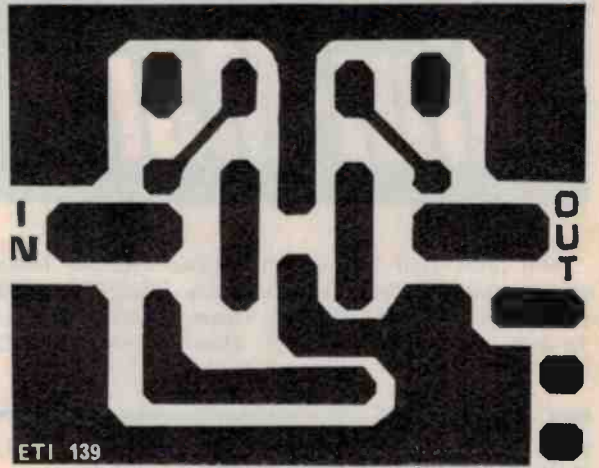

# Mini-Mart

We'll print your 24 words (maximum) totally free of charge. Copy must be with us by the 7th of the month preceding the month of issue. Please, please write or preferably type your adverts clearly, using BLOCK LETTERS.

## CONDITIONS

Name and address plus phone number (if required) must be included within the 24 words allowed.

Reasonable abbreviations, such as 25 Wrms, count as one word. Private adverts only will be accepted. Please let us know if you find a commercial enterprise using this service.

Every effort will be made to publish all adverts received - however, no responsibility for so doing is accepted or implied.

Adverts must relate to electronics or audio - general adverts cannot be accepted.

PLEASE USE BLOCK LETTERS

|  |  |  |  |
|--|--|--|--|
|  |  |  |  |
|  |  |  |  |
|  |  |  |  |
|  |  |  |  |
|  |  |  |  |
|  |  |  |  |
|  |  |  |  |
|  |  |  |  |

Wanted. Electronics Designer's Handbook by T.K. Hemingway. Any reasonable price accepted. Contact J. Borg, 11 Grace St., Liverpool, 2170. Ph (02) 602-8657

Terminals Ascii 8 level Olivetti with paper tape reader direct interface to microprocessors \$450 - Tony King 03-729.5730 (A.H.).

Wanted: Practical wireless. August 1976 or photocopy part two of a versatile transistor tester will compensate. George Schneider, 12 Evans St., Fairfield, 2165. Ph. 72-0007.

Experienced BASIC programmer available for work in Western Australia. Please write. J. Downs, 1 Saltash Avenue, City Beach. 6015.

FT200 transceiver with 240V supply and speaker for sale. Good working cond. \$280. Phone (02) 81-2854 after 5.30 pm or weekends.

Wanted: P.C.B. plans for 2650 PC1500 microcomputer, buy or photocopy. Write: M. Blowes, P.O. Box 28, Molong, NSW, 2866.

Wanted: Specifics. on JRC NMR1030G radio receiver. Geoff Swan, 20 Cashel Crescent, Killarney Heights, Sydney, 2087. Ph. 451-9097.

Sell: Marconi TF1066 signal generator 470 MHz range with technical handbook. Very good condition. \$450. o.n.o. John Edge, 7/27 Hartley Road, Flinders Park, S.A. (08) 352-2661.

Programmable Musical Doorbell, \$35, plus AM/FM Tuners, Amplifier, Preamplifier, TV. Games and other partly and fully assembled electronic items. Sydney 30-8261.

Dual A50KΩ sliders \$20/100 Hitachi 3500 3 head cass. dk. \$325. Stabilac electronic mains stabilisers 2, 5, 10 kW ½ price. Tesla 25 MHz lab oscilloscope \$400. Heathkit portable CRO \$125 (02) 604-5664.

AVO valve tester, transistor analyzer & 200 plus valves many boxed \$150. D. King, 4/67 Elouera Rd., Cronulla, 2230. Ph. 523-9726.

Sell: CMOS 4017, NE555, LEDs, Transistors, switches. All in good condition. Send S.A.E. for price list. G. Aydon, 46 Dickens St., Hamilton, Victoria. 3300.

For sale back issues: E/A 1960-1976; E/T 1971-1976; P/E 1971-1976; P/W 1971-1975. Information: G. Sampson, 7 Homewood St., Nunawading, Vic. 3131. Ph. 878-8945.

Desperate need of 'Transformer's in measurement and Control' by Prof. Will pay: Contact Chris. 31-6270 6.00 pm-11.00 pm. Working days - thanks.

Wanted: Working Microprocessor System for student. Full Documentation, power supply required. Write details and price: K. Chewlun, 319 Pain Street, Rockhampton, 4701.

AKAI X355 with remote control in perfect condition. Vega 8 mm sound projector, never used. Sydney 337-4150.

Wanted: Radiotron Designer's Handbook by Langford-Smith. Any cond. Jim Verrenkamp, 4 Commercial Rd., Highett. Vic. 3190. Ph. 95-4766 or 95-4889.

National semi-conductor. S C/CMP. evaluation kit. Brand new. Never opened best offer. Ring Brad Ferguson, Winston Hills. Sydney 639-5981.

Sell: Power transformer. Primary: 230, 250V. Secondary 18V @ 12 Amps with shield. Wt. 6.5 kg. \$25. Foster, C/- P.O. Box 1, Ferntree Gully, Melb, 3156.

Sell issues ETI from '71 and E.A. From '68. Bulk or separate. Min \$5 sale. Phone Phil Denniss, after 6.30 pm. 646-3504 (Sydney).

ASR-33 Teletype - as new condition. Complete with RS232C and manuals. \$600 ONO. Phone (054) 438536 Bendigo.

Printed circuit boards privately made cheaply and efficiently made using latest techniques. No design too big. Contact T. Coulson. 27 William St., Ringwood, Vic. 3134.

Intermittent windscreen wiper controllers 1 wire attachment variable time delay, suit permanent magnets. \$210 for 60. Ph. (02) 449 3968.

Wanted. QST September 77. Pay \$2. Contact first. Only one reply will be answered. Peter Carwardine, 2A Victoria Rd., Malvern, Vic, 509-0622 office hours.

Melbourne Tape Friends The Recording Society of Australia meets monthly for lectures life-recordings and demonstrations. For further information ring (03) 459-1717 AH or write Don Patrick, 36 Argyl St., Macleod, 3085.

TS520X 2 weeks old. Absolutely as new, Incs. Yaesu base mic, spare 6146B finals, 6 months guarantee \$720. Phone Bert 425312 AH 758-4086.

Wanted urgently by student. Practical Electronics. Sept. 71, Oct 71, July 76. T. Sangster, 87 Wattle Valley Rd., Canterbury, 3126 Vic, Phone 836-2597.

Sell: ETI 132 Power Supply. (ETI Feb 77) 0-15V, 0.1.2A. Load regulation 0.2%. Metered, protected. \$30. Foster, C/- P.O. Box 1, Ferntree Gully, Melb, 3156.

Complete 2650 system including 4K RAM expandable to 16K cassette interface. Full Ascii keyboard ETI VDU and HD power supply. Complete in case - stacks of software \$850. 451-6243 (home) 43-5972 (business).

send your ad to -  
ETI MiniMart,  
Modern Magazines,  
15 Boundary Street,  
Rushcutters Bay,  
NSW 2011.



# Now everyone can afford to own a digital multimeter

## The Sinclair PDM35

### Technical Specification:

**DC Volts (4 ranges)**  
Range: 1 mV to 1000V.  
Accuracy of reading:  $1.0\% \pm 1$  count.  
Note: 10 M $\Omega$  input impedance.

**AC Volts (40 Hz-5 kHz):**  
Range: 1 V to 500 V. Accuracy of reading:  $1.0\% \pm 2$  counts.

**DC Current (6 ranges):**  
Range: 1 nA to 200 mA.  
Accuracy of reading:  $1.0\% \pm 1$  count.  
Note: Max. resolution 0.1 nA.

**Resistance (5 ranges):**  
Range: 1 $\Omega$  to 20 M $\Omega$ .  
Accuracy of reading:  $1.5\% \pm 1$  count.  
Note: Also provides 5 junction-test ranges.

**Dimensions:** 6 in x 3 in x 1 1/2 in.  
**Weight:** 6 1/2 oz.  
**Power Supply:** 9 v battery or Sinclair AC adaptor.  
**Sockets:** Standard 4 mm for resilient plugs.  
**Supplied with:** Leads, test prods, operating instructions, carrying wallet.

**Options:** 240 V Adaptor \$9.00\*  
30 KV High Voltage probe \$35.00\*  
Deluxe padded carry case \$9.00\*

\* Plus 15% Sales Tax if applicable.

### Features of the PDM35

3 1/2 digit resolution.  
Sharp, bright, easily read LED display, reading up to  $\pm 1.999$ .  
Automatic polarity selection.  
Resolution of 1 mV and 0.1 nA.  
Direct reading of semiconductor forward voltages at 5 different currents.  
Resistance measurement up to 20 M $\Omega$ .  
1% of reading accuracy.

Operation from replaceable battery or AC adaptor.  
Industry standard 10 M $\Omega$  input impedance.  
Automatic Overload Protection.  
Automatic over-range Indication.

**sinclair**  
World leaders in fingertip electronics



To: Sinclair, 308-312 High Street, Kew Victoria, 3101.  
Please send me Sinclair PDM35 Multimeter(s) at \$75 (plus \$6.90 Sales Tax if applicable)\*  
Name: \_\_\_\_\_  
Address: \_\_\_\_\_  
I enclose cheque/money order for \$ \_\_\_\_\_ \* p & p included

# redpoint

**TV-3 Powerfin**  
Description  
Twisted vane design uses total metal content of base length to radiate.  
Specification  
Thermal rating 9 = 72°C/watt  
Sizes  
38 x 42 x 25mm High

# EX STOCK

**NV-Type**  
Extruded section for robust power handling. 4 tee-slots and 4 tie-bar slots allow easy filtering stacking and electrical connections

Height 4.72"-1.20mm  
Width 4.72"-1.0mm

|     |           |
|-----|-----------|
| 4NV | 4"-1.02mm |
| 6NV | 6"-1.52mm |
| 9NV | 9"-2.29mm |

Height 1.34"-34mm  
Width 4.62"-118mm

|    |          |
|----|----------|
| 2P | 2"-51mm  |
| 3P | 3"-76mm  |
| 4P | 4"-102mm |
| 6P | 6"-152mm |

**P-Type**

**99 ALEXANDER ST., CROWS-NEST**  
TELEPHONE 439 2488

Adelaide 42 6555 Melbourne 598 9207  
Brisbane 277 5311 Newcastle 95 2722  
Canberra 82 3581

# **DISTRIBUTORS**

**for the Electronic Industry**

## **ARE YOU AWARE??**

**THAT WE HAVE PROBABLY THE LARGEST RANGE IN AUSTRALIA OF TOP-BRAND, QUALITY PRODUCTS AT CURRENT MARKET PRICES WITH OFF-THE-SHELF AVAILABILITY.**

### **Semi-Conductors**

Delco  
E.D.I.  
General Electric  
Intermetall  
I.T.T.  
National Semiconductor  
N.E.C.  
Philips  
Sanyo  
Signetics  
Solitron  
Texas Instruments  
A.M.D.  
Intersil  
Monolithic Memories

### **Passive Components**

Bournes  
Elna  
Erie  
I.T.T. Capacitors  
I.T.T. Thermistors  
Philips (Elcoma)  
R.C.A.  
Soanar  
Sprague

### **Electro-Mechanical and Hardware**

Alco  
Cannon  
Delco Heatsinks  
I.T.T. Diecast Boxes  
I.T.T. Fans & Blowers  
Dica I.C. Accessories  
I.E.E.  
I.T.T. Relays  
Jean Renaud  
J.A.E.  
National Relays  
Pomona Accessories  
Rotron Fans  
Switchcraft Connectors  
Thermalloy Heatsinks  
T.I. I.C. Accessories  
Weller Soldering Erous  
G.E. Rechargeable Batteries

*Trade enquiries to:*

## ***Instant Component Service***

P.O. Box 2, Arncliffe. N.S.W. 2205. Ph (02) 597-1444  
Adelaide 267-2393. Melbourne 95-9566. Sydney 597-1444

# Instant Component Service

DISTRIBUTORS:-

**NORTH.**  
**J. A. SEVERN**  
P.O. Box 47  
Epping 2121  
869-1058

**EAST.**  
**RADIO DESPATCH  
SERVICE.**  
869 George Street,  
Sydney, N.S.W. 2000  
Phone: 211-0191

**NEWCASTLE.**  
**DIGITRONICS**  
186 Parry Street,  
Newcastle West, 2302  
Phone: (049) 614991

**BRISBANE.**  
**NOW OPEN AT**  
**Cnr Montague Road &  
Victoria Street,**  
**West End. Qld. 4101.**  
**Phone: 44-6667**  
**RON BURR**

**CANBERRA**  
**ELECTRONIC**  
**COMPONENTS PTY. LTD.**

29 Woolongong St,  
Fyshwick. ACT. 2609.  
Phone 95-6811, 95-9138.  
Telex 62468.

## MIND, ORDER, ENERGY.

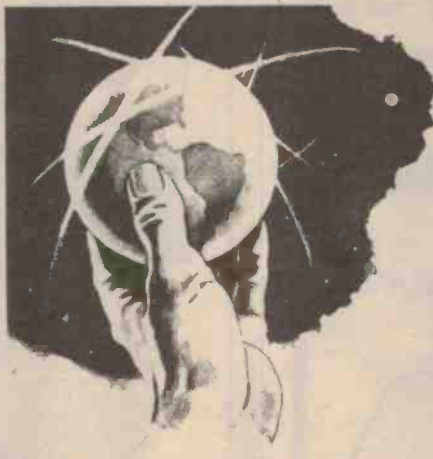

*Which Governs the  
Universe and You?*

What lies behind all existence? Is everything a product of supernatural design? Are humans shifted about by an arbitrary will like pieces on a chessboard? Or does a stupendous energy, without reference to purpose, bring about a ceaseless transformation from atoms to stars and to life itself?

Mind—Order—Energy—may these not be summed up in one word: Consciousness? Behind all a Universal Consciousness, impersonal, eternal. It composes the order of matter, the sensitivity of life, and that personal awareness that is Self.

This is a new age! It is time to reconcile science, philosophy, and mysticism. Truth is found in unifying all experience and knowledge that man has acquired—no longer must man be dealt with separately with prejudice or preference.

### ACCEPT THIS FREE BOOK

For a frank, fascinating presentation of a rational personal philosophy of life that dispels superstition and obsolete traditions, write for the free book The Mastery of Life. It is presented by the Rosicrucians (not a religion), a world-wide cultural society. Through this book thousands have learned how they may acquire a fuller life.

*Please use this coupon  
or write to:*

SCRIBE: P. F. H.

**The ROSICRUCIANS**  
(AMORC)

P.O. Box 21, Redfern, N.S.W. 2016 Australia

Scribe P. F. H.  
The ROSICRUCIANS (AMORC)  
P.O. Box 21, Redfern, N.S.W. 2016 Australia

Gentlemen:

In sincere interest, not out of curiosity, I ask for a free copy of THE MASTERY OF LIFE.

Name \_\_\_\_\_

Address \_\_\_\_\_

City \_\_\_\_\_

 **TRIO**

Dual Trace, Triggered Sweep

# SCOPES

**10MHz  
CS1562**

- 130mm CRT
- DC-10MHz/10mV
- Automatic sweep (AUTO FREE RUN)
- Full sensitivity X-Y
- Display modes (CH1 CH2 DUAL)

#### SPECIFICATIONS

Bandwidth DC to 10MHz (-3dB)  
Deflection 10mV/div to 20V/div  
Factor  
Input R.C. 1M $\Omega$ , 22pF  
Risetime 35nsec  
Overshoot Better than 3%  
Sweep time 1.5  $\mu$ s/div to 0.5  $\mu$ s/div  
Magnifier  $\times 5$   
Linearity Better than 3%

Calibrator 1Vpp (AC sine wave square wave)  
Intensity modulation Less than 5Vpp  
Phosphor P31  
Power AC 100 120 220 240V  
50/60Hz, 20W  
Dimensions W260  $\times$  H190  $\times$  D375 (mm)  
Weight 8.0kg

If you need more bandwidth-

**BEST  
VALUE**

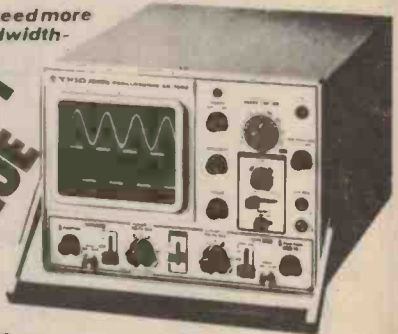

**15MHz CS1560A**

*The 15MHz  
dual trace*

- 130mm CRT
- DC-15MHz/10mV
- Automatic sweep (AUTO FREE RUN)
- Display modes (CH1 CH2 DUAL ADD SUB)
- Full sensitivity X-Y operation

#### SPECIFICATIONS

Bandwidth DC to 15MHz (-3dB)  
Deflection 10mV/div to 20V/div  
factor  
Input R.C. 1M $\Omega$ , 22pF  
Risetime 23nsec  
Overshoot Better than 3%  
Sweep time 0.5  $\mu$ s/div to 0.5  $\mu$ s/div  
Magnifier  $\times 5$   
Linearity Better than 3%

Calibrator 1Vpp (1kHz square wave)  
Intensity More than 20Vpp  
modulation  
Phosphor P31  
Power AC 100 120 220 240V  
50/60Hz, 23W  
Dimensions W260  $\times$  H190  $\times$  D385 (mm)  
Weight 8.4kg

**30MHz CS1570** ★ NEW LOW PRICE ★

130mm DUAL TRACE  
TRIGGERED SWEEP  
OSCILLOSCOPE

#### SPECIFICATIONS

Bandwidth DC to 30MHz (-3dB)  
Deflection 5mV/div to 5V/div  
factor  
Input R.C. 1M $\Omega$ , 24pF  
Risetime 11.7nsec  
Overshoot Better than 3%  
Signal delay 160nsec  
Polarity CH2 can be inverted  
Sweep time 0.2  $\mu$ s/div to 0.5  $\mu$ s/div  
Magnifier  $\times 5$   
Linearity Better than 3%

Calibrator 0.5Vpp (1kHz square wave)  
Intensity modulation More than 5Vpp  
Phosphor P31  
Power AC 100/120/220/240V  
50/60Hz, 25W  
Dimensions W260  $\times$  H190  $\times$  D375 (mm)  
Weight 8.5kg

Available from  
leading Electronic  
Stores

**PARAMETERS PTY LTD**

Sydney: 439 3288 Melbourne: 90 7444

# SCALAR UHF/CB ANTENNAS

## FOR CITIZENS BAND RADIO

DESIGNED AND MANUFACTURED IN AUSTRALIA

SCALAR'S UHF  
MOBILE MOUNT FOR CORRECT  
TERMINATION OF CO-AX  
AT UHF FREQUENCIES  
PAT. PENDING  
No. 20506/76

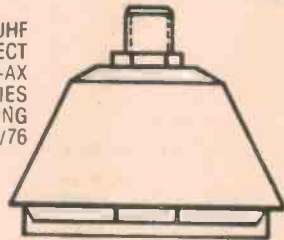

MODEL OB

**CB420**  
HIGH PERFORMANCE DUAL BAND  
476 AND 27 MHz  
MOBILE CO-LINEAR WHIP  
GAIN AT 476 MHz 4.5 dB  
OVERALL HEIGHT 42"



**CB410**  
HIGH PERFORMANCE  
4.5 dB GAIN MOBILE  
WHIP. REQUIRES NO  
TUNING. OVERALL  
HEIGHT 21"



CB420

**CB470** GDB GAIN CO-LINEAR  
BASE ANTENNA. ENCLOSED IN  
FIBREGLASS RADOME. LENGTH, 8ft.

A WIDE RANGE OF SCALAR UHF/CB AND 27 MHz CB ANTENNAS  
(FROM 30" to 108" LONG) AND ACCESSORIES ARE AVAILABLE  
FROM LEADING RETAILERS AND DISTRIBUTORS THROUGHOUT  
AUSTRALIA.

TRADE ENQUIRIES WELCOME.

**SCALAR INDUSTRIES PTY LTD**  
COMMUNICATION ANTENNA ENGINEERS  
18 SHELLEY AVENUE, KILSYTH, VICTORIA 3137  
TELEPHONE 7259677.  
CABLES WELKIN TELEX AA34341

NSW: 20 THE STRAND, PENSHURST 2222. TEL: 570-1392  
QLD: 969 ANN ST, FORTITUDE VALLUE, QLD 4006  
TEL: 52-2594. TELEX AA43007

# CB AUSTRALIA



WE GOT THE LOT...  
MATE!

- ALL THE NEWS THAT'S FIT TO PRINT  
.....and some that isn't!
- EQUIPMENT REVIEWS  
.....you can *believe* us!
- ANTENNA EVALUATIONS  
.....we do them *right*!
- SKIP PREDICTIONS  
.....DXing? Only in CB Oz!
- FABULOUS CONTESTS  
.....over \$4000 in prizes already won!
- TECHNICAL ARTICLES  
.....at *your* level.

80c AT YOUR NEWSAGENT

# CB COMMUNICATIONS

## CB from Phodis

Phodis is a well-known name in vehicle accessory such as car radios, cassettes etc as well as other consumer equipment — photographics, Hi-Fi, domestic lighting ect.

They have just released a P & T approved 18 channel AM rig, the "Speed King" model ACT-1842.

This rig is claimed to have good channel separation, not suffering from adjacent channel 'bleedover', as well as good sensitivity.

It features an RF gain control, PLL synthesizer and a generous-sized panel meter for easy reading of signal strength and RF output.

The mic connection is on the front panel (still on the left side though!) and the rig has the usual complement of controls along with ANL, PA facility etc.

Phodis' head office is located in Sydney but they have a Victorian branch office and representatives in other states. They service all their own equipment and have what is reputed to be a top service set-up.

For more information, contact Phodis at 5 Campbell St., Artarmon, 2064, (02) 439-8900.

## 6A Supply

St George Communications, one of Sydney's long-established communications firms, has just released a 13.8volt DC regulated mains supply that will deliver 6 amps continuously and up to 8½ amps surge.

It's just the thing for running several mobile rigs plus a number of associated accessories on the bench.

The supply is fully protected from overload and even includes circuitry that protects your equipment should the series-pass regulator transistor fail!

The supply will retail for around \$90 and the company welcomes dealer and retailer enquiries.

Contact St George Communications, 271 Goulburn St., Darlinghurst, 2011 (02) 212-3712.

## 200 Channel Scanner

The US company, Redco, have recently released a channel scanner for those makes of CB rigs which use the Uniden 858 PLL system.

The simple modification to the rig, allowing attachment of the device, enables the receiver coverage to be extended from 26.055 MHz up to 28.045 MHz, giving 200 channels every 10 kHz between 26 and 28 MHz.

For Novice or other amateurs with

CB rigs converted to 28 MHz, full coverage of the 10 metre band is possible.

The scanner is called the "Digi-Scan RDS-1" and is suitable for use with such rigs as the President Grant mobile, President Washington base, Cobra 138XLR, Realistic TRC 457, 458, 448 and the Robyn 510D, 520D and some of the Fanon/Courier range among others.

The Digi-Scan features a large five-digit LED digital readout using 13mm high LEDs. It displays the frequency to the last 1 kHz with a resolution of 1 kHz.

It has two channel/frequency selection systems. The SCAN switch will step the receiver through each channel at a rate of 12 channels per second. It utilises a spring-return switch, marked UP/DWN for the scan function.

Alternatively, you can step up or down one channel at a time using the STEP switch.

The unit operates from a supply voltage range of 10.5 to 16 volts DC and draws 500 mA at a nominal supply voltage of 13.8 volts. Overall size is 102 mm long by 153mm deep by 32mm high.

President Electronics (Australia) is distributing the Redco Digi-Scan

RDS-1 which retails for around \$180.

The Redco brochure includes the following note: "The Digi-Scan Model RDS-1 is designed for receiver use only and is protected against transmission with an automatic shut-off feature".

## Philips' 27 MHz CBs

Apart from producing the FM320 UHF CB rigs, Philips are also importing two 27 MHz models, the AM101 and AM201.

The AM101 is an AM rig featuring PLL synthesizer, LED digital channel display, RF gain control, ANL and noise blanker and a three-function panel meter.

The mic plugs conveniently into the front panel, but on the left-hand side, on both.

Both rigs have the front panel finished in silver and grey and all the control knobs are of the flat-sided variety.

The AM201 is Philips' up-market SSB/AM transceiver. It has a full complement of controls, as you'd expect of a sideband transceiver in the price bracket, and similar features to the AM101.

Philips provide a six-month warranty with these rigs and an Australia-wide service network.

*Continued P. 104.....*



# AMATEUR COMMUNICATIONS

## Evening-type TEP extended to 432 MHz?

Recent record-breaking contacts on the 144 MHz band apparently supported by evening-type (or Class II) trans-equatorial propagation between Australia and Japan, Puerto Rico and South America, have been hot news in amateur circles amongst those who are keen on VHF/UHF DX.

However, no sooner was the upper frequency limit of Class II TEP extended to 144 MHz, previously established as being in the 100 MHz region, than evidence of the possible extension of this ionospheric propagation mode even higher in frequency — to 432 MHz — has come to hand.

YV5ZZ, located in Venezuela, is reported to have heard an Argentinian station, LU3AAT on 432.1 MHz in February during an opening when Argentinian stations were heard working Caribbean stations and stations in the northern countries of South America.

However, two-way contact was not established, but this seems only a matter of time.

The world terrestrial distance record for 144 MHz was established by LU5DJZ and KP4EOR on the 12th of February this year over a distance of 6400km (3977 miles).

LU5DJZ, located at Mar Del Plata — 400km south of the Argentinian capital, worked KP4EOR at 0015 GMT on 144.1 MHz with signals over 5 by 9 both ways. Single sideband was used by both stations, LU5DJZ running 400 watts PEP to a stacked array of two eleven element yagis and KP4EOR used 800 watts PEP to an array of four stacked nine element yagis.

Readers wanting to know more about transequatorial propagation are referred to "VHF Transequatorial Propagation" by Roger Harrison VK2ZTB in the June 1973 issue of ETI (p.88).

## Moonbounce News

Al Katz, K2UYH, moonbouncer extraordinaire, has earned the *world's first WAC (worked all continents) award entirely using moonbounce on 432 MHz*. Naturally, his Australian continent contact was the Dapto Moonbounce project, VK2AMW, about which more shortly.

Since Al's achievement, six others followed in fairly rapid succession. These were (to date): VE7BBG, W1JR, I5MSH, K3PGP, PA0SSB and SM5LE. It shouldn't be long before ZE5JJ makes the grade. Next band the moonbounce gang are going to try cracking WAC on is 1296 MHz!

The Dapto Moonbounce project buildings and equipment were severely damaged by vandals in February, necessitating closure of the facility, pending the finding of a new site.

Eight years of dedicated work by a small group has been senselessly destroyed and one of the world's leading 432 MHz EME stations put off the air. It is hoped that, with the co-operation of the University of Wollongong and the generosity of local amateurs, the project will be successfully relocated and re-equipped.

## The Ron Wilkinson Achievement Award

This award has been created as a memorial to the late Ron Wilkinson, VK3AKC. Through the generosity of his widow, Mrs Mary Wilkinson, the award will take the form of (a) a certificate, (b) \$50 cash, (c) books to the value of \$50 and (d) WIA subscription paid for one year. Mary donated \$1,100 to fund the award, which has been invested; interest from this to meet the costs of the annual award, supplemented by funds from the WIA.

Ron Wilkinson, VK3AKC, was a man of many achievements. He won the marathon Ross Hull Memorial VHF contest (held during every summer)

several times, held a number of VHF/UHF distance records at various times and was one of the world's foremost moonbounce stations on 1296 MHz, achieving a number of records in that field also.

The award is to be made annually during the month of March — nominally on the 3rd of March, relating to the previous calendar year as far as practicable.

The award is for "special achievement in any facet of amateur radio". For example: Development of state of the art techniques, microwave activity, involvement in clubs or WIA affairs, notable public service, achievement in using satellites etc.

The award is only available to amateurs from VK call areas. Individuals may nominate or make personal application (to their WIA state division) by 31st October each year.

The WIA executive will nominate the recipient by 31st January. Preference will be given to WIA members. The award will be announced in *Amateur Radio (WIA journal)* in March — 3rd March is the birthday of the late Ron Wilkinson.

Joint awards can be made, with a division of the award.

The recipients for 1977 were Wally Green VK6WG of Albany, WA, and Reg Galle VK5QR, of Enfield SA, for their world record-breaking 1296 MHz contact early in 1977.

## Another UHF record for VK

January was certainly the month for breaking records. Apart from the 432 MHz record-breaking contacts between VK6 and VK3 mentioned in previous issues, Wally Green VK6WG has contacted Reg Galle VK5QR on 2304.1 MHz. The distance between Albany (VK6) and Enfield (VK5) is some 1,900km, stretching the existing world record of 760km by some *two and a half times!*

Reg, VK5QR, used synthesized SSB running about 4 watts output to a one-metre diameter dish located about 10m off the ground.

Wally, VK6WG, used CW. The drive was derived from an SCR522 (good gosh!) at 128 MHz, multiplying nine times to the final which employed a 2C39A as a doubler giving about 3 watts into a 2 metre diameter dish.

Signals were S8/9 both ways and the QSB observed was at a slower rate on 2.3 GHz than on 1296 MHz. At times, the signals were stronger on the higher band, even though more power was being used on 1296 MHz.

Congratulations gents. Another world record for the VKs!

The propagation modes of class I and class II TEP.

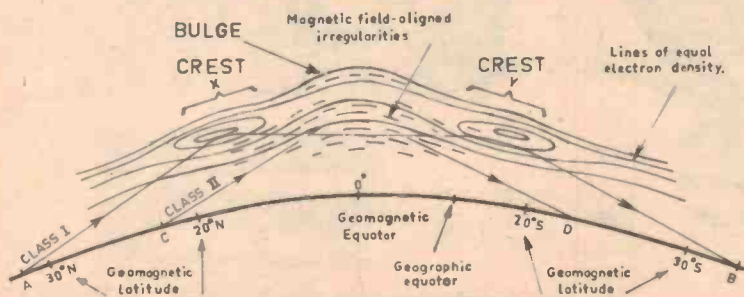

# WHAT'S BLACK & WHITE AND TURNS 2-METRE OPERATORS GREEN?



## THE KENWOOD TR-7400

This is the one, the Kenwood TR-7400 FM mobile transceiver of 25/10 watts and complete 2 metre band coverage (144-148 MHz). It has the largest digital readout in its class, and the 800 channel

coverage with PLL frequency synthesizer provides you with all existing and proposed Australian repeaters. A convenient front panel switch offsets the transmit frequency up or down 600 kHz.

### WHENEVER YOU WANT TO MOVE UP — KENWOOD HAS THE WAY



TR-2200 2-metre VHF FM portable receiver



R-300 all band or ham band communications receiver



The new TS-520S HF transceiver — ideal for the novice



TS-700 2-metre VHF all mode transceiver

Your nearest Kenwood dealer will be happy to give you more information on the entire Kenwood range of amateur radio products including the remarkable new TR-7400. Contact him direct or write to us at:—



**KENWOOD**

International Marketing Dept.  
Communications Equipment  
Division, 30 - 3, Jingumae  
5-Chome, SHIBUYA - KU,  
TOKYO 150, JAPAN

CALL SIGN \_\_\_\_\_  
ADDRESS \_\_\_\_\_  
PHONE No. \_\_\_\_\_  
NAME \_\_\_\_\_  
POSTCODE \_\_\_\_\_  
WITH MORE INFORMATION  
PLEASE SUPPLY ME

# SWL COMMUNICATIONS

## Winter Brings Good Listening on "Tropical Bands".

Our cold winter months are the best time to tune to the "tropical bands" if the varied and exotic sounds of Latin America and Africa are what you want to hear. The shortwave bands of 90 metres (3200-3400 kHz) and 60 metres (4750-5060 kHz) are used almost exclusively by stations within the tropics, being mainly for Home Service coverage due to the generally poor performance of mediumwave broadcasts in tropical areas.

Latin American signals are best between 0500 and 1200 GMT, travelling via the short path across the south Pacific. Some of the stronger signals to watch for are the two outlets of Radio Reloj de Costa Rica on 6006 and 4832 kHz, The Colombian station Radio Cinco (Villavicencio) on 5040 kHz, Radio Chinchaycocha at Junin, Peru on 4860 kHz, and Radio Santa Fe in Bogota on 4965 kHz. The above mentioned are currently operating 24 hours, and many more stations sign-on between 0900 and 1100 GMT for their morning programming. Most stations concentrate on musical programming, with advertisements and occasional news bulletins. As programmes are for local audiences, programming is in Spanish.

Tropical band signals from Africa also peak between May and September, with East African signals appearing on 60 metres from about 1500 GMT in east Australia. Stations audible from about this time include Radio Tanzania at Dar es Salaam on 5050 kHz, and on 90 metres the first signals to appear are Radio Madagascar on 3290 kHz. African signals remain audible until their evening sign-off times, which vary between 2000 GMT for east African outlets, and 0000 GMT for west African countries. Signals in this 1500-0000 GMT time span from Africa reach Australia via the Indian Ocean, and constitute short path reception. During winter, a number of West African stations are also audible on 60 metres between 0600 and 0800 GMT, these signals reaching us via the long paths across North America and the Pacific. The best of these signals include Nouakchott (Mauritania) on 4845 kHz, the two Ghanaian outlets on 4915 and 4980 kHz, and Lome (Togo) on 5047 kHz.

## 3rd Anniversary for Radio Monitors International

The special 3rd anniversary edition of Radio Monitors International will be

broadcast at 1100 GMT on Sunday May 28 in the external service of the Sri Lanka Broadcasting Corporation on 11835, 15120 and 17850 kHz. Special greetings will be broadcast from Ian McFarland of Radio Canada International's DX program, from Mr. Jens Frost of the World Radio and Television Handbook Company, and from Bob Padula of the Australian Radio DX Club and Arne Skoog of Radio Sweden's DX show. Main feature of the show will be a report on broadcasting in Antarctica. Future topics of interest to DXers to be covered in Radio Monitors International include "Independent Shortwave stations in the USA" on June 4, and "Broadcasting in the Cook Islands" in the June 11 program.

## Spain Extends Transmissions

Radio Exterior de Espana has extended transmissions hours for its Australian service and may now be heard between 0800 and 1130 GMT on weekdays, and 0800-1200 GMT on weekends, on 11910 kHz with programs in Spanish.

Spain is also making greater use of its relay facilities at Tenerife in the Canary Islands, with frequencies of 15365 and 11880 kHz being used for Spanish programs for the Americas between 1400 and 2000 GMT every Sunday, while 11880 kHz is used daily for broadcasts to the Americas between 2145 and 0000 GMT.

## "DX Guide" Coming Soon

A New book to be published in Denmark in May by the World Radio and Television Handbook Company will be of great interest to all shortwave enthusiasts wishing to improve their knowledge and enjoyment of the hobby. The book, entitled "World DX Guide" will contain 192 pages with 28 chapters covering all major fields of shortwave listening. Topics covered include: First steps in DXing, shortwave propagation, ionospheric variations, details of shortwave and mediumwave receiving antennas, plus specialised topics such as DXing particular frequency bands. The Australian Radio DX Club will be co-ordinating advance sales of the "World DX Guide" in Australia. To obtain a copy, please forward either \$11 for airmail delivery from Denmark, or \$9 for seamount postage, to: ARDXC Stationery Department, PO Box 215, Glenroy, Victoria, 3046.

## Voice of Greece

The overseas service of the Hellenic Broadcasting Corporation airs both

morning and evening services for reception in Australia. The morning service is currently scheduled between 2100 and 2150 GMT on 9760, 9655, and 6140 kHz, while transmission continues on 9655 kHz until 2250 GMT. A news bulletin in English may be heard at 2155 GMT every day. The evening service from Athens is aired from 0900 until 0950 GMT daily on 15160 and 9655 kHz, with English news at 0915 GMT. A feature of most transmissions is a wide selection of Greek music and songs.

## Broadcasts from Lebanon

The overseas service of the government station, Radio Lebanon, may now be heard between 0130 and 0330 GMT on 11825 kHz. Programmes include an English language segment at 0230 to 0300 GMT. The station controlled by the Christian Phalangists, known as the Voice of Lebanon, currently transmits on 6550 kHz and provides good reception after about 1400 GMT in east Australia. The station plays much western pop music, with occasional English announcements, though most programs are in Arabic.

# CB COMMUNICATIONS

## Top-line meter

The JD model 178 meter is a top-line, multi-function meter for hams and CBers. It measures SWR, RF power, modulation percentage, field strength and includes an antenna matcher.

This feature-packed instrument covers the frequency range from 1.5 to 144 MHz, has an accuracy of  $\pm 5\%$  or better on SWR and  $\pm 10\%$  on the power and modulation measurements.

The model 178 is rated to handle powers up to 100 W but has sufficient sensitivity to give correct indications on transmitter powers as low as 3 W.

Overall size is 160mm by 60mm high by 65mm deep and the front panel slopes backwards for easy reading of the meter and access to the front panel controls.

The JD model 178 is imported by International Foreign Trading Agencies of Australia (IFTA) and is available through a large number of retail outlets throughout Australia. If you'd like to find out more information, phone or write to IFTA, 21 Gilbert St., Dover Heights, 2030, (02) 371-5673.



## Optical Fibre Contract

A contract to further develop optical fibre technology has been awarded to Amalgamated Wireless (Australasia) Limited.

The contract from Telecom Australia follows an earlier Telecom contract to AWA which culminated in the successful first Australian field trial of optical fibre communication late last year.

The AWA Research Laboratory at North Ryde began work on optical fibre communication five years ago.

A team of scientists and engineers is working on this project under Dr. D.R. Nicol, recently appointed head of AWA's Physical Laboratory, which forms part of the Research Laboratory.

## A Good Sort

Distributive Partitioning Sort is a new method of sorting computer data which has been shown, in runs on CDC hardware, to run 30 times faster than conventional sort routines. Its creator, W. Dobosiewicz, wrote it in an Algol-like language, and it was coded in FORTRAN and run on a CDC 6400. It is believed that DPS could be improved to 200 times faster than 'classic' sorts.

## Safety Seismometer

Through structure like dams and atomic power stations, engineering has increased the potential danger of consequential damage from earthquakes. This has been recognized, and efforts are being made accordingly to guard against this heightened risk by continuous monitoring of ground shocks in the more immediate proximity of such structures. Incessant vigilance allows counter-measures to be taken in good time when major shocks occur, like lowering the water level or shutting-down the reactor.

At the request of the safety officials for a nuclear power station, Kistler Instrumente AG have developed a seismometer which measures and monitors constantly the smallest ground shocks and the resulting vibrations in the structure of the station.

It consists of a modified piezoelectric 3-component force transducer which in conjunction with a seismic mass secured to it acts as an accelerometer in three axes (zenith, north, east). The measuring range mounts to 2.5 g and the threshold is below 0.001 g. The rugged seismometer includes a self-test feature and withstands shocks up to 100 g. And, of course, it gives good service in all manner of geophysical investigations.

For further information, please contact: *John Morris Pty. Ltd., P.O. Box 80, Chatswood, NSW 2067.*

## Circuit Diagram Standards

The Standards Association of Australia has published a new standard on guiding principles for the preparation of circuit diagrams as Part 4 of AS 1103, Diagrams, charts and tables for electrotechnology.

The purpose of this standard is to give guidance on principles to be used in the preparation of circuit diagrams for the electrical, electronic and similar fields of use. In this regard it is an extension of AS 1103, diagrams. Part 4 demonstrates that a circuit diagram should show, by means of graphical symbols, the electrical connections and functions of a specific equipment without regard to actual physical size, shape or location of the parts. Numerous examples are given to demonstrate the variety of methods which may be used, to illustrate the basic principles of Part 3 and to demonstrate the simplifications which are considered permissible in achieving the main aim without unnecessary detail.

The standard, in its terminology, format and general treatment of the subject is consistent with the recommendations of Publication 113-4:1975 of the International Electrotechnical Commission. In the main the standard is technically identical with IEC 113-4 but some diagrams have been replaced with others having more meaning in the Australian context. Acknowledgement is made for the assistance received from this source.

The series of which this standard forms part is complementary to AS 1100 Drawing practice, and AS 1102 Graphical symbols for electrotechnology. Reference should be made to AS 1100 for relevant information on matters specific to drawing practice which are not covered in this part or in Part 3.

Copies of AS 1103.4 (\$6.00) may be obtained from the offices of the Association in the state capitals and Newcastle. (Postage and handling 80 cents extra.)

## Intel 8022

This summer will see the introduction of Intel's 8022 microprocessor, which incorporates an A/D converter and 2 K of ROM.

## Propagation Predictions

Unfortunately, once again this month we have had to postpone publication of the Propagation Predictions. Our apologies to readers, we hope to have predictions back next month.



## FRG -7 SYNTHESIZED RECEIVER



for amateurs,  
novices  
and  
short-wave  
listeners

Latest model includes fine-tune adjustment

### MANUFACTURER'S TECHNICAL DATA

- Electronic band changing.
- 0.5-29.9 MHz continuous coverage.
- Uses Wadley loop (drift cancellation circuit) to derive synthesized heterodyne oscillator signal.
- LSB, USB, AM and CW.
- Frequency readout better than 10 KHz (readable to 5 KHz).
- Stability within 500 HZ during any 30-minute period after warm-up.
- Better than 0.7 V for 10 dB S N/SSB and CW. Better than 2 V for 10 dB S N/N AM.
- Selectivity 3 KHz at -6 dB, 7 KHz at -50 dB.
- Input Impedance high 0.5-1.6 MHz. 50-75 ohm 1.6-29.9 MHz.
- 234V AC 50-60 Hz or 12V DC (external or internal B dry cell).
- Size 340 mm x 153 mm x 285 mm.

### ● Price \$338.00

- Prices include S/tax, freight extra. Prices and Specs subject to change.

Explore the wonderful world of short-wave listening.

Hear broadcast stations, amateurs, ships, aircraft and morse code from stations all over the globe.

Provides an introduction into many aspects of electronics and communications, CB'ers upgrade and widen your scope of operation. The FRG-7 will provide the means of listening to the amateur bands so that you can get the "feel" of amateur "ham" radio.

You can tune into the morse practice transmissions and broadcasts conducted by the Wireless Institute of Australia; the Radio Amateurs representative Society in Australia.

Write for a descriptive brochure and ask for information on study procedures etc. for the novice amateur licence.

Remember, BAIL has been the authorised agent for the YAESU MUSEN CO LTD since 1963. Our experience gathered over these years, and a lifelong participation in electronics, places us in a superior position to handle warranty, after sales service and advice on the wide range of Yaesu amateur radio equipment.

Avoid unauthorised handlers of equipment as it generally results in the supply of non-export 110V sets with 2-core AC power cables, instruction manuals printed in Japanese, lack of service etc. Consult us for advice on your requirements in the field of short-wave listening and amateur radio.

For further information call or write to the Amateur radio specialists.

Australian agents since 1963



60 Shannon St. Box Hill North  
ELECTRONIC SERVICES Vic. 3129  
Ph 89 2213

## Fairchild Microflame

Fairchild have released data on their 9440 Microflame 16-bit bipolar microprocessor. Packaged in a 40-pin package and manufactured using Fairchild's Isoplanar Integrated Injection Logic, the 9440 executes the same instruction set as Data General's NOVA line of computers. In fact, this is the subject of a suit filed by Data General against Fairchild alleging violation of contractual rights related to the development of support software for the microprocessor. Although Fairchild has not yet formally responded, we were interested to see in Fairchild's annual report under 'Contingencies' that the company 'intends to defend this action diligently'.

The 9460 runs off a 5 V supply, and is TTL compatible. The 16-bit information bus carries addresses, instructions and data in multiplexed form. There are 2192 different instructions, with eight addressing modes, and 16 priority interrupt levels. Operation is static, with up to 12 MHz clock speed. Comprehensive software is available, including a BASIC interpreter, and a disk operating system and FORTRAN compiler will be available shortly.

## CMOS MPUs On Increase

Although, for a while back there, it looked as though Intersil's IM6100 and RCA's CDP1802 had a small, static market to themselves, interest in CMOS microprocessors is on the increase. Motorola, for instance, has started to offer a CMOS version of Texas Instruments TMS1000, and is planning to produce a version of 6800 in the low-power technology. Texas Instruments isn't lying down, however, and will offer its own CMOS versions of TMS1000 and TMS1200.

Meanwhile, back at RCA, Intel have signed a non-exclusive agreement for RCA to design and produce CMOS/Silicon-on-sapphire versions of the 8085 A, the 8048, the 8155 RAM-I/O and the 8355 ROM-I/O. In return, Intel will get information on the SOS technology.

Intersil will also offer the 8048 in CMOS, while National may follow suit. Mostek are apparently designing a CMOS version of the 3870 one-chip F8, and it seems that just about everyone is planning on getting in on the act.

## Japanese Calculator Growth

In the one year period from February 1977 to February 1978, Japanese calculator exports to the US doubled to 848,115 from 423,743 for each monthly period, respectively. The value of the February 1978 shipments was US \$19,759,000.

## Philips Internal Merger

Philips has merged the activities of two major Divisions to further strengthen the Company's design, development, manufacturing, sales and installation capabilities in audio, video and communications.

Philips Electronic Systems (Vision & Sound) and Philips-TMC (Telephone Division), will combine their strengths in one operational force based at the large Philips manufacturing plant at Moorebank, Sydney.

The Group General Manager of the Philips Industry Oriented Products Group, Mr. W. Griffiths, said today:

"We are confident that the technical expertise and commercial experience of both groups will complement one another. The combined group will have greatly increased strength in the developing electronic technologies and in systems applications.

"We have taken a good look at the market needs, and we believe that the combination of the skills and experience of Philips-TMC and Vision & Sound will place us in a predominant position in terms of ability to satisfy these needs."

The head office for Vision & Sound will move to Moorebank from Clayton, Victoria. Stock and some personnel transfers already have been made, and the total move will be completed during April. A Sales and Service centre will be maintained in Melbourne.

## 114 And Not Out!

This month Tandy Electronics opened two more stores to bring their Australian store total to 114 and still growing. Both stores are situated in Victoria and both held gala celebrations to announce their respective opening dates.

In Springvale the new store is at Shop 3/288 Springvale Road. The other grand opening was in Geelong at Shop 8-11, 171-181 Moorabool Street. The gala occasions featured sensational bargains and free give-aways to all their customers.

The international store count is presently as follows:

|                         |      |
|-------------------------|------|
| Belgium . . . . .       | 83   |
| Canada . . . . .        | 721  |
| England . . . . .       | 124  |
| France . . . . .        | 10   |
| Germany . . . . .       | 47   |
| Holland . . . . .       | 47   |
| Japan . . . . .         | .6   |
| United States . . . . . | 5804 |

Tandy Electronics is pleased with the growth rate and expects more new Tandy stores to open their doors in the coming months.

## Micro Operating System

An example of the complexity levels microcomputer software is reaching can be seen in a new BASIC language operating system recently announced by Ohio Scientific. The OS-65U operating system is aimed at business applications and is based on Microsoft's 6502 9.5-digit precision BASIC (as used in PET). The memory file system is claimed to be compatible with future bubble and CCD memories without modification. In the meantime, OS-65U supports one to four floppy disks, one to four 75 Mbyte hard disk drives, multiple terminals, multiple line printers and other I/O devices.

File syntax is similar to other extended BASIC's, including OPEN, CLOSE, PRINT and INPUT statements. Other tricks include multiple-level password security that can lock out programs or data files from users, or prevent modification. The OS-65U runs on any Ohio Scientific disk-based 6502 CPU with 32K or more memory and costs \$199 (US) per CPU licence.

## New Switch as Security Aid

Breaches of high security enclosures can be detected by an inertia switch developed by a British Company. The firm, Inertia Switch Ltd, utilised its methods for aerospace applications and has adapted it for industrial and commercial uses.

The switch consists primarily of two essential elements, a loop of protection devices (sensors) and an analyser or control unit. The sensors are attached to various parts of the perimeter structure such as fence or wall, doors or window frames, and are wired with a power source to remote control equipment. The circuit is broken when a sensor — a small gold-plated ball sitting on a contact — is disturbed by the frequency of vibration or shock to trigger off an alarm.

Featured are flexibility and ease of installation, compatibility with other detection systems including direct dialling, and avoidance of false alarms caused by environmental factors such as wind and traffic.

## Texas Fibre Optic Link

One of Houston's city libraries has been linked to a nearby computer by a fibre optic link. The link, which was installed by Univac to join library CRT's to a Univac 1900 Computer Assisted Data Entry processor, has been operating for several weeks without problems. The optical cable is about as thick as a lead pencil, although the actual fibre is pin-sized, and was laid in existing underground conduits by the city. The 900m data link runs at 2,400 bit/sec.

# Ideas for experimenters

These pages are intended primarily as a source of ideas. As far as reasonably possible all material has been checked for feasibility, component availability etc, but the circuits have not necessarily been built and tested in our laboratory. Because of the nature of the information in this section we cannot enter into any correspondence about any of the circuits, nor can we produce constructional details.

Electronics Today is always seeking material for these pages. All published material is paid for — generally at a rate of \$5 to \$7 per item.

## Capacity checker

This bridge was originally designed to find values for odd, unmarked or undecipherable capacitors. While not being of great accuracy, it does give a very good indication as to the value of the capacitor.

A known value component is placed across terminals A—A, polarity is not important, but polarised capacitors must not be used, and cannot be tested. The capacitor under test is inserted in B-B, the unit is switched on and VR1 rotated until a maximum value reading is obtained on meter M1. At this point,

a reading is taken from the calibration scale on the pot which initially must be calibrated in ratios, i.e.: 1000:1, 100:1, 10:1, 1:1, 1:10, 1:100 etc. The unknown value is then calculated from this reading. Original calibration is from known values.

To increase the range of the circuit switch SW1 has been included to bypass R1. Since the frequency used is 50 Hz from the mains, ranges are limited; if another source were used, driving an audio output transformer, the versatility of the unit would then be further increased.

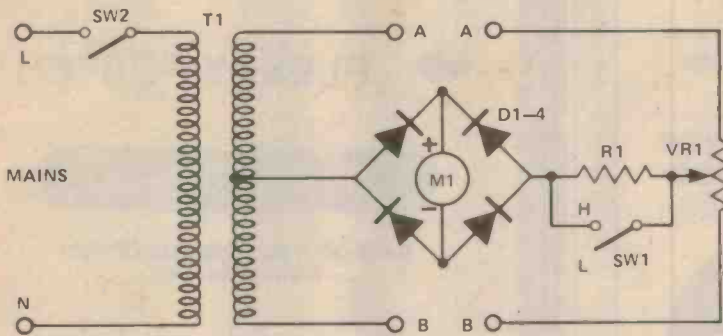

|      | H | L |
|------|---|---|
| 10n  | X |   |
| 100n | X | X |
| 1u   |   | X |

M1 = 100uA  
D1-4 = 1N4001  
R1 = 25k  
VR1 = 10k Lin  
T1: 240V/3V-0-3V

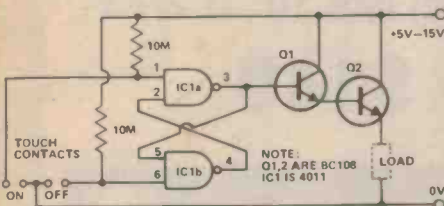

## Low Current Touch Switch

The cost of many CMOS ICs is now lower than a mechanical on/off switch. Using only one half of a 4011, plus a couple of general purpose transistors, a touch operated switch can be con-

structed which is ideal for many battery powered projects.

Assuming that the inputs to the remaining half of the 4011 are tied low, the current drawn in the off state is almost negligible and battery life is hardly affected.

Touching the 'on' contacts with a finger brings pin 3 high, turning on the darlington pair and supplying power to the load (transistor radio etc). Q1 must be a high gain transistor, and Q2 chosen for the current required by the load circuit.

- MIRRORBALLS • BEACONS
- ROPELIGHTS • CHASERS
- STROBES • SOUND TO LIGHT
- STAGE DIMMERS • BUBBLE BLOWERS • ULTRA VIOLET



• LARGEST RANGE OF 3" EFFECTS CASSETTES AND 6" WHEELS.

Australia's most helpful professional supplier of effects lighting equipment and discotheque consoles

Solar, Tutor and Aquarius effects projectors and accessories.



**ECLIPSE LIGHTING & ELECTRONICS**

100 Penhurst St.,  
Willoughby, Phone 95-4212.

Wherever there is Entertainment  
you will see a part of

# Cash-More Sound



**SOUND SYSTEMS &  
DISCOTHEQUE LIGHTING**

**INTRODUCING COMPACT III  
PROFESSIONAL SPEAKER ENCLOSURE**



ALTEC 511B HORN  
30 WATT  
CORAL DRIVER  
A.T.C. 12" HIGH  
POWER MID RANGE  
2x12" A.T.C. HIGH  
POWER BASS

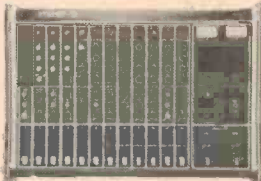

12x2 H/H  
MIXING CONSOLE.

- ☆ Superbly manufactured enclosures
- ☆ Freq. range 50Hz to 18kHz. Passive x'overs or electronics size
- ☆ Total power handling 450 watts.

☆ **Ideal for club sound** ☆ **Pop group** ☆  
**Disco**

**INTRODUCING A.T.C. HIGH POWER  
12" SPEAKERS FROM UK — USED  
BY LEADING SOUND COMPANIES.**



A.T.C. 12in. STD-LS  
Power handling 125 watts  
Freq to 6K  
Mid range speaker



A.T.C. 12in. Bass-LC  
Power handling 150 watt  
Freq to 3K  
Bass speaker

#### AUDIO PRODUCTS

- ☆ High level transformers, ie mike splitters, etc
- ☆ Canon plugs — sockets
- ☆ Gaff tape
- ☆ P + N mike stands
- ☆ Passive x'overs — high pass — low pass
- ☆ Anything and everything for the professional

**FOR YOUR ENTERTAINMENT NEEDS CONTACT  
CASH-MORE SOUND OR VISIT THE  
SHOWROOMS AT 149-151 GEORGES RIVER RD,  
CROYDON PARK, SYDNEY. TEL (02) 798 6782  
(02) 798 5647.**

FREE BROCHURES — PRICE LIST ON REQUEST

**SALES — SERVICE —  
INSTALLATION — HIRE**



## EDGE ELECTRIX

PTY LIMITED

31 BURWOOD ROAD, BURWOOD, NSW. 2134.

PHONE 747-2931

**SPEAKER SPECIALIST**

➔ ALL CORAL KITS

➔ PHILIPS

➔ PLESSY-FOSTER

**SPECIAL OFFERS**

SAVE ON THESE SPECIAL OFFERS  
NOW AVAILABLE

➔ PHILIPS 12" 3 WAY

**\$199**

➔ PHILIPS 10" 3 WAY

**\$149**

**Components now available**

**at discount prices . . . .**

**Watch for our ad in**

**Top Projects Vol. 5.**

# Ideas for experimenters

## Channel splitter for radio control

This circuit is designed to replace the electromechanical reed units used as channel-splitters in radio controlled models.

The circuit is based on the MC 1310P integrated circuit, a chip that is primarily a stereo decoder for use in stereo radio tuners. When used as a stereo decoder, the MC 1310P automatically switches itself from the mono mode to the stereo mode whenever its input contains the 19 kHz subcarrier of a stereo multiplex signal at a sufficiently high level (16 mV), and switches back to the mono mode when the 19 kHz subcarrier ceases to be present. Pin 6 of the integrated circuit drives a stereo indicator lamp to give a visual indication of whether the circuit is operating in the stereo or mono mode.

It is this lamp driver facility of the MC 1310P that makes it an ideal chip to use as a channel-splitter. When used as a channel-splitter the circuit is not tuned to the 19 kHz of the stereo decoder but to the audio frequency that the circuit is required to detect, and the lamp driver output from pin 6 is used to drive a power transistor controlling a motor or other device.

The output from the detector of a radio receiver is amplified by the BC 108 and then fed into a series of MC 1030P channel-splitters (connected in parallel) each tuned to a different audio frequency.

The audio frequency to which the channel-splitter responds is determined

by the tuning circuit R1, VR1 and C1, and is given by the formula:—

$$f = \frac{1}{2\pi C1 (R1 + RV1)} \text{ Hz}$$

The value of C1 is chosen to give the required tuning range for the preset RV1. For example, if C1 is 10,000 pF, then the tuning range is approximately 750 Hz to 1,000 Hz.

The output is a switched current output between Pin 6 of the chip and the positive supply rail. This current should not exceed 35 mA and so a 470 ohm resistor is inserted in the output connection from Pin 6 as short circuit protection. If a voltage output is required then a resistor can be connected from Pin 6 to the positive supply and the voltage output taken from Pin 6.

The MC1310P is triggered when the input to Pin 2 contains its tuned frequency at a level greater than 16 mV. It can be triggered by noise if the noise level is greater than 16 mV. Some radio control transmitters tend to transmit noise when they are not transmitting a tone, and if this is the case the transmitter should be modified to prevent noise being transmitted. This could be done by making the transmitter transmit an extra unused tone whenever it is not transmitting one of the used audio tones.

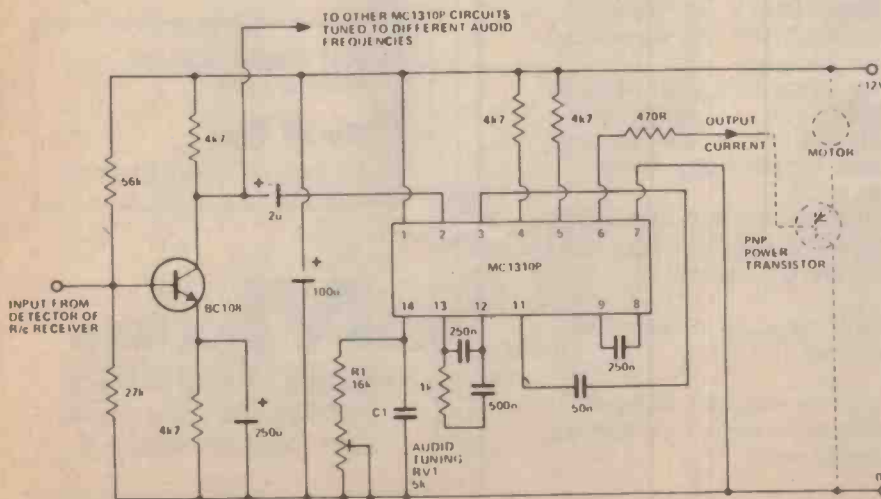

## NEW BOOKS

Just a few of the thousands in stock. Call in or write. Prices subject to fluctuation. Mail orders by return. Please add 90c per parcel post (Vic) \$1.20 per parcel interstate.

|                                             |         |
|---------------------------------------------|---------|
| ARRL Radio Amateur's Handbook 1978 .....    | \$12.95 |
| Radio Amateur Callbook 1978 .....           |         |
| US Listings .....                           | \$19.50 |
| Foreign Listings .....                      | \$18.50 |
| Radio Communication Handbook, RSGB, 5th ed. |         |
| Vol 1 .....                                 | \$21.95 |
| Vol 2 .....                                 | \$18.90 |
| World Radio TV Handbook 1978 edition .....  | \$12.95 |

### NEW BOOKS ON CB

|                                                                                                                 |         |
|-----------------------------------------------------------------------------------------------------------------|---------|
| Best Book on CB — includes all 40 channels and 1977 regulations, choosing equipment, installation and use ..... | \$6.25  |
| 99 Ways to Improve Your CB Radio — Buckwalter .....                                                             | \$5.60  |
| Pictorial Guide to CB Radio Install & Repair .....                                                              | \$8.50  |
| Practical CB Radio Servicing — .....                                                                            | \$9.75  |
| The Truth About CB Antennas — Orr & Cowan .....                                                                 | \$8.50  |
| ARRL Radio Amateur's Handbook 1978 .....                                                                        | \$12.95 |
| World Radio TV Handbook 1978 Edition .....                                                                      | \$12.95 |

### RADIO & ELECTRONIC

|                                                                               |         |
|-------------------------------------------------------------------------------|---------|
| Advanced Applications for Pocket Calculators .....                            | \$8.50  |
| Amateur Radio Techniques — Hawker, RSGB .....                                 | \$7.40  |
| Amateur Radio Theory Course — Ameco .....                                     | \$7.80  |
| Antenna Handbook, ARRL .....                                                  | \$8.80  |
| Australian Radio Amateur Callbook 1977 .....                                  | \$2.85  |
| Active Filter Cookbook — Lancaster .....                                      | \$19.00 |
| Beam Antenna Handbook — Orr .....                                             | \$7.80  |
| Best of Creative Computing Vol 1 .....                                        | \$15.95 |
| Best of Creative Computing Vol 2 .....                                        | \$15.95 |
| Building Hi-Fi Speaker Systems .....                                          | \$3.95  |
| Building & Designing Transistor Radios — Warring .....                        | \$7.40  |
| Cubical Quad Antennas — Orr .....                                             | \$6.75  |
| CMOS Cookbook — Lancaster .....                                               | \$13.50 |
| Electronic Calculator User's Handbook — Babani .....                          | \$2.75  |
| Getting to Know Oscar — ARRL .....                                            | \$5.60  |
| High Fidelity Audio Amplifier Circuits — Texas Instruments .....              | \$3.30  |
| Ham & CB Antenna Dimension Charts — Noll .....                                | \$2.95  |
| Ham Radio Operating Guide, ARRL .....                                         | \$7.20  |
| IC Op-Amp Cookbook — Jung .....                                               | \$16.25 |
| Installing TV & FM Antennas — Sands .....                                     | \$6.50  |
| International Transistor Selector — Towers .....                              | \$9.75  |
| International FET Selector — Towers .....                                     | \$10.75 |
| Introduction to Microcomputers, Vol 1 Basic Concepts — Adam Osborne .....     | \$12.55 |
| Introduction to Microcomputers, Vol 2 Some Real Products — Adam Osborne ..... | \$18.20 |
| Japanese Radio, Recorder Tape Player — Schematic Servicing Manual .....       | \$9.90  |
| Low & Medium Frequency Radio Scrap Book — Ham Radio Magazine .....            | \$9.85  |
| Magazine — Byte; Interface Age; Kilobaud — each .....                         | \$4.00  |
| Magazine — Dr Dobbs; Personal Computing; Peoples Computers; each .....        | \$3.00  |
| Master Handbook of Digital Logic Applications — Hunter .....                  | \$10.95 |
| Master Handbook of 1001 Practical Electronic Circuits .....                   | \$13.95 |
| Master Tube Substitution Handbook .....                                       | \$6.95  |
| Microprocessor/Microprogramming Handbook — Brice Ward .....                   | \$9.75  |
| Philips General Catalogue 77 .....                                            | \$4.00  |
| Programming Microprocessors, McMurrin .....                                   | \$9.75  |
| Radio Amateur's VHF Manual, ARRL .....                                        | \$7.30  |
| Radio Handbook, new 20th edition .....                                        | \$24.40 |
| Reference Data for Radio Engineers .....                                      | \$37.50 |
| Servicing Electronic Organs — Tab .....                                       | \$10.95 |
| 73 Dipole & Long-Wire Antennas — Noll .....                                   | \$6.75  |
| 73 Vertical Beam & Triangle Antennas — Noll .....                             | \$7.50  |
| Test Equipment for the Radio Amateur, Gibson and RSGB publication .....       | \$6.65  |
| Transistor Substitution Handbook, 15th ed. .....                              | \$5.85  |
| Understanding Amateur Radio, ARRL .....                                       | \$7.30  |
| VHF Handbook for Radio Amateurs .....                                         | \$8.50  |
| Introduction to Microcomputers, Vol 0 — The Beginners Book .....              | \$12.55 |
| VHF-UHF Manual, Evans & Jassop, RSGB, 3rd ed. .....                           | \$17.00 |

## TECHNICAL BOOK & MAGAZINE CO

299-199 Swanston Street, Melbourne 3000  
Ph: 663-3951



**ADVISORY  
SERVICE AND  
SPARE PARTS  
SUPPLIED  
TO TRADE**

Full Service facilities for all communications equipment. CB radio, Stereo, and HiFi etc.



*Service facilities for  
trade and public*

**419-3342**

**ROAD RUNNER  
COMMUNICATIONS**

39 Vere St, Collingwood 3066

**EASTERN  
ELECTRONIC  
COMPONENTS**  
35 Mahoneys Road,  
Forest Hill. 3131.  
Telephone 878-7876.

**A NEW SUPPLIER OF  
ELECTRONIC COMPONENTS  
IN THE EASTERN SUBURBS**

**HERE ARE A FEW EXAMPLES  
OF OUR WIDE RANGE**

**LINEAR I.C.s**

|        |      |        |      |
|--------|------|--------|------|
| LM 555 | 0-40 | LM 741 | 0-45 |
| LM 301 | 0-45 | LM 380 | 1-32 |
| LM3900 | 0-80 | 7805   | 1-20 |

**TTL I.C.s**

|      |      |      |      |
|------|------|------|------|
| 7401 | 0-31 | 7402 | 0-32 |
| 7408 | 0-32 | 7420 | 0-32 |
| 7492 | 0-81 | 7493 | 0-81 |

**CMOS I.C.s**

|      |      |      |      |
|------|------|------|------|
| 4000 | 0-32 | 4011 | 0-32 |
| 4024 | 0-70 | 4068 | 0-32 |

**TRANSISTORS**

|                 |      |
|-----------------|------|
| BC547, 548, 549 | 0-19 |
| BC107, 108, 109 | 0-30 |
| 2N 3638 SPECIAL | 0-10 |

|       |        |       |
|-------|--------|-------|
| 2708  | EPROM  | 20-00 |
| 2102  | RAM    | 1-75  |
| 2513  | ROM    | 19-80 |
| 93427 | PROM   | 3-00  |
| 3850  | F8 CPU | 14-95 |
| 3853  | F8 SMI | 12-95 |

**THIS MONTH'S SPECIALS**

|         |           |      |      |
|---------|-----------|------|------|
| 7400    | 0-16      | 4001 | 0-22 |
| FND 357 | 7-SEGMENT |      | 1-00 |
| BC208   | 0-10      | 7815 | 0-80 |

**OTHER ITEMS INCLUDE**  
RESISTORS ¼, ½, 1&5 Watt  
CAPACITORS disc, electro, tags  
and greencaps.  
R.F. CHOKES 3.3µH – 800µH  
SWITCHES and HARDWARE  
MICROPROCESSORS including  
6800, SC/MP, PACE, 2650,  
F8, 6100.  
CHARTPACK PCB ARTWORK  
PRINTED CIRCUIT BOARDS for  
ETI and EA projects.

All of the above prices include sales tax.

Quantity discounts available  
Mail orders catered for. Pack and post 50 cents.

**27-2012**  
**\$1.00**  
**each**

**P&P FREE**

LOW POWER, 650 ns  
ACCESS TIME

BRAND NEW,  
FULLY GUARANTEED!

**MAILMAN  
ELECTRONICS**  
P.O.Box 536 Lane Cove  
PH: (02) 498-3405 A.H.

# Ideas for experimenters

## Car Voltage Regulator

This circuit provides solid state control of battery charging. The field winding of the dynamo is initially energized via the ignition light as in a conventional system. Current flowing down the WL lead passes through Q1 to the F lead then to the field coil. Once the engine has started, current from the dynamo passes through D2 to Q1. The ignition light goes out because the WL lead rises in voltage to that of the battery. Current also passes through D5 to the battery. The battery voltage is sensed by IC1, which is wired as a comparator, once the voltage of the non inverting input rises above that of the inverting input (Held at 4.6 volts by D4) the output goes high. Current then flows through D3 and R2 to the base of Q2 turning it on. This then pulls down the base of Q1 turning it off and cutting off the current to the field winding. The output from the dynamo then drops bringing down the battery voltage. This

holds the battery voltage constant. The battery voltage is adjusted by RV1 to approximately 13.5 volts.

Under cold weather starting the battery voltage drops very low. Once the engine has started the internal resistance of the battery is also very low, which would draw excessive current from the dynamo causing possible damage. To limit the current R4 is inserted in the main power lead from the dynamo, the resistance of R4 is chosen so that at maximum current (Typically 20 amps) 0.6 volts is developed across it, this then turns on Q3. When Q3 turns on current flows from the power rail through R2 to the base of Q2 turning it on, which in turn turns off Q1 and cuts off current to the field winding. The output from the dynamo then drops.

No changes have to be made to the existing wiring. The circuit can be housed in an old regulator box, Q1, Q2 and D5 should be mounted on a heat sink.

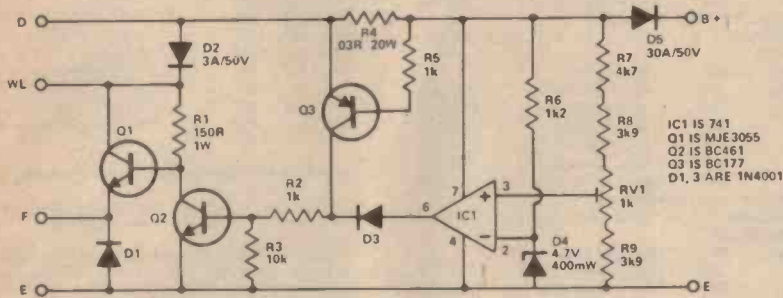

## Increasing Regulator Outputs

It is often necessary to arrange an integrated circuit 3-terminal voltage regulator to give a higher output voltage than that set by the regulator alone. The normal way of doing this is to connect the "common" terminal to the mid-point of a potential divider hung between the regulated output and ground. The regulator voltage now appears across the top divider resistor; hence, if for example equal divider resistors are used, the output voltage is twice that maintained by the regulator between its common terminal and output.

The problem with this method is that most IC regulators (eg the 78-series) have a small quiescent current (approx 10mA) flowing out of the common terminal to ground. The magnitude of this current is not closely controlled, and hence the total output voltage becomes somewhat unpredictable due to this extra current flowing in the bottom half of the divider. Low divider resistor values help, but there are likely

to be the complications of heat dissipation and inefficiency.

The circuit above avoids the problem by using transistor Q1 to generate a low impedance at the regulator common terminal by emitter-follower action, while transferring the voltage derived from a relatively high-resistance divider network. The value of R3 is not critical, but must be low enough to accept the highest likely quiescent current without causing Q1 to turn off.

The circuit shows a practical 24 Volt supply using a 7812 regulator.

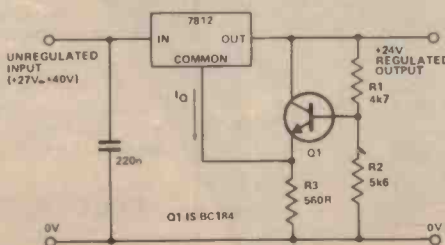

# BRIGHT STAR CRYSTALS

ESTABLISHED FOR THE  
PAST 35 YEARS FOR  
ALL YOUR REQUIREMENTS

STILL ON TOP  
ELECTRONIC UNITS

• DECADE COUNTING UNITS TO 1 Hz • WIDE BAND AMPLIFIER FOR your counter 1 MV sensitivity, band width 1-250 MHz.

DEVOTED EXCLUSIVELY TO  
THE MANUFACTURE OF  
PIEZO ELECTRIC CRYSTALS

Contractors to Federal & State Government Departments.



"All Types of Mountings"

## REPRESENTATIVES -

- NSW** Hose & Equipment Co. Pty Ltd, 11 Salisbury St., Botany, 2019 Phone 666-8144
- S.A.** Rogers Electronics P.O. Box 3, Modbury North, S.A. Phone: 42-6666
- QLD** Fred Hoe & Sons Pty Ltd, 246 Evans Road, Salisbury North, Brisbane, Phone: 47-4311
- W.A.** Communication Systems, 32 Rudlock Road, Morley 6062 Phone 76-2566
- TAS.** Dilmond Instruments, P.O. Box 219, Bellerive, Hobart, Tas. Phone: 479-077.

Send stamped addressed envelope for new catalogue or quote for your requirements.

**BRIGHT STAR CRYSTALS P/L.**  
35 EILEEN ROAD, CLAYTON,  
VICTORIA, 546-5076

**SOME OF AUSTRALIA'S LOWEST COMPONENT PRICES**

NOTE: REGULAR PRICES NOT TEMPORARY SPECIALS - KEEP US IN MIND FOR THAT NEXT ORDER

**POLYESTER FILM CAPS**

|                        |        |     |                  |
|------------------------|--------|-----|------------------|
| E12 10% 100V           |        |     |                  |
| All values .001 to .01 | 7c ea. |     |                  |
| .01                    | 7c.1   | 13c |                  |
| .012                   | 8c.12  | 14c |                  |
| .015                   | 8c.15  | 14c |                  |
| .018                   | 8c.18  | 14c |                  |
| .022                   | 8c.22  | 16c |                  |
| .027                   | 8c.27  | 16c |                  |
| .033                   | 8c.33  | 18c |                  |
| .039                   | 9c.39  | 19c |                  |
| .047                   | 9c.47  | 22c |                  |
| .056                   | 9c     |     | All values in uF |
| .068                   | 10c    |     |                  |
| .082                   | 10c    |     |                  |
| 10% off 100 same uF    |        |     |                  |

**ELECTROCAPS (UPRIGHT) (per 100 prices in brackets)**

|                             |                    |             |           |
|-----------------------------|--------------------|-------------|-----------|
| Cap.                        | 16V                | 25V         | 50V       |
| 0.47 uF                     |                    |             |           |
| thru to all                 | all                | all         | all       |
| 10 uF                       | 5c(\$3 1/2)        | 6c(\$3 1/4) | 7c(\$4)   |
| 22 uF                       | 6c(\$3 3/4)        | 7c(\$4)     | 8c(\$5)   |
| 33 uF                       | 8c(\$4)            | 9c(\$5)     | 10c(\$6)  |
| 47 uF                       | 9c(\$5)            | 10c(\$6)    | 11c(\$7)  |
| 100 uF                      | 10c(\$6)           | 12c(\$7)    | 14c(\$11) |
| 220 uF                      | 12c(\$8)           | 16c(\$10)   | 35c(\$17) |
| 470 uF                      | 16c(\$12)          | 22c(\$16)   | 45c(\$30) |
| 1000 uF                     | 22c(\$18)          | 30c(\$25)   | 75c(\$50) |
| 1000 uF/15V axial           | 20c ea. \$8 per 50 |             |           |
| 2200 uF/50V axial           | 95c ea. \$8 per 10 |             |           |
| Full axial price list - SAE |                    |             |           |

LEDS: \$12 per 100, \$110 per 1000, or 17c each, 10 for \$1.50 clips 3c each all quantities. LEDS superb - 5mm red - well diffused. Wide viewing angle - sample 40c stamp.

TO3 MOUNTING KITS: 10 for \$1 or \$4 box of 50. Generous kit includes mica, screws, nuts, washers, tag, nylon brushes.

Potentiometers: 50c ea. rotary carbon sing. gang.) log or lin: 1K, 5K, 10K, 25K, 50K, 100K, 25K, 500K, 1M, 2M (metal shafts) Trim Pots: 17c ea. - 10mm 1W horiz. or vert: 100 Ohm to 2M

ZENER DIODES: 15c each 400mW 5% E24 values 3V to 33V

Keep electronics a hobby and not a luxury, compare our prices and buy from us. Same day turnaround service (unless swamped). All goods top quality and new. No minimum order. One P/P charge of 40c regardless of quantity. Advert current 3 months for late readers.

**DIGGERMAN ELECTRONICS**

P.O. BOX 33, CORAMBA NSW. 2466.

SCRs:

|      |      |        |   |
|------|------|--------|---|
| 0.8A | 30V  | C103Y  | - |
| 0.8A | 200V | C103B  | - |
| 4A   | 30V  | C106Y1 | - |
| 4A   | 400V | C106D1 | - |
| 8A   | 400V | C122D  | - |
| 8A   | 500V | C122E  | - |
| 25A  | 400V | C37D   | - |

TRIACS:

|    |     |      |                         |          |
|----|-----|------|-------------------------|----------|
| 75 | 2A  | 400V | ESP240                  | -        |
| 60 | 6A  | 400V | SC141D                  | - \$1.30 |
| 40 | 10A | 400V | SC146D                  | - \$1.50 |
| 75 | 25A | 400V | SC260D                  | - \$2.50 |
|    |     |      | DIAC ST2                | - \$1.05 |
|    |     |      | Chart to identify leads | - \$1.20 |
|    |     |      | Plus trigger info.      | - \$2.50 |

DIODES:

|    |        |   |                         |
|----|--------|---|-------------------------|
| 65 | 1N4001 | - | 7c (1A 50V)             |
|    | 1N4002 | - | 8c (1A 100V)            |
|    | 1N4004 | - | 9c (1A 400V)            |
|    | 1N4007 | - | 12c (1A 1000V)          |
| 35 | 1N4148 | - | 6c \$4.50/100 \$38/1000 |

**TRANSFORMERS**

12 or 24 Volt Range: Primaries 220-240 volts

| Ref. No. | Amps  | Wt. Gms. | Secondary Windings      | \$    |
|----------|-------|----------|-------------------------|-------|
| 242      | 300MA | 150MA    | 198 0-12V at 150 MA x 2 | 3.50  |
| 111      | 0.5   | 0.25     | 283 0-12V at 0.25A x 2  | 4.50  |
| 213      | 1.0   | 0.5      | 425 0-12V at 0.5A x 2   | 5.00  |
| 71       | 2     | 1        | 793 0-12V at 1A x 2     | 7.20  |
| 18       | 4     | 2        | 1020 0-12V at 2A x 2    | 9.00  |
| 70       | 6     | 3        | 1538 0-12V at 3A x 2    | 11.40 |
| 108      | 8     | 4        | 2268 0-12V at 4A x 2    | 15.00 |
| 116      | 12    | 6        | 2722 0-12V at 6A x 2    | 16.80 |
| 115      | 20    | 10       | 5300 0-12V at 10A x 2   | 24.90 |

| Ref. No. | Amps | Wt. Gms. | Secondary Taps   | \$    |
|----------|------|----------|------------------|-------|
| 112      | 0.5  | 623      | 0-12-15-20-24-30 | 6.00  |
| 79       | 1    | 737      | 0-12-15-20-24-30 | 7.50  |
| 3        | 2    | 1361     | 0-12-15-20-24-30 | 10.20 |
| 21       | 4    | 2800     | 0-12-15-20-24-30 | 12.60 |
| 89       | 10   | 5670     | 0-12-15-20-24-30 | 26.10 |

Miniature transformers with screens: Primaries 220-240 volts

| Ref. No. | MA       | Wt. Gms. | Volts            | \$    |
|----------|----------|----------|------------------|-------|
| 238      | 200      | 85       | 3.03             | 3.50  |
| 212      | 1A 1A    | 595      | 0.6 0.6          | 6.60  |
| 13       | 100      | 113      | 9.0-9            | 3.50  |
| 236      | 330, 330 | 198      | 0-8, 0-9         | 3.50  |
| 207      | 500, 500 | 566      | 0-8-9, 0-8-9     | 6.30  |
| 205      | 500, 600 | 1077     | 0-15-20, 0-15-20 | 7.20  |
| 214      | 300, 300 | 623      | 0-20, 0-20       | 5.00  |
| 221      | 700 (DC) | 737      | 20-12-0012-20    | 7.80  |
| 206      | 1A 1A    | 1304     | 0-15-27, 0-15-27 | 10.80 |
| 203      | 500, 500 | 822      | 0-15-27, 0-15-27 | 10.20 |
| 204      | 1A 1A    | 1417     | 0-15-27, 0-15-27 | 14.40 |

15/30 Volt Range: Primary 220-240 volts: Secondary Windings 0-12-15v at 5 amps, 0-5-9-15v at 5 amps. Voltages obtainable: 3, 4, 5, 6, 8, 9, 10, 12, 15, 18, 20, 24, 30, or 12-0-12 or 15-0-15.

| Ref. No. | Amps | Wt. Gms. | Secondary Taps         | \$    |
|----------|------|----------|------------------------|-------|
| 51       | 10   | 5        | 3120 0-12-15, 0-5-9-15 | 18.00 |

50 Volt Range: Primaries 220-240 volts Voltage obtainable: 6, 7, 8, 10, 14, 15, 17, 19, 21, 25, 31, 33, 40, 50, or 25-0-25

| Ref. No. | Amps | Wt. Gms. | Secondary Taps     | \$    |
|----------|------|----------|--------------------|-------|
| 102      | 0.5  | 737      | 0-19-25-33-40-50 V | 8.40  |
| 103      | 1    | 1304     | 0-19-25-33-40-50 V | 9.60  |
| 104      | 2    | 2495     | 0-19-25-33-40-50 V | 12.60 |
| 105      | 3    | 3176     | 0-19-25-33-40-50 V | 15.00 |
| 106      | 4    | 4100     | 0-19-25-33-40-50 V | 18.00 |
| 107      | 6    | 5444     | 0-19-25-33-40-50 V | 26.40 |

All transformers continuously rated, vacuum varnish impregnated, and guaranteed.

Prices do not include postage or packing. Assess postage to your address using your weights given and add 10% of postage rate for packing. Unless quoting sales tax number add 15% to order cost.

30 Volt Range: Primaries 220-240 volts Voltages obtainable 3, 4, 5, 6, 8, 9, 10, 12, 15, 18, 20, 24, 30, or 12-0-12 or 15-0-15.

60 Volt Range: Primaries 220-240 volts Voltages obtainable: 6, 8, 10, 12, 16, 18, 20, 24, 30, 36, 40, 48, 60 or 24-0-24 or 30-0-30.

| Ref. No. | Amps | Wt. Gms. | Secondary Taps     | \$    |
|----------|------|----------|--------------------|-------|
| 124      | 0.5  | 737      | 0-24-30-40-48-60 V | 7.80  |
| 126      | 1    | 1361     | 0-24-30-40-48-60 V | 9.60  |
| 127      | 2    | 2495     | 0-24-30-40-48-60 V | 12.60 |
| 125      | 3    | 4083     | 0-24-30-40-48-60 V | 18.60 |
| 40       | 5    | 5670     | 0-24-30-40-48-60 V | 25.20 |

DOUGLAS TRANSFORMERS, DEPT. MO, BOX 23, COORANBONG, N.S.W. 2265.

**The SUPER CALCULATOR preprogrammed plug-in**

**with revolutionary modules**



(retaining up to 5000 steps each)

**OTHER MODULES AVAILABLE**

Marine Navigation • Aviation • Applied Statistics • Real Estate and Investment • Surveying • Leisure Time • Business Finance and Investment.

SALES TAX FORMS MUST BE DULY SIGNED AND STAMPED BY COLLEGE, UNIVERSITY OR SCHOOL.

Packing and posting - extra \$1.50 for NSW, elsewhere \$2.50 per order. Save by ordering with your friends - S/T forms available - write for full price list of all models.

TI 58 - \$115 (save \$14) - with sales tax \$127 Programmable up to 480 steps, or up to 60 memories, plus plug-in master module with calculator.

TI 59 - \$265 (save \$34) - with sales tax \$294 Programmable up to 960 steps, or up to 100 memories, plus module, plus programme cards (480 steps on each card).

PC100A - Alpha-Numeric Printer for TI 58 & 59 \$250 (if ordered with calculator \$225 for sales tax exempt).

TI 57 - \$75 (save \$9) with sales tax \$83

TI 55 - NEW MODEL! (All TI calculators include rechargeable/B and adaptors).

National Semiconductor - NS108 Liquid crystal - 850 hr battery life - 7.5 mm thin. Full scientific, statistical calculator - with billfold wallet \$45 (with sales tax \$51).

**ELECTRONIC CALCULATOR DISCOUNTS**

P.O. Box 106, Baulkham Hills, NSW. 2153 Phone: (02) 624.8849 (8 am till 3 pm)



# INTERNATIONAL ELECTRONICS UNLIMITED

**DISCOUNT ON ALL IC'S AND LED'S**  
**10% OFF ON \$25.00**  
**15% OFF ON \$50.00**

**TTL**

|      |     |       |      |        |      |
|------|-----|-------|------|--------|------|
| 7400 | .11 | 7451  | .20  | 74155  | .75  |
| 7401 | .18 | 7453  | .20  | 74158  | .75  |
| 7402 | .14 | 7454  | .20  | 74157  | .85  |
| 7403 | .14 | 7460  | .20  | 74158  | 1.39 |
| 7404 | .16 | 7464  | .35  | 74160  | 1.23 |
| 7405 | .19 | 7465  | .35  | 74161  | .95  |
| 7406 | .29 | 7470  | .38  | 74162  | 1.39 |
| 7407 | .28 | 7472  | .35  | 74163  | .95  |
| 7408 | .22 | 7473  | .35  | 74164  | .95  |
| 7409 | .17 | 7474  | .31  | 74185  | .95  |
| 7410 | .16 | 7475  | .49  | 74168  | 1.19 |
| 7411 | .25 | 7476  | .34  | 74170  | 1.90 |
| 7413 | .43 | 7483  | .68  | 74173  | 1.49 |
| 7414 | .65 | 7485  | .88  | 74174  | 1.19 |
| 7415 | .25 | 7486  | .38  | 74175  | .95  |
| 7416 | .35 | 7489  | 2.25 | 74176  | .84  |
| 7417 | .35 | 7490  | .43  | 74177  | .84  |
| 7420 | .16 | 7491  | .75  | 74180  | .95  |
| 7423 | .37 | 7492  | .48  | 74181  | 2.30 |
| 7425 | .35 | 7493  | .48  | 74182  | .85  |
| 7428 | .22 | 7494  | .75  | 74185  | 2.20 |
| 7427 | .35 | 7495  | .75  | 74190  | 1.25 |
| 7430 | .20 | 7496  | .75  | 74191  | 1.15 |
| 7432 | .23 | 74100 | 1.15 | 74192  | .89  |
| 7437 | .25 | 74107 | .37  | 74193  | .85  |
| 7438 | .25 | 74121 | .37  | 74194  | 1.15 |
| 7439 | .50 | 74122 | .38  | 74195  | .74  |
| 7440 | .15 | 74123 | .45  | 74196  | .98  |
| 7441 | .85 | 74125 | .54  | 74197  | .95  |
| 7442 | .59 | 74126 | .58  | 74198  | 1.69 |
| 7443 | .65 | 74132 | .75  | 74199  | 1.69 |
| 7444 | .73 | 74141 | .85  | 745200 | 3.95 |
| 7445 | .85 | 74145 | .90  | 74279  | .79  |
| 7446 | .81 | 74150 | .98  |        |      |
| 7447 | .59 | 74151 | .68  |        |      |
| 7448 | .79 | 74153 | .60  |        |      |
| 7450 | .17 | 74154 | 1.20 |        |      |

**LOW POWER SCHOTTKY**

|        |     |        |      |         |      |
|--------|-----|--------|------|---------|------|
| 74LS00 | .36 | 74LS32 | .38  | 74LS95  | 2.09 |
| 74LS02 | .36 | 74LS40 | .45  | 74LS107 | .59  |
| 74LS04 | .36 | 74LS42 | 1.40 | 74LS164 | 2.20 |
| 74LS08 | .38 | 74LS74 | .59  | 74LS193 | 2.20 |
| 74LS10 | .36 | 74LS90 | 1.30 | 74LS197 | 2.20 |
| 74LS20 | .36 | 74LS93 | 1.30 |         |      |

**LOW POWER**

|       |      |       |      |        |      |
|-------|------|-------|------|--------|------|
| 74L00 | .29  | 74LS1 | .29  | 74L90  | 1.40 |
| 74L02 | .29  | 74LS5 | .29  | 74L91  | 1.20 |
| 74L03 | .23  | 74L7  | .29  | 74L93  | 1.50 |
| 74L04 | .29  | 74L72 | .45  | 74L95  | 1.50 |
| 74L06 | .29  | 74L73 | .56  | 74L98  | 2.25 |
| 74L10 | .29  | 74L74 | .56  | 74L164 | 2.25 |
| 74L20 | .29  | 74L78 | .75  | 74L165 | 2.30 |
| 74L30 | .29  | 74L85 | 1.09 |        |      |
| 74L42 | 1.39 | 74L86 | .65  |        |      |

**HIGH SPEED**

|       |     |       |     |        |     |
|-------|-----|-------|-----|--------|-----|
| 74H00 | .25 | 74H22 | .25 | 74H61  | .25 |
| 74H01 | .25 | 74H30 | .25 | 74H62  | .25 |
| 74H04 | .25 | 74H40 | .25 | 74H74  | .39 |
| 74H06 | .25 | 74H50 | .25 | 74H101 | .58 |
| 74H10 | .25 | 74H52 | .25 | 74H102 | .40 |
| 74H11 | .25 | 74H53 | .25 | 74H103 | .40 |
| 74H20 | .25 | 74H55 | .25 | 74H106 | .72 |
| 74H21 | .25 | 74H60 | .25 | 74H108 | .72 |

**CMOS**

|       |      |        |      |        |      |
|-------|------|--------|------|--------|------|
| 4000A | .26  | 4018A  | 1.39 | 4066A  | .89  |
| 4001A | .25  | 4020A  | 1.72 | 4068A  | .84  |
| 4002A | .25  | 4021A  | 1.18 | 4069A  | .84  |
| 4006A | 1.35 | 4022A  | .94  | 4071A  | .26  |
| 4007A | .26  | 4023A  | .25  | 4072A  | .35  |
| 4008A | 1.52 | 4024A  | .89  | 4073A  | .39  |
| 4009A | .57  | 4025A  | .25  | 4075A  | .39  |
| 4010A | .54  | 4027A  | .59  | 4076A  | .39  |
| 4011A | .29  | 4028A  | .98  | 4082A  | .35  |
| 4012A | .25  | 4030A  | .84  | 4510A  | 1.56 |
| 4013A | .45  | 4035A  | 1.27 | 4528A  | 1.56 |
| 4014A | 1.27 | 4040A  | 1.39 | 4585A  | 2.10 |
| 4015A | 1.27 | 4042A  | 1.47 |        |      |
| 4016A | .84  | 4049A  | .59  |        |      |
| 4017A | 1.01 | 4058A  | .59  |        |      |
| 74C00 | .19  | 74C74  | 1.04 | 74C162 | 2.49 |
| 74C02 | .26  | 74C76  | 1.34 | 74C163 | 2.66 |
| 74C04 | .44  | 74C107 | 1.13 | 74C164 | 2.66 |
| 74C08 | .68  | 74C151 | 2.62 | 74C173 | 2.22 |
| 74C10 | .35  | 74C154 | 3.15 | 74C195 | 2.26 |
| 74C20 | .35  | 74C157 | 1.76 | 80C95  | 1.15 |
| 74C42 | 1.61 | 74C160 | 2.48 | 80C97  | .96  |
| 74C73 | 1.04 | 74C161 | 2.49 |        |      |

**CERAMIC DISC CAPACITORS**

|          |           |            |            |
|----------|-----------|------------|------------|
| 1pf 50V  | 56pf 50V  | 270pf 50V  | 01uf 1000V |
| 5pf 50V  | 68pf 50V  | 390pf 50V  | 02uf 50V   |
| 7pf 50V  | 82pf 50V  | 470pf 50V  | 030uf 50V  |
| 10pf 50V | 100pf 50V | 600pf 50V  | 050uf 50V  |
| 22pf 50V | 120pf 50V | 820pf 50V  | 1uf 50V    |
| 27pf 50V | 150pf 50V | 001uf 50V  |            |
| 33pf 50V | 180pf 50V | 0047uf 50V |            |
| 47pf 50V | 220pf 50V | 01uf 50V   |            |

(each) (Minimum 10 per value)

|       |           |           |
|-------|-----------|-----------|
| 0-100 | \$ .10 ea | \$ .05 ea |
| 100-  |           | \$ .04 ea |

**SPECIAL SALE**

**TTL BARGAINS**

|        |       |
|--------|-------|
| 7418   | \$.19 |
| 7430   | .16   |
| 7432   | .19   |
| 7437   | .19   |
| 7438   | .19   |
| 7440   | .13   |
| 7445   | .49   |
| 7495   | .55   |
| 74123  | .25   |
| 74141  | .59   |
| 75LS60 | .99   |

**MARK I CLOCK KIT**  
 8 DIGIT CLOCK KIT WITH ONE PC BOARD. ACCOMMODATES MM5314 CLOCK CHIP AND 8 - FND359 DISPLAYS. CONTAINS ALL COMPONENTS, 3 SWITCHES AND ASSEMBLY INSTRUCTIONS. HAS TERMINALS FOR ADDITIONAL REMOTE DISPLAY.  
**\$10.95**

**CERAMIC DISC CAPACITOR PACKAGE**  
 10 EA. OF FOLLOWING VALUES — 50 VOLT

|           |             |                |
|-----------|-------------|----------------|
| 1pf 33pf  | 82pf 220pf  | 820pf .022uf   |
| 5pf 47pf  | 100pf 270pf | .001uf .030uf  |
| 10pf 56pf | 150pf 470pf | .0047uf .050uf |
| 22pf 68pf | 180pf 800pf | .01uf .1uf     |

24u CAPACITORS **\$10.95**

**2708 FULL SPEED PROM** **\$10.95**

**1702A** **\$3.95**

**8080A, 8008** **\$12.95**

**LD110, LD111** **\$24.75**

**82S23** **\$2.95**

**5314 6 DIGIT CLOCK CHIP** **\$2.95**

**74S200** **\$3.25**

**UART AYS103A** **\$6.95**

**2513 CHARACTER GEN** **\$6.95**

**Clock Kit**  
 MM5314 with 6 NS71 .27" displays 2 P.C. boards — Display board may be remote. Internal or wall transformer can be used. 50-60 Hz, 12-24 hour. Includes all necessary transistors, resistors, capacitors, diodes, 3 switches and complete assembly instructions.  
**CK-6-3** **\$12.95**

**CALCULATOR CHIPS**

**CT5002** 12 digit, 4 function fixed decimal battery operation — 40 pin **1.95**

**CT5005** 12 digit, 4 function plus memory, fixed decimal — 20 pin **2.49**

**MM5725** 8 digit, 4 function, floating decimal 18 pin **1.98**

**MM5736** 6 digit, 4 function, 9V battery operation — 18 pin **2.95**

**MM5738** 8 digit, 5 function plus memory and constant floating decimal, 9V battery operation — 24 pin **3.95**

**MM5739** 9 digit, 4 function, 9V battery operation — 22 pin **3.95**

**OPTO ISOLATORS**

**MCD2** Opto isolator diode **1.09**

**MCT2** Opto isolator transistor **1.09**

**MINIATURE SOLID STATE ELECTRONIC BUZZER**  
 LONG LIFE — HIGH RELIABILITY  
 LOW CURRENT DRAIN  
 NO MOVING CONTACTS  
 NO ARCING — NO RF NOISE  
 RICH & CLEAR SOUND  
 78 dB min AT 1 FT. — 450 Hz

|        |     |      |          |        |
|--------|-----|------|----------|--------|
| EB-106 | 6V  | 15mA | 4-9 VDC  | \$1.99 |
| EB-112 | 12V | 15mA | 8-20 VDC | 1.99   |

**IC SOCKETS**  
 Solder Tail - low profile

|        |       |        |     |
|--------|-------|--------|-----|
| 8 pin  | \$.17 | 24 pin | .42 |
| 14 pin | .20   | 28 pin | .59 |
| 16 pin | .22   | 40 pin | .69 |
| 18 pin | .29   |        |     |

**8038 FUNCTION GENERATOR**  
 Voltage controlled oscillator — sine, square, triangular output. **\$3.95**

**MM 5330**  
 4 1/2 DIGIT DVM LOGIC **\$ 4.95**

**SIGNAL DIODES — 400 MW**  
**20/\$1.00**

**CALCULATOR DISPLAY** 9 MAN 3 M ON PC BOARD  
**\$ .75 ea.**

**Jumbo LED'S**  
 green - yellow  
 amber - clear **16¢ ea.**

**ZENER DIODE — 400MW**  
 3.6V 5.1V 6.8V 15V  
 4.7V 5.5V 10V **\$.15 EA.**  
**8/\$1.00 ANY MIX**

**RESISTOR PACKAGE**  
 CARBON FILM ± 5% 1/4 or 1/2 W  
 15 EA. OF THE FOLLOWING VALUES  
 100, 220, 470, 1K, 1.5K, 3.3K, 4.7K, 6.8K, 10K, 33K, 100K, 1M  
 180 RESISTORS **\$5.45**

**ELECTRONIC DOOR CHIME KIT**  
 WITH TITMS 1000 MICROPROCESSOR CHIP PROGRAMMED TO PLAY 24 DIFFERENT TUNES

**\$39.50** SHIPPING \$1.00

**LINEAR CIRCUITS**

|         |      |            |      |             |      |
|---------|------|------------|------|-------------|------|
| LM300H  | 5.71 | LM372N     | 2.93 | LM733H      | .79  |
| LM301CN | .28  | LM378CN    | .59  | LM739N      | .99  |
| LM302H  | .88  | LM380N     | 1.28 | LM741CN(14) | .32  |
| LM304H  | .80  | LM380N BCN | .95  | LM741CN(14) | .32  |
| LM307CN | .28  | LM381N     | 1.75 | LM741CN     | .35  |
| LM307H  | .30  | LM382N     | 1.75 | LM747H      | .79  |
| LM308H  | .89  | LM385K     | .45  | LM747N      | .71  |
| LM309H  | 1.05 | NE531V     | 2.90 | LM748CN     | .35  |
| LM309H  | .99  | NE540L     | 2.90 | LM8130N     | 2.80 |
| LM310CN | 1.07 | NE548A     | 1.09 | LM8130N     | 1.59 |
| LM311CN | .89  | NE550A     | .75  | LM8148CN    | 1.29 |
| LM311H  | .89  | LM555CN    | .75  | LM8148CN    | .59  |
| LM311H  | .89  | NE556A     | .86  | LM8149CN    | .69  |
| LM319N  | 1.13 | LM560N     | 2.95 | LM8149CN    | 2.48 |
| LM320H  | 1.50 | LM561N     | 2.95 | ULR2208     | .89  |
| LM322A  | 9.12 | LM562N     | 1.19 | ULR2209     | .89  |
| LM322A  | 1.19 | LM565H     | 1.39 | CA3028      | 1.19 |
| LM324N  | 6.12 | LM566H     | 1.39 | CA3031      | 1.49 |
| LM324N  | 1.50 | LM566CN    | 1.19 | LM3800N     | .49  |
| LM324N  | 1.50 | LM567CN    | 1.29 | LM7524      | .79  |
| LM324N  | 1.50 | LM567H     | 1.49 | LM7525      | .79  |
| LM324N  | 1.50 | LM568H     | 1.49 | 80380       | 4.59 |
| LM324N  | 1.50 | LM703H     | .39  | 74S01CN     | .39  |
| LM324N  | 1.50 | LM709H     | .25  | 74S02CN     | .35  |
| LM324N  | 1.50 | LM709H     | .29  | 74S03CN     | .35  |
| LM324N  | 1.50 | LM710H     | .59  | 74S44CN     | .35  |
| LM324N  | 1.50 | LM711N     | .39  | 74S91N      | .71  |
| LM324N  | 1.50 | LM723H     | .55  | 74S92N      | .85  |
| LM324N  | 1.50 | LM723H     | .52  |             |      |

**MM5369 Divider mDIP** **2.49**  
**Crystal 3.58 MHz color TV** **1.75**  
**Crystal 2.010 MHz** **3.95**

**CARBON FILM RESISTORS 5%**

1W — ALL STANDARD VALUES FROM .50 OHMS TO 5.0M OHMS

1/2W — ALL STANDARD VALUES FROM 10 OHM TO 5M OHMS

| QTY      | PRICE      | PRICE                  |
|----------|------------|------------------------|
|          | (per unit) | (Minimum 10 per value) |
| 8-10     | \$1.10 ea  | \$ .85 ea              |
| 10-100   | \$1.10 ea  | \$ .85 ea              |
| 100-1000 |            | \$ .84 ea              |

**METAL FILM RESISTORS 1%**  
 STANDARD DECADE VALUES FROM 10.5 OHM TO 464K OHM

| FACH   | MINIMUM 10 PER VALUE | MINIMUM 100 PER VALUE |
|--------|----------------------|-----------------------|
| 0-10   | \$ .20               |                       |
| 10-100 | .20                  | \$ .15                |
| 100    |                      | .10                   |

**UNIVERSAL BREADBOARD**  
 Values plated copper circuit board. Includes 16 DIP IC's, space for transistors, resistors & capacitors. Versatile and simple to use breadboard IC converter. **\$1.50 ea.**

Date sheets on request. Add 30¢ each if item is priced below \$1.00 each.

Satisfaction guaranteed. Shipment will be made within 3 days from receipt of order.  
 Prices are in Australian \$. Payment may be made with personal check, international money order (include receipt), charge card (include no. & expiration date) or bank cheque made payable in U.S.  
 All items are shipped via air-prepaid unless otherwise indicated.  
 Add \$1.00 service charge for orders less than \$10.00

**INTERNATIONAL ELECTRONICS UNLIMITED**  
 VILLAGE SQUARE, P.O. BOX 449 CARMEL VALLEY, CA 93924 USA  
 TELEPHONE 408 659-3171

## READERS' LETTERS

No charge for replies but a foolscap-size stamped addressed envelope must be enclosed. Project queries can only be answered if related to item as published. We cannot assist if project is modified nor if components are otherwise than specified. We regret we cannot answer readers' enquiries by telephone.

## SUBSCRIPTIONS AND BACK ISSUES

ETI subscriptions cost \$17.00 per year (inc. postage) within Australia. Cost elsewhere is \$17.65 (inc. postage — surface mail). Airmail rates on application.

Back issues cost \$1.25 (Sept. onwards) each plus post and packing.

We can supply only the following issues.

1976: Nov., Dec.

1977: All issues except Jan, Feb, March.

Photostats are available of any article ever published in ETI. We charge a flat \$1.00 regardless of page quantity from any one issue of ETI. Thus if the article is in three issues the cost is \$3.00. Send orders to address below.

Binders \$4.50 plus 80c post NSW, \$1.70 other States.

## COPYRIGHT

The contents of Electronics Today International and associated publications is fully protected by the Commonwealth Copyright Act (1968).

Copyright extends to all written material, photographs, drawings, circuit diagrams and printed circuit boards. Although any form of reproduction is a breach of copyright, we are not concerned about individuals constructing projects for their own private use, nor by pop groups (for example) constructing one or more items for use in connection with their performances.

Commercial organisations should note that no project or part project described in Electronics Today International or associated publications may be offered for sale, or sold, in substantially or fully assembled form, unless a licence has been specifically obtained so to do from the publishers, Modern Magazines (Holdings) Ltd or from the copyright holders.

## LIABILITY

Whilst every effort has been made to ensure that all constructional projects referred to in this edition will operate as indicated efficiently and properly and that all necessary components to manufacture the same will be available, no responsibility whatsoever is accepted in respect of the failure for any reason at all of the project to operate effectively or at all whether due to any fault in design or otherwise and no responsibility is accepted for the failure to obtain any component parts in respect of any such project. Further, no responsibility is accepted in respect of any injury or damage caused by any fault in the design of any such project as aforesaid.

## A MODERN MAGAZINES PUBLICATION

**Managing Director:** Arnold Quick  
**Secretary:** Charles O'Leary  
**Publisher:** Collyn Rivers

## PRODUCTION

**Art Director:** Jim Hattersley  
**Assembly:** Bill Crump  
**Production Manager:** Bob Izzard  
**Subscriptions & Circulation:** John Oxenford  
**Project Design:** Nebula Electronics  
**Acoustical Consultants:** Louis A Challis & Assoc.

## ADVERTISING

**Sydney:** Bob Taylor (Manager), Geoff Petschler (NSW Manager), 15 Boundary St, Rushcutters Bay 2011. Tel: 33-4282.  
**Melbourne:** Tom Bray (Manager), Poppe Davis, Suite 24, 553 St. Kilda Rd, Melbourne. Tel: 51-9836.  
**Brisbane:** Geoff Horne, 60 Montanus Drive, Qld. 4070. Tel: 202 6229.  
**Adelaide:** Ad Media Group of SA, 37 Fullarton Rd, Kent Town 5067. Tel: 42-4858.

**Perth:** Aubrey Barker, 133 St. George's Terrace, Perth. 6000. Tel: 322 3184.  
**Hobart:** H.W. Lincone, 23 Lord St, Sandy Bay. Tasmania. 7005.  
**Tokyo:** Genzo Uchida, Bancho Media Service, 15 Sanyocho, Shintoku-Ku, Tokyo 160.  
**London:** Electronics Today International, 25-27 Oxford St, London, W1R 1RF. Tel: 01-434-1781/2.  
**U.S.A.:** Elmatex International, PO Box 34607, Los Angeles, CA. 90034. Tel: (213) 821 8581. Telex: 18 1059 (Elmatexint USA)

## Advertisers: Index:

|                                      |           |
|--------------------------------------|-----------|
| Applied Technology                   | 88        |
| A & R Sonar                          | 50        |
| Audio Engineers                      | 34        |
| Australian General Electric          | 84        |
| Automation Statham                   | 67        |
| Bail Electronics                     | 105       |
| Blob-Board Associates                | 11        |
| Bright Star Crystals                 | 111       |
| BSR                                  | 32, 33    |
| Cashmore Sound                       | 108       |
| Cema                                 | 44        |
| Communications Devices               | 79        |
| Consolidated Marketing               | 97        |
| Convoy                               | 28        |
| Davred Electronics                   | 68        |
| Delsound                             | 79        |
| Dick Smith                           | 48-49, 85 |
| Diggerman Electronics                | 112       |
| Douglas Transformers                 | 112       |
| Eastern Electronic Components        | 110       |
| Eclipse Lighting                     | 107       |
| Edge Electrix                        | 108       |
| EEE                                  | 60        |
| Electrocraft                         | 80        |
| Electroimpex                         | 73        |
| Electronic Calculator Discounts      | 112       |
| Electronic Concepts                  | 62        |
| Ellistronics                         | 50        |
| Emona                                | 55, 74    |
| Freedman                             | 73        |
| General Electronic Services          | 97        |
| Haco                                 | 116       |
| Hagemeyer                            | 2, 115    |
| Harman Australia                     | 30        |
| I. C's Unlimited                     | 66        |
| Impact                               | 67        |
| Instant Component Service            | 98, 99    |
| Int. Component Sales                 | 74        |
| International Correspondence Schools | 57        |
| Int. Electronics Unlimited           | 113       |
| Intersound                           | 42        |
| Jade Computer Products               | 56        |
| Jaycar                               | 42        |
| Kenwood Australia                    | 103       |
| Mallman Electronics                  | 110       |
| Non Linear Systems                   | 80        |
| Parameters                           | 99        |
| Philips                              | 24        |
| Philips Elcoma                       | 51        |
| Pre-Pak Electronics                  | 43        |
| Riddell Exhibitions                  | 8         |
| Roadrunner                           | 110       |
| Rod Irving Electronics               | 41        |
| Rosicrucian Order                    | 99        |
| Scalar Industries                    | 100       |
| Semcon                               | 60        |
| Sheridan Electronics                 | 16-17     |
| Superscope                           | 22        |
| Tech. Book & Mag. Co.                | 109       |

Electronics Today International is published by Modern Magazines (Holdings) Ltd, 15 Boundary St., Rushcutters Bay NSW 2011. It is printed (in 1978) by Wilke & Co., Browns Rd, Clayton, Victoria and distributed by Australian Consolidated Press.

# The competition don't like the sound of this at all.

For quite some time, other manufacturers have been trying to produce tape with the qualities of the Maxell UD-XL. At the same time, Maxell have been quietly perfecting an even better series.

The UD-XL I and UD-XL II tapes are designed to attain maximum performance at the ferric and chrome position on your tape deck. Whichever tape position you choose, Maxell can give you a better performance.

## **UD-XL I TAPE, FOR FERRIC (norm.) POSITION (120us)**

UD-XL I offers an excellent sensitivity of 1 dB higher than even UD-XL. MOL performance is also 1 dB higher over the entire audio frequency spectrum. The result is a new standard in ferric tape, with wider dynamic range and less distortion than ever before.

How does the UD-XL I compare then, with ordinary low-noise tapes?

Sensitivity is higher by 2.5 dB, and MOL performance by as much as 6 dB.

Yet, for all this UD-XL I requires no special bias or equalization. Simply set your tape selector as you normally would at the ferric position – but there the comparison ends.

## **UD-XL II TAPE, FOR THE CHROME POSITION (70us)**

UD-XL II tape is such a dramatic improvement on most other tape that can be used in this position, that comparison is really unfair.

For example, if you're familiar with conventional chromium-dioxide tape, you'll know of the associated problems of head wear, poor output uniformity and relatively high price – plus low maximum output level and rather high distortion.

UD-XL II tape offers you excellent MOL, sensitivity, and an output improvement of more than 2 dB over the entire frequency range.

Maxell's unique 'Epitaxial' process gives you absolute sensitivity and stability, and no drop-out problems. What's more, the shells are moulded in diamond cut dies, and made to tolerances 5 times greater than the Philips standard. And, like all Maxell tapes, UD-XL II has the unique 5-second cleaning leader.

In short, if you're recording in the chrome position, you can now achieve all the advantages – with none of the drawbacks.

A prospect we think you'll find very exciting – even if the competition don't.



Pro. Series



**Technics  
MK2 Series  
turntables.  
Built by  
perfectionists  
for  
perfectionists.**

In 1970 Technics introduced the ultimate turntable drive method... the direct-drive principle.

In developing phases our first direct-drive turntable was succeeded by a whole family of them. A major innovation was the quartz phase-locked servo electronics featured in the SP10 MK2, enabling great speed accuracy to be attained ( $\pm 0.002\%$ ). Its enormous torque and super fast start/stop action make it the choice of top broadcasting stations both in Australia and the rest of the world.

Two newly released Technics models—the SL1300 MK2 and SL1400 MK2 (automatic and semi-automatic respectively)—are totally quartz controlled drive turntables. You won't find any belts, gears or idlers in these. But

you will find our lowest wow and flutter ever (0.025% WRMS) and inaudible rumble ( $-73\text{dB DIN B}$ ).

Both feature a pitch control of  $\pm 9.9\%$  on normal turntable speeds that can be obtained simply by the push of a button.

The pitch chosen is displayed in digital form by a LED readout. All controls are located on the front panel of the turntables and can be operated even with the dust cover down.

Technics MK2 series of turntables are just a few components in the new Pro. Series from Technics. Reliable as they are precise.

 **Technics**  
hi-fi