

ELECTRONICS IN '78 US AUTOMOBILES

electronics today

APRIL 1978

INTERNATIONAL

**UHF FREQUENCY COUNTER
AUDIO ANALYSER II
RAIN ALARM
Propagation**

\$1.25*

NZ \$1.50

**New
Video Display Unit**

**PLUS
News, Microprocessors,
Communications Section...**



JVC offers flexibility in sound reproduction...

Your current hi fi system most likely has a vital, but highly versatile element missing. A JVC SEA-20 graphic equalizer. Take a close look at your current amplifier or receiver and you'll notice it only offers bass and treble controls, and some include a third for midrange, but none approach the accuracy and flexibility of the SEA graphic equalizer system developed and patented by JVC.

Over 400,000 ways to hear better sound.

By adjusting the seven tone controls covering the frequency range at 60Hz, 150Hz, 400Hz, 1,000Hz, 2,400Hz, 6,000Hz and 15,000Hz you can create over 400,000 different sounds. A feat normally not achieved (with a stereo amplifier or receiver) outside a professional recording studio. But, then the SEA-20 is a true JVC professional.

Get better performance from your components and listening room.

Why do you need such tremendous variations in tone? Quite simply, they help you to overcome the shortcomings of the acoustics in your listening room; they also help you to compensate for the deficiencies in old or poor recordings.

Finally, they can do wonders for the frequency response of your speakers, and where you place them. SEA is really quite easy to use. For example, the 60Hz switch reduces record hum or rumble, and it can add greater clarity to the ultra low bass of an organ. The problem of booming speakers is simply handled with the 150Hz switch, while boosting the 400Hz switch it adds clarity to the upper bass. And in the important midranges, the 1,000 control adds new dimension to the vocals of your favourite rock performers, while the 2,400Hz controls the

upper midrange. The 6,000Hz switch brings out the best in strings. You can even reduce tape hiss and diminish the harsh sound of a phono cartridge at high frequencies, with the 15,000Hz control. Then, to double check any adjustments SEA works with a tone cancellation switch which permits you to instantly compare your setting with a perfectly flat response.

SEA equalized recording.

You'll enjoy an infinite number of practical applications for SEA in home tape recording. SEA equalized responses may be reflected on your tapes as you record them. With SEA it's easy to eliminate record scratch and surface noise, reduce tape hiss, and emphasize vocals or the highlights of any musical instrument. The Monitor and SEA Defeat Switches are also provided to enhance the SEA versatility and utility.

For around \$170 JVC offers flexibility in sound reproduction.

Do yourself a favour... listen to the SEA-20 versatile performance at your nearest JVC dealer, we believe for around \$170, you can afford the accuracy and flexibility which this JVC graphic equalizer offers. Listen... you'll find it quite an experience.

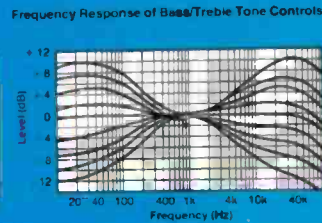
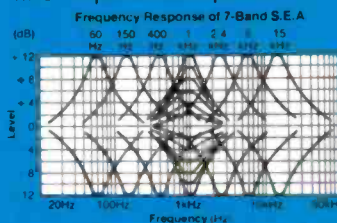

a graphic equalizer!

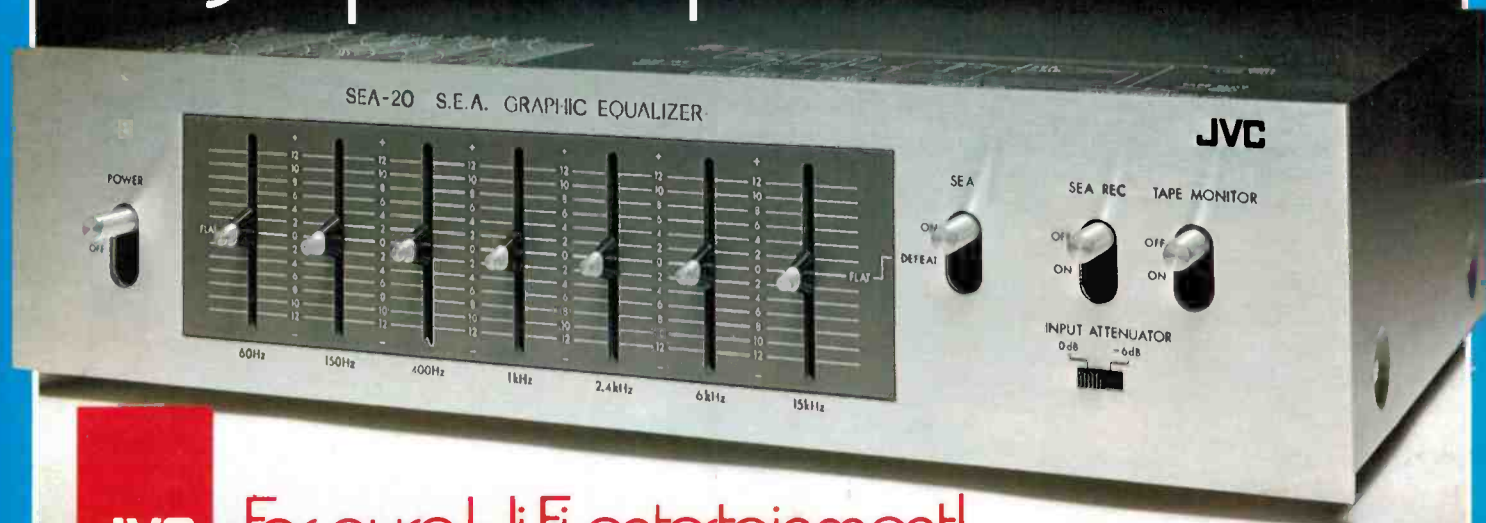

JVC
the right choice

For pure Hi Fi entertainment!

For details on all JVC Hi Fi Equipment, write to:
JVC Advisory Service, P.O. Box 49, Kensington, N.S.W. 2033

electronics today

INTERNATIONAL

Editorial: Les Bell

Publisher: Collyn Rivers



Regular readers probably won't recognise the central figure in our cover as Roger Harrison, dressed up in style to play some computerised wargames. Of course, the real star is one of the prototype ETI 640 VDUs. Photograph by George Hofsteters.



A Modern Magazines Publication
* Recommended retail price only.

Registered for posting as a publication — Category B

PROJECTS

640: S100 VDU	32
<i>Lower case, flashing, graphics, drool, drool . . .</i>	
489: Real Time Audio Analyser	62
<i>LED display, so self-contained</i>	
246: Rain Alarm	69
<i>Super-simple project.</i>	
140: 1 GHz Frequency Meter/Timer, Pt II	77
<i>Concludes this high-performance design.</i>	

FEATURES

Electronics in '78 Model Cars	13
<i>Silicon Valley comes to Detroit.</i>	
Sound	23
<i>75W Class A . . .</i>	
Date Sheet: MCM6574	40
<i>As used in ETI 640.</i>	
Print Out	45
<i>Micro News.</i>	
Applications Software Contest	51
<i>We throw out the challenge.</i>	
Special Offer: Edge Connectors	53
<i>As used in ETI 640.</i>	
Digital Electronics by Experiment	55
<i>Introducing TTL.</i>	
Communications Section	85
<i>News for hams, SWL's, CB'ers.</i>	
Propagation: A Closer Look	93
<i>The ionosphere under the microscope.</i>	
Philips UHF CB	96
<i>Quality Australian rig.</i>	
Equipment and Book Reviews	97
<i>Doorbell, Microelectronics volume.</i>	

NEWS & INFORMATION

News Digest	4	Ideas for Experimenters	99
Sound Briefs	28	Reader Services	106
Print Out News	45	Index to Advertisers	106
Mini Mart	75		

Binary Clocks

WHEN AMERICAN Eugene Amazon was accused by his boss of being antiquated, it didn't take him long to do something positive about remedying the situation. He designed, built and then installed a binary clock in his superior's Geneva office, along with the unappreciated antique furniture. It went down well and Eugene has been building binary timepieces ever since.

Mr. Amazon now works as a computer programmer in Geneva, concentrating on pipe stress analysis for nuclear power plants. After designing more of these clocks for friends, he put together an exhibition which was very well received. Now he makes them for sale as well.

Binary clocks tell time by pattern recognition, based on quartz crystal technology. As our picture illustrates, they can take many different forms, like the lightning rod or the 'pinocchio' hat. The latter is made of brass. The lower line of lights register the seconds and are therefore constantly changing. The higher horizontal line shows the minutes and hours are shown on the vertical illuminations.

It may appear somewhat complicated to tell the time by this method at a glance. Apparently it just takes a little practice, once you are used to an entirely different time rendering concept. It has been found that children, who have not been saturated by traditional methods, pick it up very quickly.

Eugene Amazon's hobby has been so successful that he himself has very little spare time on his hands. His clocks have sold internationally and the United Nations have also bought them. Perhaps one day all clocks will look like these.

Dick's '78 Cat

This year is Dick Smith Electronics' 10th Anniversary. In keeping with his "think big" philosophy, Dick has produced a monster 100 page catalogue of items sold in his 8 electronics enthusiasts' stores.

The Dick Smith catalogue has been on every electronics enthusiast's "must have" list for quite a few years now. This year's is bigger than ever before, with 100 pages of which 8 are in full colour. Also included is a special section on icebergs.

It lists and gives prices for nearly 3,000 items with many of them illustrated and described. There is also an 8 page data section full of semiconductor specs and base connections, data for amateurs and CB'ers, useful circuits and component colour codes.

The Dick Smith 1978 catalogue is priced at 75 cents at all Dick Smith Stores and Dealers or by mail order from Box 747, Crows Nest, 2065.



Photograph by Ralph Crane, Camera Press, London.

US CB Tariffs Up

Late in March, President Carter ordered tariffs on imported CB radios to be more than tripled. The move follows vigorous campaigning on the part of E.F. Johnson and other companies for tariff increases.

Towards Future System

Looks as though transistors in logic circuits are going to become outmoded, thanks to the Josephson junction, according to IBM. Their experimental logic and memory circuits are much faster and dissipate less heat than current circuits. Typical switching speeds are 50-100 picoseconds, while memory circuits have access times of 7 ns.

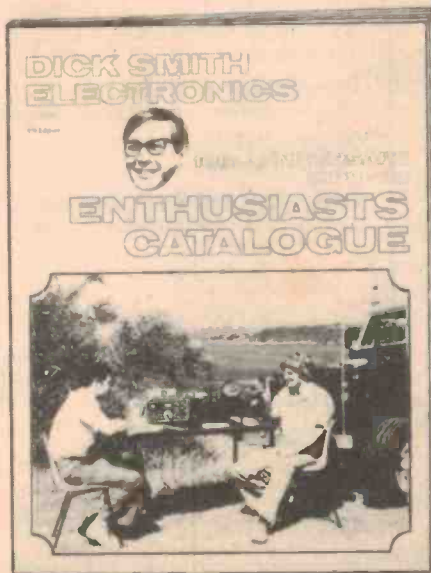

New Wollongong Store

A new store called Madjenk Lighting and Electronics has now opened at Shop 5, 246 Princes Highway, Dapto, Wollongong. The shop will sell electronic components, microprocessors, electrical accessories, and will hire out all types of lighting for entertainment purposes. Unusually, in the electronics business, the owner and proprietress is a lady, by the name of Rhonda Jenkins. We wish her every success in her new venture.

1 Amp DIL Bridge

The latest addition to Soanar Electronics' extensive range of Bridge Rectifiers is the VM48, a 400 Volt 1 Amp Dual In-Line Bridge, manufactured by Varo Semiconductors Inc., USA.

Mechanical construction includes glass passivation of the diode chips which are then housed in a compact moisture-resistant epoxy casing. Lead configuration and spacing conform to the standard 0.1" grid giving the added advantage of complete compatibility with integrated circuits (e.g. Two VM48s will fit into the normal 14 pin I.C. socket). In addition the AC connections are placed together on one side of the device with the DC connections on the opposite side. This simplifies circuit layout.

Rated at 1 Amp, the VM48 is capable of withstanding surge currents of 11 Amps for 1 second and 25 Amps over one half cycle on 60 Hz frequency.

DC blocking, working peak reverse and peak repetitive reverse voltages are all specified at 400 Volts.

In line with company policy, Soanar will be maintaining large stocks of VM48 Rectifiers at all their interstate branches and agents.

Further information including technical specifications is available from: Soanar Electronics Pty. Ltd., 30 Lexton Road, Box Hill, Vic, 3128.



6A, 400V Diode

Soanar Electronics now include a 400 volt 6 amp plastic encapsulated rectifier in their comprehensive range of discrete diodes and silicon bridge rectifiers.

Designated type P600G, this 6 amp diode has a uniformly moulded plastic case and is lead mounted. Polarity is indicated by a silver coloured band at the cathode end of the casing.

P600G can withstand a 400 amp surge current and provides a 400 volts DC blocking voltage when operating at rated load. Average forward rectified current is 6 amps at ambient temperature (T_a) of 60°C.

This diode is immediately available from Soanar branches and agents in all states and costs only a fraction of the price of 6 amp stud mounted rectifiers.

Further information is available from *Soanar Electronics Pty. Ltd., 30-32 Lexton Road, Box Hill, Vic. 3128.*

Talking Machine

Speech synthesis researchers at UCLA have moved one step nearer a practical, useful application for these devices by combining one with a computer and a typewriter to aid stroke victims and other persons with speech disabilities. Words or sentences typed into the machine are translated into understandable speech, and the computer can also track down words by semantic or phonetic associations, or rhyming words. This machine could make writing poetry a snap!

Sony VTR Case

In the continuing case between Sony and the Universal and Disney film studios over claimed copyright infringement, five major Hollywood studios and several independent producers and unions are seeking to file amicus curiae briefs in support of Universal and Disney. The studios are charging Sony and their codefendants, three large department store chains, with copyright infringement because Sony Betamax video tape recorders are used to tape tele-vision shows.

Columbia Pictures, 20th Century Fox, Warner Brothers, MGM, United Artists, Allied Artists, Avco Embassy Pictures, Bud Yorkin Productions, Tandem Productions, TAT Communications, Viacom International, Desert Book Co, Movies En Route, Inc, Swank Motion Pictures, as well as the Writers Guild, the Screen Actors Guild and the international Alliance of Theatrical Stage Employees intend to support Universal and Disney in the case. Curiously, several of these companies are also planning to sell software for the video tape recorders.

Tilting at Windmills

Strong prairie winds, for years a nuisance to the small town of Clayton, Nex Mexico, are now helping supply the town with up to 15 per cent of its electrical power thanks to a new wind turbine generator installed recently.

The generator is equipped with two 60½ft aluminium blades built by Lockheed Aircraft Service Company under contract with NASA.

Officials from NASA and Lockheed gathered on an appropriately gusty Saturday morning as a big red button was pushed to activate the system and the blades began their first revolution, making Clayton the first US town served by wind energy.

At their standard speed of 40rpm, the blades, which form a 125ft. rotor, produce 200 kilowatts of power at wind speeds measuring between 18 and 34 mph. To protect the equipment, the turbine shuts off automatically when winds exceed 35 mph.

Produced with Lockheed technology developed for the Cheyenne helicopter, the blades, and the attached generator, are mounted on a movable platform atop a 100 ft tower that "tracks" — or swings — with the direction of the wind. The blades are also capable of feathering, or turning at right angles into the wind to prevent equipment damage in high winds.

The wind turbine is especially welcome to the townspeople of Clayton, who have seen their power bills skyrocket recently due to increasing fuel costs.

Talking Computer

The IC's used in modern US phones to generate the audio tones which have replaced dialling pulses can often be put to other uses. US amateur radio operators, for instance, use the tones when accessing repeaters in order to perform command instructions. One of the latest applications for these chips is in a system called ROTE (Remote Order Terminal Entry), being operated by Pfizer, Inc., a US pharmaceutical company.

Their sales reps each carry a small key pad and acoustic coupler which fits over the telephone mouthpiece. From a client's office, the reps can dial the Pfizer office and talk to 'Joanne', who is the alter ego of an IBM System/7 with audio response and is the central 'character' in ROTE. After entering an ID number, the rep can enter the customer's account number and the quantity and product code for each product ordered, guided through the process by 'Joanne's' doubtless soothing and patient voice. If the salesman enters invalid data, 'Joanne' will put him on the right track.



TI Patent

US Patent 4,074,351 has been awarded to M J Cochran, of TI's Dallas staff, and G W Boone, a former TI staffer, for their digital microcomputer.

Sinclair DMMs

Foreseeing the demise of the calculator market, Uncle Clive, of Sinclair is moving more into the instrument field, and will soon announce several new digital multi-meters.

The DM235 is a bench-type meter with five functions and 21 ranges. 3½ digit resolution with 1% accuracy make it a good choice for the hobbyist. It also features auto polarity, over-range indication and automatic decimal point, runs on batteries or AC adapter and is expected to retail in Australia for around \$145.00.

The provisional spec on the DM350 shows it to be a similar instrument, but with 0.2% +/- 1 digit accuracy.

The top-of-the-line DM450 is a 4½ digit autoranging instrument with true RMS reading. Basic accuracy is 0.05% of reading. The DM450 is expected to sell for around \$350.00 when it becomes available in Australia in July.

COMPUTER BACKGAMMON

Futuretronics have done it again. The World's first microprocessor based Backgammon game is here right now. It's you against the computer. A sophisticated, totally computerized Backgammon game, utilizing a Motorola 6800 microprocessor with 2K ROM and 6K RAM, designed for excitement and ease of play. It will defeat the average player more often than not, and compete evenly with experts. When you play against the computer, each move is displayed and recorded electronically. The position of every piece on the board can be verified at any time and since the dice are "rolled" electronically at random, each game is different.

The computer plays an aggressive offensive game, but will change its strategy depending on how you choose to play. Running game, block and hit, back game, it know them all, and plays them all well. Playing against the computer is a true measurement of skill. If you are a beginner it is a remarkable learning instrument. **This beautifully finished, top-quality product complete with its own carrying case is available now. for \$299.00 delivered free anywhere in Australia.**



COMPUTER CHESS

It's you against the computer.

The first microprocessor based chess game, using an 8080A C.P.U. It utilizes an 8224 clock generator/driver, 8228 system controller, 512 8-bit bytes of random access memory, that stores the position of the chess pieces, and a 16,384-bit read only memory. Software contains such elements as the rules of chess, the relative importance of the pieces, allowable moves and strategies. The micro computer plays by the book, working on the weighed value of the pieces, and completely scanning the board for the best available move each time. It plays aggressively, tries to control the centre of the board, and, if it's in trouble, will try for a stalemate.

The keyboard can be used to verify the position of each chess piece at any time during the game.

User selectable 3 levels of difficulty, choice of black or white pieces. New shipment just arrived, new low price \$345.00 delivered free anywhere in Australia.

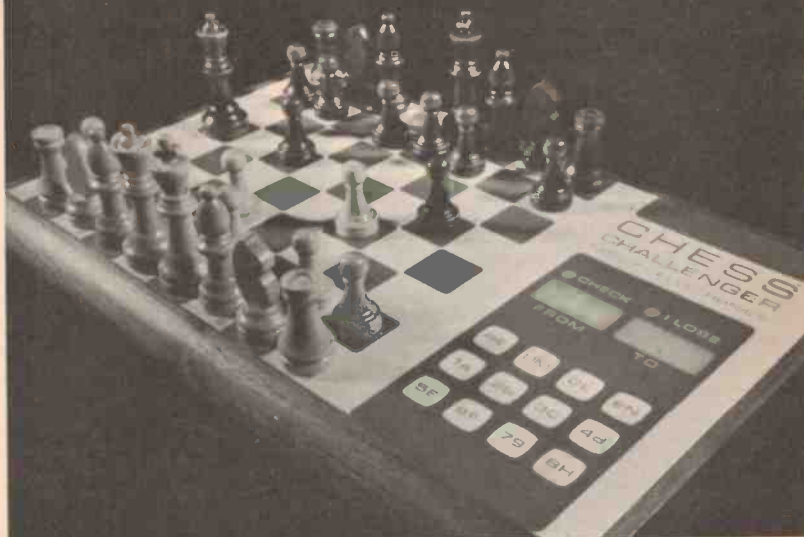

To order or for
information contact:

**Future
tronics** Pty. Ltd.

1 Dallas Crt, Hughesdale 3166, VIC.
Phones: (03) 823732 — (03) 579297

- Please send Gammonmaster. I enclose \$299.00
- Please send Chess Challenger. I enclose \$345.00
- Please send both games. I enclose \$599.00

NAMES.....

ADDRESS.....

STATE.....

AWA Hearing Aid Advance

A lightweight hearing aid developed in Australia sets new standards in miniaturization and battery life.

The aid uses an integrated circuit about the size of a matchhead, developed by AWA Microelectronics, under contract to the National Acoustic Laboratories. The chip contains 38 transistors and 27 resistors. It is mounted on a hybrid microcircuit smaller than a one cent piece, developed by STC Components Division, also under contract to NAL.

The aid is a Class B type which means that significant power is only drawn from the battery when a signal — a human voice or other sound — is picked up. This is a distinct advantage in terms of battery life when compared with Class A aids, which draw constantly from the battery.

Because of the sensitive nature of the device, AWA engineers had to pay great attention to background noise, which is far more critical than in a normal hearing aid.

A modern miniature electret microphone, with its wide frequency response, is used with the amplifier. A special design feature also enables a two-wire speaker to be used, making the device simpler than most overseas made hearing aids of this type and also permitting external earphones to be attached.

The aid is now in production, and a number of patients have reported that it gives them new standards of hearing.

VHF Ferrite-rod Antenna

By winding a single wire onto a ferrite rod in alternate groups of left- and right-handed turns to resonate at a quarter wavelength, the backroom boys at Britain's Royal Military College of Science have been able to make a VHF ferrite rod antenna. Lab tests have shown that the antenna is almost as effective as a whip when utilised without a ground plane, as is the case with handheld equipment. If a ground plane is available for the whip to work against, however, the ferrite antenna has markedly less gain.

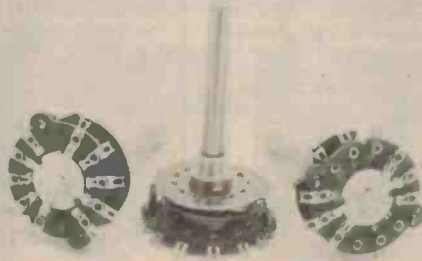
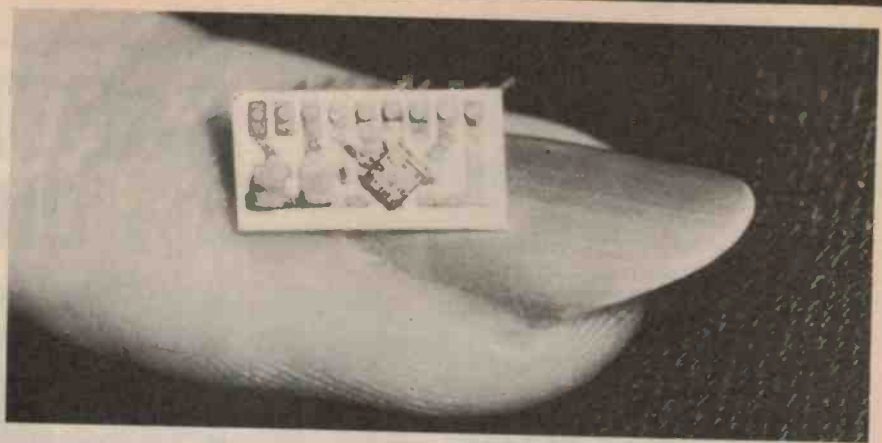
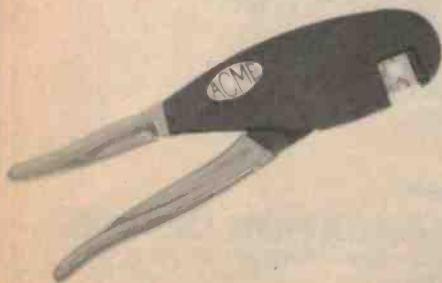

New Riston Process

The Riston Products division of Du Pont has introduced a new dry film photo-polymer series which offers lower costs. The new series includes two types of solvent film, Series 1000 and Series 1200, and two aqueous films, Series 3000 and Series 3300. The four films are light green in colour and turn a vivid blue when exposed, which makes board inspection easier.

ACME Crimp Tools

When it comes to terminating RF connectors, the crimp method has proved to be the fastest and most economical method. Acme Engineering company now offers a range of hand or power operated crimp tools to suit ENC, TNC, UHF, N and SMA series connectors.

In the Acme hand crimping tool range there are two varieties available which are designed to accept a common range of interchangeable crimping dies. The Acme hand crimping tools terminate a wide variety of coaxial connectors by crimping contact pins, and sockets and outer ferrules used to crimp the braid shield of coaxial connectors.

For comprehensive literature on the ACME range of crimping tools, please write to the ACME Engineering Office or agent in your state or contact ACME Engineering Company Pty. Ltd., 2-18 Canterbury Road, Kilsyth, Victoria, 3137. Phone 729-6211.

Rotary Wafer Switches

Soanar Electronics are pleased to announce that they are now stocking a range of top quality rotary wafer switches manufactured by Noble of Japan.

Unlike the shorting type of wafer switches that are normally available on the Australian market, these are non-shorting (break-before-make) switches that have previously been available only to special order.

Soanar will be maintaining large stocks of the single wafer varieties at their own and agents branches throughout Australia. Multiwafer and special requirements however, will continue to be supplied on an indent basis.

Noble switches are well constructed and use a particularly robust detent plate to ensure positive switch selection. The wafer is made from high grade phenolic and features silver plated contacts having a contact resistance of less than .02 ohms at 6 V 1 amp DC.

Overall switch rating is 30 V DC at ½ amp and insulation resistance between terminals and shaft is considerably better than 100 Meg ohms. Shaft length is 50 mm FMS with the standard 6.35 mm (¼") diameter.

Switch types readily available at Soanar branches include:—

1 pole	11 positions
1 pole	6 positions
2 poles	4 positions
2 poles	5 positions
3 poles	3 positions
4 poles	2 positions

Further information is available from *Soanar Electronics Pty. Ltd., 30-32 Lexton Road, Box Hill, Vic, 3128.*

Price rise shock

A 30% import duty has been applied to CB transceivers since the first week of March and prices are expected to rise very soon as the stocks of pre-duty rigs are sold off.

The duty will mean a price increase ranging from \$30 to more than \$100 on transceivers and will probably put a further damper on an already depressed CB market, industry sources say.

COMMUNICATION
DEVICES present

THE **SABTRONICS**
3 1/2 DIGIT DM M



SPECIFICATIONS:

DC volts in 5 ranges: 100uV to 1000V; AC volts in 5 range: 100uV to 1000V; DC current in 6 ranges: 10n A to 2A; AC current in 6 ranges: 10n A to 2A; Resistance in 6 ranges: 1 to 20M; Input Impedance: 10M; Display: 9mm (36") LED; Power requirements: 4.5 VDC to 6.4 VDC (4 "C" cells — not included); Size: 8 "W" x 6.5" D x 3.0"H (203W x 165D x 76H mm).

PRICE (KIT) **\$97.75** incl. sales tax

PRICE (FACTORY ASSEMBLED **\$129.75**
AND TESTED) incl. sales tax

ABOVE PRICES INCLUDE DELIVERY WITHIN AUSTRALIA

COMPLETE 40 CHANNEL CB SERVICE CENTRE



Features:

- RF Power Meter
- Audio Generator
- Digital Frequency Counter
- Digital Mod Read
- Digital Off Channel Read
- Digital Percent Mod Read
- Audio Power
- Sig/Noise Measure
- RF Generator to .1NV
- Built-in Mic Test
- Built-in Load & Speaker

PRICE
\$1,350

plus 15
percent
sales tax

**NB: INCLUDING DELIVERY
ANYWHERE IN AUSTRALIA.**

This service monitor
provides all functions for
the complete service
alignment and test of all
Australian CB rigs.

Walk through all Receiver troubles

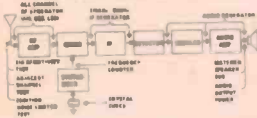

Walk through all Transmitter troubles



Australian Agents:

COMMUNICATION DEVICES
271 Goulburn Street, Darlinghurst, NSW 2010
Phone: (02) 211-3399, 211-3652, 212-3712

Akai VCR

A compact, lightweight three-hour video cassette recorder has been introduced by Akai Electric Co. Ltd., of Japan.

The new video cassette recorder, VHS-format VS-9300 uses economical half-inch tapes, soon to be available in one-hour, two-hour and three-hour lengths. Three versions are available: VS-9300EG for the PAL system on the European continent, VS-9300EK for the PAL system in the United Kingdom and VS-9300S for the SECAM system.

The system, equipped with built-in TV tuner, can record a program being watched on TV or another program being broadcast on a different channel simultaneously, or, by use of a video timer, a program aired when no one is at home. The video camera can be used to make one's own programmes.

Close Encounters

Philips Electronic Components & Material Product Marketing Manager, Kevin Gest, had a close encounter of the aural kind, recently. He was called in by Ron Ferguson, Projection Engineer of Hoyts in Sydney to solve a sound problem.

It seems that all the action in the film "Star Wars" just wasn't getting across to the audiences as it should have been. The sound system couldn't cope.

"Part of the trouble", says Kevin, "was that the speakers were in small enclosures and this was distorting the sound, for example, in the laser sword fight."

"Hoyts were looking around for something to fit in with the decor of their new cinema complex in George Street, but naturally they wanted something at a good price."

After visiting the theatre and spending some time in the projection room, Kevin suggested a loud-speaker kit system (Model ADI 2K12 - no relation to R2D2) which was not only easy to assemble and install, but also comparatively inexpensive.

On that advice Ron Ferguson decided to install 12 pairs down the side walls of the theatre - all within public view. "They certainly improved the bass end in 'Star Wars'," he says.

Low Energy House

A team from Salford University in Britain have developed a method for storing heat in ice to reduce bills for space heating. A prototype house is being built for Salford Borough Council, and it is claimed that an ice container 1/10 the size of the swimming-pool sized tank required for water heat storage will be used. Latent heat can be extracted from the ice by a heat pump, and exhaust air from the house reverses the process by melting the ice.



Viewdata in US

The British Post Office developed Viewdata system may soon be operating in the States. The PO has teamed up with Insac Data Systems Ltd, a government-sponsored software export company, in negotiations with AT & T, the US telephone system. The US is a huge potential market for Viewdata, which gives telephone subscribers, both private and commercial, access to a large database as well as computing facilities. Insac have already set up a demonstration computer in their New York office, linked to London, and are surveying potential commercial users of the system. The word we have is that Telecom Australia are also interested in Viewdata, especially in view of the forthcoming introduction of Teletext.

ETI/Unitrex Calculator Contest

Well, we really blew it in February! A typographical error crept into the puzzle, and instead of referring to 'the weight of the weight and the weight of the rope and the weight of the monkey', we had 'the weight of the weight and the weight of the weight and the weight of the monkey'. Fortunately, as far as we can make out, all the entrants took the puzzle as printed, and not as they thought it should be, so after a great deal of brain-wracking to work out the correct answer to the amended problem, we were able to choose a winner - J.T. McLeod, of E. Bentleigh, Vic. The correct answer to the problem as printed is 5 ft, and if you work out the answer to the problem as we should have printed it, you will get 5½ ft.

For this month's problem a deck of cards will prove useful. Take a suit of 13 cards, face down, in your hand. Remove the top card and slide it into the bottom position. Then remove the new top card and turn it face up beside you. Next slide the new top card to the bottom of the pack, turn over the next top card and lay it down, and carry on repeating the process, alternately returning the top card to the bottom of

the pack and turning the next one over until all the cards have been turned up.

The question is: in what order would the cards have to be originally for them to be played out in the order A, K, Q, J, 10, etc. down to 2?

Seal an empty envelope, write your answer on the back of it, with your name and address, and send it to: Unitrex Calculator Contest (April), ETIMagazine, 15 Boundary Street, Rushcutters Bay, NSW 2011. The closing date is 19th May.

Errata

In the Sound Level Meter (Feb '78), some nonlinearity occurs in the meter circuit due to the offset current of IC3. It is recommended that this IC be replaced with a CA3140 (same pinout) and C14 be deleted (it is not required with this IC).

Looking back even further, to Feb '77, a few errors in the 132 Power Supply slipped past us (and all but one of the readers who built it!). In the parts list, ZD1 and ZD2 have been transposed, and RV1 should be 10k. On the overlay diagram, R1 and R2 have somehow been transposed, but they are of the same value, so the operation of the circuit is unaffected.

A few errors crept into the Sheridan Electronics ads in the Dec. and Jan. issues. In January, Cat. No. CP19, disc ceramics were shown as .01mf, but should have been .001mf. Cat. No. CP33 should have read 5 pos. 2 pole and not 10 pos, 2 pole, and CP25 should have read 12 V DC and not 240 V AC. In the February issue, the reed switches CP53 and CP54 are normally open and not normally closed as described.

In the last two issues the address of Semcon Microcomputers was mistakenly omitted from their advertisement. Their showroom address is 1 Chilvers Road, Thornleigh, 2120, and mail orders should be addressed to P.O. Box 61, Pennant Hills, 2120. Phone 848 0800. Apologies to Semcon for the error.

MAD MAL'S MAD SALE!

THIS MONTH ONLY!
OR WHILE STOCKS LAST!



CB SPECIALS
MAD MAL'S GOT THE CB BUG NOW AND HE'S LINED UP THESE BARGAINS

LESON BASE STATION
Microphone
\$44

CAR AERIAL CONVERTOR
Reduced from \$17.50 to \$11

LIMITED QUAM AVAIL. with SWR adjustment.

POWER SUPPLY KITS

13.8V 4A (Peak)
2 Amps continuous
Power switch & LED on front panel, terminals at rear, regulated & filtered, hum free, easy to build yourself and save 6ft

CO-PHASE AERIAL CABLE \$9
20ft long, for twin aeriels.

RG-8U CO-AX CABLE \$1/m
Just arrived, best quality.

HELICAL KW 5FT 9FT \$11
AERIAL KITS
Complete, wire, Fiberglass, insts etc.

NI-CAD BATTERIES
2 FOR 3 ONLY.
Voltage: 1.44
Capacity: 450mAh
Charge at 45-50mA for 14-16 hours.

CHARGING CARTRIDGE 9.95
WITH TRANSFORMER just Charges 4 batteries at same time!

GENERAL PURPOSE SPEAKER BOXES \$10
17" X 12" X 9" deep
TEAK COLORED VINYL
Suit 6" x 3" Speakers
DE-LUXE GRILLE CLOTH
FRONT - Few only avail.

HI-FI BOXES
17" X 12" X 10" deep
SUIT 8" x 3" SPEAKERS
Ready Built, just install
Speakers - Teak wood
Colored vinyl finish - De-luxe
Grille Cloth Front

MAL'S MICS MAKE YOU THINK YOU GOTTA BUY BIG
De-Luxe 50K
Magnetic Microphone
Ideal for hobbyists
Experimenters & Suits most tape Recorders
LAST FEW \$6

RECORDING TAPES
Made by PHILIPS

5"	1800ft	\$3.50
5"	1200ft	\$2.50
4"	600ft	\$2.50
4"	400ft	\$1.50
3"	300ft	\$1.00
3"	200ft	75¢

REELS only
4" 40¢ New
3" 20¢ New
CREAT VALUE!
75¢

MAD MAL reckons he's only got a few UNIVERSAL COMPLETE ready-made AMPLIFIER WITH SPEAKER \$5.90
Max 3W Output with 34V Supply

MULTIMETER \$9
FOR POCKET or TOOL-BOX 1KΩ/Volt
0-10, 50, 250, 1000 V AC DC, 0-1, 100mA DC, 0-1KA, 48-2KHz

220V AC RELAY \$2.65
EA. 4 1/2 PLUG-IN 10 Amp Contacts Socket to suit with screw terminals \$2.70

RECORDER \$6
LAST FEW

RECORDING TAPES \$6

RECORDING TAPES \$6

RECORDING TAPES \$6

INTHE TRADE MALS SPECIAL BARGAINS

- PHILIPS RF/IF AM TUNER** Complete & trans module a info. \$2.50
- 52 PIN CONNECTORS** Gold-plated pins, Plessey made \$2.50
- PERMEABILITY TUNERS** Manual, 4 coils, with knobs. \$1
- PUSH-BUTTON TUNERS** 4 coils suit Synchrodyne tuner \$2
- 2M SPEAKERS** Miniature imported speakers \$1
- PCB ETCH RESIST PENS** Dalo 33 top quality pens \$1.50
- 10¢ FERRIC CHLORIDE PAK** 100g mix with 600mls water \$1
- 30 PVC MAINS TERM. BLOCKS** Insulated terminal blocks \$1
- 30 REES SPAGHETTI TUBE** 55 x 3 coils, all 6" long \$1
- 12 POT NUTS & WASHERS** Standard brass nuts, etc. \$1
- 16 PIN PLUG & SOCKET SET** Gold-plated pins, Mercurdo \$1
- 5K 25W CERAMIC POTS** 3KHz heavy duty, brand new \$2
- ALL 2W POTS REDUCED TO 50c** - 100kΩ, clearancer. \$2
- ALL 5W POTS REDUCED TO 30c** - 100kΩ, clearancer. \$3
- TO-18 TRANSISTOR HEATSINKS** Space Saving circular design, 10 for 2 x FLAT-PACK HEATSINKS \$1
- Compact finned heatsinks for TO-220 trans.** \$1
- 2 x 3/8" FERRITE RODS** Handy 9" long, replacements THUMBWHEEL SWITCHES 0-10 \$2
- Top quality, with mty. a end plates.
- 5x MINIATURE NEONS NE-2** Extra cheap, 60-90v operation \$50¢
- 5x 2.5mm PLUGS** Red or black, new - MAD PRICES! \$50¢
- 5x SOCKETS** Enclosed earphone type sockets \$50¢
- 2 x 6.5mm STEREO SOCKETS** For Stereo Headphones etc. \$80¢

SEMICONDUCTORS

- *Originals or equivalents supplied.
*All new, top grade, no rejects.
- | | | | |
|--------------------------------|---|--------|-----|
| AY6108 | 95c | 7441 | \$1 |
| AY6109 | 95c | 7473 | 70c |
| BC107 | 15c | 7490 | 70c |
| BC108 | 15c | 0A91 | 12c |
| BC109 | 15c | EM404 | 12c |
| BC337 | 25c | VA 709 | 50c |
| BC338 | 25c | 2N3053 | 35c |
| BC179 | 20c | 2N3643 | 30c |
| BFX88 | 50c | 2N4250 | 40c |
| 1N5059 | 200 PIV | 2.5A | 20c |
| 1N5400 | 50 PIV | 4A | 40c |
| 1R 60 | 600 PIV | 2.5A | 75c |
| ITT or STC TAOB | 10Watt | \$6.50 | |
| 2SB337 | TO3 Germanium | \$1 | |
| VJ148 | 100V 10A Bridge | \$3.76 | |
| TIC44 | 40V 600mA SCR | 20c | |
| 5023 | RED LED | 25c | |
| 5023 | GRN, WHITE, YELL. LEDS | 50c | |
| BZY88 | ZENERS 4.3V, 4.7V, 5.6V ea | 10c | |
| 14 Pin DIL SOCKETS | | 35c | |
| 14 Pin DIL PLUGS | | 15c | |
| 16 Pin DIL SOCKETS | | 40c | |
| 16 Pin DIL PLUGS | | 15c | |
| 5 TO3 MICA WASHERS | | 50c | |
| 10 ASST. GERMANIUM TRANS | Ideal for servicemen, hobbyists | \$1 | |
| 2x 20V 1A SELENIUM BRIDGE RECT | Suit battery chargers, power supplies | \$1 | |
| HONEYWELL MICROSWITCH | 2x 150v Chatterer, light action | \$1 | |
| PLESSEY REED RELAYS | 24V only, 2 or 3 pins normally open | \$1 | |
| TRANSISTOR RADIO REPAIR KIT | Speaker, IF's trans, gny, vol. cont etc | \$2 | |

MULTIMETER \$9
FOR POCKET or TOOL-BOX 1KΩ/Volt
0-10, 50, 250, 1000 V AC DC, 0-1, 100mA DC, 0-1KA, 48-2KHz

220V AC RELAY \$2.65
EA. 4 1/2 PLUG-IN 10 Amp Contacts Socket to suit with screw terminals \$2.70

TURN TABLES BRAND NEW at MAD PRICES!

NEW IMPORTED 240V PLAYERS
Complete with Teak Wood-Grain Appearance Base IDEAL FOR KIDDIES EA PLAYER

STEREO CHANGERS \$49 EA
COMPLETE WITH BASE COVER AND ALL LEADS
Ready to Play
• Auto/Manual
• Ceramic Cart.
• 3 Speeds
• Walnut Colour Base
• Tinted Cover
AVAIL. AS CHASSIS ONLY

\$29.95 SUPER BUY

MAD MAL'S ONE-EYED SPECIALS

- TAPE HEAD DEMAGNETIZER** \$5
12V AC, easy to use, was \$6.50
- TAPE HEAD DEMAGNETIZER** \$5.50
12V DC, a must for clean sound, was 16.75
- TAPE HEAD CLEANER** \$2
Spray - Pack, was 12.25
- SPRING-CLEAN HEAD CLEANER** \$1.30
Special cassette a fluid, was \$1.99
- RECORD CLEANER SPRAY** \$2
Easy-clean your records, was \$2.25
- INDOOR FM AERIAL** \$1.50
Digital aerial, was \$1.85
- LOCK-DOWN CAR AERIAL** \$2.50
De-luxe chromed, was \$4.50
- 12V MOTORIZED AERIAL** \$12-50
Never again at this price, was \$16.50
- STEREO CAR SPEAKERS** \$9.50
8.5" Rear deck behind window mags
- CAR RADIO KITS - 9 TRANS** \$10
Phillips RF pushbutton 12V Neg and FM OUTDOOR AERIAL \$8
Cines 400 to 48 gain, was \$15.50
- MOSQUITO REPELLER KIT** \$5
E.A. Jan '76 design, was \$7
- RECORD CLEANER ARM** \$3
Automatically cleans records, was \$4.95
- 2 TRANSISTOR RADIO KIT** \$2
Beantester, but last for was \$4.50
- FIBRE OPTICS STARTER KIT** \$5
All you need for experiments
- 30M REELS SPEAKER CABLE** \$3
2 Core fig. 8 brown cable
- 5M PVC ELECTRICAL TAPE** 25¢
Asst. colours 1" wide
- AUDIO LEADS x 6.5mm - 5P DIN** \$1.50
Tap grade, reduced from \$3.95
- 5 x 5 PIN DIN PLUGS** \$1
All new, 1st quality, imported.
- UMB x 4 BATTERY HOLDER** 30¢
Holds 4 penlight cells, few only
- 2 x RCA AUDIO LEADS** \$1
Standard cables to interconnect all Hi-Fi

TRANIMATE
by Ferris
2 TRANSISTOR TUNABLE RF PRE-AMPLIFIER
sale price \$2.50
Pulls in weak and distant stations.
Simple connection to radio - Tunes BC band

2" 8Ω TWEETER \$2
10W Power RMS
Made in Europe by PHILIPS Limited Qty. ea

OVAL SPEAKERS \$2.50
5" x 4" OR 6" x 4"
15Ω

SPEAKER COMBINATION \$5.95
6" WOOFER PLUS 3" TWEETER
MAD MAL'S OWN PICK!
The PAIR \$5.95 OR \$11.50 Stereo
MADE IN AUSTRALIA BY MSP
IMP. 8Ω ea. Power 10W.

3 1/2" SPEAKER \$1
MAD MAL was Selling These 8Ω 1w Spkrs at \$2

MAD LUCKY MAL'S DIP OFFER

- 10 ASST. SWITCHES D.P.A.T. \$2
Toggle, Rotary, Slide, etc.
- 20 ASST. NEW POTS \$2
Incl. ganged, switch, single etc.
- 40 VARIOUS KNOBS \$2
Assortment, Ideal for Servicemen
- 50 ASST. TAGSTRIPS \$2
Handy for Project Builders
- 100 ASST. CAPACITORS \$2
Ceramic, Poly, Mica, ALL-NEW
- 200 HARDWARE PACK \$2
Nuts, Bolts, Spacers, Clamps etc.
- 500 1/2W RESISTORS \$2
Mixed-up for experimenters
- 200 1W RESISTORS \$2
We don't have time to sort out.
- 100 CERAMIC CAPS \$2
Asst. Values and Voltages etc.
- 50 HI-STAB RESISTORS \$2
0.5, 1, 2 per cent High grade
- 40 POWER RESISTORS \$2
3W 5W, 7W, 10W Asst. Values
- 25 PRE-SET POTS \$2
Mini. Horiz. and Vert. Mts.
- 12 SLIDER POTS \$2
Quality, Various types etc.
- 10 PCES PCB OFFCUTS \$2
Some Fiberglass, 2 Silver

MAL RECKONS YOU WON'T FIND 6V-9V BETTER AC ADAPTOR
240V Input
Plugs Into Power Point
Output: 6V DC 300mA OR 9V DC 200mA
Input: 12Volts
Output: 6V at 100mA
OR 3 FOR 7.5V at 200mA
6V at 300mA

LIGHT DIMMER KITS
or motor speed control
Great Value!
700 WATT \$4.95
Capability, with RFI OR Suppression 2 for \$9

DUAL VU METERS \$7
2 Colour Scales, 2x 200mA meters

MINI H.D. RELAY \$1 ea or 10 for \$8
700Ω COIL, 10 AMP CHANGEOVER CONTACTS

DE-SOLDERING WICK \$2
Made by Serval with instructions
Reduced \$2.50

Japanese OVER CRAMMED Transistor Manuals \$3
WITH DATA & SPECIFICATIONS
Reduced, un's 3-15

NEW DE-LUXE STYLUS PRESSURE GAUGE \$4
0-8 Grams, with water level indicator for REDUCED NOW greater accuracy!

STOP PRESS JUST ARRIVED IN THE FOR MAD MAL'S SALE

TV Service PARTS
Yokes from \$3-\$5 Tuners \$5
EHT Trans \$3.50-\$6 Many others, modules, spares etc.
Servicemen, call in NOW LIMITED STOCKS

Orders To **MAD MAL'S** electronics
P.O. BOX 43, CROYDON NSW 2132
718 Parramatta Rd, Croydon NSW
OPEN 7 DAYS
PH: 797-6144
PACK/POST ADD 10%

How to get the sound of a whole new hi-fi system for around \$35

Are you sure of the quality of your loudspeakers? Most people can't afford top quality speakers at first. So they upgrade the speakers later. If you're at that stage, you will know you're not going to do it for less than \$200-\$300 — not meaningfully. We offer an alternative.

The Elcoma kit below gives you two Philips dome tweeters, cross-over capacitors and complete instructions to extend the frequency response of your existing speakers to 20kHz and beyond. (For non-technical readers, that is well beyond the range of normal human hearing).

And they do it with excellent transient response and low distortion. (That means the highs are crisp and clear without grating).

The dome construction disperses the high sounds naturally all round the room — not in a narrow beam like a flashlight. (Ordinary tweeters can do that).

You can work this miracle on your stereo system in about ten minutes. For around \$35.

Why not try it before you write a cheque for \$300?

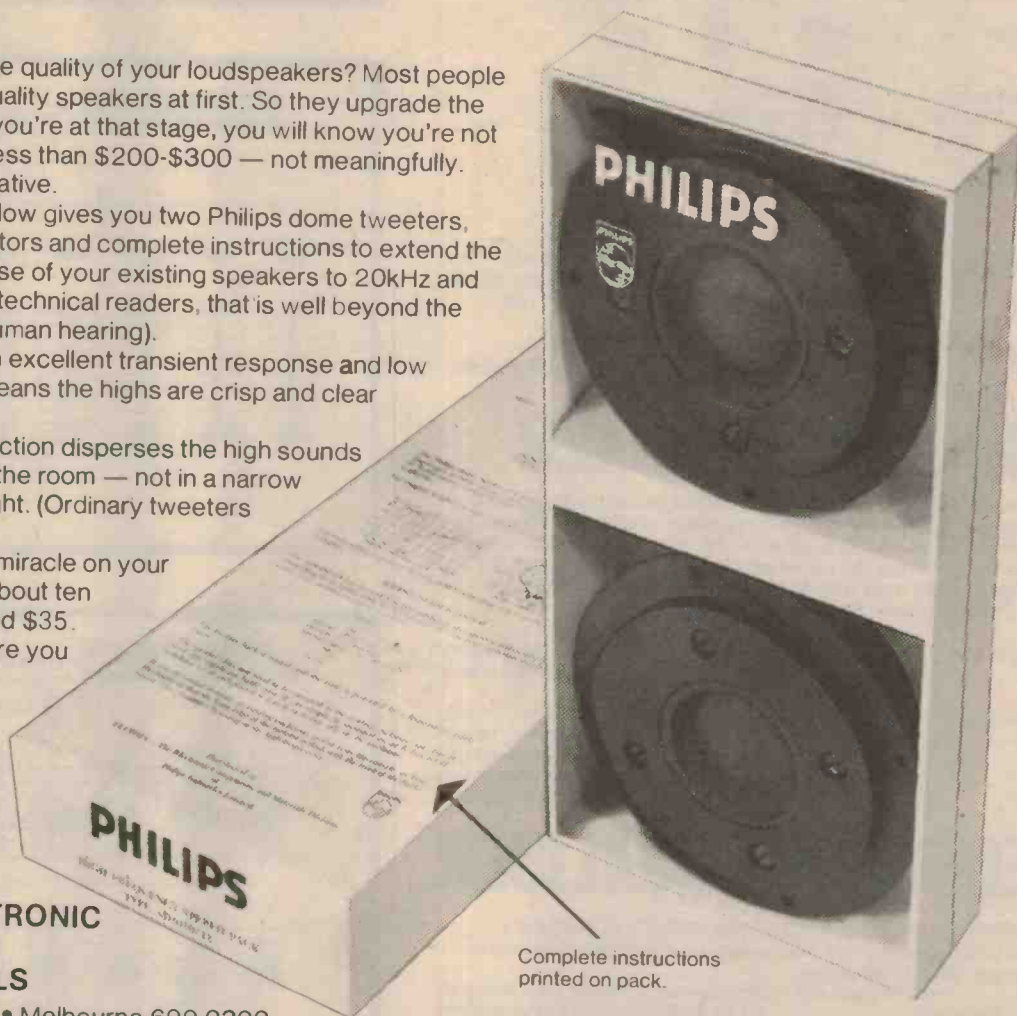

PHILIPS ELECTRONIC COMPONENTS AND MATERIALS

Sydney 427 0888 • Melbourne 699 0300
• Brisbane 44 247 11 • Adelaide 223 4022 • Perth 277 4199



Electronic Components and Materials

PHILIPS

DISCO MIXER

DISCO MIXER MODEL DM-1000 is a sound studio control unit combining the qualities of a broadcast mixing console with the features and flexibility needed by a disc jockey. Built-in low noise preamplifier for magnetic phonos and low impedance microphones.

Headphone circuit to monitor each input. Talk switch to attenuate music volume 14 dB so mics can be used without re-adjusting music levels.

Input Sensitivity	MIC	0.5mV
	PHONO	3mV
	LINE	150mV
Input Impedance	MIC	10K ohms
	PHONO	50K ohms
	LINE	50K ohms
Maximum Input Level	MIC	45mV
	PHONO	140mV
	LINE	35V
Rated Output	AMP.	1V
	REC.	1V
Output Impedance		100 ohms
Harmonic Distortion	At Rated Output	0.2%
	At 6V Output	0.3%
Hum and Noise	MIC	-52 dB
	PHONO	-62 dB
	LINE	-65 dB
Frequency Response	MIC	30 to 16000 Hz (-1 dB)
	PHONO	30 to 20000 Hz (RIAA ±2 dB)
	LINE	20 to 30000 Hz (-1 dB)
Headphone Output (CUE)		.50 mW at 75 ohms at 0.5% T.H.D.
Talk Switch		-14 dB at Phono or Line at TALK Position

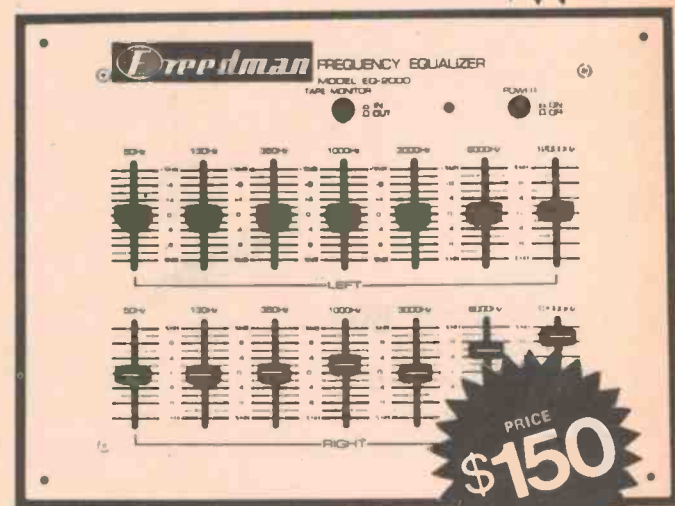
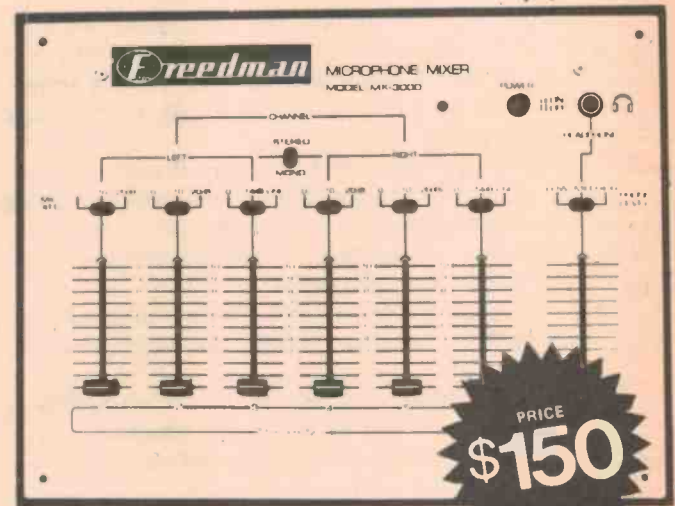
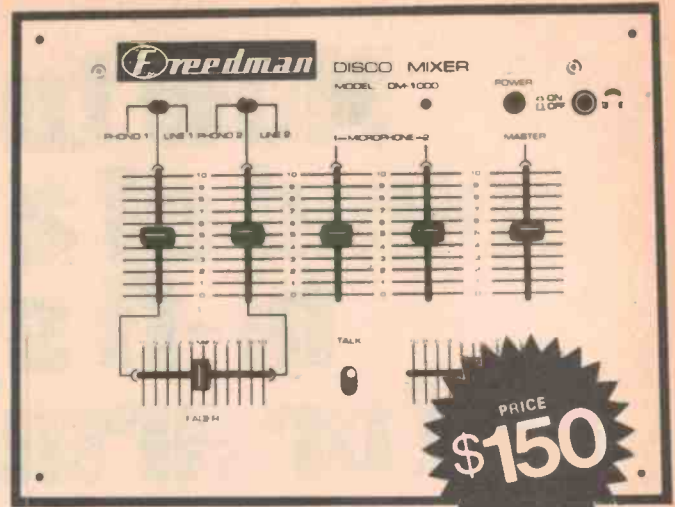

MICROPHONE MIXER

MICROPHONE MIXER MODEL MX-3000 is a sound studio control unit incorporating the most advanced integrated circuits and precision components in its design and is capable of handling any quality high power amplifier, without the use of an external pre-amplifier. It is flexible enough to be used with almost any auxiliary input in a pre-amplifier, integrated amplifier, or receiver.

Input Sensitivity	MIC	0.5mV
	LINE	65mV
Maximum Input Level	MIC	500 mV (Att. 20 dB)
		250 mV (Att. 14 dB)
		160 mV (Att. 10 dB)
		50 mV (Att. 0 dB)
		Line 30 Volt

FREQUENCY EQUALISER

FREQUENCY EQUALIZER MODEL EQ-2000 is a sound studio control unit incorporating the most advanced integrated circuits and precision components in its design.

Channels	Two (left and right with separate controls each channel)
Frequency Response	10 to 30,000Hz -1dB (flat setting)
Tone Control Range	50, 130, 350, 1000, 3000, 6000 and 12000 Hz ± 12dB 7 Ranges
Inter Modulation Distortion	At 2 Volt output 0.05%
Harmonic Distortion	At 2 Volt output 0.05%
Hum & Noise	Shorted input -80 dB below 2 Volt output.
Output Level	Maximum 10 Volts

FREEDMAN ELECTRONICS

89-91A Liverpool Road, SUMMER HILL, N.S.W. 2130. Tel. 797-9941 - 797-0986

PTY. LTD.



Before it's been just a trickle. Now in the '78 US models a flood of new electronics applications points the way toward the intelligent car of the next decade. By Karl Ludvigsen.

THE SMART CAR is coming. It was only a matter of time before it arrived. A brain and nervous system are all that today's cars are missing. Muscles, sinews, a digestive system — they're all present. But automobiles have been relatively simple hydromechanical machines, without the intelligence that powerful electronic systems could provide. That simple era is about to end. The first advanced intelligence devices are being installed in today's automobiles, devices that will point the way toward the smart car of the early 1980's.

At all the Big Three (Ford, General Motors and Chrysler) the electronic revolution is dramatically on display in the 1978 models. Chrysler has expanded its Lean Burn program, introduced a radio with a memory, and put the

finishing touches on an electronic fuel control system. Ford offers a miles-to-empty fuel range computer, a closed-loop fuel mixture control and the first combined spark and EGP adjustment system. GM has added a second and third spark control method, a closed-loop fuel control of its own, an automatic leveler, and a powerful travel guidance computer with a numerical dashboard display. In the way they are made, as well as the things they do, these ingenious innovations indicate what the automotive electronics of the near future will be like.

With but one or two exceptions, these are electronic systems of types that have been predicted widely for auto use over the past decade. Until recently, their adoption has been mainly

Automotive Electronics for 1978

dependent on the value they could offer the car buyer in relation to their cost. Engineers looked for applications in which this payoff would be most convincing. This, together with the dramatic advances in the design of small computers, assured steady progress in auto electronics. Now, however, there's a forced draft under the fire. The demands of tighter emissions standards in 1981, combined with the need for fuel economy at any cost, have directed a spotlight at electronic engine control systems. Micro-computers are being rushed into the cars of 1978 to serve as prototypes for the across-the-board applications of 1980 and beyond that will represent new sales to the auto industry soaring into the billions of dollars.

Shotgun Weddings

It all seems very sensible, but it has not been easy sailing so far. Sometimes a shotgun has been at the ready at the weddings of auto and electronics engineers. In 1974, the president of Rockwell's electronics operations, Donn L. Williams, told the Society of Automotive Engineers (SAE) how, "some time back", they'd put a crew to work on truck brake anti-lock systems:

"We assigned a team of electronics engineers to work with a team of automotive engineers. That was easy. But it was the only easy part of the entire project. The two teams of engineers talked different languages. They thought differently, and often approached problems from entirely alien points of view. And in some cases, the differences were

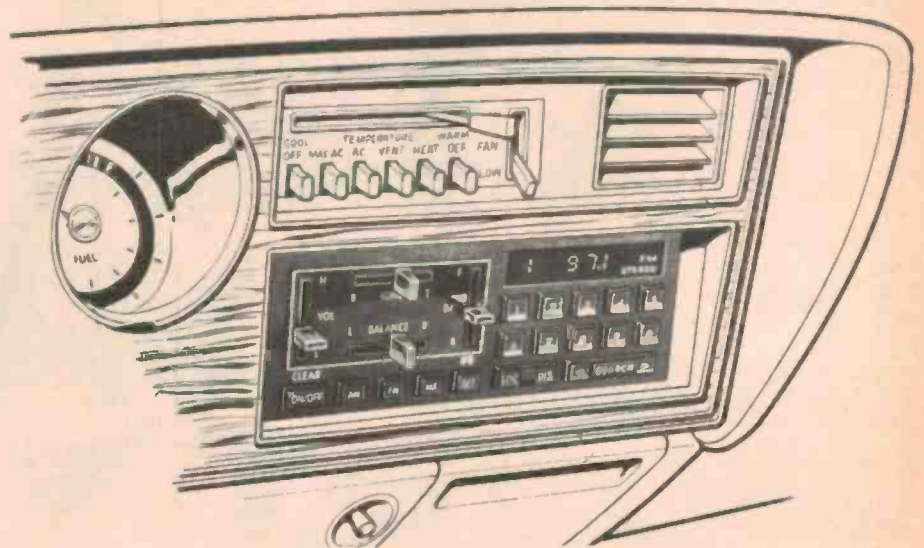

Fig. 2. Microprocessor control circuitry allows Chrysler's new AM/FM stereo electronic search radio to recall as many as ten stations from its internal memory. A LED display shows the frequency and selected band.

so startling that each group of engineers thought the other group was 'putting them on'. They found out that they had to know a lot more about how air brakes really worked before they could create an electronic system that would apply them properly.

Abortive though it turned out to be, this industry-wide work on anti-lock braking for trucks was one of the first sharp spurs to large-scale vehicle uses of advanced electronics. The revolution had begun quietly enough. The first use of an electronic device as a basic subsystem of the car came in 1960, with the solid-state diode rectifiers in

Chrysler's alternators. Custom integrated circuits were first applied in production to cars in 1972 by GM in a voltage regulator and in the unitized ignition built by Delco-Remy for Pontiac. And the first major electronic logic system used across the board by the industry was part of the short-lived seat belt interlocks.

Each of these programs helped prove the suitability for production of different electronic concepts. And less visibly, researchers inside and outside the auto companies worked hard on other electronic applications. As the space program wound down, Chrysler put its Huntsville Electronics Division to work on auto uses. Its first automotive product was an AM radio for 1971 Plymouths and Dodges. Then it came up with the solid-state ignition used first in 1972, on all V-8's in 1973, and across the Chrysler U.S. range in 1974.

At GM, an electronic control systems group was set up in 1970, under the direction of Trevor O. Jones, to help put electrons to work in General Motors cars. It pushed pioneering work ahead in several greek-letter groups. Alpha programs explored the integration of complete systems into the automobile. Beta covered systems related to the driver's physiology, such as the 'Phys-Tester' for drunkenness. Under Delta diagnostic methods were studied, and dash displays under Sigma. Complete central processors for cars were in the

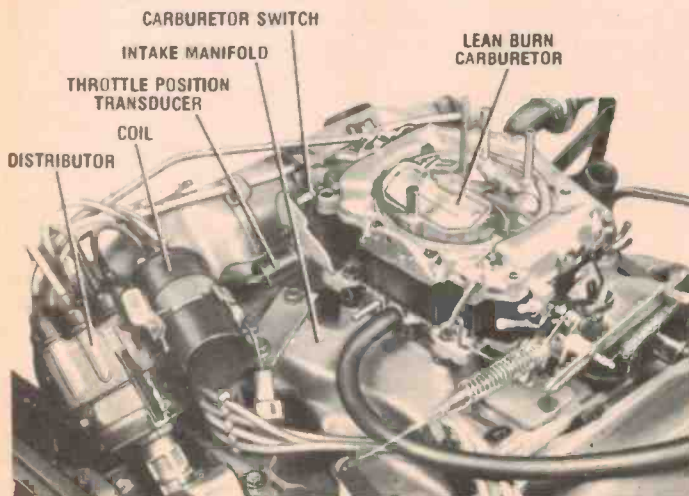

Fig. 3. The Chrysler Electronic Lean Burn engine control system mounted on the 400-CID engine.

Omega series. From this work, many of GM's new electronic applications have been derived.

Ford, which as always tracked electronic developments closely, moved in October, 1975, to make them an official part of the company structure by setting up an Electrical and Electronics Division. Under chief engineer Frederick Z. Herr, an engineering team was brought together from Ford's product development group and former Philco-Ford personnel. The new division can draw on manufacturing facilities in Michigan, Ohio, Pennsylvania, Indiana, Ontario and Brazil.

Reliability Problems

In each of these groups the advocates of electrons and mechanics butted heads in the way Donn Williams described. Some of their most bitter arguments were over the issue of reliability. Electrical systems were well-known as sources of failure in existing cars; wouldn't complex electronics be even more failure-prone?

At first sight it seemed that failures would be inevitable. Cars offered an environment far more hostile to computers than the air-conditioned and dehumidified chambers they had been used to. Underhood temperatures range from -40°C to 140°C . Salt spray, dust and vibration are constant menaces. And the car has a power supply "which, by computer industry standards, has limited capacity, minimal regulation, and is quite noisy," as a GM engineering report put it. The odds against success seemed heavy at first.

Gradually techniques were worked out that promised success. Manufacturing methods became exacting — and expensive. When building the Lean Burn electronics package, said Chrysler's Huntsville general manager, Arthur E. Douyard, "We actually try to make the unit fail during assembly. We expose it to 185-degree temperatures three times, including a final period up to 10 hours. We also pass-fail the unit by computer five times. Finally, we audit ten percent of the units we ship to grade our quality control standards".

The ten-hour test figure was not casually arrived at. "Any malfunction with an electronic device should show up quickly — usually within the first ten hours," says Sidney L. Terry, vice president for public responsibility and

Fig. 4. The Spark Control Computer is part of the Chrysler Lean Burn system.

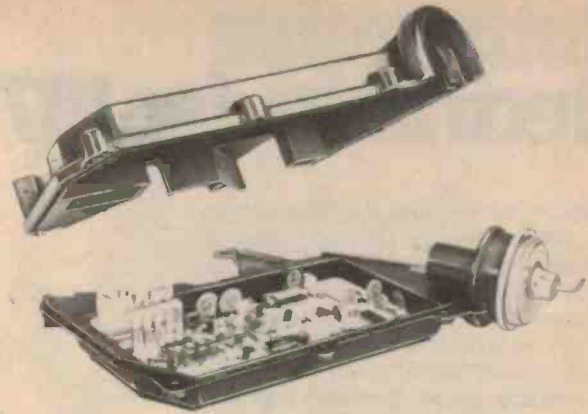

consumer affairs of Chrysler. "After that the electronic components should never wear out. Chrysler engineers estimate that for every dollar the industry has invested in electronic voltage regulators, the customer has saved nine dollars in replacement costs, and that customers have saved four dollars for every dollar we have invested in electronic ignition."

This is a good record — for relatively simple devices. For more complex systems, serviceability suited to the auto repair shop will have to be worked out. "Repair of computer-type equipment will of necessity be at the module replacement level to be practical," the SAE was told by Frank P. Caiati and James F. Thompson of GM's Engineering Staff. "Isolation to a failed module will be the technological challenge. It is very necessary that a high percentage of module failures be self-indicating," so the usual vagaries of trial-by-replacement troubleshooting could be avoided.

"The MSI and LSI semiconductor technology of today lends itself to modularity," Caiati and Thompson added. Like car radios, the first complex electronic system used in a production car — the Bendix fuel injection of 1957 — used vacuum tubes. Soon thereafter the vacuum tube was replaced by the transistor, much smaller and less power-hungry, while back in the semiconductor labs, the age of the integrated circuit was being ushered in.

"In 1959," explains Chrysler's Terry, "a commercially available chip contained only one component of a circuit. By 1964, the number of components per chip was one to ten. By 1970, the number of components was up to about 1000, and by 1976, up to 82,000. At the same time, the cost per unit dropped sharply."

The electronics industry soon discovered that the most efficient way to use those 80,000 components was to organise them into a computer-like general purpose logic chip — the micro-

processor. With that much power available in a very small package, the auto industry had to pay attention to microprocessors. "These new LSI microprocessor chips, as used in calculators, started the industry looking at applications in which their added cost could be handled," says Donald E. Colvill, staff engineer for electronic engine controls of GM's Delco Electronics Division. "To an engineer," he adds, "a computer is always attractive from a technology standpoint".

It was one thing to decide to use this know-how of the semi-conductor industry, and quite another to decide exactly how to use it. There are two main types of computer, analogue and digital, and each has its strengths and limitations. The auto industry started with analogue computers, and it is moving rapidly and irrevocably toward digital computers today.

The analogue computer was initially the most popular because it is simpler and well suited to doing many of the jobs that the automobile system requires. As its name hints, it works through the setting up of an electronic circuit that is analogous to the conditions in the mechanism that it's controlling. In an analogue computer, multiplication by a constant, for example, would be done by an amplifier of fixed, pre-set, gain. Analogue circuitry 'mimics' the motions of the machine and/or the mathematical equations that describe what it does. Analogue computers can be quite versatile, but for use in cars they're usually tailored in design to suit just the job they have to do.

Analogue Circuitry

Analogue circuits started strong in cars and are still doing many important jobs in them. The Bosch and Bendix electronic fuel injection systems use analogue computers, for example. Analogue designs were chosen because they're fairly easy to change and adjust during vehicle development and during the

Automotive Electronics for 1978

evolution of the fuel injection system. For similar reasons Chrysler chose an analogue computer to control its Lean Burn spark-adjustment system. First launched in the 1976 model year, this functioned with 99.9% reliability on the initial field of 60,000 cars. Now in 1978 it's available on all Chrysler's eight-cylinder engine families.

Analogue circuitry also does the computing in the black boxes used in the closed-loop Lambda-sensing controls that make the so-called three-way catalysts work in the cars now on the U.S. roads. Such systems were first marketed by Volvo and Saab at the end of 1976, using Robert Bosch electronics. Now for 1978 Ford's Pintos and Bobcats with automatic transmissions for the California market have such closed-loop or feedback controls. Both Motorola and Ford's own plant supply their analogue electronics. GM's Delco Electronics Division makes analogue controls for the similar air/fuel ratio control being fitted to some Buick, Oldsmobile and Pontiac subcompact models, also for the California market. Ford uses Bosch exhaust pipe sensors, while GM's come from the AC Spark Plug Division.

Two 1978 GM models have new spark control systems that also have analogue computer circuitry. One is Delco Electronics' Electronic Spark Control, which is called the Turbo Control Centre by its user, Buick, which employs it on its turbo-supercharged

Fig. 6. The Delco Electronic Spark Control system is used on Buick turbo-supercharged V-6 engines.

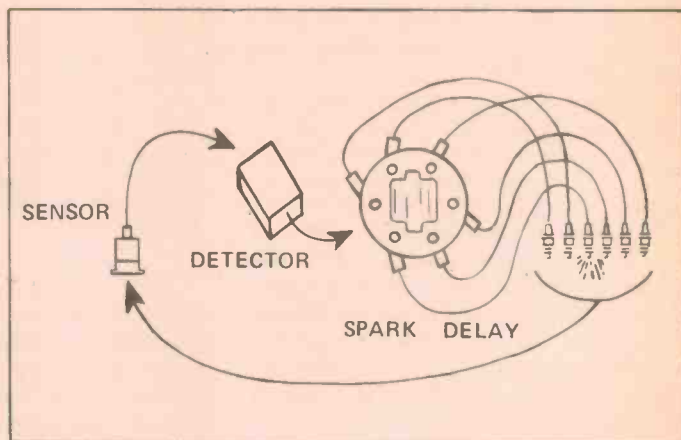

V-6 engines in the Regal and LeSabre sports coupes. This ingenious device uses a Delco Remy vibration sensor mounted on top of the inlet manifold to tell when the engine is detonating. Electronic filters on the sensor's output pass the high vibration peaks in the range of five to seven kilohertz that GM considers to be the signature of pinging or detonation. Analogue circuitry in the Electronic Spark Control modifies the spark dwell, and thus the spark timing, by a signal it sends to a special electronic module in the High Energy Ignition. Working every other crank revolution, it can retard the spark up to 20 degrees in two-degree increments until the detonation stops. It is designed to cope with extreme conditions in the running of this sensitive supercharged engine,

such as a very heavy load on a very hot day.

This spark control system is a closed-loop device, the first of its kind to be placed in volume production. Delco Electronics' other new spark controller is an open-loop design, the Electronic Spark Selector used on 1978 Cadillac Sevilles (except for the diesels, of course). This has sensors that tell it engine speed, manifold vacuum, coolant temperature and the engine cranking condition. From these, an analogue computer advances or retards the whole spark curve to suit the running conditions. During engine warmup, for example, it retards the spark so the catalyst will reach working temperatures more quickly. Like the detonation sensor, this too allows the engine to be run with a greater spark advance under most conditions, favourably affecting mileage. Cadillac expects an overall improvement of about one mile per gallon from its use. And the Electronic Spark Selector is built to "fail soft". Should it stop working, the engine simply keeps running with the last spark curve it was using before the failure.

Both Cadillac and Buick offer yet another engineering feature that combines analogue-type electronics with a simple logic chip. The new GM application is in the Automatic Level Control for the rear suspension, developed jointly by Delco Electronics and Delco Products. It uses an Optron diode sensor to measure the distance from the axle to the frame, and the, through the analogue and logic circuits, it adds or subtracts compressed air (from a 150 p.s.i. supply) in the special shock absorbers to bring the rear of the car to the correct level.

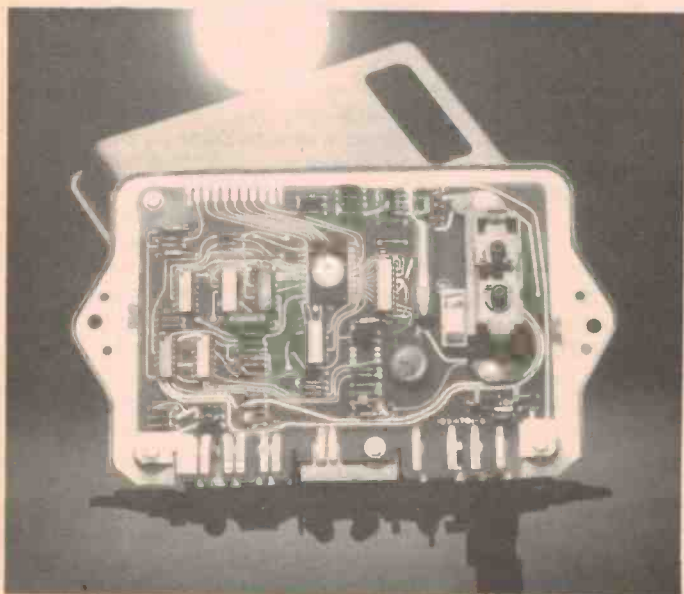

Fig. 5. This module, manufactured by Delco Remy, is an electronic controller for the GM 3-way catalyst system.

Number Crunching

With all these applications, analogue computation is well established in the electronic systems of today's cars. But it has a strong and promising competitor: digital computation. It reaches similar ends in a different way. While the analogue system is computing by making comparisons between different voltage and/or current levels, the digital system is carrying out the various calculations mathematically, just as you would on a scratch pad or calculator. You might say that digital computation is to analogue as a desk calculator is to a slide rule. Actual physical relationships play a part in the analogue circuit's findings, while the digital computer gets its results by doggedly doing the actual math — very quickly.

Each method has its pros and cons. Advocates of each claim that the other is more likely to be thrown off the track by spurious bleeps that drift into its wiring from outside sources. The analogue circuit works in "real time"; changes in its inputs are instantly reflected in its outputs. In contrast, a digital computer needs a finite amount of time to carry out its calculations. The more complex they are, in relation to the power of the computer, the longer it takes. In some automotive situations, such as very high engine speeds, this could limit the utility of the digital computer.

While the digital device gives results that are inherently accurate, the electronic components of the analogue device must be "trimmed", during assembly and testing, to make sure that the complete circuit gives the right answers. This seems to show an edge for the digital device, but that's not necessarily so. Many of the inputs to digital computers will begin as analogue signals, such as a varying voltage from a temperature or throttle position sensor, and will need to be converted into digital language that the computer can understand. Such an analogue-to-digital converter will also need to be trimmed, or calibrated, for accuracy. And digital-to-analogue converters for the computer's output will also be needed so it may perform automotive tasks.

The choice between analogue and digital for automotive computers was moot until recently. It was simply unthinkable to fit a digital computer into a production car,

Fig. 7. The small size of the 2,000-transistor microprocessor contrasts with the mechanical system it controls.



because it was too big, too expensive, or both. Now, with the arrival of the microprocessor that limitation is beginning to be removed. A digital computer needs a central processing unit (CPU) to do the work. It also needs a fixed or permanent memory (known as ROM for read-only memory) of substantial size to tell it what to do and when to do it, and in addition to that a temporary memory, or RAM (random-access memory), in which it can store data it needs for continuing its calculations. All this can now be etched on one or more small LSI chips, forming a microcomputer.

Small and powerful though it may be, such a microprocessor doesn't come cheaply. It costs tens of thousands of dollars just to tool up to make the special masks needed to etch them in production. Also, to avoid needless waste they must be tailored as closely as possible to the applications for which they're needed. A nervous period of courting between the auto and semiconductor industries is now ending, as each better understands the needs of the other, and microprocessor uses are increasing rapidly. From one in 1977 the number of applications has jumped to five in 1978, and there'll be many more in 1979, after the technique proves its value and reliability.

MISAR Sparks It Off

The beachhead for microprocessors in cars was established in the '77 model year by Oldsmobile and Delco-Remy with their MISAR spark control system used in the Toronado. Standing for Microprocessed Sensing and Automatic Regulation, MISAR senses crankshaft rotation, manifold vacuum and coolant temperature, and from these decides which of more than 200 ignition advance points on a "map" of possibilities suits the engine best at that instant. These points are stored in a ROM with a capacity of 1024 ten-bit data words. Two LSI chips are at the heart of the Rockwell CPU that computes which point will be used at any moment. It completes the 335-odd instructions its program requires in about 12 milliseconds giving a fresh spark timing at that interval. MISAR works by switching the HEI distributor's own electronic module on and off.

MISAR enters its second year in 1978, and is joined on the market by an even more competent engine control from Ford. This is Ford's first-generation Electronic Engine Control, or EEC I. In addition to the parameters sensed by MISAR, the EEC I picks up the throttle position, inlet air temperature, barometric pressure and EGR valve position. With this information it

Automotive Electronics for 1978

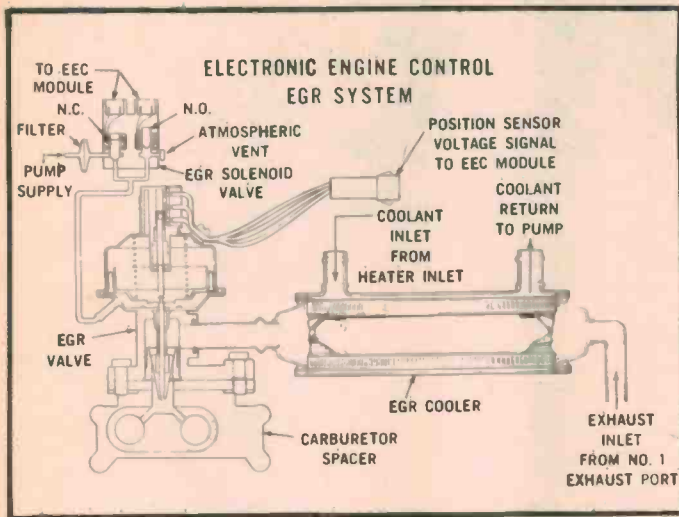

Fig. 8. The 1978 Lincoln Versailles features this control system.

capacity of 4000 eight-bit words is enough to let the Tripmaster handle these jobs, and it can be expanded by several multiples in the future, using the same CPU, to permit it to take over all engine functions and many other control tasks in the car.

Fifth among the digital microprocessors in the 1978 cars is the miles-to-empty system used, as an option, in the Lincoln Continental Mark V. Its LSI chip carries the equivalent of 3600 transistors on a surface less than a quarter-inch square. Picking up indications of car speed and fuel tank level, it calculates the distance traveled, fuel used and the resulting miles per gallon. Then it multiplies fuel mileage by the amount of fuel left in the tank to get the miles-to-empty reading shown on the dash in a bright gas-discharge numerical display supplied by Beckman Instruments.

Looking Forward

This is a promising array of digitally-controlled auto systems. Many more are waiting on the sidelines. We can expect, for example, that most and perhaps all of the present analogue car computers will be converted to digital operation in the course of the next several years. Speaking to the SAE about electronic fuel injection in 1976, Jerome G. Rivard, then of Bendix and now with Ford, said that "In the interests of cost reduction

controls not only the spark timing but also the flow through Ford's new sonic EGR valve. Called an "interactive" control by Ford, since it simultaneously juggles two interrelated engine variables, the EEC I is used on the 1978 Lincoln Versailles. Parts for its microcomputer are supplied by the Ford Aerospace & Communications Corp., by Toshiba of Japan, and by the Essex Group of United Technologies Corp.

Three other microprocessors are used to do jobs that are less vital to the running of the car. One is another Chrysler Huntsville development, an advanced solid-state search-tune radio. It has a ten-digit keyboard that can be used to choose stations directly by their frequency, or from the radio's computer memory by a push of a single button. Automatic searching for other stations, at two sensitivity levels, can be initiated by a foot switch. The frequency chosen is shown by a light-emitting diode display. This 'thinking' AM/FM stereo radio is offered in such top-line models as the Dodge Diplomat and Magnum and the Chrysler LeBaron, Cordoba, Newport and New Yorker Brougham.

The fourth microprocessor available in the '78 models is an option on the 1978-1/2 Cadillac Seville, those without diesel engines. It's at the heart of a system called Tripmaster, which uses a large LED display made by AC Spark Plugs in place of the conventional speedometer and introduces LED displays for the fuel level and, at the right of the dash, for engine speed, coolant temperature or time of day — whichever the driver selects by pushing a button.

A small panel holds a dozen push-buttons for selecting operating modes or entering data into Tripmaster.

Its CPU, a Motorola 6800 microprocessor, allows the Tripmaster to do many navigational tasks. It can handle time, distance and average speed calculations, and it can relate them to the rate of fuel consumption and the amount of fuel left in the tank. Drawing information from the electronic fuel injection, it can read out the instantaneous fuel mileage and the average mileage for the journey. Its present ROM

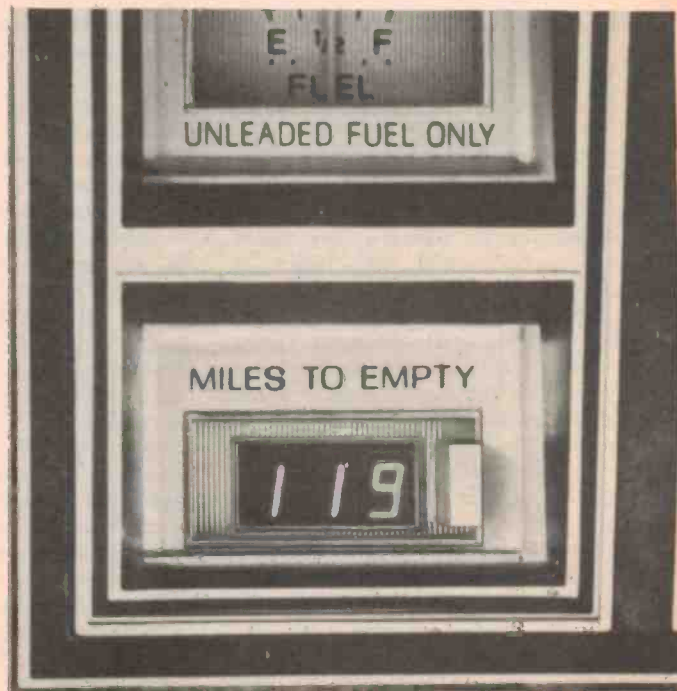

Fig. 9. This miles-to-empty gauge is an option on the Lincoln Continental Mark V.

and higher production volume, the current hybrid analogue design will undoubtedly be replaced ultimately by a design based on digital EFI controller to be in production for the 1979 model year and to be in wide use in 1980. United Technology's Essex Group has also built and tested a digital injection computer, while Chrysler will use such a controller with its forthcoming Electronic Fuel Metering system. Its key microprocessor suppliers are expected to be the RCA Corp. and Texas Instruments.

The systems on the 1978 cars are the exploratory first wave for the mass invasion of microprocessors that's coming on the 1981 models. To meet the tougher emissions and economy

standards then, the tiny LSI chips will take over control of all main engine variables: spark timing, EGR valve flow, choke control on carbureted cars, fuel preparation and fuel/air mixture control. The Motorola 6800 microprocessor, used already in Tripmaster, will be the key CPU for General Motors and, apparently, for Ford as well.

Those responsible for developing these new systems make no secret of the fact that the central brain, the CPU, has raced far ahead, in design, of the sensors and actuators that are the eyes and muscles of the brain. These are still relatively primitive, and all too susceptible to inaccuracy or failure under automotive operating conditions. Also many of them produce analogue outputs

instead of the digital data that the microprocessor would prefer to receive. This is the area in which the auto and electronics engineers will have to cooperate most genially if good results are to be achieved.

Before long there'll be no conflicts between those two engineering factions, because they'll be indistinguishable one from the other. Like the experts on electricity, hydraulics and pneumatics before them, the semiconductor specialists will be absorbed into the motor industry. And the computers, the intelligence systems that will build the first brainy cars, will be taken for granted too. They'll only be of interest when they fail — and there'll be a computer to detect that too.

Fig. 10. The Aston Martin Lagonda features an integrated electronics system designed by Cranfield Institute of Technology and manufactured by a specially set up company, Aston Martin Electronics. Even the driver's seat is computer controlled through servomotors and can be pre-programmed with two sets of adjustments for husband and wife drivers. Extensive use is made of fibre optics in the control panel, which displays revs and speed in both analogue and digital forms. The speedo can be switched to read in either km/h or mph.



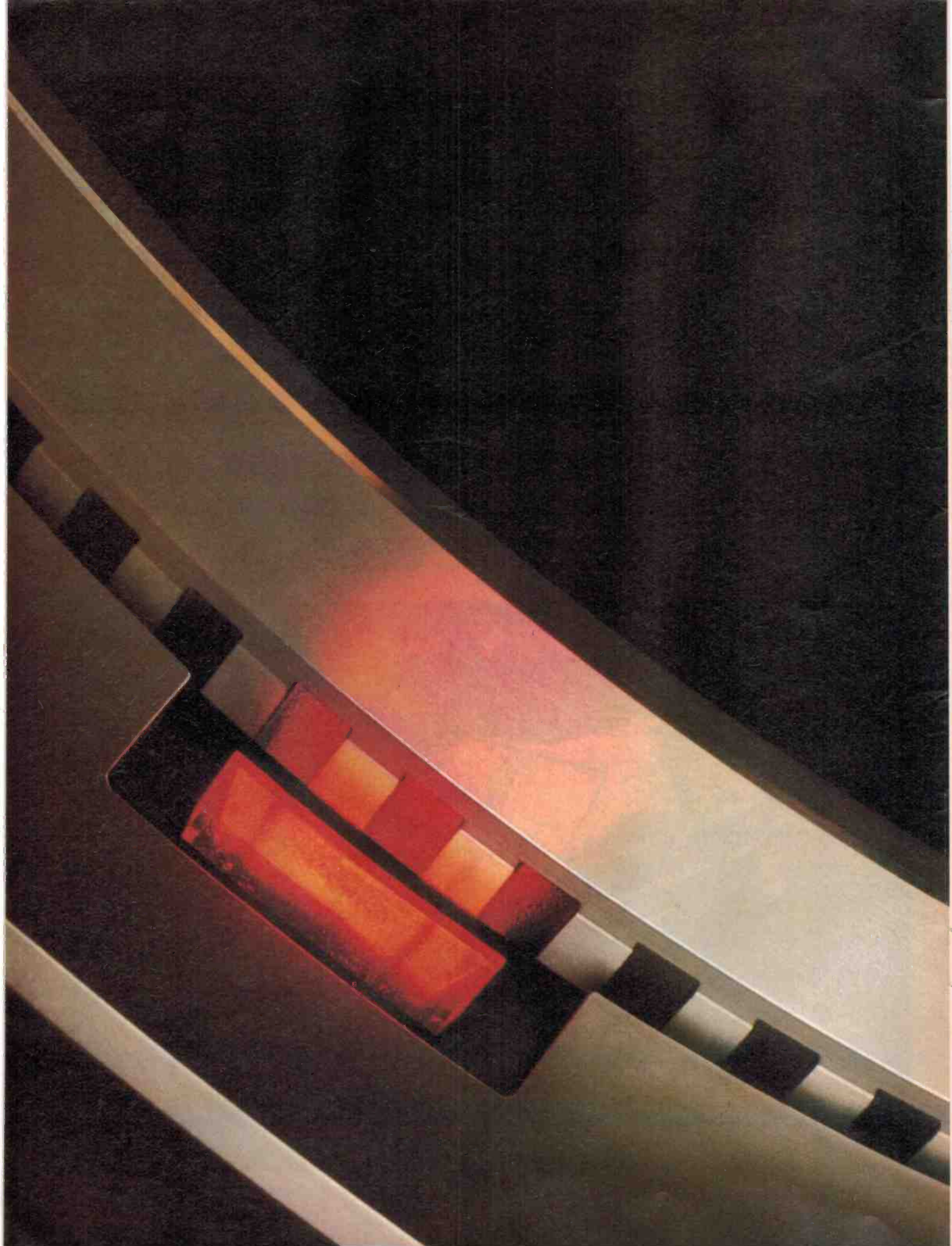

“The PL-570. It equals the best manuals and sheds a whole new light on fully automatic”

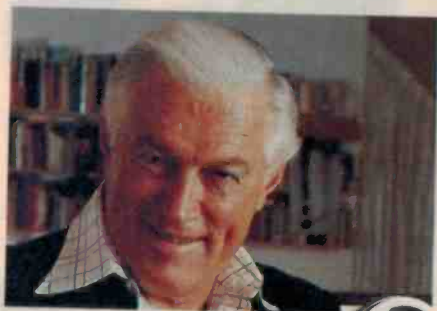

Once there was no argument. Peak performance demanded a manual turntable. Now Pioneer changes all that with the PL-570. The world's most advanced fully automatic with specifications equal to virtually any manual you can name.

In short, the PL-570 is a two-motor direct drive turntable, with a quartz-PLL servosystem, and a one-stripe strobe. In addition, it's the first fully automatic to offer such a degree of arm height adjustment — ± 5 mm for setting the correct tracking angle of any phono cartridge. Wow and flutter is within a barely measurable 0.025%. Signal-to-noise ratio is more than 70dB (DIN B). And load fluctuation, even up to 120 grams of stylus pressure is nil.

With two motors, one drives the die-cast platter direct. The other powers the tone-arm functions in a completely separate operation. Further, the arm return detection mechanism is totally electronic, using an LED and a phototransistor, so improving arm sensitivity.

As a speed control mechanism, the quartz-PLL servosystem is nearly perfect. The output waveform of a generator fixed on the rotor shaft, and the output waveform of a precision quartz reference oscillator are compared via a solid-state comparator. Any difference in phase, rather

than amplitude, is then detected for more effective rotational control.

The dramatic and easy-viewing one-stripe strobe is lit by a built-in wave-shaped source. This is derived from the quartz reference oscillator and stabilised electronically for whichever playing speed, 33 $\frac{1}{3}$ or 45 rpm, is chosen. Only a single stripe is therefore required to achieve total and precise speed control adjustment, within $\pm 6\%$.

Such is the standard of perfection that extreme care was naturally taken with the tone arm. Highly trackable, 'S' shaped, 237 mm effective length, with anti-skate, lateral balancer, stylus pressure direct readout, and counter weight.

The arm is mounted on a heavy 6 mm thick aluminium base to dampen unwanted resonance. The turntable mechanism is mounted within a rigid die-cast aluminium frame and a monocoque cabinet to eliminate howling. The whole turntable is then mounted upon elastic 'leveller' insulators for the same reason.

Manual or automatic? With the PL-570, the question is purely

academic. Shouldn't you rather be asking what sort of facilities you prefer, since the level of performance in either case will be virtual perfection.

A short specification.

Wow and flutter	No more than 0.025% (WRMS).
Signal-to-Noise ratio	More than 70dB (DIN B).
Load fluctuation	0% (within 120 g of stylus pressure).
Starting time	Within $\frac{3}{4}$ of a rotation.
Weight	13.5 kg.

All Pioneer turntables are covered by warranty for one year (excluding styli). Excellent service facilities are available throughout Australia via a network of Pioneer approved outlets.



Please mail me:
(Tick as required)

- PL-570 Turntable Folder.
- Folders on other components of equivalent compatibility.
- Other (please indicate).

To Pioneer Electronics,
P.O. Box 295, Mordialloc,
VIC. 3195.

PN 176 ET

Name

Address

State P'Code

 **PIONEER**[®]
leads the world in sound

THE LOUDSPEAKER WITH A TOUGH ACT TO FOLLOW: JBL'S NEW L40.

For the past 2½ years, we've been making a two-way bookshelf loudspeaker called the L26. The critics loved it. The dealers loved it. The customers loved it. 250,000 times to be exact.

The smart thing to do would've been to just keep cranking out those L26's for the next hundred years. Never change a winner, right? Not if you're JBL.

Meet JBL's brand new L40. It's one of the best two-way loudspeakers you can buy. Here's why:

The L40 has tremendous power handling capability. Don't let its size fool you. It'll play right up there with loudspeakers twice its size.

Every sound is clean and clear. Listen to the snap of a rimshot, the crash of a cymbal. Pure. Accurate. Perfectly defined. (If you'd like the technical information on the L40, write us and we'll send you an engineering staff report. Nothing fancy except the specs.)

Go listen to the L40. And ask for it by its first name: JBL. You'll be getting the same craftsmanship, the same components, the same sound heard in the very top recording studios in the world.

If you've been thinking about getting into high performance high fidelity, we know a great place to start: JBL's new L40. It's a whole lot of JBL for not a whole lot of money.



Ranked by the number of Top Fifty albums they produced last year, seven of the ten leading recording studios in the world used JBL to record or mix their music. They used our sound to make theirs.

Source: Recording Institute of America.

Distributed by
HARMAN AUSTRALIA PTY. LTD., 271 Harbord Road, BROOKVALE, N.S.W. 2100. Telephone: 939 2922

JBL
GET IT ALL.

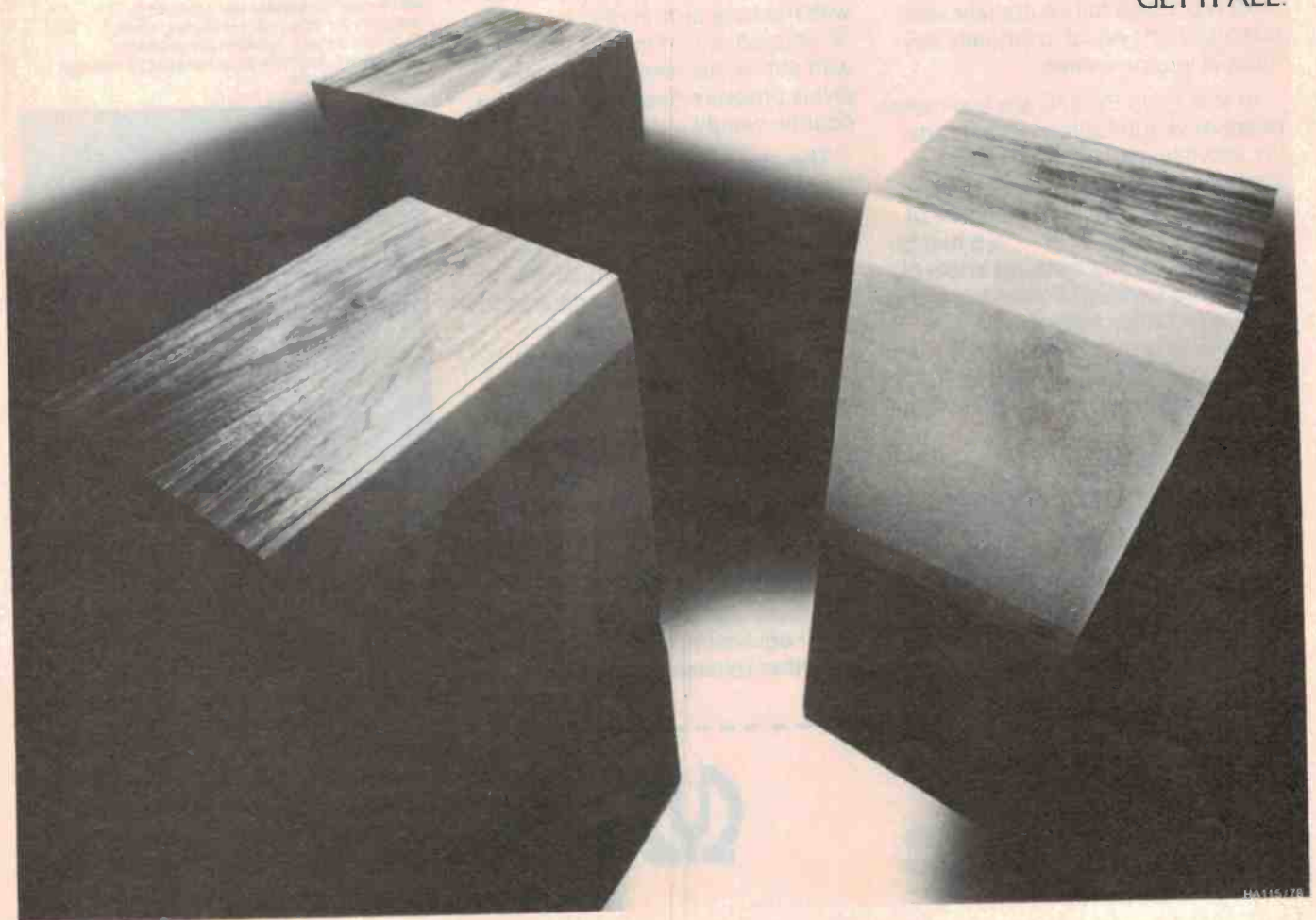

HA115/78

GOOUND



Electro Research Class 'A' Amplifier

There can really be no argument that the inherent characteristics of Class 'A' amplifiers make them the best choice for handling audio signals in a hi-fi system. However not many solid-state Class A amplifiers have actually materialised, largely because of their gross inefficiency and consequent heat output, with potential unreliability.

One of the first successful transistorised Class A amplifiers was the J.E. Sugden A21, an integrated design with an output power of about 15 watts per channel. This amplifier wasn't very popular because it wasn't sufficiently powerful to drive the then new generation of infinite baffle loudspeakers. The C51/P51 preamp/power amp system was better able to do this but was probably disregarded by many listeners because of its fairly high price relative to its power output.

Yamaha and Stax have both ventured into the field of Class A power amplifiers, Yamaha with the optional Class A operating mode for the CA1000 amp yielding 10 watts per channel as opposed to 70 watts in Class B; Stax with the DA300 and DA80 power amps.

And now we have the Electro Research A75V1 from America. This power amplifier, rated at 75 watts RMS per channel, an enormous output for a Class A device, has been given enthusiastic accord by sections of the American 'underground' audiophile press — which, we must hasten to add, doesn't automatically imply to us that the equipment is necessarily the best.

In appearance the amplifier can only be described as a brute. Our sample was predominantly black, with chrome trim and carrying handles and white lettering. It also had a front panel unlike any other we've seen; no output meters (although a centre-zero edge-mounted meter was fitted), no level controls or any of the more usual power amplifier paraphernalia.

Unfortunately no instructions were supplied with the sample, so we're unable to say exactly what the facilities provided were intended to do, apart from the electro-mechanical counter, which was an elapsed time clock indicating the hours the amplifier had operated. The readout could not be reset.

Other facilities fell into two sections — the calibrator, consisting of the aforementioned edge reading meter, a pair of rotary controls marked input trim, four screwdriver operated presets and three non-locking pushbuttons; — and the operation monitor, consisting of four back-illuminated push buttons marked respectively, load 1/load 2 (which didn't seem to do anything at all), normal/supply (which glowed orange under normal conditions and red if mains voltage were reduced), standby (self-explanatory) and reset/frequency for switching the amplifier into operating mode from standby.

The remaining control was power on/off. When switched on, the amplifier produced a loud clunk and went into standby mode, thus necessitating operation of the reset button to select operating mode.

Rear panel fitments included RCA-phono input sockets and banana/screw binding post output terminals.

Performance

The sample was very noisy, mechanically, this resulting from inclusion of a blower fan to keep the enormous side-mounted output heatsinks cool. We have never encountered such a mechanically noisy amplifier and late-night, low-level listening was rendered virtually impossible. It would probably be necessary to place the amplifier in a different room if permanent installation were envisaged.

Compared with our reference power amplifier, the Naim NAC250, the sample seemed to have a more extended and prominent bass response, an equally neutral and uncoloured midrange response and a more distant and apparently less

Continued on p. 25

Modern expertise and computer technology
have created a fine piece of equipment.

The NEW B&W DM7

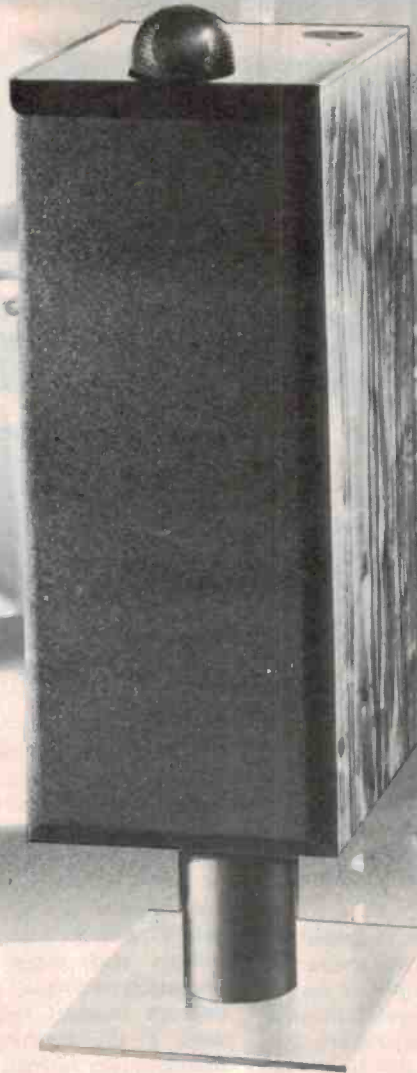

The DM7 complements a remarkable range of monitor loudspeakers from B & W.

The B & W DM6 is Britain's first linear phase loudspeaker. A dynamic system that will reproduce sound with transient accuracy usually achieved only by the very best electrostatic designs.



The DM4 is a 3-unit monitor loudspeaker system that produces high quality results from an incredibly small cabinet (20.8 litres) making it perfect for home or small studio use where space is at a minimum.



Only 28" x 9" x 9 1/2". Despite its compact size, DM5 speakers can be rated as a system of very high quality. The design philosophy of John Bowers — "To design loudspeakers that reproduce in your home sound as you would hear in the concert hall"



DM7 is the first of a new loudspeaker family reflecting our computer-aided research programme. It is a compact 3 unit system employing entirely new drive units in an enclosure engineered to exceptionally high standards. Many advances have been incorporated to reveal new horizons in loudspeaker performance, making possible a standard of musical reproduction unequalled in an enclosure of this size. The DM7 gives almost perfect amplitude linearity throughout the entire audio spectrum, and produces phase-coherent sound within a broad listening area. The drive units are purpose-designed and manufactured entirely in our own factory, employing new technology in order to achieve incredibly low distortion levels — typically less than 1% THD from 30Hz to 200Hz and less than 0.5% above that frequency. Another new feature in the DM7 is a variable energy control giving four frequency weightings — different to those obtainable from the control unit — to accommodate widely varying room acoustics.

Hear the B & W DM7 — you may well agree that this is the finest small speaker in the world today. Guaranteed for 5 years.

NSW: CONVOY SOUND WOOLLOOMOOLOO SHOWROOM 357 2444; INSTROL HI-FI PTY. LTD. 29 7290; PARK ST. HI-FI STEREO CENTRE 26 2798; MILVERSON PTY. LTD. (CHATSWOOD) 412 2122 (PARRAMATTA) 635 3588; RIVERINA HI-FI 938 2663/4; UNITED RADIO DISTRIBUTORS PTY. LTD. 232 3718; ARROW ELECTRONICS 29 8580; RUSSIN HI-FI 999 2421; PITMAN'S RADIO & TV (WAGGA) 25 2155; ALBURY AUDIO CENTRE 25 1712; LEISURE SOUND (CHATSWOOD) 411 4944; WROTH CENTRE HI-FI (BATHURST) 31 2088; BYRON BAY TV & SOUND CENTRE 85 6762; SINGLETON HIGH FIDELITY CONSULTANTS 72 2270; HI-FI JUNCTION 389 4000; ACT: DURATONE 82 1388; VIC: SHEPPARTON HI-FI 21 9006; ENCEL ELECTRONICS PTY. LTD. 42 3761; SOUND SPECTRUM (GEELONG) 9 6616; SOUTHERN SOUND (CITY) 67 7869 (MOORABBIN) 97 7245; TIVOLI HI-FI 81 2872; THE SOUND CRAFTSMAN 509 2444; BUY RITE ELECTRIX 42 6200; NATSOUND 678 158; INSTROL HI-FI 675831; INSTROL HI-FI (FRANKSTON) 789 7535; QLD: JOHN GIPPS SOUND 36 0080; PREMIER SOUND (NTH. ROCKHAMPTON) 27 4004; TARGA ELECTRONICS (CAIRNS) 53 2715; RUSS ADAM (TOWNSVILLE) 71 5618; TAS. BEL CANTO (HOBART) 34 2008; UNITED ELECTRONICS (LAUNCESTON) 31 8528; AUDIO SERVICES (BURNIE) 31 2390; WEST. AUSTRALIA: TECHNICAL SERVICES PTY. LTD. 31 5455; THE GINZA 61 7444; STH. AUSTR. BLACKWOOD SOUND CENTRE 278 1281; INSTROL HI-FI 2237622; SOUND SPECTRUM 2232181.

Sole Australian agent

**Convoy
INTERNATIONAL**

4 Dowling Street, Sydney 2001. Phone: 358 2088.

detailed treble. The Electro Research sounded powerful and spacious, giving an impression of smoothness and coherence of the sort one expects from amplifiers capable of far greater power output.

The essentially neutral tonal balance was most pleasant. However, we found dynamics seemed a little suppressed, and lacking in the sort of impact we hear from the Naim. This was largely responsible for a flat presentation of stereo images, with a shallow front/rear perspective. This effect was emphasised by the rather soft, distant extreme high frequency response; details could only be heard if one listened with concentration.

Petanger parametric equaliser

Petanger Parametric Equaliser

There is, at present, tremendous interest in the field of electro-acoustic equipment specially designed for professionals. Whilst the Americans and Europeans have produced some exceptional equipment, we are always pleased to find that some Australian firms are either on par or not far behind. One piece of equipment which has recently attracted a lot of comment is a device called the Parametric Equaliser, and it was with great interest that we received an Australian-made unit for review.

The particular unit described is a Petanger Parametric Equaliser, which is a dual channel, 4 band equaliser. This unit is both attractive in appearance, functional in its layout and relatively inexpensive considering the range of functions that it offers.

Our first questions were: "Well what does this device do that other devices don't already do?", and equally important, "How would the average amateur or professional use it?"

The answers to both of these questions are closely inter-related, for there are many pieces of equipment available for tailoring the response of an electro-acoustic system, particularly for musicians who move from location to location and feel the need, for a variety of reasons, to modify the frequency response of the standard equipment that they use.

Acoustic Problems

The most glaring problem that both the professional and amateur musician finds is the wide range of acoustical characteristics in auditoria and to a lesser extent in the out-of-door situations in which they find themselves. Most people are aware of the bathroom acoustics problem, where you can clap your hands and develop a flutter like sound effect. This can convert the modest baritone into an opera singer, even if only at a few spots within the audible spectrum. The problem of selective frequency enhancement is equally common in auditoria and generally manifests itself through an interaction with the PA system and loudspeakers to cause many heartaches and initial set up problems.

The most common of these problems is called feedback oscillation, where at some modest level of amplification the system "takes off" and howls in the most disconcerting manner. This problem can be overcome in many ways, the most common technique in the past being to utilise a graphic equaliser which provided a selective rejection at those frequencies where the problem manifests itself.

Side-to-side stereo performance was, on the other hand, very good indeed, giving the impression of plenty of space between individual elements of an ensemble to result in an easy, effortless sound which rarely became offensive.

Despite its 75 watt rating, the sample seemed capable of producing very high levels indeed, without becoming audibly distressed. It also retained an acceptable tonal balance at very low levels, although the noisy blower rather spoiled the sound.

The Electro Research A75V1 is very expensive and while its performance, as assessed from the sample, seems excellent, we feel its price is a little too high for the performance and facilities it offers. One or two more conventional power amplifiers — for example the Audiolab and the Naim — give subjective performance at least as good as our sample A75V1, using our reference loudspeakers. The sample was very well made, however, and would probably be extremely reliable in service.

The second problem in auditoria is the regular need to introduce a "fold back" system whereby the musicians utilise a supplementary amplification system to provide a small portion of the sound they are feeding to the audience in order to be able to monitor their own performance. The problem with such systems is that because of the direct radiation, the short distances and the levels at which the music is being played, such a system is rapidly and readily induced to oscillate (take off). This problem could be partially compensated for by a graphic equaliser but with more difficulty than with the first example quoted.

The third problem is that most musicians like to change their sound either selectively within a narrow range of the frequency spectrum or by introducing other gimmicks. This is particularly true with electric guitars, and other instruments where there is a need to produce unusual sounds. This can be achieved in many possible ways and whilst even the ubiquitous graphic equaliser is of some use in this area it soon shows its real limitations.

What then, you might ask, does a parametric equaliser have that a graphic equaliser does not have?

The Parametric Equaliser

Firstly, the type of usage is a little different because the characteristics of the device are significantly different. Whereas graphic equalisers, excluding the best professional units, have a selectivity that is "almost as broad as the proverbial barn door" the parametric equaliser, is capable of having the shape of its response tailored from broad to narrow, and in the best units the "narrow" is extremely sharp.

Secondly, the parametric equaliser, like the graphic equaliser, is able to have its response shape converted from boost to notch (or cut) but unlike the graphic equaliser, can be varied infinitely and exactly to any frequency within the range of a given control. It is this parameter of variable frequency which is of the utmost importance and is possibly even more important than the selectivity control.

Last, but not least, by covering a range of frequencies the parametric equaliser is able to improve the performance of electro-acoustic systems and obviate some of the worst problems of room acoustics. This is especially true in the case of loop feed back problems and natural eigentones or room resonances with the audience present or absent, as the case may be.

Continued on p.26

SOUND

The Petanger Audio Developments Dual Band Parametric Equaliser is a neat unit designed for 19" rack mounting with flat black painted fascia panel with white silk screening superimposed. The unit is divided into two identical sections; one for the left and one for the right channel. Each side section of this is then sub-divided into four similar sub-modules each of which covers bands of increasing frequencies. These cover respectively 20-640Hz, 60-1.9kHz, 180-8.6kHz and 540-17kHz. The frequency selecting slider control is located on the right with individually calibrated frequency markings that typically have points at 20Hz, 30Hz, 50Hz, 100Hz, 200Hz, 500Hz and 640Hz, whilst the left hand side of the panel contains an illuminated push button for switching that channel in or out as required, a cut and boost control that provides 18dB of cut or boost calibrated in 3dB steps and a band shape control that provides a continuously adjustable bandwidth from broad to narrow.

Construction

The internal construction is extremely neat with the main electronic components laid out on two identical printed circuit boards on the base of the unit. All integrated circuits are mounted in sockets. The front panel controls are laid out to make maximum use of the available panel area; less than 10% of the space behind the panel is unused. Connections between the channel select switches are by means of a second pair of printed circuit boards.

The power transformer, regulated power supply and Canon type input and output connections occupy the rear panel.

In general terms nothing could be simpler in use and in practice this proves to be the case. Our initial approach was to evaluate the performance of the unit in terms of accuracy of calibration, the range of band shape performance, its ability to handle transients and its inherent distortion characteristics.

In all of these areas as the level recordings show, the unit's performance proves to be exemplary and both the broad band and narrow band performance right across the spectrum was generally faultless.

When we came to utilising the parametric equaliser on a number of real, as opposed to contrived, situations we found the flexibility of the device to be superior to what we had envisaged. The first application involved providing signal enhancement and improved speech intelligibility for some tape recorded material which was picked up in one room by a radio transmitter and recorded in a distant location with a remote receiver. (*Ahem! - Ed*) The problem was that as well as the mains interference, the room concerned was subject to the vagaries of external traffic noise, interference of well defined frequency from an air conditioning system, selective frequency effects from a microphone located inside a drawer of a desk and the eigentones or natural frequencies of selective enhancement provided by the room itself. The signal was in something of a mess and really required considerable modification.

The first step was to produce a frequency analysis of the background noise in the signal to determine which components of broad band extraneous noise and electrical interference noise were dominant and the extent of modification required to improve these. This showed that the 50Hz signal was present but only of moderate importance, that the 150Hz component was extremely high and provided a significant masking effect and that components in the range 200Hz to 500Hz due to the effect of the room's eigentones and the selective modification of the position of the microphone in the drawer were dramatically changing the shape, response and overall intelligibility of the signals being recorded.

TONE BURST
RESPONSE ONE
CHANNEL OF
PETANGER PARA-
METRIC EQUALISER
WITH CONTROLS
SET TO 1kHz,
12dB BOOST, MAX.
SELECTIVITY.

UPPER TRACE IS
1kHz INPUT
SIGNAL.

Date: 20.2.78
Sig: AMC

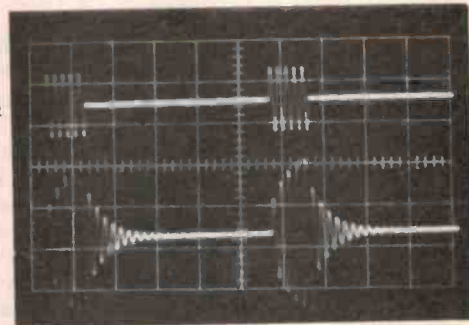

TONE BURST
RESPONSE ONE
CHANNEL OF
PETANGER PARA-
METRIC EQUALISER
WITH CONTROLS
SET TO 1kHz,
12dB BOOST, MAX.
SELECTIVITY.

UPPER TRACE IS
1.5kHz INPUT
SIGNAL.

Date: 20.2.78
Sig: AMC

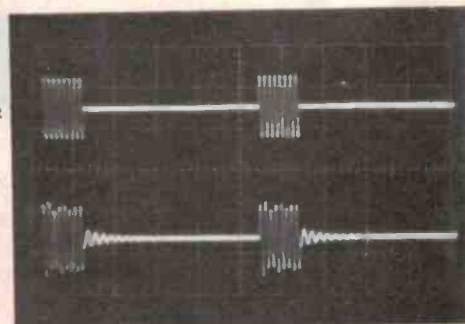

TONE BURST
RESPONSE ONE
CHANNEL OF
PETANGER PARA-
METRIC EQUALISER
WITH CONTROLS
SET TO 1kHz,
12dB BOOST, MAX.
SELECTIVITY.

UPPER TRACE IS
500Hz INPUT
SIGNAL.

Date: 20.2.78
Sig: AMC

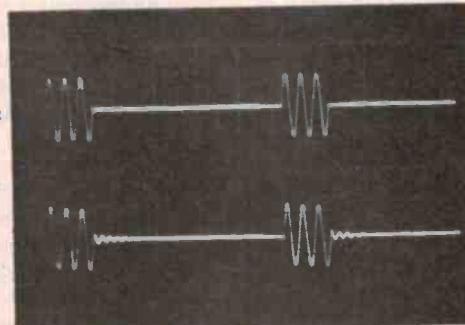

Louis A. Challis
& Associates Pty. Ltd.



The third and fourth frequency selective controls were utilised in the broad band position to modify the shape of the signal and the first stage of signal enhancement was achieved with a dramatic improvement in the ability to hear what was being said. On play back of the tape it was possible to determine that a number of key sections were being affected by traffic noise and a small number of vehicles whose frequency components contain both broad band acoustical energy together with discrete components at one or more frequencies. The right channel of the parametric equaliser was then connected in series with the output of the left channel and the individual controls adjusted to match the frequency selective components determined from an additional frequency analysis.

Whilst the original signal was 80% intelligible, the final signal was 99% intelligible and the quality of sound was miraculously improved.

Continued on p.28

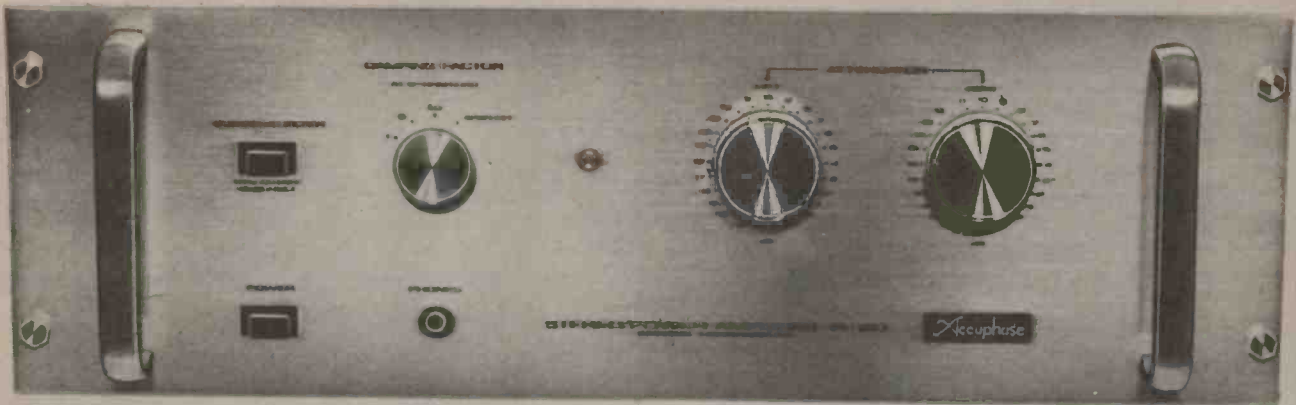

The Accuphase P20 Power Amplifier.

The 1977 Hi-Fi Grand Prix Awards
judged it as "The Best Power
Amplifier of the Year."

This Outstanding Accuphase Amplifier Is Now Available

Japan's annual Hi Fi Grand Prix is one of the most coveted and competitive Hi Fi contests in the world. Hi Fi components from around the world are stringently tested and judged on the basis of performance and design.

In 1977 the outright winner of the power amplifier category against all comers, was the new-release Accuphase P.20. It's specification of 140 Watts power output with frequency response of 5Hz to 90,000Hz (+0, -3.0dB) is impressive but to really appreciate its outstanding musical quality we invite you to test listen for yourself.

P-20 Power Amplifier \$1,287

Every Art has
its Master. in
High Fidelity
it is Accuphase.

Accuphase

Sole Australian Agents

ARENA
DISTRIBUTORS

Australasia Pty Limited

Sydney — Instrol HiFi, 91a York Street

Douglas HiFi, 338 George Street

Melbourne — Instrol HiFi, Douglas HiFi,
The Sound Craftsman

Adelaide — Decibel HiFi, Instrol HiFi

Perth — Alberts HiFi, Leslie Leonard HiFi

Brisbane — John Gipps Stereo

Launceston — Wills & Co.

SOUND

The second practical use to which the parametric equaliser was put was in the fold back system of a rock group in a small hall which featured room resonances and where a conventional graphic equaliser was still most unacceptable. Within three minutes, the parametric equaliser had notched out the dominant frequency characteristics of the fold back loud speaker system. The gain margin improvement was at least 15dB and the rock group was capable of providing 100dB levels at the front of an audience where before 80dB levels were hard to sustain.

The third use in which the parametric equaliser was tried was in the amplification chain for a guitar amplifier by

combining the controls to provide a series of sharp peaks in the amplification chain to exaggerate the harmonics of certain notes, the timbre of the instrument completely changed and a wide range of audible sound effects differing significantly from the norm could be provided. Because of the narrowness of the filter this only affected certain notes and not others without necessarily inducing gross feedback problems.

The Petanger Parametric Equaliser is more than a toy. Whilst the use of a parametric amplifier would require only one unit in a two channel PA system, the use of these units in a professional studio recording chain, could readily call for a number of units. There are many applications in the fields of both amateur and professional sound recording, where this instrument fills the gap by providing solutions to a range of problems which have been around for a long while.

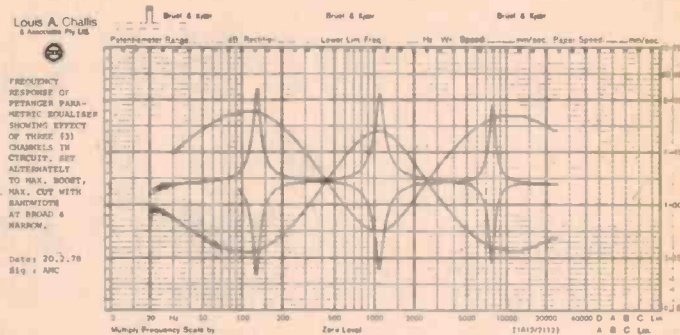
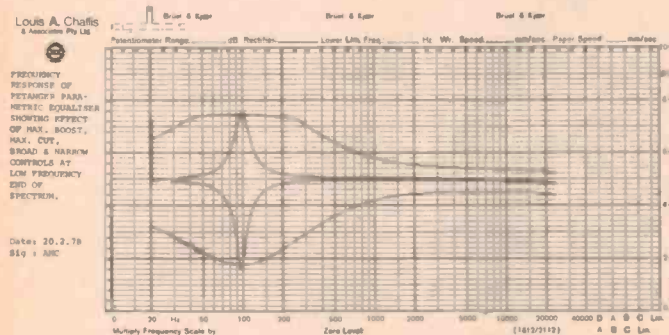
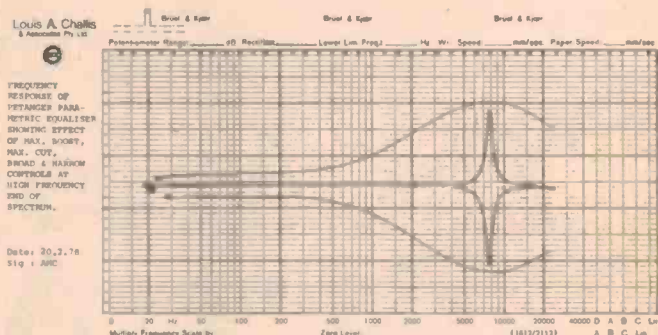
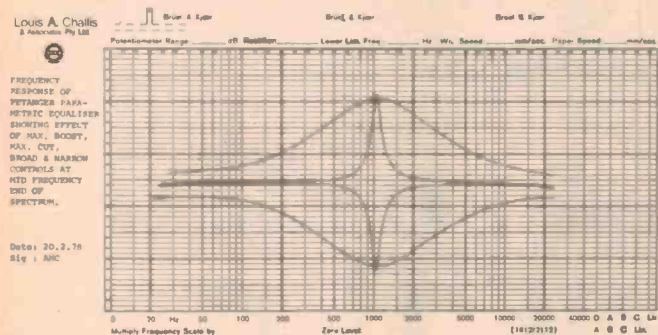

SOUND BRIEFS

New Dynavecator

A new Dynavecator cartridge, model 20C, has been introduced and will be available soon. The 20C is a low-output device, and will require transformer or head amplifier coupling to most amplifiers.

Silver Transformer

To match the new Dynavecator 20C cartridge, Onlife Corporation has developed a transformer wound using silver wire. This is in line with recent Japanese trends of using high conductivity wiring and connectors for pickup systems.

Modified Grace

Riverina Hi-Fi, Brookvale, NSW., is offering a modification service for Grace G707 arms to make them suitable for heavy moving coil cartridges. This involves decoupling the counterweight and adding a supplementary weight.

Dudley Harwood's Design

Ex-BBC head of audio engineering, Dudley Harwood, has designed a new loudspeaker (see main report) called the Harbeth HL-1. Supplies should be available within a couple of months.

Beware Low-L Cables

Some amplifiers are behaving badly to the extent of blowing their output transistors after being deprived of load inductance, thanks to the use of some of the new plaited loudspeaker cables which have virtually zero linear inductance.

Hi Fi at the Showground

This year's Consumer Electronics Show will be the biggest and brightest yet. This expansion (and the fact that at last year's show all the lifts broke down!) has necessitated a change in venue from the Sydney Hilton to the Showground.

443 COMPRESSOR EXPANDER

The 443 Audio Compressor Expander allows the home hi-fi enthusiast to restore much of the dynamic range missing from record tapes. Used during recording and playback the 443 becomes an effective dynamic noise-reduction unit and improves the dynamic capability of a good tape deck by 15-20 dB. KIT PRICE \$98 plus \$2.50 P/P.



486 FREQUENCY SHIFTER

This circuit as described in ETI Nov. 1977, increases the stability margin of sound reinforcement systems by up to 8 dB. This is achieved by shifting the frequency of signals by 5Hz. Complete kit of 486 module \$25 plus \$1.00 P/P. Suitable power supply No. 581 \$17 plus \$1.00 P/P.

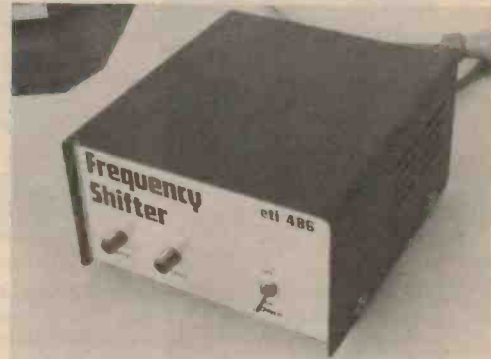

jaycar PTY LTD

Tel: 211-5077 P.O. BOX K39, HAYMARKET, N.S.W. AUST.
2000. 405 Sussex St., Sydney.
Entrance off Little Hay St.

DIGGERMAN ELECTRONICS P.O. Box 33, Coramba, N.S.W. 2466

Keep electronics a hobby and not a luxury, compare our prices and buy from us. Same day turnaround service. Quality assured.

ELECTROCAPS				T03 KITS MOUNTING		POLYESTER FILM CAPS	
CAP	16V	25V	50V	10 for \$1 or \$4 box of 50		E12 10% 100V	
.47 uF	5c	6c	7c	Generic		All values .001 to .01 - 7c ea.	
1 uF	5c	6c	8c	kit includes		.01 - 7c .1 - 13c	
2.2 uF	5c	6c	8c	mica, screws, nuts, washers, tag, nylon bushes.		.012 - 8c .12 - 14c	
3.3 uF	6c	6c	8c	LEDs: 28c ea.		.015 - 8c .15 - 14c	
4.7 uF	6c	7c	8c	big red & clip.		.018 - 8c .18 - 14c	
10 uF	6c	7c	8c	Clip alone 3c		.022 - 8c .22 - 16c	
22 uF	7c	8c	9c	Zeners: 15c ea.		.027 - 8c .27 - 16c	
33 uF	8c	9c	10c	400mW 5%		.033 - 8c .33 - 18c	
47 uF	9c	10c	11c	E24. 3V to 33V		.039 - 9c .39 - 19c	
100 uF	10c	12c	14c			.047 - 9c .47 - 22c	
220 uF	11c	13c	—			.056 - 9c All values	
470 uF	16c	22c	—			.068 - 10c values in uF	
1000 uF	22c	35c	—				
2200 uF/50 axial	—	95c	—				
Axlals price list SAE							

Specials: Economy LEDs - big red with clip - 20c ea. \$1.80/10, \$15/100.
Electrospecial: Axial 1000uF/16V - 20c ea. plus 2c ea. extra postage.

Resistors: 2c ea. 1/4W carb film 5% E12 values 1 Ohm to 1M \$1.80/100 same. Also 1/2W: 3c ea. metal glaze 5% E12 2.2 Ohm to 470K only. \$2.50/100 same.

SCRs:	TRIACS:	DIODES:
0.8A 30V C103V - 35c	2A 400V ESP240 - 65c	IN4001 - 7c (1A 50V)
0.8A 200V C103B - 60c	10A 400V SC141D - \$1.30	IN4002 - 8c (1A 100V)
4A 30V C106Y1 - 40c	10A 400V SC146D - \$1.50	IN4004 - 9c (1A 400V)
4A 400V C106D1 - 75c	25A 400V SC260D - \$2.50	IN4007 - 12c (1A 1000V)
8A 400V C122D - \$1.05	DIAC ST2 - 35c	IN4148 - 6c, \$4.50/100
8A 500V C122E - \$1.20	Chart to identify leads plus trigger info. - 15c	
25A 400V C37D - \$2.50		

Potentiometers: 50c ea. rotary carbon slng. gang - log or lin: 1K, 5K, 10K, 25K, 50K, 100K, 250K, 500K, 1M, 2M (metal shafts).
Trim Pots: 17c ea. - 10 mm .1W horiz. or vert: 100 Ohm, 250 ohm, 500 Ohm, 1K, 2K, 5K, 10K, 25K, 50K, 100K, 250K, 500K, 1M, 2M

All goods top quality & new. No minimum order. One P/P charge of 40c regardless of quantity. Advert current 3 months for benefit of late readers. Our prices a standard by which to judge others - if you are paying more you are supporting profiteers.



SOLAR CELL WATCH

(watches shown reduced size)

TAKE YOUR PICK FOR ONLY

\$64

CERT. POST PAID



Model 83SL with independent stop-watch function displays hour, min, with month, date/ secs on command.

6 digit model 852 displays hour, min, secs all at once with month date on command. Slim comfortable fit.

Both watches feature:

- * Liquid Crystal display (LCD) - Continual
- * Built in night light. Automatic Calendar
- * 1 year guarantee - exchange module by mail
- * 100% stainless steel band and case
- * Quartz crystal accuracy typically within 5 secs/month. Owners manual.

Watches offer subject to stocks.

DO-IT-YOURSELF CCTV SYSTEM FROM JAVELIN IN A SINGLE CARTON

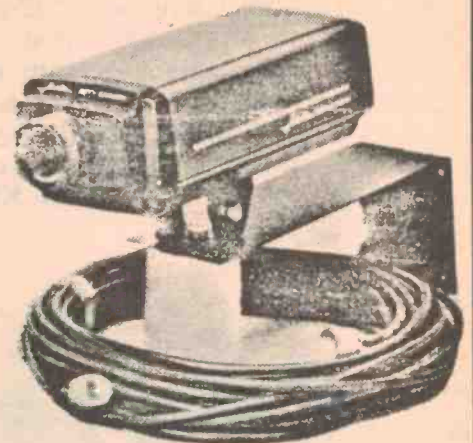
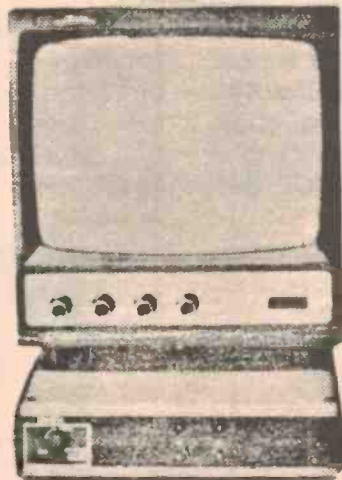
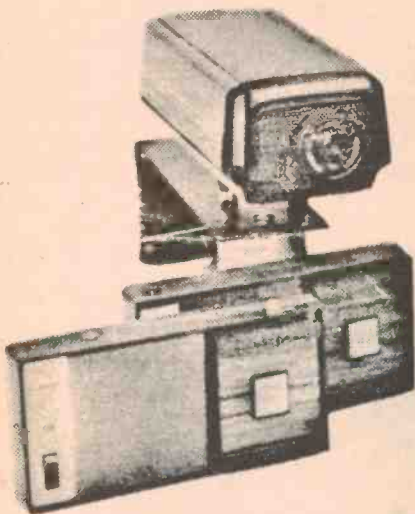

Javelin's JMS-30 and JMS-40 Mini Security Systems bring security back to basics. It's as easy to install as plugging in a T.V. set. The do-it-yourself security system will pay for itself in a short time. The deterrent factor alone will keep those would-be thieves away. Both the JMS-30 and JMS-40 Mini Security Systems are offered with optional two-way audio communication for those installations requiring audio, i.e., manager to shipping dock, babysitting, swimming pools to kitchen, etc. And it's all so easy to install!

AND IT'S ALL SO EASY TO INSTALL!

Call, write or phone

PHOTO SCAN

P.O. Box 588, Potts Point 2011

Phone (02) 31-0966

Trade enquiries welcome

Increase your SELLING POWER with these additional exclusive sound products in your range!



ASTATIC MICROPHONE

Distributors are invited, covering NSW, QLD, TAS. from organisations promoting and merchandising in the electronics industry. Who have considerable contacts with the broadcast and television industry, P.A. Specialists, Music Shops, Govt. Depts. and Consulting Engineers.

SANYO AMPLIFIERS



NOMIS SOUND COLUMNS

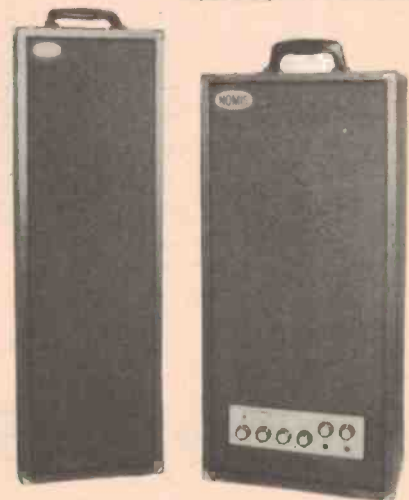

NOMIS

ELECTRONICS PTY. LTD.

For further details on all products available - write or phone national sales manager

689 SOUTH ROAD,
BLACK FOREST, SA 5035
(08) 293-4896



EMONA
enterprises

Room 208/661 George Street, Sydney Phone: 212-4815

PO BOX K21, HAYMARKET NSW 2000



EMONA
electronics

THE NEW NS108

from National Semiconductor Ultralim (7.5 mm thin) LCD Scientific Calculator!

NSC 108

NS 108 FEATURES

Full 10-digit mantissa or 8-digit mantissa and 2-digit exponent plus sign. Display prompting alpha characters below the mantissa signal the calculator mode: "X10", "DEG", "RAD", or "GRAD", "HYP" mode, "and", "out", "F" or "2nd" indicates secondary function; Direct access accumulating memory: M, M-, MR, Memory store, Memory-Display exchange, Two levels of parenthesis; Trig and log functions, inverse trig and log, hyp functions; Algebraic logic; Statistical functions: three accessible, accumulating memories for summations; Sum X, X2, and n; Calculates mean and standard deviation, adding to and subtracting from the summations at will; Separate keys for permutations and combination calculations; Mode selection in degrees, radians, or grads; Rectangular/polar coordinates; Degrees, minutes, seconds; Square, square root and factorial X!; Reciprocals, powers, and roots; Integer/fraction isolation; Degree, radian, grad conversion. Complete with vinyl billfold style carrying case and 3 silver oxide batteries.

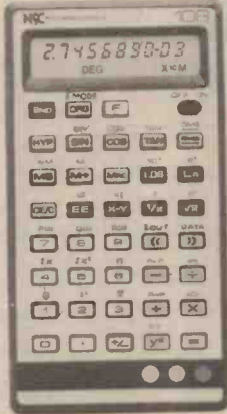

\$47.00

ALSO:

NS201R, Scientific — \$26.85
NS202R, Financier — \$29.84
NS203R, Business — \$22.38

TEXAS CALCULATORS!

PROGRAMMABLE:

T1-59 — \$262.00
T1-58 — \$114.00
T1-57 — \$74.00

PROFESSIONAL RANGE:

SR-51-II, Scient./Eng. \$54
SR-40, Scientific, \$32
T1-30SP, Student Math Kid, \$20
MBA-Business, Financial & Programmability, \$76
T1-MM, Money Manager, \$21
T1-BA, Business Analyst, \$33
PC-100A, Thermal Printer, \$222

ALSO:

BMC-LCD-8M, Billfold, \$23
BMC-1212PD, 12 digit display and printer, \$159

WRITE, PHONE OR CALL IN!

STOP PRESS! NEW! MICROCASSETTE RECORDERS BY OLYMPUS OPTICAL CO.



BORN OF THE SPACE AGE

60 Minutes on a Single MICROCASSETTE. High-performance Vibration-free Coreless Motor. Superb Sound Quality. Shirt Pocket-Size Convenience. Incomparable Versatility. High-fidelity Modular Tuners. Size: 140 x 66 x 22.5 mm

MODELS:

- De-lux pearcor SD
- Pearcor S201
- Transcriber T500
- Numerous Accessories
- Prices — on application.

Pearlcor SD

ALSO AVAILABLE: A full range of National semiconductor, Fairchild & Unik Time Watches. Digital clocks and digital clock radios.

NOTE: To all calculator prices add 15 percent ST — if applicable. P&P — Int \$3.00, NSW \$2.00

NEW-NEW **RJX SERIES** National



RJX-51011

RJX-1011

RJX-V1011

A UNIQUE NEW SSB/CW TRANSCEIVER FOR AMATEUR COMMUNICATIONS

There is no substitute for quality, performance, or the satisfaction of owning the very best. Hence, the incomparable National RJX-1011 amateur transceiver. The RJX-1011 covers all amateur bands 1.8-30 MHz (160-10 metres). It utilizes advanced Phase-Lock-Loop circuitry with dual gate MOS FETs at all critical RF amplifier and mixer stages. There's a rotating dial for easy band-scanning and an electronic frequency counter with digital readout and a memory display that remembers frequencies at the flip of a switch. And that's just the beginning. Matching speaker unit RJX-S1011 and complete external VFO RJX-V1011 also available.

- DENTRON MLS-2500 LINEAR AMPLIFIER
- DENTRON ANTENNA TUNERS

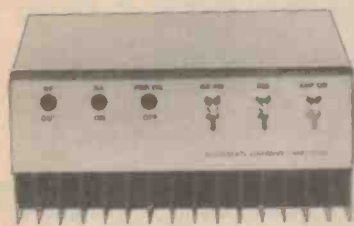

LINEAR AMPLIFIER!

**100W (AM)
250W PEP (SSB)
10-80M**

HF-10-100L AMPLIFIER

Frequency Range 3-30 MHz
Input Power 10 W Nom, 5-20 W PEP range
Output Power 100 W Nom 1/2 dB across band, 200-250W PEP output
Input Impedance 50 ohm nom, adjustable to match exciter range under 2:1 across band
Output Impedance 50 ohm nom, up to 3:1 VSWR acceptable with little degradation
Current Drain: 16 A nom, 20 A supply recommended at 13.6 VDC
Power supply 13.6 VDC recommended for best results, 11-14 VDC acceptable positive or negative ground
Pre-amp 18 dB nom gain across entire HF band, 15 dB type at 50 MHz 3-4 dB NF
Size 19.1 x 16.5 x 8.9 cm wt 1 1/2 kg.

ANTENNAS:

HUSTLER: 4-BTV — vertical trap antenna.
HUSTLER: Mobile vertical trap antenna (80-10m).
HUSTLER: G6-144A, 6 dB gain base collinear.
HUSTLER: CGT-144, 5.2 dB gain mobile colinear trunk-lit mt.
HUSTLER: BBLT-144, 5/8 mobile with trunk lip mount/spring.
CUSHCRAFT: ATB-34, 4 element beam, 10-15-20m.
CUSHCRAFT: A144-11, 11 element 2M Yagyi.
CUSHCRAFT: A144-20T, 20 element 2M twist antenna.
CUSHCRAFT: ARX-2 Ringo Ranger, 2M omnidirections.
WILSON: SY1 5 element, 10, 15, 20m, a DX'er's delight.
NEW ROBOT 400, SSTV SCAN CONVERTER
NEW INFO-TECH RTTY EQUIPMENT: Model 150 Keyboard, Model 75 RTTY to video converter.

AMATEUR BAND TRANSCEIVERS:

NEW — NATIONAL: RJX1011 — Unique SSB/CW 160-10m transceiver with digital readout and matching speaker and external VFO.
TR10 KENWOOD: TS20S — SSB/CW, 160-10 metres, with optional digital readout.
TR10 KENWOOD: TS820S, 160-10 metres digital readout.
TR10 KENWOOD: TS820, 160-10 metres.
BIGEAR TYPE 1, 2M PLL FM-SSB-CW Transceiver.
BIGEAR TYPE 2, 2M PLL FM Transceiver.
TR10 KENWOOD: TR-7400A — 144-148 MHz FM transceiver.
YAESU MUSEN: FT101E — 160-10 metres, AM, SSB, CW transceiver.
YAESU MUSEN: FT301 series, 160-10m AM, SSB, CW transceiver.

RECEIVERS:

DRAKE: SSR-1 Wadley Loop receiver.
TRIO KENWOOD: R300 general coverage BCL receiver.
YAESU MUSEN: FRG-7 general coverage Rx, Wadley Loop System.
NATIONAL: DR48 (RF4800) — general coverage, digital dial, communications and BCL receiver.



NEW: MEDIUM-SIZED HAM ANTENNA ROTATOR — FU 400.
Constructed for long trouble-free operation. 200 kg vertical weight capacity. Extra heavy duty disc brake that prevents wind-milling.

ALL AMATEUR RADIO EQUIPMENT IS AVAILABLE ON
10 PER CENT DEPOSIT TO APPROVED BUYERS!

CHECK EMONA'S MOST COMPETITIVE PRICES!

S100 VDU

New design boasts many sophisticated features

- ☆ Upper and lower case
- ☆ 16 rows of 64 characters
- ☆ Flashing characters
- ☆ Black-on-white characters
- ☆ Graphics
- ☆ S100 plug-in card

A SOFTWARE CONTROLLED VDU (SCVDU) (otherwise known as a memory-mapped VDU) is one in which the memory that is storing the VDU's display is part of the processor's normal main memory. Hence the processor can read or write directly to any location on the screen without having to progress sequentially down the screen as in conventional VDUs.

The advantages of the SCVDU are almost limitless and new applications will keep occurring to you as you use one. For example, the processor can write to this memory as quickly as it can write to any other memory, so a complete screen of information can be output quicker than you can blink. This allows you to continually look at listings of a program as you modify it without waiting hours. If the screen is displaying the output of a game the display can be updated every few milliseconds to provide the effect of movement. It is possible also to just update one portion of the screen and leave the rest static, such as having a time count in one corner of the screen or having a 'Bytes left to load' count when reading from tape. (This is one facility I wouldn't be without.)

Any portion of the screen can be scrolled as desired, maybe three lines scrolling at the bottom with the rest of the page staying fixed, or scroll downwards just for variety. Writing across the screen and down gets dull, why not make the processor write vertically for a change? Because the processor can read back from the screen it is possible

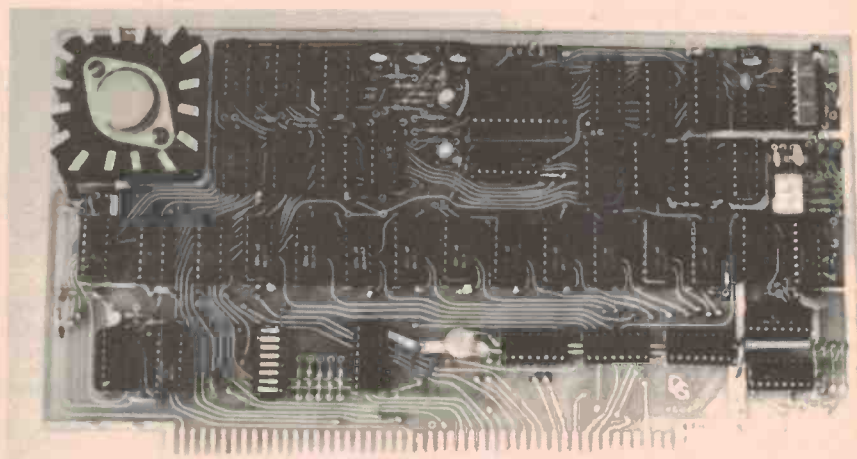

Fig. 1. The ETI 640 VDU board.

to do text editing on the screen including insertion and deletion and then simply read it back without the need to keep a scratch copy elsewhere.

Let your imagination run wild, the display possibilities keep coming.

Screen Format

The characters are displayed as 64 characters per line and 16 lines on the screen. The character generator displays a 7 x 9 dot matrix with appropriate lower case characters (g, j, p etc) descending below the line by 3 dots effectively giving a 7 x 12 display. The font has 128 characters including upper and lower case letters and various mathematical and general symbols (see *Data Sheet*). Other fonts are also available,

in pin compatible ROMs, such as Greek, French, German and Japanese letters.

Flashing Characters

With a SCVDU the processor can make a character(s) flash by writing the character then a blank after a suitable delay and then repeating this cycle. However, this keeps the processor busy when it could be away doing better things and the flash rate will vary depending on how much other work the processor is doing at the time. A much neater alternative is to have the flashing done in hardware and selected by a bit (bit 8) with each character which is how this VDU approaches it. Thus any character on the screen can be selected as flashing or not. The flash

rate is set with a preset control on the board.

Black on White Characters

The area around a character is turned white and the character is seen as a black letter in this area. This is particularly useful to indicate a cursor as it can be backspaced over characters leaving the characters readable. The inverse video function can also be used to emphasize a line. As with the flashing function, Black on White is selected by an extra bit for each character. (Bit 7).

Chunky Graphics

These are low resolution graphics that are useful for large headings or borders, or for simple diagrams. The graphics are formed by taking the area occupied by one character (the same area seen as white around a Black on White character) and breaking it up, two across and four down. (See How it Works). These eight dots can be selected as White or Black by the eight bits that are stored for the character that would have occupied the space. Graphics or normal is selected by another bit for each character.

Memory Organisation

As you can see from the above points, there are quite a few bits stored for each character, ten in fact. This is how they are organised:

- Bits 0-6 Seven bit ASCII code (giving 128 characters)
- Bit 7 Black on white bit
- Bit 8 Flashing bit
- Bit 9 Graphics bit

Storing 10 bits per character presents a problem for an eight bit micro-processor. The way around the problem is to store the first eight bits of information for the 1024 characters on the screen as one kilobyte and then store the extra two bits exactly 1024 addresses above the character that they belong to. Thus the VDU occupies 2 Kilobytes of addresses but the second K only has two bits.

As an example of the above arrangements, if you locate the VDU at F000 HEX then it will occupy from F000-F7FF (2K). The character in the top left hand corner of the screen will be stored at F000 HEX and the bits to make this character flash or be a graphic are stored at F400 HEX. The last character (at the bottom right hand corner) will be stored at F3FF HEX.

S100 Bus Standard

The S100 standard is a 100 pin bus standard that was introduced by Altair

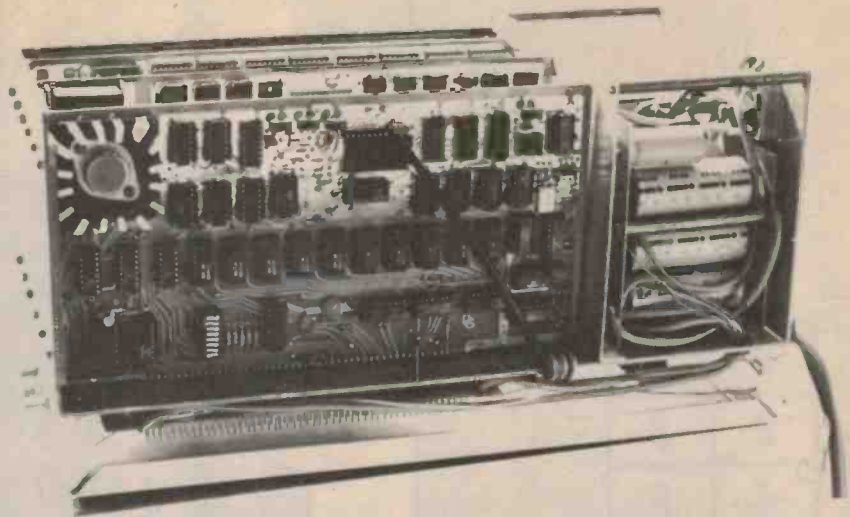

Fig. 2. The ETI 640 VDU is designed to plug into any S100 microcomputer system, as is shown here.

and has been widely accepted in the USA. S100 was originally designed around the 8080 processor but can be adapted to virtually any processor. If your system is not S100 oriented all you need do is plug the VDU into a 100 pin socket and wire the appropriate signals out of your processor. None of the signals used are specialised and should be available on any processor or at least derivable with two or three gates.

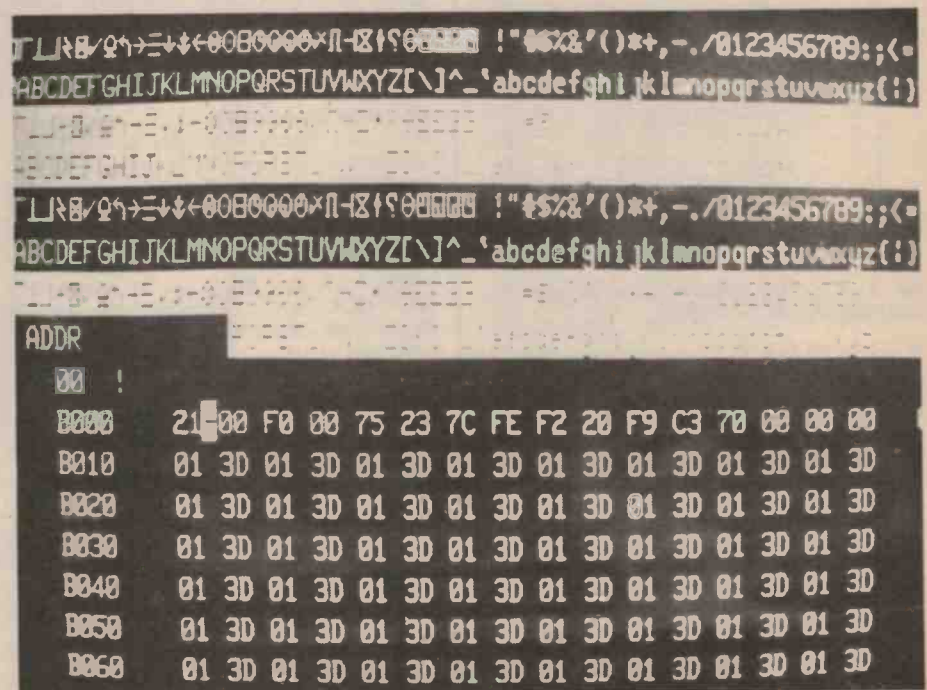

Fig. 3. This photograph is taken from the screen of a monitor and shows the character set of the 640 VDU.

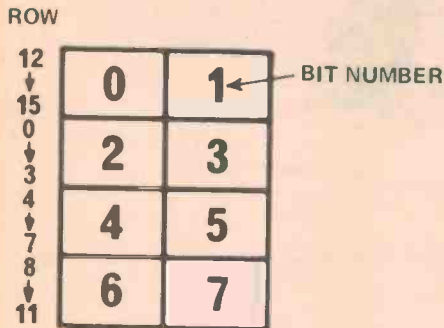

Fig. 4. Each character space is broken up for the creation of graphic characters.

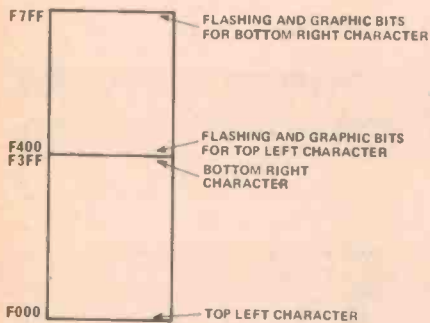
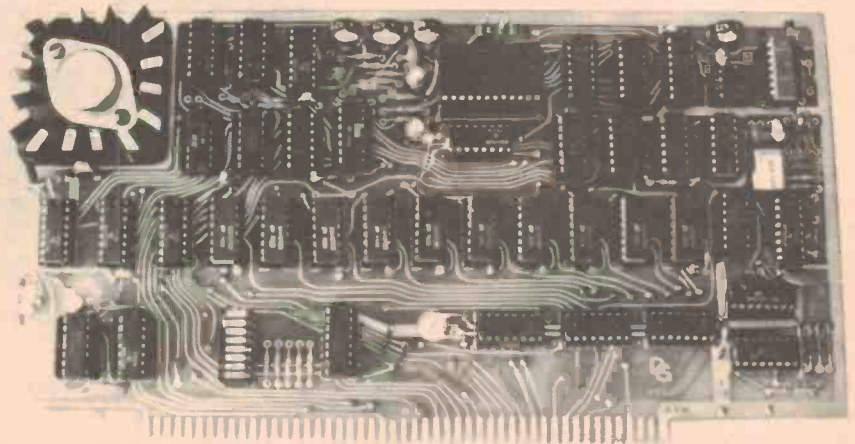

Fig 5. The VDU actually looks to the processor like 2K of memory.

We have published the 'How it Works' section this month so that it can easily be read next to the circuit diagram to be published next month. It's too big to fit otherwise.



Synchronising Pulse Generator

The start of the chain is the 12MHz crystal oscillator (IC9) which is divided down to 15,625 Hz and 50 Hz (by IC's 38, 39, and 40). The 15,625 Hz signal triggers a 5 μS monostable (IC 41A) to provide line synchronising pulses and the 50 Hz signal triggers a 300 μS mono (IC41B) for field synchronising pulses. These synchronising pulses are added to the final video signal before it leaves the board to give composite video out as well as providing a timing reference for the rest of the VDU.

Character Generation

It is not intended to give a complete explanation of how characters are generated on a screen as this has been explained in previous VDU articles and the basic principles used here are the same. The characters are displayed on a matrix 7 dots across by 9 high. The character generator ROM (IC4, MCM6574) outputs the 7 bits across each character in parallel as it is told what character is being constructed (on pins 15, 16, 12, 11, 9, 8, 4,) in ASCII code and which row of the character is selected (on pins 21, 22, 23, 24).

IC 5 and IC 6 are Quad 2 in 1 out multiplexers which simply act as an eight pole two position switch. They connect the output of the character generator ROM (IC4) or the output of the graphics multiplexer (IC14) through to the parallel inputs of the 8 bit shift register (SR) (IC7). Ignoring the graphics mode for a moment, the output of the ROM is connected through to the SR and the eighth bit is tied low (pin 14, IC5) to give black; this is the space between each character. Once

the SR is loaded with this information and is clocking it out at the right rate (12 MHz) the RAMs and ROM are already looking up the information for the next character as both the RAMs and the ROM have a noticeable access time to consider.

The data out of the SR is essentially the information that goes to the screen, although there is some gating after it to invert the data for flashing characters and inverse video, as well as blanking circuitry which will be discussed later.

Counters

The above combination of RAM, ROM and SR will happily produce characters all over the screen provided the RAMs are given information about which character is being produced (ie character on the line, and line on the screen) and the ROM is told which row of the character is being produced, so there are three sets of counters which keep track of this information. The first set (ICs 11 and 12) count 0-63 for character on the line (COL). This counter is incremented by the same pulse that loads the SR (from IC13, pin11) at the end of each character. When this set of counters reaches zero (64) it sets the first 'end of line' flip flop (IC2B). IC2B enables the second 'end of line' flip flop to set after the 64th character has been clocked out by the SR. This combination of two flip flops is necessary to provide a one character delay, otherwise the screen would be blanked as soon as the counters reached zero and the 64th character would be lost. Aha! When the second 'end of line' FF has set it inhibits any further clocking

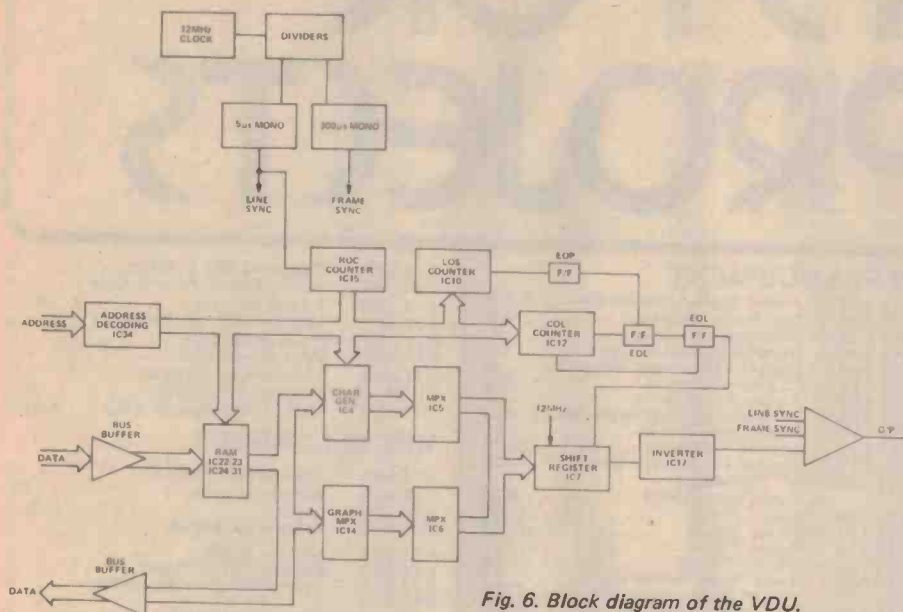

Fig. 6. Block diagram of the VDU.

of the SR and COL counters and forces the screen to black (via the diode to IC16, pin12) until the beginning of the next line. The clearing of the next FFs is discussed under 'Positioning'.

The second counter that counts the row of the character (IC15) is incremented every time the 'end of line' FF sets. One of the confusing parts of the circuit is the fact that this counter actually counts 12, 13, 14, 15, 0, 1, 2, 10, 11 for each character. The ROM outputs blanks for rows 12, 13, 14, 15 so this puts the four lines of blanks above the character instead of below. The result of this is that each character is centred in the character position for Black on White characters, rather than being hard up against the top of the white area. The effect of the row counter counting in this sequence is achieved by incrementing the third counter (the 'line on screen', LOS) when the row counter reaches 12. (IC 16 pins9, 10 gates C, D of Row Counter).

The LOS counter counts 0-15 for the 16 lines of characters on the screen and when it overflows to zero it sets the 'end of page' flip flop (IC2A). This will occur at the end of a line, as that is when the row counter is incremented, that then increments the LOS counter, so the 'end of line' flip flops will both be set. The end of the page' flip flop simply stops the 'end of line' FFs being cleared until the top of the next page.

Positioning

The position of the characters on the screen is determined by the time after the synchronising pulses that the EOL and EOP FFs are cleared. These two times

(Vertical and Horizontal) are set by two monostables (IC3A and IC3B respectively) which are triggered off the leading edges of the vertical and horizontal synchronising pulses respectively. As each of these monos drop off they cause a negative going pulse via a capacitor to the reset pins of the appropriate FF. The EOP FF holds a reset on the horizontal positioning mono.

The final counter which wasn't mentioned earlier is the counter (IC 14) which counts the number of bits that the SR has clocked out to provide a load pulse for the next character. This counter is clocked at the same rate as the SR (12 MHz) and counts to 9 before resetting to zero, so the SR clocks out the eight bits it has been loaded with plus one more which will be whatever was on the Serial In Pin of the SR (pin 10) when it clocked out the first bit. This is arranged to be a zero (black) when making characters or whatever is appropriate when making graphics.

Graphics

The graphics circuitry only needs to be told which row of the line is being made to select which two bits to feed to the SR (via the graphics/character multiplexers). The same two bits are selected for four rows so only the two highest bits of the row counter are used by the graphics multiplexers (IC15).

Black on White Characters (Inverse Video)

The 'black on white' (BOW) bit (bit 7) is latched by a 'D' Flip Flop (IC19A) at the same time the SR is loaded. This bit is forced to normal when a graphic is being made, (IC16A) as there is obviously no

point in inverting a graphic and the eighth bit (bit 7) is used by the graphic anyway. The output of the FF controls an exclusive OR gate which acts as a switchable inverter, if a '1' is held on the 'control' input (pin 10) the data on the other pin will be inverted at the output.

The XOR is in the output of the SR so when it is switched to the invert mode it simply inverts the bit stream.

Flashing

The flashing bit (bit 8 - 1st bit 2nd K) is latched in a 'D' FF (IC 18B) the same as the BOW bit described above. When a '1' is stored in the FF it forces the output to black. The flashing is generated by an oscillator (IC8) clearing the FF down at the flash rate.

On The Bus Side Of The Board

To the processor, the VDU looks just like normal memory with the exception that the upper 1 Kilobyte only has 2 bits. Thus the circuitry involved here is fairly typical of any memory board, the notable difference is that the lower 10 address bits to the RAMs go via multiplexers so that the VDU counters can scan the RAMs when the processor is not accessing them.

The incoming data (off the bus) is buffered by IC35 and part of IC37 before going to the RAMs. The outgoing data is buffered by IC36 and IC37 which are enabled whenever the board is addressed for a read cycle.

IC34 is a comparator that looks for a match between the DIP switches and the high order address bits on the bus. When it finds a match (pin 9 = '0') it means the board is being addressed and the RAMs are taken away from the VDU temporarily. During this period the screen is forced to black (by the transistor off IC34's output otherwise a series of white flickers would be seen on the screen.

Output Circuit

The output circuit combines the digital (5 V) signal representing the black and white information with the vertical and horizontal synchronising signals to give an analogue video signal which is the output signal from the VDU board. The shift register is being clocked at 12 MHz, so the worst case output signal would be one bit on and one bit off which represents a 6 MHz video signal. The transistor used in the output stage is critical as it needs a very fast rise time. A domestic TV receiver has a sound trap at 5 MHz after the IF strip so the loss of quality by modulating the VDU signal would be considerable. For this reason it is suggested that the TV set be modified to accept video in or a proper video monitor be used. A lot of sets on the market today have video in and out facilities for VTR's already fitted.

KITS FOR ETI PROJECTS

We get many enquiries from readers wanting to know where they can get kits for the projects we publish. The list below indicates the suppliers we know about and the kits they do.

Any companies who want to be included in this list should phone LES BELL on 33-4282.

Key to companies:

- A** Applied Technology Pty. Ltd. 109-111 Hunter St, Hornsby. 2077. NSW.
- C** Amateur Communications Advancements, PO Box 57, Rozelle, NSW.
- D** Dick Smith Pty. Ltd. of Crows Nest, NSW. (see Ads. for address).
- E** All Electric Components (formerly ED & E Safes), 118 Lonsdale Street, Melbourne, Victoria, 3000.
- J** Jaycar Pty. Ltd. 405 Sussex St., Sydney 2000.
- L** Delsound Pty. 1 Wickham Terrace. Queensland.
- M** Mode Electronics. PO Box 365, Mascot 2020.
- N** Nebula Electronics Pty. Ltd. 15 - 19 Boundary St., Rushcutters Bay 2011. NSW.
- O** Appollo Video Games of Hornsby, NSW.
- P** Pre-Pac Electronics. 718 Parramatta Rd., Croydon NSW 2132.
- S** BKX Electronics Supply Service. 179 Victoria St., Kings Cross. NSW 2011.
- T** Townsville Electronics Centre. 281E Charters Towers Rd, Rising Sun Arcade, Hermit Park. 4812

PROJECT ELECTRONICS

ETI 041	Continuity Tester	DS
ETI 043	Heads or Tails	DATSE
ETI 044	Two-Tone Doorbell	DATSE
ETI 045	500 Second Timer	DS
ETI 047	Morse Practice Set	DS
ETI 048	Buzz Board	DS
ETI 061	Simple Amplifier	DATS
ETI 062	Simple Amplifier Tuner	DSE
ETI 063	Electronic Bongo's	DS
ETI 064	Intercom	ATS
ETI 065	Electronic Siren	DS
ETI 066	Temperature Alarm	ADTSE
ETI 067	Singing Moisture Meter	DS
ETI 068	Led Dice	ADSE
ETI 072	2-Octave Organ	DS
ETI 081	Tachometer	E

TEST EQUIPMENT

ETI 102	Audio Signal Generator	E,DS
ETI 105	Lab Power Supply	E
ETI 107	Widerange Voltmeter	E
ETI 108	Decade Resistance Box	ES
ETI 109	Digital Frequency Meter	E
ETI 111	IC Power Supply	ES
ETI 112	Audio Attenuator	ES
ETI 113	7-Input Thermocouple Meter	P,E
ETI 116	Impedance Meter	ES
ETI 117	Digital Voltmeter	E,AS
ETI 118	Simple Frequency Counter	E,AS
ETI 119	5V Switching Regulator supply	ETS
ETI 120	Logic Probe	L,ES
ETI 121	Logic Pulser	L,ES
ETI 122	Logic Tester	ES
ETI 123	CMOS Tester	ES
ETI 124	Tone Burst Generator	ES
ETI 128	Audio Millivoltmeter	L,ES
ETI 129	RF Signal Generator	L,ES
ETI 130	Temperature Meter	E
ETI 131	General Purpose power supply	E,N
ETI 132	Power Supply	NSE
ETI 133	Phase Meter	E
ETI 134	True RMS Voltmeter	E

SIMPLE PROJECTS

ETI 206	Metronome	T
ETI 218	Monophonic Organ	ET
ETI 219	Siren	ET
ETI 220	Siren	ETS
ETI 222	Transistor Tester	ETS
ETI 234	Simple Intercom	T
ETI 236	Code Practice Oscillator	E
ETI 239	Breakdown Beacon	E
ETI 240	High Powered Emergency Flasher	E

MOTORISTS' PROJECTS

ETI 301	Vari-Wiper	ET
ETI 302	Tacho Dwell	ET
ETI 303	Brake-light Warning	E
ETI 305	Car Alarm	E
ETI 309	Battery Charger	P,E
ETI 312	CDI Electronic Ignition	P,ET
ETI 313	Car Alarm	E,DT
ETI 316	Transistor Assisted Ignition	E
ETI 317	Rev. Monitor	E

AUDIO PROJECTS

ETI 401	Audio Mixer FET Four Input	E
ETI 406	One Transistor Receiver	T
ETI 408	Spring Reverb. Unit	E
ETI 410	Supor Stereo	E
ETI 413	100 Watt Guitar Amp	P,L,J,DT
ETI 413	x 200 Watt Bridge Amp	SE
ETI 414	Master Mixer	E,J
ETI 416	25 Watt Amplifier	E
ETI 417	Amp Overload Indicator	E
ETI 419	Guitar Amp Pre-Amp	P,E,DT
ETI 420	Four-channel Amplifier	L,E
ETI 420E	SQ Decoder	E
ETI 422	International Stereo Amp	S,L,D
ETI 422B	Booster Amp	E
ETI 422	50 Watt Power Module	E
ETI 423	Add-on Decoder Amp	E
ETI 424	Spring Reverberation Unit	S,L,E
ETI 425	Integrated Audio System	E
ETI 426	Rumble Filter	E
ETI 427	Graphic Equaliser	S,L,E,J
ETI 429	Simple Stereo Amplifier	E
ETI 433	Active Crossover	J
ETI 435	Crossover Amp	J
ETI 438	Audio Level Meter	L,ES
ETI 440	Simple 25 Watt Amp	L,E
ETI 441	Audio Noise Generator	L,ES
ETI 443	Compressor-Expander	E,J
ETI 444	Five Watt Stereo Preamp	ES
ETI 445	Preamp	J,E,D
ETI 446	Audio Limiter	J
ETI 447	Phaser	E,J

ETI 449	Balanced Mic Preamp	JE
ETI 480	50 W. 100 W Power Amp	A
ETI 480P	Power Supply	DAT
ETI 481	12V to 40V DC Inverter	E
ETI 482A	Preamp Module	AE
ETI 482B	Tone Controller	AE
ETI 484	Compressor Expander	E
ETI 485	Graphic Equalizer	JSE
ETI 480	50W. 100W Power Amp	ADBE

MISCELLANEOUS

ETI 502	Emergency Flasher	ET
ETI 503	Burglar Alarm	E
ETI 505	Strobe	L,E,D
ETI 506	Infra-Red Alarm	E
ETI 509	50-Day Timer	E
ETI 512	Photographic Timer	E
ETI 513	Tape Slide/Synchroniser	E
ETI 514	Flash Unit - Sound Operated	E
ETI 515	Flash Unit - Light operated	E
ETI 518	Light Beam Alarm	ET
ETI 525	Drill Speed Controller	E
ETI 528	Home Burglar Alarm	P,ET,MS
ETI 529	Electronic Poker Machine	E
ETI 532	Photimer	E
ETI 533	Digital Display	L,E,AS
ETI 534	Calculator Stopwatch	A,D
ETI 539	Touch Switch	E
ETI 540	Universal Timer	ES
ETI 541	Train Controller	ET
ETI 543	Double Dice	A
ETI 544	Heartrate Monitor	AE
ETI 546	GSR Meter	E
ETI 547	Telephone Bell Extender	E
ETI 548	Photographic Strobe	E
ETI 549	Induction Balance Metal Locator	E
ETI 581	Dual Power Supply	E
ETI 582	House Alarm	E
ETI 583	Gas Alarm	ME
ETI 586	Shutter Speed Timer	E

ELECTRONIC MUSIC

ETI 601	4600 Synthesiser	J
ETI 601	3600 Synthesiser	J
ETI 602	Mini Organ	E,A,D
ETI 604	Accentuated Beat Metronome	E

COMPUTER PROJECTS

ETI 630	Hex Display	AE
ETI 631	VDU Keyboard Encoder	AE
ETI 632	VDU 1 k x 8 Memory Card	AE
ETI 633	VDU Sync Generator	AE

RADIO PROJECTS

ETI 701	TV Masthead Amplifier	E,D
ETI 702	Radar Intruder Alarm	DE
ETI 703	Antenna Matching Unit	E
ETI 704	Crosshatch/Dot Generator	L,A,D,ES
ETI 706	Marker Generator	ES
ETI 707	Modern Solid State Converters	C,E
ETI 708	Active Antenna	E
ETI 709	RF Attenuator	E
ETI 710	2 metre Booster	C,E
ETI 711B	Single Relay Remote Control	AE
ETI 711C	Double Relay Remote Control	AE
ETI 711R	Receiver	AE
ETI 711AR	Remote Control Transmitter	AE
ETI 711DR	Remote Control Decoder	AE
ETI 712	CB Power Supply	E
ETI 740	FM Tuner	AE
ETI 780	Novice Transmitter	E

ELECTRONIC GAMES

ETI 804	Selecta-Game	O,A,DS
---------	--------------	--------



DRAKE

C-Line Amateur Equipment

Drake TR-4Cw Sideband/Cw Transceiver with Drake RV-4C Remote VFO



The Transceiver for All License Classes

- 500 Hz cw filter now included
- Ideal for the licensee in the up-graded Novice/Technician Class.
- Runs the full 250 watt cw input.
- 80 thru 10 meters
- 1 kHz dual concentric dial
- Excellent PTO stability
- Full gating noise blanker optional
- Transceive or separate PTO
- Wide range receiving agc
- Calibration constant mode to mode
- 300 watts PEP input on ssb
- Shifted-carrier cw
- Upper and lower sideband
- Superb receiver overload and Cross-Mod characteristics
- VOX or PTT
- Output impedance adjustable

• 300 Watts PEP input on ssb, 260 watts input on cw. • Complete Amateur Band Frequency Coverage: 80 through 15 meter bands complete and 28.5-29.1 MHz of 10 meters. Rest of 10 meter band obtained with accessory crystals. • Separate Sideband Filters: Separate usb and lsb filters eliminate oscillator shifting and insure long term carrier vs filter alignment. • Nominal 1.7:1 Filter Shape Factor: These filters stand among the industry's finest with 6dB bandwidth of 2.1 kHz (chosen to slice thru QRM), 60 dB bandwidth of only 3.6 kHz and 100 dB ultimate rejection. • Provision For Highly Effective Accessory Noise Blanker. • Heavy Iridized Cadmium Plated Chassis. • Cw Side Tone Oscillator for monitoring you cw transmission. • Finish: Scratch resistant epoxy paint. • Crystal Calibrator built in. • VFO Indicator Light eliminates confusion of which main tuning knob controls the frequency when using an RV-4C remote VFO. • Automatic Cw Transmit Receive Switching sometimes called "semi" break-in. • Full Agc with Drake dual time constant system confines a 60 dB signal change to a 3 dB audio change. • Effective Transmitting Agc insures clean ssb output. • Solid State Permeability Tuned VFO for low drift and accurate 1 kHz divisions on all bands. New easy to read dual concentric dials. • VOX or PTT for use on a-m or ssb. • Receiver S-Meter automatically switches to indicate transmitting agc on transmit. • Transmitter Plate Ammeter indicates Relative Rf Output by depressing load control shaft. • Adjustable Pi-Network output circuit.



Drake W-4
1.8-54 MHz



Drake WV-4
20-200 MHz

Drake Directional RF Wattmeters

Reads forward and reflected power directly in watts (VSWR from nomogram). Two scales in each direction
• Size: 5½"H, 3¾"W, 4"D (14.0 x 9.5 x 10.2 cm).



Drake SSR-1

- Synthesized
- General Coverage **\$270.00**
- Low Cost
- Selectable Sidebands
- All Solid State
- Built-in Ac Power Supply
- Excellent Performance

The SSR-1 Receiver provides precision tuning over the short wave spectrum of 0.5 to 30 MHz with capability of reception of a-m (amplitude modulated), cw (continuous wave) and ssb (upper and lower single side band) signals.

A synthesized/drift-cancelling 1st mixer injection system giving thirty tunable ranges from 0.5 to 30 MHz is derived from a single 10 MHz crystal oscillator providing frequency stability necessary for ssb operation.

A stable low frequency VFO tunes each of the 30 one-MHz ranges with a dial accuracy of better than 5 kHz which is sufficient to locate and identify a station whose frequency is known.

Separate detectors (product and diode) are used to provide for best performance whether listening to ssb or a-m signals. Narrow band selectivity for ssb and wide band selectivity for a-m reception is provided.

A manual tuned preselector provides for maximum sensitivity and maximum interference rejection.

Solid state circuitry throughout allows efficient operation from built-in ac power supply, internal batteries or external 12 V-dc source.

Remote Coax Switch Drake RCS-4

- Remotely Selects One of Five Antennas
- Grounds All Unused Antennas
- Grounds All Antennas in Gnd Position for Lightning Protection
- Front Panel Indicator Monitors Antenna Selection Interval
- Protected Against Adverse Weather Conditions
- SO-239 Connectors Provided for Main Coax Feed-Line and Individual Antenna Feed-Lines
- Handles 2000 Watts PEP
- Available in 120 V-ac or 240 V-ac 50/60Hz Versions



MN-4 (Model No. 1507)



MN-2000 (Model No. 1509)

Drake MN-4 & MN-2000 Matching Networks

- Integral Wattmeter reads forward power in watts and VSWR directly; can be calibrated to read reflected power
- Matches 50 ohm transmitter output to coax antenna feedline with VSWR of at least 5:1
- Covers ham bands 80 thru 10 meters
- Switches in or out with front panel switch
- Size: 5½"H, 10¾"W, 8"D (14.0 x 27.3 x 20.3 cm), MN-2000, 14¾"D (36.5 cm).
- Continuous Duty Output: MN-4, 200 watts; MN-2000, 1000 watts (2000 watts PEP)
- MN-2000 only: Up to 3 antenna connectors selected by front panel switch.

P.O. Box 30, Concord, NSW, 2137
13-15 McDonald St., Mortlake, NSW.
Phone: (02) 736-2888, Telex: 25887

Adelaide: 51-3521, Brisbane: 392-2884, Perth: 325-3144

P.O. Box 107, Mt. Waverley, Vic. 3149
21-23 Anthony Drive, Mt. Waverley, Vic.
Phone (03) 233-4044.

ELMEASCO

Instruments Pty. Ltd.

MAIL ORDER COMPONENTS

TTL

7400	.35
7401	.35
7402	.35
7403	.35
7404	.40
7405	.40
7406	.48
7407	.48
7408	.38
7409	.38
7410	.35
7411	.35
7413	.63
7414	1.35
7416	.60
7417	.60
7420	.35
7422	.35
7426	.45
7427	.45
7430	.35
7432	.45
7437	.50
7438	.50
7440	.35
7441	1.50
7442	.70
7447	1.25
7448	1.25
7450	.35
7451	.35
7453	.35
7454	.35
7460	.35
7470	.65
7472	.65
7473	.65
7474	.65
7475	.70
7476	.45
7480	1.25
7483	1.25
7485	1.45
7486	.65
7489	1.20
7490	.85
7491	1.00
7492	.85
7493	.85
7494	1.10
7495	.95
74100	2.45
74107	.65
74121	.65
74123	1.10
74132	1.25
74150	1.80

74151	1.10
74153	1.10
74154	1.70
74157	1.10
74160	1.55
74164	1.55
74165	1.55
74173	2.75
74175	1.65
74180	1.35
74192	1.45
74193	1.45
74221	1.50
74367	1.50

SCHOTTKY

74LS00	.32
74LS01	.32
74LS02	.32
74LS03	.32
74LS04	.35
74LS05	.35
74LS08	.32
74LS09	.32
74LS10	.32
74LS11	.32
74LS12	.32
74LS14	1.35
74LS20	.32
74LS21	.32
74LS27	.32
74LS28	.42
74LS30	.32
74LS32	.35
74LS37	.46
74LS38	.46
74LS40	.32
74LS42	1.25
74LS73	1.25
74LS74	.50
74LS75	.70
74LS78	.55
74LS85	1.50
74LS86	.55
74LS90	1.20
74LS92	1.20
74LS93	1.20
74LS95	1.60
74LS109	.55
74LS113	.55
74LS114	.55
74LS138	1.20
74LS151	1.20
74LS154	1.60
74LS157	.90
74LS163	1.25
74LS164	1.35
74LS174	1.00

74LS175	1.00
74LS191	1.20
74LS192	1.20
74LS193	1.20
74LS194	1.20
74LS195	1.20
74LS196	1.20
74LS221	1.20
74LS253	1.85
74LS279	.65
74LS365	.80
74LS367	.80
74LS368	.80

CMOS

4000	.25
4001	.25
4002	.25
4006	1.40
4007	.35
4008	1.25
4011	.25
4012	.30
4013	.55
4014	1.35
4015	1.20
4016	.50
4017	1.40
4018	1.40
4019	.75
4020	1.60
4021	1.55
4022	1.60
4023	.35
4024	.90
4025	.40
4027	.80
4028	1.25
4029	1.90
4030	.40
4040	1.35
4041	1.25
4042	1.25
4043	1.50
4044	1.50
4046	1.95
4049	.60
4050	.60
4051	1.20
4052	1.20
4053	1.20
4060	2.65
4066	1.20
4068	.40
4069	.35
4070	.40
4071	.40
4072	.40

4073	.40
4075	.40
4076	1.85
4077	.40
4078	.40
4081	.40
4082	.40
4510	1.50
4511	1.50
4518	1.50
4520	1.45
4528	1.20
4556	1.20
14553	7.50
14584	1.25
74C00	.40
74C02	.40
74C04	.40
74C08	.40
74C10	.40
74C14	1.90
74C48	2.55
74C73	1.20
74C75	1.20
74C76	1.35
74C90	2.25
74C93	2.25
74C175	1.85
74C192	2.25
27C193	2.25
74C221	2.40
74C905	14.75
74C922	6.50
74C926	11.50

LINEAR

301	.40
307	.65
308	1.35
311	1.25
324	1.35
339	1.35
349	2.25
356	1.65
379	6.95
380	2.00
381	2.00
382	2.00
386	1.95
555	.40
556	.85
565	1.95
566	2.50
567	2.65
571	11.95

709	.75
723 (VR)	.65
741	.35
747	1.25
1310	3.50
1889	3.95
3900	.90
3909	1.25

VOLTAGE REGS.

309	2.25
317	3.75
323	8.25
325	2.60
723	.65
7805	1.40
7806	1.40
7808	1.40
7812	1.40
7815	1.40
7818	1.40
7824	1.40
7905	2.55
7912	2.55
7915	2.55
78L05	.75
78L12	.75
78L15	.75
79L05	.85
79L12	.85
79L15	.85

DIODES

OA91	.20
IN914	.07
IN4004	.10
IN4007	.15
A15A	.75

BRIDGES

3501	3.75
3504	4.75



POST & PACK. COMPONENTS \$1.00

POSTAL ADDRESS: P.O. Box 355, Hornsby, 2077.

SHOWROOM 109-111 Hunter St., Hornsby 2077

(9-5 Monday to Sat.)

PHONE 476 4758 - 476 3759

PRICES SUBJECT TO CHANGE AFTER MAY 30th, 1978.



SCOOP PURCHASE !!!

Scientific Calculator Module

This incredible module measures only 2" x 1" yet is a complete calculator including 8 digit LED display with full floating decimal system. Application notes are included and addition of a suitable keyboard will produce a full calculator with:

- Reverse Polish Notation
- Common and natural logs/antilogarithms
- Sine, cosine, tangent and inverse trig functions
- Automatic calculation of powers and roots
- Conversion of radians to degrees and vice versa

The SCM100 module can readily be adapted to become a highly accurate stopwatch or even an economy output for a microprocessor. All that is required is to supply a 9V battery and address the relevant points in the 8 x 5 input matrix.

SCM100 MODULE complete with application notes \$14.75

T.V. MODULATOR I.C. LM1889

I.C. by National Semiconductor can be used to modulate video to any TV aerial socket. Ideal for microprocessor VDU's and TV games. The LM1889 has provision to modulate sound to the TV loudspeaker and can be adapted to produce colour as well. Supplied with full data and application sheets.

LM1889 \$3.75

MICROPROCESSORS

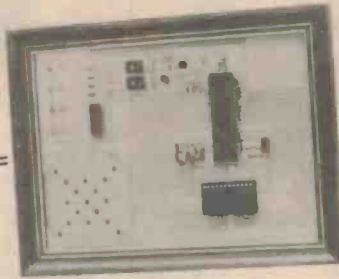

COMPUTER DOORBELL

A real first, this SC/MP controlled doorbell has been designed and produced in Australia. See ETI March 1978 for full details. This kit comes complete with all components, full instructions for assembly and unique picture frame mount. Can be readily programmed to play any tune although kit is supplied with 8 preprogrammed tunes including:

WALTZING MATILDA TRUMPET VOLUNTARY
GREENSLEEVES TWINKLE TWINKLE LITTLE STAR
RULE BRITANNIA COLONEL BOGIE MARCH
CAN CAN COMPUTER MUSIC

This is an ideal kit for everyone even remotely interested in microprocessors. Picture frame displays finished PCB with all components so you can boast to all your friends and show off the actual computer chips!

ETI 639 kit \$39.50

2650 COMPUTERS

Baby 2650 as described in E.A. this is an ideal starter kit. We include full instructions for assembly as well as programming manual and sample programs to run. Ideal to use with the new E.A. VDU. . . . \$75.00

KT9500 fully buffered 2650 with 512 bytes RAM, PIPBUG, I/O ports, RS232 and TTY serial I/O. Can be readily expanded using our mother board (see E.A. March 1978) \$199.00

Conversion Kit enables you to convert the Baby 2650 to a KT9500 \$142.00

NEW E.A. VIDEO DISPLAY TERMINAL

Described in E.A. Feb/April 1978 this project is an ideal terminal for microprocessor applications. We are pleased to offer this exciting VDU as a package deal or, for those who prefer as a set of individual kits. Naturally we offer our full technical support and backup service (full details with each kit).

VDU Logic Board complete kit with all components, crystal, plated through hole PCB and assembly/troubleshooting manual. \$99.50

KB04 Top Quality Keyboard Kit with PCB to simplify construction and connection to encoder module \$59.50

E.A. 78u4 Encoder/UART/Power supply module complete with all components including UART and 5740 encoder, power supply and transformers. \$47.50

VIDEO MODULATOR Complete kit . . . \$4.50
METALWORK: Quality enamel finished console prepunched for KB04 keyboard \$24.50

Cost of individual kits purchased separately . . \$235.50
Complete package deal including assembly manual \$214.00

LOW COST CLOCK MODULES

MA1002b
LED Alarm Clock \$11.95
Transformer JT197 \$4.05 (for MA1002 module)
MA1003
Crystal controlled 12V gas discharge module. Ideal for cars or boats and can be readily adapted to battery backup applications \$22.50

MICROPROCESSORS

8080A	16.75
6800	24.50
2650	26.50
SC/MP	16.75

SUPPORT DEVICES

8212 8 bit I/O	4.95
8215 bus driver	5.95
8224 clock generator	8.50
8228 system controller/bus driver	10.95
8255 programmable peripheral I/O	16.50
6810 128 byte RAM	6.50
6820 PIA	13.75
6850 ACIA	13.75
6860 0 - 600 BPS modem	15.75
8T26 bus transceiver	3.75
8T97/98 bus drivers	1.90
8T31 8 bit bidirectional I/O port	5.75
81LS95/96 octal tristate buffers	1.95
81LS97/98 octal tristate buffers	1.95
DP8304 8 bit bidirectional driver	6.25
DM8131 6 bit address comparator	3.50
DM854 quad switch debouncer	2.25
DM8553 8 bit addressable latch	4.25

PROMS

2708 E Prom 1K x 8	18.25
5204 E Prom 512 x 8	18.25
82S23 fusible link 32 x 8	3.75
82S123 fusible link 32 x 8	3.75

A/D D/A CONVERTERS

5357 8 bit A/D	12.75
MC 1408-7 8 bit D/A converter	3.95

ETC

2513 character generator	11.95
5303 UART	5.75
1602 UART	7.50
5740 keyboard encoder	19.75
57109 number cruncher with data	19.75
2101 256 x 4 RAM (static)	4.25
2102 1K x 1 RAM (static)	1.95
2112 1K x 1 RAM (static)	3.75
2114 1K x 4 RAM	14.25

LIMITED STOCKS
AVAILABLE ON SOME
ITEMS
POST & PACKAGE \$1.00

SOCKETS

14 pin wire wrap	.60
16 pin wire wrap	.65
8 pin solder	.35
14 pin solder	.40
16 pin solder	.45
18 pin solder	.50
22 pin solder	.85
24 pin solder	.90
28 pin solder	1.20
40 pin solder	1.60

MICROPROCESSOR CRYSTALS

1 MC	7.95
2 MC	7.95
4 MC	7.95
4.43 MC	4.25
5 MC	7.95
10 MC	7.95
12 MC	7.95
18 MC	7.95
20 MC	7.95



POST & PACK ON KITS \$2.50
POSTAL ADDRESS P.O. Box 355, Hornsby, 2077
SHOWROOM 109-111 Hunter St., Hornsby 2077
(9-5 Monday to Sat.)

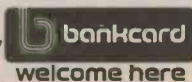

PHONE 476 4758 - 476 3759
PRICES SUBJECT TO CHANGE AFTER MAY 30th, 1978.

ETI data sheet

MOTOROLA MCM6574

THE MCM6574 is a member of the MCM6570 family of character generator ROMs. Each of these is an 8 Kbit ROM which contains 128 characters in a 7 x 9 matrix with additional circuitry provided internally to lower the whole matrix, thus allowing the tails of characters such as j, y and g to extend beyond the baseline.

The seven-bit address code which selects any one of the available characters corresponds, for the most part, to ASCII. Each character is defined as a specific combination of logic 1s and 0s, stored in a 7 x 9 matrix. When a specific four-bit binary row select input is applied, a word of seven parallel bits appears at the output. The rows can be sequentially addressed, providing a nine-word sequence of seven parallel bits per word for each character selected by the address inputs. As the row select inputs are sequentially addressed, the device will automatically place the 7 x 9 character in one of two pre-programmed positions on a 16 row matrix, with the positions defined by the four row select inputs. Rows that are not part of the character are automatically blanked.

The MCM6570 series are TTL and CMOS compatible, with a maximum access time of 500 ns. The power supplies required are +5 V, +12 V and -3 V, although the 12 V and -3 V supplies are at minimal currents and can be handled by charge pump supplies.

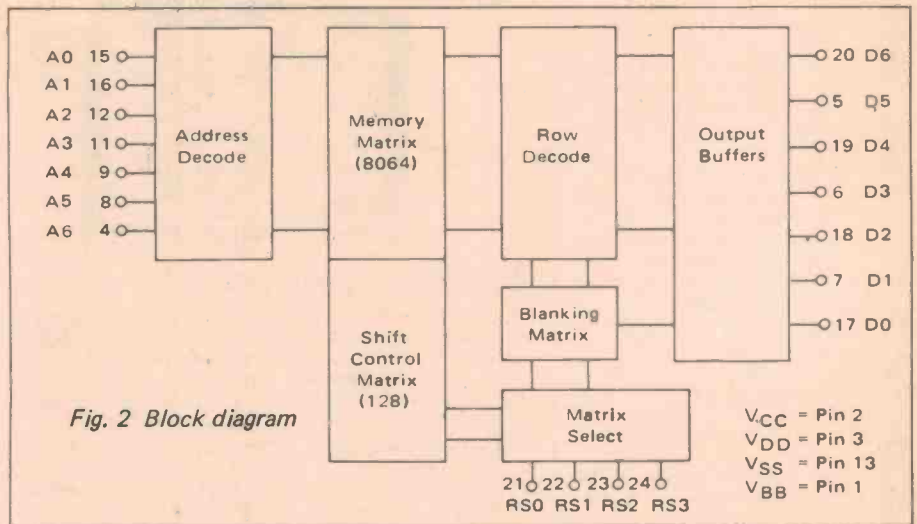
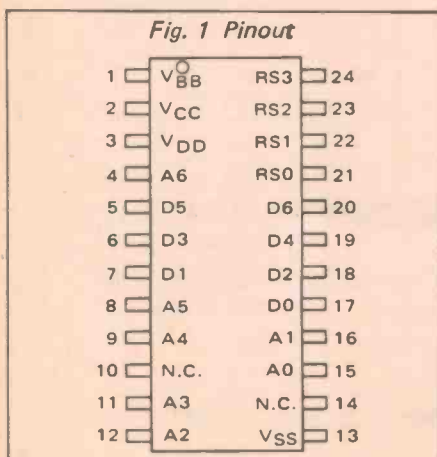

Fig. 2 Block diagram

Fig. 3 Absolute maximum ratings (voltages referred to V_{SS}).

Rating	Symbol	Value	Unit
Supply Voltages	V _{CC}	-0.3 to +6.0	Vdc
	V _{DD}	-0.3 to +15	
	V _{BB}	-10 to +0.3	
Data Input Voltage	V _{in}	-0.3 to +15	Vdc
Operating Temperature Range	T _A	0 to +70	°C
Storage Temperature Range	T _{stg}	-55 to +125	°C

Fig. 4 Recommended dc operating conditions (referred to V_{SS}).

Parameter	Symbol	Min	Nom	Max	Unit
Supply Voltage	V _{DD}	10.8	12	13.2	Vdc
	V _{CC}	4.75	5.0	5.25	Vdc
	V _{SS}	0	0	0	Vdc
	V _{BB}	-3.3	-3.0	-2.7	Vdc
Input Logic "1" Voltage (Driven by TTL)	V _{IH} *	3.0	-	V _{CC}	Vdc
		4.0	-	V _{CC}	Vdc
Input Logic "0" Voltage (Driven by Other Than TTL)	V _{IL}	0	-	0.8	Vdc

*A 4.0 V V_{IH} is required at the chip regardless of the type of driver used. However, internal MOS pullup devices on the chip can pull one TTL driver from 3.0 V to 4.0 V, without affecting access time. These pullup devices may not pull non-TTL drivers above 3.0 V.

Fig. 5 Dc characteristics.

Characteristic	Symbol	Min	Typ	Max	Unit
Input Forward Current (V _{IL} = 0.4 Vdc)	I _{IL}	-	-	-1.6	mA
Input Leakage Current (V _{IH} = 5.25 Vdc, V _{CC} = 4.75 Vdc)	I _{IH}	-	-	100	μA
Output Low Voltage (Blank) (I _{OL} = 1.6 mA)	V _{OL}	0	-	0.4	Vdc
Output High Voltage (Dot) (I _{OH} = -40 μA)	V _{OH}	3.0	-	-	Vdc
Power Supply Current	I _{DD}	-	-	10	mA
	I _{CC}	-	-	125	mA
	I _{BB}	-	-	100	μA
Power Dissipation	P _D	-	600	800	mW

Fig. 6 Timing Characteristics.

Characteristic	Symbol	Min	Typ	Max	Unit
Address Access Time (See Figure 1A)	t _{acc(A)}	-	350	500	ns
Row Select Access Time (See Figure 1B)	t _{acc(RS)}	-	300	500	ns

A. ADDRESS ACCESS TIMING DIAGRAM

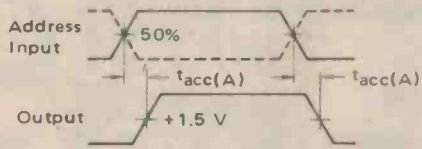

Note: Row Select inputs are set in a dc state.

B. ROW SELECT ACCESS TIMING DIAGRAM

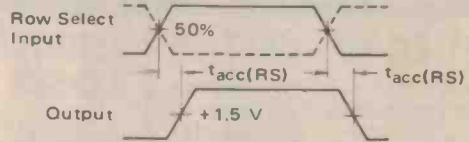

Note: Address inputs are set in a dc state.

Fig. 7 Timing diagrams.

Fig. 8 Power dissipation versus VDD supply voltage

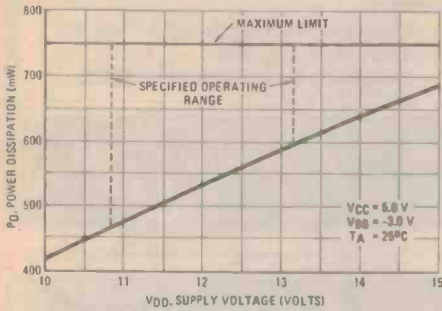

Fig. 9 VCC supply current versus temperature

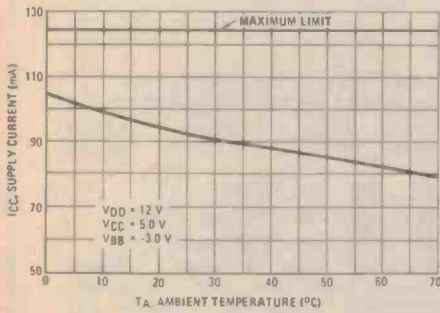

Fig. 10 Access time versus VDD supply voltage.

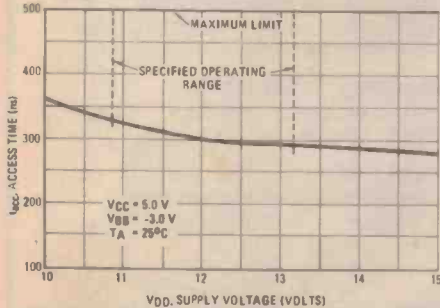

Fig. 11 MCM6571 character pattern.

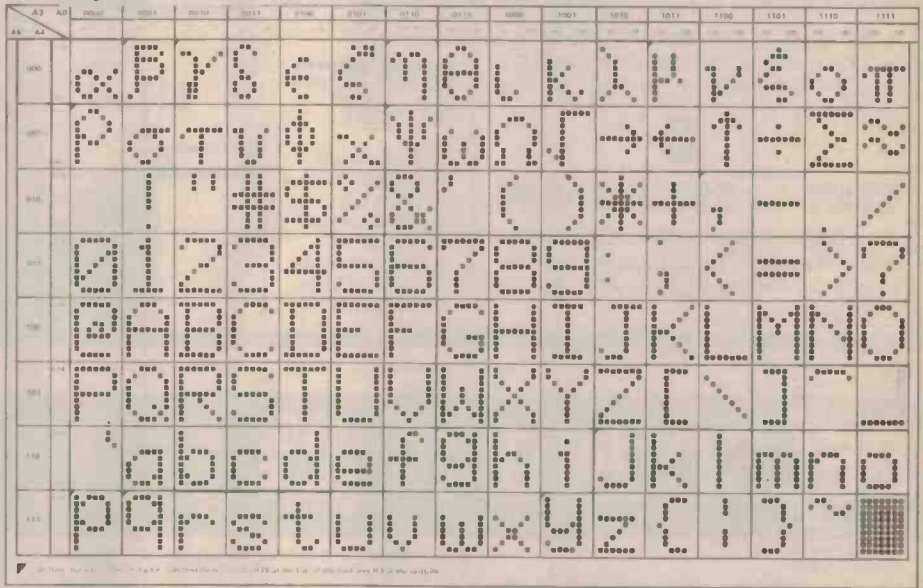
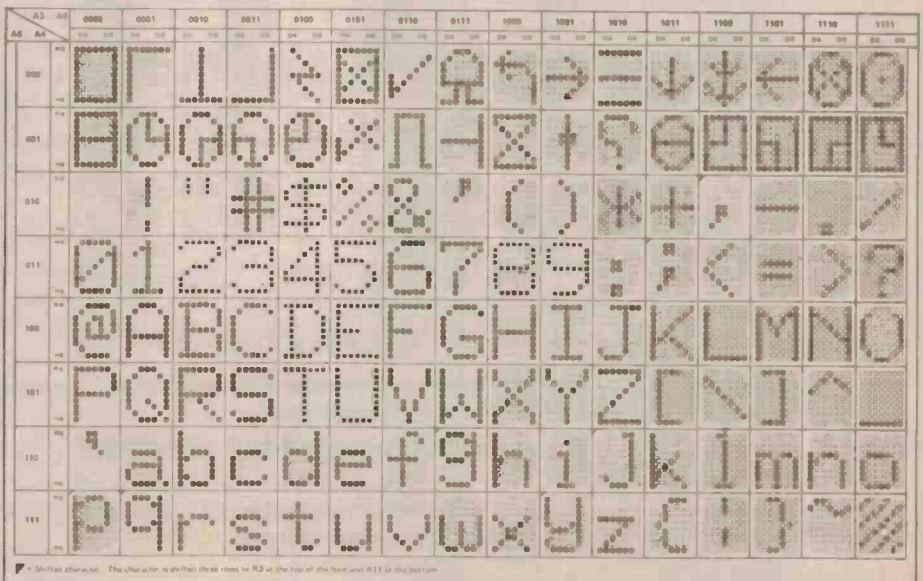

Fig. 12 MCM6574 character pattern.



GREEN
DISPLAY

Scientific Calculators

HORNET SR-46\$17.99

- 37 Function Keys • 8 Digit Mantissa and 2 Digit Exponent • Two levels of Parenthesis • Polar — Rectangular co-ordinate conversion • Trig & Log Functions



LOGITECH LC1233S\$17.99

- 8 Digit Mantissa and 2 Digit Exponent • Two levels of Parenthesis • Degree & Radian conversion • Trig & Log Functions



ZENY — 35SR . \$14.99

- 8 Digit Floating Point or 5 Digit Mantissa and 2 Digit Exponent • Two levels of Parenthesis • Trig & Log Functions

SUPER THIN

LCD Calculators

LOGITECH LC-52S

\$29.99

- 8 Digit LCD Display Floating Point or 5 Digit Mantissa and 2 Digit Exponent • Two levels of Parenthesis • Trig & Log Functions • Statistical Functions • Battery Life 1000 Hours



LOGITECH LC-25T

\$17.99

- 8 Digit LCD Floating Point • Memory • Percentage Calculation • Square Root • Battery Life 2000 Hours



WATRON SOLAR CELL CHRONOGRAPH

LCD DIGITAL WATCH



\$65

- Stainless Steel • Continuous 6 Digit Readout; Hour, Minute, Second or Month, Date, Day • With 1/100 Second Accuracy Stop Watch • Start, Stop, Reset, Lap Time Instant Time Freeze • Four-year Calendar • Back Light • Solar Cell • One-year Guarantee

Notes:

1. All Calculators are Tax Exempted Price, add 15% Sales Tax if Applicable
2. All Calculators are 3 Months Guarantee
3. Add \$2 for P & P

CHAN MERCHANDISING CO PTY LTD

111 RESERVOIR ST. SURRY HILLS 2010
TEL (02) 211-4660

DELSOUND

PTY. LTD.
BRISBANE

Mail orders welcome, add 10 percent P&P 1
Wickham Tce. (Cnr Wharf St.) 229-6155 (parking at
rear). 35 Logan Road, Woolloongabba 391-7048

AUDITEC

Pre-assembled and guaranteed modules
using only high-quality components

POWER AMPLIFIER BOARDS

- 001 55 watts RMS 4 ohms \$24
 - 018 60 watts RMS 4 ohms 35 watts RMS 8 ohms 1% THD \$40
 - 009 120 watts RMS 4 ohms 70 watts RMS 8 ohms 1% THD \$63.50
 - 027 250 watts RMS 8 ohms 2% THD \$119
 - 033 VERY HIGH QUALITY 100 watts RMS 4 ohms 70 watts RMS 8 ohms Inter-modulation Distortion .01% Total Harmonic Distortion .005% \$79.50
- All Auditec power amps require 1 volt RMS input for full rated output and are short and open circuit protected

PREAMPS

- 1-015 Hi Z or Lo Z Mic., Guitar, Music or Programme Inputs. 25 m V or IV RMS Output Volume, Bass and Treble ± 15 dB. Controls on Board. \$16.
- 2-015 2 x 1-015 On One Board Side by Side \$32
- 029 015 With No Tone Controls \$11.50
- 025 Magnetic Cart Preamp (Stereo) High Overload 2 mV. Input 25m V or IV RMS Output R1AA ± 1 dB \$21.50
- 1-036 Stereo Preamp. Performance Matches That of 033 Complete Assembly with Controls and Switches Wired with Mag. Tape In/out, Volume, Bass, Treble, Balance, Selector, Mode and Loudness \$99.50
- 016 12 Channel Mixer Module 12 x 25m V Input 1 x IV RMS Output \$12
- 022 Bass and Treble ± 15 dB Control for Mixer Module \$12

ALL PREAMPS CAN BE POWERED DIRECT FROM SUPPLIES TO AUDITEC POWER AMPS (035 Regulated Supply Recommended for 1-036)

POWER SUPPLIES TO SUIT

- 027 \$72
- 033, 009 \$36
- 001, 018 \$26

COMPREHENSIVE RANGE AT COMPETITIVE PRICES OF RESISTORS — 1/2W, 1/2W, 2%, 1W, 5W, 10W, etc.

CAPACITORS — Polyester, Polycarbonate, Polyester, Greencap, Polystyrene, Car mic, Electrolytics, Bi-Polar, Tantalum, Trimmers, etc.

POTENTIOMETERS — Carbon single and double A & C rotary. Carbon single and double A & C 45 mm slider. Switch pots single. Wire wound pots.

KNOBES — Most types (metal and plastic)

BEZELS — Neon and Incandescent

P.C. BOARD AIDS — Tapes, pads, etch pens, ferricchloride, knives, blank P.C. board, pre coated sensitized board, many more.

TRANSFORMERS — Most types of Ferguson and A & R.

PLUGS & SOCKETS — audio, cannon, edge connectors, transistor, I.C. etc.

SWITCHES — Most types.

RELAYS — 6, 12, 24V S.P.D.T., D.P.D.T.

CABINETS AND HARDWARE — Large range.

P.A. EQUIPMENT — Amplifiers and speakers, mics and stands, accessories, etc.

TOOLS — Range including soldering irons and solder.

C.B. RADIO — Range of good value P and T approved sets and accessories.

MAIL ORDERS AND ENQUIRIES WELCOME

All Prices plus P/P 15 percent to \$25. 10 percent over. Prices and Stocks as at 1/8/77

WIDE RANGE OF RIGS AND ACCESSORIES

AUSTRALIAN DISTRIBUTORS CLIFF PLASTIC PRODUCTS

Knobs, Plugs & Sockets, Terminals
14/16, 24/28, 40 Pin I.C. Test Sockets

QLD DISTRIBUTORS

R.C.A. SEMICONDUCTORS

SWANN ELECTRONICS

Switches, Plugs & Sockets, Bezels, Circuit Board Aids, Edge Connectors, Heatsinks, Power Point Testers, I.C. Tools, Fuse Holders.

SOUTH WEST TECH

Computer Kits

BEST SEMICONDUCTORS

DEALERS FOR AUDITEC Pre-Assembled & Tested Modules

ELCOMA (PHILIPS)

Semiconductors, Speakers, Components, Ferrites

WALTECK

Circuit Board Construction Aids

Sorry we don't produce a catalogue. The saving is passed on to you.



IRH can now offer you a range of FUJITSU Relays and Timers covering a wide variety of switching applications.

Mounting:

Printed Circuit Board
Plug-in
Direct Mounting

Coil Voltage:

From 6 — 110V D.C.
5 — 240V A.C.

Switching Capacity:

From 0.5 AMPS to 10 AMPS A.C.
0.5 AMPS to 30 AMPS D.C.

Contact Arrangements:

S.P.S.T. 4.P.S.T. 12.P.D.T.
D.P.D.T. 4.P.D.T. 18.P.S.T.

irh
COMPONENTS
Division of Natronics Pty. Limited

Telephone: SYDNEY (02) 50 0111 • MELBOURNE (03) 44 5021 • HOBART (002) 34 2811 • ADELAIDE (08) 51 4819 • BRISBANE (07) 379 4095 • PERTH (092) 81 6000 • AUCKLAND 49 3226 • WELLINGTON 85 9408

relays

Whatever your relay requirements your local IRH sales office will be pleased to assist.

No computer magazine gives you more applications than we do! Games. Puzzles. Sports simulations. CAI. Computer art. Artificial intelligence. Needlepoint. Music and speech synthesis. Investment analysis. You name it. We've got it. And that's just the beginning!

Whatever your access to computer power—home computer kit, mini, time-sharing terminal—Creative Computing is on your wavelength. Whatever your computer application—recreation, education, business, household management, even building control—Creative Computing speaks your language.

Read through pages of thoroughly documented programs with complete listings and sample runs. All made easy for you to use. Learn about everything from new software to microprocessors to new uses for home computers. And all in simple, understandable terms. And there's still more. Creative Computing discusses creative programming techniques like sort

IF YOU'RE NOT SUBSCRIBING TO creative computing YOU'RE NOT GETTING THE MOST OUT OF YOUR COMPUTER.

algorithms, shuffling and string manipulation to make your own programming easier and more efficient.

We can even save you time and money. Our extensive resource section is filled with all kinds of facts plus evaluations of hundreds of items. Including microcomputers, terminals, peripherals, software packages, periodicals, booklets and dealers. We also give you no-nonsense equipment profiles to help you decide which computer is best for you—before you spend money on one that isn't.

We've got fiction too. From the best authors in the field, like Asimov, Pohl and Clarke. Plus timely reviews of computer books, vendor manuals and government pamphlets. And so much more!

Isn't it about time you subscribed to Creative Computing? It's the smart way to get the most out of your computer.

Complete this coupon and mail it today.

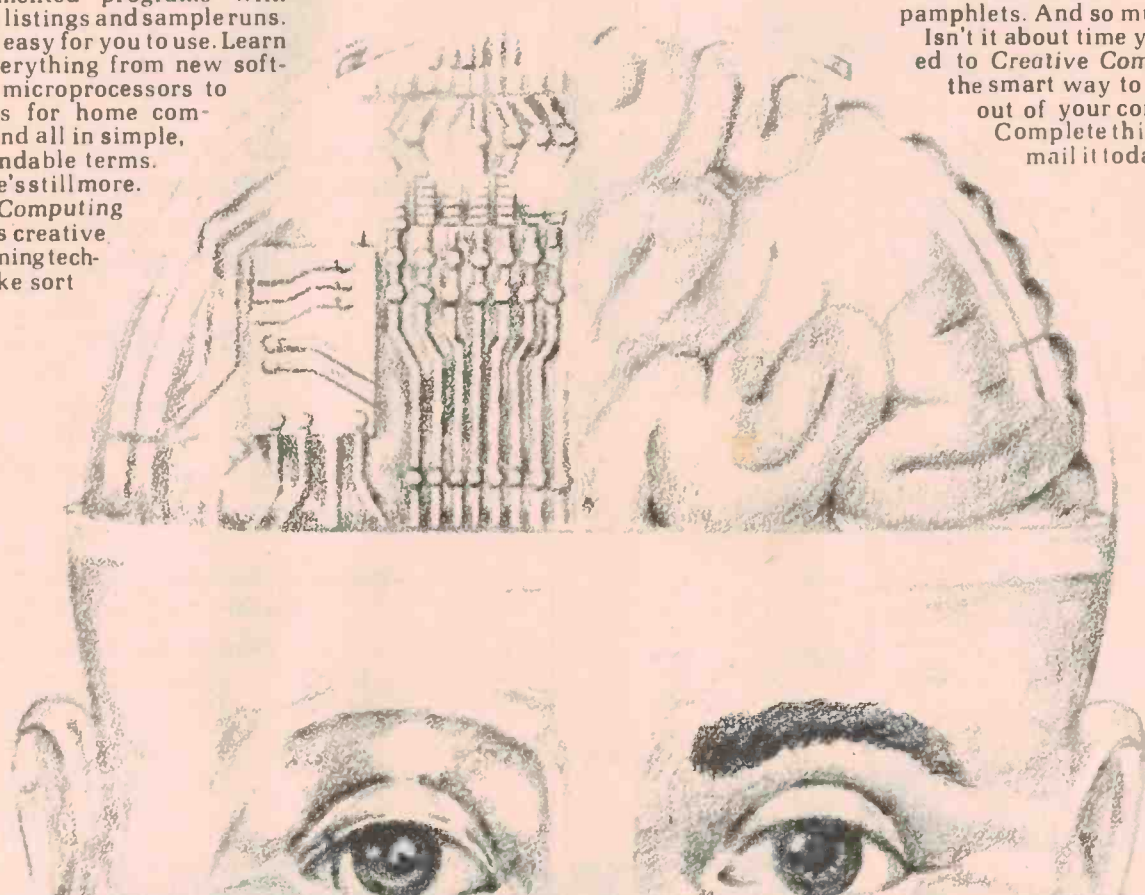

Please supply me with the following subscriptions

Magazine 1 Year Subscription * Air Mail

- | | | |
|---------------------------|------------------------------------|----------------------------------|
| creative computing | <input type="checkbox"/> 12 Issues | <input type="checkbox"/> \$46.00 |
| Byte | <input type="checkbox"/> 12 Issues | <input type="checkbox"/> \$46.00 |
| Dr Dobbs | <input type="checkbox"/> 10 Issues | <input type="checkbox"/> \$21.00 |
| Interface Age | <input type="checkbox"/> 12 Issues | <input type="checkbox"/> \$45.00 |
| P.P.C. | <input type="checkbox"/> 6 or more | <input type="checkbox"/> \$18.00 |
| Personal Computing ROM | <input type="checkbox"/> 12 Issues | <input type="checkbox"/> \$43.40 |
| Calculators and Computers | <input type="checkbox"/> 12 Issues | <input type="checkbox"/> \$46.00 |
| | <input type="checkbox"/> 12 Issues | <input type="checkbox"/> \$45.00 |

* Due to constant delays relative to ocean freights, and keeping in mind the fast moving developments in the micro industry we decided to airfreight all magazines to offer you fastest possible service.

Return to **ELECTRONIC CONCEPTS PTY LTD** 55 Clarence Street, Sydney, NSW 2000. Phone: 29-3753

CHEQUE MONEY ORDER ENCLOSED CHARGE MY BANKCARD

TOTAL REMITTANCE \$

Please send to:

Name

Address

City State P.C.

BANKCARD	
Acc. No.
Expiry Date
Signature

ELECTRONIC CONCEPTS PTY LTD
computer land
Showroom & Offices
Ground Floor
55 Clarence St,
SYDNEY NSW 2000

ANNOUNCEMENT

ETI's COMPUTER SECTION

MEMOREX

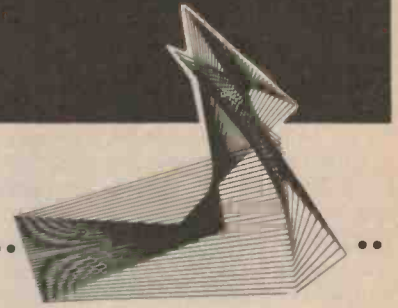

Memorex Drive

Memorex Pty. Limited has announced an expansion of its OEM disc drive family of products with the introduction of the model 552 dual-headed flexible disc drive.

The Memorex 552 incorporates two ceramic read/write heads which allow recording or reading of data on both sides of a dual-sided flexible disc. This capability significantly reduces operator handling of the disc media for better data integrity. At the same time, it offers greatly improved accessibility to stored data in comparison with single-headed drives.

It also features the same interface, dimensional characteristics and many parts as Memorex's model 550 single-headed flexible disc drive. In addition 80% of its parts are interchangeable with the 550's, so conversion from a 550 to a 552 operation is a simple factory procedure.

The 552 Flexible Disc Drive offers a recording capacity of 492 kilobytes in IBM 4964 format or up to 1,600 kilobytes of unformatted data. Access time is 3 milliseconds per track.

The data transfer rate is 250 kilobytes per second in single-density recording mode.

With an appropriate controller, the 552 can be operated in the double-density mode (MFM or M²FM recording) without modification or additional electronics. Data transfer rate for the double-density recording mode is 500 kilobytes per second.

A Drive Select feature allows the user to select any one drive in a serial or radial configuration comprising up to four units. However, the 552 is capable of being connected in an eight-unit serial configuration if desired.

An exclusive door-controlled latch/eject mechanism on the 552 makes

cartridge insertion and removal a "pop-in/pop-out" operation. In addition, a lock stop feature also makes it impossible for the user to close the door on a cartridge that is not fully inserted or removed. This feature provides further protection of the disc media.

The 552 offers exceptional reliability. For instance, data transfer reliability is 10⁹ bits read/soft error and 10¹² bits read/hard error in normal operation. MTTR is one-half hour, with MTBF of 9,000 hours. 552 options include File Busy Indicator, Program-Controlled Door Lock and Write Protection.

Further information from *Memorex Pty. Ltd.*, 61 Barry St., Neutral Bay, NSW, 2089.

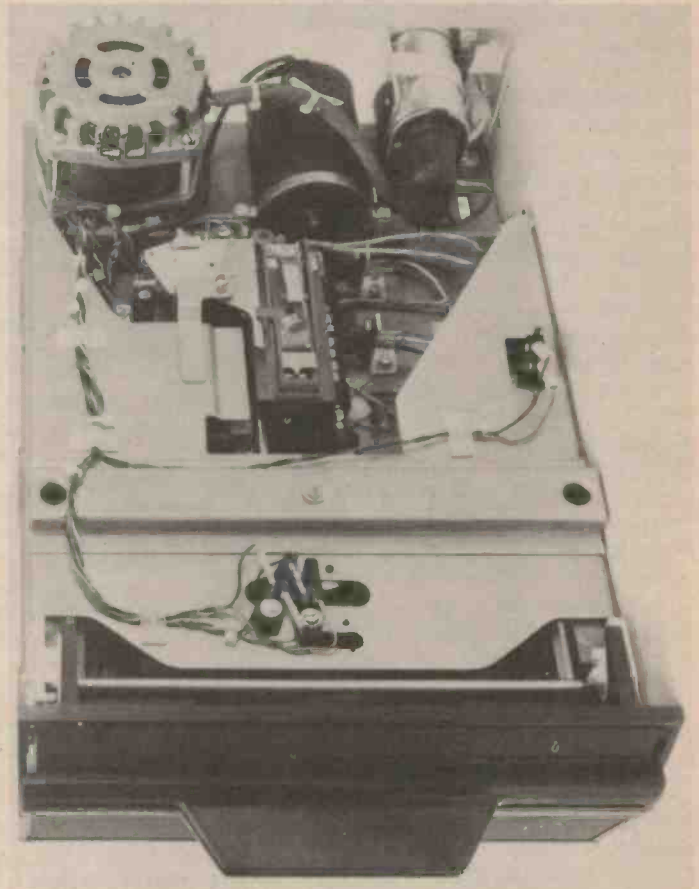

What Price 8080?

Intel have revealed that orders are being taken now for future delivery of 'large quantities' of the 8080 at a unit price of less than US\$5. Industry observers see the price of the 8080 coming down even further to around the US\$3 mark!

2708 — End of the Road?

Mid-1978 will see sampling of the first 2 Kbyte electrically alterable ROM by Texas Instruments. The 450 ns access time device is based on a floating-gate avalanche MOS cell structure. NEC already have a 1 Kbyte device and Intel are working on an EAROM based on the 2708, while GI's devices are of the slower nitride type.

Slice off Apple

Apple Computer has announced price reductions on Apple 11 computers of 15 to 23 per cent, due to increased production. Two new interface cards have also been announced, for parallel and serial communications. The A2B0002X intelligent printer interface can handle 255 characters per line at up to 5,000 characters per second though a general purpose 8-bit part. The A2B0002X intelligent communications interface is a 110 or 330 baud RS232C interface.

TI Microprocessors Seminar

TI extend an invitation to engineers to attend a 3 hour seminar covering their microprocessor families.

Main topic in the seminar will be the 16 bit TMS9900 microprocessor and its associated products including micro-computer modules. This is a highly powerful, very flexible MPU and is already being used in a wide variety of applications.

Also to be discussed in the seminar will be the 4 bit TMS1000 device and its derivatives. This is a more dedicated MPU with built-in masked read only memory ideally suited to volume production because of its cost effectiveness. Seminar dates as follows:

- Melbourne 9 May 1978 - Institute of Management, St Kilda
- Sydney 10 May 1978 - El Rancho Motel, North Ryde

Those wishing to attend are asked to contact Miss Virginia Bradshaw at the Sydney office, phone: 887-1122, thereby having their names registered.

National slashes 8080

National Semiconductor Corporation, a major supplier of 8080A microprocessors, has announced across the board price reductions for its version of the popular 8-bit device. According to Jack Rutherford, Managing Director of NS Electronics, National has been the price leader since introducing its INS8080A about one and a half years ago. In addition, he noted that the company offers more support circuits and peripherals in its 8080 product line than any other manufacturer.

The price of National's plastic package INS8080AN is now listed at \$9.98 in 1-24 quantities, reduced from a previous listing of \$15.50 each. The 100-up quantities, the device has been marked down by one-third from \$10.80 to \$7.10 as quoted in National's latest OEM price list.

Rutherford cited National's overall volume delivery of the devices as a major reason for the price cuts. "Our four-inch wafer fabrication is fully-on stream for all components," he said. Automated testing facilities and a high volume of plastic production were other factors mentioned.

CMOS Octal Interfaces

A Complementary MOS version of the industry-standard 20-pin octal interface family of devices has been developed by National Semiconductor.

According to Jack Rutherford, Managing Director of N.S. Electronics, the new devices are the first such integrated circuits in commercial production. Moreover, he says, they incorporate a unique circuit design that allows them - unlike standard CMOS devices - to drive high capacitive loads such as one might find when driving a bus and to have a fan-out of 1 when driving standard TTL loads.

First new parts in the family are the MM54C373/74C373 octal latch and the MM54C374/74C374 "D" type flip-flop.

Both devices, says Rutherford, feature a wide supply voltage, from 3 to 15 volts; high noise immunity, typically about 45 percent of the supply voltage; low TRISTATE^R output current, about 5 nanoamps; and low power consumption, about 1.0 microwatt at 15 volts. Typical drive (sourcing) current on the devices is about 20 mA per output.

The new CMOS octal interface ICs also feature TRISTATE outputs, which in addition to the octal pinouts, make them ideal for microprocessor-bus-oriented systems.

Key to the versatility of the new devices in the use of unique drive transistor configuration on the output circuitry in which an NPN emitter-follower structure is used in parallel with a p-channel transistor to source the 20 mA drive current and to pull the output voltage up to the V_{cc} supply voltage rail.

Normally, says Rutherford, in standard CMOS devices the output stage is fabricated using MOS transistors 10 to 100 times the size of those in the digital logic portion of the IC. Such structures are sufficient to bring the output to the V_{cc} rail, but not to drive high capacitive bus loads. An added benefit of the increased output drive is the ability to drive LED's and other lamps directly.

The use of NPN structures in the output stage allows the device to source the necessary 20 mA, but used

alone, this structure pulls up to only 700 mV to 1 volt of the supply voltage. A small p-channel MOS transistor fabricated in parallel with the NPN structure pulls the device up the rest of the way to V_{cc} .

Available now, the 54C373/74C373 and 54C374/74C374 are \$1.80 each in 100-unit quantities.

COMPUTER CLUB DIRECTORY

Sydney: Microcomputer Enthusiasts Group, P.O. Box 3, St. Leonards, 2065. Meets at WIA Hall, 14 Atchison St., St. Leonards on the 1st and 3rd Mondays of the month.

Melbourne: Microcomputer Club of Melbourne, meets at the Model Railways Hall, opposite Glen Iris Railway Station on the third Saturday of the month at 2 p.m.

Canberra: MICSIG, P.O. Box 118, Mawson, ACT 2607 or contact Peter Harris on 72 2237. Meets at Building 9 of CCAE, 2nd Tuesday of month at 7.30 p.m.

Newcastle: contact Peter Moylan, Dept. of Electrical Engineering, University of Newcastle, NSW 2308. (049) 68-5256 (work), (049) 52-3267 (home).

Brisbane: contact Norman Wilson, VK4NP, P.O. Box 81, Albion, Queensland, 4010. Tel. 262 1351.

New England: New England Computer Club, c/- Union, University of New England, Armidale, NSW 2351. (New club; not restricted to students)

Auckland: Auckland Computer Club, P.O. Box 27206, Auckland, N.Z.

Computer clubs are an excellent way of meeting people with the same interests and discovering the kind of problems they've encountered in getting systems 'on the air'. In addition, some clubs run hardware and software courses, and may own some equipment for the use of members. Try one - you'll like it!

If your club is not listed here, please drop us a line, and we'll list you. The same applies if you are interested in starting a club in your area. Also, if established clubs know their programme of forthcoming events, we can publicise them.

DIODES/ZENERS

1N914	100v	10mA	.05
1N4005	600v	1A	.08
1N4007	1000v	1A	.15
1N4148	75v	10mA	.05
1N753A	6.2v	z	.25
1N758A	10v	z	.25
1N759A	12v	z	.25
1N4733	5.1v	z	.25
1N5243	13v	z	.25
1N5244B	14v	z	.25
1N5245B	15v	z	.25

SOCKETS/BRIDGES

8-pin pcb	.25	ww	.45
14-pin pcb	.25	ww	.40
16-pin pcb	.25	ww	.40
18-pin pcb	.25	ww	.75
22-pin pcb	.45	ww	1.25
24-pin pcb	.35	ww	1.10
28-pin pcb	.35	ww	1.45
40-pin pcb	.50	ww	1.25
Molex pins	.01	To-3 Sockets	.45
2 Amp Bridge		100-prv	1.20
25 Amp Bridge		200-prv	1.95

TRANSISTORS, LEDS, etc.

2N2222A	NPN (2N2222 Plastic .10)	.15
2N2907A	PNP	.15
2N3906	PNP (Plastic)	.10
2N3904	NPN (Plastic)	.10
2N3054	NPN	.35
2N3055	NPN 15A 60v	.50
T1P125	PNP Darlington	.35
LED Green, Red, Clear, Yellow		
D.L.747	7 seg 5/8" High com-anode	1.95
XAN72	7 seg com-anode (Red)	1.25
MAN71	7 seg com-anode (Red)	1.25
MAN3610	7 seg com-anode (Orange)	1.25
MAN82A	7 seg com-anode (Yellow)	1.25
MAN74A	7 seg com-cathode (Red)	1.50
FND359	7 seg com-cathode (Red)	1.25

C MOS

4000	.15	7400	.15	7473	.25	74176	1.25	74H72	.45	74S133	.40
4001	.15	7401	.15	7474	.30	74180	.75	74H101	.75	74S140	.55
4002	.20	7402	.20	7475	.35	74181	2.25	74H103	.75	74S151	.30
4004	3.95	7403	.20	7476	.40	74182	.95	74H106	.95	74S153	.35
4006	.95	7404	.15	7480	.55	74190	1.75			74S157	.75
4007	.35	7405	.25	7481	.75	74191	1.05	74L00	.25	74S158	.30
4008	.95	7406	.35	7483	.95	74192	.75	74L02	.25	74S194	1.05
4009	.45	7407	.55	7485	.75	74193	.85	74L03	.30	74S257 (8123)	1.05
4010	.45	7408	.25	7486	.25	74194	1.25	74L04	.30		
4011	.20	7409	.15	7489	1.35	74195	.95	74L10	.30	74LS00	.25
4012	.20	7410	.10	7490	.55	74196	1.25	74L20	.35	74LS01	.35
4013	.40	7411	.25	7491	.95	74197	1.25	74L30	.45	74LS02	.35
4014	.95	7412	.30	7492	.95	74198	2.35	74L47	1.95	74LS04	.30
4015	.90	7413	.35	7493	.35	74221	1.00	74L51	.45	74LS05	.45
4016	.35	7414	1.10	7494	.75	74367	.85	74L55	.65	74LS08	.25
4017	1.10	7416	.25	7495	.60			74L72	.45	74LS09	.35
4018	1.10	7417	.40	7496	.80	75108A	.35	74L73	.40	74LS10	.35
4019	.50	7420	.15	74100	1.15	75110	.35	74L74	.45	74LS11	.35
4020	.85	7426	.30	74107	.35	75491	.50	74L75	.55	74LS20	.25
4021	1.00	7427	.45	74121	.35	75492	.50	74L93	.55	74LS21	.25
4022	.85	7430	.15	74122	.55			74L123	.85	74LS22	.25
4023	.25	7432	.30	74123	.55	74H00	.15			74LS32	.40
4024	.75	7437	.30	74125	.45	74H01	.25	74S00	.35	74LS37	.35
4025	.30	7438	.35	74126	.35	74H04	.20	74S02	.35	74LS40	.45
4026	1.95	7440	.25	74132	1.35	74H05	.20	74S03	.30	74LS42	1.10
4027	.50	7441	1.15	74141	.90	74H08	.35	74S04	.30	74LS51	.50
4028	.95	7442	.45	74150	.85	74H10	.35	74S05	.35	74LS74	.65
4030	.35	7443	.65	74151	.65	74H11	.35	74S08	.35	74LS86	.65
4033	1.50	7444	.45	74153	.75	74H15	.45	74S10	.35	74LS90	.95
4034	2.45	7445	.65	74154	.95	74H20	.30	74S11	.35	74LS93	.95
4035	1.25	7446	.95	74156	.95	74H21	.25	74S20	.35	74LS107	.85
4040	1.35	7447	.95	74157	.65	74H22	.40	74S40	.20	74LS123	1.00
4041	.69	7448	.65	74161	.85	74H30	.20	74S50	.20	74LS151	.95
4042	.95	7450	.25	74163	.85	74H40	.25	74S51	.25	74LS153	1.20
4043	.95	7451	.25	74164	.60	74H50	.25	74S64	.20	74LS157	.85
4044	.95	7453	.20	74165	1.50	74H51	.25	74S74	.35	74LS164	1.90
4046	1.75	7454	.25	74166	1.35	74H52	.15	74S112	.60	74LS367	.75
4049	.45	7460	.40	74166	1.35	74H53J	.25	74S114	.65	74LS368	.75
4050	.45	7470	.45	74175	.80	74H55	.20			74C04	.25
4066	.95	7472	.40							74C151	2.25
4069	.40										
4071	.35										
4081	.70										
4082	.45										
MC 14409	14.50										
MC 14419	4.85										

LINEARS, REGULATORS, etc.

MCT2	.95	LM320T5	1.65	LM340K15	1.25	LM723	.50
8038	3.95	LM320T12	1.65	LM340K18	1.25	LM725N	2.50
LM201	.75	LM320T15	1.65	LM340K24	.95	LM739	1.50
LM301	.45	LM324N	.95	78L05	.75	LM741 (8-14)	.25
LM308 (Mini)	.95	LM339	.95	78L12	.75	LM747	1.10
LM309H	.65	7805 (340T5)	.95	78L15	.75	LM1307	1.25
LM309K (340K-5)	.85	LM340T12	1.00	78M05	.75	LM1458	.95
LM310	1.15	LM340T15	1.00	LM373	2.95	LM3900	.50
LM311D (Mini)	.75	LM340T18	1.00	LM380 (8-14 PIN)	.95	LM75451	.65
LM318 (Mini)	.95	LM340T24	.95	LM709 (8,14 PIN)	.25	NE555	.50
LM320K5(7905)	1.65	LM340K12	1.65	LM711	.45	NE556	.95
LM320K12	1.65					NE565	.95
						NE566	1.75
						NE567	1.35

9000 SERIES

9301	.85	95H03	1.10
9309	.35	9601	.45
9322	.75	9602	.45

MICRO'S, RAMS, CPU'S, ETC.

74S188	3.00
1702A	4.50
MM5314	3.00
MM5316	3.50
2102-1	1.45
2102L-1	1.75
TR1602B	4.50
TMS 4044-45NL	14.50
8080AD	12.00
8T13	1.50
8T23	1.50
8T24	2.00
8T97	1.00
2107B-4, A	4.00
2708	11.50

INTEGRATED CIRCUITS UNLIMITED

7889 Clairemont Mesa Blvd., San Diego, CA 92111 U.S.A.
No Minimum

All prices in U.S. dollars. Please add postage to cover method of shipping. Orders over \$100 (U.S.) will be shipped air no charge. Payment should be submitted with order in U.S. dollars. All IC's Prime/Guaranteed. All orders shipped same day received.

SPECIAL DISCOUNTS

Total Order	Deduct
\$35 - \$99	5%
\$100 - \$300	10%
\$301 - \$1000	15%
\$1000 - Up	20%

Phone (714) 278-4394 BarclayCard / Access / American Express / BankAmericard / Visa / MasterCharge

Microcomputers underwater

Inspection of underwater pipes and oil drilling platforms, and searching for and retrieving objects from the ocean floor present many problems when they are thought of in terms of divers and manned vehicles. The main problem, of course, is man. Even equipped with elaborate life-support systems, the workday is limited, the costs are high, and the dangers great.

Hydro Products of San Diego, California, has an answer which is probably the next best thing to a porpoise with an engineering degree. It is a highly "intelligent", microcomputer-controlled undersea robot vehicle that has the eyes, ears and arms that give great flexibility in many applications. Called the RCV-150, it is probably the most sophisticated and flexible commercially-produced submersible in use today.

The key to the design is a pair of identical PACE microcomputers from the Microcomputer Systems Group of National Semiconductor Corporation, represented in Australia by N.S. Electronics. One is in the undersea vehicle, the other on the surface mother ship. Virtually all communications, display and control functions are managed by the microcomputers.

The undersea portion of the RCV-150 consists of a cable-tethered vehicle, which measures about 4 feet by 3.5 feet by 4 feet and is propelled by four 10-inch-diameter thrusters. The vehicle's small size makes it easy to launch and retrieve while a large array of equipment gives the capability of much larger submersibles. Four 250-watt lamps provide illumination for the television camera.

Only 50 percent of the available space is currently being used, allowing the addition of options such as marine magnetometers, acoustic trackers, sonar magnetometers, 35mm still cameras, depth-finders, 35mm still cameras, search sonars, or even a second manipulator arm should it be desired.

"The microcomputer approach we took further enhances the vehicle's flexibility," explains Jim Tierney, Hydro Products Senior Electronics Engineer. "Our software and firmware approach allows us to add any number of features later on to meet the specific requirements of any customer application. Control firmware can be supplied on programmed read-only memory (PROM) for convenient field installation."

Internal depth and yaw programs referenced to depth and turnrate signals are under PACE microcomputer control. This relieves the operator of many manoeuvring tasks, allowing him to concentrate on observation, inspection and manipulation duties.

"Using the microcomputers had made system response faster. It turns smoothly and quickly and can stop on a penny," says Tierney. "Since it automatically controls its own depth and heading, it can remain stationary in these axis without operator intervention."

The development of this advanced vehicle took some nine months to complete and about 1.5 man-years went into the software development.

Pace System

Three National Semiconductor PACE Board-Level Computer cards comprise the vehicle's microcomputer while the same three plus a second PROM board make up the surface control station microcomputer. The compact 4.5-inch boards include the 16-bit IPC-16C/100 PACE CPU, the 2K by 16-bit IPC-16C/002B PACE PROM and the 1K by 16-bit IPC-16C/001 PACE random-access memory (RAM).

The PROM memory firmware houses the operating programs for the vehicle and the control unit. The second PROM board in the control station contains the maintenance and self-test program and CRT display formats. The RAM boards temporarily store intermediate results during processing.

An array of standard sensors includes various depth, heading rate, roll, pitch and temperature sensors and sea-water

intrusion sensors. The temperature of the electronics package and hydraulic system is constantly monitored as a safety feature. Tools can be placed on the undersea vehicle as the three-foot long manipulator which has four degrees of freedom, a cable cutter, a soft-line cutter, cleaning brush, pinger dropper, and a grabber arm.

The surface-ship control station has two monitors — one shows the video pictures from the undersea television camera, while the other displays operations data. Selected data can be superimposed on the video channel annotating video tapes with position information, valuable in later review.

Illuminated bar graph displays on the control station indicate power levels and temperatures. Illuminated switches indicate control position and serve as warning annunciators. Problems in the vehicle are immediately reported to the operator by the RCV's microcomputer which continuously monitors vehicle performance.

The micro in the control station scans the control panel at a 20-times-per-second rate. When a control manoeuvre is given by the operator, the signal is encoded and passed through a RF-telemetry data link via coaxial cable to the vehicle microprocessor. This microprocessor then interprets the command, activates the electrohydraulic servos, continuously solving the equations of motion at a rate of 30 times per second.

Data sensed by the vehicle sensors and detectors is transferred through the microprocessors for surface display.

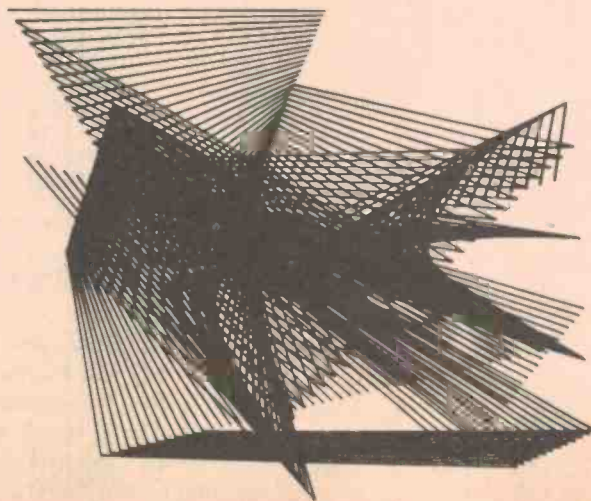

One of the problems that had to be overcome in designing the new vehicle software system concerned the tight time constraints for program execution. It was first thought that a surface minicomputer would make the necessary equations-of-motion calculations and transmit the data to operate the RCV servos.

"The data transmission system couldn't handle high-speed data rate from the mini to the vehicle," comments Tierney. "Using the microcomputer in the vehicle to perform its own calculations, we have less complex data transmission and a more reliable system."

System Cost Reduced

"Cost was another consideration in selecting the National microcomputers," Tierney says. "At the time we were designing the RCV-150, National Semiconductor was one of a few companies that was offering assembled, tested and guaranteed boards. Others offered only individual chips. The hardware development costs were less compared with building the system from the chips up. These application boards were small enough to fit in the vehicle's confined space."

"Another factor in our selection of National Semiconductor's PACE system was the fact that the 16-bit microcomputer offered advantages such as increased efficiency compared with some eight-bit systems. The 16-bit machine requires less memory access and it can handle 16-bit parallel data."

"National's PACE/IMP-16P microcomputer development system featured a reasonably-priced disk-operating system and could accommodate a high speed printer and other peripherals."

"The disk-operating system contained an assembler. We could create files, shuffle and change them as we wanted to. The development system was made to look just like the CPU so when the software was tested, we could use the system to burn the program into the PROM and place it in the RCV."

"The development system not only served its purpose on the RCV-150 software development, but it will continue to be used for future program changes and as a stand-alone computer performing tasks such as maintaining parts lists, running management programs, and making engineering computations."

"We received excellent support from National during the development stages. Once, for example, when we blew up the development system, we only had to make one phone call and two replacement boards were mailed immediately. They knew from our description of what happened where the fault was located," Tierney concluded.

Due to shortage of space, we have unfortunately had to postpone our review of the Tandy TRS-80 microcomputer.

While visiting Computerland, 55 Clarence St, Sydney, recently, we grabbed a few pics which are reproduced below.



This is typical of the kind of system many small businesses are buying now, this one based on the Vector 1 microcomputer by Vector Graphics, with twin floppies and a terminal (or two).



Computerland also stock a range of publications, as hobby computerists have a thirst for knowledge that has rarely been equalled by any other group of hobbyists.

End noise and cross-talk with our exclusive
Noiseguard™ system

The WunderBuss™

A product of Morrow's Micro-Stuff for

Capacity	20 positions for edge connectors
Edge Connectors	5-100 type, 25 spacing Available from Thinker Toys or Masterite
Shielding	Every signal fully shielded by both interconnected ground lines
Termination	Active termination of each line Termination network includes 1M201 op amp, 2N3904, 2N3906, TIP29 and TIP30 transistors 2.4 volts, 180 ohms

COMPUTER BITS A DIVISION OF AUTOMATION
STATHAM PTY. LTD.
47 Birch Street, BANKSTOWN N.S.W. 2200 Phone (02) 709-4144 Telex AA26770

**TWO BYTES ARE
BETTER THAN ONE**

IMPACT PRESENTS WHAT TO LOOK FOR IN CHOOSING A MICROCOMPUTER

1. YOU NEED THE RIGHT MICROPROCESSOR

Be sure to look at the features of the Texas Instruments 16-bit 9900 microprocessor (you will find these listed in the IMPACT adv. in last month's ETI).

2. YOU NEED THE RIGHT CPU BOARD FOR IT

Let us introduce you to the
**T-9900-SS SINGLE-BOARD
STAND-ALONE MICROCOMPUTER**

A dual purpose board.

The Technico T-9900-SS is a masterpiece of design. It is dual purpose: it can operate on its own as a self-contained complete microcomputer, needing only a power supply and a terminal; or it can be interfaced to a complete range of other boards and peripherals, and function as the CPU of a powerful minicomputer system.

Thus this board can be used as a Starter System, an initial stand-alone microcomputer with which a person can learn about microcomputers and programming without spending a fortune. But — unlike some other "beginner's kits" on the market — you never reach the point where you outgrow it and discard it. You just add to it as you want to, without sacrificing a cent of your initial investment. It costs more than the cheaper itty-bitty introductory kits. But then, it gives you 16 bits to work with right from the start, and you will still be using it next year, and for many years after that.

We invite you to send
for further details to:

**INNOVATIVE MICRO
PROCESSOR AND
COMPUTER TECHNOLOGY**

P.O. BOX 177, PETERSHAM 2049
(560-7603 AH)

The world
has begun
to discover
the T-9900-SS
HAVE YOU?

Design Features

- The T-9900-SS can provide minicomputer performance because its heart is the Texas Instruments TMS9900 microprocessor that was designed to be the CPU of a data-processing system, not to be just a controller or logic replacement device like the 8-bit chips. The TMS9900 looks more like an IBM 360 than it does an 8080 or Z80 or 6800 or 6502. Yet the T-9900-SS costs approximately the same as or only marginally more than systems with equivalent RAM, EPROM, and Monitor that utilize these 8-bit microprocessors.
- The T-9900-SS is fully socketed and fully buffered, and provides hardware multiply and divide, 16 accumulators, 15 index registers, separate 16-bit data and address lines, 8 vectored interrupts, a parallel and serial RS232 and 20 milli-amp current loop. Under the software control of the Monitor, the T-9900-SS automatically adjusts to the baud rate (up to 9600 baud) of the interfaced peripheral.
- The T-9900-SS is NOT S100 bus, but uses the much more flexible and more efficient universal bus system, with ten 16-pin I.C. sockets along one side of the board for interface plugs; connection to other boards and peripherals is made using 16-conductor cable and 16-pin dual-in-line connectors. Since no backplane or motherboard is needed, a chassis is not required (though one is available) — the unique modular design of the system allows it to operate inside a chassis or without one.
- The ten sockets provide connection for CRU OUT, CRU IN, Ground, Address, Power, Control 1, Control 2, Interrupt, Data, and RS232/TTY. The board provides for connection of either RS232 or 20ma current loop terminals.
- The board has a 1-chip clock (TMS9904) which will operate up to 3.3 MHz.
- One of the most valuable — and unique — features of the board is that it contains an EPROM Programmer for 2708s. These are programmed on the board under the control of the Monitor.
- The T-9900-SS can directly access 64K bytes of memory, and up to 16 megabytes of memory via memory mapping.
- The board can be supplied either as an unassembled kit, or assembled and tested, and in any one of three configurations: T-1.5K-ss: With 5K RAM, and 1K PROM monitor. T-6K-SS: With 2K RAM, 2K user-programmable EPROM, 1K Monitor and 1K Input Assembler. T-5K-SS: With 2K RAM, 2K EPROM, and 1K Monitor (for use with the T9948-C baud cassette machine, which comes with 1K Expanded Monitor to control it).

Please send me full details and prices for the T-9900-SS.

NAME.....

ADDRESS.....

STATE.....POSTCODE.....

eti/computerland software contest

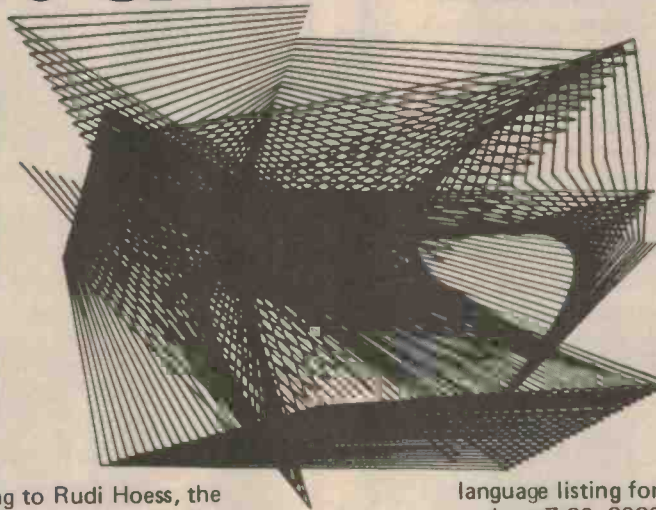

A few weeks ago, we were talking to Rudi Hoess, the principal of Computerland Australia, about the various things people were doing with their computers. We came to the conclusion that most people were writing bits of debugging software, disassemblers, monitors and the like, but not many people were really using them to create what we'll call application-oriented software (as far as we could gather). Most of the application software seems to be games software, to boot.

Well, we reckoned by now most of you have written games and disassemblers till you pretty well know the game backwards, and now you're looking for something to really get your teeth into. So, we decided to offer a little encouragement and the chance to prove you can do it.

Computerland and ETI are searching for applications oriented software, and we want you to write some, or submit some you've already written. The application you choose to implement is entirely up to you; however, here are a few suggestions which illustrate the kind of thing we're looking for:

- * *Burglar alarm with police notification.*
- * *Address/telephone file.*
- * *Calendar/clock/reminder list.*
- * *Chequebook balancing program.*
- * *Applications to help the handicapped.*
- * *Point of sale terminal.*
- * *Recipe file.*
- * *Mailing list processor.*
- * *Small business accounting package.*
- * *Inventory control.*
- * *Circuit analysis.*
- * *Amateur radio station control.*
- * *Music synthesis.*
- * *Computer communications set.*

The idea is to get your computer doing something that is in some way useful. The only stipulation we'd like to make is that software must be written either in BASIC or in the form of a well-annotated assembly

language listing for one of the popular microprocessors such as Z-80, 8080, 6800, 6502 and 2650. This means that we stand some chance of running your software to check it out. For the same reason, specialised hardware should be kept to an absolute minimum.

The criteria the judges will use to decide upon the winning entries will be: the value of the software to the user; its complexity, i.e. the size of the program; the 'elegance' of the software; the degree of 'human engineering' in the design of software features; and the quality, amount and presentation of the documentation supplied. It is likely that other factors will also influence the judges to some extent, as different criteria will apply in varying degree to different programs. The judges will be Dr R Graham, of NSW Institute of Technology, Rudi Hoess, of Computerland, and Collyn Rivers and Les Bell of ETI.

The prizes? Overall first prize is a Cromemco ZPU Z-80 CPU card while the second prize winner will receive a Vector Graphics 8K RAM kit. Third prize is a Vector Graphics 260 x 260 graphic display generator and fourth prize is a PROM/RAM card from Vector Graphics. In addition, each of the prizewinners will receive a two year airmail subscription to the US computer magazine of their choice and a two year subscription to ETI.

There will also be three special prize categories — the awards for 'Best Documentation' and 'Most Original Application' will each be a two year subscription package, while the 'Most Marketable Software' winner will, subject to agreement, be marketed on a royalty basis. In addition, the winning entries will be published in ETI, and payment for this will be made at our usual (excellent!) rates.

The closing date for this contest will be Friday, 3 November 1978, which should give plenty of time for development of some good software. The winners will be announced in the January or February 1979 issue, but if there are a lot of entries to be checked this may be delayed.

SEMCON MICROCOMPUTERS PTY. LTD.

ATTENTION MOTOROLA D2 OWNERS!

If you want a functional, expandable system, you need:

8K BYTE, STATIC MEMORY CARD

Australian Designed and Built

- Fast Access 350 ns Chips (2102LF)
- Low Current — 1.3 Amps
- Motorola Bus Compatible
- Write Protect
- Parity Generation/Checking available
- Professional Finish
- Plated through Holes
- \$275 assembled board
- \$219 in kit form
- 298 Assembled with Parity
- * \$110 for 8k kit without rams
- Built Boards Guaranteed 12 months



CARD CAGE/BACKPLANE:

- Designed for Motorola Cards
- Anodised Aluminium chassis
- Sturdy Construction
- Tin Plated Backplane
- Accommodates 8 cards

\$74.00

EDGE CONNECTORS —

43 x 2 x 0.156" \$8.50 each
Eight for \$59.00

\$100 Connectors \$8.50



THIS MONTH'S SPECIALS

Microprocessors

6802: The 6800 with a chip clock \$27.00
8080A \$15.00
280A 4 MHz version \$38.00
6820: PIA \$8.50

Memories

2708 EPROM \$16.50

1 Amp Voltage Regulators

7805, 7806, 7812, 7815 all \$1.20
555 Timer \$0.35

LOW POWER SCHOTTKY

74LS00 33	74LS38 40	74LS109 53
74LS02 33	74LS40 37	74LS138 1.20
74LS04 34	74LS42 1.30	74LS160 1.20
74LS05 37	74LS47 1.30	74LS161 1.20
74LS08 33	74LS74 0.55	74LS174 1.00
74LS09 33	74LS75 0.70	74LS175 1.00
74LS10 33	74LS85 1.58	74LS190 1.20
74LS11 33	74LS86 0.60	74LS191 1.20
74LS13 80	74LS90 1.20	74LS192 1.20
74LS14 1.40	74LS91 1.20	74LS193 1.20
74LS20 33	74LS92 1.20	74LS367 80
74LS30 33	74LS93 1.20	74LS368 80

I.C. SOCKETS — LOW PROFILE

SOLDER	DIL — TIN	WIRE WRAP GOLD
8 25	22 35	24 1.40
14 28	24 45	14 70
16 28	28 50	16 70
18 35	40 90	

SHOWROOM: 1 Chilvers Road, Thornleigh, NSW 2120.
MAIL ORDER: PO Box 61, Pennant Hills, NSW 2120.
PHONE: 848-0800. Add 15 percent sales tax. P&P \$1.50.

CITIZENS BAND ANTENNAS

Made in Australia by **SCALAR Industries**, suppliers of communication antennas to Government, Industry and Commerce.

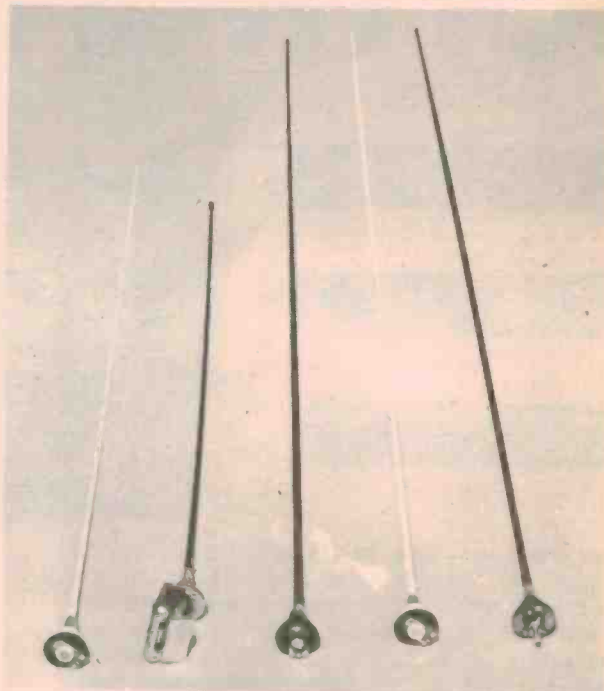

CB 1220 CB 1120 CB 1420 CB 1520 CB 1320

CB 1220	42" centre loaded
CB 1120	30" centre loaded
CB 1420	60" helical
CB 1520	60" helical/sector/top loaded
CB 1320	60" centre loaded

SCALAR Citizen Band antennas are designed to provide efficient performance with reduced length. Either helical, centre or top loading on fibreglass rods, many thousands are already efficiently in use throughout Australia in vehicle, marine and base installations.

Dipole Simulator meets the need of installations of 27 MHz antennas where a ground plane is not available. It can be used with any **SCALAR** 27 MHz whip top and is particularly useful in installations on fibreglass and wooden boats and vehicles having fibreglass cabins. The helipole converts the whip into a 1/2 wave centrefed dipole, assuring a very stable and efficient antenna system.



Modified CB accessories, for use with any **SCALAR** mobile whip top: o GUTTER GRIPS
• SLOPE ADJUSTERS
• MARINE KNOCK DOWN
• VEHICLE KNOCK DOWN



Available from leading retailers and distributors throughout Australia.

Trade enquiries to: **SCALAR Industries Pty Ltd.**

18 Shelley Ave, Kilsyth, Vic. 3137.
Tel: (03) 725 9677. Telex: AA 34341.
Cables: Wetkin.
NSW: 20 The Strand, Penrith, 2222.
Tel: (02) 570 1392 Telex: AA 27067.
QLD: 969 Ann Street, Fortitude Valley.
4006. Tel: (07) 52 2594. Telex: AA 43007.

SPECIAL OFFER

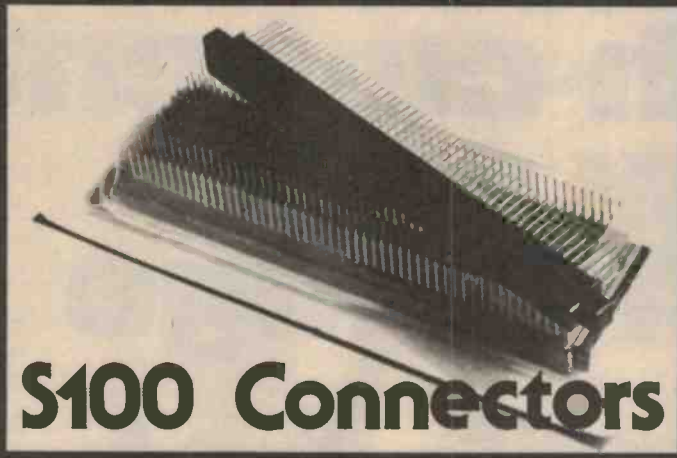

\$100 Connectors

Regular readers who have any interest in microcomputers will probably be aware of the S100 bus structure used in many microcomputers. Although its opponents claim that its design philosophy is outdated, it carries a lot of redundant signals and uses large expensive edge connectors, nobody has been able to come up with another bus to usurp it in the US.

At ETI, the question of bus structures has been a particularly vexed one, but there are just too many goodies available to S100 users for us to ignore. Add to this the fact that it's not too difficult to splice S100 cards onto other systems, and you can see the advantages of the S100 approach we took to the 640 VDU which appears this month.

One of the bugbears of the system, however, is obtaining the 100-pin connectors at a reasonable price, and so, in conjunction with General Electronic Services, we have arranged a special offer on these connectors. We are offering these in packs of 5 for \$29.50 (\$26.30 if you claim sales tax exemption) or 10 for \$54.00 (\$47.60 with tax exemption).

Just complete the coupon, enclose a cheque payable to 'Connector Offer', and send it to Connector Offer, Electronics Today, 15 Boundary Street, Rushcutters Bay, NSW 2011. Please allow at least three to four weeks for delivery.

Please send me five-packs and ten-packs of 100-pin

edge connectors. I enclose a cheque for
Please make cheques, money-orders etc. payable to 'Connector Offer', and post together with this form to: 'Connector Offer', ETI Magazine, 15 Boundary Street, Rushcutters Bay, NSW 2011.

Name

Address

Postcode

If you are claiming sales tax exemption, please give your sales tax number and sign here

ELECTRONIC DISPOSALS

297 Little Lonsdale St., Melbourne, 3000
Phone 663-1785

- AWA Solid State TV Tuners \$7.50 ea.
- AWA Thorn Valve TV Tuners \$5.00 ea.
- EHT Stick Rectifiers 75c ea.
- 13KV, 18KV, 20KV
- Plessey 8" 10W 8Ω or 15Ω \$6.50 ea;
- 4" 8Ω \$1.50 ea. Many other types in stock.
- 12V DC 5 Ω Solenoids \$2.00 ea.
- 12V AC Min. Relays 5 Amp. \$1.50 ea.
- Slide Pots. 20K to 3meg. Singles 35c ea. Dual 60c ea.
- Resistors. Most values ¼ to 1 Watt. 3c ea.
- Carbon Pots. Most values 30c ea. Duals 60c ea.
- resistors 100 mixed \$1.50
- Skeleton Preset Pots 100Ω to 3 meg. 8c ea.
- Green Caps .001 to .022uF 5c ea.
- .033 to .22uF 15c ea. .47 to .68uF 20c ea.
- Polystyrene Capacitors. Many Types 5c ea.
- Disc Ceramics. Large Range. 5c ea.
- Disc Ceramic capacitors 100 mixed \$2.00.
- Polyester Capacitors. Large Range. Up to 1.5uF 250V 10c to 25c ea.
- New Desk Telephones - Grey. \$15.00 ea.
- Polyester Capacitors 6.8uF and 3.3uF 60c ea. 2.2uF 40c ea. Tantalum Capacitors. Good range 15c ea.
- BC. 107 Transistors 10c ea.
- OA636 600V 2A Fast Recovery Silicon Diodes - TV Type 25c ea.
- Dual 100 Ω 3W Wire Wound Pots. \$1.25 ea.
- S.C.R. BT100A 300V 2AMP 60c ea.
- Triacs. 2AMP 400V 60c ea.
- 2N3055, 90c ea. AD149, \$1.00 ea.
- AY8110, 80c ea. OC912, \$1.00 ea.
- AY8139 and 9139, 45c ea. IN914 diodes 10c ea.
- 5 amp AC panel meters \$3.50 ea.
- 2500 uF 35V P/T electrolytics, 60c ea.
- 2200 uF 25V P/T electrolytics, 40c ea.
- Aluminium and plastic instrument boxes and ARLEC multimeters NOW IN STOCK.
- Spkrs MAGNAVOX 5"x3" 8ohm \$1.50 ea.
- Belt drive T/T kits 240V AC motor with speed change. 12" cast alloy platter, rubber mat, bearing, spindle and belt, \$25.00 ea.
- CTS 10" woofers Mod10W14P 8 ohm 50W continuous power, 30-2000Hz. Air suspension foam cone surround, 15oz ALNICO V magnet. \$19.50 ea.
- Silicon bridge rectifiers 400V, 1.5A, 85c ea.
- Balance meters 35Mm x 15Mm, \$2.00 ea.
- A&R 240V ac primary, 115V secondary at 95Vamps, \$7.50 ea.
- Phone enquiries and personal shopping only.
- Also in stock - large range of electrolytic capacitors - wire wound resistors - switches - panel meters - transistors - diodes - plugs - sockets - edge connectors - vero board - transformers - chokes. We could go on and on, so call in and browse around and check our low, low prices.

Motorola announces the high-current low cost 35 A bridge

We don't think anybody will admit coming even close to the MDA 3500's high-current, low-cost 35 amp capability.

Like giving 10 extra amps current handling at the 25 amp price. Plus 100 extra amps surge-protection at the 25 amp price, and super-efficient, 70 watt power dissipation at the 25 amp price.

Check these features:—400 ampere surge capability, electrically isolated base, fast recovery availability on request, cost effective in low current applications — and you'll have to admit our point — superior performance at equal cost.

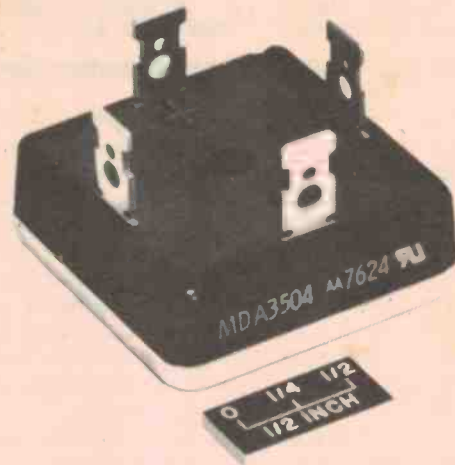

	MDA 3504	
1-24	25-49	50-99
\$2.77	\$2.46	\$2.30

PLUS TAX

CEMA ELECTRONICS PTY LTD



SYDNEY: 21 CHANDOS STREET,
ST. LEONARDS, N.S.W. 2065
Phone: 439 4655

MELBOURNE: 208 WHITEHORSE ROAD,
BLACKBURN, VIC. 3130
Phone: 877 5311

ADELAIDE: 170 STURT STREET, ADELAIDE,
S.A. 3130. Phone: 51 4080

NEW ZEALAND: CEMA-ELEKON LTD,
7-9 KIRK STREET, GREY LYNN,
N.Z. Phone: 76 1169

BRISBANE: Electronic Components (QLD.) — 371-5677 • CANBERRA: Daicom — 82-3581 • PERTH: Reserve Electronics — 87-1026
• HOBART: Tasmanian Electronic Supplies — 44-1337 • WOLLONGONG: Macelec — 29-1455.

DIGITAL ELECTRONICS BY EXPERIMENT pt2

THE IC WE HAVE CHOSEN to introduce TTL is the SN7414 Schmitt inverter, placed at the top left hand side of the blob-board. (As all the TTL series start with the letters SN, we shall omit these in future, and refer, for example, to the 7414.)

The circuit of an inverter is that of a high-gain inverting d.c. amplifier (Fig. 1), with the input at the emitter of a transistor and the output from a single-ended push-pull stage which is capable of passing of up to 16mA in either direction (to +5 V or to earth). This type of design, typical of TTL circuits, has several important implications for us.

Source or sink

One important result is that the input impedance is fairly low when the input stage is conducting. If the input is left floating, the connection of the base of the first transistor to +5 V will ensure that the emitter terminal will also be at high (+5V) voltage: The first transistor will be cut off in this state. The normal action of an inverter is that a high (or "1") input produces a low ("0") output, so that Q_2 is switched on by the high voltage at the collector of TR_1 and connects the output terminal to earth

through Q_4 . As mentioned above, this will allow a current of up to 16mA to pass from a positive source; in TTL language, the output stage will sink a current of up to 16mA.

Fanout

When we connect the input of the inverter to earth (0), what we are doing is to earth the emitter of Q_1 , with the base still connected, through its current limiting resistor, to +5 V. When this is done, a current of about 1.6 mA (set by the value of the limiting resistor) will flow from base to emitter, and it is very important that any resistance between the emitter (input) and earth should be small enough to prevent the emitter voltage rising above about 0.5 V in normal use. This is ensured when we drive a TTL input from the output of another TTL device, since a TTL output can sink a current of up to 16 mA, the current from ten inputs, without the emitter voltages rising too high for reliable operation. This is referred to as a "fan-out" of ten at the output.

Since in these circuits we are interested only in high and low signal levels,

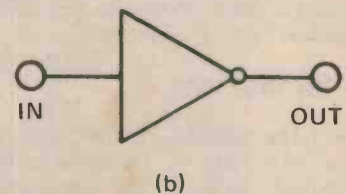
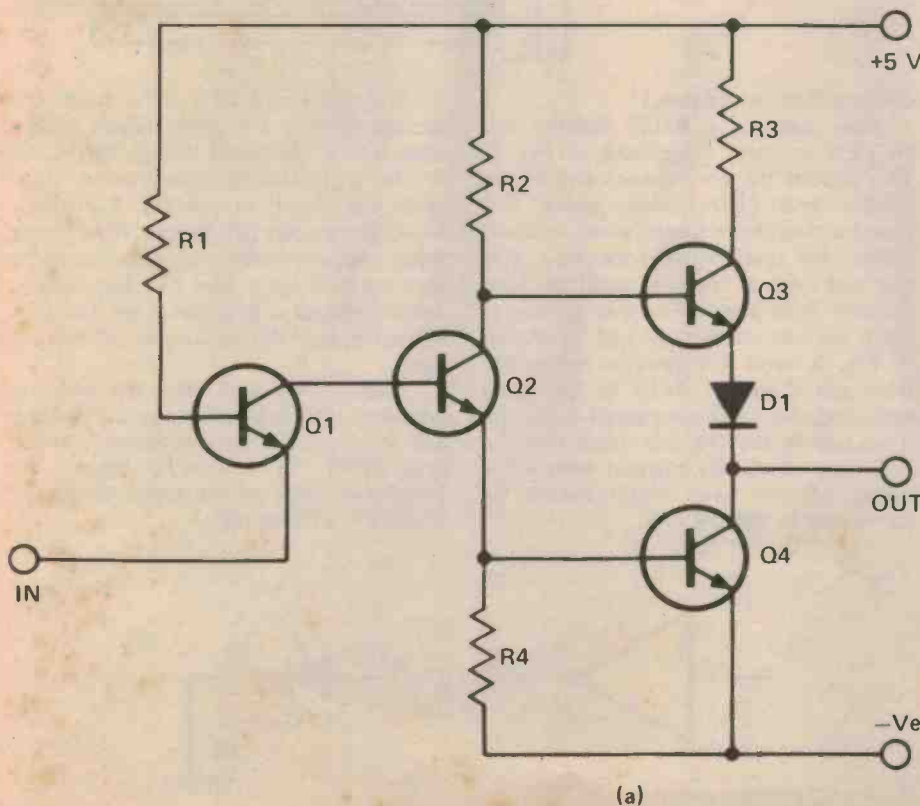

Fig. 1. A typical TTL inverter circuit (a). The value of R_1 is about $3k$, to limit the base current to 1.6mA. (b) Symbol.

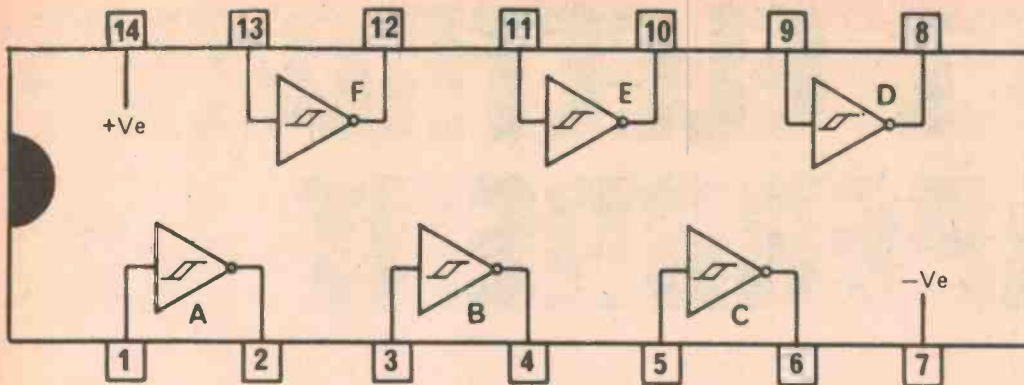

Fig. 2 Pin-out of the SN7414N Hex Schmitt inverter.

we must make sure that there is no uncertainty about either of these levels, and the usual TTL limits are; maximum of 0.8 V for the low; minimum of 2.2 V for the high. We prefer if possible not to approach these limits too closely, and if we drive a TTL input from any other type of output, we must be sure that the source impedance of the driver output will be low enough to allow a current of 1.6 mA to be sunk at a voltage level of 0.5 V or less; this corresponds to an output impedance of 300Ω or less.

Starting work

Ensure that the supply lines on your blob-board are fully linked up and, if you are using it, connected to the regulated supply. Join + and - leads to the power supply. If you have a separate supply, these regulated leads, which should be colour coded, will connect directly to the supply lines on the board. If you are using a built on regulator the leads should run to the regulator input.

With no other connections made (none of the ICs wired to the supplies) ensure that the supply voltage is between 4.75V and 5.25V with the supply on. Switch off again. This check should be repeated whenever the board is used from a variable voltage supply, since TTL circuits will be damaged if any input is taken to 0 with the applied voltage too high.

Four for four uses

Connect the supplies to the 7414, pin 14 to +5V, pin 7 to earth. These connections, like all the connections which follow, are made by soldering short lengths of insulated wire between pads on the blob-board, as shown in Fig. 3. The IC supply connections can be left permanently. (With no other connections made, the IC will draw a

Fig. 3. Connections to + and - lines using wires. This also shows the LED and its limiting resistor (Fig. 4) in place.

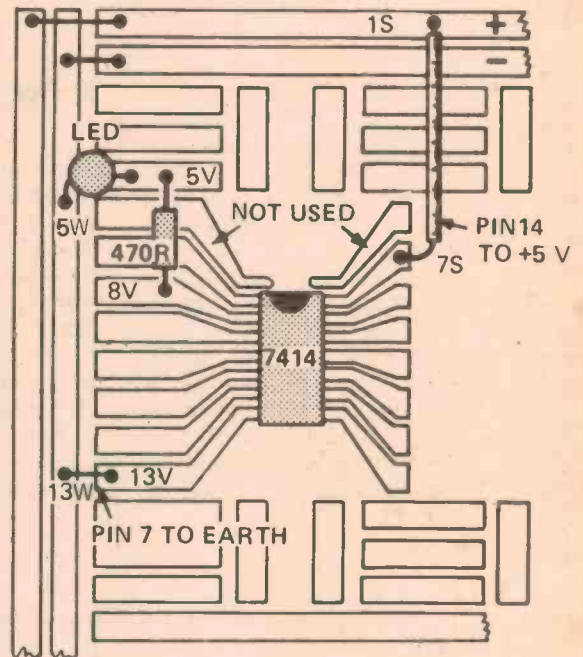

current of about 85 mA.)

Now connect a 470R resistor and an LED to form the circuit of Fig. 4. This is done by tinning each end of the resistor and LED leadout wires, and then butting these tinned wires, in turn, against the blob-pad and touching wire and pad with a hot iron until the lead "blobs" into place. For this particular joint, we can use a spare pad, as shown in Fig. 3, with the resistor connected from pin 2 of the 7414 to the spare pad, and the LED connected from the spare pad to the OV line. Note that the LED case is usually marked with a flat section at the wire which should be connected to the OV line.

The LED will now light when the output of No. 1 inverter (there are six inverters in the pack) is high. Switch on - the LED should remain unlit, since with the input, at pin No. 1, floating high, the output will be low. Now check what happens when pin 1 is temporarily earthed through a wire link (no need to solder) placed with one end on the pin 1 blob-pad and the other end on the OV line.

Remove the wire, and try bridging between the blob-pad for pin 1 and the OV line with low value resistors, starting with 220R and working up. What is the maximum value of resistance which will allow the LED to light?

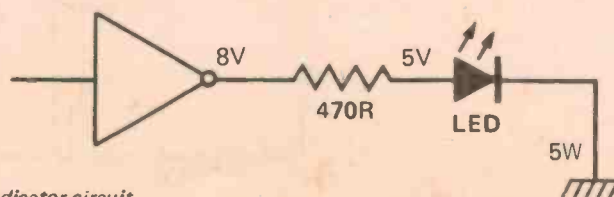

Fig. 4. LED indicator circuit.

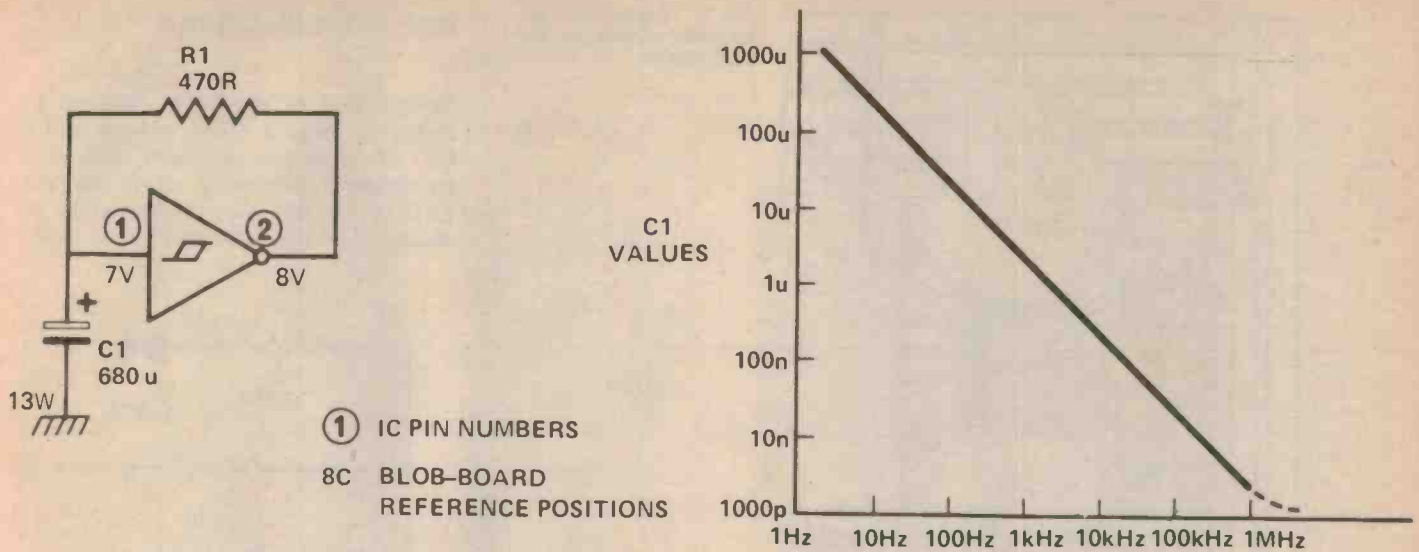

Fig. 6. Oscillator circuit, with a graph of approximate frequency against capacitor value. The frequency changes considerably when the operating voltage is changed, also as the resistor value is varied.

FREQUENCY

Schmitten with complexity

The actual circuit of the 7414 is more elaborate than the outline which has been shown in Fig. 1. These inverters are Schmitt trigger inverters, indicated by the symbol of Fig. 5(a), in which some positive feedback is used to make the changeover between 1 and 0 very much more rapid than that of an amplifier alone.



Fig. 5. Schmitt Trigger. (a) Symbol. (b) Typical circuit. (c) Graph of output voltage plotted against input voltage.

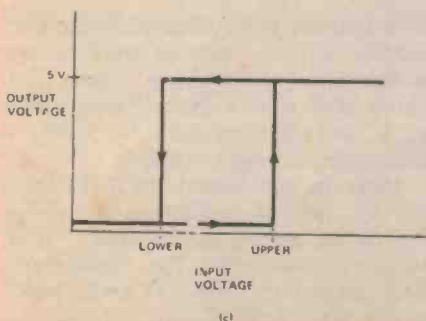
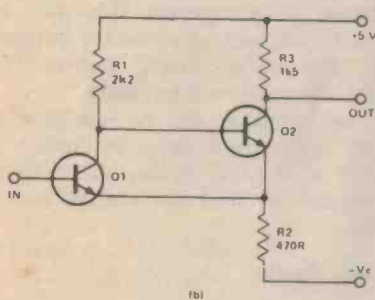

Let's examine what happens as the input rises from 0 V. When the input voltage reaches approximately 2.2 V, the current into the base of Q2 will drop to less than that needed to hold Q2 in saturation. The voltage on Q2 collector will therefore rise, reducing the current in R3 and hence R2. Herr Ohm has told us that the voltage across R2 must drop as a consequence, thus forward biasing Q1 even further, and reducing the current into the base of Q2, and so on, until Q2 is finally off. Positive feedback at work!

The voltage across R2 is maintained (at 0.6 V less than V_{in}) by the emitter current of Q1, which is, of course, the collector current flowing through R1 plus Q1 base current. When V_{in} drops below 1.48 V, the base current is too low to hold Q1 in saturation. At this point the voltage across R2 is 0.88 V. Current will now flow into the base of Q2 and the resulting current in R3 raises the voltage across R2, turning Q1 off, thus saturating Q2 again.

Slow, slow, quick quick . . .

Since the normal type of TTL circuit consists of a very high gain d.c. amplifier, there is a risk of positive feedback, causing high frequency oscillations, if the amplifier is ever operated, even momentarily, in a linear region, that is with the input biased so that the output voltage is between 1 and 0, or slowly changing. There is no problem if the change between 1 and 0 is fast, 30 ns or so, but slow in this context can mean 1 μs!

• Slowly changing waveforms are most likely to be found when other circuits such as photocell amplifiers, micro-switches or tachogenerators are connected to TTL inputs. This is an interface problem. Using a Schmitt stage at the input solves this, assuming we have a low enough impedance to drive the Schmitt, since the Schmitt action will give a 30 ns rise or fall time at its

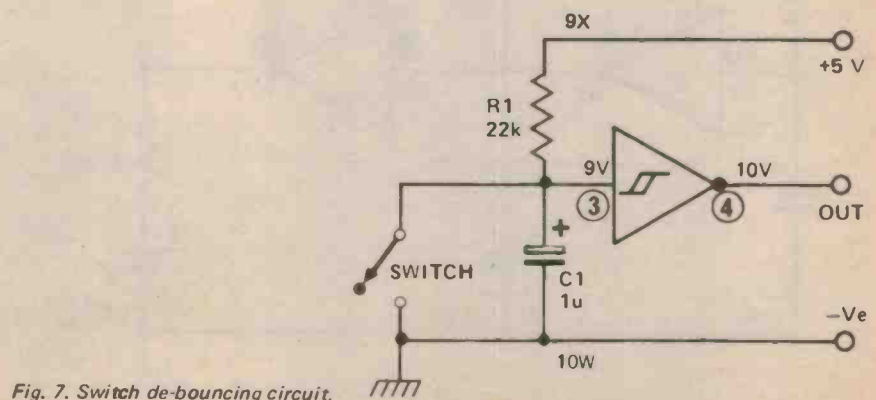

Fig. 7. Switch de-bouncing circuit.

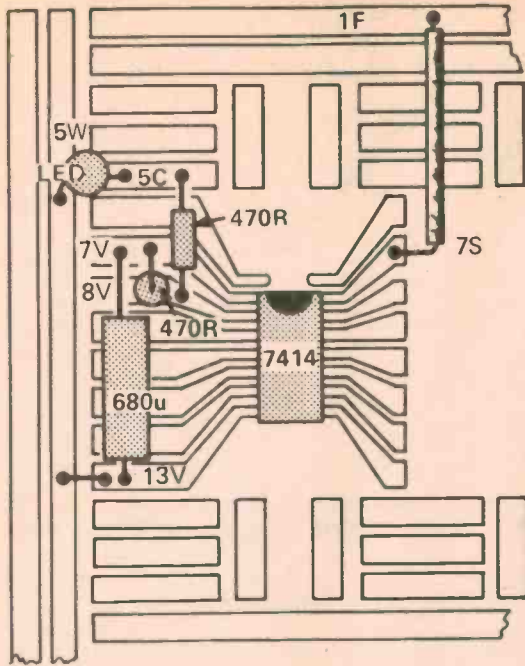

Fig. 8. Layout of the oscillator circuit on the Blob-board.

output for any type of input, however slowly changing. Once the Schmitt has triggered, a comparatively large voltage swing is needed to make it change back. A Schmitt stage with high input impedance is also available (SN72560).

Debouncing

One of the unique features of this type of stage is that it can very simply act as an oscillator or as a switch debouncer. Oscillating action is achieved by connecting a resistor of between 330R and 820R between output and input, with a capacitor between input and earth. The circuit is shown in Fig. 6. The output waveform is a square wave with very short rise and fall times, and unequal mark and space times.

When mechanical switches are used to provide waveforms for TTL circuits, contact bounce may cause problems. It occurs as contacts close, and cause a TTL input to be left briefly floating during the time of the bounce.

The effect of this can be to cause several output pulses from the switch where only one is intended. This is harmless if the switch is simply setting d.c. levels, but causes errors if the pulses are being counted. To de-bounce a switch, the circuit of Fig. 7 can be used. The principle is that the time constant is longer than the bounce time of the switch, so that the voltage change when the contacts bounce is small, less than the hysteresis of the Schmitt circuit, hence no change in the trigger output when the bounce occurs.

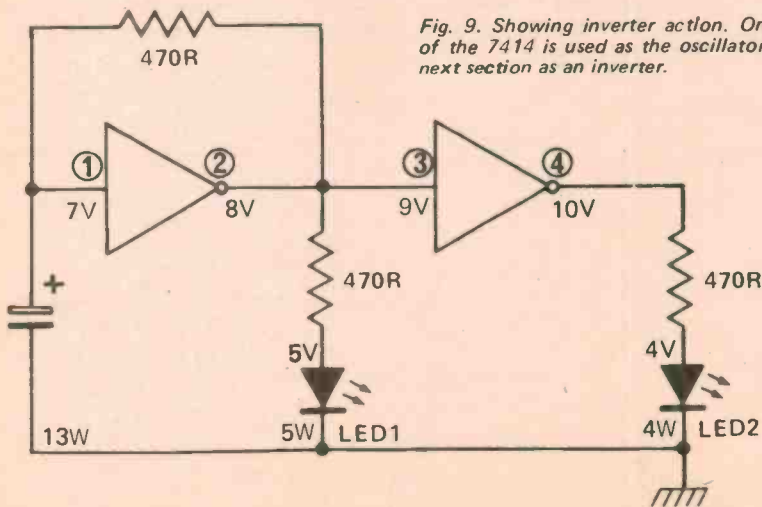

Fig. 9. Showing inverter action. One section of the 7414 is used as the oscillator, and the next section as an inverter.

Back to the Blob-Board

Using unit 1 of the 7414, make up an oscillator using a 680R resistor and a 680 μ F capacitor as shown. Keep the connections previously made to the LED, since this can now be used to check that the oscillator is working.

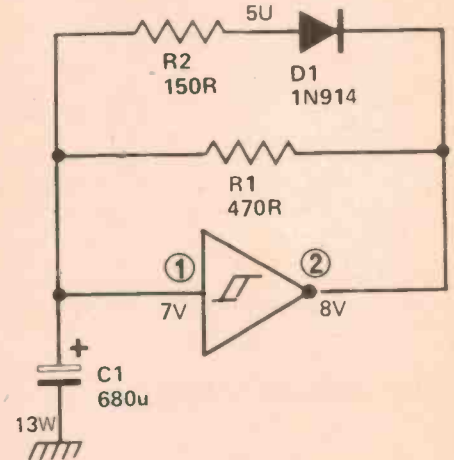

Fig. 10. Modification of the oscillator circuit for equal mark-space ratio. This is not needed for any of the applications in this series.

Estimate the frequency by counting the number of LED flashes in one minute, and then dividing the number counted by 60. Demonstrate the inverter action by using unit 2 as shown in Fig. 9. Wire a connection from pin 2 to pin 3 of the IC, and a 470R resistor from pin 4 to a spare pad. Connect another LED between this pad and earth to indicate when unit 2 output is high. Switch on again, and the two LEDs should blink alternately.

The oscillator can be modified for equal mark-space ratio by using the circuit of Fig. 10. Some trial and error is needed to find the correct resistor value.

Organ Bank

Note that the 7414, with its six separate inverter circuits, can be used as the oscillator for an electric organ. Two 7414s will give a basic twelve note scale, and dividers can be used to produce lower frequencies.

Later in this series, the 7414 units will be used as oscillators to provide slow clock pulses, as inverters, and as switch de-bouncers. The connections made during this month's experiments can be left in place.

Two valuable new additions to TI's reference library for the design engineer.

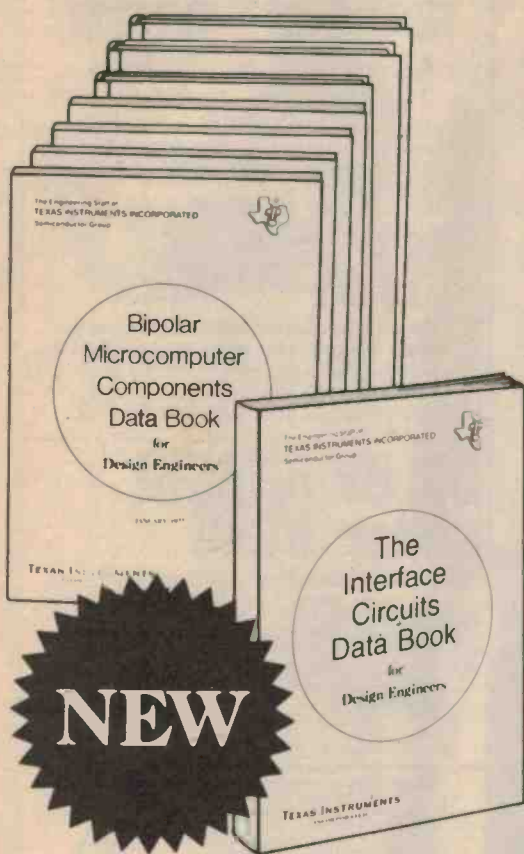

Announcing two new additions to Texas Instruments library of comprehensive data books for design engineers:

The **Interface Circuits Data Book** contains complete information on line drivers and receivers, MOS interface circuits, peripheral drivers and more.

The **Microcomputer Components Data Book** details 59 digital building blocks designed to implement high-performance computer and controller systems.

Like their companion volumes, these new reference aids contain data sheets, applications notes and product selection guides...everything you need to make optimal device selections and plan cost-effective systems.

The Interface Circuits Data Book, 576 pages, 1977.

Complete information on interface circuits including line drivers, receivers and transceivers, memory drivers, MOS interface drivers, sense amplifiers and peripheral drivers. Also display drivers for LED, AC plasma, gas discharge and thermal print displays. Includes selection and interchangeability guides and complete thermal information on all applicable package types. Margin tabs and alphanumeric indexes provide easy reference.

The Bipolar Microcomputer Components Data Book, 300 pages, 1977.

59 high-complexity bipolar building blocks for use in high-performance computer and controller systems: Schottky and I²L 4-bit slice processor elements, SBP9900 I²L 16-bit microprocessor, plus TTL ROMs, 4096-bit RAMs, Schottky PROMs, high-performance Schottky TTL RAMs and a Schottky TTL asynchronous first-in/first-out memory. Support circuits covered include latched bus receivers, TTL line drivers and more.

The TTL Data Book, 832 pages, 1976.

Detailed specifications on over 900 TI devices including standard TTL and high-technology Schottky TTL ICs. Pin assignment drawings of all TTL types including bipolar memories and microprocessors; interchangeability guides; EIA- and IEC-approved terms and symbols; JAN IC data with 38510 cross-reference tables; up-dated MACH IV hi-rel procurement specification; complete line of TI IC sockets and inter-connection panels.

The Optoelectronics Data Book, 368 pages, 1976.

252 devices including infrared emitters, photodetectors, optocouplers, sensor/emitter arrays, visible-light-emitting diodes, visible displays, advanced opto products; expanded glossary of terms updated in accordance with recent JEDEC guidelines, interchangeability guide listing over 800 opto devices, 11 applications articles on subjects such as operation theory, measurement techniques and device reliability.

The Linear Control Circuits Data Book, 368 pages, 1976.

Operational amplifiers including new JFET-input devices, differential comparators, voltage regulators, and special functions including monolithic analog switches previously available only as hybrid circuits; updated glossary of terms and definitions, handy selection guides, interchangeability guides, and military products cross-reference; complete mechanical data and thermal information for all available package types.

The Semiconductor Memory Data Book, 272 pages, 1975.

Detailed specifications on 111 memory products including 61 MOS RAMs, ROMs and Shift Registers; 43 TTL RAMs, ROMs and PROMs; 7 ECL RAMs, PROM. Plus summary of TI microprocessor circuits, complete mechanical data for all available package types, glossary of symbols and terms used with memory integrated circuits, updated 38510/MACH IV Procurement Specification.

The Transistor and Diode Data Book, 1,248 pages, 1973.

800 transistor types — grown-junction, multijunction, unijunction, and field-effect transistors; 500 silicon diode types — switching, rectifying, voltage-regulating, voltage-variable-capacitance, and general purpose diodes, as well as multi-element diode arrays and matrices; individual transistor chip characterizations.

The Power Semiconductor Data Book, 816 pages, 1972.

Germanium and silicon power transistors, SCRs, triacs, and power function modules; silicon power high-voltage and low-voltage, high safe-operating-area (SOA) designs, power Darlingtons, fast switching types, radiation-tolerant designs, JAN and JANTX, metal can and plastic packages.

- LCC4330 Interface Circuits Data Book, (2 lbs. 6 oz.)
- LCC4270 Bipolar Microcomputer Components Data Book, (1 lb. 7 oz.)
- LCC4112 TTL Data Book (second edition), (2 lbs.)
- LCC4230 Optoelectronics Data Book (fourth edition), (1 lb. 12 oz.)
- LCC4241 Linear Control Circuits Data Book, (1 lb. 12 oz.)
- LCC4200 Semiconductor Memory Data Book, (1 lb. 5 oz.)
- LCC4131 Transistor and Diode Data Book, (3 lbs. 8 oz.)
- LCC4041 Power Semiconductor Data Book, (3 lbs. 5 oz.)

To: Texas Instruments Limited, P.O. Box 106
North Ryde, N.S.W. 2113

Name _____
Address _____
City _____ State _____ Zip _____



TI Distributors

New South Wales:

Instant Component Service
16 Gertrude St.
Arncliffe, NSW 2205
597-1444

CEMA Electronics Pty., Ltd.
21 Chandos St.
St. Leonards, NSW 2065
439-4655

Victoria:

Instant Component Service
248 Wickham Rd.
Moorabbin, Vic. 3189
95-9566

South Australia:

Instant Component Service
147 Ward St.
Nth. Adelaide, S.A. 5006
267-2393

TEXAS INSTRUMENTS
AUSTRALIA LIMITED

SAVE
LOOK AT
OUR
HITACHI
TAPE
PRICES!



They must be the cheapest around!

TYPE	Cat. No.	1-9	10 or more
C60LN	C-3060	\$1.75	\$1.50
C90LN	C-3065	\$2.20	\$1.90
C60UD	C-3070	\$2.75	\$2.20
C90UD	C-3075	\$3.20	\$2.70

MINISCAMP

STILL THE BEST MINICOMPUTER
VALUE FOR THE BEGINNER...

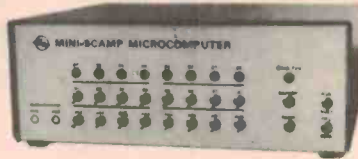

This is the original Mini-scamp micro-computer kit as described in E.A. It is ideal for teaching (and learning) basic computer functions — it really works! Kit is complete with 256 byte memory — easily expandable to 1k at low cost. Team it up with our other computer kits (e.g. tape reader, video display unit, ASCII encoder, etc) and you're really in business.

\$105⁰⁰ Cat. K-3446.

WATCH THIS SPACE...

AND FIND OUT WHAT YOU MISSED OUT ON!

We're going to have a below-cost special in each of our stores each month. We're not going to tell you what it is — that's for you to find out! There's one on right now — we'll tell you what it was next month. For personal shoppers only.

Mail order customers: Don't think you're missed out — watch your mail box for exclusively mail-order customer specials.

HOBBYISTS make life easier!

GENERAL PURPOSE
TOOL BOX

- *HOBBIES
- *FISHING
- *GARDENING
- *TRADESMEN
- *TECHNICIANS

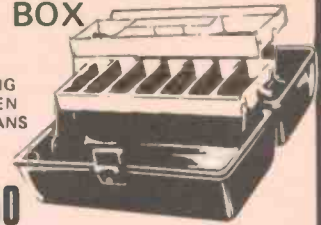

\$17.50

These tool boxes sell elsewhere for around \$25 — \$35 and even more. Now look at our price for the same thing! Ideal for tools and components. Divided sections swing out at top. Incredibly useful; incredibly priced!

Cat. H-2600.

Value

MULTIMETER ALSO TESTS TRANSISTORS.

High sensitivity (100k/V) multimeter with highly useable ranges also checks transistors, diodes etc. Complete with test leads and batteries. Cat. Q-1136.



\$49⁵⁰

Scare off the burglars & intruders. This kit is ideal for the handyman — so easy to install. Comes with master module, window switches, panic & trap switch, fire sensor plus alarm module. Full inst. supplied. Protect your family NOW! Cat L-5105

A HOME BURGLAR ALARM



\$49⁵⁰ GREAT HOME
BURGLAR ALARM KIT!

DOLBY HITACHI under \$150!

Save now — was selling for around \$200. Top loading deck, ideal for up-grading your system. Be quick!



Cat A-3683

\$149⁰⁰

THE DICK SMITH HEATED TOILET SEAT

At last — the ultimate in luxury and comfort! Low power consumption, easy to install. Instructions supplied.



Cat. X-2000

\$32.50

Mains operated.

DICK TRACER



We know it's hard to believe — a radar detector under \$50.00! But here's one — the Dicktracer is about the size of a couple of packets of cigarettes — and beeps at the slightest smell of radar!

\$49⁵⁰ Cat. A-8500.

WHY PAY \$100 OR MORE?

MINI CASSETTE RECORDER

Take dictation, record events, etc. Has review facility. Microphone in-built & comes with batts.



Cat. A-4050.

\$49.95

MICROCOMPUTER DOOR- BELL PLAYS 24 TUNES!

Sure does — you select the tune. Complete kit is so easy to build. Cat. K-2020.



\$49⁵⁰

'RUBBER DUCK' CAR ANTENNA

Durable, ideal for AM or FM reception. Rubber-type material, just 390 mm high. Superb new design offers high efficiency. Cat A-7345



\$9.95

OWN A BOAT RADIO? GETTING INTERFERENCE?

We've arranged a special batch of 'Hi-side' crystals for the marine channels. These should effectively remove or minimise interference to the marine 27MHz channels.

For 27.88 — Cat D-6123
For 27.89 — Cat D-6124
For 27.90 — Cat D-6125
For 27.91 — Cat D-6126

\$5
each

REPLACEMENT WHIPS

Stolen? Strayed? Maybe even broken! Replace your CB antenna with one of our fibreglass whips.

Left: Our famous 'no-snip' helical antenna. Easy to SWR. Standard 3/8 base. Cat D-4077.

Right: Huge 9' fibreglass 1/4 wave whip. Best performance. Standard 3/8 base. A beauty! Cat D-4416

\$22⁵⁰
\$14⁵⁰

DID YOU GET YOURS?

THE 1978 DICK SMITH SUPER-CATALOGUE WAS IN ELECTRONICS AUSTRALIA LAST MONTH.

If you missed out, copies are still available from your nearest Dick Smith store or dealer for only 75c.

Also available through the mail order department — P.O. Box 747, Crows Nest, NSW, 2065.



DICK SMITH — where the hobbyist's dreams can all come true

SCOTCHCAL: We are now a distributor of famous 3M 'Scotchcal' photosensitive products. You can make your own professional quality printed circuit boards and front panels easily and with a minimum of fuss.

- Cat H-5696 — 8500 Developer solution .. . \$1.00
- Cat H-5690 — 8007 Exposure film .. . \$3.90
- Cat H-5692 — 8001 Photosensitive aluminium sheet — black .. . \$6.00
- Cat H-5694 — 8005 Photosensitive aluminium sheet — Black .. . \$6.00

See the articles in Electronics Australia, Dec. '77 & Electronics Today, Sept. & Dec. '77 for full details outlining the use of photo-sensitive products.

PRINTED CIRCUIT MATERIALS: Simple to use, in either negative or positive working forms. Ideal for the experimenter doing 'one offs' or the prototype laboratory, etc.

- Cat H-5720 — CCPR12 positive working photo resist for PCB's .. . \$3.75
- Cat H-5722 — CCNR204 negative working photo resist for PCB's .. . \$2.75
- Cat H-5724 — CCPD16 Developer for CCPR12 .. . \$1.85
- Cat H-5726 — JCND206 Developer for CCNR204 .. . \$3.00

BLANK PCB & ALUMINIUM Ideal for above chemicals, or other methods.

- Cat H-5500 — Blank bakelite copper board, 75 x 150mm65c/m
- Cat H-5510 — Blank bakelite copper board, 300 x 300mm square .. . \$2.95
- Cat H-5540 — Blank fibreglass copper board, 75 x 150mm .. . \$1.00
- Cat H-5560 — Blank fibreglass double sided copper board, 150 x 228mm .. . \$3.50
- Cat H-2560 — Aluminium sheet, 18 gauge 298 x 298mm .. . \$2.00
- Cat H-2558 — Aluminium sheet, 18 gauge 149 x 149mm .. . \$1.00

TOOLS: Come to Dick Smith for all your hobbyist's tools. We've got them — quality tools at budget prices. Specialist tools. Handy tools. Service tools and aids. Outstanding selection.

- Cat T-3566 — Mini flatnose plier (for delicate work) .. . \$3.25
- Cat T-3561 — Mini diagonal cutting plier .. . \$3.25
- Cat T-3220 — Cutting nipper/stripper — two tools in one .. . \$5.25
- Cat T-5106 — Vacuum base vice — mounts on any polished surface. 2" opening .. . \$19.95
- Cat T-3165 — Pliker — plier, cutter, crimper and stripper in one. .. . \$7.95
- Cat T-4670 — 40 piece socket set with ratchet driver & bar .. . \$16.50

SERVICING AIDS: They'll make your life easier, serviceman or hobbyist!

- Cat N-1051 — Freon spray. Cleaner, degreaser, moisture remover. Not toxic .. . \$2.75
- Cat N-1040 — Electrolube Preclene. Cleans tuners, switches, plugs etc. .. . \$3.90
- Cat N-1060 — CRC 2-26 Ideal for wet ignitions, etc. Loosens frozen nuts .. . \$4.75
- Cat N-1056 — Spray freezer — canned cold for tracking down intermittents .. . \$3.00
- Cat N-1200 — Thermopath 167 — silicone based heatsinking compound .. . \$1.20

WIRES & CABLES: For all purposes — mains leads, jumper leads, connections etc.

- Cat W-2010 — Mini Fig. 8 cable. Ideal for speaker leads. Polarity marked .. . 15c/m
 - Cat W-2055 — 3 core mains cable, 240V rated. .. . 40c/m
 - Cat W-2220 — flexible light duty hook-up wire. Many colours available .. . 8c/m
 - Cat W-2045 — 12 colour rainbow cable. A great source of hook-up wire .. . 60c/m
- PLUS MILLIONS OF METRES OF WIRE — TOO NUMEROUS TO LIST!

SEMICONDUCTORS — INTEGRATED CIRCUITS — VOLTAGE REGULATORS

Dick Smith has a huge range of solid state devices . . . this list is just a tiny section. If the device you want isn't here, it's probably stocked anyway. (See our new cat.)

AC127	Z-1062	80c	TT801	Z-2068	\$1.00	DSE12	Z-4802	75c	4449AE	Z-5720	55c
AC128	Z-1064	80c	2N3055	Z-2145	\$1.20	ZN414	Z-6520	\$3.95	MC14584	Z-5413	\$1.60
AC188	Z-1082	95c	Z5C1306	Z-2501	\$4.50	IC-24	F-4420	\$12.50	74C00	Z-5410	50c
BC107	Z-1300	75c	Z5C1307	Z-2502	\$6.50	MM5314	Z-6814	\$5.90	74C925	Z-5414	\$12.00
BC108	Z-1308	25c	1N4002 (EM401)			CT7001	Z-6821	\$6.50	MM3001	Z-6132	\$13.50
BC109	Z-1319	27c		Z-3202	15c	7400	Z-5010	45c	MM5369	Z-5781	\$3.50
BC109C	Z-1329	49c	1N4007 (EM410)			7404	Z-5014	45c	MM5303	Z-9204	\$5.90
BC157	Z-1340	33c		Z-3207	30c	7413	Z-5023	45c	MM5740AAF	Z-9202	\$27.50
BC158	Z-1348	33c	1N5624	Z-3222	45c	7447	Z-5047	\$1.80	2102	Z-9302	\$4.50
BC159	Z-1359	30c	MR110	Z-3240	90c	7473	Z-5073	\$1.10	2114	Z-9306	\$14.50
BC639	Z-1368	75c	BYX21L/200	Z-3260	\$2.20	7474	Z-5074	\$1.10	LM301	Z-6040	\$1.05
BC640	Z-1389	75c	0A91	Z-3140	25c	7490	Z-5080	\$1.00	LM380	Z-6080	\$2.00
BD130	Z-1443	95c	BA100	Z-3060	75c	7493	Z-5093	\$1.10	UA705	Z-6352	\$1.00
BD140	Z-1444	95c	1N914	Z-3120	12c	74121	Z-5260	80c	UA741	Z-6382	60c
BF115	Z-1560	90c	CI220	Z-4330	\$2.60	9366	Z-5354	\$3.52	LM3909	Z-6109	\$1.50
DI3T1	Z-1780	\$1.54	SC1410	Z-4510	\$2.00	95H90	Z-5360	\$16.50	NE555	Z-6145	\$1.00
DS2646	Z-1786	\$1.20	ST4	Z-4740	\$1.10	4000AE	Z-5600	46c	NE556	Z-6146	\$2.75
FP1100	Z-1950	\$2.00	RL-209R	Z-4010	30c	4006AE	Z-5606	\$3.02	OM321	Z-6180	\$15.00
MPP102	Z-1832	80c	TL-220R	Z-4030	35c	4017AE	Z-5617	\$2.92	SAK140	Z-6230	\$3.10
TP318	Z-2020	90c	DL1704	Z-4110	\$2.50	4023AE	Z-5623	46c	SL440	Z-6250	\$8.94
TP328	Z-2024	\$1.00	TGS812	Z-6860	\$8.90	4027AE	Z-5627	\$1.28	7805	Z-6545	\$2.00
TT800	Z-2064	\$1.00	ORP12	Z-4800	\$1.45	4028AE	Z-5628	\$2.31	7812	Z-6552	\$2.00

**** PROJECT KIT BUILDERS ****
This column is just for YOU! Each month, we will endeavour to bring you the very latest in kits from the magazines (providing, of course, you have details in time). Remember, we not only stock kits, but the parts to make them as well. So if you just want the PCB board, we have it! Or other special components. Just ask! If we don't stock a particular kit, it's probably because all the component parts are normal stock lines. So if a project you want to make isn't listed, ask at your nearest store.

VK POWERMATE (See May '78 EA)

Short form kit includes all electronic parts but not metalwork, heatsink, mains wiring or terminals

- Kit: Cat K-3449 .. . \$32.00
- PCB (only) Cat H-8342 .. . \$2.00
- Special 5600uF/40V electrolytic capacitors: Cat R-4570 .. . \$3.90
- Power Transformer Cat M-2000 .. . \$17.32



ELECTRONIC MORSE CODE KEYS (See March '78 EA)

- Complete kit, supplied with paddle, undrilled case & plain painted panels.
- Kit: Cat K-3470 .. . \$37.50
- Paddle only: Cat D-7103 .. . \$17.50
- 9 volt battery: Cat S-3200 .. . \$2.00
- PCB only: Cat H-8340 .. . \$3.75

R-C-L BRIDGE (See March '78 EA)

- Complete kit, supplied with printed, but un-punched panel,
- Kit: Cat K-3468 .. . \$34.50
- PCB only: Cat H-8339 .. . \$4.75

Special kits for the following are not made up, but parts are normally stocked for these and most other EA constructional projects:

- White & Pink Noise Generator (see April '78 EA)
- Photo Timer (See April '78 EA)
- LED Chaser (See April '78 EA)

DICK SMITH ELECTRONICS



SHOP HOURS
Mon-Fri 9AM - 5:30PM
Sat 9AM - 12 noon
Brisbane (hour extra)

bankcard
welcome here

Order value P&P charge
\$5 \$9.99 \$1.00
\$10 \$24.99 \$2.00
\$25 \$49.99 \$3.00
\$100 or more \$4.00

SYDNEY
125 York St.
City Ph 29-1126

147 Hume Hwy,
Mullora. Ph: 642 8922
We've moved!

SYDNEY
162 Pacific Hwy.
Gore Hill Ph 439-5311
Ample parking at door.

SYDNEY
30 Grose St.
Ph 683 1133

MELBOURNE
399 Louise St.
City Ph 67 9834
1st floor - friendly store! New right in town!

MELBOURNE
656 Bridge Rd
Richmond. Ph 42-1614
Easy access - huge stock

BRISBANE
166 Logan Rd.
Buranda. Ph 391 6233
Opens 8:30AM

ADELAIDE
203 Wright St.
City Ph 212 1962
Now Open. See us!

MAIL ORDER DEPARTMENT PO Box 747, Crows Nest, NSW 2065 Phone 439 5311 Post & Pack extra

WE HAVE DEALERS RIGHT ACROSS AUSTRALIA THERE'S ONE NEAR YOU!

Audio Spectrum Analyser 2

LED display for compact, easy-to-build unit.

OUR PREVIOUS Real Time Audio Analyser design produced beautiful displays on the screen of an oscilloscope but this means, of course, that to use the device one has to have a scope. Not everyone has, and with this in mind, we contemplated the design of a more conventional analyser with LED bargraph display. Urged on by reader response to our hint that this design was on the cards, we have gone ahead and produced the project in double-quick time.

This version has the great advantage of portability over the previous design, and also looks better than a scope sitting next to your brand new, 21st Century styled hi-fi! It is also easier to set up and trouble-shoot.

Design Features

When we proposed a LED version of the spectrum analyser we initially were going to use the original filter board and design a new logic board which multiplexed the LED display. The only question at that time was whether to multiplex the LEDs as columns or as individual LEDs. The column method is easier on the power supply as the peak current is only 10 times the average current while singly the peak current is 80 times the average. This is not quite accurate because a multiplexed LED requires less average current for the same output than one continuously on. However the column method also requires one extra diode per LED to give the isolation required between columns.

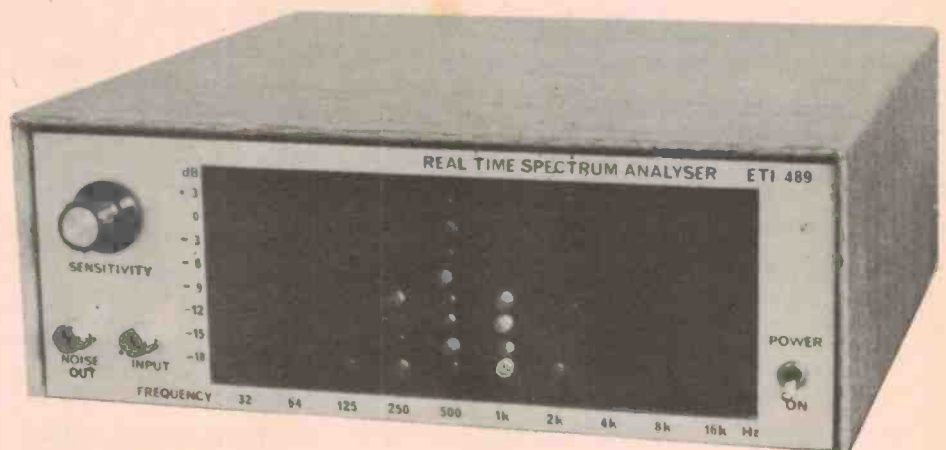

SPECIFICATION – ETI 489

No. of bands	10
Frequencies	31, 63, 125, 250, 500, 1k, 2k, 4k, 8k, 16k
Filter characteristics	-12dB, one octave from nominal centre frequency
Display	LED display 3dB spacing
Input level	50mV – 10V
Input impedance	200k
Pink noise output	200mV

After struggling with the PC board layout which was developing into a double sided board similar the filter board of the previous analyser, we decided there must be an easier way to make a living! The question was then raised of whether it was worthwhile to multiplex the display at all and the answer was the project as it appears here.

The individual board approach not only makes fault finding easier and less likely, it also allows single sided PC boards to be used throughout. The system can also be expanded (or cut down) as desired simply by changing the filter components and the number of display boards. The power supply is capable of supplying up to 20 display boards without increasing the filter capacitors.

Construction

Assemble the power supply board and the ten filter display boards with the aid of the overlays. The filter components can be selected from Table 1 noting that when the tantalum capacitors are used in the three lower octaves a bias resistor R15 is needed. The LEDs should be installed as evenly as possible with the polarity correct.

We assembled the units on 1/8" brooker rod with 12.5mm spacers between the boards. Metal brackets are used at each end to support the assembly. On the filter display boards the power rails and the input are all common and for the power supply we used long lengths of tinned copper wire threaded through the holes. The input lead should be done with separate links to allow the units to be serviced later if needed.

Before assembling the unit however each board should be checked with an oscillator to check it for the correct frequency and to adjust the calibration potentiometer. This is best done by measuring the sensitivity of the 16 kHz board with RV2 set for maximum sensitivity and adjusting all the others till they are the same.

We made a metal box with a piece of red perspex for a window to house the unit. If it is to be used with an equaliser (such as the ETI 484) it could be built into the same box.

It will be found with the economical LED available that there will be a difference in brilliance between them. If desired matched LEDs are available but not for 20 cents each!

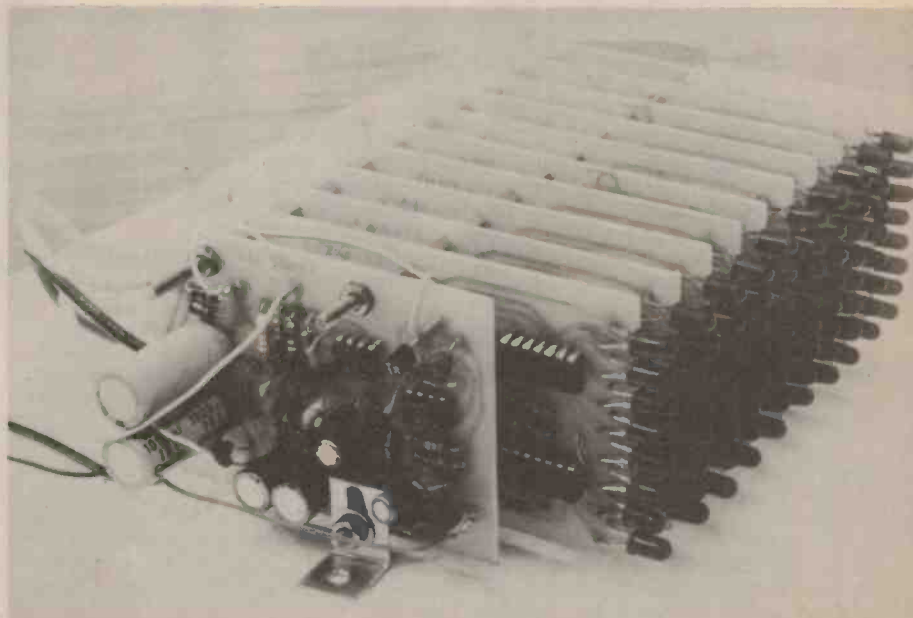
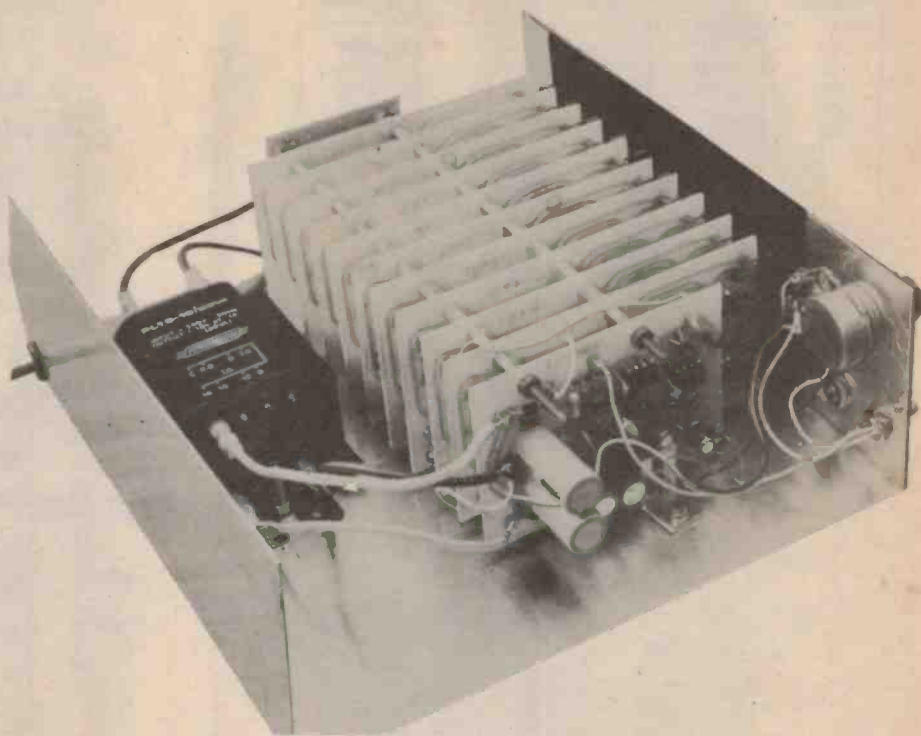

Project 489

TABLE 1

Centre frequency	R15	C14,C15 tantalum	C16 polyester	C17 polyester
32	1M	3 μ 3	—	68n
63	1M	1 μ 5	—	33n
125	1M	1 μ 0	—	18n
250	—	—	220n	8n2
500	—	—	100n	3n9
1k	—	—	47n	2n2
2k	—	—	27n	1n0
4k	—	—	12n	560p
8k	—	—	6n8	270p
16k	—	—	3n3	150p

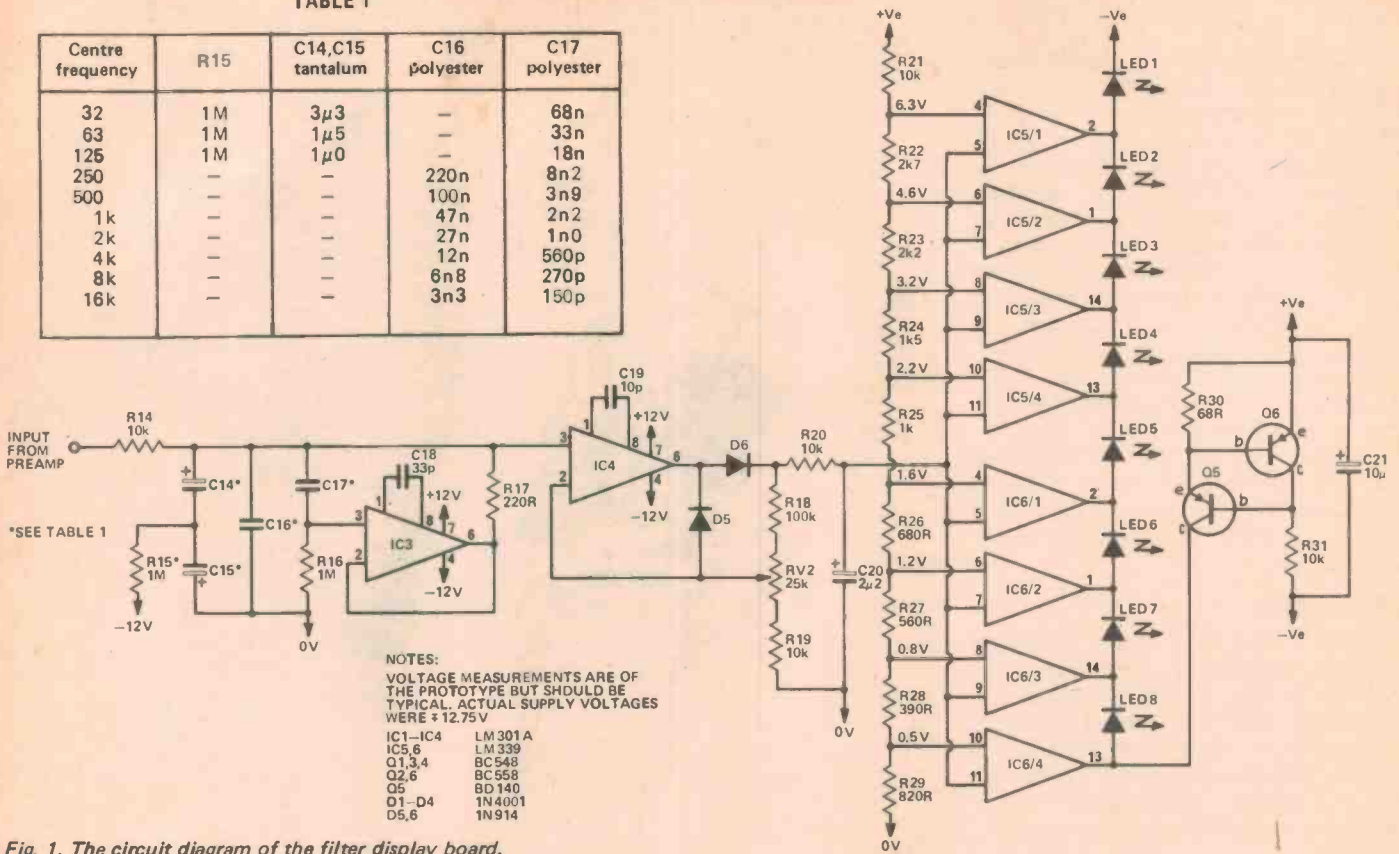

Fig. 1. The circuit diagram of the filter display board.

HOW IT WORKS - ETI 489

The input signal to the unit is initially buffered and amplified by IC1 and is then split into octave bands, rectified and displayed by a "bar" of LEDs. We have used 10 separate boards for the rectifier-display as only the component values in the filter are different.

The filter is a parallel LC network where the inductive part is a gyrator formed by IC3, C17, R16 and R17. The value of such an "inductor" is $R16 \times R17 \times C17$ Henrys (C17 in Farads). This, with the parallel capacitor C16 and the series resistor R14, form a band pass filter.

The output of the filter is half wave rectified by IC4 which also provides a gain of about 5 before the signal is smoothed by C20.

The eight LEDs in each individual display are connected in a series chain which is supplied with 10 mA by the constant current source Q5, Q6. Control of how many LEDs will be on is done by IC5 and IC6. These are quad voltage comparators which have as the output

stage an open collector NPN transistor with its emitter connected to the negative supply rail. These compare the output of the rectifier with the voltage set on the resistive divider R21-R29 and "short" out the unwanted LEDs.

The power supply is a simple fullwave rectified with a centre tap giving $\pm 12V$ dc. Due to the load (about 150 mA) there is about one volt ripple on the supply rail but this does not affect the operation of the unit. As the current drawn by the filter display boards does not change with the number of LEDs on the supply voltage remains reasonably constant.

The 100 Hz ripple does however affect the noise generator and this has been changed from the 487 analyser to accommodate this. The noise generator consists of Q3 which is used as a zener diode where the noise current is amplified by Q4. The output of Q4 is white noise and to give pink noise a 3 dB/octave filter is needed. IC2 and the associated capacitors and resistors provide this filter.

PARTS LIST - ETI 489 A

Filter-Display boards 10 required

Resistors all $\frac{1}{2}$ W 5%

- R14. 10k
- R15. see table 1
- R16. 1M
- R17. 220R
- R18. 100k
- R19-R21. . . 10k
- R22. 2k7
- R23. 2k2
- R24. 1k5
- R25. 1k
- R26. 680R
- R27. 560R
- R28. 390R
- R29. 820R
- R30. 68R
- R31. 10k

Potentiometers

- RV2 25k trim

Capacitors

- C14-C17 . . . see table 1
- C18. 33p ceramic
- C19. 10p ceramic
- C20. 2 μ 25V electro*
- C21. 10 μ 25V electro*

Semiconductors

- IC3,4. LM301A
- IC5,6. LM339
- Q5. BD140
- Q6. BC558
- D5,6. 1N914
- LED1-LED8

Miscellaneous

- PC board ETI 489 A

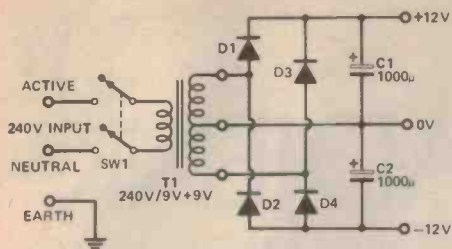

Fig. 2. The power supply circuit.

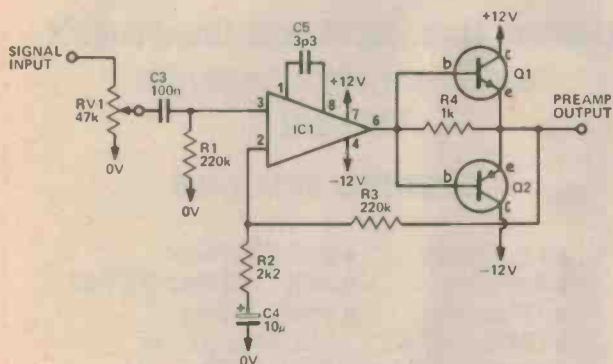

Fig. 3. The circuit of the preamplifier-buffer.

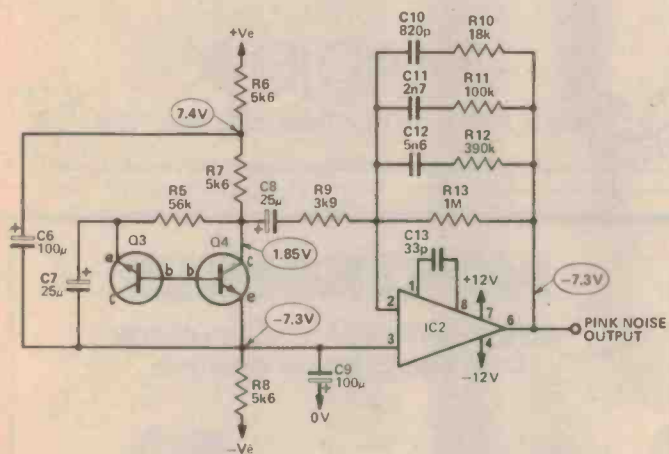

Fig. 4. The circuit diagram of the pink noise generator.

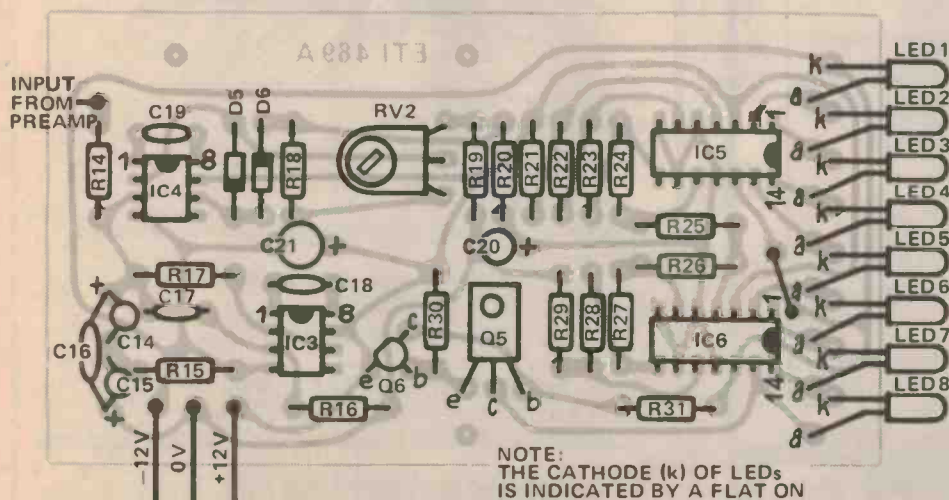

Fig. 6. The component overlay of board A.

NOTE:
THE CATHODE (k) OF LEDs
IS INDICATED BY A FLAT ON
THE BODY OR A SHORTER
LEAD.

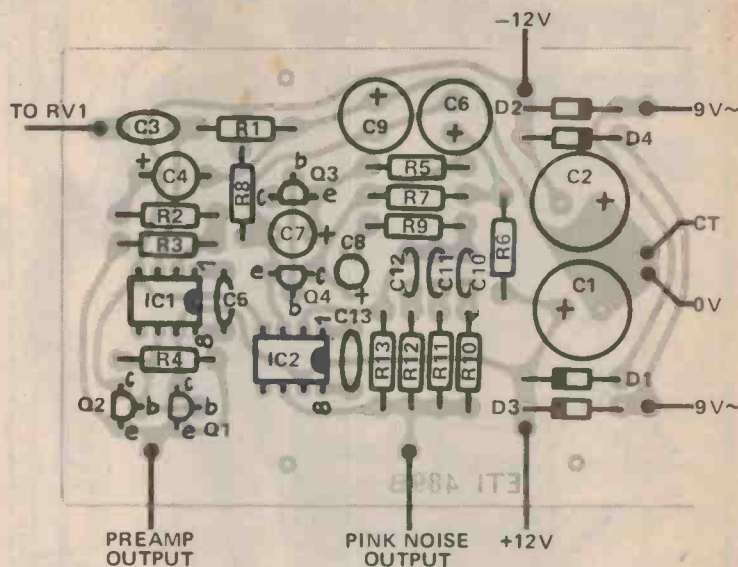

Fig. 5. The component overlay of board B.

PARTS LIST - ETI 489B

Power Supply board

- Resistors** all 1/2W 5%
- R1 220k
 - R2 2k2
 - R3 220k
 - R4 1k
 - R5 56k
 - R6-R8. 5k6
 - R9 3k9
 - R10. 18k
 - R11. 100k
 - R12. 390k
 - R13. 1M

Potentiometers

- RV1 47k log rotary

Capacitors

- C1,2 1000µ 16V electro*
- C3. 100n polyester
- C4. 10µ 25V electro*
- C5. 3p3 ceramic
- C6. 100µ 25V electro*
- C7,8 25µ 25V electro*
- C9. 100µ 25V electro*
- C10. 820p ceramic
- C11. 2n7 polyester
- C12. 5n6 polyester
- C13. 33p ceramic

Semiconductors

- IC1,2 LM301A
- Q1 BC548
- Q2 BC558
- Q3,4 BC548
- D1-D4. 1N4001

Miscellaneous

- PC board ETI 489B
- Transformer 240V/9V+9V PL18/20VA
- SW1 DPDT 240V toggle switch
- Case to suit

*all electrolytic capacitors PC board or single ended type.

Convert your CB into a base station



Power your rig direct from mains electricity with an SEC approved power supply. These small portable units provide a factory-set 13.8V DC regulated output for maximum transmitting power.

High performance integrated circuitry guarantees clean, hum-free reception. Quick-connect terminals facilitate rapid changeover from static-mobile-static operation.

ARLEC CB radio power supplies



ELECTROPAK PS352

For CB Radios up to 5 Watts Rating

1.8 Amp peak capability. Automatic overload protection.
1.0 Amp continuous output. Size: 140 x 80 x 133mm



SIDE 4 BAND PS353

For CB Radios up to 15 Watts Rating

4 Amp peak capability. Automatic overload protection.
2 Amp continuous output. Size: 140 x 80 x 133mm

See them at your local CB Store or write to A&R Electronic Equipment Co. Pty. Ltd. for further details

A+R ELECTRONIC EQUIPMENT CO. PTY. LTD.
A MEMBER OF THE A+R-SOANAR ELECTRONICS GROUP
SALES OFFICES VICTORIA 89 0661
N.S.W. 78 0281
S. AUSTR. 51 6981
30 Lexton Road, Box Hill Vic., 3128
Australia. Telex 32286
QUEENSLAND 52 5421
W. AUSTR. 81 5500



MADJENK

Lighting and Electronics

Lighting Hire, Electronic Components and Electrical Accessories
FOR SALE

OPENING SPECIALS

- I.C. Sockets
- stud SCR Motor
- 8-pin 34c
- 3835-3 35 Amp 100V \$2
- 16-pin 42c
- rubber buffers for amps etc. 3c
- CMOS 4027 \$1
- diodes IN5059
- P and P 50c.
- 1A 200piv 7c

MADJENK

Shop 5, 246 Princes Hwy. Dapto 2530. Wollongong.

NORTRONICS

AUDIO & DIGITAL TAPE HEADS
Long Life-Extended Response



Replacement heads for:

- Domestic Recorders Cassette decks.
- Cassette players.
- Reel to reel.
- Cartridge.
- Professional Recorders Broadcast recorders in reel to reel & cartridge or cassette.
- Studio recorders 1/4" to 2" multi track.
- Duplicators Reel to reel & cassette.
- Aircraft Recorders, cockpit & background.

To fit: AMPEX, SCULLY, TEAC, ATC, GATES, PENTAGON, INFONICS and many others.
ALIGNMENT TAPES – Reel to reel, Cartridge, Cassette.

EMAC INDUSTRIES PTY. LTD.
9 Meriton Place, Clayton South, Vic. 3169.
Ph: 544-5157

Electronics is where it's all happening

...if you're into it you've got it made!

It's the world's fastest growing industry... with new discoveries...new products every day. And, every day, there are more jobs...bigger salaries...better opportunities...for people who are trained.

You can be part of this boom now by training with International Correspondence Schools. Learn to design, build, install, test, control and maintain modern electronic equipment...from your own colour TV or hi-fi set to a digital computer.

Your career opportunities are limitless...in broadcasting, industry, the military, aerospace programs, medical science and communications. With your enthusiasm and ICS tuition, a well paid job and a secure future in electronics is well within your grasp.

How do I get into it? ICS have put together a FREE Electronics Career Folder. It tells you all about the many courses open to you including Communications and Broadcasting, Industrial Electronics, Computer Servicing and Audio/Radio Servicing...courses endorsed by the Television and Electronics Technicians Institute of Australia. Post the coupon and the career folder will be on its way to you without obligation. Don't wait another minute...progress won't. The big developments in electronics are happening now and the demand for skilled people is growing all the time.

Special Colour TV repair course. Colour TV is booming all over Australia, beyond the expectations of all the manufacturers, resulting in a shortage of qualified people to fill the service gap.

You could make a successful career in this growing field with the help of the ICS School of TV Servicing. You can benefit by this course - all you need is the enthusiasm to learn and enjoy rewarding work.

Your ICS course could be a start of an exciting new career or you can use your new-found knowledge to earn extra money in your spare time.

This special course is endorsed by the Television and Electronics Technicians Institute of Australia.

Send the coupon today. It could be the first step in an exciting new future for you.



Find out how you can be where it's all happening - in Electronics. Fill in the coupon and post today!

**ICS Home Study
...your passport
to success in life!**

Your invitation to join the thousands of successful ICS graduates.

To: International Correspondence Schools
400 Pacific Highway, Crows Nest. NSW. 2065
18-20 Collins Street, Melbourne VIC. 3000
182 Wakefield Street, Wellington. N.Z.

YES!

Please send me, entirely without obligation, a copy of the:
 ICS Electronics Career Guidance Kit
 ICS Colour TV Servicing Career Guidance Kit.

MR/MRS/MISS _____

ADDRESS _____

POST CODE _____

PRESENT OCCUPATION _____

AGE _____

**Take the first step -
Fill in and mail this coupon today!**

ICS

DAVRED'S 1ST CATALOGUE

Yes, it's been a whole year since we issued our very first 'Electronic Component Catalogue' and boy, has our mail order department been busy!

Well, instead of getting, we're giving. That's right we're giving **FREE BONUS GIFTS** this month.



FREE 24-page Electronic Project Publication



When you send in your order just ask and we'll include FREE a 24-page copy of 'Electrokits wonder world of electronics! It comes fully

illustrated and has many project circuits you can build with parts from your junk box or purchase the parts from us. Contains technical information and suggestions on building projects, with general symbols for many components.

\$FREE for the asking

FREE Tape Headcleaner Kit

Just what every tape owner needs. Kit containing 50 ml bottle of head-cleaning fluid and cotton buds to safely clean the head's surface. All this is a **BONUS** when you buy our **LASER C60 CASSETTE PACK**.



10 x C60 Cassettes (plus free headcleaning kit) **Only \$5.45** Value

SWR/Power Meter

Just arrived in, is a shipment of Model ME-11X meters that are the best value around. Selling while stocks last at

\$19.95

5" Reflex Horns. Metal/top quality. **Only \$9.25**

DAVRED October '77 catalogue prices STILL HOLD GOOD



ILLUMINATED VU's

Two sizes to choose from
Medium \$9.50 Small \$8.50

Latest Semiconductors

LM317K	\$4.75	LM555	95c
LM319	\$5.95	LM2917	\$2.50
LM324	\$1.50	LM3900	\$1.90
LM380	\$2.25	LM340/T	\$2.40
LM381	\$3.48	LM3909	\$1.75

NEW

PS369 Battery Eliminator

3V, 6V, 9V DC. Multipurpose, calcs, etc.

\$9.50

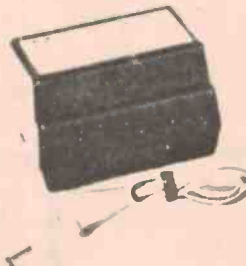

A&R DMM10 Now available

PERSONAL CALLERS

- Plenty of free parking
- 5 minutes from Newtown railway station.

Mail Order Instructions

Minimum P + P \$1.00	\$5 — \$9.99	Nil
Orders over \$9.99 must include additional postal charges (see right).	\$10 — \$24.99	\$0.50
	\$25 — \$49.99	\$1.50
	\$50 — \$99.99	\$2.50
	\$100 or more	\$4.00

ADDITIONAL POSTAL CHARGES

Order value	Charge
\$5 — \$9.99	Nil
\$10 — \$24.99	\$0.50
\$25 — \$49.99	\$1.50
\$50 — \$99.99	\$2.50
\$100 or more	\$4.00

Stop Press

Prices valid till 31st May or stocks expire.

Semiconductors

All top quality — no manufacturers surplus many for C.T.V. Stock up now.

AA143	10c	IS2092	12c
AC125	95c	IS4008A	16c
AC126	66c	IS4039A	16c
AC128	75c	IS4051	16c
AC187	80c	IS5009A	65c
AC188	85c	IS5020A	65c
AC187-0T	65c	IS5039A	64c
AC188-01	58c	IS5027A	65c
AD149	\$2.20	IS5039A	64c
BC107B	24c	IS5051A	70c
BC108B	24c	IS5075A	85c
BC108C	24c	IS5091A	65c
BC109B	24c	IS5120A	70c
BA148	18c	RA-1Z	9c
BA182	16c	S34	16c
BB105	28c	SIB02	8c
BC146	25c	SIB04	8c
BC183L	15c	SV04	25c
BC183LB	15c	SP835	80c
BC183LC	20c	TIS4	15c
BC184B	10c	TIS5	20c
BC184C	10c	TIS7	30c
BC213B	12c	TIC226D	80c
BC637	20c	TD15M	48c
BC682L	20c	TIL107	\$1.00
BD116	20c	TIP29A	77c
BD135	32c	TIP30A	88c
BF271	20c	TIP31A	91c
BF594	12c	TIP32A	95c
BF595	12c	TIP33A	\$1.27
BF694JR	35c	TIP34A	45c
BFR40	20c	TIP35A	\$2.20
BFR80	20c	TIP 36A	\$3.06
BFR81	18c	TIP41A	60c
BFT43	45c	TIP42A	40c
BFW30	\$1.40	TIP2955	\$1.46
BSW66	90c	TIP3055	\$1.10
BU105	\$4.95	U06C	38c
BU108	\$4.25	U06G	35c
BU126	\$3.45	V723	66c
BU208	\$4.20	Y969	66c
C103-Y	60c	2N3055	\$1.25
CM4-53A	16c	2N1307	\$1.40
EQ801-152	38c	2N2646	78c
E5386	14c	2N3703	14c
IN2069	14c	2SA564Q	10c
IN4002	4c	2SA564R	10c
IN4003	5c	2SA673AC	20c
IN4005	8c	2SC65YB	50c
IN4006	8c	2SC383	35c
IS44	6c	2SC643A	\$3.50
IS188	4c	2SC1175CD	15c
IS1658	20c	2SD348	\$3.60
IS2091	12c	2SD24	50c

I.C.'s

Prices until stock expire or valid until 31st May. Many C.T.V.

AN234	\$1.00	TAA570	60c
AN320	\$1.25	TBA7508Q	\$1.40
AN331	\$1.00	TBA900	\$1.50
HA1125	\$1.00	TBA5500	\$2.00
SB7400N	14c	TDA2620	\$1.00
SN7401N	16c	TP4007AN	60c
SN7403N	16c	TP4028AN	\$1.48
SN7444N	75c	PT4029AN	62c
SN7453N	12c	TP4040AN	60c
SN76502N	\$1.30	TP4042AN	66c
TA7148	\$1.20	TP4044AN	60c
TA7149	\$1.40	SN72555P	95c
		SN72741P	60c

DAVRED ELECTRONICS PTY. LTD.

104-106 King Street Newtown Sydney Australia P.O. Box 317 Newtown, N.S.W. 2042.

THE NEW BREED IN ELECTRONICS SERVICE

Telephone 516-3544

RAIN ALARM

Super-simple project saves a lot of washday hassles.

MARCH WINDS AND APRIL showers bring forth May flowers, runs an old saw which obviously applies much better to Britain than Australia. This old meteorologist's tale actually applies quite well over there, but if you require something a bit more scientific, and generally applicable, it's not so hot. Additionally the bit about April showers is likely to bring forth more than the odd May bud if one of these unpredictable periods of precipitation disrupts a busy housewife's washday by relegating her almost-dry laundry to the ranks of the wet-behind-the-eiderdown brigade.

Singin' in the...

The problem of rain showers is an annoying one, but here we come to the rescue with a Rain Alarm. This little gadget might well upstage any canine companion as a housewife's best friend, at least on washday, by giving a warning at the first sign of rain, leaving plenty of time to get the laundry in before it gets wet.

The rain alarm should be placed out in the open and a length of two core wire run between it and a box containing the battery, on/off switch and speaker. We used an old intercom substation to provide a home for our speaker but a car extension speaker or indeed any suitably boxed eight ohm device would be fine.

Any rain falling on the sensor track, which is formed as part of the PCB (neat innit?), will set off the alarm and produce a distinctive intermittent beep-beep.

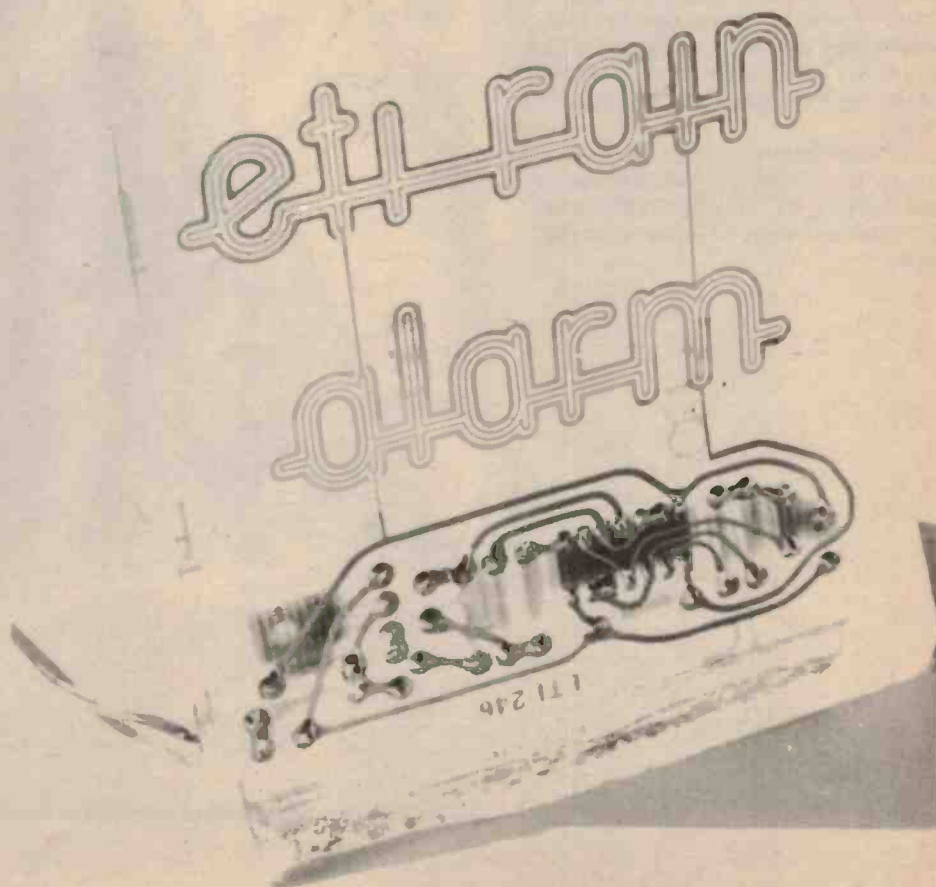

Project 246

Construction

Although the project is very simple, we recommend use of the PCB layout shown, as this is (we feel) much more attractive than a hacked-up piece of Veroboard.

Assemble the components onto the board using the overlay, remembering to solder pins 7 and 14 of IC1 before the others, to allow the device's internal protection circuitry to work.

In our prototype we used a value of 4M7 for R1 which acts as a sensitivity adjustment. This value leads to a 'hair-trigger' alarm and could well be reduced according to the level of sensitivity required.

When construction of the board is complete and the alarm has been tested, the area of the PCB that holds the components should be covered, front and back, with some suitable non-conductive potting compound to render it waterproof. We used Epirez 135 epoxy resin to encase the base of the board in a wedge shape so that it will stand up, thus obviating the need for a case.

More Power to Your...

Power consumption of the unit is so low when the alarm is not triggered that an on/off switch is not needed for that reason, but we recommend one unless you enjoy being woken up in the middle of the night by some light rain (or even mist)!

While this unit is not as effective as a device to control the weather (we're still working on that one), it should at least prevent some of those washday blues.

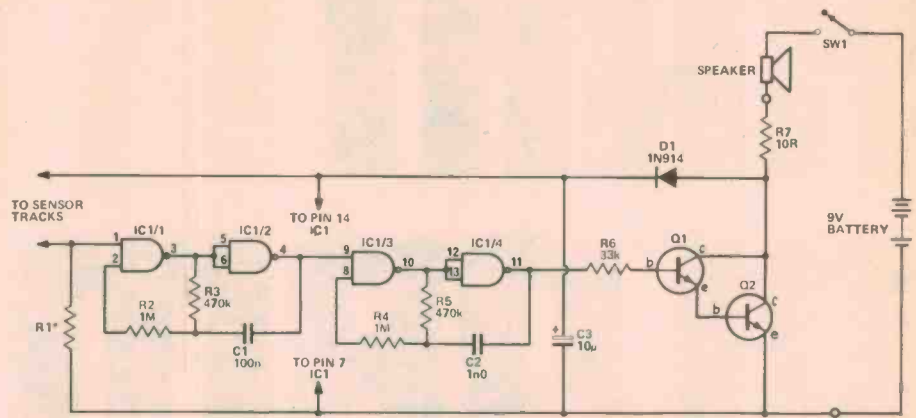

Fig. 4. Circuit diagram of the Rain Alarm.

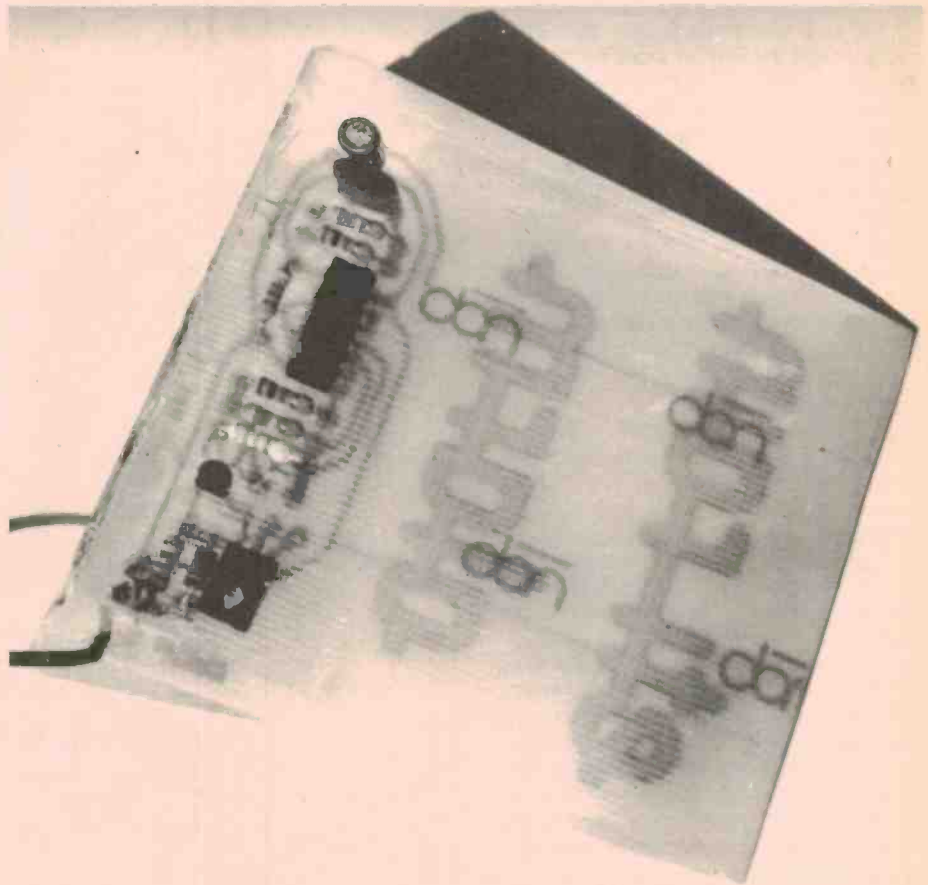

Fig. 5. The epoxy resin which encapsulates our board can just be seen in this photograph.

PARTS LIST – ETI 246

Resistors	all ¼W 5%
R1	see text
R2	1M
R3	470k
R4	1M
R5	470k
R6	33k
R7	10R

Capacitors	
C1	100n polyester
C2	1n0 polyester
C3	10µ electrolytic

Semiconductors	
IC1	4011
Q1	BC107
Q2	BD139
D1	1N914

Miscellaneous
PCB as pattern, 8R speaker, switch, battery.

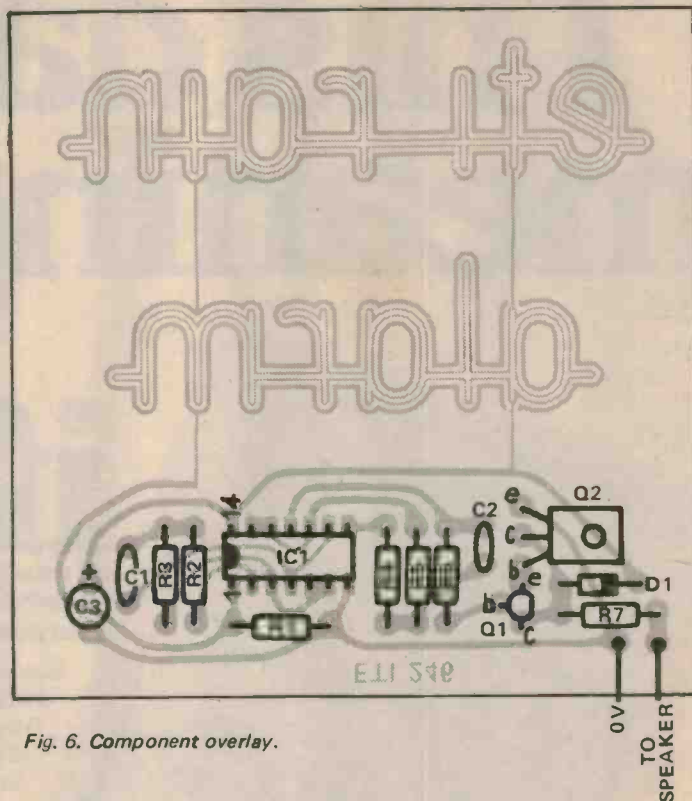

Fig. 6. Component overlay.

HOW IT WORKS – ETI 246

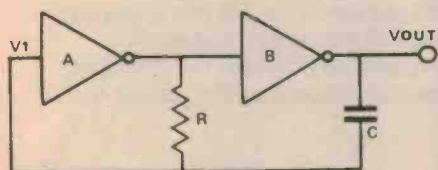

Fig. 2. A basic CMOS oscillator.

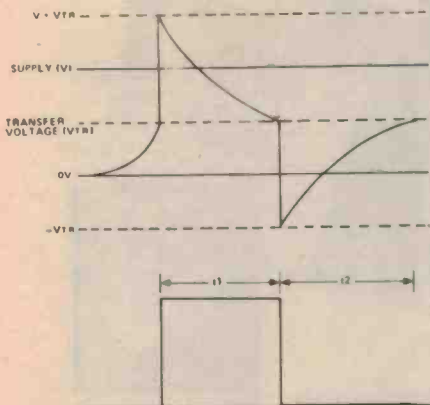

Fig. 3. Waveforms at various points in the circuit.

The rain alarm is formed by two gated CMOS oscillators and an audio output stage.

The basic CMOS oscillator is shown in Fig. 2. Upon switch on, with C discharged, the output of inverter B will be low, the input to A low and its output will go high. Capacitor C will now commence to charge towards supply, the voltage on A output, via resistor R.

We can consider a CMOS gate to be a comparator that will change output state when the level of the the input voltage reaches a specified value, the transfer voltage (V_{tr}), usually about half supply. Thus as the voltage on C increases due to the charge current supplied by R there will come a point when the voltage on the input of A will pass its transfer voltage and the output of B will go high.

At this point the charge on C corresponds to a voltage level of about half supply.

As the inverters A and B change states the end of C that was held at 0 V is now at supply and the end of C that was connected to supply via R is now returned to 0 V via the same resistor.

These changes together with the charge stored on C mean that the potential across C is now supply plus the transfer voltage of gate A. This is shown in Fig. 3.

Capacitor C will now discharge via R until once again the transfer voltage of A is reached whereupon the outputs of the

inverters will assume their original states.

The conditions are not quite the same as they were at switch on, as can be seen in Fig. 3, because the potential across C is now a negative value equal to A's transfer voltage.

From this point C charges via R again to repeat the cycle.

The output is shown in Fig. 3 where $t_1 = t_2 = 1.1 RC$ (the time taken for C to charge (discharge) via R to two-thirds of the maximum value of voltage across it).

In practice, due to the protection networks built into modern CMOS devices, it is necessary to include a resistor in series with the input of A in order to ensure that the voltages across C are allowed to reach the values shown in Fig. 3.

The final circuit diagram (Fig. 1) of the unit shows that the inverters are in fact formed from the four NAND gates of a 4011 package. In each oscillator, while one gate is configured as a straightforward inverter, the other has one input that can act as a control input, oscillator action being inhibited if this input is held low.

The first oscillator (IC1a and IC1b) has this input tied low via a high-value resistor (R1) that acts as a sensitivity control. Thus this oscillator will be disabled until the control input is taken high by any moisture bridging the track, so enabling the output, which is a 10 Hz square wave. This in turn will gate the 1 kHz oscillator formed by IC1c and IC1d on and off.

The latter oscillator drives the loudspeaker via R6, the Darlington pair formed by Q1 and Q2, and resistor R7.

This data is meaningless!

if... This data is meaningless if your STANTON 681EEE Calibration Standard Cartridge is not fitted with a genuine STANTON stylus (type D6800EEE).

Every STANTON 681FEE Cartridge is individually calibrated using a STANTON D6800EEE stylus. The finest equipment in the world is used for this calibration and this is your guarantee of performance. Naturally you cannot get the same performance if you fit any other type of stylus. STANTON styli are the result of intensive use of STANTON'S own Scanning Electron Beam Microscope which is used to examine styli tips at up to 20,000 times magnification to reveal minute blemishes in the highly polished surface which could ultimately lead to distortion and cumulatively significant record wear. Conventional high powered microscopes are hopelessly inadequate for such a task.

CALIBRATION PERFORMANCE DATA



STANTON

Each Stanton 681 Triple-E is calibrated individually and the information below applies specifically to your pickup and stylus.

CALIBRATIONS:
 Frequency Response: 10 Hz to 12,000 Hz $\frac{1}{2}$ dB
 10 Hz to 17,000 Hz $\frac{1}{2}$ dB
 17,000 Hz to 22,000 Hz $\frac{1}{2}$ dB
 Output: 0.65 mv per cm per second

CALIBRATION CONDITIONS:**
 a) Load resistance for measured response: 47,000 Ohms
 b) Cable capacitance for measured response: 275 pF
 c) Calibration temperature 1 Grams tracking force
 d) Calibration at 72 of

SPECIFICATIONS:
 1. Channel separation: 35 @ 1,000 Hz
 2. Recommended tracking force: 3/4 to 1 1/2 Grams
 3. Cartridge D.C. resistance: 1268 ohms
 4. Cartridge Inductance: 904 ohms

*Does not apply to D6810 or D6827 Styl.
 **All play back conditions must be optimized to meet above information.

Serial No. E0318 Inspector's Stamp 

6801-9350-01 3-74

Protect your performance guarantee, and your records. Insist on Genuine Stanton Replacement Styli for your Stanton Cartridges.



Sole Australian Distributors

LEROYA INDUSTRIES PTY

Head Office, W.A.: 156 Railway Pde., Leederville 6007. Phone 381 2930.

N.S.W. Office: 100 Walker St., North Sydney, 2060. Phone 922 4037.

VICTORIA Office: 103 Pelham St., Carlton. 3053. Phone 347 7620.

SHOP AT MELBOURNE'S MOST HELPFUL ELECTRONICS OUTLET

OPEN FRIDAY NIGHT TILL 7.00 PM

THE ORIGINAL SUPER SPECIALS

1. 10 555's for \$3.50
2. 8D139's and 8D140's 10 for \$5.00
3. Motorola MJ2955's 2 for \$2.00
4. 7805 and 7812 voltage regs mixed 5 for \$5.00
5. 4016 CMOS 10 for \$5.00



PCB's precision-drilled fibreglass boards

ETI 134	\$1.70	volt meter
ETI 135	\$1.70	digital meter
ETI 245	\$1.40	
ETI 445	\$1.40	stereo pre-amp
ETI 446	\$1.60	limiter
ETI 449	\$1.40	mic amp
ETI 450A	\$1.90	bucket brigade
ETI 450B	\$1.90	mixer filter
ETI 480	\$2.00	100w power amp
ETI 480 PS	\$1.80	P/S for above
ETI 480 1M	\$1.80	mixer, tone control
ETI 481 PS	\$2.00	12-40v Inv
ETI 484	\$2.00	comp/expander
ETI 485	\$2.00	graphic equalizer
ETI 486	\$2.00	
ETI 581	\$1.60	dual P/S
ETI 583	\$1.70	gas alarm
ETI 585R	\$1.60	ultrasonic switch
ETI 586T	\$1.40	ultrasonic switch
ETI 586	\$2.00	shutter timer
ETI 603	\$2.30	synthesizer sequ
ETI 604	\$1.60	metronome
ETI 635	\$2.50	micro computer P/S
ETI 713	\$2.80	add on FM tuner
ETI 714	\$1.70	
ETI 716	\$2.00	2M power amp (RF)

CERAMICS

10pF to 680pF	1-9	10 up
820pF to .0015uF	.06	.05
E12 Values	.07	.06
ETI 480 50w kit (includes heat sink BKT)	\$16.95	
ETI 480 100w kit as above	\$19.50	

LINEARS

uA311	1-9	10 up
uA339	0.85	0.80
uA3401	0.90	0.85
uA556	0.90	0.85
uA741	1.20	1.10
9368	0.40	0.35
RL4136	1.90	1.75
LM380	3.90	3.60
LM301	1.30	1.25
LM381	0.55	0.50
LM382	2.20	1.90
LM3900	2.20	2.00
	0.95	0.90

I.C. SOCKETS

8-PIN DIL	0.25	0.23
14-PIN DIL	0.33	0.30
16-PIN DIL	0.35	0.33

Weller cordless iron kit
Model WC100 DK 15w
complete for only \$28.50

Diodes and bridges

0A91	0.17	0.15
0A95	0.18	0.16
IN 4002 200/1A	0.08	0.07
IN 4004 400/1A	0.09	0.08
IN 4007 1000/1A	0.23	0.20
IN 5625 400/5A	0.50	0.40
IN 4148	0.06	0.05
W02 (1.5A 200v Bridge)	0.80	0.75
W04 (1.5A 400v Bridge)	0.85	0.80
VJ448 (400v 10A Bridge)	3.65	3.50

PC BOARD

1 oz Copper F/glass	s/sided	d/side	Lam
8" x 2"	0.85		0.35
6" x 3"	1.00	1.20	0.40
6" x 4"	1.20		0.50
8" x 4"	1.50	1.70	0.65

Larger sizes available.

ZENERS

400mW 5pc E24 Values 3V to 33V			0.20
-----------------------------------	--	--	------

RESISTORS

IRH Metal Glaze GLP or GL 1/2 Watt			2.20
HM to 1 MEG 3 cents each of 2.5 cents for 100 plus.			

Voltage regs

8706	6v	1A	1-9	10 up
7808	8v	1A	1.40	1.30
7815	15v	1A	1.40	1.30
7818	18v	1A	1.40	1.30
7824	24v	1A	1.40	1.30
7912	-12v	1A	2.25	2.00
723	14 PIN DIL Metal Can		0.55	0.45
723			1.20	1.10

CB Regulator

YA78CB	13.8v at 2A	2.75	2.60
--------	-------------	------	------

Optoelectronics

FND 357	.375"	cc	1.40	1.30
FND 500	.5"	cc	1.50	1.40
RED LED			0.25	0.22
GREEN LED			0.40	0.35
YELLOW LED			0.45	0.40
FND 800	.8"	cc	3.50	3.30

Electrolytics

4.7 uF	25v	PCB	0.08	0.07
10 uF	25v	PCB	0.09	0.08
10 uF	50v	PCB	0.10	0.09
22 uF	16v	PCB	0.08	0.07
22 uF	35v	PCB	0.10	0.09
33 uF	16v	PCB	0.09	0.08
33 uF	50v	PCB	0.11	0.10
47 uF	16v	PCB	0.10	0.09
47 uF	35v	PCB	0.12	0.11
100 uF	10v	PCB	0.11	0.10
100 uF	16v	PCB	0.12	0.11
220 uF	25v	PCB	0.15	0.14
470 uF	16v	PCB	0.17	0.16
1000 uF	25v	PCB	0.38	0.36
2500 uF	50v	Axial	1.95	1.85
2200 uF	25v	PCB	0.55	0.90
6800 uF	50v	LUG	4.75	

Please note: March prices for TTL and CMOS are still current. Also in stock: Multimeters, relays, veroboard, solder, solderwick, soldering irons, transformers. All components brand new by top companies. Prices current until end of May.

ROD IRVING ELECTRONICS

Shop 499, High Street, Northcote, Vic 3070. Ph (03) 489-8131. Open Mon-Thurs 9.00-5.30, Sat 9.00-1.00. Mail Orders: PO Box 135, Northcote Vic. 3070, Minimum 50c post and pack. Send SAE for free condensed catalogue.

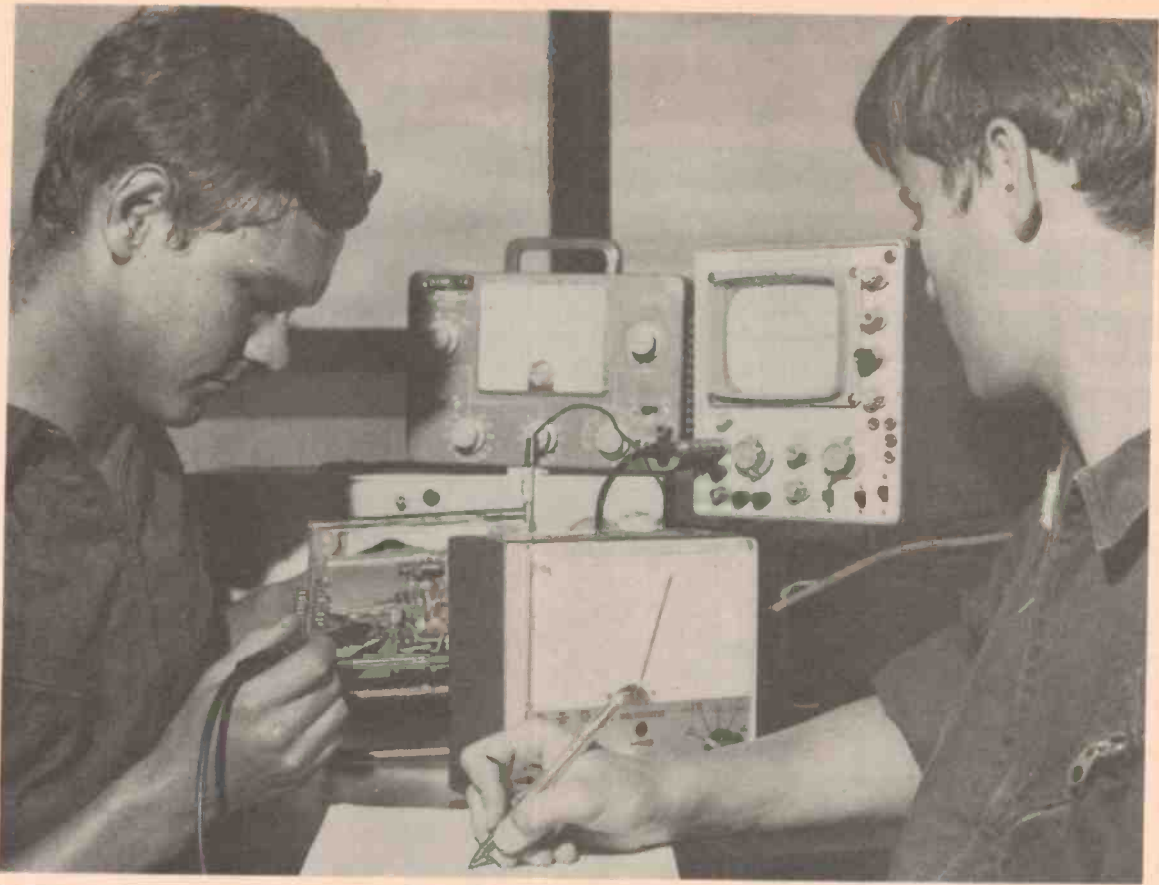

ELECTRONICS TRAINING IN TODAY'S AIR FORCE.



If you're aged between 17 and 34 and you're into radio equipment, navigation aids, computers, radar and advanced telecommunications equipment, the Air Force can train you as a radio technician.

You'll work with people your own age on good pay — in excess of \$10,700 per year on completion of training. You'll have the chance to travel, and a secure future.

And, when in due course you leave the Air Force, there are tremendous opportunities in civilian life. Training is free, so is medical, dental and optical care, and you'll be eligible for a low interest housing loan, after a qualifying period.

So if you're between 17 and 34 on entry, an Australian citizen, or meet our nationality requirements and have good results in English, Maths and Science, give the Air Force a call.

Your future's in your hands.

Brisbane: 226 2626, Townsville: 71 3191,
 Sydney: 212 1011, Newcastle: 2 5476,
 Wollongong: 28 6492, Wagga: 21 1100,
 Canberra: 47 6530, Melbourne: 61 3731,
 Hobart: 34 7077, Adelaide: 223 2891,
 Perth: 325 6222.

To RAAF Careers Officer, GPO Box XYZ (Insert your nearest Capital City and Postcode) Please send me full details about electronics training in today's Air Force.

Name _____

Address _____

Date of Birth _____

State _____ Postcode _____

**YOUR FUTURE'S
 IN TODAY'S AIR FORCE.**

RG64.FP.38

Auth. by Director-General Recruiting, Dept. Defence

'ELECTRONICS TODAY'

DIGITAL FREQUENCY METER KIT

50 MHz **\$159.00**
1 GHz **\$189.00**

- Chassis, marvplate cover and front panel as per article.
- Crystal and oven components supplied.
- All IC's are LS, Schottky, ECL or CMOS.
- High Brightness LED's.
- Polaroid filter.
- All components first grade, guaranteed.
- Service back-up.
- Registered post-free in Australia.
- Instructions included.
- Money back guarantee — if not satisfied for any reason, return unassembled in original packing within 7 days for refund less postage.
- Prices include Sales Tax.
- All components supplied.

*Assembled units
will be available — please enquire.*

J.R. COMPONENTS

P.O. Box 128,
Eastwood, NSW, 2122
Phone: (02) 85-3976



12" 3-WAY 75-litre 80 W
Handling **TIMBER VENEERED**
ENCLOSURE COMPLETE KIT.

\$139 PAIR

COMPLETE
\$189 PR.

10" 3-Way 75-litre
70 Watts **HANDLING**

\$109 PAIR
COMPLETE
\$159 PR.

10" 2 WAY 50 LITRE
60 WATTS. **KIT \$89 PR.**
COMPLETE **\$129 PR.**

8" 2 WAY 30 LITRE
40 WATTS
KIT \$75 PR.
COMPLETE **\$102 PR.**

HI FI SPEAKERS & KITS DIRECT FROM MANUFACTURER

75-litre cabinets.....**KIT**..... \$48 pr

50-litre cabinets.....**KIT**..... \$40 pr

30-litre cabinets.....**KIT**..... \$35 pr

**DISCO LIGHTING SYSTEMS
& CONSOLES P.A. BINS
AMP ETC MADE TO ORDER
YOUR DESIGN OR OURS PLEASE
WRITE FOR QUOTE**

*All orders forwarded by road
transport payable on delivery*

**ALL CHEQUES & MONEY ORDERS TO
AUDIO SPECTRUM**

audio spectrum

41 WHITEHORSE ROAD
DEEPDENE 3103

Ph **(03) 80.1074** or
(03) 488821

TRADE ENQUIRIES WELCOME



ADVISORY SERVICE AND SPARE PARTS SUPPLIED TO TRADE

Full Service facilities for all
communications equipment.
CB radio, Stereo, and HiFi etc.



*Service facilities for
trade and public*

419-3342

ROAD RUNNER COMMUNICATIONS

39 Vere St, Collingwood 3066

1 GHz FREQUENCY METER - TIMER

Pt.2 Construction

Lab-quality instrument offers superb performance and features at low cost.

LAST MONTH we described the circuit details of our new UHF frequency counter. We now finalise the article with the constructional side of the project.

Construction

For a project of this complexity it is almost essential that a PC board be used. This is especially so in the preamplifier section where high frequencies are involved.

The fact that the components are used as links between the tracks on the two sides of the board prevents the use of sockets. Assemble the PC board with the aid of the overlay taking care to orientate the ICs correctly as the mark is sometimes difficult to pick out. As the component leads are used as feed throughs it is not practical to build and test the unit in sections. Ensure that *all* pads on the top side of the board are soldered. Soldering the top surface is easiest if the tip of the iron is filed to a

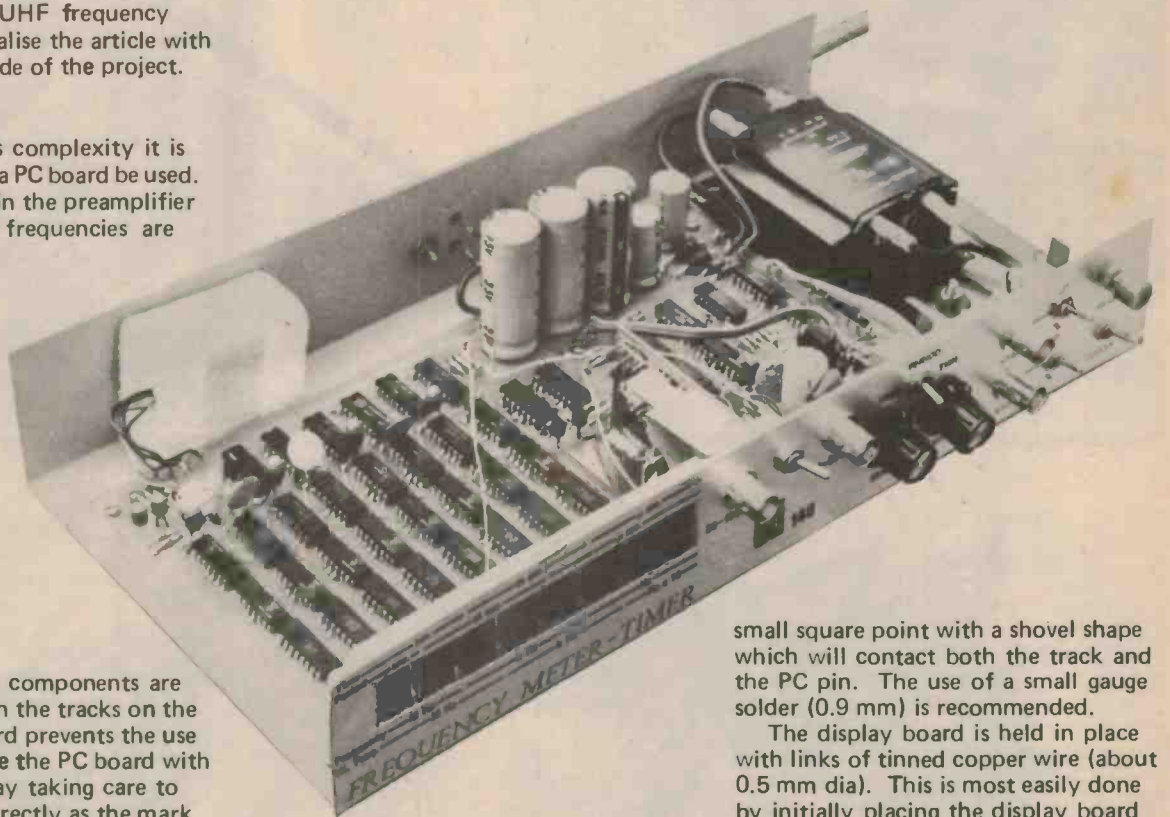

small square point with a shovel shape which will contact both the track and the PC pin. The use of a small gauge solder (0.9 mm) is recommended.

The display board is held in place with links of tinned copper wire (about 0.5 mm dia). This is most easily done by initially placing the display board horizontally on the main board and inserting loops of wire through the holes provided (see photo). When all the links are in place the board can be twisted into a vertical position and by pulling on the ends of the links the display board can be pulled down flush with the

Project 140

main board. It can now be soldered into place. Two additional resistors are needed per digit; the photo shows their position. The potentiometers are mounted on a small bracket (see Fig.20) before being soldered onto the main board.

The prescaler, if used, is also mounted in a similar way except that due to the small number of connections the links should be passed through the holes in the prescaler, bent flush with both sides and then mated with the main board. Solder the pads on the underside of the main board only at this stage. On the prescaler board there is a tin plate shield which should be soldered into position with a fillet of solder. Don't solder the top edge yet as capacitor C15 can only be fitted after the unit is in the chassis. Also note that the capacitors C43 and C44 are mounted on the rear of the PCB as shown in Fig. 15 along with R116.

The crystal is fitted into a polystyrene box (about 50 x 40 x 25 mm) with transistor Q5, R86, 87 and TH1 being glued onto the crystal body to act as a heater and sensor.

Before mounting the unit into the chassis assemble all the front panel components, also glueing the polarised plastic into position. Note that there is an earth lug under the prescaler input socket and the nut for the socket should be in the position shown in Fig. 8 as the board fits between the nut and the earth lug which is bent back along the surface of the board.

The unit should now be temporarily mounted into the chassis to locate the prescaler board in its correct position between the nut on the input socket and the earth lug. Fix it in this position by running a small fillet of solder between the two boards. When the unit is removed run the fillet of solder the full length (where there is copper!!) on

both sides of the prescaler board.

Assemble the unit finally and wire it up as shown in the wiring diagram. The transformer can be mounted and wired along with the 5V regulator. Insulation washers should be used with this regulator even though the case is at earth potential to prevent any problem of having two earth points (the other is the lug under the prescaler input socket).

Errata

On the power supply circuit diagram last month the transformer was specified as 240V/15V+15V. It should have been 240V/9V+9V. Also the diodes D16 and D17 have been shown in reverse polarity. The regulator IC47 should have been marked as a 7905 not 7915.

On the control logic circuit diagram the diode D17 should have been D18.

The resistor R117 was omitted from the preamplifier circuit diagram and is connected between pin 6 of IC44 and 0V. This is to reduce the sensitivity at high frequency and improve stability.

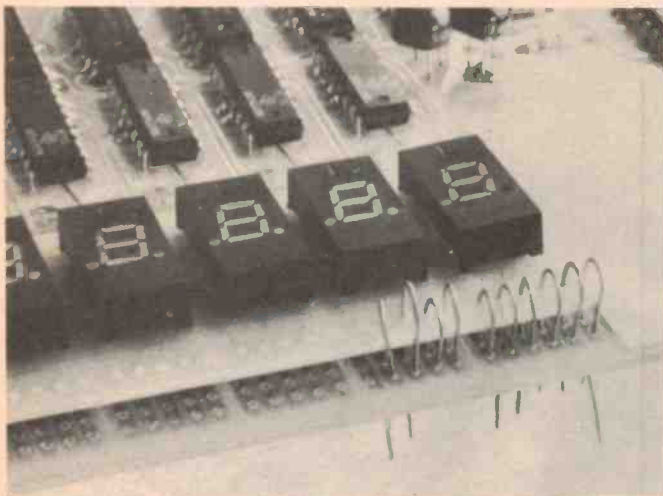
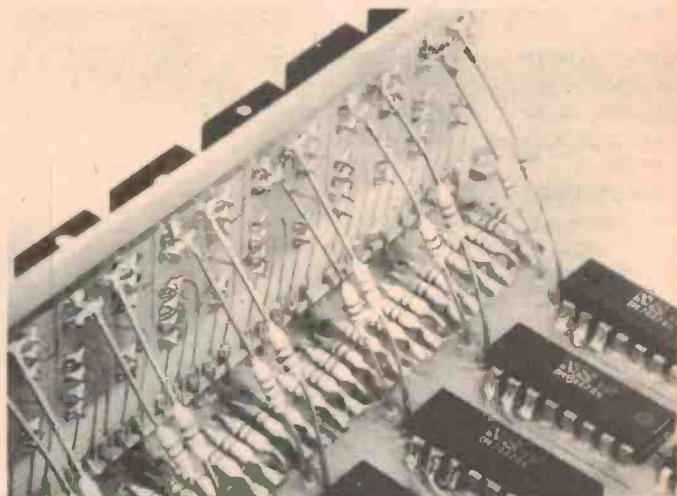
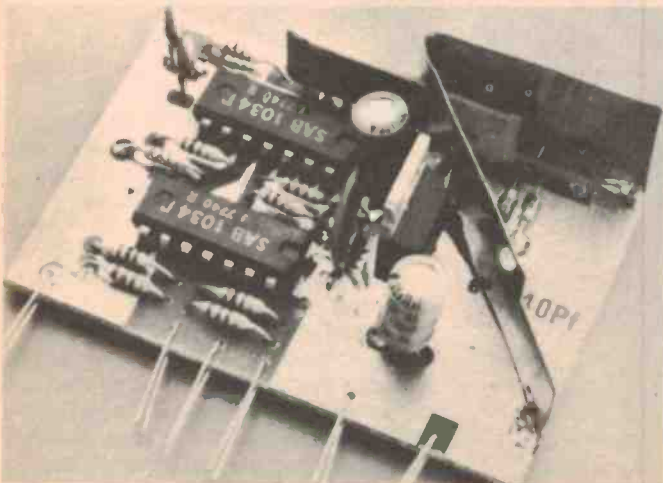

Photo showing the method of connecting the display board.



The position of the two additional resistors required per display is shown in this photograph.



The prescaler board showing the shield used.

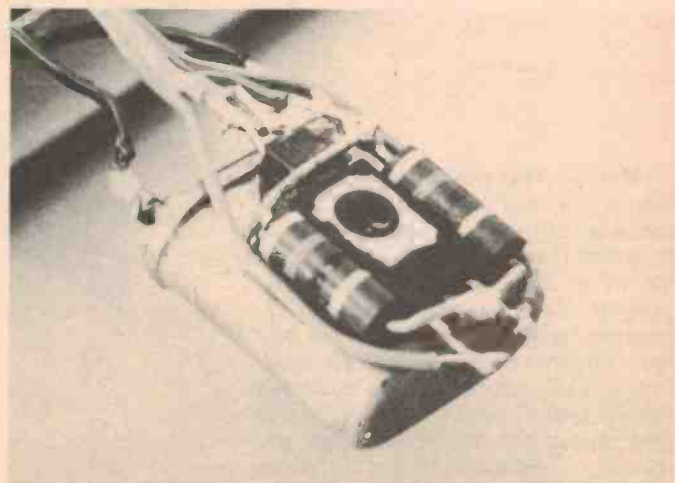

The method of mounting the components on the crystal.

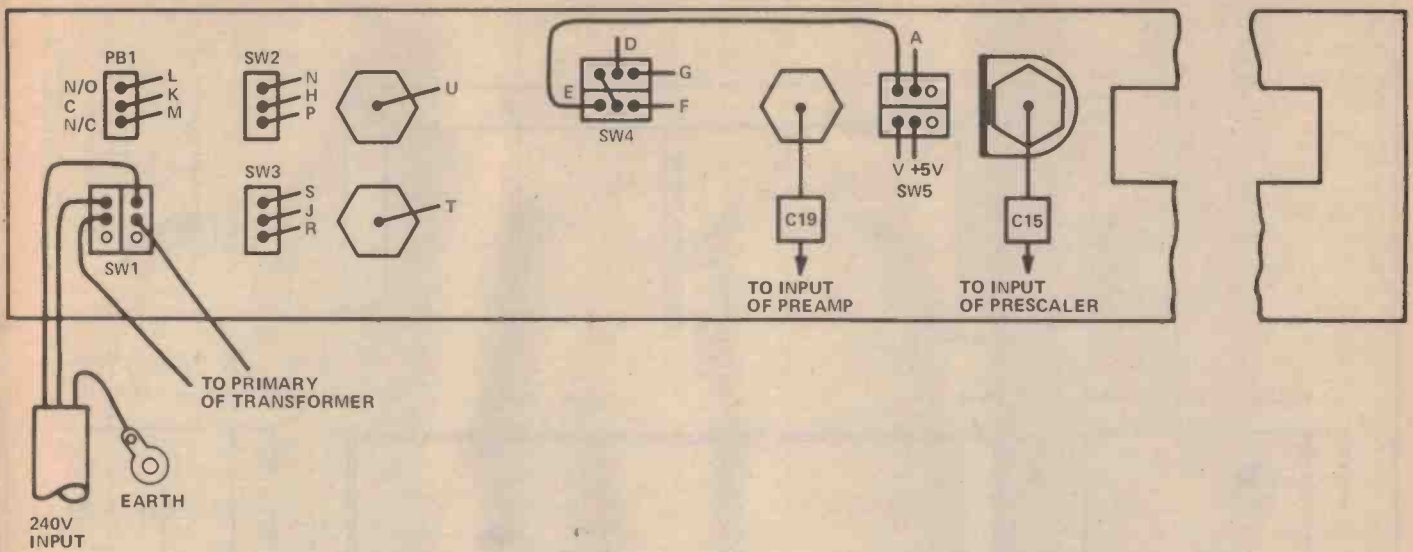

Fig. 8. Rear view of the front panel wiring.

ICs used in the prescaler.

Most of the ICs used in this project are standard TTL or CMOS and only the prescaler ICs are unusual. For this reason details of these ICs are given below.

OM335

This is a high frequency linear amplifier designed for instruments or TV amplifier.

Gain	27dB typ.
Freq. resp. \pm 1dB	20–1000MHz
Input impedance	75ohm
Output impedance	75ohm
Power Supply	8–28V dc @ 35mA

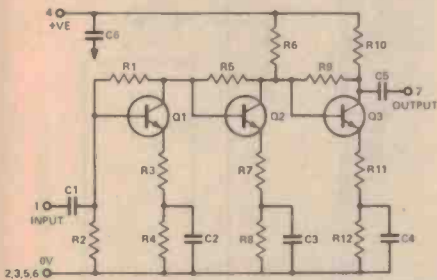

Fig. 9. Internal circuit diagram of the OM335.

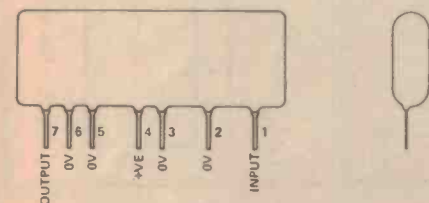

Fig. 10. Pin connections of the OM335.

SAB1048

This is a high frequency 4/1 divider (prescaler) and is designed to operate from a sinewave (50MHz min) or square wave (dc). The output is ECL compatible. The internal circuit - block diagram is given below. The differential inputs are internally biased and should be ac coupled. If only one input is used the other should be ac grounded.

Freq. range (sine wave)	50–1000MHz
Sensitivity	see graph
Power requirement	5.2V @ 53mA

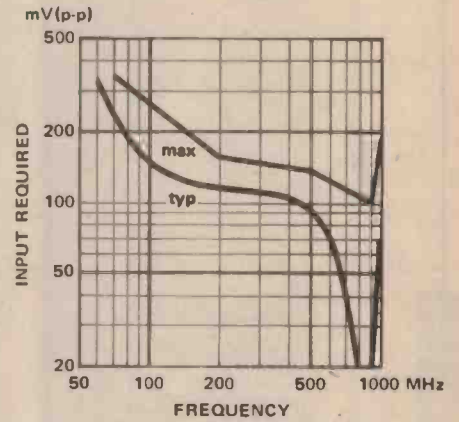

Fig. 12. Sensitivity of the SAB1048 with a sinewave input.

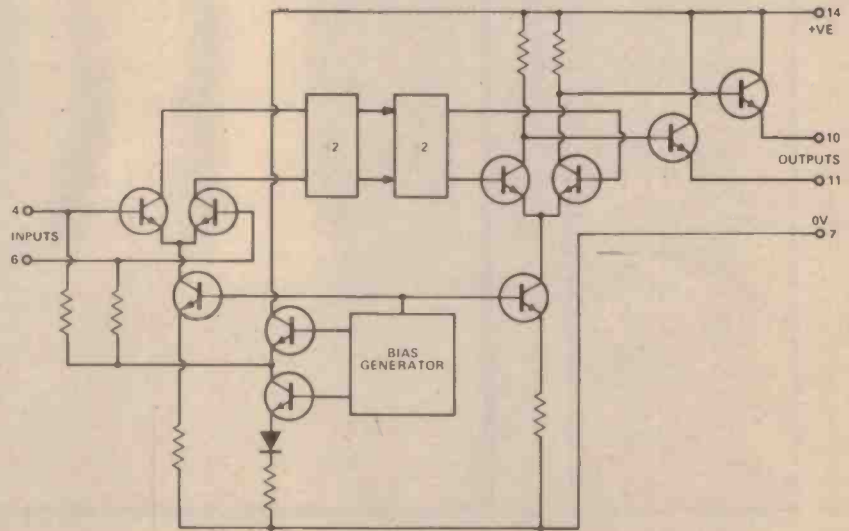

Fig. 11. Block diagram of the SAB1048.

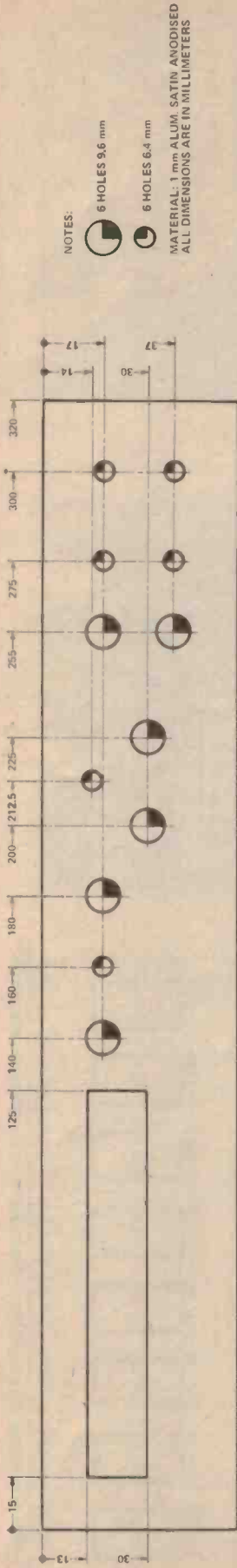

Fig. 18. The dimensions of the front panel.

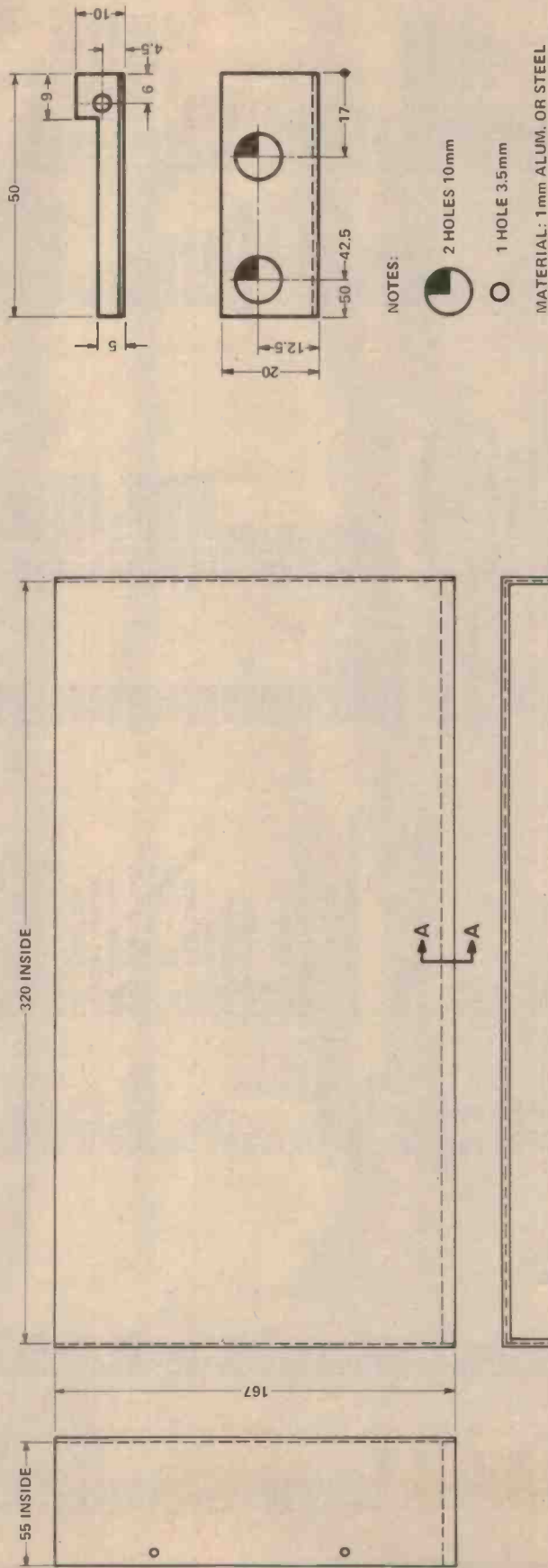

Fig. 20. The potentiometer mounting bracket.

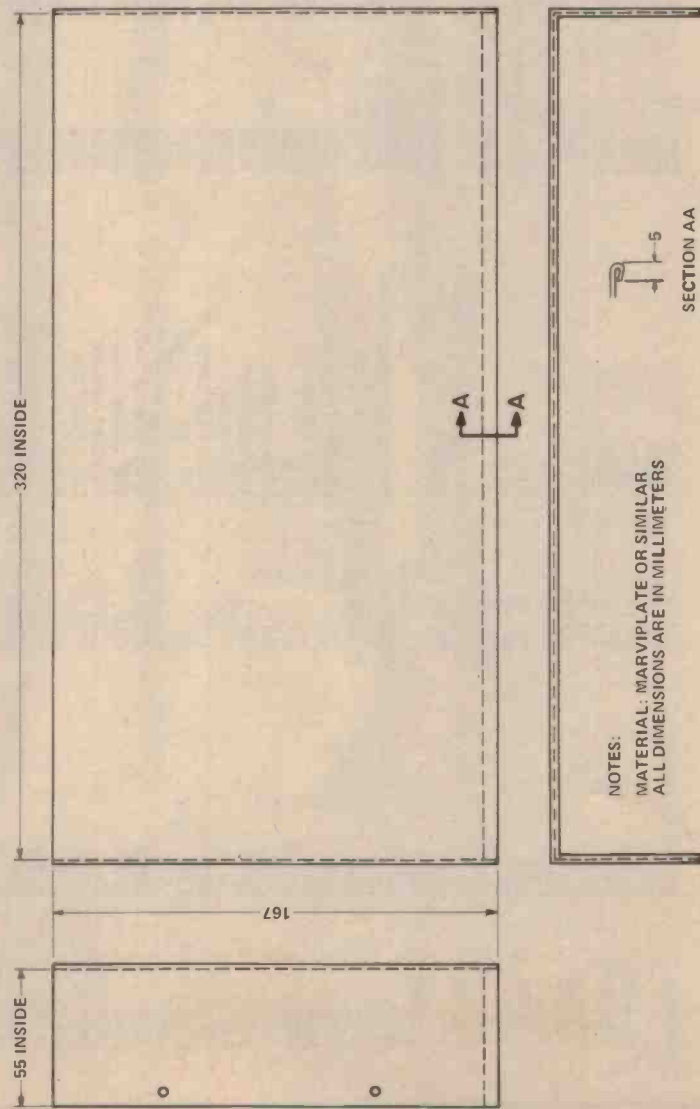

Fig. 19. The cover for the frequency counter.

1 GHz FREQUENCY METER - TIMER

PARTS LIST - ETI 140

Resistors	all 1/4W, 5% unless stated
R1-R56	470R
R57-R60	3k3
R61	33k
R62,63	3k3
R64	470R
R65,66	3k3
R67	15k
R68	330R
R69,70	10k
R71	3k3
R72-R74	10k
R75	470R
R76	10k
R77	33k
R78	10k
R79	33k
R80	470R
R81	2k2
R82	220R
R83	1k
R84,85	3k3
R86,87	47R 1/2W
R88	1M
R89	220R
R90	47R
R91-R95	1k
R96-R101	220R
R102	33R
R103	100R
R104	33R
R105,106	100R
R107	150R
R108	100R

Capacitors	
C1	22p NPO ceramic
C2	10n polyester
C3	1n0 "
C4	100p ceramic
C5	1n0 polyester
C6-C9	100p ceramic
C10	220µ 16V electro *
C11	100n disc ceramic
C12,13	33µ 10V tantalum
C14	100n disc ceramic
C15	220p silver mica
C16,17	1n0 disc ceramic
C18,19	100n 100V disc
C20	10p 100V ceramic
C21	220µ 35V electro *
C22-C24	2500µ 16V electro *
C25	220µ 35V electro *
C26	10µ 16V tantalum
C27	10µ 35V electro *
C28-C33	33µ 10V tantalum

Potentiometers	
PV1	1M log PR16PC (Plessey)
PV2	1k lin "

Thermistor	
TH1	Philips 2322 640 90004

IC48	7818 (500mA version)
IC49	7805 (500mA version)
Q1,2	PN3643, 2N3643
Q3,4	BC559
Q5	BD139
Q6	2N5485
Q7	PN3643, 2N3643
Q8	PN3645, 2N3645
Q9	PN3643, 2N3643
Q10,11	PN3645, 2N3645
Q12,13	PN3643, 2N3643
D1-D9	1N914
D10,11	BAW62
D12,13	1N4004
D14,15	1N5404
D16-D18	1N4004
Displays 1-8	DL707
Miscellaneous	
PC board	ETI 140A
PC board	ETI 140D
PC board	ETI 140P
Crystal	4MHz, 30pF, 70°c
SW1	7201 toggle switch
SW2,3	7101 toggle switch
SW4	7211 toggle switch
SW5	7201 toggle switch
PB1	8168 push button
Transformer	240V - 9V + 9V @ 1A PL 18/20VA
Metalwork to suit	
4 B&C sockets	
3 core flex and plug	
cable clamp	
Piece of polarised plastic	

Variable Capacitors	
CV1	2-10p trimmer

Semiconductors	
IC1,2	74S74
IC3-IC9	74LS90
IC10-IC17	74LS75
IC18-IC25	74LS47
IC26	74S02
IC27	74LS90
IC28	74S10
IC29,30	74LS00
IC31	74LS73
IC32	4518 (CMOS)
IC33	4520 (CMOS)
IC34	4081 (CMOS)
IC35	4518 (CMOS)
IC36	4011 (CMOS)
IC37	74LS123
IC38	4001 (CMOS)
IC39	4011 (CMOS)
IC40	4013 (CMOS)
IC41	4011 (CMOS)
IC42	9582 (ECL)
IC43	OM335
IC44,45	SAB1048P, SAB1034P
IC46	7805 (TO3 package)
IC47	7905 (500mA version)

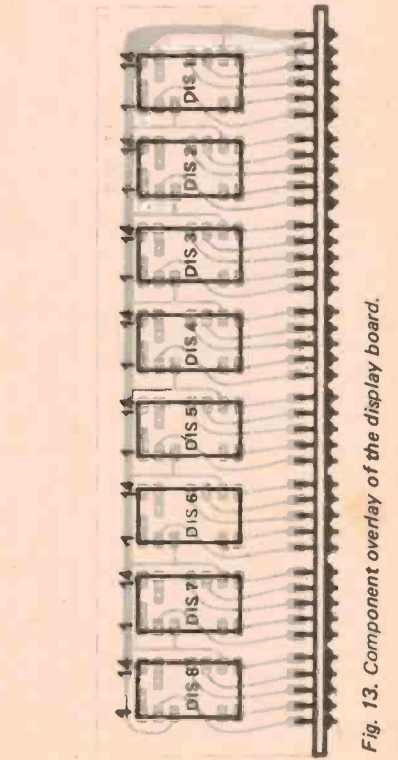

Fig. 13. Component overlay of the display board.

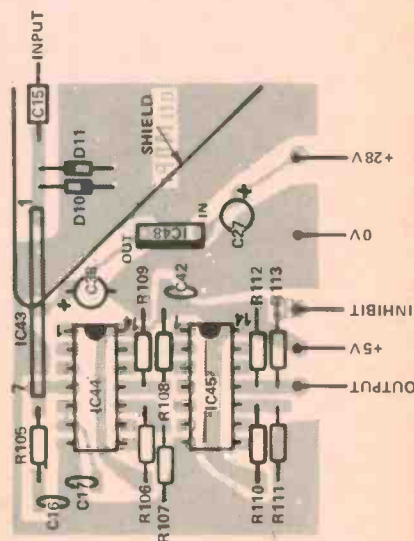

Fig. 14. Component overlay of the prescaler.



Fig. 15. View showing the position of C43, 44 and R116 on the rear of the prescaler board.

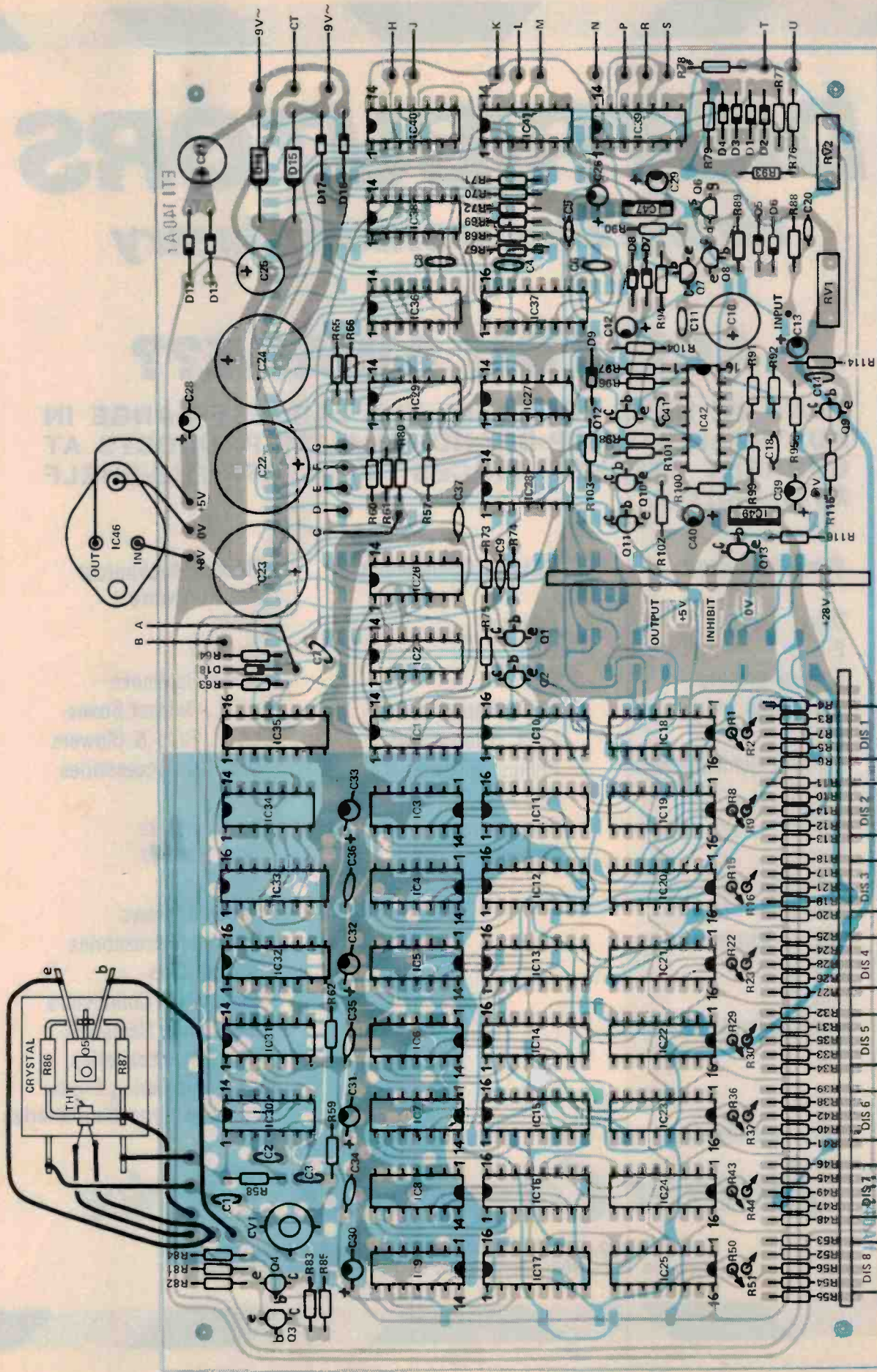

Fig. 16. The main component overlay. For the connection of wires marked A - U see Fig. 8. Wire B goes to the decimal point on DIS 5 (Pin 6) while wire C goes to the decimal point of DIS 1 (Pin 6).

DISTRIBUTORS

for the Electronic Industry

ARE YOU AWARE??

THAT WE HAVE PROBABLY THE LARGEST RANGE IN AUSTRALIA OF TOP-BRAND, QUALITY PRODUCTS AT CURRENT MARKET PRICES WITH OFF-THE-SHELF AVAILABILITY.

Semi-Conductors

Delco
E.D.I.
General Electric
Intermetall
I.T.T.
National Semiconductor
N.E.C.
Philips
Sanyo
Signetics
Solitron
Texas Instruments
A.M.D.
Intersil
Monolithic Memories

Passive Components

Bournes
Elna
Erie
I.T.T. Capacitors
I.T.T. Thermistors
Philips (Elcoma)
R.C.A.
Soanar
Sprague

Electro-Mechanical and Hardware

Alco
Cannon
Delco Heatsinks
I.T.T. Diecast Boxes
I.T.T. Fans & Blowers
Dica I.C. Accessories
I.E.E.
I.T.T. Relays
Jean Renaud
J.A.E.
National Relays
Pomona Accessories
Rotron Fans
Switchcraft Connectors
Thermalloy Heatsinks
T.I. I.C. Accessories
Weller Soldering Erous
G.E. Rechargeable Batteries

Trade enquiries to:

Instant Component Service

P.O. Box 2, Arncliffe. N.S.W. 2205. Ph (02) 597-1444
Adelaide 267-2393. Melbourne 95-9566. Sydney 597-1444

Instant Component Service

DISTRIBUTORS:-

NORTH.
J. A. SEVERN
P.O. Box 47
Epping 2121
869-1058

EAST.
**RADIO DESPATCH
SERVICE.**
869 George Street,
Sydney, N.S.W. 2000
Phone: 211-0191

NEWCASTLE:
DIGITRONICS
186 Parry Street,
Newcastle West, 2302
Phone: (049) 614991

BRISBANE

NOW OPEN AT

**Cnr Montague Road &
Victoria Street,
West End. Qld. 4101.
Phone: 44-6667**

RON BURR

AMATEUR COMMUNICATIONS

Articles of Note

Apart from the already-mentioned article on narrow band voice modulation in the December issue of QST, that issue also carries a good introductory article on the subject of meteor scatter. 'VHF DX Via Meteor Scatter' should be of interest to the new crop of VHF enthusiasts that are thinking of trying something else apart from 2m FM and repeaters.

If you want to look over what's at the forefront of current amateur radio technology then you might take a peek at the January issue of Ham Radio magazine. There are five articles of note in this issue.

First up there's a 'Broadcast-Quality Television Camera', by Arthur Towslee, WA8RMC. Although built to the US 525-line standard, many of the techniques detailed in this article are directly applicable to other systems. A very detailed description of circuitry and construction together with the important design parameters is given.

Then there's 'Microstrip Transmission Lines' by the incomparable Jim Fisk, W1HR -- editor in chief of Ham Radio. Undoubtedly this will become one of the reference articles on this subject. The subject is covered in depth, including the development of the theory etc and includes a complete range of tables and graphs to enable the talented home-brew to carry on for himself. The subject is topical, of course, and will certainly be of interest to ETI readers who have followed the recent series on VHF solid state power amplifiers. An excellent bibliography of 17 relevant papers and articles is included.

FACT SYMPOSIUM

The FACT Symposium, mentioned in last month's news, is to be held at the Strata Motor Inn, 287 Military Rd, Cremorne in Sydney over the weekend of 20-21 May.

Organised by Roger Harrison VK2ZTB and the NSW VHF & TV Group committee, the Symposium papers have been finalised and the following topics will be covered:

Sunspot Cycle 21 (Ken Mackracken VK2CAX)

ATV Techniques for 420 & 1290 MHz (Peter Cossins VK3BFG and Les Jenkins VK3ZBJ)

Solid State Power Amplifiers (Phil Wait VK2ZZQ and Roger Harrison VK2ZTB)

Microprocessors and Amateur applications (Les Bell GM4CFM)

Solid state SSB on 1296 MHz (Les Jenkins VK3ZBJ)
Pulse Techniques for Amateurs (Kieth Gooley VK2BGZ)
Using Anomalous Propagation for HF and VHF DX (Roger Harrison VK2ZTB)
Modern Repeater Techniques (Jeff Pages VK2BYY, John Sheahan VK2ZPC and Jamie Campbell VK2YCY)
A Review of Antenna Systems for UHF Amateur Use (Les Jenkins VK3ZBJ)

Apart from presentation of the above a number of practical 'workshops' will be presented in conjunction with the lectures. A trade show is also being organised.

Basic registration for the whole weekend, for local attendees or those with their own accommodation, is \$20. This includes a copy of the symposium papers, plus lunch and morning and afternoon teas on both days.

Accommodation is available on a twin share basis for interstate attendees at \$51 per person for two nights, which includes registration and all of the above items. Accommodation for one night, twin share basis, costs \$35.50 per person which also includes all of the above with registration.

Registration application forms and complete information can be obtained from the "FACT SYMPOSIUM ORGANISER," C/- 14 Atchison St Crows Nest 2065 NSW. Do it now!

Persons wanting accommodation will have to register by 28th April, all others by 5th May.

VFO operation for Novices

As from 15th March novice amateur licence holders will be allowed to use VFO control in their sub-bands. The usual restrictions about seeing that transmissions are confined within the band limits are applicable. Slide-on, as they say in the classics!

ATV gear

There seems to have been an upsurge of ATV activity in NSW and Victoria in recent months. However, the video side of things seems well catered for, but suitable transmitting equipment and UHF converters have been scarce. Some equipment fashioned after articles that have appeared in the German publication "VHF Communications" has been pressed into service, not to

Continued on p. 86

AMATEUR COMMUNICATIONS

mention some 'bodged up' designs intended for narrow-band operation.

Microlink P/L, a Melbourne firm of communications engineers — namely Les Jenkins' VK3ZBJ and cohorts, is putting out some interesting gear for UHF ATV enthusiasts.

Microlink has an excellent little converter that can be obtained already built-up and operating for \$25. You can get it for 420MHz or 580MHz operation with a nominal output on channel 3.

Also in the line of ATV goodies is a transmitter and video modulator, with 10W peak output at the sync tip. Price on application.

Custom-made antennas are also available from Microlink, reputedly having the best performance of any of the antennas currently available, bandwidth to burn and no matching problems.

If you want to know more then contact Les at Microlink, 12 Rosella Street, Frankston, 3199.

Tropo Link for Groote Eylandt

Australia's first low-power tropospheric radio link will soon be installed to link Groote Eylandt, in the Gulf of Carpentaria, with the mainland.

Systems of this type will open up new possibilities for reliable trunk line telephone communications in remote parts of Australia and other countries.

Designed and built by Amalgamated Wireless (Australasia) Limited, the system is expected to be in operation within a few months.

Groote Eylandt, a 2,000 sq. km. island 48 km from the east coast of Arnhem Land, has the largest single manganese mine in Australia, operated by the Groote Eylandt Mining Company a subsidiary of the Broken Hill Proprietary Company Limited. The island's total population is about 2,200.

Opened in 1966, Groote Eylandt has had to rely on HF (high frequency) radio for communications with the mainland. This service has often been restricted by bad weather and adverse atmospheric conditions.

The troposphere is the layer of the atmosphere closest to the earth, extending upward for a distance of 10 to 15 km, and can be used to reflect radio beams back from a transmitter to a distant receiver.

Tropospheric communications can

Continued on p. 88

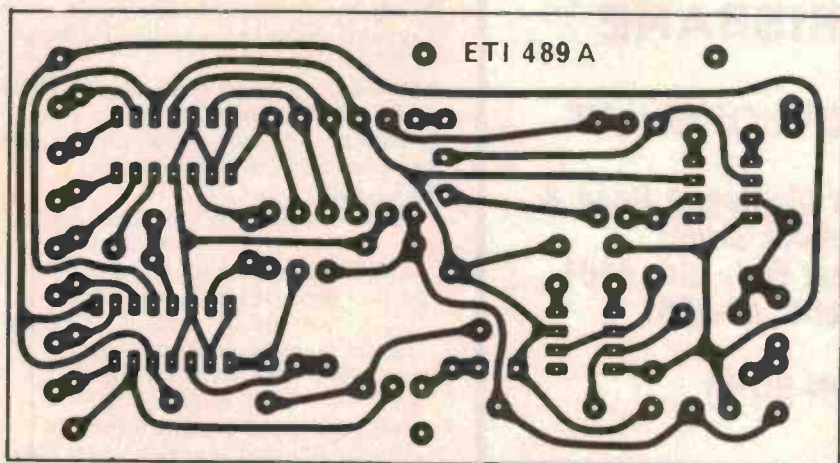
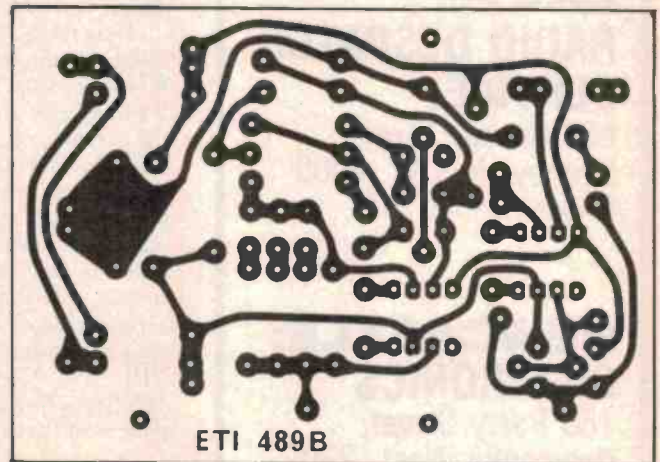
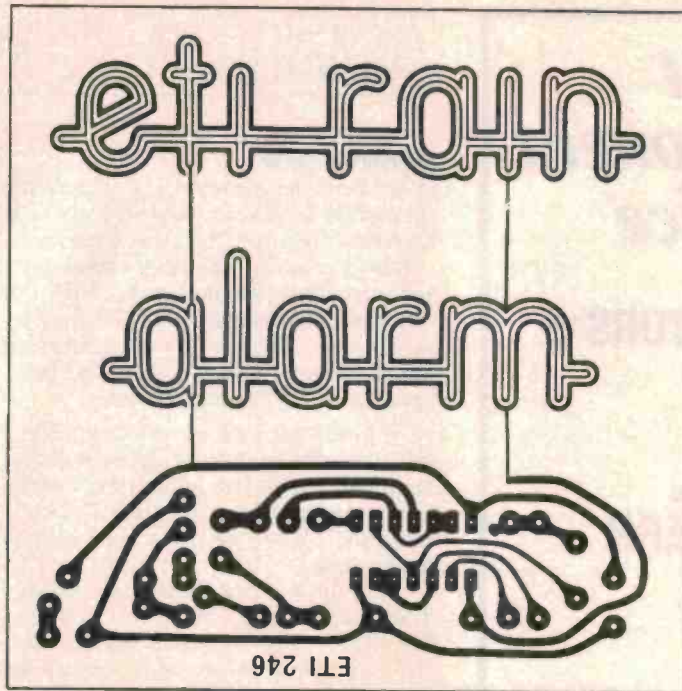

Owing to space restrictions, we have had to omit our propagation predictions this month. Normal propagation will be resumed next month.

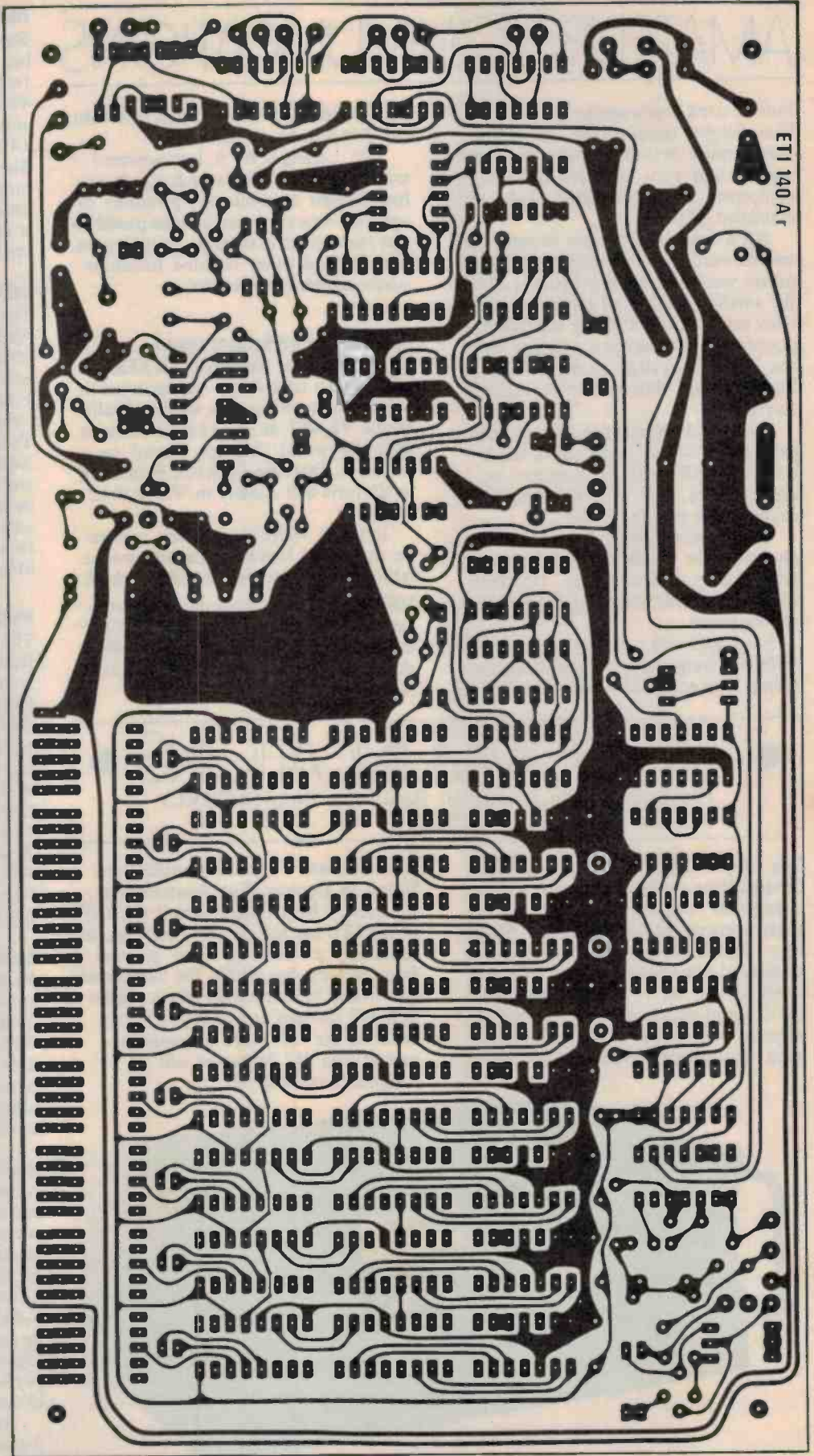
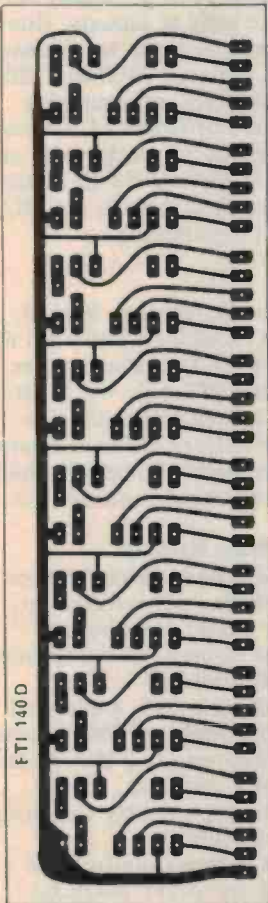

AMATEUR COMMUNICATIONS

thus be used to eliminate the need for line-of-sight transmitters. Normally, they require extremely powerful transmitters and very sensitive receiving equipment, such as are used in Telecom's mainland system.

AWA designed a system to meet the special needs of Groote Eylandt. High power was not necessary because of the smaller number of telephone and telex services called for by the island's population. The system will link with the Telecom system in the Northern Territory and thus with the rest of Australia.

The AWA microwave system will provide a 24-hour seven day a week service, unaffected by weather or atmospheric conditions, and will provide 12 channels for speech or data.

The system incorporates quadruple diversity. On the island will be two seven metre dish antennae, 100 feet apart, each with matching transmitters and receivers.

Each unit will operate on a slightly different frequency, to guard against fading. This equipment will be duplicated

on the mainland where it will feed into the Telecom trunk system.

The concept of a low-powered tropospheric system which needs no line-of-sight transmitters, promises to open up new communications possibilities for remote townships, mining sites, oil rigs, and other isolated locations where telephones are vital.

432MHz record broken again!

Seems like Les Jenkins (VK3ZBJ) can't take a trick lately. As reported in the February issue, Les worked Wally House VK6KZ on the 11th January to gain the world distance record on 432MHz. Distance between Frankston in Victoria and Albany in WA is 2442 km.

Les and Wally's jubilation was to be shortlived however. Several weeks later (date to be confirmed) Michael VK3ZQV at Carrabung in Gippsland, eastern Victoria, worked Orb VK6XY on 632MHz from Albany, extending the just-established record by 100 km! Nice work chaps.

Indonesian news.

Radio Republik Indonesia at Jayapura has recently introduced two new frequencies. Jayapura has moved from 4980 to 4993 kHz for evening programs and is well heard between 1000 and 1400 GMT when transmission closes. The other new outlet is 11940 kHz, noted for morning programs from 2200 until 2300 GMT. The news from Jakarta is relayed at 2200 GMT. All programs are in Indonesian.

Ethiopia.

The Voice of Revolutionary Ethiopia, in Addis Ababa, has recently been observed on the new outlet of 7245 kHz, with good signals during a program in French at 1530 GMT. This is followed by a program in Somali at 1600 GMT. This is the International Service from Addis Ababa, scheduled between 1200 and 2000 GMT in various languages including English Afar and Arabic. This service is carried on 9610 kHz also, though best reception is noted on 7245 kHz.

Philippines

The relays of the American Forces Radio and Television Service (AFRTS) from the transmitters at Poro in the Philippines, resumed during March. AFRTS-Philippines had previously been off the air since early in January. Good reception is given by the new frequency of 21670 kHz, between 0400 and 1200 GMT. The AFRTS programming includes featured programs of various American domestic networks such as ABC, NBC and National Public Radio. Coverage of domestic sport in the USA is a feature of programming.

Spain.

Radio Exterior de Espana, Madrid, currently gives excellent signals with the Spanish service to Australia between 0800 and 1100 GMT daily on 11910 kHz. Madrid is using this channel in place of 11740 kHz, on the recommendation of the Australian Radio DX Club, in order to avoid harmful interference.

New Receiver from National

A new National DR48 ten-band communications receiver, just released in Australia by Haco Distributing Agencies, offers many advanced features for the SW enthusiast.

These include a bright, easily-read 5-digit electronic display of SW frequency and newly-developed I²L (Integrated Injection Logic) circuitry which performs functions previously requiring about 2000 transistors.

An antenna trimmer control and 2-speed tuning are other advanced features of this new premier model in

● SWL COMMUNICATIONS ●

Prepared by the Australian Radio DX Club (ARDXC)
PO Box 67 Highett, Vic, 3190.

The major international shortwave broadcasting stations make frequency changes at four set times each year, these being on the first Sunday in March, May, September and November. These transmission periods are known respectively as the "M", "J", "S" and "D" periods and all stations are required to register their channels in advance of each transmission period with the

International Telecommunications Union in Geneva. The International Frequency Registration Board (IFRB) of the ITU has the task of international frequency co-ordination to prevent frequency clashes within the designated shortwave broadcasting bands. International stations are currently in the midst of the "M" - 78 transmission period. The "J" 78 period will commence on May 7th.



the National range.

Recommended retail price of the DR48, which is available from National Dealers in all States, is \$470.00.

Uruguay

This is a difficult country to hear in Australia, and one of the few stations which may be heard is Radio El Espectador, at Montevideo, operating on 11825 kHz. Reception is possible during February and March, and again during September and October during the period 0900 until 1025 GMT following morning sign on, Uruguay time. Reception was noted in March at this time with programming in Spanish. Signals from Uruguay, and the rest of south-eastern South America must cross the Antarctic regions to reach Australia, thus making reception highly seasonal. For example the summer brings constant daylight to Antarctica, and results in signal absorption. The winter brings total darkness, meaning the maximum usable frequency for reception paths crossing the Antarctic drops to very low levels. Thus the international shortwave bands of 6 Mega-Hertz and above will not generally support Antarctic propagation in these months.

The band which provides the greatest scope for reception of stations in Brazil, Uruguay, Argentina and other centres in south-east South America is the 49 metre band, between 5950 and 6200 kHz. Many stations are audible from their early morning sign-on at 0800 or 0900 GMT, and are heard in south east Australia from about February until early May. Here are details of some of the stations currently audible: 5965kHz, Radio Guaiba at Porto Alegre (Brazil) opens transmission at 0900 GMT and remains audible until about 0940 GMT. All programming, as with all Brazilian stations, is in Portuguese.

6025kHz, Radio Nacional at Asuncion (Paraguay). Morning sign-on may be observed at 0900 GMT, with announcements in Spanish. This station may only be noted on week-days however, as Radio Portugal uses this channel for weekend programs in the same time period.

6165kHz, Radio Cultura at Sao Paulo (Brazil) becomes audible at about 0900 GMT after signals from Switzerland fade-out on this channel. Programming often includes classical music concerts.

African signals

The island state of Mauritius broadcasts on 4850kHz, with programs in French and English. Reception is possible in Australia between 1600 and 1830 GMT.

The Mauritius Broadcasting Corporation has recently been observed with a news bulletin in French at 1730 GMT, while a bulletin of English news relayed from the BBC is audible at 1800 GMT. Station close-down is at 1830 GMT.

Finland

Radio Finland now has a daily transmission in English beamed to Australia. This service is scheduled for 0930-1000 GMT on 17785 kHz, and this is followed by a program in Finnish until 1100 GMT on the same channel. The popular "Sunday Best" program in English, which is heard weekly and presents highlights of Radio Finland's programs for the week plus special features, continues to be aired 0800-0930 GMT on 21495 kHz for Australian listeners. The Sunday Best program is also carried on 11755 kHz at this time, for European listeners.

Switzerland

The Swiss Broadcasting Corporation, Berne, has been using several new channels during the current transmission period. The English service to North America is now heard daily on 15305 kHz from 0145-0215 GMT and also gives good reception here in Australia. The station has moved here from the 49 metre band as the northern hemisphere summer approaches. Another new outlet from Berne is 17830 kHz which is well heard in Australia with Italian to South American at 0030 GMT, followed by Spanish at 0100 GMT.

Chile

Radio Nacional de Chile has recently installed eight new 100 kilowatt transmitters at Santiago, and thus its broadcasts are now more frequently and easily heard in Australia. The station has been experimenting with frequency usage. The external service, La Voz de Chile, carries an English program at 2200 GMT, and the latest frequencies used for this service have been 11950 and 15115 kHz. Other frequencies which may carry this program are 11800, 15150, and 11920 kHz, as well as 17715 kHz. La Voz de Chile is planning to introduce a regular service for Australian listeners shortly, for morning reception here in Australia, as two steerable curtain antennas have been installed for this purpose.

These notes are compiled for ETI by members of the Australian Radio DX Club. People wishing to know more of the club's activities, and about shortwave radio listening in general, should write to the General Secretary of the ARDXC, PO Box 67, Highett, Victoria 3190, enclosing a 20c stamp for return postage.

CB COMMUNICATIONS

Ban on Linears

Linear amplifiers (boosters, kickers, boots . . . etc), illegally used to boost the output of CB rigs to powers from 100 watts up to 1 kW, are to be banned very shortly in the US.

Probable date of the ban is 1st July this year. Waivers will be granted to manufacturers and dealers who can show that the date of the ban and required type-acceptance cannot be met. The FCC in proposing the ban, decided to require type-acceptance of linears intended for sale on the amateur radio market, so that technical standards could be developed to prevent the units being used by CB operators in the 24-35 MHz range.

The FCC's action was taken to cut down interference with TV and other home appliances caused through illegal use of the linears.

One FCC commissioner, and the agency's engineering staff, opposed the ban on the grounds that type-acceptance would be enough to have the desired effect. But, other officials said the ban would help enforcement efforts.

SSB Handbook

"The New CB Sideband Handbook" by Don Stoner will be available in Australia shortly through Mobile One.

This book is a must for all existing sidebanders and those contemplating going SSB.

Don Stoner has been into CB in the USA since he was knee high to a PL259. His advocacy of SSB is nothing new either - he was building his own SSB ham rigs back in the early 1950s and has written a sideband handbook for hams. He should know something about the subject.

The book has eight chapters covering history, why SSB reduces airwave pollution, some theory of SSB, skip and DX, on-air etiquette, the world of ham radio and buying a rig.

Some of the material pertains specifically to the CB scene in the USA but it is interesting and informative nonetheless.

Don Stoner's book is reviewed exclusively in the April issue of CB Australia. Copies available through Mobile One dealers or directly from Mobile One (02) 516-4500.

Continued on p. 95

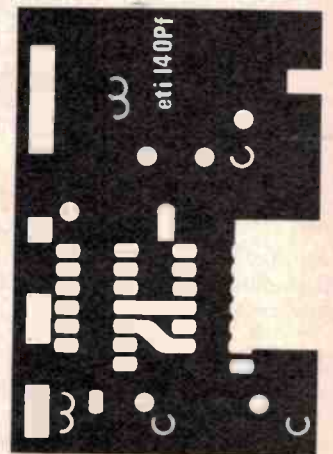
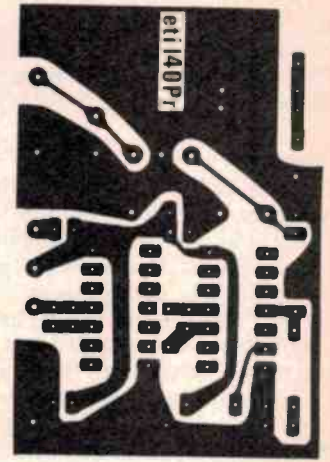
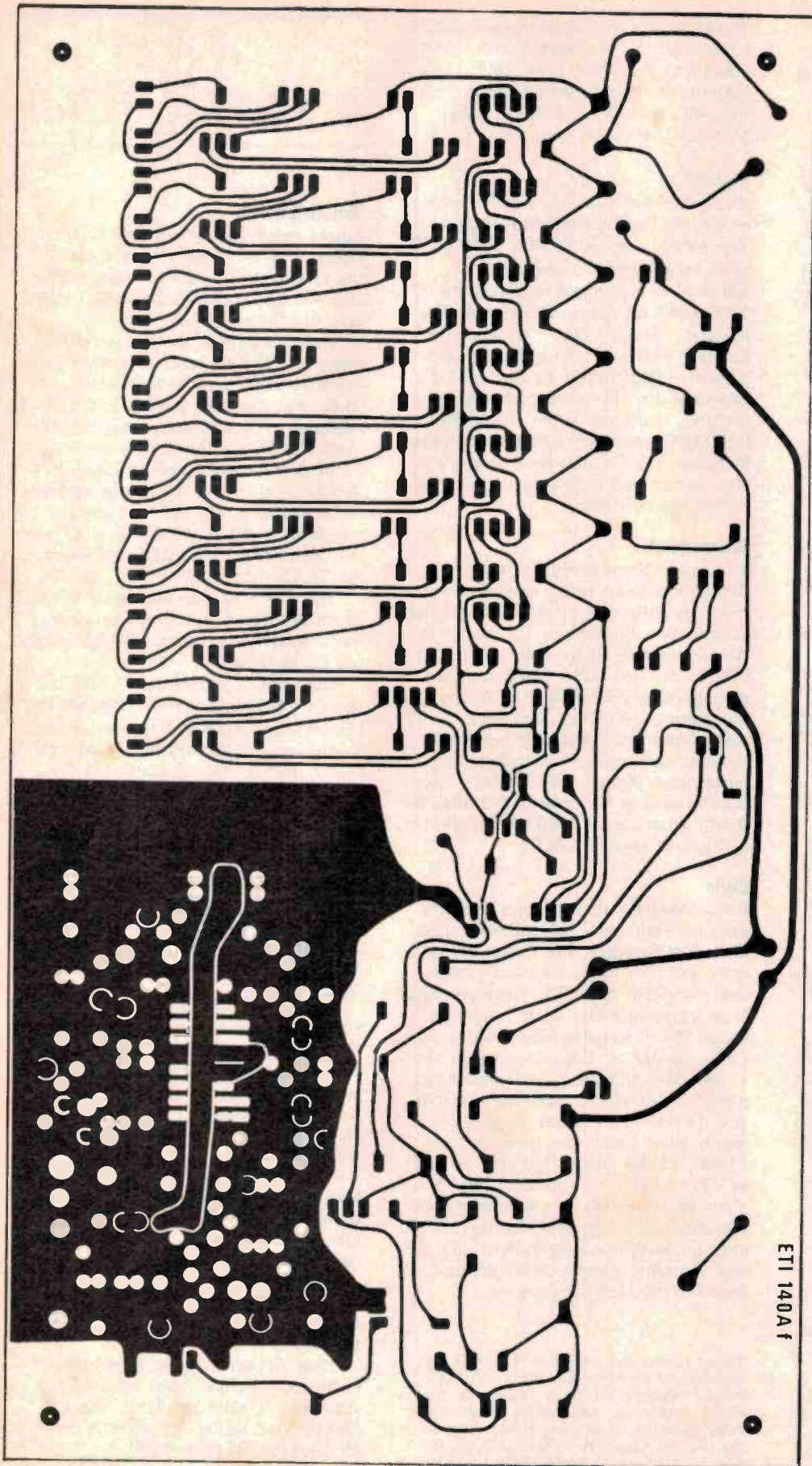



Solar, Tutor II, Litò 250
Huge range of accessories
6" wheels and cassettes

BVA

PROFESSIONAL

SOUND LIGHTING

Importers and Manufacturers of

- Disco Lighting
- Sound Systems
- Special Effects
- Design & Installation Advisory Service

Manufacturers of



- Mail Order Service to Country Areas
- Phone — write — call for free Brochures

RAVE

Berkeley Arcade,
2388 Gold Coast Highway,
Mermaid Beach, Queensland.
Phone: (075) 38-3331.

"THE STOCKING EXPORTER"

FREE FREE FREE FREE FREE

WITH EVERY ORDER FOR OVER \$25.00 YOU WILL RECEIVE A GRABBAG OF "DO-IT-YOURSELF-TESTING" CALCULATOR CHIPS

TTL			
7400	\$.12	7486	.32
7401	.12	7490	.36
7402	.13	7492	.32
7403	.13	7493	.30
7404	.13	7495	.45
7406	.19	74107	.20
7410	.12	74121	.25
7413	.25	74123	.42
7420	.13	74141	.32
7430	.15	74151	.45
7438	.24	74153	.50
7440	.13	74154	.95
7442	.50	74157	.60
7445	.60	74161	.60
7447	.60	74163	.75
7448	.55	74164	.60
7450	.15	74174	.80
7454	.12	74175	.80
7474	.21	74192	.75
7475	.40	74193	.60
7485	.45	74367	.45

LOW POWER SCHOTTKY			
74LS138	\$.25	74LS00	.50
74LS139	.25	74LS02	.50
74LS151	.25	74LS04	.42
74LS157	.25	74LS08	.42
74LS160	.25	74LS20	.60
74LS161	.25	74LS30	.60
74LS162	.30	74LS32	.60
74LS163	.31	74LS38	.60
74LS174	.55	74LS42	.70
74LS175	.60	74LS47	.70
74LS192	.60	74LS48	.70
74LS221	.40	74LS74	.85
74LS257	.40	74LS75	.55
74LS266	.30	74LS86	.35
74LS283	.60	74LS90	.63
74LS365	.60	74LS94	.55
74LS366	.30	74LS109	.55
74LS368	.40	74LS126	.55
74LS386	.60	74LS132	.45

C-MOS			
4001	\$.22	4020	1.20
4002	.20	4021	.95
4006	.90	4022	.80
4007	.22	4023	.20
4008	.90	4024	.60
4009	.50	4025	.18
4010	.50	4028	.60
4011	.20	4030	.40
4012	.20	4035	.95
4013	.35	4040	1.00
4014	.80	4049	.50
4015	.80	4050	.50
4016	.40	4071	.22
4017	.80	4507	.28
4018	.85	4510	.50
4019	.35		



S-100 BUSS KITS

8K	RAM	179.95
16K	RAM	449.00
2K/4K	1702A EPROM	
	less	
	PROMS	59.95
8K/16K	2708 EPROM	
	less	
	PROMS	75.95
2+2	I/O Kit	139.95

Write for complete catalog of manufacturer and kits.

Memories and Micros

1702A-2K PROM	\$ 5.49
2708 - 8K PROM	15.00
21L02-1K RAM	1.39

Low Power

8080A	CPU	15.99
MC6800L	CPU	13.50
7489	64BIT ROM	1.59

LINEAR

LM1458CN	\$.35
LM3900N	.42
75451N	.30
75452N	.30
75454N	.30
N8T97N	1.30
N8225B	.65

LINEAR

LM301AH	\$.35
LM301AN	.28
LM304H	.75
LM307N	.25
LM308AH	2.00
LM308H	.75
LM308N	.75
LM309H	.75
7805KC	.95
LM311D	1.90
LM311N-8	.40
LM312H	1.00
LM317H	1.80
LM317K	3.00
LM318H	1.30
LM318N	1.25
LM320H	
5,6,8,12,15,18,24V	.75
LM320K	
5,6,12,15,18,24V	1.00
LM320T	
5,12V	1.00
LM323K	6.50
LM324N	.80
LM339N	.60
LM340K	
5,12,18,24V	1.30
LM340T	
5,6,12,15,18,24	.95
LM380N	.85
LM381N	1.20
LM387N	.40
LM555CN	.40
LM567CN	1.25
LM723CH	.55
LM741CH	.32
LM741CN	.30
LM747CH	.62
LM1458CH	.50

CLOCK-CHIPS

MM5314n	6-DIGIT CLOCK CHIP	\$3.99
MM5316N	4-DIGIT CLOCK CHIP	4.49

OPTO-SPECIAL

FND503	.5	7 SEGMENT DISPLAY COMMON CATHODE	\$.85
FND510	.5	7 SEGMENT DISPLAY COMMON ANODE	\$.85

Payment conditions:

Check, International Money order, or Bankdraft (in US Dollars)
Prices are quoted in Australian Dollars.
Please incl. Air Parcel Post charges.
Shipment will be made within 1 week.
All merchandise guaranteed.

INTERNATIONAL COMPONENTS SALES

5220 West El Segundo Blvd. • Hawthorne, California 90250 U.S.A.
Phone: (213) 679-8125 Telex: 673268

BUILD THESE SUPERB PLAYMASTER 12" 3-WAY SPEAKERS IN 2 HOURS AND SAVE \$105

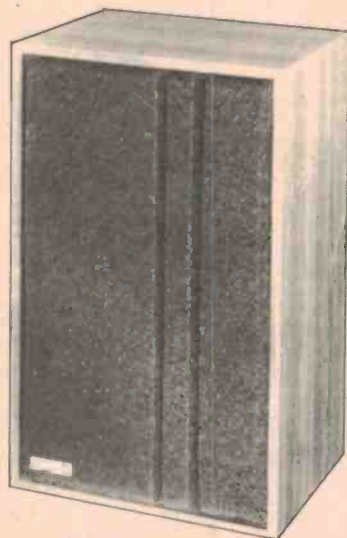

GREAT NEWS! Dick Smith now has the famous Playmaster speaker systems in two forms — as a kit and fully built up.

Make them up from a kit and save \$105.

It's so simple too — everything is precisely cut and shaped, so you don't have to know anything about woodwork.

Just follow the simple instructions and in a very short time you will be sitting back listening to the magnificent sound of your new Playmaster speakers — feeling very pleased with yourself because you've just saved \$105.

Of course the Playmaster speaker systems are so well renowned they need no introduction. Designed by Neville Williams M.I.R.E.E. (Aust.) Editor-in-chief of Electronics Australia magazine, we have arranged for them to be manufactured under tight quality control to the exact Electronics Australia specifications.

All Playmaster speakers feature removable de-luxe foam grilles and are finished in wood-grain vinyl that's almost impossible to tell from real timber — except that it's washable and more durable.

12" 3-WAY

Speaker Enclosure: 75 litre, infinite baffle
 Frequency Response: 28Hz — 20kHz
 Impedance: 8 ohms
 Sensitivity: 93 dB
 Power Rating: 80 watts music
 Crossover: 3-way (1500Hz & 5000Hz)
 Dimensions: 71.7(H)x47.5(W)x29.3(D) cm

10" 3-WAY

Speaker Enclosure: 53 litre, infinite baffle
 Frequency Response: 35Hz — 20kHz
 Impedance: 8 ohms
 Sensitivity: 92 dB
 Power Rating: 60 watts music
 Crossover: 3-way (1500Hz & 5000Hz)
 Dimensions: 62.0(H)x39.3(W)x29.3(D) cm

PLAYMASTER 12" KIT

Cat. C-2042
 Speaker Kit (Pair).....\$130.00
 Cat. C-2622
 Box Kit (Pair).....\$124.00

Total System Price.... \$254.00

Cat. A-2364
 Fully Built-up (Pair)..\$359.00

PLAYMASTER 10" KIT

Cat. C-2044
 Speaker Kit (Pair).....\$99.75
 Cat. C-2624
 Box Kit (Pair).....\$89.50

Total System Price.... \$189.25

Cat. A-2362
 Fully Built-up (Pair)..\$289.00

SEE THESE MAGNIFICENT PLAYMASTER SPEAKER SYSTEMS. LISTEN TO THEM YOURSELF. AT ALL DICK SMITH STORES.



DICK SMITH ELECTRONICS



SHOP HOURS
 Mon-Fri 9AM - 6:30PM
 Sat. 9AM - 12 noon
 (Brisbane hour earlier)

bankcard
 welcome here

Order value P&P charge
 \$5 - \$9.99 \$2.00
 \$10 - \$24.99 \$2.00
 \$25 - \$49.99 \$2.00
 \$50 - \$99.99 \$2.00
 \$100 or more \$5.00

SYDNEY:
 125 York St.
 City. Ph 29-1126.

147 Hume Hwy,
 Chullora. Ph: 642 8922.
 *We've moved!

SYDNEY:
 162 Pacific Hwy,
 Gore Hill. Ph 439-5311
 Ample parking at door.

SYDNEY:
 30 Grose St.
 Parramatta. Ph 683-1133
 1st floor — friendly store!

MELBOURNE
 399 Lonsdale St.
 City. Ph 67-9834
 New right in town!

MELBOURNE
 656 Bridge Rd.
 Richmond. Ph 42-1614
 Easy access, huge stock.

BRISBANE
 166 Logan Rd.
 Buranda. Ph 391-6233
 Opens 8.30AM

ADELAIDE:
 203 Wright St.
 City. Ph 212-1962
 Now Open. See us!

MAIL ORDER DEPARTMENT. PO Box 747, Crows Nest, NSW 2065. Phone 439-5311. Post & Pack extra.

WE HAVE DEALERS RIGHT ACROSS AUSTRALIA — THERE'S ONE NEAR YOU!

propagation a closer look

Radio communications beyond the horizon in the high frequency (HF) spectrum between 3 MHz and 30 MHz are carried on as the result of the bending of the radio waves in the ionosphere, that region of our atmosphere extending from about 60 km to about 1000 km above the earth.

The ionosphere can bend radio waves so that they return to earth from hundreds of kilometres to many thousands of kilometres distant.

Without the existence of the ionosphere, long distance radio communications, shortwave broadcasting, amateur radio 'DX' etc would not be possible — and one G. Marconi would probably have died an unknown pauper!

The ionosphere enables shortwave radio stations such as Radio Australia, Radio Peking, The Voice of America etc to broadcast programmes across the world. It enables radiotelephone communications to ships at sea and contact with international aircraft. Closer to home, the ionosphere enables the Royal Flying Doctor Service to operate across the wide-spread sparsely populated centres of Australia's inland. The Outback Radio Network depends on it!

The Solar prime mover

The sun, which dominates almost every phase of our lives, influences all HF radio communication beyond the horizon. The sun generates the ionosphere; solar activity has a considerable influence on this area of our atmosphere and thus affects propagation of HF radio waves.

Ionisation of the upper atmosphere is brought about largely by ultraviolet radiation from the sun, along with solar X-ray radiation. This solar radiation strips electrons from the atoms of the rarified atmospheric gases existing in our upper atmosphere.

The result is not a single, thick region or 'band' of ionisation, as you may suppose. The ionosphere separates into several readily defined regions having varying densities, located in layers at different heights.

Each layer has a relatively dense region, called the *peak* of the layer, the ionisation tapering off above and below this region. The peak is not necessarily located in the centre of the layer, nor

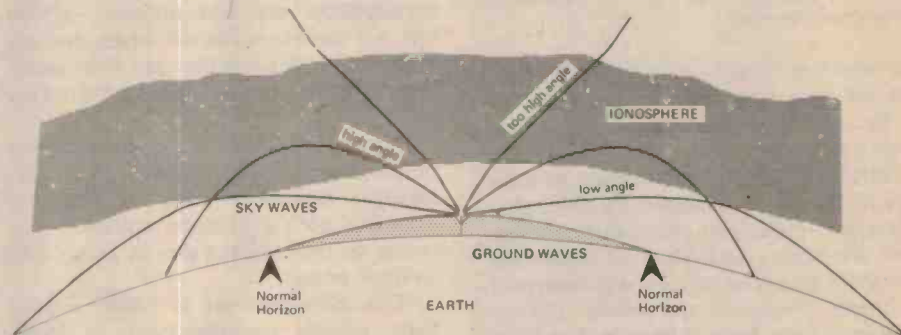

Figure 1. The ionosphere bends radio waves such that they travel great distances beyond the horizon.

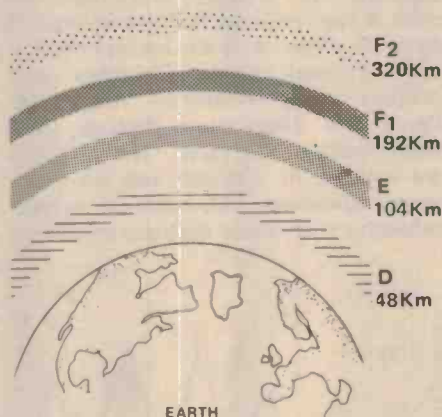

Figure 2. The ionosphere divides into readily defined regions which have been designated as illustrated here. The amount of ionisation in each layer varies diurnally (i.e.: throughout the day), seasonally (throughout the year) and through the 11-year sunspot cycle. Disturbances on the sun have a variety of effects on the ionosphere and thus on radio communications.

does the ionisation always disappear completely between layers.

Spotting good propagation

The sun's UV radiation output varies over an approximately 11-year cycle, greatly influencing the behaviour of the ionosphere. For many years this cyclic behaviour of the sun has been monitored by means of *sunspots* — dark areas

which appear on the face of the sun, and over the last two decades, by measurement of the *solar flux* (RF noise radiation) at 2800 MHz (10.7 cm wavelength).

Sunspots are enormous areas on the sun's surface which are cooler, and thus do not appear as bright as the surrounding area. Hence, they look like 'spots' on the face of the sun. Their size can range from several hundred kilometres across to greater than 100,000 km. By comparison, the earth's diameter is only 13,000 km.

The spots usually appear in clusters, the largest extending nearly half a million kilometres across the face of the sun on occasions.

Sunspots can form and remain visible from several days to several months, often growing in size the longer they last.

The sun rotates about its axis with a period of about 27 days. If a sunspot persists long enough, it can be seen to move across the face of the sun, taking about 13½ days to go from one side to the other (*limb to limb*, as they say). Having reached one side and disappeared, it may reappear on the other side about 13½ days later.

Man's interest in the sun and solar phenomena is clearly older than recorded history. Ancient Sumerian and Chinese cultures observed and recorded sunspots. Galileo turned his telescope,



Figure 3. The sun as viewed in the visible light region showing several small spots, a relatively large spot and sunspot groups. (Photo courtesy of the Ionospheric Prediction Service.)

the first ever made, onto the predominant celestial body and observed spots! — he was labelled a heretic for telling what he saw.

WARNING: Do not attempt to look directly at the sun, especially through a telescope — this can result in blindness. The alternative technique of projecting the sun's image onto a card is described in many books on astronomy. Galileo may not have been a heretic, but if he ever looked through his telescope at the sun, he was probably a silly old twit.

Records of systematic sunspot observations date back some 300 years. However, reasonably reliable data is only available since about 1850.

The sun is monitored continuously from a number of observatories around the world. Sunspot observations are statistically smoothed to provide a continuous record — this is termed the Zurich Sunspot Number, which is a statistical 'fudge factor' on which ionospheric propagation predictions are based. More on this later.

Sunspot Number does not mean 'number of sunspots'. It is a statistical term which allows comparison with past figures and provides an index of sunspot activity.

The sunspot number has a cyclical variation with a mean period of 11 years. Periods between sunspot peaks have been as short as 9 years and as long as 13 years. The sunspot number between the peaks and minimums of the cycles also varies greatly. The sunspot cycles have been 'numbered', for the convenience of reference, back for 200 years. Cycle 18 peaked in 1947, cycle 19 — the biggest on record — peaked in 1957 with a sunspot number in excess of 200. Cycle 20 peaked in 1969 reaching a sunspot number of 120, which is about average intensity.

If you thought the DX wasn't any-

thing spectacular in 1969-70, you should have been around in 1907 when the sunspot number barely reached 60 during the peak!

Sunspot cycle minimums don't always reach zero levels. Some minimums however have shown little or no activity for many months.

The sunspot cycle, while having an 11-year mean period as observed between peaks, has been identified in recent years as actually being a roughly 22-year period based on the magnetic field variations of the sun. Alternate sunspot cycles show a pole reversal in the solar magnetic field.

Solar Disturbances

On occasions, the surface of the sun is disturbed by sudden 'storms'. These disturbances are not normally visible but are readily detected when the sun is viewed at a particular red light wavelength, known as H-alpha, emitted by hydrogen.

These very intense, localised outbursts increase very rapidly to a peak, taking a minute or less, and then the intensity of the H-alpha emission decreases to its normal value in about half an hour or so.

This phenomenon is called a *solar flare*, usually occurring near, or associated with, a sunspot.

Solar flares generate enormous amounts of energy, and increased solar X-ray radiation from these regions cause disturbance to the ionosphere and to communications. Electrons and protons are also emitted from solar flares, and these travel through solar wind towards the earth. The particles are emitted in a stream and are much more numerous and move at greater velocities than those particles contained



Figure 4. The sun as viewed in the red wavelength region emitted by hydrogen — H-alpha emission. Two large active regions can be seen along with associated 'filaments'. (Photo courtesy of the Ionospheric Prediction Service.)

in the normal solar 'wind'.

Upon reaching the region near the earth these particles have a considerable influence on the earth's ionosphere and magnetic field, producing sudden and dramatic changes as well as precipitating other events — such as aurorae — which will be described in more detail later.

Apart from flares, disturbances not associated with sunspots also cause disturbances to the ionosphere and the earth's magnetic field. *Hot Spots* — which are of longer duration than flares, are emitting regions on the sun's surface that expel streams of particles which affect the ionosphere. These, and other areas on the sun's surface which emit persistent streams of particles, have longer durations than flares but the effects of the particles emitted is less severe.

To be continued . . .

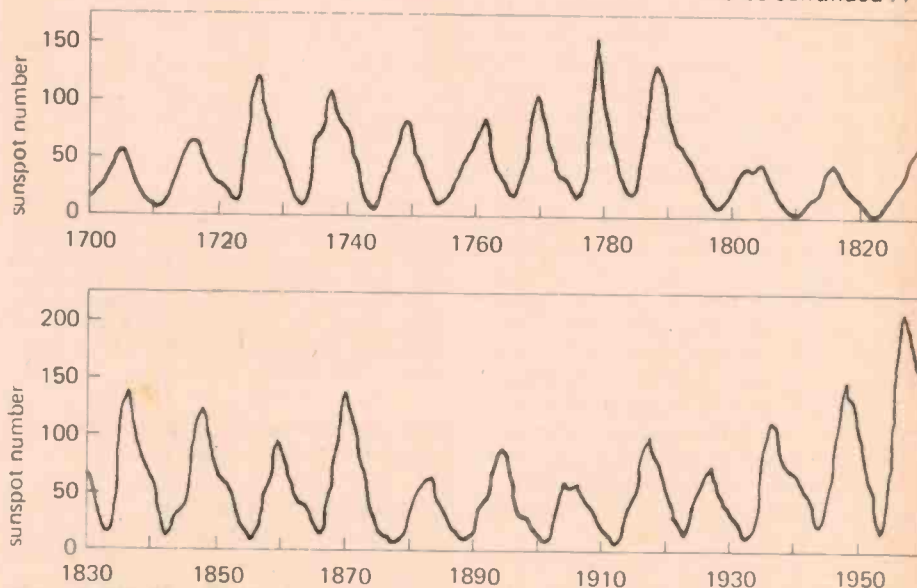

Figure 5. The 11-year solar cycle is clearly evident from this plot of the Sunspot Number from 1700 to 1960.



ELECTROCRAFT PTY LTD

106A HAMPDEN RD,
ARTARMON 2064
PHONE: 411-2989
411-3772

TELEVISION AERIAL AND DISTRIBUTION EQUIPMENT
CB RADIOS, AERIALS & ACCESSORIES

TELEVISION

ELECTROCRAFT DISTRIBUTION AMPLIFIERS AND AMPLIFIER SPLITTERS

NEW Medium and high gain distribution amplifiers suitable for all applications with 1, 2, 3 and 4 outputs suitable for small home unit, showroom or household type installations.

TYPE 1.75 DI has one output, 16 db gain with low N/F **\$45.50**

WHILE TYPE 4.75 T19 has 4 outputs 19db of gain with low N/F **\$61.84**

ANTENNAS

A COMPLETE RANGE OF TV & FM AERIALS. HILLS CHANNEL MASTER. MATCHMASTER & H1.Q.

HILLS \$....

CA16 — High gain phase array **45.94**

215.2710 — 8 element yagi **25.29**

2010.2710 — Airways screened

co-linear **58.26**

EFC 1 — 75 for colour low gain **36.00**

FC2 — 75 for colour medium gain **56.96**

EFC 3 — 75 for colour high gain **75.50**

CHANNEL MASTER

3110 — 2 element coloray **27.96**

3111 — 6 element super coloray **41.98**

H1.Q. LOG PERIODICS

8 element & 10 elements **\$39.00** (Excellent back to front ratio).

ACCESSORIES: Outlet plates, Transformer splitters, Attenuators, filters, plugs, sockets for 75 ohm x 300 ohm applications

AERIAL HARDWARE: Wall brackets, chimney mounts, U brackets, guy wire, guy rings, masts from 8ft to 50ft.

SPECIAL

DEGAUSSING COILS complete with power cord plug and push button switch **\$14.00.** Ready for use

CB EQUIPMENT

WAVE SPIRAL TUNED BASE STATION AERIAL

Omnidirectional (top view) radiation pattern with excellent ground wave and sky wave characteristics. Ideal for "Point to Point" & "Skip" communications. Sturdy plated base bracket, 4 telescopic radials and vertical radiator. Spiral tuning stub at base for quick and easy tuning. SWR of 1.1 possible. Aerial comes complete with SO 239 socket, U bolt and saddle and detailed instruction sheet **\$37.75****

A 5/8 ground plane CB Base antenna top loading. **\$54.95.**

DELIVERY ARRANGED IN SYDNEY AREA FOR ORDERS OVER \$10.00

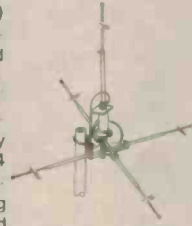

SCOOP

TRANSCEIVERS

Clearance sale of all our CB Radio stock to make way for new shipment

COBRA 21 x TRANSCEIVERS, COBRA 19M TRANSCEIVERS, PRESIDENT "GRANT" AM/SSB.

MOBILE AERIALS: Royce, Belling Lee Gilco (heavy duty) topix **ACCESSORIES:** Plugs, sockets, jumper leads, coaxial cable SWR Meters, etc. **ALL TYPES OF CABLE:** in stock, coaxial, twin, 300, 75, 850. From 30 cents per metre.

SPECIAL

COMPONENTS

FERGUSON TRANSFORMERS

240V to 18V 60VA (Low profile) **\$8.95****

240V to 18V 20VA (Low profile) **\$6.55****

240V to 18V 0.18V 5A (PC Type) **\$4.56****

PLUG TYPE POWER PACKS

240V to 18V DC. Full wave rectification.

470LF Filter capacitor, c/w 1 metre lead & 3.5mm plug **\$5.50****

METAL BOXES

L=200mm, W=135mm, H=70mm. Black vinyl covered, suitable for CB Power supply, etc. ideal project box **\$3.50****

** RECOMMENDED RETAIL PRICE (NSW)

CB COMMUNICATIONS

Continued from page 86.

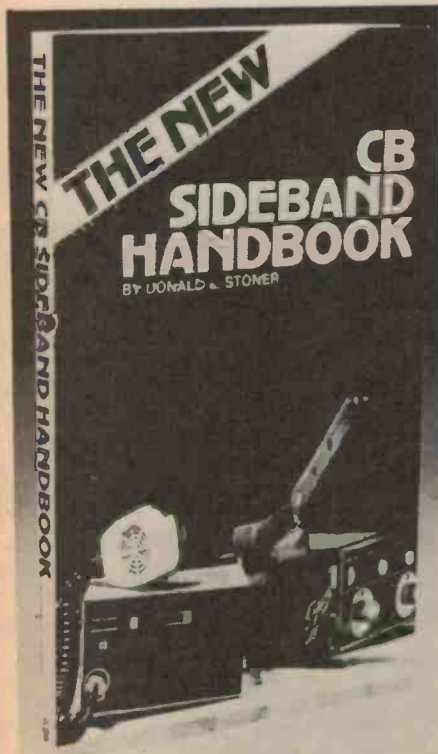

The Stoner CB Sideband handbook.

Tandy hide-away

The Tandy TRC-461 was released quietly late last year, but has only recently become generally available.

Called the "one-hander" the TRC-461 has a remote-mounting transceiver and a unique microphone with all the controls right at your fingertips.

No longer do you have to grope around under the dash while trying to keep your eyes on the road, steer, look to the right, miss the bike on the left and watch the highway patrol coming up behind!

The transceiver module is small and

compact allowing it to be mounted in tight spaces — like under the dash — or unobtrusively in the boot, under a seat etc. The rig can be kept away from the prying eyes of potential thieves. A 5m long extension cable allows the transceiver and handset to be well separated for remote operation in almost any vehicle.

On the technical side, the TRC-461 incorporates a PLL synthesizer for precise frequency control as well as a noise blanker and a noise limiter that operate all the time.

Fully P & T approved, the TRC-461 retails for just under \$200 and is available from any of the 111 Tandy stores throughout Australia.



FM320



PHILIPS WILL RELEASE their model FM320 UHF CB transceiver late March through early April, and judging from the performance of early production sets, both on the bench and in field trials, it seems that UHF CB will set new directions in CB operation in the near future.

The Philips FM320 is an FM transceiver covering the 40 UHF CB channels from 476.425 MHz through to 477.400 MHz. It incorporates a PLL frequency synthesizer and runs 5 watts output from the transmitter. The FM320 has received type-approval from the P & T Department as it meets their specification for UHF CB transceivers, RB250.

Controls

The volume control dominates the front panel. The large thumb-and-forefinger knob operates smoothly providing a smooth variation in the receiver volume.

The S/Rf meter located on the left hand side of the front panel indicates signal strength and RF output in separate colours as is conventionally found on 27 MHz rigs.

The mic socket is a standard DIN type and is sensibly located on the right hand side of the front panel.

The channel readout is a seven segment LED display that is quite bright and easy to read over a wide range of angles. The channel change control is beneath it. This is a lever switch, as the channels are changed electronically by pressing the lever left for decreasing the channel number, right for increasing it.

A single press changes the channel once, holding it down causes the transceiver to step through the channels at the rate of several per second.

Beneath the meter are the mute switch and the channel reset switch. The mute switch has a centre position (0) which opens the mute, a 'high' position where the receiver will only unmute on strong signals and a 'low' position where the receiver unmutes on quite weak signals. Saves fiddling with a squelch knob when you're mobile!

The channel reset switch provides the facility of resetting the transceiver to Ch.11, from whatever channel you're on. Presumably, this is the 'call channel' Philips have selected. Note however, that channels 11 to 35 on UHF are not currently available for CB use.

The channel reset switch also allows selection of a channel nominated by the owner of the transceiver. This is provided by a diode ROM which is part of the PLL synthesizer control circuitry.

The power on/off switch is located right next to the mic socket and can be easily found by feel - no taking your eyes off the road - indeed, most of the controls can be operated this way. Three LED indicators above the mic socket show power on, Rx or Tx.

The case is a three-piece plastic moulding - front panel, top and bottom covers. The whole business is secured by four self-tapping screws and locking tabs that fit together on the three mouldings. The whole assembly is quite robust.

The front panel lettering is in fluorescent orange which is quite visible even in very low light. The model number and company name are picked out in white.

The handset to be provided with the FM320 will be a neat, palm-fitting type with a comfortable press-to-talk bar and a channel change switch. This is very convenient as most operation with FM transceivers requires the majority of controls to be simply preset and only the channel change and Tx switch are operated to any extent. Having these on the mic is a big asset.

The overall styling, with the black matt-finish cabinet, brilliant lettering and panel layout, gives the rig a very professional look. The styling of the panel and the layout of the controls is clearly designed for maximum operator convenience and is streets ahead of most 27 MHz rigs.

Internal construction is also carefully thought out. The majority of the transceiver circuitry is located on one PC board, with a smaller PC board behind the front panel locating the channel display and controls.

Performance

Operationally, the FM320 is smooth and unflustered. Panel layout proves to be an operator's dream. Sound quality and clarity are excellent - performance here is well beyond that obtained from many high-quality 27 MHz rigs. FM certainly has the edge in this department. However, it remains to be seen how the FM320 performs in a crowded band situation, but the specs are certainly encouraging in this area.

The FM320 was put through its paces on the bench with the kind assistance of the St George Communications Company of Darlinghurst in Sydney. They are specialists in VHF/UHF mobile and base station installation.

From the measurements, sensitivity is excellent and the test report noted that no blocking of the receiver was noted at high signal levels. Unlike the case with most 27 MHz rigs, good copy can be maintained between two vehicles very close together. The transmitter gave the full 5W output and the spurious emissions were well down.

Stability of the transceiver was particularly notable, however, the set submitted for test was 1 kHz higher than the channel frequency on transmit. This had no noticeable effect on the air.

In summary, we think the FM320 is an excellent first effort from Philips for UHF CB equipment. UHF may not replace 27 MHz, only time will tell, but it will certainly provide something impressively different - vive la difference!

Reviews

Chroma-Chime

Regular readers will recall that one of our projects last month was a micro-processor-based electronic doorchime. Well, we've never known Dick Smith to be slow off the mark with a new idea, and electronic doorbells are no exception. Dick is now importing the British-designed Chroma-Chime doorbell kit, which is, like our design last month, based on a microcomputer.

The Chroma-Chime kit is about as complex as a pocket calculator kit, but with none of the problems of miniature components. The assembly manual is extremely well written and put together, with very clear photographs and drawings. All the components fit on a single board which is by no means crammed, making it easy to work on. This board then fits into the moulded plastic case and is secured by three screws.

The circuit is not very complex, with most of the work being done by a Texas Instruments TMS 1000 microcomputer, basically in the same fashion as our SC/MP-based design last month. The TMS 1000 contains the read only memory with the note patterns for 24 tunes. Apart from a transistor to latch the power on for the circuitry, and an audio amplifier, there is also some wave-shaping circuitry which allows the user

to alter the tone of the music from a buzz-like square wave sound to a chime effect. In addition, the volume and speed can also be varied.

The tonal quality of the unit is quite pleasant but the initial enthusiasm of the household when the unit is installed will, in many cases, cause the owner to regret that he ever bought the darned thing! However, after this honeymoon period is over, it is possible to restore sanity and 'ring the changes' by changing the selected tune periodically.

We found the kit to be very easy to assemble, and an ideal kit for the beginner. The Chroma-Chime is available from Dick Smith stores for \$49.50.



'Microelectronics'

Microelectronics. A Scientific American Book, W H Freeman, 1978, \$6.75. Review copy supplied by ANZ Book Pty Ltd of 23 Cross Street, Brookvale, NSW 2100. We are delighted to see that the celebrated September '77 Microelectronics issue of Scientific American has been reprinted in book form. This magazine was rumoured for some months prior to publication, and upon its appearance in Australia, just about every copy was spoken for, leaving many disappointed would-be purchasers.

This soft cover book version of the magazine incorporates all the articles from the September '77 magazine (except the Amateur Scientist and Mathematical Games columns) with the important addition of an index. An introductory chapter by Robert Noyce, chairman of Intel, is followed by a chapter on Microelectronic Circuit Elements and one on The Large-Scale

Integration of Microelectronic Circuits. The next two chapters cover the most important devices in the microelectronic revolution - memories and microprocessors. The following three chapters deal with the influence of the microprocessor on three areas of hitherto 'conventional' electronics - Data Processing, Instrumentation and Control, and Communication: firstly, the effects microelectronics advances will have on the design of large computers and secondly, the small personal computer the microprocessor makes possible.

Each of the chapters is presented in typical Scientific American style, with plenty of good photographs and clear drawings. The book is mainly written for the layman, with no heavy delving into details. A minor annoyance for some readers is the omission of adverts which appeared in the original magazine, many of which were informative and showed current personal computing hardware.

'Microelectronics' will be of great value

to anyone wishing to understand the influence microelectronics will exert on electronic design over the next few years.

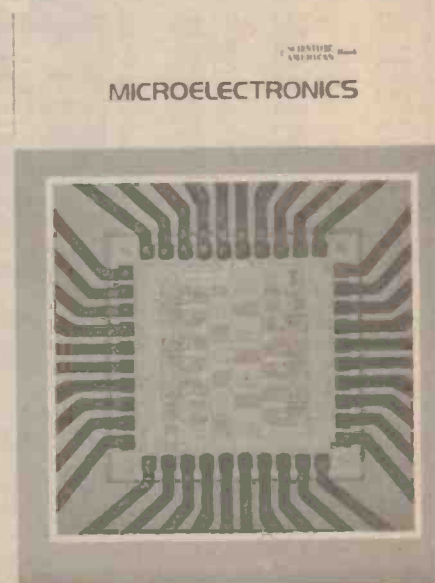

INTERNATIONAL ELECTRONICS UNLIMITED

DISCOUNT ON ALL IC'S AND LED'S
10% OFF ON \$25.00
15% OFF ON \$50.00

TTL

7400	.11	7451	.20	74155	.75
7401	.18	7453	.20	74156	.75
7402	.14	7454	.20	74157	.85
7403	.14	7480	.20	74158	1.39
7404	.16	7484	.35	74160	1.23
7405	.19	7485	.35	74161	.95
7406	.29	7470	.38	74162	1.39
7407	.28	7472	.35	74163	.95
7408	.22	7473	.35	74164	.95
7409	.17	7474	.31	74165	.95
7410	.16	7475	.49	74166	1.19
7411	.25	7478	.34	74170	1.90
7413	.43	7483	.68	74173	1.49
7414	.65	7485	.88	74174	1.19
7415	.25	7486	.38	74175	.95
7416	.35	7489	2.25	74176	.84
7417	.35	7490	.43	74177	.84
7420	.16	7491	.75	74180	.95
7423	.37	7492	.48	74181	2.30
7425	.35	7493	.48	74182	.85
7428	.22	7494	.75	74185	2.20
7427	.35	7495	.75	74190	1.25
7430	.20	7496	.75	74191	1.15
7432	.23	74100	1.15	74192	.89
7437	.25	74107	.37	74193	.85
7438	.25	74121	.37	74194	1.15
7439	.50	74122	.38	74195	.74
7440	.15	74123	.45	74198	.98
7441	.85	74125	.54	74197	.95
7442	.55	74126	.58	74198	1.69
7443	.85	74132	.75	74199	1.69
7444	.73	74141	.85	745200	3.95
7445	.65	74145	.90	74279	.79
7446	.81	74150	.98		
7447	.59	74151	.68		
7448	.79	74153	.80		
7450	.17	74154	1.20		

LOW POWER SCHOTTKY

74LS00	.36	74LS32	.38	74LS95	2.09
74LS02	.36	74LS40	.45	74LS107	.59
74LS04	.36	74LS42	1.40	74LS164	2.20
74LS08	.36	74LS44	1.50	74LS193	2.20
74LS16	.36	74LS47	1.39	74LS197	2.20
74LS20	.36	74LS50	1.50		
74LS24	.36	74LS53	1.30		

LOW POWER

74L02	.29	74L51	.29	74L90	1.40
74L04	.29	74L55	.29	74L91	1.20
74L08	.23	74L71	.29	74L93	1.50
74L10	.29	74L72	.45	74L95	1.50
74L16	.29	74L73	.56	74L98	2.25
74L20	.29	74L74	.56	74L164	2.25
74L30	.29	74L78	.75	74L165	2.30
74L42	1.39	74L85	1.09		
		74L86	.65		

HIGH SPEED

74H00	.25	74H22	.25	74H61	.25
74H01	.25	74H30	.25	74H62	.25
74H04	.25	74H40	.25	74H74	.39
74H08	.25	74H50	.25	74H101	.58
74H10	.25	74H52	.25	74H102	.58
74H11	.25	74H53	.25	74H103	.60
74H20	.25	74H55	.25	74H106	.72
74H21	.25	74H60	.25	74H108	.72

CMOS

4000A	.26	4018A	1.39	4066A	.89
4001A	.25	4020A	1.72	4068A	.44
4002A	.25	4021A	1.18	4069A	.44
4006A	1.35	4022A	.94	4071A	.26
4007A	.26	4023A	.25	4072A	.35
4008A	1.52	4024A	.89	4073A	.39
4009A	.57	4025A	.25	4075A	.39
4010A	.54	4027A	.59	4078A	.39
4011A	.29	4028A	.98	4082A	.35
4012A	.25	4030A	.44	4518A	1.56
4013A	.45	4035A	1.27	4528A	1.56
4014A	1.27	4040A	1.39	4585A	2.10
4016A	.48	4049A	.59		
4017A	1.01	4050A	.59		

74C00	.19	74C74	1.04	74C162	2.49
74C02	.26	74C76	1.34	74C163	2.66
74C04	.44	74C107	1.13	74C164	2.66
74C08	.68	74C151	2.62	74C173	2.22
74C10	.35	74C154	3.15	74C195	2.26
74C20	.35	74C157	1.76	80C95	1.15
74C42	1.61	74C160	2.48	80C97	.96
74C73	1.84	74C161	2.49		

CERAMIC DISC CAPACITORS

1pf 50V	56pf 50V	270pf 50V	01uf 1000V
5pf 50V	68pf 50V	390pf 50V	022uf 50V
7pf 50V	82pf 50V	470pf 50V	030uf 50V
10pf 50V	100pf 50V	600pf 50V	050uf 50V
22pf 50V	120pf 50V	820pf 50V	1uf 50
27pf 50V	150pf 50V	001uf 50V	
33pf 50V	180pf 50V	0047uf 50V	
47pf 50V	220pf 50V	01uf 50V	

(each) (Minimum 10 per value)

0-100	\$.10 ea	\$.05 ea
100-		\$.04 ea

SPECIAL SALE

TTL BARGAINS

7416	\$.19
7430	.16
7432	.19
7437	.19
7438	.19
7440	.13
7445	.49
7495	.55
74123	.25
74141	.59
75LS60	.99

MARK I CLOCK KIT
 8 DIGIT CLOCK KIT WITH ONE PC BOARD. ACCOMMODATES MM5314 CLOCK CHIP AND 6 - FND359 DISPLAYS. CONTAINS ALL COMPONENTS, 3 SWITCHES AND ASSEMBLY INSTRUCTIONS. HAS TERMINALS FOR ADDITIONAL REMOTE DISPLAY.
\$10.95

CERAMIC DISC

CAPACITOR PACKAGE
 10 EA. OF FOLLOWING VALUES — 50 VOLT

1pf	33pf	82pf	220pf	820pf	.022uf
5pf	47pf	100pf	270pf	.001uf	.030uf
10pf	56pf	150pf	470pf	.0047uf	.050uf
22pf	68pf	180pf	600pf	.01uf	.1uf

24u CAPACITORS **\$10.95**

LINEAR SPECIALS

LM300 TO-5	\$.49
LM302 TO-5	.39
LM307 mDIP	.19
LM308 TO-5	.59
LM311 TO-5	.49
LM311 mDIP	.49
340T-5V	.79
340T-6V	.79
340T-15V	.79
LM380-8 mDIP	.69
LM585 DIP	.89
LM723 DIP	.39
LM739 DIP	.79

5738 CAL. CHIP FUNCT WITH MEMORY **\$2.95**

SHIFT REGISTERS

2510	\$1.75
2511	1.95
2518	2.50
2522	1.95
2532	2.29
5016	.89

8038 FUNCTION GENERATOR
 Voltage controlled oscillator — sine, square, triangular output. **\$3.95**

MM 5330
 4 1/2 DIGIT DVM LOGIC **\$4.95**

SIGNAL DIODES — 400 MW
20/\$1.00

CALCULATOR DISPLAY
 9 MAN 3 M ON PC BOARD
\$.75 ea.

Jumbo LED'S
 green - yellow
 amber - clear **16¢ ea.**

ZENER DIODE — 400MW
 3.6V 5.1V 6.8V 15V
 4.7V 5.5V 10V **\$.15 EA.**
8/\$1.00 ANY MIX

RESISTOR PACKAGE
 CARBON FILM ± 5% 1/4 OR 1/2 W
 15 EA. OF THE FOLLOWING VALUES
 100, 220, 470, 1K, 1.5K, 3.3K, 4.7K, 8.8K, 10K, 33K, 100K, 1M
180 RESISTORS \$5.45

LED DISPLAYS

FND359	RED CC 375" RHD	\$.58
FND500	RED CC 50" RHD	.79
FND507	RED CA 50" RHD	.79
DL10A	RED CA 27" LHD	.99
DL702	RED CC 30" LHD	.99
DL707	RED CA 30" RHD	.99
DL747	RED CA 80" LHD	1.49
MANS	GREEN CA 27" LHD	.68
MAN 8	YELLOW CA 27" LHD	.69
MAN 82	YELLOW CA 30" LHD	.99
MAN 610	ORANGE DOUBLE DIG.	.89
	CA 56" RHD	.99
MAN 630	ORANGE 1 1/2 DIG.	.99
	CA 56" RHD	.99
MAN 670	RED DOUBLE DIG	.99
	CC 56" RHD	.99
MAN 6750	RED DOUBLE DIG	.99
	CC 56" RHD	.99
MAN 630	RED CA 40" RHD	.89
NSN74R	RED CC 30" RHD	.89

CALCULATOR KIT
 LITRONIC 1502 MEMORY

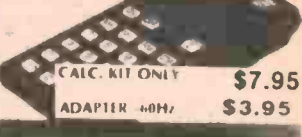

RESISTOR PACKAGE
 CARBON FILM ± 5% 1/4 OR 1/2 W
 USAGE EVALUATED ASSORTMENT
 455 RESISTORS, 44 VALUES
\$12.95

KEYBOARD
 20 KEYS
 2 SLIDE SW
 3" x 3"
\$.99

2708 FULL SPEED EROM
\$10.95

1702A
\$3.95

8080A, 8008
\$12.95

LD110, LD111
 1 1/2 DIGIT A/D CONVERTER
\$24.75

82S23
 256 BIT PROM
\$2.95

5314 6 DIGIT CLOCK CHIP
\$2.95

74S200
 256 BIT RAM TRI-STATE
\$3.25

UART
AY51013A
\$6.95

2513
 CHARACTER GEN 64 x 8 x 5 ASCII
\$6.95

ELECTRONIC DOOR CHIME KIT

WITH TI TMS 1000 MICROPROCESSOR CHIP PROGRAMMED TO PLAY 24 DIFFERENT TUNES

INTERNATIONAL TRADE PATENTED IN AUSTRALIA, BRITAIN, FRANCE AND BELGIUM. HAS OTHER FOREIGN PATENTS AND IS AN ORIGINAL DESIGN.

• MICROPROCESSOR CHIP PROGRAMMED TO PLAY 24 DIFFERENT TUNES
 • COMPLETE KIT FOR HOME OR OFFICE USE
 • 4 MEMORY TRANSISTOR BATTERIES (NOT INCLUDED)
 • LOW POWER OPERATION
 • OPERATIONAL SETTINGS BY USE OF 8-DIGIT DISPLAY AND 8-DIGIT KEYPAD
 • PROGRAMMED MODIFICATIONS BY PEAK IN PULSE WIDTH
 • OPERATIONAL SETTINGS BY USE OF 8-DIGIT DISPLAY AND 8-DIGIT KEYPAD

\$39.50 SHIPPING \$1.00

DISCRETE LEDES

ME4 Infrared Clear	.17" dig	8.29
MY108 Clear TO-18	.17" dig	.25
MV500 Clear axial	.09" dia.	.12
NSL100 Red - point	.19" dig	.12
RL209 Red diff.	.12" dig	.12
RL-TT-03 White diff. no flange	.124" dig	.15
RLC200 Red diff.	.19" dig	.25
Current reg.		
RL403 Red diff.	.19" dia.	.15
Jumbo Green, yellow amber or clear diff.	.19" dia.	.18

TANTALUM CAPACITORS
 Solid dipped ± 20%

.1 mid	35V	\$.25	10 mid	16V	\$.40
.33 mid	35V	\$.25	10 mid	25V	.45
1 mid	35V	.25	15 mid	10V	.40
2.2 mid	20V	.25	15 mid	20V	.45
2.2 mid	35V	.30	22 mid	16V	.45
3.3 mid	35V	.30	33 mid	10V	.40
4.7 mid	16V	.30	47 mid	6V	.40
6.8 mid	6V	.30	56 mid	6V	.45
6.8 mid	50V	.40	150 mid	15V	1.50

MM5369 Divider mDIP **2.49**
Crystal 3.58 MHZ color TV **1.75**
Crystal 2.010 MHZ **3.95**

CARBON FILM RESISTORS 5%

1/4 W — ALL STANDARD VALUES FROM 10 OHM TO 5.0M OHM
 1/2 W — ALL STANDARD VALUES FROM 10 OHM TO 15M OHM

QTY.	PRICE (each)	PRICE (minimum 10 per value)
0-10	\$.10 ea	
10-100	\$.10 ea	\$.05 ea
100-1000		\$.04 ea

METAL FILM RESISTORS 1%
 STANDARD DECADE VALUES FROM 10.5 OHM TO 464K OHM

QTY.	MINIMUM 10 PER VALUE	PER VALUE
0-10	\$.20	
10-100	.20	\$.15
100-	.10	\$.09

UNIVERSAL BREADBOARD

Silver plated copper circuit board 8-1/2" x 5-1/2" x 1/16" 2 rows of 27 holes for DIP IC's — space for transistors, resistors & capacitors. Versatile and simple to bread-board. Fits circuitry **\$1.50 ea.**

Date sheets on request. Add 30¢ each if item is priced below \$1.00 each.

Clock Kit

MM5314 with 6 NS71 .27" displays 2 P.C. boards — Display board may be remote. Internal or wall transformer can be used. 50-60 Hz, 12-24 hour. Includes all necessary transistors, resistors, capacitors, diodes, 3 switches and complete assembly instructions.
CK6-3 **\$12.95**

CALCULATOR CHIPS

CTS002 12 digit, 4 function fixed decimal battery operation — 40 pin	1.95
CTS005 12 digit, 4 function plus memory, fixed decimal — 20 pin	2.49
MM5725 8 digit, 4 function, floating decimal 18 pin	1.98
MM5736 6 digit, 4 function, 9V battery operation — 18 pin	2.95
MM5738 8 digit, 5 function plus memory and constant floating decimal, 9V battery operation — 24 pin	3.95
MM5739 9 digit, 4 function, 9V battery operation — 22 pin	3.95

OPTO ISOLATORS

MCD2 Opto isolator diode	1.09
MCT2 Opto isolator transistor	1.09

MINIATURE SOLID STATE ELECTRONIC BUZZER

LONG LIFE — HIGH RELIABILITY
 LOW CURRENT DRAIN
 NO MOVING CONTACTS
 NO ARCING — NO RF NOISE
 RICH & CLEAR SOUND

78 dB min AT 1 FT. — 450

Ideas for experimenters

These pages are intended primarily as a source of ideas. As far as reasonably possible all material has been checked for feasibility, component availability etc, but the circuits have not necessarily been built and tested in our laboratory. Because of the nature of the information in this section we cannot enter into any correspondence about any of the circuits, nor can we produce constructional details. Electronics Today is always seeking material for these pages. All published material is paid for - generally at a rate of \$5 to \$7 per item.

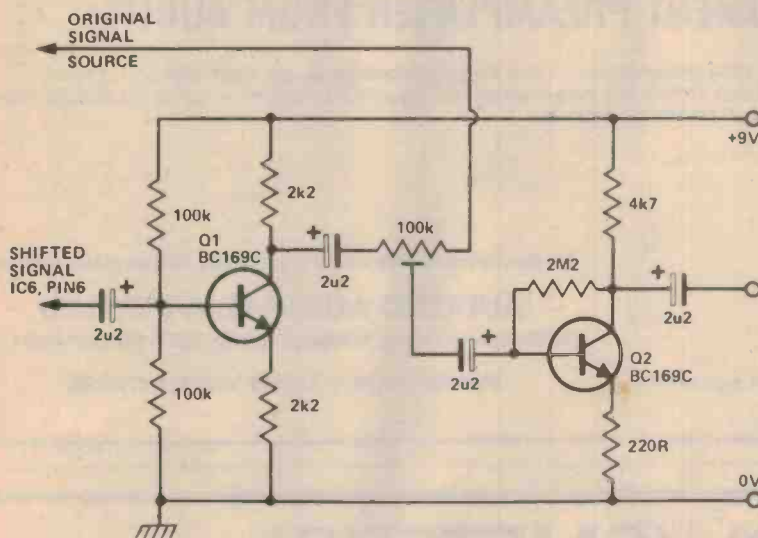

Shifty Phase Adapter

This circuit can be used in conjunction with the Audio Phaser from December's ETI, or with any other phasing unit for that matter. The circuit provides a complementary (antiphase) shifted waveform and amplified.

When this is fed through stereo speakers, it provides the ear with some very peculiar sounding phase information.

At slow speeds, the effect is very much like panning, except that the image is ambient irrespective of the position of the listener. At higher frequencies, where actual frequency shift occurs, a delayed tremolo effect is obtained.

This phase or frequency shifted panning would be most useful in stereo PA systems where the only place where all of the instruments can be heard is in the middle of the dance floor!

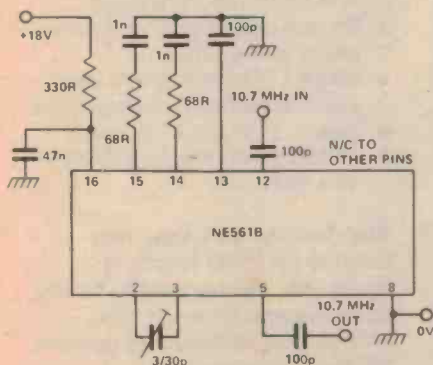

FM Signal Conditioner

As an alternative to an extra IF stage in an FM tuner, a PLL IC can be used as a signal conditioner. The VCO of the PLL tracks the input signal to provide a less noisy and stronger signal at its output.

The circuit shown is built around the Signetics NE561B PLL. The only thing necessary is adjustment of the 3/30 p trimmer which sets the VCO's centre frequency to 10.7 MHz.

The circuit should be effectively screened to avoid interaction with the FM front end that provides the circuit's input.

Tech-craft

PROFESSIONAL SOUND PRODUCTS
BY BOGEN

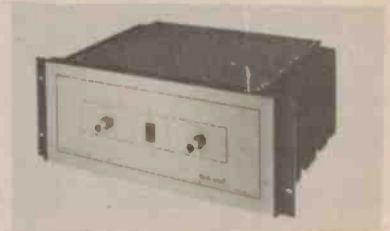

**DUAL CHANNEL (STEREO)
POWER AMPLIFIERS**
± 1dB 20 to 20,000 Hz
75 or 160 watts per channel



1/3 OCTAVE GRAPHIC EQUALIZER
• 24 active filters provide up to 14 dB or attenuation at 1/3 octave increments
• Filter bypass switch

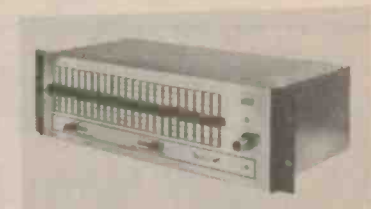

MIXER AMPLIFIERS
• +28 dBm rated output. Less than .5% distortion
• Up to 8 channels expandable to 24 with extenders



COMPRESSOR/LINE AMPLIFIER
Can be used as a compressor/limiter, mixer amplifier or line amp. +18 dB o.p. 2 input channels.

FOR FURTHER INFORMATION:
AUDIO TELEX COMMUNICATIONS PTY. LTD.

SYDNEY
54-56 Alfred Street,
Milsons Point 2061
Telephone: 929-9848

MELBOURNE
828 Glenferrie Road,
Hawthorne 3122
Telephone: 819-2363

BRISBANE
Audio Telex Comm.,
394 Montague Road,
West End 4101

FOR THE PROFESSIONAL . . .

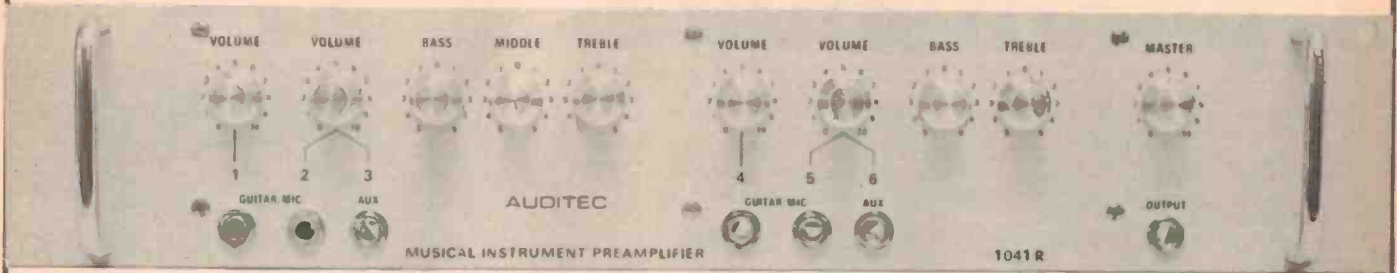

A NEW MUSICAL INSTRUMENT PREAMPLIFIER FROM AUDITEC

Using the same advanced techniques as the unique 1036 preamplifier — low noise performance, coupled with an infinite signal-handling capacity (the input cannot be overloaded). Drives any power amplifier requiring 1 volt rms. — up to six simultaneous inputs. For descriptive leaflets on this preamplifier, call, phone or write to:

AGENTS

Melbourne: Zephyr Products, phone 568-2922
 Brisbane: Delsound Pty Ltd, phone 229-6155
 Adelaide: Neil Muller Pty Ltd, phone 74-1162
 Perth: Willis Trading Co, phone 21-7609
 Canberra: Musique Boutique, phone 82-2553
 Bundaberg: Bundaberg Hi-Fi, phone 71-3176
 Darwin: Darwin Communications Systems, phone 85-3184
 Alice Springs: Farmer & Davies Electronics, phone 52-2967
 Albury: Ray Walsh Sound Systems, phone 21-1502
 Surfers Paradise: Beno's Musical Supplies, phone 38-1568
 Geelong: Steve Bennett Audio, phone 21-6934
 NSW: President Sound, Wentworthville, phone 631-6689; WMR Electronics, Glenfield, phone 605-1203;
 Dawes Sound Systems, Blaxland, Phone 39-4421

For descriptive leaflets on this preamplifier, call, phone or write to:

AUDITEC AUSTRALIA PTY LTD

10 Waitara Avenue, Waitara, N.S.W. 2077. Phone: 48-4116

(PACIFIC HIGHWAY SIDE OF WAITARA STATION)



NEW VOLKSMETERS!

With LCD Display —
 Excellent Readability in direct Sunlight!



LM-300 Full three digits
\$95.00*



LM-350 3½ digits
\$105.00*

USE THEM ANYWHERE!

FEATURES:

- Measures DC volts, AC volts, ohms and current.
- Automatic polarity, decimal and overload indication.
- No zero adjustment and no full scale ohms adjust.
- Large LCD display for easy reading without interpolation.
- Size: 1.9" H x 2.7" W x 4.0" D.
- Parts and labor guaranteed for one year.

Standard AA-size batteries provide up to 20 hours of operation. Rechargeable NiCad batteries and charger unit available as optional equipment. *Batteries not included.



Non-Linear Systems, (Aust) Pty. Ltd.

61 Lothian Street, North Melbourne, Victoria, 3051, Australia.
 Telephones: (03) 329-9951 — (03) 329-9377 Telex: 34082.

Ideas for experimenters

Novel loudspeaker coupling circuit

In most amplifier designs the speaker is fed by a high value capacitor to provide DC blocking, but this may result in a heavy switch-on surge, as the capacitor charges up.

An alternative approach, which is worthy of experiment, is shown in the diagram below. Here the ground side of the speaker is connected to the junction of two equal high value capacitors (1000 uF is typical), across the supply.

The amplifier output voltage will be at $V_s/2$, and so will the voltage across C_1 (if C_1 and C_2 are equal); so as the supply voltage builds up, the DC voltage

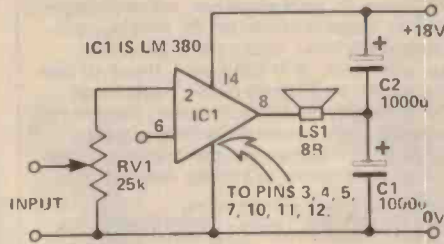

across the speaker will remain zero, eliminating the switch-on surge. C_1 and C_2 will also provide supply smoothing. The circuit is shown with the LM380, but could be applied to any amplifier circuit, providing that the DC voltage at the output is half the supply voltage.

Selective Alarm Controller

This circuit provides greater versatility than the simple "in-series" switches mode of alarm, but is still cheap and easy to build.

When SW3 and 4 are closed, the output of the AND gate goes high. This high is fed to the second AND gate only when SW9 is pressed. The output of this gate goes high and providing no other switches are pressed, it will operate the relay: if any other switches are pressed, the OR gives an output to the inverter and cuts off the power to the AND gate, preventing the coil being energised.

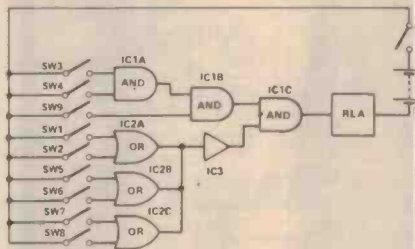

CMOS Radio

The circuit shown is of a simple MW receiver based on the 4011 CMOS IC.

The four gates in this package are used as linear amplifiers by connecting their inputs together and applying negative feedback.

L1, 80 turns of 22 SWG enamelled wire close wound on a 3/8" diameter ferrite rod, is the pickup coil. This is tuned by the 500pF trimmer and the resulting tank circuit referred to earth at RF by C1.

The high input impedance, that of IC1/1, 'seen' by the tank circuit ensures

that little damping occurs, and thus the receiver is highly selective. The output of IC1/1 is an amplified RF signal and is passed to IC1/2 for detection.

The unwanted RF appearing at the output of the detector is removed by the lowpass filter formed by R4 and C2.

The audio signal is then fed to an amplifier formed by IC1/3 and IC1/4.

The circuit's current consumption is about 10 mA when operated from a 9 V supply.

Note that the IC used must be a 40011AE and not the 4011B whose input protection network will prevent it from operating in the linear mode.

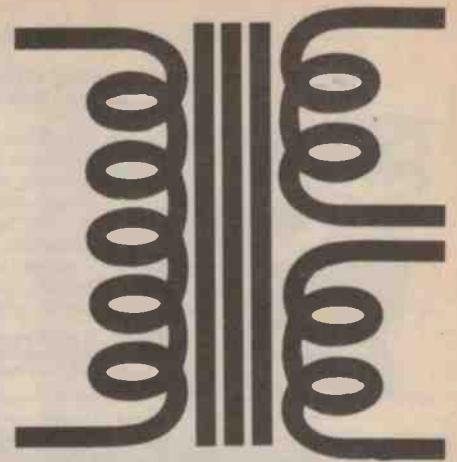
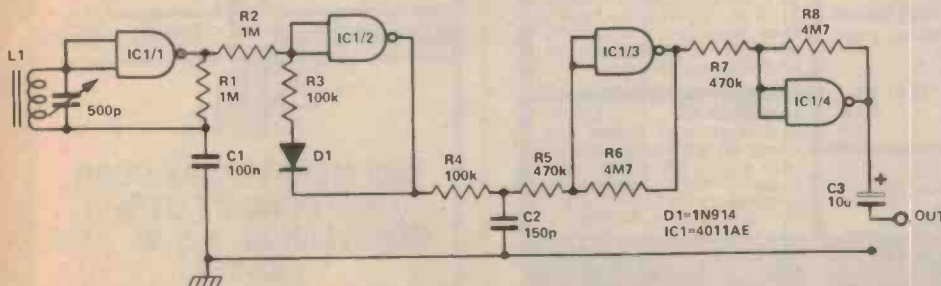

GENERAL PURPOSE
TRANSFORMERS TO SUIT
EVERY PROJECT WITH
TWIN SECONDARIES FOR
GREATER VERSATILITY...



5VA P.C.B. MOUNTING

SERIES V	A	PARALLEL		TYPE
		V	A	
6	.83	3	1.67	PL6/5VA
9	.56	4.5	1.11	PL9/5VA
12	.42	6	.83	PL12/5VA
15	.33	7.5	.67	PL15/5VA
18	.28	9	.56	PL18/5VA
24	.21	12	.42	PL24/5VA
30	.17	15	.33	PL30/5VA

20VA CHASSIS MOUNTING

12	1.67	6	3.33	PL12/20VA
15	1.33	7.5	2.67	PL15/20VA
18	1.11	9	2.22	PL18/20VA
24	.83	12	1.67	PL24/20VA
30	.67	15	1.33	PL30/20VA
40	.5	20	1.0	PL40/20VA
50	.4	25	.8	PL50/20VA

40VA CHASSIS MOUNTING WITH TAPS

V_s	15, 13.5, 12, 9, 3	2.67A	PL15/40VA
V_p	7.5, 6, 1.5	5.33A	
V_s	30, 27, 24, 18, 6	1.33A	PL30/40VA
V_p	15, 12, 3	2.67A	
V_s	50, 45, 40, 30, 10	0.8A	PL50/40VA
V_p	25, 20, 5	1.6A	
V_s	30V at 0.5A and 9V at 3A		PL30-9/40VA
V_p	15V at 1.A and 9V at 3A		

60VA CHASSIS MOUNTING WITH TAPS

V_s	30, 27, 24, 18, 6	2A	PL30/60VA
V_p	15, 12, 3	4A	
V_s	50, 45, 40, 30, 10	1.2A	PL50/60VA
V_p	25, 20, 5	2.4A	
V_s	80, 70, 60, 50, 20	.75A	PL80/60VA
V_p	40, 30, 10	1.5A	

Available from Electrical Wholesalers
or contact:

FERGUSON

FERGUSON TRANSFORMERS PTY. LTO.
331 High Street, Chatswood, NSW. 2067
Tel: 407-0261 Telex: AA25728



TOP PROJECTS - Volume No. 3.
Available from newsgates or direct from ETI.

Contains: - FM Tuner, 25 watt amplifier, active crossover, crossover amplifier, booster amplifier, 50 watt power module, 400 speaker system, audio noise generator, cross-hatch/dot generator, ETI utiliboard, linear IC tester, dual beam adaptor, impedance meter, tone burst generator, digital display, digital volt-meter, frequency counter, logic probe, logic pulser, switching regulator supply, nickel cadmium battery charger, radar intruder alarm, colour organ, car alarm, transistor connections.

\$2.50 plus 40 cents postage and packing.
Send orders to:- Electronics Today International,
15 Boundary Street, Ruschucotts Bay, NSW, 2011.

P.O. Box 4430P Santa Clara, CA 95054

For will call only: (408) 988-1640
2996 Scott Blvd.



Same day shipment. First line parts only. Factory tested. Guaranteed money back. Quality IC's and other components at factory prices.

INTEGRATED CIRCUITS

74001	74LS00	41	LM3401-12	110	CMOS	CD4811	94	21078	4.00
74002	74LS01	29	LM3401-15	110	CMOS	CD4815	232	2111-1	7.00
74003	74LS02	35	LM3401-18	110	CMOS	CD4818	110	2112-2	7.00
74004	74LS03	35	LM3401-24	110	CMOS	CD4820	102	25138	8.75
74005	74LS04	45	LM3401-30	110	CMOS	CD4822	51	MM4115	14.90
74006	74LS05	45	LM3401-36	110	CMOS	CD4824	21	CD4828	7.00
74007	74LS06	45	LM3401-42	110	CMOS	CD4826	25	MM5369	4.00
74008	74LS07	45	LM3401-48	110	CMOS	CD4828	25	MM5330	5.99
74009	74LS08	45	LM3401-54	110	CMOS	CD4830	40	MM5333	5.99
74010	74LS09	45	LM3401-60	110	CMOS	CD4832	40	MM5336	5.99
74011	74LS10	45	LM3401-66	110	CMOS	CD4834	40	MM5339	5.99
74012	74LS11	45	LM3401-72	110	CMOS	CD4836	40	MM5342	5.99
74013	74LS12	45	LM3401-78	110	CMOS	CD4838	40	MM5345	5.99
74014	74LS13	45	LM3401-84	110	CMOS	CD4840	40	MM5348	5.99
74015	74LS14	45	LM3401-90	110	CMOS	CD4842	40	MM5351	5.99
74016	74LS15	45	LM3401-96	110	CMOS	CD4844	40	MM5354	5.99
74017	74LS16	45	LM3401-102	110	CMOS	CD4846	40	MM5357	5.99
74018	74LS17	45	LM3401-108	110	CMOS	CD4848	40	MM5360	5.99
74019	74LS18	45	LM3401-114	110	CMOS	CD4850	40	MM5363	5.99
74020	74LS19	45	LM3401-120	110	CMOS	CD4852	40	MM5366	5.99
74021	74LS20	45	LM3401-126	110	CMOS	CD4854	40	MM5369	5.99
74022	74LS21	45	LM3401-132	110	CMOS	CD4856	40	MM5372	5.99
74023	74LS22	45	LM3401-138	110	CMOS	CD4858	40	MM5375	5.99
74024	74LS23	45	LM3401-144	110	CMOS	CD4860	40	MM5378	5.99
74025	74LS24	45	LM3401-150	110	CMOS	CD4862	40	MM5381	5.99
74026	74LS25	45	LM3401-156	110	CMOS	CD4864	40	MM5384	5.99
74027	74LS26	45	LM3401-162	110	CMOS	CD4866	40	MM5387	5.99
74028	74LS27	45	LM3401-168	110	CMOS	CD4868	40	MM5390	5.99
74029	74LS28	45	LM3401-174	110	CMOS	CD4870	40	MM5393	5.99
74030	74LS29	45	LM3401-180	110	CMOS	CD4872	40	MM5396	5.99
74031	74LS30	45	LM3401-186	110	CMOS	CD4874	40	MM5399	5.99
74032	74LS31	45	LM3401-192	110	CMOS	CD4876	40	MM5402	5.99
74033	74LS32	45	LM3401-198	110	CMOS	CD4878	40	MM5405	5.99
74034	74LS33	45	LM3401-204	110	CMOS	CD4880	40	MM5408	5.99
74035	74LS34	45	LM3401-210	110	CMOS	CD4882	40	MM5411	5.99
74036	74LS35	45	LM3401-216	110	CMOS	CD4884	40	MM5414	5.99
74037	74LS36	45	LM3401-222	110	CMOS	CD4886	40	MM5417	5.99
74038	74LS37	45	LM3401-228	110	CMOS	CD4888	40	MM5420	5.99
74039	74LS38	45	LM3401-234	110	CMOS	CD4890	40	MM5423	5.99
74040	74LS39	45	LM3401-240	110	CMOS	CD4892	40	MM5426	5.99
74041	74LS40	45	LM3401-246	110	CMOS	CD4894	40	MM5429	5.99
74042	74LS41	45	LM3401-252	110	CMOS	CD4896	40	MM5432	5.99
74043	74LS42	45	LM3401-258	110	CMOS	CD4898	40	MM5435	5.99
74044	74LS43	45	LM3401-264	110	CMOS	CD4900	40	MM5438	5.99
74045	74LS44	45	LM3401-270	110	CMOS	CD4902	40	MM5441	5.99
74046	74LS45	45	LM3401-276	110	CMOS	CD4904	40	MM5444	5.99
74047	74LS46	45	LM3401-282	110	CMOS	CD4906	40	MM5447	5.99
74048	74LS47	45	LM3401-288	110	CMOS	CD4908	40	MM5450	5.99
74049	74LS48	45	LM3401-294	110	CMOS	CD4910	40	MM5453	5.99
74050	74LS49	45	LM3401-300	110	CMOS	CD4912	40	MM5456	5.99
74051	74LS50	45	LM3401-306	110	CMOS	CD4914	40	MM5459	5.99
74052	74LS51	45	LM3401-312	110	CMOS	CD4916	40	MM5462	5.99
74053	74LS52	45	LM3401-318	110	CMOS	CD4918	40	MM5465	5.99
74054	74LS53	45	LM3401-324	110	CMOS	CD4920	40	MM5468	5.99
74055	74LS54	45	LM3401-330	110	CMOS	CD4922	40	MM5471	5.99
74056	74LS55	45	LM3401-336	110	CMOS	CD4924	40	MM5474	5.99
74057	74LS56	45	LM3401-342	110	CMOS	CD4926	40	MM5477	5.99
74058	74LS57	45	LM3401-348	110	CMOS	CD4928	40	MM5480	5.99
74059	74LS58	45	LM3401-354	110	CMOS	CD4930	40	MM5483	5.99
74060	74LS59	45	LM3401-360	110	CMOS	CD4932	40	MM5486	5.99
74061	74LS60	45	LM3401-366	110	CMOS	CD4934	40	MM5489	5.99
74062	74LS61	45	LM3401-372	110	CMOS	CD4936	40	MM5492	5.99
74063	74LS62	45	LM3401-378	110	CMOS	CD4938	40	MM5495	5.99
74064	74LS63	45	LM3401-384	110	CMOS	CD4940	40	MM5498	5.99
74065	74LS64	45	LM3401-390	110	CMOS	CD4942	40	MM5501	5.99
74066	74LS65	45	LM3401-396	110	CMOS	CD4944	40	MM5504	5.99
74067	74LS66	45	LM3401-402	110	CMOS	CD4946	40	MM5507	5.99
74068	74LS67	45	LM3401-408	110	CMOS	CD4948	40	MM5510	5.99
74069	74LS68	45	LM3401-414	110	CMOS	CD4950	40	MM5513	5.99
74070	74LS69	45	LM3401-420	110	CMOS	CD4952	40	MM5516	5.99
74071	74LS70	45	LM3401-426	110	CMOS	CD4954	40	MM5519	5.99
74072	74LS71	45	LM3401-432	110	CMOS	CD4956	40	MM5522	5.99
74073	74LS72	45	LM3401-438	110	CMOS	CD4958	40	MM5525	5.99
74074	74LS73	45	LM3401-444	110	CMOS	CD4960	40	MM5528	5.99
74075	74LS74	45	LM3401-450	110	CMOS	CD4962	40	MM5531	5.99
74076	74LS75	45	LM3401-456	110	CMOS	CD4964	40	MM5534	5.99
74077	74LS76	45	LM3401-462	110	CMOS	CD4966	40	MM5537	5.99
74078	74LS77	45	LM3401-468	110	CMOS	CD4968	40	MM5540	5.99
74079	74LS78	45	LM3401-474	110	CMOS	CD4970	40	MM5543	5.99
74080	74LS79	45	LM3401-480	110	CMOS	CD4972	40	MM5546	5.99
74081	74LS80	45	LM3401-486	110	CMOS	CD4974	40	MM5549	5.99
74082	74LS81	45	LM3401-492	110	CMOS	CD4976	40	MM5552	5.99
74083	74LS82	45	LM3401-498	110	CMOS	CD4978	40	MM5555	5.99
74084	74LS83	45	LM3401-504	110	CMOS	CD4980	40	MM5558	5.99
74085	74LS84	45	LM3401-510	110	CMOS	CD4982	40	MM5561	5.99
74086	74LS85	45	LM3401-516	110	CMOS	CD4984	40	MM5564	5.99
74087	74LS86	45	LM3401-522	110	CMOS	CD4986	40	MM5567	5.99
74088	74LS87	45	LM3401-528	110	CMOS	CD4988	40	MM5570	5.99
74089	74LS88	45	LM3401-534	110	CMOS	CD4990	40	MM5573	5.99
74090	74LS89	45	LM3401-540	110	CMOS	CD4992	40	MM5576	5.99
74091	74LS90	45	LM3401-546	110	CMOS	CD4994	40	MM5579	5.99
74092	74LS91	45	LM3401-552	110	CMOS	CD4996	40	MM5582	5.99
74093	74LS92	45	LM3401-558	110	CMOS	CD4998	40	MM5585	5.99
74094	74LS93	45	LM3401-564	110	CMOS	CD5000	40	MM5588	5.99
74095	74LS94	45	LM3401-570	110	CMOS	CD5002	40	MM5591	5.99
74096	74LS95	45	LM3401-576	110	CMOS	CD5004	40	MM5594	5.99
74097	74LS96	45	LM3401-582	110	CMOS	CD5006	40	MM5597	5.99
74098	74LS97	45	LM3401-588	110	CMOS	CD5008	40	MM5600	5.99
74099	74LS98	45	LM3401-594	110	CMOS	CD5010	40	MM5603	5.99
74100	74LS99	45	LM3401-600	110	CMOS	CD5012	40	MM5606	5.99
74101	74LS100	45	LM3401-606	110	CMOS	CD5014	40	MM5609	5.99
74102	74LS101	45	LM3401-612	110	CMOS	CD5016	40	MM5612	5.99
74103	74LS102	45	LM3401-618	110	CMOS	CD5018	40	MM5615	5.99
74104	74LS103	45	LM3401-624	110	CMOS	CD5020	40	MM5618	5.99
74105	74LS104	45	LM3401-630	110	CMOS	CD5022	40	MM5621	5.99
74106	74LS105	45	LM3401-636	110	CMOS	CD5024	40	MM5624	5.99
74107	74LS106	45	LM3401-642	110	CMOS	CD5026	40	MM5627	5.99
74108	74LS107	45	LM3401-648	110	CMOS	CD5			

Ideas for experimenters

Deaf Touch Switch

Many designs for touch controls suffer from the disadvantage of low noise immunity, and this circuit was designed seeking to rectify this vault.

AC voltage from, for example, the hand is applied to the gate of the FET buffer. The resultant positive signal is applied via the diode, to the input of IC1. This IC is made up from three triple gates connected in a Schmidt trigger configuration. At the threshold voltage, a positive pulse is fed to the clock input of IC2, a D-type flip-flop. Connection is made between Q and the

D input, so as to cause the flip-flop to run in the 'triggered' mode. Thus the input signals are divided by two and the output appears at the Q terminal.

In operation, a single positive pulse sets the Schmidt trigger to its low level. (Removal of the hand causes reversion to the 'high' state). This, in turn, feeds the clock input of IC2, which changes the state of the Q output. When this is high, the output stage is driven on, enabling current to flow in the external load and the current limiting resistor, R.

A second positive pulse changes the state of Q to its low level, causing the output stage to be biased off.

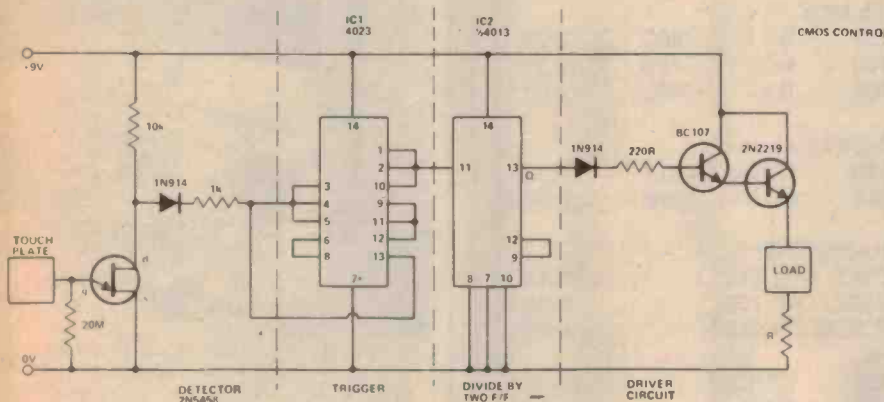

Car Lights Reminder

Many circuits to warn motorists that they have left their headlights on after switching the engine off have appeared in the past. I feel this circuit is an improvement over many of these in that it requires no switches, and it is only necessary to make three connections to the car's electrical system.

If the ignition is switched off while the lights are on, an audible warning is sounded for about ten seconds. This tone is produced by NAND gates IC1/2, IC1/3 and IC1/4. Operation of this oscillator is inhibited by an '0' on the gating input of IC1/2. This in turn corresponds to a logic '1' present at the input to IC1/1 while the ignition switch is on, supplying a high logic level to IC1/1, the oscillator is thus disabled.

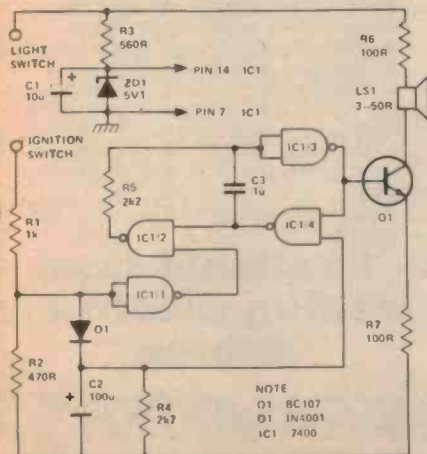

When the ignition is switched off, the output of IC1/1 goes high, enabling the oscillator. At this stage C2, which has until now been charged up via D1, begins to discharge via R4. While the voltage on C2 is high, the gating input of IC1/4 allows oscillator operation, however as C2 discharges, this action is inhibited. This occurs after about ten seconds.

Power for the circuit is provided by R3 and ZD1 from the vehicle's 12 V rail.

FRG -7 SYNTHESIZED RECEIVER



for amateurs,
novices
and
short-wave
listeners

Latest model includes fine-tune adjustment

MANUFACTURER'S TECHNICAL DATA

- Electronic band changing.
- 0.5-29.9 MHz continuous coverage.
- Uses Wadley loop (drift cancellation circuit) to derive synthesized heterodyne oscillator signal.
- LSB, USB, AM and CW.
- Frequency readout better than 10 KHz (readable to 5 KHz).
- Stability within 500 Hz during any 30-minute period after warm-up.
- Better than 0.7 V for 10 dB S N/SSB and CW. Better than 2 V for 10 dB S N/N AM.
- Selectivity 3 KHz at -6 dB, 7 KHz at -50 dB.
- Input Impedance high 0.5-1.6 MHz. 50-75 ohm 1.6-29.9 MHz.
- 234V AC 50-60 Hz or 12V DC (external or internal B dry cell).
- Size 340 mm x 153 mm x 285 mm.

● Price \$338.00

● Prices include S/tax, freight extra. Prices and Specs subject to change.

Explore the wonderful world of short-wave listening.

Hear broadcast stations, amateurs, ships, aircraft and Morse code from stations all over the globe.

Provides an introduction into many aspects of electronics and communications, CB'ers upgrade and widen your scope of operation. The FRG-7 will provide the means of listening to the amateur bands so that you can get the "feel" of amateur "ham" radio.

You can tune into the Morse practice transmissions and broadcasts conducted by the Wireless Institute of Australia; the Radio Amateurs representative Society in Australia.

Write for a descriptive brochure and ask for information on study procedures etc. for the novice amateur licence.

Remember, BAIL has been the authorised agent for the YAESU MUSEN CO LTD since 1963. Our experience gathered over these years, and a lifelong participation in electronics, places us in a superior position to handle warranty, after sales service and advice on the wide range of Yaesu amateur radio equipment.

Avoid unauthorised handlers of equipment as it generally results in the supply of non-export 110V sets with 2-core AC power cables, instruction manuals printed in Japanese, lack of service etc. Consult us for advice on your requirements in the field of short-wave listening and amateur radio.

For further information call or write to the Amateur radio specialists.

Australian agents since 1963

bail 60 Shannon St., Box Hill North
ELECTRONIC SERVICES Vic. 3129
Ph 89 2213

NESSEL LOUDSPEAKERS

PROFESSIONAL SERIES



Rugged cast aluminium

27½" W x 7" High x 19" deep.
90° lip horn
Throat adaptors for screw-on
1 ¾" and 1" entry.
500 c/s crossover



Range of speakers

Model:

SL1201: 12" 4" coil, 100W, Guitar Bass
PA, 8 kg, 80 c/s.
SL1502: 15" 4" coil, 150W, Guitar Bass
PA, 9 kg, 55 c/s.
SL1403: 15" 4" coil, 200W, Bass PA, 14
kg, 70 c/s.
SL1803: 18" 4" coil, 200W, Bass, 14 kg,
50 c/s.

TRADE ENQUIRIES WELCOME

Available from



NESSSEL AUDIO

9 Nellbern Rd,
Moorabbin East, Vic. 3189
Ph (03) 95 9510

**EASTERN
ELECTRONIC
COMPONENTS**
35 Mahoneys Road,
Forest Hill. 3131.
Telephone 878-7876.

**A NEW SUPPLIER OF
ELECTRONIC COMPONENTS
IN THE EASTERN SUBURBS**

**HERE ARE A FEW EXAMPLES
OF OUR WIDE RANGE**

LINEAR I.C.s
LM 555 0-40 LM 741 0-45
LM 301 0-45 LM 380 1-32
LM3900 0-80 7805 1-20

TTL I.C.s
7401 0-31 7402 0-32
7408 0-32 7420 0-32
7492 0-81 7493 0-81

CMOS I.C.s
4000 0-32 4011 0-32
4024 0-70 4068 0-32

TRANSISTORS
BC547, 548, 549 0-19
BC107, 108, 109 0-30
2N 3638 SPECIAL 0-10

2708 EPROM 20-00
2102 RAM 1-75
2513 ROM 19-80
93427 PROM 3-00
3850 F8 CPU 14-95
3853 F8 SMI 12-95

THIS MONTH'S SPECIALS
7400 0-16 4001 0-22
FND 357 7-SEGMENT 1-00
BC208 0-10 7815 0-80

OTHER ITEMS INCLUDE
RESISTORS ¼, ½, 1&5 Watt
CAPACITORS disc, electro, tags
and greencaps.
R.F. CHOKES 3.3µH – 800µH
SWITCHES and HARDWARE
MICROPROCESSORS including
6800, SC/MP, PACE, 2650,
F8, 6100.
CHARTPACK PCB ARTWORK
PRINTED CIRCUIT BOARDS for
ETI and EA projects.

All of the above prices include
sales tax.

Quantity discounts available
Mail orders catered for. Pack and
post 50 cents.

BK PRECISION

**B&K 2810 is STILL
best buy in portable
3½ digit DMM's with
its .01Ω resolution,
RF shielding and
selectable Hi/Lo
Power Ohms ranges.**



The B&K-PRECISION Model 2810 has
a combination of features uncommon in a
portable digital VOM. Basic DC accuracy is
0.5% with a 3½ digit display.
Auto zeroing on all but the 10 Ω range
minimizes set-up time while the 100%
overranging capability reduces the need
for frequent range changes.

A highly valuable feature is the 10 Ω range.
This range, with its .01 Ω resolution, is ideal
for locating a shorted winding in a
transformer, motor or coil. For high
accuracy, a front panel 10 Ω ZERO control
allows the user to zero-out the minute
amount of test lead resistance.

The low power ohms position permits
resistance measurements in solid-state
circuitry without biasing semiconductor
junctions.

Unlike many voltmeters, the 2810 can also
be used in R-F energy fields: Near business
band, CB and amateur radio transmitters.
When working with R-F circuitry, the
optional PR-21 probe is also helpful.

The 2810 is well protected against overloads
on all ranges. The ohms circuitry is
protected against momentary overloads up
to 1000 volts, DC or AC peak. Continuous
ohms range protection is ± 100V and
-450VDC or 300VAC. Current ranges
receive the double protection of diodes and
a fuse.

If you only need 1% accuracy, save with
the B&K 2800.

**Available from
leading Electronic
Stores**

PARAMETERS PTY LTD

Sydney: 439 3288 Melbourne: 90 7444

Blob — Board for Digital Electronics by Experiment

YOUR NEAREST
BLOB DEALER?
THAT'S EASY.
WRITE TO:

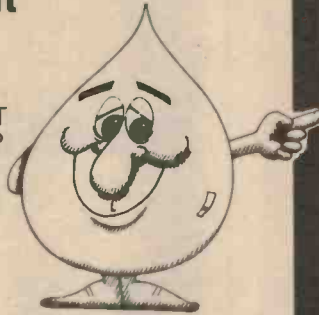

BLOB BOARD ASSOCIATES

P.O. Box 23, SURREY HILLS,
VIC. 3127. or RING (03) 89-1019.

Mr. Blob says "The Technique of Inserting components on one side of a board and soldering on the other is done for reasons which are now completely out of date; Namely this technique was established originally because heavy and bulky components were used. This no longer applies and has big disadvantages, the circuit is impossible to follow unless the board is continually turned over to inspect each side, its difficult to work on both sides of the board and soldering basically needs three hands. A common fault is to mount both leadout wires on the same track. Blob — Boards give you the modern, low cost, easy to build circuits. Blob — Boards are roller tinned circuit boards on which each roller tinned copper track is identified by the letter and or number system. Simply in the end of the component, butt the component lead against the roller tinned track, apply a blob of solder and the component is blobbed into place. All construction is from one side, component location could not be simpler, soldering is much easier, sub-circuits can be tested, then assembled together, the plain side of the Blob-Board is free and so the Blob-Board can be mounted flush on case walls. And they can be re-used simply apply a soldering iron to the Blob and remove the component."

Now start Digital Electronics by Experiment.

No need to lose your way round a circuit board that needs a layout drawing — Blob-Boards make construction easy. Blob-Boards have numbered tracks that make layout drawing out of date, the tinning ensures easy soldering, and the tracks don't strip off when you unsolder components. Blobbing components on to the tracks (no holes, no drilling) makes layout easy to follow. Use the 8-IC board for 'Digital Electronics by Experiment' in this issue, but remember that we have "A Blob for every job".

FRONT PANEL DISPLAY



Designed for 8080 but will suit most systems. Input lines are 16 ADD. Lines, 8 Data lines, 2 x 8 Bit prog. output port, status Flags etc. All inputs buffered, flat cable interface. Also available as an option a HEX DISPLAY with 1/2" high 7 seg. Led display for Address & Data Bus. 4 displays for address bus and 2 displays for data bus. 10 x 8 ins board size.

STANDARD PANEL KIT PRICE **\$75.00**

WITH HEX DISPLAY KIT PRICE **\$105.00**

NUMBER CRUNCHER

MM57109 Number Cruncher. Buffered I/O will suit 8080, 6800, SCAMP, etc., will perform floating point and scientific calculations under software control. Full data and software support.

KIT PRICE	BUILT AND TESTED
\$52.00	\$72.00

PAPER TAPE READER



Manual operation, self contained in case 160X110X50. Flat cable interface to I/O port. Handshake logic, Status LEDs, Data & software supplied. Simple to use on all systems. 8080, 6800, etc.

KIT PRICE **\$75**

BACKPLANE BOARDS

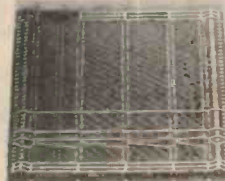

Quality fibreglass boards, 5 sockets per board with wide spacing, provision for linking boards together even different types.

8" x 8" 6800 board with wide centres
12" x 6" 8080 board with provision for both sockets

PRICE **\$24.50**

GOLD PLATED SOCKETS

To suit 8080 & 6800 43 way double sided \$9.50 or 5/ \$45.00

Built & Tested Prices and Tax Free Prices on application.

S.M. ELECTRONICS 10 Stafford Crt, Doncaster East,
3109. Box 19, Doncaster East, 3109. (03) 842-3950 (03) 842-3950.

U.V. EPROM ERASER

Erase up to 4 eproms at once such as 2708 etc in 15/30 mins. 240V operation, small size, 3" x 4" x 8", Assembled and tested only

\$47.50

SINGLE STEP CONTROL for 8080

Push button single step mode. Auto. step low speed (Variable speed) mode, Interrupt facility. Run mode LED, will suit other systems, works off wall, & ready, lines. Panel mount.

KIT PRICE
\$23.00

ALL PARTS POST FREE

See adv. JAN 78 Elec. Aust. for digital tach, stop watches, trans. Ign. system, burglar alarm etc.

FACT SYMPOSIUM

" FUTURE AMATEUR COMMUNICATIONS TECHNIQUES "

20 - 21 May. Venue: The Strata Motor Inn,
287 Military Rd CREMORNE

Organised by Roger Harrison VK2ZTB and the NSW VHF & TV Group, WIA.

This symposium will be of interest to the beginner and advanced amateur alike. It promises to be the amateur radio event of 1978. Papers will be presented covering the following topics:- SUNSPOT CYCLE 21' SOLID STATE POWER AMPLIFIERS, MICROPROCESSORS & AMATEUR APPLICATIONS, PULSE TECHNIQUES, MODERN REPEATER TECHNIQUES, SOLID STATE SSB ON 1296 MHZ, REVIEW OF ANTENNAS FOR UHF, ATV TECHNIQUES FOR 420 & 1290 MHZ, USING ANOMOLOUS PROPAGATION FOR HF/VHF DX.

There will be, in addition, a number of workshops associated with the papers demonstrating equipment using state of the art techniques. Papers and workshops will be presented by many well-known amateurs:- Les Jenkins VK3ZBJ, Ken MacKracken VK2CAX, Peter Cossins VK3BFG Jeff Pages VK2BYY, Roger Harrison VK2ZTB, Phil Wait VK2ZZQ, Les Bell GM4CFM.

For further information, registration forms etc, contact:

THE FACT SYMPOSIUM ORGANISER
C/- WIA, 14 ATCHISON ST
CROWS NEST 2065 NSW

or see page 85 this issue.

SPEEDY, EFFICIENT



Service for CB Radio

FULLY EQUIPPED
WORKSHOP.

FULL RANGE OF SPARES FOR
DICK SMITH AND MIDLAND
CB RADIOS — AS WELL AS
MOST OTHER BRANDS.

DICK SMITH SERVICE DEPT.
5/4 Carlotta Street. Artarmon.
(entrance in Clarendon Street.)
Telephone: 439 5164.

READERS' LETTERS

No charge for replies but a foolscap-size stamped addressed envelope must be enclosed. Project queries can only be answered if related to item as published. We cannot assist if project is modified nor if components are otherwise than specified. We regret we cannot answer readers' enquiries by telephone.

SUBSCRIPTIONS AND BACK ISSUES

ETI subscriptions cost \$17.00 per year (inc. postage) within Australia. Cost elsewhere is \$17.65 (inc. postage - surface mail). Airmail rates on application.

Back issues cost \$1.25 (Sept. onwards) each plus post and packing.

We can supply only the following issues.

1976: Nov., Dec.

1977: All issues except Jan, Feb, March.

Photostats are available of any article ever published in ETI. We charge a flat \$1.00 regardless of page quantity from any one issue of ETI. Thus if the article is in three issues the cost is \$3.00. Send orders to address below.

Binders \$4.50 plus 80c post NSW, \$1.70 other States.

COPYRIGHT

The contents of Electronics Today International and associated publications is fully protected by the Commonwealth Copyright Act (1968).

Copyright extends to all written material, photographs, drawings, circuit diagrams and printed circuit boards. Although any form of reproduction is a breach of copyright, we are not concerned about individuals constructing projects for their own private use, nor by pop groups (for example) constructing one or more items for use in connection with their performances.

Commercial organisations should note that no project or part project described in Electronics Today International or associated publications may be offered for sale, or sold, in substantially or fully assembled form, unless a licence has been specifically obtained so to do from the publishers, Modern Magazines (Holdings) Ltd or from the copyright holders.

LIABILITY

Whilst every effort has been made to ensure that all constructional projects referred to in this edition will operate as indicated efficiently and properly and that all necessary components to manufacture the same will be available, no responsibility whatsoever is accepted in respect of the failure for any reason at all of the project to operate effectively or at all whether due to any fault in design or otherwise and no responsibility is accepted for the failure to obtain any component parts in respect of any such project. Further, no responsibility is accepted in respect of any injury or damage caused by any fault in the design of any such project as aforesaid.

A MODERN MAGAZINES PUBLICATION

Managing Director: Arnold Quick
Secretary: Charles O'Leary
Publisher: Collyn Rivers

PRODUCTION

Art Director: Jim Hattersley
Assembly: Bill Crump
Production Manager: Bob Izzard
Subscriptions & Circulation: John Oxenford
Project Design: Nebula Electronics
Acoustical Consultants: Louis A Challis & Assoc.

ADVERTISING

Sydney:	Bob Taylor (Manager), Geoff Petschler (NSW Manager), 15 Boundary St, Rushcutters Bay 2011. Tel: 33-4282.	Perth:	Aubrey Barker, 133 St. George's Terrace, Perth. 6000. Tel: 322 3184.
Melbourne:	Tom Bray (Manager), Poppe Davis, Suite 24, 553 St. Kilda Rd, Melbourne. Tel: 51-9836.	Hobart:	H.W. Lincoln Advance Publicity, 281 Elizabeth St, North Hobart, 7000.
Brisbane:	Geoff Horne, 199 Jesmond Rd, Indooroopilly, Brisbane, 4068. Tel: 378-3273.	Tokyo:	Genzo Uchida, Bancho Media Service, 15 Sanyecho, Shintuku-Ku, Tokyo 160.
Adelaide:	Ad Media Group of SA, 37 Fullarton Rd, Kent Town 5067. Tel: 42-4858.	London:	Electronics Today International, 25-27 Oxford St, London, W1R 1RF. Tel: 01-434-1781/2.

Advertisers: Index:

Applied Technology	38-39
Areana Distributors	27
A & R Sonar	66
Audio Telex	99
Auditec	100
Automation Statham	50
Bail Electronics	103
Blob-Board Associates	105
Cema	54
Chan Merchandising	42
Communications Devices	8
Convoy	24
Davred Electronics	68
Delsound	42
Dick Smith	60-61, 92, 105
Diggerman	29
Director of Recruiting	74
Eastern Electronic Components	104
Electrocraft	95
Electronic Concepts	44
Electronic Disposals	53
Ellistrions	107
Elmeasco Instruments	37
Emac	66
Emona	31
Ferguson Transformers	101
Freedman	12
Futuretronics	6
Haco	108
Hagemeyer	2
Harman	22
I. C.'s Unlimited	47
Instant Component Service	84, 85
International Components	91
International Correspondence Schools	67
International Electronics Unlimited	98
Impact	50
IRH Components	43
Jaycar	29
JR Components	76
Leroya	72
Madjenk	66
Nessel Audio	104
Nomis Electronics	30
Non-Linear Systems	100
Parameters	104
PDK Hi-Fi	76
Philips Elcoma	11
Photo Scan Distributors	30
Pioneer	20-21
Pre-Pak Electronics	10
Quest Electronics	102
Rave	91
Roadrunner	76
Rod Irving Electronics	73
Scalar Industries	52
Semcon Microcomputers	52
SM Electronics	105
Texas Instruments	59
Unique Electronic Security	102

Electronics Today International is published by Modern Magazines (Holdings) Ltd, 15 Boundary St., Rushcutters Bay NSW 2011. It is printed (in 1978) by Wilke & Co., Browns Rd, Clayton, Victoria and distributed by Australian Consolidated Press.

**ELECTRONICS
ENTHUSIASTS**

Melbourne's
newest

ELECTRONICS SUPERMARKET

is

NOW OPEN

JUST THREE DOORS WEST OF ELIZABETH STREET

Centrally located in the city, this is the only place to choose your project equipment in bright, colour co-ordinated surroundings

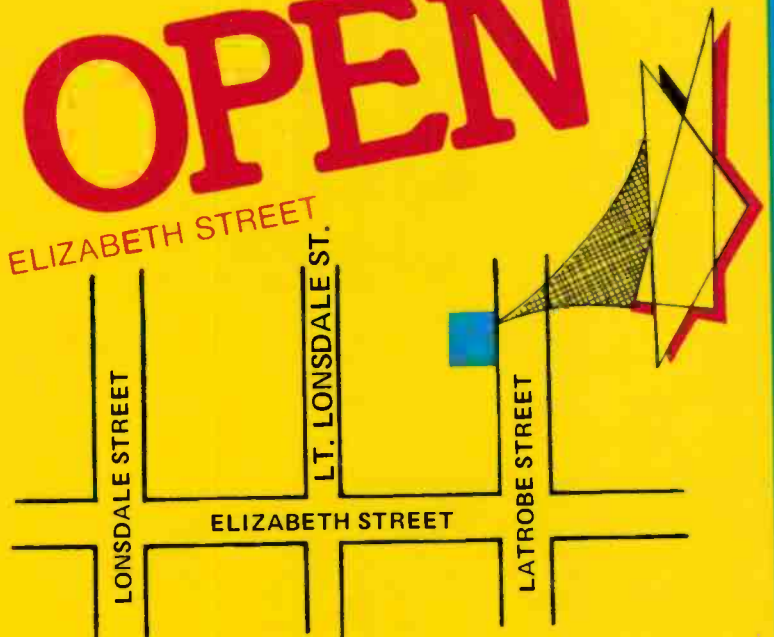

PRODUCTS AVAILABLE AS LISTED:

Semi-conductors, potentiometers, resistors, capacitors, aluminium and plastic project boxes. Project kit boards, amateur and CB radio plus accessories. Test equipment, vero board, transformers, knobs, wire, radio/TV antennae, speakers, turntables. In fact just about everything electronic.

CALL IN AND CHECK OUR LOW LOW PRICES

ELLISTRONICS

MAIL ORDERS
AVAILABLE TOO

289 LATROBE STREET, MELBOURNE. Ph (03) 602-3282.

ST-9030

SU-9070

SH-9010

SH-9020

SE-9060



**Technics DC
'Flat Series'
Components
literally made
for each
other.**

In creating the 'flat' system, Technics engineers separated the basic amplifier / tuner into five components, researched and developed each, then recombined them into a system of audio excellence.

The system consists of: Stereo Tuner (ST-9030) with wide and narrow IF bands.

Stereo DC Preamp. (SU-9070) with phono signal-to-noise ratio of 88dB (for 2.5 mV input).

Stereo Universal Frequency Equaliser (SH-9010) for exact response control in any acoustic environment.

Peak / Average Meter Unit

(SH-9020) for exact response measurement.

Stereo/Mono DC Power Amplifier (SE-9060) with all-stage direct-coupled pure complementary symmetry circuitry. Total harmonic distortion is 0.02%.

Each individual component offers a degree of fidelity in sound reproduction, and a flexibility and ease of operation that makes it a natural choice for the audio fan who cannot be content with less than the best.



Technics
hi-fi

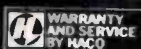

For a National Technics Catalogue, please write to:
National Technics Advisory Service, P.O. Box 49, Kensington, N.S.W. 2033.