

# The Queensland Radio News

"Your Own Wireless Journal"

6<sup>D</sup>  
6<sup>C</sup>



Vol. III.

Wednesday, 1st JUNE, 1927

No. 5

Registered at the General Post Office, Brisbane, for transmission by Post as a Newspaper.

## NOTE THESE NEW PRICES

**A**MPLION A/sia Ltd. announce that the prices of *RADIOLUX AMPLION* have been substantially reduced.

New and improved methods of manufacture have lessened considerably the cost of production, thus enabling a reduction of the cost to the public.



**RADIOLUX  
AMPLION**

The Prices are now as follows

SMALL TYPE			LARGE TYPE		
R.S. 2 Metal	...	£5 0 0	R.S. 1 Metal	...	£7 0 0
R.S. 2 Oak	...	£6 0 0	R.S. 1 Oak	...	£8 0 0
R.S. 2 Mahogany	...	£7 0 0	R.S. 1 Mahogany	...	£9 0 0
R.S. 3 Maple	...	£7 0 0	R.S. 5 Maple	...	£ 0 0
R.S. 4 Blackwood	...	£7 0 0	R.S. 6 Blackwood	...	£7 0 0

Advertisement of  
**AMPLION (Australasia) LTD.**  
Sydney and Melbourne

*Unsurpassed for  
Volume, Selectivity  
and Pure Tone!*



*The* **SPLITDORF 5-Valve Radio Set**

This Tuned Radio Frequency Receiver is designed for simplicity and ease of operation with economy, both in first cost and maintenance. Special Splitdorf patented circuit insures selectivity and gives remarkable volume and exceptional range with wonderful purity of tone. The metal panel is richly finished; large tuning dials make accurate tuning easy. Encased in attractive hinged top cabinet, lacquer finish in two-tone effect—dark walnut and light natural grain. Five terminal cable, permanently attached to rear, permits battery connections to be easily made ..... **£47/10/-**

**CROSLEY 2-Valve Set**

We can positively guarantee the splendid tone of this remarkably low-priced set. The Crosley Two-Valve Set is within the reach of every one and it is known as Brisbane's leading suburban set. You'll find it unexcelled for ease of operation and economy in both first cost and maintenance. .... **£10/15/-**

**CROSLEY 3-Valve Set**

Beautifully finished in every respect, and positively guaranteed to bring in all southern stations as well as 4QG with clear tones and big volume. The Crosley Three-Valve Set is the best value in radio sets now available. Come and hear it. The efficient working of this set **£13/10/-** is guaranteed.

On Sale by all Home Radio Service Ltd. Authorised Dealers  
(with the Red Sign on their windows)

QUEENSLAND'S WHOLESALE RADIO HOUSE

**Home Radio Service Limited**

First Floor, Ewing House, Adelaide Street, (Next Bryce's,) Brisbane  
Phone 6143  
Telegrams—"HOMRAD"



# The WONDERFUL P.M. FILAMENT



## SAY P.M. AND YOU SAY PERFECT MUSIC

Yes! and more, you get the most economical radio reception. The pyrometer cannot get down to the operating temperature of P.M. Filament, it works at too low a temperature. Your set is for pleasure and does not form a part of the house heating system.

Obtainable from all dealers in Australia

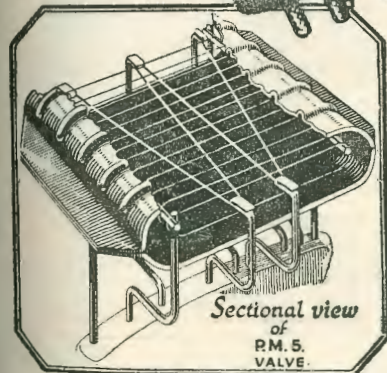

Sectional view of P.M. 5. VALVE.

For 2-volt accumulator	For 6-volt accumulator or 4 dry cells
P.M.1 H.F. 0.1 amp. 13/6	P.M.5 (General Purpose) 0.1 amp. 13/6
P.M.1 L.F. 0.1 amp. 13/6	P.M.5.B (Res. Capacity) 0.1 amp. 13/6
P.M.2 (Power) 0.15 amp. 13/6	P.M.6 (Power) 0.1 amp. 13/6
For 4-volt accumulator or 3 dry cells	Super power valves for last L.F. stage
P.M.3 (General Purpose) 0.1 amp. 13/6	P.M.254 4 volts, 0.25 amp. 15/-
P.M.4 (Power) 0.1 amp. 13/6	P.M.256 6 volts, 0.25 amp. 15/-

# Mullard

## THE MASTER VALVE

ARKS? A.

All Mullard Valves are manufactured at Mullard Works, London, England.

Advertisement of the MULLARD WIRELESS SERVICE CO. LTD, "MULLARD HOUSE," Denmark Street, London S.W. 2 England,

# POWER

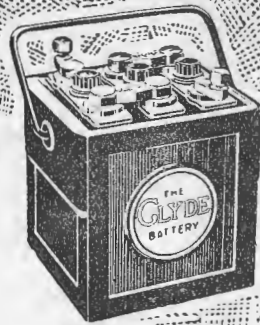

is what you want when you buy a Battery . . . . and Power is what you get when you buy a Clyde.

A steady power supply is essential to clear reception because plenty of power is required to amplify all tones equally

THE C.R. type CLYDE Radio Battery (above) is strongly recommended for all Multi-Valve Radio Sets. It is the Radio Battery De Luxe for those requiring a battery of particularly High Capacity and Long Life. Made in 6-volt units in four sizes, it is contained in a highly-polished one-piece ebonite case, guaranteed positively leak-proof practically unbreakable.

The increased popularity and widespread demand for CLYDE C.R. Radio Batteries has enabled the manufacturers to make drastic reductions in their prices. Type C7 may now be had for £4/10/-, C9 £5/10/-, C11 £6/15/-, and C13 £7/10/-.

OBTAINABLE AT ALL DEALERS AND GARAGES.

**THE CLYDE ENGINEERING CO. LTD.**

GRANVILLE N. S. W.

# CLYDE

*Costs less because it is Economical*

# Notes from 4QG.

Professor Elin, whose vocal recital was broadcast from station 4QG on the night of Sunday, May 2nd, is head of the voice department, Conservatorium of Music, University of the Philippines (Manilla). During his recital at 4QG he sang in no less than five different languages, these being English, French, German, Italian and Russian.

Professor Elin gave two additional radio recitals from the Brisbane station, one of them on Sunday, May 22nd, and the other on Sunday, May 29th.

\* \* \* \*

From far and near letters have reached 4QG expressing appreciation of the radio musical play which was broadcast by Mr. Erich John's party of entertainers some little time ago, entitled "The Sheik of Mezadah." The play was written and produced by a well-known Brisbane journalist, Mr. Michael Crozier, and was certainly a credit to Queensland. So popular did it prove that arrangements have been made to repeat it this month. Very few writers seem to have realised the completely new field which radio has opened up for them. Mr. Crozier's effort has done much to show other writers just exactly how they may adapt their capabilities towards the provision of plays which will please the unseen audience.

\* \* \* \*

During the summer months, listeners will recall that on a number of occasions 4QG was suddenly cut off the air without warning for a few moments, due to insects fouling a safety device carrying high voltages. A month or two ago some large specimens of various in-

sects were used at 4QG in connection with a demonstration over the air of "Sounds you do not hear," but the daddy of all cockroaches was captured the other day by one of the staff, who sent it to the museum, the authorities of which accepted it on account of its being a large specimen.

Last week a grasshopper was found at the station, and was of such dimensions that its identity was questioned. This insect was also forwarded to the museum, the authorities pronouncing him to a giant of the species.

In these days of electroculture one wonders if the powerful high frequency currents generated at 4QG have any bearing upon the abnormal growth of insects sometimes found on the premises.

\* \* \* \*

### FROM A COAL MINE.

On Wednesday, June 1st, Station 4QG will conduct a novel transmission. The evening will be divided into three sections, each of which will be relayed from the New Chum Colliery at Dinmore, a distance of about 25 miles from Brisbane. From eight o'clock until half-past eight a description of the pithead machinery at the New Chum No. 3 mine will be relayed and from half-past eight until nine o'clock a special description of the manner in which coal is won will be relayed direct from the bottom of the pit. Then from nine o'clock until ten o'clock a concert party will be taken down the mine, and a concert will be relayed from the bowels of the earth. Radio enthusiasts far and near are looking forward to this very unique broadcast.

## Get Clearer Reception and Bigger Volume — use

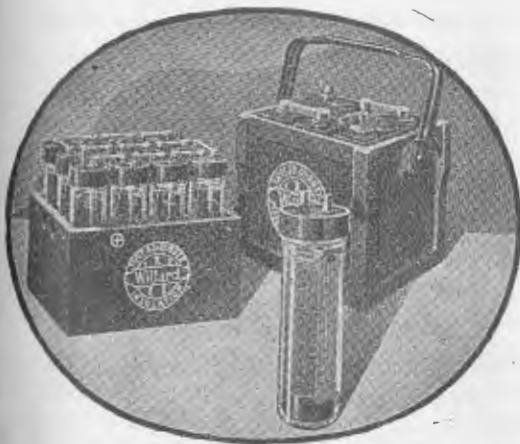

# WILLARD RADIO BATTERIES

These Batteries need practically no attention throughout their long life. Their construction ensures remarkably clear reception and bigger volume than is usual—instal a WILLARD in your set to-day.

Ask the Willard Dealers

## MOTOR SUPPLIES LIMITED

PERRY STREET

Off Boundary Street

BRISBANE

# The New IGRANIC

## SUPER HETERODYNE

*The Most Perfect Set Yet Produced*

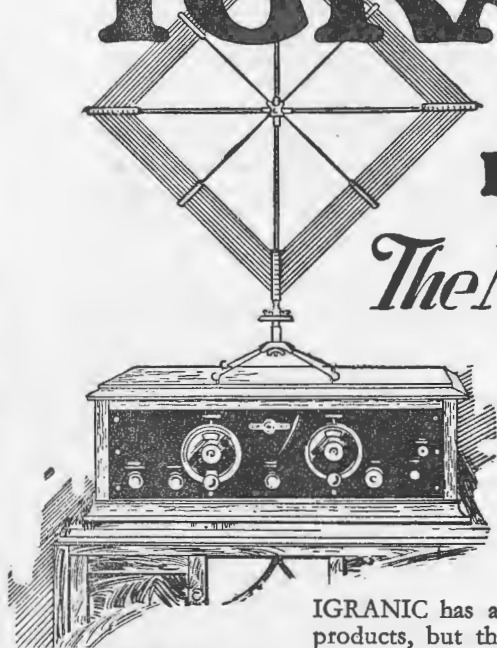

*There is no finer performance than Super-Heterodyne performance and no finer Super-Heterodyne than Igranic*

IGRANIC has always set an exceedingly high standard in all its products, but the latest product of this famous British Factory has created a tremendous interest that is world-wide.

The advantages possessed by a well-designed Super-Heterodyne Radio Receiver are Range, Volume, Sensitivity, Selectivity, Stability, Purity and Ease of Operation. The Igranic Super-Heterodyne Receiver offers all these. For instance, it is capable of receiving from all interstate stations (with the possible exception of Perth), and from Auckland, 1YA, on a frame or indoor aerial at full loud speaker strength.

It is exceedingly selective, no trouble being experienced in tuning-out any station not required. 2BL, 2FC and 3LO might be a thousand or only ten metres apart for all it matters to the Igranic Super-Heterodyne. It is pleasingly free from all extraneous noises, and the purity of tone and absence of distortion are a revelation even to the most exacting critic.

Price (including everything) from £75, according to cabinet work.

TERMS MAY BE ARRANGED

*I have recently completed one of your "Igranic" Super-Heterodyne Kits and wish to inform you that I am exceedingly pleased with it in every way.*

*I have not heard any set to give such volume on the same number of valves and I was able to tune-in all the Australian stations on the loop with considerable strength. The New Zealand station 1YA was very nearly as loud as Melbourne.*

*The selectivity is all that could be desired and no trouble was experienced from interference between 2BL and 3LO.*

The original of this letter from a leading Sydney expert may be seen on request.

# NOYES BROS.

(SYDNEY) LTD.

Sydney - - - - 115 Clarence Street  
 Newcastle - - - - 11 Watt Street  
 Brisbane - - - - Perry House, Elizabeth Street

Agent for W. Australia - - -

(MELBOURNE) PTY. LTD.

Melbourne - - - - 495 Bourke Street  
 Adelaide - - - - Darling Building, Franklin Street  
 Hobart - - - - 145 Macquarie Street  
 Launceston - - - - 123A Charles Street

- J. R. W. GARDAM, PERTH

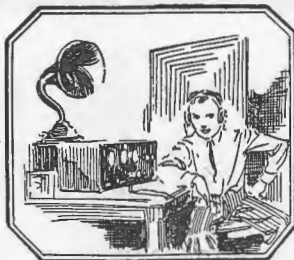

## “Distance Lends Enchantment”



REMARKABLE feature of most of the evidence before the Royal Commission of Wireless, as it sits in the various capital cities of the Commonwealth, is the marked tendency of many witnesses to laud the programmes of the more distant stations in preference to those of their own local station. This was first apparent when the Commission sat in Melbourne. Quite a number of the witnesses expressed the view that the transmissions of other stations, particularly 4QG, were superior to those of 3LO.

To we Queenslanders this expression of opinion came in the nature of a surprise, for those of us who tune in 3LO are generally impressed with the excellence of this station's transmissions. We realise that 3LO, along with other of the more financial stations, can afford to make expensive engagements and to include items and features that our station could not, with its present revenue, ever hope to imitate.

There are Queenslanders, too, who think that 4QG's programmes are inferior to those of southern stations, although this opinion was not strongly expressed by witnesses before the Royal Commission in Brisbane.

As we go to press the Commission is sitting in Sydney. The first press report states that quite a number of witnesses living in various parts of N.S.W. expressed their preference for the programmes of Melbourne and Brisbane to those of Sydney.

And so the controversy goes on. By the time the Commission has completed its investigation it should arrive at the conclusion that the lure of distance is strong within the heart of every wireless listener, upsetting at times his sense of judgment.

The Greenest Hills are invariably the Farthest; in no other sphere does this truth apply so forcefully as in the science of radio. Probably it is well that this is so, for if it were not for the long-distance receptions now possible on a well-designed receiver, radio would lose much of its fascination.

# The Cabinet makes "A World of difference"

Fine quality Cabinets are essential to the success of your "Wireless," and in our "Exhibition" Line you will find, absolutely thorough workmanship, fine appearance and lasting finish.

Numerous complimentary references in our files from satisfied customers are proof that they measure up to all requirements.

## ROBERT'S EXHIBITION WIRELESS CABINETS



**R.W. 100 3-Valve Cabinet**

Illustration R.W. 100 is for a Three-Valve Set, the measurements being 15 inch x 7 1/2 inch x 1/2 inch (Bakelite Panel Size.)

PRICE ..... 45/.

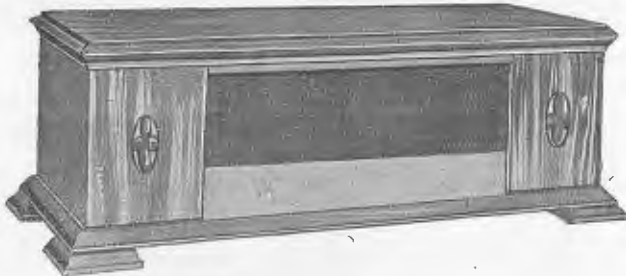

**R.W. 101 4-Valve Cabinet**

This is a Four-Valve Model. Panel Size 18 inch x 9 inch x 1/2 inch.

PRICE ..... 50/.

ON VIEW AT

the Gramophone Exchange, George Street, Brisbane, or at our showrooms in Brunswick Street.

### Low Prices

STANDARDISED methods of production result in lower prices.

### Period or Special Designs

We also supply special designs in Cabinet in any size or style, designing them where necessary to harmonise with any furnishing scheme.

Estimates and Sketches Free on Application.

Complete Sets Supplied Where Desired.

Those living out of town may order with every confidence. Goods are carefully packed and placed free on rail Brisbane. Immediate delivery guaranteed.

HENRY ROBERTS  
**BRUNSWICK**  
 HOME FURNISHERS

BRUNSWICK ST. - OPP. JACKSON'S BOND  
 STORES - NEAR EXHIBITION - VALLEY - BRISBANE



5.0.6

# THE QUALITY THREE

Involved and tested in the Queensland Radio News Laboratory



An Inexpensive Receiver, incorporating one stage of Resistance-Coupling with a stage of high quality Transformer Coupling, delivering unusual purity without necessitating the high voltage common to Resistance-Coupling

Not so many months ago little or no attention was given to tone when choosing a broadcast receiver, but nowadays, fortunately, intending purchasers select a receiver more for its tonal qualities than its volume or distance getting ability.

The volume fiend is dying fast, and will need to, if broadcasting is to reach the high standard here that it has now reached in other countries.

After all, a broadcast receiver is simply an instrument from which we derive pleasure and instruction, but unless the loud-speaker is capable of giving us a very good imitation of the original performance we certainly cannot enjoy it.

We use the phrase "imitation of the original performance" as it is fully realised that radio is not yet perfect, though at the same time it is possible to get remarkable reproduction, provided the apparatus used is suitable.

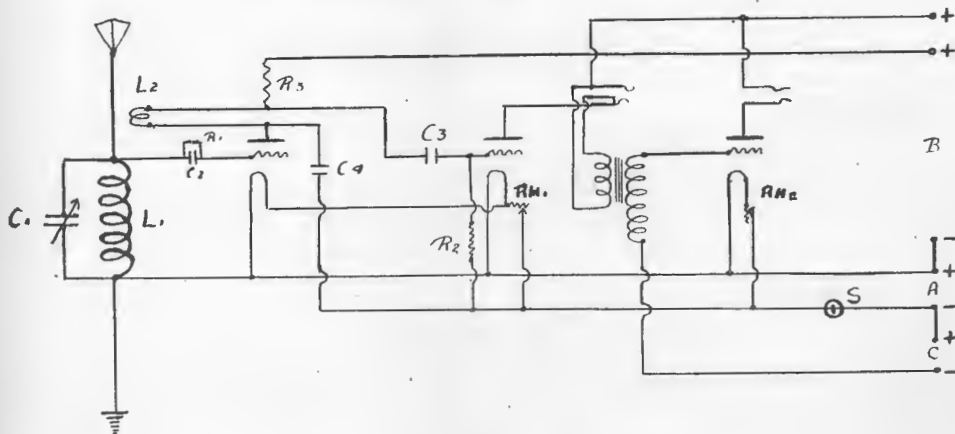

Fig. 1.

- 0.0005 M.F. Variable Condenser
- 0.00025 Fixed Grid Condenser
- 0.1 Fixed Condenser
- 0.001 Fixed Condenser

- R1—2-Meg. Grid Leak
- R2—5-Meg Grid Leak
- R3—100,000 ohm Anode Resistance
- L1—35-Turn Honeycomb Coil

- L2—75-Turn Honeycomb Coil
- S—Battery Switch
- RH1—15-ohm Rheostat
- RH2—30 ohm Rheostat

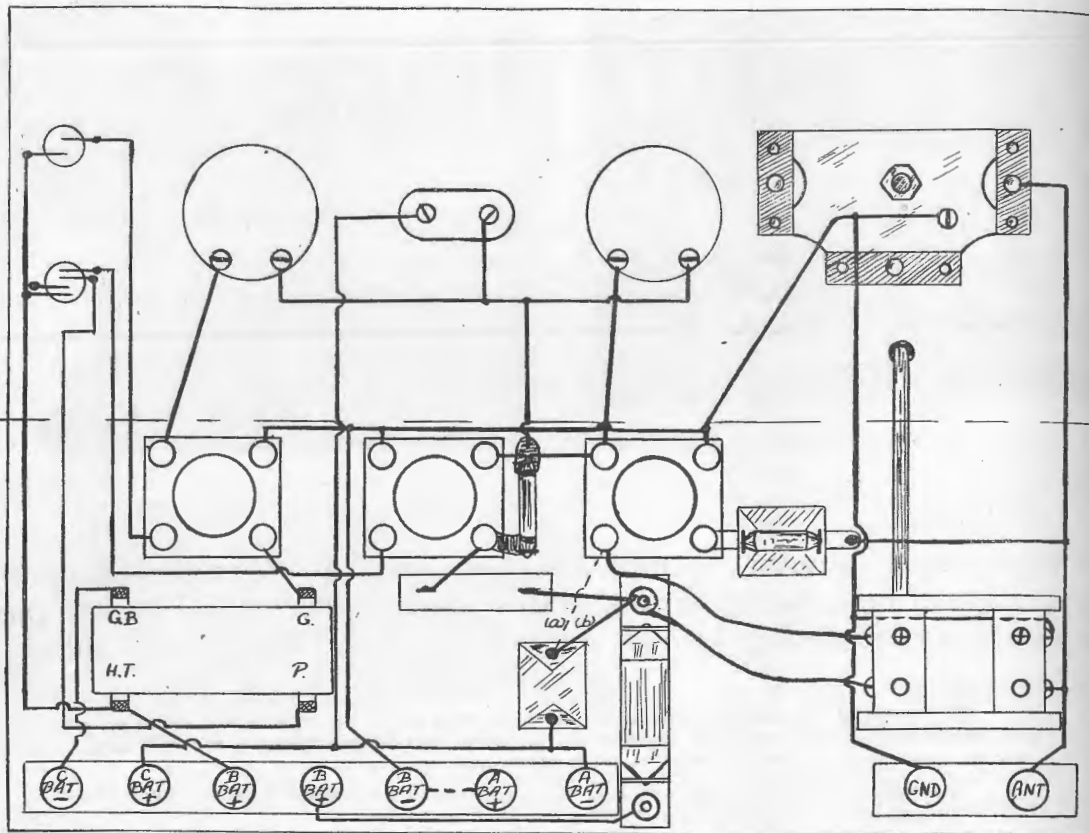

Fig. 3.

The "Quality Three" is an inexpensive three-valve receiver employing a detector and two stages of carefully-designed audio frequency amplification.

Of the three main systems of low frequency amplification the resistance capacity method is becoming more and more popular, though it has one or two slight disadvantages, inasmuch as it requires additional "B" batteries to make up for the voltage drop caused by the resistance. It also has a lower step-up per stage when compared with the transformer method.

However, in the receiver described here these disadvantages have been overcome to a large extent by coupling the detector valve to the first audio amplifier by means of the resistance capacity method, and the second audio amplifier to the last valve by

means of a low frequency transformer.

It will at once be apparent that this gets us over the voltage difficulty, as the detector valve only requires about 30 to 40 volts for best results, which will be about right in this case if a total voltage of 70 to 80 volts is applied to the anode resistance circuit.

The amplification for this stage can be brought up to a fairly good figure if a high MU valve and 100,000 ohm anode resistance are used.

The anode resistance should be of the wire-wound variety as these remain constant, which is a big factor in this particular type of amplification.

Low frequency transformers vary a great deal, both as regards price and quality, and care should be exercised when purchasing the transformer for this receiver, as a great

### Material Required

- 1 Bakelite Panel 15in. x 7½in. x ½in.
- 1 Baseboard, 14½in. x 7in. x ½in.
- 1 .0005 Variable Condenser with Vernier
- 2 H. & H. Rheostats (30 ohm and 15 ohm).
- 1 Yaxley or C.H. Battery Switch
- 1 Ebro 2- Coil Holder
- 1 Wooden Block 2½ x 2 x ½
- 1 Zn. Dial
- 1 .00025 mf. Grid Condenser
- 1 2-meg Electrad Grid Leak
- 1 Tobe .1 mf. Fixed Condenser
- 1 Sangamo .001 mf. Fixed Condenser
- 1 Mullard Wire-wound 100,000 ohm Resistance
- 1 5 meg Igranite Leak
- 1 B.M.S. S.C. Jack
- 1 B.M.S. D.C. Jack
- 1 Ferranti H.F. Transformer (3½-1).
- 3 H. & H. Bakelite Sockets
- 1 Box Engraved Terminals
- 1 Terminal Strip, 8 x 1 x ½
- 1 Terminal Strip, 3½ x 1 x ½
- 4 Supports
- 1 Dozen Lengths Bus-Bar Wire
- 2 Lengths Spaghettic
- 1 Box Assorted Screws

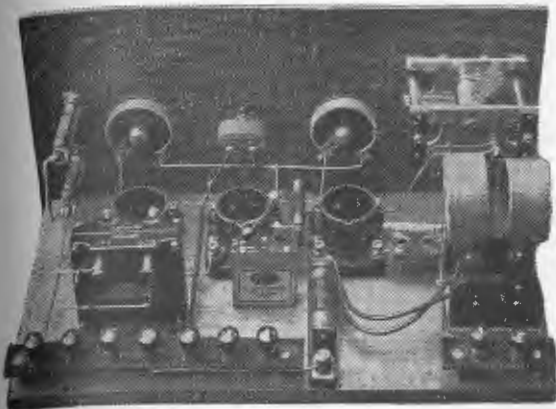

A photograph showing arrangement of components.

deal of its success depends upon this component.

The tuning coils should be of good quality, a 35-turn being used in the case of aerial coil, and a 75 in the reaction.

Grid bias is essential for best results, as it improves the amplification, as well as the tone, and at the same time increases the life of the "B" battery.

A "C" battery of 4½ volts is necessary when voltages in the vicinity of 90 volts are used.

**General Layout.**

It will, of course, be necessary to first mark out the panel in accordance with the dimensions given in Fig. 2, then carefully drill the various holes, taking care not to force the drill, as this will badly chip the bakelite panel.

When the drilling is complete the components which go on the panel are mounted and the panel screwed to the baseboard.

It now becomes necessary to refer to the semi-circular diagram Fig. 3, in order to ascertain the correct positions for the various baseboard components. These components should be mounted in the exact positions shown in the diagram, as care has been exercised in laying it out in order to simplify the wiring etc.

**Wiring.**

The back of panel photograph should prove useful when mounting and wiring the components.

Do not rush the wiring of the receiver, always remember that it is a very important part, and if not properly done causes endless trouble.

Extra care should be taken when soldering the wires to the small jack lugs; these lugs should be carefully tinned before attempting to solder on the wires.

The flexible leads which connect the plate terminal of the detector valve and one side of the anode resistance to the reaction coil should be made of good quality flex. De Range flex covered with spaghetti makes an excellent pigtail for this purpose.

Upon referring to the diagram Fig. 3, it will be noticed that two wires, one dotted, are shown connected to the small .001 fixed condenser. The best position for this wire will be found by experiment; it not critical, but will have a certain effect upon regeneration.

**Valves.**

The valves recommended for this set are as follows—Detector, Mullard DFA4 or Osram DE5B; first audio, Mullard PM5 or PM6; second audio, Mullard PM6.

**Operation.**

It is advisable to carefully check over the wiring before connecting up the batteries, as it is rather dis-

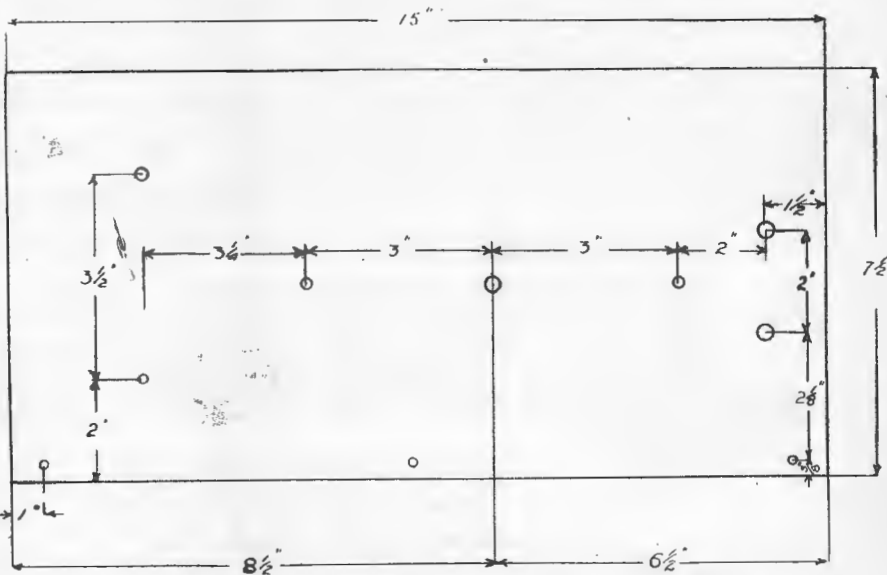
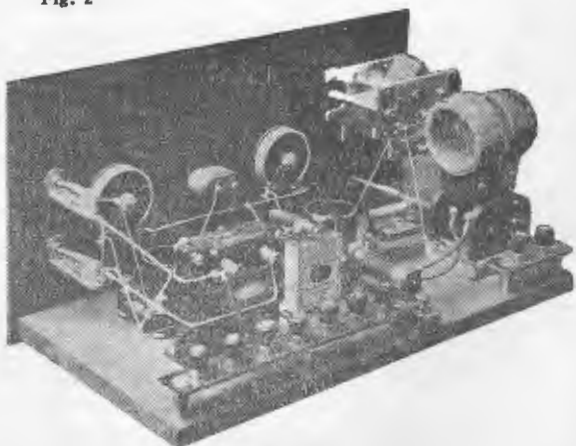

Fig. 2



Another view, which clearly shows the wiring of the jacks.

# RADION

!! *The Supreme Insulation* !!

THE Radio Set builder looks for two things in choosing his panel ~ finish, and how long it will take to work it. Radion supplies these two qualities and one better. It's finish in either black or mahoganite is superb. It comes cut ACCURATELY to any size making the initial work easy. It may be drilled and slotted with ease at the same time retaining its strength. Finally it is the supreme insulation accepted by all as standard.

## RADION

Panels—Tubes—Sockets

FROM ALL DEALERS

INTERNATIONAL RADIO CO. LTD.

200 CASTLEREAGH STREET, SYDNEY

91-92 Courtenay Place, Wellington, N.Z.

In Queensland, Home Radio Service, Ltd., Adelaide Street, Brisbane.

...rtening to see a set of brand new valves pass out through some slight error.

Having reassured yourself that everything is in order, connect up the batteries to their respective terminals on the battery terminal strip.

Next place the valves in their sockets, and (assuming aerial and earth have been connected) proceed to tune in a station as follows:—Bring the reaction (movable) coil towards the aerial or main tuning coil until a double click is heard, when a moist finger is placed on the aerial terminal. This is known as the point of collation.

Next rotate the tuning condenser until a high-pitched whistle is heard; as soon as this happens immediately bring the reaction coil away until the signal becomes clear.

There is nothing to be gained by working on the collation point. Keep away from it, and enjoy better quality. (Your neighbours will also be better pleased).

After a little practice no difficulty should be found in tuning this receiver, as there is only one dial to turn.

In conclusion, we would like to state that no claims for excessive volume are made for this receiver; its outstanding feature is quality, though of course it will give sufficient volume to fill the average home.



MAMMOTH MICROPHONE.

"The biggest mike in the world." An appropriate symbol erected over the main entrance of the new studio of 3LO Melbourne.



# DIAMOND DRY CELLS



## "Diamond Batteries Make Good Sets Better"

Diamond Radio Batteries are powerful, silent, and outlast any other make of Dry Cell. More than a million are manufactured in Australia annually. Every cell is guaranteed, and should a fault be found in any Diamond Dry Cell it will immediately be replaced. Remember a Radio Set is no better than its battery, therefore it is most essential to choose a battery that will give long and honest service. Such are Diamond Dry Cells.

### RETAIL PRICE LIST

- A— 1.5-volt Buzzer, for dull emitter valves, 2/9.
- B— 60-volt Super Capacity 27/6, 9 1/2 in. x 8 1/2 in. x 3 1/2 in.  
45-volt Super Capacity 22/6, 8 in. x 6 1/2 in. x 3 in.  
60-volt Standard Capacity 18/6, 6 in. x 5 1/2 in. x 2 1/2 in.
- C— 4.5-volt "Blason" 3/3 each.

### ASK YOUR DEALER FOR DIAMOND



### SUPPLIED TO

- |                |              |
|----------------|--------------|
| P.M.G. Dept.   | Water Board. |
| Q'ld Railways. | Ordnance     |
| Public Works.  | Stores. etc. |
| Department.    |              |

Wholesale only from:—  
JOHN REID & NEPHEWS,  
CHARLOTTE STREET,  
BRISBANE.

Manufactured by WIDDIS DIAMOND DRY CELL COY. LTD. W. Melb., Vic.

# Royal Commission

## The Brisbane Sitting

On Tuesday and Wednesday, May 17th and 18th, the Royal Commission which, at the instigation of the Commonwealth Government, is enquiring into wireless matters throughout Australia, sat in Brisbane.

The Commission, which comprises Mr. J. H. Hammond, K.C. (chairman), Sir James Elder, Mr. J. McMaster, and C. E. Croker, sat in the Legislative Council Chamber at Parliament House, and the inquiry lasted for two days.

It is not intended to deal fully with the evidence tendered by each witness, as this was published in detail by most newspapers. It is merely desired to set on record the names of those who appeared, and the criticisms or suggestions which they had to offer in the interests of radio.

Mr. M. M. O'Brien (4MM) was the first witness to be called, and he put the case for the amateur. He stated that a permanent wave-band should be reserved for amateurs, in view of the good work that was being done by that class of experimenter. He claimed the amateur's license should be less than the listener's license, in view of the high cost of operating an amateur station.

Mr. W. G. Hetterick, a listener of Maryborough, stated that reception of 4QG in Maryborough was very poor, particularly in the day time, and suggested that the bedtime sessions be put forward half-an-hour during winter months, and the time now taken up by advertising be devoted to programme matter.

In reply to questions the witness admitted the importance of advertising from the viewpoint of revenue, and was not aware that if it were not for advertising revenue the station would have a loss instead of a profit.

Mr. E. Gabriel, in evidence, stated that in his opinion 4QG's programmes were, on the whole, highly satisfactory.

Mr. J. H. Hindman stated that he found 4QG's transmission to be perfect, but the programmes were decidedly limited. He did not blame 4QG for that. The trouble lay in the rarity of artists, and the limitation of finance. He suggested a centralised system of relay stations.

In reply to questioning, witness stated that he was not aware that it cost £1500 a year to rent and maintain 100 miles of landline.

Mr. Wilson (vice-president of the Townsville Radio Club) stated that 4QG faded badly in the north. The programmes were considered poor, and could be greatly improved. He stressed the need for a more complete news service for country listeners.

Mr. T. Armstrong (radio inspector) said that there were 21,250 licenses in force in Queensland, of which 17,000 were in the metropolitan area. Legal action had been taken in cases where listeners had attempted to evade paying their license fees.

Mr. L. D. Edwards, B.A., Chief Inspector of Schools, referring to wireless in schools, stated that the Department of Education had not yet determined

whether broadcasting should be given a place in the school curriculum.

Mr. J. W. Robinson (Director of 4QG) presented a most comprehensive report to the Commission. He detailed the establishment of the station, and gave the Commission a concise explanation of controlling the station.

Dealing with finance Mr. Robinson presented some interesting figures. He stated that the capital cost of the station was £33,552. During the first year's operations the station showed a profit of £730. This was not due to a flourishing financial position of affairs, but rather to a tight rein being kept on expenditure.

He pointed out that it was hardly fair to expect 4QG to provide a bill-of-fare equivalent to southern stations, where the listening population was greater and the revenue larger. He was of the opinion that in view of the large number of listeners outside of this State who listened to 4QG nightly, a more equitable method of appropriating the revenue among "A" class stations should be devised, so that stations such as 6WF, 5CL and 4QG, who were not so financially as the others, may be helped along.

Referring to programmes, Mr. Robinson admitted that they in a measure lacked variety, due largely to the dearth of good artists and limited finance. To overcome this difficulty "stunt" transmissions were frequently introduced, so as to provide something different.

The correspondence received at 4QG seemed to indicate that programmes generally found favour among the listeners. The percentage of complaints was very small.

Submitting some programme figures, Mr. Robinson stated that during nineteen months no fewer than 1175 artists had contributed 13,593 items to the programmes. These figures were arrived at by counting a band or a choir as one performer.

In concluding, Mr. Robinson stated that the children's session and farmers' session at 4QG were without a par in the Commonwealth. No effort was spared to make these sessions as near perfect as possible. The State Government had established the service for the listeners, and he had his Minister's authority to state that the Government was quite satisfied with the administration of broadcasting in Queensland.

### Second Day's Sitting.

Mr. E. T. Battle, a listener of Tumoulin, in the Cairns Hinterland, stated that he could receive all Australian stations on his five-valve receiver. He was of opinion that 3LO's and 4QG's programmes were superior to the rest, as regards both quality and volume.

Mr. J. J. Knight (of the Brisbane Newspaper Coy.) representing "The Courier," "The Telegraph," "Daily Mail" stated that the papers strongly objected to Government control of wireless, as it presented the opportunity for "news colouring," and indirect political propaganda by the Government in power. The news-

papers were not opposed to broadcast news services as the news broadcast generally was in abbreviated form and merely created the desire to buy papers to read the complete account. The control of cables was also much discussed by Mr. Knight.

Mr. Robinson, in reply, refuted the statements that 4QG was guilty of political influence. The station was strongly opposed to such a policy, and he had strict instructions from his Minister to this effect.

Mr. A. E. Joseph (manager of The Country Press, Ltd.), appeared to refute a statement made by a witness on the previous day that wireless news was received in Townsville three days ahead of publication in the local paper. He produced evidence to show that country papers are supplied promptly with news.

Mr. J. B. Chandler (managing director of J. B. Chandler & Co., radio dealers) gave particulars as to the sale and manufacture of wireless receivers. He put forward the suggestion that to help overcome the practice of "pirating," the radio dealer should, when selling sets, take out the license in the name of the purchaser in the same manner as do motor car agents. He agreed that this method could not apply to the sale of parts. Continuing, Mr. Chandler stressed the need of revising the wave-lengths of "A" class stations to overcome interference.

Mr. W. T. Monkhouse appeared on behalf of the Wireless Institute. His evidence has been included in the Institute's Club report of this issue, and need not be repeated here.

Mr. E. Gold, conducting a B class wireless station at Gowwomba, stated that reception of 4QG was badly disturbed at Toowoomba, particularly at night. To

remedy this defect he suggested the establishment of a relay station.

Apart from Mr. Robinson's replies to several questions asked by the Commission, this concluded the Brisbane sittings of the Commission, which left for Sydney next day.

**CONTROL OF WIRELESS.**

(By "Hello.")

What an imperfect world it is, my masters! Many people think that the panacea for all ills is to be the patient in the hands of Dr. Government. That's what they did with broadcasting in England, and lo! The weeping and the wailing and the gnashing of teeth are louder than ever.

I have just been reading some English files, and from what they tell me it looks as if the inhabitants of the British Isles are blaming the Government control of British broadcasting for everything that has gone wrong, including the wet English summer.

From which I conclude that broadcasting companies, under whatever control they are vested will, to the end of time, draw criticism from some section or sections of the public.

A very important step forward has been taken by the British Government in connection with the great English stations. "Uncles" and "Aunts" have been officially abolished, with a view of purging the programmes of false information calculated to deceive the young. One breathes again, as at the passing of a grave danger.

**Every Listener Should Own—**

**BROADCASTING** By J. W. Robinson.

A history of broadcasting in Australia from its inception. Mr. Robinson, now Director of Station 4QG, Brisbane, has been connected with the movement since it started. Included in this volume are the three episodes which the author has broadcast from 4QG under the collective title of "The Divine Spark." **PRICE, 1/6; POSTED 1/8**

**THE FARMER GRAY VERSES**

A little book containing all the verses given by Uncle Ben and Uncle Jim from Station 4QG. Get one for your kiddies. We are being inundated with orders from the story-tellers' little friends, and the number printed will not last very long. A post card of the complete Bedtime Session Staff of 4QG is given free with each book. **PRICE 6D.; POSTED 7D**

**WIRELESS** By J. W. Robinson and G. Williams.

The best introductory book on the subject. Every owner of a set should read it; it is the most concise and clear exposition of the subject yet presented, and thoroughly explains the operation of sets from the simple crystal to the multi-valve without the use of highly technical terms. **PRICE 3/6; POSTED 3/9**

*Three new titles in Amateur Wireless Handbooks—*

**The Practical Super-het Book.**

**The Short Wave Handbook**

**Wireless Controlled Mechanism for Amateurs**

**PRICE 2/9** Each Post Free

**A. McLEOD**

Brisbane's Best Bookstore  
107 ELIZABETH STREET

**Brisbane**

# Sweep the Air

As a Searchlight

THE NEW MODEL "L" UDISCO upsets all previous standards of good radio reception.

New Circuit — new control — new beauty — incorporated with astounding selectivity and crystal-like purity.

## The NEW UDISCO FIVE (Model "L")

No other "five"—and few "sixes"—can equal the performance of this new Model "L." Interference and crowded wavebands do not bother it. It behaves as well in our Queen Street show-rooms as it does 'way out west.

YOU need but one hand to operate a UDISCO ONE-DIAL RECEIVER, and you do not have to be expert with that.

Sit in the dark as you like. Turn the vernier slowly, and hear in quick succession every programme within range.

All Australian and New Zealand stations at full speaker strength on rough aerial; 5CL, 3LO, 2FC, 2BL, 4QG on speaker without aerial. This is the regular nightly performance of a new Udisco Five operating within half a mile of 4QG's Aerial.

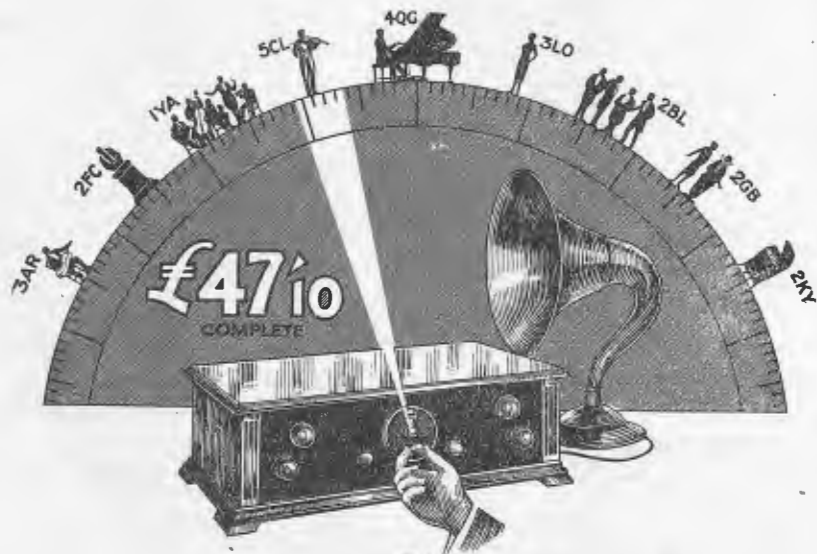

Choose Your Programme With a Flick of the Wrist

# With ONE Dial Sweeps the Sky!



## Scrap Your Wavetrap!

Don't fumble—don't grope—don't waste your time and patience fiddling with wave-traps or secondary tuning controls. Simply set the dial to the station you want—and it's there—ALWAYS.

This is the Receiver radio men have long waited for. Udisco engineers saw the need, and in filling it, exceeded their most sanguine expectations. In the truest sense the new Model "L" is a distinct triumph for Australian radio engineering.

### Enthusiastically Received

The few short weeks that have elapsed since the appearance of this wonder set have been sufficient to win for it enthusiastic praise from all parts of Australia. In fact the sets are selling faster than the factory can build them, and orders should be placed at least a week before date of delivery.

### Value Unsurpassed

The UDISCO MODEL "L" is wonderful value at £47/10/-. Equipment includes Clyde "A" Battery, 2 Heavy-duty Ray-O-Vac "B" Batteries, Baldwin Full-size Concert Speaker, and complete aerial equipment.

**£47/10/0**

Complete with everything of the best.

Order from your Dealer or from—

## United Distributors Ltd.

343 Queen Street, Brisbane

And at Sydney, Melbourne, Adelaide, Perth, Launceston (Tas.), and Wellington (N.Z.).

See Review and our Announcement in May "Old Radio News"

### Read these Opinions of Satisfied Owners—

Roma.  
The Set was hooked up and the following stations tuned in right away:—2FC, 2BL, 2GB, 2KY, 3LO, 3AR, 4QG, 5CL, 7ZL, 1YA, 2BL, 2LB, KORM (Radio, Manly).  
All these stations, excepting 7ZL, came in with great strength. Most could have been heard 400 yards away, and the "A" grade stations easily half-a-mile away." (Sgd.) F.E.S.

Gladstone.  
"The sermon from 2BL at 4 p.m. came in at full speaker strength, and the church service from 1YA New Zealand at 5.30. At night every "A" class station had to be choked back as the volume was so great, while 3LO and 5CL could be brought in without either aerial or earth and could be heard plainly 20 feet from the speaker." (Sgd.) S.C.

Longreach.  
"Fixed up an inside aerial and tuned in all stations at full speaker strength with the best results I have ever had here on any set." (Sgd.) H.J.S.

Pittsworth.  
"I tuned in all interstate stations with wonderful volume and clarity. It is a very fine set indeed, and is a pleasure, not only to the eye, but to handle also." (Sgd.) L.G.L.



# "London Calling"

*Amazing Feat of Re-broadcasting accomplished by Station 2BL.*

For the second time in two months Station 2BL, Sydney, has made Australian broadcasting history. In April it will be remembered that this station (in its afternoon session) re-broadcast the Dutch Station PCJJ. On the same night WGY (New York) was picked up and re-broadcast. This was the first time that the re-broadcasting of overseas stations had been accomplished in Australia.

Not being content with the undoubted success of these two achievements, 2BL looked around for fresh fields to conquer, and decided to attempt the re-broadcast of the British Broadcasting Commission's big London station, 2LO.

Those who read the morning papers of Friday, May 20th, may or may not have noticed a brief paragraph referring to the attempt that was to be made between 1 a.m. and 7 a.m., Saturday morning. Others who were listening to 2BL shortly after 10 p.m. on Friday night heard the announcement concerning the re-broadcast.

Thus, it is safe to assume that only 25 per cent. of listeners knew of the event, and had the matter been given a little more publicity from the station, few indeed would have been the listeners who would not have availed themselves of the opportunity of listening to London.

### Results Most Satisfactory.

It was something of a thrill to sit at home in the early hours of the morning and hear 2LO's announcer

cheery, "London Calling!" One almost forgot the cold as, in scant night attire, he heard the music and speech from far away England come floating from the speaker.

Although the reception was not as clear as 2BL's usual transmissions, the results were highly satisfactory. The greater part of the speech could be easily followed, and the musical numbers were quite distinct. Reception was best shortly after 3 a.m., when darkness was falling in London.

### Details of the Transmission.

In the first place 2LO was received by PCJJ, in Holland, an experimental station operating on a power of 50 kilowatts, owned by the Phillips Radio Co. The programme was then re-broadcast by PCJJ on short waves and received on a special short-wave receiver designed and built by Mr. Raymond Allsop, one of 2BL's engineers, who resides at Lindfield. The loud speaker reception from this receiver was then transmitted by land-line to 2BL's Studio, and thence to the broadcasting station at Coogee, where it was put on the air with 2BL's usual power of 5000 watts.

### May Now Be a Weekly Feature.

There is now some talk of making these re-broadcasts a weekly feature from 2BL, and listeners as a body are sincerely hoping that the management of this progressive station will see their way clear to adopt the practice.

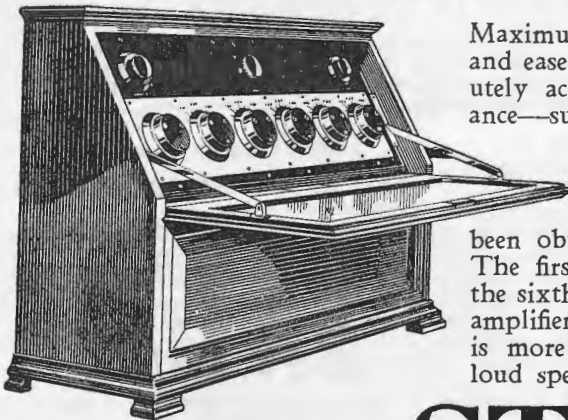

The instrument is contained in a handsome lock-up cabinet with space for housing the H.T. batteries.

Write for full particulars and prices of Sterling Radio Receivers, Loud Speakers and Components.

Maximum range and selectivity, finest possible tone and ease of manipulation under all conditions, minutely accurate construction, and handsome appearance—such is the STERLING "STRAIGHT-EIGHT."

To ensure absolute perfection of quality, the use of reaction has been avoided, sensitivity and selectivity having been obtained by increasing the number of valves. The first five valves are high frequency amplifiers, the sixth a detector, and the last two low frequency amplifiers. Even from distant stations the volume is more than sufficient for any ordinary type of loud speaker.

# STERLING

## STRAIGHT EIGHT 8-VALVE RECEIVER

Representative—A. COLLINS, Room 12, 5th Floor, 'Daily Telegraph' Buildings, Sydney, N.S.W.

# Useful Wireless Formula

## For the Radio Experimenter and Constructor

(By R. C. V. Humphery.)

If we glance down the "query" columns of any of our wireless journals we will note that queries dealing with wave-length, capacity, inductance and resistance values of wireless apparatus predominates.

Here are a few typical queries:—

What size condenser shall I need, used in conjunction with a coil having 50 turns of No. 22 D.C.C. wire, wound on a 3½ in. diameter former, to tune up to 550 metres?

How many turns of No. 22 gauge wire will be required, when wound on a former 3 in. in diameter, and tuned by a .0005 mf. condenser, to reach up to a wave-length of 500 metres?

I intend using 3 A.W.A. 101X valves, the filaments of which are to be controlled by a single filament rheostat. What would be the correct value of its resistance?

The above are typical of many questions which appear each week and which, with a very elementary knowledge of arithmetic, may be calculated after a careful perusal of this article. As will be seen from the above, wireless calculations may be roughly divided into four headings:—Calculations dealing with wave-length; inductance; capacity and resistance, each of which will be dealt with separately.

### Wave-length formula:

We usually refer to transmissions from broadcast stations in terms of wave-length, whilst the L.C. constants of a closed oscillatory circuit are spoken of in terms of frequency. Now, wave-length and frequency are synonymous and their relation may be expressed by the formula:—

$$\lambda \text{ equals } \left\{ \frac{3 \times 10^8}{f} \right.$$

Where  $\lambda$  equals wave-length in metres.

f equals frequency, or number of cycles per second.

Thus, a circuit having a natural frequency of, say, 550,000 cycles will have a wave-length of  $\frac{300,000,000}{550,000}$  or 545 metres.

Similarly, a station transmitting on 340 metres is equivalent to saying that the station is sending with a frequency of  $\frac{300,000,000}{340}$  or 882,353 cycles.

A certain fixed relationship exists between the natural wave-length of a closed oscillatory circuit, and its inductance and capacity.

Referring to Fig. 1, which represents the tuned circuit of a receiver, it will be noted that this circuit consists of a coil L having a certain inductance, and a condenser C having a certain capacity. Now, the inductance of L and the capacity of C have a

direct bearing on the wave-length, which is expressed by the formula:—

$$\lambda \text{ equals } 1885 \sqrt{LC}$$

Where  $\lambda$  equals wave-length in metres

L equals inductance in microhenrys

C equals capacity in microfarads.

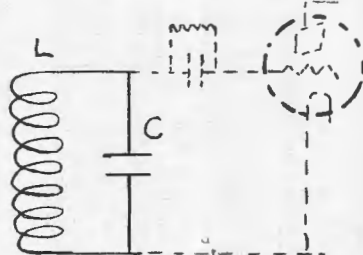

Fig. 1.

Thus, let us assume that the inductance of L is 400 MHS, and the maximum capacity .001 mf; the wave-length will be  $1885 \sqrt{400 \times .0001}$  or 1187 metres (approx.).

In a similar manner it is possible to calculate the capacity (or inductance) of a circuit, knowing its inductance (or capacity) and wave-length.

By turning the formula  $\lambda \text{ equals } 1885 \sqrt{LC}$  around

$$C \text{ equals } \frac{\lambda^2}{1885^2 \times L} \text{ and } L \text{ equals } \frac{\lambda^2}{1885^2 \times C}$$

From the above, it will be observed that by doubling either the inductance or capacity of the circuit of Fig. 1 we increase the wave-length by  $\sqrt{2}$  or 1.41, and by increasing the inductance or capacity by four we double the wave-length.

As an example of the above, let us suppose that we wish to construct a receiver capable of tuning up to 600 metres with a condenser of .001 mf. We desire to know the inductance of our coil:

$$L \text{ equals } \frac{600^2}{1885^2 \times .001} \text{ equals } \frac{360,000}{3553} \text{ equals } 101.3 \text{ MH.}$$

### Inductance Formula.

The inductance L in centimetres of a coil may be calculated by the following formula:—

$$L \text{ equals } \frac{(2.71 RN)^2}{b} \times K$$

Where R equals mean radius of coils in CMS.

N equals number of turns

b equals length of winding in CMS

K equals a factor depending upon the ratio  $\frac{2R}{b}$

Before proceeding further it should be stated that there are 2.54 CMS to one inch, so that if the diameter

of the former and the length of the winding are taken in inches, it will be necessary to multiply both measurements by 2.54 in order to convert inches into centimetres.

By "Mean Radius" is meant the radius of the former plus half the thickness of the wire.

However, as this formula is only applicable to single layer coils, we may omit the thickness of the wire and take R as being the radius of the former.

The values corresponding to K are given in the table underneath.

D/b	K	D/b	K	D/b	K	D/b	K
0.00	1.0000	0.80	0.7351	2.60	0.4626	7.00	0.2584
0.05	0.9791	0.85	0.7228	2.80	0.4452	7.50	0.2469
0.10	0.9588	0.90	0.7110	3.00	0.4292	8.00	0.2366
0.15	0.9391	1.00	0.6884	3.20	0.4145	8.50	0.2272
0.20	0.9201	1.10	0.6673	3.40	0.4008	9.00	0.2185
0.25	0.9016	1.20	0.6475	3.60	0.3882	9.50	0.2106
0.30	0.8838	1.30	0.6290	3.80	0.3764	10.00	0.2033
0.35	0.8665	1.40	0.6115	4.00	0.3654		
0.40	0.8499	1.50	0.5950	4.20	0.3551		
0.45	0.8337	1.60	0.5795	4.40	0.3455		
0.50	0.8181	1.70	0.5649	4.60	0.3364		
0.55	0.8031	1.80	0.5511	4.80	0.3279		
0.60	0.7885	1.90	0.5379	5.00	0.3198		
0.65	0.7745	2.00	0.5255	5.50	0.3015		
0.70	0.7609	2.20	0.5025	6.00	0.2854		
0.75	0.7478	2.40	0.4816	6.50	0.2711		

This will be more easily understood if we take a numerical example. Let us suppose that we have a former (Fig. 2) 3 1/2 in. in diameter, wound with 55 turns of 22 DCC wire and we require to know the inductance.

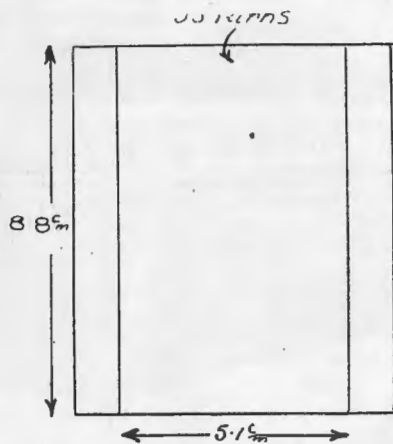

Fig 2.

ance. Now 55 turns of 22 DCC wire will occupy about two inches. Let us first convert the radius of the former and the winding length into centimetres.

$$\text{Radius equals } \frac{3.5 \times 2.54}{2} \text{ equals 4.4 CMS}$$

Winding length equals  $2 \times 2.54$  equals 5.1 CMS approx.

Referring to our inductance formula:—

$$(6.28 \times 4.4 \times 5.1)^2$$

$$L \text{ (CMS) equals } \frac{\text{---}}{5.1} \times K \text{ equals } 452,423 \times K$$

In order to find the value of K it is necessary to divide the the diameter of the former by the winding length.

8.8

Thus — equals 1.7

5.1

Referring to our table we find that the value of K corresponding to 1.7 is 0.5649, so that L equals  $452,423 \times 0.5649$  equals 255,600 CMS.

There are 1000 CMS in one micro-henry, so that the inductance of our winding will be 255 MHS.

If this coil is used in shunt with a .0005 mf. condenser, by applying the wave-length formula we will find that the circuit will tune to about 660 metres.

If it is desired to tune to a maximum of, say, 600 metres, the simplest method is to reduce the number of turns by about eight and repeat the calculation. So long as the answer is a little over 600 metres, the exact amount is immaterial for all practical purposes. Although there are other methods of calculating inductance, the one enumerated above is the simplest one. True, it will not enable us to calculate the inductance of multi-layer coils such as the duo-layer or honeycomb type, but on the other hand it is the single layer coil which is most commonly used in present-day receiver design.

**Capacity Formula.**

The majority of set builders and experimenters buy their fixed condensers ready-made, and therefore have no occasion to calculate their condenser capacities. However, the following formula may be of some use.

AKN

C equals ————— where

$$4 \pi \times D \times 9 \times 10^5$$

C equals capacity in MFDS.

K equals dielectric constant

N equals number of dielectrics

A equals area of one plate in sq. CMS.

D equals thickness of dielectric in CMS

( $9 \times 10^5$  equals 900,000).

For those readers who prefer to work in inches the following formula is added:—

AKN

C equals ————— where

$$4,500,000 \times D$$

C equals capacity in MFDS

K equals dielectric constant

A equals area of one plate in inches

N equals number of dielectrics

D equals thickness of dielectric in inches.

The dielectric is the substance (whether air or mica, etc.) which separates one condenser plate from another. Every insulating substance (dielectric) has a factor called the dielectric constant, denoted by the letter K, and in order that the above formula may be complete the dielectric constants of the more common dielectrics are given:—

Substance.	Dielectric Constant	K.
Air	.....1	
Ebonite	.....2.2 to 2.77	
Glass	.....5 to 10	(very variable)
Dry Paper	.....2 to 2.8	
Mica	.....4 to 8	
Bakelite	.....5 to 7	

The unit capacity is the farad (abbreviated FD), but as this unit is too large for practical purposes we take for our unit, the more familiar microfarad (mf) which is the millionth part of a farad. In addition to these units there are the jar and the centimetre. The centimetre is the CGS unit of capacity, and there are one thousand CMS to one jar, and 900 jars to one microfarad. Thus, there are 900,000 CMS to one MF.

**Resistance Formula.**

This heading will be of particular interest to those readers who prefer to construct their own receivers, and who are not quite certain what value of resistance to employ to regulate the filament current. The resistance of the filament control may be computed from the following formula:—

$$R \text{ equals } \frac{E - e}{i \times N} \text{ where}$$

- R equals resistance of rheostat
- E equals accumulator voltage
- e equals operating voltage of valve filament
- i equals operating current of valve filament
- N equals number of valves to be operated off the one control.

When selecting the rheostat, it will be necessary to choose one having the nearest higher resistance to the resistance calculated. Let us take the example shown in Fig. 3, which illustrates the filament circuit

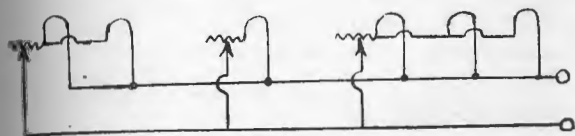

Fig. 3.

of a receiver having 2 RF stages, controlled by the rheostat R1; one detector valve controlled by the rheostat R2, and finally three resistance valves controlled by the resistance R3. We will assume that three UX 199 valves each taking .06 amps at three volts are to be used for the two RF and detector stages, and two Mullard PM3 and one PM4, each taking 3.8 volts at 0.1 amps., all of which are operated off a 4-volt accumulator.

When fully charged a 4-volt accumulator will rise to about 4.4 volts for a short period, and in order to safeguard the valve filaments we must take E as 4.4 volts, so that the value of R will be:—

$$R1 \text{ equals } \frac{4.4 - 3}{.06 \times 2} \text{ equals } \frac{1.4}{.12} \text{ equals 12 ohms.}$$

The nearest higher value of resistance to this will be 20 ohms, which value will be found correct.

For R2 we have

$$\frac{4.4 - 3}{0.6 \times 1} \text{ equals } \frac{1.4}{0.6} \text{ equals 23 ohms or a 30 ohm rheostat}$$

For R3 we have

$$\frac{4.4 - 3.8}{0.1 \times 3} \text{ equals } \frac{0.6}{0.3} \text{ equals 2 ohms or a 6 ohm rheostat.}$$

When 6-volt accumulators are used in conjunction with 6-volt valves such as the 201A, PM5, PM6, A.W.A. #01X, the value E should be taken as 6.6 volts.

In conclusion, it is hoped that the above formulae and examples will enable the reader to wind his own coils to any premediated wave-length, as well as to select the correct value of resistance for his rheostats. The writer has carefully avoided all formula requir-

ing the use of mathematical tables in order that anyone with a knowledge of arithmetic may follow the calculations.

**MR. ERICH JOHN'S PIANOFORTE RECITALS.**

Many listeners in to the monthly pianoforte recitals given by Mr. Erich John from 4QG have made the request for the performance of certain pieces of music.

In response we thought ourselves obliged to explain that the programme for each pianoforte recital is already mapped out for the rest of the year. However, requests can only be considered when they are selected from compositions already played at previous recitals. Request pieces will be played after the performance of the items advertised in the monthly programme.

Listeners-in wishing to hear any items repeated should write to 4QG Brisbane.

Following is a list of compositions played by Mr. Erich John at previous 4QG pianoforte recitals:—

- Beethoven, "Sonata Opus 26"; Chopin, "Nocturne Op. 9, No. 2," "Nocturne Op. 72, No. 1," "Mazurka Op. 17 No. 1," "Polonaise (military) Op. 40 No. 1," "Prelude ('Raindrop') Op. 28 No. 15," "Prelude Op. 28 No. 17," "Waltz Op. 64 No. 1," "Waltz in E-Minor"; Chopin-Liszt, "Bacchanale"; Mendelssohn, "Hunting Song Op. 19 No. 3," "Duetto Op. 38 No. 6," "Determination Op. 53 No. 3," "Spring Song Op. 62 No. 6" (from Songs without Words); Mozart, "Sonata in A-Major"; Liszt, "Eleventh Rhadsodie"; Saint Saens, "Etude Valse"; Schumann, "Novelettes Op. 21 No. 1," "Why? Op. 12 No. 3"; Schumann-Liszt, "Spring Night"; Wagner-Liszt, "Tannhauser" overture.

**LOEWE Multiple Valves**

*A Marvellous Advance in the Radio Art*

Are meeting with exceptional success everywhere. Because of their high sensitivity and simplicity they permit of the construction of extremely powerful yet inexpensive local and long range sets, the ideal instruments for music lovers.

Sole agencies open for various territories, radio factors of good financial standing please apply.

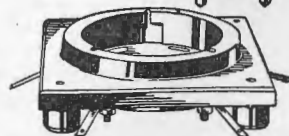

**Loewe Radio G.m.b.H.**  
BERLIN—STEGLITZ WIESENWEG 10

**Powerful!****Magnetic!**

A PERFECT RECEIVER

**"The MAGNAVOX"****One Dial Control****Just Arrived—A Shipment of these  
Wonderful Sets**

A Five-Valve Receiver of perfect construction, giving full speaker strength on the world's broadcasting stations at all times without interference. Expert opinion the best yet heard. We wish you to hear this set demonstration free—in your home if desired.

**RADIO**

TERMS TO SUIT YOUR CONVENIENCE.

**MICK SIMMONS LTD.**

QUEEN ST., BRISBANE  
(opposite Town Hall)

Also Our Wonderful

**SIMOLIAN SPEAKER 21/-***A Splendid Speaker for All Work*

Have a chat with our expert, Mr. Finch. He will be pleased to advise you in all your requirements.

**Fascinating!****Thrilling!**



# Beam Wireless

## How the System Works

### A Most Interesting Description of the New Beam Transmitter and Receiver at Ballan, [Victoria]

The opening of the beam wireless service between Australia and Great Britain has provided for Australia the most modern and efficient wireless service in the world. All the best recent developments in a science which the whole history has been one of phenomenal achievement have been combined to produce in the beam system between Australia and Great Britain the longest telegraph service—and this includes land line services—which has yet been established. Moreover, beam wireless communication is being developed so rapidly that it is already clear that the beam telegraph service is merely the foundation stone on which a few years will be built up, not only an extremely efficient telephone service between Australia and England, but also a service which will enable pictures to be telegraphed from one country to the other, and families of documents on the one side of the globe to be reproduced in the most perfect detail at a few minutes' notice on the other.

In Australia the beam wireless service will be owned and controlled by the Amalgamated Wireless (Australasia) Ltd., for whom the beam stations have been erected by the Marconi Company of Great Britain. The stations in England will be controlled by the British Post Office. The transmitting stations in Australia are situated at Ballan, a town about 50 miles from Melbourne on the main railway line between Melbourne and Adelaide. The receivers will be at Rockbank, about 20 miles from Melbourne on the same railway line.

There are really two different stations at each site. One of the two transmitters at Ballan will work with Great Britain, while the other will work with Canada. Similarly, at Rockbank, one of the receivers will pick up signals from Great Britain, while the other will be used to receive signals from Canada. All four units will be able to work simultaneously, and quite independently of each other.

Six stately steel towers stretching for a height of more than 250 feet into the air, and supporting a delicate web of fine wires—a dull coloured building, which contains the transmitting equipment, large in itself, but dwarfed almost into insignificance by the aerial towers—and a delightfully bright little village which has sprung up to accommodate the station staff—are the visitors' first impressions of the beam wireless transmitter at Ballan.

The transmitting station itself can most conveniently be considered as three distinct units. The first of these is the power house—itsself larger than the electric power houses of many country towns—which supplies the electric current to work the transmitter. The second unit is the transmitting equipment proper, and the third is the intricate aerial system on which the generation of the wireless beam depends.

#### Wonders of Power House.

A spectacle of a type which few people would expect to find in a wireless station confronts one on entering the Ballan power house. The actual energy to operate the wireless station is derived from three large crude oil engines. Each one of these engines develops 160 b.h.p. The engines each have three cylinders, and each drives an electric generator which develops a direct current at a pressure of 400 volts. The output of each of these generators is taken to a switchboard, and from there it is diverted to drive a series of other machines. A modern wireless transmitter uses valves which are essentially the same as the valves in a wireless receiving set. Hence, a current is required to light the filaments, and another current is employed to operate the plate circuits of the valves. The filament current is really supplied from batteries, but these batteries are kept charged by a motor generator supplying current at an appropriate pressure. This motor generator is operated from portion of the current from the main engine driven generators.

The plate circuits of the main transmitting valves require a pressure of no less than 10,000 volts to operate them. Intricate and elaborate apparatus is needed to supply this pressure. Another electric motor, driven from one of the main generators, operates an alternating current generator. The current delivered from this machine is passed into a transformer which steps up the voltage to a pressure considerably exceeding 10,000 volts. This high-pressure current then passes into an appliance known as a rectifier. The rectifier consists of 16 valves, each about the size of a large football arranged in a rack and insulated on slabs of glass. Owing to the extremely dangerous pressure employed, all this apparatus is carefully protected by shields.

The rectifying valves differ from ordinary receiving valves in that they containing only a filament and a plate. The grid, which is the third element in an ordinary valve, is not required.

The alternating current from the transformers is converted by means of the rectifier into a direct current of a pulsating nature. That is to say, the pressure alternately rises to a pressure exceeding 10,000 volts and then falls away to zero.

This current must be converted into a perfectly steady direct current before it can be employed on the transmitting valves. In other words, the pulsations or ripples referred to must be "ironed out." The appliance by means of which this is done is known as a filter. The filter consists of a carefully designed arrangement of inductance coils and condensers. The pulsating current is fed into this filter, and when it is

# TIT FOR TAT

By W. S. HOGG

"Come on, Dad, don't strain your eyes reading that old radio book. Listen to 4QG—there's Miss Mona Struggles just going to sing "The Prickles of a Rose."

"Oh, alright, alright—let her moan. I paid three and six for this book and I'm going to understand it; if I have to read it another four times. Now it says "Frequency equals Velocity"—there's a line under that bit. Struth! what does a line—"

"Oh, for Goodness Sake, read it to yourself—I never saw such a man," said his wife, impatiently.

"Here, Percy," Dad whispered hoarsely, "look here, It sez Frequency equals—"

"I don't know anything about the perishing stuff," said Percy, edging away rapidly.

Dad finding a lack of sympathy—placed his elbows on the table, took hold of his hair in both hands and appeared to go into a trance.

"We are now to have a few Commercial Announcements," boomed a sonorous voice.

Mrs. Landson gave a loud sniff and with a determined hand switched off. "Come on, Dad,—bed!"

"Whatcher reckon they mean by—"

"Oh, for Goodness Sake, forget it and come to bed. Goodnight Percy."

Percy was a fresh cheerful-looking youth, not long out from the old land. He was working for Joe Landson on the farm, and, as Joe himself said, "learning to become a bit of the backbone of the Country."

"Did you ever think what a lot of good electricity is going to waste in these days, Percy?"

"No," said Percy, looking round for means of escape.

"Look at all this Broadcasting—" continued Dad, taking Percy gently by the arm, "electricity squirted out—radiated—I mean; all wasted."

"You get some beastly, bally music out of it, don't you?"

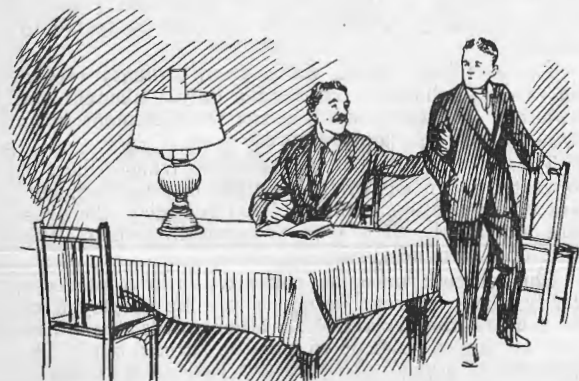

"Music!" said dad, with a snort; "You can't eat music, Percy. No, my idea is to put it work on the farm; electro-culture—see what I mean?"

"No," murmured Percy weakly.

Dad tightened his grip on Percy's arm. "I ain't said nothing to the wife about it yet. She's always been throwing off at my ideas ever since I made her that patent incubator." Dad's face darkened at the memory of that ill-fated machine. "How was I to know the flaming thing would blow up and scald her?"

Percy murmured something which might have been words of sympathy.

"Now, my idea is to put up an aerial and experiment on a banana sucker at first. You see, I get all the broadcasting stations up till about midnight; after that there may be some ships giving me a little—the a bit of static might come along and, see, I should say 'cut' my aerial. See what I mean?"

"No," said Percy. "If this blinking static cuts your perishing aerial down—what I mean to say is, if the bally—"

"Struth! Percy, have a bit of common sense; have a bit of common. When I say 'cut' I'm using technical language. Now what you do is to go and dig a hole where I've stuck that peg in, two foot by two foot by two foot, and fill it in again."

Percy wrinkled his forehead. "I beg your pardon, Mr. Landson, but I'm afraid that the last bit escaped me."

"Struth! Percy, don't they teach you anything in the country? A hole—you know what a hole is—two feet square and two feet deep, see? That's where I'm going to plant the banana sucker."

Next morning, as Mrs. Landson was busy cooking the breakfast, dad dashed in, breathing hard with excitement. "Come out here, mother! Look at this banana sucker—it was only a foot high yesterday, wasn't it, Percy?"

"No," said Percy, "eleven inches—the way I measured it."

"Well, it's eighteen inches high now, and chance it. See what my sort of electro-culture will do. Struth! I've got broadcasting broken into harness and eating out of my hand. 'The Landson System of Electro-culture!' said dad with a relish. "I've not done yet—this is only the beginning. I'll put the whole of my banana crop under aerials. See what I mean?"

Dad quite expected to find that more marvellous growth had taken place during the next night; nor was he disappointed. Twenty-three inches the sucker measured that morning—a growth of twelve inches in less than two days. A neighbour, coming over to get the loan of a scuffler, was so greatly impressed indeed, that he had to knock off work to go and talk it over with the neighbours. The consequence of which was that dad also had to knock off work to explain his 'system' and deliver a series of lectures to numerous inquisitive visitors.

"You've all seen," said dad, "a stone chucked into a creek, or something, and you've probably noticed the ripples radiating out in circles. Well, that's just what the radio does. For instance, 4QG chucks, or I

should say discharges, bunches of—that is to say 'os-  
latory currents'—which is electrons, which am—I  
should say 'is'—electricity. This electricity travels at  
the rate of 186,000 miles per second. Now, I sticks  
my aerial, and this electricity—travelling pretty  
—hits the end of it, travels along it and down that  
wire to earth, where the banana sucker is. That's the  
simple explanation. I won't go into the technical part  
of it. Whatcher laughing at, Percy?"

"Oh, nothing, only—only 186,000 miles a second,  
you know—that's coming it a bit thick, what!"

"Struth! Percy; have a bit of sense."

"Well, you know, you told me once the white ants  
ate the blacksmith's bally anvil, and you sent me over  
to a perishing blighter to borrow half-a-dozen post  
—es, and you—"

"Struth!" said dad, appealing to his listeners, "these  
young blokes from the old country don't seem to have  
any sense at all. You better get on with scuffling  
those pineapples, Percy. You see," said dad, contin-  
uing his lecture, "my system of electro-culture stimu-  
lates the growth of plant life, makes fertilisers unnec-  
essary, kills disease, stupefies the bacteria we don't  
want, puts pep into the bacteria we do want, grows  
the crops in a quarter of the time, and, don't forget,"  
said dad impressively, "the law can't make us pay  
4QG, or any of the rest of them either."

"Eh, Mon," said Angus MacPherson, gloomily,  
shaking his head, "this will bring down the price of  
bananas."

Dad scratched his head. This aspect of the case  
had not struck him before; but he brightened up at  
the thought that he would patent his 'system' and  
make money without work. Who was MacPherson  
that he should stop the march of science. "Pooh!" he  
mentally blew MacPherson out.



Dad pattered about his aerial all day, measuring  
the banana sucker at intervals to check up the growth;  
but strange as it may seem, no growth was apparent  
until dad went into the house for a drink. It hap-  
pened that Percy, passing by at that time, and being  
a conscientious youth, pressed the soil down around  
the plant with his boot. Thus, when dad took his  
next measurement he had the satisfaction of record-  
ing a growth of one inch. Most of the growth must take  
place during the night dad ruminated.

"You know, Mr. Landson, Archimedes or 'some old  
erisher once said that a 'watched pot never boils.'  
Perhaps that plant won't grow while you're looking  
at it."

"Struth!" said dad in a resigned way, "talk sense  
Percy, have a bit of common."

The clock in Mr. Landson's kitchen ticked away  
steadily and aggressively as though conscious of the  
fact that the time it registered had been passed as  
"O.K." by 4QG. Its hands pointed to midnight—  
outside the moon, sinking to rest, cast long shadows  
across the land. Mr. Landson might have noticed,  
had he been awake, a denser shadow than the rest  
moving about his electro-culture aerial. The shadow  
hovered about the banana plant, which, in a flash,  
seemed to shoot up to double its height. Perhaps it  
was the mysterious Genii of electricity appearing in  
the world of men while they slept—who knows? Two  
words softly spoken floated on the midnight air, "Per-  
ishing Blighter!" followed by a giggle—and the moon  
went down behind a cloud.

Morning found dad out with a rule in his hand,  
and by a queer coincidence Mr. MacPherson appeared  
at the same time with a rule in his hand also.



"Morning, Mac. Come to measure the growth?"

"Aye, mon," said Mac, who was a man of few  
words.

"Struth!" exclaimed dad, staring at the plant, "It  
must have grown two feet last night. By George!  
you would never believe it!"

"I don't," said McPherson. "Yon is a Lady's Fin-  
ger—yesterday it was a Cavendish." He stepped over  
to the banana plant and gave it a tug, which pulled  
it out of the ground. "I thought so; no roots; just  
been cut off and stuck in." MacPherson stood, look-  
ing accusingly at dad.

Dad stood gasping like a fish. Suddenly a look of  
enlightenment came over his face, and he turned quick-  
ly away.

"Where are you going, Mon?"

"I'm going to find that there Percy!" bellowed dad.

### BURGINPHONE RECEIVERS.

Queensland radio dealers desirous of handling a  
good line of radio receivers in this State are invited  
to communicate with the Burgin Electric Coy., of  
342 Kent Street, Sydney, who are seeking Queens-  
land representation of their receivers.

The Burgin line has always been a quality line.  
This fact coupled with the attractive selling prices  
and the liberal discount allowance should induce wide-  
awake dealers to link themselves up with this pro-  
gressive organisation immediately.



**BEAM WIRELESS.**

(Continued from Page 21.)

withdrawn it is perfectly smooth without any trace of the original ripple on it.

One of the most striking features of the power house is the exceedingly complete nature of the arrangements which have been provided to prevent a breakdown of portion of the apparatus from interfering with the service. In the first place, there are three complete and independent engine-driven generating units, and all the apparatus for filament supply and plate current supply is in triplicate.

Normally, one unit of each set of apparatus will be used to operate the English beam transmitter, and one set will be used to operate the Canadian beam transmitter. The third set will be available as a spare and, at a moment's notice, it can be switched in to replace either of the other sets. But, in addition to this, all the other apparatus is interchangeable. For instance, in the extremely unlikely event of a failure of two or the units, the third can be used to operate either the English or Canadian station at will, and any individual machine can be grouped in with any others to make up a complete unit. All this is made possible by an elaborate switchboard system, which is so comprehensive that the switchboard occupies a wall nearly 100 feet long.

**Transmitting Equipment.**

To the layman, the transmitting equipment proper, in comparison to the imposing engineroom, looks small and disappointing—yet it is its very smallness and compactness in comparison with older wireless transmitters which makes it so remarkable to the engineer. The beam wireless transmitter at Ballan is the very latest development in wireless, and it incorporates so many new features that alterations to the very building in which it is housed were made after the building had been erected, in order that the latest appliances could be employed.

Each of the two transmitters consists of three main panels. One is known as the control panel, and its duty is to permit the actual signalling to be effected. The second panel is known as the drive panel, and the third is the main amplifier panel which supplies the current to feed the aerial system.

The purpose of the transmitter is merely to produce an alternating current which can be fed to the aerial, but this current must alternate, or change its rate at a frequency which staggers the lay mind. It must generate currents which surge up and down the aerial wires no fewer than 11,660,000 times a second. The alternating current used in ordinary domestic and commercial supply system changes its direction only about 50 times a second.

It is also extremely important that the rate of alternation should be absolutely constant. If the number of alternations, for some reason, slowed down slightly, a wave longer than the correct wave would be radiated from the aerial. If the rate were increased above the proper number a second, the radiated wave would become too short. Carefully locked away in a heavy copper case which is the basis of the drive panel of the transmitter is the instrument which assures that just the right number of alternations per second are produced in the aerial currents. This instrument is known as a master oscillator. It consists merely of a fairly large valve associated with a dozen or so turns of wire. This valve oscillates or generates alternations of the correct frequency. These alternations are then passed on to another valve

where they are amplified just as a radio frequency amplifier in an ordinary receiver amplifies the feeble aerial currents. From this first amplifying valve, they are passed into another amplifier, which consists of two valves each a foot or more in diameter. Amplified by these two valves, the alternations are then ready for transmission to the main amplifier, which supplies the aerial system.

The main amplifier is a panel in itself, and it consists of two valves of a special kind. They are not at all like an ordinary valve, but they resemble more a copper tube about 18in. long and about 9in. in diameter. This copper tube is really the plate of the valve, and a filament and grid of the ordinary kind are sealed and insulated with glass from the plate. The copper plate is really a copper jacket like the cooling jacket on the cylinder of a motor engine. In it circulates a constant current of specially prepared oil the whole time the valve is working. The reason for this is to keep the valve cool.

Each valve is capable of handling the electrical equivalent of about 26 horse power, and unless special precautions were taken to carry off the enormous heat generated by the passage of this heavy current through the valve, the plate would be melted and the valve would collapse after a few seconds working.

As a further safeguard against the overheating of the valves, however, an electrically operated blower directs a constant stream of cool air on to the glass portions of the valve while it is working.

**How Signals are Controlled.**

Speeds of no fewer than 325 words a minute have been found possible, even in preliminary transmission tests on the beam system. This is about three times as fast as many public speakers speak. It is clear, therefore, that ordinary hand keying could never be employed, because it is far too slow.

The actual sending is performed in machines in Melbourne, which will be described later. These machines are connected by land lines to the control panel at Ballan. Here, their signals are amplified by a series of valves, and then made to control two oil cooled valves identical with the main transmitting valves. The purpose of these two control valves is to allow current to flow to the main sending valves when the automatic key is closed to send the signal, and to withdraw it from the transmitting valves when the key is raised, and no signal should be sent. The principle employed is simple. The two control valves are connected across the main plate supply to the transmitter in such a way that they could act as a short-cut path for the current. When the key is up, and no signal is required, the control valves by pass all the current from the main transmitting valves. Nothing is then radiated from the aerial. When the key is depressed to send a signal, however, the resistance of the control valves rises to a high value, and the current, being unable to pass through them, is forced into the main transmitting valves, which accordingly feed the aerial and produce waves. The control valves are really a tap which can either turn the current into the main transmitter, or else allow it to escape without doing any useful work just as the operation of the key requires.

**Prevention of Vibration.**

An interesting feature of the station is the care which is taken to prevent accidental vibrations from disturbing the transmitting equipment.

If the transmitter was subject to vibration, it is possible that the operation of the master oscillator, which controls the wave-length, might be upset. The main source of vibration in the station is the oil engines operating the primary generators. To prevent any of this vibration being transferred to the building the main engines and generators are set on a heavy concrete slab, which is entirely insulated by shock absorbing cork from the remainder of the foundations of the building. As a further safeguard, however, the transmitting panels are also set on concrete bases which are similarly insulated from the rest of the building. A double precaution against vibration reaching the transmitting equipment is thus provided.

### The Aerial System.

The aerial system used in the beam stations is quite unlike the aerial of any other form of wireless station, because in addition to having to perform the ordinary duty of producing the wave, it exercises the further function of concentrating it into a narrow beam. The use of the beam is important for two reasons.

In the first place, it is an important factor in ensuring the secrecy of communication. Instead of being radiated broadcast all round the transmitter, signals are concentrated into one direction. The second function of the beam is to greatly increase signal strength. Suppose the beam was 100 degrees wide. Then, instead of being radiated all round the aerial in the full 360 degrees of the circle, the energy the transmission would be concentrated into one thirty-sixth of the area it would otherwise cover. It follows therefore that the wave at any point along the path of the beam would be 36 times stronger than it would be if the beam was not employed.

Three masts are used to support the aerial for the English portion of the transmitter, and three for the portion for working with Canada. Each of the masts is made of lattice steel, and each weighs about 50 tons. The masts are 12 feet square, and are so strong that they are almost self-supporting. At its top, each mast carries a cross-piece 90 feet long. The masts for each station are arranged in a line exactly at right angles to the direction in which the beam is to be projected. The masts supporting the aerial system for Great Britain are therefore laid out along a line pointing to the north-east and south-west. The cross-pieces at the top of the masts support at their extremities two heavy steel cables which are suspended along the line of masts. These cables are the supporting members for the aerial system proper. The aerial consists of a series of vertical copper wires, each of which is kept taut by a heavy weight at the bottom. At the back of the row of aerial wires is another series of vertical wires which form a reflector. This reflector assists in the concentration of the waves in the proper direction. The aerial system for the transmitter for sending to Great Britain is really a double system consisting of two separate aerials, one of which sends the beam in a north-westerly direction from the aerial, while the other sends the beam in a south-easterly direction. This permits of signals being sent either north-westerly across Australia, the Indian Ocean and the Indian Ocean to the Indian Ocean, the Indian Ocean and the Indian Ocean, or else in a south-easterly direction down towards the South Pole, and then up on the opposite side of the earth to Great Britain. The reason for this is that signals can be sent through darkness more satisfactorily than they can be sent through daylight.

In the early morning, when the hemisphere of the earth lying immediately to the west of Australia is in darkness, the north-westerly route to Great Britain is used. As daylight spreads over this half of the earth, however, signal strength begins to fall away, and as the other half of the earth is becoming dark at the same rate as the first portion is being lighted up, the direction of transmission is changed by turning over a simple switch in the transmitting-room.

On the Canadian station it will not be necessary for the time being to provide for transmission in both directions to Canada, and signals will be sent in a north-easterly direction only.

### Aerial Feeder System.

The method by which the aerial wires are excited with the currents generated in the transmitting-room is unusual, and exceeding interesting. Instead of the usual aerial and earth lead-in wires usually employed in a transmitting or receiving station, the leads consist of two concentric copper conductors. The earth lead is in the form of a copper pipe about three inches in diameter, and the aerial lead is a copper rod inside this pipe suspended exactly in the centre of it, and insulated from it by porcelain discs. The leads are several hundreds yards long, and it has therefore been necessary to provide means of allowing the pipe and rod to expand without actually increasing the length of the leads. At the aerial, the lead pipe branches, and one branch goes to the base of each aerial wire. Here the copper outer tube ends in a large copper box, which is carefully "earthed." The inner aerial supply conductor is terminated in an inductance coil situated inside the box, and, of course, carefully insulated from it. The aerial wire is excited from this inductance coil.

### Receiving Equipment.

The aerial system used at the receiving station at Rockbank is identical with that employed at the Ballan transmitting station, and in addition to merely picking up the signals, the special beam aerial is able to pick them up much more strongly than they would ordinarily be received. Moreover, the marked directional properties of the beam aerial greatly reduces interference from static, and practically eliminates interference from other stations. It is clear that since the aerial will only respond to signals coming in one direction, static disturbances coming from any but this direction will not affect the receiver.

The receiving building at Rockbank is much smaller than the transmitting building at Ballan, mainly because the elaborate power-house necessary at Ballan is not required to work the receiving equipment.

Two electric generators driven by kerosene engines supply current to operate a series of charging units which keep a large bank of accumulators permanently charged. These accumulators supply the filament and plate current for the receiver, and also provide electric light for the station.

The two lead-in systems from the aerials terminate in a small room where two receivers, one for reception from Canada, and the other for reception from Great Britain are installed. Each receiver employs no fewer than 24 valves, several of which are specially constructed for short-wave work. The beam receiver is really a super-heterodyne receiver which does not vary in essential principle from the super-heterodyne

(Continued from Page 26.)

# SPITFIRE HEADSETS

These Headsets are noted for their extreme lightness. They are made of the best materials, and are fitted with adjustable headbands. The Spitfire Headset is recommended by the best authorities for its efficiency at all times for valve or crystal set.

The Best Headset Value in Australia  
15/-

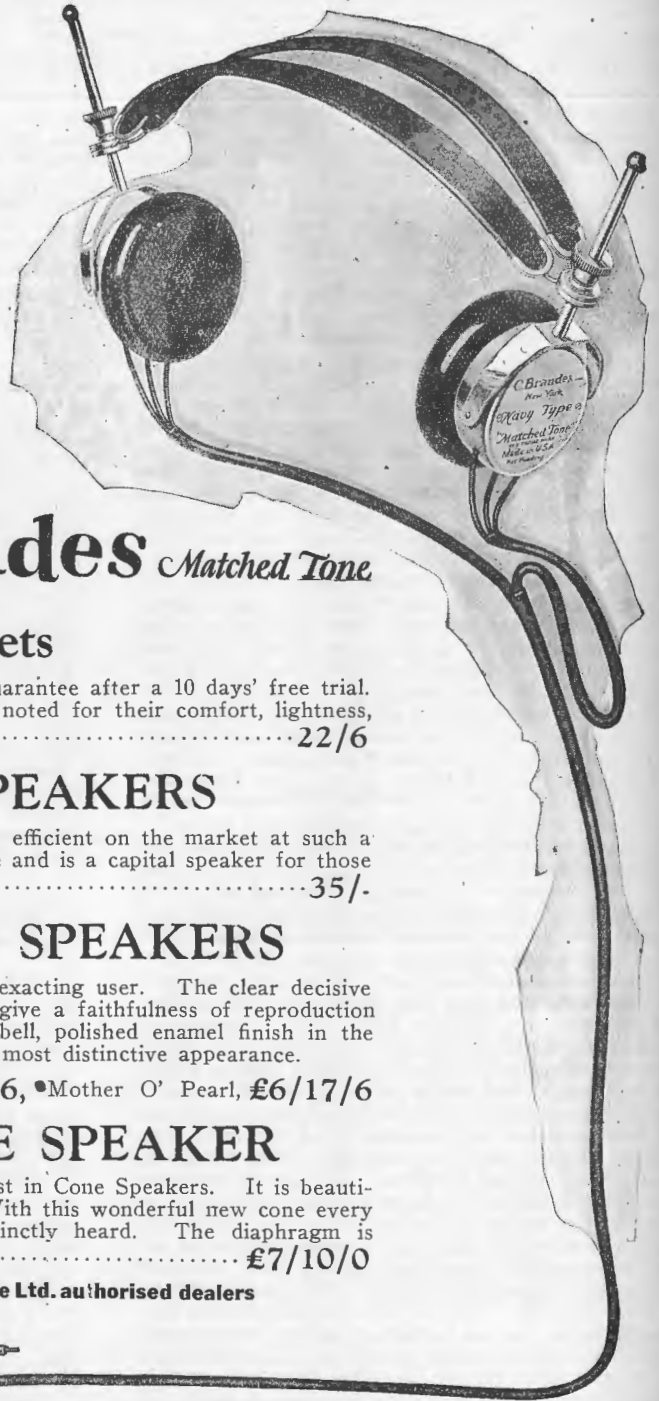

## Brandes *Matched Tone* Headsets

These Headphones carry a money-back guarantee after a 10 days' free trial. They have adjustable headbands and are noted for their comfort, lightness, and efficiency. ....22/6

## SPITFIRE SPEAKERS

Without a doubt this Speaker is the most efficient on the market at such a low price. It represents truly great value and is a capital speaker for those who do not desire a more expensive one. ....35/-

## BURNS LOUD SPEAKERS

They meet the requirements of the most exacting user. The clear decisive tones, together with remarkable capacity, give a faithfulness of reproduction that satisfies. With its handsome Pyralin bell, polished enamel finish in the following colours, the Burns represents a most distinctive appearance.

Black, £6/6/, Tortoiseshell, £6/17/6, •Mother O' Pearl, £6/17/6

## TE FAG CONE SPEAKER

The Te Fag represents the newest and best in Cone Speakers. It is beautifully finished in a dark walnut shade. With this wonderful new cone every instrument in the orchestra can be distinctly heard. The diaphragm is adjustable. Price .....£7/10/0

On Sale by all Home Radio Service Ltd. authorised dealers

Phone 6143

Telegrams—  
"Homrad"

QUEENSLAND'S WHOLESALE RADIO HOUSE

# Home Radio Service Limited

First Floor, Ewing House, Adelaide Street, [Next Bryce's] BRISBANE

# 4QG's Musical Radio Plays

## Two Productions for June

### "THE SHEIK OF SHEZADAH" AND "THE LOVE CHARM"

Early in May there appeared on the second half of 4QG's printed programme the brief announcement that a musical radio play entitled "The Sheik of Shezadah" would be broadcast.

No synopsis, no cast, not even the musical numbers appeared, and apart from the fact that the musical numbers were to be given by Mr. Erich John's party, there was nothing to induce the average listener to "sit out" the hour's organ recital until 9 p.m., at which time the play was to commence.

Those who listened in to "The Sheik of Shezadah" class it as the most entertaining piece of transmission that has yet radiated from 4QG's aerial. It was, true enough, a "surprise packet," and the fact that it had been written and produced by a Brisbane man (Mr. Michael Croger) made it all the more interesting.

"The Sheik of Shezadah" is a play that would do justice before the footlights. The lines are good, the humour clever, and the music under Mr. John's capable direction, most enjoyable.

So great was the public appreciation of "The Sheik of Shezadah" that 4QG has been requested to broadcast it again. This has now been arranged to take place on Wednesday, June 8th, commencing at 8 o'clock, and listeners should make a point of hearing it.

#### "THE SHEIK OF SHEZADAH."

##### A Tale of the Orient.

(By Michael Croger.)

(Specially written for radio transmission.)

Produced under the direction of the author, with musical numbers arranged by Erich John, and sung by Mr. John's Radio Vocalists.

"The Sheik of Shezadah" is a tale of three seamen who, finding themselves in an Oriental port, at a loose end, so to speak, look for adventure. Bill, who doesn't happen to be 'bosun, is a hardened salt of the old school who takes things as he finds them; Chips, the carpenter, who came from north of the Tweed, has not lost at sea his natural caution; and the third, "Snowy," is a modern product of the sea, a seaman but not a sailor, just out of his apprenticeship, who thinks the other word for adventure is a lady—white, yellow or black. Naturally, he falls in love. But as it happens, with a lady he hasn't seen. To feast his eyes, as well as his imagination, on the lady he leads a party to the harem of the Sheik, who is the happy possessor of this treasure. The Sheik resents this intrusion, and the adventurous party is threatened with a diabolical tragedy. How this is averted will be told to listeners-in on June 8th.

#### The First Act.

The first act takes place in the Cafe of a Thousand Breezes on the water-front of the port,

#### The Second Act.

In the home of the Sheik of Shezadah, perched high up on a mountain side, from where the beautiful voices of his many wives are wafted on the evening air.

#### A Few of the Musical Numbers.

- Two Friends (duet) ..... Black
- Hindu Song ..... Rimsky-Karssakow
- In the Shade of the Palm ..... Stuart
- Sea Dogs ..... Grey
- Allah ..... Erich John
- Egyptian Dance ..... Edward German
- In the Great Bazaar ..... Woodforde-Finden
- My Desert Flower ..... Norton

#### "THE LOVE CHARM."

The second play for the month will be on Monday, June 13th, and will be produced by the same company of artists. This play has been written by a Brisbane lady, Miss Thelma Champion, and the production will be under the direction of Mr. Michael Croger.

The setting of "The Love Charm" is Eastern, mostly in the old historic city of Shanghai.

Not having heard the play, we cannot disclose anything of the plot, but we are assured by those connected with it that it is quite as good as "The Sheik of Shezadah."

A glance at a few of the musical numbers show that that portion, under the direction of Mr. Erich John, will be most enjoyable.

- In the Temple (from "Songs of Japan")—  
Granville Bantock
- Butterfly Song (from "Songs of Japan")—  
Granville Bantock
- The Kiss ..... Beethoven
- Song of the Bells ..... Granville Bantock
- Friendship (duet) ..... Haydn
- Hence! Away With Care! ..... Meyerbeer
- Feast of the Lanterns ..... Bliss
- In the Palace (from "Songs of China")—  
Granville Bantock
- Song of the Bells (from "Songs of China")—  
Granville Bantock

#### More Radio Plays to Follow.

The company are working hard rehearsing future productions. Early in July Station 4QG will broadcast the first performance of "Careers," a comedy of manners, written by Michael Croger.

This production will be under the direction of the author, and the musical numbers are being arranged by Mr. Erich John to be sung by his Radio Vocalists,

**BEAM WIRELESS.**

(Continued from Page 25.)

receivers used for broadcast reception. There are, however, several important secondary features of the receiver which contribute materially to its effectiveness. In the first place, it is made so that, if the transmitting wave-length of the stations in Great Britain or Canada should vary, it will not be thrown out of tune. In effect, it responds over a narrow wave-length band, instead of merely responding to a single wave-length. This feature of the receiver necessitates the introduction of several other features of a technical nature.

Another interesting feature of the receiver is the fact that, while it is in operation, the aerial is kept constantly feebly excited by what amounts to an extremely weak local transmitter. The oscillations of this transmitter in the aerial system serve to lower its resistance to the incoming signals and greatly increased signal strength is obtained. The signals, after being picked up and greatly magnified by the receiver, are passed on to a land line which conveys them to the central radio office in Melbourne. Here they are automatically recorded.

**Central Radio Office.**

One of the most interesting features of the system is the fact that, although the receiver and transmitter are situated respectively about 20 and 50 miles from Melbourne, all the actual work of transmission and reception is performed in Melbourne. The latest form of the Wheatstone method of transmission is employed. A message for transmission to Great Britain is handed to a man seated at a machine resembling a typewriter. As quickly as the most expert stenographer types the message is typed out on this machine. Instead of recording it in the letters of the ordinary alphabet, however, the machine punches it in the form of a series of small perforations on a long paper tape about half an inch wide. There is a distinctive series of perforations, corresponding closely to ordinary morse characters, for each letter. When the tape, containing generally considerably more than one message, is punched out, it is placed in an automatic transmitter, through which it is fed at high speed. What really happens in the transmitter is that as the tape runs through it, a system of contact brushes presses on its surface. These brushes can make contact through the perforations and close an electric circuit. Thus the perforation groups on the tape are translated in the automatic transmitter into electric impulses resembling ordinary morse impulses.

These impulses are conveyed by the land line to Ballan where they directly operate the transmitter. The rate of transmission is much greater than the rate at which one man can work the perforating machine, and it is therefore necessary to keep several men employed punching tape for a single transmitter.

The receiving process is broadly the reverse of the transmitting process. The signals from the receiver at Rockbank enter the office on another series of land lines, and are passed into an amplifier. They then go through several technical processes, and are finally impressed on a machine consisting essentially of an ink fed stylus touching on a paper tape. The tape is run at high speed through the machine, and if no signal is being received, the stylus traces a straight line on it. The effect of a signal on the receiver is to swing the stylus to one side, and a kink

is drawn in the line. If the signal is a dot, the reflection of the stylus is only momentary, and it is recorded as a sharp peak rising from the stylus line. If the signal is a dash, the deflection is more prolonged and it is recorded as a flat topped bump in the straight stylus line. The speed of transmission is in practice so great that the stylus traces a wavy line which can readily be translated into ordinary letters by a morse operator.

In the radio office, sections of the tape are conveyed to touch typists, who are also morse experts, and they translate the messages directly on to radiogram forms in their typewriters, and the messages are then available for delivery.

**Living Quarters at Stations.**

All the latest resources of modern building practice have been employed to make the living quarters for the staff who will be engaged at the transmitting and receiving stations comfortable. The little villages which have been built under the shadow of the masts at Rockbank and Ballan have been equipped with all the latest conveniences which can be obtained in the capital cities, and the buildings themselves have been designed by the best architects who were available.

At Ballan there are six small houses for the married members of the station staffs, and their families, while a large and well equipped quarters, which will be conducted as a boarding house, will provide accommodation for the unmarried men.

The buildings are fitted with electric light throughout, and provision is made for the use of domestic electric appliances. A complete sewerage system has also been installed, and a permanent supply of fresh water is laid on and gives a pressure equal to the best water pressure in the metropolis.

The occupiers of the houses will even be spared the duty of attending to their own front gardens, because the houses open on a large square space which is the main entrance to the station, and this will be kept in order by a gardener employed by the Amalgamated Wireless (Australasia) Ltd.

Each house has a commodious enclosed back yard which will offer the fullest facilities for vegetable growing. A special bus service will be provided free of charge between the station and the town of Ballan.

An interesting feature of this service will be the running of two special trips each day—one to take the children of the station staff into the town to school in the morning, and the other to return them in the evening.

The buildings at the Ballan station include a large hall which will be available to all members of the staff for concerts, dances, or any other purpose necessitating the use of a large building.

Tennis courts will also be laid down shortly, and provision has been made for the installation in the men's quarters of a billiard table if it is found desirable.

In the single men's quarters, each man has a carpeted and comfortable furnished living room, which is far superior to the accommodation available in many hotels and boarding houses.

The living quarters at the station at Rockbank resemble those at Ballan, except that there are fewer cottages for married men. The reason for this is that a smaller staff is required to keep the receiver operating than is needed for the transmitter.

# Build the "QUALITY THREE" from CHANDLER Components

(As described in this issue of "Q.R.N.")

Judged by its results the "QUALITY THREE" will appeal to every radio enthusiast. For ease of operation, ample volume and, above all, exquisite tone, the "Quality Three" arouses the most confirmed radio lover to realisation that here is a set which will bring the utmost in radio entertainment into every home. CHANDLERS have listed below all the necessary components for building this remarkable set. With all the components at hand you will find it easy to follow the author's explicit instructions. You fellows who have tinkered with radio will do it in less time than it takes to tell.

## List of Components Required for Building the "QUALITY THREE"

1 Bakelite Panel 15 x 7½ x ½	9 6
1 Baseboard, 14½ x 7 x ½	1 6
1 .0005 Variable Condenser with Vernier	12 6
1 33 ohm Rheostat	3 9
1 15 ohm Rheostat	3 9
1 Battery Switch	2 9
1 2-Way Coil Holder	12 0
1 2in. Dial	1 6
1 .00025 Grid Condenser	2 6
1 2-meg. Grid Leak	2 6
1 1 mfd. Fixed Condenser	6 0
1 .001 Fixed Condenser	2 9
1 Mullard 100,000 Resistance	10 9
1 .5 meg Grid Leak	2 6
1 S.C. Jack	2 6
1 D.C. Jack	3 6
1 Ferranti 3-1 Transformer	1 12 6
3 Valve Sockets	13 6
1 Box Engraved Terminals	2 9
1 Terminal Strip, 8 x 1 x ½	4
1 Terminal Strip, 3½ x 1 x ½	4
12 Bus-Bar Wire	1 0
2 Spaghetti	1 0
Assorted Screws	1 6

# J. B. CHANDLER & CO.

"For Radio Service"

45 Adelaide Street, Brisbane

(Next to Allan & Stark's)

S.A.S.

The concerted engineering genius of 200 scientists of R.C.A., Westinghouse and General Electric Laboratories evolved and perfected this receiver

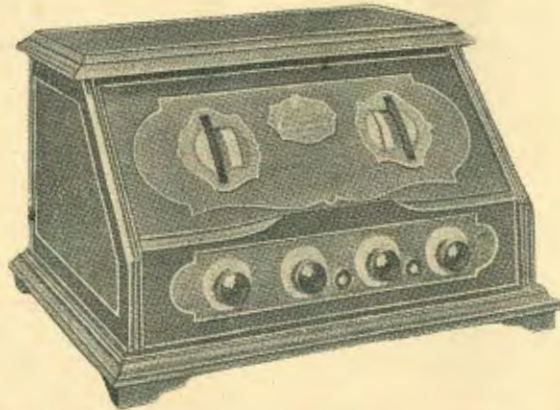

Send to  
Wireless House  
for  
Free R.C.A.  
Catalogue.

No other Five-  
Valve Receiver can  
compare to the  
R.C.A. Model 20.

## The R.C.A. (Model 20) Receiver

*The Finest Five-Valve Receiver Made*

Whether you are well versed in radio theory or whether you have no technical knowledge, immediately you operate and hear the R.C.A. you will hold a profound admiration for its tone and simplicity of control.

Its principles are new, revolutionary, but sound. It is entirely different to other receivers—simpler, more capable, more beautiful. It represents the fruit of the skill and knowledge of 200 of American leading scientists. A set that will always be modern—and never give you one moment's regret.

### Super-Het. Performance and Uni-Control

The R.C.C. Model 20 has uni-control mechanism. You can select your station with one finger, and never again suffer the tiring and exasperating experience of prolonged "tuning"—a triumph of the technical ability of R.C.A. engineers. You can mark the positions of all stations on the calibration strip, and thereafter turn the cylinder directly to the exact position for finding whatever station you want.

The R.C.A. Model 20 is a five-valve balanced tuned radio-frequency receiver with the additional feature of variable regeneration in the detector circuit.

A short indoor aerial or outdoor aerial can be used with this set. Tuning is simple and certain.

On a set recently installed by us in the country as many 20 stations were received one night, while Sydney, Melbourne and Brisbane afternoon sessions were received regularly.

It is but natural to assume that such a huge organisation with such resources at its disposal can produce a perfect receiver. Let us demonstrate, or write for further particulars.

Complete with B.T.H.  
Speaker and all  
Equipment

**£50-0-0**

A Handsome and Inter-  
esting Book of Instructions  
supplied with each receiver.

## WIRELESS HOUSE LIMITED

Queensland's Pioneer Radio Supply House  
CITY BUILDINGS, EDWARD STREET, BRISBANE

Where Quality Counts—

USE A

## B.T.H. (Model C2) Speaker

B.T.H. Speakers have long been admitted to be among the very forefront for Quality of Tone, but never before have they represented such amazing value.

The wonderful B.T.H. full floating diaphragm protected by a fine gauze grill within the bell; the handsomely moulded bakelite base; the nickel-plated throat are but a few of the refinements that make the B.T.H. to-day's best Speaker buy.

The price is now within reach of all, and Wireless House recommend this Speaker to all who appreciate the value of a good Speaker in radio reception.

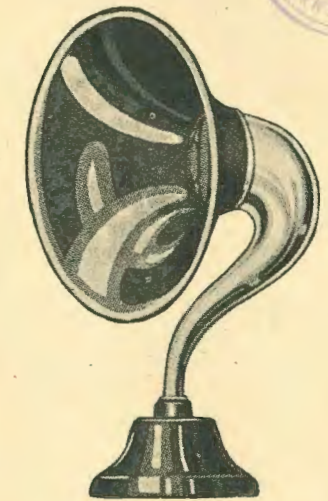

£4/15/-

Build

### The Quality Three

*Described in this issue of "The Queensland Radio News"*

with Wireless House Parts

1 Bakelite Panel, 15in. x 7½in. x ¾in.	13	4
1 Baseboard, 14½in. x 7in. x ¾in.	3	0
1 .0003 Var. Condenser (with vernier)	1	0
2 H. & H. Rheostats (30 and 15 ohm)	10	6
1 Yaxley Battery Switch	4	6
1 Ebro 2-Coil Holder	8	6
1 Wooden Block 2½in. x 2in. x ¾in.	6	
1 2in. Dial	1	6
1 .00025 mf. Grid Condenser	2	3
1 2-meg. Electrad Grid Leak	2	3
1 Tobe .1 mf. Fixed Condenser	4	6
1 Sangamo .001 mf. Fixed Condenser	2	9
1 Mullard Wire-wound 100,000 ohm Resistance	10	6
1 6-meg. Igranite Leak	3	0
1 Ferranti H.F. Transformer (3½-1)	1	12 6
1 B.M.S. S.C. Jack	2	9
1 B.M.S. D.C. Jack	3	0
3 H. & H. Bakelite Sockets	12	0
1 Box Engraved Terminals	3	3
1 Terminal Strip, 8 x 1 x ½	9	
1 Terminal Strip, 3½ x 1 x ½	4	
4 Supports	1	0
1 Dozen Lengths Bus-Bar Wire	2	0
2 Lengths Spaghetti	1	0
1 Box Assorted Screws	3	6

## SPECIAL LINES

for JUNE

"SOLODYNE" MATERIAL.

3-Gang Condensers	4	4	0
Copper Shield and Base	1	0	0
Aerial Coil	12	6	
Split Primary	18	6	
<i>(These parts are of British manufacture and of highest grade, essential for the perfect operation of the Solodyne.)</i>			
No. 2 Crystal Set (Brownie Coy.)	1	2	6
Browning-Drake Kit Complete	10	10	0

SPECIAL LINES.

General Radio "B" Eliminators	17	10	0
General Radio Transformers	3	0	0
General Radio Chokes (double)	3	0	0
Tobe Block (8 microfarad)	3	2	6
Tobe Buffer Condensers (double)	9	0	
Ratheon Tube	1	5	0

SPECIAL BARGAINS.

Seven only, 2-Valve Sets (bare)	2	15	0
One only, 3-Valve Set (bare)	3	0	0
Power-Plus Phones 4000 ohm	12	9	
Sferavox Speaker	4	4	0

## WIRELESS HOUSE LIMITED

Queensland's Pioneer Radio Supply House  
CITY BUILDINGS, EDWARD STREET, BRISBANE

# New brilliant Radio reproduction combined with beauty of line and colour

THIS new Philips Loudspeaker has met with unprecedented success throughout Australasia. Compare it with the most costly instruments for volume, sensitivity, electrical and mechanical craftsmanship, and you will be astonished, amazed at its performance. In addition Philips designers gave this loudspeaker a beauty of appearance quite new in radio. The instrument comes to you tested, sealed and guaranteed by the world-famous Philips organisation.



**£6/10**  
at all dealers

*A co-product of Philips Lamps, Valves,  
"B" Eliminators and Battery Chargers.*

**PHILIPS** NATURAL  
TONE  
**LOUDSPEAKER**



# Wireless Anticipations in Great Britain

(by N. J. Rohan.)

The broadcast public as at present constituted may be divided into two groups. The first consists of those listeners who are limited to the reception of one fixed programme from the local station. The second embraces those who are sufficiently fortunate, either in their geographical location or their wireless equipment, to be able to make a reasonable selection from amongst the many stations now in constant operation.

This is merely another way of pointing out the difference between the performance of crystal or single-valve sets on the one hand, and various more or less expensive multi-valve circuits on the other hand, provided one admits the limitations of the latter type of receiver when situated within three or four miles radius of a broadcasting station.

It is extremely doubtful whether the same distinction will hold good in the near future.

So far as crystal reception is concerned, it is unlikely that any alteration of wave-length or redistribution of the broadcasting stations will do more than provide one reliable programme per night, though this, at least, will be ensured, no matter where the crystal user may be situated.

If, however, as is seriously proposed, the present system of relay stations is replaced by a series of from six to ten super-power stations, each rated up to 100 kilowatts, and suitably separated in wave-length, then a selection of at least two or three alternative programmes will become feasible, even with the simplest type of valve set.

## Wired-Wireless.

The same problem of selectivity is likely to be solved in large cities and other urban districts by making use of wired-wireless as a means of distribution. This method of "broadcasting" is already in operation both on the Continent and in America.

It simply consists in feeding high-frequency signalling energy into a wired circuit, instead of radiating it outwards in all directions through the ether.

Wired-wireless signalling has certain definite advantages over ordinary radiation. It has, of course, one serious limitation, namely, that there must be a suitable network of wires to carry the signals. Such a network, however, already exists in all large towns, either in the form of telephone lines or the electric house supply mains.

Curiously enough, the high-frequency currents necessary to convey music or speech do not interfere in any way with the normal use either of the telephone line or of a power circuit. Moreover, at least, four, and if necessary six, different programmes can be impressed upon the same carrier-current by using suitable sub-frequencies. Each item can then be clearly separated, without any trace of overlap, by employing a simple type of filter-unit at the receiving end.

In addition to providing an adequate programme variety, the use of wired-wireless effects a considerable saving in power. Owing to the fact that the signal currents are confined to a wire circuit, the energy applied to the detector is much greater than can be picked up by any aerial.

In other words, an ordinary crystal detector, fitted with three or four filter-units—the whole forming a comparatively cheap outfit—will distinguish between the same number of alternative programmes, and will supply ample signal-strength to half-a-dozen pairs of headphones.

Alternatively, an inexpensive single-valve detector-amplifier will easily provide the same loudspeaker strength as a three-valve set fed under present conditions from an outside aerial at from 10 to 20 miles range.

As regards the supply of alternative programmes for wired-wireless distribution this need not involve serious expense. A branch circuit or trunk line from each of the main radio stations could be arranged to feed the separate items into a central modulating unit supplying the wired network.

In this way each crystal-user in the larger towns will enjoy the same service and variety as can at present be secured from the most up-to-date super-heterodyne or other multi-valve circuit working on an ordinary aerial. At the same time the programmes would be free from any trace of overlap or "atmospherics."

## Simplifying the Valve Set.

Although the development of wired-wireless promises to solve the particular problem of the town-dwellers, there still remains a widespread rural population who can only be served by radiation through the ether.

Here the demand for wide selectivity must be met by the use of multi-valve circuits. The tendency in this direction is towards simplification of control on the one hand, and the reduction of accessories on the other.

The ideal multi-stage high-frequency receiver is one operated from a single control and capable of being handled by an unskilled operator.

The task of designing such a set presents a number of formidable difficulties, some of which may not appear obvious at first sight. They are, however, being slowly but surely overcome, and the result will, in due course, be seen upon the market.

The next point to be aimed at is the abolition of the accumulator and high-tension batteries. A partial solution of this difficulty has already been found in the shape of high and low tension rectifier or reducing units for tapping the necessary current supplies from the domestic house mains.

(Continued on Page 40.)

# How Listeners can help to Improve Broadcasting

Broadcasting has become such an intimate affair, interesting so many people, that we are all concerned in its development. If we can help to improve the service to listeners we should consider how best we can do so.

## By Helpful Criticisms and Suggestions.

Critical comments are to be expected in a public utility like this; but if the criticism is to be of any use, it should be constructive. There are many ways in which listeners may help. It should not be left to the broadcasters to do it all.

The listener is entitled to have a say in calling the tune he is paying for, and the only way in which he can do that is by remembering that the broadcasting stations frequently say "Help us to help you." They wisely endeavour to ascertain the desires of the listeners when preparing programmes. If the listeners do not indicate their desires or opinions, they cannot well blame the unfortunate programme directors if the programmes are not suitable.

## By Not Making Extravagant Claims for Broadcasting.

One of the best ways of damaging the future of broadcasting is to tell our neighbours and friends extravagant stories of the beauties and wonders of wireless. Some of us know the type of over-enthusiastic listener who boasts of the clarity of reception of a complete undistorted programme from New Zealand or some other distant place. How he ardently advises others to take up broadcasting! He mentions none of its shortcomings and limitations. Rather, he creates the impression in the mind of the prospective listener that any programme of any station in any State can be tuned in at any time anywhere.

If the prospective listener be from the country he will find that his friend has overstated the capabilities of wireless, and if he be a city dweller he will find that there is such a thing as interference.

The attractiveness and usefulness of broadcasting, even with its limitations, are sufficient to induce any reasonable person to invest a few pounds in purchasing a set. The services are satisfying enough without making foolish claims regarding unattainable features.

## By Not Overstating the Capabilities of Receivers.

Akin to this overpraising of the broadcasting services is the other evil of extravagant claims of the capabilities of our favourite type of set or circuit. People have been induced to buy, or worse still, to construct, a five-valve receiver "that will bring in all Australian stations with loud speaker strength." They have been given the impression that the construction of such a set, or the installation and operation of a shop type is an easy matter. And they find later on—very soon in fact, if it is in summer—that the noises they get in their speakers do not encourage a healthy enthusiasm for radio generally, and some distrust of their friend's knowledge of the art. Indeed one of the results frequently is the development of an opinion to the effect that such and such a station has distorted transmission.

The use of two and three valve receivers incorporating reaction construction, installation and operation,

demands a fairly good knowledge of the principles involved. Otherwise the results will not only be unsatisfying to the owner of the set, but also he will find that he is making a decided nuisance of himself to his neighbouring listeners. He also runs the risk of prosecution in the police court by the authorities for causing interfering signals, to be sent out from his "howling" receiver to the annoyance of neighbouring listeners.

Advice regarding the type of set to be used for a given locality should be given sparingly. With the best of intentions the adviser (not being in possession of all the facts concerning the listener's location and desires) may find later that he has innocently helped to produce a dissatisfied listener. The advice should be given by a qualified person and only after very carefully discussing the matter with the enquirer.

## THE "GIBSON" WAVETRAP.

We recently had the pleasure of testing out a "Gibson" wavetrap, supplied by Mr. L. Gibson, of Greenslopes, Brisbane.

Upon test we found this wavetrap to do all that was claimed of it, and at a distance of about three miles from 4QG we had no difficulty in bringing in all southern stations, without any appreciable loss in volume.

**HELPFUL TO A RADIO SET**

**Exide**  
**BATTERIES**



For a silent, clear  
reception, instal an  
**Exide**  
Wireless Battery

**EXIDE BATTERY SERVICE**  
(Q) LTD.  
PETRIE BIGHT, BRISBANE

**S.A.S.**

When the shadows lengthen, your wireless set becomes interesting in the home. It is entralling, but unless efficient batteries are used to give uniform current, it would be displeasing. To save disappointment be sure of efficiency by seeing that your set is fitted with EXIDE BATTERIES.

# Notes from 3L.O.

(By Our Special Correspondent.)

## THE BELLS OF ST. PAUL'S.

The transmission by 3LO Melbourne of the bells of St. Paul's Cathedral is an outstanding feature in the Sunday programmes. It does more, perhaps, than anything else to broadcast throughout the length and breadth of the land the spirit of the Sabbath.

There is something soul-stirring and inspiring in the reverberating tones of big bells—a peculiar melody in their resonant notes that proclaims the fullness of peace and goodwill.

## MOVING DAY.

By the time this sees the light, 3LO will have moved to its new palace. A friend was reminding me the other day of the rapid metamorphosis through which this big Victorian station has passed. It seems a far cry from the rooms in Collins Street whose walls were covered in green rep, and whose windows were almost hermetically sealed, to the splendid building with every modern device for making transmission perfect, and with rest and practice rooms for artists.

Yet, as time goes, it is a very little while ago. It is invention and progress that have whizzed so quickly as to emphasise the size of the gap between the "now" and the "then". Not only the best station quarters in Australia, but among the best in the world will the new home of 3LO take rank.

## A NEW TITLE REQUIRED.

What is one to call an official fulfilling the functions of a describer of passing events for broadcasting? "Describer" is ugly and "Announcer" is misleading because an announcer usually only announces things prepared for him. It is difficult to hit precisely the word that will euphoniously fit the function. The British use "Commentator" and call the talk "a commentary." That is better, but still hardly fills the bill. "The Herald" recently called for suggestions in this regard and got some hundreds of replies, none really meeting the situation. It is a function that really needs a suitable word to describe it, and the "not quite" would be used, not only here, but abroad, for it is coming to be more and more of a necessity to have public events described through the microphone. Newspapers might ask their readers to rack their brains. Stations might put the problem to listeners. In a multitude of counsellors there should be enough wisdom to evolve a suitable term.

## AN ECHO FROM THE FLEET

When the United States fleet visited Australia two years ago, radio enthusiasts among the personnel made a point to visit 3LO Melbourne to study Australian methods, and many of them have since kept in touch with the studio. One such correspondent writes from Alaska to say that 3LO Melbourne is received at the U.S. Naval Radio Compass Station, Cape Hinchinbrook, with clock work regularity together with

clarity, and is a source of excellent entertainment to the personnel attached to this isolated section of Alaska. He states that there is a little interference from a Japanese station, but taking it on the average the reception from Australia is as accurate and regular as that from American Stations.

## 3LO'S LAUGHING COMPETITION.

Victorian listeners may be detected in solitary places smiling, giggling and laughing from "sniggers" to "Guffaws" these days. The reason for the wholesale merriment may lie in the fact that 3LO Melbourne has instituted a competition to find the heartiest laughter in Australia. Anybody who has pretensions to laughing capabilities may enter, and the most sustained, natural and infectious effort will earn a handsome prize. The date for this novelty has not been fixed, but already entries have been received. Prominent competitors include Miss Kookaburra and Cyril Northcote and "Dismal" Desmond of the Futurists.

## THE PERFECT RADIO VOICE.

Many artists who are successful in the theatrical or concert stage are disappointed to find themselves hardly so effective in broadcasting, and excuse the fact by stating that they have not got that mysterious quality a "radio voice". Apparently a "radio voice" need not be technically perfect, nor yet of exception volume or quality. It must have just some strange vibratory effect which makes it record well. At least that is how the unsuccessful explain it. Whether they are right or not, it seems apparent that 3LO Melbourne have discovered the perfect "radio voice". Miss Lee White, who, together with her clever partner Mr. Clay Smith has an appealing voice which has established her fame and popularity in the world's best theatres. Her songs lose none of their appeal over the radio, and her's is a voice which loses nothing in transmission. Listeners regard the engagement as one of the best since the inception of radio.

## RIVAL TRAVELLERS.

Until the advent of Lew James to the programmes of 3LO Melbourne, the "Futurists," a clever company of comedy entertainers, felt safe in regarding themselves as the most travelled artists in the studio—or in Australia for that matter. Lew James, however, can dispute their claim with some basis of fact. This clever delineator of Jewish comedy types has penetrated into just as many far distant corners of the earth as the "Futurists." Chile, Peru, Burma, North West China, Khyber Pass, Zanzibar, Alaska, Broome, Borneo, Afghanistan, and many other remote lands have laughed at his character comedy work, so the air has no terrors for him. Lew James was the original "Abe Potash" in the Australian productions of the famous "Potash and Perlmutter" comedies.



**BOWLS.**

Mr. E. M. Pascoe describe a game of bowls for the benefit of listeners to Station 3LO.



The Car which toured Brisbane and Suburbs in connection with 4QG's Radio Motor Hunt.

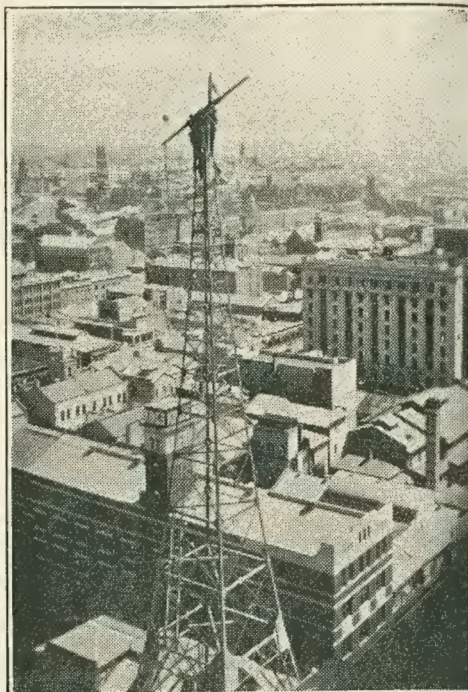

Intrepid Engineers Inspecting 4QG's Aerial.



"The Sandman" on Holiday helps "Farmer Gray" Milk the Cows.

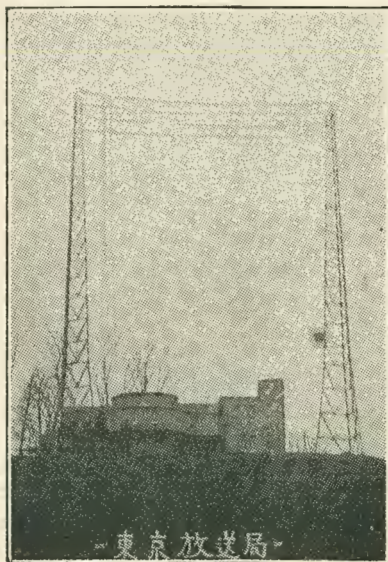

**A JAPANESE STATION.**

The Aerial at Station JOAK—a Japanese Station which many Queensland Listeners can tune in regularly.

A Page of Pictures  
 from the Pages of  
**'The Broadcast Bulletin'**  
 Queensland's New Radio Weekly

2d. Weekly. **9/6** Per Annum  
 Address—Box 1095N, G.P.O., Brisbane



Mr. K. E. SCHULZ,

A Director and a Founder of the Electricity Meter Mfg. Coy., Ltd. of Sydney, who Manufacture the well-known "Emmco" Lines.

## Send Along Your Sub.

For months you've been going to send along your sub. to "The Queensland Radio News," but somehow you've just "put it off!"

Six shillings and sixpence is not a big sum for the wealth of information these pages contain in the course of twelve months.

**DO IT NOW!** Slip your postal note or cheque into an envelope address to Box 1095N, G.P.O., Brisbane.

## ARTISTS HEARD FROM 2FC



CHARLES STEPHENS,  
Tenor, 2FC.



ERNEST ARCHER,  
Tenor, 2FC.

# Short Wave Broadcast Tests

From WGY (Gen. Electric Co., U.S.A.).

### (1)—Transmission Schedule.

Two 24-hour schedules will be maintained.

The first will begin Saturday, May 28th, at 12 o'clock noon, Eastern Standard Time, and continue till 12 o'clock noon, Sunday, May 29th. Wave-lengths of 26.8 and 32.77 metres will be used simultaneously, both being modulated from the same source with voice or music.

The second will begin Saturday, June 4th at 12 o'clock noon, Eastern Standard Time, and continue till 12 o'clock noon, Sunday June 5th. Wave-lengths of 22.02 and 32.7 metres will be used simultaneously, both being modulated from the same source with voice or music.

### (2)—Observing and Recording of Signal

#### Characteristics.

Since comparatively few observers have been asked to observe the tests, it is highly important that those selected make every effort to secure a complete 24-hour record. Records which cover only a portion of a 24-hour period are useful, but, in general, the data they contain are too meagre to permit the drawing of accurate conclusions.

In this connection, we wish to point out that at certain periods of the day the signals will likely be inaudible; therefore, reports stating that a station was listened for but not heard may be just as valuable as those which give the characteristics of a received signal.

To facilitate the recording data, we are enclosing a quantity of our reception log sheets, and the necessary instructions for using them.

Inasmuch as one of the primary objectives of the test is to determine the utility of given wave-lengths for international broadcasting, it is essential that a record be kept of the times, if any, when in the observer's opinion the signals are suitable for re-broadcast purposes. If the signals are actually re-broadcast by a local station, a brief account of the result will be of considerable value.

### (3)—Anticipated Results.

From the quantity of reception data which will undoubtedly be forthcoming from this test, we expect to materially augment our present knowledge relative to—

- (1) The comparative merits of 22.02, 26.8 and 32.77 metres for the rendering of international broadcast service;
- (2) The period, or periods, of the day that are most favourable to foreign reception of these waves;
- (3) The co-ordination of time and wave-length so as to give maximum service to foreign listeners;
- (4) The probable utility of these waves for the handling of international commercial telegraphic traffic.

*Sensational Reception accorded Queensland's New Radio Weekly!*

The  
"BROADCAST  
BULLETIN"

All the Programmes ——— All the News

The sensational reception accorded the New "Broadcast Bulletin"—a 32-page Weekly Radio Paper with a page size equal to this journal—was nothing short of phenomenal.

Radio enthusiasts in all parts of Queensland write to tell us what wonderful value it represents, how useful they find the programmes, and how interesting they find the breezy parts about 4QG.

Posted Thursday evening to catch Western and Northern mails, so as to give country readers the full programmes for the following week.

**Full Weekly Programmes from 4QG, 2BL, 2FC, 3LO**

And pages of interesting matters about the broadcasting stations. The cheapest Radio Paper in Australia—and one of the best.



PRICE **2<sup>D.</sup>** COPY

For Sale at all Radio  
Dealers and Stationers

Subscription Price 9/6 per annum.

**Subscription Form**

The READ PRESS LTD.  
Adelaide Street, Brisbane.

Dear Sirs,—

Enclosed please find Postal Note for  
Cheque

12 months' subscription to "The Broadcast  
Bulletin."

Name .....

Address .....



# Questions Answered

"D.C.G." Cairns.—It would be necessary to use the valve as a radio frequency amplifier; this simply means that the valve is placed in front of the crystal detector in order to boost the signals before they are rectified. A suitable circuit has been posted to your address.

"Leo A."—The lead from H to earth tends to stabilise the low-frequency amplifier. This connection is nearly always used in valve receivers. We are pleased to know that our balanced crystal receiver is giving you such splendid results.

"J.V.B."—There is no reason why a fixed carborundum detector should not work well in the receiver you mention; in fact, we recollect having seen such a circuit in an American technical magazine. Another way of overcoming the difficulty would be to use one of the small low-consumption valves as a detector, using dry cells to heat the filament.

"P.A.G."—The parts needed for making a good cage aerial may be purchased from a reliable radio store. They generally comprise: 2 cooper hooks, 3ft. diameter, and five copper tube spacers 1ft. 3in. long. Holes are drilled through the hoops at

equal distances to enable the hoops to be screwed to the distance pieces. Bare copper wire is then wound over the frame, and the whole mounted on insulators on crosspieces at the head of the mast. At some date in the near future we will publish an article on vertex aerial construction.

"Reader," Nundah.—The circuit you request has been posted to your address.

## THE SOUL OF THE EMPIRE.

What thrilled the world on Empire Day,  
When hearts pulsated and love held sway?  
What brought men closer in brotherly tie,  
In every land and 'neath every sky?  
'Twas the soul of the Empire looking to God,  
Who marketh the way that she hath trod.

—Will H. Lister.

## ARE WE TO HAVE A RADIO EXHIBITION THIS YEAR?

If we are to have a Radio and Electrical Exhibition this year, it is time some one began to move in the matter.

Show Week is just a little more than two months away, and to our knowledge, no start has yet been made to organise.

The intense public interest shown in the last Radio Exhibition should encourage those responsible to launch a similar project this year.

# NEW WIRELESS SENSATION

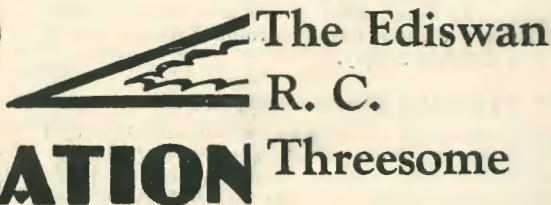

THIS WONDERFUL EDISWAN PRODUCTION sets a new standard in wireless receivers. Remarkably pure in tone, with volume in abundance, yet so simple that anyone with a screwdriver can assemble this set and enjoy reception in the one evening. And the cost of the parts is only £3/15/-. Truly a sensation in wireless reception.

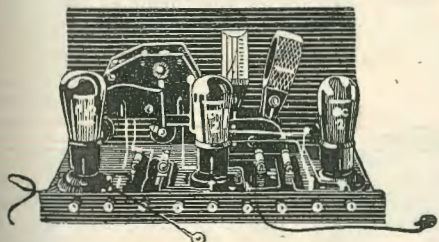

### Instruction Book & Blue Print FREE!

Fill in the coupon below and post to us. We will send you, free of all obligation, a blue print of the wiring diagram and a book of simple instructions. Tells all about the set and why it is so good. Send now! There's no time to waste!

THE EDISON SWAN ELECTRIC CO., LTD.

Please send me "R.C. Threesome" Free Instruction Book and Blue Print.

Name .....

Address .....

Q.R.N. 1/6/27.

THE EDISWAN ELECTRIC CO. LTD.,  
156 Creek St., Brisbane.  
And at Melbourne, Sydney, Adelaide.

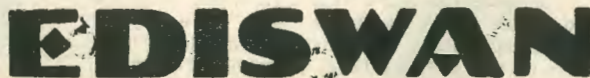

**WIRELESS ANTICIPATION IN GREAT BRITAIN.**

(Continued from Page 33.)

These afford a convenient and popular substitute for separate wet and dry cells, where electric supply mains are available, though there is still room for considerable improvement in the future, both as regards initial cost and freedom from noise.

Another interesting expedient is the new type of valve now being marketed by the Marconi Company, in which the full voltage of the mains is used to heat a special filament without either rectification or reduction. The heat from the current-carrying filament is conveyed by radiation to an independent and highly sensitive secondary cathode, which thereupon liberates electrons in sufficient quantity to enable the amplifier to function in the ordinary way.

So much for the low tension battery. A promising prospect of eliminating the necessity for using a separate source of high-tension lies in the potentialities of the four-electrode type of valve.

It has been known for some time that a few positive volts impressed upon a second or space-charge grid will give electrically the same over-all amplification as ten times that voltage applied to the plate of a standard three-electrode valve.

The limits of this principle have not yet been reached, and it may be that the standard set of the future will operate quite satisfactorily without using any higher voltage than that necessary for heating the filament.

As the price of valves becomes less—and this will continue to be the tendency for some time to come—the incentive for reducing the number in circuit to the lowest possible figure will largely disappear. Designers will then prefer to add an extra valve of two to the set, if by doing so they can eliminate the high tension battery without unduly straining the resources of the low-tension supply.

**Two-Way Sets for General Use.**

Another aspect of wireless communication that still remains to be exploited is the small-powered combined receiver and transmitter outfit, suitable for holding private conversation over comparatively short distances. The advantages of such an equipment are obvious, particularly for use in country districts or between the individuals of a scattered community.

It would, of course, be necessary to arrange some system of fixed wave-length working between selected individuals (the wave-length to be varied with the individual), and also to guard against undue mutual interference, but there is no inseparable difficulty in this particular if ultra-short wave-lengths are used.

On the other hand, the provision of some such elastic means of communication would meet a very real need in certain districts, and it is a service for which a small-powered, inexpensive "duplex" set is admirably fitted.

**Television.**

It is somewhat difficult to estimate what part will be played in the future by "radio vision" as a popular adjunct to broadcasting. Whilst it is no doubt possible, even at the present time, to transmit moving-picture effects by wireless, the cost involved in re-

producing a scene in sufficient detail to be pleasant or even easily recognised by the eye, places such apparatus quite outside the reach of the average purse.

Until a clear-cut picture can be reproduced on scale and at a cost commensurate with that given, say, by a kodascope or home kinematograph, it is hardly to be expected that "home" television will come into popular use amongst the general broadcast public.

A more promising prospect seems to lie in the development of television as an accessory to the standard programme of the moving-picture theatre. Here the cost of installing the necessary receiving apparatus for reproducing, say, an international football match simultaneously with the actual event, would not be prohibitive in view of the added attraction such an item would offer to large audiences.

It is, in fact, somewhere along these lines that the first practical application of radio-vision is likely to be seen, rather than in the manufacture of receiving sets for private individuals.—"The Broadcaster."

## Erich John's Fifth Pianoforte Recital

To be Broadcast June 20th.

Music lovers who have been following the series of pianoforte recital given from 4QG by Mr. Erich John will be interested to note the works listed hereunder, which are to be played by Mr. John on the evening of Monday, June 20th.

1.—(a) "Waltz" Opus 29, No. 5; (b) "Intermezzo" Opus 76 No. 4; (c) "Ballade," Opus 10 No. 1,

2.—(a) "Funeral March on the Death of a Hero"; (b) "Rondo" (finale), from "Sonata," Opus 26 (Beethoven).

3.—(a) "Consolation" (Liszt); (b) "Liebestraum" (Liszt).

At this recital, as at other recitals broadcast by this artist, Mr. Geo. Williamson (known to 4QG listeners as a vocalist), will read annotatory notes in reference to the composer and composition before each piece is played. This system is a good one. It enables the listeners to follow the theme of the item to be performed much easier than if he is ignorant of the thought that lies behind the composition.



### Miss Elsie Boyes

aged 14 years, of Torwood Brisbane, who was awarded second prize in "Little Miss Brisbane's" recent story competition.



# Club Activities



## RADIO CLUBS OF QUEENSLAND.

- CHENFLOWER AND DISTRICT**.—Secretary, L. Cribb, "Frampton," Ridley Street, Auchincloffe.
- AIRNS AND DISTRICT**.—Secretary, Mr. Tarbit, c/o Mr. Les. Fitzsimmons, Cairns.
- EASTERN SUBURBS**.—Secretary, A. E. Newnham, Logan Road, Fiveways, Woolloongabba, Brisbane.
- BEVILLE**.—Secretary, H. Carter, Cr. Molonga Terrace and Wylie Streets, Graceville.
- SWITCH**.—Secretary, S. J. Aspinall, Brisbane Street, Ipswich.
- SOUTH BRISBANE**.—Secretary, W. R. Gilbert, Gordon Street, Coorparoo.
- TOOMBUL**.—Secretary, T. Starkie, Sandgate Road, Nundah.
- WINDSVILLE**.—Secretary, E. J. Jefferies, Fletcher Street, West End, Townsville.
- WIRELESS INSTITUTE (Queensland Division)**.—Secretary, JACKSON, A.M.I.E. (Aust.), "Clock House," Elizabeth St. Brisbane.
- WOOLWIN**.—Secretary, H. A. Jiear, Lisson Grove, Woolwin.
- WYNNUM AND MANLY**.—Secretary, P. J. Golden, c/o Trackson Bros., Ltd., Elizabeth Street, Brisbane.

## Wireless Institute [Q'land Division]

The activities of the institute have now been launched for the year, and members are looking forward to a very successful period ahead.

The recent sitting of the Royal Commission on wireless attracted much of the committee's attention at its last meeting, when discussion regarding the institute's evidence took place. Mr. W. I. Monkhouse was delegated the institute's representative at the Commission's sitting in Brisbane.

Mr. Monkhouse, in his evidence on behalf of the Queensland division, stated that "The Queensland Division of the Wireless Institute of Australia was formed in 1919 and has, since that date, been responsible for most of the amateur activities in the State. From its Morse classes have graduated a large proportion of the present holders of amateur transmitting licenses. The membership during the last session reached a total of 60, and included most of the wireless experimenters in the State. Various other organisations have appeared, but apparently most of them are now not in existence."

Prior to the station, 4QG, being established in 1925, the members of the division designed, built, and operated the first broadcast station in the State, and the Brisbane members, working in conjunction with the wireless traders, were also responsible for the first wireless exhibition held in Queensland. This was organised by the then Mayor of Brisbane in August, 1924, and did a lot to further the interest of the public in wireless matters. Various tests have been carried out by the members, amongst which may be mentioned one on apparent blind spots between Brisbane and Goowoomba, the broadcast at the National Show, and the investigation of interference from power circuits in Brisbane."

From the above portion of Mr. Monkhouse's evidence it will be seen that the institute has certainly

been a great factor in the development of radio in Queensland, and also in the production of efficiency among the experimenters of Brisbane and the outlying towns.

Regarding the points to which Mr. Monkhouse, the institute president, drew attention to at the Royal Commission's sitting, that are important in assisting and safeguarding the interests of the amateur wireless experimenter throughout the State, the following are outstanding:—

(1) "That a definite wave-length be allocated for amateur work, and the following are suggested by the institute. Below 10, 15 to 16½, 30 to 33, 60 to 66, and 100 to 200 metres."

It was pointed out that with no definite wave-length to work on, now that the Navy is reserving certain of the shorter wave-bands for their own exclusive use, amateurs are left in a very undesirable position in regard to possible interference. If the allotted wave-bands are made progressive, as suggested, it will enable the various bands to be worked without the need of making expensive changes to the gear in use.

(2) "That conditions under which the amateur transmitting license is granted be amended to allow that more personal data be transmitted, provided that it only applies to the persons exchanging messages."

(3) "That provision be made whereby amateur stations can be used in times of stress for the transmission of public messages." Regarding this point the institute's delegate pointed out that an example of the need of this occurred in this State early in the present year, in which use was made of two amateur stations to obtain information from isolated towns that had been cut off by floods.

(4) "That provision be made whereby isolated out-back stations be allowed to make use of the amateur station to send messages of everyday value, and that a license fee for same be made of sufficient value to cover the probable loss of revenue."

(5) "That provision be made so that a power of more than 10 watts can be used continuously without the necessity for the periodical application for the right to use the higher power."

(6) "That all the parties using wireless be placed under the one controlling authority."

(7) "That permission should be given to amateurs to work on broadcast bands while such stations are not working."

(8) "That if the Board of Research is brought into existence the amateur experimenters be represented thereon, and that they should have the right to receive financial assistance when participating in tests."

(9) "That greater use could be made of the activities of the wireless amateurs, and suggesting that they could be enrolled into sectional groups along the lines of the American plan. Relay organisation would, in this way, be built up so that messages could readily be transmitted any distance. The value of this in times of national stress could not be estimated."

\* \* \* \*

## Toombul Radio Club

Since the last report the Technical Committee drew up a roster of lectures to be delivered periodically by members. The first lecture was given by Mr. W. E. Vining, of 4WE, the subject being "Frame Aerials." The speaker, after dealing with the theoretical section of the subject, demonstrated the constructional side

of various forms of frame aerials, and finally described the methods used in discovering the whereabouts of the hidden transmitter in a field-day "stunt," held a few months ago.

A fortnight later, 11th May, the second lecture was delivered by Mr. A. E. Walz, 4AW, the subject in this case being "Portable Receivers and Transmitters." Quite a number of portable (more or less) outfits were described, as well as the various methods of obtaining both high and low tension supply for portable transmitters.

The following Wednesday the third lecture was delivered by Mr. L. Hubner. The subject chosen was "Aerials and their Construction," and Mr. Hubner evidently had read up the matter well, for he provided a very interesting lecture.

The Technical Committee has again been at work, and has drawn up the following roster:—

May 25th: "Accumulator 'B' Batteries," by A. E. Walz, 4AW.

June 1st: "Questions Night."

June 8th: "Short-wave Reception," by T. W. Starke, 4NW.

June 15th: Debate.

June 16th: Debate, Woolloowin v. Toombul.

June 22nd: "Valve Amplification," by W. E. Vining, 4WE.

June 29th: "Radio Experiences."

During the month one new member was elected in the person of Mr. A. Raynbird, and a new president was also elected to office. The president now is Mr. H. E. Hannington, a resident of the district, and a very enthusiastic experimenter, being in possession of

a short-wave set. The transformer for the high-tension supply of the club's transmitter is now completed, after quite a few weeks' work on the part of several energetic members.

At a recent meeting it was decided to join up with the "Queensland Radio Transmitters' League," a newly-formed association which is open to all four district amateur transmitters.

A cordial welcome is extended to visitors and intending members at the meetings which are held every Wednesday at the resident of Mr. C. A. Walz, corner Eton Street and Sandgate Road, Nundah.

\* \* \* \*

## Woolloowin Radio Club

At last it's here—or at least coming—our much-talked of but much put-off debate with 4TC—the Toombul Radio Club. If I remember rightly this debate was first suggested about two years ago, but for some reason or other it has been constantly postponed. However, the date has been fixed at last, so we hope to show 4TC how good we are at debating. Of course, the Toombul boys don't know that we had two debates with the South Brisbane Club and lost both, but you know South Brisbane must have been fairly good to beat US—so Toombul, look out! It has been suggested that this debate be made an impromptu one, neither side knowing the subject until just before the debate.

At a recent meeting a committee was detailed to draw up a syllabus for six months or so, and several

## The Latest Accessory Arrivals

### BULLPHONES—

These new Loud Speakers, lately arrived from the Old Country, are the last word in purity of tone, and clear big volume. We can honestly say in all our experience of radio accessories, that never before have we heard their equal. Call in and see these latest arrivals.

De Luxe Black 21in.  
£3/17/6

De Luxe Mahogany  
£4/0/0

BELLING-LEE INDICATING  
TERMINALS,  
10 Each.

PROGRAMME SELECTORS,  
(Limited Quantity Only),  
£2/10/ Each.

Stocks of the ALL-AMERICAN SUPER-HET KITS still available at £9/5/ each.

**W. E. PETERMAN**  
160 EDWARD ST. BRISBANE

brained notions were put forward, one of them being a mock trial. A most peculiar title on the list is "A Night of the Willies—by Professor Willys Knight"—what it means, however, remains to be seen. A junk sale is also listed, to say nothing of a good old impromptu speech evening.

Several of our military men have been away at camp. It is fine to see them working, and Nim, the treasurer, has just returned from a visit to Canberra where, he says, he spent his spare time breaking ice and looking round. The attendance, however, is still up to normal and was, in fact, above normal, when at a recent meeting our old and tried "Zeck-tree" Harry Jear, appeared looking as cheerful as ever, though, as previously explained, he is extremely busy with something or other.

Our transmitter now often tends to transmit. In fact, at times, it actually does, and reports from South Australia and Victoria consistently come to hand. Within a few weeks it is hoped to have 4WN operating on a wave of about 200 metres, so that ordinary broadcast sets will be capable of receiving the transmission. However, all the Technical Committee seem to be busy with study, shift work, etc., or we would have had a long-wave set working before.

The club has made application for its transmitter to be recognised by the Queensland Transmitters' League, which has been recently formed in Brisbane. This league should do a deal of good to radio in general in Queensland. We have also made application to be allowed to affiliate with the A.R.R.L.—the big American amateur body.

\* \* \* \*

## Eastern Suburbs Radio Club

By the time this report is in print the club will have held its first annual meeting, and the first of a series of dances to raise funds which, at present, are getting low.

The work still proceeds merrily. The low loss set is now complete, and a start has been made on the construction of a transformer.

One of our members is very fortunate in being able to visit Canberra for the official opening ceremony. We hear he does not like the weather conditions at Canberra. We are looking forward to a talk from "Jimmie" on his experiences and impressions when he returns. Of course, he is sure to tell us he got a special smile from the Duchess.

The social committee is kept very busy preparing for the dance. Every effort is being made to make it a success, and on several nights members of the social committee have been working until past midnight. "George's" car(?) comes in handy on these occasions (that is, when it goes). To two of the ladies on the committee are the special thanks of the club due for their strenuous efforts in connection with the dance.

Another dance will be held in the Druids' Hall on Saturday, 25th June, and the E.S.R.C. would like to see as many members of other clubs as can possibly attend present at this function. Tickets are now on sale at two shillings. A full jazz band will be in attendance, and supper will be provided.

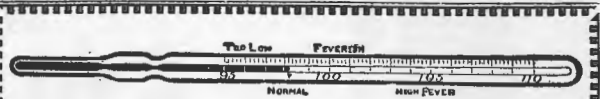

**PLAGUE, INFLUENZA, DENGUE FEVER,** and all other diseases are first indicated by a rise in temperature; therefore, a Clinical or Fever Thermometer is a necessity in every home, especially where there are children. Order one NOW and have it ready. **Price 3/9 each.** Posted 9d extra. If you paid a guinea you could not buy a better article.

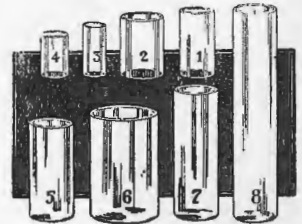

Radio Battery Cells, Crystal Detector, and Lubricator Glasses (all sizes).

### TEST YOUR BATTERIES.

New up-to-date Hydrometer for testing the gravity of the electrolyte of storage batteries. The only Hydrometer that will float right and give accurate tests. The best made. **Price 10/6 each.** Postage and packing 2/ extra.

Others at 5/6 each.

### IMPROVED PETROL TESTERS

The unsatisfactory working of the petrol motor is often due to the spirit being too dense. The tester will indicate the quality. **Price 10/6 each.** Posted 12/6.

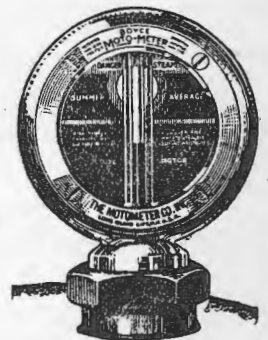

### MOTO METERS.

Midget size 15/ each; posted 1/ extra.  
Universal size, 27/6 each; posted 1/6 extra.  
New tubes fitted to broken ones.

Illustrated catalogue posted free on request~

## Wilson Nafis & Co. Ltd.

99 Wharf Street, Brisbane  
(next Fire Station)

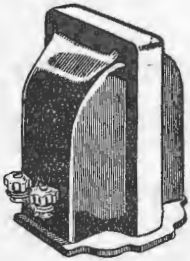

The Emmco Bakelite Case Transformer is an entirely new line. Terminals placed at base to ensure easy wiring. The moulded bakelite case gives a handsome finish and increased efficiency. Ratios 2-1, 3½-1, and 5-1.  
PRICE ..... 21/-



Emmco Midget Transformer. Answers the requirements of those desiring high frequency and low price. Shielded core, perfectly insulated windings. Ratios, 2-1, 3½-1, and 5-1.  
PRICE ..... 13/9

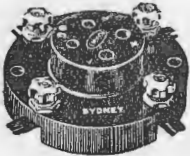

Emmco Balanced Sockets. A new departure in the push type valve socket design. Valve pins fit easily into the socket and are gripped tightly. Positive contact. The natural balance of the socket absorbs any jarring, so that microphonic noises are entirely eliminated. Bakelite frame.  
PRICE ..... 3/9

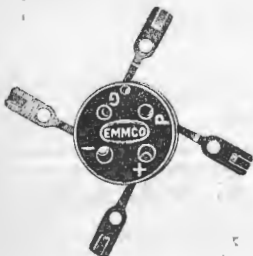

Emmco Balanced Socket supplied without frame for base panel mounting. Price .... 2/9

# New Emmco Apparatus

In line with their policy of keeping just a little ahead of the trend in radio development EMMCO have released a large number of new season's Radio Parts which carry the same guarantee of efficiency and quality that has always characterised Emmco Radio Products. Don't fail to see these New Emmco Parts at your dealer's.

During the last year or so the sale of EMMCO Parts has reached huge proportions, mainly due to their mechanical and electrical perfection, and partly due to the fact that mass production methods, coupled with enormous up-to-date factory equipment, enables them to be sold at prices which are more than competitive.

**Run Your Set off the Light Socket with the new Emmco 'B' Eliminator.**

The Emmco "B" Battery Eliminator—specially adapted for the current and voltages of the Australian electric A.C. lighting mains. Has five terminals, one earth, one "B" —, one detector † adjustable by a knob for voltages of from 20 to 45, one radio † adjustable up to 100 volts, and audio † for the full 135 volts. If a lesser voltage is desired in one or more of the audio valves, they may be connected to the radio terminals and adjustable knobs while the eliminator is in use.

A scientifically made job, sturdily built in a neat metal case with bakelite top. Compact; weight 13lbs.; measurements, 8½in. x 5in. x 7½in.  
PRICE ..... £10/10/-



Designed for controlling the filament current for all types of valves, for use in resistance coupled amplification and for "B" battery eliminators, the Emmco-stad line is unequalled for performance on this market. Nos. 1 to 6.  
PRICE ..... 7/6



Emmco Back Panel Mounting Vernier Dial is a distinct advance upon anything yet produced. It offers a most handsome appearance, remarkably fine tuning and easy mounting.  
PRICE, including Bezel and Template, 5/6; illuminations only, complete with switch and bulb, 4/6.



Emmco De Luxe Bakelite Vernier Illuminated Dial has many distinctive and exclusive features. It incorporates the well-known hairline adjustment, logging window, and wonderfully fine tuning. Gives your set that factory finish impossible to obtain otherwise. PRICE, complete with Switch and Bulb ... 13/6 Same dial without illumination, Price ..... 9/6



The Emmco Stratelyne Condenser embraces correct minimum and maximum capacities, perfect insulation, pigtail connection true alignment, cut-away brass plates in both stator. Base panel mounting. Has a hollow quarter-inch shaft interlocking, allowing tandem mounting, two or more condensers.  
PRICES: .0005, 12/6; .00025, and .00035, 12/-

Made by  
**ELECTRICITY METER MFG.  
CO. LTD.**  
SYDNEY N.S.W.

*At all Dealers*

# How Receivers Have Developed since 1923

(By "Ray Dio.")

It is interesting to look back a few years and see how wireless receivers have developed from the rough and ready crystal sets to the highly efficient types of sets in use to-day. It is not necessary to go back further than 1923 (as that was the virtual commencing year of broadcasting in Australia. Actually the first stations were opened in December, 1923.

Prior to 1923 there were not many valve sets in use—in fact, there were not many sets of any type. Broadcasting stations, as we have them to-day, did not exist, and the only transmissions to listen to besides telegraph stations for communicating with ships were the amateurs' stations.

### Volume was the First Consideration in 1923 and 1924.

The receivers operated before the broadcasting station commenced regular services were mainly home-assembled. There were very few places where one could buy component parts suitable for assembly in a receiver, and complete receivers did not come on the market in any quantity until 1924.

The idea that urged on people who made their own sets, or to buy complete sets for that matter, was to listen to stations in their own city. Melbourne wireless enthusiasts—they were not called listeners then, or even listeners-in (that horrible description)—did not have 3LO to entertain them; and Sydney amateurs were similarly placed. They had only the amateur transmissions of gramophone records to listen to. It is only fair to say that those amateurs provided quite attractive entertainments, considering their limited facilities.

After the novelty of hearing the nearby station wore off or lessened, amateurs aimed at hearing distant stations. To be able to hear Sydney was a proud boast for a Melbourne enthusiast.

But when the powerful broadcasting stations started the big idea was to get loud volume. To be able to hear the loud speaker a hundred yards off was quite a boast.

### Selectivity was Next Factor.

When the broadcasting stations gradually sprung up in the various cities another element entered into

the design of receivers. That was selectivity. It was not sufficient to get the stations loudly; if due regard were not paid to the requirements of selective tuning the volume was about equal from several stations on the one tuning. Hence it became necessary to pay more attention to the aerial and earth connection, to the quality of the inductances and the condensers, to the correct placing of the various components, and to the careful soldering of properly spaced connecting wires.

This requirement of selectivity also was responsible for considerable interference being caused by inefficient handling of reaction. Reaction even carelessly handled was not so serious a problem when the stations were few in number, but with the introduction of other stations the interference became greater.

### Quality is Now the Main Consideration.

After 1925 the sets generally were seen to possess better selectivity with reasonable volume. The factors that then claimed attention were quality of reproduction and economy of maintenance.

The economies of maintenance—use of valves of low current consumption and batteries of long life received great attention. This attention to current consumption naturally led to a desire for some form of device or method that would render batteries unnecessary. Towards that end the employment of battery eliminators has been pushed very satisfactorily. Simplicity of tuning received due attention, and the average good set to-day reduces the operator's controls of his set to one, two or three knobs or dials.

But the most important development of last year was the improvement of the tonal quality of receivers. By proper engineering attention to the quality of parts and transformers, circuit design and modifications of loud speakers the reproduction of music has been improved considerably, a very much greater degree of faithfulness has been obtained, and the enjoyment of broadcasting has been assured to critical listeners.



Our Artist's Version of 4QG's recent Radio Motor Hunt.

# Jottings from 4QG.

## RUGBY LEAGUE FOOTBALL.

The efforts made by 4QG to give football enthusiasts in all parts of Australia a full description of the important Rugby League match between Brisbane and Toowoomba teams met with the utmost success. The game was played at Toowoomba, and special land lines connected the athletic ground in that city with the station in Brisbane. Mr. Stan. Phillips, the secretary of the Rugby League, whose knowledge of the game is unquestioned, acted as announcer for the game, and the whole match from start to finish was followed eagerly by lovers of football.

In addition to broadcasting the match, Station 4QG used one of its land lines to the Exhibition Ground at Brisbane, and football followers who patronised the game in Brisbane were posted regularly with the results of the big match at Toowoomba. A special officer of the League wore a pair of telephones at the Exhibition Ground and heard the whole details of the match discussed. Towards the end of the local game, interest was centred more on the scoreboard at the Exhibition Ground than on the oval. The game at Toowoomba was a very keen one, and the finish was exciting. Since the relay, 4QG has received congratulations from far and wide on its enterprise in catering for football lovers.

## UNCLES AT 4QG.

Uncles Ben and Jom of 4QG have blossomed forth as builders and contractors. Some few nights ago, "The Professor," the weird gentleman who assists them with their bedtime stories, put in a late appearance and said that he had had difficulty in building a fowlhouse at his home. Uncles Ben and Jim volunteered to go out and help him, and then by their magic aeroplane did so. They built the fowlhouse, but unfortunately it did not last long, and the next night on which their stories were told, they received an urgent call from the "Professor," who claimed that the "poultry bungalow" had fallen down. Uncles Ben and Jim raced out to re-erect the structure, but this time the "Professor" insisted on an agreement being framed. Uncles Ben and Jim gave this agreement, and then proceeded to rebuild the fowlhouse. Listeners in all parts of Australia followed their doings with the greatest of interest.

## "THE SANDMAN" ON THE ROOF OF 4QG.

"The Sandman" is always on the lookout for some new innovation with which to amuse the children, and braving the cold elements, he can sometimes be seen perched on the top of 4QG with a small but fairly powerful searchlight signalling to his little radio friends. In return the youngsters acknowledge "Sandy's" greeting by waving lights of various descriptions, indicating that they have spotted the searchlight signals. The innovation is rather unique, and that it appeals to the children is evidenced by the hundreds of lights being waved to and fro in all parts of Brisbane and suburbs, from which 4QG is visible,

## THE ROYAL COMMISSION.

The Royal Commission, which is inquiring into wireless, has visited Brisbane, and has left again for the south. Its sittings in Queensland lasted only two days, and during that time there was a most noticeable absence of criticism of the local station. This fact, coupled with the clear and straightforward evidence given by the director of the station, seems to signify that "all is well" with wireless in the northern portion of Australia.

Adaptations of musical works for other instruments than that originally written for, oftentimes lose their effectiveness, but such a number to be broadcast from Station 4QG on June 15th, as the "Serenata" by Moskowski, should be an exception, and prove an especially interesting item in an interesting programme. This is a vocal arrangement of the famous pianoforte solo to be sung by Miss Ruth Portrate the well known soprano.

\* \* \* \*

Many patrons of Station 4QG, during its inception stage, will remember with pleasure the enjoyable singing of Miss Pat. McOnigley, and will therefore welcome her reappearance on the studio programme for June 17th, when she will sing the "Flower Song" from Gounod's "Faust."

\* \* \* \*

Uncle Ben's Kookaburra at 4QG has a rival for the position. It frequently pays a visit to the station, perching on one of the aerial masts, entertains the engineers with the laughing notes so familiar to our people. A few days ago one of the engineers succeeded in getting a close-up snapshot of this pleasant visitor.

Uncle Ben's kookaburra will have to look to its laurels.

\* \* \* \*

Vocalists have not infrequently taken us in fancy to the depths of the sea, or to the bowels of the earth, and many other inaccessible places known to poets; but Station 4QG intends to take its listeners, in fact, to the bottom of a coal mine on June 1st, and there give them a programme of music by prominent artists, who will descend to the bottom of the main shaft at No. 3 Colliery, Dinmore, and literally perform in the depths so often described in song.

\* \* \* \*

A programme of interest to patrons of Station 4QG should be the recital by the Corpus Christi Choir of Nundah on June 15th, who will, without doubt, prove a welcome addition to the choral side of the local station's programmes, assisted as they will be by capable soloists,

The  
**Children's Corner**

**Grandfather's Page  
 and His Competition**

MY DEAR GRANDCHILDREN,—  
 The Editor whispered to me one day,  
 Just in his quiet, kindly way:  
 "All your grandchildren would like to see  
 their Grandfather who speaks, from 4QG."  
 And so, my dear grandchildren all,  
 Young and old, and short and tall,  
 The Editor upon this page will show  
 that Grandfather, whom you wish to know.



**Will H. Lister—"Grandfather," 4QG.**

And now that you know just who I am, and you see my photograph, do not say I am too young to be your "Grandfather."

Certainly, your truly grandfather, if you have one, may be older, and you love him more than you love me, which is just what I expect, for after mother and father you should love brothers and sisters, and your grandparents. Then after them, you should love your school mates, your teacher, and me, and other people like me, and that is the right way—  
 You need to be kind and loving and true,  
 And grow up good men and good women, too;  
 If you want to be happy and jolly and gay,  
 Just do what is right, every hour of the day.

Now, grandchildren, you may think that I am getting somewhat serious, but it is not so—all I want you to understand is that those who do wrong are unhappy, and those who do right are happy. So—do right and be happy, so as to please everybody, including  
**"GRANDFATHER."**

**GRANDFATHER'S COMPETITION.**

**FIND THE BURIED NAMES.**

In each of the following sentences will be found the names of boys and girls. My little grandchildren will have to find them.

The names are in full, none are abbreviated, so all are very plain, but as they are buried amongst the words and the letters you may find it difficult to find them—yet it's easy when you know how. I can find them quite easily. Now, you try.

**BOYS' BURIED NAMES.**

(1) You will, I am sure, take Lancelot to the party.

Names .....

(2) Mother, Bert says he likes all the jam, especially the plum.

Names .....

(3) He may be rich because a man drew money from the bank for him.

Names .....

**GIRLS' BURIED NAMES.**

(1) If ever you see my racket tell them I lost it a week ago.

Names .....

(2) She was filled with dismay as she arose from the ground after falling.

Names .....

(3) They sell engagements rings, and they do rather a good trade with others as well.

Names .....

Fill in the names you find buried in each sentence on the dotted lines beneath the sentences, and post your finding to "The Editor, 'Queensland Radio' News, Brisbane," marking the envelope Grandfather's Competition.

Sign your name and address here—

Name .....

Address .....

A first prize of 5s. and a second prize of 2s. 6d. will be sent to the first and second drawn from those who have found the names correctly.

**RESULT OF LAST MONTH'S COMPETITION.**

**What Time Did Uncle Jim Rise?**

Hundreds of replies were received from little readers, and by the position of the hands on most of the dials the general opinion seems to be that Uncle Jim is a very late riser.

The correct time that Uncle Jim rose on Saturday, May 14th, was 8.50, or ten minutes to nine.

No child guessed the correct time. The nearest attempt came from Master Stanley Craddock, Lang Street, Dutton Park, who guessed twenty minutes to nine o'clock, and to whom a prize of 5s. will be posted.

The second prize has been awarded to Miss Madge White, Nellie Street, Nundah. Madge also guessed twenty minutes to nine, but her envelope was opened after Master Craddock's. The second prize of 2s. 6d. will be posted to her.

# *Special* *Announcement* —

TO

## **Queensland Radio Traders**

*T*HE Burgin Electric Co. Ltd., whose Burginphone Wireless Receivers have been successfully distributed throughout Queensland for some years past, are desirous of appointing district agents throughout the State, who will operate direct with the Company's factory in Sydney.

We desire to appoint in every town an agent who can demonstrate and sell Burginphone Receivers. "Burginphones" are manufactured by one of Australia's pioneers in Wireless and have a reputation of many years standing.

A full range of Receivers are manufactured, supported by an attractive price and discount policy. Prompt inquiry is invited from prospective agents.

## **Burgin Electric Co. Ltd.**

342 Kent Street, Sydney

*Telegraphic Address* — "Burgineco," Sydney



# With the Hams



More 20-metre activities to report on this month. Several of the local fellows, including 4BD, 4RB, 4AM, 4AW, and 4NW have been heard down there. 4BD and 4RB are the most consistent, both are usually heard working the world during the week-end afternoons.

4AW reports hooking a few Yanks the first day he tuned his Xmitter down. Some of the other Aussies listed in my log as being heard between 19 and 23 metres are—2NO, 2MH, 2UK, 2JY, 3AT, 3HR, 5BW, 6AM, 7DX and 7CW. All of them received at good strength during the afternoons.

A peculiarity noticed on 20 metres is that all stations begin to gradually fade around about 6 p.m. Australian and New Zealand signals go out completely, while it is only the very strong Americans and Europeans that remain in audibility. Two hours later, and everything is back again at usual strength, and keeps up steadily until midnight, when things start fading again. Nobody seems enthusiastic enough to like the idea of losing any beauty sleep in tackling observations after this hour—not for yours truly, anyway.

It seems a general opinion among a large percentage of Australian amateurs that the 20-metre band is of no use after darkness sets in; some have even got hold of an idea that 20-metre waves travel to distant points, round the world, by the "daylight" route. Both these ideas are absolutely bunkum—the fact is that waves at this frequency differ not the slightest from the propagation method of any other frequency band, and they travel through darkness, maintaining their efficiency even higher than the 30-40 metre sigs. This can be proved any night after 8 p.m., by getting a DX station (over 8000 miles) to QSY with you from the 40 band to 20, and note the difference!

4RB reports a QSO on 20 metres with NU-1ASF, Medford, Mass., U.S.A., when the latter was testing out a portable transmitter for the first time and using an input of only point 8 of a watt. His signals at this end were from strength R3 to R4, and could be copied OK while he was sending "single" (without QSZ's). This just about holds second cake for the world's record low power long distance QSO.

4HG is a new one who has recently sprouted up in the Toowong district. (Loud wails from the B.C.L.'S!) He has been punching out some honest sigs., and waggles a wicked key.

4CG, in his spare time, gladdens the hearts of Sunday B.C.L.s by putting out some phone on 250 metres. Heard him the other night, and must say he can show 4QG a few points, especially the way he winds up the amophone.

A weekly "prayer meeting" of members of the Q.R.T.L. on the 150-250 metre band has been sug-

gested. This would certainly be a fine idea if the suggestion is put into practice. It is a simple matter to wind a temporary 25 or 30 turn helix and stick it in place of the short-wave inductance. With no DX distractions a good evening could be put into rag-chewing, phone tests, etc. Besides this, the average B.C.L. with a sense of variety will look forward to listening-in on our weekly "air smoke concerts." He will naturally become interested in our doings, and this may ultimately lead to his er—conversion. Anyway, another member for the Q.R.T.L.

Our worthy radio cap. has been on the air again under the nom de—what's it?—of 4ZA. (Thought it was another of those bootleg calls when first heard it!) He puts out a fine, steady signal, plenty of strength; he is at all times a good "rag chewer."

2XAF, New York, U.S.A., is often heard on phone during the day. Wavelength 22.18 metres. I have spent nearly a whole Saturday—from 8 a.m. until 1.30 p.m. (when they close down—listening to them and making observations. At noon the "carrier" strength was R5, and the music and speech between R2 and R3; even at this time the music was quite clear, and most of the speech could be followed. A good tip when receiving phone is to earth the plate of the last tube instead of the filament. This will hold the wave steady and the receiver can be adjusted to almost "spilling over" point; any movement of the head or the phone cords will not cause the whole business to fly into oscillation. This tip, of course, only holds good below 50 metres.

\* \* \* \*

Mr. George J. Maki, chief operator of ex-AB-1, asks that interested parties be advised that, as from 1st April, 1927, the station call has been changed to WUAN.

Mr. Maki states that the transmitter at his station is crystal controlled, on 34.6 metres, and has a power of 500 watts. The power supplied to the set is 60 cycle alternating current, and the circuit is a self-rectifying one. The series of tests which this station was recently conducting, was for the purpose of ascertaining what effect a certain tower, near the aerial, had on the signals.

The full QRA of this stations is War Department Headquarters, Fort Sheridan, Illinois, U.S.A.



**A CROSS** in this square denotes that your subscription expires with this issue.

Subscription 6/6 year



Getting stations hundreds of miles away—picking up and reproducing with startling clarity the faintest sounds drifting through the ether—your set can do that—any set can do it—if it is equipped with CONDOR VALVES. For Condor Valves, the result of years of patient experimenting, are flawless—and they LAST. So insist on getting genuine Condors.

*Condor Valves and Lamps are obtainable everywhere at attractive prices.*

CONDOR LAMPS (AUSTRALASIA) LTD.,  
Sydney, Melbourne, Adelaide, Brisbane (Wellington (N.Z.)).

# OA4WN

## A Description of the Station

Power is drawn from the city supply, 240 volts, 50 cycle, the meter, fuses and main switches are attached to the wall at the right-hand end of the bench high up. Leads are taken from here down behind the lining at the end of the bench to the transformer, which is attached to the wall under the bench. The transformer has both plate and filament windings, the former giving 1000 volts. This winding is centre tapped, and only one-half giving 500 volts is generally used. The filament winding gives six volts from each side of its centre tap. A sixteen jar rectifier of the type vulgarly known as "slop jar," is also housed on the floor of the cupboard containing the transformer, and the leads from both go to a terminal strip let into the lining at the end of the bench. A filament and plate lead are, however, first brought to two switches near the front of same.

The transmitter is laid out in the bread board" style, the coupled Hartley circuit being employed. The plate meter can be seen at the right of the set close to the alarming notice "Danger" (contact with this apparatus means death). At present a 7½-watt tube is in use for the American tests. It is mounted at the back of the set, the socket showing white between the two condenser panels. The key is on the left of the set.

The earth leads run from the terminal strip at the back of the bench, half-way between the transmitter and receiver, through the back of the building, to a plate in the ground—a distance of about 5ft. A quarter-inch copper tube runs from the terminal strip

to the aerial earthing switch, which can be made out about fifteen inches above same, and just below the single pole double throw send receive switch. Another length of copper tube goes from here through a glass lead-in tube in the left-hand wall, about 4ft. away, to the down lead of the aerial, which is of the inverted



L type, with a span of about 70ft., and a height of 37ft. The tubing stands out about six inches from the back wall, on which some QSL cards are displayed. These are all from stations worked with a 5 watt tube. The receiver employs the Schnell circuit with one stage of audio, and dull emitter valves are generally used.

The cupboard under the left-hand end of the bench, which is closed, contains spare parts, tools, etc. (commonly known as junk). On the bench under the middle of the bench can be seen a number of periodicals and other books.



## The "Blue Spot" Supertone III. CONCERT SPEAKER

Price 70/-

Ask your Dealer, or write for List of "Blue Spot" Specialties

## The Masterpiece of Loud-Speaker Construction

A Master Piece indeed!

No other loud speaker constitutes such an elegant and valuable instrument at so modest a price. Built in accordance with principles laid down after long years of study devoted to the problem of tone and conductivity, the "Blue Spot" Supertone III embodies an achievement of supreme importance in the realm of sound technique. In its design, materials and construction, nothing has been missed in obtaining the most handsome appearance and perfect tone production.

That the "Blue Spot" Supertone III is indeed a masterpiece is amply evidenced in the extraordinary popularity it enjoys.

### "BLUE SPOT" PHONES

Mahogany, Green or Black, 27/6. Green Cross, 21/6  
White Cross, 13/6

Wholesale only

# ALEC. McCULLOCH & Co.

Agents and Importers

King House, Queen Street, Brisbane

PHONE -  
CENTRAL 1718

TELEGRAMS -  
"ALECMAC"

## Mr. Arthur C. Bateman

*New Publicity Manager Amplion A/sia.  
Ltd.*



The illustration shows Mr. Arthur C. Bateman, who is about to take up the post of Publicity Manager of Amplion (A'sia) Ltd. Mr. Bateman was educated at the University of Bristol where he was first junior, and afterwards senior technical scholar, and winner of several science prizes. He specialised in physics and the first part of his career was spent in the teaching profession as a science lecturer.

During this time he contributed freely to scientific journals, and the press generally. He then took up publicity work, and was associated with such concerns as British Thomson Houston Ltd., Sterling Telephone and Electrical Co. Ltd., and later with Messrs. Graham Amplion. He was also well known in British amateur theatrical and entertainment circles, as an elocutionist.

As a school boy he heard Senatore Marconi speak on wireless and was immediately interested. He has remained a wireless fan ever since. Having been intimately acquainted with the publicity organisation of Graham Amplion, his work in this direction for the Australasian Company should be received with great interest.

## W.L.W. To Broadcast Special Transmission to Australia

The Crosley Radio Corporation, in conjunction with the International Radio Co. of Sydney, their Factory Representatives have arranged a special Broadcasting for Australian Listeners, from their super Broadcasting station. WLW. This will take place on the 26th of June in America, which corresponds to the 27th here. The wave length will be 52 metres and the programme has been specially arranged for Australian listeners. The time the programme should be received in Australia will be 8.0 p.m.

It is interesting to note that station WLW is one of the super power stations of America, it was made as elaborate and perfect as possible, and has two sub-stations feeding into it. One of these sub-stations is fitted on a motor truck and runs around to all the sporting events, and other events that may be of interest to WLW listeners. The other is fitted on to a launch and is of a similar type to the motor truck. Both of these sub-stations work on a wave length of 100 Metres, which is backed up by station WLW and re-broadcasted. Hence there is never any trouble as to the land lines or suchlike.

On the occasion of their broadcasting to Australia the big station WLW will broadcast on a wavelength of 52 metres.

*The New  
British*  
**Loud Speaker**

**C.A.V.**

*(Clarity and Volume)*



Manufactured by the same people who have built up a world-wide reputation for batteries, etc., to a reputation for thoroughness in constructional detail, these new Loud Speakers offer you something unique in purity of tone at any volume. They are made with plain and satin finish with special tone adjustment.

**£3 - 0 - 0**

*At all Radio Dealers or from*

**BARNES AUTO CO.**

Queen Street, opp. Treasury Buildings  
BRISBANE

# A New Receiver

## Low Tension Voltage from A.C. Mains

Some few weeks ago I wrote of a new valve, the K.L.1, which seemed to me to have tremendous possibilities. and now, by the courtesy of the General Electric Company (Ltd.), who supplied the valves and transformer, and the Igranic Company (Ltd.), who supplied the other components, I have been able to make up a receiver incorporating the new valves and abolishing the accumulator (writes the wireless correspondent to "The Weekly Scotsman").

This K.L.E. valve, it will be remembered, was designed to operate from alternating current mains, and it is not practicable to heat a filament which is supplying the plate with electrons by alternating current, a fourth electrode had been introduced in the new type of valve.

This new component of the valve is an electron-heating cathode, which is indirectly heated by the filament, and as this filament in the Osram K.L.1 valve has no connection with the wireless circuit proper, it will easily be seen that alternating current may be used for heating it, and that the hum which has hitherto been associated with low-tension eliminators will be entirely absent.

### Only for A.C.

It must be borne in mind that this new valve has been designed to run only from A.C. mains. It can be worked from a D.C. source, of course, but this would be most uneconomical. As a matter of fact, I tried this receiver out first by driving the filament from a new charged 6-volt 60-ampere hour battery, and the result was that this battery was run down in ten minutes or so.

When, however, an A.C. supply is available, the new valve forms the basis for the most economical wireless receiver that has been possible so far. Let us compare the annual cost of an ordinary three-valve receiver using a power valve in the third position and a three-valve receiver using K.L.1 valves.

The average three-valve receiver of ordinary type will take something like fifteen milliamperes of high tension current, and, depending on the number of hours it is used, the cost of H.T. batteries will come to between £4 and £6 a year. The L.T. accumulator will need to be charged fortnightly, so here we have an annual cost of £2, to which has to be added depreciation for the accumulator. The annual upkeep, then, of a three-valve set is between £7 and £9.

### Economy Upkeep.

Using three K.L.1 valves, this upkeep is considerably reduced. The average consumption for such a set is about 30 watts, and therefore we should get over 30 hours' use from the receiver for every unit recorded on the meter. Using the receiver for 4 to 5 hours per day we should only consume one unit of electricity per week, and as the cost per unit in Edinburgh is 4d. it will be seen that the annual cost would be under £1. As well as this great saving in actual cost, we have to set off the greater conveniences that the K.L.1 valves gives us. There is no need for a spare

accumulator; we do not have to be carrying heavy loads to the garage or charging station every fortnight; and there is no danger of finding our batteries are giving out in the middle of an evening's entertainment.

On the other hand, there is the increased cost of the valves, which are 30s. each, and the transformer, which also costs 30s. to 37s. 6d., and there is also the untested lifetime of the valve. From personal experience I cannot, of course, give any idea what will be the length of life of the new type of valve, though to all appearances it should be longer than the lifetime of the older form of valve. The filament or heater of the new valve is stoutly built, and the cathode itself is a neckle tube, which has been specially treated.

### Conventional Circuit.

The actual receiver made up was a two-valve circuit of detector and low-frequency amplifier of quite conventional form, a regenerative circuit using Igranic coils in aerial and reaction positions, the aerial coil being tuned by a .0005 condenser. For the single stage of low frequency the coupling was made by means of an Igranic 5 to 1 transformer. Ordinarily for a single stage of low frequency amplification, I recommend a ratio of not more than 4 to 1, but in view of the low impedance of the Osram K.L.1 valve a higher ratio is advisable.

The only departure from conventional design is in the filament circuit. The 230 volt mains are connected to the input side of a step-down transformer and reduced to five volts of the output side, which is connected to the heating elements of the valves. In this respect it must be noted that these valves are taking two amperes each, and therefore heavy wire must be used for connections, and the filament rheostats used must be of heavy construction to carry this current. The usual type of rheostat constructed of fine wire would burn out very quickly.

The cathodes of the valves, which are connected to terminals fixed in the valve caps, are connected together and joined to earth and to the high tension negative, while grid bias is applied to the second valve in the usual way, the positive of the battery being connected to earth.

### Good Components.

I have often written of the importance of using good components in wireless receivers, and in this particular set everything except the Osram K.L.1. valves and power transformer is of the well-known Igranic make.

In actual performance the receiver did everything that was expected of it. Edinburgh comes in at full loud speaker strength, and Glasgow at moderate strength, while there was not the slightest trace of burn from the mains. In operation there was little of exception to note. The cathode of the first valve was found to function quite well when its glow could only just be seen, while the second valve was kept slightly brighter.

# de Forest Radio Audions

*A Definite Standard of Construction*

**QUALITY**



D.V.5.  
Filament 5 volts  
.25 amp.

DE FOREST Audions are manufactured now to Suit all types of sets. For Radio Frequency work there is the special DL4. The Detector the DL5. First Audio the DL5 and the DL7 for semi power audio.

Isolantite Bases gives a basically sound construction at the same time allowing them to function perfectly in all stages.

AT ALL DEALERS

Factory Representatives:

**INTERNATIONAL RADIO CO. LTD.**

200 CASTLEREAGH STREET, SYDNEY.

Queensland Distributors:

**HOME RADIO SERVICE LTD. ADELAIDE STREET, BRISBANE.**

# 'A' Battery Charging from A.C. Mains

(By D. Winterford.)

The advantages of the accumulator type of battery are many, the only disadvantage being the trouble and inconvenience of carrying them to and from a charging station every six weeks or so.

Battery chargers for recharging batteries at home are, of course, available, and to those amateurs who can afford the initial outlay of a few pounds find that they are not only time and trouble savers, but are, in the end, a money-saving proposition.

By far the easier way to secure a reliable battery charger is to walk into a radio store and buy one. If the purse is not long enough to stand this expense, or if the reader takes a pride in making his own radio apparatus, the following method of constructing an "A" battery charger should appeal to him. The writer has been using a charger constructed to the same specifications for some months, and finds that results are really excellent.

The circuit used employs a step-down transformer with variable secondary windings and chemical rectifier of the iron-aluminium type in a solution of borax.

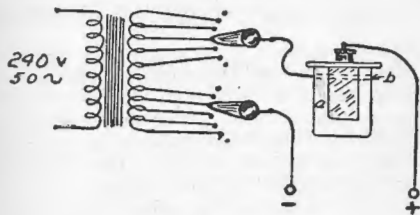

Fig. 1.  
(a) Electrolyte; (b) Layer of Oil.

There is nothing very difficult in the construction of the charger; the transformer entails a little work and thought in the making, but should not present any difficulties to the constructor.

The core is composed of soft-iron laminations, which may be in the form of store pipe iron or ordinary benzine tin sheets.

Laminations measuring  $4\frac{1}{2}$  in. x  $1\frac{1}{2}$  in. are cut until four piles  $2\frac{1}{2}$  in. high are made. These should now be annealed or softened to a red heat and allowed to cool as slowly as possible. They should then be varnished with either shellac or Stirling armature varnish before assembling, as this reduces "eddy currents" which are miniature electric currents always present in the iron core.

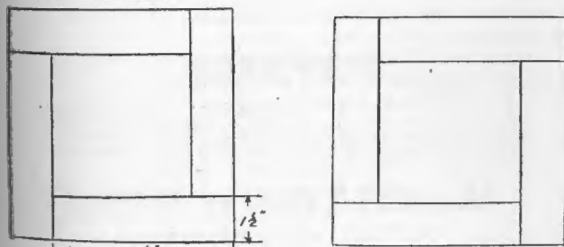

Fig. 2.

The laminations should now be assembled as shown in the above diagram, and placed between two clamps made from  $1\frac{1}{2}$  in. angle iron and 3 in. iron bolts. The bolts should be tightened as much as possible, and the thickness of the resulting core measured, adding or taking away laminations until the exact 2 in. thickness has been obtained.

The primary and secondary coils are the next to be tackled. A former measuring  $2 \times 2\frac{1}{2} \times \frac{1}{2}$  inches and sides  $1\frac{1}{2}$  inches deep (see Fig. 3) must first of all be made. The former should then be wound with 200 turns of 24 D.C.C. wire.

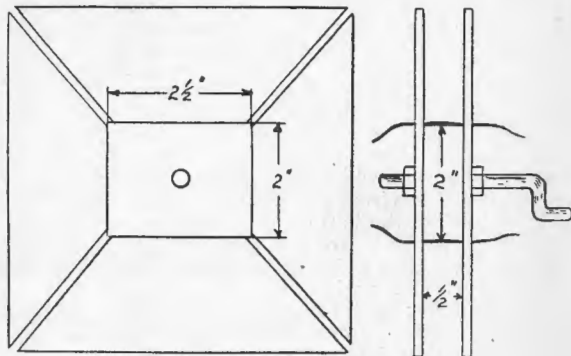

Fig. 3.

Four coils such as detailed will be required to complete the primary. Each coil should be well shellaced, baked in a fairly hot oven, and when cool, carefully insulated with two layers of good white tape and again shellaced and baked. To facilitate the winding the former should be slotted diagonally from each corner of the core as shown in Fig. 3.

A piece of string is now placed through these slots temporarily so as to hold the coil in place until it is finally taped.

The secondary is wound in one coil in the same manner as the primary coil, 115 turns of No. 18 D.C.C. wire being necessary. The secondary is tapped at every three turns until 15 turns are wound, i.e., 5 taps, then 10 turns untapped. Taps are then taken at every 18 turns.

We now have a coil of 115 turns tapped in five 1-volt taps at one end and five 5-volt taps at the other end. (It should be noted that 3.5 turns equal 1 volt in this construction.)

One clamp should now be removed from the core and the laminations forming one side removed. The primary coils are placed on one limb, the secondary coil on the other, and the laminations replaced. This job will be found a bit "ticklish," but is by no means difficult. After this is done the clamp is then replaced.

The complete transformer may now be mounted on a base measuring about 7 in. x 9 in., together with four terminals, and two rotary selector switches. Each switch has eleven contacts, every second one being

dead to prevent shorts between adjacent taps by the switch-arm resting on two taps simultaneously.

We now turn our attention to the rectifier, which is constructed from a benzine tin cut down to half-size and filled with a concentrated solution of borax and pure rain water. A layer of lubricating oil should then be poured on the surface to prevent creeping and evaporation. An aluminium sheet measuring 10in. x 6in. is bent into a cylinder (roughly) and the upper edge secured to a board which is about 2in. wider than the tin container. This completes the rectifier.

A few words may now be said about the operation of the charger. Connect up everything, but the accumulator to be charged and switch on with a lamp (240v. 60 watt.) in series with the primary. If it does not light or barely glows and a faint hum can be heard by placing the ear very close to the core, then everything is O.K. Should the lamp light to nearly full brilliancy, then something is amiss, the most likely fault being a reversed primary coil or coils.

Try reversing connections between coils until the lamp burns at its dimmest. When this is done the lamp may be removed and its place taken by a 3 amp. fuse. Set the switches at their lowest reading and short the output for about 5 or 10 minutes. This will pull a high current through the rectifier, and it will probably "bubble" a bit, but don't be alarmed, as this is forming the aluminium's surface with a thin film of aluminium borate which only allows current to pass in one direction (from the tin to the aluminium).

Now connect the battery to be charged and an ammeter in series to the output terminals and switch on the current. The switches are then varied until the required current is registered by the ammeter.

This rectifier will handle up to 5 amps. without heating; if larger currents are required increase proportionately the plates of the rectifier.

## New Apparatus

### EMMCO STRATELYNE CONDENSER.

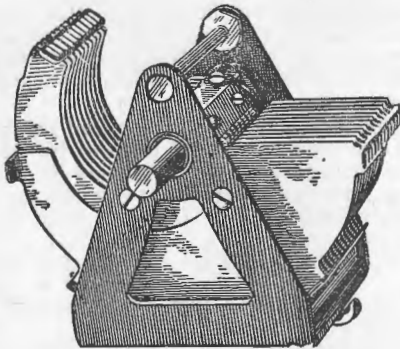

Heading the list of a very complete line of new seasons apparatus produced by the manufacturers of Emmco radio products, is the Emmco Stratelyne Condenser, a beautifully-finished job of high quality. There are many features which will place this condenser high in the esteem of radio enthusiasts. Correct minimum capacities eliminate all uncertainty in tuning, while the insulation properties are as nearly

perfect as it is possible to get. The cut-away brass plates in both stator and rotor are unique features, and a pig-tail connection makes contact always certain. The Stratelyne condenser is adaptable for either baseboard or panel mounting.

One of its main features is the hollow  $\frac{1}{4}$ in. shaft interlocking—an extremely handy arrangement which allows of the tandem mounting of two or more condensers. Considering its mechanical and electrical characteristics, it is extremely economically priced.

## The Queensland Radio Transmitters' League Its Aims and Objects

After preliminary meetings the above league was formed, and to date, the majority of "ticket-holders" are members. The executive has drawn up the various forms, regulations, etc., required to administer an organisation of this description, and now are waiting anxiously for a clear start.

The league differs from other local clubs in that amateur operators only are eligible for membership. Also that whilst only a nominal subscription is made to league funds, provision is made whereby a levy may be made up members to meet any unusual demand.

Its objects are briefly to encourage research into matters peculiar to its undertaking, and to promote goodwill between all interested bodies; to carry out tests, such as reliability in traffic exchanging; to keep and assimilate data from all stations, so that the operating peculiarities of all locations may be accurately gauged and difficulties met and defeated; to open up reliable, speedy traffic routes throughout the State; to obtain from the Federal Authorities proper recognition for work past and future; to ensure protection for best wave-bands.

A standard message form has been drawn up for use by all stations.

Every station is to submit, monthly, to headquarters a detailed account of his activities. This is for the purpose of collecting data and publication of suitable material.

International correspondents and contact stations (4CG and 4CM) are appointed. They will form the channel through which international contact is to be made.

More of our methods anon. Suffice it to say that some such organisation was required, and we hope that Q.R.T.L. will live up to the ideals of its promoters. M. M. O'Brien, 4MM, President Q.R.T.L.

## REPAIRS

We do rewinding and overhauling of all kinds of Electrical Apparatus, including Armatures, Meters Loud Speakers, Coils, etc., and guarantee the work. Also Panel Engraving.

## HAMILTON & PASS

BURNETT LANE, BRISBANE.

'Phone Croso.



# The Transmitting License

(By Q.R.N.)

(All Rights Reserved.)

Article No. IX.

In this article attention will be given to the action of rectifiers, that is, of devices intended to change the to-and-fro nature of Alternating Current into a directional pulsating Direct Current

One realises that Direct Current is essential in the Plate circuit of a transmitting as of a receiving valve. Though the filament of a transmitter is preferably run from an alternating current supply—as explained in an earlier article—such an A.C. supply is not feasible in the Plate circuit.

The reason for this is not hard to find. One knows that the ordinary Thermionic Valve consists of three elements in side a more or less evacuated glass bulb. These elements are: The Filament, surrounded by the grid—usually a spiral or mesh of fine wire and both turn enclosed by the plate or anode which is usually of nickel, cylindrical or oval in shape. Such elements are common to both transmitting and receiving valves.

In this article the action of the filament and the plate will be dealt with and the action of the grid referred to the next issue.

The filament is heated—whether by direct current or alternating current matters not—and the heat causes a certain amount of decomposition in the material of which it is formed. All the atoms that go to make up the filament are themselves composed of small nuclei of electricity—infinitesimally minute particles of positive and negative electricity known respectively as protons and electrons—and under the stress of the applied heat the atoms break up and the electrons are thrown from the surface of the filament.

So long as the filament is heated there will be a state of stress within the valves, for the heat is causing the rejection of electrons while the superfluity of protons on the filament, due to such rejection of electrons, has made it positive compared to its usual condition, and this positive state naturally tends to counteract the effect of the heating by attracting the free electrons.

Suppose now that a battery—the familiar B battery—be connected in circuit with the valve so that the positive pole of the battery is linked with the plate of the valve and the negative pole with the filament. Then the plate of the valve will of positive polarity in respect to the filament, and all the electrons emitted by the heated filament, being negative particles of electricity, will be attracted to the plate. Under such circumstances the B battery circuit will be complete, for a current will flow from the negative terminal to the filament, thence by the escaping electrons across the filament-plate gap and thence to the positive terminal of the B battery.

From such a consideration it becomes obvious that, if the plate be made negative, the valve will not function, for the free electrons around the heated filament will be repelled by the plate, and there will be no means of completing the B battery circuit, and if the

B battery circuit be inactive the valve is useless either as a receiver or a transmitter.

To apply alternating current to the plate of such a valve would cause it to function only for the instants when the plate was positive—that is to say, the plate circuit would only respond to the positive alternations of the current, and for half the time (during the negative alternations) would be dead. The disadvantage of this are so obvious that recourse is had to devices which will rectify the cheap alternating current supply into a direct current.

Rectifiers are of three chief types. Firstly there is the chemical rectifier—colloquially known as "Slop Jars"—wherein the uni-directional passage of an electric current flow through certain chemical solutions is utilised. By reason of its relative cheapness this type is the one usually used in amateur stations. Secondly, comes the thermionic or valve rectifier, of which the action has been largely traversed in the earlier part of this article. The thermionic type is highly efficient, though more expensive than the chemical rectifier, both in initial outlay and in upkeep. The third type is the mechanical rectifier, wherein the vibration or rotation of a current carrying conductor is made to perform the desired rectification.

## The Chemical Rectifier.

A chemical rectifier consists of a battery of containers—usually, be it said, a dozen or two of the cheapest kind of Japanese glass tumblers—filled with a strong solution of borax in water. Ordinary household borax will do; chemically pure borax is reputedly better, though practical results do not always confirm this. Amateurs throughout the world, however, clamour for the stuff known as "20 Mule Team" borax, obtained from certain localities in the United States, and packed out on mule teams—hence, the name. Readers who have come across the expression in various papers have often been at a loss to understand what sort of commodity this particular expression denoted.

However, the "slop jars" are filled with "20 Mule Team" and aluminium and lead electrodes are inserted. The aluminium electrode in one jar is connected to the lead of the next and so on throughout the series.

Refer now to Fig. 1—wherein the aluminium is shown as the bigger, and the lead as the smaller electrode.

The terminals A B represent the input terminals of the alternating current, and the terminals X Y the output terminals of the direct current.

A description of the action is as follows:—Imagine that, for an instant the incoming current flows in the direction AP. When it reaches P it may choose either of two directions. It may, theoretically, flow towards the upper row of jars—in practice, however, it will flow towards the lower row. The reason for this explains the action of the rectifier. Currents can pass through the borax electrode from the lead anode to the aluminium cathode without hindrance, but

# NEW!

Both in Prices, Quality and performance — everything speakers should be—at prices within reach of every set owner, a combination of essentials long demanded by all, have been achieved in the BRANDES REPRODUCERS.

Its beauty, the ability of the unit to handle great power, are realised beyond description.

But there is only one way of testing this statement. Send for one and compare it with any Speaker. If you are not satisfied we will refund your money.



<b>The Table Talker</b>	<b>45/-</b>
<b>The Table Cone</b>	<b>70/-</b>
<b>The Brandola</b>	<b>90/-</b>
<b>The Ellipticone</b>	<b>130/-</b>

FROM ALL DEALERS

## BRANDES Reproducers

INTERNATIONAL RADIO CO.

200 Castlereagh Street, Sydney

91-93 Courteney Place, Wellington, N.Z.

In Queensland—HOME RADIO SERVICE LTD  
Ewing House, Adelaide Street, Brisbane

as soon as the reverse direction is attempted chemical action causes a number of oxides and other salts of aluminium to form upon the surface of this metal, which causes a tremendous resistance to the flow of current in the aluminium-lead direction.

A reversal of the current, however, dissolves this coating almost at once and allows the flow from lead to aluminium to pass virtually unhindered. Of course, if the frequency of the applied A.C. be too high, there will be no time for the dissolution of the salts round the aluminium electrode, and the rectifier will be paralysed. However, it is found that the common municipal A.C. supply at 50 or 60 cycles per second can be handled quite comfortably by the rectifier.

Therefore, to return again to Fig. 1, the full direction of current flow from A through P to B is as shown by the plain arrows—note that it flows through any external circuit connected to XY in the direction from Y to X. But during the next alternation the direction of the incoming current is reversed, and it will flow from B to Q. Consideration of the action just described will show that the path during this alternation will be as traced by the feathered arrows, wherein the direction from Y to X remains unchanged. Trace the diagram out until satisfied that this is so. Therefore, it is seen that no matter what the direction of the current applied at AB the direction of the current flow at XY is unchanged—that is to say, the chemical rectifier or Noden valve, as it commonly named, changes alternating current into direct current.

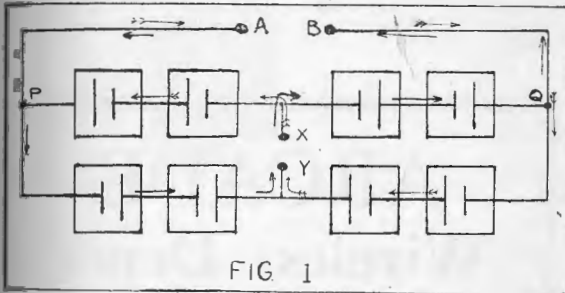

FIG 1

The above diagram (Fig. 1) illustrates what is known as full-wave rectification—that is to say, both alternations of the incoming current are utilised to send a pulsation of direct current through XY. Very often, however, half-wave rectification is used, wherein one of the alternations of the A.C. is utilised and the other alternation wasted. Such a half-wave rectifier as connected to a step-up transformer is shown diagrammatically in Fig. 2. The current may

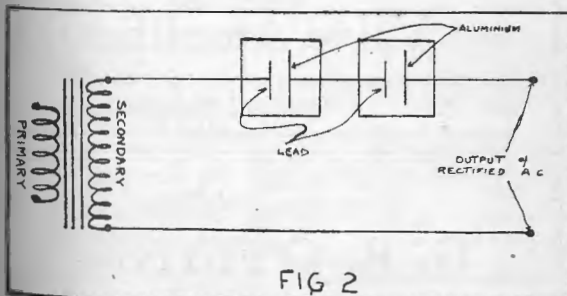

FIG 2

flow through an external circuit in the direction AB and DC, but not in the direction of BA and CD.

In amateur full-wave rectification a centre tap is usually taken from the secondary winding of the transformer, so as to give, say, 500 volts on either side. This centre tap acts as the positive pole of the resultant D.C. current, while Noden valves are connected in both sides of the transformer and brought

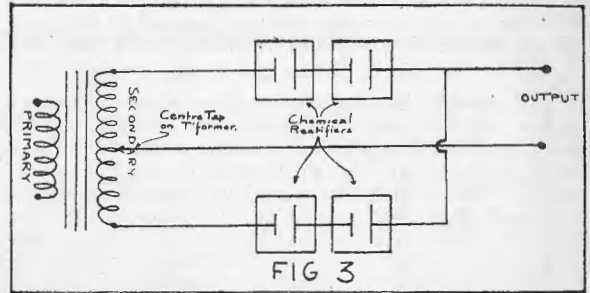

FIG 3

to a common lead, as shown in Fig. 3, which acts as the negative terminal. The output from this system will for any given transformer be half that of half-wave rectification, similar to that in Fig. 2.

In constructing a chemical rectifier it is usual to allow one jar to every 50 volts input, though the ratio is not arbitrary in any sense, and throughout Queensland amateur stations the number of jars in use varies probably between 10 and 40 for inputs of similar voltage.

Other electrolytes than borax may be used, such as ammonium phosphate, but in Queensland borax is usually more readily available and so comes in for greater attention.

It is unfortunate, however, that before a Noden valve rectifier will work properly its electrodes must be put through an action known as "forming." This is done by connecting ten or a dozen of the jars in series across the 240-volt A.C. line current, together with a lamp in circuit, and leaving them for five or six hours until no current passes through the jars.

**ON WEDNESDAY EVENINGS**

If you are a wireless enthusiast you'll want to know all about the Morse Code. You'll then be able to understand those wonderful dot and dash messages from the ships.

**LEARN MORSE**

Mr. H. L. Miller, the well-known wireless expert, conducts our Morse Class every Wednesday night. Whether you are a beginner or whether you already have a working knowledge of Morse, you'll find the course most interesting, instructive and helpful.

Get Particulars.

**UNDERWOOD BUSINESS COLLEGE.**  
452 Queen Street, (Opp. Customs House).

# Whispers from Maoriland

Last month (April) saw the commencement of a new radio year in New Zealand, and since March 31st a steady stream of renewals of receivers' and dealers' licenses have been issued. A summary of the position to date is as follows:—Auckland, receiving licenses 8860, and dealers' licenses 405; Christchurch, 4410 and 195; Dunedin, 1564 and 109; Wellington, 3346 and 478.

\* \* \* \*

The reason for the recent change in the wave-lengths of the broadcasting stations at Christchurch and Dunedin was explained recently by Mr. G. McNamara, secretary of the Post and Telegraph Department. The Christchurch station's wave-length was increased from 400 metres to 405 metres, and the Dunedin station from 380 to 435 metres. The change was made so that listeners-in in all parts of New Zealand could pick up the greatest number of stations both in the Dominion and in Australia. Mr. McNamara said that in deciding on wave-lengths they were limited and could not run all over the place. The difference between the wave-length of New Zealand stations compared very favourably with the difference between the wave-lengths of Australian stations. Mr. McNamara quoted a table showing variations between the various stations. Station 2BL Sydney had a wave-length of 353 metres. Then followed 3LO Melbourne 371 metres, 2YA Wellington 380 metres (when in operation), 4QG Brisbane 385 metres, 5CL Adelaide 395 metres, 3YA Christchurch 405 metres, 1YA Auckland 420 metres, 4YA Dunedin 435 metres, and 2FC Sydney 442 metres. "In making these alterations we felt we were meeting the needs of the great majority of listeners-in," said the speaker. "I personally have heard no criticism about the change."

The position so far as it affected Auckland was explained to Mr. McNamara by a deputation representing the radio dealers, who waited on him a short time back. Their chief complaint was that they found, on the average, that the owners of five-valve heterodyne sets found it difficult to separate the Auckland and Christchurch stations under the present conditions.

In reply, Mr. McNamara promised that the department would go into the question and have tests made. He pointed out the position was peculiar when there was a difference of 15 metres between the wave-lengths of two stations. Also, only listeners-in within a radius of five miles of the Auckland station seemed to be affected.

\* \* \* \*

Mr. K. H. Thow is supervising the erection of the new 2YA station in course of erection at Wellington. He is acting on behalf of Messrs Standard Telephones and Cables Ltd.

\* \* \* \*

The new broadcasting station, 2YA, shortly to be opened in Wellington, was designed and built in the Hendon (London N.W.) works of Messrs Standard Telephones and Cables, Ltd., formerly the Western Electric Co., Ltd. With the exception of a few of the valves and the metres, the entire equipment is

British made, and is a very fine example of the very latest radio engineering practice, combined with the highest quality of workmanship, finish and material. The whole of the equipment is designed to give the greatest possible faithfulness of transmission of all speech and music frequencies, extreme stability of wave-length and high frequency. All these ambitions are as nearly realised as is possible in the present state of radio science, and New Zealand is to be congratulated on the acquisition of what will undoubtedly be one of the finest stations in Australasia.

\* \* \* \*

Punters and bookmakers alike are delighted with the broadcasting of the progress of cup races in this country. Since this was done there have been one or two little swindles worked, and in most cases the bookmakers have fallen. However, at the recent Christchurch meeting they came out on top. A wealthy set of bettors had listened in to a hurdle race, and when they heard the loud speaker say "Sayonara" is an easy winner" they rushed out of their officers and bet heavily on this horse with the bookmakers, who did not know that the race was being broadcasted. Judge the dismay of the punters when they found, on reading their evening papers, that "Sayonara" had been disqualified and the race given to "Gamecock."

## ARCADE Wireless Depot

BRISBANE ARCADE,  
(Adelaide St. End.)

We stock the Famous Crossley Sets,  
Fada Neutrodyne, Rico-Dyne,  
Udisco Three and Five Valve Sets,  
Radiola 4, latest.  
Demonstrations daily.

### 1 Valve Amplifier

1-Valve Amplifier to attach to Xtal  
Set, £3/5/—beautiful tone and guaranteed loud speaker results.

Let us quote you for Repairs,  
Accessories, and Sets.

**G. R. O'FLYNN**

# "ELECTRAD" CERTIFIED RADIO PRODUCTS



### ELECTRAD GLASS GRID LEAKS

Electrad Grid Leaks are made by a new and controlled process. Each Grid Leak is individually tested before it leaves the Electrad factory. They are non-microphonic and moisture proof, while the resistance is constant.

Sizes 1/2 to 5 megohms, plain. Price ... .. 2/3



### ELECTRAD LIGHTING ARRESTER

Consists of an air gap between two copper conductors, arranged in an improved manner, so that it is impossible for the spacing of the gap to vary. It is then hermetically sealed and the gap is therefore absolutely watertight. The housing protecting the air gap is moulded in glazed porcelain with a highly ornamental finish. These arresters comply with Fire Underwriters regulations. Price ... .. 3/6



### ELECTRAD CERTIFIED CONDENSER

**The Six Pressure Points:**—Ingenious riveting and binding method fastens parts securely at six different points and exerts **EVEN PRESSURE** upon the largest possible surface.

Thin sheet copper is used in place of tin-foil. A slip of the soldering iron cannot damage the copper and thereby ruin this condenser.

.001 M.F. ... .. 2/6

.00025 M.F. (as illustrated) ... .. 3/-

Supplied in all Capacities.

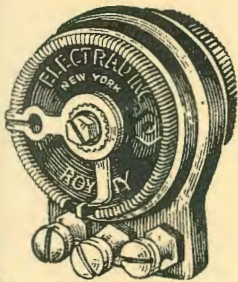

### ELECTRAD ROYALTY VARIABLE RESISTANCES NON-INDUCTIVE

Ideal for Volume Control; Wire Wound, Resistance remains Constant at every Point. Permits full range in One Turn. Non-Inductive, Unusually High Current-carrying Capacity.

Type "A" Variable Grid Leak 1/10 to 7 megs.

Type "B" Variable Grid Leak High Resistance 1,500 to 100,000 ohms

Type "C" Variable Grid Leak High Resistance 500 to 50,000 ohms.

Price 11/- Each.

Type "D" Detector Control for 'B' Eliminators 10,000 to 700,000 ohms

Type "E" Compensator 500,000 ohm Potentiometer (for volume Control)

Price 13/6 Each.



OBTAINABLE AT ALL RADIO DEALERS OR AT

**Amalgamated Wireless**  
*(Australasia) Ltd.*



167-9 Queen St., Melb. 47 York St., Sydney Charles St., Adelaide  
King and King Chambers, Queen St., Brisbane

There is a "Radiokes" Coil for all Popular Circuits.

The

# RADIOKES

## LINE OF COIL KITS

"Radiokes" Satisfaction puts the "Ray" in Radio.

### "Radiokes"

#### NEW! SCREENED TRANSFORMER SUPREME!

Clears reception of disturbances from regeneration, re-radiation, and body capacity effects.

Tuning, no longer a matter of guessing, but positively precise. Stations, once located, always found at the same point on dial.

For Solodyne—Elstree, Mewflex, and Reinartz and later circuits.

Space reserved for Illustrations Blocks not completed in time for printing.

~

**A Fine Folder**

**"The Radiokes Line"**

Is available for distribution, gives particulars of all manufactures with six circuit diagrams.

### Shielded Coils

#### WONDERFUL SELECTIVITY & CLARITY

"Radiokes" shielded coils fill the insistent public demand for perfect reproduction, with nothing added or lost. Made in three styles—Split Primary and Split Secondary and Reinartz.

Connection diagram with each set.

PRICE £1/5/- each.

### "Radiokes" Binocular Type Coils

#### T.R.F. TRANSFORMERS.

For the most fastidious. Confine the electromagnetic field, neutralise the tendency to oscillate, no peak, high amplification over all broadcast wave-length. Perfectly constructed.

Space reserved for Illustration. Blocks not completed in time for printing

~

**A Fine Folder**

**"The Radiokes Line"**

Is available for distribution, gives particulars of all manufactures with six circuit diagrams.

#### THE VERY LATEST.

Their non pick-up qualities reduce the annoyance of static and interference.

Wound on air—as only "Radiokes" can do it. Price £1/19/6 per kit of 3

#### "RADIOKES" CIRCLOID DE LUXE

"Radiokes" Circloid R.F. Transformers have proved by actual nation-wide test to be more highly selective than any other instrument of their nature.

Owners write us that they get distance without interference from powerful local stations—enjoy broadcasting 1000 miles distant—astounding volume—perfect tone quality, and easily operated.

PRICE £2/5/- set of three matched.

#### "RADIOKES" BROWNING-DRAKE.

"Radiokes" Browning-Drake Coil Kit builds the most popular and best four valve set. Full volume from all stations, no difficult tuning, good selectivity, moderate cost.

Twenty Kits being sold every week in Queensland.

PRICE £2/2/- with mounts.

#### ALSO "RADIOKES" NEUTRODYNE AND BAYER AND COIL KITS.

Manufacturers:  
METROPOLITAN  
ELECTRIC CO.,  
SYDNEY.

**RADIOKES**  
**Radio Frequency Choke Coils**  
500 Turns, Price 8/6 70 Mic.H.

Distributors:  
EDGAR V. HUDSON,  
BRISBANE.