

THE
AUSTRALASIAN

Radio 1/6 World

Vol. 14 . . . No. 9

February 28, 1950

Registered in Australia for
transmission by Post as a
periodical



THE BEST SETS USE ROLA LOUD SPEAKERS

Mullard Loose Leaf VALVE DATA HANDBOOKS

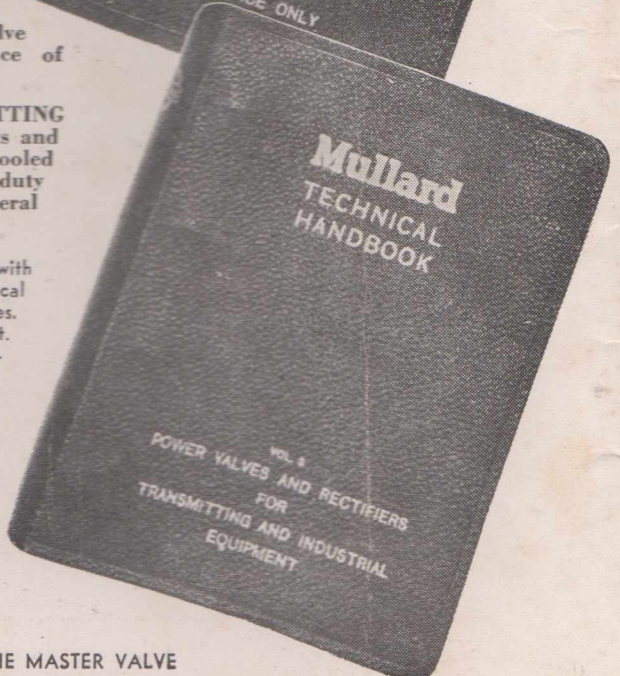
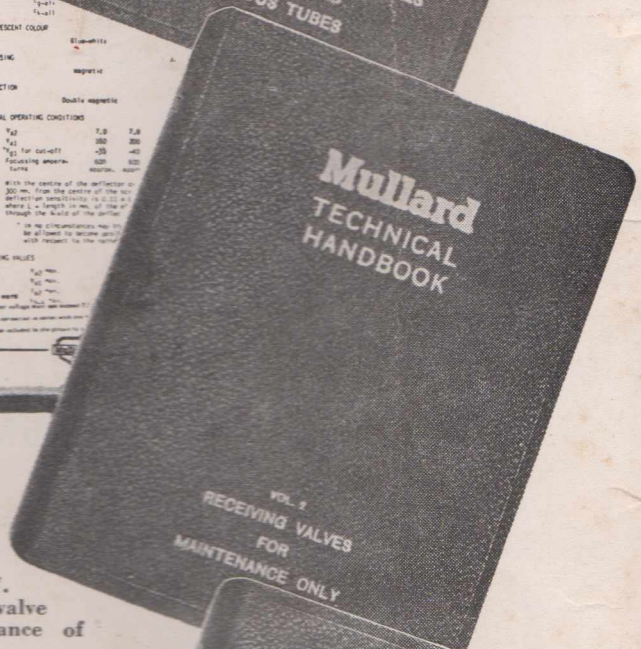
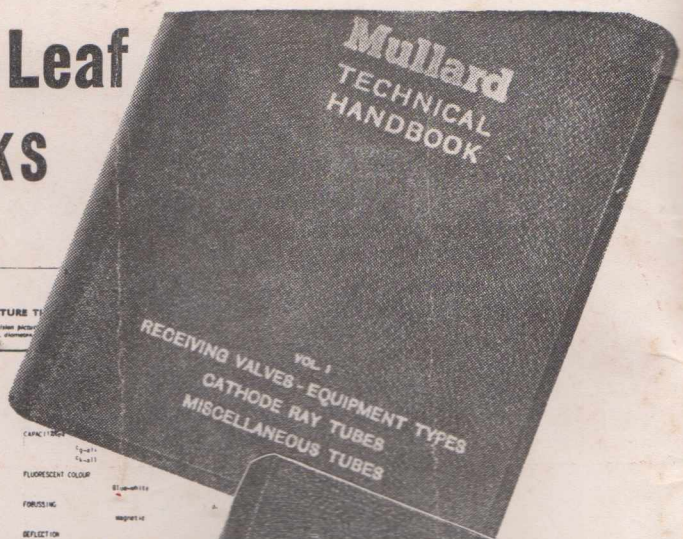
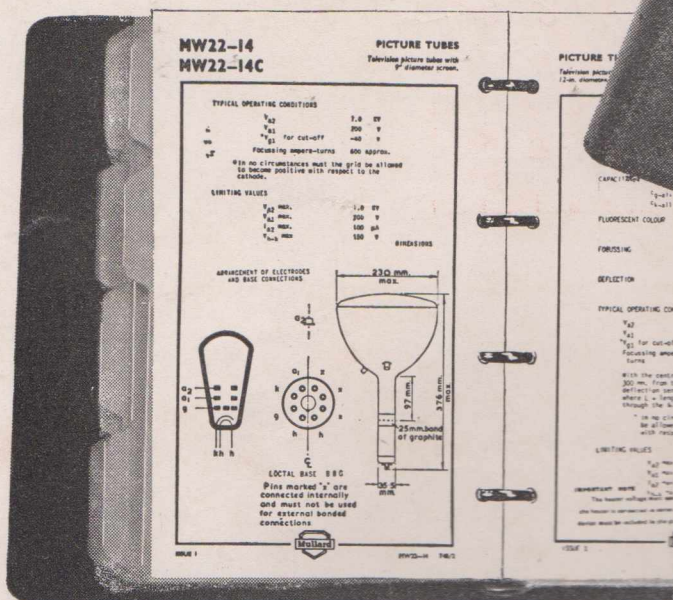

- Vol. 1: RECEIVING VALVES — EQUIPMENT TYPES, CATHODE RAY TUBES, MISCELLANEOUS TUBES.** Includes television picture tubes, photographic flash tubes, voltage stabilising tubes, accelerometer tubes and general valve data.
- Vol. 2: RECEIVING VALVES FOR MAINTENANCE ONLY.** This volume contains full data on superseded Mullard valve types as supplied for replacement and maintenance of equipment already in the field.
- Vol. 3: POWER VALVES and RECTIFIERS for TRANSMITTING AND INDUSTRIAL EQUIPMENT.** Contains data sheets and useful information relating to high power water-cooled transmitting valves, silica envelope valves, heavy duty rectifiers, VHF valves, etc., operating notes and general nomenclature relating thereto.

The three 9" by 7" volumes are leatherette covered with gold lettering, have snap rings and contain full technical data on the comprehensive range of Mullard valves. Each valve group is provided with an indexing sheet. Compiled and produced by Mullard Electronic Products Ltd., London, the data completes the gap in your valve information and comes at a most opportune time—with the expanding field of television and industrial electronics. A practical and essential addition to your reference library. The cost is £6/6/-, inclusive of the first two years' subscription for amendments and additions, subscription 15/- per year thereafter.

Mullard-Australia Pty. Ltd.
 35-43 Clarence St., Sydney.
 Representatives in Australia
 Mullard Electronic Products Ltd., London.
 Secure your set now, by writing or cutting out this coupon and enclosing a cheque or money order for 16/6/- to Mullard-Australia Pty. Ltd., Box 2178, G.P.O., Sydney.

for — Mullard Electronic

Name: _____
 Street: _____
 Town: _____
 State: _____

Mullard THE MASTER VALVE

THE AUSTRALASIAN RADIO WORLD

DEVOTED ENTIRELY TO TECHNICAL RADIO
and incorporating
ALL - WAVE. ALL - WORLD DX NEWS

PUBLISHED BY THE PROPRIETOR—
A. G. HULL,
Balcombe St., Mornington, Vic.
Phone: M'ton 344.

Short-wave Editor—
L. J. KEAST,
7 Fitzgerald Rd., Ermington, N.S.W.
Phone: WL 1101.

REPRESENTATIVES
In Queensland: John Bristoe, Box 82,
Maryborough, Q.

In New Zealand: H. Barnes & Co., 4
Boulcott Terrace, Wellington.

S.O.S. Radio Ltd., 283 Queen St.,
Auckland.

In England: Anglo Overseas Press Ltd.,
168 Regent St., London, W.1.

*Distributed throughout the World
by Gordon & Gotch (A/asia) Ltd.*

SUBSCRIPTION RATES—
12 issues 18/-
24 issues 30/-
To N.Z. and Overseas:
12 issues 18/-
POST FREE

Address for all correspondence—
AUSTRALASIAN RADIO WORLD
Box 13, Mornington, Vic.

THIS month's front cover picture shows a corner of the Rola acoustic laboratory, claimed to be the best fitted in the Commonwealth. Equipment includes loud-speaker curve tracing apparatus, inter-modulation and wave analysers, and the latest laboratory - type wide - range microphones.

Vol. 14

FEBRUARY, 1949

No. 9

CONTENTS

The New Metropolis 4	Page 5
Amplifiers For Cutting	11
High Stability V.F.O.	21
The "Panagram" Circuit	26
Valve Technique	27
Shortwave Review	33
Speedy Query Service	34

EDITORIAL

FROM the Disposals Committee of the Wireless Institute we have received the following letter:—
"With reference to remarks regarding the Wireless Institute of Australia as contained in your Editorial for December, 1949.

All goods offered by the Institute to its members are passed on for use of such members at prices which are not loaded to the extent when equipment is made available through normal trade channels who have made tremendous profits from the unsuspecting person. This applied more particularly in the early days before the Institute entered the field, when such goods were bought for so much per hundredweight, etc., by the trade.

However, goods sold under these conditions allow the member to have more money available to purchase additional equipment, produced by Australian Manufacturers, to replace any burnt out components, as well as that used when redesigning to his own particular requirements.

We trust you will publish this reply so that any fears your readers may have will, at least, be partly allayed. We say partly, because even if the Institute did not enter the field, such equipment would still have been offered by the Disposals Authorities and no one would stop a person from purchasing same from any recognised distributor. Our authorisation appears in Hansard."

As requested by the W.I.A., this letter is printed in full, not that it in any way alters the fact that radio component manufacturers have found disposals gear as opposition to their business progress. It was never our intention to blame the W.I.A. for this, but just to remark upon it as being part of the problems which are the aftermath of wars.

—A. G. HULL.

7 WAYS to Better Performance



1
Filament Transformers
Type TP55 6.3 volts, 3 amps, 15 watt, 14/6.

2
Audio Transformers
Long experience in the production of highly efficient transformers combined with extensive research into raw materials and design has resulted in the production of Audio transformers of excellent performance and complete reliability.
Size 2 3/4 x 2 3/8 x 1 3/4.
Type TB42 A class single, 3 to 1 ratio 21/-
Type TB43 A class Push Pull, 3 to 1 ratio 22/6
Type TB44 B class Push Pull, 1 1/2 to 1 ratio 21/-



3
R.C.S. Voltage Dividers
Wound with oxidised nichrome wire on round bakelite formers 3 3/4 in. x 3/4 in., complete with mounting legs.
VD25 15,000 ohms, 2 variable clips 5 6
VD28 25,000 ohms, 2 variable clips 5 6

If you are unable to obtain from your local dealer write us and we will arrange for your retailer to receive supplies immediately or advise you where supplies can be obtained

Put these R.C.S. Components into your set for **PROVEN** better performance !

4 DUAL WAVE UNIT

D.W. 37
Dual Wave Unit with R.F. Stage £6/10/-
D.W. 29 4/5
Dual Wave Unit £1/14/-



5 POTENTIOMETERS AND RHEOSTATS



7/6 Retail

PT 40	6 ohm 25 amp
PT 38	10 ohm 25 amp
PT 39	20 ohm 25 amp
PT 34	30 ohm 25 amp
PT 46	400 ohm 50 M/A
PT 47	1,000 ohm 35 M/A
PT 49	2,500 ohm 30 M/A
PT 51	5,000 ohm 30 M/A
PT 52	10,000 ohm 30 M/A

The R.C.S. volume control is constructed so as to cut off all volume, the main fittings are made from high-grade nickel silver, and they are so manufactured as to be completely noiseless.

6 LINE FILTER

Wound to P.M.G. Specifications

The R.C.S. Line Filter is specially designed and constructed to eliminate all noises which occur by reason of feedback from power mains . . . electric motors . . . refrigerators . . . elevators . . . sub-stations . . . high tension wires . . . irons . . . and jugs! Easy to install—it connects between the radio and power point.



LF20 27/-

7 Coils and I.F.'s

FM 10.7 Meg. Intermediates, 13/- each.
FM 10.7 Meg. Discriminator Transformer, 17/6 each.
FM 88—110 Aerial, Oscillator, Coupling Coil, 2/6 each.
E 356 Aerial, 7/6 each.
E 357 R.F., 7/6 each.
E 358 Oscillator, 7/6 each.
175 K.C. Intermediates, 13/9 each.
455 K.C. Standard Intermediates, 13/- each.

R.C.S. RADIO PTY. LTD.

174 CANTERBURY ROAD, CANTERBURY, N.S.W.

The NEW METROPOLIS 4

OVER the past three years, the most popular kit set by far that the Aegis Manufacturing Company has produced, has been the "Metropolis Four." Its neatness, simplicity, and performance has made it a receiver that could be con-

By

**THE ENGINEERING STAFF,
Aegis Manufacturing Co.
Pty. Ltd.**

structed and appreciated by all. This has prompted them to bring out a new and improved version to carry on the good name of its predecessor.

THE NEW RECEIVER

The first decision was to have the cabinet modernised. The general appearance has been brightened, while maintaining the original design. Second, and of course the important aspect, was to improve the radio receiver. The development of new valves has enabled us to obtain a much improved performance with a simplified circuit. The valves used in the new "Metropolis" are the Radiotron Type X61M Converter, 6AR7GT Duo Diode Pentode, KT61 Output Pentode, and 5Y3GT Rectified.

Once again, due considera-

tion had to be given to limiting the total H.T. current drain so that it does not exceed 40 mA. Use has been made of our original scheme of operating the output valve screen at 100v., this being obtained from a voltage divider network which feeds all the screens and the oscillator plate. This method of operating the output valve is much better than overbiasing to keep down plate current, as this results in the tube being operated on the curved portion of the curve with

higher distortion. With the method used, the output valve bias is only 1.8 volts, which means that only 1.8 volts peak of audio is required for full output of about 1.5 watts; adequate for a receiver of this type.

The circuit generally is quite standard and is based on the Radiotron RD33 described in Radiotronics No. 140, with some modifications to suit our

(Continued on next page)

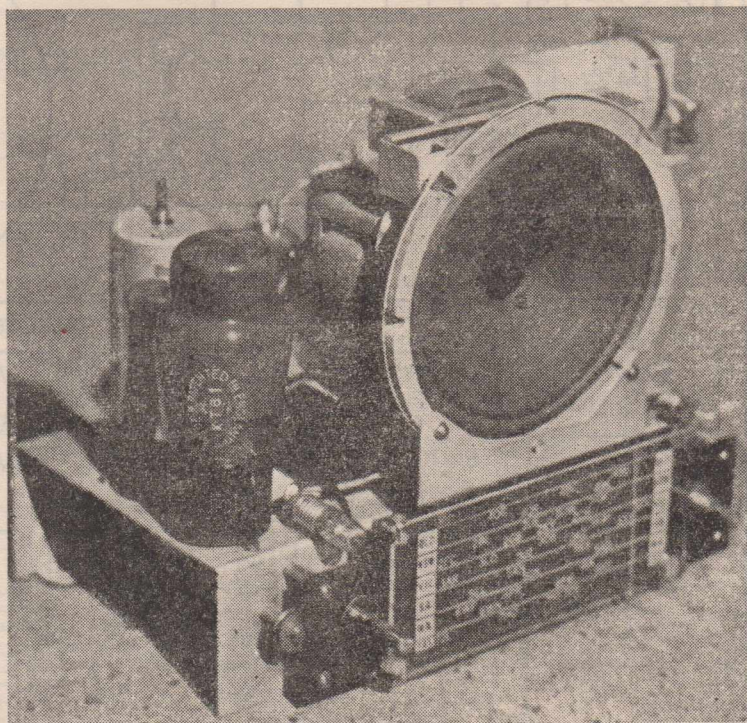

METROPOLIS

(Continued)

own components. The use of the X61M is preferred to the 6A8G, and we have designed a new oscillator coil to suit the new tube under the conditions of operation, resulting in very consistent oscillator performance. From this point of view the placement of the

oscillator grid resistor is very important, and the connection from grid to earth is much better than across the padding condenser as in the older model.

The A.V.C. has been changed to the simplified circuit. Two thirds of the A.V.C. voltage is applied to the converter and I.F. valve, this being consistent with small set design. The .05 meg. grid stopper used on the KT61 prevents the I.F.

voltages being amplified by the output valve, thus removing objectionable whistles that would be present when the volume control is at maximum.

ASSEMBLY AND WIRING

Assemble the sockets, I.F.'s, gang condenser, coils and power transformer. Wire the filaments, coils and I.F.'s, plate and guide rail, and fit the dial cord as per instructions.

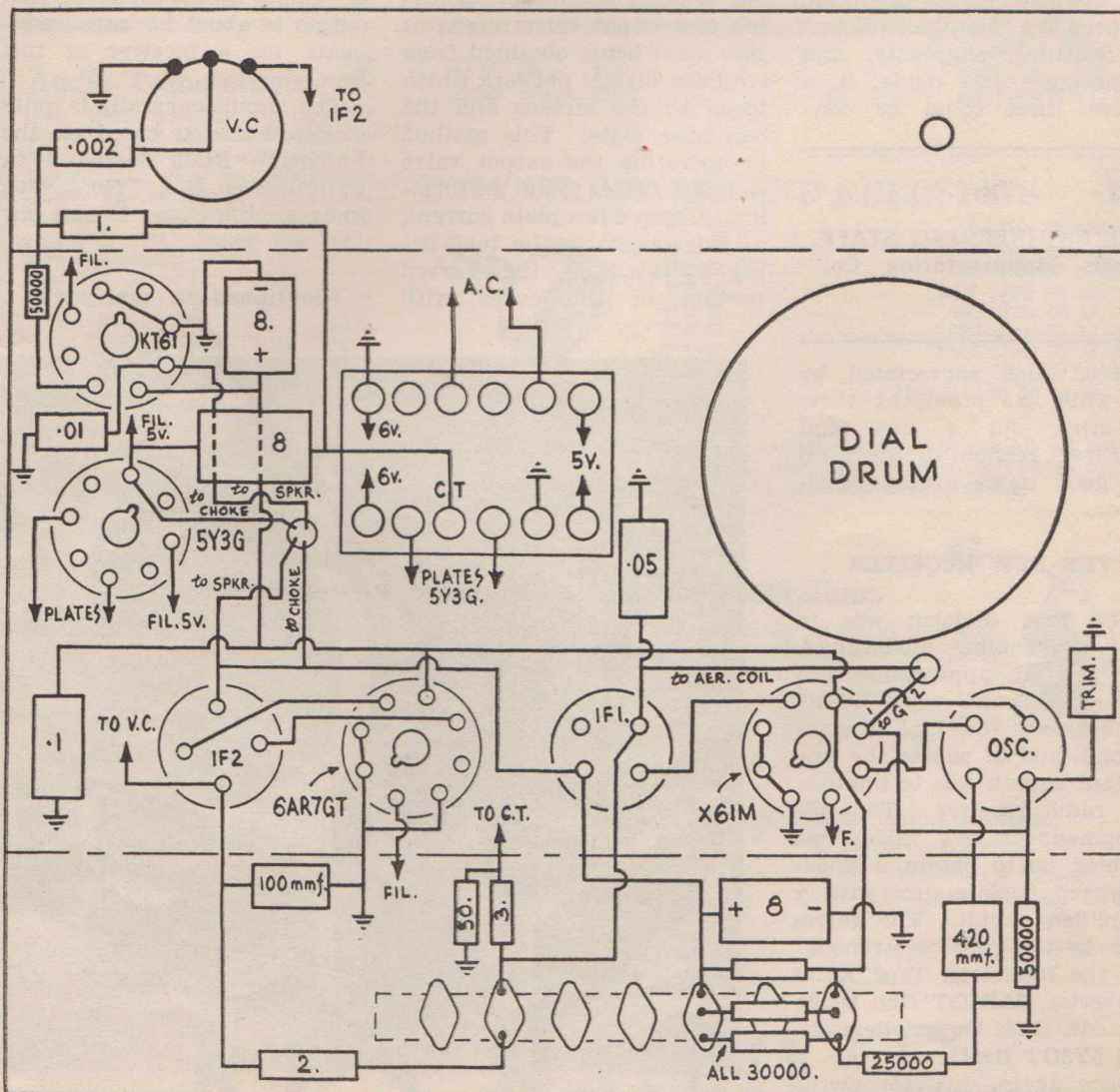

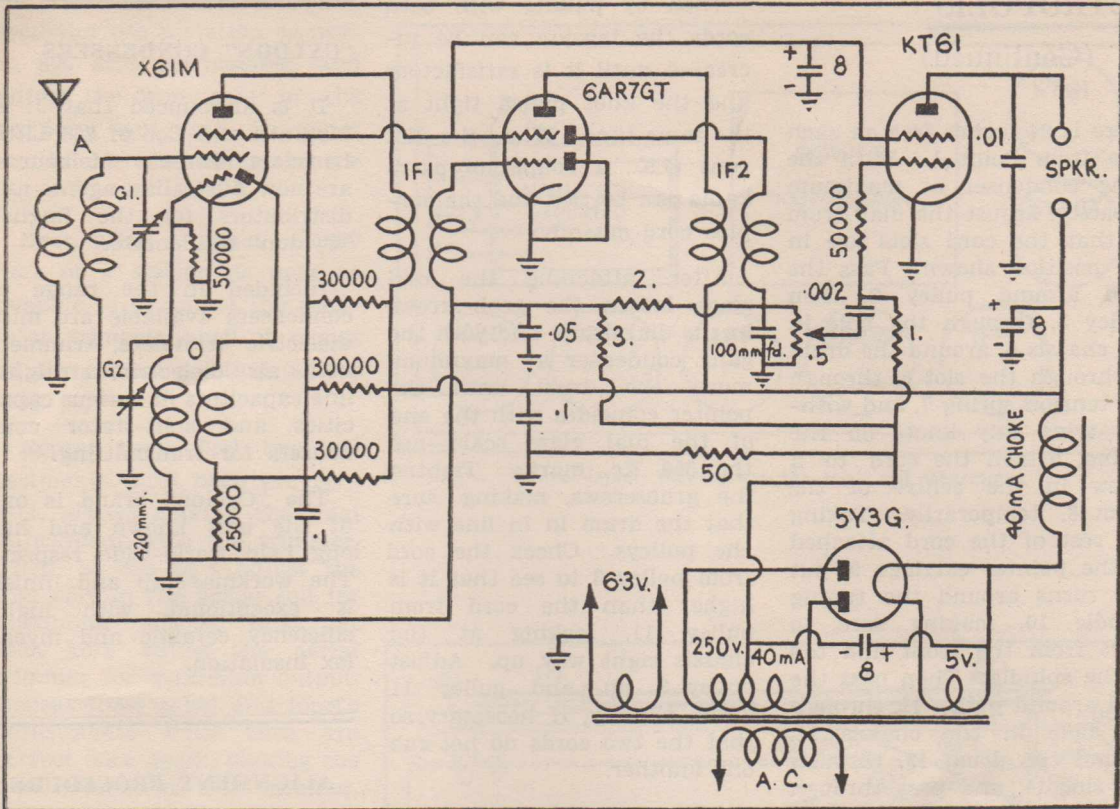

PARTS SUPPLIED WITH "AEGIS" KIT

- | | |
|---|---|
| 1—Condenser 2 Gang Type A.W.A. | 1—Condenser .01 mfd. |
| 1—Aerial coil—Aegis "Hi Core" type M.9. | 1—Condenser Paper .002 mfd. 400V. |
| 1—Oscillator Coil—Aegis "Hi Core" type M.11. | 1—Condenser Paper .05 mfd. 400V. |
| 1—No. 1 I.F. Transformer—Aegis "Hi Core" type, J.9. | 1—Condensers Paper .1 mfd. 400V. |
| 1—No. 2 I.F. Transformer—Aegis "Hi Core" type, J.10. | 3—Condensers Electro. 8 mfd. 525V. |
| 2—Trimmers, Type M.E.C. | 1—Resistor Carbon 50 ohms, 1/3 watt. |
| 1—Power Transformer 250-0-250V-40mA 6.3V-3A 5V-2A (Trimax). | 1—Resistor Carbon 25,000 ohms, 1/2 watt. |
| 1—Permag. Speaker Rola 5C 12,000 ohms to 15,000 ohms. | 2—Resistor Carbon 50,000 ohms, 1/3 watt. |
| 1—Filter Choke 40mA. | 3—Resistors Carbon 30,000 ohms, 1 watt. |
| 4—Valve Sockets. | 1—Resistor Carbon 1 megohm 1/3 watt. |
| 1—Resistor Mounting Strip. | 1—Resistor Carbon 2 megohms. |
| 1—Chassis. | 1—Resistor Carbon 3 megohms. |
| 1—Choke Mounting Bracket. | 1—Potentiometer Carbon 500,000 ohms. |
| 1—Coil Mounting Bracket. | 2—Grid Clips. |
| 1—Dial Plate. | 1—Dial Spring. |
| 1—Dial Glass. | 1—1/2-in. Grommet. |
| 1—Tuning Spindle and Bush. | 4 feet Dial Cord. |
| 1—Dial Guide Rail. | 4—Rubber Dial Glass Mounts. |
| 1—Pointer and Carriage. | 1—Cabinet, Bakelite. |
| 2—-in. Pulleys. | 1—Baffle and Silk. |
| 1—1/2-in. Pulley. | 2—Knobs, Bakelite. |
| 1—Dial Drum 2 7/8-in. Bakelite. | 1/8-in. Bolts—Nuts—Eyelets—Solder Lugs—etc. |
| 1—Condensers Mica 100 mmfd. 10%. | Tinned Copper and Hook-up Wire. Power Flex. |
| 1—Condenser Mica 450 mmfd. 2 1/2% | 2—Dial Lights and Holders. |

Finally assemble the speaker and filter choke and wire into circuit.

DIAL CORD INSTRUCTIONS FOR FITTING

Assemble the dial plate and guide rail with the pointer and carriage attached as per the sketch. You will find two short and two long spacers to mount the dial unit the required distance from the chassis. Make sure that the cork spacers are on the outside, that the guide rail is at the top, and that the pointer comes under the bottom of the dial plate. Attach the dial cord to the pointer so that

(Continued on next page)

METROPOLIS

(Continued)

there is 24 inches free on each side from Point 1. With the gang condenser at maximum capacity, adjust the dial drum so that the cord slots are in the position shown. Pass the cord around pulley 2, then pulley 3, through the hole in the chassis 4, around the drum 5, through the slot 6, through the tension spring 7, and without tying any knots on the spring, attach the cord to a screw in the centre of the drum 8, temporarily. Taking the rest of the cord attached to the pointer carriage 9, put two turns around the tuning spindle 10, making sure to start from the front and top of the spindle. Then pass the cord around pulley 11, through the hole in the chassis 12, around the drum 13, through the slot 14, and pass through the tension spring 7, from the opposite side to the first cord. Free the first cord and, holding one cord in each hand, tie a single overhand knot, as though tying a bootlace.

Then by pulling with both cords the tension can be increased until it is satisfactory and the knot pulled tight at the same time. When the dial runs O.K., a couple of extra knots can be tied and the surplus cord cut off.

After attaching the dial glass, loosen the grub-screws in the dial drum, and with the gang condenser at maximum, move the drum until the pointer coincides with the end of the dial glass scale—not the 550 Kc. mark. Tighten the grubscrews, making sure that the drum is in line with the pulleys. Check the cord from pulley 3 to see that it is higher than the cord from pulley 11, looking at the chassis right way up. Adjust pulley 3 up, and pulley 11 down, slightly, if necessary, so that the two cords do not rub one another.

A drop of thin oil on the pulleys slide and tuning spindle will improve the running of the dial, but make sure that no oil gets on the spindle where the cord runs around it.

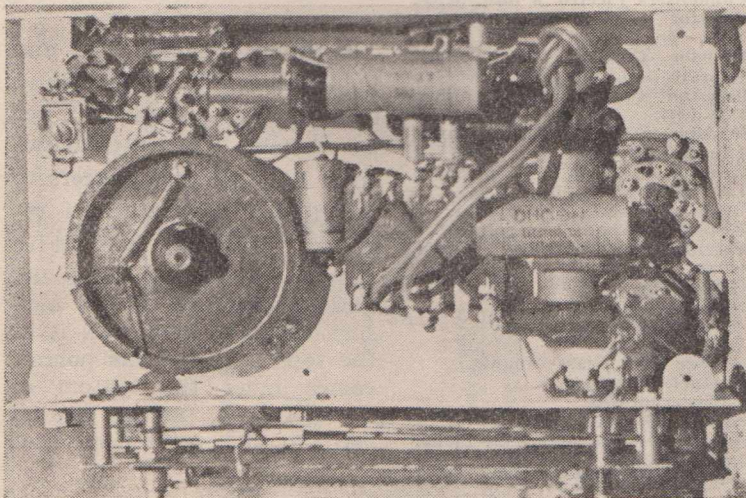

“CYLDON” CONDENSERS

It is announced that J. H. Magrath and Co., of 208 Little Lonsdale Street, Melbourne, are now Australian agents and distributors for the English “Cylidon” condensers.

Included in the range of condensers available are mica dielectric trimmers, trimmers with air dielectric, straight-line capacitors in various capacities and split-stator condensers for transmitting.

The “Cylidon” brand is one of the best known and has long held world-wide respect. The workmanship and finish is exceptional, with high-efficiency ceramic and mycalex insulation.

ALIGNMENT PROCEDURE

Having got the receiver to work, and if possible, checked, the voltages should be H.T.—220 volts, screens—100 volts, C. T. of H.T. Secondary (Bias) — 1.5 volts. If no test oscillator is available the factory setting must be relied on to give the I.F. frequency and the iron cores adjusted to give maximum output. If using a test oscillator to line the I.F.'s, feed it through a condenser to the grid of the I.F. and mixer tube in turn, without removing the grid caps so that the bias is maintained on the tubes.

After aligning the I.F. channel, bring the aerial and oscillator circuits into line, using a signal of 600 kc/s from the test oscillator (if it has no dummy antenna, use a 100 mmfd. condenser in series with the aerial lead and the oscillator) for those without an

oscillator use a station as near to 600 kc/s as possible, and adjust the iron core in the oscillator coil until it comes on the correct position on the dial.

Next, using a signal of 1400 kc/s or a station as near as possible to it, adjust the oscillator trimmer until it comes on the correct position on the dial.

Repeat these first two adjustments until both are correct, always making the final adjustment with the trimmer. Then, at 600 kc/s adjust the iron core in the aerial coil for maximum output. Next, at 1,400 kc/s adjust the aerial trimmer for maximum output. Repeat these third and fourth adjustments until both are correct once again, making the final adjustment with trimmer.

In conclusion we can say that for its economy and simplicity it is the most amazing little set that we have had the pleasure of releasing and we feel sure that it will ably carry on the traditions of the "Metropolis Four."

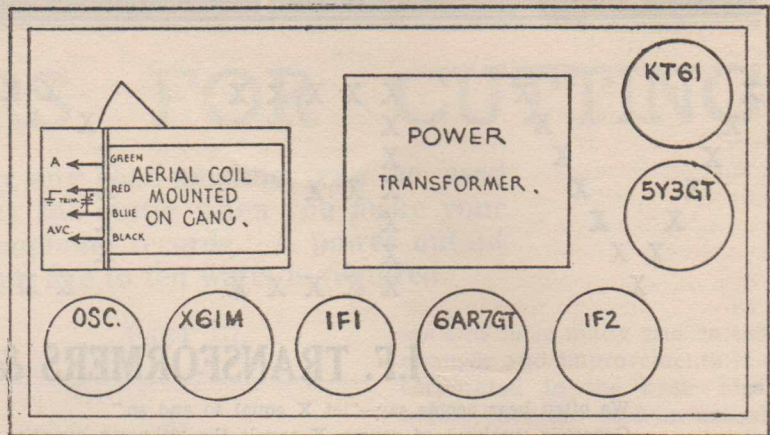

Plan of layout, showing also the aerial coil connections.

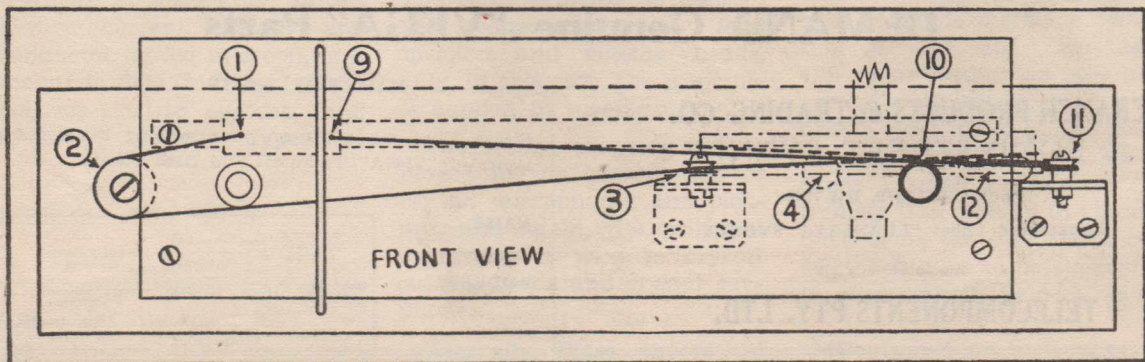
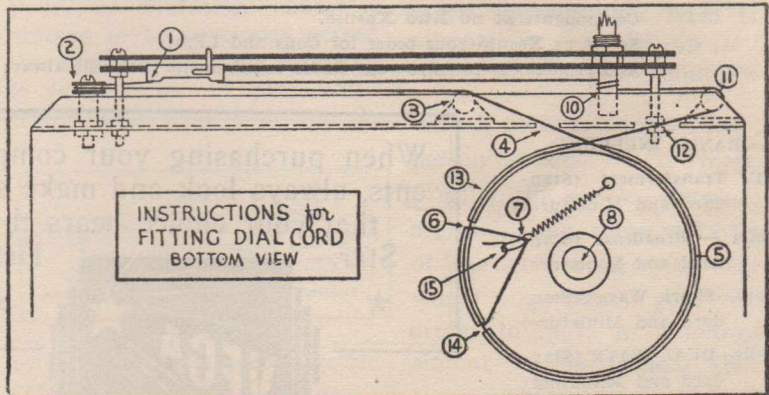

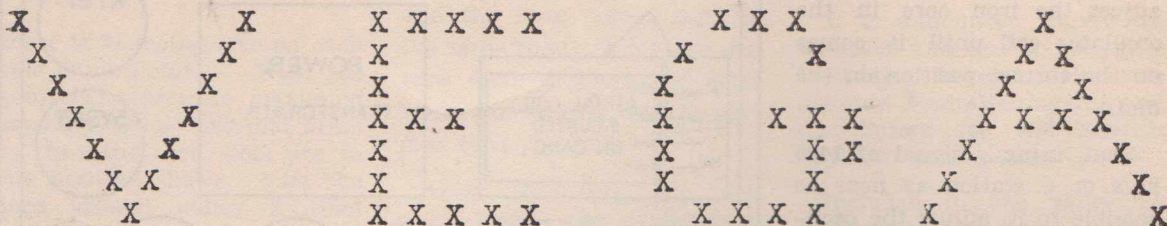

I.F. TRANSFORMERS & COILS

We often hear people say—"let X equal so and so."

Generally speaking, of course, X equals the unknown quantity, but here "VEGA" gives a slightly different interpretation of the equality of the letter X.

The Xceptional Xplanation is to Xamine the Xtraordinary Xample shown above, and we find that, in this instance, the collection of X's equals (or spells) "VEGA."

Now "VEGA" Xpressly Xpounds that the Xtensive Xperience gained over the past X number of years by our Designs Engineer is now Xpertly and Xpansively Xhibited in our I.F. Transformers and Coils.

Also, we have Xercised Xtreme care with regard to "tropic proofing" of "VEGA" Radio Components at no Xtra Xpense.

So let us Xecute your order for Coils and I.F.'s!

And remember—to solve your Radio requirement problems always let X = "VEGA."

RANGE INCLUDES

I.F. Transformers (Standard and Miniature)

Coils — Broadcast (Standard and Miniature)

Coils—Short Wave (Standard and Miniature)

Coils—DUAL WAVE (Standard and Miniature)

Tuning Units, etc.

When purchasing your components, always look and make sure that your choice bears this Star Design



OBTAINABLE FROM ALL DISTRIBUTORS

If your regular supplier cannot fulfil your requirements drop us a line, mentioning his name and address.

ASK FOR — INSIST ON —

DEMAND Genuine "VEGA" Parts

CRANCH PRODUCTS & TRADING CO.
17 BOND STREET, SYDNEY

Phones BU 3879, BW 7746

Telegraphic Code: "CRANLAY," SYDNEY

Associated with

TELECOMPONENTS PTY. LTD.

MAIL THIS TODAY

Please place my name on your mailing list for free issues of "VEGA" Technical and Data Sheets.

NAME.....

ADDRESS.....

2R/W

AMPLIFIERS FOR CUTTING

Practically any good amplifier can be used for driving the cutter when you make your own gramophone records. A power output of from five to ten watts is required.

THIS third section of our series of articles on Home Recording deals with the electronic side of the business, that of amplifiers and amplification. This article does not necessarily apply only to the recording enthusiast, but to all those whose interest lies in reproduction of good quality from audio amplifiers.

In this section we will deal with everything, from the minute electrical impulses from the pick-up and microphone, right through the amplifier to the power output stage.

INTRODUCTION

Starting right back at fundamental electrical principles, we learn the theory of generation of an electric current.

Basically, as far as we are concerned, there are two major methods of generation of an electric current. Firstly, any conductor moved in a coil, in a magnetic field, induces in that coil an electric current; and secondly, certain types of

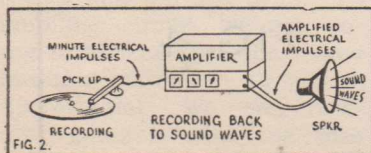
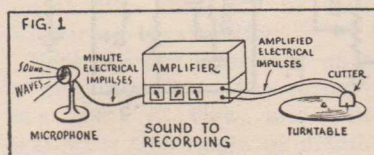

FIG. 2.

PART III

By
JOHN McLEAN BENNETT

crystals of mineral salts, when placed between two metal plates and subjected to movement or vibration cause a voltage to be developed across the two plates. This property is referred to as piezo-electricity, and such a crystal is



referred to as a piezo-electric crystal.

The first property is made use of in the dynamic and ribbon type microphones, and the magnetic type pick-up. The same principle is used in the construction of loud speakers and cutting heads, only, in this case, the principle is applied in reverse.

The second property is employed in the construction of crystal microphones and pick-ups, and again, the principal in reverse is used in crystal cutting heads and crystal ear-phones.

Naturally, these theoretical

systems have many and varied changes and improvements incorporated in the basic idea before they are used in actual practice in the construction of each different piece of equipment. The main idea behind this brief reflection on theory being to impress the reader with the thought that, in effect, the first thing to reach the amplifier from the microphone or pick-up is a series of electrical impulses.

Back to our theory, when a person speaks, he is merely causing the air to vibrate in a certain way, these vibrations of the air reach your ears, where they cause your ear-drums to move in a manner similar to the original vibrations. This movement of the ear-drums sends a message to your brain which translates the vibration into the words which the speaker uttered. The main point here being that sound is merely a vibration of the air. As these vibrations, minute as they are, are able to make your ear-drums move, there is no reason why they would not be able to cause a small coil, or an extremely thin ribbon, to vibrate. Such being the case, if the coil or ribbon were to be supported in a magnetic field a small

(Continued on next page)

RECORDING

(Continued)

electric current would be generated within the coil or ribbon.

Following along the same lines, if a crystal of Rochelle Salt were to be placed between

two metal plates, and subjected to sound vibration, as mentioned in the preceding paragraph, then an electric current would be developed across the plates.

If these two ideas were used under somewhat similar conditions, however, the vibration in this case being sup-

plied by the movement of a gramophone needle in the groove on a recording, we might expect the result to be the same; the generation of minute electric currents. These cases having been proved and thoroughly investigated, we are merely working back from an already accepted fact to

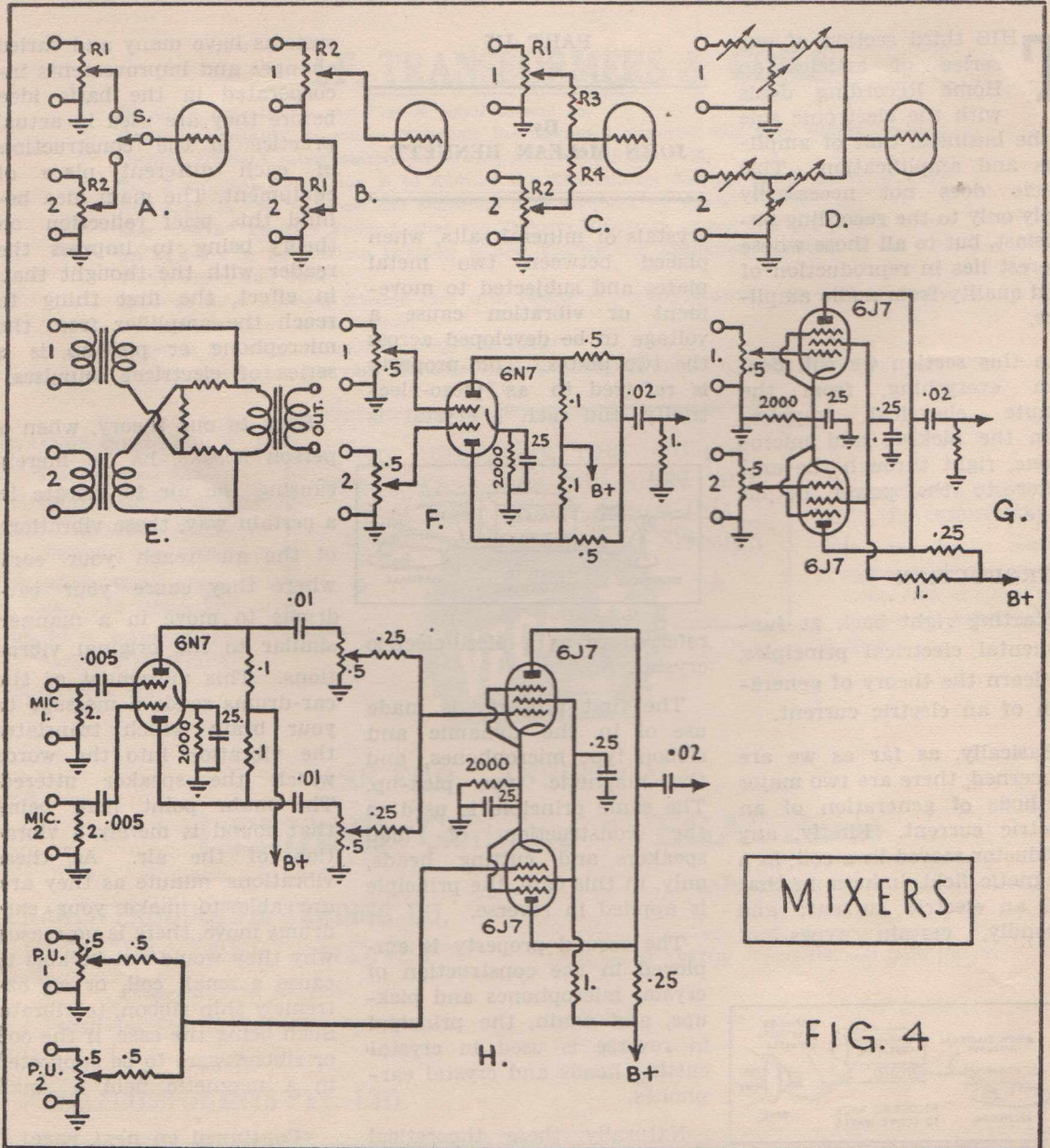

MIXERS

FIG. 4

the theoretical side of the question.

Having converted the original sound wave into minute electrical impulses, we are desirous of making these impulses of greater magnitude, this is where the amplifier moves into the field of action. It is by the use of the electronic valve, in different ways, that we are able to do the most spectacular things with these minute electrical impulses received from the microphone and pick-up.

The normal speaking voice of a sports commentator may be made available to thousands at a sports meeting, you are able to speak to a relative who is on holiday in another country, or further still, listen to your favourite radio programme.

To make these impulses audible again, in the form of sound waves, the principle of the microphone and pick-up is applied in reverse. The electrical impulses are made to vibrate a coil or armature, in a magnetic field, which, in turn, is made to move a speaker cone. The vibration of the speaker cone sets the air in motion, corresponding with the original sound waves as they reached the microphone.

So much for our sound waves, electrical impulse generation and so on; we now find ourselves confronted with the more technical aspect of the amplifier; its design.

It is not intended to set out here a detailed account of the theory and working behind an amplifier circuit, we are going to assume that the reader has this knowledge already at his disposal. We are, however, going to give the idea behind the various desirable

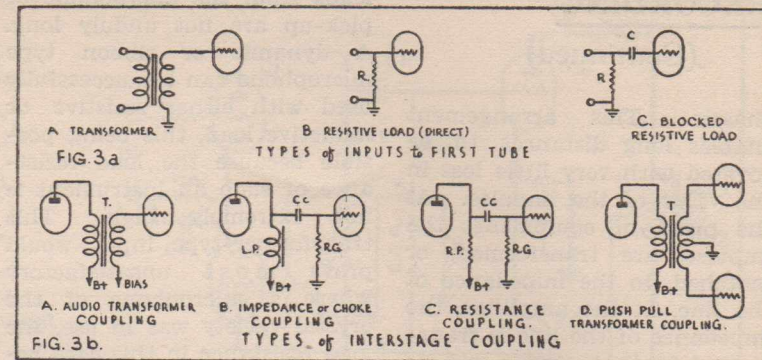

features which may be incorporated in the construction of such an amplifier.

DESIGNS

In designing an amplifier for any specific purpose, it is always desirable to first set out the purpose, requirement to attain that purpose, equipment at your disposal, and any other technical or mechanical data that will be useful during construction.

Here, we are interested only in amplifiers from the recordist's point of view, and will deal with this angle in detail, while covering the other sides of the question at the same time.

Taking the major sections first, we will divide them up later. We find that our amplifier must have at least one microphone and one pick-up input, have reasonable high-frequency characteristics and a sufficiently large power out-put to permit cutting discs without running the amplifier at its maximum.

These three major sections or requirements, which ever you prefer to call them, are now to be examined a little more closely.

Looking firstly towards the most important section of the amplifier, the input, we have

to decide what type of microphone or pick-up we are going to use with the circuit. As, upon the piece of equipment to be used, rests, to a large extent, the system or circuit to be used in conjunction with it in the input. Fig. 3a shows three methods, in their most simple form, commonly used in input stages. Before the electrical impulses can have any effect, they must be provided with some form of load or resistance across which the voltage can be developed. This load can be supplied inductively, by use of a transformer, or resistively, by using a load resistor; Fig. 3a.A. shows the transformer hook-up, 3a.B. the resistive load, and 3a.C. the condenser-blocked resistive load.

The transformer is normally used with low-impedance line, that is to say, lines or cables having an impedance ranging from 50 ohms to about 600 ohms. Low-impedance lines are used on microphones and pick-ups when a long distance has to be covered to reach the amplifier.

The idea is to have two transformers in the circuit, one on the piece of equipment, the other on the amplifier

(Continued on next page)

RECORDING

(Continued)

chassis. This arrangement enables long distances to be covered with very little loss in the value of the impulse. At the piece of equipment, the impulses are transformed, or matched, to the impedance of the line, at the amplifier, the impedance of the line is transformed to that of the grid. If this were not done, the resultant loss in the magnitude of the minute impulses would be so considerable that by the time they had been made to travel over several hundred feet of cable, they would be almost non-existent.

The resistive load is employed where the required load resistance is beyond the scope of a transformer, or where the

leads from the microphone or pick-up are not unduly long. A dynamic or ribbon type microphone can be successfully used with either resistive or inductive load, this being possible because the load resistance of such an instrument is not extremely high. This transformer-type input would prove most unsatisfactory where a microphone of the crystal variety was in use, the load resistance in this case being somewhere around the 5 megohm mark, quite out of the range of an efficient transformer. The same applies to a crystal pick-up, which is normally loaded with about .5 megohm.

The blocked resistive load is more or less a safety device, the condenser passing only A.C. and not allowing D.C. onto the grid. The condenser

also has some effect upon the frequency response of the circuit; the smaller the capacity, the higher the frequencies passed.

Having given this matter of basic output circuits some study, you will realize that the job you intend to do, or the equipment you are going to use will play a big part in the design. If you are going to tackle outdoor work, where you will be running long lines to your microphones, the only thing is a ribbon or dynamic microphone used in conjunction with low-impedance line. On the other hand, you may intend to use a crystal microphone, indoors only. There you will employ the resistive load, blocked or otherwise.

Do not gain the impression that the transformer can only be used in conjunction with low-impedance line and a line to microphone transformer. (The transformer on the amplifier is called the line-to-grid, and that in the microphone or pick-up, the microphone-to-line or pick-up line.) This is entirely wrong, many microphones have a small transformer built into them, of the microphone-to-grid type. Although these do not require a line-to-grid transformer, they still have to be loaded with a resistor, across which to develop their output.

Most pick-ups of the magnetic type require a load resistance similar to that of the crystal type, about .5 megohm. The low-impedance type pick-up, commonly found on transcription turntables in Radio Stations, uses two transformers and either 50 or 250 ohm line.

It should now be quite clear in your mind exactly which

Save Money with a Subscription !! Order Yours To-Day

Make sure you get every issue as soon as it is published. Place an order with your newsagent or send direct to us for a subscription.

**IT SAVES YOU MONEY!
IT SAVES YOU TIME!**

We guarantee that every subscriber has his copy posted the same day it comes off the press.



Enclosed please find remittance for 16/- in payment for an annual subscription to the

"Australasian Radio World," commencing with the _____ issue.

NAME _____

STREET and NUMBER _____

CITY _____ STATE _____

RATES

12 issues 16/-

24 issues 30/-

POST FREE

To N.Z. & Oversea

12 issues 18/-

AUSTRALASIAN RADIO WORLD

Box 13, Mornington, Victoria

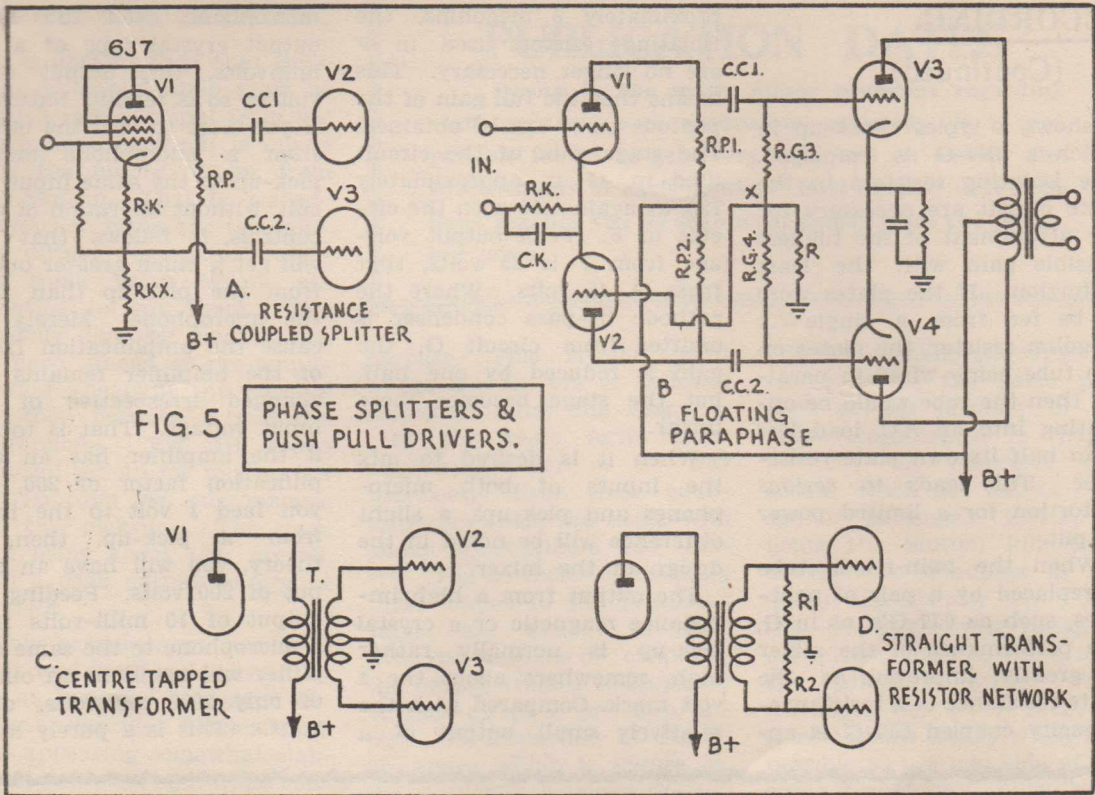

FIG. 5 PHASE SPLITTERS & PUSH PULL DRIVERS.

type of input will be necessary in your particular case.

Having arrived at your decision on the type of input, we pass on to Mixers.

MIXERS

Where two or more signals are on hand and it is wished to feed them simultaneously to the one common output, they are mixed, or blended together, the origin of the name of the circuit which does the mixing, the "mixer," being quite obvious.

A mixer may be designed to cope with any number of signals from two upwards.

Fig. 4 sets out seven methods of mixing two inputs, and one method of mixing two microphone and two pick-up inputs.

4A shows rather a poor type of mixing system, whereby the

separate inputs are switched in as directed. Any number of inputs may be brought to a rotary switch. The serious drawback with this scheme lies in the fact that considerable voltage surges are likely to build up and cause "thumps" in the output as the different circuits are switched.

The circuit of B, also, has serious limitations. As you will notice, the whole of one input is floating, i.e., one side of the input is not earthed. This is liable to lead to trouble with hum. Stray capacities to earth of input 1 are liable to by-pass the high frequencies from input 2. This system is not highly practicable.

C brings forth a somewhat improved version of B, which functions quite satisfactorily. The series resistors, R3 and R4, prevent either R1 or R2 from

shorting out the other. If the series resistor is too low, it becomes ineffective, and if too high, greatly attenuates the signal. The practical compromise being from about .25 to .5 megohm.

D and E show two systems commonly used in studio and communications work. D uses a pair of T-attenuators, these are normally used when low-impedance line is employed. The T-attenuators maintain a constant value of impedance for all settings of the control. E is a low-impedance-bridge system. Both these systems are rather costly, and out of the reach of the average experimenter.

The simple circuit used in

(Continued on next page)

RECORDING

(Continued)

F shows a typical hook-up in which a 6N7-G is employed. The isolating resistors in the plate circuit are necessary for the attainment of the highest possible gain with the least distortion. If the plates were to be fed from a single .1 megohm resistor, the plates on the tube being wired in parallel, then the tube would be operating into an A.C. load less than half its own plate resistance. This leads to serious distortion for a limited power output.

When the twin-triode tube is replaced by a pair of pentodes, such as 6J7-G's, as in G, the performance of the mixer is greatly improved. As the plate resistance of a resistance-capacity coupled 6J7-G is ap-

proximately 3 megohms, the isolating resistors used in F are no longer necessary. This means that the full gain of the pentode stage can be obtained. The stage gain of the circuit used in G is approximately 120, as against 10 with the circuit in F. Peak output voltage from F is 35 volts, that from G, 45 volts. Where the cathode by-pass condenser is omitted from circuit G, the gain is reduced by one half, but the stage becomes more linear.

When it is desired to mix the inputs of both microphones and pick-ups, a slight difference will be noted in the design of the mixer.

The output from a high impedance magnetic or a crystal pick-up is normally rather high, somewhere about the 1 volt mark. Compared with the relatively small output of a

microphone, even the high-output crystal type of a few millivolts, this output of a volt or so is terrific. Naturally, if you were to feed the output from a microphone and a pick-up to the same input circuit, without alteration of gain controls, it follows that you will get a much greater output from the pick-up than from the microphone. Merely because the amplification factor of the amplifier remains unchanged irrespective of the input voltage. That is to say, if the amplifier has an amplification factor of 200, and you feed 1 volt to the input from a pick-up, then, in theory, you will have an output of 200 volts. Feeding the output of 10 milli-volts from a microphone to the same amplifier will result in an output of only 2000 millivolts, or 2 volts. (This is a purely hypo-

A & R

Transformers and Reactors

- ✪ INDUSTRIAL POWER TRANSFORMERS
- ✪ POWER TRANSFORMERS
- ✪ INPUT TRANSFORMERS
- ✪ INTERSTAGE TRANSFORMERS
- ✪ OUTPUT TRANSFORMERS
- ✪ MODULATION TRANSFORMERS
- ✪ FILTER REACTORS

Manufactured by:—

A&R Electronic Equipment Co. Pty. Ltd.

1 LITTLE GREY STREET, ST. KILDA, MELBOURNE, VICTORIA.

PHONE: LA 3657

Available from:—

WM. WILLIS & CO., Bourke St., Melb. MU 2426).

J. H. MAGRATH & CO., 308 Lt. Lonsdale St., Melb.

(Phone Central 3688).

Wholesale Distributors:—

R. H. CUNNINGHAM & CO.,

62 Stanhope St., Malvern, S.E.5 (Phone: UY 6274).

thetical case and would not exist exist in actual practice.)

It is obvious then that some form of amplification must be applied to the output from the microphone before it is mixed with the higher output from the pick-up. That is, we endeavour to bring the two voltage output to approximately the same value before attempting to mix them. This is easily done by placing one, or more, stages of pre-amplification ahead of the pick-up amplifier, between it and the microphone. Fig. 4H shows an ideal set-up for mixing the outputs from two microphones and two pick-ups. The stage gain being about 130., overall, with a peak output voltage of 30 volts.

This arrangement has been tried and used extensively by the author, and has given excellent results. Although at first appearing somewhat elaborate, the hook-up is quite conventional and really simple. It provides the ideal basis for the "front-end" of a first-class recording amplifier.

Either the load resistors as shown, or the previously mentioned line-to-grid transformers may be used in the inputs to the mixers. Depending on the type of microphones and pick-ups to be used.

That cleans up the problem of mixers. We now explore the central or driver and second preamplifier stages.

DRIVERS AND INTERSTAGE COUPLING

Having generated and amplified our signal impulses, we are faced with the fact that these signals, although greatly amplified when compared with the original signals, must be still further amplified before they can be put to any useful

PUBLICATION DATES

Owing to the many minor problems regarding staff, printing and production generally, it is not possible for us to get every issue out on exactly the fifteenth day of each month. Rest assured that each issue reaches you as soon as it comes from the printing press.

purpose. This is the point where the drivers or follower amplifiers enter the ring.

In the basic form, these amplifiers differ in no way whatsoever from their counterparts, which we dealt with under preamplifiers and mixers. The methods of coupling these stages to the preceding stages are almost identical with the methods of "coupling" the output from a microphone or pick-up to a pre-amp. input. On inspection of Figure 3b, above which is Figure 3a, the similarity between the inputs and the coupling circuits will be quite obvious.

The audio transformer circuit shown in Fig. 3b.A. is used mainly in high-quality equipment where wide frequency response is desired. The essential difference between the audio transformer and the line-to-grid transformer is the impedance of the primary winding. On the line transformer this impedance will probably be about 250 ohms, on the audio transformer the impedance will be more like 50,000 or 100,000 ohms; the plate load of the tube in the circuit. Audio transformers are expensive items, as a rule, cheap articles usually being worse than none at all.

The choke coupling set out at B is a compromise between the audio transformer and re-

sistance-capacity coupling. The choke serves the same purpose as the primary of the audio transformer, in that it provides an inductive load across which the output voltage is developed, instead of using the mutual inductance of the two windings in the audio transformer for coupling, the alternating voltage is capacity coupled to the grid of the following stage. This method is not widely seen, but is sometimes handy when it is possible to use one side of the audio transformer only.

The common resistance-capacity coupling, or resistance coupling as it is mostly called, is outlined in C, R_p being the plate load resistor of the first tube, C_c , the coupling condenser, and R_g , the grid resistor of the following amplifier stage. This is by far the most popular method of inter-stage coupling in use. The expense: efficiency ratio, between resistance coupling and audio transformer coupling makes resistance coupling first favourite among experimenters.

The push-pull driver is not strictly a form of voltage-interstage coupling falling into the same class as the three previous systems, but is shown in D to give the reader an idea of how it is possible to use

(Continued on next page)

RECORDING

(Continued)

the transformer for coupling. This may seem odd, but now we are going to contradict our own statement which we made a few lines above, that this is not a form of inter-stage coupling. This is not true, strictly speaking; it is a form of inter-stage coupling, but what is called "single-ended" coupling, which is what we were dealing with. This is phase inversion coupling, and is used to drive push-pull output or driver stages. This phase inversion can be accomplished by the use of resistance-capacity coupling or transformer coupling, and will be dealt

with later in this article when we cover push-pull stages.

Up to this point we have dealt with voltage amplifiers only. There are two types of amplifiers which you will encounter in audio work, the voltage amplifier and the power amplifier. The voltage amplifier is used from the first input tube to the driver before the power output stage. All amplification from the input, up to and including the driver for the output, is voltage amplification. A voltage amplifier is one in which the voltage gain is the all-important factor. A voltage amplifier usually works into a rather high load impedance, normally about 1 megohm, when the load impedance is rather low there can be no distinct line

of division between the voltage amplifier and the power amplifier.

The highly amplified voltage must be given power before it can be put to any use with a speaker or cutting head. This is done by using a power amplifier in the final stage of the amplifier.

The power amplifier works into a low impedance primary of an output transformer, across which the power is developed, in a manner similar to the voltage amplifier. We do not intend to go deeply into the matter of power output stages, apart from the fact that we will set out the various different arrangements used in power stages.

Class A. Operation is the normal operating condition for

Build Your Own Player . . .

with a

STROMBERG-CARLSON

AUTOMATIC RECORD CHANGER

By making your own cabinet unit strictly to your own design—or by purchasing one you'll find it's less costly and more satisfying to "build your own," using the New Stromberg-Carlson Automatic Record Changer. It's easier to instal, easier to operate, and by far the best unit.

JUST NOTE THESE FEATURES—

Uses all standard discs. Plays ten 12-inch or twelve 10-inch discs at one continuous playing. Fast change cycle—approximately four seconds. The simple foolproof mechanism cannot jam. Feather-light needle pressure.

Record spindle precision machined, ensuring long life for discs. "Glide" change routine cannot chip or crack discs. New heavy duty motor. Motor, silent in operation, cushion mounted, no audible rumble or "wow." Discs drop quietly to the new electro statically flocked heavy pile turntable. Installations made from top—quick, easy mounting. Only two adjustments, liquidates servicing. Automatic or manual operation. New type cut-off switch—automatically stops on last record.

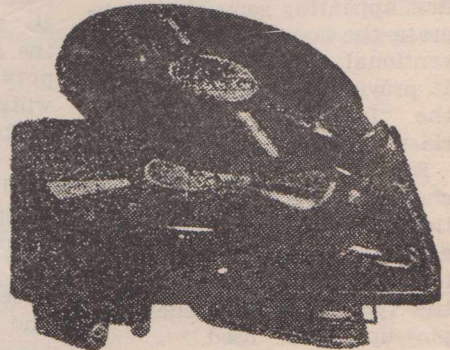

STROMBERG-CARLSON AUTOMATIC RECORD CHANGER

AVAILABLE ALL STROMBERG-CARLSON RETAILERS

Manufactured in Australia under licence from Webster Chicago Corporation—world's largest manufacturers of automatic changers.

For further particulars write direct to:

Stromberg-Carlson (A'asia) Pty. Ltd., 118 Bourke Rd., Alexandria, N.S.W.; Warburton Frankl (Melb.) Ltd., 380 Bourke St., Melbourne, Vic.; Stromberg-Carlson (A'asia) Pty. Ltd., Wilson House, Charlotte St., Brisbane, Qld.; Radio Wholesalers Ltd., 26 James Place, Adelaide, S.A.; Musgrove's Ltd., Lyric House, Murray St., Perth, W.A.; Wills & Co. Pty. Ltd., 7 Quadrant, Launceston; Findlays Pty. Ltd., Hobart, Tas.; Rabco (Wholesale Distributors) Pty. Ltd., 291 Hunter St., Newcastle, N.S.W.

a single valve, where plate current is not cut for any portion of cycle.

Class AB. Conditions apply when the valve is overbiased. Used only in push-pull stages where it is desired to balance out even harmonics.

Class B. Operating conditions apply to valves necessarily in push-pull, where they are biased almost to the point of plate current cut-off.

Where a figure 1 follows the letter, such as AB1, the 1 indicates that no grid current flows during any part of the cycle. The figure 2 indicates that grid current flows during part of the cycle at least. The 2 is omitted where B class operation is used, as grid current is the normal condition.

POWER OUTPUT AND REQUIREMENTS

Power output stages may be of either the single-ended, or one valve type; parallel, two or more valves; push-pull, two valves; or push-pull-parallel, four or more valves. Our discussion will only deal with the first three types.

When a single valve is employed in the output, especially a small valve such as the 6V6, it will be running close to its maximum rating when you endeavour to make recordings. Naturally, higher powered valves can be used with single ended operation.

As a starting point, let us take 10 watts as the minimum power output desirable from our amplifier. This is going to rule out the use of low-power valves like the 6V6 and 6F6, in single-ended operation. It may possibly allow us to use a 6L6, running at maximum.

We are obviously forced to

turn to the high-power triodes and tetrodes. An 807 used single class A would just give us the power, but just, and with nothing to spare.

When you are operating a valve close to its maximum ratings as a power amplifier, you will find that you are faced with two major difficulties. One, when the amplifier is "flat-out," all hum, electron hiss and valve noise will be very much in evidence in the reproduction from the power stage. Mainly, because all gain controls are at the maximum position, making use of every scrap of available drive, and those noises are easily passed on and amplified. Secondly, where the tube is near its limit harmonic distortion content of the signal, for a given output, will be excessive, and extremely detrimental to any good quality reproduction which the amplifier may otherwise be able to give forth. This will be noticed also where parallel tubes are in use. Parallel tubes give twice the output of one tube, but with very little improvement as regards the loss of harmonic distortion content of the final signal.

Both the above-mentioned difficulties may be overcome by the use of push-pull output stages. As the name implies, one tube is operative while the other is inoperative. That is, one pushes while the other is doing nothing. Then the inoperative tube "pulls" on the other half of the cycle, whereupon, the first operative tube falls to zero. A push-pull stage will give twice the output of a single ended type.

To bring about this state of affairs, the two valves in the output stage must have their grids fed with signals which are 180 degrees out of phase.

This can be done in a variety of ways; transformer coupling, resistance coupled phase splitter, or "Floating Paraphase" systems being quite common.

As the secondary of the transformer provides two voltages, which are 180 degrees out of phase, the circuit arrangement as shown at Fig. 5C provides an ideal system which can be used on all types of amplifiers. The transformer must be designed to meet the requirements of each individual set-up. The transformer with the resistors in parallel with the secondary, as shown at Fig. 5D allows for operation similar to that of the centre-tapped transformer of C. It must be noted that resistors in the divider network on the secondary must be carefully calculated to reflect the right load impedance into the primary of the transformer, as they constitute part of the load themselves. The load reflected to the plate, Z_p , can be calculated by using the following formula:

$$Z_p = \frac{R_1 + R_2}{N_2^2}$$

Where: Z_p is the reflected plate load,

R_1 and R_2 are the load resistors on the secondary.

N is the step-up ratio of the transformer.

e.g. When R_1 and R_2 are each 100,000 ohms and the step-up ratio of the transformer 3:1.

$$R_1 + R_2 = 200,000 \text{ ohms}$$

$$N_2 = 9$$

$$= 22,000 \text{ ohms.}$$

$$Z_p = \frac{200,000}{9}$$

(Continued on next page)

RECORDING

(Continued)

This figure is rather low for the average load impedance into which the normal general purpose triode will work satisfactorily without distortion. Consequently, the value of R1 and R2 may be increased to obtain the right reflected load of about 50,000 ohms.

By simple transformation, the formula for finding the value of the load resistors becomes:

$$R1 + R2 = Z_p \times N_2$$

$$Z_p \times N_2 \qquad Z_p \times N_2$$

$$R1 = \frac{\quad}{2}; \quad R2 = \frac{\quad}{2}$$

The resistance coupled phase splitter and the "Floating Paraphase" circuits do not use any transformers.

The circuit of the resistance coupled splitter gives little amplification to the input signal to the grid of the phase splitter tube. The cathode and plate circuits both contain the same resistance. These two resistors in series form the load of the tube.

As the input is applied to the tube between grid and earth, there will be a large loss in gain from the stage. Actually, the valve only takes the place of the transformer used in other arrangements. The inclusion of the cathode-by-pass condenser will improve the high-frequency band-pass, but at the same time will upset push-pull drive balance.

The explanation of the "Floating Paraphase" would entail much more space than we have at our disposal here, but, suffice to say, that the idea is somewhat similar in operation to the resistance coupled type; the resistance coupling being preferred to that of the Paraphase. Resistance coupling cannot be used successfully where the drive requirements necessitate the flow of grid current, as in class AB2 or class B. The use of a transformer is imperative in such a case.

So much for amplifiers in general, and the requirements in their construction. It only remains now to summarize the article and the requirements in an amplifier, from the angle of the recorderist.

Choice of the type of input circuit rests with the individual constructor, as does the type of inter-stage coupling. The main things that we can recommend are as follows:

Use a pair of tubes in the output stage, in push-pull, which will supply all the audio you need, with plenty in reserve.

(Continued on Page 34)

**WANT
MORE
MONEY?**



**LEARN
RADIO
IN YOUR SPARE TIME**
... COSTS LESS THAN
THE AVERAGE MAN
SPENDS ON TOBACCO.

BIG OPPORTUNITIES: Here's your opportunity to make big money in radio! Right now, openings in radio are greater than the number of men available to fill them. It's a wonderful chance for you to rapidly qualify for a good pay radio job or start a business of your own. **AND YOU CAN EARN WHILE YOU LEARN!**

COURSE HAS HELPED THOUSANDS: The Australian Radio College offers ambitious men a complete and proven course in radio engineering. Thousands of students owe their present success to this famous course. You, too, can prepare for a grand future helped by the College. You don't need a

previous knowledge of radio—we teach you all you need in a simple manner that makes learning easy.

EARN IN SPARE TIME: We show you, too, how you can earn extra money almost from the start. Many students make up to £8 weekly in their spare time while studying.

COSTS LITTLE: And yet the course costs surprisingly little. For a few pence a day—actually less than many men spend on tobacco—you can train for a profitable job in radio.

Prepare **NOW** for your career in this fast-growing industry. Take the first step by mailing the coupon for our interesting free book, "Careers in Radio and Television." It's a book you **CANNOT AFFORD** to miss!



**THIS
FREE
BOOK
SHOWS
HOW!**

**ACT
NOW!**

**AUSTRALIAN RADIO
COLLEGE PTY., LTD.**
206 BROADWAY, SYDNEY, N.S.W.

Please send your free book, without obligation on my part.

NAME _____

ADDRESS _____

10/1271

HIGH STABILITY V.F.O.

Here is a handy tip for converting a bit of surplus gear into an effective variable-frequency oscillator.

BEFORE starting in earnest on this article, it will be necessary to briefly outline these tuning units and their application.

Undoubtedly, many readers are already familiar with the

By

JOHN McLEAN BENNETT

unit in question, and could probably describe the thing with their eyes closed, however to the article.

Readily available through many sources to-day, are the tuning units for the BC375E series transmitters. The BC375E was used extensively

throughout the war years by the U.S. Army Signal Corps; mainly for communication between Liberator bombers and ground installations. The transmitter is comparatively low-powered, the nominal power input to the final stage being about 150 watts. The frequency coverage of the big ranges from 150 to 12,500 kc., this large coverage is made possible by the use of plug-in tuning units. Seven tuning units being used to cover the entire range. More about these later. The transmitter uses a pair of 211's, one as a plate-tuned Hartley master oscillator, the other as the P.A. tube. The R.F. section of the rig has only these two stages,

however, there are four 2115s in the whole assembly, the other pair operate as class B modulators to modulate the 211 in the final.

Drive for the P.A. stage is taken from a tap on the oscillator coil, and fed via a blocking condenser to the P.A. grid. A point of interest being that all block condensers used in these units are of the 3,000 volt variety, very nice indeed for high-voltage bypass. While talking of the P.A. stage, it might be mentioned that neutralization of the P.A. is accomplished by taking a tap on the oscillator tank, the same number of turns above the H.T. tap as the drive tapping is below, and feeding it back to the P.A. tank. Adjustment of neutralization is possible by alteration of the variable condenser in the lead. Both the oscillator tank and P.A. tank are above ground as there is H.T. on them.

DETAILS OF COIL UNITS

As was mentioned before, there are seven coil units to the complete set for each transmitter; they are as follows:—

- TU26B, of very little use. Range, 200-500 kc.
- TU5B, Range: 1.5-3mc/s. Osc. cond. 20-135 pf. P.A. cond. 20-156 pf.

(Continued on next page)

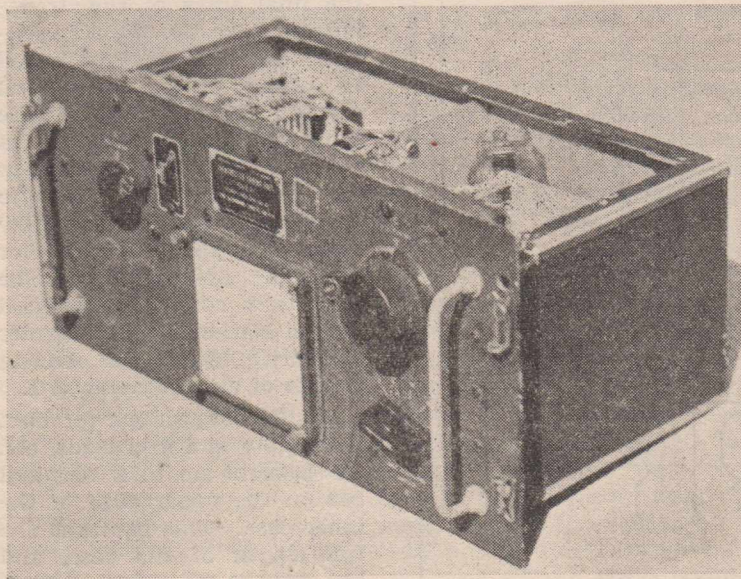

V.F.O. (Continued)

TU6B, Range: 3-4.5 mc/s., in two steps, 1. 2.85-3.65 mc/s.; 2. 3.45-5.2 mc/s.
Osc. cond. 15-75 pf. P.A. cond. 19-116 pf.

TU7B, Range: 4.5-6.2 mc/s.
Osc. cond. 23-111 pf. P.A. cond. 19-116 pf.

TU8B, Range: 6.2-7.7 mc/s.
Osc. cond. 14-66 pf. P.A. cond. 15-81 pf.

TU9B, Range: 7.7-10 mc/s.
Osc. cond. 15-77 pf. P.A. cond. 19-116 pf.

TU10B, Range: 10-12.5 mc/s.
Osc. cond. 14-62 pf. P.A. cond. 19-116 pf.

Each coil unit is housed in an outer protective case made from dural, the actual case of the coil unit and its associated panel being held in the outer case by sliding spring clips. The coil box itself is completely shielded, the top and bottom cover plates being removable.

The inside of the box is divided into two equal sections by a metal partition, the section on the left housing the oscillator inductance, condenser, all block condensers, R.F. chokes and the neutralizing condenser. The right-hand section contains the P.A. inductance and condenser, and also the ceramic, six position, antenna tapping switch.

The oscillator tank condenser is made from Invar, a metal with a low coefficient of expansion, to minimize capacity variations with change in temperature. The condenser is mounted on ceramic blocks above the coil, and is double spaced. The dial drive mechanism on the oscillator condenser gives, in effect, 2,500 degrees of rotation on the calibrated scale, for the swing of the condenser, that is, one half revolution. This allows for really accurate calibration and adjustment when the

unit is used for a V.F.O., of course the Ham Bands are not spread over a complete swing of the condensers, but only portion of it.

In the case of the TU8B unit, which was used in the preparation of this article, the band spread on the 7 mc/s band worked out to just on 290 degrees, from 580 to 870 on the dial scale. Naturally, the spread will differ with different layouts and methods of construction. However, there should be only slight variations from our figures.

The coil in the oscillator section has a temperature compensator built into it, and is tension wound with silver-plated wire on a pre-grooved former. The neutralizing condenser, in the oscillator compartment, has a value of 8-26 pf. in all units; and is adjusted by a knurled bakelite insulating wheel, made accessible by the removal of the calibration chart on the front panel.

The P.A. section contains the condenser and inductance for the final stage of the transmitter. Like the master oscillator coil, the final tank coil is wound on a pre-grooved ceramic former. Fixed inside the coil is the antenna-output coupling coil. This coil has six tapings, all of which are brought out to the heavy duty ceramic tapping switch for selection of coupling. The final tank condenser is fitted with a National velvet-vernier dial drive mechanism, having a ratio of approximately 5:1.

All the connections for bias, H.T., plate and grid leads, etc. are brought up to a terminal bar on the upper edge of the inner case. This bar runs the full length of the case, and has ten banana-type sockets

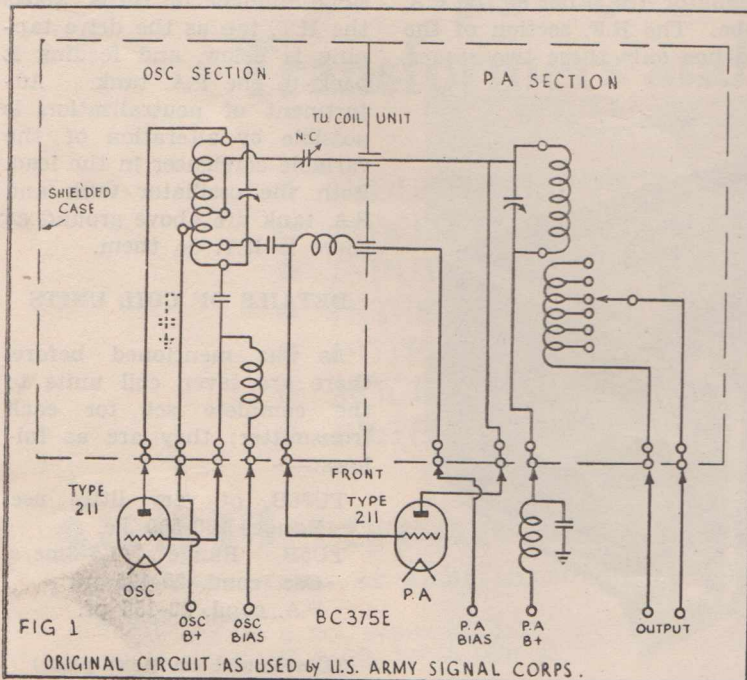

on it for the connection to the tubes and what have you in the transmitter proper. These sockets automatically connect with pin plugs in the transmitter, when the unit is plugged in.

CONSTRUCTIONAL DETAILS FOR V.F.O.

Having several types of units available, from TU6B to TU10B, it was decided that consideration would be necessary before deciding on the unit to be chosen for the V.F.O. Finally, it was decided that in all probability the TU8B unit would best serve our purpose. Such proved to be the case. The TU8B was chosen, mainly, because the frequency of the article in its original state included the 7 mc/s band, and as the intention was to construct a V.F.O. for use on a fundamental of 7 mc/s.

On inspection of the unit and its circuit diagram, it is obvious that all the components contained in the original box of tricks will not be necessary. The major components, i.e., the coils and associated tuning condensers, will be necessary, the neutralizing condenser is removed, and the block condensers and R.F. chokes left in position.

The original idea was to use a Clapp circuit, but this was scrapped, and an E.C.O. circuit used instead.

The first step in the construction of the E.C.O. is to remove all the heavy silvered-copper bus bar connections between the components. The only connections left standing are the connections from the tuning condensers to the coils. Having removed this wiring, the next step is the removal of

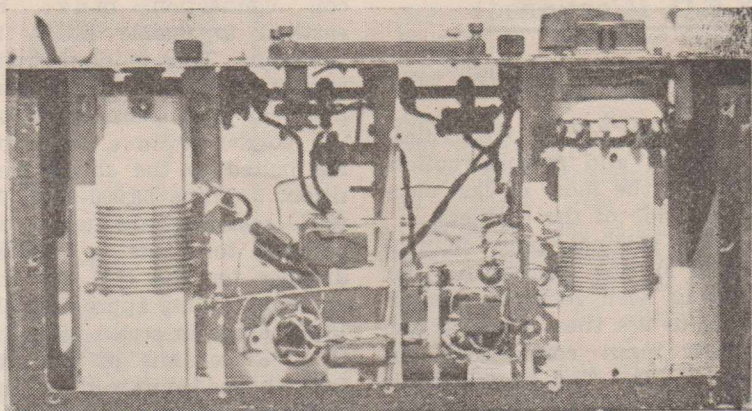

the neutralizing condenser. This is done by firstly taking off the calibration chart on the front panel, thus exposing the screws which hold the condenser in place. Most, if not all, the screws in the unit are "sealed," to prevent them loosening, with a type of cellulose lacquer. Often the lacquer makes it impossible to shift the screws. This difficulty is overcome by painting either lacquer thinner or nail polish remover on the screws. After a couple of seconds, the lacquer has softened, thus enabling you to easily shift the screw or bolt.

The lacquer on the screws holding the neutralizing condenser are treated as just described, and then removed. The condenser is anchored to the panel by four screws, which are tapped into the ceramic supporting pillars. Care should be taken while shifting these screws, that the ceramic pillars are not fractured by straining the condenser out of position before the screws are completely released. Now the condenser can be easily removed from the case, and put to one side, as it will not be used in the construction of the V.F.O.

At the extreme rear of the two compartments, near the dividing shield, there is quite a deal of space. Into this space we fit one valve in each section, a 6SK7-GT in the oscillator, and a 6V6-G in the P.A.

The Hartley master oscillator now become an E.C.O., using a 6SK7 as the oscillator tube, and the P.A. section becomes an isolator-amplifier, using a 6V6. The valve sockets for the two tubes are mounted directly opposite each other, but on different sides of the shield. A $\frac{3}{8}$ in. hole is bored in the shield, about $1\frac{1}{2}$ in. up from the bottom of the shield, and about $1\frac{1}{2}$ in. out from the back of the case. Two small right-angled brackets are made from $\frac{1}{2}$ in. steel strip, about $1\frac{1}{2}$ in. x $\frac{1}{2}$ in. (See Fig. 3.) These brackets must be extremely rigid, as any movement, no matter how slight, will eventually lead to trouble with instability and frequency drift. Both brackets are mounted on the same bolt, one on each side of the partition. To these

(Continued on next page)

V.F.O. (Continued)

brackets are bolted the valve sockets.

So much for the mechanical wrecking and re-construction, now to the more or less electrical side of the business.

The original plug connections in the connecting bar having been removed, we are able to use these plugs as the power input connections for the V.F.O. The heater leads are brought to the centre-most two of the five sockets in the oscillator section. See Fig. 2.) The heaters are wired with twisted hook-up and are not earthed, although both sides are by-passed on each tube. After wiring the heaters, the oscillator section receives some attention.

No alterations are made to any of the coils in the unit, apart from the removal of all the tapped connections on the oscillator coil, and the addition of the H.T. tap on the amplifier coil.

The rotors of the oscillator condenser and its associated

coil connection must be earthed to enable E.C.O. to function. This is done quite simply, by taking a lead from the rear-most connection on the condenser to a soldering lug bolted to the shield partition. Three 50,000-ohm, 1-watt resistors are wired in parallel to make a voltage dropper for the H.T. for the oscillator, giving approximately 16,000 ohms in series with the H.T. Either one of the two R.F. chokes contained in the oscillator section can be used as the plate load for the 6SK7.

As most of you are probably aware, voltage stability in an E.C.O. depends largely on the correct positioning of the cathode tap on the grid coil. Finding this position is generally a matter of trial and error, but in this case it was found that the centre tap of the coil was the best. This tapping had originally been the tap for the lead to the neutralizing condenser.

The grid leak in the oscillator seems to have an optimum value of about 25,000

ohms, in parallel with a condenser of about 250 pf.

Drive for the amplifier is taken from the plate of the 6SK7, via a .01 mf. condenser and a small, 12 turn, parasitic choke to the grid of the 6V6. The grid resistor being a metalized 33,000 ohm type. After trying various values of condensers as heater by-pass, in order to iron out some "wogs," we found that the only values which did the trick were 425 pf. and 750 pf. Having placed a pair of 750 pf. mica condensers on the heater leads of the V66, we found that some of our "wogs" had gone, but not all of them. On looking, it was found that there weren't any more 750 pf. condensers left, but we did find several 425 pf. types. We substituted the 425's for the 750's on the 6V6, and placed another pair of 425's on the 6SK7. Hey Presto! No "wogs"!

The Buffer amplifier tank is of the straight-out, series-feed type, with the modification that the H.T. is fed to the coil two truns up from the bottom, or cold end. This, working in conjunction with the small feed-back from the loop connected to the 6V6 plate, and twisted around the grid lead, neutralizes the job.

Many may scoff at the idea of neutralizing a buffer amplifier, especially in a V.F.O. But let us assure you that we found it necessary, as one minute you could set the oscillator on what you thought to be, say, 7.10 mc/s; several minutes later the thing seemed to be oscillating on about a dozen frequencies that it wasn't oscillating on before. We'll admit that it sounds crazy—in fact it drove us crazy—but which ever way you look at it, there it is!

Nevertheless, having ironed

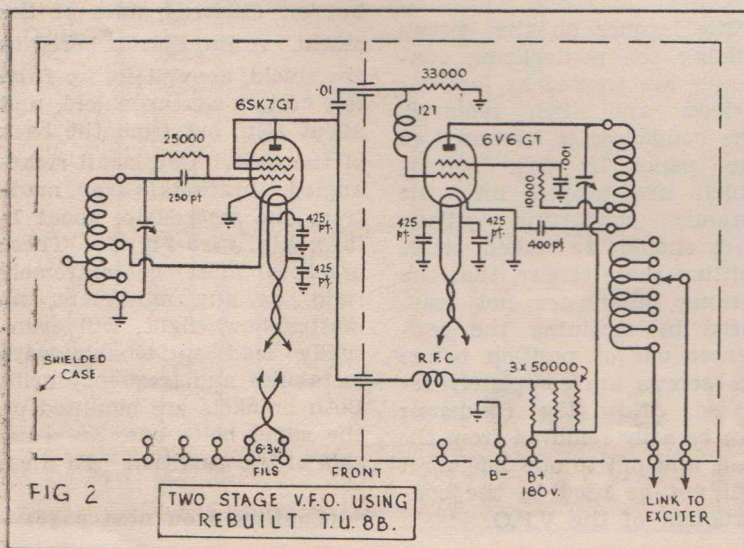

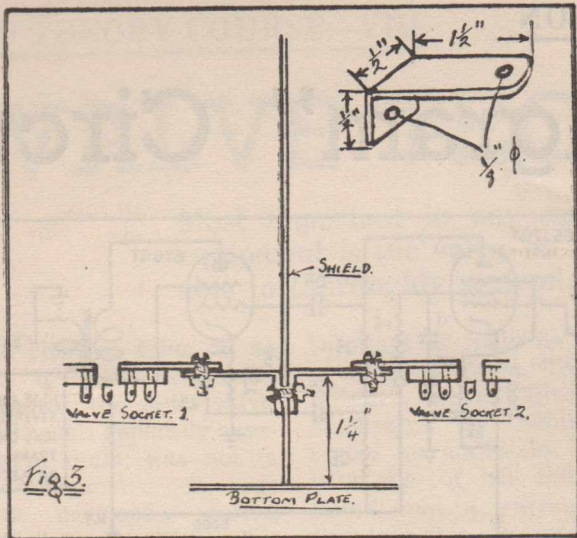

out all these difficulties, we're game to venture that it would be one of the most stable V.F.O.'s. that is around to-day, and all working off an unregulated, well filtered, 180-volt external power supply.

The 6SK7 oscillator is wired as a triode, with about 120 volts on it. One of the 400 pf. block condensers originally used in the unit is used as the R.F. by-pass on the Buffer amplifier.

As can be seen, the 7.0 mc/s band is near the low end of the scale on the oscillator, and it will be found that the Buffer resonates at about 5 to 10 on the dial scale.

MAGRATHS HAVE THEM!

In addition to the popular Connoisseur products listed below, new pick-ups and turntables specially designed for use with the latest micro-groove long-playing records are on the way. Amongst these is a two-speed turntable giving speeds of 33 1/3 and 78 r.p.m. Full 12" in diameter, lathe-turned and manufactured in non-ferrous material. The main spindle, precision-ground and lapped, runs in phosphor-bronze bearings, and is virtually vibrationless. High-grade studio microphones and recording equipment. All Connoisseur products are precision-built and individually tested.

Connoisseur (Reg'd) PICK-UP

An acknowledged leader in its class, giving an even response curve from 30-12000 C.P.S. Only 30 grams is required at needle point for correct tracking. 2 models are available; standard (illustrated) for 10"-12" discs and transcription arm model for playing 17" discs.

Connoisseur (Reg'd.) GRAMO-MOTOR

Is designed for the connoisseur who likes these fine technical developments that produce faithful reproduction. The heavy non-ferrous turntable is machined to run dead true, the flywheel action eliminating all "Wow."

Connoisseur (Reg'd.) AMPLIFIER

Is in the true tradition of Connoisseur sound reproducing instruments. Distortion at 5W is less than 0.5 per cent. Bass control variable from 3 to plus 15db at 50C.S. Treble control variable from minus 20 to plus 8 db at 15 Kcs.

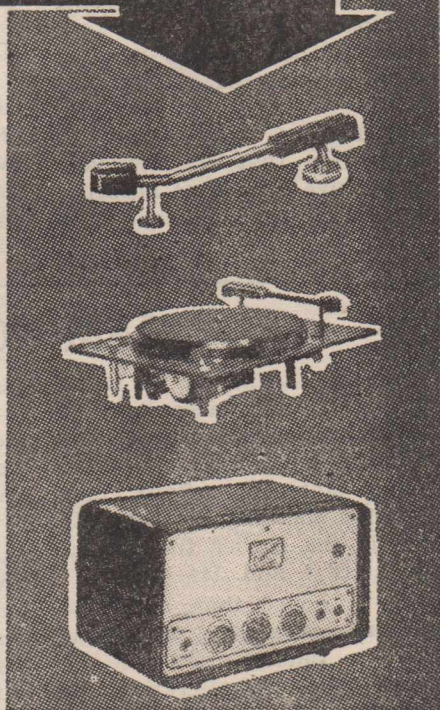

J.H. MAGRATH & Co.

208 LT. LONSDALE ST., MELBOURNE *Phones: CENT. 3688*
4414

The "Panagram" Circuit

ACCORDING to Mr. Jack Kling, of the General Sound and Film Services, of Bacchus Marsh, Victoria, this is the first time this circuit has ever been published. It is a flexible circuit for the record enthusiast. The switching circuits provide a wide range of control over the frequency response of the amplifier by altering the characteristics of the feedback circuit.

Among other noteworthy features of the circuit is a switch which allows the screen by-pass condenser to run either to the cathode or direct to earth.

As with all amplifiers using feedback, there are two ways in which the speaker winding can be connected. If the amplifier squeals when first switched on, it is simply an indication that the feedback is positive instead of negative. Reversing the connections of

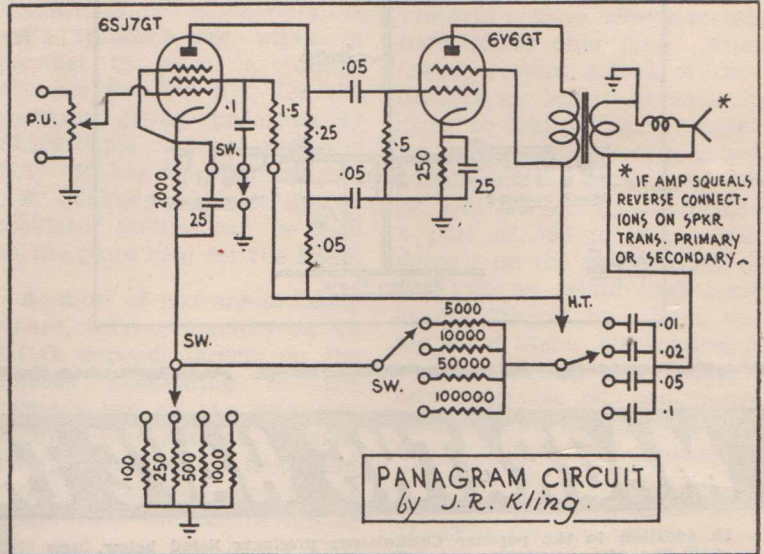

either primary or secondary of the output transformer will put things right.

If so desired, a 1,000 ohm potentiometer can be used in

place of the resistors in the cathode return circuit and a 100,000 ohm potentiometer in the other position. This will allow an almost infinite control over the feedback.

HAM NOTES

Seems as though 10 is on the out, and according to official scientific predictions, will be out for some time. This state of affairs may prompt some of you boys to tackle the higher frequencies, such as 6 and 144 mc/s.

It is hoped that, sometime in the near future, we will be able to run an article on the conversion, or alteration, of the U.S.A.S.C. Transceiver, the I.F.F. unit, for operation on the 144 mc/s. band.

We have our own ideas on

just what we want to do, but it will be a matter of experimental trial and error before we can give anything definite on the set-up.

Theoretically, everything should work out fine, having given much thought to the business. Nevertheless, as many of you will have doubtless found out for yourselves, alterations to a lot of the surplus equipment lying round does not always go quite according to plan. We're going to wait and see!

The circuit is also admirably suited for use with high-powered output valves, such as the 807, which can be used with higher plate screen voltages in order to get about ten watts of power output.

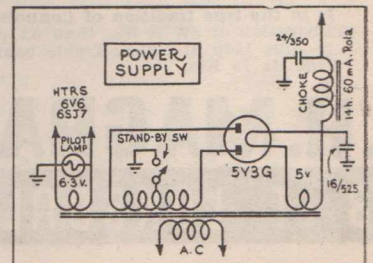

VALVE TECHNIQUE

Most important in any radio or electronic equipment is the valve, so it is highly desirable to thoroughly understand its operation.

THE electron tube, or, as it is more commonly known, the radio valve, although generally associated with radio, was not a radio development. It was originally developed during electrical experimenting, but has been modified and added

By
W. S. LONDEY,

8A Barkly St.,
Sale, Vic.

to for radio work and is probably used most in radio. Many thousands of different types have been made and increasing applications are being made in industrial and commercial work. Photo-electric controls, voltage regulation, automatic timing of processes, measuring instruments and accounting machines are only a few of the cases outside radio and telephone communications where electron tubes are used. The tubes range in type from the simple diode used as a rectifier, to amplifiers, relay tubes, photo-electric tubes, and cathode ray oscilloscopes. Some tubes are capable of carrying out two or three different operations in the same envelope and may have nine or ten connections brought out to pins or caps.

As early as 1883, long before

the days of radio as a means of communication, Thomas A. Edison, when investigating blackening of lamp globes, sealed an additional electrode into one of his lamps. He found that a current would flow into this electrode when it was positive with respect to the filament, but that none would flow when it was negative. Edison did nothing further along these lines but he told an English scientist named Preece, who developed the idea somewhat further. J. J. Thompson recognised the phenomenon to be due to the flow of electrons which are released from the hot filament and attracted by the positively charged plate near by. A German inventor promptly utilized the phenomenon to "rectify" alternating current.

In 1904, James A. Fleming, an Englishman, who was one of Marconi's associates, suggested that the rectifying action of the diode may be used

as a detector of radio signals. His subsequent development of what is known as the Fleming Valve gave the vacuum tube its first real start towards its present development.

In 1906 Dr. Lee DeForest, an American radio experimenter, modified the Fleming Valve by the addition of a third electrode consisting of a grid of fine wires in an attempt to control the cloud of electrons between the filament and the anode. The results were profound and probably no other single invention has had more influence on the development of radio.

The principle of the action of the third electrode or grid is simple. If the grid is positive it will attract electrons from the filament but most of them will be moving so rapidly that they will pass through the spaces between the wires of the grid and will then be attracted by the more positive plate. If the grid is made less positive fewer electrons will be attracted from the filament and therefore less will pass to the plate, reducing the plate current. When the grid is negative with respect to the filament it will actually repel the electrons leaving the filament and reduce the plate current still further. The amount the grid is negative controls the plate current, most valve types being designed to operate with the grid always

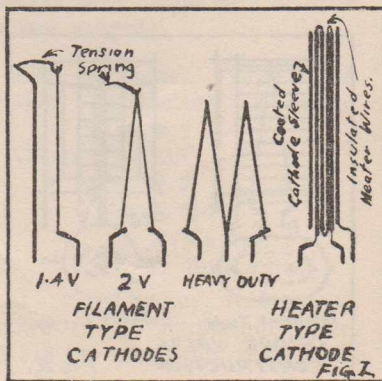

THEORY

(Continued)

more or less negative. This is done for two reasons, firstly, the plate current is reduced and this will increase the cathode life, secondly, if the grid becomes positive it immediately draws some electron to itself, therefore it draws current and requires power from the driving circuit. Very few circuits in a radio can supply appreciable power so that a grid becoming positive would cause trouble. Basically, then, the triode, as the three electrode valve is termed, is a tube in which a small voltage change on the grid can cause a large change in plate current by controlling the electron flow between filament and plate.

If this changing plate current is passed through a resistance or impedance there will be a change in the voltage drop across the resistance. As one end of the resistance is at a fixed potential—the h.t. supply voltage—the plate end must vary in voltage. This variation appearing at the plate will be several times that applied to the grid. Useful amplification obtainable with triode valves ranges from two or three times for power type valves to about 100 times for high gain types.

Terms used in connection with radio valves

It would be as well at this stage to define and explain a few of the terms used in connection with radio valves.

(a) **Cathode.** The cathode is the electron emitting surface and is the electrode by which the current leaves the

valve. A number of different types of cathode are used in practice. The cathode may be selected to emit electrons by the application of heat, by the application of light, or by bombardment by electrons.

Early valves were exclusively battery operated and the first filaments were made of tungsten. These had to be operated at a fairly high temperature and had quite a low electron emission. It was found that impregnating the tungsten with a small amount of thorium greatly increased the electron emission and allowed the filament to be operated at a much lower temperature—bright red yellow instead of white hot.

Present radio valves use a filament coated with oxides of thorium, barium, calcium, and strontium and this coating emits electrons quite freely at very low temperatures—very dull red, and has a very long life.

Attempts to operate valve filaments on alternating current were not very successful as the voltage difference between the ends of the filament, being alternating, had the same effect as a small alternating voltage on the grid, introducing excessive hum.

Attempts to reduce this by the use of a low filament voltage and high current were only

partly successful, and it was not until the separately heated cathode was introduced that this trouble was really overcome. This cathode consists of a coated sleeve inside which is a heater of resistance wire. These two parts are insulated from each other and brought out to separate terminal. As the cathode is a metal sleeve it is all at the same potential no matter what the heater voltage and is, in consequence, termed an unipotential cathode. There is a further advantage of the separate heater and cathode it allows the cathode to be at any voltage, positive or negative, with respect to the heater. By the use of a resistance in the cathode lead it is possible to connect the grid to earth potential and still have it negative with respect to the cathode—the cathode being positive. It also made possible the construction of transformerless sets with series heater connection. Early heater cathodes required a large amount of heater power—about 5 to 10 watts—but modern types use much less power and heat quicker. Modern types use as little as one watt in the heater of some valves, others range up to about five watts.

Cold cathodes. Certain materials have the property of emitting electrons if excited by some other means than heat. There are two main types of these cathodes, one which responds to bombardment by charged particles, and the other which responds to light. The first type is used extensively for some types of rectifier, such as the OZ4. The envelope is gas filled and provided the anode-cathode voltage exceeds a certain mini-

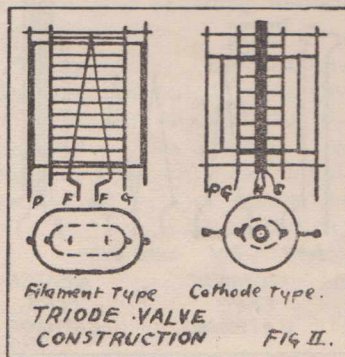

imum value a discharge will be started and the bombardment of the cathode by positive ions will cause it to emit electrons and act in a similar manner to a heated cathode—it does, in fact become heated to some extent. One important requirement of this type of rectifier is that it requires a certain **minimum** current to maintain the cathode in an operating condition.

The second type is called a photo-cathode and the effect was first noted in zinc plates exposed to light by Lenard and J. J. Thompson. The zinc was very insensitive and materials having a much greater sensitivity have been developed, one of the advantages of the newer materials being their sensitivity to light of certain selected colour, different combinations having different properties. Photo-cathodes, however, operate only at currents in the order of micro-amperes, but their operation is as a form of diode which conducts only when the cathode is illuminated. The principal cathode materials are potassium and caesium or combinations of these elements and other materials.

(b) **Anode.** This may be briefly described as the electrode by which the high tension current enters the valve. It is the electrode to which the electrons are attracted after they pass through the grid. In the case of the screen grid valve some of the electrons go to the screen grid but the anode, or, as it is commonly termed, the plate receives most of them. It is also the electrode from which the amplified signal is taken. The anode is usually a cylinder of metal although some valves use a gauze cylinder. As this plate is bombarded by the electrons

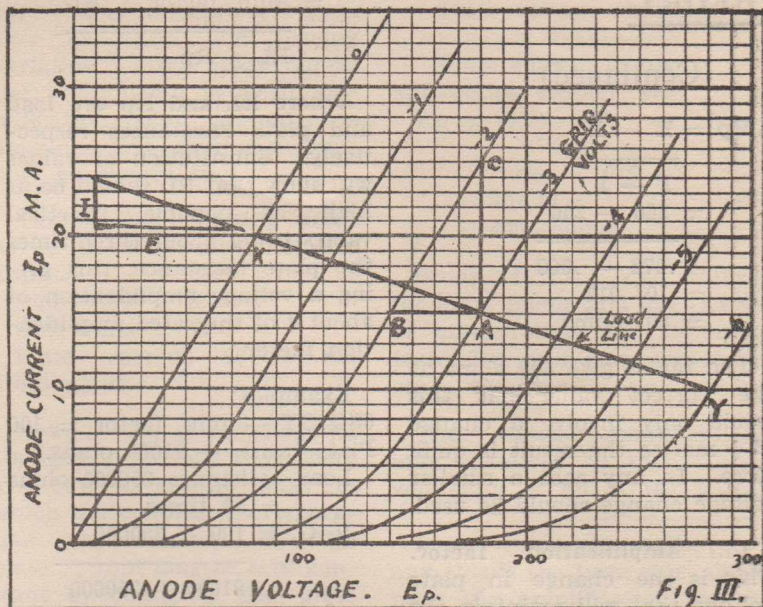

Fig. III.

reaching it, a certain amount of heat is produced and, in consequence, a rating called the **anode dissipation** is generally given in valve data. The anode dissipation is defined as the product of the anode voltage and the anode current (in amperes) and is, of course, given in watts. Strictly the power output should be subtracted from the product to give the true anode dissipation, but, as there are occasions when the power output is zero this can be neglected (except in the case of class B and class C operation when the anode is a function of the power output).

For example: Type 6V6 valve: Dissipation -2 watts.

$$W = E I$$

When $E = 250$

$$\begin{aligned} I &= W/E \\ &= 12/250 \\ &= .048 \text{ amps.} \\ &= 48 \text{ milliamps.} \end{aligned}$$

If the anode voltage is raised to the maximum value of 315 the maximum plate cur-

rent is reduced to 37 milliamps.

(c) **Plate Resistance.** The plate current of a valve may be changed by altering the grid voltage or by altering the plate voltage, the other being kept constant. The plate resistance of any valve is defined as the ratio of the change in plate voltage to the change in plate current, grid and screen grid (if any) voltages remaining constant throughout. The quotient should strictly be found for an infinitesimal change in voltage but a good approximation can be given by taking small changes. The value is expressed in ohms as it is similar in nature to a resistance.

For example: A 2A3 valve has a plate current of 60 ma. with a plate voltage of 250 and a grid bias of -45 volts.

Increasing the plate voltage to 260 increases the current to 72 ma., the grid voltage remaining constant.

(Continued on next page)

THEORY

(Continued)

$$R_p = \frac{E' - E}{I' - I}$$

$$= \frac{260 - 250}{.072 - .060}$$

$$= \frac{10}{.012}$$

$$= 833 \text{ ohms.}$$

The tables give 800 ohms as the correct value but this would only involve a change of $\frac{1}{2}$ ma. so the result is quite close. In any case a smaller voltage change should be used.

(d.) Amplification factor.

This is the change in plate voltage that will maintain the plate current constant when there is a unit change in grid voltage, all other factors remaining constant.

For example: The 2A3 valve mentioned before would require the plate voltage to be reduced to 229 to maintain the plate current at 60 ma. if the grid voltage were reduced to -40.

$$\text{Amplification factor} = \frac{\text{Change in plate voltage}}{\text{Change in grid voltage}}$$

$$= \frac{250 - 229}{45 - 40}$$

$$= \frac{21}{5}$$

$$= 4.2$$

It will be noticed that the voltage changes are in opposite directions, that is, a positive voltage added to the grid bias requires a reduction in plate voltage.

This amplification factor is the greatest theoretical amplification possible from the valve, the practical value being given by:

$$\text{Voltage amplification}$$

$$= \frac{\text{Amp. factor} \times R_L}{R_L + R_p}$$

Where R_L and R_p are load and plate resistances respectively. Substitution of values will show that R_L should be as high as possible, practical values being about three times the plate resistance, this giving a voltage amplification of about $\frac{3}{4}$ of the rated amplification factor.

Examples:

6SQ7GT — amp. factor = 100
Plate resist. + 91000 ohms.

$$\text{Load resistance } 250000 \text{ ohms} = 52 \text{ times.}$$

$$\text{V. G.} = 100 \times 250000$$

$$\frac{91000 + 250000}{250000}$$

$$= 341000$$

$$= 73 \text{ times.}$$

Reducing the load resistance to 100000 will reduce the gain considerably.

$$\text{V. G.} = 100 \times 100000$$

$$\frac{91000 + 100000}{100000}$$

$$= 191000$$

$$= 52 \text{ times}$$

Increasing the load resistance to 500000 will not increase the gain very much—increases to about 84 times but would require a higher high tension supply voltage to maintain the anode voltage. In practice lower gains than these are obtained because the plate voltage, being the h.t. voltage less the voltage drop due to the load resistance is lower than 250 and this will cause a change in plate resistance.

The load resistance should include the parallel resistance of the grid resistance of the following tube, which is in

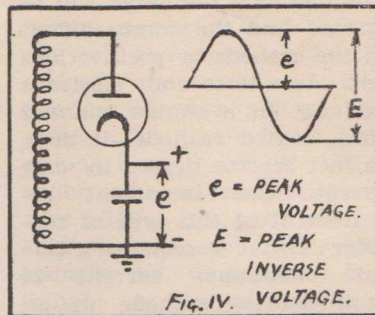

parallel with the plate load at all usable frequencies. For the above cases the load would be a 250000 and a 500000 ohm resistance in parallel, giving a net load of 166700 ohms. This would, on the above figures, reduce the voltage gain to 65 times for the first case; and to 47 and 73 times in the other two cases.

It is obvious that it will not improve matters to increase the plate load resistance to a value above the resistance of the following grid resistance. As this is usually in the order of 500000 ohms this is the maximum value of plate resistance that can be used; a value of 250000 being better.

Valves having a low plate resistance, such as 6SN7 can have a lower plate load and still obtain optimum gain. A low value should, in fact be used as these valves generally have a higher plate current than the high gain types and the maximum voltage output falls off if the resistance is too high. This makes for greater distortion as the valve is operated nearer the overload point. A 6SN7 can be operated with a plate load resistance of 25000 to 100000 ohms. The 500000 ohm grid resistance does not make much difference to the effective plate load as it is so much higher. In the case of power triodes

the load impedance is experimentally determined or is found from a set of curves termed a plate family of curves and is arranged to give the best power output consistent with low distortion.

(e) **Transconductance** — Strictly the Control-grid-plate transconductance, or mutual conductance (gm) is a factor which is really a combination of amplification factor and plate resistance, being the first divided by the second. More strictly, it may be defined as the ratio of the small change in plate current to the small grid voltage change that produced it, all other voltages being constant.

$$\text{Transconductance} = \frac{I' - I}{E - E'}$$

I and E being the original conditions and I' and E' being the final ones. It will be noted that the grid voltage becomes less to increase the plate current (assuming the grid is always negative).

If I and E are measured in amperes and volts then gm is equivalent to $.1/R$, that is, conductance, measured in ohms.

$$\begin{aligned} *R &= E/I \\ gm &= I/E \\ \text{then } gm &= 1/R \end{aligned}$$

As the practical values of transconductance are quite small, being in the order of .001 to .005 ohms, they are always given as micro-mhos, that is the value in mhos is multiplied by 1,000,000 so that values are then about 1000 to 5000 micro-mhos.

Sometimes the transconductance is simply given as milliamps per volt (ma/v) and to convert to micro-mhos simply multiply the value by 1000.

Fig. III shows a plate family of curves for a theoretical triode valve—the practical

curves may show more curvature and grid line spacing variation. From these curves the relationship between amplification factor, mutual conductance and plate resistance may be clearly seen.

Taking the operating point as "A" the following conditions apply—

$$\begin{aligned} \text{Plate volts} &= 180 \\ \text{Grid volts} &= -3 \\ \text{Plate current} &= 15 \text{ ma} \\ & (.015 \text{ amp}). \end{aligned}$$

Now, if the grid voltage is changed to -2 volts then there are two important ways in which the conditions of operation may change: (a) The plate current may be kept constant by changing the plate voltage. To do this the plate voltage would have to be reduced to 140 volts; change along line AB.

(b) The plate voltage may remain constant and the plate current allowed to change, the plate current rising in this case to 25 milliamps; along line AC.

Case "a" gives the amplification factor—

$$\begin{aligned} &\frac{\text{plate voltage change}}{\text{grid voltage change}} \\ &\text{the valve being } 180 - 140 \text{ giving a value of } 40. \end{aligned}$$

Case "b" gives the mutual conductance in mhos.

$$\begin{aligned} gm &= \frac{\text{Plate current change}}{\text{grid voltage change}} \\ &= .025 - .015 \end{aligned}$$

$$\begin{aligned} &3 - 2 \\ &= .01 \text{ mhos} \\ &= 10000 \text{ micro-mhos.} \end{aligned}$$

or = 10 milliamps per volt. The plate resistance is the slope of the grid lines in ohms. Taking the -3 volt line as an example the slope is given by

Plate voltage change

Plate current change and taking section "BC"

$$\begin{aligned} R_p &= \frac{180 - 140}{.025 - .015} \\ &= \frac{40}{.01} \\ &= 4000 \text{ ohms.} \end{aligned}$$

Study of the above values for amp. factor and gm it will be noticed that $R_p = \text{amp. factor}/gm$, and $\text{amp. factor} = gm \times R_p$.

The voltage amplification may therefore be written—
volt. amp. = gm X R_p X R_L

$R_p + R_L$
and this is the form most used now, the amplification factor being omitted from the characteristics—particularly in the

(f) **Conversion transconductance.** This is the equivalent of the above transconductance but is applied to frequency changer tube types as used in superheterodyne receivers and is the ratio of the intermediate frequency current in the plate circuit to the radio frequency voltage on the converter grid. It is used in a similar manner to grid-plate transconductance in single frequency work.

(g) **Peak inverse voltage.** This is a maximum rating which applies particularly to rectifiers and is important because it is the maximum safe voltage between the electrodes. Consider the rectifier shown in Fig. IV. On the positive half cycle the condenser C will be charged to a voltage "e" and, if we assume no current is taken from the condenser the cathode will be maintained at this voltage though

(Continued on next page)

THEORY

(Continued)

the plate voltage changes. Now, half a cycle later the plate voltage will be “-e” and, as the cathode is still at the original voltage “e” there will be a voltage difference of 2e or “E” between them. This voltage “E” is termed the peak inverse voltage and is equal to twice the peak A.C. voltage. For a sine wave the peak voltage is 1.4 times the R.M.S. value and the peak is therefore 2.8 times the A.C. voltage applied to the plate of the rectifier. In the case of a full wave rectifier the peak inverse voltage is 2.8 times the voltage applied to each plate (not 2.8 times the plate to plate voltage). Practical values are about 1500 for ordinary radio work but may range up to 50000 in cathode ray power supplies.

(h) **Peak plate current.** As a rectifier only conducts during part of a cycle it is obvious that the current during this short time must be greater than the steady current taken from the power supply by the receiver. The current curve is also of a peaker character because the valve conducts best when the voltage applied to the plate is a maximum. This peak would rise to many times the average current were it not that the plate supply system has a certain impedance which tends to reduce sudden peaks of current.

Because of this peak current rise most rectifiers have two current ratings in their published characteristics. These are (a) the maximum average current or the D.C. output current that the rectifier can deliver.

(b) The maximum peak current per plate. This is usually

about three times the average value and certain minimum impedances are generally specified in the characteristics, the values depending on the applied voltage and the characteristics of the rectifier. In transformer type receivers the transformer has more than enough impedance in most cases but series resistances may be necessary in transformerless sets.

(i) **Power Output.** This is the audio power the valve can give under a certain set of conditions. The best conditions are generally given under the normal operating conditions and several sets may be given for different power outputs and degrees of distortion.

Power output may be calculated fairly accurately from the plate curves by drawing the load line XY (Fig. III), the slope of which is given by the impedance of the load ($E/I = R$). If the voltages and currents are taken at points X ($E_g = 0$) and Y ($E_g = 2 \times$ standing bias) then
Power output = $\frac{1}{2} (I_{max} - I_{min}) (E_{max} - E_{min})$.

For the case shown the load impedance is 20000 ohms ($I = .033a$, $E = 66v$, $Z = E/I$).

Power output = $\frac{1}{2} (.02 - .01) (280 - 80)$
= $\frac{1}{2} \times .01 \times 200$
= .25 watts.

The power output of pentode valves may be found in a somewhat similar manner but a special plate family is used and more values are used.

(j) **Class A, B, AB, AB₁, AB₂.** Class A amplifiers are operated with such loads and grid bias that there is as little distortion as possible and the plate current does not reach zero at any point in the cycle.

Class B amplifiers are operated so that the plate current is zero for approximately half

Castlemaine, Victoria, has one of the few two-way radio equipped taxi services in the State. Castlemaine, one of Victoria's newly-declared cities, may well be proud of the service.

the cycle. To correct the resultant distortion two class B valves are operated in push pull.

Class AB amplifiers are operated so that plate current is zero for some portion (less than half) of the cycle. Push pull operation is necessary to reduce distortion.

Class B amplifiers are either ordinary triodes or pentodes operated in an overbiased condition or may be special valves which operate at zero bias.

Class AB amplifiers are usually overbiased triodes or pentodes and may be operated under either of two conditions:

a—No grid current flows during any part of the cycle—grid never becomes positive. This is termed class AB.

b—Grid current flows during some part of the cycle—the grid becoming positive during part of the cycle. This is termed AB₂.

Class B amplifiers are usually operated so that grid current flows during part of the cycle, most class B valves operate on zero bias and therefore draw grid current for half the cycle (per tube).

Class C amplifiers are used mainly in transmitters and are greatly overbiased so that plate current flows only for a small part of each cycle.

Shortwave Review

Conducted by
L. J. KEAST

HOLIDAY TIME

I don't know why it is, but everytime we have a holiday or holidays in N.S.W. it seems as though we must have a thunderstorm sometime during the period when one figures they can do a little extra bit o spotting. The word "spotting" may be a little careless at this time of the year so perhaps I had better say dialling. But that's how it goes at my listening post. Quite recently I had a couple of weeks off from the office and we got storms; then around Xmas week thunder and lightning made listening difficult only for the same thing to

happen during the last couple of days of the old year and on New Year's Day storms even affected telephone services in N.S.W., to say nothing of the effect on radio transmission. But as I have often said, radio is like golf, you try it out again the next day hoping for better luck.

But really all my growls apply only to the "weak sisters," the good old strong stations get through and what a variety of programmes there are to be heard. You know, sometimes I make up my mind to run right over the dial and see what is about but I find myself very often hanging on

to one or two stations and listening to the splendid fare offered.

And that brings me to this thought. I notice there is an Esperanto Conference sitting in Melbourne. What a great thing it would be if we only had a universal language, especially on short-wave radio. I really believe it would be one of the best means of bringing all peoples closer together.

TO THOSE NEW AUSTRALIANS

Believing there must be hundreds of "New Australians" who quite naturally have a forgivable feeling of nostalgia and realising how they would love to hear something of the land of their birth. I propose, commencing with March issue, to devote a fair amount of space to schedules of European transmitters broadcasting in their native tongue. Whilst most likely the full times on the air will be given, these columns will suggest the most likely times and frequencies for the best reception in Australia. This, I am sure, will be a welcome innovation and one readily availed of by those for whom it is intended. At the same time it will enable the keen Dx-er to keep his lists up to date. The writer will welcome any help from our many readers who, from time to time, care to drop a note notifying us of any change they have either noted or heard proposed. They will show a grateful consideration for the new people amongst us if they forward such information as soon as it is heard. The address is 7 Fitzgerald Road, Ermington, New South Wales, or 'phone WL1101..

New Stations

VLA-10, Melbourne, 17.84 m.c. 16.82 met.:

This is not actually a new station as this frequency was assigned to "Radio Australia" as far back as April, 1947, but it has been brought into use just recently for the transmission to South America from 8.10-9.15 a.m.

DYB2, Manilla, 4.98 m.c. 60.04 met.:

This station, operated by The Manila Broadcasting Company, with the slogan "Radio Davao," is reported by Arthur Cushen. It opens at 6 p.m. and carries same programme as DYBR, the medium wave station till closing at 10 p.m.

RADIO . . . ?, Burma, 7.37 m.c. 40.70 met.:

Mr. Cushen also sends particulars of this one which he describes as a Communist controlled station which he be-

lieves announces as "Radio Mandalay." They are in English from 9.30-10 p.m.

WNRE, Boundbrook, 9.55 m.c. 31.41 met.:

This is a new frequency for WNRE and is used by U.S.A. Dept. of State in broadcast to Europe from 4-8.30 a.m.

DZH7, Manila, 9.73 m.c. 30.82 met.:

Readers of these pages will remember in November issue I suggested watching for this new Philippine outlet. They are now being heard in parallel with DZH6 from 8 p.m.

4VRW, Port-au-Prince, Haiti 9.795 m.c. 30.61 met.:

This station has replaced HH3W recently on 10.13 m.c. 29.60 met. It is heard opening at 9.30 p.m. and English is given at 1 o'clock.

WRUW, Boston, 11.71 m.c. 25.62 met.:

Speedy Query Service

Bargain Corner

F.P. (Wagga) asks whether it is possible to replace a 600-volt condenser, of the electrolytic type, with others of smaller working voltage.

A.—Yes. It is possible to replace say an 8 mfd. 600-volt condenser with two 16 mfd. 400-volt types, connected in series. This gives a total capacity of 8 mfd. (condensers in series) with a max. working voltage of 800-volts. This is often used where high working voltages are desired from a number of large capacity condensers, with low working voltages. This scheme does not only apply to electrolytic condensers, but may be used on any and every type of capacitor.

G. H. (Myrtleford) asks about synchronous and non-synchronous vibrators, and also if we would detail the difference between the two.

A.—A vibrator is, essentially, a piece of equipment commonly used to convert D.C., from an accumulator, to A.C. This A.C. is then "stepped up" by using a vibration transformer. This high A.C. voltage must be rectified and filtered before it can be put to use in operating a receiver or other gear. The vibrator is necessary, as, it is difficult to "step up" or transform D.C. This A.C. resulting from the vibrator is of a much higher frequency than the normal 50 c.p.s. encountered in the electric supply mains. The rectification of the A.C. on the secondary side of the transformer is done by either of two methods.

Firstly, by the use of a vacuum tube rectifier, following a vibrator. Secondly, by using a special type of vibrator which makes low voltage D.C. into low voltage A.C., which is transformed to high voltage A.C. This high voltage A.C. is fed back to the special vibrator and then is converted to high voltage D.C.

Such a vibrator, which makes D.C. into A.C. and then rectifies the A.C. to D.C. again, is termed a synchronous vibrator. That is, a synchronous vibrator rectifies the current without using a vacuum tube rectifier. A non-synchronous vibrator does not rectify, and must be used in conjunction with a vacuum tube rectifier.

T.W. (Paramatta) writes and enquires whether we can help him out. He has had difficulty in soldering the wire into the pins of the new polystyrene coil formers, mainly because the heat of the iron softens the polystyrene, thus allowing the pins to move out of place, slip, and generally render the former useless.

A.—Most of these polystyrene formers, small or large, have the conventional 6-pin base. As you know, these pins are moulded

directly into the plastic. The easiest method of preventing these pins from moving when they are heated is to get hold of an old 6-pin wafer socket. The first step, then, is to remove the pin contacts and solder lugs. This will leave you with a wafer with only the six holes for the pins. When you want to solder the pins on the coil former, first push it into the old socket. This holds the pins in place when you are soldering to them. Leave the socket in place for a few minutes after soldering, to allow the poly. to harden. Then remove it. All the pins will be straight, and, in their original positions.

W.F. (Camberwell) asks whether the large 12-inch cathode ray tubes are of any practical use for an oscillograph.

A.—They cannot be used with much success, as they have a long persistence screen and employ magnetic deflection. Neither of these properties is desirable for an oscillograph. For this purpose, we recommend a 5BP1 or a VCR97. Both are ideal tubes. The best thing to do with the 12-inch tube is to give it away. Like many other chaps will doubtless be doing in the near future.

J.N. (Deniliquin) asks whether 32-volt vibrators are available.

A.—Yes, Fennocart (A'sia) Pty. Ltd. are producing a 32-volt 100 c.p.s. vibrator and associated transformer. Further data can be had from them.

RECORDING

(Continued from Page 20)

Use GOOD components. Poor quality or faulty components lead to more trouble and strife than is imaginable. They always "give up the ghost" when you are right in the middle of cutting a favourite disc or doing an important job. The extra cost will be repaid by the absence of headaches.

Plan out the circuit, component layout and requirements, thoroughly and completely, before even thinking of the actual construction.

Follow these instructions and you will find that you save hours in the long run.

Next month: Cutting the first record on your gear.

FOR SALE.—Dia's. 2-USL44, 1-USL46H, 2-AWA slow motion. Gangs, Stromberg, 1-3 gang, 2 2-gang, Garrard gramophone motor No. 20, 1-Garrard Record Changer RC65. Speakers, 2 6H and 1 8M with baffle. All brand new. £40 or near offer. Many other parts available. Trueman, Martin Street, Seaford, Vic.

FOR SALE.—15in. Goodman's high-fidelity speaker, perfect order and condition; £17/10/-. (New price £35). J. Nairn, 22 McLean Street, Morwell, Vic.

SELL Communications Receiver, AR7, Rack and Panel type, 5 coil boxes. Good order; £37. Also 522TX Receiver Chassis, complete; £8. C. W. Everdell, Glean-eagle, Beaudesert Line, Queensland.

WANTED TO BUY Kingsley S-Niner with coils; cash, or exchange Class C wavemeter in new condition with built-in voltage regulated a.c. power supply. Jack Clay, "Beach House," Point Lonsdale, Vic.

A SPECIAL SERVICE TO THE EXPERIMENTER

Aluminium Chassis and Panels made to order. Despatched within 48 hours.

Cut exactly to your Specifications. Brackets Supplied. Valve and other Sockets Mounted if Desired.

Cabinets for any design can also be supplied.

Orders direct to—

ADRIAN J. CARMICHAEL,
Thomas Avenue,
Moorabbin, Victoria.
Phone: XU2406.

Servicemen — Students Amateurs

BLUEPRINTS Now Available

Any circuit drawn up from your rough copy or from the wide range on my files. Prints of any circuit from a crystal set to an F.M. or Television Receiver, including all types of test equipment, can be supplied for 3/- per print, post free.

Special circuits based on those odd valves and components in your junk box designed and drawn up for 6/- per print, post free.

R. J. WATSON
85 BOTTING STREET
ALBERT PARK
SOUTH AUSTRALIA

Just Out!

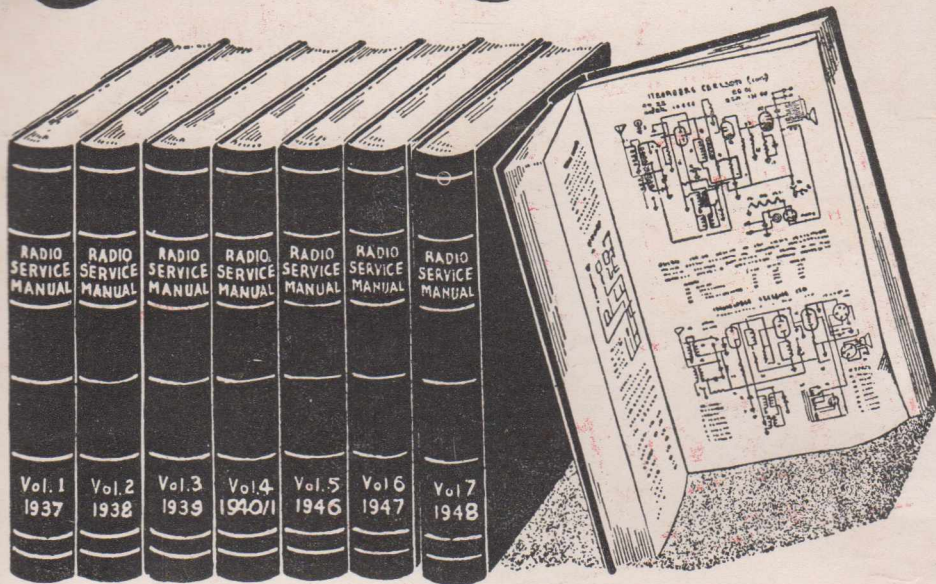

★
Containing
Circuits of 257
Receivers manu-
factured by 44
Brand-Line
Manufacturers
during 1948

Australia's Official Radio Service Manual Vol. 7 (1948 Receivers)

The latest issue of the "Australian Official Radio Service Manual" is just off the Press! This is Volume 7, covering 1948 Australian Standard Receivers.

With the release of Volume 7, the range of Service Manuals from 1937 to 1948 is complete.

Vol. 1, 1937, covers 1937 Receivers; Vol. 2, 1939;

Vol. 3, 1939; Vol. 4, 1940-41; Vol. 5, 1946; Vol. 6, 1947; Vol. 7, 1948.

The price of each volume is £1.

The Radio Service Manual is the only publication which provides you with year by year circuit data of Australian standard receivers. It cuts service time and saves guess-work.

PRICE £1 PER VOLUME

OBTAINABLE DIRECT BY SPEEDY MAIL ORDER SERVICE FROM A. G. HULL,
BOX 13, MORNINGTON, VICTORIA.

Printed by "Post" Newspapers Pty. Ltd., Mornington, for the Proprietor of the Australasian Radio World,
A. G. Hull, Balcombe Street, Mornington, Victoria.

The Aegis METROPOLIS "4"
was always a **WINNER**

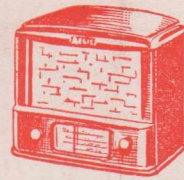

NOW *it's even* **BETTER!**

Your favourite Aegis 4 valve Broadcast Kit assembly has been rejuvenated! In appearance, simplicity and in price the Aegis Metropolis "4" is today's sensational news! Attractive new features include:—

IMPROVED

APPEARANCE The original Plastic Cabinet has been redesigned along more modern lines. Vastly improved in appearance, and more durable than ever before.

IMPROVED

CIRCUIT The main improvement here is the inclusion of the new Radiotron series of Valves: X61M, 6AR7GT, KT61, 5Y3GT Rectifier.

IMPROVED

PERFORMANCE By the inclusion of these new Radiotron Valves, the sensitivity is increased tremendously, and the usual Aegis high standard quality I.F.'s, Coils, etc., make the Metropolis "4" a true winner in Mantel Kit Sets today.

PRICE
INC.
TAX

£10/2/6

VALVES EXTRA

AEGIS

MANUFACTURING CO. PTY. LTD.

208 LIT. LONSDALE ST., MELBOURNE, C.1. Cent. 4414