

**THE
AUSTRALASIAN**

Registered at the G.P.O.
Sydney, for transmission
by post as a periodical.

Radio World

1/-

VOL. 11 NO. 5

OCTOBER 15, 1946



**Max-Plus circuit designed by
practical radio man.**



**How to suppress noise from
man-made static.**



**Latest Radiotron circuits for
five and six-valve sets.**



**Special sections devoted to
"Ham" notes and short-waves.**



LET US BE PRACTICAL

To start off knowing nothing and "learn as you go along" is both foolish and impractical.

If you plan to build a Radio Set, find out all you can about it first. Know the circuit you are going to follow — its design, construction and performance. Know too the parts you are going to use — make sure that each part of your equipment is capable of fulfilling its part 100% in the finished circuit.

Be practical and insist on "Crown" parts B/C Coils, S/W Coils, I/F Transformers, Tuning Dials, Padders, Trimmers, etc.

"CROWN" parts are built to rigid standards and are precision tested before they leave the factory, that is your guarantee of quality.

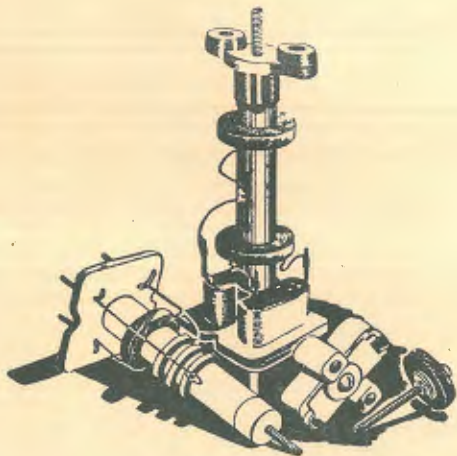

Crown



RADIO PRODUCTS PTY. LTD.

51-53 MURRAY ST.

PYRMONT, SYDNEY. TELEPHONE: MW 2628

THE AUSTRALASIAN RADIO WORLD

Devoted entirely to Technical Radio

and incorporating
ALL - WAVE ALL - WORLD DX NEWS

★ EDITOR
★ PUBLISHER
★ PROPRIETOR—
A. G. HULL

336 Waverley Rd., East Malvern,
Vic.

★ SHORT-WAVE EDITOR—
L. J. KEAST
3 Fitzgerald Road, Ermington,
N.S.W.

★ HAM NOTES By—
D. B. KNOCK (VK2NO)
43 Yanko Av., Waverley, N.S.W.

★ ADVERTISING
REPRESENTATIVE FOR VIC.—
W. J. LEWIS
20 Queen St., Melbourne
Phone: MU 5154

★ ADVERTISING
REPRESENTATIVE FOR N.S.W.—
**AMALGAMATED PUBLICATIONS
PTY. LTD.**
83 Pitt St., Sydney
Phone: B 1077

★ SUBSCRIPTION RATES—
6 issues 5/3
12 issues 10/6
24 issues £1
Post free to any address in
the world.

Address for all correspondence:
AUSTRALASIAN RADIO WORLD
336 Waverley Rd.
East Malvern, SE5
Victoria

VOL. 12. OCTOBER, 1946 No. 5.

C O N T E N T S

CONSTRUCTIONAL—	
A Practical Circuit	7
An A.C. Bridge	21
TECHNICAL—	
"Sparks" as a Career	5
Technical Notes From Up North	11
Problems of Commercial Design	15
Dealing With Man-Made Static	25
Ham Papers	29
Calling CQ	31
Doings on "One-and-Threequarters"	37
DX Possible on "Six"	34
Bargains—and Where Encountered	35
Around the Six Metre Band	36
Night Flying in Daylight	37
SHORTWAVE REVIEW—	
Notes From My Diary	38
Shortwave Stations of the World	39
THE SERVICE PAGES—	
Answers	42

EDITORIAL

Bricklayers are hard at work on a new home for "Australasian Radio World" and the proprietor-editor, A. G. Hull.

The site of the new combined office, laboratory and home is on the Beleura Hill, overlooking Morningson, bayside holiday resort about thirty miles out of Melbourne.

The choice of such a site may come as a surprise to many, but it is the considered opinion of Mr. Hull that there is much to be said for decentralisation, especially as regards a business such as the publishing of "Australasian Radio World," which is largely carried on by mail.

In an ideal country setting, with a view extending over Port Phillip Bay from Melbourne to the Heads on one side, and over the rolling hills from the Dandenongs to the Western Port Bay on the other, a brick home has been planned with all the usual features of a country home on the ground floor, but with all the city conveniences as well. Upstairs a large attic is divided into an office, studio, radio laboratory, workshop and photographic darkroom.

Mr. Hull hopes to be settled in the new home within a month or six weeks. Working under such ideal conditions he intends to launch an intensive editorial campaign, backed by a technical development programme. At the same time he hopes to be able to catch up with his somewhat overdue task of acknowledging the many hundreds of letters which are at present on hand.

—A. G. HULL.

★ PALEC ★

MOVING COIL PANEL INSTRUMENTS

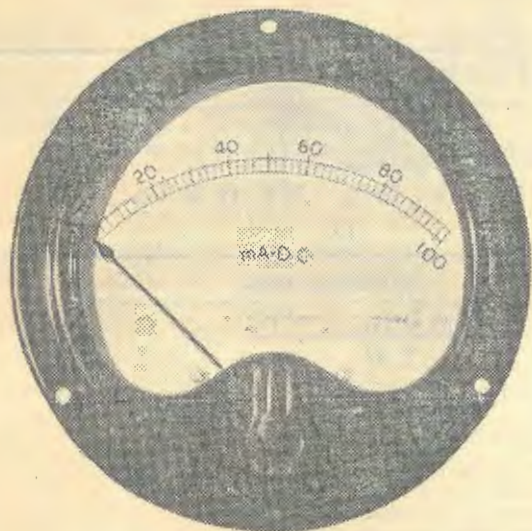

MODEL K475



MODEL K35

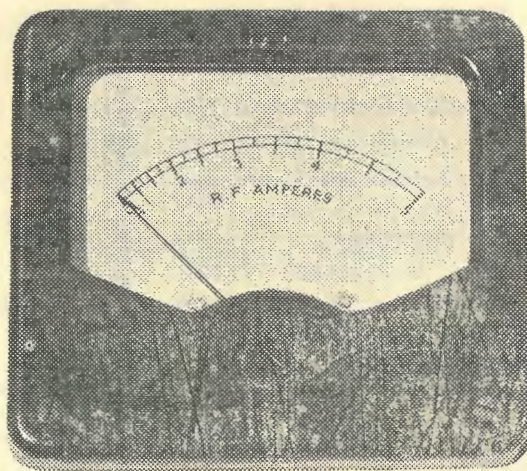

MODEL K400

"PALEC" STANDARD MODELS

Model	Type	Class	Overall Dimen.	Scale Len.	Barrel Dia.
216	Square	2"	2 3/4" x 2 1/4"	1 1/2"	2"
216	Round	2"	2 3/4" Dia.	1 1/2"	2"
32	Round	3"	3 1/2" Dia.	2 1/2"	2 1/2"
35	Square	3 1/2"	3 1/2" x 3 1/2"	2 1/2"	2 3/4"
35	Round	3 1/2"	3 1/2" Dia.	2 1/2"	2 3/4"
400	Square	4"	4 1/2" x 4 1/2"	3 1/2"	2 3/4"
475	Square	5"	4 3/4" x 5"	4"	4 1/2"
475	Round	5"	4 3/4" Dia.	4"	4 1/2"

Built to a rigid standard of accuracy (B.S.S. 1st Grade) and including over 2,000 ranges, "PALEC" moving coil panel instruments are thoroughly guaranteed and are equal to the world's best. Housed in bakelite casings, with flush mounting, they are calibrated to

the accuracy stated, when mounted on a non-magnetic panel. All meters are fitted with spade pointers for all ranges other than universal scale. Write for comprehensive list of all ranges.

Australian Distributors:

HOME CRAFTS PTY. LTD.

HEAD OFFICE MELBOURNE: 200 Lonsdale Street and 211 Swanston Street; 139 Moorabool Street, GEE-LONG; 307 Sturt Street, BALLARAT; 100 Carenca Street, SYDNEY; 26 Hunter Street, NEWCASTLE; 247 Adelaide Street, BRISBANE; 140 Adelaide Street, BRISBANE; TOOWOOMBA, DALBY and ROCKHAMPTON, QUEENSLAND; 161 Pirie Street, ADELAIDE; FOBART, LAUNCESTON and BURNIE, TASMANIA.

"SPARKS" AS A CAREER

THE commercial radio operator is the "jack-of-all-radio-trade," as the certificate requires him to be able to operate, maintain and repair any radio and associated equipment used in commercial communications, including beam, aircraft, ship, land, coastal and broadcast services each highly specialised and in most cases a high morse proficiency and the ability to touch type.

Before anyone, including a Doctor of radio engineering (if there is such a degree), can operate or take charge of a commercial transmitter, he must possess a commercial or broadcast operator's certificate, which is issued by the P.M.G. upon passing their exam. This exam, like any other one, is easy if you know your work. To gain the required knowledge it is necessary to do eighteen months to two years fairly solid study, none of which is beyond the average young man, or young woman, as higher mathematics is not required at present.

There are two or three radio schools that run operating courses and, for the average person, I



Charles Aston, our popular contributor of articles on radio theory, has been a ship's operator for several years. In his spare time his hobby is photography, and the above photograph is one of his best efforts.

to unless you are prepared to wait a possibly considerable length of time, which we are not all able to do. As far as salary goes I would say at a very rough guess that the average wage for operators is £7 or £7/10/- a week, probably closer to the seven mark. This is not a high salary, but compared to some in the radio industry it is good.

When you have received your ticket the next thing to do is to find a position. For the men who wish to go to sea as a Radio Officer, well, there are few employers in Australia, the only ones to my knowledge, are A.W.A., Colonial Sugar Refineries, on Government-owned vessels, or an occasional overseas ship, so the obvious thing to do is to make application to these people. As some of the services are to be shortly operated by the Federal Government, the procedure is not as yet known. But no matter what section it is desired to enter the best bet is to get in touch with the Professional Radio

Employees' Institute of Australia, Challis House, Martin Place, Sydney, who are aware of most of the positions vacant at any time.

THE COASTAL SERVICE

Coastal radio service is subdivided into island radio and mainland radio at present, and it looks as if it will continue in this way. If you go into Island radio you may be sent to any of the Australian-controlled Pacific Islands or in coastal radio to any part of Australia, and this also applies to some of the other services, including certain broadcasting services.

Always having the desire to go to sea and being very fortunate in there being plenty of vacancies at the time, I was at sea within a matter of days after passing the exam.

Sea life is a good one if it suits your temperament, but the best ad-

(Continued on next page)

By
CHARLES ASTON
21 William Street
Double Bay

recommend going to classes and not correspondence, mainly to obtain the required morse practice, and, as it is much easier to get the more hazy points cleared up on the theory side. It is also necessary that before the exam is attempted, the pupil has had a certain number of hours on the practical side of the equipment.

Employment in radio like anything else is not certain, but there will always be at least a limited demand for commercial operators, but this is usually limited in normal times and it is not possible to pick the branch you would like to go in

Radiokes

**THE NAME
TO KNOW
IN RADIO!**

Radiokes

RADIOKES D.W. UNITS. Highly selective with exceptional wide range. To match 'H' type gang condenser. Incorporates 4-in-1 padder. Solidly mounted with coils. Ask for type DWO-1



When buying radio parts and components, follow the lead of amateurs and experts alike — specify Radiokes — your guarantee of test-set performance, precision construction and technical excellence.

RADIOKES

PTY. LTD.

P.O. BOX 90

BROADWAY — SYDNEY

R-56

"SPARKS"

(Continued)

vice I can give anyone going away is to have a good hobby that you can take with you, as you are only on watch 8 hours a day, none in port, and the old saw about "idle moments" has to be considered. Personally, I never regretted the five and a half years I spent at sea, and in some ways I am sorry it was not longer, but as I had the opportunity of getting a position ashore which is rather hard for a seafarer to get, or want to get, I decided that then was the time. The time on ships has in most respects been the best time of my life, I have had experiences and seen things that I could not write about and that I don't talk about, as land-lubbers just think you are a "bee" liar. I have met men at sea who can make my experiences seem very tame, but these are mainly the "old hands."

Most of a Radio Officer's work is watch keeping on 500 kc/s, which is all telegraphy, also maintenance on accumulators. But there is an assortment of equipment on a ship that the Radio Officer has to be able to repair: medium power valve and spark transmitters, low-power transmitters, crystal, superhet and T.R.F. receivers, auto alarms, direction finders, echo sounders and P.A. systems. These are what I have encountered myself, while every day more ships are being fitted with radar, and every year the equipment is more complex. From this it can be seen that, although the work is not excessive, the theoretical and practical knowledge is not by any means small.

This brings me to another point: are the people responsible going to make it compulsory for all Australian-registered ships to be fitted with radar? Or are they going to wait until there has been some considerable loss of life that a radar installation could have averted? This seems to be the usual way with the "big wigs" to close the stable door after the horse has bolted. If the shipping companies were to take a long-range

view they would have radar installations on their ships as soon as possible. The one or two days saved in ship's time between ports would just about pay for such an installation.

Radio is a study that must be kept up with, and when I came ashore I thought I would have plenty of time to do a bit of practical work that is almost impossible to do at sea in the way of experimenting and leave the theory side

MOONBEAMS

Successful investigation of V-H-F reflection from the moon has aroused the keenest interest among some amateur groups in U.S.A.

They foresee definite possibilities with regard to Mars, Saturn, or Venus. Amateurs are working together with rocket societies on a programme of development of small radio-controlled rockets capable of navigating space. Within 18 months time, it is hoped to launch the first of these into space. In this "Atomic Era" those science fiction magazines with their space journeying heroes are not quite so fantastic as they once seemed, and the radio amateur of future generations will go far afield for his DX.

alone for a while. But since I have been home on three weeks' holiday (?) all I have been able to do is rebuild a five-valve super and buy a sheet of aluminium for the chassis of a communication receiver and have not even punched out the holes yet. Then I will have to get busy on a ham transmitter, and what with starting work next week and attending association meetings! I do not know where men like C. Mutton and J. G. Du Faur and others get their time from; the tin of midnight oil must be just about empty by now!

This is just about all I know about radio operating as a profession, and I think it is just about the best start-off in the radio industry for the average man, and I have never regretted it. Perhaps I was lucky, but I do not think so.

A PRACTICAL CIRCUIT

WHILE I am writing this, little "Max-Plus" stands next to me on the table, looking at me, enquiring when its special cabinet is going to come along; the one that has been on order since last December! It is still a naked chassis, but one I frankly admit I am proud of. There are not many

By

PAUL STEVENS

**21 Fletcher's Avenue
Bondi, N.S.W.**

five-valve dual-wavers that you can switch from local to overseas short-wave stations without advancing the volume control more than a mere fraction of a turn. Yes, it is a full-powered five-valve set, mounted on a mantel-size chassis ($10\frac{1}{2} \times 5\frac{1}{2} \times 2\frac{1}{4}$), with only a 40 milliamp power transformer, and not overloaded, at that.

TWO AIMS

When I started to design this set I had two aims in mind: maximum power, efficiency and durability, plus a minimum of components and cost, hence the name Max-Plus.

I do not intend to say much

about constructional details, such as chassis layout, dial mountings, etc., for you simply have to take whatever you can get these days. The chassis I used is one of special design which I have in mind to have made to order in quantities, as the design is practically a universal one for four- or five-valve sets. Each main hole can be used for coil, i.f. or socket mounting, giving the constructor the utmost freedom for his ideas of layout. To achieve the combination of high power with low cost and simplicity is by no means a miracle. We have to select the right types of valves and intermediate transformers, without which our set would be just another of the ordinary medium-powered standard receivers with 60 or 80 milliamp power transformers.

In the converter stage we find the EK2. For a maximum current drain of only 4.5 ma. it has a conversion conductance of 550 micromhos, a plate resistance of 2 megohms and very low noise level. There is no other converter in existence which comes anywhere near this performance, unless it is the ECH35.

The second valve is the EBF2. Its efficiency and low current drain

makes it the natural choice for our purpose. Its ratings of 1800 micromhos conductance and 1.3 megohms plate resistance for a total drain of 6.6 ma. are also exceptional. The EBF2 is, however, working on reduced screen voltage of 60 to 70 volts, being connected to the screen of the EK2. This lowers its performance slightly, but reduces its total cathode current quite considerably. Both the EK2 and EBF2 are metal sprayed, making valve cans unnecessary. The EBF2 diodes are not used in this version and are merely "earthed" to the chassis. There is not much to be said about the well-known 6B6G as second-detector-audio amplifier. It gives high gain and the current drain is negligible. The EL3 output valve uses the same amount of plate and screen current as the 42 or 6F6, but its conductance is three times as high, and the power output 4.5 watts, compared with 3.1 from the other types mentioned. This is a fact which is not particularly important for a small mantel model, but is worth considering if this set is to be used also for a console receiver.

The EL3G is slightly overbiased

(Continued on next page)

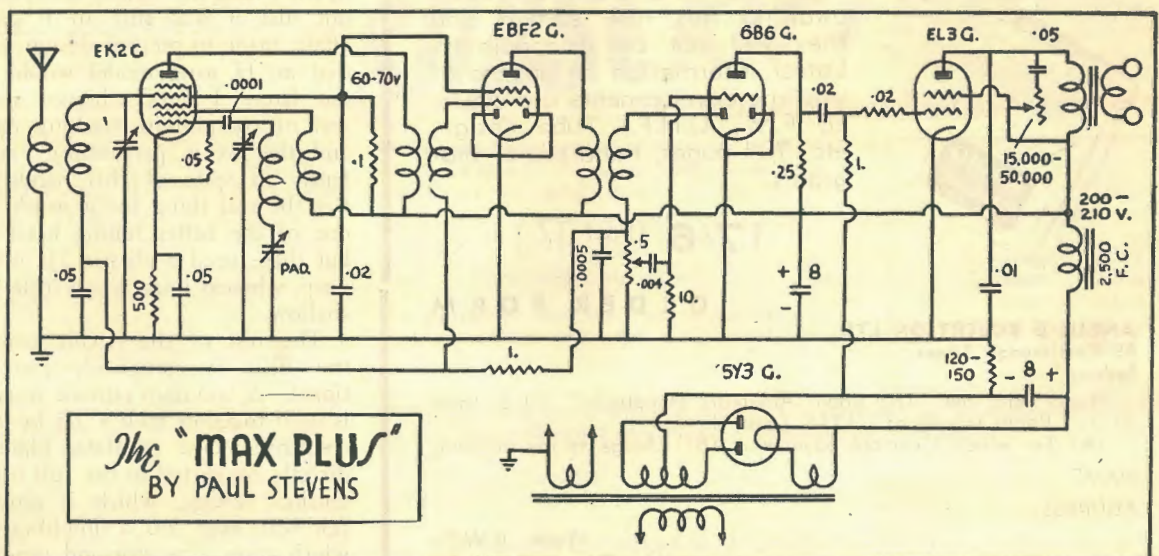

TECHNICAL BOOKS

Send to Angus & Robertson Ltd. for the latest catalogue of radio books.

1. JUST ARRIVED — 1946 EDITION



LATEST EDITION OF THE MOST POPULAR BOOK ON AMATEUR RADIO

"THE RADIO AMATEUR'S HANDBOOK"

BY THE HEADQUARTERS STAFF OF THE AMERICAN RADIO RELAY LEAGUE

The standard manual of radio communications. Covering Electrical and radio fundamentals — Vacuum tubes — Radio-frequency — Power generation — Radiotelephony — Keying — Receiver principles and design — Power supply — Wave propagation — Antenna systems — Construction practice — Receivers — Transmitters — Modulators — V.H.F. receivers and transmitters — Equipment — Tubes, etc., etc. More than 1,398,250 copies of previous editions have been sold . . . 1946 edition is more complete than any previous edition. 10/6 (post, 1/-).

2. HERE AT LAST! 1946 EDITION

" RADIO HANDBOOK "

After four years, a completely revised edition of the original "Jones' Radio Handbook." Thousands of radio amateurs throughout Australia have been anxiously awaiting this new edition and they will not be disappointed. Latest information on dozens of wartime developments are covered F.M., U.H.F., Tube design, etc. 704 pages, hundreds of diagrams.



17/6 (Post 1/-)

ORDER FORM

ANGUS & ROBERTSON LTD.,
89 Castlereagh Street,
Sydney.

Please send me "The Radio Amateurs Handbook," 10/6 (post 1/-); "Radio Handbook" 17/6 (post, 1/-).

(A) For which I enclose payment. (B) Charge to my account.

NAME

ADDRESS

(Tech. R.W.2)

MAX-PLUS

(Continued)

by using a 120 to 150 ohm back bias resistor, which carries not only its own current, but also the few milliamps of the other valves. The total current drain is around 40 to 43 milliamps, which is well within the capabilities of a 40 milliamp transformer of decent design. For a floor model set we could use a transformer rated 250 volts or 275 at 50 or 60 milliamps, and use it in conjunction with a filter choke and a big 10 or 12 inch permag speaker. We would not then have to overbias the EL3 and can take the full 4 watts of power output. To improve the tone we might introduce inverse feedback, even if it means loss of gain. To make up for it we could use a pentode such as the 6J7G or 6C6 for the audio valve instead of the 6B6, and let one of the EBF2 diodes do the detecting. Of course we could do that for the set if used as a table model, too, but there is little sense in it if we are using the circuit for a mantel model. It only makes it more complicated and expensive.

DESIGN DETAILS

And now to some details of the design. In the input I am using an ordinary air-cored dual-wave bracket, the only suitable type I could get hold of at the time. I had a lot of tracking trouble with it, till I rang the makers and found out that it was still an F gang affair, made to pre-war design, and that an H gang model would be out later. I have achieved some sort of compromise tracking now, and the set is performing excellently in spite of this handicap. But the real thing for it would be one of the better tuning brackets, but these need a chassis $2\frac{1}{2}$ inches deep, whereas mine was a trifle too shallow.

The rest of the circuit around the EK2 is completely conventional. A 500 ohm cathode resistor is used together with a .05 by-pass condenser. The oscillator plate is directly connected to the full high-tension voltage, which is only a few volts over 200, a simplification which saves a resistor and conden-

ser. The EK2 is followed by permaclad intermediate transformers, the "Q" of which is about 30 per cent. higher than the standard type, and therefore gives improved gain and selectivity. I recently had the opportunity to get a striking demonstration of the superiority of these intermediates. I had to build half a dozen four-valve mantel models in a hurry, all to the same circuit. I was only able to get three sets of permaclad intermediates, due to a temporary shortage. I had to use ordinary transformers for the other three. Results from these sets showed the difference in no uncertain manner. Stations that sounded weak and far away on the one batch of sets were quite solid on the others. The sets were in every other way as identical as peas in a pod.

NO DELAY

The second valve, the EBF2, has no initial bias. As the automatic volume control is not delayed, but taken direct from the signal diode there is always sufficient bias to keep the EBF2's grid negative as soon as the faintest signal or static gets through. I had the cathodes of EK2 and EBF2 tied together at first, with a common .1 condenser and 300 ohm resistor, but ran into trouble with instability.

FALSE IMPRESSIONS

There are three reasons for using undelayed a.v.c. Firstly, with the power reserves of this set we only need its full amplification for the weakest signals, and the a.v.c. will go into action on low signal strength. The usual three-volt delay on other sets cuts the a.v.c. action out altogether where it is most needed, on weak, fading overseas stations. Delayed a.v.c. also gives a false impression of power on those well-known sets where the proud owner demonstrates to you how he has to turn the volume control only a fraction of a turn up from zero to get the locals at full blast. What he does not add is that he has to turn it to nearly maximum to get short-waves. With the Max-Plus the volume control will always be about half-way on for both local and overseas stations. There is no a.v.c. applied to the converter on short-waves.

The second reason for the non-delay a.v.c. is the simplicity of the circuit, and thirdly, the improved i.f. selectivity on account of not loading the primary of the second i.f. by taking it to a diode, as is so often done.

BIAS ARRANGEMENTS

Bias for the 6B6 is obtained from a 10 megohm grid resistor between grid and cathode, which is earthed. I like this method of biasing. It is simple and effective. The grid lead, of course, has to be shielded, like all the hot leads to the volume control.

Another minor point: the EL3 needs a stopping resistor in the grid to prevent parasitic oscillation due to the high mutual conductance of this valve. The value of the stopper resistor is not critical, anything between 10,000 and 50,000 ohms being suitable. A .01 mfd. condenser, with a 600-volt working rating, is fitted in the plate circuit as a by-pass for any i.f. signal that may penetrate as far into the set as the plate circuit of the EL3, and at the same time lops a few of the highs to balance the tone. Owing to lack of baffling it is unlikely that lows will be reproduced at any-

where near full strength, so a lops of the highs is desirable in the interests of balance. The speaker should be a good quality one of five or six inch type. Tone control is optional, but if you wish to incorporate one put a 15,000 ohm wire-wound potentiometer in series with a .05 mfd. condenser across the speaker terminals, insulating the pot. from the chassis. This method is preferable to the practice of running the pot. and condenser between plate and chassis, as in that case the condenser has to withstand the strain of plate voltage, plus the peaks of signal voltage. Unless of high enough rating, it is then likely to break down, causing both pot. and speaker transformer to break down.

NO H.T. BY-PASS

I have omitted the usual .1 or .25 mfd. by-pass condenser from high tension to earth in parallel with the second filter condenser. I have never put one into any set I have ever built. They all worked just the same without them. I don't like them because they only form another breakdown possibility, especially if they have a voltage rating of 400 volts, as often found in commercial sets.

SAVE MONEY WITH A SUBSCRIPTION!



Order Yours To-Day

Make sure you get every issue as soon as it is published. Place an order with your newsagent or send direct to us for a subscription.

IT SAVES YOU TIME!
IT SAVES YOU MONEY!

We guarantee that every subscriber has his copy posted the same day it comes off the press.

RATES	
* 6 issues	5/3
* 12 issues	10/6
* 24 issues	20/-
POST FREE	

Enclosed please find remittance for 10/6 in payment for an annual subscription to the "Australasian Radio World," commencing with the issue.

NAME
STREET and NUMBER
CITY STATE

336 Waverley Road
AUSTRALASIAN RADIO WORLD East Malvern, SE5
Victoria

GET TEST-SET PERFORMANCE

— WITH GENUINE

Because all R.C.S. radio parts and components are precision-built to exacting standards of accuracy . . . and because only the highest quality material are used in their

manufacture . . . you get TEST-SET-PERFORMANCE from R.C.S. equipment under all conditions. Use R.C.S. kit parts, coils and replacements in your set and get the benefit of maximum performance.



RADIO PARTS

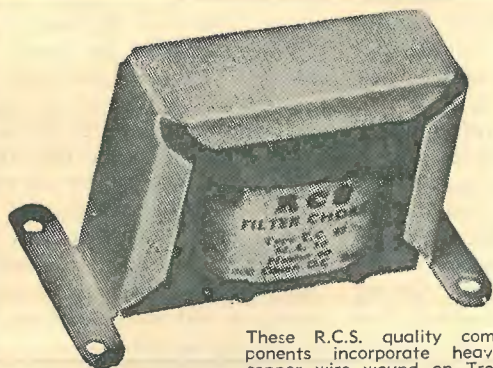

R. C. S. FILTER CHOKES AND AUDIO TRANSFORMERS

TB4. A Class. Single
TB5. A Class. PP
TB6. B. Class. PP
TC65 50 M/A 30. H
TC60 100 M/A 30 H
TA4. Audio Chokes
TC58. L.T. Vibrator
Chokes
TC70 H.T. Vibrator
Chokes

These R.C.S. quality components incorporate heavy copper wire wound on Trolitul bobbins. The use of Trolitul eliminates electrolysis, ensuring much longer effective life.

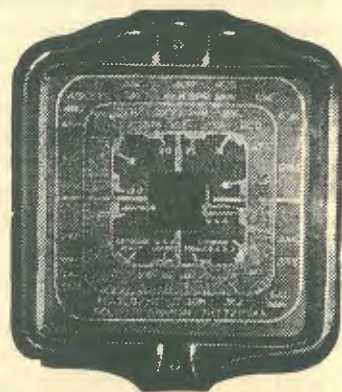

DA7



The ever popular DA7 Radio Dial! Absent for many years it is now back on your retailer's shelf. Ask for it — and other equally famous R.C.S. radio parts and components.



R.C.S. STAR AND M/C CONDENSERS

R.C.S. Midget Condensers feature Trolitul end plates and are available in single and double bearing types.

	Max. Cap. MMFD	Min. Cap. MMFD		Plates
MC	CV34	10	3	2
	CV35	15	3	3
	CV36	25	3.5	4
	CV37	35	4	5
	CV38	50	4	7
	CV39	70	5	9
STAR	CV40	100	6	14
	CV41	10	3	2
	CV42	15	3	3
	CV43	25	3.5	4
	CV44	35	4	5
	CV45	50	4	7
	CV46	70	5	9
	CV47	100	6	14

Miracle-Plastic TROLITUL

This semi-transparent, lightweight moulded insulating plastic is exclusive to R.C.S. Trolitul is used wherever possible in R.C.S. quality parts, sealing wires and connections into one solid damp-proof whole, guaranteeing longer life and maximum efficiency.

R. C. S. RADIO PTY. LTD.

174 CANTERBURY ROAD
CANTERBURY

NO DIRECT ORDERS

TECHNICAL NOTES FROM UP NORTH

UP Taree way there are many keen radio enthusiasts, and possibly one of the keenest is Mr. R. Brown, of Harvey Ivers, Taree. Mr. Brown won one of our circuit contests a few years ago, and ever since he has kept us posted on the latest doings in technical radio which he comes across in the course of his work. Unfortunately, these matters are discussed more in the form of breezy letters than technical articles of a style suitable for publication.

Much of the subject matter is sure to be of interest to our readers, so here are some extracts from Mr. Brown's recent letters.

THE ADAMS CIRCUIT

Mr. Brown writes: I was very interested to read your article entitled "My Own" in the April issue, and agree heartily with your remarks. Ever since the Adams design was first published, this circuit, or one based on a similar arrangement, has been a standby to me. The current P.A. system recently installed here for my employer is my choice in design for a shop demonstration of records, etc. My only change was a fader control for the two inputs.

PENTODES VERSUS TRIODES

Not long ago I read an article by a leading designer who proved, on paper, anyway, that modern pentodes and beam power tubes are superior to triodes in every way but their susceptibility to parasitics. I fail to see it.

Recently I had occasion to temporarily increase the power output of a country theatre, so carted my 6A6, 2A3 (Adams) job along and

ran it as a separate channel alongside the normal system installed, which was a beam tube arrangement with feedback.

Whilst my speaker was only a 10/20 permag without special baffling, against the permanent system's 40 oz. permag in a proper acoustical flare, the triode job was infinitely superior in output and

(Continued on next page)

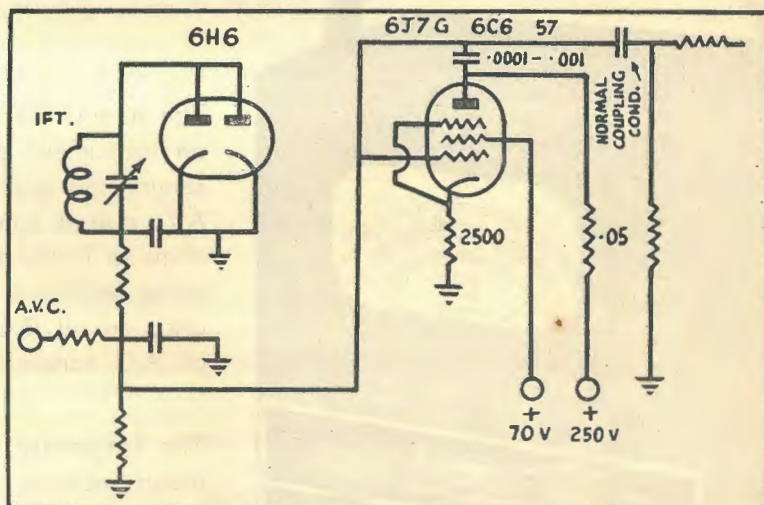

Suggested detector circuit for the elimination of noise.

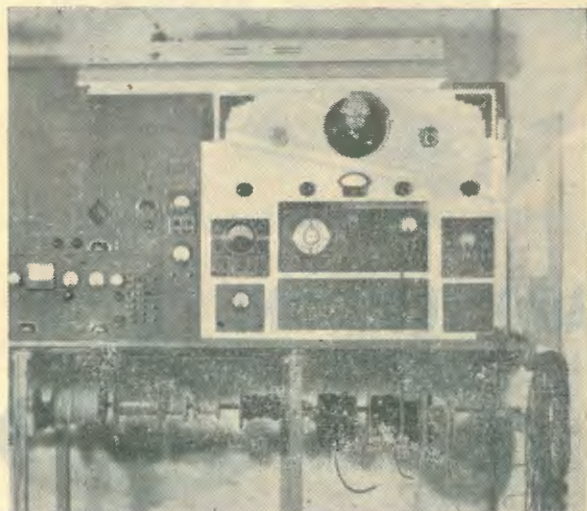
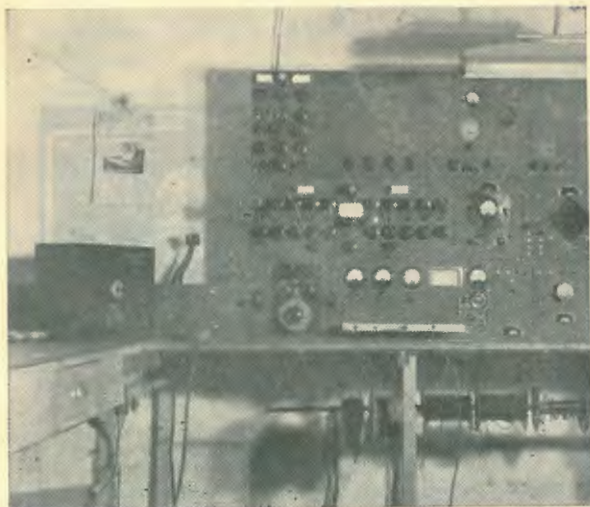

Repair bench set-up as arranged by Mr. Brown at Harvey Iver's shop in Taree.

Just Released!

REMARKABLE NEW "UNIVERSITY" VACUUM TUBE VOLTMETER

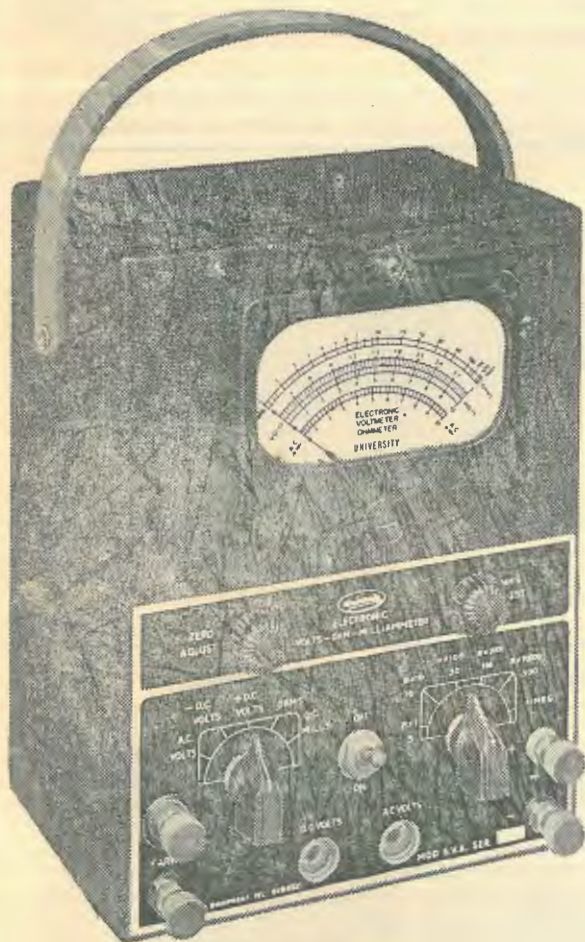

The new University Vacuum Tube Voltmeter is an instrument designed specially for the radio serviceman and experimenter. It covers D.C./A.C. output volts and milliamps to 1,000 and ohms to 1,000 megohms. Bridge circuit with inverse feed-back assures stability. Input resistance on all D.C. ranges, 11 megohm, and on all A.C. ranges 1 megohm.

The University Range of High Quality Instruments includes: VALVE AND CIRCUIT TESTERS, UNIVERSAL SPEAKERS, BATTERY & A.C. OPERATED OSCILLATORS, A.C. and D.C. MULTIMETERS, Etc.

RADIO EQUIPMENT Pty. Ltd.

375 KENT STREET,
SYDNEY, N.S.W.

Telephones M 6391-2

Telegrams: "Raquip,"

Sydney



DISTRIBUTED BY

N.S.W.: All leading Distributors.
Queensland: Homecrafts; J. B. Chandler Pty. Ltd.; A. E. Harrold.
Victoria: Vealls Electrical & Radio Pty. Ltd.; Hartleys Ltd.;
Replacement Parts Pty. Ltd.

South Australia: Gerard & Goodman Ltd.; Radio Wholesalers Ltd.
Western Australia: Atkins (W.A.) Ltd.
Tasmania: W. & G. Genders Pty. Ltd.
New Zealand: Allum Electrical Company Ltd.



"University" Universal Speaker and Output Meter makes set testing simple. No power connections required; just plug into any type speaker socket.

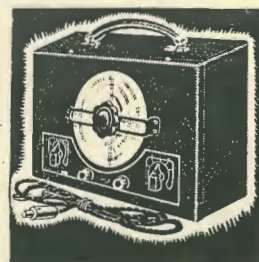

A new "University" five-band oscillator for the alignment of all types of radio receivers.

quality, to my way of thinking. Side by side with equal volume level from sound on film is a very keen comparison.

However, the two channels blended well and, although I call such arrangements "Tone Illusions," I think much more work could be carried out on dual systems. I only regret that I do not live in Victoria so that I could take along an entry on these lines to the next Amplifier Championship.

NOISE SUPPRESSORS

I have also noted with interest the numerous articles on noise suppressors, and recently tried out an idea from Audel's Radio Guide. It is an automatic tone control and has the advantage that the gain of the receiver is not impaired whatsoever. I am sending in the circuit as it was originally printed, but I used it on a normal cathode-biased 6B6G second detector with the voltages shown.

TEST BENCH

I have also mailed a photograph of the test panel I recently built up for Harvey Ivers. Unfortunately, the photograph does not quite join up as a panorama. In the blank panel in the middle of the top deck I have now installed an oscilloscope and a beat frequency oscillator which I knocked up from an early "Wireless Weekly" arrangement.

The idea of the numerous handles is that each item may be removed individually for service troubles, if any. The bench is arranged so that there are a minimum of leads hanging around and for checking to be as automatic as possible, such as battery lead connection to the A, B and C panel. All voltages and currents come up automatically. Again on the vibrator tester, if a single unit or a complete box is hooked up all voltages and currents register simultaneously and loads on both these panels mentioned can be adjusted to approximate actual working conditions.

IT is not so very long ago since the days when a young man who ran away to sea soon became disillusioned. He discovered that colourful adventure and romance had stayed behind him — in fact, within the covers of "Two Years Before the Mast" and "Moby Dick" — and that life between decks really was a rough and ready business of discomfort and danger, sometimes miserable, often brutal, but always one of hard work and poor rations.

Those were the days of wooden ships and iron men, the men whose saga has been written by Masfield, Conrad, and Lubbock, but in these days we have instead ships of iron and men who live and work in comfortable, but simple, surroundings which would amaze the weathered "shellback" of last century.

Philips Sound Reproduction units have been used successfully on many varied installations in the past, but perhaps one of the best endorsements of their merit lies in the decision of the Commonwealth Government to equip each ship of the River Class fleet with a sound system. These vessels, constructed by the Australian Commonwealth Shipbuilding Board, are each of 10,000 tons, and are employed on the coastal freight routes. Later, it is expected that they will carry the Australian flag to foreign ports.

In order to suit the particular requirements of shipboard sound

reproduction, Philips planned and built the "1002 Special," consisting of a master station and distributing speakers. The master station comprises a sensitive long and short wave receiver and a powerful 15 watt audio amplifier with a monitoring speaker and power switching panel. Each unit stands in a separate metal cabinet which may be locked when not in use.

The radio unit has been installed for the express purpose of providing radio news and recreational programmes for the crew, an amenity which should be greatly appreciated during the long intervals between ports, such as exist around the coastline of this, the world's largest island. Outlet speakers in various parts of the vessel will greatly facilitate administration duties and operations, and, as has been shown during the war years, will be an invaluable contribution towards the safety of the crew in the event of an emergency.

Radio for the entertainment of passengers has long been a feature of passenger ships, but the extension of this form of entertainment to cargo lines is comparatively new. The Australian Shipbuilding Board has set a praiseworthy example, and one which could well be followed by every shipping line which is interested in crew welfare. Such an investment, it is felt, can do much towards morale-building and thus indirectly help bring about greater industrial stability.

AN ELECTRONIC NAVIGATOR

In order to explore the post-war possibilities of radar in its application to safety-at-sea programmes, the United States Maritime Commission is testing five sets of a new type of radar equipment. The new equipment is called the electronic navigator. While somewhat different from the radar of the armed

services, the electronic navigator has indicated possibility of post-war application to Merchant Marine operations. Major sea disasters have resulted from collision at sea under fog or in darkness with icebergs or other vessels. It is expected that the electronic navigator will do much to eliminate this hazard.

LET'S GET TO THE CORE OF THINGS

As with all KINGSLEY radio products the reason why "PERMACLAD" I.F.'s are now spoken of as the best in Australia is found in the ferromagnetic iron-dust cores used in their construction. Apart from the inherent technical superiority of iron-core tuning, every "PERMACLAD" I.F. is turned out on a production line that sets a particularly high standard of quality.

So from the first to the final step . . . that of oscillograph testing and tuning . . . each I.F. is made to give the absolute maximum in performance. The use of the enclosed pot-type ferromagnetic cores give KINGSLEY PERMACLAD I.F.'s a particularly high degree of permeability, high "Q" and gain.

OBTAINABLE FROM
AUTHORISED KINGSLEY DISTRIBUTORS

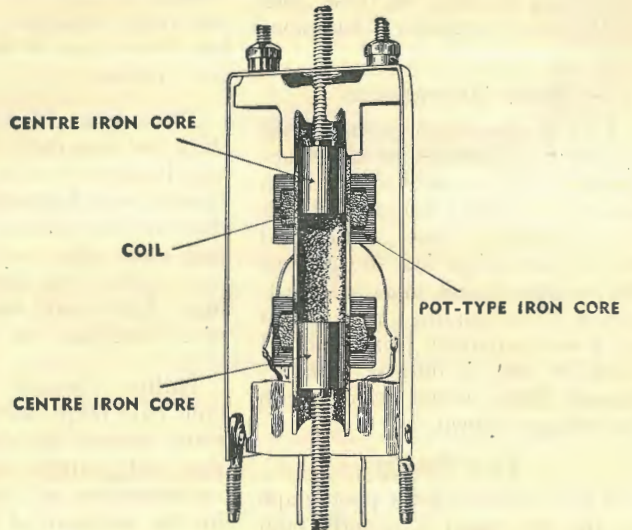

The above diagram is a cut away sketch of a PERMACLAD I.F. Tuning is done by the two centre iron-cores.

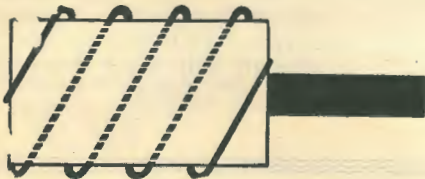

F E R R O T U N E
FERRO-MAGNETIC IRON-CORE COILS, I.F.'s AND,
GANGLESS TUNING UNITS



KINGSLEY RADIO

KINGSLEY RADIO PTY. LTD.

380 St. Kilda Road, Melbourne, Victoria . Phones: MX 1159, MX 3653

PROBLEMS OF COMMERCIAL DESIGN

There is a big difference between an experimental hook-up which may work perfectly satisfactorily in all respects, and a satisfactory design from an engineering point of view, having in mind the production of a number of receivers with equivalent performance. In an experimental hook-up the experimenter often fails to pay careful attention to the exact values of resistors, condensers

A laboratory model is developed by an entirely different procedure, with careful attention to all features, and the results obtained by good design will be better than those obtained from the short-cut methods used in an experimental hook-up; it is still, however, only a single piece of equipment.

It is not until we come to the necessity for duplicating the results of a "pilot model" that we have to consider such matters as tolerances in valves and components, standardisation, specifications and tooling up. These will be considered in detail below.

TOLERANCES IN VALVES AND COMPONENTS

No component, whether resistor, capacitor, inductor or valve, can be depended upon to have exactly the characteristics in accordance with its label. It is frequently possible to purchase resistors, for example, with different values of tolerances above and below the nominal value, the price usually increasing as the accuracy is made greater. In labora-

tory work it is frequently desirable to adopt components having characteristics within a very close tolerance of the nominal value, and they may even be branded with their precise values. This practice is, of course, impossible in production design, and it is generally regarded as good engineering design to arrange the circuit so that the majority of components in the receiver may be of the widest commercial tolerances. In most ordinary receiver and amplifier circuits the majority of resistors and capacitors will not affect the performance more than very slightly with a tolerance of plus or minus 10%, and even greater tolerances may be permitted in many cases. There may be a few especial components which require a higher degree of accuracy, such as a fixed padder condenser, and these would require

(Continued on next page)

From

"RADIOTRONICS"

published by Amalgamated Valve Co. Pty. Ltd.

or valve characteristics, since its performance may be arrived at either by a hit-and-miss process or by measurement of important features such as the plate and screen currents of valves and the voltages at important points in the circuit.

RADIOTRON 6 VALVE A.C. DUAL-WAVE RECEIVER RC53

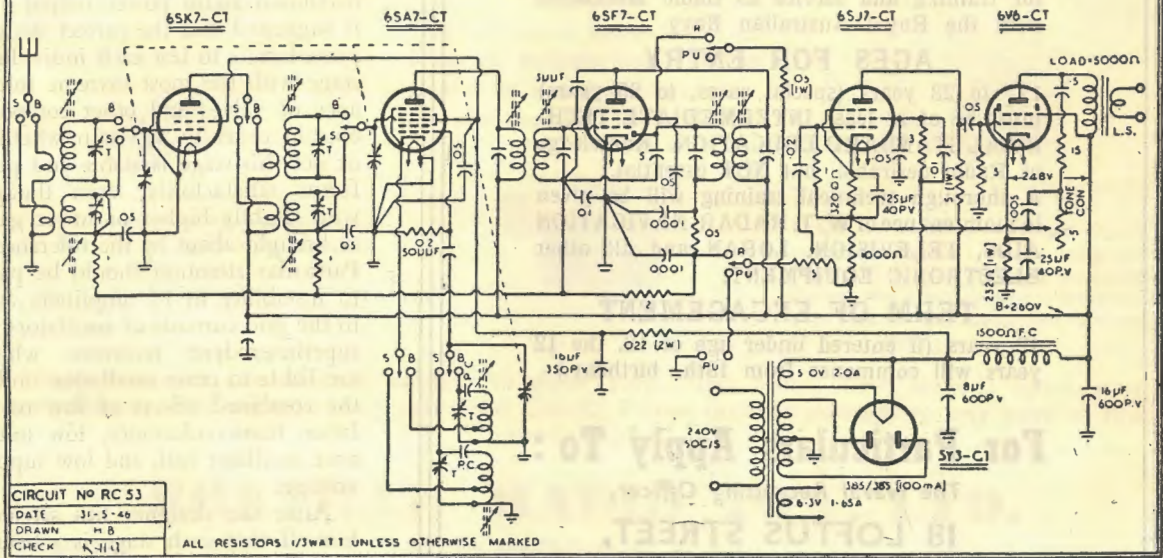

Lotest circuit for a 6-valve dual-waver as designed by the Amalgamated Wireless Valve Co. Note the feedback circuit at the audio end and the neutralization of the i.f. amplifier.

PROBLEMS

(Continued)

individual consideration in each case.

The tolerances in valve are, in general, even wider than those in the other components. For example there are variations in plate and screen currents, transconductance, plate resistance, capacitances, overall length and diameter. Some of these are of little consequence—for example, the capacitances are of negligible importance in an audio frequency amplifier, while the plate resistance of a pentode is usually so

high that the lowest value of any individual valve would still be high enough for its purpose. Other characteristics may have a more important effect on the performance, those requiring most careful attention being usually the transconductance, capacitances and plate and screen currents. In most stages the gain is approximately proportional to the transconductance, but is not so seriously affected by the other variables. The plate current is usually only of direct importance in the power amplifier stage, where it has an effect on the maximum power output. The screen current has a more general effect but only

when the screen is supplied through a dropping resistor. For this reason, it is good practice to avoid the use of a screen dropping resistor in beam power amplifier valves because the screen current is extremely variable owing to the design of the valve, and may be anything between zero and double the published value.

VALVE CAPACITIES

The capacitance from grid to plate is principally important through its tendency to cause instability in i-f amplifiers, and these should be tested with a wide enough selection of valves to ensure that stability is attained under all conditions. The input capacitance has an effect on the tuned circuits of the r-f, converter, oscillator and i-f stages, while the output capacitance has a similar effect on the tuning of the converter and i-f valves which are followed by double-tuned i-f transformers.

TOLERANCE LIMITS

As a result of the varying tolerances in all types of components, individual receivers manufactured in accordance with quantity production methods will have their performance varying within fairly wide limits. Two of the most serious of these are the overall sensitivity of the receiver and the maximum audio power output. It is suggested that the correct design procedure is to test each individual stage with the most extreme tolerance of valves and other components in order to ascertain whether or not this stage is stable and performs satisfactorily, even though with slightly higher or lower gain as brought about by the tolerances. Particular attention should be paid to instability in i-f amplifiers and to the grid currents of oscillators in superheterodyne receivers, which are liable to cease oscillation under the combined effects of low oscillation transconductance, low tolerance oscillator coil, and low supply voltage.

After the designer has satisfied himself that each stage is satisfactory, it is then desirable to insert, in each socket, valves having average characteristics, and then to

The ROYAL AUSTRALIAN NAVY *offers* A CAREER to YOUNG MEN INTERESTED IN RADIO



Young men interested in radio are required for training and service as Radio Mechanics with the Royal Australian Navy.

AGES FOR ENTRY

17½ to 23 years (special cases, to 25 years) must be of at least INTERMEDIATE TECHNICAL STANDARD EDUCATION. Knowledge of Radio desirable, but NOT essential.

A thorough technical training will be given in maintenance of W/T, RADAR, NAVIGATION AIDS, TELEVISION, LORAN and all other ELECTRONIC EQUIPMENT.

TERM OF ENGAGEMENT

12 years (if entered under age of 18, the 12 years will commence from 18th. birthday.)

For Particulars Apply To :

The Naval Recruiting Officer,
18 LOFTUS STREET,
SYDNEY

NV 2/62/86

measure the performance under these conditions. Tests should later be carried out with a large number of valves having normal commercial tolerances and all results recorded. From these results it is possible to lay down a satisfactory design specification for overall performance.

STANDARDISATION

The fundamental basis of quantity production is the standardisation of design and components. It is necessary for the receiver to be constructed so that any component may be replaced by another of its kind in accordance with a published list of component values, and for the latter to give satisfactory performance provided that the replacement component is within the specified tolerances.

It is also necessary for the manufacturer to prepare and distribute sufficient data to allow the receiver to be serviced with the minimum of difficulty. Such data requires to give the complete circuit diagram,

the list of component parts with tolerances, the list of valve types, the frequency ranges covered, the intermediate frequency, the tracking frequencies and the supply voltages and frequencies. If changes in design are made from time to time there should preferably be a change of model number, or else a reference may be made to the serial numbers of the chassis affected by the change. The notification regarding the modification should be in such clear language that it can readily be understood by all servicemen while, if it is merely a slight modification, it could with advantage be printed in such a way that the servicemen can paste it on to his original service data sheet and have it always available for reference in the right place.

CONTINUITY OF SUPPLY OF COMPONENTS

In quantity production it is essential to use components which

will be in continuous supply and will not experience any serious changes in characteristics likely to affect the performance of the receiver. Resistors and capacitors should be capable of being replaced by those of another make having the same nominal values and tolerances, but some of these may require more space than the ones originally used, and provision may have to be made for the installation of those styles having exposed metal ends. For this reason, it is usually desirable not to cramp the components too much, so as to allow for any contingencies. The position regarding other components is more difficult, this applying to loud speakers, gang condensers, chokes, coils and i-f transformers. Some manufacturers endeavour to produce the greater part of their own components so as to be independent of other suppliers and hence able to protect themselves from design changes at short

(Continued on next page)

BARGAINS

Amateurs—here is your opportunity to secure a high-quality key at a fraction of original cost.



Surplus double-contact keys made by Breville to rigid Army specifications. Expense was no consideration in the manufacture of these high-grade keys. Closing out at only 14/- each.

This well-known quality key is all brass on bakelite base. Limited number of used keys in new condition to clear at 10/- each.



Made by McElroy (world's Morse speed champion) and imported from U.S.A. for training purposes during the war. Limited number of used keys in new condition to clear at 12/- each.

These bargains are offered subject to prior sale. First come, first served! Send your remittance with order, or we can send C.O.D. Prices include postage to any part of the Commonwealth.

BREVILLE RADIO PTY. LTD.

Telegrams:

"Breville," Sydney

67-73-MISSENDEN ROAD,
CAMPERDOWN, N.S.W.

Phone:

L 3688 (4 lines)

PROBLEMS

(Continued)

notice. Those manufacturers who do not possess these facilities must therefore be prepared to introduce alternative designs without any serious change in the design or performance of the receiver.

Power transformers have different amounts of leakage flux resulting in different degrees of hum, this being particularly noticeable between vertical and horizontal types of transformers. Some designs of receivers which are quite satisfactory with the vertical mounting transformer are satisfactory with one make of transformer but not with another of the same mounting type. It is therefore important to design so as to be able to use at least one alternative type in an emergency.

TOOLING UP

Even apart from the production of component parts a considerable

amount of tooling is required for the quantity production of a radio receiver. The degree of such tooling-up is affected by the quantity to be produced and the facilities for quantity manufacture. It is obvious that the cost of tooling-up must be spread over the total number of receivers produced. This addition to the cost needs to be balanced against the saving in cost per unit due to quantity production. Considerable economy may be exercised through the use of tooled parts for more than one design. For example, it may be possible to use one chassis for several models of receivers either during the current season or successive seasons, while many of the smaller tooled parts may be used for a very wide range of receivers and need not necessarily be outdated for some years to come.

FIELD DESIGN

When a pilot model has been produced and has passed through its initial testing for performance

in the screened room, it is ready for what may be called developmental field testing. This is an opportunity for the receiver designer to try out his design under all anticipated conditions of operation and location. Special attention should be paid to such matters as selectivity, cross-modulation and overloading on strong signals, hum, quality of reproduction, tonal balance, "joys" and second spots. During this test it is desirable to operate the receiver with a mains voltage plus and minus 20% for periods of about two hour and half an hour respectively, in order to ensure that no deleterious effects occur. These tests should be carried out in the normal cabinet and with the normal amount of ventilation. Battery receivers require special attention to the effects of high and low battery voltage, and this subject will be considered in detail in a later issue.

At this stage it is also desirable

(Continued on next page)

HAMS !!

LOOK !!

THE 1946 EDITIONS ARE HERE

of

A R R L, RADIO AMATEURS HANDBOOK

Price 11s. 6d. 1s. Postage.

RADIO HANDBOOK [EX. JONES]

Price 17s. 1/- Postage.

SEND YOUR ORDERS NOW
AS SUPPLIES ARE LIMITED
to

TECHNICAL BOOK & MAGAZINE CO.

297-299 SWANSTON STREET, MELBOURNE, C.1.

(Opposite Old Melbourne Hospital)

Telephone: Central 2041

to look at the pilot receiver from the point of view of the serviceman, the ease of removing valves, chassis, speaker and the whole chassis from the cabinet.

When the receiver has completed its developmental field test, it will then be advisable to incorporate such modifications as were shown to be desirable. A second field test may then be desirable, and after its completion the performance of the receiver should be entirely satisfactory in all respects. The receiver will then be ready for developmental production to commence, but a series of production field tests are equally necessary and should be carried out on the first batch of receivers put through the production line. Some of these production tests should be carried out by experienced agents, dealers or servicemen under as wide a selection of operating conditions as is practicable. Reports received from these various observers may necessitate some slight changes to be

NEW ZEALANDERS!

The quickest and simplest way
of subscribing to the
"AUSTRALASIAN RADIO WORLD"

is to get in touch with

H. BARNES & CO.

4 Boulcott Terrace

Wellington

SUBSCRIPTION: 10/6 Per Annum

They will arrange all the details
and give you prompt and courteous attention.

DO IT NOW!

made in the final design, and provision should be made for these before proceeding to quantity production.

DESIGN TO FIT KNOWN
CONDITIONS

A particular design of receiver is

required to give good performance under certain fixed conditions. It is not satisfactory merely to design a range of 4 valve broadcast, 5 valve dual-wave, 5 valve dual-wave, 6 valve dual-wave, etc., but to look on each from the point of view of the class of listener and the service which it is required to perform. There is not always need to get the utmost in sensitivity from a particular type of receiver, and appreciable economies may be made, for example, by the use of less selective and lower gain i-f transformers, or the use of a cheaper type of converter valve. A small local station receiver intended for operation in areas of high field-strength need not have very high sensitivity, since the latter not only increases cost but brings in unnecessary background noise when tuning between stations, and may cause more interference from man-made static and power line interference.

—Radiotronics No. 118.

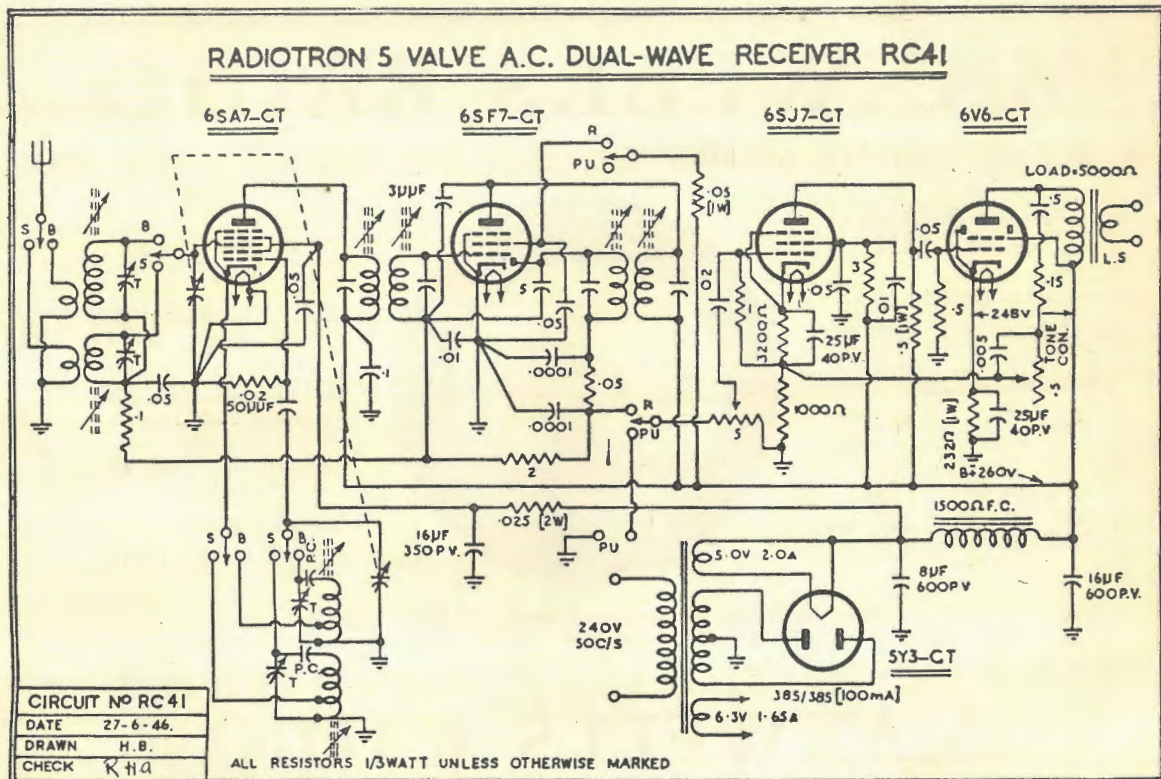

Latest Radiotron circuit for a five-valve dual-wave. This set is ideally suitable for use with the "Aegis" Conisseur foundation kit, advertised in this issue.

INTERMEDIATE FREQUENCY CONSIDERATIONS

A FEW people seem to be running into selectivity troubles with 1600 K/cs IF's, and you will recall that in the "VK2NO V Six" I used I.F.'s at this frequency. Subsequently I issued a mild warning about the lack of selectivity at the lower H.F. regions, i.e., 40 and 80 metres. There will be a measure of broad tuning with one stage of I.F., but even so the performance is still very good from other important points of view. There are no "joeys" or images to contend with, and the receiver is a pleasure to handle. In view, however, of the maelstrom-like state of affairs on 20, and to some degree 40, I make the following suggestions as an aid to improvement. Firstly . . . the use of an infinite impedance detector. This type virtually removes the damping effect across the IFT secondary-coupled thereto. The second thing to do, if you have room on the chassis, is to pop in another stage

of I.F. But if you are already using an EF50 or 1852 in the existing stage, be content with an ordinary valve in the additional stage, or you may run into trouble with oscillation. In any event, the usual precautions should be taken, such as screening of leads, and decoupling the anode feed-lines. There is another simple little trick that you can take advantage of to boost selectivity, and that is the introduction of a measure of regeneration. To do this, there is no need to make alterations to I.F. windings to provide for a small tickler coil. Connect a wire from the grid of the preceding I.F. valve and push it into a hole in the following I.F. screening can (insulated wire, of course) until oscillation takes place. Then withdraw the wire slightly until oscillation just ceases with the I.F. amplifier at full gain. As was a regenerative detector on the verge of oscillation, the selectivity of the

circuit concerned goes up considerably. It's an easy way of getting "Single Signal" action, and, if you like to be precise, you can connect an air trimmer, such as a Philips 3-30 mmfd concentric type in series with the lead and control the amount of regeneration in that way. Finally, if you want good selectivity—and who doesn't, in these days?—you will be well advised to make use of commercially-designed IFT's. I have just obtained a set of the new Kingsley Permaclad types KIF9 and KIF10. The efficiency of these is well known, and an important point is that they are set at 1900 K/cs. That is no error, either . . . the Kingsley people are looking to the time when broadcasters will be using the 1600 K/cs region, a fact that I have already pointed out in these pages.

—D.B.K.

MAXWELLS RADIO

48 ELIZABETH STREET, MELBOURNE

Cent. 4913

MAXWELLS' BARGAIN

1 Only
Shop-soiled **Calstan**
Valve and Circuit
Tester.

£25/-/-



A SPECIAL OFFER

0-1 Milliamps 1000
Ohms per Volt
Meters, as illustrated. Famous English
make, "Pullin."

Maxwell's Special
Price

20/7 nett

Extensive Range of Kingsley "Ferrotune" Units in Stock.

A Complete Range of All Radio Equipment for the Amateur and Experimenter

Special Allowances to the Trade

Mail Orders Promptly Forwarded Free of Charge

MAXWELLS RADIO

48 ELIZABETH STREET, MELBOURNE

Cent. 4913

AN A.C. BRIDGE

USING THE "MAGIC EYE" AS AN INDICATOR

IN the September and October issues of 1943 we gave details of simple "bridges" for the measurement of resistance capacity and inductance. The A.C. bridge described in the October issue was quite an accurate instrument and fairly versatile. It was self-contained as regards power and so was quite suitable for the serviceman outback. Its one disadvantage

be impossible. The amplifier valve and connections must be well shielded and the bridge enclosed in a metal case.

Standard condensers and resistors are switched in by a multi-way switch as in the case of the A.C. bridge previously described. For radio work, about 4 resistors and 3 condensers is ample. Terminals are provided for an external standard, e.g., in comparison of voice coil impedances.

By

J. W. STRAEDE
7 Adeline Street
Preston, Vic.

was that a phone or pair of headphones had to be used as a detector, thus making it unsuitable for noisy locations.

We now describe a mains-operated bridge in which 50-cycle A.C. from a transformer is used as the current source and the detector device consists of a 6E5 cathode ray indicator tube preceded by a 6J7G or 6C6 resistance-capacity coupled voltage amplifier for greater sensitivity. A good-quality wire-wound potentiometer is used as the bridge; its resistance is not critical but must remain constant over each part.

CIRCUIT DETAILS

The circuit is quite straightforward, conventional constants being used for the resistance-capacity coupling except that the coupling condenser must be large to deal with the 50-cycle signal and a rather large bypass condenser is used to get rid of any R.F. picked up. The presence of R.F. would prevent a complete "null" being obtained; perfect "balance" would

OPERATING VOLTAGES

The voltage for the bridge is taken from a 2.5 volt filament winding (most power transformers have both 2.5 and 6.3 volt windings), although 1 to 6 volts would be quite satisfactory. It is not advisable to use the same winding as for the valves. A four volt winding may also be used.

Grid-leak detection of the 50-cycle signal (produced when bridge is out-of-balance) is performed by the 6E5 triode. The D.C. voltage produced across the 6E5 grid resistor is amplified by the triode and controls the electron stream in the indicator section. As a sensitivity control the 6E5 grid resistor is made variable. As balancing is approached, the resistance is increased to obtain maximum sensitivity. Other forms of sensitivity control, e.g., bias variation on 6J7G, may be used.

AVAILABLE COMMERCIALY

This circuit (or a variation of it) is used by quite a number of manufacturers, both Continental and American. The Philips version uses the "Electron Star" indicator in place of the 6E5 and has limiting resistors at the ends of the bridge but is otherwise similar. It is known as the "Philoskop," the name proving quite a puzzle to Physics students as a certain university when they attempted to derive its meaning from skopeo = I see, philos = ? The Philoskop is now made in Australia, a different design with improved dial being especially produced to suit Australian conditions.

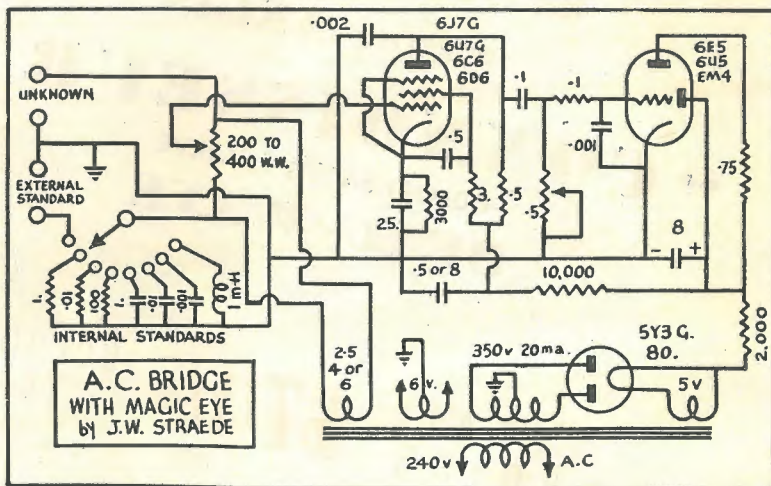

Circuit of the A.C. Bridge which has many uses in the radio laboratory or repair shop.

Sensational New Development

COMPENSATED TONE

AEGIS TYPE FKI

(AS ILLUSTRATED)
is another success by
the kit wizards!

THIS FOUNDATION
KIT IS SPECIALLY DESIGNED
FOR THE AEGIS

“CONNOISSEUR”
COMPENSATED 5 VALVE
DUAL-WAVE

RETAIL
PRICE **£7/1/-** INCLUDING
TAX



SEE YOUR
NEAREST
DISTRIBUTOR

—they're well-known
and they're in
every State!

AEGIS
MANUFACTURING COMPANY PTY.
LTD.
208 LT. LONSDALE STREET
MELBOURNE, VICTORIA

DEALING WITH "MAN-MADE" STATIC

NOW that the world is slowly coming back to normal, the shortwave bands are gradually reverting to their pre-war interests. New, more efficient shortwave receivers will make their appearance, and the owners of them will wish to make the most of their performance. One big drawback to good reception will be the ever-present interference. There are several types of such interference and they can be placed under three general headings:

1. Interference between stations.
2. Static or atmospherics.
3. Man-made static.

STATION INTERFERENCE

Interference between stations can be caused by too little separation in station frequencies or else the re-

By

G. L. F. SMITH

ceiver in use is not selective enough. In the first case little can be done about it, but the second case would call for alterations or rebuilding of the receiver to increase its selectivity.

STATIC

Static of course is caused by electrical discharges in the upper atmosphere, the best-known form being lightning. These discharges make themselves very apparent during thunderstorms by crackles, "sputters" and more or less violent crashes, and, as they are a product of Nature, very little can be done about their suppression. Noise limiters in certain receivers do have an appreciable effect but are very critical of adjustment.

MAN-MADE STATIC

What is termed "man-made static" is a very different proposition, as it is a by-product of our modern electrical equipment which is in use in home, shop and factory. Any of this equipment which

incorporates an electrical circuit which is being opened and closed continuously will cause trouble, as sparks are thus produced, and these in their turn produce a radiating field in just the same fashion as the old spark-type of transmitters which were the forerunners of present-day radio.

NOISE INPUT

There are two ways in which this noise is brought into the receivers and that is by way of the mains or through the aerial system, and it is a comparatively simple matter to discover just what path is being used by our enemy, noise. All that is necessary is to remove the aerial from its terminal, and if the noise ceases or is considerably reduced in volume, then it is quite safe to assume that the aerial is bringing in the noise. If the noise continues unabated with the aerial removed, then it is a fairly sure bet that the power supply lines into the house are the trouble.

Of course if it is possible to discover the cause of the trouble, then it is a matter for the person operating the offending apparatus to do all in his power to remedy the trouble. With so much electrically-operated equipment in use these days, some areas are so bad that it is better to attack the trouble at the receiving end rather than wearing oneself out trying to locate all troublesome gear. Assuming that the source of trouble is known,

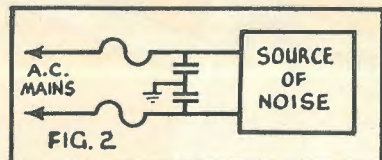
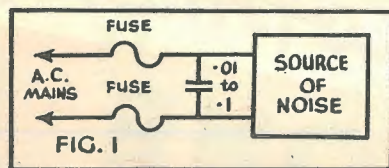

then noise suppressors may be fitted.

NOISE SUPPRESSORS

The circuits in Figs. 1, 2 and 3 are used for curing the trouble at its source and are connected in the mains leading to the apparatus, and generally would be found to provide the means for considerably reducing the noise. The condensers must be capable of operating continuously at the voltage of the lines to which they will be connected, and the fuses shown should be lighter in their fusing current than the fuses on the switchboard. These fuses prevent the whole electrical system from being put out of commission should the condensers break down and cause a short circuit.

The R.F. chokes should be capable of carrying the current taken by the apparatus. With small equipment it is sometimes possible to completely enclose it in a metal box which is earthed. This is in addition to the suppression chokes, etc., and results in very effective disposal of the troublesome noise.

Should it not be possible to attend to the source of the noise, then the only thing is to tackle the problem at the receiving end. Having ascertained whether the path for the noise is by means of

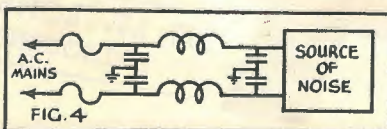
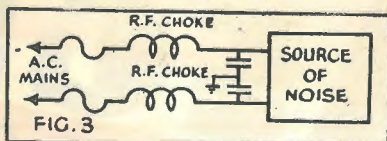

(Continued on next page)

STATIC
(Continued)

the aerial or the mains, then we know what means to adopt to remedy the trouble. If the mains are found to be bringing the noise into the set, any of the circuits recommended in the previous paragraphs, viz., Figs. 1, 2 and 3 would serve the purpose, although that shown in Fig. 4 is by far the most satisfactory. All precautions mentioned as regards breakdown voltages and fuses apply equally for this application. For preference, the whole unit should be mounted in a box with a flexible lead for connection to the mains and a receptacle mounted on the box for

receiving the plug from the receiver.

For those who do not wish to manufacture their own noise filter, there are several very excellent jobs on the market, and most radio dealers stock them or else can obtain them if they are not a normal stock line.

As these noises are radio frequency in nature, they only find their way through the power transformer by means of the stray capacities between the primary and secondary windings. Most modern power transformers are equipped with an electrostatic shield between the primary and secondary windings, and, if this is earthed, it has the effect of neutralising this interwinding capacity and thereby should reduce considerably the possibility of noise entering by this means.

The foregoing does not completely cover all the means by which noise entering via the mains may be reduced, but gives the most usual means by which it is done, and should be found very effective.

In these cases it has only been a matter of separating the H.F. noise from the L.F. power supply and returning it to earth, thus preventing it from making its obnoxious presence apparent in the receiver.

With noise which enters via the aerial system we have a very different proposition and it must be dealt with in an entirely different manner. In this case we have two high frequencies signals, namely the "noise" and the "R.F." signal from the station, and if we endeavoured to suppress the noise by any of the above systems we would also suppress the station by a like amount, and the result will be negative.

AERIAL PICK-UP

Before trying to clear up the trouble, it would be as well to find out a little about the nature and habits of the interference which is picked up by the aerial. Around all power lines, tram lines, buildings, etc., there is a blanket of this interference which is radiating from the interfering apparatus and

(Continued on page 27)

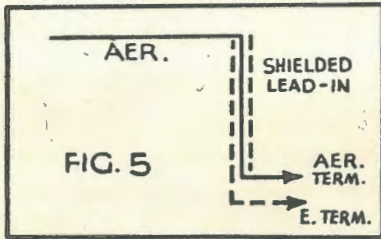

Waltham Trading Company

393 FLINDERS STREET, MELBOURNE

'Phone: MU 4719

REMOTE CONTROL UNITS

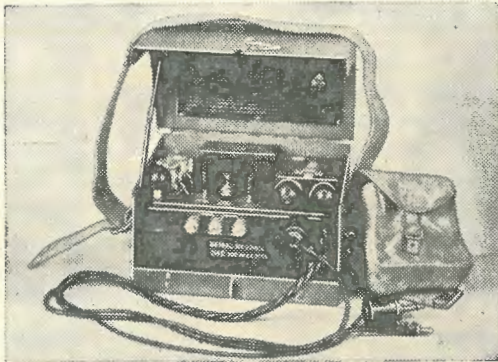

desire to thank their many customers who purchased FS6 Transceivers, and are pleased to announce that they can supply genuine FS6 Umbrella Aerials for same. Brass Sectional Aerials 15-ft. high complete with Umbrella Top Leads and Counterpoise

25/- 25/- 25/- 25/-

We have also a limited number of 101 Transceivers absolutely complete with 8 valves, RD Ampmeter, Power Pack, Vibrator and Connecting Leads.

BRAND NEW - - - - BRAND NEW
£10/10/- £10/10/- £10/10/-

ALSO

12" CATHODE RAY TUBES

As used Ships' Radar, absolutely new. Magnificently packed in wooden case

25/- 25/- 25/- 25/-

We have an excellent and varied stock of Radio and Electrical Parts, also General and Utility Campers' Requisites. Unfortunately our Lines are Government Salvage Stock and vary from week to week. City customers are invited to call in and inspect as often as they like. No obligation to purchase. Will country customers watch Saturday's Melbourne "Age" and "Argus" for complete list of bargains for the week. All orders well packed and dispatched immediately Free on Rail.

WALTHAM TRADING COMPANY PTY. LTD.

393 FLINDERS STREET, MELBOURNE

MU 4719 - - - - MU 4719 - - - - MU 4719 - - - - MU 4719

IT'S HERE

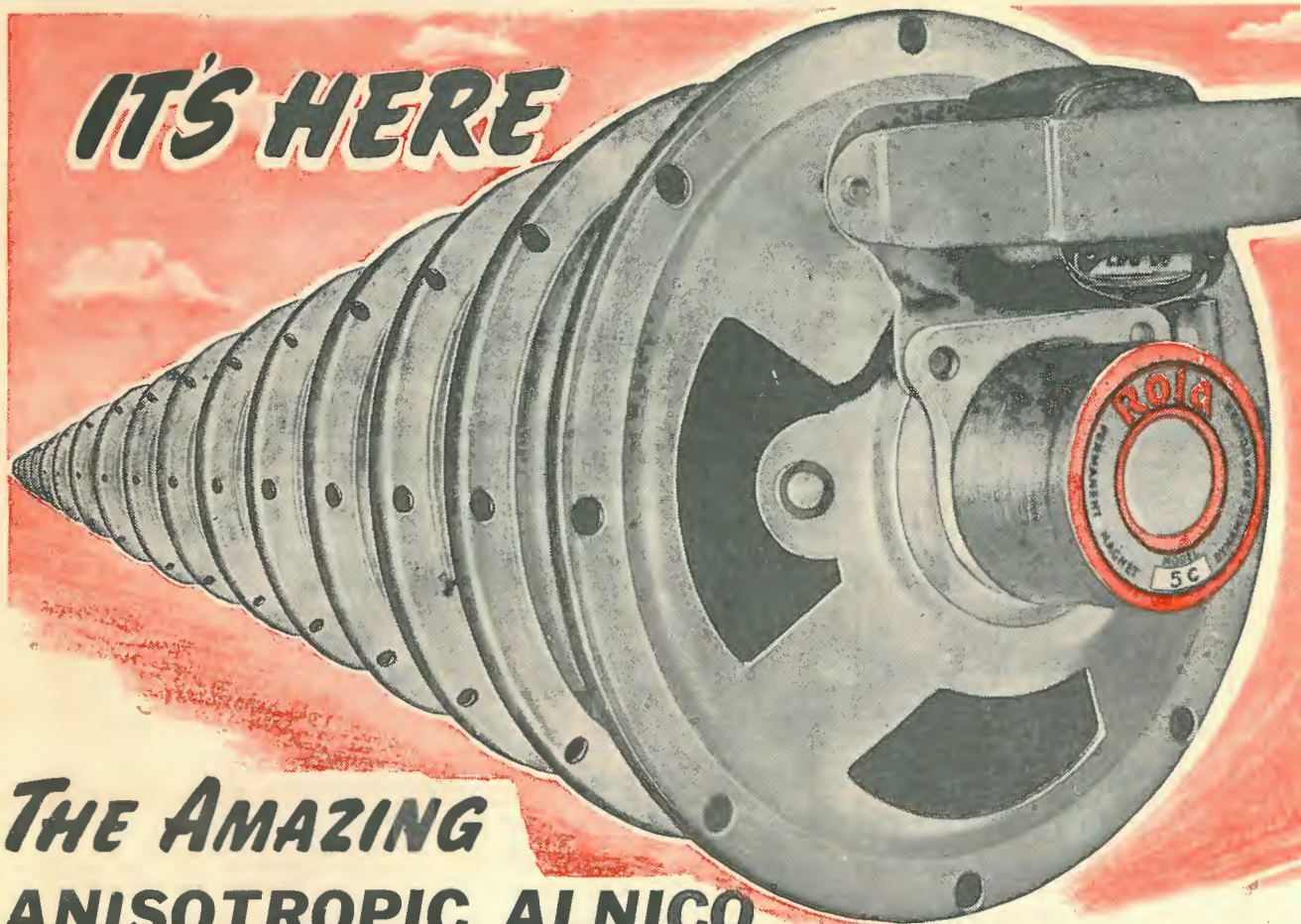

THE AMAZING ANISOTROPIC ALNICO

..... IN THE ROLA 5C SPEAKER

Using Anisotropic Alnico to achieve the maximum efficiency to weight ratio, Rola 5C is the most modern of all five inch speakers. Ideally suited for use in a.c. and a.c. d.c. receivers, it also finds useful application in vibrator and battery operated receivers.

It occupies the barest minimum of space, weighs only 12 ozs., and is thoroughly robust in construc-

tion and reliable in operation. Because of its eminent suitability in midget receivers, Rola 5C is unquestionably the most sought after speaker today. Retail price with K5 type transformer attached or detached 26/6 (With small isocore transformer detached . . 29/-)

Rola 5C (with anisotropic Alnico) is now being featured in modern midget radio receivers and limited supplies will shortly be released for resale purposes.

ROLA LOUD SPEAKERS with ANISOTROPIC ALNICO

ROLA CO. (AUST.) PTY. LTD.

THE BOULEVARDE, RICHMOND, VICTORIA

116 CLARENCE STREET, SYDNEY

STATIC (Continued from p. 25) the wiring to which it is connected. This blanket of noise can be assumed to reach from a little higher than the buildings, etc., around which it is formed down to, and probably below, ground level.

Our object is to obtain as clean a signal as possible at the aerial terminal of our receiver, by which is meant that the ratio between signal strength and noise level must be as high as possible. With this idea in view, the most logical thing to do is to put the aerial up as high as possible and so put our collector of radio frequency waves

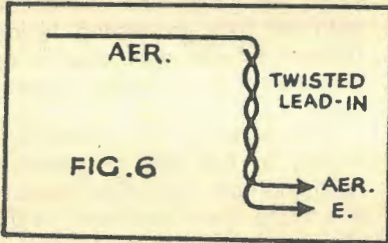

up above this devastating blanket of noise.

Yes, this is all very well; there must be a lead-in from the aerial to the set, and, this having to pass through the sea of noise, will have induced in it a goodly helping of noise to keep the signal company. The sum total will be a slight im-

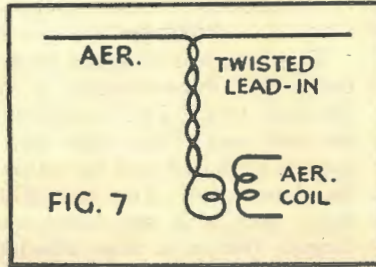

provement in signal to noise ratio, but not really worth the extra trouble entailed in installing the high aerial.

SPECIAL LEAD-INS

The next most logical proceeding now we have a high aerial is to prevent this noise from being absorbed by the lead-in, and thus

allow the clean signal from the aerial to reach the receiver unadulterated. Naturally a shielded lead-in is the answer to this problem, and by using such and earthing the shield the desired result is obtained. See Fig. 5.

Another system of lead-in is to use twin-twisted flex or twisted 18-gauge house-wiring wire as the lead. One of the leads is connected to the aerial at the upper end and the aerial terminal at the receiver, while the other lead is left free at the upper end and connected to earth (chassis) at the lower end. Fig. 6. The theory behind this system is that the induced currents in the lead-in travel down both leads at the same time and same level and cancel out in the aerial coil in the receiver. Fig. 7 shows an alternative manner in which this type may be used. This system of aerial is known as the doublet and has proved very effective and popular.

(Continued on next page)

A AUSTRALIA'S
B EST
A MPLIFIER
C OMONENTS

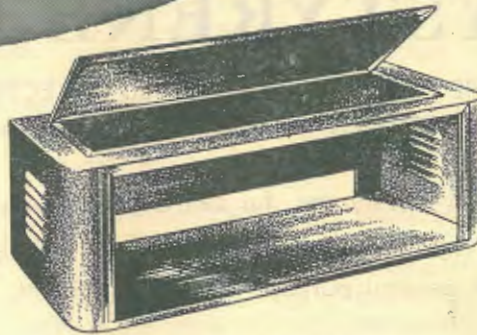

ABAC STANDARD RECEIVER

Or Instrument
Case. Takes
19 x 8 $\frac{3}{4}$ panel
with clear panel
space 17 $\frac{1}{2}$ x
7 $\frac{5}{8}$. Depth of
case 11-ins.

MANUFACTURED BY
TRIMAX TRANSFORMERS

29-35 FLEMINGTON ROAD,
NTH. MELBOURNE, VIC.
(Division of Cliff & Bunting
Pty. Ltd.)

STATIC

(Continued)

VERTICAL AERIALS

As most of the wiring, etc., which radiates interference is more or less horizontal, it is really only commonsense to assume that if we place our aerial at right angles to the wiring, thus presenting to it a minimum area of pick-up, then we should get a minimum amount of noise induced into the aerial. Such is the case and a vertical aerial, either a metal rod or a wire suspended from a tall mast placed high above the surrounding objects and using a shielded type of lead in, is very effective, although maybe not as practical to erect as the horizontal type. Its big advantage is that it takes up negligible space, which recommends itself to those poor unfortunates among us, who, owing to the present housing shortage, must live in flats, and another feature is that it is absolutely non-directional.

There is one big disadvantage about the types of lead-in so far mentioned, and that is in both cases

the two conductors act as small value condensers connected across the incoming signal and the result is a reduction in its strength, but, as we lose a much greater proportion of noise, the overall result is a greatly improved signal to noise ratio.

MATCHING TRANSFORMER SYSTEM

This system is designed to overcome the disadvantages of the previous type. Two transformers are used, one at the upper end of the shielded lead and the other at the lower end. The one at the aerial end is a step-down transformer; that is, it steps down the signal voltage, but at the same time steps up the signal current, which enables the signal to pass down the shielded lead without the losses that are experienced without the use of the transformer. The transformer at the receiver end is really the same as the first, only that it is reversed and thus the signal conditions are returned to normal and passed into the receiver.

It is not claimed that there are

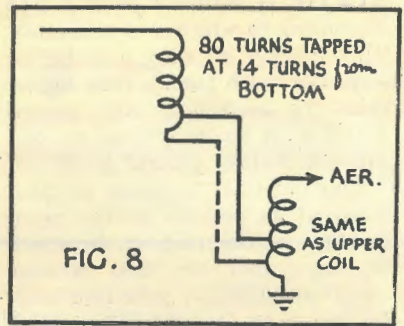

no losses in this method, but they are so small compared with the earlier types that the extra cost and trouble is well warranted. Fig. 8 shows the circuit and coil details. Both the coils are wound $1\frac{1}{4}$ -inch former and the wire used is approximately 28 to 30 gauge enamel or DCC.

After winding, the coil should be dipped in hot wax to protect it from moisture, and then mounted in a weatherproof container, so that the upper end may be mounted on top of the mast and yet not be damaged by climatic conditions. This container need not be metal,

And Now . . .

POLYSTYRENE CEMENTS

WITH THE SAME UNQUALIFIED ELECTRICAL PROPERTIES OF
ETHOLEX POLYSTYRENE SHEETS AND RODS.

"STYLON" Liquid Polystyrene, for cementing Polystyrene units together.

"STYLON G.P." for joining Polystyrene to glass, plastics, ceramics, metal, rubber, etc. A general purpose insulating cement.

IN 3-OUNCE CONTAINERS, WITH INSTRUCTIONS FOR USE

3/- each (plus tax) Post free.

ETHOLEX PLASTICS

108 CHAPEL STREET, WINDSOR, MELBOURNE, AUSTRALIA

but, as mentioned, should be thoroughly weatherproof.

The shielded wire is of the normal single shielded microphone cable which is easily procurable once again, and can be taken direct to the coil connections, after which it should be secured to the container to prevent it breaking away. One line of shielded wire available has a treated cloth braiding on the outside and this will protect the metal shielding from corrosion, etc., and should be procured if possible.

As well as mains filters there are commercial noise reducing aerial kits available and for those who lack the necessary time or mechanical bent to make their own, these kits can be recommended, as their many users can confirm.

There are a number of other ways in which noise-reducing aerials may be constructed, but, as those described will be found to cover most applications, it is unnecessary to go any further.

LOCATION OF AERIAL

This is another matter which warrants a deal of thought, as quite a lot of noise elimination can be done by judicious placing of the aerial. It should be situated as far as possible away from sources of noise and at right angles to them. As most power and tram lines usually occupy the front street in a home, then the logical position for the aerial is of course the back garden. Be sure, though, that any side streets are free from power lines. Telephone lines are almost as bad as power lines in giving trouble and should also be avoided.

With the information here provided it is to be hoped that the reader may be able to reach out for that weak overseas signal without the worry of "man-made static" to ruffle his nerves. Here's to good hunting, anyhow!

* * *

A new electronic tube has been developed that is capable of amplifying grid currents as minute as 10^{-14} (0.00000000000001) ampere. The tube is used for measuring the tubes exposed to starlight.—"Tune to the distant telephone through toll dial equipment usually without the assistance of another operator.

HAM EXAM PAPERS

The following questions were set at a recent examination of the A.O.C.P.

SECOND CLASS AMATEUR OPERATOR'S CERTIFICATE OF PROFICIENCY THEORY

Time Allowed — 2½ Hours
Note: Only seven questions to be attempted

1.—Three resistances, 10, 12 and 20 ohms, are connected in parallel. What is the total resistance of the circuit?

If 6 volts is applied to the combination, what is the total current, the current through each resistor, and the power dissipated in each?

2.—The secondary load on a transformer, having a 5 to 1 primary-to-secondary turns ratio is 300 ohms. What is the impedance looking into the primary from the source of power?

3.—Explain the effect on the resonance curve of increasing the coupling between two radio frequency circuits.

4.—Draw two different oscillator circuits with capacity feedback and explain clearly how the feedback may be controlled in each.

5.—What is a parasitic oscillation? Why is its presence in a transmitter undesirable?

Describe two forms of parasitic oscillations which may occur in a transmitter, and methods which may be adopted for suppressing each type.

6.—In connection with a Class-B modulator—

(a) what is the effect of operating without load;

(b) what is the result of overdriving it; and

(c) what anode supply requirements are necessary?

7.—What are the merits or demerits of a superheterodyne receiver compared with other types of receivers?

What is "image response."

Name other spurious signals that may be encountered in a superheterodyne receiver.

8.—What is meant by the polar-

isation of a radio wave? Into which polarisation classification does the ground wave fall?

Describe, in general terms, the relationship of the range of the ground wave to the frequency of the transmission.

9.—Draw a circuit diagram showing capacity coupling between a single-ended driver and a single-ended amplifier. Indicate a method for obtaining optimum energy transfer.

REGULATIONS

Time Allowed — 30 Minutes
Note: Only three questions to be Attempted

1.—State fully the regulation requirements regarding the transmission by experimental station licensees of unnecessary signals and improper language.

2.—Set out clearly the form of hall and reply which two experimental stations would use in establishing communication by morse.

If an experimental station licensee should hear his call-sign, but cannot read the call-sign of the caller, how should he act?

3.—What are the limiting restrictions imposed by the Department on the length of communications between experimental stations?

How would you comply with this requirement, and why is it necessary?

4.—Why is it essential that experimental transmitters should be maintained on a frequency within the limits of the allotted bands?

What steps should experimental station licensees take to comply with departmental requirements in this regard?

5.—Explain the relative obligations of the Commonwealth Government and an experimental station licensee in regard to liability for breaches of the law or injury to persons, arising from an act of the licensee by reason of the exercise of the license.



A Message to All Amateurs

TRANSMITTING DX MEN
 V. H. F. EXPERIMENTERS
 SHORT-WAVE LISTENERS

Help Us to help YOU!

PHILIPS ELECTRICAL INDUSTRIES OF AUST. PTY. LTD.
 EXPERIMENTAL RADIO EQUIPMENT SECTION
 HEAD OFFICE: 69-73 CLARENCE STREET, SYDNEY, N.S.W.

I have indicated below the components in which I am interested and which I should like to see on the market.

- Amateur band receivers (H.F.).
- Amateur band transmitters (H.F.).
- V.H.F. converters for amateur bands.
- V.H.F. transmitters.
- H.F. frequency measuring equipment.
- V.H.F. frequency measuring equipment.
- H.F. frequency standard equipment (100 Kc/s to 70 mc/s).
- Transceivers for V.H.F. band (166-170 mc/s).
- Calibrated variable freq. oscillator units.
- Field strength meters for amateur H.F. bands.
- Field strength meters for amateur V.H.F. bands.
- Special V.H.F. plug-in coils and mountings for receivers.
- Butterfly tuners for V.H.F.'s.
- Parts for rotary beam aerial arrays.
- Transmitter plug-in coils with variable links.
- Communication receivers.
- Transmitting valves (H.F.).
- Transmitting valves (V.H.F.).
- Receiving valves (H.F.).
- Receiving valves (V.H.F.).
- Kits of components for amateur band receivers.
- Kits of components for amateur band transmitters.
- Panel mounting vernier dials with logging scales.
- Power supply units.

Other items in which I am interested are:—

.....

.....

Please place me on your Experimental Radio Mailing List for future technical information. This places me under no obligation.

Name Call Sign

Address

● As radio manufacturers, we want to know just what you want in the way of apparatus, so that we can make it in the right quantity and at a reasonable price.

We will plan our future production to suit your needs—to give you the right kind of equipment and components. To do this we need your co-operation. Please read the list opposite, tick the items that interest you, add your name and address and mail to Philips. Just do that and leave the rest to us. This, of course, places you under no obligation.

One of Australia's most widely known "hams," Don B. Knock (VK2NO), M.I.R.E. (Aust.), an experimenter of long experience, is in charge of Philips Experimental Radio Equipment Department. His services are at your disposal for technical advice. Fill in the form and place yourself on his mailing list.

PHILIPS



EXPERIMENTAL
 RADIO EQUIPMENT.

AB.1

PHILIPS ELECTRICAL INDUSTRIES OF AUST. PTY. LTD.
 Sydney - Melbourne - Adelaide - Perth - Brisbane

CALLING CQ!

By DON B. KNOCK

Frequently, during the course of QSO's with fellows on one band or the other, I am told that the operator with whom I happen to be in converse "always reads your notes in A.R.W."—which is, of course, of direct interest to me—but brings me to a point. In compiling this section of "A.R.W.," much of my penned material naturally arises from personal experiences and happenings. So much so that there is danger of too much of that aspect, and therefore it is up to you readers to play your part. The way to do it is simply this: If you have any interesting items of news about amateur doings in your locality or any reasonable matter that you think should be aired, just put the matter to paper and post it to me at the address on the contents page of this issue. The same applies to technicalities, of course

... if you hit upon a bright idea, don't keep it up your sleeve, but send it to a really bright publication like this, so that your confreres can read about it.

* * *

I can think of nothing severe enough for the miscreant who literally bites the hand that feeds him. A case in point is an experience by Wal Ryan, VK2TI, chairman for many years of N.S.W. Division of W.I.A. During the war years, and on many occasions since then, VK-2TI has been outstanding for his hospitality to visitors to his station. There have been many overseas visitors, and also a number of local people, some of whom have been at the stage of entering amateur radio circles, and have been in quest of a helping hand with technicalities, and other matters.

The other day, thieves broke into VK2TI's station location, and stole an amount of valuable gear and accessories. That sort of thing is liable to happen to anybody, but the point that is obvious about Wal's experience is that the person or persons concerned quite obviously knew the layout of the "shack" and helped themselves to such important items as crystals in holders, high-quality microphones and things like that. It was done by somebody who had been a visitor at the station at some time or other, and who had evidently cast a furtive eye around as to just where some things were kept. This kind of thing is sufficient reason why the experienced Ham is not likely to throw his doors open to any individual that happens along, unless something is known of the caller. In 35 years of amateur radio I myself have had one or two experiences of light-fingered persons ... in some cases, people who would normally go unsuspected.

* * *

APPOINTMENT OF JIM MALONE

IT may not mean much to the new Ham, but old-timers in Australia will note with interest and satisfaction the appointment of Jim J. Malone, N.S.W. Director of Posts and Telegraphs, as Chairman of the Overseas Telecommunications Commission. For many years prior to the war, Jim Malone was Chief Inspector of Wireless for the Commonwealth, and, as such, had much to do with amateur radio affairs. Those who came into contact with him on official (and personal) matters found him at all times co-operative and sympathetic, and those who tried to "put anything over" found that, in a polite, but tactfully diplomatic fashion,

they got nowhere at all.

Despite his more than passing interest in radio of the Ham variety, Jim Malone at times might well be excused if he considered some Hams as "those crazy — of amateurs." Now he goes to a vitally important post and with him he carries the goodwill of those of us in the amateur world who know him well. We know that if any matters affecting amateur radio come in for international dissection, Jim Malone will see to it that Australian amateurs get a square deal in the process. More power to you, J.M.

—D.B.K.

The other night I decided to pound the key a little on 20 in search of DX reports on a new type of antenna I am trying. I raised a Canadian but, in between-times, noticed a QSO in progress between two "leading lights" of the local Ham community, one using the key and the other on phone. A caustic remark was passed about QRM from my transmission, and that prompts me to point out the error of their ways. The two stations were located no more than three miles from each other, in the Sydney area, and were cluttering up a goodly portion of the band with

(Continued on next page)

HAM NOTES

(Continued)

social chatter. Point number one: Stations should use channels other than DX ones for their mutual gossip . . . we have available perfectly good regions at 50 M/cs and 166 M/cs. Point number two: One of the stations seemed to resent the fact that I live "rather close handy to him" . . . which is just too bad for the laddie concerned, if that is the way he feels about it. I've lived in the same spot for 15 years now, and have Hams all round me, but if I experience QRM . . . to me it's all in the game, and I can wait until the air is clearer, or do something else meanwhile. Some of our VK's have a lot to learn about the once-evident spirit of amateur radio, which has suffered at the hands of wrong types.

* * *

Have just received my first post war copy of ZL magazine, "Break-In," published for the gang across the Tasman by their organisation, "N.Z. Association of Radio Transmitters." The Editors should be complimented, for it is right back to pre-war standard, printed on good art paper, and with lots of

interesting things to read about. It is evident upon reading through the ads that the ZL's are somewhat better off for gear than we are. For instance, there are available shipments of the well-known British "Raymart" variable condensers and any amount of high voltage oil-filled filter condensers.

* * *

Whether we like it or not, the license held in Australia to permit private individuals to possess and operate transmitting apparatus is issued as an *experimental license*, and whether or not it ever becomes (as now in Britain) an *amateur license*, is a matter for the PMG. Terms of the license provide for communication between stations, but underlying everything is that *experimental atmosphere*. There are wiseacres who say that the Ham cannot contribute anything more to the science of radio communication by *experimenting*; that the big Labs know all there is to know, etc., etc. Nonsense! The experimenter with a flair for things can contribute much by the development of practical applications, and by trying his humble ideas out in actual communication. Ever hear of the U.S. Sig. Corps Sgt. who broke a quartz crystal into small

portions, quite accidentally? From that incident resulted the vast increase in crystal stocks for war functions. Any idea that V-H-F's are not useful for *communication* as well as experimentation is the result of ignorance expressed by people with no experience of V-H-F techniques. They have only *heard about it*.

* * *

Recently I heard an opinion aired on a Sunday afternoon on "Ten" that "Fellows who use V-H-F's do so because they can't work the DX on Ten." Normally such vapouring into a microphone would be dismissed as a result of a pasteboard mentality . . . that of "QSL cards at any price," but in this case exponent of the idea happened to be one who is ostensibly a "leader" in amateur affairs. Being an Advisory Committeeman to boot, such statements ill befit the source. There are men interested in, and using V-H-F's in this country who were "working DX" before some aspirants for amateur fame and fortune were at the galena and catwhisker stage.

* * *

A later letter from Bill says, *inter alia*, "Recently I purchased some discarded boiler tubing (1-5/8-in.) and planned to erect a couple of 60-ft. poles. However, when joined together in such long lengths the tubing proved too flexible, so I have had to be content with two 45's and a 30. The two 45's support a half wave doublet for 14040 kcs., and a half wave matched impedance for 7020 kcs. From one of the 45's to the 30 I have a 350 foot long inverted "L" which is proving itself very efficient on the broadcast band. Last night I was able to log at fair strength WVTM, Manila, 1300 kcs., Radio Malaya 1000 kcs., and WVTM, Leyte, 1510 kcs., in addition to the Indian stations. The long aerial gives at least 50 per cent additional gain over the other aerials, that is, on the B/C band."

ANOTHER NEW CLUB IN SYDNEY

Latest radio club to open doors in the Sydney area is one formed by the St. George Technical College, Kogarah, N.S.W. Officers are: President, M. Sobels (VK-2OT); vice-presidents, Messrs. D. Patrick and N. Lee; secretary and treasurer, Miss S. Barry. Membership is open to all students and ex-students of the college with joining fee 10/6 and thereafter 2/6 annually.

At the present time morse code practice is in progress each Tuesday evening between 6 and 8 p.m.

Although the club has but recently been inaugurated, members at the time of reporting total 35. Regular monthly meetings are held, and visitors and new members will be welcomed. Lectures on radio theory and practice are being prepared and it is expected to commence the construction of club equipment shortly. Location for club meetings, etc., is at the St. George Technical College, Kogarah, the Principal having made available the facilities of the College for the club. Correspondence will reach the club at the address of the Technical College.

DOINGS ON "ONE AND THREE-QUARTERS"

THE habit of talking about "Six Metres" comes easily, just as it did in pre-war days with "Five," but when it comes to talking about the next band in the VHF regions there is a tendency to stumble. If we say "One sixty-six," that seems natural enough, but the catch is that we are likely inadvertently to tack on the word "Metres" and that doesn't make sense. So what is wrong with the mode of reference at the heading of these Notes? Whatever we like to call it, the band 166 to 170 M/cs has come in for a good airing in the Sydney area, leading lights there being VK's 2WJ, 2KI, 2YE, 2AGL, 2AFH, and 2ABZ, with the Mountains stations VK's 2LZ and 2AFO, providing the "DX." And, in comparison to results in other States, so far as I know, it IS DX. Your scribe is tied up with other matters concerned with the daily bread, and consequently hasn't had time yet to do other than break in on the band some weeks ago. I managed to get my QRP signals heard in Gladesville and Wentworth Falls, but with the temporary receiver I have on hand, the only station I have yet heard in Waverley is 2WJ, who runs on R7/8. This, be it understood, is through four lots of rolling hills, and is by no stretch of imagination in optical range. But 2WJ, located at Maroubra, reaches out nicely with a 20-watt rig using two 2C22's in P-P and a co-ax antenna. He works the Mountains boys with little or no trouble, also those stations across Sydney in the Western Suburbs. More than that, he has been able to work two-way with VK2LZ when the latter has been using a small transceiver in his car in the Katoomba area, and signal strength has been well up, around the R9 mark. Secret of success with 2LZ and 2WJ appears to be the revival of an old idea in application of the resistance-tuned I.F. superhet. This form of receiver, you will recall, was introduced in the 1930's by Frank Jones,

of the well-known "Radio Handbook," U.S.A., at a time when "Five metres" was in the embryo stage.

Modulated oscillators and super-regens were the order of things then, and the type of superhet described was an effort to provide something a bit better than the "rush-boxes." It was, too, but the catch was that, if you used it anywhere near a B.C. station transmitter, it had a habit of riding in all over the dial. Furthermore, at 56 M/cs with an IF around 20 K/cs, there were two signals on the dial quite closely spaced, a most annoying feature. VK2LZ got the idea that this kind of receiver might be a better actor at 166 M/cs, and put it to work accordingly with a suitable VHF valve as autodyne detector. Results were gratifying from the start, there being no B.C. QRM in evidence, even though the receiver was tried in the transmitter room of a B.C. station. Because of the high signal frequency involved, there is no trouble from the image; the signal and the image merge almost as one on the dial.

VK2WJ got busy and made up the same kind of receiver with equally satisfying results, and it appears that this resurrected idea of Jones' has much to commend it at the frequencies concerned. So far nobody is using beam aerials on the band, but that state of affairs will not be for long. The obvious ad-

vantage of applying high gain arrays at "One and Three Quarters" is that the most ambitious of them do not take up very much room. You can take your pick: Rhombics, Square Corners, H arrays, stacked dipoles and the rest. Remember the Reinartz square type beam? Well, it is only 16½ inches square on this band . . . literally small enough to fit in an overcoat pocket. A word of warning: don't try to break in on the region with standard valves . . . old timers like 56's and 76's just don't perform there. There are now a few types of VHF valves on the market, and if you are keen enough to make a start on this intriguing band, you should be keen enough to get the right kind of valves to ensure a measure of success.

Just as I was about to conclude this resume of happenings around Sydney on this band, news comes from VK2WJ of some fine work between his station and VK2KI, the latter operating from a car with low power. Distance covered was around the 70-mile mark with 2KI in the vicinity of BOWRAL, N.S.W. Signal strength both ends averaged R7 telephony. This communication took place during Saturday and Sunday, August 17 and 18, 1946, and reminds me strongly of the mobile pioneering days on "Five metres" in 1934.

—VK2NO.

A TIP FOR FEEDING ARRAYS

"QST's" experimental section, in a recent issue, has a tip for those who ponder over the "unbalance" of 70 or 50 ohm co-ax. cable when applied to the centre of a dipole. Scheme is an adaptation of the well-known Y-match antenna.

A parallel tubing element, split at the centre by an insulating block to take the co-ax., is spaced about 3 inches from the dipole element, and held thus by stout metal

clamps. These are the feeder connections for the Y-matching, and are adjustable along dipole and matching tubing until standing waves, etc., disappear. Approximate position for the clamps from the centre of a 28 mC/s dipole is 21 inches each side. The idea is readily applicable to the feeding of close-spaced parasitic arrays, where co-ax. feedline is normally a matching problem.

DX POSSIBLE ON "SIX"

It is a foregone conclusion that sooner or later with the sunspot activity on the increase, DX will "break out" on the band 50 to 54 mC/s. Best chance any country has of taking advantage of this is U.S.A. where the Ham population keeps the band on the buzz continually. Britain, however, has not been behind-hand with V-H-F population for RSGB Bulletin records that in April this year stations have been working between the North and South of GB on the old "Five metre" band. G's are, of course, still using the pre-war band and are not yet on "Six." Here in Australia the 50 mC/s. population is growing and with an almost nightly influx of new stations in the Capital cities, there is a reasonable chance of DX being recorded. First indication of "Six" being open at certain times for such extended range working was afforded the writer on the nights of

TRIBUTE TO A PIONEER

In a letter to Don. B. Knock (VK2NO) "QST's" V.H.F. Editor, Edward P. Tilton (WIHDQ) outlined the latest activities in U.S.A. on "Six" and "Two" metres. He concludes his interesting description thus: "Please pass along my best regards to A. G. Hull. I knew his brother, the late and highly respected Ross Hull, very well. He had a deep and abiding interest in the possibilities of the higher frequencies, and like the writer, was often laughed at for it. His wonderful work probably did more than any other one thing to establish the frequencies above 30 mC/s. as a legitimate field for serious amateur endeavour. It is an interesting coincidence that I am now occupying the same living quarters that Ross used when he embarked on his splendid VHF experiments back in 1934. Just to ponder that fact is a source of inspiration, you may be sure."

June 24 and 25 in Sydney. A QSO had just been completed with VK-2LZ (60 miles distant), and it was noticed that all local stations were being heard at unusually strong levels. Across the band there were spotted a few fading carriers, obviously of distant origin. Just past 50 mC/s., outside the LF end of the band, I ran across a CW station with a bubbly DC signal swinging between R3 and R9. He was in the middle of what appeared to be a private message, and was referring to "Lansdowne Terrace, Northumberland." The signal disappeared without identification. Next night, Tuesday, June 25, the same characteristic signal was logged again, at 7.15 p.m. Sydney time, swinging from R3 to R8, and was this time identified. It was a ship signing BDQT calling VIS with QTC. The signal held for about ten minutes and then vanished. Checking up with AWA's maritime service, this signal came from the SS *Ocean Valour* which, at that time, June 25, was in the area of Jervis Bay, N.S.W. On the previous night he was about 150 miles further distant down the coast, bound for Sydney. Actually the ship was working in the 16 mC/s. marine band, and the signal heard was the third harmonic around 48 mC/s. A fine example of stay-wires or rigging putting out a strong higher frequency signal. The point of interest deduced from this harmonic reception, which for all practical purposes may be taken as the same as a fundamental signal around 50 mC/s., is that at certain times the band does open up along the coastline around Sydney. Therefore it should be possible under some conditions to communicate with stations along the seaboard, in cities like Newcastle. There wouldn't be anything new about that for VK2NO and VK2ZC worked with each other on 56 mC/s. in 1936. VK2CI, also of Newcastle, was able to receive VK2NO on the old band quite strongly. What could be done on 56 mC/s. can assuredly be done with more cer-

tainty at the lower frequency around 50 mC/s. The reception referred to on the 24th and 25th of June is an example of extended range reflection. It is not indicative of "double hop" propagation. When that happens, there is the chance that VK2's and VK6's will break through to each other, or that VK5's may come into the picture. Nothing to be achieved by it all do you say? Of course not . . . but it is something different to the jargon of the stereotyped QSO's on the regular DX channels . . . and it is Ham radio. Just because it seems difficult or impossible, there are Hams who will persist with their observations for the sheer love of it all. That's true of any hobby isn't it?

DON B. KNOCK.

GLOBAL RECORD BROKEN

A new record for round-the-world radio transmission was established by the U.S. Army Signal Corps when it sent a nine-word radio-teletype message completely around the earth in 9½ seconds.

In a test to demonstrate the flexibility of Army Communications Service's world-girdling system, the message was transmitted from Washington, through automatic relay stations at San Francisco, Manila, New Delhi and Admara, then back to Washington. Regenerative repeaters were used at the relay points.

The transmission was almost instantaneous. Exactly one second after the perforated tape containing the message began moving through a teletype transmitter, a nearby receiving machine at the end of its round-the-world journey. The one second represented the time lag in the electrical transmission, the other 8½ seconds the time mechanically required to send the message.

—"Radio Craft."

BARGAINS — AND WHERE ENCOUNTERED

THESE remarks, I submit, might better be headed "I passed by your window," but the idea originates from a request by mail from Dick Rees (ex-A2RE) that I might be a good scout and pass on the "good oil" to the lads about bargains—and where encountered! The idea is sound, but has flaws, in that wholesale reference to Tom Dick and Harry "junk" dealer businesses is not a fair deal to "A.R.W.'s" advertisers. That's logic, and, much as I would like to tell you that up in "Uncle's with the three-ball sign" you can pick up an SX28 for a song, I must refrain from direct reference. I'll give you clues about things and localities, and leave it at that. Let it be understood that our scribe, in his eagle-eyed expeditions into the precincts of "disposals gear," refers only to Metropolitan Sydney. What goes on in Brisbane, Melbourne, Adelaide, Hobart or Perth, is your guess as much as mine. Quite obviously there are bargains to be picked up in ex-Service radio and associated equipment with surprising regularity. A good scheme is to scan the Disposals auctions advertisements in your appropriate newspaper, then keep your eye on your favourite "junk" dealer, and note what *he* produces. At the time of writing this, there is a dealer in Sydney, not far from Vic. arracks, where one can delve through a quantity of "Wireless Set No. 11" priced at anything from £5 to 25/-, according to the state of bashery it has undergone in its military—and post-war life. The higher-priced articles are obviously in fairly good shape, and the practical "Ham" can easily get busy and make them perk. As for *all* of them, they are replete with lots of high-grade useful parts, purchase of which (if you could *get* them) would run into much more than the price asked in these chasses.

I *should* know that many of these components are of particularly high quality, having served as

an inspecting office on acceptance of these jobs for the A.I.F. at one stage of the big Rumpus! Incidentally, this same dealer has a window with attractive gems such as really good "acorn" sockets, and miniature valves of types the average ham sees only in overseas magazines. There are also genemotors of many types, and heavy duty vibrator packs. In another part of Sydney—a well-known dealer is displaying "Lucas lamps—signalling" complete in box, for the sum of 10/-, and if you don't think a Lucas lamp has any utility, you are a bad guesser. As a spotlight for the home photographer it is a "daddy"—and it contains a perfectly good morse key of Service type. Also offering for 10/- are the tripods—and I leave it to camera fiends, telescope users and the like to see the utility here.

Window-shopping around radio dealers with a flair for acquiring sudden stocks of exceptional bargains is fatal for the practical "Ham." Best of intentions to make do with present possessions are likely to go overboard. For instance, in an arcade in Sydney, once known as "Radio Row," there are bargains in *transmitting* wavechange switches to delight the eye of the lad planning his band-switching TX. Massive ceramic-insulated, silver-plated, multi-contact affairs, they are offered at the price of 5/- and 7/6 in two types. Made for war equipment by one of Australia's leading manufacturers, these are superbargains and worth acquisition just "in case"!

And so the story goes on, no doubt with similar aspects in other industries. It is an era of attraction for the "Ham" with the ability to make up his own equipment from bits and pieces, and very few *pre-war* "Hams" were *not* of that breed. But, the near future will see an influx of amateurs of a different species. They will include numbers of first-class operators from the Services, but their practical ability will be slight. These are the people

who will enjoy *operating* instead of *building* their equipment, and as such they will prefer ready-made gear. Unfortunately for "Hams" of this kind, there is little of the Disposals gear available in complete *workable* condition, and in any case its use would be out of the question by reason of inappropriate frequency coverage. 28 mC/s transmitters—and receivers—don't grow on trees, and one must need make one's own or seek the guidance of experience. Readers in this category are advised to take heart for there *are* people with their needs very much in mind.

A word, in passing, about microphones. Those little "No. 7" types so easily available are not bad acquisitions at the price of 10/-, but beware of HUM troubles unless very complete screening is adopted in the output and pre-amplification circuits where R.F. is floating around the room. My personal experience has been to veto the little dynamic in favour of the P.M.G. type "neophone" carbon mike. Very good speech quality can be obtained from such a microphone, and excessive pre-amplification is avoided. If such capsules had serious failings, then they wouldn't be used in our modern telephone hand-sets, a point to reflect upon.

The amateur station is, or should be, concerned only with good intelligibility of telephony communication. "High fidelity" can be left to the B.C. and amplifier exponents. It's a thousand to one that even if the amateur's telephony transmitter *is* flat from 30 to 10,000 cycles, or so, the receiver at the other end won't take notice of the fact. Johnny with his little carbon-mike and push-pull 6V6G modulator is likely to put out speech quality just as good. That's how it may be, but then again, there *are* attempts at modulation of the "pip-squeak" variety. It all depends upon *how* you use your available material.

—D.B.K.

AROUND THE SIX-METRE BAND

ALTHOUGH the usual activity predominates in the Sydney area, there is little to report other than the fact that attempts are being made to establish contact with VK2QK, Jack Early, located at Toronto, on Lake Macquarie, N.S.W. Some evidence is forthcoming that his signal may have been heard weakly by VK2WJ at Maroubra, but there is no confirmation as yet. Another DX attempt was on the afternoon of Sunday, August 18, when VK5NR (ex VK3NR) at Katherine, N.T., sent me a message through VK2YC on "Ten" to the effect that he would be calling VK2NO and listening for replies on "Six" as from 1400 hrs. that day. The schedule was kept, with no results, but again; VK2WJ says he heard a weak carrier with speech thereon and a voice talking about "Waverley, N.S.W." This was on 51 M/cs around 1500 hrs., but VK5NR is stated to be on 52.25 M/cs. Any information or clues as to identity of the signal heard? Modus operandi among the Sydney stations appears to be: use 166 M/cs each evening until 8 p.m. and then

ARGENTINE STARTS TELEVISION

American engineering and science had its first post-VE Day triumph in the consummation of negotiations between Allen B. DuMont Laboratories, New York, and an influential syndicate of Argentinian businessmen for the sale and erection of the first television transmitter for South America. Exact details of the installation contemplated by the purchasing syndicate were not revealed, but the original proposal provided for a DuMont 250 kW. peak video and a 12.5 kW. peak audio transmitter, full field pick-up and relay equipment, together with cameras and control equipment for three studios. It is assumed that the transmitter will be located in or near Buenos Aires.

change to 50 M/cs, and it proves to be rather a difficult matter to divide attention between the two bands. In Melbourne there has been possibly more activity on "Six" than in Sydney recently, judging by the monthly quota of information to hand from Ken McTaggart, VK3NW. An item of interest, and one which has turned out to be a bone of contention, was a story that has been going the rounds that VK's 3NW and 3MJ were heard in two DX places, namely in VK4, and a country area of VK2. I heard this story through the medium of 40 metres and at once dropped a line to the stations supposed to have heard signals. Three weeks have elapsed and neither station has even offered the courtesy of a reply. Conclusions are obvious; if any distant observer had heard six-metre transmissions from another State, I feel sure that he wouldn't be keeping the details to himself. A new station to appear on the band in the Melbourne area is VK3ZO, located at Balwyn. VK3BW, Portarlington, has been heard well in Melbourne, testing a new rig. He is awaiting delivery of a new Kingsley iron-tuned converter for the band, a new line in the series made by that amateur-minded concern. As he is about 35 miles away across water, VK3BW should always be a reliable station for a fair distance contact. VK3IZ at Red Hill, 45 miles away, on the Mornington Peninsula, is reported to be very keen now on "Six," and will be on the band at any time. There is a report that old-timer VK3KU, of Mount Waverley, will be heard soon also. Most consistent stations are still VK's 3QO, 3MJ, 3YJ, 3HK, 3AFQ, 3CG and 3NW. VK3NW took a portable rig down to 3IZ's location and, despite the fact that he is some distance down the far side of the hill from Melbourne and is well screened by a belt of very large gum trees, with a large galvanised iron roof into the bargain . . . and the 50 M/cs antenna is but 4 feet therefrom . . . there

was no trouble in contacting VK-3MJ on telephony. Signal was Q5 R5 at both ends. VK's 3CG and 3QO, also 3NW's, own tone signal were heard. On return journey another test was made at Frankston, and here VK3MJ's signal was R9, with his report of 3NW's portable being R7. VK3NW has a bone to pick with stations which will insist upon using their 10-metre antennas on 50 M/cs, and in this respect I fully agree with 3NW. There is no sense in such practice . . . 50 M/cs is not in harmonic relation with 28 M/cs and, at the best, such an antenna can only be shock excited. No doubt the user of such a system may be elated because he gets a good signal report from a nearby station or one at a fair distance in perfect optical range, but when it comes to putting a signal into a station at a difficult distant location, an antenna cut for and resonant on the bands becomes a paramount necessity. Those who persist in using their 10-metre antennas thus will get similar results with any old piece of wire hooked on to the transmitter. There are others who use 40-metre Zepps and think they are doing well on "Six." It just doesn't make sense!

News of the VK5's comes from VK5QR through 3NW, and the report from Adelaide is of quite a lot of activity. Stations on the band there are VK's 5BQ, 5KZ, 5JU, 5GB, 5RT, 5RC, 5QR, 5GF, and 5GN . . . quite a sizeable list. They are planning tests from Mount Lofty (what a location!) and suggest that the VK3's tote gear up Mount Dandenong or Mount Macedon. The picture thus seems reminiscent of the G's with their pre-war 5-metre working from Snowdon across the British Isles. VK3NW is also working on 166 M/cs, of which more anon.

—VK2NO.

NIGHT FLYING - - - IN DAYLIGHT!

AIR MINISTRY DISCLOSES SECRET WAR-TIME METHOD

Flying in broad daylight, yet seeing everything under actual night conditions, was one of the secret training methods used by the R.A.F. to build up our big bombing offensive. The ingenious scheme which made this possible can now be told for the first time.

When, early in the war, plans were being laid for our large-scale night bombing offensive, it became obvious that the training of pilots in night flying would have to be stepped up considerably, and it would have been impossible to do this if training were restricted to the hours of darkness.

CONTROLLED DARKNESS

Accordingly, the scheme now known as "Day-Night Flying Training" was evolved. It is a means of simulating night flying conditions in daytime, or instrument-flying conditions in clear weather. It is actual flying under simulated night, or blind conditions, and in most respects is the equivalent of ordinary night dual instruction or actual cloud flying. The degrees of darkness is controllable at will; it is also possible to return immediately to daylight conditions, and the instructor is at no time in darkness.

The basic principle of the scheme was to use the monochromatic properties of the light from sodium electric discharge lamps on the ground or in the aircraft, in combination with special filters fitted to the pilot's goggles or the aircraft cockpit. These filters admitted sodium light but excluded any other light, including daylight.

The sodium electric discharge lamp proved the ideal source of illumination for this purpose, since its colour has the peculiarity of being one in which sunlight is deficient (its place being shown by dark bands in the solar spectrum) yet the deficiency occurs near the point of the spectrum at which the

human eye possesses its best powers of vision.

Thus, by means of suitable filters, visible daylight can be reduced to a negligible quantity, because the amount of natural light at the critical wave length of sodium light is so minute a fraction of the whole as to be of no consequence.

CONTRASTS AVAILABLE

The intensity of the isolated colour is also diminished in proportion to the density of the filters, but at a substantially lower rate than daylight. Thus, conspicuous contrast is obtained and the isolated colour remains relatively bright.

Various combinations of filters were used. For example, for circuits and landings under night-flying conditions, goggles with compound filters of greenish-brown and reddish-brown were used together. These produced a realistic effect of almost complete darkness outside the aircraft, but left the landing lights and instrument panel lighting — both using sodium lamps — plainly visible. While the pupil was thus apparently flying into the night, the instructor was able to observe everything in full daylight.

Other combinations of filters were also used to reproduce at will

conditions varying from pitch dark to bright moonlight.

In the process of developing the scheme, Philips Lamps Ltd., England, were approached by the Royal Air Force for their advice regarding the use of sodium lamps. This co-operation included recommendations regarding the design of special types of apparatus and ground equipment as well as certain airborne electrical apparatus, operated from batteries in the aircraft. For each aerodrome so equipped, nine portable units were used for flarepath lighting, each housing four 140w. Philips Sodium electric discharge lamps, while for aircraft instrument panel lighting the 60w. type was used, operated from batteries in conjunction with a rotary converter.

As the creators and pioneers in the development of sodium electric discharge lamps, Philips Lamps Ltd., played a major part in an advisory and supply capacity, and were in a position to meet the heavy demands for many thousands of 140w. and 60w. lamps and auxiliary apparatus in the minimum possible time, thus enabling a considerable impetus to be given the scheme, both in its development and eventual operation.

RECORDING THE ACTIVITY OF THE BRAIN

Corporal Walter G. Egan, W2-OKW, is an electroencephalographic technician in the Army Medical Corps and gives us some interesting information on their work in recording the electrical activity of the brain. This technique is mainly an additional diagnostic measure in epilepsy, brain lesions, tumors, etc. The amplitude of the brain wave at the scalp is of the order of 20 to 50 microvolts, and the frequencies vary between 1 and 40 c.p.s., normally lying in the range 8.5 to 12 c.p.s. Ten wires

are fastened to the patient's head with collodion, eight on top and one on each ear. The patient is put in a shielded room and his wires are connected through a shielded cable with four independent amplifiers in a recording room, where oscillographic records on a moving strip of paper are made simultaneously from four areas of the brain. The amplifiers are 5-stage audio affairs with 4- μ f. coupling condensers between stages, ending in push-pull 6L6's.

—Q.S.T.

Shottwave Review

CONDUCTED BY

L. J. KEAST

NOTES FROM MY DIARY—

AT LONG LAST

Many and many a Dx-er, both present and past, longed for the time when a verification could be had from the British Broadcasting Commission. Acknowledgement of reports was always forthcoming, but that good old QSL card never arrived. Now, from all accounts, it will, provided the report is correct and it is accompanied by two Imperial Reply Coupons. The address for this coveted prize is: Mr. Bryan Hayes, Local BBC Representative, 8 Althorpe Crescent, New Bradwell, Bletchley, Bucks, England.

* * *

AIR BOURNE

And now, thanks to a reduction in postal rate, it is probable many will be sending through the air, reports of what they heard over the air. I am referring to the new fee of 2/- for two ounces to U.S.A.

* * *

RADIO BLACKOUTS

Ran into Don Knock in George Street the other day. "Well, Les, what did you think of it?" said Don. I knew exactly what he meant. ∴ the dreadful reception on Sunday and Monday, September 22 and 23.

Were it not for the faith I have in my trusted "Ultimate" I would have thought the set was playing up, but I remembered a similar state of affairs some time ago and figured Old Sol was up to his old tricks. Anyhow, Don did not cheer me up as he said, "It will get worse and may be with us for a long time."

Well, here is what the Sydney "Sun" had to say about it on Monday, September 23:

"RADIO BLACKOUTS MAY LAST

"CANBERRA, Monday.—Radio disturbance caused by sun spots—which resulted in world cable services being blacked out at the

weekend—may continue for eighteen months.

"Director of the Commonwealth Solar Observatory (Dr. R. de V. Woolley) said today that the sun was approaching a period reached once every 11 years, in which sunspot activity was at a maximum.

"There was close association between sun spots and displays like the Aurora Australis—seen last night.

"As sun spots were increasing, repercussions could be expected to increase also.

"They would wane, and radio services would revert to normal after the maximum period of activity passed.

"As the sun-spot cycle would not reach its maximum period until the end of 1947, or early in 1948, recurring radio failures were probable.

"Dr. Woolley said that observation at Mt. Stromlo suggested that present disturbances were due to a group of sun spots which were small but extremely active.

"Phone services between Australia, England, and the U.S. almost ceased at the weekend.

"Operators at Sydney G.P.O. had difficulty in contacting London and New York. Only two callers got through on Saturday.

"Radio and cable communication between the U.S. and the world broke down at 5 a.m. in New York on Sunday, cutting off communication with Australia for eight hours.

"Transmission from the U.S. to Europe and South America functioned intermittently, with long interruptions.

"A brilliant auroral display was seen in New Zealand last night. Radio and long-distance communications are still poor there today."

And on Tuesday the 24th the "Daily Telegraph" said:

"SUNSPOTS UPSET RADIO TELEPHONES

"A G.P.O. official said last night that radio telephone communication with London was impossible yesterday because of magnetic storms associated with sunspots.

"Communication with America was possible only for an hour, from 8 a.m., and for about another hour from 2 p.m.

"New Zealand calls were fairly satisfactory.

"Government Astronomer (Mr. H. W. Woods) said last night that electrical disturbances may occur intermittently over a period of several months."

* * *

SAYS WHO?

Miss D. Sanderson, of Malvern, Victoria, writes: "Conditions have been quite fair, daylight reception having reached its peak, evening listening is improving, and many stations from New York are at good strength early, very good programmes are a feature of these stations, and the choice of music is at a very high standard.

"KZRH is heard at good strength in excellent programmes; HH3W continues to be heard quite free from interference, whilst the official Dutch station from Bandoeng on 10.07mc has varied programmes of interest and enjoyment.

"Verifications are coming along well. I received a schedule of programmes from the Burma Broad-

STOP PRESS

BBC Pacific Schedule and Frequencies as from October 6, 1946, 4-8 p.m.:

For Australia

GRX,	9.69mc,	30.96m:	4.00-8.00	p.m.
GSN,	11.82mc,	25.38m:	4.00-8.00	p.m.
GSP,	15.31mc,	19.61m:	4.00-8.00	p.m.
GVS,	21.71mc,	13.82m:	4.45-8.00	p.m.

N.Z. and Pacific Area

GVZ,	9.64mc,	31.12m:	4.00-8.00	p.m.
GSN,	11.82mc,	25.38m:	4.00-8.00	p.m.
GRD,	15.45mc,	19.42m:	4.00-8.00	p.m.
GRQ,	18.025mc,	16.64m:	4.00-8.00	p.m.

casting Service; very attractive cards from TGWA for frequency of 9.76mc, and HCJB frequency of 12.45mc. I also received schedule from C.B.C. of Canada."

"Most nights I get round the 5

megacycle mark for YV5RM, etc. The YV on 4.80mc, YV1RX, I think, is the best and holds out well—no music heard. VLC-9 very good in Suffolk's DX session; XGOY at 9.20 p.m. with a female

giving the news on 50.04 metres." —Gaden. (Am just afraid the Doctor is spending a LOT of time on "Hams."—L.J.K.)

From the "Apple Isle" comes a list of veries received by Phil Byard: Colombo, 4.90mc; Singapore, 4.78mc; KRHO (6.12, 9.65 and 17.90 mc); HE15, CHOL, VLA-8, VLW-3, VUD-9, VLH-4, HER, VLC-4, VLC-9, VUD-8.

Rex Gillett, of Adelaide, writes: "The best veries received is 'Radio Maroc,' this being for the 33.03 metre outlet. It made good time, taking only two months from the time of sending the report. Verie was by a letter in French."

Arthur Cushen sends some interesting information regarding the recent Canadian Broadcasting Corporation transmission tests. As South Island (N.Z.) observer for the C.B.C., he has an air-mail letter from J. A. Acton, the C.B.C. expert on short-wave transmission conditions: "I would like to thank you for the publicity which you gave our test transmissions, and I can assure you that it is much appreciated here at the International Service. It will be some time before I reply to the many reception reports I have received as a result of this publicity and it might perhaps be a good idea if you were to convey our thanks to the many listeners who co-operated so helpfully and made this special test a complete success."

Schedule now is:

CKNC, 17.82mc: Daily 1-8.15 a.m.; Sundays, 9 p.m.-8.15 a.m. (Mon.).

CKLX, 15.09mc: Daily, 1-4 a.m.; Sundays, from 9 p.m.

CKCS, 15.32mc: 4.05-8.15 a.m. daily.

No less than three Frisco stations were heard in the 19 metre band the other morning: KCBR, 15.33mc; KWID, 15.29mc; KCBA, 15.27mc.—L.J.K.

Ern Suffolk says he has heard CKNC, Sackville, 17.82mc, testing at 4 p.m., but signal was poor. He also goes on to say he has just received an air-mailed verie from Radio Polshie, Warsaw, 6.105mc, 49.15m. The ygive the wavelength

NEW STATIONS

Rex Gillett advises having heard the new Norwegian outlet on 6.13 mc at 7 a.m. in relay with 6.20mc. Strength was quite good. The stations use an interval signal of about 10 notes as identification.

AFRN, Tokyo, 4.88mc, 61.48m: This new Japanese being heard nicely at night from as early as 7 o'clock and until midnight. Is in relay with JLR, 6.015mc, and JCV, 3.075mc. This is contained in a letter from Rex Gillett.

"RADIO AUSTRALIA" CHANGES

VLA-4, Shepparton, 11.77mc, 25.49m: As from September 1 has replaced VLA-3 from 6.30-9.30 a.m. in programme to British Isles and Europe and from 7.15-9.30 a.m. to Forces in Pacific, Japan and Asia.

HOXA, Panama City, 15.10mc, 19.86m: This new Central American station has been heard testing, generally at the weekend between 2 and 3 o'clock. Programme usually consists of Latin type music, but English is heard at least every ten minutes. Reports are asked for and should be addressed to Box 1335, Panama City, Panama. This station, with a power of 7,500 watts, hopes to commence regular operation on or before October 1.

HOXB, Panama City, 11.81mc, 25.41m: This station, like the above, is reported by Arthur Cushen, and I notice Rex Gillett has been hearing it in Adelaide. He heard them leaving the air just after 3.30 p.m. Like HOXA, uses 7,500 watts, and desires reports, particularly from the Pacific Islands and the West Coast of U.S.A.

HOXD, Panama City, 9.66mc, 31.06m: Arthur Cushen reports hearing Panama on this frequency and the same remarks as HOXA apply. Rex Gillett, however, heard

them, once at 9.05 a.m., but signal was only fair.

CKCS, Sackville, 15.32mc, 19.58 m: Ern Suffolk, of Lobethal, South Australia, reports this new Canadian. It is in relay with CKNC, 17.82mc, from 3-7.05 a.m. (Believe it now continues till 8 o'clock.—L.J.K.)

And here are two to hunt for:

MONACO, 6.13mc, 48.94m: Ern Suffolk writes that he has information from Arne Skoog, of Stockholm, that this station has been on the air since June 9, and that schedule is 4.30-6.30 p.m.; 9-11 p.m. and 4-8.15 a.m.

Also Norway on this frequency, announcing as "Fredrikstad Short-wave Transmitter," in tests at 3-4.30 a.m. and 6.45-8 a.m. Other channels announced are 6.18, 9.54 mc, and a new transmitter on 11.735mc. Mr. Suffolk says, "Have not heard the 6.13 and 11.735mc stations here for certain, though I have noted something on these frequencies." (According to my records, 9.54 is LKJ, 11.735 LKQ, 6.13 LKJ-2, but 6.18 is new to me.—L.J.K.)

Other transmissions are as shown in September issue.

Readers are reminded that "Radio Australia" also uses VLA-9, 21.60mc, 13.89m, in addition to VLC-9, 17.84mc, 16.82m, in programme to North America (East) and Canada from 10.30 till 11.30 a.m. (VLC-9 continues till 11.45 a.m.). VLA-9 is quite a good signal at my listening-post, but not as loud as VLC-9.

XMTA, China, 12.215mc, 24.57m: This is the call of a new Chinese station heard opening strongly daily at 9 p.m. with an anthem. This one is also heard at 8 a.m., but not nearly so good at this time. Location is unknown.—Rex Gillett.

as 49.06m, and frequency as 6.115 mc. Schedule is: 12.44-11 a.m. Programmes are in Polish, English, French, Russian, Yugoslav and Yiddish languages. (The measured frequency of Radio Polshie is 6.10 mc, making the wavelength 49.18 m.—L.J.K.)

"Universalite" Bill Howe mentions ASHARQ AL ADNA, Jaffa, Palestine, 6.135mc, 48.9m, as on the air from 2.30-3.30 p.m.

Although at time of typing these notes, I have not had advice of any changes in B.B.C. Pacific Service, I would not be surprised if the times from early October are advanced one hour, making them 4-8 p.m.—L.J.K.

Listeners have probably noticed KCBA and KCBF announcing only one frequency, 15.15mc, from 7 p.m.-1 a.m. This is correct, and KCBA is directed to Philippine-N.E.I., whilst KCBF is beamed to Japan-S. China-N.E.I.—L.J.K.

"Received verification in form of letter from JODK, Seoul, Korea, for my report on 2.51mc. Station has 3,000 watts power and as from June 1 would give English announcements on each half hour. Present schedule is 6.30-11.30 p.m. Address for verification is: Mr. James Browitt, Assistant Chief, Radio Section, APO 235, C/- Post Master, San Francisco. Letterhead was: Korean Broadcasting System, 1 Chang Dong Jung, Seoul Korea."—Cushen.

"Switzerland is now verifying reception with a swell new card.

The card features a map of Europe with Switzerland picked out in red. The reverse side of the card gives details of frequencies in use by the Schwarzenburg transmitters." — Gillett.

Mr. Lund-Johansen, of Copenhagen, advises they are now forming a Danish Short-wave Club, and some of the members have asked for exchange of stamps. He would like some of the readers of "A.R.W." to help in this matter.—L.J.K.

Dr. Gaden writes: "At noon today, September 13, thinking to try VLA-9, heard 'The Star Spangled Banner' on a higher frequency, but it was a sign OFF, unfortunately. Very nice signal, only a point weaker than VLA-9. Will try him again. September 16: Made a couple of attempts to track down my Yank on approximately 13.87 m. At 11 a.m. what I took to be news given by man in Spanish. At 11.45 a female speaks and gives 'Women's Session' very similar to what is heard in New York broadcasts for South America. Closes at noon without any English announcements." (Sound very much to me as though it may be WCRC on 21.57mc.—L.J.K.)

Frank Brockbank writes from Auburn: "My latest air-mail from B.B.C. states that they are particularly interested in the reception of their new Pacific Service transmitter, GVS, 21.71mc, just recently put into service."

NOTES FROM MY DIARY (Ctd)

FLYING TIMES

In September issue I said Denmark desires data. Well, I flew that information there, and, by the same method, Mr. Lund-Johansen tells me of the Danish schedule. He says that at present they are only transmitting their ordinary programme daily over OZF, Shambleback, on 9.52mc, 31.51m, and that all broadcasts are in Danish. Power is 6 km., and schedule is 2.35-3.30 a.m., but on Sundays, using 5 kw., they broadcast on 15.32mc, 19.58m, from 10 a.m.-3 p.m.

* * *

"RADIO AUSTRALIA" DX

Have listened to several of the special Sunday broadcasts prepared by Ern Suffolk and think them very fine, but figure a good many of the overseas listeners will have difficulty in copying the schedules and frequencies given as they are read, in my opinion, far too quickly. I can understand that only a limited amount of time is available, but it would be preferable to read less, slower, than take the chance of only portion of a lot being correctly taken down.



ULTIMATE

Champion Radio

Sole Australian Concessionaires:

GEORGE BROWN & CO. PTY. LTD.

267 Clarence Street, Sydney

Victorian Distributors: J. H. MAGRATH PTY. LTD., 208 Little Lonsdale Street
Melbourne

The Ultimate factory has made the changeover from wartime production. Designs for the new models are now completed and production is about to commence.

These models should be available soon — they will be worth waiting for. Watch for further announcements.

SERVICE: Servicing of all kinds of radio sets, amplifiers and Rola speakers will continue to be available.

The Ultimate factory has made the changeover from wartime production. Designs for the new models are now completed and production is about to commence.

These models should be available soon — they will be worth waiting for. Watch for further announcements.

SERVICE: Servicing of all kinds of radio sets, amplifiers and Rola speakers will continue to be available.

The MONTH'S LOGGINGS

ALL TIMES ARE EASTERN AUSTRALIAN STANDARD TIME

Pressure on space only permits of unusual Loggings or alterations in schedules or frequencies.

Readers will show a grateful consideration for others if they will notify me of any alterations. Please send reports to L. J. Keast, 6 Fitzgerald Road, Ermington, N.S.W. Phone: WL 1101.

OCEANIA

- Australia**
- VLA-3**, Shepparton 9.68mc, 30.93m
Very good in programme to British Isles at 7 a.m.—L.J.K.
- VLC-4**, Shepparton 15.32mc, 19.59m
Good signal in Forces programme at 8 a.m.—L.J.K. Good at noon (Byard).
- VLB-8**, Shepparton 21.60mc, 13.89m
Being heard well over here (Cushen). (Schedule is: 2.45-3.45 p.m.—L.J.K.) Very nice to listen to (Gaden).
- VLA-9**, Shepparton 21.60mc, 13.89m
Doing good work (Cushen).
- VLB-6**, Shepparton 15.20mc, 19.74m
Good at 7.15-9.30 a.m. and noon-2 p.m. (Cushen).
- VLG-5**, Lyndhurst 11.88mc, 5.25m
Almost inaudible beneath Yank at 10 p.m. (Byard).
- VLW-3**, Perth 11.83mc, 25.36m
Fair at 6.30 p.m. (Byard).
- VLB-3**, Shepparton 11.77mc, 25.49m
Good from 5-6.15 p.m. (Cushen).
- VLB-2**, Shepparton 9.68mc, 30.99m
From midnight-1 a.m., very good (Cushen).
- VLB-9**, Shepparton 9.615mc, 31.2m
Good from 8 till 9.30 p.m. (Cushen).
- VLB**, Shepparton 9.54mc, 31.45m
Being heard from 10 p.m. (Cushen).
- VLQ-2**, Brisbane 7.215mc, 41.58m
Programme details and music at 7.45 p.m. (Miss Sanderson).
- New Zealand**
- ZLT-7**, Wellington 6.715mc, 44.68m
Good with music at 7.30 p.m. (Miss Sanderson).
- New Guinea**
- VIG**, Port Moresby 15.08mc, 19.89m
Heard calling VIS around 10.15 a.m. with fair signals (Byard).
- New Caledonia**
- FKRAA**, Noumea 6.208mc, 48.39m
Good when closing at 8 p.m. (Byard).

THE EAST

- Ceibes**
- Radio Macassar** 9.358mc, 32.08m
Good at 10.45 p.m. (Miss Sanderson).

China

- XGOY**, Chungking 11.90mc, 25.21m
Heard with news at 8.30 p.m. (Miss Sanderson).
- XORA**, Shanghai 11.69mc, 25.66m
News in English at 8 p.m. (Miss Sanderson).
- XGOL**, Foochow 9.995mc, 30.05m
Chinese type music at 10.15 p.m. (Miss Sanderson).
- XGOA**, Chungking 9.72mc, 30.86m
Good at 9 p.m. (Miss Sanderson).
- XNCR/XGNC**, Kalgan 9.62mc, 31.17m
News in Chinese at 8.45 p.m. (Miss Sanderson).
- XGOY**, Chungking 7.15mc, 41.96m
News in English at 9.15 p.m. (Miss Sanderson).
- ZBC**, Hongkong 9.575mc, 31.35m
Much improved signal now; give BBC news at 9 p.m., then weather forecasts followed by recordings. At 9.30 announces ZBW. ZBC then takes Chinese programme usually, whilst ZBW can be heard in English on 9.52mc (Cushen).

Ceylon

- SEAC**, Colombo 21.62mc, 13.87m
Heard testing at 1.30 p.m. (Radio Listening Post). Heard in Dutch at 11 p.m. (ABC Weekly).
- SEAC**, Colombo 15.12mc, 19.84m
News in English at 7.30 p.m. (Miss Sanderson). Gives news in English every hour on the hour till 1 a.m.—L.J.K.
- SEAC**, Colombo 6.075mc, 49.38m
Good at 10 p.m.—L.J.K.

India

- VUD-10**, Delhi 17.83mc, 16.80m
News at 9.30 p.m.—L.J.K.
- VUD-3**, Delhi 17.76mc, 16.89m
Good at 7.30 p.m. (Miss Sanderson).
- VUD-8**, Delhi 15.35mc, 19.54m
News at 9.30 p.m.—L.J.K.
- VUD-3**, Delhi 11.85mc, 25.27m
News at 9.30 p.m. (Miss Sanderson). Programme announcements in native languages at 11.45 p.m.—L.J.K.
- VUD-5**, Delhi 9.59mc, 31.28m
Heard opening at midnight.—L.J.K.

Indonesia

- PLP**, Bandana 11.00mc, 27.27m
From 6.30 till 8.30 p.m., gives talks and news in English.—L.J.K.
- , Djokjakarta 9.87mc, 30.40m
News at 11.15 p.m.—L.J.K.

Indo-China

- Radio Saigon** 11.778mc, 25.47m
Old reliable always good at night (Byard). News at 7.30 p.m. (Miss Sanderson).

Radio Saigon 4.81mc, 62.37m
Good around 11 p.m.—L.J.K.

Japan

- JLP**, Tokyo 9.605mc, 31.23m
Being heard again announcing as Armed Forces Radio Network. It is best in Adelaide about 6.30 p.m.—your time.—Gillett.

Korea

- JODK**, Seoul 2.51mc, 119.30m
Poor at 10 p.m. (Byard). The schedule of this 3000-watter is; 6.30-11.30 p.m.—L.J.K.

Philippines

- KZRH**, Manila 9.63mc, 31.15m
Programme announcements at 7 p.m.—L.J.K. Very good until XGOY opens on same frequency at approximately 8.35 p.m. (Byard).

GREAT BRITAIN

- BBC, London**
- GSJ** 21.53mc, 13.93m
Very good in General Overseas service at night (Gaden).
- GSJ** 21.47mc, 13.97m
Good also at 7 p.m. but not as loud as GSJ (Gaden). (This happens because GSJ is from 7 p.m. till 1.15 a.m. on a beam favourable to Australia.—L.J.K.)
- GVS** 21.71mc, 13.82m
Is anyone hearing this outlet? Too noisy at my little shack.—L.J.K.

HOLLAND

- PCJ**, Hilversum 11.73mc, 25.58m
Quite good around 6 and 7 a.m.—L.J.K.
- PCJ**, Hilversum 9.59mc, 31.28m
Have followed my suggestion and used the South American beam. Result, being well received here, now from 6 p.m. on Thursdays (Cushen). Also very good from 7 a.m.—L.J.K.
- PGJ**, Huizen 6.023mc, 49.82m
Can be heard at fair strength around 5 a.m.—L.J.K.

SCANDINAVIA

- Norway**
- LKJ-2**, Oslo 6.13mc, 48.94m
A new Norwegian heard on this frequency in relay with 6.20mc at 7 a.m. was quite good strength. The stations use an interval signal of about 10 notes as 'identification' (Gillett). (I have given this station the call, LKJ-2, and taken it from the latest Washington list. See also "New Stations."—L.J.K.)

Sweden

- SDB-2**, Stockholm 10.775mc, 27.83m
News in English at 3.40 a.m. (ABC Weekly).

AUSTRALIAN BROADCASTING COMMISSION

National Shortwave Stations—VLH, Lyndhurst, 10 kilowatts; VLG, Lyndhurst, 10 kilowatts; VLR, Melbourne, 2 kilowatts.

ALL TIMES EAST. AUST. STANDARD

SUNDAYS				
VLH CALL SIGNS	Wavelengths	Frequencies	Power	
VLH4	6.45 a.m.-9.00 a.m.	25.25m	11.88 Mc/s	10 Kilo
VLH5	9.15 a.m.-4.00 p.m.	19.69 "	15.24 "	10 "
VLH4	4.30 p.m.-6.30 p.m.	25.25 "	11.88 "	10 "
VLH3	7.00 p.m.-11.30 p.m.	31.32 "	9.58 "	10 "
WEEK-DAYS				
VLH4	6.00 a.m.-10.00 a.m.	25.25 "	11.88 "	10 "
VLH5	11.45 a.m.-4.00 p.m.	19.69 "	15.24 "	10 "
VLH4	4.30 p.m.-6.15 p.m.	25.25 "	11.88 "	10 "
VLH3	6.30 p.m.-11.30 p.m.	31.32 "	9.58 "	10 "

SATURDAYS				
VLH4	6.00 a.m.-10.00 a.m.	25.25 "	11.88 "	10 "
VLH5	11.45 a.m.-6.15 p.m.	19.69 "	15.24 "	10 "
VLH3	6.30 p.m.-12.00 mid.	31.32 "	9.58 "	10 "
SUNDAYS				
VLR CALL SIGNS				
VLR2	6.45 a.m.-8.30 a.m.	48.78 "	6.15 "	2 "
VLR	9.00 a.m.-6.00 p.m.	31.45 "	9.54 "	2 "
VLR2	6.30 p.m.-11.30 p.m.	48.78 "	6.15 "	2 "
WEEK-DAYS				
MONDAYS TO FRIDAYS				
VLR2	6.00 a.m.-8.15 a.m.	48.78 "	6.15 "	2 "
VLR	10.00 a.m.-5.45 p.m.	31.45 "	9.54 "	2 "
VLR2	6.00 p.m.-11.30 p.m.	48.78 "	6.15 "	2 "
SATURDAYS				
VLR2	6.00 a.m.-8.15 a.m.	48.78 "	6.15 "	2 "
VLR	10.00 a.m.-6.00 p.m.	31.45 "	9.54 "	2 "
VLR2	6.15 p.m.-12.00 mid.	48.78 "	6.15 "	2 "
VLG CALL SIGN				
VLG7	6.00 a.m.-8.00 a.m.	19.7 "	15.16 "	10 "
(Sundays: 6.45 a.m.-8.15 a.m.)				

Speedy Query Service

Hi-fi (Cremorne) asks whether it is necessary to have high-powered amplifiers to get true high-fidelity reproduction.

A.—Some years ago, some organisation in America decided on a sort of specification for high-fidelity sets and brought in the famous "15-watt" qualification, but in practice this is not necessarily correct. Firstly the human ear will not readily detect the difference between 10 and 15 watts, and certainly not without direct comparison. Beware of anyone who can listen to something and then tell you there is an output of "only twelve watts and not fifteen," for example. The main requisite is an absence of distortion, rather than a power handling ability.

* * *

"VK2" (North Sydney) sends along some suggestions for improvements.

A.—Glad to get your note, but unfortunately none of the suggestions you make are at all practical. Obviously you have not had any experience in dealing with the public. If you went to a football match you would probably get a black eye for being too one-eyed in your barracking. In the publication business you have to be able to see things from the other fellow's point of view as well as your own, and you have to make

some attempt to cater for all types and styles of enthusiasts. Being in possession of figures showing each month's sales we get a fairly good indication that our present type of editorial matter is fully appreciated. Nevertheless we do thank you for the trouble to which you have gone and for the kindly interest displayed.

* * *

A.D.F. (Blackburn) is upset about the position in regard to the supply of speakers.

A.—Yes, we know that there is a shocking shortage of speakers and it is throttling the game pretty thoroughly. There does not appear to be anything we can do about it. There is really only one speaker factory operating in Australia and doubtless they have their own supply problems, such as in getting supplies of raw materials and suitable labour. It is to be hoped that things will improve in the course of time.

* * *

M.V. (Chatswood) is designing a big amplifier to use 807's.

A.—We would not hesitate to recommend you to use two separate power transformers and rectifiers, one for the screen supply of the output valves and the driver stages high tension, and the other for the plate supply of the outputs. By this means, you can stabilise the screen voltage, which is highly desirable, and also isolate the high voltages from the coupling condensers. It is also sound practice to get your fixed bias supply from a source completely isolated from the power supply for the output plates.

* * *

N.L. (Hawthorn) is unable to finish a set without electrolytic condensers, but cannot buy any.

A.—We can only suggest Waltham Trading Co. They had a few when we were in there recently. We know the problem of condensers in general, which is darn close to being scandalous. Production appears to be almost completely in the hands of one firm and there is little that can be done about it at the moment. When the next tariff hearing is on there will doubtless be a move to get the customs tariff lowered as a protection for the public from the domination of monopolists.

POPULAR W.A. SOCIETY

The Subiaco Society has been in existence for 23 years and Mr. Congdon has been Secretary since its inception. That, I imagine, is a record in radio history. Thousands of radio enthusiasts have been in personal contact with 6BC in that period, and they are still coming; many for a Morse code refresher, etc., prior to Exam.

Those intending to enter Amateur ranks around that area of VK6 cannot do better than to break-in under the guidance of the Subiaco Club.

—D.B.K.

M.R. (Rosanno) suggests that we should give the A.O.C.P. examination questions after each exam, together with suggested answers which would be sure to pass.

A.—Yes, this is a sound suggestion and one that appeals to us as being highly practical. We will see if Don Knock or anyone else sufficiently interested can be found to do the job, and if so, will make it a regular feature in future issues. Many thanks.

* * *

H.P. (Bellevue Hill) raises the vexed point about sensitivity figures and noise ratios.

A.—Yes, there is always plenty of scope for argument on this subject. The old idea about sensitivity was to say how many microvolts of signal input were necessary for the receiver to give an output of 50 milliwatts. Many sets will give this amount of output as pure noise without any signal, so they could be said to have infinite sensitivity.

During the war the American Navy introduced a scheme for testing sensitivity with due consideration for noise. The Navy definition for sensitivity was "the weakest input signal that is 10 db. stronger than the noise. The testing was done by adjusting the gain of the receiver and the strength of the test signal, so that with an unmodulated carrier there is .6 milliwatts of noise in the speaker, and with a modulated carrier the output is 6 milliwatts of noise and signal combined. The input carrier strength in microvolts is then read off and reckoned as an indication of the effective sensitivity. Using this method of testing, the Navy considered that anything better than 10 microvolts was a good job.

HEADPHONES

Brand New! Just Released!

**S.T.C. &
STROMBERG CARLSON**

Original cost, £2/10/- pr.

130 Ohms, 10/- pair

2,000 Ohms, 25/- pair

(Postage 1/6 pr. extra)

Can supply in quantity.

**DEITCH BROS.
210A GEORGE STREET
SYDNEY**

'Phone: BW 7687

RED LINE

TRANSFORMERS and CHOKES

**PRECISION
IN DESIGN**

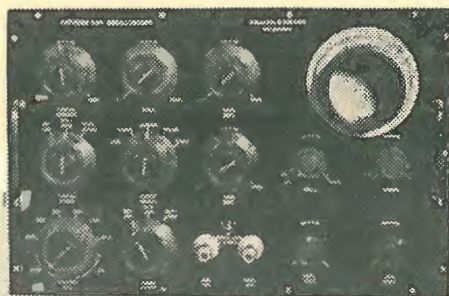

**PRECISION
IN WORKMANSHIP**

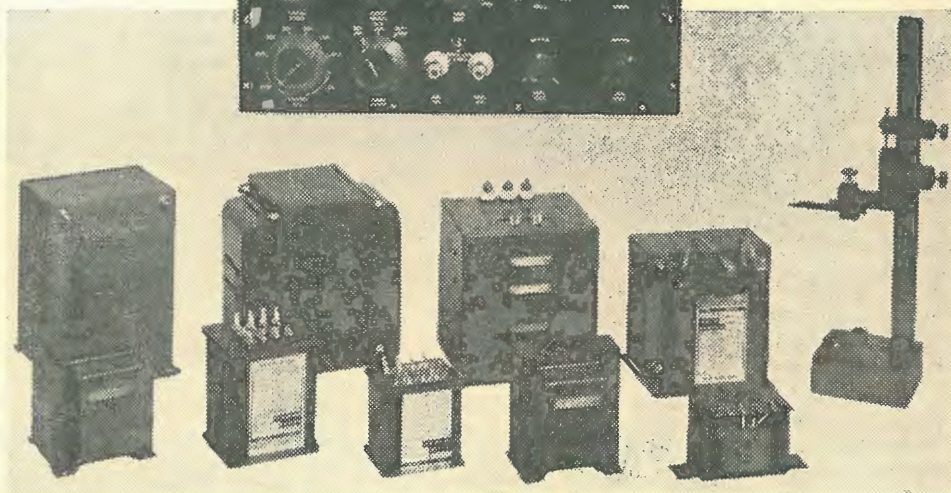

SWALES & SWANN

Technical Service, Wholesale
and Manufacturers:

A. T. SWALES, Central 4773.
2 Coates Lane, Melbourne.



Trade Sales: Allen SWANN,
MU6895 (3 lines)
157 Elizabeth St., Melbourne.

LOOK FOR

THE MONOGRAM

Nq 621.38405 AUS

MORE THAN A QUARTER NEW RADIOS NEEDED YEARLY ...and not enough men to make them

Pre-war production figures reached 280,000 per year but civilian set manufacture virtually ceased DURING the war, so imagine the huge leeway to be made up!



RADIO needs YOU—Now is the time to act!

RADIO IS STILL A NEW INDUSTRY GROWING FAST!

Every branch of the Radio industry is looking ahead to an unprecedented wave of prosperity. Electronics and the civil adaptation of Radar are now being developed with great speed, but the cry is for more and more skilled men!

We are entering now a Radio age, an Age which has a place for YOU. Radio, a young industry which has made remarkable progress in the past few years urgently wants men to train for vital positions. If you want security, prosperity, and a recognised status in the community, start training NOW.

TRAIN AT HOME, OR AT OUR BENCHES

A.R.C. offers ambitious men a sound proven course in Radio Engineering. Sound because it is the result of many years' successful operation, proven because hundreds of ex-students owe their present success to the College. You can learn with equal facility at home (by means of our correspondence course).

EARN GOOD MONEY WHILE LEARNING

You don't have to wait a year, or even six months, before you are ready to begin "cashing in." We will show you how to earn extra money almost from the word "go." Many students make £4, and up to £8, per week in their spare time whilst studying.

PREVIOUS KNOWLEDGE UNNECESSARY

You don't need a knowledge of Radio or Electricity—we'll give you all you need of both, in a simple, practical manner, that makes learning easy, presented, too, in such a way that you can remember what you're taught and how to put that knowledge to practical use.

COSTS LITTLE

Think of this—for a few pence per day—actually less than many fellows spend on tobacco—you can prepare yourself for a man-sized job in Radio NOW.

NOW IS THE TIME TO ACT!

Send in today for my free book, "Careers in Radio and Television." It's a book no man can afford to miss. It shows you the steps you can take to get into Radio immediately!

£8,000,000 was estimated prewar sales of radio receivers and Parts. The next few years should see these figures doubled.

Pre-war Radio Set output reached an estimated 280,000. All records are expected to be broken in near future.

Even a 25 per cent. increase in set sales will mean openings for perhaps 1,000 more Radio dealers—

Over 130 Australian Radio Stations employ a vast number of skilled personnel—a team of specialists which would probably be tripled with the advent of F.M. transmission.



GET THIS BIG FREE BOOK NOW!

AUSTRALIAN RADIO COLLEGE

PTY. LTD.

Cnr. Broadway and City Roads, Sydney.

Phones: M 6391, M 6392



To Mr. L. B. GRAHAM, Principal,
Australian Radio College, Pty. Ltd.,
Broadway, Sydney. Phone M 6391-2

Dear Sir—I am interested in your free book, "Careers in Radio and Television."

NAME

ADDRESS

