

THE
AUSTRALASIAN

Registered at the G.P.C.
Sydney, for transmission
by post as a periodical.

Radio World

1/-

VOL. 10 NO. 6

NOVEMBER 15 1945

BUILD YOUR OWN RADIO

Full Kits
of Parts
Available
NOW!



**Powerful 5-Valve
Dual-Wave
Mantel Model**

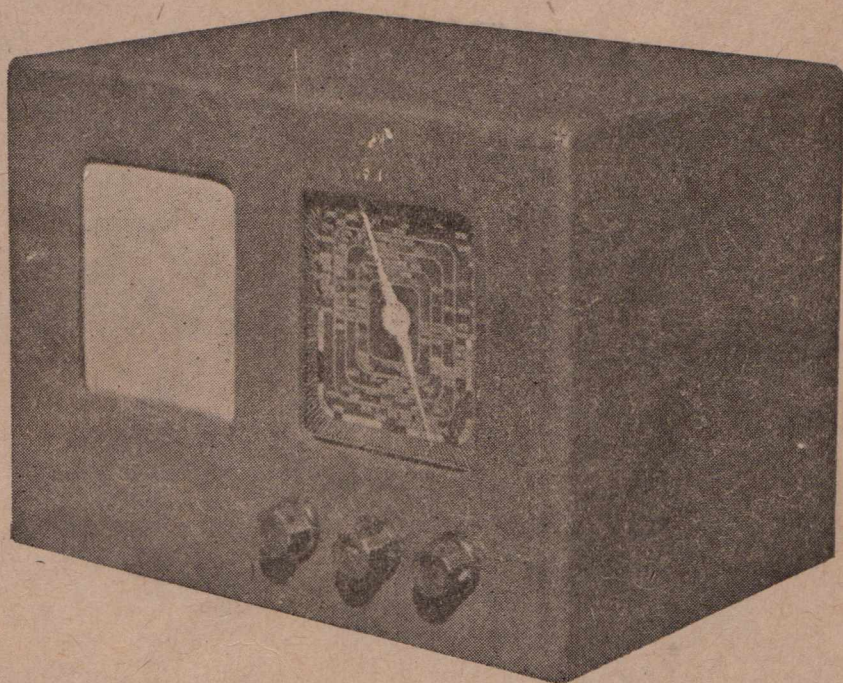

.....
INSTRUCTIONS, CIRCUIT & PICTURE DIAGRAMS
COMPLETE . . . IN THIS ISSUE . . .

1/-

The Reliable Line

COMPONENTS BY

Crown

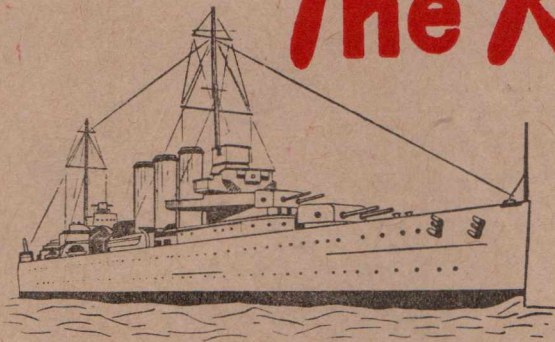

RELIABILITY and precision are the key notes in every step throughout the manufacture of "CROWN" Radio Components. Perfect co-ordination of skilled minds and hands in the "CROWN" Organisation, combined with years of experience in radio manufacturing, has resulted in the production of radio components of unequalled dependability.

The skill and experience of this Organisation is at the disposal of those seeking better Radio Components.

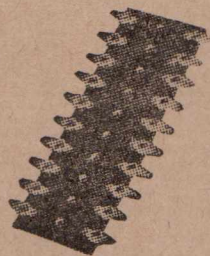
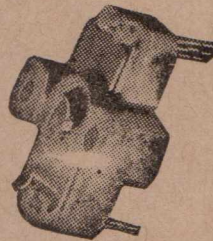
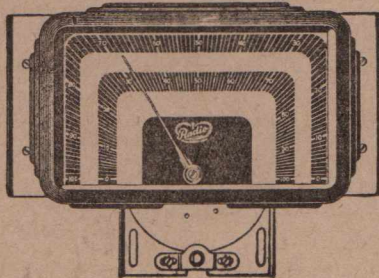
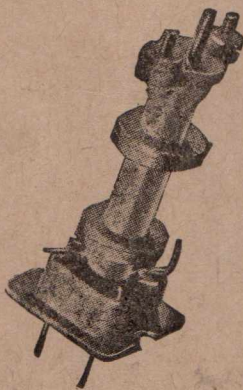

"CROWN" Radio Components include: Tuning Units, B/C Coils, S/W Coils, I.F. Transformers, Tuning-Dials, Padders, Trimmers, etc.

Crown



RADIO PRODUCTS PTY. LTD.

51-53 MURRAY STREET
PYRMONT — SYDNEY

Telephone MW2628
(2 Lines)

"CROWN" are now occupied in manufacturing vital radio components for all branches of the Fighting and Essential Services. They are, nevertheless, assiduously planning for pre-eminence in the post-war production of your radio parts.

**IF IT'S A "CROWN" PRODUCT IT'S
RELIABLE**

CR-10-45

THE AUSTRALASIAN RADIO WORLD

Devoted entirely to Technical Radio

and incorporating
ALL-WAVE ALL-WORLD DX NEWS

* PROPRIETOR —
A. G. HULL

* Manager —
DUDLEY L. WALTER

* Secretary —
Miss E. M. VINCENT

* Short-wave Editor —
L. J. KEAST

For all Correspondence

* City Office —
243 Elizabeth St., Sydney
Phone: MA 2325

* Office Hours —
Weekdays: 10 a.m.-5 p.m.
Saturdays: 10 a.m.-12 noon

* Editorial Office —
117 Reservoir Street, Sydney

* Victorian Advertising
Representative—
W. J. LEWIS,
20 Queen Street
Melbourne, CI
Phone: MU 5154

* Subscription Rates —
6 issues 5/3
12 issues 10/6
24 issues £1
Post free to any address.

* Service Departments —
Back Numbers, 1/- ea. post free
Reply-by-mail Queries, 1/- each

Vol. 10.

NOVEMBER, 1945.

No. 6.

CONTENTS

CONSTRUCTIONAL—	
Stereophonic Amplifier	7
An Electric Filter	11
"Aegis" Little Companion Mantel Model	15
TECHNICAL—	
Victorian Amplifier Contest	5
Television on Rental Basis	26
Ham Notes—Calling CQ!	27
SHORTWAVE REVIEW—	
Notes From My Diary	30
New Stations	32
THE SERVICE PAGES—	
Answers	34

EDITORIAL

During the war years no new radio receivers were manufactured for civilian use, yet sets were operated day after day for many hours. It was expected that when the war ended and civilian sets came on the market again there would be a rush to buy them. It is, therefore, with considerable dismay that some traders who have advertised sets in recent weeks have found that enquiries are not up to expectations. Whereas a few months ago it was possible to sell a secondhand radio set for almost any price, the position today is quite different.

With a view to finding a satisfactory answer to the problem we have recently conducted a sort of "Gallup Poll" on a small scale, and it is evident that people are not necessarily going to rush first sets to come on the market. We heard from plenty who are saving up for a new home, and may buy a set after they get the home. In other cases it is a new car they are saving up for. One naive person told us that he was going to wait until American sets were available in Australia!

But the worst feature of the replies was the number who said they were going to wait for television, frequency modulation and the other "wonderful improvements" to be expected after so much war-time research. Which goes to show a regrettable lack of technical knowledge on the part of those who make the wild statements, as well as those who believe them.

It seems the trade may have cause to regret that it has done so little to encourage a public appreciation of technical radio topics.

—A. G. HULL.

HOMECRAFTS PTY. LTD.

THE RADIO SPECIALISTS

A Division of Electronic Industries

Distribution in Five States



No Extra Charge for the Milk and Sugar

And there's no extra charge for THE EXTRA SERVICE which HOMECRAFTS extend to their clients.

ARE YOU ON OUR MAILING LIST?

If not send us your Name, Address and Service Licence No. Let HOMECRAFTS keep you up-to-date with the latest information on Stocks, Valve Releases—"B" Batteries, etc.

Write to our nearest Branch—If it's in Radio! Try HOMECRAFTS first.

Head Office: 290 LONSDALE STREET, MELBOURNE.

Telegraphic Address: "Homecrafts," Each State.

And at—
100 Clarence Street
Sydney

211 Swanston Street
Melbourne

307 Sturt Street
Ballarat

26 Hunter Street
Newcastle

And at—
Toowoomba, Dalby &
Rockhampton, Qld.

247 Adelaide Street
Brisbane

132 Moorabool Street
Geelong

140 Adelaide Street
Brisbane

Hobart, Launceston,
and Burnie, Tas.

VICTORIAN AMPLIFIER CONTEST

Some notes on the Professional Amplifiers in the Preliminary Heats

BY the time you are reading this issue the Victorian Amplifier Championship will have been decided, the final contest having been set down for hearing in the Melbourne Town Hall on November 14. A full coverage of the final will have to wait until next month's issue, but in the meantime we feel sure that amplifier enthusiasts will appreciate a resume of the performances in the preliminary heats, and so Charlie Mutton, our popular con-

By

CHARLES MUTTON

**1 Plow Street,
Thornbury, Vic.**

tributor, and himself one of the finalists, has jotted down a few notes.

The First Preliminary

At the first heat five amplifiers were heard, one entered by Barnes, (No. 23) and two each from Messrs. Skoglund (Nos. 6 and 7) and Rees (Nos. 15 and 16). Mr. Barnes used a 57 resistance-coupled to a 2A5, connected as a triode, transformer coupled to 4 2A3 valves in push-pull parallel. His speaker set-up consisted of two R.C.A. Photophone speakers, of 15 and 7 inch cones, with voice coils in parallel. A complete lack of bass response was most surprising in view of the elaborate set-up. The trouble appeared to be the pick-up. Highs were over accentuated, together with an abnormal scratch level which masked the highs. Rather a disappointing performance.

Amplifier No. 6 consisted of a 6J7G connected as a triode, choke coupled to another 6J7G triode, transformer coupled to a pair of 2A3 in push-pull Class A with self-bias. In this particular case the competitor spoilt his chances by playing what appeared to be a badly-worn record. The performance was poor on the lower register and the highs only mediocre. It is difficult to say whether the distortion came from

the amplifier or the record, but I suspect the latter. In any case, I don't like the idea of choke coupling. Number 7 amplifier, also entered by the same competitor, consisted of a 6J7G triode, transformer coupled to a single 2A3. This amplifier seemed to lack highs, had little bass, and the reproduction hard and metallic.

Amplifier No. 15 used a 6C6 pentode, resistance-coupled to a 6N7, resistance coupled to a pair of 6V6G in push-pull, with a B10 crystal pick-up, and a 12-in. Rola speaker in a labyrinth. No. 16 used two 6J7G drivers with a pair of 6L6G in push-pull with direct coupling.

Both these amplifiers were a vast improvement over the previous three and turned out nice reproduction. The direct-coupled job appealed as having better highs, and the bass resonance not being so prominent. I would expect that No. 16 would get top marks for the evening.

The Second Heat

In the second heat I came up against McLean, who put up such a grand show at Straede's contest, held some months ago. Mr. McLean has two amplifiers entered and Mrs. McLean has also entered one of her own construction. Being so busy looking after my own gear I did not have much time to look over the arrangement of these amplifiers, but I can tell you that McLean used a needle armature type pick-up of his own design which he converted from the old vintage B.T.H. magnetic, being a low level device. He told me that he was operating it at -60 D.B. down. As you can imagine, with the pre-amplification needed to bring this up to the desired level the 50 cycle hum was a problem. After the pre-amp came a complicated correction filter network worked in the 500 ohm line to the amp. Somewhere in the scheme was included a 6 k.c. cut off filter to reduce needle scratch, which could be switched in or out at will, and also a 6 D.B. per octave filter to bring up the bass response, as you realise that this pick-up follows the record.

Most of the description I have

given you is just a rough outline. The active dope I'll get from McLean later. The amplifier chassis was a huge affair, a mass of transformers and sundry bottles, mostly 6J7's as triodes. I think the job was PP throughout and all transformers coupled. Trimax transformers were much in evidence, also Trimax double section attenuators; £32 worth, so he told me. The whole job finished up with 4 — 2A3 P.P. parallel, fixed bias, feeding a G12 permag., mounted in a huge wooden flare, which had about a 3 feet square opening, the flare being divided up into 6 compartments done with wood and facing sundry angles. On top of the flare sat a K10-20, a Rola 10-inch per-mag. mounted in a small box for the highs. The amplifier was so arranged that it could be used as a straight-job or alternatively as a dual-channel job with independent level controls on each channel.

General opinion (not mine alone) was that it was a darn good rig, but marred by an over-powering bass response, in fact this rig has more bass than I've heard on any job yet. As you can imagine, this created the impression that the system was badly balanced. Apart from this, a nice job, and should have been, too, about £180 worth of gear in it.

I haven't got anything to say about my own job. General comments were: high note response exceptionally good, with nicely-balanced bass. Line up as follows: 6J7 triode — trans-coupled to P.P. 6J7 triode drivers, direct-coupled to 4 — 6A3 P.P. parallel, into M20 speaker with approximately 35 watts in field, fixed bias, flat baffle, using a B10 Tru-Tan crystal pick-up. A cathode follower switching arrangement was left on in case anybody wanted to hear the difference.

Third Heat

First amplifier of the third heat was No. 14, entered by T. Holden. It consisted of 6J7 triode connected trans-coupled (Trimax TA3) into 2 — 6V6's as triodes, driving 2 — 2A3 in push-pull, semi-fixed bias,

(Continued on next page)

AMPLIFIERS

(Continued)

using a G12 permag speaker; on the other end a Shure Zephyr crystal pick-up. This competitor showed excellent taste in his choice of recordings, but the pick-up spoilt what could have been rather a good amplifier. At the risk of hurting some people's feelings, the author can, without bias, say that this particular model pick-up has a preponderance of bass frequencies and requires a relatively large amount of compensation.

The second amplifier (No. 22) was entered by A. Keogh of Kingsley Radio. Mr. Keogh was one of the competitors who did particularly well in the contest last year, and also in a recent contest run by J. W. Straede. The pick-up used was a straight-arm piezo-astatic job. The output system P.P. 2A3 fixed bias, Class AB2, 6F6G or 42 triode driver, not quite sure of this set-up. The speaker system was 2 12-42 Rola's in parallel on a large flat baffle.

It appeared that this amplifier, if it was the same as used last year, had lost its nice crisp note response, in fact it could be said in all fairness and without prejudice, that the high frequency end was well down and the bass response far too prominent. In a conversation with Mr. Keogh later, it was learned that no change had been made to this particular amplifier. Seeing that this competitor had two amplifiers in, as separate entries, No's 21 and 22, an opportunity was provided to compare results. No. 21, which was played a little later in the evening was much the same as No. 22. This fact would seem to point to the crystal pick-up being the offender.

Crystal pick-ups sometimes change their characteristics, even the application of a soldering iron a little longer than necessary can cause loss of output voltage and loss

of highs. Climatic changes of extreme nature (common to Melbourne) can cause the same effect.

No. 24 was entered by K. Renshaw. Strictly an electrical man by trade. Mr. Renshaw, however is a keen amplifier fan, and an extremely good technician, as evidenced by his clean lay-out, and neat appearance of the amplifier, and also the nice construction of a special arm for his crystal pick-up. Keen attention to detail was evident when it was revealed that he had rewound the normal 18 watt fields of the two G12 speakers to 30 watts excitation, necessary for reproduction of peak levels and transients. Unfortunately, however, this competitor just overstepped the mark in his high frequency compensation circuit, which gave the reproduction a marked unbalance. However, the high note-boost was a step in the right direction, and even if a little strident to listen to, proved a welcome change to the everlasting bass. Any man who is practical and original in his ideas adds much to a competition of any kind and it is rather regrettable that this competitor did not do better. This amplifier was yet another transformer coupled job using 4 2A3 P.P. paralleled in the output.

No. 10 amplifier was entered by Mr. Stevens, another of last year's finalists who did a particularly fine job at that time under adverse conditions. It was said at the time that for a pair of 6V6G's in push-pull this amplifier did extremely well. As far as can be ascertained, the amplifier was identical to the previous one of 1944, but with a greatly improved speaker system. The speaker appeared to be a Rola G12 mounted in a box baffle with a large flare type opening, split into four sections, the mouth of the opening being approximately 3 feet square. This competitor lived up to his last year's reputation and again produced some nice quality, nice lows, pleasant highs and altogether a nicely balanced job, marred slightly, but

not of much consequence, by a just noticeable boxy effect, probably due more to the acoustics of the hall than anything. As two competitors using similar type baffles states that the boxy effect was only noticed in the hall, but not at home; a point which again makes it extremely difficult to know what to do for the best.

Summarising this, the third night of the competition, it could safely be said that Mr. Stevens probably took top marks for the night, with either one of Mr. Keogh's jobs being runner-up. Up to this stage the fly in the ointment appeared to be high frequency response, which was attributable to possibly two reasons. Firstly and most probable is that much abused expression which can cover a multitude of sins, "nice mellow tone." Certainly lots of amplifiers have just that, but those same amplifiers don't win competitions, so it would appear that most amplifier enthusiasts fail to realise that fine line of demarcation where on one side we have crisp and brilliant reproduction which adds life and zest to recorded music and on the other we have the type of reproduction which is pleasing to listen to, but is dull. It boils down to a matter of musical commonsense and good judgment. On the other hand, one can go to extremes the other way and have just the opposite, i.e., high notes which fairly shriek and are very strident and distressing, which is far worse than the other type of reproduction referred to.

And so the week closed. A total of 15 amplifiers having played off with the general opinion of those in the audience that out of the 15 contestants so far, Stevens (No. 10), McLean (No. 19) and C. Mutton (No. 13) appeared to be in the running.

Operations were again resumed on Monday night, October 23, where, at this stage, there remained eleven more contestants to play off in the Grade One Open Professional Class.

First amplifier to play was No. 3, entered by Mr. Holland, another of last year's contestants. Consisted of the audio end of the tuner and comprised a resistance coupled pentode, split-leg phase inverter into P.P. 6V6G into a K12 speaker on a flat baffle. Pick-up was an old B.T.H. magnetic job.

Seeing that this contestant's rig was later heard on the tuner section

WHO WILL WIN?

Of the four finalists in the Professional Class of the Victorian Amplifier Championship three are using direct-coupled circuits. A full description of the winning amplifier is due to appear in next month's issue.

ORDER YOUR COPY NOW!

(Continued on page 11)

STEREOPHONIC AMPLIFIER

— uses three channels

IT has long been realised that for adequate reproduction of orchestral music, a stereophonic sound system is necessary. This can only be fully achieved by the use of a multi-channel recording and reproducing system, giving the correct spatial relationships between the reproduced sounds and the various sections of the orchestra. This, of course, was done in "Fantasia," but the cost of such a scheme is

spatial relationships, a very effective stereophonic illusion can be obtained.

It is the purpose of this article to describe an arrangement whereby this stereophonic illusion has been created, and to give some of the applications of a stereophonic amplifier in the presentation of recorded music. However, it must be pointed out that the amplifier was built in wartime, using only parts which were either on hand or readily available. Thus the circuit departs in some respects from what is generally considered to be good amplifier practice. High power output had to be obtained at the expense of a certain amount of harmonic distortion, particularly in the output of the high-frequency channel, a compromise being made in the form of inverse feedback. Hence this particular circuit is not recommended to readers for constructional purposes, but is used here rather as an

illustration of stereophonic reproduction.

General Considerations

The circuit diagram is shown in Fig. 1, from which it will be seen that the low frequency channel has a response curve which descends with increase of frequency, while the other two channels have ascending response curves. (The amplifier was built upon the assumption that non-variable linear response was not desirable, and a good many musically-discriminating ears have since justified that assumption). Potentials at the input to each channel enable the three response curves to be raised or lowered bodily with respect to each other. This gives infinitely variable tone compensation, and as the three speakers are placed about 12 feet apart, the channel input potentialities also control orchestral balance. The volume of the

(Continued on next page)

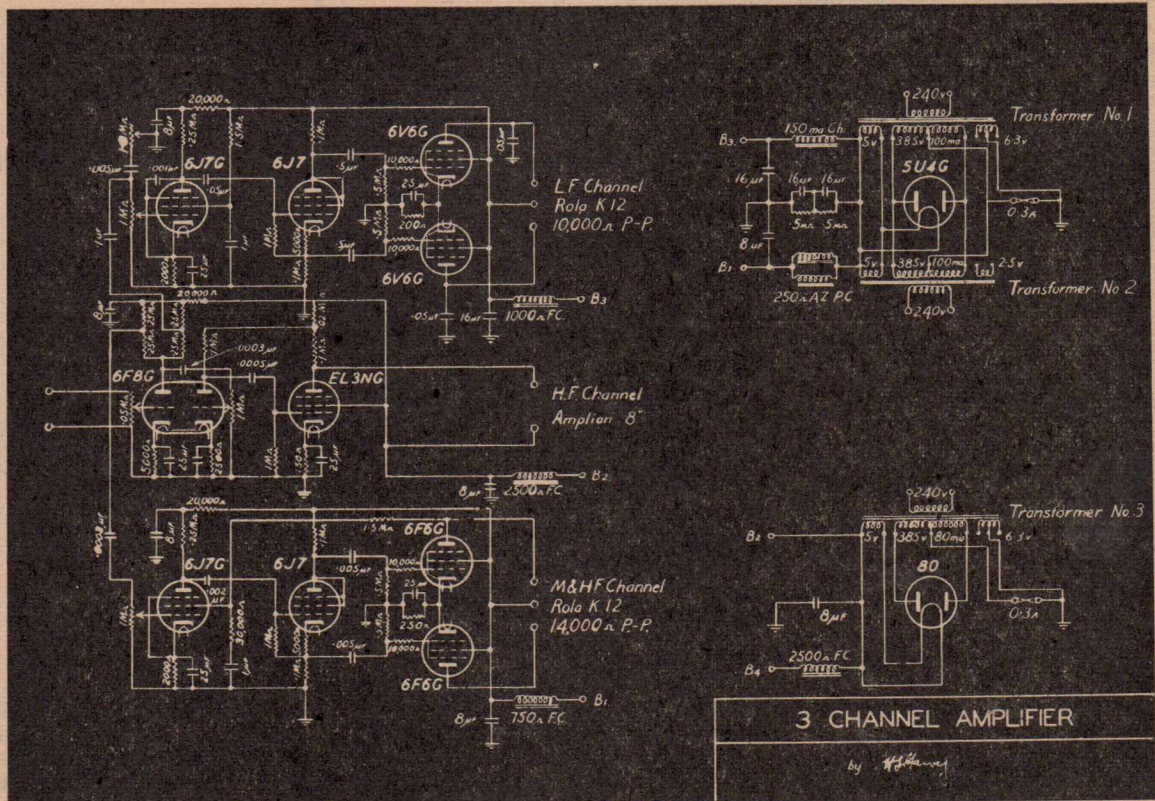

"THE NAME TO
KNOW IN
RADIO"

*Radiokes
Radiokes
Radiokes*

Radiokes' Broad-
cast Coils, both
Air Core and Per-
meability types
are now more
freely obtainable.
Features include
rigid Trolitul con-
struction. Ask for
Type ACB, Aer,
R.F. or Osc.

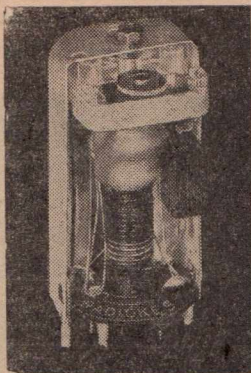

RADIOKES D.W. UNITS
Highly selective with exception-
al wide range. To match 'H'
type gang condenser. Incorporates
4-in-1 padder. Solidly
mounted with coils. Ask for
Type DWU-1.

*Radiokes' precision radio components
have long been recognised in Australia
as being the most outstanding products
of their kind available. It is with
pleasure, therefore, we announce their
return "from active service."*

RADIOKES Pty. Ltd.

P.O. Box 90
BROADWAY - - - SYDNEY

STEREO AMP.

(Continued)

whole amplifier is controlled by the input potentiometer across the pick-up.

Amplifier Details

Splitting of the signal into the three channels is done in the plate circuit of the first triode section of the 6F8. As variable treble cut is applied to the input of the low frequency channel, it is necessary to place a fairly high impedance between the input of the L.F. channel and the other two channels. This is done by using the split plate load resistance method. Thus the middle-high and high frequency channels are not affected by the operation of the treble-cut control in the L.F. channel. Only half the gain of the first triode section of the 6F8 is used for feeding the two push-pull channels while the H.F. channel is fed from the plate of the first triode section. This gives a symmetrical arrangement for feeding the three channels, besides giving a little more gain to the H.F. channel where it is needed.

Low Frequency Channel

As will be seen from the circuit diagram, the L.F. channel was a standard circuit with 6V6G's in class AB₁ push-pull. The response curve of this channel is given a descending characteristic by the .05 uf condensers from the plates of the output valves to earth, the .001 uf condenser from plate to cathode of the 6J7G, and the variable treble cut applied to the input of the channel. (More will be said of this control later.) Inverse feedback was deemed unnecessary for this channel.

Middle-High Frequency Channel

Again this channel was a standard circuit with 6F6G's in push pull, the low frequencies being eliminated by the use of small coupling condensers. In spite of the low value of the initial coupling condenser (.0003 uf) this channel responds quite audibly to about 200 c/s. The MHF channel was originally intended to have a limited amount of treble cut, but better high frequency sound distribution is obtained by allowing the high to pass unattenuated through this channel. Inverse feedback consists of the usual circuit,

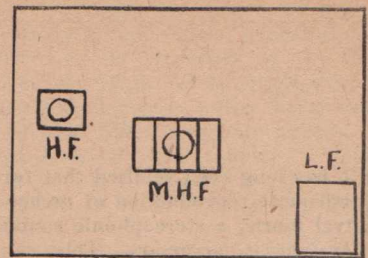

ELEVATION

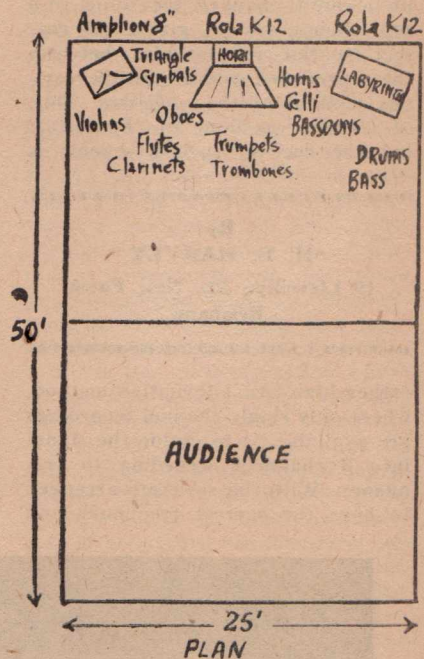

feeding from the plate of one 6F6G to the screen of the 6J7G.

High-Frequency Channel

The H.F. channel is intended to begin its cut off at about 2000 c/s, but as the cut off is very gradual, the channel responds audibly down to about 500 c/s. As this channel was added to the chassis after the other two channels were completed, economy of space had to be effected. Hence the choice of valves 6F8G, EL8NG, to give maximum power output. Inverse feedback is applied in order to decrease harmonic distortion in the EL8NG. (The three channels are built on a chassis 12-in. by 8-in. by 4-in. deep.

Power Supply

The two power packs are built on a chassis separate from the amplifier, but show evidence of wartime restrictions. The two push-pull channels are fed from two 100 ma transformers connected in parallel,

using a 5U4G rectifier. The supply for these two channels is taken through separate filter networks, using the speaker fields as part of the filter networks. It is fully realised that this does not represent good practice from the point of view of power supply regulation or speaker field energisation, but it had to be done in view of the parts position. The filter chokes marked 250 ohm A.Z.P.C. in the diagram represent a couple of potential coils out of old K.W.H. metres. The two were connected in parallel to pass the 100 ma current drain without saturation. The initial filter condenser consists of two 16 uf in series to withstand the voltage; the resistors across these are for purposes of voltage equalisation, but should be shown as 50,000 ohm instead of .5 meg. Protection of the power packs is given by 0.3 amp torch bulbs inserted as fuses in the return leads to the C.T.'s of the transformers. The 80 ma power transformer with 80 rectifier supplies the H.F. channel and the buffer pre-amplifier triode section of the 6F8G. This 3 filter-network system of power supply ensures complete decoupling between channels, while further decoupling is applied to individual valves in the channels. Although none of the valves are fitted with shield cans, the amplifier is perfectly stable under all conditions of operation.

The Speakers

The low frequency speaker is a Rola K12 mounted in an acoustic labyrinth. The K12 does not rank among the greatest of speakers, but when given sufficient acoustic load-

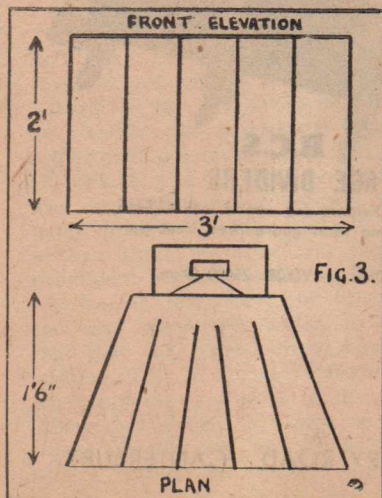

ing, it is capable of very fine performance. The labyrinth is a comparatively small, semi-portable affair, 3 feet high by 2 feet 6-inches wide by 1 foot 10-inches deep, the general arrangement of which is shown in Fig. 2. The overall air column length from the back of the cone to the plane of the front of the speaker is 11 feet. This corresponds to half-wavelength for 50 c/s., so that at this frequency the back and front waves are in phase at the plane of the front of the speaker and are therefore propagated in phase. Since the bass resonant frequency of the K12 is 55 c/s the labyrinth tends to counteract the otherwise rapid falling-off in response below the bass resonant frequency. The labyrinth is constructed of 3/8-in. plywood lined with 1/2-in. canite. It is felt that an 18 foot labyrinth would be better (i.e. one giving reinforcement of back and front waves at 30 c/s) but economy of materials and considerations of portability precluded this. However, the present arrangement gives quite good bass response, and on heavy bass passages, the vibration can be felt coming through the wooden floor 50 feet from the speaker.

The middle-high frequency speaker is another K12 mounted in a loading horn of a type described in "Wireless Weekly" about 1936. This horn is fitted with diffusion vanes to spread the high frequencies, and is shown in Fig. 3. It is constructed of 5/8-in. plywood with 3/8-in. plywood diffusion vanes. The acoustic loading increases the efficiency of the K12 and provides mechanised damping for the cone. Thus the transient response is considerably better than the high AC plate resistance of 6F6's would lead one to expect.

The high frequency speaker is an Amplion 8-in. mounted in a small horn fitted with diffusion vanes. This horn is roughly exponential and provides loading only at frequencies above about 2000 c/s.

Speaker Positioning

The amplifier is at present being used by the University of Queensland Gramophone Society, and is operated in a hall 50 feet long by 25 feet wide. The speaker positions are shown in Fig. 4. These are the normal positions, but can be varied at will to suit the type of music being reproduced. For recordings of solo instruments, the three speakers

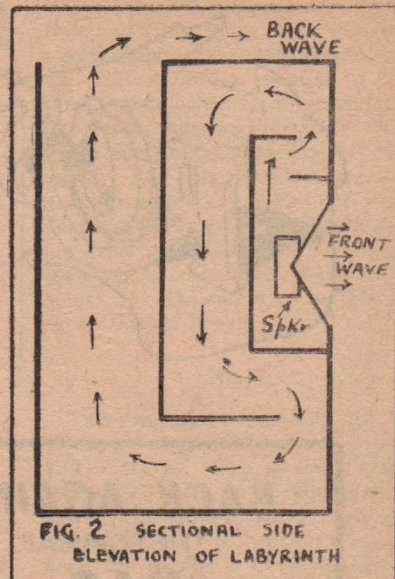

FIG. 2 SECTIONAL SIDE ELEVATION OF LABYRINTH

are placed in the middle, one above the other. The audience is kept as far as possible to the back of the hall, so as to receive the blended sound from the three speakers. A further point in enhancing the stereophonic illusion is to leave the hall in complete darkness during evening recitals. This point is mainly psychological in that the speaker positions are not immediately visible to the audience.

The effect of the stereophonic illusion is as shown in Fig. 4. Violins appear to come from the left hand side, around the 8-in. speaker, with flutes and oboes locating themselves between the H.F. and M.F.H. speakers. Trumpets and trombones come from the middle speaker. Horns, cello and bassoons appear to be situated between the middle and right-hand side, while the basses and drums centre themselves around the L.F. speaker. There are few anomalies, of course. Celli in their upper register tend to wander to the left-hand side, but this is largely overcome by the use of the variable treble cut control in the L.F. channel. For ordinary orchestral works the L.F. channel is operated at full treble cut, but for work containing important cello passages, the control on the input of the L.F. channel is opened up to extend the range of that channel up to about 1000 c/s.

(Continued on page 26)

ALL OVER AUSTRALIA

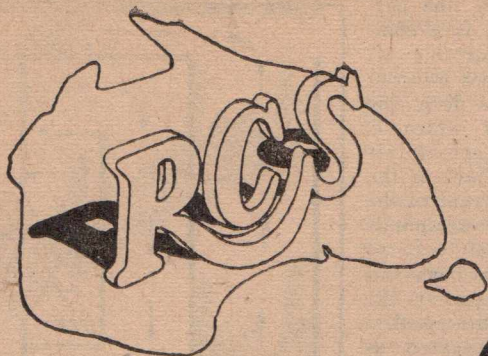

... the name R.C.S. is recognised by both the trade and the amateur set constructor as being the trade mark of quality in precision-built radio parts and components.

BACK AGAIN
THE POPULAR
DA7
RADIO DIAL

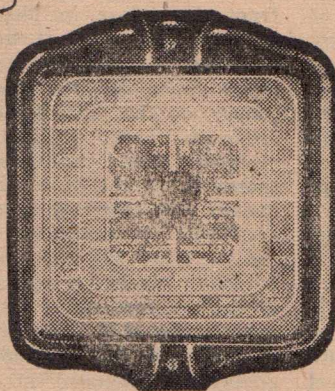

R.C.S.

FILTER CHOSES AND AUDIO TRANSFORMERS

These R.C.S. quality components incorporate heavy copper wire wound on Trolitul bobbins. The use of Trolitul eliminates electrolysis, ensuring much longer effective life.

- TB4. A Class. Single _____
- TB5. A Class. PP _____
- TB6. B Class. PP _____
- TC65. 50 M/A 30. H. _____
- TC60. 100 M/A 30. H. _____
- TA4. Audio Chokes _____
- TC58. L.T. Vibrator Chokes.
- TC70. H.T. Vibrator Chokes

R.C.S. STAR AND M/C CONDENSERS

R.C.S. Midget condensers feature Trolitul end plates and are available in single and double bearing types.

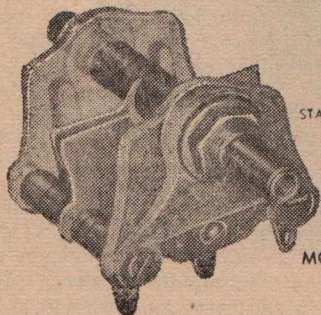

	Max. Cap.	Min. Cap.	
	MMFD.	MMFD.	Plates
STAR	CV34	10	3 2
	CV35	15	3 3
	CV36	25	3.5 4
	CV37	35	4 5
	CV38	50	4 7
M/C	CV39	70	5 9
	CV40	100	6 14
	CV41	10	3 2
	CV42	15	3 3
	CV43	25	3.5 4
	CV44	35	4 5
	CV45	50	4 7
	CV46	70	5 9
	CV47	100	6 14

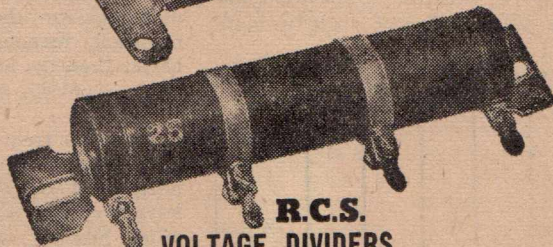
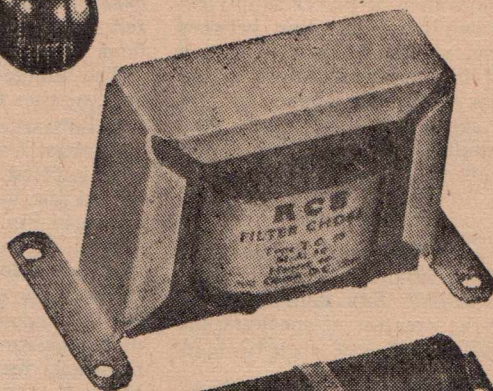

R.C.S.

POTENTIOMETERS AND RHEOSTATS

R.C.S. Potentiometers and Rheostats are made of moulded bakelite, with brass spindles. Nickel silver contact ring ensures smooth action.

0-10000 Ohms.



R.C.S.

VOLTAGE DIVIDERS

R.C.S. Voltage Dividers are wound with 42 BMS Oxidised Nichrome wire, guaranteed best performance.

VD.25. 15000 Ohm. VD.28. 25000 Ohm.

R.C.S.

RADIO PTY. LTD.

174 CANTERBURY ROAD, CANTERBURY.

Trolitul is a semi-transparent, light-weight moulded insulating plastic that is used exclusively by R.C.S. in the manufacture of R.C.S. quality radio parts.

AN ELECTRONIC FILTER

FOR those who demand a high degree of filtering but wish to avoid multi-section filters, the accompanying circuit should prove very useful. L1 and C1 are the usual filter choke and condenser, the remainder of the circuit operating by virtue of the fact that both load

By
J. WHITE

32 Edward Street,
Bexley North

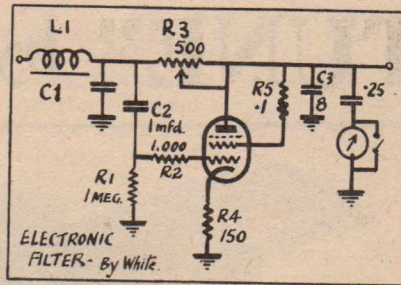

P.P. 2A3 job entered by Mr. C. Hyatt of Heidelberg, who was using a self-aligning type arm crystal pick up. This amplifier seemed to have some fundamental trouble, sounded like faulty tube or something wrong with the bias somewhere. Here again, like its predecessor, the needle resonance was bad and reproduction distorted. Many self-aligning arms such as this do more harm than good, and unless their adjustment is thoroughly understood, cause untold bother.

No. 8

current and plate current of the filter tube flow through R3.

Assuming no ripple whatsoever, filter tube plate current would be steady and together with load current would cause a steady voltage drop across R3. Any ripple appearing at the output of L1, however, is applied via G2 and R2 to the grid of the pentode and plate current varies accordingly.

A momentary increase in voltage reduces grid bias which increases plate current, and in turn increases the drop across R3, while a drop in voltage has the opposite effect and decreases the drop across R3. This

rapid fluctuation tends to cancel out and the results is a highly filtered supply.

The circuit constants shown are average values, almost any pentode can be successfully used, R4 and R5 being varied accordingly. To adjust the circuit R3 is set to minimum and slowly increased until no further improvement in filtering is possible. If a high resistance A.C. voltmeter is available it may be wired in temporarily as indicated by the dotted lines and used as a ripple indicator. If this system is used for adjustment, care should be taken to see that the meter is shorted by the switch until the equipment is at full voltage and is again shorted before switching off, or the meter may be damaged.

This amplifier entered by Mr. McGlashon of Heidelberg, was a push-pull 6J6G job. The speaker system was a G12 Rola on an irregular flat baffle, the whole outfit was particularly neat in appearance and gave an excellent performance, as was evidenced by the many smiles which suddenly sprang into being among the audience. Here was an amplifier which had exceptionally clean cut reproduction, the bass response was good, the middle register nicely balanced and the high note response clear and undistorted. Possibly readers will be interested to know that the pick-up used was a needle armature type and was made by a partner in crime of Mr. McGlashon's, Mr. Hutchison, who played off next, and was No. 9. Apparently, being bosom pals, they shared a common interest in the pick-up and speaker, but each using his own set-up. Mr. Hutchison's job used 2A3's in P.P. This last-mentioned job was heard to disadvantage, due to the writer setting up gear for a friend who was unable to operate it. Thus the reproduction from No. 9 was heard from behind the baffle. However, there proved to be very little difference between Numbers 8 and 9, perhaps No. 9 having a shade of odds in favour of the highs, but as stated, extremely difficult to make a comparison from behind the scenes.

One fact worthy of mention was the beautiful job done by Mr. Hutchison on the pick-up, it really was worth looking at. The counter-balancing arrangement and mechanical design could well be copied by some of the commercial firms. Weight at the needle point seemed to be round about 3-oz., side play and bearing slackness being completely absent.

(Continued on page 13)

VIC. AMP. CONTEST

(Continued from page 6)

and that the reproduction came through well on the air, it is only natural to say that when heard as an amplifier the reproduction being rather poor pointed a finger that the old B.T.M. pick-up was the culprit. The reproduction on records was badly distorted, and as might be expected, there were several highly prominent resonances present, one was needle resonance, the other a bad arm resonance, added to the fact that the reproduction was all middles. This in no way reflects on the competitor's ability, or his amplifier, but simply is a sign of the times, whereby we can't all be fortunate enough to possess a good pick-up, but have to be satisfied with

what is available. Provided some time and care is spent on a few modifications, some of the older type magnetic pick-ups can put up quite a favourable showing.

No. 2

Second amplifier to play was a

HONOR ROLL

Owing to an unfortunate error the name of Crown Radio Products Pty. Ltd., was not included on the Honor Roll in last month's issue.

Crown Radio has been one of our most loyal supporters over many years and we greatly regret this error.

KINGSLEY DOES IT AGAIN!

“FERROTUNE” by KINGSLEY

★ ANOTHER MAJOR TECHNICAL DEVELOPMENT

Announcing the first of a series of Gangless Tuning Units — “Ferrotune” is a device which tunes a Radio Receiver without the use of a conventional gang condenser.

★ FREQUENCY COVERAGE

540 KC to 1650 KC, each revolution of driving knob equals 100 KC.

★ DIAL READING

Straight line tuning all over dial.

★ MECHANICALLY SOUND

Robust construction, well engineered for long service under all conditions.

★ TRACKING

Unit lined and tracked during manufacture. No padding or matching, simply trim pointer to local highest frequency station.

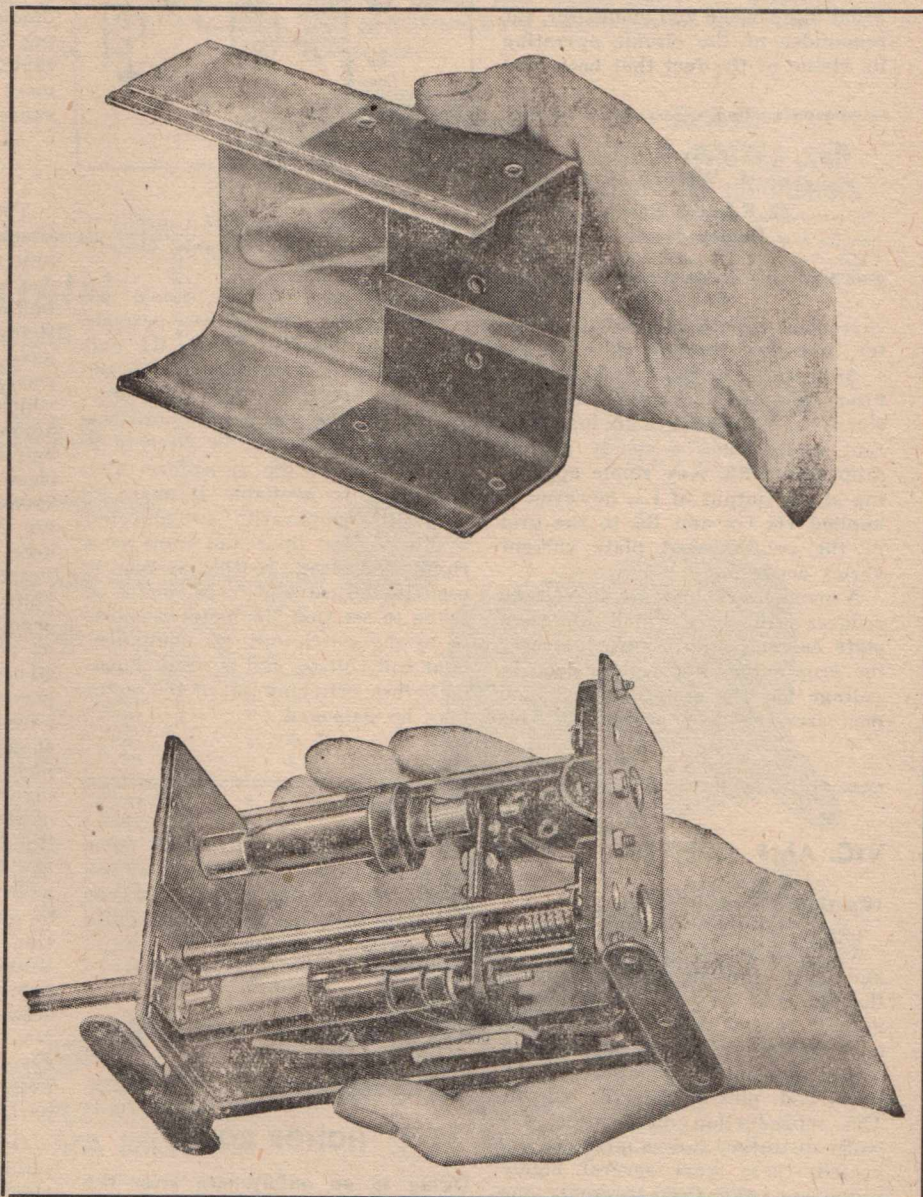

KINGSLEY RADIO PTY. LTD.

225 TRAFALGAR STREET, PETERSHAM, N.S.W.
380 ST. KILDA ROAD, MELBOURNE, VICTORIA

Phone: LM 4468
Phone: MX 1159

FROM AUSTRALIA'S LEADING DISTRIBUTORS

KR1255

VIC. AMP. CONTEST

(Continued from page 11)

The needles used were ground down to special size, approximately 4-in. to 5/16-in. long. From this fact can be gauged the surface of the pick-up was riding fairly close to the record. All trace of arm or needle resonances were absent. Mr. Hutchinson stated the design was based on an article which appeared in "Radio World" for January, 1944.

No. 25 amplifier was also neatly set up and was entered by N. H. Groves, who was the Champion of Champions last year. The set up consisted of a 6J7 triode connected, trans. coupled to push-pull 6J7 triode drivers, again T.C. to 4 P.P. parallel 2A3 using Trimax transformers throughout. Rola G12, crystal pick-up, flat baffle. This entry was also, like its predecessor, heard from behind the scenes. Opinions in the audience seemed divided, so to even comment on performance from behind a speaker would be foolish. But in line with Mr. Groves' last performance the previous year it seems reasonable to suppose that he held his own with Numbers 8 and 9. General opinion seemed to divide the honours between No. 9 and No. 25. Thus ended the 20th competitor, which now left us with the remaining six competitors, two of which could not attend.

The Last Preliminary Heat

Normally speaking this particular heat promised to be the most interesting of any, as three of the amplifiers were of unorthodox design. Two of the amplifiers entered in this heat were both of the cathode-follower output stage design using 6L6G's, transformer-coupled in both cases. In one set up a 6N7 phase inverter drove two 6J7's as triodes T.C. to the 6L6G's, while on the other a 6J7 pentode resistance coupled to another triode, which was a cathode-coupled driver. Ferranti transformer into 6L6G's. The speaker used was a Jensen M20, which was housed in a box baffle of neat dimensions, which looked attractive. This baffle was designed on the bass-reflex principle; in other words, instead of attempting to cancel the back wave from the speaker, the back wave is fed into an acoustic phase inverter column so that the back wave finishes up aiding, or in phase with the front wave. Natur-

ally the port, or vent, is located at the front of the baffle. This arrangement increases the efficiency of the speaker at the lower end of the spectrum. These two amplifiers were numbered 4 and 5 respectively, and were entered by Mr. L. Lowan, of Veall's, Swanston St., Melbourne. As a matter of added interest, the pick up used was a home-constructed job of moving coil design, to which was added a bass boost stage followed by a triode which was arranged to work in conjunction with a H.F. cut-off network, which could be varied to suit individual recordings.

The other amplifier, which caused interest because of the unorthodox

MINE-SWEEPING BY RADIO

A radio-operated device which detonates mines 20 miles distant by dialling a combination of numbers, as on a telephone, was one of a number of secret weapons, details of which have just been released. It can be used against either land mines or sea mines.

design, was a dual-channel job using transformer coupling to 2A3's P.P. fixed bias for the bass channel and a 6J7 pentode R.C. to a 6V6G

(Continued on page 25)

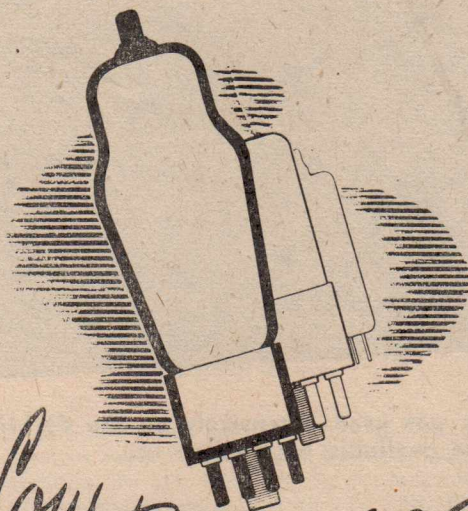

Now Released!

Keep in touch with your Local Dealer for further releases of type ranges.

BRIMAR
VALVES
British Made

A PRODUCT OF
Standard Telephones and Cables Limited

A BRILLIANT ALL-PURPOSE MULTIMETER

The "UNIVERSITY" (Model M.V.A.)

If it's an all purpose multimeter you require get details of the "University" Model M.V.A. An ideal A.C.-D.C. instrument for general radio service work or for the radio hobbyist. Complete A.C.-D.C. measurements, together with output meter ranges. Suitable for either bench use or as a portable instrument. Descriptive literature is available upon request.

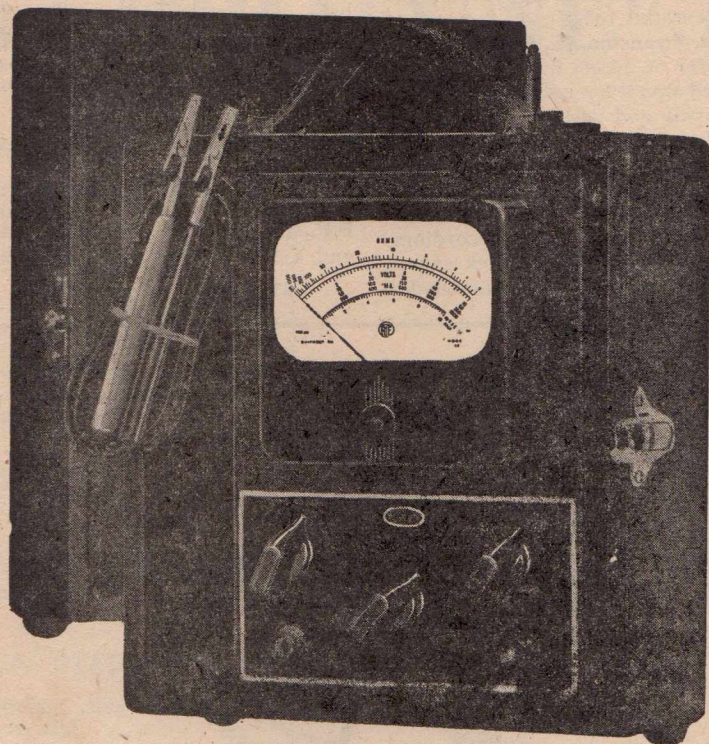

This instrument was used extensively by the Fighting Forces, but increasing numbers are now being made available for civilian use.

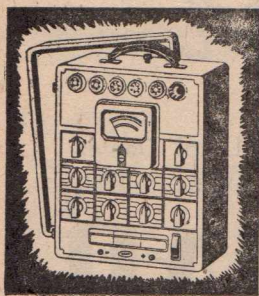

The "University" Super-tester is a most versatile Valve and Circuit Tester, featuring the extraordinary valve and condenser roller test chart — entirely new to Australia. Does many jobs well.

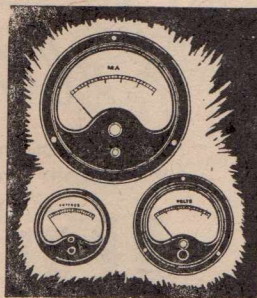

"University" offers an extensive selection of meters, ammeters, microammeters, etc., in a complete range of sizes, viz.: 2-in., 3-in., 4-in., and 5-in.



An entirely new instrument, the "University" D4 gives 48 distinct ranges and has been designed for the Radio Engineer who demands the best. Supplied with solid leather carrying case.

DISTRIBUTORS:

N.S.W.: All leading Distributors.
Queensland: Trackson Bros. Pty. Ltd.;
Homecrafts; J. B. Chandler Pty. Ltd.;
A. E. Harrold

Victoria: Vealls Electrical & Radio Pty.
Ltd.; Hartleys Ltd.; Replacement Parts
Pty. Ltd.; Victorian Agent: J. H. Magrath
Pty. Ltd.

Sth. Australia: Radio Wholesalers Ltd.;
Gerard & Goodman Ltd.
W. Aust.: Atkins (W.A.) Ltd.
Tasmania: W. & G. Genders Pty. Ltd.
New Zealand: Allum Electrical Co. Ltd.



RADIO EQUIPMENT PTY. LTD.

Head Office: 206 Broadway, SYDNEY, N.S.W.

Telephones: M6391-2. Telegrams: "RAQUIP," Sydney.

LITTLE COMPANION



It has been a long time since we had the pleasure of publishing an article to cover the constructional details for a receiver which is readily available in kit form.

BEFORE the war we devoted considerable space to these articles, but for about five years now, the radio factories have been busily engaged on the production of communications equipment for the fighting forces.

Components have not been available for domestic set production, or for experimenters.

Now we are able to say, "That was a war — we've had it!" and get right back to where we left off. Production of parts is not quite back to normal yet, and there are bound to be shortages in certain directions, and so we are most fortunate to be able to present this story, which is probably the first of the post-war series to appear in this part of the globe. It has been made possible only by a considerable amount of organisation and co-

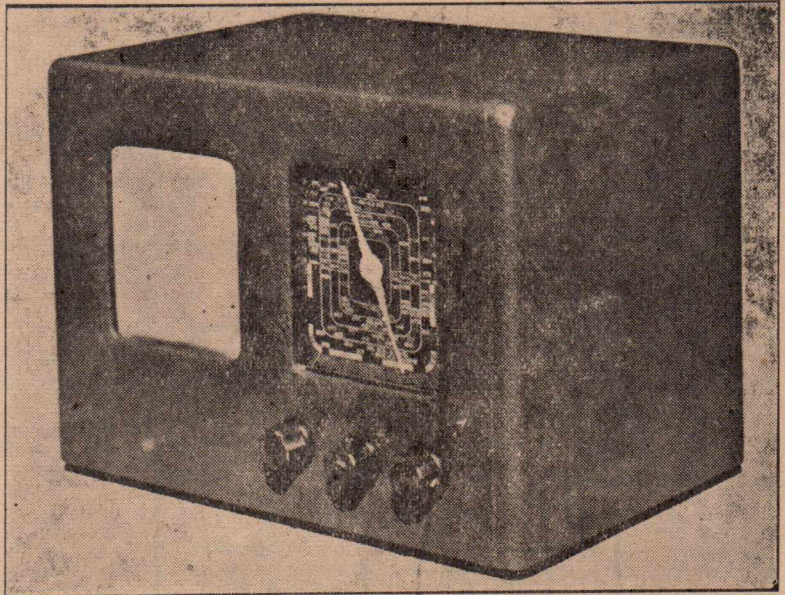

The Completed Receiver

operation. Many manufacturers of component parts might have concentrated their attention on the big factory orders if the importance of the experimenters and radio enthus-

iasts had not been pointed out to them by that champion of the cause, Mr. J. H. Magrath, of J. H. Magrath Pty. Ltd. Working with tireless energy, Mr. Magrath has arranged all the minor details for the procurement of everything, down to the last screw and nut, so that a complete kit of parts becomes available throughout the Commonwealth.

We are happy to do our bit by providing the photographs, picture diagrams and assembly instructions to complete the job.

A Pleasant Job

With this kit of parts you can build yourself a really effective dual-wave receiver of performance and appearance equal to anything on the market.

The job should take you only a few hours. The work is pleasant and interesting.

After you have finished, you will find that you have picked up a lot of useful knowledge about radio

(Continued on next page)

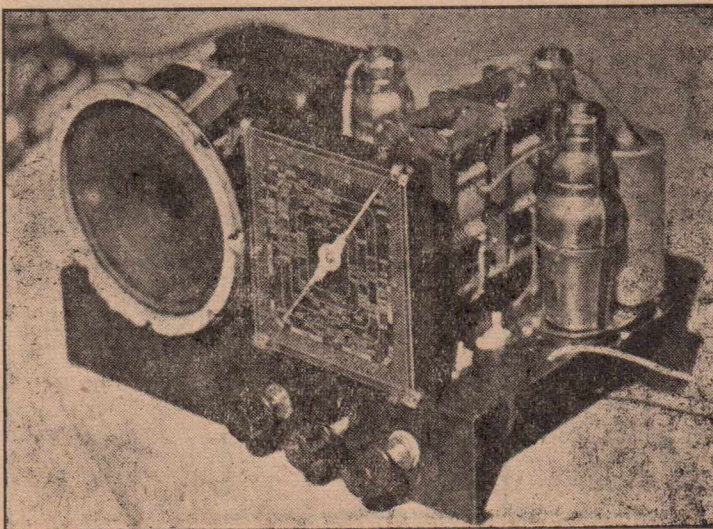

A front view of the finished chassis

LITTLE COMPANION

(Continued)

and radio sets in general. You will also have the comforting assurance that you know, personally, every component part in your set, so that if at any time it requires service attention or adjustment it will be a simple matter for you to carry it out yourself.

The kit comes to you in a complete form, right down to the last screw, lug and piece of wire. Even the necessary solder is included.

For a tool kit all you need is a soldering iron, a pair of pliers and a screwdriver. You can do all the work on the kitchen table, if your

wife (or mother) will permit you.

You'll get extra enjoyment every time you listen to a set which you have actually built for yourself, and you'll be as proud as Punch when you demonstrate its performance to your friends and neighbours.

Devoting your spare time to the building of a set is going to help the manpower position, too, so don't waste any further time; get yourself a kit and then let us get together on the assembly and wiring of it!

The Circuit

The built-up kit provides you with a powerful dual-wave receiver, using five valves in all, and giving ample reserve of power and range.

Although standard-sized components are used and a straight-forward layout, the assembly is so compact that the chassis fits into a snug little mantel model cabinet of handy dimensions.

As will be seen from a glance at the schematic circuit diagram, there are no tricks in it. Accepted practice has been followed throughout, without complication, yet embodying every refinement which is desirable to ensure uniform performance from every individual chassis, even if wiring and layout of the minor components is varied to suit various brands and styles of items.

It will be noticed that the sche-

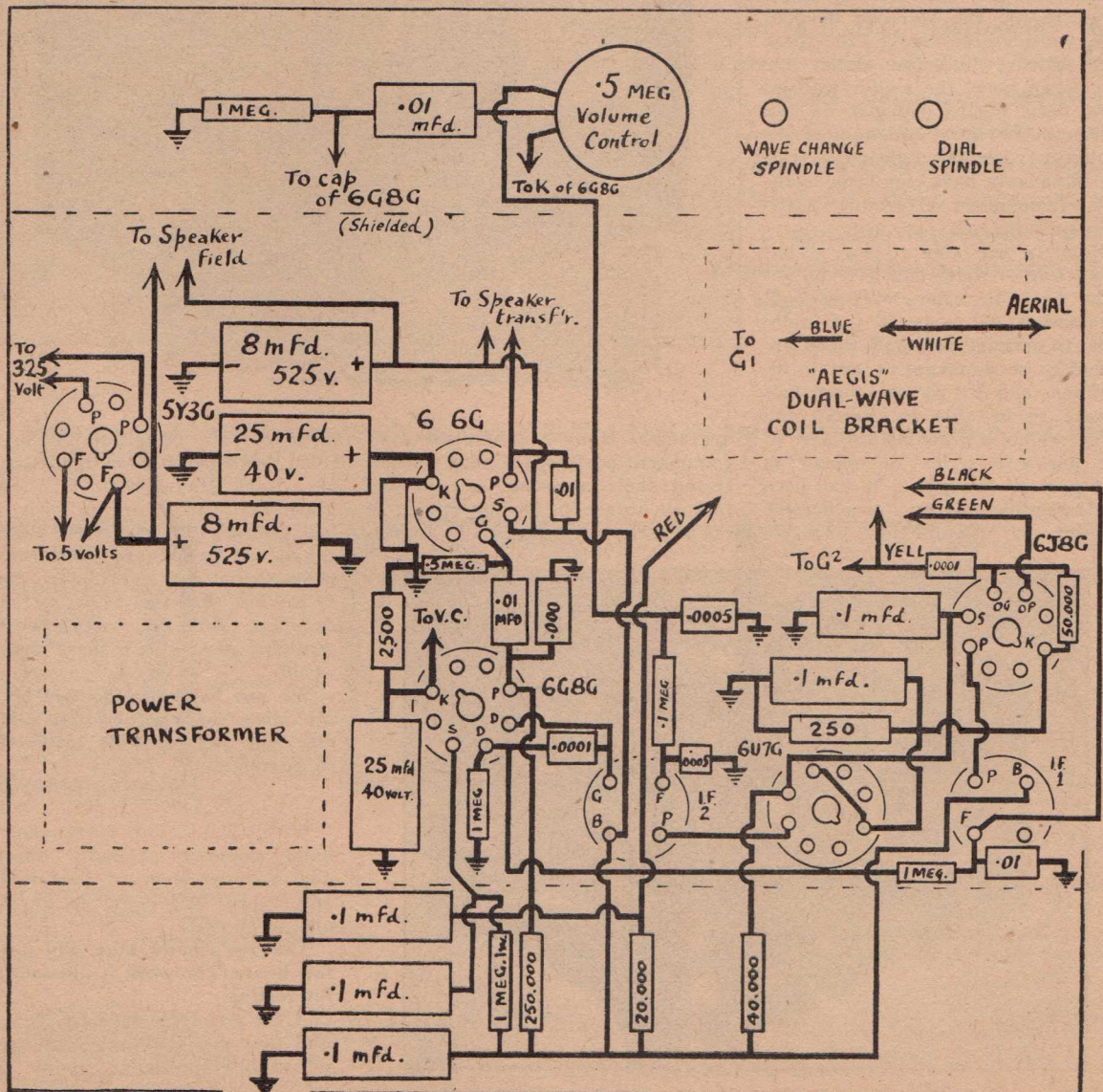

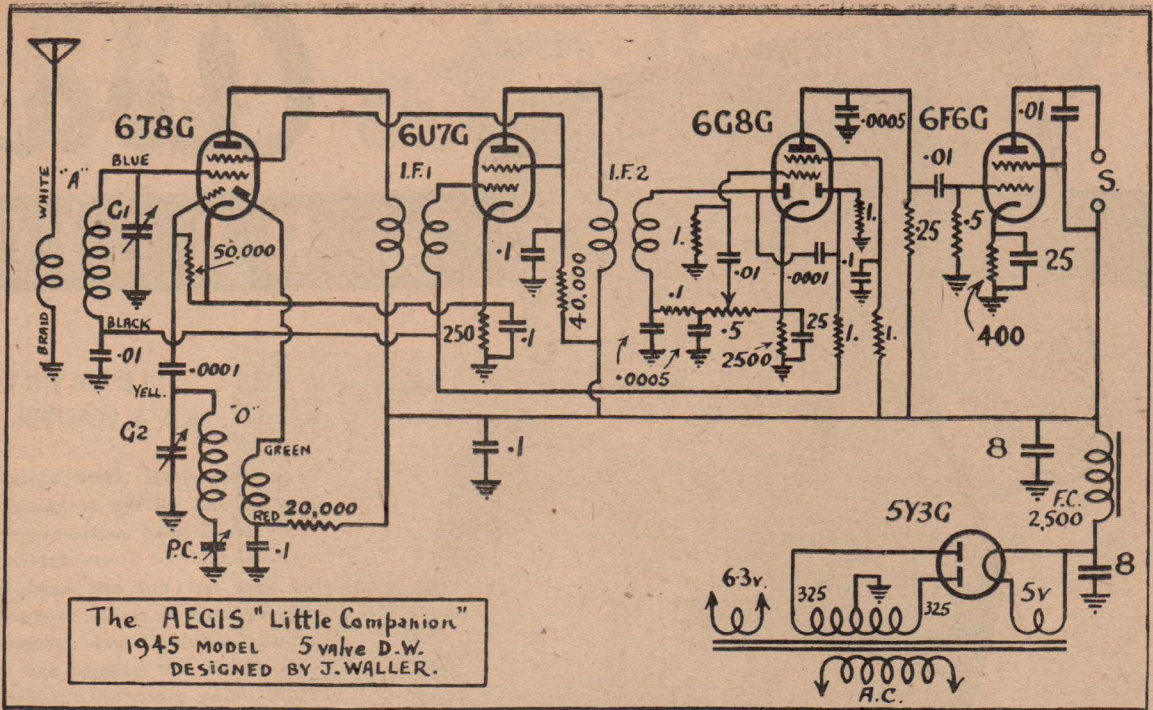

matic circuit is drawn up in its simplest form, the complicated switching of the dual-wave coils being entirely omitted. The dual-wave coil unit which is supplied with the kit is wired up with the coils, trimmers and padders mounted on it, so that it comes to you ready for fitting into the chassis. It is provided with connecting wires which are colour-coded, so there is no need for the schematic to be cluttered up with switching details which you don't need to take into consideration.

Alternative Valves

For the converter valve it is possible to use either a 6J8G or a 6A8G; and no circuit or component changes are necessary. Results are almost identical in practice. Theoretically one should give slightly lower noise level and the other slightly better stability on the short-waves, but in each case the difference is so minute that it would be most difficult to detect without specialised laboratory testing gear. So far as this kit is concerned you can take it that the 6A8G and 6J8G are interchangeable.

If at any time there is any doubt about the proper operation of the converter stage there is one quick and sure way of checking up on it. The cathode end of the 50,000 ohm

oscillator grid leak is unsoldered from the cathode and a milliammeter inserted to read the actual grid current under operating conditions. This grid current will vary according to the setting of the dial, but should not wander too far away from the normal rating of 400 microamps (.4 milliamp). If it is found, for example, that at the high frequency end of the band the grid current drops away considerably, the performance of the converter will also drop away. Many factors will be found to have an influence over the grid current, including the voltage dropping resistors in the screen and plate circuits, the grid-leak value, the capacity of the grid condenser, the coupling of the primary and secondary of the oscillator coil, and even the impedance of the intermediate transformer. Fortunately all these factors have been looked after in the design of the kit and any big variation in grid current is almost certain to indicate an error in socket connections or some such major mistake.

For the intermediate amplifier stage the valve type specified is the 6U7G, but a 6K7G could also be used without any changes of any kind.

For the detector socket you can use either a 6G8G or a 6B8G, ac-

cording to how the stocks of these types are coming through from the manufacturers.

For the output valve the type which we show on the circuit and picture diagrams and consider most favourably, is the 6F6G. These appear to be readily available, but if any difficulty is experienced in this regard it is possible to use the 6V6G by altering the value of the bias resistor from 400 ohms to 200 ohms. If the 6V6G is used the sensitivity will be greater, giving the set slightly more range, but the distortion is also up a little, making it desirable to fit a resistor or two to introduce inverse feedback. Details of the necessary alteration will be published in next month's issue if space can be found. The addition of inverse feedback improves the tone a lot, but cuts back the gain, so that there is little to choose between the 6F6 and the 6V6. The simplest way is to use the 6F6G if it is available.

For the rectifier socket the 5Y3 is the main choice and there doesn't seem to be any likelihood of these being in short supply.

Resistor Wattage Ratings

Carbon resistors of the type which we used to call grid-leaks in the

(Continued on page 20)

Available

The RADIO

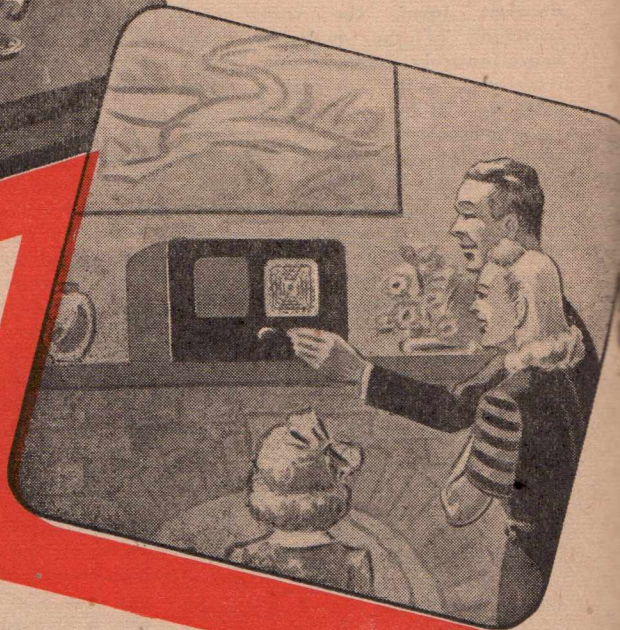
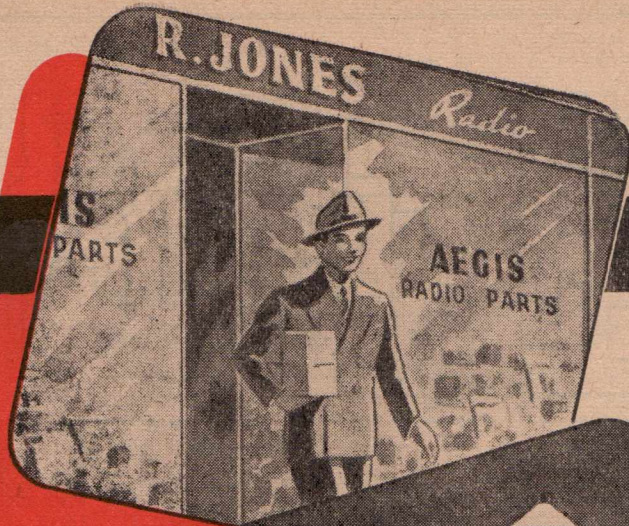

AEGIS "LITTLE COIL" KIT ASSEMBLY

Radio enthusiasts! Here at last is the features and all the technical help to a 5-valve 2-band receiver — A.C. operated easy-to-build kit form, carefully engineered the very last nut and bolt! Easily understood step by step assembly are given away include pictorial and schematic diagrams where each part belongs and where ever PLUS lining procedure for the Aegis Pe Kit and I.F.'s, type numbers K1, J1, and

Build for
Yourself this
5-Valve 2-Band
Receiver . . .

There is an AEGIS COIL for every c

Available at last!

KIT YOU CAN BUILD

COMPANION''
(Cat. No. KS5/D)

Ideal kit with all the
ensure success. It is
erated and supplied in
ered from cabinet to
derstood directions for
with each kit. These
rams showing exactly
ry connection is made,
ermeability Dual Wave
nd 2.

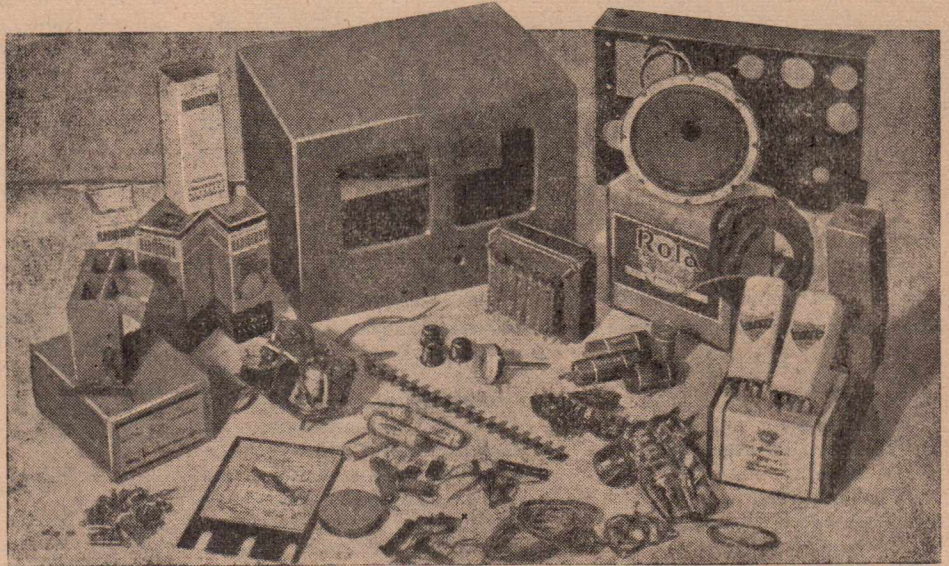

Look at these Outstanding Features:

- ★ DUAL-WAVE
- ★ PERMEABILITY IRON-CORED B/C and S/W.
- ★ PERMEABILITY IRON-CORED INTERMEDIATES.
- ★ DURABLE MANTEL CABINET.
- ★ DUCON CONDENSERS, etc.
- ★ ROLA SPEAKER

WRITE
 for name
 of your
 NEAREST
 DISTRIBUTOR

A

E G I S

MANUFACTURING COMPANY

Division of J. H. MAGRATH PTY. LTD.

208 LITTLE LONSDALE STREET, MELBOURNE

application in the radio frequency spectrum

LITTLE COMPANION

(Continued from page 17)

good old days are now available in various wattage ratings, the size of the resistor varying according to its wattage rating for any given resistance value.

In the past it has been customary to specify all resistors as "1 watt type," as these are handy in size and have an ample reserve of current carrying capacity for nearly every general use. But if space and price are factors it becomes worthwhile to use 1 watt resistors only in those positions where they actually need to have ability to carry current and dissipate power. For example, in this particular set we have several 1 megohm resistors which are not carrying any appreciable current, such as the grid leak which keeps the grid of the audio section of the 6G8G at earth potential. There should be no current flow

through this resistor under normal circumstances, and so there is need for it to have a power rating. And so we find that in this kit there are two sizes of 1 megohm resistors, three of them are quarter-watt types, while one has a rating of 1 watt. **The big resistor should be used for the screen feed of the 6G8G detector valve, as this particular resistor is called upon to carry some current.**

The Speaker

The speaker supply position does not look too bright, so that it is fortunate that alternative speaker specifications can be made optional. **With regard to the field coil resistance, this can be anything between 1200 and 2,500 ohms without results being seriously affected, although it is preferable to use either 1,500 or 2,000 ohms.**

Students of theory may be staggered at the statement that a field

of anything between 1200 and 2500 ohms can be used, but this is possible because the power transformer rating provides for a high tension voltage of 325 volts. If the highest resistance field is used the actual h.t. voltage on the plates of the valves will be well below the manufacturers' maximum ratings, probably down around 200 volts, at which plate voltage the plate current will be much lower than normal, so that the field coil may not be unduly overheated. Then, at the other extreme, the applied plate voltage will be right up to the limit, and the plate current likewise, but the actual wattage dissipated in the field will not be far from the makers' ratings. For the output transformer the load rating should be 7,000 ohms, but again it is possible to "get away" with anything between 2500 and 14,000 ohms. At the lower loading the maximum power output may be slightly less than normal, but distortion will also be less. On the other hand, at higher loading the power output capabilities may be higher, but with greater distortion. The optimum (or happy medium) value is 7,000 ohms.

LIST OF PARTS

- 1—Mantel cabinet.
- 1—Metal base.
- 1—Power transformer, 325 v. 60 ma.
- 1—Dual-wave coil uit.
- 2—Intermediate frequency transformers.
- 1—Two-gang tuning condenser.
- 2—8 mfd. 525 v. electrolytic condensers.
- 2—25 mfd. 40 v. electrolytic condensers.
- 5—.1 mfd. 400 v. paper tubular condensers.
- 4—.01 mfd. 400 v. paper tubular condensers.
- 3—.0005 mfd. mica condensers.
- 2—.0001 mfd. mica condensers
- 1—250 ohm 1-watt resistor.
- 1—400 ohm bias resistor for 6F6G.
- 1—2500 ohm 1-watt resistor.
- 1—20,000 ohm 1-watt resistor.
- 1—40,000 ohm 1-watt resistor.
- 1—50,000 ohm $\frac{1}{2}$ -watt resistor.
- 1—100,000 ohm $\frac{1}{4}$ -watt resistor.
- 1—250,000 ohm 1-watt resistor.
- 1—500,000 ohm $\frac{1}{4}$ -watt resistor.
- 3—1 megohm $\frac{1}{4}$ -watt resistors.
- 1—1 megohm 1-watt resistor.

- 1—500,000 ohm volume control potentiometer.
- 1—5-in. midget loud speaker.
- 1—set of dial assembly parts consisting of back plate, 8 lugs, 4 eyelets, dial drum, pointer, spacer, pointer screw, spring, cord, spindle, bush, nut, 2 washers and 2 lock washers.
- 1—set of sundries comprising 3 knobs, dial light and holder, 5 octal valve sockets, 2 valve cans, 3 grid clips, 2 yards of power flex, resistor strip, 14 $\frac{1}{4}$ -in. bolts, 6 $\frac{1}{2}$ -in. bolts, 30 nuts, 24 spring washers, 12 solder lugs, 2 feet of bus bar, 3-ft. red hook-up wire, 3-ft. black hook-up wire, 3-ft. green hook-up wire, 1-ft. shielded wire, 3-5/32 screws, 3 5/32 washers, 2 sticks of solder.

Valve Equipment

The following valves are required. They are not normally supplied as part of the kit. One each of types 6A8G or 6J8J, 6U7G or 6K7G, 6B8G and 6G8G, 6F6G or 6V6G and 5Y3G.

Assembly

To start the job of building up the kit, the first thing to do is to mount the power transformers on the base, then the valve sockets, taking care that the centre keyway points in the direction as shown on the picture diagram. The intermediate transformers can be mounted, also the volume control potentiometer. Then start the wiring job by connecting up the heaters of the valve sockets to the 6.3 volt winding, except in the case of the 5Y3 socket, which is connected to the 5 volt winding of the power transformer. Note that the heater terminals of the 5Y3G valve socket are different from the heater terminals of the other valves in one respect. All of this heater wiring should be carried out with twisted wires, although the point is not important. One side of the 6.3 volt winding should be earthed, for preference close to the 6J8G socket. Needless to mention (we hope) neither side of the 5 volt winding can be earthed, as this winding becomes the supply point for the rectified high tension current, and to earth it would be to short-circuit the high tension, a serious mistake.

After the heaters are wired up

the rest of the wiring can be done, bit by bit, with condensers being fitted in as neatly as possible as required. The dual-wave coil unit, gang condenser dial and speaker should not be mounted until after the bulk of the wiring has been completed. When the time comes for the mounting of the coil unit the colour-coded wires should be connected as indicated on the picture diagram, being cut to right length so as to be as short as reasonably possible. Wires for the gang condenser should be taken through to the top of the base, as that will be the next component to be mounted and wired.

Earthing Precautions

An important feature of the wiring job is to make quite certain that all the earthing connections are effective. This is best done by mounting earthing lugs under screws in convenient positions to hold the various components which are to be earthed, but making doubly sure by running a piece of bare wire around to link up all these earthing lugs after the main wiring job has been finished.

The effective earthing of the coil unit is also of great importance. Lengths of braided copper are attached to the unit and these should be cleanly soldered to earthing lugs connected up to the other earthing lugs, as mentioned above. **The earthing of the gang condenser is equally important, and it is not the slightest use depending on the mounting screws for the earthing of this component.** Short direct pieces of wire should connect the proper earth terminals of the gang to the main earthing system of the underneath wiring.

Polarity of Electrolytics

Unlike ordinary condensers, the electrolytics have polarity of the terminals, making it most important to see that due respect is paid to this polarity. The positive terminal is usually marked with a "plus" sign, or coloured red. It should connect to the high tension positive voltage. The other terminal is the negative, marked with a "minus" sign, or colour-coded black and should go to earth or the low potential end of the voltage across which it is fitted. **This matter is of great importance and has been duly indicated on the picture diagram.** Make sure that you pay attention to it.

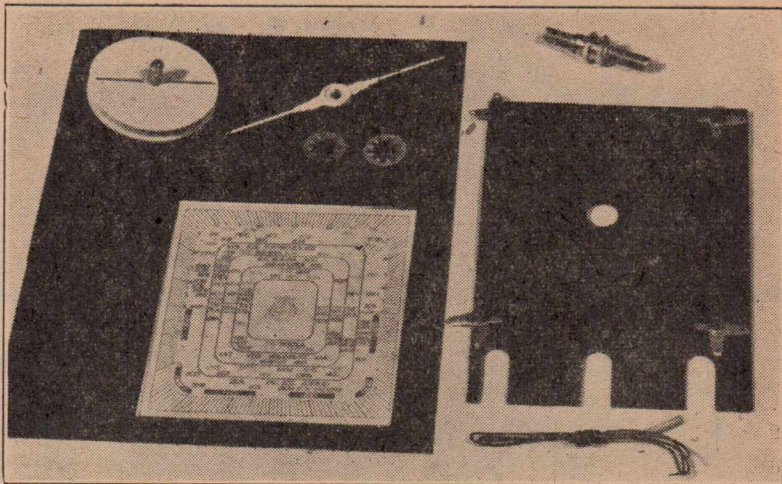

A photograph of the parts for the dial assembly

The Intermediate Transformers

There are two types of intermediate transformer cans, square and round, and you may get either type in your particular kit, according to the way supplies come through from the makers. If you happen to get the square type cans you will find that there is not much room to spare, in fact, in one case the can will come 'down on to the screw head which holds a neighbouring valve socket. A couple of nicks with your angle cutting pliers, or a touch of a round file will make it easy for the can to fit down snugly over the screw head and on to the base.

The Dial Assembly

Unlike most dials supplied for kit-set use, this one is part of the general design of the layout and requires to be assembled step by step as the gang and chassis are assembled. This is not a difficult job and means a much neater dial arrangement in the long run. To make the job quite clear, however, we will list out the steps to be taken. All the bits and pieces for the dial assembly are packed together in the kit, and consist of a back-plate, fitted with the glass retaining lugs and rubber cushions, a dial drum, dial pointer, pointer screw and pointer spacer, a spring and cord, a driving spindle with mounting bush, shakeproof lockwasher and nut and, of course, the dial glass itself.

No part of the dial should be fitted to the chassis until after the gang condenser has been mounted.

Then the dial drum can be fitted to the spindle of the gang. Next the dial spindle and bushing is mounted in the base on the bottom right hand corner. Next the cord is fitted. The cord should be fitted after the manner of a belt, except that it goes twice round the spindle, but only once round the drum. The spring is used to couple up the two ends of the cord, and without the spring extended, the overall length of the cord should be about a quarter of an inch too short. The spring will stretch that amount to allow the cord to be fitted to the drum like a belt. After the belt has been fitted and tested, and the action of the drum is considered satisfactory, the back plate is mounted by loosening the dial and potentiometer mounting nuts and sliding the back plate down behind them. When the back plate is in proper alignment for the hole in the centre of the dial drum, the nuts can be tightened. This should then clamp the back plate firmly to the base. Next fit the spacer and pointer with screw. Then the glass is mounted on the rubber cushions, held in place over it. It will be noticed that a spacing washer is required under the pointer in order to bring it forward to clear the glass. Open the gang condenser fully and then set the pointer to zero before tightening up the screw which holds it in position. Give the dial a trial run to make sure that the pointer is in track with the gang, in other words, that it is at zero when the gang is fully out

(Continued on page 23)

NEW PRICES FOR ROLA SPEAKERS

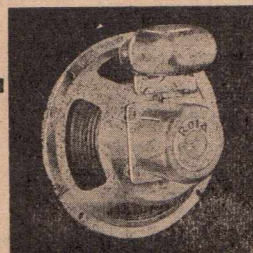

To bring the price of Rola speakers into line with present day costs, Rola has introduced a new price schedule.

In most cases Retail Prices have been reduced—particularly in the case of the permanent magnet models, where increased magnet efficiency makes possible better speakers at lower prices. Watch for future announcements from Rola.

RETAIL PRICE LIST (Including Sales Tax, 12½%) at 21/9/45 and Abridged Specifications

Type No.	Overall Diam.	Voice Coil Diameter	Voice Coil Impedance	Normal Field Excitation	Max. Weight of Field Coil	Price
G12	12-1/8"	1-3/4"	8 ohms	18 watts	3-1/2-lb.	£9/16/1
K12	12-1/8"	1"	2.3 ohms	9 watts	2-lb.	54/11
F12	12-1/8"	1"	2.3 ohms	8 watts	1-1/2-lb.	47/2
K10	9-3/4"	1"	2.3 ohms	9 watts	2-lb.	51/8
F10	9-3/4"	1"	2.3 ohms	8 watts	1-1/2-lb.	44/8
K8	8-1/8"	1"	2.3 ohms	8 watts	1-1/2-lb.	40/8
F8	8-1/8"	3/4"	3.7 ohms	6 watts	3/4 lb.	32/2
F5B	6-3/4"	3/4"	3.7 ohms	6 watts	3/4 lb.	32/9
K5	5"	5/8"	3.7 ohms	3.5 watts	1/4-lb.	27/8
G12PM	12-1/8"	1-3/4"	8 ohms	—	—	£14/6/8
12/42	12-1/8"	1"	2.3 ohms	—	—	86/6
12/20	12-1/8"	1"	2.3 ohms	—	—	53/1
10/42	9-3/4"	1"	2.3 ohms	—	—	80/7
10/40	9-3/4"	1"	2.3 ohms	—	—	51/-
8/42	8-1/8"	1"	2.3 ohms	—	—	75/6
8/20	8-1/8"	1"	2.3 ohms	—	—	49/4
6/12	6-3/4"	3/4"	3.7 ohms	—	—	40/5
5/9	5"	5/8"	3.7 ohms	—	—	32/10
5/9	5"	5/8"	3.7 ohms	—	—	32/10

Further particulars regarding Leads, Transformers, Fields, Plugs, on application.

ROLA

The World's Finest **LOUD SPEAKERS**

ROLA CO (Aust.) PTY. LTD., The Boulevard, Richmond, Victoria — 116 Clarence Street, Sydney

LITTLE COMPANION

(Continued from page 21)

and at maximum when the gang is fully closed. This is important, as the alignment procedure takes it for granted that the pointer is a true indication of the setting of the gang condenser plates.

After you have assembled this dial we fell sure you will agree that it is a great improvement over many of the simple dials, which were popular for mantel models in pre-war days.

Cutting the Spindles

It may be found that the spindles of the dial assembly, the dual-wave bracket and the potentiometer are all of different lengths. It is, therefore, necessary to cut the spindle with a hacksaw, and this should be done before assembly, as otherwise the vibration may not be too good for the chassis assembly. Normally it will be found that the dial spindle will be of the correct length, and the other two will need to be cut to the same length.

In the case of the dual-wave spindle it is necessary to take into account that the bracket does not mount right up to the front of the actual base. The volume control potentiometer mounts between the front of the base and the front of the dual-wave bracket, so make due

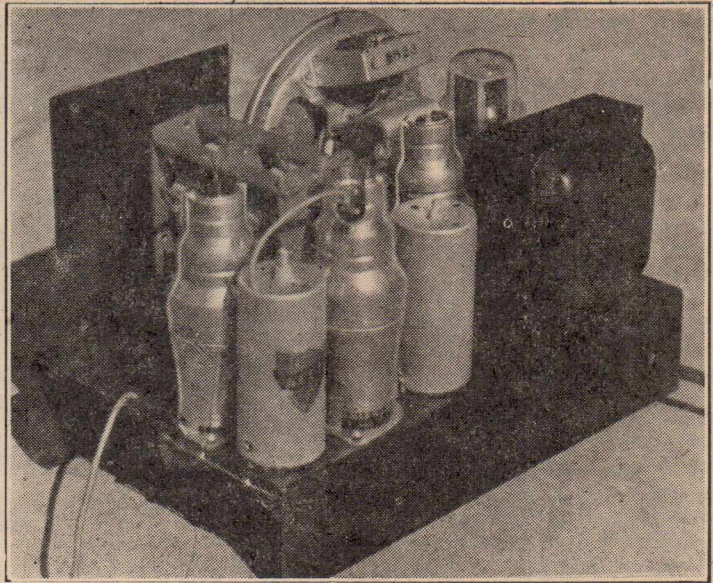

A rear view of the chassis.

allowance for this fact when you cut the dual-wave spindle.

Still another point about this spindle might be mentioned; the switch takes a fair bit of power to turn by the knob, and to avoid the knob slipping it may be advisable to file a flat on the spindle so that the grub screw of the knob can be screwed down on to a flat surface and thereby guarantee a non-slipping grip.

Speaking of filing reminds us to draw your attention to the fact that a few filings can just about ruin a loud speaker if they get into the magnetic field around the pole piece and the voice coil. Once the filings become attracted to the pole piece they are most difficult to remove. **Be careful to keep filings well away from loud speakers!**

Trimmer Colour Code

A rather novel and extremely useful innovation with the Aegis dual-wave coil kit is the colour coding of the trimmers. With most coil units it takes quite a bit of looking around to make sure that you are working on the right trimmers, but when they are colour-coded you can see what you are on in a glance. For the broadcast band the aerial trimmer is yellow, and the oscillator trimmer is red. On the short-wave band the aerial trimmer is green, and the oscillator trimmer is blue.

Aligning the Trimmers

When the assembly of the set is

finished, the chassis should be tested and aligned before it is installed in the cabinet. The first thing is to fit the valves and make sure that the speaker is properly connected. Fit an aerial of twenty or thirty feet length. Plug in to a suitable source of alternating current power and switch on. Keep one eye on the rectifier valve, 5Y3G, and if it lights up brightly, or has a blue or purple glow inside, switch off again quickly as a short circuit of the high tension is indicated. If everything is in order the set should give a quiet hum from the speaker and then, as the valves warm up, it should be possible to tune in a station by swinging the dial.

Now for the adjustment of the trimmers, which is a most important subject if the set is to give its best performance, but don't let it frighten you. Even without a signal generator it is possible to get trimmer adjustment near enough to perfect to give you excellent all-round performance. Don't get flustered, and be sure to feel your way along as you go. Only slight adjustment should be needed and the usual mistake is to adjust (?) the short-wave trimmers when the set is tuned to the broadcast band, or something equally silly. If you do that sort of thing you may get the adjustments right out and the trouble starts. The adjustment should be done in

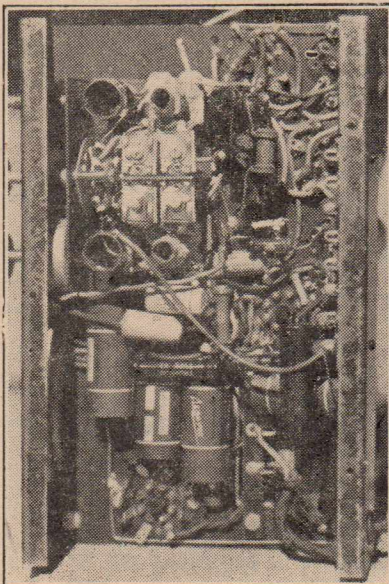

Compare this photograph of the actual wiring with the picture diagram on page 16

(Continued on next page)

LITTLE COMPANION

(Continued from page 23)

a systematic manner, so we will set out the various steps in just such a manner and hope that it will encourage you to do the same.

(1) Switch the set on and switch wave change knob to broadcast position.

(2) Swing the dial until pointer is at 600 kc. Set signal generator to 600 kc. If a signal generator is not available, tune to a powerful station up at this end of the dial, find its correct frequency and set the pointer to this frequency. Adjust iron core of the broadcast oscillator coil to bring signal to maximum, and check by peaking, viz., a fraction of a turn either way should reduce the output signal, which should be kept at a low level by the volume control, as it is then much easier to tell whether the signal is louder or softer. Next peak the iron core in the aerial (broadcast) coil. Go over this again to make sure that dial pointer is on same frequency as signal and that iron core adjustment for both aerial and oscillator broadcast coils are peaked.

(3) Now swing dial pointer to 1400 kc. and signal generator to same frequency. If no signal generator is available, tune to a station of known frequency and set pointer at that frequency. Do not touch the adjustment of the iron cores. Work only on the colour-coded trimmers. Adjust broadcast oscillator trimmer for maximum sig-

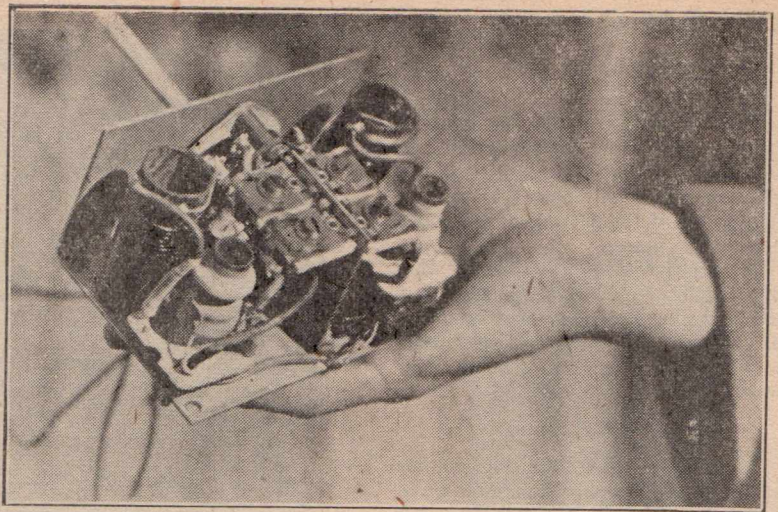

Heart of the set is this dual-wave coil assembly which comes to you completely wired and color-coded.

nal output. This is the trimmer colour-coded red. Then adjust the aerial trimmer (yellow) for maximum signal, making quite certain that you get a definite peak on both adjustments.

(4) Repeat operation number 2, working on the iron cores at the 600 kc end of the dial. Then repeat operation number 3, working on the trimmers at the 1400 kc. end of the dial.

(5) Switch to the short-wave band by operating dual-wave switch knob.

(6) Set dial pointer to 40 metre end of band by tuning dial. Get signal of this frequency from signal generator, or station of known frequency. Adjust iron core in aerial short-wave coil in the same way.

(7) Swing dial pointer to 16 metre band. Set signal generator to same frequency as pointer. Adjust short-wave oscillator trimmer, coloured blue, to give peak. Then adjust short-wave aerial trimmer, coloured green, for maximum output.

(8) Repeat operations 6 and 7.

In practice you may find the short-wave band a little hard to adjust without the aid of a signal generator, but don't let that worry you. Get the set operating to perfection on the broadcast band and then wait your chance to get a strong short-wave station on which to work. Remember that if it is up at the 40 metre end of the dial, you should bring the pointer to the right wave-length setting by means of the iron core in the oscillator coil, then lining up the iron core in the aerial coil to match. If, on the other hand,

the station is down on the 16 or 19 metre band, you should work on the trimmers only, adjusting the oscillator first and then bringing the aerial trimmer into line.

The Cabinets

The cabinet which is supplied as part of the kit is a well-built job of timber construction, covered with a leatheroid cloth. This surface wears well, and does not scratch readily. The acoustic properties of the wooden cabinet are also excellent.

The standard colour of the cabinet is a dark brown, but those who are particularly keen for a blue or a cream to match up with special colour schemes may be able to get the special colour by so ordering.

— Good Luck —

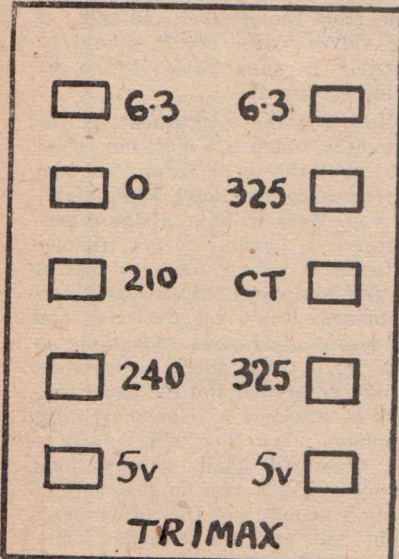

Transformer terminal board arrangement for Trimax power transformer.

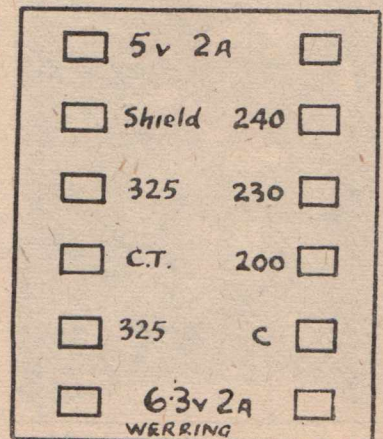

The terminal lay-out for the Werring power transformer supplied with some kits.

VIC. AMP. CONTEST

(Continued from page 13)

for the high note channel. The bass channel fed a Jensen A12 and the high note channel fed a Rola 8-inch per-mag. Added to the set up was a conventional 6L7, 6C5, 6H6 R.C.A. volume expansion circuit.

This outfit was entered by L. Wilkins, who was a competitor in last year's event, and who, incidentally, reached Grade 1 final, but unfortunately, struck trouble with a bias resistor breaking off in the high note channel.

In all fairness to these two competitors it must be said that all three amplifiers were heard a short time before the competition, and at that time were all of exceptional quality; in fact, quite equal of giving winning form reproduction. What happened in the interim is problematical, but when playing off the three amplifiers gave very mediocre results, with, possibly, No. 5 taking the honours of the night. In both cathode-coupled jobs the range seemed to be restricted at both ends, and consisted of middle

frequencies most prominent. Since both amplifiers were of sound design, and the speaker, Jensen M20, left little to be desired, the trouble seems to point to the moving coil pick-up, or its associated network.

The dual-channel job was the biggest surprise of any. Having heard this outfit previous to the competition, an opinion was formed that here was a definite contender for the title. To be perfectly candid, it

was faultless, but alas, when the important time came distortion killed the competitor's chances.

Possibly Mr. Wilkins set his expansion time delay wrongly.

Amplifier No. 11 used a pair of 6L6 beam power valves.

Apparently this competitor, R. Henderson, struck trouble, either a component or a tube breaking down, as the distortion was bad. For such things to happen is heart-breaking, to say the least.

SETS IN THE U.S.

As a result of a survey of American broadcast receiver manufacturers it is predicted that the industry will require only 83 days after Government restrictions are removed before it starts civilian production. Some five million receivers are expected to come off the production lines in the first six months, and a further eight million in the second.

The Judge's Verdict

When the judges announced the names of the finalists, it was revealed that four had been chosen, instead of three as originally intended. The four finalists are to be Mr. Stevens (No. 10), Mr. McLean (No. 19), Mr. Hutchinson (No. 9) and Mr. Mutton (No. 13).

A most significant feature of the results to this stage is the way that direct-coupled amplifiers have shown brilliant performance with three out of the four finalists using direct-coupling.

POPULAR BOOKS

FOR THE HOME LIBRARY

	Price	Ptge		Price	Ptge
Henry: 5000 Quotations for All Occasions	7/6	9d.	Wilkinson: The Encyclopaedia of Fruits, Berries and Nuts	7/6	9d.
Spaeth: The Art of Enjoying Music	8/6	9d.	Copeland: Popular Quotations for All Uses	8/6	9d.
Kaufmann: The Home Book of Music Appreciation	7/6	9d.	Fielding: Strange Customs of Courtship & Marriage	7/6	9d.
Moulton: 2500 Jokes for All Occasions	7/6	9d.	Peppard: Sight Without Glasses (Restoring Perfect Vision through Exercises)	8/6	9d.
Meier: The Joke Teller's Joke Book	7/6	9d.	Devlin: Dictionary of Synonyms and Antonyms	7/6	9d.
Nizer: Thinking on Your Feet (Adventures in Public Speaking)	8/6	9d.	Hayward: English Period Furniture	13/-	9d.
Robinson: The Story of Medicine from the Stone Age to Modern Times	7/6	9d.	Dees: The Fundamentals of Physics and Their Application on Modern Life	7/6	9d.
Collins: Working with Tools for Fun and Profit	7/6	9d.	Reither: World History at a Glance	7/6	9d.
Pomeranz: Your Respiratory System	7/6	9d.	Wood: Complete Rhyming Dictionary	17/6	1/3
Kohn: Your Digestive System	7/6	9d.	Ewen: Music for the Millions	38/6	1/6
Newcomb: Astronomy for Everybody	7/6	9d.	McDonald: The New Modern Encyclopaedia	31/6	1/-
O'Hare: Handbook for Home Mechanics	7/6	9d.	Evans: Home Hobbies in Wood	5/3	6d.
Brewster: This Puzzling Planet (An Introduction to Geology)	7/6	9d.	Funk & Wagnall: Practical Standard Dictionary (Spells and Pronounces and Defines 140,000 Words, 1309 pages)	50/-	2/-
Dietz: The Story of Science	7/6	9d.	Wier: Thesaurus of the Arts	42/-	1/3
Borth: Modern Chemists and Their Work	7/6	9d.			

STANDARD TECHNICAL BOOKS

Dykes: Automobile Encyclopaedia, 20th Edition	50/-	1/9	Simonds & Ellis: Handbook of Plastics	85/-	1/6
Audel's: Refrigeration & Air Conditioning Manual	26/-	1/-	Bennett: Formulae for Profit	10/-	9d.
Alford: Cost and Production Handbook	60/-	1/-	Coyne: Electrical & Radio Reference Encyclopaedia (Three Volumes)	Set 117/6	3/-
A.R.R.L.: The Radio Amateur's Handbook, 1945	11/6	10d.	Kempe: Engineers' Year Book, 1945 (A Complete Reference Book for all Engineers, 2855 Pages)	82/6	1/6
Ghirardi: Radio Physics Course	40/-	1/3			
Motor's: Auto Repair Manual (covers maintenance of all American cars, 1935-42)	65/9	1/9			
Hawkesworth: Australian Sheep and Wool	25/-	1/-			

Foremost in Australia for Technical Books

TECHNICAL BOOK & MAGAZINE CO.

297-299 SWANSTON STREET (opp. Old Melbourne Hospital)
MELBOURNE, C.1. — Phone Cent. 2041

TELEVISION ON RENTAL BASIS

Our American contemporary, "Radiocraft," says that the British policy of television set rentals before the war had succeeded in abundantly proving that television audiences could be built up to very large dimensions quickly, much faster, in fact, than would be possible by the time honoured outright sale methods. Dr. Lee Forest has suggested a modified form of our television set rental plan. He thinks that in America it would be sensible on the part of the manufacturers of television receivers to be willing to assume their share of the cost of building up a television audience.

If their television receivers were made available on say, a graduated rental basis, signed up for an initial quarterly period plus a reasonable installation fee, there would be a hundred customers for everyone able to purchase outright. This plan does not, of course, entail a very heavy cash investment on the part of the

set manufacturer. His hope will be that in the near future his audience will attain such dimensions that the advertiser will finance the costly night programmes.

STEREO AMP.

(Concluded from page 9)

or more. The same policy is adopted for piano concertos. The orchestral spread is still maintained, but the piano tends to take the whole stage, as it were.

The stereophonic illusion was found to be particularly effective in the reproduction of Haydn's Trumpet Concerto. The trumpet, coming from the middle speaker, seemed to stand out from the middle of the orchestra. Such tremendous works as Bruckner's 7th Symphony can be reproduced at the correct

volume-level without the concentrated blast effect which is experienced when a single speaker-position is operated at high volume. The grand organ is reproduced in all its grandeur, occupying the full width of the hall; likewise, choral works are very effectively reproduced.

The possibilities of this amplifier for sound effects in dramatic works have not been overlooked, although as yet, no such use has been made of it. It would be an easy matter to couple the output of a microphone pre-amplifier to the grid of the 6J7G of the M.H.F. channel. Music could then be played through the H.F. and L.F. channels with voice or other sound effects through the middle channel. Mixing could thus be carried out in the amplifier itself.

Those who have handled this amplifier feel that its extreme flexibility of control satisfies the artistic desire of music lovers to get from a gramophone music which can be made personally satisfying. This really amounts to "judicious distortion" in preference to high fidelity.

A AUSTRALIA'S
B BEST
A MPLIFIER
C OMPONENTS

- ★ Audio transformers on either silicon steel or nickel alloy cores for all applications.
- ★ Power transformers.
- ★ Filter chokes.
- ★ Metal loud speaker flares.
- ★ Adjustable microphone stands.
- ★ High quality communications-type volume controls.
- ★ Sheet metal cabinets and boxes.
- ★ Receiver and amplifier chassis and dust covers.

Manufactured by **TRIMAX TRANSFORMERS**

29-35 FLEMINGTON ROAD,
NTH. MELBOURNE, VIC.
(Division of Cliff & Bunting
Pty. Ltd.)

We are now able to speed arrangements for meeting civilian requirements, but naturally reconversion and retooling mean that, temporarily, there may be delay in supplying your full needs.

CALLING CQ!

By DON KNOCK

MANY moons have waxed and waned since this scribe last put pen to paper to yarn over Ham doings, and to do so again is vastly refreshing. With war clouds rapidly receding over the horizon (we hope), the effect is almost like awakening from an unpleasant dream. To the VK transmitting amateur, the feeling is one of a tonic, with uppermost thoughts of, "Although the ban is still ON, it can't be too long before it is OFF; or, in other words, 'What have we been fighting for?'"

Believe it or not, but most of the VK's I met up with on active service seemed to be imbued with a laudable idea that they were mixed up in the war with the set purpose of getting back on the air. There is much to talk about, and as the gang return from scattering to the four winds, many and varied will be reminiscences; stories of amateur ingenuity and "guts" in tight corners, as yet untold. Some stories have been told, but only with as much freedom as the censorship allowed.

Wartime Accomplishments

There was the one, for example, about the guerilla force, born of an A.I.F. unit marooned early in the Jap war in Timor. Contact with Australia was effected and certain measures taken solely because a VK amateur, a Tasmanian, VK7ML, was a member of the Army Signals Unit concerned, and did what a true blue "Ham" would do. He "scrounged" bits and pieces of gear from native and Nip sources — got on the air by sheer cussedness — and got word to Darwin and thence to G.H.Q. Decorations were handed out later — after the guerillas got back to Australia — but the story is one that might have been very different but for amateur radio.

It is just one of thousands of reasons why amateur radiomen should be given the right to continue their pre-war activities — without

interminable governmental procrastination, or "ifs" and "buts."

There is no democratic ideal more correctly expressive of man's right to freedom of speech and communion with one's fellowman than the scientific hobby of Amateur Radio.

The part played by Australian Radio Amateurs in the recent great unpleasantness has been no less important than that of their fraternity in U.S.A., Great Britain or other of the Allied Nations. The man in the street, for example, couldn't be aware that in the early days of the Nazi onslaught, R.A.A.F. communications would have been in a pickle but for a pool of wireless reservists comprised of VK's who had taken part for a few years in a special reserve as part of the R.A.A.F.

Chiefly at week-ends, these lads used their own ham stations on service frequencies and with service call signs, under direction of a control station. Traffic was handled in volume — with service procedure taking the place of the usual Ham jargon. Result was that when September 3, 1939 broke on a shocked democracy — these VK's went — mostly as aircraftsmen W/T operators — straight to important jobs at air stations. Credit is due to men

AMATEUR LICENCES IN ENGLAND

As a result of discussions between the Radio Society of Great Britain and the General Post Office, arrangements have been completed whereby applications can now be made for the re-issue of full transmitting licences to those who held them before the war.

It must not be inferred from this that licences are to be re-issued immediately. The purpose of these arrangements is to assist the G.P.O.

by giving the department concerned as much time as possible for the work involved.

like VK3ML and 3UK for prewar organisation of R.A.A.F.W.R.

Many lads who started off as A.C.I.'s came through this war as anything from Wing Commander to Warrant Officer.

As the war gathered in intensity and the call for men became vital, technical recruitment officers of R.A.N. and A.M.F. were not slow to divert Hams and those with the makings of Sig. Operators into the right channels. Your scribe, having been concerned with Army Sigs in a prewar Militia capacity, was early into camp in those 1939 days — days when war, even then remote, and training still had somewhat of a 1914 outlook. There were snags — the non-interested outlook of old "cable-bred" senior officers who simply could not see that radio was destined for an important part in a modern war. Field radio installations were not of so much importance to these gentlemen as field telephones, helijos, signalling lamps and flags. All systems had their uses, but it was inevitable that radio should, before two or three war years had progressed, assume gigantic importance in the scheme of service communications. RADAR, that 'black magic' word which was almost treasonable to refer to, stands for what? "Radio Detection and Ranging" — and as such it is a specialised form of communication — by reflection back to the source of transmission. Hams played an important part in Radar, and there should be some interesting yarns to tell about that branch of the Services.

In those early training days around N.S.W. Army Camps, particularly useful was the presence of an odd Ham or two among the raw material — the "U.S.P.'s" (Univer-

(Continued on next page)

HAM NOTES

(Continued)

sal Service Personnel). (Conscription was never a popular word with Australians — hence the description "U.S.P.").

One Ham among a group of would-be signalmen meant some of the load off the shoulders of the harassed section leader and the morse classes would improve more rapidly from a "send with the left foot" status to the stage where reasonably good traffic could be handled.

Of the A.W.A.S. — at a later stage in the war — I can write a book alone.

Experience has proved that the

male operator has nothing on the feminine, and lots of lasses tell of their intention of keeping up their key punching as Hams "after the war."

Looks as if our VK's will include a goodly number of W.R.A.N.S., A.W.A.S. and W.A.A.A.F's.

Increase in VK's Predicted

At least — radio club meetings will of necessity, be conducted with more decorum than formerly — or will they? I remember the awed hush that descended upon a N.S.W. W.I.A. meeting around the 1930's when in came, and sat down, a glamorous blonde young lady. She turned out to be a VK6 — and the "young squirts" were buzzing around like

STOP PRESS!

Ugly rumours persist that VK's are not to get back their 80, 40 and 20 metre bands. It seems that certain gold-braided people say, "These frequencies are needed for service channels."

bees — after general business had subsided.

What of the numbers of VK's to come?

Prior to September, 1939, the total of VK's, was, according to P.M.G. lists, around the 2,000 mark, which for a population of 7 million wasn't bad. Britain, with 45 million had but 3,000 licensed G's.

Of the 2,000 VK's, it was safe to assume that 60 per cent were active, the rest being dormant. Many old timers continued to hold licences, but took no active part on the air. Estimates by the W.I.A. place the probable figure for VK licences in two or three years as around 8,000. That, I think, is quite conservative, as the great influx of ex-service ops to amateur ranks, male and female, young and old, will become a flood as time progresses. Much depends on treatment of the VK licencing authorities. If the experimental licence is hedged around with unnecessary obstacles and restrictions the effect will be deterring instead of encouraging.

The radio trade has every reason to support the amateur transmitter, for the larger the number of VK's, the more the components and equipment that will be needed. That's logical, and a matter of goodwill as well as business. My guess is that the ill-informed manufacturer who dismisses amateur radio with a sneer will regret the day.

That's about enough for this issue OM's — and YL's — and in conclusion I give you a true story. It happened when I was a harassed wireless instructor at a prominent A.I.F. Sig. School. A theory paper in an exam included a question, "Explain briefly the electronic action of a triode valve." One student wrote that "the valve, originally a diode, was filled with electrons in a state of great disorder, and the grid was put there to restore order." As Harry Tate said, "My word — he's right!"

—DON.

GOOD WORK BY THE W.I.A.

MUCH credit is due to those officers of the Wireless Institute of Australia in New South Wales and Victoria, who kept the flag of Amateur Radio in Australia fluttering through the war years. Not everybody could get into uniform. With spare time at a premium and after long hours in industry the idea of almost empty club rooms and a scientific hobby under a gag must have been doubly depressing. But there were bright moments when unexpected visitors rolled up at meetings. N.S.W. and Victoria kept up monthly meetings throughout, and in N.S.W. formation of the State Emergency Network (on 28 Mc/s) gave added interest and plenty of administrative work. This, modelled upon W.E.R.S. in U.S.A., differed in the frequency used and this scribe feels that it is unfortunate that 112-116 Mc/s was not granted as in U.S.A. Nobody is likely to suggest at this stage of the game that VHF channels are not the answer to "short-haul traffic"?

A remarkable fact about W.I.A. meetings — and experiences of VK's whose names and residential addresses figured prominently in overseas mags for proffered hospitality, is that so few Americans "dropped in." When one considers the U.S. "invasion" in 1942-44, it seems ridiculous that so few made personal contact with their "DX." The same applies to British Hams. Only a handful have made personal QSO's.

What with the U.S. Signal Corps, Air Corps, U.S. Navy, Marines, R.N., Fleet Air Arm, R.A.F., and others, there must have been plenty of Hams milling around. I met a few personally — one an old 14 Mc/s DX QSO, W3DOT, but after reading several letters in "QST" from W's who refer to "when they were in Australia," I can't help thinking that most of them must have been at Luna or Hyde Parks, or perhaps they had so much radio that even the Ham variety was anathema for the nonce! Time will tell.

One "W" I met didn't appear to get on with the Digger and threatened to "give us the Razz" by 20 metre phone when he gets on back home.

Where are They Now?

One thing that endures in my curious brain is where, when and what has happened to the lashings of communication receivers and countless bits and pieces our U.S. friends were surrounded with?

Military duties once took me to a vast U.S. Signal Corps Store and the very thought of the amount of gear stacked in those sheds is still breathtaking. Everything from "Handy Talkies" to 5-kW outfits and receivers of all kinds by the mile. Miniature "toobs" were cartoned in hundreds of thousands — in all types. It was, in fact, QST's advertisements come to life, or "Alice in Wonderland."

HAM GEAR RETURNED

When, in 1939, war on a vast scale came once again to an apprehensive world, the Ham was among sections of the community who felt the direct impact in quick time. On September 2, 1939, a fateful red telegram from the P.M.G. told this story: "The following conditions have been imposed in relation to your experimental licence issued under the Wireless Telegraphy Act and regulations. The operation of radio transmitter authorised under experimental licence must cease immediately and valves, transformers, tuning coils, operating keys, and microphones must be dismantled from equipment. Please communicate by first post to Senior Radio Inspector in your State that these instructions have been complied with."

There it was: the big sign off for all VK's!

As the war progressed and events became grim and serious the P.M.G. took further action; action which may have been necessary or not, but which certainly gave the P.M.G. officials a deal of harassing work.

Into Storage!

All Australian transmitting amateurs were directed to pack their gear in containers and to have them open for inspection and then sealing by officers of the P.M.G.'s Wireless Branch. It must have been a motley collection, junk and otherwise, that went into those boxes, and undoubtedly it would have been fantastic to even consider as usable transmitting gear some of the bits and pieces that many of the gang laid reverently to rest in the sealed boxes. The boxes did not rest for long, however, for in quick time the lot were collected by P.M.G. vehicles (B.P. and R.R.—Before petrol and rubber rationing) and whisked away to some mysterious hide-out!

Thus it was, and meanwhile VK Hams went to war, and did a splendid job.

All wars inevitably end, despite the efforts of some who would prolong them, and like its predecessors, the late but not lamented World War II crashed to an ostensible close. The Hams, VK's among them, are on the way back and with them will come large numbers of fledgling

Hams, those who met up with the fascination of radio in the Services, and who now intend to be on the air with the rest of the gang. At the hub of Ham affairs, a group of W.I.A. men have meanwhile been facing up to the future for the VK, by drawing up, at the request of the P.M.G., a set of proposals for post-war operation. These proposals are a fair cross-section of opinion of all W.I.A. State Divisions and were not drawn up overnight. Close co-operation with the W.I.A. Federal Executive and Chief Radio Inspector resulted in action and the setting in motion of the machinery to put Australian Radio Amateurs back on the air. First direct result is the release of the sealed boxes which have been held in custody, and the information from W.I.A. Federal Headquarters that transmissions are to be resumed as soon as the new Regulations governing licensing and operation of amateur stations are gazetted. As this was written (October 16) the Regulations were in process of being drawn up. Expectations are that VK's will be on the air again by the time you are reading this in print. Meanwhile, it is understood that the future of the DX frequencies lies very much in the hands of a committee of Service Communications Officers, who have been conferring on propagation matters. If the Australian amateur receives the recog-



Don B. Knock

inition and justice due to him for his services in wartime, his DX frequency channels will be at least as they were in September, 1939, and not chopped to pieces, as rumour has it. The decision depends whether or not the Service Officers on such a committee are Hams themselves, and can appreciate the need for generous treatment of "80," "40," and "20."

A RUN OVER THE DIAL

By the time these words hit print, the ban on amateur transmission in many allied countries, including Australia, may be off. Brief rumours are not the only things that are flying around, my Brethren. Recently—a few spare moments in my shack have been put in by running over the dial of my latest acquisition, a Philips' type R163 Communication Receiver. The other afternoon, idly speculating on our 14 Mc/s band, I was startled to life to log a nice T9 CC sig fading up to R7 and calling "CQ, CQ, CQ, DX de VK3 —."

Hurriedly reaching for the phone book to ring the R.I. to ask why

didn't he tell me the ban was off, I recovered in time to reach for the pre-war list of VK's instead. Brother there "weren't no sich animal" as that VK3 I heard. He picked himself a buckshee call sign. Anyway, I didn't hear DX answer him, although I'll swear that the First Aust. Army Station near his frequency looked askance at him! That's the only effort I've heard, signing a VK call, but a few nights later an obviously DX T8 sign was heard calling "CQ DX de W9YZL" and, what's more, he got another W9, the complete call of which was unidentified owing to QRM from a

(Continued on page 34)

Shortwave Review

CONDUCTED BY

L. J. KEAST

NOTES FROM MY DIARY—

11 METRE BAND

In the October issue, page 34, I expressed doubt, as did Dr. Gaden also, of hearing the BBC on 26.10 mc at 11 o'clock at night. I was fortified in this thought as the BBC schedule in front of me does not suggest that the transmission from 9.15—11.45 is on a beam favourable to Australia.

But it has been heard and I have a letter from Ted Fluck of Flinders Park, Adelaide, stating he hears them at fair strength around 10.30 on some nights.

Well, that is good news and doubtless the BBC engineers will record it, if not with surprise, great interest.

"Voice of America" Broadcasts from San Francisco

Beginning November 1, at 0900 Greenwich Meridian Time (Sydney 7 p.m.) the "Voice of America" broadcasts will be heard daily between the hours of 0900 and 1600 GMT and between 2100 and 0300 GMT.

News in English will be broadcast on the hour during these transmission periods. Between the hours of 0900 and 1600 GMT transmissions will be on 6.12; 7.23; 7.25; 7.56; 7.57; 7.80; 9.70 and 9.75 megacycles. (Sydney 7 p.m.—2 a.m.). Between the hours of 2100 and 0300 GMT transmissions will be on 15.15; 15.21; 15.27 and 17.80 megacycles. (Sydney 7 a.m.—1 p.m.)

SAYS WHO?

Arthur Cushen advises "that an airmail from the BBC states GWD has been withdrawn, also frequency 15.42 mc so that GWD hasn't a frequency as yet."

The AFR Network, Tokyo, very good. News dictation speed 10 a.m.; only frequencies ever heard mentioned by Tokyo are: 7.552.5 and 9605 kcs. Multiply 7.552.5 by 2 and we get very nearly this spot, 15105 kcs—harmonic or coincidence? If the latter why not mention it? Certainly mighty good for an harmonic.—Gaden.

"I have received a verification in form of a letter from the New Zealand Post and Telegraph Department for a report I sent them on reception of ZLT on 44.67, etc. at 4.30 p.m., September 5."—R. Currow.

Reception reports for JCKW, Jerusalem, 7.22 mc, 41.55 m. are to be sent to AW 5, G.H.Q., Middle East Forces.

"Have had two cheerios over the air from PCJ, Hilversum. One I heard, the other was referred to me."—Gillett.

"The BBC 11 metre transmitter for South Africa has NOT been heard. Reports asked for on this transmitter. Maybe in order as a full daylight 'mitter for Sth Africa, but I do not expect to hear it here at night. Pre-war when Rome was testing with a 13 metre in after-

noons, reception was very good, so would like to try what Daventry could do with one of their 13s or an 11 metre by day. Yank 11s were always best in a.m. round about 11 a.m."—Gaden.

Arthur Cushen writes, "You asked for some more details re XEOX, Ciudad Obregon, Son., Mexico. It is heard here, till 3 p.m., good signal, poor modulation, blots out KCBF and TGWA at times. Heard on 9.755 mc."

HELP WANTED

Mr. Edel is hearing a station on approximately 7.264 mc, 41.30 m, that signs off in English at 11.30 pm with "The Voice of . . . , Good night, pleasant dreams." He thinks this is probably Hanoi, as that is an expression associated with that station.

Here is a puzzler mentioned by Dr. Gaden: VU-2ZZ on approx. 14.88 mc, 20.16 m., around 7.30 p.m. Very nice music. Hear the words Indo-China and Hanoi frequently mentioned. (This may be an Indian amateur as the prefix, VU suggests India.—L.J.K.)

And this is carried over from October issue:

Arthur Cushen has struck a snag. He wants to know who the stranger is on 9.52 mc at 3.45 p.m. They use a 12 note chime and he thinks it may be SBU or OZF. He had occasion to leave his set and on returning at 4.15 heard the BBC with . . . —. Has Wally Young any suggestions?

ULTIMATE

Champion Radio

Sole Australian Concessionaires:

GEORGE BROWN & CO. PTY. LTD.
267 Clarence Street, Sydney

Victorian Distributors: J. H. MAGRATH PTY. LTD., 208 Little Lonsdale Street
Melbourne

As the Ultimate factory is engaged in vital war production, the supply of Ultimate commercial receivers cannot be maintained at present.

SERVICE: Ultimate owners are assured of continuity of service. Our laboratory is situated at 267 Clarence Street, Sydney. Servicing of all brands of radio sets amplifiers, as well as Rola Speakers is also undertaken at our laboratories.

The MONTH'S LOGGINGS

OCEANIA

Australia

VLG-6, Melbourne, 15.23 mc, 19.69m: From noon till 2 p.m. is faultless — can hold its own with VLG-4 and VLA-6 (Gaden).

Guam

KU5Q, 17.83 mc, 16.83 m: O.K. at 8.30 a.m. (Young).

KU5Q, 15.60 mc, 19.23 m: Good around 8.30 a.m. (Young).

KU5Q, 13.39 mc, 22.40 m: Fairly good at 9 a.m. and good at 3.30 p.m. (Young).

Java

Radio Bandoeng, see "New Stations."

New Zealand

ZLT-7, Wellington, 6.715 mc, 44.67 m: Good at 7.30 p.m. (Young).

AFRICA

Belgian Congo

AFHQ, Algiers, 11.76 mc, 25.50 m: Usual "V. of A." programmes. Well received at 11 p.m. (Cushen).

RNB, Leopoldville, 17.775 mc, 16.88m: Good at 9.30 p.m. (Young).

French Equatorial Africa

FZI, Brazzaville, 11.97 mc, 25.06 m: This station is lovely in the afternoon. The only transmitter from here that I like (Gaden). (Me, too; afternoon programme is excellent.—L.J.K.)

Gold Coast

ZOY, Accra, 7.295 mc, 41.13 m: Heard this one with fair signal, closing at 4 a.m. with "God Save the King." English prior to closing (Gillett).

Mozambique

CR7BE, Lourenco Marques, 9.703 mc, 30.91 m: Very good at 5.15 a.m. (Young).

Senegal

Radio Dakar, 15.83 mc, 18.95 m: Heard on phone at 11 p.m. (Fluck). (This is a new frequency for Dakar, I think—L.J.K.)

THE EAST

Burma

Radio Rangoon, 11.855 mc, 25.31 m: Heard from 12.30—1 a.m. (Gillett).

China

XMEW, Kunming, 16.54 mc, 18.14 m: Good at 10.30 a.m. and 5 p.m. (Young). Splendid signal at 10 p.m. (Gaden).

XGOY, Chungking, 11.92 mc, 25.17 m: News in English at 8 p.m. (Gillett).

XGOO, Shanghai, 11.695 mc, 25.65 m: Logged at 11.15 p.m. calling KES-2 (Gillett).

XGOY, Chungking, 9.805 mc, 30.58 m: Good at 10 p.m.—L.J.K.

ZBW, Hongkong, 9.505 mc, 31.57 m: Good enough at night, but far behind Singapore (Gaden).

XGAP, Peiping, 6.10 mc, 49.18m: News in English at midnight—weak station (Gillett).

French Indo-China

Radio Saigon, 11.78 mc, 25.47 m: Very good at 8.15 p.m., news at 8.30 — L.J.K.

Radio Saigon, 4.81 mc, 62.37 m: Very fine here now, same programme as 11.78 mc (Cushen). Loud at 8 p.m. but noisy (Gaden).

India

Radio SEAC, Colombo, 3.395 mc, 88.36 m: The Forces Broadcasting Station is heard at poor strength at midnight; received better on 11.765 mc at this time (Cushen).

Japan

JLS-2, Tokyo, 17.85 mc, 16.81: Heard

at 8.30 a.m. calling KKL and also heard at 3 p.m. (Young).

JZK, Tokyo, 15.16 mc, 19.79 m: Heard at 8.30 a.m. (Young).

JLS, Tokyo, 9.65 mc, 31.06 m.: Hard calling Los Angeles at 10.30 p.m. and sometimes earlier (Cushen).

AFRN, Tokyo, 9.605 mc, 31.22 m: Schedule announced as 8.30 a.m.—midnight. News broadcasts at 7 and 10 p.m. (Cushen). Have only heard from 6 p.m.; tried once at 1.30 p.m., bad whistle —think HP-5J, Panama, was fighting it out with them (Gaden).

Radio Tokyo, 9.305 mc, 32.25m: Heard with correspondent's reports to RCA at 11.15 p.m. (Gillett).

AFRN, Tokyo, 7.552.5 mc, 39.72 m: Very loud; pity morse interference at time (Gaden).

Portuguese China

Radio Macao, 7.525 mc, 39.85 m: Heard well at 8 p.m. (Young). English news concludes at 10.50 p.m. (Edel).

Malaya

Radio Singapore, 15.34 mc, 19.56 m: This is the announced wave-length (Gaden).

Radio Singapore, 11.86 mc, 25.29 m: Very fine at 8 p.m. and even better later (Gaden).

Radio Singapore, 9.555 mc, 31.40 m.: Can be excellent at night. Too much Asiatic (Gaden).

Radio Singapore, 7.22 mc, 41.55 m: Has improved considerably after 8.30 p.m. (Gaden).

Netherlands Indies

Java

Radio Indonesia (?) Bandoeng or Djokjakarta, 18.135 mc, 16.54 m: Using old w/l of Djak. and as of old say 16.6 m. Only heard at night from 9.30—noisy. (Gaden).

Radio Indonesia, 12.27 mc, 24.45 m: In parallel with above and better signal (Gaden).

GREAT BRITAIN

B.B.C. London

Note: Pacific Service as from October 7: 4—8 p.m.

GSK, 26.10 mc, 11.49 m: Heard with fair signal around 10.30 p.m. (Fluck).

GVR, 21.675 mc, 13.84 m: Opens at 9 p.m. for the Eastern Service (Fluck).

GSJ, 21.53 mc, 13.93 m: Opens at 7 p.m. —fair signal (Gaden, Fluck). Schedule 7—11.45 p.m.—L.J.K.

GSH, 21.47 mc, 13.97m: Puts in a really fine signal from 8 p.m. (Gaden). Good here, too.—L.J.K.

GSV, 17.81 mc, 16.84m: Tremendous signal at night; as good as the best 19 m. (Gaden).

GSI, 15.26 mc, 19.66 m: Quite good in

BRAND NEW COMMUNICATION RECEIVERS

Small number in original Tropic-proof carton and case.

Philips Type R 163

Continuous coverage
0.55 to 22 mc.

Direct Reading Calibration
Operates from A.C. voltages 110, 220, 240 and 260 volts

Ideal for Radio "Ham"

Manufacturer's Fixed Price
£65, including Sales Tax
Concessionaire:

L. J. KEAST,

23 Honiton Ave. W
Carlingford

'Phone: Epping 2511

afternoons (Gaden). (Sked.: 4.30—8 p.m. in Empire Service.—L.J.K.)

A.F.N., 8.565 mc, 35.02 m: Armed Forces Network 6 p.m.—2.45 a.m. (Cushen).

A.F.N., 6.08 mc, 49.34 m: 2.30—10.15 1.55—5.45 p.m. (Cushen).

GSW, 7.23 mc, 41.49 m: Excellent signal with news at 5 p.m. News at dictation speed at 6.05 — L.J.K.

CENTRAL AMERICA

Costa Rica

TIPG, San Jose, 9.617 mc, 31.20 m: Heard well at 10 p.m. (Cushen).

Panama

HP5G, Panama City, 11.78 mc, 25.47 m: Fairly good signal with music and Spanish about 7.15 a.m. (Gillett).

HP5A, Panama City, 11.695 mc, 25.65 m: Fair at 7.15 a.m. (Gillett).

U.S.A.

'Frisco unless otherwise mentioned
KNBA, 17.78 mc, 16.87 m: My favourite on the 16 m band (Gaden).

KRHO, Honolulu 17.8 mc, 16.85 m: When closing at 2.30 p.m. announces "Will take the air again at 7 p.m. on 6.12 mc, 49.02 m."—L.J.K.

KNBI, 13.05 mc, 22.97m: Gives call as KNBI when opening at 3 p.m.—L.J.K.

KNBA, 11.79 mc, 25.44 m: Heard at 4 p.m. (Gaden). Sked. is: 3—4.45 p.m.; and 5—6.45 p.m.—L.J.K.

KCBF, 9.75 mc, 30.77 m: Very good signal at night (Byard).

KNBI, 9.49 mc, 31.61 m.: At night 100 per cent everything (Gaden).

KCBA, 7.57 mc, 39.6 m: Very good signal at night (Byard).

U.S.A.

Other than 'Frisco

WCBN, New York, 17.83 mc, 16.83 m: Can be followed at 11 p.m. (Gaden).

WLWL-2, C'natti, 15.23 mc, 19.70 m: Very fine at 8 a.m. (Cushen). The best Yank in the 19 metre band at night (Gaden).

WOOC, New York, 15.19 mc, 19.75m: A splendid night station now. (Gaden).

WOOC, New York, 7.82 mc, 38.36 m: One of the best in the afternoon (Gaden). Closes at 6.15—L.J.K.

WNRE, New York, 7.565 mc, 39.66 m: Heard closing at 6.15 p.m. (Gaden).

WOOW, C'natti, 6.12 mc, 49.02m: Heard well when closing at 6.15 p.m. (Gaden).

SOUTH AMERICA

Argentina

LRA-1, Buenos Aires 9.69 mc, 30.96 m: Heard signing at 2 p.m. with calls and clock chimes. Only fair signal — is

mixed up with HJCAB (Cushen). See also "New Stations."

LRM, Buenos Aires, 6.18 mc, 48.54 m: Believe it is this station am hearing with Spanish recordings and language at 8.15 p.m. (Gillett).

Brazil

PSE, Rio de Janeiro, 14.93 mc, 20.07 m: Asks in English for reports—easy to follow at 8 a.m. (Gaden).

Colombia

HJCAB, Bogota 9.69 mc, 30.96m.: Heard at last with good strength mainly because GRX is not on this frequency now to Nth America. HJCAB is very mixed up with LRA-1 till 2 p.m. then in the clear till signing at 2.35 p.m. with March that sounds very much like "Three Cheers for the Red, White and

Blue" (Cushen).

Ecuador

HCJB, Quito, 15.09 mc, 19.87m: Fair signal at 10.30 p.m. (Young).

Uruguay

CXA10, Montevideo, 11.90 mc., 25.21 m: Good programme and fine signal till signing at 12.17 p.m.—(Cushen).

Venezuela

YV5RN, Caracas, 4.92 mc, 60.97 m: Not as loud at YV5RM, but less noisy after 9 p.m. (Gaden).

YV5RM, Caracas, 4.89 mc., 61.35 m: My favourite Sth American. Very loud till 9 p.m., but noisy (Gaden).

NEW STATIONS

Radio Indonesia, Bandoeng, 12.27 mc, 24.45 m: "The Voice of Free Indonesia" heard on October 8 with news in English at 9.45 p.m. Thought they gave call sign as ABC. Said "Schedule was 7—8 p.m. Indonesia Standard Time, which is equivalent to 1130—1230 GMT." (Sydney 9.30—10.30 p.m.) Stated also on 18.135 mc, 16.54 m., but morse spoils reception on that frequency. Signal on 12.27 was loud and clear.—L.J.K.

(Since writing above they have been heard announcing as transmitting from Djokjakarta and schedule seems a little erratic.)

LRA-1, Buenos Aires, 9.69 mc, 30.96 m: Though this is NOT a new station it is many years since it has been reported. Now seems to be on a new schedule which gives them more chance of being heard. Strength is fine and they will prove a good second to LYR-1. Opens at 9 p.m. with news in Spanish then classical recordings till 10.30. Male and female announcers. Slogan is "Radio del Estado, Buenos Aires, Argentina." — Arthur Cushen.

A.F.R.N., Tokyo, 7.552.5 mc, 39.72 m.: This "Armed Forces Radio Network" station is heard well at night — if morse is not too persistent. News at 7 and 10 p.m. Schedule is given as 8.30 a.m.—midnight. Can be heard at 5 p.m., but best around 8.30 p.m.—L.J.K.

A.F.R.N., Tokyo, 9.605 mc, 31.22m.: Heard in parallel with 39.72 m.

A.F.R.N., Tokyo, 15.105 mc, 19.86m: This frequency is not mentioned and it may therefore be an harmonic of 7.552.5 mc. It is heard in parallel with above and is best in the mornings from 7.30. News at dictation speed at 10.30—L.J.K.

OLR-2A, Prague, 6.03 mc, 49.75 m.: This frequency replaces 9.55 mc as from October 19. Signal is weak and spoilt by GWS (6.035 mc) which overpowers it. Rex Gillett, who reports this station says he heard DLR-3A, 9.55 mc an-

nounce on October 18, that commencing next day a new wave-length of 49.75 metres would be used.

OLR-4A, Prague, 11.84 mc, 25.34 m.: This is another Czechoslovakian being heard around midnight. News is given to the BBC and at 12.30 after the familiar bugle 5 notes, a foreign broadcast is given. During the occupation by Germany the call sign was DHE-4A. — L.J.K.

CR7BE, Lourenco Marques, 6.06 mc, 49.50 m.: Mr. Edel mentioned this station to me some time ago, but it was overlooked. He is again hearing them in English at 1 a.m.

"Your American Forces Network," Salzburg, 7.205 mc, 41.64 m.: Mr. Arthur Cushen reports this one. "This is the call of the new Yank in Austria. Also uses the call KOZA or KOSA. Heard at 3 p.m. Interference is caused at 4 p.m. by BBC. Signal at any time is poor. Carries usual AFRS shows." Here is one that is over-carried from October issue:—

Radio Saigon, French Indo-China, 11.78 mc, 25.47 m: This old-timer, who is put in the category of new stations, as during the occupation by the Japanese was on the unmentioned list, is now being heard twice daily with a much more acceptable English session than recently. Present schedule is: 1.30—2.45 p.m. and 5—9 p.m. The news in English at 8.30 comes through at very fine strength and the young lady reading it appears to be much happier than the person we heard a little while ago. They announce they are also on 4.81 mc, 62.37 m, and 1050 kcs. I could not hear them on 4.81 mc owing to noise. As regards 1050 kcs, I leave that to Roy Hallett, or Ern Suffolk. Have a soft spot in my heart for Saigon as it was the first overseas station from which I received a verification, and that was away back in 1927—L.J.K.

Berne, 15.875 mc, 18.39 m: This is a new frequency for Switzerland reported heard in English at 5.20 a.m. by Arthur Cushen. (According to "Universallite" it has replaced HEO-4, from 5.20—5.50 a.m.—L.J.K.)

British Guiana

ZFY, Georgetown, 6.00 mc, 50.00 m: Heard with BBC news at 9 p.m.; much morse. Poor signal here, power is 1000 watts (Cushen).

U.S.S.R.

Moscow unless otherwise mentioned

RV-96, 15.23 mc, 19.7 m: News Reel at 8.30 a.m. — very good. Plenty of English (Gaden).

—, 15.75 mc, 19.05 m: Heard in English at 9.30 p.m.—L.J.K. Good at 4 p.m.—Young.

—, 11.632 mc, 25.79 m: Very good at 11.30 p.m. (Young).

—, 6.23 mc, 48.15 m: Good signal at 6 a.m. (Young).

—, 12.17 mc, 24.65 m: Heard around 8 p.m.—L.J.K.

—, 11.75 mc, 25.53 m: Good at 9 p.m. (Young).

—, 12.11 mc, 24.77 m: In English at 11 p.m. (Young).

MISCELLANEOUS

Canada

CHTA, Sackville, 15.22 mc, 19.71 m: Heard at 10.30 a.m. (Young). Has been very good at night, but recently cannot raise a whisper (Gaden).

CHOL, Sackville, 11.72 mc, 25.60 m: Not so bad; best about 8 a.m. (Gaden).

CFRX, Toronto, 6.07 mc, 49.42 m: At its best now at night. How I slaved once to get a report for him and now a deaf man could hear him (Gaden).

Czechoslovakia

OLR-3A, Prague, 9.55 mc, 31.41 m: Gave last transmission on this frequency on October 18. See "New Stations."

France

Radio Paris, 17.77 mc, 16.88 m: Is stronger than ever — it is not far behind the 19 m at 10 p.m. (Gaden). Heard in relay with 19.68 m. from 11 p.m. till midnight (Edel).

Holland

PCJ, Hilversum, 15.22 mc, 19.71 m: Good at 11 p.m. (Gaden). Heard at midnight now (Edel, Gillett).

Madagascar

Radio Tananarive, 4.35 mc, 68.96 m: Closes at 2 a.m. (Edel).

Mexico

XEWW, Mexico City, 9.50 mc, 31.58 m: Strong signal from opening at 11 p.m. (Gillett).

Palestine

JCKW, Jerusalem, 7.22 mc, 41.55 m: Announcing as "This is JCKW testing on 41.55 m, a frequency of 7220 kcs." This one was heard until after 8.30 a.m. (Gillett).

—, Jaffa, 6.79 mc., 44.18 m: Heard from about 12.30 a.m. (Gillett).

—, Jaffa, 6.135 mc, 48.90 m: Heard testing with English recordings and announcements in English on each half hour, Sunday, October 28, 5—7 a.m. (Gillett).

Spain

(Carried over from October issue)

Radio National Espana, Madrid, 9.32 mc, 32.2 m: News in English at 6 a.m. — L.J.K. Good at 7.15 a.m. in French (Miss Sanderson).

Here are some amended hours for BBC transmitters on beams favourable to Australia in General Overseas Service:—
GSV, 17.81 mc, 16.84 m: 7 p.m.—12.15 a.m.

GVQ, 17.73 mc, 16.92 m: 2 a.m.—7 a.m. 4.30 p.m.—7 p.m.; 9 p.m.—1.15 a.m.

GRY, 9.60 mc, 31.25 m: 2 p.m.—3.30 p.m. 11.30 p.m.—12.30 a.m.; 1 a.m.—1.15 a.m.

Printing difficulties still prevent many prepared schedules from being shown, but here are some changes in Australian S/W transmitters:—

VLA-6, Shepparton, 15.2 mc, 19.74 m: 7.15 —9 a.m.; 12 noon—2 p.m.; 2 a.m.—2.45 a.m.

VLC-4, Shepparton, 15.315 mc, 19.59 m: 8.30—9.05 a.m. in Japanese; 11.55 a.m.—12.45 p.m. to North America.

VLG-6, Melbourne, 15.23 mc, 19.69 m: Noon—2 p.m. (2.30 Suns.).

VLG-3, Melbourne, 11.71 mc, 25.62 m: 3.10—3.45 p.m. to Nth America; 6.58 p.m.—9.45 p.m. to Asia; 10 —10.45 p.m. to Batavia and Shanghai.

VLG-5, Melbourne, 11.88 mc, 25.25 m: 1.15 a.m.—1.45 a.m. to Britain.

VLC-2, Shepparton, 9.68 mc, 30.99 m: 1.15 a.m.—1.45 a.m. to Britain.

VLA, Shepparton, 7.28 mc, 41.21 m: 1.15 a.m.—1.45 a.m. to Britain.

VLG-4, Melbourne, 11.84 mc, 25.35 m: 2 a.m.—2.45 a.m. to North America.

THE VOICE OF AMERICA

Here is the latest "Voice of America" broadcasts from San Francisco: To Japan, Korea and S.E. Asia 7 a.m.—1 p.m. 15.27 and 17.80 mc. Japanese 7—8 a.m.; Korean 8—8.30 a.m.; English 8.30—9 a.m.; English and Tagalog 9—10 a.m.; English and Thai 10—11 a.m.; English 11 a.m.—1 p.m.

To China, Philippines and Indonesia 9—11 a.m.; 15.15, 15.21, 15.24 and 17.80 mc. Chinese and English 9—11 a.m.; English 11 a.m.—1 p.m.

To Japan, Korea, S.E. Asia, China, Philippines and Indonesia. 7 p.m.—2 a.m., 6.12, 7.56, 7.57 and 9.75 mc.

Japanese 7—8 p.m.; Korean 8—8.45

Sweden

SBU, Stockholm, 9.535 mc, 31.46 m: Good at 1.15 a.m. (Edel).

Switzerland

See "New Stations."

Vatican City

HVJ, 17.445 mc, 17.24 m: Good signal at midnight (Young).

WEST INDIES

Cuba

COCY, Havana, 11.74 mc, 25.55 m: Very fine signal at 9 p.m. (Cushen).

p.m.; Japanese 8.45—11 p.m.; Thai and English 11 p.m.—midnight; French and Annamese midnight—12.25 a.m.; English 12.25—12.45 a.m.

To China, Philippines and Indonesia. 8 p.m.—2 a.m.; 7.23, 7.25, 7.80 and 9.70 mc.

English and Tagalog 8—9 p.m.; English 9—10 p.m.; Chinese and English 10 p.m.—12.30 a.m. English 12.30—2 a.m.

Have not got the complete 'Risco A.F.R.S. programme schedule, but have noticed that KWID, 9.85 mc, 30.44 m is on from 5.30—9.30 p.m.

KGEI opens at 7 p.m. on 9.55 mc, 31.41 m, but by 9.30 is very poor, being most nights overpowered by Singapore.

Think KCBR opens at 5.30 p.m. on 9.70 and until pretty near 8 p.m. keeps in step with KWID and from 7 o'clock with KWID and KGEI.

News for New Zealand is given at 5.45 and at 6 o'clock "What American Commentators Say." Signal is good, although morse is a little troublesome later in the evening.

SWISS BROADCASTS TO AUSTRALIA

....As from Saturday October 20, broadcast on Saturdays and Tuesdays will be three hours later, that is, from 6—7.30 p.m.

PCJ, Hilversum, 15.22 mc, 19.71 m, as from October 31 will present English programmes from 11.30 p.m.—12.30 a.m. on Wednesdays and Sundays. This replaces the half hour session previously presented on Sundays, Tuesdays and Fridays.

HELP WANTED

Arthur Cushen has struck a snag. He wants to know who the stranger is on 9.52 mc., at 3.45 p.m. They use a 12 note chime and he thinks it may be SBU or OZF. He had occasion to leave his set, and on return at 4.15 heard BBC with ... — so what's Wally Young's suggestion?

Speedy Query Service

(Conducted under the personal supervision of A. G. Hull)

E.T. (Rutherglen) asks an interesting one to exercise one's imagination on. He writes: "If a B eliminator containing a voltage divider be connected to a battery set, will any harm be done if the eliminator is switched on for any length of time during which the filament battery is switched off?"

A.—If the filament supply is switched off, the battery set itself is not likely to draw h.t. current from the eliminator, and the only drain on the rectifier will be the bleed current in the voltage divider. At low cur-

rent drain the voltage will probably rise above normal, so that this bleed current will also be higher than normal. Just how much higher will depend on the regulation characteristics of the system, depending in turn on the design of the power transformer, as regards size of core, gauge of wire used and so on, also on the characteristics of the rectifier valve. Whether the voltage divider will be damaged by the extra current will also depend on design factors, the size of wire used, size of former, spacing of turns and the ventilation

provided. In the set itself the condensers will be subjected to the higher voltage, too, and whether this will harm them or not will depend on the condensers themselves. In practice it would be expected to find that the eliminator delivers about 135 or 150 volts and on the low load delivers about 150 to 200, and it is unlikely that this will harm a divider or condenser designed for modern use where voltages of around 400 are common.

* * *

T.S.T. (Wagga) asks if kits of parts are available yet.

A.—This issue should give you the answer in no uncertain terms!

HAM NOTES

(Continued from page 29)

FAX TX or something. The next night the same W9YZL was logged working a VK9AB! Strikes me some W ex-serviceman has a pal on one of the islands! But right on top of this a phone station was heard "calling CQ Twanny — WIAKR calling and standing by." Later he was heard in QSO with XU8MC! So the ban must be off, for some people!

Now where do we go from here? Information to hand — not verified at the time of writing, is that W's are permitted on 56-60 and 112-115 Mc/s as from September 6 last, with review of the position in November. Looks as if somebody in W. land may not be sure just where the VHF channels of "five" and "two and a half" are.

It's not surprising though that fingers are itching around Ham shacks.

Here in VK we are told that the 3.5, 7 and 14 Mc/s channels can't be returned yet awhile, as they are wanted by the Services for island communication. Judging by the W7T op chat I heard between two Service stations — it **must** be important. The chat was to this effect, with break-in operation, "Is that Fred — this is Elsie here." "No — Jack on this end, tonight, where is Daphne?" Frequency was 7050 kc/s, and this operator chat continued in social vein for quite a while. Too bad the Hams can't have

their DX frequencies back! No wonder there may be piracy!

VHF Listening

One democratic thing about our at-present national security governed radio laws is that unlike some countries — one is not likely to be gaoled for doing a spot of listening. Since your scribe doffed khaki four months ago, ample opportunity has occurred to do a spot of listening between 20 and 150 Mc/s, and there is plenty to listen to at my QTH around 116 Mc/s. What do I use for a receiver? Having laid out good cash pre-war for a few "acorns", t'was decided the time had come to use 'em.

After 3 or 4 weeks of headaches, much profanity, and rebuilding —

a super emerged with 954 R.F., similar mixer, and 955 oscillator, followed by an 11.5 Mc/s I.F. channel — BFO and usual audio. With plug-in coils of unusual design, the front end is patterned after a Halli-crafter VHF job known as the SX27.

Aviation stuff on 116 Mc/s is terrific — planes being heard up to 150 miles distant, and on some occasions Control Towers of fairly distant air stations are heard at 150 Mc/s. This receiver tunes as if at 7 Mc/s, but your scribe had a lot of fun trying to get adequate conversion gain in the mixer. If "A.R.W." has space in some future issue, a complete description may be given of this receiver.

NICE TIME FOR SPRING CLEANING

As this is written, the war hasn't been over two months, and already many are chafing at inactivity. Surely, whilst awaiting the time for the lid to blow off, there is much to do around the individual shack. There's plenty to do in the way of receiver renovation or rebuilding, to say nothing of provision for frequency checking. What could be more useful than the making of a "frequency checker" — or "band edge spotter" for location of band limits anywhere from 3.5 to 116 Mc/s? Nothing difficult about it, just a 100 kc/s e-c oscillator, harmonic amplifier and multi-vibrator to provide 100, 10 or 5 kc/s spots throughout the spectrum.

In fact, no amateur station should

be without such a piece of gear, especially if V.F.O. is planned instead of crystal control.

This VFO business, by the way, is likely to be a plague if due care is not taken. Extreme stability of operation in the oscillator is imperative, to say nothing of avoidance of the tendency to dodge around a DX band in search of a clear spot. What's the objection to crystals, anyway? They eliminate a lot of uncertainty re frequency (though not all), and in a year or so they are likely to be prolific which reminds me — the new U.S. Magazine "CQ" publishes an article telling how to grind down "Ex Service Rocks" for Ham Bands. Tut Tut!!

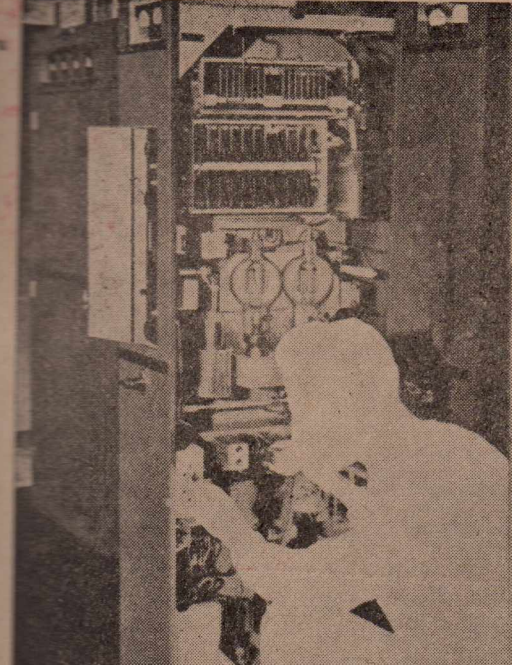

AACS Domestic Station
showing a pair of
Eimac 450-T valves

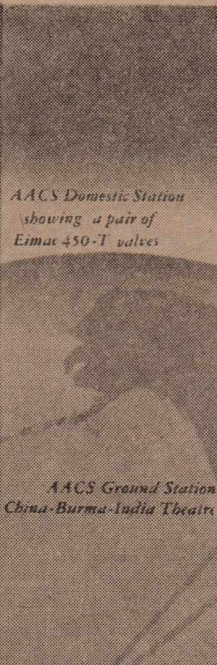

AACS Ground Station
China-Burma-India Theatre



AACS Station on an island in South Pacific

AACS* BLAZES THE TRAIL FOR SAFE FUTURE WORLD AIR TRANSPORTATION

World-wide aviation communications are an established fact today. Almost overnight a great radio network has been created. The actual physical difficulties involved were great enough, to say nothing of the variety of extreme operating conditions encountered and overcome. Needless to say, the equipment employed must be dependable, both from a standpoint of construction and performance capability.

The establishment of radio ground stations on every continent and in fifty-two different countries... overcoming the widest extremes in operating and climatic conditions (from 40 degrees below zero to 140 degrees above)... stations in jungles... in deserts... in mountains and towns... and to have these stations constantly operating at near peak levels is a tribute to the equipment employed. On this page are shown three AACS Stations located at widely separated spots on the globe.

FOLLOW THE LEADERS TO

Eimac
VALVES

Get your copy of *Electronic Tubes*... the sixty-four page booklet which gives the fundamentals of electronics. This little booklet will help electronic engineers explain the subject to laymen. It's yours for the asking... no cost or obligation. Available in English and Spanish languages.

ETTEL-McCULLOUGH, INC., 1030 San Mateo Ave., San Bruno, Calif.
Plants located at: San Bruno, California and Salt Lake City, Utah
Export Agents: Frazer & Hansen
301 Clay Street, San Francisco 11, California, U.S.A.

*A. A. C. S. (Army Airways Communications System)

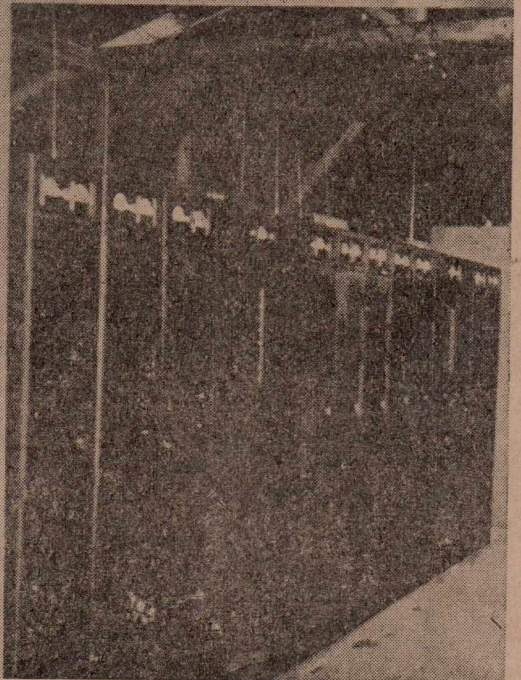

THERE IS NO PRIORITY TO LEARN!

YOUR BRAIN IS YOUR NO. 1 PRIORITY

... and in conjunction with your will-power must direct the whole course of your life.

Show your initiative by looking the Future squarely in the face and ask yourself—"Will I have a secure and settled place in the Post-War World?"

If the answer is "No"—do something about it at once. Radio engineering wants trained men urgently to fill vital positions and trained radio engineers will be in enormous demand.

Radio is a young industry which has made remarkable progress in the past few years. If you want security, prosperity and a recognised status in the community start training right away.

YOU CAN START RIGHT AWAY

Right now openings in Radio are greater than the number of men available to fill them. Here are two good reasons, moreover, why A.R.C. Radio Training must interest you vitally. (1) You will enter today's most progressive industry. (2) You will have a splendid career ahead of you now that the war is over.

COSTS LITTLE

Think of this—for a few pence per day—actually less than many fellows spend on tobacco—you can prepare yourself for a man-sized job in Radio NOW.



HERE'S PROOF

"I'm blessing the day I started with A.R.C. Already I've earned enough to cover all expenditure, including (1) Course paid for; (2) Two meters, value pre-war £26; (3) four Radios to learn on and experiment on, plus a fair amount of stock, value roughly £15—and best of all, worth more than all—A DECENT FUTURE."

H.B., Western Australia.

"Just a letter of appreciation and thanks for what your radio course has done for me. Since obtaining my Certificate in December, I have serviced 145 receivers, and I am proud to say that not one of them had me beat, thanks to your wonderful course and advice."

D.H., Home Hill, Q'land.

TRAIN AT HOME, IN CAMP, OR AT OUR BENCHES

A.R.C. offers ambitious men a sound, proven course in Radio Engineering, Sound because it is the result of many years' successful operation, proven because hundreds of ex-students owe their present success to the college. You can learn with equal facility at home, or even in camp (by means of our correspondence course), whilst the modernly-equipped College workshops are available for night students.

PREVIOUS KNOWLEDGE UNNECESSARY

You don't need a knowledge of Radio or Electricity—we'll give you all you need of both in a simple, practical manner that makes learning easy; presented, too, in such a way that you remember what you're taught and speedily gain the opportunity to PRACTICALLY use your knowledge.

SEND FOR THIS BOOK, FREE

First thing to do if you want to secure vital facts is to send for "Careers in Radio and Television," a lavishly illustrated book published by the College and available to approved enquirers. Send Coupon for your Free Copy Now!



AUSTRALIAN RADIO COLLEGE PTY. LTD.

Cnr. BROADWAY & CITY ROAD SYDNEY - Phones M6391-M6392

To Mr. L. B. GRAHAM, Principal, Australian Radio College Pty. Ltd., Broadway, Sydney, 'Phone M6391-2
Dear Sir,—I am interested in Radio. Please send me, without obligation on my part, the free book, "Careers in Radio and Television."
NAME
ADDRESS



Radio is now being used to save vital spraying materials in Industry. The spraying process of radio valves is now controlled by a new Radio device. The conveyor belt carries unpainted valves in front of two special spray guns, and then into the baking oven. A control, in the form of an electronic switch makes certain that the guns spray each valve completely, but withhold the spray if certain valves are missing from their sockets on the conveyor belt. Truly a marvellous device brought about by Radio.