

THE  
AUSTRALASIAN

MAY 2, 1938  
VOL. 3 — NO. 1  
PRICE, 1/-

# Radio World

Registered at the G.P.O.,  
Sydney, for transmission  
by post as a periodical.

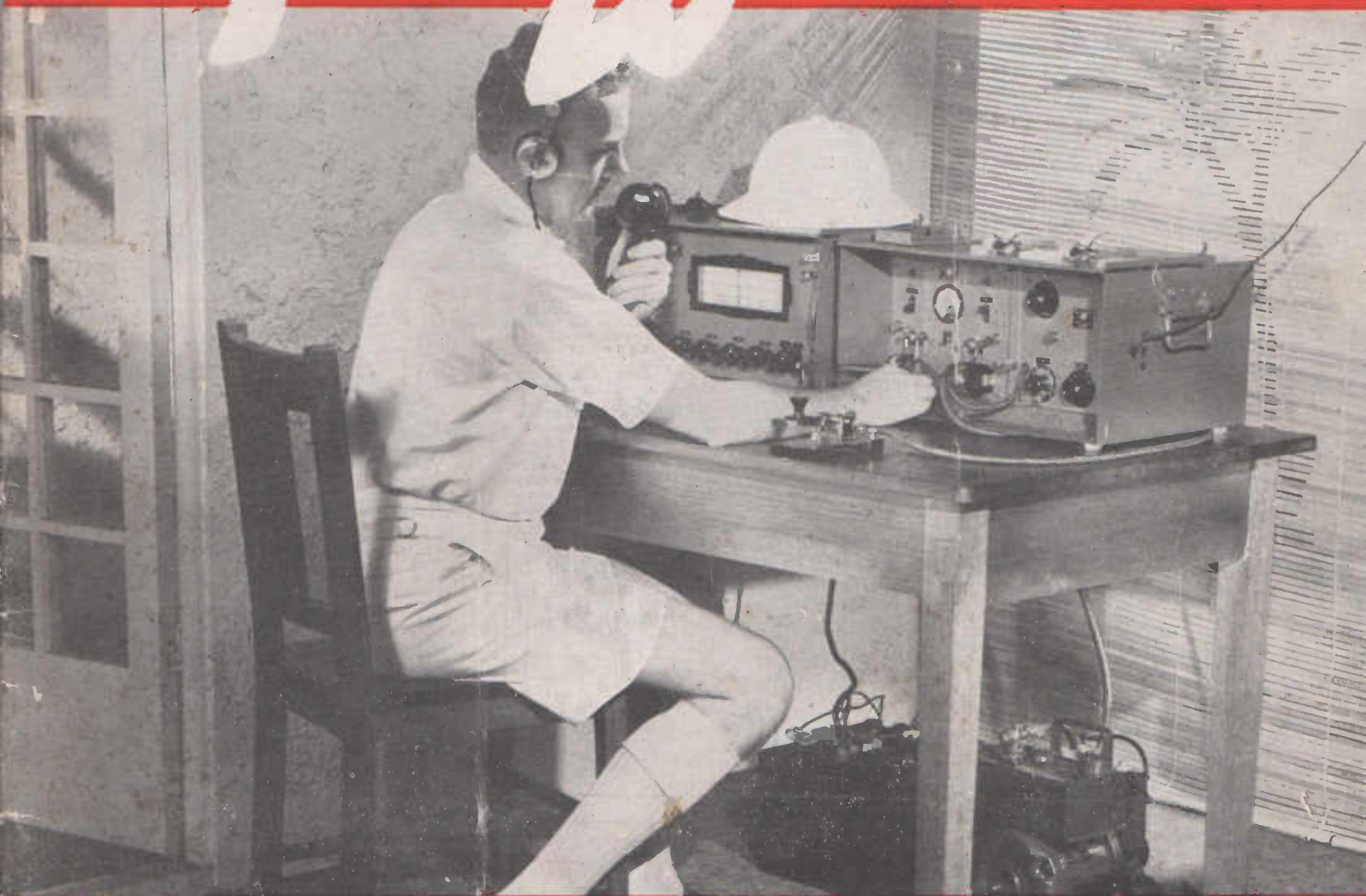

—See Page 8

- SPECIAL BATTERY SET NUMBER: "AIR-CELL DUAL-WAVE FOUR":
- "SCOUT BATTERY THREE": "COMET DUAL-WAVE FOUR": ELIMINATING
- POWER INTERFERENCE: A. O. C. P. QUESTIONS AND MODEL ANSWERS.

# Save Your Set's Life

by using the New

# RADIOKES

## Power Transformers

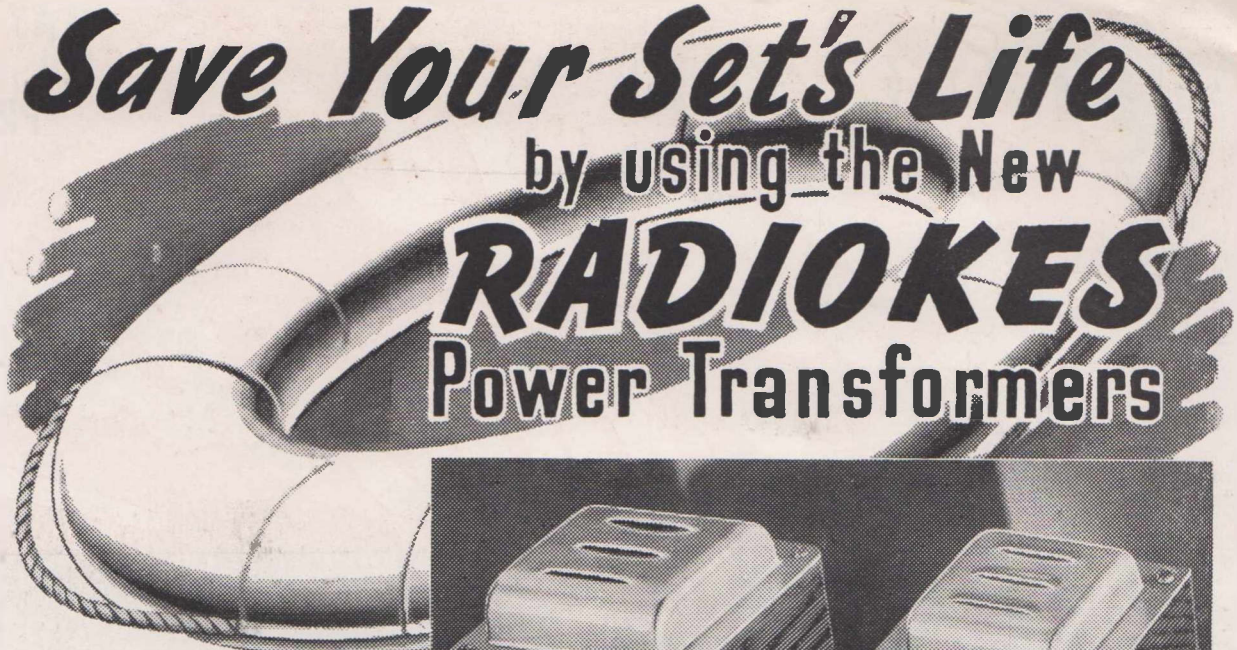

WHEN you see smoke and smell burning, or when the set takes its last breath because the power transformer failed . . . that's not the time to wish you had installed a new Radiokes Power Transformer. The time to save the life of your set is NOW . . . before it is built . . . by insisting upon Radiokes Power Transformers—the new series whose story is told on this page

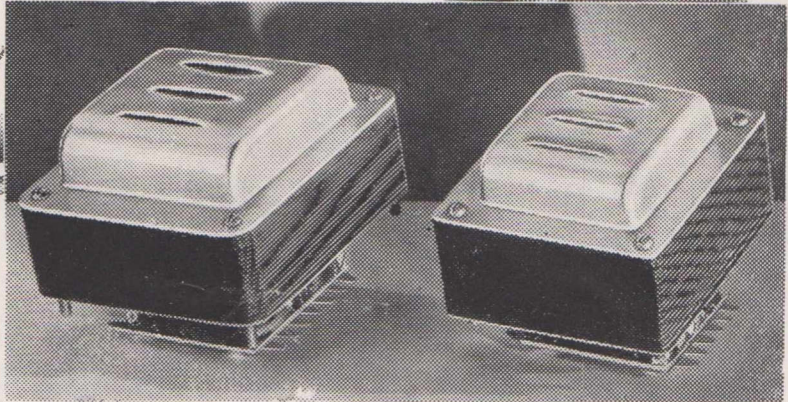

Ever since Radiokes Pty., Ltd., moved into their big new Chippendale factory—the largest radio component factory in Australia—Radiokes engineers have been hard at work to bring each Radiokes component to the very highest pitch of efficiency. In turn, the power transformers went to the laboratory, where the very latest testing equipment dissected every phase of their operation while the engineers combined the experience of manufacturing thousands upon thousands of Radiokes Power Transformers, with the latest developments of Radiokes overseas connections. And so emerged this brilliant new series—better technically than anything similar this country has ever seen, and—incidentally—more good-looking than any other power transformers at anywhere near the price.

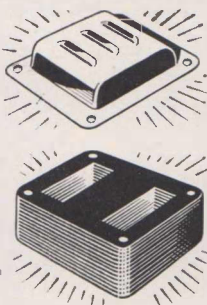

"Good-looking, huh! some may say. Yes good looks are important, too. To the homebuilder's set they give that "professional" appearance. The radio set factory demands greater elegance because it impresses the set-buyer.

In their design, the new Radiokes Power Transformers conform to the specifications of the Stand



ards Association of Australia. The laminations are stamped from special high grade resistance steel, by a new compound die. Each lamination is symmetrical and the stack is flush at every side. The quick dissipation of heat is helped by the use of a heavy, well-louvered aluminium cover.

You'll find the new Transformers much easier to use when wiring. The soldering panel is very clearly marked, for quicker, more efficient work.

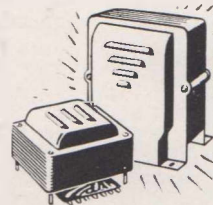

centre tap and positively eliminating the least likelihood of breakdown.

All your requirements are met in the new range. The type "E" Power Transformers are now entirely universal, having five primary windings, as well as both 6.3 and 2.5 volt filament windings.

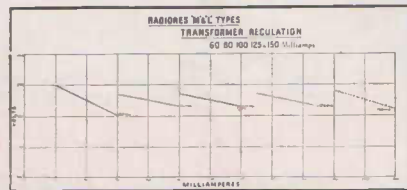
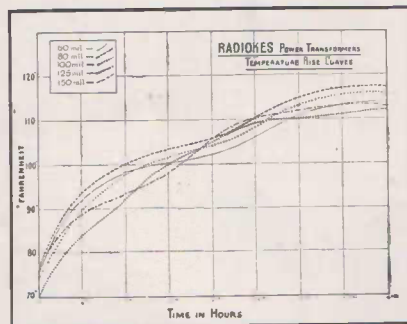

Remember—before a Radiokes Power Transformer reaches you it has been elaborately tested at various stages of its manufacture. Each winding is checked for voltage at its full load. Then the transformer is subjected to a heavy load and given a 2000 volt A.C. insulation test. Finally, a percentage of each order is given a temperature rise test.



Radiokes Power Transformers are available from high-class radio dealers and are stocked by all wholesale houses throughout Australia and New Zealand. If you have any difficulty, communicate direct with the factory.

For further information send this coupon for the FREE ART FOLDER describing them in detail. Indicate if you want a copy of the new 1938 Radiokes Catalogue too.

Radiokes Pty., Ltd.,  
Box 58, P.O.,  
CHIPPENDALE, SYDNEY.

Send me your free Power Transformers Folder.

Send me your 1938 Catalogue, too.

NAME . . . . .

ADDRESS . . . . .

A.R.W. 5/38.

... for this month's "Radio World"

You'll get greater satisfaction and more value for your money from all the sets described in this month's "Radio World" if you use Radiokes components.

Internally, the Transformers are wound with the finest grade material obtainable. All wire is heavily insulated with enamel, while the insulation used between the layers is the finest high test insulating paper. The secondaries are wound in two sections, thus ensuring accurate voltage on each side of the

THE  
RADIO  
PIONEERS

# Fear's Radio News

F. J. W. FEAR & CO. - - - - 31 Willis Street, Wellington  
New Zealand :: Telegrams: "FEAR"

FEAR'S  
FOR  
EVERYTHING  
IN RADIO

An Advertisement inserted by F. J. W. FEAR & CO., New Zealand.

## Four-Valve Dual-Wave Superhet Gives Full Five-Valve Performance Complete Kit For Under £10

A 3/4 superhet that in valve line-up is actually equivalent to a 4/5, the "Comet Superhet Four" described this month is an exceptionally fine receiver, both in design and performance. Priced at an unusually low figure, the "Comet" will give you more stations per pound outlay than any other receiver.

WRITE FOR OUR DETAILED QUOTE.

"AIR-CELL FOUR" and "SCOUT THREE."

Specially built kits of parts have also been prepared for the "Air-cell Dual-Wave Four," and the "Scout Battery Three" also described in this issue. Every part guaranteed as specified by the designer.

WRITE FOR OUR DETAILED QUOTE.

KIT-SET AND COMPONENT SPECIALISTS.

For years we have specialised in catering for set-builders and amateurs, and we invite you to take advantage of our 24-hour mail order service. "Radio World" receivers a specialty.

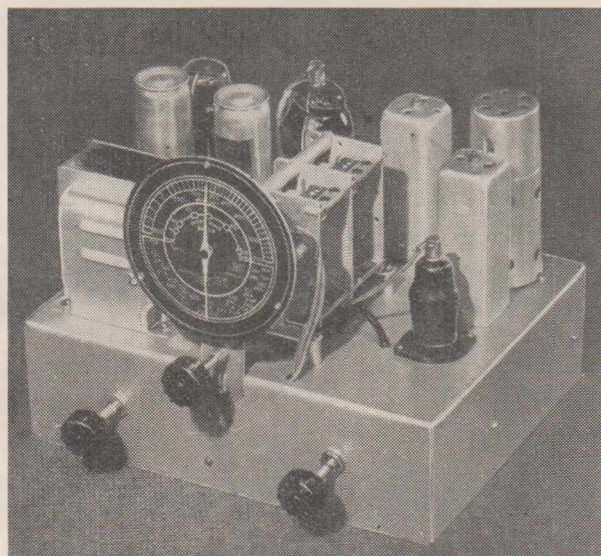

### Latest American Lines For Set-Builders And Amateurs. Meissner Coil Assemblies.

We have just landed from America an extensive range of the sensational new Meissner coil assemblies, covering from 5 to 2000 metres in 5, 4, 3, or 2-band units, together with coils and i.f. transformers.

Model No. 7512 box gives continuous coverage from 5 to 555 metres; ONLY SIX LEADS TO CONNECT. A complete tuning assembly with full electric bandspread and large microvernier dial, this unit is supplied completely wired and balanced. Model 7511 covers from 7.5 to 2000 metres.

Both the above assemblies include "Align-aire" trimmers on high frequency bands; coils are mounted direct on switch assembly.

The ideal foundation for a communications receiver, Meissner precision-built tuning units cover a wider range than most commercially-built

"ham" receivers.

Also available are Meissner i.f. transformers, crystal filters beat oscillator units, noise silencers, etc.

WRITE NOW FOR FURTHER PARTICULARS.

### Meissner 14-Valve Communications Receiver.

A high-grade communications receiver built to specified standards, covering all frequencies and incorporating a noise silencer, beat oscillator, crystal filter, amplified a.v.c., etc., this new 14-valve communications receiver is being supplied complete at a price that is only a fraction of what you would pay for an imported American communications set.

BOOK NOW TO ENSURE EARLY DELIVERY.

### Electronic Vibrators.

"Electronic" are the oldest manu-

facturers of vibrators in the world. A complete range of units is available, together with vibrator-operated converters and power supply equipment. Write now for further details, which include full specifications and circuits showing applications.

### TAYLOR TUBES.

Taylor Tubes, owing to their low price and sturdy construction, have proved in America to be one of the most popular of the wide range of transmitting tubes. They are adaptable for all frequencies up to and including 56 M.C. The T.20, as well as being an excellent Class "C" amplifier, is capable of giving excellent results as a Class "B" audio tube delivering under such conditions 70 watts of audio. The T.55 meets the requirements of those amateurs increasing power and unable to go to the expense of high-priced tubes.

- T.20 or T.Z.20 . . . . . 20/- net
- T.55 . . . . . 65/- net
- H.66 . . . . . 16/- net

# Get Better DX and more QSL Cards!

Signals jump from R4 to R9+!

Here's a quick, easy, inexpensive way to put power in your radio, and pull in far-away stations at loudspeaker strength—yes, stations that many owners of even the most expensive radios are unable to hear.

The "NOISEMASTER" Engineered All-purpose Aerial Outfit dramatically wipes out noise and local static. At the same time it boosts up signals to incredible strength, so that you get smooth, free-from-noise reception of all stations that can be heard in your locality. No matter how bad the man-made interference, no matter how distant the station, the "NOISEMASTER" Outfit will clear out all noise and boost signals anywhere from R4 to R9+!

Here's the secret of its wonderful performance: The "ANTENNEX" Aerial Energiser. The "NOISEMASTER" Aerial Outfit is the ONLY NOISE-REDUCING, SIGNAL-BOOSTING OUTFIT AUTHORISED TO USE "ANTENNEX" . . . the amazing American invention that cuts out noise and peeps up sensitivity. You get in the "Noisemaster" Kit, as well, 200 feet of special aerial wire, 12 specially designed transmission blocks, earth clamp, lead-in strip, screws, lightning arrestors, etc. Easy to follow instructions and drawings with each Kit enable you to set up your aerial in a very short time. No testing. No doubt. No delay. Once "Noisemaster" is fitted, your noise-troubles end! Send this special form for your "Noisemaster" Aerial Kit NOW, and get marvellous DX on broadcast and shortwave bands. If you want yours NOW, send this Coupon!

Antennex (A'sia) Agencies,  
Kembla Building,  
48-60 Margaret Street,  
SYDNEY.

Send me right away your "Noisemaster" Kit. I enclose 52/6 in postal notes, money order, cheque. (Add exchange to country and interstate cheques.)

Name.....

Address.....

A.R.W. 5/38.

# THE AUSTRALASIAN RADIO WORLD

Incorporating the  
**ALL-WAVE ALL-WORLD DX NEWS.**

Managing Editor:  
A. EARL READ, B.Sc.

Vol. 3.

MAY, 1938.

No. 1.

## CONTENTS:

The Air-cell Dual-wave Four .....	3
Radiokes Release New Range of Power Transformers .....	7
Radio Ramblings .....	8
The Comet Superhet Four .....	10
An Appreciation From A.T.R.S.I. ....	12
"Pirate" Uses Lakemba Club Call .....	14
The Triode And Its Applications .....	16
The Scout Battery Three .....	18
A Trip Through The Ever Ready Factory .....	22
Shortwave Aerials For DX Reception (2) .....	27
Tracking Down Power Interference (2) .....	30
What's New In Radio .....	31
A.O.C.P. Questions And Answers .....	39
All-Wave All-World DX News .....	41
Shortwave Review .....	42
DX Notes And News .....	45
Hourly Tuning Guide .....	47

The "Australasian Radio World" is published monthly by Trade Publications Proprietary, Ltd., Editorial offices, 214 George Street, Sydney, N.S.W. Telephone BW 6577. Cable address: "Repress," Sydney. Advertisers please note that copy should reach office of publication by 14th of month preceding that specified for insertion.

Subscription rates: 1/- per copy, 10/6 per year (12 issues) post free to Australia and New Zealand. Subscribers in New Zealand can remit by Postal Note or Money Order.

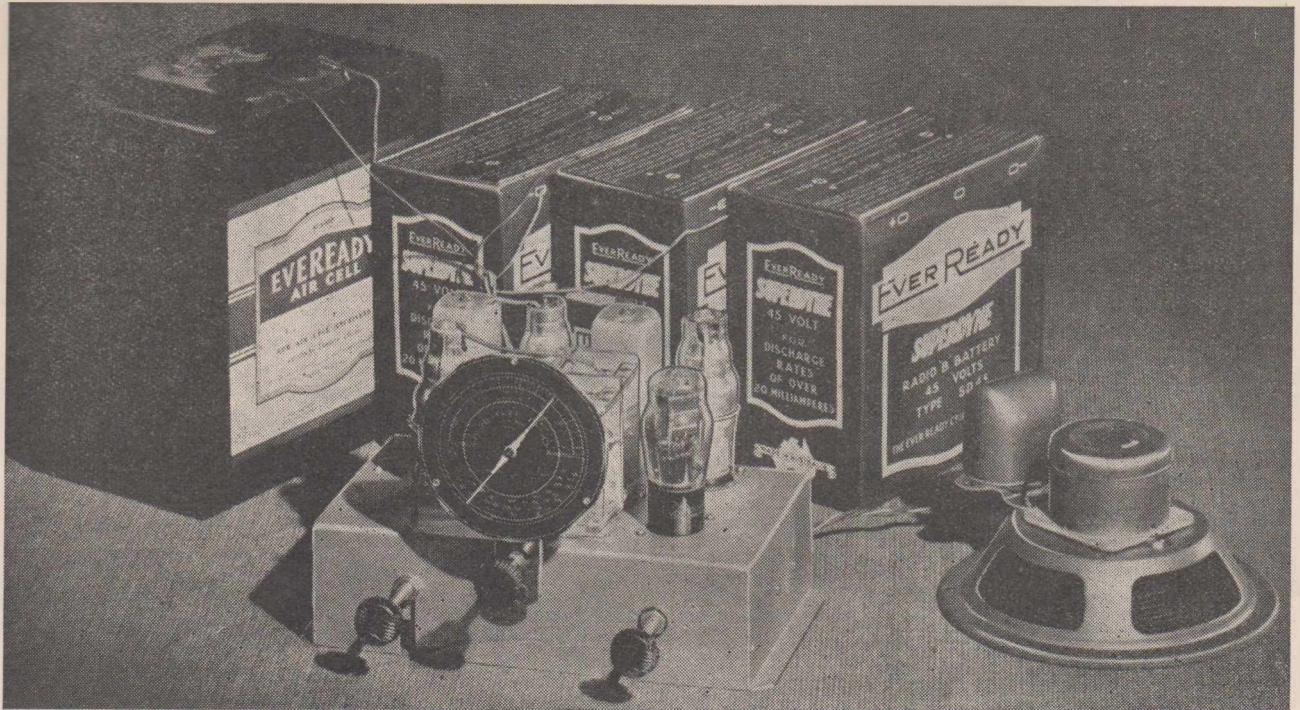

The . . . The completed receiver, with Air-cell, three Superdyne 45-volt "B" units, and 9-volt "C" battery (at rear of set). The speaker on the right is the latest Rola type 8-20 permanent magnet model.

## Air-cell Dual-wave Four

ONE of the most important advances made in this country as far as battery-operated receivers are concerned, was the introduction last year by the Eveready Co. (Aust.) Ltd. of the Eveready Air-cell. First perfected and marketed in America in 1930, millions of them have been sold since. Thus the Air-cell has reached Australia not as a new and untested development, but as a well-tried and proved success.

### Primary Cell With "Breather" Electrode.

Fundamentally, the Air-cell is a simple primary cell, the elements in it consisting of zinc plates with sodium hydroxide as electrolyte. Its vital feature, however, is the use of a special type of porous carbon electrode. There are two of these "breathers," as they are called, their function being to absorb oxygen from the air to form the depolarising agent.

### Many Important Advantages.

That the Air-cell provides an ideal source of power for battery receivers is illustrated by the advantages listed below:—

1.—It is a primary cell, so no recharging is required. This is a particularly important advantage, as with a

**Taking only .36 amp. total filament current, this four-valve dual-wave superhet can be operated three hours daily for nearly two years, using a single Eveready Air-cell as "A" supply. Other features include the use of the latest octal-based battery valves, new Radiokes D.W. coil unit, and of an economy output pentode with inverse feedback.**

lead accumulator there is not only the inconvenience of transporting it periodically to the charging station, but also while it is being charged the receiver is out of action.

2.—The capacity of the cell is 600 ampere hours. This means that at the maximum rated discharge current of .65 amp (which, incidentally should under no circumstances be exceeded) at least 1000 hours of useful life can be obtained.

If the drain is reduced, the service life increases proportionally. Thus, taking the receiver described below as an example, over 1800 hours of service can be obtained from an Air-cell, because the total filament drain is only .36 ampere. Assuming that the set will be operated on an average of three hours per day, almost

two years of service could be obtained from a single cell.

3.—Following a small initial voltage drop from 2.53 to 2.4 volts, occurring immediately after the battery is put into service, the cell supplies smooth, noiseless current at a constant output voltage throughout its entire life. This obviates the necessity for making critical adjustments with a rheostat as the battery ages, to compensate for voltage drop.

4.—The Air-cell is shipped "dry," and can be stored indefinitely without deterioration, because it is hermetically sealed by thin "knock-out" membranes under the filler holes and by sheets of cellophane over the breathing carbon electrodes. Thus, the purchaser need not be concerned about his Air-cell having become "stale"

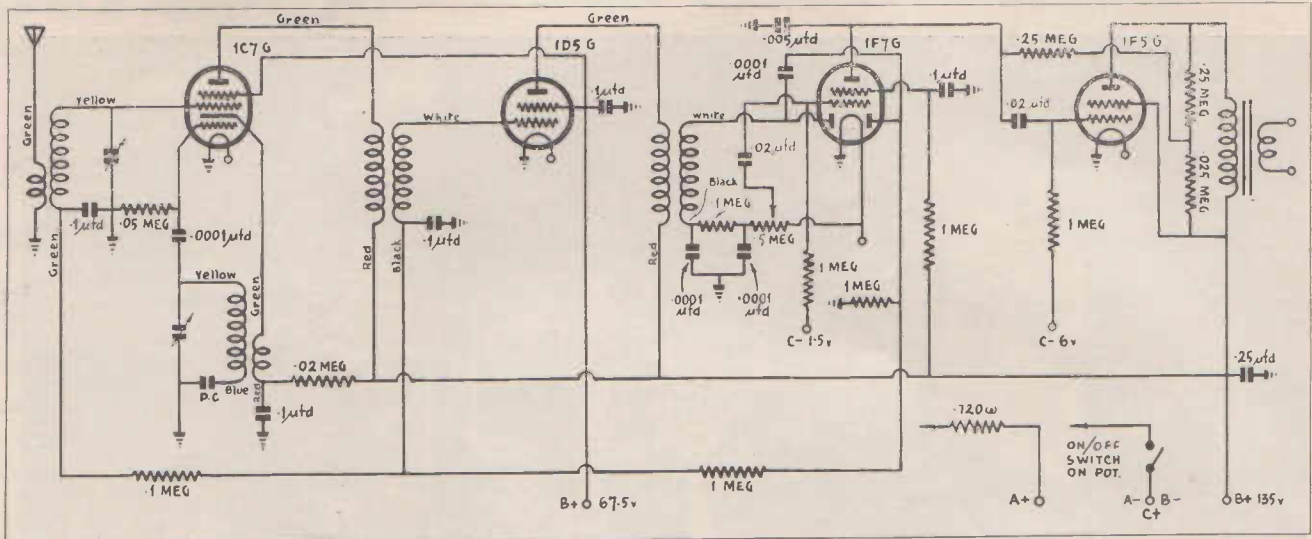

The circuit of the "Air-cell Dual-wave Four," which uses the latest octal-based battery valves throughout.

through being stored for a considerable time on the dealer's shelf.

5.—All that it is necessary to do to put the Air-cell into operation is to break the seals and pour down the filler holes enough ordinary tap water to reach the level indicated. Distilled water is not required. The only attention the Air-cell needs during its entire life is an occasional "topping

up" every month or so with tap water.

6.—An Air-cell receiver can be left out of service indefinitely without harming the Air-cell in any way.

7.—If desired, the Air-cell can be used continually, no recuperation periods being required.

**Series Resistor Vitrally Important.**

A particularly important point that

must be remembered regarding the Air-cell is that it cannot be attached to any ordinary battery-operated radio—there are two vital restrictions that must be observed.

The first is that the maximum permissible current that can be taken from the Air-cell is .65 ampere. If the total "A" drain (including dial lights) exceeds this, the Air-cell cannot be used. At the same time, in

WHY BE SATISFIED WITH ANY CONDENSER, WHEN THE BEST COST SO LITTLE . . . .

*The New* **RADIOMAC**

**TROLITUL MIDGETS**

15 mmf . . . . .	5/9			
40 mmf . . . . .	5/3	160 mmf . . . . .	8/-	15 mmf double spaced 7/-
100 mmf . . . . .	6/9	250 mmf . . . . .	8/9	40 mmf double spaced 8/-

**RADIOMAC MORSE KEYS**

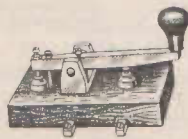

Solid Brass Construction.  
Nickle Silver Contacts.

Junior Model . . . . .	8/6
Senior Model . . . . .	17/6

**HOWARD BUTLER METERS**

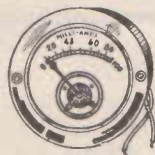

Will read A.C. and D.C.  
Ranges:— **8/6**  
25, 50, 100, 150, 250 M/A.

**CONDENSER FITTINGS.**



1/4" Extensions, 9d.  
1/4" Brass Couplings . . . . . 6d.  
1/4" Flex Couplings . . . . . 9d.

FOR . . .

**H A M PARTS**

We have the largest range in Sydney.

**TRANSMITTING CONDENSERS**

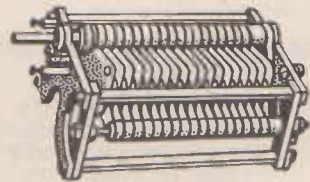

CYLDON 250 mmf . . . . .	32/6
CYLDON 100 mmf . . . . .	27/6
EDDYSTONE 100 mmf . . . . .	33/6
EDDYSTONE 50 mmf per section . . . . .	38/6
Split Stator.	

**PRICE'S RADIO SERVICE**

D. G. McINTYRE

5 & 6 ANGEL PLACE

SYDNEY

**"Air Cell Dual-Wave Four."**

List Of Parts.

- 1—Chassis to specifications.
- 1—D.W. coil kit, with 2—465 k.c. air-cored i.f. transformers and padder (Radiokes).
- 1—Dial (to suit box).
- 3—Valve shields.
- 4—Octal wafer sockets, 1—4-pin, 1—7-pin wafer.
- 1—2-gang condenser (Stromberg-Carlson).
- 3—Knobs.
- 1—5 megohm potentiometer, with switch.
- 2—60 mill. pilot lamps.
- 2—Terminals (red and black).
- 3—Grid clips.
- Length of 7-wire battery cable and 7-pin plug
- FIXED CONDENSERS:**
- 4—.0001 mfd. mica (Simp!ex, E.T.C.).
- 1—.005 " " " "
- 1—.02 " " tubular (E.T.C.).
- 4—.1 " " " "
- 1—.25 " " " "
- FIXED RESISTORS :**
- 1—20,000 ohm. 1-watt carbon (E.T.C.).
- 1—25,000 " " " "
- 1—50,000 " " " "
- 2—100,000 " " " "
- 2—250,000 " " " "
- 5—1 megohm. " " " "
- 1—"Air-Cell" resistor, .720 ohm.
- VALVES :**
- 1—1C7G, 1—1D5G, 1—1F7G, 1—1F5G, (Radiotron, Ken Rad, Raytheon, Philips).
- SPEAKER :**
- 1—8in. permanent magnet dynamic speaker, input transformer to match single pentode (Rola, 8-22).
- MISCELLANEOUS :**
- 2 doz. 3/8in. bolts and nuts, push-back (solid and flexible), solder tags.

cases where the filament drain without dial lights is within the limits stated, a simple solution is to either disconnect the dial lights or to supply them from a separate dry battery.

The second point to bear in mind is that the Air-cell delivers a voltage slightly in excess of the maximum that can be applied with safety to 2-volt battery valves. This necessitates the inclusion of a series resistor, the value of which depends on the total "A" drain. Elsewhere will be found a chart giving current drains in amperes from .06 to .60 amp., together with appropriate values of the resistances required. With most receivers this is a fraction of an ohm.

A further point that should be remembered is the resistance of the battery leads, which, of course, varies with the gauge of wire used. However, a suitable working average

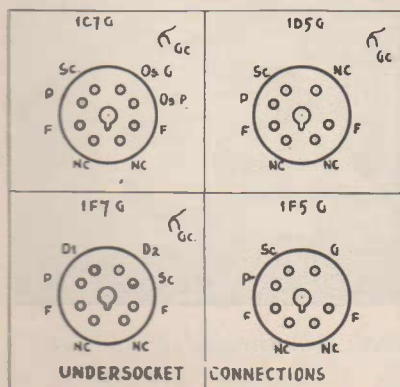

**SIX-GANG "SPINNER" TUNING**  
*Exclusive to Ultimate!*  
**WORLD CHAMPION DX RECEIVER FOR SIX YEARS**



Once again Ultimate leads the 1938 field with a wide range of magnificent new models. Check these features! No other receiver has them all . . . so no other receiver can possibly give you the peerless performance that is yours to enjoy with an Ultimate.

- \* Six-gang Condenser replacing the conventional three-gang type gives real band-spread tuning on the short waves, and what is most important, highest possibly efficiency, ensuring outstanding performance.
- \* "Spinner" Tuning Unit.—A standard exclusive fitting to all 1938 Ultimate models, this unit consists of a die-cast fly-wheel with a planetary motion attached to the rear of the tuning knob. The "Spinner" allows of a tuning ratio of approximately 30:1, but no laborious turning of the control is needed to travel from one end of the band to the other; one spin of the knob will do this. As well, the "Spinner" ensures velvet-smooth tuning.
- \* 320-Degree Dial Scale gives greater separation of stations and easier tuning.

- \* Auxiliary Logging Pointer ensures micro-accurate tuning.
- \* Three-band Coverage—Tunes in all shortwave telephony bands from 13 to 100 metres, as well as the broadcast band.
- \* Permeability-tuned Iron Core R.F. & I.F. Transformers give improved tracking and greatly increased gain.
- \* Seven Tuned Circuits ensure knife-edge selectivity.
- \* Improved Volume Control Indicator.—A rotating calibrated scale enables volume to be adjusted to a pre-determined level.

Sole Australian Concessionaires

**GEO. BROWN & CO. PTY. LTD.**

Electrical and Industrial Engineers.

267 CLARENCE ST., SYDNEY.

Cable Address: "Brownlock," Sydney.

**RUSH COUPON FOR FURTHER DETAILS:**

Please send me, without obligation, details of the Special New De Luxe ULTIMATE RECEIVERS.

NAME .....

ADDRESS .....

(State whether battery or electric and voltage and type of current of power supply.)

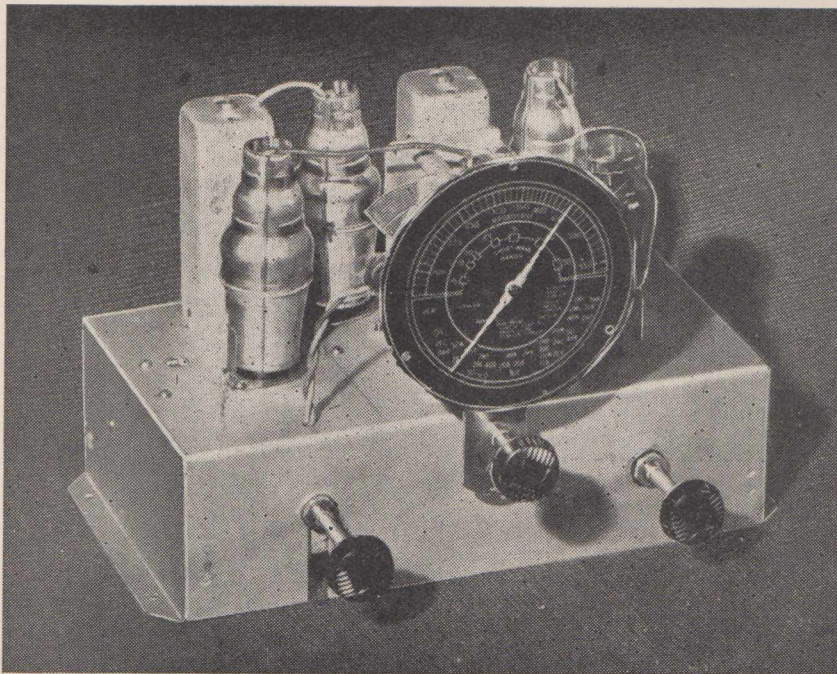

**"Air-cell Dual-wave Four."**

The "Air-cell Dual-wave Four" described below has been designed for maximum economy both in first cost and upkeep, consistent with efficient performance both on broadcast and shortwave.

The valves used are the latest battery octal-based glass types, and comprise a 1C7G mixer oscillator, 1D5G i.f. amplifier, 1F7G combined second detector, a.v.c. voltage rectifier and pentode first audio amplifier, with a 1F5G economy output pentode. The better-known equivalents are 1C6 and 1A4 for the first two types, and a 1F4 for the output pentode. The nearest Australian-made equivalent to the 1F7G is the 1K6, though the latter has a .12 amp filament as against .06 amp. for the former.

Series inverse feedback has been applied to the 1F5G, giving reduced distortion and greater economy of operation.

The dual-wave coil unit used is the latest Radiokes type DWU, a compact unit that is simple to wire and gives excellent results.

**Battery Requirements.**

Battery requirements are an Ever-Ready Air-cell, three Ever-Ready Superdyne 45-volt "B" units, and a 9-volt bias battery. Average "B" drain is approximately 14 mills., which is well within the limit for economical operation of the Superdyne "B" units used. To ensure longest life from the Air-cell, no provision has been made for using dial lights. Actually, they are not required, as the black and white scale of the Radiokes dial used is particularly legible.

The "Air-cell Dual-wave Four," wired, aligned, and ready for operation.

value is .14 ohms, and this must be subtracted from the appropriate resistance as shown in the table.

For example, in the receiver described below, taking .36 amp. "A" current, a resistance of .859 ohms is required. Subtracting .14 ohm, which is that required for the series resistance, this leaves a value of .719 ohm for the series resistor.

If these two points are borne in mind, no trouble will be experienced in obtaining the full service claimed for the cell by the manufacturers.

.26	1.190	.54	.573
.27	1.146	.55	.562
.28	1.105	.56	.552
.29	1.067	.57	.543
.30	1.031	.58	.533
.31	.998	.59	.521
.32	.967	.60	.515
.33	.938		

From the resistance shown it is necessary to subtract the resistance of the battery leads to the cell.

**Air-cell Resistor Chart.**

Current drain Amperes	Resist- ance Ohms	Current drain Amperes	Resist- ance Ohms
.06	5.145	.34	.911
.07	4.422	.35	.884
.08	3.869	.36	.859
.09	3.439	.37	.836
.1	3.095	.38	.814
.11	2.814	.39	.793
.12	2.579	.40	.773
.13	2.381	.41	.754
.14	2.211	.42	.737
.15	2.070	.43	.719
.16	1.934	.44	.703
.17	1.820	.45	.685
.18	1.719	.46	.672
.19	1.629	.47	.658
.20	1.547	.48	.644
.21	1.474	.49	.631
.22	1.407	.50	.619
.23	1.352	.51	.606
.24	1.289	.52	.595
.25	1.238	.53	.584

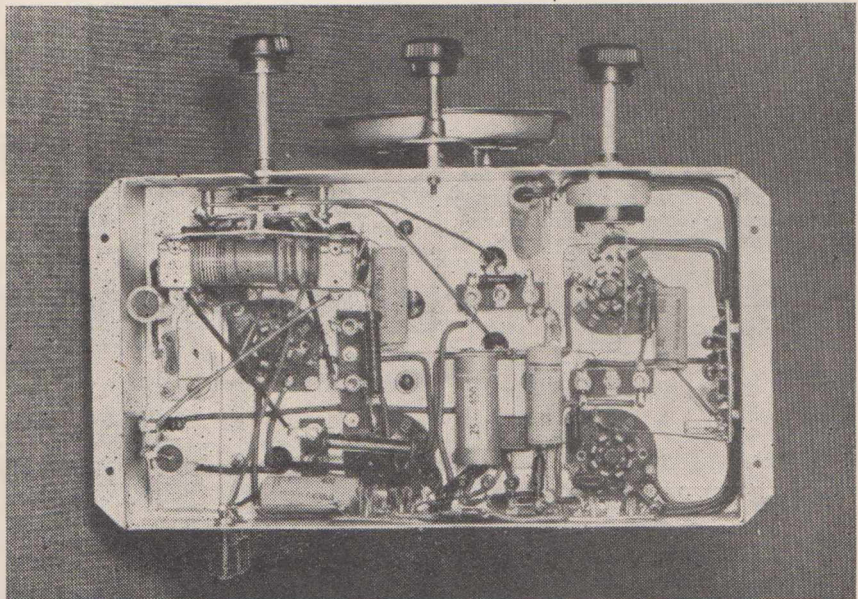

The simplicity of the under-chassis wiring is illustrated by this view.



If these are regarded as essential, however, then it would be best to use 60 milliamp. types, and run them from a separate dry battery. Alternately, the pilot lamps could be run from the Air-cell supply, the connections for them being taken from "A-" and "A+" terminals on the power socket on the rear of chassis, to avoid taking the necessary current through the special .720 ohm dropping resistor and so upsetting the filament voltage applied to the valves. To avoid undue drain on the Air-cell, it would be a good plan either to provide a separate dial lamp switch, or to use one of the special tuning dials incorporating a pilot lamp switch that have lately been placed on the market.

**Assembly Pointers.**

The receiver is assembled on an 18-gauge sprayed steel chassis, measuring 10½" x 6" x 3". The parts to mount first include the four octal wafer valve sockets, together with the 4-pin speaker socket and 7-pin power socket on the rear of the chassis. The filament circuits can then be wired.

Following this, the aerial and earth terminals, padder, combined volume control and on/off switch, i.f. transformers and condenser gang can be mounted. With the last named a lead should be soldered to each of the fixed plates terminals underneath. These pass through the chassis to the appropriate lugs on the coil unit.

Now, commencing with the plate of the mixer oscillator, wire the first i.f. transformer, 1D5G, second i.f. transformer, 1F7G, and 1F5G. Lastly, the coil unit is mounted and wired. The wiring should now be checked over very thoroughly to ensure that no mistakes have been made.

**Further Article Next Month.**

When this has been completed, the chassis can be inverted and the dial knobs and valve shields fitted. The seven-wire battery cable can be wired to the plug, a note being taken of the colours of the various leads and their designations.

The alignment of the "Air-cell Dual-wave Four" is carried out in a manner identical with that described for the "Comet Superhet Four," described elsewhere in this issue.

Next month a further article will be published containing additional hints on the assembly, and will be accompanied by a complete under-chassis wiring sketch.

**Radiokes Release New Series Of Power Transformers.**

Radiokes Ltd. announce the release of a new series of power transformers, developed to conform to the

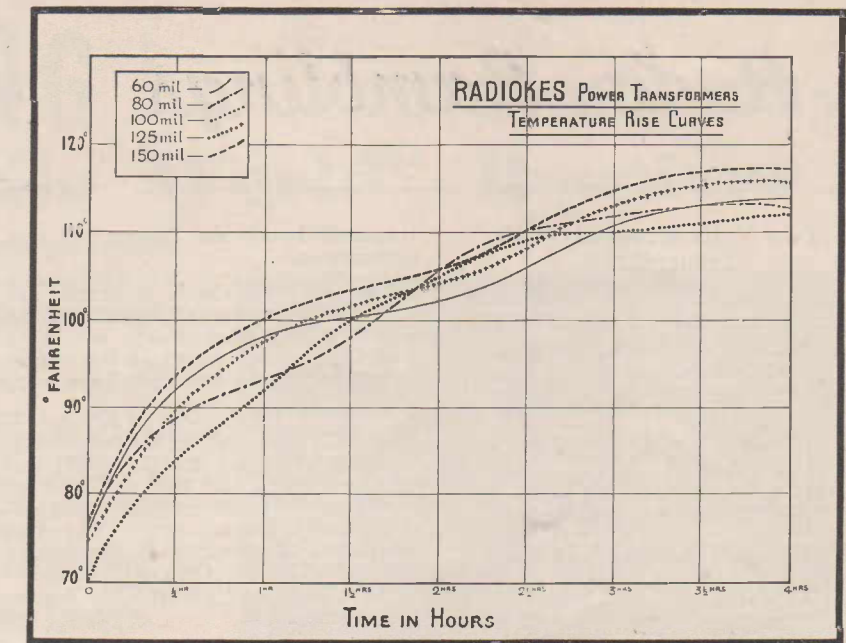

"Standards Association of Australia" specifications.

The new Radiokes transformers are manufactured from the highest grade materials obtainable. A battery of new, latest-type winding machines, which are extremely accurate, produce perfect layer windings with no crossed turns. The secondaries are wound in two sections, thus ensuring accurate voltage on each side of the centre tap and positively eliminating the least likelihood of breakdown.

**Entirely Universal.**

The type "L" power transformers are now entirely universal, having five primary tapplings, as well as both 6.3 and 2.5 volt filament windings.

Uniform quality in production is ensured by an elaborate system of

tests. Each transformer is tested at various stages of its manufacture, and no faulty units can possibly leave the factory. Each winding is checked for voltage at its full load, with precision meters. Finally, the transformer is subjected to a heavy load, and given 2000 volt A.C. insulation test.

In addition to these tests, a percentage of each order is given a temperature rise test in the Radiokes laboratory. The composite graphs of temperature rise and regulation are shown on this page.

**Handsome Appearance.**

The appearance of these new Radiokes power transformers is of very high standard; the cores are lacquered black, while the covers are finished in bright silver.

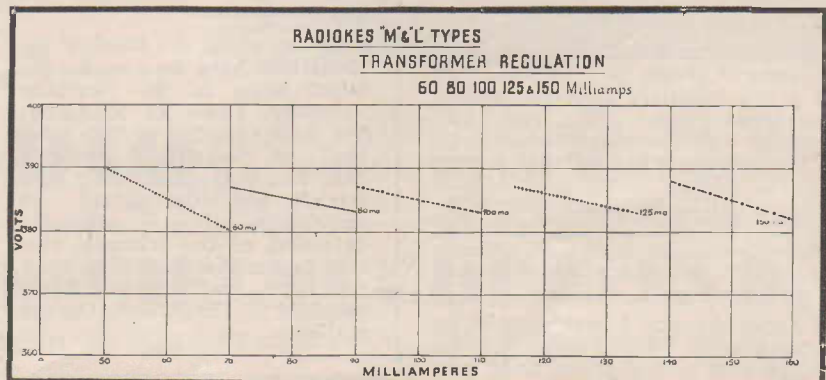

# Radio Ramblings

A page for letters from readers.  
A prize of 2/6 will be awarded  
for every technical contribution  
published.

## Two Volts From Six-Volt Accumulator.

Just a short note of appreciation some of the "Ramblings" contributed

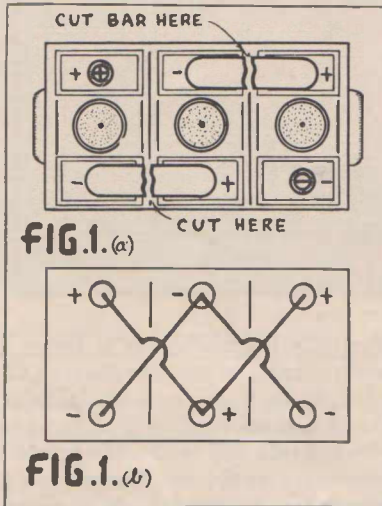

by readers—they are excellent. Perhaps the two given below would be of assistance to someone.

If a rectifier burns out and there is an old 201A lying around, this can be plugged in and will do the job until a replacement can be obtained.

The accompanying sketch shows the way of connecting a 6-volt accumulator to give 2 volts at three times the capacity of the 6-volt battery. To do this, all that is necessary is to cut through the lead bars joining the cells and connect the latter in parallel.—Jack Wallace (AW248DX), Bendigo, Victoria.



## Communications Eight Popular Overseas.

The Communications superhet I am operating is nearly two years old, but has a few additions such as parallel bandspread, 'phone jack, and "R" meter for signal strength which I go by for true reports, and also a pre-selector. Owing to my QRA I have plenty of QRM; hence use everything possible to combat this nuisance. Doublet antennas, line and antenna filters, 40ft. antenna poles, all assist in giving me good results.

I might mention I was brought in to touch with VK2NO (Don Knock) through your valued paper, as he was

stationed beside me during our war experiences.

Two of my friends overseas are building the amateur communications superhet from the "Radio World" I sent them. They maintain the magazine is one of the best they have seen.

Herewith the line-up of my set:—6D6 r.f., 6A7 pentagrid converter, 6D6 1st I.F., 6D6, 2nd I.F., 6B7 2nd detector, a.v.c., 6D6 best oscillator, 41 power pentode, 80 rectifier, and, of course, 6J7 pre-selector. I've just completed 70 countries DX yesterday through VR6AY (Pitcairn Island.—W. M. Chapman (AW112DX), Waterloo, Sydney.

## This Month's Front Cover.

Pictured on this month's front cover is the A.W.A. Teleradio 3A equipment, a small portable radio telephone/telegraph plant designed for providing communication facilities for points beyond the reach of normal radio or land-line systems.

Many of these installations have for some years provided a daily service in isolated areas in Papua, New Guinea and the South Pacific Islands. The equipment is also particularly suitable for use by survey and mining parties, lighthouses, island plantations, cattle stations, patrol launches or small trading schooners, etc.

The A.W.A. Teleradio 3A comprises the following units:—Crystal-controlled transmitter with vibrator unit, communications type receiver, 12-volt accumulator battery, with petrol-driven engine charger and accessories.

So far about one hundred installations have been made, the latest being in the Northern Territory, where an equipment has been supplied to Mr. T. A. Holt, of Royallison Pastures Ltd. Mr. Holt speaks daily with Darwin, 200 miles distant. In anticipation of a considerable extension of the teleradio system in the Northern Territory, additional facilities are being provided at the A.W.A. Darwin station.

## Two Useful Hints.

A small torch globe can be frosted if required by rubbing the glass envelope with rough glass paper.

This second hint is for those who want a positive indication as to when the pick-up is at the end of the record, assuming that the "gramo" lid is closed.

Mount a 2-volt torch bulb in a position where it is easily seen, and take a negative lead from the battery to the globe socket. The positive lead is taken to a small piece of bakelite mounted on the pick-up, and with a small terminal attached to it. A strip of springy brass is next mounted underneath the lid and a lead run from this to the remaining free terminal of the globe. When the pick-up almost reaches the end of its travels the globe will light.—R. A. Kelly, Wellington, N.Z.



## Fine Tuning On Shortwave.

The following wrinkle has often proved invaluable when fine tuning has been necessary on short waves. All that is required is to remove the tuning knob of the vernier dial, and to add another vernier on to the shaft of the first vernier drive. Another could be added if necessary, but two in series is slow enough for tuning at any time.

I enjoyed Don Knock's articles, "25 Years in Amateur Radio," and would like to see others similar by some

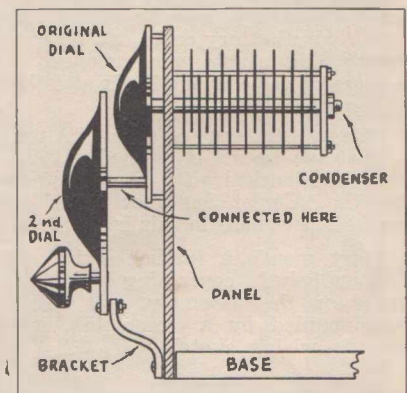

other "old-timer" in the radio game. They certainly make very interesting reading, and I am sure all readers would like to see another series like that of 2NO's.—C. F. Frost (AW22DX), Seymour, Victoria.

# WARNING ! . . . . Don't Buy ANY "Radio World" Receiver !

. . . . without first obtaining our quote, sent post free by return mail. Our prices are unbeatable, and our 24-hour mail order service the finest in Australia.

## COMET SUPERHET FOUR

Using only four valves, this amazing new design (illustrated on right) is guaranteed to give full five-valve performance on both broadcast and shortwave. All parts supplied exactly to specifications.

WRITE FOR OUR DETAILED QUOTE.

## SCOUT BATTERY THREE

As illustrated alongside and described in this issue, is the ideal battery set for country listeners who want the most in radio at the cheapest cost. Uses latest type high efficiency low consumption valves, that in conjunction with iron-cored coils give an amazing performance. All the main Australian and New Zealand stations can be brought in at fine speaker strength. Selectivity is fully adjustable to suit the requirements of any locality.

WRITE FOR OUR DETAILED QUOTE.

## AIR-CELL Dual-Wave Four

Four of the latest octal-based "G" type battery valves are used in this sensational dual-waver, specially designed for Air-cell operation. Taking only .36 amp. filament current, a single Air-cell will give almost two years of trouble-free service.

WRITE FOR OUR DETAILED QUOTE.

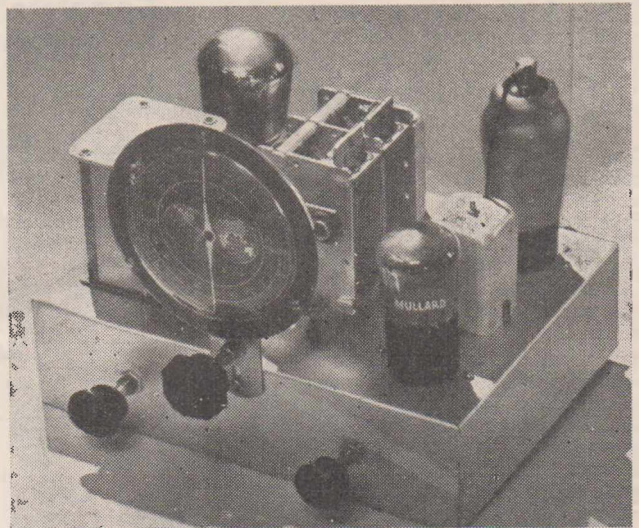
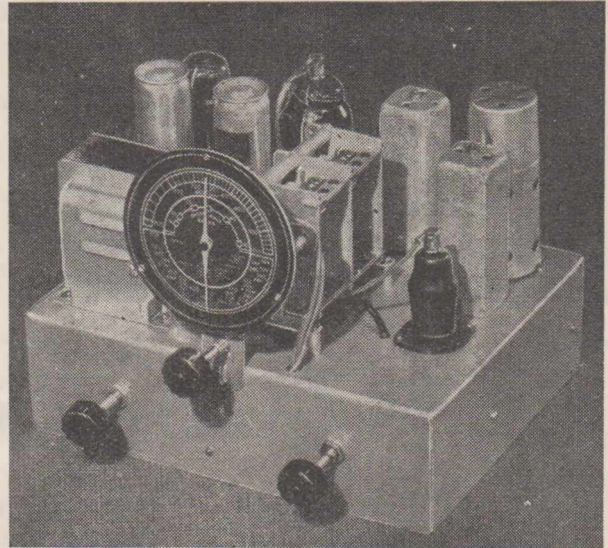

Insist On

# FOXRADIO

COILS AND COIL KITS FOR ALL "RADIO WORLD" RECEIVERS.

# FOX & MacGILLYCUDDY LTD.

MERINO HOUSE, 57 YORK ST., SYDNEY. Tel.: B 2409.

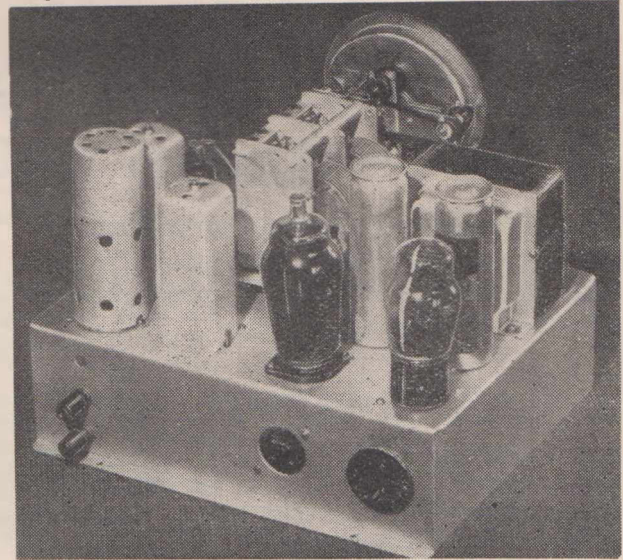
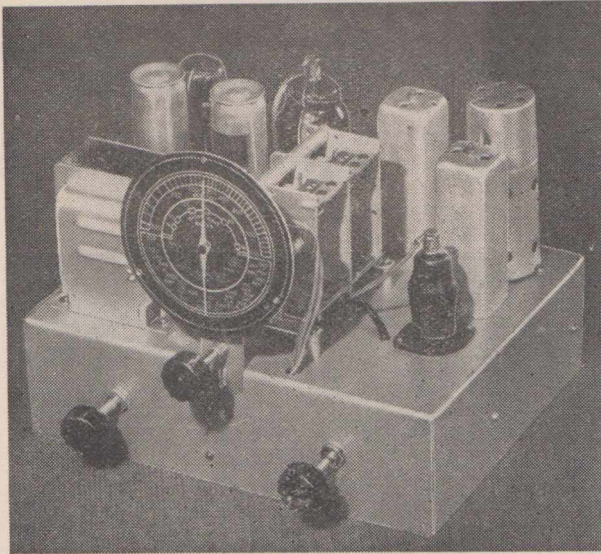

Front and rear views of the completed receiver.

# The . . . Comet Superhet Four

THE design of the "Comet Dual-Wave Four" reviewed in last month's issue has now been completed, and the receiver has proved a remarkably fine performer. Using only four valves, it gives results that are fully comparable with those obtainable from the standard five-valve superhet.

### Two Minor Amendments.

The circuit finally adopted is shown below. There are several minor changes from that published last month, the most important being the substitution of air-cored for iron-cored i.f. transformers, and the inclusion of a grid stopper resistor of 50,000 ohms in the control grid circuit of the EBL1.

The assembly of the receiver is particularly simple, while the wiring is also quite straightforward. Easily the best plan is to mount the various components, with the exception of the coil unit. After the main wiring is completed, the dual-wave unit is then mounted in place and wired according to the instructions given below.

The power transformer and electrolytics, together with the valve, speaker and power sockets are mounted first of all, and the heater wiring put in. Next, the rectifier can be wired—in fact, it is a good plan to complete the wiring of the power pack at this stage.

Next, the aerial and earth terminals, volume control and padder are

**Full five-valve performance is given by this four-valve dual-wave superhet, which incorporates the latest EBL1 duo diode output pentode. Complete with valves and speaker, a first-grade kit of parts can be bought for under £10.**

bolted into position and the i.f.'s and gang mounted. Before the latter is bolted in place, solder two lengths of push-back to the fixed plate terminal of the front section of the gang, and a single lead to the corresponding terminal underneath the rear section of the gang. One of the two leads soldered to the first section passes through the chassis to the aerial section of the coil unit, while the grid

clip to go over the EK2 is fitted to the other. The lead from the rear section of the gang passes to the appropriate lug on the coil unit (oscillator section).

### Wiring The Heaters.

Now, commencing at the plate of the EK2, wire the first i.f. transformer, 6F7 (pentode section), second i.f. transformer, EBL1 diodes, 6F7

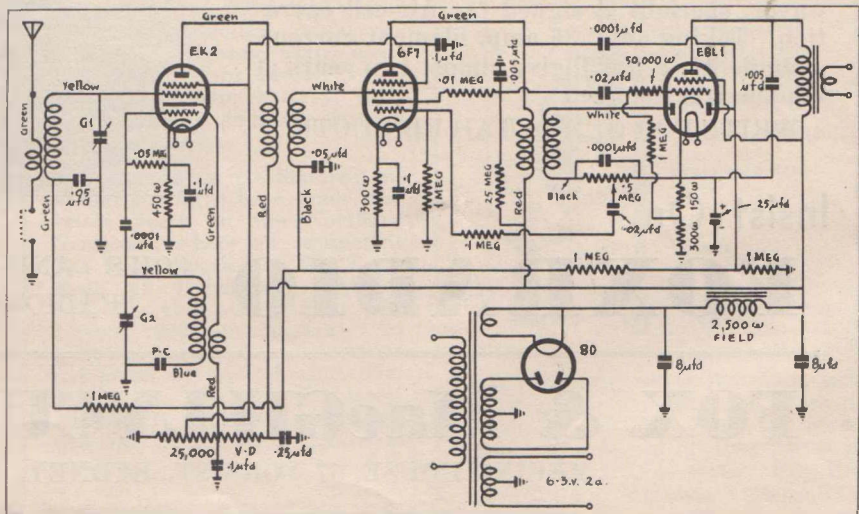

The circuit of the "Comet," which was explained in detail last month.

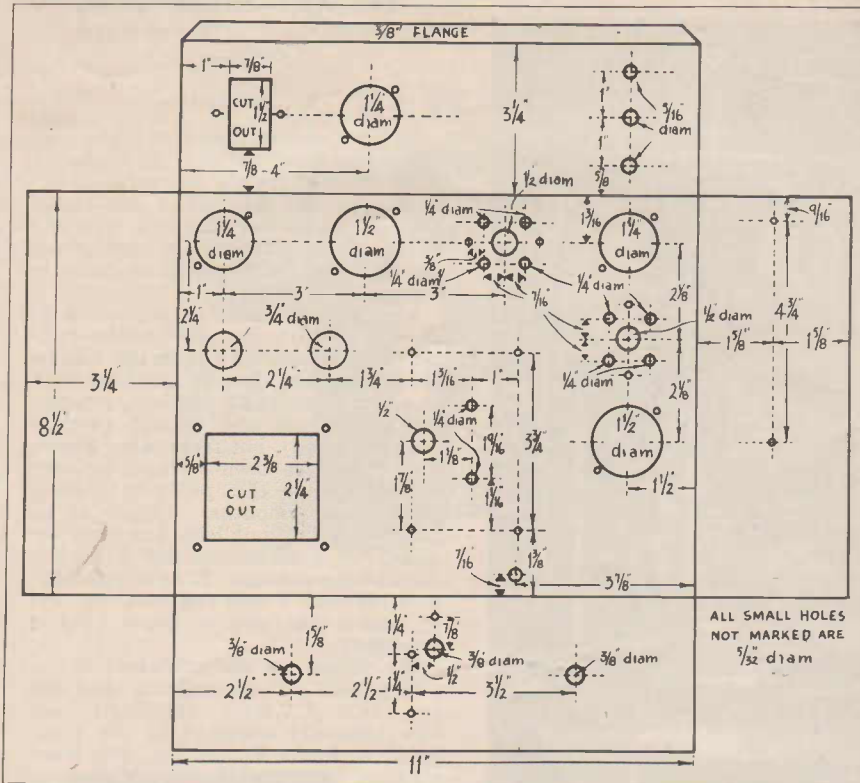

Dimensions for preparing the 18-gauge sprayed steel chassis are given in this sketch.

under-chassis wiring diagram that for the sake of clarity the wiring of the unit has not been shown in full. Instead, the leads which run to the unit have been numbered, their various designations being as follows:—

- 1—Green lead on unit (aerial section)
- 2—Red lead on unit (osc. section)
- 3—Green lead on unit (osc. section)
- 4—Yellow lead on unit (osc. section)
- 5—Green lead on unit (a.v.c. aer. sec.)
- 6—Yellow lead on unit (aerial sec.)
- 7—To earth busbar on unit.
- 8—Blue lead on unit (osc. section).
- 9—Red lead on unit (dial light).
- 10—Dial light return.

When the unit is being wired, care should be taken to keep all leads as short and as well spaced as possible.

When the wiring of the unit has been completed, the chassis can be inverted and the grid clips fitted for the 6F7 and the EBL1. Following a thorough check of the entire wiring, the set is ready for its first test.

Plug in the speaker and valves, not forgetting to fit the 6F7 valve shield, and connect up the aerial and earth leads. Then switch on, and at the same time, watch the rectifier closely for any signs of sparking, or of a

triode section and EBL1 pentode section. The voltage divider can now be mounted and wired.

Lastly, the coil unit can be bolted in place and this section of the wiring completed. It will be noticed in the



# Calstan Multimeter Model 136

with new High Sensitivity 20,000 ohms per Volt Meter.

Model 136 A.C./D.C. Price £12/12/-  
D.C. Price £10/10/-

## Precision TEST EQUIPMENT by SLADE

... the largest manufacturers of TEST EQUIPMENT in the COMMONWEALTH ... Model 136 Multimeter is an outstanding achievement in the Test Equipment field with AN ENTIRELY NEW AND DISTINGUISHED METER SCALE OF 7 INCHES LONG ... the whole instrument itself a handy portable size and built in the usual Calstan compactness. The Ranges are as follow:—

MEASURES CURRENT AS LOW AS 2 MICRO-AMPS.

- A.C./D.C. VOLTS: 2 1/2, 10, 50, 250, 1000.
- OHMS: Zero to 50 Megohms in 4 Ranges.
- M/A.'s: 0.1, 1, 10, 50, 250.

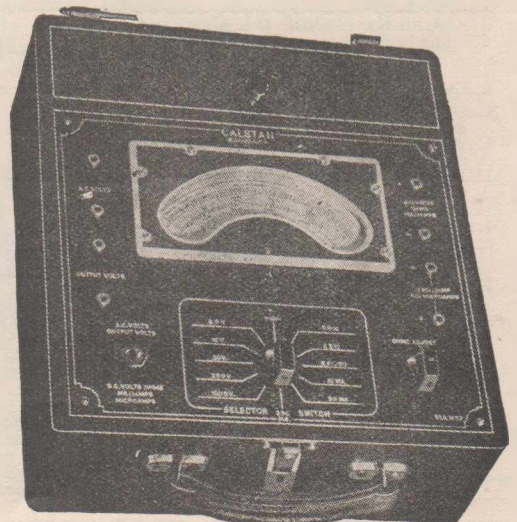

LANG STREET, CROYDON, N.S.W. UJ 5381-2

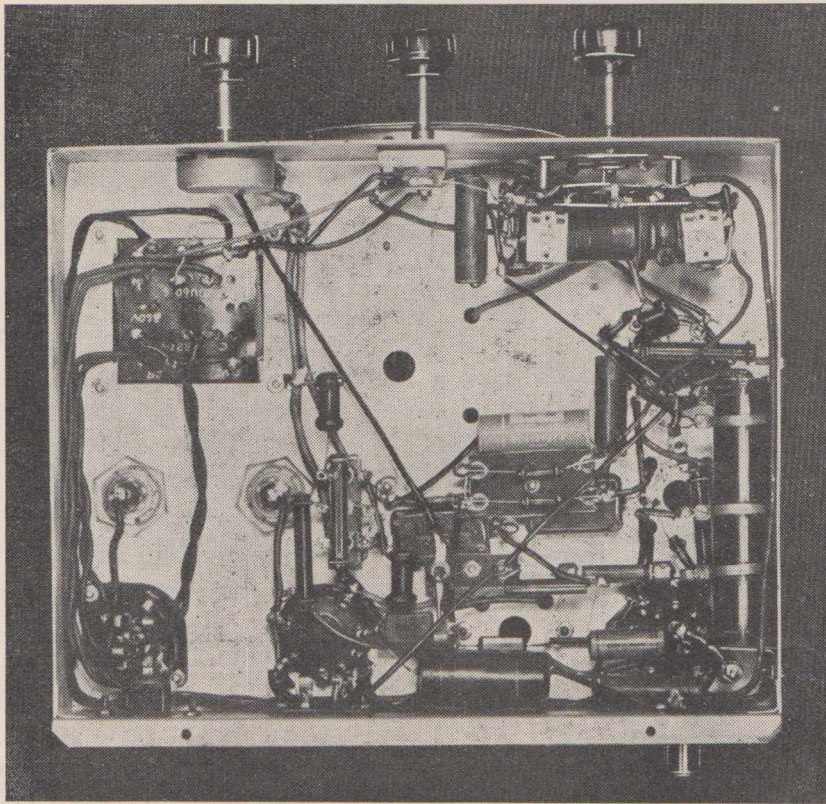

This under-chassis view illustrates the simplicity of both assembly and wiring

blue glow, either of which denotes overloading. If these do not appear, and a faint hum is heard from the speaker, the set can be switched to the broadcast band and the volume control advanced.

The alignment procedure is simple. Tune in a station towards the lower end of the broadcast band, and adjust the oscillator trimmer on the unit for maximum response. Now rotate the dial to a station near the other end of the band, and adjust the

padder for greatest volume. While the padder screw is being rotated, the dial should be rocked backwards and forwards to keep the station tuned in.

These two operations can then be checked, and the trimmers on the i.f. transformers very carefully adjusted for maximum response. It should not be necessary to move these more than a fraction of a turn, and as well the original settings should be mark-

(Continued on page 46)

### Comet Superhet Four—List of Parts

- |  |  |
|--|--|
| 1—Chassis stamped to specifications.                                     | 2—.005 mfd. tubular (E.T.C.).  |
| 1—D.W. coil kit, comprising d.w. aerial and oscillator coils (Radiokes). | 2—.02 " " " "  |
| 2—Air cored i.f. transformers (465 k.c.), padder to suit (Radiokes).     | 2—.05 " " " "  |
| 1—2-gang type "F" condenser (Strouberg-Carlson).                         | 1—.25 " " " "  |
| 1—Power transformer (Radiokes).  | 3—.1 " " " "   |
| 1—4-pin socket (Dalton).   | <b>FIXED RESISTORS :</b>   |
| 2—Type "P" valve bases, 1—4-pin, 1—7-pin wafers.                         | 1—150 ohm 1-watt carbon (E.T.C.).  |
| 1—.5 megohm potentiometer.   | 2—300 " " " "  |
| 1—Power socket and plug (Marquis).                                       | 1—450 " " " "  |
| 1—Length power cable and plug.   | 1—10,000 " " " "   |
| 3—Small knobs.   | 2—50,000 " " " "   |
| 2—Terminals, 1 red, 1 black (Dalton).                                    | 1—.25 megohm " " " "   |
| 1—Dial to suit coil kit (Radiokes).                                      | 4—1 " " " "  |
| 2—Grid clips.  | 1—.25,000 ohm. voltage divider (Radiokes).   |
| 2—8 mfd. wet electrolytics (Solar).                                      | <b>SPEAKER :</b>   |
| 1—.25 mfd. dry electrolytic, 25-v. working.                              | 1—8in. dynamic speaker, to match single EBL1, 2,500 ohm field (Rola K8).   |
| 2—6.3-v. dial lights.  | <b>VALVES :</b>  |
| <b>FIXED CONDENSERS :</b>  | 1—EK2, 1—EBL1 (Philips), 1—6F7, 1—80 (Radiotron, KenRad, Raytheon, Philips).   |
| 3—.0001 mfd. mica (Simplex, E.T.C.).                                     | <b>MISCELLANEOUS :</b>   |
|  | 2 doz. 3/8in. bolts and nuts, 8—1 1/2in. bolts and nuts, 8—3/8in. brass spacers; 3—5 lug bakelite strips, solid and flexible push-back, 2 yards 16-gauge tinned copper wire. |

### An Appreciation From A.T.R.S.I. (Queensland Division).

(To The Editor.)

Sir,—I wish to forward this note of appreciation to the "Australasian Radio World" for the co-operation extended to the Australian Associated Trained Radio Servicemen's Institute (Queensland division) in publishing the organisation's reports in its early stages.

You will no doubt be interested to know that from one short notice published some months ago in the "Radio World," no less than 54 inquiries were received from radio dealers, practising servicemen, and "hams" (mainly in Queensland), but from other States there has also been much interest shown, due to the publicity during the last few months. There is no doubt that this publicity has been the means of establishing the A.T.R.S.I. on a sound footing. It is always difficult to start a new organisation, and of course publicity of some kind is necessary.

My report on the examination recently held in Queensland, and the fact that A.T.R.S.I. certificates are now officially endorsed by the Electrical & Radio Federation, will show that we are well established in Queensland at least, and no small part of this success is due to our column in the "Australasian Radio World."

It is on behalf of Queensland members that I send this small note of appreciation.

Yours faithfully,

W. J. HUDSON.

### Tenth Anniversary of T14NRH.

I recently received from the world-famous shortwave station T14NRH Heredia, the "Voice of Costa Rica," an attractively-printed two-colour certificate of reception, entitling me to be an active member of the "NR. Fraternal Order." Photographs are included of the owner, Amando Cespedes Marin, and of the 500-watt transmitter in use at present.

Interesting facts taken from the literature accompanying the certificate are that the station was one of the original five shortwave stations of the world. Power has been progressively increased from 7½ watts to 15, 50, 75, 100, 150 and now to 500 watts crystal-controlled.

To celebrate the tenth anniversary of the station, which occurs in May, thirty-one programmes will be broadcast during that month on 9670 k.c. from 8 to 9 p.m. C.S.T. To listeners forwarding correct reports, a three-colour lithographed diploma, measuring 14ins. by 18ins., will be sent. A DX contest is also to be held, details of which will be explained during the broadcasts.—J. N. Prior, Coonamble, N.S.W.



8-20—An 8 in. permanent magnet model. Patented dust and acoustic filter assembly. New type moulded diaphragms permit greater power handling capacity without loss of sensitivity. Also features the new insulated transformer.



K-12—A de luxe 12in. wide range reproducer of the electro-dynamic type. Designed for those who are supplying the best in radio.

The rich, powerful tones of the golden-voiced virtuoso; the softest shades of glowing patterns woven by strings, woodwinds and brasses; the slightest sound during tense moments on packed playing fields . . . these things the Rola Reproducer brings you as though the artist, the actors of each drama, stood at your very elbow, or were grouped about your armchair.

Rola Reproducers have earned for themselves a reputation of efficiency and reliability in all parts of the world. Their greater electro-acoustic efficiency, fidelity of reproduction, and sturdy construction enable Rola Reproducers to give outstanding performance and thrilling realism.

Now, "ROLA" INTRODUCES A NEW RANGE of SPEAKERS

incorporating the best features of former models, and presenting new revolutionary features, chief of which is the Rola Isocore Transformer, which involves electrical and mechanical principles entirely new to loud speaker transformers, and is designed to eliminate electrolysis. This valuable feature makes these models especially suitable for humid climates, where efficient, trouble-free performance depends so much upon protection of such vital parts from moist atmospheric conditions.

# Rola

THE WORLD'S FINEST SOUND REPRODUCER

Manufactured by: ROLA CO. (Aust.) PTY. LTD., The Boulevard, Richmond, Victoria. Telephone J 5451.

Distribution and Service: N.S.W., G. Brown & Co. Pty. Ltd., 267 Clarence Street, Sydney.

# "Pirate" Uses Lakemba Club Call

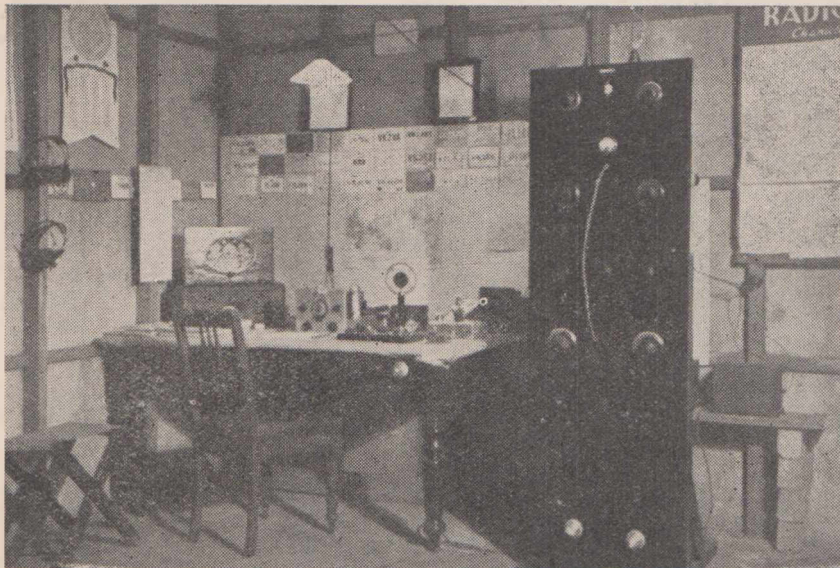

Amateur transmitting station VK2ACS, owned and operated by Mr. V. L. Cole, of Croydon, Sydney.

IN opening our notes this month it is our pleasure once again to extend congratulations to the editor and staff of "Radio World" on the occasion of the magazine commencing its third year of publication.

Generally speaking, the first two years appear to be the most critical in the history of any such periodical, the position at the end of this time usually determining its future success or failure. It is pleasing to note, however, that the progress of "Radio World" from its inception has been very remarkable.

It is to be hoped that with the continued support of its readers by subscription and recommendation, and by giving first preference to the magazine's advertisers, Australia may still continue to boast of a monthly radio publication, which, in its class, is superior to anything offered by overseas publishers.

★

## Joey's Still Active.

The epidemic of call-sign piracy mentioned in these notes last month appears to be spreading very rapidly. A stage has been reached whereby members of the above club have heard a transmitter using the club's official call (VK2LR), while another member reports hearing his own call sign being used.

If these "joey's" finally intend joining the amateur ranks, then surely

an appeal to ordinary common decency, not to thieve another person's call, should be sufficient to put an end to such practice.

The offenders can be assured that if they are caught the matter will be placed in the hands of the Radio Inspector, and they will not be let off with a caution as has been the case of a few detected in the past.

★

## VK2ACS A Wireless Sargeant

VK2ACS, owned and operated by V. L. Cole, is situated at 2 Robertson Street, Croydon. A photograph of the transmitting "shack" is shown above.

The transmitter consists of a 6F6 crystal oscillator (40 metres), 6L6G doubler, and an 801 in the final with an input of 30 watts. The receiver is a four-valve T.R.F. using a 6D6, 6C6, 76 and 42. For 20 metres the transmitting antenna consists of two half waves in phase, and for 40 metres, a half wave zepp. For telephony, the modulator consists of a 6C6, 6C6 and 6L6G's in class AB1, with a crystal and carbon microphone.

VK2ACS has only been interested in amateur work during the past two years. Prior to that the operator's main interest was in teaching morse code and conducting classes in the military forces. In this capacity he has held the position of Wireless Sargeant for eight years.

## Call

**No Quarter For Offenders When Caught : VK2ACS a Wireless Sergeant: Enmore Activity School Now Has Call : Lakemba Radio Club Notes And News.**

**By W.J.P.**

### VK2AGX — The Enmore Activity School.

(Details supplied by 2EH.)

The special Activity School at Enmore was established in January two years ago. In many ways this school differs from others, for among other things the school time-table makes provision for hobby work. In these periods groups of boys go to the various rooms to carry out work on hobby projects, in one of the following hobbies:—Model aeroplane work, physical training, art and craft work, pottery, cane chair and lounge making, leather work, mechanical hobby work and radio.

There are about 20 boys in each group. Those in the radio section displayed such interest in the short-wave side of listening that Mr. E. P. Hodgkins (VK2EH), who is conducting the radio hobby work, gave a demonstration at the school of amateur procedure, with the co-operation of Mr. E. Treharne (VK2AFQ), of Manly Boys' High School. Details of this transmission were given in a previous issue of "Radio World."

This demonstration proved to be a great stimulus to the radio hobby work—so much so that 2EH took out a call sign, VK2AGX, for the school club. For some months the activities have been confined to collecting the necessary apparatus to put the station on the air. During this time, some enterprising "joey" has been making use of the club call, and 2EH is sorry to have to advise several "hams" who have sent QSL's that these cards will be returned.

VK2AGX is now on the air with a two-stage transmitter on 40 metres, (continued on page 32)





The valves  
that aid the Airways



THE WORLD'S  
STANDARD RADIO VALVES

are the safest equipment for your radio set. A regular overhaul of your radio will give better and brighter programmes. See your local radio supplier . . .

and be sure to Re-valve with new Micro-sensitive

# RADIOTRONS

AUSTRALIAN  
GENERAL ELECTRIC  
LIMITED  
Sydney, Melbourne, Brisbane  
Adelaide, Hobart

AMALGAMATED  
WIRELESS  (A/SIA) LTD.  
47 York Street, Sydney  
167-169 Queen St., Melbourne

NATIONAL ELECTRICAL  
& ENGINEERING CO. LTD.  
Wellington  
New Zealand

# The Triode And Its Applications

THE first of a series of monthly lectures by Mr. F. Langford Smith, of the technical staff of Amalgamated Wireless Valve Co. Pty. Ltd., was delivered in the Works Cafeteria at Ashfield on Wednesday, April 20, to a large number of radio dealers, servicemen, salesmen and junior engineers. The subject treated in this lecture covered the triode valve and its multitudinous applications.

The lecturer introduced his subject by a description of the filament, grid and plate used in directly heated valves, and the arrangement of heater and cathode used in indirectly-heated valves. Electrons are minute charges of negative electricity, and therefore a flow of electrons from filament to plate is equivalent to a current flow from plate to filament.

The grid is described as a "control" or "signal" grid, since it controls the plate current and has impressed upon it the signal voltage. Positive grid currents flows when the grid is made positive in the same way that plate current flows.

## Gas Causes Negative Grid Current.

Gas in a valve causes negative grid current to flow, and this can be detected by a microammeter in the grid circuit while the valve is operating with negative bias. An alternative method is the use of a 1 megohm resistor in the grid circuit and a milliammeter in the plate circuit; if no change of plate current occurs when the resistor is short-circuited, there is no grid current and no gas.

The operation of a triode was demonstrated by means of a special model of large size and open construction, having fluorescent material on the plate. The area showing green fluorescence indicated the area being bombarded with electrons, and this varied with the grid bias.

There are various methods of obtaining grid bias. A "C" battery is frequently used in battery receivers, but it is preferable to arrange a discharge resistance so that the "C" battery is discharged (while the set is in operation) more quickly than the "B" battery. Both "B" and "C" batteries would then become exhausted together after the utmost had been obtained from the "B" battery.

Back bias is frequently used in A.C. receivers, and sometimes also in battery receivers. Self bias is to be preferred, since it isolates each stage and simplifies design, while giving a greater degree of protection and compensation with fluctuating voltages. When self-bias is used, some types of power valves are permitted to be used with a high value of grid resistor,

Published below is a precis of the first of a series of monthly lectures arranged for the radio trade by Amalgamated Wireless Valve Co. Pty. Ltd., of Sydney, to provide a refresher course for engineers and servicemen, and a useful groundwork of radio fundamentals for non-technicians.

making resistance coupling practicable, while with back-bias or fixed bias the resistance must be decreased.

General purpose valves may have a total grid circuit resistance of 1 megohm. R.F. pentodes on A.V.C. may have a total resistance of 3 megohms for a single stage, 2.5 megohms for two stages and 2 megohms for 3 stages. Power valves should be used with grid resistors within the limits given in the published data.

By-pass condensers are generally desirable across the bias resistor or supply. In the case of a valve on self-bias the by-pass condenser also by-passes hum from the cathode. Electrolytic condensers are generally used on A.F. and paper condensers on R.F. When a 6B7S or 6G8G is used as an I.F. amplifier and diode detector, the cathode bias resistor should be by-passed by an electrolytic and a paper condenser in parallel.

## Applications Of Triode Valves.

In transformer-coupled voltage amplifiers the gain is equal to the amplification factor of the valve multiplied by the step-up transformer ratio. General purpose valves used as resistance coupled amplifiers give a stage gain of approximately 70% of their amplification factor, while for 60%. In all cases poor design or low high mu triodes this becomes 50% to voltages will decrease the gain.

Other types of voltage amplifiers such as resistance capacity, choke coupled and choke capacity coupled are also used for special purposes.

Driver valves are small power amplifiers operated so as to supply power to the grids of a class "B" or "AB2" stage. For small power one or two general purpose triodes may be used, while for high power single or push-pull 42 or 6F6G valves connected as triodes are suitable.

Power valves may be Class "A," "B," "AB1," or "AB2." Class "A" triodes, either singly or in push-pull, provide the highest fidelity known. For good fidelity, distortion should

not exceed 5% second harmonic (this applies to a single triode) or 2.5% third harmonic (this being the predominant harmonic in the case of push-pull operation). Class "B" is economical in plate current, but introduces objectionable distortion which limits its usefulness, while it needs a power supply of good regulation. Class "AB1" indicates over-biased operation without grid current while Class "AB2" refers to grid current during portion of the cycle.

## Brief Appreciations From Readers.

I wish to thank you for filling a pressing need by the publication of the "Radio World." Such a magazine was needed by the radio-loving public of Australia, and as long as it maintains its present high standard its monthly appearance will be eagerly awaited.—Francis A. Burke, Waverley, Sydney.

Though I have been a shortwave DX listener for some years now, this is the first time I have thought of collecting veries and photographs. I am very glad to have joined your club, as it puts a kick in one's hobby. The reporting forms are excellent.—Thomas Forrest (AW369DX), Rose Bay, Sydney.

I have been a reader of the "Radio World" for the last twelve months, and have found it a very excellent magazine. It is always full of valuable information concerning radio activities in receiver design and amateur radio movements. Please find enclosed subscription to your club, which I am more than pleased to join.—Jack Hazzard (AW381DX), Casino, N.S.W.

Just a few lines in appreciation of your very fine publication. Unlike most magazines, which only cater for one type of reader, the "A.R.W." caters for all classes of radio enthusiasts. The Shortwave Review is excellent for any dxer who wants to log those elusive stations.—J. A. Ackerman, Carlton, N.S.W.

# Special Offers from VEALLS

Vealls, with 6 big Radio and Electrical Stores packed with goods, can offer you unequalled choice . . . from the biggest stocks in Australia. Note the special prices listed on this page and write for complete price lists—POST FREE !

**BUILD THE THREE-WATT MIDGET AMPLIFIER . . . . . £6-7-6**

For only £6/7/6 Vealls will supply the complete parts required to build the three-watt Midget Amplifier described last month. Price includes the necessary Radiotron Valves and Rola 8-20 speaker. Freight paid to your nearest railway station. It pays to deal with Vealls.

VEALLS FOR  
EVERYTHING RADIO

VEALLS FOR  
EVERYTHING ELECTRICAL

**THE COMPLETE PARTS TO BUILD THE 5-METRE TRANSCEIVER . . . . . £9-15-0**

(Microphone and Transformer extra as selected.)

See the complete constructional details in last month's issue and note Vealls keen low price for the complete kit of parts . . . everything except the microphone and transformer.

**GET THE HABIT ————— TRY VEALLS FIRST . . . AND ALWAYS**

THE FASTEST MAIL ORDER  
SERVICE IN AUSTRALIA

VEALLS PAY FREIGHT ON  
RETAIL ORDERS Excepting Batts.  
and Cabinets.

## Build the PORTABLE 4 in a CABINET

The Outdoor Portable Four, undoubtedly Australia's most popular 4-valve Battery Portable, may be brought for only 11 Gns. . . the complete kit—everything including valves, speaker and cabinet. Write for full constructional details.

For those who wish to build the "Portable 4" chassis into a standard mantel or console cabinet, Vealls will supply the complete kit—everything except cabinet for only 10 Gns.  
Mantel Cabinets from 32/6  
Console Cabinets 37/6, 42/6, 47/6, up to 85/-

# VEALLS

Letters: Box 2135T., G.P.O., Melbourne.  
490 Elizabeth St., 243 and 168 Swanston St.,  
Melb. 299 Chapel St., Prahran. 3-5 Riversdale Rd.,  
Camberwell. 97-99 Puckle St., Moonee Ponds.  
'Phoné: F 3145 (6 lines).



**This three-valve battery receiver is the ideal set for country listeners who want to obtain the maximum in entertainment at the lowest cost.**

**T**HOUGH the t.r.f. type of receiver was a firm favourite when radio broadcasting first became popular, for many years now the superheterodyne has been the exclusive choice of manufacturers. This is mainly due to the fact that, valve for valve, the superhet is inherently more selective than a t.r.f. receiver. At the same time, however, it is by no means certain that the latter will remain permanently out of favour.

The application of improved types of iron-cored coils, with perhaps some form of automatic regeneration to increase gain, with tone correction following, could easily swing the t.r.f. receiver back into popular favour once more, because basically it is simpler than the superhet and, valve for valve, is cheaper to build.

For example, the receiver described below can be built complete with valves, battery and speaker for only

£9. Because it incorporates regeneration, it could easily out-perform any three-valve superhet operated under similar conditions. In fact, its performance generally is actually superior to that given by some of the older four- and five-valve sets of similar design.

That readers appreciate what a well-designed receiver of this type can do was proved by the widespread popularity of this receiver when first described in the "Radio World" (the description is re-published below for the benefit of new readers and in response to many requests from others for constructional details of a set of this type).

The "B" drain is between 7 and 8 mills., meaning that a set of heavy duty "B's" will give nearly a year of service with normal usage. Even the light duty type could be used if desired. The "A" drain is just under

half an amp., so that an 80-amp. hour accumulator would give about 150 hours of service from a single charge. An air-cell, in conjunction with the requisite voltage-dropping resistor, could also be used, and would give close on 1500 hours of service. No "C" battery is required, as automatic bias is used.

For this receiver iron-cored t.r.f. coils are used. For maximum gain, and to level up sensitivity over the band, high impedance primaries, spaced well apart from the secondaries, have been used. Coupling between the two windings is effected by means of a midget variable trimmer condenser mounted on the coil base, and connected between the upper ends of the primary and secondary.

Thus the degree of coupling, and hence the gain and selectivity, is adjustable to suit any particular locality. Where selectivity is not all-important but sensitivity is, both coupling condensers can be screwed almost right home to give maximum gain.

Suitable valve types in the Continental and American ranges are, respectively: KF1, KF2, VP2 (Continental), 1K4, 1A4, 1C4 (American), in the r.f. socket; PM2DX, B217 (Continental), 30 (American), as triode detector, and C243N, KL4 (Continental) or 1D4, 1F4 (American), as output pentode.

All types are fully interchangeable, except that the appropriate sockets must be used. In the new octal-based American battery series, suitable types are: 1D5G or 1M5G in the r.f. socket, 1H4G detector, and 1L5G or 1F5G output pentode. Valves used in the original set were VP2 r.f., PM2DX detector, PM22A output pentode.

The circuit of the "Scout Battery Three," which uses a screen-grid r.f. stage, triode detector, and pentode output valve,

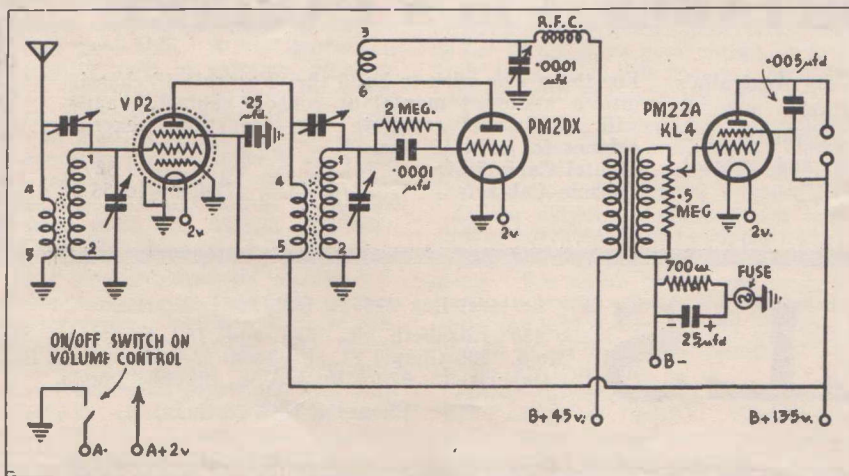

**NEW FEATURES - NEW ACCURACY - NEW APPLICATIONS**

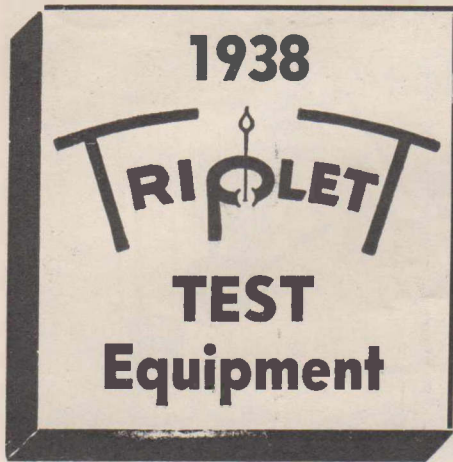

**The GREATEST  
RANGE in  
Triplet History**

**FEATURES**

- **MAXIMUM PROTECTION AGAINST OBSOLESCENCE.** All designs carefully considered from a viewpoint of possible obsolescence. Being single-purpose instruments in itself is great protection. Also damage to one unit makes repairs single and does not tie up other instruments.
- **UNITS ARE INTERCHANGEABLE IN CARRYING CASE,** inasmuch as they are contained in metal case of one size.
- **ULTRA PORTABLE.** Unit size is small, compact, hence light in weight and practical for the best results.
- **SOLID CONSTRUCTION.** The internal construction of all UNITS is designed so all small parts are rigidly supported. All units will stand up under hard usage and give service.
- **PRECISION BUILT.** Every test will show these UNITS are outstanding in quality. Every effort made to maintain accuracy throughout. Each Unit represents the most up-to-date engineering practice in every detail.

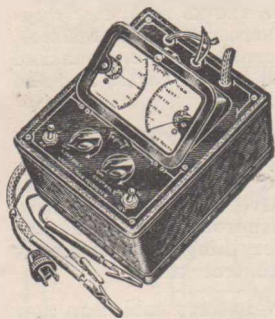

Model 1250

**MODEL 1250**

With its accuracy independent of changing tube valves, Model 1250 is the first self-calibrating Vacuum Tube Voltmeter. In this instrument tube characteristics are stabilised with the circuit, irrespective of what tube emission values may be. Replacing a tube does not alter accuracy. Model 1250 measures low A.C. and D.C. movements in a tilting type case. One indicates when tube characteristics are stabilised with the circuit. The other is a three-range voltmeter with approximately linear scales reading in peak A.C. and D.C. volts. Ranges are 25, 10 and 50 volts. All accessories included.

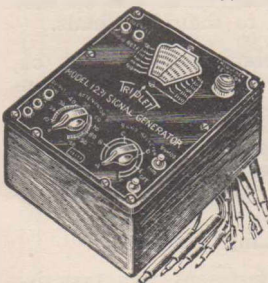

Model 1232

**MODEL 1232**

Model 1232 All-Wave Direct Reading D.C. Signal Generator now has built-in trimmer calibrated coils for accuracy of 1% on broadcast, intermediate and short wave bands. Six bands cover 120-30,000Kc. all fundamentals. Fully stabilised. Extra-long 12in. vernier type direct reading scale. Improved band selector switch. 400 cycle audio signal available. Includes batteries and two type '30 tubes. A.C. operated.

**MODEL 1210—A UNIT**

Tests all types of tubes. Direct reading. Coloured GOOD and BAD scale. Includes rectifier tube. Large meter. Line voltage regulation. All short tests. Cathode leakage test. Individual tests on diodes and full wave rectifiers. Simple to operate. Has four sockets with one 5-6 in combination to minimise panel space. Has a new RMA approved circuit with every essential for a dependable emission test of tube values. No confusion, complications or calculations.

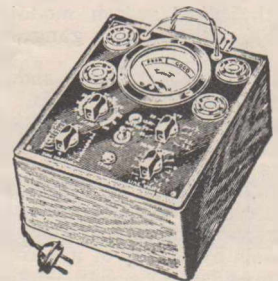

Model 1210

**TRIPLETT VOLT-OHM  
MILLIAMMETER  
(1200-A Unit)**

Has two instruments, A.C. and D.C. in moulded case. Can be tilted to any reading angle. Resistance measurements have individual zero adjustments. Selector Switch for all readings includes 22½ volts and 1½-volt batteries. Price £9 (Twin instrument and complete kit of parts to build this unit—Price £7).

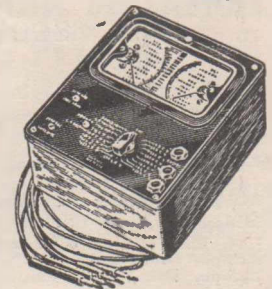

1200A Model

**W. G. WATSON & CO. Pty. LTD.**

279 Clarence Street, SYDNEY  
King & Bolton Streets, NEWCASTLE

398 Post Office Place, MELBOURNE  
91a Currie Street, ADELAIDE

and at PERTH, HOBART and LAUNCESTON

An under-chassis view, showing the extreme simplicity of the wiring.

#### Automatic Bias Used.

Volume is controlled by the potentiometer across the audio transformer secondary, the moving arm being taken to the grid of the output pentode. Automatic bias for the latter is obtained by connecting a 700-ohm resistor between "B—" and earth. All the "B" current drawn by the set passes from earth via the resistor to "B—" to complete the circuit. The voltage drop across the resistor, amounting to nearly five volts, is negative to earth, and so can be utilised for providing bias for the PM22A.

A fuse, in the form of a 60-milliamp. fuse bulb, is incorporated in the receiver between the "B—" and earth to safeguard the valve filaments in the event of an accidental short-circuit of the "B" supply through the "B" circuit.

#### Commencing The Assembly.

When the chassis and parts have been assembled, the construction can be commenced by mounting the valve and battery sockets, fuse bulb holder, aerial, earth and speaker terminals, reaction condenser, potentiometer (with on/off switch mounted on it), coils, and condenser gang.

All four terminals should be insulated from the chassis. The fuse bulb holder is mounted away from the rear wall, so that the bulb projects through a 1/2 in. hole as shown in one of the photographs. Before mounting the condenser gang, which is supported half an inch above the chassis by means of a 4-1 in. bolts and 12 nuts, solder a 6 in. length of push-back to the lug underneath each sec-

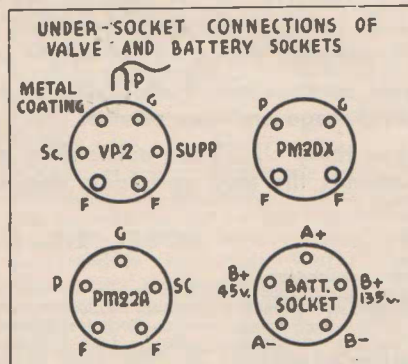
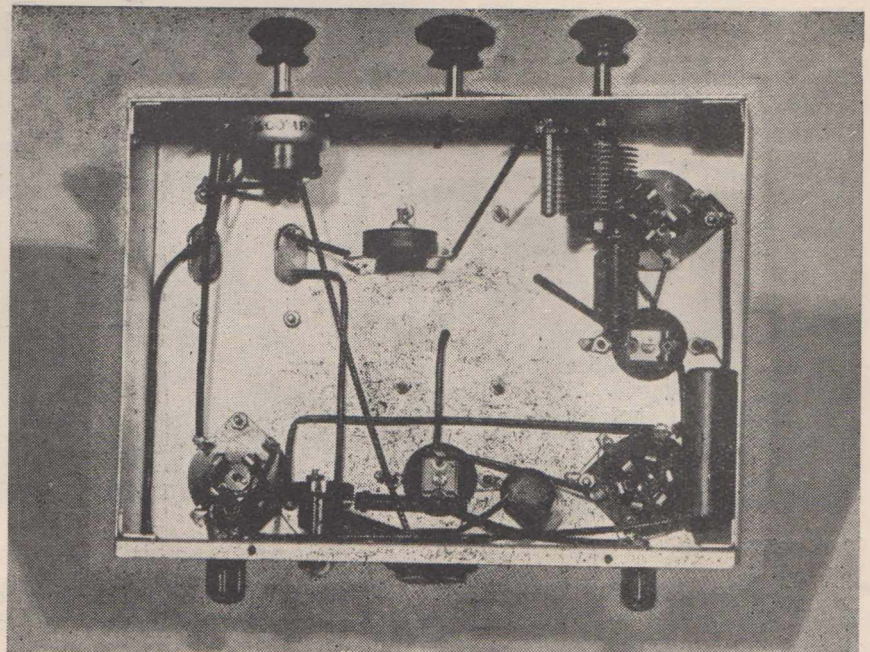

tion of the gang. Finally, before the r.f. coil is mounted, a flexible lead should be soldered to terminal 4 on the coil base, and taken up inside the can and out of a hole at the top. This

is the plate connection to the cap of the VP2.

The wiring is shown in detail in the under-chassis wiring sketch. The filament circuit should be wired first of all, and then, starting at the aerial terminal, wire the r.f. coil, VP2, detector coil, PM2DX, and so on until all the wiring is complete. When wiring in the 25 mfd. electrolytic condenser across the bias resistor, be careful to connect the end marked "1" or painted red to earth, and the other to "B—."

The chassis can now be inverted and the VP2 plugged into its socket. Solder the grid clip to the lead. Next remove the valve, invert the chassis, and make a thorough check of the wiring. If everything is in order, fit the dial and control knobs.

The five wire-battery cable can now be connected up, the valves plugged in, and the aerial, earth and speaker leads attached to their terminals.

Turn the volume control full on, and slowly rotate the reaction control until a hissing sound is heard in the speaker, denoting the set is on the verge of oscillation. Next rotate the tuning control, and stations should soon be picked up.

#### Aligning The Set.

The last adjustment necessary before the set is put into regular operation is the alignment. To do this, set the trimmers underneath the coils and those on top of the gang about half way out. Tune in a station near the middle of the band—a fairly distant one is best, so that a fair amount of reaction is needed to bring volume up to quiet room strength—and ro-

### "SCOUT BATTERY THREE"

#### List of Parts

- |  |  |
|--|--|
| <ul style="list-style-type: none"> <li>1—Chassis, 9 1/2 in. x 7 in. x 2 1/2 in., stamped and drilled as shown.</li> <li>2—Iron-cored coils, 1 aerial, 1 r.f., with reaction (Radiokes).</li> <li>1—2-gang condenset (Stromberg-Carlson).</li> <li>1—Aero dial, b.c. (Radiokes).</li> <li>1—4, 1—5, 1—6-pin wafer sockets.</li> <li>1—5-pin Dalton socket.</li> <li>1—5-pin Dalton plug with 2 yards 5-wire cable.</li> <li>1—Audio transformer (Radiokes).</li> <li>1—5 megohm potentiometer, with switch (Allen-Bradley).</li> <li>1—0001 mfd. midget reaction condenser (Radiokes).</li> <li>3—Knobs, 1 large and 2 small.</li> <li>1—r.f. choke (Radiokes).</li> </ul> <p><b>FIXED RESISTORS :</b></p> <ul style="list-style-type: none"> <li>1—700 ohm carbon resistor (Allen-Bradley).</li> </ul> | <p><b>FIXED CONDENSERS :</b></p> <ul style="list-style-type: none"> <li>1—0001 mfd. mica (E.T.C., Simplex).</li> <li>1—005 mfd. tubular (E.T.C.).</li> <li>1—25 mfd. tubular (E.T.C.).</li> <li>1—25 mfd. dry electrolytic (Ducon, E.T.C.).</li> </ul> <p><b>VALVES :</b></p> <ul style="list-style-type: none"> <li>1—VP2, 1—PM2DX, 1—PM22A (Mullard).</li> <li>(For alternative types see text).</li> </ul> <p><b>BATTERIES :</b></p> <ul style="list-style-type: none"> <li>3—45-volt "B" batteries (Ever-Ready).</li> <li>1—2-v. accumulator (Clyde).</li> </ul> <p><b>SPEAKER :</b></p> <ul style="list-style-type: none"> <li>1—Permanent magnet dynamic, input transformer to match single penthode (Rola 6-6).</li> </ul> <p><b>MISCELLANEOUS :</b></p> <ul style="list-style-type: none"> <li>4—Terminals (2 red, 2 black), 1—60 m.a. fuse bulb with holder, 1—large grid clip, solder tags, bolts and nuts, hook-up wire.</li> </ul> |
|--|--|



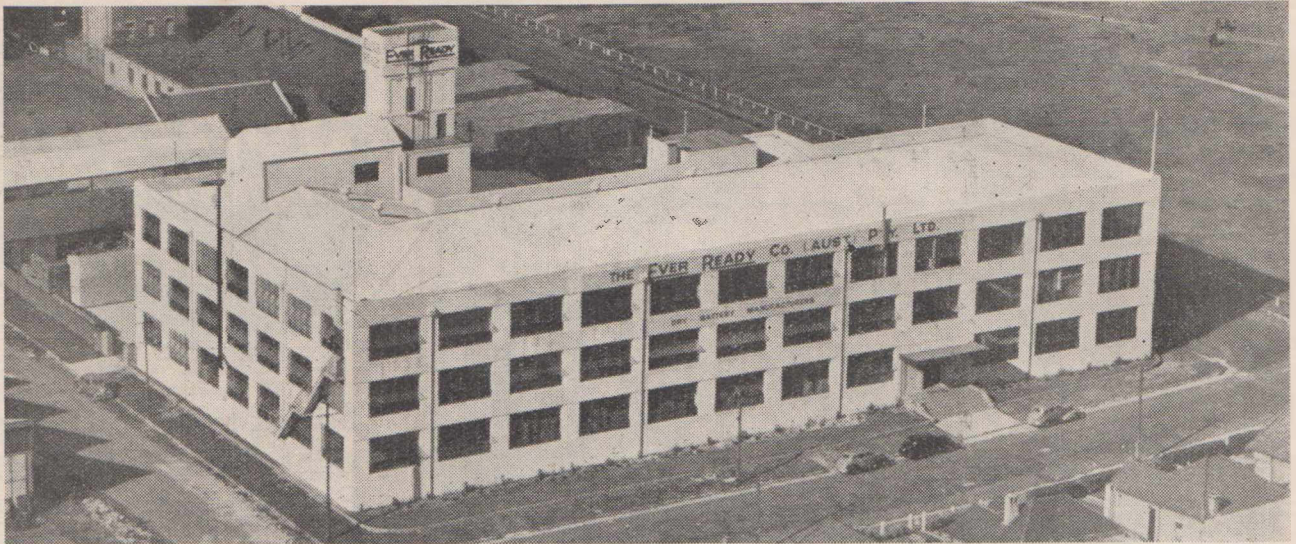

An aerial view of the new Ever Ready factory at Rosebery. It was officially opened on January 25th last by the Prime Minister, The Rt. Hon. J. A. Lyons, and is now in full production.

## A Trip Through The Ever Ready Factory

TO the technically-minded radio enthusiast there is nothing mysterious in either the theory or construction of the dry cell, of which millions are used each year throughout Australia for torches and "B" batteries. An outer zinc cylinder enclosing an electrolyte paste, which in turn surrounds a carbon rod, with a mixture of manganese and graphite as depolarising agent separating the two, comprise the main elements.

In practice, however, the manufacture of dry cells to ensure long and reliable life is an extremely complex process, as is revealed by this account of an inspection of the new Ever Ready factory at Rosebery, Sydney. From the moment the raw materials reach the factory right through the dozens of complicated processes that constitute the manufacturing procedure, until the finished cell is passed to the packing department, infinite care is taken to maintain the highest production standards.

The bulk supplies of manganese dioxide and graphite, both of which are in the form of a fine black powder, are housed in a separate store located outside the factory. Leading from this store to the top floor of the factory is a pipe through which the manganese and graphite are blown by air pressure as required into five huge

hoppers, and from these the powder is gravity fed to the floor below. Here it is dampened with a small quantity of electrolyte before it is fed down to the first floor.

On the second floor are kept huge rubber-lined containers in which the electrolyte is mixed, and flour added as a jelling agent. The electrolyte still retains its liquid form at this stage, though later, on following the cooking process, a white, jelly-like paste is formed.

### Laboratory For Research And Testing.

Also located on the second floor is the laboratory, where a staff of qualified chemists is con-

A corner of the laboratory, where a staff of skilled chemists is kept busily engaged in battery testing and general research work.





stantly engaged in research work and testing. Every batch of raw material that reaches the factory—sheet zinc, manganese dioxide, graphite, etc.—is always tested for consistency before it is passed for use in production.

Opening off the laboratory is one of the most interesting and important rooms in the factory—the test room. Here both temperature and humidity can be maintained at any desired values, within reasonably wide limits. In this room are rows upon rows of relay-controlled racks, with cells of all types strung along them undergoing tests.

In one corner is the programme machine—an intricate piece of apparatus that provides automatic relay control of the test racks. This machine is controlled by a master pendulum clock, driven by a 24-volt battery. It can be set to provide practically any type of intermittent test. For example, it is possible to discharge a single  $1\frac{1}{2}$ -volt dry cell for only four minutes in every 24 hours, or perhaps eight minutes every 12 hours, or for 12 minutes every half hour in the day, and so on.

Periodically the voltage of every cell under test is checked by assistants until the end-point, representing the lowest useful voltage of the cell, is



A section of the cell assembly department on the second floor.

reached. From this data, discharge curves are prepared, which provide accurate and reliable tests of the relative merits of the chemical constituents used in each cell, and of methods of manufacture.

#### Tube And Box-Making Machines.

Also on the second floor are machines of various types for making chip board boxes and round cell containers of all sizes, varying from the tiny variety used in fountain-pen torches to those re-



Another view of the cell assembly department. The huge hoppers in the background contain the cardboard tubes used as insulating containers for the cells.

quired for the P.M.G. type  $1\frac{1}{2}$ -volt dry cells.

The tube-making machine winds two strips of paper, with a centre strip of chip board, around a steel rod, forming a long cardboard tube of the required diameter. As the two paper tapes are passing through the machine, prior to winding, they are each coated on one side with molten pitch to ensure exclusion of moisture from the completed cell.

As this endless tube leaves the machine, it is automatically cut into lengths of approximately 4 feet each. Afterwards these are put through another machine which cuts each tube into sections several inches long. These later form the outside insulating containers of the cells.

In another section the boxes required for "B" batteries are formed from sheets of cardboard, which are first scored to give the required folds and then guillotined to the correct size. After this they are passed through a machine which glues the corners, and finally the labels are gummed on.

Wherever possible, production right throughout the factory is on the endless belt system, ensuring maximum production with a minimum of waste time.

#### 4,000 Zinc Cups Per Hour.

The zinc cups are prepared from strips of 99 per cent. pure zinc. A strip of zinc is fed into a machine which automatically cuts off the length required, folds each section in the form of a cylinder, fits the circular zinc base in the cup, and solders the side and bottom seams. Working at maximum output, one of these machines can make 4,000 complete cups in an hour.

(Continued on page 26)



# Forty Miles from town...

No matter where you are situated in Australia, the chances are that Ever Ready Batteries are serving you somewhere, somehow.

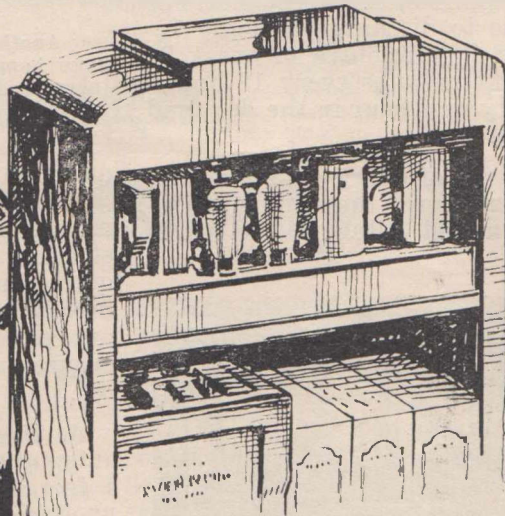

# EVER RADIO BATTERIES



*For many years Ever Ready has proved that for smooth, uninterrupted radio reception in country areas, there is nothing to equal the battery-operated receiver — especially when it is equipped with Ever Ready Superdyne B Batteries. Capable of months longer life, they are the most economical source of power you can buy for the purpose.*

*And to avoid the inconvenience and expense of recharging accumulators, there is the new Eveready "Air Cell." Guaranteed maximum power capacity the day you buy it, it is good for over 12 months' service, with normal use. Ask your usual radio dealer to demonstrate one of the new "Air Cell" operated radio receivers next time you are in town.*

# or Four Minutes from the City

If you live outback it will be Ever Ready Radio Batteries in your radio set—or perhaps an Eveready “Air Cell”—the newest development in country radio. If you live in the city it will be Ever Ready Torch Refills in your torch, Ever Ready Batteries in your doorbell and telephone, and in the boys’ cycle lamps . . . Whatever purpose it may be, however, you take no chances when you rely on an Ever Ready Product.

From the Company’s factory in Rosebery, N.S.W., millions of batteries come every year, each one the product of skilled workers, operating some of the most modern machines in the world.

When next YOU need a battery, make sure it carries the Ever Ready trademark, for better service and a longer period of useful life. . . .



# READY TORCHES & REFILLS

*Whether you live in the country or in the city, you should see that there is an electric torch within easy reach for use after dark. Inexpensive—a few shillings is all a good model costs—it will save you many a fall and much fumbling in the dark. The motorist and camper, in particular, should make it a rule to carry a torch wherever they go. And for best results see that your torch is fitted with “factory fresh” Ever Ready Torch Refills. Made in Australia, in the most up-to-date factory in the world, they give many extra months of brilliant light.*

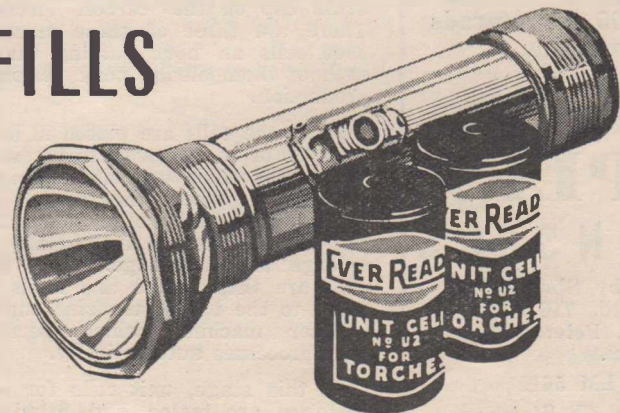

**THE EVER READY CO. (Australia) PTY. LTD. ROSEBERY N.S.W.**

# TESTED AND

TYPE

Simplex  
S/M

"SIMPLEX"  
OF  
CONDENSER

# OK'd

## AT 1,000 VOLTS A.C. & D.C.

Now you can buy moulded Mica condensers tested at 1,000 volts A.C. and D.C.—Mica condensers that have extremely high resistance to moisture—Mica condensers you can depend upon for the utmost in reliability, accuracy and permanency of calibration. Simplex . . . the "Custom-built" condensers . . . are made in three types: Type M with a capacity range of .004 microfarads to .02 microfarads. Type S/M—.000005 microfarads to .01 microfarads; Type P/T (Pig-tails) .000005 microfarads to .001 microfarads.

"Favoured By Famous  
Factories"

## SIMPLEX CONDENSERS

Manufactured by Simplex Products Pty. Ltd., 716 Parramatta Rd., Petersham, N.S.W.

'Phone LM 5615  
Agents In All States

★

The Prime Minister, The Rt. Hon. J. A. Lyons, with Mr. R. P. Walter, managing director of the Ever Ready Company (Aust.) Ltd., inspecting one of the machines on the occasion of the official opening of the new factory on January 25 last.

★

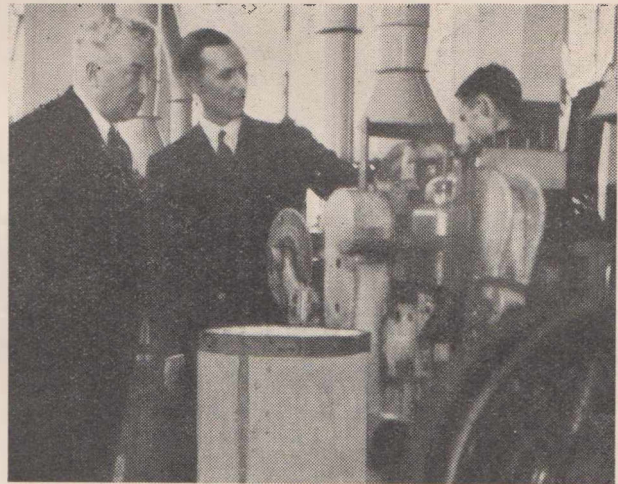

On the first floor the black mix of dampened manganese dioxide and graphite from the third floor passes into a machine which moulds it into cylinders around central carbon rods, leaving about  $\frac{3}{8}$ " of the latter projecting above. These bobbins, as they are called, are passed on to another machine, which carries out automatically the major portion of the assembly of the cell, and has an output of 15,000 cells per hour.

#### Assembling The Cells.

The zinc cups drop into sockets on an endless belt, and each cup is partly filled with electrolyte paste fed down a pipe from the third floor, where it is produced. A "star" washer of waxed board is then pressed into the base of each cup and a bobbin inserted, which raises the level of the electrolyte until it entirely surrounds the bobbin. The bobbins are accurately centred in the zinc cups automatically, and the cells then passed on through a trough of hot water for cooking. The heat applied converts the liquid electrolyte into a paste.

The cells are then ejected from the belt and passed along to another machine, which fits a waxed paper washer over the bobbin and stamps a brass cap on the carbon electrode. There are three of these machines, 8000 cells an hour passing through each of them during peak periods of production.

Next, the cells are placed in batches of 80 or so into wooden trays, and are passed along on belts to another department, where the top of each cell is filled with molten wax. Each cell is then tested individually for voltage and amperage. The brass caps are then tinned and leads soldered to the top of the zinc cups by another machine, which performs both processes automatically.

At this stage, unit cells for torch batteries are tested and fitted into their labelled containers.

The cells being used for assembling "B" batteries are next placed in cardboard boxes—30 to a box in the case of a 45-volt "B" battery—and passed along another endless belt, where the leads are soldered, connecting the cells in series.

Molten paraffin wax is then poured down the interstices, two sheets of paraffin paper and one of paraffin board placed over the top of each, and the labelled box fitted. The lids are then clipped on, and the batteries are ready for their final voltage and current tests. Following these, the batteries are passed to the packing and despatch departments.

On the ground floor are located the machine and carpenters' shops, together with a compressed air plant and oil-burning furnace to supply hot water for the cooking process.

#### Excellent Facilities For Employees.

One particularly attractive feature about the Ever Ready factory is the facilities provided for employees. Of the four floors, space approximately equivalent to one entire floor is devoted to this purpose.

On the second floor there is a large cafeteria, served by a correspondingly large kitchen, with every latest convenience. On the ground floor are located the locker rooms, with a separate steel locker for each employee. A fully-equipped dispensary with a qualified nurse in constant attendance is also maintained, free medical advice being available to employees from a doctor, who calls twice a week.

#### "Many Happy Returns."

The "Radio World" is certainly a fine magazine. Amateur shortwave receivers interest me most, while the s.w. and DX sections are wonderful and a great help in logging stations. Congratulations on your second birthday.—K. Morehead (AW45DX), Mt. Druitt, N.S.W.

# Shortwave Aerials For DX Reception . . (2)

## The Double Doublet.

As has been pointed out previously, the half-wave doublet is a most efficient collector of short-wave signals: but it has the great disadvantage of being at its best only at or near its resonance point. If, therefore, two dissimilar doublets can be connected to the same transmission line, without either interfering with the performance of the other, the overall performance of the two will be good over a wider range of frequencies than that of a single doublet.

The length of each doublet may be calculated from the following formula:—

$$L = \frac{0.95 W/L}{4} \times 3.28$$

Where L equals length in feet and W/L equals wavelength in metres.

Thus where interest is centred in not more than two frequencies, the best

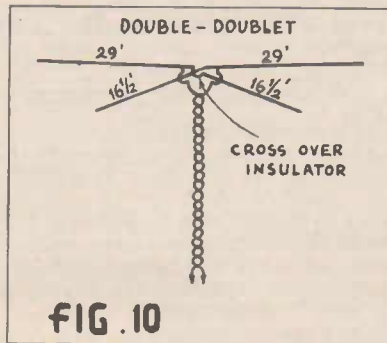

results will be obtained by using lengths calculated as above.

But if uniform results over a given range (say 20 to 40 metres) are desired, the doublet lengths must be different from the theoretical values. A typical set of dimensions are given in diagram 10. For optimum results on the amateur bands the doublets should be 51 feet and 33 feet, respectively.

The transmission line (or transposed lead-in) for the doublet in diagram 10 should be 80 feet in length. This length is not arbitrary, but is that which affords correct impedance matching to the doublets. Naturally for other frequency ranges the best results will be obtained with a different length of transmission line. Theoretically, the line should be a half

In this concluding instalment, a further variety of special aerials for shortwave reception is discussed.

By F. R. and A. H. GRAHAM

wavelength, or integral multiples thereof.

## The Quindoublet, or Spider-Web Antenna.

The spider-web, or quindoublet antenna, as it is often termed, since it consists of five doublets coupled to a common transmission line, is designed to give really efficient performance over the whole short-wave range from 4.3 to 50 metres.

The theory of operation is the same as in the case of the double doublet, except that owing to the larger number of doublets, the resonance peaks are brought closer together, resulting in a more even and constant response over the entire short-wave range. The connection of such a number of doublets to a common transmission line does not in any way spoil the performance of any individual doublet.

The doublets are selected in such a way that the resonant frequencies of any pair are not too far apart, so that the lapping of their characteristics will hold up the in-between bands, thus giving a much wider range than could be obtained otherwise.

In diagram 11 the following doublets are shown:—

- E & F, which resonate at 49 metres.
- C & D, which resonate at 16 metres.
- A & B, which resonate at 25 metres.

The two smaller doublets have been omitted, as they are for use on the

ultra high frequency bands only, and those S.W.L.'s with receivers capable of covering these bands should obtain better results by using one of the U.H.F. antennas as shown in diagrams 13 and 14.

The doublet E and F is closely coupled to the transmission line through a loading coil, which brings the resonance of this doublet to 49 metres. The coil, L1, should be sealed in a moisture-proof can, and connected as shown. It consists of 26 turns of 22g. wire wound on a 1/2 in. former. It is tapped at the 5th turn from one end.

At the receiver end of the transmission line a matching transformer is necessary, as shown in L2. This consists of 55 turns of 22g. wire on a 2 1/2 in. former, tapped 3 1/2 turns from one end.

## A Folded Doublet To Save Space

A rather unusual type of doublet is shown in diagram 12. Its peculiar shape is designed to save space.

The usual rules applying to doublet antennas apply to this one. The dimensions given in the diagram allow for most efficient reception on the 20-metre amateur band; but, of course, these may be altered as desired.

## Ultra-High-Frequency Antennas

The problem of designing an antenna for the U.H.F. bands is in no

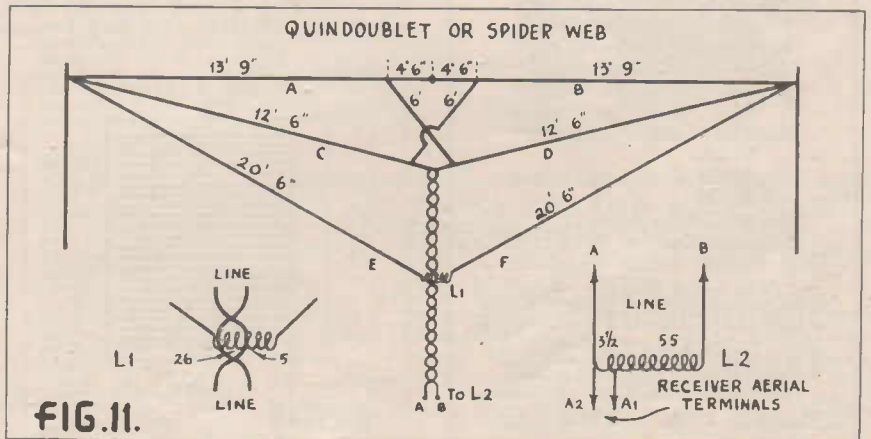

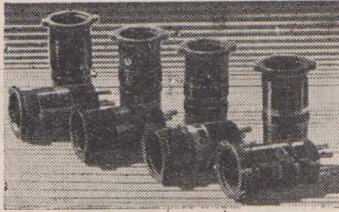

USE . . .  
**RAYWAY**  
 LOW-LOSS, HIGH-GAIN  
**COILS**  
 For "R9" + RESULTS !

You cannot expect 100 per cent. peak performance using coils that are only 40 per cent. efficient. Crudely-wound coils on "moulded mud" formers MUST bring disappointing results, particularly on the short waves, where one indifferent component can mean tremendous loss in signal strength. Wire gauge, turns, spacing, connections, former material . . . every detail must be scientifically planned if the last ounce of DX is to be obtained.

That is why, when building any "Radio World" receiver using plug-in coils, you should INSIST on the special RAYWAY LOW-LOSS HIGH-GAIN as specified and used by the Editor. Follow the designer's lead and ensure that you will duplicate his results.

RAYWAY coils are precision-wound on low-loss plug-in formers manufactured from the highest grade imported bakelite. They cost no more than inferior makes; so insist on RAYWAY.



Complete coil kits are available for any of the following "Radio World" shortwave and all-wave receivers:—

- "All-Wave All-World Two"
- "Eaglet Shortwave Two"
- "Empire Shortwave Three"
- "All-Wave Bandsread Two"
- "Empire All-Wave Three"  
(A.C. & battery models)
- "Battery Communications Seven"
- "Amateur Communications Eight"
- "Jones' Super-Gainer"

If unobtainable from your local dealer, write direct to:—

**Standardised Products**  
 629 PARRAMATTA ROAD,  
 LEICHHARDT, SYDNEY,  
 N.S.W.

'Phone - - - LM 5957

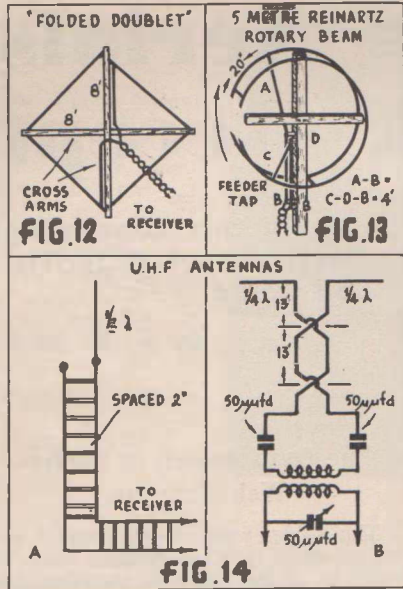

respect different from that faced on the lower frequencies. Antenna lengths are determined in the same manner, tuned feeders remain some multiple of a quarter wavelength, and matching systems are treated in the same fashion.

It has been usual to use vertical antennas for U.H.F. work, but recently the trend has been towards further investigation of the merits of horizontal antennas. Any of the arrays described may be suspended horizontally.

It should be noted, however, that a horizontal antenna on the U.H.F. bands will perform very poorly in receiving signals from a station transmitting with a vertical antenna.

**The Rotary Beam Antenna.**

The Reinartz double loop rotary beam (see diagram 13) has given extremely good results on the U.H.F. bands. It is essentially uni-directional, in a direction parallel to the plane of the loops, and away from the open end of the two loops (see diagram).

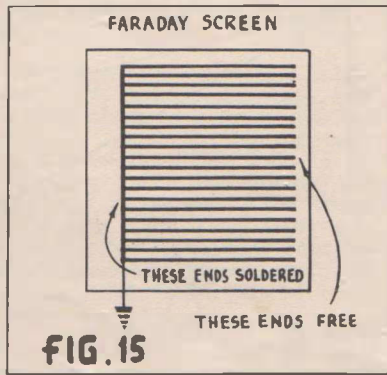

Actually the Reinartz comprises two half-wave antennas rolled into a more compact form. It should be constructed in such a way that it may be rotated in a complete circle; thus ensuring good reception from any point of the compass.

**Data for Construction of Reinartz Rotary Beam Antenna.**

Band.	Loop Lgth.	Loop Dia- meter.	Loop Spac- ing.	Loop Open- ing.	Feeder Tap.
20	33'	11' 1"	2'	18"	82"
10	16'	5' 4"	1'	8"	40"
5	8'	2' 8"	6"	4"	20"

**Two Other UHF Antennas.**

The two antennas shown in diagram 14 are recommended for long-distance reception on the U.H.F. bands.

The first antenna (B) has two horizontal arms, each a quarter wavelength, and a double lead-in with parallel wires transposed as shown in the diagram. This lead-in is coupled to the receiver by means of a coil of one or two turns of heavy wire, and two condensers of about 50 mmfd. in series with each lead-in wire.

Another simple U.H.F. antenna (A) has a vertical wire, a half wavelength in length, connected to the receiver through parallel feeders spaced 2ins. apart. One end of the feeders is connected to the antenna, the other is left floating.

**Noise Reduction Systems.**

In conclusion, a few words regarding the problem of noise reduction will not be out of place. Actually the only principle which can be applied in order to reduce man-made static is to locate the antenna in a comparatively noise-free area, and to employ a lead-in of such a type that the pick-up on the lead-in is eliminated.

The balanced transposed line is eminently suitable as a lead-in. When used in conjunction with a well-designed transformer at the set, pick-up on the line is practically nil.

In designing the line the space between the wires, and the size of the wires is important, since the inductance of the line depends on the relation between these factors.

$$\text{i.e. Impedance} = 276 \log \frac{b}{a}$$

Where a equals the radius of the wire, and b equals the distance between the wires.

The line must be matched to both the antenna and the receiver. The impedance along a half-wave antenna

(Continued on page 32.)

# Yes!

Yes! Angus & Robertson, Ltd., of 89 Castlereagh Street, Sydney, have the largest and most comprehensive stocks of text books in the Southern Hemisphere. Send in your name, address, and the subject you are interested in, so that it may be included on our mailing list. Special easy terms can be arranged for the purchase of any technical book.

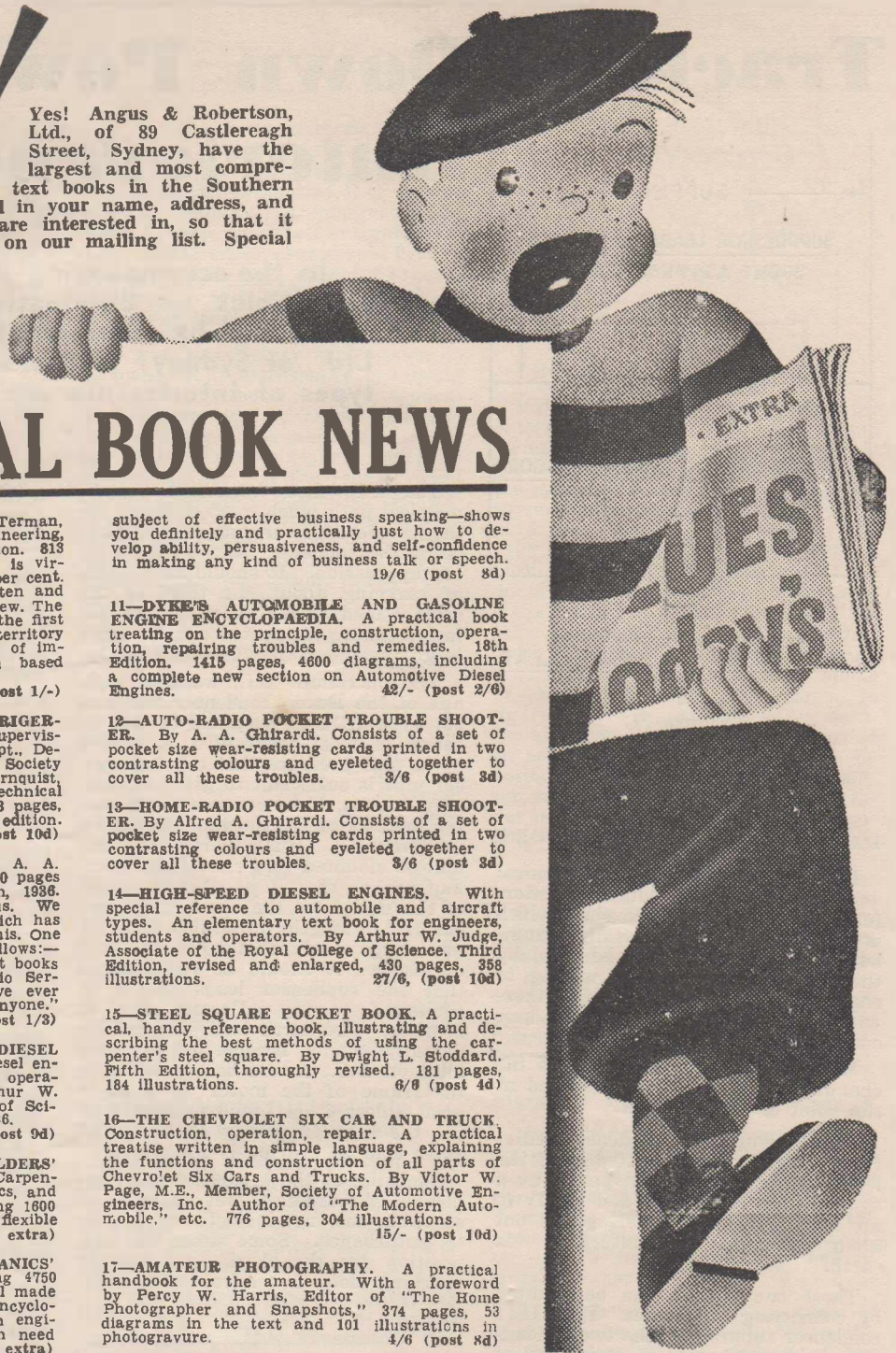

## TECHNICAL BOOK NEWS

**1—RADIO ENGINEERING.** By F. E. Terman, Associate Professor of Electrical Engineering, Stanford University. New Second Edition. 813 pages, 475 diagrams. The new edition is virtually a new book. Something like 75 per cent. of the text has been completely rewritten and over two-thirds of the illustrations are new. The book is about 10 per cent. longer than the first edition, but covers considerably more territory in proportion to its length as a result of improved organisation and presentation based upon experience with the first edition. 36/- (post 1/-)

**2—MODERN ELECTRIC AND GAS REFRIGERATION.** By Andrew D. Althouse, B.S., Supervising Instructor, Vocational Education Dept., Detroit Public Schools; Member American Society of Refrigerating Engineers, and Carl Turnquist, B.S., Refrigeration Instructor, Cass Technical High School, Detroit, Michigan, etc. 858 pages, 368 illus. Second revised and enlarged edition. 30/- (post 10d)

**3—MODERN RADIO SERVICING.** By A. A. Ghirardi. This new edition contains 1800 pages and 706 illustrations. Corrected edition, 1936. Ghirardi's books are now world-famous. We have never handled any radio book which has given more universal satisfaction than this. One buyer has recently written to us as follows:—"I happen to own a large number of text books on radio, but Ghirardi's 'Modern Radio Servicing' is the most useful book I have ever purchased, and I can recommend it to anyone." 27/6 (post 1/3)

**4—MAINTENANCE OF HIGH-SPEED DIESEL ENGINES.** A practical handbook for diesel engine fleet owners, maintenance engineers, operators, drivers and mechanics. By Arthur W. Judge, Associate of the Royal College of Science, London. 192 pages, 170 illus. 1936. 16/- (post 9d)

**5—AUDELS' CARPENTERS' AND BUILDERS' GUIDE.** Inside trade information for Carpenters, Builders, Joiners, Building Mechanics, and all Woodworkers. Four volumes containing 1800 pages, 3700 illustrations. Pocket size, flexible covers. 33/- (postage extra)

**6—AUDELS' ENGINEERS' AND MECHANICS' GUIDE.** A set of 8 volumes containing 4750 pages, 8754 illustrations, pocket size, well made and attractively bound. A complete encyclopaedia of all the working knowledge an engineer, machinist, mechanic, or electrician need have. 66/- (postage extra)

**7—THE ADVANCING FRONT OF SCIENCE.** By G. W. Gray, 364 pages. Here are important developments in our knowledge of the skies, of atoms and molecules, of the living matter of cells and tissues—findings which are providing bases for further advances; for reaching discoveries in such fields as biology, atomic physics, and geology. 19/6 (post 10d)

**8—MANAGING FOR PROFIT.** Working Methods for Profit Planning and Control. By C. E. Knoeppel, Industrial Management Counsellor. 343 pages, 102 diagrams. Mr. Knoeppel describes the recently developed aids to management in the way of profit-making tools and methods, shows how they work, explains how they can be applied to any business to better the profit position of the business. 23/- (post 10d)

**9—PRACTICAL BUSINESS SPEAKING.** By W. P. Sandford and W. H. Yeager, 316 pages. How to plan, prepare, and deliver any kind of talk for best results. This book covers the whole

subject of effective business speaking—shows you definitely and practically just how to develop ability, persuasiveness, and self-confidence in making any kind of business talk or speech. 19/6 (post 8d)

**11—DYKE'S AUTOMOBILE AND GASOLINE ENGINE ENCYCLOPAEDIA.** A practical book treating on the principle, construction, operation, repairing troubles and remedies. 18th Edition. 1415 pages, 4600 diagrams, including a complete new section on Automotive Diesel Engines. 42/- (post 2/6)

**12—AUTO-RADIO POCKET TROUBLE SHOOTER.** By A. A. Ghirardi. Consists of a set of pocket size wear-resisting cards printed in two contrasting colours and eyeleted together to cover all these troubles. 3/6 (post 3d)

**13—HOME-RADIO POCKET TROUBLE SHOOTER.** By Alfred A. Ghirardi. Consists of a set of pocket size wear-resisting cards printed in two contrasting colours and eyeleted together to cover all these troubles. 5/6 (post 3d)

**14—HIGH-SPEED DIESEL ENGINES.** With special reference to automobile and aircraft types. An elementary text book for engineers, students and operators. By Arthur W. Judge, Associate of the Royal College of Science. Third Edition, revised and enlarged, 430 pages, 358 illustrations. 27/6 (post 10d)

**15—STEEL SQUARE POCKET BOOK.** A practical, handy reference book, illustrating and describing the best methods of using the carpenter's steel square. By Dwight L. Stoddard. Fifth Edition, thoroughly revised. 181 pages, 184 illustrations. 6/6 (post 4d)

**16—THE CHEVROLET SIX CAR AND TRUCK.** Construction, operation, repair. A practical treatise written in simple language, explaining the functions and construction of all parts of Chevrolet Six Cars and Trucks. By Victor W. Page, M.E., Member, Society of Automotive Engineers, Inc. Author of "The Modern Automobile," etc. 776 pages, 304 illustrations. 15/- (post 10d)

**17—AMATEUR PHOTOGRAPHY.** A practical handbook for the amateur. With a foreword by Percy W. Harris, Editor of "The Home Photographer and Snapshots," 374 pages, 53 diagrams in the text and 101 illustrations in photogravure. 4/6 (post 8d)

**10—FUNDAMENTALS OF RADIO.** By Frederick E. Terman, Professor of Electrical Engineering, Stanford University, with the collaboration of Lt. F. W. Macdonald, U.S.N. First Edition, 1938. 458 pages, 277 diagrams. An elementary version of the author's well-known "Radio Engineering," designed for a one-term course in radio. Emphasising basic principles and their applications. No knowledge of complex quantities is required. 24/6 (post 1/-)

LIST OF BOOKS ON ANY SUBJECT SENT POST FREE ON APPLICATION.

### EASY TERMS ARRANGED

ANGUS AND ROBERTSON, LTD.,  
89 Castlereagh Street, Sydney.

ON APPROVAL  
ORDER FORM

Please send me the book(s) numbered ..... above for 7 days' free examination. For any not returned at the end of that period I agree to forward the price quoted (including postage) on receipt of your statement. State if terms desired.

Name .....  
Address .....  
Business Address .....  
Occupation .....

# Tracking Down Power Interference . . (2)

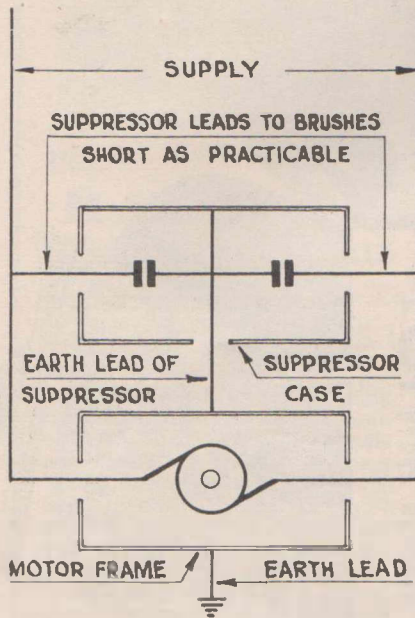

Figure "C"

## Suggested Methods Of Suppression.

### D.C. MOTORS AND GENERATORS.

It is in most cases more economical and more simple to reduce the interference by correcting the plant which is giving rise to it. Generally a number of other people will benefit by these efforts, and may be willing to share the expense—each would otherwise have to install a condenser unit on his incoming mains.

Motor interference arises from the changing magnetic fields produced at the point of commutation.

These set up high frequency oscillations, which are transmitted along the leads to the commutator, partly as a symmetrical component and partly in an asymmetrical manner, going out along the lines and returning via earth.

These components can be shunted by connecting a "Chanex" Type H.11 condenser suppressor, the two condensers being connected in series across the terminals with the centre point connected to the frame of the machine. (See Figure "C.") If the interference still persists, the earth connection of the condenser unit to the frame of the machine should be removed. If this causes a reduction in the interference it indicates a strong asymmetrical component, which may be removed by earthing the frame through a suitable H.F. choke. In this case the centre point of the condenser must go direct to earth, and not to the frame.

In the accompanying instalment of this series of articles on eliminating power interference (published by courtesy of Ducon Condenser Pty. Ltd., of Sydney) methods of suppressing various types of interference are outlined.

The H.F. choke makes the asymmetrical path much more difficult for the interference currents, and thereby helps the condenser unit in its work of suppression. It should be capable of carrying about one third of the normal load of the machine, for the interference current can be quite large.

The maximum D.C. working voltage of the Ducon condenser suppressor type H.11 is 600, and it will be found in most cases of D.C. motors up to this pressure that one suppressor unit is sufficient to give satisfactory results, if it is connected across the brushes of the machine, as shown in figure "C." It is important that the unit be mounted very close to the commutator, so that if possible the leads to the unit from the brushes are under 1ft. in length, preferably 6ins. As most large machines have several sets of brushes it should be remembered that the condenser leads should be connected to any adjacent sets of brushes. The earth lead, which incidentally cannot become continuously alive on D.C., should be connected to the frame of the motor by a short lead, unless it is found necessary to use the high frequency choke in the earth lead as previously mentioned.

Sparking at the brushes usually indicates disturbance, but absence of sparking does not indicate an absence of disturbance. Some times the best position for the brushes as regards sparking does not agree with mini-

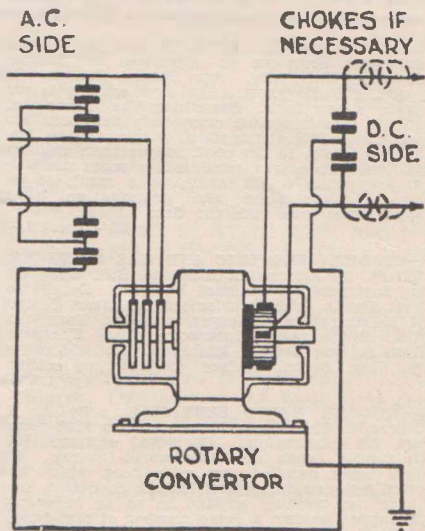

Figure "E."

mum disturbance, and in some cases the brushes have to be shifted when condensers are fitted.

### A.C. Motors.

A.C. Motors of both induction and synchronous types, like A.C. generators, do not give rise to continuous electrical interference, since there is no regular breaking of the circuit as there is with commutators, and the only form of disturbance normally obtained is in the case of single phase induction motors, which are often arranged with an internal switch to assist in starting.

Some induction motors have a commutator to give them high starting torque, but this is cut out as the speed rises. The disturbance from these motors is often produced while starting up, and with many machines it is not frequent enough to justify suppression. A.C. series commutator motors have to be treated as D.C. motors, but A.C. repulsion motors, in which a commutator is used with brushes which are short circuited, cannot effectively be suppressed by condensers across the brushes, here the

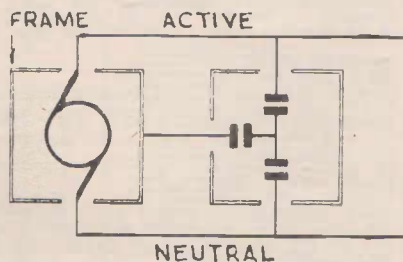

CHANEX TYPE H.12. or H.14. USED WITH UNEARTHED APPARATUS

Figure "D."



units should be connected across the main supply leads as close as possible to the motor.

**Fractional H.P. Motors.**

In this category fall the many types of household appliances, such as electric fans, vacuum cleaners, hair driers, etc. In many cases the frames of these small motors are not earthed. Consequently, the centre point of the condenser suppressor cannot be connected directly to frame of the machine, as there is a risk of the operator receiving a shock, due to the framework of the machine having a potential difference to earth, proportional to the capacity of the condenser connected.

One remedy is to connect the centre point to earth, but this is only practicable where a three-wire flex is being used, and where the third wire is connected to earth.

The other method is to use a type H.12 or type H.14 Chanex suppressor unit, where the condenser assembly is as shown in figure "D." This arrangement is satisfactory in the majority of cases, and the reactance of the condenser is high enough to cause only a very slight potential difference between the frame and earth.

With the majority of portable appliances, such as hair-dryers, vacuum cleaners, vibrators, fans, etc., the Chanex type H.12 units cannot conveniently be used and for this reason the flex lead suppressor, type H.14, has been introduced. The condenser unit circuit is similar to that shown in diagram "D." Its small size and lightness are such that it is not noticeable when fitted at approximately 1ft. from the appliance. The Chanex type H.14 is moulded in brown bakelite, and is fitted with internal cord grips. It is a very simple suppressor to fit, but in the interests of complete reliability and safety it is advisable always that these units be fitted by licensed electricians or servicemen.

The flex lead suppressor type H.14 is used by large manufacturers in ini-

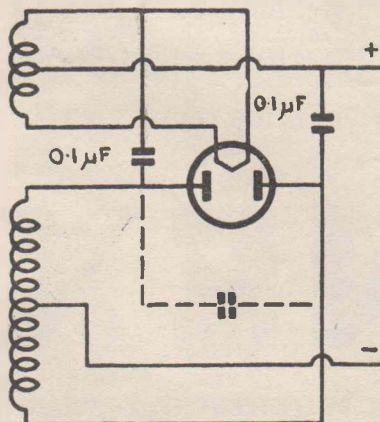

Figure "F"

tial equipment, and it can be used with every confidence on any small machine on which the frame is unearthed.

**Rotary Converters.**

The suppression of rotary converters is similar to that of D.C. motors with the addition of suppressors on the A.C. side, as shown in figure "E." A condenser suppressor should first be connected across any adjacent brushes on the D.C. side with short leads as previously pointed out, and the earth lead connected to the frame. This may give satisfactory suppression on its own, but if disturbance is leaving the source by the A.C. leads, condensers will be required across that circuit. A three-phase machine is shown and for single or six-phase the principle is similar. If the frame is not already earthed, it should be connected to some low resistance earth, such as the main water pipe or the lead covering of the incoming main cable, unless some regulation exists prohibiting such a course.

Only in a few cases are chokes required in addition to condensers, and

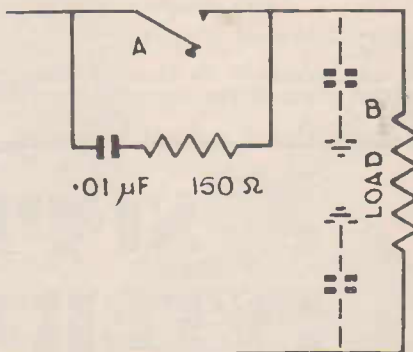

Figure "G."

they should not be tried until the condensers have proved inadequate.

The above connections apply for rotaries working from A.C. to D.C. or vice-versa, but when converting from D.C. suppressors on the A.C. side are seldom required, unless feeding the radio receiver itself.

Rotary transformers for converting D.C. at one voltage to D.C. at another are treated as if they consisted of two D.C. motors or generators.

In any of the above arrangements for suppression much more satisfactory results are obtained if all the wiring is in well bonded and earthed conduit or lead covered cable.

The commutator of a rotary converter with its brushes will require suppression in the same manner as a D.C. motor or generator, and as a general rule this will be sufficient to quieten the machine from an interference point of view.

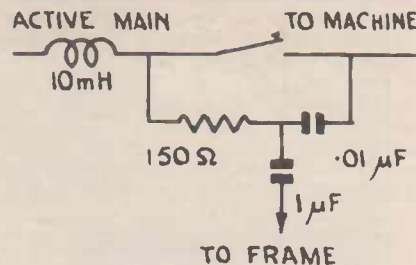

Figure "H."

**Battery Charging Equipment.**

Valve rectifiers are mostly used for battery charging in this country, and owing to the large current required the valves employed are usually of the mercury vapour type, in which the current pulse through the rectifier is of a very sharp and irregular form. This sudden pulse of current sets up high frequency oscillations in the inductances and stray capacities associated with the transformers and the other equipment, but this can generally be suppressed by the connection of type F.11 condensers across the anode of the rectifier valve, as shown in figure "F." In extreme cases additional suppression, either by means of an additional condenser, as shown by dotted lines, or a suppressor condenser, may be required on the main input leads to the transformer, but usually this is not necessary.

**Rotary Rectifiers.**

Rotary rectifiers are not in very great use in this country, but where trouble is encountered with this type of rectifier the Ducon Condenser Co. would be pleased to receive any queries and forward the necessary information as to how this type of rectifier can be suppressed.

**Vibrating And Intermittent Contact.**

Many devices use a circuit which is alternatively made and broken. The make and break may be rapid as in the case of an interrupter or a bell, or it may be relatively slow, as in the case of flashing signs, electric ovens, etc., which are controlled by thermostats or other devices.

A simple circuit of this type is shown in the figure "G." When the contact is closed the portion of the wire A.B. is at full mains potential, but as soon as the contact is broken this wire falls to zero potential. This sudden change in potential causes an instantaneous current flow through the capacity between the wire and earth, generating a train of high frequency currents, which will travel along the mains for quite a distance. The simplest method of remedying this trouble is to connect a Chanex F.11 condenser across the contact, as shown. As soon as the contact opens, the current flows into the condenser,

so that the potential of the wire does not fall down to zero, and the action becomes more gradual and less liable to cause interference. A quench resistance of a few hundred ohms should be included in series with the condenser, so that momentary charge and subsequent discharge shall not be oscillatory in character, as otherwise the effectiveness of the remedy would be lost.

It should be noted that the condenser used in this position should be of a relatively small capacity, as a condenser on A.C. passes current, and if too large a capacity is used, proper opening of the circuit may not result. Generally speaking, a condenser of .01 mfd is sufficient. If this does not cure the interference, then a high frequency choke should be connected in the main lead, as close as possible to the contact (otherwise the lead between the choke and the contact will still radiate interference) while, in severe cases, suppressor condensers across the mains may also be used.

(To be continued next month.)

### Lakemba Radio Club Notes And News.

(Continued from page 14.)

using a 53 xtal osc./doubler and 46 in the P.A. The antenna is a zepp., and the receiver a four-valve t.r.f.,

using a speaker. The location is not a good one, as interference is very bad from a local industrial centre.

Besides the amateur side of the hobby, the lads occupy their time learning the code, making simple buzzers and tappers, assembling radio parts donated by interested friends, taking apart certain defunct accessories to examine their construction, constructing filament transformers from burnt-out receiver power transformers, wiring up bells, etc. Several of the boys who have been in the club for over a year have now constructed a.c. receivers up to five valves, one lad in particular having built a Jones' "Super Gainer." He also uses the key very well, but is a little worried because most "hams" send too fast for him to copy! (Don't we all remember this?)

"If you should hear 2AGX on the air, give us a call, as we will be very pleased to QSO you," is the request of Mr. Hadgkins. "And furthermore, if you have any spare gear to help the boys along, we would be very pleased to receive it."

### Shortwave Aerials For DX Reception.

(Continued from page 28.)

is approximately 70 ohms, measured at the centre of the antenna.

It is most important to note that the noise eliminating characteristic of the system will depend entirely on the design of the transformer, which couples the line to the set. This transformer is designed to eliminate in-phase signals, while transmitting the out-of-phase signals to the receiver. The mere presence of a transformer does not eliminate the in-phase signals or noise, because if there is capacity coupling, the noise will be transmitted to the set through that capacity. Capacity coupling can be eliminated by the use of a Faraday electrostatic screen (see diagram 15).

### Making An Electrostatic Screen.

The screen is constructed by space-winding 24g. d.c.c. wire on a celluloid cylinder, temporarily supported on a 3-inch diameter form, and then treating the winding with celluloid dope. When the winding is thoroughly dry the form is removed and the cylinder cut length-wise to form a rectangle. The wire ends along one edge are soldered together to a wire for the ground connection, the ends at the other edge being left separated.

When placed between the coils of the transformer, the screen eliminates the noise picked up by the line, whilst transmitting the out-of-phase signals picked up by the antenna to the receiver.

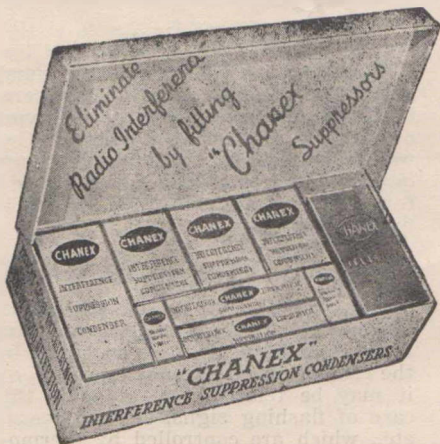

### FREE BOOK.

This free book is a complete treatise on the causes and suppression of Radio Inductive Interference, and will prove very instructive and helpful in opening up a new avenue of business. Supplies of this book will gladly be forwarded to you on application to any of our offices or distributors as listed below.

# SUPPRESS INTERFERENCE

The contents of the Chanex Kit will handle the majority of all generated interference. The Chanex Suppressors conform to all regulations and are built to British Standard Specifications 613/1946, and have been approved for connection to the mains by all Electricity Supply Authorities.

The Kit contains:—

2-Type Hll, 2 x .01 @ 4/- ea. 6 0

2-Type Hll, 2 x .1 @ 3/9 ea. 7 6  
 2-Type Hll, 2 x .5 @ 7/6 ea. 15 0  
 1-Type Hll, 2 x 1mF @ 9/6  
 ea. . . . . 9 6  
 2-Type H12, 2 x .1 + .006 @  
 4/6 ea. . . . . 9 0  
 2-Type H14, 2 x .1 + .006 @  
 7/6 ea. . . . . 15 0  
 2-Type H15, 2 x .1 @ 7/- ea. 14 0  
 2-Type H17, .5 @ 4/- ea. . . 8 0

RETAIL VALUE . . . . . 84 0

# CHANEX

**DUCON CONDENSER Pty. Ltd., 73 Bourke St., Waterloo, Sydney**

"Cornhill Chambers,"  
 450 Collins Street,  
 MELBOURNE, C.I., VIC.

P. H. Phillips,  
 123-5 Charlotte Street,  
 BRISBANE, Q'LAND.

Wm. T. Matthew,  
 95 Grenfell Street,  
 ADELAIDE, S.A.

Carlyle and Co.  
 915-917 Hay Street,  
 PERTH, W.A.

Arnold and Wright,  
 Levy Building,  
 Manners Street,  
 WELLINGTON, N.Z.

*Star pleated*  
 ANODE CONSTRUCTION



*Reliable in every climate*



**MORE EFFICIENT  
 LONGER LIVED**



The specially designed anode in E.T.C. Solar Electrolytics makes for accurate capacities and more efficient service. . . . E.T.C. Solars are specified by that large group of radio engineers who value unflinching results and greater reliability. Always make sure that replaced condenser is an E.T.C. Solar.

MANUFACTURED BY:

**E.T.C. INDUSTRIES LTD.**  
 SYDNEY and MELBOURNE

# What's New In Radio

A monthly review of latest releases  
in sets, kit-sets, and components

## New Australian-made Solar Wet Electrolytic Condensers.

Of interest to the radio trade is the announcement by E.T.C. Industries Ltd. of additions to the range of E.T.C. Solar wet type electrolytic condensers, which now comprise the following, all of which are available from stock.

8mfd. 500-volt in 1 3/8" diameter can  
8mfd. 600-volt in 1 1/2" diameter can  
16mfd. 500-volt in 1 1/2" diameter can  
24mfd. 500-volt in 1 1/2" diameter can  
35mfd. 500-volt in 1 1/2" diameter can  
16mfd. 350-volt in 1 1/2" diameter can  
8mfd. 500-volt Minicap in 1" diameter can.

Attention is particularly drawn to

the last item on the above list, which fulfils a long-felt want of manufacturers of miniature radio receivers by the production of the E.T.C. Solar Minicap wet type electrolytic condenser. This is a miniature type of condenser and performs exactly the same functions as the larger types.

The advantage of the Minicap is that whereas the standard electrolytic condenser has a 1 3/4 in. to 1 1/2 in. diameter can and overall height above the chassis of 4 3/4 in., the Minicap has only a 1 in. diameter can and overall height of 1.15/16 in.

Obviously a great space-saver in chassis construction, it is expected that the Minicap, which can also be

obtained in larger capacities at lower voltages, will meet a steadily increasing demand.

★

## "Radiomac" Trolotul Condensers.

The new "Radiomac" variable condensers lately released by Price's Radio Service incorporate Trolotul insulation, which is claimed to be superior to ceramic insulation. Trolotul is characterised by possessing remarkably low power losses and is unaffected by atmospheric changes. In fact, water absorption is nil after 24 hours immersion.

This remarkably efficient condenser is available in five sizes for receivers and low powered transmitters, and two sizes with double-spaced plates.

Another feature that is perhaps as important as the efficiency is the price. These latest "Radiomac" condensers are priced at a figure that is generally lower than the usual ceramic-insulated types.

★

## In Latest "Radiotronics."

Featured in the latest "Radiotronics" (No. 85), is a table showing recommended conditions for resistance capacity coupled operation of the Radiotron types 6L5G, 6T7G, and 6S7G, all these being of the 6.3 volts .15 amp. series.

Six pages of the latest issue are devoted to giving full details, including characteristics, of two new converter valves, the 6K8 and 6J8G, which differ from pentagrid converters in that they incorporate a separate oscillator in the same envelope, but internally connected to a grid of the mixer unit.

The 6K8 is a triode hexode and the 6J8G a triode heptode. The most important advantage these two valves possess over ordinary pentagrid converters is that they are designed to give improved performance on the high frequency band of all-wave receivers.

★

## 1938 Rola Series Now Available.

Shown opposite are two 8" models from the new range of Rola reproducers for 1938—a range that has been so completely re-designed visually, mechanically and electrically as to excite immediate interest. Firstly Rola's long-standing regular colour of brown has been replaced by the new iridescent silver-grey, which besides giving the speaker a better appearance, also has better wearing qualities.

It will be noticed that the electrodynamic K8 model (top) now has a pot-cover fitted as standard equipment. The cone housing has been re-designed also to give great mechanical strength, to resist any tendency

A Quality Built  
Valve & Circuit Tester  
With Many Desirable  
Features . . .

## PATON

Models V.C.T. & V.C.B



Will check and test every component in a Radio chassis. . . . Valves included, and is designed to enable technicians to cope with all general service and design problems with the one compact unit. The ranges of the V.C.T. are as follow:—VALVES for merit and leakage. PAPER CONDENSERS under working conditions. ELECTROLYTIC CONDENSERS for leakage. LOW OHMS from 1/10 of an ohm (for dry joints and Coil tests). MA.'s in 4 ranges. D.C. VOLTS in 4 ranges. A.C. AND OUTPUT VOLTS in 4 ranges.

The Model V.C.T., equipped with our precision ultra-large 5in. type meter, is complete in portable leatherette lidded case. 11in. x 11in. x 6in., A.C. operated.  
Trade Price:—£15/10/- plus tax.

The V.C.B., for Country Districts, draws its filament requirements from an external accumulator: The ranges of the V.C.B. are as follow:—VALVE TESTS, Tests battery, auto and A.C. valves for merit and shorts. LOW OHMS from 1/10 of ohm to 30 ohms (10 ohms half scale). OHMS have three additional ranges up to 2 megs. D.C. VOLTS in 4 ranges:—10, 100, 250, 500. MA.'s in 4 ranges:—1, 10, 50, 100.  
Trade Price, complete:—£14/15/- plus tax

Manufactured by

## Paton Electrical Instrument Company

90 VICTORIA STREET, ASHFIELD, SYDNEY  
Manufacturers of Cathode Ray Equipment, Meters  
and full range of Testing Equipment



to distort or twist even when used under the most severe conditions. A new type of cone seems to be employed. The permanent-magnet model 8-20PM follows the same general improvements as its electro-dynamic prototype.

**New Type Transformers.**

Perhaps the greatest improvement to speakers that has been introduced to the trade in recent years is the fitting of the new type totally enclosed transformers to the 1938 range. This unit is now fully enclosed and hermetically sealed in a drawn streamlined case.

New types of windings have been evolved, giving greater efficiency and better response. These are assemb-

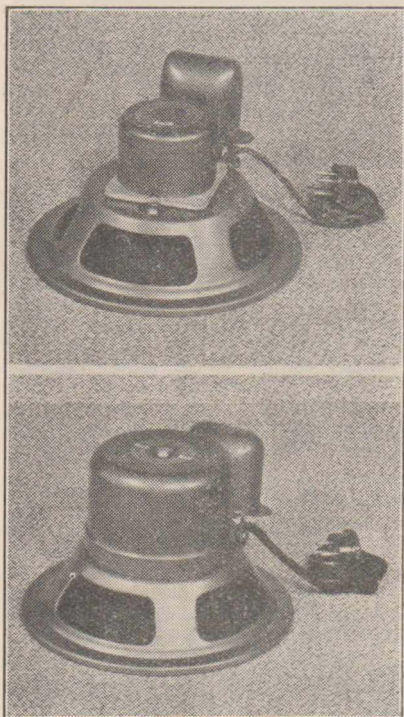

These two latest Rola releases are the K8 electro-dynamic (top) and the 8-20 P.M. permanent magnet model.

led in the case with bakelite spacers which definitely anchor the unit in a central position. The transformer is then vacuum impregnated with a special sealing compound, which absolutely prevents moisture from entering.

Transformers fitted to all P.M. speakers further have the insulated core connected to "B+" of the plug to further prevent corrosion of the transformer windings by electrolysis.

Input transformer breakdowns have been traced, in almost every instance, to electrolysis, caused by minute leakage of current from the primary winding of the transformer to the speaker frame itself. This effect is cumulative, and is therefore more evi-

dent with battery receivers, because unless special precautions are taken the primary winding is maintained at a positive potential with respect to the frame for twenty-four hours per day, whether the receiver is in use or not.

This exclusive Rola transformer now definitely eliminates any possibility of the breakdown of windings.



**Eddystone Rep. Changes Address.**

Mr. R. H. Cunningham (VK3ML), Australian representative for Eddystone products, wishes to inform readers of his new address—at 94 Robinson Road, Hawthorn, E.2, Victoria. 'Phone Hawthorn 6548.



**New Test Equipment For Electricians.**

Testing equipment of particular interest to electrical engineers, linesmen, etc., handled by Messrs. W. G. Watson and Co. Pty. Ltd., of Sydney, include the Delta portable combined ammeter and voltmeter. The combined testing set consists of two instruments in a leatherette-covered carrying case, with hinged lid and handle. Triplett moving iron instruments giving an accuracy within 2 per cent. are incorporated, dial diameters being approximately 5ins.

A similar instrument, and one that combines in one unit an insulation test set, a d.c. voltmeter and an a.c. voltmeter, is the Triometer insulation testing set, listing at £12/10/-.

**Also Agents For Smith Electric Clocks.**

Messrs. W. G. Watson & Co. Pty. Ltd. are also agents for Smith Setric electric clocks, which are available in a wide variety of designs, there being over 100 models to choose from. Accurate time, no winding or regulating, silent running and negligible running costs are features of this new line of electric clocks.

Further details regarding the above lines can be obtained from Messrs. W. G. Watson & Co. Pty. Ltd., 279 Clarence Street, Sydney.



**New Text-Book For Students.**

Recognised by radio engineers throughout the world as a standard textbook, "Radio Engineering," by F. E. Terman, is nevertheless not widely popular among those possessing only a limited knowledge of higher mathematics. Realising this, the author has prepared an elementary version of the above book, the new work being entitled "Fundamentals of Radio."

As the author states in the preface, the purpose of "Fundamentals of

Radio" is to present the basic principles of radio communications in a form suitable for use in an introductory radio course. The book is essentially a condensed version of the author's "Radio Engineering," but the treatment has been simplified to confine the discussion more closely to fundamental principles.

Chapter headings are as follows:—The Fundamental Components of a Radio System, Circuit Elements, Resonant Circuits and Circuit Analysis, Fundamental Properties of Vacuum Tubes, Vacuum-Tube Amplifiers, Power Amplifiers, Vacuum-Tube Oscillators, Modulation, Vacuum-Tube Detectors, Sources of Power for Operating Vacuum Tubes, Radio Transmitters, Radio Receivers, Propagation of

**Foolproof Radio-**

**Clyde 'Plugg-in' Radio Batteries** eliminate the possibility of wrong connections or short circuits and improves reception from every Battery-operated Radio Set.

**CLYDE 'PLUGG-IN' RADIO BATTERIES**

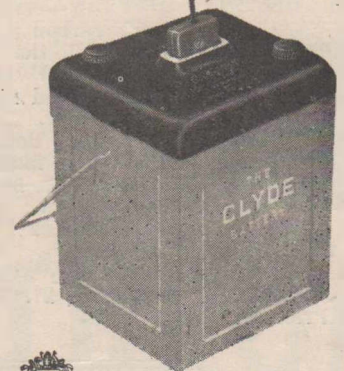

**THE CLYDE ENGINEERING CO. LTD.**  
61-65 Wentworth Avenue, Sydney  
Branches in all States

Radio Waves, Antennas, Radio Aids to Navigation, Television, Acoustics. A comprehensive set of problems has also been included.

"Fundamentals of Radio," by F. E. Terman. Our copy from Messrs. Angus and Robertson, 89 Castlereagh St., Sydney. Price 24/6, postage 10d.



**S.T.C. Model 402 Vibrator Receiver An Excellent Seller.**

Released recently by Standard Telephones and Cables Pty. Ltd., the S.T.C. Model 402 vibrator-operated mantel model is already enjoying excellent sales throughout Australia, and deservedly so, because it is a receiver difficult to fault.

A broadcast model only, the 402 uses a 6D8G mixer, 6S7G i.f. amplifier, 6T7G second detector, a.v.c., and first audio amplifier, and 38 output pentode. Intermediate frequency is 450 k.c., the set being fully air-trimmed throughout. Other technical features include the use of a.v.c. and the provision of pick-up terminals. A unique feature is the incorporation of a threshold sensitivity control mounted on the rear of the chassis. Thus maximum possible sensitivity can be obtained if desired by adjusting the control to the point of oscillation.

There are three controls—combined on/off battery switch and volume control (left), combined tuning control and dial light switch (centre), and tone control (right).

Though the vibrator unit is mounted on the receiver chassis, which in a

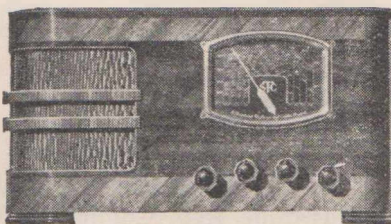

The S.T.C. Model 524 five-valve dual-wave vibrator mantel receiver. The Model 402 reviewed on this page is identical in appearance, except that it has three controls instead of four.

mantel model receiver is necessarily compact, there is not the slightest trace of vibrator "hash" or of mechanical vibration.

The station-zoned dial is of particularly attractive design, and is provided with a chromium-plated escutcheon which tones well with the highly-polished veneer cabinet.

On test, the 402 proved an exceptionally fine performer. For local and medium distance work the set brings in all that can be desired with the threshold sensitivity control backed off a trifle. For extreme DX work, however, this control is invaluable, and will undoubtedly prove an important selling feature in remote country

locations, where abnormally high sensitivity is often an essential.

**Performance Comparable With Console.**

A particularly striking feature, and one that demonstrates the progress that has been made in the design of vibrator-operated receivers, is the excellent tonal response, which is comparable to that obtained from a standard 4/5 a.c. console.



**Philips "Ten Fifty-Two" Has Many Attractive Features.**

One of the latest Philips Model 1052 Radioplayers was received recently for test by the "Radio World." A five-valve a.c. dual-wave superhet listing at 18 guineas, the Model 1052 represents the first excursion by Philips into the moulded cabinet field, and the manufacturers are to be congratulated on the striking success they have achieved, not only in the artistic cabinet design, but throughout the entire receiver.

Valve equipment comprises an EK2 octode, 6D6 i.f. amplifier, 75 second detector, a.v.c. voltage generator and audio amplifier, EL3 output pentode and 80 rectifier. Waveband coverage is from 540 to 1520 k.c. on the broadcast band, and from 8 to 22 m.c. (37.5 to 13.5 metres) on the short waves. Thus the 13, 16, 19, 25 and 31 metre

**RAYMART**  
CRAFT A CREED

**SHORTWAVE & ULTRA SHORT WAVE EQUIPMENT**

**CERAMIC COIL FORMS**  
Ceramic grooved and ribbed coil forms, 2½" diameter, with 5" winding space. Type TFX at right. List Price . . . . . 14/6  
Call in or write for full particulars of the complete "Raymart" range.

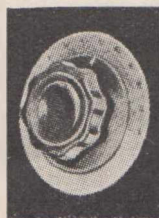
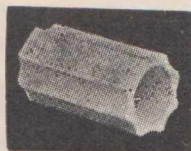

**TRANSMITTER DIALS**

Individually spun, heavy solid nickel dials with engraved (not etched) divisions and handsome knob. Diameter 4". Type T X D (above). List Price, 12/9

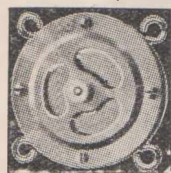

"Regal" carbon type microphones in the following ranges:—Model C-7, single button, polished nickel finish, 2½" diameter. List Price, £2/5/-. C-8, double button, same size and finish as Model C-7. List Price, £2/10/-. C-9, double button, polished chrome finish, 2½" diameter. ¾" thick. List Price, £2/15/-. Also obtainable in Desk Types, height 6½", width at base 4½". Model A-4. List Price, £7. Model A-4D. List Price, £8.

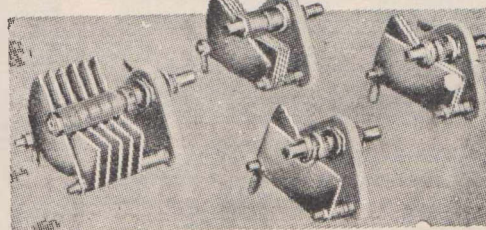

**CERAMIC SHORTWAVE MICRO-VARIABLE**

The new range of micro-variables employ their exclusive new material "RMX" for greatest efficiency at high frequencies. Ball races are electrically shorted, ensuring freedom from noise.

VC15X	15mmfd.	.....	List Price	6/9
VC40X	40mmfd.	.....	" "	7/6
VC100X	100mmfd.	.....	" "	7/9
VC160X	160mmfd. (.0016mf.)	.....	" "	9/9

(as specified for "Amateur Communications Eight")

VC250X	250mmfd. (.0025mf.)	.....	" "	10/6
NC15	(Transmitting) Neutralising, 15 mmfd., spacing, .07in.	.....	" "	8/-
TC40	(Transmitting) Tuning, 40 mmfd., spacing, .07in.	.....	" "	9/6

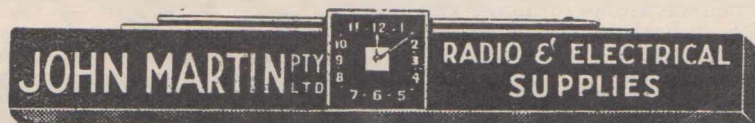

"The Friendly Wholesale House"  
116-118 CLARENCE STREET, SYDNEY.

'Phone: BW 3109 (2 lines)  
Telegrams: "Jonmar," Sydney.

international shortwave bands are all included.

**Tri-Unit Construction.**

An innovation that ensures ready accessibility to all parts of the chassis is the unique tri-unit construction adopted. As shown in the accompanying illustration, the chassis is split into three sections, the first (on the left) comprising all components

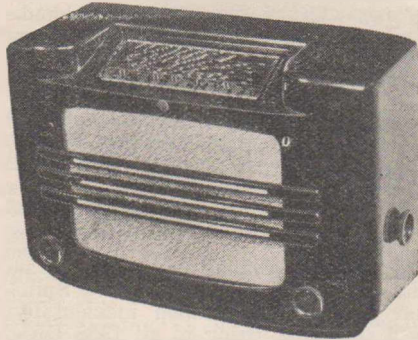

The Philips Model 1052 Radioplayer.

up to the control grid of the i.f. amplifier, the second (on the right) the i.f. amplifier, second detector and output pentode, and the third (centre) the power pack with rectifier. An important feature of this unit construction is that the mixer section is fully floated on rubber, obviating any danger of microphonic trouble. Other technical features include the use of a.v.c., audioscopic reproduction, "perma wire" trimmers, and the use of a console type 8" speaker.

One of the most attractive features of the set is the large linear dial and well-designed drive mechanism used; legibility is excellent, while the action is velvet-smooth. On the broadcast band, stations are zoned into four groups, N.S.W., Victoria and Tasmania; Queensland; West Australia, South Australia and N.Z.; while on the short waves an ingenious scheme employing numerical "station locators" has been incorporated to simplify logging of overseas stations.

There are only two controls on the front panel, volume (left) and tun-

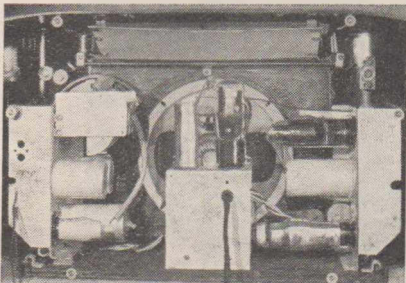

The unique tri-unit 1052 chassis.

ing (right). On the left-hand end of the cabinet is a three-position tone

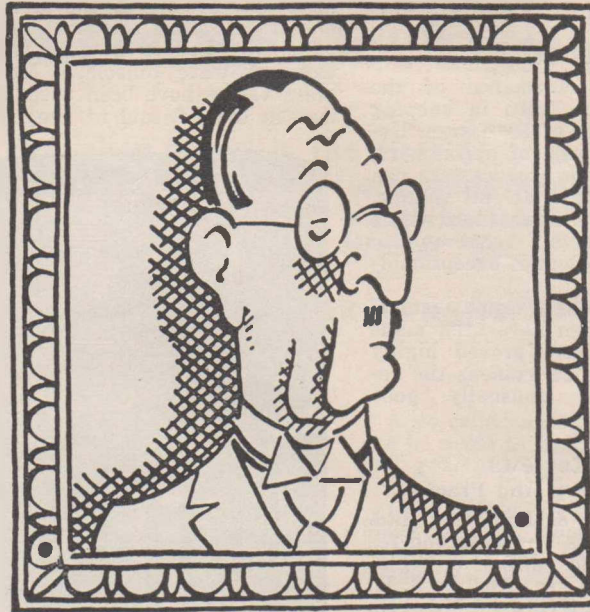

**•He who never made a mistake**

**H**E who never made a mistake probably never made a discovery either. We sometimes learn wisdom better by our failures than by our successes . . . often find out what will do by finding out what will not do.

But this trial-and-error method is a slow and costly way of finding out about radio valves. You've got to be sure with valves. They're the vital part which determines the quality and performance of your radio set.

And there's only one way to be sure: look for four pillars in a valve—not two. The only valve with this extra support—Raytheon—costs you no more. And how much it means to the accuracy, tone and life of the valve! Remember, look for the four pillars—you can't pick the wrong valve then.

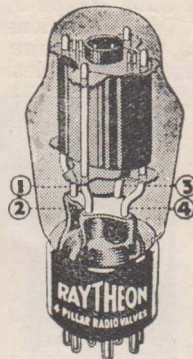

*This patented container allows your Raytheon to be tested before you buy, without breaking the carton or the guarantee seal.*



**RAYTHEON**  
THE MAKERS OF  
**4-PILLAR VALVES**

If unobtainable from your local dealer, write to Standard Telephones & Cables A/sia. Pty. Ltd., 258-274 Botany Road, Alexandria.

control, and on the right, the wave-change switch.

**An Excellent Performer.**

On test, the performance of the 1052 proved to be fully in keeping with the excellence of its design. Using only a few yards of aerial wire, local and inter-state broadcasters can be pulled in at night at full volume, while the performance on short waves is equally impressive. Tonal quality for so small a receiver is exceptionally good.

Altogether, though some radical departures in design have been made in the 1052, all have proved highly successful, and at 18 guineas the receiver represents unusually good value.

★  
**Book Reviews.**

**"Television—Theory And Practice."**

Messrs. Angus & Robertson Ltd. advise that supplies of the second revised and enlarged edition of "Television, Theory and Practice," by J. H. Reyner, B.Sc., A.C.G.I., A.M.I.E.E., M. Inst. R.E., are now available.

(An advance review of this latest textbook on television was published in the February "Radio World.")

"Television, Theory and Practice" is one of the most up-to-date and comprehensive manuals available on the subject. Dealing with both receiving and transmitting technique, and lavishly illustrated with half-tones and diagrams, it includes the very latest data on the work of numerous investigators.

"Television—Theory and Practice," second revised and enlarged edition, by J. H. Reyner, B.Sc., A.G.G.I., A.M.I.E.E., M.Inst.R.E. Obtainable from Messrs Angus and Robertson, 89 Castlereagh St., Sydney. Price 21/-, postage 10d.

**"Aircraft Radio."**

The many and varied applications of radio to modern aviation form the subject of "Aircraft Radio" by D. Hays Surgeoner, A.F.R., Ae.S. Written for civil, air force and commercial pilots, and for students of navigation and wireless telegraphy, the book traces the development of radio in aviation and deals extensively with direction finding and blind landing systems as used on all major air lines of the world. Various types of directional approach and landing systems, d.f. equipment, airport transmitters and receivers, etc., are dealt with in detail. A chapter is also included covering lighting installations of modern air ports.

"Aircraft Radio", by D. Hay Surgeoner, A.F.R., Ae.S. Our copy from Messrs. Angus and Robertson, 89 Castlereagh St., Sydney. Price 18/-, postage 7d.

★  
**Six-Gang "Spinner" Tuning In Latest Ultimates.**

Of special interest to those interested in receivers in the de luxe class, and particularly to DX enthusiasts, the 1938 range of Ultimate receivers incorporates many notable improvements, of which several of the most

important are not found in receivers manufactured in this country. Prominent in the new range is the eight-valve all-wave console. Metal and glass valves have been used, the former in the r.f. and i.f. stages where

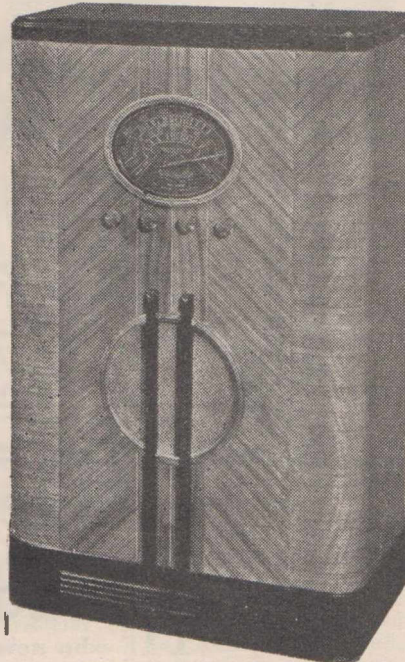

The 1938 six-valve dual-wave Ultimate, which incorporates many new and exclusive features.

the comparatively low grid-plate capacities ensure superior performance.

**Six-Gang "Band-Spread" Tuning Condenser.**

The "star" feature is the use of a 6-gang tuning condenser replacing the

conventional three-gang type. Three of the gangs tune the shortwave coils separately, while for the broadcast band the remaining three gangs are paralleled with the first three. This relatively low tuning capacity on the short waves ensures higher efficiency, greatly improved tracking, and much easier tuning. For example, stations on the 31-metre band are spread over the dial almost as much as stations at the high frequency end of the broadcast band. Two shortwave bands, covering from 13 to 100 metres, embrace all the international telephony channels.

In all, there are seven tuned circuits, permeability tuning being used throughout, enabling high gain, knife-edge selectivity and improved tracking to be obtained.

**"Spinner" Tuning Dial.**

A feature almost as attractive as the six-gang condenser is the "Spinner" tuning dial, which incidentally is a standard fitting to all 1938 Ultimate models. Consisting of a die-cast flywheel combined with a planetary motion attached to the rear of the tuning knob, the "Spinner" allows of a tuning ratio of approximately 30:1, while at the same time no laborious turning of the control is necessary to tune from one end of the broadcast band to the other. One spin of the knob will do this. As well as the advantages outlined above, the "Spinner" makes for extremely smooth tuning.

Space will not permit of a detailed description of other features, which include a 320-degree dial scale, logging pointer for micro-accurate tuning, improved type of electric eye tuning indicator, improved calibrated

(Continued on page 41.)

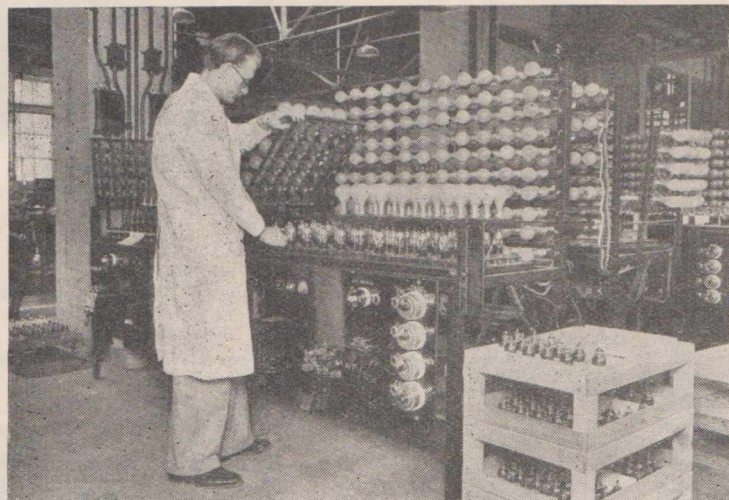

A corner of the large British factory of Standard Telephones and Cables Ltd. (London), where Brimar valves are manufactured. This view shows the activating racks in which each valve, before final inspection, is placed in a "seasoning" rack where it is operated for a length of time sufficient to stabilise its characteristics. Scores of thousands of Brimar valves are sold annually in Australia.



# A.O.C.P. Questions & Answers

## A.O.C.P. EXAMINATION PAPER —JANUARY, 1937

1. (a) Calculate the length of a "Hertz" antenna that would be suitable for operation on all three bands of 80, 40 and 20 metres. Give your answer in feet and show full working.

A.: 1 (a) The minimum length of the Hertz antenna will be one half wavelength for a selected position in the 80-metre band. Since the antenna will function efficiently at only one frequency in each band, it is necessary to choose a frequency in the 80-metre band such that the second and fourth harmonics will fall within the limits of the 40 and 20-metre bands, respectively. The natural wavelength of the antenna must therefore lie between 85.7 and 82.2 metres (3500 and 3650 k.c.).

Suppose a wavelength of 83.6 (3590 k.c.) is selected. Then the length of wire for fundamental operation will be 41.8 metres, less approximately 5% . Converting this length to feet we have—

$$95\% \times 41.8 \times 3.28 = 130 \text{ feet app.}$$

Alternatively, using the formula

$$(N - 0.05) \times 492,000$$

Freq. (k.c.)

where N is the number of half waves on the wire (in this case one) we arrive at the same result—

$$\frac{0.95 \times 492,000}{3590} = 130 \text{ feet app.}$$

The length will vary slightly according to location.

Note.—There is no Hertz antenna which will function with maximum

Published below is the first of a series of six articles comprising questions, with model answers, set in recent A.O.C.P. examinations. Specially written for the "Radio World" by . . . . .

H. WHEELER (VK5HW)

efficiency at fundamental and exact harmonic frequencies as well. Owing to "end effect" the physical length of

A so-called all-band Hertz antenna can be made to work, but it is not the best practice.

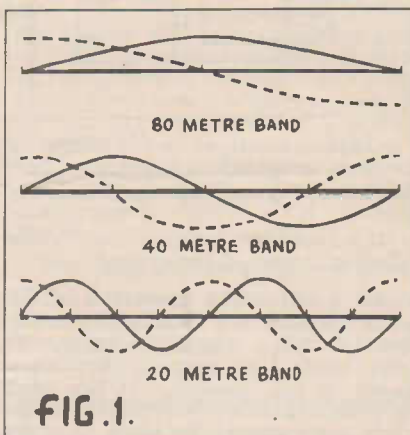

These sketches illustrate the answers to question 1 (b).

(b) Indicate by the use of simple diagrams the standing waves that would exist for each of the three bands.

1 (b). See Fig. 1. The ideal curves representing standing waves of current are shown as full lines having zero value at the ends of the wire. The voltage curves, 90° out of phase with the current, are shown as dotted lines having maximum values at the ends. In actual practice the conditions would be better represented by modifying the curves slightly at the ends.

2. Show a full schematic diagram without power supply of a superheterodyne receiver suitable for the reception of unmodulated C.W. telegraphy signals and explain the function of each stage.

A.: 2. In this simple superheterodyne c.w. receiver, all the valves, with the exception of the audio amplifier, are r.f. pentodes. The first stage, on the left of the diagram, which is a frequency changer, consists of one valve as first detector working in con-

a second harmonic antenna would be 97.5% of the fundamental wavelength, and 98.75% in the case of the fourth harmonic. However, the antenna length calculated above is suitable for operation on all three bands.

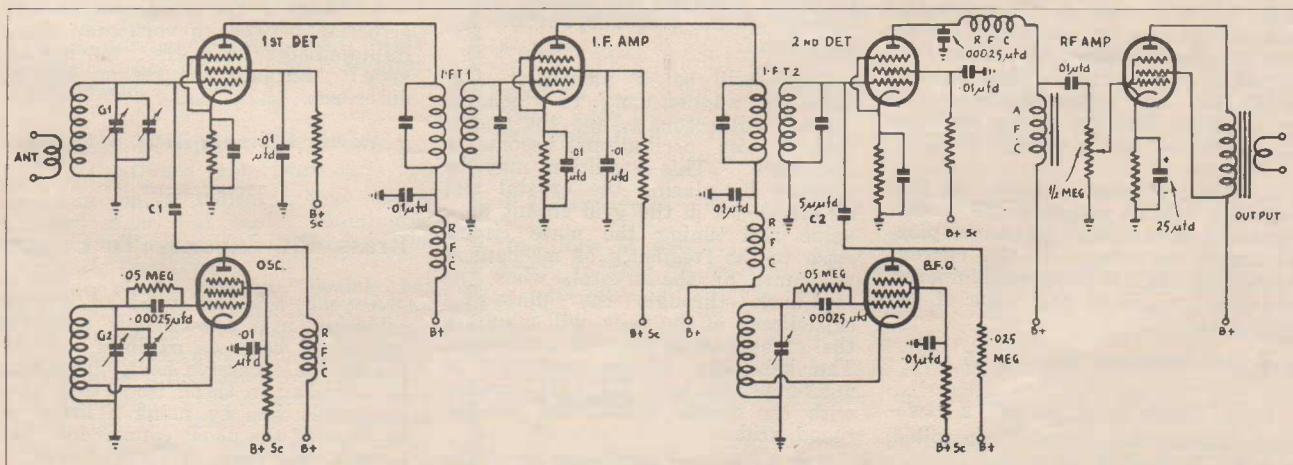

This circuit of a six-valve superhet designed for amateur use illustrates the answer to question 2





# The All-Wave All-World

Official Organ of the All-Wave All-World DX Club

# DX News



### VK2ME, 3ME And 6ME — Schedules For May.

The following transmission schedules will be observed by shortwave stations VK2ME, VK3ME and VK6ME during May:—

VK2ME (31.28 m., 9590 k.c.)			
Sydney Time G.M.T.			
Sundays:	4-6 p.m.	0600-0800	
	8 p.m.-Mtd.	1000-1400	
Mondays:	1.30-3.30 a.m.	1540-1730	
VK3ME (31.5 m., 0510 k.c.)			
Melbourne Time G.M.T.			
Nightly			
Monday to 7 p.m.-10 p.m.		0900-1200	
Saturday			
(inclusive)			
VK6ME, Perth (31.28 m., 9590 k.c.)			
Perth Time G.M.T.			
Nightly			
Monday to 7 p.m.-9 p.m.		1100-1300	
Saturday			
(inclusive)			

### QSL Exchange Bureau.

The following members would like to exchange QSL cards with other dxers:—

- Gordon Young (AW245DX), Paterson Street, Teneriffe, N.1, Brisbane, Queensland.
- L. E. H. Mallinson (AW321DX), 33 River Street, Mackay, Queensland.
- R. Cook (AW122DX), Norris Street, Bowen, Queensland.
- Louis Robertson, Derby Road, Milford, Connecticut, U.S.A.
- J. K. Sorensen (AW316DX), "Fairholme," Station Road, Gympie, Queensland.

### 1938 Ultimate Receivers.

(Continued from page 38.)

volume control indicator, fine colour-etched glass dial scale, illuminated waveband indicator ports, and a 12in. dynamic speaker.

Many other "Ultimate" models that have just been landed include five-valve broadcast and dual-wave receivers, and a six-valve dual-wave model.

Detailed information regarding the entire range will be sent free and post free to "Radio World" readers writing the sole Australian representatives, Messrs. Geo. Brown & Co. Pty. Ltd., 267 Clarence Street, Sydney.

### DX News And Views.

#### Reports Out to YDC And RNE.

I received your letter, membership form and badge, and was delighted with them. Since becoming a member I have sent reports on reception to RNE, Moscow, and YDC, Batavia, and am looking forward to veries from these two. I have already 15 QSL's. My present set is a Breville six-valve all-waver, and I am also negotiating with a firm for a seven-valve communications receiver.—D. MacDermott (AW370DX), Inverell, N.S.W.

#### One Month's Loggings On S.W.

The following stations were logged in one month on a seven-valve dual-wave A.C. receiver using a single

wire-fed Hertz aerial 67 feet long.

3 W1's, 3 W2's, 4 W3's, 9 W4's, 10 W5's, 29 W6's, 3 W7's, 8 W9's, 1 VE3, 1 VE4, 5 VE5's, 10 F8's, 4 PK1's, 3 F3's, 4 PAO's, 2 ZL's, and HB9BR, HB9J, SU1CH, YV1AP, YV5AZ, ON4SS, ON4ZA, K4ENY, K7FBE, XZ2DY, ZS2N, ZS6AJ, ZS6CT, ZE1JF, SU5AN, SU7BK, XE1BC, LA1F, J7CB, VS1AJ, SM5SD, 6 G2's, 5 G5's, 4 G6's, and 5 G8's. I have also received QSL cards from 14 stations, and have reports out to 29 others.

I would like to exchange QSL cards and photos with other dxers.—Charles H. Thorpe (AW342DX), 25 Charles Street, North Rockhampton, Queensland.

## ALL-WAVE ALL-WORLD DX CLUB

### Application for Membership

The Secretary,  
All-Wave All-World DX Club,  
214 George Street,  
Sydney, N.S.W.

Dear Sir,

I am very interested in dxing, and am keen to join your Club. The details you require are given below:

Name.....

Address.....  
[Please print both plainly.]

My set is a.....

[Give make or type, number of valves, and state whether battery or mains operated.]

I enclose herewith the Life Membership fee of 3/6 [Postal Notes or Money Order], for which I will receive, post free, a Club badge and a Membership Certificate showing my Official Club Number.

(Signed).....

[Note: Readers who do not want to mutilate their copies of the "Radio World" by cutting out this form can write out the details required.]



# Short-wave Review

CONDUCTED BY

**ALAN H. GRAHAM**

## Latest Station News from Overseas ★ Reports from Observers ★ Many New Stations Logged by Trophy Winner ★ Hourly Tuning Guide.

### Ultra-High-Frequency Bands

The broadcast stations continue to put in some good steady signals on both 9 and 11 metres. On 9.49m. W9XUY, relaying KOIL, Omaha, is by far the loudest and most consistent station. Incidentally, at the present moment the shortwave call is not used, the station merely announcing as "KOIL, Omaha." Other 9-metre stations reported are W9XPD, W4XCA and W1XOG.

On 11 metres the 24-hour Californian W6XKG is the best at present; although W9XAZ is also good. Occasionally W9XJL may be heard, but very weakly.

Several experimental stations have been granted licenses to operate on 7 metres. Most interesting of these is W8XWJ, Detroit, which also transmits on 9.49m. This station has a new allocation on 41,000 k.c., 7.32m., and is reported as testing. No reception of its signals has been reported in this country as yet.

Another new station on 7.44 m. is a short-wave transmitter relaying WDRG, Hartford, Connecticut. This station will have a power of 1k.w., unusually high for ultra-high-frequency work.

★

### Latest Police Transmitter News

Two additional verifications are to hand from American police transmitters. The first is from station W2XIJ, Rockland County Police, Viola, New York. It verifies a report on their 9.9 m. signals, adding that the report was the first received from Australia. The letter from Chief Operator Mr. W. R. McDermott adds that W2XIJ uses 300 watts: the antenna is a "J" type located on top of a steel tower, 161ft. in height. Station W2XIJ works in co-operation with 12 patrol cars over a radius of 17 miles.

The other verification is from Long Beach police, call W6XEH. This station uses only 100 watts, on 9.09 m. It works in conjunction with 14 mo-

bile units, and one lifeguard boat.

At the present moment conditions on the police bands are rather indifferent, and it seems probable that the falling-off noticed at this time last year will again take place. Earlier in the month a number of stations were heard on the 9.9 m. band. The best of these were Rockland County (W2XIJ), Newark (W2XEM), Alhambra (W6XFE), San Gabriel (W6XGC), and Los Angeles (W6XPA).

★

### Overseas Station News.

#### Activity Among Americans.

Most of the better-known American transmitters are coming in well at present on nearly all the wavebands. Several of these stations are also testing on new frequencies. W1XAL are testing on 11,730 k.c., 25.57 m., in addition to their ordinary frequency of 11,790 k.c.; they are especially anxious to receive reports on their test transmissions. W2XAD are reported on 21,500 k.c. (13.96 m.) in addition to their 19 m. transmission; whilst W2XAF are operating on both 9530 and 9500 k.c., or 31.48 and 31.58 m., respectively.

#### Central And South Americans.

HJ6ABC is the new call sign of HJ4ABC. Located in Ibague, Colombia, this station now operates on 4740 k.c., 63.2 m. Its present schedule is from 9 a.m.-2 p.m. daily.

XEWV, Mexico City, in addition to tests on 19 m., is also on the air on 34.92 m. These transmissions are simultaneous with their regular 31 m. programmes, and are heard till 3.05 p.m. daily.

COBC, Habana, Cuba, although listed as operating on 9090 k.c., 32.98 m., has been heard on approximately 9350 k.c., 32.1 m. There is no doubt that the Cubans keep SWL's busy following their frequent frequencies changes. Incidentally, COBC use the slogan "El Progreso Cubano." They verify all correct reports with an at-

tractive card, which, to add to the confusion re. their wavelength, gives as an alternative 30.1 m. (9960 k.c.). So you can take your pick. Just at present the consensus of opinion seems to be that they are using the 32.1 m. channel.

#### Europeans.

Berlin is employing a new 25 m. transmitter for African programmes. This is DJF on 11,780 k.c., 25.47 m.

Considerable activity has been noticed amongst the Italians of late. IRF and IQY on 9835 k.c. (30.5 m.) and 11,900 k.c. (25.2 m.), respectively, have been heard relaying the programmes of 2RO during the American hour.

#### Asiatics.

A new Indian station at Delhi on 31.28 (same frequency as VK2ME) has been testing daily, except Thursday from 12.30 till 1.30 p.m.).

#### Latest Japanese Schedules.

Information just received by Observer Sorensen from Tokyo gives the following details of the Japanese transmissions:—

1. To Europe: JVP (39.95 m.) and JZI (31.46 m.) 5.30-7 a.m. (Includes news in English, German, French and Japanese.)
2. To South America: JZI (31.46 m.), and JZJ (25.42 m.), 7.30-8.30 a.m. (News in Spanish, Portuguese and Japanese.)
3. To Eastern North America: JZJ 25.42 m.), 9-9.30 a.m. and 10-10.30 p.m.
4. To Western America and Hawaii: JZJ (25.42 m.), 3.30-4.30 p.m.
5. To Dutch East Indies, Malaya, New Zealand and Australia: JZJ (25.42 m.), 11 p.m.-12.30 a.m.

#### Other Schedules.

Whilst on the subject of latest schedules, perhaps those from Berlin and Prague may be of interest.

#### Berlin.

Australia-Asia Transmissions for May.

DJA (31.38 m.), DJB (19.74 m.), DJS (13.99), 3.05 p.m.-2 a.m.

DJE (16.98 m.), DJQ (19.63). 3.05-8.50 p.m.

DJQ (19.63 m.), DJE (16.89), 11.10 p.m.-1 a.m.

Prague.

1. To North America: OLR3A (31.41), and OLR4A (25.34), or OLR4B (25.51), 11 a.m.-1.35 p.m.).
2. To South America: OLR4A or OLR4B, 9.15-11.55 a.m.
3. To Europe: OLR5B (19.58 m.), or OLR5A (19.7), OLR4A, or OLR4B, 9.30-10; and OLR3A, 3 p.m. and 12.55-1.50 a.m. (Also on Sundays and holidays. OLR5B or OLR5A. 9.15-10.45 p.m.)
4. Special transmissions: OLR2B 49.75), or OLR2A (49.92) and OK1MPT (58.31). Around 7.40 a.m.

★

### Interesting Reports From Readers: Amazing Loggings By Third DX Contest Winner.

From Mr. Simpson, winner of the Replogle Globe awarded in the third DX Contest, comes a most interesting letter giving details of some extraordinary loggings. Mr. Simpson writes as follows:—

"I have found the 30,100 k.c. police band, and now have reports away to W2XIJ, W2XEM, W6XPA, W6XFE, W6XGC, and W6XKW. The latter comes in excellently till as late as 1 p.m. So far I have had no success on the 33,100 k.c. band, but am still hoping. Other ultra-high-frequency stations logged include W9XUY, W4XCA, W9XJL, and W6XKG.

"Some of the other commercials heard recently include the following interesting stations.

"CXA8, Colonia, Uruguay, 31.12 m. I hear them every Sunday afternoon, till as late, on occasions, as 5 p.m. On closing they give their call in a number of languages. They call themselves 'Radio Belgrano,' and give their address as Buenos Aires; but say they are located in Uruguay, relaying the programmes of LR3.

"HIG, Ciudad Trujillo, D.R., 32.33 m., opens nearly every night at 9.40 p.m. Their first number is a march, and announcements are in Spanish. The news follows. This station peaks at 10 p.m., and then fades out very rapidly.

"OAX4T, Lima, Peru, 31.38 m., opens at excellent strength at 10 p.m., and continues to put in a good signal until closing at 11 p.m. They give their call on the hour and half-hour.

"COBX, Habana, Cuba, 32.3 m., opens some nights at 9.55 p.m., but is rather weak, and usually has completely disappeared by 10.20 p.m.

"COCW, Habana, Cuba, 47.39 m., opens nightly except Mondays at 9.55 p.m., with an organ selection ('Estrellita', I think). They announce as

CMW and COCW, La Voz delas Antillas.

"XEUZ, Mexico City, 49.02, was heard recently till 7.40 p.m. on a Sunday afternoon. They were carrying a special programme for the Newark Radio Club. Their QRA was given as 5 de Mayo 21, Mexico City.

"XEWB, Guadalajara, Mexico, 25.63 m., are at good strength in the early afternoons till they close at 2 p.m. They usually play dance numbers during the last half hour of their transmission. Announcements, which are few, are in Spanish only.

"YV5RC, Caracas, Venezuela, 51.72 m., open every night at 10.35 p.m. with a march, followed by a news service.

"Other South and Central Americans heard recently are XEWW, T14NRH, TIPG, LRX, LRU, XEYU (31.25 m.), and occasionally TIEP.

"One station really 'out of the box' is the African ZEC, Salisbury, Southern Rhodesia, 51.72 m. They were heard on April 2 from 5.20 a.m. till they closed with 'God Save the King' at 6.15 a.m.

"On April 3 another batch of new stations was added to my log. They were CB1170, 25.65 m.; CB1190, 25.2 m.; Radio Colonial, 31.35 m.; W9XPD, 9.49 m.; and a Spanish Nationalist transmitter (Salamanca, I think) on 30.5 m.

"In addition to the above commercials, 20 metre amateurs have not been neglected. Best loggings are: VQ4KTB (Kenya), OK1FZ (Czechoslovakia), YR5AA, YR5ML (Ru-

mania), SV1KE (Greece); SU2TW (Egypt), HB9SH, HB9BB, HB9PR (Switzerland); FR8VX (Reunion), FA3QV (Algeria), HH3LA (Haiti), VE9AT (Canada), K4EMG (Porto Rico), VR6A(Y) (Pitcairn), and VP6MR (Barbados).

"Recent verifications are from YSD and CFRX. The former is a straight S.W. station, relaying the programmes of YSS. YSD is located in San Salvador, and operates on 38.0 m. CFRX, Toronto, 49.42 m., sends a verification card, letter and their year book. The letter, from the station engineer, states that my report was the first received from Australia. He adds that reports from Australia are very much desired."

Another interesting letter is that received from Mr. Payten, of Coffs Harbour, N.S.W. Loggings include OLR4A, OLR3A, DZE and Radio Colonial on both 25 m. frequencies.

Archerfield aerodrome, Brisbane, can be heard here daily contacting planes flying between Sydney and Brisbane.

### Reports On PCJ.

DX Club members are reminded that Philips Radio are still desirous of receiving detailed reports on transmissions from PCJ, especially on 19 m. These should be sent direct to Philips Radio, Box 2703-C, Sydney.

★

### Reports From Overseas.

#### G. O. La Roche (West Australia).

Mr. La Roche sends his usually comprehensive report on West Australian conditions. From it, conditions in the West appear to be much better on the lower wavelengths than on the higher bands. Reception between 19 and 29 metres is exceptionally good in the morning hours, with stations coming in at good strength from all continents. Of the Americans, W2XE (16 and 25 m.), W1XAL, W2XAD, and W8XK (19 and 25 m.) are all good; the Cubans, too, put in good signals, COCX, COBC, COCQ, COCM; the best Europeans are HVJ (19.8 m.), 2RO3 and 2RO4, the Polish stations SPD and SPW, CS2WA, and CSW; from Africa comes CR7BH (25.6 m.).

Naturally reception on the higher bands is better during the evenings. HS8BJ (31.51 m.), PMH, Colombo, Rangoon, and a number of the 90-100 m. N.I.R.O.M. stations are amongst Mr. La Roche's most interesting loggings. After midnight the higher wavelengths are not quite so good, but VQ7LO and CR6AA (48.8 m.) are two Africans the logging of which is ample compensation for burning the midnight oil.

Mr. La Roche mentions that the Polish stations SPD and SPW very much appreciate any Australian

### DX Club Requirements.

All-Wave All-World DX Club members are advised that the following DX requirements are obtainable from Club headquarters, 214 George Street, Sydney.

**REPORT FORMS.**—Save time and make sure of supplying all the information required by using these official forms, which identify you with an established DX organisation. Price . . . 1/6 for 50, post free.

**NOTEPAPER.**—Headed Club notepaper for members' correspondence is also available. Price, 1/6 for 50 sheets, post free.

**DX CLUB STICKERS.**—Enlarged two-colour replicas of the Club badge, in the form of gummed stickers, designed for attaching to envelopes, QSL cards, etc. Price, 5 dozen for 1/6, post free.

**DX CLUB LOG SHEETS.**—Designed by the Shortwave Editor, these headed and ruled log sheets are indispensable to dxers who wish to keep a simply-prepared and accurate list of loggings. Price, 3 dozen for 1/6, post free.

stamps which S.W.L.'s care to enclose with their reports. They will send a splendid collection of their own stamps in return.

Two very interesting stations reported by Mr. La Roche are Chinese transmitters on 25.2 and 32.8 m., respectively. The latter opens with eight chimes at 10 p.m. (E.S.T.); no call sign is known, but this station appears to have taken the place of XGOX. Very little is known of the 25m. transmitter.

The amateur bands are much the same as during the past few months. The best "catch" for the month was VR4BA, Brit. Solomon Is. Two other good loggings were ZE1JR and ZS6CP, S. Rhodesia and S. Africa, respectively.

#### Mr. Linehan (South Australia).

Dxing during the last month has been rather erratic; some nights conditions are very good, whilst on others there are scarcely any signals audible at all.

"Around 3 a.m., I have found the noise level on 20 m. very high, and strangely enough it is less troublesome at this time around 40 m. Between 4 and 5 a.m., several South Africans have been logged on the 40 m. amateur band. On April 4 at 4.10 a.m., ZS5CO and ZS5CA came in like locals.

On the 49 m. band VQ7LO put in a splendid signal till as late as 7.15 a.m., when they close without announcement.

Towards 6.30 a.m., reception on 20 m. improves, with a fair number of Europeans audible. Best loggings at this time include ON4MZ, YR5AA, HB9J, HB9O, F3EP, F8DL and FR8VX.

Verifications received during the past few weeks are from CO2RR, NY2AE, J2NE, W6EQI, W7BCU, VP5PZ and CO8JK.

#### Mr. V. D. Kemmis (N.S.W.).

Mr. Kemmis forwards another of his amazing lists of 20-metre calls heard, which, in this case, represents only a week or so listening, as during the earlier part of the month he was laid low with a serious bout of pneumonia, from which he is now almost recovered.

In the circumstances, reproduction of his list in full may be of interest.

Europe: F—3DT, 3GR, 3KH, 3LW, 3OO, 8XN, 8ZF; G—2AI, 2PU, 2TR, 2UT, 2XR, 5LU, 5ML, 5RV, 5ZG, 6CL, 6DT, 6JF, 6LK, 6WX, 6WY, 6XR, 6ZI, 8FB, 8MA; GI—2CC; GM—2UU, 2DR, 5NW; GW—3AX; LA—5H; ON—4MZ, 4ZA; PA—OMZ, OUN; SM—2VP, 5SB, 7YA; SP—1DC.

Africa: CN8—AV.

Asia: KA—1AF, 1AP, 1B, 1MH, 1ZL; K6—BJJ, BNR, CGK, CMC, FAB, GAS, GNW, GQF, JLV, KGA, KKC, KMB, KRG, MTE, MVV, MXM, NZQ, OQE; K6—BAZ (Portable on

Howland Is.); PK—1GL, 1MX, 1ZZ, 3WI, 4WS; VS—2AK; VS—7GJ; VU—2CQ; XU—8RB.

America: VE—1ID, 2EE, 3BF, 3QL, 4BD, 4SS, 5ACN, 5DK, 5EF, 5GS, 5HA, 5IL, 5JK, 5NY, 5OT, 5VO; VO—1D; LU—7BK, 9BV; OA—4AF; PY—3BP; TI—2AV, 2FG; XE—1A, 1GK, 1LK, 2PJ, 2JQ; YV—1AP, 4AA; CX—3BL.

Oceania: VR6—AY.

West Indies, etc.: VP9-R; VP6-TR; CO-2JJ, 2LY, 2WM.

#### Mr. J. K. Sorensen (Queensland).

Conditions of an evening as a whole are becoming bad, and many of the bands are dead; however, daylight reception is improving, especially in mornings. At this time the 49 m. band is absolutely crowded, so much so that QRM makes logging of stations rather a task. Early in the month "Radio Medellin," HJ4ABE, were logged on 49.2 m.

"After midnight the 19 m. band has been quite dead on most nights; occasionally weak signals are heard from the German transmitters. On 25 m. at this same time JZJ are good, whilst DJA and KZRM are best on 31 m.

In the early evenings PMH (44 m.) and JVN (28.14 m.) are quite strong, although the latter station is not as loud as earlier in the year.

I am still awaiting a reply from the Archerfield aerodrome. From the

press it appears that this is one of several temporary stations used by the Civil Aviation Board for aircraft guidance. At present these transmitters work on 45.87 m.; later they will shift slightly to 45.45 m.

#### Mr. R. Russell (New Zealand).

The 20 m. band has been providing very fine DX, as the list of calls heard below indicates. I now have logged 101 countries on this band, so will find it difficult to tune in new countries even with my new receiver.

I have listened to 40 m. lately during the early evenings, but without much success. Have heard a number of South and Central Americans jabbering away, but find it quite a task identifying such stations.

Recent verifications are to hand from VE3AQ and PK1VH.

Mr. Russell forwards a very fine list of 20 m. calls. They include the following splendid DX "catches":—YR5AA, YR5CS, YR5KG (Rumania); SV1AT (Greece), ILIH (Italy), VQ4KTB (Kenya), FR8VX (Reunion), YN1OP (Nicaragua), and PY4CE, PY3PS (Brazil).

E. Neill (Queensland).

Conditions on the whole are still improving here. This is especially the case with regard to 31 m. OLR4A, 2RO and EAQ are the best of the morning stations on this band; whilst W8XK and RNE are best on 19 and 25 m., respectively. A new logging on 19 m. is the Mexican XEWW. heard on several afternoons around 2.30 p.m. at very good speaker strength. Best 20 m. amateur loggings include 3 CE's, 5 CO's, 1 CT, 6 F3's, 1 EI and G's by the dozen.

★

### Amateur Review : Calls Heard. EUROPE.

France: F3DI, F3GR, F3KH, F3LW, F3OO, F3JD, F3MF, F3CH, F3SI, F3EP, F8XN, F8ZF, F8XT, F8FA, F8CE, F8KW, F8AM, F8KI, F8BP, F8DL, F8VC (Sorensen, Kemmis, La Roche, Russell).

England: G2XV, G2UT, G2AV, G2TR, G2AI, G2WD, G2PU, G2XR, G2MN, G5NY, G5ML, G5RV, G5OH, G5BJ, G5OV, G5LU, G5ZG, G5BU, G5GJ, G6AF, G6XR, G6WU, G6LK, G6GM, G6BY, G6AG, G6CL, G6DT, G6JF, G6WX, G6WY, G6ZI, G8FB, G8MA, G8BP (Sorensen, Russell, Kemmis, Linehan, La Roche).

Belgium: ON4PA, ON4MX, ON4GC, ON4BG, ON4VK, ON4ZA, ON4MX.

Northern Ireland: G12CC (Kemmis, La Roche).

Scotland: GM2UU, GM2DR, GM5NW (Kemmis, Russell).

Wales: GW2UL, GW3AX (Kemmis, Russell).

Norway: LA1G, LA1F, LA3N, LA4W, LA5H (Kemmis, Russell, Linehan).

### Philips Revised Station Chart Free To Readers.

Of extreme interest to all listeners, but particularly to DX enthusiasts, is the news that Philips have recently revised their Radio Station Chart, bringing it right up to date with regard to transmission times and new short-wave stations.

Listeners who found the last issue invaluable to them, and those who have not yet taken advantage of the opportunity presented, may obtain a free copy of this publication upon application to Philips Lamps (A/asia) Pty. Ltd., Box 2703C, G.P.O., Sydney.

This 8-page chart not only lists the principal short-wave stations of the world—with the location, call-sign, wavelength, power, and transmission schedule of each—but it also provides a complete list of Australian national and commercial stations. An invaluable feature of the chart is an extremely simple form of world time-table, presented in such a way as to do away with tiresome mental calculations.

Portugal: CT1AR, CT1JW (Russell, Linehan).  
 Sweden: SM7YA, SM2VP, SM5SB (Kemmis, Russell).  
 Holland: PAOFB, PAOUN, PAOBE, PAONF, PAOMZ, PAODH (Kemmis, La Roche, Russell).  
 Italy: I1IH (Russell).  
 Greece: SV1AT (Russell).  
 Switzerland: HB9J, HB9O (Linehan, Russell).  
 Rumania: YR5AA, YR5CS, YR5KG (Russell, Linehan).  
 Poland: SP1DC (Kemmis).

**AFRICA.**

Egypt: SU1KG, SU1RD, SU1CH (Russell, Sorensen).  
 Algeria: FA3HC, FA8IH, FA3AG (Russell, Sorensen).  
 Kenya Colony: VQ4KTB (Russell).  
 Reunion Is.: FR8VX (Russell, Linehan).  
 French Morocco: CN8AV (Kemmis).  
 Southern Rhodesia: ZE1JR (La Roche).  
 South Africa: ZS6CP (La Roche).

**ASIA.**

Ceylon: VS7RF, VS7GJ, VS7RA.  
 Japan: J2MI, J2NF, J2KJ, J2NG, J2LL, J7CR (Russell, La Roche, Linehan).  
 Dutch East Indies: PK1GL, PK1MX, PK1ZZ, PK3WI, PK4AU, PK4DT, PK4WS (Linehan, La Roche, Russell, Kemmis).  
 Burma: XZ2EZ (Linehan, Russell).  
 French Indo-China: FI8AC (Russell, La Roche).  
 India: VU2CQ (Kemmis, Russell).  
 Malaya: VS2AI, VS2AK (Kemmis, Russell).  
 Hong Kong: VS6AB (Linehan).  
 China: XU8RB, XU8ET (Kemmis, Linehan).

Philippine Is.: KA1AF, KA1AP, KA1BH, KA1MH, KA1ZL, KA1AX, KA1VH (Sorensen, La Roche, Kemmis, Linehan).

Hawaiian Is.: K6BJJ, K6BNR, K6CGK, K6CMC, K6FAB, K6GAS, K6GNW, K6GQF, K6JLV, K6KGA, K6KKC, K6KMB, K6KRG, K6MTE, K6MVV, K6MXM, K6OQE, K6LKN, K6NZQ, K6KGF, K6PAH, K6BAZ (Portable on Howland Is.) (Sorensen, Linehan, Kemmis, La Roche).

**AUSTRALASIA and OCEANIA.**

Pitcairn Is.: VR6AY (previously gave call as VR6A) (Sorensen, Kemmis, Russell).  
 Solomon Is.: VR4BA (La Roche).

**NORTH AMERICA.**

Newfoundland: VO1D (Kemmis).  
 Canada: VE1ID, VE1BW, VE2EE, VE3BF, VE3QL, VE3ACK, VE4BD, VE4SS, VE5OT, VE5ACN, VE5SY, VE5DK, VE5EF, VE5GS, VE5HA, VE5II, VE5JK, VE5NY, VE5VO (Kemmis, Linehan, Sorensen).  
 Alaska: K7FBE (Sorensen, Linehan).

**CENTRAL AMERICA.**

Mexico: XE2JQ, E2PJ, VE1A,

XE1GK, XE1LK (Kemmis, Linehan).  
 Panama: HP1A (Russell).  
 Sicaragua: YN1OP (Russell).  
 Costa Rica: TI1AV, TI2FG (Kemmis).  
 Guatemala: TG1HJ (Russell).

**SOUTH AMERICA.**

Brazil: PY2LM, PY2GC, PY3BP, PY3PS, PY4CE (Sorensen, Kemmis, Russell).  
 Venezuela: YV4AA, YV5AZ, YV5AK (Kemmis, Linehan, La Roche).  
 Peru: OA4AF, OA4AI (Kemmis, Linehan, La Roche).  
 Argentine: LU9BV, LU3EJ, LUIHI, LU9AX, LU3AQ (Linehan, Sorensen, Kemmis, Russell).  
 Chile: CE1AH, CE3AI (Russell).  
 Ecuador: HC1FG, HC1JW (Linehan, Sorensen, Russell, Kemmis).  
 Colombian Republic: HK2CB, HK3LDC (Kemmis).  
 Uruguay: CX3BL (Kemmis).

**WEST INDIES.**

Porto Rico: K4SA, K4EMS (Linehan).  
 Bermuda: VP9R (Kemmis).  
 Cuba: CO2WN, CO7CX, CO5EO, CO8BC (Linehan, La Roche).  
 Dominican Republic: HI7G, HI5X (Kemmis, Linehan).  
 Haiti: HH5PA, HH2X (Linehan).  
 Barbados: VP6TR (Kemmis).

**DX Notes and News**

**American Police Band Good.**

DX here lately has only been fair. The 20-metre band is improving, and 80 metres is good when there is no static. I have heard several W's handling flood traffic on that band.

On 10 metres in the last month I have heard all continents. The 33.1 meg. police band has been very good. W5XB, Fort Worth, is nearly always R9 between 10 and 11 a.m. I have heard about a dozen other stations, but I do not know what towns they are in.

I have added a power pentode to the "Ultra Gainer," and it is a great improvement on the U.H.F. bands. The "Outdoor Four" is such a wonderful receiver and so cheap to operate, I am wondering what the 1938 model will be like!—Jamie Ferrier (AW129DX), Coleraine, Victoria.

**Latest Loggings And Verifications.**

Just a few lines to say that since I joined the Club I have received 18 verifications from the following stations:—2GZ, 2YA (Wellington), 3BO, 3BA, 3SR, 3UL, 3GL, 3HA, 3BH, 3AM, 3RI, 3DH, 4AK, 5RM, 7BU and 7UV on broadcast, and 3XW and 9MI on shortwave.

I was pleased to see more VK stations lists published, as they are very

**Have Your "RADIO WORLD" Posted To You Direct**

Readers who want to take the "Radio World" on a subscription basis and have their copies posted to them direct each month are invited to complete the coupon below (annual sub. 10/6). New readers are advised that all back numbers in Volumes 1 and 2 are still available, price 9d., post free for copies in Volume 1 (May 1936 to April 1937) and 1/-. post free, for copies in Volume 2 (May 1937 to April 1938).

Enclosed please find remittance for 10/6, in payment for an annual subscription to the "Australasian Radio World," commencing with the..... issue.

Name.....

Street and No.....

City..... State.....

Country.....

Note.—N.Z. Subscribers can remit by Money Order or Postal Note.

THE AUSTRALASIAN RADIO WORLD,  
 214 George Street, Sydney,  
 N.S.W., Australia.

helpful, also the Hourly Tuning Guide and Amateur Review.

Some 20-metre calls heard in March are as follows:—England G2AK' U.S.A. W1's JFG, CND, KIG, W2's HJI, IKV, FMP, JT, UC1, AZ; W3's EAZ, FAY, BMA; W4's AH, BNR; W5's FIY, YS, BBE; W6's MZL, CQS; W8GLY; W9's RL, ARA, TIZ, ARL and CIH. South America, CE1BE and CE1AH (Chile), OA4A1 (Peru).—Wm. Bantow (AW353DX), Edithvale, Victoria.

**S.W. Conditions Excellent In North Queensland.**

Since I last wrote, I have heard many shortwave stations from almost every part of the world. Conditions up in North Queensland are at the present time very good, and the Empire stations simply roar in. I would like to thank all the S.W.L.'s who answered my QSO for S.W.L. cards.

The 19 and 25-metre bands are exceptionally good at the present time, but the 31-metre band is rather poor and overcrowded. Overcrowding exists also on the amateur band, and even band-spreading is not too effective.

In passing, I would like to congratulate you for publishing such a fine magazine, and here's hoping that it will get bigger and bigger as time rolls on.—J. E. Sorbell (AW277DX), Queensland.

**Latest Loggings And Verifications.**

I have received QSL cards from the following stations:—VK4's, CO, DO, EC, HA, KO, LW, NO, PL, RH, TY, UX, VK2ME, VK3ME, VK9MI, K6PCF, VPD2 and RNE. Despite poor reception conditions the following stations were heard during the past month:—ZBW3, DJQ, W5FNH, W1OM, 2RO4, ZL2QL, OLR4, PK1ZZ, F3GR and VK's 5CF, 5FB, 5LB, 5CS, 3KU, 3LA, 2YW and bJU.—J. S. Tippet (AW380DX), Koongal, Rockhampton, Queensland.

**American Wants Pen-Friends.**

Mr. Reynold G. Smith, of 71 South Union Street, Rockland, Massachusetts, U.S.A., desires correspondence with persons in South Africa, Australia, and Alaska. He is interested in anything, but particularly radio. All letters answered. Personally, I can recommend him as a correspondent worth having.—R. Ellery, N.Z.

**Has 137 B.C. and S.W. QSL's.**

My latest verifications are from the following stations, which were logged on the b.c. band:—Queensland, 4BC, 4LG, 4QR; N.S.W., 2NC, 2KO, 2HR, 2KM, 2SM, 2MW, 2WL, 2XL, 2PK; Victoria, 3WV; Tasmania, 7EX; Sth. Australia, 5AN, 5SE; West Australia, 6KG, and on shortwave, PCJ, KZRM, OZF, VK4PL and VK9MI.

I have several reports away, in fact, some have been away six to

DX Club member Charles Thorpe (AW342DX), with his seven-valve world-range a.c. superhet.



seven months. Some stations were sent two reports, both with postage included, but so far they have failed to QSL. Some of the VK's are long-winded, too. Stations who asked for reports have acknowledged them over the air and promised a QSL, but nothing has been received, so it seems a waste of time to report to some of them, though others are very prompt. My QSL's now total 137.

I have a QSL card of my own, and would like to exchange with anyone anywhere.—E. Larsen (AW387DX), Booyal, Isis Line, Queensland.

**Comet Dual-wave Four.**

(Continued from page 12.)

ed so that the trimmers can be returned to these positions as desired.

With regard to the alignment, it should not be necessary to move the trimmers more than half a turn, while the shortwave coils require no adjustment whatever.

Priced at under £10, including speaker and valves, the "Scout" is a remarkably fine performer, and will undoubtedly prove widely popular.

Under-chassis wiring of the "Comet" is shown in the sketch below.

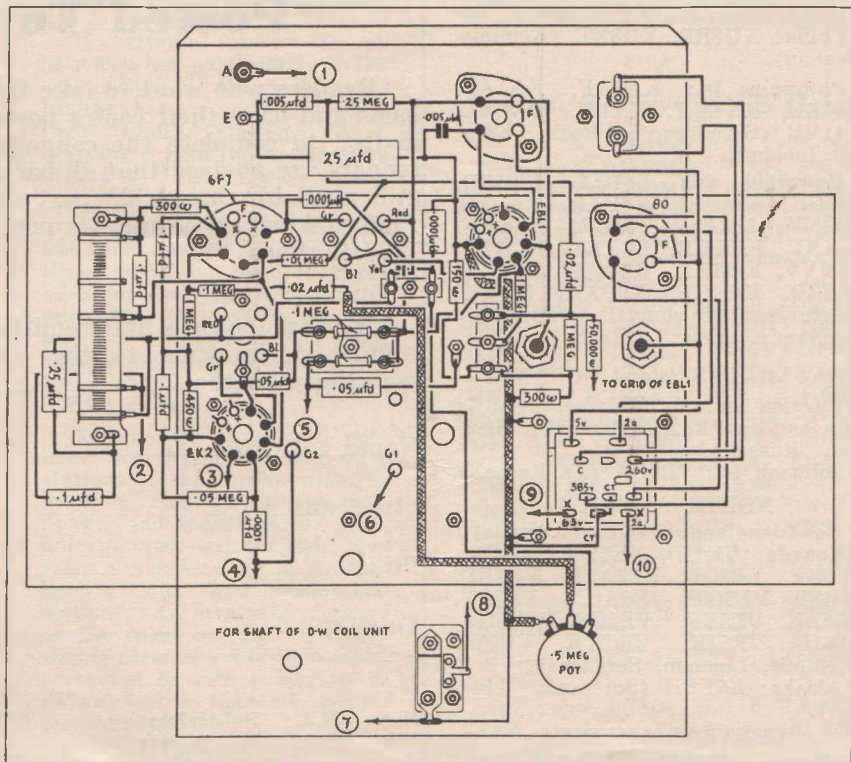
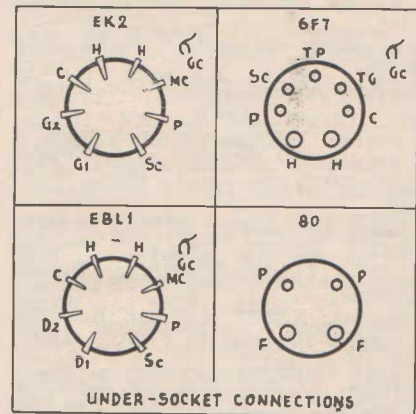



# HOURLY TUNING GUIDE

## When And Where To Search

By ALAN H. GRAHAM.

In order to assist beginners and less experienced dxers, it is intended to publish monthly a special tuning guide, setting out at what times to listen for the more easily logged stations. It should be noted that the guide is not intended to cover all stations audible; for full details as to when and where to look for the best catches are given elsewhere. Moreover, the fact that a station is shown as being on the air at a particular time is no guarantee that reception must follow as a matter of course.

All times are given in Australian Eastern Standard Time.

Key to abbreviations used: S, Sundays only; M, Mondays only; T, Tuesdays only; W, Wednesdays only; Th, Thursdays only; Sat, Saturdays only.

Midnight to 1 a.m.		25.34 TPA3
13.93 GSJ	25.4 2RO	25.49 DJD
13.97 GSH	25.49 DJD	27.27 PLP
13.99 DJS	28.48 JIB	28.48 JIB
16.86 GSG	29.24 PMN	31.4 OLR3A
16.88 PHI	48.7 VPB	49.83 DJC
16.89 DJE	49.9 COCO	58.3 PMY
19.63 DJQ	70.2 RV15	
19.68 TPA2		
19.74 DJB		
19.76 GSO		
19.8 YDC		
19.82 GSF		
25.45 JZJ		
27.27 PLP		
28.48 JIB		
29.24 PMN		
30.61 XGOX		
30.78 COCQ		
31.38 DJA		
31.28 VK2ME (M)		
31.45 DJN		
31.49 ZBW3		
31.55 HS8PJ (F)		
31.8 COCH		
32.09 COCB		
32.59 COBX		
33.2 COBZ		
48.7 VPB		
49.9 COCO		
49.98 Rangoon		
58.3 PMY		
70.2 RV15		
1-2 a.m.		
13.93 GSJ		
13.99 DJS		
16.86 GSG		
19.63 DJQ		
19.68 TPA2		
19.74 DJB		
19.8 YDC		
19.82 GSF		
19.84 HVJ		
19.85 DJL		
25.0 RNE		

24.52 TFJ	25.2 TPA3	25.49 DJD	25.53 GSD	29.04 ORK	31.13 2RO	31.4 OLR3A	31.55 GSB	49.31 VQ7LO	49.59 GSA	49.7 OLR2B	49.83 DJC
16.86 GSG	16.87 W3XAL	19.56 W2XAD	19.6 GSP	19.65 W2XE	19.66 GSI	19.67 W1XAL	19.72 W8XK	19.85 DJL	22.0 SPW		
24.52 TFJ	25.23 TPA3	25.48 DJD	25.53 GSD	27.17 CSW	28.93 EAJ43	29.04 ORK	31.13 2RO	31.28 PCJ			
31.41 OLR3A	31.46 JZI	31.55 GSB	39.95 JVP	49.59 GSA	49.7 OLR2B	49.83 DJC					
16.86 GSG	16.87 W3XAL	19.56 W2XAD	19.6 GSP	19.65 W2XE	19.67 W1XAL	19.72 W8XK	19.85 DJL	22.0 SPW			
25.0 RNE	25.24 TPA3	25.49 DJD	25.53 GSD	27.17 CSW	31.13 2RO	31.28 W3XAU	31.35 W1XK	31.41 OLR3A	31.46 JZI	31.55 GSB	39.93 JVP
49.7 OLR2B	49.83 DJC										
16.87 GSG	19.72 W8XK	19.85 DJL	22.0 SPW								
19.72 W8XK	19.85 DJL	22.0 SPW									
25.0 RNE	25.24 TPA3	25.49 DJD	25.53 GSD	27.17 CSW	31.13 2RO	31.28 W3XAU	31.35 W1XK	31.41 OLR3A	31.46 JZI	31.55 GSB	39.93 JVP
49.7 OLR2B	49.83 DJC										
16.87 GSG	19.72 W8XK	19.85 DJL	22.0 SPW								
19.72 W8XK	19.85 DJL	22.0 SPW									
25.0 RNE	25.24 TPA3	25.49 DJD	25.53 GSD	27.17 CSW	31.13 2RO	31.28 W3XAU	31.35 W1XK	31.41 OLR3A	31.46 JZI	31.55 GSB	39.93 JVP
49.7 OLR2B	49.83 DJC										

19.56 DJR	19.56 W2XAD	19.63 DJQ	19.65 W2XE	19.72 W8XK	19.74 DJB	19.76 GSO	19.82 GSF	19.85 DJL	25.0 RNE	25.2 TPA3	25.42 JZJ	25.45 W1XAL	25.49 DJD	25.53 GSD	27.17 CSW	31.09 CS2WA	31.13 2RO	31.28 W3XAU	31.32 GSC	31.35 KZRM	31.35 K1XK	31.38 DJA	31.45 DJN	31.46 JZI	31.48 W2XAF	31.55 GSB	31.58 PRF5	49.75 OLR2B	49.83 DJC
19.56 DJR	19.56 W2XAD	19.63 DJQ	19.65 W2XE	19.72 W8XK	19.74 DJB	19.76 GSO	19.82 GSF	19.85 DJL	25.0 RNE	25.2 TPA3	25.42 JZJ	25.45 W1XAL	25.49 DJD	25.53 GSD	27.17 CSW	31.09 CS2WA	31.13 2RO	31.28 W3XAU	31.32 GSC	31.35 KZRM	31.35 K1XK	31.38 DJA	31.45 DJN	31.46 JZI	31.48 W2XAF	31.55 GSB	31.58 PRF5	49.75 OLR2B	49.83 DJC
19.56 DJR	19.56 W2XAD	19.63 DJQ	19.65 W2XE	19.72 W8XK	19.74 DJB	19.76 GSO	19.82 GSF	19.85 DJL	25.0 RNE	25.2 TPA3	25.42 JZJ	25.45 W1XAL	25.49 DJD	25.53 GSD	27.17 CSW	31.09 CS2WA	31.13 2RO	31.28 W3XAU	31.32 GSC	31.35 KZRM	31.35 K1XK	31.38 DJA	31.45 DJN	31.46 JZI	31.48 W2XAF	31.55 GSB	31.58 PRF5	49.75 OLR2B	49.83 DJC
19.56 DJR	19.56 W2XAD	19.63 DJQ	19.65 W2XE	19.72 W8XK	19.74 DJB	19.76 GSO	19.82 GSF	19.85 DJL	25.0 RNE	25.2 TPA3	25.42 JZJ	25.45 W1XAL	25.49 DJD	25.53 GSD	27.17 CSW	31.09 CS2WA	31.13 2RO	31.28 W3XAU	31.32 GSC	31.35 KZRM	31.35 K1XK	31.38 DJA	31.45 DJN	31.46 JZI	31.48 W2XAF	31.55 GSB	31.58 PRF5	49.75 OLR2B	49.83 DJC
19.56 DJR	19.56 W2XAD	19.63 DJQ	19.65 W2XE	19.72 W8XK	19.74 DJB	19.76 GSO	19.82 GSF	19.85 DJL	25.0 RNE	25.2 TPA3	25.42 JZJ	25.45 W1XAL	25.49 DJD	25.53 GSD	27.17 CSW	31.09 CS2WA	31.13 2RO	31.28 W3XAU	31.32 GSC	31.35 KZRM	31.35 K1XK	31.38 DJA	31.45 DJN	31.46 JZI	31.48 W2XAF	31.55 GSB	31.58 PRF5	49.75 OLR2B	49.83 DJC

22.0 SPW	25.42 JZJ	25.45 W1XAL	25.49 DJD	25.53 GSF	25.61 TPA4	30.31 CSW	31.09 CS2WA	31.13 2RO	31.27 HBL (S)	31.32 GSC	31.35 W1XK	31.38 DJA	31.41 OLR3A (M)	31.45 DJN	31.49 LKJ1	31.48 W2XAF	31.55 GSB	38.48 HBP (S)	49.1 GSL
1-2 p.m.	19.56 DJR	19.63 DJQ	19.74 DJB	25.49 DJD	25.53 GSD	25.61 TPA4	31.28 PCJ (F)	31.32 GSC	31.38 DJA	31.41 OLR3A (T, Th, Sat)	31.45 DJN	31.48 W2XAF	31.55 GSB						
2-3 p.m.	25.61 TPA4	31.48 W2XAF																	
3-4 p.m.	13.99 DJS	16.89 DJE	19.63 DJQ	19.74 DJB	19.85 DJL	25.42 JZJ	31.28 VK2ME (S)	31.38 DJA	31.45 DJN	49.18 W3XAL	49.5 W8XAL								
4-5 p.m.	13.99 DJS	16.86 GSG	16.89 DJE	19.63 DJQ	19.74 DJB	19.76 GSO	19.85 DJL	19.82 GSF	25.24 TPA3	25.42 JZJ	31.28 VK2ME (S)	31.38 DJA	31.45 DJN	31.55 GSB	49.5 W8XAL				
5-6 p.m.	13.99 DJS	16.86 GSG	16.89 DJE	19.63 DJQ	19.74 DJB	19.76 GSO	19.85 DJL	19.82 GSF	25.24 TPA3	25.42 JZJ	31.28 VK2ME (S)	31.38 DJA	31.45 DJN	31.55 GSB	49.5 W8XAL				
6-7 p.m.	13.99 DJS	16.86 GSG	16.89 DJE	19.63 DJQ	19.74 DJB	19.76 GSO	19.85 DJL	19.82 GSF	25.24 TPA3	25.42 JZJ	31.28 VK2ME (S)	31.38 DJA	31.45 DJN	31.55 GSB	49.5 W8XAL				

19.74	DJB	31.45	VPD2
19.76	GSO	31.49	ZBW3
19.22	GSF	31.55	VK3ME
25.23	TPA3	34.0	VPD3
25.53	GSD	44.64	PMH
28.14	JVN	48.7	VPB
31.28	VK2ME	49.5	W8XAL
	(S)	58.3	PMY
31.38	DJA	70.2	RV15
31.45	DJN		
31.55	GSB		

## 10-11 p.m.

7-8 p.m.	13.93	GSJ	
13.99	DJS	13.97	GSH
19.71	PCJ (W)	13.99	DJS
19.74	DJB	16.86	GSG
25.57	Saigon	16.89	DJE
28.14	JVN	19.58	OLR5B
31.38	DJA	19.63	DJQ
31.45	DJN	19.68	TPA2
31.49	ZBW3	19.74	DJB
31.55	VK3ME	19.76	GSO
		19.8	YDC
		19.82	GSF

## 8-9 p.m.

13.93	GSJ	19.7	OLR5A
13.97	GSH	19.85	DJL (S)
13.99	DJS	25.4	2RO
16.86	GSG	25.45	JZJ
19.68	TPA2	25.57	Saigon
19.71	PCJ (W)	27.27	PLP
19.74	DJB	28.14	JVN
19.76	GSO	29.24	PMN
19.8	YDC	30.23	JDY
25.53	GSD	30.61	XGOX
25.57	Saigon	30.78	COCQ
27.27	PLP	31.28	VK6ME
28.14	JVN	31.28	VK2ME
29.24	PMN		(S)
31.28	VK2ME	31.35	W1XK
	(S)	31.38	DJA
31.38	DJA	31.45	DJN
31.45	DJN	31.49	ZBW3
31.49	ZBW3	31.8	COCH
31.55	VK3ME	32.09	COBC
31.45	VPD2	32.59	COBX
34.0	VPD3	44.64	PMH
44.64	PMH	48.7	VPB
70.2	RV15	49.5	W8XAL
		49.98	Rangoon
		58.3	PMY
		70.2	RV15

## 9-10 p.m.

13.93	GSJ	11 p.m.-midnight	
13.97	GSH	13.93	GSJ
13.99	DJS	13.97	GSH
16.86	GSG	13.99	DJS
16.89	DJE	16.86	GSG
19.58	OLR5B	16.89	DJE
19.63	DJQ	16.89	DJE
19.68	TPA2	19.56	DJR
19.7	OLR5A	19.63	DJQ
19.71	PCJ (W)	19.68	TPA2
19.74	DJB	19.74	DJB
19.76	GSO	19.76	GSO
19.8	YDC	19.76	GSO
19.82	GSF	19.8	YDC
19.85	DJL (S)	19.82	GSF
25.0	RNE (W)	19.85	DJL
25.4	2RO	25.4	2RO
25.57	Saigon	25.42	JZJ
27.27	PLP	25.57	Saigon
28.14	JVN	27.27	PLP
29.24	PMN	29.24	PMN
30.23	JDY	30.61	XGOX
30.61	XGOX	30.78	COCQ
31.28	VK2ME	31.28	VK2ME
	(S)		(S)
31.28	VK6ME	31.35	W1XK
31.38	DJA	31.38	DJA
31.45	DJN	31.45	DJN

31.49	ZBW3	44.64	PMH
31.51	HS8PJ	48.7	VPB
	(Th)	49.5	W8XAL
31.8	COCH	49.9	COCO
32.09	COBC	49.98	Rangoon
32.59	COBX	58.3	PMY
33.2	COBZ	70.2	RV15

## DX Notes And News.

## Some Interesting Veries From Overseas.

As usual, I must "hand you the bouquet" regarding your continual success in the compilation of the "Radio World." I have made several new DX friends through the Club section, and have had such a flow of QSL cards that I have had one of my



"My shack and self"—a snap from Charles R. Nelson (AW98DX), of Ararat, Victoria.

own printed. I adopted the Koala, as Queensland is still favoured by many of these little marsupials.

Regarding DX, lately I have sent reports to India, Dominican Republic and U.S.A. and have veries back from France, Phillipines and Holland. The Happy Station, PCJ, sent me an interesting souvenir in the shape of a wonderfully carved little child's wooden clog and a package of Dutch lollies called "hopjes." W8XK sent a nice card, also KZRM to take the place of written verification first sent. Last week I had a very nice letter from the chief French announcer at TPA, Radio Coloniale, Paris. The manager handed my letter to him and he asks me to keep up a correspondence with him. A member of the staff of OLR, Prague Czechoslovakia is also doing so.

I have contacted and made a friend

of another dixer in another part of Brisbane through the "Radio World," and we are building tuned resonant aerials, turning my present inverted "L" into Hertzian aerial on 49 metres and below as a  $\frac{3}{4}$  wave Marconi. My other hobby of philately has also been helped by s.w., as several other dxers are on my exchange list.—Gordon Young (AW245DX), Brisbane, Queensland.

## Dxing With The "Empire Three."

I have built the "Empire All-Wave Three" and with it have logged the following stations on 20 metres.

PCJ, W2XAD, GSE, GSW, GSF, PHI, W8XK and DJR, as well as numerous VK and ZL hams. I am using the amplifier and power pack, and find that the shortwave stations can be heard as clearly with the speaker as on 'phones.—Lester F. Evans (AW351DX), Christchurch, N.Z.

## "Excellent For Country Servicemen."

From a country serviceman's point of view your paper is an excellent one. I am particularly interested in the economical battery set, preferably a t.r.f. job of three or four valves. I find they give best service for the man with the small purse.—W. Burnett, Port Elliott, S.A.

[A three-valve t.r.f. battery set is described this month.—Ed.]

## VK Loggings In Four Nights.

The following VK's were logged in four nights on my 5-valve superhet:—

VK2's BE, BL, HD, GB, UE, KY, UW, KO, TM, NZ, GZ, MW, FC, CH, NR, KA, CA, GN, BS, KM, AY; VK3's UZ, BA, DB, KZ, GL, BO, SR, AW, TR; VK4's RK, BC, BH, AK, GR, QR, QG; VK5CM; VK6IX; VK7's NT, HO, LA, UV. VK5CM was only QSA3 R6, and I cannot understand why other South Australian stations did not come in. VK7UV and 7NT were QSA5 R8-9, and I have already received a QSL from 7NT. †

Many of my overseas friends have commented on the fine Club seals.—Adrian Nall (AW162DX), Hurlstone Park, Sydney.

## New Transmitter For Launceston.

A complete new transmitter was shipped towards the end of April by Amalgamated Wireless to Launceston for broadcasting station 7LA. The equipment now in use was installed in 1930, and the new installation is due to the Commonwealth Government having granted the operating company an increase in power from 300 to 500 watts. The station will operate on the latter power, but has a reserve up to 1000 watts.

The equipment was designed and constructed in the Radio-Electric Works of Amalgamated Wireless at Sydney, and contains all the most recent features in broadcasting technique.

# Keen Low Prices On Complete Kits Of Parts

## The "AIRCELL" DUAL-WAVE 4

Designed especially for "Air-cell" operation, the "Air-cell Dual Wave Four" fully described in this issue should be particularly popular with country readers. Note the special price for the complete kit of parts—order one to-day. Vealls pay freight to your nearest Victorian Railway Station.

COMPLETE KIT **£12-10-0**

## The "SCOUT" BATTERY THREE

Three-valve battery sets have always been popular, owing to their low first cost and upkeep. The sensitivity and reliability of the "Scout Battery Three" is such that it can be recommended with every confidence. Note Vealls special price for the complete kit—everything necessary to build the complete chassis, including valves and speaker.

COMPLETE KIT **£9-0-0**

## VEALLS PAY FREIGHT

Vealls pay freight on all Victorian retail orders excepting cabinets, and on all inter-state orders excepting batteries and cabinets.

It pays to deal with Vealls—keen low prices, fast service, expert attention. Try Vealls with your next order.

## The "COMET" Dual-Wave Super

Read the full constructional details in this issue of the "Australasian Radio World" . . . learn how easily you can build the "Comet" Dual-Wave Superheterodyne. . . . Note the special low price for the complete kit—everything necessary to build the chassis, including valves and speaker—a set you'll be proud to own . . . to demonstrate to your friends. Order a kit to-day.

COMPLETE KIT **£9-5-0**

## Everything Radio & Electrical at Vealls

With six Big Stores packed with Radio and Electrical Goods, Vealls can supply all your needs. Radio Sets, Parts and Accessories; Electrical Household Appliances and Labour-saving Devices, Irons, Toasters, Grillers, Washers, Vacuum Cleaners, and the host of electrical servants that make life worth living. Tell Vealls your needs—a quotation involves no obligation to purchase.

THE FASTEST MAIL ORDER SERVICE  
IN AUSTRALIA.

# Arthur J. Veall Pty. Ltd.

Address all correspondence to Box 2135T, G.P.O., Melbourne.

490 Elizabeth Street, Melbourne.

168 Swanston Street, Melbourne.

3-5 Riversdale Road, Camberwell.

243 Swanston Street, Melbourne.

299 Chapel Street, Prahan.

99 Puckle Street, Moonee Ponds.

'Phone: F3145 (6 lines).



**T**HE steady hands and keen eyes of trained operatives perform many intricate tasks at Philips Australian Valve Factory.

On this machine, tiny components are being electrically welded into the valve mount. Attention to detail means better valves — and that means better radio!



**REPLACE WITH...**

# PHILIPS VALVES