

**THE
AUSTRALASIAN**

**DEC. 1, 1936
VOL. 1—NO. 8
PRICE, 1/-**

Radio World

Registered at the G.P.O.,
Sydney, for transmission
by post as a periodical.

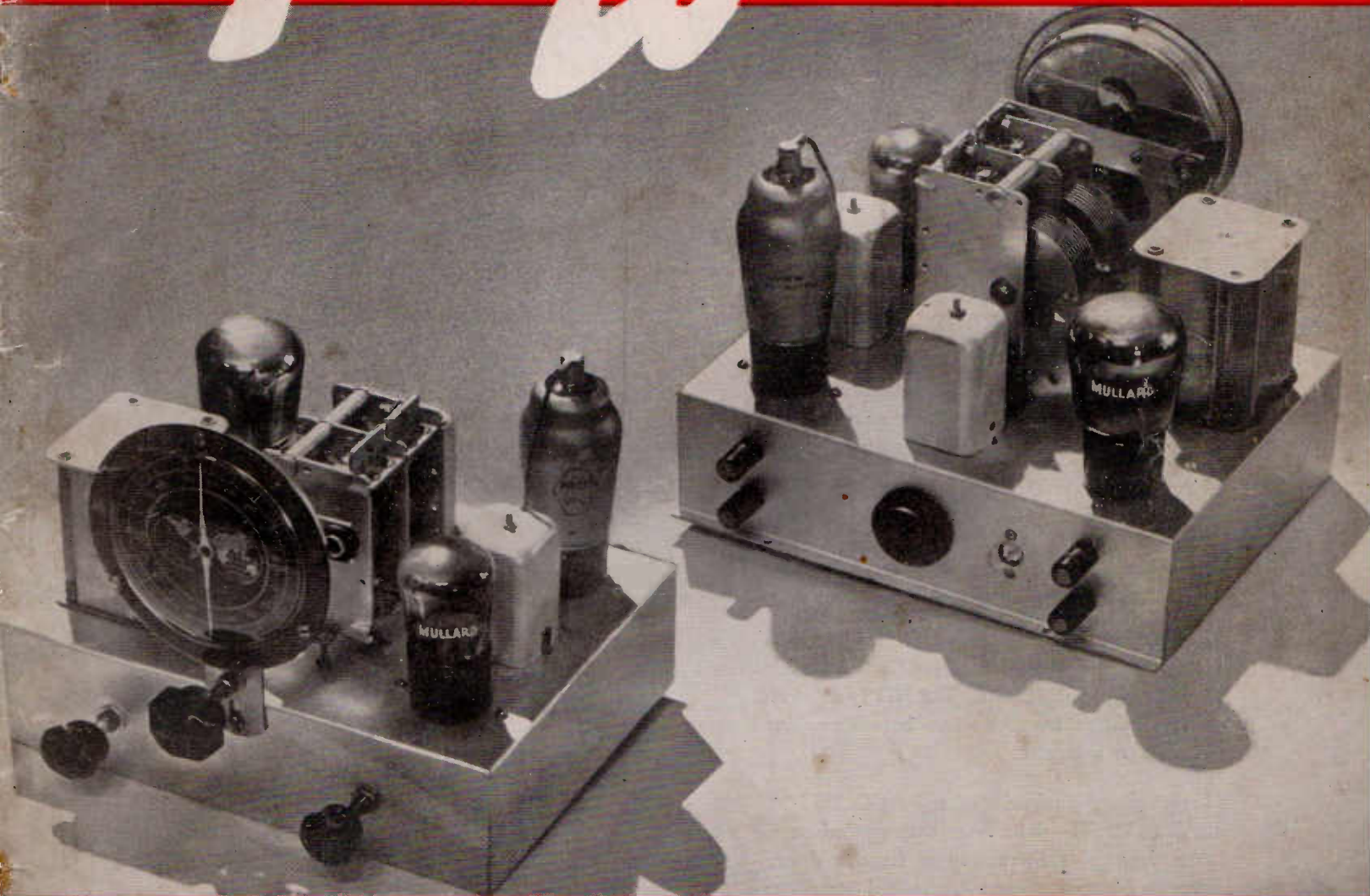

—See page 7.

- **SPECIAL XMAS ISSUE: PARTY RADIO MAGIC: SCOUT BATTERY THREE:**
- **HIGH FIDELITY AT LOW COST: FIVE-METRE SCHEDULES DURING**
- **XMAS: LATEST SHORTWAVE NEWS: THE STORY OF TELEVISION.**

ONLY

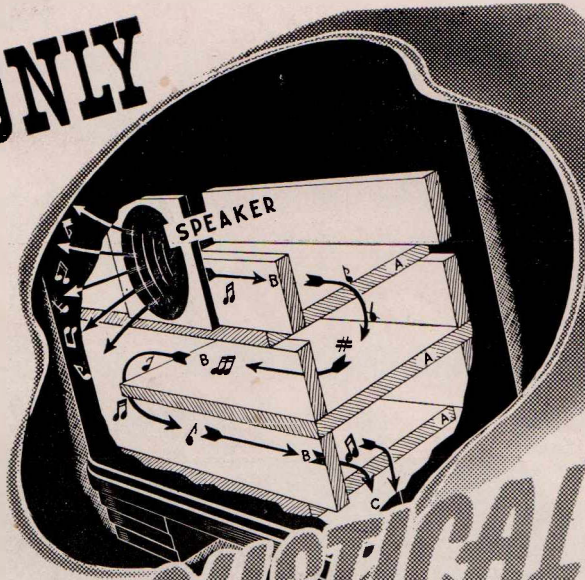

**STROMBERG
CARLSON**
HAS THE
ACOUSTICAL LABYRINTH

INCORPORATED in the magnificent new Stromberg-Carlson world-range receiver—**THE CONCERT GRAND**—is radio's most important invention—the amazing **ACOUSTICAL LABYRINTH**.

It brings you perfect Tonal Faithfulness for the first time in the history of Radio—thrilling realism at all registers and at all volumes. It is as if a familiar photograph were suddenly reproduced in full colours, giving new life to the portrait, bringing out new perspectives, new and delicate shading.

In addition to the **ACOUSTICAL LABYRINTH**, the new Stromberg-Carlson 8-valve world-range **CONCERT GRAND** incorporates many brilliant features never before combined in a single receiver.

Investigate the miracles of the **ACOUSTICAL LABYRINTH**—write to Stromberg-Carlson for free descriptive literature—or have a demonstration by your nearest Authorised Stromberg-Carlson Dealer.



The Magnificent

CONCERT GRAND

Never before has Stromberg-Carlson—or any other radio manufacturer—been able to offer so many exclusive advances combined in a single radio receiver. Its many features include:

- | | |
|---|--|
| 1. The Acoustical Labyrinth. | 9. Special Speaker designed for the Acoustical Labyrinth. |
| 2. The Beautiful Concert Grand Cabinet, illustrated above. | 10. Iron-cored Tuning Coils. |
| 3. Isolector Tuning Unit. | 11. Gramophone pick-up terminals and three-way switch—Broadcast, Short Wave, and Radio Gramophone. |
| 4. Special type tone control. | 12. Specially imported Condor Valves. |
| 5. Tru-Tone Compensation. | |
| 6. Variable Selectivity Control. | |
| 7. Magic Eye, which operates on ANY station the Model will receive. | |
| 8. Edge-lit Rectangular Vertical Non-slip Dial. | |

PRICE 39 Gns.

There is an authorised Stromberg-Carlson Dealer handy to your Home.

Stromberg-Carlson

Announcing NEW TEST EQUIPMENT BY TRIPLETT!

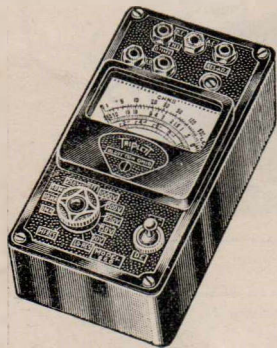

MODEL 666.

MODEL 666 Universal Pocket Volt-Ohm-Milliammeter is indispensable for measuring A.C. or D.C. volts, ohms and mills. Scale length is same as that of Triplett 3-inch instruments. Ranges: A.C. and D.C. 10-50-250-500-1000 volts at 1000 ohms per volt; 1-10-50-250 D.C. M.A.; Low ohms, ½ to 300; High ohms to 250,000. Provisions for external batteries for higher resistance measurements. Supplied complete with test leads and full instructions.

Price £5/15/-

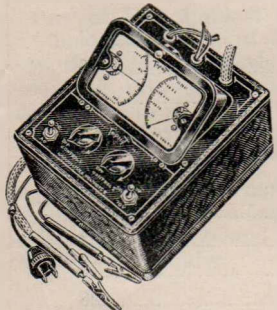

MODEL 1250 UNIT.

MODEL 1250 is the first self-calibrating Vacuum Tube Voltmeter. Replacing a valve does not alter accuracy. Measures low A.C. and D.C. voltages without current drain. Has two separate D.C. movements in a tilting type case. One indicates when tube characteristics are stabilized with the circuit. The other is a three-range voltmeter with approximately linear scales reading in peak A.C. and D.C. volts. Ranges are 2.5, 10, and 50 volts. All accessories included.

Price . . . £12/10/-

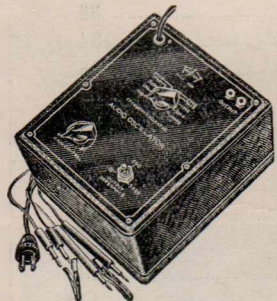

MODEL 1260 UNIT.

MODEL 1260 is a compact portable Audio Frequency Oscillator generating a pure sine wave without distortion or harmonics. Gives precision performance equal to that found in the finest of laboratory equipment. Ten frequency ranges from 100 to 10,000 cycles enable testing of audio amplifiers, speakers, P.A. systems, etc. Attenuation is extremely accurate; impedance matching variable. Operates from A.C.

Price . . . £10/15/-

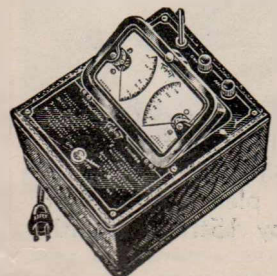

MODEL 1295 UNIT.

MODEL 1295 Modulation Monitor shows actual modulation percentage of transmitters on the direct reading dial, which indicates modulation from 40 to 120 per cent. Readings are in peaks. Visual information provided on a second dial for carrier reference level for the modulation test and also to check carrier shift during modulation. Model 1295 has a twin instrument, tilting type, with two separate movements. Factory calibrated.

Price £9/15/-

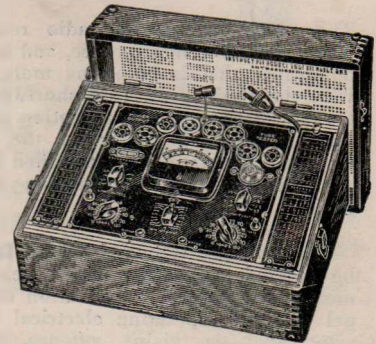

MODEL 1503.

MODEL 1503 Multi Purpose Tester combines in one instrument the equivalent of nine separate units. Checks any type valve for merit (including separate diode test)

Neon inter-element short test (made while valve is hot) detects even the slightest leakages. Tests paper condensers for opens and shorts, and electrolytics for leakages. D.C. voltmeter and milliammeter, ohm-meter, decibel meter.

D.C. scale: 10-50-250-500-1000 volts, 1000 ohms per volt; 10-50-250 M.A.; .2 ohms to 10 megohms; 10-50-250-500-1000 A.C. volts at 400 ohms per volt; down 10 and up 15 decibels. Shadowgraph line voltage indicator.

Furnished in a highly attractive quartered oak case with sloping silver and black panels. For portable or counter use. Case measures 15¼in. x 11¼in. x 7½in.

Price £16/10/-

Triplett precision quality instruments have a threefold purpose—they are most advanced in design, expertly made, and dependably accurate.

TRIPLETT D.C. INSTRUMENTS are the D'Arsonval type with an extra light moving coil and reinforced strong parts.

TRIPLETT A.C. INSTRUMENTS are the movable iron repulsion type. All are air damped. Have extra light moving parts. Both A.C. and D.C. instruments have: Sapphire jewel bearings. Finest workmanship to assure dependable performance. White enamelled metal scales. Moulded zero adjusters. Accuracy 2 per cent.

Available in 2in., 3in. and 5in. cases, round, square and portable and flush or projection mounting.

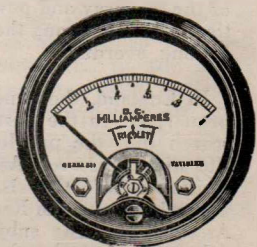

MODEL 321.
D.C. Milliammeter.

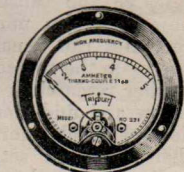

MODEL 321.
0/1 M/A.

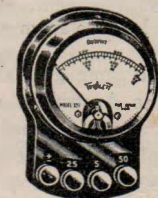

OUTPUT METER.

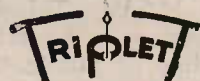

... THE MASTER TESTERS

FULL DETAILS SUPPLIED FREE ON REQUEST BY THE EXCLUSIVE FACTORY REPRESENTATIVES FOR AUSTRALIA & NEW ZEALAND

W. G. WATSON & CO. LTD.

279 Clarence Street, Sydney.
31 Hunter Street, Newcastle.

398 Post Office Place, Melbourne.
91A Currie Street, Adelaide.

and at Perth, Hobart
and Launceston.

Editorial Notes

The Power Interference Problem

The main bugbear of radio reception to-day is power interference, and it is an annoyance that is becoming more acute with the rapid growth of shortwave listening. Also, as far as reception of Australian stations is concerned, the effects of man-made static are intensified by the comparatively low transmitting powers used.

The problem is one that will have to be tackled sooner or later, even if it means the passing of legislation to compel everyone operating electrical equipment that is giving offence to fit suitable filters to silence the noise. In this respect, concerted action on the part of the tramway and power supply authorities, who are among the biggest offenders, is long overdue.

In England, thousands of pounds have been spent in the past few years on research into the problem, mainly by the Electrical Research Association with the assistance of the B.B.C., the postal authorities, and the Radio Manufacturers' Association. The subject has also been exhaustively analysed by various countries on the Continent, particularly by Germany, and as a result of all this research the causes of interference are now generally understood and suitable remedies can usually be applied. In a few cases the remedy is expensive, and so further research is now being undertaken to try and find methods of achieving the desired result more cheaply. The goal that has been set in England will be attained when, by a combination of suppressing equipment at the receiver and the fitting of filters to interference-creating equipment, radio reception for 90 to 95 per cent. of the listening public will be free from man-made interference.

The same goal should also be the aim of the Australian authorities, but so far next to nothing has been done. The first, simplest, and cheapest step would be to increase station power considerably, to provide a better signal-to-noise ratio. The next and most important move is to have legislation passed that will render owners of interfering equipment liable to prosecution. The radio inspectors appointed by the P.M.G.'s Department are already doing splendid work in quelling interference, but until they have legislative backing their task is a hopeless one.

THE AUSTRALASIAN RADIO WORLD

Incorporating The
ALL-WAVE ALL-WORLD DX NEWS.

Managing Editor:
A. EARL READ, B.Sc.

Vol. 1.

DECEMBER, 1936.

No. 8.

CONTENTS:

Radio Gifts For Christmas	3
"Scout Battery Three"	6
Radio Ramblings	10
High Quality Reproduction At Low Cost	14
New £50,000 Factory Planned By Ever-Ready	16
The "Scout Superhel Four"	17
This Pentode Business (2)	22
The Story Of Television (1)	24
Radio Step By Step (5)	26
Party Radio Magic	28
The Cathode Ray Oscillograph At Work (4)	30
Radio In India	33
The A.T.R.S. Bulletin	34
What's New In Radio	36
Radio Book Reviews	37
Round The N.Z. "B" Stations	38
VK Amateur Stations—Additions And Amendments	40
All-Wave All-World DX News	41
Radio VK4DO Is Model Amateur Station	42
Schedules Of Japan's New Shortwave Service	42
Shortwave Stations Of The World (4)	43
DX Notes And News	45

The "Australasian Radio World" is published monthly by Trade Publications Proprietary, Ltd. Editorial offices, 214 George Street, Sydney, N.S.W. Telephone BW 6577. Cable address: "Repress," Sydney. Advertisers please note that copy should reach office of publication by 15th of month preceding that specified for insertion.

Subscription rates: 1/- per copy, 10/6 per year (12 issues) post free to Australia and New Zealand. Subscribers in New Zealand can remit by Postal Note or Money Order.



Radio Gifts For Christmas



Christmas will soon be here again, and with it comes the same old problem of deciding what presents will be the most acceptable for various members of the family. To the dyed-in-the-wool "ham" or set-builder, however, there is no problem at all---a radio gift is always the best. Here are some excellent gift suggestions sent along by "Radio World" advertisers . . . take your pick!

A "Scout" For Christmas.

One of the simplest and cheapest of the wide range of Radiokes kits-sets, the "Scout Superhet Four" described in this issue would make an ideal Christmas gift.

For something less expensive, then a Radiokes aerial kit, power transformer, coil kit, or any one of the dozens of lines manufactured by this well-known firm would be welcomed by any set-builder.



Microphones And Pick-ups For Xmas Party Entertainment.

Your Christmas party can be made to go with a swing, easily and cheaply, just by fitting a pick-up to your set. Old-time and modern dances

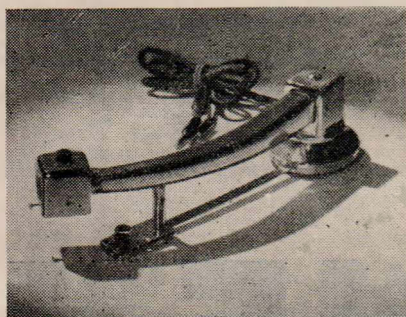

can be played, just as you desire. Every gramophone owner has a collection of foxtrot and waltz recordings, while one or two records will cover all the popular old-timers.

Messrs. A. J. Veall Pty. Ltd., of Melbourne, can supply reliable pick-ups ranging from the B.T.H. Minor at 32/6 to the Dual (illustrated) at 77/6. With this pick-up, a small

knob gives a choice of four different impedances, thus accurately matching it to your set and giving amazing reproduction.

Another great fun-maker at a party is a microphone; by installing one you can provide endless entertainment for your guests. The Harlie microphone illustrated is ideal for the purpose, and incidentally for public address or amateur radio installation as well. It is priced at £5-5-0, and is supplied complete with the necessary transformer, battery, and switch.

For those who want a cheaper model, Veall's can supply the B.G.E. Home Broadcaster at 39/6. It is supplied ready to fit to your receiver, and is provided with a 20-foot length of cord, allowing the microphone to be placed in another room.

Lastly, if you would like any further suggestions for Christmas gifts, then Veall's 76-page catalogue, with 500 illustrations, contains an amazing variety of radio and electrical components and accessories. Copies are available free.



Novel Xmas Offering By Price's Radio Service.

Price's Radio Service—that well-known radio store in Angel Place, Sydney,—is handling a new and novel Christmas line this year in Lionel model electric trains. Made

by the Lionel Corporation of America, these trains are recognised as being the best on the market. Any of the entire range of models, which are priced from £3-10-0 to £15-15-0—can be demonstrated at the store, as a special track has been installed for the purpose, complete with tunnels, bridges, station, shunting yards and so on. Mr. McIntyre, the proprietor, is always willing to show any model in operation without obligation.

Almost every set-builder in Australia must know that Price's specialise in radio parts, and that they are always ready to assist anybody to build any type of receiver or transmitter.

For those wanting an inexpensive Christmas gift that is sure to be appreciated, Price's suggest a pair of Erpee headphones. Remarkably light—they can be worn for hours on end without the slightest discomfort—they are also highly sensitive, and are suitable for all types of receivers from crystal sets upwards (resistance is 2,000 ohms). They represent excellent value at 9/6 (postage 6d.).



Crystal Set From Murdoch's.

Excellent headphone reception from nearby stations is assured for build-

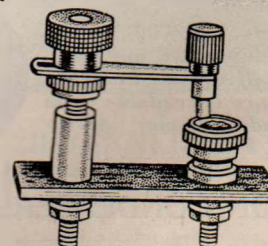

ers of the "Lodge" crystal set, sold in kit form by Murdoch's Ltd., of Sydney. The kit includes panel, base,

coil, variable condenser, terminals, and a special zincite-tellurium double contact crystal detector that is highly sensitive. Pressure is adjustable, and once set, the adjustment is permanent. The kit is supplied with full assembly instructions for 18/6, or complete with headphones, pliers, aerial, etc., for 38/6.

Readers who already have crystal sets and who want to fit the zincite-tellurium detector supplied with the above receiver (and illustrated on p. 3) can buy one for 5/-. All enquiries should be addressed to Desk C52, Murdoch's Ltd., George St. Sydney.



Morse Keys And Headphones From Fear & Co.

Messrs. F. J. W. Fear & Co. of Wellington, N.Z., can offer set-builders, amateurs and servicemen an unequalled range of quality radio lines, including kit-sets, testing equipment, and radio parts of all kinds.

Hundreds of ideas for attractive and original Christmas gifts can be gained by a glance through their latest catalogue, which is available free on request.

Here are two attractive items that

will interest amateurs and dxers. Morse keys stocked include the standard R.A.F. Model at 15/-, the S.G. Brown Flame Proof at 19/6, and the Speed-X Key, a de luxe model with coin silver contacts and chromium plated arm, at 15/6.

A good pair of headphones is always welcome in any experimen-

The Editor and staff join in wishing every reader the Compliments of the Season.

ter's shack, and the Frost headphones that Fear & Co. carry are recognised as being among the best in the world. There is a de luxe model with a resistance of 2,000 ohms available at 15/-, while super-sensitive DX Model, with a resistance of 20,000 ohms, sells for 22/6.

Suggestions For Book-Lovers.

There is a fine selection of technical radio books already reviewed elsewhere in this issue, and so Messrs. Angus and Robertson, of 89 Castlereagh St., Sydney, were invited to suggest something different for this page in the way of gift books for Christmas.

"Papuan Wonderland," by J. G. Hides, is the full, thrilling account of Mr. Jack Hides' memorable expedition through unexplored Papua which caused such a stir in the Press throughout the world. The Lieutenant-Governor of Papua, Sir Hubert Murray, describes this expedition as the most difficult and dangerous patrol undertaken in New Guinea, and the "Daily Herald" (London) says the book is easily the finest travel book of the year. It is splendidly illustrated with 24

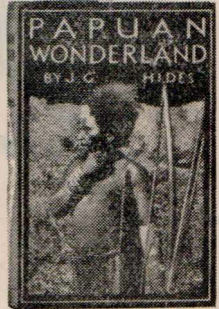

(continued on page 48).

SUPPRESS INTERFERENCE!



With the introduction of the Chanex Kit of Suppressors, your Radio Dealer is now in a position to suppress the majority of all generated interference. He will gladly advise and assist you in your interference problems.

Chanex Suppressors conform to all regulations and are built to British Standard Specifications 613/1936 and have been approved for connection to the mains by all Electricity Supply Authorities.

Whatever your interference problem, be sure to consult your Radio Dealer.

FREE BOOK
This book, which fully explains the causes and suppression of Radio Inductive Interference is available from your Radio Dealer ABSOLUTELY FREE.

CHANEX

DUCON CONDENSERS PTY. LTD., 73 BOURKE ST., WATERLOO, SYDNEY, N.S.W.

and at
"Cornhill Chambers,"
450 Collins Street,
MELBOURNE, C.1, VIC.

P. H. Phillips, Esq.,
"Clock House,"
193 Elizabeth Street,
BRISBANE, Q'LAND.

Wm. T. Matthew, Esq.,
95 Grenfell Street,
ADELAIDE, S.A.

Carlyle and Co.,
915-917 Hay Street,
PERTH, W.A.

Arnold and Wright,
173 Selwyn Street,
CHRISTCHURCH, N.Z.

A "SPECIAL" For Country Readers !

The SCOUT BATTERY THREE

described in this issue is the ideal battery set for country listeners who want the most in radio at the cheapest cost. Uses latest type high efficiency low consumption valves, that in conjunction with

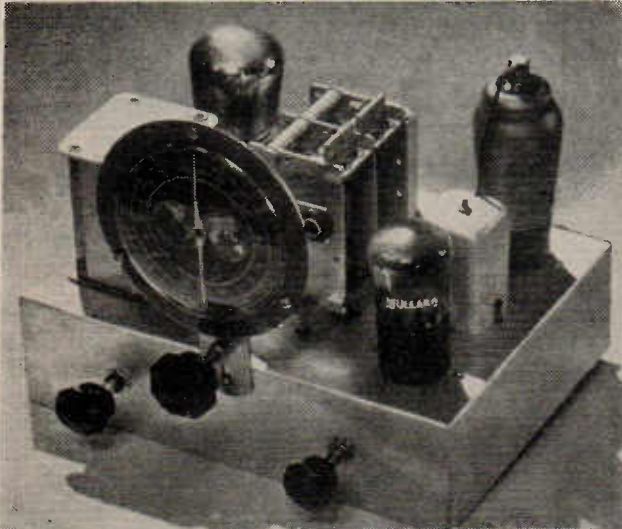

new iron-cored coils give an amazing performance. All the main Australian and New Zealand stations can be brought in at fine

speaker strength. Selectivity is fully adjustable to suit the requirements of any locality.

The complete kit price quoted below includes everything — valves, "A" and "B" batteries, and speaker. Nothing more to buy.

Complete Kit of Parts . . . £8-15-0

High Quality Reproduction at Low Cost.

Watch for full details of this amazing new receiver in the January "Radio World"—it is designed for those who know what good tone really is.

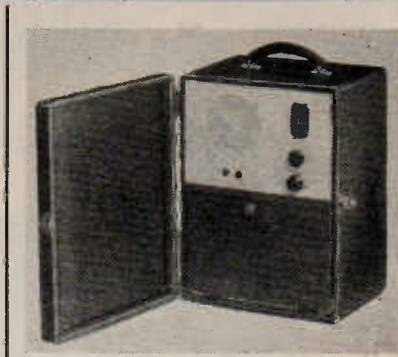

BUILD AN OUTDOOR PORTABLE FOR XMAS!

This powerful superhet. portable uses 4 latest type valves in a special reflex circuit, giving tremendous gain with very low battery drain. Complete assembly instructions supplied with every kit; success guaranteed. Special Complete Kit Price £10/5/-

WE SPECIALISE IN "RADIO WORLD" KITS —
WRITE FOR OUR COMPLETE KIT PRICES

"ALL-WAVE BANDSPREAD TWO"

Described in the September "Radio World," this little kit is proving widely popular with set-builders who want world-wide reception at the cheapest cost. Plenty of broadcast band stations can be tuned in, too. Complete kit of parts (everything except batteries) £5/5/-

"AIR-ACE DUAL-WAVE FIVE"

For those wanting a reasonably-priced dual-wave receiver that can be depended on to bring in the main broadcast and shortwave stations at good speaker volume, and with little or no fading, we can recommend the "Air-Ace Dual-Wave Five" described in the October "Radio World." Complete kit of parts £14/5/-

5-METRE RECEIVER

Build the special 4-valve receiver described last month, and be the first to hear Australia on 5 metres. Complete Kit Price will be sent on application.

"SUPER-COMET ALL-METAL FIVE"

1936 version of the famous "Comet," this new kit gives astounding results. Sensitivity and selectivity as found in most sixes and many sevens. (See September "Radio World" for full description or write us for full details.) Complete kit of parts, including valves and speaker, £13/5/-

MICROPHONE AND OUTPUT METER

We can supply the parts needed for building the Reiss Microphone and Output Meter described in last month's "Radio World." A post-card will bring you full details by return mail.

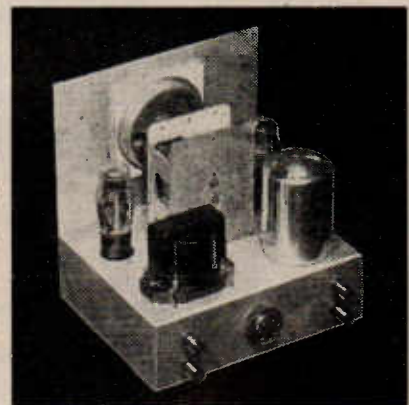

"BEGINNER'S BATTERY TWO" (See November "Radio World")

The ideal small set for headphone reception of broadcast stations. Our kit is supplied complete in every detail—including valves, headphones and batteries. Our Complete Kit Price, £6/5/-

FEAR'S

FOR EVERYTHING IN RADIO

An advertisement of

F. J. W. FEAR & CO., "The Radio Pioneers"
63 Willis Street, Wellington, New Zealand.

Telegrams: "Fear."



This three-valver is an ideal set for country listeners who want to get the maximum in radio entertainment at the lowest cost.

USING latest type Mullard battery valves, together with the new Radiokes iron-cored coils, this battery "Scout" puts up an excellent performance that is actually superior to that given by many of the older four and five-valvers of similar design. As well, both initial and running costs are very low. The complete kit of parts, including valves, batteries and permanent magnet speaker can be bought for under £10.

The "B" drain is between 7 and 8 mills., meaning that a set of heavy duty "B's" will give nearly a year of service with normal usage. Even the light duty type could be used if desired. The "A" drain is just under half an amp., so that an 80-amp. hour accumulator would give about 150 hours of service from a single charge. No "C" battery is required, as automatic bias is used.

For this receiver Radiokes Ltd. have developed special iron-cored t.r.f. coils, with the windings wound directly on the iron cores. For maximum gain, and to level up sensitivity over the band, high impedance primaries, spaced well apart from the secondaries have been used.

The circuit of the "Scout Battery Three," which uses a screen-grid r.f. stage, triode detector, and pentode output valve.

Coupling between the two windings is effected by means of a midget variable trimmer condenser mounted on the coil base, and connected between the upper ends of the primary and secondary.

Thus the degree of coupling, and hence the gain and selectivity, is adjustable to suit any particular locality. Where selectivity is not all-important but sensitivity is, both coupling condensers can be screwed almost right home to give maximum gain.

The r.f. valve is a Mullard VP2 r.f. pentode—a spray-shielded valve fitted with a standard American 6-pin base. The suppressor grid and metallic coating are both taken to separate pins.

Alternative Valve Types.

The detector is a PM2DX triode, and is transformer-coupled to a PM22A output pentode. Alternatively the new KL4, a similar valve fitted with the universal "P" base, can be used. In the Philips range, the KF1 or KF2 can be used in the r.f. socket, a B217 as detector, and a C243N as output pentode. By using a 4-pin

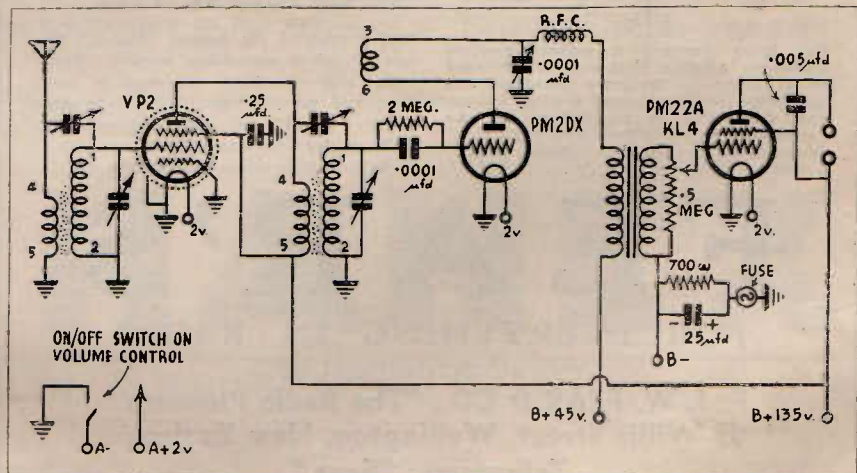

IT'S NOT MAGIC, IT'S

Mullard



There is no magic about the Scout Battery 3 described in this issue. There is nothing revolutionary in the circuit design. This set looks no different from small T.R.F. Sets of pre-superhet. days . . . but the "magic" of the new Mullard high efficiency valves gives to this set a performance immeasurably superior to that which has been obtainable heretofore.

If you expect Mullard performance you must equip your set with Mullard Master Valves

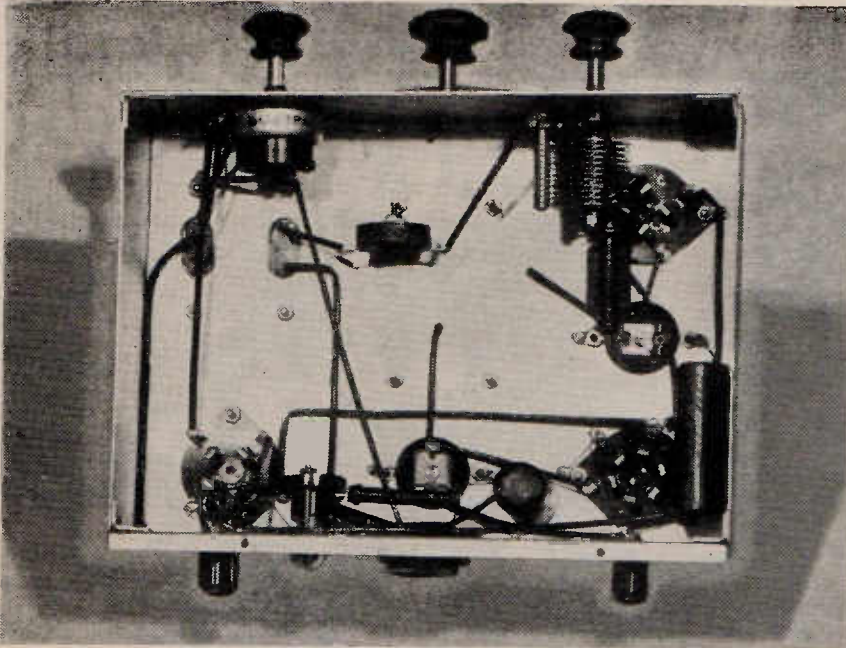

An under-chassis view, showing the extreme simplicity of the wiring.

valve socket for the r.f. valve, then a 1C4 could be used as r.f. amplifier, followed by a 30 detector and 1D4 output pentode.

Automatic Bias Used.

Volume is controlled by the potentiometer across the audio transformer secondary, the moving arm being taken to the grid of the output pentode. Automatic bias for the latter is obtained by connecting a 700-ohm resistor between "B—" and earth. All the "B" current drawn by the set passes from earth via the resistor to "B—" to complete the circuit. The voltage drop across the resistor, amounting to nearly five volts, is negative to earth, and so can be utilised for providing bias for the PM22A.

A fuse, in the form of a 60-milliamp. fuse bulb, is incorporated in the receiver between the "B—" and earth to safeguard the valve filaments in the event of an accidental short-circuit of the "B" supply through the "A" circuit.

Commencing The Assembly.

When the chassis and parts have been assembled, the construction can be commenced by mounting the valve and battery sockets, fuse bulb holder, aerial, earth and speaker terminals, reaction condenser, potentiometer (with on/off switch mounted on it), coils, and condenser gang.

All four terminals should be insulated from the chassis. The fuse bulb holder is mounted away from the rear wall, so that the bulb pro-

jects through a 1/2 in. hole as shown in one of the photographs. Before

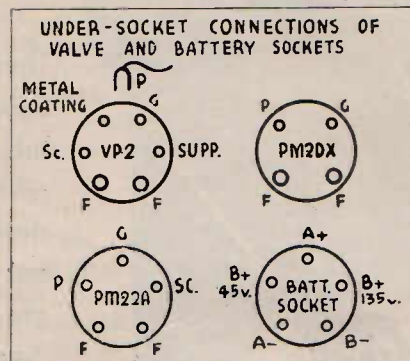

mounting the condenser gang, which is supported half an inch above the chassis by means of 4-1 in. bolts and 12 nuts, solder a 6 in. length of push-

back to the lug underneath each section of the gang. Finally, before the r.f. coil is mounted, a flexible lead should be soldered to terminal 4 on the coil base, and taken up inside the can and out of a hole at the top. This is the plate connection to the cap of the VP2.

The wiring is shown in detail in the under-chassis wiring sketch. The Radiokes coils used in the original receiver were advance experimental samples, and were not fitted with numbered lugs on the bases. However, regular supplies are now available, the lugs being numbered as shown in the circuit and wiring diagrams, so no confusion will arise with regard to this portion of the wiring.

The filament circuit should be wired first of all, and then, starting at the aerial terminal, wire the r.f. coil, VP2, detector coil, PM2DX, and so on until all the wiring is complete. When wiring in the 25 mfd. electrolytic condenser across the bias resistor, be careful to connect the end marked "+" or painted red to earth, and the other to "B—."

The chassis can now be inverted and the VP2 plugged into its socket. Solder the grid clip to the lead. Next remove the valve, invert the chassis, and make a thorough check of the wiring. If everything is in order, fit the dial and control knobs.

The five wire-battery cable can now be connected up, the valves plugged in, and the aerial, earth and speaker leads attached to their terminals.

Turn the volume control full on, and slowly rotate the reaction control until a hissing sound is heard in the speaker, denoting the set is on the verge of oscillation. Next rotate the tuning control, and stations should soon be picked up.

Aligning The Set.

The last adjustment necessary be-
(continued on page 47).

"Scout Battery Three" List of Parts

- 1—chassis, 9 1/2 in. x 7 in. x 2 1/2 in., stamped and drilled as shown.
- 2—iron-cored coils, 1 aerial 1 r.f., with reaction (Radiokes).
- 1—2 gang condenser (Stromberg-Carlson).
- 1—aero dial, b.c. (Radiokes).
- 1—4, 1—5, 1—6 pin wafer sockets.
- 1—5 pin Dalton socket.
- 1—5 pin Dalton plug, with 2 yards 5-wire cable.
- 1—audio transformer (Radiokes).
- 1—.5 megohm potentiometer, with switch (Allen-Bradley).
- 1—.0001 mfd. midjet reaction condenser (Radiokes).
- 3—knobs, 1 large and 2 small.
- 1—r.f. choke (Radiokes).

FIXED RESISTORS:

- 1—700 ohm carbon resistor (Allen-Bradley, Chanex).

FIXED CONDENSERS:

- 1—0001 mfd. mica (Chanex).
- 1—.005 mfd. tubular (Solar Chanex).
- 1—.25 mfd. tubular (Solar Chanex).
- 1—.25 mfd. dry electrolytic (Ducon).

VALVES:

- 1—VP2, 1—PM2DX, 1—PM22A—of 1—KL4 (Mullard).

BATTERIES:

- 3—45 volt "B" batteries (Ever Ready).
- 1—2v. accumulator (Clyde).

SPEAKER:

- 1—permanent magnet dynamic, input transformer to match single PM22A (Rola 6-6).

MISCELLANEOUS

- 4 terminals (2 red, 2 black), 1—60 m.a. fuse bulb with holder, 1—large grid clip, solder tags, bolts and nuts, hook-up wire.

The MAN on the LAND

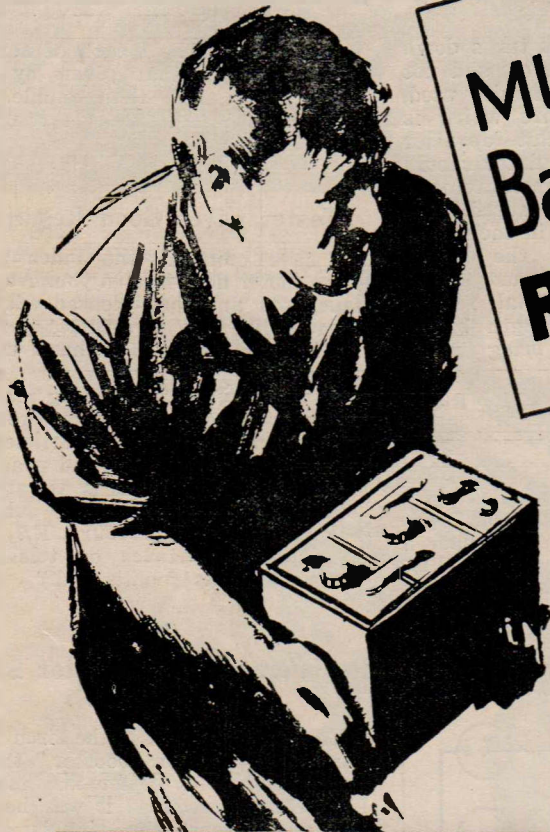

**MUST HAVE A
Battery-Operated
RADIO SET!**

EVERY Radio Receiver sold for country use must draw its power from *some* source. It cannot "run on air."

If it isn't a handy, long-lasting 2 volt accumulator with a set of dependable dry batteries, **IT MUST BE A CUMBERSOME 6 VOLT ACCUMULATOR!**

This, because it is called on to do **ALL** the work, must be recharged more frequently — must consequently be replaced more often — and is heavy and difficult to transport to and from a service station.

With a B-Battery equipped radio your first cost is your last **FOR MONTHS**, reception is smoother, more enjoyable, and entirely free from background noise.

See that *your* new set is the best that your money can buy — in other words a **B-BATTERY** set!

Ask Your
**RADIO
DEALER**
*which type of set
HE'D choose*

An advertisement issued by the Ever-Ready Co. (Aust.) Ltd. in the interests of more dependable "out-back" radio.

EX 9

**EVERY SET IS A BETTER
SET POWERED WITH**

**EVER READY RADIO
BATTERIES**

Radio Ramblings

A page for letters from readers.
A prize of 2/6 will be awarded
for every technical tip pub-
lished.

An Improvised Aerial Condenser

Sometimes set builders are in need of a small capacity series aerial condenser of the three-plate variety. If they do not possess such a component, a good substitute may be made

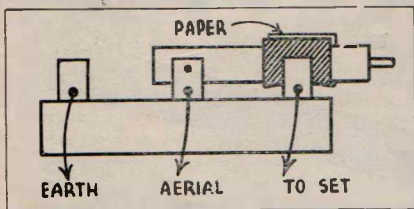

by placing a thin piece of dry paper round the blade of a knife switch, as shown in the diagram. Varying capacities can be obtained by using different thicknesses of paper.—Harry Hibberd (AW79DX), Bendigo, Vic.



Two-Valve Schnell Shortwaver.

In response to many requests from readers, I am sending along the circuit and coil details of the 2-valve Schnell I use for DX work. Since my article was published I have altered the aerial, obtaining a lift of 2 or 3 points in reception. It is still a matched impedance, but is now 67 feet long and tapped 11 feet off centre, with at least 40 feet of lead-in. The latter must be 33 feet or over to get proper matching. It is undoubtedly the "goods," and I strongly recommend it to all members who want a first class aerial.

When making any matched impedance aerial, the length of it is taken

from the point where it turns down in the eye of the insulator, and not from the full length of wire used, as the part of the wire which is wound back round the flat top after passing through the insulator should not be counted in the measurement. The aerial length is measured from the centre of the "eyes" in each insulator at the ends of the aerial. Moreover, the lead-in must be at right angles to the aerial for at least one-third of its length before any turns are made to bring it into the "shack."

Band	Sec.	React.
20-metre	8	6
40- "	12	10
80- "	25	13
Broadcast	175	65

All coils are wound on 1 1/4 in. diameter formers and spaced 1/4 in. between windings. S.W. coils wound with 24 gauge D.C.C., Broadcast with 32 gauge enamelled wire.

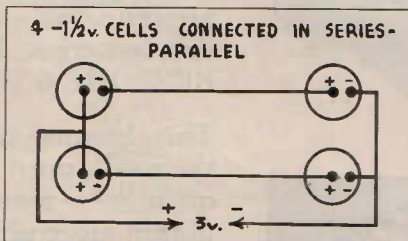

Here is a hint for those who use dry cells for "A" supply. If the drain is fairly high (above about .3 amp), then by using four cells connected in series parallel as shown

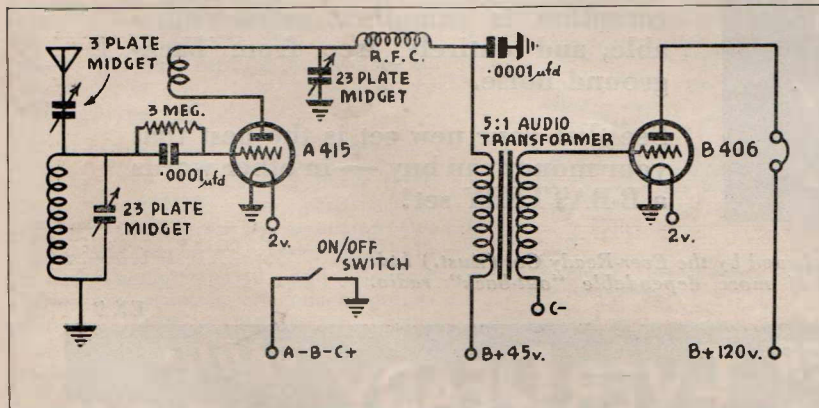

The circuit of AW69DX's two valve short-waver, with which he claims to have logged no less than 4,000 stations in 68 countries.

in the sketch, the length of service compared with that given by two cells is far more than double.—H. Whyte-Meach (AW69DX), Artarmon, N.S.W.



Tester Gives Good Results.

I have built up the Palec ni.e-range meter described in your August issue, and am very pleased with it. I would like to congratulate you on the high standard you have maintained in the "Radio World," each issue being full of interesting matter, and would suggest that you get together some authoritative articles on television, its principles and practice, for I think the public is thirsty to hear about this entralling subject.—D. L. Touzel, Canterbury, E.7, Vic. (A series of articles on television commences this month—Ed.)



Regenerative Pre-selector Steps Up Signals.

Enclosed herewith is the circuit for the pre-selector, or "booster," that I mentioned in my letter last month. It worked as soon as it was hooked up, and strengthens signals from R2-3 to R8-9. I have received the amateur station, CO7HS, on the 20-metre band at R2, and with the booster attached it increased to R9. The name of the "booster," by the way, is the "Jones Regenerative Pre-selector."

It consists of a single regenerative R.F. amplifier stage placed ahead of any shortwave superhet. By the use of variable antenna coupling and cathode regeneration, results equivalent to those given by the usual two-stage R.F. pre-selector are obtainable. Signal-to-noise ratio is greatly increased and image interference reduced.

Regeneration is controlled by means of a 15,000-ohm wire-wound potentiometer which varies the screen voltage. The screen-grid series resistor of 5,000 ohms tends to prevent the regeneration control from introducing noises as the latter is varied. The plate voltage is fed through a small R.F. choke which is effective over all bands. The plate circuit is connected through a coupling condenser to the aerial terminal of the main receiver, or this lead can be

The Big 3 in Radio

ETC

YAXLEY All-Wave and Dual Wave Switches stand pre-eminent with manufacturers who insure against future service trouble by refusing to use likely-looking substitutes. YAXLEY troublefree service is a proven and accepted fact.

SOLAR Electrolytic Condensers have attained their reputation for long-lived operation under all conditions because their anode design and construction have never been improved upon. They set the standard for quality the world over.

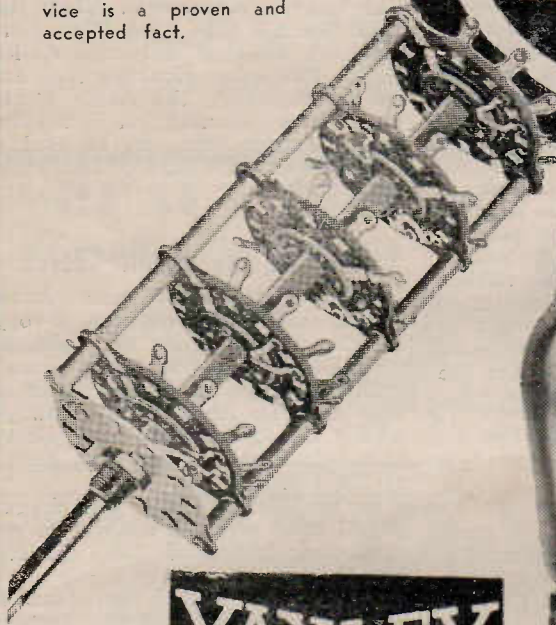

Uniformity, Dependability and Long Life characterise KEN-RAD, "The Fine Valves of Radio"

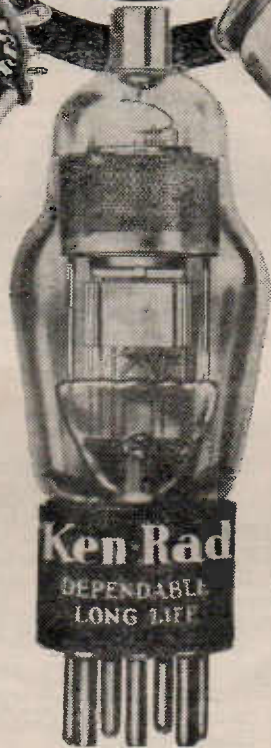

In Replacements you can safely recommend YAXLEY, SOLAR and KEN-RAD. They give quality performance of a degree unexcelled by others.



Factory Reps. **EASTERN TRADING CO. LTD.**
SYDNEY and MELBOURNE

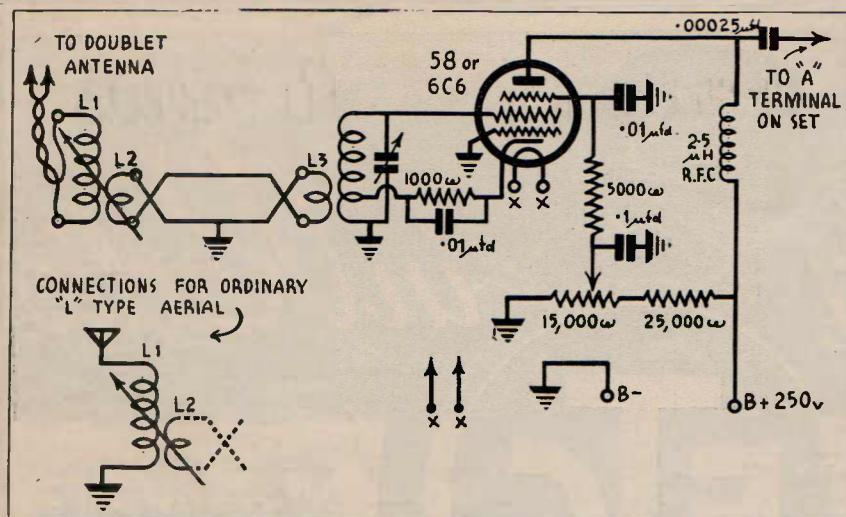

The circuit of AW5DX's regenerative pre-selector unit.

twisted around the first detector grid lead a few times to obtain capacity coupling. In the latter case, the trimmer condenser must be re-set for best results.

Regeneration is slightly affected by the plate circuit load, requiring in some cases a trial adjustment of the cathode tap or alteration to the amount of coupling to the receiver. The R.F. valve will slide smoothly into oscillation when the pre-selector is functioning properly. The point just below oscillation gives the greatest gain and selectivity.

The antenna coupling is made of two pieces of bakelite tubing each 1½ in. long. The larger one is 1½ in. outside diameter and the smaller one ¾ in. in diameter, so that the latter with its winding of 8 turns will slide readily inside the other tube. The larger tube has 20 turns of No. 28 d.s.c. wire close wound, which is connected to a doublet antenna.

The tuning condenser is of the midget type, well insulated and having a maximum capacity of about .0001 mfd. A small aluminium bracket supports the condenser at the proper level for the dial shaft connecting bushing.

All parts are mounted on a piece of 12-gauge aluminium bent in the shape of an inverted "U." The original piece should be 8½ in. long and 7 in. wide with 1½ in. on the front edge and ¾ in. on the rear edge bent down so that the top of the chassis is 8½ in x 4¾ in.

The antenna coupler mounts underneath one side of the chassis and the regeneration control on the other side of the chassis. The entire unit can be housed in a metal cabinet 9½ in. long, 5 in. deep and 6 in. high.

It is desirable to twist the antenna leads together for the two leads in to the pre-selector, and the plate coupling lead should come out of the cabinet at the closest point to the

aerial terminal on the main receiver. The lead should be as short as possible. Power for the unit can be obtained from the main receiver. If a doublet aerial is not used, one side of the aerial coil must be grounded.

In the circuit I would suggest using a 10,000 ohm w.r.-wound potentiometer instead of the 15,000 ohm potentiometer, and instead of using the 25,000 ohm resistor between "B+" and one side of the potentiometer, use a 15,000 ohm voltage divider and tap off the screen voltage so that when the potentiometer is full on there is about 100 volts on the screen of the valve.

Here are the coil details for the 20, 40, 80 and 160-metre bands:—

COIL WINDING DETAILS.

L1. Same for all bands, 20 turns No. 28 d.s.c. close-wound on 1½ in. diameter formers.

L2. Same for all bands, 8 turns of No. 28 d.s.c. close-wound on ¾ in. tubing.

Coupling between L1 and L2 variable (L2 slides into and out of L1).

R.F. Coil For 160 Metres.

L3. 10 turns of No. 22 d.s.c. close-wound on 1½ in. low-loss formers.

L4. 60 turns of No. 22 d.s.c. close-wound and tapped 1¼ turns up from the ground end. L4 is wound on the same former as L3 and is spaced ¾ in. from L3.

R.F. Coil For 80 Metres.

L3. 7 turns No. 22 d.s.c. close-wound on 1½ in. former.

L4. 35 turns No. 22 d.s.c. close-wound and tapped ½ turn up from ground. Spacing between L3 and L4 to be ¾ in.

R.F. Coil For 40 And 20 Metres.

L3. 5 turns of No. 22 d.s.c. close-wound on 1½ in. former.

L4. 12 turns of No. 18 d.s.c. space-wound over a winding space

of 1¼ in. and tapped ¼ turn from ground end.

Note. The ground end of the L4, is the bottom of the coil. The top end of the L4 connects to the grid of the 58 or 6C6 in the pre-selector.

If any members are operating a shortwave super and haven't got one of these pre-selectors, well they are missing something!—Joseph Biscoep, (AW5DX), Cronulla, Sydney.

★

Novelty Time Clock.

Although not an original idea, this should prove helpful to all members of the All-Wave All-World DX Club. Obtain an old but working clock, an alarm clock could be used, and to the face add two sets of figures—one for New York time, and the other for London time.

In the original, only two sets of time-figures were added, but there is no limit to the number of figures that can be written on, after the clock face has been divided into time zones by drawing concentric circles on it. For other countries that are not so important, the Radio World Time Chart presented free to readers in the August issue can be used.—Jack Glew (AW13DX), Bentleigh, Vic.

★

Rejuvenating 2-Volt Valves.

I am a reader of your "Radio World," and would not miss a copy for the world. I was very pleased when I received my first copy in May to find some one had at last produced the magazine that I have always wished for—a magazine with plenty of constructional articles and plenty of DX news.

In the July "Radio Ramblings" page I came across a method for rejuvenating 1A6's and 1C6's devised by Mr. P. R. Marchant, of Cootamundra. Well, I have found a way of rejuvenating 2-volt battery type valves such as the 19, 34, 32, 30 etc., that have accidentally had six volts applied to their filaments, paralysing them. All the above type valves were as "dead" as if the filaments had been burnt out, but after the following treatment they all worked well again.

Holding the valve by the base, place the glass bulb over a candle flame, making sure to apply the latter to the part of the valve that has the most silver on it. Also, slowly rotate the valve in the flame so the whole of it will be heated. It will be found that after the black has been wiped off, the silvered parts of the valve have become clear.

The valve should now be tested for shorts etc., and if found O.K. it can be put into service again. I obtained best results from the 19 and 34's.

Build the "SCOUT" Battery 3 £9.15.0

COMPLETE PARTS

- 1—Chassis, 9½ in. x 7 in. x 2½ in., stamped and drilled as shown @ 15/- 0 15 0
- 2—Iron-cored coils, 1 aerial, 1 r.f., with reaction (Radiokes) @ 10/- each 1 0 0
- 1—2 gang Condenser (Stromberg-Carlson), @ 15/- each 0 15 0
- 1—Aero dial, b.c., (Radiokes) @ 12/6 each 0 12 6
- 1—4, 1—5, 1—6 pin wafer sockets @ 5d. each 0 1 3
- 1—5 pin Dalton socket @ 9d. each 0 0 9
- 1—5 pin Marquis plug, with 2 yards 5-wire cable 0 2 0
- 1—Audio transformer @ 11/7 ea. 0 11 7

- 1—5 megohm potentiometer, with switch @ 6/6 0 6 6
- 1—0001 mfd. midjet reaction condenser (Radiokes) @ 4/6 0 4 6
- 3—Knobs, 1 large and 2 small 0 1 11
- 1—r.f. Choke (Radiokes) @ 1/6 0 1 6
- FIXED RESISTORS:**
- 1—700 ohm W.W. resistor @ 9d. each 0 0 9
- FIXED CONDENSERS:**
- 1—0001 mfd. mica @ 1/- each 0 1 0
- 1—01 mfd. tubular @ 9d. each 0 0 9
- 1—25 mfd. tubular @ 2/4 each 0 2 4
- 1—1 mfd. tubular @ 10d. each 0 0 10
- 1—25 mfd. dry electrolytic @ 2/4 each 0 2 4

- VALVES:**
- 1—VP2, 1—PM2DX, 1—PM22A 2 10 0
- BATTERIES:**
- 3—45-volt "B" batteries (Ever Ready). H.D. @ 8/9 each 1 6 3
 - 1—2v. accumulator. 110 amp. Special @ 17/6 0 17 6
- SPEAKER:**
- 1—Permanent magnet dynamic, input transformer to match single PM22A (Rola 6-6) 1 9 6
- MISCELLANEOUS:**
- 4 terminals (2 red, 2 black), 1—60 m.a. fuse bulb with holder, 1—Large grid clip, solder tags, bolts and nuts, hook-up wire 0 4 0

A Special Offer: Veall's will supply the complete parts, as listed above at the special price—£9/15/0. Everything necessary.

"DUAL" Pickups VARIABLE IMPEDANCE

Gives a choice of four different impedances, thus accurately matching the pickup to your set. Special swivel head turns completely round to facilitate needle changing. Chrome finish throughout.
Price 77/6d.

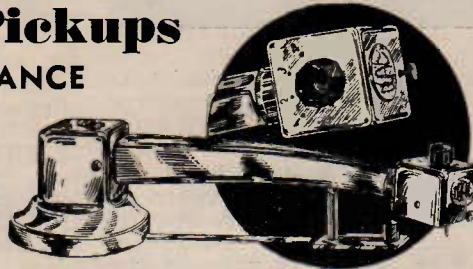

New Model ROLA

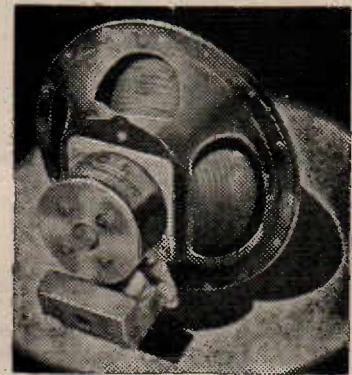

NO INCREASE IN PRICE

The Radiokes "Scout" 4-valve Kitset.

Here is the new Radiokes "Scout" Kitset. 4-valve A.C. priced at only £5 the complete Kitset. Featuring latest type dial and new high gain intermediates. No increase in price
Valves 65/6 and speaker 32/- extra.
Particularly simple construction.

£5

BUILD WITH QUALITY PARTS

ALLEN-BRADLEY RESISTORS

and Volume Controls have superior characteristics which give greater efficiency and provide real trouble free service.

E.T.C. CONDENSERS

are permanently protected from humidity and mechanical damage. Accurate and reliable.

HICKOK METERS

D.C. Voltmeters in 100 and 1333 Ohms per volt resistance.

A.C. instruments in all useful ranges. Write for complete lists of all types.

SOLAR CONDENSERS

The dependability of Solar Condensers ensures long-lived, high quality performance. Complete lists posted on request.

New Rola Permagnetic speakers at new

- Low Prices:
PM 8-8 — 8 inch Cone Dust-proof. Price 33/-
PM 6-6 — 6½ inch Cone Dust-proof. Price 29/6
This PM6-6 is a new 6½ inch. Permagnetic speaker, similar in design and equal in performance to its electro-dynamic prototype, DP5B.

VEALL'S

243-249 Swanston Street, Melbourne
299-301 Chapel Street, Prahran.
Central 3058 (7 lines)

168 Swanston Street, Melbourne.
3-5 Riversdale Road, Camberwell.
Telegrams: "ARTVEALL," Melbourne.

High Quality Reproduction at Low Cost

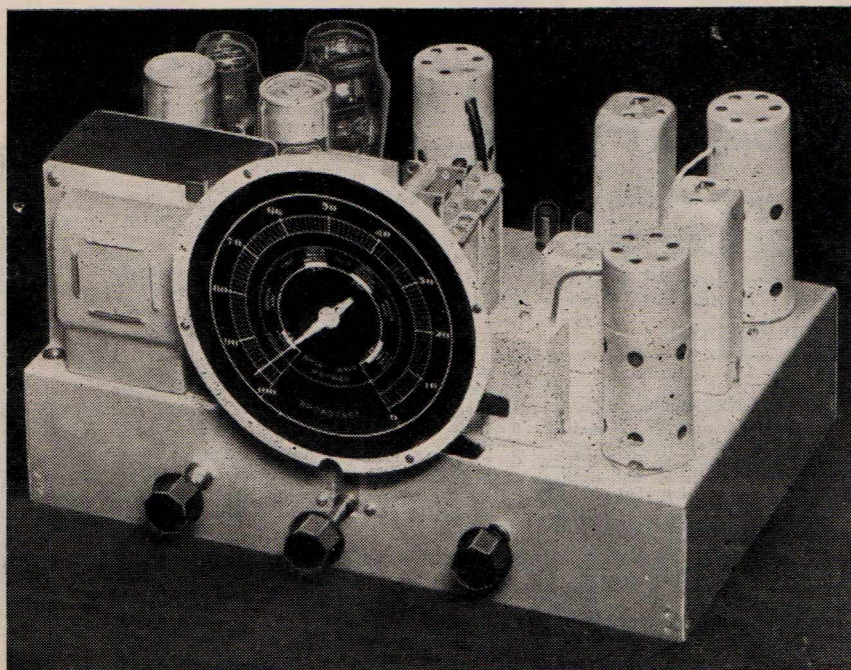

APART from DX enthusiasts, there are plenty of set-builders today who consider that high quality of reproduction is one of the most desirable features of any set, taking precedence even over distance-getting ability.

At the same time, receivers capable of giving high quality reproduction are not common, because they have always been associated with high cost. In other words, it is generally thought that if one wants good tone, one has to pay heavily to obtain it.

With the above in mind, the "Radio World" set out to discover if this very prevalent idea is based on sound foundations, or whether really high quality reproduction can be obtained without a heavy outlay. The receiver shown above is the answer, and in the opinion of those who have already heard it, it provides a remarkably successful answer too.

Pentode/Triode Combination.

In the first two instalments of a series of articles entitled "This Pentode Business," by "Third Grid" (published in this and last month's issues of the "Radio World"), the author, who has made a very close study of his subject, proves two things. The first is that the triode is still supreme as an output valve where distortionless reproduction is

required, and the second, that operated as a voltage amplifier with a purely resistive load, a pentode actually gives less distortion than a triode in the same position.

Thus by using a pentode and triode as driver and output stage respectively, one has an ideal combination. The very high gain given by the pentode compensates for the comparative insensitiveness of the triode, and so the overall gain is excellent. As well, both valves are operating to give the least possible minimum of distortion.

Four Watts Of High Quality Output

This theory works out remarkably well in practice. Using a 6C6 as first audio stage and a 2A3 in the output socket (with 300 volts on the plate), the latter can easily be fully loaded to give four watts of high quality output. This is far more than ample for all home requirements, and is even sufficient for supplying music in small dance halls and restaurants.

6B7S Solves Tuner Problem.

With the amplifier problem settled so satisfactorily, the next consideration was the tuner portion. To keep cost down, the number of valves decided on was five. Using two on the audio side and an 80 rectifier, this left only two valves for the tuner section. Because of selectivity and

Low Cost

In the special audio system of this five-valve deluxe receiver, pentode sensitivity is combined with triode quality in an ideal arrangement that gives four watts of high quality reproduction at low cost.

Five glass type valves, including the Australian-designed 6B7S, are used in this special receiver, designed for high quality reproduction.

sensitivity considerations it was planned to make the set a superhet, so by using one of the two remaining valves as mixer-oscillator this left only one to provide i.f. amplification and detection.

The Australian-designed Radotron 6B7S proved the solution. The pentode section was used as i.f. amplifier, and also as it has multi-mu characteristics, A.V.C. could be incorporated, operating on the first two valves.

For a set of this type, very high selectivity is a drawback, as it results in a certain amount of side-band cutting in the i.f. amplifier, giving poor high note response. Hence air-core rather than iron-core intermediates have been used. Even so, the sensitivity is equal to that of the average commercial 4/5 superhet.

Thus the valve line-up of this new receiver is as follows:—6A7, mixer oscillator; 6B7S, combined i.f. amplifier, diode detector, and A.V.C. voltage generator; 6C6, first audio stage; 2A3 output, and 80 rectifier.

Excellent Volume And Tone

The result is a receiver that has tonal fidelity far above the ordinary, while the volume is easily twice that obtained from the average set using a single pentode in the output. Best of all, compared with a 4/5 of similar design using metal valves and iron core intermediates, this receiver is actually cheaper to build. The circuit, together with full details of the assembly, will be published next month.

Radio Rambings.

(continued from page 12).

Before treatment they would not work, but after treatment they were placed in the set and have worked ever since. I tried a new 19 in the set in place of the rejuvenated one, and there was just a trifle more gain from the new valve.—Geo. Ingle Narrabri, N.S.W.



On The Air For 14 Years.

Being a reader of your excellent amateur magazine, I have noticed where you have called for station descriptions and photographs, and as mine may be of interest for publication, I am enclosing some dope and photograph recently taken of my equipment.

I have been on the air since 1923 consistently, and am one of the oldest of Australian amateurs. Since the passing of the old Sydney "Radio" there has long been wanted a good amateur mag. and "Radio World" is certainly the goods. Keep the good work going and I am sure you will get the support you deserve. With best wishes.—Harold L. Hobler, Rockhampton, Q'land.

(The photograph and station write-up are published elsewhere; many thanks for sending them along.—Ed.)



A Useful Tuning Tip.

If one is constantly passing over

the band looking for new stations, the hand operating the reaction control sometimes becomes a little cramped. The arrangement shown in the sketch permits the hand to be placed almost flat on the table, and the reaction is adjusted merely by moving the hand from side to side. It also gives a finer adjustment. The handle I use was originally a tuning

velopes. DX conditions have been fair on all bands here of late—Clive Holland (AW84DX), Maryborough, Vic.

(Embossed Club seals in blue and silver, with gummed backs, are now available from our offices, price 1/6 for 5 dozen, post free.—Ed.)



"Eaglet Two" A Winner.

The DX Club badge and certificate are certainly excellent. My "Eaglet Two" (described in the May R.W.) went o.k. first shot, using an eliminator for power, and the DX rolls in on my Rola permanent mag. speaker.

VK3ME, QSA5-R9, can be heard at about 20 yards away, and VK3LR, QSA5-R8, is also very good on the speaker. On higher frequencies than VK3ME there are two Japanese or Chinese at about QSA5-R9, and the one nearer 3ME is QSA5-R7. Also there is one on the 49-metre band at about QSA4-R6. Using phones I heard ZLT1 calling ZMBJ at about QSA3-4,R5. Needless to say, the "hams" in all states roll in on the speaker at excellent strength.

Two friends came up to hear the set, and were so impressed that one is going to build it using metal valves, and the other will use the same electron coupling in order to get the smooth reaction. The

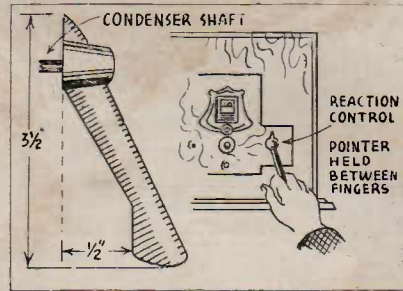

pointer on a very old Telefunken receiver. One could quite easily be made by any keen "ham" out of scrap material.

I would also like to make a suggestion, and I think all club members will think the idea is an excellent one. It is that the "Radio World" has printed small paper replicas of the A.W.A.W. DX Club badge. These could have gummed backs and could be supplied to dxers for sticking on their cards and en-

ANOTHER EFCO RELEASE!

THE 77-280 RR. "COLOR-METRIC" DIAL



This unit employs the well-known 77 drive, and the pointer travels through 280 degrees. The Bands are separately illuminated in the color desired by a simple turn of the wave change switch.

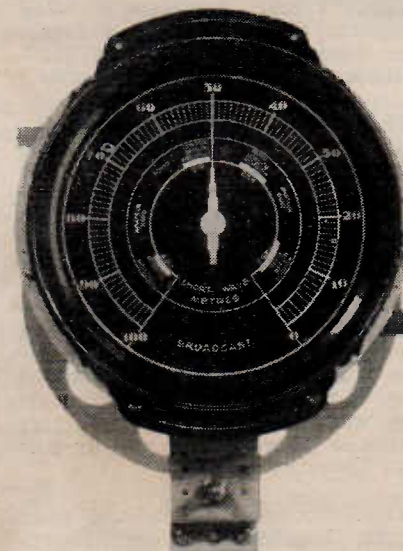

Escutcheon illustrated is No. 16, and is approx. 6 inches in diameter. Can be supplied with or without shortwave division, and supplied with 5 lamp holders.



Made in Australia by

The EFCO Mfg. Co. Ltd. Arncliffe, N.S.W.

"The Dial People"

Radio Specials

AT

MURDOCH'S

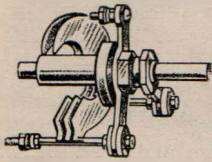

Eddystone
"Scientific"
Condensers

For short and ultra short waves, advanced technical high frequency design. All brass construction. Calit insulation (close to quartz) noiseless. Extended spindle for garging. Used by the Everest Expedition.

25 mmf. as illustrated.

180 MFF. 15/- 100 MFF. 10/-

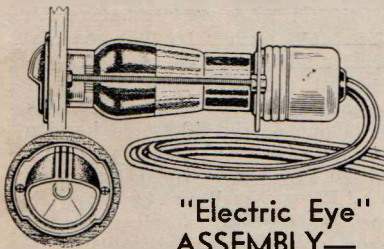

"Electric Eye"
ASSEMBLY—

Wired up complete and ready for attaching to the Set. With flex resistance, socket, cover, escutcheon, etc. Price 7/6

Electric Eye tuning valve for 6-volt or 2½ volt.
Price 15/-

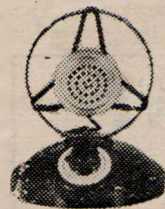

MICRO-
PHONES

Complete self-contained unit, ready for use, with built-in transformer, control battery and 20ft. of shielded cable. Hundreds sold to business concerns, dance bands, halls, etc.
Price 39/6

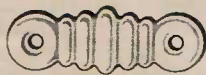

Genuine Pyrex Insulators

Genuine imported Pyrex insulators. There is no substitute for their quality. 1/9

Model Electric

Motors

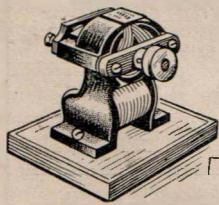

These Electric Motors will run on A.C. or D.C. current up to 6 volts, and drive model toys, etc. Excellent adjunct to any boy's possessions. In kit form unassembled. (Any boy can assemble-it) 7/6

Completely assembled 9/6

We pay freight — Kindly write to Desk "C52"

MURDOCH'S LTD.
PARK AND GEORGE STREETS, SYDNEY

"Eaglet" is certainly a big hit.

The antenna here is a half-wave matched impedance 30 feet high, and no earth is used.

The above stations were all logged

on November 11, and after about a week's listening, I will send you a list of stations heard on all bands. —Graham M. Hart, (AW151DX), Fullarton Estate, S.A.

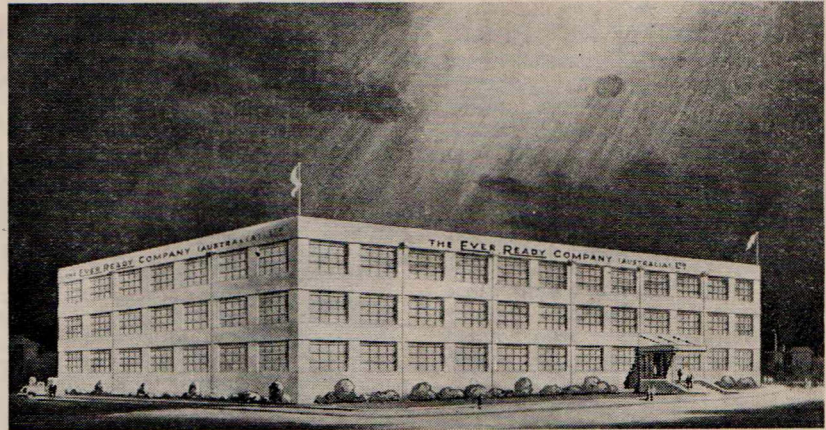

New £50,000 Factory Planned By Ever-Ready Provision For Over 400 Employees

THE new factory being erected at Rosebery, Sydney, by the Ever-Ready Company (Australia) Limited will comprise three floors, giving a total of 80,000 square feet of floor space. Provision is being made for the addition of a fourth floor when required, giving a 140% increase on the initial floor space.

The cost of building and equipping this modern factory will exceed £50,000—a striking testimony to the company's confidence in the continued growth of the dry battery industry. The fact that the building has also been designed with a view to adding a further wing gives some idea of the extent of the development of dry battery manufacture and of the ever-increasing market for this company's products. Not the least of these is the radio "B" battery, and this section of the factory output is growing more rapidly perhaps than any other.

The erection of more and more country broadcast stations has enlarged the field of prospective set owners to a tremendous degree, and has led to an unparalleled demand for radio "B" batteries. It may be contended that some of these new

buyers have invested in sets not designed to use dry batteries, but the percentage of these is so very small that its effect cannot be traced at all in the general increased demand for radio dry batteries; moreover, the testimony of so many prominent radio set manufacturers in confining themselves to dry battery-operated receivers for the country user supports the Ever-Ready Company's anticipation of wider and wider popularity for the battery-operated set.

In planning the new factory, special consideration has been given to the health and comfort of the 400 odd employees for whom, among many other conveniences, hot and cold showers will be available and a fully-equipped hospital in charge of a qualified nursing sister. A large restaurant on the second floor with seating accommodation for 300 will have a congenial outlook on to a City park.

Research laboratories will include a special test room with conditioned air and equipped with every facility to ensure the production of dry batteries in Australia at least the equal of any similar product manufactured in any part of the world.

The Radiokes ..

SCOUT

SUPERHET

FOUR

Those looking for a cheap, well-designed kit capable of giving first-class results will find it in the Radiokes "Scout," which sells for only £5. The assembly is simple, the connections few and easy to make, and the alignment perfectly straight-forward.

No matter how many important new developments come along in radio, there is always a steady demand for a simple, cheap receiver that will give first-class reception from local and a few of the more powerful inter-state stations.

Such a set is the Radiokes "Scout," which is perhaps the simplest and cheapest a.c. superhet giving really worth-while results it would be possible to design. First released nearly a year ago, it has proved a widely popular little kit, and hundreds of builders throughout Australasia are today obtaining excellent results from it.

High-Gain I.F.'s. A New Feature.

In design, the "Scout" is so up-to-date that when a new version of it was contemplated for description in the "Radio World," there were only two worth-while improvements that could be suggested—the use of special Litz-wound high gain intermediates, and of a latest type aerovision tuning dial. Both refinements will be incorporated in all future "Scout" kits released by Radiokes, at no extra cost.

Reflexing Can Be Incorporated.

The secret of the "Scout" design lies in the use of the Australian-made 6B7S—one of the

most useful of the new type valves that have been developed by the Radiotron engineers in this country. It is an improvement on the well-known 6B7 in that the pentode section has multi-mu characteristics, thus permitting the application of the well-known method of controlling volume by variation of bias.

In the "Scout," a 6A7 is used as mixer-oscillator. Then follows the 6B7S, the pentode section being used as i.f. amplifier and the two diodes being tied together to give half-wave detection. The audio output appearing across the diode load resistor is applied direct to the grid of the type 42 output pentode.



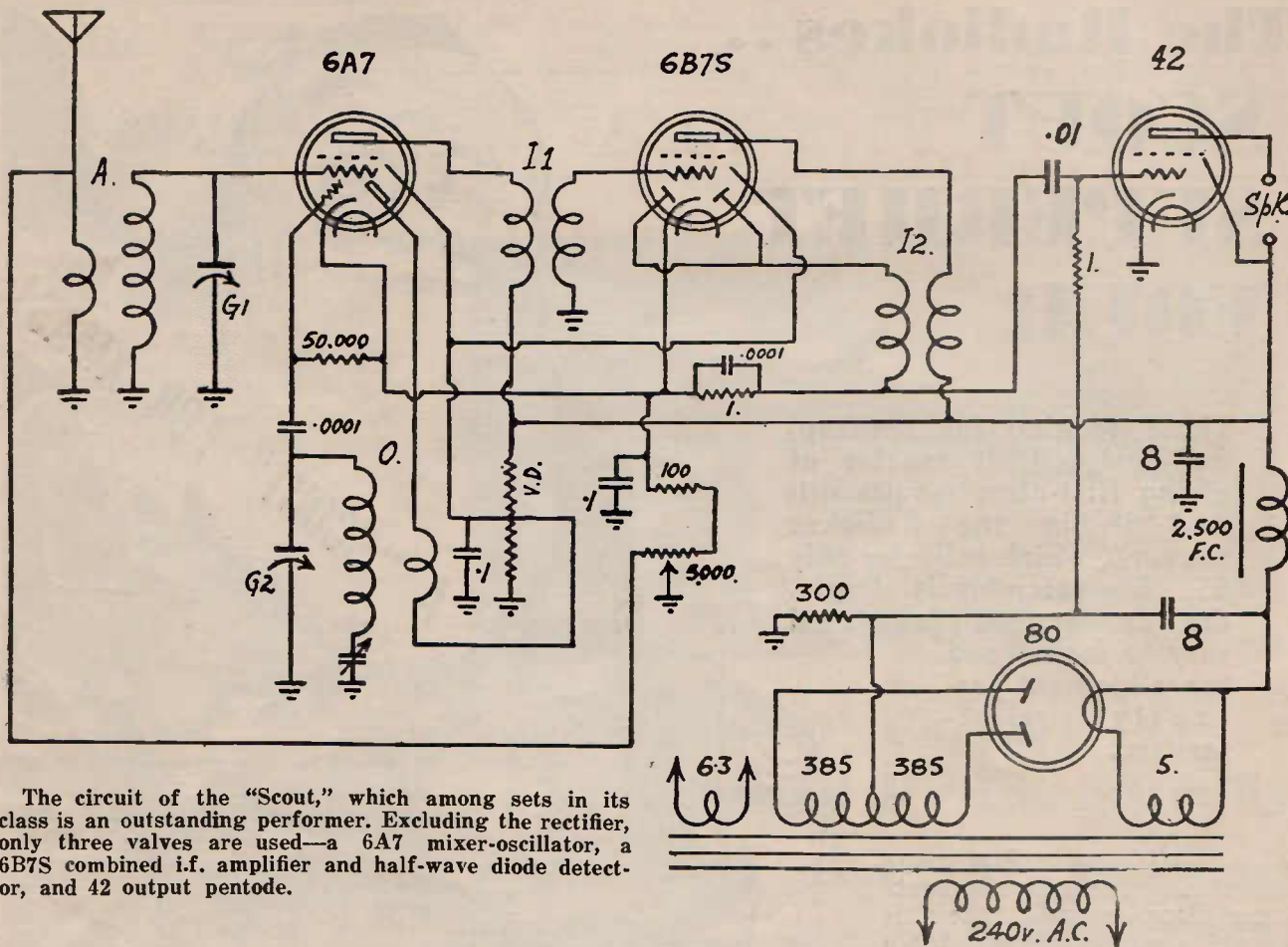

The circuit of the "Scout," which among sets in its class is an outstanding performer. Excluding the rectifier, only three valves are used—a 6A7 mixer-oscillator, a 6B7S combined i.f. amplifier and half-wave diode detector, and 42 output pentode.

The elimination of the audio amplifier between the diode detector and output valve means that hum and general noise level will be exceptionally low. Similarly, there is very little chance of the introduction of distortion.

Circuit Can Be Reflexed.

One of the biggest attractions about the circuit used is the fact that it can easily be built at a later date into a more powerful set. The set can be built and adjusted until it is working satisfactorily, and then, by making several minor alterations to the circuit, the pentode section of the 6B7S can be reflexed to give audio as well as r.f. amplification, giving five-valve performance at four valve cost. Only three resistors and two condensers are needed to make the change-over.

Other Circuit Pointers.

The pentode sections of the 6A7 and 6B7S both have multi-mu characteristics, so to provide efficient volume control the cathodes of these two valves are tied together and the bias applied to them varied by means of a 5,000 ohm potentiometer. One

side of this component is taken to a 100-ohm limit bias resistor (see circuit diagram), and the other to the aerial terminal. The moving arm is earthed.

In operation, when the moving arm of the potentiometer is turned to the left as far as possible, the aerial is shorted to earth and also the bias on the first two valves is greatly in-

creased, meaning that their amplification is reduced considerably. When the arm is at the other extreme, the full resistance of the potentiometer is interposed between the aerial terminal and earth, and consequently there is no loss in signal strength. At the same time, the bias on the first two valves is reduced to a minimum, and hence their amplification

Radiokes 3/4 "Scout" Superhet Kit of Parts

- 1—chassis, specially stamped.
- 1—U.50-6 power transformer.
- 1—2-gang condenser.
- 1—7-plate paddler.
- 1—5-66 aerial coil.
- 1—5-66 oscillator coil.
- 2—High gain I.F. transformers.
- 1—Aerovision dial.
- 2—valve shields.
- 5—sockets, 2—7-pin, 2—4-pin, 1—6-pin.
- 1—15,000 ohm C.T. voltage divider.
- 1—5,000 ohm 8-1 volume control.
- 2—knobs.

FIXED CONDENSERS

- 2—.0001 mfd. mica.
- 1—.01 mfd. tubular.
- 2—.1 mfd. tubular.
- 2—.8 mfd. wet electrolytics.

FIXED RESISTORS

- 2—200 ohm maxome.
- 1—300 ohm maxome.

- 1—.05 megohm.
- 2—.1 megohm.

MISCELLANEOUS

- 2—terminals, N.P.; 1 set insulating washers;
- 2—1/2 in. spacers; 3 grid clips; 6 solder lugs; 20—3/16 in. x 1/8 in. roundhead screws; 20—hexagonal nuts; 2 yards power flex; 3 yards hook-up wire; 2 yards 18 gauge tinned copper wire.

(EXTRAS REQUIRED (Not included in Kit):

VALVES:

- 1—6A7, 1—6B7S, 1—42, 1—80 (Radiotron, Ken Rad, Philips, Mullard).

SPEAKER:

- 1—dynamic speaker, 2,500 ohm field, input transformer to match single pentode (Rola).

Your radio needs
RADIOTRONS!

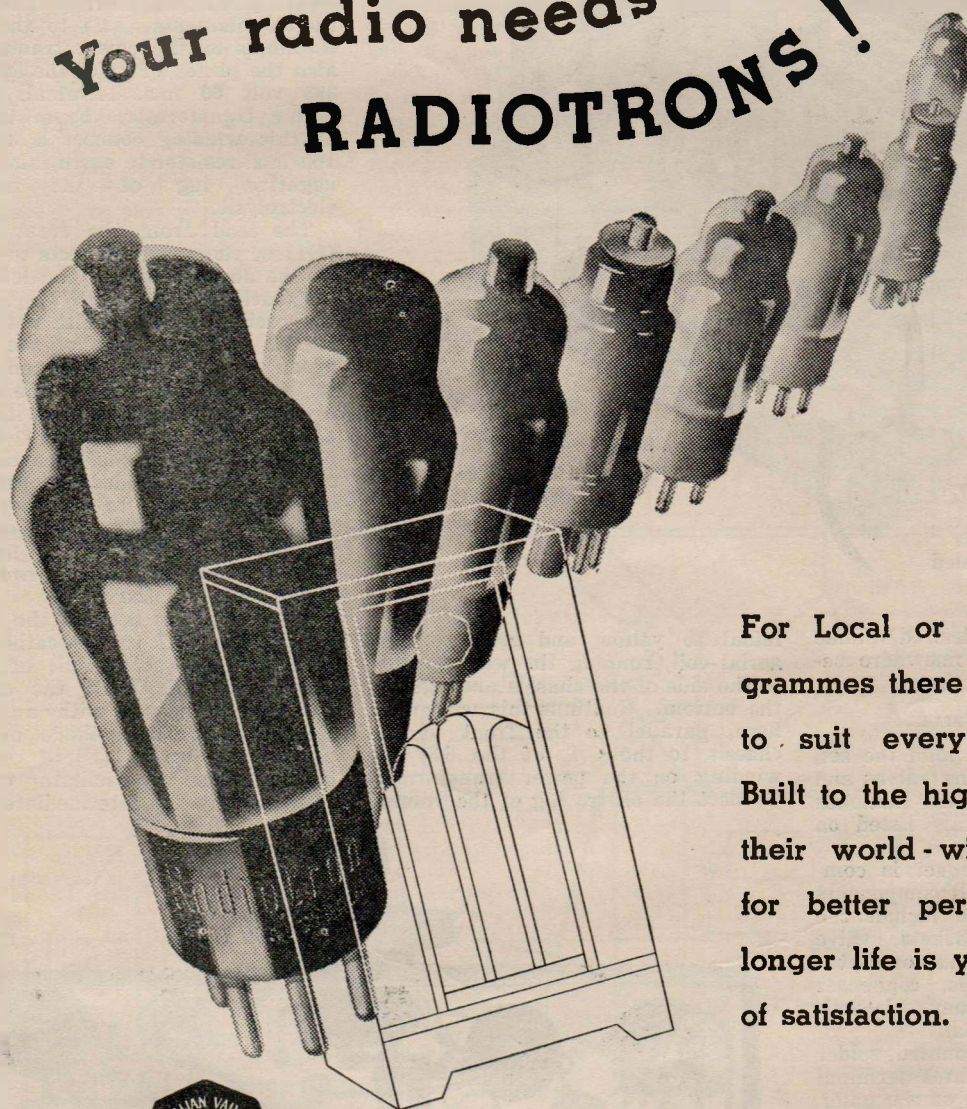

For Local or Overseas programmes there is a Radiotron to suit every requirement. Built to the highest standards their world-wide reputation for better performance and longer life is your guarantee of satisfaction. » » » »



RADIOTRONS

AUSTRALIAN GENERAL ELECTRIC LIMITED
Sydney Melbourne Brisbane
Adelaide Hobart

AMALGAMATED WIRELESS (AUSTRALASIA) LTD.
47 York Street, Sydney
167-169 Queen Street, Melbourne

v20-c

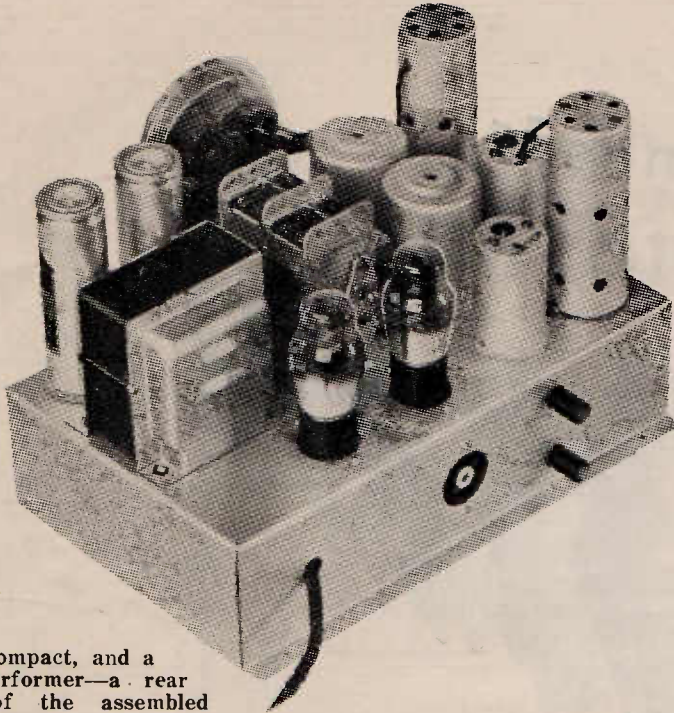

Neat, compact, and a fine performer—a rear view of the assembled receiver.

is at maximum. Any desired volume setting can be found somewhere between these two extremes.

The Kit Of Parts.

All parts required to build the set, with the exception of the valves and speaker, are supplied in the Radiokes kit, type 4/35. They are listed on the previous page.

The assembly of the set is commenced by mounting all components on the chassis. These include the valve and speaker sockets, valve shield bases, aerial and oscillator coils, two intermediates, condenser gang, power transformer, electrolytics, and full-vision dial.

Before the gang is mounted, solder a lead to each fixed plates terminal underneath each section of the gang. These leads pass through the holes marked "G1" and "G2" on the under-chassis diagram, and pass to the correct terminals on the aerial and oscillator coils respectively.

It should also be noted that as the 42 is back biased, one of the electrolytic condensers should be insulated from the chassis by means of the washers provided.

The remaining chassis components that require mounting include the volume control, aerial and earth terminals, padder, and voltage divider. The last two components are mounted under the chassis on the two quarter-inch spacers supplied for each.

Wiring Instructions.

Commence by connecting a tinned copper earth lead from the earth ter-

minial to yellow and green of the aerial coil, running the wire parallel to the side of the chassis and against the bottom. Continue this wire from here, parallel to the front of the chassis to the C.T. of the 6.3 volt winding on the power transformer. Connect the centre lug of the volume

control to this wire—also the nearest end of the voltage divider and the moving plate of the padder.

When this is completed, wire all the filaments (HH) except the 80, and connect to the 6.3 volt winding on the power transformer. Then wire the 80 filaments (FF) to the 5-volt terminals on the power transformer; also the plates (PP) of the 80 to the 385 volt 60 m.a. terminals on the power transformer. From the C.T. of this winding connect a 300 ohm 100 m.a. resistor to earth, also to the negative lug of the insulated electrolytic.

The lead from the front section (G1) of the gang connects to orange on the aerial coil, and the lead from the back section (G2) to green on the oscillator coil. Wire red of the I.F.T.1 to plate (P) of the 6A7—green to the earth wire and yellow to the unearthed end of the voltage divider. Continue by wiring in I.F.T.2—red to plate (P) of the 6B7S; yellow to the unearthed end of the voltage divider and green via a 1 meg. resistor to cathode (C) of the 6B7S. (A .0001 mfd. condenser is connected across this 1 meg. resistor); orange to the two diode (DD) plates of the 6B7S.

Following this connect the cathode (C) of the 6A7 to the cathode (C) 6B7S, and the screen (S) of 6A7 to screen (S) of 6B7S; the cathodes (C) are by-passed with a .1 mfd. condenser at the cathode of 6B7S. Connect the screen (S) of the 6B7S to orange on the oscillator coil and from here to the intermediate tap on

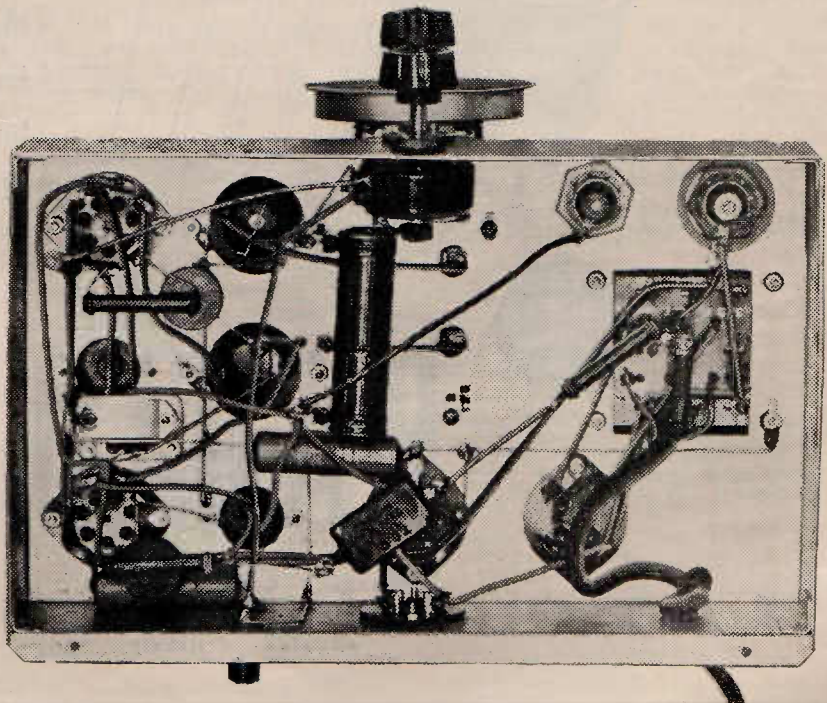

This under-chassis view illustrates the simplicity of the assembly and wiring.

the voltage divider, and by-passed with a .1 mfd. condenser from the orange of the oscillator coil. Connect yellow of the oscillator coil to the fixed plates of the padder; G2 (OP) of 6A7 to red of the oscillator coil, a .0001 mfd. condenser from G1 (OG) of 6A7 to green of oscillator coil, and a .05 meg. resistor from G1 of 6A7 to cathode 6A7.

Connect a lead from the aerial terminal to red of the aerial coil, and from here to one **outside** lug on volume control. From the remaining lug connect a 100 ohm resistor to the

cathode (G) of 6A7. Connect a .01 mfd. condenser from green I.F.T.2 to grid (G) of the 42 and a 1 meg. resistor from grid (G) of the 42 to C.T. of H.T. secondary (385-volt). The cathode (C) of the 42 is connected to earth and the plate (P) of the 42 goes to the plate (P) of the speaker socket, and screen (S) of 42 to grid (G) of speaker socket, and also to the unearthed end of the voltage divider (B+) and positive terminal of uninsulated electrolytic condenser (+).
Connect together the grid (G) and

one of the filaments (F) of the speaker socket—the remaining filament (F) of the speaker socket connects to one of the 80 filaments (F) and from here to the positive (+) terminal of the insulated electrolytic.

Aligning The Set.

After the set has been completed, the valves and speaker can be plugged in, the aerial earth connected up and the power switched on. While this is being done the rectifier should be watched, and if there is a blue
(continued on page 29).

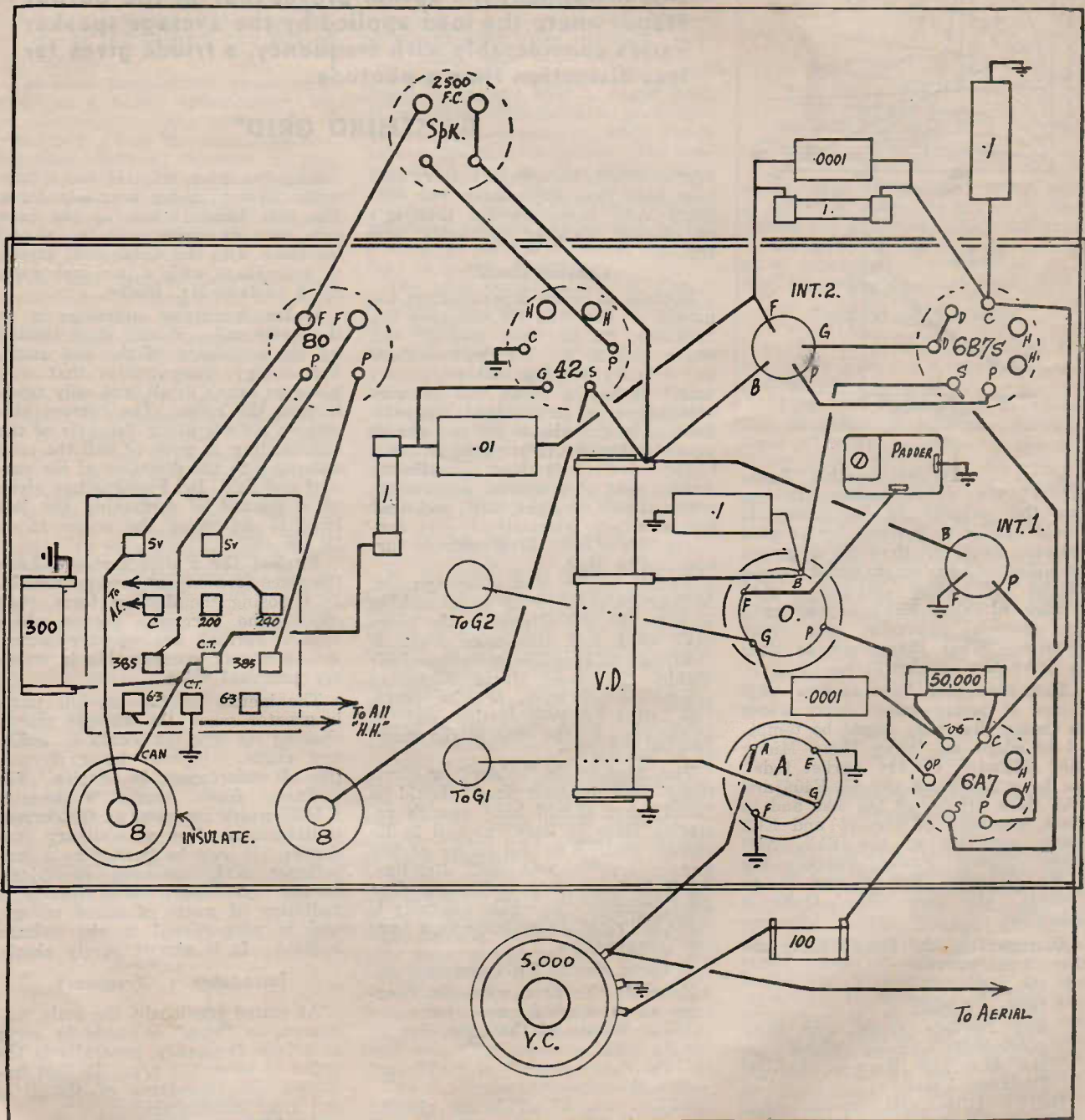

The complete under-chassis wiring of the "Scout" is shown in this sketch.

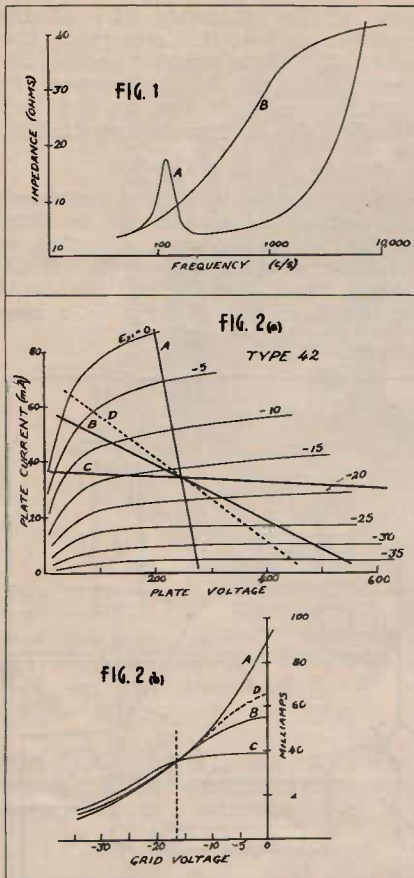

This Pentode Business 2

Last month it was shown that there are applications where pentodes give better fidelity than triodes. In this instalment the author proves that in the output stage, where the load applied by the average speaker varies considerably with frequency, a triode gives far less distortion than a pentode.

By "THIRD GRID"

ary receivers, though in battery sets they have their exponents. For ordinary A.C. work we are thus left to decide between pentodes and triodes.

Considerations.

Because so much depends upon the nature of the load (in our case the speaker), let us have another and closer look at it. We shall consider an ordinary moving coil (dynamic) unit. It has a small coil of wire mounted in a ring-shaped magnetic field. The coil should be as light as possible, but manufacturers still use copper wire. It is glued (sometimes) to the apex of a conical diaphragm, which should be light, stiff, and dead like a carpet, when struck—not sonorous like a bell. Most manufacturers realise that.

Hypothetically, that is enough, but in practice there must be something to keep the coil aligned in the magnetic field, and also some form of "baffling" to keep the compressed air within the cone from slithering around to the back, or vice versa. The latter involves further support at the edge of the cone in the shape of a "surround."

The supporting "spider" or "butterfly" and the "surround" should be "dead," but should have enough restoring force to keep the coil in its correct position in the centre of the gap in an "in and out" direction. As it is impossible to have a "live dead" support, the whole assembly is made to "ring" or resonate at a very low frequency.

Three Forces To Overcome.

To shift the cone, we must overcome three main forces.

- The inertia of the cone, due to its mass.
- The "springiness" or "stiffness" of the support, and
- The mass of air in the vicinity of the cone.

Of these three, only the last is anywhere near to being a steady force. The first becomes less as the cone gets into its stride, and the second increases with the distance of travel, in accordance with a law laid down by a certain Mr. Hooke.

Watch a current starting up in the voice coil. Firstly it is limited by the resistance of the coil itself. The energy dissipated in that way gives no music at all, and only tends to heat the room. The current also sets up a force along the axis of the coil, tending to push or pull the cone according to the direction of the current and field. Dr. Fleming has given us a method of contorting the left hand to determine the course taken by the coil.

Against the motive force we have the three forces mentioned previously. In opposing the driving force, they oppose the current. Forces which oppose current are counter-electromotive forces, measureable in ordinary practical volts.

The inertia of the moving parts is greater when the current starts, choking its flow, as would an ordinary choke. It may be expressed, like all inductances, in henries. The stiffness force causes a counter E.M.F. which increases as the current continues, as does an ordinary condenser. It may be treated as a capacitance and measured in microfarads. The third force results in radiation of watts of sound energy, and is proportional to the voltage applied. It is almost purely ohmic.

Impedance v. Frequency.

As stated previously, the main resonance, or "ring" is made to occur at a bass frequency, generally in the order of 80 or 120 c/s. At that frequency the impedance of the voice coil rises considerably.

At high frequencies (above 500

IN last month's "Radio World" the writer endeavoured to put the pentode in its place. It would appear to perform better as a voltage amplifier than as a power amplifier. You might well ask—"What of other valves? Are triodes, 6L6's or 6B5's any better?" Or more generally, you may enquire—"What then must be used to drive the speaker?"

Designers now have such a wide range of power valves from which to choose that they might be tempted to adopt an "Eeny Meny Mieny Mo" attitude. On the market today we have triodes of the 45, E406 and 2A3 class, triodes of the 6A6 and 46 class, pentodes of the 42 and EL2 class, pentodes of the EL3, AL3 class, "Beam Power Tubes", the 6L6's, Harries Valves and freak "tubes" like the 6B5. Quite a selection.

Disregarding the freaks, there are three main groups:—

Triodes.

Driven Triodes.

and Pentode types with their equivalents, among which are the 6L6 and Harries "Critical Distance Valve."

Driven (Class B) triodes have proven too costly to apply to ordin-

c/s.) the mass of the cone takes charge, and the impedance again rises as the frequency is increased. A nominal motional impedance of a voice coil may be 3 ohms, which may be correct at 400 c/s., but the impedance at 120 c/s. may be as high as 20 ohms, and at 5 k.c./s., it may be 40 ohms.

The nominal low impedance of the voice coil makes the use of a step-down transformer imperative. The primary inductance is in parallel with the load. It must pass D.C. but impede A.C. as much as possible. Its inductance must be high. At extreme bass frequencies the reactance is much reduced, and the power factor of the output load may fall off considerably.

The ideal transformer would be as large as a power transformer, but the listening public, could not, or would not, afford it. Manufacturers therefore, have to recourse to preserving the bass by making the main resonance as powerful as possible. The result—boom! boom! boom! on one bass note, or sometimes even a continuous 100 c./s. hum.

You may wonder why so much consideration is being given to speakers in an article about valves. The nature of the load, however, must be understood before considering its effect on the valve's operation.

The output valve is subjected to all kinds of treatment by its servant the disobedient speaker. The load at extreme bass is almost purely inductive. At the bass resonance it is both inductive and highly resistive. At a small band of middle frequencies it is "optimum" and nearly ohmic. At high frequencies it rises and becomes more inductive. Fig. 1. gives an idea of this. The curve A represents the impedance in ohms, and the curve B, the shunt inductive

reactance, also in ohms, for an average speaker.

Pentode Considerations.

Having an idea of the varying nature of the load, let us consider how a pentode behaves with different load resistors.

By plotting load lines of 1,000, 10,000 ohms, and .1 megohm on the ordinary E_p - I_p curves for a 4Z (Fig. 2, A and B) we may plot three different dynamic I_p - E_g curves. All are seen to be decidedly bent. That at 1,000 ohms, A, is seen to be bent differently to the other two. Between it and the curve B (10,000 ohms) is the optimum load characteristic at 7,000 ohms (dotted). It is bent both ways from the middle.

To interpret the curves, the reader must understand that a single bend in a curve introduces a predominance of even harmonics, while bends both ways produce odds. The distortion is seen to rise disgracefully with increasing load.

Power output = (Current)² × load resistance, where the current is expressed as an R.M.S. value, and the load is purely resistive.

The total current swing of Fig. 2 is twice the peak value, or $\sqrt{8}$ times the R.M.S.

We therefore put

$$Wop = \frac{(\text{Current swing})^2}{8} \times \text{load (resistance)}$$

giving 0.9, 3.2 and 8.5, at loads of 1,000, 10,000 and 100,000 ohms respectively.

The output is also seen to rise with the load.

The Effect Of Phase.

It is quite well known in A.C. engineering that a poorly regulated supply gives an undesirable power factor at the load, if it is not purely ohmic. In an output stage the valve is the generator and the speaker is the load. The regulation is the resistance (or rather, lack of resistance) in the valve itself. Pentodes are renowned for their "constant current" operation, that is, their lack of change of plate current for changes in plate voltage. In technical, rather than sales, parlance, it simply means high plate resistance, or poor regulation.

At and below the bass resonance the inductive shunt reactance can become much less than the resistive load, causing, with pentode valves, very poor power factors. As a result, the load line is expanded into an ellipse, as in fig. 3A. When the power factor is small, the plate current, during its negative excursion, may and often does reach the cut-off zone.

The dynamic curve plotted for such a load assumes a shape somewhat like fig. 3B. The ohmic curve is

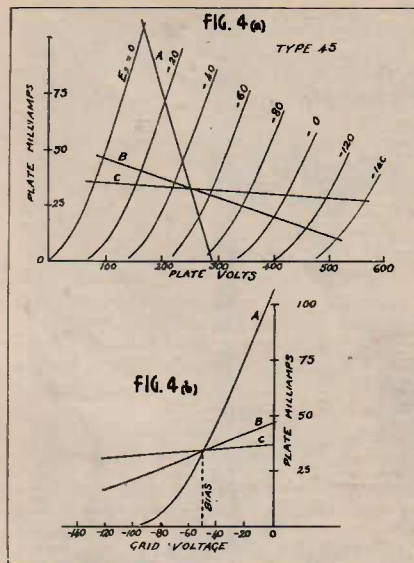

drawn as a comparison. When such a condition holds, severe even harmonics are produced, which fall most objectionably in the zone of highest aural sensitivity. "Pentode tone" is real (or unreal) enough then.

Triode Considerations.

In fig. 4, A and B, we find the dynamic curves for a triode, the once popular 45.

As the load resistance is increased, the distortion is reduced. Calculations of power outputs for the different loads give 1.8, 1.28 and .05 watts for 1,000, 10,000 and 100,000 ohms respectively.

The output is seen to fall as the load increases.

The result is that the triode output valve produces less distortion at high frequencies, though the output power falls considerably.

The low plate resistance of the triode rarely allows the load ellipse to trespass on the current cut-off zone, and the low frequency distortion is minimised greatly.

(to be continued next month.)

Determining Intermediate Frequency

Second channel interference, which manifests itself by a heterodyne whistle, is often encountered in superhets operated in close proximity to powerful locals. Though annoying, its presence affords a rough-and-ready means of determining the intermediate frequency used in the receiver. To estimate it, find the frequency of the transmission on which the whistle occurs, and subtract it from that of the local, dividing the result by two. The figure thus obtained is the intermediate frequency, to within 5 k.c. or thereabouts.

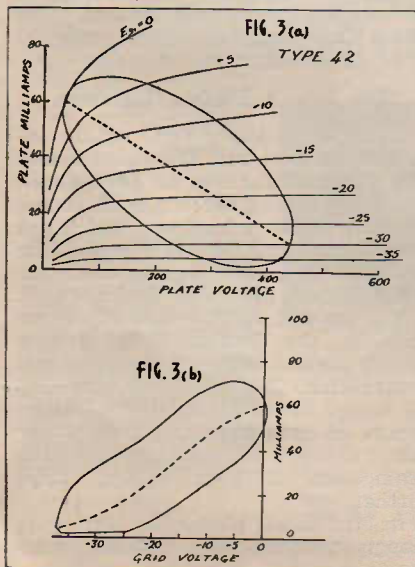

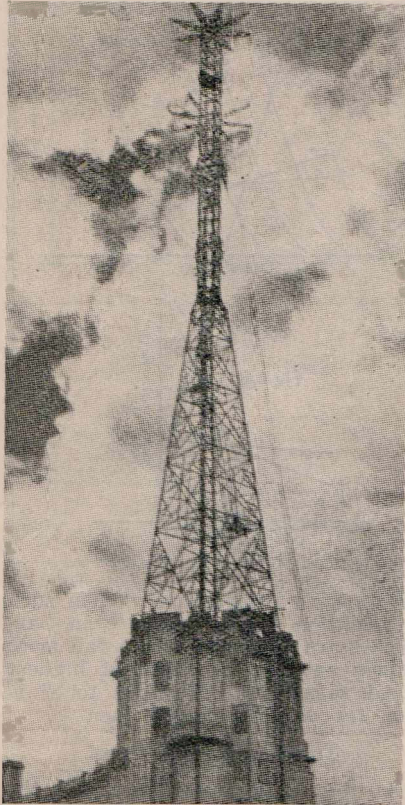

The 300-foot tower supporting the aerial system now being used to radiate the B.B.C.'s new television transmissions on the ultra short waves.

TELEVISION has now been an actuality for many years. Baird in England demonstrated television in 1926, while Jenkins in America achieved some measure of success with the first very crude apparatus in the year 1922. Strange though it may seem, however, very little scientific progress appears to have been made from that time until just recently. The earliest method used to transmit a picture or subject was by means of the mechanical scanning disc. It is true that some of the mechanics of the scanning apparatus have been improved, and that better neon tubes are now available, so that larger and clearer images can be obtained to-day than was possible five years ago. However, television has not yet actually "arrived."

The man in the street quite frequently asks the questions—"What is happening? Is it true that our large corporations are deliberately withholding television on account of the none too prosperous times?"—Has television been perfected?" and so on. To these questions it might be answered that none of the large radio

The Story Of Television (I)

It is evident that within several years there will be a regular television service operating in Australia. In accordance with its policy of keeping abreast of latest developments, and in response to many requests from readers, the "Radio World" presents below the first of a series of articles dealing with the fundamentals of the new science.

By G. BROWN.

companies is holding back television, nor has it been perfected sufficiently to compare with radio as it is known to-day.

Scanning Disc Unsatisfactory.

It is true that by means of a mechanical scanning disc, a fair to satisfactory picture can be obtained, providing certain "ifs" are fulfilled. In the first place the transmitter must be "tied in" as it were, with the lighting system which supplies the current to those who are operating the receiving instruments.

Readers no doubt have often heard of a certain lighting system being rated at say 240 volts 50 cycles. The 50 cycles means that the current being supplied changes its direction of flow 100 times per second. If the television transmitter is being run from a 50-cycle supply, then the receiver must also be run off 50 cycles, or it will not be possible to synchronise the images, unless a great deal more apparatus is installed to bring about this effect. In other words, if the receiver is located in a country town or in a suburban home far away from the A.C. mains network which supplies the television transmitter, trouble will be experienced in synchronising the images.

Secondly, so far the images have been rather small; too small, in fact, for comfortable viewing and enjoyment of a presentation. Pictures a few inches square are not clear.

Finally it has been pointed out many times that the idea of a scanning disc is not the solution to television. The use of this disc method may be compared to the crystal stage of radio reception. It can safely be stated that the transmission of pictures will never be really satisfactory until some non-mechanical form of television equipment is available.

The Cathode Ray Scanner.

This brings us to the cathode ray television scanner, from which much has been expected. So far comparatively little has been accomplished. The scanning apparatus of today may be considered as fairly good, but it is very expensive, and while the cathode ray scanning device may be one answer, it is not believed that it is the final one.

At first glance it would appear that engineers are on the wrong track as far as television is concerned, in that they still cling to the idea of "scanning." Scanning means that the image or picture to be transmitted must be "broken up" into thousands of little points, which are transmitted by translating them into electrical impulses and then re-assembled at the receiver, where the reverse action is brought about to create the image. This scanning idea would appear to be unnecessary, and when the final television invention comes along, it will probably be found that scanning will be conspicuous by its absence.

The Eye A Perfect Televisor.

Millions of years ago, nature invented the first real television machine, which so far has not been duplicated by man. Reference of course is made to the animal eye, which has been in existence on this planet for millions of years, and is open for study by all television aspirants.

The animal eye (which of course includes the human eye), is an almost perfect television receiver and transmitter. Not only does it receive an image from the outside world by means of light rays and then transmit it through the optic nerve to the brain, but it goes several steps further.

In the first place, the eye gets along marvellously without any

scanning mechanism, and furthermore, the image is transmitted in colours as well. While it may be true that colours do not actually exist in nature, but are only a psychological effect in the mind, yet if by electrical means the human eye can be duplicated, then a television machine will be available which will transmit in colours so that the human eye can receive them.

Is The Scanning Process Essential?

It will be noted that the human eye "takes in" a subject all at once; that is, it registers an image in its entirety in an instant. Even a fast moving motor-car or bird requires no scanning by the human eye. The entire car or bird is transmitted to the retina, exactly as a camera registers the entire subject on its light-sensitive plate or film in a fraction of a second.

This of course, suggests that it is possible to have television without the scanning idea, but of course there remains to be invented a means for achieving this result.

Some engineers will say that if supplied with several millions of

conductive lines between transmitter and receiver, they also could televise without scanning, because in the human eye there are actually millions of nerves which connect the retina to the brain, all these nerves being enclosed in what we call the optic nerve. It has been found that each strand leading from the rods and cones of the retina is separate and distinct, being, in fact, a separate "conductor."

While these statements may appear to complicate the situation, the solution may not be as difficult as may be thought. Take for instance a telephone diaphragm; this single 2 1/4 in. black iron disc finds no difficulty in transmitting simultaneously thousands of different kinds of sounds, that can instantly be recognised in the telephone or loudspeaker. Yet there are but two conductors which connect the telephone transmitter and receiver.

"Missing Link" In Television.

Seated in front of a loudspeaker, a person with a trained musical ear has no difficulty in recognising the different musical instruments in a

symphony orchestra, while few people find it difficult to identify the voice of a friend over the phone—one voice out of many others that may be heard daily. Yet the telephone receiver does no scanning; it does all these things with single instrumentality. The telephone diaphragm is the counterpart of the human ear, and that of the human eye is the "missing link" in television to-day.

It is possible that the final invention which will solve the problem will be so simple that it will astound everyone, just as Bell's telephone receiver seems absurdly simple from an electrical viewpoint—once it is known how it works.

Speaker Makes Good "Mike"

A dynamic speaker makes a fairly good microphone, good response on both voice and music generally being obtained. The ordinary input transformer mounted on the speaker also serves well as a matching transformer. Ordinary speakers with a wound field require excitation, of course, though permanent magnet types do not.

**FOR QUALITY AND TONE
Rola STANDS ALONE..**

**THE WORLD'S
FINEST SOUND
REPRODUCERS**

B20

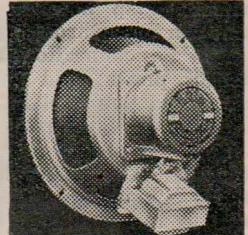

8in. Speaker,
1in. Voice Coil.

K7

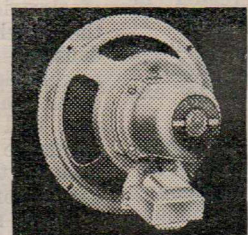

K8

8in. Speaker,
1in. Voice Coil.

G12

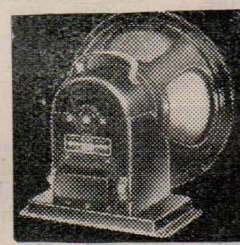

12 1/2 Speaker,
1 1/2 in. Voice Coil.

DP5B

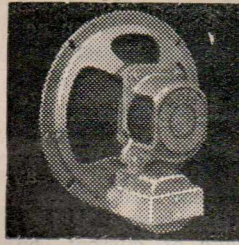

6 1/2 in. Speaker,
3/4 in. Voice Coil.

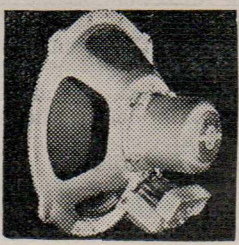

9 3/4 in. Speaker,
1 in. Voice Coil.

Rola are more than ever maintaining their superiority
How are your stocks?

Every advance made in speaker construction has been pioneered by Rola, and up-to-date production methods combined with skilful inventive engineering has earned for Rola a position of pre-eminence in the Radio industry.

Excelling in appearance, leading in performance, Rola Speakers are the choice of a standard loud speaker equipment in quality radio receivers throughout the world.

Distributors and Factory Service for New South Wales:

Geo. BROWN AND CO. LTD., 267 CLARENCE STREET, SYDNEY, N.S.W.

Distributors for Victoria:

A. J. VEALL PTY. LTD. 243-249 SWANSTON ST., MELBOURNE.

Manufactured by:

ROLA COMPANY (AUST.) PTY. LTD

81-83 CITY ROAD, SOUTH MELBOURNE, VICTORIA.

Radio Step By Step 5

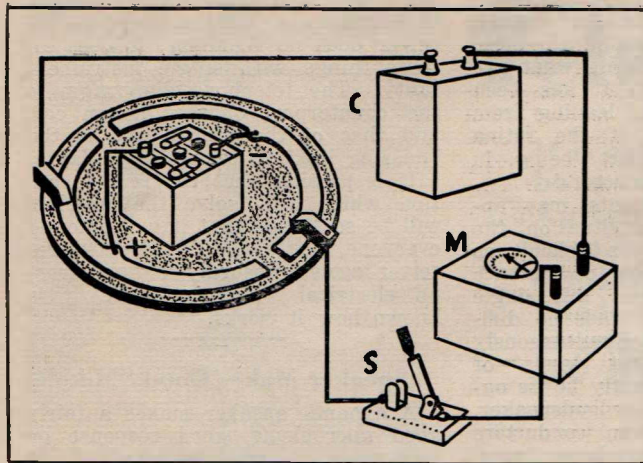

This circuit, which is explained in the article below, illustrates the behaviour of a condenser towards alternating currents.

A.C. And The Fixed Condenser

It is vitally important that the beginner in radio should have a clear understanding of the way a fixed condenser behaves towards A.C., and so this instalment will be devoted to a detailed explanation of this point.

"I am following your series of articles for beginners with great interest, and so far have understood everything except one thing—I cannot grasp how an alternating current can pass through a condenser. There is no connection between the condenser plates, and yet a current flows. Could you explain this a little more fully?"—So writes Mr. C. E. South, a "Radio World" reader in Newcastle. The point he raises is often a stumbling block for newcomers to radio, and so this month's instalment will be devoted to explaining it more fully.

In the last instalment it was shown how a battery, providing direct current, charges a condenser, the amount of charge depending on the condenser's capacity, and the voltage of the battery.

An Interesting Experiment.

The sketch on this page shows a meter M, condenser C and switch S, all connected in series with a battery mounted on a gramophone turntable provided with two semi-circular contact plates. Contact is made from these to the rest of the circuit through two brushes bearing on the contact plates.

If the switch is now closed, with the turntable motionless, a momentary current will flow, charging the condenser in the way explained in the October "Radio World."

If the switch is kept closed and the turntable rotated through half a revolution, the battery will be put into circuit with its polarity reversed. The result of this reversal is that the negative pole of the battery is now connected to that terminal of

the condenser which, owing to the charge acquired before the turntable was moved, is positive, the positive terminal of the battery being simultaneously connected to the negative terminal of the condenser.

Double Current Now Flows.

The tendency of the condenser to discharge is now assisted by the battery, and thus a double quantity of electricity flows, being made up of the discharge current of the condenser, immediately followed by a charging current charging it the other way round. This double current will flow afresh every time the turntable is rotated far enough to reverse the direction of the battery connections.

Next, suppose the turntable to be set spinning by its motor at such a rate that the momentary current has not quite ceased before the connections are reversed. The meter will then show a deflection all the time, the needle moving first to the right and then to the left as the direction of the current in the circuit changes.

If the meter is now replaced by one of a type that always deflects in the same direction, no matter which way the current is flowing, and the turntable spun so fast that the meter needle cannot flicker fast enough to keep up with the rise and fall of the current, we shall have visible evidence of a current flowing, apparently continuously, in a circuit that is broken by the insulating material between the two sets of plates in the condenser.

But we know, from the way we have had to run together a series of momentary impulses flowing in opposite directions, that current is not

really flowing through the condenser, but is passing in and out of it so continuously that the net effect, taken over any appreciable period of time, is practically the same as though the insulating material were allowing quite a heavy current to pass. In practice, the effect is as if the condenser were replaced by a resistor equal in value to the reactance of the condenser at the frequency of the "a.c." supplied by the turntable.

A Practical Proof.

A practical proof that a.c. will pass "through" a condenser can be obtained by connecting a condenser of large capacity (4 mfd, for example) in series with, say, a 40-watt lamp across the a.c. mains. The lamp will light, though not at full brilliance. With a 2 mfd. condenser the light will not be as bright, while with a 1 mfd. condenser it will be dimmer still.

Thus we now know that a condenser will permit a.c. to pass through it, and that its opposition to the flow is less the greater the capacity of the condenser.

The amount of alternating current that a condenser will pass is also directly dependent on the frequency, which will be illustrated by a further reference to the sketch.

The Effect Of Frequency.

Suppose the turntable were to revolve very slowly—making, say, one revolution every 20 seconds. Every 10 seconds there would be a momentary passage of current, but there would be long gaps between each pulse and the next. The average current, taken over the whole time, would be minutely small, be-

cause for most of the time no current at all would be passing.

Now imagine the turntable speeded up to standard gramophone speed, 78 revolutions a minute, or about 1 1/4 turns every second. Clearly, current will now be flowing for a much greater proportion of the total time, and the average current will therefore be greater.

But, in imagination if not in fact, we can speed up that turntable still more, until eventually we arrive at such a speed that the inactive periods have vanished altogether, the current in one direction having not quite died away when the next reversal comes and a fresh burst of current comes. The average current will now be higher still, since current is flowing in one direction or the other at every moment. Is it possible to obtain a still greater current by increasing the speed of rotation? At first sight one would say not, and that if a speed had been reached at which there were no intervals in the flow no further increase in the speed would make any difference.

The Meaning Of Reactance.

This argument, however, overlooks the fact that during each momentary burst of current the flow is greatest at the beginning, and tails off to-

wards the end. At the moment of reversal of the battery connections the voltage driving a current through the circuit is double that of the battery (battery voltage Plus charged condenser voltage), but as the condenser loses its initial charge it ceases to assist the battery, and when it begins to acquire a charge in the opposite direction it actively opposes it. The first burst of current is, therefore, large, but towards the end the flow falls off.

It now becomes clear that if we wait until the current drops practically to zero before reversing the connections of the battery, and starting off again with the maximum current, we are, in effect, getting remarkably little return in current for the extra time expended.

It will therefore pay us not to be content with a speed of rotation that is only just high enough to cut out the periods of complete inactivity that follow each successive charging current, but to whirl the turntable round ever faster and faster so as to take fuller and fuller advantage of the tremendous initial burst of current that follows each reversal of the battery. The faster we can spin the turntable the greater will be the current, until finally, with an infinite

speed of rotation, we attain the current that would flow if the condenser were short-circuited out altogether.

The frequency of an alternating current is simply the number of complete reversals (from plus to minus and back again) that occurs in each second, and corresponds exactly with the number of revolutions of the turntable in our hypothetical experiment. If the turntable were revolving at the very high speed of 50 revolutions per second, or 3,000 revolutions per minute, the alternating current generated would have a frequency of 50 cycles, and would be identical (apart from waveform) with the ordinary alternating current used for house lighting.

Reactance Depends On Frequency.

From what has been said it will therefore be clear that as the frequency of a current is increased, the opposition offered to its flow by a condenser (known as the condenser's "reactance") will decrease. Further, it is found that the relationship is a simple one, doubling the frequency of a current resulting in the reactance of the condenser, or, alternatively, allowing the original value of reactance to be reached with a condenser of half the capacity.

(Next Month: The Tuned Circuit)

NEW CALSTAN Portable Type Tube Checker Model 221

The Trade asked for a Portable Type Tube Checker, and in Model 221 we have produced what is unquestionably the finest Tube Checker ever placed on the Australian Market.

For the first time tests American, Philips, Osram, and Mullard Valves, including metal Philips, P. & V. Catkin valves. A turn of the switch picks out and tests every element.

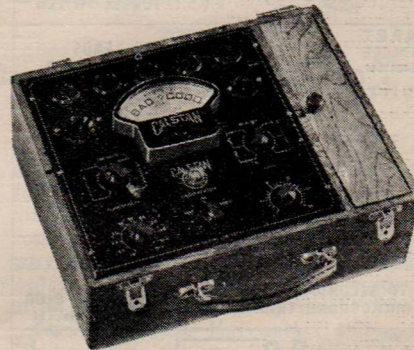

The Model 221 Tube Checker incorporates the most advanced circuit features for tube analysing. High Resistance, Leakage and Shorts between Elements indicated by the Neon Lamp even as high as 1,000,000 ohms.

Years ahead in design, performance and simplicity

Additional Features are percentage Readings in conjunction with Good - Bad sections on scale of large Fan-Shaped Meter. Time Voltage Regulation with meter check.

Price, complete in Polished Oak Portable Case **£11/15/0** PLUS TAX. } AVAILABLE ON
 Counter Model **£11/5/0** PLUS TAX. } EASY TERMS

- OBTAINABLE FROM DISTRIBUTORS:
- N.S.W.: Radio House Pty. Ltd., Sydney.
 - Queensland: J. B. Chandler and Co., Brisbane.
 - New Zealand: New Zealand Electrical Equipment Co. Carrick Weddespoon, Wellington.
 - Tasmania: Noyes Bros. (Melbourne) Ltd., Launceston.
 - Victoria: Australian General Electric Ltd., Melbourne.
 - South Australia: Radio Wholesalers Ltd., Adelaide.
 - West Australia: Carlyle and Co., Perth.
 - Martin De Launay Ltd., Sydney.
 - John Macgillycuddy Ltd., Sydney.
 - John Martin Ltd., Sydney.
 - Electric Service Co., Newcastle.

SLADE'S PRECISION TEST EQUIPMENT
 Phones UJ 5381-5382 LANG STREET, CROYDON, N.S.W.

PARTY RADIO MAGIC

THOSE who look upon a broadcast receiver as only suitable for listening to broadcast stations with do not realise the wide variety of fun-producing schemes that can be evolved by using an ordinary set in conjunction with a microphone. Here are just a few ideas—others will suggest themselves.

Talking Christmas Tree.

The talking Christmas tree, telling each one what present to take, may sound a little fantastic, but it is quite easily arranged. So are many other tricks which will amuse both old and young, keeping the proceedings moving with a swing. Many of them need only the purchasing of one or two small items, while almost everyone is sure to have odd components around the shack that can be pressed into use.

For example, the talking Christmas tree requires an inexpensive microphone and an extension loud speaker, both of which are attached to the receiver. The extension speaker can be connected between the plate of the output valve and the chassis, a fixed condenser of .25 mfd or upwards being interposed between the plate and one side of the speaker to prevent the "B" supply from being shorted. If a moving coil type of speaker is used, and the extension leads are fairly long, the speaker transformer should be removed and mounted near the set. The leads are then run from the secondary of the transformer to the voice coil lugs on the speaker. The "mike" is merely connected to the set's pick-up terminals.

Two or three different types of microphone are available, while in an emergency, an old magnetic speaker or an earpiece from a pair of headphones will work as a makeshift.

The speaker or headphone is simply connected to the pick-up terminals, no intermediate transformer being required. Of course, this form of extemporised 'microphone' is not as good as the real thing, but it is quite satisfactory for some purposes. If it is used, try placing a small watch on it, and listen to "Big Ben" ticks reproduced in the speaker. One word of warning, though—do not leave the watch in position for very long as the magnet in the headphone will not improve its working.

An even simpler stunt is to make the radio set join in the ordinary

conversation—a most startling happening if no preliminary announcement is made. Perhaps it will be more amusing to interrupt the ordinary broadcast programmes with various comments. Both of these suggestions require the microphone only. The person 'announcing' will be hidden, but able to hear the people in the room; and if he speaks close to the mouthpiece of the microphone, listeners will not hear him except through the speaker.

Then the 'birthday call' idea could be adapted for the distribution of presents when the 'broadcaster' behind the scenes will announce himself as Father Christmas and tell his story. Or the same scheme could be used with a life-sized model of Father Christmas himself, when a

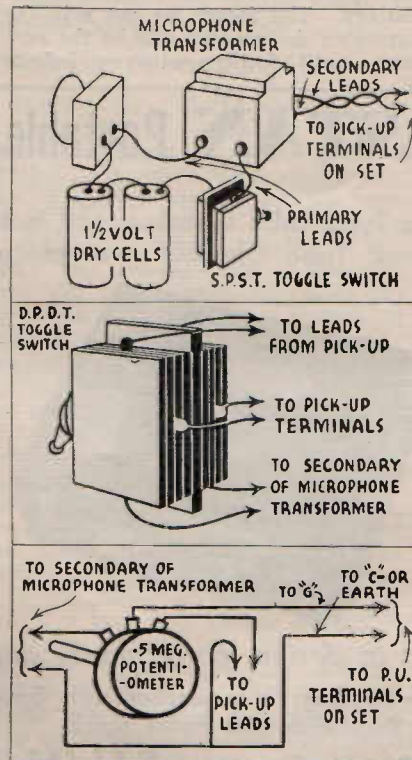

The top sketch shows how to connect a carbon microphone to the set, while the centre sketch shows the way to wire a double-pole double-throw toggle switch for changing over from speech to music, or vice versa. By connecting a potentiometer as shown in the bottom diagram, speech or music can be faded in or out at will.

Some original ideas for providing radio entertainment at Christmas parties.

By Douglas N. Linnett.

hidden microphone and loudspeaker as his 'chest' will make him talk.

Radio Set Answers Questions.

Every one will be more than intrigued if they find that the radio set will answer any questions or talk to them. And if the voice of the speaker claims to be able to tell fortunes (and the man at the microphone knows his guests well and has an imaginative turn of mind) plenty of fun will be caused.

Two microphones may be necessary if the operator is hidden any distance from the guests so that the fortune teller can hear his own clients.

This suggests broadcasting your own programmes by feeding the output from the microphone and/or gramophone pick-up into an amplifier, which operates a speaker in another room. Short dialogue plays, imitation foreign programmes, and the usual broadcast features can be 'put over' excellently in this way, while dance music with suitable announcements between the records can be broadcast to another room in the house where dancing is in progress.

An even more personal touch will be given if each guest is persuaded to 'broadcast' from the privacy of the 'studio' to the rest of the party sitting around the speaker—a modern version of the musical evening. All sorts of turns will suggest themselves; while record music faded in with a potentiometer and played through a pick-up will help fill the gaps in the programme.

Fading In Music Or Speech.

The pick-up and microphone circuits are combined through a 100,000 ohm potentiometer by means of which either source of input can be gradually brought into circuit, the music from the pick-up being faded out as the speech from the microphone is faded in and vice versa. The most suitable balance is found by setting the individual volume controls beforehand, after which they can be left in those positions.

In connecting the microphone and pick-up to the pick-up terminals of the receiver, a lead from each is taken to the pick-up terminal which

is connected internally to grid bias negative or ear, according to whether the set is battery or A.C. operated. The other pick-up terminal of the set is connected to the centre terminal of the potentiometer, to the outside terminals of which are taken the free leads from the microphone and pick-up.

With such an arrangement, however, it is almost essential to have the microphone and pick-up near to the receiver, which means that an extension speaker will probably be required to supply the output in the room where the listeners or dancers are situated. It is also a wise precaution to keep the leads from the pick-up and "mike" well apart and at right angles to each other, and even to screen them.

Another good suggestion to keep the party moving is round in identifying the sounds of various objects. For this, each one present is given a pencil and piece of paper to write down what they think is the origin of the various sounds.

The operator then rattles keys before the microphone, crinkles paper, whistles, shakes a handful of coins, rubs his hand over a balloon and so on while the competitors complete their lists. Other amusing sounds that may be included in the scheme are those of a watch (the ticks can be made to sound almost like hammer blows) the beating of the heart by holding the microphone against the chest, the dropping of a pin on to a drum or sheet of paper, the mewling of a cat, and the ring of a bicycle bell.

The operator should keep an accurate list of the sounds broadcast so that it can be read out later and the answers checked. Even more fun is added when each member of the party reads out what he or she thought the sounds were, especially if the microphone is not a good one or if so used that distortion is introduced.

"Feeling" The Music.

A slight tingling of electricity will be experienced in another trick that enables one to "feel the music". Two wires are taken from the input side of the speaker transformer of a receiver, a fixed condenser of .1mf. capacity upwards being put in each lead to isolate it from the "B" supply. Also, handles of the kind used for shocking coils are fitted at the ends.

The volume of reproduction should be increased very gradually, so that no unexpected or violent shock is given.

Using Photo Electric Cells.

Then some mystifying tricks can be fixed up by means of photo-

glow or any sign of sparking, switch electric cells, although a little more apparatus than usual is required. But a wave of the hand can be made to switch the set on or off. Alternately a fascinating "magic circle" or "musical carpet" stunt can be worked. When any one steps into the prescribed area, the light ray which operates the photo-electric cell is interrupted and the music is switched on automatically.

A little imagination and ingenuity, together with the possession of one or two suitable relays, gives a very wide scope. The commonest application is in the making and breaking of a circuit by the interruption of a beam of light falling upon a cell, while the more ambitious may modulate a beam of light by means of a pick-up or microphone, a photo-electric cell and an amplifier.

If the visible light is apt to fall flat because it is rather obvious, the more sensitive types of cell will work satisfactorily with infra-red or 'invisible rays'. They can be conveniently produced by enclosing the light source in a box, the side facing the cell being composed of very thin sheet ebonite. This allows the infra-red rays to pass through the ebonite, so that the invisible source makes possible many apparently mysterious stunts.

No doubt there are many more amusing ideas to keep up the interest at Christmas parties, with variations and improvements over those mentioned. But the foregoing will serve as a guide for developing "Party Radio Magic" at Christmas, when originality is always welcomed.

Radiokes "Scout" Superhet

(continued from page 21)

off immediately and check the wiring for short circuits. Set the padder and both trimmers on top of the condenser gang approximately half-way out. Tune in a station on about 240 metres and turn back the volume until the signal is fairly weak. Now carefully adjust the aerial trimmer for best results.

Next, swing over to the other end of the band and tune in a station near 1YA. Adjust the padder in conjunction with the dial to get best results. Every time the padder is adjusted the dial should be shifted to keep the station tuned in. The idea is to find the position at which the station is at maximum volume. When this peak is obtained, turn back to the low wavelength station and readjust the aerial trimmers. Then return again to the high wavelength station and give the padder a final adjustment. Remember to

work only on the aerial trimmer for the low wavelength (high frequency) and on the padder in conjunction with the dial for the high wavelength (low frequency).

Reflexing The "Scout."

Only three 1-watt carbon resistors and two mica fixed condensers are needed in order to reflex the pentode section of the 6B7S so that it gives audio as well as radio amplification. As mentioned before, the extra gain on the audio side makes a big difference to the all-round performance, and so the addition is well worth while.

However, it is important that the set should be built, aligned and operating satisfactorily with the "straight" circuit before reflexing is attempted, and so the change-over will not be described until next month.

Noise on Short Waves

A noise like static experienced while a shortwave set is in operation may be due to loose aluminium screening partitions, to a poor connection, or to a defective contact in a

"Q" and "R" Signals

QSA—READABILITY

- QSA1—Hardly perceptible, unreadable.
- 2—Weak, readable in patches.
- 3—Fairly good, readable with difficulty.
- 4—Good, readable signals.
- 5—Very good signals, perfectly readable.

R—AUDIBILITY

- R1—Faint signals, unreadable.
- 2—Weak signals, barely readable.
- 3—Weak signals, but can be copied.
- 4—Fair signals, easily readable.
- 5—Moderately strong signals.
- 6—Good signals.
- 7—Good, strong signals, readable through QRN and QRM.
- 8—Very strong.
- 9—Extremely strong signals.

component with a rotating shaft, such as a potentiometer or solid dielectric reaction condenser.



Wire-saving Spool

Old type-writer ribbon spools make excellent storage forms for wire taken from old transformers or coils. Tie one end of the wire to be saved to the spool, and then drive a nail through the centre hole of the latter into the bench. Then wind on the wire by spinning the spool with the forefinger, and secure it in place with a rubber band slipped over the spool.

The Cathode Ray Oscillograph At Work 4

In this instalment the author explains one of the most valuable applications of the Cathode Ray Oscillograph---its use for obtaining frequency response curves.

By A. H. MUTTON, B.E.

Paton Electrical Instrument Company

HAVING treated many of the simpler uses of the cathode ray oscillograph in previous articles, it is proposed now to deal with one use which requires a somewhat complicated set-up of gear, but whose importance to the radio man is very great.

It is the ability of the cathode ray oscillograph to plot frequency response curves showing immediately the effects of different adjustments, and indicating when adjustments are satisfactory from the viewpoints of sensitivity, selectivity and fidelity, that is bringing this device to the fore. It treats audio, carrier telephony, intermediate and radio frequencies with equal ease, and deals

An interior view of the Palec cathode ray oscillograph, an instrument that because of its numerous applications and remarkable flexibility is invaluable to servicemen and design engineers.

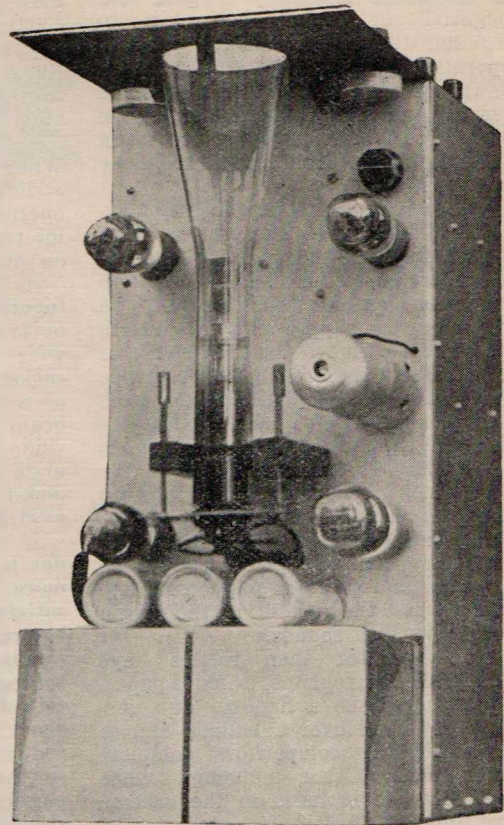

with filters, amplifiers, single components such as I.F. transformer; and complete radio sets as quickly as they can be connected up for test.

Plotting Response Curves.

Now for some information. In

figure 1 is shown a very simple electro-mechanical device for enabling the cathode ray oscillograph to plot frequency response curves. It has so many defects as to make it little more than a mechanical analogy of the present day technique, but is excellent for illustration purposes.

It consists of an R.F. oscillator across whose tuning capacity is connected a small variable condenser which can be rotated by motor also, coupled to the condenser shaft is a special form of potentiometer type rheostat.

Dealing with the potentiometer first, it will be noted that across the ends of its resistance is connected a battery, and that its moving arm and one side of the battery connects to the horizontal deflection plates of the cathode ray oscillograph. Obviously, if the shaft is rotated, the voltage applied to the cathode ray oscillograph plates will steadily increase as the arm moves from one end of the resistance to the other, causing the spot to move across the screen.

On reaching the end of the resistance (half a revolution) the contact arm moves on to a contact strip, thus suddenly bringing the spot back to its original position and keeping it there for the remaining part of the revolution. The biasing battery is merely to give an initial bias to the spot, moving it to the side so that the full screen may be utilised.

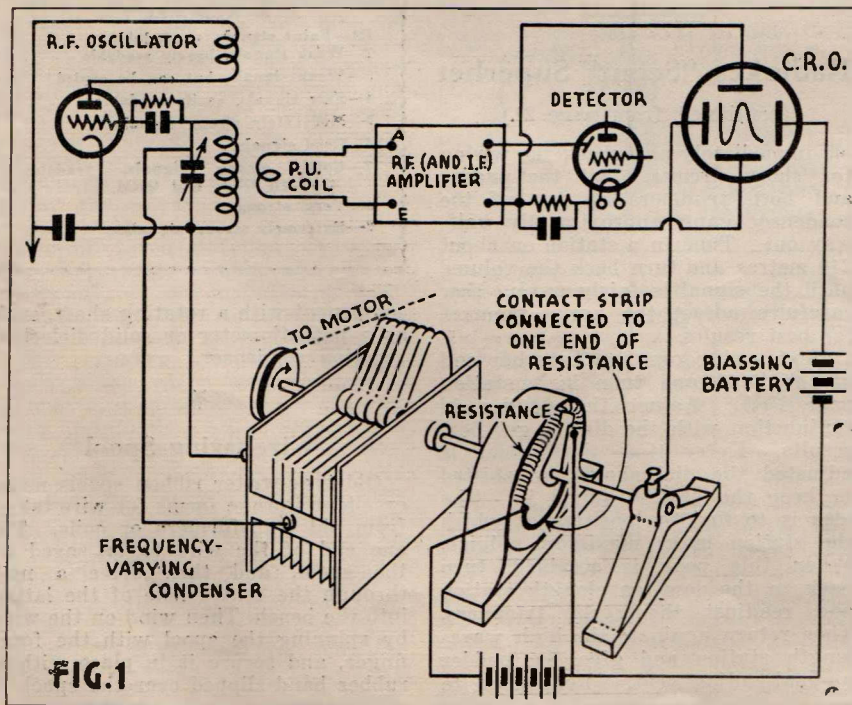
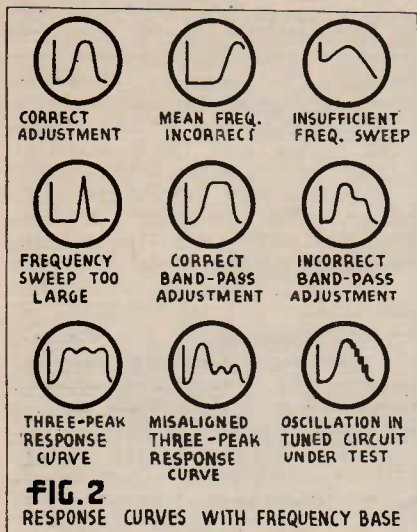

FIG. 1



In this way the whole potentiometer arrangement becomes a time base which can move the spot steadily across the screen and snap it back rapidly, with a considerable pause there, before the next cycle.

How The Frequency Is Varied.

Ganged to this time-base is the variable condenser which affects the tuning of the oscillator. By correctly positioning the condenser plates with respect to the potentiometer, the frequency of the oscillator can be made to rise, for example from a minimum to a maximum and suddenly return to minimum in time with the time base.

Now consider what happens if this varying frequency is fed into an amplifier which is tuned to its mean frequency. Further, suppose the amplifier is followed by a detector as shown. Suppose the frequency is at first considerably off-tune. The amplifier will pass little voltage to the detector resulting in small D.C. voltage across the detector load resistance, and the vertical deflecting plates will only cause a slight lift of the spot.

As the frequency, with rotation, approaches more closely to the tuned frequency of the amplifier, the rectified D.C. output from the detector will become greater, reaching its maximum at the tuned frequency. As the frequency passes to off-tune values, the D.C. drops again until, if the frequency sweep is great enough, it may reach zero.

Now, at the same time as this lifting of the spot is going on, the time base is moving the spot sideways. The resultant path of the spot thus becomes a curve. Further, the movement of the spot sideways is proportional to the frequency alteration.

Putting this another way, every point on the curve becomes representative of two things, namely, the

frequency of the oscillator, and the response of the amplifier to this frequency. The whole curve is in this way a plot representing the response of the amplifier to a band of frequencies—its "frequency response curve."

It will be noticed that so far we have considered but one trace across the screen. With the present system, at the end of the trace or sweep the spot returns immediately to its starting point, while the frequency-varying condenser continues its rotation.

With a "straight-line frequency" condenser the frequency sweeps according to a straight line law with regard to time, as long as the plates are turning from the right-out to the right-in position but if rotation continues so that the plates come out of mesh again this law does not (normally) hold, so it is advisable to see that the spot is not allowed to trace out a curve while this non-linear variation is going on. Hence the provision of the contact strip on the potentiometer to cause the spot to cease horizontal movement, so that all that occurs during the unwanted part of the cycle is a lifting and falling of the spot at one end of the picture, as shown in Fig. 1.

If the motor rotates the condenser shaft at about 25 times a second the response curve is visible on the screen as a steady picture. Figure 2 shows a few of the types of picture obtainable on the screen with the gear described above. The straight vertical line in all the pictures is produced during the half revolution when the spot does not traverse. It does not complicate the picture in any way but is always present.

Figure 2 with a little thought should be self explanatory.

Improved Modern Methods.

The electro-mechanical gear described above is never used nowadays outside experimental laboratories. It is very difficult to construct, is costly, requires much maintenance, and is most inflexible.

It will be realized at once that the frequency sweep of an oscillator tuned by the rotating condenser of Fig. 1 depends very largely on the setting of the oscillator tuning condenser, when its capacity is large the sweep is small, and vice versa. To

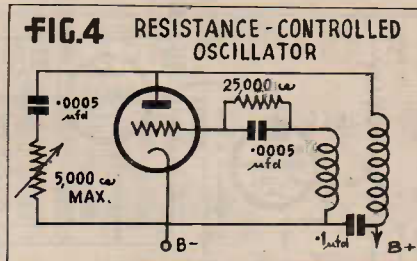
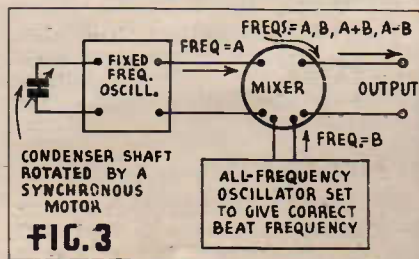

get a picture free from flicker it is necessary to run the condenser shaft some 1,800 R.P.M. or more, and the wear on the potentiometer wire is very great. These few points should show the serious difficulties that can be expected from such apparatus.

Another method showing some promise is to use an ordinary time base locked to do, say, 50 c/s., and to rotate the condenser by a synchronous motor. The cost of this scheme is still high, due to the expensive motor required, but it is free from contact troubles. Variation of frequency sweep with tuning condenser setting, however, still exists, and

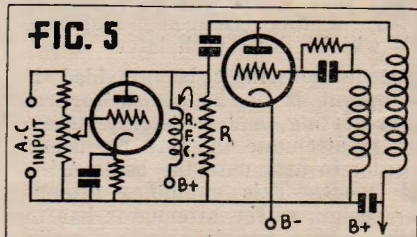

other undesirable features such as sensitivity to vibration.

In the modern gear the beat-frequency principle has been used to overcome variation of frequency-sweep with the setting of mean frequency. Fig. 3 shows the usual scheme of overseas frequency bases.

Two oscillators are used, one of frequency "A," which is fixed, but which can be modulated in frequency to the desired amount (say 40 k.c./s.) by the revolving condenser, vibrating condenser, revolving inductor, or other partly mechanical means in common use.

This oscillation "A" mixes with another oscillation from an unmodulated oscillator of frequency "B," giving two beat notes A+B and A-B in the usual way, as well as "A" and "B." Thus in the output circuit there are four frequencies:—"A" is fixed at one frequency always, but is frequency modulated; "B" is set to a desired frequency, but is unmodulated; A+B is of higher frequency than "A" or "B," and is frequency modulated; while A-B is of lower frequency than "A" and is frequency modulated. This is because whatever frequency modulation exists on "A" is reproduced on the beat notes.

Thus, if A is set at 275 k.c./s.

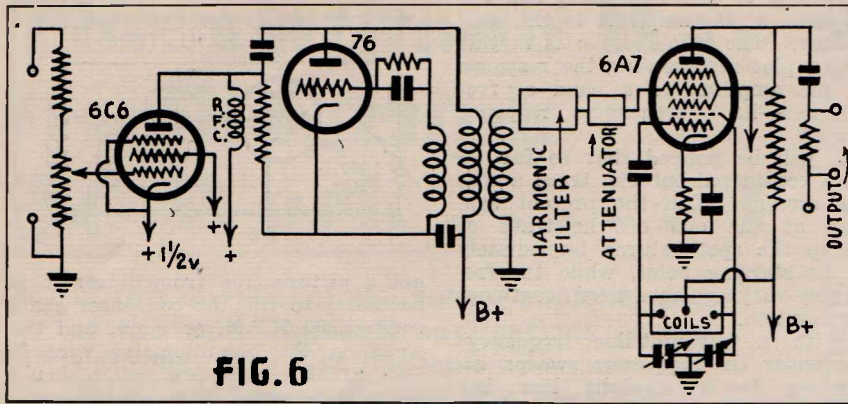

FIG. 6

and "wobbles" through a band 50 k.c./s. wide, then the beat frequencies A+B, A-B also wobble 50 k.c./s., no matter what their mean frequency may be. If it were 10,000 k.c./s., the band covered in the sweep is 10,025 to 9,975 k.c./s. If it were 1,000 k.c./s., the band is 1,025 to 975 k.c./s. If it were 25 k.c./s., the band is 50 k.c./s. to zero. The latter means that audio amplifiers can be tested for their frequency response. This will be dealt with later.

Attenuation must be provided if the output is to be useful for receiver testing, and it is only necessary to attenuate the "A" frequency in order to attenuate the beats A+B and A-B. This simplifies attenuator design, as the attenuator has to work at only one frequency, usually a low one, while the beat output frequency in use may be a very high one.

It is hoped from what has been said that the reader will realise that the two beat frequencies in the mixer output can each be used for testing purposes. They are commonly about 500 to 1,000 k.c./s. apart, and cause no confusion in testing.

Australian Practice.

The undesirable mechanical features of overseas frequency bases has led the Paton Electrical Instrument Company, as manufacturers of oscillograph apparatus, to attempt to produce a frequency base purely electrically operated—without rotating machinery at all.

Messrs. Gordon and Makinson, two young Sydney scientists, patented

last year an oscillator whose frequency is controlled by resistance: A simplified version of this oscillator, which has been used to obtain the necessary sweep, is shown in Fig. 4. It is different from the usual oscillator only in that a resistance is placed in the tank circuit in series with the condenser. Varying this resistance varies the oscillator's frequency. By good design, the oscillator can be made to tune through, say, 1,000 k.c./s. about 1,000 k.c./s. as a mean just by altering the resistance.

If, now, the plate to cathode resistance of a valve is paralleled across this "tuning resistance," and grid bias is altered by feeding a signal into the grid circuit, then the plate resistance of this valve is altered, and hence the frequency of the oscillator. Fig. 5 shows this arrangement simply. By correctly proportioning the value of "R" and using the right "tuning valve," a frequency band of 300 k.c./s. or more can be covered. For the examination of response curves of most circuits and filters, whether A.F. or R.F., a band of 50 k.c./s. is quite adequate, so it will be seen that here exists a method of obtaining the sweeping signal required for a frequency base.

Fig. 6 shows one of the circuits used in the linear frequency bases produced by the Paton Electrical Instrument Company. The attenuator can be of the simple piston capacity type, or simple wire-wound type. The harmonic filter is merely to reduce harmonics in the output of the 76, and in this way to get rid of spurious response curves.

The 6C6 is used at low plate voltage to obtain a low plate resistance. The all-frequency oscillator is the triode section of the 6A7 pentagrid mixer.

Obtaining Uniform Sweep.

To sweep the output frequency, it is merely necessary to feed A.C. into the terminals at left of Fig. 6. If the 50 c./s. mains are used the

sweep occurs at this rate, i.e., sweeping 50 times from low to high and 50 times from high to low per second. The company, however, recommends using the output from the linear time base of the oscillograph in use with the base. This method of operation has many advantages over the pure A.C. method. The frequency is then swept uniformly from low to high, and instantly returned to low again by the saw-toothed waveform of the time base.

On the screen this gives a "single-trace" picture, printing the response curve as shown in Fig. 7, whereas the pure A.C. method super-imposes two response curves on one another. Due to time delay in the circuits under test, these response curves are usually staggered as shown in Fig. 8. With the method of Fig. 7, no backward sweep picture is produced, due to the speed at which the time base returns the frequency to the starting point at the end of the forward trace.

It will be noted that in these pictures there is no vertical line at

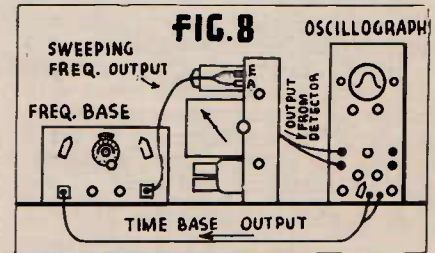

the side of the picture. Further, the tracing is going on without pause, that is, no time is wasted waiting for a revolving condenser to become effective again.

The set up of apparatus necessary for taking response curves is shown in Fig. 9.

This shows a set under test for overall response, and indicates the extreme simplicity of the test. Only four wires are connected to the receiver, just as in testing by signal generator-output meter method, but the information is complete and instantly available on the oscillograph's screen.

The oscillographic testing of receivers has brought along with it a new technique, and space would not permit of its being discussed in this article. It is therefore intended that next month's issue will contain a full account of this new development, which permits of making "Q" measurements, power factor tests on condensers, and many other measurements, as well as those for which it is primarily intended.

(To be continued next month.)

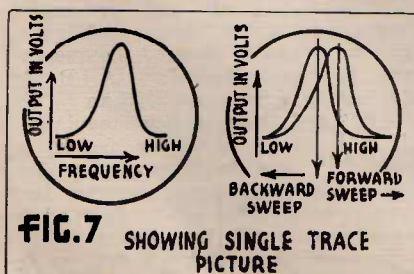
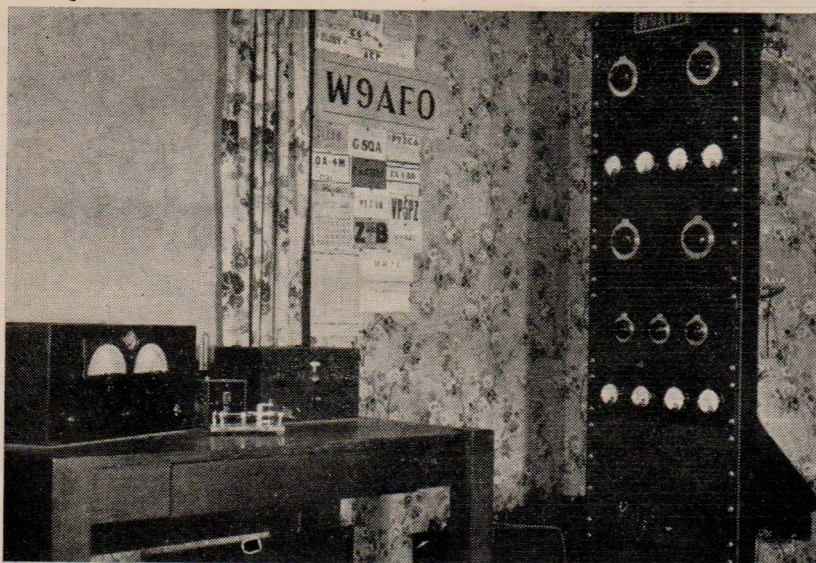

FIG. 7 SHOWING SINGLE TRACE PICTURE



A typical modern American amateur station, equipped with a communications type receiver and rack and panel transmitter.

A few interesting sidelights on radio in India supplied by our Bombay correspondent indicates most forcibly that we in Australia are certainly more fortunate in many ways than many of our overseas friends.

India—a land of static—a land of divided tongues and races—a land of poverty; all serious obstacles that are hindering the development of broadcasting. The chief broadcasting stations of India are situated at Delhi, Bombay and Calcutta. In July of this year the Bombay station (VUB, 350.9 m. and 31.36 m.) celebrated its ninth birthday, also the ninth anniversary of the beginning of broadcasting in India.

The expenditure on radio has lagged further and further behind the revenues, so that the listener is not getting anything like full value for the license he pays. Out of India's 350 million people, only about 20 million are at present within the service area of at least one station.

It is hoped, with the correct application of broadcasting, to achieve great things in the matter of education. Distance, poor communication and poverty have all combined to divide India into watertight compartments, and to fortify the barriers of language and race. Broadcasting can and must break down these barriers, by providing a direct and daily channel for the interchange of ideas between all parts of the country.

But what of the short waves; India is such a vast country and its climatic conditions are so variable that it is impossible to generalise regarding reception. Generally speaking, shortwave reception is pure agony,

although at times with favourable conditions, overseas reception is excellent. However, reception must be reckoned over periods of months, and not one or two days when receiving conditions are particularly good.

★

5-Metre Schedules For Xmas.

Ultra-shortwave enthusiasts contemplating a holiday at Christmas time would be well advised to take a 5-metre receiver, especially if they anticipate holidaying on the mountains or at any elevated location. Two years ago VK2OD obtained some rather startling results from a simple 5-metre receiver on his tour through the Blue Mountains, the reception of Sydney stations from Katoomba and Mt. Boyce being surprising, in consideration of the apparatus being used at the time.

The following 5-metre schedules will be maintained by either 2OD, 2CL or 2DL over the Christmas period:—December 25, 26, 27, transmission of speech, music or I.C.W. each night between 8 and 9 p.m. Sydney Time. Reports will be greatly appreciated, especially from those who may be in isolated or distant locations.

★

The "Hams Of Yesterday.

By Chas. Luckman, VK2JT.

(Continued from last month)

Jim Colletti, 2CL, was operating a transmitter long before the writer thought of obtaining a license, and I used to cast longing eyes at his tall masts in Annandale, and look upon Jim as a second Marconi. However, 2CL as an amateur has been off the air for many years, but still

Radio In India

5-Metre Schedules for Xmas: "Hams" of yesterday: Lakemba Radio Club Notes and News.

By W.J.P.

retains his interest in the radio side of the defence forces.

2AR, Bill Hudson, of Dulwich Hill, is too busy selling and repairing radio sets to worry about "ham" radio these days. Perhaps one day the old 210 will get a surprise by having a few volts applied to it, and 2AR will be on the air once again. Anyway, we hope so.

Arthur Freeman, 2AS, of Burwood, until a few years ago was 4FC, but says he likes the Sydney QRM the best, so he came to N.S.W. His hobby and work is radio, and he is one of the few VK "hams" who hold a W.A.C. for 10 metres.

2AU. In 1921, Jack Cureton was running the very exclusive Burwood Radio Club under the call sign of 2IX, and my first impressions of this station was a mass of motor generators, a massive Magnavox speaker and a 50-watt transmitting valve. Later his call was changed to 2AY, and the broadcasting of the local church organ each Friday night is still a very clear memory. Although not heard on the air, Jack still retains his interest in radio.

2AW used to scoop up all the prizes at the radio shows with his small-powered transmitter (?) with a pair of 250-watt valves. However, both A. W. Dye and son were interested in amateur radio until about 5 or 6 years ago, when they were active on 20 metres.

2BV, the Waverley Radio Club has been 2BV for many years, and to all appearances will go on for ever. The club was very fortunate in having a couple of pre-war spark "hams" as its foundation members, and the club rooms are second to none in N.S.W. Several old-timers are still included in the membership.

2DJ, Basil Cooke, was at one time known as 2LI, and used to transmit musical test programmes from the Sydney observatory. Although he has dropped out of the amateur game, he still retains the call sign of 2DJ.

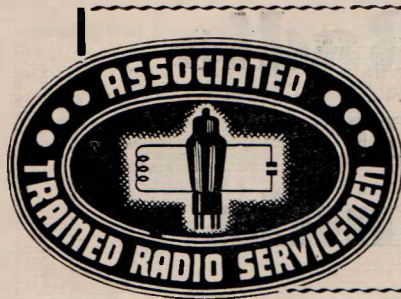

The . . .

A. J. R. S. Bulletin

Conducted by the
Secretary, 287 Clarence
Street, Sydney, N.S.W.

New Organisation Is Growing Rapidly.

READERS who have already joined the A.T.R.S., and the many who are planning to join, will be interested to know that the organisation is growing rapidly. Collective buying, which of course means better prices, is already an established fact, and other similar benefits for members are under consideration.

During the past month we got into touch with all radio training institutions in this State, with a view to approaching their graduates. In this they gave their whole-hearted support, and have expressed the opinion that an organisation such as ours is much needed to give the present-day serviceman his proper status.

It is evident the next step worthy of note is to get legal recognition of the serviceman, similar to that of the licensed electrician in this State. We have a precedent in both Queensland and New Zealand, and this should be of considerable assistance to us in the matter.

A visitor called at Head Office in the person of Mr. Bill Hudson (ship's operator) deputed to make inquiries by service colleagues in Brisbane who are anxious to form a branch of the A.T.R.S. in Queensland. Among those who are interested are Messrs. A. R. Burton, Merivale St., South Brisbane, and A. Hadley, Rothwell Chambers, Adelaide Street, Brisbane. It is to this last mentioned colleague that we wish all Queensland servicemen to direct their communications.

Next, what of the servicemen in Victoria, South Australia, Tasmania, and West Australia? We want this to be an Australian-wide organisation, and so would be glad to hear from any servicemen in these States who would be prepared to do the necessary "spade work" with regard to the formation of branches.

It is very gratifying to have received the many inquiries that have come along through the publicity given us by the "Radio World." To

date we have scarcely been able to cope with our correspondence.

Mr. S. White inquires re the standard of training one needs to be om

a member of our organisation. The reply is that it is essential that the executive committee closely examines credentials of all prospective members.—C. Y. Hook (Acting Hon. Sec.)

Why Suppressors Are Needed For Auto Radio Installations

By W. A. WILDASH, M.I.A.M.

(continued from last month.)

FIG. 1 shows the essential components of a simple ignition circuit, "G" and "B" being the generator and battery respectively, "R" the ohmic resistance of the various connecting leads, primary of ignition coil etc., "S" the secondary winding. The spark gap of only one plug is shown. When the breaker points close, the primary current is unable to build up instantaneously to the value determined by the voltage

applied and the resistance "R" of the circuit.

Due to the fact that the average ignition coil has an inductance of from 5 to 10 millihenrys, the current takes a definite time to build up, increasing from the zero value at A to its definite E/R value at B, roughly in the way shown by the graph in Fig. 2. During this time the condenser is also charging.

Self-Induction Effects.

At a certain time the breaker opens and breaks the circuit. When this occurs the voltage across the coil's primary increases considerably above the battery voltage (6 or 12 volts) due to the self induction, and may reach a peak value of 200 volts for an instant.

This self-induction effect may keep current flowing across the gap in the form of a spark even though the breaker points have separated. Therefore current will not drop instantaneously at B, but somewhat as shown by curve B-C. Condenser "Cb" now discharges through the primary coil in a direction opposite to the normal flow of current and quickly reduces the magnetism to zero. Due to the high step up ratio of the coil, this induces a high voltage (about 3,000 volts) in the secondary.

At the instant the breaker opens and the high voltage is induced in the secondary, the distributor rotor closes the circuit to the spark plug, the spark gap breaks down, its resistance dropping almost to zero while

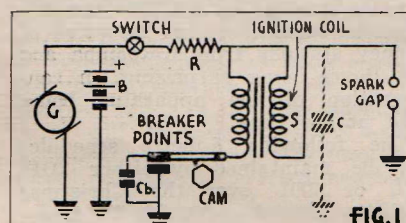

FIG. 1

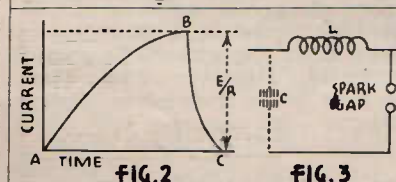

FIG. 2

FIG. 3

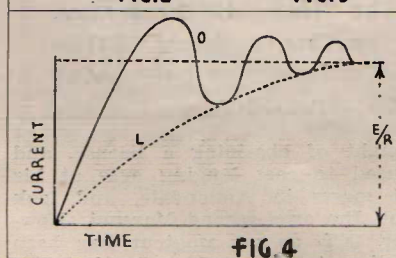

FIG. 4

the high voltage spark jumps across it.

The distributed capacity "C" (shown in dotted lines in fig. 1) of the secondary coil also discharges like "Cb." The current from it leaks through the spark plug gap to ground and back to condenser "Cb," which is the breaker points. The discharge of the condenser "Cb" sets up comparatively heavy currents in both primary and secondary circuits.

Resistance Of Gap Varies.

However, the important point is that when the spark plug discharge ionises the gas between the electrodes, the resistance of the gap drops practically to zero for an instant.

Now if "L" represents the inductance of the secondary circuit, we have the case of a condenser discharging through an inductance plus a spark gap. This forms an oscillatory circuit as shown in fig. 3. The discharge is of a logarithmic nature, the current increasing (as shown by curve in fig. 3) so long as the resistance of the circuit is greater than $2\sqrt{LC}$. But if R is less than $2\sqrt{LC}$,

the discharge of the condenser results in the generation of damped oscillations, the frequency depending on L, R and C.

Usually in automobile high tension circuits the latter is the case, since when the resistance across the gap (degree of ionisation) changes, the resistance of the entire oscillatory circuit varies considerably. This causes the frequency as well as the amplitude of the oscillations to vary over a wide range.

How Interference Is Caused.

As the aerial of the car receiver is usually in the field of these oscillations, interference is experienced every time a spark passes. Once heard, this particular cause of interference can be readily identified again.

There are several methods of dealing with this particular type of interference, the most practical and logical method being to insert resistance in the circuit to change these discharges from those of an oscillatory nature as illustrated by curve

"O" in fig. 4 to those of a logarithmic nature, shown by "L." For since oscillations will only be set up if the total resistance of the circuit is less than $2\sqrt{LC}$, we require only sufficient resistance to damp the oscillations by making the total resistance of the circuit greater than $2\sqrt{LC}$ when the spark gap breaks down and its resistance is zero.

Amount Of Resistance Required.

On modern cars a resistance of from 8,000 to 12,000 ohms is quite sufficient for this purpose, though in some of the older makes up to 25,000 ohms is required. However, it can be seen that when the total resistance of the circuit has been made to exceed $2\sqrt{LC}$, nothing can be gained by increasing this resistance.

As these resistors are used to suppress oscillations, they are called "suppressors." They should be mounted as near as possible to the spark plugs—if practicable, on them. Some spark plug manufacturers manufacture a spark plug with the required resistance forming a part of the top of its electrode.

(to be continued.)



CHRISTMAS SUGGESTIONS FROM A RADIO STORE

FLYING SCALE MODEL AEROPLANE KITS

SEELY Jr. 14in. Span, 6 types	2/6 ea.
CLEVELAND 20 in. Span, 6 types	6/6 ea.
DUNCAN 20in. De H. Comet	10/-

We have over 70 types to choose from and the prices are 1/- to 31/- . Write for lists.



LIONEL ELECTRIC TRAINS

Will operate from A.C. mains or battery.
Positively Shockproof.

JUNIOR FREIGHT OUTFIT Complete	£ 3-10-0.
AUTOMATIC Jr. FREIGHT	£ 4- 4-0.
AUTOMATIC Jr. PASSENGER	£ 4- 4-0.
AUTOMATIC Jr. STREAMLINER	£ 4- 4-0.
SENIOR FREIGHT OUTFIT	£ 7- 0-0.
RED COMET PASSENGER OUTFIT	£ 7- 0-0.
FLYING YANKEE, With Whistle	£ 9- 5-0.
SENIOR PASSENGER, With Whistle	£15- 5-0.

Above prices include transformers.
Write for price list.

AMERICAN PORCELAIN INSULATORS



New shipment just landed

Small	5d.
Medium	6d.
Large	9d.
Beehive	1/-
Leadthru	1/3



9/6

Electric Soldering Irons

Build The Outdoor Four Portable

Complete kit of parts as specified **£10**

Multi-Metre High Grade.

Reads 0 to 10, 50, 250 & 500 volts. 0 to 10, 50 & 250 mills 0 to 80,000 ohms.

£3-7-6

Kit of Parts **£3-2-6**



PRICE'S RADIO SERVICE

D. G. McINTYRE

5 & 6 ANGEL PLACE . . . SYDNEY

New Chanex Interference Suppression Units.

With the development of high-powered sets and the rapid growth of overseas shortwave listening, the problem of power interference with radio reception is rapidly becoming acute. For this reason, both the radio trade and the listening public will welcome the efforts made by the Ducon Condenser Pty. Ltd. in designing and marketing their new Chanex Condenser and Choke Suppressor Units. In many cases interference can be remedied at the source, and it is mainly in connection with this phase of the problem that these new Ducon products will be employed.

An excellent book entitled "The Suppression of Radio Interference" and dealing with the causes and cures of power interference, has just been released by the company, copies being available free on request.

The causes of interference are discussed in the first section, while the second deals with the procedure to adopt in locating the source of noise. A particularly useful and comprehensive list is given of all types of electrical machinery and appliances, together with the characteristic electrical noise generated by

each. The remaining few pages are devoted to suggested methods of suppression, using the special Chanex Suppressor Units designed for the purpose.

Copies of this booklet, which both the trade and technically-minded listeners would find invaluable, are available on request from radio dealers or direct from the Ducon Condenser Pty. Ltd., 73 Bourke St., Waterloo, Sydney, N.S.W.



Characteristics Of New Philips Red Coats.

Complete characteristics of the new Philip's "Red Coats," together with plenty of valuable data as regards their operation, are contained

in the latest 36-page Phillips Technical Communication No. 54.

All types in this new 6.3 volt metal-clad series use the universal "P" base, are compact in size, robust in assembly, have particularly low heater consumption and are highly efficient. Types reviewed are the EK2 Octode, EF5 r.f. pentode, EF6 r.f. pentode, EB4 twin diode, EEC3 duo-diode triode, EBF1 duo diode pentode, EL2 power pentode, EL3 power pentode (high mu), EL5 super power pentode (high mu), and types EZ2, EZ3 and EZ4 rectifiers.

Accompanying the Technical Communication dealing with the above types is an ingeniously designed two-colour chart showing the under-socket connections of all valves in the "Red Coat" series.



New Radiotron Metal Duo Diode Pentode.

The release of a new all-metal duo diode pentode, type 6B8, is announced by the Amalgamated Wireless Valve company Ltd., of Sydney.

This new all-metal Radiotron is the equivalent to the 6B7 in the glass series. The characteristics of the two valves are not quite identical, the 6B8 having a higher mutual conductance than the 6B7, but the two are sufficiently close to one another to be regarded as equivalents.

TENTATIVE DATA

Heater Voltage (A.C. or D.C.) 6.3V.
 Heater Current 0.3 Amp.
 Direct Interelectrode Capacitances—
 Pentode Unit: Grid to Plate (with shell connected to cath.) 0.005 uuf.
 Input 6.0 uuf.
 Output 9.0 uuf.
 Maximum Overall Length 3½ in.
 Maximum Diameter 1½ in.
 Cap Miniature.
 Base Small Octal 8-Pin.

PENTODE UNIT

CLASS A AMPLIFIER

Plate Voltage 250 max. V.
 Screen Voltage 125 max. V.
 Grid Voltage -3 V.
 Plate Current 10 Mills.
 Screen Current 2.3 Mills.
 Plate Resistance 0.6 Megohm. approx.
 Amplification Factor 800 approx.
 Mutual Conductance 1325 Micromhos

"PALEC" VALVE TESTER

A.C. Portable Type

Tests all standard valves, English and Octode types. Subjects each element of A HOT valve to a micro leak test. Portable type - £11/10/-

Counter type - £13/10/-

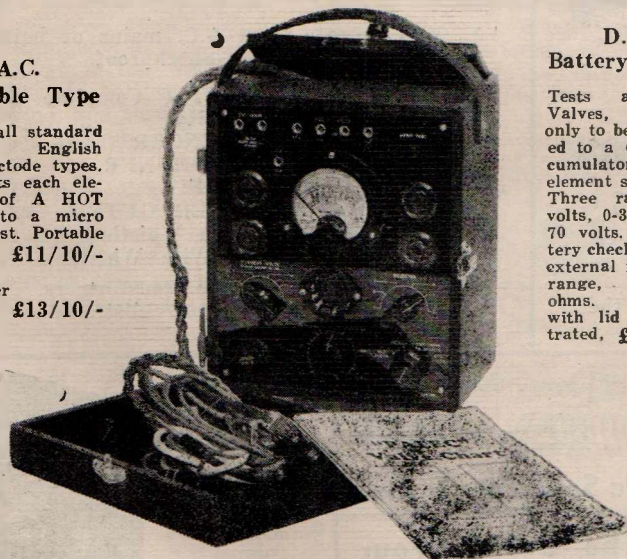

D.C. Battery Model

Tests all D.C. Valves, requiring only to be connected to a 6-volt accumulator. Has element short test. Three ranges of volts, 0-3.5, 7 and 70 volts, for battery checking; also external resistance range, 0-250,000 ohms. Complete with lid as illustrated, £12/10/-

All Prices Subject to Tax.

The Paton Electrical Instrument Co.

SEND FOR PARTICULARS AND ILLUSTRATED CATALOGUE TO
 90 VICTORIA STREET, ASHFIELD, N.S.W.

Manufacturers of the well-known PALEC Meter and Cathode Ray Oscillograph (as supplied to the Commonwealth Government). Obtainable from:—
 Sydney: Fox and MacGillycuddy, Bloch and Gerber, Lawrence and Hanson.
 Melbourne: A. H. Gibson (Electrical) Co. Pty. Ltd., Lawrence and Hanson.
 Brisbane: Lawrence and Hanson.
 South Australia: Lawrence and Hanson, Newton McLaren.
 New Zealand: The Electric Lamp House, Ltd., Wellington.

Grid-Bias Voltage -21 V. approx.
(For cathode current cut off)

DIODE UNITS

Two diode plates are placed around a cathode, the sleeve of which is common to the pentode unit. Each diode plate has its own base pin.

PIN CONNECTIONS

Pin 1—Shell	Pin 5—Diode
Pin 2—Heater	Plate
Pin 3—Plate	Pin 6—Screen
Pin 4—Diode	Pin 7—Heater
Plate	Pin 8—Cathode
	Cap—Grid

(Pin numbers are according to RMA System).

★

New Calstan Valve Tester.

The A.C.—operated portable valve tester shown in the photograph forms the newest addition to the well-known Calstan range of test equipment, manufactured in Sydney by Slade's Radio.

Known as the model 221, the new tester is housed in a polished oak carrying case with removable lid and

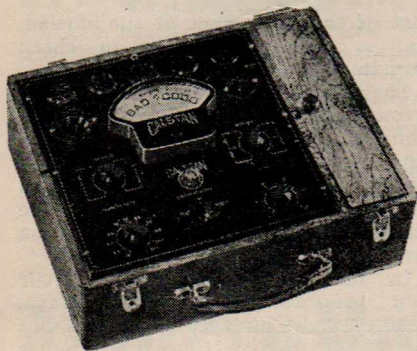

a separate compartment for the power flex, grid leads, etc. Entirely self-contained, the new tester weighs only 11 pounds.

Checks All Valves.

All types of valves, both American and European, can be checked for emission and leakage, a "Bad-Good" meter being provided for emission checking and a neon lamp for leakage tests. A rotary selector switch enables individual element leakage tests to be effected without any difficulty.

The model 221 can also be supplied with a sloping panel for permanent installation in a shop.

Slade's Radio advises that this new model valve tester does not replace any of the existing instruments produced by this firm. The general characteristics of this unit are the same as other models in the range, and it has only been produced for the convenience of servicemen; therefore it must be regarded as purely supplementary to the existing instruments.

Country servicemen and retailers

Radio Book Reviews

Jones Radio Handbook.

According to advice just to land from the publishers in San Francisco, a completely new edition of the well-known Radio Handbook will be off the press shortly. This year the title has been changed to the Jones Radio Handbook, as it has been prepared by Frank C. Jones, a leading American radio writer who needs no introduction to Australian amateurs and shortwave enthusiasts.

With the exception of the chapters on electrical and radio theory, the book is entirely new, and contains hundreds of new circuit diagrams, photographs, and material that has never previously been published. The following brief review of the contents is taken from an advance announcement to hand from the publishers.

The Vacuum Tube Chapter, which occupies more than 100 pages, analyses more than 300 valves, while more than 300 valve circuits are shown. Many new sets are described in detail in the new chapters on c.w. and radio telephone transmitters, which occupy 200 pages. New antenna charts, new formulae, and new facts are given in the Antenna Chapter of 64 pages, which also gives data on the newest directive arrays for amateur and commercial services.

The Ultra-High Frequency Chapter occupies another 64 pages, and it covers 5 metres, 2-½ metres, 1-¼ metres and the microwaves and diathermy equipment. 44-centimeter sets are shown, and the newest u.h.f. valves are analyzed. About 40 types of u.h.f. sets are described.

The Exciter Chapter is outstanding, in that it shows, for the first

should note that Calstan have a valve tester available which is specially designed for their needs. This instrument is the model 202, and it is arranged to obtain all of its power from a six-volt accumulator, a vibrator unit being incorporated for the provision of high tension voltage.

★

Noyes Bros. Handling New Microhm Potentiometer.

In the review of the new Microhm potentiometer published last month no mention was made of the fact that Noyes Bros., of Sydney, have been appointed sole distributors for this new line.

time, how to build the Jones One-Tube Exciters that operate on several bands from a single quartz crystal, without doubler or buffer stages. This is perhaps the most outstanding contribution to experimental radio in many years. Then there is a new Jones Exciter that goes down to five metres, from a 40-metre crystal, providing the solution of u.h.f. crystal-control problem.

Messrs. Angus and Robertson advise that supplies of the Jones Radio Handbook will be to hand very shortly, and readers are advised to order early to make sure of securing their copies.

★

Radio Field Service Data.

A new 400-page edition of Ghiradi's "Radio Field Service Data," published originally as a supplement to "Modern Radio Servicing" by the same author, has just come off the press in America, and will shortly be available in this country.

Though a fair amount of the data given deals with American receivers, much of it is general in nature, and servicemen would find it invaluable. A particularly useful feature is the section on auto ignition systems, which has been brought completely up to date, covering all models of American cars.

Other outstanding features of the handbook include R.M.A. standard colour code data, auto interference data, wire tables, and nearly 30 other reference tables and charts.

"Radio Field Service Data," by A. A. Ghiradi. Available from Messrs. Angus & Robertson, price 9/6, postage 6d.

★

Servicing Superheterodynes.

Published in December, 1931, John F. Rider's "Servicing Superheterodynes" has proved a best-seller in radio text-books, in five years running into two editions and eight printings. And it is certainly a book that should be in the library of every serviceman and set-builder.

The opening chapters are devoted to a detailed explanation of the difference between the t.r.f. type of receiver and the superheterodyne, the operating principles of the latter being analysed simply and clearly. The important subject of harmonic generation and the relation between harmonics is dealt with in detail in a separate chapter, as a thorough

(continued on page 39).

Round the N.Z. "B" Stations

IZF ... "Voice Of The Manawatu"

The first of a series of articles, written for the "Radio World" by a prominent New Zealand dxer.

By "The SOUTHLANDER"

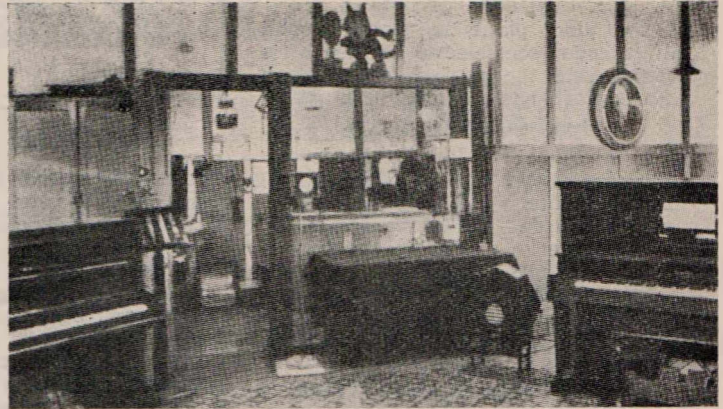

The main studio of "B" class station IZF, Palmerston North—"Voice Of The Manawatu."

STATION 2ZF, Palmerston is owned and operated by the Manawatu Radio Club. It has the distinction of being the oldest station on the air in New Zealand, and is now in its 13th year of broadcasting.

The original call-sign was 2GI, and the first transmitter was battery-operated, a matter which caused considerable trouble and expense. Often listeners took turns to lend their "B" batteries, or there would have been no broadcast! Those were real pioneering days, when a wireless listener was looked upon as a crank. The Pick-up was not known in those days, and gramophone records were played on an ordinary gramophone into a telephone microphone, which was fitted with a cardboard horn to catch all the precious sounds.

On The Air In 1924.

The first listeners' meeting was held on July 9, 1924, at a time when there were only 38 radio sets in the city of Palmerston North. Everyone became a member of the Club, which was called the Palmerston North Radio Club. Today the receivers within a reasonable range of the transmitter number many thousands, as there is a population of 143,000 within a 50-mile radius. Immediately after this first meeting a five-watt transmitter was built and put into operation.

About 1926 the licensing of broadcast stations came into force, and the club was allotted the call-sign of 2ZF, while its name was changed to the Manawatu Radio Club. Toward the end of the third year of operation one of the 50-watt valves blew out, which placed the club in serious financial difficulties. Debts totalled £97, but at the special meeting called to consider the position a committee was appointed to

raise funds, as a result of its efforts £150 was collected in 10 days.

Some Technical Details.

The first transmitter in 1924 used a 210 as oscillator. Later a motor generator was purchased, and 50-watt De Forest valves were used. In 1928 a transmitter radiating 150 watts was built, and this did yeoman service for some years, when

This gives an unmodulated carrier of 250 watts to the aerial, which is an earthed Marconi "T" located on the roof of a two storey building. A cathode ray oscillograph is also part of the equipment at the station, and is used periodically to check adjustments of speech circuits, etc.

The studio is large enough to accommodate an orchestra or band, while the announcers' room contains all the amplifiers, control panel, electric turn-tables, etc. The Club has a condenser microphone, one velocity type, and two double button carbon microphones.

In addition to broadcasting their own programmes on Wednesdays, Fridays and Sundays, at other times the Club relays the programmes from the National Station 2YA, Wellington, the programme being received over 100 miles of the Post and Telegraph Department land-lines.

First S.W. Re-Broadcast.

One of the notable pioneering transmissions of 2ZF, occurred when PCJ was first picked up in New Zealand. The Club cabled the now famous station in Holland that their second transmission had been picked up, and they would like to hear England. In the next test transmission from PCJ, that station re-broadcast 2LO London and Daventry for the benefit of the Club, and then Paris and Langenberg, in Germany. The Club officials at 2ZF had secured the help of the local telegraph engineer for a relay line, picked up the transmission from PCJ, and re-broadcast the whole programme.

The public was incredulous, and many considered it a first-class hoax! But it was a real thrill for the officials of 2ZF, as this was the first time that the public of New Zealand had heard England.

MAIN FEATURES

Call and Location: 2ZF, Messrs. Collinson and Cunninghame's Buildings, King Street, Palmerston North, New Zealand.

Owners: Manawatu Radio Club.

Frequency: 960 k.c., 312.3 metres.

Power: 250 watts unmodulated carrier.

Transmission Times: (E.A.S.T.),
Mon., Thurs., Sat., 6.30—8.30 p.m.;
Wed., Fri., Sun., 4.45—8.30 p.m.

Area Served: 143,000* population within 50 mile radius.

Longest Distance Verified Report:
Honolulu, Los Angeles, New York.

the whole transmitter was completely re-built, using crystal control, and a linear amplifier installed to give 250 watts unmodulated carrier.

The present transmitter uses a 210 crystal oscillator, and two 865 screen-grid Radiotrons for buffers and amplifier stages, driving a 211 modulated oscillator. The first audio stage is also a 211, and the modulators are a pair of 845's in parallel, capable of modulating the class "C" oscillator to 100% without distortion.

The final stage is a class "B" linear amplifier using four 250-watt Marconi valves in parallel pushpull, supplied from a three-phase full-wave mercury vapour rectifier outfit, giving 3,500 volts on the plates.

Radio Book Reviews.

(continued from page 37)

knowledge of this phase of superheterodyne operation is vital to a complete understanding of this type of receiver.

The various types of superheterodynes and of oscillator and mixer circuits, and the meanings of adjacent channel selectivity, image frequency, cross talk and of other commonly-used terms are all explained in subsequent chapters, together with the principles underlying the design of intermediate frequency amplifiers. The book concludes with chapters on trouble-tracking and on the alignment of superhets.

Both as a text-book for amateur set-builders and for those studying radio as a profession, as well as a reference book for practising servicemen, "Servicing Superheterodynes" will be found invaluable.

"Servicing Superheterodynes," by John F. Rider. Our copy from Messrs. Angus & Robertson Ltd., price 6/6, postage 6d.



Short Wave Wireless Communication.

There are few books devoted exclusively to shortwave transmitting and receiving technique, and in this respect "Short Wave Wireless Communication," by Ladner and Stoner, fills a widespread need.

In the third edition, which is now available in Australia, most of the

text has been revised and a new chapter on Commercial Wireless and Telephone Circuits added. The chapter on aerials has also been re-arranged and enlarged. A valuable feature is that, although the book deals especially with shortwave communication, the field has not been restricted entirely to the peculiarities of short waves, as principles common both to long and short waves are dealt with.

Every phase of shortwave transmission and reception is covered, from the theory of propagation of electro magnetic waves to modulation of high frequency waves singly and push-pull transmitting circuits, high frequency feeders, aerials and aerial arrays, reception problems and simple receivers, commercial receivers, and commercial wireless telephone circuits and transmitters.

The final chapter deals with the ultra short waves, giving an outline of the different methods of transmitting and receiving them, and a general discussion of their peculiarities.

"Short Wave Wireless Communication," by A. W. Ladner, A.M.Inst.C.E. and C. R. Stoner, B.Sc. (Eng.), A.M.I.E.E. Our copy from the publishers Messrs. Chapman & Hall, London. Available from Messrs. Angus & Robertson, price 31/6, postage 10d.



The Mathematics Of Wireless.

"The Mathematics of Wireless," by that well-known English radio author

Ralph Stranger, is a book that has been written especially for the radio enthusiast whose enjoyment of his hobby is to some extent marred by an incomplete knowledge of mathematics.

The book opens with a chapter giving a survey of modern ideas on electrical energy. In following chapters the fundamentals of arithmetic, algebra, geometry, and of the differential and integral calculus are all covered simply and lucidly, with constant reference to every-day radio problems and their solution. Powers and roots, co-ordinates, and the use of logarithms are all explained, together with the mathematics of alternating currents, wavelengths and frequencies, and of the electrical and magnetic circuits. Following a survey of units and definitions, the book concludes with a chapter devoted to an explanation of the use of the slide rule.

Beginners will find that some knowledge of mathematics is needed even for an elementary study of radio, and this book will supply just what is required.

"The Mathematics of Wireless," by Ralph Stranger. Our copy from Messrs. Angus & Robertson, price 6/., postage 6d.



The Cathode Ray Tube At Work

With reference to the series of articles on the cathode ray oscillo-

Modern Radio Servicing

By A. A. GHIRARDI

World-Famous Radio Authority

The enthusiastic reception given the 1st edition of this book "Radio Servicing Course," by both students and radio service men, prompted Mr. Ghirardi to revise it completely in order to bring it up-to-date. To do this he had to write an entirely new book. Mr. Ghirardi is recognised as one of the greatest living authorities on modern radio and in this book he has solved most of the problems that confront radio men.

Now, more than ever before, such a book is necessary. Complexity of circuits and tubes demands a greater knowledge of the fundamentals of electrical and radio circuit design—servicing—trouble-finding and remedies. Nowhere else is such complete information on these subjects available.

This new edition contains 1,300 pages and 706 illustrations. Throughout the book there are very many useful cross-references. Combined with

an unusually complete index this makes the information on any particular point quickly available. The book is divided up into (1) theory and construction of modern radio test equipment; (2) the practical servicing of radio receivers; (3) specialised servicing problems.

A glance at the table of contents below will show how exhaustively the whole field of radio servicing is covered.

CONTENTS—MODERN

Radio Servicing

Milliameters, ammeters and voltmeters—Methods and instruments for measuring resistance—How to construct ohmmeters—Typical commercial ohmmeters—Condenser testers and capacity meters—Output meters and V.T. voltmeters—The tube checker—How to construct a modern tube checker—Typical commercial tube checkers—The voltage-current set analyser—Point-to-point testing—How to construct a complete set analyser—Typical commercial set analysers—The service test oscillator—How to construct and calibrate a test oscillator—Typical commercial test oscillators—Preliminary tests for trouble—Peculiarities of A.V.C. and Q.A.V.C. circuits—Receiver analysis by voltage-current tests—Receiver analysis by resistance tests—Testing individual radio components—Obscure troubles not revealed by analysers—Aligning and Neutralising T.R.F. receivers—Aligning and Neutralising superheterodyne receivers—Repairing individual radio components—Installing and servicing auto-radio receivers—Servicing all wave receivers—Installing and servicing marine radio receivers—Reducing electrical interference—High-fidelity receiver problems—How to sell your service—Vacuum tube charts.

ANGUS & ROBERTSON LTD.,

Publishers to the University,
89 Castlereagh Street, Sydney.

ORDER FORM

Please send me Ghirardi's Modern Radio Servicing. I enclose the first instalment of 10/- and agree to make two further monthly payments of 10/-. (Postage, 1/3 extra). The price for cash within 30 days is 27/6, plus postage.

NAME

ADDRESS

OCCUPATION

BUSINESS ADDRESS

DATE

R. W. Dec.

graph at present being published in the "Radio World," several readers wishing to study the subject at greater length have written in asking for advice regarding suitable text-books.

One that can be recommended without reserve is the "Cathode Ray Tube At Work," by John F. Rider. It presents a complete explanation of the various types of cathode tubes, and what role each element plays in making visible the voltages and currents encountered in various kinds of tests.

Among other subjects, the theory of the tube sweep circuits, different types of oscillographs, and a wide range of applications are covered in detail.

"The Cathode Ray Tube At Work," by John F. Rider. Our copy from Messrs. Angus & Robertson. Price 16/6, postage 8d.

The Month on Shortwave

By ALAN H. GRAHAM

CONDITIONS continue to be excellent—the main feature of the month's reception being the improvement of the lower bands. With the advent of summer conditions the noise level on 49m. is becoming rather troublesome. Despite this, how-

ever, an occasional station can be logged. In the early mornings OXY on 49.5m. is worth a few minutes' attention. Also look out for VPB, Colombo, Ceylon; ZGE, Kuala Lumpur, and ZHI, Singapore.

Excellent Entertainment on 31 metres

Moving down to the now overcrowded 31m. band, we find a variety of entertaining stations. The latest arrival to this band is the Japanese JZI (31.4m.), which can be heard between 5 and 6 a.m. on Wednesdays and Saturdays. (The same programme is broadcast simultaneously on 19.7m. through another new Japanese transmitter JZK).

South Americans on 31 metres include COCH, TGWA, TIPG and TI-4NRH. These have been mentioned previously; but HJ1ABB of Barranquilla, Colombia, which used to be on 46m., has now made an appearance on 31.4m. around 11 p.m.

On 30m. COCQ continues to come in nicely, but appears to have moved up from 30.7m. to 30.9m. A recent verification from this station gives the power used as 4 k.w. The station verifies with two nice cards. Full address is Calle 25, No. 445, Habana, Cuba.

Also on 30 metres is the Lisbon transmitter CSW, which has shifted

from 31m. It is heard in the early mornings.

Another station to be heard by early-risers is Radio Ruysselede, ORK, on 29m. Schedule is 4.30—6 a.m.

New Canary Islands Station

The Spanish civil war has given us a second new station, Radio Tenerife, on the Canary Islands. Wave-length is approx. 29 metres. It is on the air every morning with a multilingual news service. (EAI, Madrid, is another Spanish station, which was momentarily overlooked. It operates on 31.65m.)

Two more Latin-Americans appear on 26m. One is new, namely, HIH, Dominican Republic, 26.6m. It has been reported at only moderate strength around 8 a.m. The other is the Cuban COCX on 26.2m.

On 25 metres the Mexican XEWI, and the Stockholm University station SM5SX, are the most noteworthy.

On 19 metres the new Japanese JZK has already been mentioned. Watch out for the Addis Ababa 19.4 metre station IUG also.

Below 19 metres conditions are remarkably good. There are splendid signals on 16m. from PHI and DJE, while GSH is very good on 13 metres. Also, there are a number of Americans on 9 and 10 metres.

VK AMATEUR STATIONS . . . Additions and Amendments

Additions.

CALL SIGN	LICENSEE	ADDRESS
3XW	Blyth, O. E.	10 Hartwell Hill Road, Camberwell, E.6, Vic.
2ADW	Hay, P. W.	30 Clark Street, Berala, N.S.W.
3TW	Wells, G. L. D.	264 Gray Street, Hamilton, Vic.
2ADX	Cottrell, J. W. M.	"Barrington," Kissing Point Road, Dundas, N.S.W. (Portable.)
5GM	Anderson, A. R.	16 Hauteville Terrace, Eastwood, S.A.
2ADZ	Wilson, V. H.	Assembly Hotel, cnr. Hunter and Phillip Streets, Sydney, N.S.W.
6CR	Rippen, A. H. G.	27 Clarke Street, Fremantle, W.A.
2AEB	Tbbett, E. S.	41 Balmoral Street, Waitara, N.S.W.
7DH	Hildyard, A. D.	325a Davey Street, Hobart, Tas.
4GE	Ginn, E. G.	26 Macrossan Street, Townsville, Qld.
4KK	Bradford, A. K.	"Bonville," Bringalilly, via Millmerran, Qld.
3FR	Smith, G. L. F.	62 Beavers Road, Northcote E.16, Vic.
3XS	Prowse, R. R.	4 Larch Street, Caulfield, S.E.8, Vic.
5LO	Looser, H. E.	2 Clifton Street, Goodwood, S.A.
3ZG	Lelliott, H. W.	30 Edgar Street, Glen Iris, S.E.6, Vic.
2JX	Adams, P. H. A.	Oakleigh Avenue, Thornleigh, N.S.W.
2AEF	Oswald, A. G.	46 Farr Street, Rockdale, N.S.W.
3SR	Marriott, R. J.	187 Kooyong Road, Toorak, S.E.2, Vic.
4BN	Newell, A. J.	Racecourse Road, Mill Hill, Qld.
3ON	Niven, J. C.	191 Kooyong Road, Caulfield, S.E.7, Vic.
3EN	Pearce, H. R. J.	43 Cromwell Street, Caulfield, S.E.7, Vic.
2AEG	East, W. L.	8 Perry Street, Marrickville, N.S.W.
3ST	Coghlan, J. L.	39 Jackson Street, St. Kilda, S.2, Vic.
3NU	Coffin, R. G.	9 Dickens Street, Glen Iris, S.E.6, Vic.
20F	Francis, J. W.	337 Beryl Lane, Broken Hill, N.S.W.
4GX	Barracrough, F.	Gail Street, Kedron, N.3, Qld.
2AEH	Atherden, F. A.	119 Garnet Street, Broken Hill, N.S.W.

Alterations to Call Signs.

2ZT	McDonald, W. N.	1 Dixon Street, Parramatta, N.S.W. Now VK4ZT. (See also Changes of Address.)
2HR	Anthony, T. R.	44 Park St., Auburn, N.S.W. Now VK2AEC.
2LM	Wilson, L. M.	Malboona Station, via Mudgee, N.S.W. To be VK2LMW as from 1/4/1937.
3LK	Knyvett, E. L.	12a Douglas Street, East Malvern, S.E.5, Vic. Now VK3LC.
2XM	Worrall, L. A.	56 Rossmoyne Street, Punchbowl, N.S.W. Now VK4XM. (See also Changes of Address.)

Changes of Address.

2BR	Brooke, Rev. W. H. L.	The Rectory, Dora Creek, N.S.W.
2LJ	Rayner, J.	8 Everson Street, Belmore, N.S.W.

CALL SIGN

LICENSEE

ADDRESS

3RX	Serle, C.	2 Ormsby Grove, Toorak, S.E.2, Vic.
3BZ	Morris, G. I.	Boundary Road, Mordialloc, S.12, Vic.
4MM	O'Brien, M. M.	Villa Street, Annerley, S.3, Qld.
6RK	Choat, R. S.	6 St. Albans Road, Lamington, Kalgoolie, W.A.
3MW	White, S. G.	5 Cairnes Crescent, East Malvern, S.E.5, Vic.
2XJ	Broome, F. M.	Beach House, Denning Street, The Entrance, Tuggerah Lakes, N.S.W.
2XW	Voysey, A. J.	"The Gables," 85 Alt Street, Ashfield, N.S.W.
6WQ	Green, W. W.	Prior Street, Wiluna, W.A.
5FA	Anderson, F. B.	Elizabeth Street, Tanunda, S.A.
2RD	Longworth, R.	9a Marshall Avenue, North Wollstonecraft, N.S.W.
2ZT	McDonald, W. N.	267 Main Street, Kangaroo Point, Qld. (See also Alterations to Call Signs.)
20A	Winch, R. M.	35 Hermitage Road, West Ryde, N.S.W.
20E	Allworth, W. M.	Meehan Street, Yass, N.S.W.
2PK	Hainsworth, P. T.	"Roselea," Castlereagh Street, Penrith, N.S.W.
2YQ	Pollock, G.	c/o E. Davies, Colliery Office, Abermain No. 2, Kearsley, N.S.W.
20T	Sobels, M. D.	Hogarth Avenue, Dee Why, N.S.W.
2LD	Dodds, L. H.	3 Anthony Street, Chatswood, N.S.W.
7NC	Jonasson, R. P.	252 Main Road, Derwent Park, Tas.
7CJ	Finch, A. E.	35 Button Street, Mowbray Heights, Tas.
2PS	Stephon, P. C.	144 Croydon Road, Croydon, N.S.W.
5JK	Kidman, I. M.	Robertson Street, Naracoorte, S.A.
2NQ	Pieremont, N. S.	"St. Elmo," Dodson Ave., Cronulla, N.S.W.
3SX	Wellington, S. H.	2 Arthur Avenue, Brighton, S.5, Vic.
2ABE	Love, L. G.	4 Pitt Street, Randwick, N.S.W.
2AV	Thurstan, A. W.	33 Stoney Creek Road, Penshurst, N.S.W.
4MI	Goford, T. W.	Radio Hut, South End, Mt. Isa, Qld.
5JW	Wilkin, J. W.	"Willow-Bend Stud Poultry Farm," North Walderville, S.A.
6YZ	Samphier, R. L.	53 Gloucester Street, Victoria Park, W.A.
2XM	Worrall, L. A.	c/o Bank of N.S.W., Cairns, Qld. (See also Alterations to Call Signs.)
4RP	Carne, R. L.	c/o C.S.R. Co. Ltd., Goondi Mill, Innisfail, Qld.
6CA	Bold, C. A.	13 Solomon Street, Beaconsfield, W.A.

Cancellations.

6KC	Katanning Amateur Radio Club,	Richardson Street, Katanning, W.A.
2FQ	O'Dea, J. N.	12 Lancaster Cres., South Kensington, N.S.W.
4GP	Hamilton, L. W. H.	Quandong St., Ashgrove, Brisbane, Qld.
4KG	Nicholson, R. M.	"Coombermartin," Ilfracombe, Qld.
5SR	Signals (S.A.) Radio Club,	Drill Hall, Keswick, S.A.
2CB	Berry, W. C.	Knockrow, via Bangalow, N.S.W.
3YJ	Wookey, G. W. L.	26 Pine Avenue, Elwood, S.3, Vic.

Amendment.

3CX	Brown, A. G.	252 Riversdale Road, Hawthorn, E.3, Vic. Now 248 Riversdale Road, Hawthorn, E.3, Vic.
-----	--------------	---



The All-Wave All-World

Official Organ of the
All-Wave All-World DX Club

DX News



DX Contest Drawing Near

Club members are reminded that notification of entry for the All-Wave DX Contest must reach the Editor on or before January 15, 1937, while entries close on February 20, 1937. The conditions of the contest are outlined below:—

Conditions Of The Contest

1. The All-Wave DX Contest is open only to members of the All-Wave All-World DX Club.

2. Prizes will be awarded for the best logs of broadcast and/or short-wave station, compiled between August 1, 1936, and February 20, 1937, when the Contest closes.

3. Verifications must be dated or post-marked on or after August 1, 1936.

4. Broadcast stations ONLY count—not commercials or amateurs. ("B" Class broadcast stations are of course included). The only shortwave stations allowed are those that are on the air for entertainment or general news purposes.

5. Allowance will be made for the type of set used, every entry being judged purely on its merits.

6. Notification of entry for the Contest must reach the Editor not later than January 15, 1937. After that date, entrants in any part of Australia or New Zealand may be called upon to permit a "Radio World" representative to examine their receivers and be given a demonstration of their DX capabilities.

Plenty Of Valuable Prizes

Some excellent prizes have been donated for the Contest by "Radio World" advertisers, a complete list being given below:—

AUSTRALIAN SECTION

First Prize ... Radiokes "Moneysaver" Kit-Set (value £9/17/6).

(Kit donated by Radiokes Ltd., except for condenser gang and wave-change switch, given by Stromberg-Carlson (A/sia) Ltd.)

Second Prize "1936 Master Five" (Complete Velco kit of parts, value £6)

(Donated by Messrs. A. J. Veall Pty. Ltd., Melbourne).

Third Prize ... Palec Nine-Range D.C. Multi-Tester (value £5)

(Donated by the Paton Electrical Instrument Company, Sydney).

Fourth Prize Set of three Ever-Ready Superdyne 45-volt "B" Batteries (value 54/-).

(Donated by Ever-Ready Co. (Aust.) Ltd.)

Fifth Prize — Noisemaster All-Purpose Aerial Kit (value 52/6).

(Donated by Antennex (A/sia) Agencies, Sydney).

NEW ZEALAND SECTION

First Prize — Kit of parts for "Super-Comet All-Metal Five"

(Donated by Messrs. F. J. W. Fear & Co., Wellington, N.Z.)

Second Prize — Set of three Ever-Ready Superdyne 45-volt "B" Batteries (value 54/-).

(Donated by Ever-Ready Co. (Aust.) Ltd.)

Third Prize — Noisemaster All-Purpose Aerial Kit (value 52/6).

(Donated by Antennex (A/sia) Agencies, Sydney).

Every prize-winner will also receive an Award Certificate in two colours, while six Certificates of Merit will be awarded for the six best logs entered, apart from those of the prize-winners.

ALL-WAVE ALL-WORLD DX CLUB

Application for Membership

The Secretary,
All-Wave All-World DX Club,
214 George Street,
Sydney, N.S.W.

Dear Sir,

I am very interested in dxing, and am keen to join your Club.
The details you require are given below:

Name.....

Address.....

[Please print both plainly.]

My set is a.....

[Give make or type, number of valves, and state whether battery or mains operated.]

I enclose herewith the Life Membership fee of 3/6 [Postal Notes or Money Order], for which I will receive, post free, a Club badge and a Membership Certificate showing my Official Club Number.

(Signed).....

[Note: Readers who do not want to mutilate their copies of the "Radio World" by cutting out this form can write out the details required.]

★
★ **AMAZING SACRIFICE OF** ★
★ **4,000** ★
ARCTURUS

**AMERICAN
TYPE**

RADIO VALVES

to be sold at

HALF-PRICE (and less)

Only once in a lifetime do extraordinary circumstances give you the opportunity to buy valves of such acknowledged superiority at such ridiculously low prices.

ALL GENUINE — ALL TESTED — ALL GUARANTEED NEW and IN ORIGINAL CARTONS — ALL POPULAR TYPES — including

TYPE	LIST PRICE	OUR PRICE	TYPE	LIST PRICE	OUR PRICE
58	15/6	7/9	36	16/6	8/3
59	18/-	9/-	38	17/-	8/6
26	13/6	5/-	39	17/-	8/6
27	14/-	7/-	55	16/-	8/-
46	15/-	7/6	Wunderlich ..	28/-	2/6
82	18/-	6/6			
35	16/6	8/3			

AND MANY MORE.

Also **TRANSMITTING VALVES** at **HALF PRICE** and less.

Write, 'phone or call for full particulars.

Special quotations to dealers for quantities.

PRICE'S RADIO SERVICE

(D. G. McIntyre)

5 ANGEL PLACE, SYDNEY, N.S.W.

'Phone B4146.

Mail Orders

Owing to extremely low prices, please add postage costs—approx. 6d per valve.

Shortwave Stations Of The World 4

Eastern Shortwave Stations

The fourth of a series of articles on world shortwave stations . .

By ALAN H. GRAHAM,



A view of the German broadcast station at Munich. It operates on 740 k.c. (405.4 metres).

China

Although radio has made rapid strides in the last few years in China, most of the broadcasting stations in this country are to be found on the medium-wave band. The only short-wave station which can be said to

broadcast at all regularly is XGOX, (Nanking, China).

This station has an allocated frequency of 9,490 k.c. (31.61 m.), on which it transmits from 9.30 till 11.40 p.m. daily except Sundays, when the hours of transmission are 10.30 p.m. till 12.30 a.m. (Monday).

Recent reports indicate, however,

that XGOX has been active during the evening hours on approx. 6,900 k.c. (43.3m.), on which frequency fairly regular broadcasts have been logged.

XGW and XGM, located in Shanghai, may also be heard. The former operates on 10,420 k.c. (28.79m.), and the latter on 17,650 k.c. (17m.). Both are principally 'phone stations, working with London. Their address is Sassoon House, Shanghai.

Japanese Shortwave Stations

CALL	KC. & M.	LOCATION	SCHEDULE
JVE	15,660 : 19.16	Nazaki	Phones Java, 6-8 p.m.
JVF	15,620 : 19.2	Nazaki	Phones U.S.A., 8 p.m. and 7 a.m.
JVH	14,600 : 20.5	Nazaki	Phones Europe, 7-11 p.m.
JVM	10,740 : 27.93	Nazaki	Broadcasts morning and afternoon. Irregular broadcasts
JVN	10,660 : 28.14	Nazaki	Phones U.S.A., 5-10 p.m.
JVO	10,380 (approx) 28.9	Nazaki	Broadcasts approx. 5-11 p.m.
JVP	7,510 : 39.95	Nazaki	
JVT	6,750 : 44.44	Nazaki	
JVU	5,790 : 51.81	Nazaki	
JYK	13,610 : 22.04	Kemikaua-Cho, Chiba-Ken	Phones California till 2 p.m.
JYR	7,880 : 38.07	Kemikaua-Cho, Chiba-Ken	From 7 p.m. Irregular
JYS	9,840 : 30.49	Kemikaua-Cho, Chiba-Ken	
JYT	15,760 : 19.04	Kemikaua-Cho, Chiba-Ken	
JZG	6,350 (approx.) 47.3		
JZI	9,535 : 31.46	Nazaki	Wed. & Sat., 5-6 a.m.
JZK	19.7	Nazaki	Wed. & Sat., 5-6 a.m.

Hong Kong

Just off the mouth of the Si-kiang River near Canton, lies the island of Hong-Kong, on which is located station ZBW. Since 1935 ZBW has been heard regularly on 8,750 k.c. (34.29m.), but recently it has expanded its shortwave activities by placing three more S.W. transmitters on the air. Complete details are:—

- ZBW2: 8,750 k.c., 34.29m.
- ZBW3: 9,545 k.c., 31.42m.
- ZBW4: 15,190 k.c., 19.73m.
- ZBW5: 17,751 k.c., 16.98m.

The three first-mentioned of these stations have been heard recently, but, no reports have appeared of reception of ZBW5.

ZBW's schedule is rather uncertain because of recent changes, but it comes on the air around 9.30 p.m. and continues till after midnight.

Japan

As would be expected, Japan has not lagged behind the rest of the world in the short-wave field. A considerable number of transmitters are located on the "shaky isles," but as many of them are very irregular in their transmissions, only the better-known ones will be listed.

In sending reports to any of the Japanese transmitters, the following addresses should prove sufficient.

"JV" and "JZ" stations—International Wireless Telephone Company of

Japan, Osaka Building, Tokyo, Japan. "JY" stations—Radio JYR, Kemi-kaue—Cho, Chiba-Ken, Japan.

NOTE: In the following list of principal Japanese stations, the schedules given, although the latest available, are only approximate, and recent changes may have rendered them quite out-of-date.

Siam

HS8PJ, Bangkok, is the chief Siamese shortwave station. Its allocated frequencies are quite numerous. Some time ago it was usually heard on 10,955 k.c. (27.33m.), but recently S.W. listeners have reported its reception on a variety of wavelengths—19.34, 22.49 and 32.09m.

The commercial station **HSJ** conducts irregular tests on 10,169 k.c. (29.5m.), around midnight, while **HSP** works on 'phone with Germany on 17,741 k.c. (16.91m.). The address of these two stations is Government Post and Telegraph, Radio Technical Section, Bangkok, Siam.

French Indo-China

Radio Saigon, which was one of the regulars on 49m. many years ago, has recently reappeared on the air, on approx. 25.7m. The station comes on the air between 9 and 9.30 p.m., and continues transmitting till about 1 a.m. Announcements are made in

French and English. The address is P.O. Box 295.

Just below Radio Saigon is another French station, **FZS2** (11,991 k.c., 25.02m.), which may be heard 'phoning Paris.

FZR3 (16,233 k.c., 18.48m.) and **FZS** (18,345 k.c., 16.35m.) are two other 'phone stations which are easily logged.

All three stations will verify reports on their contacts with Paris. Their address is P.O. Box 238, Saigon.

Philippine Islands

The stations of the Philippine Long Distance Telephone Co., Manila, are heard regularly in Australia. However, they will not verify unless reports are specially requested. The most frequently received trio of stations are **KAX** (20,010 k.c., 15m.), **KAY** (14,980 k.c., 20.03m.) and **KAZ** (9,990 k.c., 30.03m.)

Hawaii

Only one Hawaiian station has been heard in Australia recently, and that is **KIO** on 11,680 k.c. or 25.68m. The station is used for relaying programmes to and from America (via **KKQ**, Bolinas, California). As these are point-to-point transmissions, no verifications are obtainable.

Macao

Not many miles from Hong-Kong is the Portuguese possession, Macao, the

site of S.W. station **CQN**, which is operated by the Postmaster-General's Department.

CQN used to be heard regularly on 49.8m., but in common with many other stations, it has recently moved down to the 31m. band. It now transmits on 9,660 k.c., or 31.07m., from 10—11.30 p.m. on Mondays and Fridays.

Malaya

There are quite a number of transmitters located in the Malay Archipelago, but many of them are low-powered and are very seldom heard in Australia; consequently details are lacking. Three stations, however, are heard regularly:—

ZGE, Kuala Lumpur, on 6,130 k.c. (48.94m.). Schedule 9.40—11.40 p.m. Sun., Tues. and Fri.

ZHI, Radio Service Co., 2 Orchard Road, Singapore on 6,018 k.c. (49.9m.). Schedule 8.40—11.10 p.m. Mon., Wed. and Thurs.: Also 1.40—4.40 p.m. Sundays and 8.10—9.40 p.m. alternate Sundays.

ZHJ, Radio Society of Penang, on 7,630 k.c. (39.32m.). Schedule 10 p.m.—midnight daily. Also Sundays 2—4 p.m.

Fiji

The mid-Pacific transmitters of A.W.A. Ltd., **VPD** and **VPD2**, are naturally heard well in Australasia. The former on 13,075 k.c. (22.94m.) from (continued on page 47).

USE

RENRADE

WIRE WOUND RESISTORS

For Accuracy, Dependability & Range

Other Renrade Components

RENRADE VALVE SOCKETS

The unique design of this series provides the correct kind and amount of contact for all uses. This design is the result of a careful study of the problem of cost reduction—without sacrificing material. The socket is of the wa'cr type, UX and UY, with an extra layer of insulating material, thus

enabling it to be mounted on a much smaller hole than usually required. Another feature is the two-hole mounting instead of four-hole.

RENRADE SOLDER LUGS

These are made in two types—Tinned Copper and Tin. These little lugs are indispensable to any set-builder.

R. W. REYNOLDS LTD.

200 CHALMERS ST., SYDNEY, NEW SOUTH WALES

Agents in all States: Obtainable in Victoria from A. J. Veall Pty. Ltd., 243-249 Swanston Street, Melb.; S. Australia:

Newton McLaren Ltd., Leigh St., Adelaide.

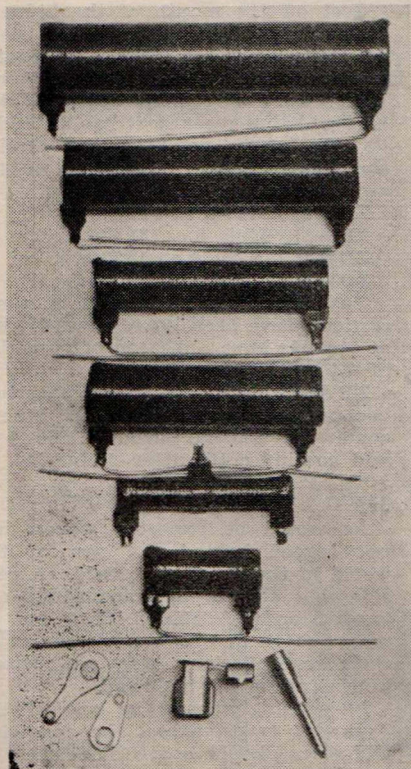

DX News and Views

A page for
letters from
DX readers

Will Exchange QSL's.

In the November issue of the "Radio World" I see that you have made available Club seals at 1/6 per 60 seals, and I would be very pleased to receive 60, for which I enclose P.N.

I am enclosing a snap of my shack, for which you may be able to find space. Also, I will only be too glad to exchange QSL's with anybody.

Wish the A.W. DX Club and R.W. the best of success and long life.—James M. Klein, (AW65DX), Cooma, N.S.W.

Excellent Filing System For Loggings.

Allow me to congratulate you on your fine achievement in publishing the "Radio World." It is one of the finest radio magazines I have yet read, and the wide variety of subjects covered should interest any owner of a radio. I may add that after reading the No. 4 issue of the "Radio World," I promptly procured all back numbers and then placed my order for it each month. A month seems very long between issues of the paper.

As I am more interested in s.w. DX, the enclosed list is for s.w. only. Long-wave reception in my locality is practically out of the question on account of power interference.

For keeping a record of stations received, I have half a dozen loose-leaf memo books 6in. x 4in., every page containing full details of a

station. The pages are arranged in order of wavelength; e.g., 13.89, OLR; 13.91, XGBA, etc. If any alteration is made all I have to do is to renew the page. Also, I have a coloured wall map, 4ft. x 3ft., and when a s.w. broadcast station is logged, I stick a black headed pin into the location. White pins denote "hams" (VK's not shown on account of lack of space). Another idea I have is to use Perth as a centre and scribble circles denoting mileage from Perth. If the owner of a shortwave radio is successful in his loggings, he can make quite a show with the Perry Pins. Later, when I can procure them, I will have different coloured pins for each waveband.

The aerial system here is an ordinary "L" type, 60ft. flat top and 65ft. high. The masts are of water pipe—30ft. of 1½in. and 35ft. of 1in. guyed in three places. The masts at the base are insulated from earth by glass—by beer bottles filled with pure cement and set, inverted, into a concrete block. A 3in. lead ball is placed in the cavity in the inverted bottle and the 1½in. pipe rests on the ball; this prevents chipping or other damage to the insulator. I intend erecting a transposed doublet very soon. By the way, the aerial runs N.E. to S.W.

The following may save some readers the price of a new volume control. Recently mine started to create scratching sounds in the speaker every time it was adjusted. I rubbed some pencil lead right round the circular band where the moving arm

had rubbed the original coating off. This gives 100% quiet operation.

Incidentally, neat transposition blocks can be made from old disc records by cutting them out carefully with a fine hack-saw.

The following is a list of s.w. stations received during the first week of November. (Amateurs not included).

GSG, 16.86; W3XAL, 16.87; PHI, 16.88; DJE, 16.89; DJR, 19.56; W2XAD, 19.56; GSP, 19.60; DJQ, 19.63; TPA2, 19.68; DJB, 19.74; ZBW4, 19.75; YDC, 19.80; RK1, 19.81; GSF, 19.82; DJL, 19.85; DZE, 24.73; RNE, 25.00; TPA3, 25.23; OLR, 25.26; GSE, 25.29; DJP, 25.31; W2XE, 25.36; ZRO, 25.40; DJD, 25.49; Saigon, 25.50; GSD, 25.53; SM5SX, 25.63; COCX, 26.25; PLP, 27.26; JVN, 28.14; ORK, 29.04; DZC, 29.15; PMN, 29.24; RIO, 29.50; CSW, 30.80; COCQ, 30.77; YDB, 31.10; 2ME, 31.28; 3LR, 31.32; GSC, 31.32; W3XAU, 31.38; DJA, 31.38; DJN, 31.45; XTR, (New Japanese), 31.46; W2XAD, 31.48; ZBW3, 31.49; GSB, 31.55; COCH, 31.80; ZBW, 34.29; XGOX, 43.98; PMH, 44.60; Colombo, 48.60; Belgrade, 49.18; VQ7LO, 49.30; OLR, 49.92; ZHI, 49.92; DJE, 49.83; ZGE, 48.93; PMY, 58.30; YDL2, 62.37; RV15, 70.20; YDA, 98.00.

Wishing your magazine every success—G. O. La Roche (AW155DX), Perth, W.A.

(Congratulations on your week's fine dxing. Glad you like "R.W."—Ed)

Wants To Exchange QSL's

I am willing to exchange QSL cards with anybody in the Club or with dxers anywhere in the World.—G.C. Arnold, (AW9DX), Roma, Q'land.

Wants To Become A "Ham."

At last Australia has a radio journal to be proud of in the "Australasian Radio World." I only noticed it on sale in September, but believe me I'm on the permanent list for two copies, one for myself and one to pass on to the boys round Mother Earth. I've sent my second September copy to America and the October one to Africa, so I'm helping to spread 'em abroad.

"Hams" and also dxers should appreciate your up-to-date list of VK stations. In later issues I, for one, would like to see an amateur operator's section—i.e. for persons

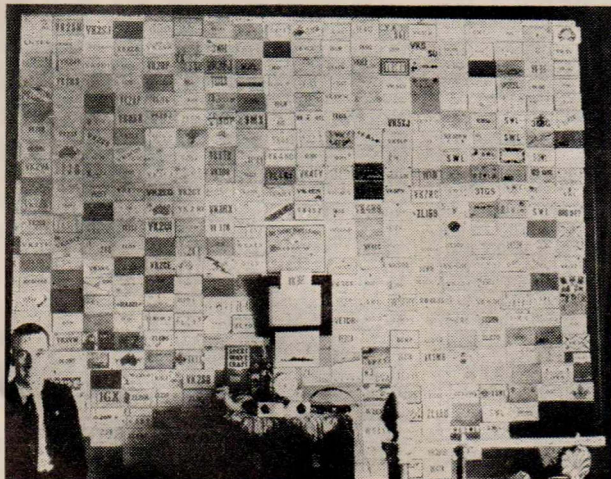

This radio shack and fine collection of QSL cards, of which their owner has over 700, belongs to B. G. Hewerdine, Electra Street, Bundaberg, Queensland. He would like to exchange QSL's with other "Radio World" readers.

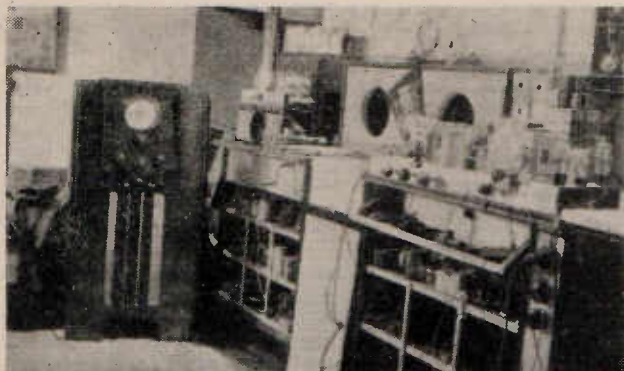

This shack belongs to J. M. Klein (AW65DX), of Cromwell St., Cooma, N.S.W. He would like to exchange QSL's with other readers.

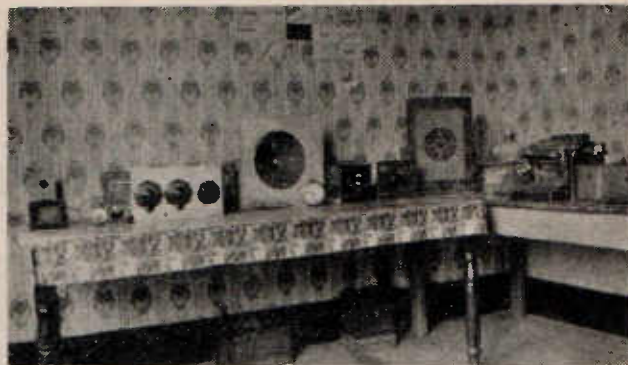

This shortwave listening post with its fine array of receivers and equipment belongs to Jim Ferrier, of Geelong (AW129DX).

wishing to become transmitters.—A. J. Gibbs (AW148DX), West Subiaco, W.A.

(Many thanks for your efforts to publicise "R.W."—they're certainly appreciated—Ed.)

Is Interested In Five Metres

I am enclosing herewith Postal Note for 3/6 for my membership fee to the All-Wave All-World DX Club. My receiver is a 1-valve battery-operated short waver.

"I am becoming interested in the 5-metre band and would be pleased to see the details of a 1-valve five metre receiver in the "Radio World" using a valve something like a '30. I do not doubt the possibilities of 1-valve receivers, as I have heard nine countries ('phone) on mine.

Wishing the Club every success,—Wm. Plant, (AW152DX), Stockton, Via Newcastle, N.S.W.

(The circuit of a 2-valve 5-metre receiver was published in the September "Radio World." The audio stage could be omitted if desired.—Ed)

Report Forms Help QSL's.

I am very pleased to say that my Club badge and certificate arrived O.K. The report forms are very neat indeed, and I feel sure that all my reports in future will bear more fruit as far as QSL's are concerned.

I have made a few alterations to the receiver since my last letter. The valve line-up is now 57 det., E6 first audio, and 59 pentode. After reading the various reports in our mag. I decided to try the 10-metre band also, but so far have not logged anything important.—Edric Marley, (AW150DX), Sth. Brisbane, Q'land.

Will Exchange Station Photographs.

I received my certificate and badge a few weeks ago, and am very pleased with them. My receiver is a 4-tube T.R.F., using a 40-metre half wave zepp. aerial.

On 20-m. I have heard VK(2-7), G, W(1-9), ON, OA, CO, G, F, NY, LU, HI, HK, ZL (on C.W. only), K6, VS, KA, XE and others.

I have received cards from OA4R, W61TH, ZL3BK, VK6MW, and 23 other VK's. I have done very little dxing on the B.C. band, as 20, 40, and 80 metres are my bands.

I am willing to exchange station photographs (no QSL's) with other

Club Seals Now Available Embossed In Blue and Silver

Club members who have been inquiring for Club seals to attach to correspondence, Q.S.L. cards etc., are advised that supplies are now available from the Secretary, 214 George Street, Sydney. Slightly larger than the Club badge, the seal is an exact replica of it, embossed in blue and silver. For those having QSL cards printed, the space occupied by the seal is 1 1/4 inches across. The price is 1/6 for 5 dozen, post free.

members or readers. I am enclosing a photo of my station.

Wishing the Club the best of luck and success,—James Ferrier, (AW129DX), Geelong, Vic.

A Fine Shortwave Log.

I enclose application for membership of the All-Wave All-World DX Club. I am a keen S.W. enthusiast and next year hope to obtain my "ham" license. I would like to congratulate you on the standard of your publication—it's just the book that has been needed by Australian listeners for some time.

My official verified log to date may be of some interest to members. It is as follows—(frequencies in mcs. also given):—GSG, 17.79; W3XAL, 17.78; DJI, 17.76; HAS3, 15.37; W2XAD, 15.33; TPAZ, 15.245; PCJ, 15.22; DJB, 15.20; HVJ, 15.12; D'VR, 15.34; SPW, 13.635; VPD, 13.075; RNE, 12.00; ETB, 11.955; TPA3(2), 11.88; DJP, 11.855; 2RO(2), 11.81; W1XAL, 11.79; DJD, 11.77; PH1, 11.73; TPA4, 11.715; HS8PJ, 10.955; PMN, 10.26; DJJ, 10.042; ORK,

10.33; EAQ, 9.86; DJI, 9.675; CQN, 9.66; YDB, 9.65; CT1AA, 9.65; 2RO, 9.635; HJ1APB, 9.60; VK2ML, 9.59; VK3LR, 9.58; W1XK, 9.57; VUB, 9.565; DJA, 9.56; DJN, 9.54; VPD2, 9.54; W2XAF, 9.53; VK3ME, 9.51; PRF5, 9.50; COCH, 9.428; HAT4, 9.125; 2CK, 8.75; XOGA, 6.896; COCO, 6.13; W3XAL, 6.10; 2RO, 6.085; VQ7LO, 6.083; DJM, 6.079; W8XAL(2), 6.06; 2RO, 6.083; HJIABG, 6.0425; DJC(2), 6.02; ZHI, 6.018; Radio Tanerive, 6.00; RV59(5), 6.00; VK9MI, 6.01; YV2RC, 5.80. Amateurs. PK1MX, HI7G(2), W6ITH, VE5OT, G5NI, G6XR and 48 VK's.

B.C. Stations. 7NT, 710 k.c.; 6KG, 1,210; 3KZ, 1,180; 4BC, 1,120; 4QG, 800; 3AK, 1,500; 5RM, 850; 2NR, 700; 4YA, 790. Total is 133. All Continents.

Apart from the above, I have about 150 veris. due and have heard some few hundred other stations during the time I have been a S.W. fan—12 months.

Trusting the above will prove of interest—J. F. Bull (AW146DX), Beria, West. Aust.

Twelve Months' Dxing.

I received my badge and certificate with the report forms, and they certainly take some beating. I am now enclosing my complete list of verifications obtained during 12 months' DX. N.S.W. 2AY, 2BH, 2BL, 2CA, 2CH, 2CO, 2GB, 2GN, 2GT, 2KO, 2MO, 2NC, 2QN, 2SM, 2TM, 2UE, 2UW, 2WG, 2WL, 2LV, 2NR. Vic. 3AK, 3AW, 3BA, 3BO, 3DB, 3GI, 3GL, 3HA, 3HS, 3KZ, 3MB, 3SH, 3TR, 3UZ, 3XY. Q'ld. 4AK, 4BC, 4BH, 4BU, 4GR. S.A. 5AD, 5CK, 5KA, 5PI, 5RM. W.A. 6AM, 6KG, 6WF. Tas. 7LA, 7NT, 7UV, 7ZL. N.Z. 1ZB, 1ZM, 2ZF, 2ZH, 2ZM, 2ZO, 2ZP, 2ZR, 3ZR, 4ZC, 4ZL, 4ZM, 4ZO, 4ZR. U.S.A. WLW, KNX, KMOX, KSL, KFAC.

Mex. XENT, XEAW, XEPN.
Suva. ZJV.

I have not had much time lately to report to shortwave stations, but have a few cards back and five reports out. I have VK's 2QY, 3HL, 3HM, 2GX and VK3ME and VPD2, and reports are out to VK2ME, Radio Coloniale, and amateurs VK7CL, 2ABD, and 3KX.

Wishing the Club the best of luck—E. H. Barker (AW130DX), Christchurch, N.Z.

List Of Amateurs Appreciated.

I would like to add my praise to that of W. Sievers (Nov. "R.W.") regarding the VK calls. The alterations and amendments list each month is certainly a great idea. The constructional details of the Reiss "mike" were also greatly appreciated here. I have seen many ideas for Reiss "mikes" published before, but none as simple as VK2CP's. Wishing the club every success—Vic. Smith (AW23DX), Melbourne, Vic.

All The Latest "Dope."

Please find enclosed 3/6 for membership fee to the All-Wave All-World DX Club. I have been reading the "Australasian Radio World" since the first issue, and find them full of the latest and most useful "dope" for the home constructor.

I am building a receiver, but am taking my time to ensure a good job. When it is working I will send in a log of the stations received.

Wishing the Club every success—Graham M. Hart (AW151DX), Fullarton Estate, S.A.

World Shortwave Stations.

(continued from page 44).

3.30 till 4.30 p.m.: and the latter on 31.45m. at 8.30 p.m.

Dutch East Indies

Full details of the D.E.I. S.W. organisation were given in an article by H. I. Johns, which appeared in the October issue of "Radio World."

Additional transmitters include:—PMY, 5,145 k.c., 58.31m., the station of the Amateur Radio Society of Bandoeng. The power used is only 0.6 k.w. Schedule 8.30 p.m.—2 a.m. daily. Address: Nilluny Building, Bandoeng, Java.

PMA, 15.51m. Bandoeng, broadcasts irregularly around midnight.

PLE, 15.93m., Bandoeng, may be heard every night calling Holland.

As also may another Bandoeng station PMC, 16.54m. PLV, 31.87m., Bandoeng, is another 'phone station which works with Holland.

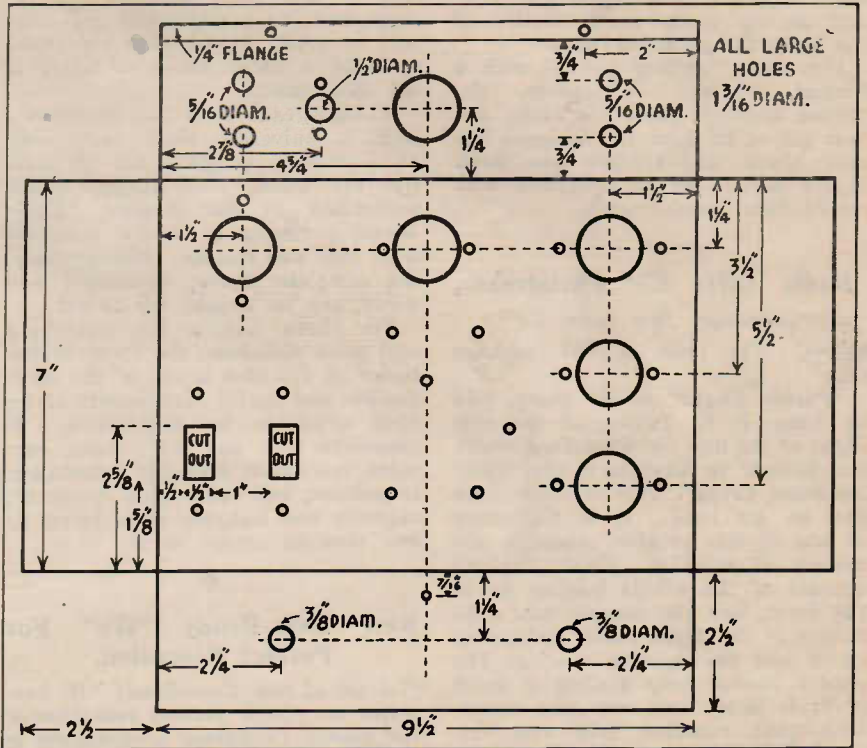

This sketch shows full dimensions for stamping and drilling the chassis.

"Scout Battery Three."

(continued from page 8).

fore the set is put into regular operation is the alignment. To do this, set the trimmers underneath the

coils and those on top of the gang about half way out. Tune in a station near the middle of the band—a fairly distant one is best, so that a fair amount of reaction is needed to bring volume up to quiet

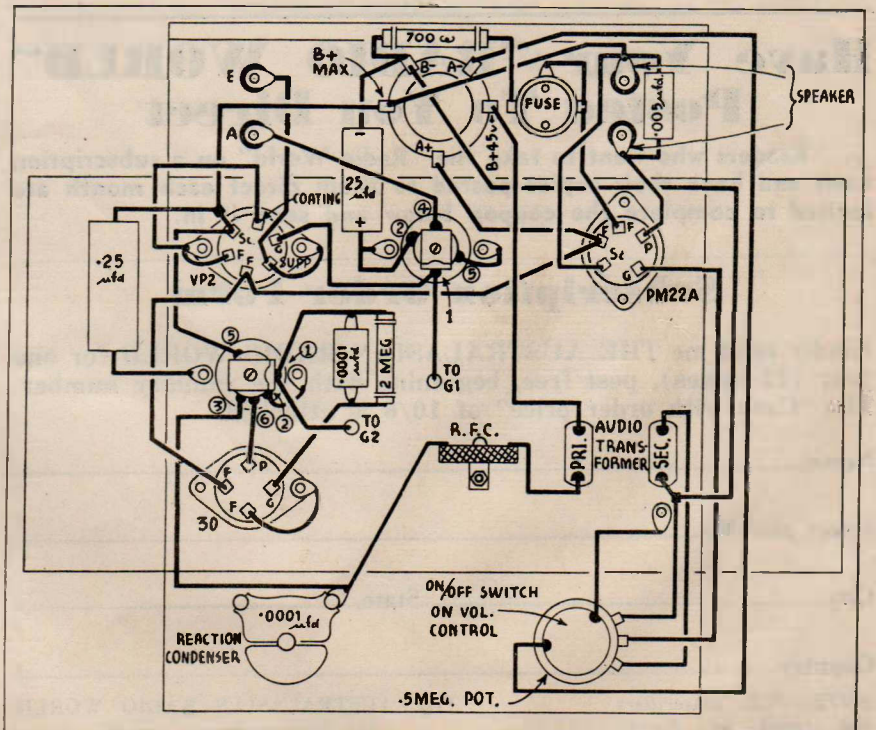

The under-chassis wiring is shown in this sketch.

room strength—and rotate the trimmer on top of the aerial section of the gang for greatest volume.

For sheer "pulling power" with a limited number of valves, the "Scout Battery Three" is easily the best set of its kind the designer has ever heard, and readers who build it are certain to be delighted with its excellent performance.

Radio Gifts For Christmas.

(continued from page 4).

plates. The price is 9/6 (postage 6d.)

"Pacific Flight" is the story, told by Capt. P. G. Taylor, of the epic flight of the late Sir Kingsford Smith and himself to America in the "Lady Southern Cross." This is more than just an air book. It is the story of one of the greatest feats in the history of aviation. Capt. Taylor's account of the events leading up to the flight, and the dangers and difficulties of the flight itself, makes exciting and entertaining reading. The reader cannot help feeling a thrill of pride in the two men who undertook that amazing trip and triumphed in their effort. There are 24 half-tone illustrations, and the price is 8/6 (postage 5d.).



Palec Meter Or Multi-Tester

Testing equipment in some form or other is always a welcome addi-

tion to any radio amateur's workshop, and for a Christmas gift that will be really appreciated for years to come, a Palec meter or tester is the ideal choice.

A high-grade 0 to 1 millimeter with a universal scale costs only 35/-, while a complete kit of parts for the Palec Nine-Range Tester (described in the August "Radio World") retails at £4-0-0 complete with case and handle. Alternatively, the complete tester, assembled and wired, can be bought for £5-0-0.

For those looking for something still more elaborate, the Palec Multi-tester at £13-10-0 is one of the most flexible and useful instruments of its kind available in Australasia. It measures D.C. and A.C. volts, currents, resistance, capacity, inductance, impedance, and electrolytic condenser capacity and leakage, there being no less than 22 ranges in all.



New Ever-Ready "B's" For Perfect Reception.

A set of new Ever-Ready "B" batteries to ensure perfect reception of the special Christmas programmes is the Ever-Ready Company's happy suggestion for a gift that will please the whole family.

For small sets there are light and heavy duty types that will give economical running with maximum current drains of 6 and 16 milliamps, respectively, while for large receivers, the Superdyne (illustrated) is

recommended. Built for discharge rates of over 20 milliamperes, a set of three 45-volt Superdynes will en-

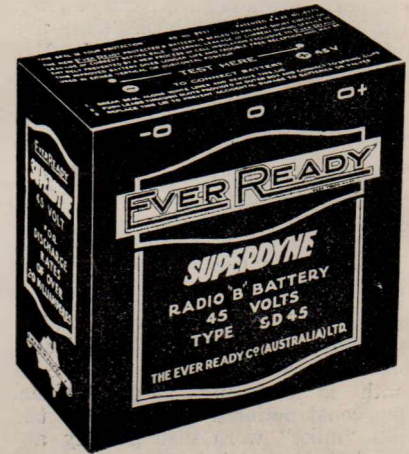

sure nearly a year of smooth, silent "B" supply, even at high discharge rates.

Two Good B.C. Logs.

"Mr. G. P. Hawkins, of New Plymouth, N.Z., has joined our Club, bringing the following log:— 60 Australians—best being (IX, 6AM, 4BU and 3WR—VK's 2ZO, 2KV, 3FW, 3RI, 4JJ, 4HA, 4PK; 21

"Outdoor Portable" An Outstanding Success

To The Editor,
Sir.—Just a short note to compliment you on the outstanding excellence of the design of your "Outdoor Portable," described in the "Radio World" for October and November.

We intended marketing a portable receiver this summer, and tried out quite a few circuits in our laboratory. Then the "Outdoor" appeared and, as you can imagine, no time was lost in building one up. Results were absolutely astounding—so much so that your circuit is used without a single alteration in our new commercial portable, marketed under the name of "My Companion." It is selling so well that we are having difficulty in keeping up with orders, and so far every customer is highly delighted with results.

One buyer living as far away as Cunnamulla, Queensland, is getting excellent reception from a number of stations—which does not surprise me at all, because in the evening quite good Interstate reception can be obtained in Sydney on the loop aerial alone!

Yours faithfully,
W. A. WILDASH
Director.

Ashley Radio Products
107 Regent Street
SYDNEY, N.S.W.

Have Your "RADIO WORLD" Posted To You Direct

Readers who want to take the "Radio World" on a subscription basis and have their copies posted to them direct each month are invited to complete the coupon below and send it in.

Subscription Order Form

Kindly send me THE AUSTRALASIAN RADIO WORLD for one year (12 issues), post free, beginning with the January number. The "Cash with order price" of 10/6 is attached.

Name.....

Street and No.....

City..... State.....

Country.....

NOTE.—N.Z. subscribers can remit by Money Order or Postal Note.

THE AUSTRALASIAN RADIO WORLD,
214 George Street, Sydney,
N.S.W., Australia.

New Zealand stations; Eastern stations:—XGOA, XMHA, JOBK-2, HS7PJ and KZRM; 15 Americans, including WGY, KGU, XEMO, KSL and WLBZ. Total verifications, 115. My own log has jumped from 78 to 98.—Vic. E. Deadman, Arncliffe, N.S.W.

New Wonder Aerial

"NOISEMASTER"

improves Short - Wave Reception 70%



The Kit comprises 200 feet of special aerial wire, a dozen specially designed Transposition blocks, the exclusive wonder aerial energiser unit, "Antennex," earth clamp, lead-in strips, screws, lightning arresters, etc., with full instructions for installing no less than three highly scientific aerials

Priced at 52/6, the "Noisemaster" represents a great saving in money, as the price of the American "Antennex" unit itself is considerable.

Easy to Install

Detailed instructions and drawings with each "Noisemaster" Kit means that you can put up the "Noisemaster" aerial in a very short time. No testing, no doubt, no delay. Once "Noisemaster" is fitted, your noise troubles end. Don't delay in ordering "NOISEMASTER."

PRICE ONLY

52/6

Cuts out Local Interference

Dxers! Boost up your set . . . cut out those maddening hums, crackles and roars . . . get that EXTRA punch that means greater distance, more stations, and clear, undistorted reception.

No matter how sensitive or selective a short-wave receiver may be, best results can be obtained only with a scientifically designed aerial. In fact, MORE noise will be picked up by a highly sensitive receiver unless used with this specially tuned aerial system.

The "Noisemaster" Aerial works perfectly with ANY receiver, and is guaranteed to improve reception from 23 to 76 per cent. "Noisemaster" not only increases signal strength, but entirely eliminates the background of local interference (such as electrical noises caused by trams, cars, electrical household appliances, etc.), which ordinarily ruin reception.

Instal the marvellous "Noisemaster" Engineered Aerial TO-DAY and enjoy glorious trouble-free entertainment ever after.

Exclusive use of **"ANTENNEX"**

The "Noisemaster" Aerial Kit is the only one authorised to use the wonderful American invention "Antennex," which was recently introduced into Australia, after millions had been sold in America. It acts like a purifier and cleans out every trace of locally-created noise, and leaves the Stations beautifully clear and astoundingly strong.

If you already have sufficient aerial wire, insulators, etc., you can construct a "Noisemaster" Aerial system yourself. The "Antennex" Unit, together with a dozen transposition blocks, can be obtained separately for 30/-, with detailed instructions for constructing and installing a "Noisemaster" Aerial.

If you have any difficulty in obtaining a "Noisemaster" Aerial Kit, write to Antennex (A'sia) Agencies, Box 3695 SS, G.P.O., Sydney, N.S.W.

"Noisemaster" All-Purpose Aerial

DISTRIBUTED BY:
VICTORIA:

A. J. Veall Pty. Ltd.
Swanston Street, Melbourne.

WEST AUSTRALIA:

Carlyle & Co.
915-917 Hay Street, Perth.

TASMANIA:

Oldham, Beddome & Meredith
Pty. Ltd.
Hobart.

QUEENSLAND:

Irvine Radio & Electrical Co.
Perry House, Brisbane.

N.S.W.:

Antennex (A/sia) Agencies
Box 3695SS, G.P.O., Sydney.

N.S.W.:

A. J. Veall (Agencies) Ltd.
127 York Street, Sydney.

Heiron & Smith (Salonola)
91 Hunter Street, Newcastle.

TWO SPECIAL OFFERS

BUILD YOUR OWN SET
AND SAVE POUNDS

The Outdoor Portable 4 **£10**
COMPLETE PARTS

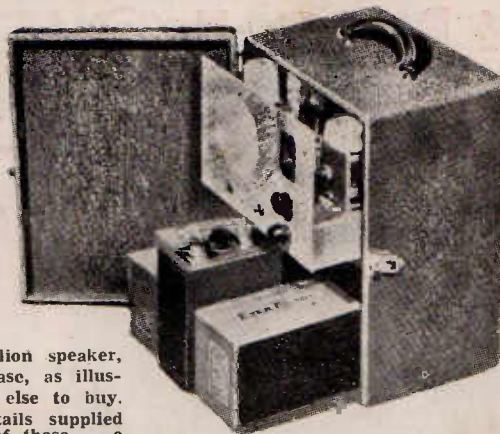

Double your holiday enjoyment. Bush, city or seaside—shooting, camping, fishing, or yachting—wherever you go, whatever you do, you'll find an outdoor portable the ideal companion. Light, compact and powerful. Vealls can supply the complete kit of parts—everything necessary, valves,

batteries, accumulator, Amplion speaker, and ready-made carrying case, as illustrated. Price £10—nothing else to buy. Complete constructional details supplied with every kit. Snap one of these—a limited number only available at this price.

5 VALVE Battery SUPER HET.

COMPLETE KITSET, WITH VALVES
BATTERIES and ROLA SPEAKER

£10/12/6

An amazing bargain—positively everything necessary to build the complete chassis, with valves, accumulator, B batteries and Rola speaker, for the Velco Xmas 5—a powerful 5-valve battery superheterodyne that no matter where you live will give exceptional

results. Sensitivity and tone equal to any 5-valver on the market... quality components ensure success. The complete kit of parts, everything as specified above, only £10/12/6. Limited number only available so act quickly.

AND, VEALLS PAY FREIGHT TO YOUR NEAREST STATION

ELECTRIC FANS

Stromberg-Carlson Household 8in. Fans 200/230 volts.

19/11

22/6

Genuine Precedent 200/240 volt 8in. 4-blade Fans. Price 22/6 (N.)

american made "Polar Cup" Fans, 29/6.

Write for Lists

NOISEMASTER

Banish noise and improve reception from 25 to 75 per cent. The Noisemaster Kit, including famous "Antennax" Aerial Energiser. Price 52/6.

Improves Reception

52/6

MARQUIS POTENTIAL METERS, ALL VALUES **3/-** ea.

LEONARD OFFERS THE MOST FOR EVERY POUND YOU SPEND



Write for illustrated folders. You can buy a Leonard on Easy Terms from £5/15/- Deposit.



SAFETY FIRST!

When you fit Electric Lighting to your Cycle, fit the best and ensure satisfaction.

RADSONNE—The best made. Complete outfits comprise Generator, Headlamp and Tail-lamp. Price 17/6. Heavier models, 22/6 and 27/6, all Complete.

UTILITY SHORT WAVE DIALS, Price 12/6

B.G.E. Home Broadcasters
A real Microphone—**39/6**
Not a Toy.

VEALLS RADIO & ELECTRICAL STORES

243-249 Swanston Street, Melbourne.

299-301 Chapel Street, Prahran.

Phone Orders Cent. 3058 (7 lines).

168 Swanston Street, Melbourne.

3-5 Riversdale Road, Camberwell.

Telegrams "ARTVEALL," Melbourne.