

## Plain Talk and Technical Tips

Jan.-June, 1974 • Volume 17/No. 1-6

### 20th Anniversary of Color Television

The year was 1954. RCA began commercial production of color TV sets in March of that year, signaling the birth of a major new industry that was to reshape the political, economic, and mental landscape of America.

But color TV was not an instant success. The proponents of color television would eventually prevail, but not on the timetable they had so confidently predicted in 1954. With RCA and NBC virtually going it alone, the industry's first decade of growth was slow and erratic.

Only 5,000 color TV sets were sold in 1954, hardly a figure to buoy confidence. By 1960, there were only 500,000 color sets in use throughout the country. However, things began to change for the better about this time. More and more manufacturers began merchandising color sets and broadcasters increased the hours of color programming. Sales began to perk up and by the end of 1963 there were 1.7 million color sets in use.

In the second decade of its development, with all the TV manufacturers and all the networks now firmly on board, color TV became the fastest growing segment of the consumer goods industry. From the 1.7 million sets in use at the start of 1964, color TV sales rose to a new all-time high of 9.3 million units in 1973 and total color sets in use at the beginning of 1974 stood at an impressive **52.6 million**.

From zero saturation in 1954, color TV had grown to where two out of every three American households had at least one color set in 1973. By 1980 this saturation is expected to reach 90 per cent.

Of course, the color TV set that launched the industry in 1954 is as different from today's sets as the Ford Tri-Motor is from the Boeing 747. The 1954 receiver, called the CT-100, originally retailed for \$1,000 and featured a round, long-neck tube and a chassis with 37 electron tubes. The fact that it could receive signals out of the air and convert them into live images on a screen in full color was a milestone in electronic engineering.

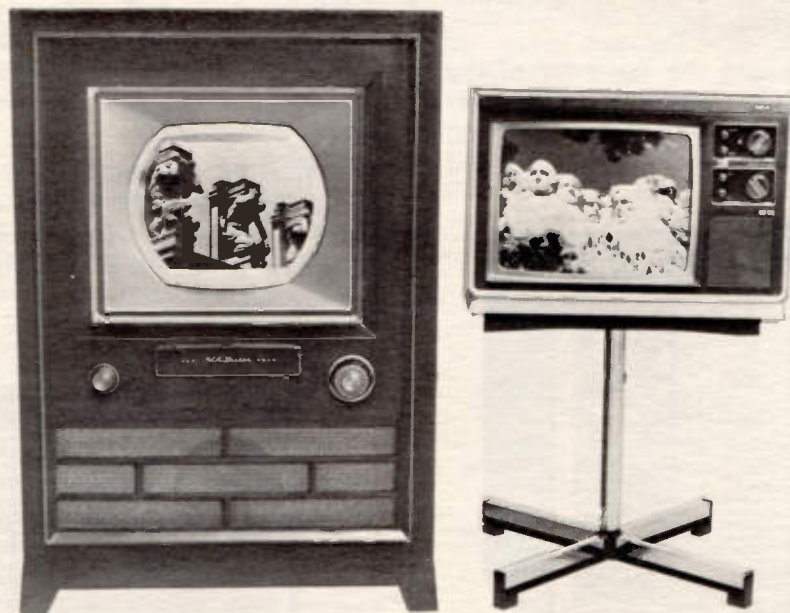

Figure 1—CT-100 of 1954 and XL-100 of 1974



Today's sets, using rectangular tubes with short necks and all solid state (tubeless) chassis, are economical, lighter, smaller, simpler to operate, more reliable, brighter and technologically superior in every way.

As color TV emerged from the scientific shadows to become a multi-billion-dollar industry, it has significantly affected the social, economic, and political life of the nation, having an impact possibly greater than any Twentieth Century innovation with the exception of the automobile.

Including some 64.4 million black-and-white sets, there now are approximately 117 million color and

monochrome television sets in American homes, or more than the number of automobiles, bathtubs, washing machines or refrigerators in use. Despite its phenomenal growth in the past decade, color's outlook continues bright.

At the present time, almost 50 countries are broadcasting programs in color and a dozen more are scheduled to begin color programming this year. Several additional countries have targeted 1975 for the start of color broadcasting.

With the advent of communications satellites, television now measures its live audiences in the hundreds of millions and some foresee the day when the total will be in the billions.

## 1975 T-Line Color Television

Six chassis provide a wide range of choices in 1975 color television. All-solid-state chassis include the **CTC 58, 68, 71, and 72**—and all Models with a "T" designation through June of this year use one of the above XL-100 solid-state chassis.

Two "special" models series—EX 334W, WX, EX 405W, WX, manufactured prior to the transition of RCA to an entirely solid-state line—feature continued hybrid chassis CTC 51 and CTC 53, in 14-inch and 18-inch diagonal screen sizes, respectively.

The XL-100 chassis series for 1975 have many common features: **modular** construction, a **MOSFET mixer** in the VHF tuner, **negative matrix** picture tube and **screen temperature** setup to **6500° Kelvin**, rather than the 9300°K used previously. The lower screen setting produces a more pleasing picture, especially rendition of fleshtones.

At the top of the line—and the mainstay of the T-Line—is the **CTC 68 chassis**, offered in a wide range of console instruments, many featuring **ACM IV, Digital Channel Indication** (for all "V" and

"U" channels), and **Remote Control**. All models using the CTC 68 chassis have **Automatic Fine Tuning (AFT)**, a **25-inch** (diagonal) picture tube, and develop a high voltage of 31 kV.

Complementing the CTC 68, and sharing many of its all-solid-state circuits is the **CTC 58** chassis. Instruments using the CTC 58 feature **AFT, 70-position detent UHF tuner**, and a **25-inch** viewable picture tube.

The solid-state **CTC 71** is continued in T Line Model FT 478W, with a 30 kV anode voltage, 19-inch viewable picture tube, and 70-detent UHF tuning.

The **AccuLine™ CTC 72 chassis** displaces the CTC 62 of last year. The CTC 72 is used in instruments featuring 15-inch and 17-inch viewable, "In-Line" picture tubes. Many models are equipped with **ACM IV, AFT**, and remote control. The remote version—Model ET 396WR—has remote functions for On-Off, volume, and channel-change; the latter function controls all VHF channels and up to 8 preset UHF channels.

The **Remote Control** system in this year's color instruments is similar to that used in R-Line products. A new mechanical hand unit—the **KRT 6B**, operates in conjunction with familiar **CTP 22** remote receiver circuitry.



Figure 2—Model FT 478 (CTC 71 Chassis)

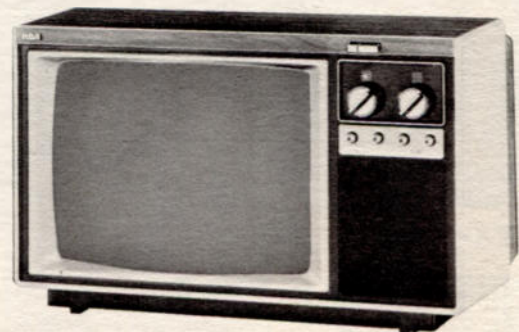

Figure 3—Model ET 396 (CTC 72 Chassis)

## The CTC 68 Chassis

The mainstay of the 1975 console color line is the CTC 68 chassis. This chassis first appeared in the S-Line; however, several refinements in its design have been made. These include new, but compatible, audio output and kine driver modules, elimination of standby filament power consumption, an improved tuner, digital channel indication in some models, and a different remote control system in some models. Some of these changes were incorporated in late production of the S-Line CTC 68's; but all have been put in production since the 1974 Product Technical Manual was published.

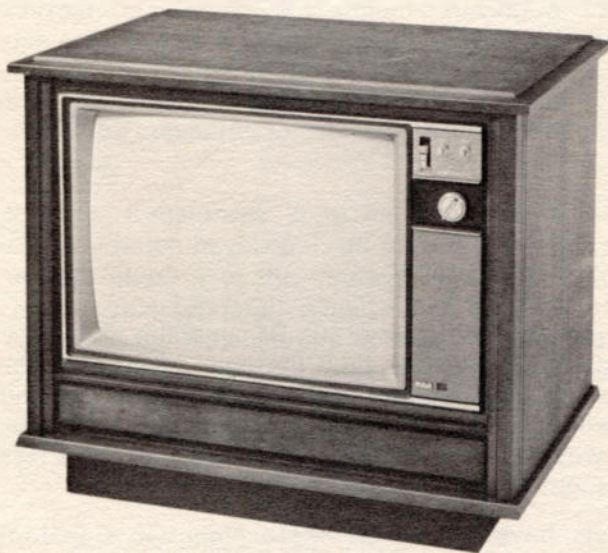

Figure 4—Model GT 720 (CTC 68 Chassis)

### KRK 211 Tuner

The essential difference between the KRK 211 tuner used in the T-Line and the KRK 205 that was used in early S-Line is found in the mixer stage. The two-transistor, "cascode-type" mixer that was formerly used has been replaced by a MOSFET device employed in a similarly configured circuit. The schematic diagrams (Figures 5 and 6) of the "transistor" and "MOSFET" tuners serve to illustrate the differences between the two.

The dual-gate MOSFET has been recognized as an excellent RF amplifying device for several years. A MOSFET (dual-gate type) was used earlier in RCA Consumer Product in the RF stage of the CTC 40 solid-state chassis, first introduced in 1968. The KRK 142 VHF tuner used in that chassis featured a MOSFET RF amplifier stage, and a "cascode" mixer stage, using two discrete transistors. (The detailed discussion of the device used in RF application appears in "Solid State Color Tele-

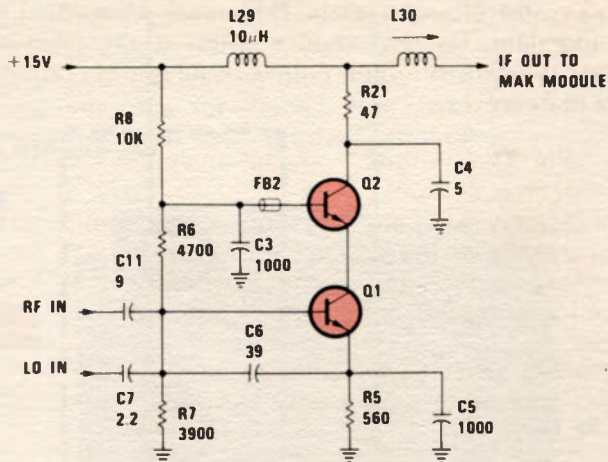

Figure 5—Transistor Cascode Mixer

vision," covering the CTC 40 color chassis, published by RCA Sales Corporation in 1968.)

To summarize the highlights: The MOSFET has **high input impedance, a very good noise figure, and low susceptibility to cross modulation.**

Figure 5, illustrating the cascode type of configuration adapted to bipolar transistors, shows Q1 is operated as a common-emitter amplifier whose collector load is the input impedance of Q2. Since this impedance is intrinsically low, Q1 has very little voltage gain, although there is significant power gain. The low voltage gain insures good stability (little tendency to oscillate) even without neutralization. Q2 is connected as a common-base amplifier. The voltage gain is high, but the stability is good because the low impedance of the grounded base virtually isolates the input from the output. Therefore, neutralizing is not required.

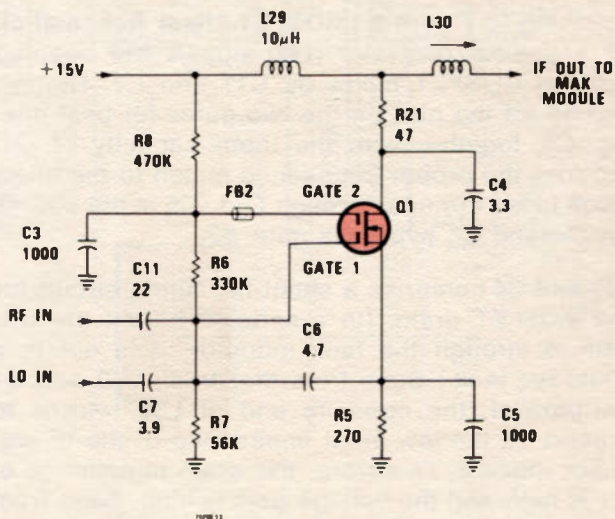

Figure 6—MOSFET Mixer

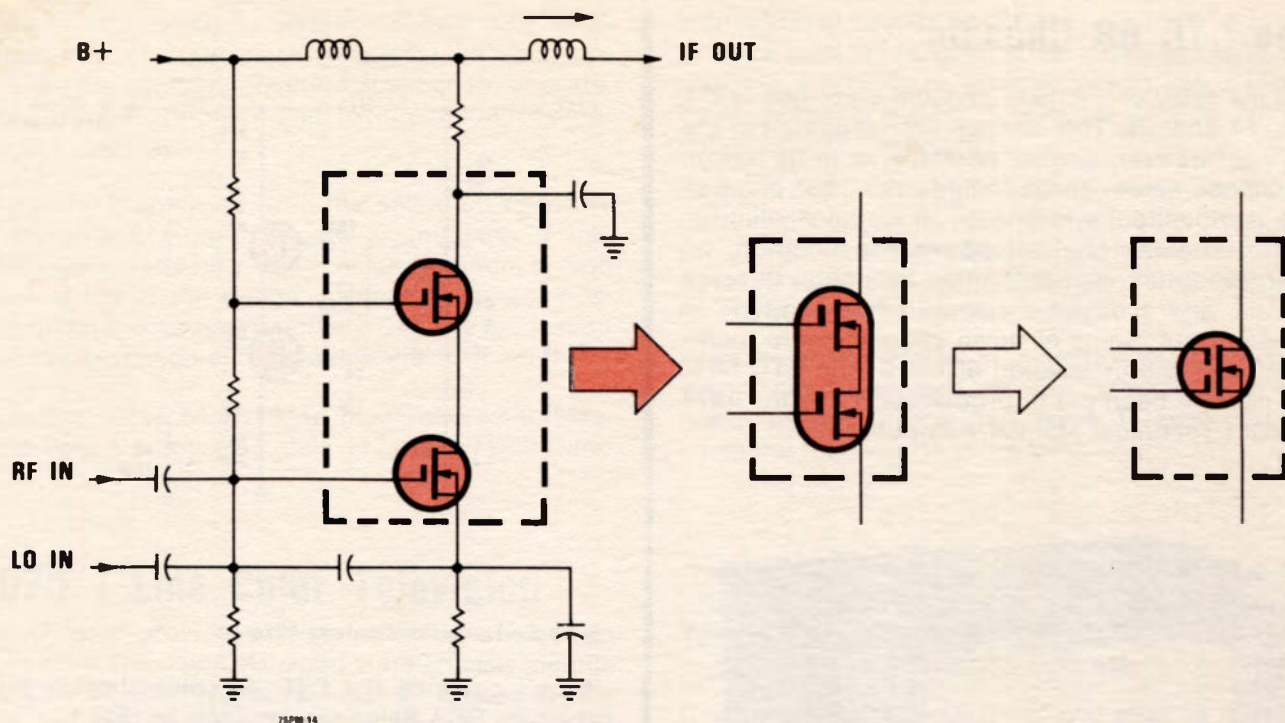

Figure 7—Evolution of Dual-Gate MOSFET

If the dual-gate MOSFET mixer (Q1 in the "MOSFET Mixer Schematic") were actually two devices, as illustrated in "Evolution of Dual-Gate MOSFET," the similarity to the discrete cascode circuit would be obvious. Now it can be seen that the drain of Q1 (bottom device) is connected to the source of Q2 (top device) without intervening circuitry—just as the collector of Q1 and the emitter of Q2 are common in the discrete transistor circuit. In essence, the drain of one device and the source of the other are reduced to a point in the channel located between the two gates. The final symbol illustrates the dual-gate MOSFET as it appears on schematic drawings.

Referring to Figure 6 (MOSFET Mixer Schematic), RF and local oscillator (LO) signals are coupled into the MOSFET mixer by C11 and C7. R6, R7, and R8 set the bias on the two gates for best mixing. C6, together with the input capacity of Q1, provides the proper impedance match to the interstage tuned circuits, through C11. C5 is the source bypass and C3 bypasses gate #2.

L30 and C4 comprise a shunt-fed tuned circuit for the MOSFET drain. (In a series-fed tank the B+ path is through the tank inductor, it is not in a shunt-fed tank.) Seen from the drain, L30 and C4 are parallel; the opposite end of L30 returns to ground via the low input impedance of the IF amplifier module. Therefore, the drain impedance of Q1 is high and the voltage gain is high. Seen from the IF amplifier, L30 and C4 are series resonant and the impedance is approximately equal to R21.

In practice, the gain of the RF amplifier should be reduced by AGC to limit the level of input to the mixer. Otherwise, the mixer will be overdriven and it will produce objectionable modulation products. However, as mentioned, the MOSFET mixer is less susceptible to overload than bipolar devices.

Tests have shown an improvement in signal-to-noise ratio that can be realized by using a MOSFET mixer. Its ability to accept a stronger signal allows the start of RF AGC to be delayed longer and this improves the tuner signal-to-noise ratio for moderately weak signals. Also, the lower noise inherent characteristic of the MOSFET tends to reduce overall total tuner noise, and therefore, improves the general receiver signal-to-noise ratio at all signal levels.

### Power Supply

In the interest of energy conservation, "Instant-Pic" has been eliminated from all T-Line color receivers. "Instant-Pic" consumes about 5 watts in S-Line models, an annual consumption of about 29 kWh based on eight hours of viewing per day.

A few early-production T-Line chassis will have the standby filament transformer that was used in S-Line chassis, but the wiring has been changed as shown in the "Power Supply Connections" schematic. In the S-Line CTC 68, those with "instant on," the **solid line** connections indicated circuits to the standby transformer T104, power transformer T103, and the picture tube filaments; anytime the AC power cord was connected to a "live"

receptacle. T104 was "on," providing reduced filament voltage to the picture tube.

Two slightly different power transformer circuits are used in T-Line CTC 68 chassis. In some early production T-Line CTC 68 chassis, "Instant-Pic" is eliminated by simply shifting the primary lead of the standby filament transformer (T104) to the "off" side of the line switch—as indicated by the dotted-line connection; under these conditions, T104 is switched "on" only when power is applied via on-off switch S401 (switched on). In later production CTC 68 chassis—the majority of those for T-Line—a new design power transformer (T103) has a full 6.3-volt picture tube filament winding; here, T104 is eliminated.

If T103 is to be replaced, be sure to install the correct transformer. Instruments having a T104, use a T103 with a 1-volt filament windings. If there is no T104 in the original chassis, use the T103 that has a 6.3-volt filament winding. Service Data should be consulted for correct replacement stock numbers.

If either transformer is to be replaced in those chassis which have both, be sure to maintain the correct phasing of the filament windings (following the color coding). When either transformer is reversed, the two filament voltages will be out of phase and the "on" filament voltage will drop to about 4 volts. This produces much the same symptoms as a low-emission picture tube.

## Digital Channel Indicator

Selected T-Line models using the CTC 68 chassis feature digital channel indication by using seven-segment, gas-discharge lamps. The same lamp-pair-unit (one for "tens", the other for "units"), indicates both VHF and UHF channels.



Figure 9—Digital Channel Indicator

A pair of neon lamps—separate from the channel number lamps—are used to indicate VHF or UHF operation.

Figure 10, on page 6, shows how the digits 0 through 9 can be formed by illuminating various

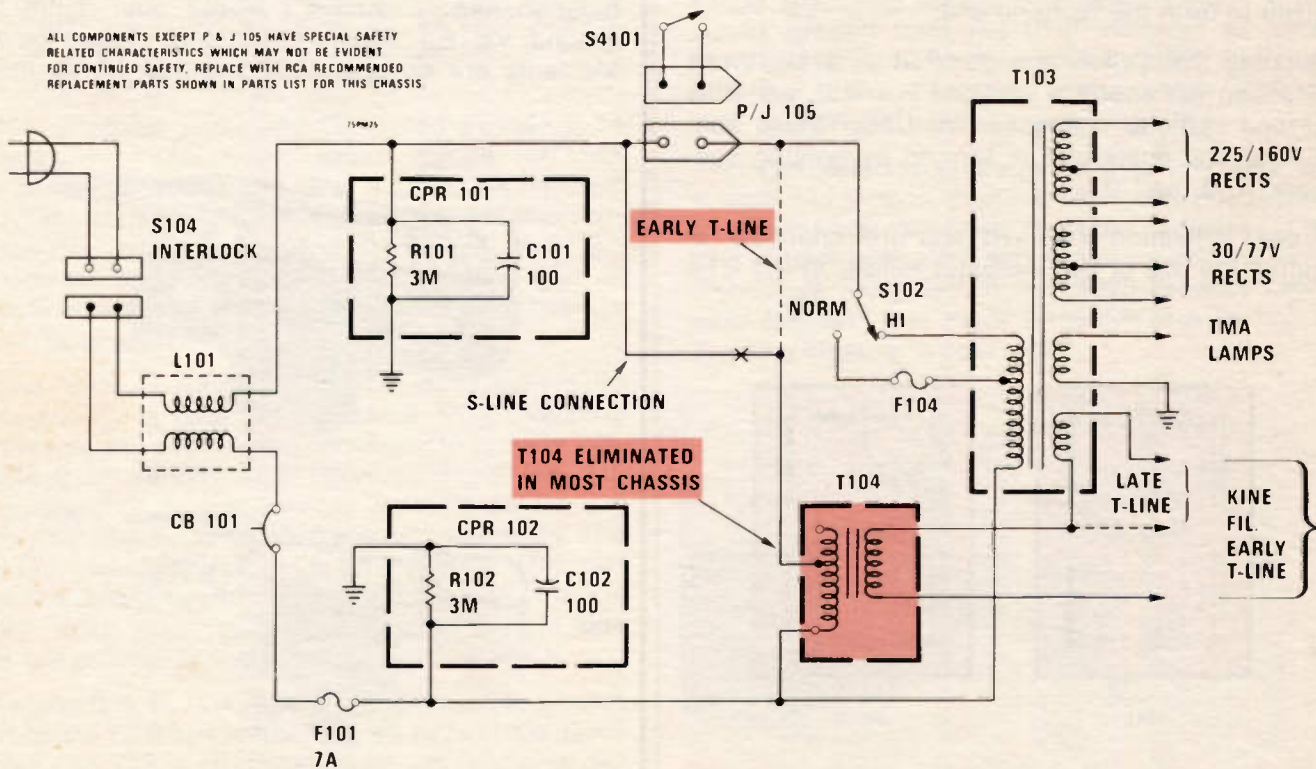

Figure 8—CTC 68 Power Supply Connections



Figure 10—Lighting Different Elements Form Numerals

sections of the seven-segment display. Each of these segments could be a row of incandescent lamps or LED's (Light Emitting Diodes), a fluorescent tube, or in the display system used in the CTC 68, one of the seven cathodes of a gas-filled indicator lamp. The segments are designated A through F in clockwise order from the top; G is the center (horizontal) segment.

When a particular cathode is energized (circuit completed), it glows to make that segment visible. In the illustration, notice the numeral 8 is formed when all seven segments are energized.

Any of several methods could be used to successfully switch the individual cathode sections to form specific numerals. In the illustration **Simplified Indicator Switching (Number One)**, a simple switch is shown, with contacts connected to energize sections B and C of the lamp; B+ input, which is common to all elements (anode connection), is supplied via a dropping resistor to the indicator lamp unit. The individual cathode elements B and C within the lamp are connected to ground via the switch—therefore, segments B and C are energized to form the numeral one.

Rotating the switch one position in a clockwise direction will energize sections B and C, and also ground cathode connection A. Under these conditions, the numeral 7 is formed by lighting sections A, B, and C.

Proper indication of all VHF and UHF channels requires the use of two indicator lamps. In the CTC

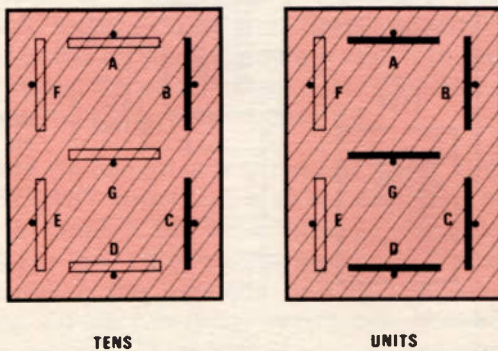

Figure 11—Two Indicators Form Channel Numbers

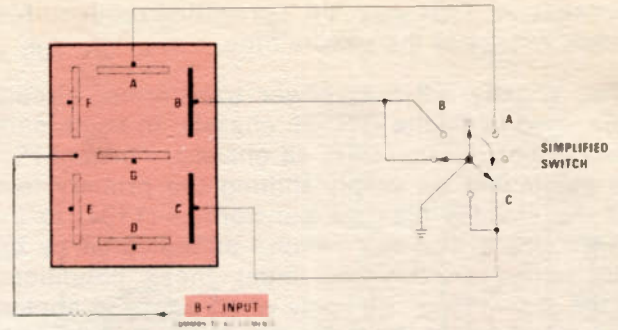

Figure 12—Simplified Indicator Switching (Number 1)

68, these two units (although encased in the same assembly) are labeled "tens" for the left-side indicator, and "units" for the right-side indicator. An example is shown in the simplified drawing. Here, the indication for VHF Channel 13 is formed by illuminating the B and C segments of the tens lamp, and A, B, C, D, G segments of the units lamp. For VHF Channels 2 through 9 (single digit indication), the "units" lamp (right side) is utilized; Channels 10, 11, and 12, as does 13, uses the "tens" lamp for the "1" digit.

The dual lamp unit has a total of 20 connecting pins. In the CTC 68 system, 18 of these pin contacts are used, and connect to pin-socket jacks—plug in—on printed circuit board PW 6000. Fourteen (14) pins are the light-emitting cathode elements, switched as required to form numerals; each lamp has a separate pin for B+ input (anode connection) accounting for two more pins. Each lamp also has separate keep-alive elements (small, triangular-shaped "cathodes") whose pins return to ground via 2.2 megohm resistors. These small elements are energized, and remain lit, so long

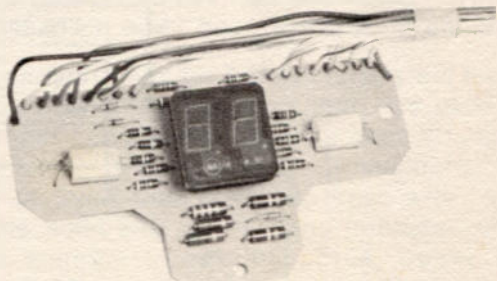
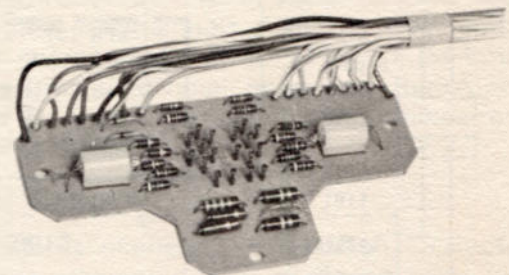
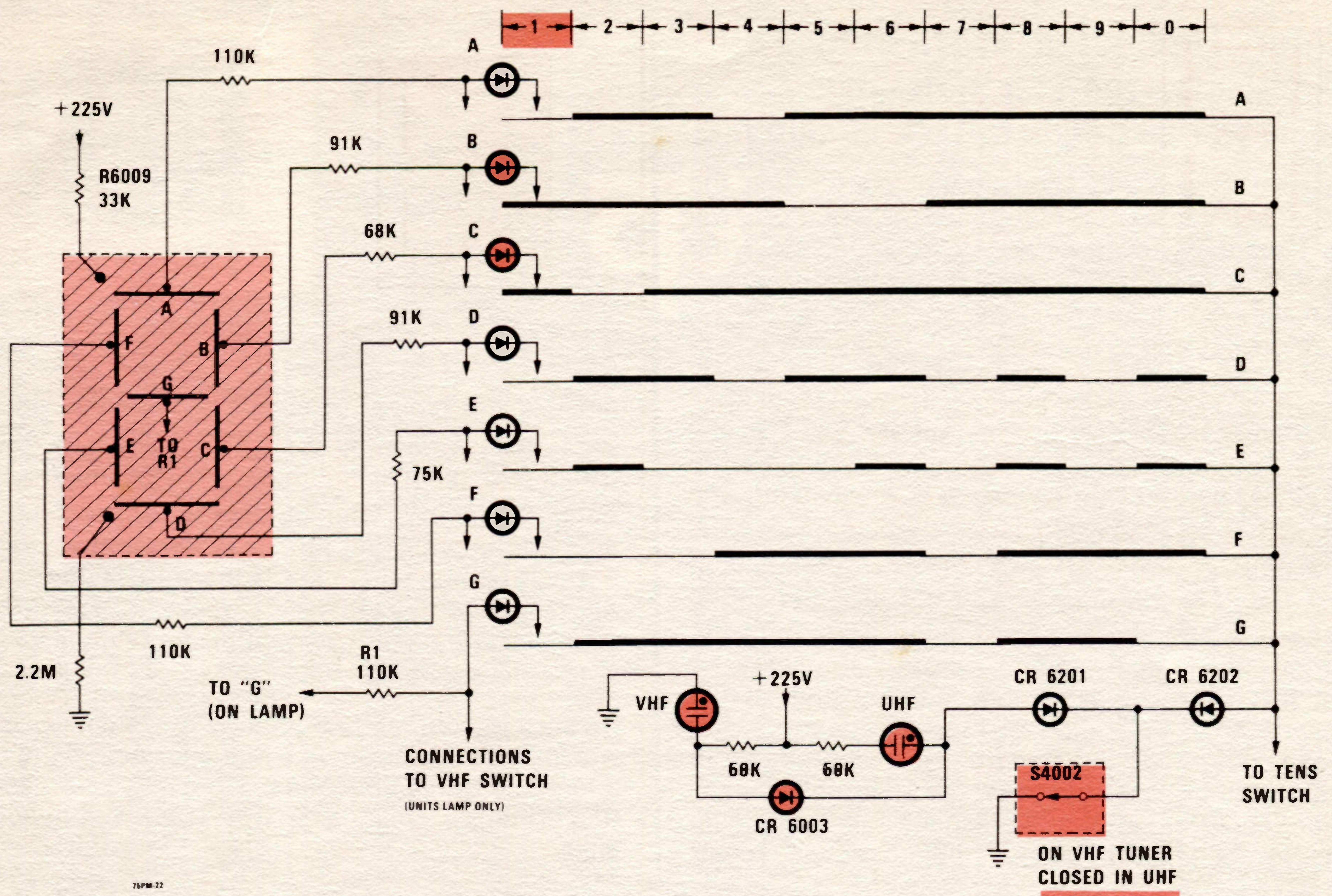

Figure 13—Indicator Connects to Socket Pins



75PM 22

Figure 14—Simplified UHF Switching (Units Section)

as the instrument is powered "on." However, the triangle elements cannot be seen without removing the front controls panel. (The two pins **not used** in the CTC 68 connect to a pair of similar-shaped triangles—one on each lamp, located slightly above the active triangles; these are used in some applications for decimal points.)

The simplified schematic illustrated in Figure 14 shows the "equivalent" switch circuit for UHF channel indication (right side). To form the numeral "1," for example, ground is connected to lamp segments B and C via isolation diodes "B" and "C," diode CR 6202 and switch S4002. Notice that all other contacts of the switch assembly are open in this position.

(The "tens" switch and diode assembly, schematic not shown, is basically the same, with switching contacts and sequencing necessary to provide left-side numerals indication. However, due to the VHF switching contact sequence, isolation diodes are only necessary for the "B" and "C" segments. The "tens" switch also depends on diode CR 6202 and switch S4002 to complete its ground circuit in the UHF mode. The "common" line on the right side of the schematic indicates this connection.)

Segments A, B, G, E, and D are returned to ground when the UHF tuner is advanced to form the numeral "2." Other right-side numbers follow in sequence as UHF channels are selected—3, 4, 5, 6, 7, 8, 9, 0.

The resistors in series with each of the lamp segments (of different values) are used to equalize their brilliance.

S4002 is located on the VHF tuner shaft and removes ground from the UHF indicator switches (tens and units) for VHF reception. S4002 also controls the two neon mode lamps which indicate UHF or VHF (to be discussed presently).

The VHF selector operates in a similar way, although it is simpler than the UHF indicator system because fewer channels must be indicated. Details of VHF operation, and important service techniques are contained in the "1975 Product Technical Manual" that you will receive at a Technical Training meeting in your area.

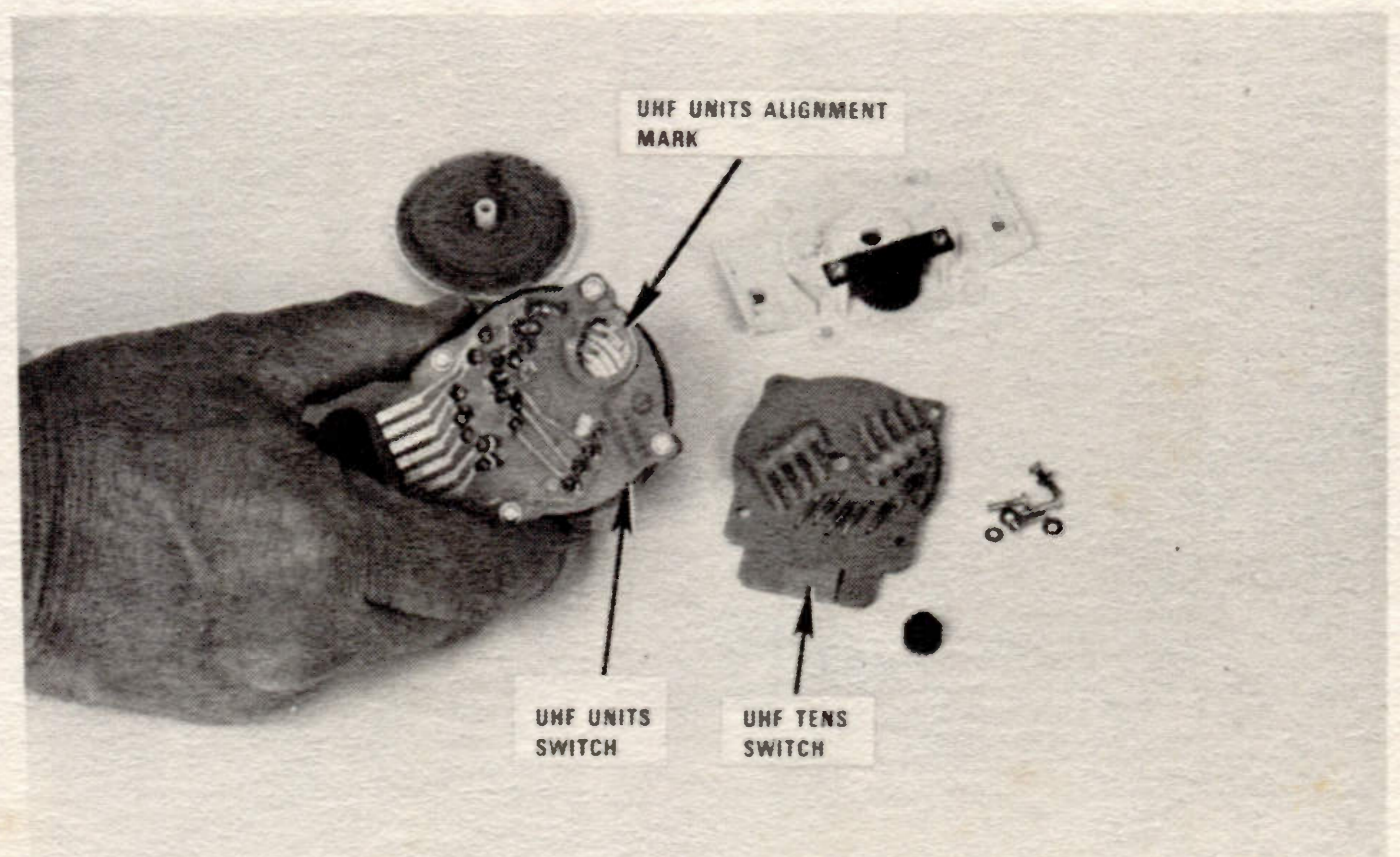

Figure 15—UHF Units and Tens Switches

## Color Television Workshop 13

### Servicing XL-100 SCR Horizontal Deflection and High Voltage Circuitry

Starting in mid-July, and continuing through the fall, RCA Consumer Electronics Distributors will be conducting a new training workshop covering XL-100 SCR horizontal deflection circuitry operation and servicing techniques.

Workshop 13 serves to enhance the understanding of the operation of the SCR circuitry, and to introduce several new servicing techniques and procedures which not only will apply to the XL-100 circuitry, but in most instances, to all RCA chassis which use the SCR system.

Contents of the workshop include a simplified discussion of the operation of the SCR horizontal deflection circuitry, several demonstrations of the various techniques and procedures that may be employed in servicing the system, and actual "hands on" application of these procedures and techniques to the servicing of faults pre-placed in the training chassis. From knowledge and experience acquired in the workshop, the technician should be able to quickly diagnose and repair

## New 6500° K Screen Color Temperature

Experimentation has shown that RCA T-Line color receivers produce a more pleasing picture if they are operated at a lower color temperature. Previous color setup was to a color temperature of 9300°K, which produced a blue-white raster. All XL-100 instruments manufactured after March 1, 1974 have been adjusted for a color temperature of 6500°K, instead of 9300°K. This change produces a slightly warmer-appearing raster, for better rendition of flesh tones.

Color temperature standards are not generally available in the field. Nevertheless, a satisfactory setup to 6500°K can be made by setting up the controls as follows:

1. Preset the receiver controls as usual—screen controls fully CCW, drive controls fully CW, kine

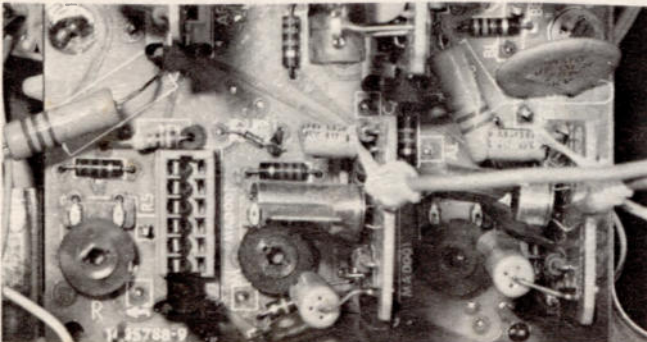

Figure 16—Drive Controls



Figure 17—Workshop Materials

most of the typical problems associated with the SCR system, and know how to apply procedures which will minimize the elusive "tough dogs."

Each technician who attends Workshop 13 will also receive valuable reference material which will not only enable him to recall the various techniques discussed in the workshop, but will also contain valuable additional information pertaining to SCR deflection servicing.

Be sure to contact your local RCA Consumer Electronics Distributor Service Manager to find the time and place of his upcoming Workshop 13 presentation. This is a training program you won't want to miss.

bias fully CCW, service switch in "service" position (collapsed raster).

2. Advance each screen control until the line it produces is **barely** visible. If necessary, advance the kine bias control if one or more guns do not produce a colored line.

3. Put the service switch in the "raster" position, adjust brightness for normal viewing and set the drive controls **exactly** as in previous color instruments. Repeat steps two and three as necessary to produce the familiar blue-white 9300°K raster.

4. Decrease blue drive until the raster has a **barely perceptible** reddish-orange cast (a more neutral grey appearance). This will normally require a considerable reduction of blue drive and a **slight** reduction of red drive if overall screen appearance is too red.

5. Normally, the green drive will be at maximum; occasionally both the red drive and green drive will be maximum.

After developing an "eye" for this new color temperature, modify steps three and four to set it directly without the intervening 9300°K setup.

RCA Corporation  
Consumer Electronics

Technical Training  
600 N. Sherman Drive  
Indianapolis, Indiana 46201