

### Solid-State IF Stages—CTC 38

The CTC 38 chassis features a three-stage transistorized IF system. Figure 1 (IF Input Circuit) illustrates that output from the VHF tuner (KRK 140) is applied to the first picture IF stage (Q203) via a double-tuned link circuit comprised of the mixer output coil (located on tuner), bandwidth adjustment capacitor (C220), and input transformer (T204). The CTC 38 (unlike the CTC 31, which has a similar link circuit) does not utilize a sound rejection control in the primary circuit of transformer T204. Instead, a 12K, 5% fixed resistor (R216) is used to provide adjacent sound rejection in conjunction with the 47.25 MHz trap coil. The simplified schematic also illustrates that separate 41.25 and 47.25 MHz sound traps are used as they were in the CTC 31.

Link circuit output is coupled via a 10 pf capacitor and 47 ohm resistor to the base of the first IF stage (Q203). Amplified signal from the collector of the 1st IF transistor is coupled to the 2nd IF stage (Q204) through a similar impedance matching network consisting of a 10 pf capacitor and 56 ohm resistor.

The 1st and 2nd IF stages in the CTC 38 are stagger tuned. The 1st IF transformer (L203) peaks near 42.17 MHz. Signal from the 2nd IF stage is then impedance coupled to the base of the 3rd IF

*Continued on Page 4*

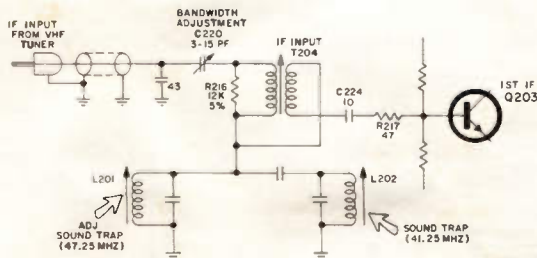

Figure 1—IF Input Circuit

### CTC 40 Brightness Limiter

One of the interesting and unfamiliar new circuits in the CTC 40 chassis is the Brightness Limiter circuit. The drive capability of the new horizontal deflection system in the CTC 40 is such that with high, nonlimited brightness settings, it is possible to exceed the current capabilities of the picture tube. The limiter circuit is employed to maintain picture tube beam current within proper limits. It is important to note that the correct limiter control setting in the CTC 40 chassis may **not** be coincidental with the point at which the raster "blooms" or defocuses at high brightness settings as in previous RCA tube chassis employing a brightness limiter circuit.

The brightness level (picture tube beam current) in the CTC 40 is controlled basically by the emitter-base bias of the second video amplifier transistor. Changes in this bias vary the current flow through the second video amplifier load resistance that is translated by the remaining video amplifiers as changes in picture tube cathode bias. Brightness limiting action in the CTC 40 operates by reducing the forward base bias voltage on the second video amplifier when the preset limit of picture tube beam current is reached; beam current limit is preset at 1600  $\mu$ a (1.6 ma) by properly adjusting the brightness limiter control.

The brightness limiter circuit operates as follows: Referring to Figure 2, the high voltage transformer secondary winding is returned to B+ through the brightness limiter potentiometer (R129). Therefore, all of the beam current drawn by the picture tube must pass through R129. However, placed between the low side of the brightness limiter control and ground is the brightness limiter transistor, (Q301). The fixed base bias on this transistor allows it to operate in such a manner that the voltage drop across it is relatively independent of the current through it, as long as it is conducting. Therefore, the transistor acts much like a zener diode, the "zener" voltage being determined by the resistive divider network in the limiter base

*Continued on Page 2*





## Brightness Limiter

Continued from Page 1

circuit (Figure 4). The current through R129 flows through two parallel paths — one through the brightness limiter transistor, Q301, and the other through the picture tube. If the brightness control is set so that the picture tube is cut off (black screen) the only path for current flowing through R129 is via Q301. With the picture tube cut off, the current through Q301 is set at  $1600 \mu\text{a}$ —the desired picture tube beam current limit (first condition, Figure 2). When the brightness control is advanced so the picture tube draws beam current (second condition, Figure 2), part of the  $1600 \mu\text{a}$  current through R129 flows through the picture tube, while the remainder flows through Q301. The second condition in Figure 2 exemplifies a brightness control setting such that the picture tube draws  $1000 \mu\text{a}$  (1 ma). The remaining current,  $600 \mu\text{a}$ , flows through the brightness limiter transistor.

The constant voltage on the brightness limiter emitter supplies a constant bias voltage of approx-

imately 4 volts to the base of the second video amplifier throughout the operating range of the brightness limiting system. When the brightness control is advanced to the point where the picture tube draws the preset limit of  $1600 \mu\text{a}$  (third condition, Figure 2), all of the current through R129 flows as beam current. There is no remaining current to sustain Q301 conduction, and it stops its regulating action. As a result the voltage on the base of the second video amplifier will no longer be held constant. If more current is demanded by the picture tube, the voltage at point "A" drops, decreasing the forward bias on the second video amplifier. This action rapidly decreases the average conduction of the second video amplifier, decreasing brightness, and therefore reducing picture tube beam current to the desired  $1600 \mu\text{a}$  limit.

Additional components in the brightness limiter circuit (Figure 3) provide necessary filtering and circuit stabilization duties. Filtering action and arc suppression are provided by a circuit consisting of C121, R115 and C113. This filter is physically and electrically associated with the high voltage transformer secondary winding and removes most of the horizontal "ripple" from the brightness limiter circuit. It also acts to initially suppress any "spikes" resulting from high voltage arcing.

### Adjustment Procedure

The brightness limiter control is factory preset and normally needs no adjustment. However, if components are changed in the limiter circuitry or if the control is misadjusted for any reason, the limiter control must be reset. Misadjustment of this control may result in damage to the kinescope. (The correct procedure as outlined in Service Data covering the CTC 40 should be followed.) Referring to Figure 4, the brightness limiter control (R129) is set for Q301 collector current of  $1200 \mu\text{a}$  (1.2 ma) at minimum brightness. Limiter current is set for  $1200 \mu\text{a}$  instead of  $1600 \mu\text{a}$  since other elements of the kinescope, not returned through the limiter, draw approximately  $400 \mu\text{a}$ .

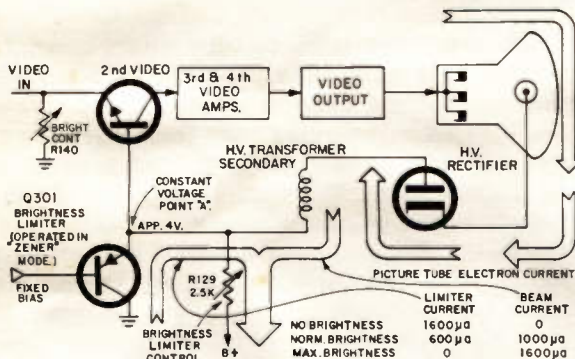

Figure 2—Brightness Limiter Operation

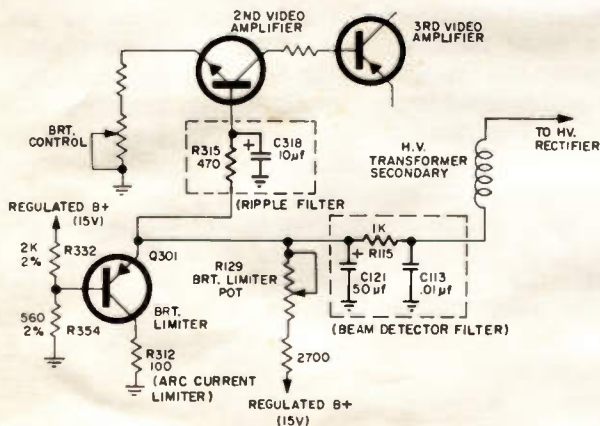

Figure 3—Simplified Brightness Limiter Circuit

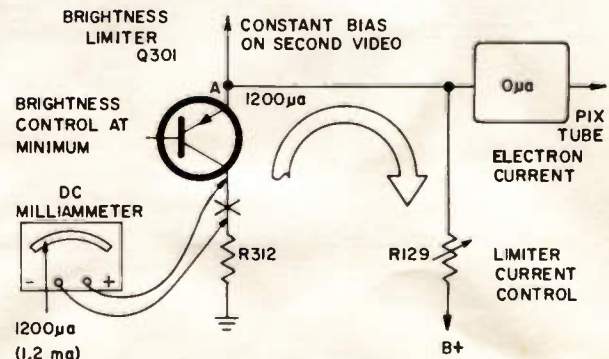

Figure 4—Limiter Current Measurement





## Servicing Direct-Coupled Circuitry

Technicians are being required to service more and more equipment that utilizes direct-coupled transistor stages. This type coupling is simple and transistors readily adapt to it. Many service technicians first encountered direct-coupled stages in portable radio audio output circuitry. Next came complete direct-coupled amplifiers for stereo instruments. Now, with the advent of transistorized television, even more direct-coupled circuits are being used.

In the direct-coupled circuit shown in Figure 5, resistor  $R_3$  serves as both the collector load resistor for transistor  $Q_1$  and the bias resistor for transistor  $Q_2$ . Resistor  $R_L$  is the output load of the amplifier. If another stage were added,  $R_L$  would serve the same function as  $R_3$ —collector load for  $Q_2$  and bias supply for the added stage. Resistors  $R_1$  and  $R_2$  enhance circuit stability for providing a feedback path. Stability is of prime consideration in direct-coupled stages since temperature-caused bias variations in one stage will be amplified by all following stages, resulting in temperature instability. This is often a limiting factor to the number of stages that can be direct-coupled.

Servicing direct-coupled stages requires a technique that is somewhat different from those used to troubleshoot R-C or transformer-coupled stages. A different approach is needed since each stage is dependent on the preceding stage for bias. If several stages are direct-coupled, a defect causing incorrect operation of one will affect the bias of the next, and therefore all succeeding stages. Normal signal injection/tracing techniques cannot completely isolate the trouble.

The actual troubleshooting technique involves checking individual transistor element bias poten-

tials. Start at the output stage of the circuit and check back through each stage to the input of the circuitry involved. Each reading is noted (written down if necessary) then compared to both the expected normal reading **and** to the readings taken at other points in the circuit. The starting point for troubleshooting circuitry in Figure 5 would be to measure the voltage drop across  $R_L$  to determine the operating condition of  $Q_2$ . Little (or no drop) would indicate non-conduction, while heavy conduction would cause a large drop. In either case, it is necessary to measure the bias potentials on  $Q_1$  to determine whether the trouble is **actually** in the circuitry of  $Q_2$ , or caused by **incorrect** bias supplied to  $Q_2$  (as a result of  $Q_1$  circuit defects). As an example: if tests indicate  $Q_2$  is conducting heavily, the cause could be  $Q_2$  emitter-to-collector leakage; however, the symptom would be similar if a defective  $Q_1$  did supply excessive bias to the base of  $Q_2$ . The defect can be isolated to a particular stage by checking bias potentials of **all** transistors in the circuit (starting at the output), and comparing these readings to the normal expected potentials and to each other. Other methods of direct coupling may be encountered. One is illustrated in Figure 6. The servicing technique described in this article is also applicable to this, and most other direct-coupled circuits.

Don't overlook the possibility of a defect in one stage supplying excessive bias to one or more succeeding stages, thereby causing other devices to fail. Some circuit designs have current limiting built-in to prevent subsequent device failure; in other designs, multiple device failure is quite possible. Remember, however, a logical analysis of all the DC bias potentials in a circuit will greatly simplify the troubleshooting procedure—regardless of the circuit configuration.

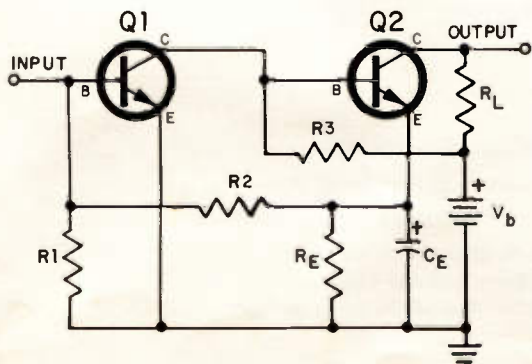

Figure 5—Typical Direct Coupled Circuit

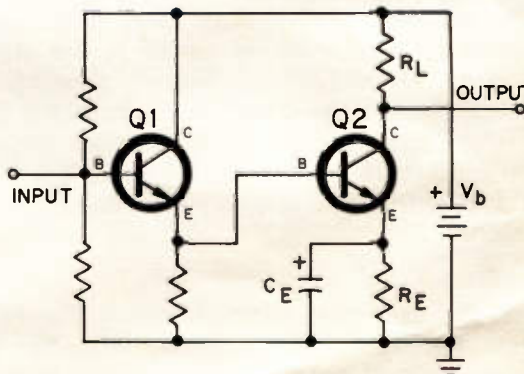

Figure 6—Another Example of Direct Coupling



