

RCA Plain Talk and Technical Tips

July, 1968 • Volume 11, No. 7

Television Sync

The composite video signal contains synchronizing information in the form of pulses that are added to the video signal during the horizontal and vertical blanking intervals. These serve to keep the scanning beam in step with the original scan produced at the broadcast station by controlling the frequency and phase of the vertical and horizontal sweep systems.

To better understand sync it is helpful to understand the composition of a video signal. The composite video signal (Figure 1) illustrates approximately 3 horizontal lines of a television picture. Scene brightness information is modulated on the video carrier so that increasing modulation produces a black picture. The black level of the video signal is set to produce 75% transmitter modulation. This means that the picture brightness information is contained between white at about 12½% modulation and black at 75% modulation.

At the end of each scan line, a blanking pulse (75% black signal) cuts off the picture tube to blank out the horizontal retrace line. During this interval, a horizontal sync pulse is produced and inserted in the "blacker-than-black" area above 75% modulation. Therefore sync rides on top of the blanking pulse and drives the transmitter to 100% modulation.

Continued on Page 4

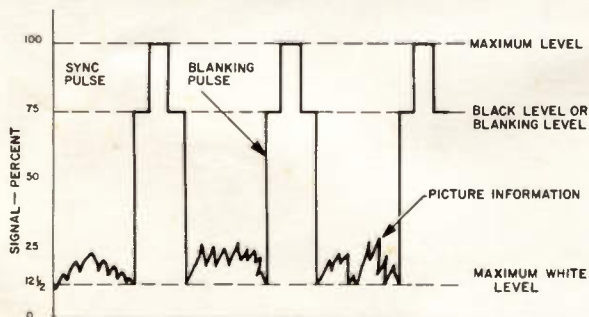

Figure 1—Composite Video Signal

CTC 38 Color Demodulators

The chroma circuitry in the hybrid CTC 38 chassis is very similar to that used in the CTC 31. It includes two chroma bandpass stages and a transistorized ACC/color killer system that operates in conjunction with the familiar injection-locked oscillator.

Additional solid-state components are used in a new balanced diode color demodulator circuit. This circuit should be of special interest to the reader, as it is the first use of solid-state color demodulators in RCA color chassis.

The balanced diode circuit is best understood by examining the action of one of the demodulators. The diode pair illustrated in Figure 2 will demodulate on any color axis—R-Y and B-Y in the CTC 38. The color difference signal obtained is determined by the phase of the chroma information with respect to the reference signal. To simplify the illustration the chroma bandpass stages are replaced by generator producing 3.58 MHz sidebands that vary in phase and amplitude with respect to the 3.58 reference signal. A second generator supplies a 3.58 CW signal that is phase displaced from burst by a pre-determined angle. The exact phase angle is chosen to obtain a particular color difference signal such as R-Y or B-Y.

Demodulator Action—Simplified

The cathode of diode D1 and the anode of diode D2 are connected to the 3.58 MHz reference signal. Chroma information from the bandpass transformer (varying in phase/amplitude) is applied to the anode of D1 and the cathode of D2. The center-tapped secondary of the bandpass transformer permits diode D2 to receive voltage which is equal in amplitude but opposite in phase to that applied to diode D1. Diode conduction occurs when the voltage relationship between chroma and the reference are such that the anode of the diode is more positive than the cathode. The conduction time of each diode is determined by the relative phase

Continued on Page 2



Color Demodulators

Continued from Page 1

and amplitude of the two voltages applied to the diode at that particular instant.

The waveforms associated with Figure 2 show the demodulator circuit under three signal conditions. The first condition occurs when the phase of chroma and the CW reference signal differ in phase by exactly 90° . The red and blue sections of the waveforms indicate the conduction time of the appropriately colored diode in the illustration. The red sinewave indicates the chroma voltage impressed on the anode of diode D1. The black waveform is the reference 3.58 CW and the blue waveform is the out of phase chroma signal that is applied to the cathode of diode D2.

As the instantaneous anode voltage of diode D1 becomes more positive than the reference voltage (at time A) the diode switches on and remains on until the chroma voltage drops below the reference voltage as shown at time B. Diode D2 conducts when the instantaneous chroma voltage at the cathode becomes more negative than the reference voltage (time C) and conduction continues until time D when the chroma voltage becomes more positive than the CW reference.

Blocking capacitors C1 and C2 receive a charge that is proportional to diode conduction; the polarity of the charge is determined by the diode connection. The demodulator output voltage is the difference between the two diode voltages.

Assuming R1 and R2 are matched values, equal diode conduction results in equal but opposite voltages on capacitors C1 and C2. The addition of these voltages obviously results in zero.

A negative output voltage results when the chroma applied to D1 is phased so that it leads the reference signal. In this case, the red curve (chroma to anode of diode D1) is positioned so that the diode conducts for a longer period of time than diode D2. This produces an imbalance between diode voltages, causing a negative voltage output.

Positive output results when the phase of the chroma signal applied to diode D1 lags the reference phase; conduction time of diode D1 decreases and diode D2 conduction increases. As a result, the positive voltage from diode D2 is larger than the negative voltage produced by diode D1.

Demodulator Action—Color Bars

When a color signal is received, (using keyed rainbow color bar pattern for example) maximum positive or negative demodulator output is obtained when the incoming chroma signal is in phase with the CW drive at one or the other of the diodes. Zero output results when the chroma information is leading or lagging the CW reference signal by exactly 90° . This indicates that the demodulator output from a color bar signal will roughly resemble a sine wave as the chroma phase from the generator varies a full 360° .

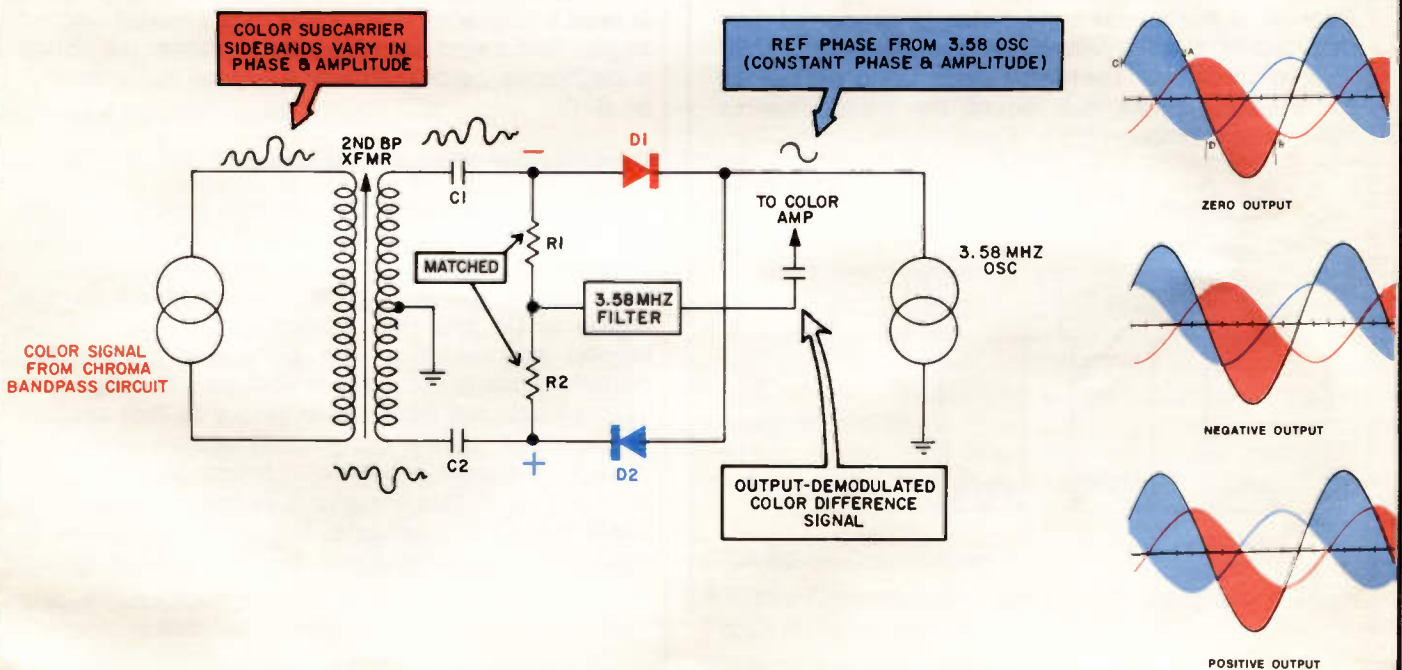

Figure 2—Simplified Diode Demodulator



The Silicon Controlled Rectifier

Conventional television receivers utilize a flyback type horizontal output stage which operates with relatively high pulse voltages. This challenges engineering talent to design components which will withstand these high-voltage pulses. In transistorized receivers, the situation is aggravated because of the economic limitations imposed when transistors of sufficiently high breakdown voltage are needed for a horizontal output stage. Therefore operating voltages in transistor deflection systems, are reduced to a minimum practical limit by using low impedance horizontal circuit components. But, to supply the necessary deflection and high voltage requirements, it is necessary for a transistor horizontal output stage to operate at relatively high peak currents—again makes transistor selection somewhat critical.

RCA's new CTC 40 all solid state chassis utilizes **two** silicon controlled rectifiers (SCR's) in a new type horizontal deflection system which is capable of handling substantially higher current and voltage than can be obtained using economically feasible transistors.

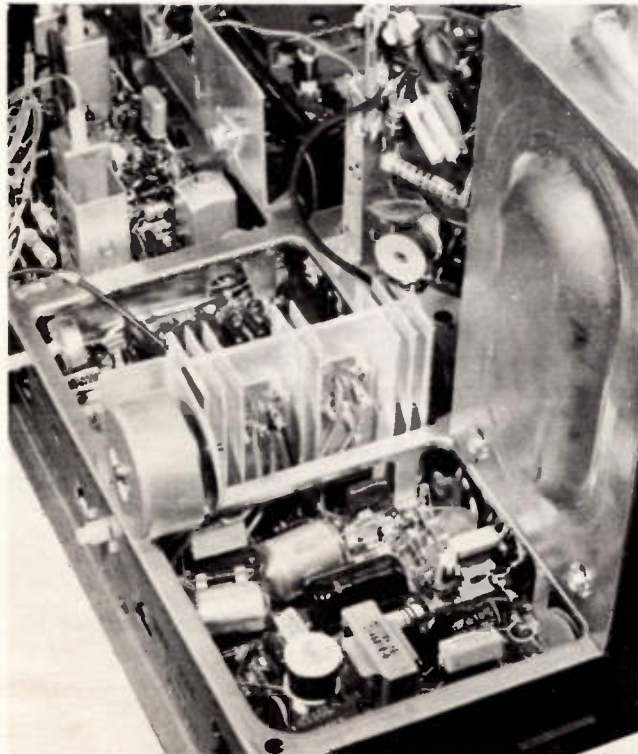

Figure 3—CTC 40 Chassis Showing SCR Location

The silicon controlled rectifier is similar in operation to the thyatron tube, in that it is non-conductive until turned on by a control electrode. When turned on the device acts as a normal rectifier and is capable of conducting high currents with very little forward voltage drop between the anode and cathode. Once turned on, the SCR continues to conduct until it is turned off by either reversing the anode-cathode voltage or by reducing the current through it to the point where the SCR again exhibits a high resistance.

In addition to the anode and cathode found in conventional rectifiers, the SCR includes a control electrode called the gate. When a sufficient control current is applied between the gate electrode and the cathode of the device, it switches "on" and the SCR conducts like a conventional rectifier.

It's obvious that the **high off resistance** and the **low on resistance** make the SCR a nearly ideal switch. Coupling these two advantages to the desirable **high breakdown voltage**, it is evident that the SCR can be used to advantage to switch large amounts of power—such as in horizontal deflection systems.

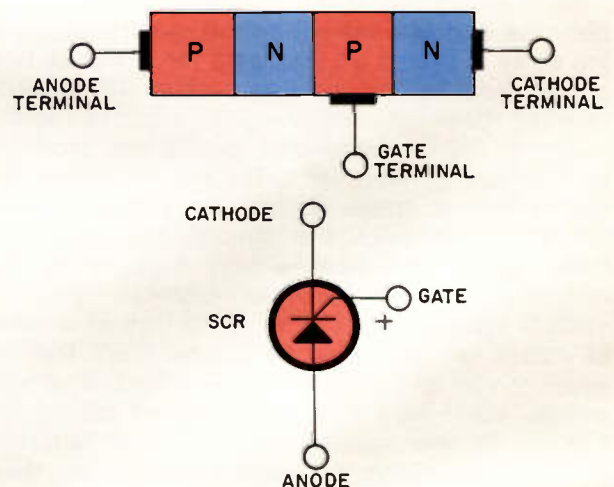

Figure 4—SCR Schematic Symbol

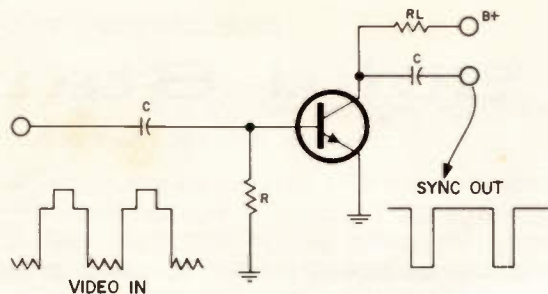

Figure 5—Simplified Sync Separator

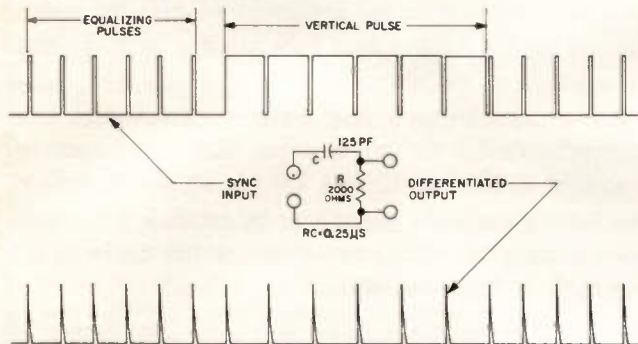

Figure 6—Differentiator Action

Television Sync

Continued from Page 1

Sync Separation

In a TV receiver it is necessary to separate the synchronizing information from the video signal. This is accomplished by a stage usually called the sync separator. The sync separator utilizes either a tube or transistor that is biased so that it conducts only during the "blacker-than-black" sync interval. As a result, its output contains only sync pulses. Figure 6 illustrates a highly simplified sync separator circuit. The circuit is biased into cut-off so that the transistor is driven on only by the high-level sync pulses. Thus the output consists of amplified sync.

Near the end of each scan field, a vertical blanking pulse is produced that lasts for about 22 horizontal lines. During the first part of the blanking interval, prior to beginning vertical retrace, a series of narrow equalizing pulses are produced at a frequency equal to twice the horizontal line rate. Although these pulses are shorter in time and occur at twice the normal line scan rate, there is still sufficient energy content so that alternate pulses can provide horizontal sync. The vertical sync information is comprised of a **series of pulses** (at twice the horizontal rate) that are much longer in duration than the horizontal sync pulses. Horizontal sync is furnished during this interval by the leading edge of each alternate pulse. After suitable processing (integration) these wide pulses provide synchronizing information for the vertical sweep system.

Because the horizontal and vertical sweep frequencies are widely separated it is possible to use frequency-selective R-C networks to recover

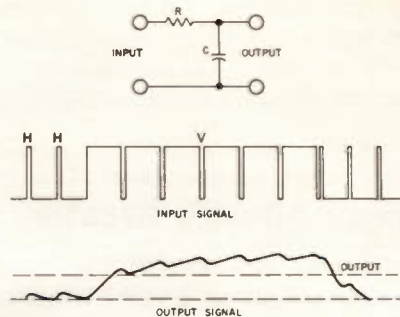

Figure 7—Integrator Action

the necessary synchronizing information for each deflection system. The output of the sync separator drives two networks; a high pass differentiating network provides horizontal sync and a low pass integrating circuit supplies vertical sync.

Differentiator Circuit

The differentiator circuit, which processes horizontal sync, in its most elementary form consists of a small capacitor and a relatively low resistance connected as shown in Figure 7. The small capacitor is charged **quickly** through the low resistance by the leading edge of the sync pulse. The voltage developed across the resistor (produced by the capacitor charging current) decays very rapidly, producing a voltage spike which is used to control the horizontal oscillator. This spike is compared to a pulse produced in the horizontal deflection system. Any timing difference between these pulses is converted to an error voltage by the horizontal AFC system and serves to correct horizontal oscillator frequency.

Integrator Circuit

During the vertical blanking interval, vertical sync is processed by a low-pass, long-time-constant circuit called an integrator. This circuit (Figure 8) averages the applied sync pulses so that the voltage developed on capacitor C is proportional to the sync pulse width (energy content). As a result, when the short-duration horizontal pulses, and even narrower equalizing pulses are applied to the integrator, very little capacitor voltage is developed. When longer duration pulses (vertical sync) are furnished, the output voltage of the integrator increases as illustrated in Figure 9. Vertical sync is accomplished because the vertical sweep circuit is designed to trigger at a certain voltage level, and when the integrator voltage exceeds this value, vertical retrace is initiated.

RCA Sales Corporation

A Radio Corporation of America Subsidiary
Product Performance—Technical Training

600 North Sherman Drive
Indianapolis, Indiana 46201

Copyright 1968—RCA Sales Corporation