

PLAIN TALK

AND

Technical Tips

a monthly publication for the service industry prepared by:



RCA VICTOR



VOL. **8**

NO. **1**

JANUARY, 1965

PRODUCT PERFORMANCE
RCA SALES CORPORATION

CHECK YOUR SERVICE DATA

You should check the condition of your service literature frequently during the year to insure that your technical information is complete and properly filed. The start of a new year is an ideal time to organize your service data files.

Remember if you are missing data, or have badly shop worn issues, these can be ordered at nominal cost by writing to:

RCA Sales Corporation
Consumer Relations
Building 1-206
600 North Sherman Drive
Indianapolis, Indiana 46201

Specify which issues you require (indicate file number, model number, or chassis number). The cost for single copies of data is \$.50 each for television issues, and \$.25 each for Radio/"Victrola" issues.

A Service Technician can subscribe to RCA Victor Service Data at *any* time of the year by contacting his local RCA Victor Distributor. All new subscribers receive a complete retro-active mailing covering all Television and Radio/"Victrola" instruments for the current subscription year.

SOLID STATE TOPICS

You may have noticed that the last five issues of "Plain Talk and Technical Tips" have had page three devoted to Solid State Topics. This feature will continue through 1965 with exceptions only when other subjects prevent the use of page three for this purpose.

Each Solid State article is brief and written in the usual "Plain Talk" style. A single topic is used, and the highlights of this particular topic are brought out to help the service technician acquire Solid State information.

The practical approach is stressed in these Solid State discussions with special illustrations to bring each point across.

Remember to check page three of "Plain Talk and Technical Tips" for the current solid state topic—be sure your file is complete so you will have a ready reference to the Solid State articles.

THE NEW RS-212 AMPLIFIER

The RS-212 chassis is the latest addition to the new concept in power amplifier design. The new unit is a Solid State power amplifier and power supply chassis containing eight transistors and three diodes. It is used in conjunction with the RC-1215 tuner in a group of recently announced high-fidelity stereophonic Radio "Victrola" combination consoles. All components on the chassis are top-mounted as in the RS-209, 210 and 211 chassis. The four output transistors on the RS-212 chassis are mounted on the outer surface of a single vertical end plate. The driver transistors are mounted in heat sink clips attached to the inner surface. The end plate provides for the required heat dissipation for the transistors. The interstage transformers are also mounted on the outside of the vertical end plate to provide shielding and minimize the possibility of hum pickup.

The RS-212 chassis is electrically similar to the RS-210 chassis. It embodies an audio amplifier impedance matching input stage, a driver stage, and a Class B output stage for each channel. It has two power supplies, one for the amplifier chassis and one for the tube type RC-1215 tuner chassis with which it is used.

The RS-212 delivers a music power output of 20 watts E.I.A. (40 watts peak).

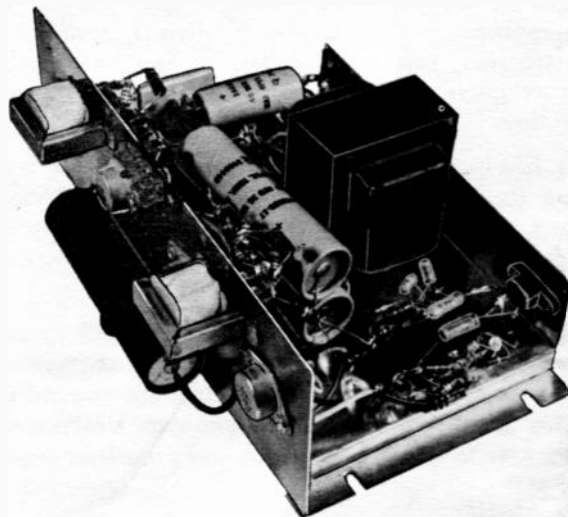

Figure 1—The RS212 All Transistorized Audio Amplifier

UHF RECEPTION

UHF reception characteristics vary with distance, terrain and transmitter power output. Under ideal conditions over fairly level terrain, good reception can be obtained at 35 miles. By using an efficient outdoor antenna, good reception is often obtained at 50 miles or more.

Tests indicate that interference problems in the UHF band are few compared to the VHF band. Many interferences encountered in VHF reception do not normally occur at UHF. The effect of electrical interferences such as truck ignition, medical diathermy, and electrical devices which can be bothersome to the VHF installation are absent in the UHF band. Additionally UHF is essentially free of adjacent channel and co-channel interference, as a result of allocations.

UHF installation procedure is similar to that of VHF with some few exceptions. For UHF the receiving location and associated signal conditions are the principle factors in determining the type of installation.

The installation requirements in strong signal areas are less requiring than in weak signal areas. Selection of the antenna and transmission line should be more carefully considered for UHF than in a VHF installation.

It should be kept constantly in mind that dielectric losses in materials at several hundred megacycles are far greater than at the comparatively low frequencies used in the VHF band. Losses at UHF frequencies make it necessary to select materials with care and to install the antenna and transmission line in the best mechanical and electrical way to avoid these losses.

Selecting the Antenna

UHF antennas in general are smaller, less conspicuous and offer much less wind resistance than VHF antennas. The installation of a UHF antenna requires care, with emphasis on orientation and antenna placement.

The service technician should concern himself with the appropriate UHF receiving antenna. Simplicity of construction, ease of installation, and the resulting picture quality are the factors to determine antenna selection.

It has been demonstrated that under many conditions, the indoor antenna may perform satisfactorily. When results indicate less than a good "Commercial quality" picture, it will then be necessary to make use of an outdoor antenna for UHF reception.

There is a wide selection of good UHF antennas available today. The choice of outdoor antenna type will have to be based upon the actual signal conditions at any given location. Some common UHF antenna types are:

(Continued on page 4)

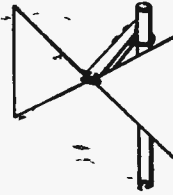

Fan Dipole
(Bow Tie)



Fan Dipole/
Reflector



Stacked
Fan Dipole



Stacked Fan
Dipole/Reflector

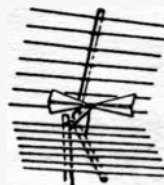

Corner
Reflector



Yagi

Figure 2—Typical UHF Antennas

TRANSISTOR CONNECTIONS

In many ways the transistor can be compared to a vacuum tube. While the two devices *operate* on different principles, the way in which they are connected can be compared to illustrate circuit similarities.

Grounded-Base Amplifier

The grounded-base amplifier circuit is similar to the grounded-grid vacuum tube amplifier which has extensive use as an RF amplifier in television tuners. A comparison of these two basic circuits is shown below. As can be seen, the base of the transistor and the grid of the vacuum tube are grounded. The emitter is biased in the direction of greatest electron flow and the collector is biased in the direction of least electron flow. With this bias arrangement the input of the transistor has a low resistance in the order of 20 to 50 ohms and the output has a high resistance which is approximately 1 to 2 megohms.

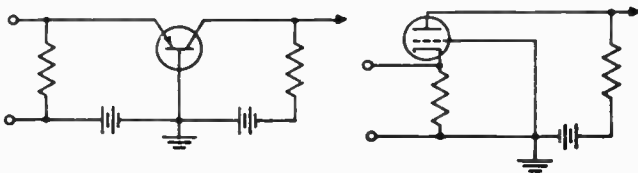

Figure 3—Grounded Base Compared to Grounded Grid

The current gain (or alpha) is always less than unity in this type of circuit and is usually in the order of 0.98 to 0.99. The voltage gain in this type of circuit may be in the order of 1500.

It is very important to maintain the proper collector voltage and emitter current so as not to exceed the maximum dissipation of the transistor. The grounded-base circuit is used when a circuit calls for a very high output impedance.

Grounded-Emitter Amplifier

The grounded-emitter amplifier is similar to the conventional, grounded-cathode, vacuum tube amplifier. The signal is applied to the base of the transistor, whereas in the vacuum tube the grid is the driven element. A comparison between the transistor and vacuum tube circuits is shown below.

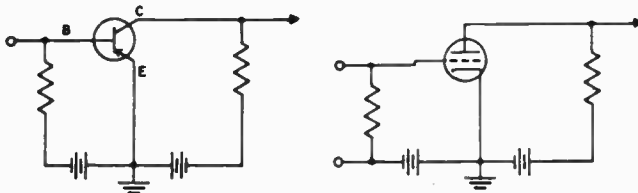

Figure 4—Grounded Emitter Compared to Grounded Cathode

As in the case of the grounded-base amplifier the emitter is biased in the direction of greatest current flow and the collector is biased in the direction of least current flow. The resistance of the input circuit is normally in the range of 1,000 to 2,000 ohms, however it may be as low as 100 ohms or as high as 10,000 ohms. The output resistance is normally about 50,000 ohms, however, it may be as low as 5,000 ohms and as high as 500,000 ohms.

Power gains of 42 db or approximately 10,000 times can be realized with this circuit arrangement. The voltage gain of this circuit arrangement is the same as that of the grounded-base connection, but the current gain is considerably higher. Due to this increase in current gain over the grounded-base connection, this circuit is popular for many circuit designs.

As with the grounded cathode vacuum tube circuit, a voltage reversal takes place between base and collector.

Grounded-Collector Amplifier

The grounded-collector amplifier circuit is similar to the vacuum tube cathode follower circuit. Both circuits are illustrated below.

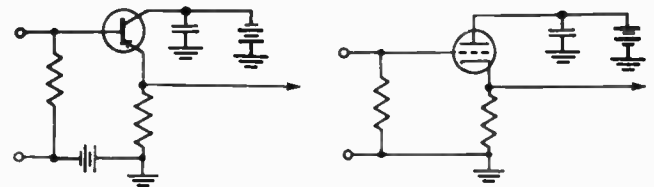

Figure 5—Grounded Collector Compared to Grounded Plate

The output impedance of the transistor circuit is dependent on the input impedance, however, this is not the case in electron tube circuits. In the case of the grounded collector circuit, the voltage gain is less than unity and the power gain of the stage is usually lower than either the grounded emitter or grounded base stages. The circuit is often used as an impedance matching device, matching fairly high input impedances to a low output impedance.

As in the case of the grounded base amplifier there is no phase reversal of the signal between the input and output. The same is true in the cathode-follower vacuum tube circuit and the grounded grid tube circuit.

Notice that each transistor circuit can be compared to a similar vacuum tube circuit. Although the vacuum tube circuit (under comparison) is always a triode, the transistor counterpart may perform more like a pentode — This is one of the advantages of transistorized circuitry.

UHF RECEPTION

(Continued from page 2)

The Fan Dipole

The fan dipole (bow tie) is the simplest of all UHF antennas. The antenna is constructed of two metal triangles lying in the same plane. The fan dipole shows some gain over a half-wave dipole. The fan dipole has a wide bandwidth. Its usage has generally been confined to strong signal, reflection free areas.

The Fan Dipole With Reflector

Improves front-to-back ratio. Used to minimize minor reflections.

Stacked Fan Dipole

To obtain added gain and vertical directivity, the fan dipole can be stocked vertically. The gain is increased over that of a fan dipole, and displays a rising gain characteristic with frequency. Additional gain may be obtained by stacking four dipole antennas. The horizontal directivity pattern of the stacked units is essentially the same as the single unit.

Stacked Fan Dipoles With Reflector

Improves front-to-back ratio for greater directivity.

Corner Reflector Antenna

At UHF frequencies, the constructional limitations encountered at VHF are considerably eased, and the use of a sheet reflector-type antenna becomes practical. The corner reflector is one antenna of this type that has been used and found to yield very good results. It may be made light in construction, and electrically has outstanding characteristics. This antenna is a high gain antenna, with substantially uni-directional field pattern in the horizontal plane. The almost complete absence of unwanted lobes should minimize reflections and multipath reception.

Yagi Antenna

The Yagi antenna has been found equally as useful at VHF when single channel reception is desired. It produces more gain for its size and weight than any other type of antenna. However, to obtain optimum results, the mechanical construction is very critical, and close dimensional tolerances must be held if its potentialities are to be realized. The Yagi antenna is an excellent performer with respect to reflection elimination and unwanted signal reductions; however, it is a "one channel" antenna due to its narrow band characteristics. To obtain increased gain, Yagi's may be stacked if desired.

Among the antennas listed the fan, stacked fan, and corner reflector antennas are considered most practical for present purposes. As the service technician gains experience in handling various UHF installations, it will become evident that certain conditions will call for certain antenna types and installation methods. Just as with VHF, the fringe, near fringe, and problem areas will require the elaborate installation while the strong signal areas will use the more simple installations.

CRITICAL LEAD DRESS

The high frequencies which are used in television and FM receivers require that careful attention be given to the location, arrangement, and "dressing" of all circuit wiring.

At high frequencies even a short length of wire can represent considerable impedance.

In the design of RCA Victor products special emphasis is placed on this important aspect. Ground points, component locations, and the overall physical layout of a particular chassis are studied and checked for stray coupling and susceptibility to oscillation as well as optimum electrical performance before a design is finalized for production.

The same precautions are taken even in audio amplifiers to assure desired performance characteristics and minimize any possibility of self-oscillation.

In chassis which utilize etched circuit construction, lead dress is firmly established in the initial design which insures correct lead dress even when various components are replaced in the course of servicing.

Service data for RCA Victor products include information regarding critical lead dress and the service technician should be guided by this data whenever performing service work on an instrument.

SPEAKER PHASING

All internal and external speakers in a Television or Radio/"Victrola" instrument must be properly connected in order to have "in-phase" sound outputs. Similarly the speakers in each system must be phased with each other. Incorrect connections may be evidenced by "loss of frequencies" or distortion in the sound when playing a monophonic recording and listening from a point midway between the two speaker systems.

Always make certain speaker systems are phased correctly. Speaker connection diagrams are shown in RCA Victor Service Data.

RCA SALES CORPORATION

600 NORTH SHERMAN DRIVE
INDIANAPOLIS, INDIANA 46201
A RADIO CORPORATION OF AMERICA SUBSIDIARY
Tmks. © Reg. U. S. Pat. Off.