



Ham Tips

PUBLISHED - IN - THE - INTEREST - OF - RADIO - AMATEURS - AND - EXPERIMENTERS

VOLUME VIII, No. 2

EDITORIAL OFFICES, RCA, HARRISON, N. J.

MAY—AUGUST 1948

DELUXE TRANSMITTER USES PAIR OF 812-A TUBES IN FINAL

COMPACT 6-BAND 1/2-KW RIG HAS SIMPLE BAND-SWITCHING EXCITER

TURN DOWN THE GAIN CONTROLS!

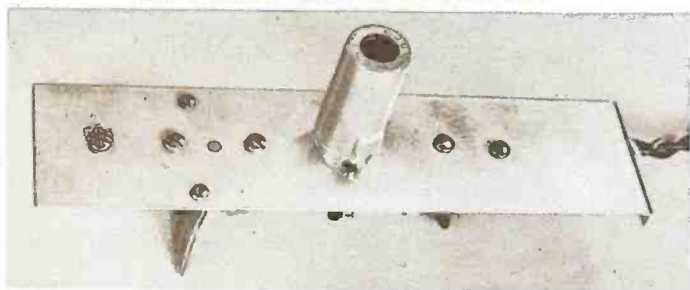

This easily-built pre-amplifier unit greatly increases signal strength and improves receiver sensitivity on the popular 2 meter band.

By GEO. H. JONES, JR., W2CBL

This easy-to-build transmitter works as nice as it looks, on 10, 11, 15, 20, 40, or 80, with a full 1/2-kw input to a pair of RCA-812-A's from a 1500-volt power supply. The new 812-A handles more power and is better than the superseded 812, which makes it an attractive choice for this flexible rig. The transmitter is built on a 17"x13"x3" chassis, with a standard rack-mounting 19"x12 1/4" panel. The power supplies and modulator, not illustrated, are of similar construction, and are mounted in a standard 3 1/2-foot relay rack.

LOW-NOISE BROAD-BAND PRE-AMPLIFIER DESIGNED FOR 2-METER RECEIVERS

By E. M. BROWN, W2PAU and J. T. BLAKE, W2PFQ
Engineering Products Department, RCA

In the two-meter band, one of the best ways to improve receiver sensitivity is to add a properly designed pre-amplifier. The one described in this article will increase the signal strength two to three points on the "S" meter of a receiver and has such a high signal-to-noise ratio, that its performance is limited only by antenna noise.

The pre-amplifier is inserted in a 300-ohm feeder, between the antenna and the regular two-meter receiver. The unit has a broad-band response so that only an occasional touch-up of the tuning is necessary.

Design Considerations

On the low-frequency bands, the limit of useful receiver gain is set by QRN, man-made or natural. Signal-to-noise ratio is of minor significance and the features usually considered for determining the merit of a low-frequency receiver include such factors as bandwidth of if stages, audio response, ease of tuning, and image rejection.

On the vhf bands, atmospheric noise is practically non-existent. Man-made noise may be troublesome, but in most locations it is a minor problem. The noise which limits the performance of an ideal vhf receiver, however, is the thermal noise generated by the antenna. The thermal noise across a 300-ohm input line is equivalent to about 0.2 microvolts in a good communications-type receiver having an if band-pass of 10 kilocycles. If a gain of 5 can be ob-

tained from a "quiet" rf pre-amplifier, the 0.2 microvolts of thermal noise can be detected by a receiving system including the pre-amplifier and a receiver capable of detecting a one-microvolt signal.

Circuit Selection

If the proper circuit is chosen, considerable reduction in tube noise generated within the amplifier stage can be achieved. Since triodes generate less noise than pentodes, it is well to consider utilizing a triode in the rf stage. Triodes in push-pull were selected for the pre-amplifier because such a circuit permits the use of a step-up antenna transformer and takes advantage of the full gain of the triode stage.

Of course, the triodes have to be neutralized but the new miniature tubes and components that are now available permit such compact circuit layouts that nearly perfect neutralization is easy to achieve. The push-pull connection reduces the input capacitance by 50% which makes for a broadly resonant, high-inductance circuit.

The RCA-6J6 twin triode was selected for this pre-amplifier chiefly
(Continued on Page 4, Column 1)

Panel, chassis, and shields are constructed of aluminum to minimize rf losses, since the circuit components are compactly assembled. The layout of rf components follows in the same order as in the schematic diagram, Fig. 1, starting with the 80-meter crystals and proceeding counterclockwise to the 812-A's.

Fairly high screen and grid-biasing resistors are used in the crystal-oscillator circuit to facilitate doubling when an external vfo is used. A 560-ohm cathode resistor limits the non-oscillating plate and screen currents to a low value. Crystals X₁ and X₂ operate near the edge of the 80-meter band and can be used as band-limit markers when adjusting the vfo.

The first multiplier grid is tapped down about 1/3 from the plate end of L₁ to provide proper excitation to the following multiplier grid. A

three-turn link, switched through S₂, gives ample coupling to the 807 grid tank L₂. For 80-meter operation, S₂ couples the oscillator output to the 807 grid circuit and removes plate voltage from the three multiplier stages. L₂ tunes sufficiently below 3500 kc to provide excitation for the 11-meter band when multiplying eight times.

Approximately 3 milliamperes of grid drive are supplied to the first multiplier stage by the crystal oscillator, and about 10 milliamperes are delivered to the 807's.

Tank L₂C₁₀ of the first multiplier stage covers double the frequency range of the crystal stage. This first multiplier drives the second multiplier through C₁₁; or, with S₂ in the "40" position, the first multiplier drives the 807's through the link coupled to L₂. Grid drive to the 807's on the 40-meter band is

(Continued on Page 2, Column 1)

BUSINESS-LIKE AND EFFICIENT

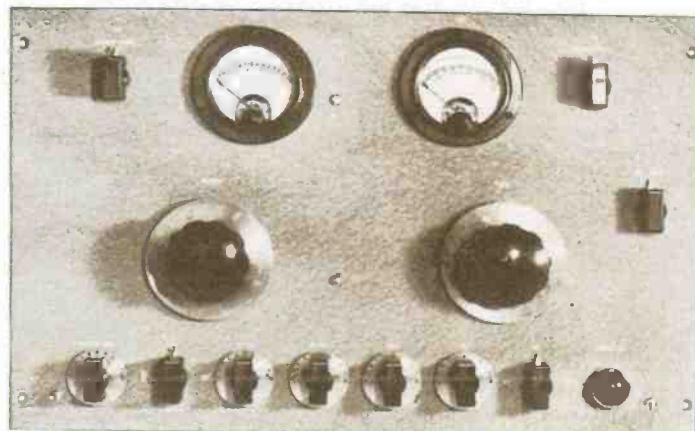

The efficient manner in which this versatile rig was designed and constructed is reflected in its panel symmetry.

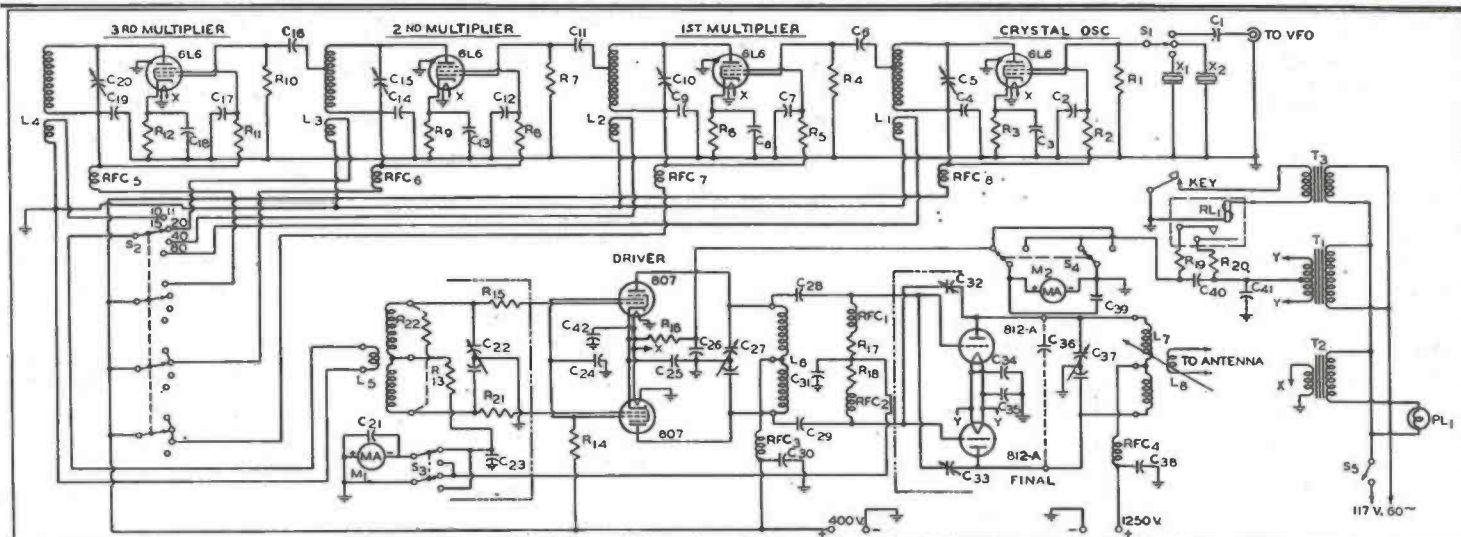

Figure 1. Schematic of the 6-band transmitter.

COMPACT 6-BAND RIG

(Continued from Page 1, Column 4)

practically the same as when operating directly from the crystal oscillator on the 80-meter band.

For 20-meter operation, L_3C_{15} is tuned to four times the oscillator frequency; for 15-meter work L_3C_{15} is tuned to six times the oscillator frequency. Equal excitation (10 milliamperes) is delivered to the 807 grids when doubling or tripling. With S_2 in the "15-20" position, plate voltage is applied to the second multiplier and the link-coupling circuit is completed between L_3 and L_5 .

The third multiplier tank L_1C_{20} covers a frequency range eight times that of the crystal stage, and supplies 10- and 11-meter drive (10 milliamperes) to the 807's when S_2 is in the "10-11" position.

Circuit Symmetry

Suitable values of L_5 must be plugged-in to operate on the various bands. On 80, 40, and 20, it was found desirable to shunt L_5 with the 20,000-ohm resistor R_{27} for suppression of normal-frequency parasitics. No shunting resistor is needed for the 10-meter coil. The 33-ohm resistors R_{15} and R_{21} are parasitic-oscillation suppressors and are mounted as closely to the socket pins as possible.

The 807 stage was laid out with considerations of circuit symmetry and good shielding between plate- and grid-tank circuits, since this stage operates at all times with grid and plate circuits at the same frequency. Two 807's are used to provide push-pull excitation to the 812's with simple circuit means. Plug-in coils are used in the grid and plate circuits of this stage. Standard B&W coils cover the 80-, 40-, and 20-meter ranges, but the plate coil required modification for the 10-meter band. For 10-meter operation, L_5 is a 6-turn coil 1 1/4 inches in diameter, wound 3 turns per inch with No. 10 wire.

Due to effective shielding and layout, the 812-A final is stable when neutralized. The stage is neutralized with the transmitter adjusted for 10-meter operation. Once C_{32} and C_{33} are set, no further adjustment is necessary when other plug-in coils are used.

Standard B&W coils for the 812-A final were found satisfactory for operation on the 10-, 20-, and 40-meter bands, but the 80-meter coil required modification. Four turns were removed from each outside end of this coil to obtain an improved L/C ratio. Plug-in capacitor C_{30} is a fixed padding capacitor which is used only for 80-meter operation; it is removed when shifting to higher frequency bands. Grid drive to the final (read on M_1) runs 50 to 60 milliamperes under full plate power input to the final.

Filament center-tap keying is used because it gives clean keying and because the transmitter is completely self-biased. With key

up, the filament circuit may rise to a maximum of 480 volts above ground. C_{10} , R_{10} , and R_{20} comprise a filter which materially reduces key clicks.

The plate-power requirements are simple: a 400-volt, 200-milliamperere supply for the crystal oscillator, multiplier stages, and the push-pull 807 driver stage; and a 1500-volt, 350-milliamperere supply for the 812-A final stage will fill the bill.

No special tools or fittings are required for construction of the transmitter. Shielding construction is all of flat aluminum with no forming other than right-angle bends for mounting to the chassis and panel.

The plate-circuit components and tubes for the driver stage are above and on the left-hand front portion of the chassis. The final 812-A tubes are mounted in a horizontal position through the inter-stage shield between the 807 and final stages, with the filaments in a vertical

plane. The neutralizing capacitors and plate-circuit components for the final stage are on the front right-hand portion of the chassis. This layout affords short and direct coupling from stage to stage and allows front-panel controls to be brought out in a symmetrical arrangement.

Metering and switching is provided for reading grid current to the 807 or 812-A stages on one meter, and cathode or total tube current on another meter. This metering is ample for complete tuning of the transmitter on all bands and keeps the meters at ground potential.

Shock Proof Panel

One important feature of the transmitter is its shock-proof front panel. One terminal of each meter is bonded to the panel. The two final-stage tank-tuning capacitors are mechanically grounded, and all switch shafts are grounded metal. The oscillator-, multiplier-, and antenna-coupling shafts are insulated, but pass through grounded 1/4-inch bushings at the front panel.

There are four small inter-shield panels, all made of 1/16-inch aluminum. One of these is mounted under the chassis 4 inches from the rear edge. The crystal oscillator is mounted on this shield, in addition to three multiplier tuning capacitors and switches S_1 and S_2 . A second inter-shield is mounted above the chassis just to the left of center, separating the 807 and 812-A stages. Two other small shields are used to box off the 807 grid coil and shield it from the 807 plate coil.

Mounting of other parts is evident from the illustrations. Besides the four inter-stage shields, there are two rear support brackets for the 807 and 812-A plate-tuning capacitors. A lucite panel is used to insulate the crystal-oscillator and multiplier tuning capacitors. Three-quarter inch holes were first punched in the under-chassis shield for the four capacitors; the lucite strip was then mounted behind this

A "BALCONY" VIEW

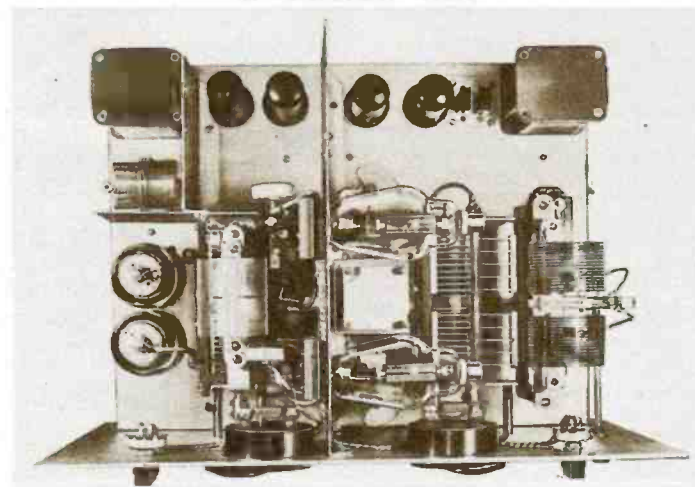

Good shielding between plate and grid-tank circuits was incorporated in the compact 1/2 kw rig.

shield and shaft-bushing clearance holes were drilled concentric with the 3/4-inch holes for the tuning capacitors.

Band switch S_2 was partially disassembled and the rf-link switching section was reassembled behind the under-chassis shield panel. The crystal switch S_1 is mounted behind this panel on the left-hand end. This switch is wired to a coaxial connector on the chassis so that excitation from an external vfo can be brought to the transmitter. When using an external vfo, its frequency should be one-half that of the normal crystal frequencies; the 80-meter stage is then used as a doubler and operates the same as the other multiplier stages in the transmitter.

Cabinet Considerations

All parts can be mounted before wiring with the exception of the tank coils, the links for the crystal oscillator, and three multiplier stages, and the tuning capacitor C_{22} for the 807 stage. With these parts out, all socket lugs and wiring points are accessible for wiring.

A transmitter of these voltage and power requirements should be completely encased in a grounded metal cabinet for elimination of shock hazard. The metal cabinet also helps to reduce harmonic radiation and television interference. (See page 166 of the ARRL Handbook, 1948 edition). If ventilating louvers are used, they should be covered completely with close-meshed screening on the inside of the cabinet.

Tuning of the transmitter is simple, once the operator becomes acquainted with the controls. A change from band to band can be made in less than two minutes.

The first tune-up should be made on 80 meters. With the 80-meter coils plugged into positions L_5, L_6, L_7 , with C_{26} inserted and S_2 turned

to the "80" position, the unit is ready for tuning. Oscillator tuning control C_3 is tuned until a change in 807 cathode current (read on M_2) is noted. This change indicates that the crystal is oscillating. C_{22} is then tuned to resonance to give maximum grid drive to the 807 stage (read on M_1 with S_2 in the proper position). **CAUTION:** When the final tank is out of resonance, excessive plate dissipation must be avoided by reducing the plate voltage, or by tapping the key rapidly.

Tuning Details

The plate circuit of the 807 stage is then tuned to resonance (indicated by minimum current as read on M_2). The 812-A final stage should next be neutralized. With the plate voltage off, and key down, C_{21} and C_{23} are adjusted until there is no dip in the final grid current when tuning the final tank capacitor C_{21} through resonance. The final grid current (read on M_1 with S_2 in the proper position) will be approximately 75 milliamperes with plate voltage to the stage off. This current will fall to approximately 60 milliamperes with plate voltage and full loading applied.

The transmitter is next tuned up on 40 meters. Coils L_5, L_6, L_7 are changed, and C_{26} is removed. (Note that C_{26} is left out on all bands except 80 meters). Band switch S_2 is changed to the "40" position. C_3 is left unchanged, and with the crystal stage oscillating as tuned for 80 meters, C_{10} is next tuned until a change is noted in the 807 cathode current, as observed when tuning-up on "80". After this current change is noted, tune-up the 807 and 812-A stages as explained for "80". C_{22} and C_{23} should not need adjustment if properly set in the first tune-up.

Tuning on 20 or 15 meters follows next. Proper coils are in-

NOW—A BETTER TRIODE



The new RCA-812-A is easy to drive, and easy on the pocketbook. A pair in class B can deliver 340 watts of audio at 1500 plate volts (ICAS rating). A single 812-A will handle an input of 260 watts (ICAS rating) in class C telegraphy up to 30 Mc. At \$3.75, it's an excellent buy in its class.

serted at L_5, L_6, L_7 , and S_2 is turned to the "15-20" position. C_3 and C_{10} are unchanged, and 40-meter drive is supplied to the grid of the 15-20 meter multiplier stage. C_{15} will give two indications of resonance: the first point, at double frequency of the previous multiplier, occurs when C_{15} is adjusted to nearly full capacitance, and supplies 20-meter drive to the 807 grids. The second point occurs near minimum capacitance of C_{15} , and provides 15-meter drive to the 807 grids. Tuning of the 807 and 812-A stages is accomplished as before.

Tune-up on 10 or 11 meters as follows: insert the proper coils at L_5, L_6, L_7 . Turn S_2 to the "10-11" position. Leaving C_3, C_{10} , and C_{15} set for 20-meter operation, C_{20} is then tuned for a current change in the 807 cathode circuit as explained above. The 807 and 812-A stages are tuned as before.

Note that the frequency coverage of L_1, C_{20} does not include 7.5 meters, so that if the tuning of the 15-20 meter multiplier is set at 15 meters, no resonance point will be found for the 10-11 multiplier.

Once the transmitter has been tuned up on the various bands, approximate settings of all controls will be known, and changing from band to band will become a simple operation.

- C_{20} = ZR25AS Cardwell Trim-air capacitor
 - C_{22} = EU100AD Cardwell capacitor
 - C_{27} = MT100GD Cardwell capacitor
 - C_{27}, C_{23} = NA10NS Cardwell capacitor
 - C_{26} = JCO-50-OS Cardwell capacitor
 - C_{27} = XG-50-XD Cardwell capacitor
 - R_1, R_4, R_7, R_{10} = 47,000 ohms, carbon, 1 watt
 - R_2, R_3, R_8, R_{11} = 47,000 ohms, carbon, 2 watts
 - R_3, R_4, R_9, R_{12} = 560 ohms, carbon, 2 watts
 - R_{13} = 10,000 ohms, carbon, 10 watts
 - R_{14} = 15,000 ohms, 10 watts
 - R_{13}, R_{21} = 33 ohms, carbon, 1 watt
 - R_{16} = 250 ohms, 10 watts
 - R_{17}, R_{18} = 5000 ohms, 10 watts
 - R_{19}, R_{20} = 50 ohms, 10 watts
 - R_{22}^* = 20,000 ohms, carbon, 1 watt
 - M_1 = Weston 301, 150 milliamperes
 - M_2 = Weston 301, 500 milliamperes
 - L_1 = B & W Miniductor No. 3016; 35 turns wound 32 turns per inch, 1" diameter, tapped at 10 turns from plate end; 3-turn link spaced 1/8" from ground end
 - L_3 = B & W Miniductor No. 3015; 22 turns wound 16 turns per inch, 1" diameter, tapped at 7 turns from plate end; 3-turn link spaced 1/8" from ground end
 - L_5 = B & W Miniductor No. 3014; 10 turns wound 8 turns per inch, 1" diameter, tapped at 3 turns from plate end; 3-turn link spaced 1/8" from ground end
 - L_6 = B & W Miniductor No. 3014; 7 turns wound 8 turns per inch, 1" diameter; 3-turn link spaced 1/8" from ground end
 - L_4 = B & W Type JCL; 5-pin socket mounting
 - L_4 = B & W Type B; center-tapped coil without link
 - L_7 = B & W Type TVL, variable linked, center-tapped
 - L_8 = B & W swinging link and base for TVL coils
 - T_1 = Filament Transformer, 2.5 volts, 5 amperes
 - T_2 = Filament Transformer, 6.3 volts, 8 amperes
 - T_3 = Filament Transformer, 6.3 volts, 8 amperes
 - S_1 = Mallory Hamband Switch, 4 pole, 1 section
 - S_2 = Mallory Hamband Switch, 4 pole, 4 section
 - S_3, S_4 = Shorting-type Switches, 2 pole, 2 section
 - S_5 = SPST Switch
 - RFC₁, RFC₂, RFC₃, RFC₄, RFC₅ = National Type R-100 Chokes, 2.5 millihenries
 - RFC₂ = National Type R-300 Choke
 - RFC₄ = National Type R-154U Choke
 - RL₁ = Keying Relay, 2.5 volt winding
- * One resistor mounted across each coil for 80-, 40-, and 20-meter bands on L_5 .

A "BOTTOMS UP" VIEW

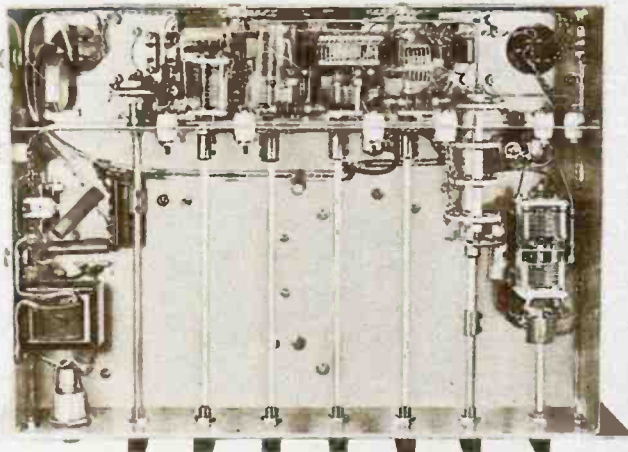

The logical placement of components and wiring on a 17"x13"x3" chassis was a major consideration in the transmitter's design.

PARTS LIST

- C_1, C_4, C_{11}, C_{16} = 0.0001 μ f, mica, 500 working volts
- $C_2, C_3, C_5, C_7, C_8, C_9, C_{12}, C_{13}, C_{14}, C_{17}, C_{18}, C_{19}, C_{21}, C_{24}, C_{25}, C_{26}, C_{28}, C_{31}, C_{42}$ = 0.005 μ f, mica, 500 working volts
- C_{21}, C_{23} = 0.01 μ f, mica, 300 working volts
- C_{29}, C_{25} = 0.0001 μ f, mica, 1200 working volts
- $C_{31}, C_{32}, C_{41}, C_{42}$ = 0.002 μ f, mica, 500 working volts
- C_{25} = 0.002 μ f, mica, 3000 working volts
- C_{23} = 0.05 μ f, oil-filled paper, 500 working volts
- C_5 = ZU140AS Cardwell Trim-air capacitor
- C_{10}, C_{15} = ZU75AS Cardwell Trim-air capacitors

EASILY BUILT PRE-AMPLIFIER

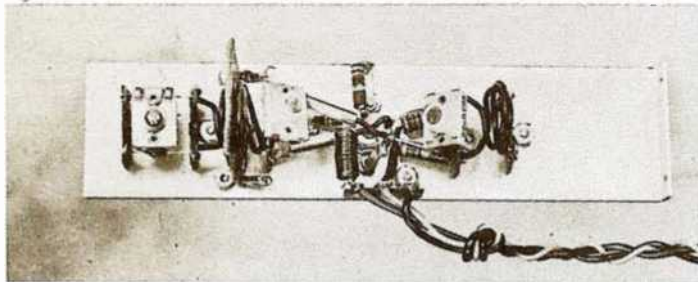

Simplicity and low cost components do not detract from the effectiveness of the 2 meter pre-amplifier.

LOW-NOISE PRE-AMPLIFIER

(Continued from Page 1, Column 2)

because of one feature—it has only one cathode, and one cathode lead. In a push-pull class A circuit, no rf current flows through the cathode lead, and, consequently, degeneration due to cathode lead inductance is eliminated. As a result, the grids of a properly neutralized 6J6 present an input load of better than 10,000 ohms at 144 megacycles. By way of comparison, the 6AK5 rf pentode has an input resistance of approximately 3,000 ohms, a value less than one-third that of the 6J6.

The low interelectrode capacitance of the 6J6 also aids in making the amplifier broad band. A voltage gain of 8 to 10 can be obtained over the entire 144-148 megacycle band with this tube.

The tube noise of an amplifier stage containing a 6J6 should be, theoretically, about 1.5 to 2 times the thermal noise. The corresponding value for a 6AK5 is about 3 times the thermal noise. This difference may often be enough to bring some weak signals up out of the noise level so that they may be copied.

Construction Details

This low-noise broad-band pre-amplifier is built on a small sheet of metal. Six bakelite solder lug terminal strips are used. Ceramic and other low-loss mounts will not improve the performance.

The antenna coil is tuned in order to compensate for a possible serious mismatch in the feeder sys-

tem and to provide a flatter response than a single-tuned circuit provides. The coil requires a tuning capacitance of about 20 to 30 uuf which can be well provided by a mica compression-type trimmer capacitor. Mica trimmers introduce small losses at low capacitance settings, their leads are short, their stray capacitances are nearly balanced to ground, and they are not expensive.

Electrostatic Shield

An electrostatic shield is used between the antenna coil and the grid coil. At first glance, this shield may seem superfluous, but when the possibility of the long feeders picking up noise or signals from powerful local stations is considered, it seems wisest to be on the safe side and include an electrostatic shield.

The shield can be made as follows: Fold a piece of plastic about 2" x 4" x 1/32" into a 2" x 2" square. Then, wind a flat coil of cotton- or silk-insulated copper wire (approximately #22 AWG) along most of the length of this flat form. Sandpaper the insulation off one side of the coil and lay a piece of heavy tinned copper bus wire along the edge. Solder each turn of the flat coil to the bus wire, but be very careful not to melt or ignite the plastic. Coat one side of the assembly liberally with household cement or coil dope. After it is thoroughly dry, cut the uncoated side away with a pair of tin snips. When completed, the shield looks like a "picket fence" of copper wires with the tips of the

pickets all insulated from each other, and the bottoms all soldered to the heavy bus wire.

Grid Coil Construction

The grid coil is of the "figure-eight" variety made from solid plastic-insulated wire. This type of coil has balanced stray capacitances to ground and can be backed right up to the electrostatic shield without becoming unbalanced. Figure 2 shows the development of this winding. Some slight spreading or squeezing may be required to permit tuning the coil with the lowest possible value of grid-tuning capacitance.

The connections between the terminal strip on which the grid coil is mounted and the grid terminals of the tube socket (No. 5 and No. 6) are made with thin tubing, not wire. These tubes can be brass or copper with a bore of about 1/16 of an inch, or they can be made by rolling a strip of soft copper foil into a tubular cylinder. The socket connections are soldered so that the holes in the ends of the connecting tubes are exposed and accessible.

The grid coil is tuned by means of a 1-to-20-uuf compression-type mica capacitor. In practice, this trimmer is run almost wide open.

The neutralizing "capacitors" are short lengths of plastic-insulated #18 wire inserted about 1/2 inch into the grid-connecting cylinders. Some slack in the wires should be left for adjustment.

The rf plate tank is identical with the rf grid tank. No bypass capacitors or plate chokes are needed. On the assumption that the output line will be coupled tightly to a tuned circuit in the next stage, the output coil is not tuned.

Adjustment and Test

For the adjustment of this pre-amplifier, no special test equipment is needed. The procedure is as fol-

lows: Tune in a strong local signal near the middle of the band on your regular station receiver. Insert the pre-amplifier in the antenna feed line. It is well to mount the unit at a point two or three feet from the receiver, especially if the receiver is not fully shielded.

Turn on the heater voltage of the 6J6 but not the plate voltage. The signal should still be present, but weak. Then, peak up the trimmers for maximum signal. Next, with a fiber screwdriver work the neutralizing leads in and out of the tubular grid connectors. A definite signal null point should be encountered. A very great reduction in feed-through signal can be obtained when optimum neutralization is reached.

Properly neutralized, the 6J6 will not oscillate even though it is lightly loaded. From a standpoint of signal-to-noise ratio and bandwidth, however, it is best to use tight coupling in both plate and grid coils. Push the coils together and at the same time trim the tuning adjustments for greatest gain in the center of the band until the point of maximum gain is reached and passed. The unit should be operated with the coils over-coupled.

If everything has been done correctly thus far, the pre-amplifier is ready to operate. Turn on the plate voltage and stand by to turn down the gain controls!

PARTS LIST

- C1 30 uuf (at mid-range) Mica-Sandwich Trimmer
- C2 C3 1.5 uuf to 25 uuf Mica-Sandwich Trimmer
- L1 L4 1 full turn #18 AWG plastic-insulated solid wire, 3/8" ID
- L2 L3 See Figure 2, and text
- L5 2-meter rf choke (20 inches, approximately, of #24 enameled wire, wound on 1/4" dia. form.)
- R1 R2 560,000 ohms, carbon, 1/2-watt
- R3 56 ohms, carbon, 1/2-watt
- R4 R5 47,000 ohms, carbon, 1-watt

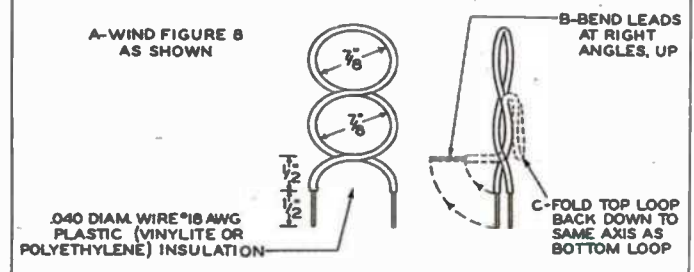
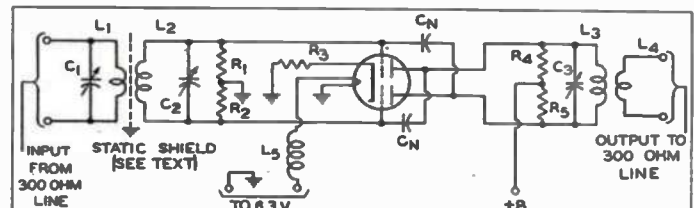

Figure 2. Schematic drawing of the pre-amplifier, and a pictorial sketch showing how the "figure-eight" grid coil is made.

HAM TIPS is published by the RCA Tube Department, Harrison, N. J., and is made available to Amateurs and Radio Experimenters through RCA tube and parts distributors.

J. H. OWENS, W2FTW *Editor*
H. S. STAMM, W2WCT *Associate Editor*

RADIO EQUIPMENT CORP.
ELECTRONICS DIVISION
147-151 GENESEE ST.
BUFFALO 3, NEW YORK

Devices and arrangements shown or described herein may use patents of RCA or others. Information contained herein is furnished without responsibility by RCA for its use and without prejudice to RCA's patent rights.