

© 1965 RCA  
RCA 1005

# RCA ENGINEER

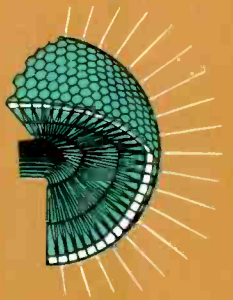
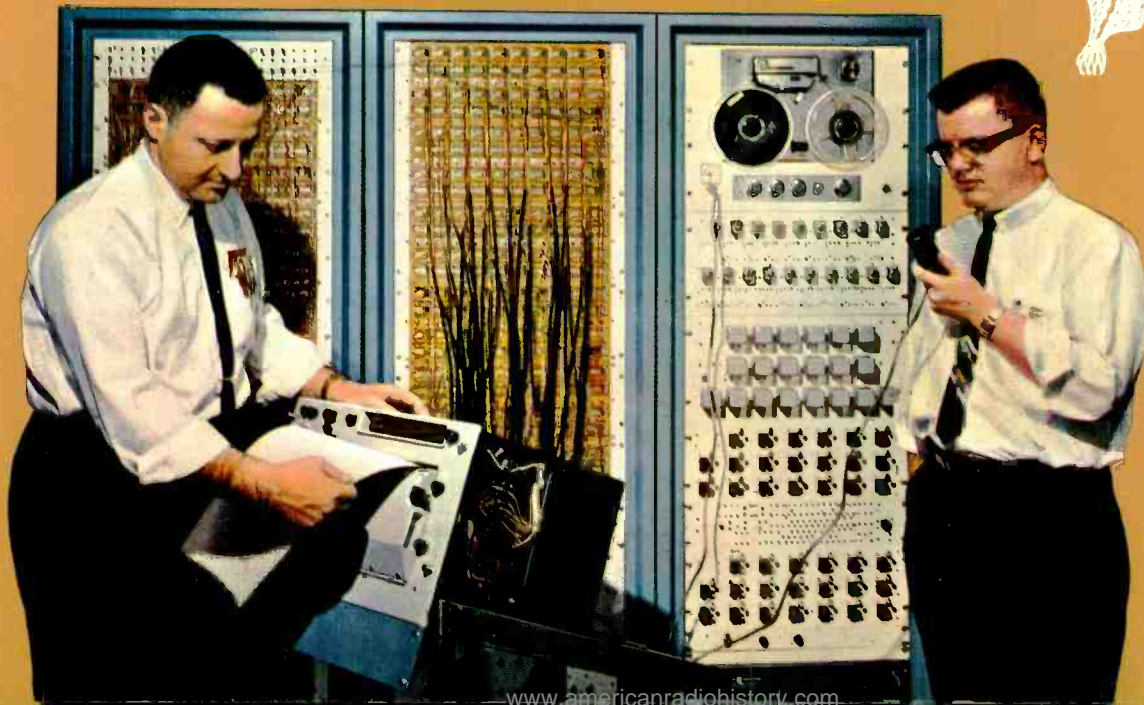
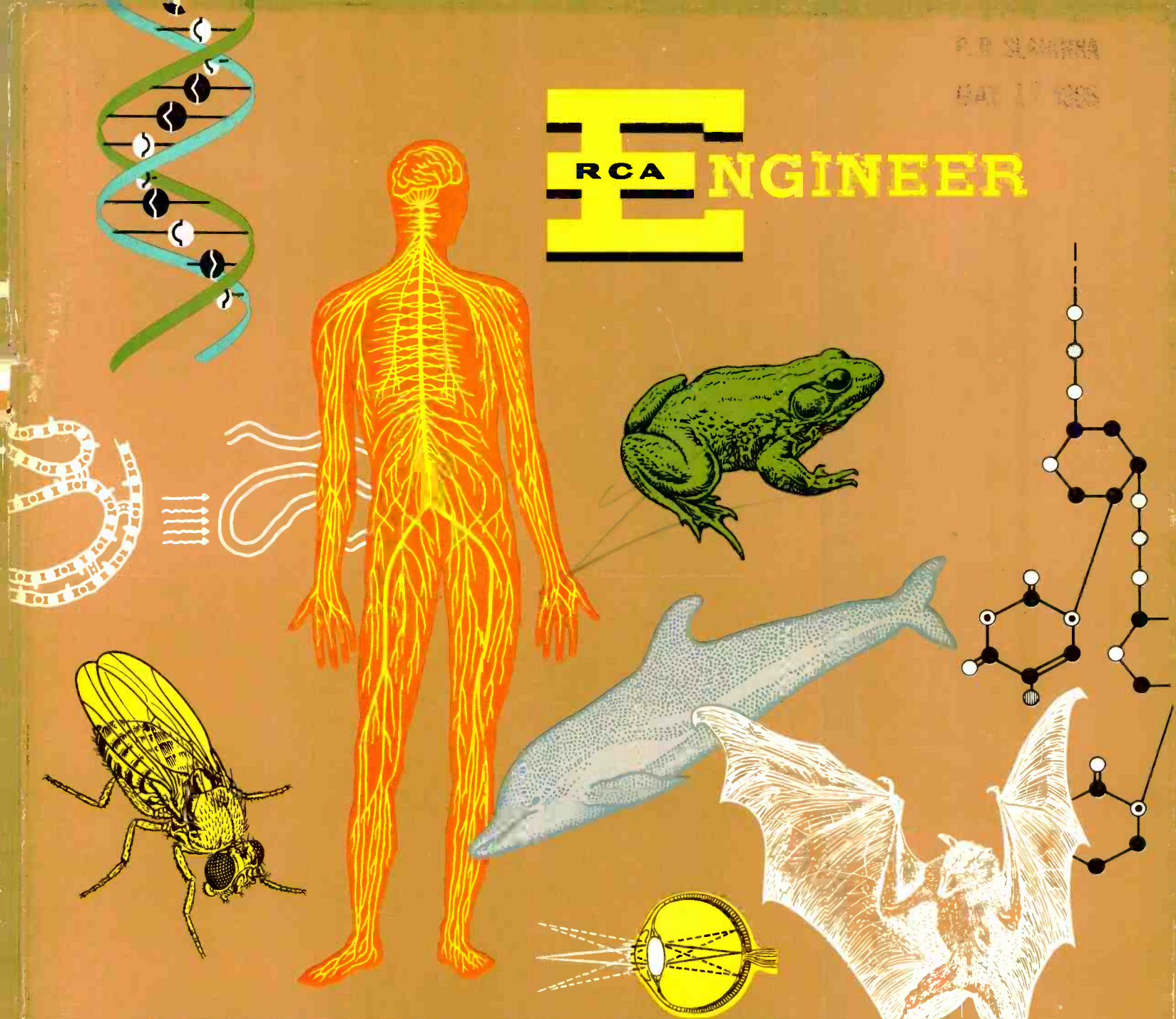

Vol. 10 — No. 6  
APR. - MAY 1965

### RCA ENGINEER Staff

W. O. Hadlock ..... Editor  
E. R. Jennings ..... Associate Editor  
Mrs. C. S. Marchionni ..... Editorial Secretary  
J. L. Parvin ..... Art Director

### Consulting Editors

C. A. Meyer, Technical Publications  
Administrator,  
Electronic Components and Devices  
C. W. Sall, Technical Publications  
Administrator, RCA Laboratories  
H. H. Spencer, Technical Publications  
Administrator, Electronic Data Processing  
F. D. Whitmore, Technical Publications  
Administrator, Defense Electronic Products

### Editorial Advisory Board

A. D. Beard, Chief Engineer  
Electronic Data Processing  
E. D. Becken, Vice President and Chief Engineer,  
RCA Communications, Inc.  
J. J. Brant, Staff Vice President,  
Personnel Administration  
C. C. Foster, Mgr., RCA REVIEW  
M. G. Gander, Mgr., Consumer Product  
Administration, RCA Service Co.  
Dr. A. M. Glover, Division Vice President  
Technical Programs,  
Electronic Components and Devices  
C. A. Gunther, Division Vice President,  
Technical Programs, DEP and EDP  
E. C. Hughes, Administrator, Technical  
Committee Liaison,  
Electronic Components and Devices  
E. O. Johnson, Mgr., Engineering,  
Technical Programs,  
Electronic Components and Devices  
G. A. Kiessling, Manager, Product Engineering  
Professional Development  
L. R. Kirkwood, Chief Engineer,  
RCA Victor Home Instruments Division  
W. C. Morrison, Chief Engineer, Broadcast and  
Communications Products Division  
H. E. Roys, Chief Engineer,  
RCA Victor Record Division  
D. F. Schmit, Staff Vice President,  
Product Engineering  
Dr. H. J. Watters, Chief Defense Engineer,  
Defense Electronic Products  
J. L. Wilson, Director, Engineering  
National Broadcasting Co., Inc.

## Electronics and the Life Sciences

The use of electronics to study, to monitor, to reinforce or to repair the mental and physical processes of human beings represents an important and growing humanitarian competence within our industry—one filled with hope for the future health and well-being of the individual. This competence has produced the electrocardiograph and the electron microscope, the radio pill, the heart-pacer and the electronically controlled artificial limb, the laser “knife”, and the possibility of medical diagnoses by computer, to name a few.

Important as these are, however, they constitute only one facet of the complex interplay between electronics and biology. Another, which, in my opinion, is of *even greater significance* for RCA is the relationship between biology and the future course of our traditional business of information handling.

As a company, we were born out of the possibility of using electronics to remove the limitations of time and distance from human communications. Our growth has depended on the recognition that through electronic and electromechanical systems it is possible to give a much greater scope to many of man's physical and mental skills. Our future, in turn, will depend on the continued expansion of the interaction between electronics and man's skills. Only by understanding the bases of life and thought will we be able to design the machines and machine systems which will continually increase man's capability to meet the soaring economic, social, educational, and technological demands of the coming decades.

I am pleased, therefore, that the RCA ENGINEER has devoted this issue to the vital interplay between electronics and the life sciences and the part we are playing in the effort to realize the great promise of that interplay.

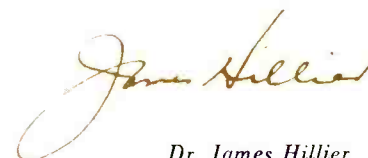

Dr. James Hillier  
Vice President, RCA Laboratories  
Research and Engineering  
Radio Corporation of America

### OUR COVER

... for this "Life Sciences" issue presents sketches of some of the natural-sciences phenomena that have become of great interest to the physical sciences: upper left, a DNA molecule and, just below, the temperature destruction of protein secondary structure. Spaced across the page are some more-familiar natural species, ending at lower right with a fly's eye, and at upper right with an organic carbon molecule chain. The interplay of physical and natural science is seen in many interdisciplinary fields such as bionics, biomedical electronics, life support, space biology, etc. One of these (bionics) is illustrated in the bottom photo: M. Herscher (left) and T. B. Martin (right) of DEP Applied Research, Camden, N.J., and a portion of experimental speech recognition equipment (six racks in all), which is implemented with analog threshold logic networks of DC neurons. (Cover art direction, J. Parvin. Bottom photo, R. Allen.)





VOL. 10, NO. 6  
APRIL-MAY 1965

**CONTENTS**

	The Engineer and the Corporation: Biomedical Engineering . . . . .	Dr. A. N. Goldsmith	2
	Electronics Technology in Medicine . . . . .	L. E. Flory	8
	Microcircuit-Microwatt Design Techniques for New Internal Medical Sensors . . . . .	L. E. Flory and F. Hatke	13
	Development of Electron Microscopy in the Life Sciences . . . . .	Dr. J. H. Reisner	16
	Elucidation of Ultrastructure with the Electron Microscope . . . . .	Dr. J. W. Coleman	20
	Adaptation Theory—A Tutorial Introduction to Current Research . . . . .	Dr. J. Sklansky	24
	Neural, Threshold, Majority, and Boolean Logic Techniques—A Comparative Survey . . . . .	C. R. Atzenbeck and D. Hampel	31
	Speech Recognition Using Artificial Neurons . . . . .	M. B. Herscher and T. B. Martin	36
<b>PAPERS</b>	The 1965 David Sarnoff Outstanding Achievement Awards . . . . .		42
	Life Beyond the Atmosphere—Origins, Detection, and Support . . . . .	Dr. A. G. Holmes-Siedle	44
	A Proposed Satellite for TV Observation of Zero-G Effects on Development of the Opossum Fetus . . . . .	S. H. Fairweather and J. E. Mortimer	50
	Thermal Control of Spacecraft . . . . .	Dr. G. D. Gordon	56
	Thermoelectric Water Reclamation for Manned Space Systems . . . . .	P. E. Wright	60
	Human Factors Engineering—More Than Just the “Blessing” . . . . .	Dr. H. B. Matty	63
	Selection of Letter Size and Lighting for Display and Control Panel Legends . . . . .	W. Baskerville and R. N. Gillis	66
	New Approach to Writing Operator Procedure Manuals . . . . .	Dr. F. H. Ireland and T. G. Wiedman	69
	Data Plotting by Digital Computer . . . . .	R. E. Simpkins	72
		Computer Calculation of Frame-Grid Winding Tension . . . . .	P. J. Musso and T. E. Deegan
	New-Design Pressure Transducer for Cable and Pipe Networks—More Reliable and Economical . . . . .	C. N. Merrell	77
<b>NOTES</b>			
<b>DEPARTMENTS</b>	Pen and Podium—A Subject-Author Index to Recent RCA Technical Papers . . . . .		78
	Patents Granted . . . . .		81
	Professional Activities—Dates and Deadlines . . . . .		81
	Engineering News and Highlights . . . . .		82
	Index to RCA ENGINEER Volume 10 . . . . .		86

A TECHNICAL JOURNAL PUBLISHED BY **RADIO CORPORATION OF AMERICA**, PRODUCT ENGINEERING 2-8, CAMDEN, N. J.

● *To disseminate to RCA engineers technical information of professional value.* ● *To publish in an appropriate manner important technical developments at RCA, and the role of the engineer.* ● *To serve as a medium of interchange of technical information between various groups at RCA.* ● *To create a community of engineering interest within the company by stressing the interrelated nature of all technical contributions.* ● *To help publicize engineering achievements in a manner that will promote the interests and reputation of RCA in the engineering field.* ● *To provide a convenient means by which the RCA engineer may review his professional work before associates and engineering management.* ● *To announce outstanding and unusual achievements of RCA engineers in a manner most likely to enhance their prestige and professional status.*

An index to RCA ENGINEER articles appears annually in the April-May issue.

Copyright 1965  
Radio Corporation of America  
All Rights Reserved

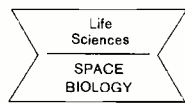
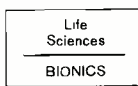
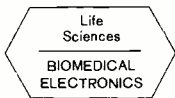

This review of biomedical engineering and its growing importance emphasizes the challenges facing the electronics engineer in understanding the almost limitless and elusive variables of the phenomena of life, and stresses the present and future role of sophisticated electronic devices to aid in studying and sustaining life. In addition to introducing biomedical engineering, much basic terminology of this complex, interdisciplinary field is discussed, thereby providing a background for understanding more-detailed papers and specific biomedical topics. Widespread interest in this field is evidenced by the 1,200 electronics engineers, physical scientists, physicians and other life scientists who attended the 1964 IEEE Conference on Engineering, Medicine, and Biology.

man-like extraterrestrial life form) is an organism sensitive toward his surroundings and reacting to them; enjoying spontaneous movement and the feedbacks necessary for such effective reaction to environment; possessing a selective information storage and retrieval system; and capable of communicating comprehensive information or requests for information to its fellow men or like life forms. Man therefore poses a vast field for biological engineering study.

It is natural that biological engineering in its present early stage resembles more a group of oases than a large intensively cultivated area. Its divisions are only beginning to be clearly defined and some of its areas are not only expanding but overlapping. In such a fluid field, the opportunities for accomplishment are many and diverse.

Since this paper is inherently a brief summary of the subject, credits for individual devices or methods are not listed. Only broad principles are presented, generally without details, to show the scope, diversity, and capability of available apparatus. Some of the methods and equipment herein cited are in the research stage; others are in development; and some are fully operational.

#### INSTRUMENTATION

Measuring instruments form the solid basis of most scientific developments. The phenomena of biology are often encouragingly amenable to study, measurement, and orderly classification by methods recently developed in the electrical and electronics field. Available, for example, are control sensors, networks, feedback, circuit simulation of biological processes, telemetry, information sensors, and miniaturization. The impedance changes of parts of the body yield significant information. Thus a high-frequency current may be passed through the thorax and the respiratory rate and depth of inhalation related to recordings of the current variation.

The heart beat, or cardiac cycle, generates systematic blood-pressure changes, and related voltages that may be recorded by connection to electrodes in conductive contact with selected sections of the body (chest and legs). Such records are known as electrocardiograms (EKG). Detectable magnetic fields also accompany the cardiac cycle, making possible more remote study of the cardiac cycle. Heart beats can also be detected and measured by placing the subject on a freely movable platform and measuring the exerted muscular forces, thus enabling study of the training of athletes and the cause of such handicaps as limps.

Blood flow may be measured electromagnetically; it can also be determined by an ultrasonic meter operated by comparisons of ultrasonic pulses transmitted up- and downstream. Electronic counters of the number and size of particles in the blood stream (sanguinometers) give corresponding information on the blood corpuscles. The location of internal intestinal bleeding can be found by Geiger counters placed at intervals along a "swallow tube" ingested into the intestinal tract after "labelling" the red blood cells with a harmless, short-life radioisotope.

Blood velocity can be measured by applying an alternating voltage to two coils on opposite sides of a probe in one of the heart blood vessels (the aorta).

Voltages derived from other body activities can be recorded. These include encephalograms (EEG, or brain-wave records), and electromyograms (EMG, or muscle-activity waves). Electromyograms, directly viewed on a kinescope, assist in the study of muscular and nervous disorders. Encephalograms assist in diagnosing brain lesions and areas involved in epilepsy, and are said to be useful in psychiatry. Records of potentials in the brain cortex (outer shell of the

## The Engineer and the Corporation

### BIOMEDICAL ENGINEERING

DR. ALFRED N. GOLDSMITH

Hon. Vice President and Senior Technical Consultant

Radio Corporation of America  
New York City, N. Y.

**B**IOMEDICAL engineering is among the most recent additions to the technological professions. It is a "cross-disciplinary" branch of engineering, applying the skills and capabilities of modern electronics to the fields of biology, medicine, and surgery. Its broad scope will tax the resources of the multi-disciplinary training of its practitioners. But it will offer corresponding rewards through the many benefits to the health of the inhabitants of this globe.

The worker in biomedical engineering should have a natural taste for the study of broader, more generalized, and more complex relationships than those found in most technologies. The training of the biomedical engineer will resemble that of the patent attorney who is both engineer and lawyer. At first, biology may seem strange to the engineering mind. Many biological phenomena are highly changeable, auto-dynamic, only approximately uniform, and only broadly controllable. They may also be inherently complex in their interrelationships; basic theories of biology only partially parallel those of the physical sciences.

On the practical side, the biomedical engineer needs close contacts with the user of biomedical equipment as well as knowledge of medical and surgical problems; the biomedical engineer must be thoroughly at home in the fields of medical practice and biological procedures.

One nonexclusive way of studying man is through biology, medicine, and engineering. To oversimplify, man (or any

*Final manuscript received October 19, 1964*

brain) are available through direct probes and are termed electrocorticograms.

Pressures in body cavities or on the body surface are measurable through tonometry. A piezoelectric transducer (e.g., a quartz crystal) is pressed against the sensitive area, and suitable electronic measurements enable derivation of the internal pressure. Strain gauges attached to the finger tip are known as plethysmographs.

Respiration rates and the carbon-dioxide cycle in breathing can be measured and electronically studied using analog computers. Stomachic activity (including peristaltic or digestive motion) can be registered even on the body surface using specialized amplifiers. Thus electrogastragraphy permits systematic investigations of digestion.

Various types of eye movement can be recorded by electrooculography (EOG). The functioning of the normal and impaired eye motor system is thus recorded for diagnosis; often without any ocular restraint. Minute photoelectric or magnetic contacts to the eye are used.

Internal body structures (including intrusions such as calculi, or stones) are visualized by ultrasonic means. A source of ultrasonic energy is focussed through "sound optics" on the region to be examined. The reflected ultrasonic waves give an echo pattern permitting, for example, study of heart-valve movements, blood clots (thromboses), tumors in the heart, and heart-valve constrictions.

Among the most powerful and useful electronic devices for biomedical applications are the electron microscope and the image amplifier. The electron microscope vastly expands the available magnification range (up to 200,000 times magnification or more with a resolution of 10 angstroms or better). It has been invaluable in the study of bacteria, cell structures, and viruses. The chromosomes (bodies in the cell nucleus carrying hereditary information) are made up of the basic flat or threadlike assemblies (genes) which contain orderly assemblies of the so-called nucleic acids and other chemical components. It is hoped that the electron-optical qualities of the electron microscope can be improved to the point where these sequences of nucleic acids can be seen, classified, and their significance visually decoded.

A convenient adjunct in biological temperature measurement is the thermistor whose stability, sensitivity, and thermal conductivity are obviously advantageous.

Thermoelectric modules can be used for cooling in such procedures as surgical or dental probings and microscopic examination of tissue.

Considerable experimentation and mathematical development have gone into producing electrical networks which simulate the neuron (nerve) system. Efforts, in considerable measure successful, have gone into developing a readily adjustable, low-power, compact, and inexpensive positive or negative pulse generator simulating the action and inhibition nerve impulses.

The techniques and apparatus of modern engineering, suitably modified, seem appropriate and largely adaptable to the needs of the biological arts. Further miniaturization, greater versatility, increased reliability, simplicity of operation, improved means of telemetering or carrying indications from inside the body, and reduced cost would be helpful.

#### LASER APPLICATIONS

The utility of the laser for biological purposes stems from its peculiar capabilities and limitations. Though operating at very low energy efficiency, it can produce coherent light of an output peak power up to the range of 1 to 1,000 megawatts in very brief pulses; power densities from  $10^{12}$  to  $10^{15}$  watts per square centimeter; and correspondingly high opti-

**DR. ALFRED N. GOLDSMITH** received his BS from the City College of New York in 1907, and studied under a fellowship there from 1907-1910. He received his PhD from Columbia University in 1911. (He also holds an honorary ScD from Lawrence College, 1935.) He taught at CCNY from 1910 through 1923, becoming an Associated Professor of EE. He was Director of the RCA Research Department from 1919-1922, Chief Broadcast Engineer of RCA from 1922-23, and Vice President and General Engineer of RCA from 1927-1933. He is now an Honorary Vice President of RCA, and has been a consulting engineer to RCA since 1933. Dr. Goldsmith has been honored many times for his extensive activities in electronics engineering by industrial and professional societies and organizations too numerous to include here completely.

Among these have been: Modern Pioneer's Award, NAM, 1940; Harris Medal, 1942; RCA Laboratories Achievement Award 1950; Fellow, IRE; Fellow, British IEE; Associate Fellow, AAS, 1958; Hon. Fellow, International College of Surgeons, 1955; Eminent Member, Eta Kappa Nu, 1955; Assoc. Fellow, AIAA, 1964; Benjamin Franklin Fellow, Royal Society of Arts, London, 1958. He is also a Member of many other professional societies and organizations here and abroad. Dr. Goldsmith's professional interests have ranged widely throughout his career, and have included study of and contributions to radio telegraphy and telephony, motion picture engineering, precision electronic measurements, color televisions, and electronics applications to medicine and the biological sciences. Dr. Goldsmith served as Editor of the Proceedings of the IRE from 1912 to 1954, and is now Editor Emeritus and a Director Emeritus of the successor Society, IEEE. He served as Secretary of IRE in 1918, and its President in 1927; he received the IRE Founders Award in 1954. He is also on the Board of Editors of the RCA Review.



cal field strengths. It can be used in place of the usual spark or arc excitation for vaporizing materials in solid samples over 50 microns in diameter, thus enabling spectrometric analysis.

So powerful a source may produce biological, therapeutic, or even genetic effects. It can be used to treat detached retinas (within the eye), or to extirpate intraocular tumors. The retinal exposure time to the prefocused laser beam is about 500 microseconds. If tissue portions are stained with a dark dye, the laser beam energy will be selectively absorbed and the chosen tissue portion will be destroyed. The laser may ultimately be used in submicroscopic surgery or even, conceivably, for cellular dissection.

Monofrequency laser beams passing through certain organic liquids emerge as multifrequency light thus pointing the way to chemical analytic methods of use in biology.

#### COMMUNICATION

Communication from within the body to local or distant points is another challenge. Data on physiological, chemical, or physical conditions in the tissues or cavities of the body can sometimes be secured from implanted or applied sensors, or by ingested combinations of sensors and signal-transmitting units (either inductive or radio "sondes").

Sometimes measurable by sondes are pressure, chloride-ion concentration, bioelectric potentials, partial pressures of gases (such as oxygen or carbon dioxide), ionizing-radiation intensity, motility, bleeding, respiration rate and fetal (embryonic) heart beat records.

In the "radio pill" placed in the intestinal tract, frequency- or pulse-modulation of a carrier in the 100 kc to 10 Mc range is used. Internal mercury battery sources may be employed, and signal transmission can be initiated or halted from outside the body.

Signals from within the body can be processed by known electronic methods for extraction of the signal from superimposed noise, signal recording, analysis of waveforms,

record retrieval, and transmission to remote points over wire lines. The general practitioner may even run such tests from portable equipment in the patient's home under normal conditions, and send the signals by telephone line to a central collating, analyzing, and diagnosing station.

Some less usual applications of the sonde include telemetry of the condition of astronauts (e.g., blood pressure, body temperatures, respiration rate, and cardiographic data). An industrial application of telemetry is the determination or recording of physiological or psychological changes occurring in the worker on a specific job. Sophisticated methods of electrocardiography also enable early study of the developing heart beat in the fetus sometimes enabling avoidance or alleviation of later difficulties.

As microminiaturization and improved signal-identification methods are developed in the electronics field, they will find ready and useful application to the biological sonde equipment and techniques.

#### INFORMATION DISSEMINATION

The individual biologist, physician, specialist, or clinician will in growing measure require a modernized and comprehensive information-retrieval system to meet his current needs speedily and effectively. The corresponding concept of a "World Biomedical Information Center", while appealing, is perhaps too ambitious for complete and immediate realization; but local centers for the dissemination of requested information are frequently and hopefully proposed.

The individual physician, hospital, clinic, or biological investigator could call such an information center (by telephone or data circuit) requesting specific information and, through computerized techniques, receive a speedy answer.

While such information centers could not replace the lengthy experience and trained judgment of the scientist, they would be useful and dependable adjuncts or aids.

Diagnostic information thus provided would be based not only on comprehensive statistical data but also on modern diagnostic methods (e.g., the use of electrical analogues of the human cardiovascular system). Prognoses would become more dependable if based in part on an analog study of the various relevant parameters and their effects.

#### HOSPITALIZED AND AMBULATORY PATIENT SUPERVISION

In the 7,000 American hospitals, 1,400,000 patients receive care every day, and about 24,000,000 are hospitalized each year. The annual operating cost is \$8 billion, about two-thirds of which goes for labor. Although labor costs are not

inherently high, they are increasing about \$500 million per year. Obviously, devices for reducing routine labor are urgently required.

Hospitals need elaborate data on patients, including identification, present illness, general history, results of examination and tests, data resulting from consultations, x-ray studies, tissue data, provisional diagnosis (including indicated medication or surgical intervention), progress of the patient under treatment, later or more definite diagnosis, and biopsy or autopsy results. Certain necessary data such as electrocardiograms may be electrically and continuously or intermittently sent and recorded at central monitoring stations which, in turn, may be provided with automatic alarm systems responsive to unfavorable developments.

Analogous recording systems have been devised for psychiatric cases, based to some extent on the patient's answers to a lengthy and largely standardized series of questions. It is attempted to elicit, record, and analyze (largely using electronic means) a complete history of the patient, his life and environment, and relevant data on his family.

#### PROSTHETICS

Prosthetics primarily includes the temporary substitution of organs of the human body in emergencies or during operations, as well as longer-term replacement of essential organs. Biomedical engineering is called on to provide machines (generally electromechanical) to take over the organ's functions temporarily or permanently.

When heart action stops, the "cardiac pacemaker" applies timed electric impulses to stimulate heart action until it is restored to normal. More radical measures are required for some heart operations where a "dry heart" or "open heart" condition is needed by the surgeon for fairly prolonged activities. Unless the heart were by-passed during this period by means of an external artificial heart, the patient would die. It is hoped that a permanently implantable electro-mechanical heart will ultimately become available, or that replacement of heart valves or arteries by cardiovascular prostheses will become practicable.

Cryobiology (the use of extreme cold to deep-freeze tissues and, hopefully, to kill bacteria, viruses, or damaged cells) is under early study and shows some promise.

Under intensive development, and with considerable success, are artificial lungs and kidneys. A long series of important accomplishments in these and similar fields may be anticipated.

War-inflicted injuries and their repair greatly stimulated



Fig. 1 — Laboratory model of an electrocardiogram transmitter. Patient dips finger into a conducting solution, and cardiogram is displayed on oscilloscope.

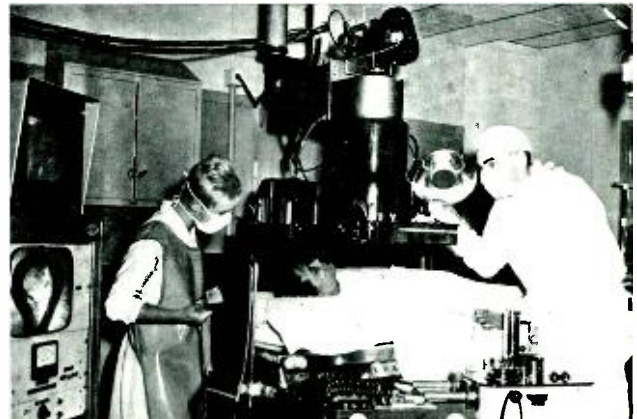

Fig. 2 — RCA closed-circuit TV at Johns Hopkins Hospital displays moving X-ray images. Examining room camera is linked to RCA TV tape recorder in adjacent room, permitting later playback and study.

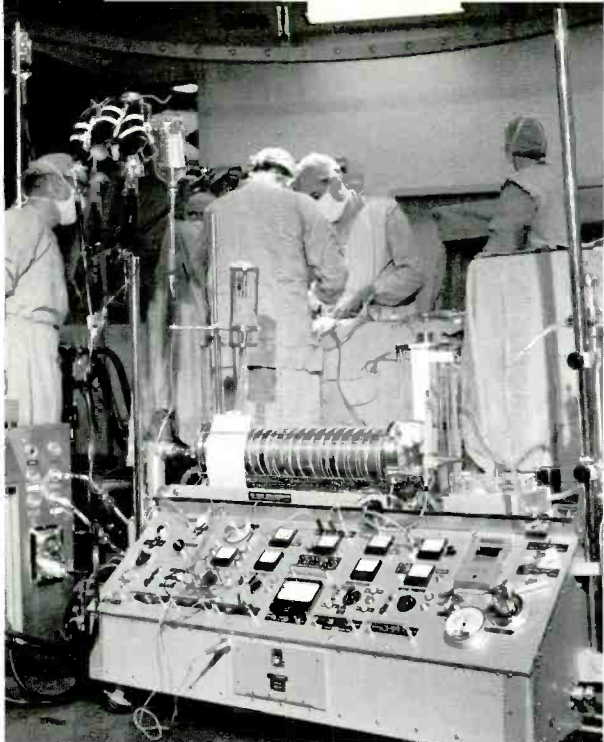

Fig. 3 — Complex open-heart surgery can now be performed that was too risky a few years ago. A patient's heart and lungs can now be by-passed for 6 hours without irreversible damage to the brain or other organs through the use of pump-oxygenator heart-lung machine at right.

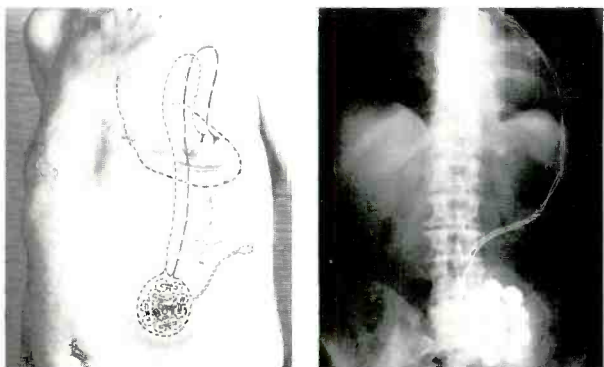

Fig. 4—Left: patient with fluoroscope superimposed to show subcutaneously implanted pacemaker, an instrument that can stimulate failing heart action with electric impulses until normal action resumes. Right: X-ray of implanted pacemaker.



Fig. 5 — Surgeon in heart catheterization room is guided by TV image (fluoroscopic) of catheter as he threads the catheter through leg vein into left chamber of heart. This "transseptal left heart catheterization" aids diagnosis of heart defects.

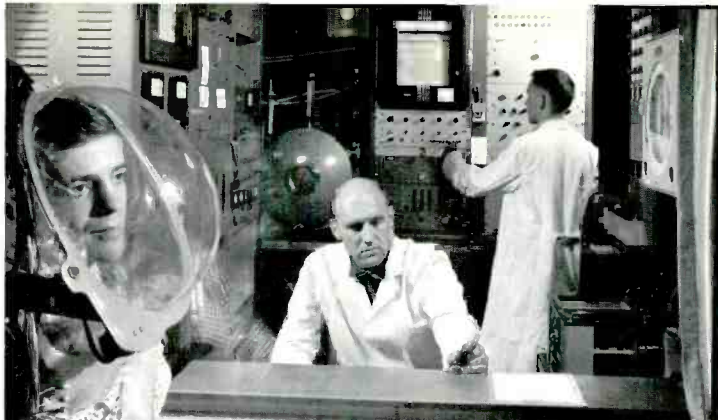

Fig. 6 — Metabolic chamber of National Institute of Arthritis and Metabolic Diseases helps studies of life processes. Expired air collected under mask is collected by continuous-stream gas analyzers.



Fig. 7 — At University of Pennsylvania's School of Dentistry, an RCA closed-circuit TV system carries the pictures and the instructor's commentary to students at 16 monitoring locations.

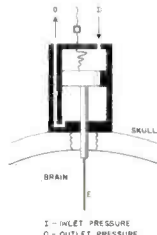

Fig. 8 — Subminiature hydraulic lift that controls precise penetration of electrode into brain of a hibernating squirrel during studies of life processes.

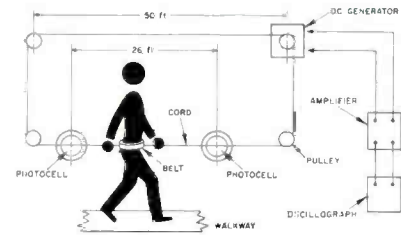

Fig. 9 — Tacograph system records data about an amputee's walk across an instrumented platform in studies of artificial limbs. Pattern of walk is recorded by interrupted-light photographs of the amputee's artificial leg.

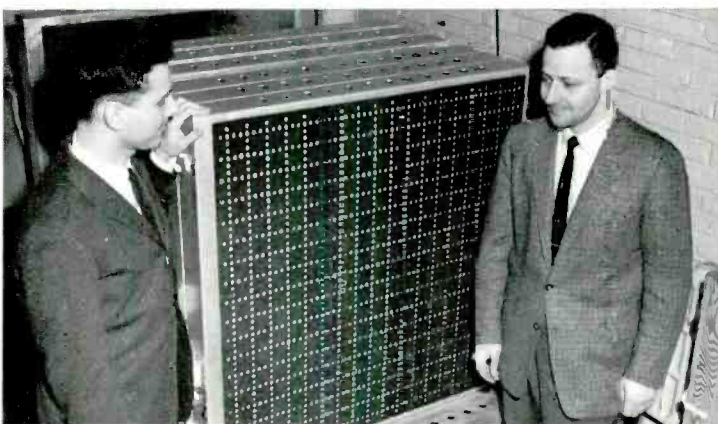

Fig. 10 — T. P. Kelley (left) and M. Herscher, and the functional electronic model of the frog's retina built by DEP Applied Research, RCA, Camden, N. J. This kind of simulation illustrates how biological processes are studied so that electronics can learn more about the processes of complex information handling.

the development of prosthesis of limbs and hands. Something of the attained refinement of operation can be gained from a listing of the capabilities of an artificial arm which is electronically controlled, uses external power, is preprogrammed including storage of a number of programmed motions as well as patient selection between them or their modifications, and which has five degrees of freedom. Automatic hands provide a wide variety of chosen movements, either automatic action or voluntary control, and reasonable simplicity of construction and acceptable cost. Clenching of the hand and adjustable grasping with the fingertips are available. Some highly sophisticated pressure-sensitive controls, and also feedback at appropriate parts of movements for avoiding excessive pressures, are provided.

Various electronic aids for the blind are in an early stage of practical development. In one guidance equipment, an ultrasonic airwave generator produces a highly directional narrow beam, which is reflected by the target or obstacle and picked up by a receiver and earphone. Such devices are somewhat rudimentary and not as yet adequately satisfying to the user. Means have been developed for permitting the blind to operate a telephone switchboard, for example. Talking typewriters are also planned to enable typing by the blind.

Aids for the deaf and dumb also show promise. An "artificial ear" under development calls for the design and construction of assemblies of suitable electronic components reasonably closely simulating the normal ear and its associated processing structures and nerves.

The artificial larynx enables persons whose physical speaking capability has been lost to develop speech sounds of intelligible nature. It involves the resonant modulation, controlled by the user, of a buzzing sound generated by the device.

Stammer sufferers have been helped by the controlled production of a low-frequency masking tone which, when desired, prevents the patient from hearing his own voice.

#### COMPUTER APPLICATIONS

In modern physical research, interest is largely centered on the submicroscopic elements of matter—that is, the atomic nucleus, and the so-called "elementary particles," their arrangements and interactions, and their internal and external effects. In biomedical research, there is growing emphasis and great potential utility to be derived in the study of the submicroscopic elements of living matter—that is, the cell nucleus, the chromosomes and genes, their component amino acids and porphyrins, their arrangements and controls, the enzymes which are their "messengers," and the resulting life forms, bodily characteristics, and behaviors.

In view of the many and complex mathematical calculations which may be required in biomedical research, recourse is had to the electronic computer. For example, in a thorough statistical analysis of 300 cardiac patients, values of 60 separate clinical parameters were required for each patient. Fortunately, computers can supply huge memories and random-access retrieval of stored information.

Such organs as the lungs, muscles, blood vessels, and even the skin produce variable and informative electric fields. A properly programmed computer can assimilate, analyze, and systematically help to interpret such field variations. Heart activity, as measured on the surface of the body, is usually shown in a somewhat distorted form due to interfering field forms. Computer techniques enable the detection, evaluation, and effective annulment of such unwanted artifacts and thus give the physician a correct record of heart action.

Using advanced pattern recognition techniques, electro-

cardiograms can be systematically classified and analyzed thus providing a useful aid in hospital administration.

Computers, in the psychological realm, can simulate the interactions between the members of groups in which reward or punishment result from the response of the remaining group members to the proposals or responses of a particular member of the group. It seems to be within the scope of computers to study human behavior, through a model, as a function of its payoffs.

#### GENETIC STUDIES AND SELECTIVE BREEDING

The biological inheritance of each human being is carried in detail, and later effectively developed, by complex chemical systems. Information governing the characteristics of the next generation is found in rather stable chemical configurations (genes, or heredity determinants). The genes are found as portions of larger threadlike structures (chromosomes) located within the nucleus of almost all living cells. When cell division (mitosis) occurs, the genes also replicate (duplicate) without change. Information from the genes is carried unidirectionally by "message-carrying" materials to the point where the final and desired chemical reaction and conformation occurs. These and other cellular reactions are thus apparently initiated and guided by enzymes.

The basic or chief material within the genes, called DNA (deoxyribonucleic acid) is a highly polymerized giant-molecular substance of peculiar double-intertwined-helical structure. Certain specific items of hereditary information with corresponding genes have been located within the chromosome of the fruit fly. Yet it is clear that the decoding of the full information within DNA genes, and chromosomes is a truly colossal task for the biochemist, biologist, and the computer expert. Further discussion of this unfinished task is beyond the scope of this paper. It should be mentioned, however, that when the computer has successfully contributed to the solution of the decoding problems involved, important medical results will follow such as understanding of the reasons for hereditary susceptibility to certain diseases such as cancer and hemophilia (uncontrollable bleeding), the action of carcinogenic (cancer-producing) chemicals and chemotherapeutic methods of controlling cancer, as well as the role of viruses, cell mutations, and enzymes in diseases.

#### BIOMEDICAL INSTRUCTION

The role of electronics and other aids in the instruction of biological and medical students is partly established and steadily growing. Even so, the advantages of biomedical-electronic education are as yet not fully recognized. Less than 50% of queried college deans and hospital administrators answered a questionnaire on this subject, although of those returning the questionnaire almost 80% were largely favorably disposed toward the field. About one-half of the queried medical school deans and one-third of the engineering school deans believed that biomedical-electronic instruction should be at postgraduate level.

Television is an obviously desirable agency for medical instruction in general. Images can be shown to large groups. Inaccessible locations within the body can be displayed via the endoscope (an optical probe, sometimes using flexible fiber optics). Infrared or ultraviolet illumination can be used to produce a visible television picture. The television camera can peer through a microscope and thus show greatly enlarged images. Desired degrees of contrast and color can be adjustably secured. Textual and graphic material can be displayed on a large screen. And medical, surgical, or psychiatric patients can be viewed in one room while the physician or lecturer shows the images, and addresses the students in another room.



On the teaching side, it is necessary that the equipment and operation be of high technical quality, convenient and flexible in operation, and capable of growth even into the postgraduate field. Available statistics indicate that, of the 86 medical schools in the United States, 40 use television with a corresponding investment of about \$3,000,000 in television and associated gear. Similarly 30 of the 48 United States dental schools use television.

In a parallel field, hospitals have found television useful in general administration, patient monitoring, radiology, surgical teaching, inventory control (including pilferage detection), as well as in various associated activities such as diagnosis and treatment.

Color television offers added and sometimes essential advantages. In diagnosis by a group of physicians, color television is a most helpful aid. Operations, e.g., on the eye or ear, become most definitive and instructive in color. Microscope views can be shown effectively on large screens with the added color information. Instruction to nurses, refresher courses or timely information to practitioners, and even examinations of students are facilitated by the use of color television.

A highly ingenious method for creating informative artificially colored pictures has been invented and realized in practice wherein television images taken by illumination at three different ultraviolet frequencies are reproduced, for example, in a conventional three-color television system. The color pictures thus displayed are often highly instructive in relation to tissue composition and structure even though they are specialized artifacts.

#### CONTRIBUTIONS OF BIOLOGY TO ENGINEERING

Study of the physical (and psychological) behavior of animals has led to the formulation of rules or procedures that enable approximate engineering analogs of animal performance and controls to be devised. A new field has thus come into being called "cybernetics." In a narrow sense, cybernetics deals with physical or chemical feedback control in man and other animals. In a broader sense, this field (also termed "bionics") deals with methods existent in nature for the control and functioning of biological processes and their possible adaptation and application in man-made systems or artifacts.

The negative feedback referred to above has as its element the initiation of a movement, the sensing of the magnitude of the error in the movement, a feedback correction of the error, and repetitions of the preceding processes with the aim of minimizing the error in the final step.

One obvious contribution which biology makes to engineering is that it shows that certain difficult problems can be solved (though often by methods based on, but differing radically from, those found in nature). As examples, the soaring flight of seagulls or condors showed that heavier-than-air flight was possible. The humming bird demonstrates that hovering flight as well as vertical or short take-off and landing are possible and that the ornithopter (flapping-wing) principle merits study. The bat shows that a highly precise and sophisticated "radar" or "sonar" system (using supersonic airwaves) is operative, thus indicating the feasibility of radar location and its further development. The retina and optic nerve system of man, and his cochlea and aural nerve system show respectively that (at least in conjunction with the brain) image recognition and speech understanding are possible. Scotopic vision (in dim light) and photopic vision (under normal illumination) show that wide ranges of illumination are feasible in producing useful luminous response.

Sensory systems of many animals have been intensively

studied with possibly helpful or useful results in some cases. Among the animals in question are cats, cockroaches, dolphins, fruit flies, frogs, porpoises, and sea lions. It is also found that on occasion nature even provides alternative methods of achieving desirable results. For example, studies of the retinal structures of the frog and of the fly show methods of visual image-production, and probably of perception as well, differing widely from those of man.

Modern cybernetics leans heavily on information theory, automation theory and practice, artificial and natural neural-network structures, communication theory, and methods for increasing reliability of operation using partly unreliable components. Further, the world of living organisms operate with dependence on so many variables interacting in such complex fashion that the usual mathematical theories of statistics and probability do not always hold for living systems.

Much interest has been aroused recently in the possibility of extraterrestrial life; on the environmental factors helpful or prejudicial to such life; and even on the requisite tests and supplies required to sustain life in space.

Survival of man in space may depend on use of shielding against high magnetic fields, various types of electromagnetic radiation including x-radiation, meteorite impact, proton bombardment, and other injurious factors. Absence of usual gravitational fields may well prove to be so damaging after prolonged exposure, that artificial gravity (centrifugal force) may be necessary in spacecraft.

Of necessity, such matters as artificial atmosphere, food supply, water supply, and re-use of waste exhalations and secretions must be considered. Available supply systems seem fairly complex. Their present rather rudimentary stage of development may well be a precursor of workable and viable ecological systems.

#### CONCLUSION

Considering the wide scope, and major value to humanity of biomedical engineering, it may fairly be said that in this era of often affluent scientific endeavor, engineering in the life fields has been a somewhat meager beneficiary. Its relatively limited (and far from large-scale) support contrasts sharply with the highly favorable opinion held by many thoughtful scientific analysts of its high relative and absolute importance to our present and future civilization.

The field is, however, a difficult one in one fairly obvious respect. To "explain" a biological phenomenon implies its qualitative and quantitative understanding and the capability of its reasonably accurate prediction. It is true that many biological processes and their results can be measured with acceptable accuracy and sufficiency of interpretation by instrumentation based on presently known physical and chemical laws. Yet we cannot presently exclude the possibility that some principles and methods outside of present day scientific knowledge are necessary for a satisfying explanation and a logical understanding of many basic biological phenomena (e.g., genetic structure and mitotic (cell-divisional) growth).

Whether new branches of science or other disciplines will be required for the desired broadened knowledge in the biological field, and needed for its engineering congener, only time will tell. Clearly the field presents challenging vistas of potential major advances. It is already certain that the rational thinker and original investigator will have ample opportunity for rewarding accomplishments in biomedical engineering. This is indeed a domain for the ingenious, the creative, the determined and the tenacious. And its fruition bids fair to give much to humanity at large and to each of us in particular.

**TABLE I—Current Medical Instrumentation**

**Heart and Blood Vessels (Bioelectric Potentials)**

Electrocardiography  
Phonocardiography  
Cardiac output recorders  
Cardiotachography  
Cine X-ray heart profile recorders  
Blood-pressure gauges  
Flowmeters  
Pacemakers  
"Defibrillators"  
Heart valve prostheses  
Blood vessel prostheses

**Respiratory System**

Respiration rate  
Oxygen consumption gauges  
Inhaled gas analyzers  
Hyperbaric chambers  
Respiratory aid apparatus  
Diaphragm-nerve stimulators

**Central Nervous System**

Electroencephalography  
Ultrasonic encephalography  
Brain, nerve stimulators  
Implanted electrode techniques  
Microelectrodes  
Nerve impulse recorders  
Integrators  
Cryosurgery

**Special Sense Systems—Hearing**

Acoustic stimulation  
Hearing prostheses

**Special Sense Systems—Speaking**

Voice analyzers  
Larynx prostheses

**Special Sense Systems—Seeing**

Optometry  
Electroretinography  
Intra-ocular tension recorders  
Eye movement gauges  
Nystagmus recorder  
Retinoplastic, thermic and laser beam surgery  
Protheses for the blind

**Dentistry & Surgery**

Radiography  
Telemetry  
Focussed ultrasonic surgery  
Cryosurgery  
Electro-cauterization, coagulation  
Suturing instruments

**Other Clinical Specialties**

Devices to see inside body  
Surface, depth thermometers  
Skin voltage, resistance gauges  
Telemetry gear to measure temperature, pH, study dynamics of stomach, intestines, uterus, etc.  
Infrared recorders

**Clinical Laboratory Specialties**

Blood and other cell counters, differentiators  
Blood color analyzers  
Flame photometry  
Liquid, gas phase chromatography

Sample collectors  
Microchemistry apparatus

**Radiology, Radioisotopes**

X-ray apparatus  
Radiation detectors, dosimeters, spectrometers  
Scintillation counters  
Image intensifiers, TV systems  
Synchronizers  
Radiotherapy equipment  
Particle accelerators  
High energy isotope therapy

**Muscles and Skeleton**

Nerve impulse recorders  
Electromyography  
Nerve, muscle stimulators  
Bone, limb and articulation prostheses

**Anesthesiology, Reanimation**

Gas analyzers  
O<sub>2</sub> saturation photoelectric meters  
Monitoring systems  
Oxygen tents, equipment  
Anesthetic gas apparatus  
Breathing apparatus  
Pump oxygenators  
Dialyzers  
Servo-anesthesia systems

**Psychology, Psychiatry**

Behavior monitor systems  
Programming apparatus  
Electro-narcosis equipment  
Electro-convulsive treatment equipment

Note: This data was gathered and categorically listed by Dr. John F. Davis, Director, International Institute for Medical Electronics and Biological Engineering, Paris.

# ELECTRONICS TECHNOLOGY IN MEDICINE

## A State of the Art Review

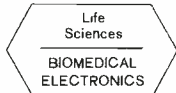

L. E. FLORY\*

*Astro-Electronics Applied Research Laboratory, Astro-Electronics Division, DEP, Princeton, N. J.*

Electronic techniques and devices are used in medical research, diagnosis, therapy, monitoring, and analysis. Ailments are discovered with ultrasonics and isotopes, lasers weld retinas, color TV monitors sophisticated heart surgery, and computers assist in medical information processing and analysis. Reviewed herein is the present state-of-the-art of medical electronics, including the techniques and instruments now in use in areas of medicine that can be classified as heart engineering, nerve-system engineering, physiological monitoring, prosthetic devices, and medical repairs. In addition to present capability, some current problems and limitations are pointed out that need the attention of electronics engineers. A reference Bibliography to some of the extensive literature in the field is included.

**T**HE two applied sciences of medicine and engineering have been searching over the past decade for a common ground. It has been the feeling in engineering circles that medicine and biology could greatly benefit by the application of the principles of the more exact physical sciences.<sup>1</sup> The doctor, on the other hand, is just as anxious to bring to bear on his problems the most up-to-date technology. The two groups have been held apart to a certain extent

by a lack of understanding. Each discipline has its own history and its own character and in many cases neither is too sympathetic with the other's mode of expression.

Living systems are difficult to analyze in the terms of the physical sciences, so the engineering approach has been made through many isolated cases rather than through a systematic development of the interdisciplinary area. Many of the first contacts have been made as the result of doctors asking assistance in the operation of new instruments. In the process,

the engineer begins to appreciate the problems of dealing with a device as complex and unpredictable as the human system. The doctor, on the other hand, learns something of the limitations as well as the capabilities of engineering methods. Many of the leaders in biomedical engineering today have come from such contacts. The doctors have sought more training in engineering sciences and the engineers in physiology, biophysics, etc. As a result, we are on the threshold of the development of biomedical engineering as a full fledged discipline in its own right. Numerous schools are now offering both undergraduate and graduate courses in biomedical engineering and several are already offering advanced degrees. When this new generation of scientists begins to make its influence felt, the real progress will have begun.

Accomplishments to date have not been insignificant and the informal, if somewhat uncorrelated, merging of engineering techniques with medical and biological practice has already paid

*Final manuscript received January 21, 1965*  
\* Mr. Flory is a Fellow, RCA Laboratories



Fig. 3—This doctor is injecting a dye-indicator into the left side of his patient's heart to detect a suspected abnormal hole inside the heart. To do this, he inserted a catheter in a leg vein and threaded it into the left heart chamber, a catheterization technique developed at the National Heart Institute called "transeptal catheterization." (courtesy of National Institutes of Health).

Fig. 2—Contrast enhancement by television techniques. The top photo is the original X-ray while the lower is the same X-ray after contrast enhancement.

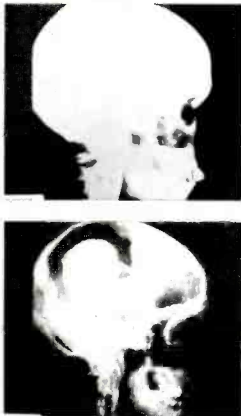

Fig. 1—The author, L. E. Flory, and a color TV system used to display images from a light microscope.

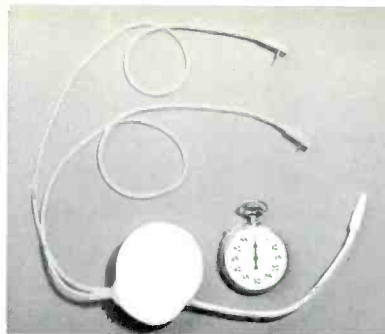

Fig. 4—Implantable Cardiac Pacemaker. (courtesy of Mennen-Greatbatch Electronics, Inc.)

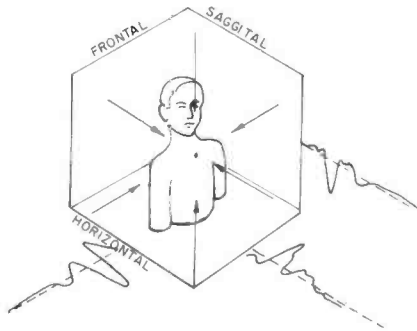

Fig. 5—This principle of vectorcardiography provides a three-dimensional perspective view of heart activity by modulating brightness and size of scope trace. (courtesy of International Science and Technology)

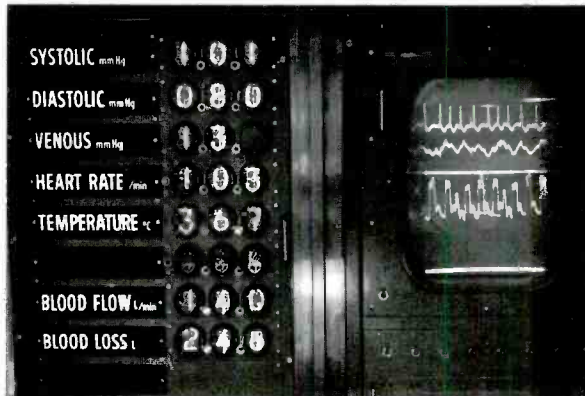

Fig. 6—Physiological parameters are recorded continuously and displayed digitally and as waveforms within a surgical team's glance (courtesy of National Institutes of Health).



Fig. 8—Complex open-heart surgery can now be performed that was an impossible risk a few years ago; a patient's heart and lungs can now be by-passed for up to 6 hours without irreversible damage to the brain or other organs through the use of pump-oxygenator, heart-lung machine shown at right and plugged into floor pedestal. (courtesy of National Institutes of Health).



Fig. 7—The use of color television in the operating room during major heart surgery.

LESLIE E. FLORY received his BSEE at the University of Kansas in 1930. From 1930 to 1942 he was a member of the research division of RCA Manufacturing Company in Camden, N. J. During that time he was engaged in research on television pickup tubes and related electronic problems, particularly in the development of the iconoscope. In 1942, he was transferred to RCA Laboratories Division, Princeton, N. J., continuing to work on electronic tubes and special circuit problems, including electronic computers, infrared image tubes and sensory devices. From 1949 to 1953, he was in charge of work on storage tubes and industrial television at RCA Laboratories. Since 1953, he has continued in charge of work on industrial television with emphasis on transistor circuitry and has supervised the work on Electronic Vehicle Control and Medical Electronics. Mr. Flory, a Fellow of the Technical Staff, RCA Laboratories is now affiliated with Astro Electronics Division. He has published numerous articles in the fields of Television and Medical Electronics. Mr. Flory is a member of Sigma Xi; a Fellow of the IEEE; a Member of the SMPTE; and is Secretary General of the International Federation for Medical Electronics and Biological Engineering. Forty U.S. Patents have been issued in his name.

off handsomely in accomplishments as we can see by looking in detail at a few of the engineering techniques that are being applied to medical problems. We in the electronic field are so interested in the application of electronic techniques to medicine that we created the term *medical electronics* to describe the field. It soon became apparent, however, that possible applications go far beyond electronics into every branch of engineering, i.e., mechanical, hydraulic, chemical, nuclear, etc.

#### INSTRUMENTATION

However, because instrumentation plays such an important role in most every case, electronics is perhaps the most universally applied branch of engineering in medicine.

Classified according to the use to which engineering techniques and devices are put, they may be used in research, diagnosis, therapy or monitoring with perhaps another justifiable classification, analysis. It was natural that engineering techniques were first applied in the research area in order to gain more insight into the operation of the human machine. As more knowledge is obtained, the techniques are then applied in diagnosis or therapy. (See Table I, which includes a fairly extensive list of examples of current medical instrumentation.)

#### VISUALIZATION TECHNIQUES

Visualization techniques very often play an important part in medicine. The oldest electronic visualization technique is the x-ray itself which needs no more than a mention at this point. However, a number of electronic devices are now in use as auxiliaries to the conventional x-ray. Some of these are concerned with ways of increasing the brightness of a fluoroscopic image in order to reduce the dosage to which the patient is exposed and at the same time protect the technician from excessive exposure. An image intensifier tube may be used to achieve a high degree of intensification. The intensified image may be viewed directly or for greater convenience may be viewed by a television camera. Some television pickup tubes with proper optical systems are more sensitive than the human eye and may be used to view a fluoroscope screen directly.

In addition to intensification, electronics can be of help in the study of x-ray images. Because of the flexibility of electronic amplification it is possible to alter the contrast range of an x-ray photograph, selecting and expanding certain contrast ranges at will. Fig. 2 illustrates this contrast enhancement technique.

Television and other scanning techniques find many other uses in medicine.<sup>2,3</sup> The most obvious, of course, is direct observation where the ability of television to transmit visual information to a remote point is used in surgery (Figs. 1, 7), dentistry, medical schools and to provide visual communication between hospital patients and visitors.

The use of television scanning in various analytical processes is very important.<sup>4</sup> The most familiar use is direct observation with the light microscope where the ability of the television system to enlarge and reproduce a microscope image either in monochrome or color, or translate an image in ultraviolet or infrared into a visible one, can be of great convenience.<sup>5</sup> Television microscopy also permits electronic particle counting and in vivo study of cell metabolism.

#### HEART ENGINEERING

As another example of an area in which important progress has already been made but which offers a fertile field for further accomplishments, consider the heart. The heart is without a doubt the most important organ in the body. From an engineering viewpoint, it is a mechanically operated hydraulic pump controlled by electricity. The most important measure of performance of the heart is the *cardiac output*—the quantity and pressure of the blood put into circulation with each stroke of the pump. This would be easy to measure if we could insert a meter in the aorta, but it cannot be measured very well in the intact human, so it is necessary to resort to indirect methods. For example, by aiming a beam of ultrasonic energy along the axis of the aorta as it leaves the heart, a doppler measure of blood velocity is obtained. Also, the diameter of the aorta can be measured by injecting a dye and observing it by x-ray; from these measurements the cardiac output can be obtained (Fig. 3).

The pumping energy comes from the contraction of the heart muscle. This action is closely related to and controlled by an electrical discharge. Every action of the heart muscles and the valves results in or results from a change in the electrical activity.

We would like to measure this electrical activity deep within the heart. However, we cannot place our electrodes in the right place except during an operation. So, we must usually be content to measure electrical potentials on the surface of the body and deduce from these measurements what actually goes on inside the heart. Electrically, the body acts as a quasi-cylindrical con-

tainer of salt water, and a lot of research has gone into a determination of what happens to heart potentials as they find their way to the surface of this odd shaped volume—this is *electrocardiography* and is one of the oldest of the applications of medical electronics. By a combination of basic research and empirical correlation, it has long since emerged from the research laboratory and is used in everyday clinical diagnosis. This is not to say that it is completely understood or that all of the information carried by the electrocardiogram can yet be interpreted. In recent years, three-dimensional *vector cardiography* (Fig. 5) has been studied using twelve or more electrodes and sophisticated stereo-type displays in order to learn more about the way in which the heart operates. Relatively simple techniques for inserting electrodes, pressure transducers, or miniature microphones directly into the heart by means of catheters inserted through a vein in the arm have been worked out and are daily contributing new information.

Open heart surgery to correct congenital defects or heart difficulty due to accident or disease has become almost as commonplace as any other major surgery. It is hard to realize that many of these operations could not have been attempted even a decade ago. They have been made possible largely by the heart-lung machine which is a combination pump and oxygenator which is temporarily used to by-pass the heart and lungs so that the natural organs can be repaired (Fig. 8). When the heart is again connected into the system, it must often be coaxed into normal operation in a manner which will best be understood after a brief explanation of the manner in which the heart muscle is triggered or stimulated.

The main heart muscle, the ventricular muscle, if left unexcited, will normally contract rhythmically at 10 to 20 beats per minute. In the right auricular region, there is a small bundle of specialized tissue called the sino-auricular node which generates an impulse at the normal heart rate of the order of 60 to 80 beats per minute. This impulse is conducted over a bundle of nerve fibres to the ventricles and acts as a synchronizing pulse to stimulate the ventricular contraction. After the shock of heart surgery, regions of the muscular tissue may rhythmically contract, but in a random and uncoordinated manner called *fibrillation*. In this case, a strong electric shock may stop the fibrillation and cause the entire muscle to contract together. In the past, such defibrillators have been as crude as two flat, paddle-

shaped electrodes connected to a plug which was momentarily inserted into a wall outlet by an assistant to the surgeon. This procedure has since been refined. In spite of defibrillation, the heart may not start normal contraction after surgery. It is often necessary to apply an artificial stimulating pulse to the heart from an external *pacemaker*. This is satisfactory in cases where external stimulation is needed only for a short time until the natural pacemaker regains control. In cases of heart damage where the natural pacemaker is no longer effective, an external pacemaker is not satisfactory because the body tends to reject foreign materials and an infection invariably results at the point of entry of wires.

In these cases, a permanently implanted pacemaker is indicated.<sup>6</sup> Such devices have been built with projected battery life of 5 years. There are now an estimated 5,000 patients leading relatively normal lives with their hearts continuously stimulated by implanted pacemakers (Fig. 4).

The heart-lung machine is in reality an artificial organ. Another device now saving lives is the artificial kidney,<sup>7</sup> which substitutes for the natural kidney but in its present form requires weekly hospital visits by the patient. It appears only a matter of time until the techniques in these areas will be combined to produce completely implanted artificial organs including the heart<sup>8</sup> and kidneys.

Surgeons today frequently install synthetic "spare parts" in the cardiovascular system. Artificial heart valves made of teflon have been installed, and it is relatively common to correct even large aneurysms by replacing a section of blood vessel with one made of woven dacron.

#### NERVE-SYSTEM ENGINEERING

As with the heart and almost any other active tissue of the body, the activity of the brain and nerve tissue is accompanied by an electrical phenomenon. The nerve signals pass from cell to cell as an electrochemical action which involves a delay which appears as a transit time. The electrical potentials generated in the process carry information regarding the activity in the brain or nerve cells. As with the heart, it is difficult to record from the surface of the skull in the intact human the activity of individual cells deep within the brain because every cell is surrounded by millions of others, all generating electrical potentials. What we do observe on the surface is a pattern of voltages varying in time which can be recorded in a recognizable manner. Rhythmic variations are found which

can be associated with mental activity, relaxation, sleep and wakefulness. The patterns observed during such abnormal activity as an epileptic seizure are clearly differentiated from normal waves. To learn more of what goes on in the depths of the brain without inserting electrodes, the main problem is that of signal-to-noise. When the signal to be studied is a rhythmic one or, as often the case, a response to a stimulus, the wanted signal can be lifted above the noise by integration. Special purpose computers are available for this purpose.

The relationship between the brain's functions and the voltages observed helps the doctor diagnose troubles and leads him to therapeutic measures. In brain surgery, the electroencephalographic waves (EEG) can be observed as the surgeon probes the brain to determine where it is safe to cut to avoid damage to vital nerve fibres which may affect the operation of parts of the brain remote from that being operated on. In the case of Parkinson's disease,<sup>9</sup> it is known that a tiny volume of brain tissue deep inside must be deactivated to relieve the symptoms. The brain is well mapped so the surgeon knows pretty well where the offending cells are located. With very precisely engineered mechanical devices, EEG electrodes are inserted and moved about to find the exact area. Once this is done, the same instrument permits the insertion of another electrode which can provide an electrical shock. A mild shock is applied and if the precise area has been located, the symptoms cease for a few seconds or so. In this case, a greater shock can be applied which permanently destroys the offending tissue. Alternatively, the destruction can be carried out by a cryogenic process or by a drop of chemical.

#### PHYSIOLOGICAL MONITORING

Monitoring the physiological variables (Fig. 6) of a patient during an operation or in intensive care requires a formidable array of equipment.<sup>10</sup> To maintain control of a patient's reaction to anesthetics and to the surgery, the anesthetist needs to monitor not only the usual variables of heart rate, temperature, blood pressure and respiration, but may also need to know the rate of blood flow in a transfusion, the oxygen in the blood as indicated by an oximeter and the partial pressure of gases in the inhaled and exhaled air. Help in sorting, correlating, and analyzing this information would be welcome.

Physiological monitoring is being extended into post-operative wards, intensive care areas and in some cases where only routine nursing care is re-

quired. Certainly, techniques are available to instrument this function even though the experience to date has not been overwhelmingly successful. More study and experience is needed before it can be determined how completely a patient can be instrumented before the system becomes too cumbersome to be practical.<sup>11</sup>

Monitoring of less-routine parameters is now being carried out by means of tiny self-transmitting radio telemetry devices which are attached to the body, ingested into the intestinal tract, or implanted in the body. Present developments in integrated circuits and other miniaturization techniques are contributing rapidly to these areas. One problem common to all active implanted devices is that of supplying the power, although the demand may be small, for long periods. In the pacemaker, for example, 90% of the weight is in the batteries necessary to operate the device over a satisfactorily long operating life. To overcome this limitation, several approaches are being investigated—such as secondary cells recharged by inductive coupling from outside the body, biologically powered devices operated by muscular action, or spring operated devices that are wound magnetically.

Numerous ingested and implanted monitoring devices have been developed and used, some powered by internal batteries and others externally powered by various means.<sup>12,13,14</sup>

#### PROSTHETIC DEVICES

Various engineering devices have been devised to relieve the handicapped. Guidance devices as well as reading aids have been made to aid blind subjects. None have been very successful, perhaps because we do not yet know enough about the information processing system of the brain to be able to feed the information to the subject in the proper manner.

Prostheses for limbs has been given considerable research attention.<sup>15</sup> An electrical muscle stimulator operated by a switch on the heel of the shoe facilitates walking by patients who have been deprived of normal control of leg muscles. Artificial hands operating by means of sensors and feedback systems are being produced in some quantities in Yugoslavia.<sup>16</sup> Buttons on the arm are depressed by the other hand to program the hand. A variation of this method uses the voluntary twitching of muscles in the intact part of the arm to operate the controls.

A further development in this direction makes use of biological potentials for control. Potentials generated by muscular activity appear on the surface

of the skin where they can be sensed and coupled into the control circuits of a prosthetic limb. Quite-sophisticated circuits for analysis and recognition of patterns in these myographic potentials are possible and with modern micro-circuitry techniques can be quite practical. The problem of supplying power for artificial limbs (which can require considerable power for lifting) is difficult and needs further investigation.

#### MEDICAL REPAIRS

Repairing parts of the body damaged in accidents, reconstructive surgery (already mentioned in connection with the artificial heart and kidney but actually much more extensive), substitution of live tissue from other parts of the body or from a "bank" and many other repair jobs from simple broken bones to transplanting of complete muscles, involve many engineering techniques. Any organ replacement or transplantation or replacing a severed limb requires the joining of literally hundreds of blood vessels. The more complete the union down to the smallest vessel, the more chance the operation has of success. An important contribution of mechanical engineering has been the development here and abroad of stapling devices<sup>17</sup> which can, in a single stroke, completely join the two ends of a vessel. Time is of the utmost importance in these cases, and the greater speed with which vessels may be joined and circulation restored contributes greatly to the patient's chances. More recently work has been done to improve techniques of electro-coagulation of tissue for suturing blood vessels. This involves the adaptation of RF dielectric heating techniques to coagulate the tissue to exactly the proper extent to provide maximum adhesion. It is felt that natural healing occurs most rapidly with this type of bonding.

Other special tools for retrieving swallowed objects or for performing other manipulatory or even surgical procedures in inaccessible places has drawn heavily on the ingenuity of engineers with remarkable results.

Even the designer of submarines has been called upon to apply his knowledge to provide practical hyperbaric chambers<sup>18</sup> in order that the advantages of high pressure (2 to 4 atmospheres) and high concentrations of oxygen can be made available to patients suffering from oxygen deficiency due to heart insufficiency, carbon monoxide, or other poisoning which destroys the oxygen carrying capacity of blood cells, or gangrenous infections which are often miraculously cleared up by high oxygen pressure.

#### INFORMATION PROCESSING AND ANALYSIS

Information of a recurrent nature such as EKG or EEG and that recorded on a time basis in response to a stimulus carries a great amount of information which must be extracted by some sort of analytical process. In the simplest case the doctor visually studies the EKG and looks for abnormalities in the height, shape, or position of some anticipated elements of the waveform or for unexpected artifacts which may indicate malfunction. To search for more subtle correlations or to analyze waveforms as complicated as those in vector cardiography or electroencephalography requires a degree of analysis beyond that which one can expect to accomplish by visual examination. Computer analysis of these waveforms is being actively investigated<sup>19,20</sup> and promises to extract many unsuspected correlations from rather routine waveforms. Pattern recognition in waveforms or by scanning two-dimensional plots of information, particle sizing, counting and selection and many other time-consuming tasks, many of them beyond human capacity, are now being undertaken by computers.

Medical diagnosis requires a special type of pattern recognition, a search for correlations in pathological features. The problem in this case is not hardware, because computers exist which have enormous memories and the immediate access necessary. Rather, the problem is in the organization of the data. More thought is needed by doctors on the logic and the process of making a diagnosis and how to feed the medical information into the computer so that it can use the data the way the doctor does in making a diagnosis. Of course, as more is learned about how the information can be handled by the computer, completely new logic steps may be developed to assist the doctor in making more accurate diagnoses. At the very least, once the medical information can be written in computer terms, the doctor will be provided with a memory and retrieval system which will far outstrip his own both for capacity and accuracy and permit him to expend his energies in more fruitful endeavors.

#### CONCLUSIONS

While I have indicated numerous examples of engineering and instruments being used, the medical field is by no means receiving all of the technical help it can use. Many of the devices are still experimental and costly and many of them are far too complicated and temperamental to receive wide-spread use.

The developments so far have served to point up possible applications as well as some of the problem areas. The real answers to the challenges to engineering in medicine are still around the corner.

#### BIBLIOGRAPHY

1. Davis, J. F., "Medical Engineering," *International Science & Technology*, September 1964.
2. Flory, L. E., "Television Techniques in Bio-Medical Applications," *Proc. 3rd Int'l. Conf. on Med. Elec.*, Institution of Electrical Engineers, London, 1960.
3. Shackel, B., "Medical Applications of Television," *Medical Electronics & Biological Engineering*, Vol. 1, No. 1, Jan.-Mar. 1963.
4. Flory, L. E., "Scanning Microscopy in Medicine and Biology," *Proc. IRE*, November 1959.
5. Zworykin, V. K., and Hatke, F. L., "Ultraviolet Color Translating Microscope," *Science*, Vol. 126, No. 3278, October 25, 1957.
6. Chardack, W., et al, "A Transistorized Self Contained Implantable Pacemaker," *Surgery*, Vol. 28, pp. 643-654, October 1960.
7. Jackson, R. C., "The Artificial Kidney and Its Place in Medicine Today," *British J. Clinical Practice*, 1962, Vol. 16, 303-313.
8. Seidel, W., et al, "Performance of an Adjustable Heart Substitute," *Am. J. of Med. Elec.*, Vol. 2, No. 3, 1963.
9. Petrovick, M., et al, "Instrumentation Applications in Neurosurgery for Parkinsonism," *Am. J. of Med. Elec.*, Vol. 1, No. 2, 1962.
10. Thompson, N. P., "An Instrumentation System for Open-Heart Surgery," *Am. J. of Med. Elec.*, Vol. 1, No. 4, 1962.
11. *Techniques of Physiological Monitoring*, 3-Volume Technical Documentary Report, No. AMRL-TDR-62-98, By RCA Service Co., for Aerospace Medical Div., Air Force Systems Command, Wright Patterson AFB, Ohio.
12. Jacobson, B., "Endoradiosonde Techniques, A Survey," *Med. Elec. & Biol. Engr.*, Vol. 1, No. 2, 1963.
13. Nagumo, J., et al, "Echo Capsule for Medical Use," *IEEE Trans. Bio-Med. Elec.*, BME-9, 1962.
14. Hatke, F. L., Flory, L. E. and Zworykin, V. K., "Telemetering Internal Biological Potentials with Passive Type Capsules," *Proc. 5th Int'l. Conf. on Med. Elec.*, Liege, Belgium, 1963.
15. *Bulletin of Prosthetics Research*, Dept. of Medicine and Surgery, Veterans Administration, Wash., D.C.
16. Rakic, M., "An Automatic Hand Prosthesis," *Med. Elec. & Biol. Engr.*, Vol. 2, No. 1, March 1964.
17. Mallina, R. F., et al, "Surgical Stapling," *Scientific American*, October 1962.
18. McDowall, M. B., "The Scope and Limitations of a Pressure Chamber," *World Medical Electronics*, Vol. 2, No. 6, 1964.
19. *Topics in Computer Techniques for Electrocardiography*, Pamphlet prepared by Airborne Instruments Laboratory, 1962.
20. Kozhevnikov, V. A. and Meshehskiy, R. M., *Current Methods of Electroencephalographic Analysis*, (book) USSR, Translation #JPRS 23590.

# MICROCIRCUIT-MICROWATT DESIGN TECHNIQUES FOR NEW INTERNAL MEDICAL SENSORS

Until recently, internal medical sensors have been limited to those transducers that were not only small enough, but also extremely sensitive in response. Now, with modern miniature semiconductor devices and integrated circuits, it is becoming practical to combine a relatively insensitive transducer with some electronic gain inside the body to achieve the needed overall system sensitivity with reduced size. Work on such microcircuit-microwatt sensors is reviewed herein.

F. L. HATKE and L. E. FLORY\*

*Astro-Electronics Applied Research Laboratory  
Astro-Electronics Division, DEP, Princeton, N. J.*

**S**ENSORS for measuring physiological functions have been with us for many years. The measurements have, in general, been mechanical or acoustical and relied upon the senses of the doctor for their detection and interpretation—for example, the stethoscope. Today, with modern electronics, such basic medical information may be obtained not only with much better fidelity but in many cases directly from the source. Small microphones<sup>1</sup> can be (and are) inserted into arteries and veins, floated into the heart, and used for listening for valve and other defects.

But such devices obviously must be extremely small and very sensitive. As might be expected, doctors anxious to use such sensors often want from designers twice the sensitivity, half the size, or both. In the past, most of the effort has been concentrated on devising transducers with high sensitivity and small size. But with up-to-date transistors and integrated circuits, it is now

sometimes possible to use the combination of a small but relatively insensitive transducer with some electronic gain to produce the required sensitivity together with reduced size. Examples of completely electronic transducers only recently available are: sensitive tunnel-diode pressure transducers,<sup>2</sup> thermistors, varactor diodes, and semiconductor strain gauges. By adding thermocouples, variable-reluctance inductors, and temperature-sensitive capacitors to these standards, there are a variety of ways in which the job could be done.

## TELEMETRY FROM WITHIN THE BODY

RCA Laboratories work in this field has concentrated on obtaining physiological information from within the human body without any connecting wires. The pioneering work in this field occurred almost simultaneously in the U.S.<sup>3</sup> and in Europe<sup>4-6</sup> where investigators, spurred on by the invention of the transistor, developed active (battery-powered) telemetering capsules. These units broadcast pressure, temperature, etc. from

the alimentary tract. Unfortunately, the experiments were limited to a few days or weeks by the capacity of the battery. Many new and more interesting experiments became apparent if the capsule could be made smaller and its life, inside the body, could be made infinite.

With these additional requirements, a second,<sup>9-11</sup> or passive system, was devised incorporating more complexity on the outside of the body and less on the inside. This system, with but two passive electrical components inside the body, made it possible to reduce the capsule volume approximately 50%.

## PASSIVE TELEMETERING SYSTEM

In the passive system, energy is supplied to the capsule from the outside, which energizes the circuit of the capsule, which in turn returns a portion of the energy to the outside equipment, together with the telemetered information. The capsule itself consists of an inductance and a capacitor, each of which may also be the transducer, depending on the required information. The variable inductance has been found useful for the measurement of pressure and a temperature-sensitive capacitor for temperature. In either case, bursts of energy with a frequency at, or near, the resonant frequency of the capsule are supplied from the outside antenna. Some of this energy is absorbed by the capsule during this transmitting time. When the transmitter is turned off, the capsule dissipates this energy at its own resonant frequency. Some fraction of this energy, modulated by measured parameters, is received by the same outside antenna. All that is required is to measure the frequency of this returned energy—this will be a direct measure of the internal physiological phenomena. To facilitate the transfer of energy both into and out of the capsule, the *Q* of its resonant circuit should be as high as practical. Even with optimum conditions, the ratio of the transmitted to received energy may be in the order of 100 db. Considerable

Final manuscript received January 18, 1965.  
\*Mr. Flory is a Fellow RCA Laboratories

Fig. 1—A completely transistorized passive system including transmitter and receiver.

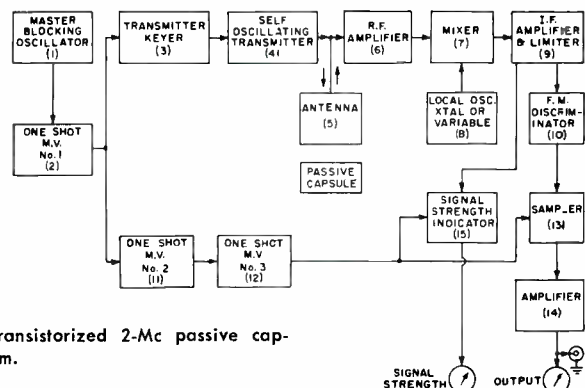
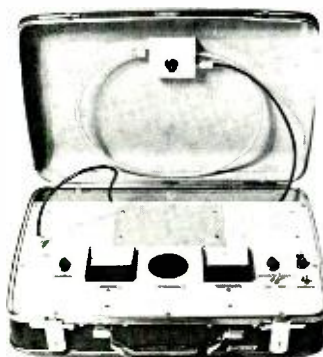

Fig. 2—Transistorized 2-Mc passive capsule system.



**FRED L. HATKE** received a BEE and MEE at New York University in 1950 and 1951. From 1951 to 1955, he worked as a development engineer at NBC in New York. During that time he contributed to the development of electronic masking techniques and the introduction of vidicon cameras to the broadcasting business. In 1955, he joined the Staff of the Medical Electronics Center of The Rockefeller Institute in New York. While working here he contributed to the design of the Active Endoradiosonde System which was used by Dr. J. T. Farrar for gastrointestinal studies at the Veterans Administration Hospital in New York. He later was responsible for the design of the ultraviolet color translating TV microscope. Mr. Hatke joined the Staff of the RCA Laboratories in 1958 where he was continued his work in medical electronics. He is presently carrying on work in the design of passive endoradiosonde systems and microminiature sensor transmitters. He has also been very active in the design of color TV microscopy systems and other applications of TV to medical problems. A mem-

ber of the Technical Staff of RCA Laboratories, Mr. Hatke is now affiliated with Astro Electronics Division. Mr. Hatke is a Senior Member of the IEEE and their Professional Group on Bio-Medical Engineering. He has three U.S. Patents issued in his name.

LESLIE E. FLORY received his BSEE at the University of Kansas in 1930. From 1930 to 1942 he was a member of the research division of RCA Manufacturing Company in Camden, N. J. During that time he was engaged in research on television pickup tubes and related electronic problems, particularly in the development of the iconoscope. In 1942, he was transferred to RCA Laboratories Division, Princeton, N. J., continuing to work on electronic tubes and special circuit problems, including electronic computers, infrared image tubes and sensory devices. From 1949 to 1953, he was in charge of work on storage tubes and industrial television at RCA Laboratories. Since 1953, he has continued in charge of work on industrial television with emphasis on transistor circuitry and has supervised the work on Electronic Vehicle Control and Medical Electronics. Mr. Flory, a Fellow of the Technical Staff, RCA Laboratories is now affiliated with Astro Electronics Division. He has published numerous articles in the fields of Television and Medical Electronics. Mr. Flory is a Member of Sigma Xi; a Fellow of the IEEE; a Member of the SMPTE; and is Secretary General of the International Federation for Medical Electronics and Biological Engineering. Forty U.S. Patents have been issued in his name.

effort has been expended to keep the capsule  $Q$  high and, at the same time, reduce the size to an even smaller volume. Recently, a completely transistorized passive system based on earlier work has been designed, (Fig. 1). This passive telemetering system is divided into three essentially separate sections; the transmitter; the capsule; and the receiver. All three are loosely tied together by the antenna system and the timing system. Fig. 2 shows the overall system operation. The whole system cycle is divided into three almost-equal time intervals: transmit time; delay time; and, receive time. Their repetition rate and duration are controlled by the master blocking oscillator and one-shot multivibrators No's. 1, 2, and 3. The transmitter is activated by multivibrator 1 and energizes the capsule during its *on* time. Thereafter, multivibrator 2 determines the length of time before an uncontaminated signal is received from the cap-

sule, and multivibrator 3 controls the time at which the receiver output is measured to determine the capsule's natural resonant frequency.

The transmitter is a self-oscillating power transistor delivering about 300 volts peak-to-peak across the antenna. The length of time the transmitter is energized, as determined by multivibrator 1, controls the *on-off* keyer in the emitter of an oscillating transmitter. The capsule, after absorbing some of the energy from the transmitter, returns a small portion of it to the antenna at a frequency determined by the information to be telemetered. This combination of signals is fed into the receiver, which amplifies and limits over the 100-db range between the *transmit* and the *receive* level. A sample of the combined signal is taken at the last limiter during the receiving time. This sample is rectified and displayed on a front panel meter indicating the amount of energy the capsule is returning to the receiver.

The output of the limiter is also applied to a conventional frequency discriminator. The output of the discriminator is amplified and passed through an emitter follower to reduce the driving impedance. At this point it is sampled during the receiving interval. To make the output signal continuous instead of pulsed, the pulse amplitude is stored during the *transmit* and *delay* times and corrected to the new value when the next *receive* time interval occurs.

This results in the system measuring the natural resonant frequency of the passive capsule, being independent of both transmitter frequency and, within operating limits, distance from the antenna.

#### PRESSURE AND TEMPERATURE SENSORS

It became evident early in these RCA Laboratories investigations that measurements of temperature and pressure might be made using either the inductance or the capacity as the transducer. In the case of pressure some nominal mechanical power is available to move the variable reluctance transducer and cause a change of inductance in the tuned circuit. For temperature conversion, a ceramic condenser is available whose capacity is a measure of its temperature. This, when combined with a suitable inductance, in a resonant circuit, forms a passive temperature transmitter of high sensitivity. An example of each of these types is shown in Fig. 3. These temperature sensors are now in use in the study of ovarian function.<sup>12,13</sup>

#### VOLTAGE SENSOR

In designing a potential-measuring capsule with sufficient deviation in the returned signal to make measurements in the 1-mv range, some sort of electrical gain must be acquired inside the capsule. To do this, some of the energy transmitted into the capsule must be converted into a source of direct current. In addition, the voltage must be regulated so as to keep the amplifier stable with respect to the coupling between capsule and transmitter. Also, the amplifier must not consume very much power because every drain on the tuned circuit is reflected in a reduction in circuit  $Q$ , accompanied by a loss in operating distance of the capsule from the transmitter.

Recently, junction transistors became available which operate at extremely low collector currents and still exhibit high current gains. These transistors are of necessity made of silicon to keep leakage currents low compared to the signal and bias currents. Fig. 4 shows such a transistor incorporated into a circuit capable of telemetering low-level dc potentials using the passive system.

Fig. 3—Examples of the use of capacitance and inductance to form passive temperature transmitters of high sensitivity.

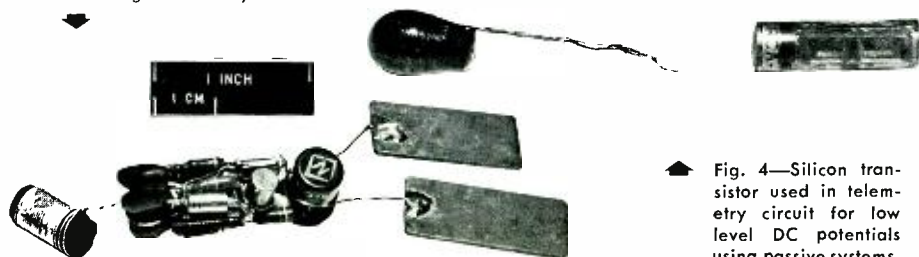

Fig. 4—Silicon transistor used in telemetry circuit for low level DC potentials using passive systems.



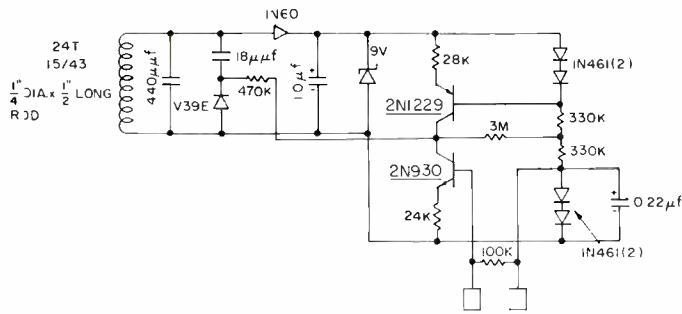

Fig. 5—Passive biological potential capsule.

Fig. 5 is a schematic diagram of the potential transducer.

Operation of the circuit is as follows. During transmit time, energy is coupled from the transmitter into the inductance. This inductance is roughly resonated with the 440-pf condenser and modulated in its resonance by the 18-pf and the V39E varactor diode. A small part of absorbed energy is rectified by the 1N60 diode and regulated and filtered by the 1.0-µf capacitor and 9-volt zener diode. Transistors 2N930 and 2N1229 form the dc voltage amplifier, the 2N930 being the active amplifier and the 2N1229 forming a synthetic load resistance. Proper biasing is afforded by the 1N461 diodes and the emitter resistors. The amplifier provides a gain of about 200. The output of the amplifier modulates the V39E varactor diode. This assortment of semiconductors, resistors, capacitors, and one inductance with no serious attempt at miniaturization fits into a volume of about 0.3 cubic inch. It is obvious that integrated circuit techniques could reduce this volume by a large factor.

A simpler circuit design is possible if advantage is taken of the time sequence of the transmitter-receiver. Fig. 6 gives one such capsule design. In this system, energy is absorbed during transmit time and charges the storage capacitor C up to the full zener voltage. Since there is a time delay between transmit and receive time, the potential across C will decay to a value determined by the current load of the field effect transistor.

The potential on the capacitor is also

the bias voltage on the varactor diode so that the input to the field effect transistor effectively modulates the bias on the varactor and, therefore, the resonant frequency of the ringing circuit. This design reduces the number of active and inactive elements in the capsule, thus enabling an additional reduction in size.

The sensitivity of this sensor is determined by the available gain in the field effect transistor at the low voltage ( $\cong 5$  volts) available across the capacitor. Developments in this type of transistor are expected to improve this parameter. Meanwhile, it is also practicable by microcircuitry techniques to provide a field effect transistor directly coupled to a junction transistor in the same assembly at very little expense in power. A typical input-output curve is seen in Fig. 7.

#### NEW TECHNOLOGY

As can be seen, the newly emerging microcircuit-microwatt technology is beginning to give the designer of implantable medical sensors the ability to use some electronic gain inside the body. In the past, only transducers sensitive enough to produce proper system deviation directly could be used. Since most electronic transducers convert information to electrical potential, this type of capsule appears to have the widest range of application. Some examples include: direct monitoring of the electrocardiogram; monitoring other internal functional potentials; measurement of internal pH using glass electrodes; in addition to an alternative way of

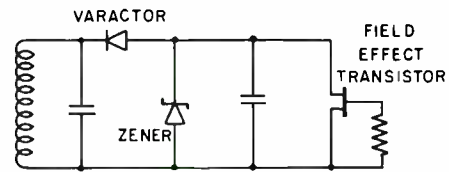

Fig. 6—Simplified passive biological potential capsule.

measuring temperature (thermistors) and pressure (strain gauges).

Each of these devices is presently being used in an experimental manner in an effort to learn more about the functions of the human body. It may not be too long before these devices will be used more widely as new tools for medical diagnosis.

#### BIBLIOGRAPHY

- Warnick, A., and Drake, E. H., M.D., "A New Intracardiac Pressure Measuring System," 1958 IRE Convention Record, Pg. 68.
- Sikorski, M. E., "Sensitive Tunnel-Diode Pressure Transducer," TA 7.5, International Solid-State Conference 1962.
- Farrar, J. T., Zworykin, V. K., and Baum, J., (1957), "Pressure-Sensitive Telemetering Capsule for Study of Gastrointestinal Motility," *Science*, 126, 975-976.
- Mackay, R. S., and Jacobson, B. (1957), "Endoradiosonde," London 179. *Nature*, 1239-1240.
- Jacobson, B., and Mackay, R. S. (1957), "A pH-Endoradiosonde," *Lancet*, 272, 1224-1225.
- Von Ardenne, M., and Sprung, H. B., "Über Versuche mit Linem Verschluckbaren Intestinakender," *Die Naturwissenschaften*, 45, (7), 154-155.
- Nüller, H. G., "Die Endoradiosondentechnik und Ihre Bedeutung für die Inner Medizin," *Verhandl. deut. Ges. inn. Med.* 65, 727, 730.
- Jacobson, B., "Endoradiosonde Techniques—A Survey," *Med. Electron. Biol. Engng.* Vol. 1, pp. 165-180. Pergamon Press, 1963.
- Haynes, H. E., and Witchey, A. L., "The Pill That Talks," RCA ENGINEER, Feb.-Mar. 1960, 52-54.
- Zworykin, V. K., Farrar, J. T., Hatke, F. L., etc., "The Measurement of Internal Physiological Phenomena Using Passive-Type Telemetering Capsules," 1961 IRE Convention Record, Part 9.
- Farrar, J. T., Zworykin, V. K., etc., "Telemetering of Intraenteric Pressure in Man by an Externally Energized Wireless Capsule," *Science*, Vol. 131, No. 3416, P. 1814, June 17, 1960.
- Dordick, H. S., Balin, H., Israel, S. L., and Hatke, F. L., "The Determination of Ovarian Function by Means of Permanently Implanted Endoradiosondes," *IFME 4th Conference Digest*, July 1961.
- Balin, H., Busser, J., Hatke, F., Fromm, E., Wan, L., Israel, S. L., "Radio Telemetry System for the Study of Ovarian Physiology," *Obstetrics and Gynecology*, Vol. 24, No. 2, August 1964.

Fig. 7—Input vs. output at various distances from antenna.

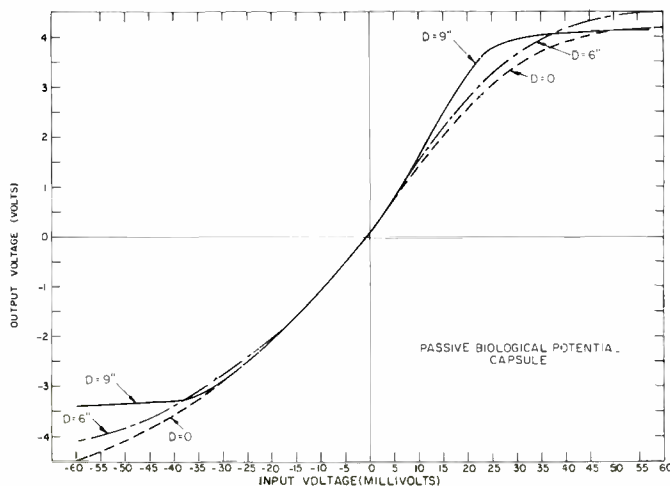

## DEVELOPMENT OF ELECTRON MICROSCOPY IN THE LIFE SCIENCES

Every major university biology department, medical school, life sciences research institute, and commercial pharmaceutical company has at least one electron microscope—and some as many as eighteen. The life sciences are now experiencing what the physical sciences did at the start of this century when instruments were first devised for studying the "ultrastructure" of the physical world. The outpouring of knowledge on the ultrastructures of living matter promises to be even greater than that which occurred in the physical sciences because of the greater complexity of structure and function of living matter. Thus, the electron microscope is a key instrument in this life sciences revolution because it provides information about the size, shape, and density of biological entities, and about their structural relationships. Reviewed here is the historical development of electron-microscope capabilities for the life sciences, along with indications of present capabilities and some future potential.

**DR. J. H. REISNER, Ldr.**

*Advanced Development and Systems  
Scientific Instruments Engineering  
Broadcast and Communications Products Division  
Camden, N. J.*

**T**HERE are many examples of the changes occurring in the life sciences as a result of modern instrumentation. With the light microscope, the characterless material around the recognizable elements of a cell was termed the ground substance, or *cytoplasm*; but now, with electron microscopy, it is seen to be made up of many specialized functioning elements and apparatus of the cell. Biological agents whose presence and/or function was suspected from cytochemical and biophysical studies have been physically identified, typified by the classic work in photosynthesis where the seat of the primary photochemical process has been identified with the chloroplast. The presence of virus was known prior to this century, and some of the larger viruses were detected with the light microscope. Now with the electron microscope

*Final manuscript received January 20, 1965*

(Fig. 1) smallest viruses are seen and measured and even the major surface structure can be recognized. The DNA molecules which comprise most of their substance have been seen extruding through their enveloping walls. Viruses have been seen in both plant and animal cells. Anatomists have plunged into the task of re-examining all anatomy at cellular and subcellular levels. Pathology has started to make clinical use of the electron microscope to identify structural changes which characterize deceased cells heretofore beyond the range of vision.

### PROBLEMS OF APPLYING ELECTRON MICROSCOPY IN THE LIFE SCIENCES

The commercial availability of RCA electron microscopes in the year 1940 was hailed as a great event by pioneering biologists who saw in its hundred-



Fig. 1—A modern electron microscope, here operating with a television display system.

fold increase in resolving power (over the light microscope) a means for actually seeing structure in biological materials—then-unseen structure, which they knew from experience must exist. However, because of the great difficulties involved in developing techniques for the microscopy of biological materials, the early progress seemed slow.

The great resolving power of the electron microscope comes only at the considerable price of imposing serious restrictions on the physical properties of the specimen suitable for use in it. In the early days of electron microscopy, these requirements on the form of the specimen seemed insurmountable to many. The specimen must be extremely thin—e.g., 100 to 500 angstroms. This

Fig. 2—Enhancement of contrast of bacterial flagella by metal shadowing. (Wyckoff and Williams, 1946.)



Fig. 3—The  $\phi$ X-174 bacteriophage extruding DNA, showing the resolution (15 angstroms) now possible with shadowing. (C. E. Hall).



is several times thinner than the best microtomes could cut prior to 1948, and thinner than most single-cell material (such as bacteria). In specimens composed of the light elements, as most organic material, the contrast in the image is extremely low because of low density differences, and methods of "staining" must be used to give images of useful contrast. The specimen in the microscope is desiccated in the vacuum required, and it may even be heated and otherwise altered by the beam. No living matter, even if thin enough to avoid sectioning, can survive these conditions. Thus all specimens are dead, which imposes the first and probably most serious major difficulty on the life scientist, since his specimens are usually living at the outset.

Electron microscopy of such dynamic subjects requires sampling representative examples of a given biological system at time intervals and then studying the resultant micrographs for characteristic changes in order to reconstruct a description of its behavior. Such procedures require much sampling and great numbers of micrographs to come out with statistically reliable answers. Such studies are being applied with excellent results to many biological problems including such a dynamic subject as cell metabolism. Here relatively simple and fast-changing systems such as protozoan are used and the whole process of ingestion, digestion, and elimination of food is displayed in a series of time sequential "snapshots." The technique of sampling periodically is also used in the study of effect of aging of cells to find out what parts of the cell actually are involved in degeneration with age.

Most of the samples of life sciences deal with parts of larger systems, such as organs; and the cell structures take on characteristics specific to their function in the larger systems. Here the relationships of the substructures are significant. However, the problems of producing a thin section of specimen, strong enough to keep its dimensions, chemically changing it to produce contrast, yet without changing the physical relationships of the structure it had while alive, are a continual source of concern and difficulty to the scientists who use electron microscopy.

In spite of these difficulties, most of the tissue that has been studied under the light microscope is being restudied under the electron microscope. However, because of the tremendous increase in the amount of resolvable structure, the process will take more effort and give far more information than the earlier studies with light mi-

croscopy. One must not have the impression that the earlier work with the light microscope has been set aside, but rather that it has been augmented at more basic structural levels by electron microscopy. Light and electron microscopy are *complementary techniques*.

#### MAJOR STEPS IN SPECIMEN PREPARATION

The first biological materials used for microscopy were those that could be separated, or purified, and thus could be spread upon the electron microscope specimen screen. Collagen fibrils, which make up connective tissue, were extensively studied, and indeed were used to check x-ray data on structural dimensions. Viruses fell in this category also, but larger particles such as bacteria, blood cells, protozoa and sperm cells, etc. were not very usefully studied because they are too thick to permit electron penetration for imaging internal detail. It was not until these particles could be sectioned that electron microscopy became truly important in their study.

More recently (1953), with the advent of routine high resolving power the separation of very small biological components such as ferritin or DNA has become a useful technique. In the case of ferritin its structure is sufficiently fine and consistent enough to be used by some workers as a microscope performance standard.

The need for enhancement of contrast in biological specimens was apparent from the first. Such thin organic materials as the flagella of bacteria, or the fibrils or collagen, were barely perceptible. The first step forward came with the development of "shadowing" by Wyckoff and Williams in 1946 (Fig. 2). Heavy metals such as gold are evaporated obliquely across a specimen in a vacuum. Since the evaporated metal travels in line-of-sight direction, irregularities in the specimen cast shadows which are of very high contrast. Fig. 3 shows this technique applied to recent studies of minute DNA molecules. It is a technique used with particulate materials such as viruses.

The great breakthrough for cellular materials came with the development of *ultramicrotomy* (1948)—the cutting of slices of materials (Figs. 4, 5) thin enough to be penetrated by the electron beam (e.g. less than 500 angstroms). Microtomy was well known to light microscopy but conventional microtomes could not be made to cut slices thinner than a few thousand angstroms. The history of the development of ultrathin sectioning is worthy of an article alone.

The contrast problem with sections was even more severe than with dis-

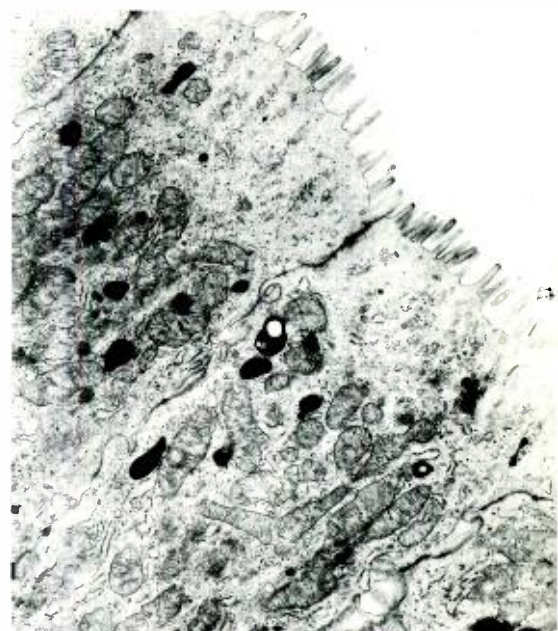

Fig. 4—Tissue section (intestinal cells showing intricacies of structure that are now resolved). (J. A. Freeman).

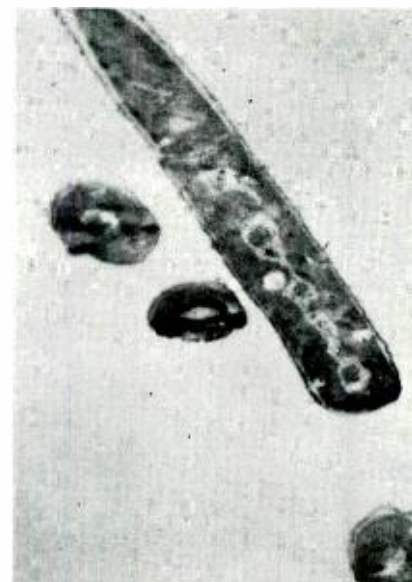

Fig. 5—Top: A section of a bacterium showing the internal detail, in comparison with (bottom) a micrograph of a whole bacterium.

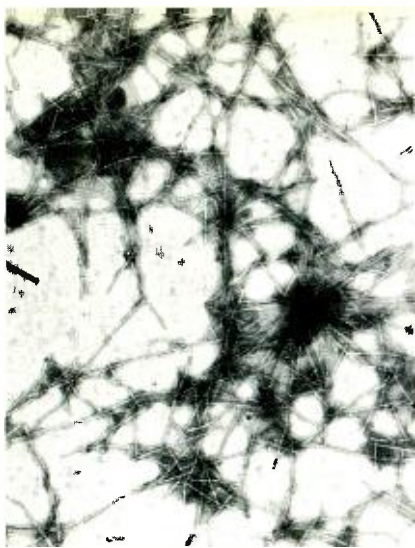

Fig. 6—One of the first micrographs using negative staining. Specimen is tobacco mosaic virus negatively stained with phosphotungstic acid. (C. E. Hall, EMU-3A microscope, 1953.)

persed materials because of the large amount of extraneous support material in the section. This problem was overcome by the fixation of specimens with osmic acid and later by using other *stains* containing high atomic weight atoms which provide the electron scattering power necessary to show their presence. These staining materials exhibited preferential absorption for various cellular constituents and thus increased their electron optical density, making them "visible."

More recently (since 1955) a similar technique known as *negative staining* has come into use. Just as a *stain* indicates an area into which it is selectively absorbed, so will it also delineate an area where it is *not* absorbed (Fig. 6). This has been particularly useful in viral specimens.

#### INSTRUMENTAL DEVELOPMENTS

Once the commercial microscope became available, changes in the instrument have kept pace with the developments in the art of specimen preparation. The RCA Model EMU-1 electron microscope (brought out in 1944), had a magnification range of from 8,000 to 20,000 $\times$ . As long as specimens were particulate this range was adequate, but as soon as sections became useful it became important to relate the newly seen structure from electron microscopy with the familiar structures recognized in light microscopy. To do this, the range of magnification was lowered to 1,000 $\times$ . Even today, fully half the electron micrographs taken are below 8,000 $\times$  magnification. As specimen techniques improved, specimens began to show finer detail, and higher magnifications had to be achieved. This became possible after 1947 with the development by Dr. Hillier (RCA Laboratories) of objective lens correction and a high-intensity self-bias electron gun. Much microscopy is done today at over 100,000 $\times$

magnification when high resolution is required.

Since many of the problems with specimen techniques are imposed by the instrumental requirements, an important area of instrumental development has been and will remain in the area of relaxing these restrictions.

Before sectioning became a routine technique and while the highest instrumental voltages were still 60 kv, it was thought that higher accelerating voltage (i.e. 100 to 300 kv) would be extremely useful. However, it is now realized that the limitation on specimen thickness is generally the size of the structures to be observed (10 to 100 angstroms), and specimens need to be cut still thinner to keep from the confusion of superposition of detail in the image of the specimen. Actually, the use of the 100-kv acceleration in microscopy has gradually increased because of the reduced damage produced in specimens at high voltages. The reason it hasn't been used more is the reduced contrast with higher voltages.

The improvement of instrumental factors affecting image contrast has helped relax some of the restrictions upon the staining of biological specimens. The mechanism of contrast in the electron microscope is the scattering of electrons by the matter in the specimen, so that the scattered electrons are lost to the image, or at least do not return to image points corresponding to the points in the object where they were initially scattered. Instrumentally, two things are done: First, stray illumination scattered on the walls and optical elements of the instrument can be minimized, which (strangely enough) is a rather difficult task. Second, as much as possible of the electrons scattered by the specimen are removed from the optical system by the objective aperture. Unfortunately, however, the use of an objective aperture is presently the most serious inconvenience and sometimes a problem to the electron microscopist.

The difficulty with aperturing stems from the requirement that the openings must be very small (25 to 50 microns). As a consequence, their edges are close to the beam and they become contaminated and electrostatically charged by scattered electrons. The result is that a supposedly passive element such as a "stop" becomes active, generally asymmetrically, and becomes an extraneous lens with high enough anisotropic astigmatism to degenerate the image. Thus, the device to gain contrast can (and often does) throw away its advantage, by reducing resolving power.

The first approach to this problem

has been to accept the contamination-induced asymmetry, but to *correct* for it with externally adjustable stigmators—a system introduced by RCA in 1953. The latest approach is to introduce an aperture disk that can be kept at high enough temperatures (250 to 300°C) that it will not contaminate—and thus will never become charged asymmetrically. Such a so-called *permanent aperture* has just been introduced by RCA.

Another frequently suggested alternative to the improvement of contrast is to increase both the angle of scattering and amount of scattering by the specimen material. This can be done by decreasing the electron accelerating voltage. Successful microscopy has been done down to a few kilovolts. Unfortunately, instrumental problems such as extremely serious charging effects including charging of photographic materials, susceptibility of the electron beam to stray fields, and specimen preparation problems, have made operation of commercial instruments below 30 kv impractical.

To accommodate the life scientists' need for statistical information, the speed of microscopy has to be increased. He was given more photographic plate area in 1953 (increased from 2 x 2 inches to 3 $\frac{1}{4}$  x 4 inches), which represented a threefold increase

DR. J. H. REISNER received his BS in Mathematics from Davidson College in 1939, and a PhD in Physics in 1943 from the University of Virginia. He joined the Crystal Engineering Department of RCA Camden upon graduation, and in 1945 transferred to the Electron Microscope Group, where he was promoted to leader in 1950. He is currently Leader of Advanced Development and Systems for the Scientific Instruments Engineering Group, which is responsible for electron microscopes, and electron and x-ray diffraction equipment. While his main effort has been in electron optics, he has made significant contributions in vacuum technique, mechanical and electrical design, and magnetics. He is best known for his successful development of permanent magnetic lenses and electrostatic stigmators. He has written and lectured widely, and is a member of Phi Beta Kappa, Sigma Pi Sigma, Sigma Xi, and the APS, and is a Fellow of the AAAS. He was president of the Electron Microscope Society of America in 1959, and previous to that, a Director. He is past-president of the Philadelphia Electron Microscope Society, a member of the New York Society of Electron Microscopists, and was Associate Chairman of the International Congress of Electron Microscopy for 1962. He is currently Chairman of ASTM Project on Resolution in Electron Microscopy. A member of the Franklin Institute since 1946, Dr. Reisner now serves on its committee on Science and the Arts.



in speed for each exposure. He had been given fast vacuum cycling in 1944, with the EMU-1, so that many plates could be exposed in the course of a day and specimen change would be rapid. The appearance of focusing aids (1950), with subsequent improvement from time to time, increased his yield of good exposures. A few years ago, microscopists would take a series of pictures at fixed focal increments around visual focus, in hopes that one picture in this so-called *through-focus series* would be good. Now, most work is "single shot," and a trained worker can be confident that a large percentage of his day's output (100 to 150 exposures) will be useful.

#### SEPARATION OF OPERATION AND INSTRUMENTATION

An essential development in the design of the electron microscope has been the simplification of operation and a reduction of operator responsibility for the correct operation of the instrumental system. This is another way of recognizing an extremely important but often overlooked contribution engineering has made to electron microscopy. Most modern operators' involvement with the instrument never concerns the electrical or vacuum systems further than the control knobs, and these are often merely pushbuttons which initiate automated functions.

During the first decade of commercial instruments, the microscope operator had to be involved in instrumentation to keep it going, and many of the early microscopists' papers on electron microscopy dealt with such matters as finding leaks, or trouble shooting, electrical or optical problems. This was a responsibility that chemists and physicists were relatively well trained to assume, but which was quite foreign to the experience and training of the majority of biologists. With the increased specialization of recent years, even physicists and chemists are not prepared for such instrumentation, especially with its increased complexity. Engineering has provided the reliability and automation necessary to separate the operator from instrument maintenance, but even so, only with the help of a well trained field service organization.

#### TRAINING FOR MICROSCOPY

Successful microscopy requires three elements, an adequate specimen, an operating instrument, and a competent microscopist. The human factor has actually prevented an even more rapid development of electron microscopy. The microscopist's function is partially technical and partially scientific, and

unfortunately, they can not be completely separated. The scientist who is doing research can not divorce himself from the techniques of microscopy, so the problem of training, can *not* be solved by training technicians alone.

Most microscopists in the life sciences have been trained in graduate schools of biology and medicine. There they have had some relatively elementary formal course work in the physical principles of the electron microscope, and actual operating experience on microscopes. Most of the emphasis has, rightly, been on specimen preparation and image interpretation. Thus the formal training of a biologist or pathologist, etc. for research with the electron microscope generally involves at least a year of graduate, or past doctoral study at an institution doing microscopy. The life sciences have done a relatively responsible job in accepting a training function in most new laboratories as they became competent, but the process has been slow and expensive.

In the early days, do-it-yourself was the only way to learn, and today some of this persists. Self training is still frequently undertaken. There is a large supply of literature on the techniques for microscopy, and a number of short survey courses (2 to 3 weeks) are given each year by educational institutions on instrumental and specimen techniques for beginners. RCA has almost from the beginning given a one-week course in instrumental techniques to its customers. During the year 1964, about 120 people made use of the opportunity.

A second, and very important training area has been that of the laboratory technician, who cleans and checks the instrument and otherwise maintains it. The technician usually also does the photographic development and enlargement and often phases of specimen preparation, and even some of the routine microscopy. Technicians are usually trained by on-the-job guidance by a qualified microscopist and receive help from field service personnel of the manufacturer who maintain the instruments. Often they also receive instruction in the short courses mentioned earlier. A year of on-the-job training will usually be sufficient to qualify an individual as an electron microscope technician. With all the effort that is going into training, there is still an acute shortage of trained personnel.

#### FUTURE DEVELOPMENTS

The remarkable developments in specimen preparation can be expected to continue. Techniques are improving rapidly and the structures they reveal are beginning to tax the resolving

power of the microscope. Thinner specimens, stronger specimens and supports, less-disruptive processes, conducting imbedding materials, and "tagging" techniques for macromolecules are all subjects of research activity by the microscopists.

In the area of instrumentation, the problems of specimen contamination is receiving major effort and already devices which materially reduce contamination are available. One can anticipate that in the future the noncontaminating microscope will be an everyday reality. Accessory devices and techniques presently available to the microscopist, but which have as yet had little use, will be studied and exploited. These include high- and low-temperature stages, and devices for carrying on chemical reactions with the specimen directly in the microscope.

By far the most exciting area in instrumentation is that of applying television techniques to the microscope image, as has been done recently by RCA (Fig. 1). The first advantage is that of image intensification because it permits reduction of irradiation of the specimen, thus easing one of the serious restrictions the electron microscope puts on specimens—that they shall be able to survive alteration by action of the electron beam. This will widen the range of samples that can be viewed, and the materials, such as imbedding media, that can be used in specimen preparation. Another advantage to specimen preparation occurs with the use of television techniques to enhance contrast, thus providing a way to relax contrast requirements in specimens, or for permitting far more useful microscopy with existing specimens.

Television techniques transform the instantaneous microscope image into time-sequential information, thus permitting several useful processing procedures. Contrast is enhanced, or even decreased if desired, by biasing the sequential signal or subjecting it to non-linear circuital elements. The positive visible microscope image may be made negative by an electrical process of phase inversion. The sequential signal may be digitalized for use in computers for particle counts, size distributions, or size-density distributions. The television signal can be displayed on a kinescope to give a single line trace of any chosen element of the two dimensional microscope image; and the trace is easily measured for linear dimensions or brightness. Added to these great advantages is perhaps the most obvious one, that of display of the microscope image on a television screen, thus permitting viewing by many observers.

# ELUCIDATION OF ULTRASTRUCTURE WITH THE ELECTRON MICROSCOPE



DR. JOHN W. COLEMAN received his BS in Physics from Howard University in 1950, MS in Biophysics from University of Illinois in 1957, and PhD in Biophysics from University of Pennsylvania in 1963; also, in conjunction with his studies, he received the Lucy Moten Fellowship for study at the Institut für Physik in Germany; U.S. Fulbright Award for study at the Technical University at Delft, Netherlands; an AEC Fellowship in Radiation Physics and at RCA, the David Sarnoff Award for study at the University of Pennsylvania. Dr. Coleman joined the U.S. Bureau of Standards, Electron Physics section in 1952, was Research Assistant at University of Illinois for several years, taught at Howard University 1957-58, and joined RCA in 1958 in the Scientific Instruments Engineering, Broadcast and Communications Division. He has published eleven professional technical papers and has three patents to his credit. Dr. Coleman is a member of the APS, AAAS, Biophysical Society, Electron Microscopy Society, Sigma Pi Sigma, and the American Society for Cell Biology.

Ultrastructure is the probable three-dimensional molecular arrangement of bio-matter in a functional thermodynamic system. Studies in ultrastructure lean downward from microscopic entities to their building blocks, yet not so far as to the individual atoms. Ultrastructure's proper province, therefore, is the intermediary world of molecules, and in particular the world of molecular giants, or high polymers. At present, only the electron microscope can look directly into this realm. This is the macromolecular kingdom, where physics is chemistry, chemistry is biology, and biology is statistical geometry.

**Dr. J. W. COLEMAN**

*Scientific Instruments Engineering  
Broadcast and Communications Products Division  
Camden, N. J.*

**I**N the world of macromolecular systems, *geometry* is a synonym for *decisive control*. The configuration of matter at  $P_1(x_1, y_1, z_1, t_1)$  becomes a necessary and sufficient condition for phenomenon  $Q_1$  to occur. Phenomenon  $Q_1$  may be the process of "no change", or it may entail the formation of new molecular bonds or the fracturing of old ones. There may be coiling or uncoiling, tensing or relaxing, condensation or splitting, synthesis or catalysis, about either moving or stationary points on either static or dynamic frames of reference. Energy is thus freed to maintain processes, stored or shunted to initiate processes, or trapped to terminate processes. A new geometry may evolve, and  $P_1$  may transmute to  $P_2$  to cause  $Q_2$ . In such a system with one geometry, the run of a process proceeds precisely according to the order of monomers in a single programmer molecule; with an incremental change in a single parameter, the run of the process may proceed according to groups of monomers, may be directed by a different programmer, or may stop altogether.

Alternatively stated, in a functional thermodynamic system of macromolecules, all physics and chemistry is ultimately *topography*. The characterization of topography is the elucidation of *ultrastructure*. Hence, the study of ultrastructure is necessary to describe living systems quantitatively.

## STUDIES OF SYSTEMIC CHANGES

If ultrastructure observed is topography preserved, then a high-resolution electron micrograph showing such detail can yield results about the physicochemical properties of a system at some time  $t$  in the past. At times  $(t - \Delta t)$  and  $(t + \Delta t)$ , the geometry was incrementally different, hence the activity was incrementally different—perhaps not significantly so—but the point must be made that a specimen is unique. Many micrographs of similar specimens must usually be taken to establish a characteristic systemic plan.

A single giant molecule has primary structure in its arrangement of constituent monomers, and perhaps even repetitive primary substructure in monomer groups. Ultrastructure, however, is defined as distinctly different from intramolecular structure, and is the name reserved for a probable transmolecular or intermolecular configuration. There may be several levels of ultrastructure in one infinitesimally small system.

## A HYPOTHETICAL EXAMPLE

For a hypothetical example, consider a barely visible bit of apparently amorphous substance detected with the light microscope as a cytoplasmic inclusion in a living cell. Assume the substance is found to consist of molecular species  $A$ , which is a two-monomer long-chain carbon compound (primary structure  $A^1$ ) with a repeating monomer grouping (primary substructure  $A_1$ ); and of molecular species  $B$  (which is an aro-

matic compound having primary structure  $B^1$ ). The ultrastructure might be as follows: Species  $A$  is folded back upon itself and latched with bonds to give a twin chain (secondary structure  $A^{11}$ ). The twin chains are latched and entwined together in groups of six to make fibrils (tertiary structure  $A^{111}$ ). The fibrils are interlaced at regular intervals in an essentially two dimensional array about molecules of species  $B$  (quaternary structure  $A^{111}, B^1$ ) to form sheets. The sheets are pleated (quintenary structure  $A^{111}, B^{11}$ ), and several sheets are stacked with ridges interlocking (sestenary structure  $A^{111}, B^{111}$ ). The stack of sheets is then the apparently amorphous bit of substance first seen.

## A PRACTICAL OBSERVATION TOOL

Unfortunately, ultrastructure studies seldom lead to models as clear as the plausible fiction above. The main reason for this is that usually (as of today's technology) information from several different types of research has to be correlated to produce even a very simple model in ultrastructure. There is no single tool as of now which can be used to examine an intact functional biological system at the molecular level at time  $t$ , fix the geometry, characterize the molecular species, assay the energy relations, account the functions, and tabulate the values of the arbitrarily large number of other pertinent variables bearing upon the complete system. But if no such single instruments exists as yet, by far the closest approximation to

it is the electron microscope. This instrument, with its resolution capability of a few angstroms, in principle can resolve macromolecular geometry even to the level of the primary structure. The problem remains, however, to bring to the microscope specimens with ultrastructure intact.

#### SPECIMEN PREPARATION

The methods of ultrastructure elucidation are at present, therefore, largely the methods of specimen preparation for electron optical studies. Notwithstanding the fixing, the drying, the electron-optical staining, etc., the specimen must remain a "geometric freeze" of the functional system at time  $t$ , if the ultrastructure is to be resolved or if the results are to have meaning. With what skill and to what degree this is being accomplished will be evident from the examples below. It will be understood that detailed accounts cannot be given here, and only a few representative of the hundreds of studies currently being undertaken can be mentioned.

#### CELLULAR SUBSTANCES

One type of ultrastructure problem is that concerned with materials fabricated in great amounts by living systems, either extracellularly or intracellularly basically for mechanical reasons of support. An example is cellulose, which is the basic material of plants. How this industrially important polymer, completely insoluble in water yet made of very soluble glucose monomers, is synthesized and arranged in the cell is of widespread interest.

The cellulose molecule is a string of thousands of glucose bead-like units. The electron microscope has not yet positively resolved a single cellulose molecule; but bundles of about 500 parallel glucose chains (secondary structure) have been resolved as microfibrils in the cell walls of some specimens. The individual molecules are synthesized and "spun" from granular material which precipitates in the cell cytoplasm.

In *valonia*, a seaweed, the parallel fibrils form thin layers (tertiary structure), stack together with fibril axes perpendicular in successive layers (quaternary structure). This basic ultrastructure explains two important properties of cellulose: 1) the individual molecules lying axially parallel are latched with hydrogen bonds through their hydroxyl groups, and the bonds (though weak) are so numerous that water molecules cannot interlope and separate the individual cellulose molecules—thus cellulose is insoluble in water; and 2) the energy of the bonding keeps cellulose from liquifying under heat.

More complex cellulose ultrastructure gives additional properties. Thus spiralling with different pitch, direction, etc. and with other similar arrangements gives the thousands of different timbers and fibers their thousands of individual properties, largely as a result of the lignin-impregnated cellulose ultrastructure. Selection of natural cellulosic materials for specific purposes can now be made on the basis of comparative ultrastructure.

#### BIOLOGICAL MEMBRANES

A second type of problem concerns biological membranes, which from the standpoint of physical chemistry are often so complex in function as to defy quantitative description. Recent typical work on membrane ultrastructure is that of D. Abram<sup>1</sup> with the bacterial cytoplasmic membrane. She finds that the membrane, while smooth on one side is covered on the other with spheres (60 to 80 angstroms in diameter) typically on stalks (30 to 20 angstroms long) like balloons on strings. This is a higher level of ultrastructure, and the lower levels have yet to be resolved. Nonetheless, work by other investigators has indicated that this same stringed balloon high-level ultrastructure may be the primary machinery for respiratory electron transport, whether it is found in cell membranes or in mitochondria.

Another current example of work in membrane ultrastructure is that of L. Herman<sup>2</sup>, T. Sato<sup>2</sup>, and P. Fitzgerald<sup>2</sup> on the species characteristic ultrastructure of pancreatic beta granules. The granules show progressive insulin polymerization leading ultimately to the formation of insulin in membranous sacs. The periodicity of the insulin crystals is species specific; thus for example in dog pancreas, the crystals have lamellae of 10 to 12 angstroms. In the salamander, the bands repeat at 18-angstrom intervals, and in the congo eel at 36-angstrom intervals. The species variable ultrastructure is attributed to the stereo-chemical configuration of the insulin *A* and *B* secondary structure, as well as to other environmental factors.

#### PARTS OF CELLS

A third type of ultrastructure investigation is that concerned with specialized organelles such as flagella or microscopic tail-like organs. W. A. Anderson<sup>3</sup>, for example, has shown the thread-like flagellum of one type of bacterium to be composed of peripheral tubules with clockwise asymmetry, excepting one subtubule which is divided into a doublet by a diagonally running counterclockwise arm originating on a median diaphragm. The counterclockwise arm has projections extending into a basket shaped intraflagellar suborganelle. On

#### GLOSSARY

**amino acids**—Acids in which the hydrogen of the alkyl group has been replaced by the amino group  $\text{NH}_2$

**autoengineering**—In molecular biology the term applied to the seemingly spontaneous arrangement of molecules into highly specific configurations for specialized functioning.

**bacteriophage**—Viruses which infect bacteria

**condensation**—In organic chemistry a reaction involving union between atoms in the same or different molecules to form a compound of greater complexity and usually greater molecular weight

**cytoplasm**—The material of the cell exclusive of the nucleus and the cell membrane

**decisive control**—In chemical kinetics and thermodynamics the power to determine whether or not a phenomenon e.g., a chemical reaction will go, and if it goes, to determine the overall rate constant  $K_a, b, c, d, \dots, n$ , regardless of the rates  $k_a, k_b, k_c, k_d, \dots, k_n$  of the constituent subreactions  $a, b, c, d, \dots, n$

**fibril**—A thread or fiber of microscopic dimensions

**fixing**—The treatment of microscopy specimens with chemicals to kill, harden, and preserve the structure, and to stain the material for enhanced contrast in the image

**flagellum**—A microscopic whiplike appendage, as of a cell

**lipoprotein**—A conjugated protein made up of a simple protein (polymer of alpha amino acids or their derivatives) plus an additional higher fatty acid group

**meiotic prophase**—An early stage in nuclear division in germ cells

**mitochondria**—Subcellular bodies in which the conversion of food to energy takes place. The resultant energy is loaded onto adenosine triphosphate (ATP) which is then analogous to a coiled spring, ready to release its energy elsewhere when triggered

**monomer**—A single molecule. If two unite, the result is a *dimer*. If three unite, the result is a *trimer*. If  $n$  unite, the result is a *polymer*.

**nucleus**—A distinct control center present in most living cells, being an essential agent in metabolism, growth, reproduction, and hereditary transmission

**organelle**—A specifically functioning unit below the cell level; analogous to the organ, which is a specifically functioning unit below the body level

**peptide**—A combination of amino acids in which the amino group of one acid is united with the carboxy group of the other through the elimination of a water molecule

**phage**—see *Bacteriophage*

**plastids**—Any of certain subcellular bodies of specialized protoplasm and function lying in the cytoplasm of some cells

**polypeptide**—A series of amino acid residues united through peptide linkages

**programmer molecule**—A macromolecule which determines a stepwise sequence of events in its immediate neighborhood, e.g., the replication of itself, the synthesis of new molecules, a change in chemical kinetics, a change in chemical reactants, etc. according to some stepwise aspect—usually linear—of its own structure or configuration

**ribosomes**—Subcellular bodies under nuclear control which are factories for manufacture of protein. They are often also part of a conveyor system known as the endoplasmic reticulum

**splitting**—In organic chemistry, depolymerization

**T<sub>6</sub> particles**—A specific type of bacteriophage

**taxonomy**—The laws and principles of classification of plants and animals according to their natural (classically macroscopic) relationships

**virus**—An infectious agent



Fig. 1—Bacteriophage  $\phi$ X174, shadowed at 1:1; Magnification of original micrograph, 180,000X.

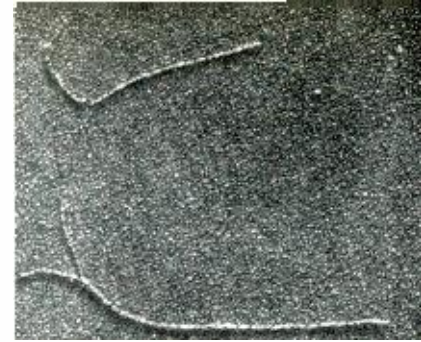

Fig. 2—Detached strand from heated preparation of bacteriophage  $\phi$ X174. Magnification of original micrograph, 112,000X.

NOTE: Both Figs. 1 and 2 courtesy E. C. MacLean and C. E. Hall, "Studies in Bacteriophage  $\phi$ X174 and its DNA by Electron Microscopy," *Journal of Molecular Biology* 4, 173-178, 1962. (Reproduced from halftone copy; some degradation unavoidable.—Ed.)

the other hand, the central flagellar tubules show a double helical lower-level ultrastructure with 50-angstrom cross striations at spacings of 200 to 250 angstroms. The ultrastructure in this case has been resolved even further, but would be of little value to describe here. The point to be made is that even structures a few tens of angstroms in diameter or thickness may contain very high level ultrastructure.

#### STUDIES OF THE TOTAL CELL

The investigation of cell ultrastructure is a main effort among researchers, since nothing is more basic to the life sciences than the need to understand fully the functioning of the "atom" of life which is the cell. This is the fourth type of investigation and these studies are intimately entwined with investigations on the ultrastructure of artificial protein systems; a living cell has thousands of different proteins which perform thousands of functions in exact sequences, the sum total of which is life.

#### Protein Molecules

The protein molecule is a tour de force of specificity. It is gigantic, with molecular weights ranging from hundreds to millions, yet all of the thousands of species are made of only twenty some monomers, the amino acids. All amino acids have a common atomic group, but each has a distinguishing side group. Through these side groups, the amino acid are linked in peptide units to form

polypeptide chains. The polypeptide chains then are very intricately arranged in unique spatial configurations to form proteins, which hold their specificity (biological activity) only as long as the given spatial configuration is held within very narrow limits. A great amount of very detailed knowledge of protein structure is available from x-ray analyses of preparations. The organization of protein in living cells, however, is another matter, and what information there is has come from the electron microscope.

#### Monomers and Polymers

In cells, proteins themselves, colossal as they are, become monomers in still larger polymers, the cell parts themselves; the strata of ultrastructure thus compound exponentially, and the task of peeling the levels becomes herculean. While the cell as a whole synthesizes proteins and other macromolecules as part of its functioning, these macromolecules then autoengineer themselves into structures, and form subcellular organelles which may be either temporary or permanent. Alternatively, the proteins may be transported, or even stored. At present, only the highest levels of cellular ultrastructure have been resolved, and these in terms of the highly structured subcellular inclusions, e.g. ribosomes, mitochondria, plastids, etc. But if protein arrangement in the cytoplasm is fantastically complex, the arrangement of material in the cell nucleus is scarcely less so.

#### Nucleic Acids

In every living cell there are two species of macromolecules known as nucleic acids: deoxyribonucleic acid or DNA, and ribonucleic acid or RNA. These two compounds are often called the blueprints of life. They not only direct the manufacture of the building blocks of life (the proteins) but they also determine the architecture of life, since all evidence shows that they alone determine the hereditary characteristics of all living things.

Both DNA and RNA are high polymers also, and chemically much alike. Both are lengthy chains of phosphate and sugars with side groups (bases) attached. In DNA, the sugar is deoxyribose, whereas in RNA the sugar is slightly different, being ribose. Both have only four bases; three (adenine, guanine, and cytosine) are common to both type molecules. In DNA, the fourth base is thymine; in RNA it is uracil. The bases do not follow any regular order along the backbone of the nucleic acid, and the belief that any given order in a molecule constitutes a set of genetic instructions has been widely publicized.

#### Chromosomes

No less publicized has been the double helix primary structure for DNA, found from x-ray analysis. The DNA in the cell is always and only associated with the chromosomes and nucleus, whereas RNA may be found anywhere in the cell although mainly in protein complexes in the cytoplasm. The ultrastructure of RNA thus becomes again the ultrastructure of the cell, while the ultrastructure of DNA in the cell becomes the ultrastructure of the nucleus.

A typical current investigation in nuclear ultrastructure is that of B. Brinkley<sup>4</sup> and J. Bryan<sup>4</sup>. These workers find that in meiotic prophase, the chromosomes in a certain type of sperm cell have bipartite lateral components, consisting of twin 100-angstrom-diameter fibrils separated by a distance of 200 angstroms. This probably represents secondary or tertiary ultrastructure. The paired fibrils intertwine at intervals of about 375 angstroms in ultrastructure of a higher level.

Fig. 3—Left: T6 bacteriophage particles, shadowcast with platinum to accentuate dimensionality. (Shadowcast specimens were not used in the diffraction experiments). Right: T6 bacteriophage particle specimens such as used in the diffraction experiments.

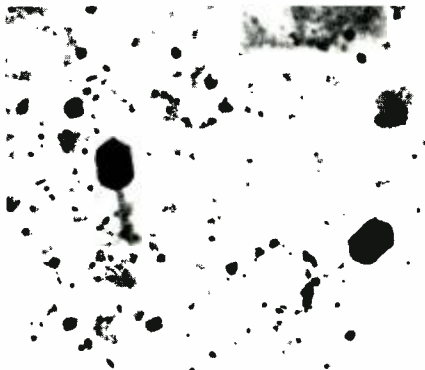



## STUDIES OF VIRUSES

The major advances to date in ultra-structure studies are represented by investigations of the fifth type, those concerned with viruses. In print, viruses have been described in many ways, from "the link between the animate and the inanimate" to "naked genes." Precisely, however, they are infectious agents, as they were so defined many years ago. They are particularly interesting for research in ultrastructure since, among many other reasons, they are natural and complete nucleic acid and protein systems which may be obtained as isolated particles.

A typical example of a virus morphology study is the recent work of J. Hyde<sup>5</sup>, L. Gafford<sup>5</sup>, and C. Randall<sup>5</sup> on fowl pox virus. They find an external layer representing higher ultrastructure consisting of randomly oriented sub-unit knobs of 300 to 400 angstroms which tend to "unwind" from the main particle. Under this lipoprotein knobby coat is an internal coat of tubular sub-units 45 angstroms in diameter by 250 angstroms long (medium ultrastructure), and at the center are densely coiled strands of DNA.

Another example is the study of R. Bils<sup>6</sup> and C. E. Hall<sup>6</sup> of wound-tumor virus which attacks sweet clover. They find the virus to be an icosahedron of about 600-angstrom diameter with 92 surface subunits about 75 angstroms in diameter. The core (350-angstrom diameter) consists of strands of RNA or RNA-protein complex.

### Bacteriophage

Viruses which attack bacteria have the special name *bacteriophage*. These are the viruses which have played so great a role in the work on heredity and the genetic code through studies in microbial genetics. The arrangement of viral DNA in the dormant phage particles has been studied by many workers, including the author.

The work of E. Maclean<sup>6</sup> and C. E. Hall<sup>6</sup> on bacteriophage  $\phi$ X174 is a recent example for studies in phage ultrastructure. As shown in Fig. 1,  $\phi$ X174 has twelve knobs at the vertices of an icosahedron. Upon heating, the virus extrudes strands up to 1.3 micron in length (Fig. 2). These strand diameters are in the range 10 to 40 angstroms, and consist of DNA coated with protein. Based on their results, Maclean and Hall have proposed a model for  $\phi$ X174 in which 80% of the phage protein adheres to the single DNA strand at a regular spacing; this is in order to strengthen the DNA and hold it in a certain configuration. The chain is then wound tightly into a ball in such a way that at no part of the DNA is exposed.

The rest of the phage protein is divided into sixty equal parts, and in groups of identical units of five form the twelve knobs of the outer shell.

### ELECTRON DIFFRACTION AND ULTRASTRUCTURE

The author has investigated the ultrastructure of T6 bacteriophage, using the electron microscope and selected area electron diffraction. The selected area diffraction technique allows the microscopist to select a portion of the high-magnification high-resolution image on the microscope fluorescent screen, then—by switching optical modes—to image the corresponding electron diffraction pattern if the image portion selected was that of a crystalline part of the specimen. It will be remembered the *crystallinity* implies ordered structure only, and that the repeating motifs need not be atoms as in metals, but also may be molecules, macromolecules, or even macromolecular aggregates.

T6 phage particles are polyhedra (600 by 900 angstroms) with a hexagonal crosssection (Fig. 3). At one end is a long tubular tail (1,000 angstroms by 35-angstrom diameter) by which the particles attach to a bacterium. The polyhedral head is a protein coat for the DNA inside. During infection, the DNA (up to 90 microns in length) passes through the tail and into the bacterial host. The problem was to find the arrangement of the DNA in the intact particle by means of electron diffraction, since no micrographs had shown it.

After considerable special instrumentation and specimen preparation, long-spacing patterns were obtained. Mainly because the single T6 particle as a diffraction grating was so limiting, the patterns were very diffuse. Statistically meaningful results were eventually obtained however, and these together with data from other studies allowed the following model to be constructed (Fig. 4).

The double-strand DNA (23 angstroms in diameter) is wound into a tight coil 76 angstroms in diameter (secondary ultrastructure). The secondary coil is then wound into conical coils (tertiary ultrastructure). The continuous secondary coil is wound into eleven of the tertiary coils which fit like cups into each other. Every other conical coil of the eleven is wound counterclockwise with the intervening ones wound clockwise (quaternary ultrastructure). The resultant packing arrangement allows the head to hold the known amount of DNA, and during infection allows the DNA to pass through the tail without becoming entangled.

### CONCLUSION

The above cited works show some examples of current research in "the new

biology," which has come to maturity only two decades after its heralding. Now chemistry and physics replace taxonomy and sketching, at least at the subcellular level; and old generalities such as 'Ontogeny recapitulates phylogeny' are prefaced at length or abandoned entirely.

By no means by chance have electron microscopy and biology evolved together; their relation is in fact symbiotic. And largely from this symbiosis has resulted a new discipline, a fundamental new foundation for all life science. This is the "ultimate biology," the "biology of molecules," the "molecular biology," itself reared on the incontrovertible evidence that although the unit of life is indeed the cell, the unit of life control is the local molecular matrix. the *ultrastructure*, on view with the electron microscope.

### BIBLIOGRAPHY

1. Dept. of Biological Sciences, Purdue University, W. Lafayette, Ind.
2. Dept. of Pathology, State University of New York, Downstate Medical Center, Brooklyn, N.Y.
3. Dept. of Biology, Brown University, Providence, R.I.
4. Dept. of Zoology and Entomology, Iowa State University, Ames, Iowa.
5. Dept. of Microbiology, University of Mississippi, School of Medicine, Jackson, Mississippi.
6. Dept. of Biology, Massachusetts Institute of Technology, Cambridge, Massachusetts.

Fig. 4—Postulated model for T6 bacteriophage. Cross section showing curved layers of the tertiary coil, formed by the spiraling of the secondary coil, and the 51-angstrom-diameter spiraling channel left along the phage axis. The arrows represent transitional spirals from layer to layer. In (A) and (B) are shown different side views of the model; (C) shows the top and/or bottom view; (D) shows axis of the secondary coil viewed in projection from top of the model.

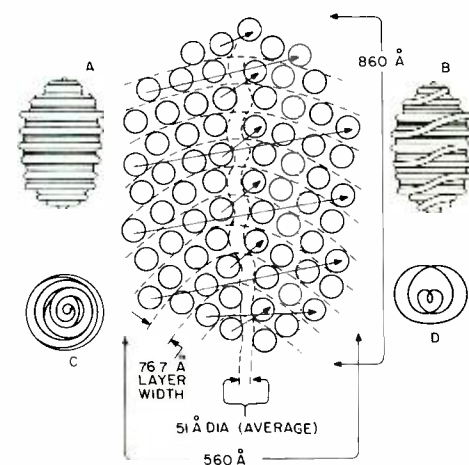

# ADAPTATION THEORY

## A Tutorial Introduction to Current Research

In 1961, RCA Laboratories initiated a program of research toward the development of a theory of adaptation. With this theory, the engineer will gain fundamental insights into the ways he can use simple feedback mechanisms to give adaptive properties to complex systems. Recent results center on adaptive signal detection and adaptive pattern recognition. This paper introduces the concepts of adaptation theory, and then discusses the particular class of adaptive process on which RCA Laboratories work has concentrated thus far—that of the threshold learning process and Markov chains, the specific mathematical techniques associated with it. Included are some recent results on learning waves, feedback-adaptivity relationships, and learning times, as well as mention of some as-yet-unexplained phenomena. Some directions of future work are discussed, and a reference Bibliography is included.

DR. J. SKLANSKY

*RCA Laboratories, Princeton, N. J.*

A DUCK stands on a rock at the edge of a pond. As it stands there, it reaches out for a nearby grasshopper (the duck's goal is to have some lunch). Later the duck jumps into the pond (its goal is to avoid an approaching cat). Still later it mates with a friend (its goal, apparently, is to produce more ducks to stand on rocks). All this time the rock did nothing, except to sink somewhat further into the pond.

Most of the duck's actions can be ascribed to goals of various types. But the rock—to the untrained eye, at least—has no visible goal other than to cover some of the bottom of the pond. It is not surprising, therefore, that *goal-seeking* and *life* have been closely associated in men's minds for a long time.

Goal-seeking can be viewed as the subjective drive behind adaptive behavior. An animal adapting to its environment often is motivated by a goal. The duck instinctively *wants* to achieve various specific goals. All of these goals contribute to the duck's capability to adapt to a wide variety of changing en-

vironments. This capability promotes the duck's survival, and, less directly, the survival of the species of which the duck is a member.

Until the present century, adaptation was thought to separate living things sharply from the nonliving. Today adaptation no longer accomplishes this separation. The feedback concept, the servomechanism, and the electronic computer have made commonplace the appearance of complex organizations and goal-seeking behavior in man-made machines. Adaptive processes have entered the domain of serious concern to the engineer.

The adaptive nature of living things enables them to maintain acceptable performance levels in the face of fluctuations in their environments and fluctuations in their internal structures. Taking this cue from biology, an engineer often will try to incorporate adaptive behavior in a machine when he wants to overcome his ignorance of the environment and his ignorance of the reliability of machine parts.

Consequently, both engineers and life scientists have tried to find useful theories of adaptive processes. In recent years, the demonstrated ability of modern computers to simulate certain non-trivial goal-seeking activities of man—

such as theorem-proving and checker-playing—has added further incentive to the search for theories.

Since 1961, the Computer Theory Group of RCA Laboratories has been participating in this search through its program of research on adaptation theory. The ultimate goal of this program is the development of a theory that: 1) will provide mathematical tools for the analysis of discrete adaptive processes, such as adaptive pattern recognition; 2) will provide a means for modeling these processes by simple feedback systems; 3) will provide a way of predicting the ability of feedback mechanisms to overcome ignorance or unpredictability in the environments of adaptive systems; 4) will provide a way of estimating the learning waves, i.e., the curves of success index versus time, of adaptive systems; and 5) will benefit the life sciences and engineering simultaneously.

### SOME DEFINITIONS

A first step in the development of a theory of adaptation is the refinement of the old concepts of "adaptation" and "learning." The definitions, however, must remain broad enough to be applicable to a wide variety of mathematical models.

In the life sciences a cell, an organ, an organism, or a species is said to be adaptive if its behavior in a changing environment is "successful" in some sense. The sense to a great degree has been colored by each particular discipline, as well as by the individual researcher. Using "success" as an undefined primitive we have postulated two properties that distinguish adaptive machines from nonadaptive machines: *stability* and *reliability*.

1) *Stability*—A well-known definition of adaptation was proposed by Ashby<sup>1</sup>: "A form of behavior is *adaptive* if it maintains its essential variables within physiological limits." For example, the concentration of glucose in the blood may be disturbed by exercise or malnutrition. These disturbances are opposed by a number of mechanisms—such as the appetite, the adrenal glands, the pancreas, the kidneys, and the skin—which act to maintain the glucose concentration between 0.06 and 0.18%. Ashby views this as an adaptive process, because a proper glucose concentration is essential to physiological survival and hence to successful performance of any desired task. This viewpoint gives us the first distinguishing property of adaptive machines: *persistence of success in a changing environment*.

2) *Reliability*—Suppose one or more parts of a machine are suddenly damaged or destroyed. The "damage" may be severe or it may be just a temporary

*Final manuscript received January 18, 1965.*

The research reported in this paper was sponsored by the Aerospace Medical Research Laboratories, Aerospace Medical Division, Air Force Systems Command, Wright-Patterson Air Force Base, Ohio, under Contract Numbers AF33(657)-11336 and AF33(615)-1764 and RCA Laboratories, Princeton, N. J.



DR. JACK SKLANSKY received his BEE from the City College of New York in 1950, his MSEE from Purdue University in 1952, and his Doctor of Engineering Science from Columbia University in 1955. From 1953 to 1955, he worked at Columbia University's Electronic Research Laboratory, where he developed techniques for shaping the dynamics of sampled-data control systems. He joined RCA five computer memories, and adaptive systems. Laboratories in 1955, where he has conducted research on radar data-processing, satellite dynamics, fast binary adders, switching theory, association. During 1960-1961, he taught a course on Digital Computers at the Graduate School of Villanova University. He has published over twenty papers in his fields of interest. He is presently a member of the Computer Theory Group at RCA Laboratories, where he is conducting research on adaptation theory and pattern recognition. Dr. Sklansky is a Senior Member of IEEE, and a member of the Association for Computing Machinery, Tau Beta Pi, Sigma Xi, and Eta Kappa Nu. He was chairman of the IEEE Discrete Systems Theory Subcommittee during 1961-1963. He was the principal organizer of the first AIEE Symposium on Adaptive Processes in June 1962.

loss of efficiency in the functioning of these parts. If the machine is adaptive in the sense of Ashby's definition, the effect of the damage will gradually be masked until the machine's performance reaches an acceptable level. This viewpoint gives us the second distinguishing property of adaptive machines: *overall functional reliability in the face of unreliability of parts of the machine.*

A biological example of reliability is the continued functioning of the human brain and nervous system under the influence of alcohol. The alcohol changes the thresholds at which the neurons fire, yet the nervous system continues to function adequately—with some loss of efficiency, but yet adequately. (This type of reliability has inspired engineers to search for ways of constructing reliable systems from unreliable components. The Computer Theory Group has contributed one of the important solutions to this problem.<sup>2</sup>)

To summarize, adaptation is defined as a manifestation in a machine of one or both of these properties: 1) persistence of success in the face of a changing environment, and 2) persistence of success in the face of failures of machine parts. We call the first property *stability*, and the second *reliability*.

Both *stability* and *reliability* are forms of *adaptivity*. Explicitly, we define adaptivity as the persistence of success in the face of a changing environment and/or failures of machine parts.

(*Adaptivity* is a term coined and defined by Zadeh.<sup>12</sup> Zadeh's adaptivity is equivalent to our *stability*. Thus our adaptivity is broader than Zadeh's. On the other hand, with a little imagination, failures of machine parts can be viewed as changes in the environment. Under this condition Zadeh's and our adaptivity are equivalent.)

Closely related to adaptation is the process of *learning*. We view learning as a favorable variation of a success index during unchanging environmental conditions. More precisely, suppose  $z(t)$  is the success index of a machine  $M$  as a function of the time  $t$ . We say that  $M$  "learns" over a specified time interval  $(0, T)$  if the environment remains constant over  $(0, T)$ , and if  $z(T) > z(0)$ . When we say "the environment is constant," we mean that certain descriptive parameters of the environment are constant. Other quantities of the environment may be time-varying even though the descriptive parameters are constant.

A comparison of our definition of learning and Shannon's formulation<sup>3</sup> in 1953 shows a similarity of viewpoint: "Suppose that an organism or a machine can be placed in, or connected to, a class of environments, and that there is a measure of 'success' or 'adaptation' to the environment. Suppose further that this measure is comparatively local in time, that is, that one can measure the success over periods of time that are short compared to the life of the organism. If this local measure of success tends to improve with the passage of time, for the class of environments in question, we may say that the organism or machine is learning to adapt to these environments relative to the measure of success chosen."

Adaptation, a purely behavioral feature of machines, is often seen in association with *feedback*, a purely structural feature. Feedback is a scheme of feeding some of the response of a physical or biological machine back to a point closer to the sensing or input elements. For engineers, feedback is a convenient way of imparting adaptation to a machine. Life scientists, on the other hand, often use feedback (or "reinforcement") in their constructions of models that simulate the adaptive properties of life processes.

*But feedback is not essential to adaptation, and vice versa.*

A machine may be adaptive without

feedback. This is possible if an a priori description of the environmental or structural fluctuations has been anticipated in the design of the machine. An example is an automatic control system in which a controller turns a motor on and off in response to special waveforms appearing on the input lines.

A machine containing feedback may not be adaptive. In particular, if the feedback is "regenerative," it usually reduces the adaptivity of the machine, and sometimes causes a sustained oscillation.

Thus, feedback is neither a necessary nor a sufficient feature of adaptive machines—both open-loop and closed-loop adaptive systems are possible. Nevertheless, feedback frequently appears in real adaptive machines, and in many cases yields important simplifications in the mathematical models.

The question arises, *Do special conditions exist under which feedback is essential for adaptive behavior?* The answer is yes: If the fluctuations of one or more of the important environmental parameters are not observable on the input lines, or if the machine's internal structure fluctuates significantly, and if these fluctuations are unpredictable by the designer and are independent of the signals on the input lines, then adaptive compensation for the fluctuations cannot be achieved without feedback, except by accidental good fortune in the choice of an open-loop controller.

*Adaptation theory* is partly concerned with the relationships between feedback structures and adaptive behavior. It is also concerned with the development of mathematical techniques that facilitate the estimation of learning waves and various indexes of stability and reliability in adaptive processes.

At RCA Laboratories, development of adaptation theory has, so far, restricted itself to a single class of adaptive processes—the *threshold learning process*, an elementary form of adaptive pattern recognition. Associated with this process is a specific class of mathematical techniques—the *Markov chain*. The threshold learning process, the associated Markov chains, and our reasons for choosing them as objects of research, will be discussed in the next two sections.

#### THE THRESHOLD LEARNING PROCESS

Although intuition tells us that a unifying thread runs through all natural and man-made adaptive processes, experience shows us that adaptive behavior takes on such a variety of forms and such differences in complexity that no single all-encompassing theory of adaptation is possible. Consequently, a rea-

sonable approach to the development of such a theory is to select a *class* of adaptive processes whose role in engineering and the life sciences is currently important, and whose behavior is not well understood.

An example of such a class of processes is trainable signal detection. Another example is adaptive numerical integration of differential equations. RCA Laboratories' research on adaptation theory has centered on trainable signal detection. The model representing this class of processes is called the *threshold learning process*, or TLP for short.

The TLP is a "core" model which, upon elaboration in various directions, can adequately represent a wide variety of adaptive processes in engineering and the life sciences. Among the processes to which the TLP model has been applied are radar communication<sup>4</sup>, psychological models of learning<sup>5</sup>, and adaptive pattern recognition<sup>6</sup>. A more remote application of the TLP appears in information retrieval systems<sup>7</sup>.

The TLP (Fig. 1) consists of an information source and an observer. The observer consists of a noisy channel, a threshold detector, and a feedback policy. The source transmits a random sequence of 0's and 1's through the channel. The observer senses an analog signal  $v$  at the output of the channel, and, comparing this observation to a reference  $i$  (the *threshold*) guesses the value of the transmitted signal. The observer "learns" by moving this threshold to a new value whenever he receives a "reinforcement" signal indicating whether or not his guess was correct. (We use "he" and "his" for convenience, even though the observer may be a machine—or a woman.) After a training period of prescribed length, the TLP moves into a "working" phase, in which the observer receives no reinforcement signals.

Fig. 1—The threshold learning process.

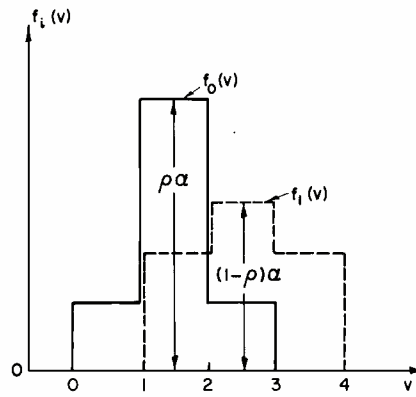
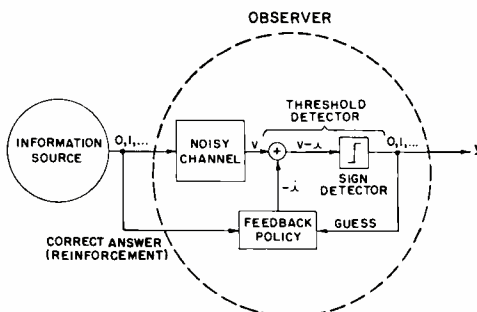

Fig. 2—An example of staircase constituent densities.

This system is an elementary form of a trainable pattern recognizer. The quantity  $v$  represents an observed feature. The 0's and 1's are two categories into which the observed feature is classified. In a more complex recognizer, the single quantity  $v$  would be replaced by a group of features. The recognizer in that case would assign each observed group of features to one of two categories. In another form of recognizer based on the TLP, the reinforcement signals would not be perfect—they would be formed by an imperfect "critic", thereby obviating the need for alternate cycles of "training" and "working". With an imperfect critic, the training and working could take place simultaneously. (This matter is amplified under *Concluding Remarks*.)

In the elementary TLP, the effect of the noisy channel on the source is described by a pair of "constituent" probability densities  $f_0(v)$  and  $f_1(v)$ . Examples of these densities are shown in Fig. 2. The differential quantity  $f_0(v) dv$  is defined as the joint probability of transmitting  $u$  and observing a signal occupying the interval  $(v, v + dv)$ . In other words,  $f_0(v)$  is the distribution of the  $v$ 's caused by the 0's, while  $f_1(v)$  is the distribution of the  $v$ 's caused by the 1's. The area under  $f_0(v)$  is  $\rho$ , the probability of transmitting a 0; the area under  $f_1(v)$  is  $1 - \rho$ , the probability of transmitting a 1. The noise in the channel contributes to the obtuseness or variance of the constituent densities; without noise  $f_0(v)$  and  $f_1(v)$  would be non-overlapping narrow spikes. To facilitate analysis, the densities considered so far have been staircase-shaped, as in Fig. 2.

A "feedback policy" determines the new threshold after each reinforcement. Particular attention has been devoted to the following simple, yet important, feedback policy: The threshold has  $K$  possible values. The threshold is moved up or down by one increment in response to a false alarm or false rest, respectively. (A *false alarm* is a guess of 1

when the source sent a 0; a *false rest* is a guess of 0 when the source sent a 1.) The threshold remains fixed if no error is incurred or if a boundary threshold prevents a desired adjustment. This policy, the so-called *simple incremental feedback policy*, frequently appears in the literature on trainable pattern recognizers. We refer to TLP's having this feedback policy as *simple incremental TLP's*.

The feedback policy is envisioned as being removable or "unpluggable"; i.e., the feedback policy may or may not be in operation at any particular time. When the feedback policy is not operating, the TLP is said to be in an *open-loop* mode of operation. When the feedback policy is operating, the TLP is said to be in a *closed-loop* mode of operation. In the case of the simple incremental policy, *open-loop* operation means that the threshold remains fixed independently of the observed signals.

The TLP was chosen as a core model because it seems to be the simplest model having all of the following properties:

- 1) The untrained observer behaves probabilistically. The probabilistic behavior is a way of expressing the engineer's ignorance of the future environment or of the mechanisms inside the observer.
- 2) The stimuli and responses are discrete in amplitude and in time. This is important for computer applications, such as pattern recognition and information retrieval.
- 3) The feedback policy is deterministic in nature. This reflects the engineer's preference for building deterministic, rather than probabilistic, mechanisms.
- 4) The model is a good descriptor of important adaptive processes in both engineering and the life sciences.
- 5) The model can be elaborated to include many of the more complex trainable pattern recognizers studied by other investigators.

#### MARKOV CHAINS

From a theoretician's point of view, one of the important features of a TLP is the ease with which its adaptive behavior can be analyzed. Consider, for example, a TLP with a simple incremental feedback policy permitting  $K$  possible threshold values, and suppose that the 0's and 1's emitted by the information source are statistically independent. Under these conditions, the motion of the threshold is a  $K$ -state random walk in which each state represents one of the  $K$  allowed thresholds. Fig. 3 illustrates this random walk by a state transition graph. In this graph, a branch connecting node  $i$  to node  $j$  represents the conditional probability  $p_{ij}$  that the next state is  $j$ , given that the present state is  $i$ .

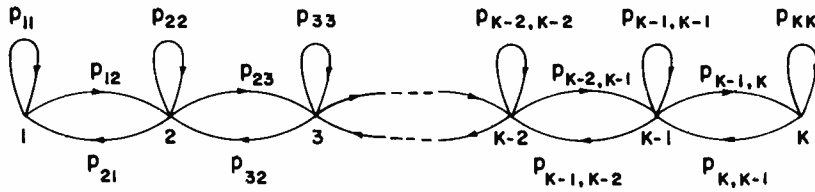

Fig. 3—The state transition graph of a K-threshold TLP.

The success index of the TLP is defined as the probability  $z(n)$  of a correct guess at time  $n$ . Since the random walk is a special form of Markov chain,  $z(n)$  can be found in terms of the  $p_{ij}$ 's by means of the well-known theory of Markov chains. This analysis yields the following result:

$$z(n) = \mathbf{r}(0) \mathbf{P}^n \mathbf{q} \quad (1)$$

where  $\mathbf{r}(0)$  is a  $K$ -dimensional row vector each of whose elements is the probability that the TLP will occupy one of the  $K$  states at time 0;  $\mathbf{P}$  is the  $K \times K$  matrix of  $p_{ij}$ 's; and  $\mathbf{q}$  is the  $K$ -dimensional column vector each of whose elements is the conditional probability of a correct guess, given that the TLP occupies a particular state. Actually, Eq. 1 is not limited to simple incremental feedback, nor to statistically independent information sources.<sup>5</sup> (For the reader who would like to have a fuller understanding of Eq. 1, a derivation is presented in the Appendix.)

Eq. 1 may be interpreted as follows. The vector  $\mathbf{r}(0)$  represents the initial distribution of threshold probabilities. The product  $\mathbf{r}(0)\mathbf{P}^n$  is  $\mathbf{r}(n)$ , the distribution of the threshold probabilities at time  $n$ . When  $r_i(n)$ , the probability that the threshold is  $i$  at time  $n$  is multiplied by  $q_i$  (the probability of success at time  $n$ , given that the threshold is  $i$  at time  $n$ ), we obtain  $z_i(n)$ , the joint probability that the threshold is  $i$  and that the TLP is successful at time  $n$ . The total success probability  $z(n)$  is just the sum of the  $z_i(n)$ 's. This sum is brought about by post-multiplying the row vector  $\mathbf{r}(0)\mathbf{P}^n$  by the column vector  $\mathbf{q}$ .

The  $p_{ij}$ 's can be obtained directly from the constituent densities. Suppose, for example, that the TLP has the constituent densities shown in Fig. 2. In Fig. 2,  $\rho$  represents the frequency of  $\theta$ 's emitted by the information source, and  $\alpha$  is a parameter that controls the shapes of the distributions. A value of  $\alpha$  close to 1 yields a highly spiked distribution, while a value of  $\alpha$  of 1/3 or less results in a flat or doubly peaked distribution. Suppose state  $i$  represents a threshold

occurring at  $v=2$ , and state  $j$  represents a threshold at  $v=3$ . Then:

$$p_{ij} = \int_2^3 f_{\alpha}(v) dv = \frac{\rho(1-\alpha)}{2} \quad (2)$$

Thus, in the case of Fig. 2, all the  $p_{ij}$ 's can be expressed as functions of  $\rho$  and  $\alpha$ . In a similar manner, all the elements of  $\mathbf{q}$  can be expressed as functions of  $\rho$  and  $\alpha$ .

Since  $\rho$  completely determines the external statistics of the observer (for the class of densities in Fig. 2), a direct measurement of stability requires a change of  $\rho$  alone. Similarly: since  $\alpha$  determines the internal statistics of the observer, failures of machine parts will be reflected in changes of  $\alpha$  but not in  $\rho$ ; hence a direct measurement of reliability requires a change of  $\alpha$  alone.

As we mentioned earlier, adaptation theory is partly concerned with the insensitivity of success index to changes in environmental and machine parameters—i.e., stability and reliability. In the case of the TLP, the tools of Markov chain theory provide a relatively easy way to find  $z(n)$  in terms of the stability parameter  $\rho$  and the reliability parameter  $\alpha$ .

An example of a specific numerical result in this study is the evaluation of the asymptotic success probability,  $z(\infty)$ , as a function of  $\alpha$  and  $\rho$  when the num-

Fig. 4—Contours of  $Z(\infty)$  on the  $\alpha\rho$ -plane.

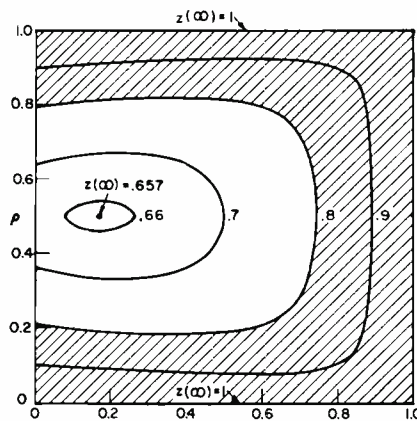

ber of available thresholds,  $K$ , is three. In a TLP the asymptotic values of  $z(n)$  can be found with particular ease by converting the state transition graph of the Markov chain to a zero-frequency signal flow graph, and using some of the well-known techniques of signal-flow-graph reduction.<sup>9</sup> (Several improvements and extensions of these techniques grew out of our research.<sup>10</sup>) These techniques yielded the contours of  $z(\infty)$  shown in Fig. 4.

The shaded region in this figure represents all the physically realizable values of  $\alpha$  and  $\rho$  for which  $z(\infty)$  exceeds 0.8. Thus, if 0.8 is the minimum acceptable value of  $z(\infty)$ , the area of the shaded region represents a combined measure of stability and reliability—i.e., a measure of adaptivity. Note that the reliability is large when  $\rho$  is close to 0 or 1, while the stability is large when  $\alpha$  is close to 1.

#### A FEW RESULTS

A study was made of TLP's embedded in a variety of environments and feedback policies. This study yielded a number of insights into the adaptive nature of the TLP and the effectiveness of specific feedback policies in their roles as enhancers of adaptive behavior.<sup>8,10,13</sup>

The results of this study fall in two categories: theoretical (i.e., contributions to adaptation theory) and empirical (i.e., interesting but unexplained observed phenomena). Among the subjects in the theoretical category are: learning waves, adaptivity, and "learning times" (to be defined). Among the unexplained phenomena are certain relations among the adaptation characteristics and the feedback policies of TLP's.

#### The Learning Waves

A *learning wave* of an adaptive process is defined as a curve of success index plotted against time while certain prescribed parameters of the environment remain constant. A learning wave displays the ability of a process to accommodate a sudden change in the environment. Consequently, adaptation theory is strongly concerned with understanding why certain shapes and sizes of learning waves occur.

Most learning waves in psychological experiments are monotonic increasing or monotonic decreasing. A similar situation has been observed in the TLP. We have demonstrated, in fact, that when the number of thresholds is sufficiently large and when the feedback policy is of the simple incremental type, the learning wave *must* have one of the following three forms: monotonic increasing, monotonic decreasing, or

single-peaked. Examples of these three forms are shown in Fig. 5.

The restriction to these shapes is explained by the fact that as training progresses the probability distribution of thresholds, plotted against the threshold value  $i$ , moves like a traveling wave over a nondistortionless transmission line. At first the distribution is spike-shaped and centered over the initial threshold. As training progresses the distribution becomes more bell-shaped, and the mean (roughly the axis of the bell) moves asymptotically toward a "learned" threshold. The learned threshold is often—but not always—quite close to the mathematically optimum choice. The traveling-wave effect is caused by the random walk associated with the simple incremental feedback policy (Fig. 3). (The difference equations of the state probabilities of a random walk are similar to those of the currents and voltages on a lumped-parameter artificial transmission line.)

At any particular threshold  $i$ , the success probability is the sum of the areas of the appropriate truncations of  $f_0(v)$  and  $f_1(v)$ : specifically, the area under  $f_0(v)$  to the left of the threshold and the area under  $f_1(v)$  to the right of the threshold. This sum will have one of the three forms in Fig. 5, because:

- 1)  $f_0(v)$  and  $f_1(v)$  intersect at just a single point, so that the curve of the success index plotted versus the threshold  $i$  is single-peaked, and
- 2) the traveling wave moves in the direction of the learned threshold throughout the training period. (The motion of the traveling wave should be distinguished from the motion of the threshold. The traveling wave is a probability distribution, and has a deterministic, unidirectional motion. The threshold has the biased, noisy motion of a random walk.)

#### Adaptivity

Of major concern to adaptation theory are the relations between feedback and adaptivity. An understanding of these relations could yield methods for choosing training strategies to maximize the adaptivity—or expected adaptivity—of

Fig. 5—Examples of learning waves in TLP's.

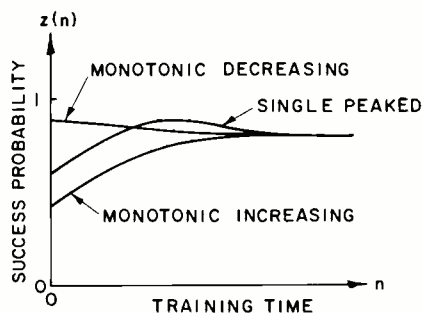

adaptive pattern recognizers and related adaptive processes.

In all TLP's, as in most psychological learning processes, a learning wave will reach a "steady-state" or "asymptotic" value,  $z(\infty)$ , after a long training period, provided the statistics of the environment and the internal failures remain constant. Thus,  $z(\infty)$  is an important descriptive parameter of a TLP's learning wave. Consequently the adaptivity of TLP's may be partially understood through studying the insensitivity of  $z(\infty)$  to environmental and structural fluctuations.

In accordance with the traveling-wave effect described in the preceding section, the threshold of a simple incremental TLP tends to approach an optimal or near-optimal value as training progresses. The best achievable "optimal" value of the threshold may be found as follows: Compute the success probability  $z_i(\infty)$  associated with a threshold fixed at a specific value,  $i$ . Recompute  $z_i(\infty)$  for every available value of  $i$ . The optimal success index,  $z_{opt}(\infty)$ , is the largest of these  $z_i(\infty)$ 's. That is:

$$z_{opt}(\infty) = \text{Max}_i [z_i(\infty)] \quad (3)$$

The value of  $i$  at which  $z_i(\infty)$  equals  $z_{opt}(\infty)$  is the optimal threshold. We denote this threshold as  $i_0$ .

The learned threshold is approximately  $i_0$ . Hence the  $z(\infty)$  of a TLP is approximately the largest of the available  $z_i(\infty)$ 's. That is, the success probability of a fully trained TLP is approximately the largest of the possible success probabilities of an untrained TLP. (A *fully trained TLP* is a TLP whose learning wave has, within measuring accuracy, reached its asymptotic value.) This relationship is expressed symbolically as follows:

$$z(\infty) \cong \text{Max}_i [z_i(\infty)] \quad (4)$$

Note that each  $z_i(\infty)$  is a success index of an open-loop feedback policy, since an *open-loop TLP* is a TLP whose threshold remains fixed during the training period. Hence, Eq. 4 provides a relatively convenient way to compute the contours of closed-loop success probability from the contours of the open-loop success probabilities of fully trained TLP's.

With each feedback policy is associated an *adaptivity index*—an index that expresses the degree to which the feedback policy is able to mask unpredicted environmental or structural fluctuations. A measure of adaptivity that we have used is the area of the  $ap$ -plane covered

by all contours of  $z(\infty)$  for which  $z(\infty) \geq 0.8$ . The shaded region of Fig. 4 illustrates this method of measuring adaptivity. (The value 0.8 is an arbitrary level of lowest acceptable performance. Recall that  $\rho$  is the frequency of transmitted  $O$ 's, and  $\alpha$  is a number associated with the narrowness of the shapes of the constituent densities.) We have found<sup>19</sup> that Eq. 4 provides a convenient way of finding the closed-loop adaptivity from the contours of the open-loop  $z_i(\infty)$ 's. We have used this method of computing adaptivity in a number of specific TLP's.

A measure of the utility of any particular feedback policy is the difference between the closed-loop adaptivity and the average of the open-loop adaptivities. Let us call this measure  $U$ . Our initial evidence indicates that  $U$  depends strongly on the specific feedback policy, and only weakly on the amount of noise in the channel. This lends support to a conjecture that adaptivity, as we have defined the term, is closely tied to feedback policy.

#### Learning Times of Time-Varying TLP's

The learning waves of most real adaptive processes are monotonic or almost monotonic. In such a learning wave, a useful descriptive quantity is the number of training samples required to reduce the transient component of the wave to one-tenth of the transient's initial value. We call this number the *learning time*—a measure of the slowness of learning.

Because the mathematical techniques associated with Markov chains are powerful and efficient, the problem of estimating the learning time of a simple incremental TLP is relatively easy. In fact, the problem remains straightforward, albeit tedious, so long as we are dealing with *fixed-increment TLP's*, i.e., so long as the size of the increments by which the feedback moves the threshold is constant throughout the training period. Thus, for example, a feedback policy that moves the threshold a fixed amount in response to two successive false alarms or two successive false rests yields learning waves that can be analyzed by a Markov chain model.

The problem of estimating the learning times becomes severe, however, when the feedback moves the threshold through varying increment sizes during the training period. These *time-varying TLP's* are often important, because in certain environmental conditions, the learned threshold automatically moves to the exact optimum threshold when the size of the threshold is steadily reduced as the training progresses.

The following question arises: *Is the learning time of a time-varying TLP related in some simple way to the learn-*

ing times of the constituent fixed-increment TLP's? Suppose that at each training sample, say the  $j$ th sample, the time-varying TLP uses a predetermined increment size for correcting the threshold. If this increment size were kept constant the learning wave would have the form of a fixed-increment TLP with a relatively easily determined learning time, which we denote as  $L_j$ . We have found that the learning time  $\lambda$  of any time-varying TLP is related to the  $L_j$ 's by the following approximate relation:

$$\sum_{i=1}^{\lambda} \frac{1}{L_j} \cong 1 \quad (5)$$

A simplified explanation of this relation is as follows. During the time interval between time  $j$  and time  $j+1$ , the transient component of the learning wave moves approximately  $1/L_j$  of the distance toward one-tenth of the transient's initial value. Consequently the sum of the  $1/L_j$ 's over the entire learning time must be approximately unity.

Thus Eq. 5 enables us to use the learning wave of fixed-increment TLP's as basic elements in estimating the dynamic behavior of time-varying TLP's.

#### Inadequately Explained Phenomena

A number of properties of the adaptive behavior of TLP's are as yet inadequately explained. One such phenomenon is the fact that reliability and stability can be obtained separately but not together when the constituent densities have a large overlap. In other words, when the noise in the channel is much larger than the signal, the use of simple incremental feedback will overcome fluctuations in  $\rho$  or fluctuations in  $\alpha$ , but *not* fluctuations in  $\rho$  and  $\alpha$  simultaneously.

Another inadequately explained phenomenon is the near-invariance of the asymptotic success index  $z(\infty)$  with respect to changes in the sizes of the threshold increments in simple incremental TLP's. When the increment by which the feedback moves the threshold is changed, the effect on  $z(\infty)$  is usually small. This means that some of the adaptive properties of a many-threshold TLP can be studied by analyzing mathematically simpler TLP's having only five or even three thresholds.

#### CONCLUDING REMARKS

A start has been made toward the development of a theory of adaptation, with emphasis on adaptive pattern recognition as a link between engineering and the life sciences. The initial results show that quantitative estimations and qualitative explanations of the effects of

feedback on the adaptive behavior of simple trainable systems are possible, even when the engineer's ignorance of the environment or failure laws forces him to work with probabilistic rather than deterministic models.

Further development of the theory is likely to come from elaborations of the basic TLP model. A few expected directions of this development are:

- 1) *Multidimensional Thresholds.* The TLP's studied so far involve the adjustment of a zero-dimensional threshold (a point) in a one-dimensional space of observed signals. Many adaptive processes involve several variables adjusted simultaneously. In adaptive pattern recognizers, the adjusted variables may be modeled by an  $(n-1)$ -dimensional threshold (a hypersurface) in a space of  $n$  observed features. Fig. 6 illustrates the threshold dynamics in a two-feature trainable recognizer in which the threshold space is one-dimensional. The coordinates  $x$  and  $y$  are features, such as the radius of gyration, the sum of the lengths of lines exceeding a prescribed curvature, etc. The circles and squares in the figure enclose points representing observed feature pairs. The task of the recognizer is to separate the points enclosed by circles from those enclosed by squares. The occurrence of an observed feature pair below the threshold line results in a guess of  $\circ$ , otherwise the guess is  $\square$ . Each reinforcement signal causes an adjustment of the threshold.

An example of the motion of the threshold line in response to a sequence of reinforcements is displayed in Fig. 6. In this figure the threshold line's motion is traced by the point of intersection of the threshold line and the perpendicular through the origin. This point of intersection happens to be the point on the threshold line closest to the origin. Imagine that a lighted light bulb is located at this point. The path of the threshold line's motion as traced by this light bulb is indicated by the dashed line in Fig. 6.

Fig. 6—Example of the motion of a one-dimensional threshold in a two-feature adaptive pattern recognizer.

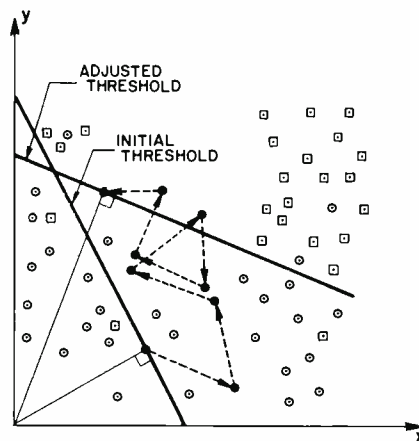

The motion of this light bulb is a random walk in multidimensional space. The present theory of single-dimensional TLP's will probably be extended to include this multidimensional process.

- 2) *More-sophisticated feedback policies.* In many adaptive systems, optimum or near-optimum performance can be obtained if all the available knowledge of the environment is exploited in the synthesis of the feedback policies. In certain types of environments, for example, optimum asymptotic performance will occur when the size of the increment of the threshold adjustment becomes smaller with each new training sample. Hence, greater complexity in the feedback policies is sure to appear as the theory develops.
- 3) *Imperfect reinforcement.* A TLP in which the reinforcement signals contain the correct answers must of necessity undergo alternate periods of training and working. This is not the case when the reinforcement signal contains an imperfect estimate of the correct answer. The reason for this is that perfect answers can only be derived from a specially stored "look-up table."

But imperfect answers can be derived from a special algorithm, which we call the *critic*. The critic provides an imperfect estimate of the correct answer, based on the present and past answers of the machine. This critic need not store the correct answers. It may compute an estimate of the size of the error by observing the present and recent past of the input and output signals, and checking the degree to which these signals obey certain required constraints. An example of such a critic is a device which calculates the frequency of guessed  $\theta$ 's over a finite number of recent samples and compares this calculation to a known value of  $\rho$ .

Under these conditions training and working can take place simultaneously. In computer parlance, this is called *on-line operation*. By relating the case of imperfect reinforcement to that of perfect reinforcement, adaptation theory would bring about a fuller understanding of the important process of on-line adaptive pattern recognition—in which the machine learns not from correct examples, but from scores emanating from an imperfect critic.

Returning to that duck on the rock, we can point out where the present theory can help us understand his goal-seeking behavior, and where the theory falls short. Suppose the duck eats an insect it hasn't seen before, and suppose the new "delicacy" gives the duck a stomachache. Suppose the duck slowly learns to shun that particular insect after a few such unpleasant experiences. This process is related to the discrimination learning processes of psychology. Discrimination learning has often been modeled<sup>7</sup> by TLP's or elaborations of TLP's. Consequently the present state of adaptation theory should be able to help the biologist understand the ability

of the duck to overcome environmental fluctuations — such as, for example, changes in the size and color of the insect.

But now suppose the biologist tries to model the duck's adaptive behavior in learning the direction of approaching cats. In this case the biologist will find the present theory inadequate. Of still greater difficulty is the task of modeling adaptive strategy-formation and game-playing in the higher animals.

There is hope, however, that adaptation theory will be applicable to certain parts of the more complex game-playing processes. Recent results at RCA Laboratories in the simulation of theory formation and theorem-proving by machine show that probabilistic "local" decisions appear at certain nodes in the machine's decision tree<sup>11</sup>. The present theory raises the possibility of modeling the adaptive behavior of these local decisions, and in this way contributing toward an understanding of the overall process.

#### ACKNOWLEDGMENTS

The author is indebted to the members of the Computer Theory Group at RCA

Laboratories for many discussions and criticisms during the course of this research. Dr. K. R. Kaplan, in particular, contributed over two years of basic research on the methodology of analyzing Markov chain models of adaptive processes.

#### BIBLIOGRAPHY

1. W. R. Ashby, *Design for a Brain*, second edition, John Wiley and Sons, Inc., New York, 1960.
2. S. Amarel, J. A. Brzozowski, "Theoretical Considerations on the Reliability Properties of Recursive Triangular Switching Networks," *Redundancy Techniques for Computing Systems*, ed. by R. H. Wilcox and W. C. Mann, Spartan Books, Washington, D.C., 1962.
3. C. E. Shannon, "Computers and Automata," *Proc. IRE*, vol. 41, October 1953, pp. 1234-1241.
4. W. W. Peterson, T. G. Birdsall, W. C. Fox, "The Theory of Signal Detectability," *IRE Trans. on Information Theory*, vol. PGIT-4, September 1954, pp. 171-212.
5. D. A. Norman, "Stochastic Learning and a Quantal Model of Signal Detection," *IEEE Trans. on Applications and Industry*, vol. 83, No. 74, September 1964, pp. 292-296.
6. N. Abramson, D. Braverman, "Learning to Recognize Patterns in a Random Environment," *IRE Trans. on Information Theory*, vol. IT-8, September 1962, pp. 58-63.
7. J. A. Swets, "Information Retrieval Systems," *Science*, July 19, 1963, vol. 141, No. 3577, pp. 245-250.
8. J. Sklansky, *Two-Mode Threshold Learning*, Technical Documentary Report No. AMRL-TDR-64-39, Aerospace Medical Research Laboratories, Wright-Patterson Air Force Base, Ohio, May 1961.
9. W. H. Huggins, "Signal Flow Graphs and Random Signals," *Proc. IRE*, vol. 15, January 1957, pp. 74-86.
10. K. R. Kaplan, J. Sklansky, *Analysis of Markov Chain Models of Adaptive Processes*, Technical Documentary Report, to be issued by the Aerospace Medical Research Laboratories, Wright-Patterson Air Force Base, Ohio.
11. S. Amarel, "On the Automatic Formation of a Computer Program which Represents a Theory," *Self-Organizing Systems 1962*, ed. by M. C. Yovits, G. T. Jacobi, G. D. Goldstein; Spartan Books, Washington, D.C., 1962, pp. 107-175.
12. L. A. Zadeh, "On the Definition of Adaptivity," *Proc. IEEE*, vol. 51, March 1963, pp. 469-470.
13. J. Sklansky, "A Markov Chain Model of Adaptive Signal Detection," Contributed Paper Preprints of the 1963 Bionics Symposium, Air Force Systems Command, Wright-Patterson Air Force Base, Ohio.

#### APPENDIX

##### An Intuitive Derivation of Equation 1

To simplify our discussion, we consider a  $K$ -threshold TLP in which the thresholds are incremented by no more than one increment after each guess. (The simple incremental feedback policy results in such a TLP.)

Let  $r_i(0)$  represent the probability that the  $i$ th threshold of this TLP is occupied at time 0. The probability that this threshold will be occupied at time 1 is  $r_i(1)$ . The latter probability is related to the probabilities that the  $(i-1)$ th, the  $i$ th, and the  $(i+1)$ th threshold will be occupied at time 0 by a weighted sum of the transition probabilities  $p_{i-1,i}$ ,  $p_{i,i}$ , and  $p_{i+1,i}$ :

$$r_i(1) = r_{i-1}(0) p_{i-1,i} + r_i(0) p_{i,i} + r_{i+1}(0) p_{i+1,i} \quad (A1)$$

This relation comes about because in the TLP under discussion the thresholds are increased or decreased by only one increment at a time; hence the probability of occupying the  $i$ th threshold at time 1 depends only on the probability of occupying the same threshold at time 0 and the probabilities of occupying the two immediately neighboring thresholds at time 0.

Eq. A1 can be summarized in vector notation as follows:

$$\mathbf{r}(1) = \mathbf{r}(0) \mathbf{P} \quad (A2)$$

where  $\mathbf{P}$  is a matrix of the following form:

$$\mathbf{P} = \begin{bmatrix} p_{11} & p_{12} & 0 & 0 & 0 & 0 & \dots \\ p_{21} & p_{22} & p_{23} & 0 & 0 & 0 & \dots \\ 0 & p_{32} & p_{33} & p_{31} & 0 & 0 & \dots \\ 0 & 0 & p_{43} & p_{41} & p_{41} & 0 & \dots \\ \dots & \dots & \dots & \dots & \dots & \dots & \dots \\ 0 & \dots & 0 & 0 & p_{K-2,K} & p_{K-1,K} & p_{K,K} \end{bmatrix} \quad (A3)$$

By recursively repeating the derivation of Eq. A2 for times 2, 3, etc., we observe the general formula for  $\mathbf{r}(n)$ :

$$\mathbf{r}(n) = \mathbf{r}(0) \mathbf{P}^n \quad (A4)$$

Now, suppose we observe that the  $i$ th threshold is occupied at time  $n$ . The probability of a successful guess at time  $n$  is then just  $p_{i,i}$ , since a successful guess is associated with a return to the  $i$ th threshold at time  $n+1$ . But if we know only that the  $i$ th threshold at time  $n$  is occupied in a fraction  $r_i(n)$  of all learning experiments, then the success probability at time  $n$  is a weighted sum of the  $p_{i,i}$ 's, each  $p_{i,i}$  weighted by the fraction  $r_i(n)$ . Hence, if we let  $\mathbf{q}$  be a column vector representing all the  $p_{i,i}$ 's, the probability of a correct guess at time  $n$  is:

$$z(n) = \sum_i r_i(n) p_{i,i} = \mathbf{r}(n) \mathbf{q} \quad (A5)$$

Substituting Eq. A4 in Eq. A5 yields Eq. 1.

In more-complex TLP's, Eqs. A4 and A5 continue to hold, provided the elements of  $\mathbf{q}$  are defined as the conditional probabilities of a correct guess, given that the TLP occupies a particular state. Hence in these complex TLP's, Eq. 1 will also hold.

In the more complex processes, a "state" of a TLP may involve more than just the threshold value. An example is a *two-mode TLP*, in which the noise statistics takes on one of two sets of values (i.e., two *modes*) at random after each guess. Here, the state of the TLP involves the mode of the noise as well as the threshold value.<sup>8</sup>



# NEURAL, THRESHOLD, MAJORITY, AND BOOLEAN LOGIC TECHNIQUES

## A Comparative Survey

This paper presents the basic characteristics and relative merits of the four types of logic classified (in decreasing order of complexity) as neural, threshold, majority, and Boolean—and considers combinational switching functions, logic configurations and synthesis, and factors in circuit realization. Although the mathematics of synthesis and component choice for neural logic are not today as well defined as for Boolean or threshold logic, present work indicates that future neural network systems should be not only feasible but also competitive with Boolean or threshold logic. In the long run, only neural networks—because they strive to imitate the human brain—will prove powerful and reliable enough to efficiently realize the goal of adaptive (self-learning) machines and the solution of other complex information handling problems.

C. R. ATZENBECK and D. HAMPEL

Systems Laboratory

Communications Systems Division, DEP, New York City, N. Y.

THE study of logic techniques may be categorized into four basic types: 1) neural, 2) threshold, 3) majority, and 4) conventional Boolean *and-or* logic—taken in order of decreasing characteristic complexity (Fig. 1 and Table I). Thus, neural logic is capable of performing threshold and majority logic—threshold logic is capable of performing majority logic—etc. Each logic method can perform the basic Boolean functions of *and*, *or* and *not*.

The emphasis in this paper is on threshold and neural logic, since probably less is known about these than about the others. Furthermore, any major change from the present logic-design philosophy would probably result, at least in part, in the use of these more-advanced logic systems.

### BOOLEAN LOGIC

Boolean logic (conventional *and-or* logic) is the backbone of existing data-processing and computing systems. The techniques for implementing the basic functions of *and*, *or*, *not*, *nand*, and *nor* are well known. A great amount of theory is available in the literature and in textbooks, under the heading of "Switching Theory and Logical Design". The usual problem encountered in the design of a data-processing system is: Given a basic set of elements, arrange the elements in a configuration which performs the required data-processing function with reliability and economy. Usually, minimizing the number of basic elements provides both. This logic is well

Final manuscript received November 3, 1964.

known, and will be given little attention here aside from its use as a baseline.

Briefly, switching theory provides the tools for algebraic and graphical manipulation of truth functions to obtain a synthesis with a minimum of the basic set of elements. This solution is then examined for contradiction to restrictions, such as fan-in and fan-out, which are imposed by the basic elements. The "goodness" of the synthesis is determined by the number of basic elements required in the synthesis.

### THRESHOLD LOGIC

Threshold logic involves the optimum synthesis, or composition, of a set of fundamental switching functions to realize a prescribed function. The basic elements of a threshold logic system are threshold gates. The threshold gate realizes a switching function by computing the weighted sum of binary variables, compares this sum to a fixed threshold or bias, and produces *true* output only if the threshold is equalled or exceeded. Fig. 2 shows the symbol for a threshold gate;  $a_0$  is the bias, and  $a_i$  are the weights.

Interest has been focused on this topic because physical implementations of Boolean gates (*and*, *or*, *not*, *nor*, etc.) actually operate in this manner. For example, resistor-transistor implementation of the four-input *nand* gate consists of a Kirchoff resistive adder that sums the four input voltages and a bias voltage. A transistor senses when the sum is above or below threshold. Other implementations<sup>4</sup> using the parametron,

magnetic core, and tunnel diode, also operate in this manner.

The promise of threshold logic is that more-complex switching functions, as well as the basic *and*, *or*, and *not* functions can be performed by a *single* gate. This implies fewer components, hence higher reliability. An example of the reduction in gates required is shown in Fig. 3. The threshold method, (top of Fig. 3) directly synthesizes the following function:

$$F = X_1(X_2 + X_3 + X_4) + X_2X_3X_4,$$

In so doing, it uses only *one active gate* with a bias, or threshold, of 3, and input weights of 2, 1, 1, and 1.

A common approach in conventional logic synthesis utilizes *nor* gates. The synthesis of the same function,  $F$ , with these gates is shown next in Fig. 3. The output of the first stage with inputs  $X_2$ ,  $X_3$ , and  $X_4$  is  $\overline{X_2 + X_3 + X_4}$ , and similarly with the four other *nor* stages. The total synthesis, assuming that each variable and its prime are available, requires *five active gates*.

An alternate approach utilizing *nand*

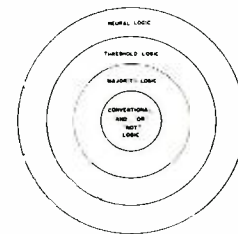

Fig. 1—Hierarchy of logic systems.

TABLE I—Glossary of Terms

**conventional, conventional boolean, or boolean logic**—That type of logic which utilizes a system of: 1) *and*, *or*, and *not* gates, or 2) *nand* and *nor* gates, to synthesize a given Boolean expression or function.

**threshold gate**—A gate which accepts binary inputs and computes a switching function by computing the weighted sum of inputs and comparing this sum to a threshold. If and only if the weighted sum exceeds the threshold, the gate output is binary 1. The switching function synthesized is determined by the weights and threshold chosen.

**majority gate**—A subclass of threshold gates in which odd numbers of binary inputs are applied to the gate. The weights on the inputs are equal, and the threshold is set such that the output of the gate is binary 1 when a majority of the inputs are binary 1, and binary 0 under all other conditions.

**threshold logic**—That type of logic which utilizes threshold gates in the synthesis of logical functions.

**majority logic**—That type of logic which utilizes majority gates in the synthesis of logical functions.

**neuron, artificial neuron**—Two terms, used interchangeably, which refer to an electronic circuit which strives to simulate the characteristics of a biological neuron, such as: threshold, excitatory inputs; inhibitory inputs; refractory period; etc.

**neuristor**—A device postulated primarily on the refractory period of the biological neuron, and with characteristics similar to a nonlinear transmission line.

**neural logic**—That type of logic employing networks of neurons, and used to perform logical functions.

**neuristor logic**—That type of logic employing networks of neuristors, and used to perform logical functions.

**adaptive logic**—That type of logic (any of the types already defined) which can change its purpose or function according to a series of sequential events.

gates is shown last. The output of the top gate, with inputs  $X_1, X_2$  is  $\overline{X_1 X_2}$ , etc. Again, five active gates are required.

Theoretical work has considered the following questions. Given a switching function, can it be realized by a single threshold gate? If so, what are the weights required? If not, how many threshold gates are required, and what are the weights?

A switching function  $f(x)$  is a threshold function when there exist real weights  $(a_0, a_1, \dots, a_n)$  such that the function can be realized by a single threshold gate. These functions are called *1-realizable*. The problem of determining whether a given function is *1-realizable* or not, and if it is, what weights should be used, has received much attention. They are all *unate* functions<sup>2</sup>—they can be expressed by Boolean expressions in which each variable appears uniformly; everywhere with negation, or everywhere without. The notions of *monotonicity* and *assumability* further generalize characteristics of threshold functions. Much literature has been devoted to these conditions<sup>1</sup>, and most functions can be shown to be either threshold or non-threshold. More work is needed, however, to adapt the ideas more specifically to the case of sparse specification; that is, when there are many inputs but where most input functions don't have outputs specified. That is, most of the input combinations do not specify either 0 or 1 as outputs, but imply "don't care" states.

After the test for the threshold function comes the synthesis problem; that is, which weights and threshold assignments realize it. Approaches used here include *linear programming* and *game theoretic*.<sup>1</sup> These methods are not feasible when the number of arguments become large (over 20). The problem of network synthesis has also been approached *algebraically* and *geometrically*. A geometric approach can determine whether a given function can be realized using just two threshold gates. One algebraic method leads to the constraints on the threshold magnitude.

A convenient representation for switching functions, when dealing with threshold logic, is the geometric representation. The truth table and Boolean algebraic expressions can also be used as in conventional logic, but the geometric display preserves some of the important relationships between argument  $n$ -tuples. The geometric definition of a threshold function is:

A switching function is a threshold function, if, and only if, in its  $n$ -cube representation, there exists a hyperplane such that all solid-dot points (the 1 vertices) lie upon, or on one side of, the hyper-

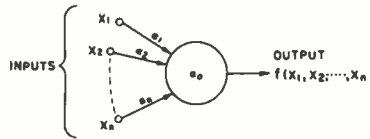
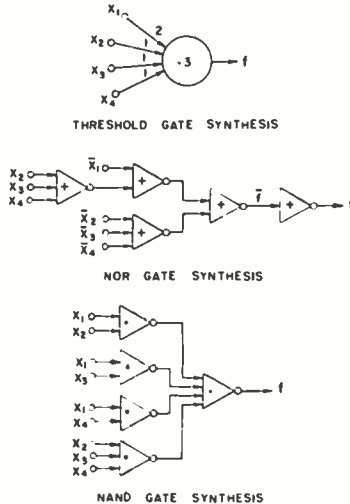

Fig. 2—Threshold gate symbol.

Fig. 3—Synthesis of  $F = X_1(X_2 + X_3 + X_4) + X_2X_3X_4$ .



plane, and all hollow-dot points lie on the other side of the hyperplane.

For example, the function  $f(x_1, x_2, x_3) = x_1 + x_2 x_3$  is represented by the three-cube in Fig. 4a. To plot the function, all vertices which correspond to an output of 1 are marked with a solid dot, all vertices which correspond to an output of 0 are marked with a hollow dot. A hyperplane which separates the 1 and 0 vertices is also shown; therefore, the function is *1-realizable*, hence a threshold function.

A four-cube representation of the function  $f = x_1(x_2 + x_3) + x_2 x_3 x_4$  and a hyperplane is shown in Fig. 4b as a further illustration. The right-hand cube represents all points for which  $x_4 = 1$ . All the vertices for both cubes represent the same function for the three other variables as indicated in Fig. 4a. R. O. Winder (RCA Laboratories) has done a considerable amount of work in threshold logic theory.<sup>1</sup> He has composed a table,<sup>1</sup> which determines whether switching functions of six or less variables are realized by a single gate, and provides the weights required.

W. A. Kautz<sup>2</sup> has studied the synthesis of symmetric switching functions using threshold gates, and derived bounds on the minimal number of threshold gates required. He has also provided a synthesis technique for symmetric switching functions of up to 12 variables which is not too cumbersome. The odd-parity function of  $n$  variables is synthesized quite directly with the general network configuration shown in Fig. 5. In this figure, all the inputs,  $x_1, \dots, x_n$  are

applied to each of the  $r$ -threshold gates. The bias value  $r$ -threshold of each gate is  $\beta_{nn}$  as long as none of the previous gates  $\beta_{11}$  to  $\beta_{n-1, n-1}$  have an output of one. Otherwise the bias values are as follows (depending on which previous gates have outputs of one):

- bias for first threshold gate:  $\beta_{11}$
- bias for second threshold gate:  $\beta_{22}$  or  $(\beta_{12} + \beta_{21})$
- bias for third threshold gate:  $\beta_{33}$  or  $(\beta_{12} + \beta_{23} + \beta_{31})$  or  $(\beta_{12} + \beta_{33})$  or  $(\beta_{23} + \beta_{33})$

For the case of seven inputs,  $r = 3$  threshold gates and

$$\begin{aligned} \beta_{11} &= 4 & \beta_{12} &= 4 \\ \beta_{22} &= 2 & \beta_{23} &= 2 \\ \beta_{33} &= 1 & \beta_{13} &= 4 \end{aligned}$$

As a result, the network will have an output  $f_p$  only if there are one, three, five, or all seven 1's present. Note that the number of inputs is quite large ( $n$  to  $n+r-1$ ) and the weights are also quite large ( $1$  to  $2^{r-1}$ ).

The parametron, as mentioned previously, operates as a threshold element, but its use has been confined to major-

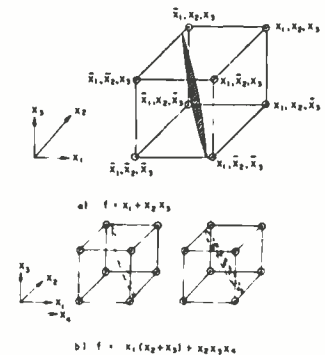

Fig. 4—N-cube representation.

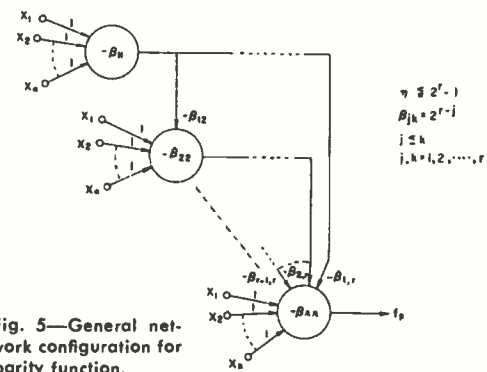
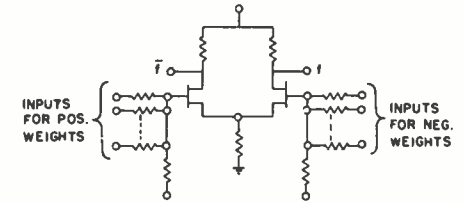

Fig. 5—General network configuration for parity function.

Fig. 6—Quasi-universal threshold-logic element.



ity-logic applications. Parametrons have been used with five, seven, and nine inputs. However, users have noted that nine-input parametrons must be carefully selected and operate reliably only in small systems. Parametrons used in large systems may use seven inputs if they are selected carefully. Five-input parametrons require no selection. The number of inputs on the parametron gives us a restriction on the number of threshold functions which may be performed, since this may be interpreted as:

$$\sum_{i=0}^n |a_i| \leq \text{number of parametron inputs.}$$

For seven inputs, all the threshold functions, with three arguments, as well as the six-argument *or* function may be computed by properly connecting the input windings on the parametron.

A suggested implementation of a quasi-universal threshold logic element is shown in Fig. 6. The gate provides both the function and its complement at the output. For positive weights, the input is applied to the left side. Negative weights are obtained by applying the input to the right side. Different weights are obtained by strapping the resistors in the summing circuit. Cross-coupling the gate produces a flip-flop configuration; therefore, shift registers and counters should be possible with suitable coupling networks.

The number of resistors provided in the Kirchoff summing circuit will determine the number of threshold functions which may be performed by strapping the resistors in the summers.

Of course, the number of resistors in the summing circuit will be limited by

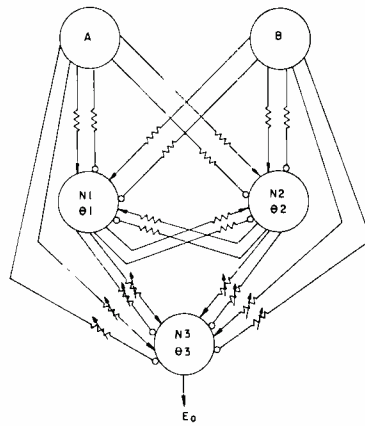

Fig. 9—Neural network.

circuit element tolerances, but such an implementation shows much promise.

### MAJORITY LOGIC

A special case of threshold logic is majority logic. This logic deals with a restricted class of threshold functions. Referring to Fig. 2, all of the weights  $a_0, a_1 \dots a_n$  are of equal value. The operation of the gate is identical to the general threshold gate. However, now the threshold is exceeded when the number of 1 inputs,  $m$ , is greater than the number of 0 inputs,  $(n-m)$ . Methods have been devised for synthesizing three-input majority gates. In one case, a truth table is constructed, simplified, and utilized, and then an iterative method of circuit synthesis is applied. Another method is diagrammatic, which facilitates the selection of gates for maximum table reduction at each step of the process (the link-diagram method).

### NEURAL LOGIC

Neural logic is an approach to the general switching problem, data-processing problem, or artificial-intelligence problem, with the use of neurons as the basic building block. The electronic neuron strives to simulate physiological nerve cells with all their processes, and networks of these (neural nets) simulate neurological patterns.

It is possible to achieve logic operations with the simulated neurons because of the existence of a threshold in the input-output characteristics. The output state of a neuron indicates whether the summation of the input signals is above or below a given threshold. The neuron may function as a conventional threshold gate and applied to threshold logic if the output is quantized into two levels (0 and 1). As applied to neural logic, the output of the artificial neuron is an analog quantity (either a variable pulse rate or variable DC level), whose magnitude is a measure of the amount by which the inputs exceed the threshold. It is this feature which provides neural logic with

the capabilities required in speech and pattern-recognition systems.

Several kinds of electronic models of biological neurons have been built.<sup>9,10</sup> Some of them are elaborate electronic circuits which behave almost as real neurons, while others are simplified versions with the view toward economical production for network design, while still preserving the important neuron characteristics. These models usually consist of transistor circuits (anywhere from two to five transistors) but many later versions utilize magnetic devices such as multi-aperture cores. A neuron's input-output characteristics<sup>8</sup> are shown in Fig. 7. It is seen from the top characteristic, without any feedback present, that there is no output until the threshold is exceeded. Then, the output jumps to some value and increases with increasing input until its saturation value is reached.

The second characteristic has positive feedback, i.e., feedback to an excitatory input. The output is zero again until the threshold is attained on the input. Then it goes immediately to saturation as the threshold is exceeded.

In the last characteristic (feedback to an inhibitory input) as the threshold is exceeded the input rises at a low rate toward saturation. One other important characteristic of the neuron is its *refractory period*, i.e., once it has been excited beyond its threshold and produces an output, it cannot be fired again for a given period of time after the input has been withdrawn. This period begins only after removal of the input.

Thus, the neuron is digital in the sense that the integrated sum of the inputs is either above or below threshold and, consequently, the neuron is either firing or not firing. The analog properties result from the fact that both the inputs and the threshold setting are analog quantities. Neural logic is capable of recognizing a marginal decision as a *marginal decision*, whereas binary logic makes no distinction between a marginal decision and a firm decision. In neural logic, noise and incidental distortions in the input pattern simply decrease the confidence level of the final decision, while in binary logic such pattern deviations may result in an erroneous decision. These advantages of neural logic hold for sequential as well as combinational information processing.

### NEURISTORS

H. D. Crane of Stanford Research Institute has postulated a neuron-like computer element called the *neuristor*. This device may be used to synthesize all digital-logic functions, so that any digital-logic system can be realized using

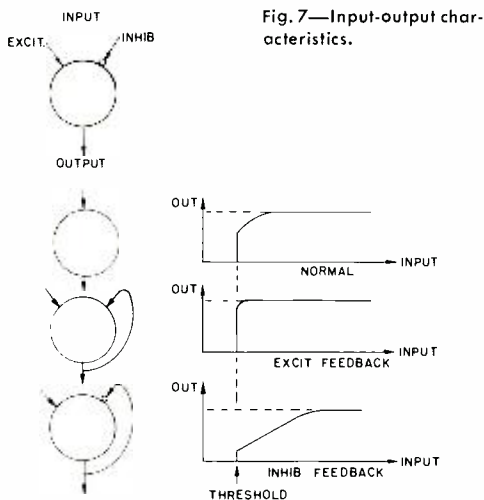

Fig. 7—Input-output characteristics.

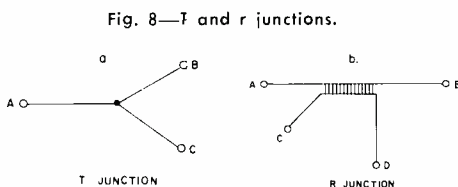

Fig. 8—T and r junctions.

arrays of neuristors only. This device is distinguished from the lumped-neuron model in that multilevel signals are not considered, and its use in adaptive logic, if at all practical, would assume different techniques.

A neuristor line,<sup>5</sup> a hypothetical implementation of the neuristor, is any of a class of nonlinear transmission lines wherein every point on the line is: 1) associated with a localized energy source that can be caused to discharge (with subsequent recovery), and 2) coupled with adjacent points on the line in such a way that the discharge of the localized energy source at the point is sufficient to excite, or trigger, its coupled neighbors. The following are the two important properties of a neuristor line:

- 1) A discharge initiated at a point will propagate in both directions from the point without attenuation, and at a velocity determined by the composition of the line.
- 2) A point on the line, once excited, cannot be excited again until its local energy source has been replenished; thus, a fixed recovery time (or *refractory period*) must elapse after passage of a discharge before a subsequent discharge can be sustained at the same point.

Neuristors may be interconnected in two basically different modes: *T* junctions and *R* junctions. Combinations of networks with these junctions can realize practically all digital-logic functions.

A *T*-junction has the property that a discharge signal reaching it on any line triggers a discharge signal on every other connected line, each signal propagating away from the junction point with uniform velocity. A *T*-junction with three branches is shown in Fig. 8a. A signal appearing at *A* will appear at both *B* and *C* with energies and velocities equal to that of *A*.

An *R*-junction has the property that the refractory period following the passage of a wave on one line is simultaneously experienced by the *R*-connected line. An *R*-junction between two channels is indicated in Fig. 8b. A signal propagating from *A* to *B* would be annihilated if there was a pulse going from *D* to *C* because it would render the junction refractory. Thus, the gating possibilities become evident—the transmission from *A* to *B* being controlled by a signal at *D*. Many examples and applications of are given in Ref. 5.

#### NEURISTOR LASERS

The neuristor concept is basically that of a one-dimensional, bi-directional channel transmitting a signal in the form of a propagating discharge. Networks of these neural lines offer versatility and simplicity in the synthesis of neural logic systems. Depending on exactly what these neuristors are made

Fig. 10—*and* function, neural vs. digital net.

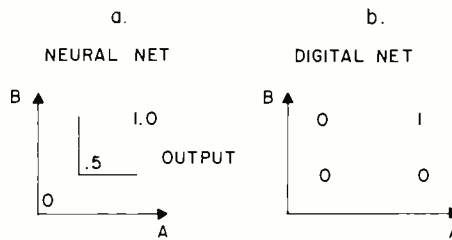

from, other important advantages become evident. Miniaturization, reliability, and power efficiency are neuristor design goals. The neuristor concept seems more suitable for these goals than the lumped-neuron models now employed for neural logic. In one of the approaches, optical energy is to be used as the discharge vehicle in the neuristor lines." All the information and control signals are in the form of optical energy. Fiber optic elements with appropriate concentrations of active emissive ions and passive absorptive ions are the basic components of the system. The system is powered by being in a continuous-light environment. Among the attractive features of such a system are the freedom from power-supply connections for individual circuits, the possibility of transmission of signals without actual connections between certain locations, and a promise of high-speed operation.

The work to date on such neuristors has demonstrated that, in principle, continuously-pumped laser components can provide a threshold of amplification, amplitude standardization, unidirectional transmission of signals, and inversion or inhibition of the pulse signals. Hence, it can be concluded that an 'all optical' continuously-pumped neuristor system should be possible, with optical masers as the only active components. As more suitable materials be-

**CHARLES R. ATZENBECK** completed the Advanced Technology course at RCA Institutes in 1952, earned his BEE from City College of New York in 1960 and his MSEE from the Brooklyn Polytechnic Institute in 1963. Mr. Atzenbeck joined RCA in 1952 at RCA Laboratories where he assisted in development of the RCA electronic MUX-ARQ. In 1956 he transferred to DEP Surface Communications, New York; he later was awarded an RCA study scholarship. In 1960, he became a member of the Surface Communications Laboratory Technical Staff in New York where he designed circuits for the BMEWS Dipulse and Minuteman Dipulse data transmission systems. He developed the design approach for the UNICOM digital-to-digital converter, the basis for a patent application. Next, he was concerned with testing an error detection technique for the Dipulse digital data modem which was the basis for his master's degree thesis and the basis for another patent application. Presently, he is concerned with evaluating a special class of recurrent error-correcting codes with the aid of an RCA 601 computer. Mr. Atzenbeck is a member of IEEE and the IEEE Groups on Digital Computers and Information Theory, and an honorary member of Eta Kappa Nu, Tau Beta Pi, Sigma Xi.

**DANIEL HAMPPEL** received the BSEE in 1953 and the MSEE in 1958 from the Newark College of Engineering. He joined the Bell Telephone Labora-

Fig. 11—*or* function, neural vs. digital net.

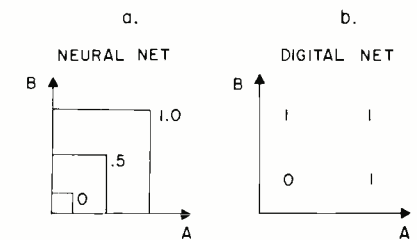

come available, this form of neuristor should be quite feasible.

#### LOGIC CONFIGURATION

Although neuristors could conceivably be used in any logic system, most of the work has been done with other neuron models. The following discussion of a *neuron network* will aid in understanding neural networks in general.

The general circuit layout is shown in Fig. 9. Each circular symbol represents an artificial neuron  $N_i$  with threshold value  $\theta_i$ . The two input signals *A* and *B* could be coming from other neurons in a system, and the resistors are interconnecting weights. By varying these resistor values, and the thresholds for the neurons, a great number of combinations of input-output relationships may be realized. With a simplification of this network, and with appropriate weighting values, this basic network can generate the analog equivalents of the 16 logic functions that are possible with a two-input digital-logic network. Fig. 10a shows the output amplitude as a function of the two inputs when the network is connected as an *and* gate. The output signal is proportional to the smaller of the two inputs. The corresponding digital function is shown in Fig. 10b. Here, the output is either 1 or 0. Fig. 11a shows the output for the *or* gate and Fig. 11b the corresponding digital function.

He joined the technical staff in 1953, and worked on electronic switching systems and circuits for the Electronic Central Office until 1957. He then joined the IIT Laboratories, working as a Senior Engineer in their Countermeasures Laboratory. He developed data-processing systems for radar and communications signals detection. He joined the RCA Service Co. in 1960 in Nuclear Engineering Services as a Project Engineer, and has worked on RCA Service Co. assignment to the Computer Engineering Section, Instrument Division, Oak Ridge National Laboratories, Oak Ridge, Tennessee. Mr. Hampel joined CSD's Systems Laboratory in New York in 1962 as a Senior Member, Technical Staff. He has worked on the study of data processing equipment required for a command and control system. He also studied logic techniques, and the application of different logic systems to various data processing problems. He is a member of Tau Beta Pi and Eta Kappa Nu, and during 1957-1960 was an Instructor in Electrical Engineering at the Newark College of Engineering. He has authored several papers in the communications field.



The neural network gives a continuous range of output signals throughout the ranges of the two input signals. In this case the circuit responds to the larger of the two input signals. When set as an *and* gate, the general neural network simplifies to that shown in Fig. 12a. The *or* gate is shown in Fig. 12b.

When it is desired to enhance the small difference between two quantities *A* and *B*, a mutual inhibition connection (Fig. 13) can be used. If *A* is only slightly larger than *B*, the output *A* is much larger than *B*. Other comparisons between signals may be made by using different connections, thresholds, and weights.

By introducing reactive impedances or time delays into the logic connections of the previously described networks, it is possible to extend the neural-logic system to respond to the dynamic changes in the input patterns. One transition *and* gate has an output only if signal *A* ceases and *B* begins soon afterward. The time of transition may be controlled by adjusting the time constants constituting the weighting connections.

Other dynamic neural gates are the simultaneous *and* gate and the sequence-detector type. Examples of these are discussed in Ref. 8.

#### ADAPTIVE NEURAL LOGIC NETWORKS

It was noted that the logic functions realized by the general neural network form a continuum. This enables the building of an adaptive logic system which will converge to the desired logic state as the weighting connections are varied by a series of successive approximations. The main problem encountered is that of finding a suitable variable weighting element. The *memistor* seems to be a promising approach.<sup>7</sup> An electrochemical device, providing resistance with memory, the memistor has a large, easily-controllable range. Magnetic devices having nondestructive

readout and storage have also been used successfully in adaptive neural-logic."

#### CONCLUSIONS

##### Threshold Logic

Threshold logic could conceivably promise higher reliability than Boolean logic, due to its ability to perform more complex switching functions with fewer gates. Most of the work in this field has been confined to theory. The only application has been in the restricted form known as majority logic, and primarily with parametrons.

There are some tradeoffs that will have to be made in a threshold logic system. For example, it seems almost certain that more precise and stable resistors will have to be used (as weighting elements), as well as better-regulated power supplies, than are normally employed in conventional logic circuits. What overall effect these factors will have on the speed, cost, size, etc., of the threshold circuits has yet to be determined. However, in view of the work done to date, it is felt that a threshold-logic system is not only feasible but will offer definite advantages in reliability. Furthermore, it will probably be the next major breakthrough from the conventional in logic design, being closer to realization for a general data-processing system than is neural logic.

##### Neural Logic

From the preceding discussion, it becomes quite evident why neural logic is used for pattern recognition. The versatility provided by connections, weighting, thresholding, and differentiating of the analog signals in processing is immense. It lends facility to identify shapes and patterns acoustical or visual. Many systems of these types have already performed successfully.

But how can these devices be advantageously applied to general data-processing problems of the type that digital computers or digital-logic systems are now used for? First of all, many types of artificial neurons can be used as straightforward threshold gates with the same considerations as discussed in the threshold-logic section of this paper. By using the excitatory feedback mode of operation (Fig. 7), the neuron characteristic is identical to that of a threshold gate; if the input threshold is exceeded, the output goes from 0 to 1. Now, by making use of the analog output capabilities, and by using some of the techniques which were discussed, it would seem that much could be done in the way of data-processing capabilities of neural logic. However, a different approach will have to be taken. Presently, a problem is transformed into a logical or Boolean expression, and after mathe-

tical simplifications, if any, a conventional digital or threshold network is synthesized to solve the problem. Merely substituting artificial neuron gates will not offer much, if any, improvement in operation or reliability. By attacking the problem directly without transformation, the neural-logic approach can provide many advantages. For example, in the pattern-recognition problem, conventional logic systems could be, and have been, used in the past, after a pattern has been digitized. By comparing these with the capabilities of any of the neural networks used today, the advantages become obvious. Many data-processing problems are of the pattern-recognition type, even if they do not involve an audio or visual pattern as such. It is felt that the solution of the many other data-processing problems can make effective use of neural logic, particularly in view of its adaptive capabilities. As of today, the mathematics for synthesis and component choice are not as well defined as for the conventional or threshold-logic approaches, but work is being done in both areas, and neural network systems seem not only feasible but will, in the future, compete with the more conventional and threshold logic. In the long run, only neural networks (since they at least strive to imitate the human brain) will prove powerful enough for the efficient, reliable solution of the complex data-processing problems of the future.

#### BIBLIOGRAPHY

1. R. O. Winder (RCA Laboratories), *private communication*.
2. W. H. Kautz, "The Realization of Symmetric Switching Functions with Linear-Input Logical Elements", *IRE Transactions on Electronic Computers*, Vol. EC-10, #3, pp 371-378, Sept. 1961.
3. R. McNaughton, "Unate Truth Functions", *IRE Transactions on Electronic Computers*, Vol. EC-10, #1, pp 1-6, March 1961.
4. R. C. Minnick, "Linear-Input Logic", *IRE Transactions on Electronic Computers*, Vol. EC-10, #1, pp 6-16, March 1961.
5. Crane, Minnick, and Short, *Neuristor Logic*, Stanford University ASD-TDR-62-55, AD 282497.
6. W. F. Kosonocky (RCA Laboratories), *private communication*.
7. B. Widrow, *An Adaptive Adaline using Chemical Memistors*, Stanford University Technical Report No. 1553-2, 17 October 1960.
8. T. B. Martin and J. J. Talavage (RCA Applied Research), "Application of Neural Logic to Speech Analysis and Recognition", 1963 Bionics Symposium, Wright-Patterson AFB, Dayton, Ohio, March 1963. See also paper by T. B. Martin and M. B. Herscher, "Speech Recognition Using Artificial Neurons," *RCA ENGINEER*, *this issue*.
9. E. P. McGrogan, RCA Applied Research, *private communication*.
10. T. B. Martin, RCA Applied Research, *private communication*.

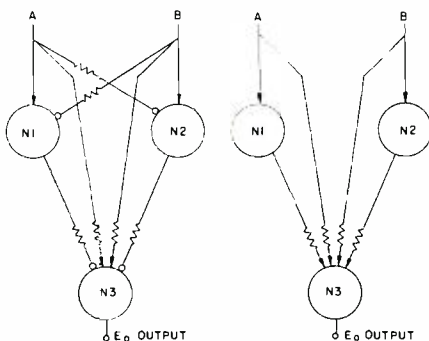

Fig. 12—a) *and* gate, and b) *or* gate.

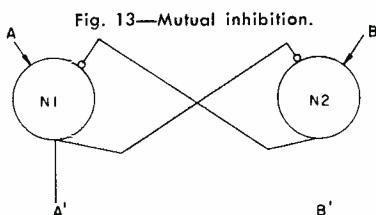

Fig. 13—Mutual inhibition.

# SPEECH RECOGNITION USING ARTIFICIAL NEURONS

Studies on machine recognition of speech in DEP Applied Research utilize neural-network logic for both vowels and complex consonant sounds. This paper describes basic speech analysis techniques, and presents results for consonants in the fricative, liquid, semivowel, and nasal class. Also described is the acoustic analyzer built with analog-threshold-logic networks of direct-current neurons developed by Applied Research (as opposed to pulse-type neurons). While results correspond closely to previous speech studies, a significant deviation was in the features utilized for recognition of individual phonemes—primarily spectral regions of increasing and decreasing energy, found relatively invariant and machine recognizable. Future goals include recognition of continuous speech through higher-level neural logic based on linguistics and context. Eventual realization of a reliable speech-recognition system would allow voice inputs to computers, voice-operated typewriters and telephone dialing, and—of high current interest—reduction of bandwidths required for voice communications.

M. B. HERSCHER and T. B. MARTIN

*Applied Research  
DEP, Camden, N. J.*

**R**EDUCTION of the bandwidth necessary for transmission of spoken information is the prime motivation for the speech recognition investigations presently being conducted by Applied Research under Air Force sponsorship.

A general-purpose speech recognition system capable of recognizing continuous speech must examine the salient features of the speech signal itself (sometimes termed *acoustic analysis*), as well as perform higher-level functions, utilizing context and linguistics. An acoustic analyzer can detect and abstract the invariant features contained in each of the speech phonemes (smallest individual speech units) and utilize these data for tentative recognition outputs. In many cases, acoustic analysis is sufficient for the recognition of isolated speech (words individually spoken and separate from each other). However, machine recognition of continuous speech can be achieved only through the inclusion of higher-level processes. For this latter case, the tentative outputs from the acoustic analyzer have to be modified by the employment of context (utilizing known probabilities of various combinations of phonemes) and language constraints.

Acoustic analysis is a necessary building block for any recognition system, but it is the area that has presented the greatest barrier toward the development of an automatic speech recognition machine. The system developed by Applied Research performs acoustic analysis primarily, although a small amount of local context utilized.

## TECHNIQUES FOR ACOUSTIC ANALYSIS

The development of acoustic analysis techniques has been guided by five basic decisions based on anticipated requirements and the known characteristics of speech. They are:

- 1) Speech recognition to be accomplished by the recognition of individual phonemes, the smallest units of speech that distinguish one utterance from another. (For example, *hid* and *did* are identical except for the initial phonemes /h/ and /d/).
- 2) Methods for identifying phonemes to consist of isolating and recognizing a particular group of features characteristic of each phoneme (feature abstraction). These features to be frequency-energy relationships that usually vary with time. Features to be fed to phonemic decision circuits that give weight to them in accordance with their importance in the identification process. This method allows for the fact that the features of each phoneme are significantly modified by the features of the phoneme immediately preceding and following.
- 3) Because of the dynamic nature of speech, recognition equipment must be designed to follow and to recognize the most rapid transients that might occur.
- 4) System to operate in real time.
- 5) Logic of the equipment to be arranged to perform all feature-abstraction processes simultaneously. In addition, particular attention to be given to establishing the logical relationships between neighboring frequency channels (neighborhood logic).

The recognition of speech by phoneme identification offers the best means to accommodate a large vocabulary. When recognized, the 40 phonemes in the English language form the basis upon which the other aspects of a bandwidth-compression system can be built.

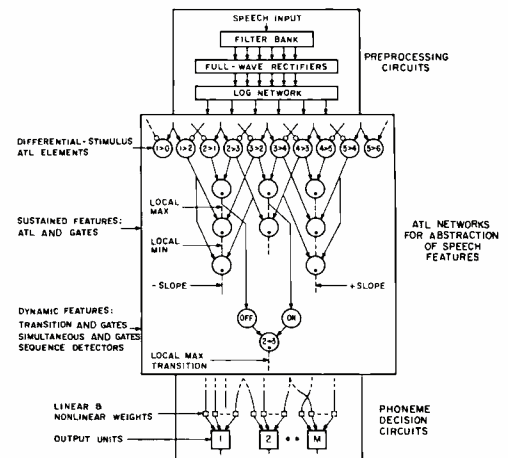

Fig. 1 — Speech analysis system.

In contrast, a speech-recognition system based upon the identification of longer speech units requires additional bandwidth for speech transmission. A communication link for transmitting speech information nominally might require a 3,000-cps bandwidth; the transmission of 40 phonemes, on the other hand, could be accomplished in less than 100 cps.

## Feature Abstraction

The concept of feature abstraction is based on the realization that a group of simple observations, judiciously chosen, can convey more information toward a decision than a single all-encompassing evaluation. In this approach, the identification of phonemes is achieved by recognizing a combination of several characteristic attributes (i.e., features) of each phoneme. Consequently, feature abstraction will not permit incidental variations of the phoneme to dilute the decision process. Thus, the decisions are made essentially independent of variations from speaker to speaker and from utterance to utterance.

When it is realized that not all of the features comprising a particular phoneme may occur with equal probability, it becomes desirable to perform logical operations that retain a measure of probability. Neural logic can maintain a quantitative measurement of probability throughout all logical operations. For example, a measurement can be made of the probability that a transition of speech energy from one frequency band to another has occurred within a given time interval. One or more such measurements make up the assurance level

M. B. HERSCHER received a BSEE in 1953 and an MSEE in 1959 from Drexel Institute of Technology. He is presently enrolled in the PhD program at the University of Pennsylvania. His experience includes work at the Frankford Arsenal on electronic fuse circuitry. He joined RCA in 1953 where he worked on transistor circuit development and a study of noise in junction transistors. He spent 21 months as an officer in the U. S. Army Signal Corps where he worked on transistor circuits as applied to frequency control. He returned to RCA in 1956 and for four years worked on applied research in new semiconductor devices. Since 1961, he has been engaged in bionics and neural information processing. He contributed significantly to a functional model of the frog retina system, and presently, is Engineering Leader responsible for applied research in bionics, neural processing, pattern recognition, and adaptive logic. Mr. Herscher has taught transistor circuit courses both at RCA and at the Signal Corps Engineering Laboratories. During the summer of 1964, he taught a graduate course in Bionics at Drexel Institute of Technology. He has authored technical papers and is a co-author of the 2nd edition of the "Handbook of Semiconductor Electronics" (McGraw-Hill, 1962). Mr. Herscher is a member of the IEEE, Franklin Institute, Tau Beta Pi and Eta Kappa Nu.

of a specific feature. Depending upon the probability that this feature will or will not occur in a particular phoneme, a weighted connection from this feature is combined with other weighted feature measurements to make up the final phonemic decision. It is important to note that not only is the presence or absence of a feature indicated in the networks, but also related is the amount to which the feature is present. Retention of this analog measure of quantity has been found essential for separation of nearly identical phonemes with overlapping characteristics.

#### Response to Rapid Transients

The need to provide a recognition system that can respond to rapid transients of speech has been determined from speech analysis, speech synthesis, physiology, and neurology. Research in speech synthesis has shown that consonants are characterized by the rapid movement of sound energy across the frequency spectrum. The duration of this energy within any one frequency channel may be as short as 10 milliseconds. For this reason, low- $Q$  resonant circuits are required so that a rapid response to the onset and termination of energy in a particular frequency band can be detected. In addition, timing accuracies of the order of 5 milliseconds between adjacent frequency channels must be maintained.

#### Parallel Logic

Subsequent logic operations must also be performed with sufficient speed to maintain the desired timing resolution. This problem is solved with parallel

T. B. MARTIN graduated magna cum laude from the University of Notre Dame in 1957 with a BSEE. He received the MSEE in 1960 on the RCA Graduate Study Program at the University of Pennsylvania and is currently pursuing studies for the PhD at the University of Pennsylvania. Since joining RCA, he has worked on applied research in temperature stabilization of DC amplifiers, composite transistor structures, Hall-Effect devices, parametric oscillators, semiconductor delay lines, and applications of the field-effect transistor. He has also contributed to a project concerned with all phases of a long-range communications system. In 1959 he began work on pattern recognition and adaptive machines, resulting in a system for speech recognition with neural networks, on which he is currently project engineer. He has developed numerous neural networks for abstraction of the invariant features of patterns, using a universal logic element that he designed which makes possible parallel processing networks that possess both analog and binary properties. He has investigated numerous adaptive devices and adaptive decision networks. He recently originated an adaptive technique for a pitch-synchronous speech analyzer and pitch extractor. He has authored several technical papers. During the summer of 1964, he taught a graduate course in Bionics at Drexel Institute of Technology. He has been awarded two patents and has several pending.

logic, performing all functions simultaneously. The movement of speech energy within the frequency spectrum is recognized as a progression of energy through adjacent filter sections. Thus, the output from one logic operation is typically determined by the output of one or more neighborhood logic operations.

#### Logarithmic Compression

Another requirement for a speech-recognition system is derived from the fact that the total dynamic range of speech energy is as much as 62 db over a 200-to-6,000-cps frequency spectrum. Therefore, a fundamental requirement for a speech-processing system is a dynamic range approaching 60 db. A common technique for reducing the dynamic range is the use of automatic gain control (AGC). However, this introduces an additional time variable that may lead to false conclusions in a study having as its prime purpose the determination of the time-varying features of speech sounds. By the use of logarithmic compression, the Applied Research speech-analyzer is capable of abstracting speech features over the entire 60-db dynamic range. An additional advantage of this technique is that the subsequent neighborhood logic operations consist of ratios so that features can be abstracted independent of overall signal amplitude. This is further explained in the next section.

#### IMPLEMENTATION OF TECHNIQUES

Applied Research employed the techniques described to construct an acoustic analyzer (Figs. 1, 2).

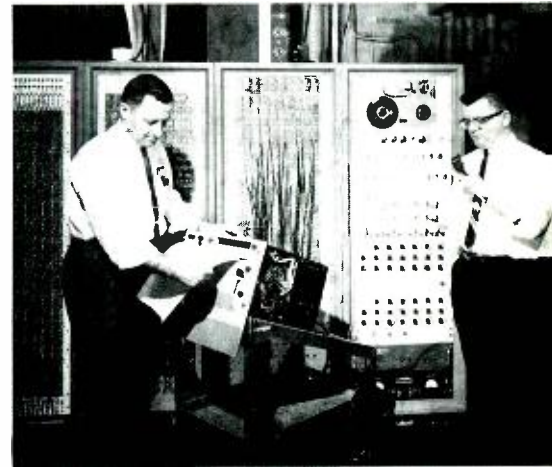

Fig. 2 — Authors M. Herscher (left) and T. B. Martin, with a portion of the speech-processing equipment, which consisted of six racks in all.

Basically, the speech spectra are divided into 19 segments by an overlapping bank of bandpass filters whose outputs are full-wave rectified and integrated. The filter bank is composed of 19 low- $Q$  (1 to 2) bandpass filters. The center frequencies of the filters vary from 260 to 7,626 cps. Fig. 3 is a plot of the actual response of two of the filters. The crossover points between adjacent filters occur around 2-db.

The rectified outputs of each filter are logarithmatized before the various features are derived. This reduces the dynamic range of energy at any one bandpass from 30 or 40 db to approximately 20 db. An additional advantage is that the differences in energy between adjacent filters become ratios and produce a degree of amplitude-independent feature abstraction. A common log-attenuator circuit was designed to avoid the difficulties which would result in matching 19 such attenuator circuits over a large dynamic range. The outputs of the full-wave rectifiers are converted by a multiplexer to a pulse train as the input to the log circuit. A second bank of synchronous switches converts the serial pulse train emerging from the log-attenuator back to individual samples, which are then integrated prior to the initial levels of parallel processing.

From Fig. 1, it may be seen that differences in energy between adjacent filters are then derived by 36 difference-taking circuits. With further processing, the envelope shape of the spectrum and its time variations can be obtained from the difference circuit outputs. Ref. 1 contains a detailed description of the

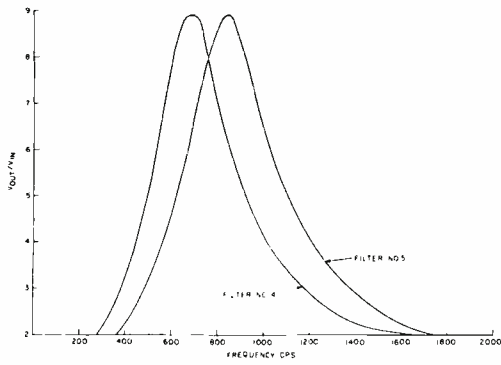

Fig. 3 — Typical filter characteristics.

networks used to abstract local energy maxima, local minima, positive and negative local slopes, and their time variations.

#### NEURON LOGIC ELEMENT

The logic networks are composed of electronic models of neurons developed by Applied Research. The neuron models (previously described<sup>1,2,3</sup>) correspond to Fig. 4. Outputs of this circuit are positive (*excitatory*) and negative (*inhibitory*) pulses of varying repetition rates. The excitatory and inhibitory inputs to a neuron are summed by a 5-millisecond time-constant integrator analogous to the biological synapse.

Since the pulse duration is 0.5 millisecond, the pulse trains are essentially converted by the integrator to a dc voltage proportional to the repetition rate. It is thus possible to consider the resultant input to a neuron to be a dc quantity, and a pulseless or dc model of the neuron can be conceived. This neuron model would, of course, be a functional equivalent and not a one-to-one biological analog.

The fact that the outputs of biological neurons appear in the form of pulses of uniform voltage has caused many investigators to emphasize the binary aspects of operation and employ Boolean algebra as a tool for a quantitative treatment of the characteristics of the individual neuron and neural networks. However, it is sufficiently evident that a neuron sees the output of its neighbors only after integration at the synapse. That is, as far as the individual neuron is concerned, no pulses exist. Its input and output are voltages which continue through varying periods of time and which are, within limits, continuously variable.<sup>1,5</sup> The transformation of the neuron's output voltage into frequency seems to be mainly an elegant method devised to avoid the difficulties of transmitting small voltages accurately through conductors of extremely high resistance.

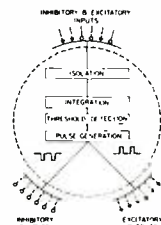

Fig. 4 — Neuron model functional diagram, pulse-type.

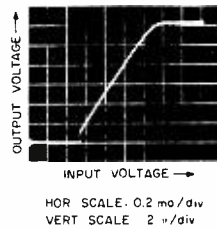

Fig. 5 — DC neuron transfer function.

(The internal longitudinal resistance of a single *A*-fiber going from the spinal cord to the foot is greater than  $10^{10}$  ohms, while for *C*-fibers it is larger than  $10^{13}$  ohms.) By transforming output voltages into frequencies, the transmission becomes independent of the characteristics of the amplifier stations along the fiber (nodes of Ranvier).

With the premise that pulses are not essential for logic operations, a dc neuron was designed for use in neural networks for the abstraction of features from speech sounds. It was found that the circuitry for a dc neuron (compared to a pulse-type neuron) could more readily meet the over-all system performance requirements. To highlight the characteristics of the dc neuron and to distinguish this element from earlier neurons, the processing technique employing dc neurons has been named *analog-threshold-logic* (ATL).

The ATL element has an output that is linearly proportional to the net sum of excitatory and inhibitory inputs, provided that this net sum is greater than an adjustable threshold. The discontinuity in the transfer function (Fig. 5) ensures reliable discrimination between quiescence and a minimum output value, thereby avoiding sequential amplification of thermal drifts in cascaded networks. This transfer function is equivalent to the pulse-type neuron if the pulse firing rate is substituted for the input and output signals. Using networks of ATL elements, both the presence and magnitude of significant features can be abstracted from the speech signals. Both relatively sustained and complex dynamic spectral variations can be abstracted.

Over 1,500 of these printed-circuit ATL elements are being utilized in various applications. The acoustic analyzer (Fig. 2), containing over 600 ATL elements, can recognize all the important phonemes. Once the feature abstraction networks have been developed for the recognition of all the phonemes, the overall size of

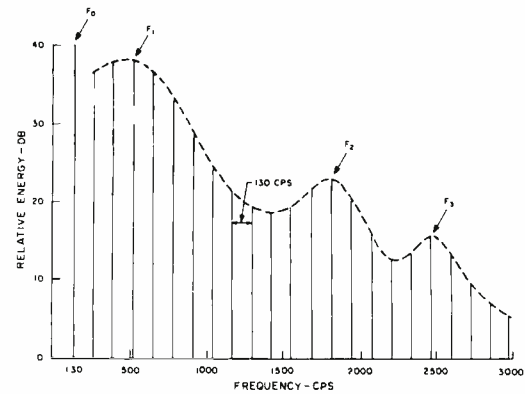

Fig. 6 — Idealized characteristics of the vowel sound in the word "bed".

the equipment can be materially reduced. In this regard, a microelectronic version of the ATL element is presently being developed by RCA Defense Microelectronics, Somerville.

#### SOUNDS INVESTIGATED AND METHODS OF ANALYSIS

Very little information is presented in the literature concerning the statistical distribution of speech parameters. Most of the early work on speech was concerned with vowel sounds, specifically the determination of the frequencies of the first and second formants (local maxima of energy). Fig. 6 shows an idealized representation of the vowel sound in the word "bed." Assuming no time variations, it is apparent that in addition to the formants ( $F_1$ ,  $F_2$ ,  $F_3$ ), the vowel is typified by local energy maxima, minima, and regions of positive and negative energy slopes ( $dE/dE$ ). In actual context, the entire structure of a vowel is modified by the preceding and following sounds.

Analysis of the spectral content of consonants requires an even greater capability to perform complex spectral analysis. Many consonants have no steady-state representation, but are instead composed of dynamic time variations throughout their duration. For these sounds it is necessary to determine the time variations of the local energy maxima, minima, and slopes.

Although experimental investigation in Applied Research is being directed toward the development of the logic required for the acoustic recognition of both vowels and complex consonant sounds using noncontinuous speech samples, only the results obtained for consonants in the fricative, liquid, semi-vowel, and nasal class will be described here. For these sounds, recognition tests have been tabulated for six male speakers. The speech samples that have been analyzed consist of recordings of isolated consonant-vowel-consonant (cvc) sounds, with the investigated consonant



in the initial position followed by each of ten vowels, and with the same final consonant /d/ for all samples.

The first step in the analysis and tabulation of the data was to play the sounds through the system and obtain oscillographic recordings of the primary features—consisting of the responses from the local maxima, minima, and positive- and negative-slope networks. The positive- and negative-slope outputs indicated at any instant of time the regions of increasing and decreasing spectral energy. Trained investigators familiar with the characteristics of speech tabulated this initial data in order to determine the distinguishing characteristics of the individual phonemes. Specific feature-abstraction networks were interconnected for each phoneme, and combinations of these specific networks were then used to develop the final recognition networks for each phoneme.

Some typical examples of features utilized for the acoustic recognition of some of the fricatives and semivowels are presented next. A more complete analysis of these phonemes is given in Ref. 3.

#### FRICATIVES

Fricative consonants are produced by the passage of air through the narrow openings in the vocal tract or over the edge of the teeth. As a result, their energy spectra usually exhibit broad noise-like frequency bands, with certain frequency regions accentuated. The fricatives may be sustained in duration, and may vary considerably in acoustic power, depending both on the fricative and the talker.

The fricatives that have been analyzed here are: /s/, /ʃ/, /ʒ/ (“sh” as in *should*), /h/, /v/, and /z/. Of these, /v/ and /z/ are voiced—that is, the vocal cords are in vibration at their fundamental frequency producing a large amount of low frequency energy—and the remaining four are classified as unvoiced.

Five major classes of features have been derived from the speech energy spectra. These classes are local maxima, useful for locating the familiar frequency formants; local minima; positive slopes, ( $dE/dF$ ); negative slopes ( $-dE/dF$ ); and channel energy intensity ( $E$ ). The most prominent features for identifying fricative consonants were found to be displayed by the positive slope, the negative slope, and the spectrum energy distribution data. Many of the unvoiced fricatives are characterized by complete absence of negative slopes, however, and the recognition decision depends entirely upon the positive slope and the spectrum energy distribution data.

#### Voiceless Fricatives

The spectra of unvoiced fricatives /s/ and /ʃ/ are characterized by broad frequency noise, with a very strong energy component in the region above 7.6 kc. This characteristic is evident for /s/ from the positive slope oscillographs of Fig. 7, and agrees closely with data reported by Hughes and Halle,<sup>6</sup> and Heinz and Stevens.<sup>7</sup> The continuity of the positive slopes and the initial onset suggests that the energy spectra begins at the uppermost frequency band and falls off sharply at the transition into the following vowel. No negative slopes were observed for these sounds. Considerable overlap in the positive slopes of /s/ and /ʃ/ due to variations in talkers were noted, and, additional energy features were required to attain satisfactory separation of these two.

In general, the /ʃ/ spectrum is characterized by high energy content above 500 cps, with a pole around 4,000 cps. This sound consistently exhibits continuous positive slopes in channels 1 through 11 for all talkers investigated, but no negative slopes have been observed. Because of the lack of poles above 4,000 cps and to the absence of a continuous positive slope pattern in the upper frequency channels, /ʃ/ was easily distinguished from /s/ with practically no confusion. The response of the /ʃ/ decision network to /h/ was the most frequent error encountered. But the duration of the /ʃ/ stimuli was much greater than that of /h/, and this cue alone was sufficient for accurate (/ʃ/ - /h/) discrimination.

The fricative /h/ was found to be very dependent on the following vowel, and no single feature with only one invariant set of acoustic parameters could be utilized in the perception of /h/. For this phoneme, an examination of the general trend of the spectral energy of several talkers proved useful. A large concentration of energy was noted in the region of the second formant for the vowels with low-frequency first formants, and concentrations of energy were observed in the region of  $F1$  and  $F2$  in the vowels with low  $F1$  and high  $F2$ ; e.g., /æ/ and /e/. Consequently, /h/ was subclassified into four separate categories determined by grouping the most similar patterns in Fig 8. Feature-abstraction networks were developed for each of the four classes, and these in turn excited a single decision circuit, which responded to a stimulus from any of the four networks.

#### Voiced Fricatives

Spectra of voiced fricatives /z/ and /v/ contain a strong energy component below 500 cps or, more precisely, at  $F1$ . This factor has been utilized as the

primary cue for distinguishing between the voiced and unvoiced fricatives, and has been employed successfully for six talkers with nearly 100% accuracy. In the region above 1,000 cps, the spectra of voiced fricatives do not differ markedly from the spectra of many voiceless fricatives, as was also reported by Hughes and Halle.<sup>5</sup>

To separate /z/ from /v/, the positive slope data and energy data were found to contain the most useful features. Since /z/ contains more energy in the frequency bands above 1,500 cps than /v/, this characteristic was utilized as the primary cue in distinguishing between /z/ and /v/ in the instances where the positive slopes of /v/ resembled those of /z/. An additional feature depended upon the successful recognition of /z/, which was performed solely through utilizing the positive slope features of /z/, and inhibiting the /v/ decision with this response.

#### LIQUIDS, SEMIVOWELS, AND NASALS

The liquids, semivowels, and nasals were considered as a group because of their similarity. Phonemes included in this group are /w/, /l/, /m/, /n/, /r/, and /j/ (“y” as in “you”). These sounds are voiced and are typified primarily by transitions, vowel-like formant structure, and lower energy than vowels. The frequency of the first formant for these consonants is lower than the first formant of eight of the ten following vowels used in this study. Only /i, u/ (corresponding to the vowels in “weed” and “wood”) have similar low-frequency first formants. The first formant for these consonants falls in filter 1 ( $f_c = 0.26$  kc) of the analyzer so that the first four to six channels are typically regions of decreasing energy (negative slopes).

Fig. 7—Positive slope variations due to talker for /s/.

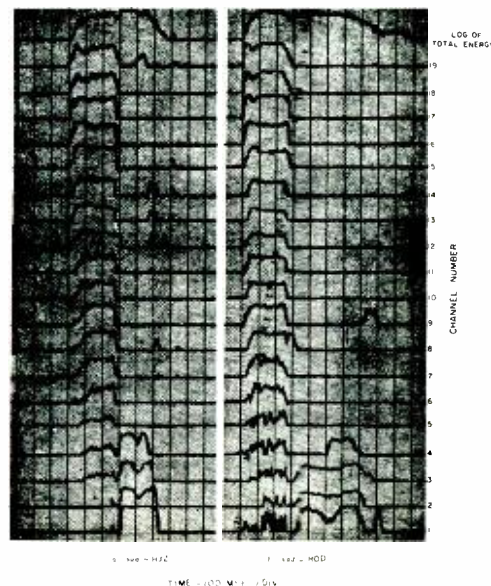

The transitional characteristics of these four phonemes as reported by O'Connor et al.<sup>8</sup> can be summarized by referring to Fig. 9. This figure shows the four phonemes in combination with the vowel /ε/ (as in the word "bed"). Each sound possesses an initial short, steady-state vowel-like formant structure, or *locus*. The transitions from this initial steady state are continuous from the locus to the following vowel formant positions.

Many varied characteristics have been presented in literature about both nasalization and nasal sounds.<sup>9-12</sup> This is a feature which tends to vary widely with speaker. Nasal sounds /m, n/ possess a voicing bar which produces a maximum of energy around 250 cps. The most consistent feature that has been reported for the nasals is the dominating intensity of the voicing bar with respect to all other formants. These low-intensity formants are also characterized by broad, highly damped resonances. In addition to being very similar to one another, /m, n/ can also be quite similar to /l/. The higher frequency for *F1* of /l/ helps to discriminate between this sound and the nasals. Several investigators<sup>9,10</sup> have mentioned that transitions from the nasal to the following vowel are the most important clues for separating /m/ from /n/. Nasal consonants have been synthesized with both continuous and discontinuous transitions from the locus of the nasal sounds to the formants of the following vowel.

The least difficult sound to separate from the other five was phoneme /j/.

Fig. 8 — Spectral energy distribution for /h/.

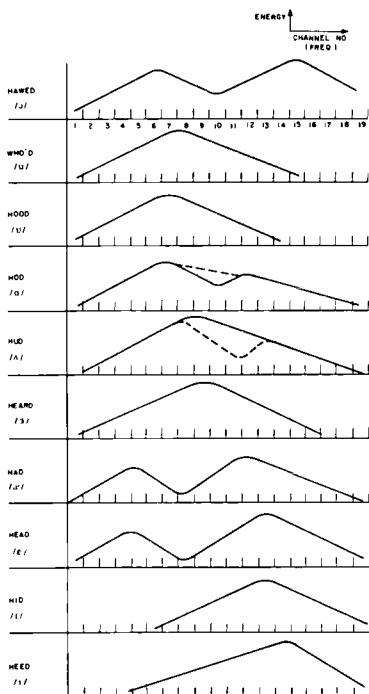

Fig. 10 shows a spectrograph of the sound *yed*, and the output of the positive and negative slope networks in response to this sound. This spectrograph shows a good correlation with the formant transitions of synthesized (machine-generated), speech (Fig. 9). The initial locus, or hub position, of the maximum for /j/ occurs about Channel 15 or Channel 16. The transition of this maximum from the locus position down to the second formant of the following vowel can extend from about two channels for the vowel /i/ to as high as ten channels for the vowel /u/. Networks interconnected to abstract the transitions of maxima would have to detect a wide range of transitions. On the other hand, a single positive slope transition was found to be sufficient to recognize phoneme /j/ for all ten following vowels. The oscillographs of the positive slopes consistently show a transition of onsets beginning at Channel 14 and concluding with Channel 6. The duration of this onset transition is about 150 milliseconds. This particular feature was found to be the most distinguishing characteristic of phoneme /j/. The most significant aspect of this feature is that this transition is essentially independent of the following vowel.

Phoneme /w/ is distinguished by its locus being located at the lowest frequency of the six phonemes in this class. Since the initial starting locus is located generally in the first channel, it can be expected that the transition for this phoneme would utilize negative slopes. The initial location of the formant is such that the only initial feature is one of decreasing energy from Channel 1 up to the higher-frequency channels. It was found that the only feature necessary to recognize /w/ was the transition of the onsets of the negative slopes from Channel 1 (260 cps) through Channel 10 (1,892 cps).

The phoneme that is most likely to be confused with /w/ is phoneme /r/. It was again found that a single feature, a transition of the onsets of the negative energy slopes, was sufficient for the recognition of /r/. The primary distinction between /r/ and /w/ is the absence of negative slopes in the vicinity of 1,000 cps.

Two features were found to be useful for separating /l/ from the nasal consonants. The first feature is the higher frequency of the locus of *F1* for /l/, as previously mentioned. A second useful feature is the lack of transition of the third formant for /l/. The locus of *F3* for the nasal consonants is below the third formant of the following vowel. Correspondingly, the initial regions of negative slope for the third formant

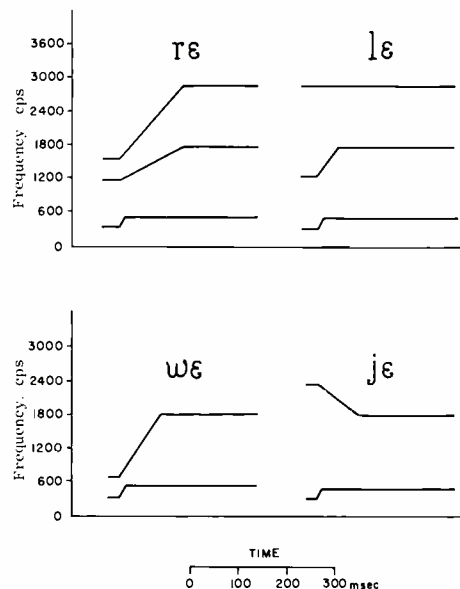

Fig. 9 — Characteristics of synthesized /w, r, l, j/ with the vowel /ε/. (Data based on Ref. 8, O'Connor.)

occur at lower frequencies for the nasals than for /l/.

It is well known that the nasal consonants have similar characteristics. As mentioned previously, two types of features have been reported in the literature that are useful for discrimination between the sounds. One of these features corresponds to a transition of the onsets of positive slopes from 1,600 cps down to 1,200 cps for /n/. This feature does not occur for /m/ because the frequency of the *F2* locus for /n/ is higher than that for /m/. The second useful feature is related to the location of the first antiformant of the nasal consonants. For /m/, it was noted that the antiformant occurs quite close to *F2*, whereas for /n/ the antiformant is much closer to *F3*. Correspondingly, the negative slopes for /n/ extend over a much greater region than those for /m/.

#### RECOGNITION SCORES

The features summarized in the preceding discussions were abstracted with analog-threshold-logic recognition networks. The experimental results obtained with these networks are presented in the form of confusion matrices in Table I for the fricatives and in Table II for the vowel-like consonants. These results were obtained with two repetitions of the word lists for six male speakers for the fricatives and one repetition for the vowel-like consonants.

Since parallel processing has been used throughout, an individual recognition unit must be characterized both by its response to the phoneme to be recognized and by its rejection of all other phonemes. For example, if it is desired to recognize phoneme X, errors can be

**TABLE I—Confusion Matrix for Fricative Consonants**

	/f/	/s/	/ʃ/	/h/	/z/	/v/
/f/	115	11				
/s/	11	116				
/ʃ/		1	112	2		
/h/			10	119		
/z/					117	1
/v/					9	103

**Notes:**

- 1) Vocabulary: 60 cvc words, 10 vowels with each fricative.
- 2) Six Talkers, 2 repetitions of the 60 words.
- 3) Total number of words, 720.

produced in two ways: lack of response to phoneme X and false responses to all other phonemes. Because of this, the recognition scores have been computed considering both the response and the rejection capabilities of the recognition units. The response accuracy is:

$$\% \text{ response accuracy} = \frac{\text{No. of responses to phoneme X}}{\text{No. of X's presented}} \cdot 100.$$

Accordingly, the rejection scores are:

$$\% \text{ rejection score} = \frac{\text{No. of responses to all other phonemes}}{\text{No. of all other phonemes presented}} \cdot 100.$$

These scores are presented in Table III for each of the phonemes tested. The recognition scores were obtained by separately testing the two groups of sounds in combination with 10 following vowels for six male speakers. No attempt was made to compute the rejection scores of one class with respect to the other two classes of sounds. The main effort was spent in separating accurately the very similar sounds within a given class, rather than the significantly easier task of separating quite dissimilar classes of sounds from one another.

**CONCLUSIONS**

A significant deviation between the present work and past investigations has been the type of features utilized for the recognition of the individual phonemes. In previous investigations, the location in the spectrum of the formants and their movements with time have been considered to be the primary features of speech. The results of the present work, however, indicate that

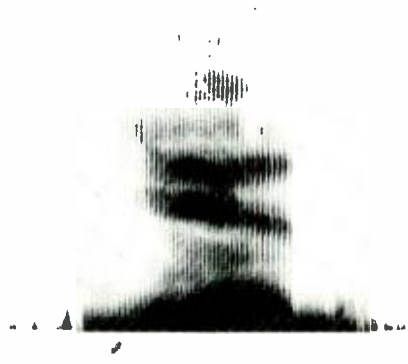

Fig. 10 — Characteristics of "yed" by WFM.

**TABLE II—Confusion Matrix for Vowel-Like Consonants**

	/w/	/r/	/j/	/l/	/m/	/n/
/w/	59	9				
/r/	2	56				
/j/			59			
/l/	5	4	54	10	2	
/m/	1	2		49	14	
/n/			1	3	11	53

**Notes:**

- 1) Vocabulary: 60 cvc words, 10 vowels with each consonant.
- 2) Six Talkers, 1 repetition of the 60 words.
- 3) Total number of words, 360.

the spectral regions of increasing and decreasing energy (positive and negative slopes) are also highly significant clues for recognition. A striking example of the invariance of the slope features is the fact that a single onset transition of slope features was sufficient for the recognition of a semivowel in combination with ten following vowels for all six male speakers used in the investigation. The formants, on the other hand, undergo wide ranges of movement within the spectrum for the ten following vowels. The invariance of slope features and the ease with which they could be implemented for machine recognition are two of the most significant findings of the present work.

The best recognition scores were obtained for the fricatives, reflecting the fact that since this was the first group studied, the longest period of time was spent on these sounds. Present data indicate that the vowel-like consonants, the plosives, and the vowels can be recognized with the level of success obtained for the fricatives.

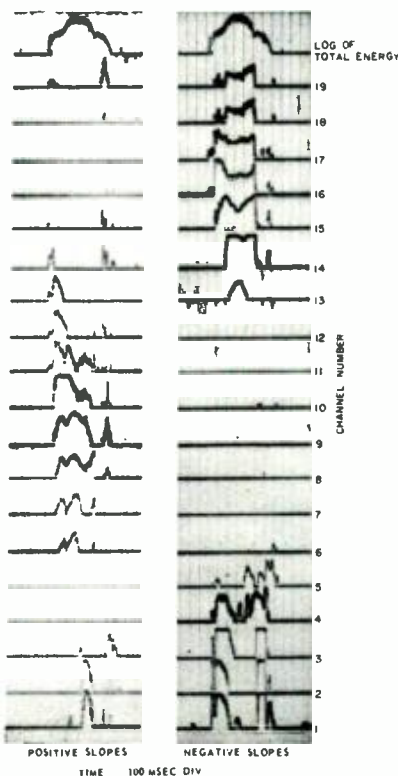

**TABLE III—Summary of Response Accuracy and Rejection Score**

Phoneme	% Response Accuracy	% Rejection Score
/f/	96.0	1.83
/h/	99.2	1.67
/s/	96.7	1.83
/ʃ/	93.5	0.50
/v/	86.0	1.50
/z/	97.5	0.17
/j/	98.4	1.67
/w/	98.4	2.66
/r/	93.3	3.66
/l/	90.0	4.00
/n/	88.3	6.67
/m/	81.7	9.33

The next goal is to apply these techniques to the recognition of continuous speech through the inclusion of such higher-level functions as linguistics and context.

**ACKNOWLEDGEMENTS**

This work was supported by the Air Force Avionics Laboratory, Research and Technology Division, Air Force Systems Command. The authors are grateful to A. L. Nelson and H. J. Zadell of RCA Applied Research for their contributions to this program.

**BIBLIOGRAPHY**

1. M. B. Herscher, T. B. Martin, E. P. McGrogan and F. L. Putzrath (RCA App. Res.), "Neurons and Neural Networks," *RCA ENGINEER*, 8-1, June-July, 1962.
2. T. B. Martin, F. L. Putzrath, J. J. Talavage (RCA App. Res.), *Speech-Pattern Recognition by Simulated Neural Networks*, ASD-TDR-62-511, Part I, July 1, 1962, and Part II, December 1, 1962, (AD-277200).
3. T. B. Martin, A. L. Nelson, H. J. Zadell (RCA App. Res.), *Speech Recognition by Feature-Abstraction Techniques*, AL-TDR-64-176, August, 1964, (AD-604526).
4. G. C. Eccles, *The Neurophysiological Basis of Mind*, Oxford Clarendon Press, 1953, p. 191.
5. G. B. Preston, and D. Kennedy, "Integrative Mechanism in the Caudal Ganglion of the Crayfish," *Journal of General Physiology*, Vol. 43, 1959, p. 691.
6. G. W. Hughes, and M. Halle, "Spectral Properties of Fricative Consonants," *J. Acoust. Soc. Amer.*, Vol. 28, No. 2, March, 1956, pp. 303-310.
7. J. M. Heinz, and K. N. Stevens, "On the Properties of Voiceless Fricative Consonants," *J. Acoust. Soc. Amer.*, Vol. 33, No. 5, May 1961, pp. 589-596.
8. J. D. O'Connor, L. J. Gerstman, A. M. Liberman, P. C. Delattre, and F. S. Cooper, "Acoustic Cues for the Perception of Initial /w, j, r, l/ in English," *Word*, Vol. 13, pp. 24-43, 1957.
9. A. Malecot, "Acoustic Cues for Nasal Consonants," *Language*, Vol. 32, pp. 274-284, 1956.
10. A. M. Liberman, et al., "The Role of Consonant-Vowel Transitions in the Perception of the Unvoiced Stop Consonants," *Psychological Monographs: General and Applied*, Vol. 68, No. 8, 1954.
11. K. Nakata, "Synthesis and Perception of Nasal Consonants," *J. Acoust. Soc. Amer.*, Vol. 31, No. 6, pp. 661-666, 1959.
12. O. Fugimura, "Analysis of Nasal Consonants," *J. Acoust. Soc. Amer.*, Vol. 34, No. 12, pp. 1865-1875, 1962.

# The David Sarnoff



## The 1965 Individual Awards for Science and Engineering



H. G. Greig

**HAROLD G. GREIG**, Fellow of the Technical Staff, RCA Laboratories, Princeton, N.J., recipient of the 1965 David Sarnoff Outstanding Achievement Award in Science "for original and significant contributions to the development of the Electrofax process of electrophotography."

**MR. GREIG**, winner of the individual science award, has gained considerable recognition for his technical contributions to the electrophotographic and graphic arts fields. He has been on the staff of RCA Laboratories since 1943. Much of his early work was concerned with the chemistry of high-speed electrolytic facsimile recording. Since 1950, he has been primarily engaged in research on the chemical problems of electrophotography and, in particular, the Electrofax process, a special form of electronic printing which employs a photoconductor-coated paper as part of its electrostatic copying process. Mr. Greig has made original and significant contributions to almost all the major areas of the Electrofax system. He has developed high-sensitivity dye-sensitized photocopy paper and coating materials, processing methods, and materials and methods for image development for both black and white and color pictures. More recently, he has made important contributions in organic photoconductive materials and image recording methods for electronically produced printing plates, a development which may have a significant impact on future graphic communications.



Dr. G. D. Cody



D. R. Carley

**DONALD R. CARLEY**, Industrial Transistor Design Activity, RCA Electronic Components and Devices, Somerville, N.J., recipient of the 1965 David Sarnoff Outstanding Achievement Award in Engineering "for the extension of the frequency and power of solid-state devices by the invention and development of the RCA Overlay Transistor."

**MR. CARLEY**, recipient of the individual engineering award, has been responsible for a series of devices which have exploited the capabilities of high-power semiconductors. Since joining RCA in 1957, he has been engaged almost exclusively in the design and development of silicon power transistors. In 1963, he developed a concept for interconnecting isolated emitter sites by metallized and diffused regions to produce the Overlay Transistor, a device with a very significant increase in the frequency at which many watts of power can be obtained from a transistor power amplifier. This overlay transistor is unique in combining a major reduction in device cost with an improvement in device performance. Mr. Carley was directly responsible for developing the necessary new technology, including new photoresist and photomasking techniques, to make the overlay transistor possible, for directing the pilot production of this new transistor, and for bringing it to full scale manufacture. More than any other individual, he has been responsible for achieving a clear-cut position of technical leadership for RCA in the field of high-power, high-frequency transistors for industrial and military use.



A. J. Gravel, Sr.

### ... About the Awards

RCA's highest technical honors, the four annual David Sarnoff Outstanding Achievement Awards, have been announced for 1965 by Dr. George H. Brown, Vice President, Research and Engineering, David Sarnoff, RCA Board Chairman, and Dr. Elmer W. Engstrom, RCA President, will present the awards, which consist of a gold medal, a bronze replica citation, and a cash prize for each.

The Awards for individual accomplishment in science and in engineering were established in 1956 to commemorate the fiftieth anniversary in radio, television, and electronics of David Sarnoff, RCA Board Chairman. The two awards for team performance were initiated in 1961. All engineering activities of RCA divisions and subsidiary companies are eligible for the Engineering Awards; the Chief Engineers in each location present nominations annually. Members of both the RCA engineering and research staffs are eligible for the Science Awards. Final selections are made by a committee of RCA executives, of which the Vice President, Research and Engineering, serves as Chairman.

# Outstanding Achievement Awards



Dr. G. W. Cullen



Dr. J. J. Hanak

**DR. GEORGE D. CODY, DR. GLENN W. CULLEN, and DR. JOSEPH J. HANAK**, Materials Research Laboratory, RCA Laboratories, Princeton, N.J., recipients of the 1965 David Sarnoff Outstanding Team Award in Science *"for team performance in research leading to development of a novel technique for synthesizing superconductive niobium stannide for application in high-field superconducting magnets;"* and

**DRS. CODY, CULLEN, and HANAK**, winners of the team award in science, have made vital individual and collective contributions to the development of a novel technique for preparation of the compound superconductor niobium stannide and its application to high-field superconducting magnets. Their joint research over four years has placed RCA in a position of leadership in a new technology. Early studies of Dr. Cody on the physical properties of niobium stannide and the need for a better method of preparation led in 1960 to Dr. Hanak's development of a unique vapor-deposition process. Subsequently, Drs. Hanak and Cullen utilized the new technique to synthesize niobium stannide on both metallic and ceramic substrates in a variety of configurations, making it possible for the first time to carry out experiments on its basic properties. In all of these studies, Dr. Cody played a vital role not only through his direct experimental work but also in guiding the work of other scientists in the RCA research program on superconductivity. Drs. Cullen and Hanak, on the other hand, supplied all of the materials specimens necessary for this basic research. A most important feature of Dr. Hanak's vapor transport technique was its adaptability to continuous deposition on metal wire or ribbon. This advance, suggested by Dr. Cody, led to the production of flexible niobium stannide ribbon and the subsequent construction early in 1964 of a 107,000 gauss solenoid magnet with a one-inch bore operating at 4.2°K, one of the most powerful such magnets ever constructed.

## Team Awards for *Science and Engineering*

**MESSRS. ARTHUR J. GRAVEL, SR., JAMES J. HAWLEY, and ROBERT F. SCHMICKER**, Astro-Electronics Division, RCA Defense Electronic Products, Hightstown, N.J., recipients of the 1965 David Sarnoff Outstanding Team Award in Engineering *"for team performance in the successful design and development of the television cameras, associated circuitry, and mechanical elements of a system for high-resolution photography of the lunar surface from an impacting vehicle."*

**MESSRS. GRAVEL, HAWLEY, and SCHMICKER**, winners of the team award in engineering, are members of an engineering group at RCA's Space Center who were responsible for the design, development, and testing of the television camera system for Ranger 8, which accomplished its highly successful lunar photographic mission on February 20, 1965. The Ranger 8 television subsystem, consisting of six television cameras, was designed to take high-resolution pictures of the lunar surface for the last ten minutes prior to impact. One of the problems which Messrs. Gravel and Hawley successfully solved was that of developing cameras capable of reliable performance over the wide temperature range of the space environment and versatile enough to achieve both initial coverage of wide areas and increasing surface resolution as the Ranger shot neared the moon. One of their most noteworthy achievements was development of a high scanning rate and a rapid-erase technique for the picture-taking sequence so that the final picture of the sequence could be taken at minimum altitude. Mr. Schmicker was primarily concerned with mechanical elements of the system, including mounting of camera tube and lens in a light-weight housing. He was responsible for developing an electromagnetically operated shutter with 1-5 millisecond exposures and capable of over 1,000,000 operations without failure. Another important contribution of Mr. Schmicker was development of camera equipment resistant to mechanical vibration and shock.



J. J. Hawley



R. F. Schmicker

# LIFE BEYOND THE ATMOSPHERE

## Origins, Detection, and Support

This paper discusses the existence and detection of life forms in the universe (with emphasis on our planetary system), and the support of life in manned space travel. It is shown that while we have several good ideas as to the origin of life, much sophisticated research awaits before we arrive even at a good set of hypotheses of how life occurred. Likewise, while we can detect many forms of life chemically, much more sophisticated sensors are needed for space missions to help decide whether a certain observed phenomenon may constitute "life." Finally, although we have demonstrated short-term life-support outside the atmosphere, the present crude automatic control of a few gases and fluids will have to be refined greatly before we can, for example, establish a colony on the Moon. The advanced electronics for each of these pursuits offers engineers one of the greatest practical challenges of an already challenging technology.

**DR. A. G. HOLMES-SIEDLE**

*Physical Research Groups*

*Astro-Electronics Division, DEP, Princeton, N. J.*

THE usual artist's impression of the solar system shows a bright, colorful, crowded panorama of planets revolving about the Sun, against a backdrop filled with comets and star-clusters; but, by no fault of his own, the artist is giving a false impression. For the most part, the solar system is a very empty place, and very inhospitable to humans.

Artists' pictures, of necessity, show the solar system as more crowded than it really is. This is for the simple reason that, if the artist were true to his scale, and then drew the solar system on a 6-inch sheet, the Sun (to scale) would be a dot smaller than a period, and the Earth would be completely invisible as a dot one millionth of an inch across. To visualize these relations at a more familiar level, let us imagine the Sun as a very large balloon on the White House porch: then the Earth would be a softball on the Capitol terrace. The planet Venus would be another softball half-way down Pennsylvania Avenue and Mercury would be a pinhead on the pavement outside the White House. Pluto, the furthest planet, would be a pinhead way out past Baltimore, while the rest of the planets would turn inside Pluto and outside Earth. No other star or sizable body would exist in the rest of the Americas.

Our discussion here is on two questions which arise out of the emptiness and inhospitality of the universe. First: *How long can we support our own lives effectively outside the atmosphere?* Second: *Is any other planetary body anywhere as effective as Earth in providing a "greenhouse" for life?* Thus, it is useful first to recognize the universe for

what it is—a dark, barren place on a scale which dwarfs humanity, very sparsely dotted with matter, some of it incandescing with nuclear reactions at several million degrees (in stars)—mostly a void occupied by a very thin "dust." These fragments of matter are commonly no larger than a grain of sand and frequently no larger than the atom and may be moving at several miles per second. Thus, the islands where life could possibly support itself are very few and are widely scattered.

### HABITABILITY

If we wish to gauge which of these larger bodies might be habitable, we must remember how radiation from light and heat decrease with distance. Pluto would see the Sun as a distant star with no warming effect; air on this planet would be cold enough to liquefy. In fact, the only planets above freezing point would be those which, on our "Washington scale," lie in the downtown area, while those planets much nearer than the Capitol would probably be hotter than the boiling point of water.

Only planets large enough to retain, by gravity, their thin skin of gas (0.005 inch thick on our "softball" Earth), would be protected from the powerful particle radiation which needs considerable metal shielding to stop it. Thus, even in the "comfortable" zone, many sterile pieces of rock must exist, of which the Moon is probably one.

The above perspective, may lead us to be surprised that we are here at all; but it may also help us to decide where to look for signs of life. For example, we would clearly not spend much of our search effort on Pluto or on Mercury.

We would, for the above and several other reasons, concentrate on Venus and Mars, our neighbors in the "comfortable" downtown area. The perspective may also give engineers and physicists some feel for the problems they face in detecting and supporting life forms in this barren environment.

### LIFE SUPPORT

When we take a man outside the atmosphere, we must reproduce as many of its functions as we can. We find that, quite apart from giving us air to breathe, the atmosphere serves us in many ways:

- 1) It provides a cooling or a warming system, whichever is needed, to even out extremes of temperature; in other words, it is a transport and damping system for heat, cold, and moisture.
- 2) It absorbs the harmful ultraviolet light from the Sun and the fast atomic particles from space, only letting through a little of each.
- 3) It acts as a "meteor bumper", burning up the showers of dust and larger stones which cross our path at thousands of miles per hour.
- 4) It acts as a diffuser, softening the Sun's light by scattering it; hence, we see a blue and not a black sky and have "twilight" after sunset.
- 5) The even distribution of moisture allows the formation of a firm soil which produces plants which, in turn, produce oxygen and food to keep animals alive; the soil also acts as a disposal system for the husks, bones, hair or horns of dead animals or of the wastes which our bodies reject from food.

Any manned spacecraft, or Moon base, is mainly a device which reproduces these functions, possibly ignoring the diffusion of light as unnecessary, and, up to now, replacing the oxygen-producing function by tanks of oxygen, while wastes are, at present, stored. However, for a very long flight, or a long-stay base on the Moon, it will be very uneconomical to import all oxygen, while the waste problem could become serious. Thus, we would do well to consider creating, in our Moon base, a microcosm of the oxygen-food cycle which occurs on Earth. Some of the principles for doing this are discussed below.

### The Oxygen-Food Cycle

The maintenance of our atmosphere on Earth is done solely by means of the Sun's energy. At the same time as the Sun's energy liberates oxygen from plants, it causes the plant cells to build sugars and other food substances from carbon dioxide. We ingest these foods, extract the chemical energy as "work," and our bodies release chemicals of the type which first went into the plant. If these are "ploughed back" into the soil, the process can start all over again. It would be ideal if we could instate a cyclic process like this in a Moon base.

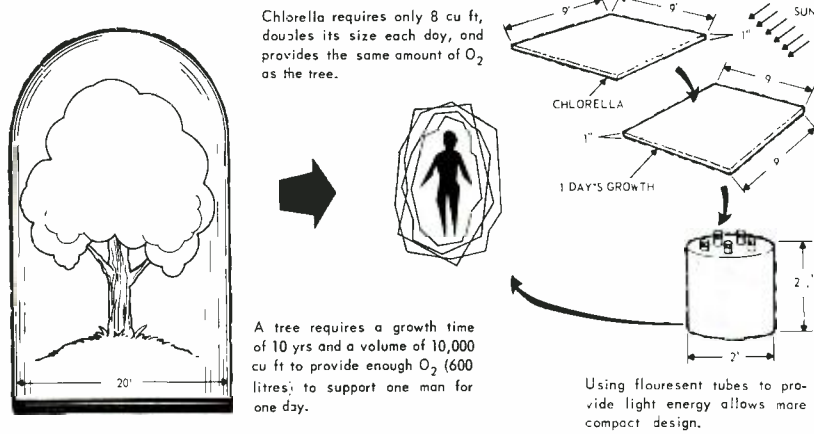

Fig. 1—A rapidly growing chlorella culture can serve a man's daily O<sub>2</sub> needs and is a thousand times smaller than a tree having a growth time of ten years.

We would not have to import new atmospheric chemicals, just keep the cyclic, or "regenerative," process under control, using the Sun as driving force. The automatic control of such a process could fascinate generations of electronic engineers.

As a basis for this cyclic process, therefore, our Moon base must contain plant life; however, we cannot use all the immense variety of plants that do the work on Earth, so we must choose one or two hardy and adaptable ones to do the whole job. The problem is—which to choose? We might choose the tree on the basis that it is a hardy, powerful plant. It is, but it is not adaptable. Fig. 1 shows the volume of tree needed to keep one man supplied with oxygen; also, trees develop very slowly. For each man, a tree would have to be planted about ten years before he came to the Moon. And what to do with all the spare timber? It could not be used for construction; if it caught fire, it would suffocate the whole Moon base. This all shows how the Earth system has the advantage of good waste disposal, a long, stable cycle, and a reservoir estimated at 10<sup>11</sup> tons of oxygen (about 200 years' supply).

#### Chlorella Plants as Food

It can soon be seen that, to give flexibility to our Moon base, we want to choose a plant which packs closely, produces little inedible waste, tastes good, and is adaptable to "flow" production rather than "batch" handling. The best organism so far found is the minute, simple seaweed or "green slime" species, the algae. These are what we see in a fish-bowl which has stood for some time. In the bowl, they are doing what we want them to do on the Moon: they are growing rapidly, using the body wastes and carbon dioxide of the fish plus daylight to produce oxygen and more of themselves. The Chance-Vought Company has actually kept two mice,

"Mousetronauts" as they called them, alive for over two months on oxygen photosynthesized from chlorella, one of the hardier, free-floating algae. Other companies claim to have kept a man alive for several days with a similar system. Fig. 1 shows, conceptually, how the volume of chlorella culture needed to serve one man is about a thousand times smaller than that occupied by a tree. Furthermore, using stored sunlight (e.g., electricity, to light fluorescent tubes) as the energy source, a one-man supply of this plant can possibly be packaged in a container the size of a waste basket.

The chlorella plants double their weight every day, contain most of the necessary vitamins and proteins, and are entirely edible. Here is the "crop" of food that we need; unfortunately, it is not very palatable. After all, who would want to live exclusively on green slime? Dr. Alain Bombard tried to cross the Atlantic living only on the surface plankton, a mixture of similar types of organisms. He soon found he would rather starve. Hungry mice, given dried chlorella, sweep it aside and use it as bedding. It can, however, be used to fortify other foods, and "chlorella cookies" containing up to 20% chlorella are edible. On the whole, though, it would be better if we could find, as on Earth, an animal or a fish which would thrive on these useful little plants and then provide us with better fare.

This approach, however, brings more problems. Most animals have a fair proportion of bone, gut, hide, or hair which we just cannot eat—one third in the case of cattle—and we at once have a real rubbish problem. We must seek an animal which is all edible. The slug is one of the few nearly so and it is eaten in parts of the world, as slug jam; but perhaps we might prefer to forgo this treat and use a compromise like shrimp, the edible insects, or, perhaps, just mushrooms. I am sure there are still

many bright suggestions in this plant-animal combination game which have not yet come to light and the author is tempted to propose a prize for the best combination suggested. The Boeing Company suggested the Tilapia fish, a South American species which enjoys algae, is hardy, tasty, and breeds fast.

In a Moon base, we may find it an advantage not to rely on the Sun for photosynthetic regeneration. Nuclear power could supply artificial light for underground photosynthetic cells, solving the problem of supporting these cells for the two-week Lunar night.

#### Protection Against Particle Radiation and Meteoric Damage

The next most important function of the Earth's atmosphere is to act as a shield for space particle radiation. The Sun and other stars emit streams of charged atomic nuclei, some of which will penetrate inches of lead. All high-energy particle radiation can cause damage to living cells, either causing death of the cell or causing a break or change in the chromosomes so that daughters of that

DR. A. G. HOLMES-SIEDLE received a BA from Trinity College, Dublin, in 1954, and a PhD in Organic Chemistry from Cambridge University, England in 1958. He conducted postdoctoral chemical research at the Cambridge University Chemical Laboratories from 1958 to 1960 studying the transfer of energy in biological and chemical systems. In 1960 he joined the Advanced Projects Group of Hawker-Siddeley Aviation as a project engineer cooperating in preliminary design studies of communication satellite systems and lunar vehicles; in these system studies he specialized in the effects of environment on components and humans, simulation of space environment, and telemetering of scientific data. In 1962, he joined the Physical Research Group of the Astro-Electronics Division where he is doing research on radiation damage and scientific instrumentation of satellites. Such work includes experimental research on radiation effects in materials, analysis of the space radiation environment and its effect on space systems, irradiations of satellite components and systems designed for NASA satellite projects, definition of radiation effects criteria for RCA spacecraft, and engineering studies and research on space radiation detectors. Dr. Holmes-Siedle has been assigned as coordinator of radiation experiments and representative for this information at the Astro-Electronics Division. He is a Fellow of the British Interplanetary Society and a Member of the IEEE and IEEE Group on Nuclear Science. He has published several research notes in chemistry, technical articles on space technology, and a book on the haem enzymes.



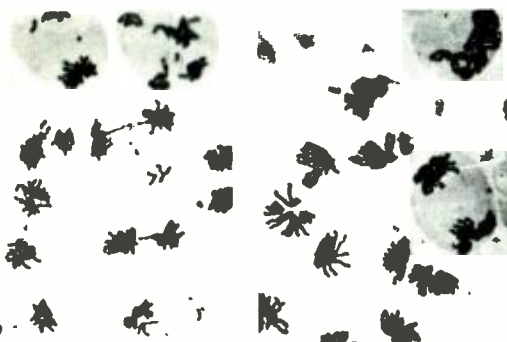
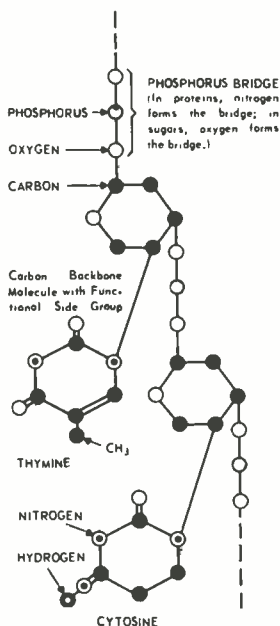

Fig. 2—One of the effects of radiation on living tissue. The dark bundles are chromosomes—cell units which control the rate and direction of tissue growth. In healthy cells (left-hand photograph) the bundles pull apart into two lots just before the cells divide, one lot going to each "daughter" cell. In cells which have been given a dose of X-rays (right-hand photograph) the bundles do not divide cleanly and the cells may die or produce abnormal "daughters."

cell are somehow different, or "mutated." Fig. 2 shows how a dose of radiation has disorganized the right-hand group of cells. They are not dividing cleanly like the unirradiated cells on the left and may either die or reproduce irregularly. The results of several intense efforts in predicting solar flares, and the "storm" of particles which reaches the Earth shortly after, have given us some hope that inhabitants of a Moon base will have enough warning to get underground, or behind thick shields, before the "storm" arrives.

Protection against meteoroid damage is one of the most difficult atmospheric functions to simulate. It is possible to build structural shielding to ward off the heavy rain of sand-size particles but, apart from building entirely under-

Fig. 3—Organic carbon chains linked by oxygen and phosphorus bridges. The example here is a section of the genetic polymer DNA, a nucleic acid.



ground, there is little one can reasonably do to stop the very occasional brick- or boulder-sized meteoroid, which may arrive at a speed greater than 30,000 feet per second, from penetrating surface shelter. We have to rely on their relative rarity and the laws of chance.

#### Psychological Factors

By no means the least important factor which may limit our activities in space is the psychological factor. We probably do not realize how much we rely on familiar sounds, light, textures, and companionship to keep us on an even keel. We must not underestimate what loneliness, harsh light, odd food, and danger may do even to the most determined man. It may be this factor which will limit extensive space travel to a few trained astronauts rather than a commuting throng.

#### ORIGINS OF LIFE

In the previous description, life appears to require a protective atmosphere; we will now consider how, if this atmosphere is provided on a planetary body, living forms could arise from the raw materials of its surface and in what forms they might arise.

#### Basic Life Requirements

It is not easy to define life, but it is generally agreed that at least three things are indispensable: 1) a liquid solvent, like water or ammonia, 2) a system of polymers to provide structure, and 3) polymers having the ability to reproduce themselves out of raw materials. It seems fairly certain that the polymers making up the living system must be carbon-based, since carbon appears to be by far the most efficient in producing extended "backbones" where organic carbon chains of two to six units are linked to one another by oxygen, phosphorus, or nitrogen bridges, such as are shown in Fig. 3. The "backbone" commonly has other chemical groupings as useful appendages, adapted to doing the necessary chemical work for the polymer (hence they are called "functional groups"). The main classes of polymer used in Earth-based life are the proteins (such as muscle, fiber, bone, or albumen) and polymeric sugars (such as cellulose, starch, or DNA, the last being the basic heredity carrier).

#### Polymers and Temperature Effects

In order to construct a system of polymers which reproduce themselves, it can be deduced that the polymers must be complex; moreover, they must be laid out in a very specific spatial pattern. The patterns must persist both within each individual polymer molecule and in the relation of one molecule to the

neighboring molecule. How the polymers may achieve suitable spatial orientations to one another is dealt with later. Here we will deal with one important conclusion of the above—thermal stability. For a protein or polysaccharide to maintain its delicate, internal "secondary" structure, it must stay within a certain fairly narrow temperature range. Virtually no enzyme will stand boiling, and even egg white, a simple protein, loses its secondary structure, or "denatures," on boiling (or even by whirling round the head in a nylon stocking). We can say that the heating literally shakes the secondary structure to pieces. This condition sets the upper temperature limits for carbon-based living forms at well below 100°C.

On the other hand, if we cool down any chemical mixture sufficiently, we can virtually stop all chemical reaction. By Arrhenius' Law, chemical reactions slow by about a factor of two for every ten degrees fall in temperature. Because of this effect, we can store many biological materials (such as food, spermatozoa, or bacterial cultures) for years in the deep-freeze without their changing appreciably, either functionally or chemically. The need for a minimum reaction rate for active life to proceed places the lower temperature limit above the freezing point (0°C).

#### Livable Zones—Ecospheres

The mature conclusion is that if, as seems likely, life can only exist by employing sensitively positioned arrays of carbon-oxygen and carbon-nitrogen chains in an ionizing solvent such as water, then advanced forms of life can only exist in a narrow range of temperature between about 10°C and 60°C. This means that life around our Sun can only exist on the Earth and possibly on Mars and Venus. Although the MARINER flight has given weight to the conclusion that the surface of Venus is well above boiling point, balloon experiments have pointed to much lesser temperatures.

Around other stars, there will also exist narrow livable zones, or *ecospheres*, although these are only of reasonable size and stability in the medium-temperature stars like the Sun (F, G, and K type). Though it is impossible to be sure, it is probable that stars like the Sun (smaller than type F5) also have planets around them. The nearest of these is Tau Ceti, which is about  $5 \times 10^{12}$  miles away. At the speed of our present interplanetary spacecraft, it would take about ten million years to get there. Therefore, there is no point in considering such stars for a search at present.

On the other hand, it is worth recalling that plant catalyst, light can produce



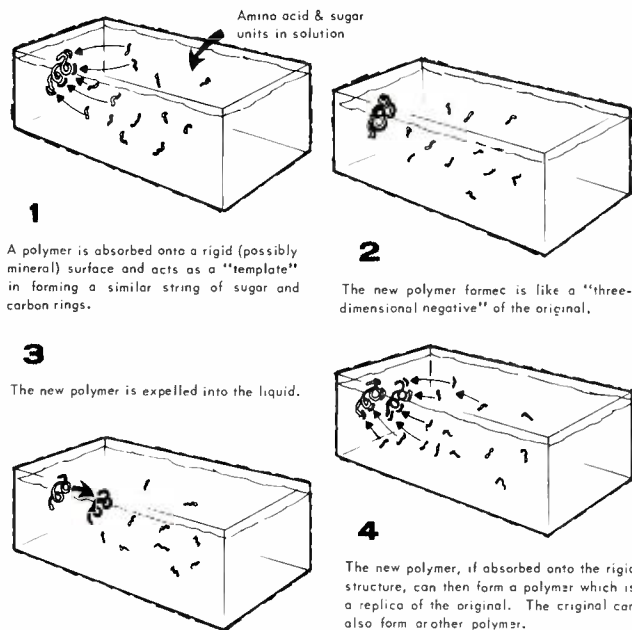

Fig. 4—Representation of self-reproduction of a nucleic acid polymer in primitive aqueous environment.

ing that there are about  $10^{20}$  stars which fall into the above categories and so, if as some biologists think, life is a phenomenon which is likely to arise whenever chance sets the conditions right, this number of "chances" is quite a high one. Thus, we might find life around other stars once we have vehicles which will get us around the galaxy in reasonable times. But, if we discover Mars and Venus to be sterile (a very likely possibility), we can resign ourselves to our own company for some time. It will still, of course, be of interest to discover whether Mars is *colonizable*. If world population grows, the possibility of some temperate real estate on Mars may become very attractive.

It is not too difficult to deduce, as above, from the results of simple biological experiments, what conditions are required for life to survive. It is still not within the scope of our knowledge to reconstruct, in detail, how life arose on Earth. Intensive biochemical analysis, even of the simplest known living organisms, does not yet provide a clear answer.

#### Self-Reproducing Polymers

The simplest self-reproducing system—the virus—is well known to us by its effects. Viruses consist of little but the necessary self-reproducing polymer, DNA (deoxyribonucleic acid) usually isolated as a colony of spherical or simply-shaped units. The units contain no cell wall or other retaining structure. Hence, unless conditions are exactly right, they cannot, like other simple cellular organisms, collect their own raw material, settle back and then build it up into new replicas of themselves. One splash of water, and the colony is dispersed into individual molecules. Because of this,

they only survive and multiply when they find themselves in a "host" living cell. Here they act as complete parasites and apparently usurp the cell's production facilities in order to replicate more of their kind. This behavior sounds like a by-product of biological evolution, not a likely first stage.

The account of the virus points out one of the prerequisites of life—a bag, cell wall, or other retaining structure to isolate the self-manufacturing process from the nonliving medium. It is not too difficult to propose a model of how this first step could occur in a warm, sunlit "soup" of amino acids and sugar on the Earth's surface. As shown in Fig. 4, clay (or a crystalline mineral surface) could act as a regular structural "backbone," absorbing, as is natural with surfaces, some of the organic matter onto it in a regular array and catalyzing its further polymerization onto the surface. It has been shown that the correct conformation of nucleic acid polymer can, in fact, act as a "template" and build up on itself a string of sugar and carbon rings similar to itself, but a kind of "negative" image of the original. The negative can be expelled from the "mold" and then repeat the process, building up on *itself* an exact replica of the original nucleic acid polymer. It can be seen that, given a supply of raw material, a spatially confined nucleic acid polymer system could

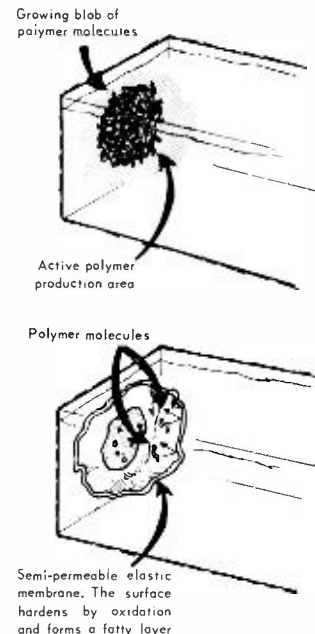

Fig. 5—Polymer molecules as an elastic membrane.

act as a perpetual factory of replicas of itself. As a result, a blob of thickened "soup" could form. Around it, a further-polymerized, elastic coating (or crust) could form perhaps by oxidation and the separation of fatty constituents. This could isolate the building process from the medium, allowing only some types of osmotic transport of the necessary raw materials into the "cell," but retaining the larger manufactured molecules. Fig. 5 puts this simple model in visual form.

However, we cannot say we have hereby solved the mystery of life; the "growth" of this cell is still uncontrolled. How the "cells" decide, as true living cells do, to divide and redivide, always retaining the right geometry and size is a problem no more than nibbled at by contemporary biochemistry, or *molecular biology* as this field of study is more accurately called.

#### Function of Light

The kind of growth described is possible without oxygen or sunlight, if some other suitable fund of chemical energy is available. However, a biological system requires chemical energy rapidly, and the best source of rapid energy is sunlight. As organic chemists have known for some time, light, especially in the ultraviolet wavelengths, can be used to put together a wide variety of organic molecules. Fig. 6 illustrates how, with the

Fig. 6—Effect of light to produce carbon backbones in the form of sugars.

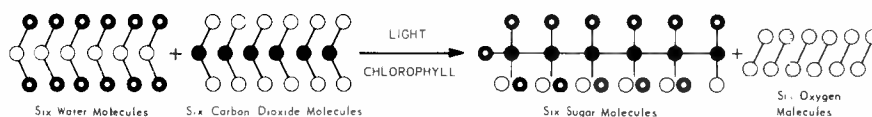

carbon backbones in the form of sugars by oxidizing water and reducing carbon dioxide—the gaseous by-product being oxygen. In the plant chloroplast cell, the chlorophyll molecule is arrayed in a highly organized manner which makes a highly efficient system for producing carbon chains.

#### **Motion**

For an organism to become advanced in function, one final basic attribute is required: it must be able to move parts of itself mechanically, or be *motile*. It must transduce chemical energy into mechanical energy. Very recent biochemical research has isolated the polymers involved in this process. The form of the secondary structure of a protein called actomyosin is normally long and thin; however, when a simple organic chemical called adenosine triphosphate is added, the secondary structure changes very rapidly into a bunched-up, almost spherical form; the effect can be reversed by other chemicals. Given the right “hooks” at each end of the molecule, we could, in the laboratory, make one molecule do an unlimited amount of work by repeating this cycle indefinitely. Again, however, it is a long step from this test-tube model to the construction of a single animal muscle fiber.

#### **Prerequisites of Life Forms**

Summarizing biological evolution in a few words, we might say that from the biochemist’s point of view, the prerequisites of advanced life forms are: 1) moderate temperatures, 2) an ionizing solvent, 3) self-reproducing polymers, 4) cell wall structure formation, 5) a respiratory system, and 6) an available photosynthetic source of raw materials.

#### **LIFE DETECTION**

As the discussion so far indicates, our main hopes for detecting extraterrestrial life in the near future rest on Mars, although we must not completely exclude the Moon and Venus. Mars would, in any case, be the object of intensive scientific study; it is the only planet on which we can obtain a reasonably unobscured view of a cloudless surface. Dark patterns come and go on the surface of Mars, while patches looking like ice appear at the poles in winter. Much can be done to study these changes from the surface of the Earth. Telescope observations have been carried on for many years, but the obscuring effect of our own turbulent atmosphere has brought this to a limit. Very soon, balloon and satellite telescope observations will produce a much clearer view of the puzzling surface patterns now seen in a blurred fashion from Earth.

#### **Concerted Effort and Analysis Needed**

Much more detailed analysis is also possible by analyzing the spectral distribution of the reflected sunlight, from the ultraviolet wavelength into the infrared. The light reflected or transmitted by a chemical compound bears a characteristic “fingerprint” of the chemical classes present in that compound. Given a small tube of an unknown Martian material, a chemist could put it into his laboratory absorption spectrometer and identify, or at least class it, in a few minutes. What we get from Mars in Earth-bound telescopes is a less informative reflectance spectrum, further obscured by the smearing effect of the atmosphere and the low “signal-to-noise” ratio from this weak source of light. Even so, one person has observed, from the Earth, definite reflectance peaks in the 3-micron wavelength region, only obtained when the telescope was centered on a dark blue-green region near the Mars equator. Such a region is the dark, comma-like area known as Syrtis Major. The reflectance peaks are at wavelengths characteristic of green plants, where they arise mainly from the C-OH groups in cellulose and sugars. However, a similar band is present in all alcohols; thus, this band could just as well arise from pools of pure hundred-proof spirit which, for all we know, wells from the ground on this planet! The STRATOSCOPE II balloon flight also obtained somewhat noisy spectra of Mars. These indicate that there is little oxygen or water vapor in the atmosphere—a damper on our hopes for advanced life forms there.

#### **Mars Biological Test Laboratory**

Mars will be the object of the first unmanned planetary landing, which may take place in about 1969. The major part of such a landing capsule will be a biological test laboratory containing experiments to determine the existence of life by the most advanced methods which can be employed remotely, (Table I lists some of the possible tests being considered by NASA).

The practical problems of these remote laboratories are immense. If we think of the diversity of Earth life, it would be very difficult to design a ma-earthworms, and germs—especially if the weight of the laboratory is limited to 100 to 200 pounds. The first machines will thus be limited to the forms of life most likely to be widespread and most easily handled—soil microorganisms. Most of the tests will be of the following type: A clear soup (or culture medium) and oxygen will be provided for the detection of a few pinches of Martian soil. The accompanying instrumentation will be designed to detect the smallest

change in the composition or appearance of the culture medium (production of turbidity, production of carbon dioxide from the oxygen, release of new phosphorus compounds, etc.).

#### **Great Decisions to be Made**

One cannot help feeling that some great issues and decisions may rest on quite fallible tests such as these, but it is very chine to detect them all—elephants, flies, difficult to design an infallible test of this type. For a beginning, we have to be completely sure that we have sterilized our equipment so perfectly before launch that it will not carry any of its own bacteria and then detect *them* on Mars. Also, no knowledge exists of the culinary likes and dislikes of Martian organisms. Judging by Earth organisms, an error of a few fractions of a pH (acidity) unit can inhibit otherwise rapid bacterial or viral growth. Perhaps only the TV microscope or telescope will provide us with enough “feel” to recognize highly foreign forms of life. It is quite possible that all the remote instruments will remain “blind” to an existing form of life on the planet and that these forms will only be discovered when man arrives.

A manned Martian landing has its own major problem: Mars does not carry enough atmosphere to slow a heavy capsule efficiently. Probably a large amount of uneconomical rocket braking will be required; although concepts for Mars capsules capable of landing (and employing some aerodynamic braking and control) have recently been advanced.

#### **PROGRESS IN SPACE EXPERIMENTS**

Actual biological experiments in space began early in the space age with the flight of the Russian dog, Laika, in SPUTNIK II in November 1957. Of course, many suborbital flights by small animals have preceded and followed this flight, even outside the US and Russia. For example, the French have recovered a white rat, “Monsieur Hector,” and several other animals from powerful liquid-fuelled rocket flights over the Sahara.

The story of the more recent successful manned orbital flights needs little further description except to note that the feared physiological effects of weightlessness, space radiation, and enclosure have been reassuringly mild. No other country yet has serious plans for such expensive manned orbital experiments; although in Britain, the concept of the “Aerospace Plane” is being pursued. This concept comprises a fully-maneuverable winged craft similar to the X-15 but made capable of longer missions by

the use of a ramjet in the atmosphere and rocket propulsion in orbit.

The earliest unmanned orbital biological experiment for the US came with the launching, in the DISCOVERER XVII satellite, of a payload of living mammalian and plant-cell cultures in November 1960. The nose-cone of the satellite was then fired downwards from orbit after two days. The capsule re-entered the atmosphere and was caught in the air. Although a moderately large solar flare occurred during the mission, depositing a radiation dose of about 30 rads of protons (about one-tenth the lethal dose for a man) in the samples, no noticeable effects of the flight were noted in the subsequent lifetimes of the cell cultures.

Several RCA projects investigating physiological telemetry have been completed. Many of the transducers used in ground-base clinical telemetry require adaptation to space use, where long-term discomfort cannot be tolerated and light weight is required. To overcome these deficiencies, new sensors were investigated by the Systems Support Engineering group of the DEP Aerospace Systems Division.

The first was a blood-pressure transducer that picked up the entire pressure wave from the body surface. Present blood pressure techniques are cumbersome and awkward, using a pressure cuff and microphone to detect the high (systole) and low (diastole) points on the pressure curve. To develop a cuffless technique, radial vascular pressure, sensed by miniature strain gauges, and changes in tissue capacitance were investigated. Another area of sensor development is with pressure and temperature measurements by means of endoradiosondes. These miniaturized, passive devices are used currently to study temperature changes and organ potentials of mammals. Other sensors have been developed for respiration rate and volume, blood-oxygen saturation, blood flow rate, deep body temperature, and cardiac function information.

Weight and size reductions in circuitry were also achieved. For example, an electrocardiograph (ECG) with a total volume of 1.5 in<sup>3</sup> has been developed that is capable of transmitting the ECG signal to a distant receiver. Similarly, an electroencephalograph (EEG) was developed that could be carried in the shirt pocket and will be capable of transmitting a half dozen channels.<sup>1</sup>

A recent project within RCA's Astro-Electronics Division (in collaboration with the Marquardt Corp.), has produced an outline design of biosatellite carrying embryos of opossums.<sup>2</sup> These are particularly well-adapted for the

observation of development in the weightless state. Several opossum fetuses are maintained in incubation cells in the satellite while rotating optics supply pictures from each cell to a central black-and-white TV camera. Interposed filters give indications of color changes in the fetus. The polar orbit (300 nautical miles altitude) and spacecraft configurations are chosen to keep radiation within the compartments at a low level.

#### CONCLUSIONS

The main aim of this article has been to demonstrate the following: While we have several good handles on the problem of the origin of life, we have a lot of sophisticated research to do before we arrive even at a good set of hypotheses of how life occurred. Likewise, while we can detect many forms chemically, we need much more sophisticated sensors to

help us to decide whether a certain observed phenomenon may constitute "life." Finally, although we have demonstrated short-term life-support outside the atmosphere, our present crude automatic control of a few gases and fluids will have to be refined greatly before we can, for example, establish a colony on the Moon. The design of the advanced electronics required for each of these pursuits should offer engineers and scientists one of the greatest challenges of an already challenging technology.

#### BIBLIOGRAPHY

1. Dr. M. H. Halpern, "Life Sciences in Space Systems Support—Electronics + Biology + Medicine," in *Systems Support*, RCA reprint PE-108.
2. S. Fairweather and J. Mortimer, "Proposed Satellite for TV Observation of Zero-G Effects on Development of the Opossum Fetus," RCA ENGINEER, *this issue*.

TABLE I—Current Life Detection Instrumentation

Instrument	Physical Quantity Observed	Limitations
<i>Life Detection Sensors Under Development by NASA</i>		
Multivator	Fluorescence of enzymatically hydrolyzed synthetic substrate.	Substrate subject to spontaneous hydrolysis. Enzyme activity varies widely, hence response time is uncontrolled and may be the same as base-line drift.
Gulliver	Radioactive CO <sub>2</sub> from radioactive sugars.	Result measured from a difference in rates of spontaneous and bacterially caused decarboxylation. Base line may drift badly over the course of a long experiment, e.g., four hours. Reliable determination is needed of the radio-active background on Mars. Also, the presence of materials that will cause oxidation of the sugars by non-metabolic mechanisms may result in a false positive response.
Wolf Trap	Increase in hydrogen ion activity and turbidity from growth of bacteria.	"Universal" substrate required. Growth rate slow, and base line drift may obscure pH and/or turbidity change.
J-Bands	Spectral absorption band of dyed bacteria.	Detects equivalent of 10 <sup>7</sup> bacteria/ml. Substrate subject to deterioration. Interference or false alarms from non-living tissue possible.
Vidicon Microscope	Displays image plane of microscope on TV.	Very wide data bandwidth needed, or automatic pattern recognition. Spurious shapes are possible.
High-Resolution TV	Observes and displays macroscopic morphology of planetary terrain and possible animals.	Transmission of TV image necessary.
Gas Chromatograph	Measure column chromatographic retention times of several dissolved compounds.	Slight variations of retention times because of environmental changes will alter analytical results. Columns require cleaning and renewal.
Mass Spectrometer	Molecular fragments of degraded sample.	Limited specificity because it measures only mass number.
MARBAC	Essentially redox potential measurement.	Limited specificity.
Ultraviolet Spectrometer	Absorption in the far ultraviolet.	Sensitivity low (about 10 <sup>6</sup> bacteria/ml.).
Optical Rotatory Dispersion	Optical activity associated with biological materials.	Will not detect optical rotation if equal quantities of optical antipodes are present. Sensitivity low, about 10 <sup>6</sup> bacteria/ml.
<i>Life Detectors Under Investigation</i>		
Protein Pyrolyzer	NH <sub>3</sub> from pyrolysis of airborne particles.	Non-living substances would respond identically with biogenically formed protein or amino acids. Sensitivity good, about 10 <sup>4</sup> bacteria would be detectable.
Partichrome Analyzer	Blue (ethyl violet stainable) particles in the microscopic size range.	Abiogenically formed organic particles should also stain. Sensitivity good, about 30 bacteria/liter of air. Specific to organic particles.
<i>Other Sensors Applicable to Life Detection</i>		
Gas Chromatograph	Lipids of bacteria.	Non-living lipids would interfere. Sensitivity good, (about 10 <sup>4</sup> bacteria). Other problems similar to those described previously. Reagent may undergo changes.
Spot Scanning Microspectrofluorimetry	Fluorescence of stained particles.	Similar to Partichrome Analyzer. Staining more specific, directed at nucleic acids. Reagent may undergo changes.
Polarization of Fluorescence	Degree of polarized fluorescence from solutions of fluorescent dyes plus biological material.	Non-living materials may interfere. Reagent subject to changes. Sensitivity about 10 <sup>4</sup> bacteria/ml.

Fig. 1—Cutaway view of biomodule payload including viewing optics.

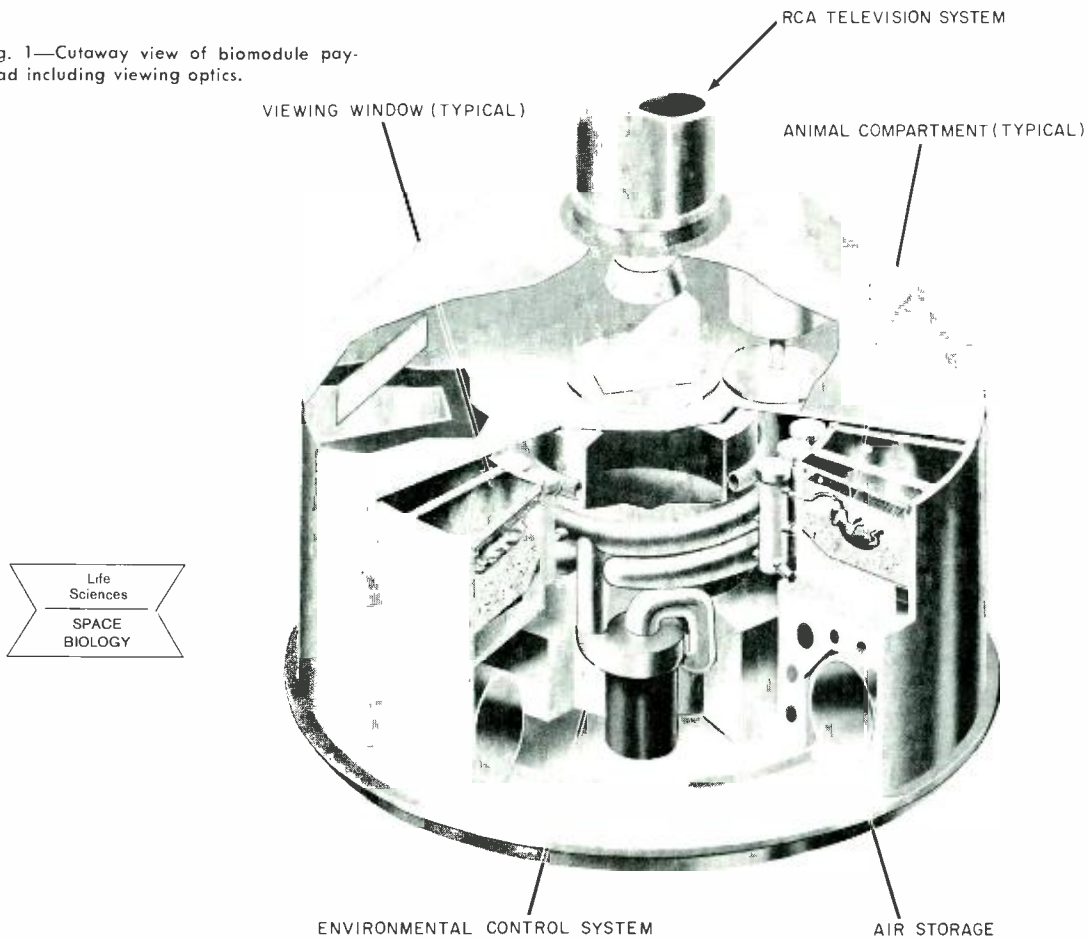

## A PROPOSED SATELLITE FOR TV OBSERVATION OF ZERO-G EFFECTS ON DEVELOPMENT OF THE OPOSSUM FETUS

Fig. 2—Proposed television camera configuration.

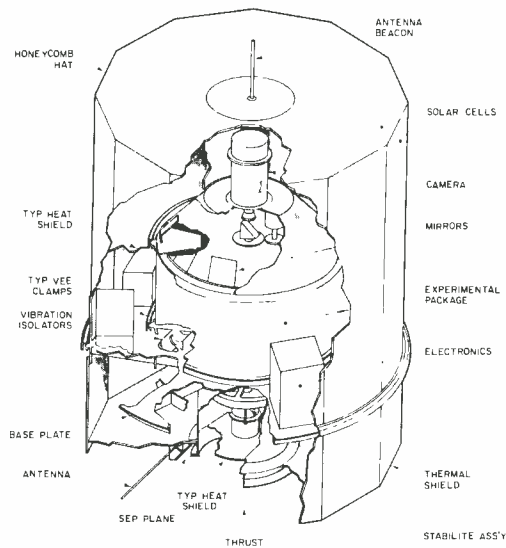
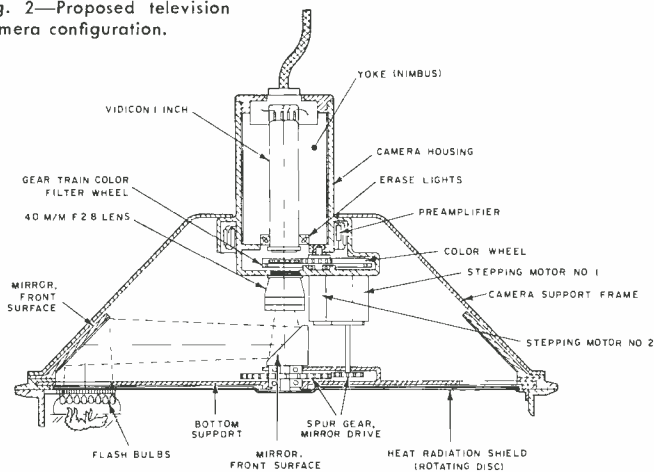

Fig. 4—Cutaway view of spacecraft.

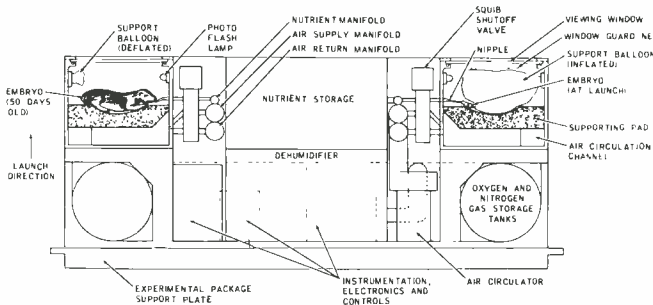

Fig. 3—Cross section of an individual cell of the biochamber.

The biological effects on mammalian tissue resulting from extended periods of weightlessness is of great interest to those concerned with life-support equipment and systems for space travel. This paper, based on a proposal submitted to the Air Force by RCA and the Marquardt Corporation, describes an experiment in which opossum embryos are orbited in a spacecraft and observed during development with an RCA TV-camera system. (The opossum is uniquely suited because of rapid maturation and the large amount of clinical data available on them.) This experiment is designed to establish benchmarks for measuring the effects of weightlessness on human tissue.

**S. H. FAIRWEATHER and J. E. MORTIMER**

*Astro-Electronics Division, DEP, Princeton, N. J.*

**T**HIS paper presents a new concept for exploring gross zero-g effects on mammalian tissue arising from possible anomalies at the cellular level. The basic idea involves the use of an opossum embryonic fetus to provide a sensitive biological indication.

In effect, the embryonic fetus serves as a biological amplifier of growth irregularities, thus providing a means for studying physiological development in a telescoped time interval. The problems attendant with the instrumentation required to detect possible growth irregularities are discussed, together with the proposed means for data recovery and evaluation. The design of a life support biomodule is presented, along with a method for television viewing of the embryonic fetus and a method for command and control of the system in space. A technique for investigating possible "latent" zero-g effects is also proposed. The design of a lightweight longlife spacecraft to meet the attitude, thermal, power, and communication constraints imposed by the biomodule is summarized. The paper includes a brief description of the monitoring station requirements and a definition of the necessary supporting ground "control" experiments.

*(Credit for the biological aspects of this paper are gratefully given to Dale Carpenter, Principal Biologist for the Marquardt Corp. Mr. Carpenter has had considerable experience in the study and use of the opossum embryonic fetuses and is, at present, using such specimens in drug research for the National Institute of Health.)*

#### **WHY AN OPOSSUM FETUS WAS SELECTED**

In any biological experiment, the test specimen should be sensitive to the phenomena being investigated and should display this sensitivity in a short period of time. In addition, specimens selected for study in a weightless environment should have simple feeding habits, minimum waste disposal problems, and an

uncomplicated means of free tethering during space flight. The opossum fetus uniquely satisfies all of the above requirements.

The opossum embryo develops in an extra-uterine state during a major part of its early life in the pouch of the female opossum. For this reason, the fetus is suitable for study in a confined environment away from the mother. During fetal growth, waste disposal is essentially non-existent and feeding is accomplished through simple nipple attachment to the mother. These characteristics greatly simplify a life-support system required for normal development away from the mother. During the time period of 10 through 90 days from birth, the opossum also exhibits an accelerated growth-cycle. The development of physiologic functions can be observed in a time interval in which the growth parameters are changing most rapidly, thus providing a sensitive indication of physiological development and possible growth abnormalities under zero-g conditions. An additional advantage in using an embryo is that the effects introduced by the emotional reactions of more mature animals are not present. The opossum also has an extensive clinical history that can be used as a basis of comparison during experimentation under zero-g conditions.

#### **EXPERIMENT OBJECTIVES AND PROPOSED PLAN**

Objectives for the overall experiment are:

- 1) To isolate qualitative and quantitative effects of weightlessness on the physiological functions of the opossum fetus.
- 2) To determine the biological effects of the combination of weightlessness and exposure to radiation, and to establish any synergistic relationships, if present.
- 3) To determine the effects on biological rhythm of the removal of living organisms from the earth's rotational influence.
- 4) To determine possible latent effects of zero-g on the specimens when simulated one-g conditions are established after growth at zero-g.

- 5) To develop hypotheses about zero-g mechanisms by determining at what point effects first are evident in the development cycle of the specimens.

To accomplish the above objectives, it is proposed that a rapidly-maturing embryonic opossum fetus be subjected to the zero-g environment of space before it has had a chance to develop its gravity-dependent physiologic functions. The effects of weightlessness on the various functions can be differentiated, since these functions evolve at different, but known, times in the 60 to 90-day growth cycle of the opossum fetus. The proposed duration of the orbital mission (Figs. 1-5).

The effect of the zero-g environment can be determined by observing gross changes in physical appearance on high-resolution TV, and by measurement of EKG rate, body temperature, sucking rate, and respiration. Monitoring the response of the animals to controlled stimulations (such as electric shock, sound, and light) at sequential stages in the development cycle would indicate any significant departures from normality.

At the end of the growth cycle, the satellite can be made to spin at a rate such that an "artificial gravity" of one-g will exist within compartments where the opossums reside. This "return spin-up" to one-g level should provide data on any latent damage and function recovery. Measuring recovery from an observed trauma during orbital flight introduces a new dimension into biological testing in space.

#### **PLAN FOR THE OPOSSUM EXPERIMENT**

Opossum embryos are born 12 days after conception. Their development at birth compares to a human embryo in about the 8th week of pregnancy. The fetal opossums crawl into the mother's pouch, find a nipple, and attach themselves firmly. The sucking action causes the nipple tips to swell into an effective plug, sealed by oral mucus and a dry film of milk (Fig. 6).

The opossum fetus measures only 10 to 14 mm and weighs 1.3 grams at 14 days after "birth" (entering the pouch). By day 40 in the pouch, they are about six times longer and heavier, and from day 40 until weaning their sensory organs develop. Since the fetus is naturally adapted to a closed ecological system (the marsupium), metabolic by-product production and accumulation is minimum.

#### **Effects of Weightlessness**

The key factor in this experiment is that the specimens mature rapidly. This high rate of development produces a biological amplification of the effects of weight-

**S. H. FAIRWEATHER** received the BS in Physics (cum laude) from Rensselaer Polytechnical Institute in 1949, and the MS degree in Physics from Case Institute of Technology in 1950. He was a Research Scientist from 1948 to 1950 with the Lewis Flight Propulsion Laboratory. In 1950, he worked as an Engineer with Thompson Ramo Wooldridge, Inc. He advanced to Project Manager in 1954, directing the design of a reactor and turbo-jet engine control system and a control for a hot-gas turbogenerator. He was promoted in 1957 to Senior Project Manager, responsible for the technical management of experimental groups working on both ion and plasma propulsion, also directing the activities in dynamic heat engine, thermoelectric, and thermionic power conversion systems. He joined the Astro-Electronics in 1962 as the Manager, Propulsion Systems Engineering. Mr. Fairweather is currently the administrator of IR&D projects at AED. Mr. Fairweather was also responsible for the overall direction of the systems engineering, integration, and environmental test of the SERT Spacecraft. He is a member of Sigma Xi, APS, IEEE, and the AIAA. He is currently Chairman of the Princeton Section of the AIAA. He has published several technical papers.

lessness. Although it is difficult at this time to relate these effects to man, a very good indication of possible effects and areas for further investigation will be obtained. This is especially true regarding abnormalities at the cellular level and in the calcium mobilization phenomena. Present knowledge indicates that calcium in man's skeletal system becomes excessively mobilized and excreted under zero-gravity conditions. Reduction of afferent stimulation in the vascular system may be the cause. Because the interplay between the bones and the blood is more active in young animals, the structural deviations detected during the experimental period (30 to 90 days) could serve as a long-range indicator of possible effects of weightlessness on the human skeletal system.

#### Television Monitoring

Opossums do not develop fur until relatively late in their growth cycle.

Fig. 5—Correlation of experiment factors (with mission profile).

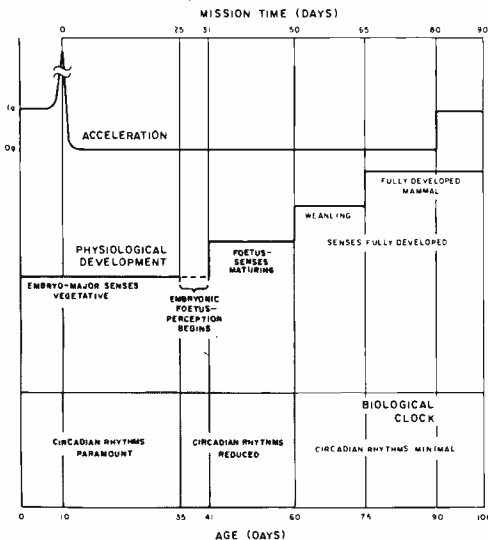

**J. E. MORTIMER** received his HNC-EE and full Tech. Certificate C and G-EE from Acton Technical College, London in 1952. He also completed a 5 year student apprenticeship in electrical engineering with the General Electric Co., London. From 1952 to 1955 Mr. Mortimer worked at Ultra Electric and GRL on VHF, UHF and control systems. During 1957 and 1958 he resided at Douglas Aircraft Corp. to supervise the Canadair team responsible for the transfer to Canada of the all design-development information and hardware associated with the Sparrow IID Weapon System. At English Electric Aviation, Mr. Mortimer was responsible for the design and development of a highly complex analog integrator and digital computer system for the flight inertial guidance equipment on the Blue Water Missile system; as Senior Project Engineer, he was also responsible for the Blue Water Australian trials operation. He joined AED in 1963 and has since been responsible for the overall system and systems integration (and test) of the prototype and flight SERT spacecraft. He is also responsible for a team designing and fabricating various SERT Components. He is presently Leader of Systems and Systems Integration.



S. H. Fairweather



J. E. Mortimer

Changes in skin color due to cardiovascular disturbances can be monitored via color-interpretation TV during their development of vasomotor control. The opossum fetus, from birth to 40 days, has not developed the organs of equilibrium and accompanying sensory nervous input to the central nervous system; thus, gravity-sensing (kinesthetic) capabilities would be undeveloped at the time the satellite was launched. Any traumatic effect of the zero-gravity environment on fetuses under 41 days of age, therefore, would reflect the effect of weightlessness at the general cellular (tissue) level and not at the neuromuscular system level. Each fetus would serve as its own control for studying the effect of weightlessness on the ontogenesis of gravity-sensing and equilibrium adjustment, since self-righting reflexes would not yet be developed. On the 40th day after birth, organogenic specialization of sensory tissues develops rapidly, and any cumulative effects of weightlessness at the cellular level would then appear. Stimulus-response reactions from ground command would be used to investigate the nature of any observed abnormal responses.

Equilibrium (righting) reflexes appear late in fetus development. If development of gravity-oriented capability has occurred under zero-gravity conditions, valuable data can be obtained from follow-up observation of these mammals. Examination of conditioned reflexes before, during, and after neuromuscular maturation will be compared with ground control experiments.

#### Eliciting Responses

Fig. 7 summarizes the time displacement of embryo maturation and the methods of monitoring growth and development.

By appropriate stimulation methods, the beginning of responses to photic (visual) and auditory stimuli at zero gravity can be recorded by the reaction of the fetus to both automatic and/or command noise signals. For example, mechanical stimulation of the artificial nipple and/or oral region would allow observation of any changes in the sucking or other gross body reflexes. The sucking reflex is established at birth, and variation in sucking rate could be an index to circadian rhythm.

By modulated electroshock stimulation, pain and certain motor responses can be elicited. The early responses of pulse rate, respiration, and sucking to such stimulation are to be monitored through pickup leads.

The transition of the specimens from the poikilothermic (cold blooded) condition to the homoiothermic (warm-blooded) state will occur under weightless conditions, and thermal responses can be recorded.

Olfaction, the sense of smell, is one of the earliest to develop in the opossum embryo, allowing monitoring of gross motor responses to olfactory stimuli released into the chambers during flight. One type of combined olfactory-tactile stimulus that could be attempted near the weaning period is a "sneeze-reflex" using a chemical irritant.

#### INSTRUMENTATION

Intra-animal instrumentation involving surgery, and extra-animal instrumentation involving strapping or cementing, are not used in this experiment because they could injure embryonic tissues and lead wire attachments could create an entanglement problem. The embryos are physiologically instrumented by sensors attached to the artificial nipples.

Cardiac, sucking, and respiration rates, in addition to nipple temperature, can be determined in this manner. Physical well-being and growth progress will be determined optically through tele-metered television pictures of the specimens.

Thermistors are used to measure sucking and respiratory rates and nipple temperature. The difference in temperature between the embryo and nutrient supply causes variations of nipple temperature while the animal is sucking. Average sucking rates are computed from the changes in nipple temperature over a fixed period of time. Several counts are made to obtain a valid rate measurement. Nipple temperature is calculated from the absolute magnitude of thermistor average output. During a nonsucking period, thermistor readings correspond to embryo body temperature.

A second thermistor is located in the vicinity of the embryo nostrils to measure temperature oscillations in exhaled and inhaled air. Again, a rate is obtained by a timed count and the ambient temperature. The electrocardiogram (ECG) circuit can be instrumented in one of two ways: In the first method, one lead is placed on the nipple and fastened with a soluble binder. This lead is ingested by the embryo and remains in the lower esophageal or gastric area. In the second method, a common posterior EKG could be used for all animals and would be placed on the supporting pad of each chamber.

#### BIOMODULE DESIGN

The biochamber (Figs. 3, 4) can contain up to a total of 24 compartments separated by sealed partitions. The inner and outer walls and the partitions form a frame for a quartz glass viewing window that seals the top of the indi-

Fig. 6—Cutaway showing opossum on artificial nipple.

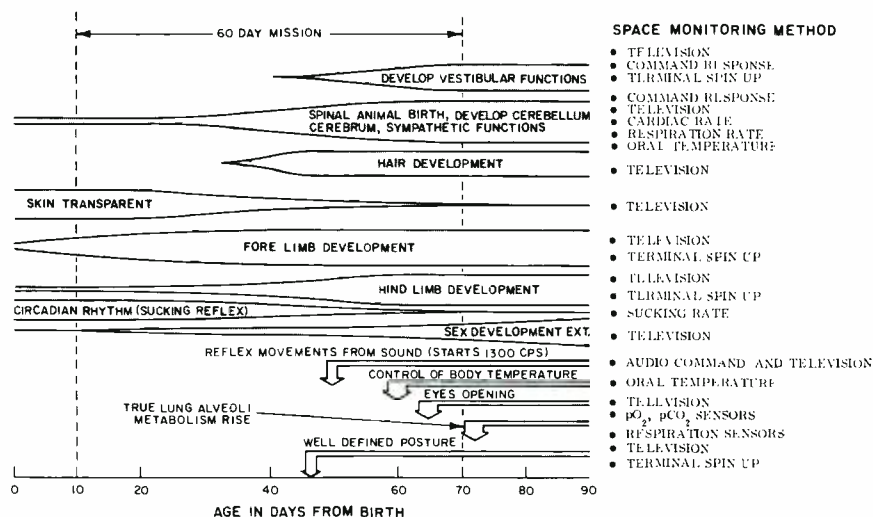
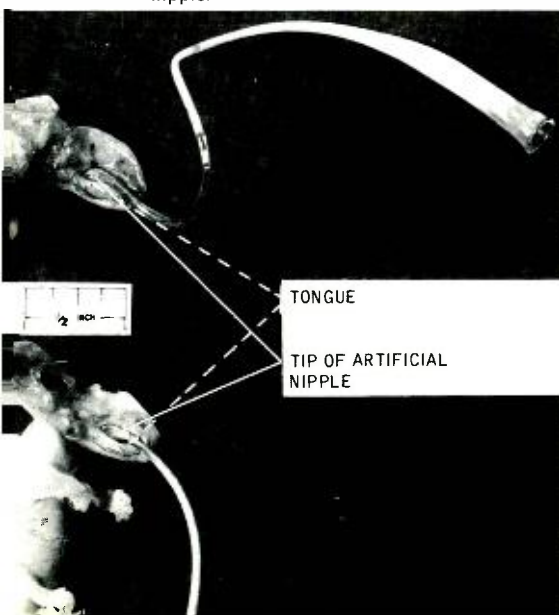

NOTE: EXTENSIVE DETAILED BASE LINE DATA AVAILABLE (OVER 1000 REFERENCES)

Fig. 7—Embryo maturation and monitoring methods.

- SPACE MONITORING METHOD**
- TELEVISION
  - COMMAND RESPONSE
  - TERMINAL SPIN UP
  - TELEVISION
  - COMMAND RESPONSE
  - TELEVISION
  - CARBAC RATE
  - RESPIRATION RATE
  - ORAL TEMPERATURE
  - TELEVISION
  - TELEVISION
  - TERMINAL SPIN UP
  - TELEVISION
  - TERMINAL SPIN UP
  - TELEVISION
  - SUCKING RATE
  - TELEVISION
  - AUDIO COMMAND AND TELEVISION
  - ORAL TEMPERATURE
  - TELEVISION
  - pO<sub>2</sub>, pCO<sub>2</sub> SENSORS
  - RESPIRATION SENSORS
  - TELEVISION
  - TERMINAL SPIN UP

vidual compartments. Conditioned air and a liquid nutrient are brought in from common manifolds through a single quick-acting shutoff valve on each compartment. The air circulated through the compartment also is carried out through this valve to an outlet manifold. To simulate the pouch environment, the chamber is maintained at 35.0 ± 1.5°C. Relative humidity is maintained between 70 and 90%. Oxygen content of the compartments is kept between 15 and 20%, and the CO<sub>2</sub> content is kept between 2 and 6%.

#### Chamber Optics

A thin, metallic disc with a reflective coating on the bottom is located just above the viewing windows. The disc rotates with the optical prism of the RCA TV camera system. The disc contains a single window cutout and is used to reduce the radiant heat loss from the windows. Each compartment, in turn, is viewed by the camera system optics. Lighting is supplied by a small flash bulb located in the compartment. The light flash is synchronized with the motion of the prism and cover disc.

#### Nutrient Supply and Control

The embryo is placed on an artificial nipple prior to launch and remains attached to the nipple during the entire period in orbit. The flexibility of the nipple allows the opossum to float freely in the absence of gravity while insuring that it is supplied with nutrient. The nutrient supply is cut off temporarily during launch to prevent flooding the compartment due to high g-forces. Nutrient is resupplied immediately on attainment of orbit. Selected compartments can be sealed off in orbit to conserve nutrient. In flight, the embryo is

free to move between the sponge-wick and a nylon net suspended just below the viewing window.

The nutrient milk will be specifically constituted to supply all needs of the embryos during the mission. During normal growth, for example, the percentage fat content of natural milk increases with maturation of the embryo. If laboratory tests indicate that variations in nutrient content are significant to the experiment, the formula supplied to the artificial nipples will be changed during the experiment. Back (retrograde) contamination from the embryo to the primary milk supply will be controlled by shut-off valves, individual chamber isolation valves, and, if necessary, by small, sealed, plastic milk containers within the primary nutrient storage tank.

#### Biochamber Environment

A balloon-like elastic membrane will be used to cushion the 25-mm, 10-day-old embryo. The membrane will be inflated just prior to launch, will support the top and back sides of the embryo during the period of high loads, and will be deflated in orbit. In addition, the entire experimental package will be mounted on the spacecraft structure with flexible supports to isolate vibrational loads.

Thermal control of the compartments is coarsely obtained through the thermal design of heat paths between the experiment and the spacecraft structures; fine thermal control is obtained by electrically heating the circulating air. In the animal compartments, a small fraction of the circulating air is diverted over the embryos to prevent carbon dioxide stratification and fogging.

The embryo rests on a sponge-like couch which serves as an axial-load ab-

sorber and a wick for water removal. Heated air at a relative humidity lower than the chamber is circulated in baffled air passages below the sponge. A wire mesh screen supports the couch above the baffled air passage. The atmosphere in the chamber is maintained at the proper conditions by an environmental control system.

Composition control involves maintaining total air pressure and partial pressures of carbon dioxide and oxygen within the prescribed limits. The system proposed uses an oxygen and nitrogen supply that bleeds into the system with air being vented to space to maintain the prescribed tolerances. This system, compared to a completely closed system, offers minimum cost, minimum development time, and maximum reliability. The environment air is effectively changed about 400 times during the mission. This eliminates the problem of absorption of trace gases which otherwise could be harmful to the experiment. The vented system more nearly corresponds to the natural conditions found in the pouch of the mother opossum.

#### Mechanical Layout

The mechanical arrangement of the bi-module (including the top-mounted television system) is shown in cut-away perspective in Fig. 1. This configuration minimizes the volume occupied by the experiment and places the nutrient tank (with its changing mass distribution) near the center of gravity of the spacecraft. The modified toroidal biochamber design permits compartment geometry suitable for embryo growth from 25 to over 70 mm during the mission, and also provides a central volume for nutrient and air control for the 24 compartments.

#### SPACECRAFT DESIGN

Spacecraft design is based on meeting the special requirements of the biological experiment. The following goals were established for the vehicle:

- 1) Effective gravitational forces less than  $10^{-7}$  g in orbit.
- 2) Thermal control of the biological chamber to  $35 \pm 1.5^\circ\text{C}$ .
- 3) Capability to spin-up to 1 g on ground command.
- 4) High-resolution TV monitoring of the payload.
- 5) Adequate data storage over prolonged time periods.
- 6) Convenience of data handling and transmission methods.
- 7) High flexibility in the command and control system, and
- 8) High over-all reliability of the spacecraft in orbit.

The first two considerations suggest the use of a slow spin in conjunction with

position control with respect to sun-angle (to provide proper thermal balance). These constraints are satisfied by the use of an inertia-wheel that provides angular momentum to keep the vehicle's momentum stabilized. The vehicle itself is de-spun to limit centrifugal accelerations to less than  $10^{-7}$  g. A magnetic torquing capability ensures that, if unpredicted temperature or vehicle-misalignment problems arise, the spacecraft can be reoriented from the ground. Spin-up rockets are used in conjunction with the inertia wheel to trim final spin rate. Since the spin rate of the spacecraft with respect to the inertia wheel can be controlled, the 1-g environment can be simulated.

A conservatively-rated solar-power system has been designed to meet the power demands of the experiment and vehicle subsystems. Additional solar cell area is available around the skirt of the vehicle should future power requirements increase.

#### Mechanical Design

The spacecraft is of a baseplate-solar-array hat configuration (Fig. 4). The hat is a twelve-sided honeycomb panel forming a right polyhedron 30 inches in diameter and approximately 27 inches high. The total weight of the proposed spacecraft is 188 pounds, including an allowance of 5 pounds for radiation shielding.

To minimize ground-loading time, three vee-type quick-disconnect clamps are used to 1) separate the top hat from the baseplate to expose the camera and experimental package assembly, 2) separate the camera experimental package assembly from the baseplate, and 3) separate the camera from the experimental package.

The camera assembly and prism-mirror viewing system is rigidly attached to the top of the experimental package by means of another vee-clamp. This permits simple and accurate alignment of the cameras with the experimental package, and precludes possible misalignment that might develop from launch loads if the units were mounted separately.

#### Television Viewing

The video subsystem, built with space-proven RCA hardware, is capable of scanning any one of the 24 animals in 10 seconds.

The camera system (Fig. 2) is designed to take pictures of each individual nursery cell in the biological experiment. During contact with the ground station, the camera can be indexed to photograph a particular cell,

or the series of 24 cells can be scanned automatically. The field of view at the cell will provide 0.11-mm-per-TV-line resolution on the specimen. Depth of field will be 1 inch in the 2-by-3-inch field of view. The optical path of the camera is switched from cell to cell by rotating a mirror in the optical path. Color interpretation can be obtained by placing a wheel with three color filters in the optical path. Each picture will require 4 seconds for readout. Four additional seconds are required to prepare for the next exposure. Each cell will be illuminated by a flashbulb to freeze the motion of the subject during exposure.

#### Command and Control

A digital command and control system has been designed for use with an analog tone system. The use of the Spacecraft Control Facility, which has an eight-tone, seven-command capability, is recommended. Two commands would be used for 1 and 0 bits.

A seven-bit serial digital command system provides 128 individually coded commands. This allows:

- 1) Individual stimulation of any animal with one of five available types of stimuli.
- 2) Shut-off of any one of the 24 compartments.
- 3) Selection of any set of animal parameters for continuous monitoring in parallel with the main over-all data system.
- 4) Control of housekeeping and vehicle-control requirements.
- 5) Provision for backup capability, and
- 6) Capacity for spare commands.

#### Data Storage

Two data storage units will be used for the experiment data. Each is capable of storing all the data acquired between ground readouts. One data store will be sequenced through all of the 24 payload experiment positions and will store, as a 7-bit binary code, the data acquired from each experiment station. This will be repeated until the memory is filled. The other data store will provide continuous storage for all data acquired from any one selected experiment position. Each memory will have total storage capacity of approximately 6,000 bits.

The data-storage system can record for approximately 12 hours, and all recorded data can be telemetered to a ground station in 1 minute. Adequate time for the transmission of the 24 high-resolution television pictures is available during the shortest possible pass over the ground station. On a typical pass, 72 pictures with color interpretation on each of the 24 specimens can be obtained.



## SYSTEM OPERATION

Visual observation of the developing opossums is provided by the high-resolution television system in the spacecraft. Three color filters on a coded color-wheel are employed as a means of inferring color by multiple observation of a single specimen. The video data will be telemetered to the ground station upon command. Television and "house-keeping" data telemetered from the spacecraft will be immediately available for analysis. One hundred channels of experimental data on EKG rate, respiration rate, sucking rate, and temperature will be stored as digital data in magnetic cores. This data also will be telemetered to the ground station upon command. The digital data will be reduced by a general-purpose computer and presented for analysis. Five direct commands and 128 coded commands will be available for housekeeping and controlled stimulation of the individual animals.

Storage of biomodule data will commence prior to launch, and continue through the launch phase for total mission life. The initial data obtained during launch will be read out to the ground station on the first pass. The initial de-spin to 8 rpm is provided by a set of detachable yo-yo's—a set of weights attached to long cables which are wrapped about the satellite. When these weights are released, they extend to the full length of the cables, decreasing the satellite moment of inertia and reducing spin rate; the cables are then released, restoring the satellite moment of inertia to almost its original value. The motor-driven flywheel is used to further de-spin and stabilize the vehicle at a spin-rate that results in less than  $10^{-3}$  g. At the end of the planned mission, the vehicle will be spun-up to produce approximately one-g centrifugal acceleration on the remaining animals. This will be accomplished by an inertia wheel and TIROS-type spin-up rockets.

### Ground-Control Experiment

Real-time "control experiments" will be performed at normal gravity gradient on embryos within ground biomodules. The same patterns of chamber environment and the same sequence of commands experienced by the orbiting animals will be duplicated.

In addition to the real-time ground control experiments, pre- and post-flight experiments will be designed to duplicate as nearly as possible the acceleration and vibration stresses incurred during launch. These stressed control animals also will be subjected to the same sequence of command stimulations and environmental chamber variations.

## Radiation Effects

Although the spacecraft's 300-nautical-mile orbit is below the region of most intense radiation, sufficient shielding has been incorporated to reduce the integrated dosage to less than 5 rads for a 90-day mission. The Marquardt Corporation has conducted tests which demonstrated that flash exposures to  $Co^{60}$  of up to 25 rads produced no deleterious effect on opossum embryos. It is felt, therefore, that five rads will not "interfere" with the experiment. A radiation dosimeter should be incorporated, however, to cross-check the daily radiation dosage absorbed by the animals. To determine the combined effect of zero-g and radiation, shielding may be removed from half of the specimens.

## Pictures and Data

The pictures are recorded on the ground by means of a 35-mm film camera. The video also can be recorded on magnetic tape for backup. Direct black-and-white pictures will be observed on a TV monitor and polaroid photographs will be obtained. The pictures will be analyzed by the experimenters and compared with those taken of the ground-based animals.

Analysis of data received on each orbital read-out will be the basis for ground-command decisions. Decisions will be made on the basis of the over-all read-out, supported by the video observations, and commands will be given for stimulation of each animal during the next orbit. Analysis of the concurrent ground-control experiments will support analysis of the orbital data.

## Recovery

The proposed experiment is considered to be Phase I of a fundamental investigation of zero-g effects on living organisms. Basically a survey type of experiment, the present effort may determine what gross physiologic problems and biological mechanisms are involved. Based on the results of this experiment, key stages in the development cycle of the opossum fetus can be selected for future tests. Recovery and pathological examination is anticipated. Chemical fixation of cells may be indicated and recovery of animals at specific stages of maturation may be necessary.

Recovery is an expensive operation, however, and is not a "sure thing." In this case, data must be collected that substantiates the need for recovery. With specific data to backup the need, recovery may be more firmly justified.

One possible recovery mode is to use the present "man in space" program.

Future flights of APOLLO and GEMINI involve an orbital rendezvous exercise and extra-vehicular tasks. One of these tasks could be the orbital rendezvous and recovery of a biological module. The proposed spacecraft altitude and beacon capability should be compatible with such an operation. Further, the quick disconnect features of the solar-cell hat and the biomodule chamber also are adaptable to manipulation in space.

## CONCLUSION

The opportunity to observe sequential physiologic development under zero-g conditions is without parallel in our space program. Compression of the time-scale for such an investigation should be of singular advantage in rapidly acquiring more knowledge about zero-g effects. In consideration of the unknowns involved, the proposed experiment is designed on a quick-reaction, non-recovery basis. However, these present exploratory investigations will establish future needs and problem areas in which detailed experimentation will be most fruitful to the present man-in-space program.

## ACKNOWLEDGEMENT

The authors particularly want to acknowledge the guidance given by Dr. William Lawrence of Johns Hopkins Hospital and Jack Bitterley of the Bio-Astronautics Department of the Marquardt Corporation in preparing this paper.

## BIBLIOGRAPHY

1. H. C. Reynolds, "Studies on Reproduction in the Opossum," (Didelphis Virginiana), *University of California Publications in Zoology* 52:3, 223-284, 1952.
2. E. J. McCrady, "The Embryology of the Opossum," *The American Anatomical Memoirs*, No. 16, 233, 1938.
3. O. R. Langworthy, "Correlated Physiological and Morphological Studies of the Development of Electrically Responsive Areas in the Cerebral Cortex of the Opossum," Carnegie Institution of Washington, *Contributions to Embryology*, XIX:103, 149-175, 1927.
4. J. A. Roman and B. H. Braybiel, "The Function of the Semicircular Canals During Weightlessness," *Aerospace Medicine*, 1085-1090, December 1963.
5. S. R. M. Reynolds, "Nature of Fetal Adaptation to the Uterine Environment, A problem of sensory deprivation" *American Journal of Obstetrics and Gynecology*, 800-808, Vol. 83, No. 6, March 15, 1962.
6. M. Block "The Blood Forming Tissues and Blood of the New Born Opossum," I. Normal Development Through About the One Hundredth Day of Life. *Ergebniss der Anatomie und Entwicklungs Geschichte*, Sonderdruck Aus 37, Band, 237-366, 1964.

Fig. 1—Thermal balance in a spacecraft. The temperature will change until the heat radiated by the spacecraft is equal to heat absorbed by the sun.

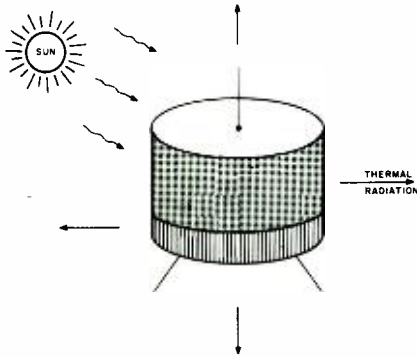

## THERMAL CONTROL OF SPACECRAFT

An understanding of the thermal environment within a spacecraft and the methods for its efficient control under widely varying conditions in space is vital to the success of manned (and unmanned) space missions. In addition, for manned missions the design of protective "space suits" for astronauts must consider proper thermal control. This paper describes the important basic thermal parameters in space, and discusses some of the techniques for thermal control. It is shown that relatively simple thermal control is adequate for a variety of space missions.

**Dr. G. D. GORDON**  
Product Engineering\*  
Research and Engineering  
Camden, N. J.

On earth, the temperature environment can be specified in terms of the temperature of the air or of the surrounding walls. In space, the molecules may have temperatures (average kinetic energy) of thousands of degrees, but these molecules are so few and far between that their effect is negligible; any heat transfer by conduction or convection can therefore be neglected in the high vacuum of space.

The only heat transfer of any significance is the heat radiated by the sun and earth to the spacecraft, and the heat radiated from the spacecraft into space. The basic heat balance is illustrated in Fig. 1. Radiant heat transfer is governed by the Stefan-Boltzmann Law, which states that the quantity of heat radiated is proportional to the fourth power of the absolute temperature. While this fourth power complicates the mathematics, in many cases the theoretical analysis is easier (but less familiar) than the analysis of thermal convection on earth.

A few basic problems will be presented to illustrate the concepts involved in spacecraft temperatures, such as the effects of spacecraft shape, mass, sur-

face properties, and internal power dissipation. The first examples will be of unmanned spacecraft, since most of an astronaut's time will be spent inside a relatively large spacecraft, and the physical concepts are basically the same whether it is manned or unmanned.

### PASSIVE AND ACTIVE THERMAL CONTROL SYSTEMS

An understanding of passive thermal control (no moving parts), which is basically the same whether the spacecraft is manned or unmanned, is necessary even when an active system is used: by reducing the load on the active system, the latter is made more efficient, and the reliability of the entire thermal control is increased. For example, it would be pointless to have a shiny copper exterior to a spacecraft, which we shall see heats up the spacecraft excessively, and then require an active system to continuously remove this excess heat. When passive thermal control is possible, it has the advantage of being lightweight, inexpensive, simple, and reliable.

An active thermal control system requires a temperature sensor, an actuator to produce the necessary motion, and moving vanes to change the radiative properties of some surfaces. A variety

of active controls that regulate the amount of heat transfer have been built, tested, and flown. The ABLE satellite had bimetallic-actuated discs, TELSTAR has a gas-actuated radiation cover, RELAY has gas-actuated circular discs, NIMBUS has gas-actuated movable louvers, and Oco has bimetallic-actuated movable louvers. The choice of the actual system may have depended more on personal preferences of the designer, rather than any actual difference in spacecraft requirements. More-complex active thermal control systems have also been built, using forced convection of air or a fluid to transfer the heat. In all systems, however, a good passive system is the first step, and, therefore, this paper will now concentrate on these fundamentals.

### SPHERICAL SPACECRAFT

A simple problem is to determine the equilibrium temperature of an isothermal, spherical spacecraft, far from the earth.

The energy absorbed is equal to the product of the solar constant  $S$ , the projected spacecraft area  $a$ , and the absorptivity of the surface  $\alpha$ . (Absorptivity is the fraction of radiation energy absorbed by a surface in a specified condition; in this paper it refers to incident sunlight.)

The energy radiated by an isothermal sphere is equal to the product of the fourth power of its temperature  $T$ , the Stefan-Boltzmann constant  $\sigma = 3.66 \times 10^{-11}$  w/in<sup>2</sup>-(°K<sup>4</sup>), the total spacecraft area  $A$ , and the emissivity of the surface  $\epsilon$ . (Emissivity is the ratio of the energy radiated by a surface to that radiated under the same conditions by a black body.)

When the sphere reaches thermal equilibrium, these two quantities must be equal and, therefore,

$$\alpha a S = \epsilon A \sigma T^4 \quad (1)$$

A sphere's total surface area ( $4\pi r^2$ ) is equal to four times its projected area ( $\pi r^2$ ). Therefore, the temperature of the sphere is a function only of the solar constant and the ratio of absorptivity to emissivity:

$$\sigma T^4 = \frac{\alpha}{\epsilon} \cdot \frac{S}{4} \quad (2)$$

The spacecraft temperature for various ratios is shown in Fig. 2.

It may surprise some that the absorptivity  $\alpha$  is *not always* equal to the emissivity  $\epsilon$ , and this ratio is *not* unity. Kirchhoff's law states that at a specific wavelength, the absorptivity is equal to the emissivity, but these surface properties do vary with wavelength. For spacecraft, the absorptivity usually refers to solar radiation, with wavelengths from 0.3 to

Final manuscript received January 29, 1965

\*This paper written while the author was with the Astro-Electronics Division.

3 microns, whereas the emissivity refers to wavelengths from 5 to 50 microns which are emitted by the spacecraft surface at ordinary temperatures. Because of this large difference in wavelengths, many surfaces have  $\alpha/\epsilon$  ratios which differ from unity. Most materials have a ratio of  $\alpha/\epsilon$  within the range shown in Fig. 2, from 0.3 to 10, but special surfaces have been made with ratios as low as 0.1 or as high as 20. As examples of typical surfaces, white paints usually have low absorptivities and high emissivities, with  $\alpha/\epsilon$  ratios of 0.3 to 0.5; black paints have high absorptivities and emissivities, with  $\alpha/\epsilon$  ratios close to unity. Aluminum and copper have low emissivities due to their metallic nature; copper has a high absorptivity, as can be seen by its dark color, and hence a high  $\alpha/\epsilon$  ratio of about 5, while aluminum has a lower absorptivity, and an  $\alpha/\epsilon$  ratio of about 2. The importance of the emissivity, which was neglected in early science fiction stories, is emphasized by noticing in Fig. 2 that a spacecraft with an aluminum surface will be hotter than one painted black (150°F vs. 50°F), even though it absorbs less solar energy.

The solar constant, for Fig. 2 and for most of this discussion, is assumed to be that measured above the earth's atmosphere, in the vicinity of the earth's orbit, and equals 0.9 w/in<sup>2</sup> (2 cal/cm<sup>2</sup>-min). For spacecraft which go closer to or farther from the sun, the solar constant will change. The temperatures of spacecraft at various distances from the sun are shown in Fig. 3. It is clear that spacecraft closer to the sun than Mercury have a tendency towards very high temperatures, and special procedures must be used to cool the spacecraft, one of these being a low  $\alpha/\epsilon$  ratio.

#### CYLINDRICAL SPACECRAFT

Many spacecraft have been spherical; the thermal design is easier because the projected area is constant. However, other considerations sometimes dictate another shape; a cylinder is a typical example. The radiation balance equation is similar but the ratio of projected area to total surface area is no longer  $1/4$ . If the sun shines on the cylinder end, the *projected area* =  $\pi r^2$ ; if the sun shines directly on the side, the *projected area* =  $2rh$ . In some cases it may be advantageous to make these two equal, by having the cylinder height about one and a half ( $\pi/2$ ) times the radius. However, the projected area is still not constant; the ratio of projected area to total surface area is then equal to:

$$\frac{a}{A} = \frac{\cos \theta + \sin \theta}{\pi + 2} \quad (3)$$

where  $\theta$  is the angle between the sun's rays and the cylinder axis. The maxi-

**DR. GARY D. GORDON** received his BA from Wesleyan University in 1950, and his MA and PhD in Physics from Harvard University in 1951 and 1954 respectively. For two years, Dr. Gordon worked for the U.S. Army at Fort Detrick, Maryland, doing experimental research on powders and design of mechanisms for dispersing powders. As a physicist at Operations Research, Inc., in Silver Spring, Maryland, for two years, he studied cloud transmissions of visible and infrared radiation, and radiation reflection from ground surfaces. As a senior engineer at the Astro-Electronics Division of RCA, Dr. Gordon worked five years on the analyses of problems relating to spacecraft. He contributed to the thermal design of the TIROS weather satellite and was responsible for the thermal design of the RELAY communication satellite; he has presented a series of lectures on Spacecraft Thermal Control to other RCA engineers. He has done research on plasma engines. He has written papers on plasma acceleration, geodetic use of satellites, and spacecraft thermal properties. In his present



staff position with Product Engineering as Administrator, Course Development, he is participating in the development of a program for the continuing education of RCA's engineering managers and leaders. Dr. Gordon is a member of APS, AIAA, AAS, AAAS, American Association of Physics Teachers, Sigma Xi, and Phi Beta Kappa.

mum projected area occurs for an angle of 45°, at which the ratio  $a/A$  is equal to 0.275, which can be compared to the minimum ratio of 0.195. Using these ratios in Eq. 1, with an  $\alpha/\epsilon$  ratio of unity, we find that the spacecraft temperature will vary from 10°F to 60°F.

Over a long time, such as a year, the average temperature will be given approximately by the average projected area. If an average is taken over all angles, with equal weighting for any direction in three dimensions, the average projected area is equal to  $1/4$  of the total surface area, the same as that of a sphere. It can be shown that this is true for all convex solids—the average projected area is always equal to  $1/4$  the total surface area. Therefore, the average temperature is the same as that calculated for a sphere.

#### TIME DEPENDENCE

It has been assumed that the spacecraft was at thermal equilibrium. If the cylinder is in one orientation, it will have one temperature; if it is then shifted to a different orientation its temperature will not shift instantaneously, but will gradually approach the new equilibrium temperature. To determine this time dependence the rate of change of temperature ( $dT/dt$ ) times the spacecraft thermal mass ( $m_c$ ) is set equal to the net energy input:

$$m_c \frac{dT}{dt} = \alpha a S - \epsilon A \sigma T^4 \quad (4)$$

Fig. 2—Average spacecraft temperature as a function of surface properties.

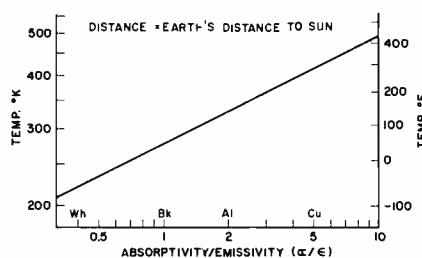

One solution of this differential equation is:

$$\frac{t}{2\tau} = \coth^{-1} \frac{T}{T_L} - \cot^{-1} \frac{T}{T_L} \quad (5)$$

Where:

$$T_L^4 = \frac{\alpha a S}{\epsilon A \sigma} \quad \tau = \frac{m_c}{4\epsilon A \sigma T_L^3}$$

The temperature  $T_L$  is simply the steady-state temperature given by Eq. 1. The temperature drop as a function of time is shown in Fig. 4. The initial point is determined by the initial temperature, after which the temperature decreases approximately exponentially with time, towards its final steady-state value. Similar equations and curves can be calculated for temperature rises, when the initial temperature is below the equilibrium temperature.

The time constant  $\tau$  is a useful spacecraft characteristic. Variations of energy inputs during times which are short compared to the time constant do not produce corresponding temperature variations; whereas if the times are long compared to the time constant, then the satellite temperature fluctuates with the energy input. The time constants for many spacecraft range from 1 to 10 hours.

#### EFFECT OF THE EARTH

Spacecraft in the vicinity of the earth present a more complicated thermal problem, because of the shadow pro-

Fig. 3—The effect of distance to the sun on average spacecraft temperatures.

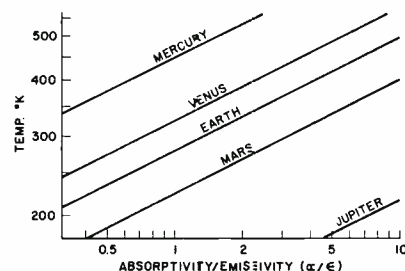

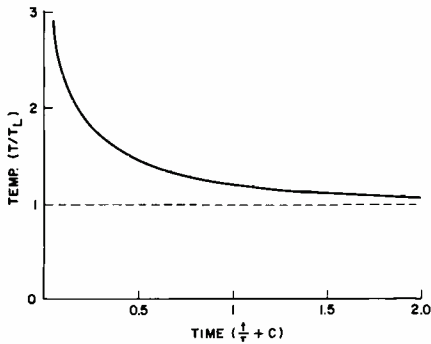

Fig. 4—A typical spacecraft cooling curve, assuming the spacecraft can be considered as one isothermal mass, and that the external conditions do not change.

duced by the earth, and the radiation coming from the earth. The latter can be a significant part of the total heat input for spacecraft less than a few thousand miles in altitude. This heat input from the earth must be included in any accurate temperature calculation, but will not be considered further here.

The other effect of the earth is to cut off the sunlight when the spacecraft enters the shadow of the earth. For a spacecraft in an orbit around the earth, this eclipse produces two effects on the spacecraft temperature, which are shown in Fig. 5. The average temperature drops from  $T_H$  to  $T_A$  because on the average there is less sunlight on the spacecraft. And there is a periodic fluctuation in temperature from  $T_D$  to  $T_N$  during each orbit.

The drop in the average temperature can be calculated from Eq. 1 by inserting the reduced sunlight. The ratio of average temperatures for two different orbits will therefore vary as the fourth root of the ratio of fractional suntimes. In particular, compared to the temperature  $T_H$  in an orbit with no eclipse (100% suntime), the average temperature  $T_A$  is given by:

$$T_A = T_H \psi^{1/4} \quad (6)$$

In the particular case chosen for Fig. 5 the fractional suntime  $\psi$  is 0.75 and the steady-state temperature in the sun  $T_H$  is 300°K, so the calculated average temperature  $T_A$  is 280°K. The apparent motion of the sun along the ecliptic, and the precession of orbits caused by the shape of the earth, will produce a variation in eclipse time for most spacecraft orbits. Over a period of months and years the average temperature will fluctuate, depending on the fractional suntime. In the early TIROS orbits, this produced a rise to about 90°F for a one-week duration every few months.

The drop in temperature in the actual eclipse is along the cooling curve shown

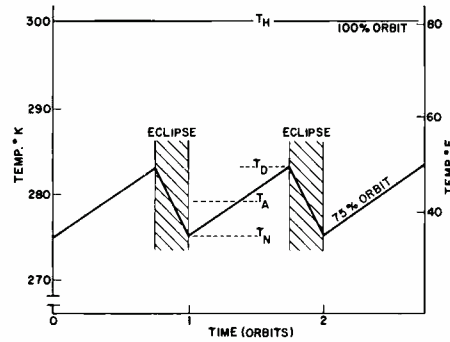

Fig. 5—Effect of solar eclipse on a spacecraft orbiting around a planet or a moon. The eclipse lowers the average temperature from  $T_H$  to  $T_A$ , and also produces a fluctuation of temperature from  $T_D$  to  $T_N$  each orbit.

in Fig. 4. However, for short eclipse times (short compared to the time constant), it looks like, and can be approximated by a straight line. The total temperature drop ( $T_D - T_N$ ) is, then

$$T_D - T_N \approx t_o T_A / 4\tau \quad (7)$$

For the assumed example in Fig. 4, a spacecraft with a time constant  $\tau$  of 6 hours, a time  $t_o$  in eclipse of 45 minutes, with an average orbit temperature  $T_A$  of 280°K, the calculated fluctuation each orbit is 8°K (or about 14°F).

The above analysis is useful for the large mass of most spacecraft, since these have time constants long compared to the orbit period. For short time constants, such as the ECHO balloon or a solar cell paddle, the steady-state temperature will be attained during the sunlight portion. The temperature drop during eclipse can still be approximated by Eq. 7, but is more accurately calculated from Eq. 5.

#### SPACECRAFT COMPONENTS

Two factors determine the temperature of an individual component in the spacecraft—the temperature of the environment, and its heat dissipation. A component such as a resistor may reach a high temperature due to internal dissipation. With the lack of air convection, and air conduction the power ratings of components often have to be reevaluated. Two methods of heat dissipation remain, conduction in solids and radiation.

#### Conduction in Solids

The heat conducted along the wire leads from a component to the mounting structure may be sufficient to cool the component. The heat conducted is, simply:

$$q_c = \kappa A' \Delta T / l \quad (8)$$

where  $\kappa$  is the thermal conductivity,  $A'$  the cross section available,  $l$  the length of the leads, and  $\Delta T$  the temperature difference.

#### Radiation

In other cases, the surface area of the component may be sufficient to radiate the heat. The heat radiated is then

$$q_r = \epsilon A (\sigma T_1^4 - \sigma T_2^4) \approx \epsilon A 4\sigma T_A^3 \Delta T \quad (9)$$

where  $A$  is the total surface area of the component. For very small power dissipations, this may be the easiest calculation to prove that no excessive temperature will occur. The power radiated for small temperature differences is shown in Fig. 6; larger internal dissipations may result in greater temperature rises, which often are excessive.

#### Conduction and Radiation

A combination may occur, in which the heat is conducted from the component and then radiated to the environment. If it is a simple wire, rod, or any other object with constant cross section, an effective length  $l_e$  is

$$l_e^2 = \frac{\kappa A}{\epsilon p 4\sigma T_A^3} \quad (10)$$

where  $A$  is the cross section and  $p$  the perimeter. As shown in Fig. 7, the rod may have a large area, but its effectiveness is reduced by the drop in temperature. The effective radiating area is equivalent to the perimeter multiplied by the effective length, and the amount of heat dissipated is equal to that dissipated if the effective area is added to the component area.

A striking example of this method of heat dissipation was the 50 watts dissipated by the travelling wave tube in the RELAY communication satellite. The structure was made up of struts and the calculated effective length of each was approximately 8 inches. The tubes were mounted so that the heat was conducted to a central fitting to which 12 struts are fastened. With a perimeter of 4 inches on each, an effective radiating area of almost 400 in<sup>2</sup> was achieved, with a negligible increase of weight. Neither a heavy heat sink nor a heavy radiator was necessary; in flight the tube temperatures have been well below limits.

#### MANNED SPACE FLIGHT

The manned spacecraft will be larger than many unmanned spacecraft, and the reliability requirements will be higher. Larger spacecraft will have longer time constants, averaging out temperature fluctuations, and making the thermal design easier. In an orbit around the earth, the temperature drop during eclipse will be smaller, and less important. The need for reliability will require some redundancy in the design; while active control will be used, the re-

liability and simplicity of passive control will be attractive wherever used.

Most of a man's time in space will be spent in relatively large spacecraft. In a well designed capsule or orbiting laboratory, any necessary repairs will be done from the inside. However, space suits will be available for emergencies, for lunar surface exploration, and possible erection of large structures in space. While active cooling units may be used for a space suit, a passive system can be adequate for a wide range of conditions.

Consider a man in a space suit exploring the dark side of the lunar surface (no sun). The dark surface of the moon is around  $-250^{\circ}\text{F}$ , and keeping the astronaut warm might appear to be a major problem. But the lack of air provides excellent thermal insulation, just as the lack of wind minimizes the effect of a cold day. With some additional insulation, a man may keep comfortable without extra sources of heat. The natural heat from a man  $q$  is of the order of 100 watts; the total surface area  $A$  of a space suit may be as high as 10,000 in<sup>2</sup>. With no heat inputs, a comfortable temperature of  $70^{\circ}\text{F}$  could be achieved by using an effective emittance  $\epsilon$  of 0.03, as can be shown from the heat balance equation

$$q = \epsilon \sigma T^4 \quad (11)$$

This effective emittance of 0.03 can be achieved with ordinary metallic surfaces, plus the insulation of a few layers of aluminized mylar. Variations of natural heat due to different physical activities could be compensated by different amounts of insulation. When a man is working hard he could take off his "sweater" of aluminized mylar; when he lays down to sleep, he could use a "sleeping bag" of aluminized mylar. Thus in an environment of  $-250^{\circ}\text{F}$  (or even absolute zero) a man could be comfortable without extra heaters or any active thermal control.

For a man in the sunlight, the problem is slightly more complicated, but still not too difficult. Suppose a man in a space suit is erecting a large structure in space, such as an orbiting laboratory. If the space suit were shiny copper, the man would roast, but with white paint, the temperature could be quite cool, as was shown earlier in Fig. 2. With the proper white paint, the effect of the sun can be minimized, and the same space suit used in the shade or in the sun. A different approach would be to use an umbrella and stay in the shade all the time; a slightly translucent umbrella would ease the thermal problem, shade the eyes from direct glare and ultraviolet, and illuminate the surroundings with diffuse light. The fact that um-

rellas and white coats are already used in the tropics is no coincidence.

The more difficult thermal problem is the astronaut exploring the sunny side of the moon, where the surface temperature can be as high as  $250^{\circ}\text{F}$ . This heat input is harder to reject than the sun, because all the spectral discrimination, and much of the angular discrimination is lost. This radiation is infrared, and, therefore, the absorptivity/emissivity ratio for all surfaces is practically unity. The radiation is coming from many directions, so a shield (an upside-down umbrella) might be awkward. Theoretically, it may be possible to develop surfaces that will not absorb heat coming from below the spaceman, but will emit heat in an upward direction. A simpler alternative would be to follow the example of desert caravans, and not travel at high noon; during the noon hours (for one earth week) the men would rest up in the spacecraft or in a cool cave, and exploring (traveling) would be done when the sun was closer to the horizon, and the lunar surface a more comfortable temperature.

In a few special situations, an active thermal control in a space suit will be required, with a cooling unit, a radiator to dissipate excess heat, and batteries or solar cells to supply the power. Initially, these may be desirable as back-up units. Fortunately, the time constant of hours allows a man some time to take corrective action if he finds himself getting too hot or too cold. In the long run, however, the method of thermal control will be the choice of an experienced astronaut, who will not carry around a cumbersome pack if simpler methods will suffice. The gadget that

he leaves behind will never give him any trouble!

### CONCLUSION

The computation of accurate temperatures for a specific point on a spacecraft in a given orbit is considerably more complicated, because of the interactions between various parts of a spacecraft. However, the same basic concepts that have been presented must still be used, with the heat balance equations involving the surface thermal properties, the geometry and areas of each surface, and the incident radiation from the sun, earth, and other parts of the spacecraft. For nonequilibrium conditions, the time constant determines the rate of change of temperature. In some cases, the internal heat generated is significant and must be included.

For space suits, the requirements of the thermal design will have to be integrated with the many other requirements of a space suit. Active cooling units may be used for some space suits, but a passive system can be adequate for a wide range of conditions.

### BIBLIOGRAPHY

1. *Surface Effects on Spacecraft Materials*, (F. J. Clauss, Editor) J. Wiley & Sons, New York, 1960. A collection of pertinent papers.
2. *Measurement of Thermal Radiation Properties of Solids*, NASA-SP-31, National Aeronautics and Space Administration, Washington, D.C., 1963. A collection of 57 papers presented at a NASA-NBS-USAF symposium in Dayton, Ohio, on September 5-7, 1962.
3. Dr. G. D. Gordon, "Measurement of Ratio of Absorptivity of Sunlight to Thermal Emissivity," (RCA-AED), *The Review of Scientific Instruments* 31-11, pp 1204-1208, Nov. 1960.

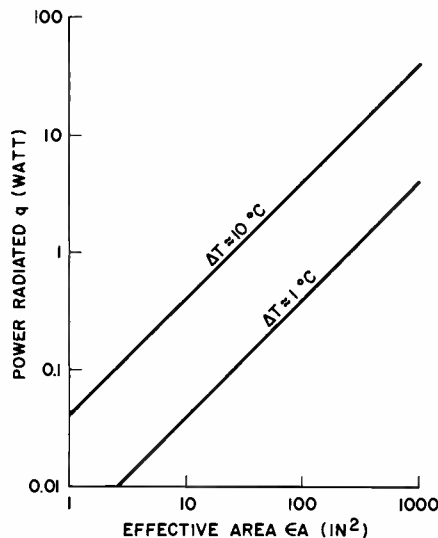
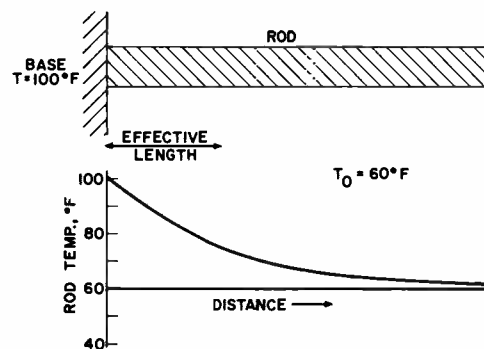

Fig. 6—Power that can be radiated by a component for a given temperature difference  $\Delta T$  between the component and the surrounding spacecraft. Power dissipations substantially below the curve can usually be considered negligible.

Fig. 7—Temperature distribution of an infinite rod, in an environment at one temperature, with the base of the rod held at a different temperature.



# THERMOELECTRIC WATER RECLAMATION FOR MANNED SPACE VEHICLES

One of the life-support problems for manned satellites and rocket trips through space is drinking water storage and handling. Discussed herein is a practical method for reclamation of drinking water from urine by use of thermoelectrics, including both theory of operation and data from working models.

**P. E. WRIGHT, Ldr.**

*Applied Research, DEP, Camden, N. J.*

A SPACE VEHICLE capable of carrying a three-man crew on a twelve-month mission requires a minimum amount of water for drinking and body hygiene of 1,500 gallons, or approximately 12,500 pounds. This is an unacceptable addition to the pay-load, even without a margin of safety for an unexpected extension of the mission length. The alternative to storage of the entire water requirement is water reclamation on board the space vehicle.

The major portion of the impurities in urine can be removed by distillation; however, the high content of solids in the distillant can lead to particulate carry-over in the distillate, requiring supplementary treatment for removal.

The feasibility of water recovery from urine by distillation has been studied by several investigators. The technique is considered to be feasible; however, its efficiency has been questioned as to the potability of the water recovered. Ingram<sup>1</sup> presented evidence that about 50% of the water recovered from urine by distillation needs further treatment to make it potable. Hawkins<sup>2</sup> examined other techniques, such as freezing, electro-osmosis, and ion exchange. He found that potable water could be obtained with each of these techniques. Sendroy and Collison<sup>3</sup> examined two techniques for recycling potable water from urine, i.e., acid distillation and lyophilization (freeze-drying). Potable water was recovered by both techniques. Acid distillation included adding sulfuric acid ( $H_2SO_4$ ) and potassium chromate ( $K_2CrO_4$ ) to the raw urine, then boiling out 85% of the initial volume, which was in turn poured over a column of moistened activated charcoal. Lyophilization of the

urine was accomplished with a methyl cellulose and dry ice mixture. The resultant frozen material was vacuum dried. Recovery of the sublimate yielded almost all of the original water content. Konikoff<sup>4</sup> described a technique that consists of vacuum distillation and oxidation of the vapor products in the presence of a catalyst at high temperatures, followed by condensation.

Under normal conditions of health, urine is usually sterile; however, latent pathogenic organisms may be present in the body and these can be extracted in the urine. The usual process of distillation has sufficient heat to kill these.

Thermoelectric distillation devices have been investigated as a means for meeting the time-temperature conditions set by the USPHS Drinking Water Standards for bacteria destruction.

## THERMOELECTRIC DISTILLATION

Recent work at RCA has demonstrated that thermoelectric distillation techniques have significant advantages for

P. E. WRIGHT received his BSME from the California State Polytechnic College and his MSME from the University of Pennsylvania. From 1958 to 1960, Mr. Wright participated in the RCA Graduate Study Program. Mr. Wright joined RCA in 1958 as a member of DEP Applied Research and has remained in this department, moving through various assignments and responsibilities to the present position of Engineering Leader. His work has been generally in the area of thermodynamics with specific emphasis on direct energy conversion systems. His work with Applied Research has included thermoelectrics, both refrigeration and power generation, thermionics, fuel cells, and battery systems. Mr. Wright was responsible for the development of the first thermoelectric air conditioner with a coefficient of performance of greater than two. He was responsible for the first fossil-fuel, silicon germanium thermoelectric generator. Under Mr. Wright's direction, a magnesium-mercuric oxide battery was developed which exhibited an energy density of watt-hours per

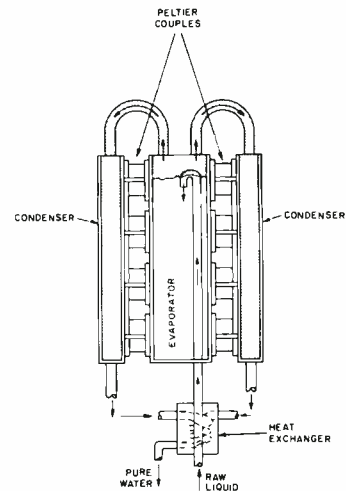

Fig. 1—Thermoelectric distillation device principle.

application in manned space systems. This approach leads to high temperature bacteria destruction, while having reduced weight requirements and lower power consumption than other systems. The application of thermoelectric theory<sup>5,6</sup> to the distillation problem is shown schematically in Fig. 1.

Peltier couples are sandwiched between a boiler and condenser. In operation these Peltier couples absorb heat in the condenser from the condensing vapors and pump it up to a temperature where it will be usable in the boiling operation. The couples serve the same function as the compressor in a vapor compression cycle, and permit regeneration of the energy of the process so that the only energy that must be supplied is the joule heat generated in the thermoelements and the heat conducted back through the thermoelements.

The power  $P$  required to operate the thermoelectric still is a function of the temperature difference across the couples  $\Delta T$  and the figure-of-merit  $Z$  of the

pound. Mr. Wright has directed several system studies in the area of direct energy conversion. Mr. Wright is the author of several technical papers on the subjects of energy conversion and heat transfer.



Final manuscript received January 19, 1965.

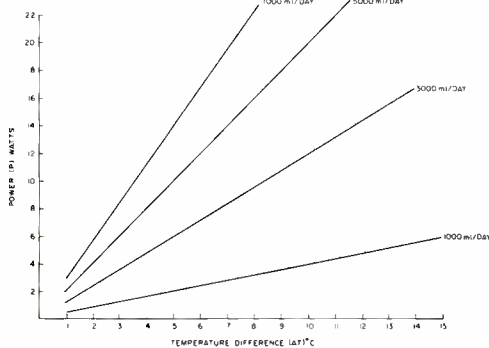

Fig. 2—Power consumption of a thermoelectric distillation device.

thermoelectric material. For constant  $Z$  and small  $\Delta T$ 's the power is:

$$P = \frac{K}{T} \left( \frac{\sqrt{1+ZT} + 1}{\sqrt{1+ZT} - 1} \right) \Delta T \quad (1)$$

Where:  $K$  is a measure of the distillation rate. Fig. 2 shows power consumption as a function of temperature difference for various distillation rates.

The temperature difference across the thermoelectric circuit is established by the heat flux rates and the heat transfer coefficients at the boiling and condensing surfaces. The temperature difference is a function of the heat flux rate for water boiling and condensing on vertical surfaces. Since the temperature difference at the boiling surface is the largest, it limits the efficiency of the thermoelectric still. It has been experimentally established by RCA that 2,500 milliliters of water per day can be distilled at a power consumption of 20 watts. This can be improved by thin-film boiling techniques, or by operation in a high force field.

#### CREATION OF A FORCE FIELD

The zero gravity of space or the reduced gravity of other planets adversely affects boiling and condensing, or phase separation, natural convection, and even forced convection.

This problem could be attacked by the use of free surface energy or capillary action. The use of this mode of fluid transport, however, would inherently lead to a large and bulky distillation device. A more desirable solution to the problem is to supply an artificial acceleration field in which boiling and condensing may take place. When supplying an artificial acceleration field, one need not be satisfied with the 1-g acceleration field found on the earth's

surface. It can be shown, in fact, that improvements in the thermodynamic performance can be achieved by increases in the value of the acceleration field. This is especially true when considering natural convection and the separation of a liquid and gaseous phase, as in boiling and condensing.

Considering natural convection, McAdams<sup>5</sup> states that

$$N\mu = 0.14 (G_R \times P_R)^{1/3} \quad (2)$$

Or:

$$\frac{hL}{K} = 0.14 \left[ \left( \frac{L^3 \rho^2 \beta \Delta T g}{\mu^2} \right) \left( \frac{C_p \mu}{K} \right) \right]^{1/3} \quad (3)$$

Since  $Q/A = h\Delta T$ :

$$Q/A = 0.14 \left[ \left( \frac{L^3 \rho^2 \beta g}{\mu^2} \right) \left( \frac{C_p \mu}{K} \right) \right]^{1/3} [\Delta T]^{1/3} \frac{K}{L} \quad (4)$$

In these equations,  $N\mu$  = Nusselt number,  $h$  = surface coefficient of heat transfer,  $L$  = geometrical factor,  $K$  = thermal conductivity of fluid at bulk temperature,  $\rho$  = fluid density,  $\beta$  = coefficient of volumetric expansion,  $\mu$  = viscosity,  $g$  = acceleration of gravity,  $C_p$  = specific heat of fluid, and  $Q$  = heat transfer rate.

Therefore,  $Q/A$  is increased by the ratio of the acceleration fields raised to the 1/3 power, all other parameters being held constant. The acceleration field could be produced by an angular velocity acceleration in the radial direction. The power  $P_g$  required to produce a gravity field in this way is:

$$P_g = K_g \omega R \quad (5)$$

Where:  $\omega$  is the angular velocity,  $R$  is the distance from the center of rotation to the center of mass of the rotating element, and  $K_g$  is the constant of proportionality. The total power consumed by the space vehicle thermoelectric still is a linear combination of the power  $P$  in the thermoelectric circuit and the power  $P_g$  required to create the gravity field. Simultaneous consideration of Eqs. 1, 4, and 5, together with a graph of heat flux rate vs. temperature difference, controls the design for minimum total power consumption.

#### POST-DISTILLATION TREATMENT

In order to meet the USPHS Drinking Water Standards, the product of urine distillation must be treated further. In general, the material produced is malodorous, alkaline, and contains materials which make it unfit for human consumption. The quality can be improved by chlorination, ion exchange, filtration, acidification, or oxidation. The distillate is generally turbid,

yellow in color and has an ammonia odor. These impurities can be removed by using absorption filtration and mixed-bed ion exchange. Activated carbon as the adsorption filtration medium will remove turbidity, color, and organic matter. The mixed-bed ion exchange column will remove ammonia, chlorides, and sulfates.

Consider the case in which the requirements are for a minimum yield of 85% with a minimum recovery rate of 11 pounds of potable water in 24 hours (1.3 gallons/24 hours); a minimum of 1.5 gallons of urine per 24-hour period would have to be processed. If a high concentration of dissolved solids in the distillate is assumed, the size of the ion exchange column could be calculated. For example, for a 3-day test period, 4.5 gallons of urine would be treated. If it is assumed that the distillate contains 100 ppm (i.e., 6 grains per gallon) dissolved solids, then a total of 27 grains of dissolved solids would have to be removed from 4.5 gallons of urine. A mixed-ion exchange bed consisting of strong-acid cation resin and a strong base anion resin will remove one grain of dissolved solids per gram of resin at the reasonable flow rate of 3 to 5 gpm per square foot of surface area. At this exchange capacity, 27 grams of resin would be required and the volume of the resin would be about 0.002 cubic feet. For a 14-day mission, 130 grams of resin would be required, and this would occupy about 0.010 cubic feet. Commercial ion exchange cartridges which claim to give the equivalent of triple-distilled water are available. The research model Illcoway ion exchange cartridge can process 1,500 gallons of water and remove 29.2 grams of solid waste. Its size is about 19 x 2.5 inches. In addition to the assembled cartridges, ion exchange resins are available for anion, cation, mixed-ion beds for solid particle removal.

A filter of activated charcoal (carbon) should be used in conjunction with the mixed-bed resin to remove color, turbidity, and organic matter from the urine distillate. The carbon filter would precede the resin bed to minimize any organic fouling of the resin beads. Using the volume ratio of 2 to 1, resin to carbon, the volume of activated carbon required is 0.001 cubic feet for 3 days, or 0.005 cubic feet for 14 days. Assuming the density of carbon to be 15 lbs/cubic foot, 7 grams would be required for 3 days, or 35 grams for 14 days. Therefore, the total volume of resin and carbon required for supplemental treatment of the urine distillate to provide potable drinking

water for 14 days would be 0.015 cubic feet, or 26 cubic inches.

**MODEL THERMOELECTRIC DISTILLATION DEVICE**

Applied Research has designed and tested a model thermoelectric distillation device for the purification of urine (Fig. 3). The device has 72 thermoelements, 7 mm in diameter and 3 mm long. It delivered 2,500 milliliters of water per day using 20 watts of electrical power. The model weighs 1 pound and occupies 16 cubic inches.

The distillate was typical of that usually obtained by distillation processes. Further treatment with activated charcoal produced potable drinking water meeting USPHS Drinking Water Standards. Subsequent use of a mixed-bed ion exchange column substantially improved the quality of the water. Distillate from the thermoelectric still was fed into a filter of activated carbon, thence into the ion exchange column. The resultant clear, odorless fluid exceeded in purity the standards set by the USPHS.

**BATCH-TYPE THERMOELECTRIC DISTILLATION DEVICE**

Fig. 4 shows the design of a batch-type thermoelectric distillation device for manned space vehicles. Since it is a batch-type unit, some means for the storage of both unprocessed urine and potable water had to be provided. The receptacle for storage also had to provide the means of fluid transport, that is, positive displacement. Both of these requirements were met by a collapsible bladder of the type shown in Fig. 4. The distillation unit itself consists of two concentric cylinders separated by a wall of thermoelectric modules. The two storage spaces can be isolated from each other by means of a valve at the top of the unit. The entire unit is rotated at 196 rpm by a small electric motor, providing an acceleration field of 2 g at the urine wall. Power for the unit is brought in through two slip rings on the outer shaft. A typical batch cycle would proceed as follows.

The plunger *A* is in the retracted position. The valve block *C* is in the forward position, preventing urine from flowing into the condenser area. A bladder holding one batch load of 7.5 pounds is connected at *B* and is depressed, forcing the fluid into the boiler cavity. A spring-loaded check valve at connection *B* prevents the escape of fluid. The bladder is now removed from connection *B* and the spin motor started, thereby causing the fluid to be forced against the walls of the cavity. Power is applied to the thermoelectric modules, causing the fluid in the boiler

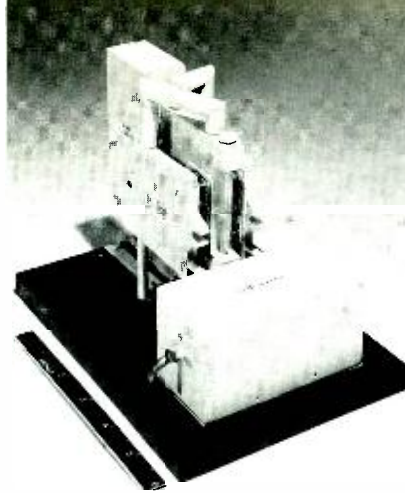

Fig. 3—Experimental thermoelectric distillation device.

cavity to boil. When the boiling condition is reached, valve block *C* is pulled back, allowing the vapor to diffuse to the cold side of the condenser chamber (wall *E*). As soon as vapor condenses on this surface it will be thrown to the outer wall and collected there. When all of the fluid has vaporized, thermoelectric power is shut off by a temperature sensor in the boiler cavity.

At this time, valve block *C* is put in the forward position and a clean bladder is connected at *D*. A hand pump is connected at *F* and the bladder in the condenser inflated, forcing the water into the receiver bladder. The inlet to this bladder includes a removable charcoal filter and an ion exchange volume for final processing of the water. This bladder can now be used for dispensing of the water. Another bladder is now connected at *B* and plunger *A* is pushed forward, displacing the residue. A fresh supply of urine is connected at *B* and the cycle repeated.

It is estimated that a distillation unit of this type built to operate in a space environment could distill 15,000 milliliters of water per day with less than 100 watts of power consumption. Such a device would weigh less than 25 pounds. These specifications substantially exceed those of any alternate approaches.

**ACKNOWLEDGEMENTS**

Many members of the RCA engineering staff have made contributions to this investigation. The author wishes to acknowledge the efforts of all those involved, particularly B. Shelpuk and J. F. Panas of Applied Research, and Dr. M. H. Halpern of the Aerospace Systems Division.

**BIBLIOGRAPHY**

1. W. T. Ingram, "Orientation of Research Needs Associated with Environment of Closed Space," *Proceedings of the Fourth Annual Meeting of the Advances in Astronautical Sciences*, Vol. 2, December 1957.
2. Hawkins, *J. Av. Med.*, Vol. 29, p. 525, 1958.
3. Sendroy and Collison, *Aerospace Med.*, Vol. 30, p. 640, 1959.
4. Konikoff, GE MSVD Rept. TIS R59SD-443, October 1959.
5. A. F. Joffe, *Semiconductor Thermoelements and Thermoelectric Cooling*, Information Ltd., London, 1957.
6. P. E. Wright, "Thermoelectric Refrigeration, Heating, Temperature Control, and Distillation," *RCA Engineer*, Vol. 9 No. 3, October-November 1963.
7. M. Jakob, *Heat Transfer*, Vol. 1, p. 620, John Wiley and Sons, Inc., New York, 1949.
8. W. H. McAdams, *Heat Transmission*, 3rd Edition, McGraw-Hill, 1954.

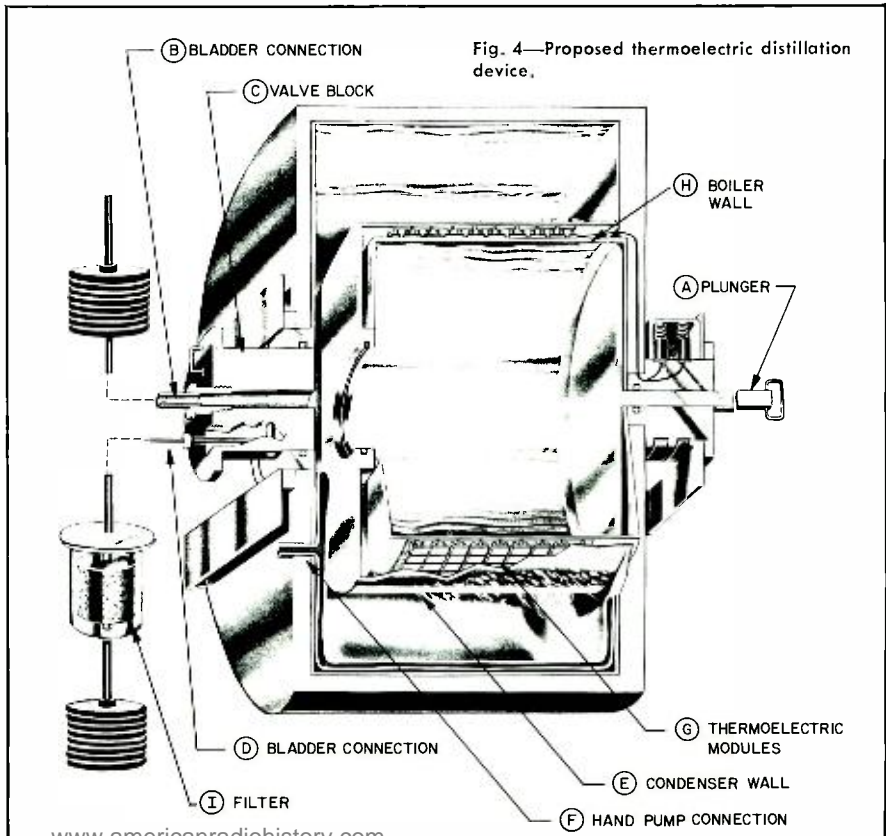

Fig. 4—Proposed thermoelectric distillation device.



## More than just the "Blessing"

May the light of MIL STAN-  
DARD 803 shine upon thee.



**DR. H. B. MATTY, Ldr.**

*Human Factors Engineering Group*

*Communications Systems Division, DEP, Camden, N. J.*

IN THE Communications Systems Division, the human factors group performs most of its work in three engineer areas: systems engineering, design engineering, and product assurance. The human factors engineer's performance in systems engineering and in design engineering are quite different from his duties in product assurance activities.

The role of the human factors engineer in product assurance is that of a design evaluator. As a standing member of the design review board, his function is to provide assurance that equipment designs conform to human factors engineering design standards and/or mil specs. Program managers and design managers sometimes characterize this as having their design "blessed," and naturally are concerned about the cost related to obtaining the "blessing."

It is hoped that this paper will show that human factors engineering should be included as an integral part of the systems and design engineering; whenever this approach is taken, no additional costs are introduced. Thus, the human engineering effort should be defined at the initial planning stages and funds allocated for such work. Since the human factors engineering costs are

comparable to those of other engineers, the overall contract cost is not increased.

Since there are differences among nearly all contracts, not all the work to be described is applicable to any one specific contract. Nevertheless, human factors engineering contributions can be related generally to those portions of the engineering development cycle of frequent concern to CSD's engineering department.

### HUMAN FACTORS ENGINEERING TASKS IN SYSTEM ENGINEERING

Human factors engineering tasks performed as part of systems engineering have to do with generating specifications of system requirements. At the risk of some oversimplification, these tasks can be classified as follows:

- 1) Man-machine allocation of system functions
- 2) Task-equipment analysis
- 3) Operations analysis
- 4) Model and mockup analysis
- 5) Environmental analysis

The purpose of these is to define the role of the operator in the system, to determine the most desirable combination of manual and automatic operations, to specify the requirements for the operator's ambient environment, and to specify the system requirement for dis-

plays, controls, and display-control arrangement. The human factors engineer doesn't solve these problems by himself. Rather, he contributes as a member of the systems engineering team.

### Man-Machine Allocation of System Functions

This is an examination of various combinations of manual and automatic functions, and selection of the preferred combination. Often the preferred combination is the one which minimizes cost without decrement in performance, but a variety of other parameters such as weight, availability, reliability, etc. also must be considered and traded off.

In addition to the system's gain in adaptability resulting from employment of an operator, there are other gains. A system which takes full advantage of the operator's capability to perform subsystem functions manually will be simpler and less costly than one which does not. The obvious reason for this is that there will be less requirement for the design and fabrication of complex automatic equipment. There are two classes of human factors which set the limit on the extent to which manual operation can be successful.

One class is the limitations which are independent of any specific system, but are inherent in the human. Some examples are the smallest visual angle which can be resolved; reaction time, i.e. lag between signal and initiation of action; the unreliability of recall from memory of large stores of information; frequency response characteristics for both vision and audition; and a variety of other limitations such as reach, locomotion rates, visual field, and many others.

The other class is the limitations which are imposed by system operating requirements. Put simply, the human can only accomplish so much within a given period of time or for a given length of time.

These two classes of limitations on manual operation are not independent. Clearly, the amount of workload which an operator can handle effectively is a function of things we have called inherent limitations. However, for practical purposes, i.e. system design allocation of functions to man and to machine, it is useful to distinguish the classes in order to clarify the two consequent needs for automatic equipment.

The first need for automatic equipment is to do things at a speed, strength, sensitivity, or precision, of which the operator is inherently incapable. The second is for equipment to perform system functions which conceivably could

be done manually but should not be because of potential operator work overloads and consequent deleterious side effects on other system parameters.

This allocation of system functions is the first step toward specification of the system requirement for displays and control. But first, the functions allocated to man must be analyzed further.

#### Task-Equipment Analysis

This consists of listing and breaking down the system functions allocated to man, and a breakdown of those functions into logical elements or task steps. Each step is examined and its implication for display design is derived from a statement of what information will enable the operator to make the required decision. The step's implication for control design is derived from a statement of the operator motor action required to execute the step.

#### Operations Analysis

Problems of display-control arrangement or work area layout often require analyses of the operations, more dynamic than that of the task-equipment analysis. These operations analyses are made as needed, when the necessary arrangement is not immediately inferable from the task-equipment analysis. These are of several types, two of which are often done in CSD:

- 1) *decision diagrams* are used to examine sequential interaction between operator events and equipment events, and
- 2) *link analysis* is used to study the relationship between any two operating variables such as frequency of use vs. panel location, locomotion vs. rack location, or hand movements vs. eye movements.

#### Model and Mockup Analysis

Equipment arrangements should be tried before design decisions are made firm. For problems of environmental arrangements, locomotion traffic, and rack location, it is easier to work with large scale models because the items to be manipulated are too large to be moved around easily. For work area layout, such as a given console or rack, a mockup to actual scale is preferred, since the items to be manipulated are no larger than a single panel.

Area models are used for study of the interaction, of the system under development, with other systems. These are of the largest scale, usually about 40:1. Fig. 1 shows such a model used in the course of synthesizing operations in an Army support system at a time when system design alternatives were still under study.

The next step is to construct models for use in preliminary planning of equip-

ment packaging and work space. These could be as large a scale as 16:1 or as small as 1:1. They are usually constructed as soon as operations analysis has proceeded far enough to suggest a likely division of the required equipment and of the related operations. Fig. 2 illustrates such a model, used for preliminary layout of equipment in an Air Force contract.

The actual size mockups are started after work with the large scale models has led to a feasible packaging arrangement. At this stage, the area allocated for each display/control unit is roughly identified. As the task-equipment analysis is elaborated, its implications for equipment design are encompassed in the mockup by elaborating details; Fig. 3 shows full scale mockups of the upper left area of Fig. 2.

#### Environmental Analysis

The operator's requirements for air movement, light, and ambient noise control, are quantitative. The related design problems are susceptible of solution by computation. The precision of solutions obtained by quantitative analysis is considerably greater than design decision based on off-hand opinion. It pays off in greater comfort and convenience for the operator, less operator fatigue and distraction, and consequently fewer performance errors (higher overall system reliability). Toward this end, the human factors engineer writes the system requirement, for the operator's ambient environment, in quantitative terms.

In summary, the human factors engineer uses a variety of techniques to accomplish those system engineering tasks which have to do with man-machine relationships. However, the results often converge to written outputs such as specification of the system display-control requirement and specification of the ambient operating environment. Some of his tasks, such as task-equipment analysis and model and mockup analysis, are originated prior

to such specification but continued throughout the equipment design phase.

#### HUMAN FACTORS ENGINEERING TASKS IN DESIGN ENGINEERING

The major human factors engineering tasks in design engineering are:

- 1) human engineering the operable equipment
- 2) human engineering the overall layout
- 3) human engineering the ambient environment
- 4) providing inputs to maintainability engineering
- 5) generating operating procedures

The purpose of these tasks is to contribute to the design those features which will make operation and maintenance of the equipment safe, reliable, and effective. These tasks are accomplished in a face-to-face working relationship with the design engineer.

#### Human-Engineering the Operable Equipment

Displays and controls are the primary interface between operator and equipment. Since the requirements for these will have been specified previously, this task is to implement the details of display-control design. Ordinarily this includes consulting with the design engineer on selection of display and control components, and furnishing him with a layout which is consistent with the anticipated operating procedure. The related packaging problem is resolved mutually when further tradeoffs or compromises are necessary.

#### Human-Engineering the Overall Layout

Usually, the shelter, or room where the equipment is to be installed, requires a layout accommodating the movements and actions of operators and maintenance technicians. The human factors engineer must account for needs for visual surveillance, verbal communication, locomotion traffic, storage of job aids, and the space requirements entailed by anthropometry. His recommendations are based on further elaborations of operations analysis and trying

Fig. 1—An area model (40:1) used by RCA human factors engineers for synthesizing operations in an Army support system.



alternative arrangements in the large scale model. The approach was established in a pre-design phase (Fig. 2); the details are firmed up as the equipment design proceeds.

#### Human-Engineering the Ambient Environment

The environmental variables of concern are temperature, air motion, light, and sound. Temperature and air motion are interacting variables which can be controlled by proper selection of the heating-cooling equipment. The shelter lighting requires a determination of both luminance and location. Noise control is a greater problem. The primary noise sources in our systems are the blowers in the air conditioner and the equipment racks. Beyond noise consideration in the designer's choice of blower, there remain three techniques for noise reduction: treating the source (baffling), treating the path (absorption), and treating the ear (protective covering or insert). The effect of each treatment is predictable. The human factors engineering solution is obtained from computation of available data and empirical measurements.

#### Human Factors Inputs to Maintainability Engineering

Design for maintainability is of concern to the human factors engineer because maintenance is performed by a human. Inputs to the maintainability engineer include anthropometric requirements for installation and removal, human lift capabilities, and dexterity limits.

#### Generation of Operating Procedures

Operator procedures are of interest not only for their impact on equipment design, but also in their own right for inclusion in instruction manuals. These procedures are collected from data available from operations analysis and task-equipment analysis. The procedures are tried out on the mockup, and a modification made in either design or procedure at each point of difficulty. The engineering writer of instruction manuals can

obtain all necessary information on procedures from human factors engineering, thus saving an interview of each design engineer.

In summary, during the design phase, the human factors engineer works with the design engineer to implement those system requirements related to displays and controls, to work area and environment, and to procedures.

The human factors engineer also performs a wide range of tasks not of major concern here, such as research, simulation, proposal writing, test and evaluation, and many others. However, the purpose of outlining his work in the areas of systems engineering and design engineering was to lead up to this point: whenever these cooperative methods have been followed, the design review for conformance to human factors standards and mil specs, is bound to be favorable.

#### THE TOPIC OF EXTRA COST

When others sometimes misconceive his function, the human factors engineer sees the misunderstanding as an occupational challenge. But, if he is experienced, he has found that such misconceptions do not yield to argument; usually, he must wait for the opportunity to demonstrate the value of his work.

One exception to this is the topic of extra cost; this always provides the human factors engineer a golden oppor-

tunity to expound on the difference between cost and *extra* cost. For example, it costs something to derive the system requirement for displays, controls, and display-control arrangements, and to write the systems specifications for them. But it has to be done, and some systems engineer must do it. The human factors engineer can re-apply his experiences and knowledge gained from other projects; and his engineering rates are comparable. Since the project engineer can allocate such work to the human factors engineers, much precious design engineering time can be directed toward the other phases of equipment design and development.

#### CONCLUSION

The solution of human factors engineering problems in this manner, starting with the early system design and continuing through the hardware design phases, avoids the unnecessary risk of having the systems and design engineers attack the entire problem and not solve the human factors problems. Such employment of the human factors engineer also avoids many ECN's that would otherwise be generated at the design review. To include the human factors engineer as a member of the system engineering team and the design engineering team not only saves time and money but also yields a better product. *And that's much more than just the "blessing"!*

DR. H. B. MATTY is a graduate of the University of Arizona, and holds the PhD in Psychology from Florida State University. From 1941 to 1947, he was employed by the New York Telephone Company, and was on leave of absence with the U.S. Army during World War II. Recalled to active duty with the U.S. Air Force in 1948, he worked two years with airborne radar and two years in electronic countermeasures. During 1952 and 1953, as an electronics engineer for Bell Aircraft Corporation he participated in R&D testing of the RASCAL missile's guidance system and also established operating procedures for the guidance operators. While a Graduate Assistant at Florida State University from 1954 to 1957, he taught psychology and conducted behavioral research. In 1957, he established the Psychology Laboratory in the Research

Department of the Coral Gables Hospital. Dr. Matty joined RCA in 1960, as Systems Engineer and became a group leader in 1961. Currently, his group is responsible for all human factors engineering within his Division. He also consults throughout the company on man-machine problems, and is RCA's representative to the EIA subcommittee on Human Factors in Electronics. Dr. Matty is a Senior Member of the IEEE and a Member of the IEEE Groups on Engineering Management and on Human Factors in Electronics, a Member of the Eastern Psychological Association, and of the American Psychological Association (Society of Engineering Psychologists). He is the author of numerous technical papers, and is listed in "American Men of Science." (Dr. Matty is shown in Fig. 3.)

Fig. 2—A van model (16:1) used for preliminary layout of equipment in Air Force communications system.

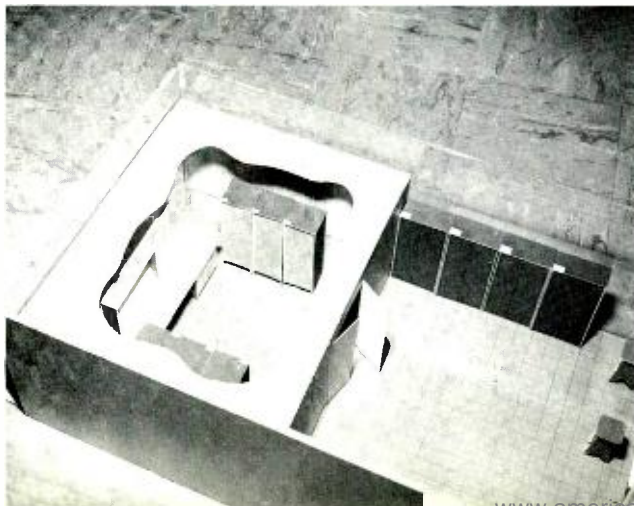
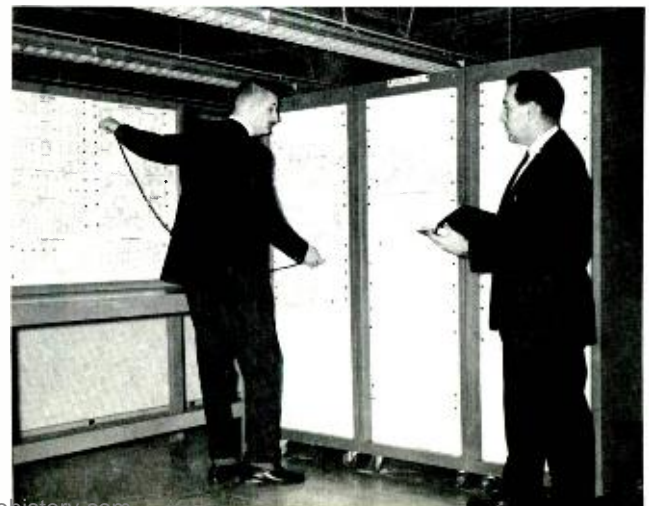

Fig. 3—F. DeWitt Kay (left) and the author, Dr. Matty, use a full scale model for verifying compatibility of design and operating procedures. These racks are shown in the upper left corner of Fig. 2.



# SELECTION OF LETTER SIZE AND LIGHTING FOR DISPLAY AND CONTROL PANEL LEGENDS

Selection of proper letter size, background and illumination conditions for display panels is vital to good legibility. An experimental investigation of legibility using various letter sizes, ambient illumination conditions, viewing distances, and figure-background relationships is discussed herein; recommended letter heights for various viewing conditions are given in tabular form. A bibliography of basic works on legibility is included.

W. R. BASKERVILLE and R. N. GILLIS

Human Factors Engineering  
Systems Engineering, Evaluation, and Research  
DEP, Moorestown, N. J.

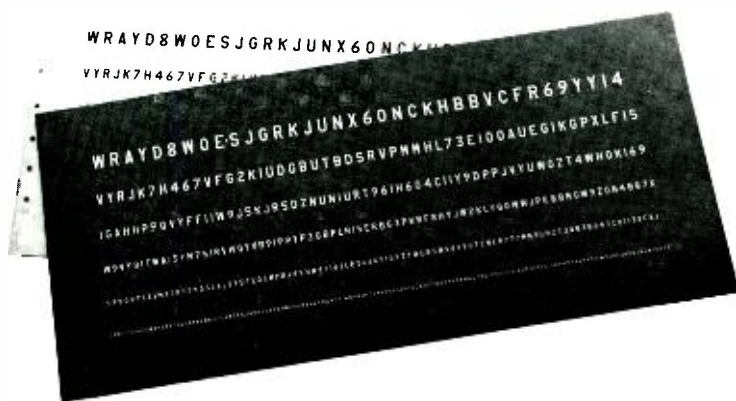

Fig. 1 — Test panels used for the experiment.

**A**MBIENT illumination requirements in monitoring and control rooms range from levels as low as 0.1 foot-candles where certain cathode-ray tube displays must be observed, to levels of 50 foot-candles or higher for other tasks. No matter what the ambient lighting requirements are, legends on display and control panels must be easily read from viewing distances determined by the operator's tasks. Well coordinated designs for displays and room illumination are required for efficient operation.

### LEGIBILITY

Legibility of panel lettering is affected by a great many factors. For the panel

*Final manuscript received January 20, 1965*

design, the most important of these factors are: letter size, figure-ground contrast, viewing distance and ambient illumination. Too often these factors are treated as if they were unrelated. Occasionally legends are not sufficiently legible, but more often designs are more costly than required. For example, expensive back-lighting is used where a slight increase in letter size might, instead, have provided adequate legibility. Or, panels are made larger than would have been necessary if smaller lettering, with proper ambient illumination, better figure-ground contrast or back-lighting had been used. Although most human factors handbooks recommend minimum letter sizes for given viewing distances

under "average" lighting conditions, similar data are not available for various levels of ambient illumination found in operations rooms. Clear-cut guidelines are also unavailable for determining under which viewing conditions panel legends should be back-lighted. Brief laboratory experiments were therefore conducted to fill the need for this type of design information.

### LEGIBILITY LAB TESTS

Two fiberglass display panels (Fig. 1) with inverse figure-ground contrast relationships were used to check legibility. Pigments and translucent materials for these test panels were the same as those used in the BMEWS system, but the ex-

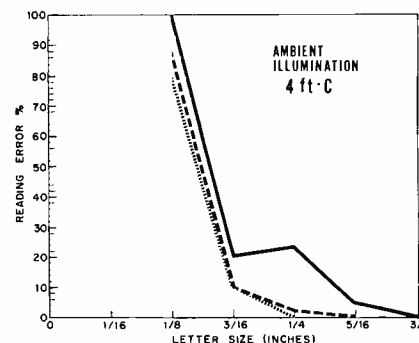
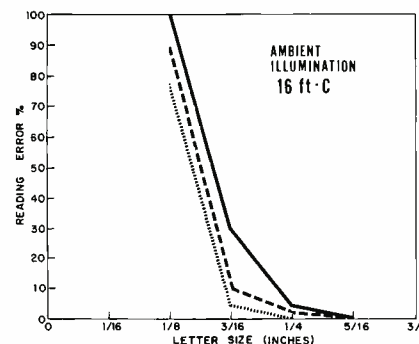
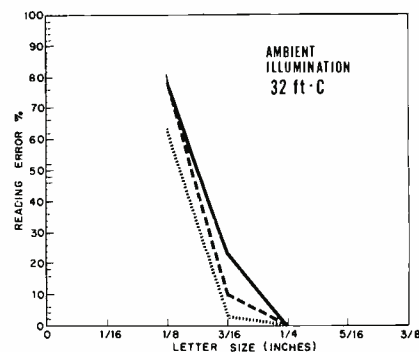

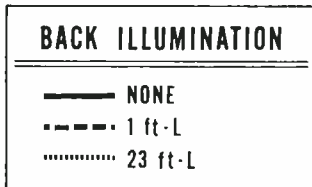
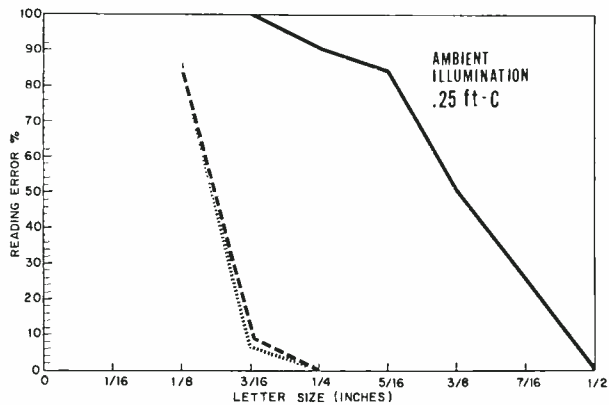
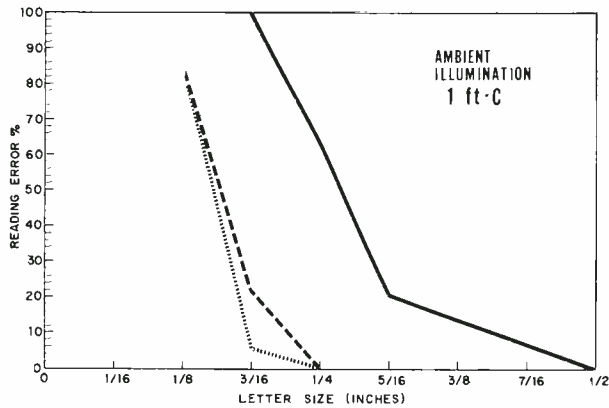

Fig. 2—Effects of ambient and back-illumination on legibility (black letters on translucent background viewed from 10-foot distance).



WORTHAM R. BASKERVILLE received his BA in Psychology from Brown University in 1958 and an MA degree in the same field from Temple University in 1960. In 1959 he joined RCA and is now a member of the Human Factors Engineering activity in DEP's Systems Engineering, Evaluation and Research (SEER) organization. He has participated in the BMEWS, Dyna Soar, ComLogNet and AADS-70 programs. He specializes in the analysis of control and display requirements for man-machine systems and in the development of operating procedures.



ROBERT N. GILLIS holds a Bachelor of Fine Arts degree in Industrial Design awarded by the Philadelphia Museum College of Art in 1959. The same year he joined RCA, Moorestown, where he is now a member of SEER's Human Factors Engineering team. He has participated in the design of display and control facilities and operation centers for BMEWS, for an Executive Coordination Center, The SAC Airborne Command Post, the Apollo Ground Operational Support System and for an advanced mobile air defense system (AADS-70).

perimental results should be applicable to other systems as well.

Test Panels	% Reflex-tance	Figure Ground Contrast Ratio
A. Opaque black letters on translucent white	2.4 11.	1:4.6
B. Translucent white letters on opaque dark gray	26.6 6.6	4:1

Each panel had six rows of randomized letters with a different letter size for each row. Letter sizes were 1/2, 3/8, 5/16, 1/4, 3/16, and 1/8 inch. Adjustable lights in a wooden box behind the panels provided two levels of back illumination, a high value resulting in a brightness of 23 foot-lamberts and a low level yielding 1 foot-lambert as measured on the trans-

lucent white background of Panel A. The panels could be moved from side-to-side behind a mask opening that exposed three letters at a time. Tests were conducted at five ambient illumination levels of 32, 16, 4, 1, and 0.25 foot-candles. Illumination and brightness measurements were taken with a Spectra Brightness Spot Meter.

Six subjects were tested. They either had normal vision or their sight was correctable by glasses. Those normally wearing glasses were asked to use them. The subjects were asked to read aloud five groups of three letters each, for every letter size starting with the largest. This procedure was repeated for both panels. Legibility was established for

each of the five room illumination levels and the two back-illumination levels at distances of ten and two feet.

#### BACK-LIGHTING EFFECTS

Graphs in Fig. 2 show typical effects of back-lighting on legibility for a panel with dark lettering on a translucent white background viewed from a distance of 10 feet. It can be seen that, even with high ambient illumination, back-lighting of legends can reduce reading errors. However, for perfect legibility (zero reading errors) at 32 foot-candles of ambient illumination, letters cannot be made any smaller, whether back-lighting is used or not. With 16 foot-candles ambient illumination, slightly

smaller letters could be accurately read when these were back illuminated. At 4 foot-candles, and below, legibility was significantly improved through back-lighting. To be readable without errors at 4 foot-candles of ambient illumination, letters that were not back-lit had to be made about 50% larger than back-lit ones. At 1 foot-candle, the required difference in size was 100%, and at 0.25 foot-candle, it was even greater. Or, as the graphs show, under the 1 foot-candle ambient, back-lighting reduced reading errors for 0.25-inch letters from 60% to 0; and under 0.25 foot-candles of ambient illumination, back-lighting reduced reading errors for 0.25-inch letters from 90% to 0. Thus, at 4 foot-candles of ambient illumination and below, back-lighting of legends is advisable. However, for only moderately low ambient levels, economic factors may dictate the use of larger lettering in place of back-lighting.

#### BLACK-ON-WHITE VS WHITE-ON-BLACK

Comparing the two types of panels, one with black letters on translucent white, the other with white letters on a dark background, also produced some interesting results. When no back-lighting was used, both panels were about equally legible with an ambient illumination above 4 foot-candles. But at 4 foot-candles, and below, the panel with white letters on a dark background was significantly easier to read than the other. When back-lighting was used, improvement in legibility was greater for the black-on-white panel than for the white-on-dark, with the result that both back-lit panels were nearly equal in legibility. For non-back-lit legends, with ambient lighting of about 4 foot-candles or less, it is therefore recommended that white letters on a dark background be used. The same recommendation also applied to back-lit panels, since bulb failure may require them to be read under existing ambient illumination.

#### HIGH AND LOW BRIGHTNESS

Comparing data for high and low brightness produced by the two levels of rear-illumination, the following was found: for the panel with dark letters on a translucent white background the two levels produced no differences in legibility. However, at low ambient levels, white letters on a dark background were harder to read with high back-illumination than with low. The latter effect has been attributed to dazzle, or "blooming" of letters when the figure-to-ground contrast becomes too severe. It is recommended that the back-illumination of legends be adjusted to yield a brightness no greater than about two to three times

that produced by the ambient illumination on an ideal, diffusing reflector. Thus, for an ambient illumination of one foot-candle, brightness of a rear-illuminated legend should only be about two or three foot-lamberts.

#### RECOMMENDATIONS AND CONCLUSIONS

Recommendations based on this study are summarized in Table I. Entries in the table also show distances, in inches, at which letters of the sizes listed across the top can be read without error. The table reflects the effects on legibility of: 1) white-on-dark lettering versus black-on-white, and 2) back-lighting.

In using this information, a designer should consider economic factors. For example, as already mentioned it may be cheaper to increase letter size than to provide back-lighting. Or, the ambient illumination may be increased somewhat to allow the use of smaller characters. Though further investigation is required to provide statistical validity, the data presented here are conservative and can serve as useful guidelines for panel designers. This experiment dealt with only a few of the more important factors influencing legibility of panel lettering.

Other aspects of legibility are discussed in the bibliography listed below.

#### BIBLIOGRAPHY

1. C. Berger, "Stroke-Width, Form and Horizontal Spacing of Numerals as Determinants of the Threshold of Recognition," *Journal of Applied Psychology*, Vol. 28, No. 3, June 1944 pp. 208-231.
2. C. Berger, "Stroke-Width, Form and Horizontal Spacing of Numerals as Determinants of the Threshold of Recognition," *Journal of Applied Psychology*, Vol. 28, No. 4, August 1944, pp. 336-346.
3. F. R. Brown, E. A. Lowery, *A Study of the Requirements for Letters, Numbers and Markings to be Used on Trans-Illuminated Aircraft Control Panels: Part 1—The Effect of Stroke Width Upon the Legibility of Capital Letters*, Naval Air Materiel Center. Aero Medical Equipment Laboratory, Report No. NAM EL 609, Part 1, September 26, 1949.
4. F. R. Brown, et al., *A Study of the Requirements for Letters, Numbers and Markings to be Used on Trans-Illuminated Aircraft Control Panels: Part 3—The Effect of Stroke-Width and Form Upon the Legibility of Numerals*, Naval Air Materiel Center. Aero Medical Equipment Laboratory, Report No. NAM EL. 609, Part 3, May 24, 1951.
5. F. R. Brown, E. S. Mendelson, *A Study of Requirements for Letters, Numbers, and Markings to be Used on Trans-Illuminated Aircraft Control Panels: Part 4—Legibility of Uniform Stroke Capital Letters as Determined by Size and Height to Width Ratio and as Compared to Garamond Bold*, Naval Air Materiel Center. Aero Medical Equipment Laboratory, Report No. NAM EL 609, Part 4, March 10, 1952.
6. M. N. Crook, et al., *Effects of Apparent Amplitude, Brightness and Type Size on Numeral Reading*, Air Force. Air Materiel Command, Technical Report No. 6246, September 1950 (PB102917).
7. J. G. Gleason, *Design of Numerals for Use in Counter-Type Instruments: A Review of the Literature*, Purdue University, Report No. 166-1-39, December 20, 1947.
8. W. C. Howell, C. L. Kraft, *Size, Blur, and Contrast as Variables Affecting the Legibility of Alpha-Numeric Symbols on Radar-Type Displays*, Ohio State University Research Foundation, WADC TR 59-536.
9. P. C. Squires, *New Digit Designs for Use Under Reflected Red Light of Low Brightness*, Naval Medical Research Laboratory Report—MRL Report No. 284.
10. A. J. Slivinske, L. M. Crumley, *The Effects of Contrast Color and Viewing Illumination on the Legibility of Letters and Numerals*, Pennsylvania State University, Report No. NAMC-ACEL, 329.
11. A. J. Slivinske, L. M. Crumley, *The Effects of Contrast, Color and Viewing Illumination on Scale Reading*, Pennsylvania State University Report No. NAMC-ACEL-324.

TABLE I—Recommended Maximum Viewing Distances for Different Letter Sizes, Ambient Lighting Levels and Letter-to-Background Relationships

Ambient Illumination Level (foot-candles)	Letter to Background Relationship*	Max. View Distance, Inches, for 1, 8- to 1/2-inch Letter Heights					
		1/8	3/16	1/4	5/16	3/8	1/2
32	B/W or W/B	60	90	120	150	180	240
16	B/W or W/B	48	72	96	120	144	192
4	B/W	40	60	80	100	120	160
4	W/B	48	72	96	120	144	192
1	B/W	30	45	60	75	90	120
1	W/B	40	60	80	100	120	160
0.25	B/W	16	24	32	40	48	64
0.25	W/B	30	45	60	75	90	120
Back-Lit** at all Ambients of 16 ft-c and lower	B/W or W/B (latter preferred)	48	72	96	120	144	192

\* B/W—black letter on white background

W/B—white letter on black background

\*\*Back-lit areas of the panel should be illuminated to a brightness not exceeding two to three times that produced by the ambient on an ideal, diffusing reflector (e.g. for 1 ft-c ambient, panel brightness should be no greater than 2 or 3 foot-lamberts).

# NEW APPROACH TO WRITING OPERATOR PROCEDURE MANUALS

Described herein is a scheme for an easy-to-use, completely stimulus-oriented procedures manual. For maximum efficiency, concise instructions and procedures closely follow the pattern in which the operator must carry out his tasks.

**T. G. WIEDMAN and Dr. F. H. IRELAND, Mgr.**

*Human Factors Engineering*

*Systems Engineering Evaluation and Research*

*DEP, Moorestown, N. J.*

**P**ROCEDURE manuals are intended to provide an operator with necessary guidelines for performing his functions as a systems component. Depending upon the selection and organization of the content, such manuals can either be very useful job-aids or merely added burdens for the operator.

Unfortunately, many present procedures manuals are wordy and difficult to follow. They concentrate on how procedures are to be performed without sufficient attention to the conditions under which they must be carried out. Frequently they do not give the operator sufficient information either on the meaning of the stimuli he receives or on the effects his actions have upon the system. Lacking such information a console operator becomes a mere automaton who cannot be expected to exercise proper judgment during unusual operating conditions or emergencies.

## REQUIRED ORIENTATION

In our opinion, a procedures manual should be patterned closely after the manner in which the operator must actually carry out his tasks. Since most operational tasks are triggered by signals or stimuli reaching the operator through his senses, a procedures manual should first answer the question: *Given a certain stimulus such as the lighting of an indicator or the sounding of a buzzer, what specific action or actions should the operator perform?* If more than one action is required, the operator should be told how, and in which sequence to perform them. All of this should be done in a manner which leads the operator most directly, and with minimum time wasted in reading instructions, from the stimulus to the action sequence required.

But, a good procedures manual should also increase the man's understanding of his job; it should clarify the meanings of the various indications, requests and commands he may receive and explain how each of his actions affects the system. These explanations should be

associated with the listings of stimuli and prescribed operator actions in such a way that an operator can learn immediately the meaning of the stimuli or the effects of his actions without having to hunt through other sections of the manual for the information. And yet, such explanations should not interfere in any way with the simple and direct presentation of the essential stimulus-action sequences. This article presents a method of selecting and organizing material for procedure manuals to satisfy these objectives.

## ACTION ANALYSIS

The first step in generating material for a procedures manual is to analyze, in detail, the functions an operator is to perform and the man-machine interactions that are involved. This analysis should also include the identification of all known stimuli that should trigger appropriate operator responses. Many stimuli are equipment generated, such as audible alarms or visual indications on console panels, wall displays, or printouts; some may come in the form of verbal commands and requests. A few operator actions such as the checking or adjusting of his equipment may be considered self-initiated.

It is convenient to record the analysis results in the form of action-decision flow diagrams which show operator action sequences appropriate to specific stimuli and identify the feedback indications which he can expect from the equipment as a result of his control actions. Such diagrams later become very useful elements of the actual procedures manuals (Fig. 3) where they serve as "road maps" for operator actions. Annotated rectangles in these diagrams represent individual operator task elements. Arrows interconnecting the rectangles indicate the proper sequences in which actions must be carried out. Diamond-shaped boxes identify decision points where *yes* or *no* judgments are required. The decision boxes, in turn, form branch-points from which alter-

nate action paths originate. Sometimes these paths may lead back to the beginning of a previously executed set of steps, thus reiterating certain portions of the procedure. Or they may continue forward with new action steps. Feedback indications from the equipment, on the successful completion of actions are also shown in the diagrams. Let us next consider how the manuals themselves should be structured.

## STRUCTURING THE MANUAL

Briefly the proposed scheme involves including in the manual, an action directory which lists all operationally relevant stimuli and relates these to the specific operator actions called for. This directory is followed by a procedures section with a series of easily interpretable action-decision diagrams which pictorially show the steps in the lengthier or more involved action sequences. All stimulus listings and action-decision diagrams are presented in the left-hand pages of the manual while concise notes in the right-hand pages explain the significance of each indicator, control or action. Thus, the left-hand pages are strictly reserved for extremely simple, direct, and in many cases pictorial, presentations of stimuli, actions and procedures, while those on the right contain the explanations that tell an operator the meanings of these and the consequences of his actions.

This organization of the material is apparent in Fig. 1, which shows a procedures manual opened to a typical page of the *Action Directory* section. The left-hand pages contain the actual directory, while accompanying notes are presented on the facing pages. A thumb index permits ready access to any desired section of the manual. The major sections are: 1) *Illustrations*, 2) *Instructions*, 3) *Action Directory*, 4) *Procedures* and 5) *Appendices*.

## Illustrations

The thumb tab for the illustrations section is not visible in Fig. 1, since it is attached to the left-hand margin of the panel illustration shown unfolded toward the left. The panel illustration is so fastened in the manual that it can remain unfolded and completely exposed while the operator turns to any page. Every panel component shown in the fold-out is keyed to the text by means of its name and location code, so that the operator can readily associate listed stimuli or actions with pertinent panel indicators and controls.

## Instructions

The *Instructions* section of the manual states the functions to be performed by

Fig. 1—Procedures manual opened to the Action-Directory section.

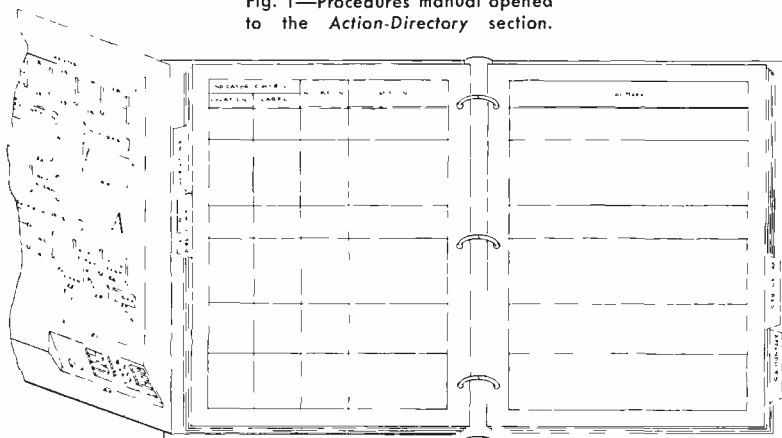

the operator and his equipment within the system context and describes the purpose and organization of the book. It also contains detailed directions for the proper use of the manual.

Contents of the *Action Directory* and *Procedures* sections will be covered in greater detail below. The *Appendices* contain such auxiliary job-aids as look-up tables for digital codes, and nomographs or charts that have to be referred to occasionally.

#### Action Directory

Fig. 2 shows two pages in the *Action Directory* section of a typical manual. Location codes for panel indicators (operator stimuli) are shown in the first column. These are the same as used on a panel illustration such as the one shown folded out to the left in Fig. 3. A complete location code for a given panel component consists of a letter designation for the functional area plus a number for the component. An operator can thus readily associate a called-for action with the pertinent panel indicator or control.

In the second column all panel indicators and controls are listed by name. Below each name, in parenthesis, the component type is indicated (e.g. *PS* = push switch, *RS* = rotary switch, *IND* = indicator light).

Indications calling for action (e.g. red illumination of an indicator light) are shown in the third column, while the actions themselves are listed in column four. Where only a few actions are needed, these are stated in the *Action Directory*. But for a lengthy action sequence, especially if it involves alternate action paths, the operator is referred to the appropriate action-decision diagram in the succeeding *Procedures* section of the manual.

On the right-hand pages of the *Action Directory*, keyed directly to the stimulus-action listing on the left, are remarks which explain the meaning of each indication and the effects which each panel control has on the system. Thus, to learn what a given panel indi-

cation means or how a control works, the operator need merely look at these accompanying remarks. Yet, by keeping the notes separately in the right-hand pages, they do not interfere with the terse, logical presentation of essential operating procedures. Stimuli which may come to the operator from sources other than his console panel, such as from printers or wall displays or via telephone from other persons are similarly listed and annotated in separate subsections of the *Action Directory*.

#### Procedures Section

Some action sequences are too lengthy or complicated to be adequately described in the narrow *Action* columns of the directory. For these, a notation in the *Action* column will refer the operator to the *Procedures* section of the manual. For example, if Item A-1,

DR. FRED H. IRELAND received his BS (1948), MA (1949) and PhD (1955) in Experimental Psychology from Fordham University. From 1950 to 1952 he was Senior Research Associate with the human factors consulting firm of Dunlap and Associates where he worked on the Terrier Land Based Fire Control System, various mobile radar units and on a submarine fire control project. He then spent two years as a Research Psychologist with the N.Y. State Psychiatric Institute. In 1955 he joined RCA. As Manager of the Moorestown Human Factors Engineering activity he directed the human engineering efforts for TALOS, for the Atlas Launch Control and Checkout System and for BMEWS. He also held an appointment of human factors consultant with the HQ. USAF Directorate of Installations. For an eighteen month period, starting early in 1962, he held the position of Assistant Director for Information and Control Systems and Human Factors in NASA's Office of Manned Space Flight. Since rejoining RCA in 1963 he has been manager of Command Systems and Human Factors in DEP's Systems Engineering, Evaluation and Research (SEER) activity. He holds membership in IEEE, APA, and Sigma Xi.

THOMAS G. WIEDMAN received the BS in Psychology in 1954 from St. Louis University, where he subsequently continued with graduate studies. During a two year period starting 1956, he carried on psychological research for the State of Illinois. Subsequently, as a member of the Systems Development Corporation he participated in the design of simulation and training problems and defined operator information requirements for the Air Defense Command. At RCA since 1962, he

the *New Alarm* indicator in Fig. 2 lights, accompanied by an audible alarm, the operator should refer to Procedure I-1. Fig. 3 shows the pertinent pages in the *Procedures* section of the manual that tell the operator how to perform Procedure I-1. The diagram on the left-hand page tells the operator with few words: 1) the action sequence he is to perform, 2) the feedback information to be expected as a result of each action, and 3) the decision points in the sequence. Required iterations of certain action sequences, as well as alternate action paths, can be clearly identified in such a diagram. The, by now, familiar location codes of panel components referred to in the diagram are again included for easy reference. As before, notes on the right-hand pages explain the meanings of indications and operator actions.

#### CONCLUSION

The manual is thus completely stimulus oriented; given a certain stimulus, the book tells the operator specifically what procedure to use. The feasibility of structuring a procedures manual in this manner has been tested for the main console in the computerized message center of the AUTODIN system. While the scheme, thus far, has only been considered in connection with console operator procedures, it may prove equally useful for other personnel tasks, including trouble shooting and maintenance activities.

has participated in the analysis of systems operations, operator monitoring and control functions and display information requirements for NASA's Integrated Mission Control Center, for a Navy Combat Information Center, and for a Navy Advanced Surface Missile System. As a member of SEER's Human Factors Engineering team, he has had primary human factors responsibility on the CAPE project, a study of large board display techniques for the Navy's Communications Automatic Processing Equipment. His current work on operating procedures for AUTODIN led to the revision of procedure manuals discussed in his article. He holds membership in The Human Factors Society, The Institute of Aeronautics and Astronautics, and in the Association for Computing Machinery.



Dr. F. H. Ireland



T. G. Wiedman



Fig. 2—Typical pages in the Action Directory section.

SYSTEM CONSOLE ACTIONS			
INDICATOR/CONTROL LOCATION	LABEL/TYPE	INDICATION	ACTION
A-1	NEW ALARM (IND*)	Red & minor audible alarm ***	Perform Procedure I-1: Selective Search - New Alarms
A-2	NEW ALARM (PS/**/IND)	White (momentarily) when depressed)	Part of Procedure I-1: Selective Search - New Alarms. (Light indicates program acceptance of operator command given by depressing A-2).
A-3	OLD ALARM (PS/IND)	White (momentarily when depressed)	Part of Procedure III-1: Selective Search - Old Alarms. (Light indicates program acceptance of operator command given by depressing A-3).
A-4	COS (PS/IND)	White (momentarily when depressed)	Part of Procedure III-3: Selective Search - Channels Out of Service. (Light indicates program acceptance of operator command given by depressing A-4).
A-5	RESET ALARM (PS/IND)	White (momentarily when depressed)	Part of Procedures I-1 and III-1. (Light indicates program acceptance of operator command given by depressing A-5).
A-6	DISPLAY KEYSSET (PS/IND)	White (momentarily when depressed)	Part of Procedure III-4: Selective Search - Special Channels. (Light indicates program acceptance of operator command given by depressing A-6).
A-7	CLEAR DISPLAY (PS/IND)	White (momentarily when depressed)	Part of Procedures III-3 and III-4 (Light indicates program acceptance of operator command given by depressing A-7).

\* IND - Indicator  
 \*\* PS - Pushswitch  
 \*\*\* Minor audible alarm (chime)

AD-4

REMARKS
NEW ALARM A-1 indicator illuminates red, channel pushswitch G-5 illuminates red and minor audible alarm sounds whenever channel error occurs. A-1 indicator light is extinguished when NEW ALARM A-2 is actuated.
NEW ALARM A-2 pushswitch is depressed whenever NEW ALARM A-1 indicator is illuminated red. Actuating A-2 causes the following: A-2 illuminates white momentarily and is reset by program control; A-1 indicator light is extinguished; identification code of faulty channel is shown on DESIGNATION A-22 and NUMBER A-23 displays; alarm cause(s) are displayed on relevant indicators A-8 through A-18.
OLD ALARM A-3 pushswitch is depressed in order to scan through alarmed channels in old alarms list. Actuating A-3 causes the following: A-3 illuminates white momentarily and is reset by program control; identification code of faulty channel is shown on DESIGNATION A-22 and NUMBER A-23 displays; alarm cause(s) are displayed on indicators A-8 through A-18.
COS A-4 pushswitch is depressed in order to scan through channels whose out-of-service bit has been set. Actuating A-4 causes the following: A-4 illuminates white momentarily and is reset by program control; identification code of faulty channel is shown on DESIGNATION A-22 and NUMBER A-23 displays; alarm cause(s) are displayed on indicators A-8 through A-18.
RESET ALARM A-5 pushswitch is depressed to reset alarm bits in ADJ tallies of channel currently being displayed. Actuating A-5 causes the following: A-5 illuminates white momentarily and is reset by program control; identification code of faulty channel in DESIGNATION A-22 and NUMBER A-23 displays is erased; alarm cause(s) displayed on indicators A-8 through A-18 are erased.
DISPLAY KEYSSET A-6 pushswitch is depressed, along with insertion of a particular channel number on keyset A-24 to determine the status of that channel. Actuating A-6 causes the following: A-6 illuminates white momentarily and is reset by program control; identification code of faulty channel is shown on KEYSSET DISPLAY A-21, DESIGNATION A-22 display and NUMBER A-23 display; alarm cause(s) are displayed on indicators A-8 through A-18.
CLEAR DISPLAY A-7 pushswitch is depressed to clear information set into keyset logic and displays. Actuating A-7 causes the following: A-7 illuminates white momentarily and is reset by program control; channel numbers shown on the DESIGNATION A-22 and NUMBER A-23 displays are erased; alarm cause(s) displayed on indicators A-8 through A-18 are erased.

AD-5

Fig. 3—Typical pages in the Procedures section.

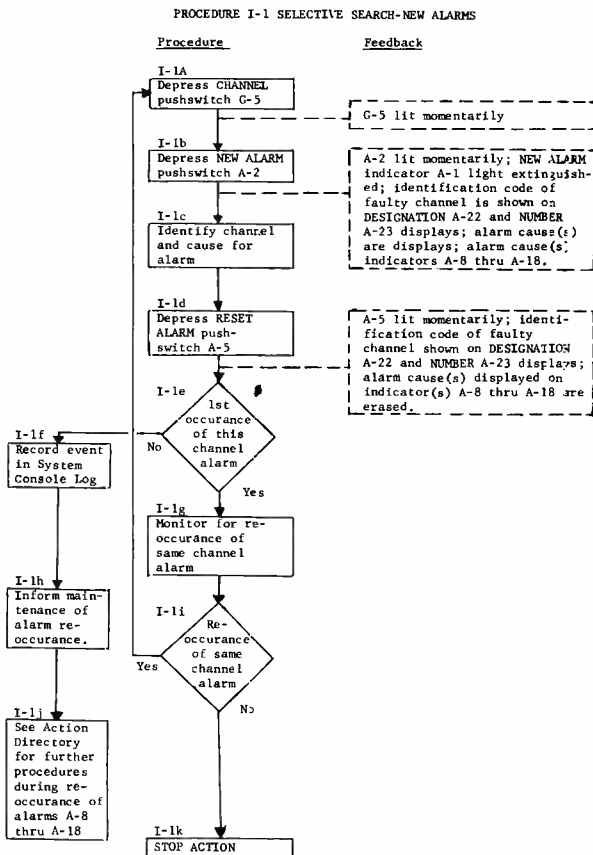

NOTES

- I-1a Actuating G-5 silences audible alarm.
- I-1b Actuating A-2 extinguishes A-1 light and causes the identification number of the channel with a new alarm to be shown on DESIGNATION A-22 and NUMBER A-23 displays; cause(s) of alarm are also presented by indicators A-8 through A-18.
- I-1c Causes for alarm are indicated on panel as: NO SYNC A-8; EXP DM REQ A-9; BUFFER IN A-10; BUFFER OUT A-11; BLOCK RR IN A-12; BLOCK RR OUT A-13; TTY ACT A-14; ERROR DET A-15; ONE WAY IN A-16; ONE WAY OUT A-17; or COS A-18 (See Action Directory for meaning of each).
- I-1d Depressing A-5 will reset the "alarm" and "displayed" bits in the ADU tallies of the channel currently being displayed.
- I-1e Alarm reoccurrence will be identified by illumination of NEW ALARM A-1 indicator and presence of minor audible alarm.
- I-1f Refer to APPENDIX B-1 for format used in recording entries in System Console Log.
- I-1g The first occurrence of a channel alarm may not be critical since the error may be self correcting within the system.
- I-1h If an alarm does not reoccur after depressing the RESET ALARM A-7 pushswitch, no further operator action is required; a re-occurrence of the same alarm, however, will require additional procedures to be followed as outlined in the Action Directory, for alarm indications A-8 through A-18.
- I-1j Actions to be performed following reoccurrence of alarm indications A-8 through A-18 are found on pages 24-27 of the Action Directory.

# DATA PLOTTING BY DIGITAL COMPUTER

The computerized test-data system now in use in Harrison for tube production has been expanded to include automatic data plotting. Several fast and comprehensive data-plotting programs have been written for both the RCA 301 and 501 computers which take advantage of the computer's inherent capabilities for large-volume, high-speed handling of the basic data. This paper describes histograms, X-Y plots, statistical calculations, and scientific curve plotting, and draws some comparisons between computer-plotted curves and those possible with an automatic data plotter.

R. E. SIMPKINS

*Electronic Components and Devices, Harrison, N. J.*

Fig. 1—Histogram.

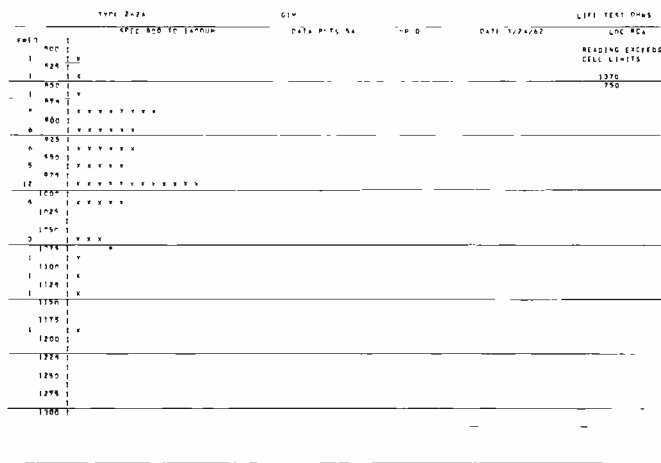
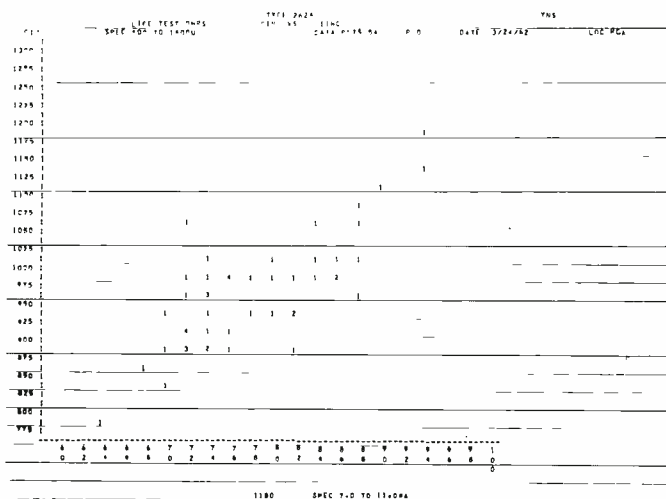

Fig. 2—Frequency table X-Y chart.



MANUAL data plotting, especially of readings from production testing, has always been a favorite method of data reduction with engineers. Data in tabular form are usually difficult to interpret, but when they are presented in the pictorial form of a histogram or X-Y chart, they not only yield to ready interpretation, but make the results easier to explain to others.

In January of 1961, a test-data system<sup>1</sup> was established using the RCA 501 computer at Harrison, New Jersey. This system collects test data from many locations, system-orientates this data, and then stores it in large volume, both on punched cards and on magnetic tape. The computer capability of fast data preparation and low-cost analysis replaced the slower and more costly manual method of compiling and analyzing data from printed test-sheet files. Data can now be analyzed, not only in times of trouble, but on a continuous basis. The probability of improved product performance because of large-volume analysis and rapid feedback of control information to the production areas was greatly increased.

As a next step to enhance the data analysis, the data-reduction technique of plotting histograms and X-Y charts from computer-prepared data was desirable. At first, the possibility of plotting large quantities of data by means of an automatic data plotter was investigated. This plotter had the capability of plotting data from either punched cards or

*Final manuscript received October 5, 1964*

Fig. 3—Scatter diagram X-Y chart.

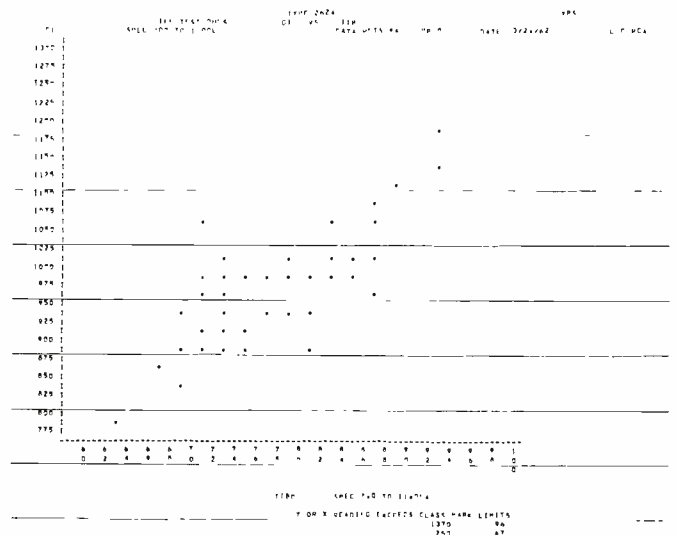

magnetic tape. Although the charts produced were satisfactory, it was felt that certain definite advantages could be realized if a plotting program could be written for the computer. The initial program<sup>2</sup> was written for the RCA 501 computer and produces the following charts:

- 1) Histogram (Fig. 1)
- 2) X-Y Charts: frequency table (Fig. 2), scatter diagram (Fig. 3), and multi-plot (Fig. 4).

As soon as the 501 computer data-plotting program became operational there was an immediate favorable response from engineering. Charts were requested not only for their value in process control and component design, but also for their value as performance indicators that could be sent to a customer on request.

The speed with which a computer accepts and plots data can result in a considerable saving in time over manual plotting. The time required to form and print a histogram or any X-Y chart for 200 data points, using the initial program, is approximately 7 seconds. The same chart, hand-plotted, requires at least 30 minutes.

Several faster and more comprehensive plotting programs for the RCA 501 and 301 computers, all operationally similar, have been written since the initial 501 program. The initial 501 program operates as follows:

- 1) A data table is formed in the computer memory or on a magnetic tape from data that are read into the computer memory either on punched paper tape or on magnetic tape.

R. E. SIMPKINS received the BA in Physics from Oberlin College in 1950 and the MS in Applied and Mathematical Statistics from Rutgers, the State University, in 1956. He joined RCA in 1951 as a Quality Control Engineer in the Electron Tube Division. His responsibilities included the establishment and maintenance of process controls, the statistical design and analysis of experiments, and the instruction of personnel in Quality Control techniques. Since 1959 he has been a Senior Analyst Programmer for Data Systems and Services in the Electronic Components and Devices organization. His work involves the analysis and design of technical data systems, scientific computer programming, the instruction of engineering personnel in problem solving by computer and the statistical analysis of data from various engineering sources. He designed and wrote the RCA 501 and 301 plotting programs described in this paper. His most recent assignment involved the systems analysis and programming of a high-reliability testing program in support of an aerospace contract for integrated-circuit devices. Mr. Simpkins served in the U. S. Navy in 1944-45 as an Electronics Technician. He is a member of the ASQC and the IEEE.



- 2) Histogram and X-Y plot parameter messages (a *message* is the unit of information for the RCA 501 computer) are read in on punched paper tape.
- 3) The data table is then consecutively searched for the data requested by each plot parameter message.
- 4) The requested plots are formed in the computer memory and then either printed immediately on the on-line printer or are written onto a magnetic tape for later off-line printing.

The size (i.e., the number of cells) and the labeling of each plot is entirely controlled by the information contained in each plot parameter message. Several charts of the same data can be plotted to different scales within the same plotting run by slight changes in the content of the plot parameter messages. Therefore,

the chart most advantageous to the data presentation can be selected at the end of the run.

In addition, because the "plotting" is done within the computer, an excellent opportunity is afforded for making statistical calculations and comparisons at the time of plotting. These reduced data results can then become an integral part of the printed-out chart.

Although the value of the histogram and X-Y chart are well known and can usually be found in elementary texts on statistics or quality control, a few words about each may serve to explain why the computer plotting programs were written and also to make the discussion which follows more meaningful.

**Editor's Note:** Diagrams photographically reduced from full-size computer print-outs, with unavoidable loss of detail.

Fig. 4—Multi-plot X-Y chart.

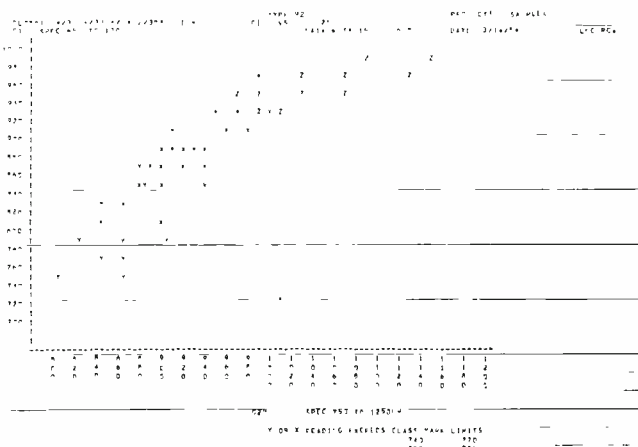
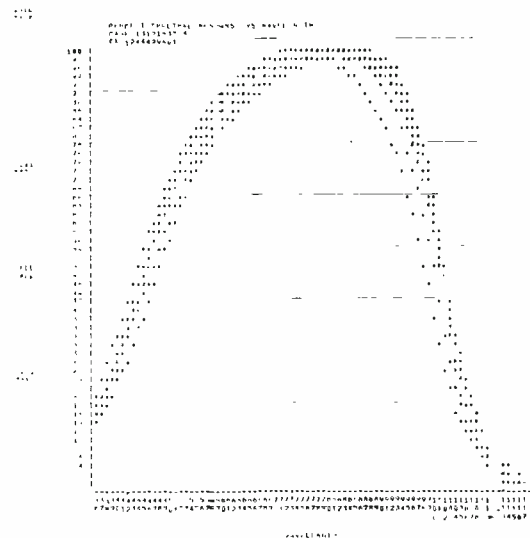

Fig. 5—Multi-plot showing average curve (#) together with band of individual curves.



## THE HISTOGRAM

Fig. 1 is a histogram of 55 plate-current readings for electron tube type 262A. This histogram presentation is typical for production test data, and is formed by dividing the spread of data into equally spaced cells and adding an increment of space such as occupied by an  $X$  (or any other convenient symbol) to the cell for each unit of data that falls within that cell.

The histogram has "central tendency." The average of all the readings is a measure of the location of this central tendency. If the plotted readings represent a random sample of all the production readings of the same kind, produced within a given period, then the histogram is a good estimate of the true underlying mathematical distribution of the variable being studied in the production process. In general, the larger the random sample, the better the estimate will be.

If the histogram is peaked at the center and trails off symmetrically to both sides, the mathematical curve that it estimates may be the well known "normal" distribution. If the histogram is skewed in one direction, it may be an estimate of the asymmetrical Poisson distribution.

The histogram plot does not prove which particular curve represents the distribution of a given variable of the production process; this determination must be proved by mathematical analysis. This analysis can usually be performed most efficiently with the aid of the computer at the time of plotting, and the results can be recorded on the printed chart.

Once it has been determined that a particular mathematical curve is a satisfactory representation of the distribution of a production variable, all of the statistical theory associated with this curve can be confidently applied in process quality control, component design, statistically-designed experimentation, reliability studies, etc. With knowledge of the existence of a particular mathematical curve, the error associated with an estimate can be determined with predictable confidence.

The spread or dispersion of the histogram is often compared to upper and lower specification limits for a particular test in order to estimate the amount of scrap that may be expected in production testing. The center (average) of the distribution may be compared to the "bogie" or "target value" for the characteristic being studied, and in this way the histogram can serve as a rapid estimator of performance. It can also serve to indicate when a process should be subjected to an extensive analysis or when it is better left unchanged.

## THE X-Y PLOT

The frequency table, Fig. 2 and the scatter diagram, Fig. 3 indicate whether or not two variables are related and the nature of the relationship. The closer the plotted points fall to a narrow path, the closer the relationship or correlation. If the data collected comprise random sample of measurements from a production process, then the curve that is suggested by the plotted points is often a good estimate of the mathematical curve that represents the true relationship between the two variables. If this relationship is close, then the dependent variable  $Y$  can be accurately estimated from the independent variable  $X$ . A line or curve can be mathematically fitted to the data at the time of plotting and used for estimating. This technique can be used to eliminate one of two production tests, and is especially useful when one test is destructive, and the other is not. The elimination of unnecessary testing is one of the major advantages of large-volume plotting. Other advantages are the setting of proper test limits, and the calibrating of test equipment.

The frequency table, like the scatter diagram, is an excellent indicator of the relationship between two variables. In addition, since the frequency table indicates the number of plotted points that fall coincidentally, it can be used to plot many sets of frequencies, each representing the frequencies for a histogram, in time-series sequence on the same chart.

The multi-plot shown in Fig. 4 is an example of the plotting of several groups of data, each with a separate symbol, on the same chart. These groups may represent samples from a production process taken at different time periods, and plotted to detect "out-of-control" situations as indicated by a shifting position of the line or curve. The multi-plot is also useful in indicating the relationship between two variables when they are subjected to varying operating conditions.

When a scatter diagram indicates a weak relationship between two variables, and theoretically a strong relationship is expected, the cause may be a strong third variable that has not been considered. The plot of the independent variable  $X_1$ , for example, may indicate a close relationship with  $Y$ , but the independent variable  $X_2$ , even though it is believed to be closely correlated with  $Y$ , may indicate almost no relationship. The relationship between  $X_2$  and  $Y$  may only become apparent when the influence of  $X_1$  is removed. The technique for removing the influence of  $X_1$  will not be discussed here<sup>4</sup> but is mentioned only as a warning against hastily rejecting independent variables that are to be sub-

jected to multiple correlation and regression analysis, merely because their simple plots indicate a weak relationship with the dependent variable  $Y$ .

## PRODUCTION DATA PLOTTING

The real values of the histogram and the  $X$ - $Y$  chart are often overlooked. Even without a mathematical analysis, these plots can serve as indicators of the direction that an investigation should take or at what point in a production operation the greatest effort should be spent.

Histograms and  $X$ - $Y$  charts often show surprising facts about variables.<sup>5</sup> The relationship that was expected by known principles may exist for most of the data, but often there are "wild" or "maverick" points, or groups of points, that behave in a strange manner. An analysis of these peculiarities frequently leads the investigator to important discoveries about the process being studied. Such an analysis should be conducted before the data are subjected to statistical analyses such as multiple regression or variance. In a regression analysis, for example, a wild point would cause the line or curve to pass through the wrong average (unless balanced by another wild point) and would produce erroneous correlation parameters. Data plotting is therefore a valuable screening device. In addition to indicating the distribution of variables about their average, and the relationship between two variables, the histogram and  $X$ - $Y$  plots are useful in detecting data irregularities caused by testing errors or component defects. It is from the investigation of "maverick" points that some of the most useful production and design information is obtained. For this reason, apparent wild values should be discarded only after careful consideration. As previously mentioned, the maverick point may be caused by a strong variable not included in the analysis, and therefore, indicates that a mathematical model other than the one being considered is appropriate.

## STATISTICAL CALCULATIONS

Although the histogram and  $X$ - $Y$  plot serve as valuable guides in themselves, they can be made even more useful when they include statistical calculations made at the time of plotting. This information can be conveniently generated by adding a scientific program, written in a scientific programming language such as FORTRAN, (formula translation) to the plotting program on the same magnetic tape. Calculations such as standard deviations, averages, and correlation and regression coefficients can be made at the time of plotting and printed on the finished chart. Such statistics are especially useful for judging component perform-

ance. With the present emphasis on component reliability, especially in the missile field, there has been an ever increasing demand for new and more rigorous production testing. The histogram and X-Y charts, together with statistical calculations, can be used to great advantage in the making of required production changes and in checking the effectiveness of these changes after they have been made.

#### SCIENTIFIC CURVE PLOTTING

The computer is a valuable tool in the plotting of scientific curves. For example, to get the response curve for a solar cell, light of varying wavelengths is directed at the test cell and the output response is measured. These measurements are inputs to a FORTRAN program which makes extensive scientific calculations and finally directs the curve-plotting program into the RCA 301 computer memory, where the polynomial is plotted and printed out. The RCA 301 computer is especially adaptable to this type of plotting because of its 160-character print line capability.

A plot of 150 calculated values requires approximately seven seconds. The resolution of the resulting curves has proved to be satisfactory for several engineering applications, and these curves are almost always useful as first approximations to plots requiring a greater degree of plotting accuracy.

As in the multi-plot for the RCA 501 computer, the curve-plot program for the RCA 301 computer can be used to plot two or more curves on the same chart. Each curve may represent a particular component design, perhaps designs used in production over a given period of time. An average curve shown by the symbols #, can be calculated and plotted on the chart, together with the band of individual curves, as shown in Fig. 5. or each curve can be plotted individually, and printed with the average curve for the entire group. Having each individual curve plotted with the group average provides a convenient means of comparing the performance of an individual design with that for the overall group.

With the capability of plotting multiple curves on the same chart, many types of output are possible. Consider, for example, a multicurvilinear equation relating the critical dimensions of a component as calculated with a program such as the Multivariate Regression Analysis Program used in the RCA 501 computer. This complex equation can be broken up into its constituent net regression curves and each curve can then be plotted together with its calculated confidence limits and other statistics.

Some other applications of the com-

puter curve-plotting program are 1) in time series, and 2) in control charts of variables for processes where considerable delay time exists between the successive production steps.

#### COMPUTER VERSUS DATA PLOTTER

For the plotting of production data and simple scientific curves, the digital computer, as experienced with the RCA 501 and 301, appears to have the following advantages over plotting by an automatic data plotter:

- 1) Plotting by digital computer is faster; the plotting of 200 points of a histogram or an X-Y chart requires seven seconds on the RCA 501 computer and eight seconds with the RCA 301 computer.
- 2) No special plotting paper is required by the computer and there is no need to pre-position the paper on a plotting table.
- 3) Because the plotting is done on the computer printer, there is an excellent opportunity to use the computer to prepare data and to make scientific calculations at the time of plotting.
- 4) There is no need for operator intervention. The size of the scales and the labeling of the scales and the plot are controlled entirely by the computer, from input parameter information.
- 5) Computer plotting can be especially useful to small installations where the workload may not justify the expense of purchasing or renting an automatic data plotter.
- 6) The quality of the plots appears to be entirely satisfactory for many scientific and business applications.

#### CONCLUSIONS

The introduction of computerized data systems requires that new and faster techniques of data reduction be developed and applied if full advantage is to be taken of the increased speed of data collection and storage. Unlike manual plotting, which is fatiguing and error-prone, the digital computer has the capability of rapid data retrieval, data editing, and an untiring ability to make extensive calculations and comparisons. A chart that may require 45 minutes to be completed by hand can be supplied by the computer, together with calculated parameters, in a matter of seconds.

By reducing vast quantities of test data to an easily interpreted form, the computer can continuously provide information indicating where the concentration of efforts should be, where new and improved tests are needed, where unnecessary tests can be eliminated, or where experimentation for new component designs should be conducted. Histograms and X-Y charts provide rapid initial analyses to production problems and are a valuable aid in meeting performance goals. The faster results can be put into practice—the greater the savings.

In addition to supplying valuable process control information, the histogram

and X-Y charts are excellent data-screening devices because they are extremely useful in detecting data irregularities prior to running statistical programs such as used in regression and correlation analyses. Groups of data from different sources or data obtained during various production periods can be plotted on the same chart, and shifting levels or other irregularities can be corrected before further analysis is made.

The RCA 301 digital computer, because of its 160-character print line capability, is especially suited to the plotting of scientific curves. The resolution of the computer-plotted curves is usually satisfactory for many applications and is at least suitable for obtaining approximations to problems requiring a greater degree of refinement.

Data plotting can be used to advantage in the business as well as the scientific field. In marketing, for example, the histogram is a convenient form of presentation for the distribution of a product line by customer. The X-Y chart can be used in accounting to represent such comparisons as total expense versus actual dollar-cost per unit. The X-Y chart and the scientific curve plot find ready applications in the field of forecasting.

As for the future, digital-computer plotting promises greater control over manufacturing processes resulting in an improvement in component performance and cost, and rapid decision-making functions in all the production, scientific, and business fields.

The development and application of digital-computer plotting programs has not stopped with the plotting of data to linear scales. Plots requiring logarithmic scales have been requested and are being planned.

#### ACKNOWLEDGMENT

The author wishes to thank J. R. Gates for suggestions made in the development of the original plotting program, and A. C. Grover, Jr., H. W. Kirk, and G. A. Alexander for suggestions and encouragement in the writing of this paper.

#### BIBLIOGRAPHY

1. "Quality Control Test-Data System Uses RCA 501," RCA ENGINEER, Aug-Sept., 1963.
2. Data Plotting on 501 Printer, *Program Applications Library*, (97-20-072), Electronic Data Processing, Radio Corporation of America, Camden 8, N. J.
3. *Statistical Quality Control*, E. L. Grant, McGraw-Hill Book Company, Inc., New York and London, 1946.
4. *Methods of Correlation Analysis*, Mordecai Ezekiel, John Wiley and Sons, Inc., 1950, pp. 163-174.
5. "A Scatter Diagram Used to Compare 'Before' and 'After' Measurements," Ellis R. Ott, Practical Aids — *Industrial Quality Control*, Vol. XIII, No. 12, June 1957.

# Engineering and Research NOTES

BRIEF TECHNICAL PAPERS OF CURRENT INTEREST

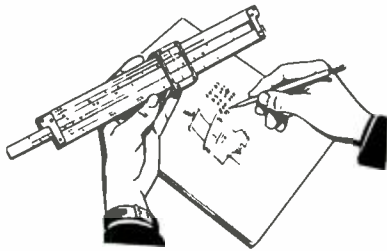

## Computer Calculation of Frame-Grid Winding Tension



P. J. MUSSO AND T. E. DEEGAN  
Electronic Components and  
Devices, Harrison, N. J.

Final manuscript  
received July 10, 1964

Reduction in noise figures and increase in transconductance-to-plate-current ratios ( $g_m/I_p$ ) in many new tubes results from new techniques in grid design—finer wire and closer grid-to-cathode spacing. On the frame grid, (Fig. 1) the diameters of the side rods are carefully controlled, since they determine the MOD (minor outside diameter) distance between lateral wires on opposite sides of the grid. The grid wire is helically wound on the frame with sufficient tension so that the lateral segment between the side rods lie in parallel planes and vibrate with minimum amplitude when shaken, as in testing for microphonics. If the frame did not bend, the tension on the lateral wires would remain constant at the tension used to wind them. However, in actual practice, the side rods bend and the tension is lessened, the effect being more pronounced as the length of the frames increases. The slack in the lateral wires decreases the transconductance of the tube and increases its susceptibility to microphonics. Although satisfactory results had been obtained by using an empirical variation of winding tension to compensate for the side rod bending during frame winding, a more-scientific determination of the variations in winding tension would improve the characteristics of the tube appreciably.

For simplicity in developing a mathematical model, it was assumed that: 1) all stresses involved for both the side rod and lateral wire are within the elastic limits of the materials; and 2) the straps do not deflect, and they provide point support; (the point-support assumption was checked experimentally and found to be approximately correct). The desired end result was defined as: *The final tension in all lateral wires should be equal in the finished grid.*

The method used to solve for the winding tension is based on this.

Fig. 2a shows a uniformly-loaded beam which represents the final load conditions of the frame grid. By setting a value for  $T_n$ , the final tension, the final deflection at any point along the side rod can be determined. As the first turn is wound with a tension value  $T_1$ , a deflection  $d_1$  due to the first turn occurs (Fig. 2b). This deflection, at the position of the first turn  $d_1$ , is subtracted from the final deflection at the first turn. The remainder is the change in deflection,  $d$ , that occurs as the winding process continues to completion. This additional deflection ( $d$ ) that occurs reduces the tension at the first turn to a value below that used to wind it. The change in tension that occurs is added to the desired final tension  $T_n$ , to obtain the required winding tension  $T_1$  for the first turn.

For the second turn (Fig. 2c) the analysis is similar. The deflection at the second turn, as it is wound, is the cumulative effect of winding the first and the second turn. Winding the second turn also causes an increase in side rod deflection at the first turn which results in a reduced tension in the first turn. Thus, the tension in the first turn is reduced from the winding tension and is at a value between the final tension  $T_n$  and the winding tension  $T_1$ .

In general, as shown in Fig. 2d for the third-turn condition, the analysis is similar for each additional turn. As any particular turn is being wound, the deflection of the side rod at that point is expressed in terms of the winding tension used. This deflection, plus the already-present deflection at the same point due to all turns previously wound, is subtracted from the final deflection for that point. The result is the additional deflection that will occur at that point as the rest of the grid is wound. The loss in tension for that turn caused by this additional deflection at the given point is added to the desired final tension to yield the required winding tension for the current turn.

**General Solution:** The general equation to express the physical process described above is

$$T_i = KnT_n \sum_{i=1}^a \left[ \left[ T_i + (t_{ni} - t_{ii}) \right] \left[ \frac{(1 - C_i)(x_j)^3(x_j - x_k)^3}{6} \right] - x_j \frac{L^2}{6} \left[ T_i + (t_{ni} - t_{ii}) \right] \left[ (1 - C_i) - (1 - C_i)^3 \right] \right]$$

Where:  $j = -<a$ ;  $k = j$  when  $i > -j$ ;  $k = i$  when  $i < -j$ ;  $t_{aj}$  = the tension due to the deflection of the side rod at section  $j$  due to the winding up to and including section  $a$ ;  $a = ath$  section along the winding length of the grid;  $j = jth$  section along the winding length of the grid;  $K =$  deflection to tension conversion constant for a specified grid;  $n =$  number of sections that the grid is divided into along the winding length of the grid;  $T_n =$  winding tension to be used at the  $nth$  section = the final tension for all sections of the finished grid;  $i = ith$  section along the winding length of the grid;  $T_i =$  winding tension to be used at the  $ith$  section;  $t_{ni} =$  see definition of  $t_{aj}$ ;  $t_{ii} =$  see definition of  $t_{aj}$ ;  $C_i = (2i-1)/2n =$  moment arm of the  $ith$  section in proportion to the total winding length of the grid;  $z_j$  or  $x_k =$  length to the  $jth$  or  $kth$  section; and  $L =$  length of the winding of the frame grid.

Fig. 1 — Typical frame grid of a receiving tube.

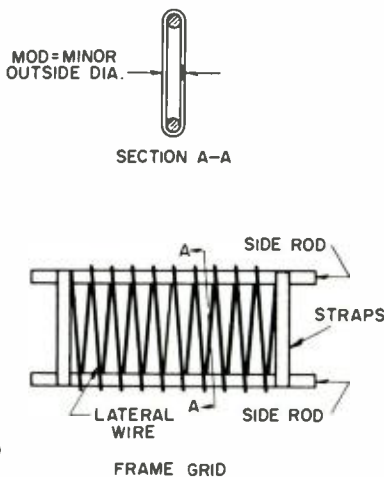

Fig. 2 — Deflection drawings (a, b, c & d) of a frame grid at various stages of winding.

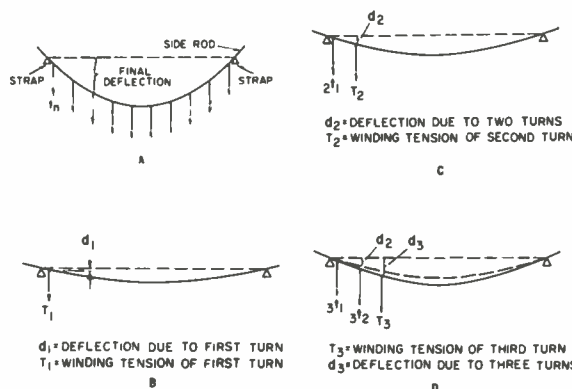
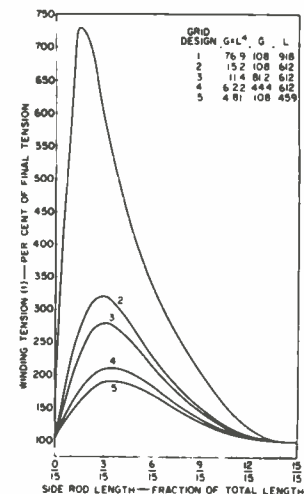

Fig. 3 — Winding tension curves for various grid designs.



The solution to the general equation generates as many unknown as the number of the turn being evaluated. For a typical frame grid, the average number of turns is 150. To reduce the number of unknown, turns were grouped to form sections along the length of the side rod, but it was apparent that the calculations involved, considering both time and accuracy could efficiently utilize a computer. After slow-charting the solution of the general equation, it was decided that an algebraic compiler such as UMAC (i.e., University of Miami Algebraic Compiler for the RCA 301) would be used in the preparation and writing of this scientific program. This compiler allows one *not* familiar with computer machine details to write in a pseudo-language that is easily usable.

The next step was to calculate, manually, using a desk calculator, a sample problem that would 1) allow the checking of the computer programmed output, 2) assure that all steps were correctly specified in the original step-by-step flow charting, and 3) allow the reduction or elimination of mathematical computations that were not apparent previously in the reduction of the mathematical formulae. As a result of the sample calculation, minor revisions were made in the logic which increased computer efficiency by eliminating repetitive calculations during iterative processes.

Because of the computer memory limitations, two programs, written in UMAC, are used in solving this problem. The first solves the basic equation for the number of sections into which the grid is divided and sets up and writes out matrices of coefficients of unknowns for each section evaluated. For example, if the number of sections = 10, and one is solving for successive sections, then

Section	Matrix Size	Section	Matrix Size
1	2 x 3	6	7 x 8
2	3 x 4	7	8 x 9
3	4 x 5	8	9 x 10
4	5 x 6	9	10 x 11
5	6 x 7		

The second program solves the matrices using the Gaussian elimination method of solving simultaneous linear equations. These results define the winding tensions required for proper fabrication of frame grids.

**Conclusions:** By evaluating several frame-grid designs on the computer, it was established that winding tension could be expressed in percentage of the desired final tension and was independent of the absolute value of tension.

In actual manufacture of the frame grid, the winding tension used lies between a lower limit determined by the minimum value necessary to keep the lateral wire from slipping, and an upper limit, the breaking point of the wire. The breakage of the lateral wire is a factor found in practice that does not appear in the calculated results because of the assumption made in setting up the mathematical model that all stresses are within elastic limits. Thus, for grids that mathematically require a large increase of winding tension, a compromise may be necessary to prevent wire breakage.

A side benefit obtained from this study was the development of a rating factor, " $G \times L$ " which evaluates frame-grid designs in terms of the winding tension range required for tension corrections. The "give factor"  $g$ , is a measure of the tendency of the side rod to bow, per unit length, and can be expressed by:

$$\frac{E_L}{E_{sr}} \times \frac{TPI \times D_L^2 \times 10^6}{B \times D_{sr}^4}$$

where:  $TPI$  = turns per inch;  $D_L$  = diameter of lateral wire, mils;  $B$  = centerline-to-centerline of the frame side rods, inches;  $D_{sr}$  = diameter of the side rod, mils;  $E_L$  = modulus of elasticity of lateral wire;  $E_{sr}$  = modulus of elasticity of the side rod;  $l$  = the wound length of the grid from strap-to-strap, inches.

The tension range that is required to produce equal tension in all turns increases as the "give factor",  $G$ , increases, as shown by curves 2 and 3 of Fig. 3. These factors, in turn, may lead to winding-tension ranges which are outside lateral-wire or winding-machine capabilities.

Grids constructed using the calculated tension values exhibited improved characteristics when compared to grids wound either with a constant tension or with the empirical winding programs formerly used. On some production machinery, a compromise was necessary to prevent lateral-wire breakage but this program also gave better results than the previous empirical program.

## New-Design Pressure Transducer for Cable and Pipe Networks—More Reliable and Economical

C. MERRELL, *Systems Laboratory,*  
*Communications Systems Division, DEP,*  
*New York, N. Y.*

*Final manuscript received February 23, 1965*

The author designed and built a feasibility model of a pressure transducer having advantages over the conventional bellows-potentiometer type. It is applicable to a variety of installations requiring remote, automatic monitoring of pressure. It is ideally suited to fixed positions, (free from vibration) such as power plants or processing plants for monitoring natural gas, or steam; and air pressure in cable networks using air pressure for moisture-proofing.

A sketch of the transducer is shown in Fig. 1. Air pressure, admitted at the bottom, presses up against a diaphragm, displacing mercury from the well into the column. Because the diameter of the well is much larger than the diameter of the column, a small movement of the diaphragm results in a large change in the level of mercury in the column. A resistance wire is mounted in the column between terminals *A* and *B*. This wire is partially shorted out by the mercury in the column. When pressure at the pressure inlet rises, the diaphragm is forced upward, the level of mercury in the column rises, and more of the resistance wire is shorted out. Thus a rise in pressure results in a drop of resistance measured between terminals *A* and *B*.

A variation of the design in Fig. 1 is shown in Fig. 2, where a series of terminals extending into the mercury are connected by fixed resistors. The Fig. 2 device has step resolution compared to the infinite resolution of the resistance wire in the Fig. 1 device. However, the Fig. 2 device may be superior for physical reasons.

An important advantage is the reliability of the new transducer, compared to a conventional bellows-potentiometer type of transducer—i.e., no mechanical linkage, no problem of abrasion of the resistance winding, no problem of maintaining a very fine value of contact pressure. Movement of the diaphragm can be kept small, since the transition from large-diameter well to small-diameter column can provide whatever multiplication of motion is desired.

Another advantage is reduced cost; the new design contains no linkage. The diaphragm should be cheaper to make (than the bellows of a potentiometer type of transducer), since it is intended for use over a very small range of deflection. And as can be noted in Fig. 1, it has no moving parts (except for the diaphragm). It should cost roughly half the price of a bellows-potentiometer transducer of equivalent accuracy.

A third advantage is simplicity of manufacture.

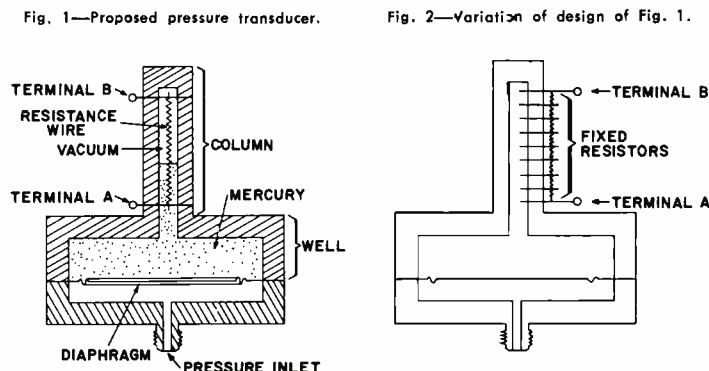

PEN and

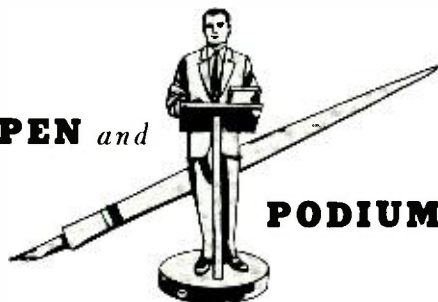

PODIUM

### A SUBJECT-AUTHOR INDEX TO RECENT RCA PAPERS

Both published papers and verbal presentations are indexed. To obtain a published paper, borrow the journal from your library—or write or call the author for a reprint. For information on verbal presentations, write or call the author. This index is prepared from listings provided bimonthly by divisional Technical Publications Administrators and Editorial Representatives—who should be contacted concerning errors or omissions (see inside back cover).

## SUBJECT INDEX

Titles of papers are permuted where necessary to bring significant keyword(s) to the left for easier scanning. Authors' division appears parenthetically after his name.

### ANTENNAS

**Impedance of an Electric Dipole in a Magnetic Ionic Medium**—H. Staras (Labs, Pr.) *IEEE Trans. on Antennas and Propagation*, Vol. AP-12, No. 6, Nov. 1964

**Quasi-Isotropic Antennas. A Made Analysis of**—O. M. Woodward, (DEP-MSR, Mrstin.) *RCA Review*, Vol. XXVI, Mar. 1965

**Wave Tilt of an Electromagnetic Wave Propagating in the Earth-Ionosphere Cavity**—B. E. Keiser (Labs, Pr.) *IEEE Trans. on Antennas and Propagation*, Vol. AP-12, No. 6, Nov. 1964

### ATOMIC THEORY; PHENOMENA

**Thermodynamics of Normal Fermion Systems**—R. Klein (Labs, Pr.) *Coll., Univ. of Cologne*, Feb. 17, 1965

### BIONICS

**Acoustic Recognition by Analog Feature Abstraction Techniques**—H. J. Zadell, A. L. Nelson, M. B. Herscher, T. B. Martin (DEP-AppRes, Camden) *Symp. on Models for the Perception of Speech and Visual Forms*, AFCRL, Nov. 14, 1964; *Proceedings*

**Speech Recognition Using Analog Threshold Logic**—T. B. Martin, H. J. Zadell, A. L. Nelson, M. B. Herscher (DEP-AppRes, Camden) 68th Mtg. Acoustical Soc. of America, Austin, Texas, Oct. 22, 1964

### CHECKOUT; MAINTENANCE

**Automatic Fault Location Equipment; Concepts and Practical Aspects**—O. T. Carver (DEP-ASD, Burl.) *Maintainability-Engineering and Management Program*, the George Washington Univ., Feb. 15, 1965

**Decision Tables as the Source Language for Automatic Testing. An Application of**—B. H. Scheff (DEP-ASD, Burl.) *IEEE Trans. on Aerospace*, Vol. AS3, No. 1, Feb. 65

**Decision-Table Structure as the Input Language for Programming Automatic Test Equipment Systems**—B. H. Scheff (DEP-ASD, Burl.) *IEEE Trans. on Electronic Computers*, Apr. 1965

**Manned Spacecraft, Electronic Equipment Maintenance on**—H. R. Sutton (DEP-CE, Camden) *IEEE Reliability Group*, Phila., Nov. 24, 1964

### CIRCUIT INTERCONNECTIONS; PACKAGING

**Integrated Circuit Packages, Factors Influencing the Selection and Use of**—D. P. Schnorr (DEP-CE, Camden) *Electrical Design News*, Oct. 1964; (Electronic Packaging Ref. Issue)

**Integrated Circuit Packaging, Design Considerations in**—D. P. Schnorr (DEP-CE, Camden) *Prof. Group on Prod. Eng. & Production*, IEEE-Phila. Sect., Dec. 3, 1964

**Integrated Circuit Packaging, Designing for Maintainability in**—D. P. Schnorr, E. A. Szukalski (DEP-CE, Camden) *Electronic Packaging and Production*, Dec. 1964

**Integrated Circuit Packaging, Factors Influencing the Use of Multilayer Wiring Boards in**—D. P. Schnorr (DEP-CE, Camden) *Technical Seminar on Multilayer Circuits*, Inst. of Printed Circuits, Chicago, Ill., Oct. 6, 1964

### CIRCUIT THEORY; ANALYSIS

**Inductorless Bandpass Filters Using a Combination of Identical RC Coupled Amplifiers. Optimum Synthesis of**—J. Pearl (Labs, Pr.) *IEEE Trans. Circuit Theory*, Vol. CT-11, No. 4, Dec. 1964

**Recursive Techniques in Transient Analysis**—J. Hilinski, W. Schaming (DEP-AppRes, Camden) *Thesis MSE(EE) Moore School of Elec. Eng.*, Univ. of Penna., Dec. 1964

### COMMUNICATIONS, DIGITAL

**Digital TV Bandwidth Reduction Techniques as Applied to Spacecraft Television**—J. Whelan (DEP-AED, Hightstown) *Joint Mtg. Monmouth Subsection IEEE and Monmouth Chapter, IEEE-PTGCS*, Little Silver, N. J., March 1, 1965

**Improved-Gray-Scale and the Coarse-Fine PCM Systems. Two New Digital TV Bandwidth Reduction Techniques**—J. Whelan, W. Bisignani, G. Richards (DEP-AED, Hightstown) 1965 IEEE International Conv., NYC, Hilton Hotel, March 22, 1965; *Conv. Record*

### COMMUNICATIONS SYSTEMS; THEORY

**Asynchronous Multiplex Principles**—A. Mack (DEP-CSD, Camden) *Joint Mtg. Monmouth Subsection IEEE and Monmouth Chapter, IEEE-PTGCS*, Little Silver, N. J., Jan. 20, 1965

**Communications System Simulator**—M. S. Corington (DEP-AppRes, Camden) *Circuit Theory Group*, IEEE, Phila., Pa., Sept. 15, 1964

**Facsimile Art During 1964. Advancements in the**—W. Bliss (DEP-AED, Hightstown) *IEEE International Conv.*, NYC, Hilton Hotel, Mar. 26, 1965; *Conv. Record*

**Relay Communications Satellite**—J. Kiesling (DEP-AED, Hightstown) *Eta Kappa Nu Committee for Undergraduate Seminars*, Purdue Univ., West Lafayette, Ind., Mar. 15, 1965

### COMMUNICATIONS, VOICE SYSTEMS

**C-Band Radar Voice Communications**—M. G. Herold (DEP-MSR, Mrstin.) *Thesis (MSE:EE) Univ. of Penna.*, Dec. 22, 1964

**Room-Temperature GaAs Laser Voice-Communication System**—D. Karlsons, C. W. Reno, W. J. Hannan (DEP-AppRes, Camden) *Proceedings of the IEEE*, Vol. 52, No. 11, Nov. 1964, pp. 1354-55

### COMPUTER CIRCUITRY; DEVICES

**High-Speed Adders and Comparators Using Transistors and Tunnel Diodes**—J. J. Amodel (Labs, Pr.) *IEEE Trans. on Electronic Computers*, Vol. EC-13, No. 5, Oct. 1964

**Threshold Gates for Digital Systems**—R. O. Winder, J. J. Amodel, T. R. Mayhew (Labs, Pr.) *International Solid-State Circuits Conf.*, Phila., Feb. 17-19, 1965; *Conf. Digest*

**Transistor Logic. MOS Micropower Complementary**—R. W. Ahrons, M. Mitchell, J. R. Burns (ECD, Som.) *Solid-State Circuits Conf.*, Phila., Pa., Feb. 17-19, 1965; *Conf. Digest*

### COMPUTER LOGIC; THEORY

**Analog Feature Abstraction Techniques, Acoustic Recognition by**—H. J. Zadell, A. L. Nelson, M. B. Herscher, T. B. Martin (DEP-AppRes, Camden) *Symp. on Models for the Perception of Speech and Visual Forms*, AFCRL, Nov. 14, 1964; *Proceedings*

**Analog Threshold Logic, Speech Recognition Using**—T. B. Martin, H. J. Zadell, A. L. Nelson, M. B. Herscher (DEP-AppRes, Camden) 68th Mtg. Acoustical Soc. of America, Austin, Texas, Oct. 22, 1964

### COMPUTER PROGRAMMING

**Decision Tables as the Source Language for Automatic Testing. An Application of**—B. H. Scheff (DEP-ASD, Burl.) *IEEE Trans. on Aerospace*, Vol. AS3, No. 1, Feb. 65

**Decision-Table Structure as the Input Language for Programming Automatic Test Equipment Systems**—B. H. Scheff (DEP-ASD, Burl.) *IEEE Trans. on Electronic Computers*, Apr. 1965

**Decision Tables in Computer Programming. Use of**—H. W. Kirk (ECD, Hr.) *Communications of the Assoc. for Computing Machinery*, Jan. 1965

### COMPUTER STORAGE

**Associative Memory, Resolving Multiple Responses in an**—H. S. Müller (Labs, Pr.) *IEEE Trans. on Electronic Computers*, Vol. EC-13, No. 5, Nov. 1964

**Content-Addressed Memory for Dynamic Storage Allocation. Application of**—Y. Chu (DEP-Bethesda) *RCA Review*, Vol. XXVI, Mar. 1965

**Recent Advances in Computer Memories**—J. A. Rajchman (Labs, Pr.) *Seminar on Automatic Computers and Their Capabilities*, Univ. of Penna., Phila., Feb. 3, 1965

**A 10<sup>5</sup>-Bit High-Speed Ferrite Memory: Design and Operation**—H. Amemiya, T. R. Mayhew, R. L. Pryor (DEP-AppRes, Camden) 1964 Fall Joint Computer Conf., IEEE, San Francisco, Oct. 27, 1964; *Proceedings*

### CONTROL; TIMING

**Automatic Timing Control System**—D. J. Woywood (DEP-AppRes, Camden) *Thesis, MSE(EE)*, Moore School of Elec. Eng., Univ. of Penna., Aug. 1964

### DISPLAYS

**Ferroelectric Transducer-Controlled Electroluminescent Matrix Display**—B. J. Lechner (Labs, Pr.) 1965 International Solid-State Circuits Conf., Phila., Feb. 17-19, 1965; *Conf. Digest*

**Matrix Addressed Solid-State Display**—G. Zin, L. J. Krolak (DEP-AppRes, Camden) *Electron Devices Symp.*, Wash., D.C., Oct. 29, 1964

### ELECTROMAGNETIC THEORY; PHENOMENA

**Cerenkov Radiation, Influence of Source Symmetry on**—Dr. L. W. Zelby, Dr. J. Vollmer (DEP-AppRes, Camden) *Journal of Applied Physics*, Vol. 36, Jan. 1965

**Frequency-Diversity Waveforms, Application of Some Linear FM Results to**—T. B. Howard (DEP-MSR, Mrstin.) *RCA Review*, Vol. XXVI, Mar. 1965

**Reentry Plasma Sheaths, Electromagnetic Wave Penetration of**—Dr. M. P. Bachynski (RCA Ltd., Montreal) *Radio Science*, Vol. 69D, No. 2, Feb. 1965

**Wave Tilt of an Electromagnetic Wave Propagating in the Earth-Ionosphere Cavity**—B. E. Keiser (Labs, Pr.) *IEEE Trans. on Antennas and Propagation*, Vol. AP-12, No. 6, Nov. 1964

### ELECTROMAGNETISM

**Hysteresis of CdSe in the Electron Conductivity**—G. Zin (DEP-AppRes, Camden) *Amer. Inst. of Physics*, Drexel Inst., Dec. 2, 1964

### ELECTROMECHANICAL COMPONENTS

**The Crying Need**—A. Siegel (DEP-CE, Camden) *Electromechanical Design*, p. 22, Dec. 1964

**Early Electric Circuit Breaker**—R. F. Ficcki (DEP-CSD, Camden) *Proceedings of the 10th International Congress on the History of Science*, 1964

**Open Letter of Mr. Kitka**—A. Siegel (DEP-CE, Camden) *Electromechanical Design*, Feb. 1965, p. 18

**Switch Application Checklist**—A. Siegel (DEP-CE, Camden) *Electromechanical Design*, Oct. 1964

**Test Procedures, A Need for**—A. Siegel (DEP-CE, Camden) *Electromechanical Design*, Sept. 1964, p. 26

### ELECTRO-OPTIC SYSTEMS; TECHNIQUES

**Electron Microscope, Future Developments of the**—Dr. J. H. Reiser (BCD, Camden) *Burton Soc. of Electron Microscopists*, Toronto, Canada, Jan. 16, 1965

**Electron Microscopy, The Theory and Practice of Image Intensification in**—Dr. J. H. Reiser (BCD, Camden) *1st Annual Microscopy Symp.*, New Orleans, Feb. 15-16, 1965

**GaAs Laser Inverter**—W. F. Kosonocky, R. Cornely, F. Marlowe (Labs, Pr.) 1965 International Solid-State Circuits Conf., Phila., Feb. 1965; *Conf. Digest*

**Infrared Detectors**—G. A. Morton (ECD, Pr.) *RCA Review*, Vol. XXVI, Mar. 1965

**Light Demodulators**—F. Sterzer (ECD, Pr.) *IEEE Sect. Mtg.*, NYC, Jan. 13, 1965

### ENERGY CONVERSION; SOURCES

**Heterojunction Photovoltaic Cells**—S. S. Perlman (Labs, Pr.) *Advanced Energy Conversion*, Vol. 4, No. 3, Dec. 1964

### FILTERS

**Inductorless Bandpass Filters Using a Combination of Identical RC Coupled Amplifiers. Optimum Synthesis of**—J. Pearl (Labs, Pr.) *IEEE Trans. Circuit Theory*, Vol. CT-11, No. 4, Dec. 1964

### HUMAN ENGINEERING

**Graphic Aids for Console Designers**—Dr. F. H. Ireland, J. L. Hanna (DEP-SEER, Mrstin.) *Industrial Design*, Feb. 1965



## INFORMATION PROCESSING; RETRIEVAL

Acoustic Recognition by Analog Feature Abstraction Techniques—H. J. Zadel, A. L. Nelson, M. B. Herscher, T. B. Martin (DEP-AppRes, Camden) Symp. on Models for the Perception of Speech and Visual Forms, AFCLRL, Nov. 14, 1964; *Proceedings*

Speech Recognition Using Analog Threshold Logic—T. B. Martin, H. J. Zadel, A. L. Nelson, M. B. Herscher (DEP-AppRes, Camden) 68th Mtg. Acoustical Soc. of America, Austin, Texas, Oct. 22, 1964

## INSTRUMENTATION; LAB EQUIPMENT

Accelerometer Performance, Effects of Unpublished Characteristics on—B. Mangolds (DEP-AED, Hightstown) U.S. Navy Eastern Standards Lab., Washington, D.C., Feb. 18, 1965

Electron Microscope, Future Developments of the Dr. J. H. Reisner (BCD, Camden) Burton Soc. of Electron Microscopists, Toronto, Canada, Jan. 16, 1965

Electron Microscopy, The Theory and Practice of Image Intensification in—Dr. J. H. Reisner (BCD, Camden) 1st Annual Microscopy Symp., New Orleans, Feb. 15-16, 1965

High Temperature Differential Thermal Analysis Apparatus—M. M. Hopkins (Labs, Pr.) *Review of Scientific Instruments*, Vol. 35, No. 12, Dec. 1964

Measurement of Absolute Optical Collision Diameters in Methane Using Tuned-Laser Spectroscopy—S. A. Ahmed, H. J. Gerritsen (Labs, Pr.) *Physics Letters*, Vol. 13, No. 1, Nov. 1, 1964

Metal-Semiconductor Barrier-Height Measurement by the Differential Capacitance Method—Degenerate One-Carrier System—A. M. Goodman, D. M. Perkins (Labs, Pr.) *Journal of Applied Physics*, Vol. 35, No. 11, Nov. 1964

Microwave Dielectric Constant of Liquids, A Two-Impedance Method for Measuring the—E. Fatuzzo, P. R. Mason (Labs, Pr.) *Journal of Scientific Instruments*, Vol. 41, Nov. 1964

Shaped Electrode Design—F. H. Edelman, R. W. Klopfenstein (Labs, Pr.) *Journal of the Electrochemical Society*, Vol. 112, No. 1, Jan. 1965

X-Ray Secondary-Emission Spectrometer, Evaluation and Application of an Improved Slit Probe for the—E. P. Bertin (ECD, Hr.) Workshop & Seminar on X-Ray Spectrometric Analysis, Stevens Inst., Hoboken, N.J., Feb. 24, 1965

X-Ray Spectrometric Analysis, Specimen Preparation of; Technique of Chemical Analysis by X-Rays—E. P. Bertin (ECD, Hr.) Workshop & Seminar on X-Ray Spectrometric Analysis, Stevens Inst., Hoboken, N.J., Feb. 24, 1965

X-Ray Spectrometric Analysis, Solution Techniques in—E. P. Bertin (ECD, Hr.) *Norelco Reporter*, Jan-Mar. 1965

## LASERS

GaAs Laser Inverter—W. F. Kosonocky, R. Cornely, F. Marlowe (Labs, Pr.) 1965 International Solid-State Circuits Conf., Phila., Feb. 1965; *Conf. Digest*

High-Efficiency Injection Laser at Room Temperature—H. Nelson, J. Pankov, F. Hawrylo, G. Dousmanis, C. Reno (Labs, Pr.) *Proc. of IEEE*, Vol. 52, No. 11, Nov. 1964

Measurement of Absolute Optical Collision Diameters in Methane Using Tuned-Laser Spectroscopy—S. A. Ahmed, H. J. Gerritsen (Labs, Pr.) *Physics Letters*, Vol. 13, No. 1, Nov. 1, 1964

Room-Temperature GaAs Laser Voice-Communication System—D. Karlsons, C. W. Reno, W. J. Hannan (DEP-AppRes, Camden) *Proceedings of the IEEE*, Vol. 52, No. 11, Nov. 1964, pp. 1354-55

## MANAGEMENT; BUSINESS

Competitive Bidding, The Art and Science of—F. Edelman (Labs, Pr.) Recruiting Seminar, Johns Hopkins Univ., Dec. 1, 1964

Electronics, Technological Advances in—J. M. Forman (ECD, Lanc.) *Sunday News*, Feb. 21, 1965

Motivation, the Urge that Results from Messages Received—G. A. Kiessling (RCA Staff, Camden) Engineers' Club of Phila., Educational Committee, Mar. 10, 1965

New Materials in the Electronics Industry—F. D. Rosi (Labs, Pr.) *Industrial Research*, Vol. 6, No. 10, Nov. 1964

Product Plan for the Technical Product Line, Establishing a—D. F. Schmit (RCA Staff, Camden) American Management Association's Briefing Session, Chicago, Feb. 24-26, 1965

RCA—The World's Most Broadly Based Electronics Company—J. J. Gillespie (DEP-CSD, Camden) PTA, G. B. Fein School, Pennsauken, N.J., Feb. 23, 1965

## MATHEMATICS

Application of the Negative Binomial Distribution with Probability of Misclassification—V. Chew (RCA Svc. Co., MTP, Cocoa Beach) *The Virginia Journal of Science*, Vol. 15, No. 1, Jan. 1964

Effects of Correlated Errors on Variate-Difference Estimates of Error Variance—V. Chew (RCA Svc. Co., MTP-Cocoa Beach) *Australian Journal of Statistics*, Vol. 7, No. 1, Apr. 1965

Statistical Mechanics of Cooperative Phenomena at Temperature Above the Curie Point—P. J. Wojtowicz (Labs, Pr.) Physical Chemistry Seminar, McMaster Univ., Feb. 18, 1965

## MECHANICAL COMPONENTS

Ingenious Mechanisms—T. Szirtes (RCA Ltd., Montreal) *Machinery*, Feb. 1965

Spacecraft Structures, Mechanical Impedance of—C. C. Osgood (DEP-AED, Hightstown) 34th Symp. on Shock, Vibration and Assoc. Environments, Monterey, Calif., Oct. 13, 1964; *Shock and Vibration Bulletin*, No. 34, Part 3, Dec. 1964

## MILITARY SYSTEMS

Minuteman—A Remarkable, Reliable Weapon System—J. J. Gillespie (DEP-CSD, Camden) Lions Club, Willow Grove, Pa., Feb. 4, 1965

Minuteman—Instrument of Peace—K. K. Miller (DEP-CSD, Camden) Beth El Synagogue, Camden, N.J., Jan. 10, 1965

## PLASMA

Non-Convective Instabilities in Drifted Electron-Hole Plasmas—M. C. Steele, B. Vural (Labs, Pr.) American Physical Soc. Mtg., NYC, Jan. 27-30, 1965

Plasma Effects in Solids—R. Bowers, M. C. Steele (Labs, Pr.) *Proc. IEEE*, Vol. 52, No. 10, Oct. 1964

Possible Two-Stream Instabilities of Drifted Electron-Hole Plasmas in Longitudinal Magnetic Fields—B. Vural, M. C. Steele (Labs, Pr.) Amer. Physical Soc. Mtg., NYC, Jan. 27-30, 1965

Reentry Plasma Sheaths, Electromagnetic Wave Penetration of—Dr. M. P. Bachynski (RCA Ltd., Montreal) *Radio Science*, Vol. 69D, No. 2, Feb. 1965

Solid State Plasma Waveguide in a Longitudinal Magnetic Field, Theory of a—R. Hirota (Labs, Pr.) *Journal of the Physical Society of Japan*, Vol. 19, No. 12, Dec. 1964

## RADAR

C-Band Radar Voice Communications—M. G. Herold (DEP-MSR, Mrstn.) Thesis (MSEE) Univ. of Penna., Dec. 22, 1964

Surveillance and Tracking—R. P. Cheetham, W. W. Weinstock (DEP-MSR, Mrstn.) *Space Aeronautic Mag. R&D Handbook*, Oct. 1964

## RADIATION DETECTION

Infrared Detectors—G. A. Morton (ECD, Pr.) *RCA Review*, Vol. XXVI, Mar. 1965

## RECORDING, DIGITAL

Digital Magnetic Tape Recording: Principles and Computer Applications—B. Bycer (DEP-CSD, Camden) Book published by Hayden Book Co., N.Y., Mar. 1965

## RECORDING, VIDEO

Wideband Direct Recording with High Frequency Bias—W. Hendershot, III (DEP-AppRes, Camden) Thesis, Univ. of Penna., Dec. 1964

## SIMULATION

Communications System Simulator—M. S. Corrington (DEP-AppRes, Camden) Circuit Theory Group, IEEE Phila., Pa., Sept. 15, 1964

## SOLID-STATE DEVICES; CIRCUITRY

(Diodes): Anomalous Capacitance Effects in Lithium-Drifted Germanium Diodes—Experiment—P. P. Webb, R. M. Green (RCA Ltd., Montreal) The American Phys. Society, Jan. 27, 1965

Micropower Circuits—R. D. Lohman (ECD, Som.) Panel Discussion, Solid-State Circuits Conf., Phila., Pa. Feb. 17-19, 1965; *Conf. Digest*

Semiconductors: Ready for 1 kw at 1 Gc—J. Hillbrand (ECD, Som.) *Electronic Design*, Jan. 4, 1965

Transistor Logic, MOS Micropower Complementary—R. W. Ahrons, M. Mitchell, J. R. Burns (ECD, Som.) Solid-State Circuits Conf., Phila., Pa., Feb. 17-19, 1965; *Conf. Digest*

(Transistors): DC Electrical Breakdown in MOS Structures, on the Mechanism of—N. Klein (Labs, Pr.) Tech. Mtg. at Technion, Haifa, Israel, Feb. 1965

(Transistors): Grown-Film Silicon Transistors on Sapphire—C. W. Mueller, P. H. Robinson (Labs, Pr.) *Proc. of IEEE*, Dec. 1964, Vol. 52, No. 12

Transistors, Metal-Oxide-Semiconductor Field-Effect—F. P. Heiman, S. R. Hofstein (Labs, Pr.) *Electronics*, Vol. 37, No. 30, Nov. 30, 1964

Tunnel Diodes—F. Sterzer (ECD, Pr.) Panel Discussion, Solid-State Circuits Conf., Phila., Pa., Feb. 17-19, 1965; *Conf. Digest*

## SOLID-STATE MATERIALS

Band Structure of Bismuth Telluride-Bismuth Selenide-Alloys—G. Harbeck, D. L. Greenaway (Labs, Pr.) Conf. on Solid-State Physics, Bristol, England, Jan. 1965

Diffusion Size Effect in Bismuth—S. Tosima, T. Hattori (Labs, Pr.) *Journal of the Physics Society of Japan*, Vol. 19, No. 11, Nov. 1964

Dislocation Etch Pits in GaAs—M. S. Abrahamis (Labs, Pr.) *Journal of App. Phys.*, Vol. 35, No. 12, Dec. 1964

A Double Injection Negative Resistance in p-Type Indium Antimonide at 77°K—K. Ando (Labs, Pr.) *Japanese Journal of Applied Physics*, Vol. 3, No. 12, Dec. 1964

Dynamics of Energy Transfer from 3d to 4f Electrons in LaAlO<sub>3</sub>:Ce<sup>3+</sup>Nd<sup>3+</sup>—Z. J. Kiss (Labs Pr.) *Physical Review Letters*, Vol. 12, No. 23, Dec. 1964

Elastic Constants of Strontium Fluoride Between 4.2° and 300°K—D. Gerlich (Labs, Pr.) *Physical Review*, Vol. 136, No. 5A, Nov. 30, 1964

Electron and Phonon Scattering in GaAs at High Temperatures—J. Kidman, E. F. Steigmeier, A. Amith (Labs, Pr.) APS Mtg., NY, Jan. 27-30, 1965

Electron Spin Resonance of and B-Cobalt Phthalocyanine—J. M. Assour, W. K. Kahn (Labs, Pr.) *Journal of the American Chemical Society*, Vol. 87, No. 2, Jan. 1965

Electron Spin Resonance of Concentrated Copper Phthalocyanine Crystals—J. M. Assour, S. E. Harrison (Labs, Pr.) *Physical Review*, Vol. 136, No. 5a, Nov. 1964

Ferroelectrics in the Far Infra-Red, Field Dependence of the Absorption Bands of—E. Fatuzzo (Labs, Pr.) *Proc. of the Inst. of Physics and the Physical Soc.*, England, Vol. 84, 1964

Hysteresis of CdSe in the Electron Conductivity—C. Zin (DEP-AppRes, Camden) Amer. Inst. of Physics, Drexel Inst., Dec. 2, 1964

A New Effect in InSb Yielding a Microwave Negative Resistance—L. F. Eastman (Labs, Pr.) Conf. on Active Microwave Effects in Bulk Semiconductors, NYC, Feb. 4-5, 1965

Near-Infrared Reflection Spectra of Heavily Doped Low-Mobility Semiconductors—L. A. Murray, J. J. Rivera, P. A. Hoss (ECD, Som.) Amer. Phys. Soc. Mtg., Jan. 1965

Octacoordinate Chelates of Lanthanides. Two Series of Compounds—H. Bauer, J. Blanc, D. L. Ross (Labs, Pr.) *Journal of the American Chemical Soc.*, Vol. 86, July 17, 1964

Optical Properties of Semiconductors at Energies Above the Fundamental Absorption Edge—M. Cardona (Labs, Pr.) 7<sup>th</sup> Congres International Physique des Semiconducteurs, Paris, 1964 DUNOD

Paramagnetic Resonance Absorption in an Optically Excited State in CaF<sub>2</sub>:Dy<sup>3+</sup>—E. S. Sabisky, C. H. Anderson (Labs, Pr.) *Physical Review Letters*, Vol. 13, No. 25, Dec. 21, 1964

Phonon Broadening of Spin Resonance Absorption Lines in CaF<sub>2</sub>:Dy<sup>3+</sup>—C. H. Anderson, E. S. Sabisky (Labs, Pr.) APS Mtg., NY, Jan. 27-30, 1965

Photo-Induced Chemisorption on Insulator Surfaces—P. Mark (Labs, Pr.) Univ. of Puerto Rico, Feb. 24, 1965; Materials Science Coll. at MIT, Feb. 19, 1965

Plasma Effects in Solids—R. Bowers, M. C. Steele (Labs, Pr.) *Proc. IEEE*, Vol. 52, No. 10, Oct. 1964

Preparation and Properties of Niobium (Columbium) Stannide on Insulating Substrates—G. W. Cullen (Labs, Pr.) Transactions of the Metallurgical Soc. of AIME, Vol. 230, Dec. 1964

Properties of Pentacyanonitrosylferrates—E. F. Hockings, I. Bernal (Labs, Pr.) *Journal of the Chemical Society*, Dec. 1964

Relationship Between Optical Second Harmonic Generation and the Electro-Optic Effect in the Molecular Crystal Hexamine—G. H. Heilmeyer, N. Ockman, R. Braunstein, D. A. Kramer (Labs, Pr.) *Applied Physics Letters*, Vol. 5, No. 11, Dec. 1964

Scattering of Phonons by Electrons in Ge-Si Alloys—E. F. Steigmeier, B. Abeles (Labs, Pr.) *The Physical Review*, Vol. 136, No. 4A, Nov. 1964

Semiconductor Device Technology II—F. P. Heiman (Labs, Pr.) Rutgers Univ. Extension Div., Feb. 3-26, 1965

Single-Crystal Gallium Arsenide Layers on Germanium Substrates, The Growth of—J. A. Amick (Labs, Pr.) *Proc. of a Conf. on Single Crystal Gallium Substrates*, Blue Bell, Pa., May 15, 1963 (Printed in 1964)

Switching Analysis of Gate-Controlled Space-Charge-Limited Emission Processes in Semiconductors—R. C. Williams (Labs, Pr.) *RCA Review*, Vol. XXVI, Mar. 1965

Ultrathin Pinhole-Free Insulation of Aluminum Oxide, Fabrication of—R. B. Schilling (Labs, Pr.) *Proc. of the IEEE*, Nov. 1964, Vol. 52, No. 11

## SOLID-STATE MICROELECTRONICS

Integrated Circuit Packaging, Design Considerations in—D. P. Schnorr (DEP-CE, Camden) Prof. Group on Prod. Eng. & Production, IEEE, Phila., Sect., Dec. 3, 1964

Integrated Circuit Packages, Factors Influencing the Selection and Use of—D. P. Schnorr (DEP-CE, Camden) *Electrical Design News*, Oct. 1964; (Electronic Packaging Ref. Issue)

**Integrated Circuit Packaging, Designing for Maintainability**—D. P. Schnorr, E. A. Szukulaski (DEP-CE, Camden) *Electronic Packaging and Production*, Dec. 1964

**Integrated Circuit Packaging, Factors Influencing the Use of Multilayer Wiring Boards**—D. P. Schnorr (DEP-CE, Camden) Technical Seminar on Multilayer Circuits, Inst. of Printed Circuits, Chicago, Ill., Oct. 6, 1964

**Integrated Circuits Incorporating Thin-Film Active and Passive Elements**—P. W. Weimer, H. Borkan, G. Sadasiv, L. Meray-Horvath, F. V. Shallcross (Labs, Pr.) *Proc. of the IEEE*, Dec. 1964, Vol. 52, No. 12

## SPACE COMPONENTS

**Automatic Picture Transmission Systems**—L. Saxton, P. Werenfels (DEP-AED, Hightstown) Unmanned Spacecraft Mtg. of AIAA, March 1, 1965, Los Angeles, Calif.

**Digital TV Bandwidth Reduction Techniques as Applied to Spacecraft Television**—J. Whelan (DEP-AED, Hightstown) Unmanned Spacecraft Mtg. of AIAA, Los Angeles, Calif., March 1, 1965

**Facsimile Art During 1964, Advancements in the**—W. Bliss (DEP-AED, Hightstown) IEEE International Conv., NYC, Hilton Hotel, March 26, 1965; *Conv. Record*

**Improved-Gray-Scale and the Coarse-Fine PCM Systems, Two New Digital TV Bandwidth Reduction Techniques**—J. Whelan, W. Bisignani, G. Richards (DEP-AED, Hightstown) 1965 IEEE International Conv., NYC, Hilton Hotel, March 22, 1965; *Conv. Record*

## SPACE NAVIGATION; TRACKING

**Doppler Navigation Satellite Systems, Accuracy and Simplification in**—N. S. Potter (DEP-SEER, Mrstn.) *Navigation*, Winter 1964-1965

**Surveillance and Tracking**—R. P. Cheatham, W. W. Weinstock (DEP-MSR, Mrstn.) *Space Aeronautic Mag. R&D Handbook*, Oct. 1964

## SPACE VEHICLES; SATELLITES

**Manned Spacecraft, Electronic Equipment Maintenance on**—H. R. Sutton (DEP-CE, Camden) IEEE Reliability Group, Phila., Nov. 24, 1964

**Relay Communications Satellite**—J. Kiesling (DEP-AED, Hightstown) Eta Kappa Nu Committee for Undergraduate Seminars, Purdue Univ., West Lafayette, Ind., Mar. 15, 1965

## SUPERCONDUCTIVITY

**Preparation and Properties of Niobium (Columbium) Stannide on Insulating Substrates**—G. W. Cullen (Labs, Pr.) *Transactions of the Metallurgical Soc. of AIME*, Vol. 230, Dec. 1964

**Temperature Dependence of the Ginzburg-Landau Parameter  $k$  in Weak and Strong Coupling Superconductors**—B. Rosenblum, M. Cardona (Labs, Pr.) *Physics Letters*, Vol. 13, No. 1, Nov. 1, 1964

## SWITCHING

**Switch Application Checklist**—A. Siegel (DEP-CE, Camden) *Electromechanical Design*, Oct. 1964

**Switching Analysis of Gate-Controlled Space-Charge-Limited Emission Processes in Semiconductors**—R. C. Williams (Labs, Pr.) *RCA Review*, Vol. XXVI, Mar. 1965

## TELEVISION BROADCASTING; TRANSMISSION

**Automatic Picture Transmission Systems**—L. Saxton, P. Werenfels (DEP-AED, Hightstown) Unmanned Spacecraft Mtg. of AIAA, Mar. 1, 1965, Los Angeles, Calif.

**Digital TV Bandwidth Reduction Techniques as Applied to Spacecraft Television**—J. Whelan (DEP-AED, Hightstown) Unmanned Spacecraft Mtg. of AIAA, Los Angeles, Calif., Mar. 1, 1965

**Improved-Gray-Scale and the Coarse-Fine PCM Systems, Two New Digital TV Bandwidth Reduction Techniques**—J. Whelan, W. Bisignani, G. Richards (DEP-AED, Hightstown) 1965 IEEE International Conv., NYC, Hilton Hotel, Mar. 22, 1965; *Conv. Record*

## TELEVISION COMPONENTS

**Color Picture Tube, Development of the RCA 25-inch 90-Degree Rectangular**—A. M. Morrell, A. E. Hardy (ECD, Lanc.) Corning Glass Co., Corning, N.Y., Jan. 11, 1965

**Sync Generator (TG-3), Development of**—J. M. Walter (BCD, Camden) IEEE, Phila. Chapter, Group 2 (Broadcasting) Feb. 10, 1965

## TELEVISION RECEIVERS

**Color Controls on Color TV Receivers in a Color TV System Operating Perfectly, A Study of the Need for**—C. J. Hirsch (Labs, Pr.) *IEEE Trans. on BTR*, Vol. 10, No. 3, Nov. 1964

**The Picture on Your Television Screen**—P. Kuznetsov (ECD, Lanc.) Immaculata High School, Somerville, N.J., Jan. 21, 1965

## TUBE DESIGN; APPLICATION

**Color Picture Tube, Development of the RCA 25-inch 90-Degree Rectangular**—A. M. Morrell, A. E. Hardy (ECD, Lanc.) Corning Glass Co., Corning, N.Y., Jan. 11, 1965

**Microwave Photomultipliers Under Transmission Dynodes**—D. Blattner, H. Johnson, J. Ruedy, F. Sterzer (ECD, Pr.) *RCA Review*, Vol. XXVI, Mar. 1965

**Traveling-Wave Tubes, Helix Support Structure for Ultra-Wide-Band**—E. F. Belohouhek (ECD, Pr.) *RCA Review*, Vol. XXVI, Mar. 1965

## AUTHOR INDEX

Subject listed opposite each author's name indicates where complete citation to his paper may be found in the subject index. Where an author has more than one paper, his name is repeated for each.

## DEP AEROSPACE SYSTEMS DIV.

Carver, O. T. checkout; maintenance  
Chu, Y. computer storage  
Scheff, B. H. checkout; maintenance  
Scheff, B. H. checkout; maintenance

## DEP APPLIED RESEARCH

Amemiya, H. computer storage  
Carrington, M. S. communications systems; theory  
Hannan, W. J. communications, voice systems  
Hendershot, W. recording, video  
Herscher, M. B. bionics  
Herscher, M. B. bionics  
Hilinski, J. circuit theory; analysis  
Karlsens, D. communications, voice systems  
Krolak, L. J. displays  
Martin, T. B. bionics  
Mayhew, T. R. computer storage  
Nelson, A. L. computer logic; theory  
Nelson, A. L. bionics  
Pryor, R. L. computer storage  
Reno, C. W. communications, voice systems  
Schaming, W. circuit theory; analysis  
Vollmer, Dr. J. electromagnetic theory; phenomena  
Woywood, D. J. control; timing  
Zadell, H. J. bionics  
Zadell, H. J. computer logic, theory  
Zelby, Dr. L. W. electromagnetic theory; phenomena  
Zin, G. displays  
Zin, G. electromagnetism

## DEP ASTRO-ELECTRONICS DIV.

Bisignani, W. communications, digital  
Bliss, W. communications systems; theory  
Kiesling, J. communications systems; theory  
Mangolds, B. instrumentation; lab equipment  
Osgood, C. C. space components  
Richards, G. communications, digital  
Saxton, L. space components  
Werenfels, P. space components  
Whelan, J. communications, digital

## DEP CENTRAL ENGINEERING

Schnorr, D. P. circuit interconnections; packaging  
Schnorr, D. P. circuit interconnections; packaging  
Schnorr, D. P. circuit interconnections; packaging  
Schnorr, D. P. circuit interconnections; packaging  
Schnorr, D. P. circuit interconnections; packaging  
Siegel, A. electromechanical components  
Siegel, A. electromechanical components  
Siegel, A. electromechanical components  
Sutton, H. R. checkout, maintenance  
Szukulaski, E. A. circuit interconnections; packaging

## DEP COMMUNICATIONS SYSTEMS DIV.

Bycer, B. recording, digital  
Ficci, R. F. electromechanical components  
Gillespie, J. J. military systems  
Gillespie, J. J. management; business  
Mack, A. communications systems; theory  
Miller, K. K. military systems

## DEP MISSILE AND SURFACE RADAR DIV.

Cheatham, R. P. radar  
Herold, M. G. communications, voice systems  
Howard, T. B. electromagnetic theory; phenomena  
Weinstock, W. W. radar  
Woodward, O. M. antennas

## DEP SEER

Hanna, J. L. human engineering  
Ireland, Dr. F. H. human engineering  
Potter, N. S. space navigation; tracking

## BROADCAST AND COMMUNICATIONS PRODUCTS DIV.

Reisner, Dr. J. H. electro-optic systems; techniques  
Reisner, Dr. J. H. electro-optic systems; techniques  
Walter, J. M. television components

## ELECTRONIC COMPONENTS AND DEVICES

Ahrons, R. W. computer circuitry; devices  
Belohouhek, E. F. tube design; application  
Bertin, E. P. instrumentation; lab equipment  
Bertin, E. P. instrumentation; lab equipment  
Bertin, E. P. instrumentation; lab equipment  
Burns, J. R. computer circuitry; devices  
Blattner, D. tube design; application  
Forman, J. M. management; business  
Hardy, A. E. television components  
Hilibrand, J. solid-state devices; circuitry  
Hoss, P. A. solid-state materials  
Johnson, H. tube design; application  
Kirk, H. W. computer programming  
Kuznetsov, P. television receivers  
Lohman, R. D. solid-state devices; circuitry  
Mitchell, M. computer circuitry; devices  
Morrell, A. M. television components  
Morrell, G. A. electro-optic systems; techniques  
Murray, L. A. solid-state materials  
Rivero, J. J. solid-state materials  
Ruedy, J. tube design; application  
Sterzer, F. electro-optic systems; techniques  
Sterzer, F. tube design; application  
Sterzer, F. solid-state devices; circuitry

## RCA LABORATORIES

Abeles, B. solid-state materials  
Abroahams, M. S. solid-state materials  
Ahmed, S. A. instrumentation; lab equipment  
Amick, J. A. solid-state materials  
Amith, A. solid-state materials  
Amodei, J. J. computer circuitry; devices

Amodei, J. J. computer circuitry; devices  
Anderson, C. H. solid-state materials  
Anderson, C. H. solid-state materials  
Ando, K. solid-state materials  
Assour, J. M. solid-state materials  
Assour, J. M. solid-state materials  
Bauer, H. solid-state materials  
Bernol, I. solid-state materials  
Blanc, J. solid-state materials  
Borkan, H. solid-state microelectronics  
Bowers, R. plasma  
Braunstein, R. solid-state materials  
Cardona, M. superconductivity  
Cardona, M. solid-state materials  
Cornely, R. electro-optic systems; techniques  
Cullen, G. W. solid-state materials  
Dousmanis, G. lasers  
Eastman, L. F. solid-state materials  
Edelman, F. management; business  
Edelman, F. instrumentation; lab equipment  
Fatuzzo, E. solid-state materials  
Fatuzzo, E. instrumentation; lab equipment  
Gerlich, D. solid-state materials  
Gerritsen, H. J. instrumentation; lab equipment  
Goodman, A. M. solid-state materials  
Greenaway, D. L. solid-state materials  
Harbeck, G. solid-state materials  
Harrison, S. E. solid-state materials  
Hattori, T. solid-state materials  
Hawrylo, F. lasers  
Heilmeyer, G. H. solid-state materials  
Heiman, F. P. solid-state materials  
Heiman, F. P. solid-state devices; circuitry  
Hirota, R. plasma  
Hirsch, C. J. television receivers  
Hockings, E. F. solid-state materials  
Hofstein, S. R. solid-state devices; circuitry  
Hopkins, M. M. instrumentation; lab equipment  
Kahn, W. K. solid-state materials  
Keiser, B. E. antennas  
Kiss, Z. J. solid-state materials  
Klein, N. solid-state devices; circuitry  
Klein, R. atomic theory; phenomena  
Klopfenstein, R. W. instrumentation; lab equipment  
Kosonocky, W. F. electro-optic systems; techniques

Kramer, D. A. solid-state materials  
Kudman, I. solid-state materials  
Lechner, B. J. displays  
Mark, P. solid-state materials  
Marlowe, F. electro-optic systems; techniques  
Mason, P. R. instrumentation; lab equipment  
Mayhew, T. R. computer circuitry; devices  
Meray-Horvath, L. solid-state microelectronics  
Müller, H. S. computer storage  
Mueller, C. W. solid-state devices; circuitry  
Nelson, H. lasers  
Ockman, N. solid-state materials  
Pankove, J. lasers  
Pearl, J. circuit theory; analysis  
Perkins, D. M. instrumentation; lab equipment  
Perlman, S. S. energy conversion; sources  
Rajchman, J. A. computer storage  
Reno, C. lasers  
Robinson, P. H. solid-state devices; circuitry  
Rosenblum, B. superconductivity  
Rosi, F. D. management; business  
Ross, D. L. solid-state materials  
Sabisky, E. S. solid-state materials  
Sabisky, E. S. solid-state materials  
Sadasiv, G. solid-state microelectronics  
Schilling, R. B. solid-state materials  
Shallcross, F. V. solid-state microelectronics  
Storas, H. antennas  
Steele, M. C. plasma  
Steele, M. C. plasma  
Steele, M. C. plasma  
Steigmeier, E. F. solid-state materials  
Steigmeier, E. F. solid-state materials  
Tosima, S. solid-state materials  
Vural, B. plasma  
Vural, B. plasma  
Weimer, P. K. solid-state microelectronics  
Williams, R. C. solid-state materials  
Winder, R. O. computer circuitry; devices  
Wojtowicz, P. J. mathematics

## RCA SERVICE CO.

Chew, V. mathematics  
Chew, V. mathematics

## RCA STAFF

Kiesling, G. A. management; business  
Schmit, D. F. management; business

## RCA VICTOR LTD.

Bachynski, Dr. M. P. electromagnetic theory; phenomena  
Greene, R. M. solid-state devices; circuitry  
Siztes, T. mechanical components  
Webb, P. P. solid-state devices; circuitry

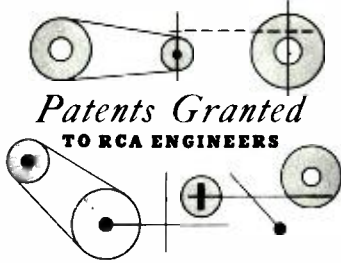

AS REPORTED BY RCA DOMESTIC PATENTS, PRINCETON

### DEFENSE ELECTRONIC PRODUCTS

- 3,165,697—Automatic Tuning Circuit for a Transmitter Cavity Amplifier, January 12, 1965; A. Reich and D. M. Osterman (Patent assigned to U. S. Government)
- 3,165,737—Electronic Acquisition Electromechanical Tracking Radar System, January 12, 1965; A. I. Mintzer (Patent assigned to U. S. Government)
- 3,166,703—Simplified Aided Tracking and Coasting System, January 19, 1965; A. I. Mintzer (Patent assigned to U. S. Government)
- 3,168,021—Electrostatic Printing, February 2, 1965; M. L. Levene
- 3,168,652—Monostable Tunnel Diode Circuit Coupled Through Tunnel Rectifier to Bistable Tunnel Diode Circuit, February 2, 1965; M. M. Kaufman
- 3,168,700—Sequential Pulse Generator Employing Plurality of Cascaded Circuits Coupled Through Shift Gates and Having Individual

- Output Gates, February 2, 1965; W. J. Gesek and J. H. Bragdon
- 3,168,857—Electrostatic Printing, February 9, 1965; E. Hutto, Jr.
- 3,169,061—Electrostatic Printing, February 9, 1965; K. C. Hudson
- 3,170,980—Optical Tunnel System, February 23, 1965; D. E. Pritchard
- 3,171,102—Memory Assembly Employing Apertured Plates, February 23, 1965; W. E. Newman
- 3,171,103—Magnetic Plate Memory System, February 23, 1965; W. V. Dix and W. G. Rumble
- 3,171,984—High Speed Switch Utilizing Two Opposite Conductivity Transistors and Capacitive, March 2, 1965; C. R. Eshelman and C. D. Brudos
- 3,173,018—Fiber Optic Load Positioner, March 9, 1965; E. D. Grim, Jr.
- 3,173,021—Negative Resistance Diode Pulse Amplifier, March 9, 1965; R. H. Bergman
- 3,174,090—Phase Responsive Motor Speed Control System, March 16, 1965; J. R. Hall
- 3,175,159—Control Systems, March 23, 1965; J. R. Hall

### ELECTRONIC COMPONENTS AND DEVICES

- 3,166,103—Grid Manufacturing Apparatus, January 19, 1965; G. Samuels
- 3,166,836—Manufacture of Electron Tube Cathodes, January 26, 1965; J. M. Bigler
- 3,172,001—High Frequency High Power Electron Discharge Device and Electrode Mount Therefor, March 2, 1965; J. W. Gaylord
- 3,172,002—Cathode Mount and Method of Fabrication, March 2, 1965; C. T. Johnson and I. E. Smith
- 3,172,244—Apparatus for Processing a Plurality of Articles or Materials, March 9, 1965; W. F. Griffin
- 3,172,433—Apparatus for Producing Series Wound Heaters for Plural Cathode Electron Tubes, March 9, 1965; J. Paull

- 3,175,119—Electrostatically Focused Traveling Wave Tube Having Periodically Spaced Loading Elements, March 23, 1965; E. F. Belohoubek

### ELECTRONIC DATA PROCESSING

- 3,166,243—Check Number Computing and Printing Apparatus, January 19, 1965; A. J. Torre

### RCA LABORATORIES

- 3,166,694—Symmetrical Power Transistor, January 19, 1965; C. W. Mueller
- 3,166,713—Tunnel Diode Converter with Forward Bias of the Diode by Rectification of Signal Wave, January 19, 1965; K. K. N. Chang and H. J. Prager
- 3,167,614—Multiplicative Stereophonic Sound Signalling System, January 26, 1965; F. R. Holt and J. Avins
- 3,169,228—Transistor Amplifier with Diode Feedback Circuit, February 9, 1965; J. O. Sinniger
- 3,170,040—F.M. Stereophonic Multiplex Receiver Having Automatic Disabling Means for the Subcarrier Channel, February 16, 1965; J. E. O'Connell
- 3,171,087—Solid-State Nonreciprocal Signal Amplifier, February 23, 1965; K. K. N. Chang
- 3,171,100—Punchable Memory Card Having Printed Circuit Thereon, February 23, 1965; J. A. Rajchman
- 3,172,084—Superconductor Memory, March 2, 1965; G. A. Alphonse
- 3,172,085—Memory, March 2, 1965; L. L. Burns, Jr. and G. A. Alphonse
- 3,172,086—Memory Circuit Employing a Superconductive Sense Plane, March 2, 1965; F. S. Wendt
- 3,172,954—Acoustic Apparatus, March 9, 1965; H. Belar and H. F. Olson
- 3,175,097—Logic Circuits Employing Transistors and Negative Resistance Diodes, March 23, 1965; M. H. Lewin

- 3,175,198—Superconductor Films, March 23, 1965; L. L. Burns, Jr.

### HOME INSTRUMENTS DIVISION

- 3,166,714—Manual Tuning Control System for FM Radio Receivers with AFC, January 19, 1965; V. D. Hien
- 3,168,710—Negative Resistance Amplifier with Oscillation Suppression Circuit, February 2, 1965; J. B. Schultz
- 3,169,207—Electromagnetic Deflection Yoke Having Interconnected Multistrand Strands, February 9, 1965; M. J. Obert and R. L. Barbin
- 3,169,222—Double-Emitter Transistor Circuits, February 9, 1965; L. M. Krugman and R. C. Graham
- 3,172,040—A.M./F.M. Receiver Having Automatic Gain Control, March 2, 1965; J. B. Schultz

### BROADCAST AND COMMUNICATIONS PRODUCTS DIVISION

- 3,167,681—Electrostatic Deflection Circuit, January 26, 1965; R. A. Dischert
- 3,168,653—Tunnel Diode Circuit with Reduced Recovery Time, February 2, 1965; H. Ur
- 3,171,955—Temperature Controlled and Adjustable Specimen Stage for Scientific Instruments, March 2, 1965; A. J. Cardile
- 3,171,956—Variant Temperature Environment for Specimen Stage of Scientific Instrument, March 2, 1965; J. W. Coleman and A. J. Cardile
- 3,171,957—Specimen Holder for an Electron Microscope with Means to Support a Specimen Across a Thermocouple Junction, March 2, 1965; J. W. Coleman and A. J. Cardile
- 3,171,958—Heated Specimen Holder for the Electron Microscope, March 2, 1965; J. W. Coleman
- 3,175,136—Concentric-Vane Variable Capacitor with Seal, March 23, 1965; R. M. Mison

### RCA SERVICE COMPANY

- 3,171,897—FM Stereo Multiplex Test Instrument, March 2, 1965; S. Wlasuk

### Meetings

**May 5-7, 1965:** 1965 MICROWAVE THEORY & TECHNIQUES SYMP., IEEE, G-MTT; Jack Tar Harrison Hotel, Clearwater, Fla. *Prog. Info.:* J. E. Pippin, Sperry Microwave Elec. Co., Box 1828, Clearwater, Fla.

**May 5-7, 1965:** ELECTRONIC COMPONENTS CONF. (ECC), IEEE, G-CP-EIA; Marriott Motor Hotel, Wash., D.C. *Prog. Info.:* B. Schwartz, IBM Components Div., Poughkeepsie, New York.

**May 6-8, 1965:** 6TH NATL. SYMP. ON HUMAN FACTORS IN ELECTRONICS, IEEE, G-HFE; Sheraton Hotel, Boston, Mass. *Prog. Info.:* Dr. James Degan, Mtre Corp., Box 208 Bedford, Mass.

**May 10-12, 1965:** NAECON (NATL. AEROSPACE ELECTRONICS CONF.), IEEE, G-ANE-AIAA, Dayton Section; Dayton, Ohio. *Prog. Info.:* IEEE Dayton Office, 1414 E. 3rd St., Dayton, Ohio.

**May 13-14, 1965:** SYMP. ON SIGNAL TRANSMISSION PROCESSING, IEEE, G-CT; Columbia Univ., New York, N. Y. *Prog. Info.:* Dr. L. E. Franks, Bell Tel. Labs., No. Andover, Mass.

**May 19-21, 1965:** POWER INDUSTRY COMPUTER APP. CONF. (PICA), IEEE, G-P & Fla. Westcoast Sect.; Jack Tar Hotel, Clearwater, Fla. *Prog. Info.:* G. W. Staff, American Elec. Power Serv. Corp., 2 Broadway, New York 8, N. Y.

**May 24-26, 1965:** 4TH ANN. SYMP. ON MICROELECTRONICS, IEEE, St. Louis Section; Chase Park Plaza, St. Louis, Mo. *Prog. Info.:* G. E. Dreifke, St. Louis Univ., Inst. of Tech., 3621 Olive St., St. Louis 8, Mo.

**May 24-29, 1965:** IFIP CONGRESS '65, IEEE-IFIP; N. Y. Hilton, New York, New York. *Prog. Info.:* Dr. A. Householder, Oak Ridge Natl. Lab., Oak Ridge, Tenn.

**June 7-9, 1965:** 1ST ANN. IEEE COMMUNICATION CONN. INCORPORATING, GLOBECOM VII, IEEE, G-ComTech, Denver, Boulder Section; Univ. of Colo. & NBS Labs., Boulder, Colo. *Prog. Info.:* Wm. F. Ulant, NBS, Boulder, Colo.

**June 7-9, 1965:** SYMP. ON AUTOMATIC SUPPORT SYS. FOR ADV. MAINTAINABILITY, IEEE, St. Louis Section; Chase Park Plaza Hotel, St. Louis, Mo. *Prog. Info.:* Don L. Reed, P.O. Box 4104, St. Louis 36, Mo.

**June 14-15, 1965:** 1965 MIDWEST SYMP. ON CIRCUIT THEORY, IEEE, G-CT, Colo. State Univ., Colorado State Univ., Ft. Collins, Colo. *Prog. Info.:* Dr. R. M. Wainright, Colo. State Univ., Ft. Collins, Colo.

## DATES and DEADLINES

PROFESSIONAL MEETINGS AND CALLS FOR PAPERS

**June 21-24, 1965:** AEROSPACE TECH. CONF., IEEE, G-AS, Houston Sect.; Shamrock-Hilton Hotel, Houston, Texas. *Prog. Info.:* Thos. P. Owen, 635-20th St., Santa Monica 2, Calif.

**June 22-25, 1965:** 6TH JOINT AUTOMATIC CONTROL CONF. (JACC), ASME, IEEE, ISA, AIAA, AIChE; Rensselaer Polytech. Inst., Troy, New York. *Prog. Info.:* Prof. Jas. W. Moore, Univ. of Va., Charlottesville, Va.

**June 28-30, 1965:** 7TH NATL. SYMP. ON ELECTROMAGNETIC COMPATIBILITY, IEEE-G-EMC; Waldorf-Astoria, New York, N. Y. *Prog. Info.:* D. Fidelman, Electromag. Meas. Co., Farmingdale, N. Y.

**July 6-8, 1965:** SAN DIEGO SYMP. FOR BIOMEDICAL ENG., IEEE, San Diego Section, U. S. Naval Hosp.; San Diego, Calif. *Prog. Info.:* Dean L. Franklin, Scripps Clinic & Res. Found., LaJolla, Calif.

**July 12-16, 1965:** ANN. IEEE CONF. ON NUCLEAR & SPACE RADIATION EFFECTS, IEEE, G-NS, et. al.; Univ. of Mich., Ann Arbor, Mich. *Prog. Info.:* S. Clay Rodgers, Sandia Corp., Sandia Base, Albuquerque, New Mexico.

**Aug. 23-27, 1965:** 6TH INTL. CONF. ON MEDICAL, ELEC. & BIOLOGICAL ENG., IFMEBE; Tokyo, Japan. *Prog. Info.:* Dr. L. E. Flory, RCA Labs., Princeton, N. J.

**Aug. 24-27, 1965:** WESCON; (IEEE, WEMA); Cow Palace, San Francisco, Calif. *Prog. Info.:* IEEE L. A. Office, 3600 Wilshire Blvd., Los Angeles, Calif.

**Aug. 30-Sept. 1, 1965:** ANTENNAS & PROPAGATION INTL. SYMP., IEEE, G-AP; Sheraton Pk. Hotel, Wash., D.C. *Prog. Info.:* Dr. R. J. Adams, Search Radar Branch, Naval Res. Lab., Wash., D.C.

### Calls for Papers

**Sept. 8-10, 1965:** 13TH ANN. INDUS. ELEC. & CONTROL INST. CONF., IEEE, G-IECI, Phila. Section; Sheraton Hotel, Phila., Pa. *Deadline:* Abstracts, approx. 5/1/65. FOR INFO: Lewis Winner, 152 W. 42nd St., New York 25, New York.

**Sept. 12-17, 1965:** 6TH NATL. ELEC'L. INSULATION CONF., IEEE, G-EI-NEMA; N. Y. Hilton at Rockefeller Ctr., N. Y., N. Y. *For Deadline Info.:* H. W. Marquardt, NEMA, 155 E. 44th St., New York 17, N. Y.

**Sept. 16-17, 1965:** 13TH ANN. JOINT ENG. MANAGEMENT CONF., IEEE-ASME, et. al.; Roosevelt Hotel, New York, N. Y. *Deadline:* Abstracts, approx. 5/1/65. IEEE Headquarters, Box A, Lenox Hill Station, N. Y., N. Y.

**Sept. 19-22, 1965:** NATL. POWER CONF., IEEE-ASME; Sheraton-Ten Eyck Hotel, Albany, N. Y. *For Deadline Info.:* IEEE Headquarters, Box A, Lenox Hill Station, New York, N. Y.

**Sept. 24-25, 1965:** 13TH ANN. COMMUNICATIONS CONF., IEEE Cedar Rapids Section; Cedar Rapids, Iowa. *Deadline:* Abstracts, approx. 6/1/65. IEEE Headquarters, Box A, Lenox Hill Station, New York, N. Y.

**Oct. 4-6, 1965:** 1965 CANADIAN ELECTRONICS CONF., IEEE Region 7; Toronto, Ont., Canada. *For Deadline Info.:* Canadian Elec. Conf., 1819 Yonge St., Toronto 7, Ont., Canada.

**Oct. 11-13, 1965:** 1965 IEEE NATCOM (COMMUNICATIONS SYMP.), IEEE G-ComTech, Mohawk Valley Section; Utica, N. Y.

**Deadline:** Abstracts, approx. 6/1/65. IEEE Headquarters, Box A, Lenox Hill Station, New York, N. Y.

**Oct. 18-20, 1965:** 12TH NUCLEAR SCIENCE SYMP.; San Francisco, Calif. *Deadline:* Abstracts, 100-300 wds., 7/1/65. TO: J. M. Harrer, 12th NSS Program Chairman, Argonne Natl. Laboratory, Argonne, Ill.

**Oct. 20-22, 1965:** ALLENTON CONF. ON CIRCUIT & SYSTEM THEORY, IEEE, G-CT, Univ. of Ill.; Conf. Center, Univ. of Ill., Monticello, Ill. *For Deadline Info.:* Prof. M. E. Van Valkenburg, Dept. of EE, Univ. of Ill., Urbana, Ill.

**Oct. 21-23, 1965:** ELECTRON DEVICES MTC, IEEE, G-ED; Sheraton Park Hotel, Wash., D.C. *Deadline:* Abstracts, approx. 8/1/65. IEEE Headquarters, Box A, Lenox Hill Station, New York, N. Y.

**Oct. 25-27, 1965:** NATL. ELECTRONICS CONF., IEEE, et. al.; McCormick Place, Chicago, Ill. *Deadline:* Abstracts, approx. 5/1/65. NEC Office, 228 LaSalle St., N. Chicago, Ill.

**Oct. 27-29, 1965:** EAST COAST CONF. ON AEROSPACE & NAVIG. ELECTRONICS (ECC-ANE), IEEE, G-ANE, Baltimore Section; Baltimore, Md. *Deadline:* Abstracts, approx. 6/1/65. Richard Allen, Westinghouse Elec. Corp., Molecular Elec. Div., Baltimore, Md.

**Nov. 2-5, 1965:** IEEE ANN. SYMP. ON SPACE ELECTRONICS, IEEE, G-SET; Fontainebleau Hotel, Miami Beach, Fla. *Deadline:* Abstracts, 5/15/65. Thos. Broskie, NASA, Cape Kennedy Complex, Cocoa Beach, Fla.

**Nov. 3-5, 1965:** NEREM (NORTHEAST ELEC. RES. & ENG. MTC.), IEEE, Region 1; Boston, Mass. *Deadline:* Abstracts, approx. 8/1/65. NEREM, IEEE Boston Office, 313 Washington St., Newton 58, Mass.

**Nov. 10-12, 1965:** 18TH ANN. CONF. ON ENG. IN MEDICINE & BIOLOGY, IEEE, G-BME-ISA; Univ. of Penna. & Sheraton Hotel, Phila., Pa. *Deadline:* Abstracts, approx. 8/1/65. Dr. H. Schwann, Moore School of EE, Univ. of Penna., Phila., Pa.

**Nov. 15-18, 1965:** 11TH ANN. CONF. ON MAGNETISM & MAG., IEEE-AIP; Hilton Hotel, San Francisco, Calif. *Deadline:* Abstracts, 8/1/65. IEEE Headquarters, Box A, Lenox Hill Station, N. Y., N. Y.

**Nov. 30-Dec. 1-2, 1965:** FALL JOINT COMPUTER CONF., IEEE, AFIPS (IEEE-ACM); Convention Center, Las Vegas, Nevada. *Deadline:* Abstracts, approx. 7/1/65. IEEE Headquarters, Box A, Lenox Hill Station, N. Y., N. Y.

Be sure deadlines are met—consult your Technical Publications Administrator or your Editorial Representative for the lead time necessary to obtain RCA approvals (and government approvals, if applicable). Remember, abstracts and manuscripts must be so approved BEFORE sending them to the meeting committee.

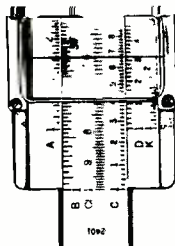

## A REPORT FROM DR. BROWN ON EUROPEAN COLOR TELEVISION

*Editor's Note:* Dr. George H. Brown, Vice President, Research and Engineering, was the RCA senior representative at the recent Vienna conference of the International Consultative Committee on Radio Communications (CCIR) and participated actively in its decisions. Dr. Brown has just returned from the Vienna conference. The following, received April 8, 1965, is his statement on the significance of the voting by the participating nations on color television standards for Europe and other areas of the world.

For additional background on these European discussions, see "Mission to Moscow" by Dr. Brown in the February 1965 issue of *Trend*. For a technical background review, see "Color Television: The First Ten Years" by J. W. Wentworth, in the Aug.-Sept. 1964 *RCA ENGINEER*.

The most significant result of the Vienna meeting of the International Consultative Committee on Radio Communications (CCIR) was the emergence of a clear-cut preference among most major countries in the world for a simultaneous color television system based on RCA technical developments. This was expressed in the balloting at the meeting, and it represented a decisive defeat of the strong political drive by France to stampede the CCIR member nations into formal adoption of the French SECAM system.

Two of the three systems initially considered at the meeting—the NTSC system developed primarily by RCA and employed in the United States, and the PAL system proposed by West Germany—represent two variants of the same technique. They were therefore considered by the conferees as a single basic system approach under the designation QUAM (for quadrature amplitude modulation). The PAL system is, in fact, an offshoot of the NTSC system. Their consideration as alternative variants of a single system provides an umbrella under which either may be employed according to the preference of the country concerned.

If the countries of Europe all decided upon the QUAM approach, for example, each could elect individually to use either the NTSC or PAL variant in its own territory. Programs could be exchanged among them without any technical difficulties by using only a small amount of extremely simple equipment at the terminal centers. In countries with microwave systems not as highly developed as in the United States, it would be entirely feasible to use the PAL variant for microwave transmission over networks, and the NTSC variant for local broadcast transmission.

In the balloting that concluded the CCIR meeting, it is significant that the Western nations representing the largest portion of the European television industry joined Japan, Canada, and the United States in favoring the QUAM system in its NTSC or PAL variants. The only Western votes for SECAM, in addition to that of France, were cast by Luxembourg, Monaco, and Spain.

The remaining votes for SECAM were cast by the Soviet Union and the Eastern European countries, excluding Yugoslavia, and by former French territories in Africa, nearly all of which do not have any television industries or services.

Votes for the QUAM concept in its NTSC and PAL variants were cast by Great Britain, West Germany, the Netherlands, Sweden,

Denmark, Norway, Finland, Italy, Ireland, Switzerland, Austria, Iceland, Brazil, New Zealand, Japan, Canada, and the United States.

Moreover, the British announced their determination to proceed immediately with the introduction of the QUAM system in its NTSC variant. This will soon provide British viewers with the same type of service now offered in the United States and Japan. In view of the strong arguments by France for immediate adoption of the SECAM system, it is interesting to note the French admission that it will not be ready for service even to French viewers before 1969 or 1970.

The support of the Russians for the French system was based on the political agreement announced by the two countries just before the opening of the Vienna meeting. When this agreement was announced, a team of Soviet technical experts was visiting RCA's color television production facilities in the United States. None of these specialists subsequently attended the Vienna meeting with the Soviet delegation. Members of the delegation who cast Russia's ballot state, in fact, that they had received no report from the group.

While the French political effort has prevented unanimous agreement upon the QUAM system concept and its NTSC-PAL variants, there is every reason to believe that the introduction of practical color service based upon this approach will proceed without serious hindrance. This offers the prospect that most of the people of Europe will soon be able to enjoy color television based on standards of the type that now provide such excellent service to the public in North America and Japan.

One final fact should not be overlooked. This is the basic electronic kinship among all of the color systems now being considered. This was demonstrated at the CCIR meeting when delegates witnessed demonstrations of PAL, NTSC, and SECAM. The German PAL and American NTSC demonstrations employed RCA receivers; the French SECAM receivers employed RCA color picture tubes.

### DR. HANAK HONORED BY ASM

Dr. J. J. Hanak received on March 17, 1965, the *John Roebling Award* from the Delaware Valley Section of the American Society for Metals in honor of his work done on vapor deposition of niobium stannide. (The Sept. 1964 issue of the *RCA Review* featured a series of papers on niobium stannide.)—C. W. Sall

### RCA ESTABLISHES NEW TV ENGINEERING ADVANCED METHODS CENTER AT PURDUE

An RCA Television Engineering Advanced Methods Center at Purdue University's Industrial Research Park, West Lafayette, Ind. has been established. Engineers from the Indianapolis headquarters of the RCA Home Instruments Division will staff the Center, supplemented by the faculty and students of Purdue's Graduate School of Engineering. The Purdue facility strengthens RCA's total consumer electronics development program, which is headquartered at the David Sarnoff Research Center in Princeton, N.J.

Since the future of consumer electronics will be determined by today's engineering students, RCA expects to maintain a firm pattern of growth in the coming years as the consumer electronics industry moves into advance concepts, such as wall-screen television and pocket-size color television receivers. The RCA Center is expected to be in full operation by June 1965.

### FOUR SCIENTISTS WIN AWARD FOR PAPER ON THIN-FILM IMAGE SCANNER

Four RCA Laboratories scientists have recently been honored by the 1965 International Solid-State Circuits Conference for their paper, "An Integrated Thin-Film Scanner," presented at the 1964 conference in Philadelphia.

Dr. Paul K. Weimer, Harold Borkan, Lorand Meray-Horvath, and Dr. Frank V. Shallcross, are the co-recipients of the *Outstanding Paper Award* plaque for their paper describing a solid-state image panel made up of integrated thin-film circuits. Dr. Weimer, who headed the prize-winning team, was the recipient last year of the same award for his 1963 paper on "Evaporated Circuits Incorporating a Thin-Film Transistor." He is the only individual who has ever received the ISSCC award for two consecutive years.

A similar version of the 1965 prize-winner on the thin-film scanner was published in *RCA ENGINEER*, 10-3, Oct-Nov 1963. Dr. Weimer's earlier winner appeared in the *RCA ENGINEER*, 7-6, April-May 1962.)

### BISCHOF NAMED SMPTE FELLOW

Wallace F. Bischof, Project Manager for the Redstone Pictorial Services, RCA Service Co., Huntsville, Ala., has been named a *Fellow* of the Society of Motion Picture and Television Engineers. Mr. Bischof was honored for significant achievements in the field of motion pictures.

### HOFSTEIN AND HEIMAN WIN IEEE PRIZE FOR MOS PAPER

Dr. Steven R. Hofstein and Dr. Frederic P. Heiman, RCA Laboratories, have been awarded the *Browder J. Thompson Memorial Prize* of the IEEE for the best technical paper published in 1963: "The Silicon Insulated-Gate Field-Effect Transistor," which appeared in the September 1963 *Proceedings of the IEEE*.

The Thompson Prize, established in 1945, is given annually to the author or joint authors, under thirty years of age.

(A similar version of this prize winning paper appeared in *RCA ENGINEER*, 8-6, April-May 1963.)

**14 RCA MEN AWARDED  
DAVID SARNOFF FELLOWSHIPS**

David Sarnoff Fellowships for graduate study in the 1965-66 academic year have been awarded to fourteen employees. The Fellowships range in value to as high as \$6,500 each. Although appointments are for one academic year, each Fellow is eligible for reappointment. The David Sarnoff Fellows are selected on the basis of academic aptitude and promise of professional achievement.

One David Sarnoff Fellow was reappointed for only the first term of a third year, during which he expects to complete his doctoral study program:

**Henry Kressel**, Electronic Components and Devices, Somerville, N.J.—toward a Doctorate in Metallurgy at the University of Pennsylvania.

One David Sarnoff Fellow was reappointed for a third year:

**Martin L. Levene**, DEP, Applied Research Division, Camden, N.J.—toward a Doctorate in ME at the University of Pennsylvania.

Three Technical David Sarnoff Fellows reappointed for a second year:

**John Randall Manning**, DEP, Aerospace Systems Division, Burlington, Mass.—toward a Doctorate in ME at Massachusetts Institute of Technology.

**Joseph P. McEvoy**, DEP, Applied Research Division, Camden, N.J.—toward a Doctorate in Metallurgy at Imperial College of Science and Technology, London, England.

**Peyton Z. Peebles**, DEP, Missile and Surface Radar Division, Moorestown, N.J.—toward a Doctorate in EE at the University of Pennsylvania.

Six Technical David Sarnoff Fellows appointed for the first time:

**Maurice Winston Cha Fong**, RCA Communications, Inc., New York City—toward a Doctorate in Systems Engineering at Polytechnic Institute of Brooklyn.

**Geoffrey Hyde**, DEP, Missile and Surface Radar Division, Moorestown, N.J.—toward a Doctorate in EE at the University of Pennsylvania.

**Raymond John Ikola**, RCA Laboratories, Princeton, N.J.—toward a Doctorate in Electrophysics at Polytechnic Institute of Brooklyn.

**Chi-sheng Liu**, RCA Victor Home Instruments Division, Indianapolis, Indiana—toward a Doctorate in EE at the University of Illinois.

**Louis Sickles**, DEP, Applied Research Division, Camden, N.J.—toward a Doctorate in EE at the University of Pennsylvania.

**Frank Irwin Zonis**, RCA Laboratories, Princeton, New Jersey—toward a Doctorate in EE at either the University of Pennsylvania or Massachusetts Institute of Technology.

One Business Administration David Sarnoff Fellow reappointed for a second year:

**J. Keith Drysdale**, RCA Victor Co., Ltd., Montreal, Canada—toward a degree of MBA at McGill University.

Two Business Administration David Sarnoff Fellows appointed for the first time:

**Richard M. Corbin**, RCA Service Co., Riverton, New Jersey—toward MBA at the University of Pennsylvania.

**Edward S. Gilbert**, BCD, Radiomarine Engineering, Meadow Lands, Pa.—toward an MBA at University of Pittsburgh.

**RCA LABS PRESENT  
1964 ACHIEVEMENT AWARDS**

The RCA Laboratories have named the following as recipients of the 18th annual RCA Laboratories Achievement Awards. These 1964 awards are in recognition of outstanding contributions by members of the RCA Laboratories.

**Marvin S. Abrahams**, for contributions to a deeper understanding of the relationship of structural features to the electronic properties of solids.

**Frank Amoroso**, for research leading to improved digital magnetic recording.

**James A. Amick**, for fundamental research on epitaxial growth of semiconductors.

**Joel E. Goldmacher**, for key contribution to the development of stabilized MOS transistors.

**Fred Herzfeld**, for resourcefulness in the conception and development of a special program for the RCA 301/601 computer.

**Richard E. Honig**, for research leading to the development of novel ionization and laser sources for mass spectrometry of solids.

**Zoltan J. Kiss**, for studies of energy transfer between unlike ions in crystals leading to an improved laser.

**Robert D. Larrabee**, for development of an indium-antimonide microwave generator.

**David M. Perkins**, for resourcefulness and ingenuity shown in the development of a sensitive photoangular device and a highly efficient solar cell.

**A. D. Robbi**, for research on methods of driving laminated ferrite memories.

**Paul H. Robinson**, for developing techniques to control deposition of single-crystal silicon films on an insulating substrate.

**William E. Rodda**, for conception and development of equipment that detects the high-frequency components of speech and converts them to intelligible form.

**Edward R. Schrader**, for research leading to the development of a superior high-field superconducting magnet.

**James J. Tietjen**, for devising and applying excellent vapor-phase methods of synthesizing semiconductor and injection-laser materials in device form.

**Robert O. Winder**, for continued contribution to the theory and application of threshold logic.

**Joseph A. Zenel**, for contributions to the development of special communications sensors.

**Maurice Artzt** and **Milton Sowiak**, for team performance in developing BARSCAN, a high-speed electromechanical printer.

**Erwin F. Belahoubek** and **Reynold Steinhoff**, for team performance in the development of a new family of broad-band microwave delay lines.

**Harold Blatter**, **John Fischer**, and **Donald S. McCoy**, for team performance in defining the factors that limit the sensitivity of seismic detector systems.

**Stanley Bloom**, **Bayram Vural**, **J. M. Hammer**, and **C. P. Wen**, for team performance leading to advances in the reduction of noise in traveling-wave tubes.

**George C. Dousmanis** and **Herbert Nelson**, for team performance in the development and analysis of room-temperature injection lasers.

**Joseph Dresner** and **H. Peter Lanyon**, for team performance in advancing the technology and understanding of thin-film photoconductors.

**N. L. Gordon**, **A. H. Simon**, and **T. M. Stiller**, for team performance in conceiving and developing scientific programs that enhance the flexibility of the RCA 301-601 computer.

**Helmut Kiess**, **Liselotte Krausbauer**, **Emmanuel Kaldis**, and **Rudolf Nitsche**, for team performance in the synthesis and investigation of ternary photoconductors.

**F. Russell Nymann**, **Henry C. Schindler**, and **Kurt Strater**, for team performance in the development of a practical vapor deposition process for making niobium-stannide ribbon.

**Akos G. Revesz** and **Karl H. Zaininger**, for team performance and experiments and studies leading to a better understanding of the electrical properties and growth mechanisms of silicon-dioxide films on silicon substrates.



**DR. BACHYNSKI NAMED DIRECTOR  
OF MONTREAL RESEARCH LABS.**

**Dr. M. P. Bachynski** has been appointed Director of Research, Research Laboratories, RCA Victor Company, Ltd., Montreal, succeeding **Dr. J. Rennie Whitehead**, who is taking up an appointment as Deputy Director of the newly created Canadian Government Scientific Secretariat in Ottawa.

Dr. Bachynski, who is well known for his outstanding work in Microwave and Plasma Physics, graduated in 1952 from the University of Saskatchewan with a B. Eng. in engineering physics, obtaining his M.Sc. in physics the following year and a Ph.D. in 1955 while at the Eaton Electronics Research Laboratory, McGill University. In 1955 he joined the newly formed RCA Victor Research Laboratories, becoming Laboratory Director, Microwave and Plasma Physics, in 1958. In recent years he has concentrated on space research concerned primarily with simulation of geophysical phenomena in the laboratory, with satellite plasma environments and space vehicle induced plasma effects.

Among the many recognitions he has received for his work is the *David Sarnoff Award for Individual Achievement in Engineering* in 1963.

Under the direction of Dr. Whitehead, who was responsible for its inception in 1955, the RCA Victor Research Laboratories have grown from an area of 5,300 square feet and a staff of 4 to the present 18,000 square feet with staff numbering 71 with considerable further extension pending. The scope of scientific research now encompasses most of the important fields in modern electronics and the Laboratories have attained a world-wide reputation.

*(Editor's Note: Dr. Bachynski has published three papers in the RCA ENGINEER on Plasma (Vol. 6-5 and 6-6) and microwave physics (Vol. 9-1). He is now advising the RCA ENGINEER staff in the planning of a future issue on plasma.)*

**U.S. ACADEMY OF ENGINEERING  
ESTABLISHED**

A National Academy of Engineering has been formed under the charter of the National Academy of Sciences. The new Academy will share in the responsibility given the National Academy of Sciences to advise the Federal Government, upon request, in all areas of science and engineering.

**Dr. Elmer W. Engstrom**, RCA President, is one of 25 charter members of the National Academy of Engineering.

**LICENSED ENGINEERS**

- L. R. Andros**, DEP-MSR, Moorestown, PE-13798, N.J.
- A. R. Campbell**, DEP-AED, Pr., PE-13821, N.J.
- P. G. Maser, Jr.**, RCA Ser. Co., Air Force Base, Colo., PE-62-20925, Ill.
- S. Yates**, DEP-MSR, Moorestown, PE-2021-E, Penna.

**DEGREES GRANTED**

- E. B. Gamble**, DEP-AED, Pr. .... MSEE, U. of Penna
- R. A. Holt**, DEP-ASD, Van Nuys .... MSEE, U.C.L.A.
- J. Klapper**, DEP-CSD, N.Y. .... D.Sc., EE, New York U.
- J. Schwartzman**, ECD, Som. .... BS, Fairleigh Dickinson U.

**NEW RCA ENGINEER  
EDITORIAL REPRESENTATIVES**

Presented here are thirteen men who have recently been named as Editorial Representatives of the RCA ENGINEER. The men and the activities they represent are: **R. C. Fortin**, Direct Energy Conversion Dept., Special Electronic Components Division, ECD, Harrison, N.J.; **E. F. Breniak**, Industrial Semiconductor Engineering, Industrial Tube & Semiconductor Division, ECD, Somerville, N.J.; **K. E. Loofbourrow**, Semiconductor and Conversion Tube Operations, Industrial Tube & Semiconductor Division, ECD, Mountaintop, Pa.; **E. K. Madenford**, Television Picture Tube Operations, Television Picture Tube Division, ECD, Lancaster, Pa.; **I. Kalish**, Integrated Circuit Dept., Special Electronic Components Division, ECD, Somerville, N.J.; **D. H. Wamsley**, Engineering, Technical Programs, ECD, Harrison, N.J.; **R. E. Winn**, Broadcast Transmitter & Antenna Eng., BCD, Gibbsboro, N.J.; **W. J. Sweger**, Mobile Communications Engineering, BCD, Meadow Lands, Pa.; **R. R. Shively**, Systems Engineering, Evaluation, and Research, Defense Engineering, DEP, Moorestown, N.J.; **T. L. Elliott, Jr.**, Missile Test Project, RCA Service Co., Cape Kennedy, Fla.; **L. H. Fetter**, Govt. Svc. Dept., RCA Service Co., Cherry Hill, N.J.; **B. Aaront**, EDP Svc. Dept., RCA Service Company, Cherry Hill, N.J.; **L. A. Shotliff**, RCA International Division, New York City, N.Y.

**Robert C. Fortin** received his BSEE from the University of Idaho in 1942 and joined RCA as a receiving-tube design engineer. He became Engineering Leader in Computer and Special Tubes in 1952, and Manager of Receiving-Tube Design in 1953. In 1959 he joined the Data Systems and Services Activity as Project Manager, Product Performance Evaluation. In this position, he developed a program for RCA 501 utilization in an integrated Quality Assurance Plan. In 1961 he joined the EC&D New Business Development group. He transferred to Thermoelectric Device Engineering in 1962, and assumed responsibility for fabrication of SNAP-10A converter modules. In late 1963 he assumed responsibility for Reliability Engineering for Thermoelectric Devices, with emphasis on SNAP-10A converter module fabrication. Mr. Fortin is a member of the IEEE and has served for several years as the RCA representative on the Joint Electron Tube Engineering Council JTC-5 Committee on small power tubes.

**E. F. Breniak** received his BS in Industrial Engineering from Rutgers University in 1951 and then joined Westinghouse Electric Corporation, Newark, New Jersey, as a manufacturing engineer. Later, as a project engineer, he was responsible for the design and installation of production systems in a modernization of all product lines in relay and instrument manufacture. In 1956 he received his MS in Engineering at Stevens Institute of Technology. In 1958 he joined the RCA Semiconductor Division, Somerville, as Administrator of New Product Planning. He co-ordinated the transfer of new products from development to continuous production and contributed to planning for initial production at the plant at Mountaintop. In 1964, he became Project Engineer for Quality and Product Assistance in transistor and special product development.

**Keith E. Loofbourrow** received his BSEE from Oklahoma State University in 1950. In 1950, he joined the RCA Harrison Tube Division as an applications engineer for new electron tubes in the VHF and UHF. In 1953, he was assigned to Semiconductor Applications as an Engineering Leader, responsible for developmental transistor application, evaluation, and test methods. In 1955, he was appointed Manager, Reliability and Test Engineering for the RCA Semiconductor Division. In July 1957 he became Manager, Industrial Transistor Applications Engineering. In 1961 he was

named manager of Industrial Transistor Development and Applications. In May 1963 he became Administrator, Operation Planning, for Industrial Transistors. He assumed his present position as Staff Resident Engineer in June 1964, responsible for the technical coordination and execution of new product programs as they progress from development to manufacture. Mr. Loofbourrow has published several Application Notes and technical papers.

**Edward K. Madenford** graduated from Lehigh University in 1949 with a BS in Business Administration. He was associated with Day & Zimmerman, Inc. Engineers, Philadelphia, Pennsylvania from 1949 to 1954 as a Cost Engineer and Field Accountant; joined RCA in 1954, and is presently Administrator, Engineering Administration, Color Picture Tube Engineering at EC&D, Lancaster. He is a member of Alpha Kappa Pi.

**I. Kalish** received the BSEE from the Cooper Union School of Engineering in 1953 and the MS degree in Electrical Engineering from Columbia University in 1956. He joined RCA in 1953 as a semiconductor-device engineer. He was promoted to Manager of Germanium Product Design in 1961, and assumed his present position as Manager of Integrated-Circuit Design in January 1963. Since 1954, Mr. Kalish has been an Adjunct Instructor in Physics and Electrical Engineering at the Cooper Union School of Engineering.

**D. H. Wamsley** received his BS in Ceramic Engineering from Alfred University in 1930, and the MS in Ceramic Engineering from the University of Illinois in 1932 while attending on a Research Fellowship. He joined RCA early in 1933 as an engineer in the Chemical and Physical Laboratory at Harrison, N.J. He moved to Lancaster in 1942 to establish and manage a Chemical and Physical Laboratory in a new plant for the production of radar and communications tubes for the armed forces. He became Manager of Engineering Services for the Lancaster plant in early 1954, and later that year was assigned as Manager of Color Tube Engineering in the establishment of a new color-tube manufacturing organization. He transferred to Somerville in 1955, and has held a series of engineering management positions there. He holds a number of patents, and has published several papers. He is a Senior Member of the IEEE and has served as Chairman of the Lancaster IEEE Subsection. He is also a member of the ACS and has served as Chairman of the Southeastern Pennsylvania ACS Section. He was President of the Lancaster Chapter of the SAMI. He served as a member of the JEDEC Council from 1956 to 1960.

**Robert E. Winn** graduated from the University of Missouri with a BSEE degree in 1957 and that year joined the Broadcast Transmitter Engineering Group in Camden. Through the RCA Graduate Study Program he received an MSEE degree from the University of Pennsylvania in 1964. Design activities while he was with the Transmitter Group include work on FM, VHF and UHF television transmitters, UHF cavity design, and automatic switching systems. Since 1964 he has been with the Broadcast Transmitter-Antenna Systems Group located in Gibbsboro, New Jersey. Mr. Winn is a member of Eta Kappa Nu.

**W. J. Sweger** received his BA in Physics from Washington and Jefferson College in 1949. From 1951 until 1955, he was with the Naval Ordnance Laboratory as an Electronic Engineer in radio-type proximity fuses for projectiles and rockets. From 1955 to 1956, he was a fuse design engineer with the Navy Bureau of Ordnance, with responsibility for administrative direction of vr fuse R and D programs at the Naval Ordnance Laboratory, and at BuOrd contractors. In 1956, he joined Curtiss-Wright Research Division's Nuclear Power Department. From 1958 to 1959, he was Group Leader of the Nuclear Instrumentation and Controls Section. In May 1960, he joined the RCA Broadcast and Communication Products Division at Meadow Lands, Pa., as a member of the Engineering Staff. He has been responsible for coordinating FCC Type Acceptance applications on Mobile Radio Transmitters and for coordinating the preparation of Two-Way Radio Product Line instruction books.

**R. R. Shively** received a BA in Business Administration from Pennsylvania State University in 1954. From 1954 to 1957 he served as an Air Force officer with responsibilities for direction of a radar station and as an instructor in air-to-air missile launch techniques. In 1957 he joined the Philco Corporation as an assistant to the Division Controller in Estimating and Pricing. In 1958 Mr. Shively joined RCA as an administrator on the AN/FPS-16 program and in 1959 was assigned to the BMEWS Program. As a member of the DEP Systems Engineering, Evaluation, and Research Group, Mr. Shively is administratively responsible for that group's contracts and proposal activities.

**Thomas L. Elliott, Jr.**, received the BS in Journalism from the University of Florida in June 1959. After serving as Director of Public Relations for the Orlando, Florida, Chamber of Commerce for four years, he joined the RCA Service Company's Missile Test Project as Publications Administrator in June 1963. In this position, he is responsible for producing the location house magazine and for related publicity, public relations, and publications affairs.

**Leon H. Fetter**, now a member of the RCA Service Company Government Field Support Group, received his BSEE from Tri State College in 1930. He also studied at Drexel Institute of Technology and the College of South Jersey (now Camden branch of Rutgers). Mr. Fetter has been employed by RCA since 1930 having both laboratory, field and test engineering experience. In 1939 he transferred to the RCA Service Company and since that time has been active in Field Engineering as related to radio, television and military equipment. He also has experience in technical publications on both commercial instruments and military equipment, including sonar, radar, and guided missiles. He was formerly Editor of RCA Service Company, Government Services magazine FEED.

**Bruce Aaront** received his BA in Physics and Mathematics from New York University in 1950. He was employed as a Research Physicist in Electronics and Optics by the U.S. Government until 1953, at which time he joined RCA Service Co. as Manager of the Bizmac Computer Installation at OTAC in Detroit. In 1959 he returned to Cherry Hill as Manager of Field Support Engineering for Electronic Data Processing Services, and was responsible for installation of the first ten RCA 501 computers. He served in this position and in subsequent positions as Manager of Project Control, EDPS, and Manager of Operation Support Planning until 1964, when he assumed his present position of Manager of Engineering for EDPS. Among his current duties is the Management of the Sustaining Engineering, New Products Service Engineering, and Training Groups for EDPS.

**L. A. Shotliff** received his BSEE in 1939 and his MSEE in 1940 from Washington University, St. Louis, Mo. He has done additional graduate work at Washington University, University of Pennsylvania, and Columbia University. He is a member of Tau Beta Pi, Sigma Xi, Pi Mu Epsilon, Phi Eta Sigma, and Omicron Delta Kappa. He is a senior member of the IEEE, a member of the Board of Editors of *RCA Review* and of the Board of Technical Advisors of the RCA Institutes. He is also a licensed professional engineer in the State of New York. After obtaining his MS, he taught EE at Washington University and then joined RCA in June 1941. After training, he was assigned to the aviation transmitter engineering design and development group. After the war he worked in communications equipment development and then transferred to the RCA International Division in late 1945. While at RCA International, he has had management positions in communications marketing, engineering product development and product planning, systems engineering, engineering products marketing and in 1960 transferred to the Licensing Operations where he was Manager of Technical Aid Development, and presently is Manager of Technical Information and Services, and of information and services to existing technical aid licensees.



R. C. Fortin



E. F. Breniak



K. E. Loofbourrow



E. K. Madenford



I. Kalish



D. H. Wamsley



R. E. Winn



W. J. Sweger



R. R. Shively



T. L. Elliott, Jr.



L. H. Fetter



B. Aaront



L. A. Shotliff

**E. R. JENNINGS NAMED ASSOCIATE EDITOR, RCA ENGINEER**

**E. R. Jennings** has been promoted to Associate Editor of the *RCA ENGINEER*. Formerly Assistant Editor, he will continue to report to **W. O. Hadlock**, Editor. In addition to duties connected with all phases of the *RCA ENGINEER*, he will continue to assist Mr. Hadlock in staff administration of *RCA* technical papers and reports, including the indexing activities of *RCA* papers and reports. Mr. Jennings received his BS in Mechanical Engineering from Illinois Institute of Technology, Chicago, Ill., in 1950 and has taken graduate work at University of Chicago and University of Pennsylvania. After working as a design engineer, he assisted in supervision of a technical-information group responsible for nuclear weapons test reports. He joined *RCA* in early 1959, working first at the Astro-Electronics Division, and then becoming Assistant Editor of the *RCA ENGINEER* in mid-1959. He is a Member IEEE, and has served as Editor, *IEEE Trans. on EWS*.

**MIT RESEARCH DIRECTORY AVAILABLE**

As a participant in the MIT Industrial Liaison Program, the *RCA* Technical Libraries have copies of the 1965 *MIT Directory of Current Research*. The Directory lists more than 1200 projects (all non-classified research programs). The research projects in the Directory usually result in publications available to *RCA*. Request for information concerning the research programs and publications, as well as a number of private symposiums to be offered for the benefit of specialists, should be forwarded through your librarian.

**INTEGRATED CIRCUITS SEMINAR IN SOMERVILLE**

A full-day Integrated Circuit engineering seminar was held in Somerville on January 27, 1965 under the sponsorship of the Integrated Circuit Department of *RCA* Electronic Components and Devices. The purpose of the Seminar was threefold: to impart to the *RCA* engineering audience of over 300 people the objectives of *RCA*'s corporate program on integrated circuits; to expose the attendees to the ultra-modern facilities for engineering and producing integrated circuits at Somerville; and finally discuss those families of integrated circuits that are now becoming available.

Note: The October-November *RCA ENGINEER* was devoted to the *RCA* integrated circuit program. In addition to the technical papers in that issue, four introductory articles (by Kihn, Day, Kalish, and Aires) described the *RCA* integrated circuit program, the organizations responsible for the program and their objectives, and the engineering-applications assistance available.]

**Correction:** In the paper by Kowallek and Melita, "Overload Considerations for Low-Cost Transistorized AM Receivers" in the Feb.-Mar. 1965 issue, there were several transpositions of lines of type at the beginning of the Summary on page 71. The first paragraph of the Summary should correctly read as follows:

**SUMMARY**

A fixed-biased amplifier operating at maximum stable gain will normally require an input signal of only a few millivolts to drive the stage into clipping. The predominant envelope distortion will occur as a "flattening" or "rounding" of the peaks of the upward modulation. As the quiescent current is reduced, the stage gain will be reduced. Then for a given output signal, a greater input signal will be required. The increased signal excursion will cause envelope distortion due to the nonlinearity of the transconductance.

**PROFESSIONAL ACTIVITIES**

*DEP-CSD Systems Lab., New York City:* **William L. Clements**, Project Administrator for the Advanced Communication Techniques Group was elected Secretary of the Metropolitan (New York) Engineering Management Group of the IEEE.—*M. P. Rosenthal*

*DEP-ASD, Van Nuys, Calif.:* A Micro-circuit Training Program was given for 10 consecutive weeks which began October 1, 1964. The program was attended by approximately 84 engineers.—*S. Hersh*.

*DEP-ASD, Burlington, Mass.:* **D. Dobson** has been named Executive Editor of the new *IEEE Transactions on Defense Aerospace and Navigational Systems*.

*DEP Applied Research, Camden, N.J.:* **Dr. James Vollmer** was appointed Adjunct Professor of Physics at Drexel Institute of Technology. He has completed teaching the first semester graduate course in Plasma Physics.—*J. M. DiAmore*

*RCA Service Company, Cherry Hill, N.J.:* The systems engineering sessions of the ASQC's 1965 Convention will have two participants from *RCA* Service Co. **R. E. Purvis** is preparing a paper for presentation entitled "Resource Requirements as a Consequence of Reliability and Maintainability Tradeoffs." **H. R. Barton, Jr.** is the session organizer, and will participate in a panel discussion entitled "Engineering the Total Man-Machine Information System." Other panel members include **H. D. Voegtlen, R. R. Jones**, and **T. H. Allen**.—*L. Fetter*

*ECD Microwave Engineering, Harrison:* **Robert W. McMurrough**, Engineering Leader, Traveling-Wave Tube Design has been elected Secretary of the New York Metropolitan Chapter of the Electron Devices Group IEEE for 1964-1965. In this capacity, Mr. McMurrough is responsible for committee minutes, organizing lectures, and handling correspondence.

*ECD Integrated Circuit Dept., Somerville, N.J.:* **R. D. Lohman** discussed Semiconductor Integrated Circuits as member of the panel at an IEEE Symposium on "Balls, Beams, and Bonds" in New York City on Feb. 23, 1965.—*I. Kalish*

*ECD Semiconductor and Conversion Tube Operations, Mountaintop, Pa.:* Members of the Wilkes College Physics Club were guests of the *RCA* Mountaintop semiconductor plant for their technical meeting on January 6, 1965. Highlights of the meeting included discussions of solid state theory and applications conducted by several members of the *RCA* Engineering Staff and a tour of the semiconductor manufacturing facilities.—*K. E. Loojbourrow*

*ECD Conversion Tube Operations, Lancaster, Pa.:* Engineers **Harold P. Krall, Andy G. Nekut** and **John P. Sverha** of Phototube Product Engineering, attended 11th Nuclear Science Symposium at Philadelphia. **Dr. R. W. Engstrom**, Manager, Conversion Tube Advanced Development, delivered a lecture entitled "Photomultipliers and Image Tubes" at the *RCA* International Distributors Symposium in Geneva, Switzerland, on March 3, 1965.

—*R. Kauffman*

*RCA Communications, Inc., New York City:* **J. C. Hepburn**, Manager, Station Facilities, Equipment and Systems Design, *RCA* Communications, Inc., was appointed Chairman, Telegraphy Subcommittee, of the U.S. Preparatory Committee for Study Group III. **J. M. Walsh**, Manager, Terminal Plant Engineering, has been appointed to the Awards Committee and reappointed to the Meetings Committee and the Radio Communication Committee of the IEEE Communication Technology Group. He recently attended the NEC Convention in Chicago.—*C. F. Frost*

*Missile Test Project, Cape Kennedy, Fla.:* **Charles E. Stone**, Manager of the Measurement Equipment Laboratories, was featured on the program of the recent National Conference of Standards Laboratories in New York City, speaking on "A Practical Approach to Standards Information Services." In addition, Stone, as a participating member of the Committee for Standards Laboratories Information Services, also served on a panel that discussed methods of exchanging information. Serving on the executive committee of the Second Space Congress (Cocoa Beach, Florida, April 5-7, 1965), were **Joseph Q. Hilliard**, Assistant General Chairman; **Dr. L. E. Mertens**, Technical Program Chairman; **Roy H. Tabeling**, Speakers Chairman; and **David Kovljain**, Arrangements and Exhibits Chairman. The Space Congress is an annual undertaking of the Canaveral Council of Technical Societies, an organization of the Cape Kennedy area chapters of 17 professional societies. **William G. Wiest**, Photographic Laboratory Engineer for the *RCA* Service Company's Missile Test Project, has been elected Chairman of the Inter-Range Instrumentation Group's (IRIG) Photographic Laboratory Working Group. IRIG is an association of scientific personnel concerned with missile range activities. Formed in the mid-1950's by the commanders of the country's ranges, its purpose is to encourage exchanges of information between the ranges on activities of mutual interest. Several Missile Test Project personnel were installed as officers of their respective professional societies at the joint banquet of the Society of Photo-Optical Instrumentation Engineers (SPIE), the American Society of Photogrammetry (ASP), and the Society of Motion Picture and Television Engineers (SMPTE). Named to positions in SPIE-ASP, which functions as a single chapter in the Cape Kennedy area, where **E. N. Bowker**, Treasurer; **S. L. Atkinson**, and **George H. Rosenfield**, Board of Directors. SMPTE installed **W. M. Sheahan**, as its chairman. He succeeds **V. D. Armstrong**. Also serving SMPTE are **R. F. Downey**, Secretary-Treasurer; **W. G. Wiest**, Program Chairman; **J. T. Stuart**, Membership Chairman; and **J. A. Hardos**, Publications and Arrangements Chairman.—*T. L. Elliott, Jr.*

*RCA Labs., Princeton:* **Dr. Fred P. Heiman** is teaching a course in "Semiconductor Device Technology" at Rutgers University evening school in New Brunswick. One section is being taught at New Brunswick and one is held at the *RCA* Labs. Both Somerville and Princeton *RCA* people are participating. **S. Dierk** is serving as Publicity Chairman of the IEEE Princeton Section.—*C. W. Sall*

# INDEX TO RCA ENGINEER VOLUME 10

This index covers Vol. 10-1 (June-July 1964), 10-2 (Aug.-Sept. 1964), 10-3 (Oct.-Nov. 1964), 10-4 (Dec. 1964-Jan. 1965), 10-5 (Feb.-Mar. 1965), and the present issue, 10-6 (April-May 1965). Since RCA ENGINEER articles are also available as reprints, the reprint number (PE-000) is noted throughout.

## SUBJECT INDEX

Titles of papers are permuted where necessary to bring significant keyword(s) to the left for easier scanning. Authors' division appears parenthetically after his name.

### AMPLIFICATION

**Electron-Beam-Plasma Amplifiers—A Future in Millimeter-Wave Amplification**—Dr. G. A. Swartz (Labs., Pr.); 10-4, (reprint PE-222)

**High-Gain, Solid-State Microwave Amplifier, The Possibility of a—R. D. Larrabee, W. A. Hieinbohm, Jr. (Labs., Pr.);** E&R Note, 10-2 (reprint PE-235-20)

**Integrated Circuit Amplifier, Computer Analysis of an—A. G. Atwood, L. C. Drew (DEP-CSD, Burl.);** 10-3, (in reprint booklets *RCA Integrated Circuits, PE-214, PE-216, PE-217, PE-218*)

**Microwave Amplification in Superconductors—A. S. Corliffe, R. D. Hughes (Labs., Pr.);** E&R Note, 10-3, (in reprint booklet *Microwave Systems and Devices, PE-210*)

**MIPR Radar Receiver—A Three-Channel Remote-Tuned Parametric Amplifier—H. B. Yin (DEP-MSR, Mrstn.);** 10-4, (in reprint booklet *Microwave Systems and Devices, PE-210*)

**Traveling-Wave Tubes (Low- and Medium-Power) as Versatile Broadband Microwave Amplifiers—A Review—H. J. Wolkstein, R. W. McMurrugh, G. Novak (ECD, Hr.);** 10-4, (in reprint booklets *Microwave Systems and Devices, PE-210*; and *Microwave Components, PE-219, PE-215*)

**Tunnel-Diode Microwave Amplifiers and Oscillators—D. E. Nelson, A. Presser, E. Casertline, R. M. Minton (ECD, Pr. & Som.);** 10-4, (in reprint booklets *Microwave Systems and Devices, PE-210* and *Microwave Components, PE-215, PE-219*)

### BIOMEDICAL ELECTRONICS

**Biomedical Engineering**—Dr. A. N. Goldsmith (RCA Staff, N.Y.); 10-6, (reprint PE-225)

**Electronics Technology in Medicine—L. E. Flory (DEP-AED, Pr.);** 10-6, (reprint PE-230)

**Microcircuit-Microwatt Design Techniques for New Internal Medical Sensors—L. E. Flory, F. Hatke (DEP-AED, Pr.);** 10-6, (reprint PE-231)

### BIONICS

**Adaptation Theory—A Tutorial Introduction to Current Research—Dr. J. Sklansky (Labs., Pr.);** 10-6, (reprint PE-232)

**Neural, Threshold, Majority, and Boolean Logic Techniques—A Comparative Survey—C. R. Atzenbeck, D. Hampel (DEP-CSD, N.Y.);** 10-6, (in reprint booklet *Life Sciences, PE-233*)

**Speech Recognition Using Artificial Neurons—M. B. Herscher, T. B. Martin (DEP-AppRes, Camden);** 10-6, (in reprint booklet *Life Sciences, PE-233*)

### CHECKOUT; MAINTENANCE

**Computer-Controlled Automatic Testing—A Review—B. T. Joyce, E. M. Stockton (DEP-ASD, Burl.);** 10-5, (in reprint booklet *Space Electronics, PE-227*)

**Predicting System Checkout Errors—W. C. Moon (DEP-ASD, Burl.);** 10-5, (in reprint booklet *Space Electronics, PE-227*)

### CIRCUIT THEORY; ANALYSIS

**Multiple Diode Theorems—R. L. Ernst (DEP-CSD, N.Y.);** E&R Note, 10-5 (reprint PE-235-38)

### CIRCUIT INTERCONNECTIONS; PACKAGING

**High-Packing-Density Module Board—Mechanical Aspects—A. C. Corrado (DEP-CSD, Camden);** E&R Note, 10-1 (reprint PE-235-15)

**Monolithic Silicon Integrated Circuits, Packaging of—A. Morena, H. Krautter (ECD, Som.);** 10-3, (in reprint booklets *RCA Integrated Circuits, PE-214, PE-216, PE-217, PE-218*)

**New Packing Arrangement for Fragile Electronic Equipment—R. E. Hersey (DEP-CSD, Cambridge);** E&R Note, 10-1 (reprint PE-235-16)

### COMMUNICATIONS, DIGITAL

**DATELEX—A New High Speed Transmission Service for International Data Exchange—R. K. Andres (RCA Comm., N.Y.);** 10-1 (reprint PE-235-5)

**Permutation Codes—F. H. Fowler, Jr. (DEP-CSD, Camden);** 10-1 (reprint PE-235-13)

**Random Access Discrete Address Communications, An Improved Detection Technique for—R. C. Sommer (DEP-CSD, N.Y.);** E&R Note, 10-4, (in reprint booklet *Microwave Systems and Devices, PE-210*)

**Random Access, Discrete-Address Communications, On the Optimization of—R. C. Sommer (DEP-CSD, N.Y.);** E&R Note, 10-2, (in reprint booklet *Microwave Systems and Devices, PE-210*)

### COMMUNICATIONS SYSTEMS; THEORY

**Evolution of RCA's Solid-State Microwave Commercial Communications Equipment—H. S. Wilson (BCD, Camden);** 10-1 (reprint PE-235-11)

**Future Microwave Communications Repeaters for Space—A. L. Berman, J. Kiesling (DEP-AED, Pr.);** 10-4, (in reprint booklet *Microwave Systems and Devices, PE-210*)

**Relay Satellite Communications System—J. Kiesling, W. Maco, S. Goldman (DEP-AED, Pr.);** 10-4, (in reprint booklet *Microwave Systems and Devices, PE-210*)

### COMMUNICATIONS, VOICE SYSTEMS

**CW-60 Solid-State Microwave Relay Equipment, Design of—E. J. Forbes (BCD, Camden);** 10-4, (reprint PE-209; also in reprint booklet *Microwave Systems and Devices, PE-210*)

**Mobile Communications Repeater Requirements—F. C. Hartwick (RCA Ser. Co., C. H.);** 10-1, (reprint PE-196)

**Solid-State CV-600 Frequency-Division Multiplex for 600 Voice Channels—F. L. Cameron (BCD, Camden);** 10-4, (reprint PE-209)

### COMMUNICATIONS, EQUIPMENT COMPONENTS

**Four-Digit Differential PCM Analog-Digital Converter for Voice Application—E. King (DEP-CSD, Camden);** 10-4 (reprint PE-235-29)

**HF Receiver Figure-of-Merit Monitor—G. E. Hansell, B. A. Trevor (DEP-CSD, Tucson);** 10-1 (reprint PE-235-7)

**Measurement of Inductor Q by Ringing-Circuit Technique—H. E. Goldstone (DEP-CSD, N.Y.);** E&R Note, 10-4 (reprint PE-235-30)

**Microwave Devices—A Survey of Business Potential—H. K. Jenny (ECD, Hr.);** 10-4, (in reprint booklets *Microwave Components PE-215, PE-219*)

**Microwave Research—Devices for the Future—Dr. I. S. Nergaard (Labs., Pr.);** 10-4, (reprint PE-220; also in reprint booklets *Microwave Components, PE-215, PE-219*; and *Microwave Systems and Devices, PE-210*)

**Transient-Free Automatic Switch-Over Standby Power Supply—J. Lieberman (DEP-CSD, Camden);** E&R Note, 10-4 (reprint PE-235-32)

### COMPUTER APPLICATIONS

**BUPAR—A System Providing Computer-Prepared Business Analyses and Forecasts—J. H. Detwiler, J. B. Saunders (DEP-CSD, Camden);** 10-1 (reprint PE-235-1)

**Computer Calculation of Frame-Grid Winding Tension—P. J. Musso, T. E. Deegen (ECD, Hr.);** E&R Note, 10-6 (reprint PE-235-40)

**Computer-Controlled Automatic Testing—A Review—B. T. Joyce, E. M. Stockton (DEP-ASD, Burl.);** 10-5, (in reprint booklet *Space Electronics, PE-227*)

**Data Plotting by Digital Computer—R. E. Simpkins (ECD, Hr.);** 10-6 (reprint PE-235-39)

**Filter Design by Digital Computer—T. G. Marshall, Jr. (BCD, Camden);** E&R Note, 10-5 (reprint PE-235-36)

**Integrated Circuit Amplifier, Computer Analysis of an—A. G. Atwood, L. C. Drew (DEP-ASD, Burl.);** 10-3, (in reprint booklets *RCA Integrated Circuits, PE-214, PE-216, PE-217, PE-218*)

**Optimizing Square-Root Computations on a Digital Computer—F. H. Fowler, Jr. (DEP-CSD, Camden);** 10-5 (reprint PE-235-33)

### COMPUTER CIRCUITRY; DEVICES

**MOS Integrated Logic Networks—A. K. Rapp (Labs., Pr.);** 10-3, (reprint PE-207; also in reprint booklets *RCA Integrated Circuits, PE-214, PE-216, PE-217, PE-218*)

**Monolithic Silicon Integrated Circuits (Emitter-Coupled) for High-Speed Computers—A Status Report—E. E. Moore (DEP-DME, Som.);** 10-3, (in reprint booklets *RCA Integrated Circuits, PE-214, PE-216, PE-217, PE-218*)

**Monolithic Silicon Integrated Circuit NAND-NOR Gate, TA-5038, Design of a—G. Cohen (ECD, Som.);** 10-3, (in reprint booklets *RCA Integrated Circuits, PE-214, PE-216, PE-217, PE-218*)

### COMPUTER INPUT-OUTPUT

**Computer Data Communications for On-Line Simultaneous Processing—B. P. Silverman (EDP, Camden);** 10-5 (reprint PE-235-35)

**VIDEOSCAN—High-Speed Optical Reader for Computer Input—S. Klein, J. L. Miller (EDP, Camden);** 10-1 (reprint PE-235-8)

### COMPUTER LOGIC; THEORY

**Neural, Threshold, Majority, and Boolean Logic Techniques—A Comparative Survey—C. R. Atzenbeck, D. Hampel (DEP-CSD, N.Y.);** 10-6, (in reprint booklet *Life Sciences, PE-233*)

### COMPUTER STORAGE

**Fixed, Associative Memory Using Evaporated Organic Diode Arrays—Dr. M. H. Lewin, H. R. Beelitz, Dr. J. A. Rajchman (Labs., Pr.);** 10-1 (reprint PE-235-9)

**Laminated Ferrite Memories—Dr. R. Shahbender, C. Wentworth, Dr. K. Li, S. E. Hotchkiss, Dr. J. A. Rajchman (Labs., Pr.);** 10-3, (reprint PE-208)

**Shmo Plot for Coincident Current Core-Memory Operation, Analysis of the—Y. L. Yao (DEP-CSD, Camden);** 10-1 (reprint PE-235-14)

### CONTROL; TIMING

**VE-DET: Electronic Vehicle Detector for Automated Traffic Control—E. C. Donald (BCD, Plymouth);** 10-5, (reprint PE-226)

### DISPLAYS

**A Completely Integrated Thin-Film Scan Generator for Crossed-Array Image Panels—Dr. P. K. Weimer, H. Borkan, Dr. G. Sadasiv, L. Meray-Horvath, Dr. F. V. Shalleross (Labs., Pr.);** 10-3, (reprint PE-206; also in reprint booklets *RCA Integrated Circuits, PE-214, PE-216, PE-217, PE-218*)

**Selection of Letter Size and Lighting for Display and Control Panel Legends—W. Baskerville, R. N. Gillis (DEP-SEER, Mrstn.);** 10-6, (in reprint booklet *Life Sciences, PE-233*)

### DOCUMENTATION; WRITING

**Exportation of Technical Data, New Information on Legal Restraints on—C. E. Yates (Labs., Pr.);** E&R Note, 10-1, (reprint PE-198)

**How to Write a Technical Book and Get It Published—M. P. Rosenthal (DEP-CSD, N.Y.);** 10-2 (reprint PE-235-17)

**New Approach to Writing Operator Procedure Manuals—Dr. F. H. Ireland, T. G. Wiedman (DEP-SEER, Mrstn.);** 10-6, (in reprint booklet *Life Sciences, PE-233*)

### ELECTRO-OPTIC SYSTEMS; TECHNIQUES

**AN/FSR-2—An Advanced System for Photo Electronic Detection and Plotting Beyond Radar Ranges—C. B. Park (DEP-ASD, Burl.);** 10-2, (in reprint booklets *Electro-Optics, PE-211, PE-223*)

**Electro-Optical Signal Processing—M. J. Cantella, R. Kee (DEP-ASD, Burl.);** 10-5, (in reprint booklets *Electro-Optics, PE-211, PE-223*)

**Infrared Fiber Optics—L. Arlan, N. Aron (DEP-ASD, Burl.);** 10-5, (in reprint booklets *Electro-Optics, PE-211, PE-223*)

**Optical Harmonics, Generation of—H. J. Okoomian (DEP-ASD, Burl.);** 10-1, (in reprint booklets *Electro-Optics, PE-211, PE-223*)

### ENERGY CONVERSION; SOURCES

**Comparison of Solar-Cell Power Supplies with Radioisotope-Powered Thermal Generators for Spacecraft—S. H. Winkler (DEP-AED, Pr.);** 10-1 (reprint PE-235-10)

**Gallium Arsenide P-N Junction Infrared Energy Sources—M. F. Lamorte (ECD, Som.);** 10-1 (reprint PE-235-6)

**Transient-Free Automatic Switch-Over Standby Power Supply—J. Lieberman (DEP-CSD, Camden);** E&R Note, 10-4 (reprint PE-235-32)

**Thermoelectric Water Reclamation for Manned Space Systems—P. E. Wright (DEP-AppRes, Camden);** 10-6, (in reprint booklet *Space Electronics, PE-227*)

### FILTERS

**Filter Design by Digital Computer—T. G. Marshall, Jr. (BCD, Camden);** E&R Note, 10-5 (reprint PE-235-36)

### GRAPHIC ARTS SYSTEMS; TECHNIQUES

**Photocomposition Machine for the Chinese Language—F. E. Shashoua (DEP-AppRes, Camden);** 10-6, (in reprint booklets *Electro-Optics, PE-211, PE-223*)

### HUMAN ENGINEERING

**Human Factors Engineering—More Than Just the "Blessing"—Dr. H. B. Matty (DEP-CSD, Camden);** 10-6, (in reprint booklet *Life Sciences, PE-233*)

**New Approach to Writing Operator Procedure Manuals—Dr. F. H. Ireland, T. G. Wiedman (DEP-SEER, Mrstn.);** 10-6, (in reprint booklet *Life Sciences, PE-233*)

**Selection of Letter Size and Lighting for Display and Control Panel Legends—W. Baskerville, R. N. Gillis (DEP-SEER, Mrstn.);** 10-6, (in reprint booklet *Life Sciences, PE-233*)



## INSTRUMENTATION; LAB EQUIPMENT

Accelerometer Performance, Effect of Unpublished Characteristics and Mounting Variables on—B. Mangolds (DEP-AED, Pr.); E&R Note, 10-3 (reprint PE-235-25)

Electron Microscope, Elucidation of Ultrastructure with the—Dr. J. W. Coleman (BCD, Camden); 10-6, (in reprint booklets *Life Sciences*, PE-233, PE-234)

Electron Microscopy in the Life Sciences, Development of—Dr. J. H. Reiser (BCD, Camden); 10-6, (in reprint booklets *Life Sciences*, PE-233, PE-234)

New-Design Pressure Transducer for Cable and Pipe Networks—More Reliable and Economical—C. Merrell (DEP-CSD, N.Y.); E&R Note, 10-6 (reprint PE-235-41)

Reed Switch as a Laboratory Tool—M. B. Knight (ECD, Hr.); E&R Note, 10-3 (reprint PE-235-26)

Supersonic Plasma Streams, A Versatile Two-Phase Mercury Tunnel for Generation of—Dr. A. I. Carswell (RCA Ltd., Montreal); 10-1, (reprint PE-194)

## LASERS

High-Power Laser Transmitter—T. Nolan (DEP-ASD, Burl.); E&R Note, 10-1, (in reprint booklets *Electro-Optics*, PE-211, PE-223)

Off-Axis Feedback Modes in a 3-Mirror Laser System—A. I. Carswell, A. L. Waksberg (RCA Ltd., Montreal); E&R Note, 10-2 (reprint PE-235-19)

## MANAGEMENT; BUSINESS

BUPAR—A System Providing Computer-Prepared Business Analyses and Forecasts—J. H. Detwiler, J. B. Saunders (DEP-CSD, Camden); 10-1 (reprint PE-235-1)

The DEP Microelectronics Activity—Applying Integrated Circuits to Military and Space Equipment—R. H. Aires (DEP-DME, Som.); 10-3, (in reprint booklet *RCA Integrated Circuits*, PE-214)

The ECD Integrated Circuit Organization and Its Objectives—L. R. Day (ECD, Hr.); 10-3 (reprint PE-235-22)

Industrial Reactor Laboratories—A Service Available to RCA—Dr. J. Kurshan, Dr. D. A. Ross (Labs., Pr.); 10-4 (reprint PE-235-28)

Microwave Devices—A Survey of Business Potential—H. K. Jenny (ECD, Hr.); 10-4, (in reprint booklets *Microwave Components*, PE-215, PE-219)

New Information on Legal Restraints on Exportation of Technical Data—C. E. Yates (Labs., Pr.); E&R Note, 10-1, (reprint PE-198)

The 1965 David Sarnoff Outstanding Achievement Awards—10-6

RCA's Integrated Circuit Program—H. Kihn (R&E Staff, Pr.); 10-3 (reprint PE-235-21)

Report on a Visit to the Soviet Union—Dr. J. I. Pankove (Labs., Pr.); 10-3 (reprint PE-235-24)

Six RCA Men Elected IEEE Fellows—10-5

Total Value Concepts in the Project Definition Phase—S. Robinson (DEP-MSR, Mrsn.); 10-5, (in reprint booklet *Space Electronics*, PE-227)

## PLASMA

Electron-Beam-Plasma Amplifiers—A Future in Millimeter-Wave Amplification—Dr. G. A. Swartz (Labs., Pr.); 10-4, (reprint PE-222; also in reprint booklet *Microwave Systems and Devices*, PE-210)

Supersonic Plasma Streams, A Versatile Two-Phase Mercury Tunnel for Generation of—Dr. A. I. Carswell (RCA Ltd., Montreal); 10-1, (reprint PE-194)

## RADAR

An Airborne Four-Frequency, Frequency-Stabilized Coherent Radar System—N. G. Hamm, E. G. McCall (DEP-ASD, Burl.); 10-1 (reprint PE-235-4)

The 4102-5 Space Track Program—E. T. Garner, J. Oseas (DEP-AED, Pr.); 10-5, (in reprint booklet *Space Electronics*, PE-227)

MIPRI Radar Receiver—A Three-Channel Remote-Tuned Parametric Amplifier—H. B. Yin (DEP-MSR, Mrsn.); 10-4, (in reprint booklet *Microwave Systems and Devices*, PE-210)

## RADIATION EFFECTS

Industrial Reactor Laboratories—A Service Available to RCA—Dr. J. Kurshan, Dr. D. A. Ross (Labs., Pr.); 10-4 (reprint PE-235-28)

## RADIO RECEIVERS, ENTERTAINMENT

Design of the RC-1218 Solid-State AM-FM Stereo-Multiplex Hi-Fi Receiver—J. B. Schultz (H.L. Indpls.); 10-5, (in reprint booklets *Home Instruments*, PE-228, PE-229)

Overload Considerations for Low-Cost Transistorized AM Receivers—D. E. Kowallek, M. C. Mehta (H.L. Indpls.); 10-5, (in reprint booklets *Home Instruments*, PE-228, PE-229)

## RECORDING, AUDIO

A High-Quality Phonograph Pickup Arm for Professional Use—Dr. J. C. Woodward (Labs., Pr.); E&R Note, 10-3 (reprint PE-235-27)

Transistorized Portable "Victrols"—J. A. Tourtellot (H.L. Indpls.); 10-3, (in reprint booklets *Home Instruments*, PE-228, PE-229)

## RECORDING, VIDEO

Photo-Tape Cameras, Recent Developments in—W. Poch (DEP-AED, Pr.); 10-2, (in reprint booklets *Electro-Optics*, PE-211, PE-223)

## RELIABILITY; QUALITY CONTROL

Microwave Devices, Test and Specification Engineering for—M. DeVito (ECD, Hr.); 10-4, (in reprint booklets *Microwave Components*, PE-215, PE-219)

Monolithic Silicon Integrated Circuits, Reliability Program for—J. T. Molnar, T. S. Spitz (ECD, Som.); 10-3 (reprint PE-235-23)

## SOLID-STATE DEVICES

Frequency Multiplier for Missiles, Miniature C-Band Solid-State—D. E. Nelson, J. J. Napoleon, C. L. Cuccia (ECD, Pr.); 10-5, (in reprint booklet *Microwave Systems and Devices*, PE-210; also in reprint booklets *Microwave Components*, PE-215, PE-219)

High-Gain, Solid-State Microwave Amplifier, The Possibility of a R. D. Larabee, W. A. Hicinbothem, Jr. (Labs., Pr.); E&R Note, 10-2 (reprint PE-235-20)

## SOLID-STATE MATERIALS

Epitaxial Layer—A Major Contribution to Device Technology—Dr. J. S. Donal (Labs., Pr.); 10-1, (reprint PE-197)

## SOLID-STATE MICROELECTRONICS

The DEP Microelectronics Activity—Applying Integrated Circuits to Military and Space Equipment—R. H. Aires (DEP-DME, Som.); 10-3, (in reprint booklet *RCA Integrated Circuits*, PE-214)

Digital Integrated Circuits for Satellites—C. Stalloff, P. J. Truscello, A. I. Aronson (DEP-AED, Pr.); 10-3, (in reprint booklets *RCA Integrated Circuits*, PE-214, PE-216, PE-217, PE-218)

The ECD Integrated Circuit Organization and Its Objectives—L. R. Day (ECD, Hr.); 10-3 (reprint PE-235-22)

Integrated Circuit Amplifier, Computer Analysis of an—A. G. Atwood, L. C. Drew (DEP-ASD, Burl.); 10-3, (in reprint booklets *RCA Integrated Circuits*, PE-214, PE-216, PE-217, PE-218)

Integrated Circuit Capability at Somerville—Goals and Progress—I. H. Kalish (ECD, Som.); 10-3, (in reprint booklets *RCA Integrated Circuits*, PE-214, PE-216, PE-217, PE-218)

Integrated Circuits, Cost Factors in—R. D. Lohman (ECD, Som.); 10-3, (in reprint booklets *RCA Integrated Circuits*, PE-214, PE-216, PE-217, PE-218)

Monolithic Silicon Integrated Circuit NAND-NOR Gate, TA-5038, Design of a—G. Cohen (ECD, Som.); 10-3, (in reprint booklets *RCA Integrated Circuits*, PE-214, PE-216, PE-217, PE-218)

Monolithic Silicon Integrated Circuits (Emitter-Coupled) for High-Speed Computers—A Status Report—E. E. Moore (DEP-DME, Som.); 10-3, (in reprint booklets *RCA Integrated Circuits*, PE-214, PE-216, PE-217, PE-218)

Monolithic Silicon Integrated Circuits, Fabrication Processes for—M. S. Saunders (ECD, Som.); 10-3, (in reprint booklets *RCA Integrated Circuits*, PE-214, PE-216, PE-217, PE-218)

Monolithic Silicon Integrated Circuits, Integration of Thin-Film Passive Components with—A. H. Medwin (ECD, Som.); 10-3, (in reprint booklets *RCA Integrated Circuits*, PE-214, PE-216, PE-217, PE-218)

Monolithic Silicon Integrated Circuits, Layout of—H. Goshgarian (ECD, Som.); 10-3, (in reprint booklets *RCA Integrated Circuits*, PE-214, PE-216, PE-217, PE-218)

Monolithic Silicon Integrated Circuits, Packaging of—A. Morena, H. Krautter (ECD, Som.); 10-3, (in reprint booklets *RCA Integrated Circuits*, PE-214, PE-216, PE-217, PE-218)

Monolithic Silicon Integrated Circuit, P-N-P/N-P-N Complementary—E. C. Conser (ECD, Som.); 10-3, (in reprint booklets *RCA Integrated Circuits*, PE-214, PE-216, PE-217, PE-218)

Monolithic Silicon Integrated Circuits, Reliability Program for—J. T. Molnar, T. S. Spitz (ECD, Som.); 10-3 (reprint PE-235-23)

MOS Integrated Logic Networks—A. K. Rapp (Labs., Pr.); 10-3, (reprint PE-207; also in reprint booklets *RCA Integrated Circuits*, PE-214, PE-216, PE-217, PE-218)

RCA's Integrated Circuit Program—H. Kihn (R&E Staff, Pr.); 10-3 (reprint PE-235-21)

Thin-Film Scan Generator for Crossed-Array Image Panels, A Completely Integrated—Dr. P. K. Weimer, H. Borkan, Dr. G. Sadasiv, L. Meray-Horvath, Dr. F. V. Shallcross (Labs., Pr.); 10-3, (reprint PE-206; also in reprint booklets *RCA Integrated Circuits*, PE-214, PE-216, PE-217, PE-218)

Thin-Film (Entirely) Integrated Circuits for Space Applications—J. J. Bowe (DEP-DME, Som.); 10-3, (in reprint booklets *RCA Integrated Circuits*, PE-214, PE-216, PE-217, PE-218)

Thin-Film Microelectronics—A Review—Dr. W. Y. Pan (DEP-CSD, N.Y.); 10-3, (in reprint booklets *RCA Integrated Circuits*, PE-214, PE-216, PE-217, PE-218)

## SPACE COMPONENTS

Astronomical Image Sensors—L. E. Flory (DEP-AED, Pr.); 10-5, (in reprint booklet *Space Electronics*, PE-227)

Comparison of Solar-Cell Power Supplies with Radioisotope-Powered Thermal Generators for Spacecraft—S. H. Winkler (DEP-AED, Pr.); 10-1 (reprint PE-235-10)

Digital Integrated Circuits for Satellites—C. Stalloff, P. J. Truscello, A. I. Aronson (DEP-AED, Pr.); 10-3, (in reprint booklets *RCA Integrated Circuits*, PE-214, PE-216, PE-217, PE-218)

Entirely Thin-Film Integrated Circuits for Space Applications—J. J. Bowe (DEP-DME, Som.); 10-3, (in reprint booklets *RCA Integrated Circuits*, PE-214, PE-216, PE-217, PE-218)

GEMINI Spacecraft PCM-FM Telemetry Transmitter—R. G. Erdmann (DEP-CSD, Camden); 10-5, (in reprint booklet *Space Electronics*, PE-227)

Microwave Breakdown in Space Communications—A Case Study of RANGER VI and VII—T. D. Bredend (DEP-AED, Pr.); 10-4, (in reprint booklet *Microwave Systems and Devices*, PE-210)

New Technique Measures Linearity to 0.1% in NIMBUS TV Systems—S. J. Rand (DEP-AED, Pr.); E&R Note, 10-2, (in reprint booklets *Electro-Optics*, PE-211, PE-223)

Photo-Tape Cameras, Recent Developments in—W. Poch (DEP-AED, Pr.); 10-2, (in reprint booklets *Electro-Optics*, PE-211, PE-223)

Sensor Operating Parameters for Unattended Camera Systems, Regulation of—E. Vaerwyh, H. Wittlinger (DEP-AED, Pr.); E&R Note, 10-5 (reprint PE-235-37)

Stereoscopic TV Observation System for a Lunar Orbiter, A Proposed—F. J. Bingley (DEP-AED, Pr.); 10-5, (in reprint booklet *Space Electronics*, PE-227)

Television for Stellar Orientation of the Orbiting Astronomical Observatory—W. Sensenig, M. Kravitz (DEP-AED, Pr.); 10-2, (in reprint booklets *Electro-Optics*, PE-211, PE-223)

Thermoelectric Water Reclamation for Manned Space Systems—P. E. Wright (DEP-App Res., Camden); 10-6, (in reprint booklet *Space Electronics*, PE-227)

Traveling-Wave Tubes for Communications Satellites, Recent Advances in—F. E. Vaccaro, P. R. Wakefield, Dr. M. J. Schindler (ECD, Hr.); 10-4, (in reprint booklets *Microwave Components*, PE-215, PE-219)

TV Camera System for the Command Module of the APOLLO Spacecraft—P. M. Zuchino, J. L. Lowrance (DEP-AED, Pr.); 10-5, (in reprint booklet *Space Electronics*, PE-227)

Vidicon Applications for Space-Borne TV Cameras—M. H. Mesner (DEP-AED, Pr.); 10-2, (in reprint booklets *Electro-Optics*, PE-211, PE-223)

## SPACE NAVIGATION; TRACKING

AN/FSR-2—An Advanced System for Photo-Electronic Detection and Plotting Beyond Radar Ranges—C. B. Park (DEP-ASD, Burl.); 10-2, (in reprint booklets *Electro-Optics*, PE-211, PE-223)

The 4102-5 Space Track Program—E. T. Garner, J. Oseas (DEP-AED, Pr.) 10-5, (in reprint booklet *Space Electronics*, PE-227)

Television for Stellar Orientation of the Orbiting Astronomical Observatory—W. Sensenig, M. Kravitz (DEP-AED, Pr.); 10-2, (in reprint booklets *Electro-Optics*, PE-211, PE-223)

## SPACE VEHICLES; SATELLITES

Proposed Satellite for TV Observation of Zero-G Effects on Development of the Opossum Fetus—S. H. Fairweather, J. E. Mortimer (DEP-AED, Pr.); 10-6, (in reprint booklet *Space Electronics*, PE-227)

SERT Capsule—Testing Ion Engines in Space—L. E. Golden (DEP-AED, Pr.); 10-5, (in reprint booklet *Space Electronics*, PE-227)

Thermal Control of Spacecraft—Dr. G. D. Gordon (R&E Staff, Camden); 10-6, (in reprint booklet *Space Electronics*, PE-227)

## SPACE SYSTEMS

Future Microwave Communications Repeaters for Space—A. L. Berman, J. Kiesling (DEP-AED, Pr.); 10-4, (in reprint booklet *Microwave Systems and Devices*, PE-210)

Life Beyond the Atmosphere—Origins, Detection, and Support—Dr. A. G. Holmes-Siedle (DEP-AED, Pr.); 10-6, (in reprint booklet *Space Electronics*, PE-227)

RELY Satellite Communications System—J. Kiesling, W. Maco, S. Goldman (DEP-AED, Pr.); 10-4, (in reprint booklet *Microwave Systems and Devices*, PE-210)

## SUPERCONDUCTIVITY

High-Field Superconductors—New Developments in Theory, Materials, and Applications—J. P. McEvoy, Jr. (DEP-AppRes., Camden); 10-1 (reprint PE-235-2)

Microwave Amplification in Superconductors—A. S. Clorfeine, R. D. Hughes (Labs., Pr.); E&R Note, 10-3, (in reprint booklet *Microwave Systems and Devices*, PE-210)

A New Effect in Superconductors—M. Cardona, B. Rosenblum (Labs., Pr.); E&R Note, 10-4 (reprint PE-235-31)

## TELEVISION BROADCASTING; TRANSMISSION

Color Television, The First Ten Years—J. W. Wentworth (R&E Staff, Camden); 10-2, (reprint PE-200, PE-202)

Color TV Camera Development, A Brief Review of—K. Sadashige, Dr. H. N. Kozanowski (BCD, Camden); 10-2, (reprint PE-201, PE-202)

Electron Image Magnification in Broadcast TV Cameras Simulates Long-Focal-Length Lenses—F. Himelfarb (NBC, N.Y.); 10-5 (reprint PE-235-34)

Lap-Dissolve Amplifier for TV Broadcasting—K. W. Jorgensen (NBC, Burbank); 10-1 (reprint PE-235-12)

The New, Transistorized TK-27 Color TV Film Camera—D. M. Taylor (BCD, Camden); 10-5, (reprint PE-224)

Product Design Philosophy for New Broadcast TV Camera Equipment—N. L. Hobson (BCD, Camden); 10-2, (reprint PE-203)

RCA's Newest Monochrome TV Film Camera, TK-22—N. P. Kellaway (BCD, Camden); 10-2 (reprint PE-235-42)

Ultra-Portable Television Camera System—J. Castleberry (DEP-CSD, Camden); 10-2, (reprint PE-191, PE-205); also in reprint booklets *Electro-Optics*, PE-211, PE-223

## TELEVISION COMPONENTS

Developments in Electron Optics Produce Two New Lines of Vidicon Tubes—R. G. Neuhauser (ECD, Lanc.); 10-2, (in reprint booklets *Electro-Optics*, PE-211, PE-223)

## TELEVISION, NON-ENTERTAINMENT

An Experimental Low-Power Vidicon Camera Chain—L. A. Boyer, F. L. Hatke, L. E. Flory, J. M. Morgan, W. S. Pike (Labs., Pr.); E&R Note, 10-2 (reprint PE-235-18)

Lightweight Low-Light-Level TV Camera Using 2-Inch Image Orthicon—R. J. Gildea (DEP-ASD, Burl.); E&R Note, 10-1, (in reprint booklets *Electro-Optics*, PE-211, PE-223)

New Technique Measure Linearity to 0.1% in NIMBUS TV Systems—S. J. Rand (DEP-AED, Pr.); E&R Note, 10-2, (in reprint booklets *Electro-Optics*, PE-211, PE-223)

Sensor Operating Parameters for Unattended Camera Systems, Regulation of—E. Vaerewych, H. Wittlinger (DEP-AED, Pr.); E&R Note, 10-5 (reprint PE-235-37)

Stereoscopic TV Observation System for a Lunar Orbiter, A Proposed—F. J. Bingley (DEP-AED, Pr.); 10-5, (in reprint booklet *Space Electronics*, PE-227)

TV Camera System for the Command Module of the APOLLO Spacecraft—P. M. Zuchino, J. L. Lowrance (DEP-AED, Pr.); 10-5, (in reprint booklet *Space Electronics*, PE-227)

Vidicon Applications for Space-Borne TV Cameras—M. H. Mesner (DEP-AED, Pr.); 10-2, (in reprint booklets *Electro-Optics*, PE-211, PE-223)

## TELEVISION RECEIVERS

Automatic Degaussing for Color TV Receivers—R. R. Norley (H.I., Indpls.); 10-4, (reprint PE-213); also in reprint booklets *Home Instruments*, PE-228, PE-229)

UHF Transistor Oscillators, Design of—L. A. Harwood (H.I., Som.); 10-1, (reprint PE-192); also in reprint booklets *Home Instruments*, PE-228, PE-229)

## TUBE DESIGN; APPLICATION

Computer Calculation of Frame-Grid Winding Tension—P. J. Musso, T. E. Deegen (ECD, Hr.); E&R Note, 10-6 (reprint PE-235-40)

Developments in Electron Optics Produce Two New Lines of Vidicon Tubes—R. G. Neuhauser (ECD, Lanc.); 10-2, (in reprint booklets *Electro-Optics*, PE-211, PE-223)

Microwave Devices, Test and Specification Engineering for—M. DeVito (ECD, Hr.); 10-4, (in reprint booklets *Microwave Components*, PE-215, PE-219)

Traveling-Wave Tubes, Automatic Techniques Used in the Development and Manufacture of—F. Ulrich, M. Frumer, K. Karol, D. Mahwinney, E. Thall (ECD, Hr.); 10-4, (in reprint booklets *Microwave Components*, PE-215, PE-219)

Traveling-Wave Tubes for Communications Satellites, Recent Advances in—E. E. Vaccaro, P. R. Wakefield, Dr. M. J. Schindler (ECD, Hr.); 10-4, (in reprint booklets *Microwave Components*, PE-215, PE-219)

Traveling-Wave Tubes (Low-and Medium-Power) as Versatile Broadband Microwave Amplifiers—A Review—H. J. Wolkstein, R. W. McMurrough, G. Novak (ECD, Hr.); 10-4, (in reprint booklets *Microwave Components*, PE-215, PE-219; and *Microwave Systems and Devices*, PE-210)

Traveling-Wave Tubes, Recent Research on Low-Noise—Dr. S. Bloom (Labs., Pr.); 10-4, (reprint PE-221); also in reprint booklets *Microwave Components*, PE-215, PE-219; and *Microwave Systems and Devices*, PE-210)

## TUBE MATERIALS; THEORY

High-Emissivity Coating for Picture-Tube Heaters—R. K. Schneider (ECD, Marion, Ind.); 10-1 (reprint PE-235-3)

## AUTHOR INDEX

Subject listed opposite each author's name indicates where complete citation to his paper may be found in the subject index. Where an author has more than one paper, his name is repeated for each.

## BROADCAST AND COMMUNICATIONS PRODUCTS DIV.

Cameron, F. L. communications, voice systems  
Coleman, Dr. J. W. instrumentation; lab equipment  
Donald, E. C. control; timing  
Forbes, E. J. communications, voice systems  
Hobson, N. L. television broadcasting; transmission  
Kellaway, N. P. television broadcasting; transmission  
Kozanowski, Dr. H. N. television broadcasting; transmission  
Marshall, T. G., Jr. computer applications  
Reisner, Dr. J. H. instrumentation; lab equipment  
Sadashige, K. television broadcasting; transmission  
Taylor, D. M. television broadcasting; transmission  
Wilson, H. S. communications systems; theory

## ELECTRONIC COMPONENTS AND DEVICES

Casterline, E. amplification  
Cohen, G. computer circuitry; devices  
Conser, E. C. solid-state microelectronics  
Cuccia, C. L. solid-state devices  
Day, L. R. management; business  
Deegen, T. E. computer applications  
DeVito, M. reliability; quality control  
Frumer, M. tube design; application  
Goshgarian, H. solid-state microelectronics  
Jenny, H. K. communications, equipment components  
Kalish, I. H. solid-state microelectronics  
Karol, K. tube design; application  
Knight, M. B. instrumentation; lab equipment  
Krautter, H. circuit interconnections; packaging  
Lamorte, M. F. energy conversion; sources  
Lohman, R. D. solid-state microelectronics  
Mahwinney, D. tube design; application  
McMurrough, R. W. amplification  
Medwin, A. H. solid-state microelectronics  
Minton, R. M. amplification  
Molnar, J. T. reliability; quality control  
Morena, A. circuit interconnections; packaging  
Musso, P. J. computer applications  
Napoleon, J. J. solid-state devices  
Nelson, D. E. solid-state devices  
Nelson, D. E. amplification  
Neuhauser, R. G. television components  
Novak, G. amplification  
Presser, A. amplification  
Saunders, M. S. solid-state microelectronics  
Schindler, Dr. M. J. spacer components  
Schneider, R. K. tube materials; theory  
Simpkins, R. E. computer applications  
Spitz, T. S. reliability; quality control

Ulrich, F. tube design; application  
Vaccaro, F. E. space components  
Wakefield, P. R. space components  
Wolkstein, H. J. amplification

## ELECTRONIC DATA PROCESSING

Klein, S. computer input-output  
Miller, J. L. computer input-output  
Silverman, B. P. computer input-output

## DEP ASTRO-ELECTRONICS DIV.

Aronson, A. I. solid-state microelectronics  
Berman, A. L. communications systems; theory  
Bingley, F. J. space components  
Breedon, T. D. space components  
Fairweather, S. H. space vehicles; satellites  
Flory, L. E. biomedical electronics  
Flory, L. E. biomedical electronics  
Flory, L. E. space components  
Garner, E. T. radar  
Golden, L. E. space vehicles; satellites  
Goldman, S. communications systems; theory  
Hatke, F. biomedical electronics  
Holmes-Siedle, Dr. A. G. space systems  
Kiesling, J. communications systems; theory  
Kiesling, J. communications systems; theory  
Kraivit, M. space components  
Lawrance, J. L. space components  
Maco, W. communications systems; theory  
Mangolds, B. instrumentation; lab equipment  
Mesner, M. H. space components  
Mortimer, J. E. space vehicles; satellites  
Oseas, J. radar  
Poch, W. recording, video  
Rand, S. J. space components  
Sensenig, W. space components  
Staloff, C. solid-state microelectronics  
Truscello, P. J. solid-state microelectronics  
Vaerewych, E. space components  
Winkler, S. H. energy conversion; sources  
Wittlinger, H. space components  
Zuchino, P. M. space components

## DEP AEROSPACE SYSTEMS DIV.

Arlan, L. electro-optic systems; techniques  
Aron, N. electro-optic systems; techniques  
Atwood, A. G. amplification  
Cantella, M. J. electro-optic systems; techniques  
Drew, L. C. amplification  
Gildea, R. J. television components  
Hamm, N. G. radar  
Joyce, B. T. checkout; maintenance  
Kee, R. electro-optic systems; techniques  
McCall, E. G. radar  
Moon, W. D. checkout; maintenance  
Nolan, T. lasers  
Okoomian, H. J. electro-optic systems; techniques  
Park, C. B. electro-optic systems; techniques  
Stockton, E. M. checkout; maintenance

## DEP APPLIED RESEARCH

Herscher, M. B. bionics  
Martin, T. B. bionics  
McShoy, J. P., Jr. superconductivity  
Shouhva, F. E. graphic arts systems; techniques  
Wright, P. E. energy conversion; sources

## DEP DEFENSE MICROELECTRONICS

Aires, R. H. management; business  
Bowe, J. J. solid-state microelectronics  
Moore, E. E. computer circuitry; devices

## DEP MISSILE AND SURFACE RADAR DIV.

Robinson, S. management; business  
Yin, H. B. amplification

## DEP SYSTEMS ENGINEERING, EVALUATION, AND RESEARCH

Baskerville, W. displays  
Gillis, R. N. displays  
Ireland, Dr. F. H. documentation; writing  
Wiedman, T. G. documentation; writing

## DEP COMMUNICATIONS SYSTEMS DIV.

Atzenbeck, C. R. bionics  
Castleberry, J. testing  
Corrado, A. C. circuit interconnections; packaging  
Detwiler, J. H. computer applications  
Erdmann, R. G. space vehicles; satellites  
Ernst, R. L. circuit theory; analysis

Fowler, F. H., Jr. communications, digital  
Fowler, F. H., Jr. computer applications  
Goldstine, H. E. communications, equipment components  
Hampel, D. bionics  
Hansell, G. E. communications, equipment components  
Hersey, R. E. circuit interconnections; packaging  
King, E. communications, equipment components  
Liebermann, J. communications, equipment components  
Matty, Dr. H. B. human engineering  
Merrell, C. instrumentation, lab equipment  
Rosenthal, M. P. documentation; writing  
Saunders, J. B. computer applications  
Sommer, R. C. lasers  
Sommer, R. C. communications, digital  
Trevor, B. A. communications, equipment components  
Pan, Dr. W. Y. solid-state microelectronics  
Yao, Y. L. computer storage

## HOME INSTRUMENTS DIV.

Harwood, L. A. television receivers  
Kowallek, D. E. radio receivers, entertainment  
Mehta, M. C. radio receivers, entertainment  
Norley, R. R. television receivers  
Schultz, J. B. radio receivers, entertainment  
Tourtelot, J. A. recording, audio

## NATIONAL BROADCASTING CO.

Himelfarb, F. television broadcasting, transmission  
Jorgensen, K. W. television broadcasting, transmission

## RCA COMMUNICATIONS, INC.

Andres, R. K. communications, digital

## RCA LABORATORIES

Beelitz, H. R. computer storage  
Bloom, Dr. S. communications, equipment components  
Borkan, H. displays  
Boyer, L. A. television, non-entertainment  
Cardona, M. superconductivity  
Clorfine, A. S. amplification  
Donal, Dr. J. S. solid-state materials  
Flory, L. E. television, non-entertainment  
Hatke, F. L. television, non-entertainment  
Hicinbothem, W. A., Jr. amplification  
Hochkiss, S. E. computer storage  
Hughes, R. D. amplification  
Kushan, Dr. J. management; business  
Larrabee, R. D. amplification  
Lewin, Dr. M. H. computer storage  
Li, Dr. K. computer storage  
Meyay-Horvath, L. displays  
Morgan, J. M. television, non-entertainment  
Nergaard, Dr. L. S. communications, equipment components  
Pankove, Dr. J. I. management; business  
Pike, W. S. television, non-entertainment  
Repp, A. K. computer circuitry; devices  
Reichman, Dr. J. A. computer storage  
Reichman, Dr. J. A. computer storage  
Rosenblum, B. superconductivity  
Ross, Dr. D. A. management; business  
Sadovis, Dr. G. displays  
Shabbender, Dr. R. computer storage  
Shallcross, Dr. F. V. displays  
Skilansky, Dr. J. bionics  
Swartz, Dr. G. A. amplification  
Weimer, Dr. P. K. displays  
Wenworth, C. G. computer storage  
Woodward, Dr. J. G. recording, audio  
Yates, C. E. documentation; writing

## RCA VICTOR LTD.

Carswell, Dr. A. I. instrumentation; lab equipment  
Carswell, Dr. A. I. lasers  
Waksberg, A. L. lasers

## RCA SERVICE CO.

Hartwick, F. C. communications, voice systems

## RESEARCH AND ENGINEERING (STAFF)

Gordon, Dr. G. D. space vehicles; satellites  
Kihn, H. management; business  
Wentworth, J. W. television broadcasting; transmission

## RCA STAFF

Goldsmith, Dr. A. N. biomedical electronics

# Editorial Representatives

The Editorial Representative in your group is the one you should contact in scheduling technical papers and announcements of your professional activities.

## DEFENSE ELECTRONIC PRODUCTS

F. D. WHITMORE<sup>o</sup> *Chairman, Editorial Board, Camden, N. J.*

### Editorial Representatives

#### Aerospace Systems Division

D. B. DOBSON *Engineering, Burlington, Mass.*

S. HERSH *Engineering, Van Nuys, Calif.*

#### Astro-Electronics Division

J. PHILLIPS *Equipment Engineering, Princeton, N. J.*

I. SEIDEMAN *Advanced Development and Research, Princeton, N. J.*

#### Missile & Surface Radar Division

T. G. GREENE *Engineering Dept., Moorestown, N. J.*

#### Communications Systems Division

C. W. FIELDS *Engineering, Camden, N. J.*

G. LIEBERMAN *Systems Engineering, Camden, N. J.*

W. C. PRAEGER *Engineering, Cambridge, Ohio*

M. P. ROSENTHAL *Systems Labs., New York, N. Y.*

#### Defense Engineering

R. R. SHIVELY *Systems Engineering, Evaluation, and Research, Moorestown, N. J.*

J. J. LAMB *Central Engineering, Camden, N. J.*

M. G. PIETZ *Applied Research, Camden, N. J.*

## BROADCAST AND COMMUNICATIONS PRODUCTS DIVISION

D. R. PRATT<sup>o</sup> *Chairman, Editorial Board, Camden, N. J.*

### Editorial Representatives

R. E. WINN *Brdcst. Transmitter & Antenna Eng., Gibbsboro, N. J.*

C. E. HITTLE *Closed Circuit TV & Film Recording Dept., Burbank, Calif.*

R. N. HURST *Studio, Recording, & Scientific Equip. Engineering, Camden, N. J.*

D. G. HYMAS *Microwave Engineering, Camden, N. J.*

W. J. SWEGER *Mobile Communications Engineering, Meadow Lands, Pa.*

## NEW BUSINESS PROGRAMS

N. AMBERG *Industrial & Automation Products Engineering, Plymouth, Mich.*

## ELECTRONIC DATA PROCESSING

H. H. SPENCER<sup>o</sup> *EDP Engineering, Camden, N. J.*

R. R. HEMP *Palm Beach Engineering, West Palm Beach, Fla.*

B. SINGER *Data Communications Engineering, Camden, N. J.*

## RCA LABORATORIES

C. W. SALL<sup>o</sup> *Research, Princeton, N. J.*

## RCA VICTOR COMPANY, LTD.

H. J. RUSSELL<sup>o</sup> *Research & Eng., Montreal, Canada*

## ELECTRONIC COMPONENTS AND DEVICES

C. A. MEYER<sup>o</sup> *Chairman, Editorial Board, Harrison, N. J.*

### Editorial Representatives

#### Commercial Receiving Tube & Semiconductor Division

P. L. FARINA *Commercial Receiving Tube and Semiconductor Engineering, Somerville, N. J.*

J. KOFF *Receiving Tube Operations, Woodbridge, N. J.*

L. THOMAS *Memory Products Dept., Needham and Natick, Mass.*

R. J. MASON *Receiving Tube Operations, Cincinnati, Ohio*

J. D. YOUNG *Semiconductor Operations, Findlay, Ohio*

#### Television Picture Tube Division

J. H. LIPSCOMBE *Television Picture Tube Operations, Marion, Ind.*

E. K. MADENFORD *Television Picture Tube Operations, Lancaster, Pa.*

#### Industrial Tube & Semiconductor Division

E. F. BRENIAK *Industrial Semiconductor Engineering, Somerville, N. J.*

R. L. KAUFFMAN *Conversion Tube Operations, Lancaster, Pa.*

K. LOOFBURROW *Semiconductor and Conversion Tube Operations, Mountaintop, Pa.*

G. G. THOMAS *Power Tube Operations and Operations Svcs., Lancaster, Pa.*

H. J. WOLKSTEIN *Microwave Tube Operations, Harrison, N. J.*

#### Special Electronic Components Division

R. C. FORTIN *Direct Energy Conversion Dept., Harrison, N. J.*

I. H. KALISH *Integrated Circuit Dept., Somerville, N. J.*

#### Technical Programs

D. H. WAMSLEY *Engineering, Harrison, N. J.*

## RCA VICTOR HOME INSTRUMENTS

K. A. CHITTICK<sup>o</sup> *Chairman, Editorial Board, Indianapolis, Ind.*

### Editorial Representatives

J. J. ARMSTRONG *Resident Eng., Bloomington, Ind.*

D. J. CARLSON *Advanced Devel., Indianapolis, Ind.*

R. C. GRAHAM *Radio "Victrola" Product Eng., Indianapolis, Ind.*

P. G. MCCABE *TV Product Eng., Indianapolis, Ind.*

J. OSMAN *Electromech. Product Eng., Indianapolis, Ind.*

L. R. WOLTER *TV Product Eng., Indianapolis, Ind.*

## RCA SERVICE COMPANY

M. G. GANDER<sup>o</sup> *Cherry Hill, N. J.*

B. AARONT *EDP Svc. Dept., Cherry Hill, N. J.*

W. W. COOK *Consumer Products Svc. Dept., Cherry Hill, N. J.*

E. STANKO *Tech. Products Svc. Dept., Cherry Hill, N. J.*

T. L. ELLIOTT, JR. *Missile Test Project, Cape Kennedy, Fla.*

L. H. FETTER *Govt. Svc. Dept., Cherry Hill, N. J.*

## RCA COMMUNICATIONS, INC.

C. F. FROST<sup>o</sup> *RCA Communications, Inc., New York, N. Y.*

## RCA VICTOR RECORD DIVISION

M. L. WHITEHURST *Record Eng., Indianapolis, Ind.*

## NATIONAL BROADCASTING COMPANY, INC.

W. A. HOWARD<sup>o</sup> *Staff Eng., New York, N. Y.*

## RCA INTERNATIONAL DIVISION

L. A. SHOTLIFF<sup>o</sup> *New York City, N. Y.*

<sup>o</sup> Technical Publication Administrators for their major operating unit.



A TECHNICAL JOURNAL PUBLISHED  
BY PRODUCT ENGINEERING.  
"BY AND FOR THE RCA ENGINEER"

RADIO CORPORATION OF AMERICA